

FREE!  
FULL-SIZE  
PATTERNS

# WOOD

Our editors reveal:

## "The Best Tool I Ever Bought"

p.28

### 21

Skills and Tools for

## PERFECT MITERS

### Skill-Builders

- Quick, Easy Half-laps
- No-fuss Veneering
- Avoid Jointer Snipe

### SHOP ORGANIZER

Build it with only a drill, circ saw, and router!  
p.32



38



70



in this issue

32



64

## PROJECTS

- 32 Bench-tool shop system**  
Build this mobile, space-saving system using only a circ saw, router, and drill.
- 38 Nesting tables**
- 48 All-in-one storage bins**  
Add ample, flexible storage to your home or garage. Melamine panels mean no finishing!
- 58 Kid's biplane shelf**
- 70 Desk clock**
- 86 Quick & easy shop project: Half-lap jig**

## TECHNIQUES

- 18 Finishing school: French polish**
- 24 10-minute miter gauge tune-up**
- 42 Low-tech, low-cost veneering**  
Plain woods become dazzling with a thin skin of veneer—no pricey tools required.
- 80 Specialty fasteners for sheet goods**
- 102 How to avoid jointer snipe**

## TOOLS & MATERIALS

- 28 "The best tool I ever bought"**  
*WOOD*® magazine editors and contributors share their sometimes-surprising favorite woodworking tools.
- 64 Shop-tested: Miter gauges and sleds**
- 74 Get into turning for under \$600**  
Setting up a woodturning shop costs less than you think. We'll tell you which tools and accessories you need.
- 84 Wise buys: Mini lathes**
- 88 Shop-proven products**  
Powered tool sharpener, low-cost bandsaw blades

## DEPARTMENTS

- 8 Editor's Angle**
- 10 Sounding Board**
- 12 Shop Tips**
- 92 Ask WOOD**
- 108 What's Ahead**

48



74



This seal is your assurance that we build every project, verify every fact, and test every reviewed tool in our workshop to guarantee your success and complete satisfaction.



84

## COME WITH US TO LAS VEGAS!

**Tools Editor Bob Hunter takes you** onto the floor of the 2007 Association of Woodworking & Furnishings Suppliers Fair in Las Vegas! Watch day-by-day videos as Bob reveals his picks of the coolest new tools at [woodmagazine.com/videos](http://woodmagazine.com/videos).

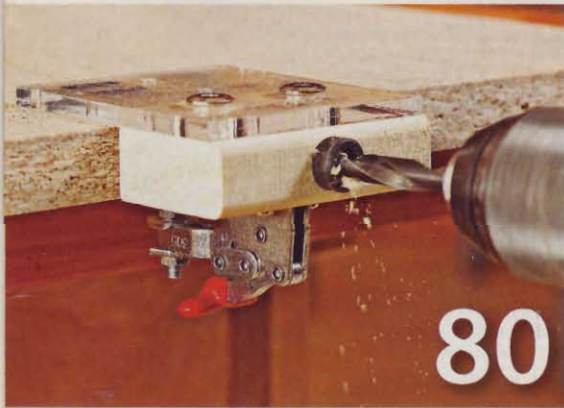

80



58



42



## SLIDE SHOWS ASSIST ASSEMBLY

See **WOOD®** magazine projects go together before your eyes. Need a little extra help assembling a project? Go to [woodmagazine.com/slideshows](http://woodmagazine.com/slideshows) to view projects as they're built. New slide shows this issue: Bench-Tool Shop System (page 32) and All-in-one Storage Bins (page 48).



## BE INSPIRED

Post photos of your woodworking projects at [woodmagazine.com/projectgallery](http://woodmagazine.com/projectgallery). Or go there to see the work of other woodworkers from around the world.



Cherry bookstand built by Gerald Lawrence, Brandon, Miss.

## WHAT THE HECK IS A WOOD WIKI?

It's an encyclopedia of woodworking knowledge that **you help create!** Look up woodworking terms you don't know at [woodmagazine.com/woodwiki](http://woodmagazine.com/woodwiki), or have fun embellishing our definitions with your own insight.

# On Your Newsstand NOW!



**We all make mistakes — learn how top woodworkers fix them!**

Solve workshop goofs with these tried-and-true solutions:

- ✓ Ensure tight, just-right joinery
- ✓ End measuring and marking snafus
- ✓ Hone your hand-tool skills
- ✓ Jointing and planing pointers
- ✓ Drilling do's & don'ts
- ✓ Router remedies

Purchase online at [woodmagazine.com/publications](http://woodmagazine.com/publications)  
or call toll-free 888-636-4478  
\$6.99 U.S., \$8.99 Canada

WD1007

## Better Homes and Gardens® WOOD®

October 2007

Vol. 24, No. 5

Issue No. 179

### We asked our staff:

What is your most satisfying moment in woodworking?



Completing a woodworking project is great, but getting the creative juices flowing to design and plan the next one is bliss.



When I got the job at WOOD magazine as a designer and builder of projects.

EDITOR-IN-CHIEF  
**BILL KRIER**

Managing Editor **MARLEN KEMMET** Deputy Editor **DAVE CAMPBELL**

Senior Design Editor  
**KEVIN BOYLE**

Techniques Editor **BOB WILSON** Tool & Techniques Editor **BOB HUNTER**

Projects Editor **OWEN DUVALL** Projects Editor **JAN SVEC**

Design Editor **JEFF MERTZ** Master Craftsman **CHUCK HEDLUND**

Art Director **KARL EHLERS** Associate Art Director **GREG SELLERS** Assistant Art Director **CHERYL A. CIBULA**

Production/Office Manager **MARGARET CLOSNER** Administrative Assistant **SHERYL MUNYON**

Photographers

**MARTY BALDWIN, JASON DONNELLY, DEAN SCHOEPPNER, JAY WILDE**

Illustrators **TIM CAHILL, LORNA JOHNSON, ROXANNE LeMOINE**

Technical Consultants **JEFF HALL, PAT LOWRY**

Contributing Craftsman **JIM HEAVEY**

Proofreaders **BARBARA KLEIN, IRA LACHER, JIM SANDERS**

SUBSCRIBER SERVICE

Go to [woodmagazine.com/service](http://woodmagazine.com/service) or write to WOOD magazine, P.O. Box 37439, Boone, IA 50037-0439

Publisher **MARK L. HAGEN**

ADVERTISING AND MARKETING

CHICAGO: 333 N. Michigan Ave., Suite 1500, Chicago, IL 60601

Marketing Manager **AMANDA SALHOOT**

Advertising Managers **JACK CHRISTIANSEN, CAROLYN DAKIS**

Direct Response Advertising Representative **RYAN INTERLAND**

Assistants **GAYLE CHEJN, JACI LESKO**

ATLANTA: Navigate Media

DETROIT: RPM Associates

Product Marketing Manager **DIANA WILLITS**

Business Manager **JEFF STILES**

Associate Consumer Marketing Director **DAN HOLLAND**

Associate Director of Marketing-Newsstand **TOM DEERING**

Senior Production Manager **MELANIE STOLTENBERG**

Advertising Operations Manager **JIM NELSON**

Senior Vice President/Publishing Director **DOUG OLSON**

Group Publisher **TOM DAVIS**

MEREDITH PUBLISHING GROUP

President **JACK GRIFFIN**

Editorial Director **MIKE LAFAVORE**

Finance & Administration **KARLA JEFFRIES**

Manufacturing **BRUCE HESTON**

Consumer Marketing **DAVID BALL**

Creative Services **ELLEN de LATHOUDER**

Corporate Sales **JACK BAMBERGER**

Interactive Media **LAUREN WIENER**

Corporate Marketing **NANCY WEBER**

Research **BRITTA WARE**

**Meredith**  
CORPORATION

President and Chief Executive Officer **STEPHEN M. LACY**

Chairman of the Board **WILLIAM T. KERR**

In Memoriam — E.T. Meredith III (1933–2003)

Our subscribers list is occasionally made available to carefully selected firms whose products may be of interest to you. If you prefer not to receive information from these companies by mail or by phone, please let us know. Send your request along with your mailing label to Magazine Customer Service, PO Box 10263, Des Moines, IA 50336-0263.

© Copyright Meredith Corporation 2007. All rights reserved. Printed in the U.S.A.



Using a portable sawmill to slice a bur-oak log into quartersawn stock. That "home-made" wood has found its way into dozens of projects.



Anytime I finish a project — there are too many that I have started and not completed.

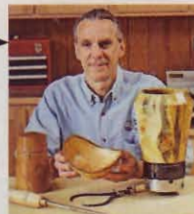

Turning a bowl on my refurbished 1947 Delta Milwaukee Homecraft lathe and the satisfaction of transforming a piece of firewood into a beautiful object.



## GAS-FIRED INFRARED TUBE HEATERS

are the *Best* Overall Method for Heating your Workshop!

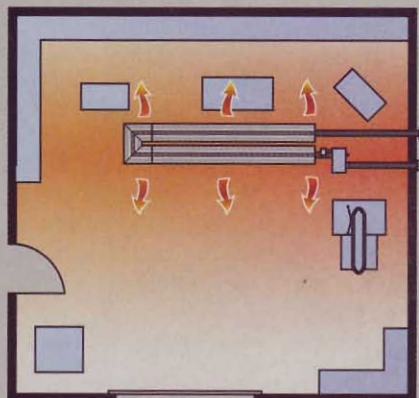
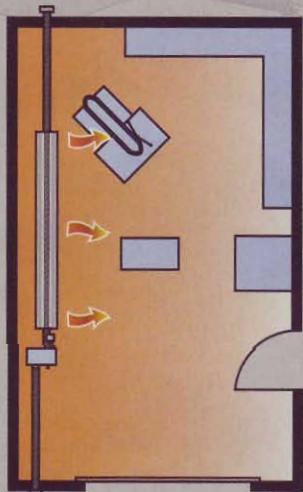

Gas fired infrared radiant heaters provide dust-free, comfortable and cost effective heat in your workshop.

Studies have shown **fuel cost savings** by as much as 50% over forced air systems.

Contact us today for your free, no-obligation analysis.



**DETROIT RADIANT PRODUCTS COMPANY**  
21400 Hoover Road,  
Warren, MI 48089

**800-222-1100**

For additional information, visit [www.woodworkerscenter.com](http://www.woodworkerscenter.com) and click on the "Free Product Info" link

## Editor's Angle

# Sometimes, Simple is Best

On page 32 you'll find the debut of a series of articles tagged "Basic-Built. Great Projects. Simple Tools." I think you'll find a lot to like.

**S**ome of us seem to own virtually every woodworking tool ever made. Others get by with no more tools than we can fit into the trunk of a car.

Most of us fall somewhere between those two extremes. Regardless of our tool collection, or budget for wood and other supplies, we all love to make beautiful and functional projects. And, I suspect, a lot of us like to do things as quickly, easily, and cheaply as possible.



The bench-tool system adheres to three laws we've laid down for all Basic-Built projects:

### **1 No expensive tools required.**

You need not spend more than \$200 for any tool necessary to build these projects. The bench-tool system requires a portable circular saw, router, and drill. Of course, if you own a deluxe tablesaw go right ahead and use it, but we've designed these projects so you get great results with low-cost tools.

### **2 You can buy everything at a home center.** This ensures that

the wood, hardware, finishes, and other supplies needed to build the project are affordable and easy to find. If you have

an urge to build the bench-tool system from an exotic hardwood and top-grade

plywood, please be

our guest, but 2x4s, MDF, and hardboard look good and work great in this application.

**3 No complicated joinery.** Expect screws, butt joints, and half-laps: whatever is simple yet plenty strong without sacrificing style. If you prefer mortise-and-tenon joints, or dovetails, by all means go for it.

Basic-Built projects enable the beginning woodworker to send the sawdust flying along with the rest of us. But, even if you own a king's ransom in tools, don't look down your nose at these projects—you'll still appreciate the low cost and easy construction.

We'll run a Basic-Built project in most issues, never more than one per issue (unless you e-mail me into submission by demanding more or fewer: try [bill.krier@meredith.com](mailto:bill.krier@meredith.com)). And you won't find just shop and outdoor projects in this series—count on everything from small gifts to indoor furniture, too.



*Bill Krier*

# Sounding Board

Our bulletin board for letters, comments, and timely updates

## Newborn enjoys Dad-made 3-in-1 crib

I am writing to you from the crib my daddy (Maurizio Del Poeta) built especially for me. It's so comfortable that I spend almost all my time in it! My daddy made the crib (3-in-1 Transition Bed, pages 44–54) from the plans in issue 173 (November 2006) of *WOOD*® magazine. I guess it was meant to be that I'd have this crib because Daddy received that issue in the mail the very same day he and Mommy (Chiara Luberto) found out they were expecting me! He started making it right after Christmas and finished it just a few weeks before I was born on April 13.

Daddy also made the other components so that as I grow, I can trade my crib for a toddler bed and later a full-size bed. He made everything from cypress and finished it with Danish oil to match the rest of our furniture. I can't thank you enough for making this all possible.

—Matteo Del Poeta, Charleston, S.C.



Photo: Maurizio Del Poeta



## Inventive reader adds new elements to gauges

I was thoroughly intrigued by your Fibonacci gauge in issue 173 (November 2006). I made one according to your plans, and soon found myself wanting to use it one-handed, but could not. As someone who enjoys designing projects on a computer, I created several alternative versions. These include one with scissorlike handles for one-handed use, one with a circular shape at the apex to hang it on the wall, and still another at three times scale for larger projects. My real pride and joy, though, I made by copying a dental caliper, *far left*. I cut them out of standard countertop plastic laminate using a CNC router; then attached pop rivets for the fasteners. I used a laser engraver for the lettering.

—Rick Hutcheson, Grimes, Iowa

## HOW TO REACH US

### ■ For woodworking advice:

Post your woodworking questions (joinery, finishing, tools, turning, general woodworking, etc.) on one of 14 online forums at [woodmagazine.com/forums](http://woodmagazine.com/forums).

### ■ To contact our editors:

Send your comments via E-mail to [woodmail@woodmagazine.com](mailto:woodmail@woodmagazine.com); or write to *WOOD* magazine, 1716 Locust St., LS-221, Des Moines, IA 50309.

### ■ Subscription assistance:

To notify us of an address change, or to get help with your subscription, visit [woodmagazine.com/service](http://woodmagazine.com/service). Or write to *WOOD* magazine, P.O. Box 37439, Boone, IA 50037-0439. Please enclose your address label from a recent magazine issue.

### ■ To find past articles:

See our index at [woodmagazine.com/index](http://woodmagazine.com/index).

### ■ To order past issues and articles:

Order past issues of *WOOD* magazine, our special issues, or downloadable articles from issue 100 to present: Visit our online store at [woodmagazine.com/store](http://woodmagazine.com/store). Some issues are sold out.

### ■ Updates to previously published projects:

For an up-to-date listing of changes in dimensions and buying-guide sources from issue 1 through today, go to [woodmagazine.com/editorial](http://woodmagazine.com/editorial).

# Shop Tips

Helping you work faster, smarter, and safer

## A safer stop for your radial-arm saw

A length stop on your radial-arm saw fence makes repetitive cuts more accurate. But short pieces can get trapped between the blade and stop, damaging them or launching them back at you. To prevent this, I built the pivoting stopblock, shown below. (You might need to vary the dimensions shown to suit your saw.)

To use it, I align the cutline on my workpiece with the blade, butt the movable end of the stop against the end of the workpiece, and then clamp the opposite end of the stop to the saw's fence. As I pull the saw head toward me to make the cut, it bumps the plywood "sail", pivoting the stop harmlessly out of the way and preventing the offcut from being trapped.

—Arthur Hoff, Lakeland, Fla.

### Top Shop Tip

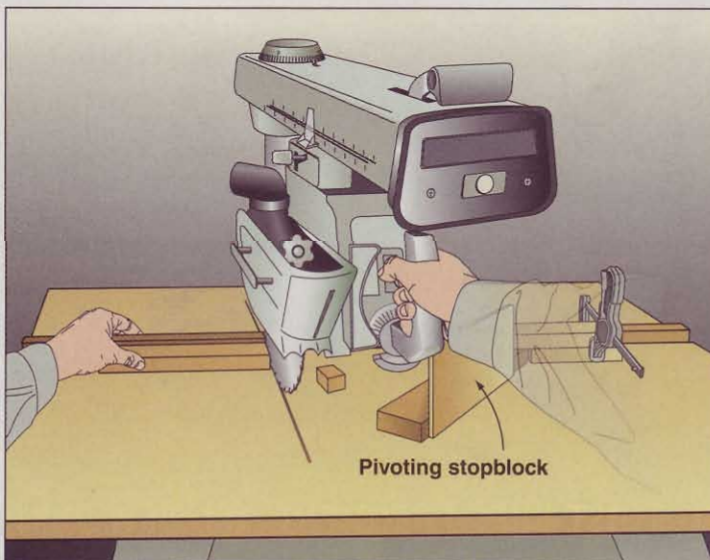
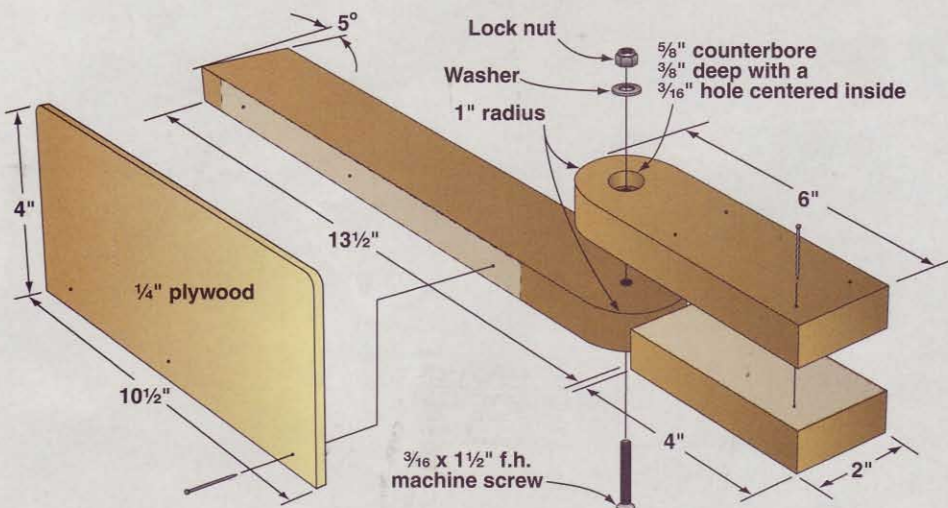

## The Top Tipster



If this guy looks familiar, it's because you've seen Arthur Hoff before. His first Top Shop Tip was published in issue 173 (November 2006), making him something of an "American Idol" to the guys he shares a shop with in his Florida community. "They were impressed," he quips. "They looked at the picture in the magazine and said, 'Hey, those are our clamps!'" As you can see from Arthur's tip, at left, the sequel proves every bit as good as the original.



Arthur's tools will be as sharp as his mind after he receives the Work Sharp system for submitting this issue's Top Shop Tip.

### Top tips earn tools!

Tell us how you've solved a workshop stumper, and you'll get \$75 if we print it. And, if your idea garners Top Shop Tip honors, we'll also reward you with a tool prize worth at least \$250.

Send your best ideas, along with photos or drawings and your daytime phone number, to Shop Tips, WOOD Magazine, 1716 Locust St., LS-221, Des Moines, IA 50309-3023. Or, by e-mail: [shoptips@woodmagazine.com](mailto:shoptips@woodmagazine.com). Include your contact info in the e-mail.

Because we publish only original tips, please send your tips only to WOOD® magazine. Sorry, submitted materials can't be returned.

## You can't use your pushstick if you can't find it

I keep a variety of pushsticks near the machines that require them. But looking for a pushstick is sometimes like hunting for deer—you always see them, but when you need one, they seem to disappear. Here's my solution.

Using heavy-duty, self-adhesive hook-and-loop tape, I secured the pushsticks in easy-to-reach spots that won't interfere with the machine's operation.

—David Birch, Syracuse, Utah

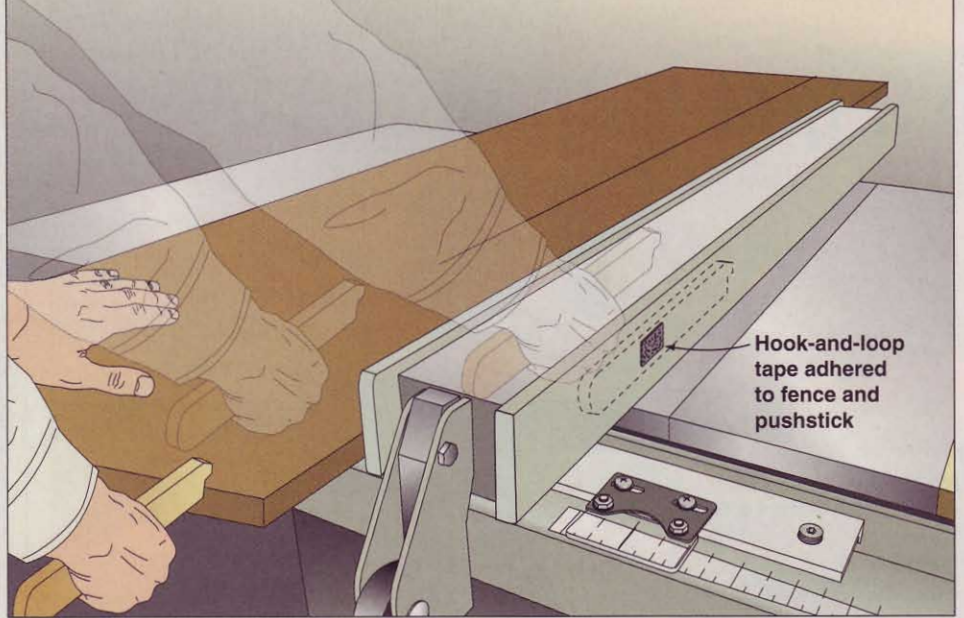

## Where's that pencil? Just hangin' around...

When working in the shop, I like to keep a mechanical pencil handy by hanging it on a string tied around my neck. But recently, a friend gave me some VIP tickets to a sporting event and we were given lanyards with our passes on them. Instantly a light went on that this would be a great replacement for my pencil on a string.

The lanyard has three advantages: First, it has a break-away connector in case it gets caught in machinery. Second, the detachable clip allows the pencil to be used at arm's length, if need be. Finally, it's much more official-looking than a piece of string.

—Mathew Fast, Dearborn Heights, Mich.

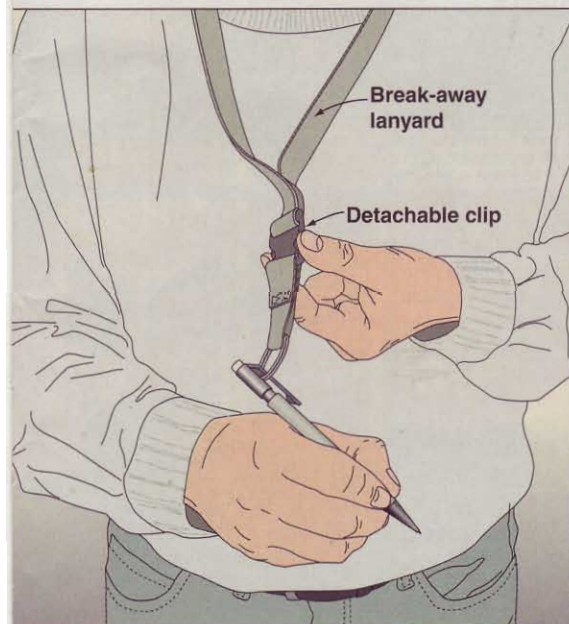

continued on page 14

**POWER SHOT.**

## Forward Action<sup>®</sup> is forward thinking

Form follows function with the exclusive ergonomic design of PowerShot<sup>®</sup> Forward Action<sup>®</sup> staplers. PowerShot<sup>®</sup> staplers, patent protected worldwide, put the power over the staple where you need it! PowerShot's design makes stapling easier by providing more control and less user fatigue. Forward Action<sup>®</sup> eliminates the kickback associated with rear action staplers and requires only one hand to operate.

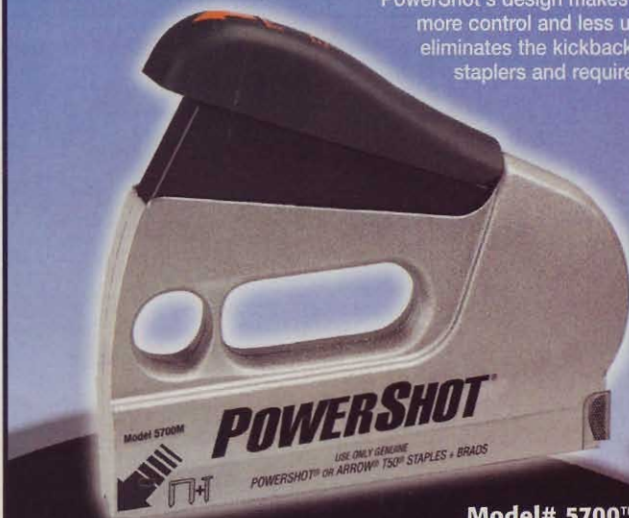

Available at home centers, lumberyards and fine hardware stores!

Model# 5700™

- Fires 1/4" thru 9/16" PowerShot<sup>®</sup> & Arrow<sup>®</sup> T50<sup>®</sup> Staples
- Drives 9/16" PowerShot<sup>®</sup> & 5/8" Arrow Brad Nails
- Low Actuation Force Required to Fire

- Less User Fatigue
- Staples/Nails Remaining Window
- Soft Grip Handle
- Easy Load Staple Chamber
- Made in U.S.A.



**POWER SHOT.**  
www.powershot-tool.com

UNITED STATES: 271 Mayhill Street, Saddle Brook, NJ 07663  
CANADA: Jandel Distributors, Inc. 6505 Metropolitan Blvd. East, Montreal, Quebec H1P 1X9  
UNITED KINGDOM: Unit 5, 2K Park, 25 Commerce Way, Groydon CR0 4ZS Surrey



# Are you buying the best?



## INNOVATIVE

Unique fully integrated soft grip handle

## SUPERIOR

40% More Clamping Force than 500QC series QUICKGRIP Bar Clamps\*

## DEPENDABLE

Value Priced Clamps for over 100 years

# "Jorgensen" ISO<sup>®</sup>

Circle No. 733

Bar/Spreader Clamp

Adjustable Clamp Co. Chicago, IL 60622

www.adjustableclamp.com

\* When tested using the same input force. Quick-Grip is a registered trademark of Irwin Industrial Tool Company.

## Shop Tips

### Simple, sturdy storage shelves for screws

In the past, I've noticed that the small plastic storage bins you buy at home centers and hardware stores won't hold all the contents of a 1 lb. box of some fasteners. However, I also noticed that those 1 lb. boxes are almost always the same size, regardless of the fasteners inside. Even better, they already come in perfectly serviceable, prelabeled, storage containers. So instead of buying buckets of bins, I built these simple shelves and store the pre-labeled boxes on them.

—Jeff Feuerstein, Neenah, Wis.

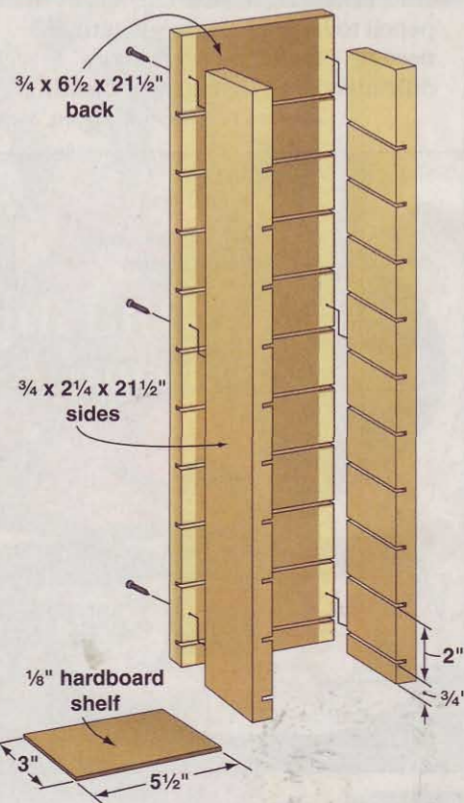
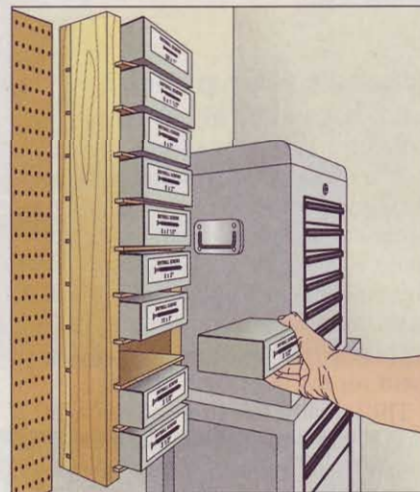

## WOODCRAFT<sup>®</sup>

For A Free Catalog Or To Find Your Local Woodcraft Store, Visit [www.woodcraft.com](http://www.woodcraft.com) Or Call 800-542-9115.

**M**ix and match with Mixol Universal Tints, now available in 200ml bottles! Mixol Universal Tints are the most concentrated, highest quality tints on the market today.

- Compatible with most water, solvent, lacquer and oil based stains, coatings, shellacs, epoxies, waxes, varnishes, wood fillers, glue, paint, etc...
- Ease of tinting or mixing
- Sophisticated color palette
- Binder-free for a very long shelf/shop life
- LW tints are color-fast, fade-resistant and weather-proof
- Oxide tints are ideal for exterior use or where UV fade may occur
- Mixol tints are not flammable or hazardous
- Clean-up is easy

**MATCH IT WITH MIXOL<sup>®</sup>**



www.woodcraft.com/mixol

QUALITY WOODWORKING TOOLS SUPPLIES • ADVICE<sup>™</sup>

Circle No. 700

## Find buried treasure while keeping your hands clean

Few things are as frustrating as watching a small metal part, such as an arbor nut or washer, disappear into a deep pile of sawdust at the bottom of a cabinet. I don't get worked up anymore since I epoxied a rare-earth magnet to the end of a 36" dowel. I simply plunge the magnet end into the dark depths and quickly find that needle in the haystack (and sometimes, a few other things as well).

—Lawrence Byers, Lansing, Mich.



## Strap adds extra margin of table saw safety

A co-worker recently had a close call with our cabinet-style table saw. While using his tape measure to set the rip fence, he leaned against the saw. The key ring in his pants pocket accidentally pressed the saw's recessed "start" button—with his hand only about ¼" from the blade. Fortunately, he wasn't injured, but after seeing this near accident, I decided to add an extra measure of safety.

I shaped a metal strap to fit over the switch box and stand out from the start button about 1". I then drilled an access hole in the strap and mounted it over the switch box with the access hole directly over the start button. Now, for the saw to turn on, you really have to want it to start. 🍀

—Mark Patrick, Ionia, Mich.

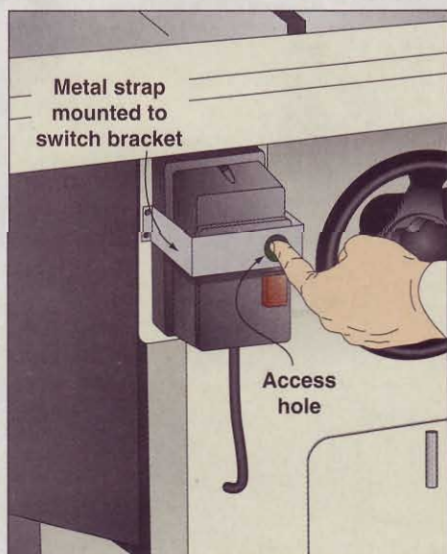

# Innovative New Sharpener

## Helps You WORK SHARP™

- Patent-Pending Air-Cooled, Dry Sharpening System
- Precision Repeatability—  
20°, 25°, 30°, and 35° Bevel Angles
- Fast & Easy to Use, No Jigs Required
- Sharpens Chisels, Plane Irons, Carving and Lathe Tools, & More



Chisel Port ensures precision repeatability of bevel angles

**WORK SHARP**  
The Wood Tool Sharpener



Innovative Edge-Vision™ Slotted Wheel lets you see the cutting edge as you sharpen

[www.worksharptools.com](http://www.worksharptools.com) • 1-880-597-6170

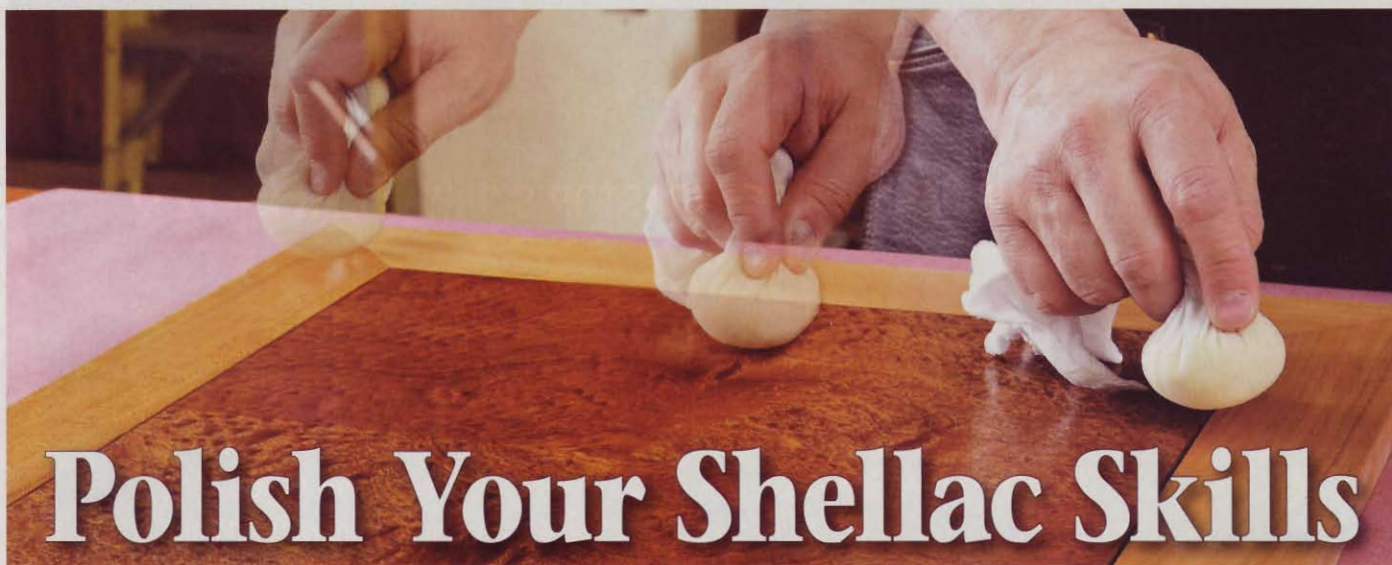

## Polish Your Shellac Skills

French polishing builds layers of shellac into a high-gloss finish without streaks or dust nibs.



Watch a FREE video on French polishing at [woodmagazine.com/videos](http://woodmagazine.com/videos).

**T**hink of French polishing—the centuries-old process of applying finish using a shellac-soaked cloth pad—as the hand-cut dovetail joint of the finishing world: It takes only a few minutes to yield beautiful results using just simple tools.

A French-polished finish's grain-popping gloss proves easier to repair than modern finishes, and it produces fewer strong fumes than oil-based coatings. Even if you never French-polish an entire project, you could use the straight-forward techniques demonstrated here to touch up minor scratches or scuffs on any glossy finish, including varnish or lacquer.

### Prepare to polish

Mix a 2-pound cut of shellac by dissolving 2 ounces of ground-up flakes (see **Sources**) in 8 fluid ounces of denatured alcohol from a newly opened container that hasn't absorbed water vapor. For a warm-color finish, use garnet or amber shellac flakes; to preserve the color of light woods, use blonde or super-blonde shellac flakes.

You also need a lint-free cotton or linen cloth, such as a frequently

washed, white cotton T-shirt or linen handkerchief, cotton or wool wadding (a T-shirt works for this, too), mineral or paraffin oil, and naphtha. You can pour shellac directly onto the pad, but an applicator bottle makes less mess.

Next, prepare your surface for finishing. Start by filling the pores of open-grain woods with a commercial pore filler or by brushing multiple coats of shellac onto the surface and then sanding them down to bare wood using 180-grit coated abrasive. Shellac quickly gums up sandpaper, so check it frequently for shellac deposits that can scratch the surface [**Photo A**]. Repeat until the shellac-filled pores become level with the surrounding wood. By hand-sanding with a flat pad, you can use shellac's gloss to discover low spots on the surface that you need to continue filling [**Photo B**].

Now it's time to make your applicator pad. Lay a piece of lint-free fabric about 8" square atop a flat surface. Add loose wadding or pieces of fabric at the center of the square, and gather the corners together [**Photo C**]. Experiment with different amounts of wadding until you create the largest pad you can hold comfortably. Once you find the right size, apply shellac to the inside wadding before twisting together the corners of the outside piece, forming the wadding into a ball with a wrinkle-free bottom. Apply additional shellac to the bottom of the pad, and allow it to soak in. Now you're ready to wipe on the finish.

*continued on page 20*

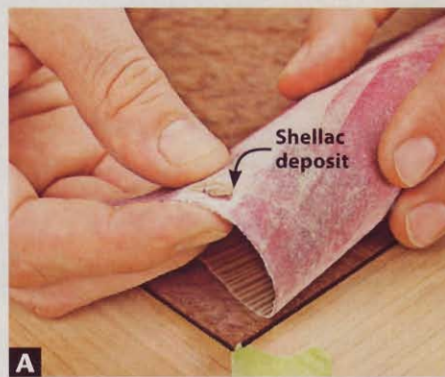

## Finishing School

continued from page 18

### Keep the pad moving

Start your polishing stroke with the pad slightly above the surface, and begin moving it sideways in the direction of the grain and down until it touches the wood. Move it quickly across the surface with moderate pressure at first, and lift it away after you reach the edge [Photo D]. You apply such thin layers of shellac that they dry almost instantly, so keep the applicator pad constantly moving to avoid leaving marks.

For a steady flow of shellac, hold the pad firmly but without squeezing it tightly at first. Increase your grip pressure on the pad and press it down increasingly harder to force out more shellac. When the alcohol in the shellac evaporates, it leaves a momentary trail behind the pad. When the trails stop, refill the pad until shellac comes to the surface when you press your finger firmly against it.

As the finish builds, you may notice the pad begin to drag against the existing shellac layers. To lubricate it, dip your fingertip into mineral oil or paraffin oil and run it across the pad [Photo E]. Use only enough oil to keep the pad from catching.

Avoid working the same area until the surface becomes tacky and dull from having the shellac continually resoftened. If you need to take a break or wait for the surface to dry, seal your polishing pad in an airtight jar [Photo F]. Should the shellac harden on the stored pad, soften it by adding alcohol.

Keep polishing until you achieve the desired gloss, but beware of a shine resulting more from oil than shellac. To check how the real finish looks after it's dried completely, remove the excess oil using a cloth saturated with naphtha [Photo G], which won't dissolve shellac. Remove any streaks or rag marks by lightly sanding them with 1,000-grit abrasive lubricated with mineral oil; then resume polishing.

After about a half hour of polishing, you should see an even, high-gloss finish [Photo H]. For still more shine, top off the finish with a wax or polish. 🌲

### Sources

**Garnet shellac flakes.** Hock dewaxed garnet flakes, \$22 for 1 lb, call Tools for Working Wood at 800-426-4613; [toolsforworkingwood.com](http://toolsforworkingwood.com). Or Hock garnet no. 143157, \$22.50 for 1 lb, call Woodcraft at 800-225-1153; [woodcraft.com](http://woodcraft.com).



## Vary your French-polishing strokes

You can French-polish a surface using simple back-and-forth strokes, but the job goes faster and is easier on your arms if you vary your polishing pattern. The strokes illustrated below allow you to move the pad constantly without frequently lifting it from the surface. As with the basic back-and-forth stroke, your pad needs to be moving when it touches down on the wood surface and as you lift it away. Avoid letting the pad come to a stop as you change directions or you'll dull the surface and leave pad marks.

Whichever pattern you choose, remember this French-polishing adage: Take care of the edges, and the middle will take care of itself. You can French-polish the frame of a tabletop separate from the center panel, but strokes should extend over all four edges of the surface you're polishing. For framed surfaces like the ones shown, we French-polished the center panel separately from the frame.

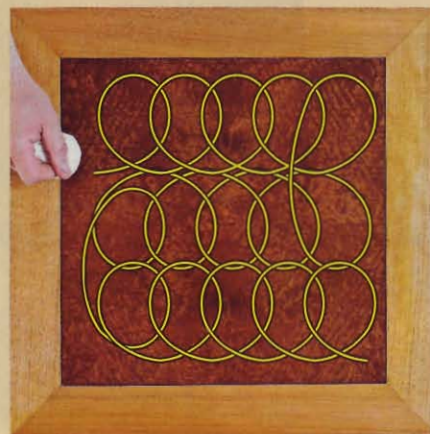

## Tool Shop

# Tune your miter gauge

Your miter gauge can be your best friend in the workshop, so keep it in top-notch working condition with this seven-step maintenance plan.

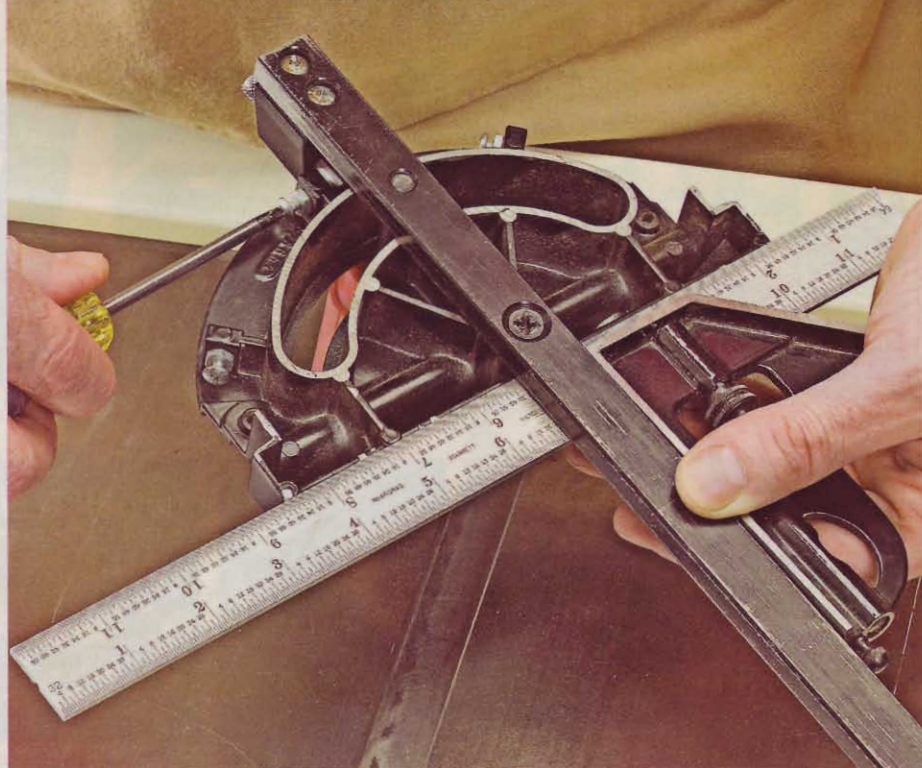

### Step #1: Clean it

Just as with any tool, a miter gauge can get gummed up with dust, chips, and debris. So disassemble it and clean all the components, using a brass bristle brush and solvent. On tough buildup we used Boeshield Blade and Bit cleaner. Lube all movable parts with a dry lubricant, such as Empire Dri-Tool.



### Step #2: Keep it straight

Check your miter-gauge bar for straightness with a long steel rule. Look toward a bright light or window; light will shine through any gaps between the bar and rule. If it has any crook in it, the bar will wear unevenly against the sides of the miter slot, as shown by the shiny ends of this bar, at far right.



### Step #3: Straighten the bar

Straighten a crooked miter bar—or one that fits too tightly in a miter slot—by rubbing the concave edge on 120-grit self-adhesive sandpaper stuck to your tablesaw top. Don't overdo it; check with a straightedge after five passes.



### Step #4: Tighten the fit

To make a slightly undersized bar fit tighter in the slot,peen one side of the bar with a hammer and center punch. Peen it at four or five equidistant points. If it's still too loose,peen the other side. If that makes it too tight, sand one side lightly to fit.



*continued on page 26*

## Quality Pen Kits and Other Turning Kits



- Designers & Manufacturers
- Wholesale & Retail

**THE BereaHardWoods** CO. Inc.

Manufacturer of quality writing instruments, components and kits.

Visit Our New Web Site: [www.penkits.com](http://www.penkits.com)

18745 Sheldon Rd. • Middleburg Hts., Ohio 44130 U.S.A.

Ph: 216-898-8956 • Fax: 216-898-8962 • E-mail: [bereahard@aol.com](mailto:bereahard@aol.com)

Circle No. 2127

## Introducing ZAR® ULTRA Max Waterborne Oil Modified Polyurethane



ZAR ULTRA Max comes in quart and gallon sizes.  
It is available in gloss, semi-gloss and satin sheens.

**ULTRA Max is an environmentally safe, revolutionary dual drying polyurethane. It dries by coalescing & oxygen cross-linking for a harder "through cure."**

- Self-leveling, smooth finish
- Ideal for floors, cabinets, furniture and woodwork
- Outstanding wear and durability
- Super fast drying-low odor formula
- Exotic hardwoods approved

**DualDrying**  
TECHNOLOGY  
DRIES HARDER FASTER

UGI  
**75**  
YEARS

For more information and a dealer near you  
call 1-800-272-3235 or visit us at [www.ugi.com](http://www.ugi.com).

Circle No. 154

## Tool Shop

### Step #5: Adjust the screws

Some newer miter gauges come with bars that can be fit easily to a slot without peening. Following the manufacturer's directions, adjust the setscrews until the bar slides easily in the slot without any side-to-side movement.



### Step #6: Set for square

If your miter gauge's 90° stop proves inaccurate, correct it by first using a reliable square to set the angle, tightening the head in place, and then adjusting the stop screws snug against the bar or flipstop, as shown on page 24. You might also need to reset the cursor to align with the 0°/90° reading on the miter scale.

### Step #7: Set the miter stops

Check and set the 45° miter stops by using a drafting triangle. Attach MDF blocks—ripped to 1½" wide—with double-faced tape to the triangle, making sure to align one edge with the square's edge. To set the stops, rest one block against the miter bar and the square's long edge against the head. Tighten the screw against the flipstop; then do the same for the other side.



### Sources

**Tool cleaner:** Boeshield Blade and Bit, 8½ oz., #128479, \$11, Woodcraft, 800-225-1153 or [woodcraft.com](http://woodcraft.com).

**Tool lubricant:** Empire Dri-Tool, 8 oz., #147038, \$14, Woodcraft, 800-225-1153 or [woodcraft.com](http://woodcraft.com).

The WOOD® magazine staff reveals...

# “The best tool I ever bought”

We asked our editors and contributors which woodworking tools they couldn't live without. Their answers might surprise you.



**A** woodworking tool can be expensive and still be a great deal; likewise, a low-cost machine or accessory can prove itself valuable far beyond its price tag. That was certainly true when we asked the folks who put together every issue of *WOOD* magazine to name the best tools they ever bought. Their answers—by their variety—proved eye-opening.

## Tested by time and still going strong

### Powermatic 66, \$2,800

WMH Tool Group  
800-248-0144, powermatic.com

Admittedly, it was a whole lot of money to spend at a time when I was early in my career, and with two baby girls, but I've never regretted it. The Powermatic 66 3-hp cabinet-style saw brought so much accuracy and ease-of-use to my woodworking by eliminating all of the frustrations I had experienced with my low-cost contractor-style saw. There's no doubt that the 66 changed my woodworking life forever.

—Bill Krier, Editor-in-Chief

### Starrett 12" combination square, C11H-12-4R, \$70

L.S. Starrett Company  
978-249-3551, starrett.com

This combination square is the true multitasker in my shop: When used with a marking knife or sharp pencil, it's more precise than a measuring tape, more accurate than a framing square, and great for marking offsets when doing trim work, such as a door casing. My Starrett combination square proves dead-on reliable when it comes to tool set-ups, as shown at *right*, and with the head removed makes an excellent bench rule.

—Jeff Mertz, Design Editor



### Delta Unifence U50, \$385 (50" rip capacity)

Delta Machinery  
800-223-7278, deltamachinery.com

I've used a number of different tablesaw fences over the years, but I like my Unifence better than any of the others, mostly because it's just so darned versatile. The L-shape fence extrusion mounts on the head two ways. So in the horizontal position (shown at *right*), it allows me several inches of extra hand space for safer cutting of narrow pieces, and it makes trimming overhanging laminates easy. In its vertical orientation, the extra-tall fence excels at resawing, and I can attach a jig or auxiliary fence face to the Unifence without clamps interfering with the passing workpiece.

—Erv Roberts, Contributing Craftsman

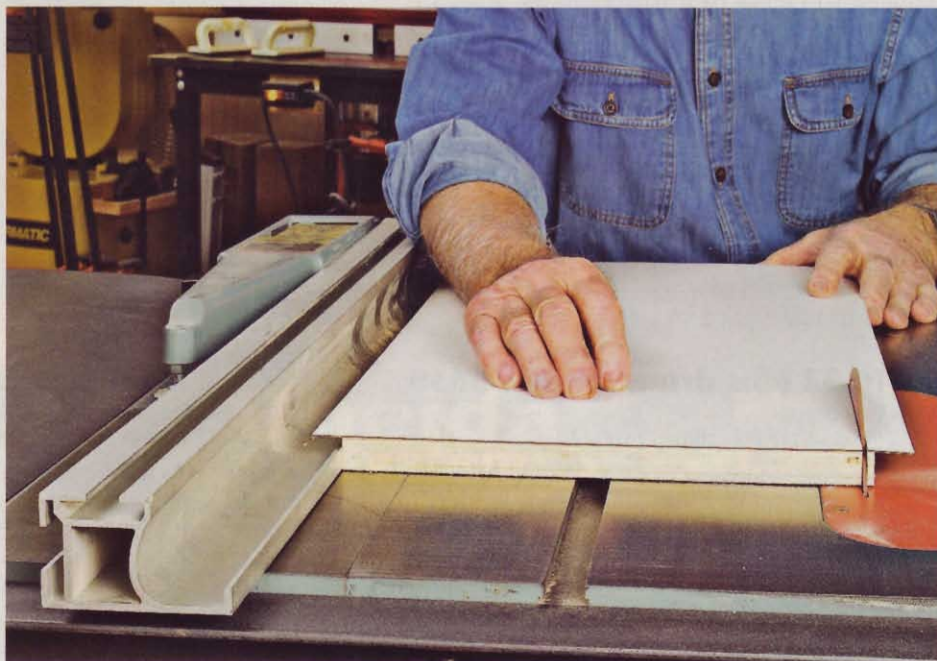

### Japanese-style handsaws, \$30–\$260

Japan Woodworker  
800-537-7820, japanwoodworker.com

I started woodworking when I was 7 years old, using the Western-style handsaws in my father's and grandfather's shops. Those saws now hang, with all due respect, on the wall since I tried my first Japanese-style saw. Their razor-sharp teeth slice through wood like butter, and they can cut a dowel or plug perfectly flush, as shown at *right*, without marring the surrounding wood. And, because Japanese-style saws cut on the pull stroke rather than the push, you get great control.

—Kevin Boyle, Senior Design Editor





## Relative newcomers, but already favorites

### Veritas Apron Plane, \$75

Lee Valley Tools  
800-267-8735, leevalley.com

As a card-carrying power-tool junkie, it's hard for me to admit that the best thing I ever bought for my shop is a *hand* tool. But I reach for my lightweight, low-angle Apron Plane (so named because it fits easily into an apron pocket) more than any other tool. Instead of dragging out a router and flush-trim bit, I'll use my Apron Plane to trim solid-wood edging flush with a plywood shelf, and then again to chamfer the edges. It also solves problems a power tool can't. For example, my dado set couldn't cut the full width of the angled faces of the domino holder, at *right*, so I finished them with a few strokes from the Apron Plane.

—Dave Campbell, Deputy Editor



### Kreg Precision Miter Gauge System, \$140

Kreg Tool Company  
800-447-8638, kregtool.com

During a recent move, my tablesaw's miter gauge suffered irreparable damage, so I replaced it with the Kreg Miter Gauge. Instantly, I fell in love with it. Unlike my "late" factory gauge, I found Kreg's miter stops and scale—including a vernier scale accurate to .1°—as accurate as my Starrett square. And the flip stop on the fence proved itself, too. After a quick initial calibration, I found I could trust the Kreg Miter Gauge like my own mother. For workpieces less than 2' long, I no longer need to measure, mark, and line up that mark with the blade; I just rely on the scale and flip stop.

—Bob Hunter, Tools and Techniques Editor



### Jet 16-32 Plus drum sander, \$850

WMH Tool Group  
800-274-6848, jettools.com

When affordable, home-shop drum sanders first came out, I wondered if I would use one enough to justify its cost. But I took the plunge a few years back, and I can honestly say that I have never been happier with a tool purchase. I use this machine all the time, especially to thickness exotic woods or end grain (such as the cutting board, shown at *left*) that my planer would absolutely tear up. With the 16-32, I can bring wood down to near veneer thickness without tear-out. I even have assembled small drawers and then used the 16-32 to remove just a hair for a snug fit. Very few projects are completed in my shop without at least one part being passed through the 16-32.

—Jim Heavey, Contributing Craftsman

### PanelMaster II \$3,295

Hawk Woodworking Tools  
800-487-2623, hawkwoodworkingtools.com

As a high-school woodworking teacher, student safety is always my highest priority. One aspect of cabinetmaking that always made me nervous, though, was teaching kids to make raised-panel doors on a router table. So I bought a PanelMaster II door maker for the shop, and what a difference it has made! A single spindle inside this machine spins three cutters: One shapes the panel edges, another machines the stick profile in the edges of the frame pieces, and the last one copes the ends of the rails, as student Ryan Remus is shown doing in the photo, *right*. The PanelMaster II makes raised-panel doors fast and, more important, safe because the cutters are so well protected.

—Jeff Hall, Technical Consultant

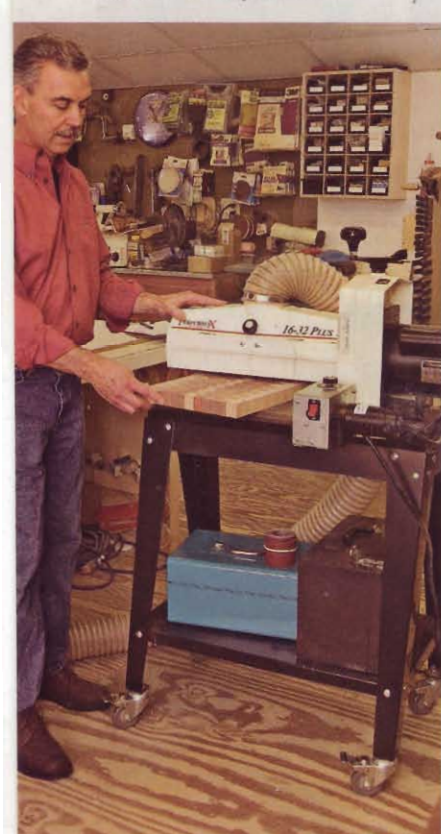

# Still in use and treasured; not available in any store

## Rockwell 2602 router with D-handle base

Modern replacement:  
Porter-Cable 691, \$165  
888-848-5175, porter-cable.com



In 1975, I was a recent college grad setting up an architectural millwork and custom cabinet shop. This router was one of my first “professional” purchases, and 30-plus years later, I still prefer it to any other I own. The D-handle base, with its trigger switch, is well-balanced and safe; I don’t have to let go of the handle to switch it on or off. The 2602 is still compatible with most current Porter-Cable 690- and 890-series accessories, and its guide-bushing system remains the industry standard. Another plus: It came in a rugged metal box that holds all sorts of bits and accessories, unlike the form-fitting cases of today.

—Jan Svec, Projects Editor

## Ryobi R-50 plunge trim router

Modern replacement:  
Grizzly H2854, \$75 (no tilt base available)  
800-523-4777, grizzly.com

Probably 90 percent of my routing chores could be considered light-duty work, so my bigger routers are just plain overkill. The R-50 trim router fills the bill for all those small routing operations, such as round-overs, chamfers, or hinge mortises. The wide-open plunge base on the R-50 affords two distinct advantages for doing inlay work: First, I can start a cut in the field of a workpiece; and second, I have a great view of the cutting action. With the accessory tilt base (foreground in the photo), I can use a straight bit to rout a gentle chamfer on laminate joints without changing bits.

—Chuck Hedlund, Master Craftsman



## Woodfast M910 lathe

Modern replacement:  
Rikon Model 70-500, \$2,700  
877-884-5167, rikontools.com

Why is this my favorite tool? Let me count the ways: 1) The wide speed range—from 50 to 3,890 rpm—gives me slow speeds for large or irregularly shaped blanks, as well as the high end to prevent catches when I’m “turning air” (pieces with large voids). 2) The Woodfast weighs nearly 600 pounds, so I get no vibration, which is important when making fine cuts or creating a thin-walled vessel. 3) The ability to reverse the spindle rotation during sanding to remove the superfine wood fibers that tend to lay over when sanding in just one direction.

—Marlen Kemmet, Managing Editor



## DeWalt 10" radial-arm saw

No modern replacement for the 10" model, but for a 12" saw based on DeWalt's design: The Original Saw Co. 3512-01, \$3,300  
800-733-4063, originalsaw.com

Or buy a used/refurbished DeWalt radial-arm saw from:  
Wolfe Machinery Co., 800-345-6659, wolfemachinery.com

As much an heirloom as it is a woodworking machine, the ring of this saw's blade as it comes to a stop still reminds me of younger days in Dad's basement workshop. The 1963-era DeWalt radial-arm saw provides me with more than a trip down memory lane, though. Given a new 60-tooth blade, a tune-up, and a dust-collection hose, it still proves accurate and sound enough to serve as my main crosscut machine. I suspect it'll be making sawdust for another 40 years. 🌲

—Bob Wilson, Techniques Editor



# Super-organized, Space-saving Bench-tool System

Save valuable space by storing your benchtop tools vertically on trays in a roll-around cabinet. The slide-out trays mount atop a mobile tool base. Build one or more of each.

See a Slide Show of this project coming together at: [woodmagazine.com/slides](http://woodmagazine.com/slides)

**BASIC-BUILT**  
GREAT PROJECTS. SIMPLE TOOLS.

## PROJECT HIGHLIGHTS

- Overall dimensions:  
Tool cabinet, 27 $\frac{3}{4}$ " wide x 25 $\frac{3}{16}$ " deep x 85 $\frac{7}{8}$ " high.  
Tool base, 21 $\frac{7}{8}$ " wide x 22 $\frac{13}{16}$ " deep x 36 $\frac{7}{8}$ " high.
- Inexpensive materials are easy on the wallet. One-stop home-center shopping and simple construction make this a great weekend project.
- Benchtop tools bolt to trays that fit over the top of the tool base. For storage, lift the tool and tray off the base, and slide them into the cabinet.
- Roll the cabinets out to work, away for storage. Dual-locking casters provide both mobility and stability. See **Source** on page 36.

### Skill Builders

- Make a simple jig to cut rabbets for half-lap joints in multiple oversize parts at once.

## Make the case sides

**1** Select straight 2x4s with as few knots as possible for the tool cabinet stiles (A), rails (B), and stretchers (C), and the tool base stiles (M), rails (N), and stretchers (O). Clean up the 2x4 faces with a random-orbit sander. Then rip and joint both edges to the 3" finished width. Now cut the parts to the finished lengths [**Materials List**, page 36].

**2** Lay out the stiles (A, M), rails (B, N), and stretchers (C, O) in the arrangements shown [**Drawings 2** and **3**]. Then mark the locations of the rabbets, notches, and grooves [**Drawings 1**, **2**, **2a**, and **3**]. Cut the rabbets and notches. For a quick and accurate way to do this, see page 86. Set the stretchers aside. Now, making two passes over the tablesaw blade, cut  $\frac{3}{16}$ " grooves  $\frac{3}{8}$ " deep in the stiles and rails for the panels (D, P).

**Note:** We used  $\frac{3}{16}$ " perforated hardboard for the panels (D, P). For  $\frac{1}{4}$ " perforated hardboard, cut the grooves in one pass with a dado blade.

**3** Cut the panels (D, P) to size. Dry-assemble the sides (A/B/D and M/N/P) to check the fit. Make any necessary adjustments. Then glue and clamp the sides with the smooth face of the panels facing out. Check the sides for square. To speed the side glue-up process, see the **Shop Tip** at right.

**4** With the sides assembled, drill  $\frac{1}{4}$ " holes through the tool cabinet stiles (A), and  $\frac{1}{4}$ " holes  $\frac{3}{8}$ " deep in the inside faces of the tool base stiles (M) [**Drawings 1**, **2**, and **3**, **Photo A**]. The photo shows drilling the holes in the tool cabinet stiles.

## 1 STILES

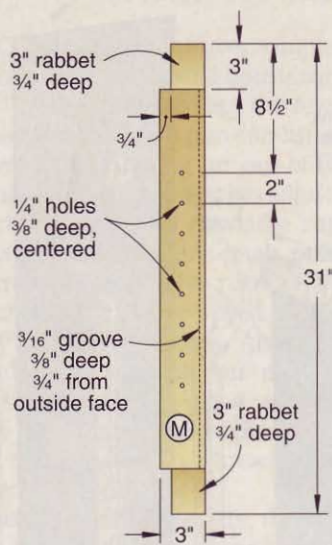

TOOL BASE STILE  
(Left front inside face shown)

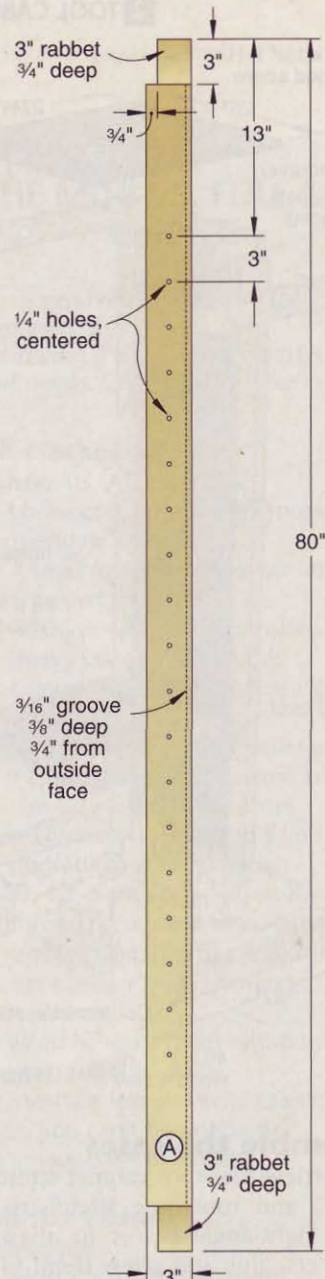

TOOL CABINET STILE  
(Left front inside face shown)

## DRILL THE STILES

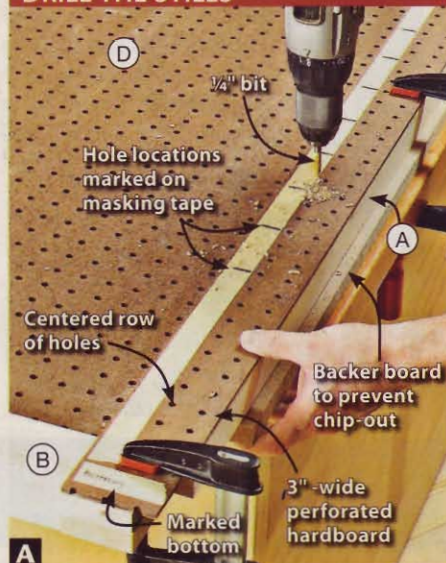

Mark hole locations on masking tape applied to a perforated hardboard strip. Using the strip as a guide, drill the holes in the stile (A).

## SHOP TIP

### Let wood screws do the clamping

Here's a way to cut down on the clamping time and number of clamps needed to glue up the sides (A/B/D and M/N/P). After clamping up the first side and checking for square, drill a screw hole centered in each half-lap joint. Then drive screws, as shown at right, remove the clamps, and set the assembly aside. Now your clamps and bench space are free for assembling the next side.

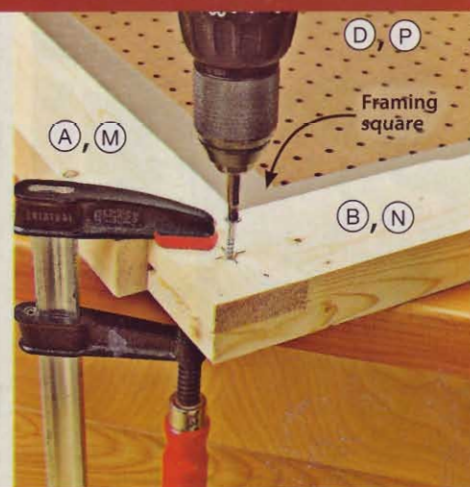

## 2 TOOL CABINET CASE

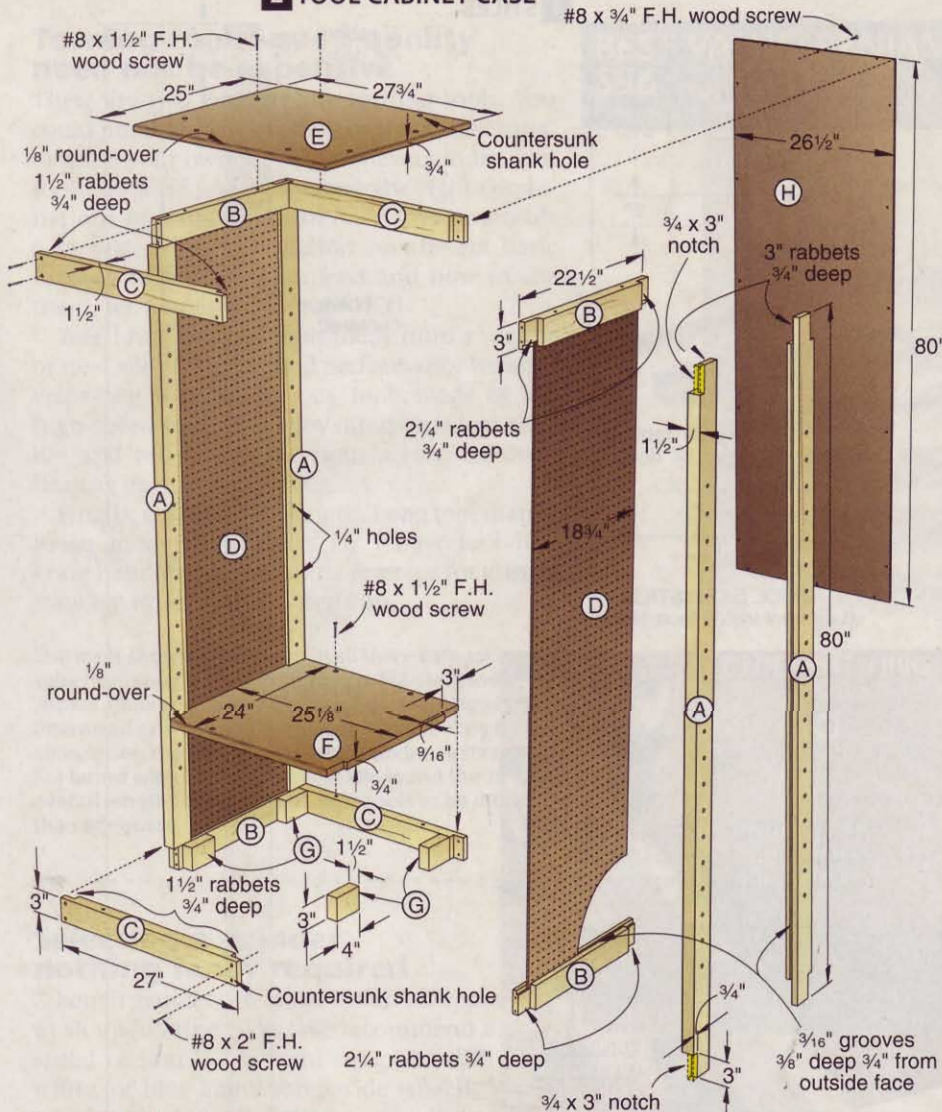

### 2a GROOVE DETAIL

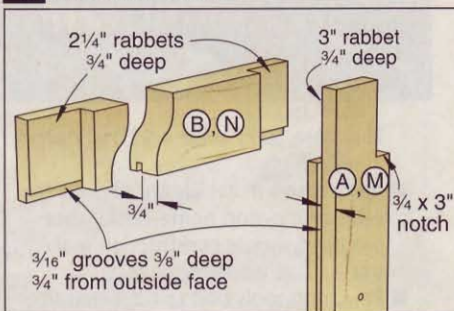

**2** Cut the tops (E, Q) to size, and rout  $\frac{1}{8}$ " round-overs along the edges [Drawings 2 and 3]. Then clamp the tops to the cases, drill screw holes, and drive the screws. Align the tool cabinet top (E) flush with the back stretcher (C), centered side-to-side, and overhanging the front stretcher. Align the tool base top (Q) flush with the case all around.

**3** Cut the bottoms (F, R) to size. [Make the necessary adjustment for  $\frac{1}{4}$ " perforated hardboard panels (D, P).] Draw the corner notches [Drawings 2 and 3], and cut them out [Photos C and D]. Rout round-overs, where shown. Apply glue to the top edges of the lower stretchers (C, O), and clamp the bottoms in place. Drill screw holes, and drive the screws.

**4** Lay the cases facedown. Cut the caster blocks (G, S) to size, and glue and clamp them in place [Drawings 2 and 3].

**5** Cut the backs (H, T) to size. Center the backs side-to-side on the cases, and clamp them in place. Then drill screw holes and drive the screws.

### Assemble the cases

**1** Retrieve the tool cabinet stretchers (C) and tool base stretchers (O). Using right-angle braces to align the stretchers, glue and screw them to one side (A/B/D and M/N/P) [Drawings 2 and 3]. (To download a free plan for a right-

angle brace, go to [woodmagazine.com/brace](http://woodmagazine.com/brace).) Then with the four stretchers attached to the first side, add the second side in place. The photo shows adding the second side to the tool cabinet.

### Add trays, shelf, and door

**1** For the tool cabinet, cut the tray panels (I) to size, and for the tool base, cut the shelf panel (U) to size. Then cut the short edging (J), long edging (K),

#### BEGIN THE CASE ASSEMBLY



**B** With the stretchers (C) attached to the first side (A/B/D), apply glue to the stretcher rabbets, and position the second side.

#### FORM THE BOTTOM NOTCHES

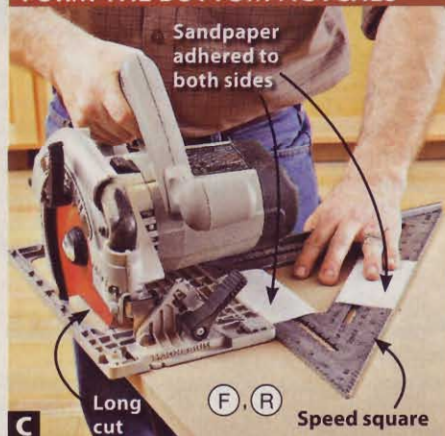

**C** To make the long cuts, adhere sandpaper to a speed square to keep it from slipping. Then use it to guide your portable circular saw.

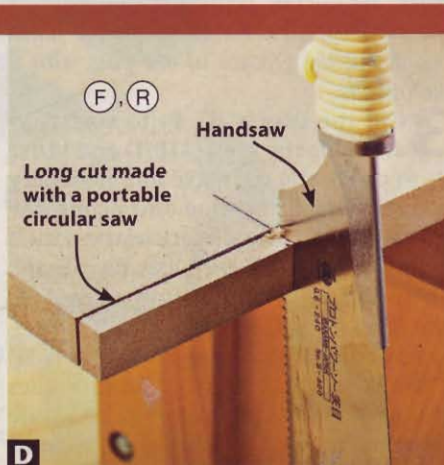

**D** After making the long cuts with a portable circular saw, finish cutting the notches with a handsaw.

### 3 TOOL BASE CASE

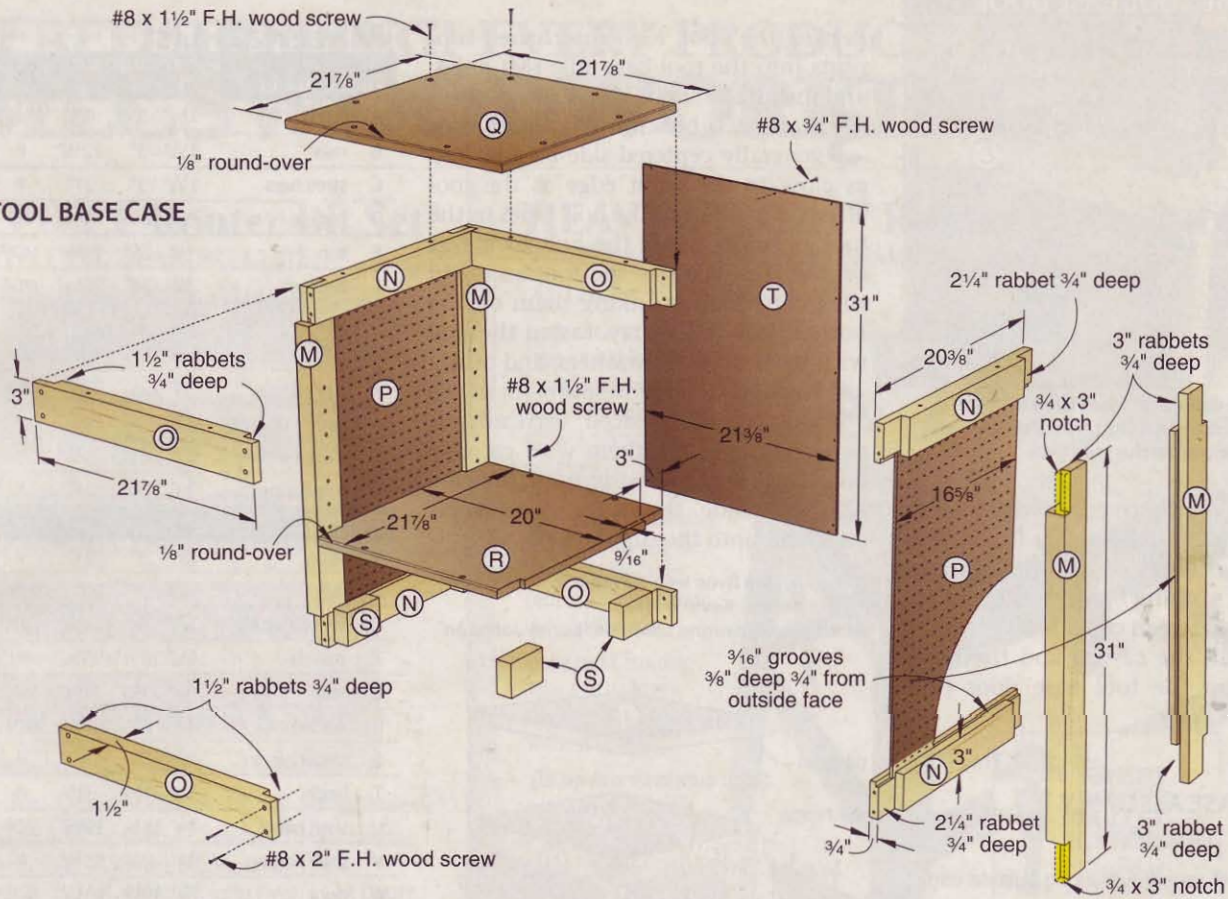

### 4a TRAY SUPPORTS

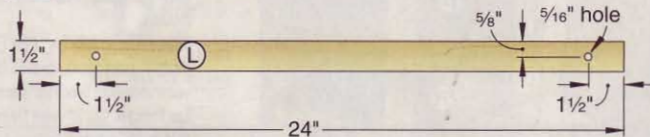

### 4 TOOL CABINET ASSEMBLY

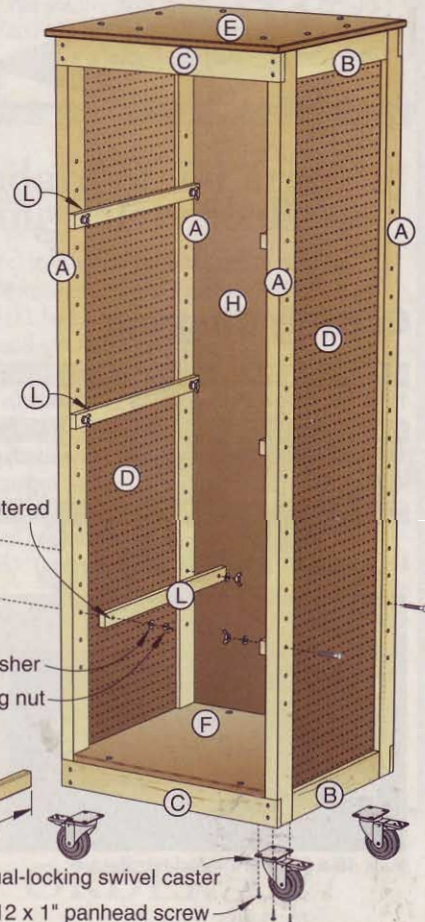

and shelf edging (V) to size. (We ripped these parts from the edge of 2x stock. You also can cut them from 3/4"-thick stock.) First glue and clamp the short edging to the trays, flush at the top and ends, and then add the long edging [Drawing 4]. Now glue and clamp the shelf edging to the shelf panel [Drawing 5]. Rout 1/8" round-overs along the top edges of the trays and shelf, and finish-sand them.

**2** Rip 3/4"-wide strips from a 2x4, and cut the tray supports (L) to size. Then drill a 5/16" hole at each end [Drawing 4a]. Finish-sand the supports.

**3** Lay the tool cabinet and tool base cases on the backs. Then position the caster plates 1/4" from the case edges, and using the holes in the plates as guides, drill screw holes. Now screw the casters in place.

**4** Cut the tool base door (W) to size, and rout 1/8" round-overs along the front edges. Then drill holes and attach

the hinges and handle [Drawing 5]. Now lay the tool base on the back, and fasten the door to the case [Photo E].

### Apply finish and assemble

**1** Remove the door from the tool base and the hinges and handle from the door. Remove the casters from both cases. Examine all the parts and assemblies and finish-sand where needed.

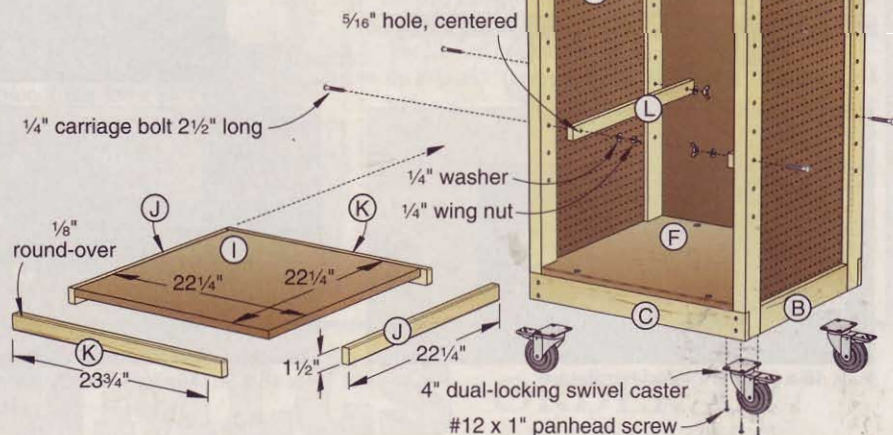

## HANG THE TOOL BASE DOOR

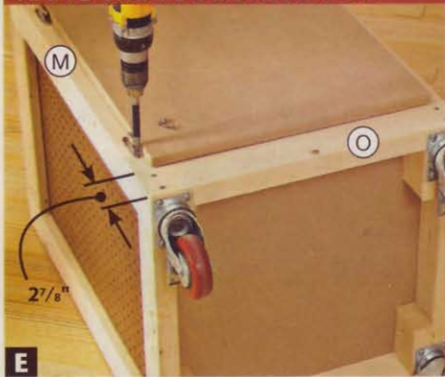

**E** Position the door  $27\frac{7}{8}$ " from the stretcher (O) bottom edge and centered side-to-side. Screw the hinges to the stile (M).

Then ease any sharp edges with a sanding block. Now apply a clear finish. (We applied two coats of Minwax Antique Oil Finish, sanding lightly with 220-grit sandpaper between coats.)

**2** Reinstall the casters and the hardware on the tool base door (W).

Rehang the door. Now insert shelf supports into the tool base stile (M) holes, and install the shelf (U/V).

**3** Place each benchtop tool on a tray, generally centered side-to-side, and as close to the front edge as the tool allows. Then, using the bolt holes in the tool as guides, mark the hole locations on the tray. Remove the tool and drill the holes, countersinking them on the bottom face of the tray. Fasten the tool with flathead bolts, washers, and nuts.

**4** Position the tray supports (L) in the tool cabinet, spaced vertically as needed, and fasten them with carriage bolts, washers, and wing nuts [Drawing 4]. Now slide the trays, with tools attached, onto the supports. 🌿

Written by **Jan Svec** with **Jeff Mertz**  
Project design: **Kevin Boyle**  
Illustrations: **Roxanne LeMoine**; **Lorna Johnson**

## 5 TOOL BASE ASSEMBLY

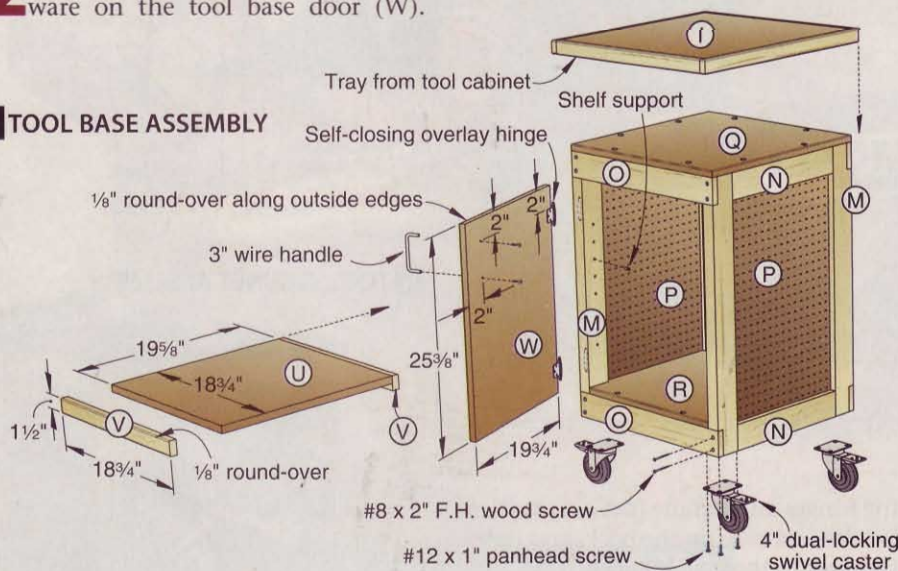

## Materials List

Tool cabinet	FINISHED SIZE			Matl.	Qty.
	T	W	L		
A stiles	1½"	3"	80"	P	4
B rails	1½"	3"	22½"	P	4
C stretchers	1½"	3"	27"	P	4
D panels	¾"	18¾"	74¾"	PH	2
E top	¾"	25"	27¾"	MDF	1
F bottom	¾"	24"	25½"	MDF	1
G caster blocks	1½"	3"	4"	P	4
H back	¾"	26½"	80"	H	1
I tray panels	¾"	22¼"	22¼"	MDF	4
J short edging	¾"	1½"	22¼"	P	8
K long edging	¾"	1½"	23¾"	P	8
L tray supports	¾"	1½"	24"	P	6

## Tool base

M stiles	1½"	3"	31"	P	4
N rails	1½"	3"	20¾"	P	4
O stretchers	1½"	3"	21¾"	P	4
P panels	¾"	16½"	25¾"	PH	2
Q top	¾"	21¾"	21¾"	MDF	1
R bottom	¾"	20"	21¾"	MDF	1
S caster blocks	1½"	3"	4"	P	4
T back	¾"	21¾"	31"	H	1
U shelf panel	¾"	18¾"	19½"	MDF	1
V shelf edging	¾"	1½"	18¾"	P	2
W door	¾"	19¾"	25¾"	MDF	1

**Materials key:** P—pine, PH—perforated hardboard, MDF—medium-density fiberboard, H—tempered hardboard.

**Supplies:** #8x¾", #8x1½", #8x2" flathead wood screws; #12x1" panhead screws (32); ¼" wing nuts (12); ¼" flat washers (12); ¼x2½" carriage bolts (12); self-closing overlay hinges (2); 3" wire handle; ¼" shelf supports (4).

**Bits:** ⅛" round-over router bit, ¼" and ⅝" drill bits.

## Source

**Casters:** 4" dual-locking swivel plate casters no. 36992, \$9.99 ea. Hartville Tool. Call 800/345-2396, or go to [hartvilletool.com](http://hartvilletool.com).

## Cutting Diagram

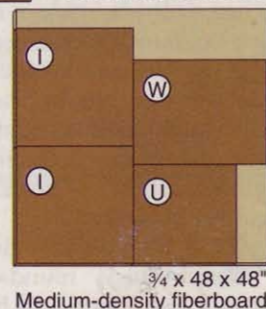
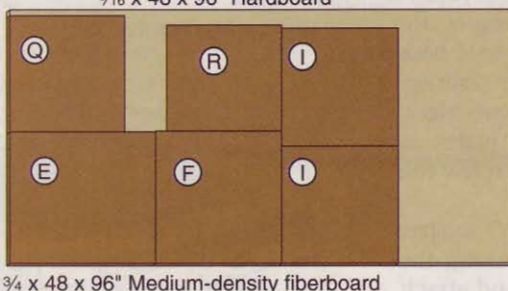
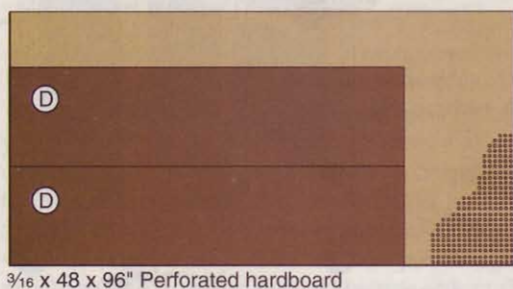
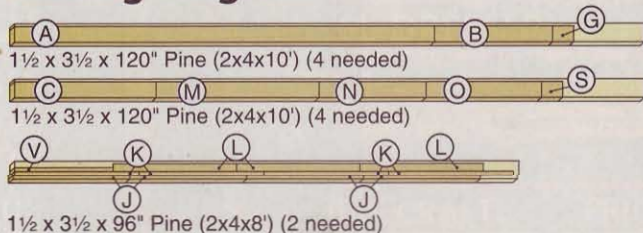

Perfect-Pair

# Nesting Tables

Create this stylish, compact duo to accompany a sofa, easy chair, or bed. You can build the set in a weekend thanks to the simple construction.





## PROJECT HIGHLIGHTS

- Overall dimensions:  
Tall table—21" square × 25¾" high.  
Short table—15¼" square × 23¾" high.
- You'll appreciate the basic joinery: just biscuits and screws required.
- As an alternative to hardwood plywood top panels, you can step up your creativity by making veneered panels to showcase an eye-catching burl, geometric pattern, or other figure, as explained on page 42.

### Skill Builder

- Learn how to easily form laminated legs with book-matched edges that rival the look—but not price—of solid stock.

### Start with the legs

**1** From laminated ¾" cherry, cut the tall- and short-table legs (A, F) to the sizes listed [Materials List, page 41]. For the best appearance, form the legs with a book-matched edge for the outside, as explained in the **Shop Tip**, below. (It's also fine to make the legs from solid stock.)

**2** To ensure correct machining of the legs, mark the location on each ("RF" for right front, for example), and identify the best face for the outside.

**3** Holding each leg in the appropriate orientation with the book-matched edge and best face outside [Drawings 1, 2, and 3a], draw centerlines for the #20 biscuit slots, and lay out the tapers where dimensioned [Drawing 3]. Note that because the tall table does not have a front rail (which allows the short table to slide under it), each front leg (A) has only one biscuit slot in the *inside* face for joining the side rails (B).

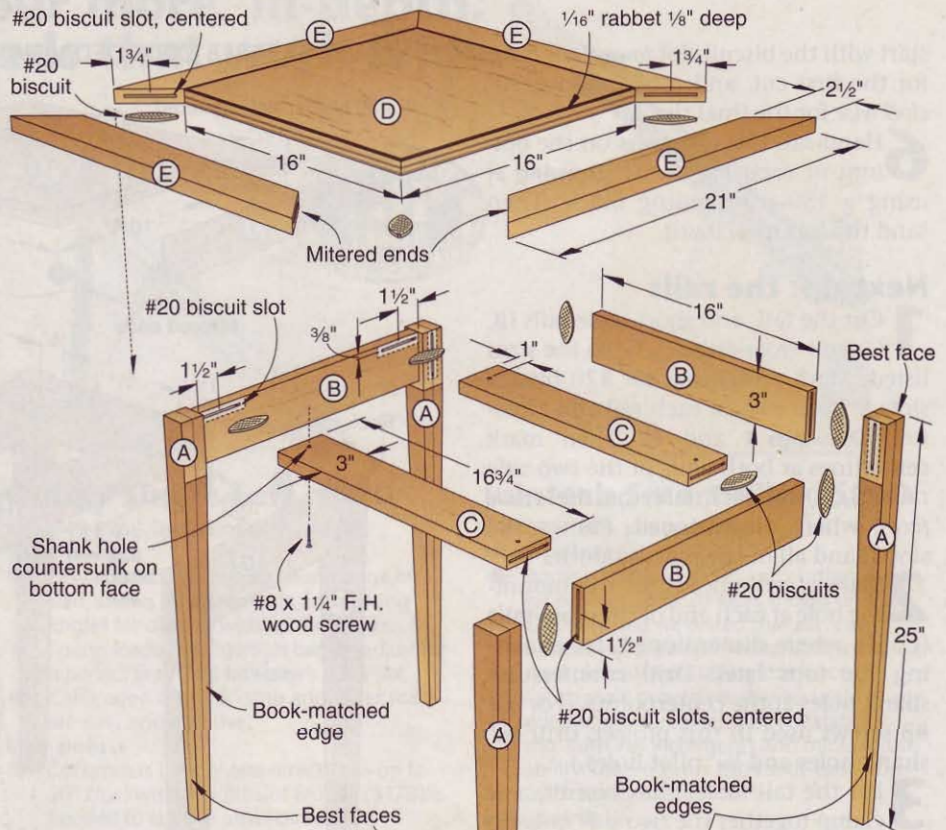

### 1 TALL-TABLE EXPLODED VIEW

**4** Using your biscuit joiner, plunge the slots into the legs (A, F) at the marked centerlines.

**5** To taper the legs, place a tall-table back leg (A) on a taper jig with one biscuit slot facedown and the other facing the blade. (For a free taper-jig plan, go to [woodmagazine.com/taperjig](http://woodmagazine.com/taperjig).) Align the marked taper lines with the edge of the jig [Photo A], and secure

the leg to the jig. Then rip the leg, rotate it 90° clockwise, and rip it again. Repeat for the other back leg (A) and for all four of the short-table legs (F).

For the tall-table left front leg (A), position the leg for the first rip with the biscuit slot *down*, and rotate the leg 90° clockwise for the second rip. For the right front leg,

### TAPER THE LEGS

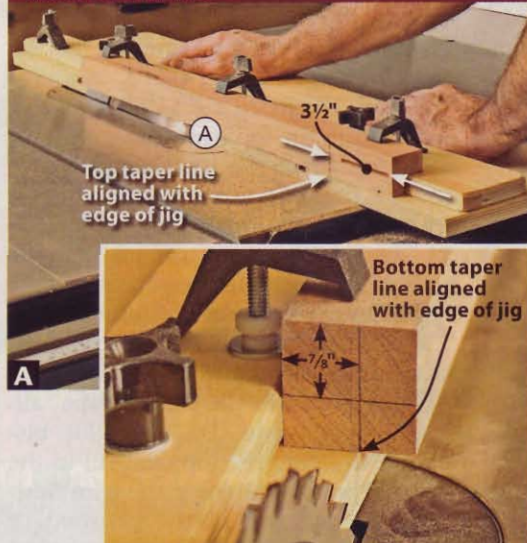

Align the marked taper lines on a back leg (A) with the edge of the taper jig. Rip the leg. Rotate the leg 90° clockwise (operator's view, top photo), and rip it again.

### SHOP TIP

#### Disguise a lamination with a book-matched edge

When you can't find solid stock to make large parts, such as the table legs (A, F), or the cost of the thick lumber exceeds your budget, glue two pieces together to make one. You can make the glue-up virtually unnoticeable by creating a book-matched edge to face outside. Here's how.

Start with a piece of stock that's twice as wide as the finished part plus ½" (3½" wide for a 1½"-wide leg, for example). To make it easy to identify the book-matched edges after ripping the piece, draw a centered line about 1" long on one end. Rip the piece down the

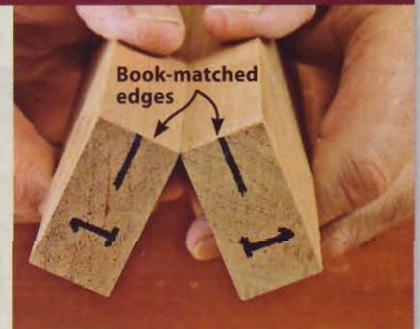

center. Then laminate the pieces together, folding them as shown to create the book-matched edge. After the glue dries, rip and plane the lamination to the finished size. When laminating multiple parts, number or letter the mating pieces identically to prevent mix-ups.

start with the biscuit slot *toward the blade* for the first cut, and rotate the leg 90° clockwise for the final rip.

**6** Hand-sand 1/8" chamfers on the bottom of each leg (A, F) [Drawing 3] using a 150-grit sanding block. Then sand the legs to 220 grit.

### Next up: the rails

**1** Cut the tall- and short-table rails (B, G) and cross-rails (C, H) to the sizes listed. Mark centerlines for #20 biscuit slots at both ends of each rail and cross-rail [Drawings 1 and 2]. Then mark centerlines at both ends of the two side rails (B, G) for each table on the *inside faces*, where dimensioned. Plunge the slots. Sand all of the parts smooth.

**2** Mark a centerpoint for the mounting hole at each end of the cross-rails (C, H), where dimensioned, for attaching the tops later. Drill countersunk shank holes at the centerpoints. (For the #8 screws used in this project, drill 5/32" shank holes and 7/64" pilot holes.)

**3** For the tall table, glue, biscuit, and clamp together the two side rails (B) and cross-rails (C) [Drawing 1, Photo B]. Repeat for the short-table side rails (G) and cross-rails (H) [Drawing 2].

**4** Noting the leg markings to ensure correct location and orientation, glue, biscuit, and clamp together the two back legs (A) for the tall table to the ends of the back rail (B). Make sure you keep the top ends of the legs flush with the top edge of the rail. In the same way, assemble the short-table front and back legs (F) to the front and back rails (G).

**5** For the tall table, glue, biscuit, and clamp the back leg/rail assembly (A/B) to the side rail/cross-rail assembly (B/C) [Photo C]. After the glue dries, glue, biscuit, and clamp the front legs (A)

## 2 SHORT-TABLE EXPLODED VIEW

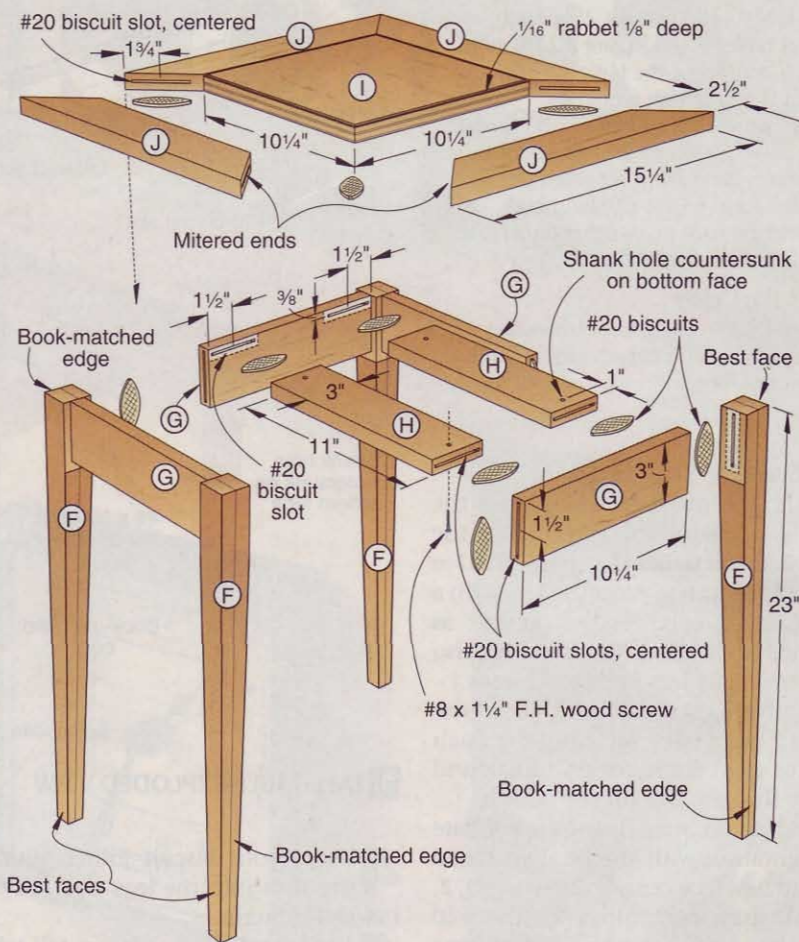

in place. For the short table, mount the front and back leg/rail assemblies (F/G) to the side rail/cross-rail assembly (G/H).

### Head for the tops

**1** From 3/4" cherry plywood, cut the top panels (D, I) to the sizes listed. If you'd like to create eye-catching veneered panels, as explained on page 42, make the parts from 1/2" medium-

density fiberboard (MDF) and cut them 1" larger than the listed widths and lengths. Do not use 3/4" MDF because the veneer will stand proud of the top trim (E, J). Trim the panels to the finished sizes after veneering.

**2** To create a reveal between the plywood or veneered top panels (D, I) and the top trim (E, J), rout a 1/16" rabbet 1/8" deep around each panel on the top face [Drawings 1, 2, and 4].

**3** From 3/4" cherry, cut a 2 1/2 x 92" blank to form the top trim (E) for the tall-table top panel (D) [Drawing 1], and a 2 1/2 x 70" blank to form the top trim (J) for the short-table top panel (I) [Drawing 2]. Then, miter-cut the trim pieces to the needed lengths to fit the panels.

**4** Draw centerlines at the mitered ends of the top trim (E, J) for biscuit slots, where dimensioned. Plunge the slots.

**5** Apply glue to the edges of the tall-table top panel (D). Then glue, biscuit, and clamp the top trim (E) to the panel [Photo D], aligning the trim flush with the top face of the plywood or veneered panel and verifying tight mitered corners. (Our cherry plywood panels measured exactly 3/4" thick, so

### ASSEMBLE THE SIDE RAILS AND CROSS-RAILS

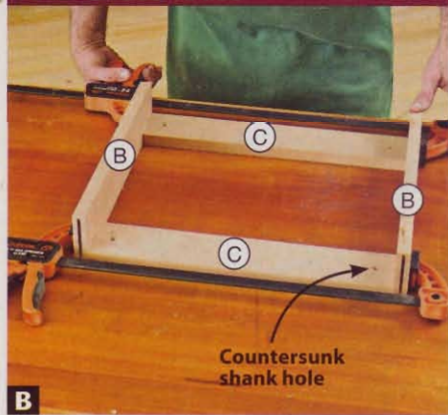

**B** With the parts upside down for easy alignment, glue, biscuit, and clamp together the tall-table side rails (B) and cross-rails (C).

### MOUNT THE BACK LEG/RAIL ASSEMBLY

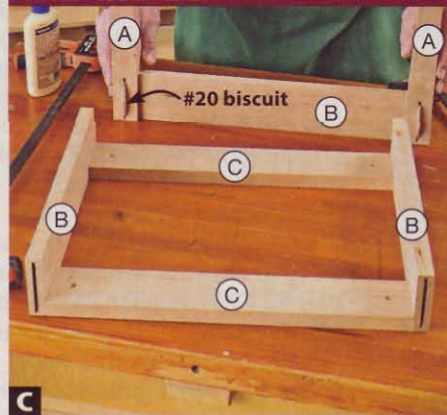

**C** Glue, biscuit, and clamp the tall-table back leg/rail assembly (A/B) to the side rail/cross-rail assembly (B/C), ensuring tight joints.

### GLUE THE TRIM TO THE TOP PANEL



**D** Using spacers for clamp clearance, glue, biscuit, and clamp the tall-table top trim (E) to the top panel (D) with the top faces flush.

### FASTEN THE BASE TO THE TOP

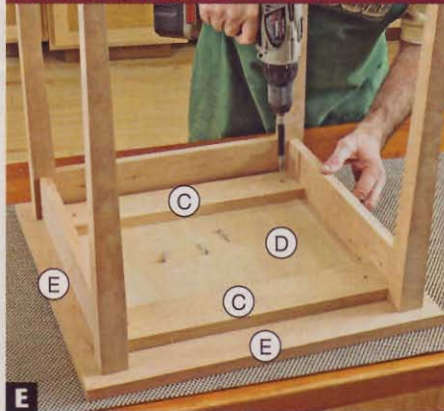

**E** Drill pilot holes into the tall-table top (D/E) using the shank holes in the cross-rails (C) of the base as guides. Drive the screws.

### 4 TOP-PANEL RABBET DETAIL

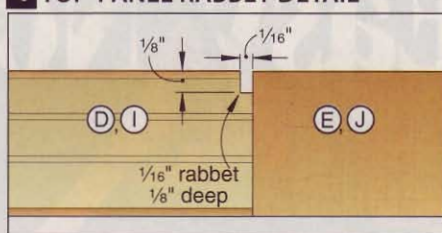

router mat) with the *bottom* face up. Center and screw-mount the base (A/B/C) to the top [Photo E]. Repeat to mount the short-table top (I/J) to the base (F/G/H). Now remove the tops for finishing.

### 3 LEGS (Left rear legs shown)

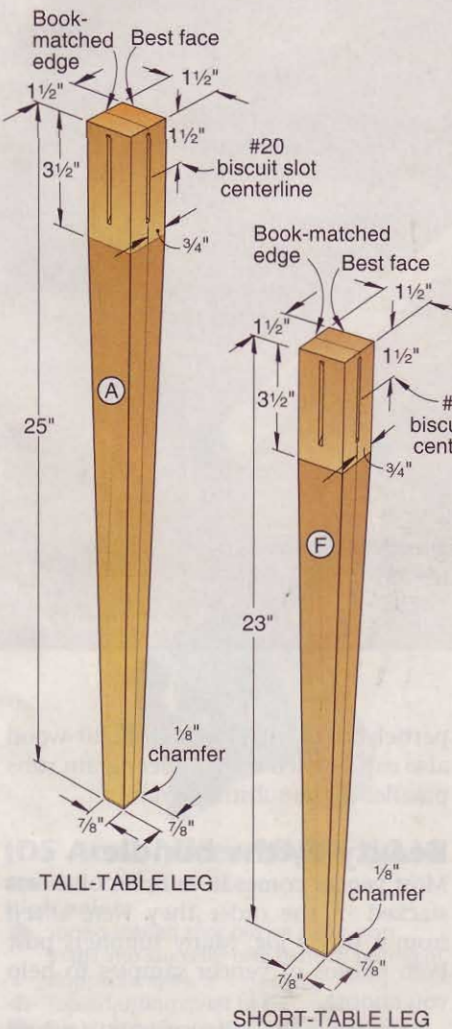

the top *and* bottom faces aligned with the trim.) Repeat to assemble the short-table top trim (J) to the top panel (I). After the glue dries, sand the top assemblies smooth, being careful not to go through the thin veneer.

**6** Place the tall-table top (D/E) on a clean, protective surface (such as a

### 3a LEG BISCUIT-SLOT LOCATION DETAIL (Viewed from top)

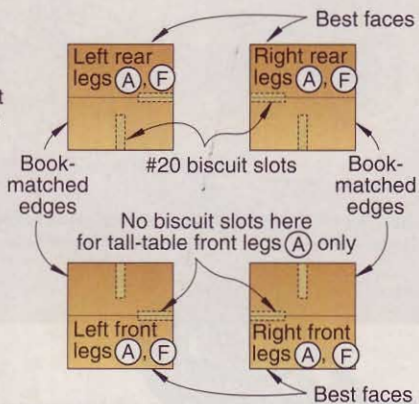

### Cutting Diagram (Both tables)

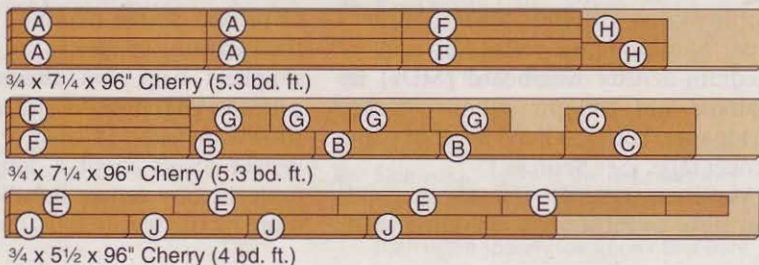
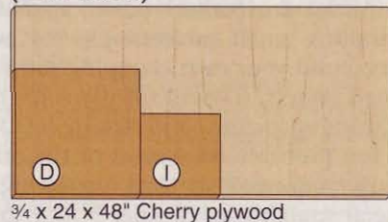

### Finish up

**1** Finish-sand any areas of the tops and bases that need it to 220 grit, and remove the dust. Apply a stain, if you wish, and a clear finish. We applied Varathane Premium Gel Stain, no. 445 Traditional Cherry, followed by three coats of Minwax Polycrylic Water-Based Clear Satin Protective Finish, sanding to 320 grit between coats. As an option, apply a French polish instead of a clear finish to the tops (D/E, I/J) to give them a super-smooth, high-gloss look. To do this, see page 18.

**2** Reattach the tops to the bases. Now move the tables to the desired location, slide the short table under the tall one, and take a moment to admire your classy craftsmanship. 🌳

Written by **Owen Duvall** with **Chuck Hedlund**  
Project design: **Jeff Mertz**  
Illustrations: **Roxanne LeMoine; Lorna Johnson**

### Materials List

Tall table	FINISHED SIZE			Matl.	Qty.
	T	W	L		
A* legs	1 1/2"	1 1/2"	25"	LC	4
B rails	3/4"	3"	16"	C	3
C cross-rails	3/4"	3"	16 3/4"	C	2
D† top panel	3/4"	16"	16"	CP	1
E* top trim	3/4"	2 1/2"	21"	C	4
Short table					
F* legs	1 1/2"	1 1/2"	23"	LC	4
G rails	3/4"	3"	10 1/4"	C	4
H cross-rails	3/4"	3"	11"	C	2
I† top panel	3/4"	10 1/4"	10 1/4"	CP	1
J* top trim	3/4"	2 1/2"	15 1/4"	C	4

\*Parts initially cut oversize. See the instructions.  
†When making veneered top panels (D, I), use 1/2" medium-density fiberboard and cut the pieces 1" oversize in width and length. Trim the pieces to the finished sizes after veneering.

**Materials key:** LC—laminated cherry, C—cherry, CP—cherry plywood.  
**Supplies:** #20 biscuits (30), #8x1/4" flathead wood screws (8).  
**Bit:** Rabbeting router bit.

# Easy, No-Fuss Veneering



Joining several veneer pieces lets you create attractive designs covering large areas at little cost compared with using solid wood.

**Simple equipment and techniques give your projects the beauty of premium woods without premium prices.**



For more on veneering, watch a series of free videos at [woodmagazine.com/videos](http://woodmagazine.com/videos).

**T**oday's adhesives and inexpensive vacuum presses make veneering easier than ever. For about \$50 (see **Sources** on page 47), you can buy a mini vacuum veneer press capable of handling small projects. Or, for even less, build your own clamping press for small panels. (Download plans for one at [woodmagazine.com/veneerpress](http://woodmagazine.com/veneerpress).)

You probably have most of the other tools you need to start veneering: a metal straightedge or ruler 2' to 3' long; a utility knife with fresh blades; painter's tape; a mini paint roller; 1/2" and 3/4" medium-density fiberboard (MDF) for platens; and 180-grit adhesive-backed sandpaper. You also need a roll of paper veneer tape. (See **Sources**.)

Most consistently flat sheet goods can serve as substrates, including MDF,

particleboard, or plywood. Solid wood also can be used if the veneer grain runs parallel to the substrate grain.

## Beauty by the bundle

Most veneer comes in bundles of sheets stacked in the order they were sliced from a single log. Many suppliers post Web photos of veneer samples to help you choose.

Each veneer bundle varies in size and quality, so tell your supplier what type of project you're making, its size, and the quantity of veneer you need. Most suppliers help you choose a bundle suited to your project. The nesting tables shown on page 38 used a bundle of 8 veneer sheets about 2' long. For larger projects, buy veneer bundles 6' long or more by the square foot. (See **Sources**.)

## SHOP TIP

### Mirrors provide a pattern peek

By taping together a pair of 12"-square mirrors and placing them atop your veneer, you gain a sneak preview of how your finished veneer pattern will look. By moving the mirror around or increasing or reducing the angle, you can gauge how the pattern changes with 4, 8, 12, or more pieces. For a 4-piece pattern shown *below*, hold the mirrors at 90°. Holding the mirrors one way shows a box match, where the grain runs parallel to the outside edges of the design, indicated by the dashed-line box. On the reverse box match, the grain runs perpendicular to the edges. For the 6-piece design shown at *bottom*, hold the mirrors at a 60° angle. Holding the mirrors at a 45° angle produces an 8-piece pattern.

#### PREVIEW A BOX MATCH PATTERN

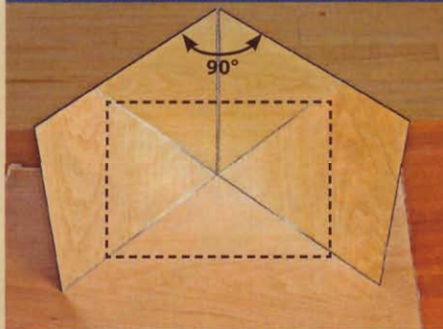

#### 6-PIECE MATCH

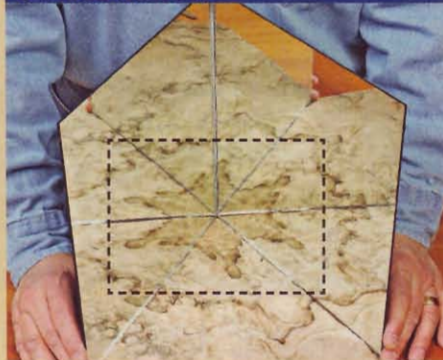

For matched patterns, as shown *above* and at *right*, order at least as many sheets as the number of pieces in the pattern, plus a couple of extras, just in case. Because you veneer both sides of a panel for wood-movement stability, order extra veneer of the same species or one with a similar density for the back side.

When your veneer arrives, use chalk to number the pieces in the order they're stacked upon arrival. On pieces you don't use immediately, apply strips of painter's tape to the ends to prevent splitting. Burl veneers require a treatment to make them flat and less brittle. (See "Take the Curl Out of Burl," *page 47*.) Store all remaining veneer between two pieces of 3/4" MDF to avoid ripples.

## PICK A PATTERN

You could just glue a single sheet of veneer to a substrate, but arranging veneer pieces into patterns offers many more creative options. (Reversed or rotated numbers indicate sheets that have been turned over or rotated from their original orientations.) Common patterns include:

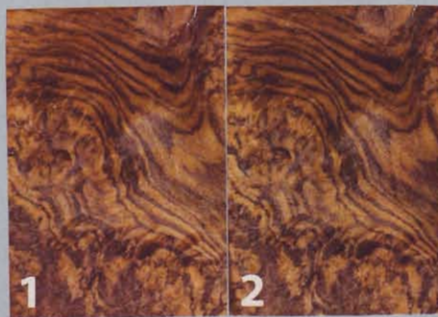

**Slip match.** Simply slide one veneer sheet from a stack to the left or right of the sheet below and you've got a slip match. Use this where you don't need to match patterns at the edges, as with a straight-grain wood, or if you want to repeat a grain pattern. For a "flip and slip," turn every other piece end-for-end for a color match at the edges.



**Book match.** As you'd turn the pages in a book, turn one sheet over and butt it against the edge of the sheet below to create a mirror image of the grain pattern. Uses for this pattern include panels for side-by-side doors in a cabinet.



**Diamond match.** The grain of each piece runs diagonally to form a diamond shape. The color difference comes from how light reflects differently from one side of the veneer than the other.

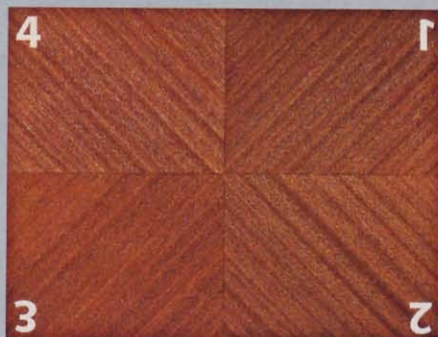

**Reverse diamond match.** Here, the grain seems to form an "X" at the center of the panel.

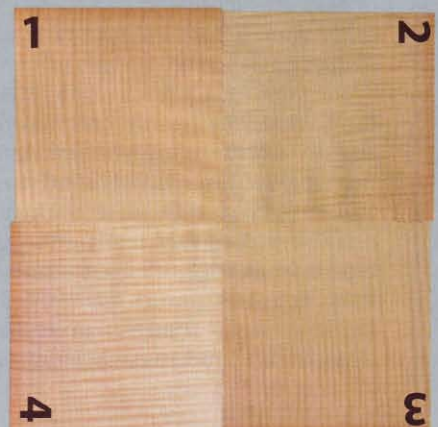

**Parquet (alternating-square) match.** The grain orientation of each sheet runs 90° to the grain of the adjoining pieces. Experiment with this pattern using woods with straight grain or a uniform grain pattern, such as this quilted maple used for the clock project on *page 70*.

# How to Build a Basic Book Match

Whether you're making this simple two-piece book match or a 16-piece pattern, the basic steps for cutting, assembling, and gluing veneer remain the same. To press veneer with a vacuum bag, as we demonstrate here, you sandwich your veneer and substrate between two platens made from  $\frac{1}{2}$ " MDF  $\frac{1}{2}$ " longer and wider than your finished panel. You also need a  $\frac{3}{4}$ " MDF or particleboard base about 6" smaller than the length and width of your vacuum bag. Score the base with a grid of  $\frac{1}{8}$ "-deep kerfs at 1" intervals. The kerfs prevent air from being trapped between the base and the lower platen. Round-over the base and top platen's upper edges to avoid damaging the bag.

**STEP 1:** For a simple book match, you need two consecutive-sliced sheets of veneer. Start by chalking numbers onto each sheet in your stack. Then stack your sheets so distinctive elements of the grain rest directly on top of each other. This may mean that each sheet slightly offsets from the adjacent one. Tape the pieces together as stacked.

**STEP 2:** Apply a strip of 180-grit adhesive-back sandpaper to the underside of a straightedge or ruler to prevent it from slipping. Then position it along one edge of your veneer stack. Using your utility knife, slice through the stack to leave a clean, straight edge. Make light, repetitive cuts to keep the blade from following the veneer grain.

**STEP 3:** Make a sanding block by attaching 180-grit adhesive-backed sandpaper to an MDF scrap about 8"

## ORGANIZE YOUR SHEETS



## CUT THE FIRST EDGE



## TAPE THE CUT AND SANDED EDGES

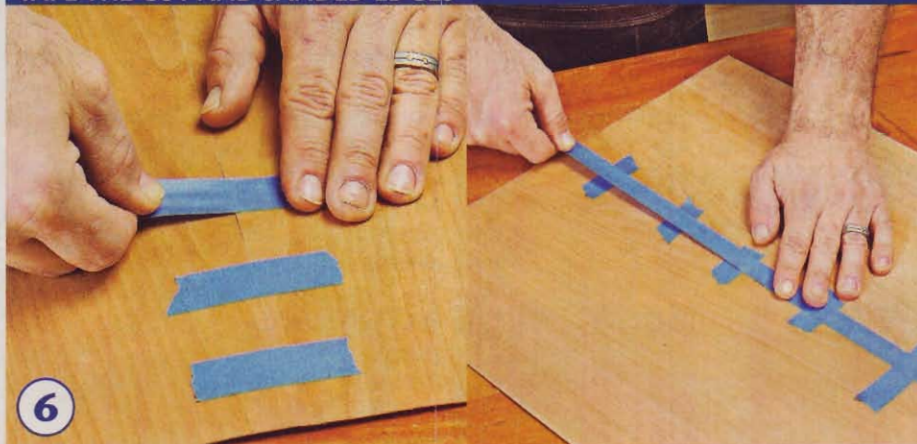

## STACK YOUR GLUE-UP

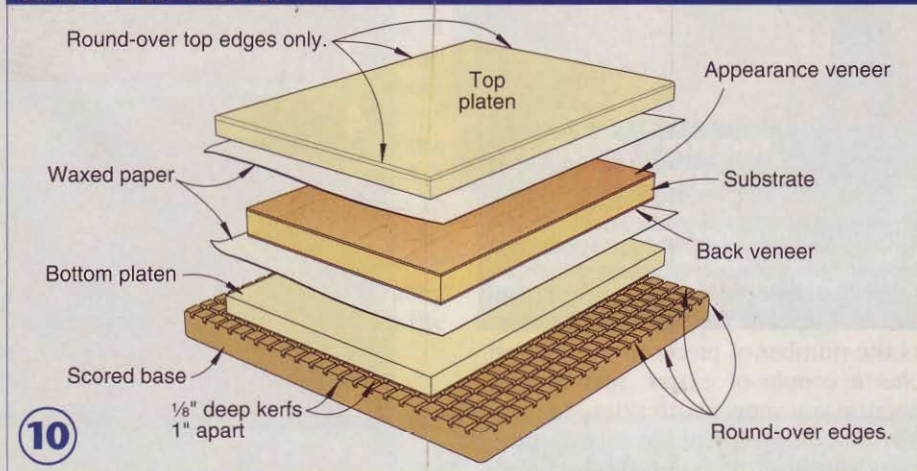

long. With the freshly cut veneer edge slightly overhanging your workspace, use long strokes to lightly sand the edges straight and square.

**STEP 4:** To avoid tearing the veneer, tape it from edge to edge over your cutline perpendicular to the sanded edge. Using a right triangle, position your straightedge, and make a series of light

cuts to remove the waste. Repeat on the opposite end to trim both pieces to length; then, remove the tape.

**STEP 5:** Turn the top sheet over, as you would turn the pages of a book.

**STEP 6:** Turn the sheets facedown, and use taut pieces of painter's tape to pull the cut edges tightly together, as shown above left. Then, reinforce the

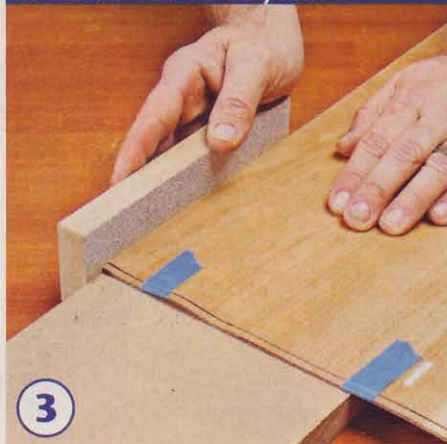
**SAND EDGES TO BE JOINED****3****CUT THE END AT 90°****4****FLIP THE PIECES****5****APPLY VENEER TAPE****7****GLUE THE SUBSTRATE****8****ATTACH THE VENEER****9****APPLY VACUUM PRESSURE****11****REMOVE THE VENEER TAPE****12**

length of the joint with one long strip of tape, as shown.

**STEP 7:** Flip the taped sheets over, and apply a strip of veneer tape over the seam. Allow the tape to dry, and remove the painter's tape from the back. Repeat steps 1 through 7 to create a backer veneer for your glue-up. Then trim both to the size of your substrate.

**STEP 8:** Using a small paint roller, apply an even coat of white glue to the substrate. Avoid roller marks or glue drops that may prevent the veneer from being pressed flat.

**STEP 9:** Center and lay the veneer on the glued substrate. Repeat the previous step and this step for the backer veneer on the underside.

**STEP 10:** Platens above and beneath your glue-up—protected by wax paper—help the vacuum bag press the veneer firmly and evenly against the substrate. Place the scored base inside the vacuum bag, then assemble the glue-up stack, and tape it together with clear packing tape to keep it from shifting. Place the stack inside the bag on the center of the base, and cover it with the plastic mesh that comes with the vacuum bag.

**STEP 11:** Seal the vacuum bag according to the manufacturer's instructions, and pump out the air. Allow the glue to dry within the bag for at least four hours. After removing the glue-up from the bag, lean the glue-up against a wall or your workbench to allow both sides to stabilize overnight.

**STEP 12:** Moisten the veneer tape with a wet sponge to reactivate the adhesive. Use a putty knife to gently scrape off the tape and wipe away adhesive residue. After the surface dries, trim the panel to its finished size, and carefully hand-sand to the same grit as the rest of your project.

# Let's Try a Diamond Match

Once you've mastered the basics, you're ready for a more sophisticated pattern. Here, we lay out four pieces of sapele pommelle with a rippling grain.

**STEP 1:** Stack and number four consecutive sheets of veneer, and tape them together to prevent shifting. Use mirrors held at a 90° angle to visualize the ideal four-way grain match, as shown on page 43. This also lets you work around any veneer defects. Then, mark the mirror location, and lay out your cuts along those lines using a straightedge and triangle. Cut one edge, remove the waste, renumber the pieces, and retape them.

**STEP 2:** Use a triangle to set your straightedge perpendicular to your first cut; then remove the remaining waste to form a 90° angle. (Don't worry if the remaining sides form odd angles.) Remove the tape.

**STEP 3:** Turn over the top two veneer pieces, using the first edge you cut as the "book" spine. Pieces 1 and 2 should be upside down.

**STEP 4:** Turn over pieces 2 and 3 as shown for the four-piece match. Sand the mating edges, as shown earlier, and use painter's tape to join pieces 1 and 2. Repeat for pieces 3 and 4; then check the seam between the two halves.

**STEP 5:** Unless your two cuts were dead-on accurate, you'll end up with a gap between the two halves that looks something like that shown at right.

**STEP 6:** Place one of the halves between your straightedge and a scrap of MDF with about 1/8" overhanging. Then, use a rigid sanding block to sand this edge flush with the straight edge of the MDF. Repeat this for the other half.

**STEP 7:** With all four pieces assembled, apply veneer tape along the seams on the top face. Next, remove the painter's tape, center your substrate on the facedown veneer using the technique in our **Shop Tip** opposite, and trim away the excess. Finish by gluing the substrate, and press this pattern, as in the basic book match.





# Stretch Veneers to Fit Your Project

Some project parts call for wider veneers than you have on hand. No problem; just use this simple technique to double the width of your veneer pieces.

**STEP 1:** To cover a substrate wider than the width of your veneer, first pick the grain angle you want, and mark it on the veneer. Although this technique works for any number of veneer sheets, we only need a single sheet to cover this substrate with a diagonal grain pattern.

**STEP 2:** On the edge where your knife blade exits, place painter's tape on

avoid tearing off the fine point of the corner. Then, place a straightedge on your pencil line, and cut the veneer in a series of light passes. Carefully remove the tape to avoid pulling off the point.

**STEP 3:** With both pieces flat on your worksurface, swing the cutoff piece around until the sanded edges butt together. Because the color and grain pattern are the same along the edge, it's easy to match them for the look of one wide piece. Then, use painter's tape on the back side to join the halves. 🌲

## MARK THE FIRST ANGLE TO BE CUT



## CUT VENEER WITH NO TEAR-OUT



## MATCH THE VENEER EDGES

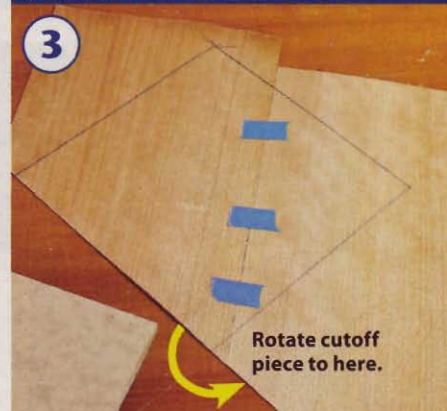

## TAKE THE CURL OUT OF BURL

Try to press rippled, unsoftened burl, and you end up with a bumpy pile of shattered wood. But by softening burl just before veneering it, you have flat sheets of flexible material that retain burl's swirling patterns.

Today's commercial wood softeners (see **Sources**) make flattening burl quick and easy. Start by mixing softener with water (where required) according to the manufacturer's instructions. Then, brush or spray softener onto both sides of each piece, and allow the sheets to absorb the softener for 10 minutes.

To flatten the treated sheets, place three paper towels on the top, and three beneath each sheet. Stack the veneer sheets and paper towels, and place them between two MDF or particleboard platens. Compress the platens using clamps or your vacuum veneer bag for three hours. Replace the paper towels with dry ones, and reclamp or vacuum-press the stack for another three hours. Repeat this process until the towels and veneer are dry. Store the flattened veneer between two platens until you're ready to use it.



## SHOP TIP

### Center veneer patterns on your substrate

To position a four-piece veneer pattern precisely in the center of a substrate, begin by marking the center of all four edges of the substrate. If necessary, to make the seams more visible, mark where the veneer pieces meet. After applying glue to the substrate, match all of the center marks with the veneer seams, and hand-press the substrate against the veneer. Then, press the glue-up using clamps or a vacuum veneer press, taking care not to shift the veneer.

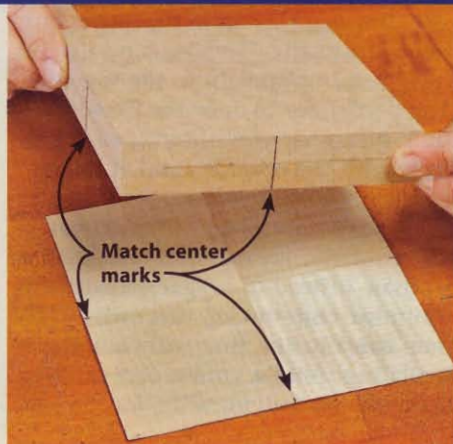

## Sources

**Veneer tape.** No. 49841, \$5.89 for a 650' roll, call Rockler Woodworking and Hardware at 800-279-4441; rockler.com.

**Vacuum veneer press.** Vacuum-press kit with a pump, sealing tape, mesh, and a 26x28" bag no. 20691, \$50, call Rockler Woodworking and Hardware.

**Veneer bundles.** Sapele pommelle, figured maple, cherry, and walnut burl available from Certainly Wood, 716-655-0206 or certainlywood.com; VeneerSupplies.com, 888-598-3633; and B&B Rare Woods, call 303-986-2585 or wood-veneers.com.

**Veneer softener:** Super-Soft 2, \$13.50/quart or \$30/gallon, VeneerSupplies.com. Veneer softener, \$33/gallon (mix 1:1 with water), call Veneer Systems, Inc., at 800-825-0840; veneersystems.com.

# All-in-Order Storage Bins



Organize the “stuff” in your garage or basement with this easy-to-build project. You’ll complete it in no time, thanks to the simple screw joinery and identical basic bin construction. And using melamine panels means ... **NO FINISHING!**

## Start with the sides

**1** From  $\frac{3}{4}$ " melamine panels, cut the sides (A) to the size listed [Materials List, page S2]. (You’ll typically find white and wood-grain pattern melamine panels at your local home center and lumberyard. You can order panels in other colors, such as the light gray that we used, from a hardwood store.) For safe handling and problem-free machining of the melamine panels, see the **Shop Tips**, opposite page.

**2** To create a “master” side (A) that you’ll use as a template to pattern-rout the other sides to identical shape,

lay out the large curved area at the front edge [Drawing 1]. Start at the  $2\frac{3}{4}$ " radius, transition to the 7" radius, and extend the layout line straight to the top edge. (You don’t need to draw the 2" radius at the top because you’ll rout it to shape, along with the other 2" radii at the corners, using a jig.)

**3** Bandsaw to within approximately  $\frac{1}{8}$ " of the layout line. (We used a bandsaw instead of a jigsaw for this to minimize chip-out of the melamine.) Then sand to the line with a 150-grit oscillating spindle sander or a sanding drum in your drill press.

## PROJECT HIGHLIGHTS

- Build one, two, three, or all four of the bins in the photo. You’ll find plans for all four. Or customize the bins to suit your storage items by mounting the shelves and divider where you wish.
- Overall dimensions (4 bins): 78" wide x 18" deep x 42" high. Each bin measures 19½" wide.
- The bins are made from materials available at your local home center or lumberyard. You’ll need four  $\frac{3}{4}$ "-thick 4x8' melamine panels and a 10'-long pine 2x4. (We found the panels for about \$28 apiece at a home center.)

## Skill Builders

- Discover how to quickly, easily, and neatly edge melamine panels with flexible T-molding.
- Learn about the best fasteners for joining melamine panels.



See a slide show of this project coming together at: [woodmagazine.com/slides](http://woodmagazine.com/slides)

## SHOP TIPS

### 6 tips for working with melamine panels

To ensure safe handling, successful machining, and assembly of melamine panels, follow these pointers.

**Tip 1:** A full sheet of  $\frac{3}{4}$ " melamine weighs about 90 pounds. To avoid injury, enlist a helper when you need to move a panel.

**Tip 2:** For safety and ease of handling, cut parts from the panels to rough size using a circular saw and straight-edge guide instead of your tablesaw. Learn more at [woodmagazine.com/videos](http://woodmagazine.com/videos).

**Tip 3:** When cutting the panels, use adequate support to prevent the offcuts from breaking away and damaging the edges.

**Tip 4:** To avoid chip-out along edges, use an 80-tooth carbide-tipped plywood/melamine or laminate/melamine blade in your tablesaw. A zero-clearance insert helps a lot, too.

**Tip 5:** To prevent the T-molding edging from catching on and chipping the sharp melamine edges when installing the molding, lightly chamfer the edges of the melamine on both faces using a 220-grit sanding block held at 45°.

**Tip 6:** Melamine panels have a particleboard core. To avoid damaging the core and to ensure strong assemblies, use cabinet-connector screws instead of wood screws to fasten the panels together. Drill the pilot holes for the screws using a connecting-screw step drill bit. (See **Sources** for the screws and bit.) For more on these fasteners, see page 80.

**4** To complete the master side, build the simple, self-indexing radius-routing jig [Drawing 2]. Then use the jig to rout the 2" radii [Photo A, Drawing 1].

**5** To pattern-route the remaining sides (A), position the master side on top of a side with the edges aligned. To keep the master side aligned and make it easy to index on the other sides, screw-mount  $\frac{3}{4} \times 1\frac{1}{2} \times 3$ " cleats to the top, bottom, and side edges of the side, flush

with one face and approximately centered on the edges.

Next, draw a line on the unshaped side approximately  $\frac{1}{8}$ " from the edge of the large curved portion of the master side [Photo B]. (You don't need to mark and pre-trim the 2" radii.) Remove the master side. Bandsaw the marked side to the line. Then reposition the side on top of the master side. Now pattern-route the curved area and 2" radii [Photo C]. Repeat to shape the other sides.

### Now make the other parts

**1** From  $\frac{3}{4}$ " melamine panels, cut the large shelves/front panels (B), backs (C), shelf/base trim (D), and small shelves/divider (E) to the sizes listed.

### 1 SIDE VIEW

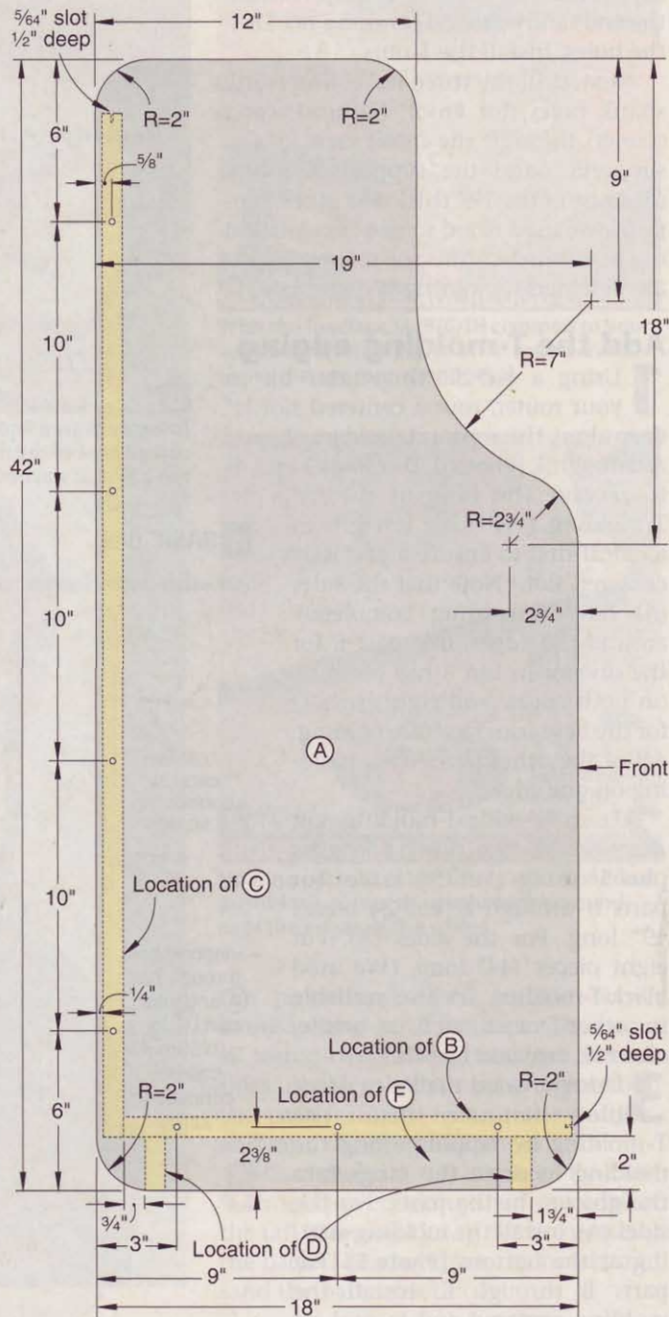

### 2 RADIUS-ROUTING JIG

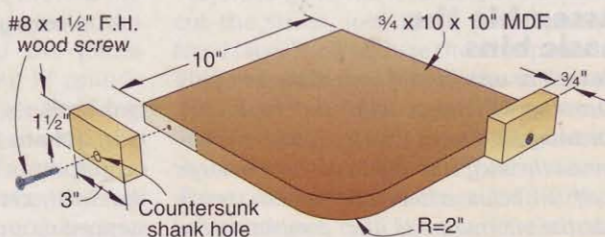

**2** From 1 1/2" pine (we used a 2x4), cut the leveler supports (F) to the size listed. To mount the levelers in the supports with  $\frac{1}{4}$ " T-nuts [Drawing 3], mark centerpoints on the bottom edges of the

### ROUT THE 2" RADII ON THE TEMPLATE

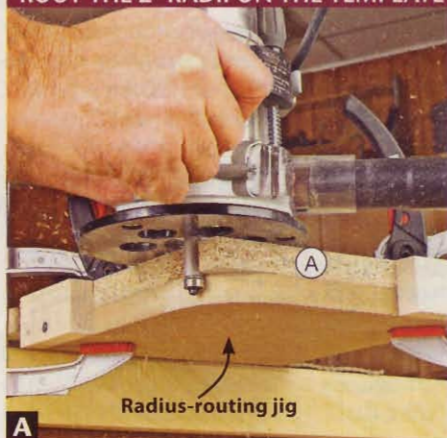

**A** Using a flush-trim bit and the radius-routing jig as a guide, rout the four 2" radii at the corners of the "master" side (A).

USE THE MASTER SIDE TO LAY OUT AND PATTERN-ROUT THE SIDES TO SHAPE

supports for  $\frac{5}{16}$ " holes  $1\frac{1}{2}$ " deep  $\frac{3}{4}$ " from the ends and centered [Drawing 3a]. Drill the holes. Install the T-nuts.

Next, drill the three  $\frac{5}{32}$ " countersunk shank holes (for #8x2" flathead wood screws) through the *inside* faces of the supports. Sand the supports smooth. (Because of the  $1\frac{1}{2}$ " thickness of the supports, we used wood screws here instead of the cabinet-connector screws, which are designed for joining  $\frac{3}{4}$ " materials.)

### Add the T-molding edging

**1** Using a  $\frac{5}{64}$ " slotting-cutter bit in your router, rout a centered slot  $\frac{1}{2}$ " deep along the appropriate edges of parts A through E [Photo D, Drawings 3 and 4] to receive the tang of the  $\frac{3}{4}$ " T-molding. (We made test cuts in a cutoff first to ensure a perfectly centered slot.) Note that the sides (A) have T-molding completely around the edges, one part E for the divider in bin 3 has molding on both edges, and eight parts D for the base trim have no molding. All of the other parts have molding on one edge.

**2** From  $\frac{3}{4}$ "-wide T-molding, cut pieces to the needed lengths plus 1" using a utility knife. For parts B through E, cut 24 pieces 19" long. For the sides (A), cut eight pieces 114" long. (We used black T-molding. It's also available in other colors such as white, almond, tan, and brown.)

**3** Using a wood mallet or dead-blow hammer, install the T-molding by tapping along the molding to drive the tangs into the grooves in the parts. For the sides (A), install the molding starting at the bottom [Photo E]. For parts B through E, install the molding centered end to end on the parts. Then flush-trim the ends of the molding.

### Assemble the basic bins

**Note:** The assembly of each of the four bins [Drawing 4] begins with the basic bin [Drawing 3]. Except for bin 3, where you'll mount the shelf trim (D) to the bottom large shelf (B) before assembling the bin, you'll add the internal parts after completing the basic bins.

**1** To mount the two base trim (D) pieces to the bottom large shelf (B) for each basic bin [Drawing 3], cut a 2x18" spacer from  $\frac{3}{4}$ " scrap. Clamp the shelf to the trim, using the spacer and

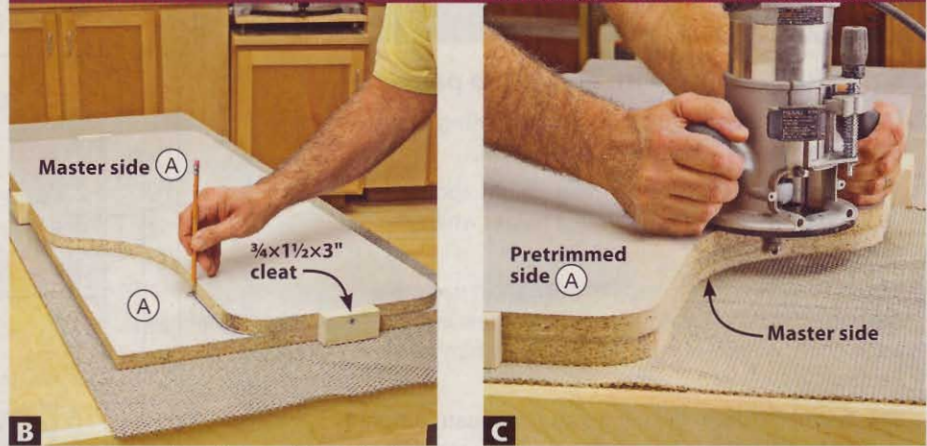

**B** To easily draw a line about  $\frac{1}{8}$ " from the large curved area of the master side onto a side (A), use a  $\frac{1}{4}$ " flat washer as a guide for a pencil.

**C** With a pretrimmed side (A) placed on top of the master side, pattern-route the large curved area and 2" corner radii to shape.

### 3 BASIC BIN

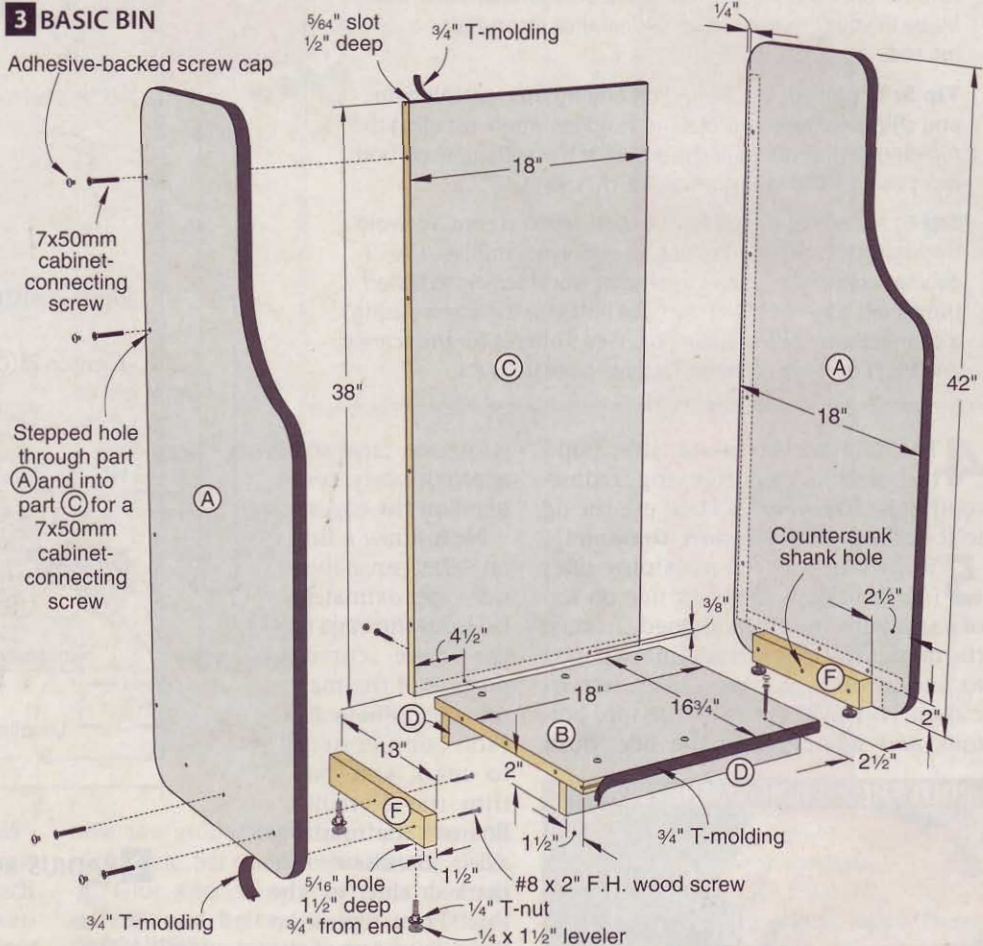

two leveler supports (F) to position the trim [Photo F]. Using a square, mark centerpoints for the mounting holes on the shelf, centered over the trim. Drill stepped mounting holes for the 7x50mm cabinet-connecting screws at the centerpoints using a connecting-screw step drill bit. (See Sources for the screws and bit.) Drive the screws. For bin 3, screw-mount the shelf trim (D) to the top of the bottom large shelf/base trim assem-

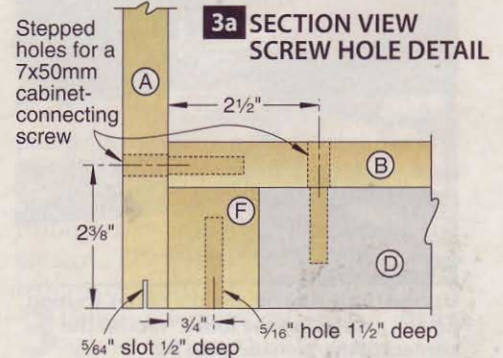

### SLOT-CUT THE T-MOLDING GROOVES

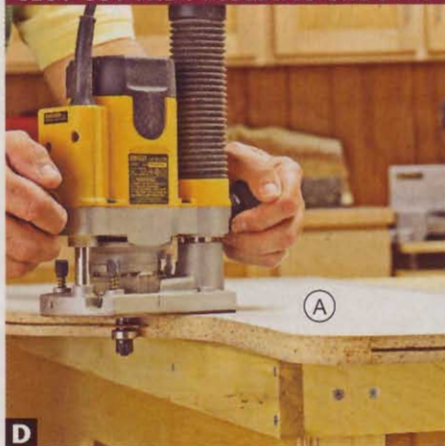

**D** Using a slotting-cutter bit, rout a centered  $\frac{5}{64}$ " slot  $\frac{1}{2}$ " deep in the appropriate edges of parts A through E to receive the T-molding.

### INSTALL THE T-MOLDING ON THE SIDES

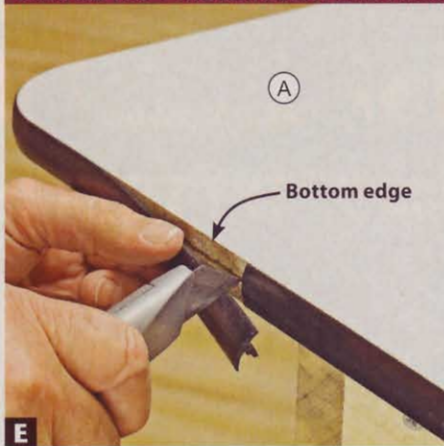

**E** Start the T-molding at the center of the bottom edges of the sides (A) to hide the joints. Overlap the ends, and trim the excess.

### ASSEMBLE THE BOTTOM SHELF/TRIM

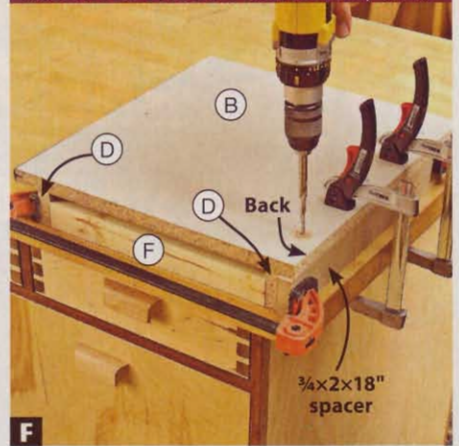

**F** Mount the base trim (D) to the bottom large shelf (B) using a  $\frac{3}{4}$ " spacer at the back and two leveler supports (F) to position the trim.

## 4 EXPLODED VIEW

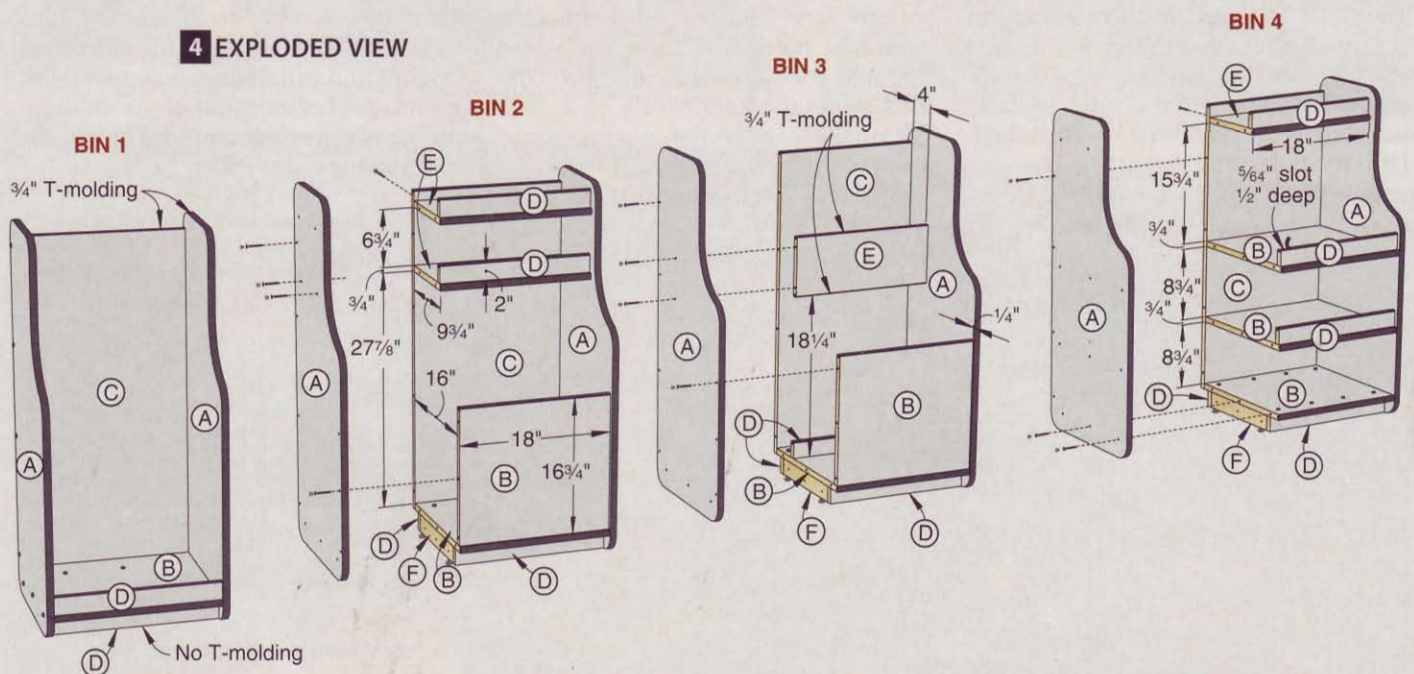

ply (B/D), positioning the trim 4" from the back edge of the shelf [Drawing 4].

**2** At the bottom of each back (C), mark centerpoints for the two mounting holes [Drawing 3]. Position a back against a shelf/base assembly (B/D) with the bottom of the back flush with the bottom face of the shelf [Photo G]. Use a right-angle clamping brace to keep the back square to the shelf. (For a free clamping brace plan, go to [woodmagazine.com/brace](http://woodmagazine.com/brace).) Drill the stepped holes through the back and into the shelf. Drive the screws. Repeat for the other backs and shelf/base assemblies.

**3** Clamp the leveler supports (F) to the inside faces of the sides (A), flush with the bottom edges of the panels (not the T-molding) and  $2\frac{1}{2}$ " from the front edges [Drawing 3]. Using the countersunk shank holes in the supports as

guides, drill  $\frac{3}{32}$ " pilot holes into the sides. Drive the #8x2" flathead wood screws, using care not to overtighten.

**4** On the outside faces of the sides (A), mark centerpoints for the mounting holes [Drawing 1]. Position a left side on a base/back assembly (B/C/D) with the leveler support (F) located between the base trim (D). Verify that the side overhangs the back (C) an equal amount ( $\frac{1}{4}$ " plus the T-molding thickness) along the length [Drawing 3, Photo H]. Then, at the marked centerpoints, drill the stepped holes through the side and into the bottom large shelf (B) and back, and drive the screws. Turn the assembly over, and mount a right side in the same way. Repeat for the other bins.

**5** Thread the  $\frac{1}{4}$ x $1\frac{1}{2}$ " levelers into the T-nuts in the leveler supports (F) [Drawing 3].

### Complete the bins

**1** Screw-mount the shelf trim (D) to the large and small shelves (B, E) for bins 2 and 4 flush with the front edges [Drawing 4].

**2** To complete bin 1, screw-mount the remaining shelf trim (D) piece to the bottom large shelf (B), flush with the front edge. To complete bins 2, 3, and 4, cut spacers from  $\frac{1}{4}$ " hardboard to the needed sizes to position the large shelves (B/D), small shelves (D/E), and divider (E) in the bins, where dimensioned, or where you wish to suit your storage items.

To mount the shelves in bin 4, for example, cut two  $8\frac{3}{4}$ x $15\frac{3}{4}$ " spacers, which enable you to position the large shelves (B/D) and small shelf (D/E). Use the  $8\frac{3}{4}$ " width of the spacers to position each large shelf in the bin [Photo I].

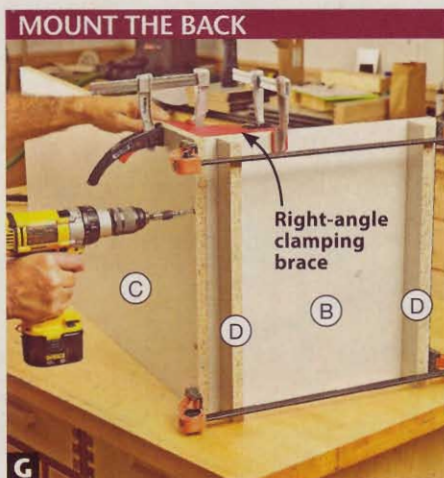

**G** Clamp a back (C) to a bottom large shelf/base trim assembly (B/D), flush with the shelf bottom. Drill the holes, and drive the screws.

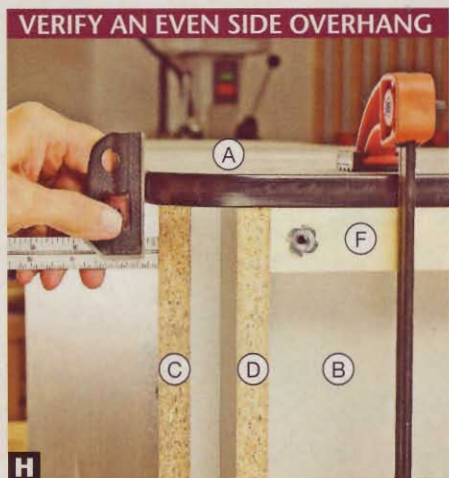

**H** Using a combination square, check that the side (A) overhangs the back (C) evenly along the length to ensure a square assembly.



**I** Position and clamp a large shelf (B/D) in bin 4 on 8 $\frac{3}{4}$ "-wide hardboard spacers. Drill the mounting holes, and drive the screws.

Then, use the 15 $\frac{3}{4}$ " length to position the small shelf at the top. With each shelf in position, mark centerpoints for mounting holes on the sides (A) and back (C), centered on the  $\frac{3}{4}$ "-thick shelf. Drill the holes, and drive the screws.

Now mount the front panels (B) in bins 2 and 3, aligning the panels flush with the front edges of the sides (A) and

bottom large shelves (B). Drill the mounting holes, and drive the screws through the sides and bottom large shelves into the front panels.

**3** Finally, conceal the exposed screws with adhesive-backed PVC screw caps. (See **Sources**.) Then, using a helper, move the bins to the desired location. Adjust the levelers as needed to align the

bins. If you wish to fasten the bins together, see *page 80* for hardware options and installation guidance. Now round up all of those out-of-place things, and neatly store them in your handsome new storage center. 🌿

Written by **Owen Duvall** with **Chuck Hedlund**  
Project design: **Jeff Mertz**  
Illustrations: **Roxanne LeMoine; Lorna Johnson**

## Cutting Diagram (for the four bins shown)

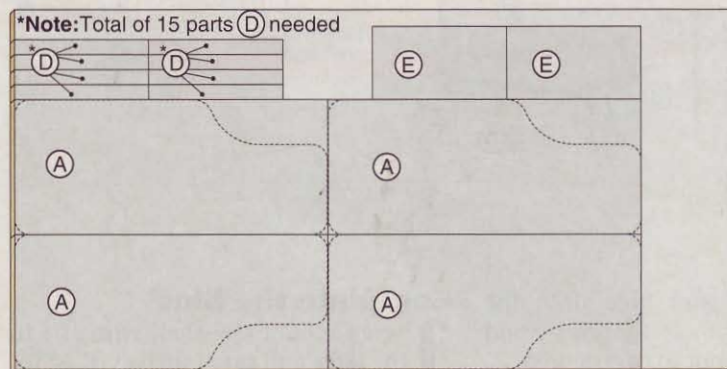

$\frac{3}{4}$  x 48 x 96" Melamine (2 needed)

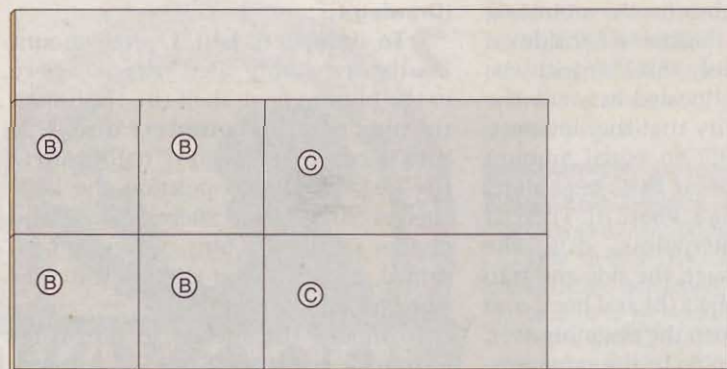

$\frac{3}{4}$  x 48 x 96" Melamine (2 needed)

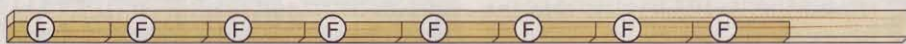

$1\frac{1}{2}$  x  $3\frac{1}{2}$  x 120" Pine (2x4x10')

## Materials List (four bins)

Part	FINISHED SIZE			Matl.	Qty.
	T	W	L		
A sides	$\frac{3}{4}$ "	18"	42"	M	8
B large shelves/ front panels	$\frac{3}{4}$ "	18"	16 $\frac{3}{4}$ "	M	8
C backs	$\frac{3}{4}$ "	18"	38"	M	4
D shelf/base trim	$\frac{3}{4}$ "	2"	18"	M	15
E small shelves/ divider	$\frac{3}{4}$ "	9 $\frac{3}{4}$ "	18"	M	4
F leveler supports	1 $\frac{1}{2}$ "	2"	13"	P	8

**Materials key:** M—melamine panels, P—pine.

**Supplies:**  $\frac{1}{4}$ " flat washer (for a tracing guide),  $\frac{1}{4}$ " T-nuts (16), 7x50mm cabinet-connecting screws, #8x1 $\frac{1}{2}$ " and #8x2" flathead wood screws,  $\frac{1}{4}$ x1 $\frac{1}{2}$ " levelers (16),  $\frac{3}{4}$ "-wide T-molding (approximately 114').

**Bits:** Flush-trim and  $\frac{5}{64}$ " slot-cutter router bits, step drill bit for 7x50mm cabinet-connector screws.

## Sources

**Cabinet-connecting screws, step drill bit, and screw caps:** 7x50mm cabinet-connecting screws, no. 7050-CSP, \$7.53 per package of 100 (2 pkgs.); step drill bit for 7x50mm screws, no. MS-0750, \$19.95; adhesive-backed PVC screw caps, Folkstone color (for light-gray melamine panels), no. FCS-6170, \$1.75 per sheet of 52 caps (4 sheets). McFeely's; 800-443-7937, mcfeelys.com.

**T-molding and slot-cutter bit:**  $\frac{3}{4}$ " black T-molding, no. 91728, \$29.99 pkg. of 100', and no. 27201, \$8.49 package of 12' (2 pkgs.);  $\frac{5}{64}$ " slot-cutter router bit with  $\frac{1}{4}$ " shank, no. 95332, \$32.99. Rockler; 800-279-4441, rockler.com.

Better Homes and Gardens®

# WOOD PATTERNS

October 2007

Issue 179

Dear Reader: As a service to you, we've included full-size patterns on this insert for irregular shaped and intricate project parts. You can machine all other project parts using the Materials List and the drawings accompanying the project you're building.

© Copyright Meredith Corporation, 2007. All rights reserved. Printed in the U.S.A. Meredith Corp., the publisher of WOOD Patterns®, allows the purchaser of this pattern insert to photocopy these patterns solely for personal use. Any other reproduction of these patterns is strictly prohibited.



Plane-fun Kid's Shelf, Page 58



Desk Clock, Page 70

1/4" hole



ⓕ  
PROPELLER  
FULL-SIZE  
PATTERN

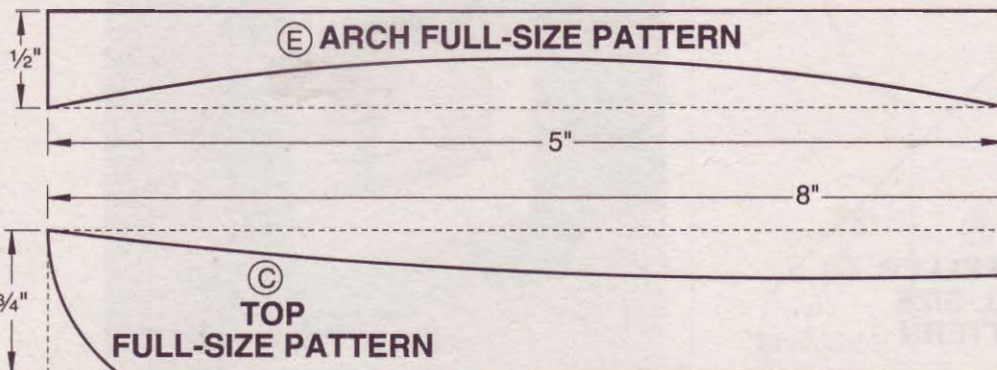
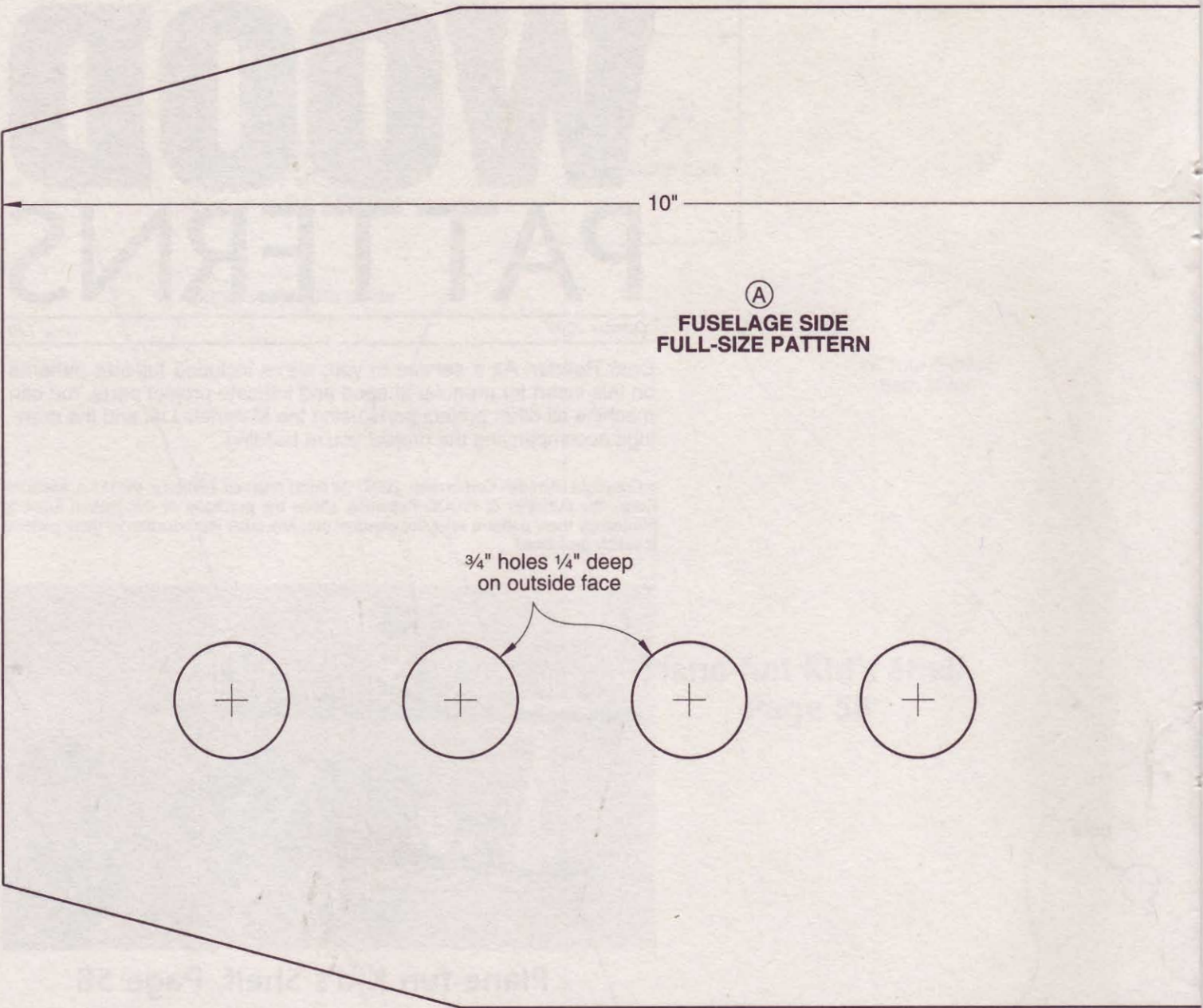

**Desk Clock,  
 Page 70**



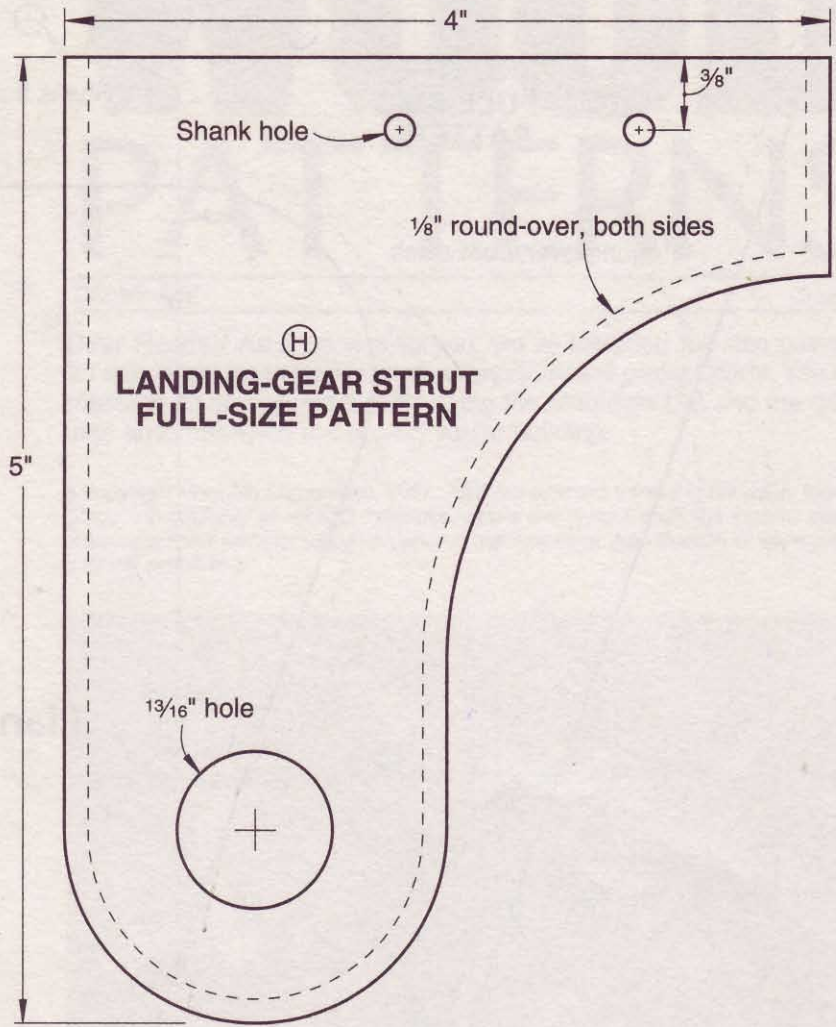
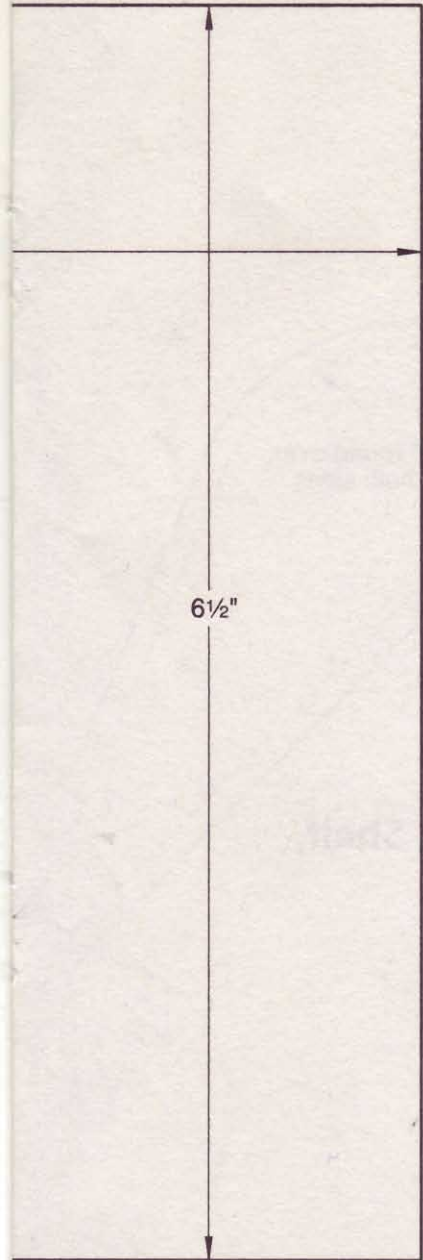

Plane-fun Kid's Shelf,  
Page 58



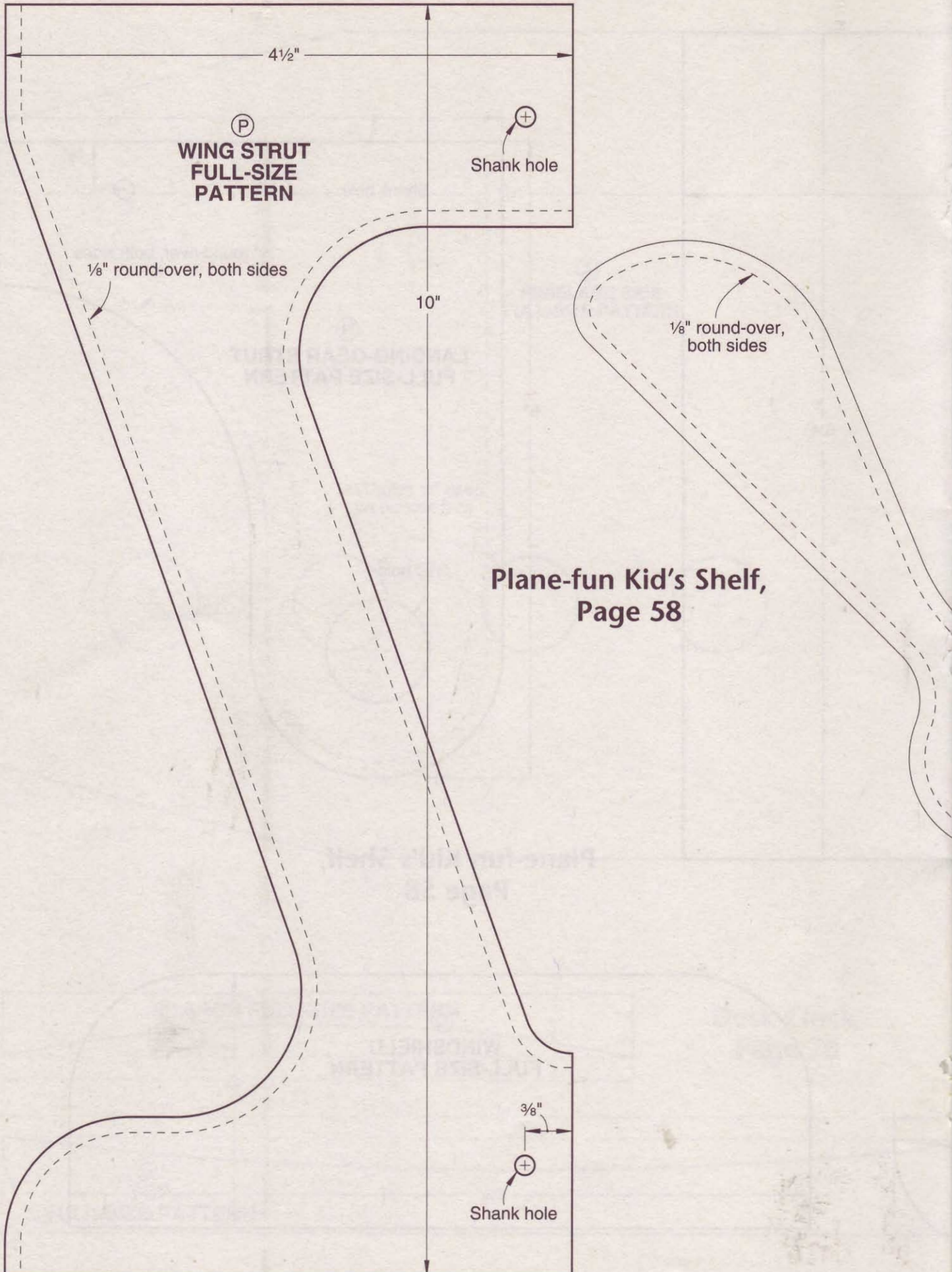

(P)  
**WING STRUT  
FULL-SIZE  
PATTERN**

⊕  
Shank hole

1/8" round-over, both sides

10"

1/8" round-over,  
both sides

**Plane-fun Kid's Shelf,  
Page 58**

3/8"

⊕  
Shank hole



**Note:** After preparing the parts as explained in the first four sections of this article, have your partner assemble the project starting with the section identified by the adult/child icon on page 62.

### PROJECT HIGHLIGHTS

- Overall dimensions are 47" wide x 11 $\frac{3}{8}$ " deep x 17 $\frac{1}{4}$ " high.
- Materials needed: A quarter sheet each of  $\frac{1}{2}$ " and  $\frac{3}{4}$ " medium-density fiberboard (MDF); small pieces of oak, poplar, and  $\frac{1}{8}$ " acrylic; and a dowel.
- The use of #8 trim washers under the screwheads eliminates the need to countersink the mounting holes and lends the look of airplane rivets.

### Begin with the fuselage

**1** Cut the fuselage sides (A), top (B), cowling (C), and nose (D) to the sizes listed [**Materials List**, page 62].

**2** Make one copy each of the patterns for the sides (A), propeller (F), landing-gear struts (H), wing struts (P), and windshield (Q) on the **WOOD Patterns®** insert. Spray-adhere the side pattern to a side. Set the other patterns aside.

**3** To save time and ensure identical parts, join the sides (A) together with double-faced tape for stack-cutting. (You also can do this for other parts, where noted.) Bandsaw and sand the sides to shape. Separate the parts, and remove the tape. Using a square, transfer



## 1 FUSELAGE

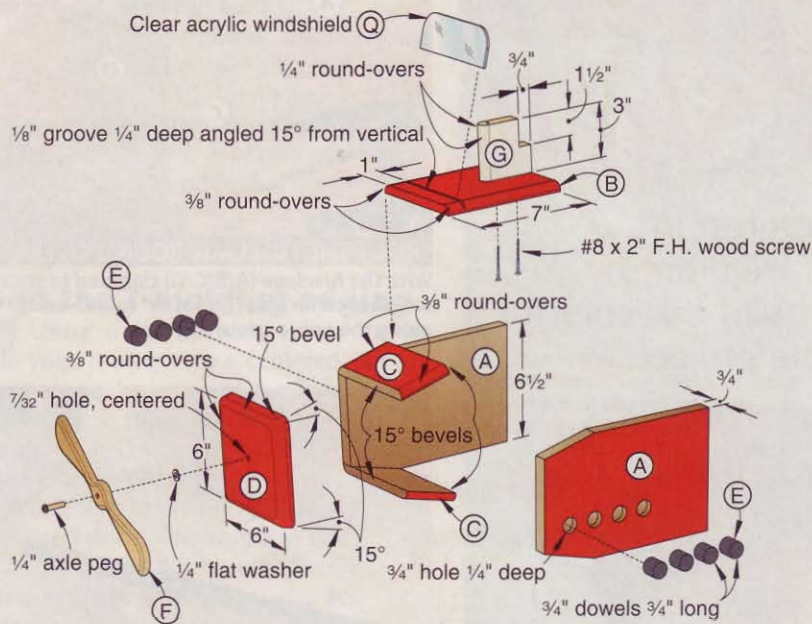

## 2 LANDING GEAR

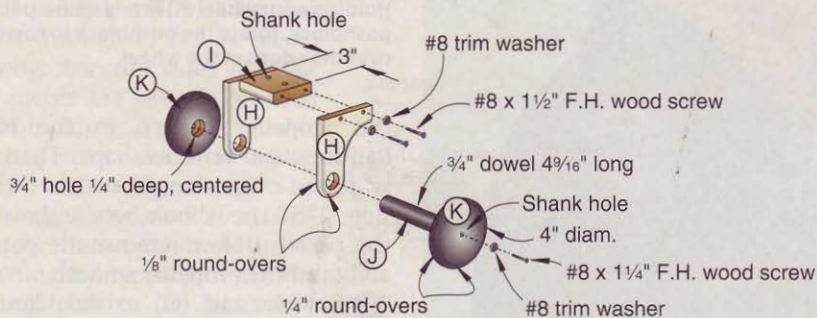

**3** To form the wheels (K), cut two 4½"-square pieces from ¾" MDF. Draw diagonals to mark the center of each blank. Using a compass, draw a 4"-diameter circle at the centerpoint of one blank. Then stack-cut the wheels to shape with your bandsaw, and sand the edges smooth. Separate the parts.

**4** Rout a ¼" round-over along both edges of each wheel (K) [Drawing 2, Photo B]. Then bore a ¾" hole ¼" deep at the center of each wheel to receive the axle (J). Now drill a shank hole, centered in the ¾" hole in each wheel, for screw-mounting the wheels to the axle. Position a wheel onto the axle, and drill a pilot hole into the axle using the shank

hole as a guide. Repeat at the other end of the axle. Set the wheels and axle aside.

**5** Glue and clamp together the struts (H) and brace (I), with the brace flush with the top ends and back edges of the struts. Using the shank holes in the struts as guides, drill pilot holes into the brace. Do not drive the screws. Then, drill the two shank holes through the brace for attaching the landing gear to the bottom wing (L) later.

## Glide into the wings

**1** Using ½" MDF for the bottom wing (L) and ¾" MDF for the top wing (M), cut the parts to the sizes listed. Lay out the shape on each wing and mark

## 3 PARTS VIEW

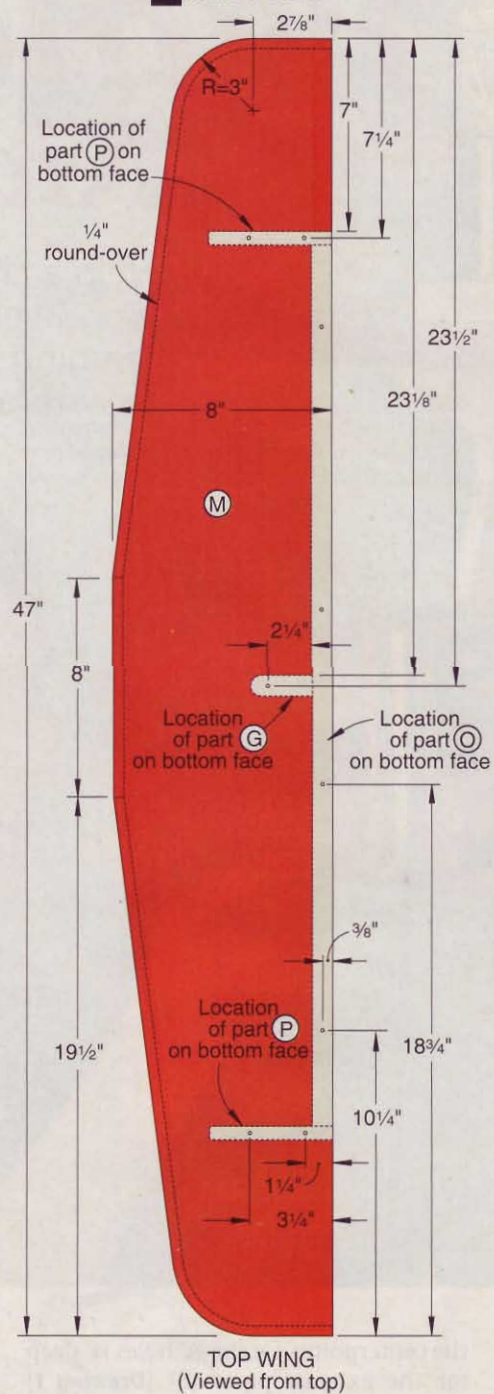

centerpoints for the shank holes [Drawing 3]. Bandsaw and sand the wings to shape. Drill the shank holes.

**2** Cut the bottom-wing cleats (N), top-wing cleat (O), and struts (P) to the sizes listed. Spray-adhere the strut pattern to a face of a strut. Stack-cut the struts to shape using your bandsaw, and sand smooth. Drill the shank holes through the struts, where shown on the pattern. Then separate the parts, and remove the pattern.

**3** Using the appropriate-size router bits, round over the edges of the bot-

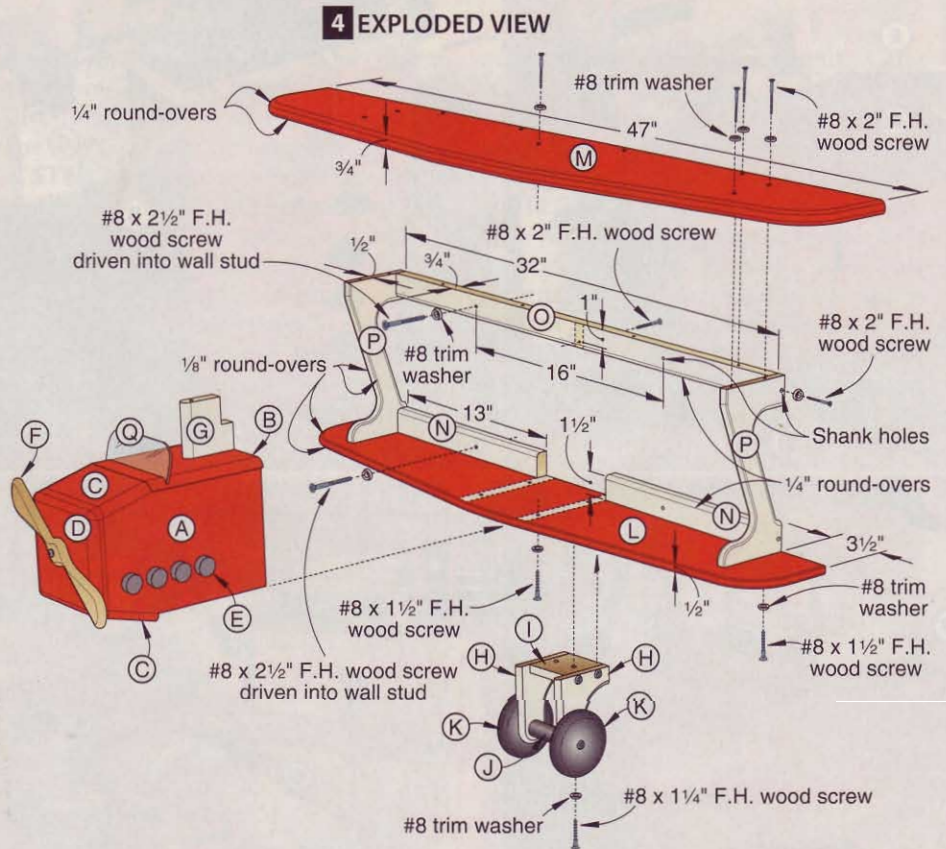
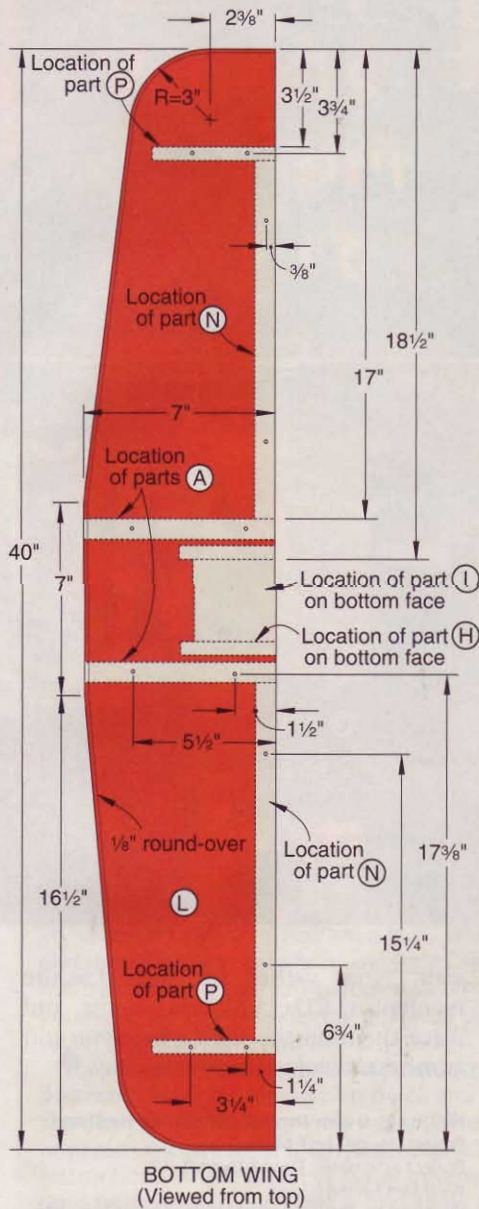

tom wing (L), top wing (M), bottom-wing cleats (N), top-wing cleat (O), and struts (P) [Drawing 4].

**4** From 1/8" clear acrylic, cut the windshield (Q) to size. Spray-adhere the windshield pattern to the piece. Scrollsaw to shape, and sand the edges smooth. To prevent scratches, leave the protective film on the acrylic until you silicone it in the groove in the top (B).

### Cruise to the finish

**1** Sand any areas that need it to 180 grit, and remove the dust. To mini-

### SHOP TIP

#### Yellow glue: It sizes up as a pre-prime sealer

When you need to prime and paint a porous material, such as the MDF for the kid's shelf, you can save considerable time—and primer—by first sealing the parts with yellow glue thinned with water, known as glue size. The glue reduces the absorption of the primer and avoids the need for a second coat. It also sands much easier than primer.

To prepare the glue size, mix three parts of water with seven parts of glue. Apply the size with a foam brush, avoiding contact areas where you need to glue parts together. Let the glue dry overnight. Then sand the glue smooth, working from 150 to 220 grit. Remove the dust, and you're ready to prime and paint.



mize absorption of the primer for the MDF parts, seal them as explained in the **Shop Tip**, above.

**2** Prime and paint the parts. We primed the parts with Krylon aerosol Interior-Exterior All-Purpose White Primer, no. 1315. We colored the parts

with these Krylon aerosol Interior-Exterior paints: no. 2101 Cherry Red Gloss for parts A, B, C, D, L, and M; no. 1601 Glossy Black for parts E, J, and K, and the head of a 1/4" axle peg for attaching the propeller (F); and no. 1501 Glossy White for parts G, H, I, N, O, and P.

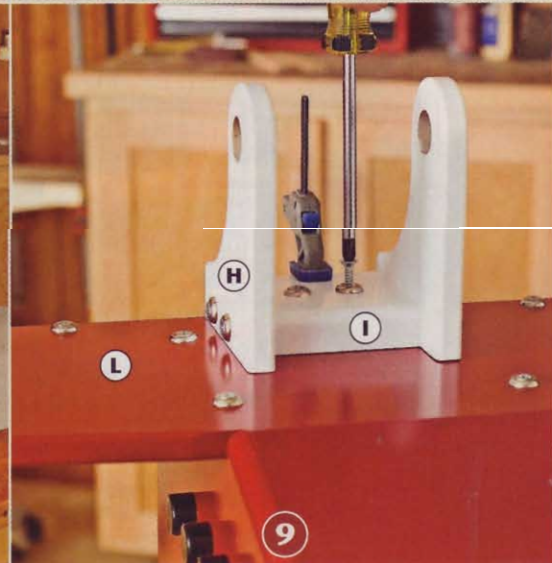
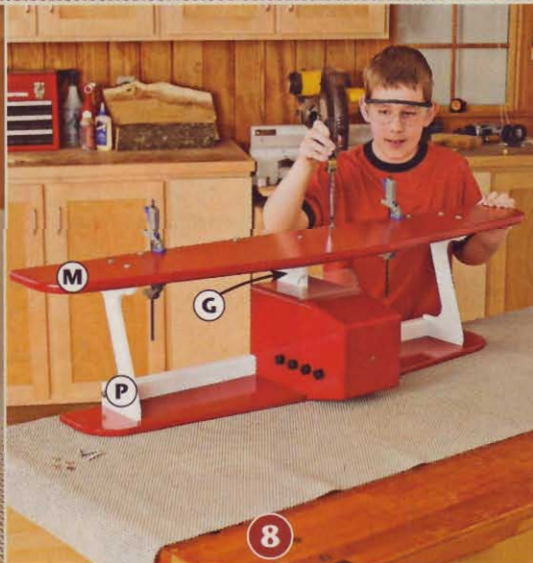
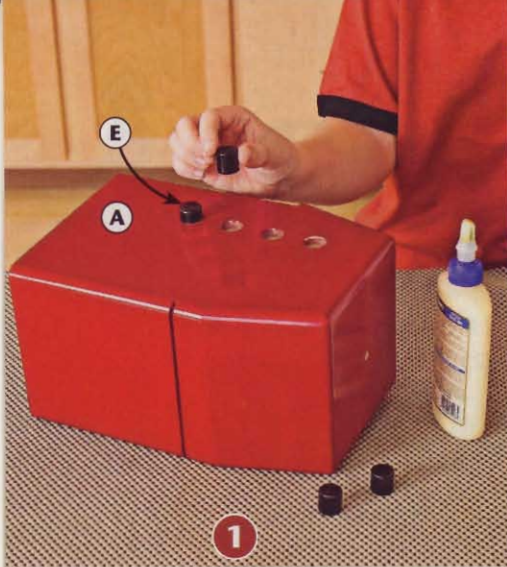

## Now let's put it together

**1** Have your young copilot assemble the shelf, as shown *above* and explained on the *opposite page*, using #8 trim washers and the appropriate lengths of #8 flathead wood screws [Drawings 1, 2, and 4].

**2** To wall-mount the shelf, mark centerpoints for mounting holes on the back face of the bottom- and top-

wing cleats (N, O) [Drawing 4]. You can mount the unit using trim washers and #8×2½" flathead wood screws driven into the wall studs, or with suitable wall anchors. Drill shank holes at the centerpoints. Then, holding the shelf level on the wall, mark the hole locations using an awl. Remove the shelf. Drill the needed holes, and fasten the shelf to the

wall. Now gather up your favorite mementos, CDs, and other items, and place them on the shelf where you can admire and enjoy them every day. 🌳

Written by **Owen Duvall** with **Chuck Hedlund**  
Project design: **Jeff Mertz**  
Project assembler: **David Duvall**, 12,  
West Des Moines, Iowa  
Illustrations: **Roxanne LeMoine**; **Lorna Johnson**

## Materials List

Fuselage	FINISHED SIZE			Matl.	Qty.
	T	W	L		
A sides	¾"	6½"	10"	MDF	2
B top	½"	6"	7"	MDF	1
C cowling	½"	6"	3¼"	MDF	2
D nose	¾"	6"	6"	MDF	1
E exhaust pipes	¾" diam.	¾"		PD	8
F* propeller	½"	15⁄8"	10"	O	1
G tail	¾"	3"	3"	P	1
Landing gear					
H struts	½"	4"	5"	MDF	2
I brace	¾"	3"	3"	MDF	1
J axle	¾" diam.	4⁹⁄₁₆"		PD	1
K* wheels	¾"	4" diam.		MDF	2

## Wings 'n' things

L	bottom wing	½"	7"	40"	MDF	1
M	top wing	¾"	8"	47"	MDF	1
N	bottom-wing cleats	¾"	1¼"	13"	P	2
O	top-wing cleat	¾"	1½"	32"	P	1
P	struts	½"	4½"	10"	MDF	2
Q	windshield	⅛"	2"	5⁷⁄₈"	CA	1

\*Parts initially cut oversize. See the instructions.

**Materials key:** MDF—medium-density fiberboard, PD—poplar dowel, O—oak, P—poplar, CA—clear acrylic.

**Supplies:** Spray adhesive; double-faced tape; #8 trim washers; #8×1¼", #8×1½", #8×2", and #8×2½" flathead wood screws; ¼" axle peg; ¼" flat washer; clear silicone caulk.

**Bits:** ¾" and 13⁄₁₆" Forstner bits; ⅛", ¼", and 3⁄₈" round-over router bits.

## For a first-class assembly, follow these pointers

- To prevent damage to the paint, assemble the parts on a clean, protective surface such as a router mat.
- Use clamps with rubber pads so you don't dent the MDF.
- To avoid stripped holes, always drill pilot holes into the MDF.
- Install all screws with a screwdriver instead of a drill so you don't damage the MDF by overdriving.

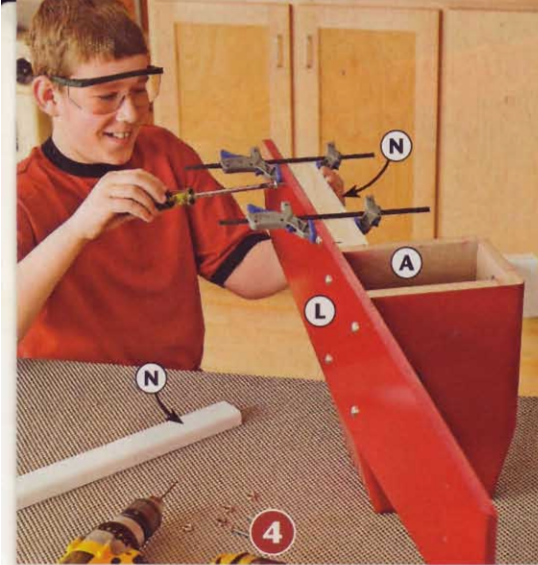

## Assemble the shelf in 11 easy steps

- 1 GLUE THE EXHAUST PIPES INTO PLACE**  
Apply glue in the holes in the fuselage sides (A). Press the exhaust pipes (E) into the holes.
- 2 GET THE TAIL ON**  
Clamp the tail (G) to the fuselage top (B), centered and flush at the back. Drill two mounting holes through the top and into the tail, and drive the screws.
- 3 ADD THE BOTTOM WING**  
Center and clamp the bottom wing (L) to the fuselage. Drill the pilot holes into the sides (A), and drive the screws.
- 4 MOUNT THE BOTTOM-WING CLEATS**  
Position a bottom-wing cleat (N) tightly against the fuselage side (A) and flush with the back edge of the bottom wing (L). Drill pilot holes into the cleat, and drive the screws. Repeat for the other cleat.
- 5 ATTACH THE WING STRUTS**  
Place a wing strut (P) tightly against a bottom-wing cleat (N) and flush with the back edge of the bottom wing (L). Drill a pilot hole into the cleat, and drive the screw. Repeat for the remaining strut.
- 6 SECURE THE TOP-WING CLEAT IN PLACE**  
Fit the top-wing cleat (O) between the struts (P) and into the notch in the tail (G). Drill pilot and mounting holes to attach the cleat to the struts and tail. Drive the screws.
- 7 INSTALL THE WINDSHIELD**  
Squeeze a few small dabs of clear silicone caulk into the groove in the fuselage top (B). Remove the protective film, and insert the windshield (Q) into the groove. Let the caulk firm before proceeding.
- 8 NOW MOUNT THE TOP WING**  
Position the top wing (M) with the mounting holes centered over the tail (G) and struts (P), and their back edges flush. Drill pilot holes. Drive the screws.
- 9 ADD THE LANDING GEAR**  
Drive the screws through the mounting holes in the struts (H) and into the brace (I). Center the gear on the bottom wing (L), flush at the back. Using the shank holes in the brace as guides, drill pilot holes into the wing. Drive the screws.
- 10 GET THE WHEELS UP**  
Screw a wheel (K) to the axle (J). Slide the axle through the holes in the landing-gear struts (H), and attach the other wheel.
- 11 FINISH WITH THE PROPELLER**  
Apply glue in the hole in the fuselage nose (D). Attach the propeller (F) with a 1/4" axle peg and a 1/4" flat washer, pressing the peg fully into the hole.

## Cutting Diagram

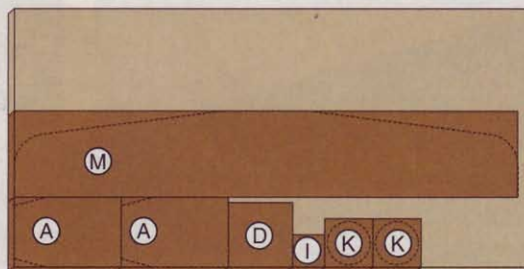

3/4 x 24 x 48" Medium-density fiberboard

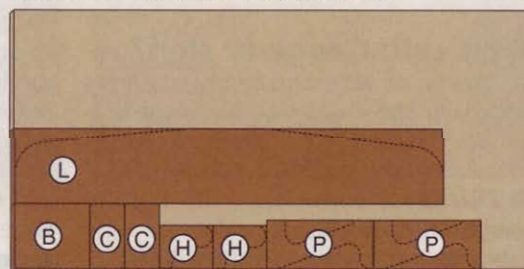

1/2 x 24 x 48" Medium-density fiberboard

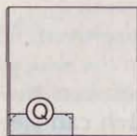

1/8 x 12 x 12" Clear acrylic

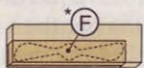

3/4 x 3 1/2 x 12" Oak (.3 bd. ft.)  
\*Plane or resaw to the thickness listed in the Materials List.

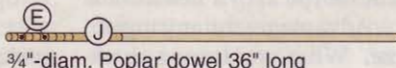

3/4"-diam. Poplar dowel 36" long

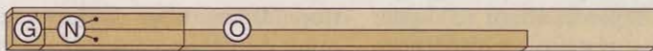

3/4 x 3 1/2 x 60" Poplar (1.7 bd. ft.)



**SHOP-TESTED**

# Miter Gauges & Sleds

Why spend your hard-earned cash on a miter gauge when one comes free with every table saw? Because today's aftermarket crosscut accessories add increased reliability and accuracy—in some cases, down to  $\frac{1}{10}^\circ$ .

Ask any woodworker to tell you the most disappointing thing about a new table saw (after the blade), and he'll probably tell you the miter gauge. That's because the fenceless, three-stop, gauges that come with most saws pale next to today's aftermarket models that help you cut perfect miters time after time with no trial-and-error testing. With upgrade gauges—and sleds that excel at cutting panels—costing from \$60 to \$360, how do you know which one to buy? To find out, we thoroughly tested 10 aftermarket miter gauges and four crosscut sleds. Here's what we learned.

## First call: Gauge or sled?

As prices of aftermarket miter gauges approach those of sleds, we asked ourselves: "Which type performs best?" Here's how the two styles compare:

■ **Thickness capacity.** With a miter gauge, the workpiece rides on the table saw top, giving you the full capacity of the 10" blade—usually about  $3\frac{1}{2}$ ". The  $\frac{3}{4}$ " thickness typical of a sled lessens that capacity. Advantage: miter gauges.

■ **Panel size.** What you lose in thickness capacity with a sled, you more than gain back in width capacity. Miter gauges limit you to workpieces about 13" wide; the expansive surface of a sled more

than doubles that capacity on most models. Advantage: sleds.

■ **Workpiece movement.** Because your workpiece rides on the sled, you encounter no friction between the workpiece and tabletop, which can steer or mar a large piece. Advantage: sleds.

■ **Cut quality.** Most sleds come oversize, and you rip off the excess during setup. That provides a zero-clearance edge for cleaner cuts; but then you can't make bevel cuts using the sled. Toss-up.

■ **Storage.** Sleds often are heavy, and their size makes them more difficult to store than miter gauges. Advantage: miter gauges.



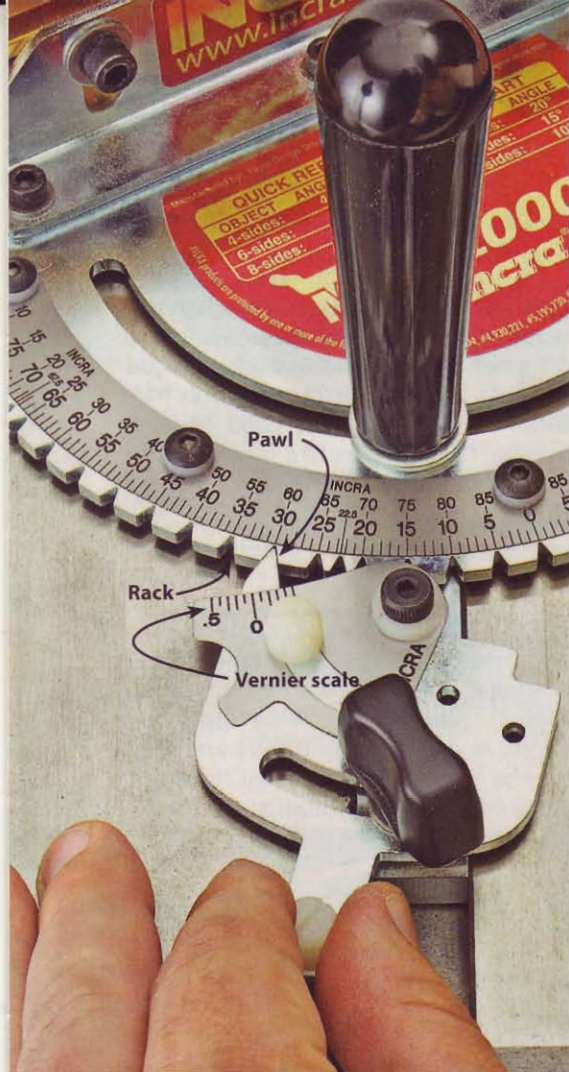

### HOW A RACK-AND-PAWL STOP SYSTEM WORKS

The pivoting pawl on the Incra 1000SE engages rack detents at 5° increments (plus a few other common angles). Without the pawl, the vernier scale slides in to show other angles with .1° accuracy.

### The four Rs of miter scales and stops

**■ Reliability.** After assembling and calibrating each gauge and sled, we tested the accuracy of scales and preset angle stops using a Wixey Digital Angle Gauge (\$40, wixey.com). To cross-check the 45° settings, we also cut four-sided mitered frames in 3½"-wide MDF to check the fit of the joints—a fraction-degree of error here becomes obvious when multiplied across the eight 45° cuts. In all cases, the readings on the miter scales agreed with the Wixey, and the 45° cuts yielded well-fitted joints.

Except for the ProMiter 100, which has no stops, all of the miter gauges and sleds have stops at common miter angles such as 45°, 30°, and 22½°. Some have many more. The stop systems consist of various mechanisms: rack-and-pawl (shown above), pin (right center), or ball

detents (not shown). All proved reliable in our testing.

**■ Repeatability.** On nearly all of the miter gauges and sleds, you're free to set any miter angle you want (except the Rockler Sure-Loc, which can be set only in 1½° increments). But how precisely can you return to it? The ProMiter 100, at right, displays the miter angle on an easy-to-view digital readout accurate to .1°, making it quick to set any angle repeatably. JessEm's MiteRExcel provides positive miter stops every ½° throughout its range, and adds a vernier scale (right center) to achieve that same .1° precision. Jointech's SmartMiter sled has ½° stops, too; Incra's 1000SE and Kreg's KMS7102 also sport .1° vernier scales.

But you don't need hundreds of stops or a digital display to get reliable repeatability. The widely spaced increments on the edge of the Dubby Board make it easy to eyeball fractional degrees, as shown at bottom right. Oddly, Woodhaven's 4954K sled has no miter scale at all, so except for its stopped angles (0°, 11¼°, 15°, 22½°, 30°, and 45°), you need a protractor to set other angles. (Woodhaven sells an accessory to assist.)

**■ Readability.** The scales on most models are easy to read and intuitive, with one exception: Rockler's 1½° increments with 4½° major divisions proved confusing except for marked angles, such as 22½°, and 45°. Rockler's Steve Krohmer calls this limitation "more theoretical than practical. Sure-Loc handles more than 95 percent of all real-world cutting applications, and the repeatability and accuracy—especially at this price point—are exceptional."

**■ Range.** Although your saw's factory-supplied gauge likely maxes miters at 45° clockwise and counterclockwise, 50° is more the norm for these gauges and sleds. That gives you room to counter an out-of-square corner. The Incra 1000SE, Sure-Loc, and Woodhaven 4996K can rotate up to 90° in both directions—parallel to the blade. You'd never actually do that, but the extra range does give you the capacity to cut steep angles, such as when making a scarf joint.

Sleds fall short here. The Dubby can't rotate counterclockwise from 0°, and both the Delta 36-205 and Woodhaven 4954 require some disassembly to hit the opposite 45° range. Only the Jointech sled can cut 45° both directions out of the box. But you pay for it with reduced crosscutting capacity—only about 13" of sled in front of the fence.

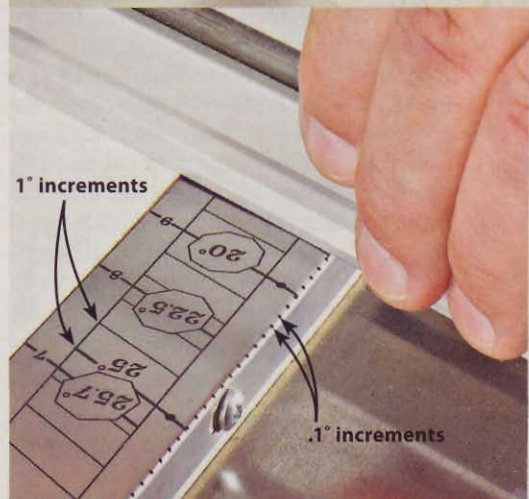
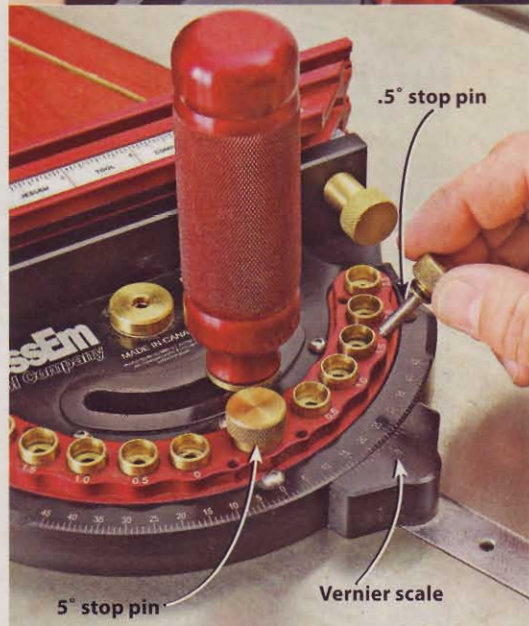

### THREE WAYS TO .1° ACCURACY

ProMiter's bright LED readout (top) displays the miter angle without any second-guessing. JessEm (center) uses two pins: The first locks in a 5° range, the second secures a specific .5° increment within that range. For .1° accuracy, pull the second pin, and read the vernier scale. The scale on the edge of the Dubby sled (bottom) is marked in .1° increments; you can eyeball smaller fractions from there.

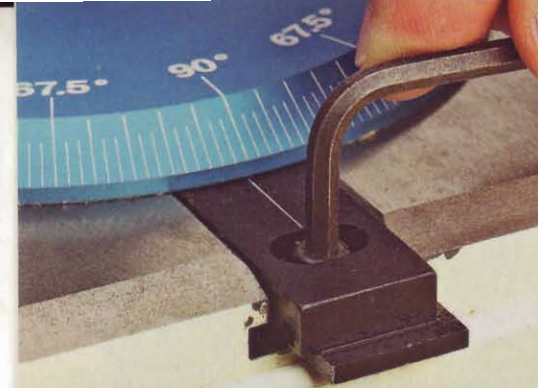

### SPLIT BAR HAS SPLIT PERSONALITY

To fit Rockler's split miter bar to a saw, simply spread the top and bottom portions to fill the slot, and then secure the locking screw. But on T-slots, you can't lift the bar out midslot.

### Passing the bar examination

Remember using a hammer and punch to "peen" the miter bar on your factory-supplied miter gauge to get a slop-free fit between the bar and miter slot? No longer. You can custom-fit the bars on today's miter gauges and sleds to your saw's miter slot with a few turns of a hexhead wrench or screwdriver.

As a rule, we prefer top-adjusting miter bars because those that adjust from the side require trial-and-error fitting. For example, fitting the bar of Delta's

30-plus-pound 36-205 sled turned into an exercise—literally. The exception to the rule is Dubby's spring-loaded plungers that self-fit, meaning we didn't have to adjust them.

Of the top-adjusting bars, JessEm's brass bearings should wear less than the nylon bearings or steel setscrews found on other models. And Rockler's unique split bar, shown at *left*, maximizes bar-to-miter-slot contact for good control, but on tablesaws with a T-style miter slot, it can only be installed or removed from the end of the slot.

### Here's where we sit on the fences

Each gauge and sled comes with an extruded aluminum fence, except for the Inkra V27, where it's optional. All of the fences proved straight and true in our tests.

Most of the models (see the chart on page 68) have measuring tapes for use with their length-stop systems, which, when calibrated to your blade, make accurate, repetitive length cutting a no-brainer. For the ultimate in repeatability, the Inkra 1000SE and Jointech both use interlocking rack systems on their stops that engage in precise  $\frac{1}{32}$ " increments. Need to dial in an exact length somewhere in between? Microadjustments found on the Inkra 1000SE, JDS Accu-Miter, Woodhaven 4996K, and Dubby afford that luxury.

Except for the Jointech fence, all can be repositioned close to the blade for good workpiece support on miter cuts. Jointech's design eliminates the need to move the fence for such cuts and the nuisance of recalibrating the scale afterwards. Kreg solves this in a different way: A stop on the back of the fence

allows you to relocate the fence to its calibrated location instantly.

We found three styles of length stops on the tested gauges and sleds:

■ **Sliding block.** This simple block rides in a slot on the fence face.

■ **Flip stop.** These pivoting stops manually rotate up and out of the way for making that first cleanup cut to square the end of a board; then flip back down against the fence for the final cut.

■ **Bypass stop.** These function like a flip stop, but nudging a workpiece against the curved stop, as shown at *right*, lifts it out of the way so you don't have to.

The downside of most bypass and flip stops is that the point of a mitered cut can slide past the stop, lifting it away from the fence face and rendering it inaccurate. The design of the stops on the Inkra and Jointech fences prevent angled ends from sliding by.

Whether by clamps or T-slots (see the chart on page 68), you can mount a wooden face onto any of the fences to prevent back-side tear-out on cuts. Woodhaven's 4996K even comes with an auxiliary wood face, and the Dubby includes a sacrificial wood block on the

cutting end of the aluminum fence. Adding that fence face on most models, though, prevents you from using the length stops. The Inkra 1000SE and Kreg are the exceptions here: Their stops can reach over a  $\frac{3}{4}$ "-thick auxiliary fence.



### FOR DOUBLE CUTTING, TAKE THE BYPASS

Kreg's bypass stop allows a workpiece to slide under to make a quick squaring cut; then drop back into place for the final cut. The breakaway section detaches to accommodate a  $\frac{3}{4}$ "-thick auxiliary wood fence face.

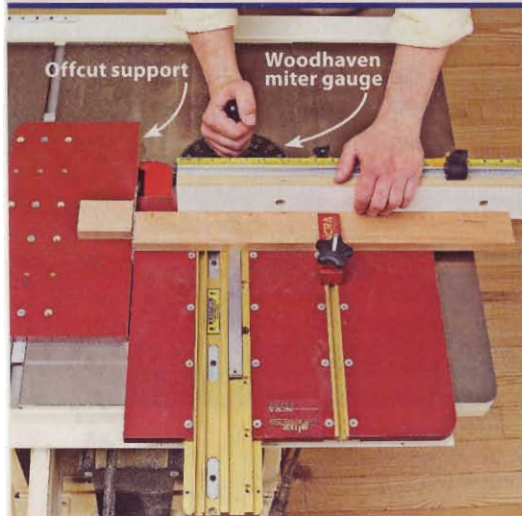

### Upgrade a good gauge to a sled

If you've already spent money on a step-up miter gauge and now wonder if you should have bought a sled instead, you're in luck. You can install any miter gauge in Inkra's Miter Express, shown at *left*, and—poof!—instant miter sled! And with a couple of quick screw turns, you can again use your gauge without the sled.

Upon initial setup, you zero-clearance-cut the edges of both the sled and the offcut support to fit your saw, just as you would with the dedicated sleds in our test. The offcut support keeps the offcut

from bouncing back into the spinning blade. Here's another benefit: Because you can replace the zero-clearance panel on the sled itself, you can keep different panels on hand for different cuts (one for 45° bevels and another for your dado set, for example) and swap them out as you need them.

Miter Express sells for \$155, or with the Inkra 1000SE miter gauge we tested for \$270. We think it's a great way to improve the cut quality and crosscut capacity of any miter gauge.

## Now, a detailed look at each tested miter gauge



### Delta 36-946, \$175

800-223-7278, deltamachinery.com

#### High points

- Top-adjusting miter bar makes fitting it to the slot easy.
- Stout, quick-release hold-down resizes to any workpiece thickness instantly.

#### Low points

- No length scale on fence, so you must measure from the blade to set the length stop.
- Miter scale is partially hidden, making it difficult to eyeball fractional degrees.
- Requires some disassembly and reassembly to use in the right miter slot.
- No way to mount an auxiliary face without drilling fence.

#### More points

- Similar to the Osborne EB-3, which costs \$40 less but lacks hold-down.



### Incra V27, \$50

972-242-9975, incra.com

#### High points

- 60° clockwise and counterclockwise miter range is wider than gauges costing 2–3 times more.
- Top-adjusting miter bar.
- The lowest-cost miter accessory in our test, and the miter angle proved dead-on accurate.

#### Low points

- No fence included.

#### More points

- Positive miter stops every 5°, plus 22.5°, but the distance between the miter scale and the pointer makes non-stopped angles tougher to hit precisely.



### Incra 1000SE, \$140

972-242-9975, incra.com

#### High points

- Positive miter stops every 5°, plus 22.5°, 67.5°, and a vernier scale to set angles with .1° accuracy.
- The best length stop in the test: precise 1/32" repeatability, microadjustability, and miter cuts can't accidentally slide past it. You can even separate it to make two stops up to about 8" apart. Works equally well with a 3/4"-thick auxiliary face.
- Top-adjusting miter bar makes fitting it to the slot easy.
- 18"-long fence extends to 31".

#### Low points

- Ball-head hex tool (included) is required to adjust fence on miter head or lengthen telescoping extension.
- Three steps required to set non-stopped angles (loosen handle, disengage pawl, swing vernier scale into place).



### JDS Accu-Miter 18-34, \$230

800-480-7269, jdstools.com

#### High points

- Spring-loaded shot pin on miter stop snaps into stops for one-handed setting of stopped angles.
- Top-adjusting miter bar.
- Flip stop on fence is microadjustable for fine-tuning workpiece length.
- 18"-long fence extends to 34".

#### Low points

- At 10 lbs, it's one of the heaviest miter gauges we tested.
- Cast-in degree markings on miter scale make it more difficult to eyeball fractional degree settings with confidence.



### JessEm MiteRExcel, \$225

866-272-7492, jessem.com

#### High points

- Unique two-pin stop system provides positive miter stops every 1/2° (one of only two with that repeatability), plus a vernier scale for .1° accuracy.
- The big handle, comfortably sized and knurled for good grip, begs to be used.
- Rigid length scale—it's mounted on a steel strip—slides easily, but locks securely to recalibrate after adjusting the fence.
- 24"-long fence extends to 37".

#### Low points

- It's heavy: 10 lbs.

#### More points

- Side-adjusting miter bar requires more trial-and-error fitting than top-adjusting bars, but brass spacers should wear longer than nylon spacers found on other bars.



### Kreg KMS7102, \$140

800-447-8638, kregtool.com

#### High points

- Vernier miter scale achieves .1° accuracy, and the high-contrast scale reads easier than any other in the test.
- A unique stop helps return the fence to its 0°-miter location without having to recalibrate the length scale.
- Breakaway portion of bypass stop can be removed to work with a 3/4"-thick auxiliary fence face.

#### Low points

- No place to store the removable miter-angle stop pin during non-stopped cuts.

#### More points

- 24"-long miter bar is longest of the tested gauges for good stability through the cut, but the side adjustments require trial and error to fit the bar to the slot.



### Osborne EB-3, \$135

800-852-9655, osbornemfg.com

#### High points

- Costs \$40 less than the nearly identical Delta 36-946, and has additional features, such as a length scale, and a 23"-long fence that extends to 41".

#### More points

- Instead of Delta's hold-down, Osborne's abrasive-covered fence face prevents workpiece slippage. Switching for right-slot usage requires some disassembly and puts the abrasive face on the back of the fence.



### ProMiter 100, \$360

719-337-8112, salazarsolutions.com

#### High points

- Bold LED display shows miter angle to .1° without squinting at little lines. Should it get knocked out of alignment, it can be recalibrated with the touch of a button.
- With the included blade magnet, you can use it to set or check the bevel angle of your tablesaw blade to the nearest .1°.
- T-slot washer is ground flat on two sides so it stores in the miter bar. Rotate the washer 90° to use it.

#### More points

- 30"-long fence extends to 50", but tends to twist as it nears full extension.
- It's a high-tech miter head with a low-tech fence. How much is digital worth to you?



### Rockler Sure-Loc, \$100

800-279-4441, rockler.com

#### High points

- Low cost, with a fenceless version for \$75.
- Can only cut miters in 1½° increments, which does cover the most common 22.5° and 45°, plus many other uncommon angles. But few numbers on the miter scale makes finding angles confusing.
- No length scale on the fence.

#### More points

- This gauge was dead-on accurate out of the box, but it had better be: There's no way to calibrate it.
- The bar fits from the top; but its split design means you can only install or remove the gauge from one end of a T-style miter slot.

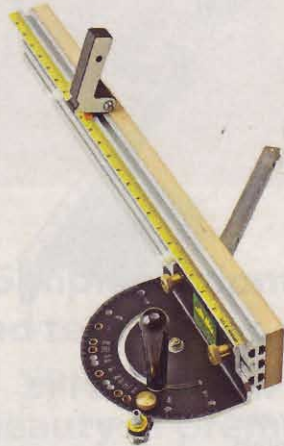

### Woodhaven 4996K, \$235

800-344-6657, woodhaven.com

#### High points

- This kit comes with three types of length stops—bypass, flip, and sliding for maximum versatility. And the bypass stop works with or without an auxiliary fence face attached.
- The most commonly used miter stops (0°, 22.5°, 30°, and 45°) have bronze bushings to reduce wear. And the threaded stop pin stores on the tool when not in use.

#### More points

- This miter gauge is also available without a fence (model 4900) for \$123.

## 14 AFTERMARKET MITER GAUGES AND SLEDS,

BRAND	MODEL	MAXIMUM MITER ANGLE, CLOCKWISE/COUNTERCLOCKWISE (DEGREES)(1)	NUMBER OF POSITIVE STOPS	STYLE (3)	LENGTH, INCHES	MITER STOP (2)		MITER BAR		FENCE (6)				
						MATERIAL (4)	METHOD OF FIT (5)	T-SLOT KEY? (YES, NO)	LENGTH, INCHES	STOP STYLE (7)	MEASURING TAPE ON FENCE? (YES/NO)	T-SLOT FOR MOUNTING AUXILIARY FENCE FACE? (YES/NO)	STOP MICROADJUSTABLE? (YES/NO) (OPTIONAL)	MAXIMUM STOP LENGTH, INCHES
MITER GAUGES	Delta	36-946	45/45	7 B	21½	S	T	Y	24	F	N	N	N	24
	Inkra	V27	60/60	27 R	15¾	S	T	Y			NA			
		1000SE	90/90	41 R	17¾	S	T	Y	18¼	F	Y	Y	Y	31
	JDS	Accu-Miter 18-34	50/50	9 P	20	S	T	Y	18½	F	Y	N	Y	34
	JessEm	MiteRExcel	45/45	180 P	20	S	T	Y	27	F	Y	Y	N	36
	Kreg	KMS7102	50/50	9 P	24	A	S	Y	24	B	Y	Y	N	24
	Osborne	EB-3	45/45	7 B	21½	S	T	Y	25	F	Y	N	N	40
	ProMiter	ProMiter100	50/50	NA	18	S	S	Y	30¼	S	N	Y	O	30
	Rockler	Sure-Loc 21670	90/90	120 I	19¾	A	T	Y	22	S	N	Y	N	20
	Woodhaven	4996K	90/90	15 P	18	S	S	Y	24	B,F,S	Y	Y	Y	24
SLEDS	Delta	36-205	45/45*	2 NA	28	S	S	Y	42	F	N	Y	N	60
	Dubby	Single-Left	50/0	1 NA	24	S	SP	N	30½	S	N	N	Y	52
	Jointech	SmartMiter JSM-48	50/50	200 B	23½	P	S	N	28½	S	Y	N	Y	49
	Woodhaven	4954	45/45*	6 P	23¾	S	S	N	24	S	N	Y	O	24

- |  |  |  |
|--|--|--|
| 1. (*) Requires partial disassembly to change from CW to CCW and back          | 4. (A) Aluminum<br>(P) Phenolic<br>(S) Steel                       | 7. (B) Bypass<br>(F) Flip<br>(S) Sliding   |
| 2. (NA) No miter stops on this model   | 5. (S) Side adjust<br>(SP) Spring-loaded plunger<br>(T) Top adjust | 8. <span style="color:red">A</span> Excellent<br><span style="color:orange">B</span> Good<br><span style="color:green">C</span> Fair |
| 3. (B) Ball detents<br>(I) Interlocking ridges<br>(P) Pin<br>(R) Rack and pawl | 6. (NA) Fence and stops not included with this miter gauge         | 9. (NA) Cannot be calibrated<br>(NS) No miter scale on this model  |

## Four more, in-depth: Sleds that work wide

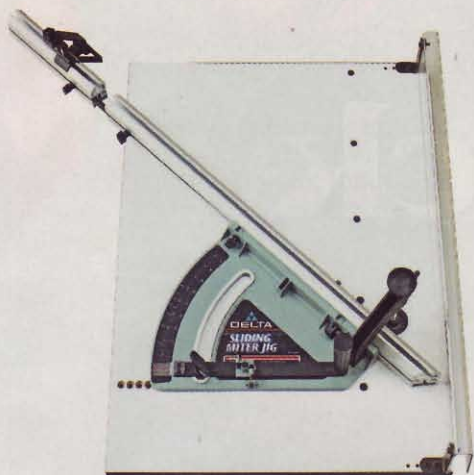

### Delta 36-205, \$170

800-223-7278, deltamachinery.com

#### High points

- Large 28x35" sled size provides excellent panel support.
- Fence extends to 60", the longest in the test.
- Quick-release stock hold-down.

#### Low points

- At 33 lbs, it's the heaviest sled in the test.

#### More points

- Fence can cut 45° one way or the other, but requires disassembly to go the other way.
- No length scale on fence, but zero-clearance edge, created at initial setup, shows exactly where blade will cut.
- The only sled in the test with a built-in blade guard, but we found it bothersome to use, and it obscured the cutline.

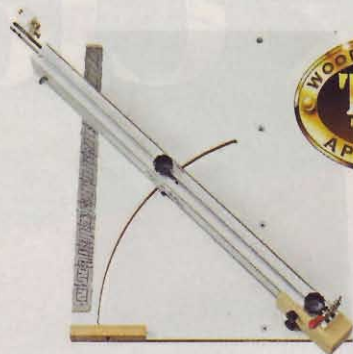

### Dubby Single-Left, \$170

508-949-2968, in-lineindustries.com

#### High points

- Easy-to-read miter scale, along edge of sled, shows .1° increments and cutting angles for objects with up to 18 sides.
- Spring-loaded plungers on bar self-adjust for a perfect fit to your table saw's miter slot.
- Calibration of the 0° stop and miter scale are easy and intuitive.

#### Low points

- Cuts miters in only one direction—up to 50° clockwise; a right-slot Dubby (\$170) is needed to cut the other direction.

#### More points

- No length scale on the fence, but the zero-clearance edge, created at setup, shows exactly where the blade will cut.



### Jointech SmartMiter, \$260

210-377-1288, jointech.com

#### High points

- Positive stops every 1/2°, and cutting angles for objects up to 20 sides shown on sled.
- The only sled we tested that can cut opposite miter angles without flipping the workpiece or reinstalling the fence.
- Fence scale proved reliably accurate at any miter angle. Great length repeatability, too, with 1/32" increments and microadjustability. Mitered cuts can't slide past stop.
- 29" fence extends to 48".

#### Low points

- At 0° miter, there's only 13" of sled in front of the fence, negating a key advantage of using a sled for cutting wide panels.

## GRADED AND RATED

		PERFORMANCE GRADES (8)			ACCESSORIES (10)					
		MITER-SCALE READABILITY (9)	EASE OF RETURNING TO SPECIFIC MITER ANGLE	EASE OF CALIBRATING MITER SCALE	EASE OF FITTING MITER SCALE TO SLOT	ACCURACY OF MITER BAR TO SLOT	ACCURACY OF FENCE STOP (6)	STANDARD	OPTIONAL	
		WARRANTY (YEARS) (11)	COUNTRY OF ASSEMBLY (12)	WEIGHT (POUNDS) (13)	SELLING PRICE					
A-	B-	A-	A-	A-	F,FS,H	2	C	4	\$175	
B	B-	A-	A-	NA		F	1	U	4	50
A	A	A-	A-	A	F,FS,MA	1	U	9	140	
B	B-	A-	A-	A	F,FS,MA	H	1	U	10	200
A	A	A-	A-	A	F,FS		1	C	10	225
A	A-	A-	B	A	F,FS	M,S	1	U	4 1/2	140
A-	B-	A-	A-	A	F,FS		2	T	4	135
A	A	A	B	A	BM,F,S	FS,MA	1	U	6 1/2	360
C	A	NA	A	A	F,S		1	U	1	100
B	B	A-	B	A	F,M,MA,S		L	U	6	235
A	B	A-	C	A	F,FS,H,M		2	T	33	170
A	A	A-	A	A	F,H,MA		L	U	13	170
A	A	A-	B	A	F,FS	H,O,T	2	U	15	260
NS	C	NS	B	A	F,S	FS,MA,P,TA	L	U	16	142

10. (BM) Blade magnet  
(F) Fence  
(FS) Flip length-stop  
(H) Stock hold-down  
(M) Miter length-stop  
(MA) Microadjust for length-stop  
(O) Offcut support  
(P) Protractor  
(S) Standard length-stop  
(T) Tenon jig  
(TA) Taper kit

11. (L) Lifetime  
12. (C) Canada  
(T) Taiwan  
(U) United States  
13. Prices current at time of article production and do not include shipping, where applicable.

## Which accessory masters miters?

It's rare that we end up with a dead heat, but that's the case here. Both the JessEm MiteRExcel and Incra 1000SE miter gauges excelled in our tests, with scales accurate to 1/10°. If you work often with unusual angles, you'll love JessEm's 180 positive angle stops. On the other hand, Incra's fence system proved superior, so if you rarely cut the odd angle, opt for the best length stop on the market. Kreg gets honorable mention for its KMS7102, bubbling just under the top two.

As for a crosscut sled, we'd opt for the Dubby. It's intuitive, accurate, and its zero-clearance edge delivers clean cuts in large panels—and that's why you buy a sled. 🌲

Written by **Dave Campbell** with **Pat Lowry**



### Woodhaven 4954, \$142

800-344-6657, woodhaven.com

#### High points

- The only sled we've found that works on either side of the blade.
- It has stops for 4-, 6-, 8-, 12-, and 16-sided frames.

#### Low points

- With no miter scales, you're on your own for non-stopped angles.

#### More points

- Fence can be set up to cut 45° one way or the other, but requires some disassembly to switch to the other way.

# Fresh-Faced Desk Clock



Veneering opens woodworking project designs to a world of exotic wood species and grain patterns not possible with solid wood. Make this small project and learn basic veneering—you don't need special tools, and it's easier than you may think.



## PROJECT HIGHLIGHTS

- Overall dimensions: 8" wide x 1 $\frac{3}{4}$ " deep x 6 $\frac{7}{8}$ " high.
- Shown in lacewood and wenge with a checkerboard pattern ribbon maple veneer front *above* and a sapele pommelle veneer front at *left*.

### Skill Builder

- Learn veneering techniques easily applied to larger projects.

## Make the parts

**1** To make a blank for the body (A), cut two  $\frac{1}{2}$  x  $5\frac{1}{4}$  x  $5\frac{1}{4}$ " pieces of medium-density fiberboard. Then glue and clamp them together with the edges flush to make a 1"-thick blank. Now, to apply a decorative wood veneer to the front and back faces of the blank, see page 42.

**Note:** If you do not wish to veneer your clock, you can make the body from  $\frac{1}{2}$ " hardwood veneer plywood or MDF.

## CUT THE BODY AND SIDES TO SIZE

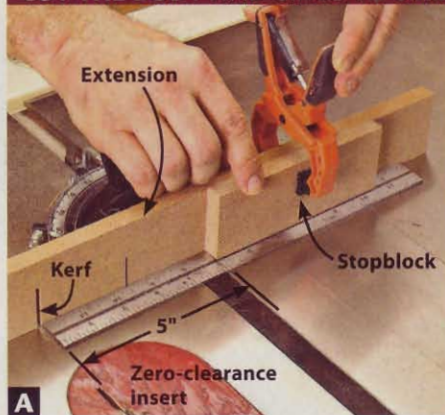

**A** Clamp a stopblock to the miter-gauge extension 5" from the saw kerf. The ruler raises the stopblock for sawdust relief.

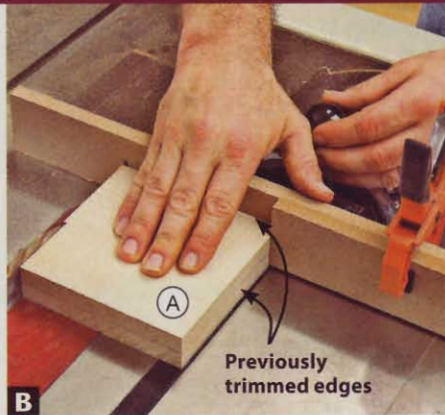

**B** With one previously trimmed edge against the extension, cut the body (A) to width, and then rotate and cut again.

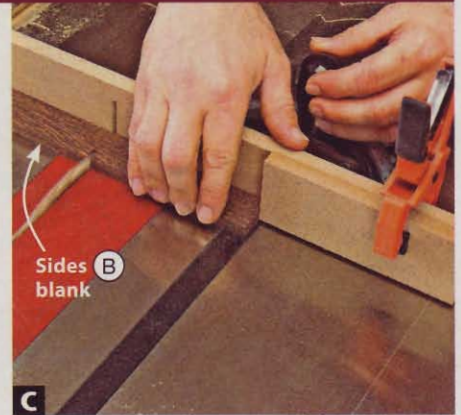

**C** Without changing the setup used to cut the body (A) to finished size, cut two sides (B) to length from the blank.

**2** For the sides (B), cut a  $\frac{3}{8} \times 1\frac{1}{4} \times 11$ " blank, and set it aside. (We used wenge.)

**3** With the veneering complete, use a utility knife to trim any overhanging veneer flush with the blank edges. Then, to square two adjacent blank edges and keep the veneer pattern centered, attach a 2"-tall extension to your miter gauge, and cut a saw kerf through it. Next mark a line on the extension face  $2\frac{1}{2}$ " from the kerf. Align one veneer seam with the mark, and trim the blank. Rotate the blank 90° with the trimmed edge against the extension, align the veneer seam with the mark, and trim again. Now cut the body to finished size [Materials List and Photos A and B].

**4** Retrieve the blank for the sides (B), and cut them to length [Photo C]. Finish-sand the sides.

**5** Chuck a  $2\frac{3}{8}$ " Forstner bit into your drill press. (See Sources.) Bore a cen-

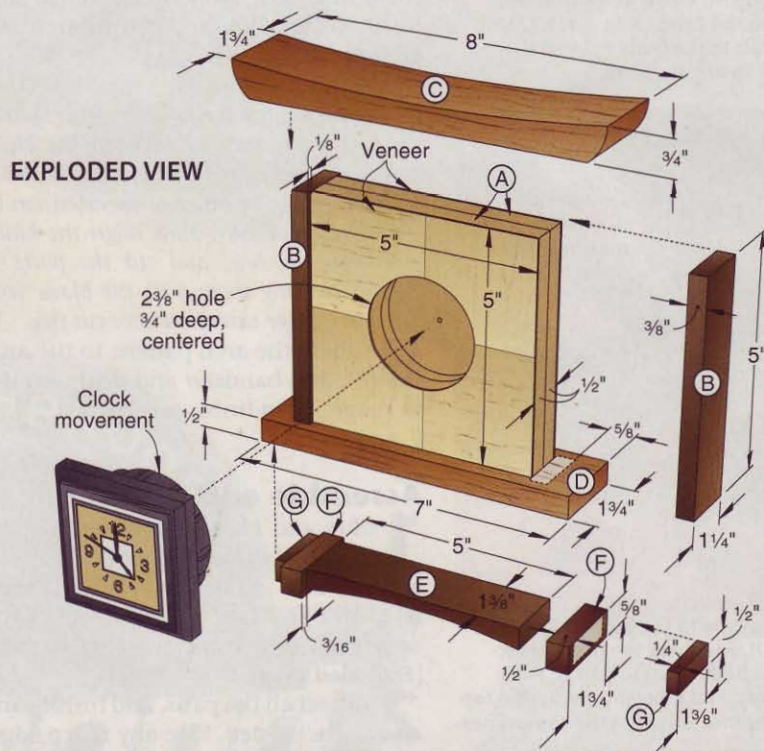

## SHOP TIP

### How to prevent a veneer catastrophe

A  $2\frac{3}{8}$ " Forstner bit cuts aggressively, and the last thing you want is for your carefully veneered clock body (A) to look like the one at right. To prevent this, cut a  $\frac{1}{2}$ " medium-density fiberboard waste block the same size as the body. Then draw diagonals onto one face to find the center. Place the waste block over the body with the edges flush, center the stack under the Forstner bit, and clamp the stack to the drill-press table. Now bore the hole, as shown at far right. The waste block prevents veneer chipping for a clean-edged hole. (Download a free drill-press table hold-down clamp plan at [woodmagazine.com/holddown](http://woodmagazine.com/holddown).)

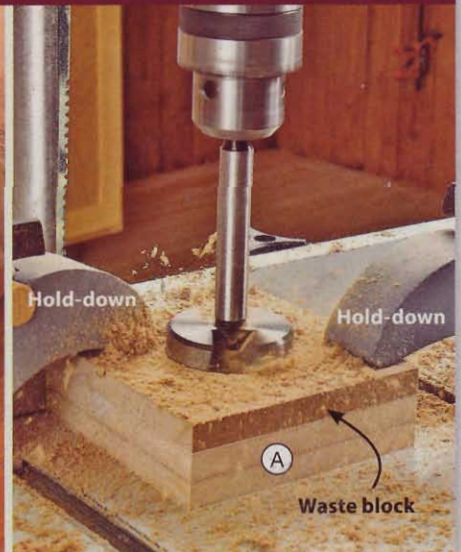

## ASSEMBLE THE CLOCK

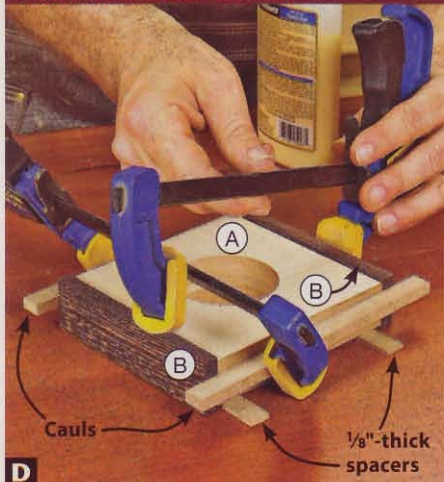

**D** Raising the body (A) on  $\frac{1}{8}$ "-thick spacers, glue and clamp the sides (B) in place. Clamp scrapwood cauls to the body to keep the parts flush at top and bottom.

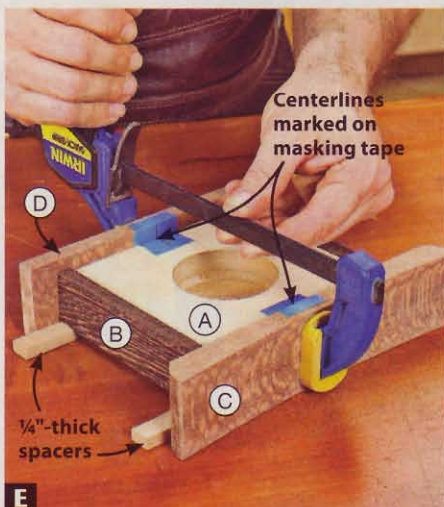

**E** Apply masking tape to the body (A), top (C), and bottom (D), and mark the part centerlines. Raise the body assembly (A/B) with  $\frac{1}{4}$ "-thick spacers, and glue and clamp the top and bottom in place, aligning the centerlines.

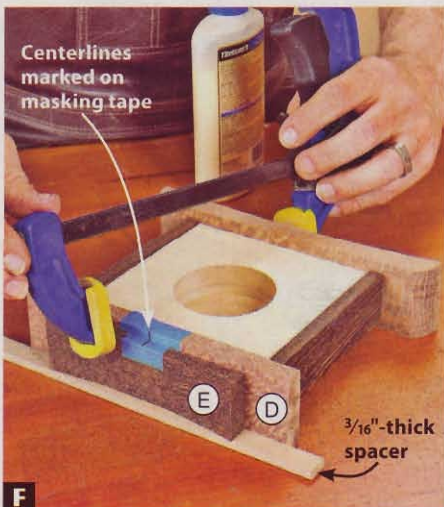

**F** Apply masking tape to the bottom (D) and arch (E), and mark the part centerlines. Raise the arch with a  $\frac{3}{16}$ "-thick spacer, and glue and clamp it in place, aligning the centerlines.

tered hole into the body (A) for the clock movement [**Exploded View**]. To prevent veneer chip-out, see the **Shop Tip** on the *previous page*. Finish-sand the body.

**6** Cut the top (C) and bottom (D) to size. Then photocopy the **Top** and **Arch (E)** patterns on the *WOOD Patterns®* insert. Cut out the patterns, and adhere the top pattern to the top with spray adhesive. Set the arch pattern aside. Now bandsaw and disc-sand and drum-sand the top to the pattern lines.

**7** For the arch (E), feet (F), and arch ends (G), cut a  $\frac{1}{2} \times 2\frac{1}{4} \times 10$ " blank. Then, referring to the **Cutting Diagram**, rip a  $\frac{5}{8}$ "-wide strip for the feet, and cut them to length. Now rip the remaining blank to  $1\frac{3}{8}$ " wide, and cut the arch and arch ends to length.

**Note:** When cutting the arch ends (G) to length, do not use a stopblock. Small parts, such as these, trapped between the blade and a stopblock, may be ejected. Instead, mark a line on the miter-gauge extension  $\frac{1}{4}$ " from the blade kerf. Now align the blank end with the line, and cut the parts to length, pushing them past the blade with the miter-gauge extension once cut free.

**8** Adhere the arch pattern to the arch (E), and bandsaw and drum-sand it to shape. Then finish-sand parts C, D, E, F, and G.

## Assemble and finish

**1** Glue and clamp the sides (B), top (C), and bottom (D) to the body (A), and the arch (E) to the bottom [**Photos D, E, and F**]. Then add the feet (F) and arch ends (G), centered front to back [**Exploded View**].

**2** Inspect all the parts, and finish-sand where needed. Ease any sharp edges with a sanding block. Then, to bring out the grain of the ribbon maple veneer,

apply boiled linseed oil. Allow the oil to penetrate for 10 minutes, and wipe away any excess with a clean cloth. Let the oil dry for three days, and apply several coats of aerosol satin lacquer, sanding between coats with 220-grit sandpaper.

**3** With the finish dry, install the battery in the clock movement [**Sources**], and set the time. Press the clock movement into place. Now place the clock where the light can play across the surface of the veneered body. 🌿

Written by **Jan Svec** with **Jeff Mertz**  
Project design: **Kevin Boyle**  
Illustrations: **Roxanne LeMoine**



This clock combines Douglas fir and wenge with a wenge veneer front.

## Materials List

Part	FINISHED SIZE			Matl.	Qty.
	T	W	L		
A* body	1"	5"	5"	LMDF	1
B* sides	$\frac{3}{8}$ "	$1\frac{1}{4}$ "	5"	W	2
C top	$\frac{3}{4}$ "	$1\frac{3}{4}$ "	8"	L	1
D bottom	$\frac{1}{2}$ "	$1\frac{3}{4}$ "	7"	L	1
E* arch	$\frac{1}{2}$ "	$1\frac{3}{8}$ "	5"	W	1
F* feet	$\frac{1}{2}$ "	$\frac{5}{8}$ "	$1\frac{3}{4}$ "	W	2
G* arch ends	$\frac{1}{2}$ "	$1\frac{3}{8}$ "	$\frac{1}{4}$ "	W	2

\*Parts initially cut oversize. See the instructions.

**Materials key:** LMDF—laminated medium-density fiberboard, W—wenge, L—lacewood.

**Supplies:** Ribbon maple veneer, masking tape, spray adhesive.

**Bit:**  $\frac{23}{8}$ " Forstner bit.

## Sources

**Clock movement:** Battery-powered quartz clock movement no. 2000914B, \$10.95. Schlabaugh & Sons, 800-346-9663, schsons.com.

**Forstner bit:**  $\frac{23}{8}$ " Forstner bit no. 400901, \$18.95. Schlabaugh & Sons, *above*.

**Veneer:** See **Sources** on page 47.

## Cutting Diagram

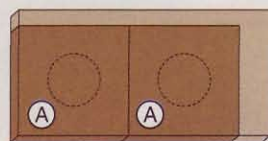

$\frac{1}{2} \times 6 \times 12$ " Medium-density fiberboard



$\frac{3}{4} \times 2\frac{1}{4} \times 20$ " Lacewood (.42 bd. ft.)

\*Plane or resaw to the thicknesses listed in the Materials List.



$\frac{3}{4} \times 2\frac{1}{4} \times 24$ " Wenge (.5 bd. ft.)



# Get into Woodturning for under \$600



LATHE:	\$250
SIX BASIC TURNING TOOLS:	\$96
GRINDER AND WHEEL DRESSER:	\$110
SHARPENING SYSTEM:	\$115
TOTAL:	\$571
FUN OF LEARNING A NEW CRAFT:	PRICELESS

What makes woodturning so popular? First, getting started requires a relatively small investment. The basic equipment costs less than a good cabinet saw. Then, for turning stock, turners can pick up almost any kind of green wood by spending only their time. Next, the ability to go into the shop and produce an object of beauty in a short time generates tremendous satisfaction. But the most important reason is the sense of community among woodturners. They like to share their knowledge. There are woodturning clubs virtually everywhere. Woodturners love their craft because they discover a central truth: The longer they turn, the more they learn how much they don't know.

—Angelo Iafate, president,  
American Association of Woodturners

Interest in woodturning is growing, and with it comes a dizzying array of tools and equipment. So how does a beginner get started without buying junk or going broke? To help you get the most for your money, we consulted with professional woodturners, pored over catalogs, and scoured the Internet searching for low-cost woodturning tools and equipment. Then we brought in the promising candidates and tested them to see which ones performed well and offered good value for the money. Here are our picks. (Prices current at time of article production and do not include shipping, where applicable.)

## Your first decision: choose a lathe

Woodturning splits into two broad categories: spindle turning (pens, candlesticks, table legs, balusters) and bowl turning (vessels, lidded boxes, hollow forms). If you're just getting started, you'll want a lathe that lets you explore the entire range without spending a fortune. Here's what to look for.

Vibration is public enemy #1 to turners, so lathe manufacturers dampen it with robust cast-iron construction and heavy-duty headstock bearings. Precise alignment of components (the tailstock center and headstock drive spur meet point-to-point without noticeable offset, and the points do not wobble in relation to one another when turning) also helps defeat vibration.

Two measurements define lathe capacity: swing (the largest-diameter workpiece you can turn over the lathe bed) and distance between centers (the longest workpiece that fits between the headstock and tailstock). A lathe with 10–12" of swing and 36" between centers handles a wide variety of turning projects. Fortunately, you'll find lots of lathes of this capacity. So you'll get the most for your tool-buying dollar in this category.

Lathes are either *multispeed* or *variable speed*. You adjust multispeed lathes manually, with the lathe stopped, by moving a belt on a pair of stepped pul-

leys. This system proves simple, economical, and durable. It boosts torque in the low-range speeds, but the few speed choices below 1,000 rpm can hinder you when rough-turning an out-of-balance blank. Variable-speed lathes adjust either mechanically (with the lathe running, by a belt and variable-pitch pulley) or electronically (at the turn of a dial). Mechanical variable speed is available only on full-size lathes. Although very handy and available on mini lathes, electronic variable speed adds significant initial cost, plus high replacement cost if a power surge knocks out your speed controller.

Headstock spindles are threaded on the outside, with a Morse-taper socket on the inside, for mounting a faceplate, four-jaw chuck, or drive center, as shown *below*. Tailstock quills feature a Morse-taper socket for mounting a live center or drill chuck. Choosing a lathe with a 1"×8 tpi spindle and #2 Morse tapers ensures compatibility with the greatest variety of aftermarket accessories.

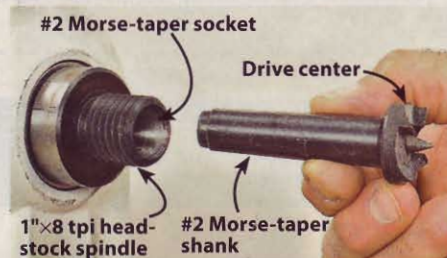

## BEST VALUE: RIKON 70-100

\$250

Rikon, 877-884-5167, rikontools.com

Weighing all the variables, we recommend the Rikon model 70-100. A smooth-running six-speed lathe with excellent power in the low speeds, the Rikon features 12" of swing, a 1"×8 tpi spindle and #2 Morse tapers. For more detailed information on the Rikon 70-100 and three other lathes, see page 78.



## THE MINI VS. FULL-SIZE CHOICE

We recommend mini lathes for beginners, but you may be wondering if a larger lathe better fits your needs. Consider the following:

### Mini lathes

#### High points

- ◆ Lower cost means more money to spend on accessories.
- ◆ A small footprint fits easier into a crowded shop.
- ◆ All minis offer bed extensions.
- ◆ Heavy competition in this category means more features for the money.
- ◆ Most have 1"×8 tpi spindles and #2 Morse tapers, the same as full-size lathes. Any accessories purchased can be used if you upgrade to a larger lathe.
- ◆ An 11"-diameter bowl, easily turned on our top-rated lathe, is plenty large. (Compare this size to the bowls in your kitchen.)

#### Low points

- ◆ Minis have a smaller swing than most full-size lathes.
- ◆ Most are less powerful than fulls, so you can't hog off large amounts of material.

### Full-size lathes

#### High points

- ◆ Most have variable speeds you adjust with the lathe turning.
- ◆ Most offer a larger swing (14" and up) and more horsepower (¾-hp and up) than minis.

#### Low points

- ◆ Some low-cost models have only a 12" swing, the same as our top-rated mini.
- ◆ With a typical footprint of 30×60", a full takes up more space than a mini.
- ◆ Expect to pay three or more times the cost of a comparable-quality mini.
- ◆ Less competition in this category means fewer models from which to choose.

## Turning tools: good quality need not be expensive

There are two ways to buy turning tools. You could purchase a set chosen by a manufacturer, or build your own set by purchasing individual tools. Because sets rarely have the right combinations of tools, we recommend buying tools à la carte. (For information on the six basic turning tools we recommend and how to use them, see **Resources**, on page 78.)

You'll find turning tools made from a variety of steel alloys. To get good performance without emptying your wallet, buy tools made of M2 high-speed steel. This alloy offers excellent edge life and resists damage from accidental overheating during sharpening.

Finally, consider tool length. Long tool shanks mean more sharpenings for longer tool life. Long handles give you more leverage for greater stability when making deep cuts.

The tools shown at right win in all three categories: selection, steel, and length. The six M2-steel tools shown allow you to turn both spindles and bowls. Interested only in spindle turning? Save money by eliminating the bowl gouge and roundnose scraper. For lathes with 12" swing or less, we found the 16–22" overall lengths of Benjamin's Best tools to be more than adequate.

## BEST VALUE: BENJAMIN'S BEST

**\$96** (cost for six basic tools)

Penn State Industries, 800-377-7297, pennstateind.com



Pictured top to bottom:

- 1/2" bowl gouge, 22" long, no. LX220, \$17.95
- 1" spindle roughing gouge, 19" long, no. LX260, \$19.95
- 3/8" spindle gouge, 16" long, no. LX320, \$10.95
- 1" standard skew, 18" long, no. LX020, \$17.50
- 1" roundnose scraper, 18" long, no. LX120, \$17.95
- 1/8" parting tool, 16" long, no. LX420, \$10.95

## Selecting a grinder: nothing fancy required

A bench grinder offers the fastest, cheapest way to sharpen lathe tools. We recommend a slow-speed version (1,725 rpm) equipped with pink, white, or blue aluminum oxide wheels. Wheel grinding makes a hollow-ground edge, and the smaller the wheel, the deeper the hollow. To balance edge sharpness and durability, a grinding wheel should be replaced when it wears to a 5" diameter. For this reason, we prefer an 8" over a 6" model. The sharpening jig shown on the next page mounts directly below the grinding wheel, so the machine base must not extend into this area. (We eliminated two 6" grinders because the bases extend under the wheels.)

The bare-bones 1,725 rpm Woodcraft grinder at right fits the bill, equipped with two 1×8" white aluminum oxide wheels: one 60-grit wheel for rough-shaping your tool profiles when needed, and one 120-grit wheel for routine sharpening.

You'll need to keep the wheels dressed to remove metal particles and maintain flat surfaces. The price shown includes the cost of a Woodcraft no. 124670 diamond wheel dresser.

## BEST VALUE: WOODCRAFT 144290

**\$110** (including the cost of a wheel dresser)

Woodcraft, 800-225-1153, woodcraft.com



## Alternate: Delta GR450, \$140

Delta, 800-223-7278, deltamachinery.com

For \$30 more, Delta's 1,725–3,450 rpm variable-speed GR450 adds versatility for sharpening more tools in your home and shop. Use the 36-grit gray utility wheel at high speed for general grinding, such as sharpening a lawn mower blade, and the 60-grit white aluminum oxide wheel at low speed for your lathe tools. We like the toolless quick-change wheel system that makes installing the included cloth buffing wheel a snap. A diamond wheel dresser and built-in work light top off the package.

## Sharpening your tools: critical for success

Many problems that bedevil the beginning turner, such as tool catches and torn grain, are caused by dull or improperly sharpened tools. Developing the skill to sharpen lathe tools free-hand takes practice and constant repetition, two big hurdles for the beginning or occasional turner. So, our turning pros recommend using a sharpening jig.

The Precision Sharpening System, at right, from Penn State Industries supplies everything you need to outfit your grinder for sharpening all six basic tools. With this jig, you'll get repeatable angles, sharp edges, and smooth bevels every time. We found the instructions supplied with the jig to be brief to a fault, so be sure to check out the lathe tool sharpening article listed in Resources on page 78.

Once you've made your tool selections, you'll need some instruction. For helpful resources, see page 78. Also, although you can do a lot of turning without a four-jaw chuck, they offer many advantages. See the sidebar below.

## BEST VALUE: PRECISION SHARPENING SYSTEM \$115

Penn State Industries, 800-377-7297, pennstateind.com



## Four-jaw chucks: a nice extra

All the lathes we tested come with a faceplate, as shown below. But for turning practically anything, four-jaw chucks offer so many advantages that anyone from novice level on up would benefit from owning one. Chucks provide quick, accurate, and positive centering of bowl blanks. There's no need to glue a waste block to your turning blank or give up blank thickness to accommodate the screws needed to fasten it to a faceplate. A bowl turned with a chuck leaves little or no trace of how it was held on the lathe. A chuck also makes turning boxes, vases, and goblets a snap. Once you use one, you'll wonder how you got along without it. For more information on four-jaw chucks and how to use them, see Resources, on page 78.

## BEST VALUE: UTILITY GRIP \$80

Penn State Industries, 800-377-7297, pennstateind.com

An entry-level chuck, the Utility Grip uses twin levers (sometimes called "tommy bars") to open and close the jaws. Lever action requires the simultaneous use of both hands, so to hold a bowl blank in place, you can temporarily lock the lathe spindle to allow one-lever operation, support the blank with the tail center while tightening the chuck, or mount the chuck to the blank on the workbench and then thread the whole assembly onto the lathe spindle.



The Utility Grip includes inserts to fit  $\frac{3}{4}$ "x16 tpi and 1"x8 tpi spindles, #1 step jaws, #2 round jaws, and a screw center. To expand the holding range of the chuck, #1 pin jaws, #3 round jaws, and two sizes of flat jaws for holding bowls by the rim when finishing the bottom are sold separately.

## Upgrade: Barracuda2, \$170

Penn State Industries, 800-377-7297, pennstateind.com

Key-operated jaws give this chuck the advantage of one-hand operation. This frees your other hand to support stock when mounting or removing it from the chuck. The chuck body is threaded for a 1"x8 tpi spindle, with a  $\frac{3}{4}$ "x16 tpi adapter included. The package features four standard jaw sets for a wide range of internal and external gripping diameters, plus a screw center. Two sizes of optional flat jaws are available separately.

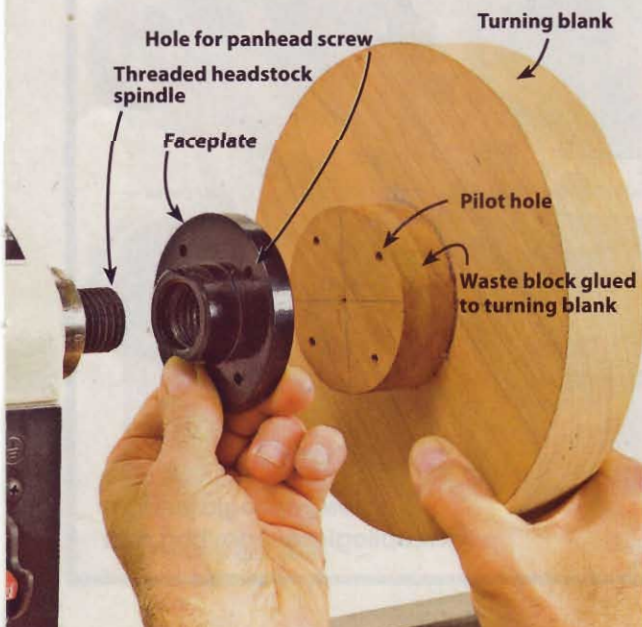

Written by Jan Svec with Brian Simmons and Chuck Dowler

# Get into Woodturning for under \$600

## Resources

The article on page 74 helps you choose the right tools. Here are some resources to assist you in learning to use them.

### Online woodmagazine.com

The following articles normally cost \$2.75–\$3.25 per download, but you can download them for free until January 31, 2008, by going to [woodmagazine.com/turninginfo](http://woodmagazine.com/turninginfo).

- 6 Must-Have Turning Tools and How to Use Them
  - Surefire Lathe Tool Sharpening
  - Getting a Grip on Four-Jaw Chucks
  - From Trees to Turning Blanks
- For additional turning topics and a selection of turning projects, go to [woodmagazine.com/turnedprojects](http://woodmagazine.com/turnedprojects). Also, professional turner Phil Brennion hosts an online woodturning forum at [woodmagazine.com/turning](http://woodmagazine.com/turning).

### woodturner.org

The American Association of Woodturners (AAW) site features resources, instructional videos, symposium info, and a directory of local chapters.

### Google

To find woodturning clubs in your area, Google “woodturning” followed by your state.

### On video

- *Getting Started Right* with Alan Lacer
- *Fundamentals of Sharpening with Four Woodturning Experts* available from the AAW

- *Woodturning Projects with Bob Rosand* available from the AAW

### On your bookshelf

- *The Fundamentals of Woodturning* by Mike Darlow
- *Woodturning, A Foundation Course* by Keith Rowley
- *Woodturning* by Phil Irons
- *Turning Green Wood* by Michael O'Donnell

### In person

- The location of the annual American Association of Woodturners symposium, usually held in June, rotates from East to Midwest to West. For information, go to [woodturner.org](http://woodturner.org).
- The Utah Woodturning Symposium in Provo, Utah, usually held in June, is the longest-running woodturning symposium in the world. For information, go to [utahwoodturning.com](http://utahwoodturning.com).
- Professional turners travel the country year-round giving demonstrations at woodturning clubs. Also, check with your local club for individual or group classes. 🌲



## Laser Engraving, Cutting and Marking Systems

# Starting at \$9,995!



### Start Your Own Laser Engraving Business!

Create and sell custom engraved and cut logos, photos, graphics and more - and it's as easy to operate as a printer. Call us today toll free at 888-437-4564 to **receive a free brochure, sample kit and CD demo** of the system in action!



1 Scan Photo



2 Import to Graphic Software



3 Print to Laser and Press Go



Create custom engravings in minutes. Contact us for more information.

### What you can Create.

Overlay Plaques



Photo Wood Cards



Inlay Signage



Architectural Modeling



Memorial Plaque



3D Engraving



Toll Free: 1.888.437.4564 • Phone: 303.277.1188  
[sales@epiloglaser.com](mailto:sales@epiloglaser.com)  
[www.epiloglaser.com/bhg.htm](http://www.epiloglaser.com/bhg.htm)

# Just-Right Joinery

## Pick the right sheet-goods fastener

The best screws for solid-wood joints may not be your best choice for projects made from medium-density fiberboard (MDF), particleboard, or plywood. Whether you want a permanent or temporary connection, you can buy fasteners specially made for sheet goods.

Three factors determine the best sheet-goods fastener for the job:

- the material type and thickness;
- whether the fastener will be concealed or exposed;
- whether the joint will be permanent, or reversible for easy disassembly.

Choose the best fastener based on the following descriptions. You'll find a list of sources for fasteners and accessories at the end of this article.

### CABINET-CONNECTING SCREWS



A stepped bit drills a narrow hole to grip threads at the lower end of the screw. A wider hole at the top grips the screw shaft.

**Uses:** These Confirmat-style screws pull MDF and particleboard faces tightly against edges or ends, and reinforce glue for permanent 90° butt joints.

**You'll need:** A stepped drill bit to make graduated pilot holes sized so just the threads grip the wood. Drive screws (*inset*) with a PoziDrive bit. Conceal screws in melamine with matching plastic caps, shown *below*.

#### Sturdiness secrets:

Clamp parts firmly together before drilling pilot holes. Place screws 2" from the edges of your workpiece and 8" to 10" apart.



For sheet-goods fasteners that require precise alignment, such as a Minifix, use a drilling guide.

### MINIFIX FASTENERS LET YOU DISASSEMBLE PROJECTS FOR EASY MOVING

**Uses:** These fasteners join 3/4" particleboard or MDF parts edge-to-edge or edge-to-surface for either permanent or reversible connections. To conceal the joint, place the cam (shown here in 3/4"-thick clear plastic for clarity) on a concealed surface of your project.

**You'll need:** A marking and drilling template like the one shown *above* to position the cam and connector bolt holes precisely, 8mm brad-point bit, and 15mm Forstner bit.

**Sturdiness secrets:** Too much torque can break the inside of the cam, so use just enough to snug the parts together. For the 8mm connector bolt hole, set a depth stop at 12mm to avoid drilling through the opposite face.

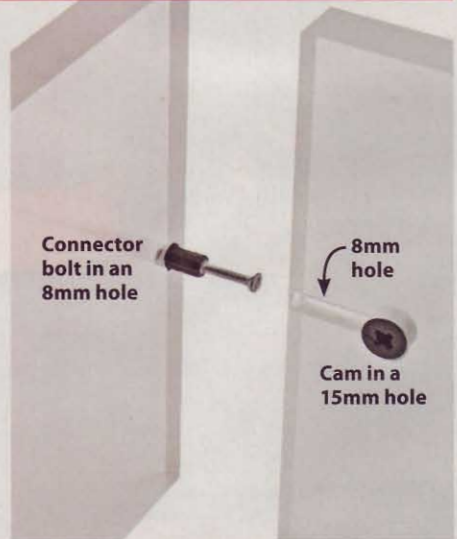

### ZIPBOLT CONNECTORS PULL TOGETHER LARGE PANELS

**Uses:** Pull together and reinforce edge-to-edge joints in 3/4" particleboard for applications where the fastener will be concealed, such as countertop underlayments. Use for permanent or reversible joints.

**You'll need:** A drive bit to turn the gear pulling the pieces together, a 1 3/8" or 35mm bit for the two holes, and a router with a 3/8" straight bit to cut the grooves connecting the holes.

**Sturdiness secrets:** Until they're tightened, these fasteners can allow the pieces to slip out of alignment, so recheck the position of both parts before snugging them together.

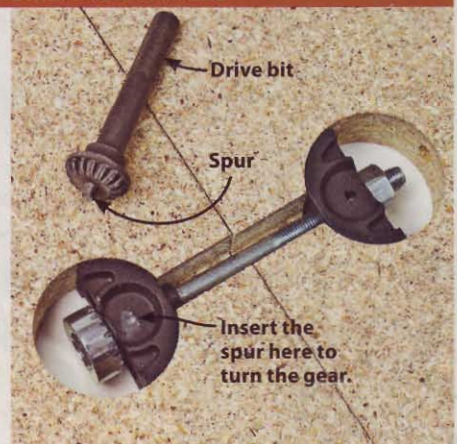

*continued on page 82*

## CONNECTOR BOLTS HAVE MORE THAN ONE APPLICATION

**Uses:** For 90° edge-to-surface joints, a barrel nut recessed into the face of one piece grips the bolt without tearing out. With its wide head, a connector bolt creates a stronger joint than Minifix fasteners can provide, especially in particleboard. To join two or more 1/2" or 3/4" MDF, particleboard, or plywood parts face-to-face (see inset), use a cap nut at the end of a connector bolt.

**You'll need:** A 13/32" or 10mm brad-point drill bit for barrel-nut holes. Cap nuts require a 3/8" bit. To center holes on a workpiece edge, use a positioning jig with a 1/4" bushing similar to the Minifix jig shown at the top of page 80 or a doweling jig. Either one should center 1/4" holes along the thickness of the material you're drilling. If you're using barrel nuts, customize your positioning jig to also mark the hole locations for the nuts.

**Sturdiness secrets:** Position barrel nuts as far from the workpiece edge as your bolt accommodates. We used 2 1/2" bolts

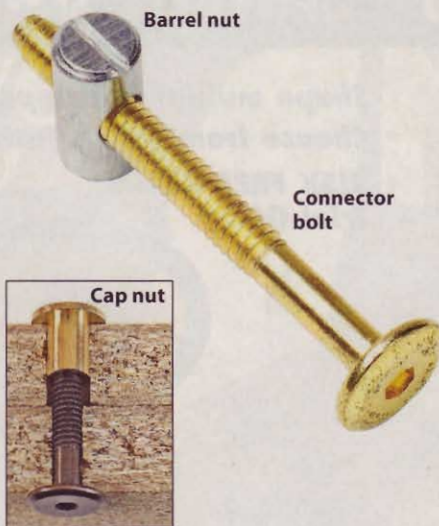

for 3/4"-thick stock. When using cap nuts, trim connector bolts to 1/8" shorter than the combined thicknesses of the panels being joined. 🌱

## Sources

**Cabinet-connecting (Confirmat-style) screws.** No. 7050-CSP 7x50mm, \$7.53 for 100, call McFeely's at 800-443-7937; mcfeelys.com.

**Stepped drill bit and driver for cabinet connecting screws.** No. MS-7050 stepped bit for 7x50mm screws, \$20; no. HPD-0310 PoziDrive bit for 7x50mm screws, \$.85; McFeely's.

**Minifix fasteners and drilling template.** No. 22161 fasteners for 3/4" stock, \$5.29 for eight; Jig It Template no. 92114, \$29; Rockler Woodworking and Hardware, 800-279-4441; rockler.com.

**ZipBolt connectors and driver.** No. 33816, \$10 for six, driver no. 32707, \$7, call Rockler.

**Connector bolts, cap nuts, and barrel nuts.** Sizes from 1/4"-20x2" to 1/4"-20x3" in bright brass or bronze, \$.05 to \$7.13 for 25; zinc-plated barrel nuts from 9/16" to 3/4" diameter, \$6.78 for 25; McFeely's. Connector bolts in statuary bronze from 1 1/8" to 3/4" long, \$3.39 to \$6.79 for eight; no. 54689 2" connector bolts in solid brass, \$9 for four; no. 55171 1/4"-20 cap nut, \$5 for four; Rockler.

**Drill guide bushing.** 1/4" bushing no. 25K62.04 and 5/16" (approximates an 8mm) bushing no. 25K62.05, both \$2.15; call Lee Valley Tools at 800-871-8158; leevalley.com.

**Metric Forstner and brad-point drill bits.** Lee Valley Tools and Rockler. (See 800 numbers and Web sites above.)

# The Ultimate Clamping Solution for Pocket-Screw Joinery... and much more!



## Introducing the **Kreg Klamp Table™** ...

You don't need an army of clamps to get the job done; you just need the right ones. The Kreg Klamp Table™ is the ultimate 'helping hand' around the work shop and the easiest way to get perfectly flush Pocket-Screw joints, one after another.

Bench Klamps™ glide across the Klamp Trak™, rotate 360 degrees, and firmly lock into place wherever you need them most.

Klamp Blocks™ can be positioned anywhere along the Klamp Trak™ and used to bring your entire project into alignment.

### Other Great Uses:



Drilling Pocket-Holes



Routing / Sanding



Sawing



www.kregtool.com | 800.447.8638

# Wise Buys

Our expert tests

# Mini-Lathes

## Why buy?

If you'd like to try your hand at woodturning, a mini-lathe proves the perfect solution. Sure, they're great for turning pens. But mini-lathes also excel at other tasks. You can turn bowls, platters, hollow vessels, bottle stoppers, drawer pulls, chair spindles, and table legs—all for about half the price or less of the cheapest mid-size lathe. We define a mini-lathe as any benchtop lathe with 20" or less capacity between centers and 12" or less of swing (the largest diameter workpiece you can turn on the lathe). These lathes typically have ½-hp motors, and most feature optional bed extensions for turning longer spindles. *WOOD*® magazine turning expert **Brian Simmons** tested 10 mini-lathes, and he recommends the models *below*.



### RIKON 70-100, \$250



**Speeds:** 430, 810, 1,230, 1,810, 2,670, 3,900 rpm.  
**Capacities:** 12" swing, 18" between centers.  
**Weight:** 86 pounds.  
**Optional accessories:** 24" bed extension, \$70; lathe stand, \$150; lathe stand extension, \$80.

### Expert test-drive:

Ssshhhhh! Don't tell the folks at Rikon, but they're selling a Cadillac for the price of a Chevy! Rikon's model 70-100 has it all: torque, capacity, low price, and lots of great features. One of only three 12" mini-lathes I found, the 70-100 handles heavy cuts without vibrating—I was able to stand a nickel on the lathe bed while turning. With two speeds under 1,000 rpm, it provides lots of torque in the range needed for roughing out stock. In fact, its ½-hp motor, ribbed belt, and step pulleys delivered so much torque at the slowest speed, I could not stall it or make the belt slip when I plowed my gouge into a 9" cherry bowl blank.

Chucks and faceplates mount easily onto the spindle, thanks to its chamfered threads. The tailstock features a quill lock separate from the keyway, which prevents the quill from spinning in the tailstock. A 2½" quill stroke delivers plenty of travel for boring holes. And it has onboard tool storage, a 12-point indexing headstock, and plenty of room for super-simple belt changing.

**To learn more:** 877-884-5167; rikontools.com

### JET JML1014-VSI, \$330



**Speeds:** Variable, 500–3,900 rpm.  
**Capacities:** 10" swing, 15" between centers.  
**Weight:** 70 pounds.  
**Optional accessories:** 23" bed extension, \$60; lathe stand, \$125; lathe stand extension, \$65.

### Expert test-drive:

Compared with the Rikon, you give up 2" of swing and 3" between centers, but the JML1014-VSI's variable-speed control provides the ability to change speeds ever so slightly—especially in the lower range for roughing out a blank. The ½-hp motor provided respectable torque when I turned a 9" bowl and 15" spindle, and because there's little vibration, it, too, passed my standing nickel test. Jet's spindle features chamfered threads, and topped the test with virtually no run-out. It also had the best alignment of centers; a spur center with long, thin points that needed only a light tap to seat in a turning blank; and 1⅞" of quill travel for boring.

However, I did find a few areas for improvement. For example, when boring holes with a drill chuck in the tailstock, the lathe's combined quill lock and keyway sometimes allowed the quill to spin within the tailstock. With three-tiered pulleys, I didn't have to change belts as often; but when I did, it proved difficult because the speed-control box limits access to the lower pulley.

**To learn more:** 800-274-6848; jetttools.com

### JET JW1220, \$350



**Speeds:** 500, 840, 1,240, 1,880, 2,630, 3,975 RPM.  
**Capacities:** 12" swing, 20" between centers.  
**Weight:** 101 pounds.

**Optional accessories:** 28" bed extension, \$150; lathe stand, \$150; lathe stand extension, \$80.

### Expert test-drive:

Although Jet's newest mini-lathe costs more than most models, it offers several unique features that make it worth the money. With a robust cast-iron body and powerful ¾-hp motor, the JW1220 never balked as I took heavier cuts than anyone really should on a mini-lathe. Although it did vibrate slightly during tough cuts, it purred smoothly for most of my testing workout. It has the same speed selections as Jet's fixed-speed version of the JML1014 (*not shown*), but the bigger housing makes belt changes much easier.

Because the JW1220 has the longest mini-lathe bed, Jet includes 6" and 10" toolrests as standard equipment. The larger toolrest allowed me to turn full-length spindles without having to move the toolrest as often as with the 6" version, common to all the other mini-lathes. Other great features on this machine: chamfered spindle threads, minimal spindle run-out, 1⅞" quill stroke, and built-in tool storage. My only wishes: I'd love to see this machine with a variable-speed motor and a longer neck on the lamp.

**To learn more:** 800-274-6848; jetttools.com



## Quick & Easy Jig

# Perfect half-laps in very long workpieces

Cutting on-the-money rabbets for half-lap joints with a portable circular saw and handheld router is a breeze with this two-in-one jig.

**Y**ou can make a simple half-lap joint on your tablesaw with a dado blade, miter-gauge extension, and a workpiece stop. But when working with very long parts, like the 80" stiles in the tool cabinet on page 32, cutting them on a tablesaw proves awkward at best, and maybe unsafe. And what if you don't own a tablesaw? Here's how to form the rabbets that make up a half-lap joint with portable tools. With this jig, you'll save time by cutting several parts with one setup.

### First, build the jig

To make the jig base, measure from the motor edge of your circular-saw base to the blade, and add  $\frac{1}{8}$ ". Then chuck a  $\frac{1}{2}$ " straight bit into your router, measure from the edge of the router subbase to the bit, and add  $\frac{1}{8}$ ". To these two dimensions, add  $1\frac{1}{2}$ " for the guide, and cut an 18"-long piece of  $\frac{1}{2}$ " medium-density fiberboard to this width.

Cut the guide to the size shown *below right*. Glue and clamp it to the base. Then, with the glue dry, clamp the base to your workbench with the saw side overhanging. With the saw base against the guide, trim the saw side to width. Now with the router side overhanging the workbench, use your router with the  $\frac{1}{2}$ " bit to trim the router side to width.

Measure the trimmed width of the base, and cut two cleats to this length. Then glue and clamp the cleats to the bottom of the base, flush at the ends and edges.

### Put the jig to work

Clamp together, edge to edge, the parts to be rabbeted. Secure them to your workbench with the ends and faces flush. [The photos show the four  $1\frac{1}{2} \times 3 \times 80$ " stiles (A) for the tool cabinet on page 32.] Mark a line across the parts at the rabbet shoulders. Then, to prevent chip-out when the router bit exits the last part, adjust the cut depth of your circular-saw blade to one-half the thickness of the parts. Now cut a saw kerf at the rabbet shoulders, as shown *top right*.

Chuck a  $\frac{1}{2}$ " straight bit into your router, and adjust the cut depth to one-half the thickness of the parts. Then rotate the jig and clamp it to the parts, pushing the infeed end cleat against the first part to keep the jig square. Now clean out the rabbets, as shown *center right*. Move the jig in from the part ends until the cut meets the saw kerf. 🌲



Align the saw edge of the jig with the rabbet layout line, clamp the jig in place, and cut a saw kerf to define the rabbet shoulders.



To clean out the rabbets, start with the router edge of the jig  $\frac{3}{8}$ " from the stile ends, and make repeat router cuts to the saw kerf.

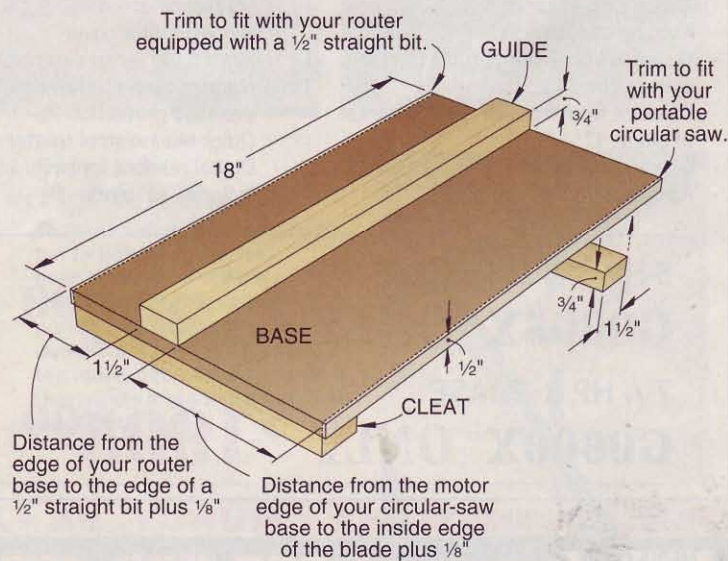

# Shop-Proven Products

These woodworking wares passed our shop trials

## Super-sharp tools, minus the aching arms

I'm a big fan of sharpening my edge tools with sandpaper rather than expensive waterstones or oilstones. But I'm not a big fan of the elbow grease required. Now the folks from Professional Tool Manufacturing, Inc.—the Drill Doctor people—have made sandpaper sharpening easy with their Work Sharp WS3000.

On this motorized system you mount self-stick abrasives to 6"-diameter, dead-flat tempered glass discs. You hold your chisel, plane iron, or turning tool against the spinning disc to sharpen it.

You can sharpen from three locations on the tool. Flatten the backs of chisels and plane irons on the top. Grind and hone the bevel on the bottom of the disc, using the tool rest with one of four bevel settings (20°, 25°, 30°, 35°). Or sharpen lathe or carving tools freehand underneath, using a slotted plastic wheel and slotted sandpaper. (The slots allow you to see your tool while you sharpen it, as shown in *top left photo*.)

After using Work Sharp to hone every chisel and plane iron in the *WOOD*® magazine shop (plus all of mine from home), here's what I like best:

■ With the tool rest, I was able to return to precise bevel angles every time.



■ It's easy to quickly restore an edge. In most cases, one or two grits got me back in business.

■ Sharpening supplies are inexpensive: just more sandpaper when I need it.

■ I can sharpen short chisels and small plane irons with equal consistency.

The WS3000 comes with two glass discs, one slotted disc, and 120-, 400-, 1,000-, and 3,600-grit abrasive discs, as well as 400- and 1,200-grit slotted abrasives. I recommend buying an extra glass disc (\$20) and the optional "coarse kit" (\$15) of 80, 120, 220, and 400 abrasives so you don't have to peel off one grit and replace it with another

## About our product tests

We test hundreds of woodworking tools and accessories, but only those that earn at least three stars for performance make the final cut and appear in this section.



when you need it. Use the coarse sandpaper for initial shaping of really dull or worn tools. Set up one disc with 120/220 for establishing the initial bevel; 400/1,000 on the second for touching up; and 3,600 and the optional leather stropping disc (\$30) on the third disc to hone and add a microbevel.

—Tested by Jeff Mertz

### Work Sharp WS3000

Performance	★★★★★
Price	\$200
Professional Tool Manufacturing 800-597-6170; worksharptools.com	

## Carter blades deliver great cuts at an attractive price

I was getting along fine with my bandsaw blades, cutting everything I needed to, not realizing I could do much better. That all changed when I began testing Carter AccuRight blades.

I tried three blades: a 6-teeth-per-inch (tpi), 1/4"-wide blade for scrollwork; a 4-tpi, 1/2" blade for general-purpose cutting; and a 3-tpi, 3/4" resawing blade. Using the 1/2" and 3/4" blades, I was able to follow a straight line in 1"-thick stock to perfection, but the 1/4" blade drifted a little, as you might expect. The wider blades also handled ripping well, gobbling up each board without any drift. Although the 1/4" blade tracked true, I had to slow the feed rate because of the finer teeth.

AccuRight blades really shine in resawing. I cut 1/4"-thick slabs from 5 1/2"-wide stock using the 3/4" blade. The blade never deflected, delivering cutoffs that measured exactly 1/4" thick across

the full length—very impressive. Next, I set the fence to cut 5/64"-thick slabs. Both the 1/2" and 3/4" blades produced cutoffs that measured within 1/64" of my target, and I consider that acceptable. If you don't want to change blades for different types of cuts, the 1/2" blade provides the best combination of performance, speed, and cut quality.

To test the blades' ability to make radius cuts, I drew S-curves on 3/4" stock and hugged the lines tightly for each cut. Both the 1/2" and 1/4" blades handled this task without fail. Next, I drew concentric circles in 1" increments. I could cut no tighter than a 5" diameter with the 1/2" blade, but was able to drop that to 1 1/2" for the 1/4" blade.

Carter sells blades ranging from 72" to 136" in length, and 1/8" to 1" in width. They also custom-make blades to fit almost any bandsaw. 🌿

—Tested by Pat Lowry

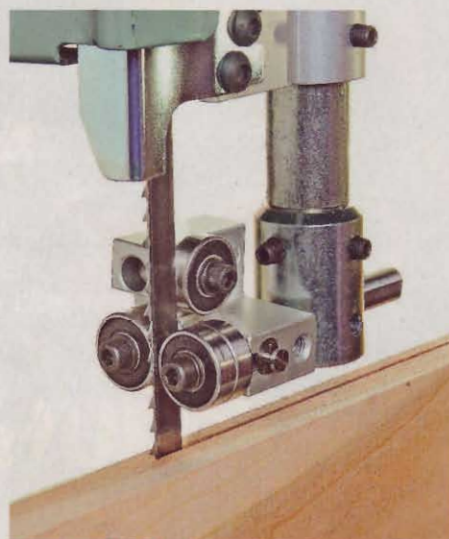

### AccuRight bandsaw blades

Performance	★★★★★
Price	\$20-\$32 (depending on size)
Carter Products Company 888-622-7837; carterproducts.com	

# Ask WOOD

Answers to your questions from letters, e-mails, and WOOD Online®

## HAVE A QUESTION?

For an answer to your woodworking question, write to **ASK WOOD**, 1716 Locust St., LS-221, Des Moines, IA 50309-3023, or e-mail us at [askwood@woodmagazine.com](mailto:askwood@woodmagazine.com). For immediate feedback from your fellow woodworkers, post your questions on one of our woodworking forums at [woodmagazine.com/forums](http://woodmagazine.com/forums).

## Choose casters without going in circles

**Q:** How do you pick the correct casters for various projects? I talked to “experts” in every building supply store and lumberyard, and they almost never agree. Is there a formula to determine which caster to use on concrete floors and on carpets?

—Ferris Pinniger, Powers, Ore.

**A:** Let your choice be guided more by what’s above the casters than what’s beneath them, Ferris. Start by determining the weight of what you want to put on wheels. Then, divide the weight by 4, and choose a caster with the next highest weight capacity.

Solid rubber or plastic tires work on hard or carpeted surfaces. But a solid rubber caster under considerable weight can, over time, develop flat spots from standing in one place. For a sturdier alternative, use casters with a rubber outer “tire” on a plastic or metal hub, such as the one shown at *right*. Though they’re harder to find than rubber casters, those with solid polyurethane wheels or polyurethane “tires” on a plastic or metal hub resist flattening. For projects you move frequently over a



Casters that lock both the wheel and the swivel action prevent tools and cabinets from moving until you want them to.

variety of surfaces, look for casters that ride on ball or roller bearings instead of just a metal axle. Larger-diameter wheels run better over carpet or rough

surfaces than small-diameter ones. Remember to account for the larger diameter when figuring the height of your project.

## Help birch flames look hot

**Q:** I picked up a stunning piece of birch with an exceptional flame pattern grain. How can I finish it to show off the patterns while retaining its light color? I’m worried that boiled linseed oil will darken over time.

—Paul Gonsalves, Ottawa, Ont.

**A:** You need to darken the early-wood slightly to show off the grain, Paul, but instead of boiled linseed oil, use a product with soy oil or at least less boiled linseed oil.

To show you the differences, we applied boiled linseed oil to the far left quarter of the test board *below*. Then, from left to right, we applied Antique

Oil (Minwax, [minwax.com](http://minwax.com)), which contains boiled linseed oil thinned with varnish, and Varathane Wood Conditioner (Varathane, 800-323-3584; [rustoleum.com](http://rustoleum.com)), made with soy oil.

For a non-darkening topcoat alone or over oil, choose super-blonde shellac, CAB-acrylic lacquer, or a water-based finish like the one shown *below right*.



Boiled linseed oil

Minwax Antique Oil

Varathane Wood Conditioner

Satin water-based finish

*continued on page 94*

## Ask WOOD

### Pinning down an odd joint

**Q:** I found an oak washstand that probably dates to around 1900. My fellow woodworkers and I had never seen joints like the ones on the drawers. Is this joint (shown below right) common to a particular region, or was it used by a specific manufacturer? Also, can I buy a jig to make this joint?

—Kevin Austin, Kokomo, Ind.

**A:** What you describe is a pin-and-crescent joint, also known as a pin-and-scallop, pin-and-cove, or scallop-and-dowel joint. This joint was a Victorian-era innovation to replace time-consuming hand-cut dovetail joints with a fast, machine-made alternative. In 1871, the Knapp Dovetailing Co. of Northampton, Massachusetts, began producing machines to make pin-and-crescent joints, soon nicknamed “Knapp joints.”

For nearly 30 years, these joints enjoyed widespread use among furniture companies that could suddenly make 10 times more drawers than with hand-cut dovetails. As the Victorian era

ended, so did the pin-and-crescent joint's popularity. Furniture style preferences shifted away from obviously machine-made details such as pin-and-crescent joints. Then came joinery machines capable of mass-producing dovetail joints that still looked hand-cut.

If you like, though, it's still possible to duplicate this joint using a router and a set of templates. (Item no. 886-459, \$210, call Woodworker's Supply, 800-645-9292; woodworker.com.)

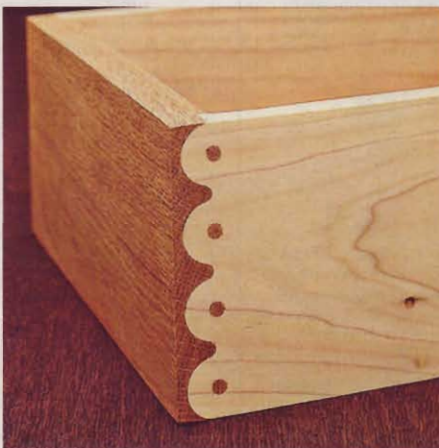

### Poly vs. planer

**Q:** Will planing wood already finished with polyurethane be hard on carbide planer knives? I've heard the finish bakes onto the knives, eventually causing them to overheat.

—Sander White, Barrie, Ont.

**A:** You could plane off an old finish, but it's not worth the risk. Planer cutterheads can generate sufficient friction to soften such finishes as polyurethane, gumming up their knives. Instead, use a belt sander set to about half its maximum speed and an 80- or 100-grit belt to remove the old film finish, as shown below. Even if the belt gums up, that's easier and cheaper to replace than planer knives. After sanding away the finish, feed the wood through a planer to erase the sanding marks.

If you're recycling old boards or ones from an unknown source, take added precautions. Treat any old painted finishes as though they contain lead, and remove them with a chemical stripper. Wear an appropriate respirator, work in a well-ventilated space, and protect exposed skin. Before feeding recycled lumber through a planer or jointer, use a metal detector to check each board for hidden nails, screws, and staples. 🌱

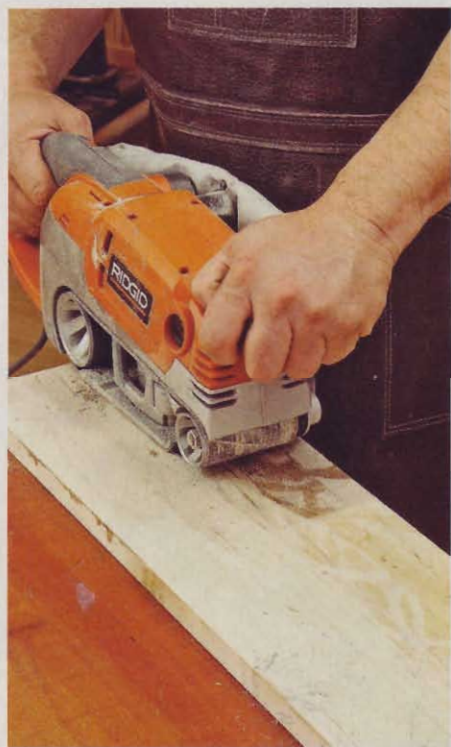

Circle No. 1301

**THIS IS YOUR BODY ON  
RADIANT HEAT  
ANY QUESTIONS?**

VISIT OUR WEBSITE CALL FOR A  
FREE QUOTE

**RADIANT**  
Floor Company

Compatible with any fuel source:  
GAS PROPANE SOLAR OIL WOOD ELECTRIC GEOTHERMAL

www.radiantcompany.com  
Barton, Vermont  
(toll free) 1.866.WARM-TOES (927.6863)

## Avoiding Workshop Goofs

# Eliminate jointer snipe

The solution lies in the outfeed table.

**A**ny time you use a jointer, planer, or drum sander to surface wood, you run the risk of snipe, that annoying scooplike depression at the beginning or end of a cut. On a planer or drum sander, snipe happens when only one feed roller engages the board, allowing the board to lift momentarily and the cutterhead or drum to gouge the workpiece.

Jointer snipe, on the other hand, occurs only at the end of a cut, caused by the outfeed table being set too low. As the end of the workpiece clears the infeed table, it drops onto the outfeed table and the cutterhead, as shown *below*, with the knives sniping it across the width of the jointed surface.

### Outfox snipe at the table

Getting rid of snipe means tuning up your jointer for optimum performance. First, set the knives so their cutting edges are flush with the infeed and outfeed table tops. Use a store-bought knife-setting jig or the jig and technique found

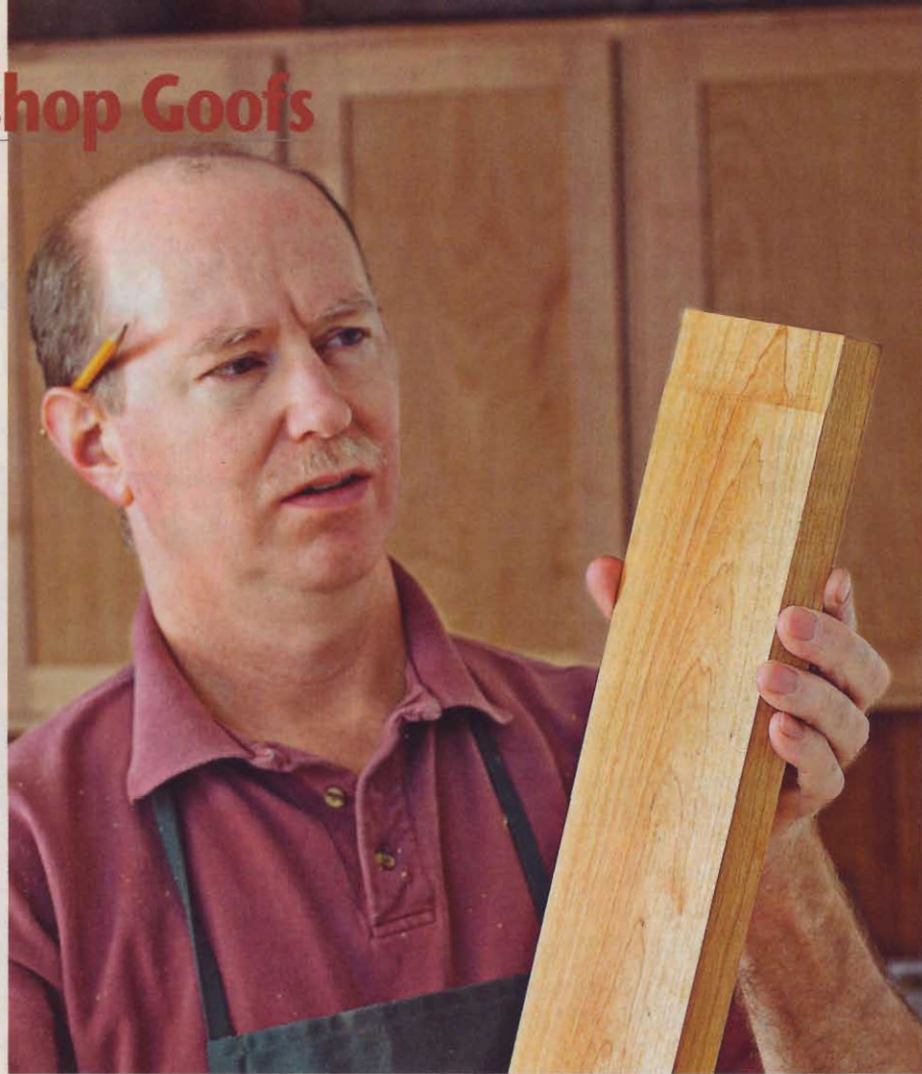

on pages 36–37 of issue 165 of *WOOD*® magazine (October 2005) or online at [woodmagazine.com/jointerjig](http://woodmagazine.com/jointerjig). It's important to set the knives flush with the outfeed table rather than to the cutterhead, because the cutterhead might not be perfectly parallel to the tables.

With the knives set and the machine unplugged, go to work on the outfeed table. Begin by removing the safety guard for better access. Lower the outfeed table about 1/8" below the top of

the knives' arc. Lay a piece of perfectly flat stock on the outfeed table so that it reaches across the cutterhead, as shown *below*. (We use 3/4"-thick MDF; don't use a steel rule that could ding the knives.) Raise the table slightly. Next, turn the cutterhead clockwise by pulling on the drive belt. If it moves the MDF, then raise the table a little more. Repeat these steps until the knives glance off the MDF without moving it. Finally, lock the outfeed table in place. 🌲

### SNIFE GOUGES THE TAIL END

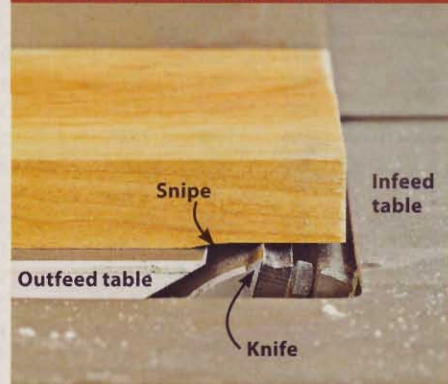

The depth of jointer snipe equals the difference between the outfeed table height and the highest arc of the jointer knives.

### NO MOVEMENT ENSURES PERFECT TABLE HEIGHT

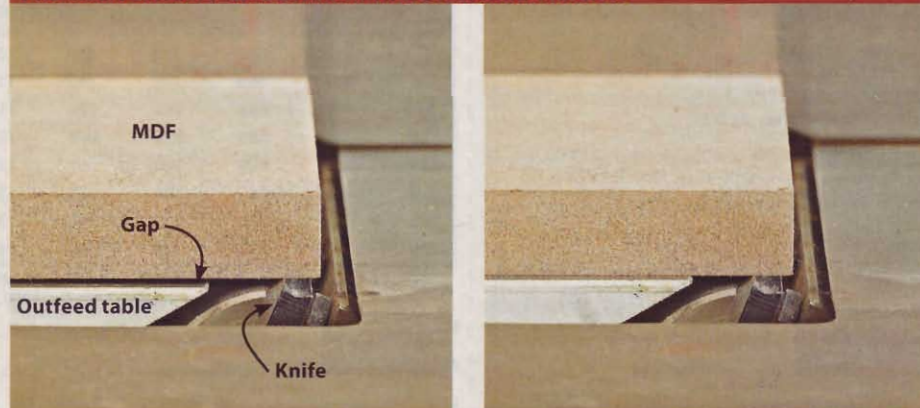

The jointer knives lift and move the MDF (*left*) when the outfeed table is set too low. Raise the outfeed table until the MDF lies flat (*right*) without moving as you turn the cutterhead.

# What's Ahead

Projects, tools, and techniques in the November issue (on sale October 9)

## FEATURED PROJECT



### Mission Bookcase

Don't be fooled by the masterful look of this project. It goes together with straightforward rabbit, dado, and groove joinery.



### Home/Shop Storage Cart

Build it as shown for your kitchen or home office—you'll also find plans for a more-utilitarian workshop version.

## TOOL TEST

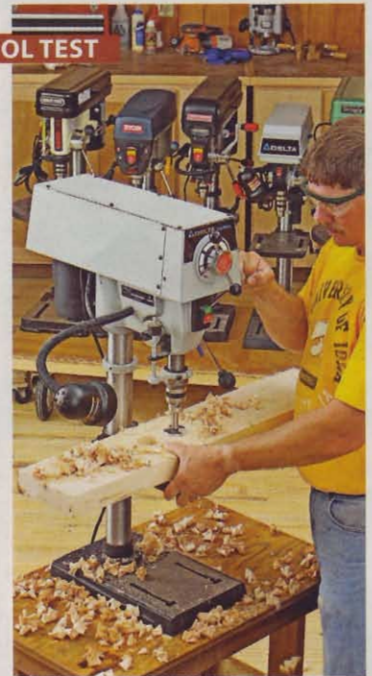

### Benchtop Drill Presses

With nearly as much capacity and power as floor-standing units, these brutes get the job done—for half the price.



### Holiday Ornaments and Cards

Try these easy-to-scrollsaw ornaments, and make matching greeting cards at the same time. Choose from 7 patterns.



### Wood ceiling

Set your home apart with an all-wood suspended ceiling. It's perfect for a finished basement, and easier to install than a metal-track system.



### 3-Window Photo Frame

Here's a great last-minute gift you can make from scrapwood. The other side holds three additional photos.

Better Homes and Gardens WOOD® magazine (ISSN 0743-894X) is published seven times a year in March, May, July, September, October, November, and December/January by Meredith Corporation, 1716 Locust St., Des Moines, IA 50309-3023. Periodicals postage paid at Des Moines, Iowa, and additional mailing offices. Better Homes and Gardens trademark registered in Canada and Australia. Marca Registrada en Mexico. One-year subscription prices: U.S. and its possessions, \$29; Canada, \$41; other countries, \$48. Canada Post Publications Mail Sales Product Agreement No. 40069223. Canadian BN 12348 2887 RT. Return undeliverable Canadian addresses to: Better Homes and Gardens WOOD magazine, 2835 Kew Drive, Windsor, ON, N8T 3B7. POSTMASTER: Send address changes to Better Homes and Gardens WOOD magazine, P.O. Box 37439, Boone, IA 50037-0439.