

TOOL TEST: TOP-VALUE ROUTER FOR \$40! p.44

ISSUE 177 JULY 2007

Better Homes and Gardens®

FREE FULL-SIZE PATTERNS INSIDE

WOOD

Get Square & Stay There

p.48

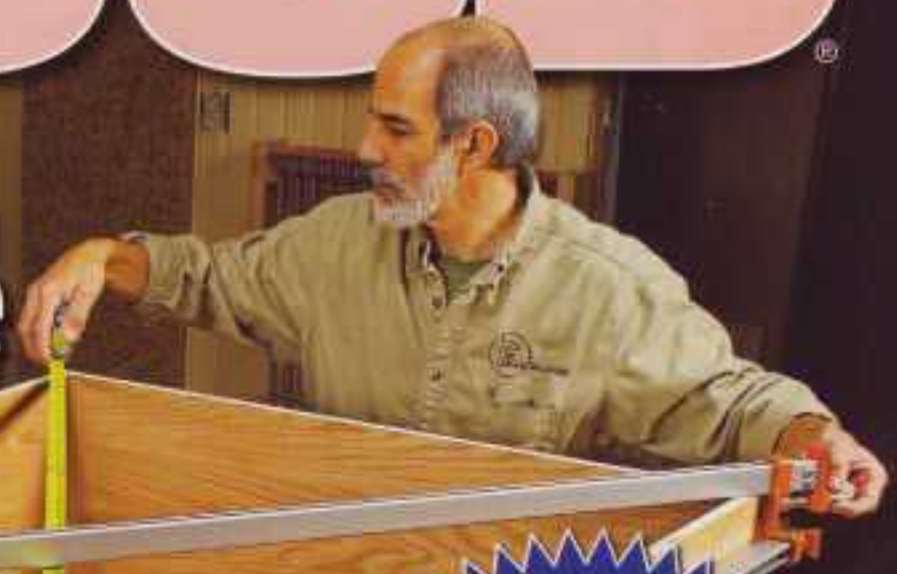

74
Tips & Tricks
to Use Right Now

Plus **6**
Easy Projects

- Stackable Bins
- Plant Stand
- Turned Lamp
- Jewelry Tree
- Gum Ball Machine
- Step Stool

Accuracy
Made
Simple p.34



Display until July 17, 2007

92567 14072

0 7 >

in this issue

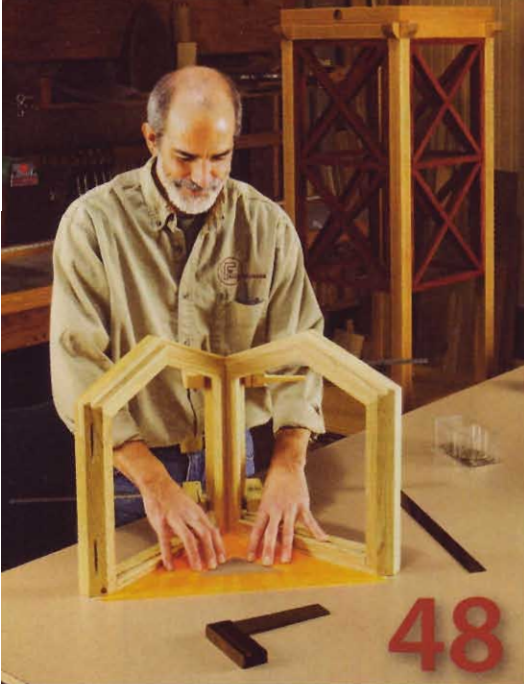

48



28



38



79

PROJECTS

- 20 Magazine binder jig**
Drill evenly spaced holes in your favorite magazines for three-ring binder storage.
- 28 Bistro table**
- 38 Turned table lamp**
Shape choice figured stock into an elegant light. Find template patterns and part sources inside.
- 58 Dresser-top jewelry stand**
- 70 Easy-to-build storage bins**
- 76 Scrollsawn goose gum dispenser**
Kids will love flicking the tail of this merry water-fowl to see her lay a gum-ball egg in the nest.
- 79 Three-step plant stand**
- 102 Workshop stool and tool tote**

TOOLS & MATERIALS

- 26 One-person panel handlers**
- 44 Trim routers tested and rated**
Don't own one? We shop-tested 12 models to help you buy the best.
- 66 What's what in loose-tenon tools**
We compare Festool's new Domino machine with three other methods of loose-tenon joinery.
- 74 Tablesaw molding cutters**
- 84 Replaceable-cutter router bits**
Discover the advantages of this style of cutter and when owning one or more makes sense.
- 86 Four shop-proven products**

TECHNIQUES

- 9 How to cut large panels safely**
- 18 Sound-system options for your shop**
- 22 Make screw holes disappear with plugs**
- 34 Attainable accuracy**
See how to gauge when measurements and setups are "good enough" for quality woodworking.
- 48 Proven squaring methods from a pro**
- 62 Project design software secrets**
Get a step-by-step look at computer-assisted-design programs and find which one is right for you.
- 82 Quick fixes for portable power tools**
- 90 Six great uses for trim routers**

DEPARTMENTS

- 6 Editor's Angle**
- 8 Sounding Board**
- 10 Shop Tips**
- 93 Ask WOOD**
- 108 What's Ahead**



70



84



This seal is your assurance that we build every project, verify every fact, and test every reviewed tool in our workshop to guarantee your success and complete satisfaction.



66

TAKE OUR EDITORS INTO YOUR SHOP

View **FREE** how-to woodworking videos from **WOODVision**. Visit woodmagazine.com/videos to watch tools and techniques in action. With a Web-enabled PDA or cell phone, it's like having a really smart woodworking buddy—in your pocket!



NEW VIDEOS

- Learn how to safely handle and cut sheet goods
- See how Festool's "Domino" and other loose-tenon tools strengthen joints
- Watch as the Table Lamp on page 38 is turned, from start to finish



82

GET GREAT ROUTER-BUYING ADVICE

Find everything you need to know about choosing a router at woodmagazine.com/routerbuying. We've even included downloadable test results. (A small fee applies for some downloads.)

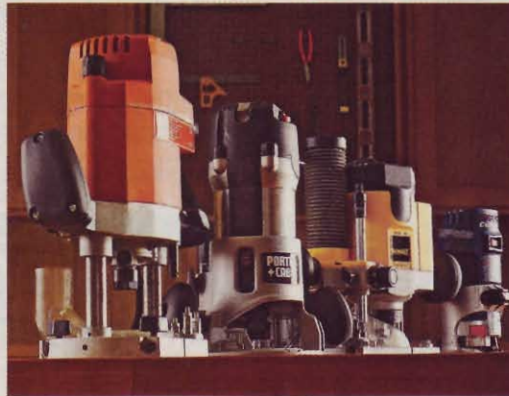

74

MORE TOY PLANS ONLINE

Kids love wooden toys. Find a mountain of children's toys and furniture to build when you visit woodmagazine.com/kidsfurntoy.



NAME + E-MAIL = FREE STUFF!

Membership has its benefits, and when you register at woodmagazine.com, you get:

- Our weekly e-newsletter packed with info to make you a better woodworker
- A free downloadable project plan monthly
- Total access to our woodworking forums—the busiest and best on the Internet

Registration is **FREE** and fast by visiting woodmagazine.com/members.



44

FOR THE TOUGHEST JOBS ON PLANET EARTH.™

From building, to creating to repairing and more.



Bonds Wood, Stone, Metal, Ceramic and More.

1-800-966-3458 • GORILLAGLUE.COM

© 2007 The Gorilla Glue Company. G3PR

Circle No.50

We asked our staff:
Why do you live to work with wood....



...it's a constant challenge and learning experience at the same time.



...I like making one-of-a-kind projects and take pride in knowing that I made them.



...because I can use my mind and hands to create something unique, beautiful, and definitely born in the USA.



...you can transform an ugly board into the most beautiful thing in the world.



...I like knowing that my gifts are treasured by those who receive them.

EDITOR-IN-CHIEF
BILL KRIER

Managing Editor **MARLEN KEMMET** Deputy Editor **DAVE CAMPBELL**

Senior Design Editor
KEVIN BOYLE

Techniques Editor **BOB WILSON** Tool & Techniques Editor **BOB HUNTER**

Projects Editor **OWEN DUVALL** Projects Editor **JAN SVEC**

Design Editor **JEFF MERTZ** Master Craftsman **CHUCK HEDLUND**

Art Director **KARL EHLERS** Associate Art Director **GREG SELLERS** Assistant Art Director **CHERYL A. CIBULA**

Production/Office Manager **MARGARET CLOSNER** Administrative Assistant **SHERYL MUNYON**

Photographers

MARTY BALDWIN, JASON DONNELLY, DEAN SCHOEPPNER, JAY WILDE

Illustrators **TIM CAHILL, LORNA JOHNSON, ROXANNE LeMOINE**

Technical Consultants **JEFF HALL, PAT LOWRY**

Contributing Craftsman **JIM HEAVEY**

Proofreaders **BARBARA KLEIN, IRA LACHER, JIM SANDERS**

SUBSCRIBER SERVICE

Go to woodmagazine.com/help or write to WOOD magazine, P.O. Box 37439, Boone, IA 50037-0439

Publisher **MARK L. HAGEN**

ADVERTISING AND MARKETING

CHICAGO: 333 N. Michigan Ave., Suite 1500, Chicago, IL 60601

Marketing Manager **AMANDA SALHOOT**

Advertising Managers **JACK CHRISTIANSEN, CAROLYN DAKIS**

Direct Response Advertising Representative **RYAN INTERLAND**

Assistants **GAYLE CHEJN, JACI LESKO**

ATLANTA: Navigate Media

DETROIT: RPM Associates

Product Marketing Manager **DIANA WILLITS**

Business Manager **JEFF STILES**

Associate Consumer Marketing Director **DAN HOLLAND**

Associate Director of Marketing-Newsstand **TOM DEERING**

Production Manager **TIM STOUFFER**

Advertising Operations Manager **JIM NELSON**

Senior Vice President/Publishing Director **DOUG OLSON**

Group Publisher **TOM DAVIS**

MEREDITH PUBLISHING GROUP

President **JACK GRIFFIN**

Editorial Director **MIKE LAFAVORE**

Finance & Administration **KARLA JEFFRIES**

Manufacturing **BRUCE HESTON**

Consumer Marketing **DAVID BALL**

Creative Services **ELLEN de LATHOUDER**

Corporate Sales **JACK BAMBERGER**

Interactive Media **LAUREN WIENER**

Corporate Marketing **NANCY WEBER**

Research **BRITTA WARE**



President and Chief Executive Officer **STEPHEN M. LACY**

Chairman of the Board **WILLIAM T. KERR**

In Memoriam — **E.T. Meredith III (1933-2003)**

Our subscribers list is occasionally made available to carefully selected firms whose products may be of interest to you. If you prefer not to receive information from these companies by mail or by phone, please let us know. Send your request along with your mailing label to Magazine Customer Service, PO Box 10263, Des Moines, IA 50336-0263.

© Copyright Meredith Corporation 2007. All rights reserved. Printed in the U.S.A.



Easy-to-Build Summer Seating



Comfy Classic Garden Bench Plan
DP-00512 \$9.95



Easy Glider Plan
DP-00305 \$8.95



Adirondack Chair & Footstool Plan
DP-00197 \$8.95



Garden Bench Plan
DP-00362 \$5.95

Download any of the woodworking plans above starting at just \$5.95, or have them mailed directly to you with prices starting at \$8.95.

To download a plan yourself or to view 600 more plans, go to woodmagazine.com/plans

Call toll free **1-888-636-4478** for paper-plan credit card orders.

Editor's Angle

Searching for the Ultimate Joinery Method

Is there one best way to join projects? No. But are there a few no-fuss ways that will meet most of your needs? Absolutely!

I'm a biscuit man, and not ashamed of it. I like to plug in my trusty biscuit joiner, cut a few quick slots, "butter up" the biscuits with glue, and then fit and clamp the parts. I end up with sturdy, well-aligned joints in minutes.

If you're one of my biscuiting brethren, you may be wondering why I'm defending our beloved biscuit. Well, it goes back to a sleigh-bed project article I wrote in the September 2001 issue. In that article we used multiple #20 biscuits to join the bed's headboard and footboard rails to the curved legs.

It didn't take long for the sawdust to hit the proverbial dust-collector impeller. More than a few readers thought we were crazy to put biscuits where mortise-and-tenon (preferred) or dowels (at a minimum) were required.

Well, seven years later that bed is holding up fine. Would mortise-and-tenon or dowel joints be stronger in that application? No doubt. Were biscuits strong enough? Definitely!

Pick just a few good joints

Now, I'm not advocating biscuits for every type of joint. When my joints need more strength, I opt for dowels or pocket screws. I prefer methods that are fast and straightforward. That's me—we all have different needs, budgets, and levels of patience.

For example, I asked Bob Hunter and Jeff Mertz (who collaborated on the article comparing loose-tenon tools on page 66) about their favorite joinery tools. Bob prefers the Festool Domino, the Leigh dovetail jig, and a quality dado blade (for dado and rabbet joints). Bob's choices aren't cheap, but he loves the combination of speed, strength, and beautiful results they offer.

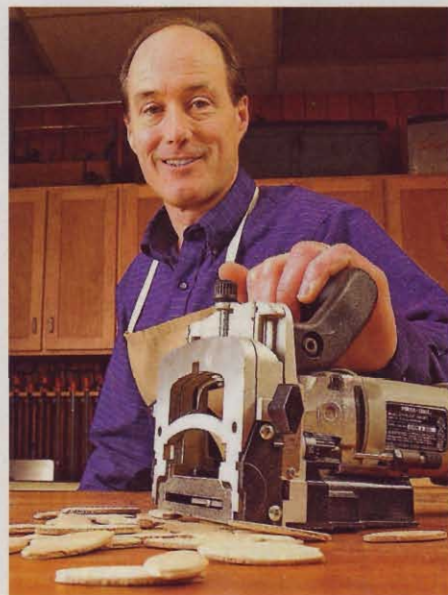

A biscuit joiner meets many, though not all, of my joinery requirements.

Jeff favors the Domino and a dado blade as well, but includes a chisel set, dovetail saw, and mallet as his third choice. (He likes handcut dovetails.)

My point is that our woodworking lives become more satisfying when we settle on a few types of joinery that we become proficient at and use for most of our cabinets and furniture.

To help you determine the best joinery methods for your needs, we scientifically strength-test various joints and review the machines and jigs for making them. You don't want to miss Bob and Jeff's report as well as Bob Wilson's Wood Joint Torture Test (issue 173) and the accompanying free video at woodmagazine.com/jointtest. These articles and videos not only tell you which joint is the *strongest*, they also give you insight into which joints are *most appropriate* for your projects. If you're curious about a joint or joinery tool we haven't tested, e-mail me at: woodmail@woodmagazine.com.

We'll give it a hard, hands-on look.

Bill Krier

Sounding Board

Our bulletin board for letters, comments, and timely updates

Build-A-Gift earns \$11,300 for St. Jude's Hospital

The generosity of readers involved in *WOOD* magazine's Build-A-Gift contest proved unbelievable. We received 227 official entries, plus two from craftsmen who simply donated their items for auction. The triple-dovetailed jewelry box, shown at right, netted a \$405 top bid on an eBay auction of the top 50 entries to win the St. Jude Award for top price.



Mark Hagen, publisher of *WOOD* magazine, presents a check for \$11,300 to Susan Sieja, regional director for St. Jude's Hospital.



We're looking for a multi-talented journalist



The staff position of Multimedia Editor is currently open at *WOOD* magazine. This person will produce a wide variety of woodworking content in both electronic and print formats including videos, slide shows, podcasts, and articles for *WOOD* magazine's web site and print products. Occasional travel is required.

Minimum qualifications are:

- Bachelor's degree in journalism, mass communications, or broadcasting. Technical writing experience helpful.
- Specific knowledge includes understanding basic woodworking processes.

Beyond that, you must possess the ability to work in a team-oriented environment and use desktop publishing equipment; you must be a self-starter and a strong writer with a keen instinct for uncovering compelling article concepts and information, and have the ability to communicate well over the phone and in person.

Please note that this position is in Des Moines, Iowa.

For more on this exciting opportunity with *WOOD* magazine and Meredith Corporation, visit our Career site at Meredith.com; once there click Careers. Qualified applicants, send cover letter and resume to:

D. Rock, Meredith Corporation, HR/Publishing Group, Dept #34530, 1716 Locust St., Des Moines, IA 50309, fax 515/284-2958. EOE.



Article updates

Issue 171 (September 2006)

■ If you're building the heirloom bookcase on pages 38-46, cut the biscuit slots in the front legs (F) before attaching the side edging (G). To best do this, perform step 2 of "Complete the bottom case" on page 41 after steps 3 and 4.

Issue 174

(December/January 2006/2007)

■ In "23 tablesaw tips, tricks, and techniques," Tip #22 says to never use your miter gauge and rip fence together in guiding a workpiece through a cut. We should have specified this applies only to through cuts, where the cutoff piece, trapped between the fence and blade, could be ejected. It's okay to use

both when making partial-depth cuts for dadoes, rabbets, or tenons, as we did on page 45 (Photo P) and page 79 (Photos A and B).

■ Also from the tablesaw tips article, in Tip #1 (page 82), you need to first attach your temporary hardboard tabletop to the saw's tabletop, then raise the blade through it, and finally, set the distance from the rip fence.

HOW TO REACH US

For woodworking advice:

Post your woodworking questions (joinery, finishing, tools, turning, general woodworking, etc.) on one of 14 online forums at woodmagazine.com/forums.

To contact our editors:

Send your comments via e-mail to woodmail@woodmagazine.com; or write to *WOOD* magazine, 1716 Locust St., LS-221, Des Moines, IA 50309; or call 515/284-3236.

Subscription assistance:

To notify us of an address change, or to get help with your subscription, visit woodmagazine.com/help. Or write to *WOOD* magazine, P.O. Box 37439, Boone, IA 50037-0439. Please enclose your address label from a recent magazine issue.

To find past articles:

See our index at woodmagazine.com/index.

To order past issues and articles:

Order past issues of *WOOD* magazine, our special issues, or downloadable articles from issue 100 to present by visiting our online store at woodmagazine.com/store, or call 888/636-4478. Some issues are sold out.

Updates to previously published projects:

For an up-to-date listing of changes in dimensions and buying-guide sources from issue 1 through today, go to woodmagazine.com/editorial.

Safety: Real-life Lessons

Don't let a panel become a projectile

The incident

I had crosscut several 4x8 sheets of plywood on my cabinet saw without a problem. As I was completing the cut on one more sheet, my left hand rotated slightly, forcing the large offcut against the blade. Instantly, the saw shrieked and the offcut struck me in the stomach, causing a rush of pain that doubled me over. Before I could shut off the saw, the shriek returned. When I had straightened up, the piece between the blade and fence launched and hit me—this time in the crotch! In agony, I fell to the sawdust-covered floor.

After about 10 minutes, I crawled upstairs to call 911. Unable to stand to retrieve the phone, I reached into a cabinet, grabbed a skillet, and threw it at the wall, knocking the phone onto the floor. After considering my embarrassing situation, though, I decided not to follow through with the call. Thirty minutes later, when I finally was able to stand, I discovered a 3"-long gash across the top of my left thigh, which I dressed myself.

—Greg Sowinski, Lima, Ohio

The woodworker

Greg is a reporter in his hometown for *The Lima News*, covering the criminal justice system. An intermediate-level woodworker with four years experience, he enjoys building cabinets and furniture.



The warning signs

Greg was crosscutting a large, awkward workpiece without proper support and help, making it difficult to feed the piece straight through the cut. Although he had done this a number of times without a problem, he mistakenly grew confident that he could do it again. Further, he did not have a blade guard with a splitter and anti-kickback pawls in place that could have prevented the incident.



The lessons

The lessons that Greg learned "are old ones I knew but didn't obey."

To make sure that an accident like this never happens to you, follow these pointers:

- Use support stands and a helper to safely cut a large panel on a tablesaw [Photo A].
- As an alternative, cut pieces from a large panel using a portable circular saw, a straightedge guide, and reliable panel support [Photo B]. Cut the pieces approximately 1" oversize to allow for edge clean-up on the tablesaw.
- Use a blade guard with splitter and anti-kickback pawls. The splitter keeps the kerf open while cutting the stock, and it prevents the piece from twisting and lifting onto the blade. The pawls dig into the wood to keep it in place if it begins to kick back.

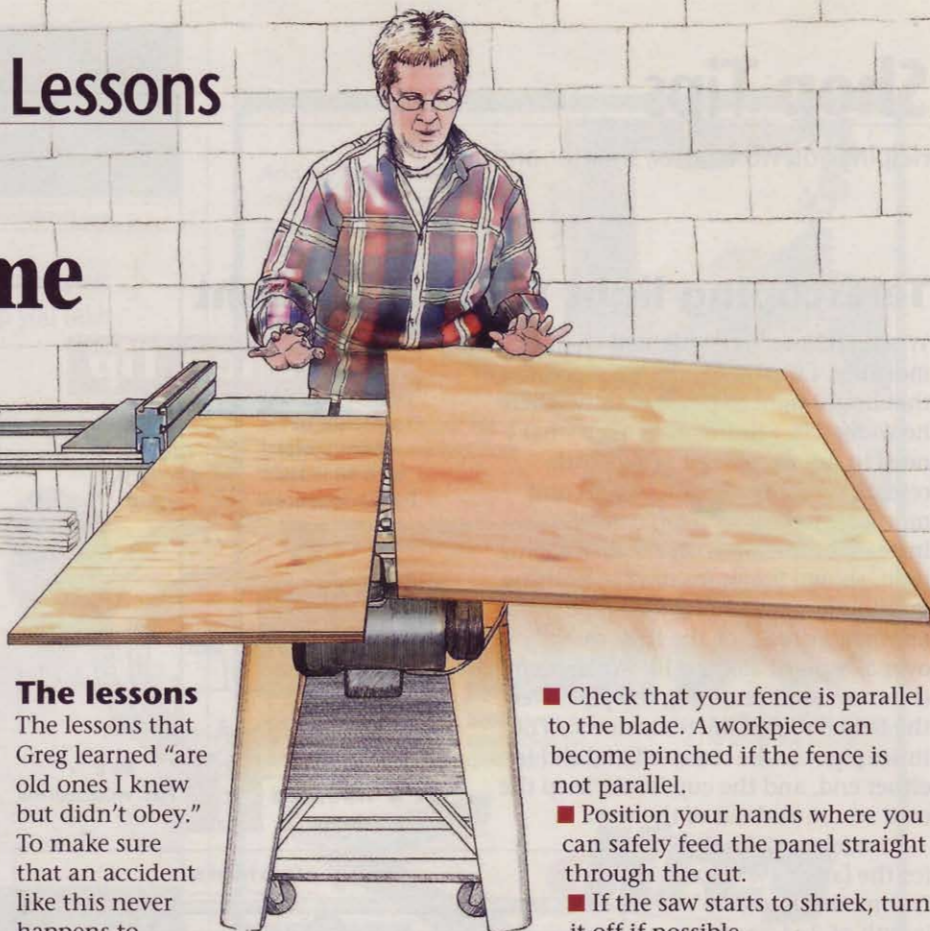

■ Check that your fence is parallel to the blade. A workpiece can become pinched if the fence is not parallel.

■ Position your hands where you can safely feed the panel straight through the cut.

■ If the saw starts to shriek, turn it off if possible.

■ Bring a telephone with you or install one in your shop for quick access if needed. And, regardless of the injury, don't hesitate to call for help. 🌲

Opening illustration: **Melanie Powell**

Earn \$100 for your story

Help other readers work safely by sharing a personal shop-related mishap or near miss. Send a detailed description of the incident (about 150 words) along with photos or illustrations and a daytime phone number, to: **Safety: Real Life Lessons, WOOD Magazine, 1716 Locust St., LS-221, Des Moines, IA 50309-3023.** Or e-mail us at safety@woodmagazine.com.

CROSSCUTTING AT A TABLESAW

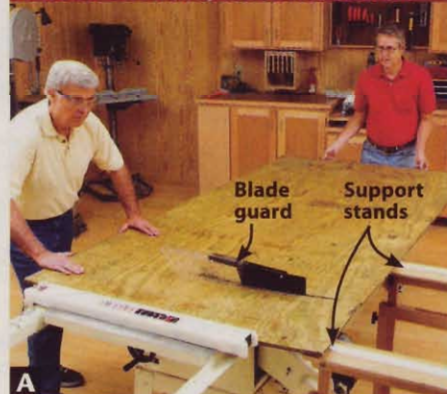

A Position at least two support stands behind the saw and a helper at the side.

USING A PORTABLE CIRCULAR SAW

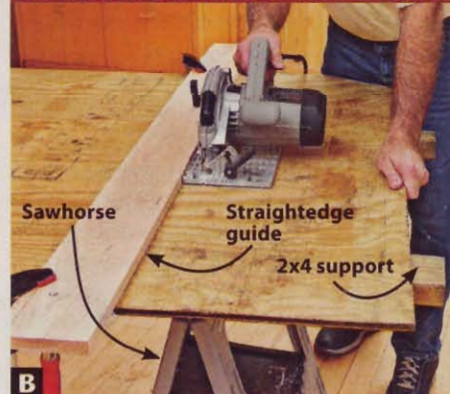

B Clamp a straightedge guide to the panel. Keep the saw tight against the guide.

Shop Tips

Helping you work faster, smarter, and safer

Telescoping light for perfect sight

While reclined in the dentist chair one morning, I watched as he manipulated that bright light to put it exactly where he wanted it. I thought: "That's what I need in my shop!" But after a little research, I realized I'd need a second mortgage to buy such a fixture. So, instead, I came up with the telescoping light, shown *below*, for next to nothing. By sliding one 48"-long PVC pipe inside another, I can place the light directly over any point along a 10' workbench. (I recommend centering the pipe over the bench to minimize shadows.) The inner pipe can be removed and slid into either end, and the cup hooks keep the cord secure and out of the way.

To safely cut the slot for the larger 1½" pipe, first mount it to a 48" length of 2x4, screwing through the wood into the pipe. Set your tablesaw blade at the minimum height needed to cut through the pipe wall. With the pipe down and the 2x4 up, let the edge of the 2x4 ride along the fence to make a straight cut. With the second cut, complete a slot ½" wide, as shown in the illustration.

—Joe Dellaria, Woodbury, Minn.

Top Shop Tip

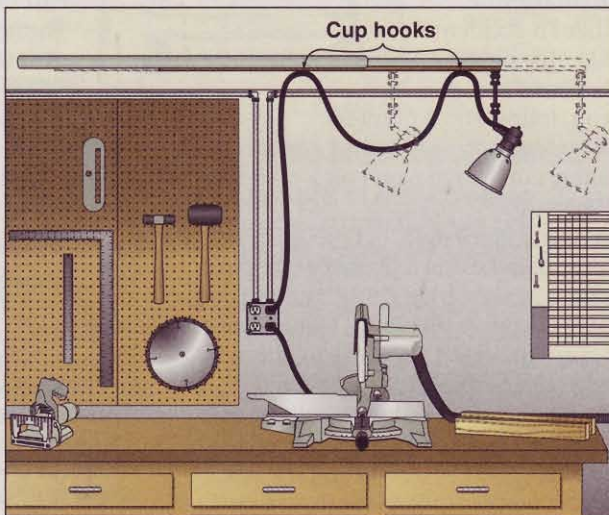
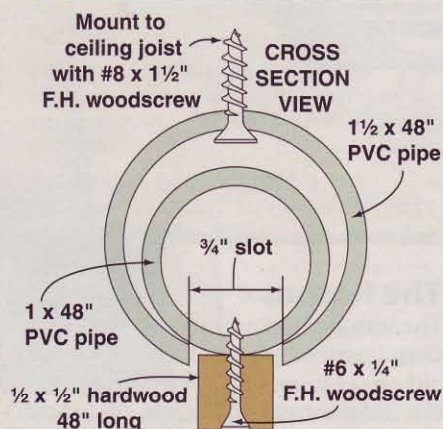

Magnetic anchor deadens fence deflection

My tablesaw's front-locking rip fence sometimes deflects, causing problems when I'm ripping a large workpiece. To stop the deflection, I use a magnetic dial-indicator base (part no. H3328, \$8, from Grizzly Industrial, 800/523-4777 or grizzly.com) to steady the outfeed end of the fence. I place the magnet on the outside of the fence, where shown, and flip the switch. The magnet holds the fence in place under 10–15 pounds of pressure, giving me just enough insurance to cut with confidence.

—Sayed Nooraga, Enola, Pa.

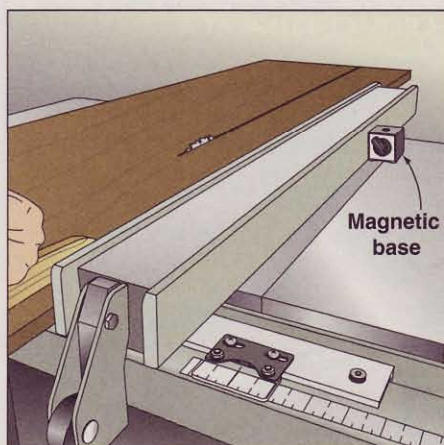

continued on page 12

The Top Tipster

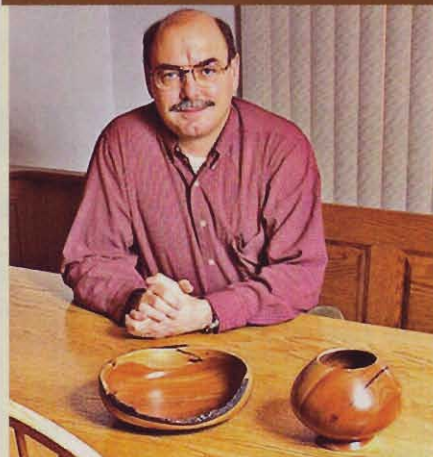

Photo: Adam Veltcher, Amos/Smith Inc.

When Joe Dellaria isn't at his day job synthesizing new compounds to advance modern medicine, you might find him helping construct an orphanage in Fedja, Haiti, with his church group. Closer to home, Joe likes to spend his spare time turning natural-edge bowls and building furniture for his home and kids. Whew! Check out "Busy Joe's" Top Shop Tip, at left.

For sending this issue's Top Shop Tip, Joe Dellaria receives an Oneida Dust Deputy mini cyclone collector. Way to go, Joe!



Top tips earn tools!

Describe how you've solved a workshop stumper, and you'll get \$75 if we print it. And, if your tip garners Top Shop Tip honors, we'll also reward you with a tool prize worth at least \$250.

Send your best shop solutions, along with photos or illustrations and your daytime telephone number, to: Shop Tips, WOOD® Magazine, 1716 Locust St., LS-221, Des Moines, IA 50309-3023. Or e-mail your tips to: shoptips@woodmagazine.com.

Remember to include your contact info in the e-mail as well.

Because we publish only original tips, please send your pointers only to WOOD magazine. Sorry, submitted materials can't be returned.

Shop Tips

Small bits help lighten the boring load for big bits

It takes a lot of torque to spin large Forstner bits. And the bits have to hog away so much material that they overheat easily, which makes them dull faster. To make your expensive big bits last longer, you can have smaller bits do some of the work.

Start with the Forstner bit and bore just deep enough to create a well-defined shoulder. Next, switch to a 1/2" bit and drill several holes through the single hole to remove much of the wood. Finally, re-chuck the Forstner bit and finish the hole.

—Buck Nall, Alma, Ga.

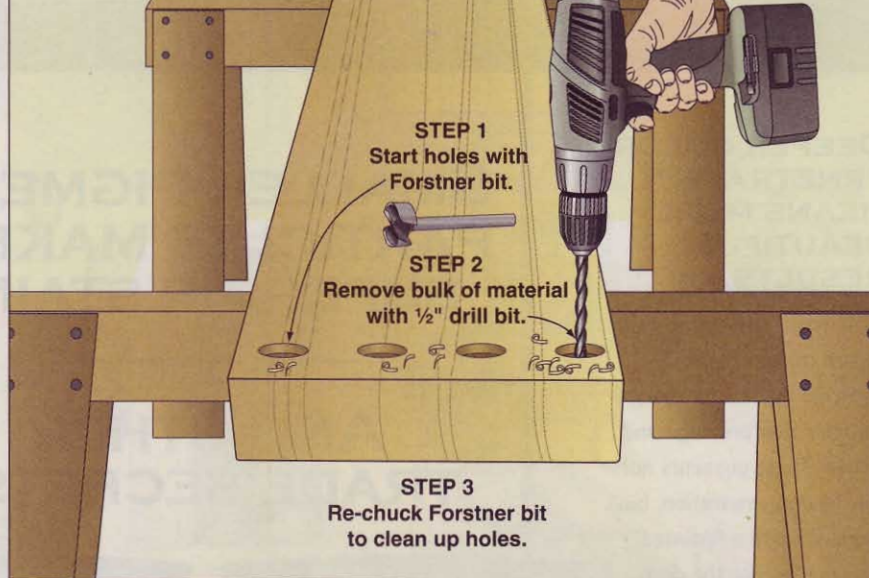

“Ouch.”

That's gotta hurt.

But you can prevent this kind of pain by sharpening your drill bits with Drill Doctor, The Drill Bit Sharpener.

With Drill Doctor, you can restore most bits to precision sharp in less than 60 seconds. Working sharp is working smart. Your bits will be sharp, and so will your projects. If you're looking for precise results every time, work with the drill bit sharpening expert—Drill Doctor.



- Fast and easy to operate—sharpen most bits in less than 60 seconds



- Sharpens 3/32"–1/2" bits—HSS, masonry, cobalt, carbide, TiN-coated



- Sharpens and creates BACK-CUT™ split-point bits for faster penetration and less drill bit “wandering”

**Work Smart
Work Sharp**



(Features apply to model XP shown)

Drill Doctor
The Drill Bit Sharpener

Look for the Drill Doctor at Sears, Lowes, Ace, The Home Depot, Northern Tool, and wherever you buy your tools.



1-888-MYDRILL (693-7455) • www.DrillDoctor.com

Custom-fit roller tray for small rollers

I do quite a bit of laminating and, for applying adhesive to a large area, I prefer to use a 3"-wide trim roller rather than a standard-width paint roller because large roller covers soak up—and waste—a great deal more adhesive. Unfortunately, small roller trays can be expensive and hard to find. My cheap, disposable solution to this problem is a half-gallon milk carton cut at a slant, as shown below.

The carton acts as a disposable liner for a box I built from hardboard scraps. The angled base of the box holds the carton liner in the proper position so that it forms a reservoir, just like a paint tray.

—Frank Penicka, Mount Pearl, Newfoundland

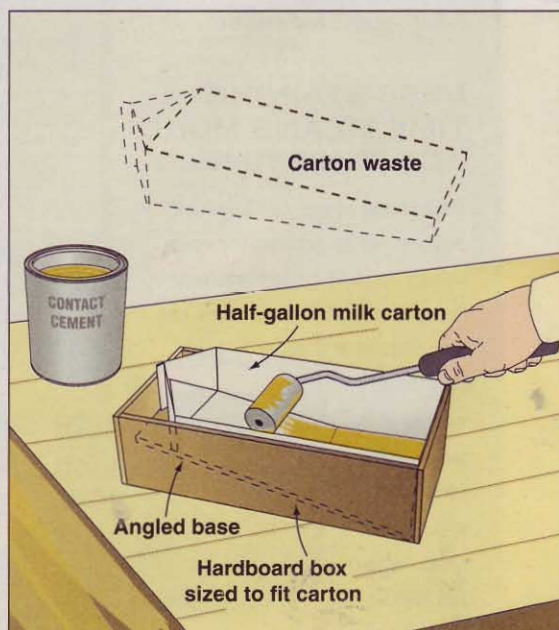

Corner clamping braces offer hinge helping hand

I use a set of shop-made right-angle clamping braces to ensure square assemblies. They came in handy for another use when I went to mount the heavy lid of a hope chest, as shown *right*, which is always an awkward job. I installed the no-mortise hinges on the chest first, then clamped the braces to hold the lid flush with the top of the chest. This setup allowed me to move the lid in any direction for precise positioning without all the struggle.

—Mack Cameron, Brooklyn, Ont.

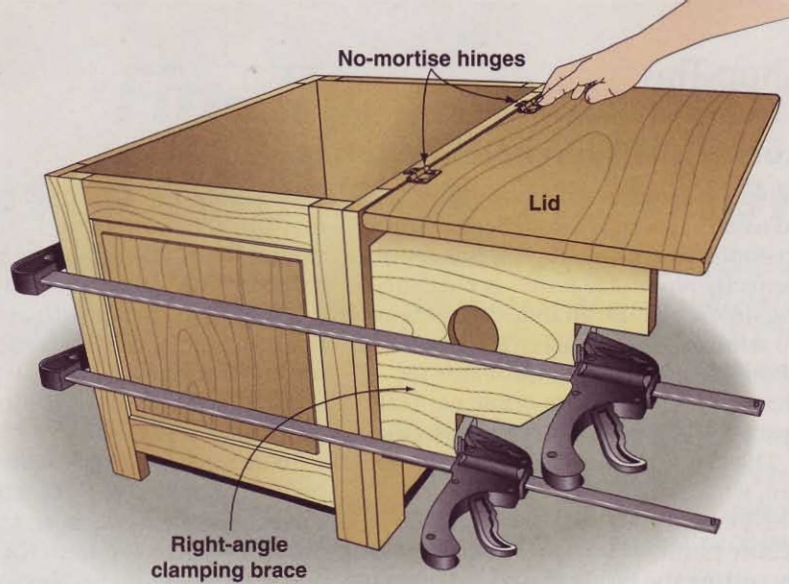

You'll find free plans for right-angle clamping braces at woodmagazine.com/brace.

continued on page 14

Check the mirror: You're boring and square

Most of us believe that mirrors don't tell the truth on their best day. But when I need to drill a perpendicular hole and can't use a drill press (such as in the field of a large workpiece or on a wall), I use a piece of mirrored acrylic with common hole sizes predrilled through it. When the image in the mirror and the drill bit align, the hole is perpendicular. Just be sure to view the bit from both front-to-back and side-to-side orientation.

I keep my drill mirror in my toolbox. To protect it from scratches during storage, I made a cardboard sleeve.

—William Shockey, Portland, Ore.

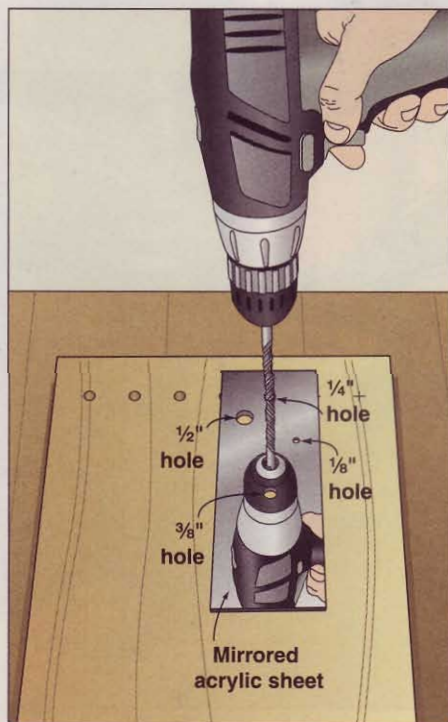

Innovative New Sharpener

Helps You WORK SHARP™

- Patent-Pending Air-Cooled, Dry Sharpening System
- Precision Repeatability—
20°, 25°, 30°, and 35° Bevel Angles
- Fast & Easy to Use, No Jigs Required
- Sharpens Chisels, Plane Irons, Carving and Lathe Tools, & More



Chisel Port ensures precision repeatability of bevel angles

WORK SHARP
The Wood Tool Sharpener

Innovative Edge-Vision™ Slotted Wheel lets you see the cutting edge as you sharpen

www.worksharptools.com • 1-880-597-6170

Locate shelf-pin holes in a snap

When I build shelves, I want them adjustable, and the most effective way to do that is with shelf pins. But getting perfectly repeatable results is challenging unless you use an indexing system. To remove the risk and virtually eliminate measuring, I made this see-through indexing jig to create perfectly spaced $\frac{1}{4}$ " shelf-pin holes by the bushel.

The key to the jig is the spring-loaded pin, which snaps down into the previously drilled shelf-pin hole to ensure positive location. I made the pin by cutting the head off a $\frac{1}{4} \times 3$ " bolt and

then grinding a slight taper on the non-threaded end. Next, I drilled it and inserted a $\frac{1}{16}$ " roll pin in the rod to compress the spring. You can make the jig housing as shown with almost any material, but I used $\frac{1}{4}$ " acrylic for the top and bottom, as shown. It provides a slick surface and allows me to see the previously drilled hole.

To use the jig (as shown, it spaces holes 1" apart and $1\frac{1}{4}$ " on center from the edge of the workpiece), set your drill press fence 1" from the bit center, and drill the first hole. Next, place the

jig over the workpiece so that the pin snaps into the hole. Move the workpiece and jig together along the fence until the drill bit fits perfectly into the bit-index hole in the base, and then clamp the jig to the fence. Once attached to the fence, it will now "float" over the workpiece, so you can drill a hole, lift the pin, slide the workpiece along the fence until the pin snaps down into that hole, drill, and repeat.

—Vell Holcombe, Milton, Penn.

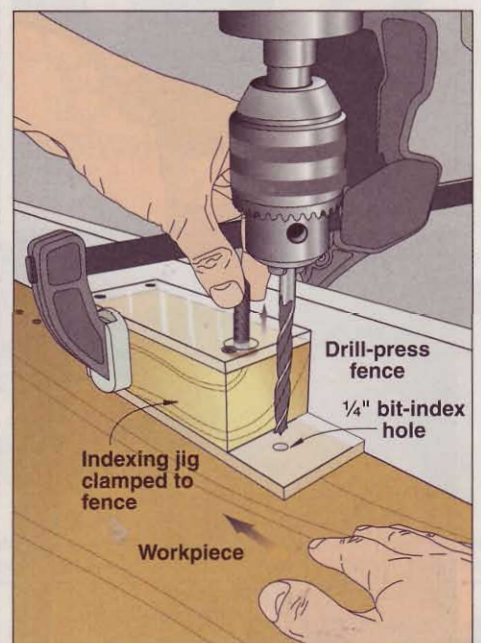
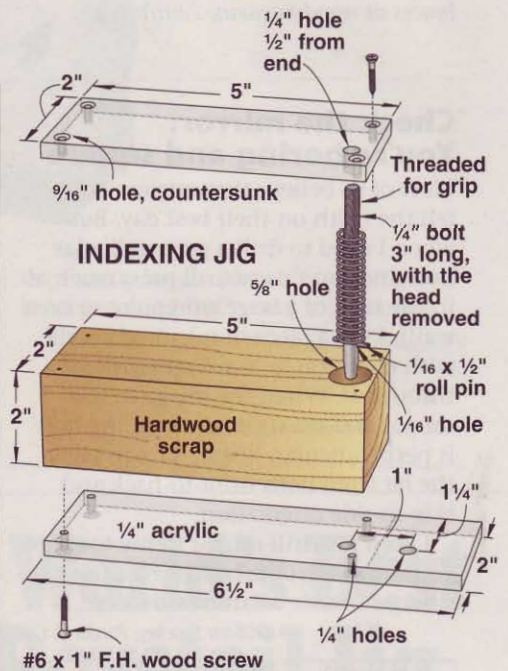

Introducing our newest line of cordless power tools.

3M™ SandBlaster™ Flexible Abrasives and Accessories.
Try them today and experience how fast and easy sanding can be.

www.3MSandBlaster.com

Making your job a whole lot easier.

SandBlaster
High Performance Abrasives

3M

3M, SandBlaster, the PUMPS logo and the Palm Design are trademarks of 3M. © 3M 2007

Super simple drill-press table

Most of the auxiliary drill-press tables I've seen are unnecessarily complicated to install. This simple slide-on auxiliary table mounts to round or square drill-press tables, and you don't need to keep installing and removing bolts and nuts. Make the spacers about $\frac{1}{16}$ " narrower than the thickness of the drill-press table. Place the table on the drill-press table before installing the cleats, and then tighten the cleat mounting screws just enough to hold it firmly. (Overtightening can distort the table.) To remove the table, simply loosen the rear cleat mounting screws a couple of turns each and slide it off.

—Paul Amberg, Hubertus, Wis.

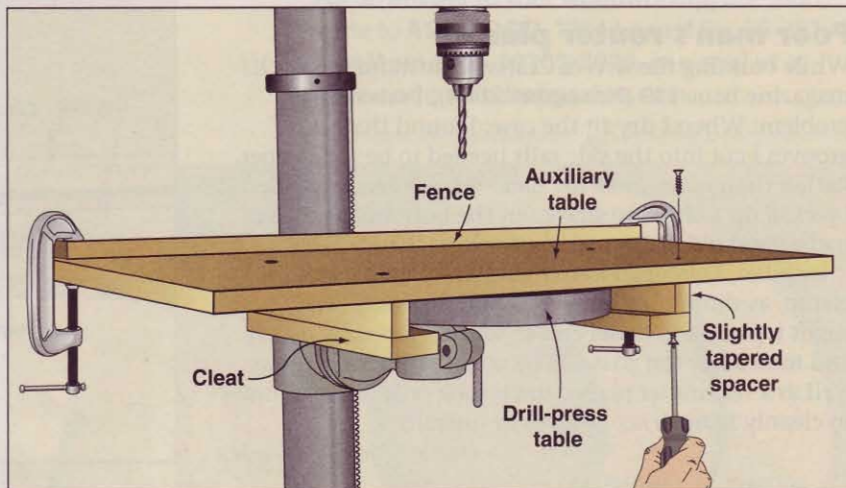

Nailing gauge puts 'em in the perfect spot every time

When driving screws or nails into a joint, I would either eyeball the row of fasteners (which sometimes sent them splitting out the back of the joint) or, if I was in a perfectionist mood, measure and mark a line (one I would later have to sand off). But recently, I stumbled on a third option: this simple edge-nailing gauge, inspired by the shape of a flat pry bar. The gauge not only helps me place the fastener dead center every time, it also helps steady the fastener, limits hammer dings, and makes a tidy row of the exposed heads. The gauge works so well, I made several more for different stock thicknesses.

—R. B. Himes, Vienna, Ohio

Thickness of joining workpiece edge

$\frac{1}{2}$ x 1 x 1" scrapwood

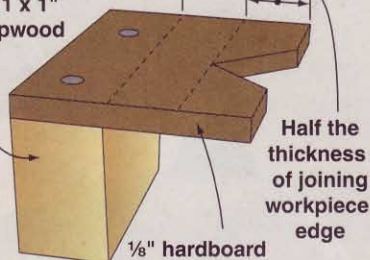

Half the thickness of joining workpiece edge

$\frac{1}{8}$ " hardboard

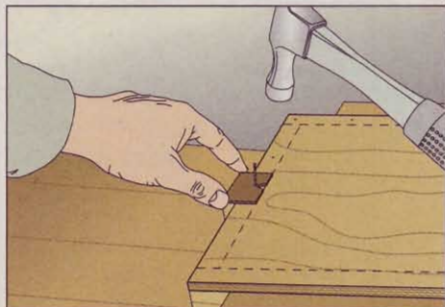

continued on page 16

POWER SHOT Forward Action[®] is forward thinking

Form follows function with the exclusive ergonomic design of PowerShot[®] Forward Action[®] staplers. PowerShot[®] staplers, patent protected worldwide, put the power over the staple where you need it! PowerShot's design makes stapling easier by providing more control and less user fatigue. Forward Action[®] eliminates the kickback associated with rear action staplers and requires only one hand to operate.

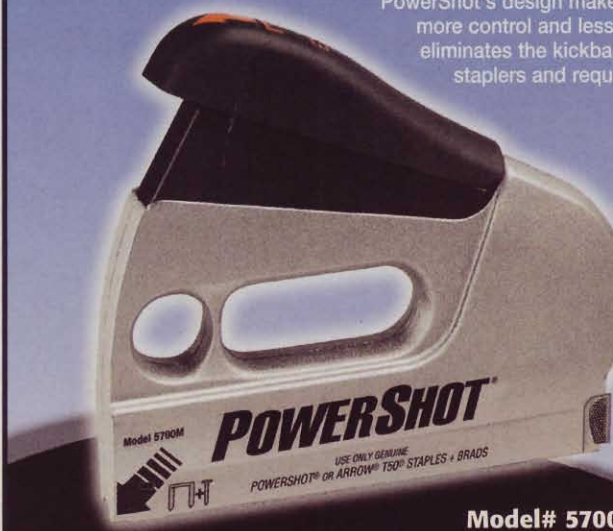

Available at home centers, lumberyards and fine hardware stores!

Model# 5700™

- Fires $\frac{1}{4}$ " thru $\frac{9}{16}$ " PowerShot[®] & Arrow[®] T50[®] Staples
- Drives $\frac{9}{16}$ " PowerShot[®] & $\frac{5}{8}$ " Arrow Brad Nails
- Low Actuation Force Required to Fire

- Less User Fatigue
- Staples/Nails Remaining Window
- Soft Grip Handle
- Easy Load Staple Chamber
- Made in U.S.A.



POWER SHOT[®]
www.powershot-tool.com

UNITED STATES: 271 Mayhill Street, Saddle Brook, NJ 07663
CANADA: Jardel Distributors, Inc. 6505 Metropolitan Blvd. East, Montreal[®] Quebec H1P 1X9
UNITED KINGDOM: Unit 5, ZK Park, 23 Commerce Way, Croydon CR0 4ZS Surrey

Shop Tips

Poor man's router plane

While building the Arts & Crafts Nightstand in *WOOD* magazine issue 159 (November 2004), I ran into a problem: When I dry-fit the case, I found that the grooves I cut into the side rails needed to be $\frac{1}{64}$ " deeper. Rather than reassemble my dado set and recut the pieces, I picked up a chisel to shave out the bottoms, wishing I had a good old-fashioned router plane. Hmm...

Inspired, I clamped a sharp chisel into a handscrew clamp, as shown, with the bevel side down. Then I used slight taps on the chisel end to set the necessary depth and took a few test passes. The setup worked almost as well as a real router plane, and it took only a few minutes to cleanly trim all six grooves in the rails.

—Marwin Feldman, Amherst, N.Y.

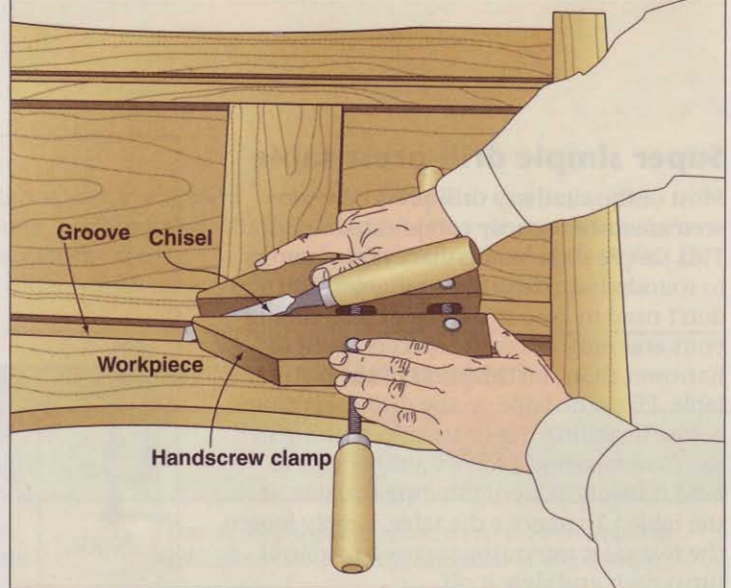

Introducing ZAR® ULTRA Max Waterborne Oil Modified Polyurethane



ZAR ULTRA Max comes in quart and gallon sizes.
It is available in gloss, semi-gloss and satin sheens.

ULTRA Max is an environmentally safe, revolutionary dual drying polyurethane. It dries by coalescing & oxygen cross-linking for a harder "through cure."

- Self-leveling, smooth finish
- Ideal for floors, cabinets, furniture and woodwork
- Outstanding wear and durability
- Super fast drying-low odor formula
- Exotic hardwoods approved

DualDrying
TECHNOLOGY
DRIES HARDER FASTER

UGL
75
YEARS

For more information and a dealer near you
call 1-800-272-3235 or visit us at www.ugl.com.

Bind bandsaw blades, then hang 'em high

I store my bandsaw blades on the perforated-hardboard walls of my shop with steel binder clips (the kind you find at office supply stores). The blades fit loosely in the clip, and the coils are kept together. I wrap electrical tape around each "jaw" inside and out to protect the blade teeth. To store them, I flip the handles around and hang the blade on a peg hook, as shown. $\frac{5}{8}$ " binder clips work for most blades, but for blades wider than $\frac{1}{2}$ ", use 1" clips.

—Jim Frye, Toledo, Ohio

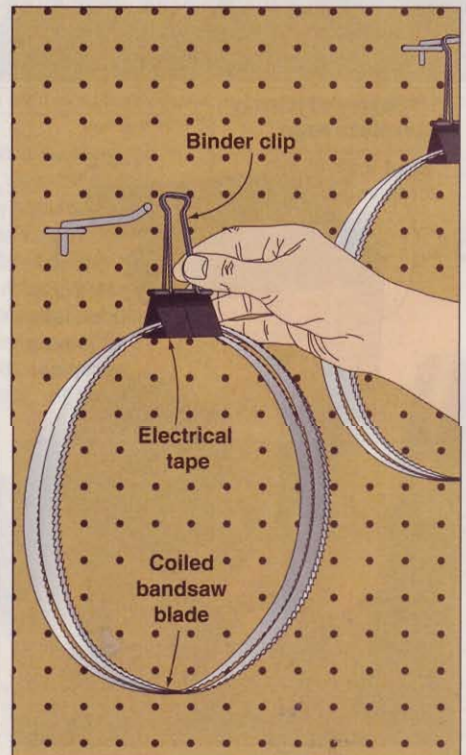

Sound advice for your shop

Your workshop is your getaway space. So toss out that tinny portable radio and fill your shop with high-fidelity tunes and talk.

The whir of a tablesaw rings like music to some woodworkers' ears. But others prefer a real melody or perhaps a favorite all-news station in the background, even when these badly distorted sounds blare from a raspy old radio. With a small investment, however, you can bring your sound system up to a new level—and not just volume level.

Sounds of silence

The perfect sound system would be one you could hear no matter what you're doing, whether sawing in the basement or out in the garage. WorkTunes (see Sources), provides portability with a bonus: It also muffles harmful noise from woodworking equipment. (See

HEAR MUSIC AND BLOCK NOISE



WorkTunes combines an AM/FM radio with earmuffs that reduce noise by 22 decibels.

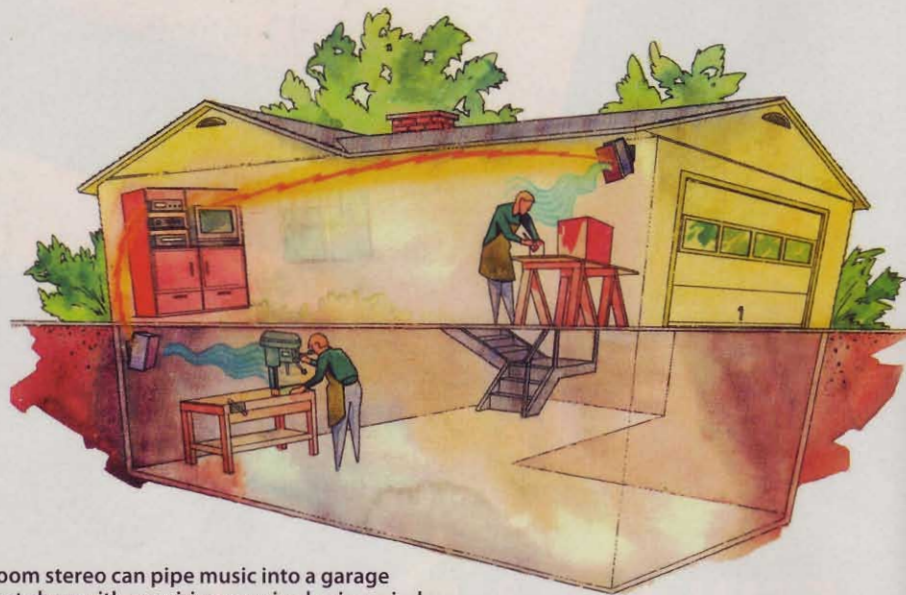

A family-room stereo can pipe music into a garage or basement shop with no wiring required using wireless speakers. Rechargeable batteries as well as AC adapters power some models, allowing you to use the speakers for backyard entertaining when you're through in the shop.

below.) The newer WorkTunes i.3 includes a jack to connect a CD or MP3 player to the radio. Just keep any wires well away from power tools.

No cables needed

If you already have a stereo elsewhere in your house, you can route those sounds to speakers in your shop without wiring hassles. For example, the AW811 (\$140 suggested retail price) from Acoustic Research transmits the output from your home stereo system to a remote indoor/outdoor speaker—one tough enough to survive temperature extremes in a garage workshop and a light layer of sawdust.

To install these speakers, plug the speaker's transmitter into your home stereo's speaker or signal output line or the headphone jack. The transmitter forwards a signal to the speaker. Additional speakers can be added for mono use in multiple locations, shown in the illustration above, or paired for stereo sound.

As with any product that uses radio waves, however, there's always the opportunity for interference from other electronic devices or the structure of the house. Even without interference, the sound may not be as clear as a wired system. Test these systems with the transmitter and speakers where they'll be used before making your choice final.

Singular sound

If you have an outdated stereo that still has some life in it, consider replacing the two old stereo speakers with

"summed mono" speakers, suggests Jim Hunter, design engineering vice president for speaker manufacturer Klipsch Audio Technologies. These combine both channels of a stereo signal into a single speaker, something that may make sense for workshop applications. That's because stereo sounds best only when you place yourself in just the right spot between two speakers, something that's tough to do in a shop where you don't stay put.

Normally meant for bathrooms or other tight spaces, summed mono speakers provide clear sound throughout a room, not just where sounds from stereo speakers intersect. By mounting these speakers throughout the shop, you're free to move around and still hear both channels. Multiple summed mono speakers also allow you to turn down the volume, unlike a radio on a shelf at one end of the shop that has to be cranked up to be heard, Jim says.

Sticking with stereo

If you still want conventional stereo sound, the speakers you choose and where you mount them make a big difference in sound quality. Where dust and temperatures present a problem, as in a garage workshop, choose outdoor speakers. This type of speaker is also less prone to focusing sound in one direction. Though durable, avoid shop dust accumulation on these or any other speakers for best performance.

To get the most from these speakers, Jim advises mounting them in opposite corners near the ceiling, as shown on page 19. This mounting arrangement

WALL MOUNTS SAVE SPACE

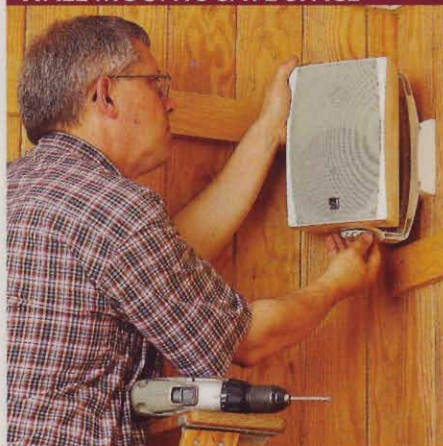

Shop speakers are best mounted high and in a corner where they can use the walls and ceiling to direct sound into the room.

uses hard surfaces to bounce the sound through a wide area.

To avoid losing signal strength between the radio and the speakers, use 18-gauge speaker wire for distances up to 20', 16-gauge wire up to 50', and 14-gauge wire up to 100'. If in doubt, thicker wire is better.

Plan to give in-shop electronic equipment a dust-free home, especially systems with a tape player or CD changer. Tailor your stereo storage cabinet to hold components, CDs, or tapes, and add ventilation holes to the bottom and the top of the side panels. Cover the ventilation holes with filters cut from pleated paper furnace filters. Then add a dust-blocking foam gasket around the inside face of the door frame. If you plan to use an infrared remote control, make the cabinet door panel out of clear plastic.

If heat buildup becomes a problem, wire the cabinet for a 4" ventilation fan (see Sources). Draw filtered air in from the bottom of the cabinet—where less dust builds up—and force warm air out through vents at the tops of the cabinet sides.

Sources

WorkTunes: About \$55 for the standard WorkTunes, \$53 for the WorkTunes i.3. Peltor, 800/327-3431 or peltor.com.

Summed mono speaker: Model R-2650-CSM (about \$250) or R-1650-CSM (about \$150). Klipsch Audio Technologies, 800/554-7724 or klipsch.com.

Wireless speaker: Acoustic Research AW811 Indoor/Outdoor Speaker (\$83). Thomson, 800/336-1900 or araccessories.com.

Ventilation fan: 120-volt AC 4" fan (No. 273-241, \$25) or 12-volt DC 4" fan (No. 273-243, \$18), RadioShack, 800/843-7422 or radioshack.com.

15th Anniversary Ultimate Dust Collection Package

This limited time offer has special pricing and is for the 2 & 3hp Dust Gorillas. Call today or buy online!



Circle No. 2039

The Ultimate Package Includes:

- ▶ 2 or 3hp Super Gorilla Dust Collector
- ▶ Wireless Remote
- ▶ Filter Efficiency Gauge
- ▶ Deluxe Dust Deputy
- ▶ Bag Gripper Hold Down Unit
- ▶ **FREE** Duct Design

Order Online! **www.oneida-air.com** Call Today. Limited Time Offer! **1.800.732.4065**

Scrapwood Project

Smart Ways to Store WOOD® Magazine

Multiple options for keeping your favorite publication close at hand

Starting with the December 2003 issue of *WOOD* magazine, we increased the overall size of the magazine. And, because we know many of you save your issues year after year, we've come up with several options to store these upsized copies and your other issues of *WOOD* magazine as well.

First, consider building the binder jig at right. This lets you drill equally spaced holes in your magazine to store them in a three-ring binder. It's a simple procedure, but you might drill into a bit of copy on the inside edge of your magazine. Or, you can purchase 3-holed plastic edge strip magazine holders, such as the one shown in **Photo A**, to avoid drilling holes. To build customized wood binders, as shown in **Photo B**, or to buy the plastic holders, see **Sources** on page 19.

Another method for keeping your magazines neatly organized is box-jointed file boxes [**Photo C**].

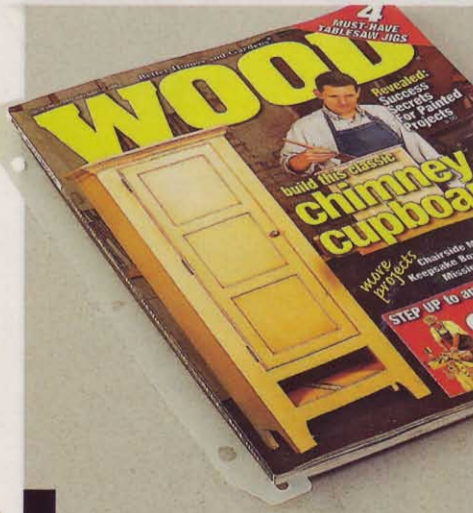

Plastic edge strips slip between the pages of *WOOD* magazine allowing for easy three-ring binder storage.



B For the ultimate in customization, build your own *WOOD* magazine binders using our free downloadable plan. It includes color labels that you can print off.

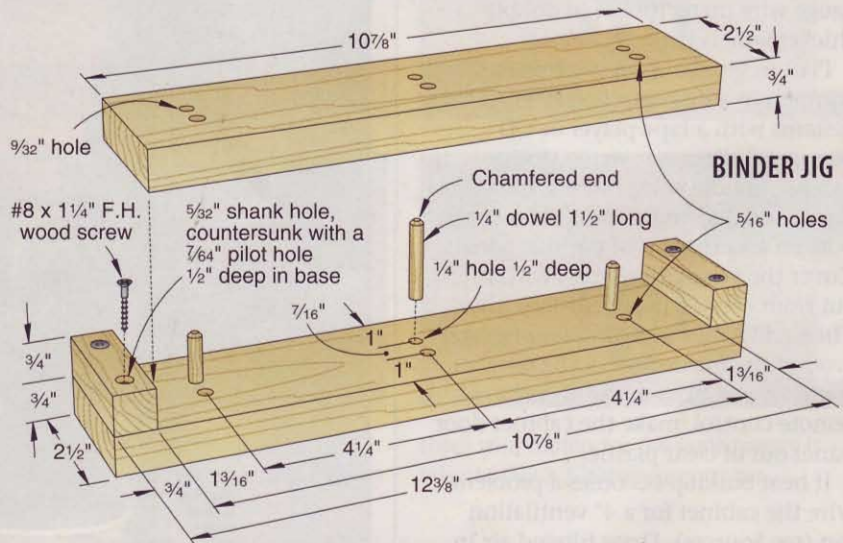

C Use our free downloadable plans to mass-produce your own box-jointed file boxes. Attach the brass pulls for easy access and labeling.

A pre-made product is the slipcase file box shown in **Photo D**. Or go with the plastic or cardboard magazine keepers shown in **Photo E**. 🌲



D These manufactured slipcases hold about a dozen copies and include a **WOOD**® magazine logo.



E Plastic or cardboard magazine files are an inexpensive means for handy storage.

Sources

3-hole-punched plastic edge strip magazine holders. Available at office-supply stores or Amazon.com using their search and the description *plastic edge strips*. A packet of 12 sells for about \$3.75, plus shipping.

Wood binders. Free downloadable plan available at woodmagazine.com/binderplan

Magazine file-box plan. This downloadable plan is available at no cost at woodmagazine.com/fileboxplan

Slipcases. Constructed with bookbinder's board and covered in maroon leatherette material. \$15 each, plus shipping and handling. Phone 215/674-8476, or order online at woodmagazine.com/slipcase

Magazine files. Available in cardboard and plastic at most office-supply stores or Amazon.com using their search and the description *magazine files*. Prices range from \$1.40 to \$6.70 each, plus shipping.

For A Free Catalog Or To Find Your Local Woodcraft Store, Visit www.woodcraft.com Or Call 800-542-9115.

Does your honing guide miss the mark?

Fast, Accurate, Consistent.
The New Pinnacle™
Honing Guide.



Dept: 07W07R To learn more about Pinnacle™ tools visit www.woodcraft.com/pinnacle.aspx

QUALITY WOODWORKING TOOLS • SUPPLIES • ADVICE™

Circle No. 700

YOU'RE PROBABLY JUST AS AMBITIOUS.



Whether you are a do-it-yourselfer, a professional woodworker or somewhere in between, you have a world full of projects in the home or in the shop that will be easier and more enjoyable to complete when you use quality clamps, bench vises and miter boxes/saws from the Adjustable Clamp Company. Look for them under the Jorgensen, Adjustable and Pony brand names wherever fine tools are sold.

Adjustable™ **"Jorgensen"** **"Pony"**

Made in the USA by the Adjustable Clamp Co.,
433 North Ashland Ave., Chicago, IL 60622,

www.adjustableclamp.com



Circle No. 733

Just-Right Joinery

Make screw holes disappear *practically*



Now you see them ...

... now you don't!

Screwed-together joints are strong and easy. Here's how to make them attractive, too.

We love all-wood joints, but there's no denying the advantages of those held together with screws. A couple of screws can securely connect two parts in a fraction of the time needed to cut a fitted joint. What they don't add is beauty, but an easily filled counterbore can make it look as though those screws never existed.

Your strategy for hiding screw heads will vary with each job. On projects that will be painted, for example, simply counterbore holes to plant screws at least 1/8" below the surface, fill the cavities with putty, and sand the surface smooth before brushing on a primer coat. For clear finishes, however, you'll want to use wooden plugs cut from the same stock as your project parts for maximum invisibility.

Step one: drill 'em

Every method of hiding screws starts with drilling a counterbore or combined countersink and counterbore. The countersink refers to sloping sides of the hole that allow a flathead wood screw to sit flush with the surface, while a counterbore is the portion of

the hole that drops the screw head below the surface. To match the countersink/counterbore to the size of screws you'll use, see the chart below. Your choice of methods depends on which fasteners you'll use, as shown below right. If you're working with

panhead screws, first drill the counterbore slightly larger than the screw head using a Forstner bit, followed by a pilot hole at the dimple created by the Forstner bit's center spur. That way, the underside of the screw head rests flat on

continued on page 24

Choose the right size counterbore for the job

Combination pilot hole and countersink/counterbore pilot bit sizes range from 3/16" to 5/16", most with counterbores of 3/8" or 1/2". Use this chart to match the countersink/counterbore to your fastener.

Screw Size	Pilot hole in hard-wood*	Pilot hole in soft-wood*	Counter-sink/counter-bore diameter
#4	5/64"	1/16"	3/8"
#6	3/32"	5/64"	3/8"
#8	7/64"	3/32"	3/8"
#10	1/8"	7/64"	1/2"
#12	9/64"	1/8"	1/2"

* Use these pilot hole recommendations for flathead wood screws.

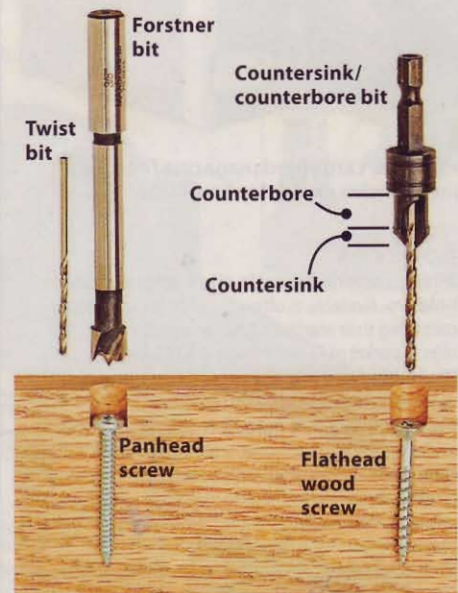

Choose the countersink/counterbore bit or combination to match your screw.

Just-Right Joinery

the bottom of the counterbore. A speedier method for flathead wood screws uses a one-step countersinking bit that drills both the pilot hole and countersink in one action.

Unlike Forstner bits, one-step bits can be used in a portable drill as well as a drill press. To save time switching between drilling and driving, use two drills: one with the one-step bit, and the other with a screwdriving bit. (In the *WOOD*® magazine shop, we get by with one drill by using a Jack Rabbit brand one-step bit that mounts on a hex-shank driver bit, as shown *far right*. See Sources.) When using a hand-held drill, attach a depth stop for consistent counterbore depths.

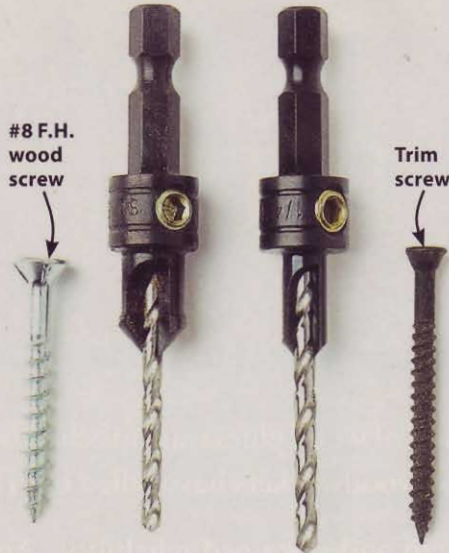

Match the countersink/counterbore to your screw head's diameter. The bit on the right has a 1/4" counterbore for trim screws.

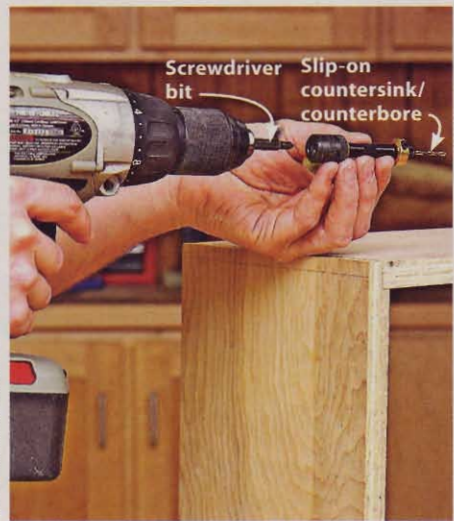

The Jack Rabbit set saves time by letting you mount the countersink/counterbore bit over a screwdriver bit chucked in your drill.

Step two: fill 'em

Now it's time to plug your screw holes. You'll need scrapwood that matches your project parts, a plug cutter the same size as your counterbored holes, a mallet for seating the plugs, and a flush-cutting saw or chisel. For snug-fitting plugs, use a cutter that tapers the sides of the plugs as it cuts, as shown *below*. The taper makes plugs easier to start but leaves a snug fit at the top of the hole. Chuck the plug cutter into a drill press set to about 1,200 rpm, then plunge about 1/2" deep into your scrap. Move the scrap and repeat the process until you have at least 10 percent more plugs than you need for the project. This "cushion" gives you more choice for color and grain match and allows for broken plugs.

You can bandsaw the plugs free from the surrounding scrap, or pop them loose using a screwdriver as shown *below center*. Prying plugs loose has one

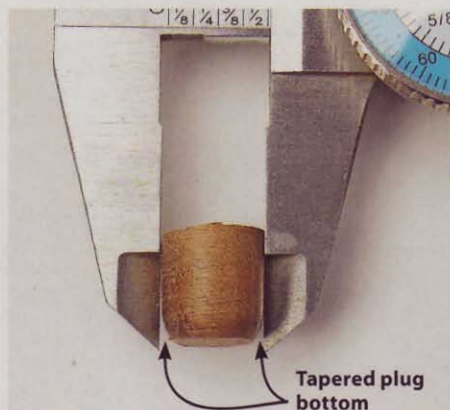

A tapered plug has two major benefits over non-tapered plugs: It's easier to start and produces a snug fit at the top of the hole, where it matters most.

advantage: You can better see the plug's grain direction. Spread glue on the sides of the screw hole, and orient the plug's grain with the surrounding wood. Gently seat the plug with a mallet or hammer, and allow two hours for the glue to dry. Why make the plug and surrounding grains parallel instead of turning it into a perpendicular accent? Wood shrinks and swells twice as much across the grain as with it. So a plug that's perpendicular to the wood grain stands a better chance of cracking from unequal expansion.

Before chiseling a plug flush with the surface, slice a portion from the top to gauge the slant of the grain. Then chisel the plug from the low to the high portion of the plug to keep it from splitting off beneath the surrounding surface. You also can flush-cut the exposed portion level with the surface, as shown *below right*, then sand it smooth. To turn this cover-up into a



To free plugs cut into scrap, insert a screwdriver into a plug hole at the end grain and pry gently. Cut extras to improve your chances of matching workpiece surfaces.

design accent, just make your patches from a contrasting wood species, such as walnut against an oak surface. You can use plugs or cut dowels to mimic a pinned joint. 🌲

Sources

Countersinks/counterbores: Set of five two-flute countersinks no. MS-4030, \$25, call McFeely's at 800/443-7937; mcfeelys.com. Set of five two-flute countersinks no. 50J04.20, \$29.50, call Lee Valley at 800/871-8158; leevalley.com. Set of five no. 830846, \$25, call Woodcraft at 800/225-1153; woodcraft.com. Set of four four-flute countersinks, countersink holder, screwdriver bits, and accessories, \$60, call Jack Rabbit Tool Co. at 800/445-5969; jackrabbittool.com.

Specialty countersink/counterbores: Trim head screw (1/8" pilot with 1/4" counterbore) countersink no. MS-7010, \$10, McFeely's.

Tapered plug cutters: Set of three no. SP-0510, \$43, call McFeely's. Set of three no. 05J05.10, \$36.50, call Lee Valley. Set of three no. 146723, \$30, call Woodcraft.

Wood putty: Durham's Rock Hard Water Putty, call The Donald Durham Co., 515/243-0491; waterputty.com.



Exposed plugs can be sawn flush or shaved flush with a chisel. Masking tape reduces the likelihood of marring surrounding wood with the saw's teeth.

Wise Buys

Our editors test One-Person Panel Handlers

Why buy?

Handling 4x8' sheets of plywood, medium-density fiberboard (MDF), or other sheet goods by yourself—especially ¾"-thick sheets that can weigh nearly 100 pounds—can be tricky, cumbersome, and unsafe. So we decided to see which panel handlers deliver the (sheet) goods. Whether made of plastic, steel, or aluminum, they all proved sturdy enough to lift a sheet of ¾" MDF. Three models lift from beneath the sheet; one lifts from the top edge. While you need to position the panel handlers in the center of the sheet for balance, for photo clarity we placed them at the end to show how they work. (For a shop-made panel carrier, check out our free plan at woodmagazine.com/carrier.) For tips on handling sheet goods by yourself, see a free 6-minute video at woodmagazine.com/videos.



STANLEY PANEL CARRY (#93-301), \$6

THICKNESS CAPACITY: 1½"

Editor test-drive:

Made entirely of a sturdy plastic, the Panel Carry's handle angles about 10° to keep your knuckles from rubbing against the panel. (Still, a softer or textured grip would be better.) Even though it adds 14½" to my reach, I still had to stoop low to get in position to lift, while resisting the temptation to lift with my back. And I had to keep my other hand on the top edge of the panel for balance—more so than with the other models. Despite this quirk—and the fact that I wish it was longer—the Panel Carry is a good low-cost way to move sheet goods. I bought mine at The Home Depot.

—Tested by Jeff Mertz, Design Editor

To learn more:

800/262-2161; stanleytools.com

THE POCKET TROLL, \$20

THICKNESS CAPACITY: 1"

Editor test-drive:

I've had back surgery in the past, so I know how critical it is to lift with your legs instead of your back. With the Pocket Troll you only need to lift the sheet an inch or so to get the steel shoe under the bottom edge, then slide the sheet until it's centered. (Avoid setting a sheet down on the lip of the shoe; it took a bite out of an MDF sheet when I did this.) I had to stoop just a couple of inches and then lift with my legs, keeping my other hand on the top edge to steady it. The steel handle features a durable, grippable rubber sleeve. I'd like to see the handle angled away from the panel to avoid rubbing my knuckles. The Pocket Troll measures 29" long when extended and only 9" folded.

—Tested by Chuck Hedlund, Master Craftsman

To learn more:

800/448-0822; telprodirect.com

THE TROLL, \$30

THICKNESS CAPACITY: 1½"

Editor test-drive:

The wheeled Troll is a real back-saver. It's made of stout but lightweight steel, and the 5"-diameter wheels are solid plastic. After you center a panel in the 9¼"-long rounded channel, you balance and guide it by holding the panel's top edge—no need to hold the handle at that point. To get over a door threshold or power cord, simply grab the Troll's handle and lift. (Although, I wish the handle was thicker than the ¾"-diameter steel bar for less bite into my fingers.) The 28"-long Troll required me to bend my legs slightly (I'm 5'11") to lift it.

—Tested by Marlen Kemmet, Managing Editor

To learn more:

800/448-0822; telprodirect.com

GORILLA GRIPPER, \$50

THICKNESS CAPACITY: ¾–1½"

Editor test-drive:

Gorilla Gripper grabs panels from the top edge with self-adjusting aluminum parallel jaws covered with a resilient, rubbery material. Grasping the handle and stooping to bring it to shoulder height feels natural, and that means you can't

help but lift with your legs, ensuring less back strain. It also makes it easy to adjust the balance of the load without having to fully lift the sheet. Once the panel is elevated you can easily maneuver it around corners. To carry a panel upstairs I simply shifted the grip forward, and then to the rear for going downstairs. Although its price topped our test, I equate it to one chiropractor visit, something I, hopefully, won't have to do again.

—Tested by Jan Svec, Projects Editor

To learn more:

805/523-1800; gorillagripper.com

Simple, Sturdy, and Stylish Bistro Table



You'll love how this project looks on your deck or patio, and appreciate how quickly and easily it goes together. Build the table now, and then watch for the matching stools in the next issue.



View a 10-photo slide show of the Bistro Table coming together at woodmagazine.com/slides

PROJECT HIGHLIGHTS

- Overall dimensions: 34½" wide × 34½" deep × 36" high.
- Readily available project materials give you the convenience of one-stop shopping at your local home center.
- Simple joinery means you can pick up your materials on Saturday morning and be ready to apply the finish by Sunday afternoon.
- For the lumber and other items needed to build this project, see page 32.

Skill Builder

- Learn an easy way to form a row of closely spaced mortises with a groove and fillers.

1 EXPLODED VIEW

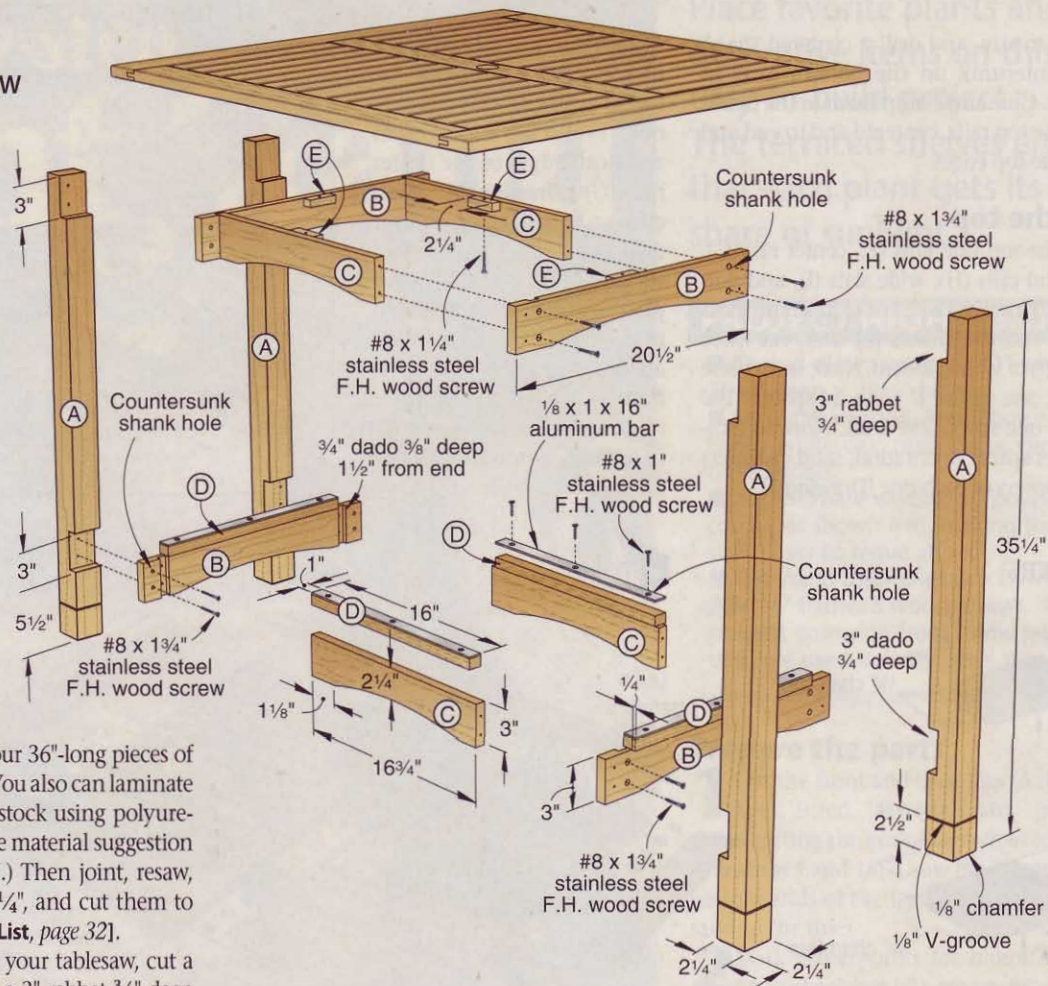

Build the base

1 For the legs (A), cut four 36"-long pieces of 4x4. (We used cedar. You also can laminate these parts from thinner stock using polyurethane glue. For an alternate material suggestion see the sidebar on *page 31*.) Then joint, resaw, and plane them to 2 1/4"x2 1/4", and cut them to finished length [Materials List, *page 32*].

2 With a dado blade in your table saw, cut a 3" dado 3/4" deep and a 3" rabbet 3/4" deep in each leg [Drawing 1].

3 To form the decorative grooves near the bottom of each leg (A) [Drawing 1], chuck a V-groove bit into your table-mounted router, and position the fence as a stop, 2 1/2" from the bit center. Then using a follower block to keep the leg square to the fence and prevent chip-out, rout the grooves. Now reposition the fence, and use the same bit to rout 1/8" chamfers along the bottom end of each leg. Finish-sand the legs.

4 Cut the end rails (B) and side rails (C) to size. With a dado blade in your table saw, cut 3/4" dados 3/8" deep near each end of the end rails [Drawing 2]. Then drill the countersunk shank holes. (For the #8 screws in this project, drill 5/32" shank holes and 3/32" pilot holes.)

5 Lay out the end- and centerpoints of the arches on the end rails (B) and side rails (C) [Drawings 1 and 2]. Connect the points with a fairing stick, and draw the arch. (For a free downloadable fairing stick plan, go to woodmagazine.com/fairing.) Bandsaw and sand the arches. Finish-sand the rails.

6 Assemble the two frames (B/C) and add the legs (A) to form the base [Photos A and B]. Then cut the rail caps (D) to size, and glue and clamp them to the tops of the bottom end rails (B) and side rails (C), flush at the inside edges [Drawing 1]. Now cut the

2 END RAIL (Inside face)

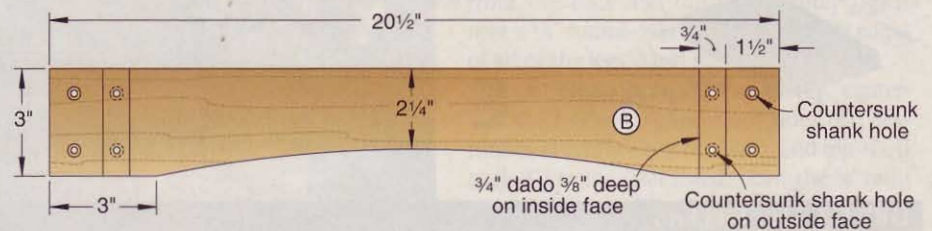

ASSEMBLE THE BASE



A Glue and clamp the side rails (C) into the end rail (B) dadoes. Check for square, drill pilot holes, and drive the screws.

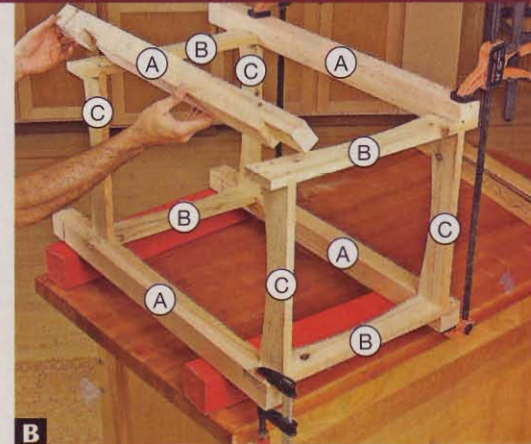

B Glue and clamp the frame (B/C) end rails (B) into the leg (A) dadoes and rabbets. Drill pilot holes, and screw the legs in place.

cleats (E) to size, and drill a centered shank hole, countersunk on the bottom face, in each cleat. Glue and clamp them to the inside faces of the top rails, centered end to end and flush at the top edges.

Make the top

1 Cut the top side rails (F), center rail (G), top end rails (H), wide slats (I), and narrow slats (J) to size. Then, to position the short fillers (K) and long fillers (L) later, cut three 2x12 strips of 1/4" hardboard. Next, from these strips, cut one spacer 1" wide, 14 spacers 1 1/2" wide, and one spacer 2 1/2" wide. Now, to indicate proper spacer orientation, sand chamfers on two corners of each one [Drawing 3].

2 On your tablesaw, cut centered grooves in the inside edges of the top side rails (F) and top end rails (H) and both edges of the center rail (G) [Drawing 4]. Then chuck a Forstner bit into your drill press, and drill a hole slightly larger than your patio umbrella pole, centered in the center rail. (We drilled a 1 1/2" hole.)

Note: If you will use the table on a covered patio, porch, or in a three-season room, omit the umbrella hole.

4a TABLETOP TENON DETAILS

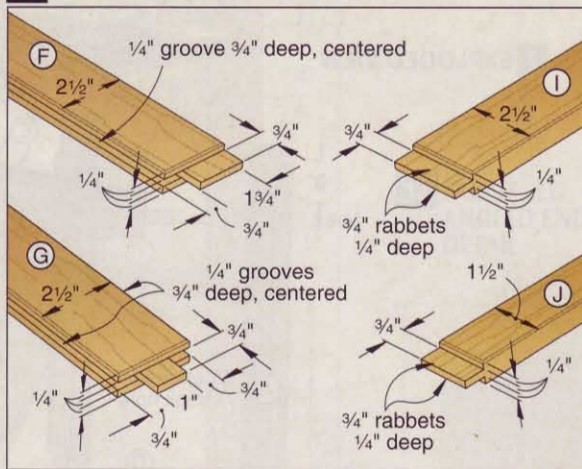

3 SPACERS

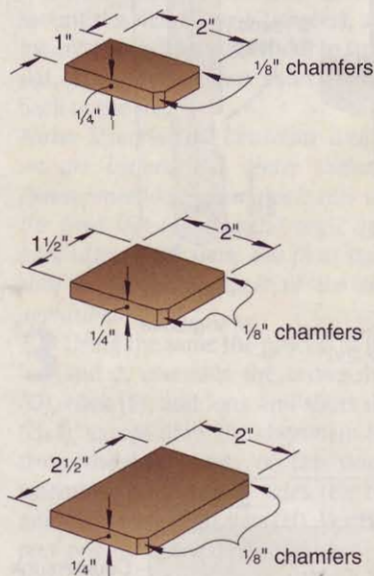

4 TOP

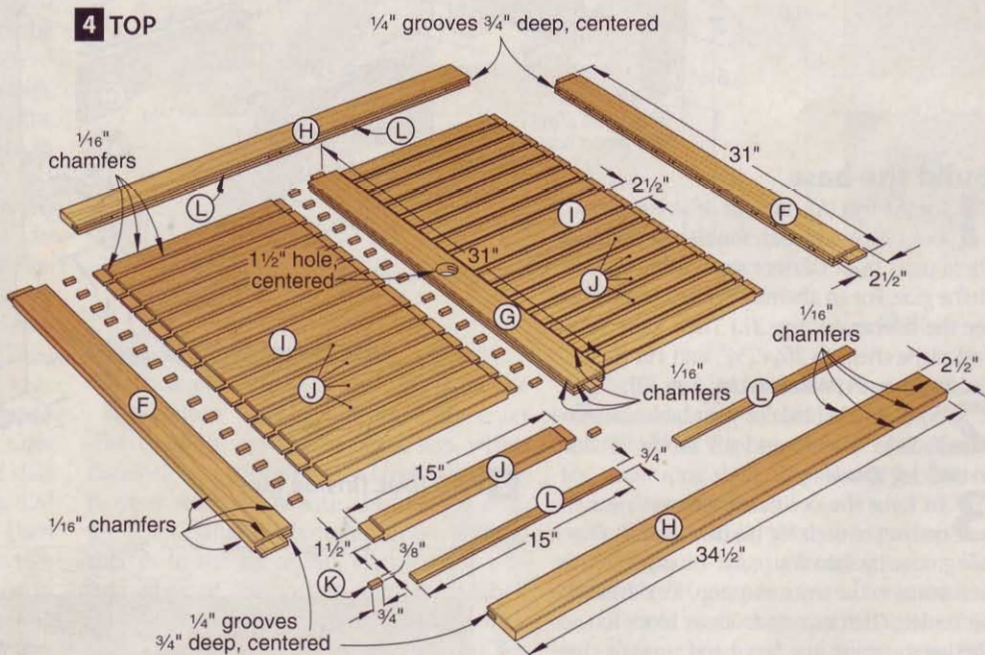

DRY-FIT THE FILLERS

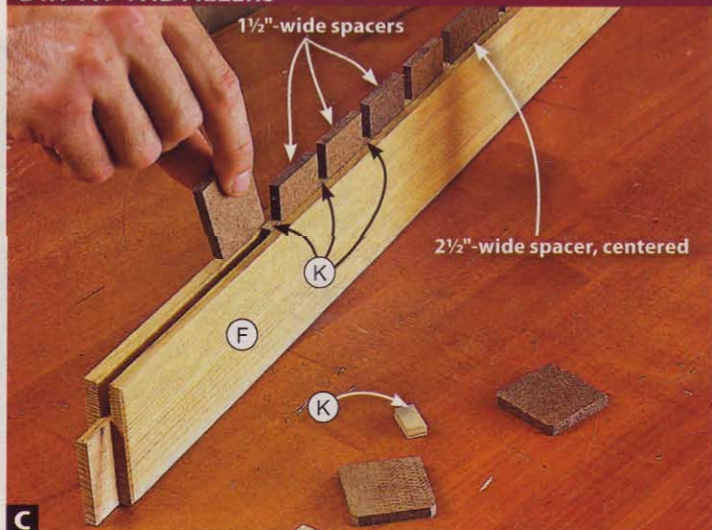

C With the 2 1/2"-wide spacer centered in the top side rail (F) groove, alternately insert short fillers (K) and 1 1/2"-wide spacers.

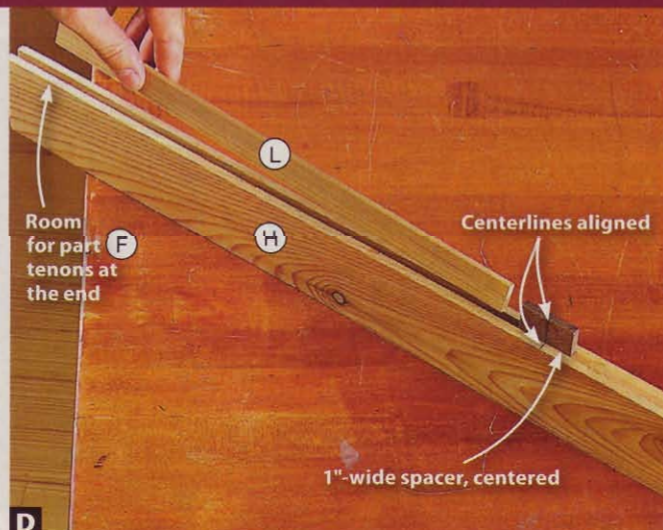

D With the 1"-wide spacer centered in the top end rail (H) groove, insert the long fillers (L), leaving room for the top side rail (F) tenons.

MARK THE UMBRELLA HOLE ARCS

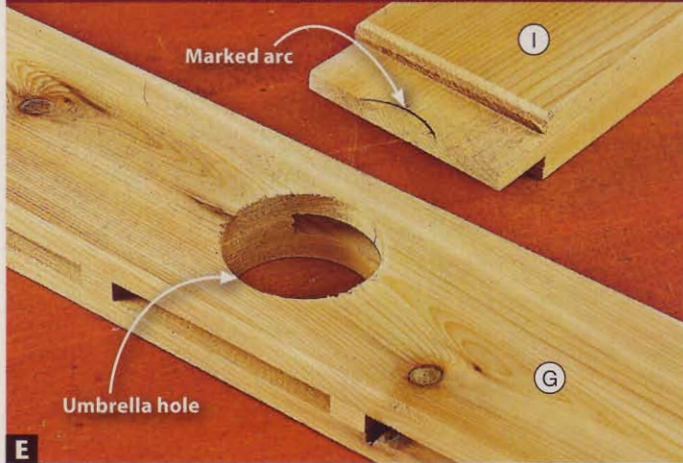

E Insert the wide slat (I) tenons into the center rail (G) mortises, and trace the umbrella hole arc onto the tenons.

3 With a dado blade in your tablesaw, form tenons on the ends of the top side rails (F), center rail (G), wide slats (I), and narrow slats (J) [Drawing 4 and 4a]. Check the tenons for a snug fit in the $\frac{1}{4}$ " grooves. Then chuck a chamfer bit into your handheld router, and rout $\frac{1}{16}$ " chamfers along the ends and edges of the top end rails (H) and the edges of the top side rails, center rail, and slats. Now use a sanding block to chamfer all of the tenon shoulder edges. To ease assembly later, sand slight chamfers on the ends of the slat and center rail tenons.

4 To make the short fillers (K) and long fillers (L), rip six $\frac{1}{4}$ "-wide strips from the edge of a $\frac{3}{4}$ "-thick board 18" long. Then cut four strips to length for the long fillers. Now from the two remaining strips, cut 64 short fillers $\frac{3}{8}$ " long.

Note: The grain runs across the $\frac{3}{8}$ " dimension of the short fillers.

5 Retrieve the $1\frac{1}{2}$ "- and $2\frac{1}{2}$ "-wide hardboard spacers. Mark centerlines on the $2\frac{1}{2}$ "-wide spacer and a top side rail (F). Then insert the spacer in the rail groove, aligning the centerlines. Next dry-fit 16 short fillers (K) in the top side rail groove [Photo C]. The edges of the end fillers should be flush with the tenon shoulders at each end of the rail. Adjust the filler spacing as necessary, and glue the fillers into the groove. Now carefully remove the spacers before the glue sets. Repeat with the remaining side rail and both grooves of the center rail (G).

6 Retrieve the 1"-wide spacer. Mark centerlines on the spacer and a top end rail (H). Then insert the spacer in the rail groove, aligning the centerlines. Next dry-fit two long fillers (L) into the rail groove [Photo D]. Insert the top side rail (F) tenons into the end rail groove with the tenons tight against the ends of the long fillers. The ends of the end rails should be flush with the outside edges of the side rails. Adjust the filler spacing as necessary, and glue the fillers into the

CEDAR VS. WHITE OAK: YOU DECIDE

We chose cedar for our bistro table, but white oak makes a viable alternative. Here's what to consider:

- **Weatherability:** A draw; both are rated as resistant or very resistant to decay.
- **Durability:** For dent resistance and screw-holding ability, white oak wins hands down. If you make your bistro table from white oak, eliminate the aluminum rail cap protectors.
- **Cost:** Cedar has the edge here. And you'll find it at your local home center or lumberyard. You'll have to purchase white oak from a hardwood dealer.
- **Weight:** The cedar bistro table weighs in at $25\frac{1}{2}$ lbs, white oak at $54\frac{1}{2}$ lbs. While this makes the cedar table easier to move, the white oak table would be less likely to tip over in the wind.

ASSEMBLE THE TOP

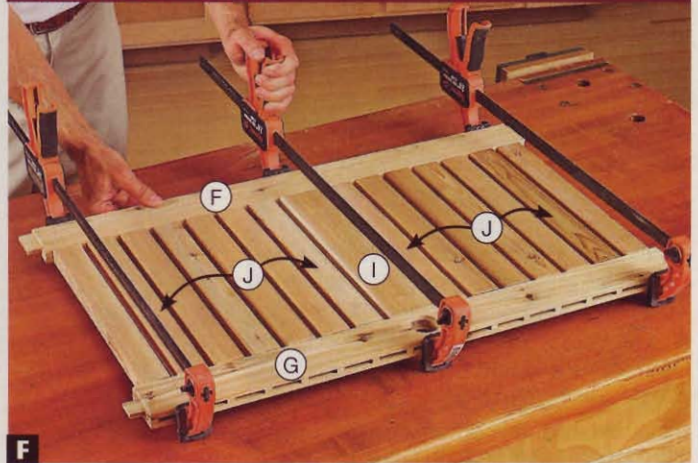

F Glue and clamp the tenons of one wide slat (I) and 14 narrow slats (J) into the top side rail (F) and center rail (G) mortises. Check for square, and let the glue dry.

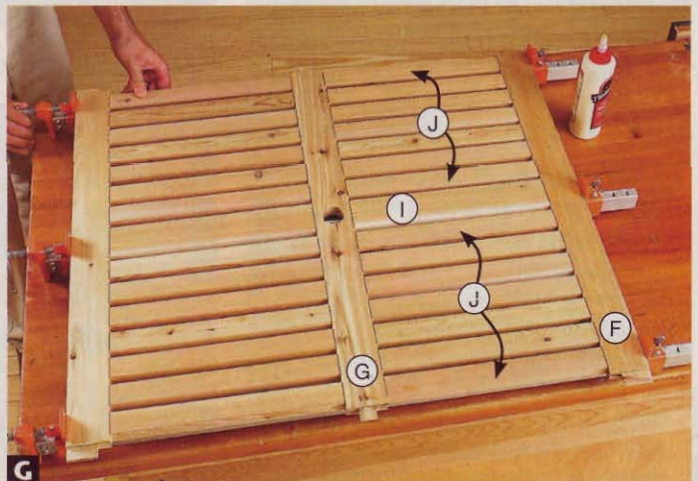

G Then glue and clamp the tenons of the remaining wide slat (I) and narrow slats (J) into the center rail (G) and remaining top side rail (F) mortises. Check for square, and let the glue dry.

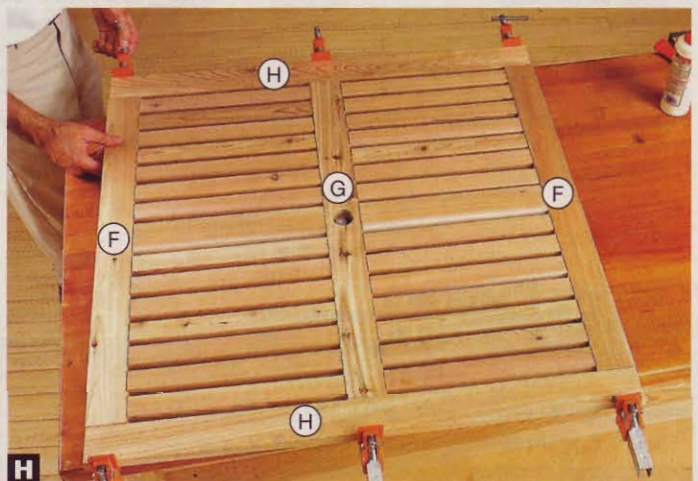

H Now glue and clamp the top end rails (H) onto the top side rail (F) and center rail (G) tenons.

groove. Now carefully remove the spacer before the glue sets. Repeat with the remaining top end rail. Finish-sand the top side rails, center rail (G), top end rails, wide slats (I), and narrow slats (J).

7 Mark the arc of the center rail (G) umbrella hole on the wide slat (I) tenons [Photo E]. Cut the arcs. Now glue and clamp the top [Photos F, G, and H].

Apply finish and assemble

1 Inspect the base and top, and finish-sand, where needed. Apply an exterior finish. (We applied two coats of Cabot translucent exterior stain no. 3002 Cedar.) Double-coat all exposed end grain. To seal the bottom ends of the legs, see the **Shop Tip** below.

2 To protect the base rail caps (D) from foot wear, cut four 16"-long pieces of $\frac{1}{8}$ "x1" aluminum bar. Drill three countersunk shank holes in each one [Drawing 1]. To remove any marks or scratches and give the aluminum bars a uniform satin appearance, sand them with 320-grit sandpaper. (We used a 3M Sandblaster sanding sponge.) Then fasten them to the rail caps [Photo I].

3 Carry the base and top out to the deck or patio. Center the top on the base. Using the holes in the cleats (E) as guides, drill pilot holes into the center rail (G) and wide slats (I). Drive the screws [Drawing 1]. Now pull up a stool and enjoy the afternoon. 🌳



I **ADD CAP PROTECTORS**

Position the $\frac{1}{8}$ "x1" aluminum bars on the rail caps (D), flush with the edges. Drill pilot holes, and drive the screws.

SHOP TIP

An easy way to seal outdoor furniture leg end grain

Because the end grain at the bottom of outdoor furniture legs can wick up water standing on a deck or patio, leading to premature rotting, you'll have to make extra effort to adequately seal them. Of course, end grain absorbs finish almost as well as water, so brushing on the finish will require repeated applications. Here's a simple time-saving solution that turns the wicking action of end grain to your advantage.



Place each leg in a shallow container, such as a paper bowl, and pour in finish, as shown. After a few hours, the



grain will be saturated. Then turn the furniture upside down, wipe away any excess finish, and let it dry.

Written by **Jan Svec** with **Erv Roberts**

Project design: **Kevin Boyle**

Illustrations: **Roxanne LeMoine; Lorna Johnson**

Cutting Diagram

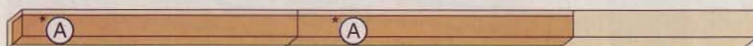

$3\frac{1}{2}$ x $3\frac{1}{2}$ x 96" Cedar (4x4) (2 needed)

*Plane or resaw to the thickness listed in the Materials List.

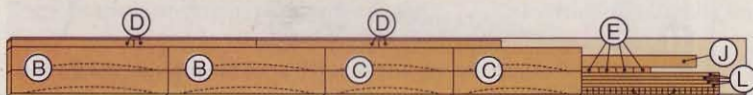

$\frac{3}{4}$ x $7\frac{1}{4}$ x 96" Cedar (1x8)

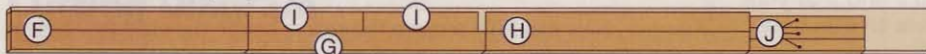

$\frac{3}{4}$ x $5\frac{1}{2}$ x 120" Cedar (1x6)

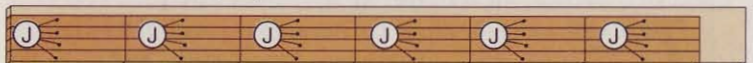

$\frac{3}{4}$ x $7\frac{1}{4}$ x 96" Cedar (1x8)

Materials List

Base	FINISHED SIZE			Matl.	Qty.
	T	W	L		
A* legs	2 $\frac{1}{4}$ "	2 $\frac{1}{4}$ "	35 $\frac{1}{4}$ "	C	4
B end rails	$\frac{3}{4}$ "	3"	20 $\frac{1}{2}$ "	C	4
C side rails	$\frac{3}{4}$ "	3"	16 $\frac{3}{4}$ "	C	4
D rail caps	$\frac{3}{4}$ "	1"	16"	C	4
E cleats	$\frac{3}{4}$ "	$\frac{3}{4}$ "	2 $\frac{1}{4}$ "	C	4
Top					
F top side rails	$\frac{3}{4}$ "	2 $\frac{1}{2}$ "	31"	C	2
G center rail	$\frac{3}{4}$ "	2 $\frac{1}{2}$ "	31"	C	1
H top end rails	$\frac{3}{4}$ "	2 $\frac{1}{2}$ "	34 $\frac{1}{2}$ "	C	2
I wide slats	$\frac{3}{4}$ "	2 $\frac{1}{2}$ "	15"	C	2
J narrow slats	$\frac{3}{4}$ "	1 $\frac{1}{2}$ "	15"	C	28
K* short fillers	$\frac{1}{4}$ "	$\frac{3}{4}$ "	$\frac{3}{8}$ "	C	64
L* long fillers	$\frac{1}{4}$ "	$\frac{3}{4}$ "	15"	C	4

*Parts initially cut oversize. See the instructions.

Material key: C—cedar.

Supplies: #8x1", #8x1 $\frac{1}{4}$ ", and #8x1 $\frac{3}{4}$ " stainless steel flathead wood screws; $\frac{1}{8}$ "x1" aluminum bar.

Blade and bits: Stack dado set, V-groove and 45° chamfer router bits, 1 $\frac{1}{2}$ " Forstner bit.

Attainable Accuracy

(How to know when "good enough" is good enough)

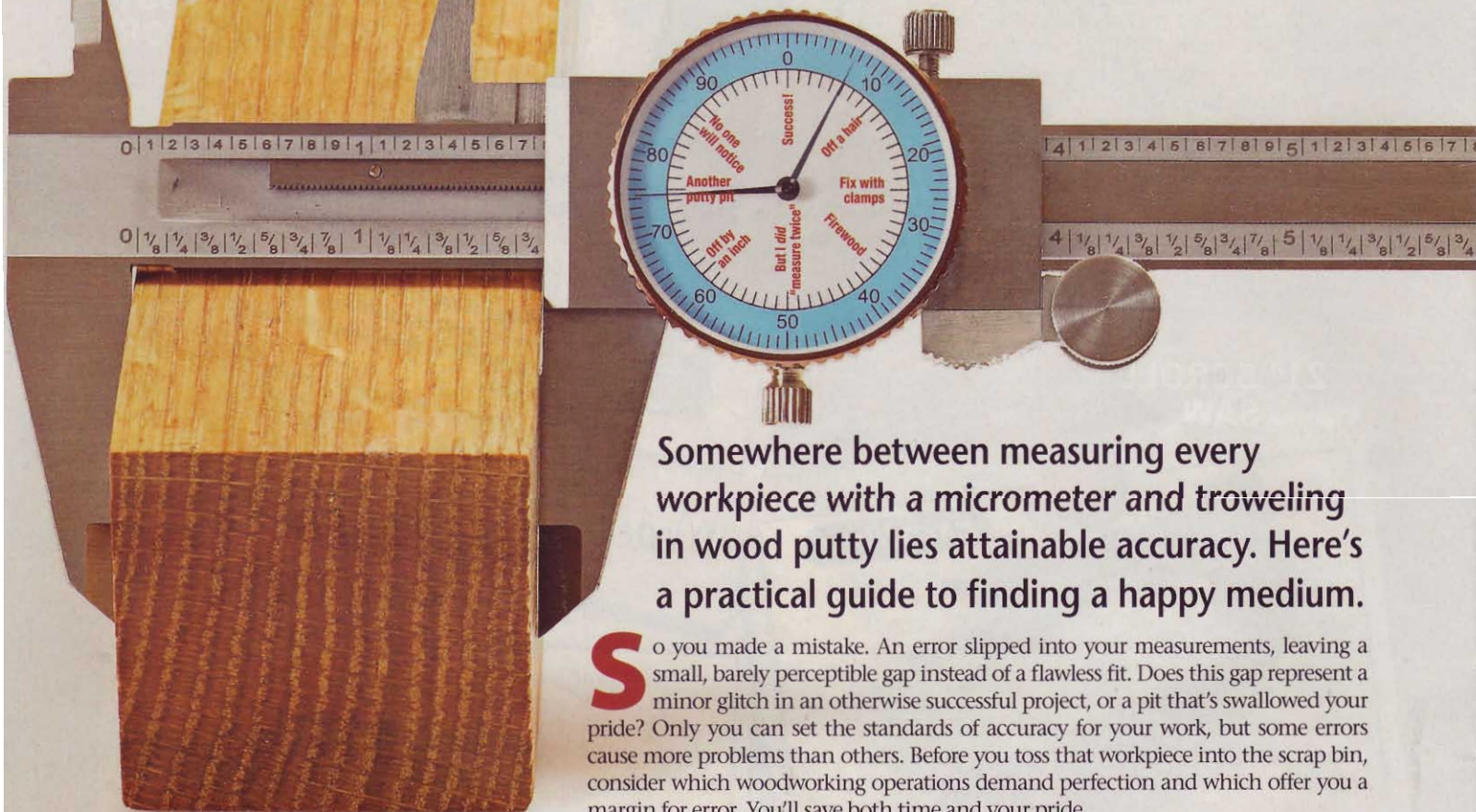

Somewhere between measuring every workpiece with a micrometer and troweling in wood putty lies attainable accuracy. Here's a practical guide to finding a happy medium.

So you made a mistake. An error slipped into your measurements, leaving a small, barely perceptible gap instead of a flawless fit. Does this gap represent a minor glitch in an otherwise successful project, or a pit that's swallowed your pride? Only you can set the standards of accuracy for your work, but some errors cause more problems than others. Before you toss that workpiece into the scrap bin, consider which woodworking operations demand perfection and which offer you a margin for error. You'll save both time and your pride.

PREP FOR PRECISION

Precision starts with spot-on measurements, marking, and cutting. So first make sure your measuring tools and power equipment can deliver the accuracy you require.

■ Buy the most precise measuring tools you can afford, especially combination and engineer's squares for marking workpieces and setting up power tools. Supplement these with steel rulers, a plastic drafting triangle, and a tape measure. Consider adding a dial

caliper for gauging material thickness, measuring dado and rabbet depth, and power tool set-up.

■ Check each measuring tool for accuracy, and return or replace any that fall short. For example, test a new square by marking two parallel lines, as shown *below*.

■ Just because you set up your benchtop and stationary power tools precisely when you got them, don't assume they're still that

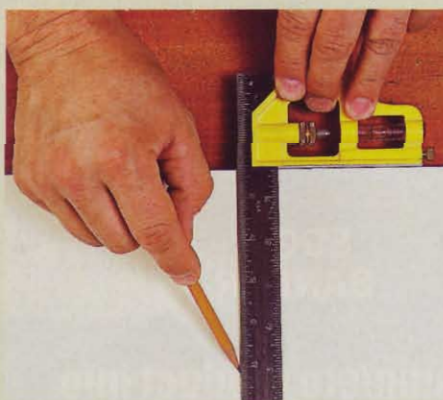
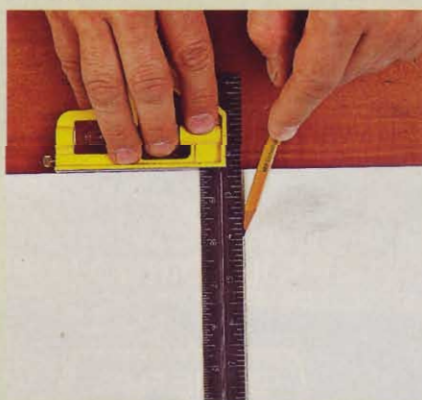

To tell whether your square is true, hold it against the straight edge of a scrap piece and use a sharp pencil to mark a line the length of the rule, as shown at *left*. (We covered the scrap with paper to show the technique better.) Then flip the rule over, as shown at *center*, and mark a second line by the first. If they're not parallel (*right photo*), your square's not square.

The skinny on thickening

Making stock flat and consistently thick sometimes takes priority over planing it to a specified thickness. Even planed and sanded stock sold in home centers can throw you a curve when it comes to being dead-flat and straight. A quick trip through the jointer and planer turns this $\frac{3}{4}$ "-thick stock into something closer to $\frac{5}{8}$ ". That, plus odd-size thicknesses of plywood, means you're better off customizing dado and rabbet widths to your stock rather than the other way around.

Good enough: Plane stock to within $\frac{1}{8}$ " of the thickness specified.

Keys to consistency:

1. Start by cutting project parts to rough length before jointing and planing them. You'll lose less thickness from bowed boards that way.

2. Tune up your planer to reduce snipe to no more than .002", which can easily be sanded away. If that's not possible, cut pieces extra long and cut off the sniped portions.

3. Plane all frame, drawer, or similar pieces to the same thickness at the same time.

4. Your most sensitive gauge for planing separate pieces to identical thickness is right at your fingertips. Lay pieces on a flat surface, such as your tablesaw top, and run your fingertips across the surfaces to feel for any difference in thickness, as shown at *right*.

5. When it's necessary to plane stock thinner than specified, some project parts may be less forgiving than others. Door frame parts, for example, may require a specific stock thickness for rail-and-stile router-bit sets to work correctly.



Two boards may appear to have the same thickness, but running fingertips over the surface will turn up planing inconsistencies.

Stops make any cut repeatable

Imagine building a frame with square corners using parts of four different lengths. Even if your miter gauge is dead-on, nothing will fit. Unequal frame or case parts produce out-of-square joints, and there's not much margin for error.

Good enough: Cut parallel parts for your projects to within less than $\frac{1}{4}$ " of each other in length.

Keys to consistency:

1. Before ripping jointed and planed stock to final width, test your fence setting using scrap. Cut parts to their final widths before cutting them to final lengths.

2. Cut all pieces of the same length at the same time. Use your miter gauge with an extension and stopblock, as shown at *right*, to ensure equal length and reduce tear-out.

3. Stopblocks have one drawback: Dust and chips wedged between them and the workpiece being cut can reduce accuracy. Between cuts, use compressed air or a brush to clear dust from the stop.

4. When cutting both ends of a part at an angle, make the first cut in an extra-long blank. Make the second cut with the angled end resting against an angled stopblock for consistent results, as shown at *right*.



This angled stop block, clamped to a miter-gauge extension, ensures that all mitered frame parts are cut to identical lengths.

way. Check and adjust them before starting work on each new project, as shown *below*.

■ If you upgrade miter gauges for your tablesaw, recycle the old gauge by setting it at an angle and leaving it there. If you make octagonal frames, for example, fine-tune the old gauge for $22\frac{1}{2}^\circ$ cuts, then leave it at that setting. You'll save set-up time and keep a still-accurate miter gauge from landing in the garage sale pile.

■ Use machine scales and rulers for approximate measurements, not final dimensions. Periodically confirm the accuracy of machine scales by using a reliable measuring device, as shown *below center*.

■ The same practice applies to tablesaw angle markings. Even 45° bevel stops can be thrown off by a pinch of sawdust, so check blade settings using an inexpensive plastic drafting triangle, as shown *below*. Confirm the 90° angle when returning the saw to that setting.



A misaligned jointer fence means out-of-square stock. Check the fence regularly to ensure it's square to the bed.

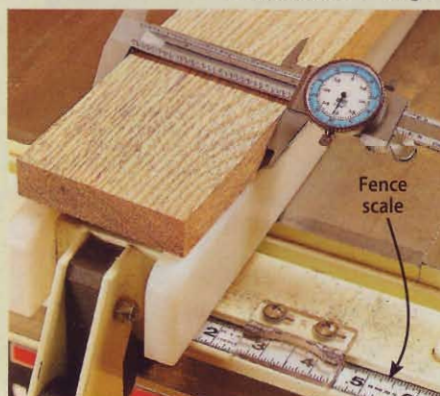

Installing a different blade or adjusting the fence parallel to the blade can throw off your tablesaw fence scale's accuracy.



A plastic drafting triangle from an office supply store provides an accurate, inexpensive way to measure blade angles.

Two wrong miters don't make a right angle

Glue makes poor filler because it has no strength by itself and leaves gaps as it dries. Joints require solid wood-to-wood contact for woodworking glue to do its job. Loose joints, such as the mortise-and-tenon shown at *near right*, lack both an effective glue bond and mechanical strength.

Good enough: Fitted joints, such as mortise-and-tenons, should assemble snugly by hand without slipping apart during dry-fitting. On mitered corners and butt joints, gaps should be no wider than a glue line.

Keys to consistency:

1. Here's where you need a dead-on square for both marking stock and calibrating your machines. Two 6" lines just 1° out of parallel will be nearly 1/8" apart at the other end. Even on much shorter distances, that can produce gaps like the one shown at *far right*.

2. Test your miter-gauge settings on scrap to eliminate all error. A four-sided frame involves eight 45° cuts, which multiplies a .1°

error into a detectable heel or toe gap where the pieces come together.

3. When cutting mortise-and-tenon joints,

cut the mortise first; then fine-tune the tenon for a snug fit. Don't expect a dead-on fit on your first try.

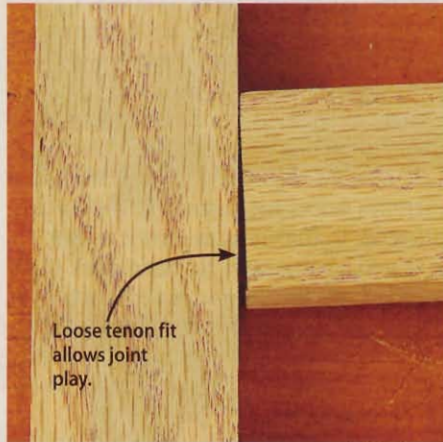

When you can wiggle a tenon within its mortise this much, the joint is too loose. Joints should require only hand pressure to dry-fit, not a mallet.

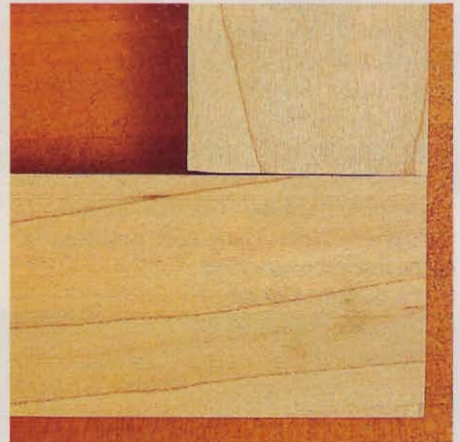

This half-lap corner joint suffers from an out-of-square rabbet. Check the alignment of the tablesaw miter gauge using scrap stock and a precision square.

Craftsmanship: Part skill, part philosophy

No one knows the pride of quality work as well as the professional or amateur woodworker.

—Patrick E. Spielman, *The Basic Book of Woodworking* (1984)

The easiest thing in the world is to make mistakes. The difficult thing is to know how to get out of those mistakes.

—Tage Frid, *Tage Frid Teaches Woodworking/Joinery: Tools and Techniques* (1979)

One-sixty-fourth of an inch is kind of a Grand Canyon when it comes to joints.

—Bill Hull, veneering instructor and owner of Patternworks Veneering, Inc.

The best is the enemy of the good.

—Voltaire

(Woodworking translation: In your quest for perfection, you can mess up a good joint by trying to make it better.)

Revealing facts about fitting doors and drawers

Appearances aside, excessive or unequal gaps (or reveals) between drawers or doors and the surrounding cabinet or face frame can create problems for drawer slides and door latches. Reveals that are too small create jammed doors and drawers when wood expands with weather changes.

Good enough: Produce a uniform reveal, ranging from 1/16 to 5/64".

Keys to consistency:

1. Rather than rely on the dimensions in the project plan, cut drawer fronts and door pieces to fit the size of the opening where they'll be used. Start with no allowance for reveals, and then slowly trim the drawer front or door frame to fit. You also can compensate for slightly out-of-square framing at this stage.

2. Tailor the size of your reveals to the scale of the project. A 5/64" reveal works great on a nightstand drawer, like that shown at *near right*, but appears too wide on the smaller scale of a tabletop display cabinet, like the one shown *far right*. For that project, we shrank the gap to just greater than 1/16".

3. Some types of door hinges automatically determine the width of your reveal. For example, a no-mortise hinge may require a

1/32" reveal on the hinge side that must be duplicated on the remaining three sides. 🌳

Written by Bob Wilson with Chuck Hedlund



Small projects call for small reveals. The nickel provides an easy way to establish a 5/64" reveal between the drawer and frame of this nightstand (*left*). The penny represents a gap closer to the 1/16" more suited to a tabletop display case (*right*).



Light fantastic Table Lamp

An elegant, easy-to-turn shape showcases exceptional curly walnut grain. Make one, a pair, or more—we provide a convenient source for both the lamp parts and sand the outstanding figured wood.



Watch a FREE four-part video on turning the lamp at woodmagazine.com/videos.

1 Gather the materials

For this project, you'll need the materials listed *below*. To make the turning templates, photocopy the **Lamp Base** and **Lamp Shaft** patterns on the *WOOD Patterns*® insert. Adhere them to cardboard with spray adhesive, and cut them to shape with a crafts knife. See **Source** for the figured walnut turning blanks and lamp parts.

Materials List

Part	FINISHED SIZE			Matl.	Qty.
	T	W	L		
base blank	1 1/4"	5 1/4"	5 1/4"	W	1
shaft blank	2 1/4"	2 1/4"	11"	FW	1
adapter blank	2"	2"	7"	LH	1

Materials key: W—walnut, FW—figured walnut, LH—laminated hardwood.

Supplies: Base and shank pattern photocopies, card stock, spray adhesive.

Source

Turning blanks. 1 1/4×5 1/4×5 1/4" walnut base blank, 2 1/4×2 1/4×11" figured walnut shaft blank, \$40 ppd. Johnson Wood Products, 34897 Crystal Rd., Strawberry Point, IA 52076. Call 563/933-6504.

Lamp parts. 8' brown cord with molded plug, brown line switch, plastic bushing, hex nut, 3/8" O.D. × 11" lamp pipe, double bushing body, 3/8" O.D. × 1" lamp nipple, shade rest, glass dome shade, finial, \$35 ppd. Johnson Wood Products, *above*.

International shipping: Shipments to Canada add \$25 for parcel post delivery.

2 Make the base

Tools: $\frac{3}{8}$ " bowl gouge, $\frac{1}{2}$ " square-nose scraper, $\frac{7}{16}$ " brad-point drill bit.

Tool rest: Gouge, slightly below center; scraper, slightly above center.

Speed: Lathe tools, 800 rpm; drilling, 500 rpm.

Mark the center of the top face of the base blank. Then use a compass to draw a $5\frac{1}{4}$ "-diameter circle. Next chuck a $\frac{1}{4}$ " brad-point bit into your drill press. With the blank on edge and the bit aligned with the blank center, drill a $2\frac{1}{4}$ "-deep cord hole, $\frac{1}{4}$ " from the bottom face. Now drill a $\frac{3}{8}$ "-deep centered pilot hole for your screw center in the top face of the blank. Bandsaw the blank round.

Install the screw center in your four-jaw chuck, and thread on the blank. (To shorten a too-long screw center, see the **Shop Tip** at *bottom*.) True the blank edge with a bowl gouge, turning it to a 5" diameter. Then true the bottom face, turning away the waste to within $\frac{1}{8}$ " of the cord hole. Using the base template as a guide, form the bottom bevel. Now use

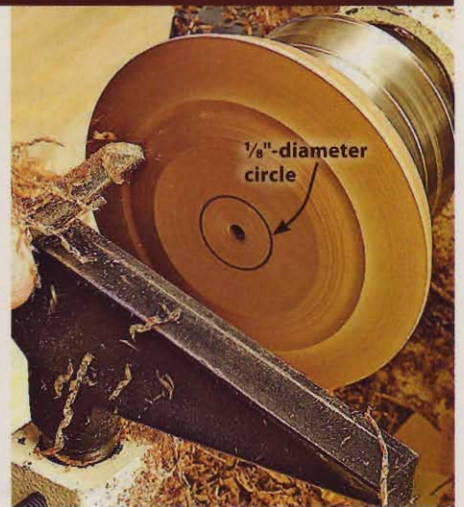
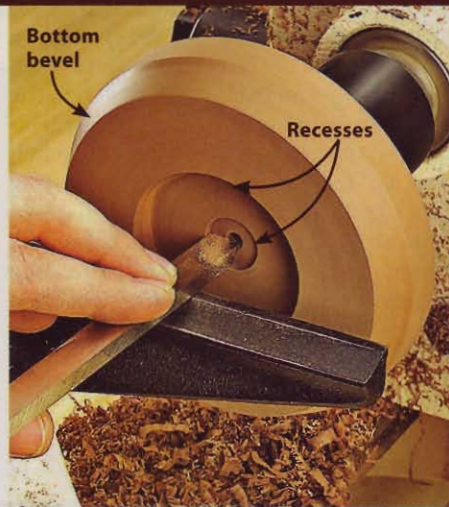

a square-nose scraper to turn a $2\frac{1}{2}$ "-diameter recess $\frac{3}{8}$ " deep, and a $1\frac{1}{2}$ " recess $\frac{3}{8}$ " deep, centered in the larger recess as shown *above*. Finish-sand the bottom.

Remove the base blank from the screw center, and the screw center from the four-jaw chuck. Then flip the blank and remount it, expanding the chuck jaws

into the large recess. Use the bowl gouge to turn the blank to 1" thick, and mark a $1\frac{1}{8}$ " circle at the center. With the base template as a guide, form the top bevel, as shown *above*. Now install a drill chuck with a $\frac{7}{16}$ " brad-point bit in the lathe tailstock. Drill a lamp pipe hole in the base. Finish-sand the base.

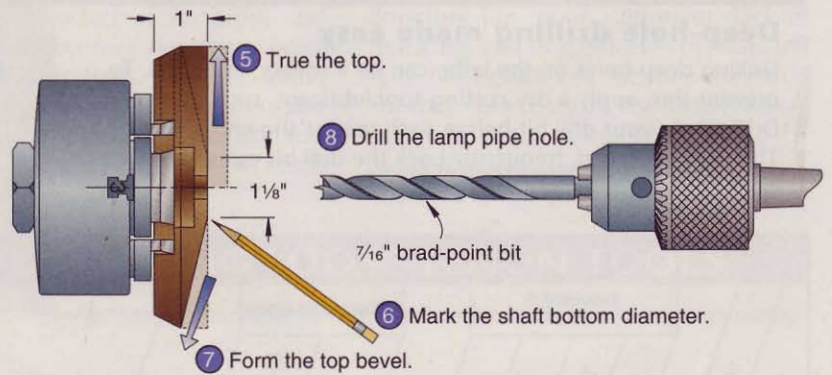
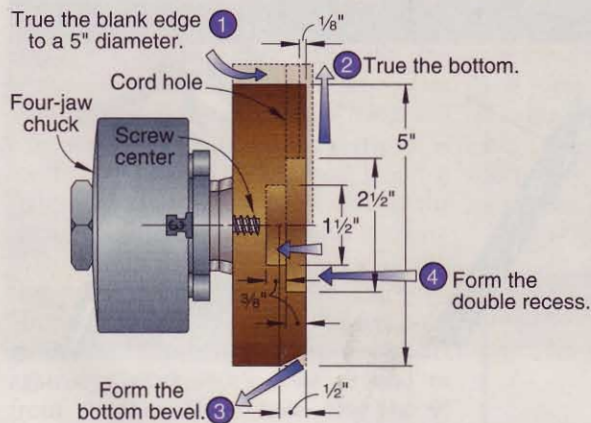

SHOP TIP

How to "shorten" your screw center

Sometimes you don't need the entire length of your four-jaw chuck screw center. To adjust the screw length to the $\frac{3}{8}$ " required for this project, cut a plywood disk of the needed thickness to slightly larger than the diameter of the chuck jaws with the screw center installed, and drill a clearance hole for the screw center. Then place the disk over the screw center before threading on the base blank, as shown at *right*.

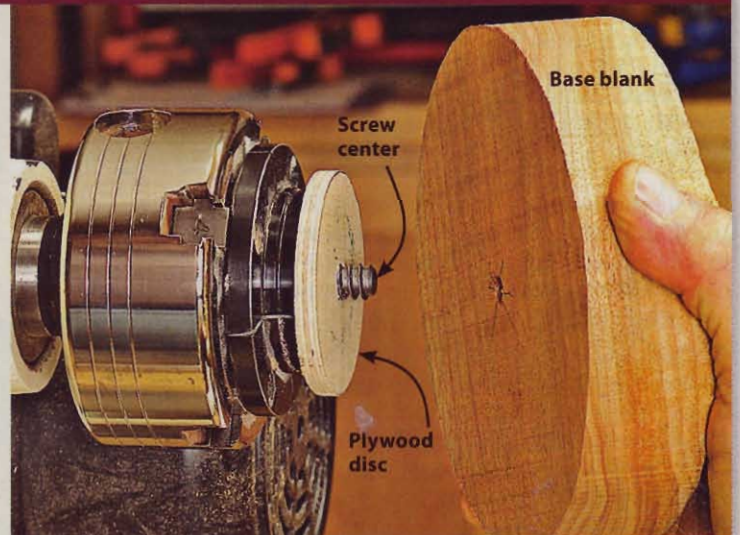

3 Drill the lamp-pipe hole in the shaft

Tools: $\frac{7}{16}$ " brad-point drill bit, $\frac{7}{16}$ " \times 12" drill bit.

Speed: 500 rpm.

Find the centers of both ends of the shaft blank, and mark them with a center punch or awl. Then mount the drill chuck with a $\frac{7}{16}$ " brad-point bit in the lathe head stock, and the lathe drive center in the tail stock. Next mount the blank between the tip of the brad-point bit and the drive center.

Turn on the lathe, keep the blank from turning with your left hand, and

advance the tail stock quill with your right hand, as shown at *right*. When you reach the end of the quill travel, turn off the lathe, retract the quill, advance the tailstock, and resume drilling. Drill as deep as the brad-point bit allows, switch to a 12"-long bit, and continue drilling to a depth of $10\frac{3}{4}$ ". For successful deep-hole drilling, see the **Shop Tip** below.

Remove the blank from the lathe. True both ends on your tablesaw or miter saw, cutting the blank to 10" long, exposing the hole at both ends.

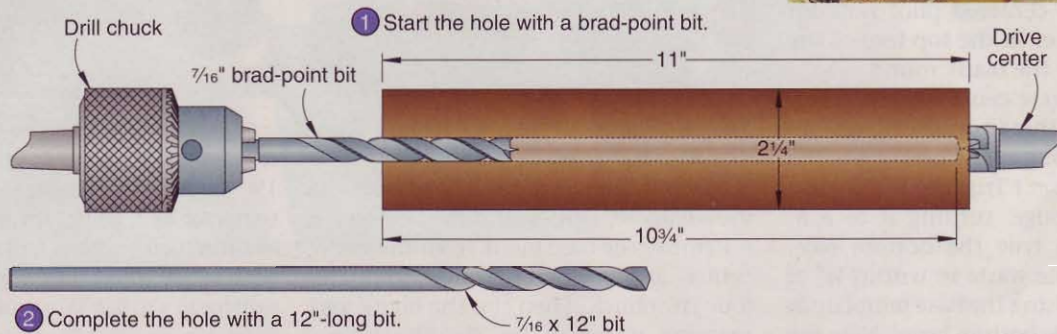
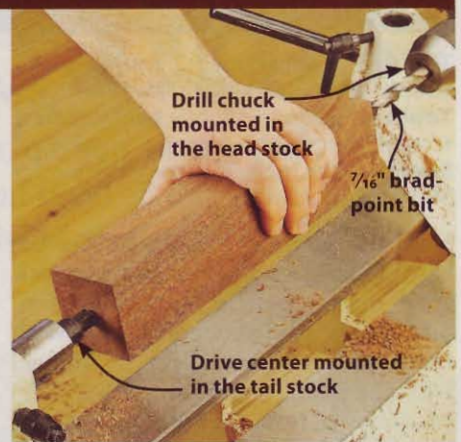

SHOP TIP

Deep-hole drilling made easy

Drilling deep holes on the lathe can be a smoky, noisy job. To prevent this, apply a dry cutting-tool lubricant, such as Bostik DriCoat, to your drill bit before each use, as shown at *right*. Then while drilling, frequently back the drill bit out of the hole to clear chips from the flutes.



4 Turn adapters to hold the shaft blank

Tools: Forstner bit, roughing gouge, parting tool.

Tool rest: Center.

Speed: Drilling, 500 rpm; parting tool, 1,800 rpm.

Install the four-jaw chuck in the head stock, and mount a 2 \times 2 \times 7" scrap block in the chuck. (You can laminate the block from thinner stock.) Support the tail stock end with the live center. True as much of the block as possible to a 2"-diameter cylinder with the roughing gouge. Then use a parting tool to turn a $1\frac{3}{4}$ "-diameter tenon $\frac{1}{4}$ " long on the tail stock end. Reverse the block, gripping the tenon with the four-jaw chuck, and supporting the unturned end with the

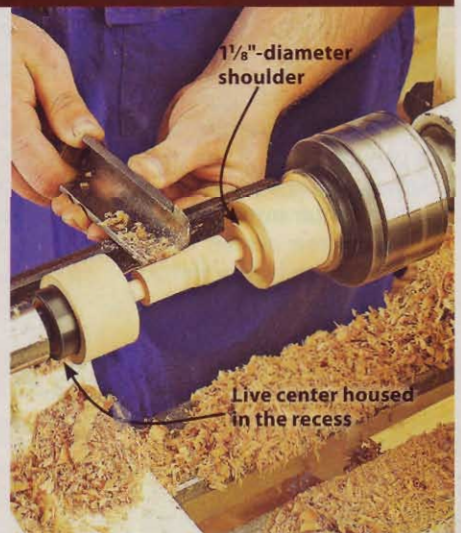
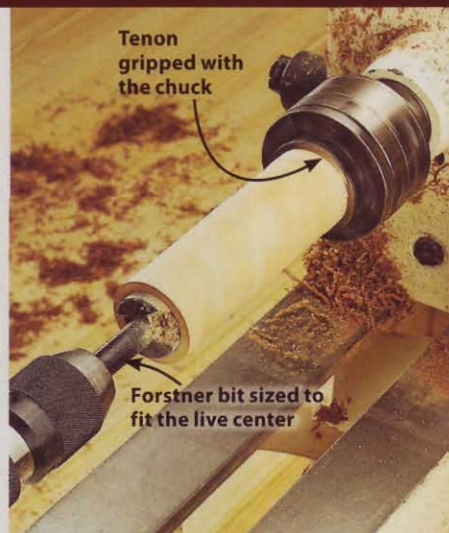

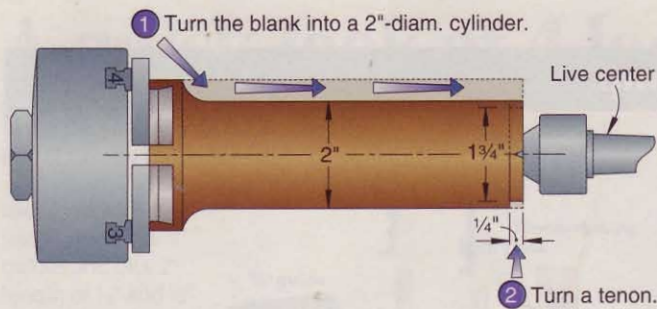

live center. True the rest of the block. Then install the drill chuck with a Forstner bit slightly larger than the diameter of your live center in the tail stock. Advance the tail stock quill and bore a 1"-deep hole into the block, as shown in the photo on the *previous page, bottom center*. Next replace the drill chuck with the live center, and insert it into the hole to support the block. Now form the 1 1/8"- and 3/4"-diameter shoulders and make gauging cuts for the 7/16"-diameter shank with a parting tool. (The shoulders will gauge the bottom and top diameters of the shaft.) Turn the shank to finished diameter, as shown on the *previous page, bottom right*. Stop the lathe, and cut the shank at the midpoint with a fine-tooth saw.

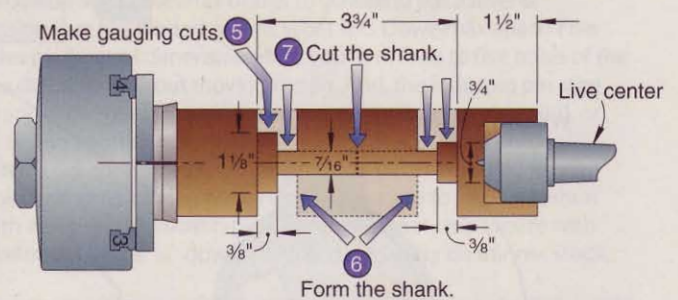
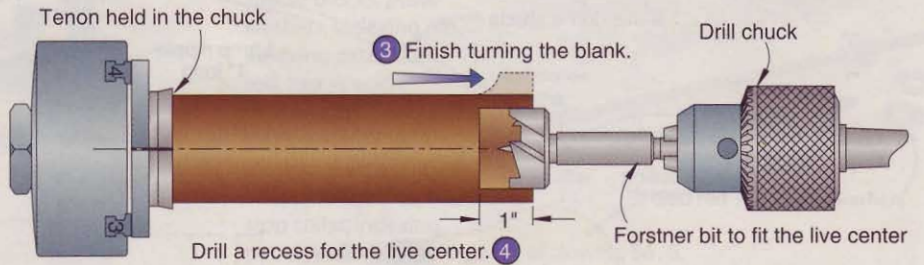

5 Shape the shaft

Tools: Roughing gouge, parting tool, skew chisel.

Tool rest: Gouge, parting tool, center; skew chisel, slightly above center.

Speed: 1,800 rpm.

With the drive adapter still clamped in the four-jaw chuck and the live center housed in the live center adapter, mount the shaft blank by inserting the 7/16"-diameter adapter tenons into the hole. Now true the blank to a 2 1/4"-diameter cylinder with the roughing gouge. Mark the critical diameters on the cylinder, where shown on the shaft template. Make a V-cut to the 3/4" diameter at the bottom of the "double cone" profile at the top of the shaft. Now, checking your progress with the template, turn the shaft to shape. Use the roughing gouge to form the broad profile, as shown in the photo at *near right*, and the skew chisel to cut to the adapter shoulders and form the double cone profile, as shown at *far right*. Finish-sand the shaft.

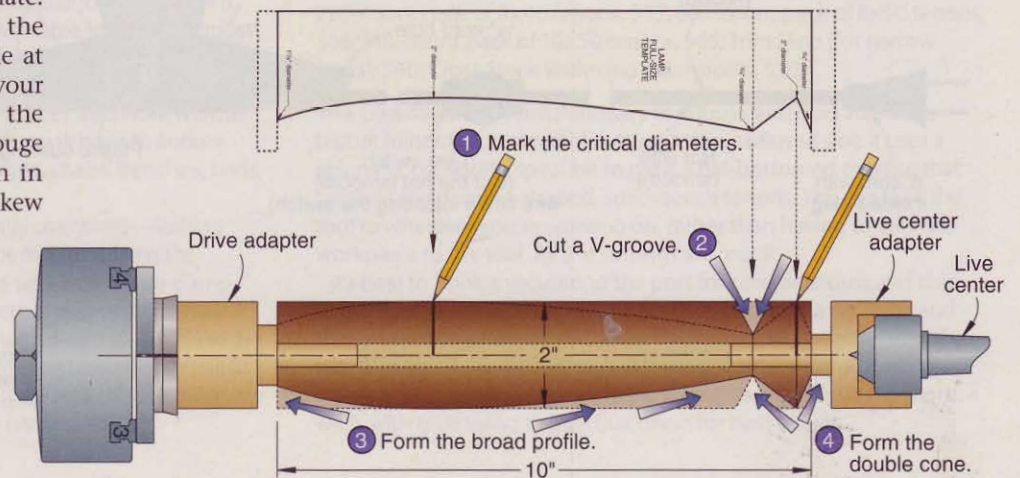
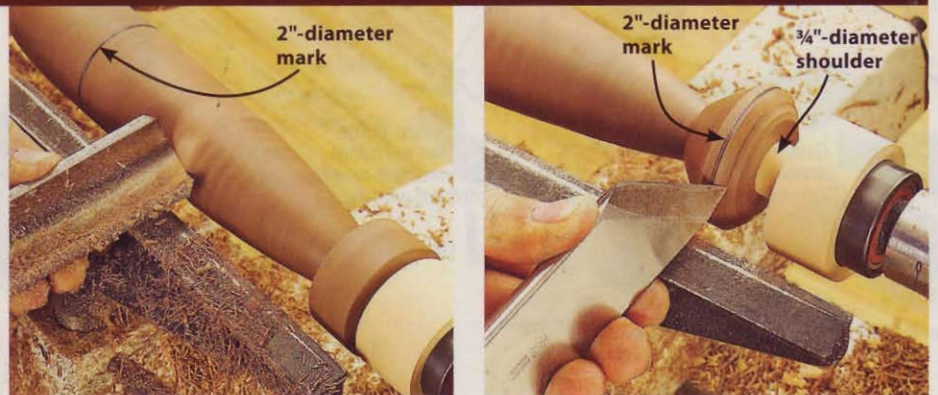

6 Finish the parts and assemble the lamp

Apply three coats of a semigloss oil/polyurethane finish, such as Minwax Antique Oil Finish, to the base and shaft. Sand lightly with 320-grit sandpaper between coats. Then assemble the lamp as shown below.

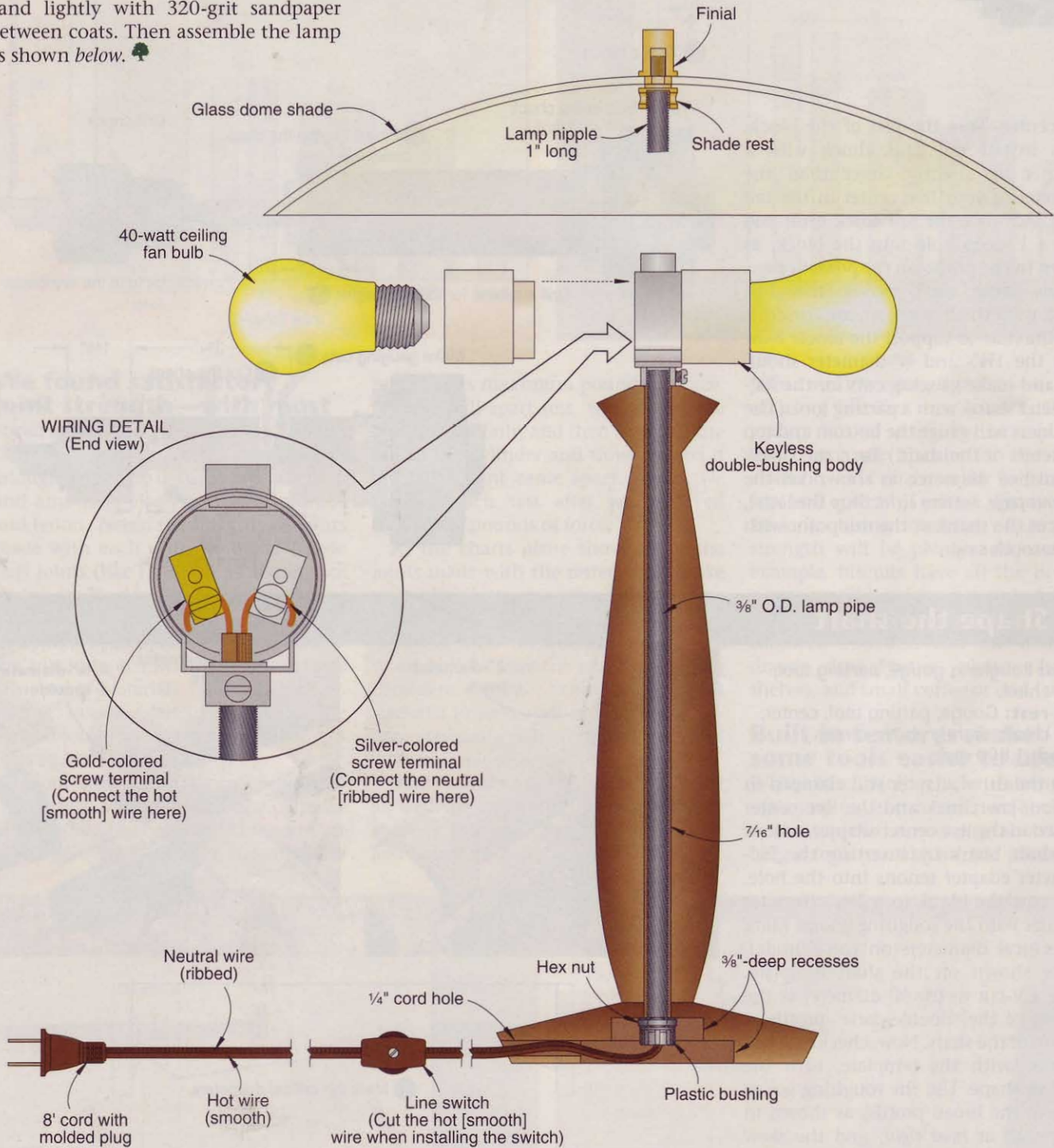

Written by Jan Svec with Brian Simmons
 Project design: Phil Brennon
 Illustrations: Roxanne LeMoine; Lorna Johnson

Trim Routers

For many of your day-in day-out routing chores, a little fistful of fury is all you need.

To call a trim router by its better-known name—lamine trimmer—is to seriously undersell this mini machine's usefulness in the shop. Fitting easily into one hand, it's the perfect tool for chamfering, rounding-over edges, mortising for hinges, as shown at left, and more. (See Router Clinic on page 90 for other great uses.) And, with its smaller base, you can guide one along a straightedge on narrower workpieces better than a full-size router.

Sold on owning one? Then it's time to figure out which to buy. We gathered up 12 trim routers, both corded and cordless, and used them for more than a month to find a favorite. Here's what we learned.

Power and cut quality: Not a problem

Despite motor ratings ranging from 1.7 to 6.5 amps (and voltages of 18 and 19.2 volts on the cordless Ryobi P600 and Craftsman 11583, respectively), we just couldn't tell much difference in muscle from one trim router to another. All of them handled $\frac{1}{2}$ " chamfers in both cherry and hard maple at a reasonable feed rate without hesitation or bogging. As a group, they have ample power for all $\frac{1}{4}$ "-shanked bits except those that hog away a lot of material in one pass, such as $\frac{1}{2}$ " cove or lock-miter bits. None will accept $\frac{3}{8}$ " or $\frac{1}{2}$ " shanks, but the MLCS Marvel 40 will run $\frac{1}{8}$ "-shank bits.

The quality of cut was very good from all of the routers, too. Given the high motor speeds, we expected our chamfering bit to burn the cherry, but we had to run the Bosch PR20EVSK at its full 35,000 rpm speed, and a snail's-pace feed rate, to get it to scorch. As a result, we can't make a strong case for variable speed in these tools when used with most $\frac{1}{4}$ "-shank bits. (Bosch's identical PR10E, fixed at 35,000 rpm, will save you about \$20.)

Depth setting: From fast to fine

The tested routers provide coarse depth adjustments (unlock the base and slide

For light-duty tasks, such as routing a hinge mortise (left), a trim router fills the bill.



TRIM ROUTERS WITH BOTH FINE AND COARSE ADJUSTMENTS ARE BEST

Lacking a fine-adjustment mechanism, accurately setting the depth on the Ryobi (left) trim router can be hit-or-miss. At the other end of the spectrum, Freud's thumbwheel depth-adjuster (center) can make superfine changes in depth, but proved time-consuming for large changes. The rack gear on the Ridgid router (right) free-turns easily for big changes, but allows for fine adjustments, too, by rolling it with your thumb.

it up or down on the body), fine adjustments, or both. Tools with only coarse adjustments (from Craftsman, MLCS, and Ryobi, shown *top left*) make it fast to move or remove the base when changing bits, but can be difficult to tweak to a precise cutting depth. Those with only fine adjustments (the Freud FT750T, shown *top center*, and the Porter-Cable 310) allow you to dial in cutting depth perfectly, but make gross changes tedious.

So, the best depth-setting systems incorporate both coarse and fine adjustments. On three of the routers, you simply unlock the base and then slide it up or down for coarse adjustments, and then roll either a rubber wheel (Makita 3707FC) or rack gear (Grizzly, MLCS, and Ridgid R2400, shown *top right*) to make fine adjustments. This system works pretty well, but unlocking the base lets the motor move freely, and you can lose the depth setting if you're not careful.

That's why we prefer the systems found on the Bosch, DeWalt D26670, and Porter-Cable 7310. Twist the Bosch's base slightly in one direction, and it free-slides for gross changes; turn it the other way, and it engages a thumbwheel for fine-tuning cutting depth. The DeWalt and P-C systems are similar, but instead of rotating the base, you loosen the base's lock knob until the base slides freely, and then tighten it until it re-engages the thumbwheel fine-adjuster.

Except for the DeWalt, Freud, and P-C 7310, all of the tested trim routers sport a depth scale. However, because



LIGHTEN UP FOR BETTER BIT VISIBILITY

Lighting is the key to good bit visibility, and Makita's clear base (left) allows plenty of natural light in, then supplements it with a pair of bright LEDs. On the other hand, the cavetlike base of the Porter-Cable 310 (right) nearly surrounds the bit, blocking much of the available light.

bit lengths vary and the scales can't be "zeroed," as on a plunge router, we found these scales mostly meaningless, and they shouldn't figure into your buying decision.

Bit visibility: Now you see it...

Countertop makers probably don't care much about bit visibility, because they usually use bearing-guided bits. But if you'll use your trim router to rout a recess for an inlay, or to plow out a hinge mortise, you need to see what's going on down there. The transparent plastic bases on half of the tested machines

(Craftsman, Grizzly, Makita, MLCS, and Ryobi) provide a good view of the cutting action, although Craftsman's "smoked" base was a bit harder to see through than the others. Makita wins the visibility race hands-down with its crystal-clear base, shown *above left*, and dual LED lights that illuminate the cutting area.

But most of the opaque bases provide decent visibility, too, except for the P-C 310, shown in the photo *above right*. Between its smallest-in-test 1/16" bit opening, light-blocking solid base, and large-diameter motor, we had to go down almost to eye level to view our cuts.

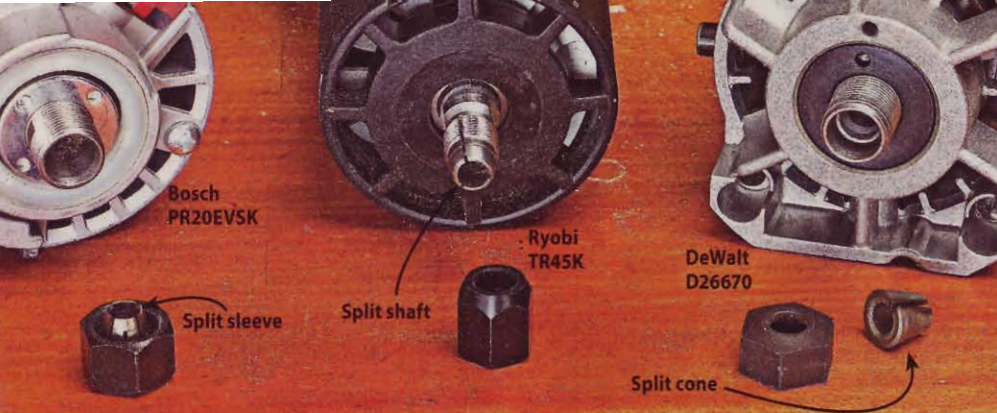

MOST COLLETS ARE LIKE THE BIG BOYS

Trim routers use split-sleeve collets (*left*), similar to those on full-size pro-grade routers, and split-shaft collets (*center*), like those often found on DIY-level routers. Some—but not all—of the split-cone collets (*right*) gave us trouble in our tests.

Changing bits: A sometimes sticky subject

The photo *above* shows the three different collet styles found on the machines we tested. Bosch, Craftsman, Freud, MLCS, and the cordless Ryobi P600 routers all employ a reliable split-sleeve collet similar to those used on full-size routers. The split-shaft collet on the corded Ryobi TR45K is machined on the end of the motor shaft. This style of collet holds bits well, but if it should become scored or damaged beyond repair, you'll have to replace the motor (or at worst, the tool).

The remaining trim routers use a split-cone collet, which proved to be a mixed

bag in our tests. We had no problems with the Grizzly, Makita, and Ridgid collets, but the DeWalt and Porter-Cable collets held bit shanks so tightly that we regularly had to cover the bits with a rag and pull them out with a pliers. DeWalt's Michele Tomlinson told us they know about the issue and "will fix it in the next generation of trim routers."

As for securing bits in those collets, some woodworkers prefer a two-wrench system, while others swear by a spindle lock and one wrench. If you have a strong preference (we don't), you'll find each trim router's collet-tightening method in the chart *below*. More impor-



BIG BASE IS A BONUS

The beefy, soft-grip handles on the Craftsman (shown) and Ryobi "woodworking base" give it the feel of a full-size router.

tant on these tiny tools is how much room you have to swing that wrench or wrenches. Thankfully, most of the bases have plenty of working room. We found it easier on most routers (except the DeWalt, Freud, and Porter-Cable 7310) to simply remove the base when changing bits.

Bases: Let's get something straight

Nearly all of the trim routers we tested have a square or rectangular base that we prefer to the round bases on the Porter-Cable 310 and Ridgid. Why? Obviously, a flat edge travels better along

THE DISH ON A DOZEN TRIM ROUTERS

BRAND	MODEL	MOTOR		COLLET		BASE				PERFORMANCE (6)				ACCESSORIES (7)		CORD LENGTH (FEET) (8)	WARRANTY (YEARS)	COUNTRY OF ASSEMBLY (9)	WEIGHT (POUNDS) (10)	SELLING PRICE (11)					
		CORDED (C) OR CORDLESS (CL)	SPEED (X 1,000 RPM)	SOFT START (YES/NO)	STYLE (1)	TIGHTENING METHOD (2)	MATERIAL (3)	SIZE (W x L, INCHES)	BIT-OPENING DIAMETER (INCHES)	ACCEPTS P-C GUIDE BUSHINGS (4)	DEPTH-ADJUSTMENT STYLE (5)	DEPTH-OF-CUT SCALE (YES/NO)	BIT-VISIBILITY	BIT-CHANGING EASE	BALANCE AND CONTROL						BASE-CHANGING EASE	STANDARD	OPTIONAL		
Bosch	PR20EVSK	C	16-35	Y	SL	SL	A	3 1/16 x 3 3/8	1 3/16	Y*	B	Y	A	B	A	A	A	E	H,O,R,R,G,S,T,TG,U	10	1	M	3.3	\$115	
Craftsman	11583	CL	28	N	SL	SL	P	3 3/16 x 3 1/2	1 3/32	N	C	Y	B	B	B	C	A	W	B,BC	N/A	1	C	4.5*	\$60*	
DeWalt	D26670	C	30	N	CN	SL	A	3 3/16 x 3 3/16	1 3/16	Y	B	N	A-	B+	D	B	B		O,T	8	1	MX	3.75	\$109	
Freud	FT750T	C	27	N	SL	2W	A	2 13/16 x 3 3/8	1 5/64	N	F	N	C	B-	A	B	C			7 1/2	5	S	4.4	\$100	
Grizzly	H7791	C	30	N	CN	2W	P	3 7/16 x 3 3/16	1 3/8	N	B	N	B	A-	A	B	A	E,RG,TG	O,P,T	8 1/2	1	C	4	\$40	
Makita	3707FC	C	26	Y	CN	2W	P	3 1/2 x 3 1/2	1 3/8	N	B	Y	B	A	A	B	B		RG,TG	T	8	1	J	3.25	\$140
MLCS	Marvel 40	C	30	N	SL	SL	P	3 7/16 x 3 3/16	1 3/8	N	C	Y	B	A-	A	B	B		C,CO,E,RG,T	6	1	C	4	\$80	
Porter-Cable	310	C	28	N	CN	2W	A	4 (dia.)	1 3/16	Y	F	Y	C	C	D	C	A			7	1	MX	3.75	\$160	
	7310	C	30	N	CN	SL	A	3 3/16 x 3 3/16	1 3/16	Y	B	N	A-	B+	D	B	B		E,O,T,U	10	1	MX	3.75	\$100	
Ridgid	R2400	C	20-30	Y	CN	2W	A	3 1/2 (dia.)	1 3/16	Y	B	Y	B	B	B	A	A		E,RG	12	3	C	3.6	\$100	
Ryobi	TR45K	C	25	N	SH	2W	P	3 3/16 x 3 1/2	1 13/32	N	C	Y	B	A-	B	B	A		W	10	2	C	3	\$80	
	P600	CL	26	N	SL	SL	P	3 3/16 x 3 1/2	1 13/32	N	C	Y	B	A-	B	C	A		B,BC,W	N/A	2	C	4.4*	\$50*	

NOTES:
1. (CN) Split cone
(SH) Split shaft
(SL) Split sleeve

2. (SL) Spindle lock & wrench
(2W) Two wrenches

3. (A) Aluminum
(P) Plastic
4. (*) Requires accessory base

5. (C) Coarse only
(F) Fine only
(B) Both coarse and fine

6. **A** Excellent
B Good
C Fair
D Poor

a straight edge for guided cuts. And it makes “plunge” cutting—tipping the router and bit into a cut, such as when routing a stopped groove for inlay—easier. The Craftsman and Ryobi TR45K each come with an oversize “woodworking base,” shown *left*, with large handles and more than three times the area of the typical trim-router base. (This base is an optional accessory on the Ryobi P600.) We love the additional fingertip control these bases provide, especially when routing freehand, such as when cutting hinge mortises.

On balance: Better with a cord

Because you often use these tools one-handed, good balance is essential to keep your cuts on track. Most of the routers felt well balanced—even the rather stout P-C 310—and we were able to easily control them when trimming solid-wood edging on plywood shelves. The battery packs on the cordless Craftsman and Ryobi machines make them heavy and a little unbalanced, especially when routing around the edge of a workpiece without rotating the router. Sometimes, the tool’s center of gravity was over the workpiece, and sometimes not. Freud’s

tallest-in-the-test trim router also felt a little top-heavy, especially when riding along its narrow 2¹³/₁₆”-wide base.

The top tools in the trim-router test

After extensive use of all of the trimmers, there was no question which earned the Top Tool award: the Bosch PR20EVSK. Easy and precise depth adjustments, good bit visibility and balance, and a

boatload of optional accessories make this a trim router you’ll use right away, and long into the future. You can save yourself about 20 bucks—without consequence—if you opt instead for the fixed-speed version of this router (PR10E, \$95). And Grizzly’s \$40 H7791 offers an inexpensive way to add a capable trim router to your tool collection, making it our Top Value. 🌿



Written by **Dave Campbell** with **Pat Lowry**

	COMMENTS	FOR MORE INFO:	
		PHONE	WEB
	Full-size router features in a compact tool. Comfortable soft grip absorbs vibration. Excellent depth adjustments help make this our Top Tool.	877/267-2499	boschtools.com
	Top-mounted battery pack makes the tool heavy and a little imbalanced. Add \$85 for two batteries and charger if you don't have them.	800/377-7414	sears.com
	Very good depth adjustments: fast and accurate. But split-cone collet grabbed bits and wouldn't let go without breaking out the pliers.	800/433-9258	dewalt.com
	Narrow base and tall body contribute to a “tippy” feeling when routing edges. Large cutting-depth changes are time-consuming.	800/334-4107	freudtools.com
	A capable trim router at a rock-bottom price. Buy a couple, dedicate a bit to each one, and see how much time you save. A Top Value.	800/523-4777	grizzly.com
	Excellent bit visibility, thanks to the clear base and LED lights. Above-average depth-setting mechanism.	800/462-5482	makitools.com
	Included accessories turn this router into a Roto-Zip-like cutout tool. Only tested trim routers that accept 1/8” bit shanks.	800/533-9298	micswoodworking.com
	This stout little router felt good in hand, but bit visibility is poor, and the split-cone collet refused to give up bits without a fight.	888/848-5175	porter-cable.com
	Identical to the DeWalt D26670, except for the color and the shape of the cap on top.		
	Overall, our second-favorite trim router. Round base makes it hard to tip into a stopped cut, such as fluting.	800/474-3443	ridgid.com
	A solid performer, and we love the included oversize woodworking base that gives you deft and precise control.		
	Identical to the Craftsman 11583, except for the voltage. Also, the woodworking base is optional on the Ryobi, but standard on the Craftsman.	800/525-2579	ryobitools.com
7.	(B) Battery pack (BC) Battery charger (C) Circle-cutting guide (CO) Cutout tool kit (E) Edge guide (H) Hinge template kit (O) Offset base (P) Plunge base (R) Round base (RG) Roller guide (S) Side handle base (T) Tilt base (TG) Template guide (U) Underscribe attachment (W) Woodworking base	8. (N/A) Not applicable—cordless model	10. (*) Including battery
		9. (C) China (J) Japan (M) Malaysia (MX) Mexico (S) Spain	11. Prices current at time of article production and do not include shipping where applicable. (*) Does not include battery pack or charger.

Learn from a Master

Don't Swear Get Square

Can't-miss methods
for squaring projects

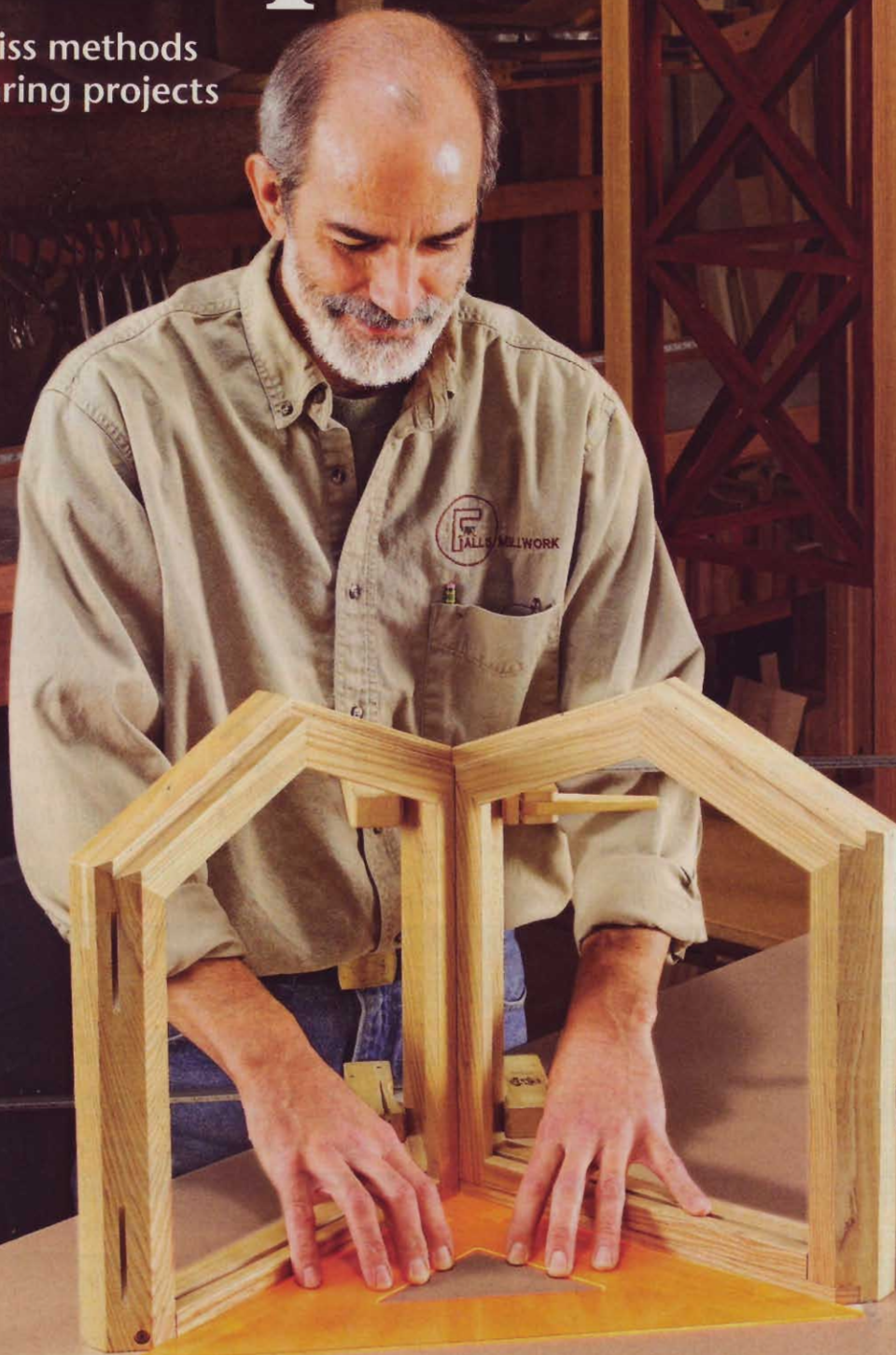

Before you can build projects with square corners you're proud of, you need the proper tools and setups in your shop: Squares must be truly square, measuring instruments must be accurate, and power tools must be set to machine precisely. But precise tools by themselves don't guarantee square assemblies; you also need good technique. To help you learn the ropes we went to craftsman Ben Svec, owner of Falls Millwork in Kelley, Iowa. Ben has been working with wood professionally for over three decades. He and his brother, *WOOD*® magazine Project Editor Jan Svec, used to restore ornate woodwork in older homes in Philadelphia. Both brothers eventually returned to Iowa and Ben now specializes in custom-made cabinets, furniture, and moldings. A recent commission: the set of liturgical furnishings shown at left.

Square projects start with dead-on-accurate tools

Ben learned from experience how to avoid the frustrations of unsquare corners. "Your work is only going to be as accurate as the tools you use," he says. "Once you know your machines are set up square, then you don't have to spend a lot of effort trying to compensate all the way through a project for a joint that's not square."

Ben offers the following tool tips as foundations that will steer you toward achieving accuracy and squareness in your shop:

- Never trust any tool right out of the box. Even minor bumps or dings during packaging or shipping could alter the tool's accuracy. Always check it and set it up with squares, rules, and calipers that you know to be accurate.
- Use quality plastic drafting squares—which prove reliably accurate—to check your woodworking squares, as shown in **Photo A**. You might be surprised to discover that your square's not truly square. See **Drawings 1 and 2** for methods to check flat squares and, if necessary, correct your framing square.
- Use a steel rule for measurements whenever possible. It lies flat, and most have markings in four different increments ($\frac{1}{8}$, $\frac{1}{16}$, $\frac{1}{32}$, and $\frac{1}{64}$ ") for increasing precision. How do you know your steel rule is accurate? For starters, don't skimp on this tool. Buy a 12" steel rule from a trusted company (Starrett or Incra, for example) known for accurate

Some squares can't be tamed



Don't bother trying to correct a try square, or any fixed square with a handle thicker than its blade. Instead, either send your square back to the manufacturer for repair or buy a new one that tests square.

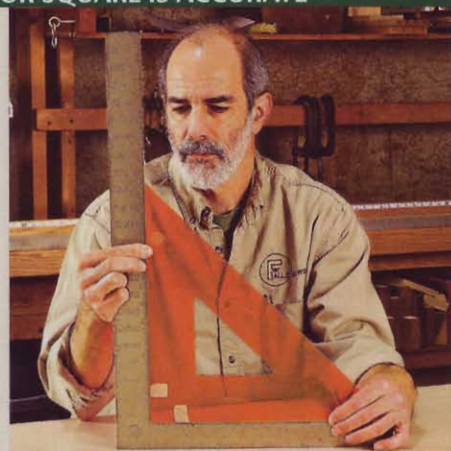

A Keep several plastic drafting squares, including a 12" model for maximum surface contact, in your shop to check tools.

1 TESTING SQUARE

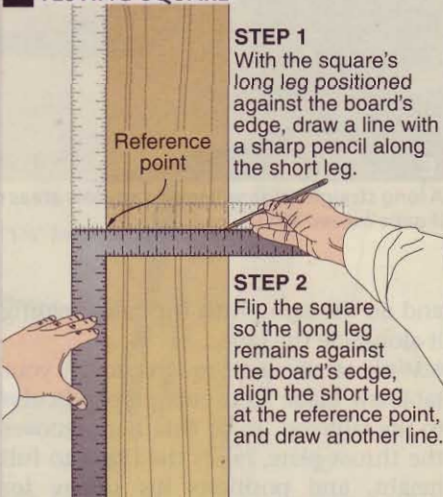

STEP 1
With the square's long leg positioned against the board's edge, draw a line with a sharp pencil along the short leg.

STEP 2
Flip the square so the long leg remains against the board's edge, align the short leg at the reference point, and draw another line.

Check your square's accuracy by comparing drawn lines made from opposing sides of the same reference point.

2 CORRECTING SQUARE

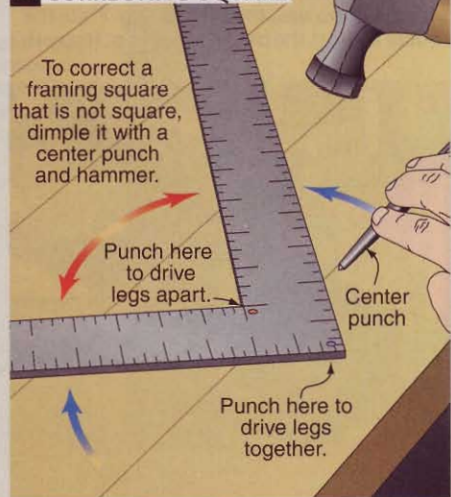

To correct a framing square that is not square, dimple it with a center punch and hammer.

Punch here to drive legs apart.

Center punch

Punch here to drive legs together.

Correct any flat square by laying it on a flat surface and striking its intersection with a hammer and center punch.

FIND AN ACCURATE STANDARD, THEN USE IT TO CHECK OTHER TOOLS



B Rely on an accurate steel rule to check your measuring tape at the 12" mark. This tape proved to be $\frac{1}{32}$ " longer than the rule at that mark.

tools, and use that as your benchmark with which to check all other measuring tools. Or, buy an architect's scale at an art or drafting supply store and use that to check all your rules.

- Take your drafting square and accurate steel rule to the store and check new

squares and measuring tapes for accuracy before buying. To test the tape for outside measurements, hook the tape on the end of your steel rule and compare the two at the 12" mark, as shown in **Photo B**. For inside accuracy just push the front of the hook against a rigid surface

DON'T TRUST YOUR MACHINES TO BE TRUE—MAKE THEM TRUE



C Check the blade's squareness from the side with the narrowest throat opening. Place the square against the blade's body, not its teeth.

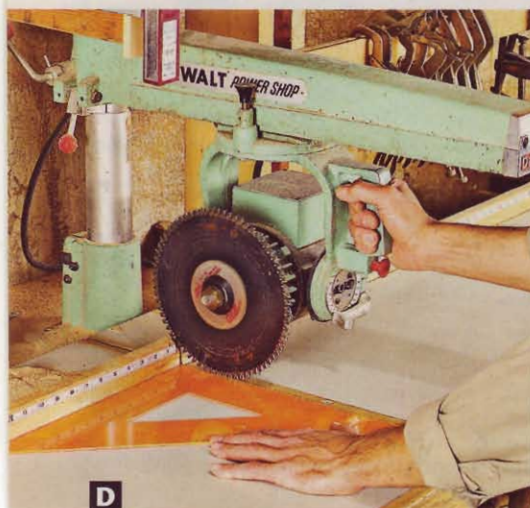

D With the saw unplugged and the blade guard removed, check your saw for square. Never use the saw with the guard off.

3 HOW TO BUILD A BETTER ASSEMBLY TABLETOP

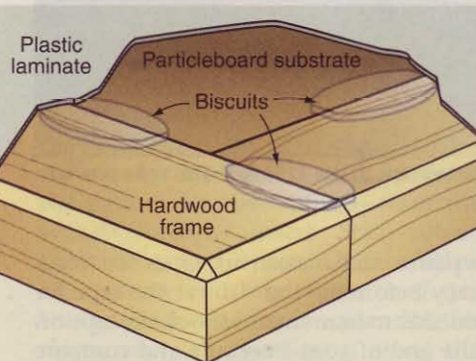

The hardwood frame provides a more rigid, durable surface than the particleboard for clamping workpieces to the table.

A FLAT WORKSURFACE MAKES PRECISION POSSIBLE

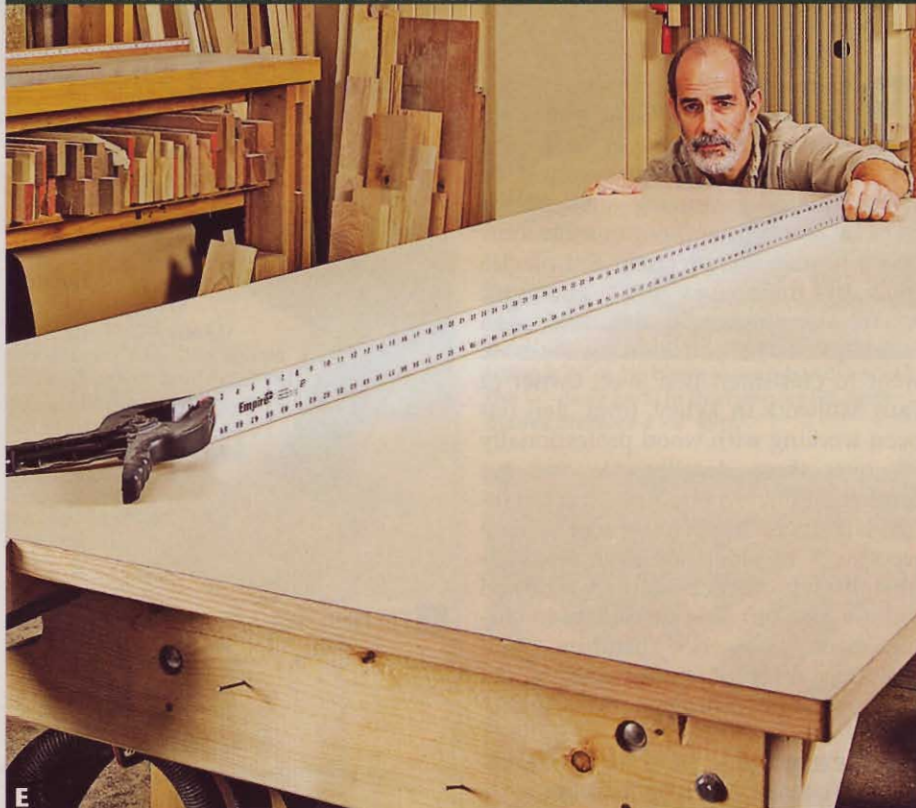

E A long straightedge will reveal any low areas on your assembly table. Shim the top from below if gaps exceed $\frac{1}{8}$ ".

and do the same with the rule, holding it alongside the tape.

- With an accurate square, adjust your tablesaw blade so it cuts perpendicular to the tabletop. To do this, Ben removes the throat plate, raises the blade to full height, and positions his square for maximum contact with the table surface, as shown in **Photo C**.

- Regardless of what tool you use for crosscutting (miter gauge, radial-arm saw, or sliding table on a tablesaw), the blade and fence must be at exactly 90° to each other. Ben does all his crosscutting with his radial-arm saw and, although he never moves it from 90° , he still checks it regularly, as shown in **Photo D**. He squares it to the table vertically and horizontally, both at the fence and at its farthest reach.

Here's the correct way to machine stock square

Once your tools and machines are set up correctly, transfer that accuracy to your rough lumber with the proper machining techniques. After allowing the lumber's moisture content to acclimate to his workshop's environment, Ben follows these steps, in order, to ensure squareness and accuracy when milling boards to their final dimensions:

1. Crosscut boards to rough length. After cutting off all checks to reveal a good end, measure and mark your work-piece's length plus 1". Rough out your longest and widest workpieces first—to make sure you can get them from the boards you have on hand—then move on to your smaller workpieces.
2. Straighten one edge on the jointer.
3. Rip to rough width, about $\frac{1}{4}$ " wider than the finished dimension.
4. Joint one face flat.
5. Plane the opposite face parallel to the jointed face. Plane to thickness, removing equal amounts of stock from both faces whenever possible.
6. Joint one edge square to the faces.
7. Rip to $\frac{1}{32}$ " wider than finished width.
8. Joint the edge with saw blade marks to finished width.
9. Crosscut to finished length.

A large, flat assembly table can be your best tool

To assemble and clamp your projects square, you need a reliably flat surface to work on, as shown in **Photo E**. This assembly table might be separate from your workbench, which can take abuse from

THIS TIME-TESTED METHOD YIELDS SQUARE CORNERS



F

You've squared the case when the diagonal measurements read the same. Attach the back panel to help hold the case square.

tools and accessories. Ben built his assembly table from a 4×8' sheet of 1¼" particleboard, edged with 2"-wide hardwood attached with biscuits, as shown in **Drawing 3**. He then glued plastic laminate to the top because it resists finishes and glue better than a porous wood surface.

"For putting together cabinets, a flat assembly surface is crucial," Ben says. "Otherwise, it's hard to get your cabinet square." Having a flat surface also allows you to clamp a glue-up to the table, enabling three-dimensional squaring.

Another tip: Apply a sealer finish such as polyurethane to all wood surfaces, including the top's underside, to resist moisture absorption that can cause your table's flat surface to warp.

Measuring diagonals still gets the job done

Admittedly an old standard in woodworking, comparing the diagonal dimensions of a rectangular case continues to be a reliable method for squaring projects—provided opposing sides have been cut to the same length. Don't rely on a framing square to check corners, however; you can get an inaccurate reading because the assembly clamps can bow the sides slightly. (This bow will revert once you remove the clamps.)

To check diagonals, glue and clamp your assembly as needed. Then, using a measuring tape, compare the diagonal measurements across opposing corners. Hook the tape onto the outside corner and read the measurement from the outside of the corner nearest you. Your project is square if the measurements are equal. If they're not equal, correct them by clamping across the longer diagonal, as shown in **Photo F**. Measure from the inside of the corners if your clamp is in the way. Determine the midpoint between the two measurements, and tighten the clamp until both read the same.

Hold corners square with clamping braces

Clamping right-angle braces in the corners of a glue-up such as those shown in **Photos G, H, and I**, ensures that those corners remain square. Ben makes his braces from two pieces of ¾" plywood laminated together to create more surface contact with the workpiece, as well as more for the clamp. But the braces *must* have perfectly square corners. Build your own braces from the free plan at woodmagazine.com/brace. You also can buy metal or plastic braces that work equally as well.

LOCK CORNERS SQUARE SO THEY CAN'T MOVE



G

Make your own corner braces from plywood sized to a specific project, like this drawer. Clamping opposing corners ensures that all four are square.

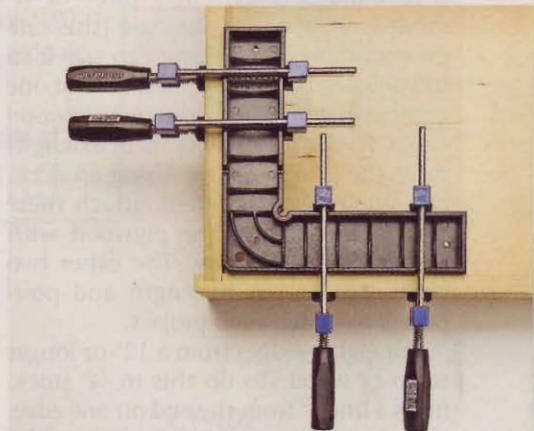

H

Manufactured braces, made from molded synthetics, aluminum, or steel, take up little room in a project corner. They sell for \$7–25 apiece, depending on size.



I

Corner clamps not only hold assemblies square, but a floating inner jaw also adjusts automatically for workpieces of different thicknesses. Cost: \$22 each.

Attach hidden cleats to secure square corners

For projects that present challenges when clamping, such as the leg-and-apron assembly with the protruding leg base, as shown in **Photo J**, use cleats to permanently hold the corners square. Because the leg prohibits clamping a right-angle brace tightly into the corner, use glue and screws to attach mitered cleats—machined to exactly 45° on each end—that will ensure square corners.

Square up doors or frames without using clamps

Make your own clamping jig that relies not on manufactured clamps, but rather on science and mathematics. The jig, shown in **Photo K**, uses opposing wedges to effectively clamp workpieces together at right angles until the glue dries.

To build this jig, cut a piece of ¾" sanded plywood for the base (this one measures 24×28", but you can size it to fit your needs) and machine at least one corner square. Next, rip four hardwood cleats 2" wide. Cut two of them to length to fit the square corner. Using an accurate square for alignment, attach these two to the face of the plywood with wood screws and glue. The other two cleats will be cut to length and positioned to match each project.

Cut eight wedges from a 12" or longer scrap of wood. To do this in ¾" stock, mark a line 5" from the end on one edge, then draw a diagonal line from corner to corner. This should be about 5°. Free-hand this cut at the bandsaw, then after one wedge falls away crosscut the other at the 5" mark. It's not necessary to sand the wedges smooth, but place self-adhesive sandpaper on the smooth face of four of them.

Use this jig by first dry-fitting your project, orienting it against the two

ANCHOR HARD-TO-REACH CORNERS WITH CLEATS



J These cleats not only hold the assembly square but also provide contact points from which to secure the tabletop.

square cleats. Next, from the remaining 2"-wide cleats, cut the other jig sides to length and attach them—with screws only—so you have a ¾" gap for the wedges between the workpiece and the cleats. Glue and assemble the project. Position the wedges where clamping pressure is needed most—in this case, where the

CLAMP PROJECTS SQUARE WITH WEDGED PRESSURE



K Apply a film finish to the jig's base or place waxed paper underneath your workpiece so it doesn't become glued to the jig.

rails and stiles meet. The sandpaper side of the four wedges must be against the jig's cleats to keep the wedges from slipping. Place the other wedges as shown, and tap them evenly with a mallet to draw the project joints together. 🌿

Written by **Bob Hunter** with **Ben Svec**
Illustrations: **Tim Cahill**

SHOP TIP

Your geometry teacher would be proud

Long before the invention of modern clamps and jigs, people used their intellect to create square corners. They did this by using the Pythagorean theorem, a geometric proof in which the square of the longest side of a right triangle equals the sum of the squares of the remaining sides. Woodworkers, carpenters, and engineers use this method to create square corners when dimensions exceed the realm of a standard framing square. By using a triangle with sides in exact multiples of 3, 4, and 5 (for example: 6, 8, and 10), you'll always get a square corner opposite the longest side.

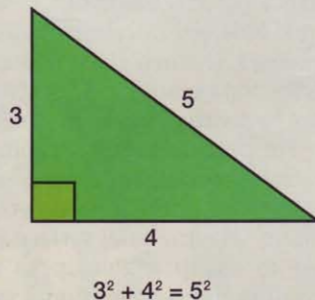

Apply proven geometry to make sheet goods square

Sheet goods have reliably straight edges but don't necessarily have square corners. Check all plywood, medium-density fiberboard (MDF), particleboard, melamine, or hardboard with a large square, such as a framing square or a 3-4-5 square, or simply map out a right triangle using the Pythagorean theorem (see Shop Tip, above). If the sheet does not have a square corner, make one square with a circular saw or router and a straightedge set at 90° to the edge, as shown at right. You can purchase a 3-4-5 square (\$53, model 345EK, at Amazon.com), or make your own from ¾" plywood. For larger projects you can map out a right triangle and multiply the values (6-8-10 or 9-12-15) to get the same result.

Ben Svec runs a trim router along a straightedge to square a sheet of veneered MDF. He uses his 3-4-5 square to align the straightedge.



Better Homes and Gardens®

WOOD PATTERNS®

July 2007

Issue 177

Dear Reader: As a service to you, we've included full-size patterns on this insert for irregular shaped and intricate project parts. You can machine all other project parts using the Materials List and the drawings accompanying the project you're building.

© Copyright Meredith Corporation, 2007. All rights reserved. Printed in the U.S.A. Meredith Corp., the publisher of WOOD Patterns®, allows the purchaser of this pattern insert to photocopy these patterns solely for personal use. Any other reproduction of these patterns is strictly prohibited.

Turned Lamp, Page 38
Jewelry Stand, Page 58
Gum Ball Goose, Page 76



1 1/8" diam.

Gum Ball Goose, Page 76

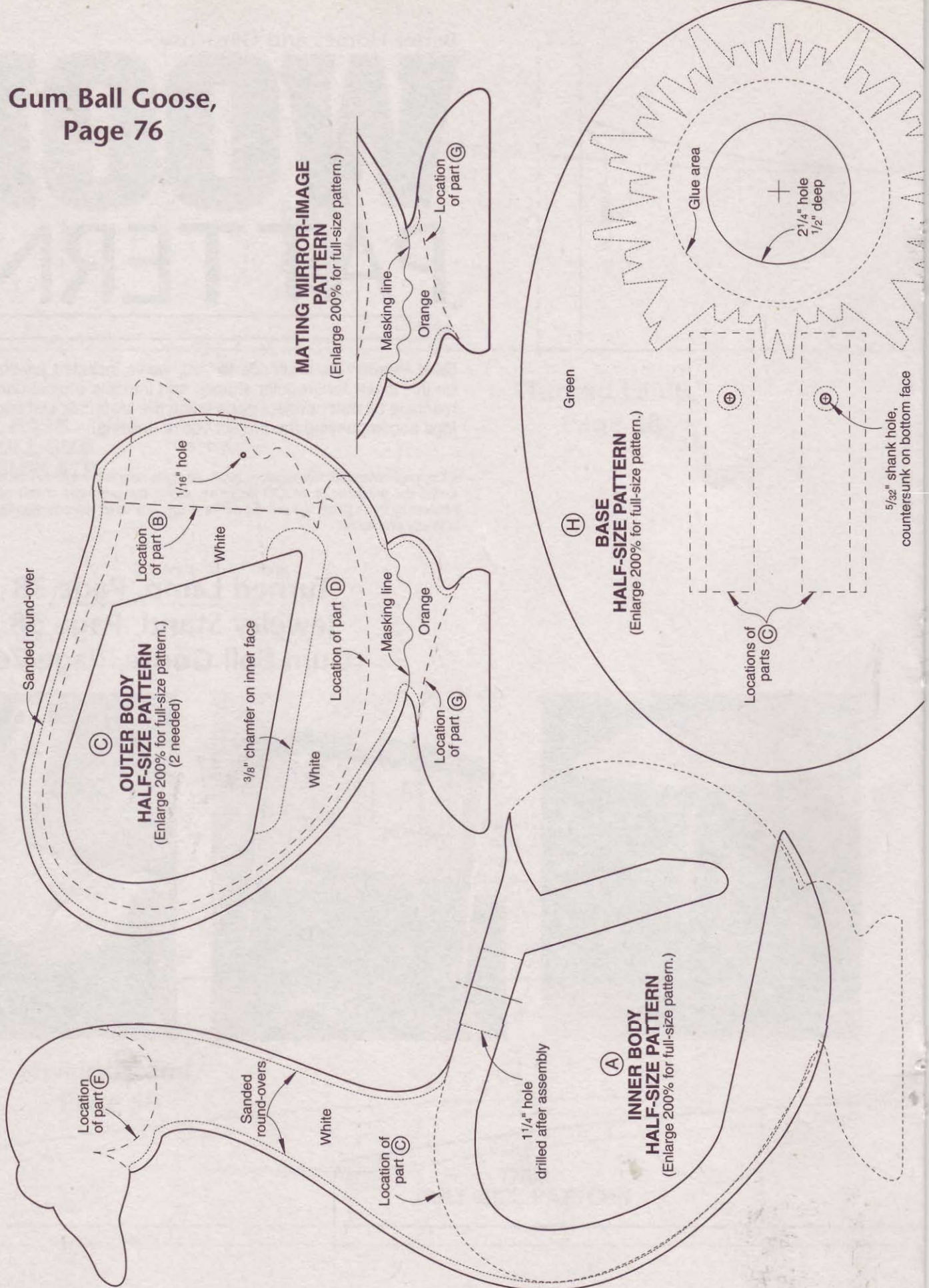

1/4"-THICK PART HALF-SIZE PATTERNS (Enlarge 200% for full-size patterns.)

1/4 x 12 x 12" Baltic birch plywood

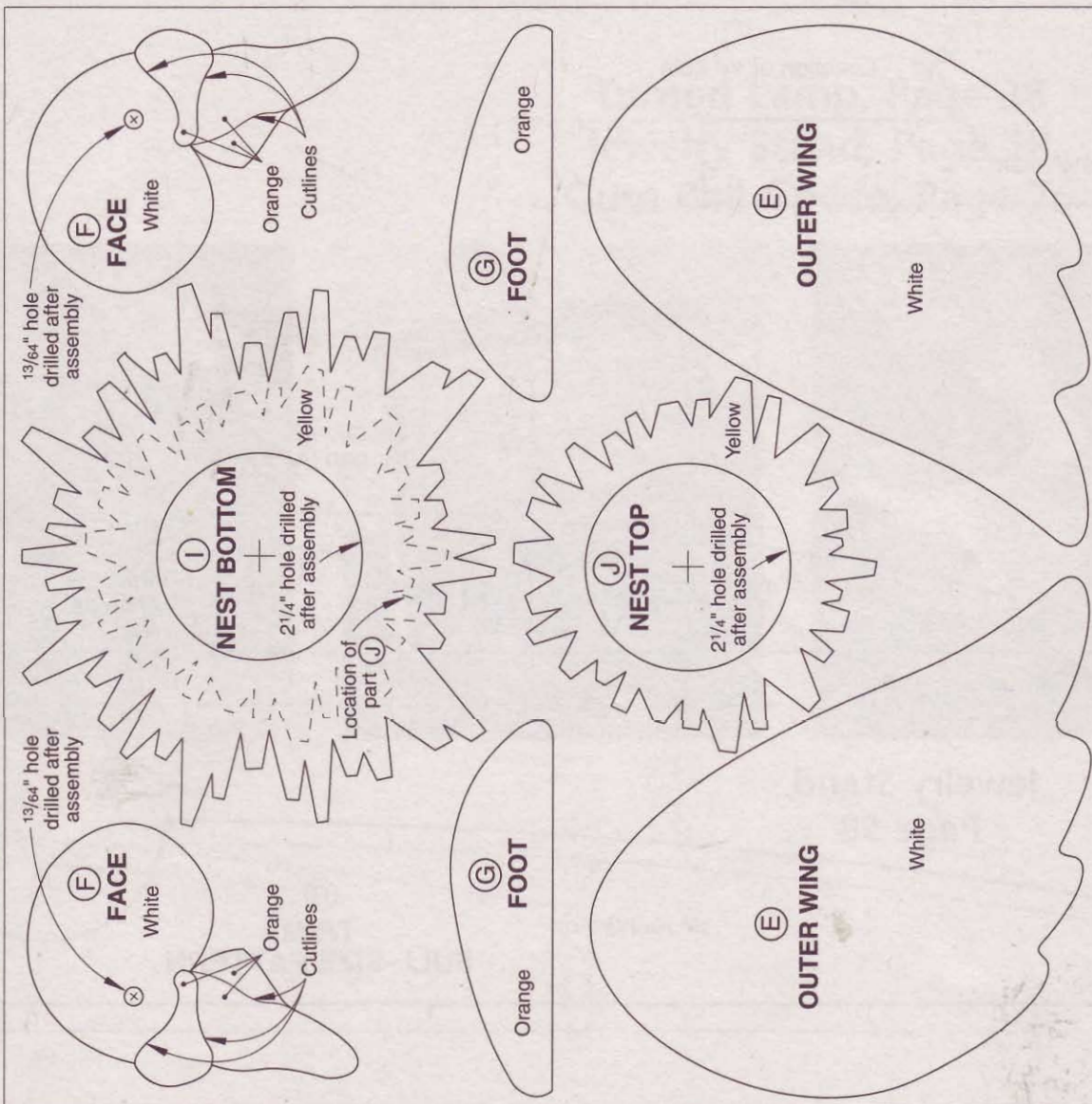

Location of part (I)

Green

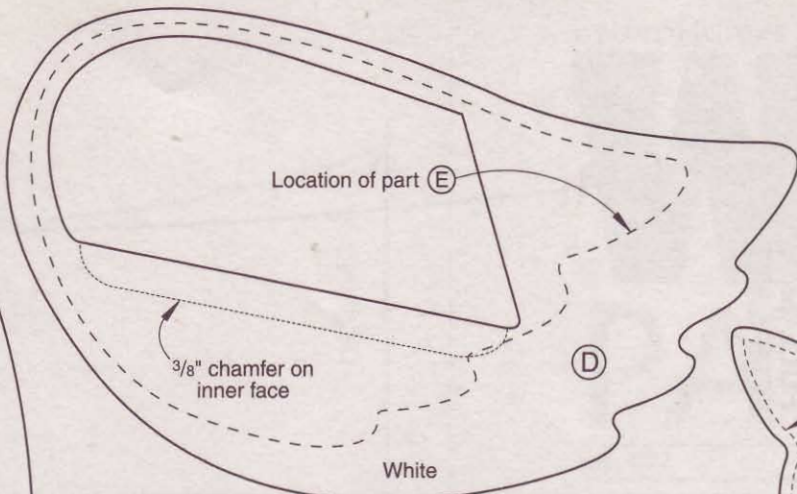

INNER WING HALF-SIZE PATTERN
(Enlarge 200% for full-size pattern.)
(2 needed)

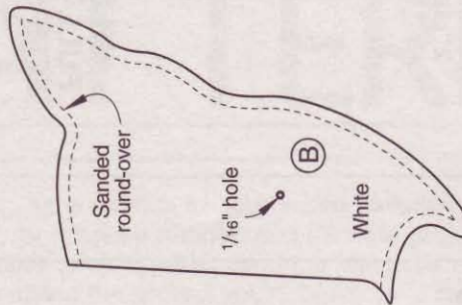

TAIL HALF-SIZE PATTERN
(Enlarge 200% for full-size pattern.)

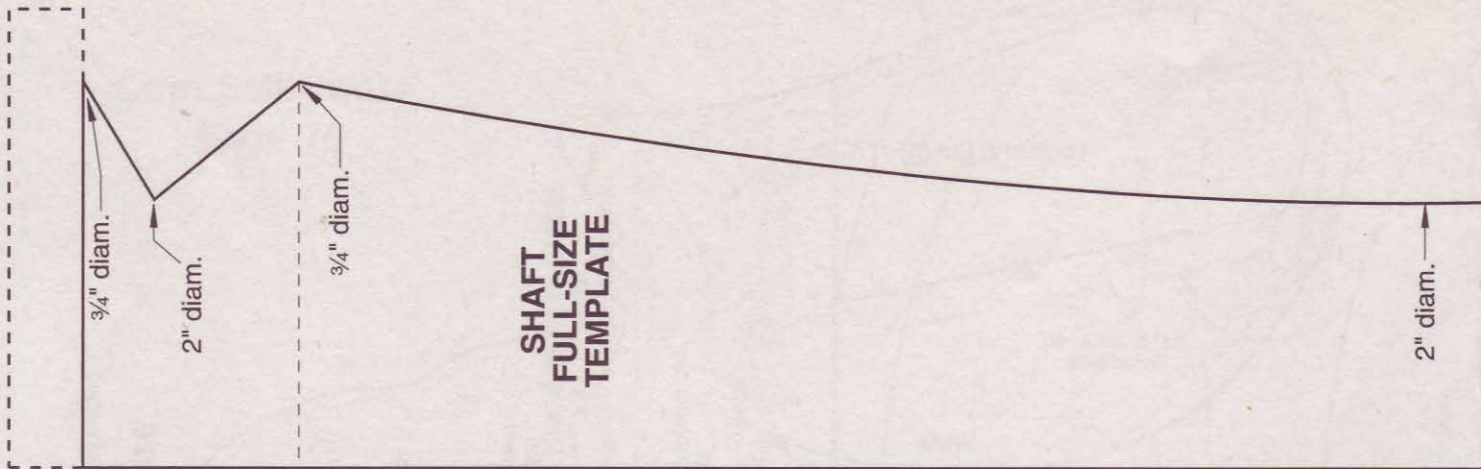

Turned Lamp,
Page 38

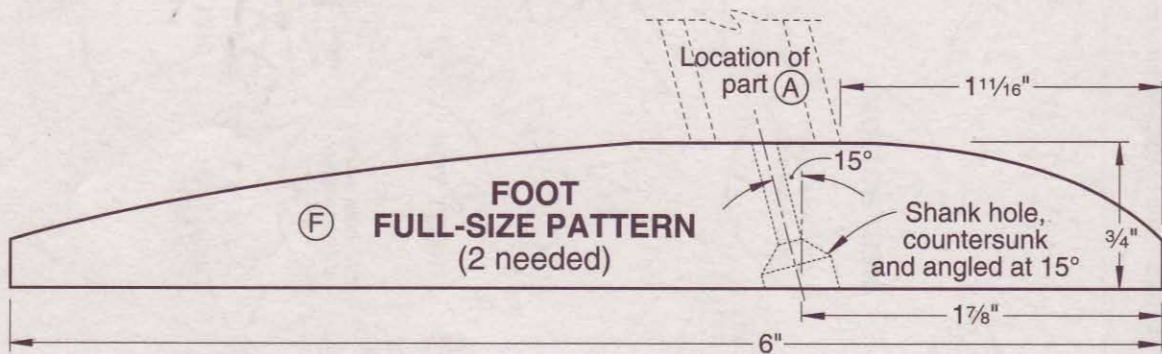
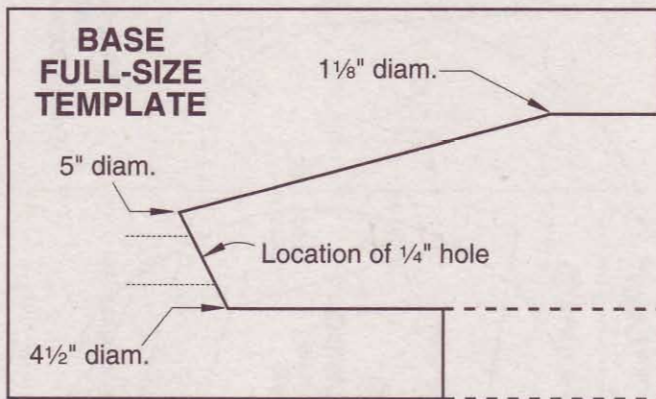

Jewelry Stand,
Page 58

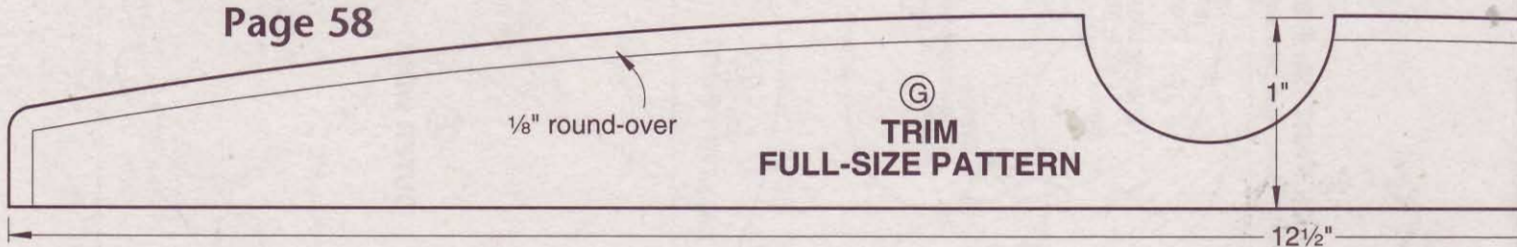

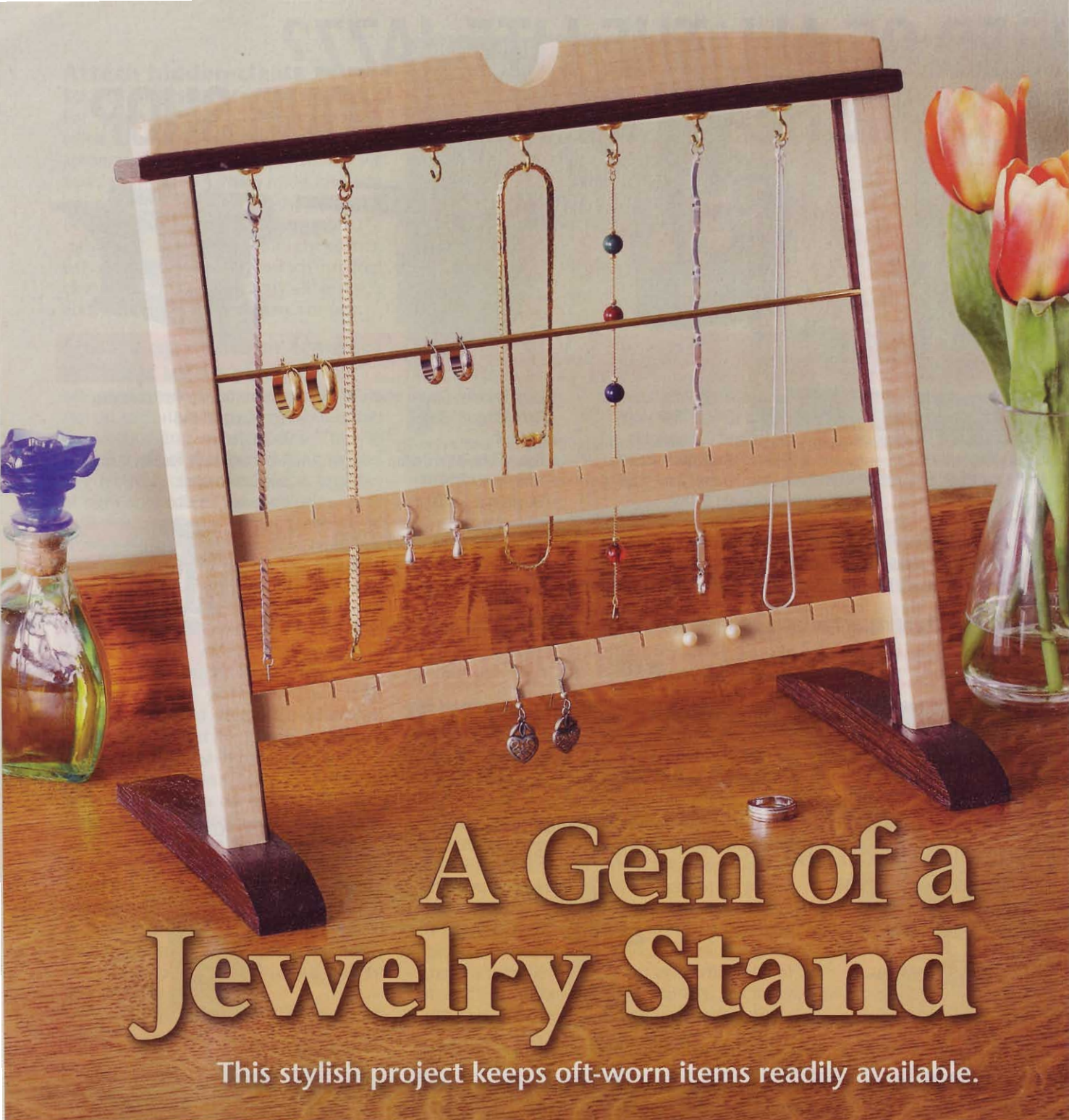

A Gem of a Jewelry Stand

This stylish project keeps off-worn items readily available.

Build this eye-catching stand from small scraps of contrasting woods such as this curly maple/wengé duo.

First, rough out the parts

1 Prepare a $\frac{3}{4}$ ×4×14" blank from each of two contrasting woods of your choice (or one of the combinations shown *above* and *opposite page, top*). You'll cut parts A, E, and G from one blank and parts B, C, D, and F from the other [**Cutting Diagram**, *page 61*]. We'll call the blank you choose for parts A, E, and G "blank 1" and the one for parts B,

C, D, and F "blank 2." Identify the pieces as you cut them from the blanks to keep the parts straight.

2 From blank 1, rip two $\frac{3}{4}$ "-wide pieces for the posts (A). You'll cut the posts and all other parts to the finished lengths [**Materials List**, *page 61*] later. Set the remaining blank aside. Using a standard $\frac{1}{8}$ "-kerf blade in your tablesaw, cut a centered $\frac{1}{4}$ "-deep groove along the

inside face of each post [**Drawing 1**] to receive the long and short fillers (B, C).

3 To make the long and short fillers (B, C) and cap (D), rip a $1\frac{3}{4}$ "-wide piece from blank 2. Set the remaining blank aside. Resaw and plane the $1\frac{3}{4}$ "-wide piece to $\frac{3}{8}$ " thick. Then rip two $\frac{1}{8}$ "-thick strips for the fillers from the piece to fit into the grooves in the posts (A). (We made test cuts with scrap first

PROJECT HIGHLIGHTS

- Overall dimensions are 12 $\frac{7}{8}$ " wide x 6" deep x 11 $\frac{3}{4}$ " high.
- Materials needed: Two $\frac{3}{4}$ x4x14" contrasting wood blanks.
- Don't have the stock or hardware needed? See **Source** for kits that contain everything to build one or more of the project, including woods presanded to the finished thicknesses.

Skill Builders

- Learn how to quickly secure small parts when driving screws.
- Discover a safe way to rip thin strips with identical thickness.

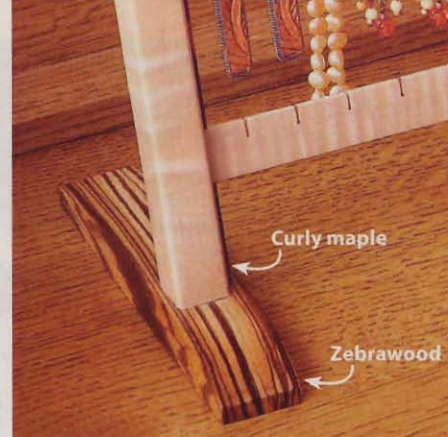
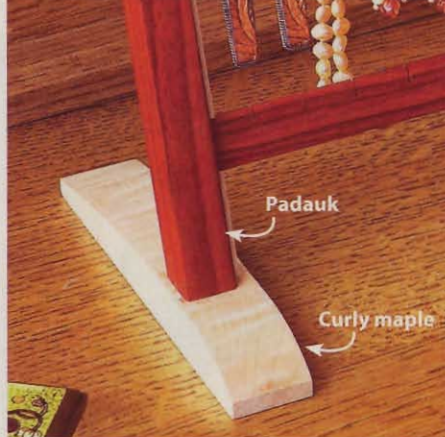

Pairing other contrasting exotic woods such as padauk or zebrawood with curly maple also looks great. Or try a domestic wood combo, such as cherry and ash (not shown).

1 EXPLODED VIEW

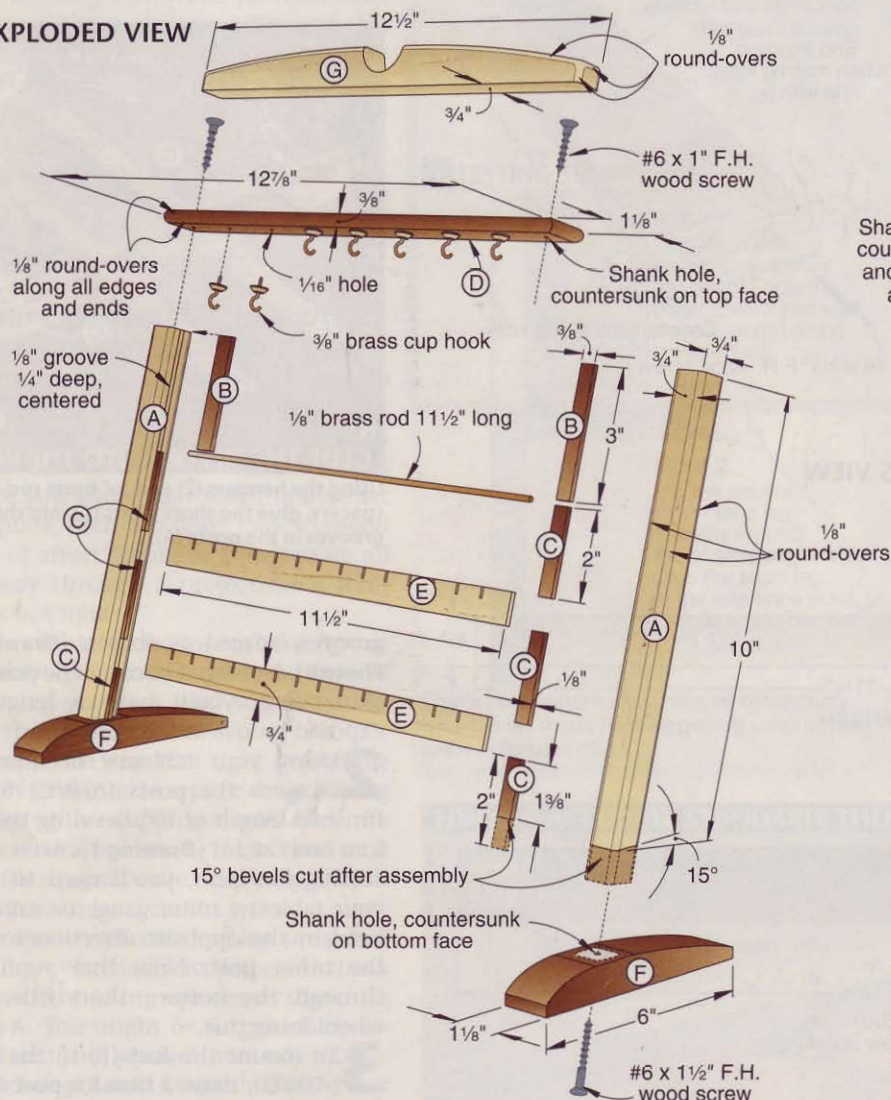

1a FOOT MOUNTING DETAIL

(Bottom view of right foot shown)

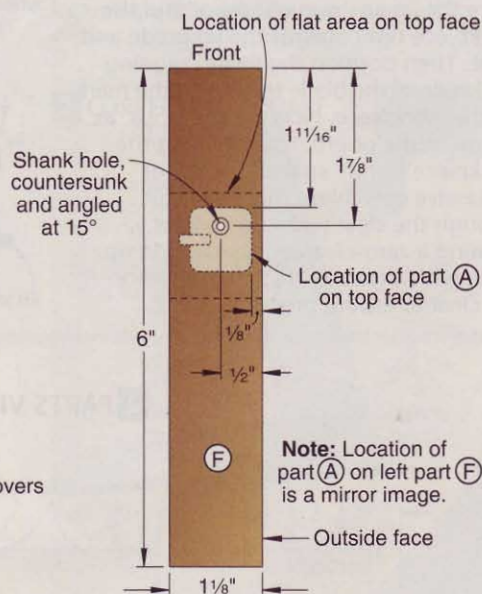

to ensure a snug fit in the grooves.) For a safe and easy way to rip the strips, see the **Shop Tip**, next page, top. Without changing the saw setup, rip two $\frac{1}{8}$ "-thick strips from blank 1 for the hangers (E). Now adjust your setup and rip the left-over $\frac{3}{8}$ "-thick piece from blank 2 to 1 $\frac{1}{8}$ " wide for the cap.

4 With the fence still positioned $\frac{1}{8}$ " from the blade, rip a piece from the

remaining blank 2 for the feet (F). Then reposition the fence and rip a 1"-wide piece from blank 1 for the trim (G).

Complete the machining

1 From each of the two $\frac{1}{8}$ x $\frac{3}{8}$ x14" strips for the fillers, crosscut a 3"-long filler (B) and three 2"-long short fillers (C). For identical lengths, use a stopblock and a miter-gauge extension.

2 Crosscut the cap (D) to the finished length of 12 $\frac{7}{8}$ ". Then crosscut the hangers (E) to 11 $\frac{1}{2}$ " long. Next, crosscut two 6"-long pieces from the piece for the feet (F). Now crosscut the trim (G) to 12 $\frac{1}{2}$ " long.

3 Rout $\frac{1}{8}$ " round-overs along the edges of the cap (D) [Drawing 1]. Then round over the ends using a 150-grit sanding block. Mark centerpoints on the cap for $\frac{1}{16}$ " holes to mount $\frac{3}{8}$ " brass cup hooks [Drawing 2]. Drill the holes.

4 Lay out $\frac{1}{16}$ " kerfs $\frac{1}{4}$ " deep (for holding such items as studded earrings) on the face of a hanger (E), where dimensioned [Drawing 2]. To save time cutting the kerfs and to ensure identical kerf locations, adhere the two hangers together with double-faced tape. Cut each kerf in one pass with your bandsaw [Photo A]. You also can use a scrollsaw, but you'll need to make a couple of passes to form each kerf. Separate the hangers. Remove the tape.

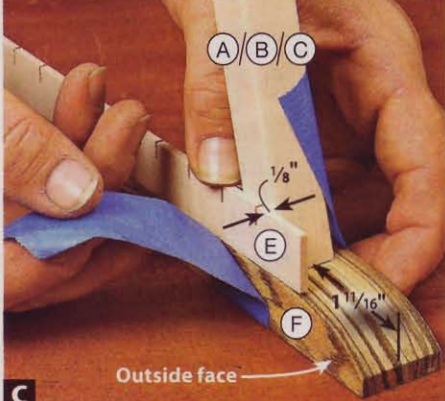

C
MOUNT THE FEET

Glue and tape an angled post (A/B/C) to a foot (F), using a hanger (E) to position the post $\frac{1}{8}$ " from the outside face of the foot.

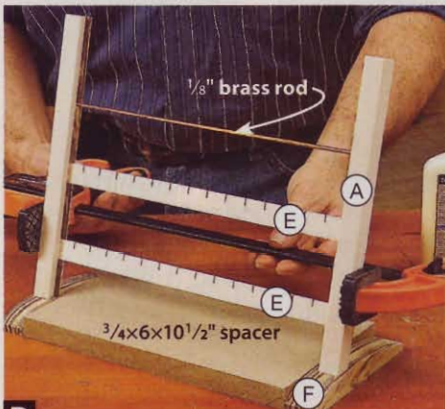

D
ASSEMBLE THE STAND

Using a spacer to square the assembly, glue and lightly clamp together the posts/feet (A/B/C/F), hangers (E), and $\frac{1}{8}$ " brass rod.

face of the post $\frac{1}{8}$ " from the outside face of the foot [Photo C]. After the glue cures, drill a countersunk mounting hole angled at 15° through each foot and centered into the post at the marked location. (For the #6 screws in this project, drill countersunk $\frac{3}{4}$ " shank holes with $\frac{3}{32}$ " pilot holes.) Drive the screws. To quickly bond the posts, see the **Shop Tip**, above.

4 To assemble the posts/feet (A/B/C/F), hangers (E), and $\frac{1}{8}$ " brass rod, cut a $6 \times 10 \frac{1}{2}$ " spacer from $\frac{3}{4}$ " scrap to fit between the feet (F) and keep the assembly square. Apply a small amount of glue in the grooved openings in the posts (A) for the hangers only. Then assemble and clamp the parts together [Photo D], applying light pressure to prevent distortion.

5 Mark a centerpoint at each end of the cap (D) on the top face for a countersunk mounting hole [Drawing 2]. Apply glue to the top ends of the posts (A). Then center the cap, end to end and front to back, on the posts, and tape it in place. (Again, to save time, you can use the quick-bond technique, as

SHOP TIP

A super-fast way to bond small parts

When you need to glue-and-screw small parts together, such as the feet (F) to the posts (A), you have to let the glue cure before drilling the mounting holes and driving the screws to ensure that the parts do not slip out of position or separate. You can save hours of downtime by bonding the parts with a fast-drying, gel-type cyanoacrylate (CA) glue instead of yellow or white woodworking glue. After applying the CA glue as directed, hold the parts firmly together for 30 seconds to ensure that the glue grabs. Then clamp or tape the parts, as appropriate, and set them aside for five minutes to let the bond fully develop.

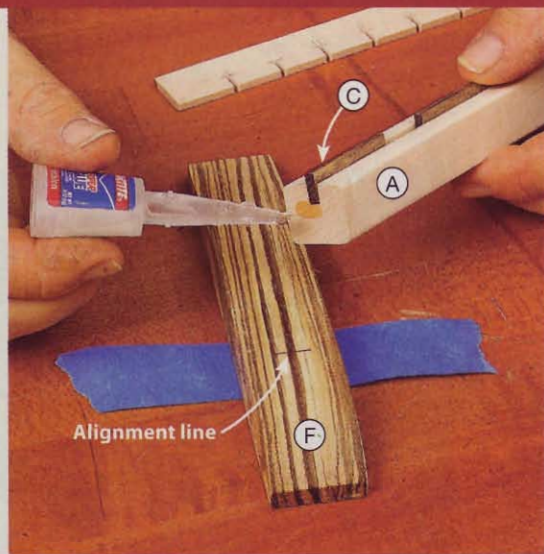

Cutting Diagram

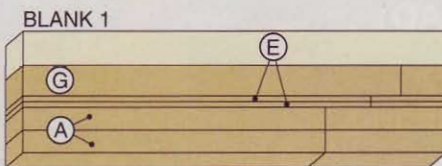

$\frac{3}{4} \times 4 \times 14$ " (.38 bd. ft.)

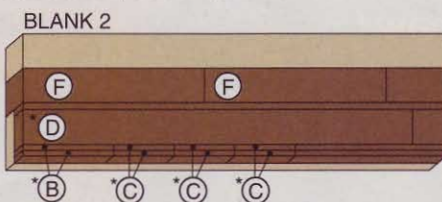

$\frac{3}{4} \times 4 \times 14$ " (.38 bd. ft.)

*Plane or resaw to the thicknesses listed in the Materials List.

Blank 1 end view

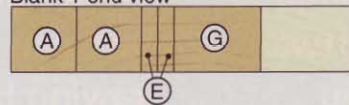

Blank 2 end view

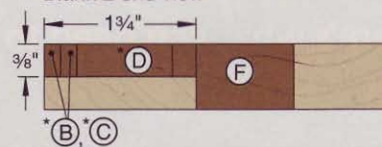

Materials List

Part	FINISHED SIZE			Matl.	Qty.
	T	W	L		
A* posts	$\frac{3}{4}$ "	$\frac{3}{4}$ "	10"	C	2
B* long fillers	$\frac{1}{8}$ "	$\frac{3}{8}$ "	3"	C	2
C* short fillers	$\frac{1}{8}$ "	$\frac{3}{8}$ "	2"	C	6
D* cap	$\frac{3}{8}$ "	$1 \frac{1}{8}$ "	$12 \frac{7}{8}$ "	C	1
E* hangers	$\frac{1}{8}$ "	$\frac{3}{4}$ "	$11 \frac{1}{2}$ "	C	2
F* feet	$\frac{3}{4}$ "	$1 \frac{1}{8}$ "	6"	C	2
G* trim	$\frac{3}{4}$ "	1"	$12 \frac{1}{2}$ "	C	1

*Parts initially cut oversize. See the instructions.

Materials key: C—choice of such contrasting woods as curly maple and padauk, curly maple and purpleheart, ash and cherry, and curly maple and ash.

Supplies: Double-faced tape, spray adhesive, $\frac{1}{8}$ " brass rod 36" long, #6x1" flathead wood screws (2), #6x1 $\frac{1}{2}$ " flathead wood screws (2), #8x1 $\frac{1}{2}$ " flathead wood screws (2) for thin-strip ripping jig only, $\frac{3}{8}$ " brass cup hooks (7).

Blade and bit: $\frac{1}{8}$ " round-over router bit, $\frac{1}{4}$ " or $\frac{3}{8}$ " bandsaw blade.

Source

Wood/hardware kits: Each kit contains all of the needed stock, brass rod(s), and $\frac{3}{8}$ " brass cup hooks to complete the project(s). To build one jewelry stand, order kit no. 1771, \$17.95 ppd. To build five jewelry stands, order kit no. 1775, \$59.95. Specify the wood combination(s) for the selected kit (curly maple/wengé, padauk/curly maple, or curly maple/zebrawood). Part blanks are presanded to the finished thicknesses to simplify the project. Call or click Heritage Building Specialties; 800/524-4184, heritagewood.com.

Written by **Owen Duvall**
Project design: **Jeff Mertz**
Illustrations: **Roxanne LeMoine; Lorna Johnson**

Project Design Software Secrets

Computer-aided design (CAD) software will save you many hours at the drawing board and yield more-satisfying results. Here's what you need to know to get started.

Shift to extend select. Drag mouse to select multiple.



You've labored hour after meticulous hour designing your next project. Blowing eraser dust off the sheet, as you admire your creativity, it hits you: The proportions don't look right. Frustrated, you take out a clean sheet of paper and prepare for another evening of sketching, not building.

With a CAD program, however, a mouse and keyboard can fix in minutes what requires hours using pencil and paper. CAD programs also let you create detailed, full-size drawings of whole projects and project parts. And when you're finished, you can share electronic file copies of the project with friends by e-mail, or take those files to a print shop to make full-size patterns for cutouts, like the one shown on [page 64](#).

Find the right software

Powerful and expensive software, such as TurboCAD Professional, produce highly realistic drawings that can help a woodworking pro sell projects to clients,

as shown at the bottom of [page 64](#). But such robust programs also require more time and practice to master. Free or low-cost programs, such as SketchUp or DeltaCad, won't produce photo-quality illustrations from your drawings, but they have the sophistication to make working drawings. For help choosing a software package, see the chart [opposite](#).

Before you buy any software, check for downloadable free or trial versions. These range from complete programs, such as DesignCAD, that disable themselves after the trial period, to simplified versions of complete programs, such as Alibre XPress.

You'll also want a program that helps you learn how to use it. Interactive tutorials, like those available for SketchUp, let you practice each step during the lessons. With other programs, you can print a set of instructions to guide you through the learning process of drawing a project. Some include instructions for

getting started along with their written manuals. To prepare for your first lesson, learn frequently used terms, such as those listed in "Increase your vo-CAD-ularity," on [page 64](#).







You wouldn't buy a shop full of power tools and expect to master them only hours or days before a project deadline. So don't expect to shop for, load, and learn any CAD program when you feel hurried to design a project.

Ready, set, draw

Before you start, customize the program and the window where you'll do your sketching. For example, you can show dimensions in fractions instead of decimals and establish a drawing scale.

After completing your program's tutorials, practice making simple shapes. For example, learn to create lines of a set length, and then use snap tools to connect the ends. Then, move on to more complicated shapes, such as arcs or combinations of straight lines and curves. If

Pick the CAD software that's right for you

Design Software	Price	Training/Tutorials	Comments
 Alibre Design Workshop Alibre, Inc. 877-525-4273 or alibre.com	Free XPress version; \$500 for Alibre Design Workshop; \$995 to \$1,995 for pro versions.	Begin with a quick-start tutorial at alibre.com and advance to specific skills. For tips on designing specific objects, visit instructables.com/group/cad.	The Workshop version of Alibre Design Professional handles 2-D design and 3-D modeling. You can start simple for free and upgrade as your needs require and skills develop.
 AutoSketch vers. 9 Autodesk autodesk.com/ autocadlt	\$129	The program includes introductory tutorials. An application wizard simplifies the set-up for making drawings.	A low-cost but sophisticated option, especially for persons with AutoCAD experience. Though only a 2-D program, you can simulate 3-D views.
 CADPro 4 Delta Software International cadprosoftware.com	\$70 for the software alone; \$80 for a platinum package that includes training materials	CADPro4 Platinum comes with an interactive training CD. You also can print off handy reference cards.	A 2-D program with features and symbols for floor plan design, this is a low-priced option for woodworkers, too.
 DeltaCad vers. 6 Midnight Software deltacad.com	Download a free 45-day demo of the full version; \$40 for the full licensed version.	On-line tutorials can help you master the basics in only a day.	Straightforward toolbars with easy-to-understand symbols make this a good program for beginners and those who don't use 3-D modeling.
 DesignCAD 3-D Max (vers. 17) IMSI 800/833-8082 or imsisoft.com	\$50 for the 2-D version; \$100 for the 3-D Max version, available as a free 15-day trial download.	A \$50 CD provides about five hours of training to lead you from basic skills to the ability to make 3-D models from 2-D drawings.	A converter lets you turn scanned paper drawings into CAD files. This program also can be used to create sophisticated construction drawings and realistic models.
 Design Intuition GizmoLab, Inc. gizmolab.com	\$180. A trial version that doesn't print or save files can be downloaded.	The GizmoLab Web site offers free written tutorials.	Available in Mac or Windows versions. A cutting diagram feature allows you to create a materials list based on the project parts in your design.
 SketchUp Available as a download from Google.com	Free downloads can be upgraded to a \$500 full version.	Interactive tutorials let you practice skills as lessons are presented.	Windows and Mac versions are available. Not a drafting program, but handy for visualizing designs and adding dimensions.
 TurboCAD IMSI 800/833-8082 or imsisoft.com	\$45 for the 2-D Designer; \$150 for the Deluxe; and \$900 for the Professional.	IMSI offers a 2-D training guide for \$50 and a 2-D/3-D bundle for \$90. More detailed third-party training materials also are available.	Add-on packages include a Furniture Maker Plug-In (\$200). Both the Deluxe and Professional versions are 2-D/3-D and handle sophisticated designs. The sophistication of the Professional version makes it mainly for CAD pros.
 TurboCAD (Macintosh vers. 2) IMSI 800/833-8082 or imsisoft.com	\$100	No tutorials are available from IMSI for the Mac version. There is a 240-page user manual available for \$13.	With some 275 design tools, this is among the more sophisticated programs available for Macs, though still not on par with the Deluxe version for Windows.



Make your own super-sized part patterns using CAD drawings saved as PDF files that can be printed at a local copy shop.

your program allows 3-D modeling, learn to combine 2-D drawings and add colors or textures to create project models.

The digital difference

Once you're familiar with a program's features, practice drawing a real project. Before you begin a CAD drawing, know the style and size of your project plus details of the joinery you'll use. This can be anything from a quick pencil sketch to an existing *WOOD*® magazine-created design you'd like to customize.

We can't teach how to use every program, but we can outline how the CAD drawing process works in general. For a demonstration, we'll recreate the plant stand project from page 79 using the free version of SketchUp. We attempted this only after completing each SketchUp tutorial and practicing with the program's tools.

To prepare, we first set the template under "preferences" to "woodworking" for the appropriate scale to draw the plant stand.

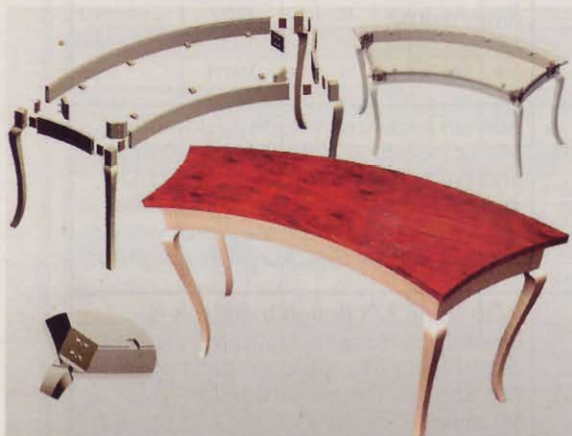

Kelsey Wood Works custom furniture makers used Alibre Design to design this table for a customer. The firm offers tutorials at kelseywoodworks.com.

Increase your vo-CAD-ulary

By learning a few basic CAD terms, you'll better understand a program's tutorials and instructions.

File format. Different computer programs use different ways to save CAD files and those methods are often defined as a three-letter suffix after a period on a file name. For example, TurboCAD might save a file named "cabinet" as "cabinet.tcw" (for TurboCAD for Windows) while AutoCAD might use the DXF (drawing exchange format) to call it "cabinet.dxf." Many programs have converters to turn one file format into another or into a PDF (portable document format) file that can be read but not altered.

Fillet. Think of this as a round-over bit for two-dimensional drawings. Using a fillet tool, you can connect two lines that meet at 90° with an arc instead of an angle.

Grid. Like lines on graph paper, a grid helps guide you as you work. These grids can vary in size and be set so the end of a line automatically "snaps" to an intersection on the grid, like a pencil that knows where to stop. For tabletop projects, use a 1/16" grid. For larger projects, you can use 1/4" grids.

Hatching. A pattern that fills squares, circles, and other areas. On official blueprints or site plans, hatch patterns represent various surfaces or materials. Hatching is different from a fill pattern used to add interest or realism.

Inference line. These temporary lines signal when an object aligns with another object, a line is drawn at a commonly used angle, or meets a certain condition. For example, this inference line indicates when the rectangle's dimensions reach a 1:1.618 ratio, or "golden section."

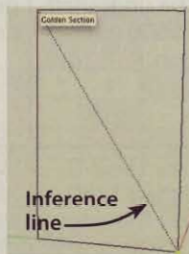

Keyboard shortcut. Menus and icons make a program easy to learn, but slow to use once you're proficient. Quickly typing a key combination instead of stopping to move your mouse and click on a word or icon greatly increases how fast you can create a design.

Layer. This is the electronic version of transparent acetate sheets over a drawing. By adding different objects to separate layers on a cabinet, for example, you could create a carcass on one layer and the cabinet doors on another layer. This lets you modify one part without affecting the rest of the design.

Library. Here's a real time-saver that lets you reuse existing drawings or parts of drawings. For example, a raised-panel door drawing stored in your library can be copied into another project design and resized instead of being redrawn. Handy parts to file away include drawers, casters, and table legs.

Offset. This is a tool or setting for drawing parallel and concentric lines. Imagine drawing two concentric rectangles to represent a raised-panel door. You might draw a rectangle (the green one) for the outside dimensions of the door frame. Then use an offset tool or setting to create a second rectangle (the red one) a distance from the first that is equal to the width of the door frame.

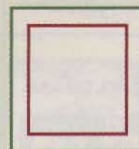

Mirroring. This handy tool lets you duplicate and reverse a part or collection of parts, such as the plant shelf legs and shelf sides shown in Step 5 *opposite*. This saves you the trouble of rotating and moving duplicate parts using several different steps and tools.

Snap. When you draw a line on a piece of paper, you physically slow your pencil and stop it at a point on your graph paper. Programs use a snap tool to automatically make lines the correct length and angle. You also can snap two lines together at an exact point, or snap the edges of two squares to form a single line.

View. As in hand-drawn plans, this is the perspective you see the object you're drawing. These include the top, bottom, front, back, and sides. But with 3-D programs, you can take an object drawn in two dimensions and view it at an angle as a three-dimensional object. Programs also allow you to zoom in close or back away from an object, depending on the amount of detail you need to see.

Go from blank screen to a CAD drawing in 10 steps

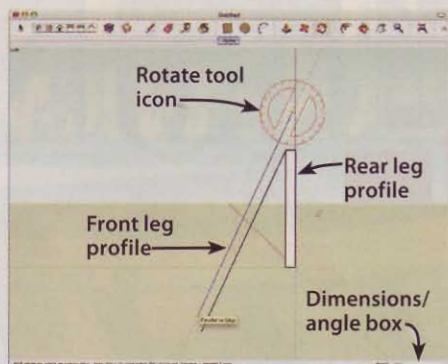

1 Starting from this side view, we used the rectangle tool to draw the rear leg's face. You can save time by typing in dimensions or angles that are displayed here in the lower right corner. To draw the parallelograms that form the angled front legs, we first drew two oversized vertical lines, and angled them 25° using the rotate tool. Then we moved the right one until it attached to the upper left corner of the rectangle. Using the tape measure tool, we placed the left angled line 1/2" from the right one—the width of our part.

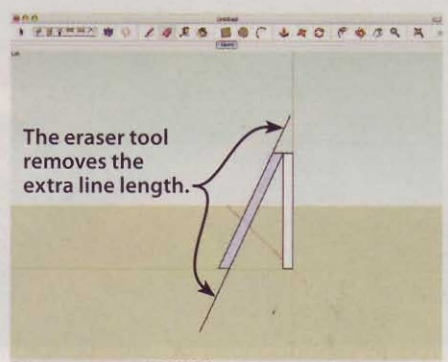

2 Using the line tool, we joined the angled lines with two horizontal lines. The snap feature automatically helps place the lines.

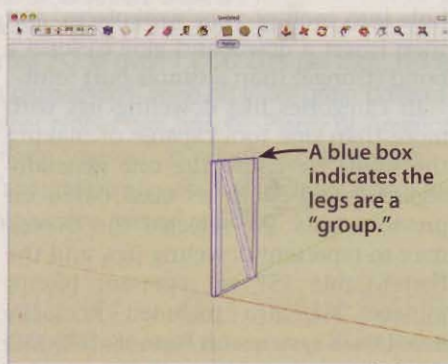

3 Most programs let you group shapes or parts, such as the two legs, making them easier to move, alter, or copy. SketchUp's push/pull tool turns the 2-D shapes into 3/4"-thick 3-D pieces.

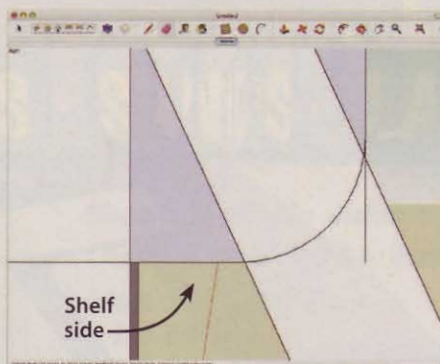

4 After adding the shelf sides and then using the push/pull tool to make them the correct thickness, we zoomed in on the top-shelf side and added a 2"-radius corner. CAD programs let you combine lines, arcs, circles and other shapes to form more complex objects. The more sophisticated the program, the greater the number of drawing and editing tools. Among them are tools for filleting corners, as shown above.

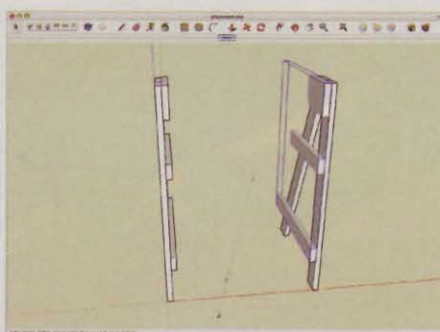

5 The group and copy tools simplify copying the legs and shelf sides, though not as quickly as with a mirror tool on some programs. Using the move tool, we connected the copied group of shelf sides to the legs on the right.

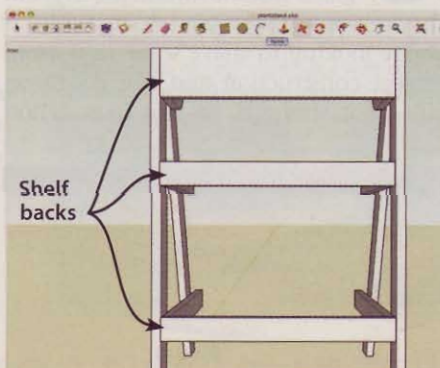

6 Unlike paper drawings, CAD lets you use existing lines and corners as starting and ending points for adding lines. To add the three shelf backs, we just stretched lines between the shelf sides and pulled the rectangles into three-dimensional parts.

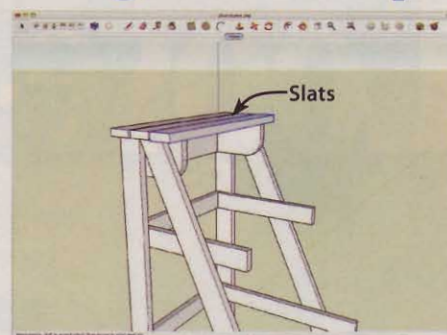

7 CAD software duplicates parts fast. Just copy and paste one finished slat to complete the top shelf.



8 By shortening copies of the original slat, it's easy to add parts to the middle and bottom shelves.



9 Use the brush tool to add a wood tone. Switch to the orbit tool to view your project from any angle.



10 Use the dimension tool to insert project measurements; then print out your drawing. 🌳

Loose-tenon Tools

Is Festool's new Domino joinery tool worth its \$700 price tag? We compared it head-to-head with three other tools that create similar joints.



Watch a FREE 7-minute video on Loose-Tenon Tools at woodmagazine.com/videos.

LOOSE TENONS FIT MORTISES TIGHTLY

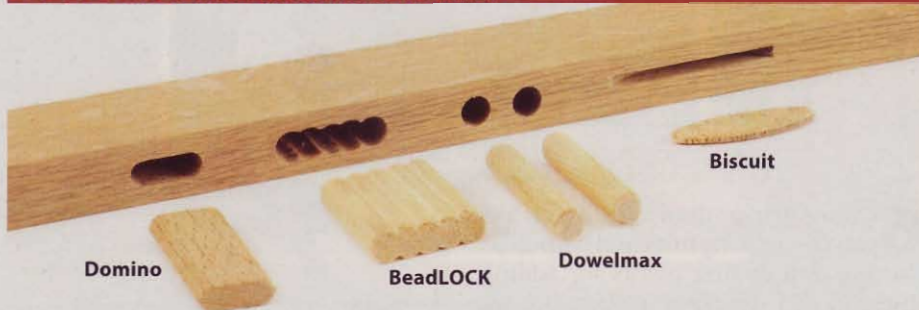

Shown are four types of loose tenons with their mortises, as machined by the tools in our test.

Our tests prove it: Mortise-and-tenon joints are the strongest glued wood-to-wood joinery, but they're time-consuming to cut and fit. If you're looking to shave some time from project construction and still get favorable joint strength, try out loose-tenon

joinery. Also called floating tenons, these wood inserts fit into quickly machined, mating mortises, as shown below.

Dowel joints provide a perfect example of a loose-tenon joint. You drill a hole into each of your workpieces, and then insert a dowel and glue to form a bond stronger than a simple butt joint.

In categories like doweling jigs with more than one tool capable of making the joint, we chose the one generally regarded as best in its class based on previous tests. We selected the Dowelmax to represent doweling jigs, and the Porter-Cable 557 to represent biscuit joiners. We also included Rockler's BeadLOCK system and Festool's DF500Q Domino, a new power tool that operates like a biscuit joiner but uses a special spiral router bit to cut its mortise.

Continued on page 68

A quick look at 4 loose-tenon systems

BeadLOCK 20772, \$47
800/279-4441; rockler.com

Included with jig: $\frac{3}{8}$ " and $\frac{1}{2}$ " drill guides and bits, 2' length of $\frac{3}{8}$ " and $\frac{1}{2}$ " tenon stock, shims for fine-tuning a mortise location on your workpiece.

Optional accessories: $\frac{3}{8}$ "x2' tenon stock, \$6; $\frac{1}{2}$ "x2' tenon stock, \$7; $\frac{3}{8}$ " tenon-making router bit, \$45; $\frac{1}{2}$ " tenon-making router bit, \$90.



The Lowdown: BeadLOCK makes a strong joint because the shape of the tenon provides more gluing surface than a traditional tenon of the same size. And you can make mortises as deep as the drill bits allow because you cut tenons to length from longer stock.

However, we found too much play in the mortises when we inserted the tenons, resulting in up to $\frac{1}{16}$ " of twist in 2"-wide workpieces. And, because the faceplate extends beyond the drill guides, it limits the jig's versatility. For field joints, such as the shelves in a bookcase, you'll need to block up the jig to make it work. We'd also like a stop collar for drill-bit depth control.

Dowelmax, \$240
877/986-9400;
dowelmax.com

Included with jig: $\frac{3}{8}$ " drill guides and bit, stop collar, right-angle bracket, aluminum spacer blocks, brass washers, indexing pin, indexing extension rod, hex wrench, $\frac{3}{8}$ " dowels, instructional DVD.

Optional accessories: $\frac{1}{4}$ " kit (drill guides, bit, stop collar, indexing pin, dowels), \$60; refill packs of dowels, \$6-8.

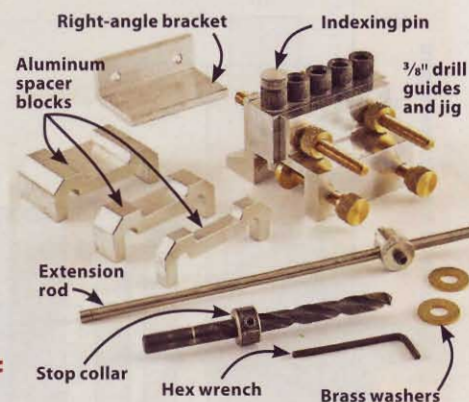

The Lowdown: Dowelmax brings to doweling jigs a level of precision that has eluded others. What sets Dowelmax apart? Five guides of identical dimension allow you to drill up to five holes of the same diameter without moving the jig. And, the indexing pin slips into any of the guides to reference from a workpiece edge, end, or face or into another hole.

And it's not complicated to use, until you get into angled joints (think chair arms into leg posts) that require you to align and shim it with wedges. Still, most typical furniture joinery is a breeze with Dowelmax. Get the $\frac{1}{4}$ "-dowel kit to add versatility on thinner stock.

Porter-Cable 557, \$220
888/848-5175; porter-cable.com

Included with tool: 2" and 4" blades, dust bag, hex wrench, storage case.

Optional accessories: 1,000 assorted biscuits, \$20; 150 #0 biscuits, \$7; 125 #10 biscuits, \$7; 100 #20 biscuits, \$7; 175 face-frame biscuits, \$7.

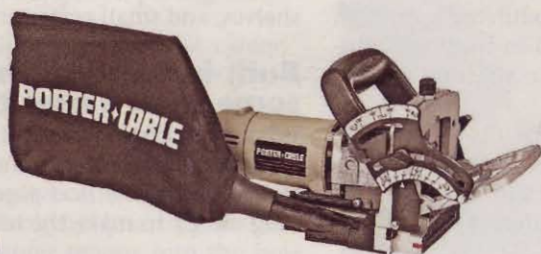

The Lowdown: Not many tools can beat a biscuit joiner for speed and efficiency in creating joints, and it's a versatile tool that's almost intuitive to use. Biscuits ($\frac{1}{8}$ "-thick, football-shaped tenons made of plywood or compressed wood fibers) remain a great way to reinforce miters, bevels, and edge-to-edge joints, and they also work well for case joinery. Just don't put them in joints that will have to endure high amounts of stress or weight (for example, chairs, benches, beds, or dining table structural joints).

Because biscuit joiners cut mortises slightly oversized—leaving room for the biscuit to expand as it absorbs moisture from the glue—you have a little wiggle room to line up joints as you clamp them. We also use a biscuit joiner to cut slots in aprons or carcasses for tabletop fasteners. You can use three size biscuits (0, 10, 20) with the 4" blade, or switch to the 2" blade for smaller biscuits that will fit into narrower workpieces, such as face frames. Two more settings are used for installing hinges and knockdown hardware.

Festool Domino DF500Q, \$700
888/337-8600; festoolusa.com

Included with tool: 5mm bit, right-angle fence, wrench, case.

Optional accessories: Case of 1,105 assorted tenons and 4 bits (5, 6, 8, 10mm), \$240; 1,800-count pack of 5x30 tenons, \$65; 1,140-count pack of 6x40 tenons, \$65; 780-count pack of 8x40 tenons, \$65; 600-count pack of 8x50 tenons, \$65; 510-count pack of 10x50 tenons, \$65; Trim Stop (for narrow parts), \$40; Cross Stops (indexing extensions), \$50.



The Lowdown: This revolutionary tool looks and operates like a biscuit joiner. But, instead of cutting a thin, radiused slot, it uses a spinning, oscillating spiral bit to plow a flat-bottomed mortise that receives the domino-shaped, solid-beech tenons. You can take the tool to whatever you're working on, rather than having to take the workpiece to the tool. All the settings are metric.

It's best to hook a vacuum to the port for complete dust and chip extraction; we were able to plug the chute without a vacuum, and that created alignment difficulties. The tenons fit so tightly into the mortises you'll need pliers to pull them out after a dry-fit. Still, that won't prevent a good glue bond; just be sure to saturate the mortise walls with glue using a small flux brush for best results.

BREAKAGE TESTS CONFIRM LOOSE-TENON STRENGTH

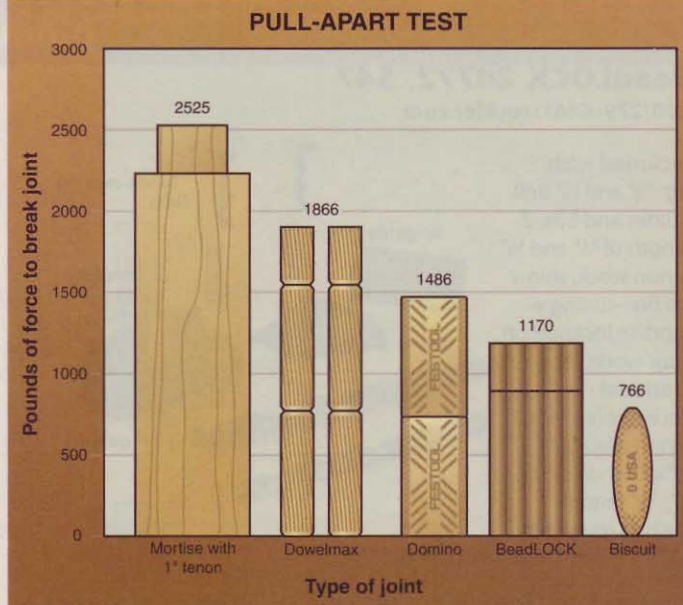
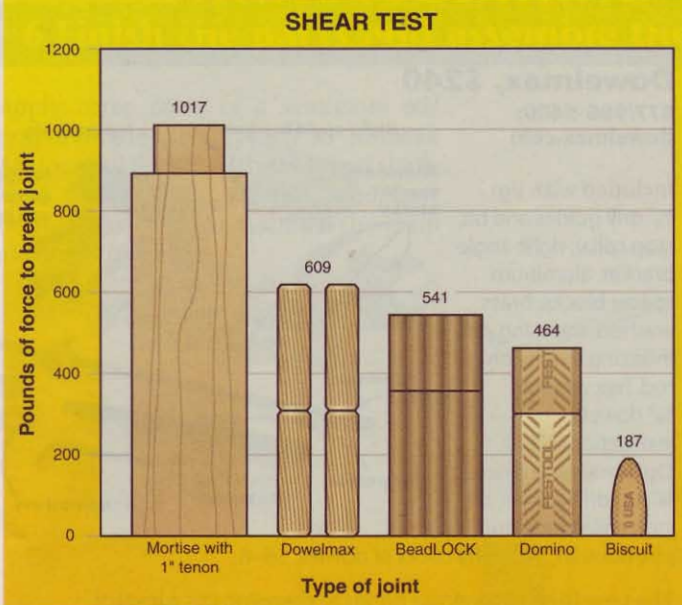

We found satisfactory joint strength—with most

Speed and convenience mean nothing if these tools can't produce joints strong enough to hold up in furniture, cabinets, and anywhere else you'd use a mortise and tenon. To test the integrity of joints made with each unit, we made T-style butt joints (like those on a cabinet face frame) in 2"-wide red oak using yellow woodworking glue. We then broke them by applying force using a hydraulic testing machine at Iowa State University's Structural Materials Testing Facility, testing in the same manner as the "Wood-joint torture test" from issue 173 (November 2006).

In our shear test, the machine held the vertical stile fast while the cylinder pressed the horizontal rail down until it broke. We stopped after the machine

recorded its maximum pounds of force. For the pull-apart test, we secured the rail to the cylinder and slowly raised it until the joint came apart. Again, we stopped each test after we achieved maximum pounds of force.

As the charts *above* show, all of the joints made with the tested tools broke under less force than the true mortise-and-tenon joints. But in all BeadLOCK, Domino, and Dowelmax joints the wood failed before the glue joint. We're confident they exhibited enough strength to serve well in furniture joinery, especially when sharing stresses with multiple joints.

Joints made with biscuits did not fare as well. In each test the biscuit broke apart or split rather than the glue. The amount of force required to break those

joints was low enough to make us wary of using biscuits in a joint that will endure lots of stress. For example, we would not use biscuits for the frame assembly of a chair, or for joining the legs and aprons of a large dining table. Stick to using biscuits where their strength will be plenty adequate. For example, biscuits have all the holding power you'll need for not only making face frames, but also attaching them to cabinets. You also can use them for drawer dust frames, picture frames, shelves, and small coffee or end tables.

Built-in features make some tools easier to use

What a biscuit joiner lacks in strength, it makes up for in convenience. The chart at the top of the *next page* shows how long it took to make the test joints, and

LOOSE-TENON JOINTS HOLD FAST WHILE WOOD FAILS



Both the BeadLOCK and Domino glue joints held fast in the pull-apart test. Note how the stiles broke apart at the bottom of the mortises.



In the shear test, Domino's sample broke along the stile's grain. The Dowelmax sample failed when wood between the dowels gave way.

TIME REQUIRED TO MAKE SIX JOINTS

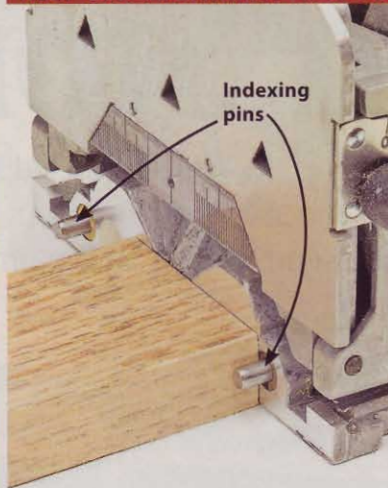
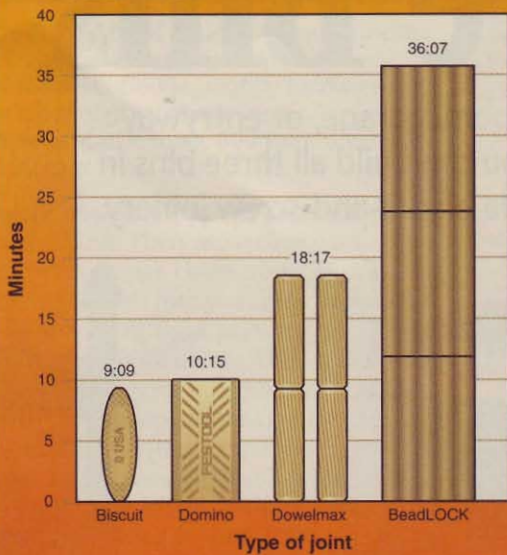

Using the Domino's retractable indexing pins to reference from workpiece edges or ends ensures perfect alignment of the mortises.

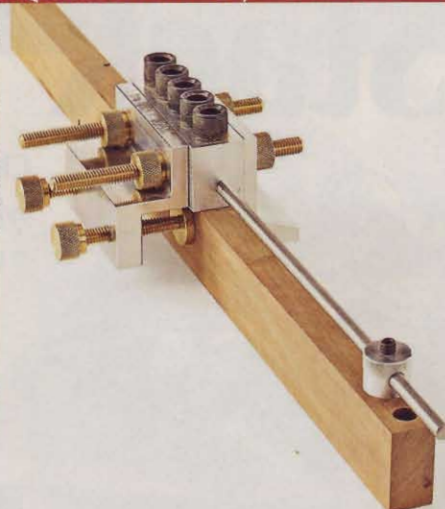

Dowelmax's extension indexing rod allows you to accurately reference the jig from previously drilled holes, as shown, or the end or edge of a board.

the biscuit joiner was the quickest of the four. By comparison, Festool's Domino was just a minute behind.

But Domino and Dowelmax each have indexing systems that save you time because you don't have to measure and mark the locations of your mortises. Spring-loaded indexing pins on the Domino's front face, *above center*, allow you to align the tool quickly from any edge, end, or other mortise. Do the same for both workpieces and you'll get a flawless fit. For extra reach, attach the optional fences with additional pins.

Dowelmax features an indexing pin that works similarly to the Domino. Simply drop it into one of the five drill guides and it becomes a stop to register against a workpiece's edge or end or from another dowel hole. Use the 9" extension rod, shown *above right*, to index from farther away, or substitute a 1/4" dowel for the steel rod and add even more length.

Our recommendations fit two types of budgets

When a tool comes along that saves time while increasing precision, we want it in our shop. In this test we found two such tools: the Domino and Dowelmax. Both create joints exponentially quicker than you can cut the same number of mortise-and-tenon joints—and you still get dependable joint strength.

Our tester, Design Editor Jeff Mertz, built the Arts and Crafts rocking chair from issue 146 (December 2002) and replaced all 26 mortise-and-tenon joints, as well as eight of the 24 non-structural screw joints, with Domino joints—and

he built the whole project in eight hours (excluding finishing). Jeff estimates it would have taken him 16 hours to build it according to the original plans. Couple that with the quick indexing capabilities, ease of use, choice of five tenon sizes, and complete dust and chip extraction (with an attached vacuum), and the Domino becomes our first choice among the four tools. And you don't have to be a professional furniture maker to justify this tool's hefty price tag: just someone who values their time as much as their work.

However, for about one-third the Domino's price you could get a Dowelmax, which ran toe-to-toe with the Domino for accuracy and indexing ability. You only need a handheld drill to get started. The Dowelmax proved to be free of the problems common to other doweling jigs: poor alignment, lack of indexing, and single sleeves per size. Jeff said he would not hesitate to build another rocker using the Dowelmax—high praise for a doweling jig.

Written by **Bob Hunter** with **Jeff Mertz**
Illustrations by **Tim Cahill**

TIME-SAVING LOOSE-TENON TOOLS

BRAND	MODEL	WORKPIECE CAPACITIES			PERFORMANCE GRADES (4)						
		MINIMUM WIDTH, INCHES (1)	MINIMUM THICKNESS, INCHES (2)	TENON COST PER JOINT, CENTS (3)	STRENGTH OF JOINT	EASE OF ALIGNMENT	SPEED OF MAKING A JOINT	VERSATILITY	WARRANTY, YEARS (5)	COUNTRY OF ASSEMBLY (6)	SELLING PRICE (7)
BEADLOCK	20772	1 3/8*	3/4	17	A-	C	C	C	1	U	\$47*
PORTER-CABLE	557	2 5/16**	1/2	2	C	A-	A	B	1	M	\$220
DOWELMAX		1 1/2***	3/4*	8	A	A-	B	B+	L	C	\$240
FESTOOL	DF500Q	1	1/2	8	A-	A	A-	A	3	G	\$700

NOTES:

- 1. (*) With 3/8" thick tenon
(**) With #0 biscuit
(***) With two 3/8" dowels
- 2. 1/2" thickness using 1/4" dowels
- 3. Prices based on 3/8" x 1 1/2" BeadLOCK tenon, two 3/8" dowels for Dowelmax, one 8 x 50 mm domino for Festool, and one #0 biscuit for Porter-Cable.
- 4. A Excellent
B Good
C Fair
- 5. (L) Lifetime warranty
- 6. (C) Canada
(G) Germany
(M) Mexico
(U) United States
- 7. Prices current at time of article production, and do not include shipping where applicable.
(*) 3/8" and 1/2" drill bits and guides; 3/8" model #63686, \$30.

Stack 'n' Store Bins

Clean up the clutter in a kid's room, garage, or entryway with this stacking organizer. You can build all three bins in a weekend, thanks to the simple biscuit-and-screw joinery.



The bins stack and align in a jiffy. They easily screw together from the inside for solid stability.

PROJECT HIGHLIGHTS

- Overall dimensions are 31 $\frac{1}{8}$ " wide x 12 $\frac{3}{4}$ " deep x 36 $\frac{3}{4}$ " high.
- Materials needed: You can **build a trio of bins** from one 4x8 sheet of $\frac{3}{4}$ "-thick medium-density fiberboard, a half-sheet of $\frac{1}{4}$ " hardboard, and a small piece of poplar, **for less than \$35**.
- Need more storage? You can stack up to six bins. When doing this, make sure you secure the unit to the wall studs with an anti-tip safety cable kit (available at your local home center).

Skill Builder

- Learn how to safely and accurately plunge slots into the edges and faces of parts with your biscuit joiner.

Start with the MDF parts

1 From $\frac{3}{4}$ " medium-density fiberboard (MDF), cut the dividers (A), ends (B), tops/bottoms (C), and fronts (D) to the sizes listed [Materials List, page 73]. To get all of the parts for the three bins from a 4x8 sheet of MDF, see the **Cutting Diagram**, page 73. To ensure proper support and safety when crosscutting the large sheet, see page 9.

MITER-CUT THE DIVIDERS AND ENDS

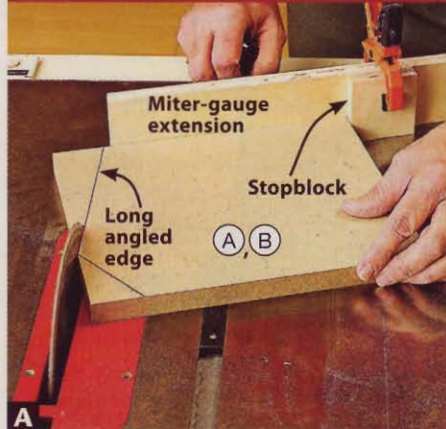

Angle your miter gauge to align the blade with the layout lines on the dividers (A) and ends (B), and miter-cut the parts to shape.

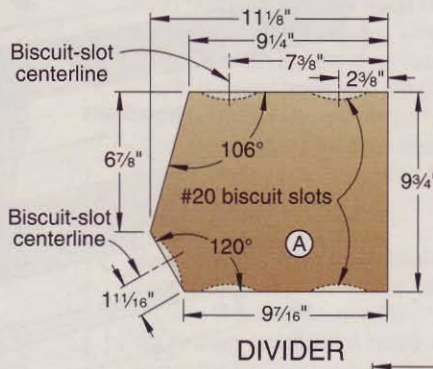

DIVIDER

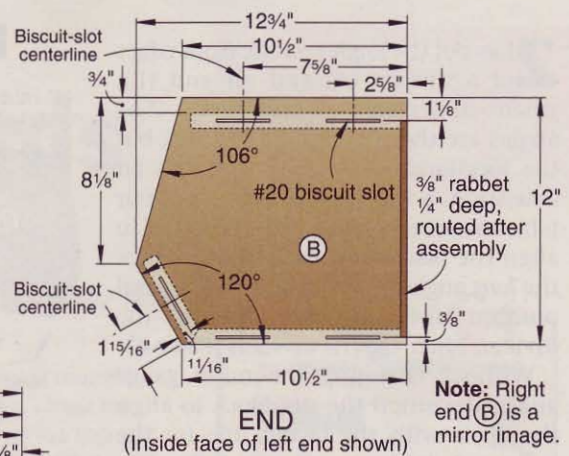

END
(Inside face of left end shown)

1 PARTS VIEW

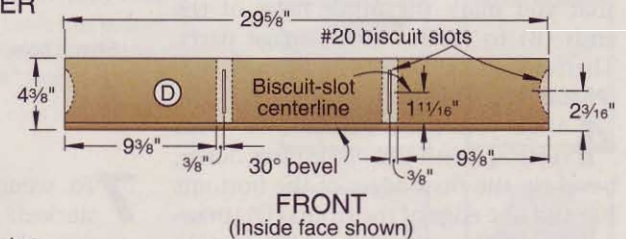

FRONT
(Inside face shown)

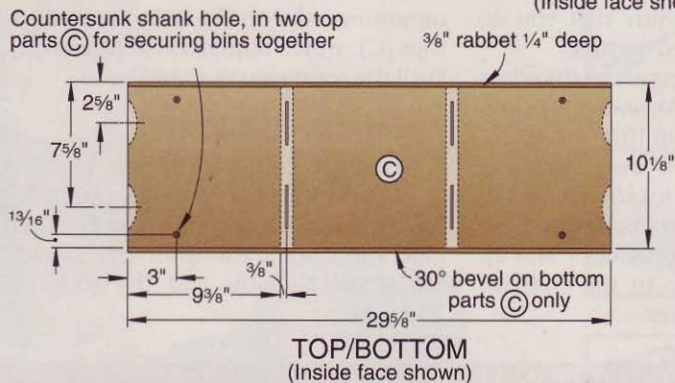

TOP/BOTTOM
(Inside face shown)

WITH THE PARTS SECURED FOR SAFETY, PLUNGE THE BISCUIT SLOTS INTO THE EDGES AND FACES

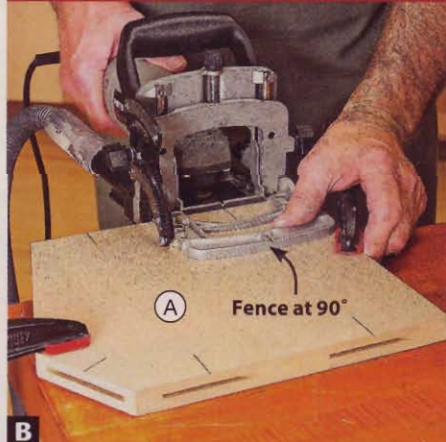

Plunge slots centered into the edges of the dividers (A), tops/bottoms (C), and fronts (D) at the marked centerlines.

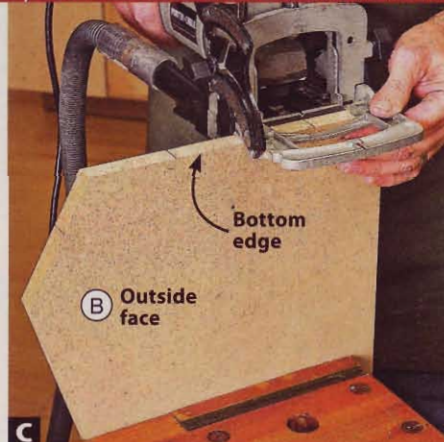

Adjust the fence height as needed, and plunge the slots into the inside faces of the ends (B) at the marked lines.

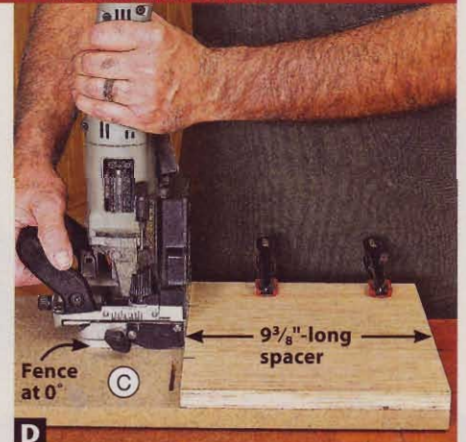

Using a spacer at each end of the tops/bottoms (C), and fronts (D) to position the biscuit joiner, plunge the slots into the faces.

2 Lay out the angles on the front edges of a divider (A) and an end (B), where dimensioned [Drawing 1]. (The angles are the same on both parts, but the locations are different.) Attach an extension with a stopblock to your tablesaw miter gauge. Angle the gauge to align the blade with the layout line for the *long* angled edge on the divider, and position the stopblock against the divider. Miter-cut the dividers [Photo A].

Without changing the miter gauge angle, reposition the stopblock to align the blade with the layout line for the *long* angled edge on the end (B). Cut the ends. Using the same process, miter-cut the *short* angled edges on the dividers and ends. You'll need to rotate the miter gauge in the opposite direction to make these cuts.

3 Draw centerlines for #20 biscuit slots on parts A through D where dimensioned [Drawing 1], making sure that you mark the *inside* faces of the ends (B) to create mirror-image parts. Then plunge the slots into the parts [Photos B, C, and D].

4 Angle your tablesaw blade 30° from vertical. With the *inside* faces down, bevel-rip the *front* edges of the bottoms (C) and one edge of the fronts (D) [Drawings 1 and 2], making sure that you do not change the finished widths.

5 Rout 1/8" round-overs along the edges of the dividers (A), ends (B), and fronts (D), where shown [Drawing 2].

6 Rout a 3/8" rabbet 1/4" deep along the *back* edges of the tops/bottoms (C) on the *inside* faces to receive the 1/4" hardboard backs (E) [Drawings 1 and 2]. You'll rout the rabbets in the ends (B) after assembling the bins.

2 EXPLODED VIEW

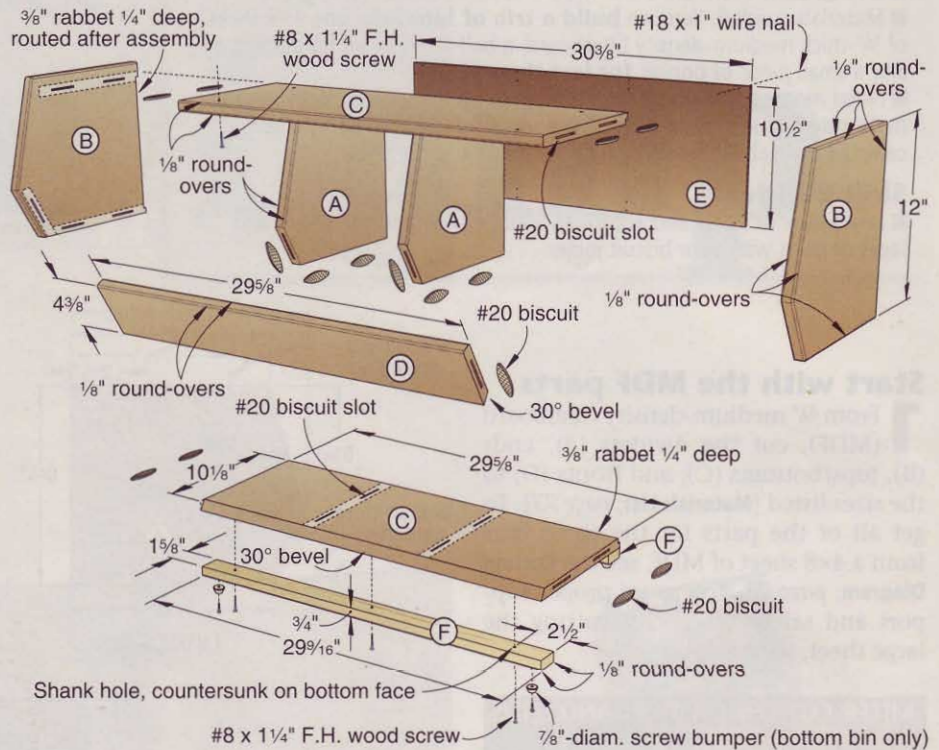

7 To secure the bins together when stacked, mark centerpoints for mounting holes on the *inside* faces of two tops (C), where dimensioned [Drawing 1]. Drill the countersunk shank holes.

Assemble the bins

1 Glue, biscuit, and clamp together the dividers (A) and top/bottom (C) for each bin [Drawing 2, Photo E]. Then glue and biscuit the front (D) to each bin [Photo F]. Now add the ends (B) [Photo G].

2 Using your rabbeting bit, rout a 3/8" rabbet 1/4" deep along the *inside* back edges of the ends (B), as explained in the **Shop Tip**, next page, to complete the openings for the backs (E). Square the corners with a chisel.

3 Measure the openings for the backs (E). Then cut them to size, and set aside.

4 Cut the cleats (F) to size. Note that the 29 9/16"-long cleats are 1/16" shorter than the bottoms (C) to provide clearance for the cleats to fit between the ends (B) when stacking the bins. Rout

BISCUIT THE BINS TOGETHER IN 3 EASY STAGES

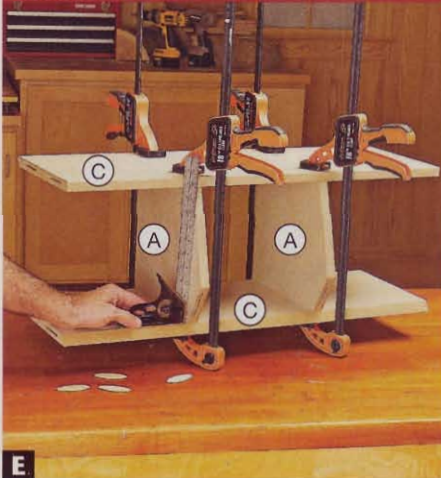

E Using #20 biscuits, glue and clamp the dividers (A) and top/bottom (C) of each bin together. Check the assembly for square.

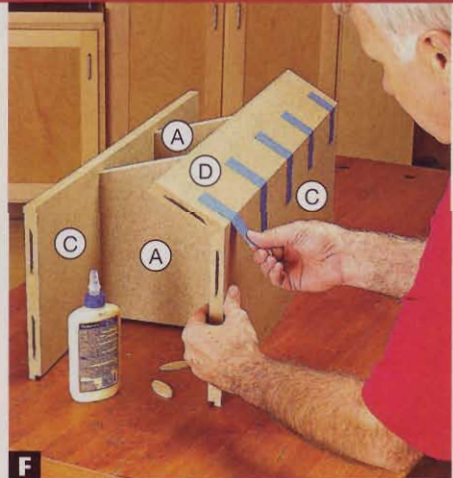

F Glue and biscuit the front (D) to the dividers (A) and bottom (C) of each bin. Draw the beveled front/bottom joint tight with tape.

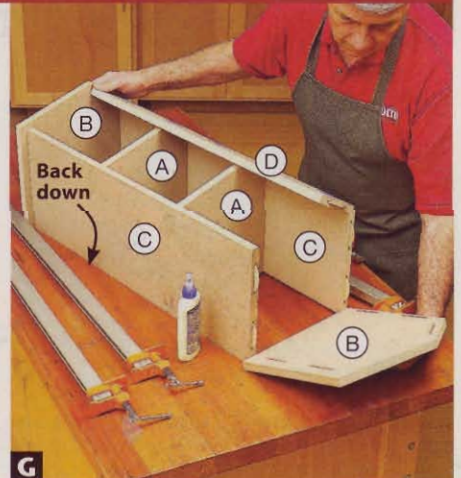

G Position each bin with the back down. Then glue, biscuit, and clamp the ends (B) to the top/bottom (C) and front (D).

1/8" round-overs along the bottom edges [Drawing 2] of the cleats. Then, drill three countersunk shank holes through each cleat on the bottom face, where dimensioned. Sand the cleats to 150 grit. Now glue and screw a pair of cleats to the bottom of each bin, aligning the cleats with the front and back edges [Drawings 2 and 3] and centering them end to end.

Time to finish up

1 Sand any areas of the bins that need it to 150 grit. Remove the dust.

2 Prime and paint the bins a color of your choice, or apply a clear protective finish. (We applied Behr Premium Plus Enamel Undercoater Primer & Sealer, followed by two coats of Kitchen & Bath Interior Sateen Lustre Enamel, color: Chestnut Stallion.)

3 Attach the backs (E) to the bins using #18x1" wire nails [Drawing 2]. Then, drill pilot holes and mount the 7/8"-diameter screw bumpers to the cleats (F) of one bin only for the bottom [Drawings 2 and 3].

4 Finally, stack the bins in the desired location, keeping the backs flush

SHOP TIP

How to safely rout along a narrow edge

Here's a simple way to support your router when machining along the edge of a part, such as for rabbeting the ends (B) after assembly to receive the backs (E). Clamp a 1 1/2"-wide scrap (a 2x2 works great) of the needed length to the part, flush with the edge, as shown. The scrap provides sufficient bearing surface, so you can keep the router stable and make a straight cut.



and making sure that the bin that has the top (C) without mounting holes is on top. From inside the bottom two bins, drive screws through the mounting holes in the tops into the cleats (F) of the bins above. Now, start fillin' the bins. 🌲

Written by **Owen Duvall** with **Chuck Hedlund**
Project design: **Jeff Mertz**
Illustrations: **Roxanne LeMoine; Lorna Johnson**

3 SIDE SECTION VIEW

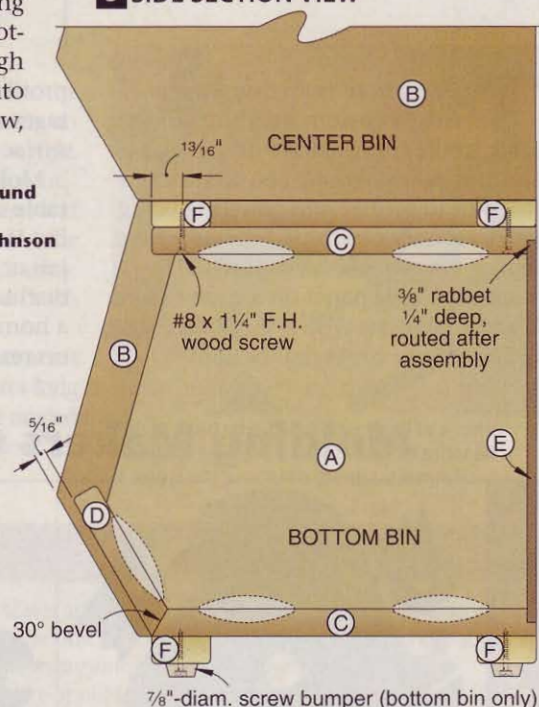

Cutting Diagram

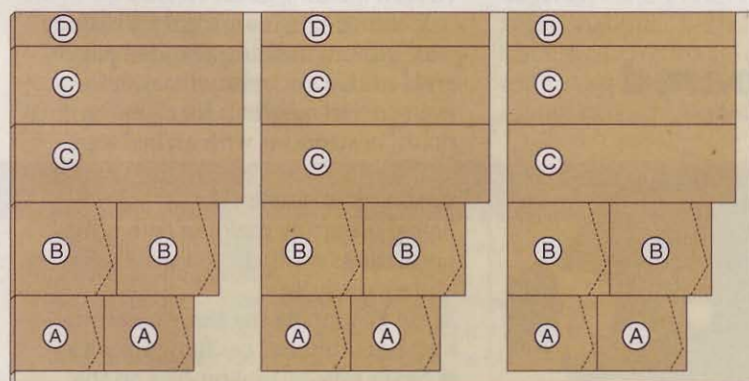

3/4 x 48 x 96" Medium-density fiberboard

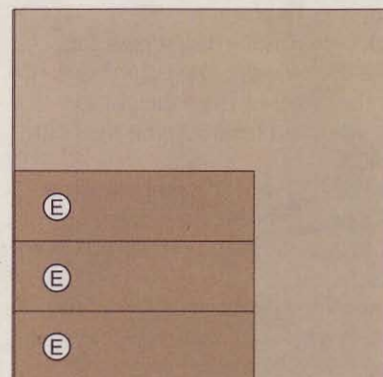

1/4 x 48 x 48" Hardboard

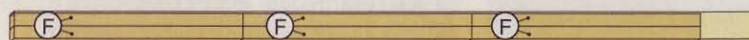

3/4 x 3 1/2 x 96" Poplar

Find more shop organizer plans at:
woodmagazine.com/freeplans



Materials List (3 bins)

Part	FINISHED SIZE			Matl.	Qty.
	T	W	L		
A dividers	3/4"	9 3/4"	11 1/8"	MDF	6
B ends	3/4"	12"	12 3/4"	MDF	6
C tops/bottoms	3/4"	10 5/8"	29 5/8"	MDF	6
D fronts	3/4"	4 3/8"	29 5/8"	MDF	3
E backs	1/4"	10 1/2"	30 3/8"	H	3
F cleats	3/4"	15 5/8"	29 1/16"	P	6

*Parts initially cut oversize. See the instructions.

Materials key: MDF—medium-density fiberboard, H—hardboard, P—poplar.

Supplies: #20 biscuits, #8x1 1/4" flathead wood screws, #18x1" wire nails, 7/8"-diameter screw bumpers (4), anti-tip kit safety cable (when stacking more than three bins).

Bits: 1/8" round-over and 3/8" rabbeting router bits.

Tablesaw Molding Cutters

Use either of these saw accessories to cut custom molding profiles lickety-split.



There's more than one way to make a custom molding, and a router isn't always the quickest method. For example, you could cut a three-bead profile into paneling using four precisely positioned passes with a plunge round-over bit—all while balancing your panel on a router table. Using a tablesaw with a molding cutter, however, you could cut the same

profile in one pass with all the advantages that come with a large work surface and an easily positioned fence.

Molding cutters won't replace a table-mounted router for many tasks. But if you're facing a major molding job or just want something more distinctive than what's standing in a home center millwork aisle, keep on reading.

Both tablesaw molding cutters shown here use a cutterhead that installs in place of your tablesaw blade and holds a set of interchangeable cutters. One cutter may have a combination of profiles—a round-over and a cove, for example. Profiles can be altered by using just a portion of the cutter or tilting the saw arbor, giving you an unlimited range of custom molding cuts.

Molding cutters are ideal for making wide custom moldings, beaded panels, and—with a curved auxiliary fence—even curved moldings for cabinets, doors, or windows with arched tops.

Molding Makers Compared

Brand and Model		
	<p>Craftsman No. 3217 cutterhead with eight sets of cutters and spacer, \$100. Sears 800/349-4358; sears.com</p>	<p>Magic Molder Starter set with two pairs of cutters and spacer, \$300. LRH Enterprises 818/782-0226; lrhent.com</p>
Cut Quality	Cuts showed minor tear-out and chatter marks. Chips lodged between the cutters and the cutterhead.	Cutters left smooth curves and crisp edges, but closely spaced chatter marks.
Notes	Choose from 25 steel cutter sets; some high-speed steel cutters included with the head had rough cutting edges.	Choose from 83 carbide cutter sets; an accessory fence adapts to cut curved workpieces; a cutterhead with one pair of cutters costs \$206.

Cut with care

Before using any molding cutter, these precautions will help you work safely and successfully.

- Always unplug the saw when installing the cutterhead or changing cutters.
- Never mix cutting profiles on the same cutterhead or run the saw without all the cutters in place.
- Check cutter mounting screws for tightness before using the cutterhead.
- Lock the tablesaw blade height to prevent vibration from forcing the blade downward.
- For profiles on a workpiece narrower than 4", cut the profile on a blank at least 4" wide and rip the profiled piece to final size.
- Add hold-downs on your fence, and use feather boards plus push blocks that ride atop your workpiece.
- Don't stand directly behind the path of your cut in case of kickback.
- Check your molding cutter's instructions for additional precautions.

Design your own molding

Cutters measure only about 1" wide, so you'll need to repeat the same profile or mix two or more profiles to create wide moldings. Either way, first map out on paper an area equal to the end dimensions of your workpiece. Then trace around one or a mix of cutter profiles

MAP OUT A MOLDING PROFILE

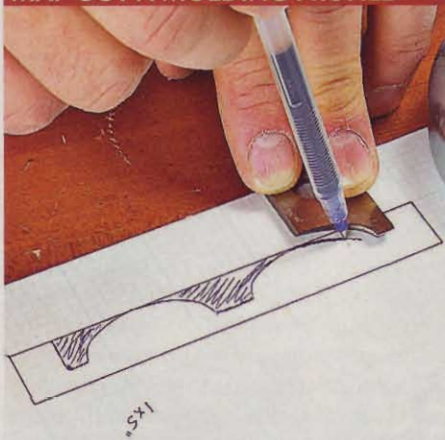

Trace profiles within a rectangle the width and thickness of your stock for a rough design. Waste areas have been shaded.

to create a rough molding profile, as shown *above*. If the cutter can't be laid flat, trace the profile on cardboard, and cut out a copy of the profile.

To install a set of cutters on the cutterhead, first unplug your saw and mount the cutterhead on the saw arbor. Check that the cutterhead clears all internal parts on the saw. This typically requires inserting a provided spacer between the cutterhead and the arbor flange.

ADD A ZERO-CLEARANCE INSERT



The fence and a scrap piece hold the insert in place while you raise the blade.

USE AN AUXILIARY FENCE



An auxiliary fence with a recess for the cutters allows you to cut partial profiles. (The hold-down was removed for photography.)

You'll reduce tear-out by equipping your saw with a zero-clearance insert. Secure the insert using the fence and a piece of scrap clamped into place, as shown *below left*. Then turn on the saw and slowly raise the spinning cutterhead up through the insert to the desired height,

Where you're using only a portion of the cutter or the cutter is less than $\frac{1}{2}$ " from the fence, add an auxiliary fence with a semicircular cut-out, as shown *above*. Molding cutters can create a considerable upward push as

GO FROM PATTERN TO PROFILE

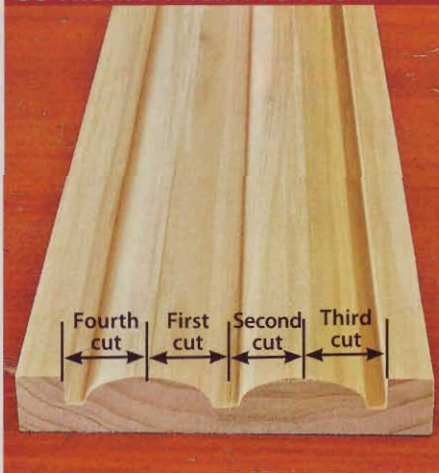

We made this molding using a single cutter, two fence adjustments, and four passes.

MAKE A JIG TO CUT CURVES



The Magic Molder fence can be turned upside down to hold a jig in place for cutting curved moldings.

they cut, so attach a hold-down to the auxiliary fence as needed.

With the cutterhead and insert installed, position the fence to feed a scrap piece of stock over the cutter as indicated on your sketch. Adjust the cutter height and fence position until you achieve the desired profile. When possible, plan cuts so you can make one pass; then rotate the workpiece end-for-end before making the second pass. On the sample shown *below left*, the profile on one half mirrors the profile on the other half. This required just one depth setting and two fence positions.

Molding cutters at work

The Magic Molder is quieter than you'd imagine from its 2-lb., 10-oz. mass, compared with the slightly louder Craftsman at 2 lb. The real noise starts when you feed a workpiece into the cutters. Despite the clatter, both left crisp profiles with minor chatter marks.

Once you gain experience with molding cutters, experiment with different techniques, such as cutting profiles on curved stock, as shown *above*. Or angle an auxiliary fence across the cutter to widen the profile, and tilt the arbor to alter the shape of the profile. 🌲

Gum Ball Goose

What kid wants a golden egg when this fun goose lays a tasty treat at the flick of a tail?



PROJECT HIGHLIGHTS

- Overall dimensions: 8" wide x 12" long x 14 $\frac{3}{4}$ " high.
- The goose lays $\frac{5}{8}$ "-diameter gum balls.
- For the board feet of lumber, $\frac{1}{4}$ " Baltic birch plywood, $\frac{1}{16}$ " rod, filler-hole plug, nest cup, eyes, patterns, and other items needed to build this project, see page 78

Form the $\frac{3}{4}$ "-thick parts

1 Photocopy the patterns for the $\frac{3}{4}$ "-thick parts on the *WOOD Patterns*® insert, enlarging them as indicated. You'll need two copies of the part C and D patterns. (For full-size patterns, see **Source** on page 78, or go to woodmagazine.com/goosepatterns to download free full-size patterns.) Then cut

blanks for the $\frac{3}{4}$ "-thick parts to size [**Materials List**, page 78]. Adhere the patterns for the inner body (A), tail (B), outer bodies (C), inner wings (D), and base (H) to the blanks with spray adhesive. Set part H aside.

2 Drill blade start holes in the inner waste portions of the inner body (A), outer bodies (C), and inner wings (D). Scrollsaw the inside cuts.

3 Chuck a $\frac{1}{16}$ " bit into your drill press, and drill holes in the tail (B) and outer bodies (C), where indicated on the patterns.

4 Chuck a chamfer bit into a handheld router, and rout $\frac{3}{8}$ " chamfers along the inside edges of the outer bodies (C), where indicated on the pattern [**Photo A**]. Repeat with the inner wings (D). Make sure the bodies and wings are mirror images.

5 Scrollsaw the parts to shape. Then dry-clamp the outer bodies (C) to the inner body (A). Sand the tail (B) to $\frac{1}{16}$ " thick, testing for a loose fit between the outer bodies. Now sand slight round-overs along the outside edges of parts A, B, and C, only where indicated on the patterns. Transfer the centerline of the $\frac{1}{4}$ " hole indicated on the inner body pattern to the edge of the part. To locate the inner wing (D) on the outer body, see the **Shop Tip** on the following page. Remove the patterns. Sand round-overs along the outside edges of part D, and finish-sand the parts.

6 Paint the tail (B), and the tail-recess areas of the inner body (A) and outer bodies (C) [**Photo B**]. (We sprayed on Krylon no. 1315 All Purpose Primer White followed by Krylon no. 1501 Glossy White.)

7 Glue and clamp the outer bodies (C) to the inner body (A) [**Exploded View, Half-Size Patterns, Photo C**]. With the glue dry, sand the edges of the bodies flush between the neck and the tail (B).

8 Chuck a $\frac{1}{4}$ " Forstner bit into your drill press, and drill a gum ball filler hole in the goose body [**Photo D**].

9 Glue and clamp the inner wings (D) to the outer bodies (C) [**Exploded View, Half-size Patterns**]. Then seal the edges of the gum ball cavity. (We brushed on two coats of polyurethane varnish.)

Add the $\frac{1}{4}$ "-thick parts

1 Photocopy the patterns for the $\frac{1}{4}$ "-thick parts on the pattern insert, enlarging them as indicated. Then adhere the resulting 12x12" pattern sheet to the $\frac{1}{4}$ " Baltic birch plywood included in the parts kit [**Source**].

CHAMFER THE OUTER BODIES

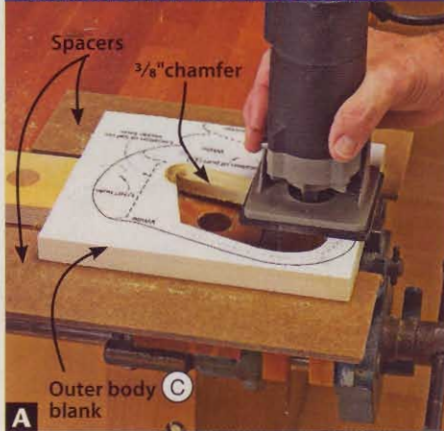

Secure an outer body (C) blank with a bench vise and dog, inserting spacers for pilot bearing clearance. Rout the chamfer.

PAINT THE TAIL RECESS

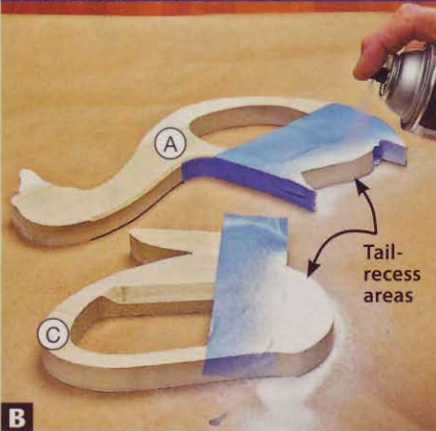

Mask the tail-recess areas of the inner body (A) and outer bodies (C). Then spray prime and paint on these areas.

ASSEMBLE THE BODY

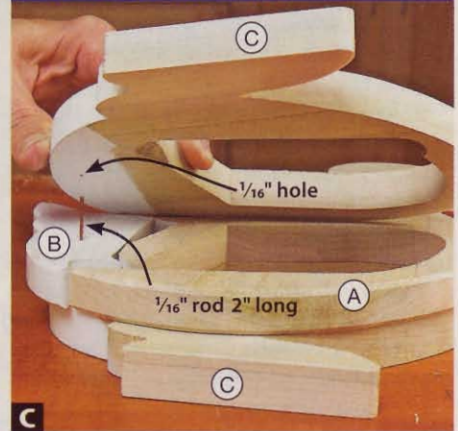

Insert a rod in the tail (B) hole. Glue and clamp the outer bodies (C) to the inner body (A), capturing the rod in the part C holes.

DRILL THE GUM BALL FILLER HOLE

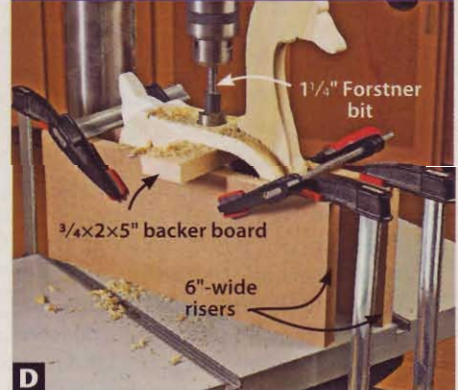

With the body supported by a backer board and a pair of risers, center the bit, align it with the hole centerline, and drill the hole.

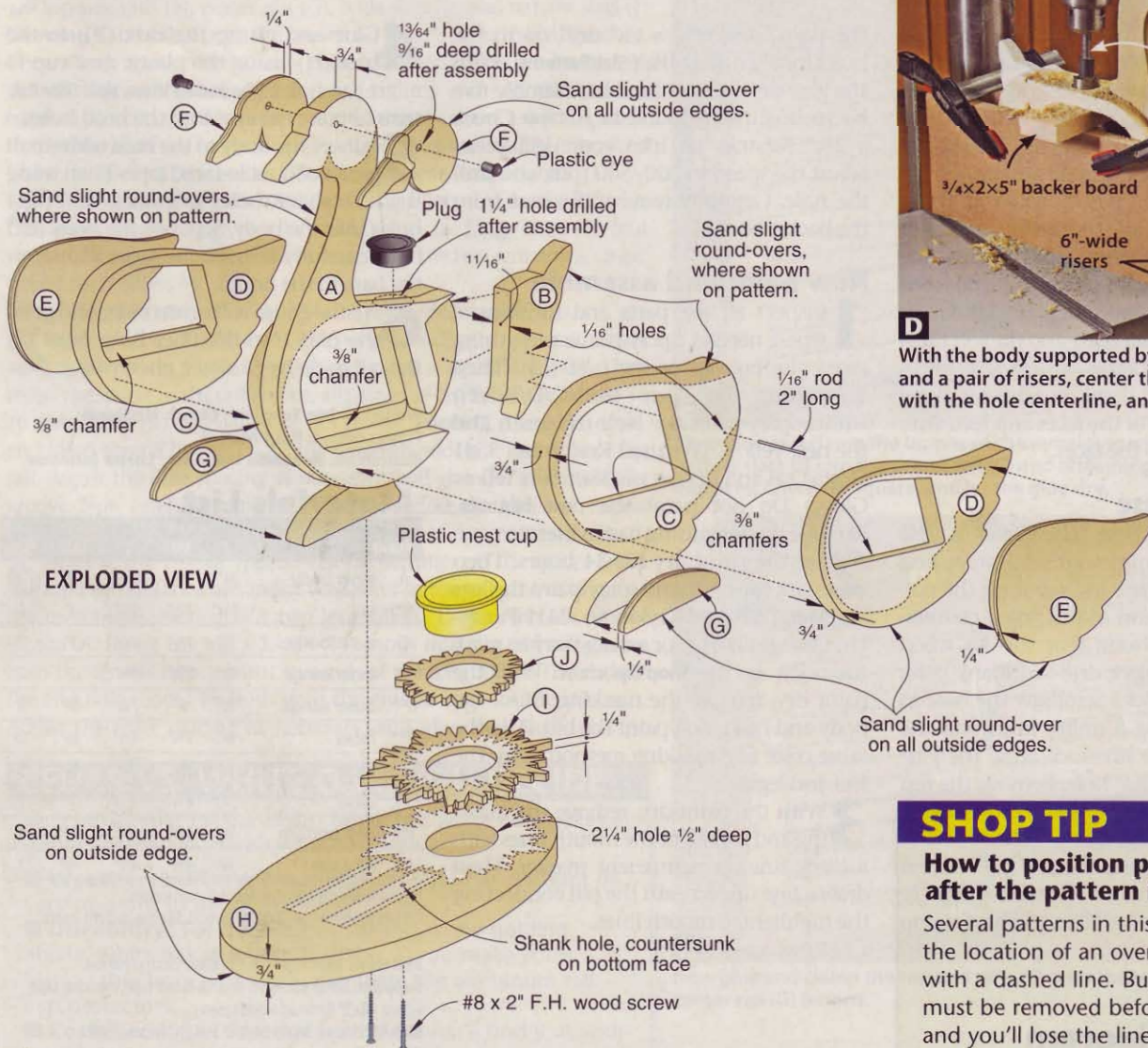

2 Scrollsaw the parts to shape. Do not cut out the 2 1/4" holes in the nest bottom (I) and nest top (J). Scrollsaw each face (F) into four pieces along the interior cutlines indicated on the patterns. Mark the eye-hole

centers with an awl. Remove the patterns and finish-sand all the parts. Then sand slight round-overs along the edges of the outer wings (E) and along the interior cutlines of the four pieces of each face.

SHOP TIP

How to position parts after the pattern is gone

Several patterns in this project show the location of an overlying part with a dashed line. But the patterns must be removed before assembly, and you'll lose the lines. To preserve the overlying part locations, make indentations at critical points along the dashed lines with an awl. Now you'll have guide points for aligning the overlying parts.

SHOP TIP

How to mask large areas and tricky profiles

Here's an easy way to cover the body of the goose and mask the wavy line between the body and the legs when spray-painting the legs and feet.

Photocopy the lower portion of the Outer Body Pattern and Mating Mirror-Image Pattern on the insert, enlarging them 200 percent. Then apply masking tape to a smooth surface, and adhere the patterns to the tape with spray adhesive. (We applied the tape to the smooth side of a tempered hardboard scrap.) Next cut along the wavy line and the dashed line for the location of part D with a crafts knife. Now peel off



the tape and pattern strips, as shown *above*, and adhere them to the body.

To finish the job, mask straight lines at the front and back where the legs meet



the body. Then cover the body with a plastic bag, securing the bag edges to the masking around the legs with more tape, as shown *above*. Now spray away.

3 One at a time, position the outer wings (E) on the inner wings (D), and temporarily secure them with masking tape. Then trace the inner wing opening onto the back of each outer wing. Remove the outer wings and seal inside the outlined areas.

4 Glue and clamp the outer wings (E) to the inner wings (D), the four pieces of each face (F) to the inner body (A), and the feet (G) to the outer bodies (C) [**Exploded View, Half-Size Patterns**]. Then sand the faces flush with the inner body and the feet flush with the outer bodies where the edges match. Now sand slight round-overs along the outside edges of the faces and feet. Drill the eye holes into the faces.

Make the base

1 Retrieve the base (H). Chuck a 2 1/4" Forstner bit into your drill press, and drill the hole, where indicated on the pattern. Then drill two shank holes, countersunk on the bottom. (For the #8 wood screws in this project, drill 5/32" shank holes and 7/64" pilot holes.) Scrollsaw the base to shape. Now using a utility knife, cut the pattern along the line indicating the glue area around the 2 1/4" hole. Remove the rest of the pattern, and sand a round-over along the edge of the base.

2 Drill a 1/16" hole at the 2 1/4" hole centers in the nest bottom (I) and nest top (J). Remove the patterns. Then glue and clamp

the parts, inserting a 1/16" drill bit in the holes for alignment [**Half-Size Patterns**]. With the glue dry, adhere the nest assembly to a backer board with double-faced tape. Chuck a 2 1/4" Forstner bit into your drill press, adjust the speed to 200–500 rpm, and drill the hole. Carefully remove the nest from the backer board.

Now paint and assemble

1 Inspect all the parts and finish-sand where needed. Spray-prime everything *except* the bottom of the nest (I/J). Then spray-paint the body (A/B/C/D/E/F/G) white. Spray-paint the base (H) green and the nest yellow. (We used Krylon no. 3541 Hosta Leaf and Krylon no. 1806 Sun Yellow Gloss.) Do not paint the nest bottom. Remove the remaining base pattern.

2 Let the paint dry for 24 hours. Then mask the body and spray-paint the legs and feet. (We used Krylon no. 2411 Pumpkin Orange Gloss.) For an easy way to mask the body, see the **Shop Tip** *above*. With the paint dry, remove the masking. Mask the body and head, and paint the bill. (Use the same color and masking method as for the feet and legs.)

3 With the paint dry, remove the masking and highlight the mouth lines with a black fine-tip permanent marker. Then draw a line underneath the bill connecting the highlighted mouth lines.

4 Glue and clamp the nest (I/J) to the base (H), using the plastic nest cup to align the holes [**Exploded View, Half-Size Patterns**]. Epoxy the eyes into the head holes.

5 Adhere the body to the base with small pieces of double-faced tape. Then using the base shank holes as guides, drill pilot holes into the body. Separate the body and base, carefully remove the tape, and screw the base to the body.

6 Fill the goose with gum balls, and press the plug into the filler hole. Now lift the tail to deliver a sweet, chewy treat. 🍬

Written by **Jan Svec** with **Chuck Hedlund**

Project design: **Paul Meisel**

Illustrations: **Roxanne LeMoine; Lorna Johnson**

Materials List

Part	BLANK SIZE			Matl.	Qty.
	T	W	L		
A inner body	3/4"	8"	13 1/2"	P	1
B* tail	1 1/16"	3 1/2"	5 1/4"	P	1
C outer bodies	3/4"	7 3/4"	8 1/2"	P	2
D inner wings	3/4"	5 1/2"	8 3/4"	P	2
E** outer wings	1/4"	5"	7 1/4"	BP	2
F** faces	1/4"	2 3/4"	4 1/2"	BP	2
G** feet	1/4"	1 1/2"	4 1/2"	BP	2
H base	3/4"	8 1/2"	12 1/2"	P	1
I** nest bottom	1/4"	5 3/4"	6 1/2"	BP	1
J** nest top	1/4"	4 1/2"	4 1/2"	BP	1

*Part initially cut oversize. See the instructions.

**Parts cut from 1/4x12x12" plywood. See the pattern insert.

Materials key: P—poplar, BP—Baltic birch plywood.

Supplies: Spray adhesive, double-faced tape, masking tape, epoxy, #8x2" flathead wood screws.

Bits: 45° chamfer router bit, 1 1/4" and 2 1/4" Forstner bits.

Source

Parts kit. 1/4x12x12" Baltic birch plywood, 1/16" rod 2' long, 1 1/4" plastic plug, 2 1/4" plastic nest cup, plastic eyes (2). Kit no. WM2068, \$3.99 plus shipping. Meisel Hardware Specialties. Call 800/441-9870, or go to meiselwoodhobby.com.

Full-size patterns. Set of full-size patterns no. W3183, \$8.99 plus shipping. Meisel Hardware Specialties, see *above*.

Cutting Diagram

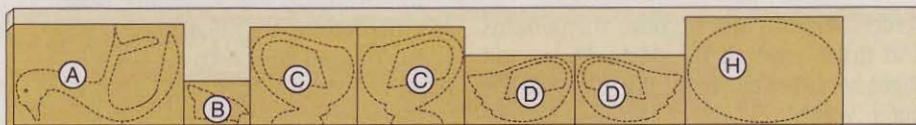

3/4 x 9 1/4 x 72" Poplar (5 bd. ft.)

Step-by-step Plant Stand



BONUS: See a Slide Show
of extra project assembly shots at:
woodmagazine.com/slides

Place favorite plants and decorative items on this easy-to-build project. The terraced shelves ensure that each plant gets its fair share of sunlight.

PROJECT HIGHLIGHTS

- Overall dimensions are 20" wide x 20³/₈" deep x 29³/₄" high.
- Materials needed: Your choice of cedar, white oak, mahogany, cypress, or redwood.
- Approximate weight: 10 pounds (cedar, as shown left), making the stand easy to move about.
- The stand assembles quickly with #8x1¹/₂" flathead wood screws. To prevent corrosion from acidic interaction, we used stainless steel screws.

Prepare the parts

1 Cut the front and back legs (A, B) to the sizes listed [Materials List, page 81], miter-cutting the ends of the front legs at 25° [Drawings 1 and 1a]. Draw the ³/₄" radii at the bottom ends of the legs. Then bandsaw and sand to the lines.

2 Mark centerpoints for mounting holes on the back legs (B), where dimensioned [Drawing 1]. You'll mark centerpoints on the angled front legs (A) by transferring them from the back legs during assembly. Then rout a ¹/₈" round-over along the outside edges of all of the legs. Sand the legs to 150 grit.

3 Cut the bottom-shelf sides (C), center-shelf sides (D), top-shelf sides (E), bottom- and center-shelf backs (F), and top-shelf back (G) to the sizes listed. Draw the ³/₄" radii on the bottom front ends of the bottom- and center-shelf sides and the 2" radii on the top-shelf sides [Drawings 2 and 3]. Bandsaw and sand to shape. Sand all of the shelf parts smooth.

4 Mark centerpoints for mounting holes on the bottom- and center-shelf backs (F) and top-shelf back (G), where dimensioned, for joining the shelf sides to the backs.

5 Cut the long shelf slats (H) and short shelf slats (I) to the sizes listed. Rout a ¹/₈" round-over along all of the edges, ends, and corners of the slats [Drawing 3]. Next, mark centerpoints for mounting holes on the slats, where dimensioned. Note that the hole locations are the same for all of the long shelf slats except the one at the back of the top shelf [Drawing 2a]. Identify the back edge of this slat to ensure correct orientation during assembly.

Assemble the shelves

1 Lay out the bottom-shelf sides (C) and back (F) in the configuration shown [Drawing 3]. Drill the mounting holes at the marked centerpoints through the back and into the sides. Then drive the #8×1½" stainless steel flathead wood screws.

2 To mount the long and short shelf slats (H, I), position a 14½"-long spacer between the shelf sides (C) and clamp a framing square against the assembly to keep it square [Photo A]. Draw an alignment line for positioning the inner long shelf slat across the top edge of each shelf side 14⅞" from the back end of the part. Align the back edge of a long shelf slat with the marked lines, and center the slat end to end on the sides. Drill the mounting holes, and screw-mount the slat. Using ¼" spacers, as shown, mount another long shelf slat in front of the slat. Then mount two short shelf slats in back of the slat.

Note: Mounting the inner long shelf slats (H) on the bottom and center shelves at the dimensioned locations makes it easy to position the front legs (A) at a 25° angle against the back edges of the slats. The front slat on each shelf overhangs the ends of the shelf sides approximately ¼".

3 Using the same the process as in Steps 1 and 2, assemble the center-shelf sides (D), back (F), and long and short shelf slats (H, I), except draw the alignment lines 8⅞" from the back ends of the sides. Then assemble the top-shelf sides (E), back (G), and three long shelf slats (H). Verify the correct orientation of the marked slat for the back, and mount it flush with the back face of the shelf back. Mount the remaining slats spaced ¼" apart.

MOUNT THE BOTTOM-SHELF SLATS

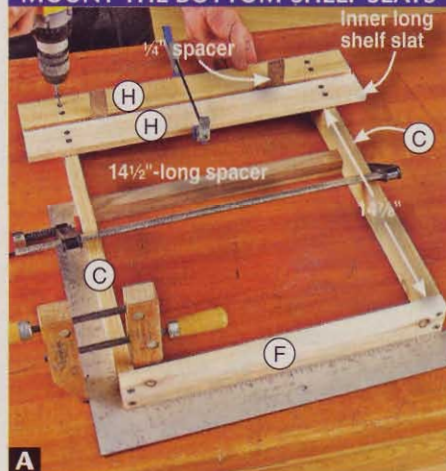

A With the inner long shelf slat (H) in place, mount another long shelf slat at the front with ¼" spacers inserted between the slats.

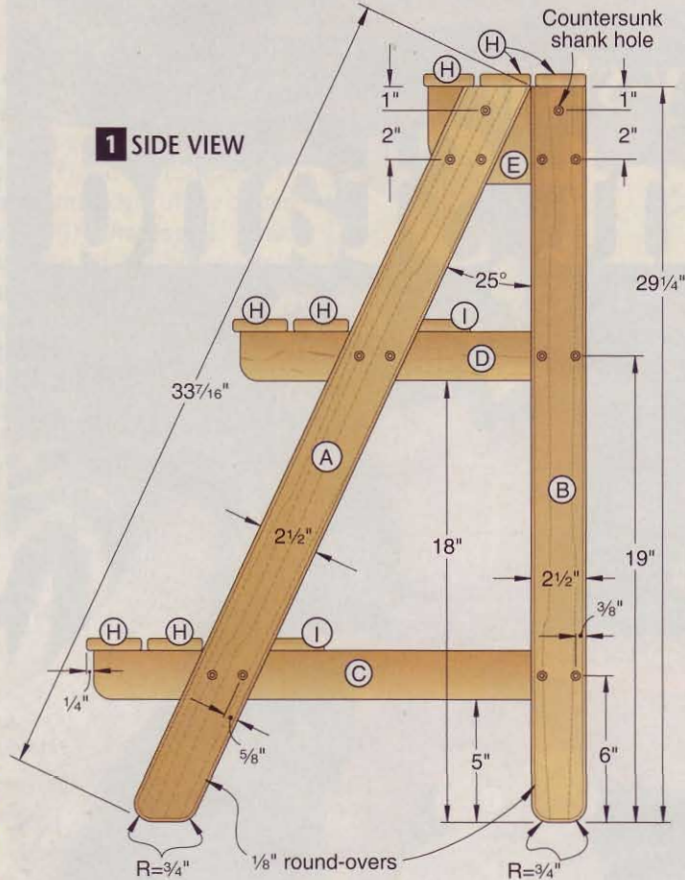

1a FRONT LEG ANGLED ENDS DETAIL

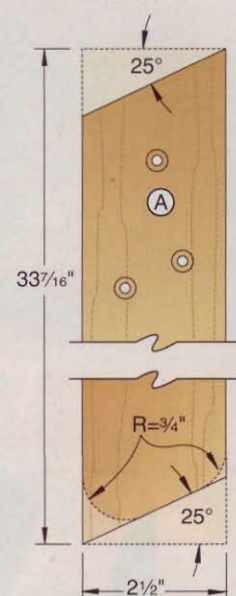

Now let's wrap it up

1 To mount the back legs (B), mark the locations for the bottom and center shelves on the front edges of the legs, where dimensioned [Drawing 1]. Clamp a back leg to your workbench with the marked edge up. Then clamp the bottom, center, and top shelves to the leg at 90°, aligning the bottom edges of the bottom- and center-shelf sides (C, D) with the marked lines [Photo B]. Drill the mounting holes through the leg and into each shelf, and drive the screws. Now mount the other back leg.

2 With the back of the plant stand still down, clamp a front leg (A) in position with the front edge against the back edges of the inner long shelf slats (H) on the bottom and center shelves and the angled top end against the bottom faces of the top-shelf slats [Photo C]. Align a framing square with the centers of the mounting holes in the back leg (B), and mark centerpoints on the front leg ⅝" from the front and back edges. Drill the mounting holes, and drive the screws. Repeat for the other front leg.

ATTACH A BACK LEG TO THE SHELVES

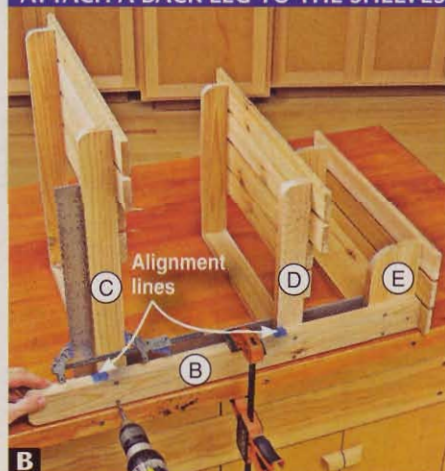

B Using a framing square to position each shelf at 90°, drill the holes and screw-mount the back leg (B) to the shelves.

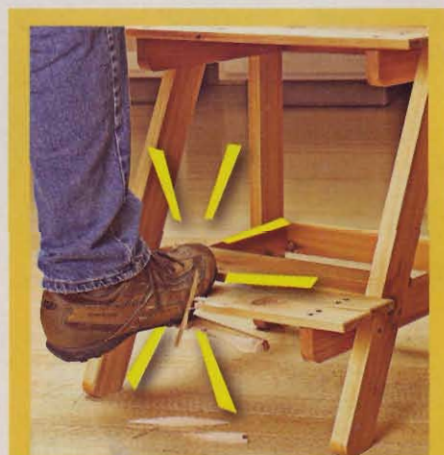

Caution: Although the plant stand resembles a stepladder, do not use it for one. The stand is designed to safely support plants and small items, but not a person.

2a TOP-SHELF SCREW-HOLE DETAIL

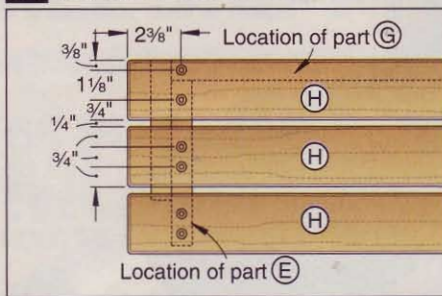

3 Finish-sand any areas that need it, and remove the dust. Then apply a protective finish. (For indoor/outdoor use, we applied two coats of Cabot oil-based Clear Solution, no. 3002 Cedar.) Now move the stand to the desired location, and place some beautiful plants on the shelves to soak up the rays and draw admiring eyes. 🌿

ADD AN ANGLED FRONT LEG

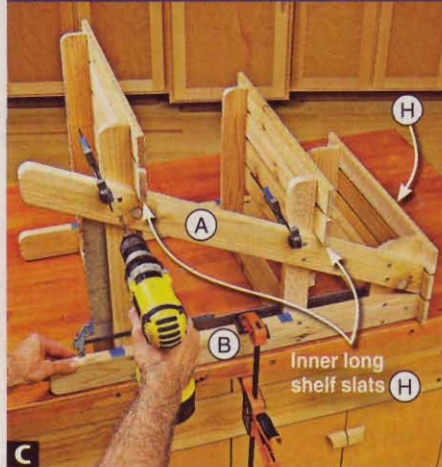

Clamp a front leg (A) in position with the front edge and angled top end against the shelf slats (H). Then screw-mount the leg.

Written by **Owen Duvall** with **Chuck Hedlund**
Project design: **Jeff Mertz**
Illustrations: **Roxanne LeMoine; Lorna Johnson**

Materials List

Part	FINISHED SIZE			Matl.	Qty.
	T	W	L		
A front legs	1"	2 1/2"	33 7/16"	C	2
B back legs	1"	2 1/2"	29 1/4"	C	2
C bottom-shelf sides	3/4"	2"	19 3/8"	C	2
D center-shelf sides	3/4"	2"	13 1/4"	C	2
E top-shelf sides	3/4"	4"	6 1/4"	C	2
F bottom- and center-shelf backs	3/4"	2"	16"	C	2
G top-shelf back	3/4"	4"	16"	C	1
H long shelf slats	1/2"	2 1/4"	20"	C	7
I short shelf slats	1/2"	2 1/4"	16"	C	4

Material key: C—cedar (or white oak, mahogany, cypress, or redwood).

Supply: #8×1 1/2" stainless steel flathead wood screws.

Bit: 1/8" round-over router bit.

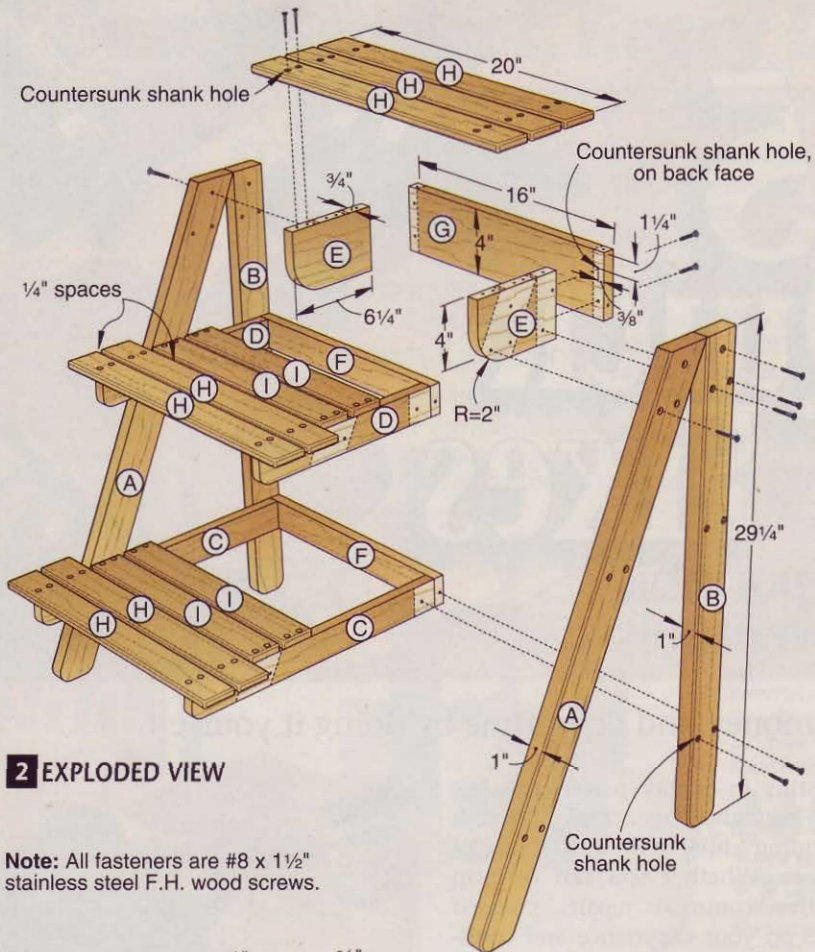

2 EXPLODED VIEW

Note: All fasteners are #8 x 1 1/2" stainless steel F.H. wood screws.

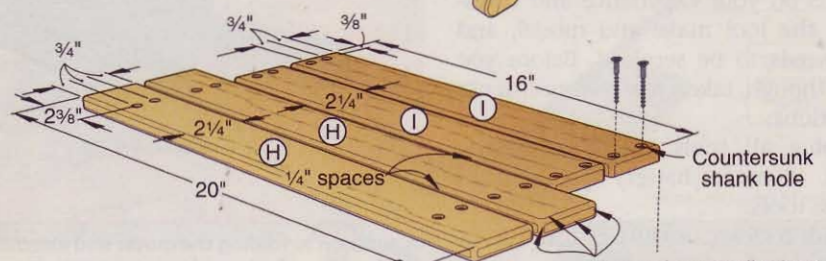

3 BOTTOM AND CENTER SHELF ASSEMBLY

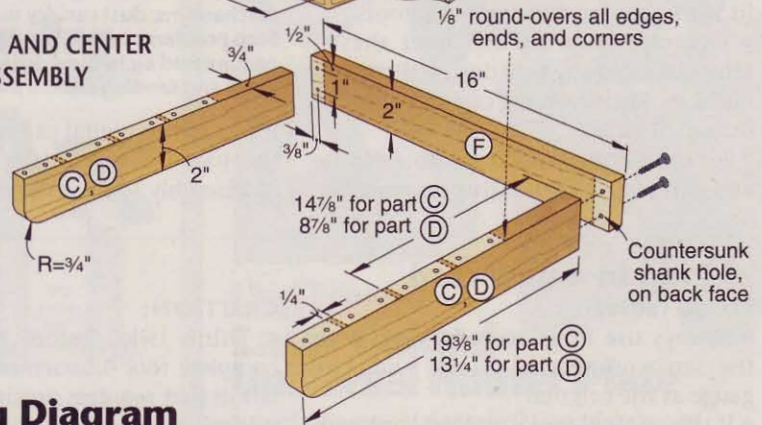

Cutting Diagram

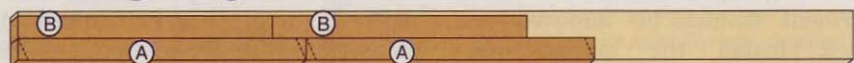

1 x 5 1/2 x 96" Cedar (5/4 x 6)(5 bd. ft.)

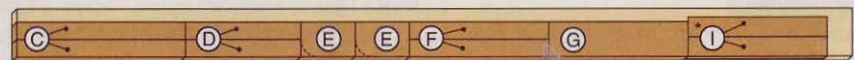

3/4 x 5 1/2 x 96" Cedar (1x6)(4 bd. ft.) *Plane or resaw to the thickness listed in the Materials List.

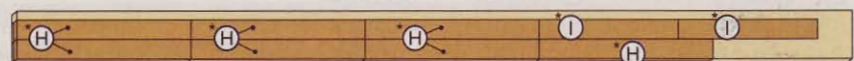

3/4 x 5 1/2 x 96" Cedar (1x6)(4 bd. ft.)

5 Quick Fixes

for portable power tools



Save money and downtime by doing it yourself.

Investing in quality power tools has one big advantage: They're worth spending a little to fix instead of a lot to replace. Whether you can perform these five common repairs yourself depends on your experience and confidence, the tool make and model, and what needs to be serviced. Before you begin, though, take a few common-sense precautions:

- Unplug all tools before beginning repairs. Remove battery packs from cordless tools.
- Provide a clean, uncluttered, and well-lit work area for disassembling tools.
- Organize parts in the order they're removed from the tool during disassembly. A molded foam egg carton helps sort out small parts.
- For complicated jobs, take note of wire and part placements during disassembly.



In addition to fouling the motor and internal mechanisms, dust can dry out grease. Stop problems before they start by using compressed air to blow dust out of vent holes and sanding pads.

If you have a digital camera, photograph the tool before starting each stage of disassembly to use as a reference.

1 Switch your switch

Fix-up facts:

- Suspect a bad switch if the tool loses power suddenly or starts and stops sporadically when operating the switch.
- Use tape to identify the locations of connecting wire colors, as shown above.
- Carefully reconnect levers and buttons that operate parts of the switch other than the trigger. These can include forward-reverse buttons or switch locks.

CAUTION:

- Some cordless drills require extensive disassembly to reach the switch, possibly letting the gear assembly come apart.
- Study the position of all wiring before removing the old switch. Avoid pinching wires in the tool case sides or within the tool. Check that connectors fit tightly on the replacement switch and weren't loosened from their wires while removing the old switch.

2 Plug in a new cord

Fix-up facts:

- Always use a replacement cord with the same number of prongs and wire gauge as the original.
- If the original tool's molded cord reinforcement cannot be removed and reused, install the manufacturer's replacement power cord instead of a generic cord.
- Label connectors, as shown at right, before removing the old cord.
- If the replacement cord lacks connectors found on the original, these can be purchased from electronics supply stores or your tool parts supplier.

CAUTION:

- Think twice before beginning any complete tool disassembly or an installation that requires precise soldering.
- Wrap electrical tape around the cord where it emerges from the molded reinforcement inside the tool body to keep tension on the cord from pulling wires loose inside the tool.
- Check for loose connections and bare wires touching each other near the connections.
- Check for crimped or squeezed wires during reassembly. Wear and pinch points can create electrical shorts.



3 Brush up on replacing motor brushes

Fix-up facts:

- A motor receiving sporadic power could be suffering from worn-out brushes. Once brushes wear beyond a certain point, a wire surrounded by the spring coils prevents the worn brush from damaging the motor.

- On tools with external brush caps, such as the sander shown at *right*, use your shop vacuum to remove debris before removing the caps and before installing the new brushes.

- Replace brushes in pairs when either one has less than $\frac{1}{4}$ " of carbon.

- Replacement brushes may vary slightly from the original, as shown here. Check that



Damaged, old brush

New brush

they will mount securely in the same location within the tool.

- Some toolmakers recommend repacking bearings with grease at the same time you replace the tool's brushes, a job that can involve specialized tools. Consult the owner's manual for guidelines specific to your tool.

CAUTION

- For tools with external brush caps, make certain the metal contact on the brush seats firmly against the metal contact ring within the tool body covered by the cap.

- When replacing internally accessible brushes, double-check the connections to avoid loose wires or fittings.

- If the old brush appears damaged, check the motor for loose debris or damage before installing its replacement.



NEW BRUSHES: \$10/PAIR*

4 Stuck with a bad pad? Here's the easy cure

Fix-up facts:

- Constantly replacing random-orbit sander discs, plus the heat and vibration of sanding, can wear out hook-and-loop or pressure-sensitive adhesive pads until discs no longer stick. Fortunately, pads are easy to replace, as shown *below*.

- With the old pad off, check or replace the braking belt used on some models,

as shown *below*. This belt keeps the pad from spinning freely and causing accidental damage to the work surface.

- Use compressed air to remove dust trapped beneath the pad.

CAUTION

Seat pad-mounting screws firmly to prevent them from working loose because of sanding vibration.

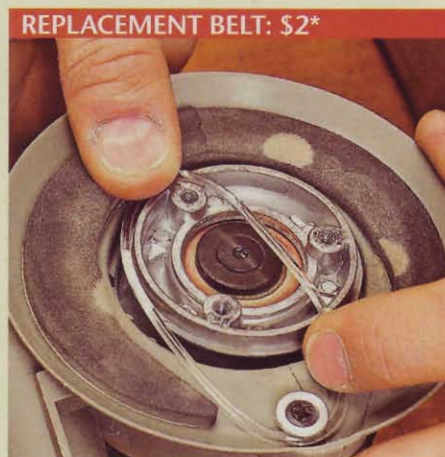

5 Don't get stuck with router motor burrs

Fix-up facts:

- Frequently switching bases on your combination router kit can accidentally nick the motor housing, making height adjustments difficult. The motor could even become trapped in the base. Flatten large burrs using a fine triangular needle file, as shown *below*. Smooth away smaller burrs with 100-grit silicon carbide abrasive pulled tight against a wood block.

- When finished, thoroughly clean the housing with mineral spirits to remove filings and sanding debris.

CAUTION

- Don't file or sand the motor housing enough to leave a scratch or flat spot.

- Don't sand the entire exterior of the motor housing to remove surface scratches—you risk loosening the motor's fit in the base.

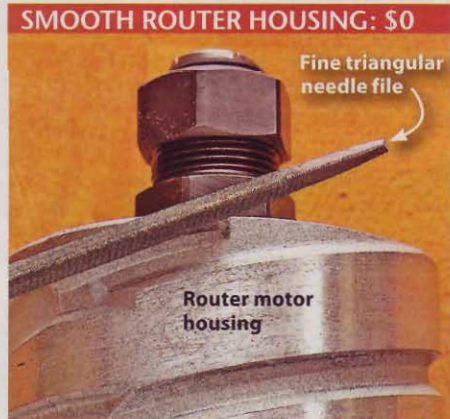

Find replacement parts with a quick click

Repair centers offer parts and repair tips from trained technicians. Unfortunately, service centers aren't on every corner. When that's the case, turn to these multi-line Internet parts suppliers: **Tool Parts Direct** (toolpartsdirect.com). On-line tool schematics help track down the parts you need from their inventory of more than 330,000 items. Use their mail-in repair service for complicated maintenance problems.

ServiceNet (dewaltservicenet.com). Along with DeWalt parts, this site provides factory parts for Porter-Cable, Delta, Black & Decker, DeVilbiss, and Emglo tools. To find the right parts, download copies of owner's manuals and exploded parts views.

Check other tool manufacturers' Web sites for tool information, parts diagrams, mail-order replacement parts, or service center locations.

Blades and Bits



Cut after cut, these endurance champs hold their edges—for a price.

Replaceable-Cutter Router Bits

Replaceable-cutter router bits cut crisp profiles on enough materials to dull a handful of brazed-cutter bits—earning them a place in your shop for routing jobs you can measure in hundreds of board feet.

Key to how they work is a bit body that accurately indexes the positions of the cutters so they remove stock equally. On some, you can replace the cutters with those of a different profile.

By avoiding the stress of being brazed to a bit body, cutters can be made from hard C4 carbide—instead of the softer but less brittle C2 or C3 on brazed bits—for edges that last at least twice as long, depending upon the manufacturer and the profile.

Pay now, save later

That durability comes with a higher upfront cost than conventional bits. One Internet source priced an Amana flush-trim bit with replaceable knives at \$87, while a comparable brazed-cutter bit was \$35. But a pair of replacement cutters cost \$5 and can be rotated for a second pair of cutting edges.

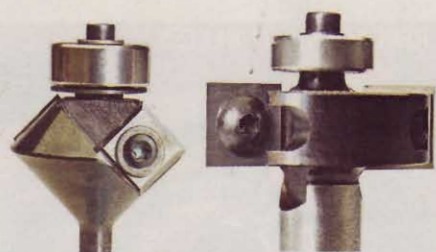

Both the Freud 45° chamfer bit and CMT rabbeting bit use four-edged replaceable cutters to extend bit life.

Some, like the chamfering and rabbeting bits shown *above*, provide four cutting surfaces on each insert. For about \$80, you can buy a chamfering bit with replaceable four-edged cutters. Or you can spend about \$112 for four comparable conventional bits with less durable brazed cutters.

Replaceable-cutter bits that let you insert more than one profile on a single bit body make sense if you switch between two or more profiles to do a large amount of work. For the \$140 Infinity panel-raising bit shown *top*, a pair of replacement cutters cost \$33, compared with \$67 for one of the company's brazed-cutter bits in a



Concave or convex retainers support the edges of the interchangeable cutters in Amana's Nova bits.

similar profile. Where you save money is on the life of the replaceable knives.

You also can save a few bucks buying bit sets that come with interchangeable profiles you use frequently. For example, the Amana Nova System set shown *above* costs \$80 with three pairs of cutters, about the same as three less-durable brazed-cutter bits with comparable profiles.

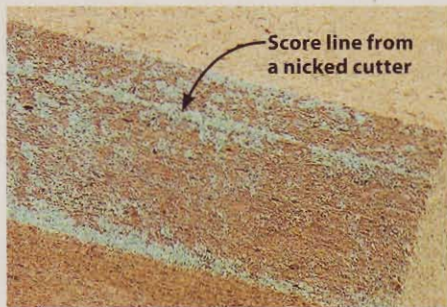

Expect good cut quality

We used an assortment of replaceable-cutter router bits on two materials known for abrasiveness and hardness: MDF and maple. On one of our initial passes, using a 45° chamfer bit in MDF, we struck an impurity in the material that nicked a cutting edge, producing a ridge (highlighted with colored chalk), shown *above*. A problem that might have ended the life of a conventional bit was fixed by rotating the damaged cutter to one of the three other edges.

Cutting MDF with the Infinity raised-panel bit yielded a surprise. After reducing the router's cutting speed to 10,000 rpm, we compared cuts using

multiple passes to a single pass. The results were nearly identical, thanks to the harder carbide that increases the sharpness of the cutters.

We tried the same comparison again, this time in curly maple, a wood that's notorious for showing scallops and chip-out from machining. After making a raised panel in three passes along one edge, we routed the opposite edge in one pass. Again, the edges were nearly identical.

Beware of speeds faster than the manufacturer's recommended 12,000 rpm. Both single- and multiple-pass cuts at 16,000 rpm displayed severe tear-out, as shown *above*.

Super-sharp carbide doesn't let you rush the feed rate, either. The Amana bit, with 1/4" round-over knives, left smooth edges in maple at normal speeds. But rushing the cut created visible chatter marks.

Are they right for you?

Whether replaceable-cutter router bits make performance and economic sense depends on the type and amount of woodworking you do. If your router table seldom gets a workout—or you rely on a variety of bits when it does—you're unlikely to get your money's worth from a replaceable-cutter bit. But if you cringe at the thought of what routing large amounts of particleboard and MDF do to conventional bits, consider switching to the ultra-hard cutting strength of replaceable-cutter router bits. 🌲

Sources

Replaceable-cutter bits. Amana Tool, call 800/445-0077; amanatool.com. CMT, call 888/268-2487; cmtusa.com. Freud, call 800/472-7307; freud-tools.com. Infinity Cutting Tools, call 877/872-2487; infinitytools.com.



Laser Engraving, Cutting and Marking Systems

Starting at \$9,995!



Start Your Own Laser Engraving Business!

Create and sell custom engraved and cut logos, photos, graphics and more - and it's as easy to operate as a printer. Call us today toll free at 888-437-4564 to **receive a free brochure, sample kit and CD demo** of the system in action!



1 Scan Photo



2 Import to Graphic Software



3 Print to Laser and Press Go



Create custom engravings in minutes. Contact us for more information.

What you can Create.

Overlay Plaques



Photo Wood Cards



Inlay Signage



Architectural Modeling



Memorial Plaque



3D Engraving



Toll Free: 1.888.437.4564 • Phone: 303.277.1188
 sales@epiloglaser.com
 www.epiloglaser.com/bhg.htm

Shop-Proven Products

These woodworking wares passed our shop trials

About our product tests

We test hundreds of tools and accessories, but only those that earn at least three stars for performance make the final cut and appear in this section. Our testers for this issue include: **Steve Feeney**, **Dean Fiene**, and **Pat Lowry**. All are avid woodworkers.

Move over, Tormek; Jet's Wet Sharpener is here

Tormek's slow-speed wet-wheel sharpening system has long been considered the Cadillac of powered sharpeners. But the well-respected system carries a handsome price tag, starting at \$400 for the basic set. Jet's Slow Speed Wet Sharpener functions like a Tormek (even the accessory sharpening jigs are interchangeable between brands) for about \$100 less.

Despite the lower price, Jet's engineers added features not found on the Tormek. For example, they enclosed the motor to protect it from water and gunk that invariably find their way inside the tool housing. And they added two more nice touches: a wide water tray that captures more runoff than Tormek's wheel-hugging tray; and a built-in storage drawer to hold honing compound, the stone grader, and small sharpening jigs.

The machine also boasts a variable-speed motor, which lets you maintain the wheel's speed as it gets smaller. The benefit of this feature seems dubious, though. The water-cooled wheel already turns so slowly that I can't imagine over-heating a tool edge.

When the rubber met the road (or the chisel met the wheel, in this case),

the Slow Speed Wet Sharpener put a keen edge on every tool in my shop. Beyond grinding chisels and plane irons, you'll need a tool-specific optional jig for other tools or cutters, such as jointer knives, scissors, and turning gouges.

All the tool-sharpening jigs I tested were well-made, but the cast-aluminum and plastic components didn't seem quite up to Tormek standards. For example, while setting the straight jig to sharpen a chisel, one of the knobs broke, and I had to borrow one from another jig to finish the job.

Bottom line: If you're hard on your equipment and do a lot of sharpening day in and day out, you might be better off spending the extra hundred bucks on a Tormek. But if you're like most woodworkers, the Jet Slow Speed Wet Sharpener will do just as good a job and allow you to put that savings toward tools you'll use more often.

—Tested by Pat Lowry

Slow Speed Wet Sharpener

Performance	★★★★☆
Price	\$300

Jet Equipment & Tools
800/274-6848; jettools.com

Cordless Dremel tool keeps going...and going...and...

I use a high-speed rotary tool in my workshop for a number of tasks, from sanding into tight spots to cutting off screws to polishing cabinet hardware. One annoyance, though, is the power cord that makes the tool feel unbalanced. The folks at Dremel came up with the 10.8-volt variable-speed Cordless Rotary Tool, and the result is a lightweight, well-balanced, and surprisingly powerful tool.

When I chucked in a grinding stone and went to work sharpening my mower blades, I couldn't tell any difference in power between this tool and my corded model. More impressive was the run time: Both blades were badly dinged and, although I kept expecting the Cordless Rotary Tool to fade away, it finished the job and only one LED of the tool's 3-LED "fuel gauge" had gone dark.

Back in the shop with a fully charged battery (it takes 3 hours), I started drilling $\frac{1}{8}$ " holes 1" deep into red oak. Going nonstop, the Cordless Rotary Tool bored more than 100 holes before the lithium-ion battery pack ran dry. Li-ion batteries don't lose their charge sitting in a drawer, so that cordless convenience will always be ready to go.

The model 8001-01 I tested (shown) comes with 60 bits and accessories, plus an LED flashlight and a soft-sided case. Model 8000-01 comes with a hard-shell case and no light.

—Tested by Dean Fiene

10.8V Cordless Rotary Tool Kit

Performance	★★★★★
Price	\$80, Model 8001-01; \$67, Model 8000-01

Dremel
800/437-3635; dremel.com

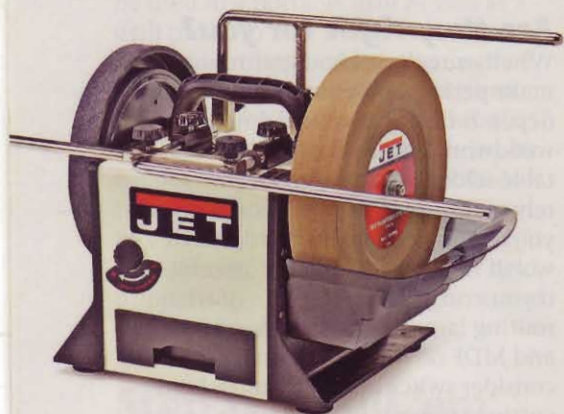

WOODWorkersCenter.com

Your Best Source for Product Information 24/7!

Drill shuts itself off before it can twist your wrist

We've all experienced it: While boring a big hole with a Forstner bit or hole-saw, the bit binds in the workpiece. All of that turning torque has to go somewhere, and before you can react, the drill practically breaks your wrist. DeWalt's ½" drill with Anti-Lock Control (DW239) senses the sudden stop and shuts down the motor almost before you know it.

Like a masochist, I tried everything to make the DW239 bind: drilling steel with a 2" holesaw (larger than recommended by DeWalt); drilling pine, plywood, and chipboard with a 4" holesaw; and boring red oak with every spade bit I could find—dull or sharp. When I did cause the cutter to bind, I felt only a slight jolt before the motor stopped, certainly far short of the normally brutal wrist-twist.

Those tests proved more to me than the value of the anti-lock control: They also convinced me that the DW239 is one tough tool. Trying to overheat the motor, I used a 4" holesaw with teeth that were 90 percent ground away and forced it through exterior-grade oriented-strand board (OSB). I finally had to stop, but only because I could no longer stand the smoke coming from the wood. The drill itself was barely warm to the touch.

It seems that corded drills get short shrift these days, while cordless drills get all the attention. The DW239 is one drill that deserves to be in the spotlight.

—Tested by John Cebuhar



DeWalt DW239 Heavy-Duty ½" VSR drill with Anti-Lock Control

Performance ★★★★★
Price \$179

DeWalt Industrial Tool
800/433-9258; dewalt.com

continued on page 88

FREE PRODUCT INFO

Request woodworking catalogs and product info directly from manufacturers and leading retailers.

TOOL BUYING FORUM

Ask a tool-related question and get an answer within hours.

TOOL REVIEWS

Read summaries of recent WOOD magazine tool reviews.

MONEY-SAVING TIPS

Get the most out of your tool and accessory-buying dollars.



Find the latest sales on woodworking tools and accessories offered by advertisers featured in WOOD® magazine!

ENTER ONLINE TO WIN GREAT WOODWORKING PRIZES!

MAY SWEEPSTAKES:

Update Your Shop Tools with a \$250 Lee Valley Tools Gift Card



JUNE SWEEPSTAKES:

PSI TurnCrafter™ Variable Speed Mini Lathe



\$255 retail value

Penn State Industries

More Power For Your Workshop

Use it once and it will become your favorite woodworking tool!

Get fast, accurate answers with these easy-to-use rugged hand-held calculators. Input measurements and see your results in Feet, Inches, Fractions or Decimals. Ideal for beginners or advanced woodworkers.



Model 4020

MEASURE MASTER[®] PRO

Feet-Inch-Fraction and Metric Dimension Calculator

You'll get professional woodworking results with ease. The Measure Master makes it simple to work in, and convert between, most common dimensional formats, as well as Areas and Volumes. Plus built-in Board-Foot solutions.

PROJECTCALC[®] PLUS

Feet-Inch-Fraction Home Project Calculator

This economical little Feet-Inch-Fraction calculator features single key solutions to many common home improvement projects. It is ideal for woodworking, or those do-it-yourself projects around the home.



Model 8525

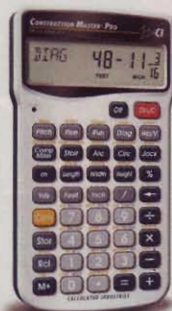

Model 4065

CONSTRUCTION MASTER[®] PRO

Advanced Feet-Inch-Fraction and Metric Construction-Math Calculator

Our most complete calculator for the advanced woodworker. In addition to those found in the Measure Master Pro, it features more powerful built-in solutions. The perfect tool if your woodworking passion includes projects such as remodeling or adding a room. It even provides Angles for compound miters.

Select the one that's right for you and you'll spend less time on the math and more time on your craft

CALCULATED INDUSTRIES[®]

4840 Hytech Drive
Carson City, NV 89706
1-775-885-4900
Fax: 1-775-885-4949

For the nearest dealer call
Toll-Free 1-800-854-8075

Visit us on the web at:
www.calculated.com

Promo Code: WDSIP-607

Shop-Proven Products

Festool plunge router gobbles dust like crazy

Festool's fine German engineering is evident in every aspect of its OF 1400 EQ 2¼-hp plunge router. In my tests, this router showed no signs of being underpowered, even when plowing ¾" dados ½" deep into red oak.

The plunge mechanism operates silky-smooth, and the cutting depth locks easily with a twist of the round handle. I found it easy to adjust the variable-speed control (10,000–22,000 rpm) located within a finger's reach of the unusual pistol-grip handle. And I felt little vibration from the machine. But you'd expect all of those things in a high-end router.

What sets the OF 1400 EQ apart from other midsize plunge routers are features such as its ratcheting collet: Like a socket wrench, you never have to remove the wrench from the nut when tightening or loosening the collet. (The rocker-switch-style collet lock also switches the direction of the ratcheting action.)

Two standard-equipment dust-collection accessories really make the OF 1400 EQ shine. The clear top-of-base dust hood installs without tools and works so well (when connected to a shop vacuum), it not only contained all of the debris that would have scattered while routing dados, but it also evacuated the sawdust that typically gets left behind in the dado. The below-the-base cup (not shown in photo) works nearly as well at capturing dust created when routing edges. It caught about 95 percent of the debris and easily followed around the corner of a tabletop.

My chief beefs with the OF 1400 EQ are minor but irritating: The plunge-depth scale is marked only in millimeters, and it comes with ½" and 8mm collets, so you'll have to buy or borrow a sleeve-type adapter to use with ¼" bits. That adds about \$30 to the cost of this fine, but pricey, router.

—Tested by Pat Lowry

Festool OF 1400 EQ plunge router

Performance ★★★★★
Price \$405

Festool
888/337-8600; festoolusa.com



6 great uses for Trim Routers

Don't let a trim router's small package fool you: These one-handed wonders have emerged from the shadows of their full-size cousins to earn their keep in your workshop.

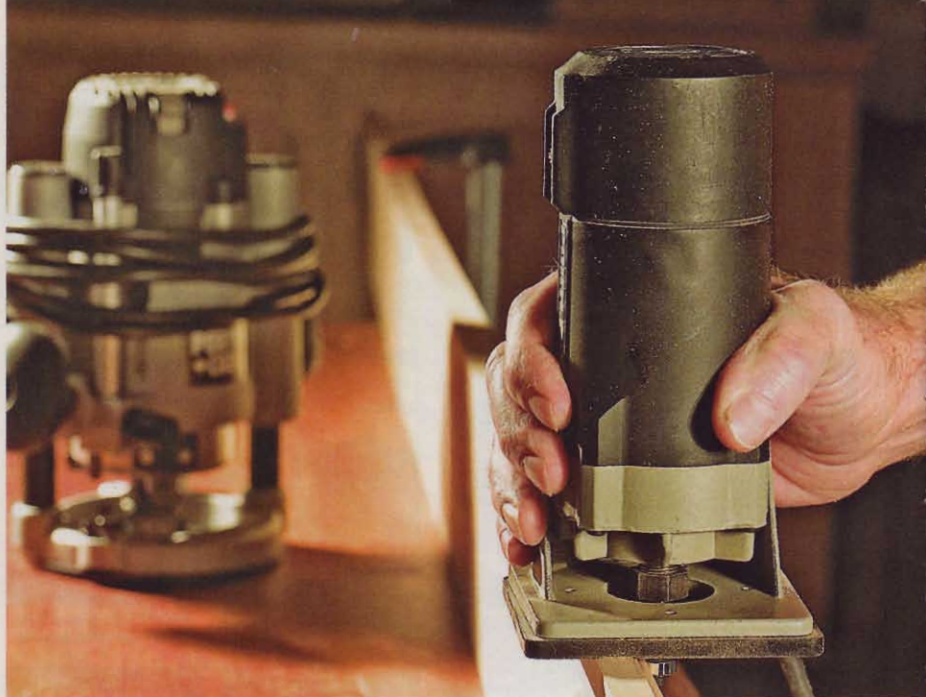

Sometimes, David doesn't have to kill Goliath; just pushing him aside can be good enough. Meet David, the one-handed trim router (aka: laminate trimmer). In the role of the giant, the full-size router has been dominating fine profile and joinery work for decades. But times, they are a-changing. Here are the tasks where a trim router can assist you in your shop by saving time or money or doing jobs better than a big router.

1 Dedicate trim routers to doing specific tasks

At *WOOD* magazine we frequently work with four forms of decorative edge-routing, shown *right*: Round-overs and chamfers are the most common, followed by coves and beads. To save time changing and setting up these bits, we like to keep a 1/8" round-over bit ready to use in one trim router, and

Four edging bits perfect for trim routers



a 45° chamfer bit in another. Many trim routers sell for about \$100, so you could buy

three trim routers for the same money it takes to buy a 3-horsepower router.

2 Cut perfect flutes

Make quick work of routing flutes by installing a round-nose or core-box bit in your trim router. When you don't have a detachable edge guide (standard on some small routers, optional for others), these routers' small bases allow you to set a straightedge close to the cutting area. Those with square subbases follow that straightedge perfectly, as shown at *right*, to cut the flutes with no worries.

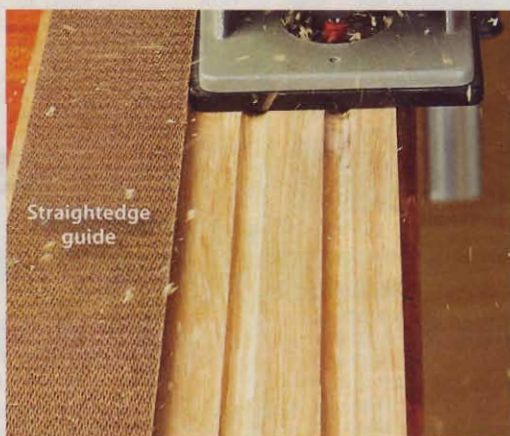

3 Make no-tip hinge mortises

Using a trim router for routing shallow hinge mortises proves a no-brainer. A full-size router can tip or wobble when you balance it on a workpiece edge (a door, for example). But a trim router, with its narrow base, light weight, and low center of gravity, makes the job easy. Use a template with a top-bearing dado cleanout bit (with a small cutterhead), as shown at *right*. Square up the corners, if needed, with a chisel.

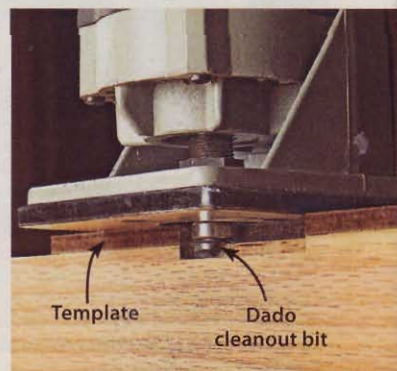

continued on page 92

Love At First ...Slide!

THE NEW

Mast-R Slide™



JessEm's New **Mast-R-Slide™** Precision Sliding Cross-Cut Table is the ultimate add-on for your tablesaw. Thirty double-sealed precision bearings in an innovative linear guide mechanism provides an exceptionally smooth and accurate cross-cutting solution. Fits most tablesaws and offers a maximum cross-cut of 36 inches. Upgrade your saw with a **Mast-R-Slide™** from JessEm Tool today.



Visit us at www.jessem.com
Call: 866-272-7492 • Barrie, Ontario Canada

Circle No. 1979

Router Clinic

4 Rout no-fuss inlay grooves

Decorative inlays add striking contrast and an air of quality to projects. Using a trim router, as shown *below*, helps you get into tighter, narrower surfaces—such as aprons attached to table legs. Follow a straightedge or attach an edge guide to the router's base to ensure dead-straight grooves. Use a straight bit or downcut spiral bit.

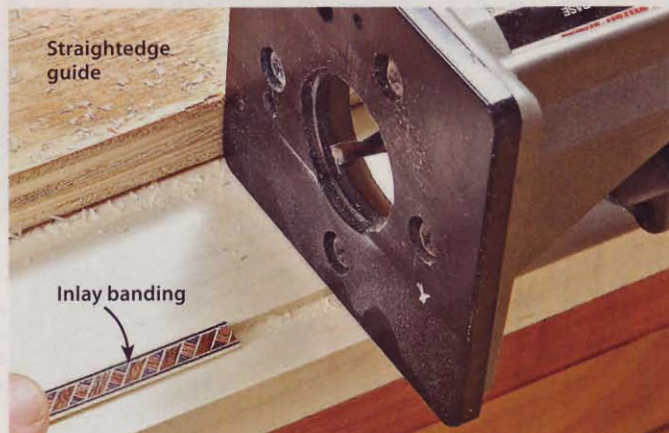

5 Wing it with butterflies

Need to remove an unsightly knot or repair a split in your workpiece? A butterfly (or similar decorative patch) is one of our favorite patches for these flaws. Use a trim router to remove the material, and to cut out the patch. A trimmer works great following a template with a top-bearing bit or guide bushing. When freehand routing, as shown at *right*, the trim router, using a straight bit or downcut spiral bit, feels like an extension of your hand. Cut out the butterfly first, trace its pattern over the flaw, then cut away the recess starting in the middle and gradually routing toward the lines. Cut crisp inside corners with a chisel.



6 Oh, and one more thing...

Yes, trim routers still do an exceptional job of flush-trimming laminate, veneer edge banding, and solid-wood edging (shown at *right*). Bearing-guided flush-trim bits prove best for this task. Rout in a climb-cutting fashion (for edging 1/4" thick or less) to avoid tearing out the grain.



Source

Dado cleanout bit: model #5382, \$20, MLCS, 800/533-9298 or mlcswoodworking.com.

FESTOOL DOMINO

- See Demonstration Videos @ www.mcfeelys.com/domino
- **Faster than Dowels, Stronger than Biscuits, more gluing area too!**
- Perfect for **Edge, Butt, Miter** and Complex Joints
- Oscillating Carbide-tipped bit cuts **cleanly and quickly**
- Provides **positive alignment** and joint strength



On Any Festool Order
FREE
Shipping & Handling
Over \$150 From McFeely's

McFEELY'S
SQUARE DRIVE SCREWS

PO Box 11169 • Dept WDMHFW • Lynchburg • VA • 24506
Toll Free 1-800-443-7937 or at www.mcfeelys.com

Ask WOOD

Answers to your questions from letters, e-mails, and WOOD Online*

HAVE A QUESTION?

For an answer to your woodworking question, write to **ASK WOOD, 1716 Locust St., LS-221, Des Moines, IA 50309-3023**, or e-mail us at askwood@woodmagazine.com

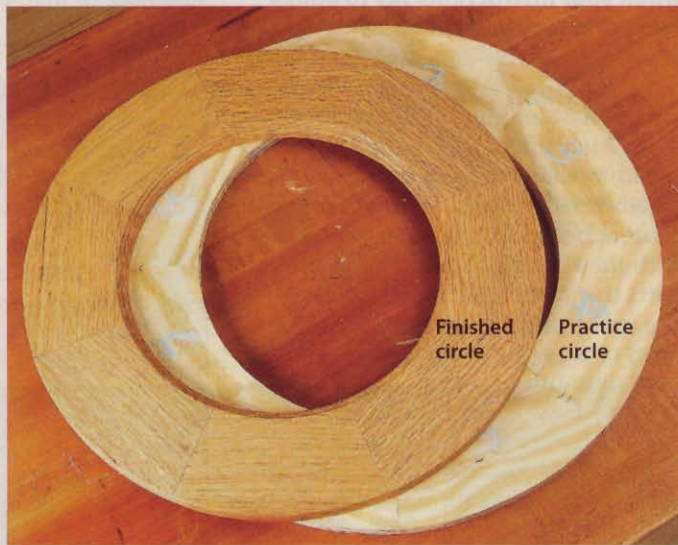
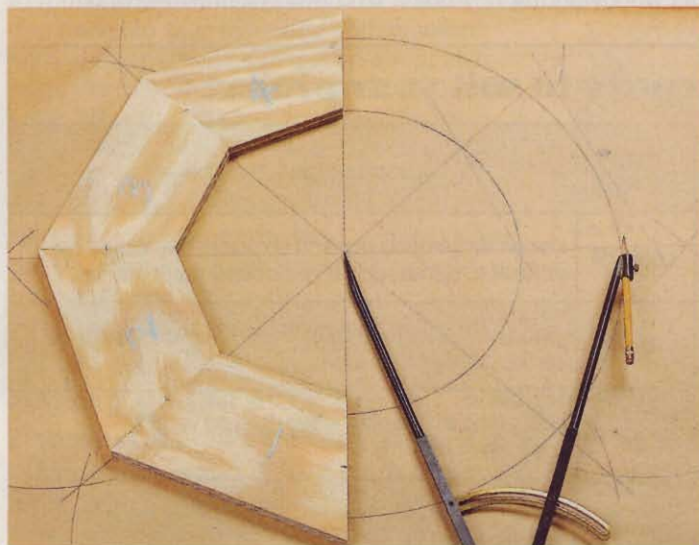

Short segments make grain come full circle

Q: I'm making a large circular frame to trim out a round window in an old house. The outside diameter needs to be 22", and the inside diameter 14". I would like to use the same 5"-wide board so the grain is continuous. Given the dimensions of the circle and the lumber, how do I figure out how many segments to make, and at what angle is each to be cut?

—Craig Vanaken, Aloha, Ore.

A: The more segments you combine to make a circle, the smoother the grain appears to flow between segments, Craig. For the diameter of your circle, eight segments should be enough. Also, this makes the necessary 22.5° miter angles easy to cut.

First, on a 2'-square piece of paper, use a compass to draw two concentric circles with 11" and 7" radii. Then draw a line through the center and use a framing square to draw a perpendicular line dividing the circle into quarters. Using either the compass or a ruler, divide each quarter in two for a total of eight equal sections.

Because you don't want to risk ruining your lumber, practice on a 5"-wide strip of 3/4" plywood to fine-tune your miter gauge setting and assembly technique. Use the circle to determine the final outside length of each section, and cut your board slightly oversize. (In this case, we cut 10" blanks for 9 1/2" sections.) With a miter gauge and auxiliary extension, cut 22.5° angles on

one end of each piece. Then, set a miter gauge stopblock to cut the sections to final length.

Assemble two half-circles of four pieces each, like the one shown *above left*, using biscuits for alignment, and tape to hold the pieces tightly together.

Next, cut your paper pattern in half, and clip out the half-circles to within about 1/2" of the inside and outside lines. Spray-adhere a half-pattern to each half-circle glue-up. Bandsaw and sand both to the pattern lines, leaving just a little extra on the inside and outside of the ends. If your miter gauge is misaligned, you may need to file or sand the ends of the half-circles for a tight fit. Glue the two half-circles together, then sand the joints smooth.

Cabinetmakers set frame standards

Q: Is there a standard rail and stile width for kitchen cabinet doors? I was thinking of using 2" face frame material for the door frames to save milling time, but I think it might look a bit dainty.

—Clint Barden, Asheville, N.C.

A: There's nothing dainty about that 2" door frame size, Clint. Merrilat, the largest maker of cabinets installed in new construction, long ago

settled on 2"-wide cabinet face frames and door frames (even though it tried other door frame widths such as 1 1/8"). Merrilat favors 2"-wide door frames because they use valuable hardwood efficiently without sacrificing strength. Also, that width suits many cabinet door sizes and styles without making the center panel look disproportionately small. For example, a 12" square door with 4"-wide frame pieces would have a center panel of just 4" square.



These unfinished door frames measure 2" (top) and 2 3/4" wide.

Pick the right epoxy

Q: The local home center has dozens of types of epoxy. Do you have something specific in mind when your instructions say to epoxy two parts together?

—Paul Bianchina, Bend, Ore.

A: A 30-minute epoxy handles most needs, Paul, but there's a wealth of liquid epoxies for various woodworking chores, as shown in the chart at right. Save the quick-set epoxies, with their limited working time, for parts that can't be clamped together. Use epoxy putty to fill misplaced screw holes or gaps, but avoid it where you need tight-fitting pieces.

For parts you'll have to clamp, take advantage of the longer working times of the slower-curing formulas. Although some quick-setting formulas can be sanded or drilled within an hour, all epoxies should be allowed to cure overnight for maximum hardness.

You mention shopping at home centers, but don't limit yourself to those

sources. You can buy epoxy in different quantities, containers, and formulas from hobby shops, marine repair suppliers, or mail-order woodworking

suppliers. You also can buy some epoxies directly from manufacturers such as System Three Resins (800/333-5514; strsales@systemthree.com).

Choose the epoxy to suit your project

Epoxy Formula	Set Time	Shear Strength	Advantages and Applications
Quick-set	4-6 minutes	1,600 PSI	Use on simple glue-ups and on pieces that would be difficult to clamp such as compound-miter frames.
Putty	5 minutes	1,000 PSI	Handy as a filler for mispositioned holes or gaps that can be painted or hidden.
Gel	10 minutes	1,900 PSI	Less prone to dripping when used on vertical surfaces.
Marine	50 minutes	1,900 PSI	Can be applied and allowed to cure underwater for maximum water resistance.
Extended time	60 minutes	1,750 PSI	Use for large glue-ups or those involving several parts where extra working time is needed.

continued on page 96

WOOD magazine July 2007

ORDER ON-LINE

Our extensive offering of stock wood turnings, custom quoting, and order tracking is available 24-hours a day, 7 days a week at:

www.osbornewood.com



CALL FOR A CATALOG:
1.800.481.2307

ORDER LINE:
1.800.849.8876

www.osbornewood.com

4620 GA Highway 123 • Toccoa, GA 30577 • Email: turn@alltel.net



WOODCRAFT®
Helping You Make Wood Work®

For A Free Catalog Or To Find Your Local Woodcraft Store, Visit www.woodcraft.com Or Call 800-542-9115.

Sharing your passion for success and personal satisfaction, Woodcraft promises a wide array of quality products. We're convinced that Whiteside makes the finest router bits in the world – that's why we reduce the price of a different Whiteside bit each month! It's our hope that you'll take advantage of this offer and see for yourself just how good Whiteside bits really are.



Dept: 07W107Q

QUALITY WOODWORKING TOOLS • SUPPLIES • ADVICE™

Close the gap on jointer accuracy

Q: When I run edges of boards over my jointer, the leading and trailing thirds join perfectly for glue-ups, but there's a gap between the middle third of the boards. The blades are set correctly, and the outfeed table is level with the cutting arc of the blades.

—Tony Grasso, Muncie, Ind.

A: Sounds like your tables aren't coplanar, Tony. To correct this problem, start by unplugging the jointer, removing the cutter guard, and pushing the fence clear of the table. Then, back off the depth stop to raise the infeed table to the same height as the outfeed table. Center a metal straightedge over the cutters, and lay it across both tables. If you see light beneath the straightedge at one end, you've got a sagging table.

Following the manufacturer's recommendations, adjust the gib screws until the tables are coplanar—lying in a



Problem: The infeed table, outfeed table, or both are sagging at the end.

Solution: Adjust the tables until they're coplanar.

common plane. Then, lower the infeed table, check that the outfeed table is still level with the cutting arc, reset your

depth stop, and replace the cutter guard before making test passes using scraps.

continued on page 98

Boring just got exciting.



Drill quickly and cleanly with our cool-running Power Bore Bit set. Extra-deep flutes clear chips so well that you'll never have to "back out" again!

Discover how we can help feed your passion for woodworking. Get your **FREE** catalog today!



ROCKLER
WOODWORKING AND HARDWARE
Create with Confidence™

Code: 740

For a **FREE** catalog, visit www.rockler.com or call 1-800-403-9736. Stores Nationwide

Circle No. 661

The World's Best 16" Dovetail Jig.



- perfect through, half-blind and sliding dovetails
- fully adjustable spacing of pins and tails
- includes three bits and one guidebush
- optional templates for box and Isoloc joints



FREE DVD & CATALOG!
Call Now 800-663-8932
www.leighjigs.com

LEIGH
Leigh Router Joinery Jigs

Ask WOOD

Bust dust before it spreads

Q: Is it possible to have a shop in my basement and still not have fine dust appear on everything upstairs? My garage gets below zero in winter.

—Lester Borja, Lansing, Ill.

A: Start by containing the dust within your workshop, Lester. That means walling off the shop and installing a ceiling. Where air exits the shop, mount a furnace filter over the return air vent to trap dust in the outgoing air.

Next, connect your equipment to a dust collection system designed to trap particles down to 1 micron and smaller. This includes cyclone systems plus single-stage dust collectors, although some may require an aftermarket high-efficiency filter.

Even with the best dust collectors, you'll still have to contend with airborne particles. So add an air cleaner capable of filtering all the air in your shop every 10 minutes. To determine how much cubic feet per minute (CFM) of airflow you need, multiply the length, width, and height of your shop,

98

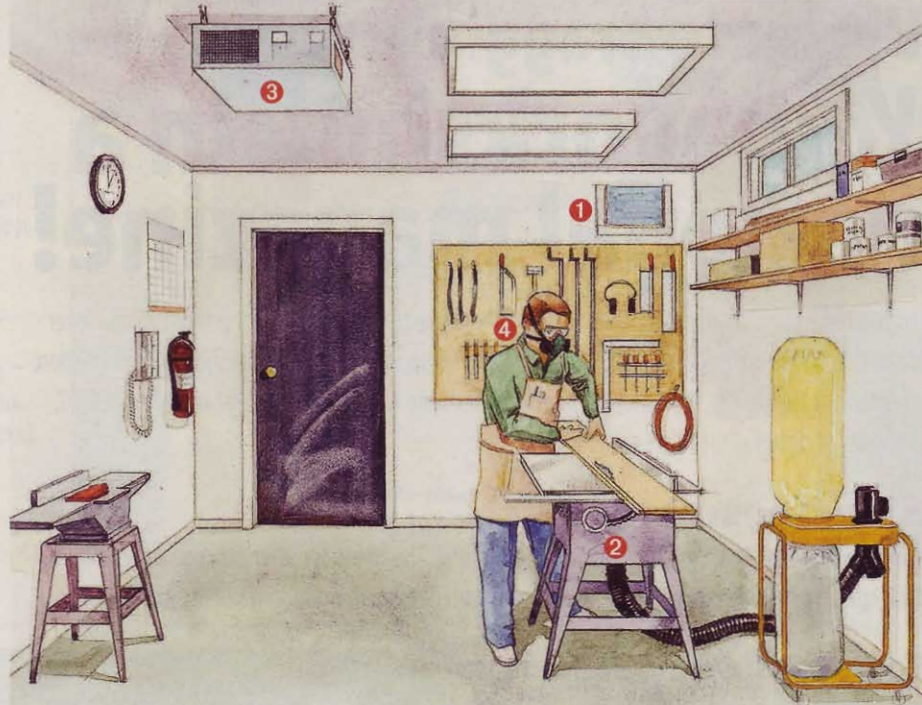

No single system can capture all the dust from your workshop, even when it's enclosed. Start by containing dust within your shop, including a frame around the air return to hold a furnace filter **1**. Then capture dust and chips at the source: your tools **2**. Filter out airborne dust with an air cleaner **3**, and wear a respirator to avoid breathing dust while you work **4**.

and divide that total by 10. Buying the next size larger than necessary helps the cleaner compensate for partially dirty filters. Don't stop with concern over dust entering your house. Keep it out of

your lungs, too, by wearing a tight-fitting respirator—no paper masks—rated to trap 95 percent or more of all airborne dust. Look for filters with a P95, P97, or P100 (the best) rating. 🌳

WOOD magazine July 2007

...the performance in the 11" oak was just as smooth.
 ...we were floored by the ..resaw capacity." "RIKON
 city." "Great idea." "...moved through the 7" oak without a problem
 ver." "RIKON..uses a superior edge-bearing thrust-guide design."
 "...we were really impressed." "This thing has some real guts."
 s." "...also caught my eye." "...we had a winner on our hands."
 es." "Huge Capacity." "...great job on the upgrad
 "...the perform
 "Best New Product 2007"
 etter." "...our enthusiasm for this 14" machine has yet to pe
 y other 14" saws." "...we really liked this saw's tension-release lever."
 guts." "Editor's Choice" "That earned our respect
 ue." "...an excellent value." "RIKON 14" Bandsaw has big resaw capac
 ed." "...this saw was impressive."
 tem." "I like what I see." "Best New Tool 2006"
 nds." "...moved through the 7" oak without a problem or hesitation
 "...great job on the-upgrades." "...we were floored by the..resaw cap
 trust-guide design." "This thing has some real guts." "This saw's perfo
 e really liked this saw's tension-release lever." "...we were really in

SEE WHAT ALL THE BUZZ IS ABOUT.

RIKON

www.rikontools.com
 877-884-5167

Circle No. 1679

WOODWORKING TOOLS AT WHITTLED DOWN PRICES!

Air Locker P630

►\$79.99

- 23-Ga Headless Micro Pin Nailer
- Including extra Driver
- O-Ring Kit
- Swivel Adapter
- Carrying Case & one pack each of 2000 pins: 1/2", 5/8", 3/4", 1" & 1-3/16"

Uses 23-Ga Senco & Porter Cable Micro Pin Nails. \$3.99 per pack of 2000.

Air Locker U630

►\$69.99

- 22-Ga Upholstery Stapler in molded plastic carrying case
- Includes one pack each of 10,000 staples in 1/4", 3/8", 1/2", & 5/8" sizes

Uses 22-Ga Senco & Porter Cable Staples. \$4.99 per pack of 10,000.

12 Roller Table

►\$79.99

Model T1733
 Incredible bargain!

Hitachi NR83A2

►\$289.99

Framing Gun
 Extra NR83A Driver for only

►\$19.99

Free \$39 Value Framing Bag

Hitachi NT32AE2

►\$59.99

18 Gauge 1-1/4" Finish Nailer

Accordion Roller Table

►\$109.99

Model T1732
 Reduced!

Hitachi NT65MA3

►\$169.99

15 Gauge 2-1/2" Finish Nailer

Hitachi NT50AE

►\$79.99

18 Gauge 2" Finish Nailer

WWW.TOOLMARTS.COM

1-800-735-8665

Circle No. 1770

Stool & Tool-Tote Combo

This simple carrier is a step up for odd jobs around the home.

Stand it upright, and you've got a sturdy stool for reaching the top of your lumber rack or doing household chores. Flip the stool over, fill it with tools, and you're ready to tackle a repair anywhere on your property.

To cut the pieces to size and shape, use the dimensions on the drawing. Miter-cut both ends of the legs at 15°. Use 1/2" plywood for the top, sides, and ends. For the legs and handle, cut 2x4 stock to size. Cut a 1/2" groove 1/2" deep centered along the *inside* face of each leg. Mark the slot, drill a blade start hole, and cut the handle opening in the top to shape. Cut the arcs in the ends. Rout 1/8" round-overs along the handle opening and on the remaining parts where shown at *right*. Glue, clamp, and screw the project together in the configuration shown. Sand smooth, and add a finish. 🌲

Project design: Lynn Lawrenz, Algoma, Wis.

Find more shop project plans at:
woodmagazine.com/freeplans

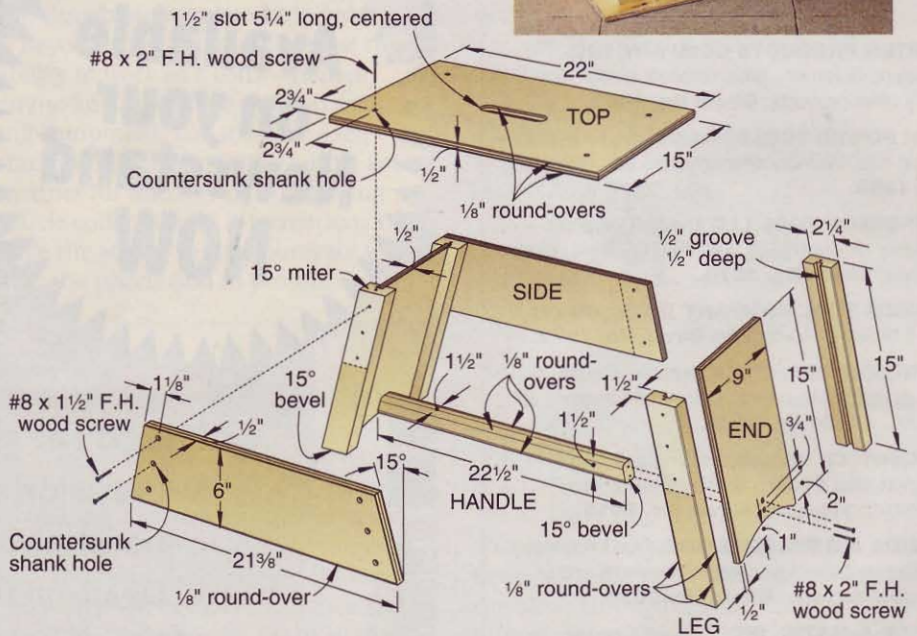
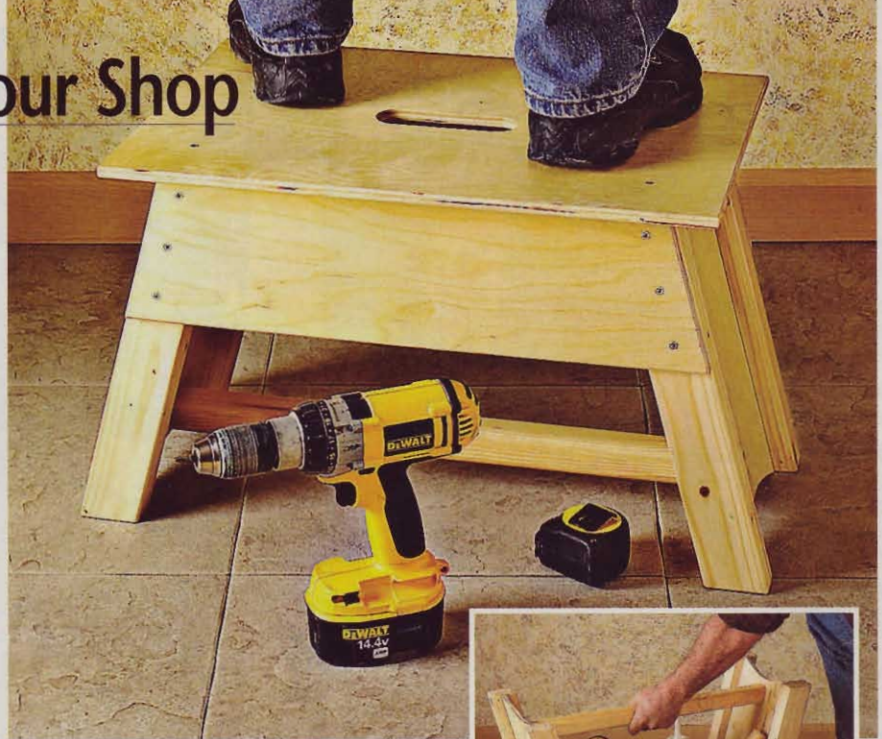

Try a "green" version of the stool

We designed this stool and tool-tote combo so you can build it from commonly available materials. If you have access to construction debris, repurpose that waste by building the project from it. That's how the stool's designer, Lynn Lawrenz, constructs them. "The raw materials are headed for the landfill, until I snag them for stools," says Lawrenz. "I've given away dozens of them, always in pairs, because people

like to set a plank on top of the stools when spread apart for painting and other chores."

In his version (see photo *right*), the end panels/legs are scraps of 12" engineered I-joists, the cross brace/handle joining them is a 2x2" cutoff, the top is discarded roof sheathing (typically oriented-strand board), and the side panels are cut to shape from spare 1/2" cabinet plywood.



What's Ahead

A sneak peek inside the September issue (on sale July 7)

FEATURED PROJECT



Heirloom cradle

This knockout, knock-down project stores flat in its companion storage case when not in use. Removable wedges that secure the ends to the sides make disassembly a snap.

Tower shelves

Add stylish storage in a small space with this narrow-case, biscuit-joined project.



Catchall box

Create the perfect pairing with favorite photos in the lid and treasured keepsakes inside.



Working with kids

With many schools dropping shop, who will teach woodworking to kids? You can with this fun, safe program.

TOOL TEST



Parallel jaw clamps

Four new models recently joined this category of clamps long dominated by the Bessey K-Body. We tested eight models, and what we found may surprise you.

TOOL TEST



12" Compound miter saws

We put eight popular models through their paces. The result: Some cut flawlessly; others are best left to rough carpentry tasks.



The perfect small-shop workbench

A simple elevating mechanism raises this mobile bench a couple of inches so you can store your tablesaw under it. Once lowered, the bench sits flush with your saw top for use as an outfeed table.

