

Build outdoor projects that hold up to any weather!

ISSUE 169 APRIL/MAY 2006

Better Homes and Gardens®

FULL-SIZE  
PATTERNS  
INSIDE

# WOOD

## Build this heirloom China Cabinet

plus learn to make:

- goof-proof raised panels
- built-up moldings
- window grilles
- dovetail drawers
- quick & easy door frames

Get a *fast, super-smooth finish!*

## Spray Guns

- 10 systems tested
- How to use one
- Tips from a Pro



**31**  
Shop Tips  
& Tricks

Display until May 15, 2006



U.S.A. \$6.99

Simple-to-build Window Planter • Tudor Birdhouse

## PROJECTS

- 16 **jig: router-table backer block**
- 18 **easy-access router-bit organizer**
- 44 **heirloom china cabinet**  
Display treasured items in this handsome, lighted showcase; find more storage in its buffet base.
- 56 **freestanding planter box**
- 68 **Tudor-style birdhouse**
- 82 **picture-perfect countertop organizer**
- 86 **nicely detailed photo frame**  
Create a special look using riftsawn grain and ebonized square pegs.
- 94 **brass-and-hardwood beam compass**

## TECHNIQUES

- 14 **make bowls that last a lifetime**
- 30 **jigging up for half-blind dovetails**
- 54 **grilles for glass cabinet doors**
- 60 **guide to building outdoor projects**  
See what woods, glues, hardware, and finishes to use for making weather-tough furniture and decks.
- 78 **spraying finish with an HVLP system**  
Discover the basics of using a high-volume, low-pressure sprayer for super-smooth results.
- 99 **how to shine brass trim**
- 102 **3 uses for glue size**  
Seal surfaces with thinned shop glue.

## TOOLS & MATERIALS

- 40 **four shop-proven products**
- 72 **shop-tested: HVLP spray systems**
- 106 **12-volt impact drivers**

## DEPARTMENTS

- 8 **editor's angle**
- 12 **sounding board**
- 22 **shop tips**
- 36 **ask WOOD**
- 116 **what's ahead**



This seal is your assurance that we build every project, verify every fact, and test every reviewed tool in our workshop to guarantee your success and complete satisfaction.

60



56



68



82



86



54

72

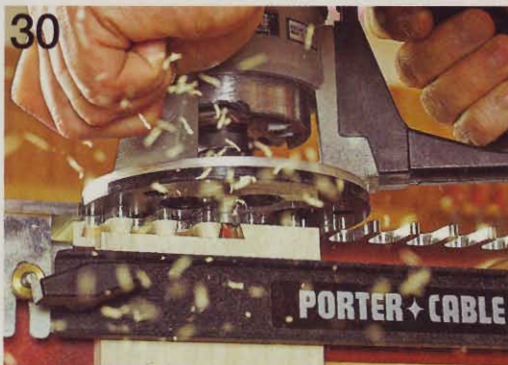

30

PORTER + CABLE



# Better Homes and Gardens® WOOD

April/May 2006

Vol. 23, No. 2

Issue No. 169

## We asked our staff: What's your favorite finish?

I like the simplicity of a wipe-on oil-varnish, such as Danish oil. It helps the wood grain show through.



Wipe-on polyurethane goes on easily with a cloth, dries in about two hours, and offers excellent protection.



EDITOR-IN-CHIEF  
**BILL KRIER**

Executive Editor  
**JIM HARROLD**

Editorial Manager, Tools and Techniques  
**DAVE CAMPBELL**

Techniques Editor  
**BOB WILSON**

Projects Editor  
**OWEN DUVAL**

Design Editor  
**JEFF MERTZ**

Art Director  
**KARL EHLERS**

Production/Office Manager  
**MARGARET CLOSNER**

Photographers **MARTY BALDWIN, SCOTT LITTLE, BLAINE MOATS, JAY WILDE**

Illustrators **TIM CAHILL, LORNA JOHNSON, ROXANNE LeMOINE**

Technical Consultants **JEFF HALL, DEAN FIENE**

Contributing Craftsman **JIM HEAVEY**

Proofreaders **BARBARA KLEIN, IRA LACHER, JIM SANDERS**

**CUSTOMER SERVICE: 800/374-9663**

For more ways to reach us about specific matters, see page 12.

Senior Vice President/Publishing Director **DOUG OLSON**

Publisher **MARK L. HAGEN**

### ADVERTISING AND MARKETING

**CHICAGO:** 333 N. Michigan Ave., Suite 1500, Chicago, IL 60601

Phone: 312/580-7956 Fax: 312/580-7906

Marketing Manager **AMANDA SALHOOT**

Advertising Managers **JACK CHRISTIANSEN, CAROLYN DAKIS**

Assistants **GAYLE CHEJN, JENNIFER RUGGIERI**

**ATLANTA:** Navigate Media

1875 Old Alabama Rd., Suite 1320, Roswell, GA 30076

Phone: 678/507-0110 Fax: 678/507-0118

**DETROIT:** RPM Associates

29350 Southfield Rd., Suite 31, Southfield, MI 48076

Phone: 248/557-7490 Fax: 248/557-7499

### BUSINESS DEVELOPMENT

**NEW YORK:** Concepts Media Group

52 Truesdale Dr., Croton On Hudson, NY 10520

Phone: 914/239-3483 Fax: 912/239-3493

**LOS ANGELES:** Southcoast Projects

12682 Pacato Circle North, San Diego, CA 92128

Phone: 858/673-0921 Fax: 360/246-5661

Business Manager **JOEL ETIENNE**

Consumer Marketing Director **ROBIN HUTCHINSON**

Assistant Consumer Marketing Manager **BILL WOOD**

Associate Director of Marketing-Newsstand **TOM DEERING**

Production Manager **TIM STOUFFER**

Advertising Operations Manager **LIBBY EHMKE**

### MEREDITH PUBLISHING GROUP

President **JACK GRIFFIN**

General Manager **TOM HARTY**

Finance & Administration **KARLA JEFFRIES**

Consumer Marketing **DAVID BALL**

Manufacturing **BRUCE HESTON**

Creative Services **ELLEN DE LATHOUDER**

Interactive Media **LAUREN WIENER**

Corporate Sales **JACK BAMBERGER**

Group Marketing **NANCY WEBER**

Director, Corporate Sales **DORENE BAIR**

Executive Director, Corporate Research **BRITTA C. WARE**

**Meredith**  
CORPORATION

Chairman and Chief Executive Officer **WILLIAM T. KERR**

President and Chief Operating Officer **STEPHEN M. LACY**

In Memoriam — E.T. Meredith III (1933–2003)

Managing Editor  
**MARLEN KEMMET**

Senior Design Editor  
**KEVIN BOYLE**

Techniques Editor  
**BOB HUNTER**

Projects Editor  
**JAN SVEC**

Master Craftsman  
**CHUCK HEDLUND**

Assistant Art Director  
**CHERYL A. CIBULA**

Administrative Assistant  
**SHERYL MUNYON**

Polyurethane. It's tough, looks great years down the road, and today's fast-drying formulations make three coats in a day possible.



Lacquer applies quickly, dries fast, and repairs easily. I can finish small projects with it in one day.



A shellac base with a varnish finish brings out the grain and helps prevent blotching.



## The Toughest Glue On Planet Earth.™



Bonds hundreds of materials including wood, stone, metal, ceramic & more! Incredibly strong & 100% waterproof!

Circle No. 50

1-800-966-3458 • www.gorillaglu.com

## The Toughest Tape On Planet Earth.™



**Extra Thick. Extra Stick.**  
New Gorilla Tape sticks to things ordinary tapes simply can't.

1-800-966-3458 • www.gorillatape.com



# POWER IS NOW ON REBATE



Save up to \$200 on select JET products with JET Power Rebates!

OFFER EXTENDED THROUGH APRIL  
Purchases must be made between  
September 1, 2005 and April 30, 2006 to qualify.

For more details, visit your nearest quality  
JET woodworking dealer or [jettools.com](http://jettools.com).

# JET

BUILT BETTER TO BUILD BETTER™

[jettools.com](http://jettools.com)

©2006 WMH TOOL GROUP, INC.  
The color WHITE is a registered trademark of WMH Tool Group, Inc.

## editor's angle

# talk about a treehouse

Remember that childhood treehouse you built? If it had a level floor, a window or two, and a roof of any kind it was really something special. Well, we've all grown up, and so have our "treehouses." Let me tell you about one our staff recently created.



Taking a break from the building are (from left): Jan Svec, Greg Sellers, Kevin Boyle, Dave Campbell, Marlen Kemmet, Owen Duvall, Jeff Mertz (on roof), yours truly, and Bob Wilson.

A few months back I got a call from our company's president and COO Steve Lacy asking if the *WOOD*® magazine staff would design and build a treehouse to benefit a good cause. My brain filled with images of the treehouses of my youth, and I wondered how those cobbled-together structures could benefit anyone other than a young man seeking refuge from his annoying sisters. However, as I soon learned, this was to be a treehouse on an entirely grander scale, and for a much higher purpose.

The good cause was a local Easter Seals camp for disabled adults and children, aptly dubbed Camp Sunnyside. Many of the campers are wheelchair-bound, and for them it is an exhilarating experience to be elevated above their surroundings. It just so happens that Camp Sunnyside sits in a leafy forest of oak, maple, and walnut, and one wooded ravine provided the perfect location for a structure that would extend over the sloping scenic terrain.

So design editors Kevin Boyle and Jeff Mertz swung into action and designed the treehouse shown in the illustration. It's not in a tree, of course, just among them. (We had to cut down just one small tree to make room for it.) The structure consists of a 30×30' deck with an 8×8' deck off to its side connected by a bridge. Centered on the

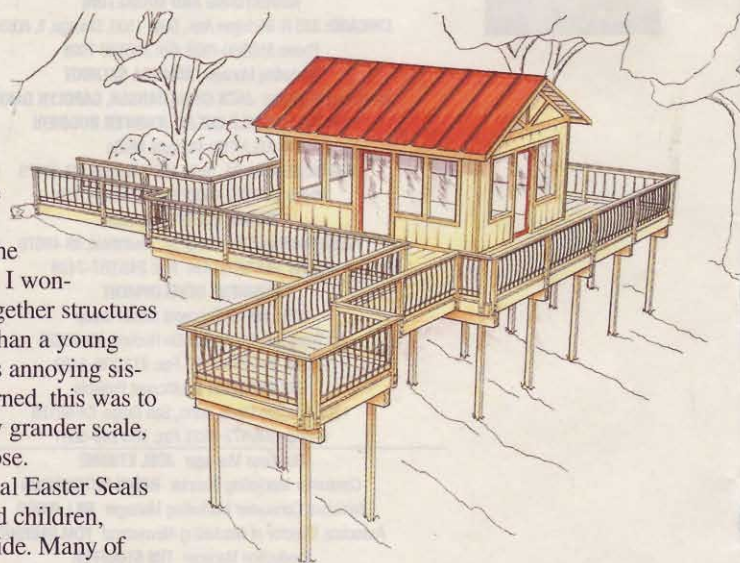

deck is a 14' wide × 17' long × 13' high house with large screen windows. The deck, understructure, and railings are made of pressure-treated southern pine—a strong material that will stand up to the damp, shady, forest conditions for decades to come. We selected and installed a metal roof for the same reason.

And though it's been 35 years since I last constructed a treehouse, building this one was every bit as much fun.

*Bill Krier*

# sounding board

Our bulletin board for letters, comments, and timely updates

## A tale of two cities. . . and two woodworkers

Mentoring a budding woodworker seems like something you have to do working side by side, and definitely not long distance. But that wasn't the case when experienced woodworker Frank Cackowski, 63, of Mishawaka, Indiana, chose to reply to a posting on woodmagazine.com's "General Woodworking" forum. The poster, Chris Maddix, a 33-year-old newbie from Lynnwood, Washington, expressed interest in designing and building a table he'd seen at a local furniture store, but he "lacked the confidence in making his own plan and moving forward," says Frank.

The table, Chris explained, was ideally suited for scrapbooking, a popular hobby his wife had taken up. Upon reading that, Frank's interest increased—his own daughter was a scrapbooker, too. "That's when the idea of making two tables at the

same time miles apart using the computer, digital camera, fax machine, and cell phone entered my mind," Frank says. He replied to Chris through the forum, "If you want to try

this project, I'll mentor you through it."

Thus the electronic relationship began, ending five months later in the design and construction of the two identical tables below.

—WOOD Staff



Photographs: Frank Cackowski and Chris Maddix

Frank Cackowski (above) helped Chris Maddix build an identical table from 2,000 miles away in five months, working with him on design, joinery details, and finishing.

## Don't despair over an old tool repair

I read your piece "Buying Used Machines" in the 2005/2006 December/January issue and thought I should pass along a tip to your



readers. I repaired used shop tools and my best source for repair parts is acetoolrepair.com. They have schematics and parts for countless old models made by Rockwell, Delta, DeWalt, Black & Decker, Makita, and Porter-Cable.

—Lewis Helgren, Tacoma, Wash.

## Article updates

■ In the photo-display easel in the December/January 2005/2006 issue of *WOOD* magazine, note on page 85 that the #6-32 machine screws in the Exploded View should read 1½" instead of 1⅞". Under "Supplies:" on page 86, change the machine screw length to #6-32×2".

■ The Powermatic 8" jointer we tested for our review in the February/March 2006 issue is actually model PJ-882 (stock no. 1610079), and sells for \$1,650. All other information in the chart and article is correct, and we stand by our Top Tool recommendation.

■ The pattern referenced on page 67 in the February/March 2006 issue for the hand-cut dovetails article was omitted from the *Patterns*® insert. Find it in this issue's *Patterns* insert.

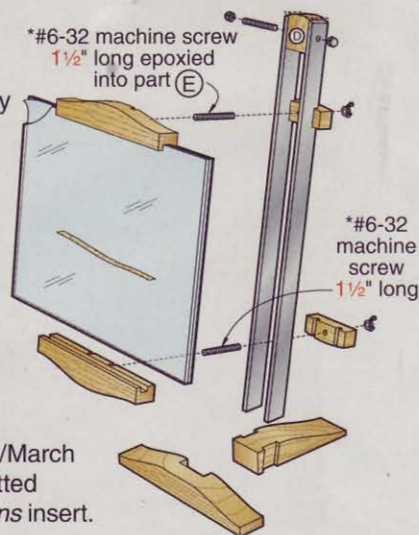

## HOW TO REACH US

### ■ Woodworking advice:

Post your woodworking questions (joinery, finishing, tools, turning, general woodworking, etc.) on one of 20+ online forums at [woodmagazine.com/forums](http://woodmagazine.com/forums)

### ■ Editorial feedback:

Send your comments via E-mail to [woodmail@woodmagazine.com](mailto:woodmail@woodmagazine.com); or call 800/374-9663 and press option 2; or write to *WOOD* magazine, 1716 Locust St., LS-221, Des Moines, IA 50309-3023.

### ■ Subscription assistance:

To notify us of an address change, or to get help with your subscription, go to [woodmagazine.com/service](http://woodmagazine.com/service); call 800/374-9663 and press option 1. Outside the U.S., call 515/247-2981. Or write to *WOOD* magazine, P.O. Box 37439, Boone, IA 50037-0439. Please enclose your address label from a recent magazine issue.

### ■ To find past articles:

See our index at [woodmagazine.com/index](http://woodmagazine.com/index).

### ■ To order past issues and articles:

Order past issues of *WOOD* magazine, our special issues, or downloadable articles from issue 100 to present. Visit our online store at [woodmagazine.com/store](http://woodmagazine.com/store), or by calling 888/636-4478. Some issues are sold out.

### ■ Updates to previously published projects:

For an up-to-date listing of changes in dimensions and buying-guide sources from issue 1 through today, go to [woodmagazine.com/editorial](http://woodmagazine.com/editorial).

# making bowls that last a lifetime

Renowned woodturner Mike Mahoney shapes hundreds of utility pieces every year and guarantees each for life. Here's how he does it.

**U**tility bowls and platters face a life of hard knocks—literally. They get bumped and dropped; exposed to hot foods; spend chilling episodes in a refrigerator; and receive frequent washings. For these wooden kitchen helpers to withstand such abuse for the long haul, you need a few tricks up your sleeve.

## Start with a soft hardwood

It may seem like an oxymoron, but there are a number of relatively soft hardwoods in the deciduous family. These species have greater flexibility and shock resistance than hard hardwoods, making them the materials of choice for treenware (household utensils made from wood). Pieces made from soft hardwoods tend to bounce or dent when dropped and bumped. Those made from hard hardwoods generally crack or shatter.

Surprisingly to many, suitable soft hardwoods include all maples, black walnut, and white oak. Avoid red oak, though, which has large pores that can let food liquids seep through. Ash—another porous wood—is fine to use because it has a honeycomb, rather than tubular, cell structure that prevents penetration of liquids. “Among the maples, silver maple

and box elder make excellent choices,” Mike points out, “and I consider them my favorite species due to their eye-catching grain patterns and color variations.”

Steer away from hard, unforgiving hardwoods, such as locust, acacia, and rosewood, and from fruitwoods, which tend to split due to their sensitivity to hot and cold. For a more inclusive list of suitable/unsuitable species, see the chart, *below left*.

## Apply a penetrating finish

Membrane (film-forming) finishes, such as lacquer, polyurethane, and friction polish, rub off with use, leaving the piece unprotected and unattractive. For best protection, use a food-safe mineral or nut oil that deeply penetrates the wood. Apply the oil as shown *below*.

“For ultimate protection,” Mike reveals, “I use a special utility finish made by blending filtered, heat-treated walnut oil and waxes. Unlike mineral or untreated nut oils that evaporate over time, this oil deeply penetrates and hardens, leaving a super-durable finish.” After the finish dries, Mike



applies a special oil/wax topcoat that adds a lustrous satin sheen. (Learn more about the finish and topcoat at [bowlmakerinc.com](http://bowlmakerinc.com).)

## Care a little, enjoy a lot

To keep your serving pieces in top-notch shape for years on end, follow these tips:

- After each use, hand-wash the item in warm, soapy water. Rinse the item clean, towel dry, and set it aside to air dry.
- *Never* let the piece soak in water or put it in a dishwasher or microwave oven.
- At least every three months or whenever the wood looks dry, reapply a protective oil finish to prevent water from penetrating and damaging the wood. 🌲



Mike Mahoney of Orem, Utah, specializes in utility bowls, nested bowls, and burial urns. He has produced several videos on woodturning and teaches at a number of wood-working schools.

## Woodturner's Stock Guide

### Species ideal for utility pieces

ash	chestnut	maples (all)
aspen	cottonwood	poplar
basswood	elm	red alder
beech	hackberry	sweetgum
birch	holly	sycamore
black walnut	magnolia	white oak

### Species to avoid

acacia	ebony	padauk
cherry (and other fruitwoods)	hickory	pecan
	locust	purple heart
	osage orange	red oak



Using a clean cloth, apply three coats of oil to a bowl or platter, allowing each coat to soak in for five minutes. Then wipe off the excess.

Polyseamseal. As a caulk, it's durable, paintable and stays flexible after drying. Perfect for bathtubs, windows and cabinets. You name it, it'll seal it. Oh, and it's also a great adhesive. See bottom.

**It's a caulk.**



**It's an adhesive.**

Polyseamseal. As an adhesive, it's strong, easy to use, and, of course, permanent. It bonds virtually any materials together, permanently. Oh, and one more thing, it's also a great caulk. See top.

quick and easy **jig**

# router-table backer block

For flawless half-lap joints, rough-cut them with a dado blade, then do some fine-tuning on your router table using this versatile helper.

**I**n the best of all worlds, half-laps are simple, sturdy joints formed with just a tablesaw and dado blade. Unfortunately, not all stacking dado sets leave a smooth surface on the bottom of a dado or rabbet. And because of their design, wobble dado blades leave a slightly concave surface. Both products often create half-lap joints with unattractive gaps and uneven glue lines. For fine furniture, such as the china cabinet on page 44, you want cleanly cut half-laps with tight, uniform glue lines. And while sanding, scraping, and planing help, they take time and don't always result in perfection. Thankfully there's a better way.

First lay out the rabbets and remove most of the waste with your dado blade, cutting about  $\frac{1}{16}$ " less than the finished depth and width of the rabbet. Then build the backer block shown below right. This simple jig keeps the workpiece square to the fence while preventing chip-out at the back edge.

Chuck a  $\frac{3}{4}$ " straight bit into your table-mounted router, and adjust it to the finished rabbet depth. Then position the fence to stop the workpiece at the finished rabbet width. Now holding the edge of the backer block against the fence and the workpiece against the front end, rout the rabbet to final depth and width by making multiple passes over the bit, as shown above right, stopping when the end of the workpiece contacts the fence.

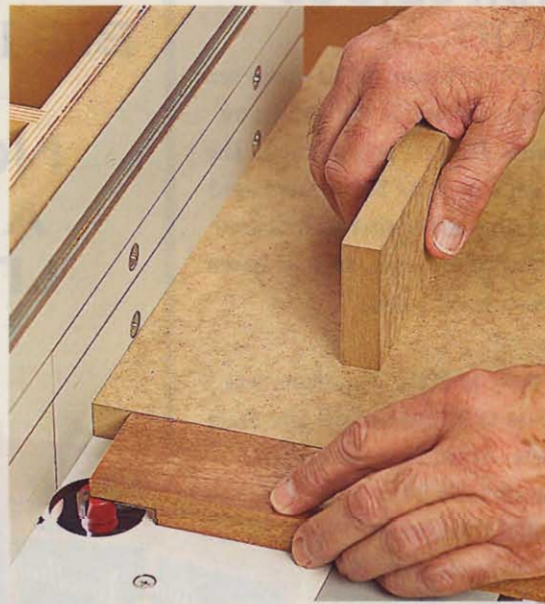

After rabbet-cutting with a dado blade, rout away the final  $\frac{1}{16}$ ".

Use one corner of the backer block to cut all the rabbets of the same size. When you need a fresh backer, rotate the block and use the opposite corner. When both corners are cut up, remount the handle on the opposite face of the block and use the other two corners. Then you can trim away the cut-up ends of the block on your tablesaw to expose four new corners. 🌲

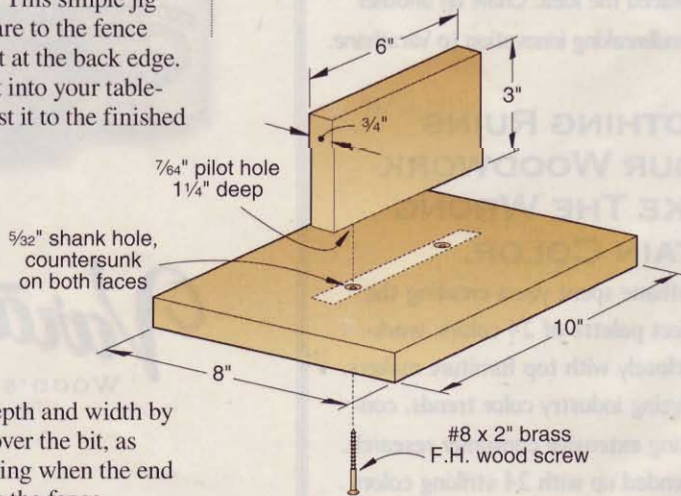

# easy-access router-bit organizer

Combine pull-out shelves with a clear-view window in one well-ordered cabinet.

**W**hen *WOOD*® magazine reader David Riel needed router-bit storage close at hand, he built this organizer and attached it to the side of his freestanding router table. Whether you attach it to your router table or to the wall, this handy storage unit, with its four pull-out shelves, is a must-have for any shop.

To construct the unit, cut the back, support, five dividers, and acrylic front to size. (We cut the 1/8"-thick clear acrylic with a 60-tooth, triple-chip carbide-tipped blade.) Countersink the mounting holes in the acrylic so the screwheads don't protrude. Assemble the unit in the configuration shown below, using just four screws to temporarily attach the acrylic front panel.

ration shown below, using just four screws to temporarily attach the acrylic front panel.

Cut the four hardwood shelves and ends (one tall and three short) to size. Drill holes in the shelves to house your router-bit collection. Drill mounting holes and screw the ends to the shelves. The shelf assemblies simply slide on the dividers for ease in construction and use.

Remove the four screws connecting the acrylic panel to the front of the assembly.

Now, drill four mounting holes through the back for mounting the completed organizer later. Mount the assembly to a shop wall, and screw the acrylic panel in place.

Written by **Marlen Kemmet**  
Illustrations: **Roxanne LeMoine**



## TOP SECTION VIEW

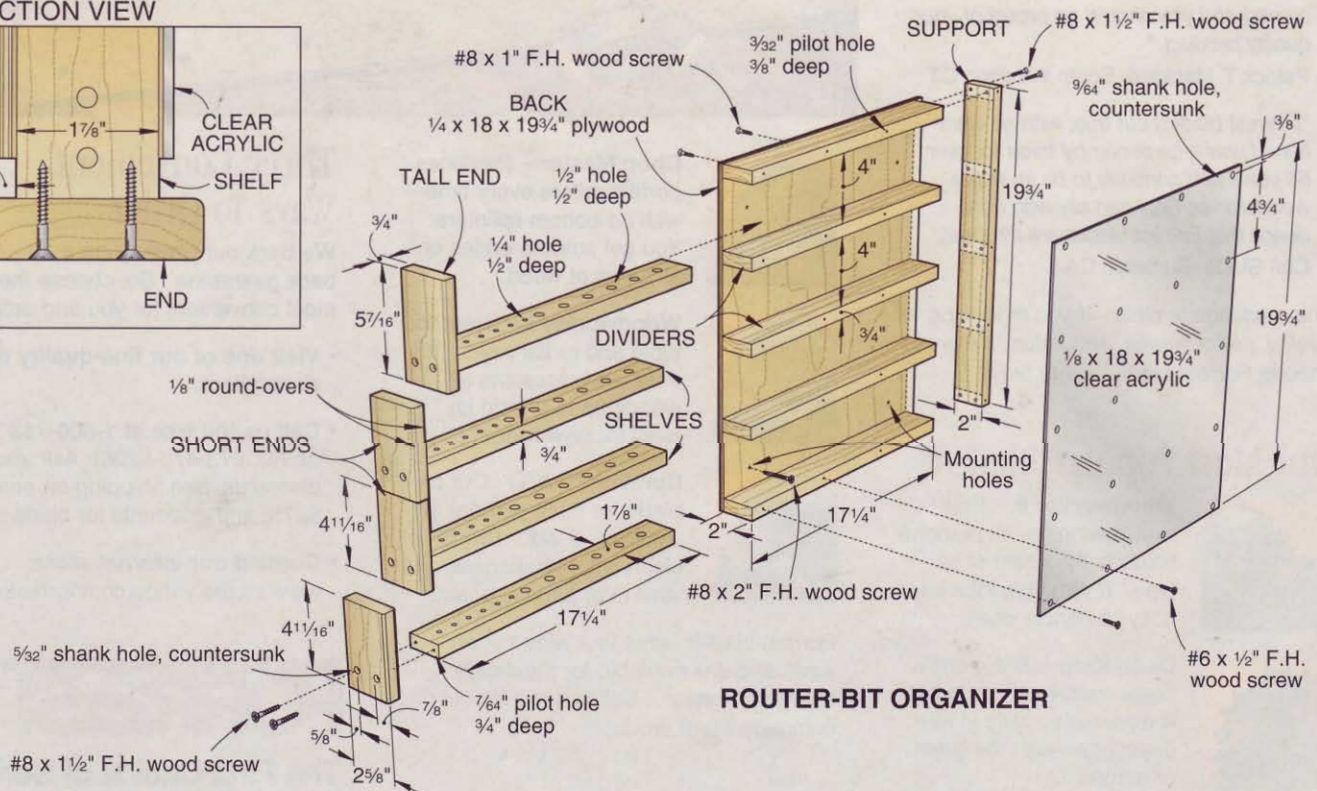
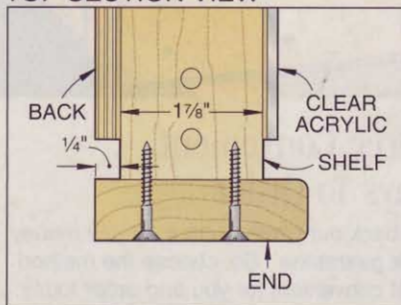



# shop tips

Helping you work faster, smarter, and safer

## Ride the rails for safer ripping

While using a pushstick to rip some thin strips, I realized that there must be a better, safer way to get the work done. This fence-riding pusher provides downward pressure on the workpiece and keeps your hand well clear of the blade.

The pusher consists of two subassemblies: the sled and the hold-down, which are held together by a 1/4" wood dowel. The dimensions shown are for a fence body that's 4" wide and 2 1/2" tall, so you may need to adjust them to fit your fence. And you can skip the cutouts if you like—I used them to lighten the overall weight of the jig.

Assemble the parts as shown, and don't forget to bevel and notch the sled parts where indicated. The bevel allows the hold-down to rotate freely. Also, cut the dowel rod 3/4" longer than the width of the assembly so you'll have space to install cotter pins at both ends.

—Bob Carter, Owens Cross Roads, Ala.

### top shop tip

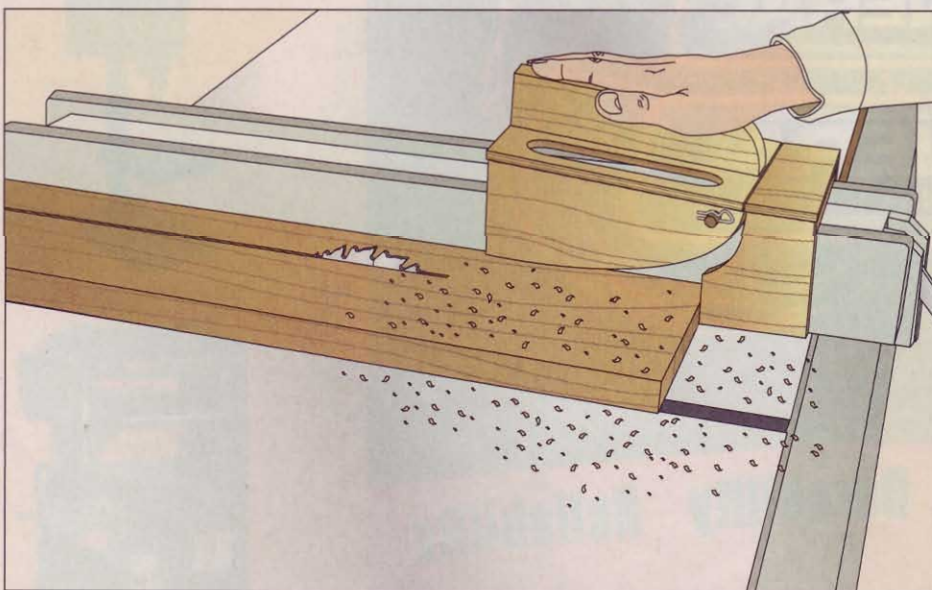
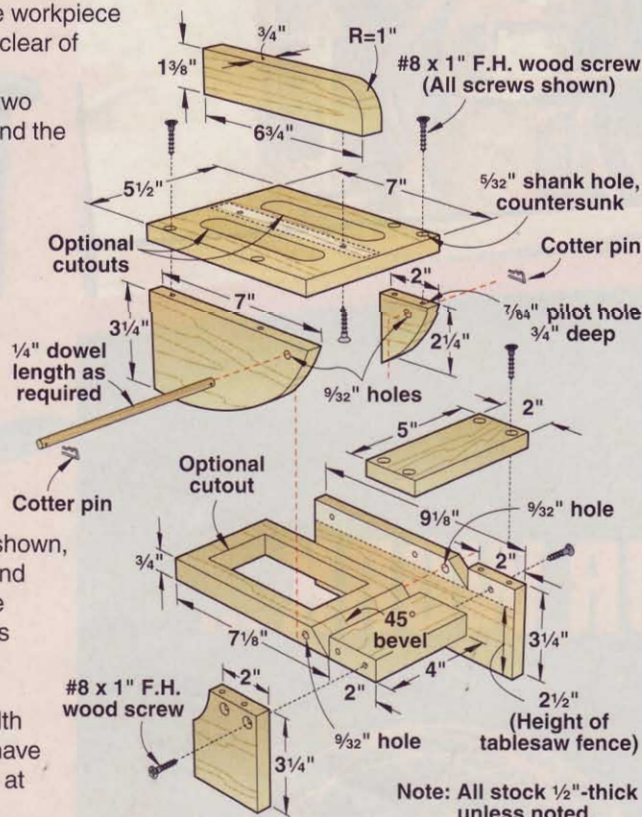

## Our Winner



Woodworking ain't rocket science, but you don't need to tell that to Bob Carter. The retired aerospace engineer couldn't keep it simple when he started woodworking full-time. After going back to college at age 60 to earn a degree in cabinetmaking, he started making wooden "carousel" animals, such as the ones shown with him above. Our Top Shop Tip winner has made six so far, which he says he'll pass on to his kids and grandkids. Each basswood critter takes 600–800 hours of work.



Bob Carter receives Ridgid's new router combo kit (R2930) and belt sander (R2720) with our thanks for sending in this issue's Top Shop Tip. Attaboy, Bob!

## Top tips win tools!

Describe how you've solved a workshop puzzler and you'll earn \$75 if it appears here. And, if your tip garners Top Shop Tip honors, you'll also win a tool prize worth at least \$250.

Send your best tips, along with photos or illustrations and your daytime phone number, to: **Shop Tips, WOOD Magazine, 1716 Locust St., LS-221, Des Moines, IA 50309-3023.** Or e-mail tips to: [shoptips@woodmagazine.com](mailto:shoptips@woodmagazine.com). Remember to include your contact info in the e-mail as well.

Because we try to publish original tips, please send your tips only to **WOOD®** magazine. Sorry, submitted materials can't be returned.

continued on page 24

## Mobile base modification extends adjustment knob

In a Shop Tip on page 32 of issue #134, you showed a great way to extend the locking knobs of a mobile base that lets us lock or loosen the base without bending over. However, on some machinery, you can't run the locking knob to a position directly above the wheel, so I improved on the tip by creating a "universal joint" from  $\frac{3}{8}$ " eyebolts, as shown at far right.

Here's how to do it. Pry open the eye of one of the bolts and join the two together as shown. Use a vise to close the eye and create the swiveling joint. Add this U-joint to the end of the long threaded rod using a coupler and jam nuts, and you're in business.

—George Ziemba,  
St. Marys, Ga.

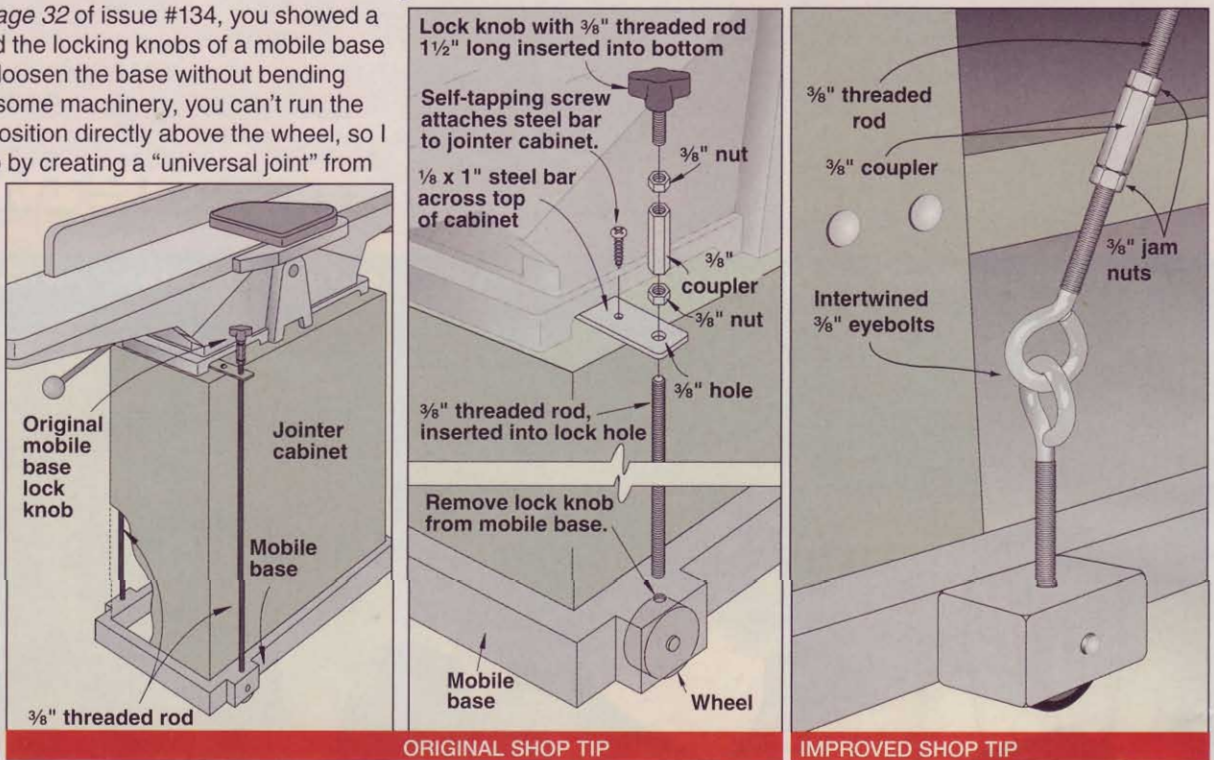

ORIGINAL SHOP TIP

IMPROVED SHOP TIP

WOOD magazine April/May 2006

**“Very simply, they are fabulous machines at excellent prices.”**

**Editor's Pick**

American Woodworker - Jan. 2006

**“Its new Gorilla line delivers top performance at a competitive price.”**

Our 3hp Gorilla tested in a class by itself with the most airflow (CFM). Our 2hp Gorilla tested with more CFM than the 3, 2.5 and 2hp competitors except for one 3hp unit. *See CFM test results on our website.*

*“I just wanted to express how pleased I am with your cyclone. I used to own an imported cyclone and upgraded to the 3hp Dust Gorilla. All I can say is WOW! What an amazing difference. Your machine is every bit as good as advertised and then some.”*

Lou Miller - North Wales, PA

**Complete Ready-to-Ship Ductwork**

Free shipping on \$100+ / 48 States / Some Restrictions Apply

- ▶ Duct Design Service
- ▶ 1.5 - 25hp Systems
- ▶ Dust Collection Since 1993

**www.oneida-air.com**

Call Now for **FREE Brochure!**

**1.800.732.4065**



**2hp Super Dust Gorilla:**  
Comes with 2hp U.S. made Baldor motor / Cyclone Collector / Filter / Wall Bracket / Internal Silencer / Magnetic Starter / 35 Gal. Dust Drum - \$895.00

**3hp Super Dust Gorilla - \$1,195.00**

Shown with Angle Iron Stand: \$159.00 Upgrade

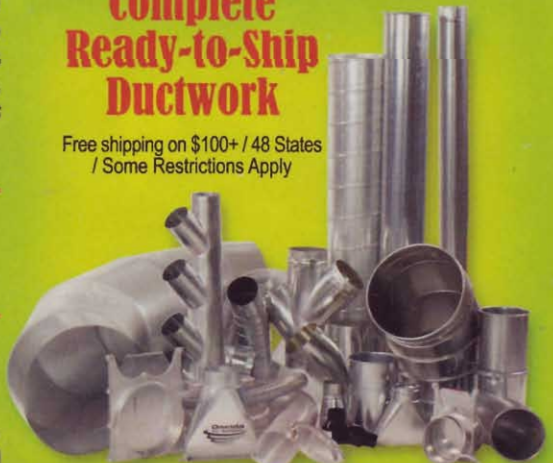

## Table saw fence jig with magnetic personality

Because I don't care for the idea of drilling into my expensive Biesemeyer-style table saw fence to attach jigs, I mount them to the fence with rare earth magnets. To attach the magnets to the jig, cut a filler strip of wood to fit on top of the fence and between its polyethylene or laminated wood faces. Bore through holes in the filler strip for the magnets, glue and screw the strip to the jig, and epoxy the magnets in place. To prevent the jig from sliding down the fence as you feed, attach a steel L-bracket to the jig as shown.

The magnetic attachment grabs the steel body of the fence and offers several advantages. First, I don't have to work around clamps. Second, with no clamps or screws, installing and removing the jig takes only seconds. Finally, I was able to easily retrofit several existing jigs to make them work with the new mounting system.

—Scott Spencer, Rochester, N.Y.

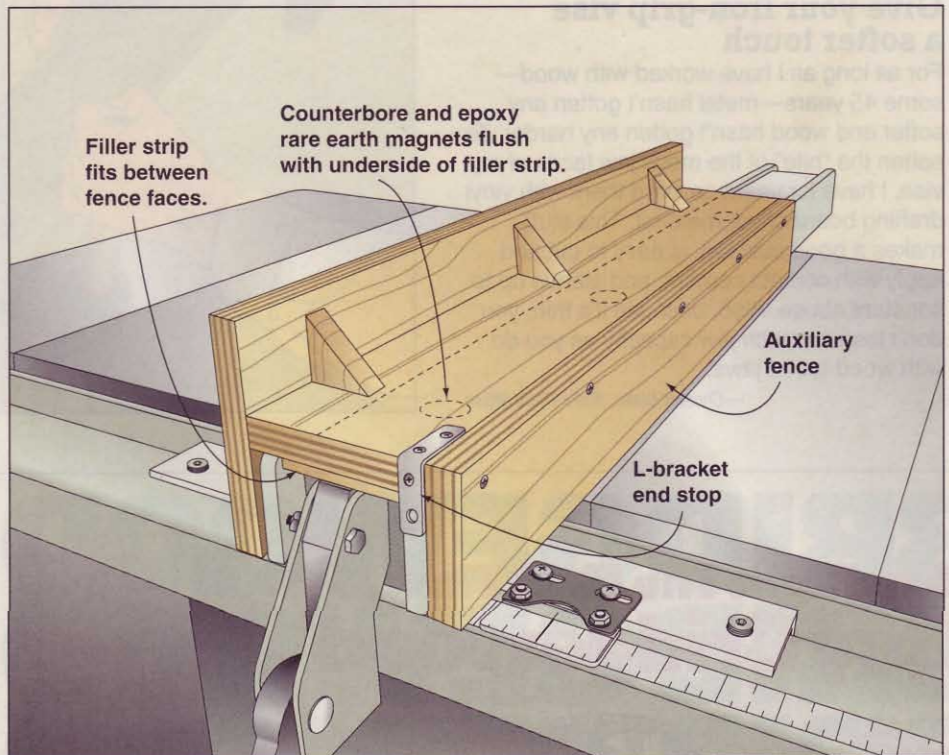

continued on page 26

## Improve Your Shop Vacuum's Performance!

Now you can sand 50-100x longer between filter cleanings!

*New!* **Dust Deputy™** Starting at Under \$100!

Rounds Up the Dust that Used to Get Away!

- ▶ 99% of the dust goes into the drum before your filter!
- ▶ Heavy duty construction! Seam-Welded!
- ▶ Protect your health!
- ▶ Easily attaches to your shop vacuum!



Deluxe container and hose packages available.

Order On-Line!

[www.oneida-air.com](http://www.oneida-air.com)

Call today for **FREE** brochure!

**1.800.732.4065**

Shop Vacuum, Hoses, Sander Not Included.

Circle No. 2039

Pat. Pending

Buy a complete system or make your own!



Make your own bucket and top.

## shop tips

### Give your iron-grip vise a softer touch

For as long as I have worked with wood—some 45 years—metal hasn't gotten any softer and wood hasn't gotten any harder. To soften the "bite" of the metal jaw faces of my vise, I have for years covered them with vinyl drafting board cover material. This stuff makes a good cushion, is easy to cut and apply with contact cement, and stands up to constant abuse. Also, because it's thin, you don't lose as much jaw capacity as you do with wood-faced jaws.

—Chester Blake, Walla Walla, Wash.



## Buy Right The First Time... Buy Bridgewood®

### BW310SL Sliding Table Shaper

- Smooth-sliding table is supported by adjustable ball bearings. Excellent for end grain.
- Forward/reverse switch
- Two spindle speeds
- 1/2" Collet chuck
- Three interchangeable spindles
- Magnetic starter



Note—  
Includes drum dolly shown.  
55 gallon drum not included

### BW-CDC3 Cyclone Dust Collector

Two-stage collector separates wood particles from dust. Never chokes on wood chips.

- 3 HP 1 PH motor
- 1700 CFM at 6" static pressure
- One 8" or three 4" hose inlets



### BW-200PV 20" Planer

- 5 HP 1 PH or 7.5 HP 3 PH USA made main motor
- 20" x 6.5" Capacity
- Extra large 21" x 28" table
- Sectional in-feed roll and chip breaker
- Variable feed rate 16 to 32 FPM
- Square D magnetic switches

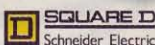

### PBS-540 22" Band Saw

- 5 HP 1 or 3 PH USA made motor
- 14" Resaw height capacity
- Precision balanced cast iron wheels
- Made in Italy
- Cast iron rip fence
- Exclusive double box beam frame
- Made in Italy
- Euro tri-bearing blade guides



Ask about...

**SPECIAL SALE PRICES**



For information and a **FREE** catalog  
**1-866-764-7934**  
**www.wilkemach.com**  
write or visit our showroom:  
3230 N Susquehanna Trail, York, PA 17402-9716



### A fine-tooth trowel foils uneven glue spreading

The next time you finish off a roll of foil, waxed paper, or plastic wrap, save the side of the lid with the serrated cutting edge and cut it into credit-card-size pieces. Use the serrated edge as a fine-toothed trowel for medium- to large-surface laminating. To stiffen the cardboard spreader and make it last longer, glue it to one of those fake plastic credit cards companies send in your junk mail.

—Len Urban, Rancho Mirage, Calif.

Serrated cutting edge  
from roll dispenser

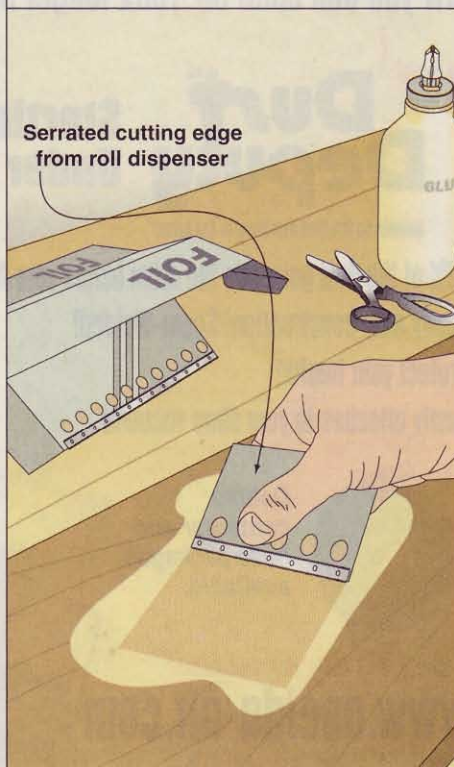

## When dimensions throw a curve, keep it simple

After turning the "trunk" of a walnut coat tree and attaching the top finial, I realized I hadn't laid out the holes for mounting the hangers. Rather than taking risks with the infamous Pi rule and trying to measure a curve, I found a way to make a potentially frustrating task as simple as, well, pie. The three steps to success are shown below.

—Peter S. Bosse, South Portland, Maine

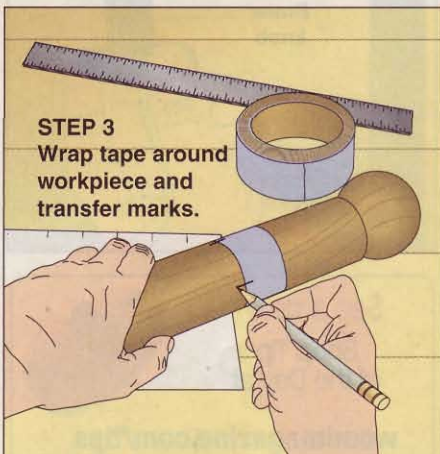
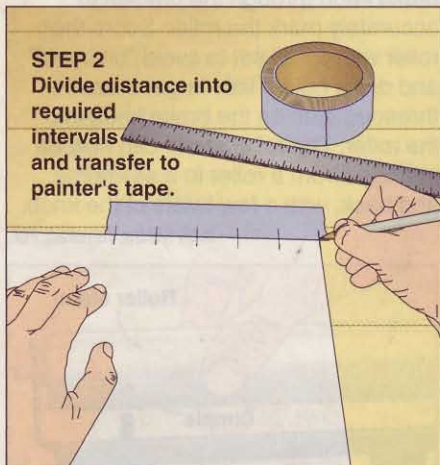

continued on page 28

## Quality Pen Kits and Other Turning Kits



- Designers & Manufacturers
- Wholesale & Retail

**THE BereaHardWoods** CO. Inc.

Manufacturer of quality writing instruments, components and kits.

CALL FOR FREE CATALOG

18745 Sheldon Road • Middleburg, Ohio 44130 U.S.A.  
Ph: (216)898-8956 • Fax: (216)898-8962 • bereahard@aol.com

Circle No. 2127

# The First to FINISH WINS!

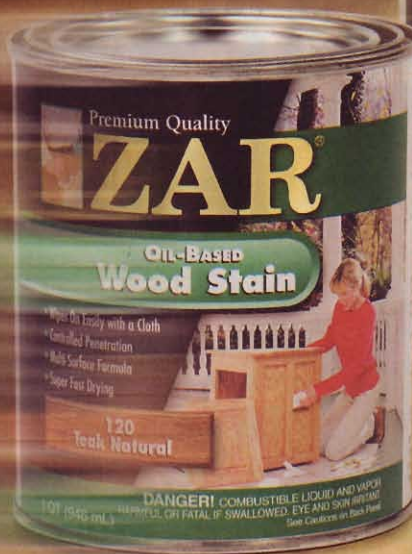

**SUPER-FAST  
Drying  
FORMULAS**

If you want a quality finish and you want it fast, the name to look for is ZAR®.

ZAR Premium Quality Oil-Based Wood Stain provides rich uniform color in just **3-hours**. This new fast-drying formula is available in 20 popular colors and a tint-base for custom colors.

ZAR ULTRA Fast Drying Polyurethane is an oil-based polyurethane which provides a beautiful

protective finish that will last in the toughest conditions. It dries and can be recoated in just **2-hours**. Available in gloss, semi-gloss, satin and antique flat sheens for the look you want.

ZAR Wood Stain and Clear Finishes, the perfect choice for the fastest finish — Making you the winner.

**ZAR®** The fastest way to a beautiful finish!  
For a free brochure and dealer nearest you, call  
**1-800-272-3235** or visit [www.ugl.com](http://www.ugl.com)

Circle No. 141

## You'll love this high-wire act

If you're tired of tripping over extension cords and accidentally kicking them loose from the outlet, hang 'em high using the simple suspension cable shown here. When you're done for the day, the whole cord system slides back against the wall.

Begin by driving two screw eyes into a ceiling joist to hold the clothesline. Fasten the clothesline to one screw eye, slip the metal shower curtain rings over it, and attach the other end to the other screw eye. Space the rings along the clothesline as shown, slip the extension cord through the rings, and secure the cord to them with wire ties.

—Buck Nail, Alma, Ga.

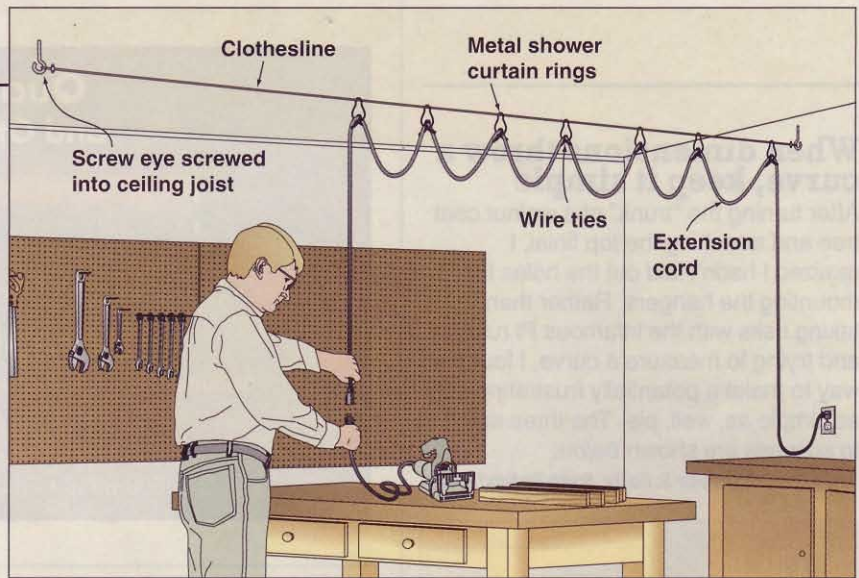

## Put the brakes on a runaway roller stand

With a small shop, I constantly look for ways to save space. In practicing this shop conservation, I recently invented a roller brake that makes my roller stands serve double-duty as sawhorses.

Drill and tap a hole in one end of the bracket holding the roller. Thread the brake knob through the bracket to accurately mark the roller. Score the roller with a nail set to avoid "bit travel" and drill a hole a little larger than the threaded stud on the brake knob into the roller. The roller stand can now be changed from a roller to a sawhorse, and back, with a few twists of the knob.

—Yaniv Matza, Tamarac, Fla.

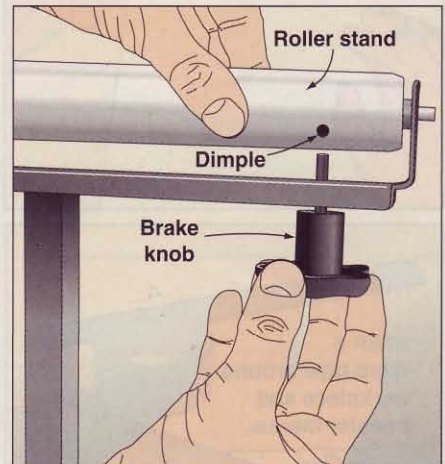

See a new

Shop Tip  
of the Day at

[woodmagazine.com/tips](http://woodmagazine.com/tips)



## DRIVES 4 SIZES OF NAILS WITH NO EFFORT

■ Comfortable  
Ergonomic  
Styling with  
Cushioned  
Non-Slip  
Grip.

■ Trigger and  
Surface  
Safety Locks.

■ Non-Marring  
Bumper.



DRIVES 4  
DIFFERENT SIZE  
BRAD NAILS UP TO  
1 1/4" LONG

14  
AMPS

■ New Heavy Duty  
Nail Driving  
Power with  
Built-in 10' Cord.



Available at home centers, lumber yards  
and hardware stores, wherever fine tools are sold.



Arrow Fastener Co., Inc., 271 Myhill Street, Saddle Brook, New Jersey 07663  
Canada: Jardel Distributors, Inc., 6505 Metropolitan Blvd. East, Montreal, Quebec H1P 1X9  
United Kingdom: Arrow Fastener (U.K.) Ltd., Unit 5 ZK Park, 23 Commerce Way, Croydon CR0 4ZS, Surrey  
[www.arrowfastener.com](http://www.arrowfastener.com) Rev.1002

# tails you win

Our setup tips help you turn out perfect half-blind dovetails every time using a basic dovetail jig and router.

**E**ven an inexpensive dovetail jig can zip you through the job of making super-strong half-blind dovetails, such as those on the drawers of our china cabinet on *page 44*. Without the right setup and technique, though, any jig will produce more disappointments than dovetails.

Your dovetail jig manual should provide information on bit selection, setting the dovetail bit cutting depth, and the basics of making template and edge guide adjustments. To fine-tune those settings, use the troubleshooting chart on *page 32*.

Start by mounting the template on your jig for making half-blind dovetails  $\frac{1}{2}$ " wide at their widest point. Depending on the jig

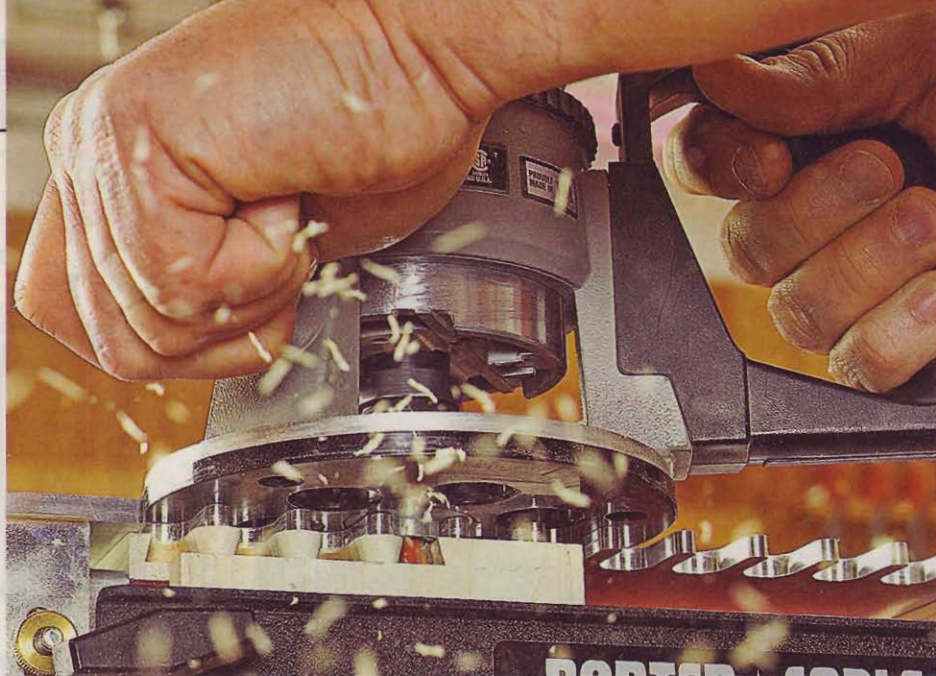

you're using, you also may need to adjust or install edge guides sized to work with the half-blind dovetail template.

Templates partially determine the widths of parts you can join for uniform half-pins on the top and bottom (see photo at *right*). For example, the half-blind dovetail template on the Porter-Cable 4200 series jig works best with workpiece widths in 1" increments beyond  $\frac{1}{4}$ ", such as  $\frac{2}{4}$ ",  $\frac{3}{4}$ ", or  $\frac{4}{4}$ ". But the comparable template on the Craftsman 25790 jig works best with stock widths in  $\frac{7}{8}$ " increments ( $\frac{2}{8}$ ",  $\frac{3}{8}$ ",  $\frac{4}{8}$ ",  $\frac{5}{8}$ ", etc.). See the owner's manual for its recommended stock widths. Now you're ready for what the manual may not cover.



**DON'T DO THIS**  
To avoid incomplete pins, make certain that the part dimensions coordinate with the template you're using.

This joint starts with a half-pin...

...but it ends with a half-tail.

## A highly visible mount

Screwing the jig onto a scrap that you can clamp atop your workbench does the job, as you can see on *page 32, top left*, but here's a more convenient option: Raise the jig closer to eye level using a jig holder like the one shown *below* and featured in the December 2004 issue (#160).



This  $12\frac{1}{4}$ "-high stand makes routing easier by letting you work without bending over.

## The ABC's of organizing parts

Avoid confusion by labeling all four drawer parts on their inside faces, and mark an "X" on the top edges. To rout pins in the front and back with tails on the sides, lay out the parts as shown at *right* and mark the four corners to be joined. Dovetail corners A and C using the jig's right edge guide and corners B and D against the left edge guide to ensure uniform half-pins at the tops of the front and back. The insides of all parts should face out, with drawer fronts and backs placed horizontally on top and the drawer sides positioned vertically on the front of the jig.

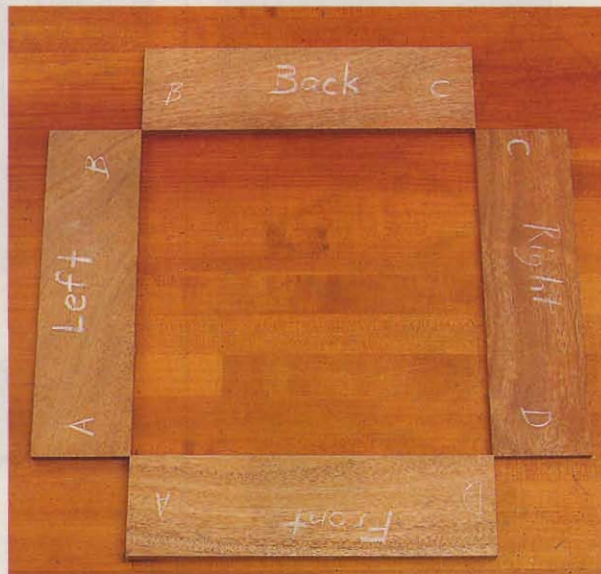

Clear markings help you clamp the front and back pin parts on top of the jig with the inside facing up, and clamp the tail parts vertically, again with the inside facing out. Mark ends with letters A-D to match pieces A to A, B to B, and so on.

*continued on page 32*

### Save those scraps

When machining project parts, make extra pieces of the same thickness for practice scraps to adjust the template and to keep the hold-down clamps flat against the parts you're cutting, as shown *below*.



### Pins on front; tails on sides

This pin and tail arrangement hides the joint from the front and resists pulling apart when opening the drawer repeatedly.

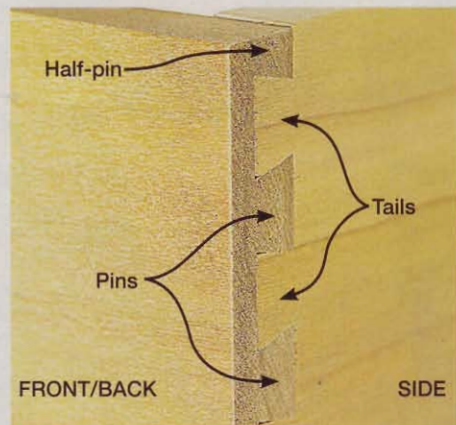

### The enemy of accuracy

We're talking about sawdust. Between cuts, clean away any dust and debris on the jig surfaces, especially around the edge guides shown at *right*. Buildup here can cause the top edges of a joint to misalign.

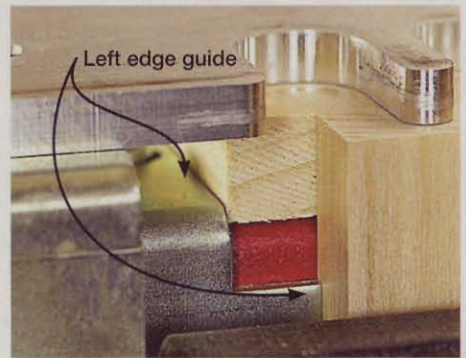

Both the pin and tail parts must press firmly against the edge guide to avoid uneven edges on the parts.

### Adjust the template for a flush and even dovetail

Moving one or both sides of the jig template forward or back adjusts the fit of your dovetails between the pins. The template is

held in place by two pairs of adjustment nuts. On this model, the edge guides also can be adjusted to fine-tune the joint.

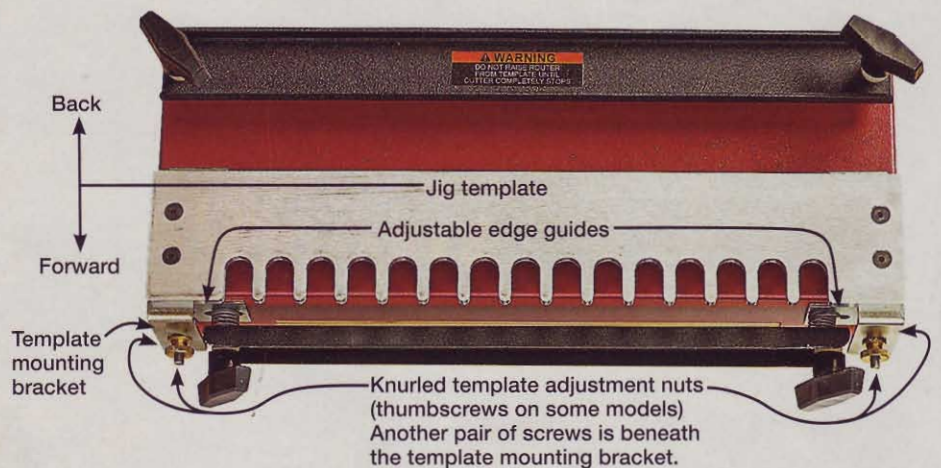

### If your dovetail looks like this...



#### Here's what went wrong...

The template sits too far back on the jig.	The template sits too far forward on the jig.	The template sits at an angle from side to side.	The edge guides are misaligned or clogged with dust.	The dovetail bit cuts too shallow.	The bit cuts too deep.
--	---	--	--	------------------------------------	------------------------

#### And here's how to fix it.

Back out (loosen) both sets of template adjustment nuts equal distances until the tails rest flush with the pins.	Advance (tighten) the template adjustment nuts an equal distance until the tails rest flush with the pins.	Advance or back out both sets of adjustment nuts to equalize the pin depths.	Use the correct edge guides. Snug both parts against the guide edges and remove all dust after each of your cuts.	Lower the dovetail bit in 1/64" increments until the parts fit snugly. Check that practice scraps equal the thickness of parts.	Raise the router bit in 1/64" increments until the parts fit together snugly. Check that practice scraps equal the thickness of parts.
---	--	--	---	---	--



## Clamp, adjust, reclamp

Parts mounted on the jig must fit tightly against each other, and the templates must rest tight against the parts, as shown *below*. Do this in stages by first clamping the front or back project part loosely in place on the

top of the jig with a piece of offsetting scrap. Press the template firmly against the surface of the part and secure with the outside adjustment nuts.

Next, clamp the side workpiece firmly into position vertically on the front of the

jig, with the end seated tight against the underside of the template fingers. To make the final adjustment, loosen the top clamping bar and press the end of the front or back piece snugly against the face of the side piece. ♣

### TIGHT JOINTS START HERE



Gaps between parts, or between a part and the template or edge guide, can translate into a loose joint.

## SHOP TIP

### No-slip grip

Upgrade a low-priced dovetail jig inexpensively with two strips of adhesive-backed, 100-grit or 120-grit abrasive. Remove the hold-down bars and wipe away any dust or contaminants. Trim the sandpaper to width and press the strips firmly against the hold-down bars. Then remount them on the jig. The result: better holding power for just pennies.

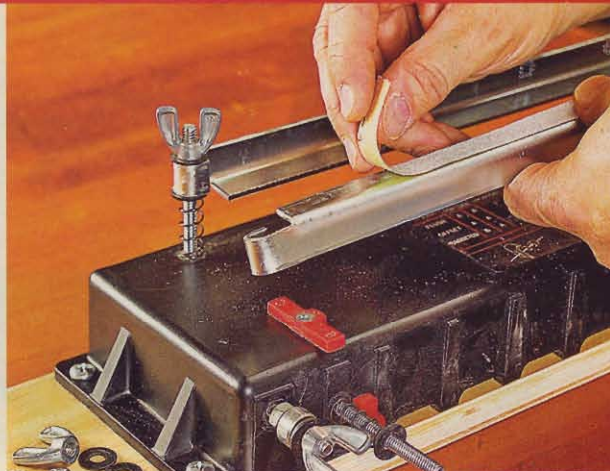

## CELEBRATE APOLLO'S 40TH ANNIVERSARY! A SPECIAL EDITION AT A SPECIAL PRICE



**Apollo Model  
1000SE  
Including All-New  
Apollo  
TrueHVLP™ A5510  
Spray Gun!**

**40th Birthday Sale: \$999**

**Apollo Sprayers**, industry leader in complete TrueHVLP™ turbine systems, celebrate 40 years of quality, engineering, and durability, with **big savings** on the new **Special Edition Apollo, Model 1000SE**:

- ▲ Tough industrial duty 8.0 psi 4-stage turbine unit
- ▲ Double air filtration
- ▲ Handles light, medium, and heavy viscosity finishes

**Order Model 1000SE Today  
Get an APOLLO PRO PACK FREE!**

**Part #5319LE \$200 VALUE!  
CALL 888-900-4857 (HVLP)  
Online: [www.hvlp.com/w406](http://www.hvlp.com/w406)**

Ask us about our other turbine models and HVLP spray guns - Available from **\$369**

W406

## CUSTOM TURNINGS

*Meeting the needs of the creative wood worker with custom wood components since 1979.*



- Shorter or taller
- Thinner or wider
- Using your wood
- Design from your sketch
- And more!



**CALL FOR A CATALOG:  
1.800.603.4557**

**ORDER LINE:  
1.800.849.8876**

**[www.osbornewood.com](http://www.osbornewood.com)**

4620 GA Highway 123 • Toccoa, GA 30577 • Email: [turn@alltel.net](mailto:turn@alltel.net)

Answers to your questions from letters, e-mails, and WOOD Online®

## Drill the whole hole

**Q:** I have a benchtop drill press that lacks enough stroke to drill through a blank for making pens. I have to flip the pen blank over to complete the hole, and that causes alignment problems. What drill presses will give me enough drilling depth that I don't have to do this two-step process?

—Naomi L. Kocean, Madera, Calif.

**A:** Many stationary drill presses have more than a 4½" stroke, enough to drill either half of an average 5" pen blank, Naomi. But don't rule out your benchtop drill press just yet. First, cut the pen blank into two pieces, both about ⅛" longer than the two brass tubes you'll later insert into the holes to be drilled. That should reduce your drill's required stroke to less than 3" for most pen styles.

If that's still longer than your benchtop press can handle, give the blank a boost using a simple jig. The jig's base thickness raises the longest piece of this blank to just below the tip of the brad-point bit. (Use a

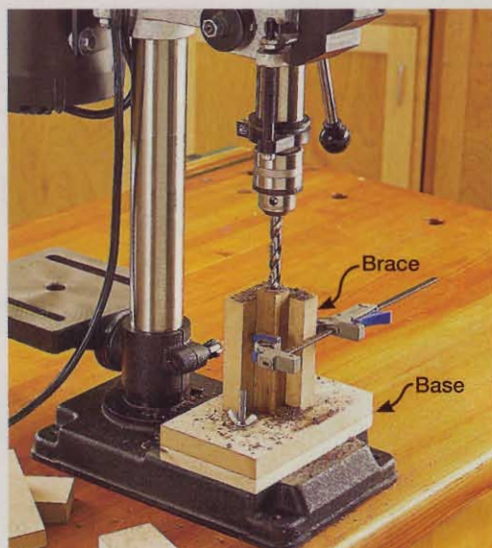

Clamp the pen blank firmly against both inside faces of the L-shaped brace, with the end of the blank just beneath the bit.

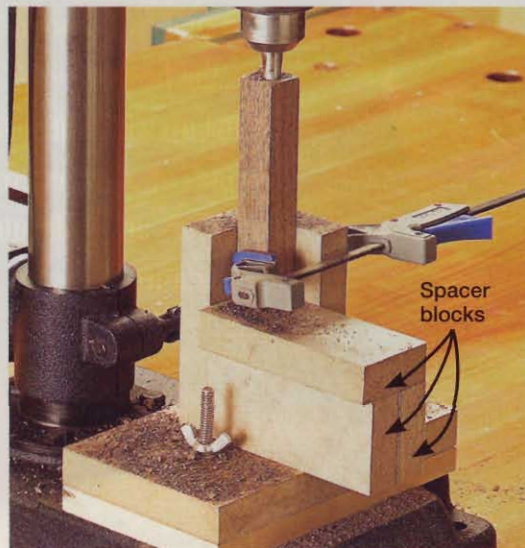

Use spacer blocks to raise the pen blank up around the lower half of the bit. Then finish drilling the rest of the hole.

drill bit long enough to bore through the longest piece of the blank.) An L-shaped brace no longer than your pen blanks attaches at 90° to the base. Then cut spacer blocks to stack beneath the blank.

Mark a center point on the blank end, and clamp the blank into place directly beneath a brad-point drill bit, as shown *above left*. Begin slowly drilling into the end and

withdraw the bit frequently to eject the chips. When the drill press reaches its maximum depth, withdraw the bit and stop the motor. Raise the blank and support it with the spacer blocks, as shown *above right*. Clamp the blank back on the jig and resume drilling, again periodically backing off the bit to eject chips. Repeat the process until the bit cuts the complete aligned hole.

## Vac sack facts

**Q:** I was watching an advertisement for Space Bags where you insert garments to be stored and vacuum the air out to reduce their size. I wonder if these would work as a low-cost vacuum press. Has anyone else had this brainstorm?

—Jess Pidlin, Long Island, Va.

**A:** The prospect of buying seven veneer bags for less than \$28 intrigued us, Jess, but we're going to have to rain on your brainstorm. We put a piece of ash veneer on a scrap of MDF in a Space Bag (800/469-9044, or spacebag.com) and sealed it according to the instructions. Space Bags require a household vacuum cleaner, so the

pressure they exert may vary with the vacuum you use. Not taking any chances, we used our largest and most powerful shop vacuum to remove the air.

By the next morning, however, we discovered the Space Bag had lost vacuum, allowing the bag to be pulled free from the veneer, as shown at *right*. A second test confirmed these results.

The Space Bag may be better for storing clothes than clamping veneer, but you still have low-cost alternatives to high-end veneer presses. One of those is a 26×28" hand-pumped vacuum press (no. 55K67.26, \$56.50) from Lee Valley (800/871-8158 or leevalley.com) that produces about 12 psi of vacuum pressure, similar to larger and costlier systems.



Lifting on the Space Bag's one-way valve shows how much hold-down pressure the bag lost overnight.

*continued on page 38*

## Choosing glass

**Q:** I never knew that buying glass for a display cabinet could be so difficult. The clerk at the glass shop asked whether I wanted single-strength, double-strength, tempered, or laminated. How do I decide?

—Frank Siorek, Saint Louis

**A:** Here's a quick comparison, Frank. Single-strength glass is  $\frac{3}{32}$ " thick; double-strength is  $\frac{1}{8}$ " thick and costs only 50 cents more per square foot from our local supplier. Tempered glass is available in a variety of standard thicknesses starting at  $\frac{1}{8}$ ". Tempered glass is difficult to break, but if it does, it shatters into tiny pieces, minimizing its danger. You must order it in the exact finished size you want because it can't be cut after it's tempered.

Laminated glass consists of a plastic layer bonded between two sheets of glass. Car windshields use laminated glass because the plastic holds broken pieces together instead of letting them scatter after breaking. A glass shop can cut laminated glass to any size you

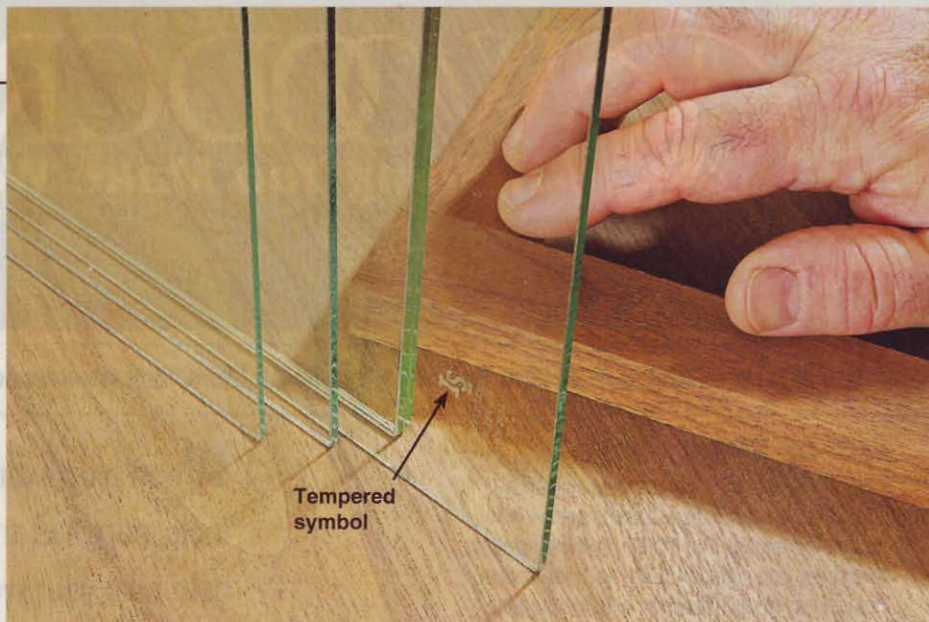

Here's a lineup of common glass choices plus their square-foot prices from our local supplier (from left to right): single-strength (\$3), double strength (\$3.50), tempered (note the symbol etched in the corner) (\$8), and laminated (\$8). Beveled, rounded or polished edges are available at an extra charge on all types of glass.

need. Laminated glass thickness starts at  $\frac{1}{4}$ ", however, so the weight may be too great for hinged cabinet doors.

For a medium-size cabinet, use double-strength glass in the sides and doors for its

light weight and low cost. Tempered or laminated glass can be substituted as a safety precaution for cabinets used in bathrooms or where the cabinet is likely to be damaged by young children. ♣

## Unlimited Possibilities

Novice or expert, wood turning provides endless possibilities for making creative and beautiful projects. Penn State Industries offers a huge selection of lathes, projects, tools, and lathe accessories- everything you'll ever need to participate in this favorite pastime. Get started now!

Visit our website or call to order our free catalog with over 70 pages of select woodworking products.



*The Barracuda2 key chuck gives a powerful grip on your work. This complete 10-piece set has everything you need in a lathe chuck - easy to use, great value, and quality engineering.*  
CSC3000C . . . \$154.95

*The award-winning Turncrafter Pro sets a standard in economy and features for midi lathes. It has an 18" turning capacity, 1/2HP motor, and a cast iron construction.*  
TCLPRO . . . \$169.95



1-800-377-7297  
www.pennstateind.com

**PennState**  
Industries



# shop-proven products

These woodworking wares passed our shop trials.

## 18 volts of drilling power that weighs like 12 volts

Lithium-ion (Li-Ion) batteries—the same technology proven in cell phones and laptop computers—have entered the power tool world in a big way in the past year. We introduced you to Milwaukee's 28-volt line in issue #163, and Bosch and DeWalt launched 36-volt (36 volts!) models at the International Builders' Show in January.

Truth is, 12- or 14.4-volt cordless tools are plenty capable for most woodworking tasks—the excess power just leads to extra weight in NiCd- and NiMH-powered tools. On the other hand, if you could get 18 volts of performance for the same weight as a 12-volt tool, then you'd have something. That's exactly what Makita has done with its LXT line of 18-volt Li-Ion cordless tools.

I was building a deck when the BDF451 ½" drill driver arrived. The tool felt so light, I had my doubts about its power, but I bored more than a dozen ½" holes with an auger bit through 7" of pressure-treated lumber without draining the battery pack. I used the low-gear speed for this torque-demanding task, and then switched into high gear to drill holes for lag screws into 2x treated lumber. The middle-gear range provides the



right balance of torque and chuck speed for making short work of driving long screws.

At the end of the day, the BDF451 was still a joy to use: I wasn't worn out from lugging around a heavier drill, and the twin LED lights—which until now I figured for a useless gimmick—let me keep working past dusk. The LEDs fade to black several seconds after releasing the trigger, giving me enough time to line up the next screw.

The next day, I tried out the Makita BTD140 18-volt impact driver, and was equally impressed. The BTD140 (as well as the LXT circular saw, reciprocating saw, and hammer drill) uses the same 45-minute

diagnostic charger as the BDF451. This charger "learns" how the battery was discharged, thanks to a computer chip embedded in the battery pack, and adjusts its own charge cycle based on that information to optimize battery life.

—Tested by Kevin Boyle

### LXT 18-volt cordless drills

Performance	★★★★★
Price	\$320, BDF451 drill driver; \$320 BTD140 impact driver
Makita	800/462-5482; makitatools.com

## Jet reinvents the parallel-jaw clamp

Parallel-jaw clamps are popular because, as the name implies, the jaws remain parallel as they close to prevent bowing or "lifting" of a glue-up during assembly. And their oversize jaw faces distribute clamping pressure over a wide area, so you need fewer of them than, say, pipe clamps or bar clamps. Jet's improved parallel-jaw clamps threaten to topple the throne of Bessey's K-Body clamps, which have long dominated the category.

Jet's engineers did their homework before building an impressive clamp. They added a quick-release trigger (similar to that found on one-handed bar clamps) that both releases clamping pressure and engages the bar to prevent the jaw from free-sliding open or closed. They marked the bar in 1" increments to quickly tell the distance between the jaws—no more guessing and



coming up short with a glued-up assembly in hand.

One of my favorite features, though, is the optional dogs that thread onto the bottom of both the fixed jaw and the movable kickstand/jaw stop. When inserted into dog holes on your bench, the dogs keep the clamps upright and in place. I drilled dog holes in a scrap of ¾" MDF to fashion a quick clamping fixture for gluing a series of raised-panel doors I was making, and the dogs made the task almost idiot-proof.

—Tested by Dave Campbell

### Jet Parallel Clamps

Performance	★★★★★
Price	from \$30 (12", stock no. 70412) to \$65 (98", stock no. 70498)

Jet Equipment & Tools  
800/274-6848; jettools.com

## “Mini” lathe stretches the definition with big features

As a professional wood turner, the term “mini lathe,” immediately conjures a machine with only enough power and capacity for turning pens and small weed pots. So, perhaps Rikon’s Woodfast Series Mini Lathe (model 70-100) understates its features and capacities. For starters, it boasts a self-extracting tailstock with spur center and 12” of swing for faceplate turning. I also like the 12-position indexing head, and a carrying handle that makes it easier to move from shelf to benchtop.

I limited my testing to 8” bowl blanks—I prefer a full-size lathe for anything larger—and found it has good power when turning with sharp tools, even when end-grain hollowing. In fact, for spindle turning (16” between centers, with optional bed extensions) and faceplate turning, I found its performance nearly flawless. Large blanks or aggressive cuts bogged it down, however, probably because the 70-100 has some true mini-lathe components: small belt and pulleys, a narrow bed, and weight under 100 lbs.

The tailstock and tool rest locked down tight, and didn’t creep, perhaps because the machining on the bed ways proved rough. That also made them more difficult to reposition. Actually, the unit I tested was overall a little rough: The castings had some sharp edges, the handwheel wasn’t bored properly (it wobbled noticeably), and the provided spur drive bottomed out and tended to spin under load. (I tried another #2 Morse taper drive of my own, and it did the same thing.)

Rikon’s Steve Mangano told me that the lathe I tested was one of the first off the assembly line, and that by the time I reported my findings, they’d already found and corrected most of those issues. He promised to look into the others.

Here’s the bottom line: The 70-100 brings some welcome features to the mini-lathe category, but falls short of the venerated Woodfast name. Still, if I were looking for a stout machine that gave me a bit more than most minis for a modest price, this lathe would be on my short list.

—Tested by Phil Brennon

### Rikon Woodfast Series 70-100 mini lathe

Performance ★★☆☆☆  
Price \$250  
(bed extension, \$60; stand, \$140)

Rikon Power Tools  
877/884-5167; rikontools.com



continued on page 42

## EXPERT DRILL BIT SHARPENING & EXTREME REBATE SAVINGS

It’s no wonder that Drill Doctor is the number one name in drill bit sharpeners. With Drill Doctor, you get sharp bits in less than 60 seconds—to keep your work momentum going. And now our **NEW X** Models offer additional features to make sharpening faster and easier than ever. See the Drill Doctor for yourself at your favorite tool dealer.

Buy the Drill Doctor of your choice before April 30, 2006 and get a \$15 mail-in rebate!

Circle No. 1511

**Drill Doctor. EXTREME SAVINGS COUPON**

Rebate offer good Jan. 1–Apr. 30, 2006.

Look for the Drill Doctor at Sears, The Home Depot, Lowe’s, Ace, Northern Tool, Grainger, and wherever you buy your tools.



**\$15.00 MAIL-IN REBATE** on any Drill Doctor model

To receive your rebate, just send this coupon with your name, address, phone number, and which model you purchased, along with the original UPC from the box and a copy of your original sales receipt as proof of purchase, to:

Dept. 68828  
Drill Doctor Products \$15 MIR  
P.O. Box 134  
Niagara Falls, NY 14302-0134

For details, visit your Drill Doctor retailer, or go to [www.DrillDoctor.com](http://www.DrillDoctor.com).

Rebate cannot be combined with any other offer or promotion.

### Handy Sander lives up to its name

I don't know any woodworker who likes to sand, so I'm always on the lookout for ways to make this necessary evil less of a chore. Handy Sander does the trick by giving me a better way to sand curved and contoured workpieces.

This flexible foam pad conforms easily to most shapes, and the hook-and-loop-backed abrasives that come with it (80, 120, and 240 grit) didn't kink up or crease while sanding some turned lathe-chisel handles. Could you do the same with an ordinary sheet of sandpaper? Possibly, but the way Handy Sander straps onto my hand with its elastic loop kept my fingers free to control the abrasive without cramping.

Handy Sander works equally well on flat surfaces, but I'll stick with my random-orbit sander for flat work, thank you. For buffing, a synthetic abrasive pad easily hooks to Handy Sander. ♣

—Tested by Pat Lowry

#### Handy Sander

Performance

★★★★☆

Price

\$6, Wood Combo Pack;  
\$3, replacement abrasives)

Handy Sander Corporation  
800/381-8622; handsander.com



# Build Precision into your Shop!



PRECISION  
BAND SAW  
FENCE

Versatile fence mounts to most 14" band saws and features easy adjustability for blade drift.



PRECISION MEASURING  
SYSTEMS KIT

Turn your shop miter saw into a precision cutting station, no pencil or tape measure needed.

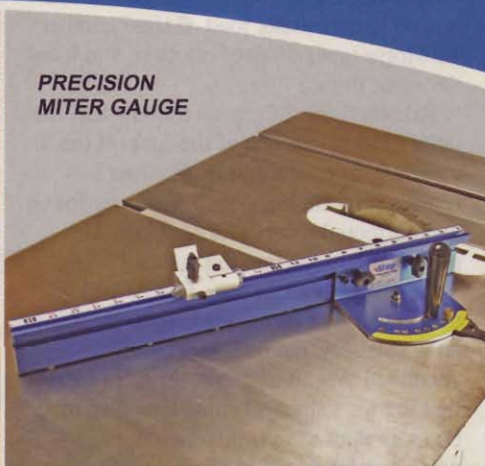

PRECISION  
MITER GAUGE

Factory calibrated and precise right out-of-the box. Vernier scale for 1/10th of a degree adjustability.



As you know your projects turn out only as accurate as the wood that goes into it. Our Precision Measuring products help ensure that your materials turn out flat, straight, and square allowing you to build your best!

See these products in action on our website!



800.447.8638 | www.kregtool.com

# heirloom china cabinet

A fitting showcase for fine tableware, collectibles, and your woodworking skills



For a handsome buffet, build just the lower cabinet. Three drawers and an adjustable shelf behind doors provide ample storage.

## AT A GLANCE

- Overall dimensions for the buffet are 50 $\frac{1}{4}$ " wide x 19 $\frac{1}{4}$ " deep x 35 $\frac{3}{4}$ " high.
- Overall dimensions for the complete china cabinet are 50 $\frac{1}{4}$ " wide x 19 $\frac{1}{4}$ " deep x 85 $\frac{7}{8}$ " high.
- For the board feet of lumber and other items needed to build this project, see pages 50 and 53.

**B**ecause the lower and upper cases, face frames, and door frames of this handsome project employ the same joinery, you can eliminate repeat setups by machining the parts for both cabinets at the same time. Assembly steps for both cabinets are so similar that once you've built the lower cabinet, you'll find putting together the upper cabinet second nature.

You'll learn how to make unique raised-panel doors and matching drawer fronts and to simulate divided-light glass doors by applying simple grilles. (See page 54.) To complement the traditional design and fine materials, the drawers feature half-blind dovetail construction. So dust off your router dovetail jig and check out page 30 for sure-fire setup tips.

**COVER PROJECT**



## Build the buffet

### Start with the case

**1** From  $\frac{3}{4}$ " plywood, cut the sides (A); top, bottom, and center panels (B); and dividers (C) to the sizes listed on the **Materials List** on page 50. (We used mahogany plywood.) Then with a  $\frac{3}{4}$ " dado blade in your table saw, cut  $\frac{3}{8}$ "-deep dados and rabbets in the sides, top, and center panel, where shown on **Drawing 1**. Now, making certain you have mirror-image parts, cut a  $\frac{1}{4}$ " rabbet  $\frac{3}{8}$ " deep along the rear inside edges of the sides for the back (D). Next lay out the shelf support hole centers, chuck a  $\frac{1}{4}$ " brad-point bit into your drill press, and drill  $\frac{3}{8}$ "-deep holes.

**2** Finish-sand the *inside* faces of the sides (A) and the *top* surface of the bottom and *bottom* surface of the center panel (B). Now glue and clamp the lower case in the arrange-

### 1 CASE

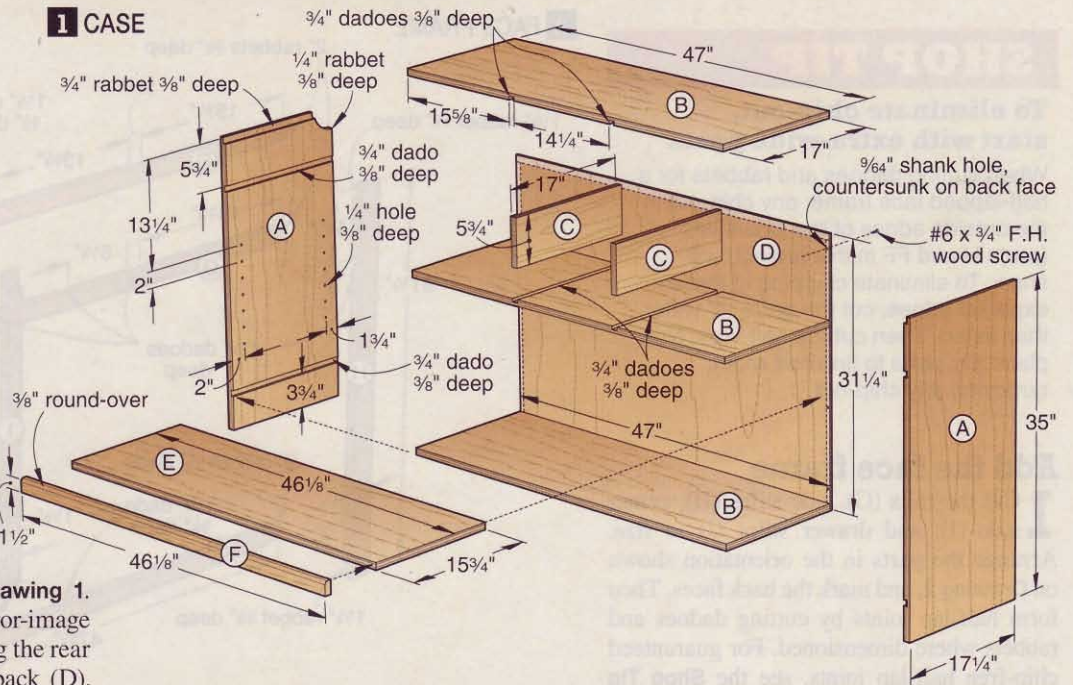

ment shown on **Drawing 1** and as shown in **Photos A, B, and C** below. Let the glue dry between each step.

**3** From  $\frac{1}{4}$ " plywood, cut the back (D) to size. Then drill countersunk shank holes, where shown on **Drawing 1**. Finish-sand the front face and set it aside.

**4** Cut the shelf (E) and shelf edging (F) to size. Glue and clamp the edging to the shelf, keeping the top edge of the edging and the top surface of the shelf flush. With the glue dry, sand the joint flush. Now rout a  $\frac{3}{8}$ " round-over along the top front edge of the edging, where shown on **Drawing 1**.

### ASSEMBLE THE CASE IN FIVE EASY STEPS

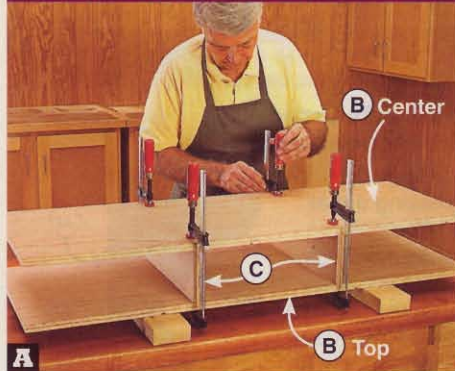

**A** Spread glue in the top and center panel (B) dados, and clamp the dividers (C) between them. Keep the front and rear edges flush.



**B** Spread glue in the side (A) rabbets and dados, and clamp the sides to the top and center panel (B) with the front edges flush.

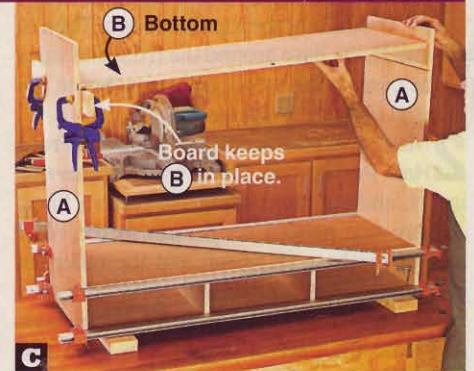

**C** Glue and clamp the bottom (B) into the side (A) dados. A board clamped to one side keeps the end of the bottom in the dado.



**D** Spread glue on the front edges of the case parts and clamp the assembled face frame in place, keeping the outside edges flush.

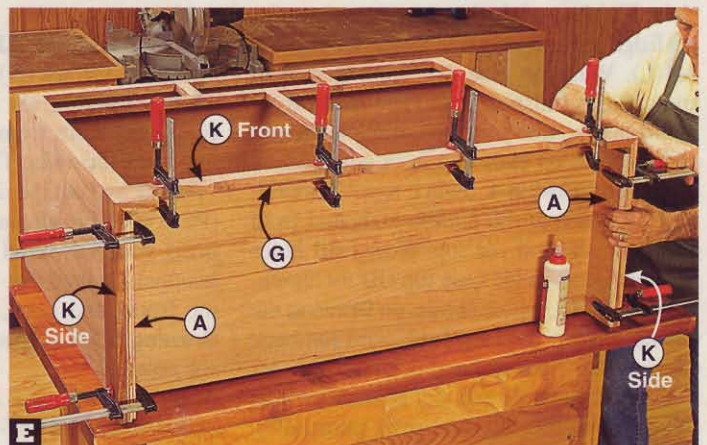

**E** Glue and clamp the base sides and front (K) to the sides (A) and rail (G). Keep the bottoms of the base sides (K) and the sides (A) flush.



## SHOP TIP

### To eliminate chip-out, start with extra-wide parts

When cutting dadoes and rabbets for a half-lapped face frame, any chip-out in the outside edges of the side stiles (parts H and FF in this project) will show. To eliminate chipping in these exposed edges, cut the parts  $\frac{1}{8}$ " wider than listed. Then cut the half-laps. Now plane the parts to finished width, removing any chip-out.

## Add the face frame

**1** Cut the rails (G), side stiles (H), center stile (I), and drawer stiles (J) to size. Arrange the parts in the orientation shown on **Drawing 2**, and mark the back faces. Then form half-lap joints by cutting dadoes and rabbets where dimensioned. For guaranteed chip-free half-lap joints, see the **Shop Tip** above. Now glue and clamp the face frame.

**2** Glue and clamp the face frame to the case, as shown in **Photo D** on page 45. With the glue dry, sand the joints smooth. Then finish-sand the face frame and the outside of the case.

## Make the base and top

**1** Cut the base blank (K) to size, and rout a  $\frac{1}{2}$ " cove along the top front edge. Then to cut and fit the base around the front and sides of the case so the wood grain matches at the mitered corners, see page 104.

**2** Make two photocopies of the **Base Front Half Pattern** on the *WOOD Patterns*® insert, and cut them along the pattern lines. Adhere one pattern set *faceup* to the right half of the base (K) front and the other set *facedown* to the left half with spray adhesive, where shown on **Drawing 3**. Then bandsaw and sand the part to shape. Now glue and clamp the base front and base sides to the case, as shown in **Photo E** on page 45. To prevent glue squeeze-out, see the **Shop Tip** at right. Finish-sand the base.

**3** Edge-join an oversize blank for the top (L). With the glue dry, sand it smooth and cut it to finished size. Then chuck a  $\frac{3}{8}$ " round-over bit into your table-mounted router and rout the top ends and front edge, where shown on **Drawing 4**. Switch to a  $\frac{1}{4}$ " round-over bit and rout the bottom ends and front edge. Finish-sand the top. Now drill holes and form slots in the case top (B) for attaching the top (L), where shown on **Drawing 4a**. Clamp the top in place flush with the back edges of the sides (A) and centered side-to-side. Mark the hole and slot centers with an awl, remove the top, and drill pilot holes. Using a stubby screwdriver, fasten the top to the case with panhead screws and washers.

## 2 FACE FRAME

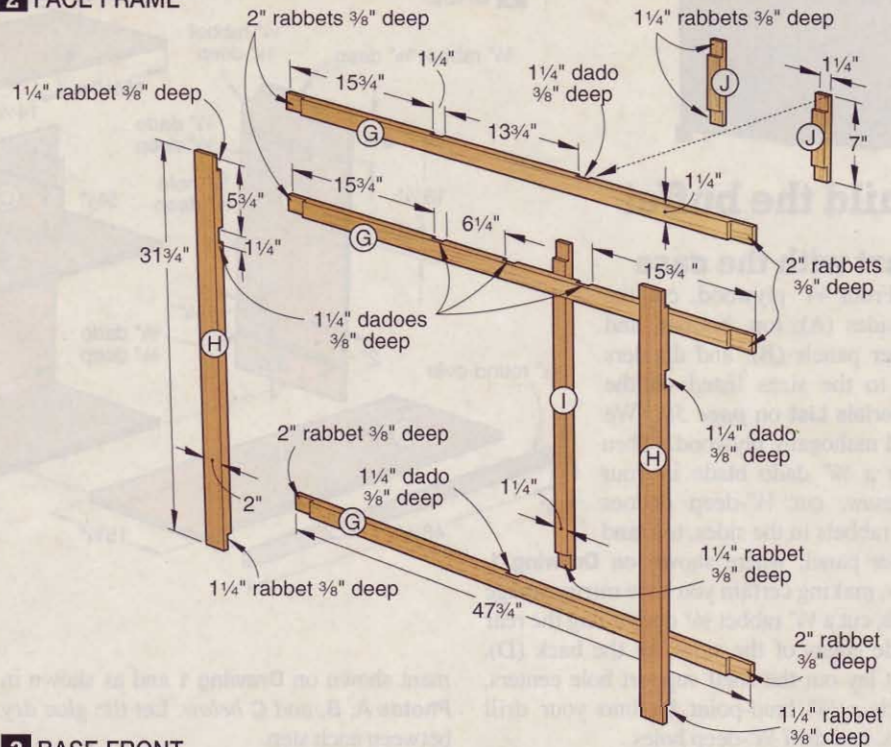

## 3 BASE FRONT

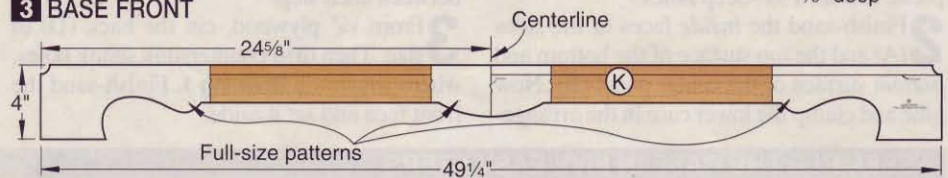

**4** To make the cove blank (M), joint one edge of a 96"-long piece of  $\frac{3}{4}$ " stock that is at least 3" wide. Then rout a  $\frac{1}{2}$ " cove along one edge. Now position your tablesaw rip fence to rip a  $\frac{3}{4}$ "-wide cove blank from the edge of the stock. If you are making the upper cabinet, joint, rout, and rip two more parts for the cove blanks (HH). Following the procedure for fitting the base parts (K), cut and fit the cove, where shown on **Drawing 4**. Glue and clamp the cove to the sides (A) and top face frame rail (G). Do not glue the cove to the top (L).

## Build three drawers

**1** Cut the fronts (N) to size. To match the wood grain across all three fronts, cut them from a 48"-long board and mark the order. Then plane stock to  $\frac{1}{2}$ " thick and cut the sides (O) and backs (P) to size. Finish-sand the parts. Now using your half-blind dovetail jig and a handheld router, cut dovetail joints in the fronts and sides, where shown on **Drawing 5**. For help setting up your jig, see page 30.

**Note:** The drawers are sized for  $\frac{7}{8}$ " center-to-center half-blind dovetails.

**2** Measure the thickness of the plywood for the bottoms (Q), and cut

## SHOP TIP

### Saw kerfs tame glue squeeze-out

Excess glue squeezing out at the edges of applied moldings, such as the base (K), coves (M, HH), bullnose (II), frieze (JJ), and cap (KK), creates a cleanup problem. A damp rag removes the glue but raises the grain, creating a sanding problem. To avoid both of these hassles, cut  $\frac{1}{8}$ "-deep saw kerfs near the part edges where shown at right, before gluing moldings in place. Now excess glue squeezes into the saw kerf instead of onto an adjacent surface.

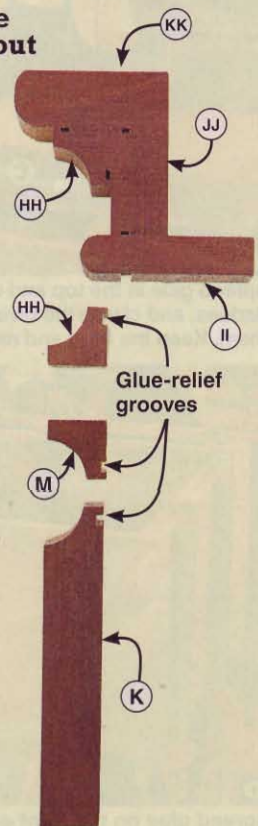

#### 4 EXPLODED VIEW

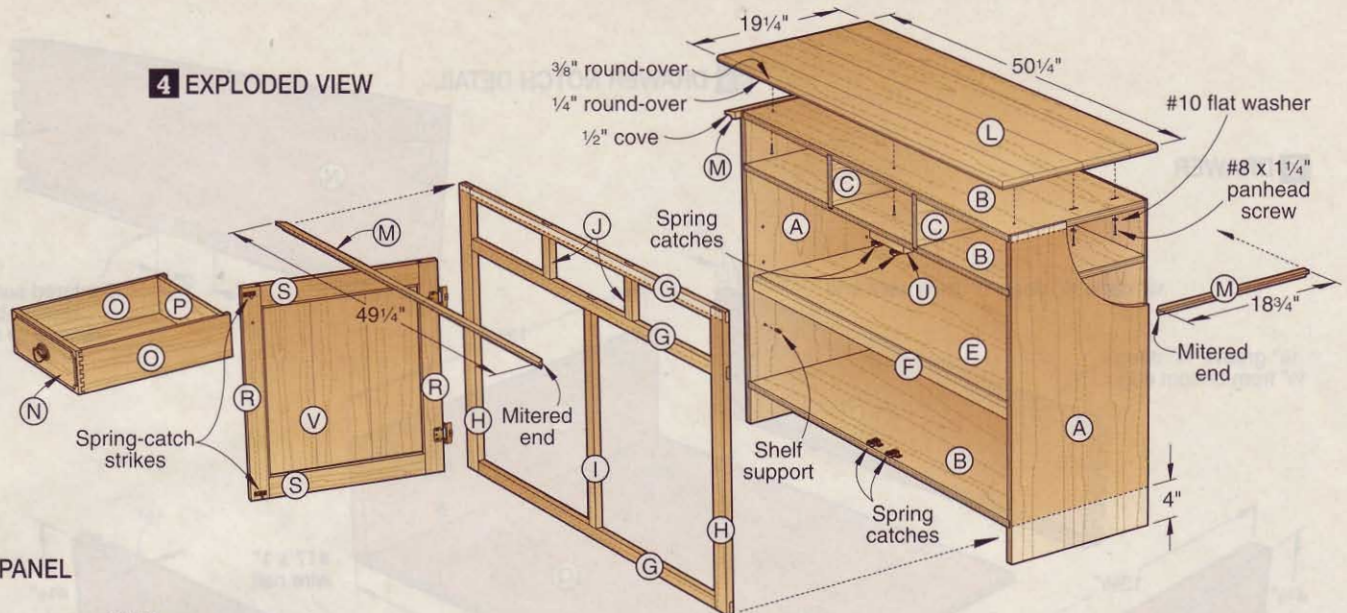

#### 4a TOP PANEL

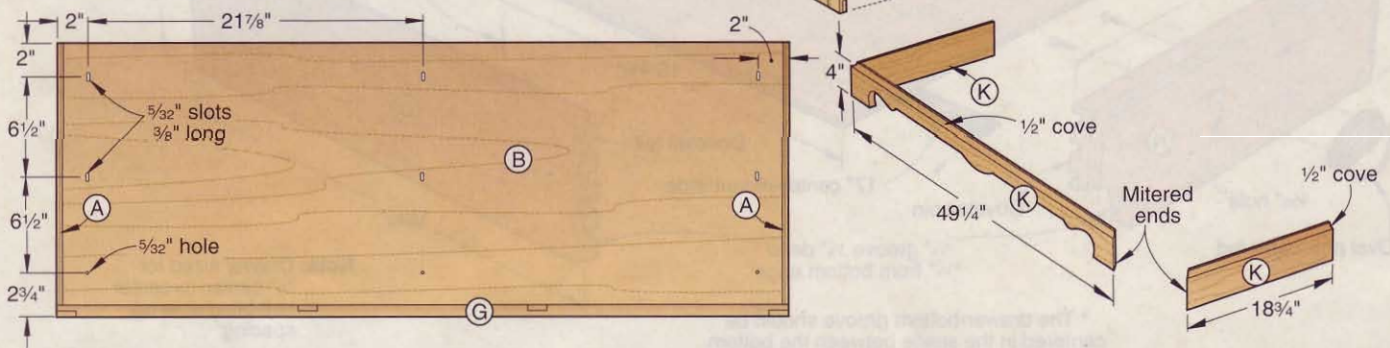

1/4"-deep grooves 1/4" from the bottom edges of the fronts (N) and sides (O), where shown on **Drawing 5**. Then cut 1/2" dados 1/4" deep in the sides to accept the backs (P). Now drill 5/32" holes in the fronts for the oval pulls.

**Note:** The drawer-bottom groove should be centered in the space between the bottom two dovetail pins in the drawer fronts (N).

**3** To form the raised fronts (N), cut a 3/4x3 3/8x12 5/8" template from scrap stock. Make a photocopy of the **Drawer Front End Patterns** on the insert, and adhere them to

the template with spray adhesive. Bandsaw and drum-sand the corner cutouts. Then attach the template to a drawer front, as shown in **Photos F** and **G**, below. Now chuck a 3/4" top-bearing dish carving bit into your table-mounted router, and rout the fronts, as shown in **Photo H**. (See **Sources** for the bit.) Make extra passes at the corners to remove all the waste. Finish-sand the routed area.

**4** To accommodate the center-mount drawer slides, cut away a 2"-long section of the lower lip of the drawer-bottom groove

in the drawer fronts (N), where shown on **Drawing 5a**. Then cut the bottoms (Q) to size. Glue and clamp the front (N), sides (O), and back (P) of each drawer. Squeeze glue into the front groove, and slide in the bottom. Check the drawers for square, and nail the bottoms to the backs. Attach the pulls.

**5** Separate the drawer slides, and attach the drawer members to the drawer fronts (N) and backs (P) and the case members to the center panel (B), where shown on **Drawing 6**. Slide the drawers into the case.

#### RAISE THE DRAWER FRONTS WITH A TEMPLATE AND ROUTER BIT



**F** Adhere the template to the front face of the drawer front (N) with double-faced tape, centering the template on the front.



**G** Secure the front (N) to the template by driving 1 1/4"-long wood screws through the previously drilled pull holes.



**H** Follow the template with a top-bearing dish carving bit raised 1" above the table. Make extra passes to remove waste at the corners.

## 5 DRAWER

### 5a DRAWER NOTCH DETAIL

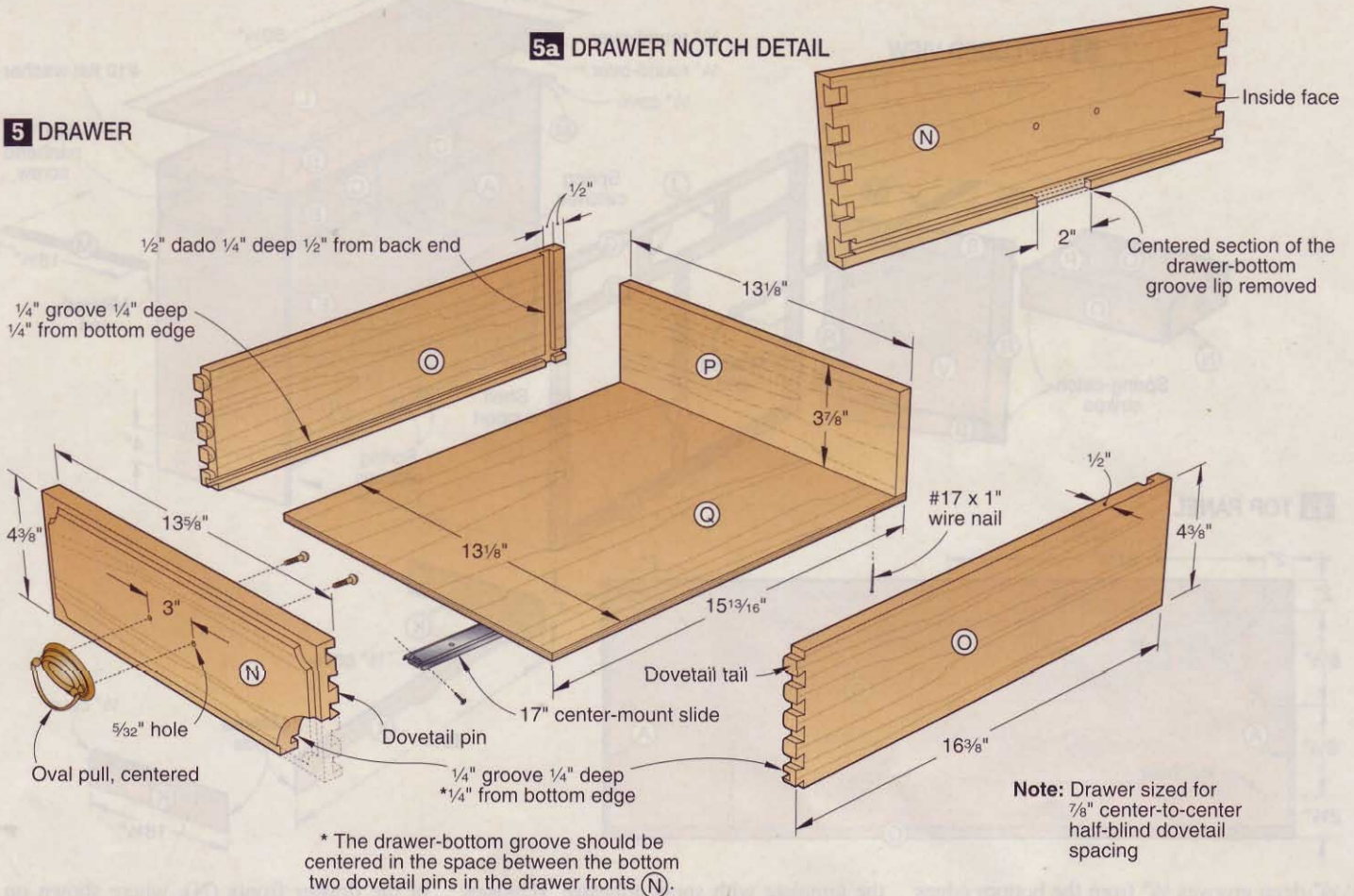

## Now make a pair of doors

**1** Cut the stiles (R) and rails (S) to size. Referring to **Drawings 7** and **7a**, arrange and mark the parts as they will be assembled. Mark the back inside edges of each part. Then with a dado blade in your tablesaw, cut 3/8" rabbets 1/2" deep along the marked edges. Now, without changing the height of the dado blade, cut 1 7/8" rabbets in the back ends of the stiles. Next lower the dado blade to cut 2" rabbets 1/4" deep in the front ends of the rails. Glue and clamp the door frames, checking them for square. For tight-fitting joints, clean up the rabbets with your table-mounted router, as shown on *page 16*.

**2** For the corner fans (T), resaw and plane stock to 1/4" thick and cut four 1 1/8" x 6" fan blanks. Adhere the blanks face-to-face with double-faced tape, keeping the ends and edges flush. [If you are making the upper cabinet, cut four more blanks for the corner fans (NN) and make two four-blank stacks.] Then lay out 1 1/8" radii at both ends of the stack and cut them to shape, as shown in **Photo I**. Sand the cuts smooth. Now attach an extension to your tablesaw miter gauge and cut the fans from the stacked blanks, as shown in **Photo J**. Separate the fans and glue and clamp them into the door frame corners, as shown in **Photo K**. Sand the fans flush

## 6 DRAWER SLIDES

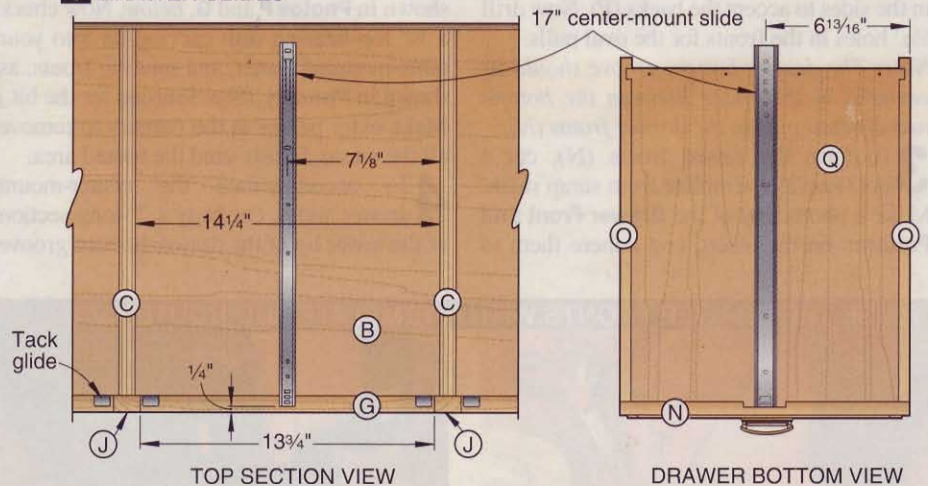

with the frame outside faces, and finish-sand the frames.

**3** Use your drill press to drill 5/32" holes for the teardrop pulls, where dimensioned on **Drawing 7**. Mount the pulls. Then fasten the hinges to the doors and hang the doors in the face frame openings. Cut the catch block (U) to size. Glue and clamp it to the bottom of the center panel (B), tight against the back of the face frame and centered on the center stile (I), where shown on **Drawing 4**. Mount

the catches on the catch block, bottom panel (B), and insides of the door frames.

**4** Plane stock to 5/8" thick and edge-join oversize blanks for the panels (V). Cut the panels to size, and sand them smooth. To form the raised panels shown on **Drawing 7**, cut a 3/4" x 16 3/16" x 18" template from scrap stock. Make four photocopies of the **Door Panel Corner Pattern** on the insert, and adhere them to the template with spray adhesive. Bandsaw and drum-sand the corner

## STACK-CUT AND INSTALL THE CORNER FANS

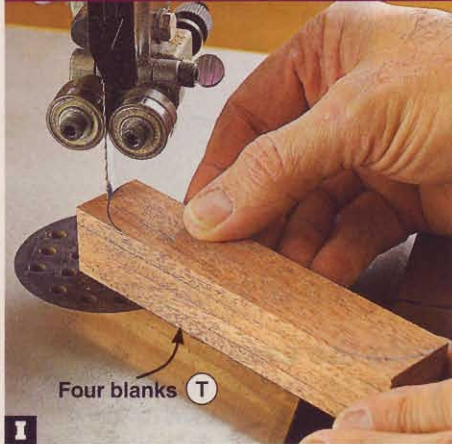

**I** With four corner fan (T) blanks held together by double-faced tape, lay out and cut  $1\frac{1}{8}$ " radii at both ends of the stack.

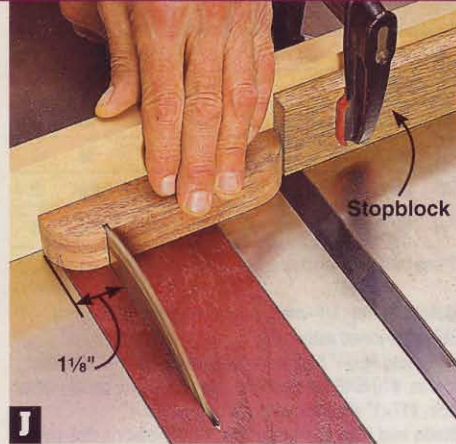

**J** Positioning the corner fan (T) blanks with a stopblock, cut  $1\frac{1}{8}$ " off one end of the stack. Repeat at the other end of the stack.

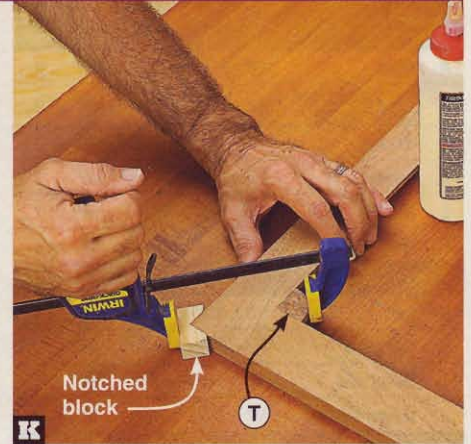

**K** Glue and clamp the corner fans (T) into the frame corners with the front faces flush. A notched block keeps the clamp from slipping.

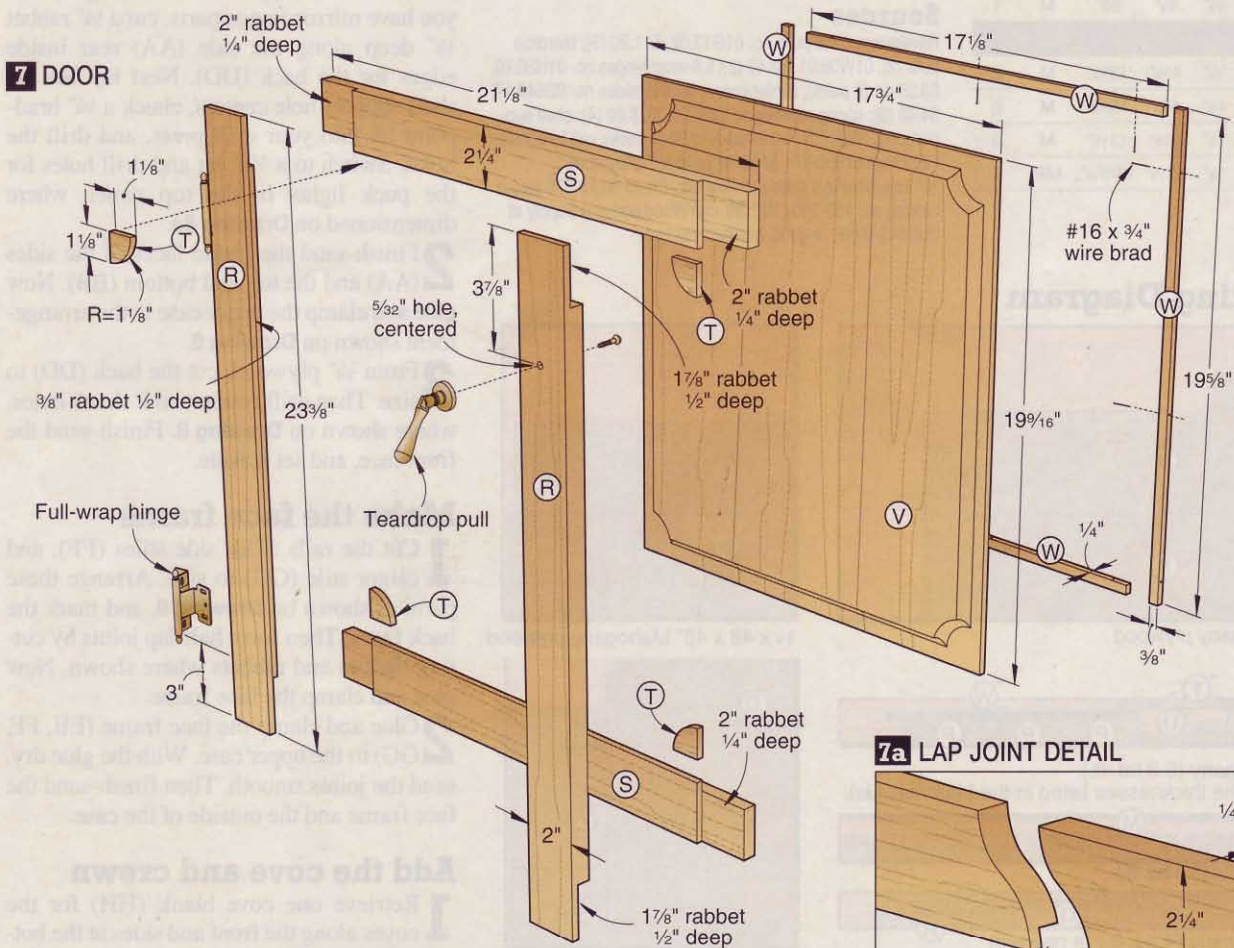

### 7a LAP JOINT DETAIL

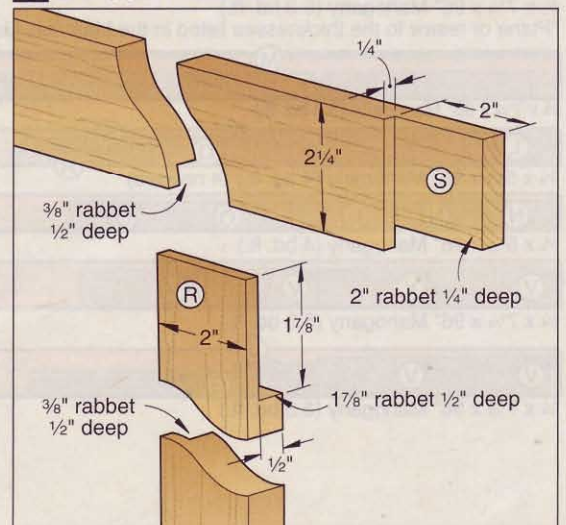

cutouts. Then adhere the template to the front of one panel with double-faced tape, centering the template on the panel. Chuck the dish carving bit into your table-mounted router, and raise it  $1\frac{1}{8}$ " above the table. Adjust the fence to expose  $\frac{3}{8}$ " of the bit, and rout one pass around the panel. Readjust the fence to expose  $\frac{5}{8}$ " of the bit, and rout a second pass. Now remove the fence and make a third pass, allowing the router-bit guide bearing to ride on the template. Make extra

passes at the corners to remove all the waste. Repeat with the second panel. Finish-sand the panels.

**5** Cut four panel stop blanks (W) to size. If you are making the upper cabinet, cut an additional six blanks for the glass stop (RR). Then cut the panel stops to length to fit the rabbeted door opening in the arrangement shown on **Drawing 7**. Finish-sand the stops.

## Buffet Materials List

Case	FINISHED SIZE			Matl.	Qty.
	T	W	L		
A sides	3/4"	17 1/4"	35"	MP	2
B top, bottom, and center panels	3/4"	17"	47"	MP	3
C dividers	3/4"	5 3/4"	17"	MP	2
D back	1/4"	47"	31 1/4"	MP	1
E shelf	3/4"	15 3/4"	46 1/8"	MP	1
F shelf edging	3/4"	1 1/2"	46 1/8"	M	1

### Face frame

G rails	3/4"	1 1/4"	47 3/4"	M	3
H side stiles	3/4"	2"	31 3/4"	M	2
I center stile	3/4"	1 1/4"	26"	M	1
J drawer stiles	3/4"	1 1/4"	7"	M	2

### Base and top

K base blank	3/4"	4"	96"	M	1
L* top	3/4"	19 1/4"	50 1/4"	EM	1
M* cove blank	3/4"	3/4"	96"	M	1

### Drawers

N fronts	3/4"	4 3/8"	13 5/8"	M	3
O sides	1/2"	4 3/8"	16 3/8"	M	6
P backs	1/2"	3 7/8"	13 1/8"	M	3
Q bottoms	1/4"	13 1/8"	15 1/16"	MP	3

Doors					
R stiles	3/4"	2"	23 5/8"	M	4
S rails	3/4"	2 1/4"	21 1/8"	M	4
T* corner fans	1/4"	1 1/8"	1 1/8"	M	8
U catch block	3/4"	2"	6"	M	1
V* panels	5/8"	17 3/4"	19 9/16"	EM	2
W panel stop blanks	1/4"	3/8"	42"	M	4

\*Parts initially cut oversize. See the instructions.

**Materials key:** MP—mahogany plywood, M—mahogany, EM—edge-joined mahogany.

**Supplies:** #6x3/4" flathead wood screws, #8x1 1/4" panhead screws, #10 SAE flat washers, spray adhesive, double-faced tape, #17x1" wire nails, #16x3/4" wire brads.

**Blade and bits:** Stack dado set; 3/4" top-bearing dish carving router bit; 1/4" round-over, 3/8" round-over, and 1/2" cove router bits; dovetail router bit as specified in your dovetail jig instructions; 1/4" brad-point drill bit.

### Sources

**Hardware.** Oval pulls no. 01G13.02, \$11.20 (3); teardrop pulls no. 01W06.01, \$3.40 (2); full-wrap hinges no. 01H30.20, \$3.20 pr. (2 pairs); center-mount drawer slides no. 02K40.17, \$4.40 (3); spring catches no. 00W11.02, \$8.00 (4); shelf supports no. 63Z06.04, \$5.25 pack of 20 (1 pack); call Lee Valley Hardware at 800/871-8158, or go to [leevalley.com](http://leevalley.com).

**3/4" top-bearing dish carving bit.** Freud no.19-576 (order catalog no. 130-280), \$31.99, call Woodworker's Supply at 800/645-9292, or go to [woodworker.com](http://woodworker.com).

## Buffet Cutting Diagram

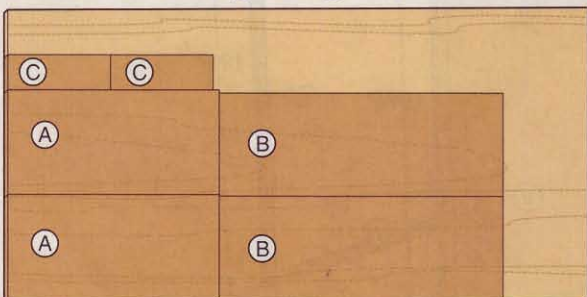

3/4 x 48 x 96" Mahogany plywood

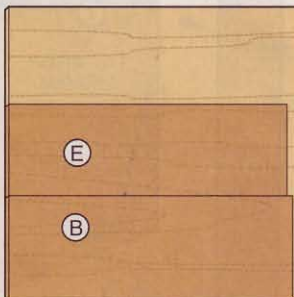

3/4 x 48 x 48" Mahogany plywood

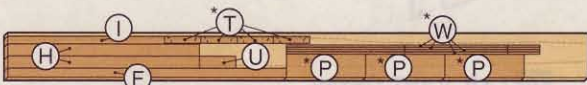

3/4 x 7 1/4 x 96" Mahogany (5.3 bd. ft.)

\*Plane or resaw to the thicknesses listed in the Materials List.

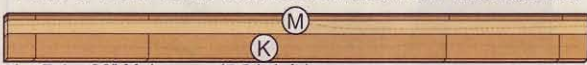

3/4 x 7 1/4 x 96" Mahogany (5.3 bd. ft.)

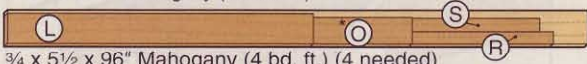

3/4 x 5 1/2 x 96" Mahogany (4 bd. ft.) (4 needed)

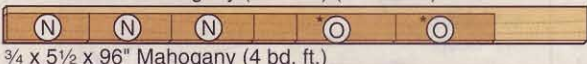

3/4 x 5 1/2 x 96" Mahogany (4 bd. ft.)

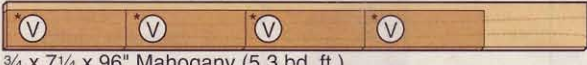

3/4 x 7 1/4 x 96" Mahogany (5.3 bd. ft.)

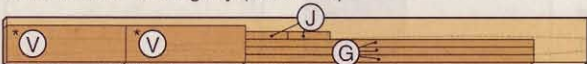

3/4 x 7 1/4 x 96" Mahogany (5.3 bd. ft.)

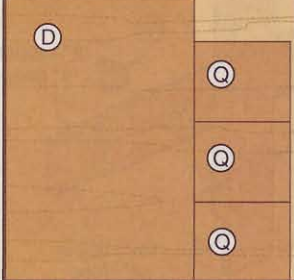

1/4 x 48 x 48" Mahogany plywood



## Now, the display cabinet

### Build the case

**1** From 3/4" plywood, cut the sides (AA), top and bottom (BB), and divider (CC) to size. Then with a 3/4" dado blade in your table saw, cut 3/8"-deep dadoes and rabbets in the sides and the top and bottom, where shown on **Drawing 8**. Now making certain you have mirror-image parts, cut a 1/4" rabbet 3/8" deep along the side (AA) rear inside edges for the back (DD). Next lay out the shelf support hole centers, chuck a 1/4" brad-point bit into your drill press, and drill the holes. Switch to a 3/16" bit and drill holes for the puck lights in the top panel, where dimensioned on **Drawing 8a**.

**2** Finish-sand the inside faces of the sides (AA) and the top and bottom (BB). Now glue and clamp the upper case in the arrangement shown on **Drawing 8**.

**3** From 1/4" plywood, cut the back (DD) to size. Then drill countersunk shank holes, where shown on **Drawing 8**. Finish-sand the front face, and set it aside.

### Make the face frame

**1** Cut the rails (EE), side stiles (FF), and center stile (GG) to size. Arrange these parts as shown on **Drawing 9**, and mark the back faces. Then form half-lap joints by cutting dadoes and rabbets where shown. Now glue and clamp the face frame.

**2** Glue and clamp the face frame (EE, FF, GG) to the upper case. With the glue dry, sand the joints smooth. Then finish-sand the face frame and the outside of the case.

### Add the cove and crown

**1** Retrieve one cove blank (HH) for the coves along the front and sides at the bottom of the upper cabinet, where shown on **Drawing 10**. Then, as when cutting and fitting the base blank (K), miter-cut the front cove from the center of the blank and miter-cut, mark, and trim the side coves from the remaining pieces. Glue and clamp the coves to the case, flush at the bottom.

**2** Plane stock to 1/2" thick and cut the bullnose blank (II) to size. Chuck a 1/4" round-over bit into your table-mounted router, and position the fence flush with the pilot bearing. Then rout round-overs along

the front top and bottom edges of the blank, where shown on **Drawing 11**.

**3** Cut the frieze blank (JJ) and cap blank (KK) to size. With the  $\frac{1}{4}$ " round-over bit in your table-mounted router, rout the top front edge of the cap blank, where shown on **Drawing 11**. Switch to a  $\frac{3}{8}$ " round-over bit and rout the front bottom edge.

**4** Retrieve the last cove blank (HH). Then referring to **Drawing 11**, glue and clamp the frieze blank (JJ) to the bullnose blank (II), the cap blank (KK) to the frieze blank, and the cove blank to the frieze and cap blanks, keeping all the ends flush. Now, as when cutting and fitting the base blank (K), miter-cut the front crown from the center of the assembled blank and miter-cut, mark, and trim the side crowns from the remaining pieces. [The bullnose portion of the crown protrudes  $\frac{3}{8}$ " beyond the face frame top rail (EE) and the case sides (AA).]

**5** Drill countersunk shank holes through the bullnose (II) parts of the front and side crowns, where shown on **Drawings 10** and **11** (four evenly spaced holes in the front crown and three in each side crown). Then glue and screw the crown front and sides to the top (BB).

## Make the doors

**1** Cut the stiles (LL) and rails (MM) to size. Referring to **Drawing 12**, arrange and mark the parts as they will be assembled. Mark the back inside edges of each part. Then with a dado blade in your tablesaw, cut  $\frac{3}{8}$ " rabbets  $\frac{1}{2}$ " deep along the marked edges. Now, referring to the instructions for the lower case doors, cut the lap joints and glue and clamp the door frames.

**2** Retrieve the corner fans (NN), and glue and clamp them into the door frame corners. Sand the fans flush with the frames, and finish-sand the frames.

**3** Use your drill press to drill  $\frac{5}{32}$ " holes for the teardrop pulls, where dimensioned on **Drawing 12**. Mount the pulls. Then fasten the hinges to the doors and hang the doors in the face-frame openings. Cut the catch blocks (OO) to size. Glue and clamp them to the bottom of the top (BB), tight against the divider (CC) and the back of the face frame, where shown on **Drawing 10**. Mount the catches on the catch blocks, bottom panel (BB), and insides of the door frames.

**4** Retrieve the glass stop blanks (RR). Then cut the stops to length to fit the rabbeted door openings in the configuration shown on **Drawing 12**. Finish-sand the stops.

**5** First verifying the inside dimensions of the door frames, cut the vertical mullions (PP) and horizontal mullions (QQ) to size. Then to build half-lapped grilles to simulate divided lights, see page 54.

## 8 CASE

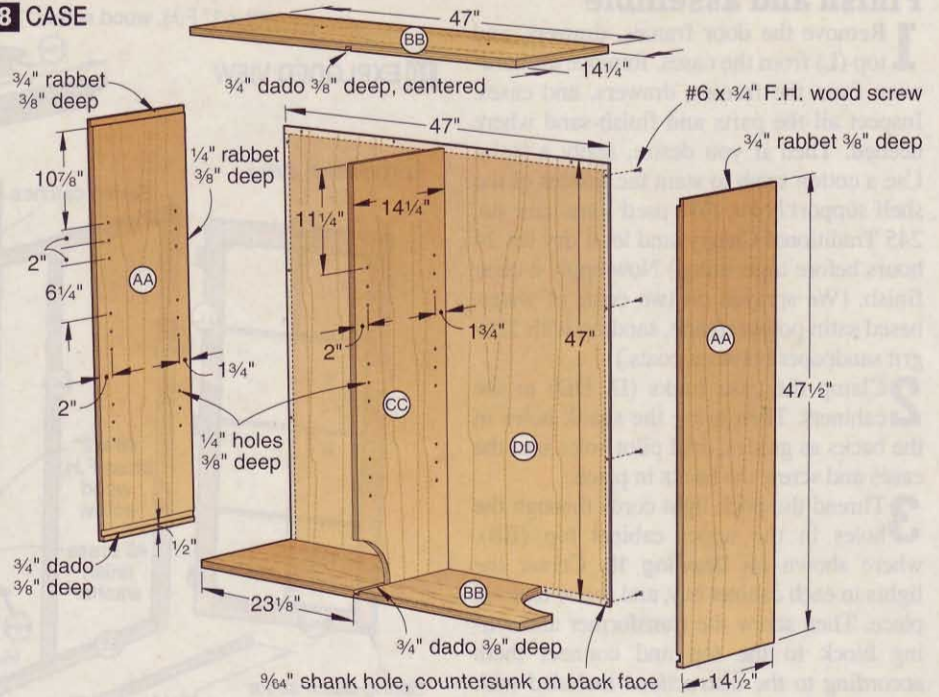

## 8a TOP

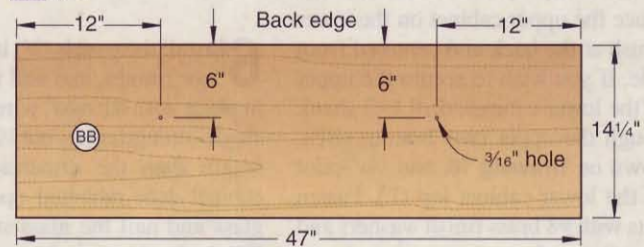

## 9 FACE FRAME

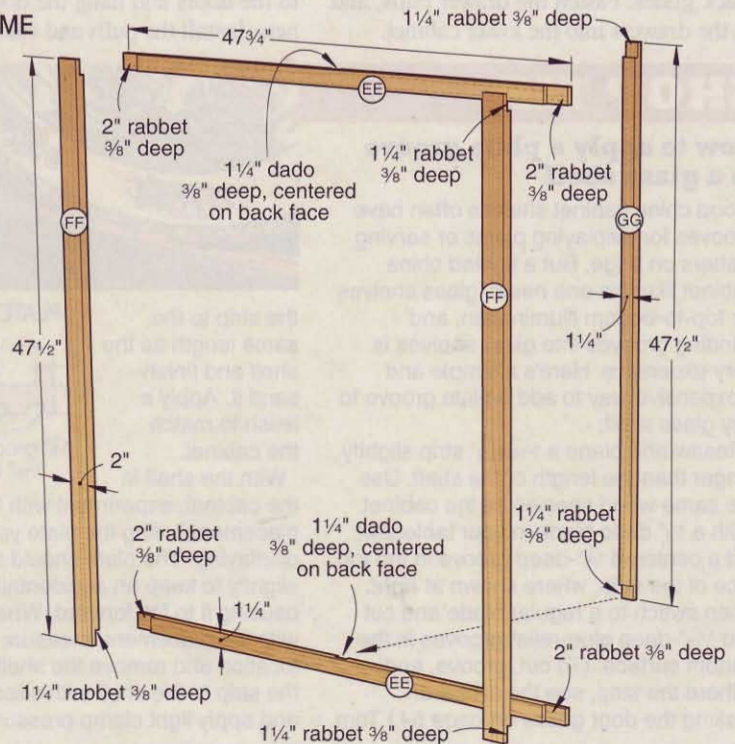

## Finish and assemble

**1** Remove the door frames, drawers, and top (L) from the cases. Remove all hardware from the frames, drawers, and cases. Inspect all the parts and finish-sand where needed. Then if you desire, apply a stain. Use a cotton swab to stain the insides of the shelf support holes. (We used Varathane no. 245 Traditional Cherry, and let it dry for 24 hours before topcoating.) Now apply a clear finish. (We sprayed on two coats of water-based satin polyurethane, sanding with 220-grit sandpaper between coats.)

**2** Clamp the case backs (D, DD) to the cabinets. Then using the shank holes in the backs as guides, drill pilot holes into the cases and screw the backs in place.

**3** Thread the puck light cords through the holes in the upper cabinet top (BB), where shown on **Drawing 10**. Center the lights in each cabinet bay, and screw them in place. Then screw the transformer and wiring block to the top and connect them according to the instructions included with the lights.

**4** Move the cabinets to the desired location and place the upper cabinet on the lower cabinet, flush at the back and centered from side-to-side. If you wish to secure the upper cabinet to the lower cabinet, drill  $\frac{5}{32}$ " shank holes through the upper case bottom (BB), where shown on **Drawing 10**, and  $\frac{1}{64}$ " pilot holes into the lower cabinet top (L). Fasten the cabinets with #8 brass finish washers and #8x2" brass flathead wood screws, as shown in **Photo L**.

**5** Install the drawer slides and supplied tack glides. Fasten the drawer pulls, and slide the drawers into the lower cabinet.

### 10 EXPLODED VIEW

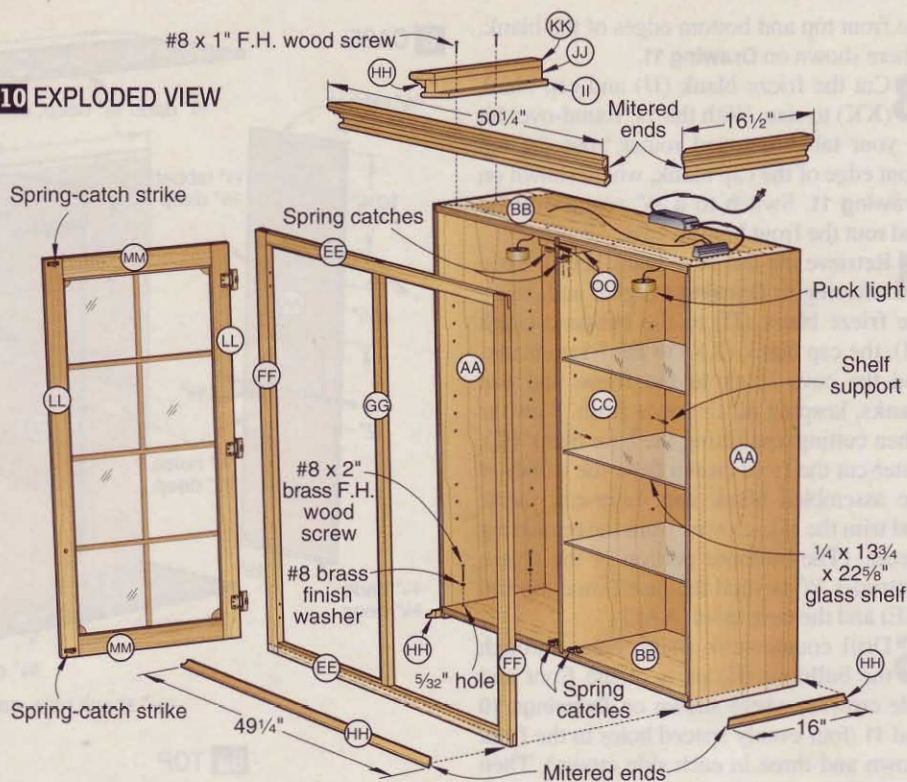

**6** Install the panels (V) in the lower cabinet door frames, and nail the panel stop (W) in place with #16x $\frac{3}{4}$ " wire brads. Then have single-strength glass cut  $\frac{1}{8}$ " less in width and length than the dimensions of the upper cabinet door rabbeted openings. Install the glass and nail the glass stop (RR) in place. Fill the brad holes with a color-matched wax filler stick. Apply the grilles to the glass, as instructed on *page 54*. Now fasten the hinges to the doors and hang the doors in the cabinets. Install the pulls and catches.

### 11 CROWN MOLDING SECTION VIEW

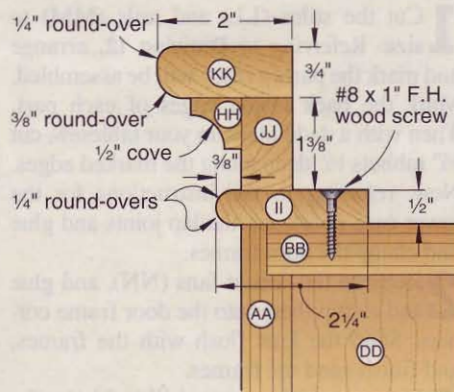

### JOIN THE TWO CABINETS



**L** Drill screw holes through the bottom (BB) and into the top (L), and fasten the cabinets with brass finish washers and flathead screws.

## SHOP TIP

### How to apply a plate groove to a glass shelf

Wood china cabinet shelves often have grooves for displaying plates or serving platters on edge. But a lighted china cabinet like this one needs glass shelves for top-to-bottom illumination, and grinding grooves into glass shelves is very expensive. Here's a simple and inexpensive way to add a plate groove to any glass shelf.

Resaw and plane a  $\frac{5}{16}$ x $\frac{1}{2}$ " strip slightly longer than the length of the shelf. Use the same wood species as the cabinet. With a  $\frac{1}{4}$ " dado blade in your tablesaw, cut a centered  $\frac{1}{8}$ "-deep groove in the top face of the strip, where shown at *right*. Then switch to a regular blade and cut two  $\frac{1}{16}$ "-deep glue-relief grooves in the bottom surface. (To cut, groove, and adhere the strip, see the article on making the door grilles on *page 54*.) Trim

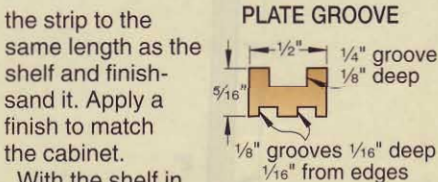

the strip to the same length as the shelf and finish-sand it. Apply a finish to match the cabinet. With the shelf in the cabinet, experiment with the strip placement, using the plate you will be displaying. The plate should tilt back slightly to keep an accidental bump from causing it to fall forward. When satisfied with the placement, measure the location and remove the shelf. Adhere the strip to the shelf with silicone caulk and apply light clamp pressure.

**7** Install the shelf supports and the shelf in the lower cabinet. Then measure the *inside* dimensions of the upper cabinet bays for 1/4" glass shelves. Subtract 1/2" from the front-to-back dimension for the shelf width and 1/8" from the side-to-side dimension for the shelf length. Have six shelves cut to size. (We ordered our shelves with a pencil edge on the front and the remaining edges ground just to remove the sharpness.) To add plate grooves to the glass shelves, see the **Shop Tip**, *opposite bottom*. Install the shelf supports and the shelves. Now store your utilitarian pieces in the lower cabinet. Display your finest china, glassware, or collectibles in the upper cabinet; turn on the lights; and see them sparkle. 🌟

## 12 DOOR (Viewed from the back)

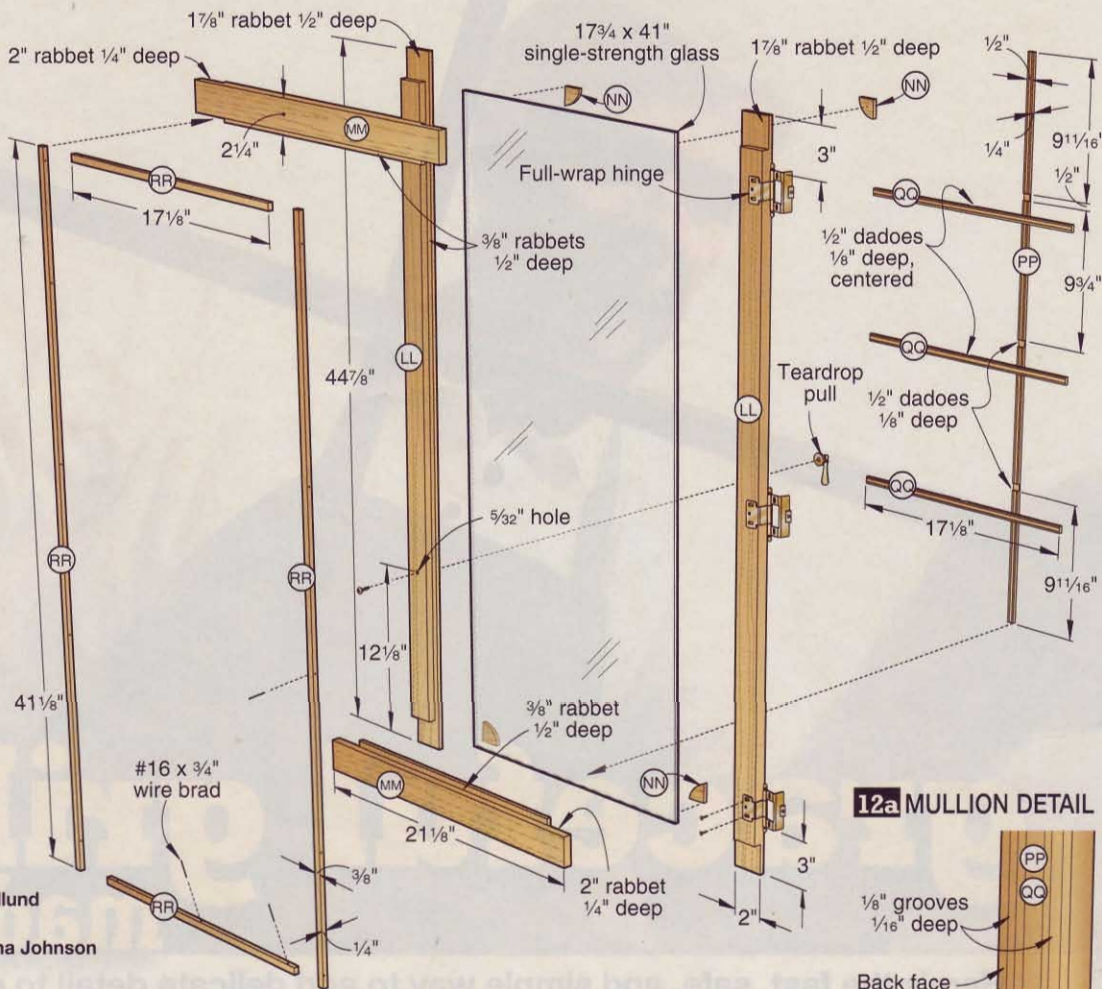

### 12a MULLION DETAIL

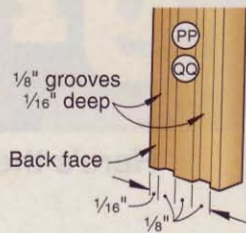

Written by **Jan Svec** with **Chuck Hedlund**  
 Project design: **Kevin Boyle**  
 Illustrations: **Roxanne LeMoine**; **Lorna Johnson**

## Display Case Materials List

Case	FINISHED SIZE			Matl.	Qty.
	T	W	L		
AA sides	3/4"	14 1/2"	47 1/2"	MP	2
BB top and bottom	3/4"	14 1/4"	47"	MP	2
CC divider	3/4"	14 1/4"	46 1/4"	MP	1
DD back	1/4"	47"	47"	MP	1
<b>Face frame</b>					
EE rails	3/4"	1 1/4"	47 3/4"	M	2
FF side stiles	3/4"	2"	47 1/2"	M	2
GG center stile	3/4"	1 1/4"	47 1/2"	M	1
<b>Cove and crown</b>					
HH cove blanks	3/4"	3/4"	96"	M	2
II bullnose blank	1/2"	2 1/4"	96"	M	1
JJ frieze blank	3/4"	1 3/8"	96"	M	1
KK cap blank	3/4"	2"	96"	M	1
<b>Doors</b>					
LL stiles	3/4"	2"	44 7/8"	M	4
MM rails	3/4"	2 1/4"	21 1/8"	M	4
NN* corner fans	1/4"	1 1/8"	1 1/8"	M	8
OO catch blocks	3/4"	2"	3"	M	2
PP vertical mullions	1/4"	1/2"	40 3/8"	M	2
QQ horizontal mullions	1/4"	1/2"	17 1/8"	M	6
RR glass stop blanks	1/4"	3/8"	42"	M	6

\*Parts initially cut oversize. See the instructions.

**Materials key:** MP—mahogany plywood, M—mahogany.

**Supplies:** #6x3/4" and #8x1" flathead wood screws, double-faced tape, #16x3/4" wire brads, single-strength glass for doors, 1/4" glass for shelves, set of two low-voltage puck lights, silicone caulk, optional #8x2" brass flathead wood screws and #8 brass finish washers.

**Blade and bits:** Stack dado set; 1/4" round-over, 3/8" round-over, and 1/2" cove router bits, 1/4" brad-point drill bit.

### Source

**Hardware.** Teardrop pulls no. 01W06.01, \$3.40 (2); full-wrap hinges no. 01H30.20, \$3.20 pr. (3 pairs); spring catches no. 00W11.02, \$.80 (4); shelf supports no. 63Z06.04, \$5.25 pack of 20 (1 pack); call Lee Valley Hardware at 800/871-8158, or go to [leevalley.com](http://leevalley.com).

## Display Case Cutting Diagram

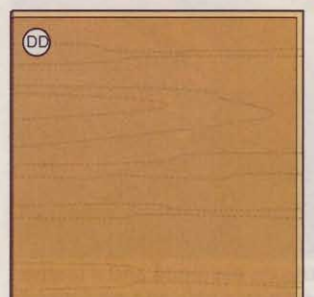
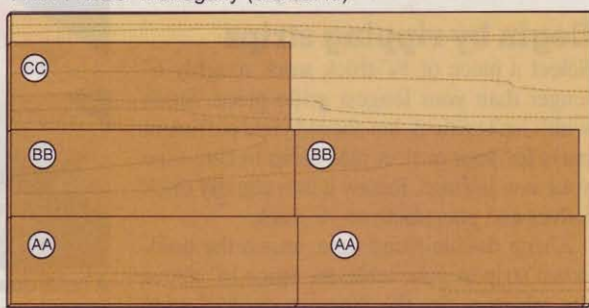
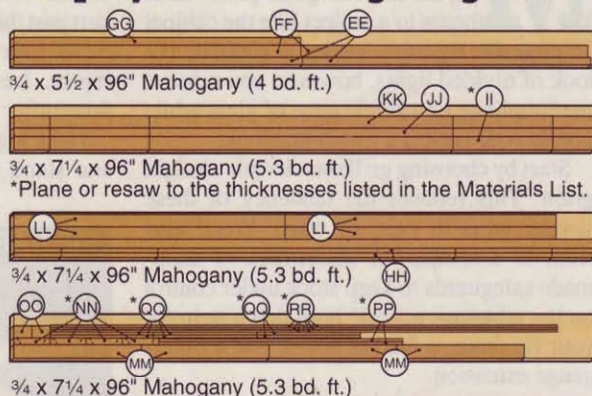

1/4 x 48 x 48" Mahogany plywood

3/4 x 48 x 96" Mahogany plywood





# graceful grilles made easy

Here's the fast, safe, and simple way to add delicate detail to glass doors.

**M**aking cabinet doors with individual divided glass panes adds hours to a project like the cabinet on page 44. By using grilles to simulate the look of divided lights, however, you achieve the simplicity of a single pane of glass while giving your project a traditional look.

Start by choosing grille stock with straight grain. This reduces the tendency of these slender parts to twist or warp. You'll also want to assemble an assortment of shop-made safeguards to keep stock under control on the tablesaw: a  $\frac{1}{4} \times 1$ " hold-down strip for your rip fence, a feather board, and a miter-gauge extension.

## Begin by ripping strips

Select a piece of  $\frac{3}{4}$ "-thick stock roughly 6" longer than your longest grille piece. Stock width isn't critical, but should yield sufficient parts for your project plus scrap to fine-tune your saw settings. Resaw it into equally thick halves and plane both to  $\frac{1}{4}$ " thick.

Using double-faced tape, attach the hold-down strip to your tablesaw fence  $\frac{1}{4}$ " above the tabletop. Set the fence to cut  $\frac{3}{16}$ "-wide strips, and position the feather board to press

the workpiece against the fence just in front of the blade, as shown *below*. Guide your part past the blade with a sacrificial pushstick. Reset your feather board after each cut and repeat. Leave the hold-down strip on the fence after ripping the strips.

Hold together two strips of equal length and stand them on edge as you feed them

into a planer to remove any saw marks, as shown *below*. Plane the grille parts to  $\frac{1}{2}$ " wide. Then cut parts to finished length to remove any planer snipe, however slight.

Set your tablesaw's rip fence  $\frac{1}{16}$ " from the blade, and use the hold-down and feather board plus a sacrificial pushstick to cut a  $\frac{1}{16}$ "-deep kerf on the back of one strip, as

### RIP NARROW STOCK SAFELY



A hold-down strip on the fence and a feather board help keep fingers safe and workpieces under control.

### PLANE STOCK TO FINAL WIDTH



Pairing strips tightly together as you feed them into the planer helps keep them on their edges for this light cut.

### CUT KERFS WITH CARE

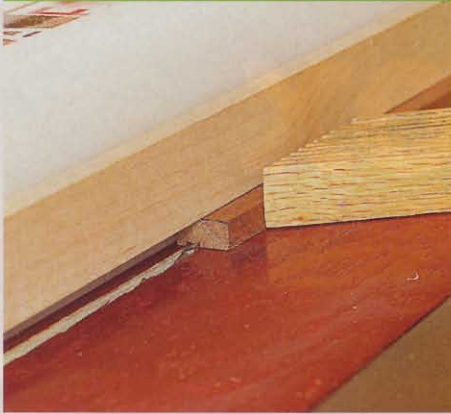

Use the same safeguards for ripping grille stock to cut kerfs on the undersides.

### HALF-LAP THIN STOCK SAFELY



A miter-gauge extension keeps fingers away from the blade while cutting half-laps.

### APPLY A THIN BEAD OF SILICONE



Thin and even beads of silicone adhesive look more attractive from inside the door.

shown *above*. Turn the piece end for end, saw a second kerf, and repeat the process for the remaining strips. (The kerfs catch silicone squeeze-out when you install the grille.)

### Cut half-laps at grille joints

Mark an "X" on one end of each horizontal piece. Then adjust your saw fence to position a 1/2"-wide dado 1/8" deep at the center of each horizontal grille piece. Place the end with the "X" against the fence and cut the dado using a miter-gauge extension to stop tear-out, as shown *above middle*. (Placing the "X" against the fence helps you precisely align the horizontal pieces when you assemble the grille.) The shallow dado allows you

to use the fence and miter gauge together. For the cabinet, we cut half-laps on the face sides of the horizontal pieces and on the undersides of the vertical ones.

With the marked ends of the horizontal pieces on one side, apply a drop of glue to the joints, and press the pieces into place. Clamp them together until the glue dries, and then flush-sand the joints. Apply finish to both sides of the grille before installing.

### Mount the grille

Lay the door frame flat with the glass supported by a piece of scrap. Then dry-fit the assembled grille in the door frame, and fine-tune the length of the pieces for a snug fit.

With the grille temporarily in position, mark its location on pieces of masking tape.

Next cut the applicator tip on a tube of clear silicone adhesive to lay a 1/8" or narrower bead on the center of the grille's back, as shown *above*. Lay the grille against the glass, taking care to position the ends where marked on the tape. Clamp a caul over the vertical piece and use wedges at the joints to distribute pressure to the horizontal pieces, as shown *below left*. If necessary, use tape to hold the horizontal pieces against the glass and in position. Leave the grille clamped overnight while the caulk cures. Should any silicone escape your kerfs, scrape it away with a razor after it sets up.

### SECURE THE GRILLE WITH CLAMPS AND WEDGES

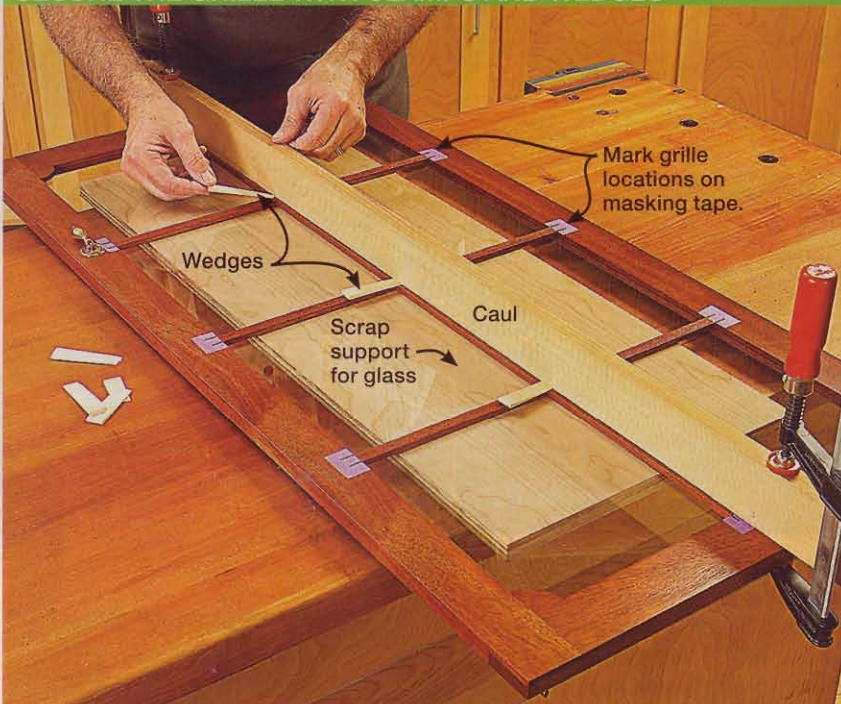

Glass can sag slightly when suspended in a door frame, so we supported it on the underside with a plywood scrap. Wedges beneath the clamping caul add pressure at the grille joints.

### Design your own grille

You can apply these assembly methods to many common grille styles, including ones you design to suit a project's style and your personal preferences.

For example, the cabinet featured on *page 44* uses a grille with two columns of four lights in each. Between the two doors, these form a pattern of four columns of four lights each for a traditional, symmetrical look.

When designing grilles for traditional door styles in general, make them as close as possible to the classical golden mean ratio of 5:8—an opening 5" wide by 8" high, for example. You also can adjust grille proportions to coordinate the doors with other parts of a project. For example, horizontal grille pieces can be spaced vertically to match the locations of shelves inside a cabinet.

Not all grille styles create lights of equal sizes and shapes. An Arts and Crafts project, such as the tall clock in *issue #156* and shown at *right*, may use combinations of sizes and shapes to form a pattern. 🌲



# freestanding planter box

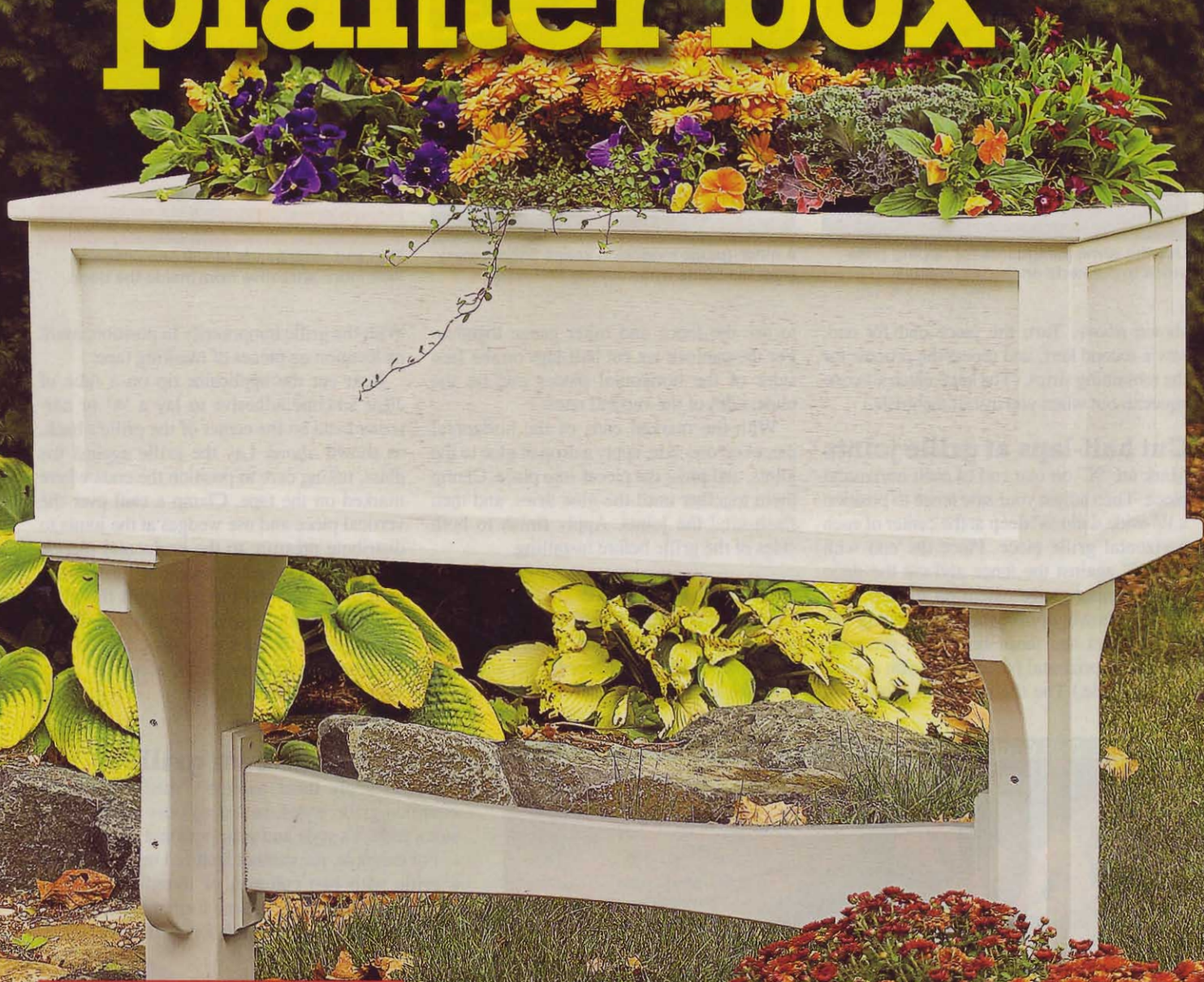

## AT A GLANCE

■ Overall dimensions: The box is 16" wide x 44½" long x 13½" high, features adjustable mounting height, and holds three 10"-diameter flowerpots.

■ For the board feet of lumber and other items needed to build this project, see page 59.

**Y**ou can locate this easy-to-build planter box anywhere in your yard. Use it to create a border—at the edge of a walkway or patio, for example. Place it in front of a window close to the sill or spaced farther away to make room for existing shrubbery. Because the 4x4 posts can be cut to any length, positioning the top

of the box at just the right height is easy. Drive-in steel post bases (available at hardware stores and home centers) free you from the chore of digging postholes. And as the growing season wanes, replace summer flowers with colorful fall-, winter-, or holiday-themed arrangements, letting you enjoy your planter box year-round.



Locate the planter box under any first-story window in your home without drilling mounting holes into the side of the house.

## 1a POT SUPPORT END

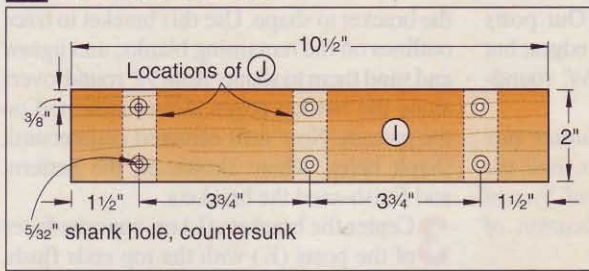

### First make the box

**1** From  $\frac{3}{4}$ " exterior-grade plywood, cut the sides (A) and ends (B) to the sizes listed on the **Materials List**. (We used type BCX plywood.) Clamp the ends and sides in the configuration shown on **Drawing 1**, with the ends and edges flush and the good faces to the *outside*. Drill countersunk screw holes through the sides and into the ends and drive the screws. Finish-sand the outside of the box to 150 grit.

**2** From  $\frac{3}{4}$ "-thick cedar, cut the end vertical trim (C) and side vertical trim (D) to size. (Can't find  $\frac{3}{4}$ "-thick cedar boards? See the **Shop Tip**, below.) Then rout a  $\frac{1}{4}$ " round-over along the outside corner of each side vertical trim piece, where shown on **Drawing 1**, and finish-sand the parts. Now glue and nail the end vertical trim to the box assembly (A/B), aligning the trim ends with the top and bottom edges of the box and the trim outside edges with the box corners. (We secured the trim with Titebond III glue and 4d galvanized finish nails.) Next glue and nail the side vertical trim in place flush with the edge of the end vertical trim.

**Note:** Although we used cedar for our planter box, you also can use redwood or cypress.

**3** Measure the distance between the end vertical trim (C) and side vertical trim (D), and cut the side horizontal trim (E) and end horizontal trim (F) to fit. Then tilt your tablesaw blade  $30^\circ$  and bevel-rip one edge of parts E and F, where shown on **Drawing 1**.

## SHOP TIP

### "Plane" rough cedar to thickness on your tablesaw

When purchasing material for this project, you may find that instead of  $\frac{3}{4}$ "-thick cedar, your supplier carries cedar boards almost  $\frac{7}{8}$ " thick planed smooth on one side and rough-sawn on the other. If you don't have a planer, rather than going on a time-consuming search for  $\frac{3}{4}$ " material, try this.

Cut the stock for parts over 12" long to width and length. For safety sake, combine shorter parts into a longer blank. Then position your tablesaw rip fence  $\frac{3}{4}$ " from the blade and raise it to about two-thirds the width of the stock. Now cut the parts to thickness by first making one pass, as shown at *right*. Flip the parts end for end and make a second pass. Use the cut face as the back of the part.

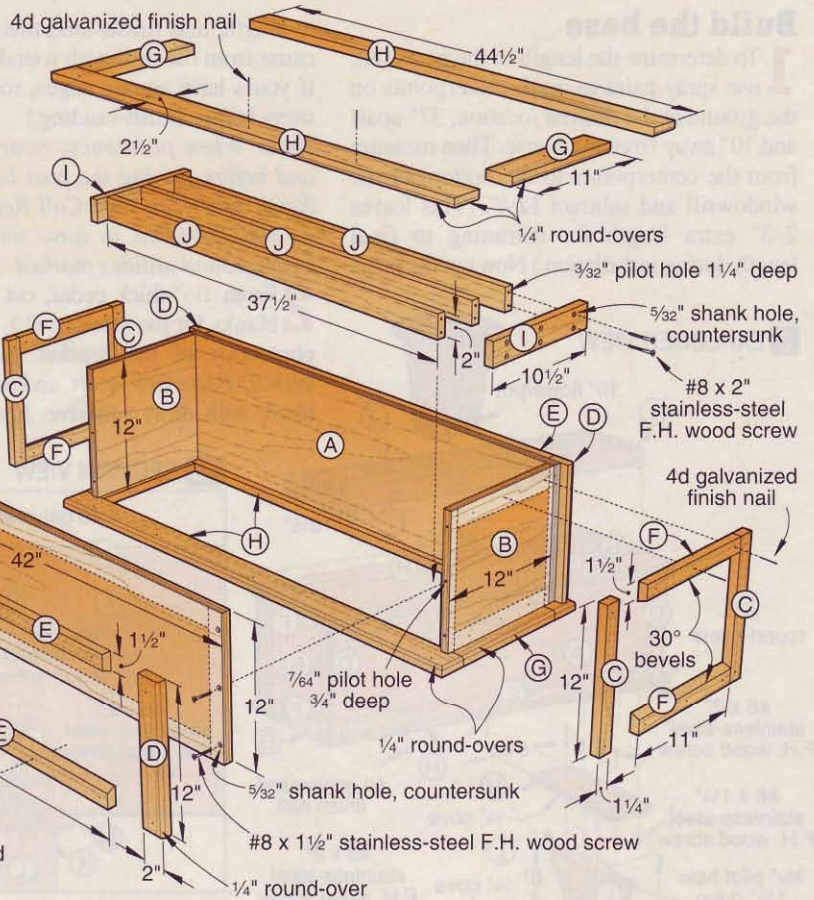
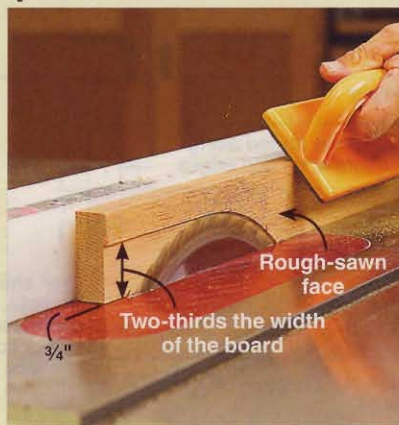

Finish-sand the parts. Now glue and nail the horizontal trim to the box assembly (A/B), flush at the top and bottom edges.

**4** Cut the end caps (G) to size. Rout  $\frac{1}{4}$ " round-overs along one edge of each part. Then referring to **Drawings 1** and **2a** for the orientation of the round-overs, nail and glue the end caps in place, as shown in **Photo A**.

**5** Measure the distance from the outside edge of one end cap (G) to the other end cap outside edge. Then cut the side caps (H) to this length. Rout  $\frac{1}{4}$ " round-overs along both ends and one edge of each cap. Now,

aligning the round-overs on the side caps with the round-overs on the end caps, glue and nail the side caps in place. Finish-sand the cap frames (G/H).

**6** Make sure all the finish-nail heads are set below the surface, and then fill the holes with exterior wood filler. Let the filler dry, and sand it smooth.

**7** Cut the pot support ends (I) and slats (J) to size. Drill countersunk shank holes in the ends, where shown on **Drawing 1a**. Finish-sand the parts, and set them aside.

### POSITION THE CAP WITH A SPACER

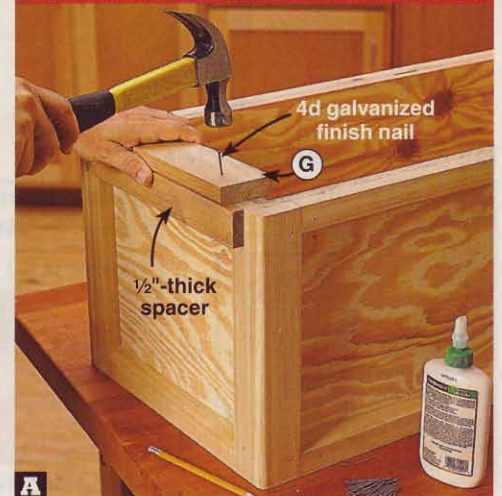

**A** Cut a  $\frac{1}{2}$ "-thick spacer. Then apply glue, center the end cap (G) side-to-side, align the edge with the spacer, and nail it in place.

## Build the base

**1** To determine the length of the posts (K), use spray paint to mark centerpoints on the ground at the desired location, 37" apart and 10" away from the house. Then measure from the centerpoints to the bottom of the windowsill and subtract 12¼". (This leaves 2–3" extra length for trimming to final length during installation.) Now cut the posts

to length, and finish-sand them. (Our posts came from the mill with rounded edges, but if yours have square edges, rout ¼" round-overs before finish-sanding.)

**Note:** When positioning your planter box and before driving the post bases, call the *North American One Call Referral System* at 888/258-0808 to have the location of underground utilities marked.

**2** From 1½"-thick cedar, cut four 5×16½" blanks for the brackets (L). Then make a photocopy of the bracket pattern on the *WOOD Patterns*® insert, and adhere it to one blank with spray adhesive. Jigsaw and sand

the bracket to shape. Use this bracket to trace outlines on the remaining blanks, and jigsaw and sand them to shape. Rout ¼" round-overs along the bracket edges, where indicated on the pattern. Now drill centered countersunk shank holes, where shown on the pattern, and finish-sand the brackets.

**3** Center the brackets (L) on opposite faces of the posts (K) with the top ends flush, where shown on **Drawing 2**, and clamp them in place. Using the bracket shank holes as guides, drill pilot holes into the posts and drive the screws.

**4** Cut the box supports (M) and cleats (N) to size. Chuck a ¼" cove bit into your table-mounted router, and rout coves along the ends and edges of one face of all four parts, where shown on **Drawings 2** and **2b**. Then drill ⅝" countersunk shank holes, where shown on **Drawing 2b**. Finish-sand the parts. Now center the box supports on the post assemblies (K/L), and using the shank holes as guides, drill pilot holes into the posts and brackets, and drive the screws.

**5** From 1½"-thick cedar, cut a 5¼×34" blank for the stretcher (O). (You'll trim it to finished length during installation.) Using a fairing stick, mark the curved edges, where shown on **Drawing 2c**. Jigsaw and sand the stretcher to shape. Then rout ¼" round-overs along the edges. Finish-sand the part.

## Apply the finish

**1** Finish-sand the parts and assemblies where needed. Apply paint in a color of your choice. (We used exterior oil-based primer followed by two coats of exterior acrylic latex satin enamel.) Take care to completely coat any exposed end grain.

**2** With the paint dry, clamp the pot support slats (J) between the pot support ends (I), where shown on **Drawing 1**. Using the shank holes in the ends as guides, drill pilot holes into the slats, and drive the screws.

## Now install the planter box

**1** Purchase two steel post bases for 4×4 posts. Following the instructions that come with the bases, drive them into the ground at the previously marked post centerpoints, as shown in **Step 1**, opposite. Stop driving the post bases when the bottoms of the post sockets are 1" above the ground.

**2** To position the top of the planter box even with the bottom of the windowsill,

### 2 EXPLODED VIEW

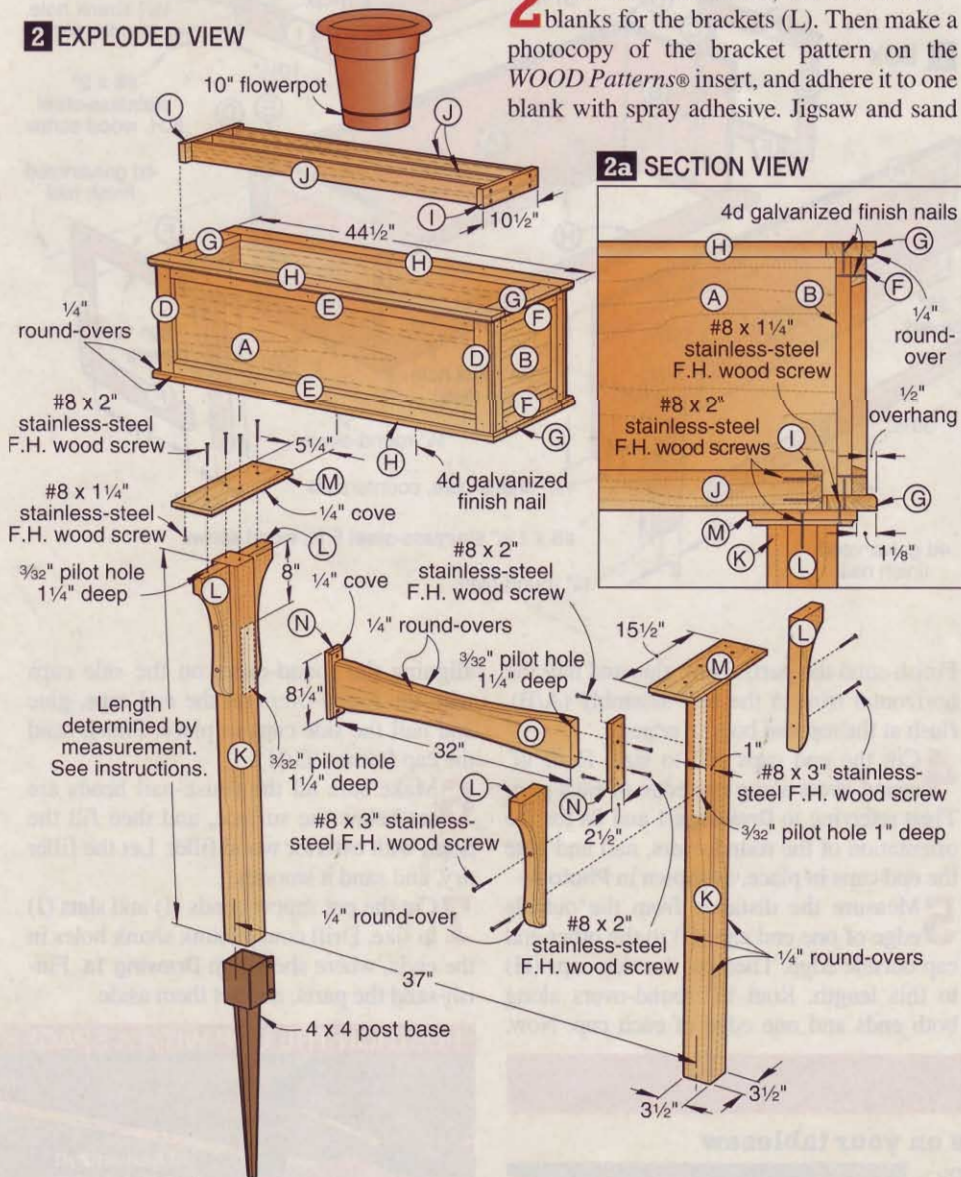

### 2a SECTION VIEW

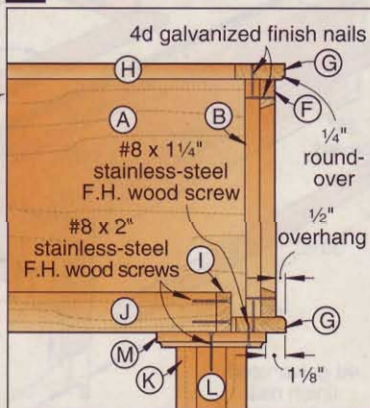

### 2b BOX SUPPORT AND CLEAT

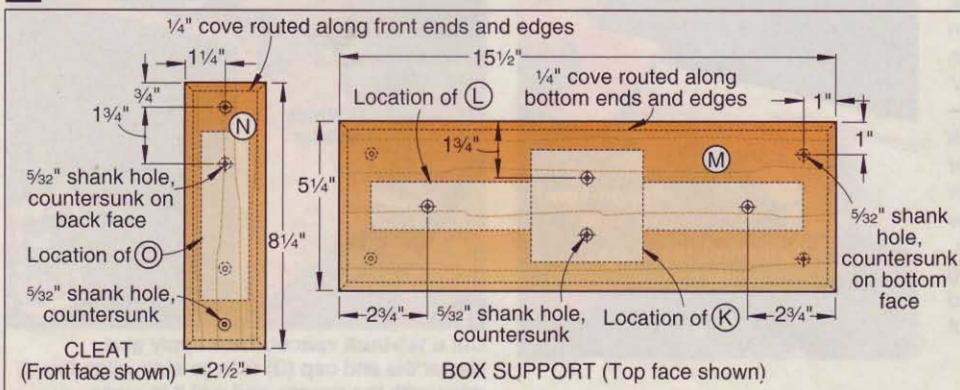

### 2c STRETCHER

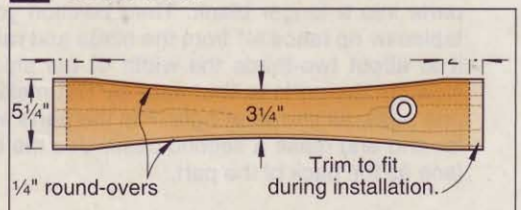

## Cutting Diagram

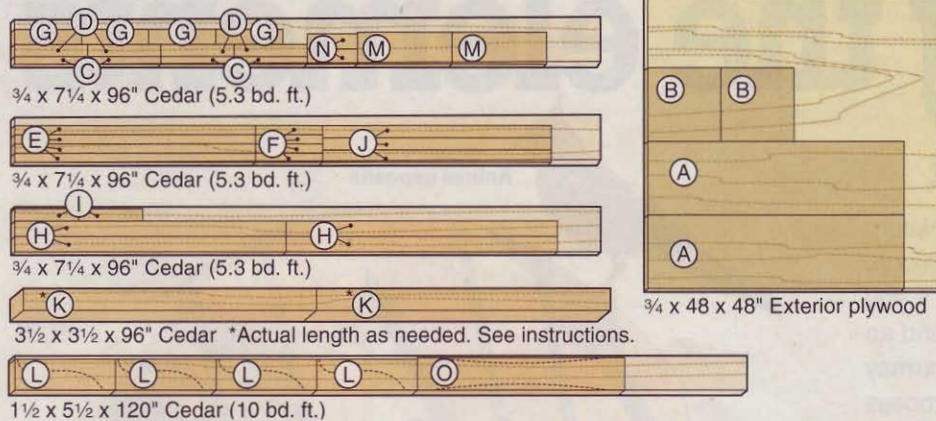

measure the vertical distance at each post location, as shown in **Step 2**. Then subtract  $14\frac{1}{4}$ " from each measurement and cut the posts (K) to length. Paint the cut ends.

**3** To trim the stretcher (O) to length, measure the distance between the posts, as shown in **Step 3**. Then subtract  $1\frac{1}{2}$ " from this measurement to allow for the cleats (N), and cut the stretcher to this length, trimming equal amounts from each end. Prime and paint the cut ends. Now fasten the cleats to the stretcher, as shown in **Step 4**.

**4** Adhere masking tape to each post (K) with the bottom edge of the tape 8" below the bottom surface of the box support (M). Then position the stretcher assembly (N/O)

between the posts, aligning the top edge of each cleat (N) with the bottom edge of the tape. Center the cleats on the posts, and clamp the assembly in place. Now fasten the stretcher assembly to the posts, as shown in **Step 5**. Remove the masking tape, and tighten the base socket bolts.

**5** Center the planter box on the box supports (M), and fasten the planter box to the box supports, as shown in **Step 6**. Then rest the pot support (I/J) on the box supports. [The pot support fits inside the frame formed by the lower end and side caps (G, H) with a  $\frac{1}{4}$ " space all around.] Now round up some potted annuals, and add a splash of color to your window view. 🌱

## Materials List

Box	FINISHED SIZE			Matl.	Qty.
	T	W	L		
A sides	$\frac{3}{4}$ "	12"	42"	EP	2
B ends	$\frac{3}{4}$ "	12"	12"	EP	2
C end vertical trim	$\frac{3}{4}$ "	$1\frac{1}{4}$ "	12"	C	4
D side vertical trim	$\frac{3}{4}$ "	2"	12"	C	4
E side horizontal trim	$\frac{3}{4}$ "	$1\frac{1}{2}$ "	$39\frac{1}{2}$ "	C	4
F end horizontal trim	$\frac{3}{4}$ "	$1\frac{1}{2}$ "	11"	C	4
G end caps	$\frac{3}{4}$ "	$2\frac{1}{2}$ "	11"	C	4
H side caps	$\frac{3}{4}$ "	$2\frac{1}{2}$ "	$44\frac{1}{2}$ "	C	4
<b>Pot support</b>					
I ends	$\frac{3}{4}$ "	2"	$10\frac{1}{2}$ "	C	2
J slats	$\frac{3}{4}$ "	2"	$37\frac{1}{2}$ "	C	3
<b>Base</b>					
K* posts	$3\frac{1}{2}$ "	$3\frac{1}{2}$ "	†	C	2
L* brackets	$1\frac{1}{2}$ "	5"	16"	C	4
M box supports	$\frac{3}{4}$ "	$5\frac{1}{4}$ "	$15\frac{1}{2}$ "	C	2
N cleats	$\frac{3}{4}$ "	$2\frac{1}{2}$ "	$8\frac{1}{4}$ "	C	2
O* stretcher	$1\frac{1}{2}$ "	$5\frac{1}{4}$ "	32"	C	1

\*Parts initially cut oversize. See the instructions.

†Length determined by measurement. See the instructions.

**Materials key:** EP—exterior plywood, C—choice of cedar, redwood, or cypress.

**Supplies:** 4d galvanized finish nails; exterior glue; steel post bases for 4x4 posts (2); #8x $1\frac{1}{4}$ ", #8x $1\frac{1}{2}$ ", #8x2", #8x3" stainless-steel flathead wood screws, exterior wood filler.

**Bits:**  $\frac{1}{4}$ " round-over,  $\frac{1}{4}$ " cove router bits.

Written by **Jan Svec** with **Jeff Mertz**

Project design: **Kevin Boyle**

Illustrations: **Roxanne LeMoine**; **Lorna Johnson**

## SIX SIMPLE STEPS TO A PERFECT PLANTER INSTALLATION



**Step 1**

Place an 8"-long piece of 4x4 into the post base socket and, keeping the base plumb, drive it into the ground with a mallet.



**Step 2**

To calculate the post lengths, measure the distance from the bottom of each post socket to the bottom of the windowsill.



**Step 3**

Place the posts (K) in the bases and snug them by tightening the socket bolts. Measure the distance between the posts.



**Step 4**

With the stretcher (O) cut to length, center the cleats (N) on the stretcher ends, drill pilot holes, and screw the cleats in place.



**Step 5**

Clamp the stretcher assembly (N/O) between the posts (K). Drill pilot holes into the posts, and screw the cleats (N) in place.



**Step 6**

Center the planter box on the box supports (M). Drill pilot holes into the side caps (H), and screw the supports to the caps.

# beating the elements

## A guide for building outdoor projects that last

**S**ure, wood can rot. And Mother Nature works hard to help the process along. (Check out her arsenal at *right*.) But if you like to build outdoor furniture, arbors, and an occasional deck—and who doesn't—you may want to put the brakes on the decay process by choosing your building materials wisely.

With that in mind, we pulled together all of the right stuff for combating nature's onslaught, including the best exterior woods, glues, hardware, and finishes. As a bonus, we included several time-tested tips. Used together, you should be able to create that handsome Adirondack chair or potting bench, and have it last for years, possibly decades, come rain or come shine.



## Weather-tough rules for outdoor projects

Wouldn't it be great if you could build an outdoor project and have it last as long as the trees it came from? You can come close—by providing a regimen of protective care, and by faithfully practicing these seven outdoor project “golden rules”:

**Rule 1:** Select wood, adhesive, hardware, and finish that can withstand the abuse of outdoor conditions.

**Rule 2:** Keep wood materials dry and cool during construction.

**Rule 3:** Glue and screw parts together.

**Rule 4:** Sand all wood surfaces for finishing.

**Rule 5:** Protect all wood with finish or paint.

**Rule 6:** Keep the project from standing in or holding dirt or water.

**Rule 7:** Maintain the finish as needed before problems become serious.

## Building Tips

Simple, sensible tricks are often what it takes to extend a project's life. For starters, build outdoor furniture, structures, and other pieces to shed water. Doing this limits water's tendency to penetrate exposed surfaces while providing a means of escape. For surfaces that catch water, such as the planter box bottom shown *below*, drill weep holes to give excess water a way out. Space them 5–6" apart. Pay particular attention to joints located in horizontal surfaces—regardless of your finish choice. You'll want to seal the entire joint. The trick is to prevent dampness from settling into a joint's seams and other

openings, leading to wood rot, mildew, and weakened joints.

Another good idea: Seal end grain as shown *below*. End grain, by far, is the most vulnerable point of penetration on a piece of wood. It acts like a soda straw, readily sucking up moisture and holding it. To minimize this problem, seal exposed end grain with extra coats of finish. If painting your project, seal end grain with a water-based paintable adhesive sealant that contains elastomeric polymers (see "Adhesives that bond, seal, and fill," page 63). This strategy bears particular importance when protecting plywood edges.



Drill weep holes through the bottom of planter boxes to drain off standing water.



Press an effective clear adhesive sealant into end grain. Here we use an elastomeric.

## 9 mighty woods for outdoor projects



**A**lthough no wood is completely immune from rotting and insect damage, some resist decay better than others. Because of naturally occurring preservatives in heartwood, insects and fungi find the woods listed in the chart on the *next page* undesirable. Each choice has its advantages and disadvantages, so decide which wood best suits your building needs and budget.

### American softwoods, the traditional choice

The three most widely available and suitable exterior lumber choices, not treated with chemical preservatives, include *Western red cedar*, *redwood*, and *cypress*. Your geographic location will determine the availability and cost of these materials. Redwood, for example, is widely available and used in

*continued on next page*

## Softwood savvy

**Tip 1:** Avoid sapwood. It's generally not decay resistant. Almost always it appears as the lighter material in a given piece of lumber, as shown *below top*.

**Tip 2:** If possible, use quartersawn lumber to resist warping and improve dimensional stability. Quartersawn wood expands and contracts across its width only about half as much as flatsawn lumber. (See the examples *below middle*.) While such wood can sometimes be difficult to find, you can usually create it by buying wide boards (more than twice as wide as you need) and cutting out the unstable pith wood center (the innermost rings).

**Tip 3:** Look for tight-grained lumber. Such dense pieces are more stable, making them less prone to cracking, cupping, warping, and shelling (see next tip) than wide-grained stock. See *below bottom*.

**Tip 4:** Place horizontal boards crown up in projects. If you can't avoid flatsawn (also called plainsawn) lumber, placing the crown up will help shed water and reduce the effects of shelling. Shelling occurs when the bands of earlywood (lighter wood grain) and latewood (darker wood grain) separate. It occurs on the pith side of a board rather than the bark (crown) side. See the photo *below bottom* for reference.

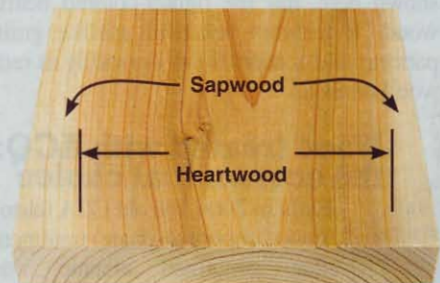

Sapwood, seen here as the lighter portions of this board, offers the least resistance to decay. It borders the darker heartwood.

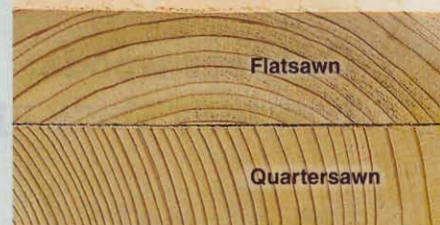

A flatsawn board (top) expands twice as much across its width as a quartersawn one, leading to less stability.

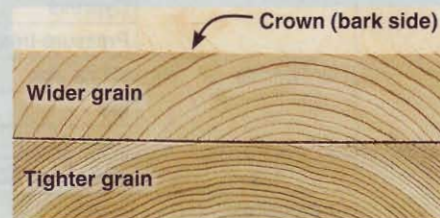

Choose tighter-grained wood (bottom) over wider-grained material for maximum stability.



Cedar

the western United States. Western red cedar is commonly sold in the Midwest, and eastern U.S.

cypress, which grows throughout the South and Southeast, often gets the nod in those locales due to its availability and economical price.

Redwood

Western red cedar and redwood stock tend to appear straight-grained and are dimensionally stable and naturally decay resistant. Both, however, can split when driving fasteners. (See "Screw-Driving Tips" on page 64.) Also, both species bleed tannins that make using fasteners and painting more problematic. The tannins appear as stains around fasteners and can even show through painted surfaces. Proper prepping of the wood, however, lets it accept all wood stains and clear finishes.

Cypress

The third major player, cypress, grows in swamps and has a conical base, with roots that seem to stand out of the water. Its sapwood is almost white, while the heartwood color varies from a light yellow brown to a reddish brown and dark brown. Inland cypress, like the sample shown here, has the lighter-colored heartwood. It features beautiful ashlike grain patterns and accepts finish as readily as redwood or cedar.

Pressure-treated pine

### Wood treated with ACQ: the economical choice

Early in 2004, the old CCA (chromated copper arsenate) treatment that contained arsenic was replaced by various treatments, but the most common is ACQ (alkaline copper

quat). In spite of its shortcomings, ACQ-treated wood holds up well. It might crack, warp, or shrink, but it won't rot or prove tasty to insects.

ACQ is a water-based preservative forced deep into the lumber, usually Southern yellow pine. Consequently, the lumber is saturated when banded and shipped. This practice makes treated wood heavy and prone to the troubles listed previously. To avoid these tendencies, you can air-dry treated lumber for two warm months, or purchase KDAT (kiln-dried-after-treatment) lumber. The downside: cost (usually double the wet stuff) and the need to special-order it from lumberyards or home centers beforehand.

Because the preservatives are accepted only by the sapwood, heartwood of pressure-treated lumber is not decay resistant, typically appearing tan or pink instead of green.

### Tough-as-nails white oak

White oak, the "whiskey barrel" wood, differs from red oak in that it is much less porous. Moisture can't wick up its end grain.

Super-strong, white oak features stainable, straight-grained wood with heartwood that resists decay.

Like redwood and cedar, it splits rather easily, so you do need to predrill screw holes for fasteners.

White oak

### Imported dense hardwoods

Ipe, a relative newcomer, is imported from Central and South America, where it grows rapidly. Also called Brazilian walnut and ironwood, it is so dense that it barely floats. Strong and stable, the functional life of ipe can be as long as 40 years if left untreated. It resists

movement, surface checks, warping, cracking, decomposition, and denting. Also, while it is expensive (and sometimes hard to find), ipe is comparably priced with many composite wood products.

Teak is still available in small quantities, but you'll pay a hefty price for it. Largely associated with boatbuilding, it doubles as an excellent choice for small outdoor projects where you want the beauty of the wood to speak as loudly as the craftsmanship.

Mahogany serves as a great project wood. It machines, sands, and finishes well, but costs more than ipe. Be sure to ask for African or Honduran mahogany, (avoiding Philippine mahogany). One nice thing: You can buy it in broad thicknesses for use in large projects.

### The upstart composites

Wood/plastic composites (WPCs) are made from thermoplastic resins, wood flour, and wood fiber. Some make use of recycled material, but all are rotproof. Composites have no defects, and do not compress like wood. This density poses special problems for fastening (see page 64) and movement. Solid composites, shown left, have greater expansion and contraction rates, especially along their lengths. They heat up in sunlight, and don't absorb paint and stain. Also, they lack rigidity. However, they don't splinter and offer good traction in wet conditions.

## Outdoor woods: how they stack up

Type

Type		Density (1)	Unfinished rot resistance	Rigidity	Finishability (2)	Ease of use (3)	Stability	Stain acceptance	Cracking tendencies	Warping tendencies	Availability (4)	Cost per 1x6 lin. ft. (5)	Best use
American softwoods	Western red cedar	L	B-	B-	C	A	B	A	B-	B-	A*	\$1	All purposes
	Redwood	L	B	B	C	A	B	A	B-	B	C	\$2-\$7*	All purposes
	Cypress	M	B	B	C	A	B	A	B	B	B*	\$2	All purposes
	Pressure-treated pine	L	A	B	B	A	B	B	C	C	A	\$1	Deck frame, decking, ramps
Hardwoods	White oak	H	A	A	A	C	B	A	B	B	C	\$2	Benches, arbors, chairs
	Ipe	VH	A	A	B	D	A	D-	A	A	C	\$3	All purposes
	Teak	H	A	A	C*	C+	A	D	A	A	D	\$15	Small items
	Mahogany (African/Honduran)	H	A	B	A	A	A	A	A	B	B	\$5-\$7	Furniture projects
Composites	Solid	VH	A	D	D-	D	A	D	A	A	A	\$2-\$3	Decking, ramps, railings
	Hollow core	VH	A	C+	D-	C	A	D	A	A	A	\$2-\$3	Decking, ramps

1. L-Low, M-medium, H-high, VH-very high

2. Must remove waxy resin with acetone

3. Includes difficulty of driving fasteners, cutting, weight

4. Depends on region

5. Price depends on grade

A excellent

B good

C fair

D poor

# Adhesives that bond, seal, and fill



**B**ecause exterior glues can't overcome poor workmanship, build your exterior projects with the same care as when building fine furniture. Make tight-fitting joints, work the glue while it's still wet, provide even clamping pressure over the entire joint, and allow adequate curing time. Most adhesive manufacturers recommend at least 24 hours of curing before putting stress on a joint. For a look at the latest outdoor adhesive in action, see the photo at right.

No single glue can meet all your requirements, so determine how much moisture your project will be subjected to, the types of joinery you plan to use, and the level of bonding. Then consult the chart below to pick a product suited to your needs. Note that adhesive sealants provide less bonding strength but offer great flexibility.



The new polyurethane hot melt adhesives offer reliable strength and set up almost instantly. They're waterproof, gap-filling, and promise solid end-grain-to-edge-grain bonding. Their downside? They're expensive and hard to sand after being fully cured.



## All-season adhesives and sealants

Type		Ease of use	Bonding power	Gap filling	Cleanup (1)	Flexibility	Shear strength	Water resistance (2)	Cold-weather use	End-grain bonding	Stainability	Cure time	Fasteners recommended (3)	Best use
Exterior wood glues	Water resistant	A	B	D	A	C	B	R	D	D	D	24 hr.	O	Outdoor furniture
	Waterproof	A	B	D	A	C	B	P	D	D	D	24 hr.	O	Outdoor furniture
Polyurethane glues	Liquid	B-	A	B-	D	C	B	P	C	C+	C	4-8 hr.	O	Tight joints
	Hot melt	B	B	B	C	B	B-	P	B	A	D	24 hr.	O	Fast set-up
Two-part epoxy	Fast cure	C	B	A	D	C-	B-	P	C	B	D	30 min.	O	Poorly fitting joints
	Slow cure	C	A	A	D	C-	A	P	C	A	D	60 min.	O	Oily, dense hardwoods
Poly. constr. adhesive	Polyurethane	B	B+	C	C	C	B	P	A	D	D	24 hr.	Y	General-purpose construction
Adhesive sealants	Elastomeric	B	C	B	B	B	D	P	A	D	C	24 hr.	Y	Sealing joints
	100% silicone	C	C	A	D	A	D	P	A-	C	D	24 hr.	Y	Sealing joints
	Polyurethane	C	C	A	C	A	D	P	B	C	D	24 hr.	Y	Sealing joints/paint prep.

1. Includes sandability and assumes water base makes for easier cleanup
2. P-waterproof, R-water resistant

3. O-optional, Y-yes

- A excellent
- B good
- C fair
- D poor

# Fasteners for a lasting, firm hold



## Fasteners Key:

- ① Stainless-steel screw
- ② Plated construction screw
- ③ Dipped galvanized construction screw
- ④ Composite screw
- ⑤ Dipped galvanized lag screw
- ⑥ Dipped galvanized bolt
- ⑦ Coated ring-shank nail
- ⑧ Hot-dipped galvanized nail

**Y**our basic common screw isn't quite so common anymore. The ever-changing climate of tools, bits, and materials has led to an explosion of specialized designs. The greater use of dense hardwoods, the development of composite materials, and changes in preservative treatments also have exerted their influence.

To begin with, the density of composite materials creates problems of splitting, mushrooming (when material is pushed up and out around the screwhead), and screws "spinning out" (when threads lose their bite) before the heads are fully countersunk.

While better for the environment, the changeover from the old CCA wood treatment to the new ACQ treatment has proven to be far more corrosive on fasteners. Many experts recommend only stainless-steel or hot-dipped zinc fasteners for use with ACQ; however, many other screw types are billed as suitable for ACQ. Currently, the fastener industry is self-governed and sets its own standards for what constitutes an ACQ-rated screw for treated stock.

Finally, as a means of maintaining outdoor projects, we rely on all kinds of chemical solutions. We use bleaches and cleaners to kill mildew and revive surfaces. On the downside, we sometimes add salt to dissolve ice on a deck and improve traction. But while these additives may well keep outdoor wood

looking good or make it safer to walk on, they abuse and destroy the protective coatings on fasteners. So, after pondering the type of project you're building, carefully read the next section on screw features and the chart located *opposite, bottom*, to choose suitable fasteners for the job. Then, check out "Screw-Driving Tips" *below* to see how you can best put your selected fasteners to work. If using screws, consider going with an impact driver like those shown on *page 106*.

## Screw features that make a difference

Close examination of screwheads reveals a whole world of engineering that governs their design. The more you know, the easier time you'll have choosing the right one.

**Material:** Exterior fasteners are made from various grades of case-hardened or stainless steel. While stainless-steel products are left bare, all others have layers of electroplated zinc coatings and sometimes a polymer coat-

## Screw-Driving Tips

**Lubricate:** Extra lubrication reduces torque and helps save protective coatings. Beeswax works, and the cheapest and easiest source for the lubricant is a toilet wax ring. Just be sure to clean off the excess wax with mineral spirits before finishing.

**Predrill and plug:** If you don't have hundreds of screws to drive, it's worth your time to predrill. For a furniture-quality look, counterbore to hide screwheads deep in the wood. Then fill the counterbored recesses with plugs made from leftover scrap. Doing this improves appearance, and protects the fastener as well.

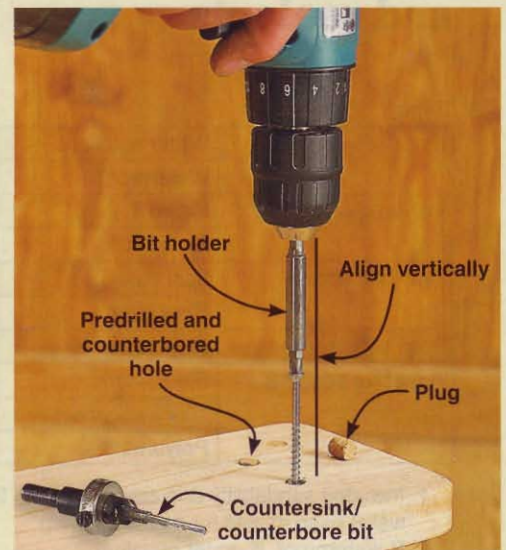

ing for color or lubrication. Or they're dipped in molten zinc to prevent corrosion. Note that yellow zinc and black screws (not shown in this article) are often not suited for the rigors of exterior use.

**Head size:** With large-headed screws, your fastener's visibility increases and countersinking becomes harder and time-consuming. Further, the chances of splitting the wood increase. Many types of trim-head exterior screws, such as GRKs (shown above), come with head sizes similar to a same-size finish nail, making them less noticeable.



**Countersink cutters:** Many exterior screws have countersink cutters on the underside of the head that aid in sinking them. The number and prominence of the ridges tell how effective they are in that task. One screw, Titan's Splitstop (shown below), has aggressive cutters to both countersink the head and minimize splitting.

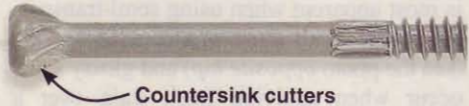

**Thread pitch and count:** As a general rule, the steeper the thread pitch and the lower the thread count, the faster you can drive a screw. However, such screw designs demand more torque, placing more stress on tools and users, and increasing the chance of snapping screws and stripping heads. One screw, the WeatherMax, has a secondary set of threads inside the main threads that reduces the torque demand on the drill and



the need for predrilling, particularly with softer woods. (See above.)

**Driver shape:** Exterior screws come with square (Robertson), combination, star (Torx), and Phillips drives. Those that tend not to slip: star and square drives. However, it's not only the shape of the driver bit that plays a role in driver ease, but also the depth of the recess. The deeper the pocket, the better the bit's bite.



**Shank size:** Shank size affects a screw's shear strength and pull-out power. A wider shank means the screw threads can be more aggressive. In general, use #10 screws for heavy-duty projects, such as deck building, and #7 or #8 for lighter-duty tasks, such as outdoor furniture construction.

**Shank slot:** Look for screws with a shank slot like those shown below. This feature improves a screw's ability to auger into a hole, improving self-tapping capability without having to predrill.

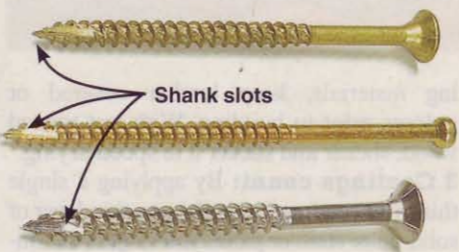

**Thread shape:** Threads are changing rapidly. A composite screw's shank usually has opposing threads designed to keep the lower threads from spinning out in less-dense natural material (i.e., a wood floor joist). Spax, a composite screw, even has serrated threads (shown below) to improve cutting ability and reduce torque. The WeatherMAX uses a W-cut for the same reason.

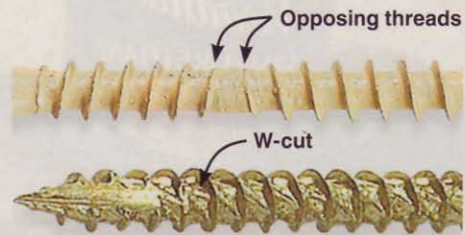

**Salt-spray specialists:** If you live in a coastal environment, make sure your fasteners can withstand salt corrosiveness. Key West lumber dealers recommend hot-dipped galvanized and stainless-steel screws.

**Splitless features:** Predrilling and counterboring are still your best bets to prevent splitting your material, particularly along the ends and edges of stock. However, these methods take time. Trimhead screws help greatly in this area, but other features also have been developed. In addition to the aggressive countersink cutters mentioned earlier, Titan's screws have a vertical knurl above the threads (shown below) that helps hog out a hole to make room for the shank. If you choose nails instead, consider the ring-shank type. The blunt tip on the ring-shank nail reduces splitting.

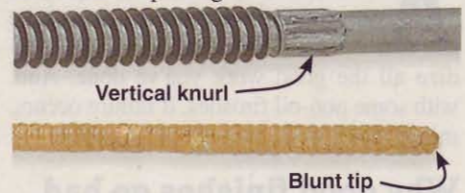

## A fast glance at outdoor fasteners

Type	Ease of use	Shear strength	Holding power	Service life	Concerns	Best use
Stainless-steel screws	B	B	A-	40+yr.	Prone to stripped heads	ACQ, redwood and cedar, coastal areas
Plated construction screws	A-	B	A-	7-10 yr.	Coating compromised during driving	All-purpose, trimheads for furniture
Dipped galv. construction screws	B	B	A-	7-10 yr.	High torque requirements, staining	All-purpose, except cedar and redwood
Composite screws	B	B	B	7-10 yr.	Mushrooming, failure to countersink	Composite decking
Dipped galvanized lag screws	C	A	A	40+yr.	Highly visible, high torque, staining	Heavy timber unsuited for bolts
Dipped galvanized bolts	C	A	A	40+yr.	Highly visible, staining	Heavy timber and post-shrinkage tightening
Coated ring-shank nails	A	B	C	15+yr.	Dents, bent nails, removal	Trim, fascia, redwood and cedar
Dipped galvanized nails	A	B+	C	15+yr.	Dents, bent nails, removal, staining	Attaching decking to non-ACQ frame

**A** excellent **C** fair  
**B** good

# Finishes for the long haul



**A**s the final step in an outdoor project, the finish is not the place to take shortcuts. By doing so, you jeopardize all the good work you've done. And, with some non-oil finishes, if failure occurs, minor repair work may not be an option.

## Why good finishes go bad

To find out why wood finishes deteriorate over time, we asked Sam Williams, a chemist with the United States Forest Products Laboratory (USFPL). He points to five significant reasons:

**1 Raised grain:** During the normal yearly wet/dry cycles, earlywood readily absorbs moisture and swells, pushing out bands of the darker latewood and raising the grain, creating cracks in the finish where moisture penetrates and expansion occurs. To control this condition, follow the "crown-up" tip (see page 61), using tight-grained stock—if possible—to limit the problem.

**2 Sunlight:** Exposing raw wood to the sun's ultraviolet (UV) radiation, even for a week, can degrade the wood fibers. This can stand in the way of paint and film finishes adhering to the smooth surface. When stor-

ing materials, keep lumber covered or indoors prior to building. With wet treated wood, shelter and sticker it to speed drying.

**3 Coatings count:** By applying a single thin-film coating (1–3 mils) or a thin layer of solid-color stain or paint, you subject the finish to early failure. This problem is especially noticeable on flatsawn lumber. To prevent it, use the recommended number of coats for each finish.

**4 Moisture content:** Changes in the moisture content also cause dimensional movement that stresses a film finish. To limit this, begin with kiln-dried lumber having less than 13 percent moisture content. Then coat all sides of the material using a flexible finish. (See finish chart, *opposite*.) Note that projects placed in shade release moisture less readily and require extra protection from mildew by using a finish with a mildewcide.

**5 Poor surface prep:** Raw lumber needs preparation. Pressure-treated wood may contain paraffin wax that should be removed with a wood cleaner (a petroleum-based solvent such as mineral spirits) before using water-based finishes. Other wood stored for a few months or exposed to sunlight should

be scuff-sanded, using 50–80 grit for wood you intend to paint, 220 grit for wood receiving a clear finish. Aluminum oxide achieves the best results—it resists loading when sanding softwoods.

## Finishes that limit UV damage

Exposure to UV causes color change and a degradation of the surface. While most of the finishes listed in the chart offer some UV protection, the level of protection can vary, with all finishes wearing out over time. On the low end of the scale, clear finishes without UV absorbers offer no protection. Paint, because of its UV-blocking pigments, is the ultimate barrier to the sun's damage. In between are the pigmented semitransparent stains that provide some degree of sun-screening shelter.

## Less-than-perfect working conditions

Heat and moisture are the enemies of effective finishing. Direct sun or hot surfaces lead to finishes drying too quickly. This in turn results in an uneven appearance. This effect is most apparent when using semi-transparent stains. With these products, lap marks (see the photo *opposite top*) and glossy spots occur when applying fresh stain over a quickly drying undercoat.

When painting, Mark Knaebe, a USFPL chemist, advises that you not paint on a cool surface that will heat up in a few hours when the sun hits it or when heavy dew or frost is expected to form at night. The ideal conditions: a moderately overcast day with no chance of rain, low humidity, highs in the mid-70s, and lows in the mid-50s.

## All finishes are not created equal

In choosing the best finish for your project, base the choice on what matters most to you. Is absolute minimum maintenance your biggest priority? Do you want to see wood grain even if it means finishing more often? Once you know, consider the following products to help you meet your needs.

**Water repellents:** These finishes accomplish their jobs by carrying a repellent, primarily paraffin wax, onto the wood via solvents. They offer minimal UV protection and have by far the shortest service life, typically a few months.

**Penetrating oils:** Many people look to linseed oil, yet it offers poor protection. And, unfortunately, its organic nature can attract mildew. Danish oil products such as Watco Teak Oil, fare no better outdoors. At best these products provide renewed looks and minor moisture protection. But, while the



Shades of difference can appear when sun-heated surfaces cause semitransparent stains to dry too quickly.

frequency of reapplication may be greater than with varnish or paint, recoating with an oil finish requires little prep work, and you can apply it quickly.

**Stains:** The sheer number of exterior stain choices has become staggering. They include water-based and oil-based, semitransparent and solid-color, and even penetrating oil stains. Consider solid-color stains as essentially a thin paint.

Oil-based stains penetrate wood better than water-based stains. Water-based stains don't enter the wood as much as leave slight film on the surface. That makes maintaining water-based stains more challenging. Water-based products clean up more easily. In all cases, these stains offer better UV protection than using a clear finish alone, even those with UV absorbers. To get the

best of both worlds, apply a base coat of compatible stain and topcoat it with two coats of varnish. This will extend the life of both the wood and the finish significantly.

**Varnishes:** Typically, the products in this category—spar varnish, marine varnish, and outdoor urethanes—are different from their indoor cousins in that they're made to be flexible when dry and contain UV absorbers. However, the quality of UV protection can vary greatly among manufacturers. A good indicator is the price you pay at the store. Better varnishes simply cost more. Some marine varnishes may run \$24 a quart, with gallons approaching \$90 a can.

In the past, varnishes were exclusively oil-based, but recently a few water-based products have made their way into the market. Mark Boufford of Varathane claims that: "Water-based finishes are now as good as or better than oil-based varnishes for hardness and durability; however, they can't compete with oil-based for protecting against damaging UV exposure." That said, the category as a whole offers the best protection in a clear finish, letting the natural beauty of the wood make a statement.

**Paints:** No other finish will outperform properly applied paint when it comes to protecting wood outdoors. Latex paints prove more flexible and breathable (allowing moisture to escape) than oil-based paints, making them better able to withstand the inevitable shrinking and swelling of wood.

For paint to be most effective, pay attention to the sections on weather conditions

and the poor surface prep." When applying paint, go with one coat of primer and two topcoats. For softwoods, such as redwood and cedar, that tend to bleed tannins, use an oil-based, stain-blocking primer, such as the one shown *opposite top*, and topcoat it with a quality latex or acrylic latex. You'll like the ease with which it goes on.

One other paint advantage: You can seal vertical joints and the upper side of horizontal joints with an adhesive sealant (see page 63) before painting. This lets the protective coat of your project resist moisture even better, especially at end grains. 🌲

Written by Mike Satterwhite with Jim Harrold

**Sources for more information: Wood materials and finishes—**

- U.S. Forest Products Laboratory 608/231-9200; fpl.fs.fed.us
- Varathane 800/635-3286; woodanswers.com
- Zinsser 732/469-8100; zinsser.com

**Adhesives—**

- Titebond 800/347-4583; titebond.com
- Gorilla Glue 800/966-3458; gorillaglu.com
- DAP 800/543-3840; dap.com

**Fasteners—**

- Titan Metal Works 888/578-3273; splistop.com
- GRK Fasteners 800/263-0463; grkfasteners.com

## Four-season finishes: how they compare

Type		Ease of refinishing	UV protection	Flexibility	Penetrating (1)	Film thickness	Number of coats	Mildewcide (1)	Breathable (1)	Reapplication frequency	Best use
Water repellents	Standard	A	D-	A	Y	NA	1	Y	Y	1-2 m.	Weathered decks and rails, pretreatment for painting
	UV-blocking	A	D	A	Y	NA	1	Y	Y	1-2 m.	Weathered decks and rails, pretreatment for painting
Penetrating oils	Linseed oil	A	D	A	Y	NA	1	N	Y	2-3 m.	None
	Danish oil	A	C	A	Y	NA	1-2	Y	Y	6 m.-1yr.	Dense hardwoods
Stains	Water-based semitrans.	B-	B	B	N	thin	1-2	Y	Y	2-4 yr.	Furniture and vertical structures
	Oil-based semitransparent	B	B	A	Y	NA	1-2	Y	Y	3-5 yr.	Treated wood decks, rails, and furniture
	Water-based solid	B	B+	B	N	med.	1-2	Y	Y	3-5 yr.	Furniture and vertical structures
	Oil-based solid	B	B+	B	Y	thin	1-2	Y	N	1 yr.	Furniture and vertical structures
Urethane	Water-based	D	C	B-	N	thick	3-10	Y	N	2-3 yr.	Furniture and vertical structures
	Oil-based	D	C+	B-	Y	thick	3-10	Y	N	2-3 yr.	Furniture and vertical structures
	Marine	D	B-	B-	Y	thick	3-10	Y	N	2-3 yr.	Furniture and vertical structures
Paints	Water-based (latex)	A-	A	B+	N	thick	3	Y	Y	7-10 yr.	Furniture and vertical structures
	Oil-based (enamels)	A-	A	D	Y	thick	3	Y	N	7-10 yr.	Furniture, oil-based primers under latex topcoat

A excellent    C fair    1. Y=yes, N=no  
 B good        D poor

# a Tudor for tweeters

Your feathered friends will love this copper-topped birdhouse.



Using only a small amount of wood, copper foil, fasteners, waterproof glue, and paint, you can build this charming home that's sure to attract songbirds to your yard. We sized the birdhouse and 1 3/8" opening for such small fliers as chickadees, nuthatches, and tufted titmice, shown *at right*. For sizing and installation guidelines to suit other birds, go to [birds.cornell.edu/birdhouse](http://birds.cornell.edu/birdhouse) and click on "Birdhouse Basics" followed by "Nest Box Reference Chart."



Chickadee



Nuthatch



Tufted titmouse

## Caring for your birdhouse

To ensure a continuous supply of tenants, clean out the birdhouse early each spring after you're certain the previous guests have departed. Remove the screw from each side (B), where shown on **Drawing 1**, and lift the birdhouse off the bottom/base (C/D). Take out the old nest. Then disinfect the interior of the house by scrubbing it with a small brush and a solution of ¼ cup of chlorine bleach and two cups of water. Rinse thoroughly with clean water. When dry, remount the house.

## Let's frame the house

**1** Edge-join ¾"-thick stock to form two 6x8½" pieces for the front and back (A). (We also edge-joined parts D, E and F later for best stability.) For bird safety, use nontreated wood. (We used cedar, but other suitable decay-resistant materials also will work, namely, cypress and redwood.)

**2** Lay out the angled roof lines on the front and back (A), where dimensioned on **Drawing 1**. Bandsaw and sand to the lines.

**3** Mark centerpoints for a 1⅜" bird entrance hole on the front (A) and two ⅜" vent holes on the back (A), where dimensioned. Using a 1⅜" Forstner bit in your drill press and a backer to prevent tear-out, bore the hole in the front with the good face up. Switch to a ⅜" twist bit. Then drill the vent holes in the back.

**4** From ¾"-thick stock, cut three 4x4" pieces—two for the sides (B) and one for the bottom (C). Using waterproof glue, assemble and clamp together the front and back (A), sides, and bottom (no glue) with the sides inset ¼" from the edges of the front and back, where shown on **Drawing 1** and as shown in **Photo A**. (You'll need to remove the bottom later, so avoid getting glue on it.) Nail the front and back to the sides with 4d galvanized finish nails. Then drill a mounting hole through each side into the bottom, and drive #8x1¼" deck screws.

**5** From edge-joined ¾"-thick stock, cut the base (D) to the size listed in the **Materials List**. Using a ¼" round-over bit in your table-mounted router and a pushblock for safety and backup, round over the ends, and then edges, of the base on the *top* face, where shown on **Drawing 1**. Switch to a ¼" cove bit. Now rout a cove along the ends and edges on the *bottom* face.

**6** Remove the bottom (C), marking the front edge to maintain correct orientation. Then glue and clamp the bottom to the *top* of the base (D) 1⅝" from the front edge of the base and centered side-to-side, where dimensioned. Drill two countersunk mounting holes through the base into the bottom, and drive #8x1¼" deck screws.

**7** Mark centerpoints on the bottom (C) ½" from the edges at each corner for drain

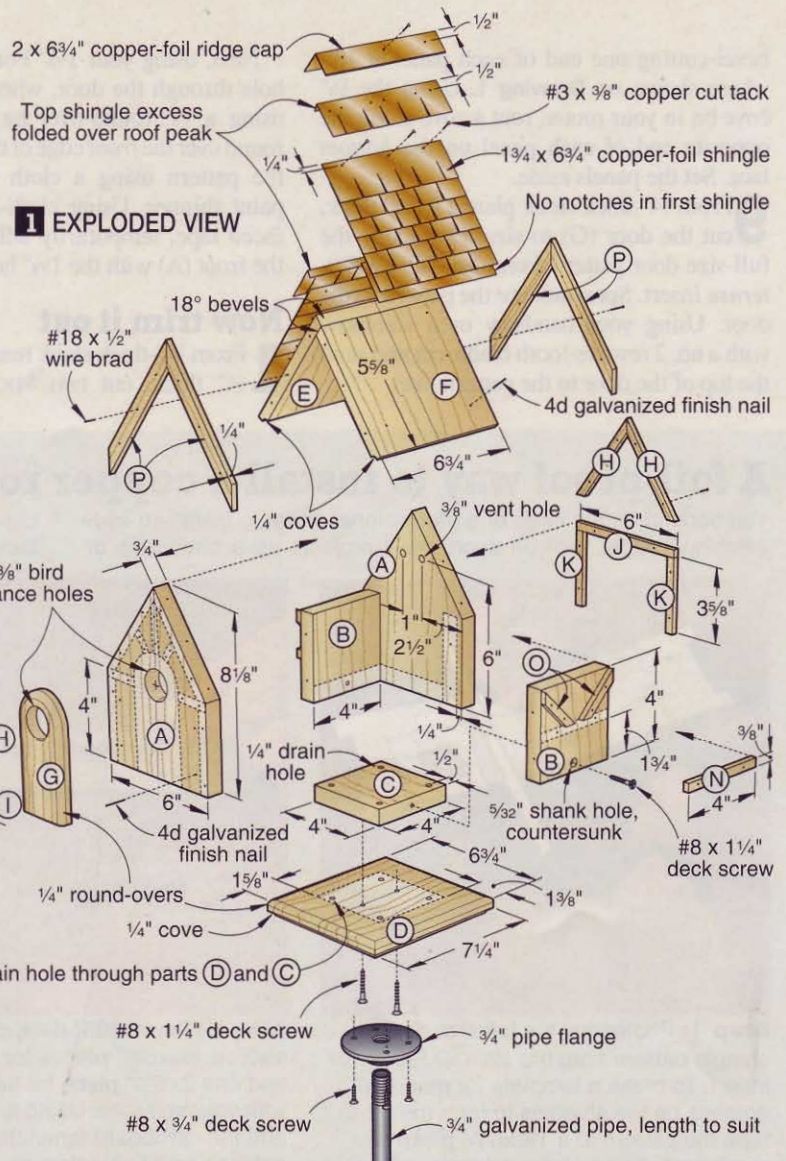

### ASSEMBLE THE BIRDHOUSE

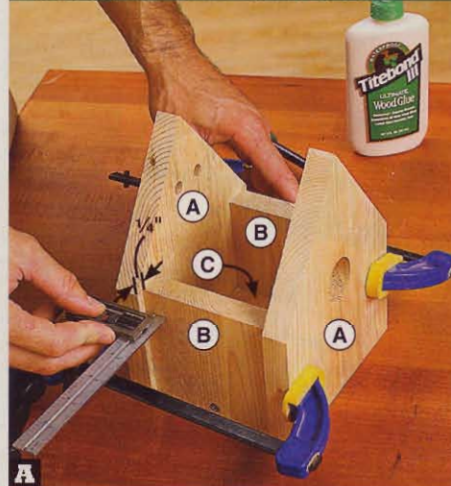

Clamp together the front and back (A), sides (B), and bottom (C) with the sides positioned ¼" from the edges of the front and back.

### DRILL THE BOTTOM DRAIN HOLES

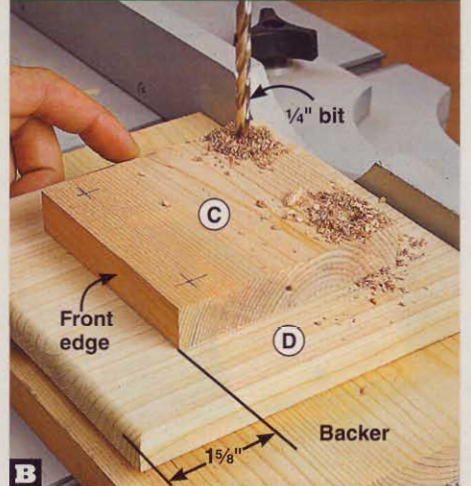

Using a backer to avoid tear-out, drill ¼" drain holes through the bottom/base (C/D) at the four marked centerpoints on the bottom.

holes, where shown. Drill ¼" holes through the bottom and base (D) at the centerpoints, as shown in **Photo B**. Set the assembly aside.

**8** From edge-joined ¾"-thick stock planed to ½" thick, cut the long roof panel (E) and short roof panel (F) to the sizes listed,



bevel-cutting one end of each panel at 18°, where shown on **Drawing 1**. Using the 1/4" cove bit in your router, rout a cove along the opposite end of each panel on the *bottom* face. Set the panels aside.

**9** From 3/4"-thick stock planed to 1/2" thick, cut the door (G) to size. Photocopy the full-size door pattern from the *WOOD Patterns*® insert. Spray-adhere the pattern to the door. Using your bandsaw or a scrollsaw with a no. 2 reverse-tooth blade, cut and sand the top of the door to the pattern line.

Next, using your 1/8" Forstner bit, bore a hole through the door, where shown. Then, using a 1/4" round-over bit in your router, round over the *front* edge of the door. Remove the pattern using a cloth moistened with paint thinner. Using cloth-backed, double-faced tape, temporarily adhere the door to the front (A) with the 1/8" holes aligned.

### Now trim it out

**1** From 3/4"-thick stock resawn or planed to 1/4" thick, cut two 5/8"x20" blanks and

three 3/8"x30" blanks. You'll use these to form the trim parts (H through O) and fascia (P). (You may need to custom fit some of the parts for tight joints. Wherever possible, measure before cutting the parts to size.)

**2** Photocopy the full-size patterns for the front and back eave trim (H), front center vertical trim (L), front curved trim (M), side angled trim (O), and fascia (P) in the quantities indicated on the insert. Spray-adhere the patterns for parts M and P to the two 5/8"-wide blanks and the patterns for parts H, L,

## A foil-proof way to install a copper roof in 6 easy steps

You don't need the skills of a professional roofer to install an eye-catching copper roof on such small projects as a birdhouse or

child's dollhouse. Using a shingle pattern, scissors, copper foil, and tacks (see **Source**), a hammer, and an awl, here's how to do it.

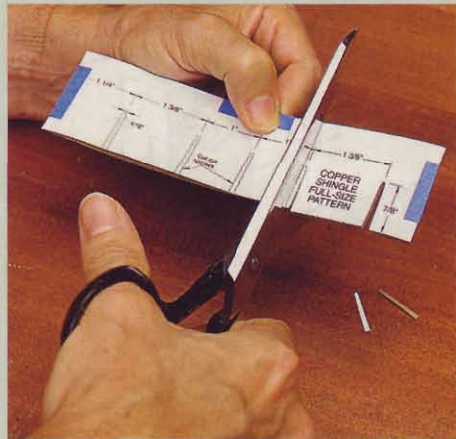

**Step 1:** Photocopy the full-size copper shingle pattern from the *WOOD Patterns*® insert. To make a template for marking notches on the shingles to form the tabs, tape the pattern to a 1 3/4 x 6 3/4" piece of cardboard. Using sharp scissors, cut out the notches, where shown on the pattern. Remove the tape and pattern.

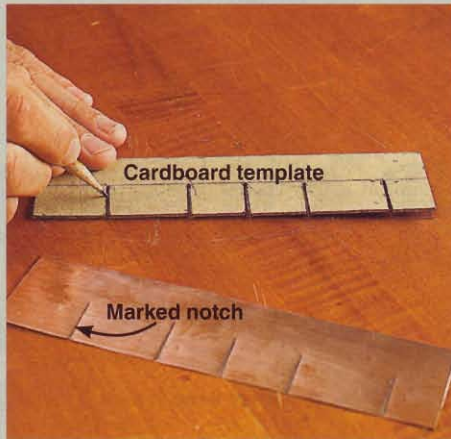

**Step 2:** From .005"-thick copper foil, cut sixteen 1 3/4 x 6 3/4" pieces for the shingles and one 2 x 6 3/4" piece for the ridge cap with your scissors. Using a sharp pencil and the cardboard template, mark the notches on 14 shingles, as shown, leaving two nonnotched shingles for the starter courses. Now cut out the notches.



**Step 3:** Position a nonnotched starter-course shingle on the long roof panel (E) flush with the bottom edge. Using an awl, punch three pilot holes for #3 x 3/8" copper cut tacks, centered along the width of the shingle, through the shingle and into the panel, as shown. Drive the tacks. Repeat for the short roof panel (F).

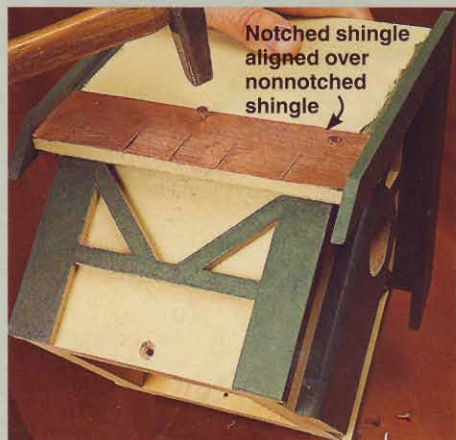

**Step 4:** Position a notched shingle over the nonnotched shingle on the long roof panel (E) with the edges aligned. Punch three pilot holes located 1/4" from the top edges of the shingles, through both shingles and into the roof panel, and drive the tacks, as shown. Repeat for the short roof panel (F).

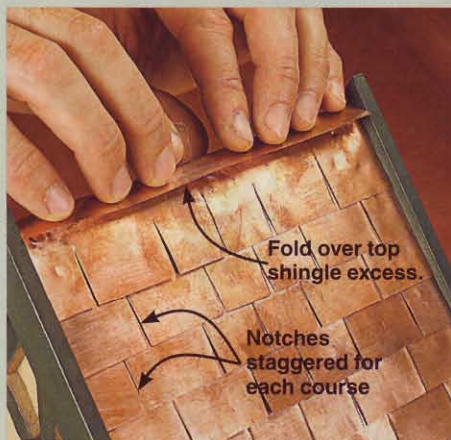

**Step 5:** Working from the bottom up on each roof panel and alternating each course end-for-end to stagger the notches, install the remaining shingles. Locate the tacks 1/4" from the *top* edge of the shingles except 1/2" from the roof peak for the top shingles. Bend over the excess material of each top shingle, as shown.

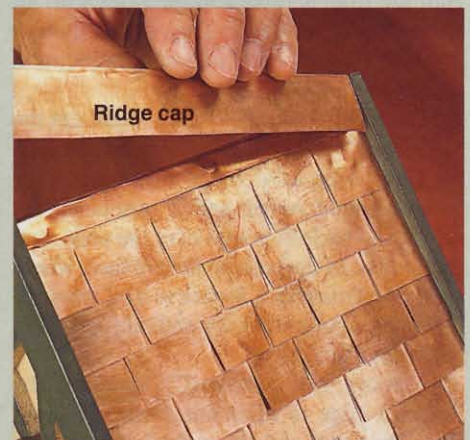

**Step 6:** Bend the ridge cap, centered along the length, to approximately 70°. Place the cap on the roof peak, as shown. Then tack the cap in place on both sides of the roof, again locating the tacks 1/2" from the peak but offsetting them slightly to avoid hitting the tacks in the top row of shingles below.

## GLUE THE TRIM IN PLACE

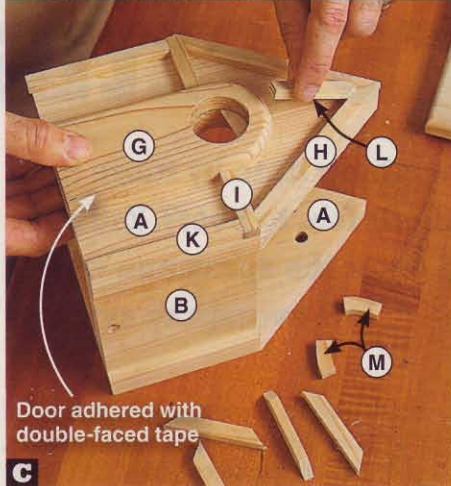

Door adhered with double-faced tape

**C** Glue the center vertical trim (L) to the front (A) with the angled top tight against the eave trim (H) and round bottom snug on the door (G).

and O to the  $\frac{3}{8}$ "-wide blanks. Bandsaw or scrollsaw the parts to shape. Then, using the remaining  $\frac{3}{8}$ "-wide blank material, cut the front horizontal trim (I), back horizontal trim (J), front and back vertical trim (K), and side horizontal trim (N) to the lengths listed. Identify the parts.

**3** Working from the top down on the front and back (A), glue the front and back eave trim (H), front horizontal trim (I), back horizontal trim (J), and front and back vertical trim (K), where shown on **Drawing 1**. Then attach the front center vertical trim (L), as shown in **Photo C**, followed by the front curved trim (M).

**4** Glue the side horizontal trim (N) to the sides (B), where dimensioned. Then glue the side angled trim (O) in place. Now secure all of the trim (H through O) with #18 $\times$  $\frac{1}{2}$ " wire brads, where shown.

**5** Glue the long and short roof panels (E, F) to the front and back (A), centering the panels front-to-back with the beveled ends together and coved ends down, where shown. Then secure the panels with 4d galvanized finish nails. (To prevent splitting the cedar, we drilled pilot holes using a 4d nail with the head snipped off.) Now glue and brad-nail the fascia (P) to the front and back edges of the roof panels, aligning the bottom edges and ensuring tight mitered corners at the top.

## Cutting Diagram

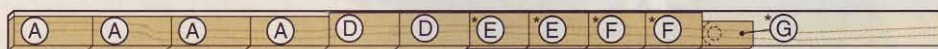

$\frac{3}{4}$  x  $3\frac{1}{2}$  x 96" Cedar (2.7 bd. ft.) \*Plane or resaw to the thicknesses listed in the Materials List.

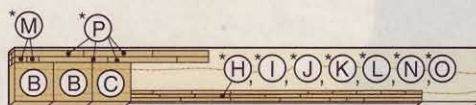

$\frac{3}{4}$  x  $5\frac{1}{2}$  x 48" Cedar (2 bd. ft.)



12 x 21" Copper foil (.005" thick)

## PAINT THE TRIM

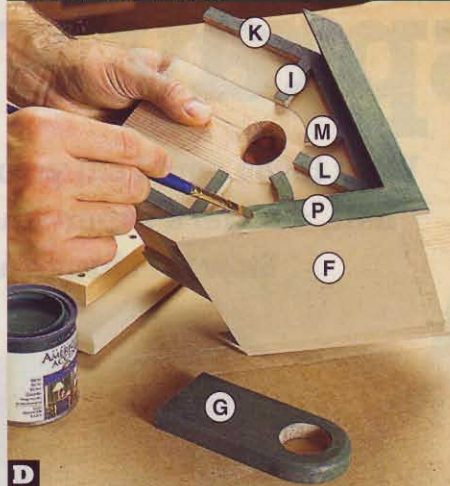

**D** Apply a contrasting paint to the front of the door (G), the faces of the trim (H through O), and all exposed surfaces of the fascia (P).

## Paint the exterior

**1** Remove the door (G) and the double-faced tape. To prevent getting paint on the interior surfaces (which is not safe for birds), cover the  $1\frac{3}{8}$ " hole in the front (A) and the top surface of the bottom (C) with easy-release painter's tape. Then reposition the door using a new piece of double-faced tape.

**2** Fill all nail holes with a weather-resistant, hardening wood putty. (We used Durham's Rock Hard Water Putty.) Sand flush when dry.

**3** Sand any areas that need it to 150 grit, and remove the dust. Then, using a color of your choice, apply three coats of paint to the house exterior and bottom/base (C/D). (We used Rust-Oleum American Accents Sand Stone aerosol paint.)

**4** Remove the door (G), double-faced tape, and all masking tape. Using a contrasting color of your choice and a small, flat artist's brush, paint the door (G), trim (H through O), and fascia (P), where shown on **Drawing 1** and as shown in **Photo D**. (We used American Accents satin finish latex paint, color Hunt Club Green, no. 7944.) After the paint dries, glue the door to the front (A).

## Add shingles, and finish up

**1** Make shingles and a ridge cap from .005"-thick copper foil, and nail them to

the long and short roof panels (E, F) with #3 $\times$  $\frac{3}{8}$ " copper cut tacks, where shown on **Drawing 1**, and as explained in the sidebar, *opposite page*. See the **Cutting Diagram** for shingle layout on a 12 $\times$ 21" piece of foil.

**2** To mount the birdhouse on a pipe, center a  $\frac{3}{4}$ " pipe flange on the base (D), where shown. Drill mounting holes, and drive #8 $\times$  $\frac{3}{4}$ " deck screws. Remount the bottom/base (C/D) to the birdhouse. Then thread a piece of  $\frac{3}{4}$ " galvanized pipe of the desired length into the flange. (You can stick the pipe in the ground or thread another pipe flange on the bottom end for mounting to a deck railing, for example.) Now keep an eagle eye out for your first inhabitants, and enjoy the activities as they settle into their stylish new home. 🐦

Written by **Owen Duvall**

Project design: **Kevin Boyle**

Illustrations: **Roxanne LeMoine**

## Materials List

Part	FINISHED SIZE			Matl.	Qty.	
	T	W	L			
A	front and back	$\frac{3}{4}$ "	6"	8 $\frac{1}{8}$ "	EC	2
B	sides	$\frac{3}{4}$ "	4"	4"	C	2
C	bottom	$\frac{3}{4}$ "	4"	4"	C	1
D	base	$\frac{3}{4}$ "	6 $\frac{3}{4}$ "	7 $\frac{1}{4}$ "	EC	1
E	long roof panel	$\frac{1}{2}$ "	6 $\frac{3}{4}$ "	6 $\frac{1}{8}$ "	EC	1
F	short roof panel	$\frac{1}{2}$ "	6 $\frac{3}{4}$ "	5 $\frac{5}{8}$ "	EC	1
G	door	$\frac{1}{2}$ "	2 $\frac{1}{2}$ "	5 $\frac{1}{4}$ "	C	1
H	front and back eave trim	$\frac{1}{4}$ "	$\frac{3}{8}$ "	5 $\frac{1}{8}$ "	C	4
I	front horizontal trim	$\frac{1}{4}$ "	$\frac{3}{8}$ "	1 $\frac{3}{4}$ "	C	2
J	back horizontal trim	$\frac{1}{4}$ "	$\frac{3}{8}$ "	6"	C	1
K	front and back vertical trim	$\frac{1}{4}$ "	$\frac{3}{8}$ "	3 $\frac{5}{8}$ "	C	4
L	front center vertical trim	$\frac{1}{4}$ "	$\frac{3}{8}$ "	2 $\frac{3}{32}$ "	C	1
M*	front curved trim	$\frac{1}{4}$ "	$\frac{1}{2}$ "	1 $\frac{1}{16}$ "	C	2
N	side horizontal trim	$\frac{1}{4}$ "	$\frac{3}{8}$ "	4"	C	2
O	side angled trim	$\frac{1}{4}$ "	$\frac{3}{8}$ "	2 $\frac{1}{2}$ "	C	4
P	fascia	$\frac{1}{4}$ "	$\frac{5}{8}$ "	7 $\frac{1}{8}$ "	C	4

\*Part initially cut oversize. See the instructions.

**Materials key:** EC—edge-joined cedar, C—cedar.

**Supplies:** Waterproof glue; 4d galvanized finish nails (20); #8 $\times$  $\frac{3}{4}$ " deck screws (4) and #8 $\times$ 1 $\frac{1}{4}$ " deck screws (4); spray adhesive; cloth-backed, double-faced tape; #18 $\times$  $\frac{1}{2}$ " wire brads; easy-release painter's tape; weather-resistant, hardening wood putty; small, flat artist's brush; #3 $\times$  $\frac{3}{8}$ " copper cut tacks; .005"-thick copper foil, 12 $\times$ 21";  $\frac{3}{4}$ " pipe flange;  $\frac{3}{4}$ " galvanized pipe (length to suit).

**Blade and bits:** No. 2 reverse-tooth scrollsaw blade, 1 $\frac{3}{8}$ " Forstner bit,  $\frac{1}{4}$ " round-over and  $\frac{1}{4}$ " cove router bits.

## Source

**Copper roof kit:** Contains enough .005"-thick copper foil and #3 $\times$  $\frac{3}{8}$ " copper cut tacks for one birdhouse. Order kit no. 5085, \$9.99 plus shipping and handling. Call or click Meisel Hardware Specialties; 800/441-9870; meiselwoodhobby.com.

# HVLP spray systems

What if you could cut your finishing time by more than half, and get a super-smooth finish, to boot? You can! Stow that brush and enter the spray age with a low-overspray system.

If you've never tried your hand at spray finishing, it's never been easier, cleaner, or safer, thanks to high-volume, low-pressure (HVLP) sprayers. Why spray? You complete more work in less time; benefit from fast-drying finishes that are far less susceptible to nibs from settling dust, such as water-base, lacquer, and shellac; and consistently produce smooth results. And, as your spraying skills improve, you can use techniques like toning and shading (adding color between finish coats) that bring depth and sophistication to your finishes.

You could get those results using a conventional spray gun powered by an air compressor. But they operate at high pressure and create a hazardous fog of overspray. As much as 80 percent of the finish that leaves a conventional spray gun bounces back off your workpiece, and winds up on every exposed surface, including the shop floor, walls, shelves, and tools.



## GOT HVLP?

If you already own an HVLP spray system, check out professional finisher Paul Snyder's tips for getting the most from it on *page 78*.

HVLP sprayers, on the other hand, use a large volume of air at low pressure to break up, or *atomize*, the stream of finish leaving the nozzle into a fine mist. This method greatly reduces finish bounce-back, saving you both money and time cleaning up.

To earn the HVLP designation, a spray gun must transfer at least 65 percent of the finish to the surface, but transfer rates upward of 80 percent are possible. That's far more efficient than a conventional sprayer, but it still leaves plenty of finish fogging the air. So wear a respirator approved for the material you're spraying and work in an area where overspray won't cause problems. Always supply adequate fresh air when spraying, and of course, don't spray flammable, solvent-based materials where a spark or pilot light could ignite the volatile vapors.

### Turbines trump conversion guns in the HVLP game

HVLP sprayers come in two forms: Conversion guns and turbine-powered sprayers. Like conventional spray guns, conversion guns atomize finish with air supplied by a compressor, and that air must be filtered of both water and oil to avoid contaminating the finish. Conversion guns require 5–25 CFM (cubic feet per minute) of air to work well. To put that demand into perspective, a 30-gallon compressor typically can power a lower CFM gun adequately, but it takes an

80-plus-gallon model to supply enough air for the hungriest guns. That makes conversion guns better suited for large-scale spraying operations.

Turbine systems, on the other hand, provide a complete, self-contained, portable package that includes the gun, air supply (the turbine unit), and hose. The air from the turbine is dry and clean so it doesn't require water or oil filters. For those reasons, and because they nicely simplify the spray-finishing operation, we prefer the turbine systems to conversion guns.

Our test includes ten HVLP turbine spray systems ranging in price from \$100 to \$800. With that much difference in price, you might expect huge differences in performance. Actually, every system we tested will spray a smooth, consistent coating—a few systems could spray any woodworking finish we poured into the cup without thinning—but most require thinning the heaviest-bodied finishes.

**A few systems could spray any woodworking finish we poured into the cup without thinning, but most require thinning the heaviest-bodied finishes.**

### HVLP's holy trinity: Gun, turbine, and hose

These three parts of the system, as shown and described *below*, work in concert to produce a smooth, level film on your project. Naturally, the gun and turbine impact

performance the most. A powerful turbine can't compensate for a poorly performing gun, nor can the best gun effectively atomize finish with an anemic turbine, but a restrictive or easily crushed hose can render the whole system ineffective. Let's examine each key component, one at a time.

### The spray gun: Finesse comes at a cost

To best atomize a finish, three spray-gun adjustments must be balanced: *fluid flow* (the amount of finish leaving the gun), *air-flow* (the amount of air exiting the spray cap), and *fan width* (how broad or narrow a pattern the gun can spray). All of the tested spray guns use the same method to adjust the fluid flow: A knob on the gun controls how far the needle can retract into the nozzle when the trigger is pulled. The deeper the needle goes, the more fluid flows into the air stream, and the more the airflow required to atomize it.

Too much airflow, though, leads to excessive bounce-back and overspray. So, to control airflow, most HVLP turbine systems use a valve either in the air line, as shown at *far left*, or on the gun. Instead of an air valve, the Turbinaire 1235GT has a knob on the turbine unit that changes the speed of the motor to vary air output. Although basically a nice feature, we like having the air control at the gun end of the hose: It saves walking back to the turbine, which should be placed as far as possible from the spraying operation.

Low-cost systems usually don't have an air-control valve, so atomization is controlled only by fluid flow and fan width (which we'll cover shortly). Give credit to Campbell Hausfeld here: CH's \$200 model HV2002 is the only system under \$600 we tested that includes an air control.

**HOW A TURBINE-POWERED SPRAYER WORKS:** A powerful fan (1) inside the turbine unit draws room air through the filter (2), removing dust and airborne overspray. That air travels via the hose (3), in some cases through an in-line air-control valve (4), and then to the gun (5). Some of that airflow is diverted to pressurize the cup (6), which contains finish. Pulling the trigger retracts the needle (7) in the nozzle (8), flowing the pressurized finish up through the pickup tube (9) and into the path of the airflow from the turbine, which leaves the gun through the horns (10) in the spray cap. The rushing air performs three asks: It siphons finish from the cup, atomizes the finish into tiny droplets, and delivers the finish to your workpiece.



## YOUR BIGGEST AND SMALLEST FAN



The best HVLP spray guns allow you to adjust the fan width from a maximum of 12" (top photo) down to about 1" (bottom photo), or anywhere in between (center photo), by simply rotating a knob at the rear of the gun.

Fan width makes up the third part of the atomization equation. Spraying a 12"-wide swath (see photos, *above*) uses more finish than a 5"-wide stripe, so narrowing the spray pattern while reducing the fluid flow helps a weak turbine better atomize a heavy-bodied finish without thinning.

All of the tested guns can spray about a 1" round pattern by simply rotating the air cap to a 45° angle. That's fine for small projects, but you wouldn't want to spray a large one, such as an entertainment center, in 1" swaths. So most guns also provide another method

of narrowing the flat fan: either turning a knob at the rear of the gun, or loosening the air cap. (You can also narrow the fan width by moving the gun closer to the surface being sprayed.)

We like the knob adjustment, found on the Accuspray 23i-T and the Turbinaire, best. By turning the knob in small increments ( $\frac{1}{4}$ – $\frac{1}{2}$  turn) and doing a test spray, we found we could quickly and easily adjust the fan from its widest setting all the way down to about 1" wide.

Loosening the air cap to change the fan width proved less effective in our tests. As the air cap moves away from the nozzle, air flows more freely, resulting in a drop in both air pressure and fluid flow. That means the finish will need to be thinned so it can spray at the lower pressure. The Capspray CS8100 and Wagner 2900 did a better job of controlling the fan width, with less thinning, than the ApolloSpray 800, Fuji Q3, or Campbell Hausfeld HV3500. Once again, lower-cost systems lack here. The Campbell Hausfeld HV2002, Rockler 61577, and Wagner 2400 don't have a fan width adjustment feature other than rotating the air cap 45° or changing the distance from the surface.

## Four more things to look for in great guns

•**Nonbleeder.** In a bleeder-style gun, air from the turbine flows (or "bleeds") through the gun all the time, whether or not the trigger is pulled. This constant airflow helps keep the turbine motor cooler, extending its life, but also can stir up dust or blow across a sprayed surface and distort the film surface. We prefer non-bleeder guns, where the air only flows when the trigger is pulled. With these models, an opening in the air line or the turbine unit relieves air pressure to keep the turbine from overheating.

•**Check valve.** All of the tested systems come with a siphon-feed gun, which uses some of the air from the turbine to pressurize the cup and help deliver fluid to the nozzle. If you tilt the gun too far while spraying, finish can block this small air supply, stopping the spray. The Accuspray, Apollo, CapSpray, Fuji, Turbinaire, and Wagner 2900 use a one-way check valve in the tube between the gun and the cup to prevent finish from getting inside the gun body, where it is difficult to clean out.

•**Multiple air ports.** A bottom-mounted hose keeps the gun better balanced in-hand, but a rear-mounted

hose lets you get the gun into tighter spaces, such as inside cabinets. To keep options open, we like a gun with air ports in both places—the unused port is capped, and moving the hose mount takes only a few seconds and a wrench.

•**Easy air cap adjustments.** To change the fan pattern from vertical (the setting for spraying a wide or long project) to horizontal (for tall projects, such as a bookcase or hutch), to round (for small parts or narrow areas), you must rotate the air cap. (See photos, at *right*.) The best air caps adjust without having to loosen the retaining ring—remember, that changes the fan width on some guns—and we found the best caps on the ApolloSpray, Capspray, Fuji, and Campbell Hausfeld HV3500.

## The turbine: HVLP's power plant

An HVLP turbine is really a vacuum cleaner motor, only in reverse. A series of fans, called stages, move a lot of air at low pressure, and more stages equal greater air output (rated in cubic feet per minute, or CFM), which means better atomization. However, a number of other factors, including motor speed and the size of the turbine blades, also affect the air volume and pressure, so you can't judge a turbine only by its number of stages.

## TWO AIR PORTS ADD VERSATILITY



You can install the air hose at either the rear or bottom of some guns. Choose the bottom position for the best gun balance and the rear port for better tight-quarters access.

## CHANGE SPRAY PATTERNS WITH A TWIST



Rotating the air cap changes the fan pattern from horizontal (left) to vertical (center) to round (right). Although it can be hard to remember, here's a simple trick: The horns on the spray cap indicate the direction you move the gun when spraying. Top-to-bottom for a horizontal fan; left-to-right for a vertical fan; and a round pattern can be sprayed in any direction.

Any dust or particles in the air supply would end up in the finish, so there's a range of filtering approaches among the brands. Some opt for a single filter, others for dual filters (one for the motor-cooling air and a

finer filter for air going to the spray gun). One model (the ApolloSpray) uses high-quality filters for both air supplies.

One complaint we often hear from HVLP users is that the turbine units are noisy, and

we agree completely. True to their roots, most sound about like a shop vacuum. Fuji's Q3 is a notable exception: We found it easy to have a conversation standing right next to the turbine while it ran.

## The best systems spray through thick and thin

Finishes can range in thickness from water-thin dyes to paints that are as thick as honey. The thickness of the finish is called its *viscosity* and it is a primary consideration in achieving quality results. The higher the viscosity, the more airflow needed to atomize the finish. The HVLP systems we tested vary in their ability to spray heavy-bodied finishes without thinning.

To measure the viscosity of a finish, most spray systems come with a viscosity cup similar to the one shown at *right*. (The Campbell Hausfeld models come with a less-precise viscosity stick, and the Accuspray didn't come with any viscosity tool.) Viscosity changes with temperature (the warmer the fluid, the less thinning needed), so we conducted all of our tests with the room and fluid temperature at 70°F.

Although all of the systems we tested sprayed stain and oil-based varnish unthinned, only three models—the Accuspray, Fuji, and Turbinaire—could spray higher-viscosity finishes without thinning. The thinning percentage listed in the chart reflects the amount needed to achieve optimal atomization across the gun's full range of fan-width settings.



### HOW THICK IS TOO THICK?

To see if a finish is light-bodied enough to spray, dip the viscosity cup into the finish and time how long it takes for the cup to drain through the hole in its bottom. If it takes longer than the time listed in the system's manual, you'll need to thin before spraying.

*Note: We tested each system with the needle and nozzle that came with it. Most manufacturers offer optional needle/nozzle sets that can spray thicker materials without thinning. If you routinely spray heavier materials than a system can spray with its standard set, these optional sets make good sense.*

### THE BEST SYSTEMS REQUIRE LESS THINNING OF FINISHES

BRAND	MODEL	THINNING REQUIRED		
		Oil-based poly (1)	Lacquer (2)	Water-based varnish (3)
ACCUSPRAY	231-T	0%	0%	0%
APOLLOSPRAY	800	15%	20%	20%
CAMPBELL HAUSFELD	HV2002	15%	20%	20%
	HV3500	10%	10%	15%
CAPSPRAY	CS8100	15%	20%	20%
FUJI	Q3	0%	0%	0%
ROCKLER	61577	50%	50%	50%*
TURBINAIRE	1235GT	0%	0%	0%
WAGNER	2400	20%	30%	30%
	2900	15%	20%	20%

A Excellent  
B Good  
C Fair

Notes: 1. Minwax Fast-Drying Polyurethane  
2. Sherwin Williams Sher-Wood Lacquer  
3. Oxford Ultima Varnish

(\* ) Could only spray this material with a narrow round spray pattern.

## The hose: important but underrated

Routing air from the turbine to the gun, the hose is the final big piece of the HVLP puzzle, and a good hose has durability, flexibility, and low weight. A too-stiff hose tends to steer the gun during spraying; a more flexible hose may not return to its original shape, restricting airflow. To make this vital link both crush-resistant and maneuverable, two manufacturers supply a flexible “whip” hose with their systems. This short length of extra-pliable hose, connected between the heavy main-supply hose and the gun, provides flexibility where you need it and durability where the hose can get underfoot.

All of the hoses became more flexible as they softened from the turbine-warmed air passing through, although the Turbinaire hose felt heavier and stiffer than the others: The optional whip hose is a must with this system. We also found that hoses reinforced with a mesh resisted crushing better than the more typical coil construction. (See photo, below.)

Hose length may not seem like an important consideration, but placing

the turbine as far as possible from the spray area extends filter life by keeping it away from the overspray. It also reduces turbine noise. However, a long hose can hinder the performance of an underpowered system, so the less-expensive units come with a shorter hose, which helps keep the pressure and airflow higher.

## Top guns and turbines

We like the AccuSpray and Turbinaire systems: Both use top-quality guns that atomized clear finishes well and could spray a fan of finish anywhere from 1" to 12" wide without thinning. We also gave high marks to the quiet Fuji Q3, so if noise level is more important to you than the ability to spray a fan narrower than 5", it, too, would be a very good choice.

Those systems all run from \$750 to \$800. If you don't have that much dough to blow, the Campbell Hausfeld HV2002 atomized clear finishes nearly as well as some units that cost more than twice as much. You sacrifice gun quality and fan-width adjustability for the savings, though, and the 15-foot hose keeps the turbine unit closer to the spray area than we like. 🌳



AccuSpray 231-T



## STRONGER-LOOKING ISN'T ALWAYS STRONGER

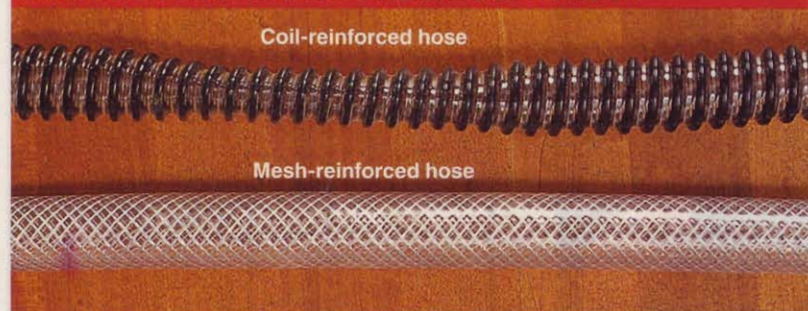

Coil-reinforced hose

Mesh-reinforced hose

Coil-reinforced hoses tended to not spring back if accidentally stepped upon. The mesh-reinforced hoses by Accuspray and Fuji flattened when stepped upon, but recovered their shape—and airflow—quickly.

## The man behind the mask

Paul Snyder, “The Finish Wiz,” is a finishing and restoration professional from Fredericksburg, Virginia. Paul teaches finishing techniques ranging from basic to master level skills, and contributed to the spray-finishing technique article on page 78. Paul's Web site, finishwiz.com, aids finishers of all skill levels.



Written by Dave Campbell with Paul Snyder

BRAND	GUN MODEL	TURBINE MODEL	GUN					
			SPRAY-GUN STYLE: (B) BLEEDER OR (N) NON-BLEEDER (1)	MINIMUM, MAXIMUM FAN WIDTH (2)	HOSE MOUNTING LOCATION (3)	VISCOSITY GAUGE INCLUDED (4)	NUMBER OF STAGES	AIR FILTERING (5)
ACCUSPRAY	10	231-T	N	1", 12"	B	N	3	D
APOLLOSPRAY	A5510	800	B	6", 12"	B/R	C	3	D
CAMPBELL HAUSFELD	HV2002		B	N/A	R	S	2	S
	HV3500		B	5", 12"	B/R	S	3	D
CAPSPRAY	Maxum II	CS8100	N*	3", 12"	B/R	C	3	D
FUJI	XT	Q3	N	5", 12"	B/R	C	3	C
ROCKLER	61577		B	N/A	R	C	1	S
TURBINAIRE	BNB	1235GT	N*	1", 12"	B	C	3	D
WAGNER	FineSpray 2400		B	N/A	R	C	1	S
	NB	Soft-Spray 2900	N*	3", 12"	R	C	4	D

- NOTES:
- As shipped from factory.  
(\*) Can be converted to bleeder.
  - With finish thinned for best atomization over full range of widths.  
(N/A) No fan-width control. Sprays 9–10" fan, or turn air cap to 45° for a narrow, round pattern.
  - (B) Bottom of gun  
(R) Rear of gun  
(B/R) Both bottom and rear of gun

Turbinaire 1235GT



Campbell Hausfeld HV2002



TEN HVLP SYSTEMS UNDER THE GUN

TURBINE	HOSE	PERFORMANCE GRADES (6)											WARRANTY (YEARS)	COUNTRY OF ASSEMBLY (13)	SELLING PRICE (14)	COMMENTS	MORE INFO:
		LENGTH (FEET)	WHIP HOSE: (INCLUDED, OPTIONAL, OR UNAVAILABLE)	EASE OF ADJUSTING AIRFLOW	EASE OF ADJUSTING FAN WIDTH	QUALITY OF GUN CONSTRUCTION	STAIN, OIL-BASED VARNISH (8)	LACQUER (10)	WATER-BASED VARNISH (9)	AIR FILTRATION	TURBINE NOISE LEVEL (11)	HOSE: RESISTANCE TO CRUSHING					
30	I	A	A	A	A	A	A	A	B	C	A	1	U	750	This feature-packed system sprayed anything we put in the cup without thinning, making it one of the top performers. One minor peeve: The hose can't be remounted at rear of gun for tight-quarters spraying.	800/618-6860 accuspray.net	
24	I	A	B	A	A	B	B-	B-	A	C	B	2	U	745	A good system with high-quality filters for both spraying and cooling air. Whip hose and dual mounting locations make the gun maneuverable. The Teflon-lined cup eases clean-up.	888/900-4857 hvlp.com	
15	O	A	N/A	C	A	B	B-	B-	C	C	B	3	U	200	Good spray performance from an economical system, but the viscosity stick gave inconsistent readings when thinning. Short hose keeps turbine close to spray area, where filter can foul.	800/626-4401 chpower.com	
25	O	A	B	B-	A	B+	B+	B	C+	C	B	5	U	600	Sprayed as well as more expensive units, and shares such features as rear or bottom hose mounting and in-line airflow valve. We'd toss the viscosity stick and get a cup for reliability.	800/292-4637 spraytechinc.com	
30	U	A	A-	A	A	B	B-	B-	B	B	B	1	U	825	This system sports unique features, such as external adjustment for the pickup tube and a light that warns when the turbine filter is clogged. Middle-of-the-pack spray performance.	800/650-0930 fujispray.com	
25	I	A	B-	A	A	A	A	A	B-	A	A	2	C	750	We didn't need to thin any tested finish to spray it well with this super-quiet system. The turbine's filter can be difficult to replace (it fits inside the unit). Hose was somewhat stiff until it warmed.	800/279-4441 rockler.com	
15	U	N/A	N/A	C-	A	C-	C-	C-	C	B	B	1	T	100	Except for stain and oil-based varnish, we had to thin every finish 50 percent before this low-dough unit could spray it. Short hose keeps turbine close to spray area, where air filter can foul.	800/866-4857 turbinaire.com	
25	O	B	A	A	A	A	A	A	B-	C*	B	3	C	800*	No thinning was needed to spray any finish we tried. Hose felt stiffer than others (get the optional whip), and airflow adjustments are back at the variable-speed turbine, which could be 25' away.	800/328-8251 wagnerspraytech.com	
20	U	N/A	N/A	D	A	B-	C+	C+	C	C	B	1	U	100	Bare-bones, all-plastic gun and a lightweight turbine unit. Sprayed a little better than the \$100 Rockler. The hose "press-fits" onto both the turbine and the gun, and could pop loose.	800/328-8251 wagnerspraytech.com	
25	U	A	B	B	A	B	B-	B-	B-	C	B	1	U	580	Similar in performance to the ApolloSpray for less money. But you'll forfeit the whip hose, and Apollo's filter is superior.		

- 4. (C) Cup
- (N) None
- (S) Stick

- 5. (C) Combination filter: Single filter for spray air and cooling air
- (D) Dual filters: Separate filters for spray air and cooling air
- (S) Only spray air filtered

- 6. **A** Excellent
- B** Good
- C** Fair
- D** Poor
- N/A** No adjustment on this gun

- 7. The amount of thinning required to get good fluid flow and atomization over the full range of fan widths using the needle/nozzle set provided.
- A** No thinning required
- B** 10-20% thinning required
- C** 30-50% required

- 8. Minwax Stain, Waterlox Varnish
- 9. Minwax Fast-Drying Polyurethane
- 10. Sherwin Williams Sher-Wood Lacquer
- 11. Oxford Ultima Varnish
- 12. (\*) Noise level improves at lower turbine speeds.
- 13. (C) Canada
- (T) Taiwan
- (U) United States

- 14. Prices current at time of article production, and do not include shipping, where applicable.
- (\*) Available with single-speed turbine (Model 1135GT) for \$700.



# HVLP: the way to spray

Using an HVLP sprayer, you can apply a smooth, consistent finish on large projects in minutes instead of hours and enjoy options you never dreamed possible, such as lacquers and toners.

By delivering finish with a wide stream of slow-moving air—slower than a high-pressure gun, that is—HVLP systems produce less overspray waste. That means less finish carried away on a breeze when spraying outdoors, and less fumes and stray finish when spraying indoors.

Whether you're a weekend woodworker or a full-time pro, there's a system out there for you, as shown in the HVLP roundup on page 72. Whichever one you choose, use these pointers, then practice on scrap before taking aim at your next project.

With a high-volume, low-pressure sprayer you'll apply smoother finishes with less mess. Here's how.



## Set the stage for spraying

Spraying solvent-based finish indoors creates unwelcome odors at best and, at worst, poisonous or flammable fumes. If you'll spray indoors somewhere other than a spray room

ventilated by an explosion-proof fan, stick with waterborne finishes.

Start by preparing a work area with adequate ventilation. Fresh air should enter the spray area from behind you, pass over your

project in the same direction you're spraying, and carry away fumes and overspray. That's true whether you spray waterborne finish in a basement with a ventilation fan or apply lacquer outdoors in a mild breeze.

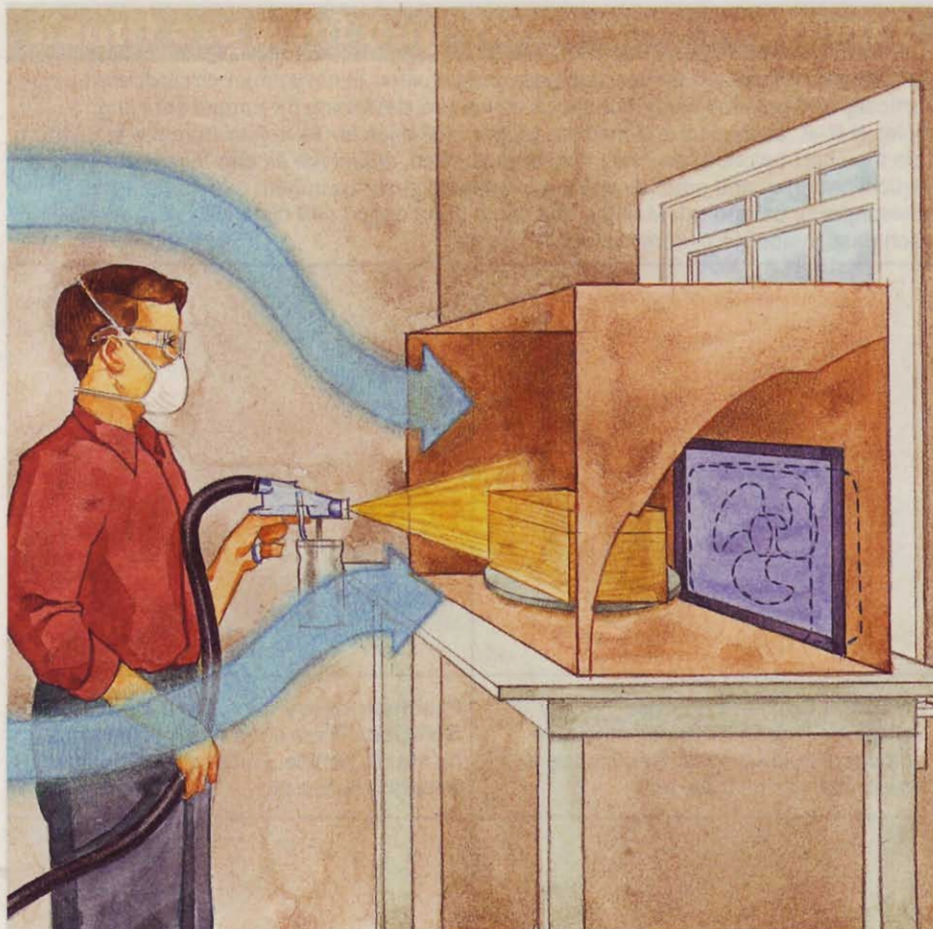

An economical setup similar to this will let you spray waterborne finishes indoors. Fresh air should enter the spray booth—fashioned from a discarded appliance carton—from behind you and be drawn away by a fan directing fumes through an open window. A replaceable furnace filter taped in front of the fan traps much of the overspray.

For outdoor spraying, choose a shaded location away from gusty breezes carrying dirt or dust, such as from a gravel driveway. See where the wind will carry overspray, and then check a thermometer and hygrometer. Spray in temperatures between 60° and 90° and humidity less than 55 percent.

Indoors, a temporary spray booth for applying waterborne finishes to small or midsize projects can be assembled for next to nothing, as shown *above*. Cut out one side of a large cardboard box to create a booth. On the opposite side of the opening, attach a box fan with a furnace filter covering the fan's air intake side. Direct air from the fan to a window or door, and make certain you have a source of clean fresh air entering the spray booth to replace the exhaust air.

To create a spray area for larger projects, place your filtered fan directly against an open window or door in a dust-free area. Hang clear plastic tarps from the ceiling on both sides of the spray area and anchor them to the floor.

For a clear look at your progress as you spray, place at least one adjustable light fixture near your booth or temporary spray

area. Angle the light to help you spot any drips, contaminants, or missed areas. Halogen lamps produce a light color close to that of sunlight.

**Think through the order in which you'll spray each surface. Divide the project into "A," "B," and "C" areas, with an "A" being the most conspicuous surface. Spray in reverse order from "C" to "A."**

While spraying, you'll need access to your project from all sides without marring the finish by touching it. So place small projects on scrap or cardboard that can be rotated within the spray booth. A lazy-susan turntable makes this even easier. To rotate larger projects, mount swivel casters on plywood to make a more sizeable turnable platform.

**FILTER FINISH BEFORE SPRAYING**



**A** Spray-gun nozzles clog quickly unless you strain out bits of debris and dried finish. Use a fine-mesh cotton filter for thin-body materials, such as lacquers, and a medium filter for most thick-body paints.

**Customize your finish**

An HVLP sprayer's air stream does two things: It atomizes the finish, creating droplets fine enough to level out for a smooth surface. It then directs this mist toward the object you're finishing.

With an HVLP sprayer's limited air pressure, thick finishes, such as latex paint, resist being atomized more than water-based dyes or thinned lacquer. The less powerful your HVLP sprayer, the more thinning your finishes will require.

Begin customizing your finish by removing lumps and debris using a medium-mesh paper filter, as shown in **Photo A**. If your sprayer comes with a viscosity cup, like the one shown in **Photo B** next page, measure the time it takes for a full viscosity cup to drain and compare that with the manufacturer's recommendations, if any. If your sprayer lacks a viscosity cup, thinning recommendations, or both, use trial and error to determine which viscosities work best. Here's how:

Determine the right viscosity by filling the spray gun cup half-way with a measured amount of finish, such as 12 ounces. Set the fluid and air flows to their maximums and adjust the fan pattern as wide as possible. Spray in one spot to see if the unthinned finish will flow through the gun and be adequately atomized by the air stream.

If the finish atomizes coarsely or not at all, thin the contents 5 percent with the appropriate solvent for your finish. Test this mix for fine atomization, and continue thinning in increments of 5 percent until you achieve the thickest fluid that still atomizes well.

## TEST BEFORE SPRAYING



**B** Most viscosity cups measure viscosity using the time it takes a finish to flow through them. Make certain the viscosity cup is filled before you start timing the runout.

Test the finish, thinned or not, with a narrower fan pattern, reducing the fluid flow until the droplets of finish atomize as well as on the wide fan setting. You'll seldom need to turn down the air flow unless you're spraying a narrow pattern. Record the type of finish and the ratio of thinner used.

Although you can thin solvent-based finishes more than 50 percent, waterborne finishes work best if thinned no more than 10 percent. If that's not sufficient, consider switching to a larger needle/nozzle set for your spray gun, if available. The larger openings allow you to spray higher-viscosity fluids, including latex paint in some cases. Less thinning also allows you to build a film finish more quickly using thicker coats.

## TLC for your HVLP

In about the time it takes to scrub a pair of paintbrushes, you can have your HVLP sprayer cleaned and ready for the next job. And unlike brushes, you can leave the finish in your sprayer for hours or sometimes overnight between coats.

While cleanup details vary by sprayer make and model, a common starting point is to disconnect the gun from the turbine unit and trigger it to allow unsprayed finish to drain back into the spray gun cup. Pour leftover finish back into its original container, and then clean the cup and the gasket with an appropriate solvent.

Adapt your cleaning routine to the type of finish you're spraying. If you sprayed lacquer, varnish, or shellac, fill the cup halfway with the solvent you would use to thin the finish. Reconnect the gun to the

## Fine-tune your spray gun for a pro finish

To dial-in your fluid and air-flow settings, hang a piece of newspaper or cardboard vertically and hold the spray gun the distance you determine for normal spraying, typically 6–8" away. Pull and hold the trigger until drips begin to flow from the fan pattern. Use the chart *below*, to evaluate the settings. Next, adjust the air cap for horizontal and vertical patterns, and practice making overlapping passes in both directions using newspaper or cardboard. Maintain the same hand speed and distance to the surface for each pass to apply a uniform amount of finish.



**Problem:** Drips at the edges

**Solution:** There's too much air for the amount of fluid sprayed. Reduce the air flow or thin the material less.



**Problem:** Heavy drips down the center

**Solution:** There's too much fluid for the air flow to handle. Reduce the fluid flow through the nozzle.



**Problem:** Light or dusty-looking spray

**Solution:** The fluid is too thick to be atomized properly. Thin as needed to improve flow and atomization.



**Congratulations.** This pattern has uniformly spaced drips along the bottom, signaling that the fluid and air are in balance for the pattern width selected.

turbine and, with the needle adjusted to allow maximum flow, spray solvent into a container until the cup is empty. Slosh the solvent around inside the cup as you work to clean the cup's top and hose.

Waterborne finishes may seem like the easiest cleanup job, but the partially cured resins within these finishes can collect and harden on the insides of fluid passages and around the air cap and needle. Start by washing the inside of the cup using soapy water, and then shoot cool, fresh water through the gun with the needle at its maximum flow setting.

After disassembling the gun, remove built-up finish on the air cap, needle, and fluid passages with soft tools, such as toothpicks or pipe cleaners, and lacquer thinner. Never use hard metal objects, such as a crafts knife, awl, or pick, to scrape or clean internal parts; they can



damage the precise size and shape of the air cap openings or needles.

Lubricate the gun according to the manufacturer's instructions. Avoid products containing silicone, which can contaminate finish and cause fish eye, or craters, where the finish refuses to settle evenly on the surface.

## Do this

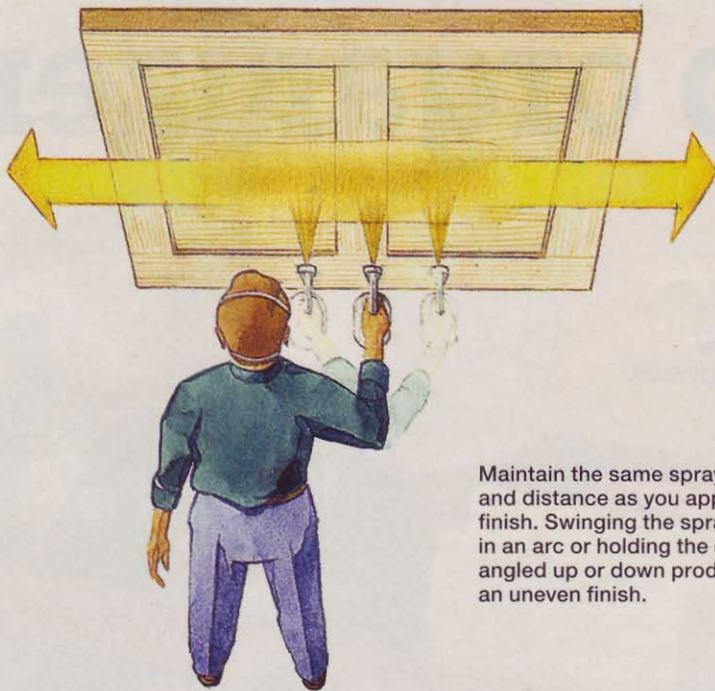

Maintain the same spray angle and distance as you apply your finish. Swinging the sprayer in an arc or holding the gun angled up or down produces an uneven finish.

## Not this

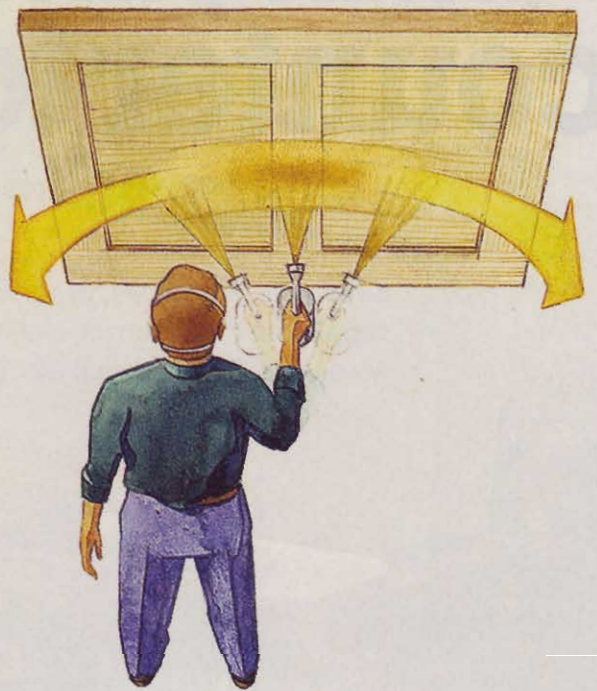

## Spray away

Think through the order in which you'll spray each surface. Divide the project into "A," "B," and "C" areas, with an "A" being the most conspicuous surface. For example, the top on a waist-high bookshelf would be an "A" surface. The less visible sides of the shelf merit a "B," and the underside of a shelf would be a "C" surface.

Spray each surface in reverse order from "C" to "A" so that overspray from the inconspicuous areas disappears beneath the finish on the high-visibility areas. For consistent results, develop a routine for each type of object you finish.

Begin each pass by triggering the gun just off the edge of your project's surface. Hold the gun a consistent distance from your project as you make your pass without angling it up or down. Avoid an arcing arm motion, as

illustrated *above right*. Release the trigger only after you've passed the edge of the surface on the opposite side.

**Don't make the mistake of spraying heavier coats on horizontal surfaces than on vertical ones just because there's less opportunity for runs.**

Always move the gun in the direction of the grain, just as you would when brushing on a finish. Overlap half of the previous pass

with your next one, as illustrated *below*. Instead of hiding brush strokes, the grain masks insufficient overlaps between spray passes that can leave stripes. Use the reflection of the angled light to make sure each pass overlaps enough to maintain a continuous wet edge. If you leave a small gap or miss a spot, respray it immediately, moving faster than normal to avoid concentrating too much finish in one spot.

Don't make the mistake of spraying heavier coats on horizontal surfaces than on vertical ones just because there's less opportunity for runs. You'll build a smoother finish by consistently spraying several light coats instead of one or two heavy coats that can run or drip. 🌿

Written by **Bob Wilson** with **Paul Snyder**

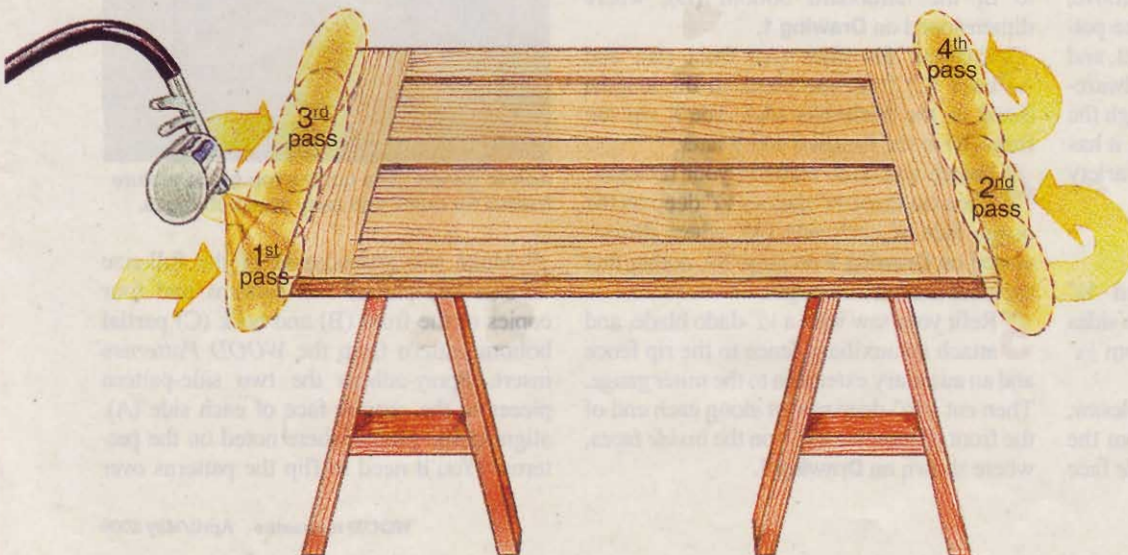

Begin each pass by triggering the gun just off the edge of the surface you're finishing, and stop spraying after you pass the opposite edge. Half the fan pattern from each pass should overlap the previous one, with the first and final passes half off the edges of the project surface.

# picture-perfect countertop organizer

Keep bills, envelopes, pens, and other supplies in this compact, clutter-busting accessory. Personalize it with a trio of photos.



**U**sing straightforward dado, groove, and rabbit joinery and full-size patterns for shaping the sides, front, and back, you can build this simple, hardware-free project in just a few hours. Although the unit occupies only  $9\frac{1}{2} \times 16\frac{1}{4}$ " of space, it has nine roomy compartments to keep a variety of items orderly and handy.

## Start with the case

**1** From  $\frac{1}{2}$ "-thick stock (we planed  $\frac{3}{4}$ " cherry), cut a  $7\frac{5}{8} \times 49$ " blank for the sides (A), front (B), and back (C). Then, from  $\frac{1}{8}$ " hardboard, cut the bottom (D) to size.

**2** Using a standard blade in your tablesaw, cut a  $\frac{1}{8}$ " groove  $\frac{1}{4}$ " deep  $1\frac{1}{8}$ " from the bottom edge of the blank on the inside face

to fit the hardboard bottom (D), where dimensioned on **Drawing 1**.

**3** Crosscut the sides (A), front (B), and back (C) from the blank to the lengths listed in the **Materials List**. You'll rip the front (B) to the finished width later.

**4** Switch to a dado blade in your tablesaw. Then cut three  $\frac{1}{4}$ " dados  $\frac{1}{4}$ " deep on the inside face of each side (A), where dimensioned on **Drawing 2** on page 84, noting that the sides are mirror images.

**5** Refit your saw with a  $\frac{1}{2}$ " dado blade, and attach an auxiliary fence to the rip fence and an auxiliary extension to the miter gauge. Then cut a  $\frac{1}{4}$ "-deep rabbet along each end of the front (B) and back (C) on the inside faces, where shown on **Drawing 1**.



Acrylic panels slide out the top of the picture frames for quick and easy photo changes.

**6** Make two photocopies of the full-size side (A) partial end patterns and four copies of the front (B) and back (C) partial bottom pattern from the **WOOD Patterns®** insert. Spray-adhere the two side-pattern pieces to the outside face of each side (A), aligning the pieces where noted on the patterns. (You'll need to flip the patterns over

## 1 EXPLODED VIEW

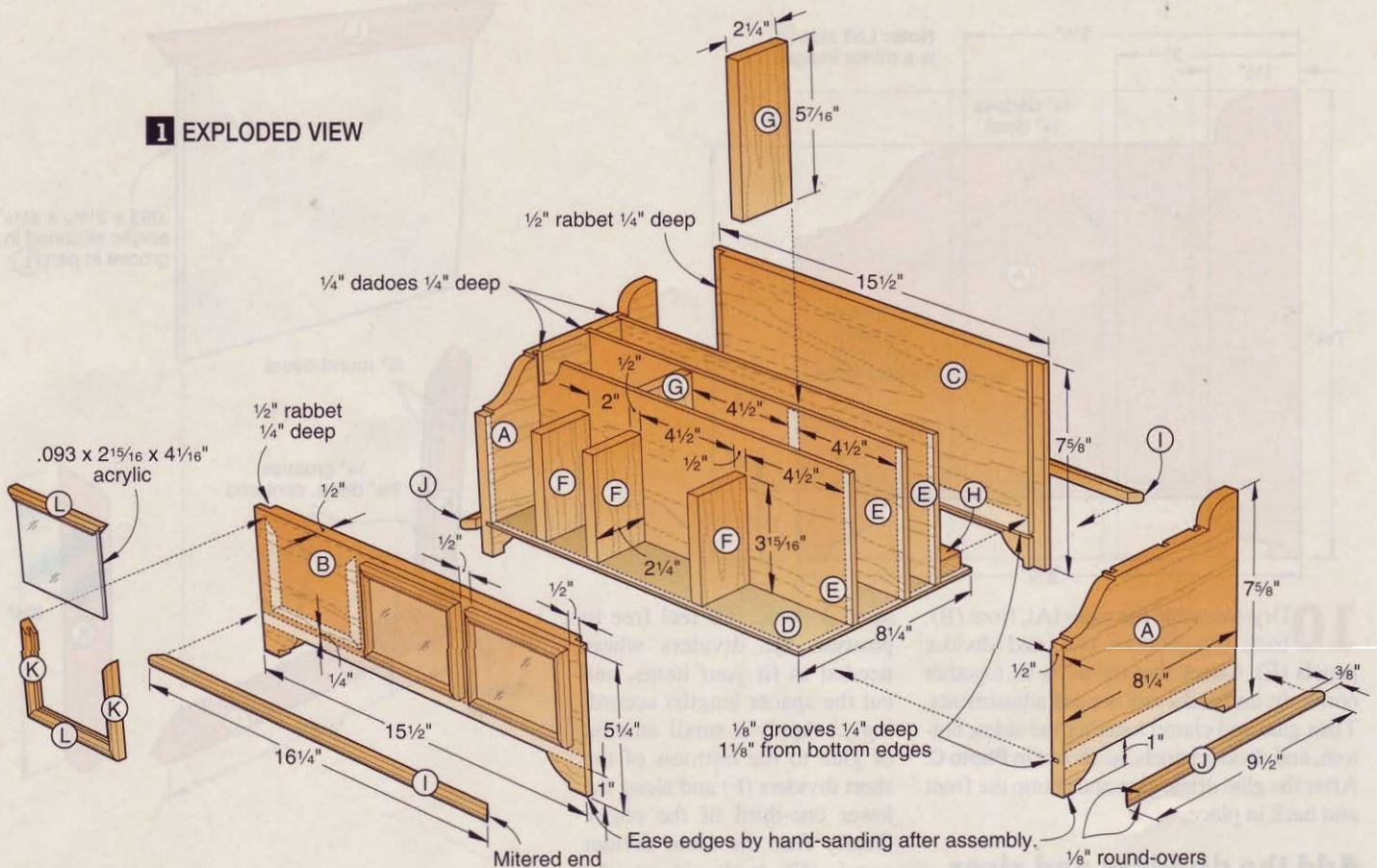

for the right side.) Then adhere two bottom patterns on the *outside* faces of the front (B) and back (C), aligned with the ends and bottom edges. (You'll need to flip the pattern over at one end of each part.) Now draw lines to connect the patterns on all of the parts.

**7** Using your scrollsaw with a #12 blade, cut the top and bottom edges of the sides

(A) to shape, as shown in **Photo A**. Then cut the bottom edges of the front (B) and back (C) to shape. Sand the parts smooth to 220 grit, clamping or taping the sides (A) together when sanding the edges to ensure identically shaped parts.

**8** To trim the front (B) to final width, flush with the top front edges of the sides (A),

fit a side into a rabbet in the front and draw a line to mark the width (height) of the side on the front, as shown in **Photo B**. Now rip the front at the marked line. (The width of our front measured 5 1/4".)

**9** From 3/4"-thick stock resawn or planed to 1/4", cut the divider panels (E) to the size listed. Sand the panels smooth.

### SCROLLSAW THE SIDES TO SHAPE

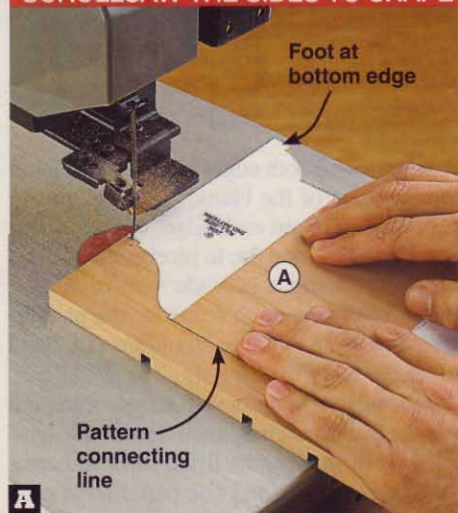

Scrollsaw along the pattern lines and marked connecting lines to cut the top and bottom edges of each side (A) to shape.

### MARK THE FRONT FINAL WIDTH

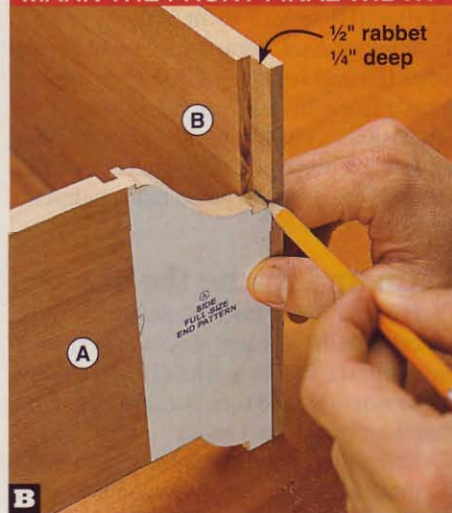

On a flat surface, fit the front end of a side (A) into a rabbet in the front (B). Mark the height of the side (final front width) on the front.

### ASSEMBLE THE CASE

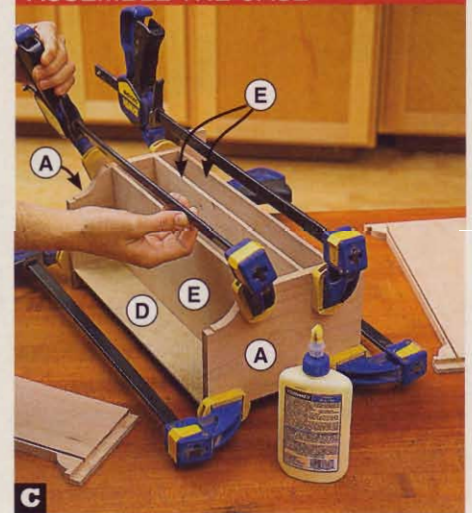

Glue and clamp together the sides (A), bottom (D), and divider panels (E), ensuring the bottom is flush with the ends of the sides.

## 2 SIDE (Inside face of right side shown)

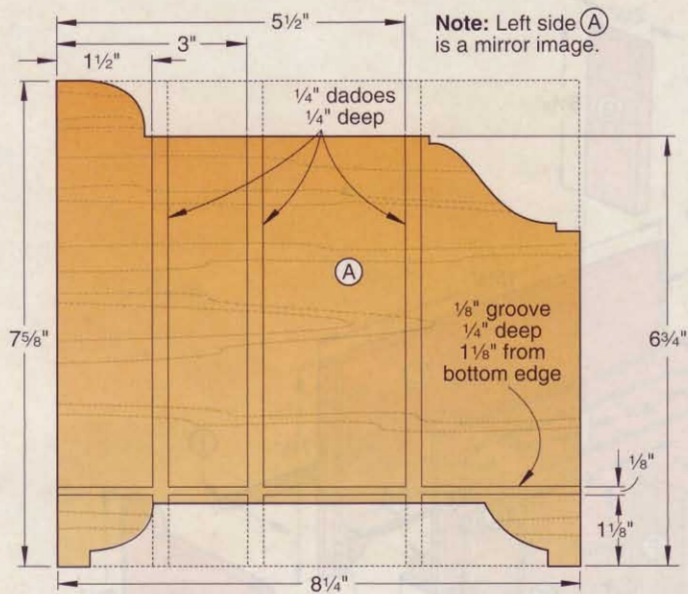

**10** Dry-assemble the sides (A), front (B), back (C), bottom (D), and divider panels (E). Check that the parts fit together correctly, and make any needed adjustments. Then glue and clamp together the sides, bottom, and divider panels, as shown in **Photo C**. After the glue dries, glue and clamp the front and back in place.

### Add the dividers and riser

**1** From 3/4"-thick stock planed to 1/2", cut a 2 1/4"x26" blank to form the short dividers (F) and tall dividers (G). Sand the blank smooth. Then crosscut three 3 1/16"-long short dividers and two 5 7/16"-long tall dividers from the blank.

**2** To install the dividers (F, G), where dimensioned on **Drawing 1**, cut one 2"-long and two 4 1/2"-long spacers from 3/4"

scrap 3" wide. (Or feel free to position the dividers where needed to fit your items, and cut the spacer lengths accordingly.) Apply a small amount of glue to the bottoms of the short dividers (F) and along the lower one-third of the edges. Gently flex the front divider panel (E) back, insert the dividers and three spacers, and release the panel. Now clamp the panel and the front (B) together to sandwich the dividers in place. Remove the spacers. In the same way, glue the tall dividers (G) in place between the front two divider panels (E), where dimensioned, using the 4 1/2" spacers.

**3** From 3/4"-thick stock, cut the riser (H) to size to fit into the compartment between the rear divider panel (E) and back (C). (The riser elevates items placed in the rear compartment for best visibility.) Sand the riser smooth. Then apply a few drops of glue to the bottom face, and slide the riser into place, tight against the bottom (D).

### Trim and frame the case

**1** From 3/4"-thick stock planed to 3/8" thick, cut a 3x30" blank to make the front/back base trim (I), side base trim (J), and picture-frame sides (K) and tops/bottoms (L), where shown on **Drawings 1** and **3**.

**2** Using a 1/8" round-over bit in your table-mounted router, round over both edges of the blank. Then rip a 3/8"-wide strip from each edge. You'll use these strips for the base trim (I, J).

### GLUE THE BASE TRIM IN PLACE

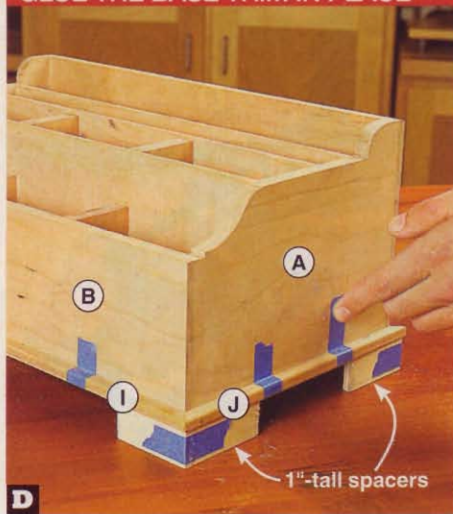

**D** Use 1"-tall spacers to position the front/back base trim (I) and side base trim (J) on the case. Glue and tape the trim pieces in place.

## 3 PICTURE-FRAME EXPLODED VIEW

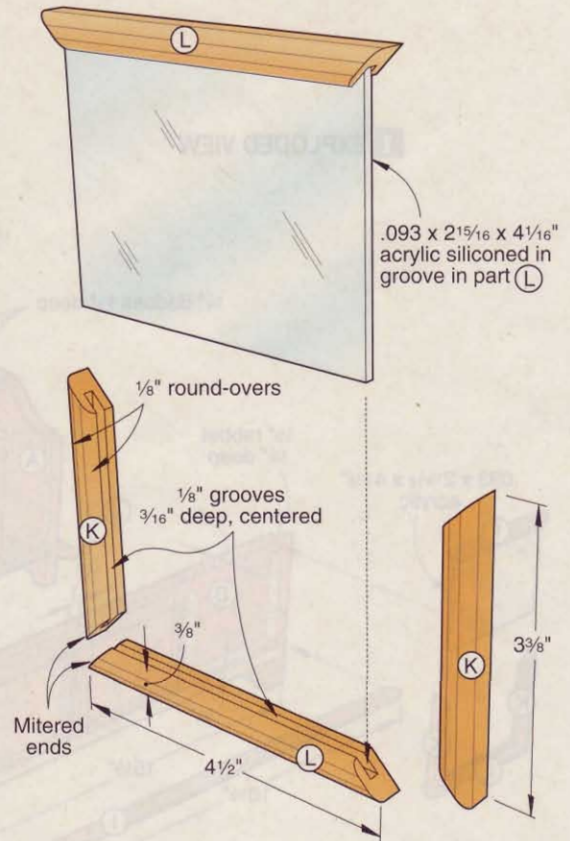

### 3a PICTURE-FRAME TOP DETAIL

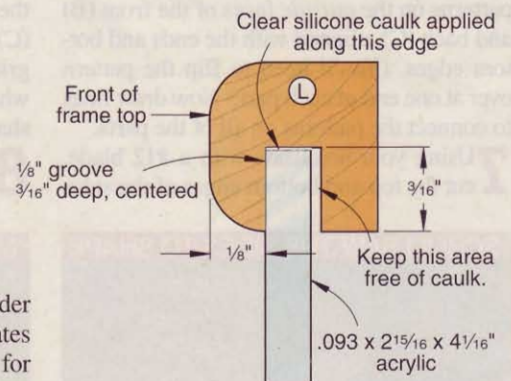

Next, round both edges of the blank again. On one face of the blank, cut a 1/8" groove 3/16" deep 1/8" from each edge, where dimensioned on **Drawing 3a**, to receive .093"-thick acrylic. Now rip a 3/8"-wide strip from each edge. You'll use these strips for the picture-frame sides (K) and tops/bottoms (L). Sand all of the strips to 220 grit.

**3** From the nongrooved strips, miter-cut the front/back base trim (I) and side base trim (J) to the lengths listed to fit the case, cutting one part I and one part J from each strip. (We cut parts I to length first, and then cut parts J to the lengths needed to form tight mitered corners with parts I.) Using 1"-tall

# Assemble and mount the picture frames in 3 easy steps

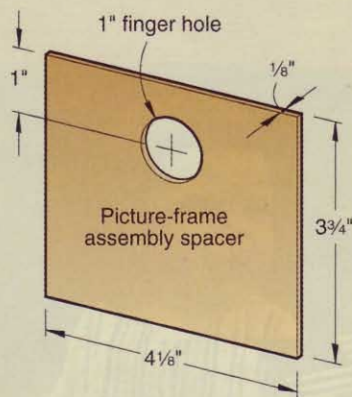
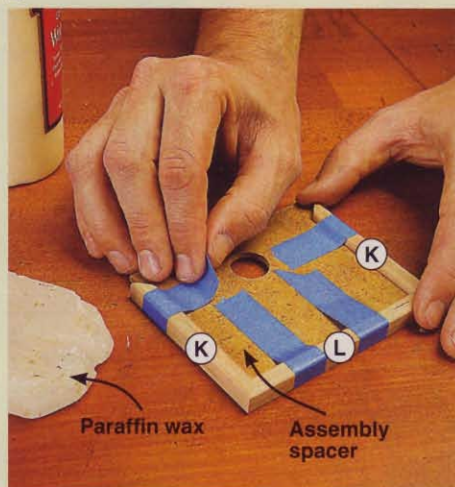

**Step 1:** From 1/8" hardboard, make the picture-frame assembly spacer, shown on the drawing. To prevent parts from sticking to the spacer, rub the edges of the spacer with paraffin wax. Then glue, assemble, and tape two picture-frame sides (K) and a bottom (L) to the spacer to square the frame, as shown. Repeat to assemble the remaining two frames.

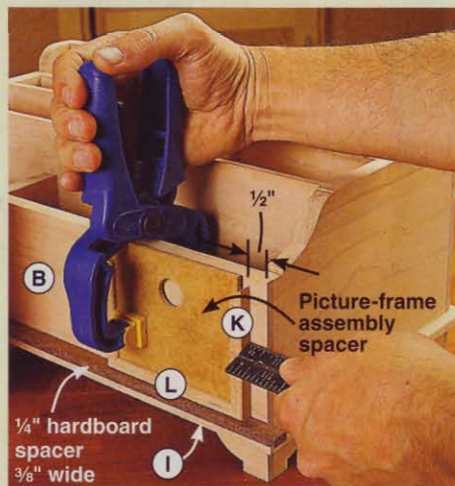

**Step 2:** Using a 3/8"-wide strip of 1/4" hardboard as a spacer on top of the front base trim (I) and the picture-frame assembly spacer as a clamping aid, glue and clamp a frame (K/L) to the case front (B), 1/2" from the right end, as shown. Repeat to glue a frame at the other end of the case front. Then glue the remaining frame in place, centered between the outer frames.

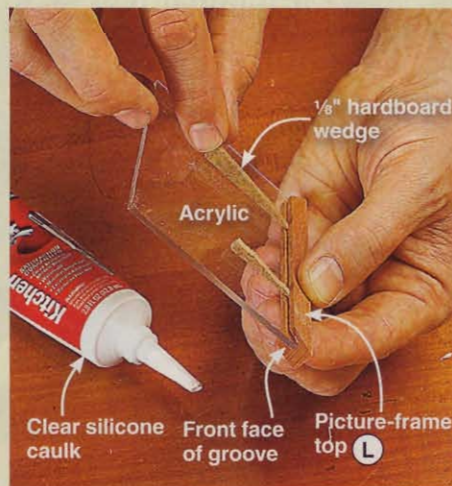

**Step 3:** From 1/8" hardboard, cut six wedges (two per frame top) to temporarily hold the .093x2 1/16x4 1/16" acrylic pieces in position in the picture-frame tops (L), as shown. Apply a small bead of clear silicone caulk to a long edge of each acrylic piece, and wedge the acrylic, centered end to end, in the grooves, tight against the front faces. After the silicone cures, remove the wedges.

## Cutting Diagram

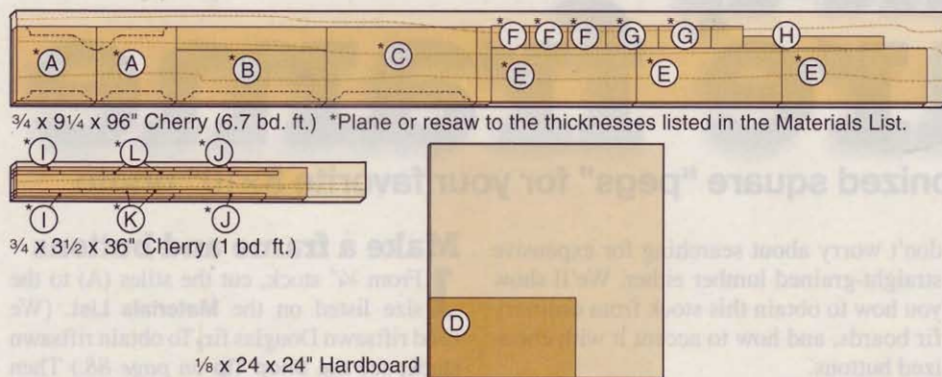

spacers and easy-release painter's tape, glue and tape the trim to the case, as shown in **Photo D**. After the glue dries, remove the tape and spacers.

**4** From the grooved strips, miter-cut the picture-frame sides (K) and tops/bottoms (L) to the lengths listed. Then, from .093"-thick acrylic, cut three 2 1/16x4 1/16" pieces for the picture frames using your table saw and a standard blade with at least 40 teeth.

**5** To avoid masking the acrylic later, finish the three tops (L). (We applied two coats of Minwax Antique Oil Finish and topcoated with two coats of Minwax water-based Polyacrylic Protective Finish, satin sheen, sanding to 320 grit between coats.) Now assemble the picture frames and mount them to the front (B), as explained at *left*.

## Finish up

**1** Sand any areas of the project that need it to 220 grit, easing the bottom edges of the case feet, where shown on **Drawing 1**. Remove the dust. Then apply oil and finish as you did for the picture-frame tops (L).

**2** Finally, trim three favorite photos to match the size of the acrylic. Insert the photos into the grooves in the tops (L) behind the acrylic, secure the photos at the bottom with a small piece of clear tape, and slide the acrylic into the frames. Now fill your picture-esque organizer with stationery, bills, notices, pens, and more. 📌

Written by **Owen Duvall**  
Project design: **Jeff Mertz**  
Illustrations: **Roxanne LeMoine; Lorna Johnson**

## Materials List

Part	FINISHED SIZE			Matl.	Qty.
	T	W	L		
A* sides	1/2"	7 7/8"	8 1/4"	C	2
B* front	1/2"	5 1/4"	15 1/2"	C	1
C* back	1/2"	7 7/8"	15 1/2"	C	1
D bottom	1/8"	8 1/4"	15"	H	1
E divider panels	1/4"	5 1/2"	15"	C	3
F* short dividers	1/2"	2 1/4"	3 1/16"	C	3
G* tall dividers	1/2"	2 1/4"	5 7/16"	C	2
H riser	3/4"	1 1/4"	14 1/2"	C	1
I* front/back base trim	3/8"	3/8"	16 1/4"	C	2
J* side base trim	3/8"	3/8"	9 1/2"	C	2
K* picture-frame sides	3/8"	3/8"	3 3/8"	C	6
L* picture-frame tops/bottoms	3/8"	3/8"	4 1/2"	C	6

\*Parts initially cut oversize. See the instructions.

**Materials key:** C—cherry, H—hardboard.

**Supplies:** Spray adhesive; easy-release painter's tape; paraffin wax; .093x2 1/16x4 1/16" acrylic (3), available at your local hardware store or home center; clear silicone caulk.

**Blades and bit:** Dado-blade set, #12 scrollsaw blade, 1/8" round-over router bit.



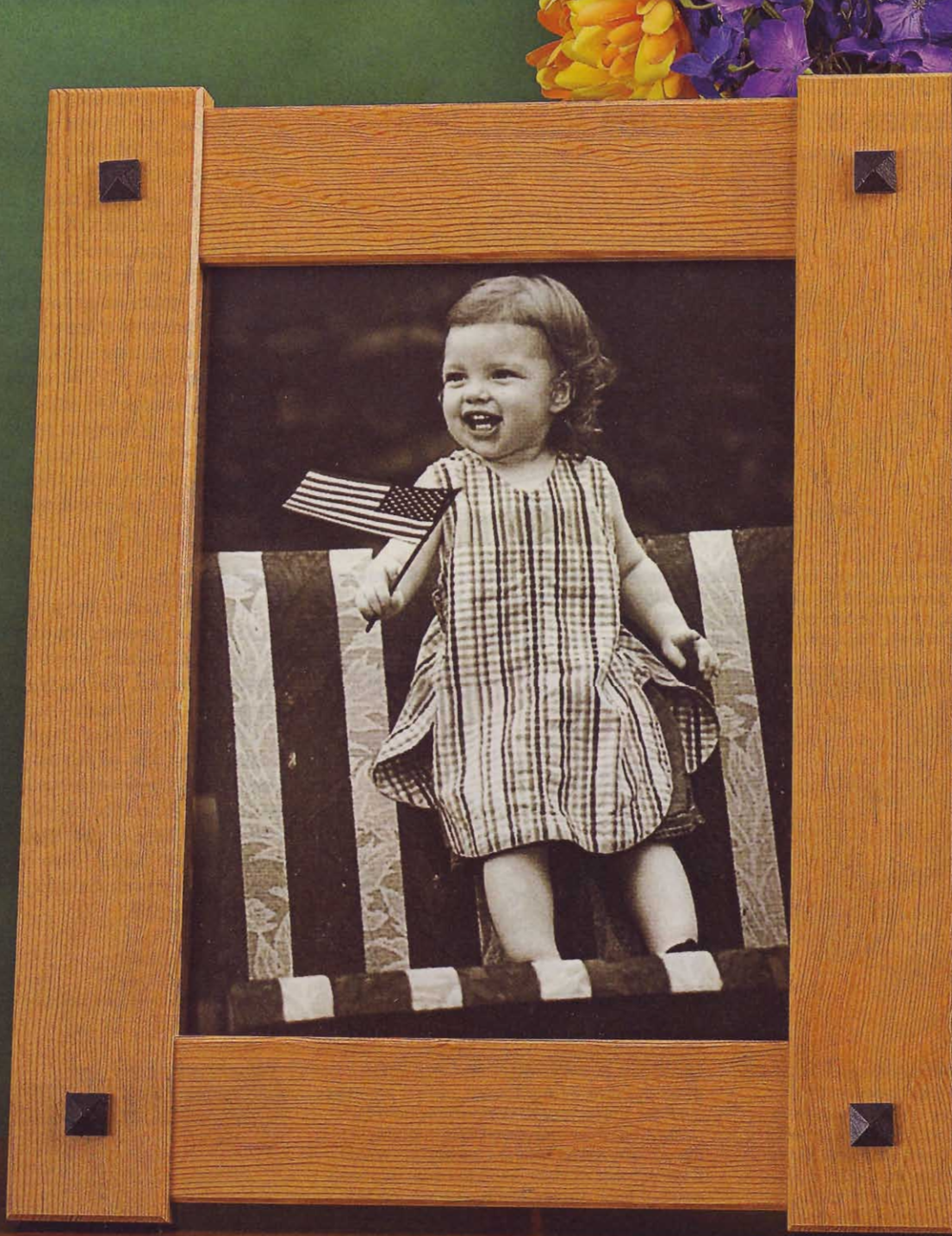

# buttoned-up picture frame

Riftsawn grain and ebonized square “pegs” for your favorite 8×10” photo

**W**hat appear to be fussy mortise-and-tenon joints pinned with pyramid-shaped square pegs are actually easy-to-build half-laps adorned with decorative shop-made buttons. And

don't worry about searching for expensive straight-grained lumber either. We'll show you how to obtain this stock from ordinary fir boards, and how to accent it with ebonized buttons.

## Make a frame and buttons

**1** From  $\frac{3}{4}$ " stock, cut the stiles (A) to the size listed on the **Materials List**. (We used riftsawn Douglas fir. To obtain riftsawn stock, see the **Shop Tip** on page 88.) Then



To hang the frame on a wall, simply omit the stand-up leg and add a sawtooth hanger.



Turnbuttons, a flush hardboard back, and a wood leg give the back a finished look.

### 1a RAIL DETAIL (Viewed from front)

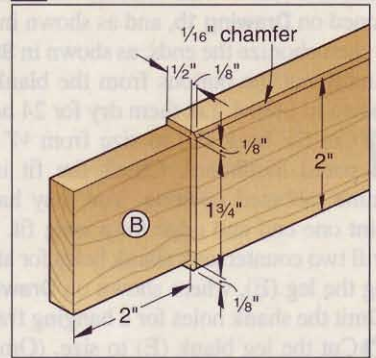

### 1b BUTTONS (4 needed)

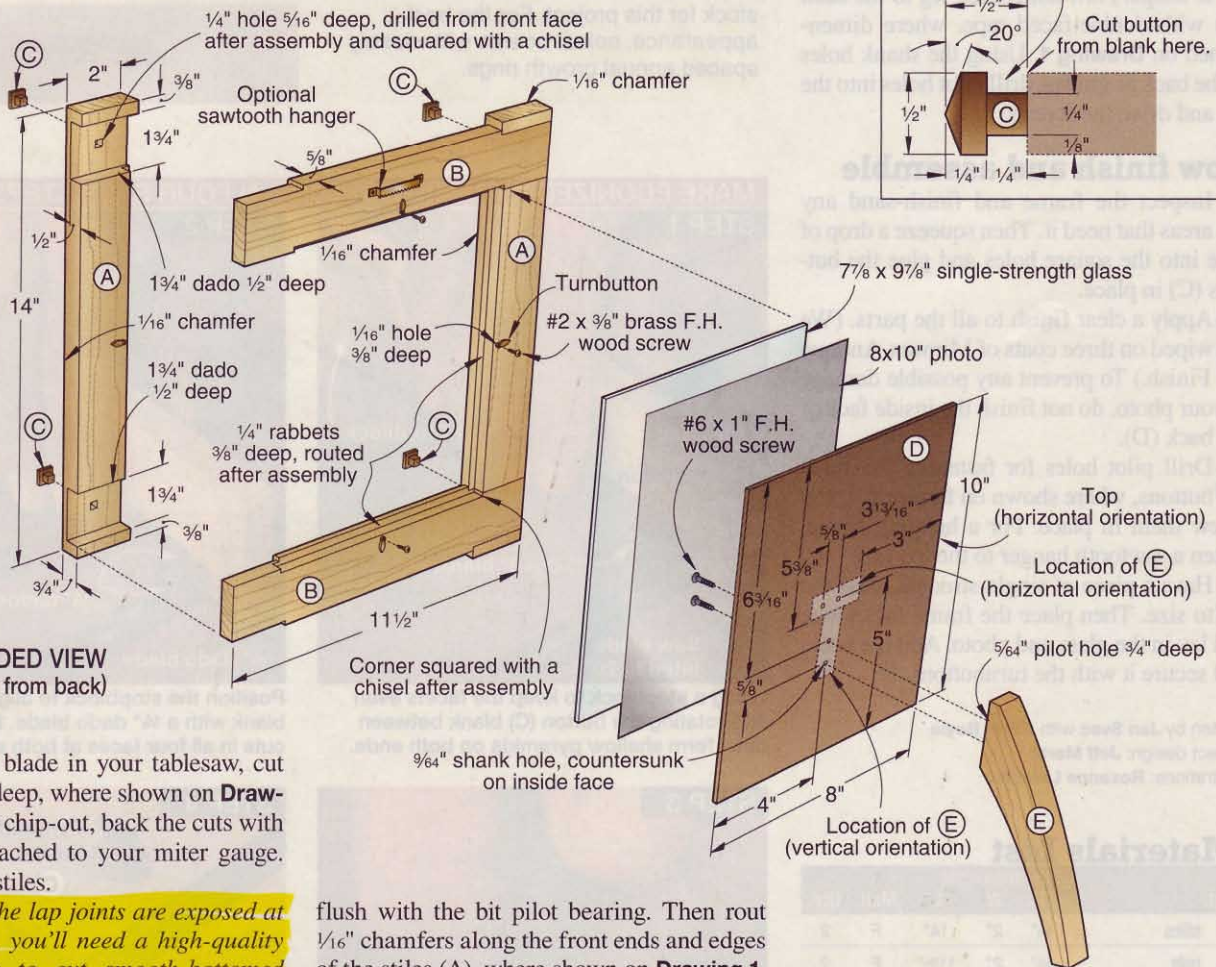
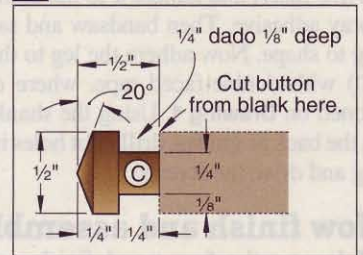

### 1 EXPLODED VIEW (Viewed from back)

with a  $3/4$ " dado blade in your tablesaw, cut  $1 3/4$ " dados  $1/2$ " deep, where shown on **Drawing 1**. To prevent chip-out, back the cuts with an extension attached to your miter gauge. Finish-sand the stiles.

**Note:** Because the lap joints are exposed at the frame sides, you'll need a high-quality stack dado set to cut smooth-bottomed dados to ensure tight glue lines. For an alternate method that compensates for a less-than-perfect dado set, see page 16.

**2** For the rails (B), plane a  $3/4 \times 2 \times 24$ " piece of stock to  $5/8$ " thick, and cut the parts to length. Adjust the dado blade in your tablesaw to cut  $1/8$ " deep, and cut three-sided tenons on the rail ends, where shown on **Drawing 1a**. Finish-sand the rails.

**3** Chuck a chamfer bit into your table-mounted router, and position the fence

flush with the bit pilot bearing. Then rout  $1/16$ " chamfers along the front ends and edges of the stiles (A), where shown on **Drawing 1**, and the front edges of the rails (B), where shown on **Drawing 1a**. Now glue and clamp the frame.

**4** With the glue dry, chuck a  $1/4$ " rabbet bit into your table-mounted router, and rout a  $3/8$ "-deep rabbet along the frame inside rear edges, where shown on **Drawing 1**. Then square the rabbeted corners with a chisel.

**5** Chuck a  $1/4$ " brad-point bit into your drill press and drill  $5/16$ "-deep holes at each corner, centered on both the stiles (A) and

rails (B), where shown on **Drawing 1**. Then square the holes with a  $1/4$ " chisel to fit the square shanks of the buttons (C).

**6** For the buttons (C), cut two  $1/2 \times 1/2 \times 8$ " blanks. (We used walnut.) Tilt your tablesaw blade  $20^\circ$  from vertical. Attach an extension to the miter gauge to back the cuts, and clamp a stopblock to the extension to position the blanks. Then bevel both ends of each blank to form pyramids, as shown in

**Step 1, below, right.** Now switch to a dado blade and cut 1/4"-wide dados, where dimensioned on **Drawing 1b**, and as shown in **Step 2**. Next ebonize the ends, as shown in **Step 3**. Finally cut the buttons from the blanks, as shown in **Step 4**. Let them dry for 24 hours.

**7** Cut the back (D) to size from 1/4" tempered hardboard. Check the fit in the frame rabbeted opening. You may have to joint one end and edge for a snug fit. Then drill two countersunk shank holes for attaching the leg (E), where shown on **Drawing 1**. (Omit the shank holes for a hanging frame.)

**8** Cut the leg blank (E) to size. (Omit the leg for a hanging frame.) Make a photocopy of the **Leg Pattern** on the **WOOD Patterns®** insert and adhere it to the blank with spray adhesive. Then bandsaw and sand the leg to shape. Now adhere the leg to the back (D) with double-faced tape, where dimensioned on **Drawing 1**. Using the shank holes in the back as guides, drill pilot holes into the leg and drive the screws.

## Now finish and assemble

**1** Inspect the frame and finish-sand any areas that need it. Then squeeze a drop of glue into the square holes and glue the buttons (C) in place.

**2** Apply a clear finish to all the parts. (We wiped on three coats of Minwax Antique Oil Finish.) To prevent any possible damage to your photo, do not finish the inside face of the back (D).

**3** Drill pilot holes for fastening the turnbuttons, where shown on **Drawing 1**, and screw them in place. For a hanging frame, fasten a sawtooth hanger to the top rail.

**4** Have a piece of single-strength glass cut to size. Then place the frame facedown, and lay in the glass and photo. Add the back, and secure it with the turnbuttons. 🐿

Written by **Jan Svec** with **Kevin Boyle**  
Project design: **Jeff Mertz**  
Illustrations: **Roxanne LeMoine**

## Materials List

Part	FINISHED SIZE				Matl.	Qty.
	T	W	L			
A stiles	3/4"	2"	14"	F	2	
B* rails	5/8"	2"	11 1/2"	F	2	
C* buttons	1/2"	1/2"	1/2"	W	4	
D back	1/4"	8"	10"	H	1	
E leg blank	3/4"	1 1/2"	6 3/4"	F	1	

\*Parts initially cut oversize. See the instructions.

**Materials key:** F—Douglas fir, W—walnut, H—tempered hardboard.

**Supplies:** Black permanent felt-tip marker, spray adhesive, double-faced tape, #2x3/8" brass flathead wood screws, #6x1" flathead wood screws, turnbuttons, single-strength glass, sawtooth hanger (optional).

**Blade and bits:** Stack dado set, 1/4" rabbet and chamfer router bits, 1/4" brad-point bit.

## SHOP TIP

### Cut riftsawn parts from ordinary plainsawn boards

Selecting the straight, even figure of riftsawn grain for narrow parts, such as the stiles and rails of cabinet doors and picture frames, greatly enhances the overall appearance of a project.

(Riftsawn grain meets the face of a board at angles between 30° and 60°, and displays straight grain on the edges as well as the faces of the board.)

Fortunately, you won't have to go out of your way to find this stock. Any pile of flatsawn boards contains many that exhibit ample riftsawn grain along one or both edges. As shown at *right*, an ordinary flatsawn Douglas fir 1x4 provided the narrow pieces of riftsawn stock for this project. For the best appearance, select boards with closely spaced annual growth rings.

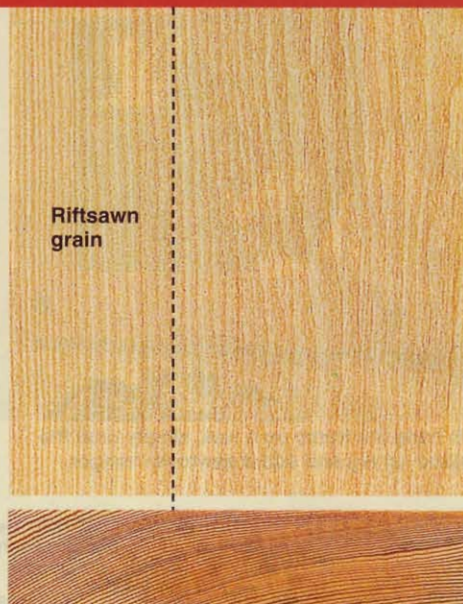

## MAKE EBONIZED PYRAMID BUTTONS IN FOUR EASY STEPS



Using a stopblock to keep the facets even and rotating the button (C) blank between cuts, form shallow pyramids on both ends.



Position the stopblock to align the button (C) blank with a 1/4" dado blade. Make 1/8"-deep cuts in all four faces at both ends of the blank.



With the buttons (C) formed but still attached to the blank, ebonize them with a black permanent felt-tip marker.

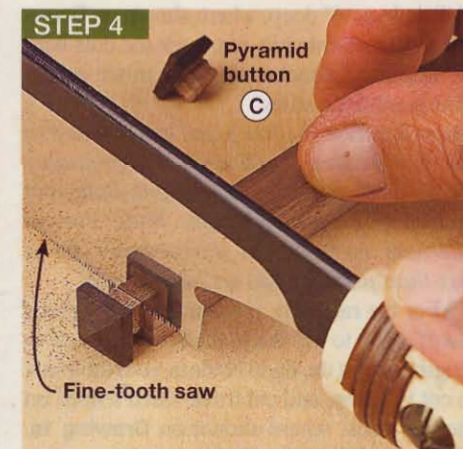

Finally, with buttons (C) formed and ebonized at both ends of the blank, separate them with a fine-tooth handsaw.

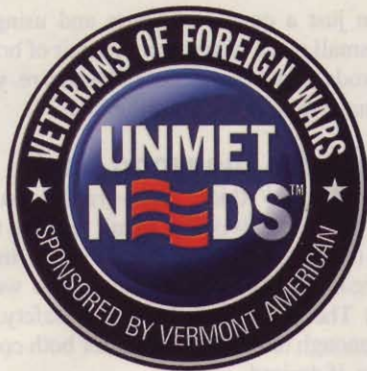

## a gift for those who serve

Help a military family  
remember a loved one  
serving in harm's way.

**W**hat can we, as woodworkers, do to help the families of men and women serving in the military? Well, you can build one or more of the picture frame shown here, so these families have a fitting way to display a photo of their loved one. (For frame-building instructions, see page 86.) Then to express your gratitude in words and identify you as the donor, go to [woodmagazine.com/unmetneeds](http://woodmagazine.com/unmetneeds) to download a temporary frame insert and a permanent label, shown above right, for the back of the frame. Send the frame(s) to:

**The Unmet Needs Program  
Picture Frame Project  
VFW Foundation  
406 West 34th Street  
Kansas City, MO 64111**

The Veterans of Foreign Wars (VFW) Foundation will identify qualified recipients and distribute the picture frames to local VFW chapters for personal delivery.



Go to [woodmagazine.com/unmetneeds](http://woodmagazine.com/unmetneeds), and download a 2½x3½" label like this one to affix to the back of the frame, and a similar 8x10" temporary insert to slip into the frame.

### About the Foundation

The Unmet Needs Program is administered by the VFW Foundation, a registered 501(c)(3) not-for-profit organization that relies on public donations. The Foundation is committed to improving the lives of veterans and service personnel, their families, and their communities. Charity Navigator, America's largest independent evaluator of charities, rates the Foundation as four out of four stars, indicating that the Foundation excels in responsibly allocating and growing its finances. For more information and VFW Foundation financial details from Charity Navigator, visit [charitynavigator.org](http://charitynavigator.org), click on the search tab, and type in "VFW Foundation." To learn more about the VFW Foundation's mission,

programs, partners, and accomplishments, visit [vfwfoundation.org](http://vfwfoundation.org).

### About the sponsor

Vermont American, a leading manufacturer of power tool accessories, partnered with the VFW Foundation to create the Unmet Needs Program. This nonprofit program provides assistance to American military families who run into financial difficulties due to deployment. To get Unmet Needs up and running, Vermont American has committed \$1.25 million over five years. When you buy Vermont American products, a portion of each purchase goes to support the Unmet Needs Program. For more information on the Unmet Needs Program, visit [unmetneeds.com](http://unmetneeds.com). 🌲

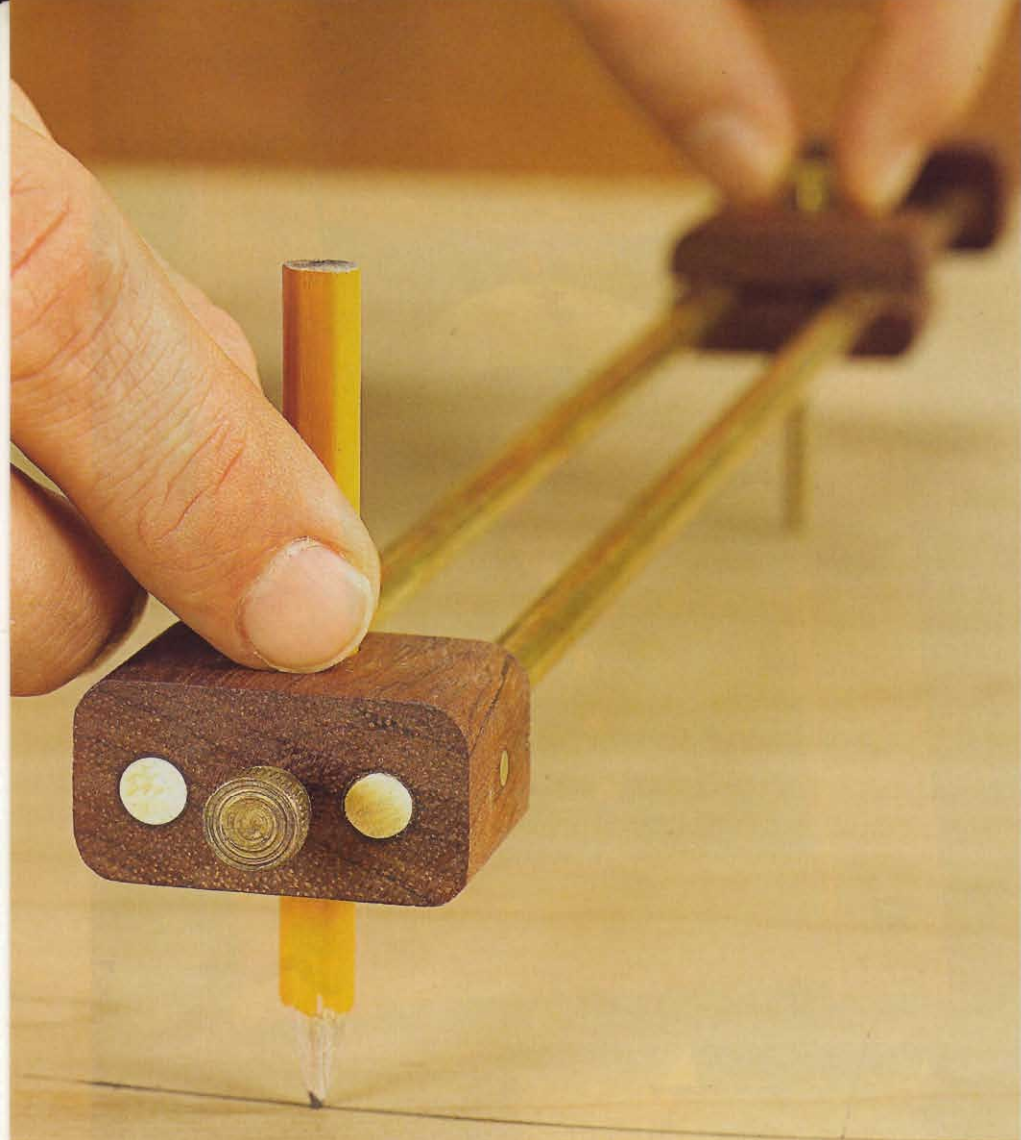

# top-brass beam compass

Draw or scribe circles and arcs precisely and easily with this handcrafted tool.

In just a couple of hours and using a small piece of hardwood, a pair of brass rods, and a few pieces of hardware, you can make this classic marking tool.

## Start with the wood parts

**1** From a  $\frac{3}{4}$ "-thick, tight-grained hardwood, cut a  $1\frac{1}{2} \times 6\frac{1}{2}$ " blank to form the head (A), pivot (B), and end (C). (We used bubinga, but cherry and walnut also work well.) The blank, lengthened for safety, is long enough to make the parts for both compasses, if desired.

**2** As appropriate, make one or two photocopies of the full-size beam compass pattern from the *WOOD Patterns*® insert. Spray-adhere the pattern(s) to a face of the blank, folding over the end(s), where shown.

**3** To drill  $\frac{1}{4}$ " holes through the blank for parts A, B, and C to receive the brass-rod beams (D), where shown on **Drawings 1** and **2**, chuck a  $\frac{1}{4}$ " brad-point bit at least 4" long in your drill press with 3" extending from the jaws. Make sure the bit's square to the table. With the blank on end against a stopblock and clamped to the drill-press fence, drill two 3"-deep holes ( $\frac{1}{8}$ " deeper than the  $2\frac{7}{8}$ "-long pattern) at the pattern centerpoints, as shown in **Photo A**. (If making both compasses, repeat this and all following operations for the other pattern.)

**4** To drill holes in the bottom of the pivot (B) for two #6-32 brass inserts to receive a knurled brass shoulder screw and threaded brass rod for the pivot pin, where shown on **Drawing 1**, switch to a  $\frac{3}{16}$ " twist bit. Then drill two  $\frac{3}{8}$ "-deep holes, where shown on the pattern and as shown in **Photo B**.

**5** Refit the drill press with a  $\frac{9}{64}$ " bit. Centering the bit in the appropriate  $\frac{3}{16}$ " hole in the pivot (B), where shown on the pattern, drill through the blank. This hole provides clearance for the #6-32 knurled brass shoulder screw that locks the pivot in place.

**6** Replace the  $\frac{9}{64}$ " bit with a  $\frac{5}{16}$ " twist bit. Now drill a hole through the head (A), where shown on the pattern, to receive a pencil or the brass scribe (E), where shown on **Drawing 1**.

**7** Using a  $\frac{1}{4}$ " round-over bit in your table-mounted router, round over each of the blank edges, where shown on the pattern and **Drawing 2** and as shown in **Photo C**.

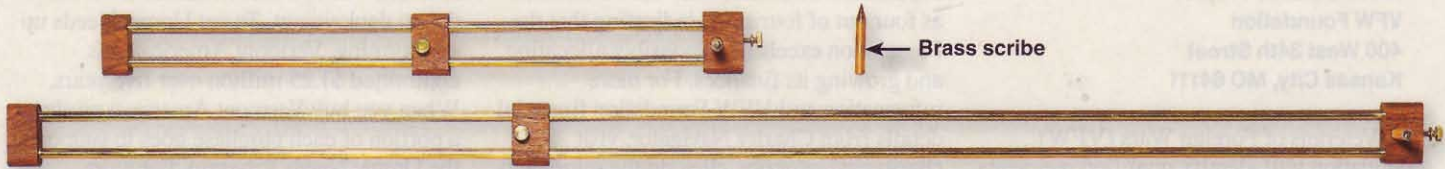

You can build the compass in two lengths. The short version marks circles from 6" to 28" in diameter; the long version works for 6" to 64" circles. The tool's head holds a pencil or brass scribe.

## 1 EXPLODED VIEW

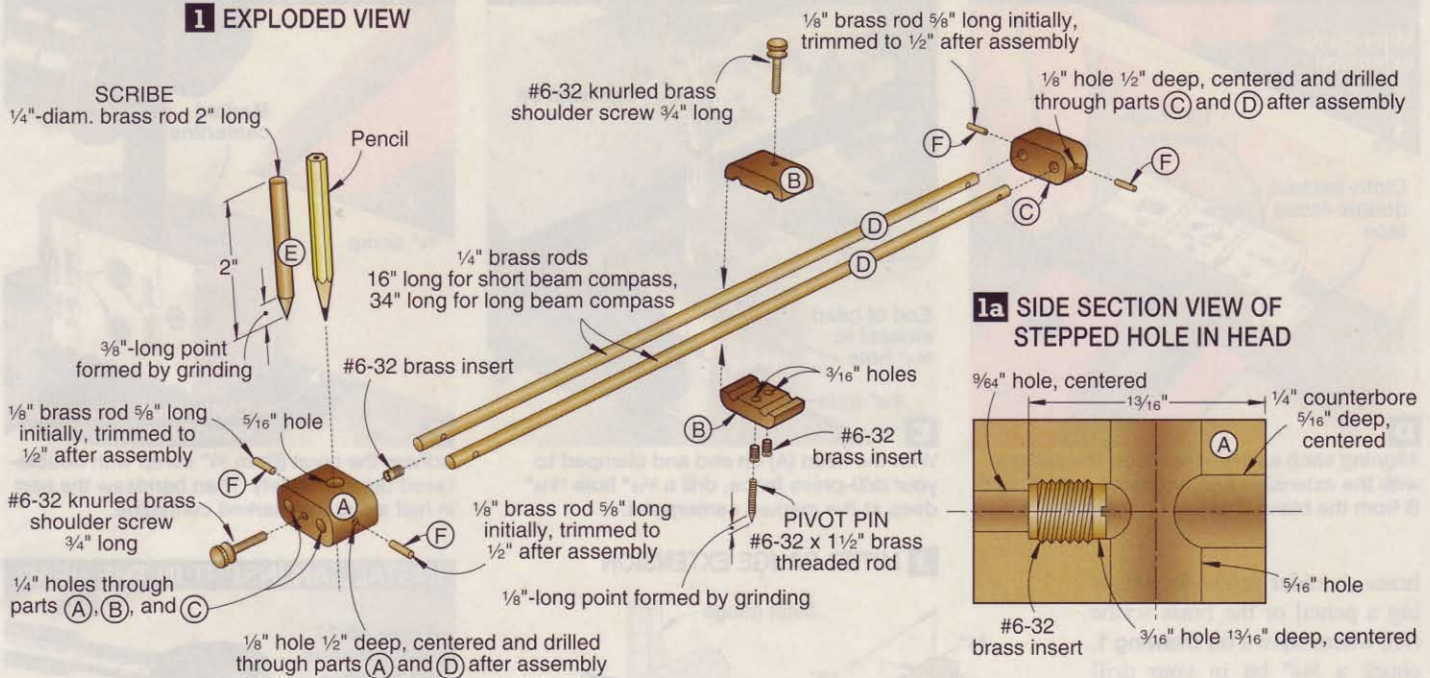

**8** To safely crosscut parts A, B, and C from the blank, make a miter-gauge extension from 3/4" scrap and 1/4" hardboard, as shown on **Drawing 3**. Screw-mount the extension to your gauge. Next, cut a 1/4"-high kerf through the extension. Adhere the blank to the extension base with cloth-backed, double-faced tape, aligning the kerf mark between parts B and C on the pattern with the extension kerf. Cut off part C, as shown in **Photo D**. Remove part C, reposition the blank to align the kerf mark between parts A and B with the extension kerf, and cut off part B. Now cut off the 1"-long part A. Sand the parts to 220 grit.

**9** To drill a stepped hole in the head (A), where shown on **Drawings 1a** and **2**, to receive a #6-32 brass insert and knurled

## 2 HEAD, PIVOT, AND END

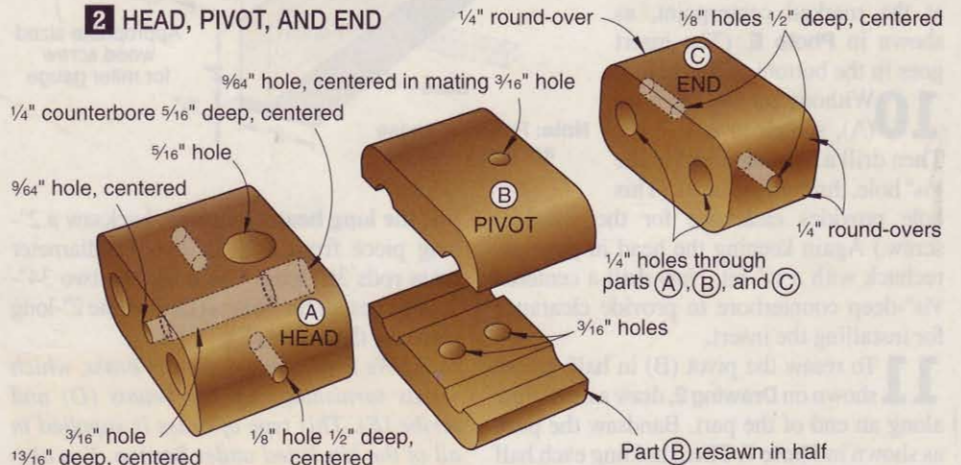

### DRILL HOLES FOR THE BEAMS

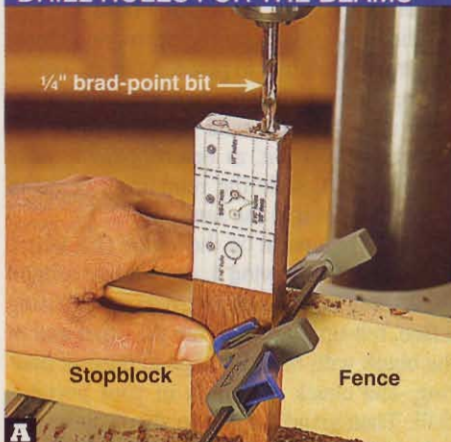

**A** Drill two 1/4" holes 3" deep into the end of the blank. For straight holes and easy drilling, raise the bit several times to clear the chips.

### NOW DRILL HOLES FOR INSERTS

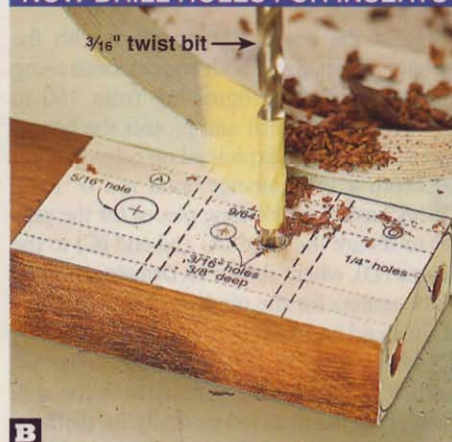

**B** Using masking tape to mark the drilling depth on the bit, drill two 3/16" holes 3/8" deep in the pivot (B) at the centerpoints on the pattern.

### ROUND OVER THE BLANK EDGES



**C** Holding the blank tight against your router table and fence with a pushblock, rout a 1/4" round-over along each edge of the blank.

## CROSSCUT THE BLANK

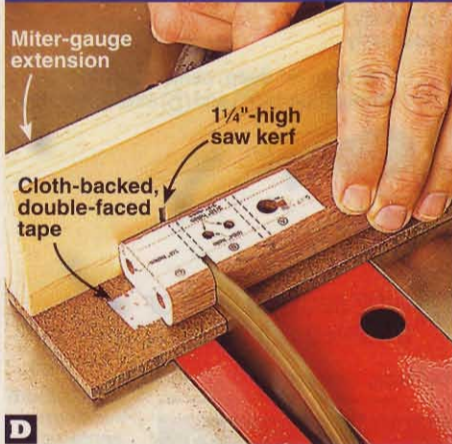

**D** Aligning each saw-kerf mark on the pattern with the extension kerf, crosscut parts C and B from the blank. Then cut off part A.

brass shoulder screw for securing a pencil or the brass scribe (E), where shown on **Drawing 1**, chuck a  $\frac{3}{16}$ " bit in your drill press. Mark the center of the end of the head closest to the  $\frac{5}{16}$ " hole. Then drill a  $1\frac{3}{16}$ "-deep hole at the marked centerpoint, as shown in **Photo E**. (The insert goes in the bottom of this hole.)

**10** Without moving the head (A), switch to a  $\frac{9}{64}$ " bit. Then drill a hole, centered in the  $\frac{3}{16}$ " hole, through the head. (This hole provides clearance for the shoulder screw.) Again keeping the head in position, rechunk with a  $\frac{1}{4}$ " bit. Now drill a centered  $\frac{5}{16}$ "-deep counterbore to provide clearance for installing the insert.

**11** To resaw the pivot (B) in half, where shown on **Drawing 2**, draw a centerline along an end of the part. Bandsaw the part, as shown in **Photo F**. Then, holding each half flat on 180-grit sandpaper, remove the saw marks from the bandsawn surfaces.

## Now work with the brass

**1** To install #6-32 brass inserts in the head (A) and pivot (B), where shown on **Drawings 1** and **1a**, thread three inserts on a #6-32x1" hexhead machine screw. Driving the screw, as shown in **Photo G**, thread an insert into the bottom of the  $\frac{3}{16}$ " hole in the head, observing your progress through the  $\frac{5}{16}$ " cross-hole. Then remove the screw, noting the two remaining inserts come out with it. In the same way, install an insert in each of the  $\frac{3}{16}$ " holes in the bottom half of the pivot.

**2** For the short beam compass, hacksaw a  $\frac{1}{4}$ "-diameter brass rod 36" long in half. Then cut a 2"-long piece off each rod. You'll use the two 16"-long pieces for the beams (D) and one 2"-long piece for the scribe (E).

## DRILL THE HEAD FOR AN INSERT



**E** With the head (A) on end and clamped to your drill-press fence, drill a  $\frac{3}{16}$ " hole  $1\frac{3}{16}$ " deep at the marked centerpoint.

## 3 MITER-GAUGE EXTENSION

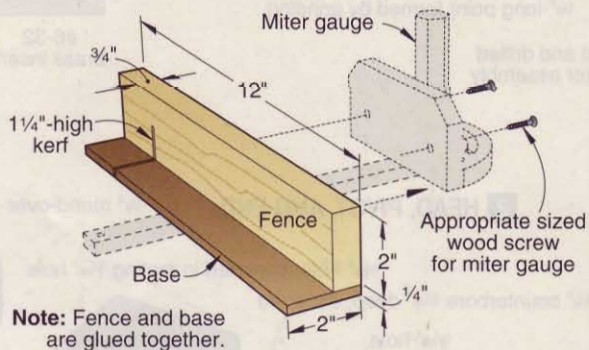

**Note:** Fence and base are glued together.

For the long beam compass, hacksaw a 2"-long piece from each of two  $\frac{1}{4}$ "-diameter brass rods 36" long. You'll use the two 34"-long pieces for the beams (D) and one 2"-long piece for the scribe (E).

**Note:** We used a naval-quality brass, which resists tarnishing, for the beams (D) and scribe (E). This type of brass is supplied in all of the kits listed under **Source**. You also can use common brass rods available at your local home center and hardware and hobby stores.

**3** Hold the beams (D) together with the ends flush. Sand both ends smooth using a sanding block, progressing from 150 to 400 grit. Now polish and protect the beams and scribe (E), as explained on page 99.

**4** From a  $\frac{1}{8}$ "-diameter brass rod 6" long, hacksaw four  $\frac{5}{8}$ "-long pieces for the pins (F) to secure the head (A) and end (C) to the beams (D), where shown on **Drawing 1**. Then mark centers for the pin holes on both edges of the head and end.

**5** Insert a beam (D) into one of the  $\frac{1}{4}$ " holes in the head (A), flush with the end. To support the head horizontally for drilling, secure the halves of the pivot (B) to the beam and 2"-long brass rod for the scribe (E) with a #6-32 knurled brass shoulder screw  $\frac{3}{4}$ "

## RESAW THE PIVOT

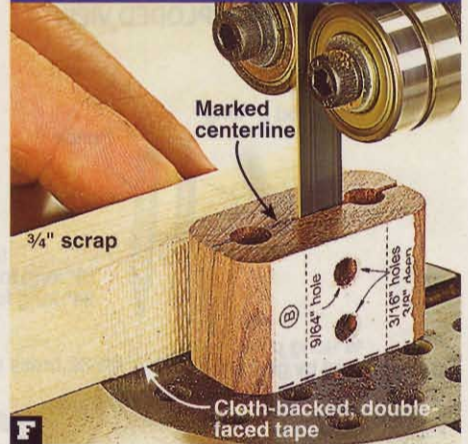

**F** Adhere the pivot (B) to  $\frac{3}{4}$ " scrap with double-faced tape for safety. Then bandsaw the part in half along the marked centerline.

## INSTALL AN INSERT IN THE HEAD



**G** Using a wrench or nut driver to turn the #6-32 hexhead screw, thread a brass insert into the bottom of the  $\frac{3}{16}$ " hole in the head (A).

long, as shown in **Photo H**. Using a  $\frac{1}{8}$ " twist bit, drill a  $\frac{1}{2}$ "-deep hole into the head and through the beam at the marked centerpoint, as shown. Lower the bit slowly so it doesn't wander when it contacts the beam.

Next, install a pin (F) in the hole with five-minute epoxy, as shown in **Photo I**. Then position the end (C) on the beam, and repeat the process to pin it in place. After the epoxy cures, hacksaw the pins to within  $\frac{1}{32}$ " of the head and end, and sand the pins flush and smooth to 400 grit, as before. Now remove the pivot (B), slide the remaining beam in place, and pin it in the same way.

**6** To form a point on the scribe (E), where shown on **Drawing 1**, draw a line around the 2"-long brass blank  $\frac{3}{8}$ " from an end using a fine, felt-tip marker. Wrap the other end of the blank with masking tape to prevent marring, and chuck the blank in your portable drill. Then grind the end to shape on an 80-grit or finer grinding wheel, as shown in **Photo J**, or on a disc or belt sander. Sand smooth to 400 grit.

## PIN THE COMPASS HEAD AND END TO THE BEAMS IN TWO EASY STEPS

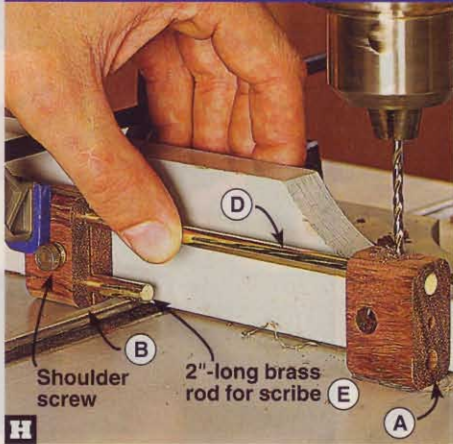

**H** Supporting the head (A) with the pivot (B) secured as shown, drill a centered  $\frac{1}{8}$ " hole  $\frac{1}{2}$ " deep into the head and through the beam (D).

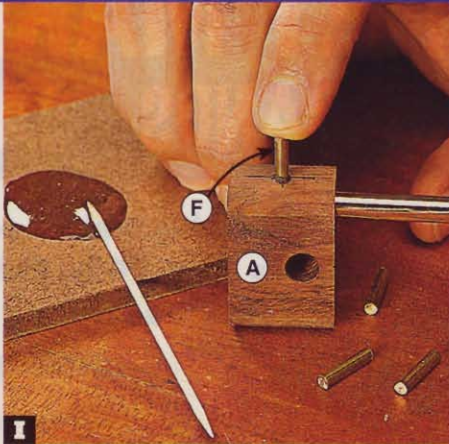

**I** Spread five-minute epoxy inside the  $\frac{1}{8}$ " hole in the head (A) with a toothpick. Then insert a pin (F) to the bottom of the hole.

## GRIND A POINT ON THE SCRIBE



**J** Using your portable drill, rotate the scribe (E) clockwise at a slow speed against a grinding wheel to form a  $\frac{3}{8}$ "-long point.

**7** From a #6-32 threaded brass rod 6" long, hacksaw a  $1\frac{1}{2}$ "-long piece to make a pivot pin for the pivot (B), where shown on **Drawing 1**. As you did for the scribe (E), grind a  $\frac{1}{8}$ "-long point on an end of the rod.

**8** Sand any areas of the head (A), pivot (B), and end (C) that need it, and remove the dust. Then apply a clear finish to the parts. (We used Minwax Antique Oil Finish.)

**9** Finally, secure the halves of the pivot (B) to the beams (D) using a #6-32 knurled brass shoulder screw  $\frac{3}{4}$ " long, where shown on **Drawing 1**. Then thread the #6-32 brass pivot pin in place in the pivot. Now thread another #6-32 shoulder screw into the head (A) for securing a #2 pencil or the brass scribe (E). Ready to make circles or arcs? See the sidebar, *below*. 🐿

## Materials List

Part	FINISHED SIZE			Matl.	Qty.
	T	W	L		
A* head	$\frac{3}{4}$ "	$1\frac{1}{2}$ "	1"	B	1
B* pivot	$\frac{3}{4}$ "	$1\frac{1}{2}$ "	$\frac{7}{8}$ "	B	1
C* end	$\frac{3}{4}$ "	$1\frac{1}{2}$ "	$\frac{3}{4}$ "	B	1
D beams	$\frac{1}{4}$ " diam.		†	BR	2
E scribe	$\frac{1}{4}$ " diam.		2"†	BR	1
F* pins	$\frac{1}{8}$ " diam.		$\frac{1}{2}$ "	BR	4

\*Parts initially cut oversize. See the instructions.

†For the short compass, one  $\frac{1}{4}$ "-diameter brass rod 36" long is needed to make two 16"-long beams (D) and a 2"-long scribe (E). For the long compass, two  $\frac{1}{4}$ "-diameter brass rods 36" long are needed to make two 34"-long beams (D) and a 2"-long scribe (E).

**Materials key:** B—bubinga, BR—brass rod.

**Supplies:** Spray adhesive; cloth-backed, double-faced tape; #6-32 brass inserts (3); #6-32 $\times$ 1" hexhead machine screw; #6-32 knurled brass shoulder screws  $\frac{3}{4}$ " long (2); five-minute epoxy;  $\frac{1}{8}$ "-diameter brass rod 6" long; #6-32 threaded brass rod 6" long; for the short compass,  $\frac{1}{4}$ "-diameter brass rod 36" long (1); for the long compass,  $\frac{1}{4}$ "-diameter brass rod 36" long (2); 3"-long pencil.

**Bits:**  $\frac{1}{4}$ " brad-point bit 4" long,  $\frac{1}{4}$ " round-over router bit.

## Source

**Beam-compass hardware kits:** Each kit contains all needed hardware, naval-quality brass rods, 3"-long pencils (2), and a #6-32 $\times$ 1" hexhead machine screw for insert installation. Order kit no. 300-BCS for the short compass, \$10.50; 300-BCL for the long compass, \$16.50; or 300-BCSL for both compasses, \$26.50. Add \$6.50 per order for shipping. Schlaubaugh & Sons Woodworking, 720 14th Street, Kalona, IA 52247. Call 800/346-9663.

**Beam-compass hardware/wood kits:** Each kit contains all of the items listed for the kits above plus a  $\frac{3}{4}\times 1\frac{1}{2}\times 6\frac{1}{2}$ " piece of bubinga. Order kit no. 300-BCSW for the short compass, \$14.25; 300-BCLW for the long compass, \$20.25; or 300-BCSLW for both compasses, \$30.25. Add \$6.50 per order for shipping. See above for address and phone number.

## Mark circles or arcs in 3 easy steps

**Step 1:** Insert a pencil or the brass scribe (E) into the  $\frac{3}{16}$ " hole in the head (A) with the pointed end extending the same length as the pivot pin from the pivot (B). Tighten the shoulder screw in the head.

**Step 2:** Loosen the shoulder screw in the pivot. Using a ruler, set the radius by positioning the pivot where needed. Tighten the shoulder screw.

**Step 3:** Align the pivot pin with a marked centerpoint on your workpiece. Holding the pivot with one hand, rotate the head (A) with your other hand. Angle the pencil a few degrees for easy marking.

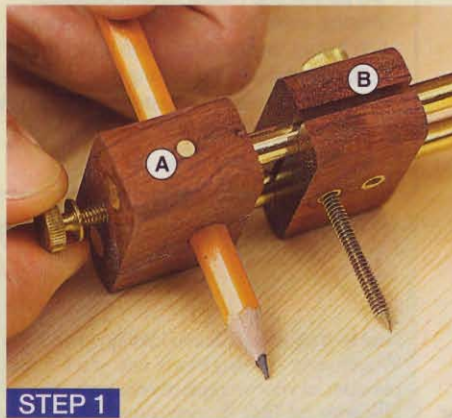

STEP 1

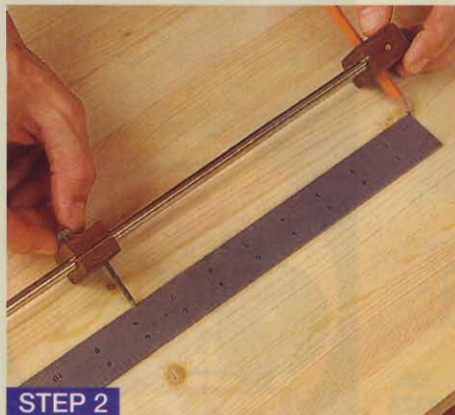

STEP 2



STEP 3



# make brass trim shine

Buff a golden glow into your projects.

**F**inishing brass parts, such as the rod of the beam compass on *page 94*, isn't so different from finishing wood. You remove tool marks and burrs with a sequence of finer abrasive grits until you achieve a smooth surface. For polishing, however, you'll go beyond sandpaper to use buffing wheels and polishing compounds.

## Be abrasive

Once you cut the brass parts to size, sand away saw marks and burrs. Start at 180 grit, as shown at *right*, and work up through 800 grit. Then clean the pieces thoroughly using lacquer thinner to avoid contaminating the buffing wheels.

## Let it shine

To begin the polishing process, you'll need tripoli and white or red rouge compounds with a buffing wheel (see Sources) for each, as shown *below*. Start with tripoli abrasive



on a spiral-sewn wheel to remove moderate scratches. The beam compass uses tarnish-resistant navel brass rods that require no scratch removal, so we went directly to white rouge abrasive on a spiral-sewn wheel.

Load the buffing wheel by pressing the stick of abrasive firmly against the spinning fabric for only about one second. Then polish the part in long passes using even pressure against the buffing wheel. Continually rotate the rod as you work to create a uniform finish, as shown on *page 100*. If you use more than one abrasive, clean your workpiece with lacquer thinner after each stage to avoid accidentally transferring tripoli grit to the white or red rouge buffing wheels.

### SAND OFF ROUGH AREAS



Polish the ends by holding the tip against the lower half of the wheel so the part pulls down and away instead of toward your body, as it would on top half of the wheel.

If you're after a high shine, finish the job with white rouge or red rouge on a flannel buffing wheel. The soft fabric and lack of

### LOW-COST TOOLS FOR HIGH-GLOSS BRASS

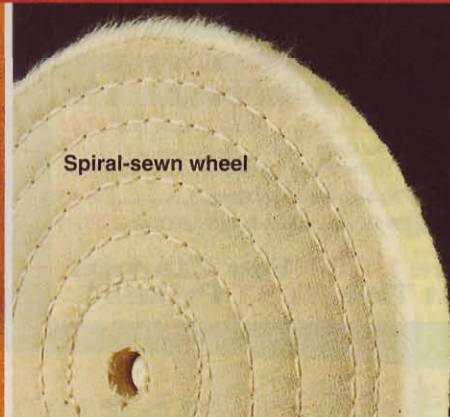
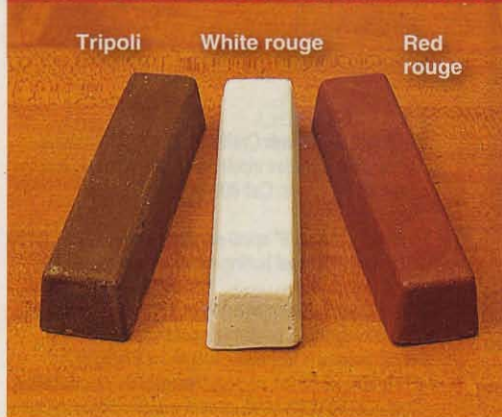

continued on page 100

# LOWEST PRICES UNBEATABLE QUALITY



Pattern Cutting Bits With Shank Mounted Guide Bearing

**DON'T SETTLE FOR SECOND BEST WHEN YOU CAN GET THE ULTIMATE PATTERN SET!**

**Including Our New Double Bearing Bit with a Huge 2" Cut length!**

**ONLY \$69**

- 1/4" and 1/2" Shank
- Multiple Cut lengths and Diameters so that you have the right bit for the Job
- Rugged Carbide Tips
- Replacable Bearing System

\$95 Value - WL-2032

## PRO CABINET MAKER

### 6 pc Door Set

- 1/2" Shank Router Bits
- 2-pc Rail & Stile (Roman Ogee)
- Drawer Lock
- 3 1/4" D Panel Raiser (Ogee) with UnderCutter
- Door Lip
- Reversible Glue Joint

ONLY

**\$119 set**  
\$175 VALUE  
WL-2020-1



**800-472-6950**

ORDER 24/7

**WOODLINE.COM**



### 8 Piece PICTURE FRAME SET

Perfect for making great looking picture frames. Bits can be combined to form complex mouldings or simple decorative frames.

OUR PRICE ONLY

**\$75 set**  
WL-2008  
\$189 VALUE



### Master Woodworking Router Bit Collection

This may not be every bit you'll ever need, but it's close! Use this set to complete your collection!

- WL 2066 1/2" Shank..... **\$189**
- WL 2065 1/4" Shank..... **\$189**



## PROGRIP YOUR PARTNER IN WOODWORKING

- Reliable cam-action system for variable pressure levels
- Double T-slot system for limitless accessory jig applications
- Unique Back-To-Back system that can be separated into 2 individual clamps for unbelievable versatility in all projects

Ask About Our 90 degree Heads for TRU-GRIP Clamps and PROGRIP Clamps



- 24" ProGrip Bar Clamp..... **\$22.95**
- 36" ProGrip Bar Clamp..... **\$24.95**
- 50" ProGrip Bar Clamp..... **\$28.95**
- 36" ProGrip Back-To-Back Bar Clamp..... **\$40.95**
- 50" ProGrip Back-To-Back Bar Clamp... **\$49.95**

SOLID ALUMINUM

Advanced Aluminum Multi-Channel Extrusion Body Provides Unmatched Rock-Solid Stability and Long-Term Reliability

**The BEST Bar Clamps At The BEST Prices!**

FREE CATALOG **1-800-472-6950**

**WOODLINE USA**  
111 Wheeler St, LaVergne TN, 37086

Circle No. 310

## finishing school

### APPLY EVEN PRESSURE

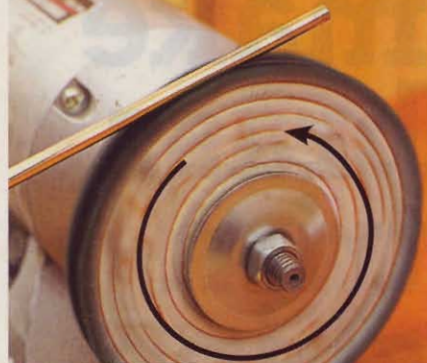

stitching close to the edge allow the polishing action to wrap around curves and contours. Then clean your workpiece with lacquer thinner before applying polish or a film finish to the metal.

### A fitting finish

The beam compass calls for bare brass instead of a film finish that moving parts could mar. To slow oxidation, apply a thin coat of anti-tarnishing metal polish and remove it completely with a clean cloth, as shown below.

For brass parts that require a protective finish, use a lacquer formulated specifically for brass (see Sources). It protects against oxidation and fingerprints and contains anti-tarnishing agents not included in nitrocellulose lacquer for wood finishing.

### ADD POLISH FOR PROTECTION



### Sources

**Buffing compound:** Craftsman Buffing Compound Set no. 2896 includes tripoli brown, white rouge, and red rouge; \$5.99; Sears. Call 800/349-4358, or visit sears.com.

**Buffing wheels:** 6" spiral-sewn cotton wheel no. 64155, \$6.29; and 6" flannel buffing wheel no. 64154; \$5.99; Sears.

**Metal polish:** Flitz metal polish; \$14 for 8.5-oz. liquid. Call 800/333-9325, or visit flitz-polish.com.

**Brass lacquer:** Mohawk Lacquer for Brass no. M1030500; \$6.95 for 11.5-oz.; Klingspor's Woodworking Shop. Call 800/228-0000, or visit woodworkingshop.com.

# 3 uses for glue size

The best “blotch guard” in the shop may be as close as your glue bottle.

**W**hen it comes to stain, not all wood surfaces are created equal. Some invariably soak up more color than others, producing blotches. You can fight—and even defeat—“the dark side” by first treating faces and end grain with glue size, which is simply one part glue thinned with 10 parts water.

## Use 1

Glue size on end grain seals the wood and hardens the fibers, making them easier to sand and stain evenly, as shown *below*. If you need to seal just the ends, mask the faces and edges before applying the size. Generously brush on glue size, then wipe off any excess and allow it to dry overnight.

### SEAL END GRAIN

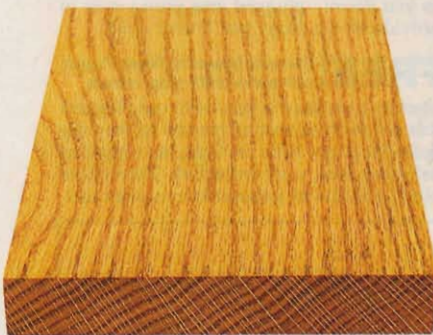

Oak end grain without glue size

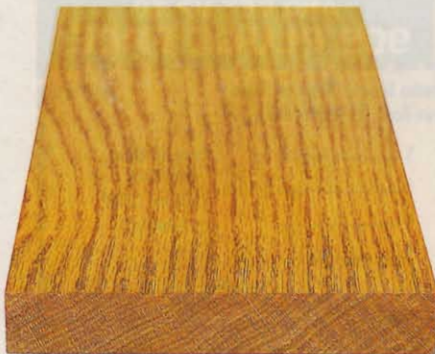

End grain with glue size



Any white or yellow woodworking glue can be used to make glue size. Mix one part glue in 10 parts water for a general-purpose size that works on face and end grains.

## Use 2

A coat of glue size can save you money when finishing porous panels. Applied to medium-density fiberboard or particleboard, glue size partially seals the pores to limit

finish penetration, as shown *below*. You can further increase size's sealing ability by reducing the dilution rate to one part glue in five parts of water.

### USE IT TO SEAL MEDIUM-DENSITY FIBERBOARD

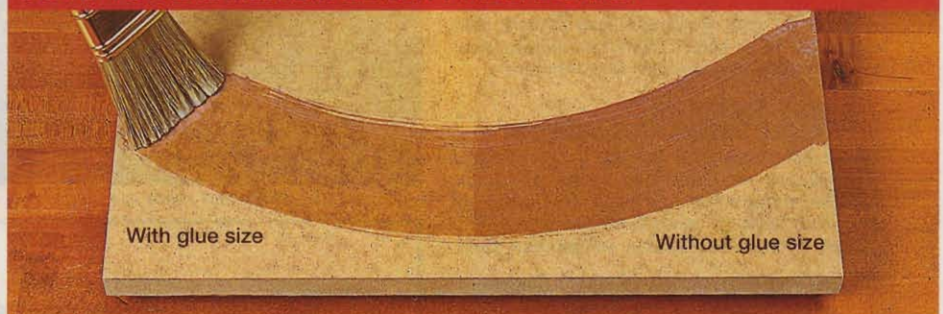

Glue size mixed at the ratio of one part glue in five parts water reduces the waterborne finish's ability to soak into the left half of this medium-density fiberboard sample, as shown by the lighter color of the coated side.

## SHOP TIP

### Strengthen end-to-end joints

Fortunately, end-to-end joints are a rarity. Most woodworkers avoid them because the porous ends of boards provide relatively weak gluing surfaces compared with edges or faces of the wood. Sometimes, however, they're unavoidable, or you may want to add extra strength to the end of a board to be inserted into a rabbet or dado.

A thicker version of glue size can help. Mix two parts water to one part white or yellow glue until the consistency is uniform.

When you reach the glue-up stage, brush or dab a small amount of the mixture onto the end grain to be glued, allowing it to penetrate into the wood. Immediately after, apply glue at regular strength and clamp the parts together until the glue dries.



# THIS IS YOUR BODY ON RADIANT HEAT ANY QUESTIONS?

VISIT OUR WEBSITE

CALL FOR A  
FREE QUOTE

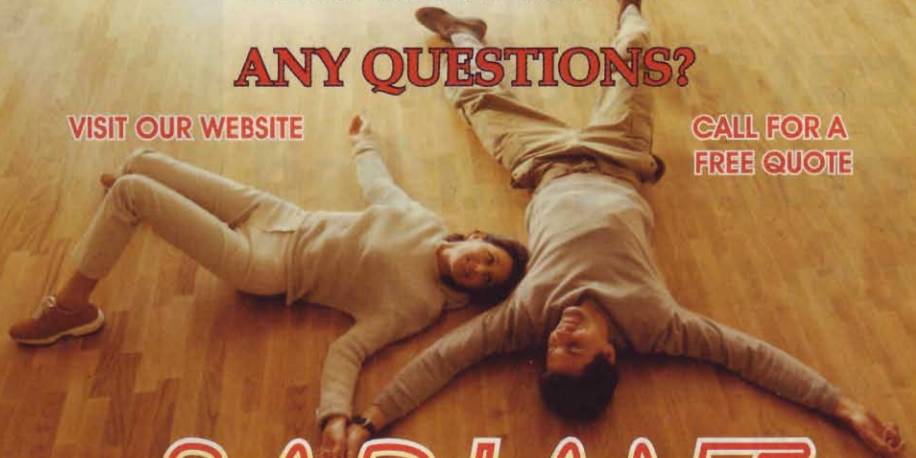

# RADIANT

Floor Company

Compatible with any fuel source:

GAS PROPANE SOLAR OIL WOOD ELECTRIC GEOTHERMAL

[www.radiantcompany.com](http://www.radiantcompany.com)

Barton, Vermont

(toll free) 1.866.WARM-TOES (927.6863)

### Use 3

As a tool to control stain blotching on face and edge grain of such species as pine and cherry, glue size penetrates less dense areas that would normally soak up stain and become dark, as shown *below*.

Allow the glue size to dry overnight, and then remove raised grain by lightly scuff-sanding with 220-grit sandpaper. The glue size stiffens tiny fibers, making them easier to sand away. ♣

### BLOCK BLOTCHINESS

With glue size



Without glue size

Glue size on the upper half of this pine board partially seals the wood to help lessen the color contrast between early and late wood caused by oil-based stain.

# DULUTH TRADING & E

These wrap-style  
cheaters with  
lower lens  
magnification  
help me read  
the small print  
in a plan

And they look good on  
geezers, too—bi-focals  
for the young at heart.  
Check 'em out in our  
latest catalog



We stock wonderful, useful Equipment and Goods designed and tested by Tradesmen for Builders and ardent Do-It-Yourselfers. Get a Free Catalog at 800-505-8888 or order on line - [www.DuluthTrading.com](http://www.DuluthTrading.com)

# cut perfect grain-matched corners

In three easy steps you can flow wood grain around project corners for a seamless professional look.

**W**hen it comes to craftsmanship, it's the little things that make a big difference, like the wood grain of a molding that matches on adjoining corners. The photo at *right* shows the effect on one corner of the base molding of the china cabinet on *page 44*. Planning and careful cutting are all it takes. Here's how.

First add up the total length of the front and two sides of the cabinet case where the molding will be applied. Then add enough to allow for the miters and a bit more as trimming margin. (For  $\frac{3}{4}$ "-thick molding, figure 1" extra stock for each miter cut, and 2" trimming margin at each end for a total of 6" of waste.) Cut a molding blank to this length. Now rout any desired edge profile along the entire length of the blank. [For the china cabinet base blank (K), rout a  $\frac{1}{2}$ " cove along the top outside edge of the blank.]

Measure the front of the case. Center this measurement on the length of the molding blank, and mark the locations of the *heels* of the front molding miters. Tilt your tablesaw blade to 45° and miter-cut the front molding to length, where shown on **Step 1** at *right*. (You also can use a mitersaw. Just orient the blank with the *back* against the fence.)

Then miter-cut the two remaining blank pieces for the side moldings, where shown on **Step 2**. (With the moldings attached, you'll be missing no more than a saw kerf of material at each corner.)

Dry-clamp the front molding to the case, and then dry-fit the side moldings, mating

the side miters with the front miters. Now mark the lengths of the side moldings flush with the rear edges of the cabinet sides, and

cut them to length, where shown on **Step 3**. Glue and clamp the moldings in place. ♣

Illustration: Roxanne LeMoine

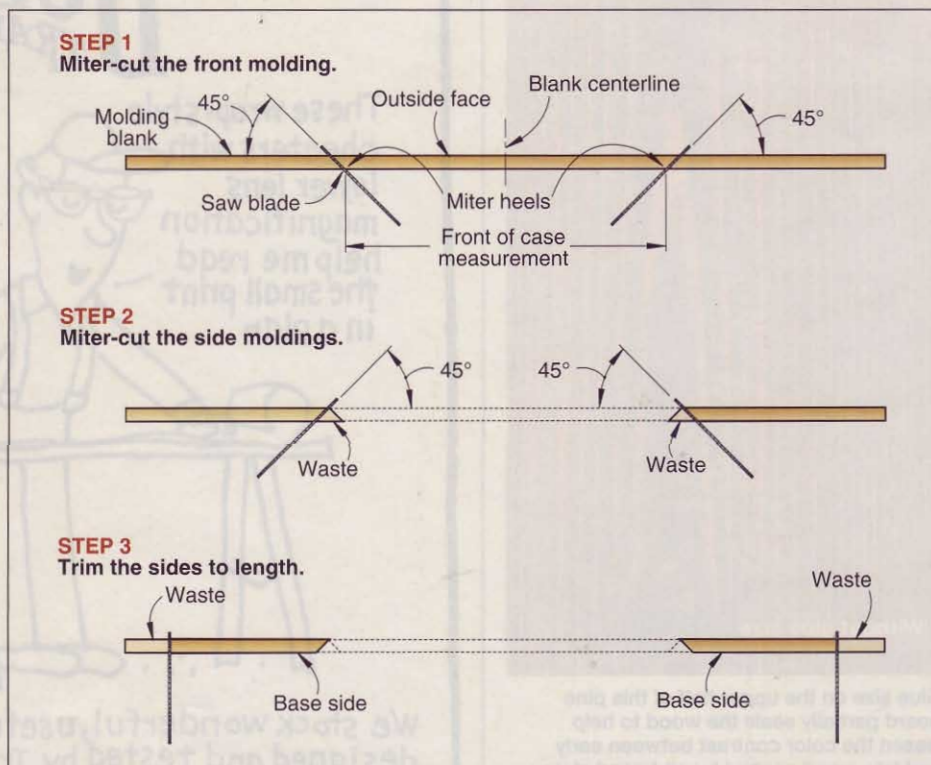

our editors test

# 12-volt impact drivers

## Why buy?

Often confused with a hammer drill, an impact driver spins like an ordinary cordless drill when the drilling and driving are easy. But when the going gets tough, this tool automatically kicks into impact mode, rotating the chuck in short strokes with a rapid-fire series (about 50 per second) of noisy taps from an internal hammer and anvil. The result: big torque, with little strain on the tool's small motor. In fact, these compact 12-volt drivers muscle fasteners—including  $\frac{3}{8}\times 3$ " lag screws into pressure-treated lumber without pilot holes—faster and with less effort and longer run time per battery charge than a bulky 18-volt cordless drill.

The smaller motor and a quick-change  $\frac{1}{4}$ " hex drive (instead of a chuck, like a cordless drill) allows an impact driver to get into tight spaces. An impact driver also requires less feed pressure in line with the bit to keep it from slipping out of a screw head. That

makes it a great tool for working overhead, or deep inside a cabinet where in-line pressure is difficult to achieve.

Don't toss out your cordless drill yet, though. The hex drive grips the bit looser than a chuck, so a drill bores more precisely than an impact driver. And the higher speed of an impact driver (about 2,600 rpm under no load) makes it harder to control when driving short fasteners, such as hinge screws.

The bottom line: A cordless drill would still be our first choice for woodworking, but we'd make an impact driver our second cordless buy. The next time the batteries on your cordless drill go belly-up, take a look at buying an impact driver that operates on the same battery pack as your drill. You get to keep your drill, the two tools can share those batteries, and you'll add a powerful driver to your arsenal.

### Black & Decker BDID1202, \$100



#### Editor test-drive:

At this price, I didn't expect to come away impressed. However, the BDID1202 surprised me, as it easily drove sixteen  $\frac{1}{4}\times 3\frac{1}{2}$ " lag screws on a single battery charge when I installed heavy-duty shelf standards on my shop wall. Downside: The batteries (two included) take 3 to 6 hours to charge, so this isn't a tool for all-day jobs. It does come with a 15-piece bit-and-driver set, which makes it an even better value for occasional use.

—Tested by Jim Harrold, Executive Editor

#### To learn more:

800/544-6986; blackanddecker.com

### Ridgid R82233, \$130



#### Editor test-drive:

The Ridgid right-angle impact driver blends two special-purpose drivers into one tool. And, because the tool requires little in-line driving pressure, it's easier to use than ordinary right-angle drills. The large paddle switch took some getting used to, but the sensitive variable speed allowed easy starting of screws and other fasteners. The R82233 comes with only one battery, but its 20-minute charger makes that a nonissue in actual use.

—Tested by Kevin Boyle, Senior Design Editor

#### To learn more:

800/474-3443; ridgid.com

### DeWalt DW052K-2, \$195



#### Editor test-drive:

Compact and well-balanced, the DW052K-2 fit easily, with a  $\frac{3}{4}$ " spade bit installed, between floor joists when I rewired my basement. I'm still amazed at the sheer driving power of this tool, as it effortlessly finished setting—from a dead stop—a  $\frac{3}{8}\times 4\frac{1}{2}$ " lag screw that my corded drill couldn't complete in a 6" landscaping timber. I do wish it had externally replaceable motor brushes, though, like those on the Makita.

—Tested by Jan Svec, Projects Editor

#### To learn more:

800/433-9258; dewalt.com

### Makita 6980FDWDE (with LED), \$200



#### Editor test-drive:

This tool takes the work out of driving fasteners. While installing an overhead garage organizer, I drove more than 100  $2\frac{1}{2}$ " and 3" screws, without the backache usually associated with shoving screws into the ceiling. The 6980FDWDE has so much power, I snapped off the tips of some inexpensive Phillips drivers I use with my cordless drill. I'll upgrade to better drivers and add impact-grade sockets, as well.

—Tested by Jeff Mertz, Design Editor

#### To learn more:

800/462-5482; makitatools.com

# what's ahead

Your sneak peek at articles in the June/July issue (on sale May 16)

## Projects from big to small

### FEATURED PROJECT



#### Classic garden bench

Complement your outdoor spaces perfectly with this comfortable and long-lasting seat. You'll also find out how to change the length of a few parts to build a chair or settee version.



#### Hummingbird feeder

Here's a quick and simple turning designed to attract a bevy of these fascinating fliers.

#### Stepped shelf

Like popular ladder shelves, this freestanding, graduated project allows ample light to fall on each shelf. And, it's easy to make.

## Tools and techniques

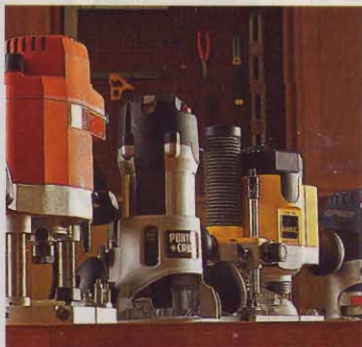

#### How to choose a router

Regardless of what type of router you're in the market for, here's what you need to make a smart buying decision.



#### Cherry secrets

Learn the keys to getting clean cuts and handsome finishes from people who work with cherry every day.



#### Tour the new WOOD® shop

After 20 years in our old shop, we've built a new one from scratch. See where we now build all those great projects.



#### Real-life lessons in safety

In this new column, fellow readers help you be safe in the shop by sharing their personal experience with an accident.



#### Bench with storage and coat rack

Build one or both—either way you'll liven up an entryway while adding valuable storage and functionality to your home.

