

# WOOD

TESTED!  
BIG-BOY  
BANDSAWS  
p.46

The Shop-Proven Woodworking Magazine

## easy-to-build, rock-solid workbench

p.36

Make this elegant hall table p.60

plus

### HOLIDAY PROJECTS

- Display shelf
- Scrapbook/album cover
- Backlit scrollsawn art
- Turned tree ornament

Get  
Organized!

**14**  
Workshop  
Projects

## REDUCE WOOD WASTE & SAVE A BUNDLE

p.84



# WOOD

November 2005, Issue 166

## PROJECTS

- 14 hole-boring guide for handheld drills
- 16 scrollsawn copper art
- 36 rock-solid workbench
- 52 turned holiday ornament
- 60 matching hall table and shelf
- 72 edge-joined scrapbook/album cover
- 78 nine easy shop organizers
- From clamp hangers to tool racks to bins and boxes—take your pick.
- 87 wine-bottle holder
- 88 shop cart/benchtop tool support
- 102 bandsaw accessory store-all



88



60

## TECHNIQUES

- 10 the split-mortise, through-tenon joint
- 34 tricks for installing Euro-style hinges
- 68 how to hang shelves and cabinets
- Discover the best hardware and most effective methods for securing heavy projects to walls.
- 76 17 ways to organize your shop
- Create dedicated storage for tools, sheet goods, and hardware while adapting a host of low-dough fixes.
- 84 trim workshop waste and save big
- See how a pro designs projects and buys and mills stock to extract the most out of every board foot.



72



52

## TOOLS & MATERIALS

- 46 tested: step-up bandsaws
- Find out how well six big-boy machines cut the hardwood when the sawing gets tough.
- 92 three shop-proven products

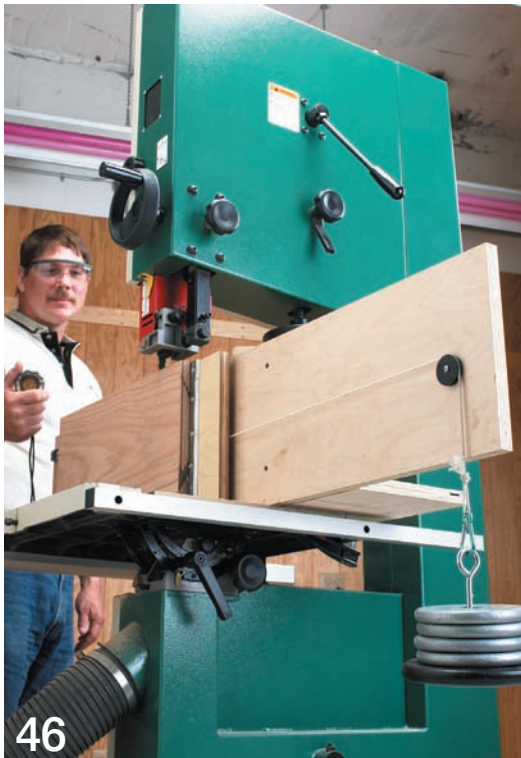

46



84

## DEPARTMENTS

- 6 editor's angle
- 8 sounding board
- 22 shop tips
- 112 what's ahead



This seal is your assurance that we build every project, verify every fact, and test every reviewed tool in our workshop to guarantee your success and complete satisfaction.



36



76

Better Homes and Gardens®  
**WOOD**®

November 2005

Vol. 22, No. 6

Issue No. 166

EDITOR-IN-CHIEF  
**BILL KRIER**

Executive Editor **JIM HARROLD**     Managing Editor **MARLEN KEMMET**

Editorial Manager – Tools and Techniques  
**DAVE CAMPBELL**

Senior Design Editor **KEVIN BOYLE**     Techniques Editor **BOB WILSON**

Projects Editor **OWEN DUVALL**     Projects Editor **JAN SVEC**

Design Editor **JEFF MERTZ**     Master Craftsman **CHUCK HEDLUND**

Art Director **KARL EHLERS**     Associate Art Director **GREG SELLERS**     Assistant Art Director **CHERYL A. CIBULA**

Production/Office Manager **MARGARET CLOSNER**     Administrative Assistant **SHERYL MUNYON**

Photographers **MARTY BALDWIN, SCOTT LITTLE, BLAINE MOATS, JAY WILDE**

Illustrators **TIM CAHILL, LORNA JOHNSON, ROXANNE LeMOINE**

Technical Consultants **JEFF HALL, DEAN FIENE**

Contributing Craftsman **JIM HEAVEY**

Proofreaders **BARBARA KLEIN, IRA LACHER, JIM SANDERS**

**CUSTOMER SERVICE: 800/374-9663**

For more ways to reach us about specific matters, see *page 8*.

Vice President/Publishing Director **DOUG OLSON**

Publisher **MARK HAGEN**

**ADVERTISING**

**CHICAGO OFFICE:** 333 N. Michigan Ave., Suite 1500, Chicago, IL 60601

Phone: 312/853-2890 Fax: 312/580-7906

Account Executive **JACK A. CHRISTIANSEN**

Direct Response Manager **CAROLYN DAKIS**

Direct Response Sales Representative **SANDY ROBINSON**

Sales and Marketing Assistant **GAYLE CHEJN**

Sales and Marketing Assistant **LISA GREENWOOD**

**NEW YORK:** Phone: 212/551-7043 Fax: 212/551-7192

Account Executive **PATRICK R. TOMLINSON, SR.**

**DETROIT:** RPM Associates

29350 Southfield Rd., Suite 31, Southfield, MI 48076

Phone: 248/557-7490 Fax: 248/557-7499

**ATLANTA:** Navigate Media

1875 Old Alabama Rd., Suite 1320, Roswell, GA 30076

Phone: 678/507-0110 Fax: 678/507-0118

Director, Corporate Sales **RICH BERENSON**

Executive Director, Corporate Research **BRITTA C. WARE**

Business Manager **JOEL ETIENNE**

Consumer Marketing Director **ROBIN HUTCHINSON**

Consumer Marketing Manager **LESLIE SHAEFFER**

Associate Director of Marketing-Newsstand **TOM DEERING**

Advertising Operations Manager **JULIE HALSNE**

Production Manager **STEVE KRIDER**

**MEREDITH PUBLISHING GROUP**

President **JACK GRIFFIN**

General Manager **TOM HARTY**

Finance & Administration **KARLA JEFFRIES**

Consumer Marketing **DAVID BALL**

Manufacturing **BRUCE HESTON**

Creative Services **ELLEN DE LATHOUDER**

Interactive Media **LAUREN WIENER**

Corporate Sales **JACK BAMBERGER**

Group Marketing **NANCY WEBER**



Chairman and Chief Executive Officer **WILLIAM T. KERR**

President and Chief Operating Officer **STEPHEN M. LACY**

**In Memoriam — E.T. Meredith III (1933–2003)**

© Copyright Meredith Corporation 2005 All rights reserved. Printed in the U.S.A.



Chuck made this oak raised-panel desk for his daughter.



Dean and granddaughters, Miranda and Madelyn, have fun at the playhouse he built.



Sales executive David Dempsey turned these wood and acrylic pens to give as gifts.



## Adapt our plans to your style—I do!

My favorite furniture style, a distinctive take-off on Arts-and-Crafts design known as Greene and Greene, is not well-known. It's a furniture design you seldom find in these pages. Still, I can use a past *WOOD*® magazine project plan to build a G&G piece. And you can do the same to make furniture in your favorite style. Here's how.



They may look dissimilar, but my G&G dresser (above) and the country dresser from issue 111 share a lot of the same DNA.

Using a *WOOD* magazine project article as a starting point in designing a customized piece, I save dozens of hours in creating project drawings, a materials list, a cutting diagram, and formulating the correct how-to steps.



My simple redesign process goes like this:

**1** First, I photocopy and enlarge the drawings from a magazine project I want to emulate. Then, I use white correction fluid to remove elements of the drawing(s) that don't match my style. For instance, when I built the G&G dresser, *above right*, the carcass construction of the country-style dresser in issue 111 (*inset*) served as a good model—most of the illustrations showed exactly what I needed.

**2** Next, I make a copy of the materials list, white-out the parts or dimensions that don't suit my redesign, and input my new parts or dimensions. Besides saving time, I'm assured that the basic design follows standard design criteria for such things as overall height, drawer depth, etc. If changes are substantial, I may start with a blank materials list. To make this step easy for you, I've created a blank materials list at [woodmagazine.com/designhelp](http://woodmagazine.com/designhelp). You can access it for free.

**3** Like the materials list, I'll often duplicate and alter the cutting diagram supplied with the *WOOD* magazine project.

**4** For the step-by-step instructions, I return to the photocopier to make a copy of the magazine article. Then, I cut and paste changes in the construction sequence wherever I need to add or delete a step. Typically, I use more than 80 percent of the existing instructions.

My updated paper copies of the instructions, drawings, materials list, and cutting diagram usually aren't pretty, but they do serve as an excellent blueprint that ensures a snag-free project without the considerable work of starting from scratch. And because of this system, I rarely make a costly cutting or construction error.

Give it a try on your next one-of-a-kind creation. I think you'll appreciate the timesaving benefits.

*Markus Kemmet*

Managing Editor

# sounding board

Our bulletin board for letters, comments, and timely updates

## Edging bits with the handheld advantage

In your review of plywood edging router bits (“Blades & Bits,” issue #163, page 10), you overlooked one important attribute of my product, The Burgess Edge. The bit set features bearings that enable the bits to be used without a router table.

This difference is crucial when edging large panels or case sides. With these awkward workpieces, router-table hold-downs need lots of pressure, which can make it difficult to feed the panel smoothly and continuously. Furthermore, the router can respond to the uneven dips on the plywood surface more precisely because the

router base is a shorter reference surface than the router table.

I have used the Burgess Edge set on countless linear feet of material and never found it necessary to use a router table.

*Michael Burgess, The Burgess Edge*

*Although we prefer to use the Burgess Edge set in a router table for smaller, easily manageable workpieces, we agree that it's the only product of those we tested that can be used effectively in a handheld router.*

—WOOD® magazine



## Position opening for a writer at WOOD magazine

The staff position of Woodworking Techniques Editor is currently open at WOOD magazine in Des Moines, Iowa. Work includes producing technique articles for the magazine, traveling as needed to complete assignments, and planning and directing photography and illustrations to complement articles.

Minimum qualifications are as follows:

- Bachelor's degree in journalism or English, or equivalent experience.
- Minimum of five years as a magazine, book, or newspaper journalist. Technical writing experience helpful.
- Specific knowledge includes understanding woodworking processes.

Beyond that, applicant must possess the ability to work in a team-oriented environment and use desktop publishing

equipment; must be a self-starter and a strong writer with a proven track record. Applicant must have a keen instinct for uncovering compelling article concepts and information, and have the ability to communicate well over the phone and in person. Some travel may be required.

Please note that this position is in Des Moines, Iowa.

For more on this exciting opportunity with WOOD magazine and Meredith Corporation, visit our Career Site at [meredith.com](http://meredith.com); once there click Careers. Qualified applicants, send cover letter and resume to:

**D. Rock, Meredith Corporation, HR/Publishing Group, Dept #34529, 1716 Locust St., Des Moines, IA 50309, or fax 515/284-2958. EOE.**

## Article updates

### September 2005, issue 164

► Pattern revisions for the salt and pepper mills may be found in the WOOD Patterns® of this issue on page 58.

■ Pages 77–79 indicate no dust-collection accessories for Porter-Cable routers. Porter-Cable does offer optional below-base dust collection (part no. 39700) for models 7518 and 7539.

■ On page 76, the Router-Lift Compatibility chart incorrectly shows that you can't change bits above the table on the Jointech Smartlift Digital. In fact, all bits can be changed from above the table with this lift.



## HOW TO REACH US

### ■ Woodworking advice:

Post your woodworking questions (joinery, finishing, tools, turning, general woodworking, etc.) on one of 15+ online forums at [woodmagazine.com/forums](http://woodmagazine.com/forums).

### ■ Editorial feedback:

Send your comments via e-mail to [woodmail@woodmagazine.com](mailto:woodmail@woodmagazine.com); or call 800/374-9663 and press option 2; or write to WOOD magazine, 1716 Locust St., GA-310, Des Moines, IA 50309-3023.

### ■ Subscription assistance:

To notify us of an address change, or to get help with your subscription, go to [woodmagazine.com/service](http://woodmagazine.com/service); or call 800/374-9663 and press option 1. Outside the U.S., call 515/247-2981. Or write to WOOD magazine, P.O. Box 37439, Boone, IA 50037-0439. Please enclose your address label from a recent issue.

### ■ To find past articles:

See our index at [woodmagazine.com/index](http://woodmagazine.com/index).

### ■ Past issues and articles:

Order past issues of WOOD magazine, our special issues, or downloadable articles from issue 100 to present. Visit our online store at [woodmagazine.com/store](http://woodmagazine.com/store) or call 888/636-4478. Some issues are sold out.

### ■ Updates to previously published articles:

For an up-to-date listing of changes in dimensions and buying-guide sources from issue 1 through today, go to [woodmagazine.com/editorial](http://woodmagazine.com/editorial).

# the split-mortise, through-tenon joint

Call this your divide-and-conquer joint. Divide the mortise cuts before glue-ups, and you'll conquer the challenge of joining large project pieces.



**H**eavy-duty projects call for thick, rugged parts with joints to match. Made using just a tablesaw dado blade, split-mortise, through-tenon joints securely connect parts far larger than those on most projects made from  $\frac{3}{4}$ " stock.

This joint was incorporated into the legs of the European-style workbench project on page 36, but the same techniques apply to joints of other dimensions and applications. Use it to attach crossarms to mailbox posts, make legs for a trestle table, or assemble such outdoor projects as a pergola or arbor.

Though simple, split-mortise, through-tenon joints require precise marking and cutting for best results. You'll be making 1"-deep mortises, a job best done with a carbide-tipped, stacked dado blade. Get off to a good start by using stock that's straight, square, and dimensioned precisely. Double-check that your tablesaw blade is set  $90^\circ$  to the table and save scraps for test cuts. Once that's done, you're ready to begin.

## First, cut the split mortises

For the workbench's  $3 \times 3\frac{1}{2} \times 32$ " laminated feet and rails (parts A on the illustration), cut eight pieces of  $\frac{1}{2}$ "-thick stock to  $3\frac{3}{4} \times 32$ ". You'll remove the extra  $\frac{1}{4}$ " after the two halves are assembled.

For these parts we planed  $\frac{1}{4}$ "-thick ash to  $\frac{1}{2}$ " thick. You also can laminate two lengths of  $\frac{3}{4}$ "-thick stock for each  $\frac{1}{2}$ "-thick piece. Arrange the  $\frac{1}{2}$ "-thick parts in

pairs for the best color and pattern matches, and then mark the inside faces of each pair.

Install a  $\frac{3}{4}$ " dado blade in your tablesaw, and attach an auxiliary face to the saw's miter gauge. Where shown on **Drawing 1** of the workbench article and illustrated in detail on page 37, cut 2"-wide dadoes 1" deep into the inside faces of the parts.

For greater precision, use your tablesaw fence as a stop while cutting the two passes

## BASIC JOINT ANATOMY

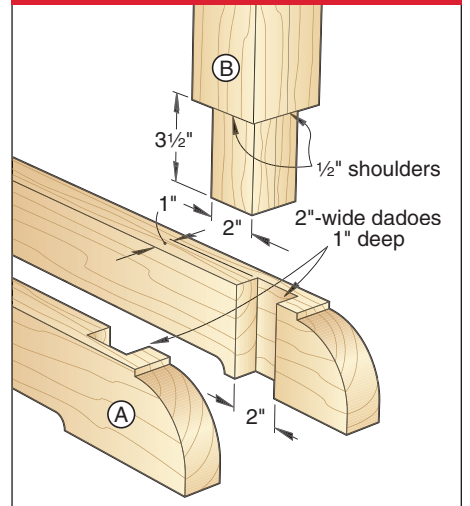

that define the outside edges of your mortise halves, as shown in **Steps 1** and **2**. The fence also ensures that the half-mortises on all four legs are the same size and the same position. Use test scraps (2x4 cutoffs work

### STEP 1: START THE MORTISE CUT



### STEP 2: NOW CUT IT TO WIDTH



### STEP 3: ALIGN THE TWO HALVES



continued on page 12

**STEP 4: CUT THE TENON**



well) to check that the combined dadoes form a square mortise.

Next, cut a pair of scrap blocks that fit the width of the dadoes but are less than their combined height. Use these to keep the mortises aligned while you glue the two halves of the feet together. Then assemble the first part A halves, as shown in **Step 3**. Let the glue set for five minutes. Tap the blocks out of the mortises and remove any excess glue. Repeat this method to assemble the remaining part A halves.

Joint one edge of each foot and rail (A). On your tablesaw, rip the opposite edge of each part to 3½" wide.

### Make the leg tenons

For the workbench's laminated legs (B) on which you'll form the tenons, cut eight pieces of 1½"-thick stock to 3¼×34". Then glue and clamp the pieces together in pairs keeping the ends and edges flush. Joint one edge of each leg, then rip and crosscut all four legs to 3" wide.

**STEP 5: FINISH THE JOINT**

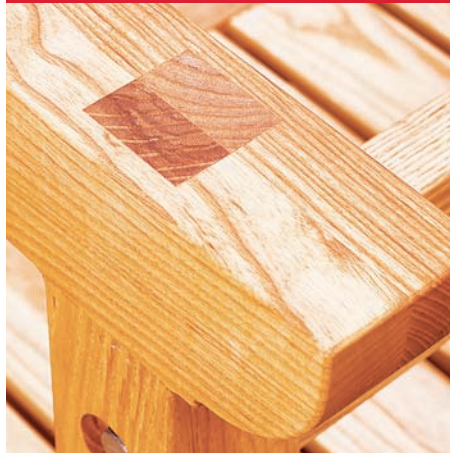

Reinstall the ¾" dado blade in your tablesaw, and set your saw's fence 3½" from the far edge of the blade.

For snug-fitting tenons, cut the first set of four tenon sides in one leg slightly shallower than the ½" depth indicated in the workbench plans. Check this tenon against the dimension of your mortises. If this tenon is oversized, raise the blade in small increments and make additional series of cuts. Test-fit your tenons between cuts until your dado blade height produces a snug-fitting tenon. Then cut the remaining tenons in all four legs, as shown in **Step 4** and at the top of *page 10*. Make the tenon length a hair greater than the mortise depth, and sand off the excess from the finished joint.

With the appearance sides facing out, glue and clamp the legs, feet, and rails together. Avoid excess glue buildup on the shoulders of the tenons. After the glue dries, use a random-orbit sander to smooth the assembled pieces. Then finish to your preference. (See **Step 5**.)

**STEP 6: START THE DOWEL HOLES**



### Add even more strength

Make this sturdy joint even more rugged by reinforcing it with pegs after glue-up. Here, we used contrasting ⅜" cherry dowels set 1" from the bottom edges of the feet. The dowels extend 2½" into the joint, allowing you to hand-drill into the tenon without worrying about where the hole exits.

A workbench leg assembly would be unwieldy to support on a drill press to make perpendicular dowel holes, so first drill starter holes down to the mortise before assembly, as shown in **Step 6**. With the joint glued and assembled, use the starter hole as a guide to deepen it to 2½" using a handheld drill, as shown in **Step 7**.

To spread glue against the sides of the hole, instead of allowing it to collect at the bottom, we used a 3" flathead wood screw that also removes some of the excess, as shown in **Step 8**. After you've driven the dowels in place and the glue dries, flush-cut the dowels even with the surface, as shown in **Step 9**, and sand smooth. ♣

**STEP 7: DRILL INTO THE TENON**



**STEP 8: SPREAD THE GLUE**

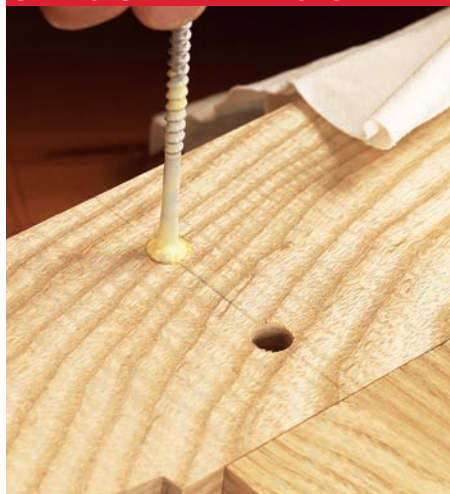

**STEP 9: FLUSH-SAW THE DOWELS**



quick and easy **jig**

# hole-boring guide

Bore clean, perpendicular holes in a benchtop—or any other large surface—where your drill press won't reach.



**R**ound bench dogs, like the ones used in the workbench on page 36, install easily. Just bore  $\frac{3}{4}$ " holes, chamfer the edges, and you're done. For the bench dogs to work properly, though, the holes must be perpendicular to the benchtop surface. You could wrestle the top onto your drill-press table, support it with outfeed stands, and bore the outside rows of holes. But what about the inside rows? They're beyond the reach of most drill presses. No problem. With just a scrap of hardwood stock and a  $\frac{3}{4}$ " brad-point drill bit, you can avoid the wrestling match and drill the inside rows of holes with dead-on precision.

First, cut hardwood stock to the width and length shown on the drawing at right. (We used a scrap of  $1\frac{3}{4}$ "-thick solid stock, but a blank laminated from

thinner stock also does the trick.) Next bore a centered  $\frac{3}{4}$ " hole with your drill press, and then cut the corner at  $45^\circ$ . The  $2\frac{1}{2}$ " width of the guide keeps the bit perpendicular to the benchtop and provides enough bit travel to bore all the way through the benchtop. At 15" long, the guide extends to the edge of the benchtop for clamping when boring an inside hole. The  $45^\circ$  cut exposes the tip of the bit and the marked hole centers for ease of alignment and chip clearance.

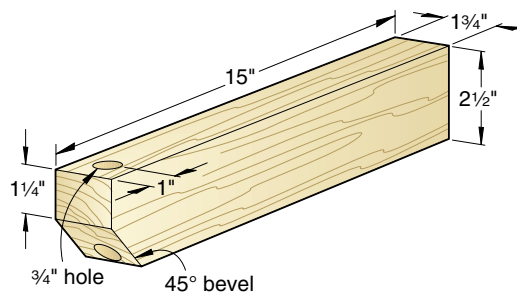

to use the guide, apply masking tape to the benchtop and lay out the bench-dog hole centers on the tape.

Then bore holes through the top, following the five steps shown in the photo below left. To bore bench-dog holes into the edge of the top, lay out the hole centers and follow the four steps shown in the photo below. 🐿

## BORING HOLES THROUGH A TOP

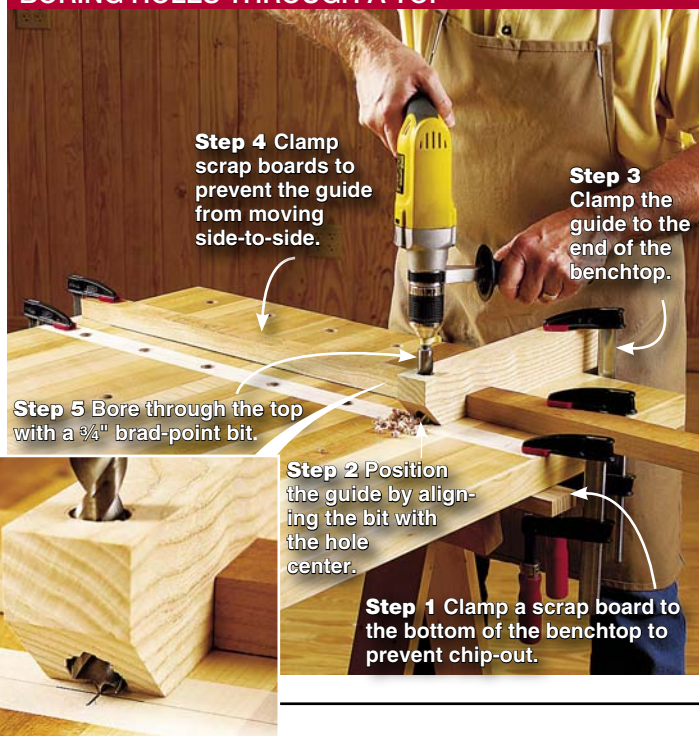

## BORING HOLES INTO AN EDGE





# see-through copper art

Create your own themed display with these framed scrollsawn copper panels.

**N**o matter the season, this project offers a motif to suit your style. Select one of the designs shown in the photos. You'll find full-size patterns for them in the *WOOD Patterns*® insert. Or, visit our Web site at [woodmagazine.com/patterns](http://woodmagazine.com/patterns) for more free full-size patterns (see page 18 for thumbnail previews of those bonus patterns). The panels look great when illuminated from behind with candles, electric bulbs, or sunlight through a window. And, if you're really ambitious, enlarge the patterns and frame pieces for more high drama.

## Building the frames

**1** For the frame, plane or resaw a piece of 1¼"-wide by 24"-long stock to ⅜" thick. Cut or rout a ⅝" rabbet ⅛" deep along the back inside edge of the piece. Then, miter-cut the four frame sections (A) to length. Use a stop to ensure all four frame pieces are the same length. Keeping the corners square, glue the frame together.

**2** Cut the stops (B) to size. To shape the feet (C), cut a ½"-thick strip 2" wide by 10" long. Then, cut a 1¼" dado ⅛" deep along the center of one face, chamfer the edges, and crosscut the feet to width.

**3** Using a sharp, carbide-toothed tablesaw blade, cut the 5"-square acrylic back (D) to size.

## Creating copper art

**1** With tin snips cut the 24-gauge copper panel to size. Then, cut two pieces of ⅛" hardboard the same size as the copper panel. Using spray adhesive, sandwich the

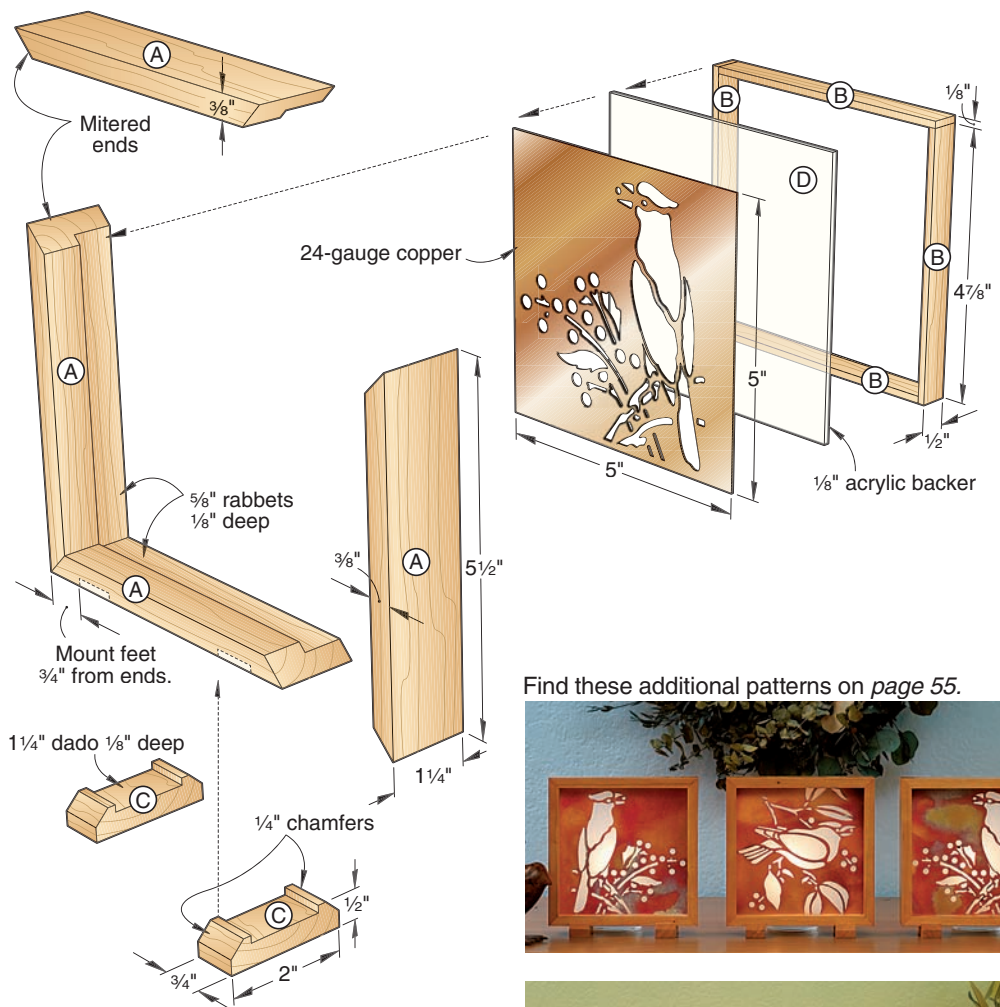

Find these additional patterns on page 55.



copper panel between the hardboard pieces. (The hardboard supports the copper when making the cuts, and keeps the metal from bending.) Next, use the spray adhesive to attach one of  
*continued on page 18*

the paper patterns to the front of the hardboard/copper lamination.

**2** Scrollsaw the pattern to shape, as shown *below*. Separate the hardboard

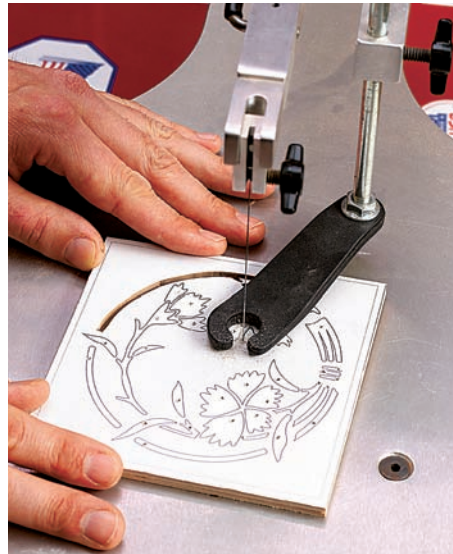

With a scrollsaw and a #5 blade, carefully cut the hardboard/copper/pattern lamination.

from the copper using lacquer thinner to weaken the bond. Then soak the copper in a pie tin partially filled with thinner to remove the adhesive residue.

**3** With a random-orbit sander and 180-grit sandpaper, carefully sand both sides of the copper to remove the scratches and burrs. Do the same with the acrylic panel to create an opaque panel.

**4** Lightly heat the copper with a propane torch to bring out a patina-like color. Practice on scrap pieces first.

## Finishing touches

**1** Glue the feet (C) to the bottom of the frame,  $\frac{3}{4}$ " in from the ends. Position the stops (but don't secure) in the frame and apply the finish. This masks off the mating surfaces in order to achieve a good glue bond.

**2** Insert the copper panel and acrylic into the rabbeted, opening. Now, glue the stops in place. 🌲

More full-size (5x5") patterns available at [woodmagazine.com/patterns](http://woodmagazine.com/patterns)

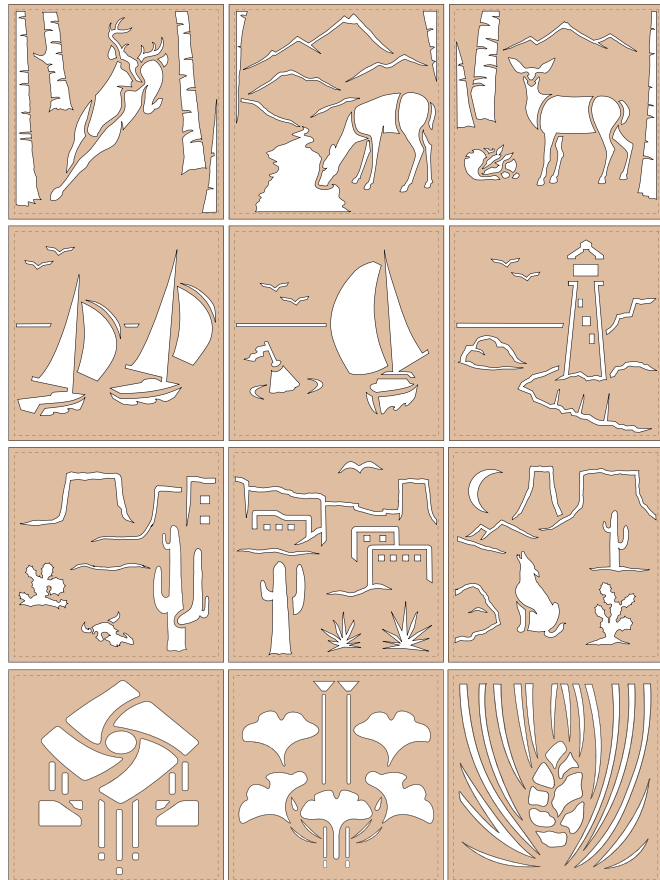

Project designs: Susan Jessen; Roxanne LeMoine

# shop tips

Helping you work faster, smarter, and safer

## Iron-grip trick for sanding small parts

Having practiced the art of intarsia for many years, I often try to shape a significant contour on the parts with a drum sander. Unfortunately, the parts are frequently small and my fingers a bit large. In the past, this meant that my fingertips would get sanded along with the part. To save my skin from further abuse, I developed the following dry-mount technique for sanding tiny parts.

Begin by drilling a  $\frac{3}{32}$ " pilot hole in roughly the center of the part's back. Mount the brass compression nut to

the back of the part with a #4x $\frac{1}{2}$ " screw, as shown in the illustration. The compression nut, which fits  $\frac{1}{8}$ " ID (inside diameter) tubing, will thread over a  $\frac{5}{16}$ " fine-thread bolt.

The bolt acts as an extension handle that allows you to safely and accurately manipulate the part to achieve the best possible contour. Even better, my sanding operation no longer involves chasing flying parts or scrounging for Band-Aids.

—Bob Wills, Coal City, Ill.

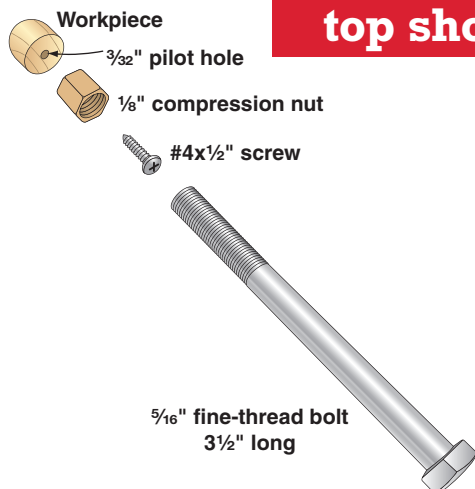

top shop tip

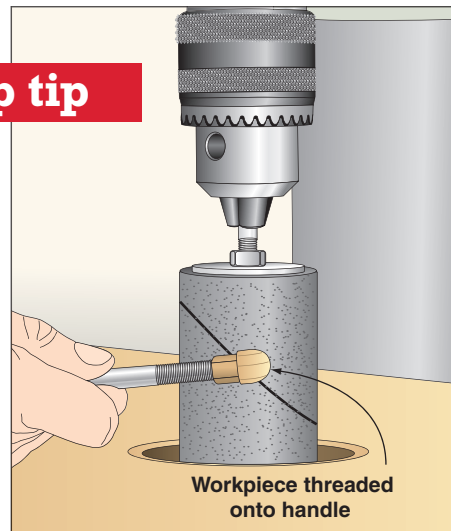

## Goofproof gauge blocks for thickness planer

I quickly grew tired of trying to reset my thickness planer when going back and forth planing different thicknesses of material. To improve accuracy and speed up the reset-ting process, I made gauge blocks for each thickness from  $\frac{1}{4}$  to  $\frac{7}{8}$ ".

First, make a gauge-block 3" wide and at least  $\frac{1}{8}$ " thicker than the thickness setting you'll want. Next, plane some scrapwood—not the gauge block—to the exact thickness desired. When it's perfect, measure the distance from the planer table to the casting. Finally, notch the gauge block so that it has a 2"-long tongue the exact thickness of that table-to-casting measurement.

Repeat the process to make as many gauges as you like. Mark the

blocks and store them with your thickness planer. The next time you plane, slip the gauge's tongue under the casting, then crank the head down until it bumps on the tongue, as shown.

—Kenneth Keen, Boyertown, Pa.

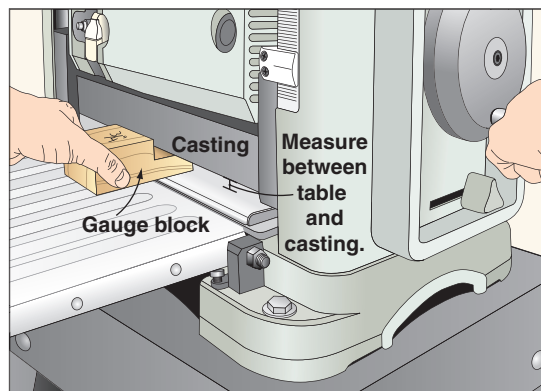

continued on page 24

## Our Winner



Photo: Love's Photography

Bob Wills has us to thank (or blame) for his obsession with intarsia. Inspired by an August 1988 *WOOD*® magazine feature on intarsia artist Judy Gale Roberts, our Top Shop Tip winner tried his hand at the craft, and quickly became hooked. Since that time, Bob and his wife, Karen, have spent their retirement years scrollsawing side-by-side, crafting hundreds of intarsia projects that have found homes as far away as England and Italy. To return the favor, Bob sent us the Top Shop Tip at left. Much obliged, Bob.



We're shipping a Grizzly G0443 cyclone dust collector to Bob Wills for sending in this issue's Top Shop Tip. Attaboy, Bob!

## Top tips win tools!

Describe how you've solved a workshop dilemma and you'll earn \$75 if it appears here. And, if your tip garners Top Shop Tip honors, you'll also win a tool prize worth at least \$250.

Send your best tips, along with photos or illustrations and your daytime phone number, to: **Shop Tips, WOOD Magazine, 1716 Locust St., GA-310, Des Moines, IA 50309-3023.** Or e-mail tips to: [shoptips@woodmagazine.com](mailto:shoptips@woodmagazine.com). Remember to include your contact info in the e-mail as well.

Because we try to publish only original tips, please send your tips only to *WOOD* magazine. Sorry, submitted materials can't be returned.

## Notch drill bits for permanent stop-collar settings

I've been very happy with my pocket-hole jig except for one minor inconvenience. When I need to change the drill depth between 1/2"- and 3/4"-thick material, I find it takes too much time. To remedy the problem, I made a quick reference mark on the bit shank to locate the stop collar. After correctly positioning the collar on the bit shank, I made a shallow notch at the top of the collar with a hacksaw. With this method, the mark won't disappear from extensive use.

—Yaniv Matza, Tamarac, Fla.

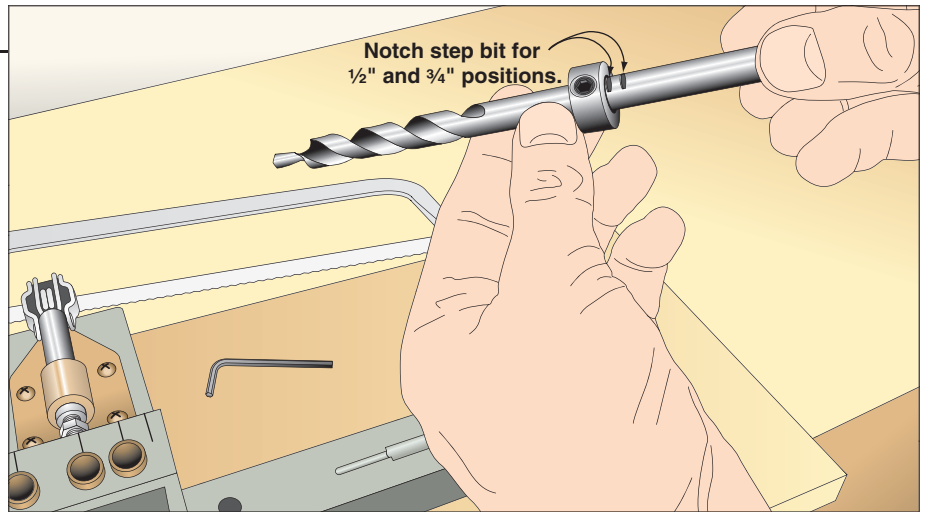

## Fresh clamping idea: Wrap a chair with cellophane

Few things offer a bigger clamping challenge than trying to glue a chair's rungs and legs. Recently, I hit on an inspired solution while watching a home-center employee secure an awkward load with stretch film. I found a roll of 5"-wide stretch film at the home center and went home to try my idea.

I first glued and wrapped the chair's rungs and stretchers together. Then I glued and connected the legs to the rung-and-stretcher assembly and to the seat bottom, and generously wrapped the entire leg assembly with tight rows of the film.

Not only is the technique extremely fast and simple, there's zero chance of a clamp slipping off and no concerns about leaving bite marks from the clamping.

—Jay Goldenberg, Royal Oak, Mich.

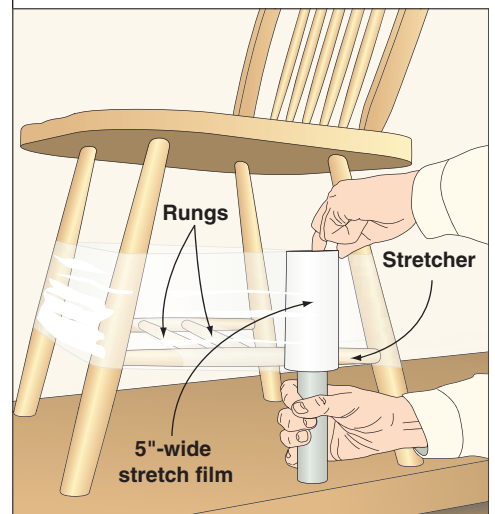

continued on page 26

### Super-simple rip fence that can throw you a curve

If you need to bandsaw a curve on the edge of a mostly straight workpiece, such as the slats in the Traditional Oak Dining Chair in *WOOD* magazine issue #154, here's a way to do it in one continuous cut. (Those slats flare out near the top. I didn't want to risk trying to cut the straight part of the slats free-hand, but neither did the cuts lend themselves to using a standard bandsaw fence.)

Build a shortened auxiliary fence, as shown, and clamp it to the bandsaw table so that the end nearest the blade stops  $\frac{1}{4}$ "– $\frac{3}{8}$ " short of the blade's teeth. This fence provides the accuracy of a fence on the straight portion, yet still allows for freehand maneuverability to make the curved exit cut.

—Kevin Boyle, *WOOD* magazine  
Senior Design Editor

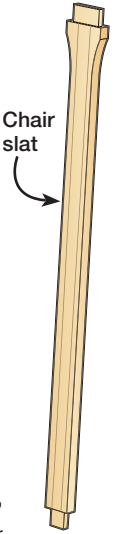

#### TOP VIEW

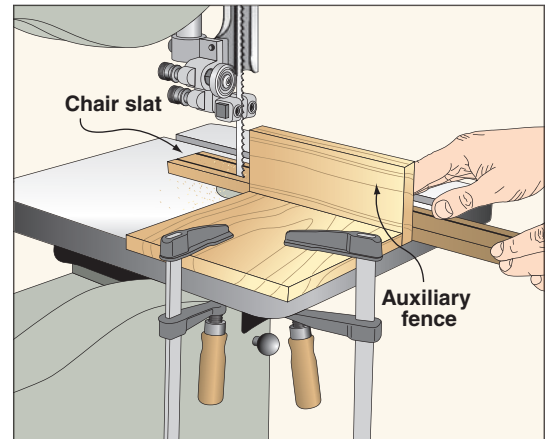
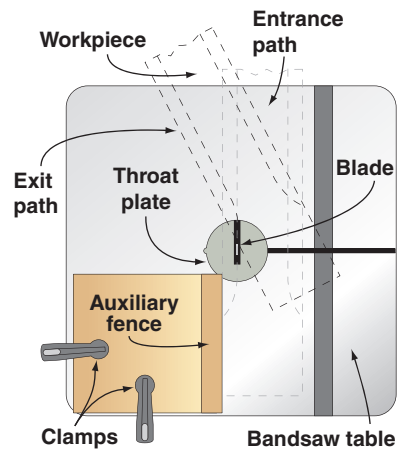

continued on page 28

## Ground fault protection for every job site

Whenever I go to help a friend on a home-improvement project, I never know whether the electrical outlets I'll be using, especially outdoor outlets, are protected by a ground-fault circuit interrupter (GFCI). To protect myself from accidental electrical shock, I built a portable GFCI-protected outlet by cutting the end from a heavy-duty extension cord and wiring it to a GFCI outlet in a weather-tight PVC electrical box.

With a tool plugged into this outlet, the other end of the cord can be plugged into any outlet and I know I'm protected. My portable GFCI is small enough to toss in my toolbox and costs considerably less than an "off-the-shelf" GFCI extension cord.

—Tom Bentsen, Columbia, Md.

*Editor's note: When a ground-fault circuit interrupter detects small amounts of stray current between the outlet and any appliance or tool plugged into it, the built-in breaker shuts off the current almost instantly. This protection is most important for tools that are not double-insulated. (Double-insulated tools usually have a two-prong, ungrounded plug).*

*A GFCI outlet offers an extra layer of protection because normal circuit breakers are designed to detect "shorts," not small amounts of stray current. However, GFCI protection is not a substitute for a properly grounded outlet. And, although acceptable for home use, this tip may not meet OSHA requirements for job-site use.*

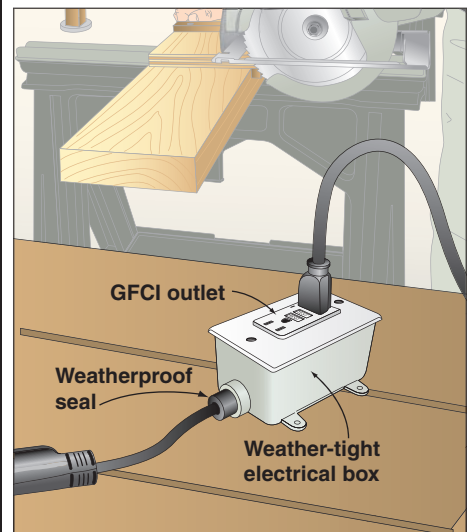

*continued on page 30*

## Sanitary station for a drippy glue brush

It's interesting how one good idea often leads to another. Not long ago, I countersunk and epoxied  $\frac{3}{4}$ " magnets into both ends of my shop bench to hold screws while assembling a project.

Later, when gluing up a project, I realized the flux brush I use for spreading glue has a steel handle. So, to keep glue off my bench, I began storing the brush on the magnet with the gooey bristles hanging over the edge. Still later, after cleaning a few glue drips off the floor, I added the flip-out drip catcher, shown *below*, to the underside of the bench.

To mount the magnets, drill a hole in the bench corners with a Forstner bit the same diameter as your magnet. The hole should be only deep enough that the magnet lies flush with the table surface. For the drip catcher, cut the handle off a cheap plastic putty knife and attach it to the bottom of the bench with a fender washer and screw. Position the drip catcher so that you can fold it completely out of the way when not in use.

—Aaron Butler, Danville, Pa.

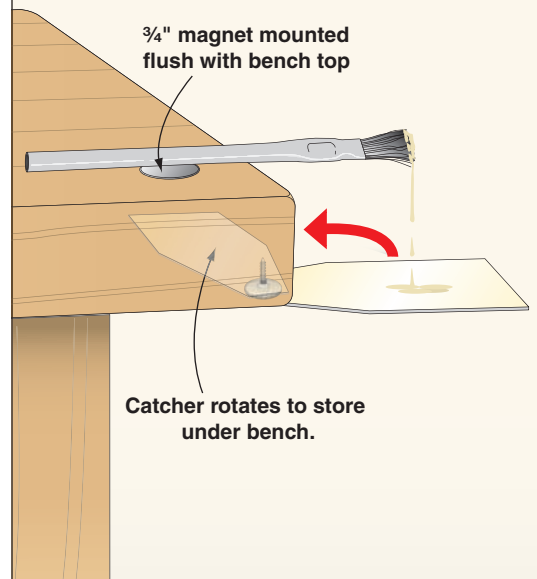

**See a new**

Shop Tip  
of the Day at

[woodmagazine.com/tips](http://woodmagazine.com/tips)



# Euro-style hinge tricks

2 quick tips that make installation a snap



**I**t's no wonder European-style concealed hinges have become so popular. With simple up-down, in-out, and side-to-side adjustability, they're just the ticket for fine-tuning the fit of

inset or overlay cabinet doors. The key to installing these hinges lies in accurately boring the 35mm hinge-cup holes in the door stile. Here are two tips for doing just that.

## Trick 1: Use a positioning guide

To get started, cut a  $\frac{3}{4} \times 3 \times 7$ " piece of plywood, particleboard, or medium-density fiberboard. Lay out the center of the hinge-cup hole, where shown on the drawing, *right*. Then chuck a 35mm Forstner bit into your drill press and bore a hole through the guide. (Don't have a 35mm Forstner bit? See the next trick for a solution.) Now position the fence and stopblock, adjust the drill-press depth stop to the required depth, and bore hinge-cup holes, as shown in the three photos *below*.

**Note:** The Blum 95° inset hinges for the workbench cabinet on page 42-43 require  $\frac{7}{16}$ "-deep hinge-cup holes with a  $\frac{7}{8}$ " backset, as noted on the drawing. The backset and depth of hinge-cup holes vary for other types and brands of hinges. Check the instructions included with the hinges. Use the  $1\frac{3}{8}$ " endset noted on the drawing for the short doors of the workbench cabinet. For longer doors, such as kitchen cabinet doors, use a 3" endset.

**Endset:** Distance from the top and bottom of the door to the center of the hinge-cup hole ( $1\frac{3}{8}$ " for the workbench cabinet doors on *page 43*)

**Backset:** Distance from the edge of the door stile to the center of the hinge-cup hole ( $\frac{7}{8}$ " for the workbench cabinet doors on *page 43*)

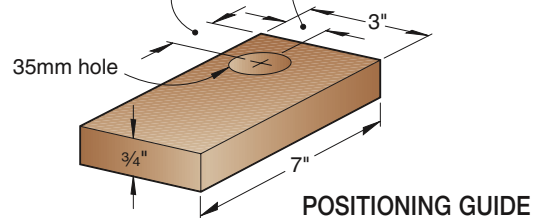

## Trick 2: Substitute a 1 3/8" bit

Suppose you don't have a 35mm Forstner bit. A  $1\frac{3}{8}$ " Forstner bit is only .003" smaller than 35mm (about the thickness of a sheet of paper) and works just fine. 🌲

### DRILL PRECISION HINGE-CUP HOLES IN 3 EASY STEPS

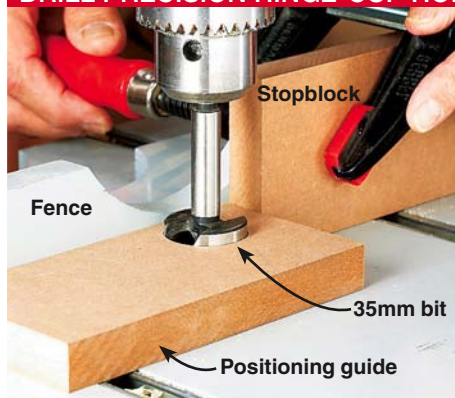

**Step 1** With the bit in the guide hole, position the fence so it touches the back edge of the guide. Place a stopblock at the right end.



**Step 2** Set the drill-press depth stop to the required depth and bore hinge-cup holes in all your doors for the first hinge.

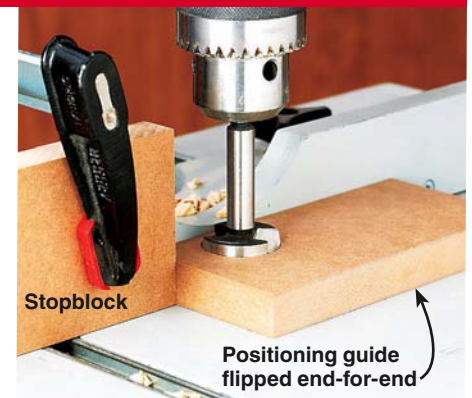

**Step 3** Flip the guide end-for-end, insert the bit, and reposition the stopblock. Now drill hinge-cup holes for the second hinge.



## COVER PROJECT

centuries old, but never outdated

# traditional workbench



To save time without compromising quality, consider purchasing a manufactured benchtop. The sidebar on the next page makes the case.

This 15"-wide front vise uses the same sturdy hardware as the end vise.

A slatted shelf provides ample space for tools or lumber.

Inexpensive hardware makes it easy to equip your bench with this 17½"-wide end vise.

## TWO GREAT OPTIONS



**Option 1:** A hanging tool tray keeps your benchtop clear. See page 41.

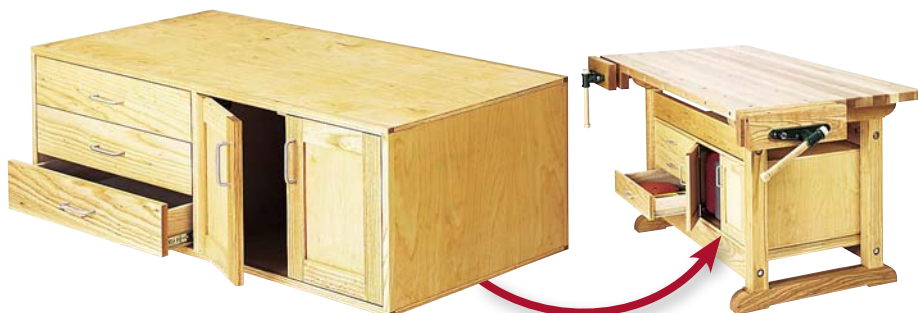

**Option 2:** An under-bench cabinet replaces the slatted shelf to store supplies within easy reach. See page 42.

Used since the dawn of woodworking, workbenches evolved by the 1600s into the form we recognize today. Although improvements, such as better vise hardware and metal bench dogs, have been added, the basic design remains the same. Even if you're not a hand-tool aficionado, you'll find this traditional workbench with front vise, end vise, and bench dogs as important a tool as your tablesaw.

To save dollars, we built our workbench base from sturdy but economical ash. To fully accessorize your workbench, make the tool tray on page 41 and the under-bench cabinet on page 42.

## 1a FOOT AND RAIL PROFILE

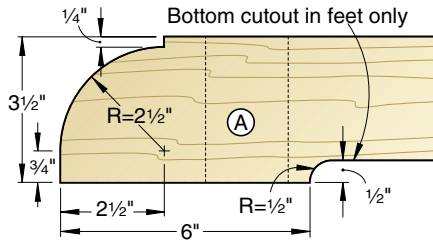

## 1 BASE END ASSEMBLY (Inside face shown)

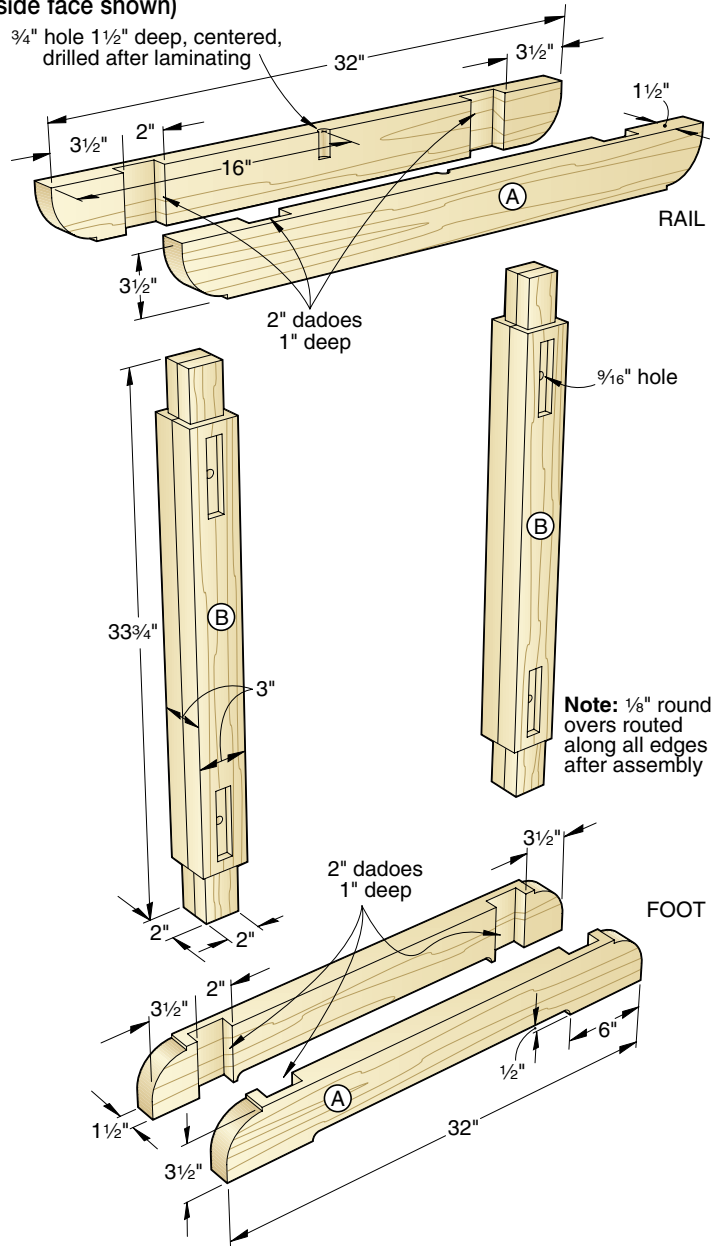

## 1b LEG FRONT VIEW

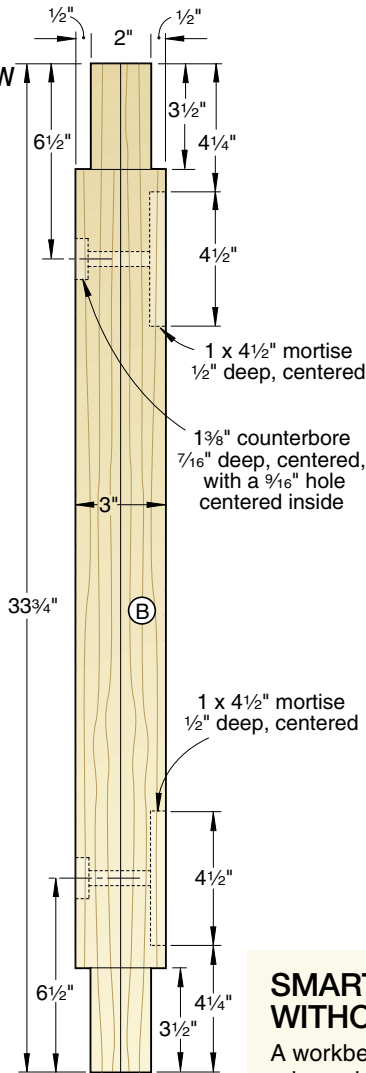

## Start with the base ends

**1** To form split mortises and laminate the feet and rails (A) shown on **Drawing 1**, see *page 10*. The parts are initially cut over-size, so refer to the **Materials List** on *page 44* for finished dimensions.

**2** Referring to **Drawing 1a**, lay out the foot and rail end profiles and the foot bottom cutouts, and bandsaw and sand them to shape. Then, for anchoring the benchtop later, use a 3/4" brad-point bit to bore 1 1/2"-deep holes, centered in the top edges of the rails, where shown on **Drawing 1**.

**3** To laminate the uprights (B) and form the tenons shown on **Drawings 1** and **1b**, see *page 10*. Lay out the mortises for the stretchers (C), where dimensioned on **Drawing 1b**. Chuck a 1" Forstner bit into your drill press, and remove most of the waste by boring overlapping 1/2"-deep holes. Then clean up the mortises with a chisel.

**4** Chuck a 1 3/8" Forstner bit into your drill press, and bore 7/16"-deep counterbores in the uprights (B), centered in the width, where

## SMART CHOICES SAVE MONEY AND TIME WITHOUT SACRIFICING PERFORMANCE

A workbench that wobbles or won't stay put is not only annoying, it also can adversely affect the quality of your work. That's why bases are built of stout, heavy members. But stout members mean lots of board feet of lumber, so a wise choice of species can save you money. Strong, heavy, and good looking, ash represents a real bargain (about \$2.50 per board foot in our area for 1 3/4"-thick stock) compared to hard maple (\$6 per board foot), or even red oak (\$4.50 per board foot).

Choosing a manufactured laminated hard-maple benchtop saves you a bundle of time. Allowing for waste, it'll take about 42 board feet of hard maple to glue up a 1 3/4 x 36 x 72" top. At \$6 per board foot, that's \$252 just for the lumber. Even though you'll have the advantage of selecting the lumber for uniform color, you still have to rip 1 3/4"-thick stock on your tablesaw, edge-join the top, and then get it reasonably flat. At \$270 delivered to your door, a manufactured top may be a better choice. You'll take your chances on color, but it'll be smooth, flat, prefinished, and ready for drilling dogholes and mounting vises.

Of course, any dense domestic hardwood will make a good benchtop and base. (Avoid lightweight species such as poplar and soft maple.) So if you have a stack of *well-dried* lumber (12–15 percent moisture range) inherited from Uncle Jake or bought on the cheap from the farmer down the road, consider using it for this project.

## 2 EXPLODED VIEW

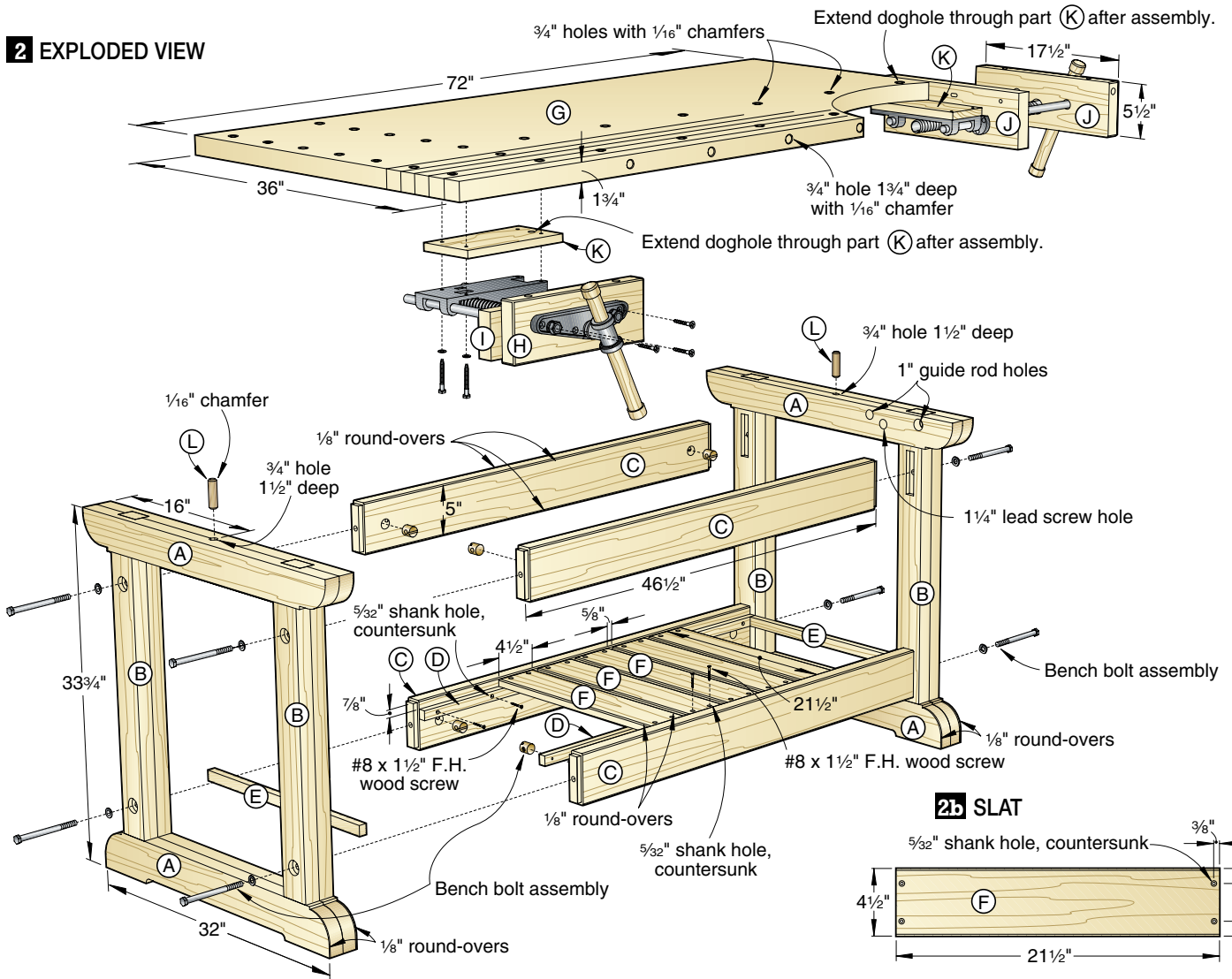

dimensioned on **Drawing 1b**. Then with a  $\frac{1}{16}$ " brad-point bit, bore holes through the uprights, centered in the counterbores.

**5** Finish-sand the feet and rails (A) and uprights (B). Take care not to round the

edges of the tenon shoulders. Then glue and clamp the base end assemblies (A/B) together. With the glue dry, chuck a  $\frac{1}{8}$ " round-over bit into your handheld router and rout all the edges.

## Make stretchers and a shelf

**1** Cut the stretchers (C) to size. Then with a dado blade in your tablesaw, form tenons on the ends, where dimensioned on **Drawing 2a**. Because the stretcher-to-upright joint is

### LET THE UPRIGHT HOLES GUIDE THE BIT FOR PERFECT ALIGNMENT

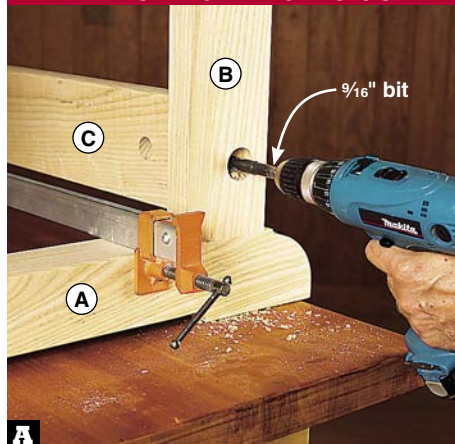

**A** Clamp the stretchers (C) between the end assemblies. Using the holes in the uprights (B) as guides, drill into the stretcher ends.



**B** Mark the  $\frac{3}{4}$ " hole depth on the drill bit with masking tape. Aiming for the center of the barrel nut hole, extend the hole to full depth.

### SPACERS POSITION THE SLATS



**C** Separate the slats (F) with  $\frac{5}{8}$ "-thick spacers. Then using the slat holes as guides, drill pilot holes into the cleats (D) and drive the screws.

## 2a STRETCHER TENON DETAIL

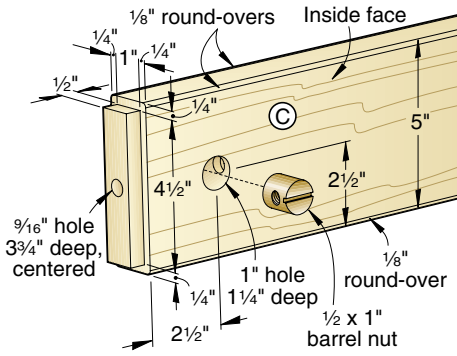

taken apart when moving the bench, make the fit of the stretcher tenons in the upright (B) mortises slightly loose. Now rout  $\frac{1}{8}$ " round-overs along the stretcher edges.

**2** Chuck a 1" Forstner bit into your drill press and bore  $\frac{1}{4}$ "-deep holes for the barrel nuts in the *inside* faces of the stretchers (C), where dimensioned on **Drawing 2a**. (See **Sources** for bench bolt sets that include barrel nuts, bolts, and washers.) Then drill  $\frac{3}{16}$ " holes as deep as the bit allows into the stretcher ends, as shown in **Photo A**. Now remove the stretchers, mark the ends and mating mortises for reassembly, and extend the holes to the full  $\frac{3}{4}$ " depth, as shown in **Photo B**.

**3** Insert barrel nuts into the stretchers (C), where shown on **Drawing 2**, and assemble the workbench base with the supplied bolts and washers. Then cut the side cleats (D) and end cleats (E) to size and finish-sand them. Clamp the side cleats in place  $\frac{7}{8}$ " from the top edges of the stretchers. Now drill countersunk screw holes through the side cleats and into the stretchers and drive the screws.

**Note:** *If you plan to build the under-bench cabinet, shown on page 42, omit the side cleats (D), end cleats (E), and slats (F).*

**4** Cut the slats (F) to size. Drill countersunk shank holes at the ends, and rout  $\frac{1}{8}$ " round-overs along the top edges, where shown on **Drawing 2b**. Finish-sand the slats. Position the slats on the side cleats (D), and fasten them in place, as shown in **Photo C**. Glue and clamp the end cleats (E) to the bottoms of the end slats with their edges flush.

## Add the top and vise jaws

**1** Unpack the laminated top (G). With a  $\frac{3}{4}$ " brad-point bit, bore  $\frac{1}{4}$ "-deep holes in the bottom face to align with the holes in the rails (A), where dimensioned on **Drawing 3**. To make a simple guide for boring these holes and the bench-dog holes perpendicular to the surface, see *page 14*. Then turn the top right side up and bore  $\frac{3}{4}$ " bench-dog holes through the top. (See **Sources** for the bench dogs we used.) Now bore  $\frac{3}{4}$ " bench-dog holes  $\frac{1}{4}$ " deep in the front edge. Chuck a chamfer bit into your handheld router and

## 3 TOP

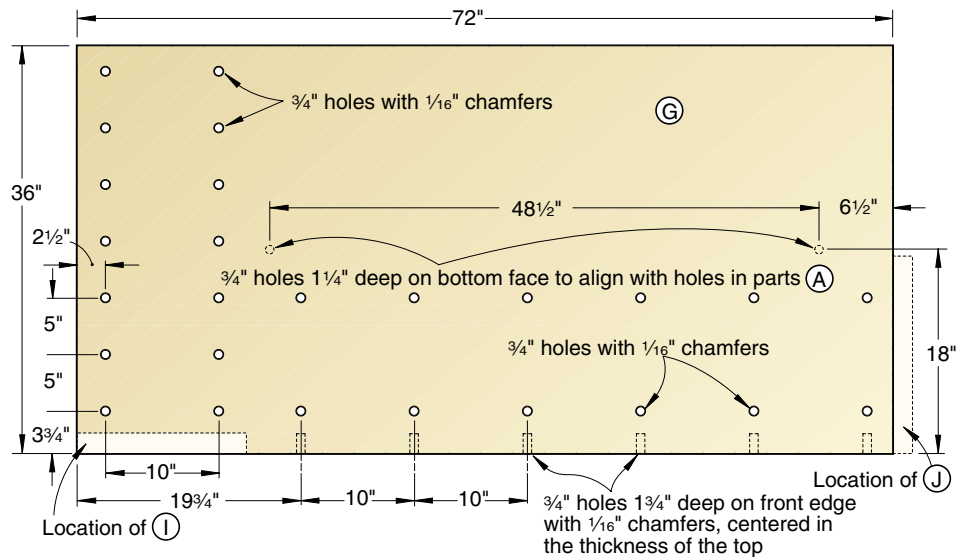

rout  $\frac{1}{16}$ " chamfers on the edges of all the bench-dog holes.

**2** Cut the front-vice front jaw (H), front-vice rear jaw (I), and end-vice jaws (J) to size. (See **Sources** for the vise mechanism.) Chuck a  $\frac{3}{4}$ " brad-point bit into your drill press, and bore bench-dog holes  $\frac{1}{4}$ " deep in the top edge of each front jaw and one bench-dog hole in the left-hand end of the end-vice front jaw, where dimensioned on **Drawing 4**.

**Note:** *Although we make references to the instruction booklet included with the vises, we found the "one-size-fits-all" approach confusing. So we tailored the following instructions for installing the vises on this workbench. We also worked out a simpler installation method.*

**3** Adhere the front jaws to the rear jaws with double-faced tape, keeping the ends and bottom edges of the front-vice jaws (H, I) and all edges of the end-vice jaws (J) flush. Draw a centerline and carriage baseline on each front jaw, where shown on **Drawing 4**. Remove page 10 (the hole drilling template for the *large* front vise) from one of the instruction booklets included with the vises. Use a utility knife to cut out two triangular alignment windows along the centerline, where indicated on the template. Aligning the template centerline and baseline with those marked on the jaws, transfer the guide rod and lead screw hole centers indicated on the template to the jaws with an awl. Save the template for use later.

**4** Chuck a  $\frac{1}{4}$ " Forstner bit into your drill press, and bore lead screw holes through both pairs of jaws. Switch to a 1" Forstner bit, and bore guide rod holes through the front jaws and just far enough into the rear jaws to mark the hole centers.

## 3a MOUNTING THE REAR JAWS

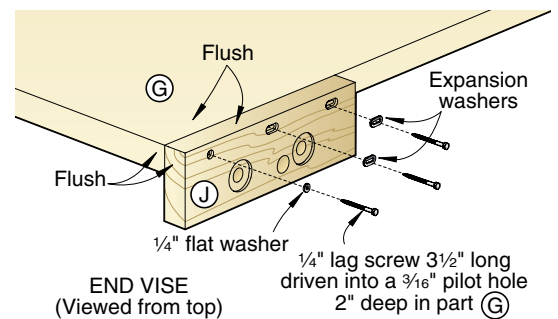
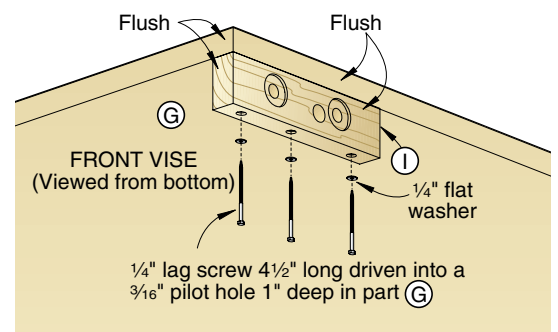

**5** Separate the jaws, and rout  $\frac{1}{8}$ " round-overs on the outside ends and edges of both front jaws. Then to recess the support collets in the rear jaws, chuck a  $\frac{2}{8}$ " Forstner bit into your drill press, center it on the guide rod holes previously marked, and bore  $\frac{3}{16}$ "-deep counterbores. Switch to a 1" Forstner bit, and finish drilling the guide rod holes through the rear jaws.

**6** Chuck an  $\frac{1}{16}$ " Forstner bit into your drill press, and bore three counterbores  $\frac{1}{4}$ " deep centered in the bottom edge of the front-vice rear jaw (I) and one in the front face of the end-vice rear jaw (J), where dimensioned on **Drawing 4**. Then in the end-vice rear jaw, bore overlapping  $\frac{1}{16}$ " holes  $\frac{1}{4}$ " deep, and clean up the edges with a chisel to form two  $\frac{1}{4}$ "-long counterbores for expansion washers. (See **Sources**.) Switch to a  $\frac{1}{4}$ "

## ACCURATE VISE INSTALLATION IN THREE EASY STEPS

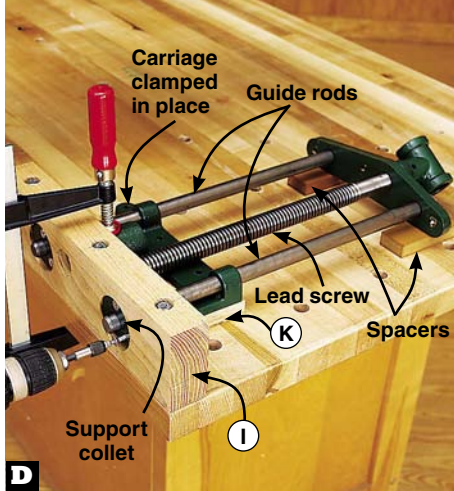

**D** Using the holes in the support collets as guides, drill  $\frac{5}{32}$ " pilot holes into the jaws and drive the supplied #14 $\times$ 1 $\frac{1}{2}$ " flathead screws.

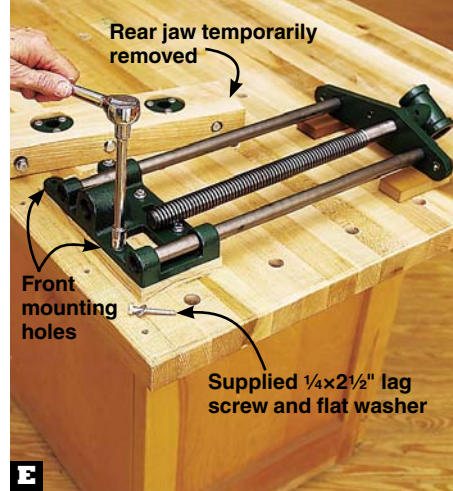

**E** Using the two front holes as guides, drill shank and pilot holes and finish fastening the carriage with lag screws and washers.

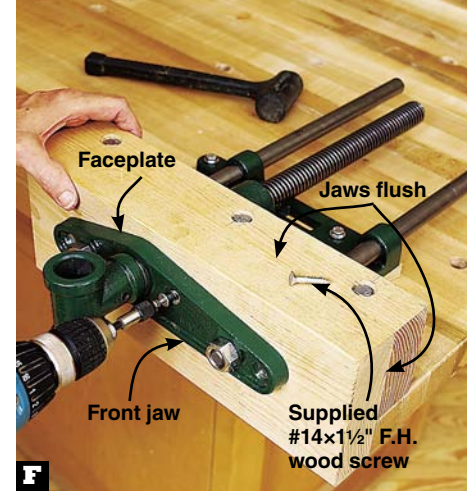

**F** Using the three holes in the faceplate as guides, drill  $\frac{5}{32}$ " pilot holes into the front jaw. Screw the jaw to the faceplate.

brad-point bit, and drill holes through the jaws, centered in the counterbores. Now drill overlapping holes centered in the elongated counterbores, and clean up the edges with a chisel to form  $\frac{1}{4}$ " slots  $\frac{3}{4}$ " long.

**7** Referring to **Drawings 3** and **3a**, clamp the front-vise rear jaw (I) to the bottom surface of the top (G), flush with the front edge and left end. Clamp the end-vise rear jaw (J) to the right end of the top, flush with the top surface of the top and the front edge. Then using the holes and centers of the slots as guides, drill  $\frac{3}{16}$ " pilot holes into the top. Fasten the jaws to the top with  $\frac{1}{4}$ " lag screws and flat and expansion washers.

### Mount the vises

**1** Lay the top (G) bottom face up on the base. Referring to page 3 of the vise instruction booklet, separate the vise front assemblies (faceplate, lead screw, and guide rods) from the vise carriages.

**2** Cut the spacers (K) to size. Center the carriages on the spacers, and position them behind the rear jaws (I, J). (The dog-hole covered by each spacer will be bored through later.) Then from the *rear*, slide the guide rods into the carriages and through the holes in the rear jaws until the lead screws contact the jaws. Support the vise front assemblies with  $\frac{3}{4}$ "-thick spacers. Slide the

support collets, countersunk sides facing out, onto the guide rods and into the  $2\frac{3}{8}$ " counterbores in the jaws. Orient the collets with the flat edges toward the top surface of the top (G). With the spacers and carriages tight against the rear jaws, move them side-to-side to center the support collets in the counterbores. Clamp the carriages in place, and fasten the collets, as shown in **Photo D**.

**3** Remove the vise front assemblies from the carriages. Then using the three rear holes in each carriage as guides, drill shank holes through the spacers and pilot holes into the top. Secure the carriages with the supplied  $\frac{1}{4}\times 2\frac{1}{2}$ " lag screws and flat washers.

Now remove the clamps and rear jaws (I, J) and finish fastening the carriages, as shown in **Photo E**. Reinsert the vise front assemblies from the rear, slide the rear jaws onto the protruding guide rods, and refasten the jaws. Remove the vise front assembly.

**4** Slide the front jaws (H, J) onto the guide rods. Insert the rods into the support collets from the front and draw the vise jaws together with the lead screw until they are snug. Tap the front jaws with a mallet to align them with the rear jaws (I, J), and tighten the lead screw. Then fasten the jaws to the faceplates with the supplied #14 $\times$ 1 $\frac{1}{2}$ " flathead wood screws, as shown in **Photo F**.

**5** Move the top (G), bottom face up, onto sawhorses. Cut the alignment pins (L) to length, sand  $\frac{1}{16}$ " chamfers on the ends, and insert them in the holes in the top. Then to mark clearance hole locations for the guide rods on the rail

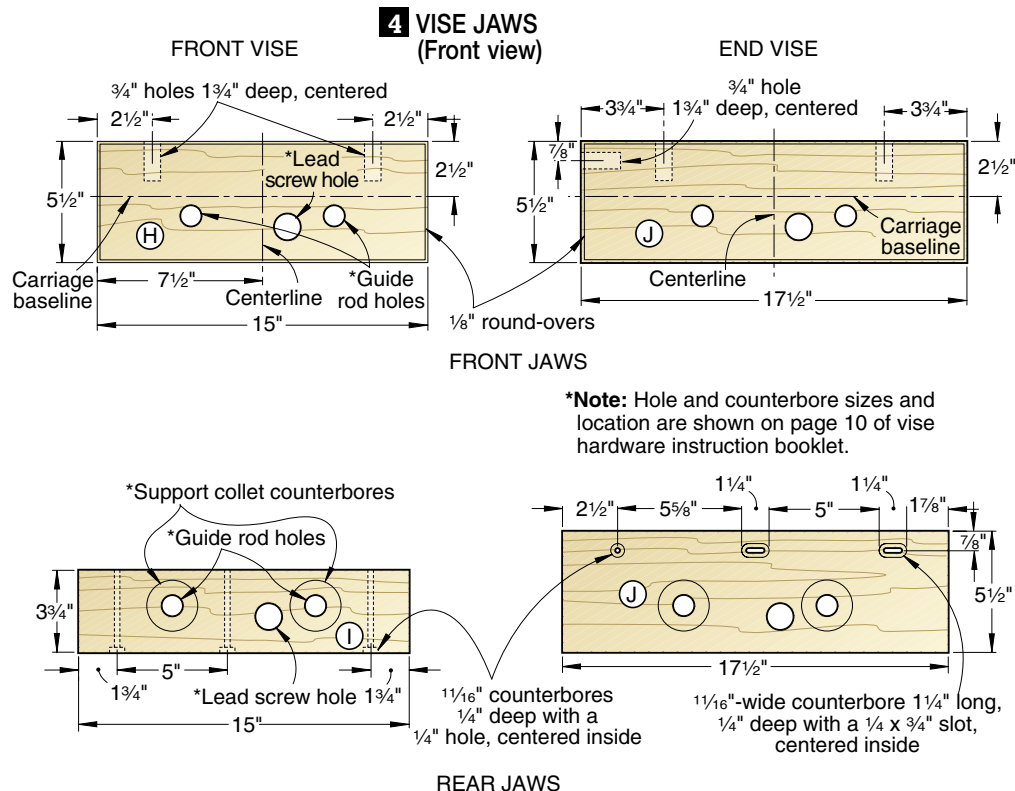

## DEAD-ON GUIDE ROD MARKING

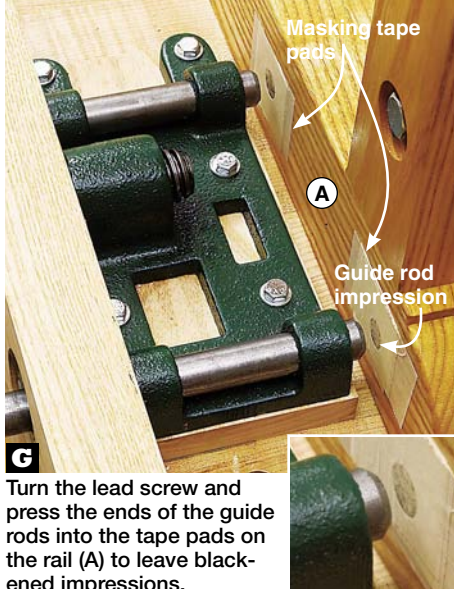

Turn the lead screw and press the ends of the guide rods into the tape pads on the rail (A) to leave blackened impressions.

(A), open the tail vise so the ends of the guide rods do not protrude beyond the carriage. Position the workbench base upside down on the top, inserting the alignment pins into the holes in the rails. Make two six-layer pads of 1½"-wide masking tape and adhere them to the rail at the tail vise end, aligning the pads with each guide rod. Use a pencil to coat the ends of the guide rods with graphite. Now mark guide rod locations on the rail, as shown in **Photo G**.

**6** Remove the top (G) from the base and unbolt the marked end assembly (A/B) from the stretchers (C). Then retrieve the drilling template and cut out the guide rod diameter holes. Align the template holes with the guide rod marks on the masking tape adhered to the rail (A). Mark the centers of the lead screw clearance hole and the guide rod clearance holes with an awl. Now chuck a 1" Forstner bit into your drill press

and bore the guide rod holes. Switch to a 1¼" Forstner bit, and bore the lead screw hole.

**7** Reassemble the base, insert the alignment pins, and reposition the top (G) on the base. Chuck a ¾" brad-point bit into your handheld drill. Using the dogholes obstructed by the spacers (K) as guides, bore holes through the spacers. Install the handles in the vises. (See **Sources** for the handles.)

## Apply a protective finish

**1** Remove the top (G) from the base and set it aside. Inspect the base parts and finish-sand, where needed. Apply a clear finish. (We applied three coats of Minwax Antique Oil Finish.)

**2** Reassemble the base where you wish to locate the bench, insert the alignment pins (L), and set the top in place. Now make your bench even better by building the tool tray or under-bench cabinet options.

## Hanging tool tray

This accessory hooks over either stretcher and slides from end to end to keep the benchtop clear and your tools handy.



### 5 TOOL TRAY

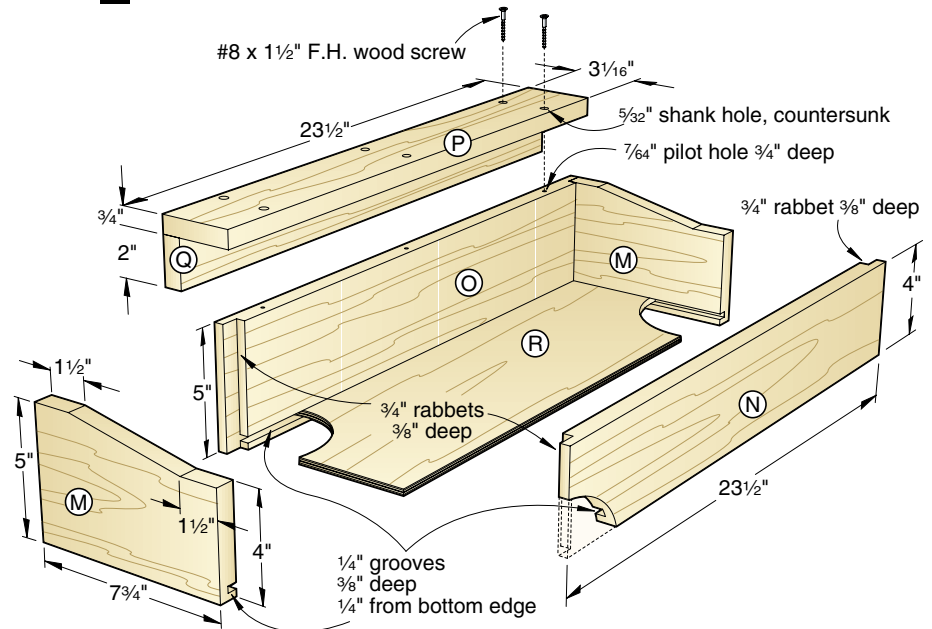

### Cut, assemble, and finish

**1** Cut the sides (M), front (N), back (O), hanger (P), and cleat (Q) to size. With a dado blade in your tablesaw, cut ¾" rabbets ⅜" deep along the ends of the front and back, where shown on **Drawing 5**. Then cut ¼" grooves ⅜" deep for the bottom (R) in the sides, front, and back. Finish-sand the parts.

**2** Cut the ¼" plywood bottom (R) to size and glue and clamp the tray. Clamp the hanger (P) to the back (O), where shown on **Drawing 5**. Drill countersunk screw holes

through the hanger and into the back and drive the screws. Then attach the cleat (Q), as shown in **Photo H**. Remove the spacer.

**3** Inspect the tray parts, and finish-sand, where needed. Apply a clear finish.

**4** To hang the tool tray on either side of the workbench, insert the hanger (P) and cleat (Q) between the benchtop (G) and the upper stretcher (C) and hook the cleat on the stretcher. Position the tool tray where you like by sliding it along the stretcher.

### SPACER ENSURES CLEARANCE

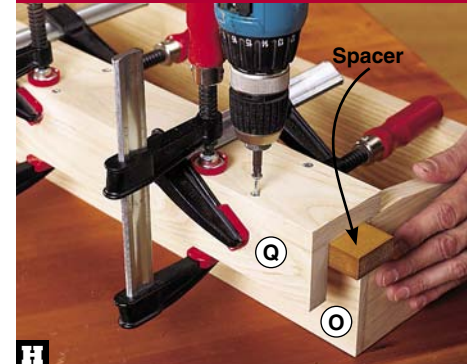

Clamp a 1⅙"-wide spacer between the cleat (Q) and back (O). Then drill countersunk screw holes, and drive the screws.

# Under-bench cabinet

Give your workbench the good looks of a classic cabinet base with this easy-to-build option.



Full-extension slides on the 3"-deep drawers give you access to every square inch of space.

A 22 $\frac{3}{4}$ "-deep cabinet has lots of room for tool cases and other large items.

## 6 CASE EXPLODED VIEW

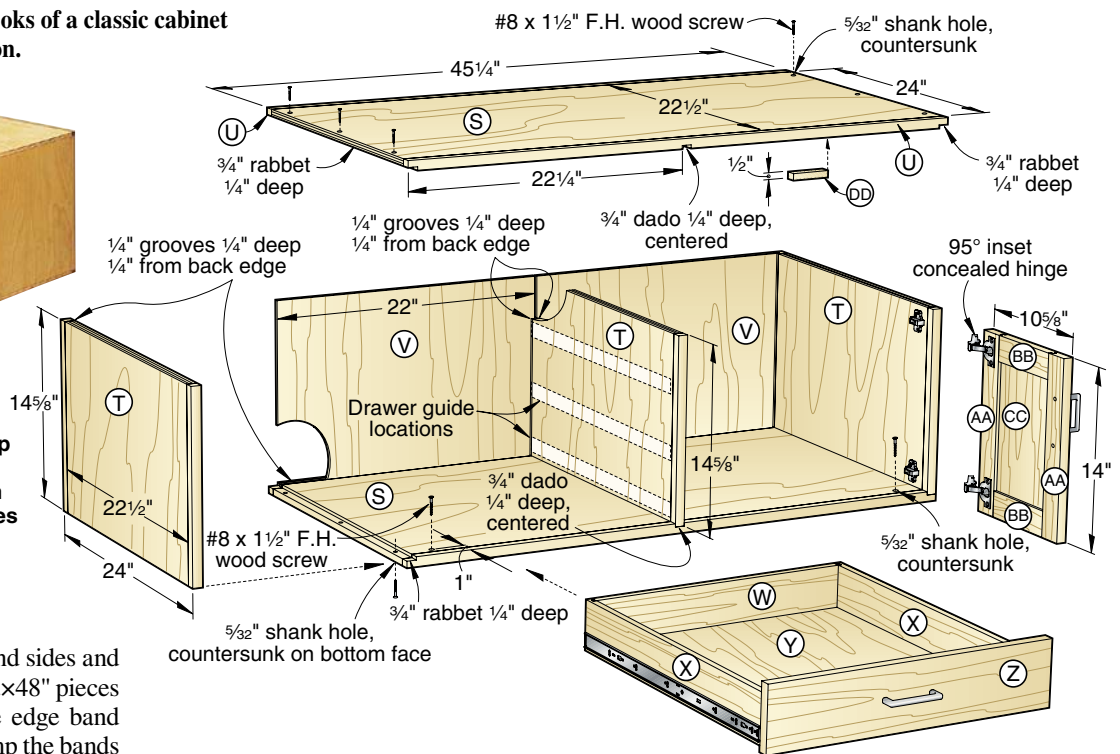

### Start with the case

**1** For the top and bottom (S) and sides and divider (T), cut three  $\frac{3}{4} \times 22\frac{1}{2} \times 48$ " pieces of birch plywood. Then cut the edge band blanks (U) to size. Glue and clamp the bands to both edges of the plywood. With the glue dry, sand the bands flush with the plywood.

**2** From the banded panels, cut the top and bottom (S) and the sides and divider (T) to size. Then cut  $\frac{3}{4}$ " rabbets  $\frac{1}{4}$ " deep and  $\frac{3}{4}$ " dados  $\frac{1}{4}$ " deep in the top and bottom, where shown on **Drawing 6**. Measure the thickness of the  $\frac{1}{4}$ " plywood for the backs (V) and cut  $\frac{1}{4}$ "-deep grooves in the top, bottom, sides, and divider, where shown on **Drawings 6** and **6a**. Cut the backs to size.

**3** Finish-sand the case parts and glue and clamp the case together in the configuration shown on **Drawing 6**. Drill countersunk screw holes through the top and bottom (S) and into the sides and divider (T), and drive the screws.

### Build three drawers

**1** From  $\frac{1}{2}$ " stock, cut the fronts and backs (W) and sides (X) to size. Then rabbet the ends of the fronts and backs and dado the ends of the sides, where dimensioned on **Drawing 7a**. Now cut grooves in the parts for the bottoms (Y). Cut the bottoms to size and finish-sand the parts. Glue and clamp the drawers. Check for square, and set the drawers on a flat surface to dry. Drill  $\frac{5}{32}$ " shank holes, countersunk on the inside face, through the fronts (W), where shown on **Drawing 7**.

**2** Separate the halves of the full-extension drawer slides and fasten the drawer members to the drawers with the supplied screws, where dimensioned on **Drawing 7**. Then fasten the case members to the side and divider (T), where shown on **Drawing 6b** and as shown in

#### 6a DIVIDER DETAIL

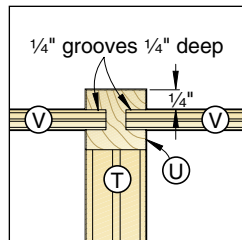

#### 6b DRAWER SLIDES

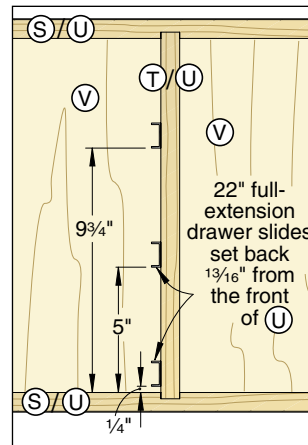

#### 6c DIVIDER DETAIL

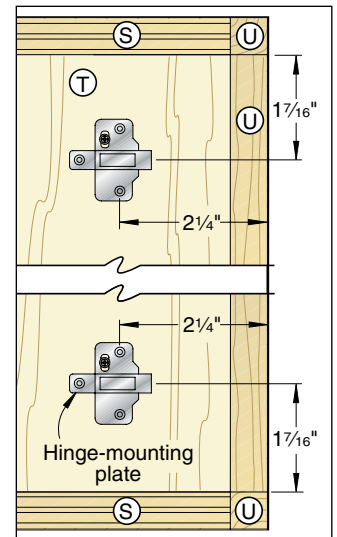

**Photo I.** Slide the drawers into the case.

**3** Cut the faces (Z) to size and finish-sand them. Then mount the faces to the drawers, as shown in **Photo J**. Using the countersunk holes in the fronts (W) as guides, drill pilot holes into the faces and drive the screws. Now drill holes for the drawer pulls, where shown on **Drawing 7**. Remove the faces, marking both drawers and faces "top," "center," and "bottom" for reassembly.

### Now make the doors

**1** Cut the stiles (AA) and rails (BB) to size. To cut centered grooves for the panels (CC), install a  $\frac{1}{8}$ " saw blade in your tablesaw and adjust it to cut a  $\frac{1}{4}$ "-deep kerf. Center the blade in the thickness of a stile and cut a groove. To ensure a centered groove, turn the stile end-for-end and make a second pass.

Then nudge the rip fence toward the blade and make two more passes. Test the fit of the plywood for the panels in the groove. Repeat the nudge and two passes sequence until the plywood fits the groove. Now, making two passes, cut grooves in the other stiles and rails, where shown on **Drawing 8**.

**2** With a dado blade in your tablesaw, form stub tenons on the ends of the rails (BB), where dimensioned on **Drawing 8a**. Cut the panels (CC) to size and finish-sand the parts. Glue and clamp the doors, checking them for square. Set them on a flat surface to dry.

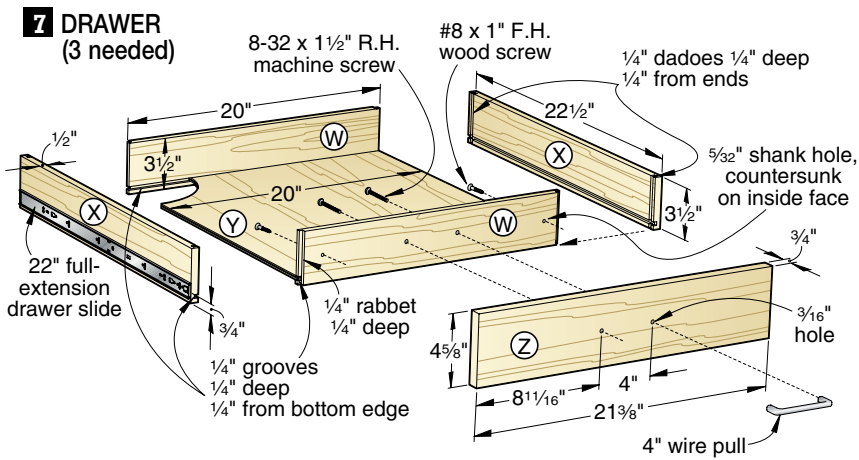

**7a DRAWER JOINT DETAIL**

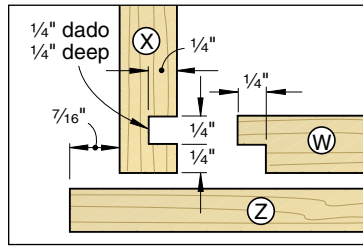

**8 DOOR**  
(Viewed from back)

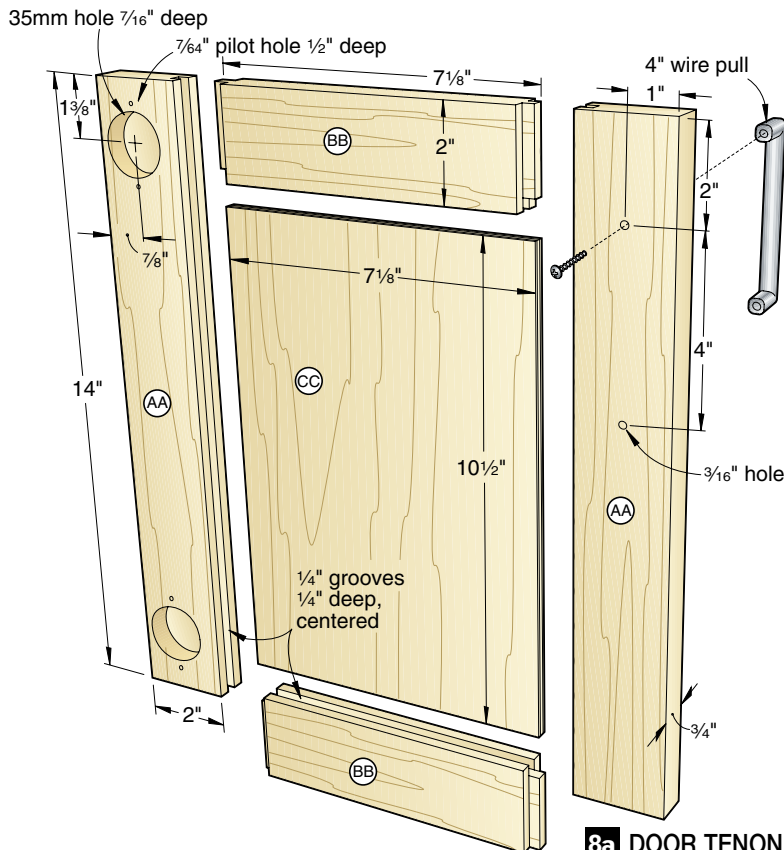

**8a DOOR TENON DETAIL**

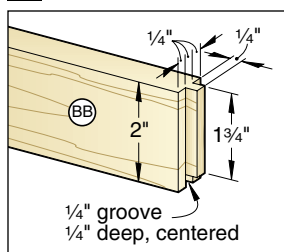

**DEAD-ON DRAWER SPACING**



**I** Cut 1/4x5x9 3/4" spacers. Use the length to align the top slides, the width for the middle slides, and thickness for the bottom slides.

**SHIMS GUARANTEE ALIGNMENT**

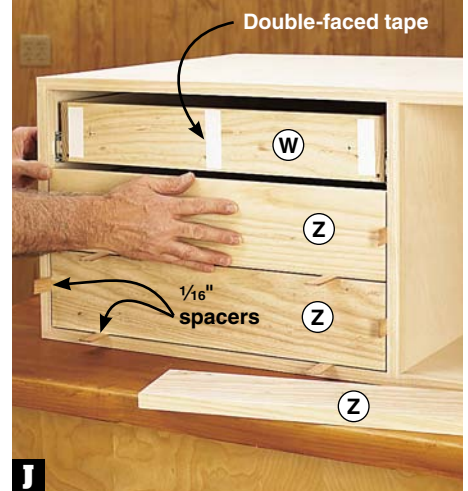

**J** Apply double-faced tape to the drawer fronts (W) and adhere the faces (Z) to them, inserting 1/16" shims to align the faces.

**3** Chuck a 1 3/8" (or 35mm) Forstner bit into your drill press, and drill 7/16"-deep hinge-cup holes, where dimensioned on **Drawing 8**. For more on installing European-style hinges, see *page 34*. Press the hinges into place and using the holes in the hinge-cup flanges as guides, drill 7/64" pilot holes 1/2" deep. Drive the supplied screws. Switch to a 3/16" bit, and drill holes for the pulls.

**4** Position the hinge-mounting plates where dimensioned on **Drawing 6c**, drill pilot holes, and screw them in place with the supplied screws. Hang the doors by screwing the hinges to the mounting plates. Adjust the doors flush with the bands (U), leaving even gaps all around. Now cut the stop (DD) to size, and finish-sand it. Glue and clamp the stop in place, centered in the case opening, where shown on **Drawing 6**.



## Apply finish and install

**1** Remove the doors, drawers, and all hardware. Inspect the parts and finish-sand, where needed. Apply a clear finish.

**2** Attach the drawer slides and hinge plates to the case. Then center the case on the base stretchers (C). Drill countersunk screw holes through the bottom (S) and into the front stretcher, where shown on **Drawing 6**, and drive the screws. Attach the drawer slides to the drawers, and screw the faces (Z) to the fronts (W). Install the drawer pulls, and slide the drawers into the case.

**3** Attach the hinges and pulls to the doors. Screw the hinges to the mounting plates, and check the door alignment. Now round up your favorite tools, and stock the cabinet. 🍷

Written by **Jan Svec** with **Chuck Hedlund**  
Project design: **Kevin Boyle**  
Illustrations: **Roxanne LeMoine**



## Materials List

Bench	FINISHED SIZE			Matl.	Qty.
	T	W	L		
A* feet and rails	3"	3½"	32"	LA	4
B* uprights	3"	3"	33¾"	LA	4
C stretchers	1½"	5"	46½"	A	4
D side cleats	¾"	1"	45½"	A	2
E end cleats	¾"	1"	20"	A	2
F slats	¾"	4½"	21½"	A	9
G top	1¾"	36"	72"	MT	1
H front- wise front jaw	1¾"	5½"	15"	A	1
I front- wise rear jaw	1¾"	3¾"	15"	A	1
J end- wise jaws	1¾"	5½"	17½"	A	2
K spacers	¾"	4¼"	9¾"	A	2
L alignment pins	¾" diam.	-	2½"	HD	2
<b>Tool tray</b>					
M sides	¾"	5"	7¾"	A	2
N front	¾"	4"	23½"	A	1
O back	¾"	5"	23½"	A	1
P hanger	¾"	3¼"	23½"	A	1
Q cleat	¾"	2"	23½"	A	1
R bottom	¼"	7¾"	22¾"	BP	1
<b>Cabinet case</b>					
S* top and bottom	¾"	22½"	45¼"	BP	2
T* sides and divider	¾"	22½"	14⅝"	BP	3
U edge band blanks	¾"	¾"	48"	A	6
V backs	¼"	22"	14⅝"	BP	2

Cabinet drawers						
W	fronts and backs	½"	3½"	20"	A	6
X	sides	½"	3½"	22½"	A	6
Y	bottoms	¼"	20"	22"	BP	3
Z	faces	¾"	4⅝"	21⅝"	A	3
Cabinet doors						
AA	stiles	¾"	2"	14"	A	4
BB	rails	¾"	2"	7⅞"	A	4
CC	panels	¼"	7⅞"	10½"	BP	2
DD	stop	½"	¾"	3"	A	1

\*Parts initially cut oversize. See the instructions.

**Materials key:** LA—laminated ash, A—ash, MT—manufactured top, BP—birch plywood, HD—hardwood dowel.

**Supplies:** #8x1", #8x1½" flathead wood screws; ¼x3½", ¼x4½" lag screws; ¼" flat washers; 8-32x1½" roundhead machine screws.

**Blade and bits:** Stack dado set; ¼", ⅜", ¾" brad-point drill bits; ⅜" round-over, chamfer router bits; 1⅜", 1", 1¼", 1⅝", 2⅜", 35mm (optional) Forstner bits.

### Sources

**Bench hardware.** Bench bolts (set of four bolts, flat washers, and barrel nuts) no. 05G07.01, \$22.50 (2 sets); vise handles no. 05G12.03, \$3.95 (2); large front vises no. 70G08.02, \$69.50 (2); #14 expansion washers no. 50K35.02, \$5.10 pk. of 12 (1 pk.); bench pups no. 05G04.04, \$14.95 pr. (2 pr.). Lee Valley. Call 800/871-8158, or go to [leevalley.com](http://leevalley.com).

**Cabinet hardware.** 95° inset concealed hinges no. 00B03.01, \$6.85 pr. (2 pr.); 22" full-extension drawer slides no. 02K30.22, \$11.90 pr. (3 pr.); 4" wire pulls no. 01W76.04, \$1.10 (5). Lee Valley, see above.

**Benchtop.** 1¾x36x72" laminated maple benchtop no. G9919, \$215 plus \$55 for shipping. Grizzly Industrial. Call 800/523-4777, or go to [grizzly.com](http://grizzly.com).

## Cutting Diagram

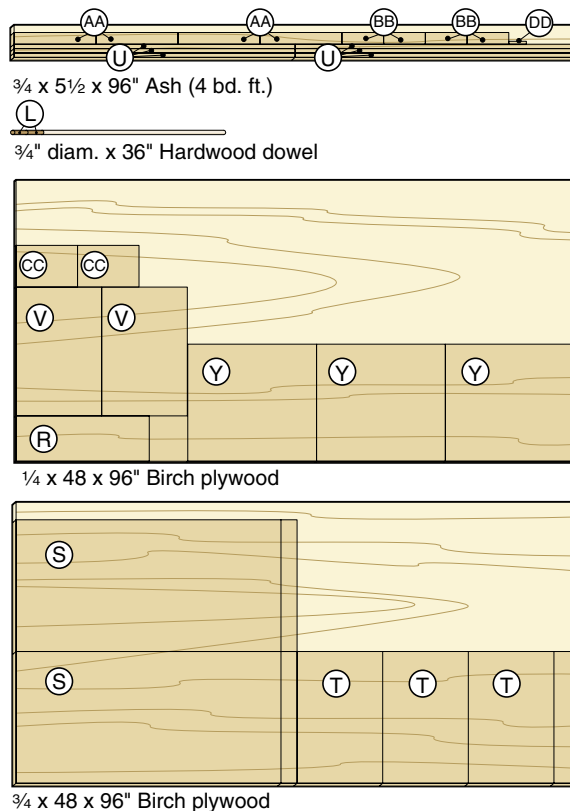
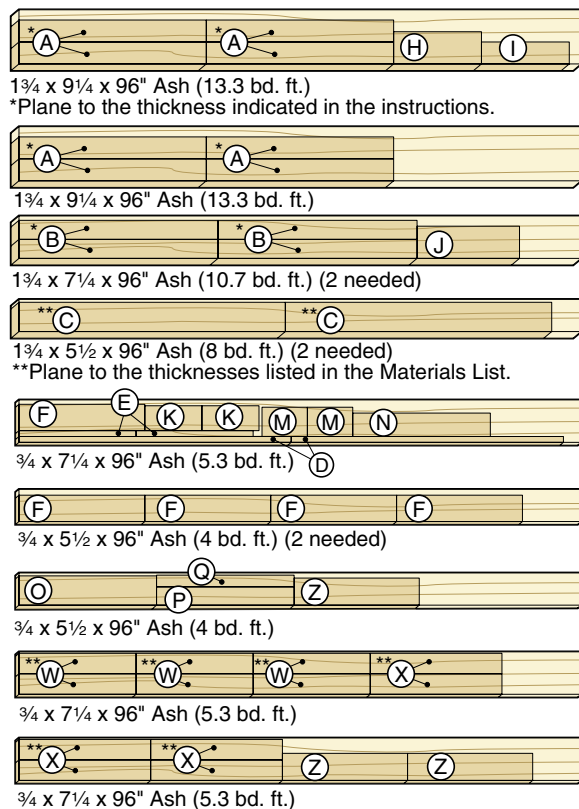

SHOP-TESTED

# step-up bandsaws

If you need more power or resaw capacity than your 14" bandsaw can provide, it's time to take your woodworking to the next level.



We measured each bandsaw's resawing power by first pulling 10"-wide red oak through each saw with 5 lbs of force, then with a stout 15 lbs, as shown here.

**W**hen we ask readers to name the most important quality of a bandsaw, “resawing capacity” ranks at or near the top of their wish list every time. You can add a riser block to many 14” bandsaws to stretch that typical 6” spec to 12”, but you can’t jack up the motor muscle needed for those hefty cuts in hardwoods. So we set out to find a group of bandsaws that

offer improved resawing capacity and power without breaking the bank.

Six bandsaws met our selection criteria: the Bridgewood BW-17WBS, Grizzly G0513 and G0514, Jet JWBS-16, Rikon 10-340, and Shop Fox W1707. Each sports at least 10” of resaw capacity, can rip stock 16” or wider, and sells for less than \$1,100. Stepping up to this class of bandsaw not only increases per-

formance, it also adds a number of meaningful features, shown *below*, that make it worth the leap.

## Pure power: The true measure of resaw capacity

To compare cutting power, we put these machines to work resawing 10”-wide red oak using identical 1”-wide, 2-tpi Olson AllPro

# 7 REASONS FOR STEPPING UP FROM A 14" BANDSAW

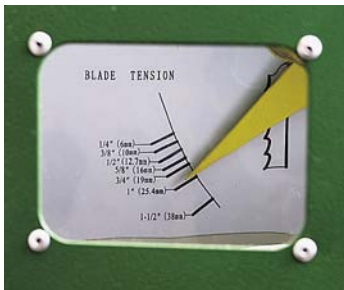

### 1 Tension gauges.

No more hard-to-read, back-of-the-saw indicators: View the blade tension easily through a window in the upper wheel cover. (Note: Jet’s window is on the back.)

### 2 Welded steel construction.

This design is said to be more rigid than cast-iron saws; we like that little assembly is required before putting the saw to work.

**3 Cutting power.** Larger, heavier wheels and more powerful motors help these saws cut through the hardest woods with ease.

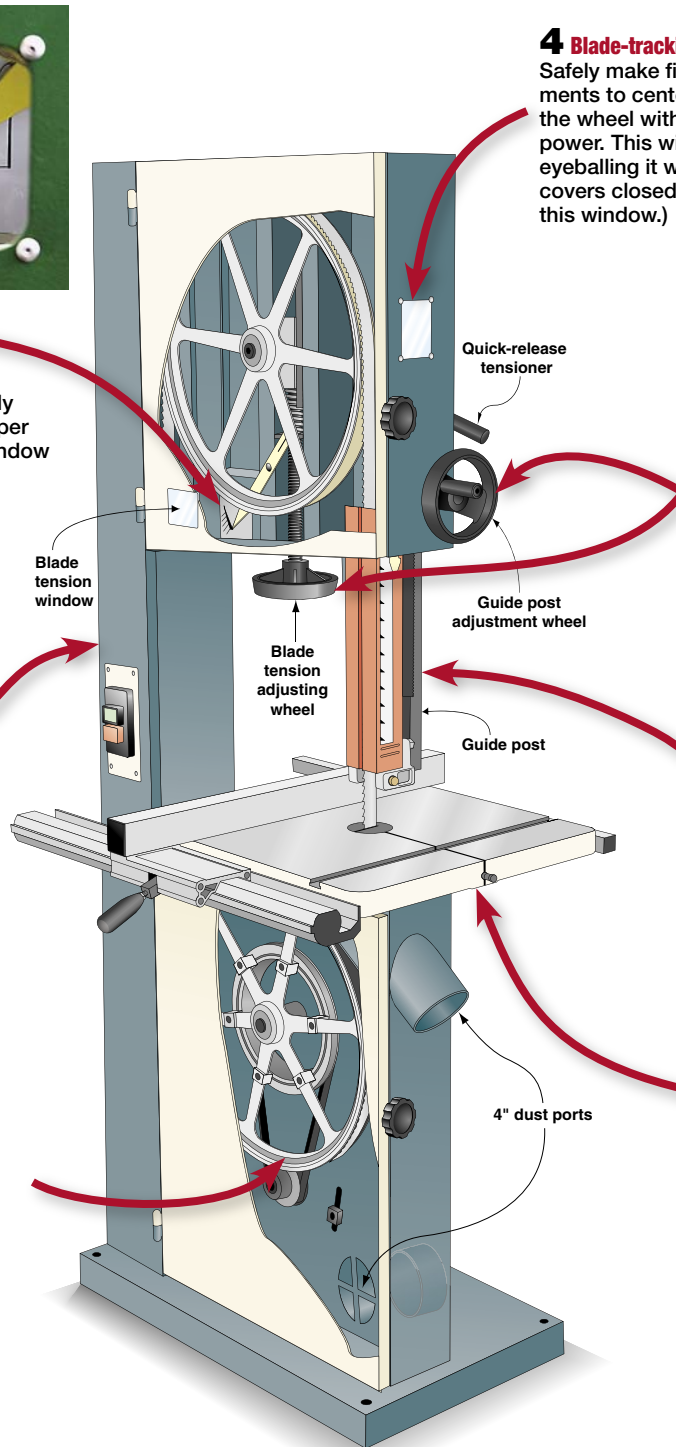

### 4 Blade-tracking windows.

Safely make final adjustments to center the blade on the wheel with the saw under power. This window allows eyeballing it with the wheel covers closed. (Jet lacks this window.)

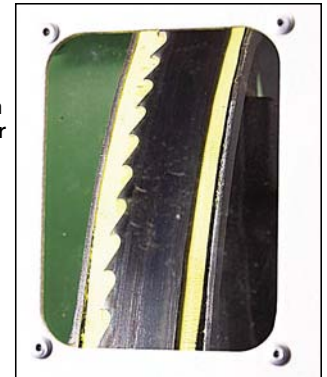

### 5 Handwheels.

Large handwheels make tension adjustments faster and with less effort than the small knobs on 14” bandsaws. Many of these saws also sport a geared guide post with a thickness scale.

**6 Resawing capacity.** Unless you add an optional riser block, most 14” bandsaws max out at a 6” resaw; these saws can handle 10–12” stock.

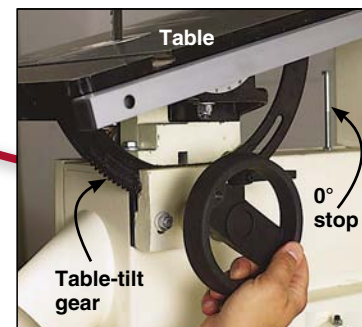

**7 Geared tables.** Tilt the table by turning a knob, lock it, and it stays put better than tables with trunnions only. Plus, gears make even tiny tilt adjustments easier.

hook-tooth resawing blades. Before cutting, though, we set the blade tension using the flutter method (see box on the *opposite page, far right*) and adjusted the blade guides. Next, we clamped our testing rig—a tall fence with a carrier mounted on precision drawer slides—to the saw table. After several test cuts to position the rig to eliminate blade drift, we started our power test.

First, we used 5 lbs of weight—a comfortable feed force—to pull the oak through the blade, timing an 18"-long cut. All of the saws completed this task without bogging down, although the length of time it took ranged from 164 to 235 seconds, as you can see from the chart at *right*. Blade speed appears to be the biggest factor here with high blade speeds generally cutting the quickest.

To really challenge these machines, we increased the feed force to a brutal 15 lbs, and repeated the test. Four saws—Bridgewood, Grizzly G0514, Rikon, and Shop Fox—averaged 30–40 seconds for an 18" cut. The Grizzly G0513 took about 80 seconds and bogged down a little. The Jet couldn't complete this test because its blade speed and motor amperage (5.8 amps at 220V, compared to 10–12.5 amps for the rest of the machines) are the lowest in the test.

Heavy wheels give a bandsaw blade the momentum to carry it through tough spots, such as dense grain or knots. Rikon is the heavyweight champ here, with wheels weighing 58 lbs. Grizzly uses the lightest wheels: The G0513's wheels weigh just 11 lbs, and the G0514's tip the scales at about 13 lbs.

### Guides keep the blade on the straight and narrow

The blade-guide systems on these bandsaws consist of a ball bearing or disc on either side

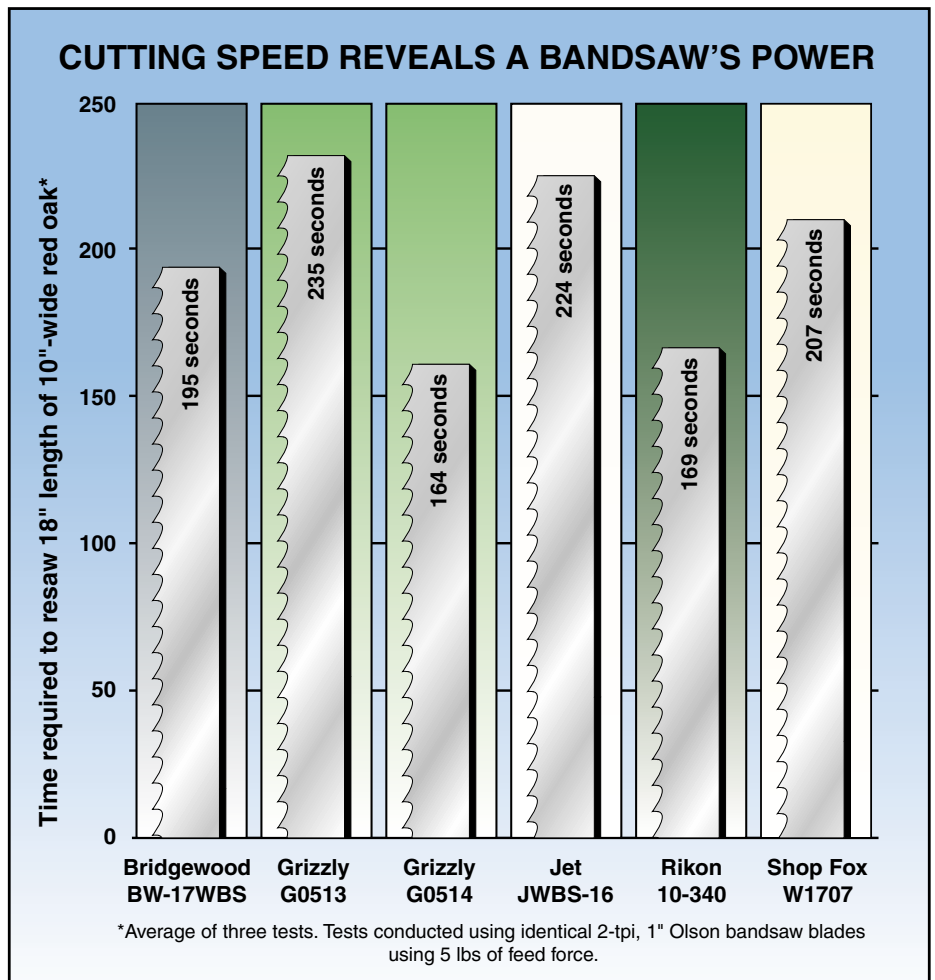

of the blade (see comparison, *below*) that keeps the blade from twisting and a thrust bearing that prevents backward deflection during a cut. We give a slight edge to the disc guides, as they better support the 1-1/2" maximum-width blades on these machines. (If you do much scroll-cutting with narrow blades, say 1/2" or less, ball-bearing guides

provide plenty of support, while rolling with the blade to reduce heat buildup from friction.) Rikon uses dual ball bearings—two on each side of the blade—to maximize support for wide blades and minimize friction.

The upper thrust bearings on almost all of the tested saws are oriented so the blade rubs against the face of the bearing. But both

### THREE BLADE-GUIDE SYSTEMS: GOOD, BETTER, AND BEST

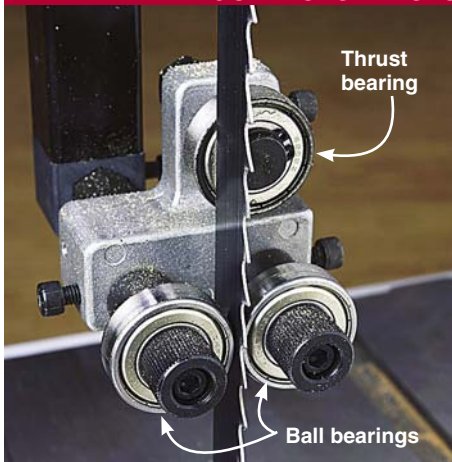

**GOOD:** A ball bearing on each side of the blade limits twisting and rolls with the blade when it makes contact, minimizing friction and heat buildup.

**FOUND ON:** Bridgewood and Shop Fox

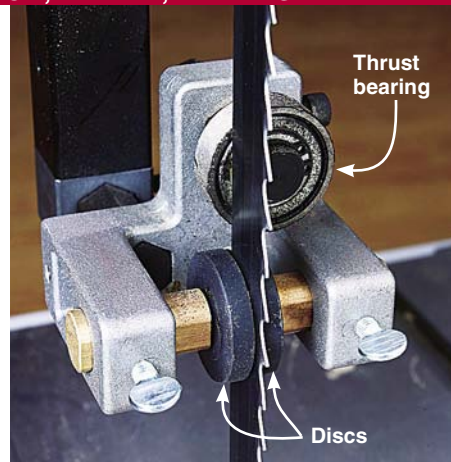

**BETTER:** European-style discs increase support as blades get wider. Note how the blade runs on the face of the thrust bearing, which is typical of most upper guides.

**FOUND ON:** Grizzly and Jet

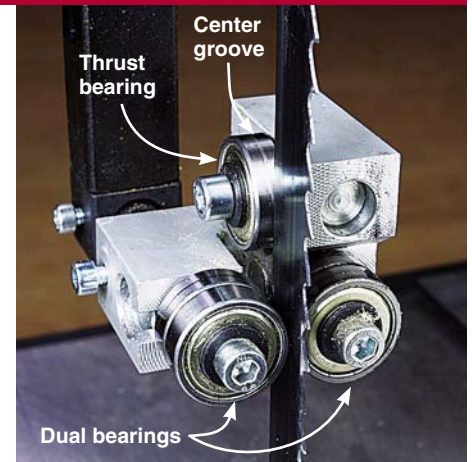

**BEST:** Back-to-back bearings roll with the blade like single bearings, but provide full support for the widest blades. The grooved thrust bearing also rolls with the blade.

**FOUND ON:** Rikon

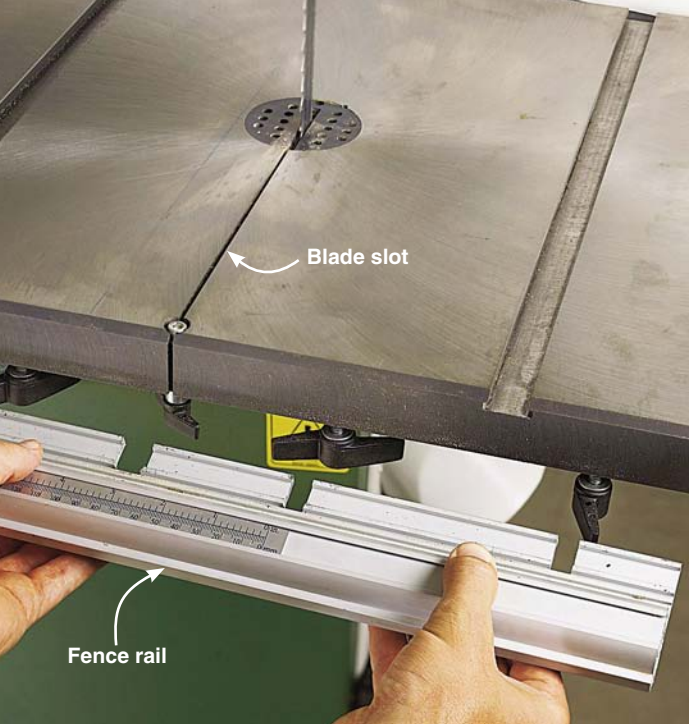

### FRONT SLOT MAKES BLADE CHANGES EASIER

Rikon's table slot—in line with the blade—eliminates twisting the blade into place. The fence rail goes on and off with a series of thumbscrews.

thrust bearings on the Rikon roll front-to-rear, so the blade runs in a groove around the circumference (see photo on *opposite* page), which prevents damaging the bearing's face. Most of the saws use this thrust-bearing orientation only on the lower guide assembly.

All of the guides are easy enough to adjust, with Jet scoring extra points for making its disc-style guides microadjustable. Otherwise, you simply hold the guide in position and lock it in place with a wing bolt or hex-head wrench.

## Changing blades and setting blade tension

Except for the Jet, all of the tested bandsaws have quick-release tensioners—a lever on the back of the saw that instantly detensions the blade and just as quickly retensions it without tedious turning of the tensioning wheel. Aside from that, we found few differences in the ease of changing blades.

On the plus side, Rikon's blade slot on the table runs the same direction as the blade, eliminating the need to rotate it into place when installing. (It does require removing the fence rail, as shown *above*, but no tools are needed for that task.) On the down side, the top hinge of Shop Fox's lower door is close to the blade channel at the left of the saw, making it tough to jockey a stiff 1"-wide blade into the channel. Narrower blades aren't a problem, though.

Once installed, tensioning the blade goes quickly, thanks to coarse, Acme-threaded tension rods on most saws. (Jet's finer machine threads took longer to achieve the

same tension.) The Grizzly and Shop Fox tension gauges are marked in increments from 1 to 10 rather than blade widths, like on the rest of the saws. Grizzly's Bill Crofutt says there are too many variables in the blade manufacturing process—even from blade to blade—to make blade width markings reliable, so they opted for the incremental scale instead. If you tension your blade each time using the flutter method, you may find the tension scale irrelevant.

## Three more considerations

■ Tables should tilt only when you want them to. You can work some pretty large and heavy workpieces on a bandsaw this size, especially if you use it to rough-size bowl blanks before turning. So, consider a

stout table a must. To simulate a large workpiece, we hung 30 lbs of weight from the side of the table (in line with the blade) and measured the table deflection under this load. Saws with geared tables held their own, dropping .005–.006". The lone tested saw without gears—the Jet—uses trunnions alone and deflected only .020" (about  $\frac{1}{64}$ ").

All of the tables tilt both left and right for making mirrored cuts, such as dovetails, but only the Rikon employs a pivoting 0° stop that rotates out of the way to tilt the table left. On all other saws we tested, you must change the 0° stop to tilt left.

■ Fences should help you work faster. Five of the six tested saws (except for Jet) come with a fence system, and all of those are adjustable for blade drift. At about 2" tall, though, these fences are designed more for ripping than serious resawing. The tallest fence in the test (Shop Fox, at 4") is still pretty short for resawing 11 $\frac{3}{4}$ " material. Rikon provides a removable pivot bar on its fence that gives you a single point of contact at the blade teeth allowing you to steer the wood slightly during resawing to compensate for blade drift.

■ Wye is needed for dust collection. Most of these saws have two 4" dust ports: one at the bottom back of the machine, and the other beneath the table. (Jet has only the bottom back port.) That means you'll need a wye to split suction between the two ports. Connected directly to a 1,200-cfm dust collector, we were impressed with how well all six machines managed dust. Jet gets our vote here: Why use two ports when one will do?

## Use the "flutter" method for foolproof blade tensioning

We've seen all kinds of methods for setting bandsaw blade tension, from fancy gauges to plucking the blade like a guitar string. But the "flutter" method for setting tension is simple and recommended by blade and saw manufacturers. Here's how to do it:

- Unplug the saw.
- After installing the blade, set the upper and lower blade guides as far out as they can go (or remove them), and remove the throat plate from the table.
- Center the blade on the wheels, adjusting tracking while turning the top wheel by hand. Close the wheel covers.
- Turn the tensioning handwheel until the tension gauge is at or a little above the recommended tension for your blade width.
- Plug the saw in and turn it on, making any final adjustments to blade tracking.
- With the saw running, slowly release the tension—about  $\frac{1}{2}$  turn of the tensioning wheel at a time—until the blade starts to flutter, as shown *below*.
- Gradually increase tension until the fluttering just stops, then turn the tension wheel another  $\frac{1}{4}$ – $\frac{1}{2}$  turn tighter.
- Power down the saw, and reset the upper and lower blade guides. You're back in business.

Use this method each time you change blades, and remember to detension the blade with the quick-release tensioner when not in use. (If your bandsaw doesn't have a quick-release lever, make it a habit to relax the tension by a specific number of turns—10, for example—at the end of each day you use the saw. Next time you need the saw, just tighten the wheel 10 turns to return to the correct tension.)



# An in-depth look at the tested bandsaws

**Bridgewood BW-17WBS, \$950**  
800/235-2100, wilkemachinery.com



### High points

- ▲ Excellent power. When pushed hard, it completed an 18"-long cut in 10"-wide red oak in about 30 seconds without bogging down or stalling.
- ▲ Great safety features: Both wheel covers must be closed before the motor can be fired up, and it's the only saw we tested with a magnetic switch.
- ▲ The blade-tension scale is intuitively marked with blade widths.
- ▲ Quick-release tensioner operates smoothly and reliably.

### Low points

- ▼ Hex wrench is needed for most blade-guide adjustments.

### More points

- ▶ Requires 220-volt service, which may not be readily available in your shop.

**Jet JWBS-16, \$900**  
800/274-6848, wmhtoolgroup.com



### High points

- ▲ Excellent dust collection from only one 4" port.
- ▲ Upper Euro-style guide discs are microadjustable for easy setting. And the guide/guard design provides the best outline visibility in the test.
- ▲ Draws only 11.5 amps at 110 volts (prewired from the factory at that voltage), so it will run on most household circuits out-of-the-box.

### Low points

- ▼ The motor is somewhat underpowered for this class of saw. It cut faster than the Grizzly G0513 under 5 lbs of feed force but couldn't complete our extreme 15-lb test.
- ▼ Fine-threaded tensioning rod makes changing and tensioning blades tedious. This is also the only tested saw without a quick-release tensioner.
- ▼ No blade-tracking window, and fence and miter gauge are not included.

**Grizzly G0513, \$795**  
800/523-4777, grizzly.com



### High points

- ▲ This bandsaw has all the bells and whistles of saws costing up to \$150 more, including a quick-release blade tensioner.
- ▲ Disc-style blade guides lock in place with thumbscrews instead of setscrews.

### Low points

- ▼ Slow blade speed and light wheels make this the slowest-cutting saw in the test. In our extreme power test (15 pounds of feed force), the G0513 struggled, but completed the cut.

### More points

- ▶ The blade-tension scale is marked from 1 to 10, instead of by blade width. For example, you may have to tension a 1"-wide blade to "8" on the scale instead of the "1" mark.

**Grizzly G0514, \$1,040**  
800/523-4777, grizzly.com



### High points

- ▲ The fastest blade speed in the category yielded lots of cutting power. The G0514 finished at the top in both our 5-lb and 15-lb pull tests.
- ▲ Disc-style blade guides lock in place with thumbscrews instead of setscrews.
- ▲ Quick-release tensioner operates smoothly and reliably.

### More points

- ▶ This machine uses the same blade-tension scale found on the Grizzly G0513 and Shop Fox W1707 (marked from 1 to 10, instead of by blade width).

## CHECKING THE

		MOTOR		BLADE			
BRAND	MODEL	VOLTAGE (1)	AMPERAGE AT 110V, 220V (2)	SPEED(S) (FEET PER MINUTE) (3)	LENGTH (INCHES)	MINIMUM, MAXIMUM WIDTH (INCHES)	BLADE TENSION SYSTEM (4)
BRIDGEWOOD	BW-17WBS	220	11.5*	1,706/3,179	131¾	⅛, 1	A
GRIZZLY	G0513	110/220*	20, 10	1,704/3,170	131½	⅛, 1	A
	G0514	110/220*	20, 10	1,796/3,625	143	⅛, 1¼	A
JET	JWBS-16	110*/220	11.5, 5.8	2,910	123	⅛, 1½	M
RIKON	10-340	110/220*	25.2, 12.5	1,752/3,442	142	¼, 1¼	A
SHOP FOX	W1707	220	12*	1,702/3,391	132	⅛, 1	A

### NOTES:

1. (\*) Wired for this voltage from the factory. (All tests conducted at 220 volts.)
2. From manufacturer's spec. (\*) 220-volt amperage only.
3. Measured by phototachometer.
4. (A) Acme threads; quick-release tensioner. (M) Machine threads; no quick release.

**Rikon 10-340, \$1,000**  
877/884-5167, rikontools.com



**High points**

- ◆ Heavy wheels and ample motor power pushed this saw to finish at the top—even with the Grizzly G0514 in our 5-lb and 15-lb pull tests.
- ◆ Dual ball bearings on each side of the blade proved the best of both worlds, creating less friction than disc-style guides while fully supporting 1½"-wide blades.
- ◆ Large table and the only one that can tilt left without changing the 0° stop.
- ◆ Instructions for blade selection, tensioning, and more are posted inside the lower wheel cover for easy reference.
- ◆ Moving the drive belt to change blade speed is simple, thanks to a handwheel that controls belt tension—a big plus if your work requires speed changes.

**More points**

- ◆ Hex wrenches needed for blade-guide adjustments store on the machine.
- ◆ Changing blades requires removal of the front fence rail, but no tools are needed for the job.
- ◆ The table has two miter slots, but no miter gauge comes with the saw.
- ◆ Requires 220-volt service (or a hefty 110-volt circuit and wiring).

**Shop Fox W1707, \$925**  
800/840-8420, shopfox.biz



**High points**

- ◆ Very good power. When pushed hard, it completed an 18"-long cut in 10"-wide red oak in about 30 seconds without bogging down or stalling.
- ◆ The large table extends all the way to the frame of the saw for wide-workpiece support, and it deflected less with a heavy workpiece than the other tested saws. It also tilts 15° left, besting the rest by 5°.
- ◆ 4"-high fence is tallest in the test, and so provides the best workpiece support when resawing.

**Low points**

- ◆ Like both Grizzlys, the blade-tension scale is marked from 1 to 10, instead of by blade width, making it less intuitive to use.
- ◆ The hinge on the lower wheel cover hinders blade changes by creating a tight spot for wide blades, which are less flexible than narrow blades.

**More points**

- ◆ Requires 220-volt service.

**STATS ON SIX BIG-LEAGUE BANDSAWS**

GUIDES		CAPACITY		TABLE				PERFORMANCE GRADES (9)						ACCESSORIES (10)							
SIDE BEARING DESIGN (5)	TOP THRUST BEARING (6)	BOTTOM THRUST BEARING (6)	RIPPING (INCHES)	RESAWING (INCHES)	SIZE (LxW, INCHES)	TILT RANGE (RIGHT/LEFT, DEGREES) (7)	HEIGHT FROM FLOOR (INCHES)	TABLE TILT METHOD (8)	NUMBER OF 4" DUST PORTS	OBSERVED POWER	BLADE GUIDES (SUPPORT & EASE OF ADJUSTMENT)	EASE OF ADJUSTING BLADE TENSION	TABLE OF CHANGING BLADES	EASE OF ADJUSTMENT & SUPPORT	STANDARD	OPTIONAL	WARRANTY (YEARS)	COUNTRY OF ASSEMBLY (11)	WEIGHT (POUNDS)	SELLING PRICE (12)	
B	F	E*	16½	11½	17x17	45/10*	37½	G	2	A	B	A	B+	A	B	F,M		1	T	390	\$950
D	F	E*	16¼	12	17x17	45/10*	37½	G	2	B	B-	A	B+	A	B	F,M	B,L	1	T	321	\$795
D	F	E*	18¼	12	19x19	45/10*	37½	G	2	A-	B-	A	B+	A	B	F,M	B,L	1	T	383	\$1,040
D*	F	F	16¼	10¼	17x17	45/10	37½	T	1	C	B	B	B-	B	B	F,M		5	T	310	\$900
2B	E	E*	18¾	12	19x21	45/10*	38½	G	2	A	A-	A	A	A	A	F	M	2	C	352	\$1,000
B	F	E*	16½	11¾	17½x23¼	45/15*	37½	G	2	A	B	A-	C+	A	B	F,M	B,L	2	T	330	\$925

- 5. (B) Single ball bearing on each side of blade  
(2B) Two ball bearings on each side of blade  
(D) European-style discs  
(\*) Microadjustable
- 6. (E) Blade runs on edge of ball bearing  
(F) Blade runs on face of ball bearing  
(\*) Microadjustable
- 7. (\*) 0° stop must be readjusted to tilt table to the left.

- 8. (G) Geared  
(T) Trunnion
- 9. A Excellent  
B Good  
C Fair
- 10. (B) Mobile base  
(F) Fence  
(L) Magnetic work light  
(M) Miter gauge

- 11. (C) China  
(T) Taiwan
- 12. All prices current at time of article production and do not include shipping where applicable.

**Two saws stand tall, one earns Top Tool**

The Grizzly G0514 and the Rikon 10-340 both demonstrated loads of power and sell for around \$1,000. But lots of little details—dual ball-bearing blade guides, a flip-out 0° stop on the table, not to mention those heavyweight wheels—drive the 10-340 into our Top Tool recommendation. For about \$200 less the Grizzly G0513 requires more patience, but it completed every cut we threw at it. It's our Top Value. 🌟

Written by **Dave Campbell**  
with **Jeff Hall**  
Illustrations: **Tim Cahill**

**Share your opinion**

of these bandsaws in our Tools and Tool Buying forum at [woodmagazine.com/toolforum](http://woodmagazine.com/toolforum)

# peek-through holiday ornament

Turn a scrap of wood, a piece of dowel, and a dab of paint into an elegant decoration.



**T**his handsome ornament holds more than one surprise. The first is the tiny tree captured within the pierced body; the second, the ease in turning this difficult-looking project. Once you get the hang of it, you'll be able to spin them out by the dozen. And after all the admiring remarks, you'll need to answer the inevitable question, "How'd you do it?"

## 1 Create the templates

Make a photocopy of the three templates on the *WOOD Patterns*® insert, and adhere them with spray adhesive to 1/8" tempered hardboard. Scrollsaw and then file the templates to shape, as shown at *bottom*.

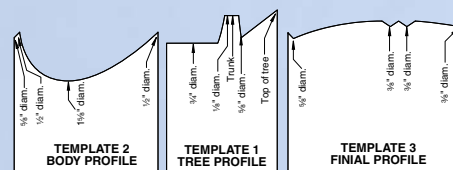



## 2 Turn a tiny tree

**Tools:** 1/4" detail gouge, 1/8" parting tool.

**Tool rest:** Gouge, slightly below center; parting tool, at center.

**Speed:** 1,000 rpm.

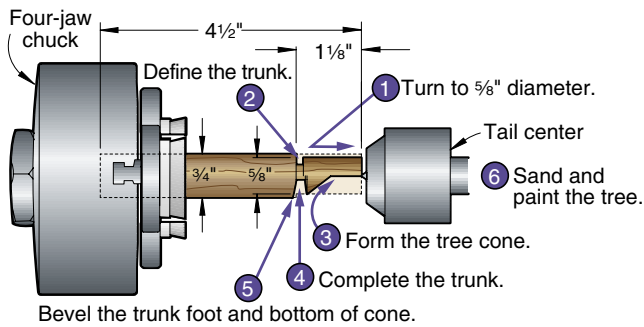

Mark the center of one end of a *straight* 4 1/2"-long piece of 3/4" dowel. (We used walnut.) Hold the other end loosely in the center opening of a four-jaw chuck, support the marked end with the tail center, and tighten the jaws. Using a detail gouge, turn 1 1/8" of the tailstock end of the dowel to 5/8" diameter. Using **Template 1** as a guide, mark the location of the tree trunk and the top of the tree. Use a parting tool to

define the trunk with a 1/8"-deep cut. Switch to the detail gouge, and form the tree "cone," as shown *above*, freeing the dowel from the tail center in the process. Switch to the parting tool, and complete the trunk. Finally, bevel the area at the foot of the trunk and bottom of the cone with the detail gouge. Finish-sand and paint the tree. (We used green glitter paint purchased at an art-supply store.)

## 3 Drill the body and insert the tree

**Tool:** 3/4" Forstner bit.

**Speed:** 500 rpm.

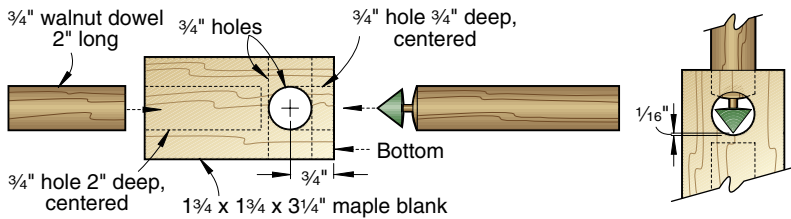

For the body, cut a 1 3/4x1 3/4x3/4" blank. (We used maple. You also can laminate the blank from thinner stock.) Chuck a 3/4" Forstner bit into your drill press, and bore intersecting holes through adjacent faces, where shown *above*. Then mark the centers of the ends, and

drill a hole in each end to the depth shown *above left*, as shown *above*. Cut a 2"-long piece of 3/4" walnut dowel, and glue it into the top hole. Now glue the dowel with the tree into the bottom hole, positioning it where shown *above center*. Let the glue dry.

## 4 Rough-turn the body

**Tools:** 5/8" spindle gouge, 1/8" parting tool.

**Tool rest:** Gouge, slightly below center; parting tool, at center.

**Speed:** 1,000 rpm.

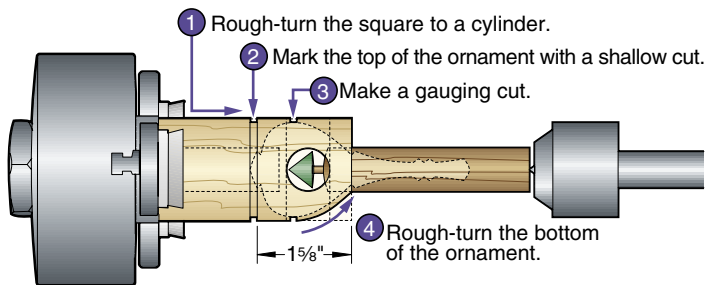

Holding the square blank loosely in the four-jaw chuck with the jaws gripping the sides and the corners between the jaws, apply *light* pressure to the center of the dowel with the tail center. Tighten the chuck. Use a spindle gouge to rough-turn the maple square to a cylinder.

Using **Template 2** as a guide, mark the top of the body with a pencil, and make a shallow cut with a parting tool. Now mark the body maximum diameter, and make a gauging cut. Starting at the gauging cut, rough-form the bottom of the body, as shown *above*.

## 5 Form the finial

**Tools:** 1/8" parting tool, 3/8" spindle gouge, 1/4" detail gouge.  
**Tool rest:** Parting tool, at center; gouges, slightly below center.  
**Speed:** 1,000 rpm.

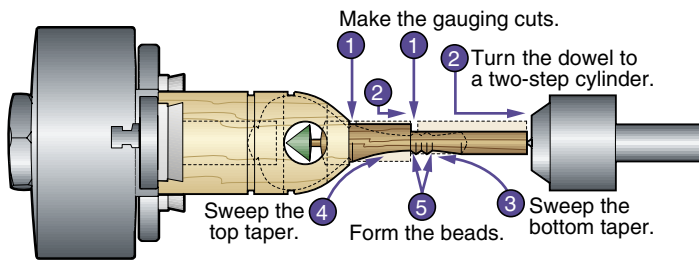

Using **Template 3** as a guide, mark the critical finial diameters on the dowel, and make two gauging cuts with a parting tool. Then with a spindle gouge, rough-turn the dowel all the way to the end, forming a two-step cylinder, where shown *above*. Using the template, mark

the maximum extent of the two finial beads. Working from the bottom and then the top of the finial, use the detail gouge to sweep tapers toward the marked bead area, as shown *above*. Mark the bead peaks and the center of the valley between them, and form the beads.

## 6 Finish the bottom of the ornament

**Tool:** 1/4" detail gouge.  
**Tool rest:** Slightly below center.  
**Speed:** 1,000 rpm.

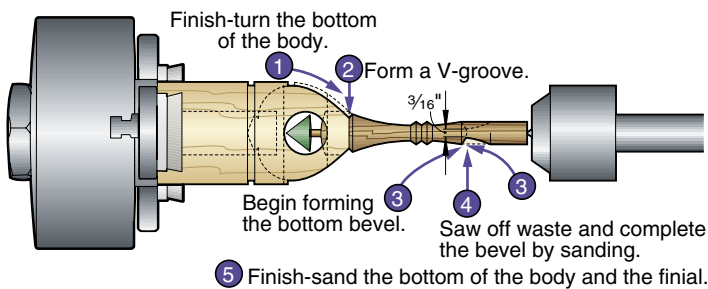

Using a detail gouge, finish-turn the bottom of the body, as shown *above right*, forming a V-groove at the top of the finial. Then begin beveling the bottom of the finial, reducing the diameter to 3/16". Stop

the lathe, and cut off the waste with a fine-tooth saw. Back the tailstock away and finish the bevel by sanding. With the lathe turning at 850 rpm, finish-sand the bottom of the body and the finial.

## 7 Complete the body and apply finish

**Tools:** 1/8" parting tool, 1/4" detail gouge.  
**Tool rest:** Parting tool, at center; gouge, slightly below center.  
**Speed:** 1,000 rpm.

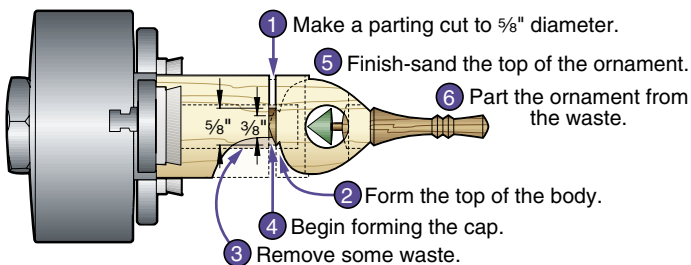

Using a parting tool, deepen the cut marking the top of the ornament to 5/8" diameter, as indicated on the template. Then using a detail gouge, form the top of the body, blending it smoothly into the finished bottom. For tool maneuvering room when forming the beveled cap, use the detail gouge to remove material on the waste side of the parting cut. Now begin forming the cap, as shown *above right*, cutting to a 3/8" diameter. Finish-sand the ornament. Finally, alternately extending the cap bevel and removing material from the waste side of

the cut, separate the ornament from the waste. Drill a pilot hole at the center of the cap and screw in a brass screw eye. Hang the ornament on a piece of wire and spray on several coats of gloss lacquer. To hang the ornament, add a loop of decorative twine. 🐿

Written by **Jan Svec** with **Phil Brennon** and **Jeff Mertz**  
 Project design: **Beth Ireland**  
 Illustrations: **Roxanne LeMoine**

# WOOD PATTERNS®

November 2005

Issue 166

Dear Reader: As a service to you, we've included full-size patterns on this insert for irregular shaped and intricate project parts. You can machine all other project parts using the Materials List and the drawings accompanying the project you're building.

© Copyright Meredith Corporation, 2005. All rights reserved. Printed in the U.S.A. Meredith Corp., the publisher of *WOOD Patterns*® allows the purchaser of this pattern insert to photocopy these patterns solely for his/her own personal use. Any other reproduction of these patterns is strictly prohibited.

## See-through Copper Art, Page 16 Holiday Ornament, Page 52

### Holiday Ornament, Page 52

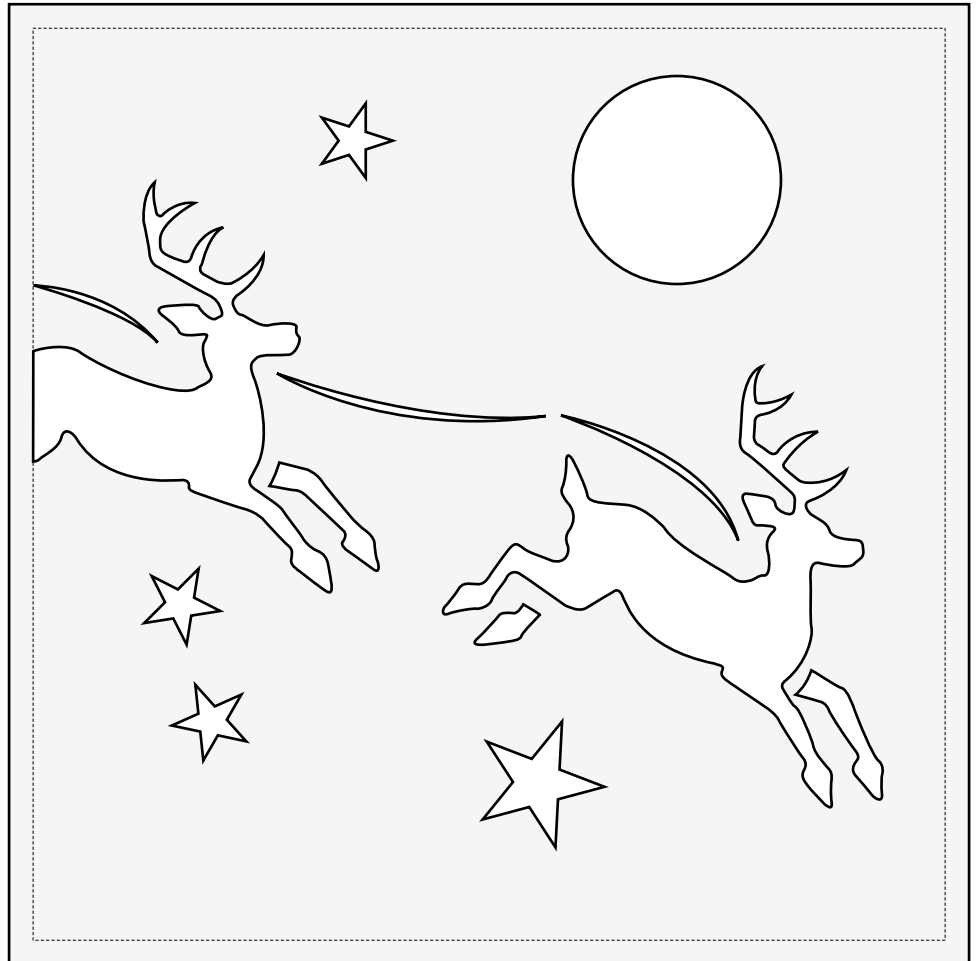
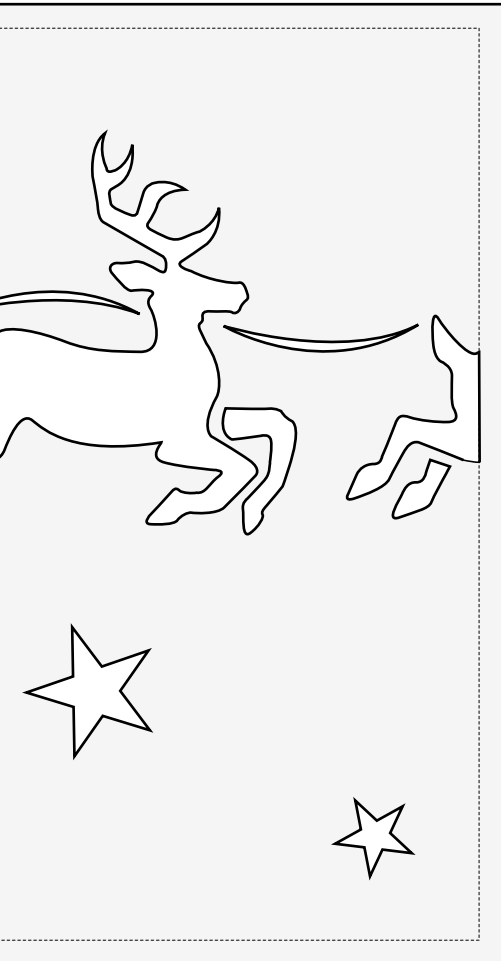
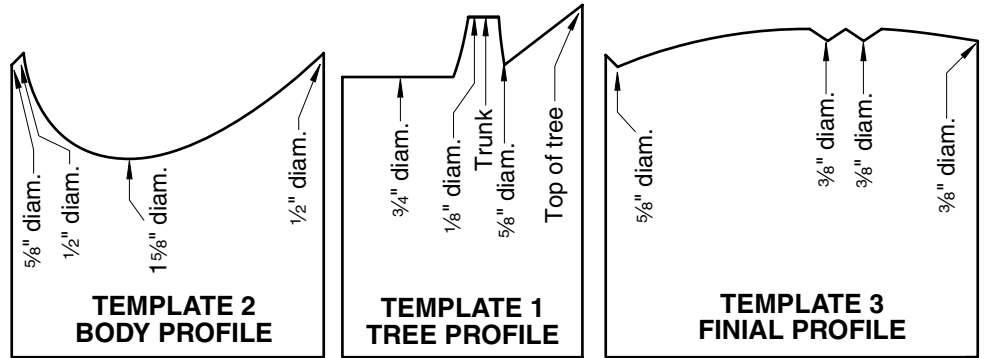

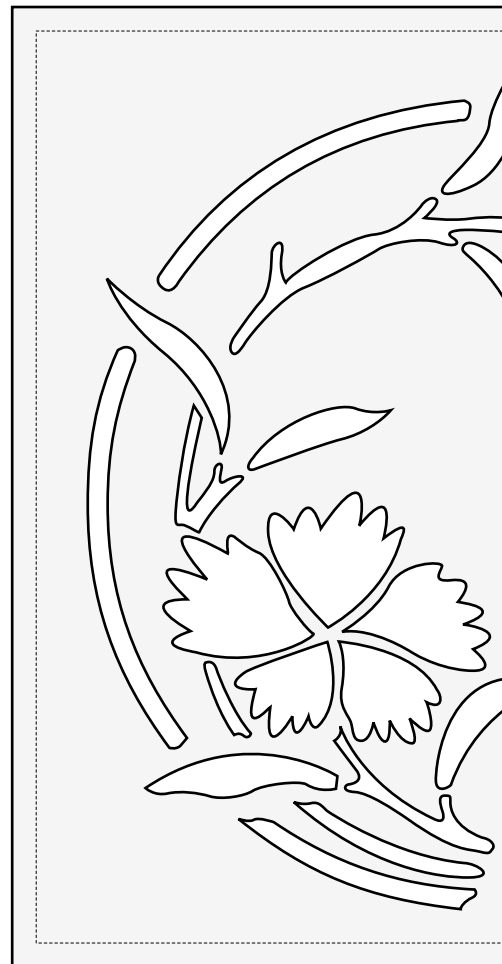
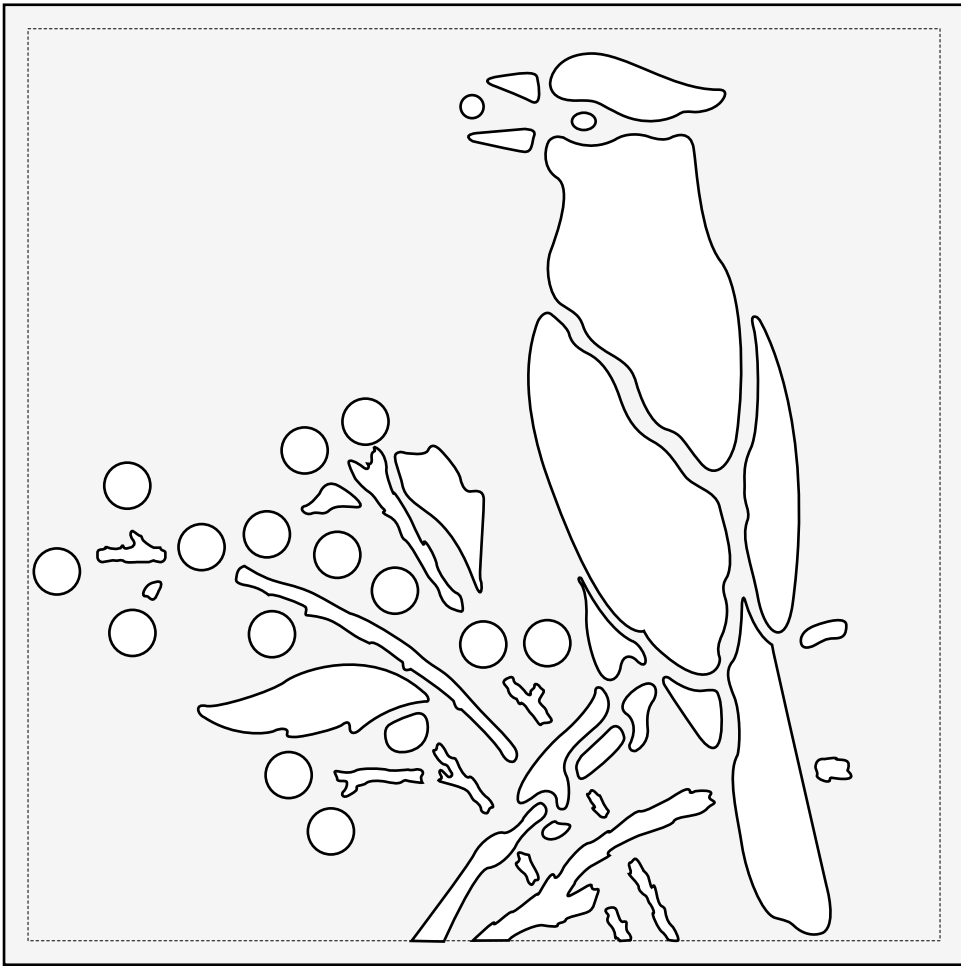

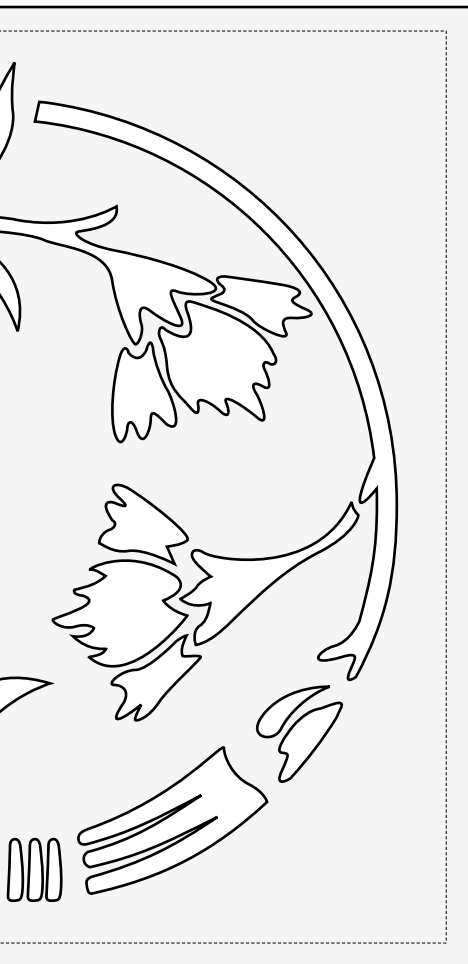
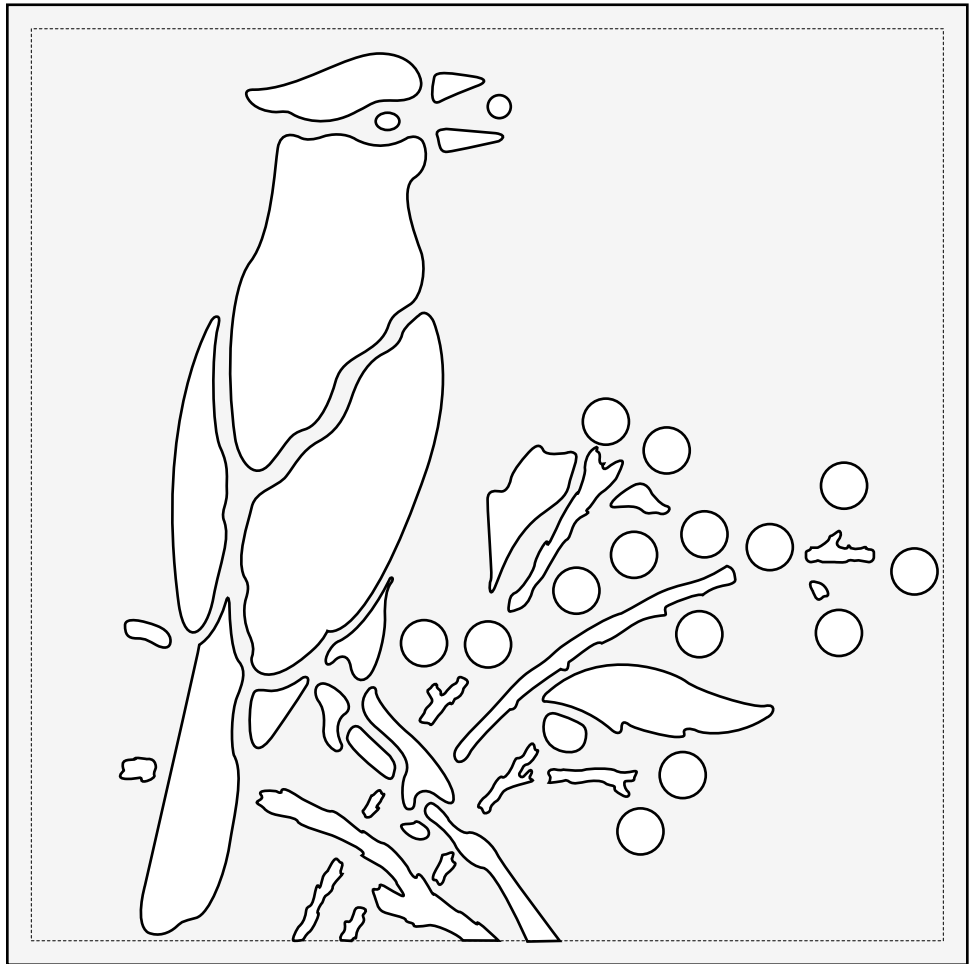
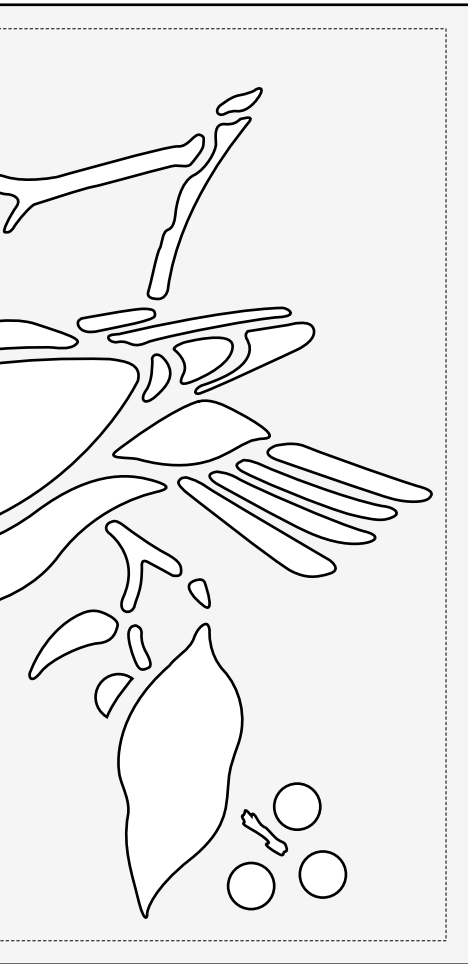

Pattern revision for salt and pepper mills in issue 164, page 58.

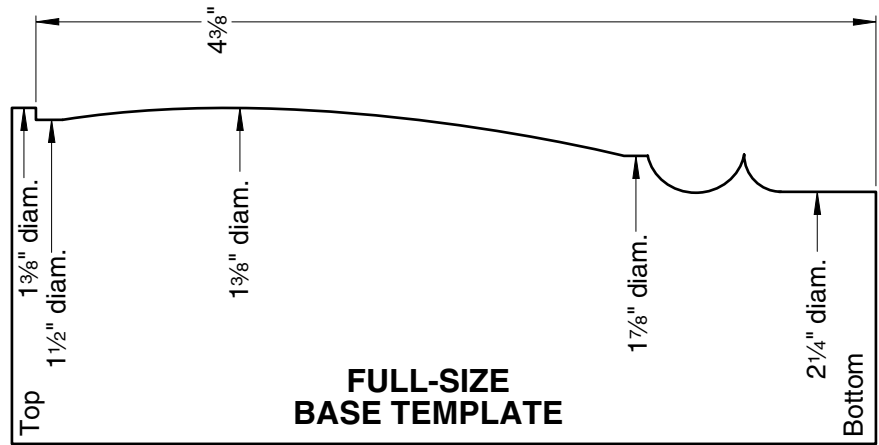
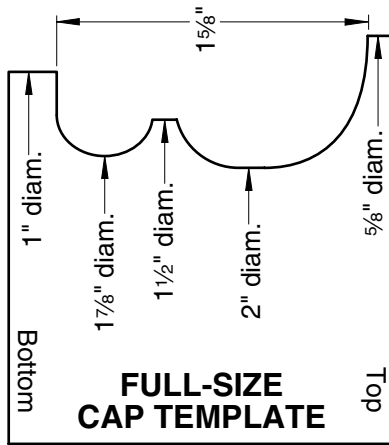

**See-through Copper Art,  
Page 16**

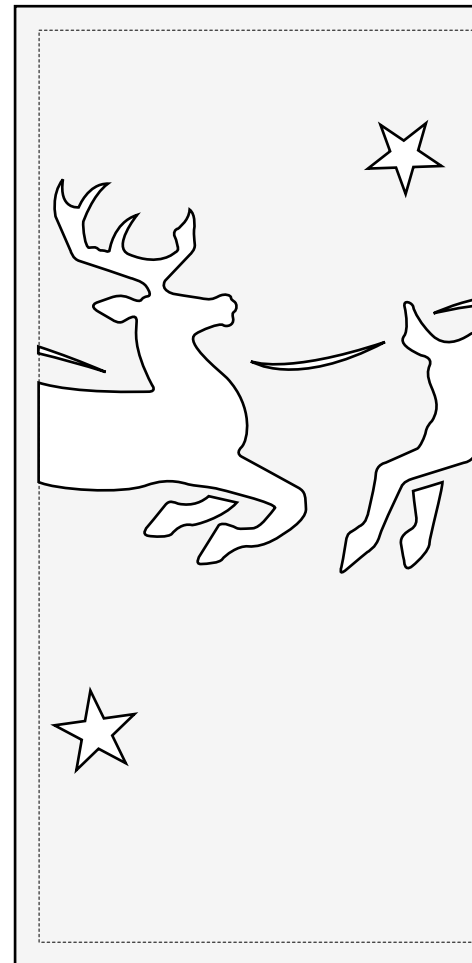
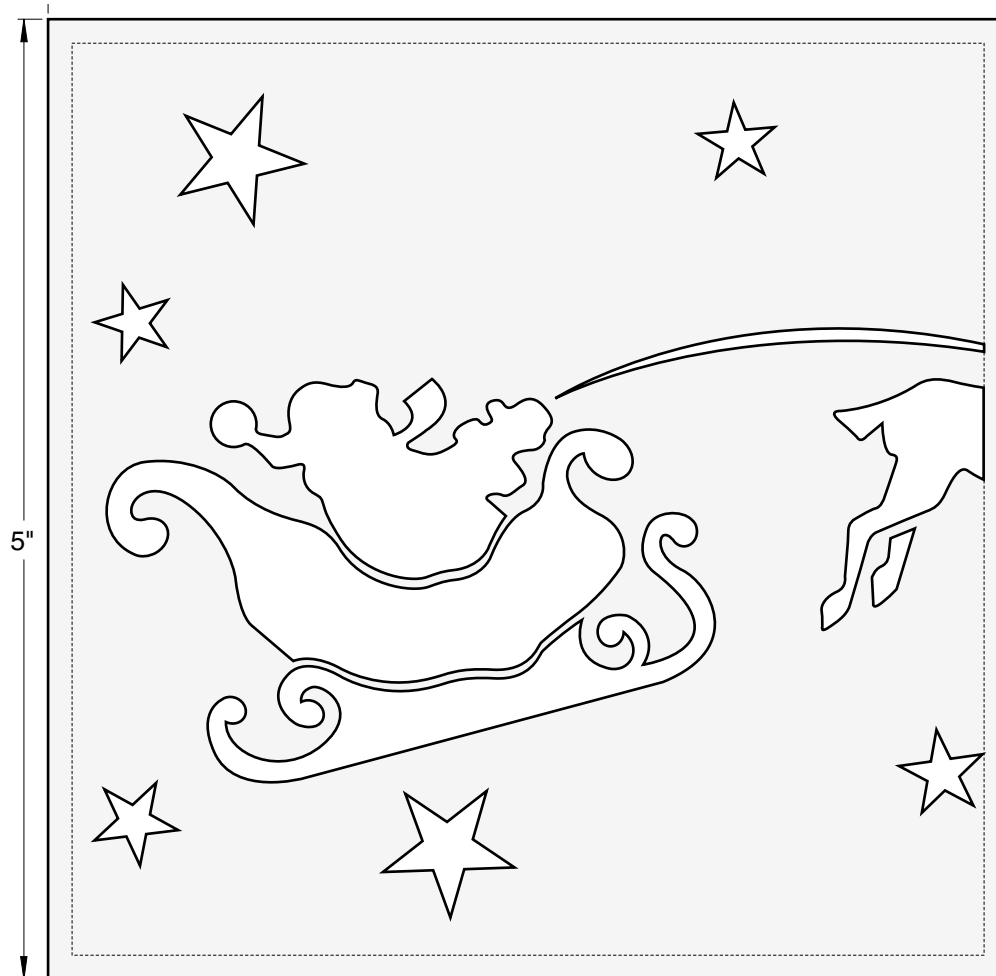

# curio shelf and hall table

Put your treasures on display  
with this perfect pair.



Looking at the rich color of these beautiful pieces, you might think they're made from high-grade mahogany or straight-grained cherry. Actually, we built them from Lyptus—a less-expensive, imported hardwood with a color similar to cherry, a fine grain like mahogany, and a hardness and cost slightly greater than hard maple. (Per board foot, we priced cherry locally at \$6, African mahogany at \$5.25, Lyptus at \$4.61, and hard maple at \$4.56.) If you'd like to try this ecologically and economically attractive wood, see the sidebar, *right*, for tips on locating, selecting, and machining it. No matter the species you choose, these projects will look terrific.

## Let's start with the hall table

### Make the tapered legs

**1** From 1 3/4"-thick stock planed to 1 1/2" thick (or laminated 3/4"-thick stock), cut the four legs (A) to the size listed in the **Materials List**.

**2** Noting that the legs are identical, mark centerpoints for four 1/4" holes 1/2" deep for the pins (E) and lay out two 1/4x3 1/2" mortises and two tapers on each leg, where dimensioned on **Drawings 1** and **2**. Instead of mortise-and-tenon joints, see the sidebar on *page 62* for optional ways to assemble the side aprons (B) and front and back aprons (C) to the legs.

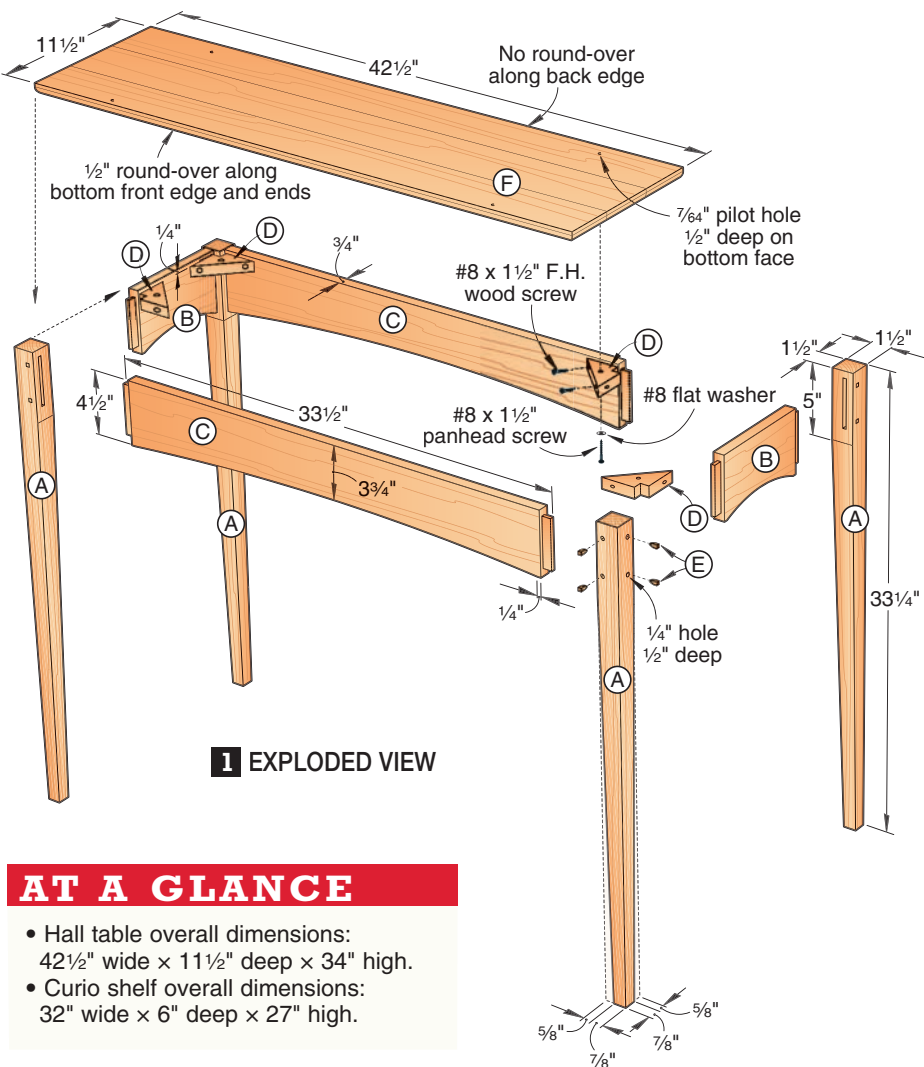

## All about Lyptus

Grown in Brazil on highly productive, sustainable forest plantations, Lyptus trees (a eucalyptus hybrid) mature in about 15 years—2 to 4 times faster than comparable hardwood species in colder climates. The bean-pole-like trees, which reach a height of about 140 feet, yield long lengths of clear, typically straight-grained wood having excellent strength, stability, workability, and finishing qualities. To successfully locate, select, and machine Lyptus stock and plywood, follow these pointers.

- Weyerhaeuser distributes Lyptus stock, plywood, and veneer in North America. To find your nearest dealer, call 877/235-6873 or 888/439-8822 in Canada, or go to [weyerhaeuser.com/wbm](http://weyerhaeuser.com/wbm) and click on "Locations." You'll find stock available in 4/4 to 8/4 thicknesses up to 12" wide.
- The color of Lyptus can vary from a light pink to dark cherry tone. For the best look, select pieces that match in color.
- Keep an eye out for figured pieces for special project parts. Although Lyptus is mostly straight grained, the piece we found for the hall table top (F) has eye-grabbing, swirled figure, as shown below *left*.
- Though dense and hard, Lyptus tends to splinter like ash. To avoid the problem, back up all cuts and drilling with scrap and use sharp, carbide-tipped blades and bits. Also, ease all edges by lightly sanding with 220-grit sandpaper. When routing, make multiple passes, as needed, removing no more than 1/8" of material at a time.
- Like cherry, Lyptus burns easily when machining. To prevent this, feed the stock at a constant rate and keep your blades and bits clean. Unlike cherry, you'll find it easy to sand away burn marks.

### AT A GLANCE

- Hall table overall dimensions: 42 1/2" wide x 11 1/2" deep x 34" high.
- Curio shelf overall dimensions: 32" wide x 6" deep x 27" high.

### LYPTUS SWIRLED-FIGURE GRAIN

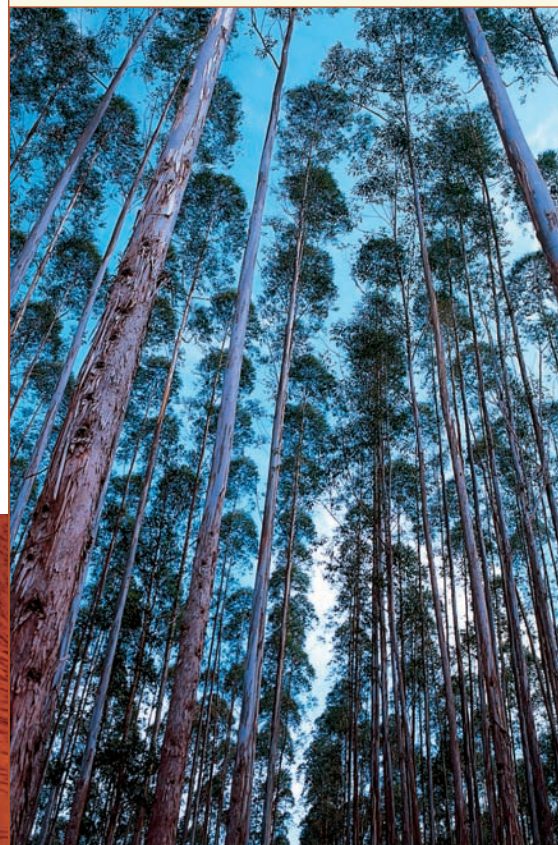



### 3 joinery alternatives

Mortise-and-tenon joints are premier furniture joints because of their inherent strength, but you could use quicker methods and still get long-lasting joints. Have a pocket-hole jig, doweling jig, or a biscuit joiner? You can use any of these tools to quickly and securely join the hall table aprons (B, C) to the legs (A) in place of the mortise-and-tenon joints. Simply locate and drill the holes for #8x1½" washer-head pocket screws or ⅜" dowels 2" long, or plunge slots for #20 biscuits, where dimensioned on the appropriate drawing below. Just as for the mortises, the hole and slot locations will position the outside faces of the aprons ¼" from the outside faces of the legs.

**NOTE:** When using these options parts B/C need to be ½" shorter in length.

#### OPTION 1 - POCKET SCREWS

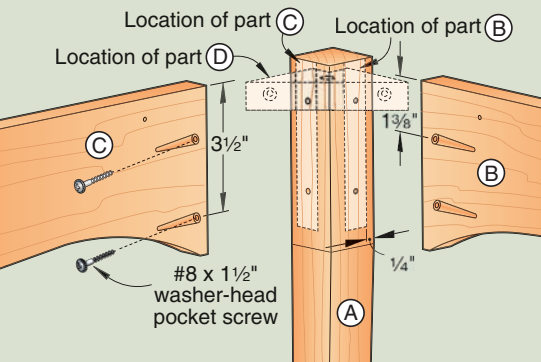

#### OPTION 2 - DOWELS

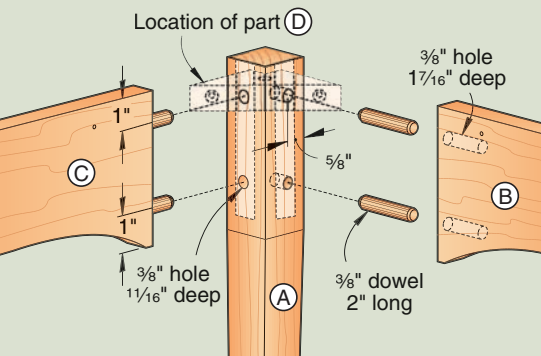

#### OPTION 3 - BISCUITS

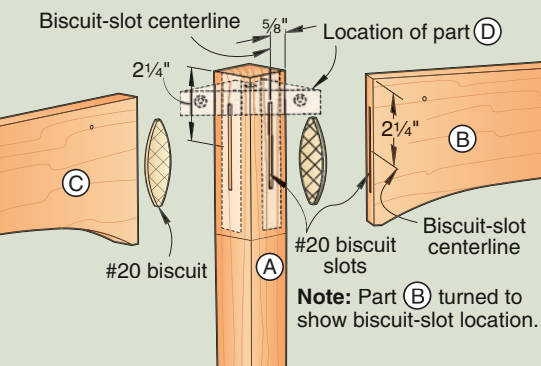

**3** Chuck a ¼" Forstner or brad-point bit in your drill press. Using a fence and stopblock for consistency, drill ½"-deep holes in the legs at the marked centerpoints for the pins (E).

**4** To mortise the legs, refit your drill press with a 7/32" brad-point bit. Drill overlapping holes 13/16" deep, centered along the length of the marked mortises. Then clean up the ends and sides of the mortises with chisels, as shown in **Photo A**.

**5** Using a taper jig on your tablesaw, cut the tapers along the mortised sides of each leg (A), where marked. For an easy-to-make jig and help with the tapering process, see the **Shop Tip**, opposite page, top. Sand the legs to 220 grit, and set them aside.

#### CLEAN UP THE LEG MORTISES



To avoid splitting, clean up the ends of the leg (A) mortises using a ¼" chisel. Then pare the sides using a chisel at least ¾" wide.

#### 2 LEG MORTISE AND APRON TENONS

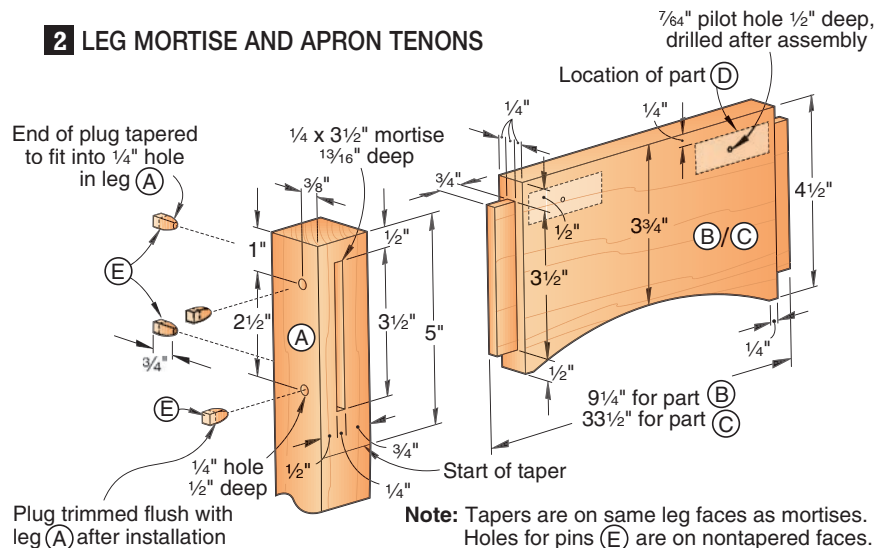

#### Now form the aprons

**1** From ¾"-thick stock, cut the side aprons (B) and front and back aprons (C) to the sizes listed, saving your cutoffs.

**2** To form tenons on the aprons (B, C), where dimensioned on **Drawing 2**, fit your tablesaw with a ¾" dado blade, and attach an auxiliary extension to the miter gauge and an auxiliary fence to the rip fence. Position the fence adjacent to the blade, and raise the blade ¼". On an apron cutoff, crosscut both faces at one end to form a ¼"-thick tenon ¾" long. Angling it in, test-fit the tenon in the mortise in a leg (A). If needed, adjust your setup. Then crosscut the faces at both ends of the aprons. To trim the 4½"-wide tenons to 3½" to fit the leg mortises, raise the dado blade to ½". Now crosscut the ends of the aprons on both edges.

**3** Mark the ends and centers of the curves on the bottom of the aprons, where dimensioned on **Drawing 2**. Draw the curves using a fairing stick. (For a free plan, go to [woodmagazine.com/fairing](http://woodmagazine.com/fairing).) Bandsaw and sand the curves smooth.

#### Assemble the base

**1** Glue and clamp a pair of legs (A) to each side apron (B), as shown in **Photo B**. To protect the legs from damage, place ¼" hardboard pieces between the legs and clamp heads, as shown. After the glue dries, glue

#### GLUE THE END ASSEMBLIES

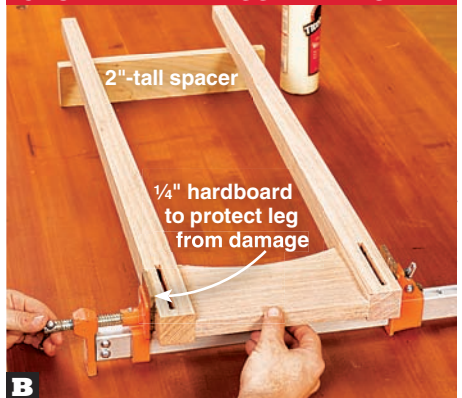

Glue and clamp together a pair of legs (A) and a side apron (B). Position a 2"-tall spacer under the legs to keep them aligned.

# SHOP TIP

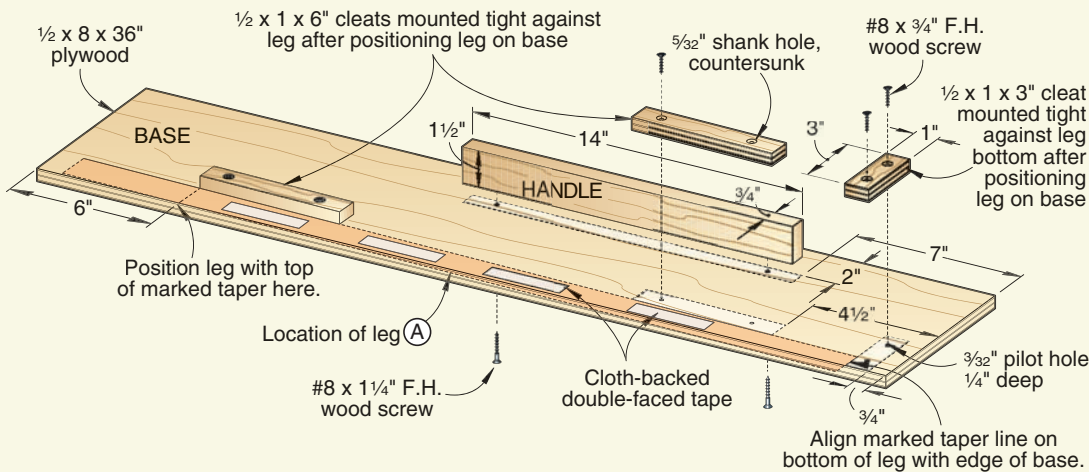

## A jig makes it easy to taper legs precisely

If you don't have a taper jig for your tablesaw, you easily can make one from scrap to safely and accurately cut tapers on legs. Using the hall table legs (A) as an example, here's how to make and put the jig to use.

Referring to the drawing, *above*, cut the base and three cleats to the sizes shown from 1/2" plywood. Cut the handle from 3/4" scrap. Drill mounting holes, and screw the handle to the base, where dimensioned. To mount the cleats to the base, adhere a leg (A) to the base with cloth-backed, double-faced tape, aligning the top

and bottom of a marked tapered side of the leg with the edge of the base, where shown. Make sure you position the leg with one mortise down and the other facing the blade. Then screw-mount the cleats to the base, where dimensioned, tight against the leg.

With the leg still taped to the base, position your tablesaw fence to align the edge of the base flush with the inside face of the blade. Cut the taper, as shown *above*. Then rotate the leg to align the second marked side with the base, and cut again. To keep the legs securely attached, replace the tape, as needed.

and clamp the end assemblies (A/B) to the front and back aprons (C), checking for equal diagonal measurements from leg to leg to verify square.

**2** Referring to **Drawing 3**, cut four triangular corner blocks (D) to the size shown from 3/4"-thick stock. Mark a centerpoint for a 1/4" hole and lay out a 5/8x5/8" notch on each block, where dimensioned. Also mark

centerpoints for two angled countersunk shank holes, noting the holes are offset 5/16" from the top face. Mark the top faces of the blocks. Drill the 1/4" holes. Then bandsaw the notches to shape.

**3** To mount the corner blocks to the side aprons (B) and front and back aprons (C) 1/4" below the top edges, where dimensioned on **Drawings 1** and **2**, draw alignment lines

on the inside faces of the aprons. Then, with the top faces up, glue and clamp the corner blocks to the aprons, aligning the blocks with the marked lines. For secure clamping and to prevent damage to the legs, see the **Shop Tip**, *below*. Now drill angled countersunk shank and pilot holes at the marked centerpoints through the blocks and into the aprons. Drive the #8x1 1/2" flathead wood screws.

### 3 CORNER BLOCK

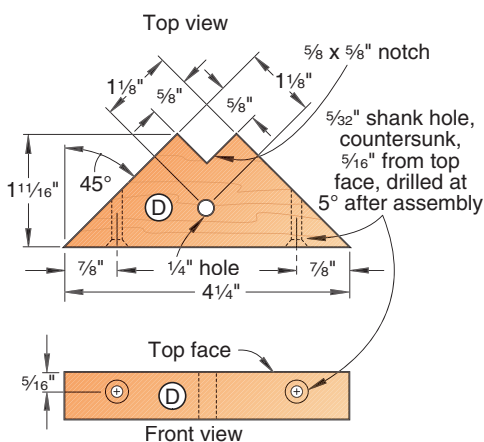

# SHOP TIP

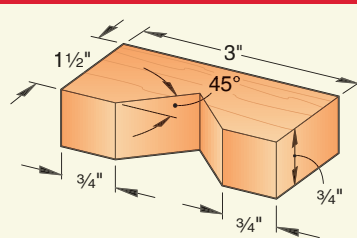

## Get a grip on corner blocks with a clamp block

When mounting corner blocks to reinforce a frame or case, use a clamp block on the outside to provide a flat surface for secure clamping and to prevent damage to parts. For example, to mount the hall table corner blocks (D), make a clamp block with a notch from 3/4"-thick scrap, as shown *above*. Then glue and clamp the corner block in place, as shown *right*. Now drill the mounting holes. (We used a combination drill and countersink bit to do this.)



## How to add eye-catching pins in 3 easy steps

Whether made from a matching or contrasting wood, square pins never fail to grab the eye of furniture connoisseurs. Though it may seem tricky to fit a square pin in a round hole, it's actually simple.

Start with 1/4" holes 1/2" deep drilled where you want the pins and a 1/4x1/4" blank of sufficient length (including 4" for waste) to yield the number of needed pins. Here's how to taper and install them.



**Step 1:** Using a sharp utility knife (or a large pencil sharpener with an adjustable guide), taper a 1/4"-long area at both ends of the pin blank to fit inside the holes for the pins. Draw lines on the blank 3/4" from the ends. Then cut off the pins. Repeat as needed.



**Step 2:** Apply a small amount of glue in a 1/4" pinhole. Position the tapered end of a pin in the hole, checking the alignment with a square. Using a hammer, tap the pin until it bottoms in the hole. This will force part of the square portion of the pin into the hole.



**Step 3:** Trim the pin flush using a flush-trim saw. (Lay card stock on the surface for protection if you don't have a flush-trim saw.) Keep the saw flat to avoid dig-ins. Sand the pin flush with the surface. Repeat the process for the remaining pins.

## Add the accent pins and top

**1** From 3/4"-thick stock resawn or planed to 1/4" thick, cut a 1/4x16" blank to form the 16 pins (E). To taper and install the pins in the 1/4" holes in the legs (A), where shown on **Drawings 1 and 2**, see the sidebar, *above*.

**2** Edge-join 3/4"-thick stock to form a 12x43" blank for the top (F). Then cross-cut the ends and rip the edges to the finished size of 11 1/2x42 1/2".

**3** Chuck a 1/2" round-over bit in your table-mounted router. Using a pushblock for safety and to prevent tear-out, round over the

ends and then the front edge of the top on the *bottom* face, where shown on **Drawing 1**. Sand the top smooth.

## Finish up

**1** Finish-sand any areas that need it to 220 grit, and remove the dust.

**2** Apply a stain and clear topcoat of your choice. (We used Varathane Premium Wood Stain, no. 254 Red Chestnut, followed by three coats of Zar Water-Based Satin Polyurethane, lightly sanding to 220 grit between coats.)

**3** Finally, place the top (F) on your workbench, *bottom* face up. Then position the table base on the top, centered side-to-side, with the back of the rear legs (A) flush with the back edge of the top. Drill pilot holes, centered in the 1/4" holes in the corner blocks (D), into the top, where shown on **Drawing 1**. (We applied masking tape to the bit to mark the drilling depth.) Drive the #8x1 1/2" panhead screws with #8 flat washers to fasten the top to the base. Now place the table in a deserving location, and crown it with a favorite picture or other special item.

## Materials List

Hall table	FINISHED SIZE			Matl.	Qty.
	T	W	L		
A legs	1 1/2"	1 1/2"	33 1/4"	L	4
B side aprons	3/4"	4 1/2"	9 1/4"	L	2
C front and back aprons	3/4"	4 1/2"	33 1/2"	L	2
D corner blocks	3/4"	1 1/16"	4 1/4"	L	4
E* pins	1/4"	1/4"	1/2"	L	16
F* top	3/4"	11 1/2"	42 1/2"	EL	1

\*Parts initially cut oversize. See the instructions.

**Materials key:** L—Lyptus, EL—edge-joined Lyptus.

**Supplies:** Cloth-backed, double-faced tape; #8x1 1/2" flathead wood screws (8); #8x1 1/2" panhead screws (4); #8 flat washers (4). To build the taper jig, #8x3/4" flathead wood screws (6) and #8x1 1/4" flathead wood screws (2).

**Blades and bits:** Dado-blade set, 1/4" Forstner or brad-point bit, 7/32" brad-point bit, 1/2" round-over router bit.

## Cutting Diagram



1 3/4 x 3 1/2 x 72" Lyptus (4 bd. ft.)

\*Plane or resaw to the thickness listed in the Materials List.



3/4 x 5 1/2 x 96" Lyptus (4 bd. ft.)



3/4 x 5 1/2 x 96" Lyptus (4 bd. ft.)

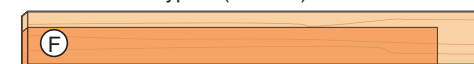

3/4 x 5 1/2 x 48" Lyptus (2 bd. ft.)



As an option to a painted plywood back, you can stain it to match the case.



## Now let's build the curio shelf

**W**hether built to accompany the hall table on *page 60* or stand alone, you'll appreciate this project's clean lines, simple construction, and interlocking cleat system for convenient wall mounting.

### Make the case

**1** From  $\frac{3}{4}$ "-thick stock planed to  $\frac{1}{2}$ " thick, cut the sides (G), sub top/bottom (H), and shelves (I) to the sizes listed in the **Materials List**. Also, cut two  $\frac{1}{2}$ "x $3\frac{3}{4}$ "x $27$ " blanks for forming two short dividers (J) and a long divider (K) from each. Set the blanks aside.

**2** Fit your tablesaw with a dado blade that matches the thickness of your  $\frac{1}{4}$ " plywood for the back (L). Then, on the *inside* face of the sides (G), cut a  $\frac{1}{4}$ "-deep groove  $\frac{1}{2}$ " from the back edge, where dimensioned on **Drawings 4** and **5**.

**3** Refit your tablesaw with a  $\frac{1}{2}$ " dado blade that matches the thickness of the sub top/bottom (H). Attach an auxiliary fence to the rip fence, and position the fence adjacent to the blade. Then cut a  $\frac{1}{4}$ "-deep rabbet on both ends of the sides (G) on the *inside* face.

**4** To cut  $\frac{1}{2}$ " dados  $\frac{1}{4}$ " deep in the mirror-image sides, where dimensioned on **Drawing 5**, to receive the shelves (I), attach

#### 4a FACE-FRAME BISCUIT-SLOT DETAIL

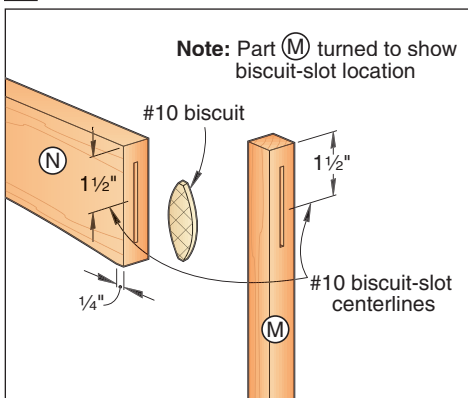

#### 4 EXPLODED VIEW

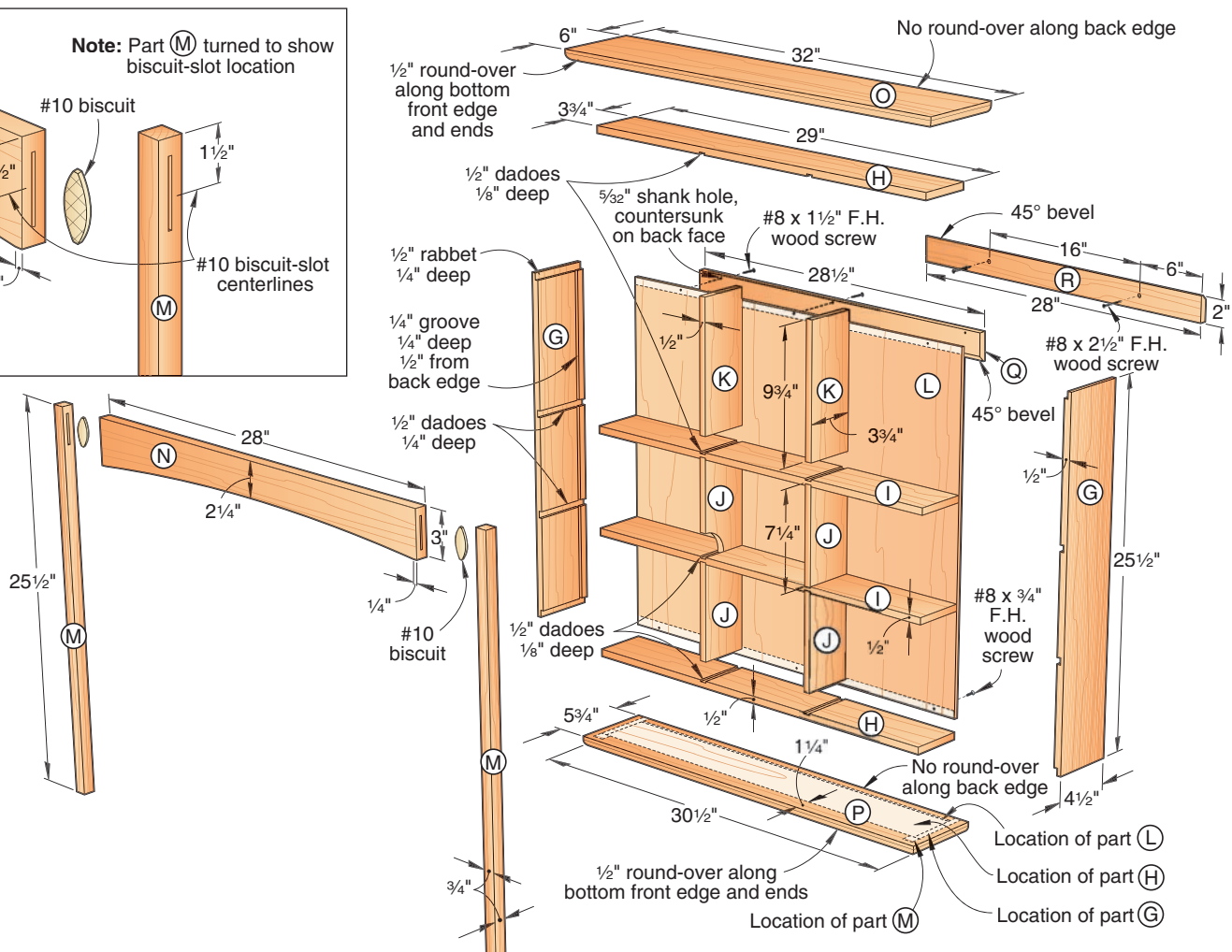

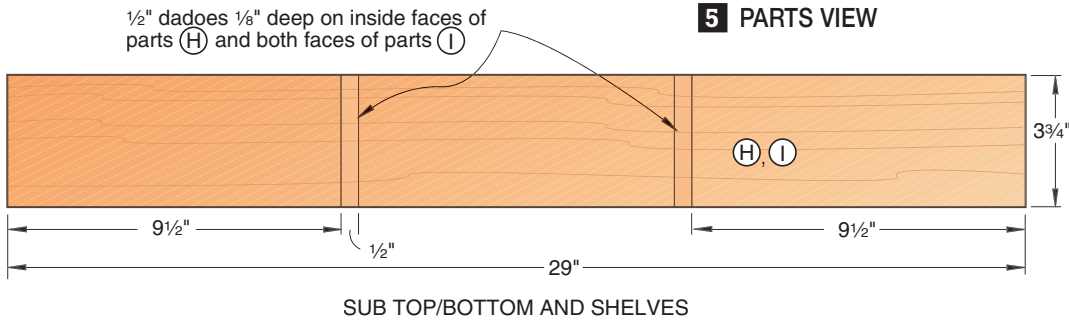

**CUT THE DADOES IN THE SIDES**

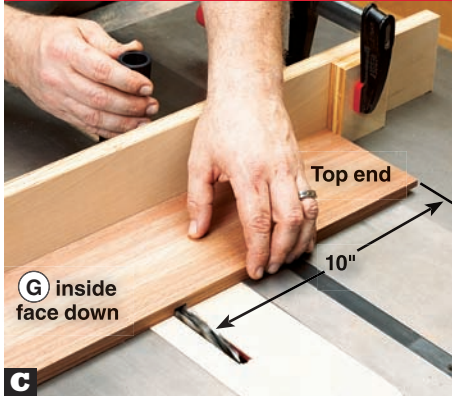

Using a stopblock clamped to an auxiliary extension, cut a 1/2" dado 1/4" deep 10" from the end of each side (G) for the top shelf (I).

**MEASURE FOR THE DIVIDERS**



Dry-assemble and align the case parts using a side (G), as shown. Then measure between the dados to find the exact divider lengths.

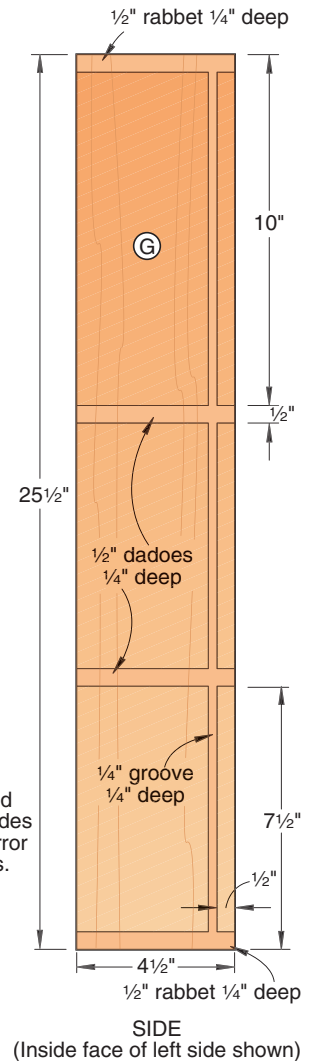

**Note:** Left and right sides are mirror images.

an auxiliary extension with a stopblock to your miter gauge. Position the stopblock 10" from the *inside* face of the dado blade. Then cut a dado on the *inside* face of the sides for the top shelf, as shown in **Photo C**. Identify the top end of the sides. Reposition the stopblock 7 1/2" from the blade. With the sides rotated end-for-end, cut another dado for the bottom shelf.

**5** Lower the dado blade to 1/8", and reposition the stopblock 9 1/2" from the blade. Then cut a dado on the *inside* face of the sub top/bottom (H) and on *both* faces of the shelves (I) at one end, where dimensioned on **Drawing 5**, to fit the short and long dividers (J, K). Now rotate the parts end-for-end, and cut the other dados in the same faces.

**6** To determine the exact lengths for the short and long dividers (J, K), assemble (no glue) a side (G), the sub top/bottom (H), and shelves (I), using the other side (G) to align the parts, as shown in **Photo D**. Measure the distance between the dados in the sub top/bottom and shelves, as shown. Then, from each of the two blanks previously set aside, crosscut two short dividers (J) and a long divider (K) to the measured lengths. Use a stopblock to ensure identical lengths.

**7** To assemble the case, glue and clamp two short dividers (J) between the sub

bottom (H) and lower shelf (I), again using a side (G) to align the parts, as shown in **Photo E**. (We glued the case together in four stages for ease of assembly.) Next, glue and clamp the remaining two short dividers (J) and upper shelf (I) to the assembly. Repeat to add the long dividers (K) and sub top (H). Now glue and clamp the sides (G) to the case, as shown in **Photo F**.

**8** From 1/4" plywood, cut the back (L) to 29x25 1/2". If you plan to stain the back to match the case stain, use Lyptus plywood. If you intend to paint the back, choose less-expensive birch plywood. Set the back aside.

**Add the face frame**

**1** From 3/4"-thick stock, cut the face-frame stiles (M) and rail (N) to the sizes listed.

**2** Mark the ends and center of the curve on the bottom of the face-frame rail (N), where dimensioned on **Drawings 4 and 4a**. Draw the curve using a fairing stick. (For a free plan, go to [woodmagazine.com/fairing](http://woodmagazine.com/fairing).) Bandsaw and sand the curve smooth.

**3** Assemble (no glue) and clamp the face-frame stiles (M) and rail (N) to the front of the case, verifying the frame members are flush with the outside faces of the sides (G) and sub top/bottom (H). Remove the frame and make any needed adjustments.

**4** Draw centerlines for #10 biscuit slots on the stiles (M) and rail (N) at both ends, where dimensioned on **Drawing 4a**. Adjust your biscuit-joiner fence to center the cutter on the thickness of the parts. Then plunge the slots at the marked centerlines.

**5** Using #10 biscuits, glue, assemble, and clamp the frame to the case.

**Complete the case parts**

**1** From 3/4"-thick stock, cut the top (O) and bottom (P) to the sizes listed. Chuck a 1/2" round-over bit in your router. Then rout along the ends and front edges of the top and bottom on the *bottom* face, where shown on **Drawing 4**. Sand the edges smooth. Set the top aside.

**2** Apply glue to the bottom of the case. Then clamp the bottom (P) in place, where shown, aligning the back edges of the bottom and sides (G) and centering the bottom side-to-side. Remove any squeeze-out.

**3** From 3/4"-thick stock planed to 1/2" thick, cut the case cleat (Q) and wall cleat (R) to

## BEGIN THE CASE ASSEMBLY

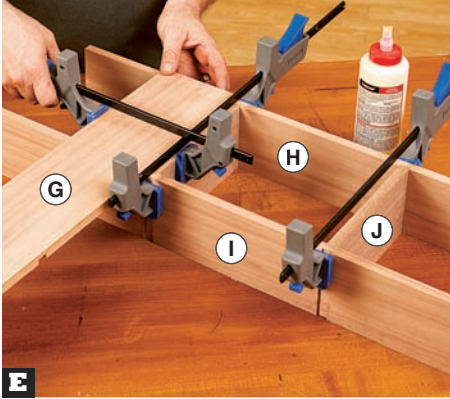

Using a side (G) to align the parts, glue and clamp together the sub bottom (H), lower shelf (I), and two short dividers (J).

## ADD THE CASE SIDES



Glue and clamp the sides (G) to the case, making sure you position the sides with the grooves for the back (L) up, as shown.

## Materials List

Curio shelf	FINISHED SIZE			Matl.	Qty.
	T	W	L		
G sides	1/2"	4 1/2"	25 1/2"	L	2
H sub top/bottom	1/2"	3 3/4"	29"	L	2
I shelves	1/2"	3 3/4"	29"	L	2
J* short dividers	1/2"	3 3/4"	7 1/4"	L	4
K* long dividers	1/2"	3 3/4"	9 3/4"	L	2
L back	1/4"	29"	25 1/2"	C	1
M face-frame stiles	3/4"	3/4"	25 1/2"	L	2
N face-frame rail	3/4"	3"	28"	L	1
O top	3/4"	6"	32"	L	1
P bottom	3/4"	5 3/4"	30 1/2"	L	1
Q case cleat	1/2"	2"	28 1/2"	L	1
R wall cleat	1/2"	2"	28"	L	1

\*Parts initially cut oversize. See the instructions.

**Materials key:** L—Lyptus, C—Choice of Lyptus or birch plywood.

**Supplies:** #10 biscuits (2), #8x3/4" flathead wood screws (3), #8x1 1/2" flathead wood screws (3), #8x2 1/2" flathead wood screws (2).

**Blades and bits:** Dado-blade set, 1/2" round-over router bit.

the sizes listed. Bevel-rip one edge of each cleat at 45°, leaving a 1/8" flat, where shown on **Drawing 6**. Set the cleats aside.

## Time to finish up

**1** Finish-sand all parts to 220 grit, and remove the dust. Mask the top of the case. Then, on the *bottom* face of the top (O), mask a 4x29" area (slightly smaller than the mating case area) along the back edge, centered end-to-end. This lets you finish the top and glue it to the case after installing the back (L).

**2** If you wish to paint the back, apply a coat of primer. Then paint it a color of your choice. Otherwise, apply a stain to the back and all other parts and topcoat with a clear finish. (We used Varathane Premium Wood Stain, no. 254 Red Chestnut, followed by three coats of Zar Water-Based Satin Polyurethane, sanding to 220 grit between coats.)

**3** Slide the back (L) into the case, captured in the grooves in the sides (G). Then remove the masking tape from the case top and the top (O). Apply glue to the unstained area. Now clamp the top to the case, aligning it as you did the bottom (P).

**4** Position the case cleat (Q) on the back of the case between the sides (G) and tight against the top (O), where shown on **Drawings 4** and **6**. Drill countersunk mounting holes through the cleat, back (L), and into the sub top (H), where shown. Fasten the cleat with #8x1 1/2" flathead wood screws. Then drill countersunk mounting holes through the back into the sub bottom (H), where shown on **Drawing 4**, and secure with #8x3/4" flathead wood screws.

**5** Finally, to hang the curio shelf, hold the wall cleat (R) level on your wall with the beveled edge positioned where shown. Drill countersunk mounting holes through

## 6 SECTION VIEW

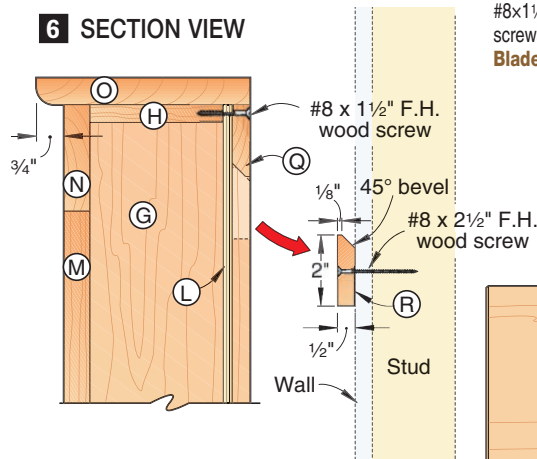

the cleat into the wall studs, and fasten with #8x2 1/2" flathead wood screws. Hang the shelf. Now place your cherished items in the cubbies for all to admire. 🌳

Written by **Owen Duvall**  
Project design: **Jeff Mertz**  
Illustrations: **Roxanne LeMoine**

## Cutting Diagram

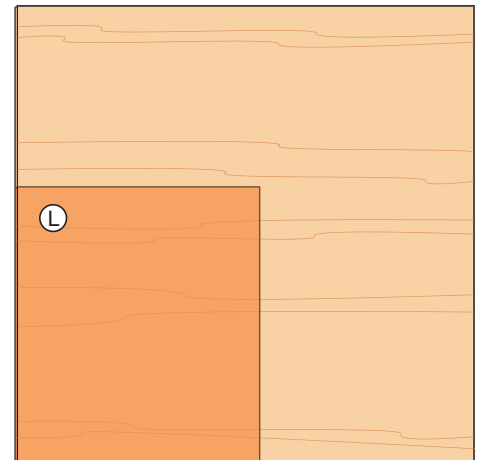

1/4 x 48 x 96" Lyptus or birch plywood



3/4 x 5 1/2 x 96" Lyptus (4 bd. ft.) \*Plane or resaw to the thickness listed in the Materials List.



3/4 x 5 1/2 x 96" Lyptus (4 bd. ft.)



3/4 x 5 1/2 x 96" Lyptus (4 bd. ft.)

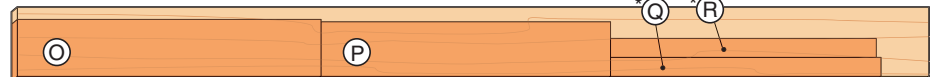

3/4 x 7 1/4 x 96" Lyptus (5.3 bd. ft.)

# 3 foolproof ways to hang

Get the hang of installing wall-mounted projects using these easy techniques.



**Y**ou've babied your shelves and cabinets from raw lumber to completed projects, but the job's not done 'til you hang your handiwork. To mount shelves and cabinets straight and securely, first match the right technique to your project.

Hardware as simple as a sawtooth hanger may work for picture frames and feather-weight decorative shelves. But for heavier projects, you'll need to size your fastener to your project's weight and purpose. Most metal hangers don't come with weight-load ratings, and variables such as fastener choice and whether you're mounting on wallboard or wood paneling affect a hanger's performance. Even the best hangers are inexpensive, however, so choose on the side of caution. The three hanging systems shown here will handle most heavy projects, but each has its distinct advantages.

## 1 Wood cleats

**T**he display shelf, shown *below left* and featured on *page 65*, hangs from a pair of mating cleats—one built into the shelf and one mounted on the wall. The wall cleat's 26" length lets you position mounting screws to connect with studs behind the drywall for added holding power. For cabinets with doors you'll tug open frequently, consider upper and lower

hangers to avoid accidentally pulling the lower portion of the cabinet away from the wall.

To make this system work, we cut a 45° bevel on the lower edge of the shelf's top back rail to form a case cleat integrated into the shelf. A like-beveled cleat mounts on the wall. Once the shelf is hung, the shelf sides conceal both cleats.



A wall-mounted cleat provides a wide, stable surface for mounting this display shelf. The wall cleat visible to the right will be hidden by the shelf.

## TWO SIMILAR CLEAT SYSTEMS

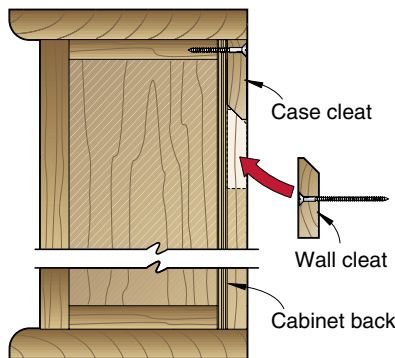

**Hidden cleats** allow the cabinet back to hang flat against the wall. We used this method to hang the display shelf.

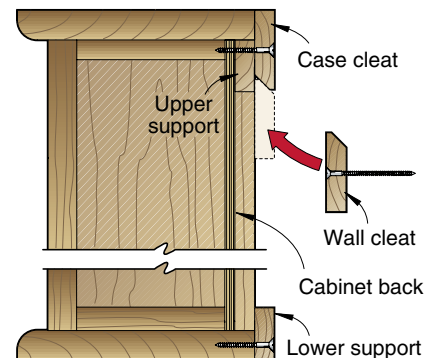

**Exposed-cleat** cabinets stand out from the wall, but are easily moved along a continuous cleat rail. This works great for shop cabinets.

# shelves and cabinets

## 2 Keyhole hanger plates

**K**eyhole-style metal hangers, like the one shown *below*, provide an inexpensive (25¢ apiece) way to hang shelves and cabinets. Recessing them also allows the back of your project to rest flat against the wall.

To install recessed keyhole hardware, begin by tracing around them at the locations you prefer. Avoid mounting screws in end grain where they can pull loose. Then score along your marks with a chisel on the straight edges, and a crafts knife on the rounded ends to define the recessed area.

Install a straight bit in a handheld router, and set its cutting depth equal to the thick-

ness of the keyhole hanger. Remove the stock between the scored lines. Test-fit the hanger in the recess, and mark the location of the keyhole and mounting screw holes within the mortise.

Next, adjust your router bit depth to twice the thickness of your keyhole mounting bracket. Rout the area directly below the keyhole and between the screw holes. Drill pilot holes for the screws, and mount the keyhole hangers, as shown *below left*.

To hang a project with keyhole hardware, center and drive a nail into a 1/4×1" strip of straight scrap until the point emerges about

1/4". Insert the tip of the nail into the narrow portion of the keyhole on one of the cabinet-mounted hangers. Then mark the location of the narrow portion of the other keyhole on your straight edge. Drive a second nail through the strip, as shown *below center*. If you're using more than two hanger plates, add nails marking the location of each plate.

At the location where you want to hang the shelf, rest the stick atop a level, as shown *below*, and lightly tap the nails to mark the locations of your wall anchors. (For a look at popular wall anchor options, see "The inside story on drywall anchors" on page 70.)

### MOUNTING KEYHOLE HANGER PLATES AND SPACING MOUNTING SCREWS





An extra recess beyond the one for the fastener allows a screw to slide into position on the narrow part of the keyhole.



For perfect spacing, make certain the tips of the nails are centered within the narrow part of the keyhole.

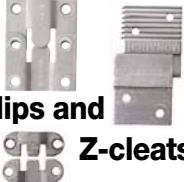

With the spacing strip braced atop a level, it's easy to mark screw and anchor locations with just two taps of a hammer.

Hanger type	Pros	Cons	Comments
<b>1 Wood cleats</b> 	Built-in cleats can hold project backs flush against walls. These provide wide support for heavy projects.	This mounting system must be incorporated into a project's design.	Shop cabinets can stand proud of cleats that span workshop walls for easy relocation, as illustrated <i>opposite bottom right</i> .
<b>2 Keyhole hanger plates</b> 	Inexpensive and adaptable to a wide range of projects, these have more holding power than routed keyholes.	Wall fasteners must be precisely spaced to align with multiple keyholes. Mortising may be needed.	Hangers like the <i>left</i> one can hide behind a project while those like the <i>right</i> one are partially exposed above the project.
<b>3 Metal clips and Z-cleats</b> 	Many types and sizes are available. Larger clips with four holes in each half hold large projects.	Most require more than one wall fastener to install. Flush-mounting projects to walls is difficult.	Pairs align easier than do keyholes and screw heads. Cleat strips can be cut to length and custom-fitted to projects.



### 3 Metal clips and cleats

Not every project can incorporate a built-in cleat system. If you don't mind a  $\frac{3}{16}$ " gap between your cabinet or shelf and the wall, metal cleats and hanging clips, such as those shown *below*, provide an alternative.

Both types of two-piece hangers mount on walls and on your project using two or four screws for each half. That's especially valuable if there's a risk the weight of a cabinet or shelf will tear out a single wall anchor. For an even stronger hanger, Z-cleat strips up to 36" long can be cut and drilled to fit a project. Clips differ from cleats for their ability to limit side-to-side movement that's not possible using the Z-cleats. The trade-off is that clips on the wall must be spaced the identical distance apart as clips on your project. That's easy to do, however.

#### POSITION MULTIPLE CLIPS FOR ACCURATE SPACING



Thin rubber bands hold clips on the edge of a scrap strip, allowing you to match the spacing of the clips on your project.

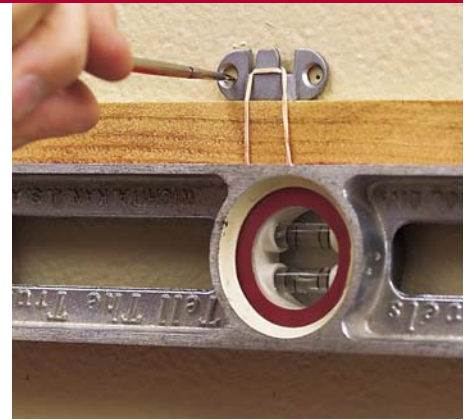

An awl marks mounting screw locations for the two clips used here. This method works just as well for spacing three or more clips.

#### Two-Piece Metal Clip

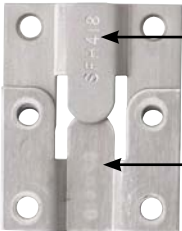

Mount on project

Mount on wall

#### Metal Z-Cleat

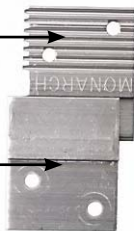

The clip on the left has four mounting holes on each half for added strength. Both it and the Z-cleat on the right are only  $\frac{3}{16}$ " thick with both halves assembled.

To hang a medicine cabinet, we used two pairs of 1"-wide clips. Position cabinet-mounted clips where you can screw into a surface or edge, not into end grain where screws may pull loose. Then drill pilot holes to avoid splitting the wood:  $\frac{3}{32}$ " holes for #8 flathead wood screws in hardwood and  $\frac{7}{64}$ " holes for #8 screws in softwood.

To space apart clips for wall mounting, use rubber bands to hold the clips against a straightedge while lining them up with the cabinet-mounted clips, as shown *above left*. With the straightedge atop a level, as shown *above right*, use an awl to mark the

anchor locations for installing the clips. Add adhesive-back felt pads to the lower corners or edges of your shelf or cabinet to prevent them from marring the wall.

#### Sources

**E-Z Toggle.** Item #00T13.02, \$5.95 for five. Lee Valley Tools, 800/871-8158 or leevalley.com.

**Other drywall anchors.** The Home Depot, 800/553-3199 or homedepot.com.

**Keyhole hangers.** Item #00S10.11 (recessed), \$2.30 for 10 or #00S10.13 (exposed), \$2.50 for 10. Lee Valley Tools.

**Flush-mount clips.** Item #00M85.01,  $1\frac{1}{16} \times \frac{5}{8}$ ", \$3.55 for 10; #00M85.02,  $1\frac{7}{8} \times 1\frac{1}{2}$ ", \$3.05 for 10. Lee Valley Tools.

**Metal Z-Cleats.** Item #00S18.15,  $1\frac{1}{2}$ " wide, \$1.70 for four; #00S18.20, 2" wide, \$1.90 for four. Lee Valley Tools.

### The inside story on popular drywall anchors

The chances of connecting with a stud when you nail or screw a hanger into a wall are less than 10 percent, but a host of fasteners will

help you get a grip on drywall. We've arranged them in order from least holding power on the left to most holding power on the right.

Fasteners	Ribbed plastic	Self-tapping	Split-point	Expanding	Toggle	E-Z Toggle
Inside view						
Comments	Available in several sizes, these anchors are easily removed. You'll need to drill pilot holes to install. The top ridge may stand above the drywall surface.	Anchors hammer in place quickly, then expand as a screw is inserted. Easily removed, the pointed tip and smooth sides minimize drywall damage.	Threads drill into drywall without a pilot hole. Tips break off to accept longer screws. Anchors can be reversed with a screwdriver for easy removal.	Anchors must be sized to fit the thickness of the drywall. Installation requires no pilot hole, but removing these anchors is difficult.	A sizeable pilot hole is needed ( $\frac{5}{8}$ " in this case). Once installed, removing the screw allows the toggle portion to fall off behind the wall.	Inserting a screw releases and tightens the toggle. Screws can be removed and reinserted, but this anchor works best for permanent installations. 🌳

# picture-window scrapbook cover

Here's an heirloom-quality book jacket built to last for a lifetime of memories. It makes a great photo album, too.



**B**uild this project and you'll not only make somebody's day, you'll also use those short pieces of scrapwood too nice to throw away. Coupled with the book-making supplies from our one-stop source, you'll create a unique cover, complete with leather page binding and a clever no-fastener photo window. For a few tips on scrapbooking, see the sidebar on *page 75*.

## First make the covers

**1** For the front cover (A) and back cover (B), cut eight pieces of  $\frac{3}{4}$ " dark-colored stock to  $1\frac{3}{16}\times 14$ " and two pieces to  $\frac{3}{4}\times 14$ ".

(We used cherry.) Then cut four pieces of  $\frac{3}{4}$ " light-colored stock to  $2\frac{1}{4}\times 14$ " and four pieces to  $\frac{3}{4}\times 14$ ". (Here, we used bird's-eye maple.) Now edge-join the pieces into three segments for the front cover and two for the back cover, in the configuration shown on **Drawing 1**. Plane the segments to  $\frac{3}{8}$ " thick. Edge-join the two segments for the back cover, sand it smooth, and cut it to the length listed on the **Materials List** on *page 75*.

**2** Crosscut two  $5\frac{1}{2}$ "-long pieces from the middle segment for the front cover (A). Then to create an opening for standard  $4\times 6$ " photos, cut a  $3\frac{1}{2}\times 5\frac{1}{8}$ " spacer and edge-join

the cover, as shown in **Photo A**. Remove the spacer and sand the cover smooth. Cut it to finished length, trimming both ends to keep the opening centered.

**3** To hold photos in the front cover (A) opening, chuck a  $\frac{3}{32}$ " slot cutter into your table-mounted router and rout  $\frac{1}{2}$ "-deep slots *only in the top and bottom edges of the opening*, where shown in **Step 1** of **Drawing 2**. Then switch to a  $\frac{3}{8}$ " rabet bit, and rout a  $\frac{3}{16}$ "-deep rabet along all the inside edges of the opening, where shown in **Step 2**. The rabet bit removes  $\frac{3}{8}$ " of the inside lip of the slots at the top and bottom of the opening,

# Inside ...



The front cover window provides a display opportunity inside as well as outside.



The cover accommodates up to 20 of the popular 12½x13½" post-style page protectors.

## 1 COVER GLUE-UP

### FRONT COVER

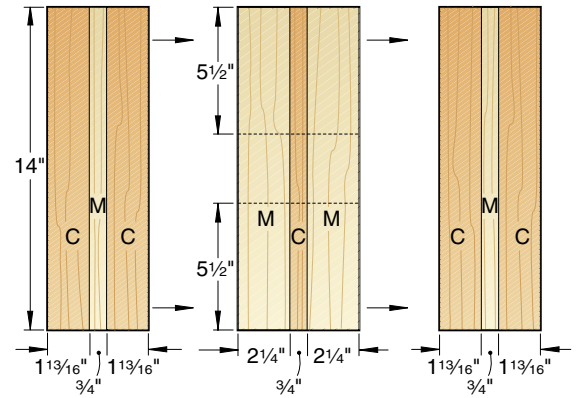

M-maple  
C-cherry

### BACK COVER

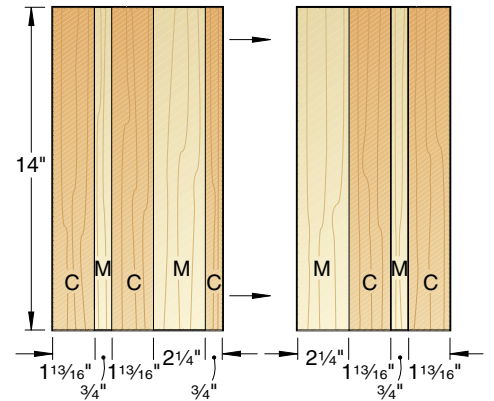

## A SPACER SIMPLIFIES GLUING

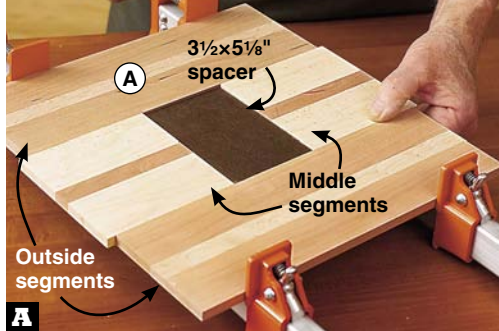

With a spacer between the middle segments, edge-join the cover. Center the outside segments on the middle segments and spacer.

leaving 3/32" slots 1/8" deep to hold the photos and protective clear acetate covers. Now switch to a 1/8" round-over bit and rout the edges of the opening, where shown in **Step 3**. Then rout the outside ends and edges of the covers (A, B), where shown on **Drawings 3 and 5**.

**4** Install a dado blade in your tablesaw, and cut 3/4" rabbets 1/8" deep along the inside edges of the covers (A, B), where shown on **Drawings 3 and 5**. Then finish-sand the covers. Apply masking tape to the cover dadoes to protect the surfaces for gluing later. Now apply a clear finish to the covers. (We applied two coats of Minwax Antique Oil Finish.) Remove the masking tape.

## 2 FORMING THE PHOTO RECESS

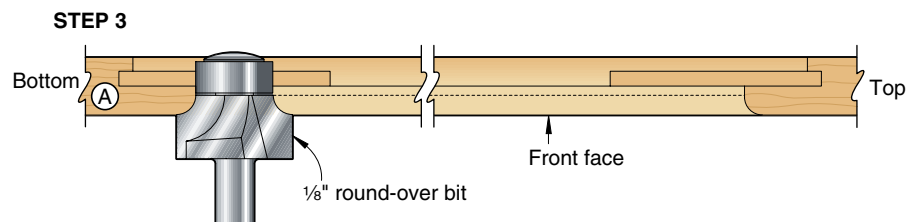
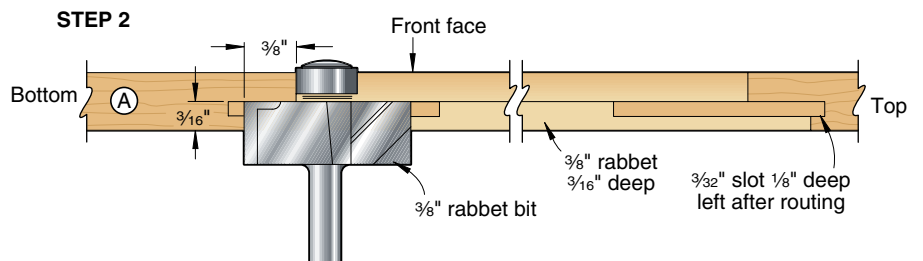
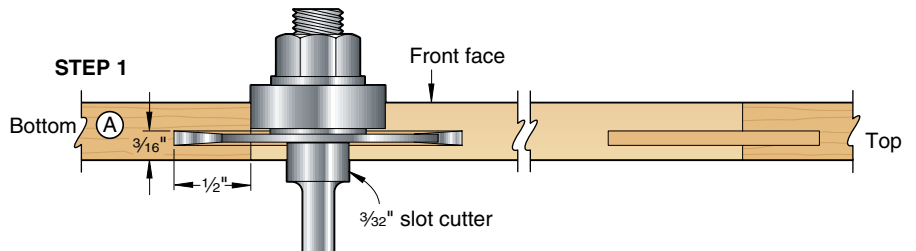

### 3 EXPLODED VIEW

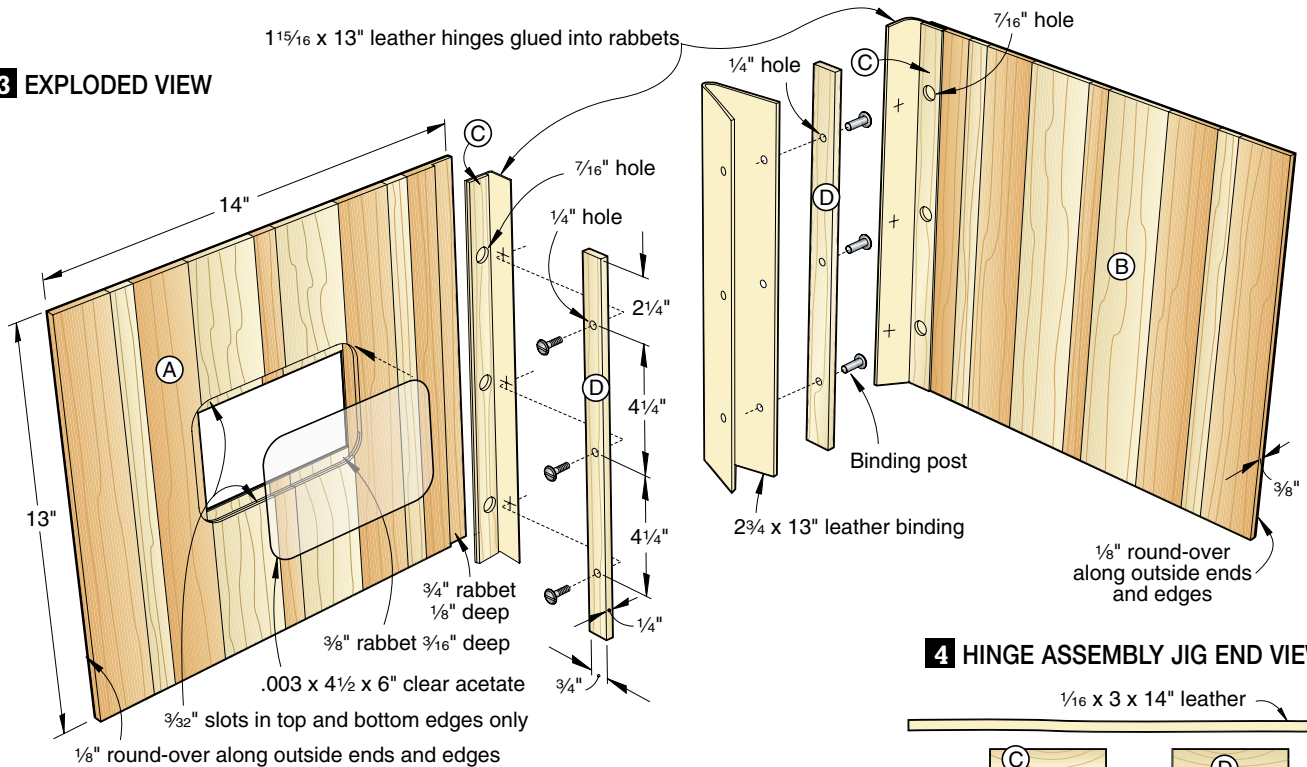

### 4 HINGE ASSEMBLY JIG END VIEW

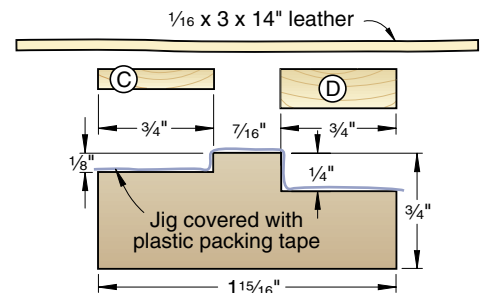

## Now add the hinges

**1** From the edge of a  $\frac{3}{4}$ "-thick piece of bird's-eye maple 13" long, rip two  $\frac{1}{8}$ "-thick cover cleats (C) and two  $\frac{1}{4}$ "-thick page holders (D). Fasten the cleats together face-to-face with masking tape and drill centered  $\frac{7}{16}$ " holes, where dimensioned on **Drawing 3**. Tape the holders together face-to-face and drill centered  $\frac{1}{4}$ " holes, where dimensioned. Separate the parts.

**2** Cut a  $\frac{3}{4} \times 1\frac{1}{16} \times 13$ " piece of scrap for the hinge assembly jig shown on **Drawing 4**. Then install a dado blade in your tablesaw and cut one  $\frac{3}{4}$ " rabbet  $\frac{1}{8}$ " deep and one  $\frac{3}{4}$ " rabbet  $\frac{1}{4}$ " deep to form the profile shown. To keep glue from sticking to the jig, cover it with plastic packing tape. Cut two  $3 \times 14$ "

pieces of leather and form the hinges, as shown in **Steps 1** through **5** below. (We used a supple pigskin leather about  $\frac{1}{16}$ " thick.)

## Assemble the scrapbook

**1** Cut a  $2\frac{3}{4} \times 13$ " piece of leather for the binding. Align each edge of the binding in turn with the edge of one of the page holders (D), and using the holes in the holder as a guide, mark the hole centers on the leather, where shown on **Drawing 3**. Using a paper punch, punch holes in the leather.

**2** Lay the back cover (B) outside face down on your table, and insert the barrel halves of the binding posts into the holes in the page holder (D), where shown on **Drawing 5**. Then add one edge of the leather binding, the page

protectors and optional spacers, the other edge of the binding, and the page holder attached to the cover (A). Thread the screw halves of the binding posts into the barrels.

**3** To mount photos in the front cover window, cut two  $4\frac{1}{2} \times 6$ " pieces of .003"-thick clear acetate film. Select two photos and clip the corners of the photos and the acetate, where shown on **Drawing 6**. Working from the rabbeted side of the window, slide one edge of one piece of acetate into the  $\frac{1}{8}$ "-deep

## 5 EASY STEPS TO MAKING THE WOOD AND LEATHER HINGES

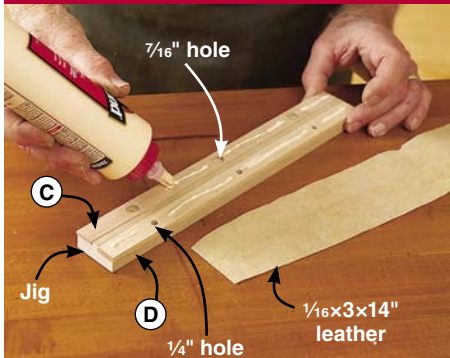

### STEP 1

Place a cover cleat (C) in the  $\frac{1}{8}$ "-deep rabbet of the jig and a page holder (D) in the  $\frac{1}{4}$ "-deep rabbet. Spread glue on the cleat and holder.

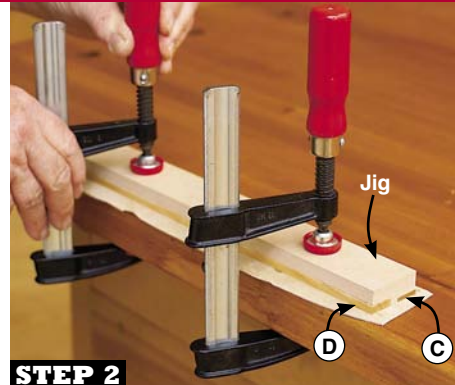

### STEP 2

Apply the leather to the glued surfaces and smooth it out. Then flip the assembly over, and clamp it to the edge of your workbench.

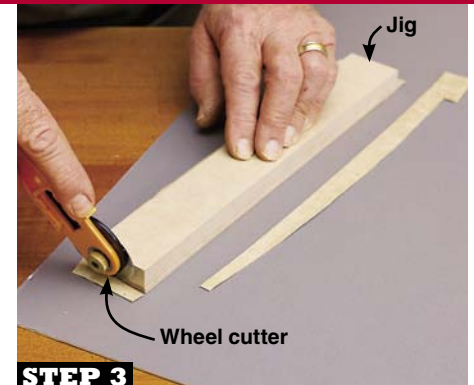

### STEP 3

With the glue dry, use a wheel cutter (available at fabric stores) or a sharp crafts or utility knife to trim the excess leather.

## 5 ASSEMBLY (Top view)

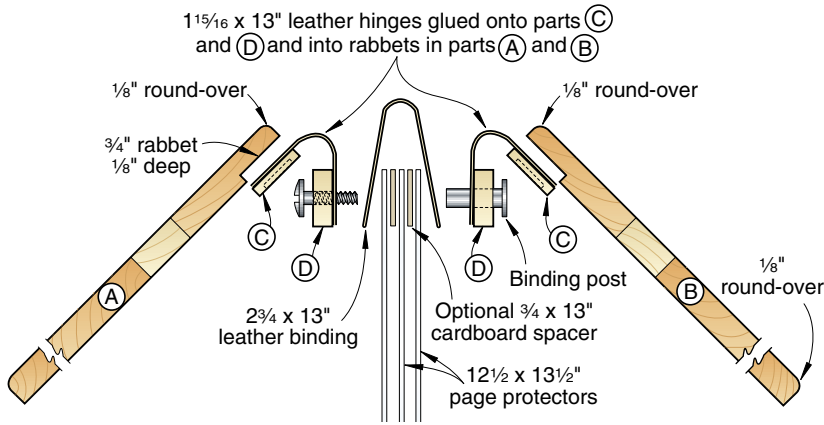

## 6 PHOTO WINDOW CORNER FULL-SIZE VIEW

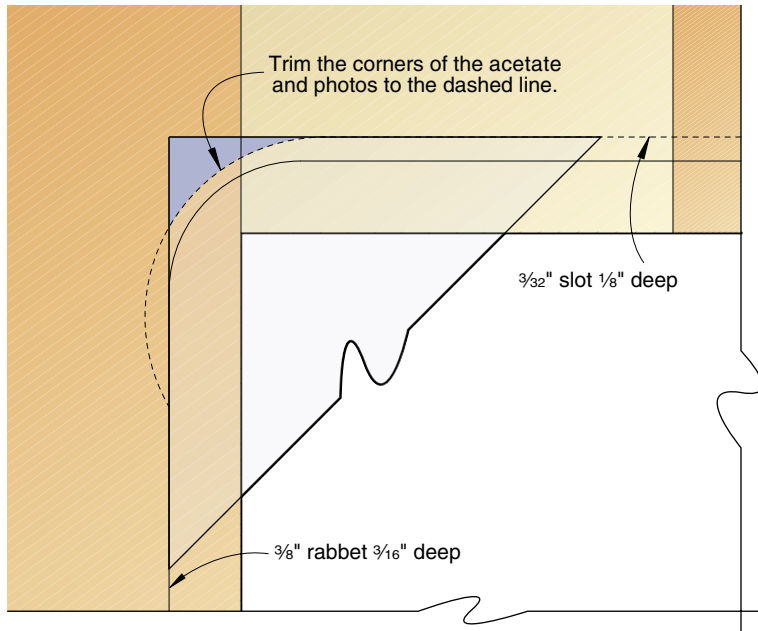

slot made by the slot cutter at the bottom of the window. Then slightly flex the acetate to slide the other edge into the top slot. In the same manner, insert back-to-back photos and the other piece of acetate. Now your

custom-covered scrapbook is ready to fill with memories. 🌿

Written by **Jan Svec** with **Erv Roberts**  
Project design: **Kevin Boyle**  
Scrapbook page designs: **Polly Maly**

## SCRAPBOOK TIPS

When *WOOD*® magazine Senior Design Editor Kevin Boyle conceived this project, he went to the authoritative source of scrapbook information, our sister publication, *scrapbooks etc.*® Here's what he learned about fitting a scrapbook cover to a collection of pages:

- 12½x13½" post-style page protectors for 12x12" scrapbook pages (like the ones sourced *below*) are the most popular size. Check the size your scrapbooker uses and make any necessary adjustments to part sizes.

- Multilayered page compositions and the thickness of some items used can result in fat pages. The ¼"-thick page holders (D) keep an accumulation of thick pages from causing the covers to splay open. For additional room between pages, insert ¾"-wide cardboard spacers, punched to match the page protectors.

- Most scrapbooks range from 10 to 20 pages. To add more pages, or to accommodate spacers inserted between extra-thick pages, add binding post extensions (included in the kit sourced) or purchase longer binding posts.

- For more information on getting started in scrapbooking and to find tips and advanced techniques, go to [bhgscrapbooks.com](http://bhgscrapbooks.com).



## Materials List

Part	FINISHED SIZE			Matl.	Qty.
	T	W	L		
A* front cover	¾"	14"	13"	EMC	1
B* back cover	¾"	14"	13"	EMC	1
C cover cleats	⅛"	¾"	13"	M	2
D page holders	¼"	¾"	13"	M	2

\*Parts initially cut oversize. See the instructions.

**Materials key:** EMC—edge-joined bird's-eye maple and cherry, M—bird's-eye maple.

**Blades and bits:** stack dado set; ⅛" round-over, ⅜" slot cutter, ⅜" rabbet router bits.

### Source

**Scrapbook cover kit.** ½x3x14" pigskin leather (3), 8-32x¾" aluminum binding posts (3), 8-32x¼" binding post extensions (3), 12½x13½" post-style protectors for 12x12" pages (10), .003x8x10" acetate film (1). Kit no. 300COV, \$9.95 plus \$3.95 shipping. Schlabaugh and Sons, 720 14th St., Kalona, IA 52247. Call 800/346-9663.

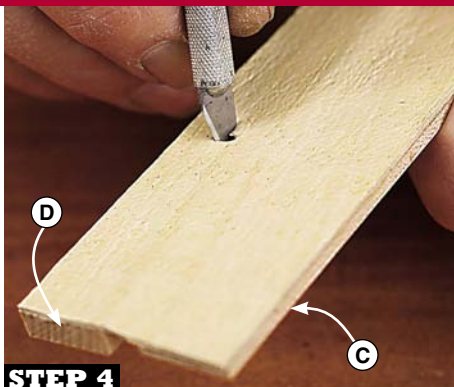

### STEP 4

Use a crafts knife to make two cuts through the leather and into the ¼" holes in the page holders (D), forming Xs.



### STEP 5

Glue and clamp the cover cleat (C) end of the hinge into the cover (A, B) rabbet. A piece of scrap evenly distributes clamping pressure.

# 17 ways to get organized

Fixes and simple projects for your shop



After

**W**hat a difference two days make! That's what it took to rehab 44-year-old Lieutenant Colonel Bill Shea's basement shop in Dalton, Massachusetts, after we selected it as our top candidate for our Workshop Workover.

Bill's shop presented some special problems worthy of our attention because they apply to so many workshops. For starters, Bill's shop appeared like a war zone (see *right*), something of which he has first-hand knowledge, having spent time in Iraq recently. Tools and hardware went homeless, placed where space allowed. Boards, sheet goods, and jigs took refuge in disorganized piles, on unused worksurfaces, and on stationary tool tops. Electrical cords and vacuum hoses snaked across the floors in high-traffic areas, creating tripping hazards. In short, there was no good or dedicated place to put anything.

Added to that, because the shop is located in a basement beneath living areas, a special set of issues come into play. Bill had addressed some of these already, while others still needed help. See *Smart Solutions for Basement Shops*, on page 78, for more.

The attack begins with eight quick fixes performed on Bill's shop, followed by nine super-simple projects that feature a variety of task-specific storage plans. Use any or all to make your shop more organized and, as the U.S. Army might say, "be all that it can be."

Before



Lieutenant Colonel Bill Shea's workshop, shown above, failed to pass our *WOOD*® magazine inspection as a model of organization. But after a weekend's worth of effort and just \$975.31 for a few shop essentials, it passed with flying colors as shown at top.



## 8 easy shop fixes

**B**ill's shop had a few restrictions at the get-go. As a hobby-dedicated basement area with concrete walls, it didn't afford the option of expanding. Nor would any tools or partition walls be removed to create space. According to *WOOD* magazine Senior Design Editor Kevin Boyle, "That meant making the most of what was there."

A quick look around isolated the major problems. They included vastly underutilized walls, ineffective lumber and sheet-good storage, a glaring lack of cabinet storage, open shelving areas beneath the workbench that became collect-alls for miscellaneous tools and dust, and the absence of a worktable where Bill could assemble Shaker boxes. Also, the area beneath the stationary tablesaw extensions went completely unused. At this point, it was time to roll up our sleeves and go to work.

**FIX ①:** As you can see in the after photo on the *previous page*, nothing cures disorganization more than a healthy dose of dedicated storage. The groundwork—or should we say wall work—began with 4x8' sheets of perforated hardboard, screwed to anchored 2x4 furring as shown *below right*. (We fastened the furring in place with 3½" masonry screws.)

**FIX ②:** Next, the lumber storage problem disappeared by attaching heavy-duty 24" straps and brackets (see **Sources**) to the anchored 2x4s behind the hardboard.

Kevin Boyle installs a 4x8' sheet of perforated hardboard against a 2x4 furring framework that was fastened in place with 3½" masonry screws.

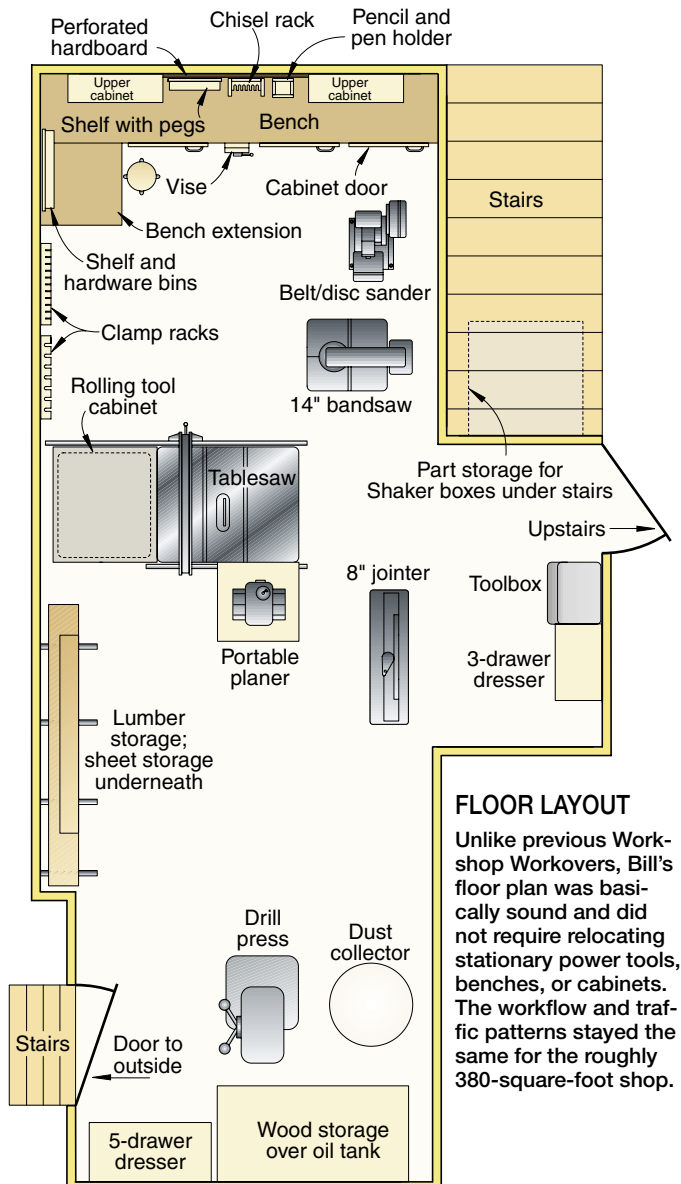



Simple (and cheaper) is always better. Here, bungee cords hooked to screw eyes pin plywood sheets to the wall.

**FIX ③:** A simple system of bungee cords and  $\frac{3}{8}$ "x2" screw eyes corralled sheet goods in one confined area, as shown *above*.

**FIX ④:** To create dust-free storage for portable power tools, sandpaper, and sundry other items, \$170 worth of basic white melamine wall cabinets did the trick.

**FIX ⑤:** That look continues by installing melamine doors (available at Home Depot in various sizes) onto the workbench shelving areas. To do this, Kevin used 1x4s to face the workbench front.

**FIX ⑥:** A woodworker's 9" vise—something no respectable shop should be without—was added to the bench.

**FIX ⑦:** Sandwiched between the wall cabinets and located above the workbench hangs a framed piece of perforated hardboard, providing hand-tool storage.

**FIX ⑧:** And finally, Bill's benchtop power tools were moved elsewhere to recapture needed countertop space. In addition, the bench extension was pushed against the wall to eliminate the nonfunctioning dead space behind it. (See the before photo.)

## Smart solutions for basement shops

Having a workshop below a home's living quarters presents several issues. Here's how they're dealt with in Bill's shop:

■ **Lighting**—The number of general lighting fixtures and wattage proved adequate in Bill's shop. However, to lighten up the space even more, white perforated hardboard, cabinets, and cabinet doors were installed to better reflect existing light.

■ **Noise**—Here, perforated hardboard helped dampen machine noise generated in the shop. Acoustic ceiling tile would further buffer such annoying sounds with fiberglass batts fitted between joists.

■ **Access**—Bill moves finished projects, sheet goods, and lumber via outside stairs and through a 3' door leading directly into the basement.

■ **Dust control**—Before we got there, Bill already had installed a full-service dust-collection system, with the ducting running along ceiling joists. A good move to help prevent airborne dust from traveling throughout the house.

■ **Organization**—As discussed throughout, Bill's shop was in desperate need of dedicated storage. The problem was met head-on with a variety of strategies and projects aimed at creating and maintaining order.

# 9 easy shop projects

**S**pecialized storage is the key to getting and staying organized. Here you'll find a raft of projects—most from scrapwood—that you can cut and assemble in short order to make your shop work harder. All but one of them have 1" holes for hanging on plain old perforated hardboard hooks. Feel free to alter the designs to better suit your assorted tool collection.

Completing the collection is a mobile base cabinet that Bill stores below his tablesaw, capable of providing extra countertop space. To add even more utility in your shop, also consider building the full-service workbench on *page 36*, and the shop cart on *page 88*.





## Project 1: Pipe-clamp rack

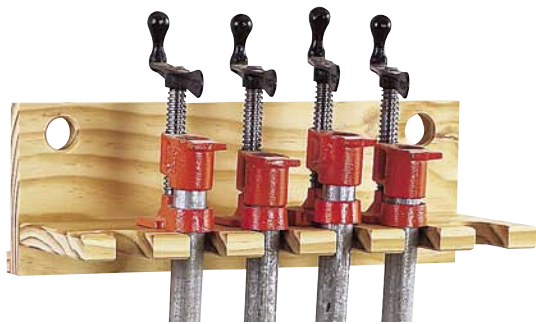

**P**ipe clamps are often found standing in the corner of the shop or on the floor in a pile. To organize Bill's arsenal, a notched shelf made from  $\frac{3}{4}$ " stock works to hold six clamps. Extend the lengths of the shelf and back in  $2\frac{1}{2}$ " increments to hold even more clamps. The spacer adhered to the bottom of the back angles the shelf slightly so the clamps don't slide to the front of the shelf and fall off.

To make one, mark the centerpoints of the notches where dimensioned on the drawing. Use a flat-bottomed or spade bit to bore a  $\frac{1}{4}$ " hole at each marked centerpoint. Rely on a small square to mark the cutlines from the front edge of the shelf to the outside edge of each

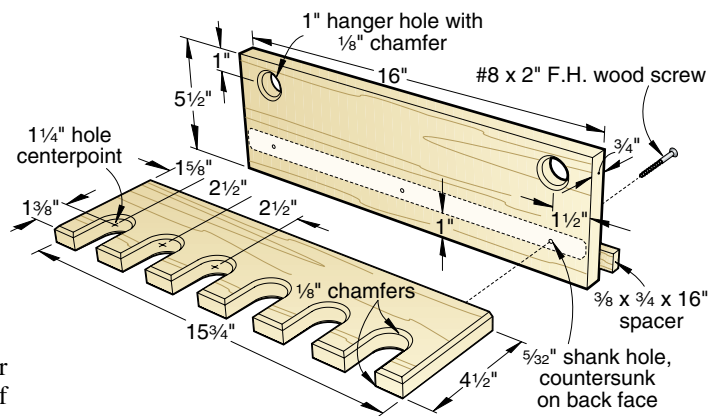

hole. Cut along the lines with a bandsaw or jigsaw to finish forming the notches. You can use the same cutouts for rectangular bar clamps, or simply cut rectangular-shaped openings. Now bore the 1" hanger holes. Rout chamfers along the edges indicated.

Next, clamp the shelf to the back, countersink mounting holes through the back into the shelf, and then glue and screw the two parts together. Glue the spacer to the back where shown.

## Project 2: Bar-clamp rack



**H**ang this bar-clamp organizer on the wall or on the rolling tool cabinet. (See project 9). Cut the back, shelf, and spacer to the sizes noted on the drawing from  $\frac{3}{4}$ " stock. Mark the centerpoints of the hanger holes and the clamp slots where indicated. Now chamfer the edges of the shelf. Bore the hanger holes, and cut the slots to shape. Drill the mounting holes, and glue and screw the pieces together where shown.

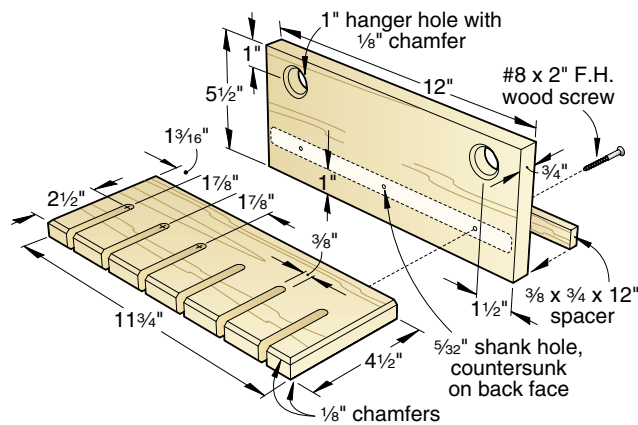

## Project 3: C-clamp holder

**T**o organize C-clamps, make one of these holders for each size of clamp. First, measure the openings of your clamps and size the width of the protruding shelf  $\frac{1}{2}$ " under that measurement. To construct the holder, cut the back, shelf, and spacer to size from  $\frac{3}{4}$ " stock. Next, mark the centerpoints and bore the hanger holes through the back. Chamfer the hanger holes plus the edges and one end of the shelf on both faces. Then attach the shelf to the back, where shown on the drawing, using glue and #8 x 2" flathead wood screws. Next glue and clamp the spacer in place.

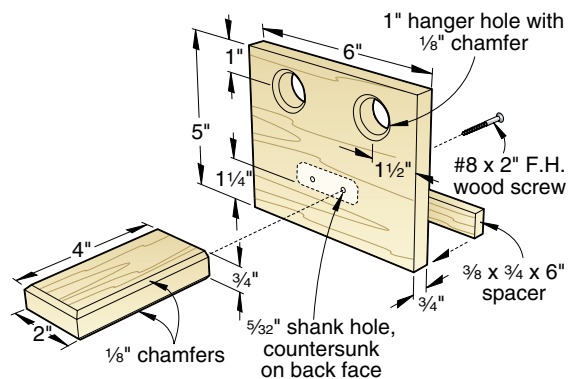

## Project 4: Simple shelf with or without dowels

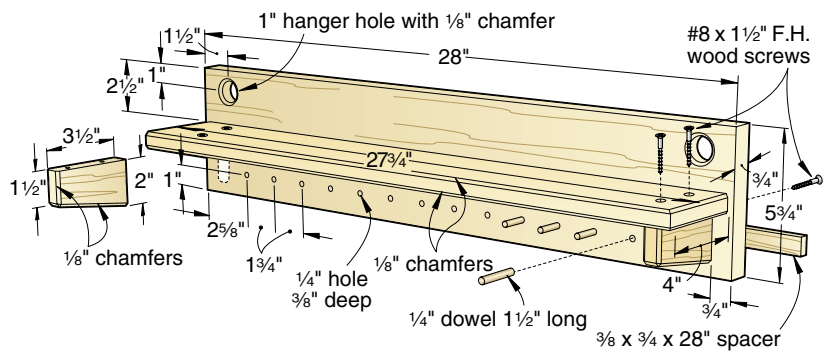

**M**any times wrenches and other small items get lost on a cluttered benchtop. This shelf unit with protruding dowels will minimize your clutter. To build it, cut the back, shelf, shelf supports, and spacer to size. Mark the centerpoints of the hanger holes and the

dowel locations where shown on the drawing. Drill the hanger and dowel holes. Chamfer the hanger holes, shelf, and shelf supports where indicated. Drill mounting holes, and glue and screw the shelf in place. Then, glue the dowels, shelf supports, and spacer in place.

## Project 5: Hardware bin

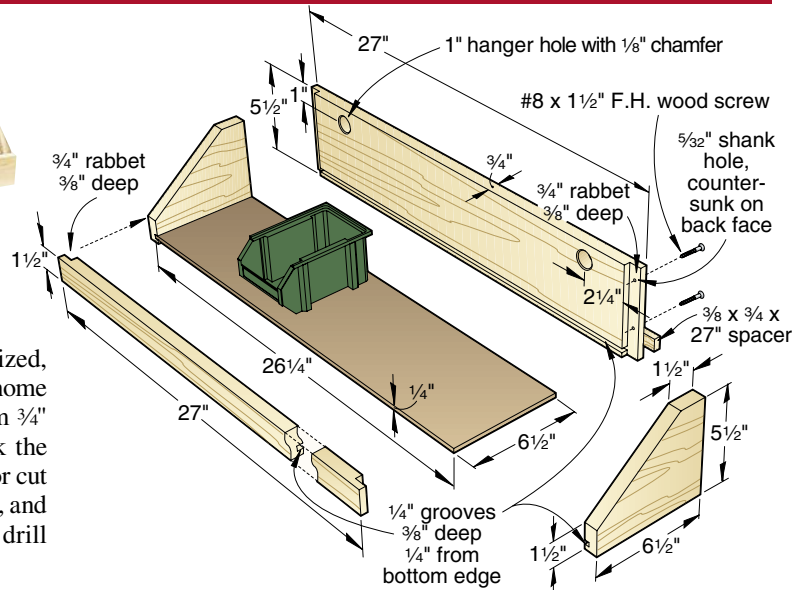

**T**o keep loose hardware, screws, or other small items organized, build this holder for plastic hardware containers found at home centers. First, cut the front, back, ends, and spacer to size from 3/4" stock. Next, cut the bottom to size from 1/4" hardboard. Mark the centerpoints, drill the holes, and chamfer the edges. Then rout or cut 1/4" grooves 3/8" deep 1/4" from the bottom edge of the front, back, and end pieces. Rabbet the front and back where shown. Finally, drill mounting holes, and glue and screw the pieces together.

## Project 6: Glue box

**T**o keep glue and glue brushes close at hand make this simple box. The 1" hanger holes in the back of this project come in handy, especially for moving the box to the project assembly area and returning it to the wall later.

Cut the front, back, ends, spacer, and divider to the sizes listed on the drawing from 3/4" stock. Cut the box bottom to size from 1/4" hardboard.

Mark the centerpoints on the back, drill the holes, and chamfer the edges. Cut or rout 1/4" grooves 3/8" deep 1/4" from the bottom edges of

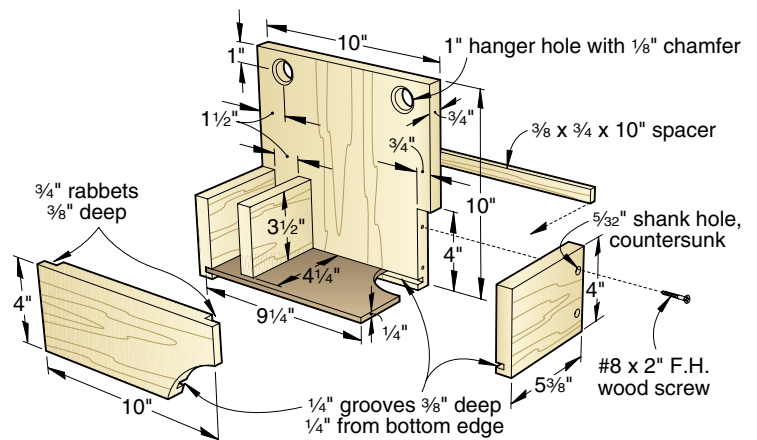

the back, front, and end pieces to house the bottom. Rabbet the front where shown. Assemble the pieces and add the spacer.

## Project 7: Chisel rack

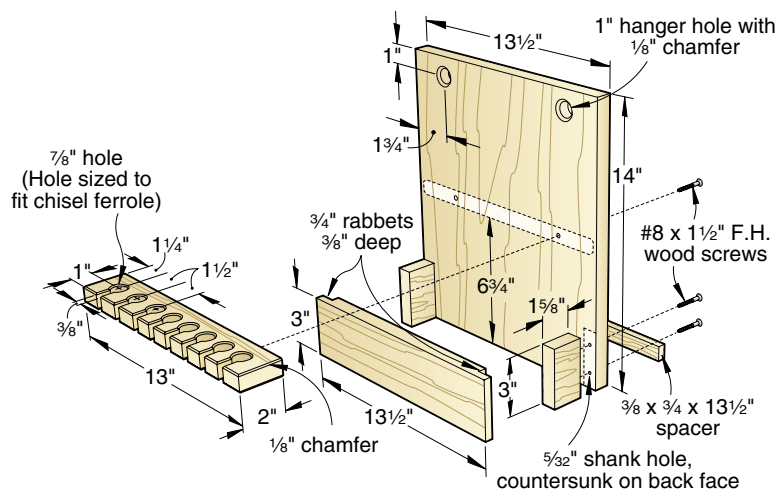

To keep chisels sharp and easy to find, place them in this basic storage rack. Cut the front, back, sides, shelf, and spacer to the sizes shown on the drawing. Locate and bore the hanger holes in the back and the chisel holes in the shelf. (You may have to adjust the

hole size in the shelf to fit your chisels.) Now, saw out the waste between the front edge of the shelf and the chisel holes. Chamfer the shelf edges and rabbet the front where shown. To finish, drill the mounting holes, and glue and screw the rack together.

## Project 8: Pencil box with sharpener support

To build this handy holder, cut the front, back, sides, bottom, and spacer to the sizes shown on the drawing from 3/4 inch stock. Drill the mounting holes, and rabbet the front as shown. Glue and screw the parts together. Complete the project by attaching a pencil sharpener, similar to the one shown, to the bottom.

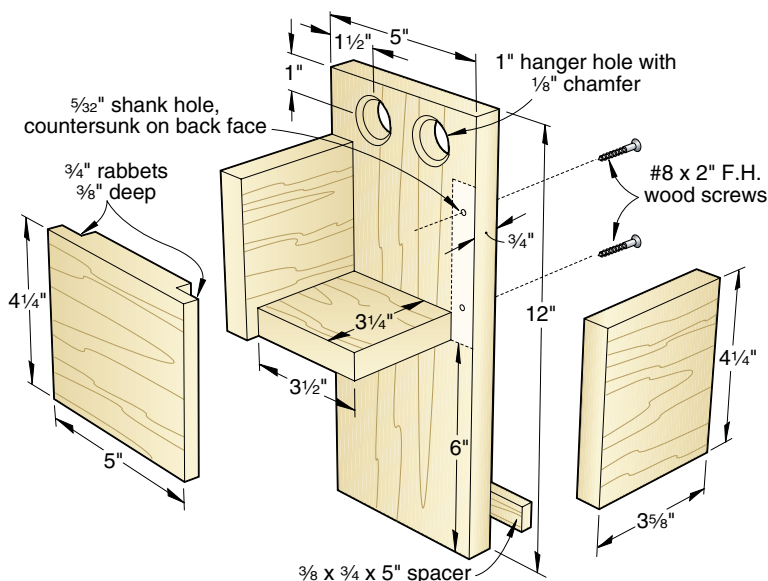

## Project 9: Rolling tool cabinet



This roomy cabinet offers much-needed storage and an extra worksurface. You can stow it out of the way in a corner or tucked beneath a tablesaw extension wing, as shown at *left*. The sides feature perforated hardboard for hanging tools and accessories, while the interior provides several shelves and a partition (inset photo). We provide specific dimensions in the **Materials List**, but change them if you're building the cabinet to fit a specific spot.

To build the cabinet, cut the carcass pieces (A–E) to size from 3/4 inch medium-density fiberboard (MDF) and 3/4 inch maple. Be sure to make a right and left side (mirror images) of the cabinet sides (B). Cut the dados and rabbets where dimensioned. Lay out the 1/4 inch shelf-pin holes on the sides. Using a 1/4 inch drill bit with stop collar, drill the 3/8 inch-deep holes.

Next, apply glue to the rabbets and dados in the sides, subtop, and bottom, and then glue the cabinet together, capturing the center partition (C) where shown.



Glue the supports (E) in place. Cut the shelves (F, G) and shelf edging (H), and band the shelf edges.

Now, cut the doors (I), and rout a 1/4" round-over along the front edges of each. Drill holes for the wire pulls, and install the pulls. Cut the side spacers (J, K) to size, and glue and screw them onto the cabinet sides (B), keeping them flush with the sides' outside edges. Cut the perforated hardboard sides (L) to size, and glue and screw them in place over the spacers. Cut the bottom cleats

(M) to size and screw them in place, flush with the outside edge of the perforated hardboard sides.

Finally, attach the casters to the bottom cleats using #10x1/4" panhead screws with 1/4" flat washers. Fasten the doors to the cabinet with no-mortise wraparound hinges, as shown. Screw on roller catches to secure the doors when closed. Round over the edges of the replaceable top (D) and screw it on. 🌲

Written by **Pat Lowry** with **Jim Harrold** and **Marlen Kemmet**  
Project designs: **Kevin Boyle**  
Photographs by **Jack Holowitz Photography**

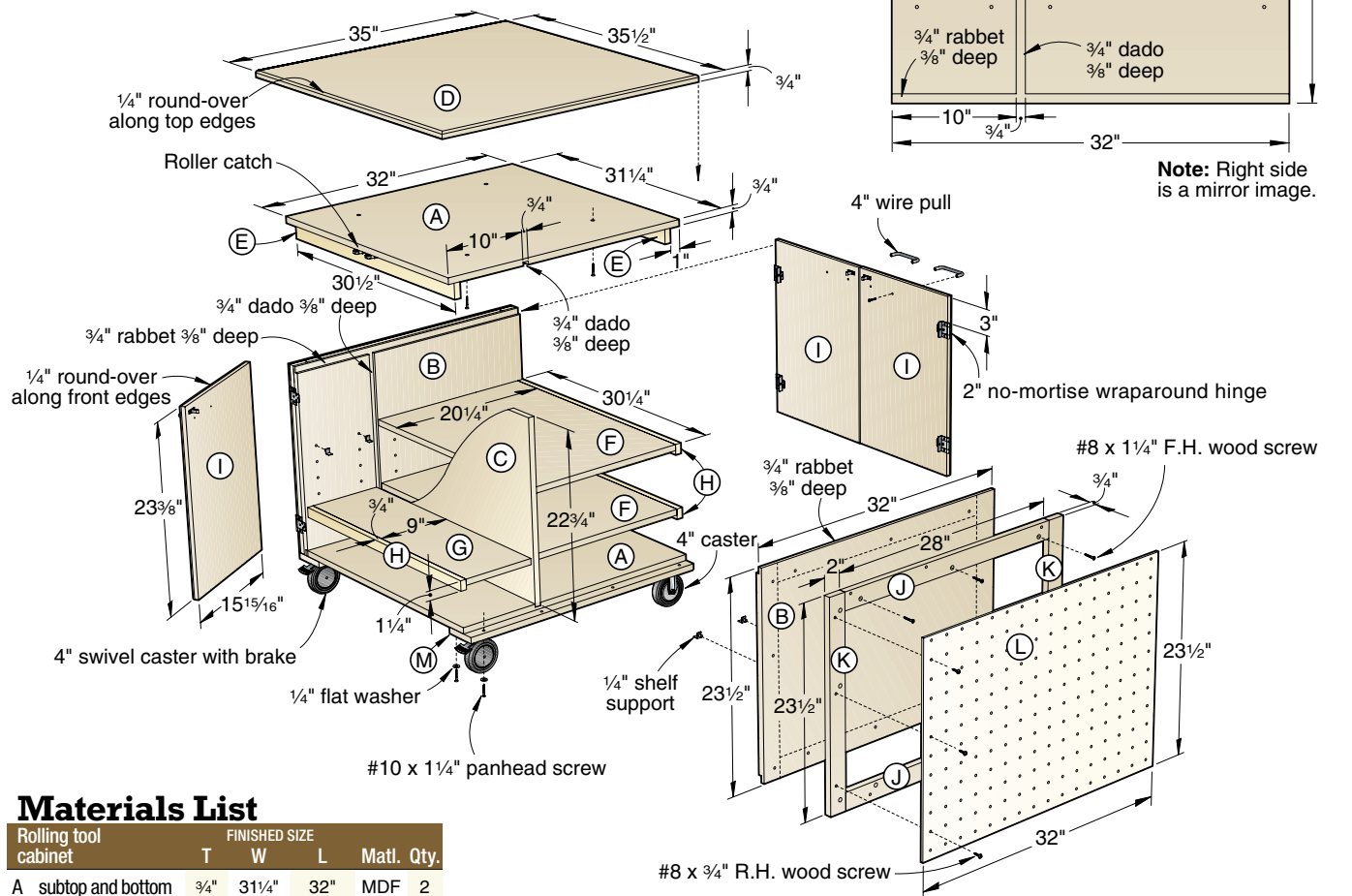

## Materials List

Rolling tool cabinet	FINISHED SIZE			
	T	W	L	Matl. Qty.
A subtop and bottom	3/4"	31 1/4"	32"	MDF 2
B sides	3/4"	32"	23 1/2"	MDF 2
C center partition	3/4"	22 3/4"	31 1/4"	MDF 1
D replaceable top	3/4"	35"	35 1/2"	MDF 1
E supports	3/4"	2"	30 1/2"	M 2
F deep shelves	3/4"	20 1/4"	30 1/4"	MDF 2
G narrow shelves	3/4"	9"	30 1/4"	MDF 2
H shelf edging	3/4"	1 1/4"	30 1/4"	M 4
I doors	3/4"	15 5/16"	23 3/8"	MDF 4
J hor. side spacers	3/4"	2"	28"	MDF 4
K vert. side spacers	3/4"	2"	23 1/2"	MDF 4
L perforated hardboard sides	1/4"	32"	23 1/2"	PH 2
M bottom cleats	3/4"	4"	32"	MDF 2

**Materials key:** MDF—medium-density fiberboard, M—maple, PH—perforated hardboard.

**Supplies:** 2" no-mortise wraparound hinges (8); 4" wire pulls (4); 4" casters (2); 4" swivel casters with brake (2); 1/4" shelf supports (16); roller catches (4); #8x3/4" roundhead wood screws (24); #8x1 1/4" flathead wood screws (28); #10x1 1/4" panhead screws (16); 1/4" flat washers (16).

**Blades and bits:** Dado-blade set; 1/4" round-over router bit; 1/4" brad-point drill bit.

## Sources

**Casters.** Set of 4: 2 swivel, 2 rigid, no. 00K20.10, \$38. Add shipping. Lee Valley & Veritas, call 800/871-8158 or click [leevalley.com](http://leevalley.com).

**Lumber storage system.** 24" wall straps no. 17K20.02 (4), \$7.95 ea.; 14" brackets no. 17K20.06 (8), \$7.25 ea. Add shipping. Lee Valley & Veritas, call 800/871-8158 or click [leevalley.com](http://leevalley.com).

# how to trim workshop waste and \$ave a bundle



## Pro Carl Stammerjohn uses smart strategies to feed less “money” through his saw.

**T**he “20 percent rule” is a widely accepted approach when buying wood for a project. It requires that you buy 20 percent more lumber than your project calls for in order to account for waste. In other words, you throw away one board

for every five you use. In an effort to challenge and reduce this figure, we consulted with furniture designer/builder Carl Stammerjohn. (See “Meet the Expert,” on page 87). He says you can trim waste and maximize your savings by focusing on four key

phases of each project: the conceptual/design phase, the material acquisition phase, the machining phase, and, finally, wisely putting your project leftovers to good use. Follow through on any or all of these strategies and you’ll be dollars ahead.



Carl carefully studies his project plans to figure his material needs down to the board foot and spot potential waste.



Optimize your wood use by making cutting diagrams on your computer. Search online for a variety of software options.

### Phase 1: Design to save

Carl always tells his students that no substitute exists for efficiently designing a project. “Knowing exactly what you want to build will define exactly what you need to buy. To minimize waste, select wood based on precise requirements of a dimensioned plan. At the same time, don’t be penny-wise and pound-foolish. An extra board foot in a materials list is much less expensive than a second trip to a hardwood outlet.” Once you’ve defined the scope of the project, follow these cost-cutting guidelines:

- Consider the sizes and quality of the stock available to you and adjust the dimensions of your project parts accordingly. For example, a 3" square table leg requires you to start with a 16/4 blank, yielding 35 percent waste. But if a 2 5/8" cross section is acceptable, then you only need a 12/4 blank (23 percent less material). Your waste will be reduced to edge cleanup. Whether you lay up three 4/4 boards or purchase solid 12/4 stock, reducing the dimension of the leg by 3/8" saves nearly 45 percent of the cost without reducing functionality. See the drawing *above right* to see how he did this.

- Choose lower-cost material where appropriate. For example, using plywood or

#### ADJUST PART DIMENSIONS TO MINIMIZE WASTE

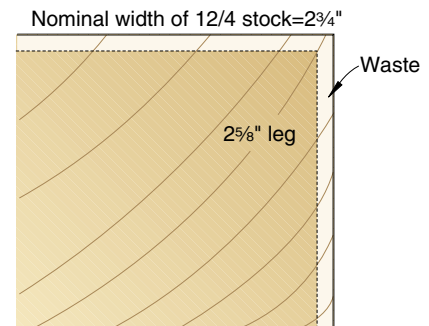
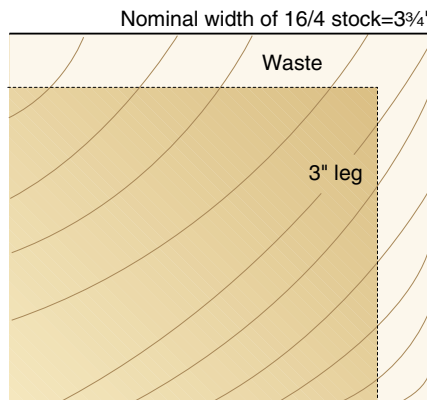

Slightly tweaking and downsizing some project parts, as shown in the leg examples above, enabled Carl to buy less-expensive 12/4 stock instead of 16/4.

poplar for the sides, bottom, and backs of drawers when building an oak dresser results in significant savings.

- Lay up panels with the final shape in mind. For example, when making an oval tabletop, use shorter boards along the outside edges of the glue-up panel and use longer boards for the full-length middle section.

- Consider high-tech solutions, such as one of the new cut-optimization software programs for personal computers. On his

PC, Carl uses CutListPlus, a product sold by Bridgewood Design, 977 Seminole Trail #145, Charlottesville, VA 22901. (Go to [woodmagazine.com/software](http://woodmagazine.com/software) to sample CutListPlus and other software.) His one-time expenditure of less than \$100 repaid itself in time and material saved after just a few projects. “As an engineer,” says Carl, “I wouldn’t have considered forgoing such an efficient tool in my work. So why treat my woodworking any differently?”



## TAKE THE TIME TO MAKE YOUR STOCK CHOICES CAREFULLY

For Carl, stock selection means sorting through as many boards as necessary, and taking the best of what's available.

While picking boards, he marks out the parts with an eye toward color and grain matching, choosing only what he needs for the job at hand.

### Phase 2: Be a smart shopper

Here's where you can really improve on the 20 percent rule. In addition to your detailed plan, a parts list with exact dimensions is crucial to reducing your waste. Take both to the lumberyard, along with your tape measure and pencil. Make the time and effort (retailer-permitting) to select your wood and you can cut waste to less than 10 percent of the total wood in the project, as shown *above*. Here's what else Carl advises:

- Pick lumber for specific project parts. Inspect each board closely for checking,

troublesome knots, cupping, and other defects that would boost your waste percentage. Mark where each cut will be made and label each part, as shown *above right*. If you overlook this step you may end up cutting the wrong part from the wrong board.

- Select boards for matching grain and characteristics. For example, if building a bed headboard with side-by-side raised panels, select boards with similar grain and color that can lay up to form consistent-appearing panels. If the bed also has a footboard that

matches the headboard design, the panels in the footboard should come from the same boards used for the headboard. That way you can get a consistent appearance throughout. And if you're stingy in board-length selection, you can reduce end-of-panel cut-off waste by nearly 50 percent. Says Carl: "For me, matching grain and color in the wood are critical elements of my designs. That may demand a little extra wood to achieve. But I still try to minimize the waste by selecting the right boards at the beginning."

### Phase 3: Machine parts efficiently

How you cut, rout, joint, plane, and drill project parts can have a big effect on your waste percentage. For example, Carl wanted the stability of sheet panels for the sides of a cherry dresser he was building. But he also wanted the look and finishing qualities of solid hardwood. The solution: make thick ( $\frac{1}{8}$ " ) veneer on the bandsaw, and then apply it to both sides of half-inch cabinet-grade plywood substrate. This proved less costly than using either solid hardwood or commercially available veneer. Says Carl: "Resawing on my bandsaw not only saves time and material, it also adds tremendous flexibility to my woodworking." See the photo at *right*. He offers more ideas:

- Make the least waste by picking the best tool for the job. For example, a tablesaw easily rips a board to finished width. But ripping a board on the bandsaw, with a kerf less than  $\frac{1}{16}$ ", sometimes leaves just enough wood to be used for another part.

- Minimize tear-out. Use backer boards for routing, drilling, and sawing whenever possible, and cut boards and panels to length before you rip them to width.

- Snip away the snipe. Too often we accept as inevitable the loss of the last couple of inches on jointed stock due to snipe. But a properly adjusted jointer should eliminate snipe. If the infeed and outfeed tables are not parallel, or if the tool's outfeed table is not level with the top of the blades, you will get that tell-tale gouge at the end of your stock.

- The planer poses a more difficult challenge, but you can eliminate snipe here, also. As the leading end of a long board runs well off the outfeed table it lifts the trailing end of the board. That can result in three or four inches of snipe. Raising the end of the outfeed table minimizes this problem on shorter boards. On long boards you can manually add upward pressure on the front end of the board as its trailing end enters the planer, further minimizing the snipe. According to Carl: "This takes some practice to get just the right upward pressure without hindering the feed rate of the board. Too much pressure and you create snipe in the middle of the board. Hinder the feed rate and you create visible mill marks. Get it just right and you get to use the entire board." A shop-made

### USE A BANDSAW TO SAVE



Carl resaws thin veneers on his bandsaw to make his own hardwood plywoods.

outfeed table could be used to control snipe, as long as you could adjust the outfeed angle to suit different length boards.

## Phase 4: It's not waste if you use it

There is a difference between leftovers and waste. Knowing where to draw the line is an art in itself. Your thinking should be: every board foot I use is a board foot I didn't waste. Or as Carl puts it, "I place value in every piece of wood in the shop. I have a space limitation, so I have to be smart about what I store and what goes in the scrap bin. But I've built a lot of jigs and small projects from wood that came out of the scrap bin."

- Keep a scrap bin handy and store in it small pieces you don't consider leftovers. Use it as a source for clamping cauls, jig components, feather boards, plugs, buttons, etc.

- Store your more desirable leftovers by species, as Carl does in the photo at right.

- Start a Small Projects file. Once or twice a year, do a quick inventory of your leftovers and use them to make simple projects. Says Carl: "It can be a fantastic source for holiday and birthday presents. I made over 50 exotic-wood wine holders for

## REAPING BUCKS FROM SCRAP



Whenever he can, Carl sorts through his organized scrap bins for project stock.

family and friends last Christmas without buying a single piece of wood." Use the drawings below to make some for your friends, laminating contrasting species for a more dramatic look. Also, see the scrapwood projects in every issue of *WOOD*®.

## Now reap the benefits

Cutting waste from 20 percent to 10 percent means that for every 10 projects you build, you get one free. Examine everything you do with your materials. Eliminating machining mistakes is an obvious point, so measure and mark with care! Clean, accurate cuts reduce waste, so keeping your tools properly aligned and cutting edges sharp can help reduce tear-out and additional machining. Finally, keep records on each project. As Carl puts it: "Knowing what you bought and what you used will give you a better understanding of what you're wasting. You can't effectively solve the problem without first knowing how big it is!" 🌲

Written by **Roger McEvoy**

Illustrations: **Roxanne LeMoine**

Photography: **Michael E. Garland**

## Meet the expert

Carl has carried on a love affair with woodworking since childhood. After spending 13 years working for a major aerospace firm, in 1998 he got serious by starting his own business designing and building custom furniture. A Los Angeles native, he holds a B.S. degree in mechanical engineering from California Polytechnic State University at San Luis Obispo, and also teaches in the Woodworking Manufacturing Technology department at Cerritos Community College in Norwalk, California. His classes include basic woodworking, workbench design and construction, finishing techniques, veneering, and advanced furnituremaking. He's become a wiz at pinching bucks from boards.

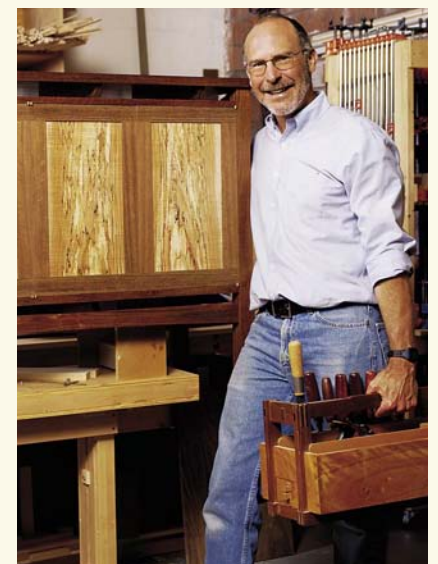

## Build this clever project from scrap

Carl's wine bottle holder design lets you use up small wood pieces while creating an intriguing gift item. To make it, cut out a blank of wood to  $1\frac{7}{8} \times 2\frac{1}{2} \times 9\frac{1}{8}$ ". See the drawing below. (Consider gluing up and planing scrap to achieve these dimensions.) Next, bore the hole in the blank, at least  $1\frac{3}{8}$ " deep, where shown. Now, lay out and bandsaw the holder to shape, cutting just outside the lines. Sand to the lines and round over the top end.

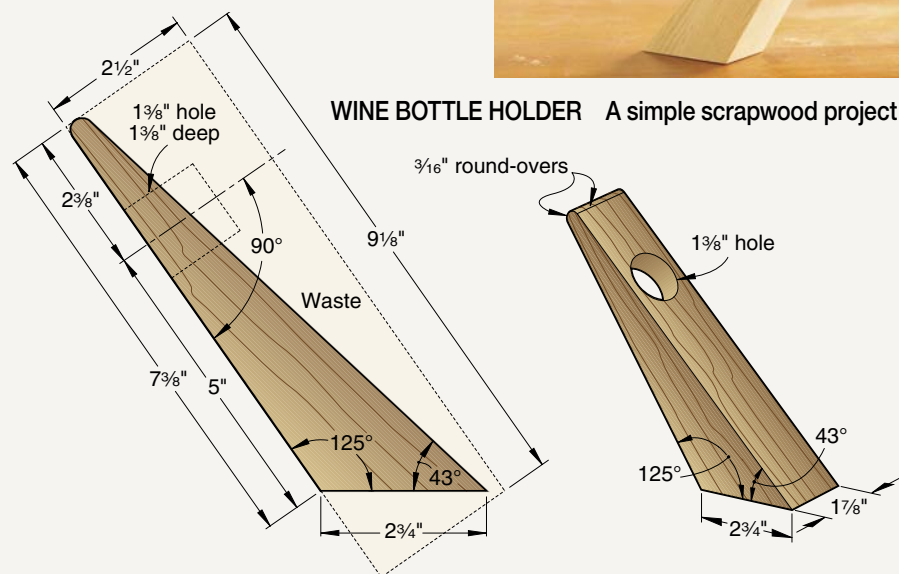



# get 'r-done shop cart

Lid conveniently swings open 270° against end of cart thanks to overlay hinges.

Keep your tools, supplies, and workpieces within easy reach, and enjoy an additional workspace with this handy mobile helper.

Compartment under this lid provides for storage of small items.

All frame members are biscuit-joined for quick and easy assembly.

Swivel casters with brakes securely park the cart in place.



When closed, the lids provide a sturdy work surface that can support a benchtop power tool.

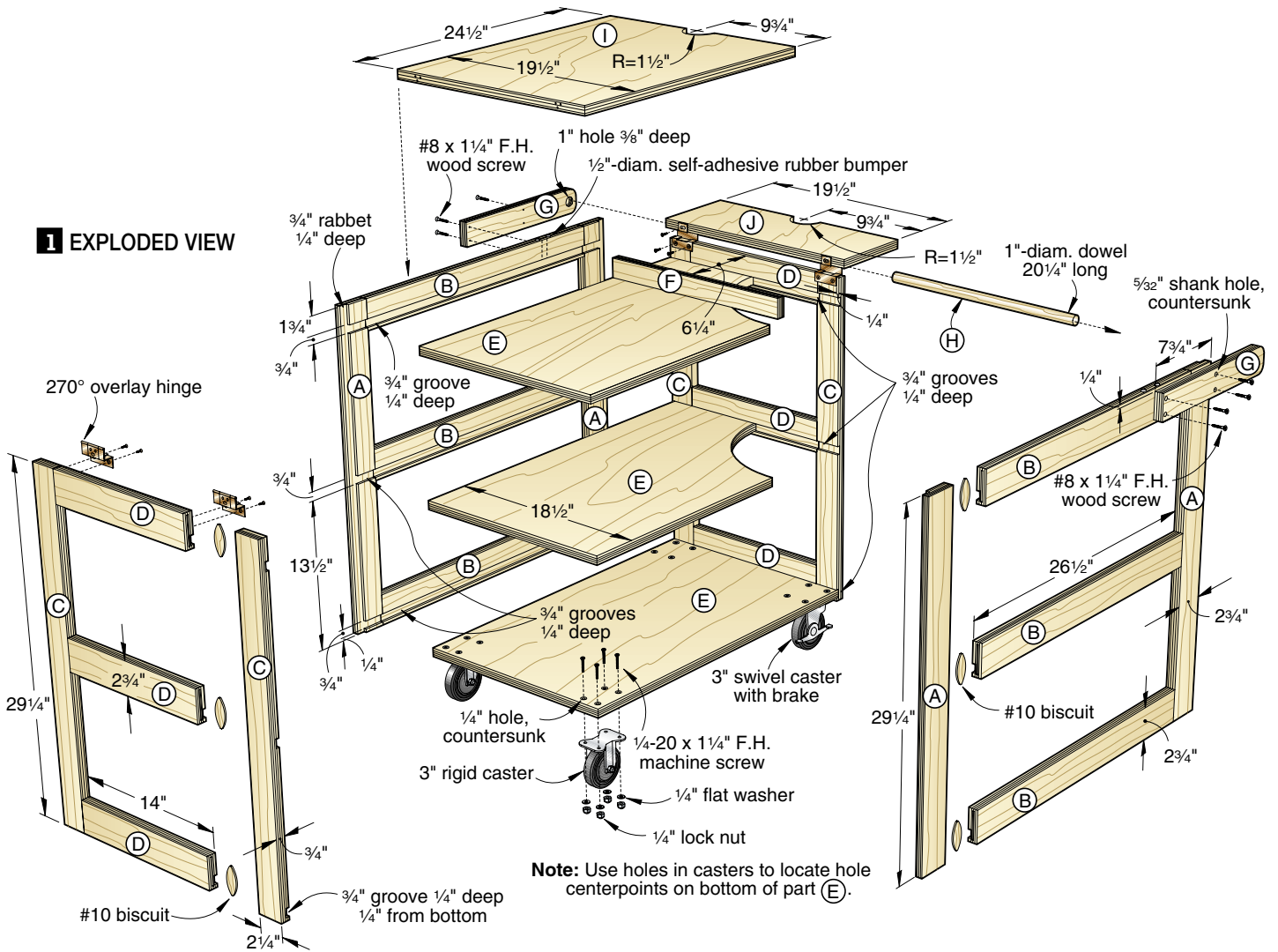

## AT A GLANCE

- Overall dimensions: 21" wide x 38 3/4" long x 33 1/4" high.
- For the items needed to build this project, see *page 91*.

For about \$85 and from just one 4x8' sheet of 3/4" plywood, you can build this sturdy shop accessory. With biscuit-joined side and end frames and simple rabbet-and-groove joinery, it's easy to complete it in a weekend. We used birch plywood that cost less than \$40 a sheet at a local home center. Surprisingly, that plywood came close to the quality of pricier Baltic birch plywood, having the same number of plies (13) and few voids for smooth, finished edges. As a cost-saving option, you can make the cart from medium-density fiberboard (MDF), which runs about \$20 a sheet.

## Start with the side and end frames

**1** From 3/4" plywood or MDF, cut the side stiles (A), side rails (B), end stiles (C),

## 1a CASTER LOCATION DETAIL (Bottom view)

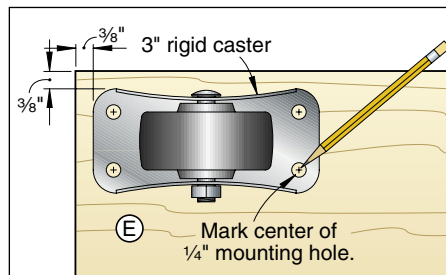

and end rails (D) for the frame assemblies, shown on **Drawing 1**, to the sizes listed in the **Materials List**. To ensure you'll get all of the cart parts from one 4x8' sheet, refer to the **Cutting Diagram**.

**2** To mark centerlines for #10 biscuit slots on the stiles and rails, where dimensioned on **Drawing 2**, *page 90*, lay out on a flat surface two side stiles (A) and three side rails (B) in the arrangement shown. To position the center side rail in the frame, where dimensioned, cut two 1x10 1/2" spacers from 3/4" scrap. Place the spacers between the bottom and center side rails, as shown in **Photo A**.

## MARK BISCUIT-SLOT CENTERLINES

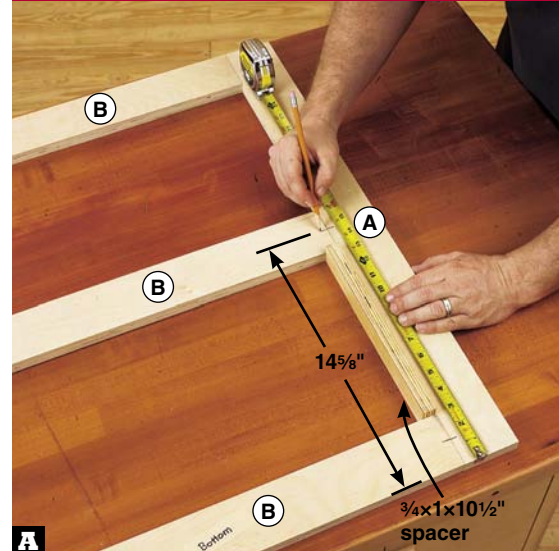

With the center side rail (B) positioned in the frame with spacers, mark the centerlines for biscuit slots on the side stiles (A) and rails.

Mark the biscuit-slot centerlines across the stile/rail joints, as shown. Also, identify the bottom rail to ensure correct frame orienta-

## 2 SIDE AND END FRAME ASSEMBLIES

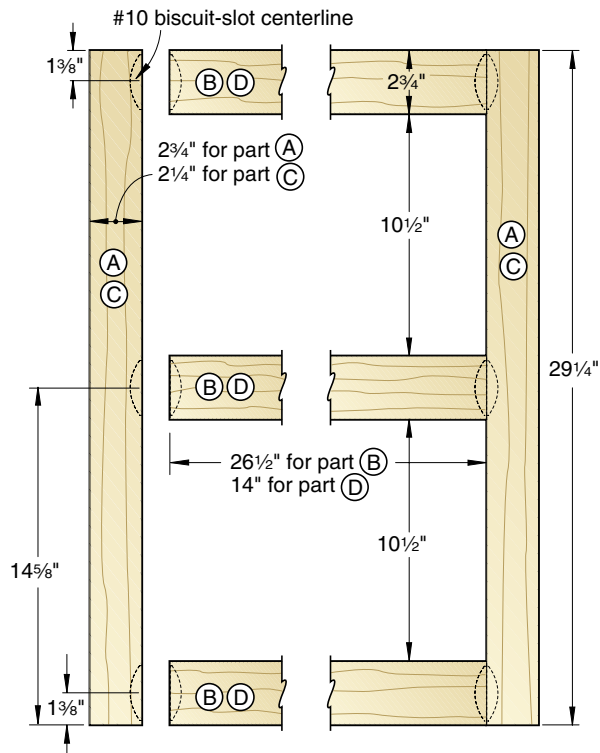

**B** Glue and clamp a side frame (A/B), end frame (C/D), and the bottom shelf (E) together, making sure you close the frame corner joint by drawing the end frame tightly in the rabbet in the side frame.

tion later. Now repeat the marking process for the remaining side stiles (A), side rails (B), end stiles (C), and end rails (D), keeping the parts for each frame together.

**3** Adjust the fence on your biscuit joiner to center the blade on the plywood thickness. Then, with the parts clamped to your workbench for safety, plunge slots for #10 biscuits in the rails and stiles at the marked centerlines. Now glue, biscuit, and clamp the parts together to form the frames, again using the spacers to position the center rail in each frame.

**4** Fit your tablesaw with a dado blade that matches your material thickness. Then cut 1/4"-deep grooves along the length of the side and end frames on the *inside* face, where dimensioned on **Drawing 1**. Keep the bottom edge of the frames firmly against the fence when cutting the bottom and center grooves, and the top edge against the fence when cutting the top groove.

**5** Attach an auxiliary fence to your rip fence. Then cut a 3/4" rabbet 1/4" deep along the outside edge of the side stiles (A) on the *inside* face, where shown.

### Add the shelves and assemble the cart

**1** Cut the three shelves (E) to 18 1/2 x 31". To locate and drill the mounting holes for 3"

casters through the bottom shelf, where shown on **Drawing 1**, position a caster on the bottom face of the shelf, where dimensioned on **Drawing 1a**. (We found the rigid and swivel casters with brakes at a local home center.) Mark the centers of the mounting holes. Repeat at each corner of the shelf. Then drill 1/4" holes through the shelf at the marked centerpoints, and countersink the holes on the *top* face so the heads of 1/4-20 x 1 1/4" flathead machine screws will sit flush with the shelf surface.

**2** Sand the side frames (A/B), end frames (C/D), and shelves (E) to 150 grit. Then, to assemble the cart, glue and clamp a side frame, end frame, and the bottom shelf together, as shown in **Photo B**. (To minimize the number of clamps needed, we assembled the cart in four stages.) When the glue dries, glue and clamp the center shelf

in position. Next, glue the top shelf in place. Now glue and clamp the remaining side and end frames to the assembly.

## 3 PARTS VIEW

### HANDLE SUPPORT (Outside face shown)

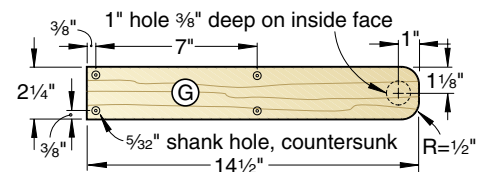

### LONG AND SHORT LID PANELS

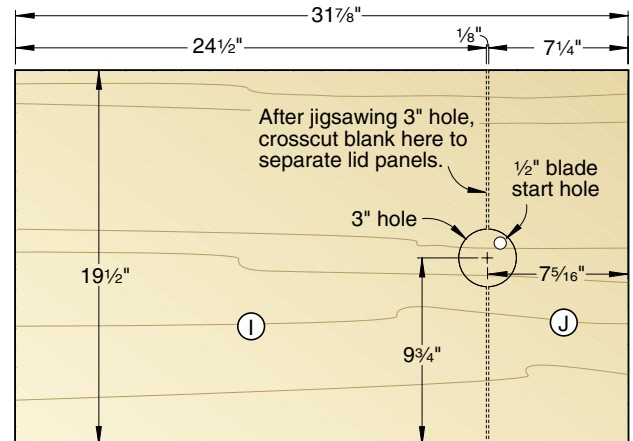

## MOUNT THE LID HINGES

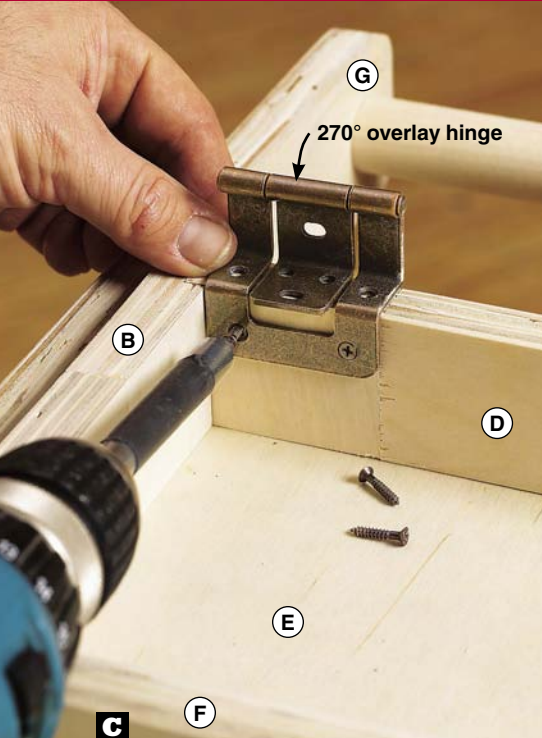

With a 270° overlay hinge positioned on a top end rail (D), tight against a side rail (B), drill the mounting holes, and drive the screws.

## Mount the casters and complete the cart

**1** To mount two 3" rigid casters and two 3" swivel casters with brakes to the bottom shelf (E), where shown on **Drawing 1**, position the cart with an end frame on the floor. Attach the casters using  $\frac{1}{4}$ -20 $\times$ 1 $\frac{1}{4}$ " flathead machine screws,  $\frac{1}{4}$ " flat washers, and  $\frac{1}{4}$ " lock nuts. Now set the cart on the casters.

**2** Cut the top-shelf divider (F) to the size listed. Then glue and clamp the divider to the top shelf (E), where dimensioned.

**3** Cut the handle supports (G) to size. On the *outside* face of the supports, mark centerpoints for four countersunk shank holes, where dimensioned on **Drawing 3**. Also mark  $\frac{1}{2}$ " radii, where shown. Next, on the *inside* face of the supports, mark a centerpoint for a 1" hole, where dimensioned. Drill the countersunk shank holes. Then, using a Forstner bit in your drill press, bore the 1" hole  $\frac{3}{8}$ " deep. Now bandsaw and sand the radii to shape.

**4** From a 1"-diameter birch dowel 36" long, cut a 20 $\frac{1}{4}$ "-long piece for the handle (H).

**5** To mount the handle supports (G), draw alignment lines on the top side rails (B)  $\frac{1}{4}$ " from the top edge and extending 7 $\frac{3}{4}$ " from the ends, where dimensioned on **Drawing 1**. Then glue and clamp a handle support to a top rail, aligning the support with the

marked line. Drive the screws. Repeat to mount the remaining support, making sure you capture the handle (H) between the supports in the 1" counterbores.

**6** Cut a 19 $\frac{1}{2}$  $\times$ 31 $\frac{7}{8}$ " plywood blank to form the long and short lid panels (I, J). Draw a circle for a 3" hole (for finger access) on the blank, where dimensioned on **Drawing 3**. Drill a  $\frac{1}{2}$ " blade start hole just inside the circle. Then jigsaw the 3" hole to shape and sand smooth. Next, position your tablesaw fence 7 $\frac{1}{4}$ " from the inside face of a  $\frac{1}{8}$ "-kerf blade. Now crosscut the blank through the center of the hole to separate the lid panels.

**7** To mount four 270° overlay hinges for the lids, where shown on **Drawing 1**, position a hinge on a top end rail (D), tight against a side rail (B), as shown in **Photo C**. Mark the mounting holes on the inside face and top edge of the end rail. Using a 3" bit extender or magnetic drive guide for chuck clearance, drill the holes. Then drive the screws supplied with the hinges. Repeat to mount the remaining hinges.

**8** Position the long and short lid panels (I, J) on the cart with the finger-access hole straddling the top-shelf divider (F). With the panels tight against the hinges and the edges flush with the outside faces of the side rails (B), drill a mounting hole centered in the slot of each hinge into the edges of the lids. (Note that the hinges offset each panel  $\frac{1}{16}$ " toward the center, leaving a  $\frac{1}{8}$ " gap between the panels.) Drive the screws. Then open the lids and drill mounting holes centered in the hinge holes and slots into the bottom faces of the lids. Drive the remaining screws.

## Finish up and get ready to roll

**1** Remove the casters, long and short lid panels (I, J), and hinges. Sand any areas

of the cart that need it to 150 grit, and remove the dust.

**2** Apply two coats of a clear finish. (We used Varathane Diamond Water-Based Polyurethane, sanding to 220 grit between coats.)

**3** Finally, remount the casters and lid panels. Open the lid panels and install a pair of  $\frac{1}{2}$ "-diameter self-adhesive rubber bumpers on each top side rail (B), where shown on **Drawing 1**. Now clear off your workbench, load the cart with your tools and supplies, and start motoring around the shop. 🌳

Written by **Owen Duvall**  
Project design: **Jeff Mertz**  
Illustrations: **Roxanne LeMoine**

## Materials List

Part	FINISHED SIZE			Matl.	Qty.
	T	W	L		
A	$\frac{3}{4}$ "	2 $\frac{3}{4}$ "	29 $\frac{1}{4}$ "	P	4
B	$\frac{3}{4}$ "	2 $\frac{3}{4}$ "	26 $\frac{1}{2}$ "	P	6
C	$\frac{3}{4}$ "	2 $\frac{1}{4}$ "	29 $\frac{1}{4}$ "	P	4
D	$\frac{3}{4}$ "	2 $\frac{3}{4}$ "	14"	P	6
E	$\frac{3}{4}$ "	18 $\frac{1}{2}$ "	31"	P	3
F	$\frac{3}{4}$ "	1 $\frac{3}{4}$ "	18"	P	1
G	$\frac{3}{4}$ "	2 $\frac{1}{4}$ "	14 $\frac{1}{2}$ "	P	2
H	1" diam.		20 $\frac{1}{4}$ "	B	1
I*	$\frac{3}{4}$ "	19 $\frac{1}{2}$ "	24 $\frac{1}{2}$ "	P	1
J*	$\frac{3}{4}$ "	19 $\frac{1}{2}$ "	7 $\frac{1}{4}$ "	P	1

\*Parts initially cut oversize. See the instructions.

**Materials key:** P—plywood, B—birch dowel.

**Supplies:** #10 biscuits (24), 3" rigid casters (2), 3" swivel casters with brakes (2),  $\frac{1}{4}$ -20 $\times$ 1 $\frac{1}{4}$ " flathead machine screws (16),  $\frac{1}{4}$ " flat washers (16),  $\frac{1}{4}$ " lock nuts (16), #8 $\times$ 1 $\frac{1}{4}$ " flathead wood screws (8),  $\frac{1}{2}$ "-diameter self-adhesive rubber bumpers (4).

**Blade and bits:** Dado-blade set, 1" Forstner bit, 3" bit extender or magnetic drive guide.

## Source

**Hinges:** 270° overlay hinges no. 15455, \$7.99 pr. (2 pr.). Call or click Rockler, 800/279-4441; rockler.com.

## Cutting Diagram

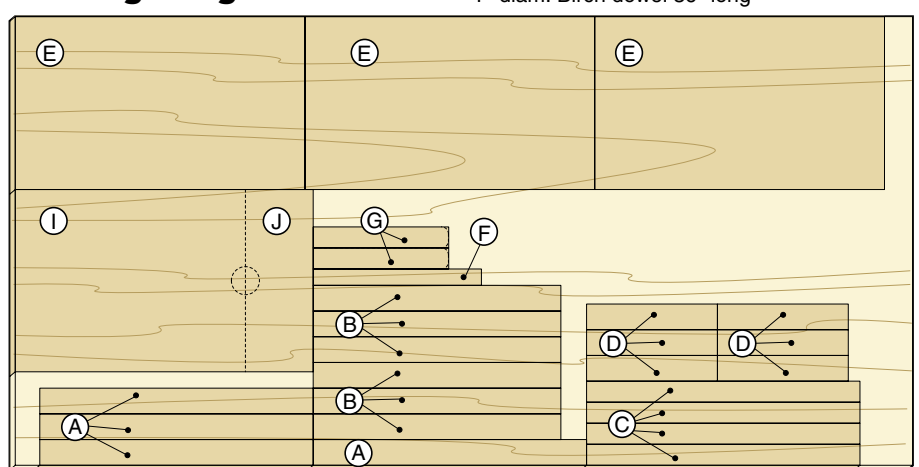

$\frac{3}{4}$  x 48 x 96" Plywood

# shop-proven products

These woodworking wares earned three or more stars in our shop trials.

## Box-joint blade set proves simple and precise

Whether I'm making drawers or decorative boxes, I've always loved the beautiful simplicity of the box joint. But my dado set never left me with perfectly flat bottoms between the fingers. (The beveled teeth on the outside blades leave a small pointed gap in each corner.) Freud's Box Joint Cutter Set is the answer to a box-joint junkie's prayers.

This 8"-diameter set consists of two carbide-tipped blades, each with 20 flat-topped teeth. Like a dado set, the blades stack side-by-side on your tablesaw's arbor. The teeth, though, *aren't* centered on the edge of the blade for a reason, as you can see in the photos, *far right*. Stack the blades one way and the teeth cut a perfect 1/4" slot; stack them the other way, and the teeth offset to the outside for a precise 3/8" slot.

The Box Joint Cutter Set made a strong impression on me right out of the (ahem) box. Clear, detailed instructions—including plans for a simple, yet effective, box-joint



jig—had me cutting perfect joints within minutes. I made a couple of decorative boxes, one with 1/4" fingers and the other with 3/8" fingers, and was amazed at the accuracy of the set. The joints on both boxes fit tightly with no gaps on the first try.



1/4" stack



3/8" stack

Don't let the product's name limit you, though. You can use the Box Joint Cutter Set anywhere you need a 1/4" or 3/8" slot, dado, or rabbet: drawer bottoms and case backs come to mind.

—Tested by Kevin Boyle

### Freud Box Joint Cutter Set (SBOX8)

Performance	★★★★★
Price	\$80

Freud, Inc.  
800/334-4107, freudtools.com

## Make your own iron-on veneer with Heat Lock

Exotic wood veneers can turn a plain wooden box or small project into an eye-popping masterpiece. But the process of gluing thin sheets of beautifully figured wood to a substrate seems to intimidate some woodworkers because they think they need special equipment, such as a vacuum press, to do the job right. Not so with Heat Lock iron-on veneer adhesive.

Using a brush or glue roller, spread Heat Lock onto both the substrate (a box top, for instance) and the back of your veneer—raw or paper-backed. Then let it dry to the touch, about 15–20 minutes. Once dry, lay the veneer on the substrate and heat it with an ordinary clothes iron to form the bond.

I veneered a small box in quilted maple using Heat Lock and found it easy to use. Because the adhesive doesn't grab on contact, I made fine adjustments to the grain orientation directly on the workpiece, something I couldn't have done with contact cement. Putting an old cotton T-shirt over the veneer to prevent scorching,

I ran a medium-hot iron over the workpiece and could actually hear the adhesive melting and bonding under the iron. In just minutes, the job was done with no clamping and no special equipment.

A couple of caveats: The heat-bonding process can shrink the veneer because it removes moisture, so the manufacturer doesn't recommend it for book-matching or other seaming. That shrinking also tends to make cracks and splits in the veneer even larger. I found that using a little steam from the iron minimized the shrinkage problem.

For most of my veneer work on projects without seams, though, I'll use Heat Lock from now on. It cleans up with water and doesn't choke me with strong solvent fumes as contact cement does, or creep the way that traditional woodworking glues tend to.

—Tested by Kevin Boyle



### Heat Lock iron-on veneer adhesive

Performance	★★★★☆
Price	\$14, pint; \$35, gallon

Better Bond Adhesives, betterbond.com  
Available from VeneerSupplies.com,  
888/598-3633

continued on page 94

## Magnetic saw guide proves attractive for dovetailers

The first time I tried to hand-cut dovetails, I thought it would be easy: Simply lay out the tails on one workpiece and start cutting.

Before I knew it, the saw started drifting off my mark and, ultimately, my inaugural joint wasn't particularly functional or pretty.

You won't have to worry about that with the AngleMag magnetic saw guide. This clever accessory uses magnets encased in a plastic disc (the *saw glide*) to hold the saw blade at any angle from  $-1^\circ$  to  $+46^\circ$ . I was surprised at how well the saw glide held onto the saw yet didn't make the sawing action more difficult.

Once set to an angle (I set it at  $7^\circ$ ), I cut the left side of my tails, moving the saw glide on its main shaft. Indexing grooves every  $90^\circ$  around the shaft ensure that the saw glide doesn't rotate. Then, to cut the right side of the tails, I rotated the main shaft  $180^\circ$  and cut the right tail sides. They were a perfect mirror of the left cuts.

After using the tail cuts to mark the pin locations on the mating workpiece, I rotated the saw glide  $90^\circ$  (to the next groove on the main shaft) and miter-cut the angle for the

pins. Finally, I rotated the saw glide another  $180^\circ$  to complete the pin cuts.

AngleMag is not a miracle in a box, but it's a great confidence builder. You still have to measure and mark precisely, place the saw accurately, and chop out the waste cleanly with a chisel. But knowing that the saw will follow your layout lines helps you produce well-fitting dovetail joints. I used AngleMag for joints besides dovetails too. Hand-cutting box joints, bridle joints, even angled tenons is easy and accurate.

To cut stock narrower than 5", I clamped a scrap piece of the same thickness into the vise next to AngleMag, as shown in the photo. On wider workpieces, you can insert the main shaft in the opposite side of the body as you approach the edge of the board. This flexibility also makes AngleMag equally user friendly for left- or right-handed woodworkers.

—Tested by Pat Lowry



### AngleMag

Performance

★★★★★

Price

\$133 (ppd.)

[anglemag.com](http://anglemag.com)

Available at 800/426-4613; [toolsforworkingwood.com](http://toolsforworkingwood.com)

### About our product tests

We test hundreds of tools and accessories, but only those that earn at least three stars for performance make the final cut and appear in this section. Our testers this issue include: cabinetmaker **Pat Lowry**, and *WOOD*® magazine staff member **Kevin Boyle** (senior design editor). ♣

# bandsaw accessory store-all

Keep your attachments organized and at arm's reach.

When *WOOD*® magazine reader Perry Johnson of Minneapolis got tired of playing hide-and-seek with his bandsaw's miter gauge, fence, and smaller items, he decided to corral them into one place. His shelf is easily customized to fit your accessories, and mounts to your bandsaw in no time.

If your bandsaw doesn't sit on an accommodating cabinet, simply create the optional wall bracket and mount the shelf near your saw.

To build the store-all, cut two pieces of 1/2" stock to 3" wide and the length of your bandsaw cabinet. On the top piece trace the outline of your miter gauge and fence head. Cut the openings slightly oversize and glue the two pieces together to create the base with the recesses. Drill a hole to hold the hex-key wrench used for the guide blocks and another hole to store the table pin.

Cut the 1/2"-thick front strips to hold the fence and miter gauge in place. Glue the strips in position. For a wall-mount shelf, cut and add the wall bracket using glue and wood screws.

Finally, using sheet-metal screws, secure the shelf to the side of your bandsaw base. Or, using wood screws, attach the shelf to a wall.

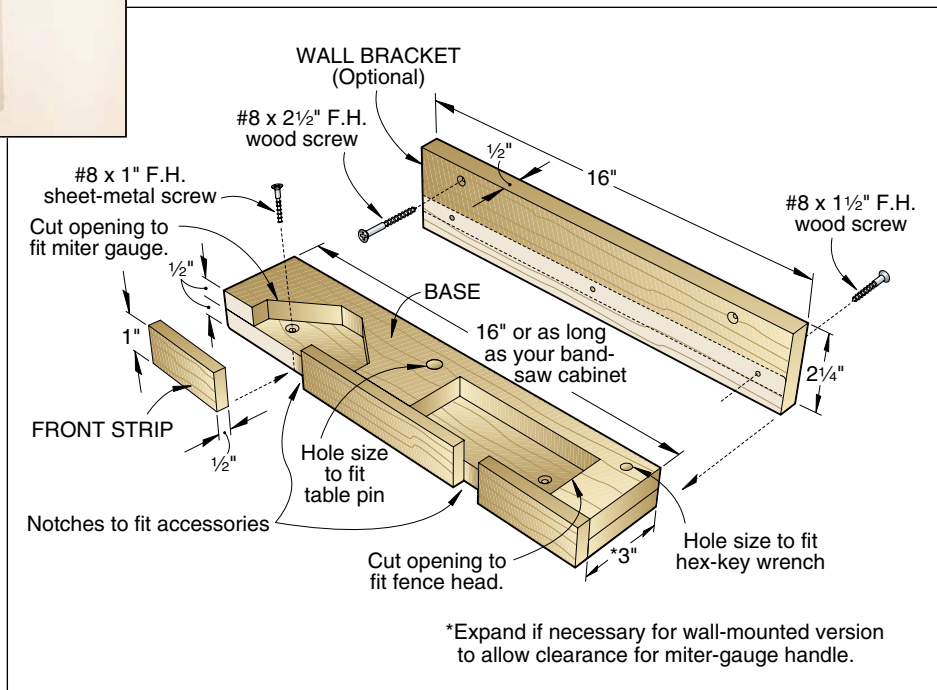

See more shop project plans at [woodmagazine.com/shoptools](http://woodmagazine.com/shoptools)



# what's ahead

Just some of the articles in the December/January issue (on sale November 22)

## Projects for the home



### FEATURED PROJECT

#### Multiuse game table

A reversible top provides a felt surface for a friendly card game or a wood surface for board games. Either way, your favorite beverage stays close at hand on a clever built-in leg shelf.



#### High-stylin' cheval mirror

This easel-backed floor mirror matches the style of a popular maple-and-cherry bedroom set presented in earlier issues.



#### Not-your-typical picture frame

Looking for a simple but attention-getting way to present your favorite photos? This maple, aluminum, and acrylic stand delivers!



#### Child's showcase

Bring order to any child's room with this organizer. There's plenty of space for awards, hats, souvenirs, photos, and other knickknacks.



#### Toy storage/play table

If you've picked up a youngster's toys lately, you know the need for this project. It puts playthings at a comfortable height, and keeps even the tiniest of pieces from scattering every which way.

## Tools and techniques



#### Hot tools for 2006

Get the scoop on the latest new tools and accessories—the ones deemed most innovative and useful by our editors.



#### Work smarter, not harder

Master woodworker Jeff Lohr shares his professional strategies for saving time, money, and wood.

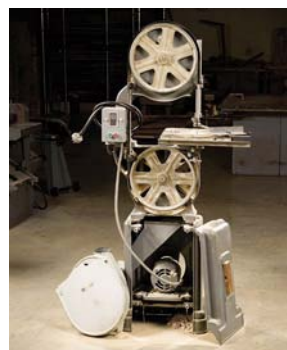

#### Buying used machines

Pre-owned tools can be a great deal...or a huge headache. Check out these tips before you buy.



#### 3 woods, 6 great finishes

Learn simple, beautiful, and foolproof finishing methods for maple (shown above), cherry, and oak.