

**BONUS**  
ROUTER-BIT POSTER & CABINET PLAN

# WOOD

The Shop-Proven Woodworking Magazine

## Build this classic slant-front desk p.50

plus **7** more great  
home and  
shop projects

**38**  
SECRETS FOR BETTER  
WOODWORKING

Learn how to...

- create perfect hinge mortises p.56
- dimension rough lumber p.126
- be a smarter wood buyer p.88
- mix and match woods p.80
- veneer small panels p.38
- apply epoxy finish p.118
- cut perfect miters

p.62





88



105



84



# WOOD®

December 2003, Issue 153

## PROJECTS

- 14 **on-the-mark mitersaw station**  
Construct a wall-hung table system that suits your saw and need for precision cutting.
- 50 **slant-front secretary**  
Add style and tradition to your surroundings with this cherry and maple classic.
- 67 **Canadian flag cutout**
- 69 **router-bit cabinet**  
Keep router bits, accessories, and a new bit reference poster in this handy storage case.
- 84 **fanciful children's bookcases**
- 105 **architectural shelf clock**
- 108 **crown-molding shelf**
- 112 **Greene and Greene picture frame**

## TECHNIQUES

- 38 **veneering small panels**  
Discover how to glue up attractive figured panels for your furniture projects.
- 56 **successful hinge mortising**
- 62 **accurate miters in minutes**  
See the tools and techniques you need to cut air-tight miters every time.
- 118 **a "bar tough" clear epoxy finish**  
Protect tabletops with this pour-on product.
- 122 **how to use a pyramid point tool**
- 126 **6 steps to perfect stock**  
Transform rough-sawn lumber into project-ready boards with these shop-savvy tricks.

## TOOLS & MATERIALS

- 12 **wise buys: power planers**
- 94 **tool test: cyclone dust collectors**
- 130 **4 shop-proven products**

## FEATURES

- 24 **mahogany mysteries solved**
- 48 **what's what in birch plywoods**
- 80 **mixing and matching woods**  
Sharpen your eye for buying and combining boards for the best look in projects.
- 88 **buy hardwood like a pro**  
Go inside a lumber mill to probe a sawyer's secrets for picking the best possible stock.
- 100 **woodworking mentors win big**

## DEPARTMENTS

- 8 **editor's angle**
- 10 **sounding board**
- 18 **short cuts**
- 26 **shop tips**
- 36 **wood words**
- 42 **ask WOOD**
- 144 **what's ahead in our next issue**



50



62



94

**The best  
warranty  
in the  
business.  
And more.**



Right now, every RIDGID power tool you buy comes with a limited lifetime service warranty with free service on batteries, switches, motors, gears, and more. Stop by [www.ridgid.com](http://www.ridgid.com) for all the details.

**RIDGID**

Powerful. Durable. Professional.

© 2003 RIDGID, INC. All rights reserved. Limited lifetime service warranty valid on tool purchases from 9/1/03 through 8/31/05. See your local RIDGID Authorized Service Center, visit [www.ridgid.com](http://www.ridgid.com), or call 1-888-523-6170 for complete details.

Better Homes and Gardens®  
**WOOD**®

December 2003

Vol. 20, No. 7

Issue No. 153



Bill built four maple wall mirrors for wedding presents.



Marlen constructed this 10x20' Greene-and-Greene style display cabinet for his family room.

EDITOR-IN-CHIEF  
**BILL KRIER**

Executive Editor <b>JIM HARROLD</b>	Managing Editor <b>MARLEN KEMMET</b>
Senior Design Editor <b>KEVIN BOYLE</b>	Products Editor <b>DAVE CAMPBELL</b>
Techniques Editor <b>JIM POLLOCK</b>	Features Editor <b>DAVID STONE</b>
Projects Editor <b>JAN SVEC</b>	Projects Editor <b>OWEN DUVALL</b>
Design Editor <b>JEFF MERTZ</b>	Master Craftsman <b>CHUCK HEDLUND</b>

Art Director  
**KARL EHLERS**

Associate Art Director  
**GREG SELLERS**

Assistant Art Director  
**CHERYL A. CIBULA**

Production/Office Manager  
**MARGARET CLOSNER**

Administrative Assistant  
**SHERYL MUNYON**

Illustrators

**TIM CAHILL, LORNA JOHNSON, ROXANNE LeMOINE, MIKE MITTERMEIER**

Technical Consultants

**JOHN CEBUHAR, JEFF HALL, GARRY SMITH**

Contributing Craftsman

**JIM HEAVEY**

Proofreaders

**BARBARA KLEIN, JIM SANDERS**



Jim designed this display shelf, see page 108.

Publisher **MARK HAGEN**

ADVERTISING OFFICE: 333 N. Michigan Ave., Suite 1500, Chicago, IL 60601 Phone: 312/853-2890 Fax: 312/580-7906

Sales and Marketing Assistant **NEILLE MORRIS**

Account Executive **RON GOLMINAS**

Direct Response Manager **CAROLYN DAKIS**

Direct Response Sales Representative **SANDY ROBINSON**

Account Executive **JOHN THORNBURGH** Detroit, Phone: 248/356-1149 Fax: 248/356-8930

Account Executive **PAT TOMLINSON** Northeast, Phone: 212/551-7043 Fax: 212/551-7192

Southeast: Lagomarsino, Dempsey & Dennis, Inc. 2651 Piedmont Rd., NE, Suite 100, Atlanta, GA 30305

Phone: 404/261-5400 Fax: 404/261-5404

Group Marketing Director **CATHY E. SMITH**

Senior Promotion Designer **SARAH DIBELLA**

Group Publisher **STEPHEN B. LEVINSON**

Associate Business Director **CRAIG FEAR**

Consumer Marketing Director **JANET DONNELLY**

Consumer Marketing Director **LESLIE SHAEFFER**

Newsstand Product Manager **LISA TROM**

Advertising Operations Manager **PAT HENDERSHOTT**

Vice President/Publishing Director **WILLIAM R. REED**

**MEREDITH PUBLISHING GROUP**

President **STEPHEN M. LACY**

President, Magazine Group **JACK GRIFFIN**

Executive Vice President, Publishing Group **JERRY KAPLAN**

Corporate Solutions **MICHAEL BROWNSTEIN**

Creative Services **ELLEN DELATHOUDER**

Manufacturing **BRUCE HESTON**

Consumer Marketing **KARLA JEFFRIES**

Finance and Administration **MAX RUNCIMAN**

**Meredith**  
CORPORATION

**WILLIAM T. KERR**, Chairman and Chief Executive Officer

In Memoriam — E.T. Meredith III (1933-2003)

©Copyright Meredith Corporation 2003  
All rights reserved. Printed in the U.S.A.

Better Homes and Gardens® WOOD® magazine (ISSN-0743-894X) is published seven times a year in March, May, June/July, September, October, November, and December by Meredith Corporation, 1716 Locust St., Des Moines, IA 50309-3023. For subscription questions call 800/374-9663. Letters to Editor: WOOD magazine, 1716 Locust St., GA-310, Des Moines, IA 50309-3023, or woodmail@woodmagazine.com. Periodicals postage paid at Des Moines, Iowa, and additional mailing offices. Better Homes and Gardens trademark registered in Canada and Australia. Marca Registrada en México. ONE-YEAR SUBSCRIPTION PRICES: U.S. and its possessions, \$28; Canada, \$41; other countries, \$49. Canada Post Publications Mail Sales Product Agreement No. 40069223. Canadian BN 12348 2887 RT. CANADIAN RETURN ADDRESS: Better Homes and Gardens WOOD magazine, 2744 Edna Street, Windsor, Ontario, N8Y 1V2. POSTMASTER: Send address changes to Better Homes and Gardens WOOD magazine, P.O. Box 37439, Boone, IA 50037-0439.



# Compare!

Oneida Air is the finest at  
Complete Dust Removal!

**Our  
Customers  
Agree!**

"It's hard to believe there is  
no dust in my shop. I love  
to sand now!"

J.G. - Fairfield, IL

"The ease of the installation  
and the efficiency of the unit  
is just what I was looking  
for. I don't have a big shop  
but the dust was still a  
problem. Not anymore!"

D.S. - Parker, CO

**New!**  
Powder Paint  
Finish!

## Ductwork Design Service

It's critical to efficient dust collection!

## Cyclone Technology

Reduces filter maintenance.

## Filter Media is Test Rated

Captures 99.9% 0.2 - 2.0 microns of test  
material @ 11 FPM face velocity.

## Easy Empty Dust Bin

Lift lid and dump out 98% of wood waste.

## Heavy Gauge Steel Construction

## Accurate Airflow Ratings

Check our website for results.

## Amazingly Quiet!

## FREE Catalog!



## In Stock Ductwork!

## FREE Shipping on Ductwork\*!

\*48 States - \$50 Min. -  
Some Restrictions Apply

Made in USA



Source Code:  
W1203



Order Online! [www.oneida-air.com](http://www.oneida-air.com)

Call Us Today!

Circle No. 2039

**1.800.732.4065**

## editor's angle

# How we choose the projects you want

Have you wondered why this issue features a slant-front secretary instead of a rolltop desk or a garden bench? Well, a lot of thought goes into selecting the projects we design and build for you in every issue. Here's how we go about it.



**E**ach member of the *WOOD*® magazine staff makes it his or her job to come up with innovative project concepts. Last year, for example, we generated no fewer than 260 such concepts. Then, the staff votes on and critiques each concept. About half survive that round.

The survivors are next voted on by you, our loyal readers, through surveys. Finally, through a process based mostly on gut instinct and several hundred collective years of woodworking experience, we narrow the field to the projects that make it onto these pages. Here are six criteria we pay particular attention to:

**Popularity.** We pore over the survey results I mentioned earlier, and your individual feedback means a lot too. To add your two cents, just write or e-mail me at the editorial addresses listed on page 6.

**Functionality.** You repeatedly tell us to bring you projects that are practical and sensibly designed. They must fit into your home's spaces and fulfill an everyday need.

**Affordability.** Most of us have budgets we have to live within. We design projects so they don't break the bank.

**Buildability.** Our approach to writing project articles is to cover every step and include all of the drawings, dimensions, and other details necessary to make your

As two of the projects from this issue show, we aim to bring you a variety of projects, from big to small, in every issue.

building experience a pleasurable one. We avoid overly complex or overwhelming projects that eat up too many pages in an issue.

**Variety.** Some of you like to build furniture, while some of you prefer weekend projects or turnings. We do our best to please all of you in every issue.

**Seasonality.** This one's simple. For issues before the holidays, expect to see projects that make good presents. In spring and summer issues, you'll find projects for outdoor living.

**Canadian readers:** After publishing a plan for a scrollsawn U.S. flag in the February 2002 issue, a good number of you wrote to remind us that you love your country too. We heard you loud and clear, so we've included a pattern for a Canadian flag in the *WOOD PATTERNS*® insert. Enjoy!

*Bill Krier*

# sounding board

Our bulletin board for letters, comments, and timely updates



## Tune-up tools revisited

I enjoyed your recent review of precision tune-up tools (issue 150). Please allow me to clarify a few features of our products.

In describing the TS-Aligner and TS-Aligner Jr. Deluxe, you cite as a "low point" the fact that you have to remove the miter-slot guide bearings to use the tools on non-slotted machines. Yes, the bearings do have to be removed and reinstalled, but the process is easy. That's because, unlike the other tools tested, our guide bearings adjust easily from the top of the tool while in the miter-gauge slot. This feature also comes in handy because miter-slot widths can vary from machine to machine, and sometimes even on the same machine. So getting accurate results can require frequent adjustment.

In your description of the TS-Aligner Jr. Deluxe, you say it does everything the TS-Aligner does, except for setting cutting depth. Actually, the Jr. is well equipped for vertical measurements such as cutter

depth and cutter height. In addition, its smaller size makes the Jr. best suited for home-shop machinery.

In the chart on page 79, the footnote indicates that the TS-Aligner Jr. Deluxe requires a 45° angle gauge to set the 45° bevel stop on a tablesaw. Actually, once the Angle Attachment Gage is calibrated, it easily sets any bevel angle.

Thanks for letting me clarify these points, and thanks for a great article.

*Ed Bennett, President, Edward J. Bennett Co.*

## Project/Tool test update

### Temps in a tube (issue 151, page 94):

The Galileo thermometers featured here are made of hand-blown glass, and can vary slightly in diameter and height. Measure the bottom of the thermometer before you bore the hole in the base (B). To determine the proper length for the pillars (D), place the thermometer in the hole in the base (B), set the top (A) in place, and measure between them. Add 1", then cut the pillars to that length.

**Cabinet-style Tablesaws (issue 151, page 74):** The price for the Delta 36-L31X-U150 saw should be \$1,750.

## Ingenuity leads to award for 16-year-old woodworker

Thanks for the great plans for the Baker's Trio (issue 147, page 50). I built the Pastry Board and Wall Rack as a project for my 4-H club, and I received the "Grand Champion" award for them at this year's Shawnee County Fair in Topeka, Kansas.

Because we couldn't find 1/8" walnut dowels to create the circles on the pastry board, my father and I came up with a way to make our own. First, I cut a 1/4" walnut dowel into short sections. Then, I chucked each one in a cordless drill, and ran the drill in reverse while holding the dowel against the running belt sander, as shown *below*. This quickly turned the dowels to size without producing flat spots. ♣

*Cassandra K. Duer, Topeka, Kan.*



## HOW TO REACH US

### ■ Editorial questions and feedback:

E-mail [woodmail@woodmagazine.com](mailto:woodmail@woodmagazine.com); call 800/374-9663 and press option 2; or write to WOOD magazine, 1716 Locust St., GA-310, Des Moines, IA 50309-3023.

### ■ Subscription assistance:

To notify us of an address change or to get help with your subscription, go to [woodmagazine.com/service](http://woodmagazine.com/service); call 800/374-9663 and press option 1; or write to: WOOD magazine, P.O. Box 37439,

Boone, IA 50037-0439. Please enclose your address label from a recent magazine issue.

### ■ To find past articles:

Go to our continuously updated online index at [woodmagazine.com/index](http://woodmagazine.com/index).

### ■ To order past issues and articles:

Order past issues of WOOD magazine and our newsstand specials at [woodstore.woodmall.com](http://woodstore.woodmall.com), or by calling 800/346-9663. Be aware that many early issues are sold out. For reprints, send \$5

per article (no phone orders), including the article name and issue number, to: WOOD Article Reprint Service, P.O. Box 349, Kalona, IA 52247; make check or money order payable to WOOD magazine.

### ■ Updates to previously published projects:

For a complete listing of known changes in dimensions and buying-guide sources from issue 1 through today, go to [woodmagazine.com/editorial](http://woodmagazine.com/editorial).

# our editors test power planers

## Hitachi P20SB, \$100

Tested by Jan Svec, Projects Editor



### Why buy?

Ever wished you could shave just a little off a workpiece without having to wrestle it onto a jointer? A power planer does the trick, whether the job is trimming a cabinet door or flushing the banding on a plywood shelf. Of course, a power planer also comes in mighty handy for smoothing rough-sawn material and straightening twisted lumber. To accomplish this neat feat, the rear part of a power planer's "shoe" (or base) is set to the same height as its knives. The front shoe adjusts to control the amount of material removed with each pass. Think of it as a handheld jointer, and you'll see the beauty. Most planers cut a 3/4"-wide swath and have a fence to ensure square cuts; some fences tilt to 45° for chamfering.

### Editor test-drive:

This bare-bones tool's major advantage is its price. Although less powerful than planers priced much higher, I had no problem with the P20SB bogging down, probably due to its 1/32" max cutting depth. Still, it's aggressive enough to flatten some very rough-sawn boards quickly, even at its 1/64" setting. Out of the box, the knives were set too high, but the included blade-setting guide helped reset them perfectly.

Niceties, such as dust collection and a tilting full-length fence, were left off this machine, and the

owner's manual doesn't explain how to set up the P20SB for chamfering or rabbeting (although it did tell me that it's capable of cutting a 15/32" chamfer and 15/64" rabbet). At the end of the day, I have no complaints about its performance, especially considering that this tool costs \$50-\$60 less than other power planers that do essentially the same thing.

### To learn more:

800/706-7337, [www.hitachi.us/powertools](http://www.hitachi.us/powertools)

## Porter-Cable 9125, \$160

Tested by Jeff Mertz, Design Editor



### Editor test-drive:

The 9125 came out of the box in pretty fine shape: The cutting-depth adjusting knob has a scale to show the depth of cut and it was right on the money. I made a minor tweak to the rear shoe to bring it into plane with the front shoe and I was ready to make chips. And make chips I did! This planer has the ponies to take a full 1/8"-deep cut as wide as the shoe (3/4") in red oak with little complaint—it bogged a little in my tests, but not enough to be a problem. I used it to clean up the face of some rough-sawn walnut and the resulting cut

required minimal sanding to smooth the knife marks. For this reason, I judged the cut quality quite good.

For chamfering, the 9125 has a tilting fence to steady the tool when angled at 45°, but the V-groove in the base is cast, not machined, and a few rough spots in the casting made it difficult to slide along the edge of the workpiece.

### To learn more:

800/487-8665, [www.porter-cable.com](http://www.porter-cable.com)

## Bosch 1594K, \$160

Tested by David Stone, Features Editor



### Editor test-drive:

The 1594K left smooth cuts in hardwood and softwood test pieces. In pine 2x stock, I was able to plane the edge at the machine's full 1/32"-deep cutting capacity with good cut quality and no notable bogging. I cut 45° chamfers using the built-in grooves in the tool's front shoe with decent results, and then did the same using the fence tilted at 45°, which worked extremely well. The planer comes with reversible carbide blades that are easy to change. (Standard-size carbide and high-speed steel blades also will work.)

One really cool feature on the 1594K is the reversible chip ejector. It allows you to send the debris stream either left or right, to a vacuum hose, or into an optional dust bag. A spring-loaded "park shoe" on the bottom allowed me to set the planer down while the cutterhead wound down without fear of marring my benchtop.

### To learn more:

877/267-2499, [www.boschtools.com](http://www.boschtools.com)

## Makita 1912B, \$220

Tested by Chuck Hedlund, Master Craftsman



### Editor test-drive:

If other power planers are SUVs, the 1912B is a Hummer. Big, wide, and powerful, this tool cuts more than an inch wider (4 9/16") than typical planers, and nearly doubles the motor amperage of the Hitachi. In both hardwoods and softwoods, it made the chips fly effortlessly, even at a full-width 1/8"-deep cut. The knife-setting gauge did its job well too, positioning the knives perfectly even with the rear shoe.

If you're a full-speed-ahead kind of person who couldn't care less about features, the 1912B is the

planer for you. It lacks a "park shoe," so I had to wait for the motor to wind down before setting it down, and the fence seems like an afterthought. (It's short and doesn't tilt for beveling the edge of a workpiece.) Although it's not a tool for making fine furniture, for shaving jobs in the shop this planer came through when the going got tough.

### To learn more:

800/462-5482, [www.makitatools.com](http://www.makitatools.com)

# on-the-mark mitersaw station

This wall-hung design gets the most from your saw and available shop space.



**W**hether you need to rough-cut a board to length or make a precise compound cut in a workpiece, this work station, coupled with your 10" or 12" miter-saw, will ensure great results. Large tables flank the saw to hold workpieces level with the saw table, while removable fences with measuring tapes yield accurate cuts. Like other projects featured in Idea Shop 5 (began in issue 151), the center rests on a set of beveled cleats (issue 152) for sturdy support and easy mounting.

*Note: We built our station with a 2' table on the left-hand side and a 6' table on the right. While the lengths of some parts vary, construction is exactly the same for both the long and short versions.*

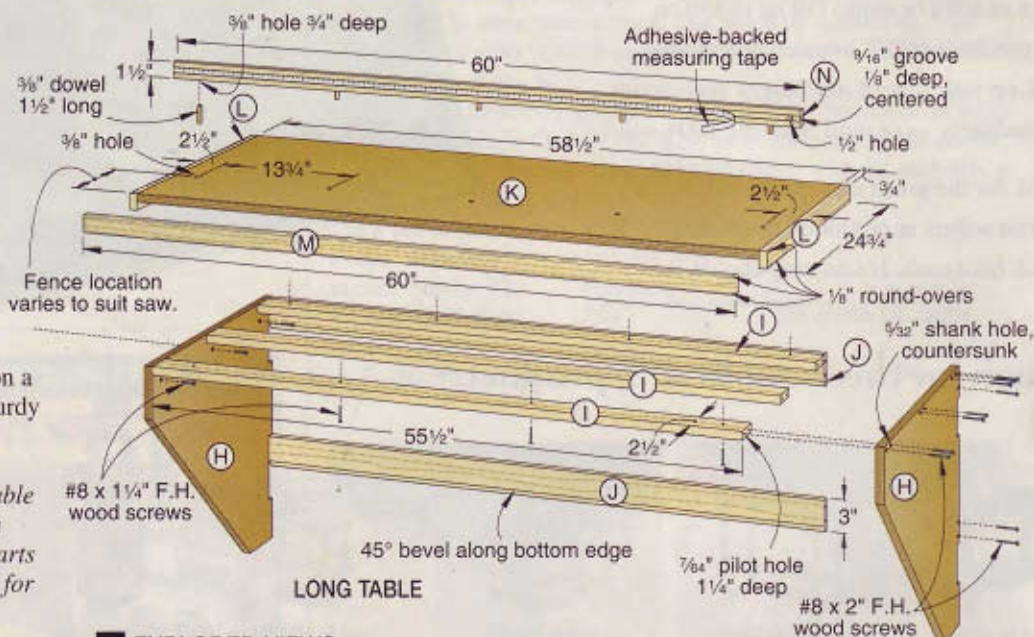

## 1 EXPLODED VIEWS

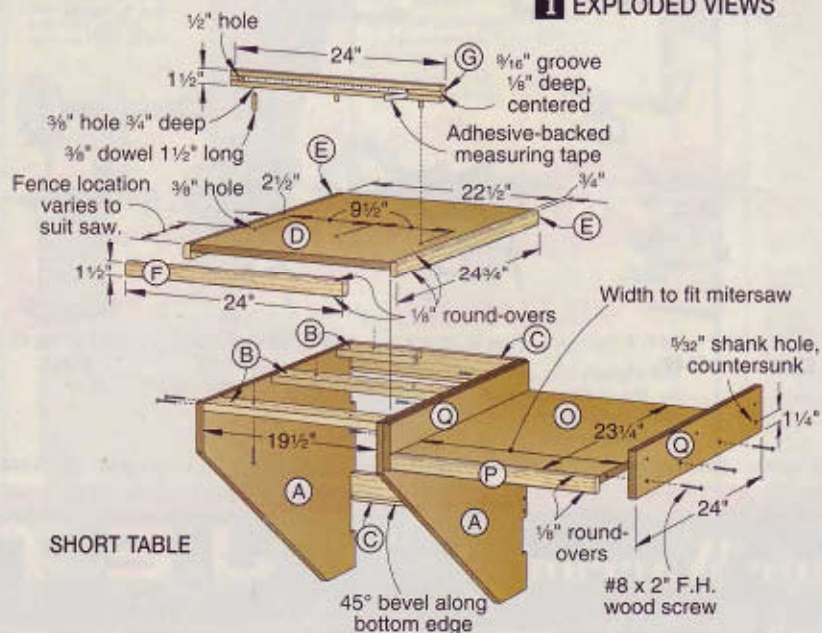

## Create a pair of sturdy tables

Start by cutting the short-table side panels (A), shown on **Drawings 1 and 2**, to the size listed in the **Materials List**. Now lay out and cut the cleat notches along the back edge of each panel, where dimensioned on **Drawing 2**.

Next, cut the short-table supports (B) to size. Make the short support cleats (C), beveling their bottom edges, as dimensioned on **Drawing 3**. Screw these parts between the side panels, where shown in **Drawings 1 and 2** to create the base assembly (A/B/C).

Create the short table (D). Cut the side and front edging (E, F) to fit, and glue them in place. Also cut the short-table fence (G) to size and set it aside. After the glue dries on the edging, rout  $\frac{1}{8}$ " round-overs, where shown. Now attach the table assembly to the base assembly, making sure it's flush with the back edges of the side panels (A) and overhangs them equally ( $1\frac{1}{2}$ " on both sides).

Now follow the same steps to build the long table (H-N). With both completed, cut a pair of wall cleats and attach them to the wall as described on page 87 of issue 152. (We

*Continued on page 16*

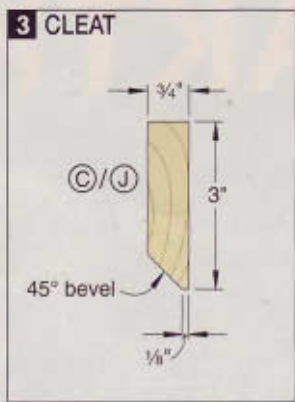
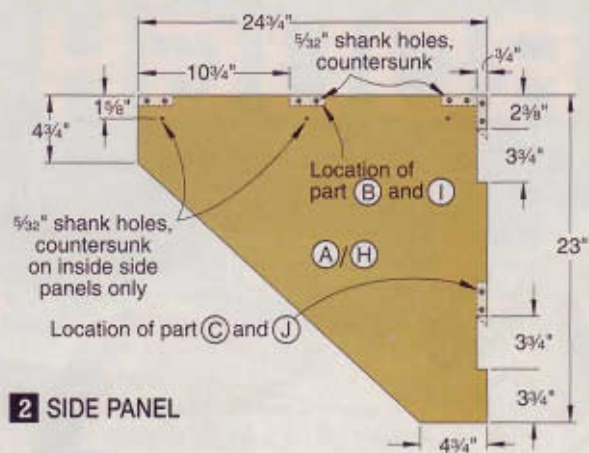

**A** Seat the platform supports against the underside of the tables, and secure the assembly with screws only. This allows you to move the platform should you ever switch saws.



**B** Removable fences allow the tables to do double-duty as work surfaces. Slightly bevel the holes in the table using a countersink to make the dowels easier to slip into place.

made our cleats 90" long and mounted the upper one 38 7/8" above the floor to position the tables at 42".) Hang both tables on the cleats, leaving about 2' of space in between.

### Custom fit your miter saw

Measure the width of your miter saw's table at the base. Then, add 2" to determine the final width of the saw platform (O).

*Note: Before cutting your platform to width, swing the miter table fully to the left and right and note how far, if at all, the handle protrudes beyond the ends of the saw. If the handle protrudes, measure how far it sticks out on each side, and add that total to the width of the saw platform (O).*

Cut the platform (O) to size from 3/4" MDO. Then cut the platform edging (P), as shown, and glue it to the front edge of the platform. After the glue dries, rout 1/8" round-overs on the edging, where shown.

Next, create the platform supports (Q). To determine their width, measure the height of your miter saw's table, and add 3/4". (Our

saw's table stood 3 5/8" high, so we made the supports 4 3/8" wide.) Screw and glue the platform supports (Q) to the saw platform assembly (O/P) with #8x2" screws.

Now clamp the platform assembly (O/P/Q) between the short and long tables, as shown in **Photo A**, and secure it with #8x1 1/4" screws.

### Mount the saw, make the fences, and finish

Set your miter saw on the platform, but don't fasten it yet. How far back you position the saw is up to you. Just make sure you can reach behind the saw to make adjustments or to access controls on a compound-cutting saw. (We placed ours so the saw's fence sat 8" back from the front edge of the platform.)

Next, use a long straightedge to mark the positions of the long and short fences. Drill 3/8" holes, where dimensioned, to receive the fence-mounting dowels, shown in **Photo B**.

Complete the fences (G, N) by first cutting a 1/8x9/16" groove on one face of each, where dimensioned. Use dowel centers to transfer the hole centerpoints from

## Materials List

Short table	FINISHED SIZE			Matl. Qty.
	T	W	L	
A short-table side panels	3/4"	23"	24 3/4"	MDO 2
B short-table supports	3/4"	2 1/2"	19 1/2"	M 3
C short support cleats	3/4"	3"	19 1/2"	M 2
D short table	3/4"	22 1/2"	24 3/4"	MDO 1
E short-table side edging	3/4"	1 1/2"	24 3/4"	M 2
F short-table front edging	3/4"	1 1/2"	24"	M 1
G short-table fence	3/4"	1 1/2"	24"	M 1
<b>Long table</b>				
H long-table side panels	3/4"	23"	24 3/4"	MDO 2
I long-table supports	3/4"	2 1/2"	55 1/2"	M 3
J long support cleats	3/4"	3"	55 1/2"	M 2
K long table	3/4"	24 3/4"	58 1/2"	MDO 1
L long-table side edging	3/4"	1 1/2"	24 3/4"	M 2
M long-table front edging	3/4"	1 1/2"	60"	M 1
N long-table fence	3/4"	1 1/2"	60"	M 1
<b>Saw platform</b>				
O saw platform	3/4"	†	23 3/4"	MDO 1
P platform edging	3/4"	1 1/2"	†	M 1
Q platform supports	3/4"	†	24"	MDO 2

† Dimension determined by miter saw.

**Materials key:** MDO—medium-density overlay plywood; M—maple.

**Supplies:** 3/8x14" dowel stock (1), #8x1 1/4" flathead wood screws (20), #8x2" flathead wood screws (48), wood glue, clear polyurethane finish.

### Buying Guide

**Hardware.** Set of two self-stick measuring tapes (one 6' left-to-right and one 6' right-to-left) #08Y40, \$17.99/set. Call Woodcraft at 800/225-1153, or visit [www.woodcraft.com](http://www.woodcraft.com).

the tables onto one edge of each fence. Then drill 3/8" holes 3/4" deep into the fences at those points. Glue 3/8x1 1/2" dowels into the fences, and slightly chamfer the exposed ends of the dowels. Drill a 1/2" hole in each fence, where dimensioned. These allow you to hang the fences when they're not in use.

Remove the saw, and apply a couple of coats of polyurethane finish to all surfaces.

Once the finish dries, reinstall the fences, set the saw in place, and use a straightedge to align the saw with the fences. Then secure it to the platform using screws or bolts.

To complete the station, add a pair of self-stick measuring tapes to the fences. (See the **Buying Guide** for our source.) Carefully measure from the blade to the inboard end of each fence, and then cut each tape to fit before sticking it in place. ♣



# short cuts

News and notes from  
the woodworking world

## See-through furniture worth a second look

Though we all love the look of wood, it can be overwhelming and massive in some projects. Barry Middleton of Schenectady, New York, has figured a way to eliminate this problem with his light and airy table design, shown *right*. By employing a see-through geometric grid work in contrasting woods within the tabletop's frame, he adds an entirely new level of interest.

To make it work, Barry first constructs the table's base and tabletop frame, followed by grid work. He then drops the grid work into the tabletop frame and onto a pair of hidden 2½"-wide support strips recessed ¾" down and glued to the longer frame members. Finally, he rests a single panel of glass over the grid work, flushing it with

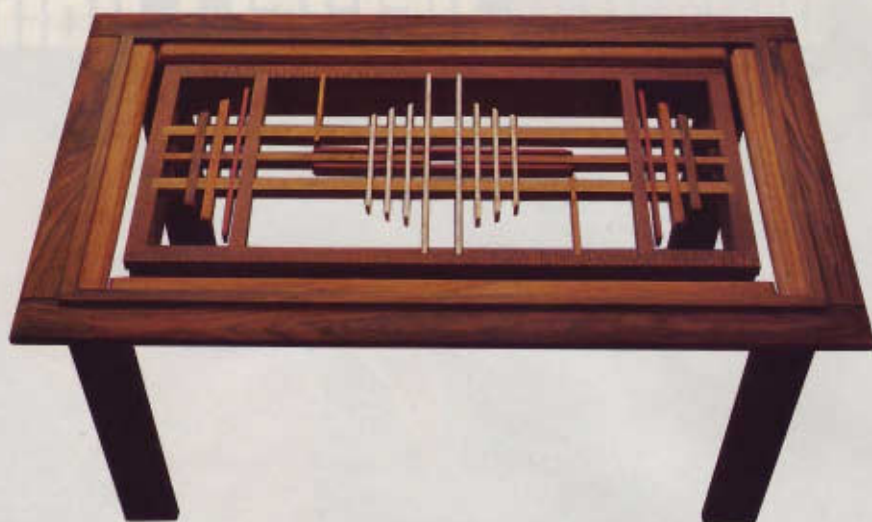

Barry Middleton's glass and wood coffee table captures attention through its pleasing see-through grid design and contrasting woods. He uses pauferro (Bolivian ironwood) for the frame and legs, and lacewood, maple, bloodwood, and jatoba for the grid work.

the frame's top surface. The end result: an intriguing interior grid work that seems to float unattached.

To see more of Barry's work, including furniture, ikabanas, and boxes, go to [www.yourwoodsongs.com](http://www.yourwoodsongs.com).

## Test your workshop smarts

Need to take a break from all of that sawing, sanding, and finishing? Well, brush the sawdust from your shirt and noodle these brain teasers. You'll find the answers in the next issue of *WOOD*® magazine's Short cuts; or, to find the answers fast, go to [www.woodmagazine.com/editorial](http://www.woodmagazine.com/editorial).

■ What was the first woodworking tool powered by electricity?

■ When an oil-based varnish skins over in the can, does that mean the finish is no longer any good and should be disposed of?

■ What is considered to be the heaviest wood known to man?

### Answers to the questions in issue 152

■ What's the wood commonly found in particleboard?

*If the source is a Southern particleboard manufacturer, expect the wood to be Southern yellow pine; if the particleboard comes from the Northwest, it will be some other coniferous wood native to that region, such as Douglas fir or ponderosa*

*pine. Coniferous woods such as these are used instead of hardwood because they are less dense and provide the needed strength without extra weight.*



■ What state contains the largest number of champion trees?

*A champion tree is defined as the largest tree of its species still standing. Florida has the most champion trees at 169, followed by California, which has 97.*

■ Does bluing negatively affect the quality of high-speed steel when sharpening?

*Bluing, a type of oxidation, occurs when you heat steel to around 600° F. Generally speaking, tools and bits carrying the label HSS (meaning high-speed steel) soften slightly by bluing while sharpening. Chisels*

*and lathe tools, which are made of "tool steel"—that is, high-speed steel containing alloying elements—soften even less than high-speed steel. In both cases, the steel's ability to hold an edge suffers slightly. To avoid this, pull the tool away from the sharpener when discoloration begins, rather than applying continuous damaging pressure to the edge. Or consider using a white (aluminum oxide) grinding wheel or a slow-speed, water-cooled grinder. Note that—with the damage done—quenching the edge in water will not restore hardness.*



Continued on page 20



**WOODCRAFT®**  
UNIVERSITY

There's a  
Woodcraft University  
location near you

**Alabama**

Birmingham Area

**Arizona**

Tempe  
Tucson

**California**

Sacramento  
San Francisco Bay Area  
Santa Rosa

**Colorado**

Colorado Springs  
Denver

**Connecticut**

Hartford Area  
New Haven Area

**Florida**

Casselberry  
Clearwater  
Jacksonville

**Georgia**

Atlanta Area

**Hawaii**

Honolulu

**Idaho**

Boise

**Illinois**

Palatine  
Peoria

**Indiana**

Evansville  
Indianapolis

**Iowa**

West Des Moines

**Kansas**

Lenexa

**Kentucky**

Louisville

**Maryland**

Towson

**Massachusetts**

Woburn

**Michigan**

Canton  
Sterling Heights

**Minnesota**

Bloomington

**Missouri**

St. Louis Area

**New Hampshire**

Portsmouth Area

**New Mexico**

Albuquerque

**New York**

Rochester

**North Carolina**

Charlotte Area  
Raleigh

**Ohio**

Cincinnati Area  
Cleveland Area  
Columbus Area  
Dayton

**Oklahoma**

Oklahoma City  
Tulsa

**Oregon**

Eugene  
Portland Area

**Pennsylvania**

Harrisburg  
Philadelphia Area  
Pittsburgh Area

**Rhode Island**

East Greenwich

**South Carolina**

Charleston

**Tennessee**

Knoxville  
Nashville

**Texas**

Austin  
Dallas Area  
Fort Worth  
Houston  
San Antonio

**Utah**

Salt Lake City Area

**Virginia**

Richmond  
Washington D.C. Area

**Washington**

Seattle

**West Virginia**

Parkersburg

**Wisconsin**

Appleton/Fox Cities Area  
Madison  
Milwaukee Area

**Woodworker's Club:**

**Connecticut**

Norwalk

**Maryland**

Rockville

short **cuts**

**In remembrance**

Carroll "Lee" Gatzke, *WOOD* magazine's art director from 1984 until his retirement in 1999, recently lost a long battle with cancer. Lee was an accomplished woodworker, turner, and illustrator, whose passion for woodworking showed in all of his work on these pages. After his retirement, Lee continued to contribute illustrations and other graphic support to *WOOD* magazine. His upbeat, friendly spirit will be greatly missed. A devoted husband, father, and grandfather, he leaves behind a loving family and countless friends who will always hold him dear.



Former *WOOD* magazine art director Lee Gatzke passed away in September 2003. He was 66.

**GREAT IDEAS FOR YOUR WOODWORKING CLUB**

**Greenville woodworkers' good works bring good fortune**

Boasting a membership of more than 230, this sizeable gathering of woodworkers from South Carolina does its share of the usual, for sure. It holds monthly meetings, offers woodworking demonstrations and educational programs, and goes on the occasional field trip. Where it derives its uniqueness is from its bold ambition—now fulfilled—of having a woodworking workshop of its very own.

In the words of the guild's publicity chairman Darryl Roberson, "We help charitable causes through our woodworking. In the past, we were limited because we've done these activities working in our own individual home workshops, many of which are quite small. Our dream was for the guild to have its own large shop equipped with lots of tools where we could continue our activities more effectively as a group engaged in mass production." But how did the guild manage this feat?

After countless discussions, guild members decided to apply for a community grant of \$8,000 that would allow them to do their good works on a grander scale. Past efforts included making toys and chairs for children with special needs at a local care center, as well as bookcases, tables, and outdoor projects for a local battered women's shelter.

Not only did the guild receive its grant, but word spread and an anonymous con-

tributor kicked in another \$10,000 to the cause. In addition, a local company that makes packaging equipment, Hartness International, leased 1,500 square feet of space in an old bottling building to serve as the guild's shop location, *below*.

Over the last few months, members have busied themselves outfitting the space with new wiring, fresh paint, storage cabinets, a dust-collection system, and loads of new and donated used tools. "When it's all done, we'll have \$20,000 worth of tools in the shop," says guild president Karl Kelly. "They include three bandsaws, a 12" jointer, four lathes, two cabinet saws, a 20" thickness planer, routers, and a whole lot more."

What will members do with the shop when not turning out projects for charitable causes? "We'll use it as a woodworking education center, where members can mentor new woodworkers," says Kelly. Looks like one of those rare times when everyone wins. Way to go, Greenville!



Greenville Woodworkers Guild members take time for a photograph while adding the final touches to their workshop where they intend to build projects for charity and teach woodworking to newcomers.

*Continued on page 22*

**WOODCRAFT®**

For your local woodcraft store, visit [www.woodcraft.com](http://www.woodcraft.com), or for a free catalog, call 800 542-9115

Dept.L03W112BE

Circle No. 924

5/8" (16mm)  
MK2

DEWALT®

START HERE



FOR A GREAT FINISH.



C4 carbide teeth are precision ground for an exceptionally smooth finish.



Ultra-sharp cutting edges dramatically reduce splintering and tear-out.



Heavy-gauge plates are laser cut and precision balanced for accurate cuts and tight joints.



Available in several sizes for any woodworking application.

## INTRODUCING NEW WOODWORKING SAW BLADES FROM DEWALT®

You put a lot into your work. After all, it takes countless hours to complete the perfect project. And when you have the right tools and the right wood, you need the right saw blade. One that's precision balanced for highly accurate cuts. With large, micro-grain carbide teeth for exceptionally smooth finishes. Ultra-sharp cutting edges to reduce splintering. And one that comes in a variety of tooth counts and configurations. DeWALT® Woodworking Blades. We put more into them, so you can get more out of them.

Circle No. 1497

For more information, call 1-800-4-DEWALT or visit our web site at [www.DEWALT.com](http://www.DEWALT.com)

©2003 DEWALT. The following are examples of trademarks for one or more DeWALT Power Tools and Accessories: The yellow and black color scheme; the "D" shaped air blow logo; the array of pyramids on the handgrip; the six box configuration; and the array of knurled-shaped bumps on the surface of the tool.

**DEWALT**

## short cuts

### Be a winner in our Tool Storage Contest

Do you have a toolbox or other tool or accessory storage project that you personally designed and built? It may be worth big bucks! *WOOD* magazine has joined forces with Chevy Silverado to bring you the first-ever Rugged 'n' Ready Tool Storage Contest, anteing up \$10,000 in cash and DeWalt tool prizes. Included are a Grand Prize of \$2,500, a First-Runner-Up Prize of \$1,500, a Second-Runner-Up Prize of \$1,000, and 10 Judges Choice Awards—in all, 13 ways to win!

Entering couldn't be easier. Just mail clear color photos of your projects according to the rules on page 31 of the November 2003 issue of *WOOD* magazine, or at [www.woodmagazine.com/contest](http://www.woodmagazine.com/contest). Attach them to the completed entry form found with the rules, along with a description of the project, and mail them to:

Rugged 'n' Ready Tool Storage Contest  
1716 Locust Street, GA310  
Des Moines, IA 50309-3023

The entry deadline is December 1, 2003. All winners will appear in the June/July 2004 issue of *WOOD* magazine, as well as online.

### Youth steals the show

Students' furniture designs proved to be one of the highlights at this year's Association of Woodworking and Furnishings Suppliers (AWFS) Fair, held in Anaheim, California, this past August. Particularly impressive, according to *WOOD* Editor-in-Chief Bill Krier, were the high-school level entries. "The maturity of the design, and the quality of the craftsmanship matched that of professionals. No doubt a bright future awaits these student participants."

Ashley Nichole Hilton from Cedar Ridge High School, North Carolina, walked away with three awards. She won \$1,000 for the "Traditional Upholstered" category for her upholstered chaise lounge; \$1,000 for her inlaid dinner table, *below*, in the "High School Creative Table" category; and another \$500 for the same design in the "People's Choice Award."

Remington Ryan Wither from Savannah College of Art and Design, Savannah, Georgia, took home \$1,000 for his first-place entry, *below, right*, in the "Post-Secondary Creative Chairs" category. The chair also netted him the "Best of Show Award," worth \$1,000, along with a handcrafted Sam Maloof sculpture. ♣



18-year-old high-schooler Ashley Nichole Hilton poses with her maple and santos rosewood dinner table at this year's AWFS show. It won the People's Choice Award. The chaise lounge at right by college student Remington Ryan Wither won Best of Show.

# uncovering mahogany mysteries

Where your wood grows influences its price and appearance



The tight, consistent grain of mahogany (Honduran in this case) enhances the elegance and perfectly matches the scale of this arch-top table clock (issue 138).

**W**hen we shopped for mahogany to build the “era-inspired picture frame” on page 112, we noticed differences in the weight and look when compared to scrap mahogany we had in the shop. That reminded us that several different species found at hardwood retailers are often marketed under the name “mahogany.”

Mention mahogany to woodworkers, and some think of the old Cuban Mahogany (*Swietenia mahogani*). From the 17th through the early 19th centuries, it was the “Wood of Kings.” Its beautiful color and consistent interlocking grain made it one of the most sought-after woods for furniture-makers and boatbuilders alike. But by the mid-1800s overharvesting wiped out the Cuban species as a commercial wood.

## Mainland mahogany

Though Cuban mahogany disappeared, woodworkers’ tastes for it didn’t. In Central and South America, loggers found trees in the same family to fill the need. Honduran mahogany (*Swietenia macrophylla*), also called genuine or American mahogany, is marginally softer than the Cuban variety, but few of us would notice that or the other differences, highlighted in the chart, below. Honduran mahogany is beautiful, and well-suited for everything the original was,

Unfortunately, Honduran mahogany, like its Cuban cousin, became costly and rare as overharvesting and export restrictions reduced supplies.

## Light wood from the dark continent

As demand lived on, and with no other trees from the *Swietenia* family available, lumber suppliers searched for woods with similar grain and color. They found what they wanted in Africa, with a variety of trees from the *Khaya* family.

Though unrelated to Cuban and Honduran mahogany, these trees, sold as African mahogany, offer characteristics that satisfied commercial clients. The grain looks similar, but both the weight and color are lighter, as seen in the photo, above right. This wood makes a reasonable substitute, but some furniture-makers and woodworkers still long for the “genuine article” woods.

## What’s available?

These days, you can count yourself lucky if you’re searching for mahogany. A few specialty lumber dealers stock small amounts of Cuban at a premium price. Honduran also is available at reasonable prices, though the supply can be

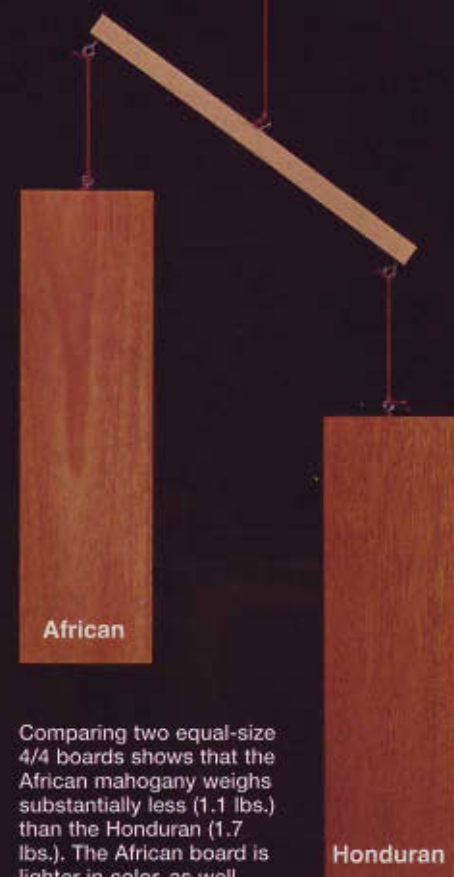

Comparing two equal-size 4/4 boards shows that the African mahogany weighs substantially less (1.1 lbs.) than the Honduran (1.7 lbs.). The African board is lighter in color, as well.

spotty due to ever-changing export restrictions. In spite of its name, most of this lumber comes from Brazil and Peru, where stands of trees still grow and plantations cultivate more for harvest.

African mahogany keeps gaining popularity and acceptance. Some dealers, especially those that serve commercial clients, stock the wood at prices lower than Honduran.

Just be careful when shopping. We found a local supplier with 4/4 Honduran and 8/4 African stocked together. Here, the price was the same, though the woods were not, meaning potential color and grain differences in any project requiring both thicknesses.

If the woods aren’t marked and you’re in doubt, ask before you buy. To do your own investigation, look for a deep red/brown tone to identify Honduran. African is usually more beige, though the color does darken some over time, and it can be stained darker.

Pay close attention to grain patterns when you are selecting stock, as well. The African varieties may contain streaks of darker wood and areas with more figure. It’s easy to tell on surfaced stock, but you’ll have to scrape the surface of rough-sawn boards to tell clearly. If all else fails, feel for weight differences in similar-size boards. ♣

### MAHOGANY SPECIES COMPARED

	Grain	Color	Workability	Stability	Density	Price
Cuban	interlocking	brown	excellent	excellent	moderate	\$20+/bd. ft.
Honduran	interlocking	red/brown	very good	very good	moderate	\$5-7/bd. ft.
African	interlocking	pink/beige	good	good	low/moderate	\$4-6/bd. ft.

# shop tips

Helping you work faster, smarter, and safer

## Make safer cuts with this panel-pushing jig

I really liked your technique for making simple raised-panel doors for the pine hutch in issue #147 (page 67). I've been using a similar technique for some time, and my panel-pushing jig, shown at right, makes it safe and easy to cut the beveled edge on the panels.

The jig raises the pressure point on the panel, holding it tight against the fence, and protects my fingers from the blade. I used biscuits to join the runners to the jig, but you also could dado the jig and glue the runners in place. (Note that the runners should be taller than the blade height.)

—Dan Batliner, Lincoln, Calif.

### top shop tip

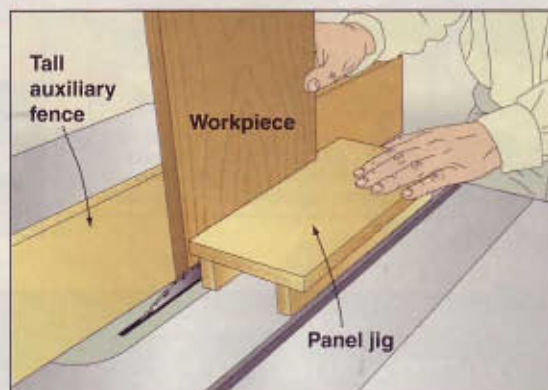
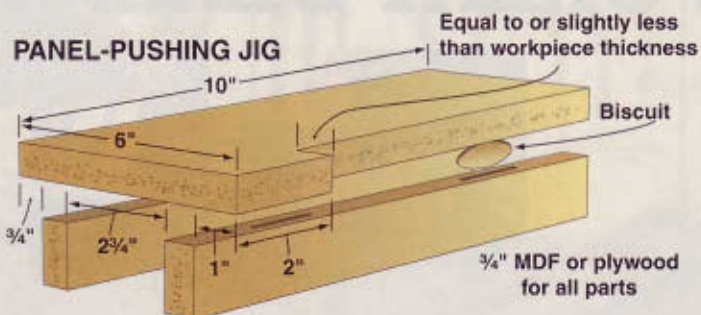

## An attractive solution for lathe-tool storage

Like many woodturners, I often lay down a chisel or gouge on the lathe ways momentarily while measuring wall thickness, changing spindle speed, and so on. Inevitably, the tool rolls off the ways and drops to the floor, sometimes dinging the cutting edge and necessitating an extra trip to the grinder.

To solve the problem, I counterbored holes on opposite sides of each of my lathe-tool handles, where shown in the drawing. I then epoxied powerful rare-earth magnets (part no. 128475 at Woodcraft, 800/225-1153 or [www.woodcraft.com](http://www.woodcraft.com), \$13 for six magnets) into them. Now when I set a

tool on the ways, it might roll a little bit, but the magnet always catches it before it falls.

—Roy McMurray, Prescott, Ariz.

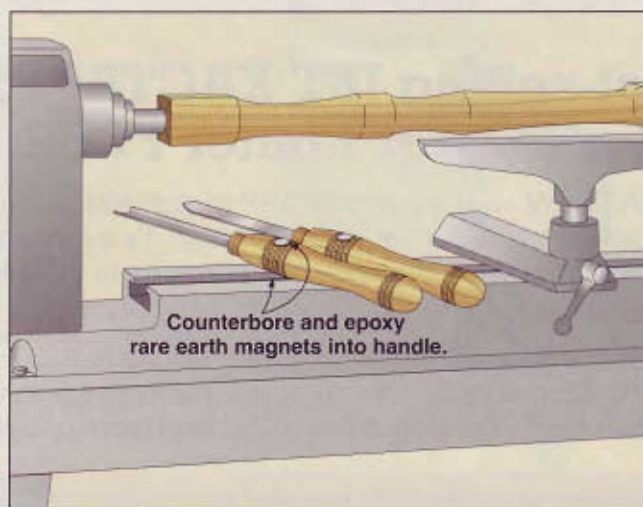

Continued on page 28

## Our Winner

Dan Batliner dabbled in woodworking before, but in 1998 he went whole-hog by taking "every woodworking class there is" at nearby Sierra



College. Just a few years later, our Top Shop Tip winner has nearly achieved his ultimate goal: to craft all of the furniture in the home he and his wife built in 2002. "I still need to build a couple of nightstands for the guest bedroom, and then I'll be done," he proudly adds.



Dan Batliner's Top Shop Tip (at far left) earned him a Grizzly G0555 14" bandsaw. Thanks for a terrific tip, Dan!

## Top tips win top tools!

Describe how you've solved a workshop dilemma, and you'll earn \$75 if it appears here. And, if your tip garners Top Shop Tip honors, you'll also win a tool prize worth at least \$250.

Send your best tips, along with photos or illustrations and your daytime telephone number, to: **Shop Tips, WOOD® Magazine, 1716 Locust St., GA-310, Des Moines, IA 50309-3023.**

You can also e-mail tips to: [shoptips@woodmagazine.com](mailto:shoptips@woodmagazine.com), or post them on the Top Shop Tip forum at [www.woodmagazine.com](http://www.woodmagazine.com).

Because we try to publish only original tips, please send your tips only to WOOD magazine. Sorry, but submitted materials can't be returned.

## Quality Pen Kits and Other Turning Kits



- Designers & Manufacturers
- Wholesale & Retail

**THE BereaHardWoods** CO. Inc.

Manufacturer of quality writing instruments, components and kits.

CALL FOR FREE CATALOG

18745 Sheldon Road • Middleburg, Ohio 44130 U.S.A.  
Ph: (216)898-8956 • Fax: (216)898-8962 • bereahard@aol.com

# WANT THIS?



A clean, sharp hole  
every time.  
No chips,  
no splits,  
no errors.  
It takes skill  
and a sharp  
drill bit.  
And *that*  
takes the  
**Drill Doctor®**  
drill bit sharpener.

# GET THIS.

- Restores bits to factory sharp
- Fast and easy to use
- Sharpens most twist bits—even split point
- Diamond sharpening wheel
- Powerful 20,000 rpm motor

**Drill  
Doctor®**  
The Drill Bit Sharpener

Drill bits are meant  
to be sharpened

www.DrillDoctor.com • 1-888-MYDRILL



*"I have never recommended a product that was so easy to use and so effective. This is one of the best tools I've ever purchased."*

—Stephen Bierhorst  
Patterson, Louisiana

Available at Home Depot, Lowe's,  
Sears and wherever fine tools are sold

Circle No. 1511

## shop tips

### Mark circles without a center hole

When using a compass to make circles for my chip-carving projects, there are times when I don't want to leave a hole in the center of the circle. What to do? I created a "temporary" hole from a small square of clear acrylic as shown in the drawing. For "feet," I went with self-adhesive cabinet-door bumpers (Woodcraft part no. 02S81, \$7, 800/225-1153 or www.woodcraft.com).

To use the device, I first pencil the center of the circle on my workpiece as shown below. Next, I position the intersection of the jig's scribed lines over the center mark. Finally, with the point of the compass in the center of the scribed lines, I draw the circle. Downward pressure on the compass and feet keep the jig from slipping on the workpiece.

—Merle Krug, Marion, Iowa

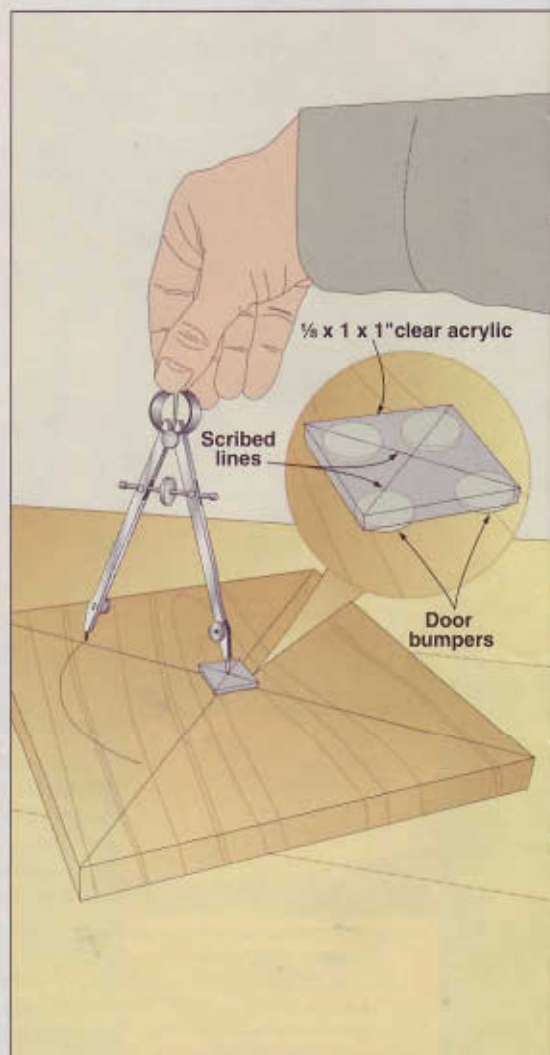

## Stretch your one-handed bar clamps

Too many times I've reached for a one-handed bar clamp/spreader only to find that it's too short to do the job at hand. To solve the problem, I created a hardwood "splice," as shown, to connect the clamps end-to-end. (You have to use the reversible spreader-type clamp so you can remove the "fixed" jaw.)

—Dennis Saxsma, Schaumburg, Ill.

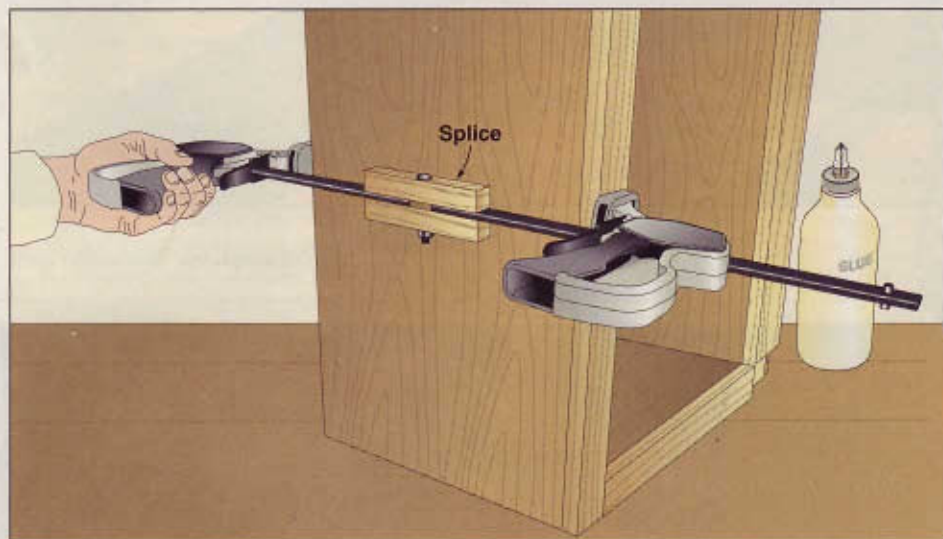
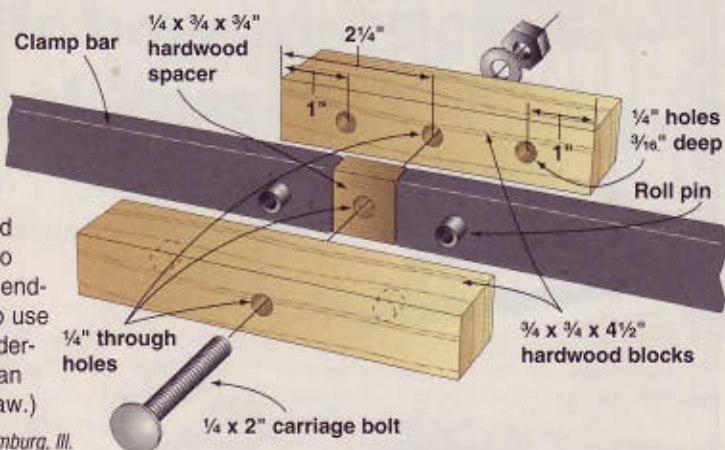

## Groovy glue spreader

You've probably already seen the trick about using the internal stiffener of a spent disposable foam brush for spreading glue, but here's a way to go it one better: I use my bandsaw to cut a series of small slots in the end of the stiffener to create teeth, as shown at right. The result is a groovy but consistent layer of glue, much like that made by a toothed trowel when installing floor or wall tile.

—Erv Roberts, Des Moines, Iowa

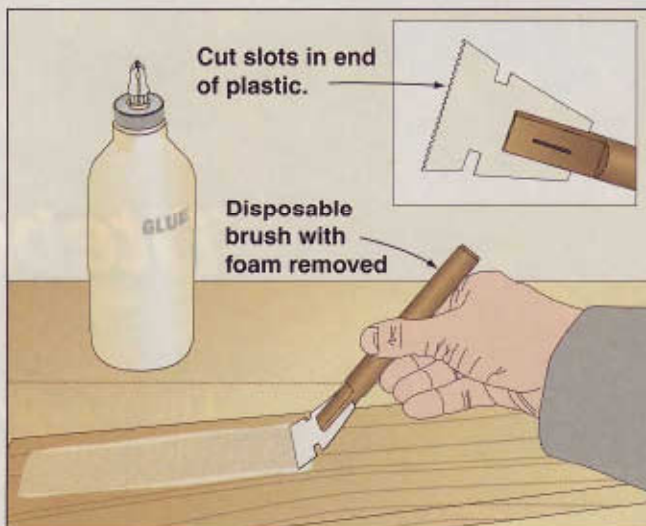

Continued on page 30

## The Delta Edge Get a \$50 rebate on cutting edge miter saws.



### 36-412, 12" Dual Bevel, Front Bevel Lock Compound Miter Saw

#### Mega Capacity, Ultimate Trim Saw

- World's largest 12" capacity.
- Cuts a 2 x 10 in one cut.
- Cuts a 4 x 6 in one cut.
- Cuts 9 1/2" base and 8 1/2" crown.
- Innovative Front Bevel Lock and detents mean no more reaching behind the saw.
- Flip-up crown molding stops and patented easy-squeeze dual sliding fences.



### 36-312, 12" Front Bevel Lock Compound Miter Saw

#### The Durable Saw You Can Take From Site To Site

- Innovative Front Bevel Lock and detents mean no more reaching behind the saw.
- Lightweight, compact and durable.
- Easy to carry from job to job.
- Cuts 7 1/2" base and 6 1/2" crown.

For your nearest dealer, visit  
deltamachinery.com/rebate.  
Rebate valid 11/1/03 through 2/15/04.

Circle No. 1501

**DELTA**

Your achievement. Our tools.

### Biscuits strengthen even narrow face frames

While making a face frame for a bathroom base cabinet recently, I felt like mortise-and-tenon joints were overkill, and half laps were too time-consuming. I wanted to use my biscuit joiner, but the face frame was too narrow to accept standard-size biscuits.

Instead of cutting biscuit slots in the edges of the frame parts, as I normally would, I cut a pair of them in the back face across each joint, as shown at right. After gluing the biscuits in place and letting the glue dry, I cut the protruding half of the biscuits off with a handsaw. (They won't be seen on the inside of the cabinet anyway.)

You wouldn't want to use this method for joints that will be under a lot of stress, to be sure. Nor would you use it where the back of the frame will be visible. But for face frames, the joint produced is quick, easy, square, and plenty strong.

—Len Estrada, Gladstone, Va.

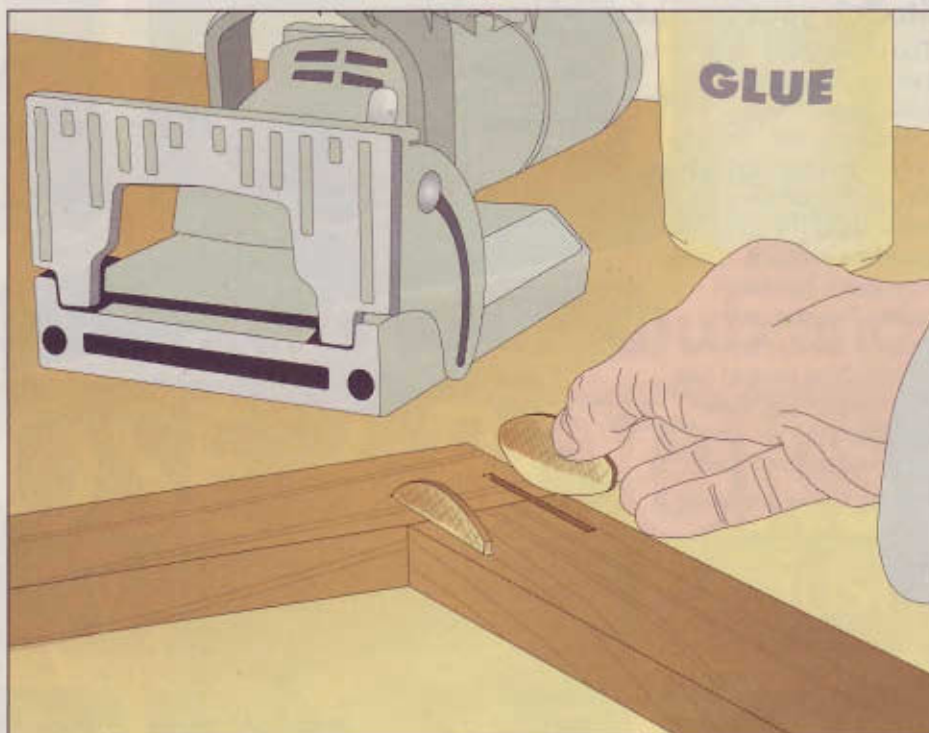
An advertisement for Titebond Wood Glues. It features a photograph of an older man with glasses and a young boy working together in a workshop. The man is holding a wooden box, and the boy is using a handsaw to cut a piece of wood. A bottle of Titebond II Wood Glue is prominently displayed on the workbench. The background shows various tools hanging on a wall.

**Titebond**  
Wood Glues

The Woodworker's  
Choice for Generations.

titebond.com 1-800-347-GLUE



## How the radial-arm saw lost its groove

The kerfs cut into a radial-arm saw's tabletop provide a ready reference for aligning a workpiece to be cut. And, the tabletop itself acts as a sort of zero-clearance insert to reduce tear-out.

Over the years, the kerfs in my saw's tabletop have become less effective for

both purposes as they have worn wider from realignments and using different blades. Rather than replace the top, which is time-consuming and costly, I filled the too-wide kerfs with two-part epoxy, and then sanded them smooth.

—Jim Overton, East Hampton, N.Y.

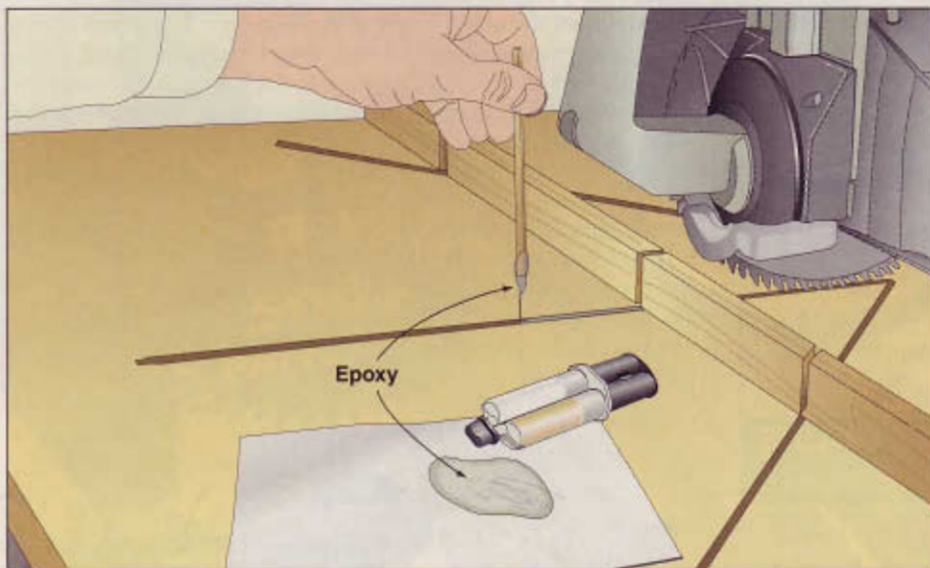

## Gauge blocks for faster rail-and-stile setup

When routing rails and stiles on the router table, it takes time to reset the fence flush with the guide bearing and parallel to the miter slot every time I swap bits. The jig shown below, however, allows me to instantly repeat the setup.

After perfecting the fence location and locking it in place, I loosen the wing nuts on the jig, set it in the miter slot, slide the

blocks up to the fence as shown, and tighten the wing nuts. Finally, I remove the jig, and begin routing.

If you don't have a miter slot in your router table, you can still use the jig. Just make the gauge blocks longer and guide the hardwood runner against the front edge of the tabletop.

—John Passamonte, Merritt Island, Fla.

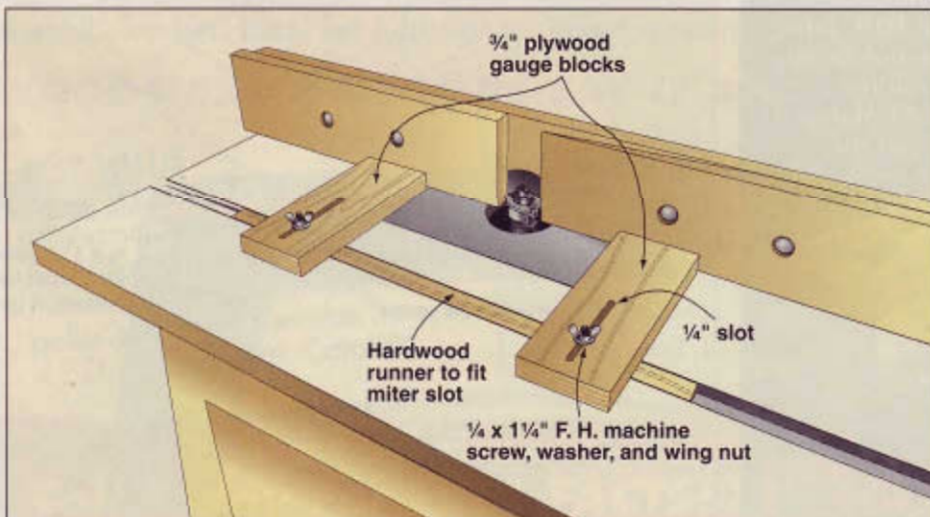

## The Delta Edge These miter saws even cut you a \$50 rebate.



36-255L, 12"  
Compound Miter Saw

Accurate, Fast, Heavy Duty

- The world's first TwinLaser™ system makes this the fastest, most accurate saw available.
- Great for precise bevel and compound cuts.
- The same saw Norm uses.



MS450, 12" ShopMaster™  
Compound Miter Saw

An Unbelievable Value

- Built for power (15 amps) - yet affordably priced
- Low price includes full features like fences, clamps and extensions

For your nearest dealer, visit  
deltamachinery.com/rebate.  
Rebate valid 11/1/03 through 2/15/04.

Circle No. 1501

**DELTA**

Your achievement. Our tools.

# KLINGSPOR'S WOODWORKING SHOP

"Quality Tools and Supplies for the Woodworker"



Whether you shop thru our catalog, our website or one of our four retail stores you will find all your woodworking tools and supplies in one convenient location.

**1,000'S OF PRODUCTS AVAILABLE ONLINE**  
1-800-228-0000 • [www.woodworkingshop.com](http://www.woodworkingshop.com)

Circle No. 629

## The Difference Between Good and Great

JessEm manufactures a variety of products for a great router table to fit your woodworking style. Choose from complete systems or individual components to configure your own custom solution. Our Mast-R-Fence™ has the thickest aluminum frame on the market. All JessEm table tops are machined from solid Phenolic for a strong, stable top that's guaranteed not to warp, sag or swell like MDF tops.

Make it great with production grade routing solutions from the Inventor and #1 Maker of Router Lifts.



New!  
Mite 18 Slide™

See JessEm products in use at  
[www.woodshopdemos.com](http://www.woodshopdemos.com)

Visit us at [www.jessem.com](http://www.jessem.com)  
Or call 866-272-7492

Distributor Inquiries Are Highly Recommended

**JessEm**  
Tool Company

Barrie, Ontario  
Canada, North America

## shop tips

### Now this is a miter gauge...

The tiny miter scale on the hub of my radial-arm saw leaves a lot to be desired when it comes to accuracy. A very small angular error at the hub can have a huge effect at the end of the yoke. Because I use my radial-arm saw to cut segmented rings and barrel staves, accuracy counts, so here's my solution.

I made an angle gauge by attaching a  $\frac{3}{4} \times 1$ " stop to one edge of a piece of  $\frac{3}{4}$ " plywood sized to fit on the right side of my saw table. Then I set this aside.

Next, I went through my normal trial-and-error process of finding the precise miter angle for the segments I was about to cut. Once satisfied, I returned my blank gauge to the saw table, placing the stop against the tabletop and the adjacent edge against the saw's fence, as shown *below*. With the blade set to cut  $\frac{1}{2}$ " deep, I fired up the saw and made an index cut the full length of the yoke. I then repeated the angle-finding and index-cutting process for other angles I use frequently.

To use the gauge, I simply place it in position on the saw table, pull the saw head out to the end of the yoke, swing the yoke until the blade lines up with the correct index cut, and lock the yoke. The time on the initial setup was well spent, and I get perfect joints every time.

—Dee Baxter, Murphys, Calif.

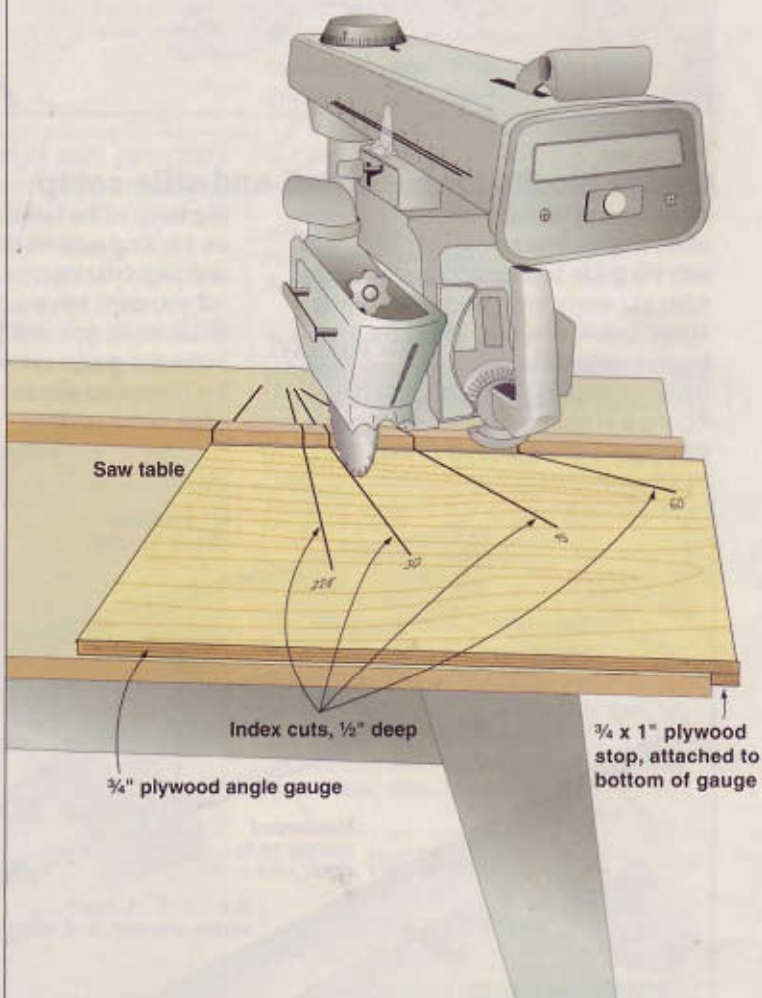

## Quick-fix mounting for permanent ductwork

When I installed dust-collection ductwork in my shop recently, I decided to make it so that I could detach individual lengths of pipe to clear the inevitable plugs that occur in the system. Plumber's pipe strap provides the perfect solution.

I attached lengths of pipe strap about  $\frac{1}{2}$ –1" shorter than the duct's circumference, as shown in the drawing right at regular intervals along the intended route of the ductwork. Then I wrapped the strap around the ductwork, and cinched it all together with nylon cable ties on each strap. (You'll find cable ties in the electronics department of your local home center.)

To remove a plug in the system, I merely cut the cable ties holding the plugged section of ductwork, clear the blockage, then reinstall the duct with new ties.

—Gale Pearce, Anchorage, Alaska

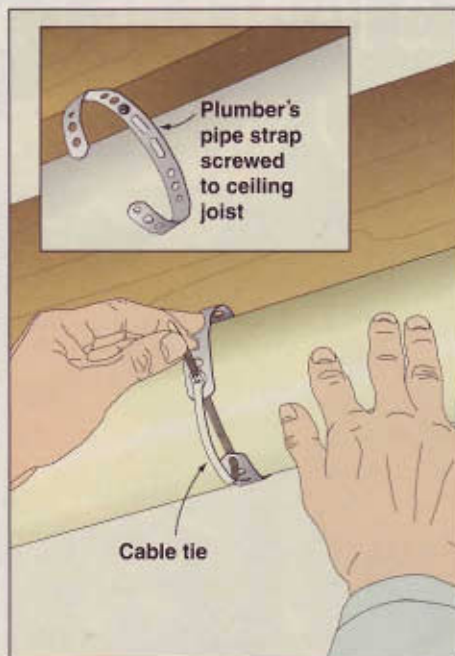

## You'll get hooked on this picture-hanging helper

Pictures or other art with wire hangers always hang a little lower than we want them to, don't they? First, you struggle with how to hold the thing while your wife decides where she wants it; then, the wire on the back sags more than you expect. This nifty little jig solves both problems.

To use it, place the jig against the wall and hang the wire over the head of the panhead screw. When the location is picture perfect, press on the frame directly over the paint stick. The screw will leave a little dimple in the wall, and that's where you locate your nail. (If I'm using a hook-type hanger instead of a nail, I put the bottom of the hook over the dimple.)

—Scott Hood, Oakville, Ont.

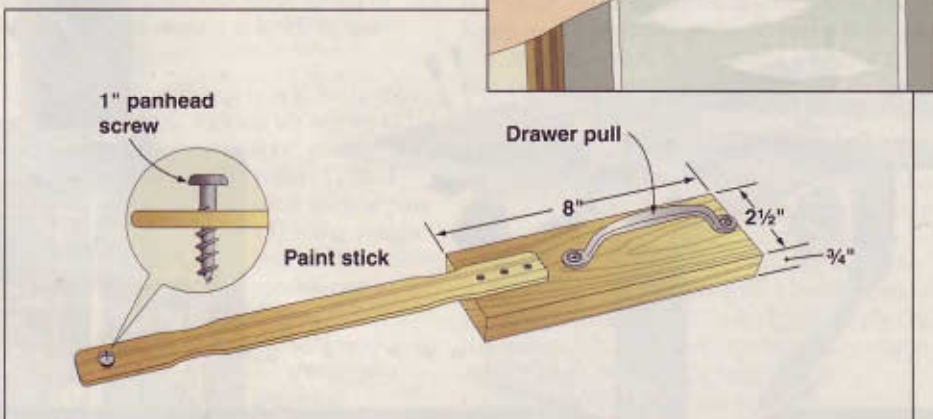
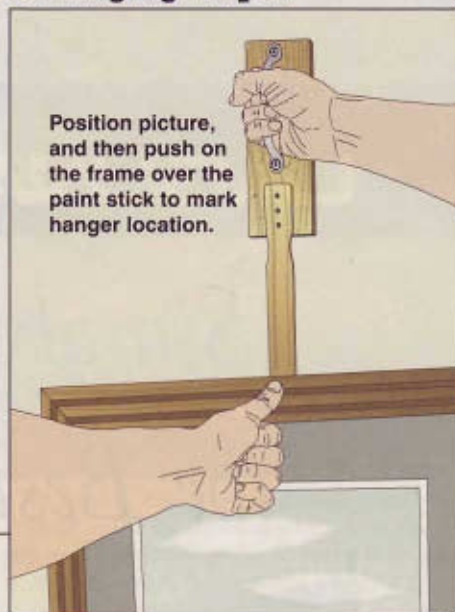

Continued on page 34

## The Delta Edge

Start building a Delta shop with this \$50 rebate.



### 28-206, 14" Industrial Band Saw

#### This Band Saw Is Simply The Best

- A fully-featured saw with 1 HP motor
- Patented quick-release tension lever
- Large 18" x 16" cast-iron tilting table.
- Integrated 4" dust collection port
- Precision balanced 9 spoke wheels



### 22-580, 13" Two Speed Finishing Planer

#### Saves Time, Less Sanding

- Does the work for you by dimensioning on one speed, and finishing on the second speed
- This award-winning planer has won every portable planer review ever entered

For your nearest dealer, visit [deltamachinery.com/rebate](http://deltamachinery.com/rebate). Rebate valid 11/1/03 through 2/15/04.

Circle No. 1501

**DELTA**

Your achievement. Our tools.

### Reliably reset your fence to rip thin strips

The only way to rip thin strips of stock safely on your tablesaw is to make a cut, then move the fence. Here's a jig that ensures each strip comes out the same.

The jig consists of a scrap of 3/4" plywood with a hardwood runner that fits the miter-gauge slot. I drilled a 7/16" counterbore 1" deep in one edge of the jig, where shown

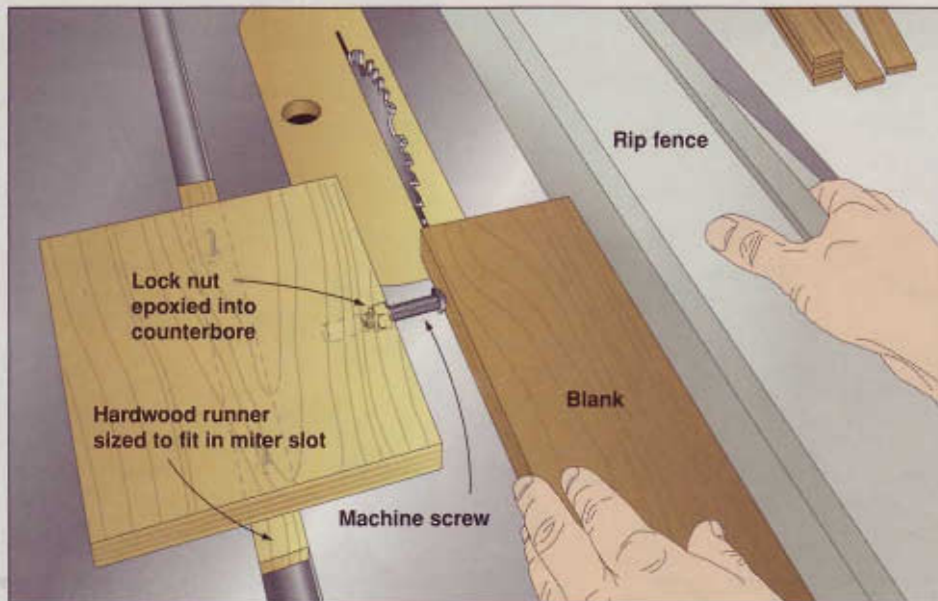

below left, and epoxied a 1/4" nylon-insert lock nut into it (nylon end in). After the epoxy cured, I threaded a 1/4-20 roundhead machine screw long enough to reach just past the blade while staying firmly seated into the nylon-insert lock nut.

To use the jig, fit its runner in the miter slot and turn the screw until the distance between the screwhead and the saw blade equals the thickness of the strips you want. Now, place your blank against the rip fence and slide both the blank and fence left until they contact the screw. Lock the fence down, remove the jig, and rip the strip.

Return the jig to the miter slot and again slide the fence and blank until they touch the screw. Remove the jig, rip, and repeat as needed until your blank gets too narrow to work safely.

—Jim Pollock, WOOD® magazine techniques editor

See a new . . .  
...shop tip daily at  
[www.woodmagazine.com/tips](http://www.woodmagazine.com/tips)



# LAGUNA TOOLS

Simply  
the Best!



Call for **FREE** Video!

1.800.234.1976

[www.lagunatools.com](http://www.lagunatools.com)

The new Laguna TS table saw is setting a new high standard by which all others will be measured. With all the features of a traditional cabinet saw, the TS also comes with its own line of bonus 'Laguna' features.

The X31 multi-task machine has a lineage second to none. This third-generation combination machine is a best seller, with updated fences and increased cutting capacity.

Meet our latest award-winning machine, the LT 14 bandsaw. Packed with outstanding features for powerful performance. 1.7 HP motor - 13 1/4" throat - 1/16" to 1" blade - 8" resaw.

mail@lagunatools.com

17101 Murphy Avenue  
Irvine, CA 92614

# A quick guide to must-know terms used throughout *WOOD* magazine

**Perforated hardboard:** The generic name for a 1/4"-thick hardboard sheet with rows of holes spaced at regular intervals. Frequently, this material gets hung vertically and used for tool storage. Often, this material is referred to as Peg-Board—the brand name of one such product.

**Double-faced tape:** Tape with adhesive on both sides. In the shop, this tape proves useful for such things as attaching templates, planing thin stock on carrier boards, and temporarily joining workpieces for stack cutting. Use the woven-cloth variety for best results. Also called carpet tape.



**Rough-sawn:** Boards, typically hardwoods, cut to thickness, and sometimes width, during the initial milling process, but not planed or ripped. This leaves tell-tale rough, splintery surfaces on all sides.

**S2S:** A lumber-industry abbreviation for "surfaced on two sides." These boards are planed on both faces to final thickness after milling and drying.

**Typical S2S Thicknesses (hardwoods):**

Nominal	Actual
4/4 (1")	13/16"
5/4 (1 1/4")	1 1/16"
6/4 (1 1/2")	1 3/16"
8/4 (2")	1 3/4"

**S3S:** An abbreviation for "surfaced on three sides." Here, boards get planed on both faces, and then straight-line ripped on one edge. Most hardwood sells as S3S or S2S.

**S4S:** An abbreviation for "surfaced on four sides." These boards get planed on both faces, and then ripped on both edges to make them parallel. Most often, this process produces "dimensional" lumber in standard sizes, such as 1x6, 2x4, and so forth. You'll find softwood construction lumber sold this way, as well as hardwoods in home centers.



**Open time:** The amount of time after glue is spread before it becomes unworkable or loses its ability to create a bond. Also called working time. Open time varies depending on temperature, glue type, and humidity. Use the following times as rough guidelines:

- Aliphatic resin (yellow) 5–10 min.
- Polyvinyl acetate (white) 10–15 min.
- Water-resistant (yellow) 5–10 min.
- Polyurethane 20 min.
- Epoxy 5 min.–12 hrs. (varies by type)
- Liquid hide glue 10 min.

*Note: Some manufacturers make glues with extended open times. Use these for large or time-consuming glue-ups.*

**Set time:** The amount of time it takes for glue in an assembly to dry or cure sufficiently for the clamps to be removed. Set time varies depending on temperature, glue type, and humidity. Use the following times as rough guidelines:

- Aliphatic resin (yellow) 30–60 min.
- Polyvinyl acetate (white) 30–60 min.
- Water-resistant (yellow) 60 min.
- Polyurethane 60 min.
- Epoxy Varies by type
- Liquid hide glue 60 min.

*Note: Several manufacturers offer quick-set glues that achieve high tack (stickiness) just after application. Use these for assembling moldings and other difficult-to-clamp projects requiring hurry-up adhesion.*

**Dry time:** The amount of time it takes for glue in an assembled joint to completely dry or cure and achieve full strength. This time varies from a few hours to 24 hours, depending on the glue type. Also called cure time. ♣



**Blade guard:** On a table saw, a plastic or metal shroud that covers the blade to prevent the saw operator from placing his hands in contact with a spinning blade. The device also prevents small cutoffs from being thrown toward the front of the table saw and the operator.

**Antikickback pawls:** Attached to a table saw's blade-guard system, these spring-loaded metal plates with sawtooth edges work in conjunction with the splitter. In the event of workpiece kickback, the pawls dig into the wood to prevent it from being propelled toward the operator.

**Splitter:** A thin vertical plate positioned directly behind a table saw blade to prevent the kerf from closing up and pinching the blade during a cutting operation. The splitter can be part of the saw's guard assembly or a separate device.

# veneering small panels

Make your projects pop by using veneers that feature species and grain figure not available in plywoods.

**O**ccasionally, when building a project with frame-and-panel components, you'll need a couple of special plywood panels. Maybe it's a panel of a common species, but with two good faces (not typical in plywood), or one with an exotic or figured face veneer. (Try to find a sheet of  $\frac{1}{4}$ " curly maple plywood at your local home center!) These panels, like the drop leaf and door panels in the slant-front secretary *above* and on *page 50*, usually are small enough that you can apply the custom veneer yourself. Here's how.

## Choosing your veneer

When buying veneer you'll have plenty of options to choose from. They include:

### Paper-backed veneers:

- Available with or without adhesive.
- Adhesives are pressure- or heat-sensitive.
- Backed veneers with adhesives come in the most limited choice of species.

### Unbacked veneers:

- Thicknesses varies from  $\frac{1}{40}$ " to  $\frac{1}{16}$ ".
- Available in the widest choice of species.

*Note:* For veneer sources, see the **Buying Guide** on *page 40*.

The curly maple veneer used on the slant-front secretary's panels comes unbacked

only. We chose the  $\frac{1}{16}$ "-thick veneer for several reasons. Substantially thicker than the  $\frac{1}{32}$ "- to  $\frac{1}{40}$ "-thickness of standard solid-wood veneer,  $\frac{1}{16}$ " veneer is less fragile, and you're not likely to accidentally sand through it.

And because its thickness resists wrinkling, you won't need to flatten it before use.

## On to more pressing matters

Applying veneer to a plywood panel is simple, and you probably have most of what you need lying around your shop. First, cut two  $\frac{3}{4}$ "-thick platens (the flat plates you'll sandwich the veneer and plywood substrate between) about 1" larger in length and width than the panel you're veneering. Because they're smooth, flat, and inexpensive, particleboard or medium-density fiberboard (MDF) make good platen material.

Place waxed paper on the bottom platen, and then the plywood substrate. Spread an even coat of white woodworking glue (for longer open time) on the substrate, as shown, *below*. Add the veneer and more



Place waxed paper on the bottom platen, and then the plywood substrate. Squeeze glue onto the substrate, using a foam roller to spread it evenly.

*Continued on page 40*

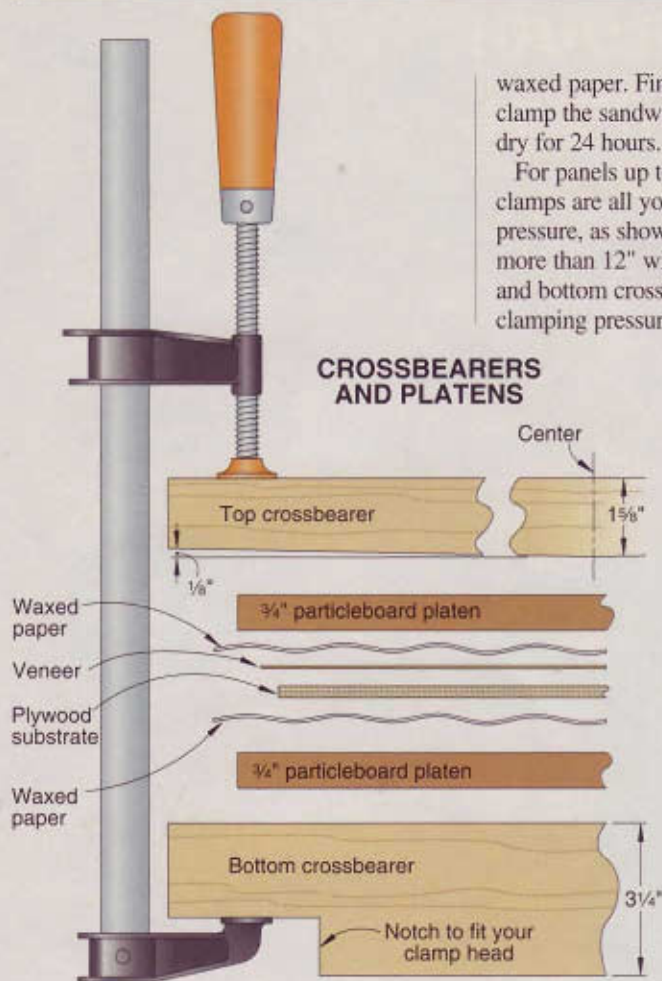

waxed paper. Finally, add the top platen and clamp the sandwich together. Let the glue dry for 24 hours.

For panels up to 12" wide, platens and clamps are all you need for even clamping pressure, as shown *below, left*. But for panels more than 12" wide, you'll need to add top and bottom crossbearers to apply adequate clamping pressure at the panel's center.

To make bottom crossbearers, cut lengths of 2x4, and joint one edge. (We cut our crossbearers 28" long for pressing panels up to 24" wide.) Then rip them to a uniform width so their tops will be in the same plane when they are lined up on your workbench. (We ripped ours 3 1/4" wide.) Next, cut notches in the ends for your clamp heads, where shown on the drawing, *left*.

In order for the top crossbearers to apply pressure at the center of the platten, you'll taper them from their centers to their ends. Then, with

the tapers down, clamping pressure at the crossbearers' ends causes them to bend, pushing down at their centers. To make the top crossbearers, joint one edge of the lengths of 2x4, and then rip them into two 1 5/8" wide pieces. Mark 1/8" tapers from the center to each end of the crossbearers, where shown in the drawing. Hand-plane, belt-sand, or joint the tapers, and then round the points at the centers with a sanding block. Mark the opposite edges with the word "UP."

To veneer a panel using crossbearers, line up the bottom crossbearers on your bench, spaced as shown *below, right*. Then stack on the platens, waxed paper, glued substrate, and veneer in the order shown on the drawing. Position the top crossbearers with the "up" edges up, and apply the clamps, tightening them just enough to hold them in place. With all the clamps in position, work your way up and down the panel's length, tightening each pair of clamps equally. When the crossbearers squeeze the platens at the edges, you'll have even pressure applied to your glue-up across its entire width. ♣

### Buying Guide

**Veneer.** The following retailers carry a wide variety of veneers, including 1/8"-thick veneer: Certainly Wood, phone 716/655-0206, or go to [www.certainlywood.com](http://www.certainlywood.com); and Bob Morgan Woodworking Supplies, Inc., phone 502/225-5855, or go to [www.morganwood.com](http://www.morganwood.com).

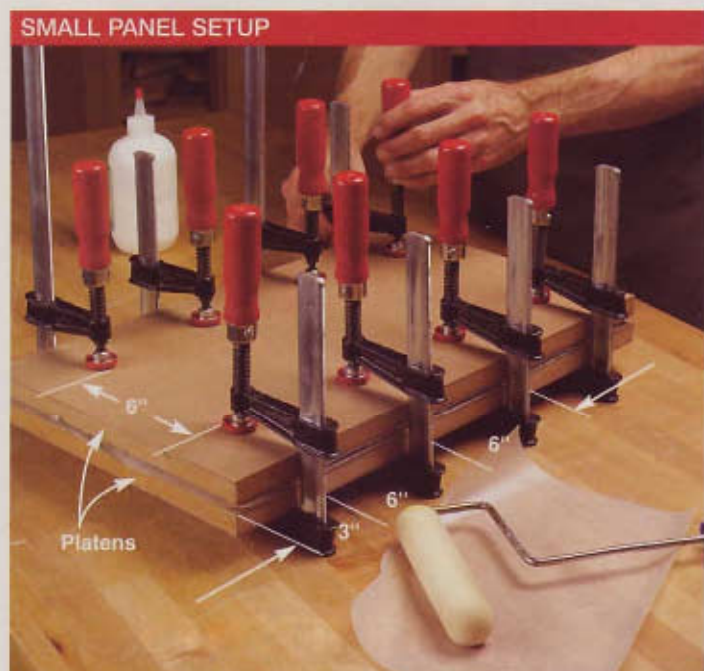

When veneering panels with only platens and clamps, position clamps 3" from each end and no more than 6" apart along the panel's length. Maintain 6" spacing between clamps on opposite sides of the panel.



Space crossbearers 3" from each end and no more than 6" apart along the panel's length. To avoid confusion, mark "UP" on the edges of the top crossbearers opposite their tapers.

# ask wood

Answers to your questions from letters, e-mails, and WOOD ONLINE®

## The keys to making a sound MDF joint

**Q:** I'm going to build a router table cabinet with medium-density fiberboard (MDF). Should I use glue and/or screws for the corner joints? If so, what kind of glue and screws work best?

—Robert Persing, Skillman, N.J.

**A:** Yellow glue and screws make solid joints in MDF, Bob, but not just any screws. Bear in mind that this material has less screw-holding power than solid wood or plywood, and tends to split.

When joining  $\frac{1}{4}$ " MDF, we recommend using #8 deck screws (featuring straight shanks and deep threads) at least  $1\frac{1}{2}$ " long. Locate the screws no less than 2" from the ends of the pieces to avoid splitting. Bore a  $\frac{5}{32}$ " shank hole through the top piece of the joint for each screw, and countersink both sides. One countersink seats the head flush with the exposed surface and the other makes room for any material pulled up from the bottom piece of MDF when you drive the screw. Next, spread glue on the



Spread a slightly thicker coat of glue than usual for an MDF joint. The porous edge is exposed on the bottom piece, and it soaks up quite a bit of glue.

edge of the bottom piece, and clamp the joint together. Finally, drill  $\frac{1}{64}$ " pilot holes into the bottom piece, centered in the shank

holes and as deep as the screw length. Drive the screws, and wipe away any squeeze-out with a damp cloth.

## "Moderation in all things" applies to sanding, too

**Q:** Some sources recommend sanding wood only to 220 grit. Why not keep going with finer grits and make the surface even smoother?

—Naomi Koceau, Madira, Calif.

**A:** In most cases, Naomi, we stop sanding at 220 grit in the WOOD® magazine shop because it's the finish you apply that determines the final smoothness of your project. By the time you've reached

220, the remaining sanding scratches are so small that a film-forming finish—such as lacquer or varnish—easily fills them. The key to producing a super-smooth finish lies in leveling each coat of finish, and then rubbing out the final coat.

However, we sand to 320 grit when we plan to apply an oil finish. Oil soaks into the wood, rather than forming a film, so you still feel the wood surface after the finishing process is complete, and the extra smoothness pays off.

Also, you might choose to use finer grits to control color when you plan to apply pigmented stain (it's not as much of a concern with dye). Stain colors wood by depositing pigment particles in pores and grain lines. When you sand to finer grits, you remove some of those lodging spots, and you wind up with a lighter color. The difference can be subtle; but if you pay close attention to color, it's worth doing a quick test on samples, as pictured here.



80 grit and stain



400 grit and stain

To emphasize the difference sanding can make, we sanded the cherry sample at left only to 80 grit, and sanded the other one to 400 grit. Then we applied one coat of cherry stain to both, producing this significant range in hue.

Continued on page 44



## Perfect Fitting Glue Joints. Guaranteed.

F038

### JointABILITY

by HAWK Woodworking Tools.

- Create invisible glue joints the entire length and thickness of your workpiece
- The easiest way to create dados and rabbets
- Square up large glued panels
- Rip sheet goods to size perfectly square
- Cuts production time in half
- Sold factory direct



Call 1-800-487-2623  
www.hawkwoodworkingtools.com

© 2003 rbindustries, inc.

Circle No. 1677

# The **ARROW** X Machine ETFX50™



**XTRA HEAVY DUTY**  
Professional

**XCEPTIONAL COMFORT**  
Cushioned Grip

**XPERT PERFORMANCE**  
Drives 6 Different Size  
Staples + Nails

**XTRAORDINARY POWER**  
14 Amps of Surge Power

**XCITING DESIGN**  
New Ergonomic Styling



... It's what  
you've come to  
**XPECT** from Arrow!

MADE IN  
USA  
HECHO EN E.U.A.

Keeping America Strong

Available at home centers, lumberyards, and fine hardware stores wherever professional tools are sold!



Arrow Fastener Co., Inc., 271 Mayhill Street, Saddle Brook, New Jersey 07663  
Canada: Jendel Distributors, Inc., 6505 Metropolitan Blvd. East, Montreal, Quebec H1P 1X9  
Arrow Fastener (U.K.) Ltd., Unit 5 24 Park, 23 Commerce Way, Croydon CR9 4ES, Surrey, United Kingdom  
www.arrowfastener.com ©2002 Arrow Fastener Co., Inc. Rev 792

## ask wood

### In tablesaw blades, hook matters

**Q:** I've bought lots of tablesaw blades over the years, but never noticed the term "hook" until recently. What does it mean, and how does it affect my blade choices?

—Greg Fowl, Prattville, Ala.

**A:** Lay a saw blade on your workbench, Greg, place a straightedge across the center of the arbor hole to define the blade centerline, and you can see what hook is all about. A tooth with positive hook leans toward the centerline. A tooth leaning back from that line has negative hook.

A tooth with a positive hook angle cuts more aggressively, allowing you to rip and crosscut wood quickly. One with a negative hook angle cuts more slowly, giving you a more controlled cut, less tear-out, and smoother results on brittle materials, such as plywood and plastic. Also, use a negative-hook blade on radial-arm saws and sliding mitersaws to help maintain control as you cut.

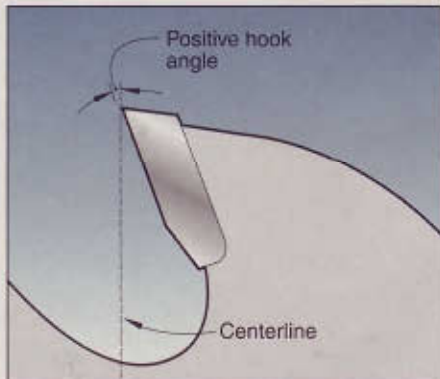
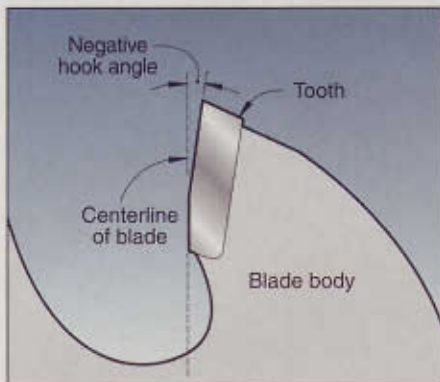

You can see from these illustrations that a blade with positive hook angle is designed to slice aggressively into a workpiece. By comparison, the blade with negative hook angle tends to ease into each cut.

## Eliminate brush marks when you use varnish

**Q:** When applying gloss polyurethane varnish to my latest project, I wound up with brush marks. I used a good brush designed for oil-based paints and stains; what should I have done differently?

—Joe Bonavita, Oxford, Conn.

**A:** Joe, several factors contribute to a great-looking finish with standard varnish or polyurethane. For your next project, buy a China bristle brush with a tapered profile and flagged (split) ends. With this, you can lay down an even coat through a long brush stroke. Next, warm your workshop, if necessary, to at least 70 degrees. Then, thin the varnish by mixing it 50/50 with mineral spirits. Thinning improves the flow-out and curing qualities of the critical first coat. Brush on a coat of varnish; hold the brush at a right angle to the surface; and, working in the direction of the grain, lightly skim the varnish with the bristle tips to help level it.

Let the first coat dry for 24 hours, sand it lightly with 220-grit sandpaper wrapped on a block, and remove the sanding dust with a cloth moistened with mineral spirits.



Thinning each coat of varnish with mineral spirits allows the finish to flow out more smoothly, making brush marks less likely to remain as it dries.

Examine the varnish for brush marks. If you see any, sand again with 220-grit paper, and remove the dust.

Now apply a second coat that has been thinned to 25 percent mineral spirits, 75 percent varnish, using the same brush technique as before; allow the coat to dry; and sand with 320-grit sandpaper. Continue through two more coats with unthinned varnish.

Finally, go a bit further to create a perfectly level surface with a consistent sheen. Allow the final coat to cure for a week, and then use 600-grit silicon carbide sandpaper wrapped on a sanding block to level it. Rub with 0000 steel wool and paste wax for a satin sheen, or follow the 600-grit sandpaper with finer sandpaper or rubbing compounds to create a glossier look.

## Collecting dust is just the first step

**Q:** MDF dust has clogged the bags of my dust collector, and I can tell the machine isn't pulling in as much air as it used to. What's the best way to clean those bags?

—Dean Thompson, St. Petersburg, Fla.

**A:** Dean, it's a straightforward task with one important distinction based on the bag material. Cotton bags can go in the washing machine after the steps outlined below. Don't wash nonwoven felt bags, though, or you're likely to leave hardened clumps lodged in the fibers.

No matter what type of bags you own, begin by rapping the sides with a light stick or dowel to knock loose the caked dust. Put on a dust mask, take the bags off the dust collector, hold the openings closed, and give each one a good shaking to take even more dust off the walls. Take the bags outdoors, and empty them into a garbage can or trash bag. Use a shop vacuum to clean the bag interiors further.

For future reference, you can judge a bag's condition by poking it with your fin-

ger while the machine is running. It should give easily under modest pressure. If the bag feels hard, it's time to clean again.



Finish cleaning your dust-collection bags with your shop vacuum, but don't worry about getting it as clean as new. A light coat of sawdust on the inside actually helps trap the tiniest dust particles, keeping them out of the air.

Continued on page 46

# The Toughest Glue On Planet Earth

Gorilla Brand Premium Glue is the all purpose, interior/exterior glue ideal for most repair and bonding needs. It's great for indoor/outdoor furniture repair, woodworking projects, as well as general repairs around the house. Bonds wood, stone, metal, ceramic and more! Incredibly strong and 100% waterproof.



for retailers near you:  
[www.gorillaglu.com](http://www.gorillaglu.com)  
1-800-966-3458

# Tools That Were Just Made For Each Other!



CMT's Industrio™ Routing System is a true production router table. It includes a rugged melamine cabinet, warp-free phenolic top and our unique pivoting fence. Ask your CMT dealer for more details.

\*The orange color on tool surfaces is a registered trademark of CMT Utensili, S.p.A.



**Industrio™  
Routing  
System**

**Pocket-Pro™  
Joinery  
System**



Two great tools  
in their own right . . .  
. . . or put them together  
to make your own pocket  
hole workstation.

For fast, easy cabinet & furniture construction, there's nothing like the new Pocket-Pro™ Joinery System. As shown below, the Deluxe System's phenolic base is a perfect match for our router table. Or use the jig on your workbench, at the job site or anywhere you need strong, accurate joints.

Circle No. 180

Call your **CMT Distributor** today to learn more about these exciting tools, or contact CMT for a free, full-color catalog



Get the full story about CMT router bits, blades, cutters and more. Visit your CMT distributor today!

CMT USA, Inc. • 307-F Pomona Drive • Greensboro, NC 27407 • 888-268-2487 • [www.cmtusa.com](http://www.cmtusa.com)

## ask wood

### Would you like glass or plastic with that frame?

**Q:** It sure would be easier to cut acrylic plastic to fit my photograph frames, rather than dealing with glass. Is there any reason not to?

—Art Hejduk, Mantua, Ohio

**A:** Acrylic does the job, Art, but your choice might depend on the situation. Glass offers the benefits of being scratch-resistant and easily cleaned. It's also rigid, so you can transport a framed picture with little risk of the glass coming in contact with the artwork.

By contrast, acrylic scratches easily in handling, and you shouldn't clean it with any household cleaner that contains ammonia (crazing and cloudiness eventually result). Also, panels of 3/32" or 1/8" thickness can flex enough to rub against the artwork beneath. On the other hand, acrylic weighs about half as much as glass of equal thickness, and it won't shatter if the picture frame falls. Those characteristics make it a better choice for large frames (anything larger than 3' square, for example) and frames that will hang in a child's room or

anyplace else where you can expect boisterous activity. To cut acrylic on your table saw, use an 80-tooth blade with negative hook.

Cost depends on your local sources, but expect plastic to be less expensive than glass. For example, at a home center we found 8x10" single-strength (3/32" thickness) glass for about \$2.25, and an 18x24" piece of 1/8" acrylic for \$3, which would provide four 8x10" pieces at 75 cents apiece.

Check into more expensive options when you frame an item that calls for top-quality preservation. Both glass and acrylic come in versions that filter out the damaging rays of ultraviolet light. Both materials also come in non-glare styles to improve viewing quality, and some glazing products combine UV filtering and non-

Non-glare acrylic  
1 1/2" above photo

Clear acrylic  
1 1/2" above photo



Non-glare glass and acrylic need to sit almost in contact with the framed object to provide a truly clear image. The non-glare acrylic at left would give a blurry look to objects mounted an inch or two behind the glazing in a display case, for example, and you might even notice a loss of clarity with double- or triple-matted artwork. The clear acrylic at right keeps display items sharp at any distance.

glare characteristics. Ask about your choices at a home center, a glass or plastics supplier, an art store, or a framing shop.

### Got a question?

If you're looking for an answer to a woodworking question, write to **Ask Wood**, 1716 Locust St., GA-310, Des Moines, IA 50309-3023, or send us an e-mail at [askwood@woodmagazine.com](mailto:askwood@woodmagazine.com). For immediate feedback from your fellow woodworkers, post your question on one of our forums at [www.woodmagazine.com](http://www.woodmagazine.com).

# Baltic and Finnish birch plywood

These premium sheet goods offer outstanding performance.

**L**ooking for the perfect material for creating shop jigs and fixtures, drawer cases, and carcasses? Consider Baltic birch and Finnish birch plywood. These imported sheet goods offer strength and stiffness, lack voids, and have edges that look as good as their faces.

## The benefits of layering

To create these materials, manufacturers start with dense, slow-growing birch trees from Finland, Russia, and Europe's Baltic region. The wood has a light color, and seldom bears excessive mineral streaks.

Those trees are sliced into thin wood layers—about  $\frac{3}{32}$ " thick—and pressed into multi-layered sheets. A comparison to domestic birch plywood, *below*, shows that a sheet of Baltic or Finnish birch plywood of equal thickness has nearly twice as many plies. That makes Baltic and Finnish products more stable and rigid, less likely to warp, and imparts excellent screw-holding power, even on the edges.



Finnish or Baltic birch  $\frac{3}{4}$ " plywood has 13 plies, compared to seven (five core plies plus face and back veneers) in domestic birch.

Plus, these materials are birch through and through, unlike domestic plywood, which may contain any variety of wood plies (most often softwoods) covered with birch veneer.

The plies in Baltic and Finnish Birch also are all virtually free of voids, meaning no surprises await when you cut into a sheet. The edges also cut cleanly, hold crisp detail, as shown *below*, and can be machined to form such joints as dovetails. In fact, an increasing number of manufactured cabinets are made with dovetailed drawer boxes of Baltic birch plywood.

## Variations on a theme

While Baltic and Finnish Birch look similar, one key difference exists: Exterior-grade adhesive joins the plies in the Finnish variety, so they can be used outdoors, if properly finished. Dark glue lines give Finnish birch away.

Several grades exist for these materials, but, in the United States, only the top grades generally are sold. In most cases, the grade



Good quality wood, fine glue lines, and void-free plies combine to make Baltic and Finnish birch plywood quite machinable.

is B-BB. That means you get one-piece face veneer, with no splices or voids. The back face and inner plies may have tightly-patched voids, *below*. Both faces are sanded, but may have a slightly fuzzy surface. Sand to 220-grit before finishing to smooth the surface.

Like any birch plywood, Baltic and Finnish varieties may accept stain unevenly. So use a stain conditioner before applying liquid stain, or choose a gel stain. Clear finishes present no problems.

Suppliers measure these materials in metric thicknesses, roughly equivalent to  $\frac{1}{8}$ ",  $\frac{1}{4}$ ",  $\frac{3}{8}$ ",  $\frac{1}{2}$ ", and  $\frac{3}{4}$ ". And, rather than the 4x8' dimensions we're accustomed to for sheet goods, Baltic and Finnish birch sheets usually measure 60x60". To find these full sheets, you'll likely have to visit a hardwood lumber dealer. Expect to pay about \$45 for a  $\frac{3}{4}$ " sheet. Many mail-order and online suppliers stock smaller pieces. As these materials gain popularity, they may find their way into home centers. ♣



Patches in the back face of the plywood fit extremely well, with reasonable color match to the surrounding veneer.



# slant- front secretary

Form meets function in this design that's as practical as it is good looking.

Combining the stunning beauty of solid cherry with quilted maple veneer, this design enhances any room setting. And there's a utilitarian side to its personality. Pull-out sleepers support a drop-down front that features an imitation leather writing surface. A large drawer for supplies and ample pigeonhole space in the desk for paper and letters are supplemented by the upper cabinet's roomy shelving.



You'll begin this project by building its base first—a great compact desk by itself if you elect not to add the upper cabinet.

## Start with the base

**1** From 1 3/4"-thick stock, cut the legs (A) to the size listed on the **Materials List** on page 61. Arrange the legs so the best grain patterns show on their front and outside faces. Mark each leg's orientation (RF for right front, LF for left front, RR for right rear, and LR for left rear) on its top.

**2** Mark the four-sided tapers on the legs, where shown on **Drawing 1**, and cut them using a tapering jig on your table-saw, as shown in **Photo A**. (See issue 151, page 82 for instructions on how to build and use the tapering jig shown, or go to [www.woodmagazine.com/wbprojects](http://www.woodmagazine.com/wbprojects).) Joint the tapers, and finish-sand the legs.

**3** Cut the side aprons (B) and rear apron (C) to size. Chuck a 3/8" round-over bit in your table-mounted router, adjust it as shown on **Drawing 1a**, and rout the profile along the aprons' bottom outside edges. Finish-sand the aprons. To make the best use of your 3/4"-thick cherry stock, see the **Shop Tip**, right.

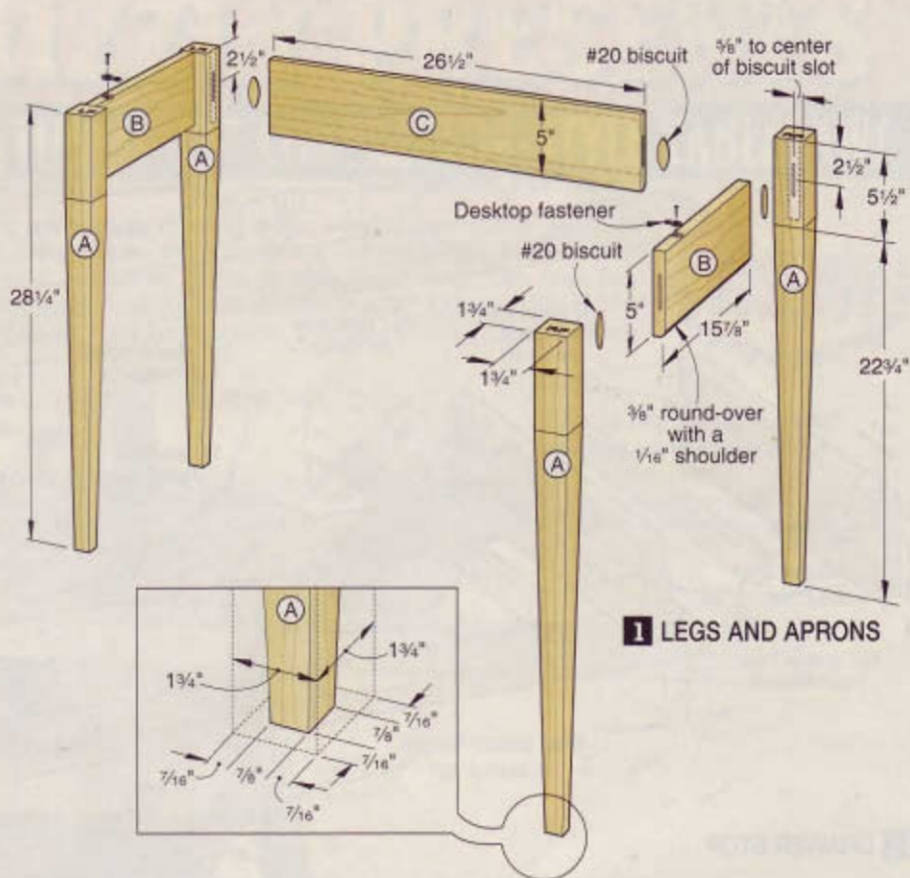

**1** LEGS AND APRONS

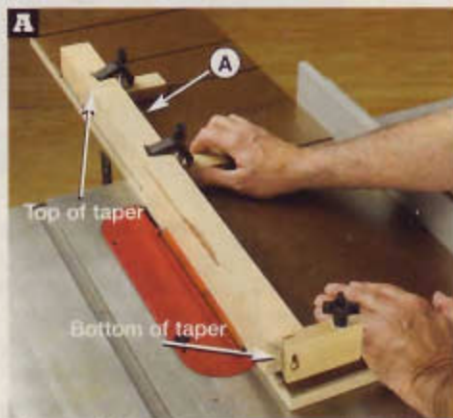

After marking the taper's upper end on the leg's side and its lower end on the leg's bottom, cut the tapers using a tapering jig.

## 1a ROUTING THE 3/8" ROUND-OVER

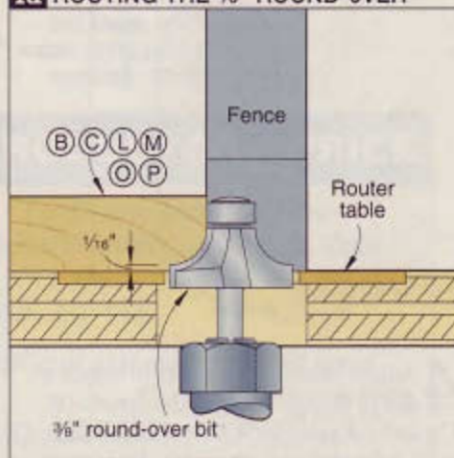

## SHOP TIP

### Getting the biggest bang from your boards

When purchasing hardwood, you're bound to get boards with grain defects, knots, or sapwood. To help you make the best use of the smallest amount of lumber, project builder Chuck Hedlund shares the tricks, shown right.

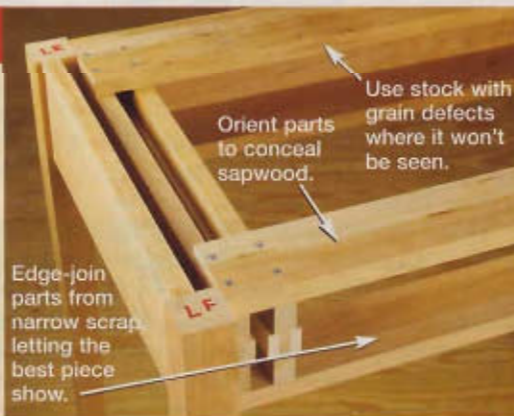

**2 GUIDES AND RAILS**

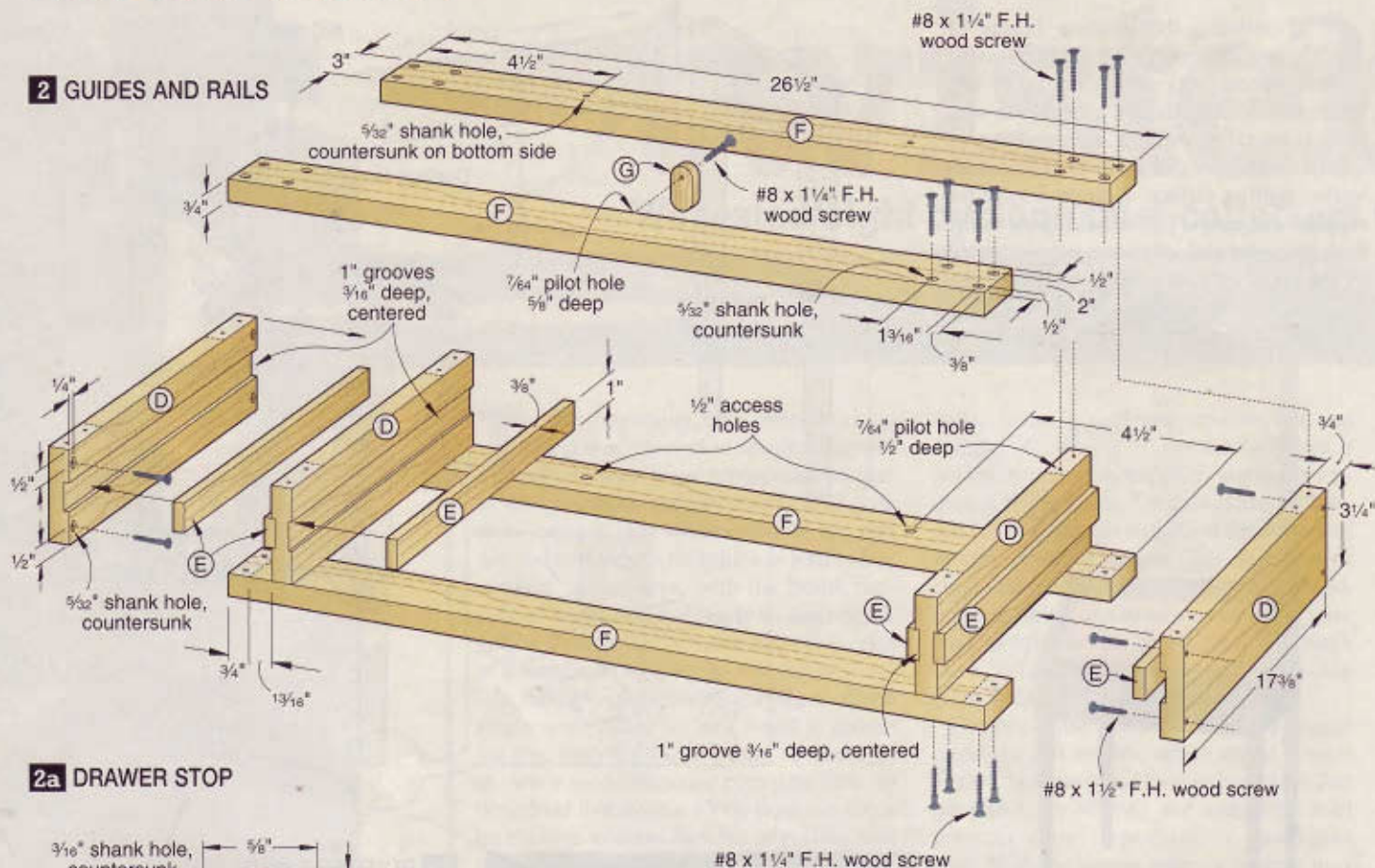

**2a DRAWER STOP**

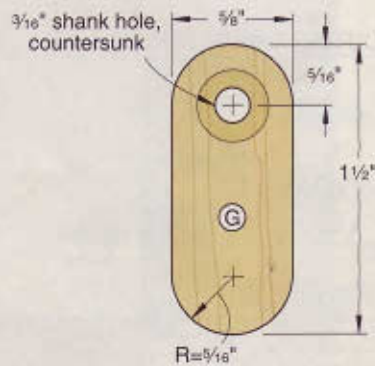

**4** Adjust your biscuit joiner to center a slot in the thickness of the aprons (B, C), and cut slots for #20 biscuits in their ends, centered in their width. Now reset the biscuit joiner to center a slot  $\frac{5}{8}$ " from the legs' outside faces, and cut slots in the front legs' rear faces and the back legs' front and inside faces, where shown on **Drawing 1**.

**5** Glue, biscuit, and clamp the side aprons (B) between the legs (A), making certain the assemblies are flat. With the glue dry, glue, biscuit, and clamp the rear apron (C) between the two leg/apron assemblies. Make sure this assembly stands on a flat surface without rocking, and check it for square.

**6** Cut the guides (D) and runners (E) to size. With a dado blade, cut centered

1" grooves  $\frac{3}{16}$ " deep in both faces of the inside guides, and the inside faces of the outside guides, where shown on **Drawing 2**. Drill countersunk shank holes in the outside guides, where shown. Glue and clamp the runners in the guides' grooves, keeping their ends flush.

**7** Cut the rails (F) to size, and drill countersunk shank holes for fastening the rails to the guides (D), where shown on **Drawing 2**. For fastening the base to the desk case's bottom later, drill a pair of shank holes, countersunk on the bottom face of the upper rear rail. To drive the screws that will go into these holes, drill a pair of  $\frac{1}{2}$ " access holes through the lower rear rail (F). Then drill a  $\frac{7}{64}$ " pilot hole  $\frac{5}{8}$ " deep for the drawer stop (G) in the back edge of the upper front rail, centered in its length and thickness.

**8** Glue and clamp the outer guides (D) to the legs (A),  $\frac{3}{4}$ " down from the tops of the legs with their ends against part (C), where shown on **Drawing 3**. Check the guides' positions with one of the rails (F) to make sure the top surface of the rail is flush with the tops of the legs. Drill pilot holes into the legs, and drive the screws. Now glue and clamp the rails in place. Using the shank holes in the rails as guides, drill pilot

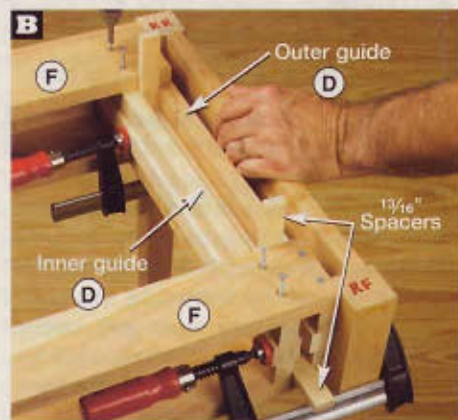

Insert  $\frac{13}{16}$ "-wide spacers between the outer and inner guides (D), and clamp the inner guide in place. Using the holes in the rails (F) as guides, drill pilot holes, and drive the screws.

holes into the outer guides, and drive the screws. Finally, cut four  $\frac{13}{16}$ "-wide spacers from scrap, and use them to position the inner guides (D), as shown in **Photo B**.

**9** Cut the drawer stop (G) to size. Drill the countersunk hole and round the ends, where shown on **Drawing 2a**. Next, referring to **Drawing 3a**, drill  $\frac{3}{4}$ " counterbores with a Forstner bit, and then drill the centered pilot holes in the side aprons (B) for the desktop fasteners.

### 3 EXPLODED VIEW

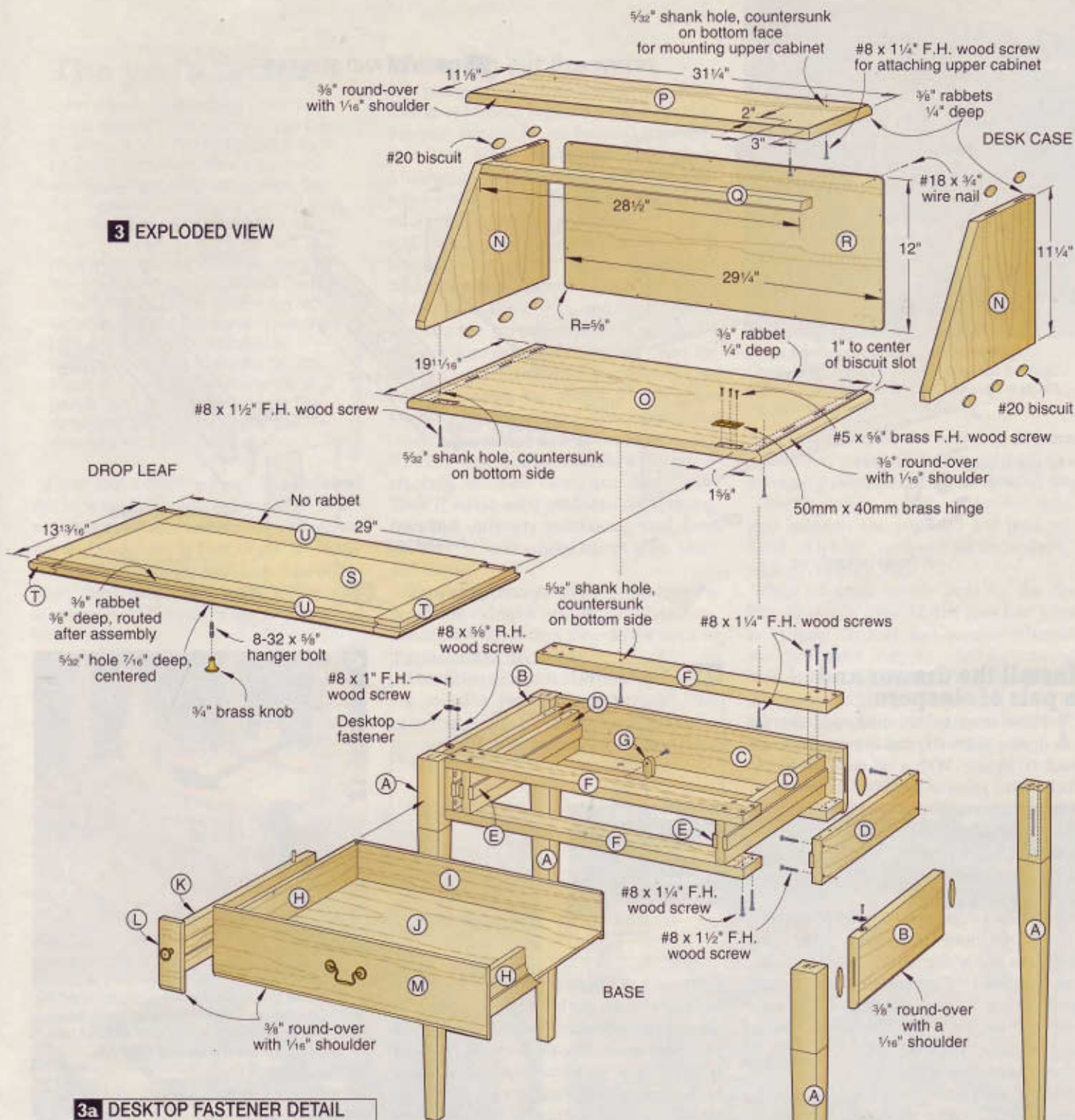

#### 3a DESKTOP FASTENER DETAIL

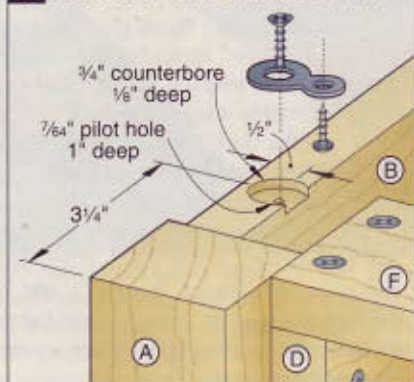

#### 3b DROP-LEAF HINGE

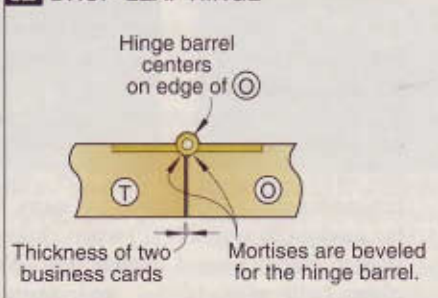



## 4 DRAWER AND SLEEPER

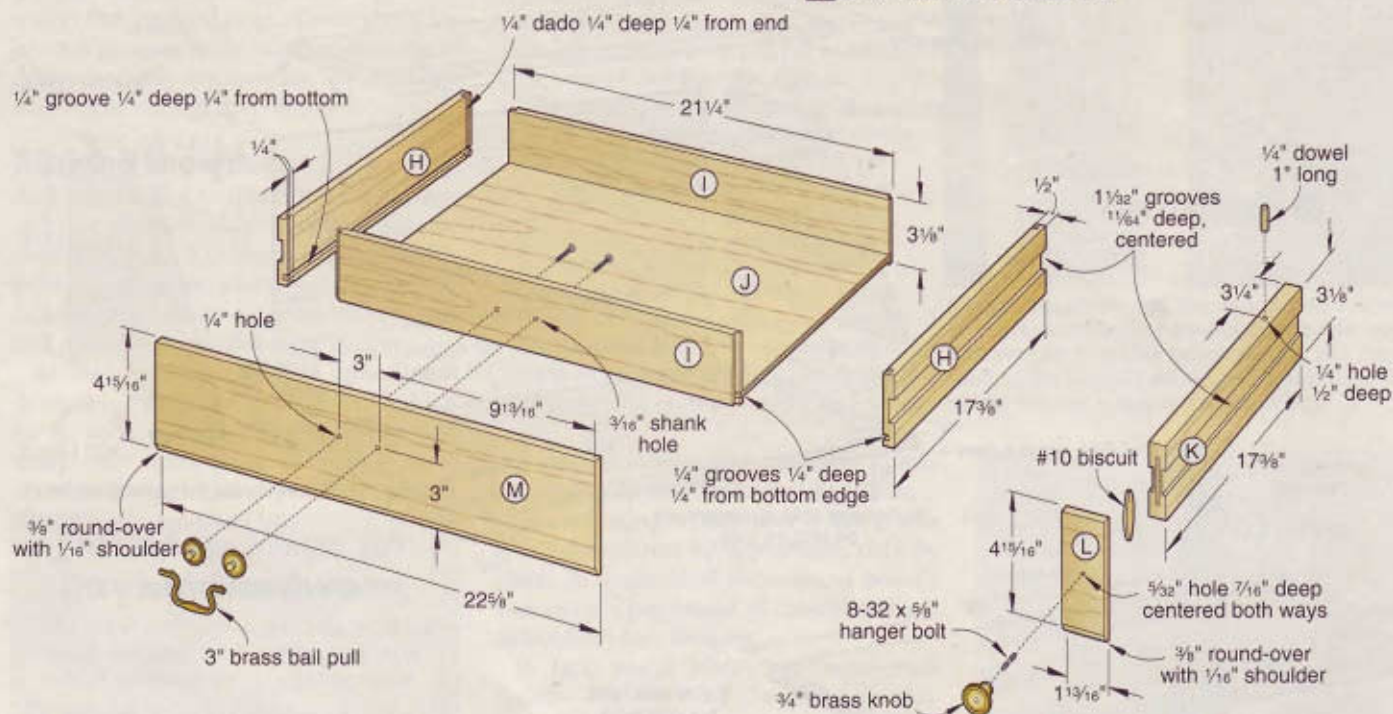

### Install the drawer and a pair of sleepers

**1** Plane stock to  $\frac{1}{2}$ " thick, and cut the drawer sides (H) and drawer front and back (I) to size. With a  $\frac{1}{4}$ " dado blade, cut lock rabbet joints in the parts' mating ends, where shown on **Drawings 4** and **4a**. Then cut the  $\frac{1}{4}$ " grooves  $\frac{1}{4}$ " deep for the drawer bottom. Cut the bottom (J) to size, and glue and clamp the drawer together, checking it for square.

**2** Cut the sleepers (K) to size, plus a couple of 6"-long scrap pieces of the same thickness and width. With a  $\frac{1}{4}$ " dado blade, cut centered  $1\frac{1}{32}$ " grooves  $\frac{1}{64}$ " deep in the scrap to test the grooves' fit on the runners (E), and the clearance between the scrap and the rails (F). Then cut the grooves in sleepers and the drawer sides (H). Drill  $\frac{1}{4}$ " holes  $\frac{1}{2}$ " deep in the sleepers for the sleeper-stop dowels, where shown on **Drawing 4**. Finally, adjust your biscuit joiner to center a #10 biscuit slot in the front ends of the sleepers (K), and cut the slots. Finish-sand the drawers and sleepers.

**3** Plane stock to  $\frac{1}{2}$ " thick, and cut a  $4\frac{1}{16} \times 27$ " blank for the sleeper faces (L) and the drawer face (M). Rout the profile shown on **Drawing 1a** along the blank's outside bottom edge.

**4** To cut the sleeper faces (L) and drawer face (M) to exact lengths, first slide a sleeper into place, and measure from the leg's inside face to the center of the sleep-

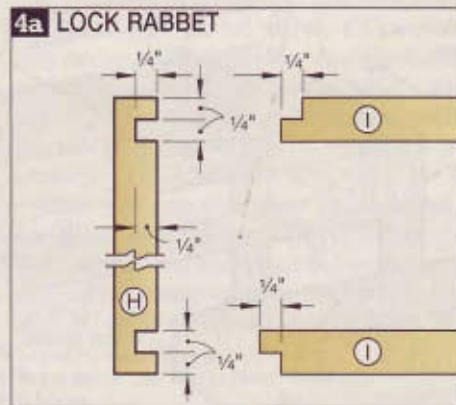

er's biscuit slot. Subtract  $\frac{1}{16}$ " from this measurement for the gap between the leg and the sleeper face. Position your biscuit joiner's fence this same distance from the center of its blade. Now cut biscuit slots into the back of the sleeper face blank at each end. Then cut a  $1\frac{1}{16}$ "-long sleeper face (L) from each end of the blank. Dry-fit the sleeper faces to the sleepers with biscuits, and measure the distance between the faces. Subtract  $\frac{1}{8}$ " from this measurement, and trim the remaining piece of the blank to this length for the drawer face (M).

**5** Place the base assembly upside down on your workbench. Slide the sleepers and drawer into place. Insert  $\frac{1}{8}$ " spacers behind them to hold their fronts away from the guides (D) and rails (F) when gluing the sleeper faces (L) and drawer face (M) in place. Now glue, biscuit, and clamp the

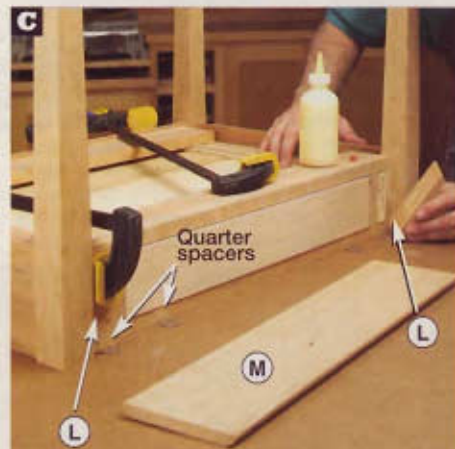

Using quarters to space the sleeper faces (L)  $\frac{1}{16}$ " from the workbench surface, glue, biscuit, and clamp them in place. A second pair of quarters awaits the drawer face (M).

sleeper faces to the sleepers, as shown in **Photo C**. Centering the drawer face between the sleeper faces, glue and clamp it in place. The  $\frac{1}{16}$ " space between the workbench surface and the sleeper and drawer faces provides clearance between these parts and the desk case's bottom (O) when it is installed later. For a source of  $\frac{1}{16}$ " spacers, see the **Shop Tip** on page 55.

**6** With the glue dry, remove the sleepers and drawer. Drill pilot holes for the knobs in the sleeper faces (L) and holes through the drawer face (M) and the drawer front (I) for the pull, where shown on **Drawing 4**.

## 5 DESK CASE SECTION

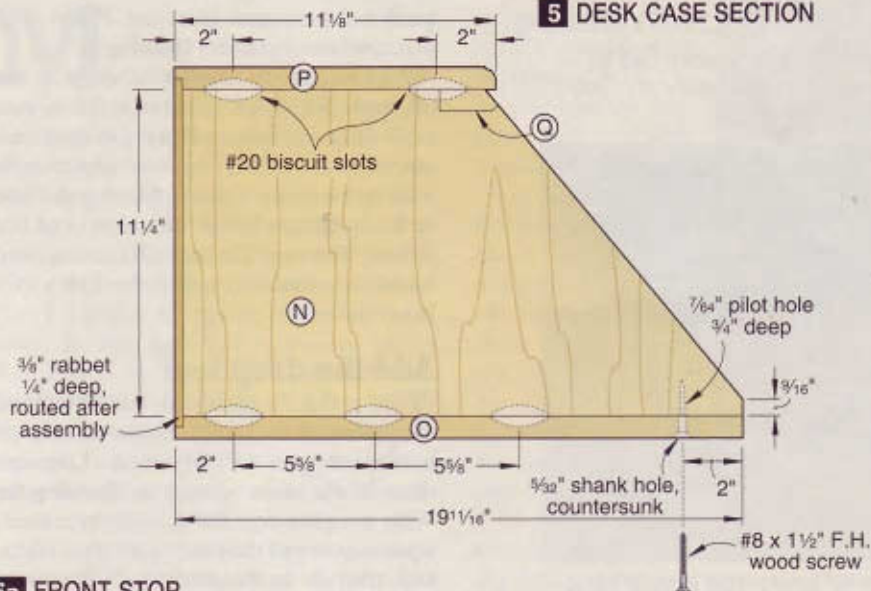

### 5a FRONT STOP

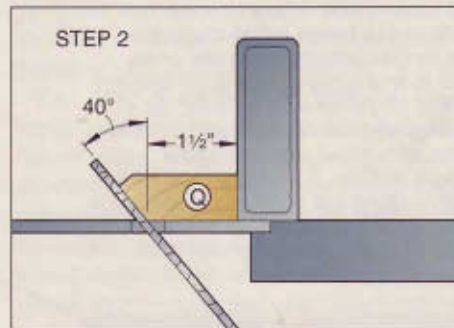
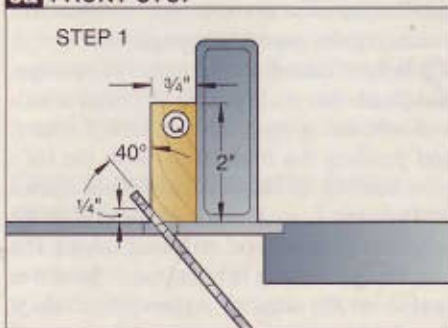

## Now build the desk case

**1** Edge-join stock, and cut the desk sides (N), desk bottom (O), and desk top (P) to size. Cut the desk sides to the shape shown on **Drawing 5**. Now, adjust your biscuit joiner to center a slot in the thickness of the sides, and cut #20 biscuit slots, where shown. Readjust your biscuit joiner, transfer the centerlines, and cut mating slots 1" in from the ends of the desk bottom and top, where shown on **Drawing 3**.

**2** Form the hinge mortises in the desk bottom (O), where shown on **Drawings 3** and **3b**. For a foolproof method for marking and cutting hinge mortises, see the sidebar on *page 56*. Because the desk bottom and the drop leaf fit closely together, slightly bevel the mortises' front edges with a chisel to provide clearance for the hinge barrels, where shown on **Drawing 3b**.

**3** Rout the profile shown on **Drawing 1a** along the ends and the front edge of the desk top (P), and along only the ends of the desk bottom (O), where shown on **Drawing 3**.

**4** For those building the upper cabinet, drill four mounting holes in the desk top (P), where shown on **Drawing 3**, and countersink them on the top's bottom face.



With the desk case clamped together, drill countersunk screw holes, centered in the sides (N), through the bottom (O) and into the sides. Then drive the screws.

**5** Finish-sand the parts, and then glue, biscuit, and clamp the desk sides, top, and bottom together with all the back edges flush. Drill countersunk screw holes through the desk bottom (O) and into the desk sides (N), where shown on **Drawing 5** and in **Photo D**. Check the desk case for square.

**6** Measure the distance between the sides (N), and cut the front stop (Q) to size. Then bevel-rip the the front edge following the two steps shown on **Drawing 5a**. Finish-

## SHOP TIP



### A two-bit solution to 1/16" spacing

When aligning drawer fronts and doors, 1/16" spacing is just about perfect. And any woodworker with a few quarters in his pocket has a handy supply of ready-made spacers. The details from **Photos C, F, and G**, below, show this government-issue tool hard at work...



● setting a 1/16" gap between the sleeper and drawer faces (L, M) and the case bottom (O),...



● positioning the door 1/16" above the upper case bottom (Z), and...

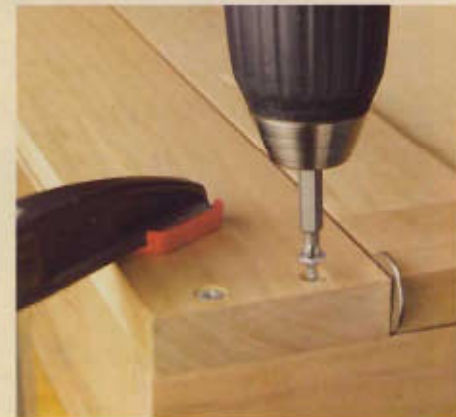

● leaving a 1/16" gap between the doors and the filler (HH).

## A quick guide to successful hinge mortising

Forming flat-bottomed hinge mortises that fit their hinges like a glove can be tricky, and when you're building a project as impressive as this secretary, you'll want to do it flawlessly. Here's how to get it right every time.

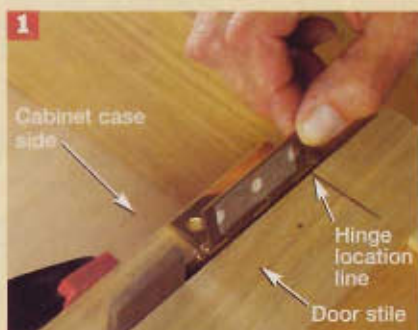

Inserting spacers the thickness of the hinge barrel between them, clamp the door to the case. Apply double-faced tape to the back of the hinges, and stick them in place.



Using a self-centering bit, drill pilot holes, and drive the screws.



Put a new blade in your utility knife, and scribe around the hinge leaves.



Remove the hinges, and mark the location of each hinge on its back. Because of slight variations in screw-hole patterns, the hinges must be remounted in their original locations.



Chuck a  $\frac{3}{8}$ " straight bit in your handheld router, and adjust its routing depth to the hinge leaf's thickness. (For hinges smaller than the ones used in this project, use a  $\frac{1}{4}$ " straight bit. For larger ones, use a  $\frac{1}{2}$ " bit.) Guiding your router by hand, rout to within about  $\frac{1}{16}$ " of the hinge's scribed outline. To support the router when routing the mortises in the edge of the case's side, clamp a scrap piece of 2x4 to the side with their edges flush.



Chisel the scribed outline to the depth of the routed portion of the mortise. Use your widest chisel.



Clean up the edges of the mortises.

sand the part, and glue and clamp it in place, where shown on **Drawing 5**.

**7** To rout the  $\frac{3}{8}$ " rabbet  $\frac{1}{4}$ " deep for the back (R), chuck a rabbeting bit in your table-mounted router. Place the desk-case assembly (N/O/P/Q) on the router table with its back edges down. Moving the case in a counterclockwise direction, rout the rabbet. Then cut the back (R) to size, and round its corners to match the case's rabbeted recess.

### Add the drop leaf

**1** To make the panel (S), cut  $10\frac{1}{2} \times 25\frac{3}{4}$ " pieces of  $\frac{1}{16}$ " curly maple veneer,  $\frac{1}{8}$ " hardboard, and  $\frac{1}{4}$ " plywood. Laminate them in the order shown on **Drawing 6a**. With the glue dry, finish-sand the veneer, square up two of the panel's adjacent edges, and trim it to finished size. For more detailed information on a simple method for veneering flat panels, see *page 38*.

**2** Before rabbeting the panel's top edge, chuck the stick profile bit from a rail-and-stile set in your table-mounted router, and position the fence flush with the bit's pilot bearing. (The stick-profile bit, shown on **Drawing 7**, routs the *edge* profile in the drop leaf's and doors' rails and stiles.) The exact height setting is not critical. Rout this profile on the edge of a piece of  $\frac{3}{4}$ "-thick scrap, and set it aside. Now, form a  $\frac{1}{4}$ " tongue on the panel's perimeter by routing a  $\frac{3}{8}$ " rabbet  $\frac{1}{8}$ " deep along the edges of the panel's hardboard face. Insert this tongue in the scrap's groove to test its fit.

*Note: Because the actual thickness of  $\frac{1}{4}$ " plywood is only about  $\frac{3}{16}$ ", the thickness of the panel (S), without the imitation leather, is about  $\frac{3}{8}$ ".*

**3** Cut a piece of cloth-backed black imitation leather to about  $10 \times 25\frac{1}{4}$ ", and adhere it to the panel's hardboard face. (We bought our imitation leather at a fabric store, and used 3M Super 77 Spray Adhesive, available at fabric stores, hardware stores, office supply stores, and home centers, to adhere it.) Install a new blade in your utility knife, and carefully trim the imitation leather to the rabbet's shoulder. To hide the imitation leather's white fabric backing, color its edge with a permanent black felt-tip marker.

**4** Cut the drop-leaf stiles (T) and drop-leaf rails (U) to size. For those building the upper cabinet, you'll want to avoid multiple setups of the rail-and-stile router bits, so also cut the door stiles (DD), door top rails (EE), and door bottom rails (FF) to size. Making test cuts in scrap the same thickness as the rails and stiles, and using the panel (S) as a gauge, adjust the height of

## 6 DROP LEAF

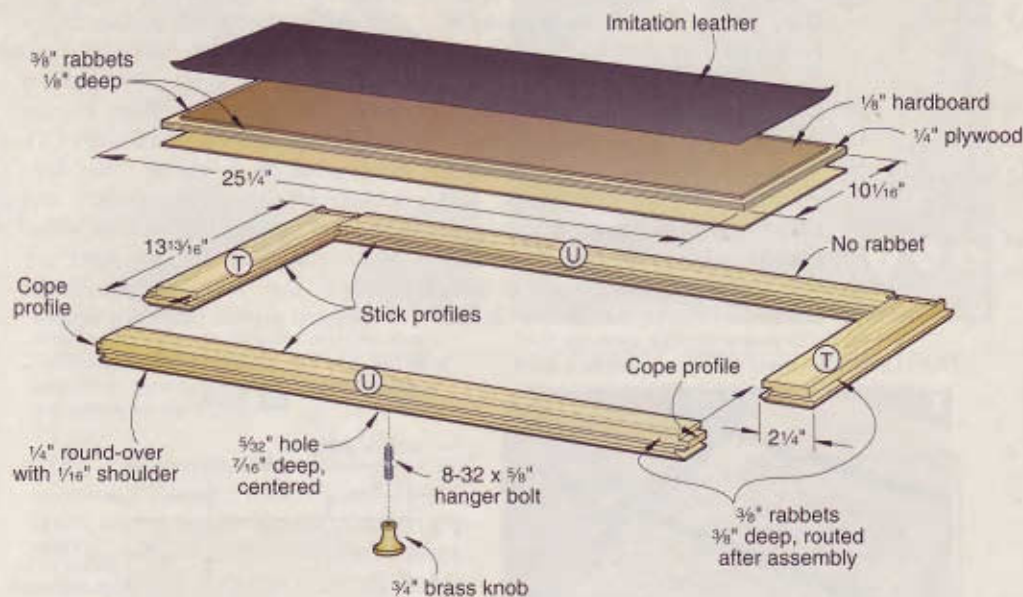

### 6a DROP LEAF SECTION

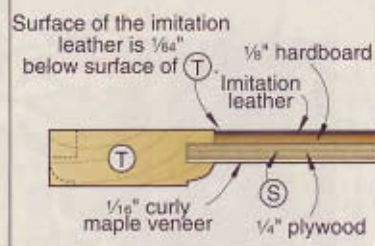

### 6b ROUTING THE 1/4" BEAD

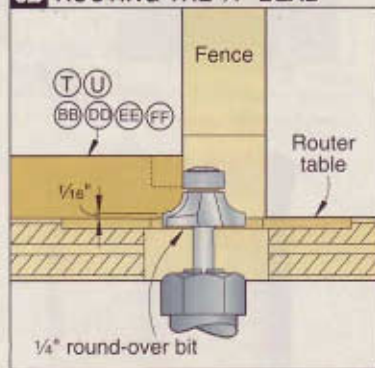

## 7 RAIL AND STILE SETUP

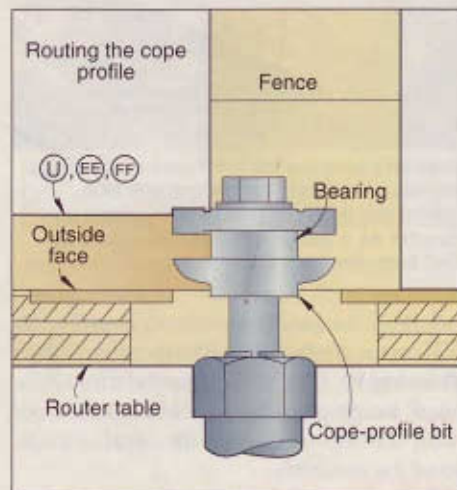
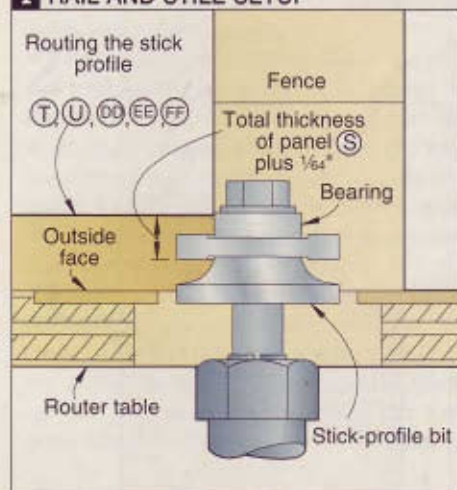

the stick profile bit so the surface of the imitation leather falls  $\frac{1}{64}$ " below the surface of the rails and stiles, where shown on **Drawing 6a**. When satisfied with the adjustment, rout the profile in a scrap block, and mark it as your set-up gauge.

**Note:** Do not rout the stick profile on the parts' edges yet. If the stick profile is routed first, it cannot be adequately backed up when routing the cope profile. The unavoidable chipout from routing the cope profile across the rails' end grain will ruin the parts.

**5** Install the cope profile bit in the table-mounted router, using the set-up gauge to adjust its height. (The cope bit routs the end profile in the rails of a frame-and-panel assembly.) Position the fence flush with the bit's pilot bearing, and parallel to the miter-

gauge slot. To back the cuts, attach an auxiliary extension to your miter gauge with its end just grazing the router-table fence. Now rout cope profiles in the ends of the drop-leaf rails (U) and door rails (EE) and (FF), where shown on **Drawing 6**.

**6** Install the stick-profile bit in the table-mounted router, setting its height to match the end of one of the rails just routed. Rout the inside edges of the drop-leaf stiles and rails (T, U) and the door stiles and rails (DD, EE, FF). Set the door stiles and rails aside.

**7** To protect the imitation leather, apply 1"-wide painter's safe-release masking tape around the perimeter of the panel (S). Then glue and clamp the drop leaf (S/T/U) together, checking it for square. Carefully sand the frame joints flush.



Inserting business card spacers, center the drop leaf on the desk case, and clamp it in place. Drill pilot holes into the drop leaf, and drive the hinge screws.

**8** Rout the profile shown on **Drawing 6b** along all the drop leaf's outside edges, where shown on **Drawing 6**. To eliminate chipout, back your cuts with a follower block where the bit exits the workpiece. Then install a rabbeting bit in the router. Making three progressively deeper cuts, rout  $\frac{3}{8}$ " rabbets  $\frac{1}{8}$ " deep along the drop leaf's front and side edges. Do not rabbet the edge where the hinges attach.

**9** To create the mortises for the drop leaf's hinges, first screw the hinges to the bottom (O) in their original mortises. Then surface-mount the hinges to the drop leaf, as shown in **Photo E**. Unscrew the hinges from the bottom, and remove the

## slant-front secretary

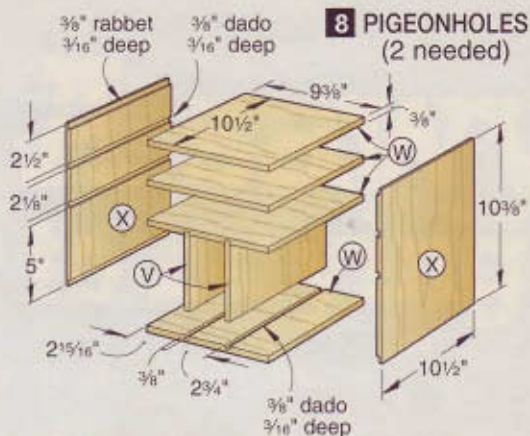

drop leaf. Now scribe around the hinges, and rout and chisel the mortises as before. Drill the knob-screw hole, where shown on **Drawing 6**. Finish-sand the drop leaf.

### Build the pigeonholes

**1** Edge-join and plane stock to  $\frac{3}{8}$ " thick, and cut the pigeonhole dividers (V); tops, bottoms, and shelves (W); and sides (X) to size. Finish-sand the parts.

**2** With a  $\frac{3}{8}$ " dado blade in your tablesaw, cut the dados in the

bottoms and two shelves (W), and the dados and rabbets in the sides (X), where shown on **Drawing 8**.

**3** Apply glue to the dados in the bottoms and shelves (W), and capture the dividers (V) between them. Then apply glue to the dados and rabbets in the sides (X), and glue and clamp the bottom/divider/shelf assemblies and the other shelves between the sides. Make sure that all the parts are flush at the front, and check the completed pigeon holes for square.



## Now the cabinet

**1** Edge-join stock for the sides (Y), top and bottom (Z), and shelf (AA), and cut the parts to size. Then cut the shelf trim (BB) to size. With a dado blade in your tablesaw, cut the dados and rabbets in the sides, where shown on **Drawing 9**, making sure you have mirror-image parts. Then cut the rabbets in the top and bottom (Z), where shown on **Drawing 10**.

**2** Drill shelf-pin holes in the sides (Y), where shown on **Drawing 9**. Then, for attaching the built-up crown later, drill the countersunk shank holes and the slots.

**3** Finish-sand the inside faces of the sides, top, and bottom. Glue and clamp the upper case together, checking it for square. Cut the back (CC) to size, and finish-sand it. Apply glue to the case's rear rabbet, and nail the back in place with #18 $\times\frac{3}{4}$ " wire nails.

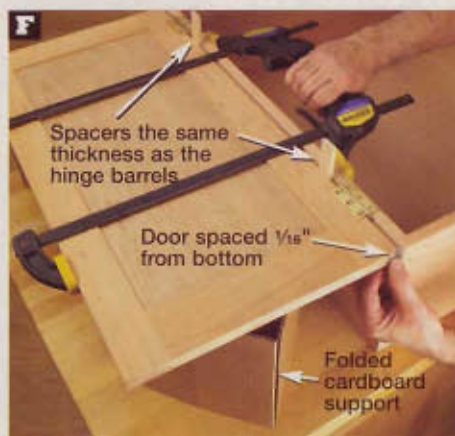

Inserting spacers the thickness of the hinge barrels between the door and the side, clamp the doors to the cabinet. Using a quarter as a gauge, position the doors up  $\frac{1}{16}$ " from the cabinet's bottom.

**4** Rout the profile shown on **Drawing 6b** on the shelf trim (BB), where shown on **Drawing 10**. Glue and clamp the trim to the shelf, keeping the top edge of the trim flush with the top surface of the shelf. Finish-sand the assembly.

**5** Cut two pieces of  $\frac{1}{16}$ " curly maple veneer and two pieces of  $\frac{1}{4}$ " plywood to 11 $\frac{3}{4}$  $\times$ 25" for the door panels (GG). Using the same technique as when laminating the drop-leaf panel (S), glue the veneer to the back faces of the pieces of plywood, where shown on **Drawing 10b**. Finish-sand both sides of the panels, square two adjacent edges, and trim them to finished size.

**6** Retrieve the door stiles and rails (DD, EE, FF), and check the panels' fit in their grooves. If needed, cut shallow  $\frac{3}{8}$ "-wide rabbets along the edges of the plywood. Now glue and clamp the doors together, making sure they are square and flat. Finish-sand the frames.

**7** Surface-mount the hinges to the doors, where shown on **Drawings 10 and 10b**. Then clamp the doors to the cabinet case, as shown in **Photo F**. Mounting the doors

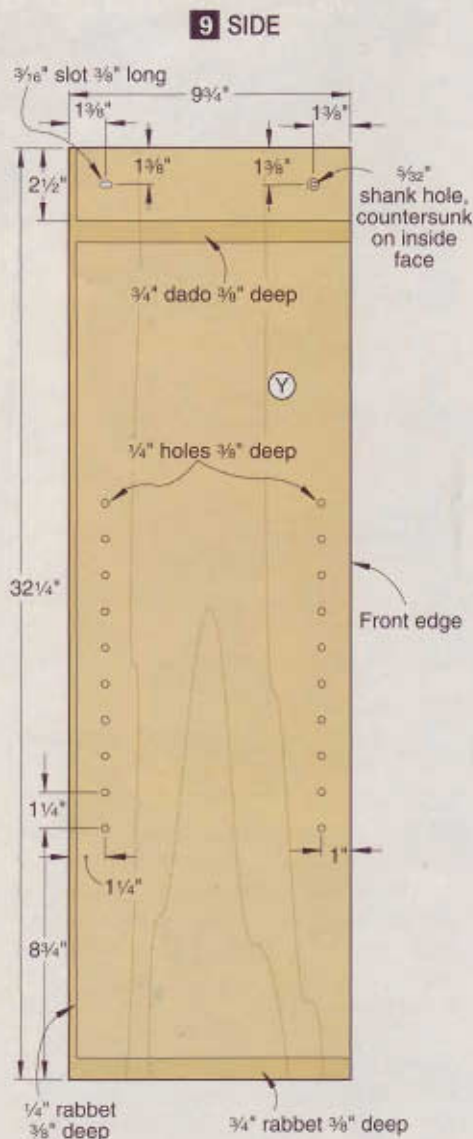

$\frac{1}{16}$ " above the bottom edge of the upper cabinet's bottom (Z) provides clearance between the doors and the desk case's top (P) when the upper cabinet is fastened to the desk case later. Scribe, rout, and chisel the hinge mortises, following the instruc-

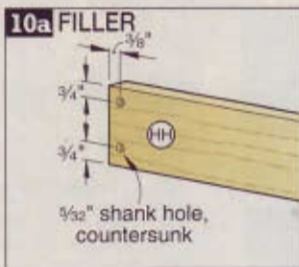

## 10 UPPER CABINET

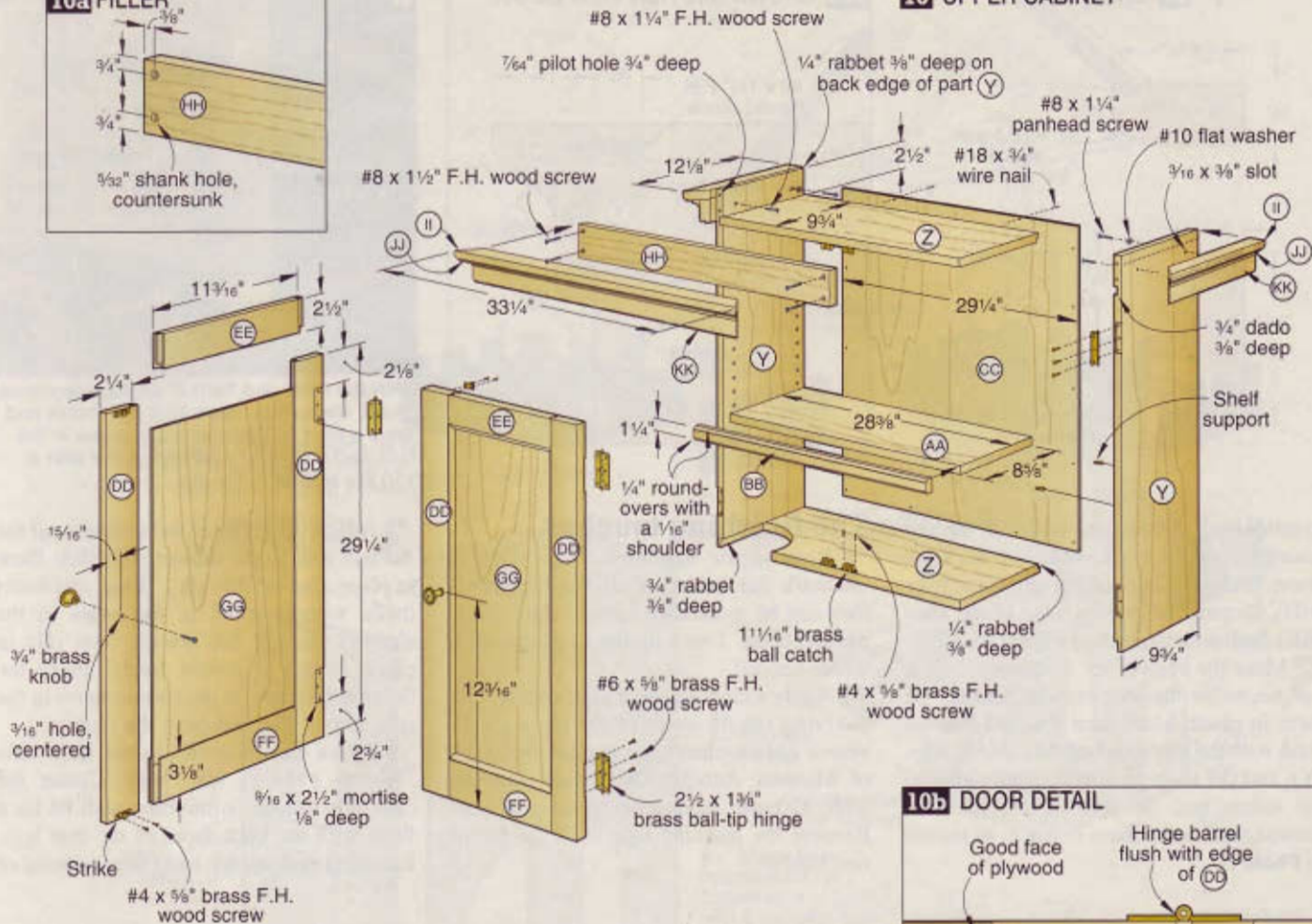

## 10b DOOR DETAIL

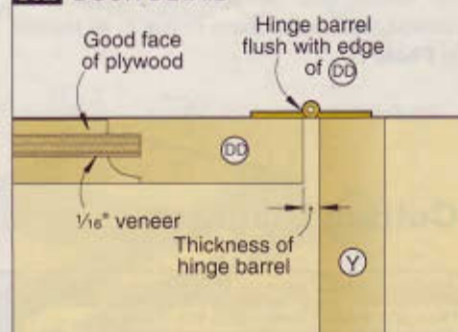

tions in the sidebar on *page 56*. Screw the hinges to the doors, and hang the doors on the cabinet.

**8** Drill holes for the knob screws, where shown on **Drawing 10**, and attach the knobs. Position the ball catches on the top and bottom (Z), centered in the width of the doors' stiles, drill pilot holes, and screw them in place. Snap the strikes into the catches, close each door in turn, and mark the locations of the strikes on the door stiles (DD). Drill pilot holes, and screw the strikes in place.

### Now crown the cabinet

**1** Cut the filler (HH) to size, and drill countersunk screw holes, where shown on **Drawing 10a**. Glue, clamp, and screw the filler in place, as shown in **Photo G**.

**2** Cut the cap (II) to size, and then plane a  $\frac{3}{4} \times 3 \times 72$ " piece of stock to  $\frac{5}{8}$ " thick for the cove (JJ) and base (KK). Rout a  $\frac{3}{8}$ " round-over with a  $\frac{1}{16}$ " shoulder, shown on **Drawing 11**, on the cap (II). Rout a  $\frac{3}{8}$ " cove on one edge of the  $\frac{5}{8}$ "-thick board, and rip off a  $\frac{3}{16}$ "-wide cove, as shown, for the cove (JJ). Rip the remaining  $\frac{5}{8}$ "-thick piece to  $2\frac{1}{8}$ " wide, and rout the  $\frac{1}{4}$ " round-over with a  $\frac{1}{8}$ " shoulder, as shown, for the base (KK).

**3** Glue and clamp the cap (II) and the base (KK) together, keeping the cap's back edge and the base's back face flush, where shown on **Drawing 11a**. Then glue and clamp the cove (JJ) into the corner formed by the cap and base.

**4** Measure the cabinet's outside width for the front crown, and mark this miter-heel-



Inserting quarters between the doors and the filler (HH), glue and clamp the filler in place. Drill pilot holes into the sides (Y), and drive the screws.

**11** CROWN

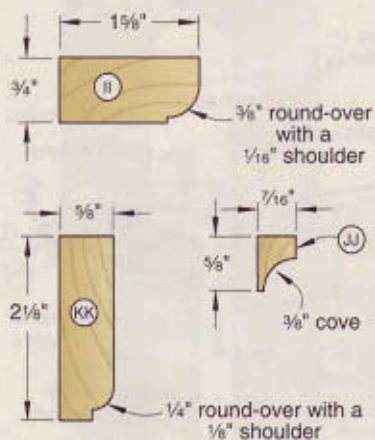

**11a** CROWN SECTION VIEW DETAIL

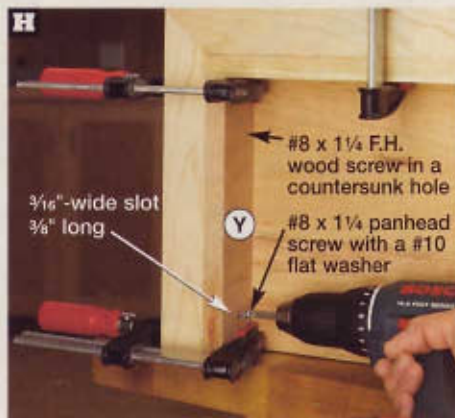
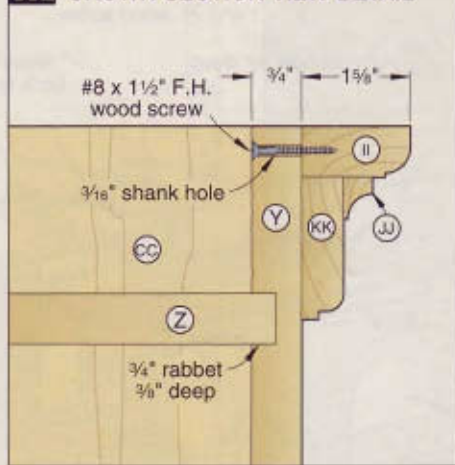

With the miter and front 2" of the side crown glued, clamp it in place. Drill pilot holes and drive a #8x1 1/4" flathead wood screw in the hole and a #8x1 1/4" panhead screw with a #10 flat washer in the slot.

to-miter-heel dimension, centered on the assembled crown blank. Miter-cut the front crown to length. Glue and clamp it to the filler (HH), keeping the bottom edge of the base (KK) flush with the bottom edge of the filler.

**5** Miter the ends of the remaining crown pieces for the side crowns, and dry-fit them in place. Mark their finished lengths flush with the rear edges of the cabinet sides (Y), and cut them to length. Apply glue to the miters and the front 2" of the side crowns, and fasten them in place, as shown in **Photo H**.

**The finishing touches**

**1** Remove the hardware. Remember to mark the backs of all the hinges so they can be reinstalled later in their original locations. Touch up the finish-sanding where needed.

**2** Apply a clear finish of your choice. (To bring out the color of the curly maple veneer and the cherry, we applied two coats of Minwax Antique Oil Finish, sanding with 320-grit sandpaper between coats.) Remove the masking tape from the imitation leather.

**3** Attach the knobs to the sleepers and the bail pull to the drawer, and slide them in place. Cut 1/4" dowels 1" long, and insert them, without glue, in the holes in the sleepers. Screw the drawer stop (G) in place, letting it swivel freely. Place the desktop fasteners in the counterbores in the side aprons (B), and drive the screws.

**4** Fasten the back (R) to the desk case with #18x3/4" wire nails. Center the case side-to-side on the base with its back flush with the back faces of the rear legs. Reaching underneath, mark the locations of

**Cutting Diagram**

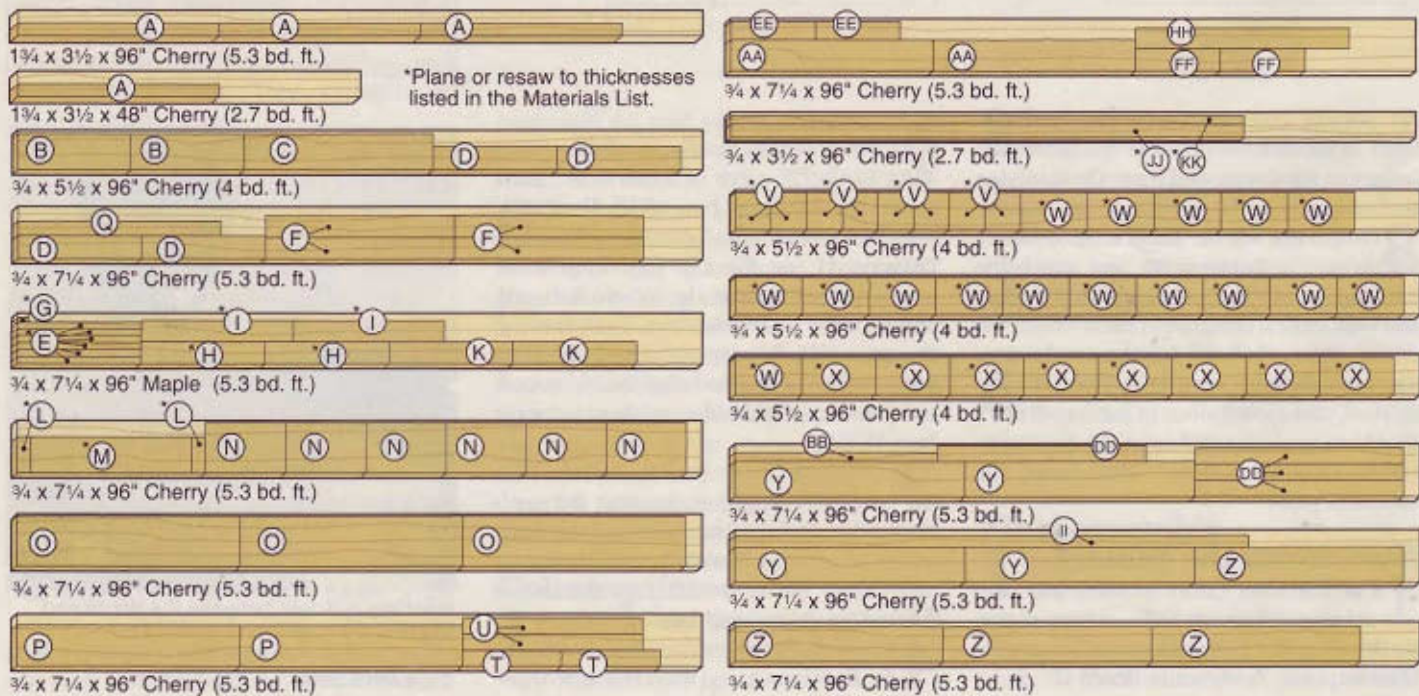

the mounting holes in the rear rail (F) and the desktop fasteners on the bottom surface of the bottom (O). Remove the desk case, and drill the pilot holes. Reposition the desk case on the base, and drive #8x1¼" flathead wood screws through the rear rail and #8x5/8" roundhead wood screws through the desktop fasteners.

**5** Screw the hinges to the drop-leaf. Then, supporting the drop-leaf on the sleepers, screw the hinges to the bottom (O). Screw the knob in place. Position the pigeonhole units in the desk case against the sides (N) and back (R).

**6** Screw the hinges to the doors, and then to the upper cabinet's sides (Y). Reinstall the knobs and catches. Carry the desk to its intended location, and place the upper cabinet on it, flush at the back, and centered side-to-side. Using the four holes in the top (P) as guides, mark pilot hole locations on the bottom of the upper cabinet's bottom (Z). Remove the upper cabinet, and drill ½"-deep pilot holes. Replace the upper cabinet, and drive the screws. Insert the shelf supports, and install the shelf. Now get that gold-nib fountain pen from your dresser drawer, and dash off a letter, putting your masterpiece to work. 📧

Written by **Jan Svec** with **Chuck Hedlund**  
Project design: **Jeff Mertz**  
Illustrations: **Roxanne LeMoine**

## Materials List

Base	FINISHED SIZE			Mtl. Qty.
	T	W	L	
A legs	1¾"	1¾"	28¼"	C 4
B side aprons	¾"	5"	15½"	C 2
C rear apron	¾"	5"	26½"	C 1
D guides	¾"	3¼"	17½"	C 4
E runners	¾"	1"	17½"	M 6
F rails	¾"	3"	26½"	C 4
G drawer stop	¾"	¾"	1½"	M 1
<b>Drawer and sleepers</b>				
H sides	½"	3½"	17½"	M 2
I front and back	½"	3½"	21¼"	M 2
J bottom	½"	16½"	21¼"	CP 1
K sleepers	¾"	3½"	17½"	M 2
L* sleeper faces	½"	4½"	17½"	C 2
M* drawer face	½"	4½"	22½"	C 1
<b>Desk case</b>				
N sides	¾"	19½"	11½"	EC 2
O bottom	¾"	19½"	31¼"	EC 1
P top	¾"	11½"	31¼"	EC 1
Q front stop	¾"	2"	28½"	C 1
R back	¾"	12"	29¼"	CP 1
S* drop-leaf panel	7/8"	10½"	25¼"	LVP/PHI 1
T drop-leaf stiles	¾"	2¼"	13½"	C 2
U drop-leaf rails	¾"	2¼"	25¼"	C 2
<b>Pigeonhole units</b>				
V dividers	¾"	10½"	5"	EC 4
W tops, bottoms, and shelves	¾"	10½"	9¾"	EC 8
X sides	¾"	10½"	10½"	EC 4

Upper cabinet	FINISHED SIZE			Mtl. Qty.
	T	W	L	
Y sides	¾"	9¾"	32¼"	EC 2
Z top and bottom	¾"	9¾"	29¼"	EC 2
AA shelf	¾"	8¾"	28½"	EC 1
BB shelf trim	¾"	1¼"	28½"	C 1
CC back	¾"	29¼"	29"	CP 1
DD door stiles	¾"	2¼"	29¼"	C 4
EE door top rails	¾"	2½"	11½"	C 2
FF door bottom rails	¾"	3½"	11½"	C 2
GG* door panels	½"	11½"	24½"	LVP 2
HH filler	¾"	2¼"	30"	C 1
<b>Crown</b>				
II cap	¾"	1¾"	72"	C 1
JJ* cove	¾"	7/8"	72"	C 1
KK* base	¾"	2¼"	72"	C 1

\*Parts initially cut oversize. See the instructions.

**Materials key:** C—cherry; M—maple; CP—cherry plywood; EC—edge-joined cherry; LVP/PHI—laminated ½" curly maple veneer, ¼" plywood, ½" hardboard, and cloth-backed imitation leather; LVP—laminated ½" curly maple veneer and ¼" cherry plywood.

### Supplies

**Desk:** #8x¾" roundhead wood screws; #8x1", #8x1¼", and #8x1½" flathead wood screws; #10 and #20 biscuits; #18x¾" wire nails; desktop fasteners (2); ¼" birch dowel; double-faced tape; 10x25¼" cloth-backed black imitation leather; spray adhesive; black felt-tip marker.

**Upper cabinet:** Add #8x1¼" panhead screws, #10 flat washers.

### Blades and bits

**Desk:** Stack dado set; ¼" round-over, ¾" round-over, ¾" straight, and ¾" rabbeting router bits; ¼" Forstner bit.

**Upper cabinet:** Add ¾" cove router bit.

### Buying Guide

**Desk hardware.** ¾" brass knobs with mounting screws no. 01G10.06, \$3.80 (3); #8-32x¾" hanger bolts no. 00N32.05, \$5.50 for a package of 10 (1 package); 3" brass ball pull with mounting screws no. 01G01.01, \$9.30; 50mmx40mm brass hinges no. 01D50.40, \$12.10 pr. (1 pair); #5x¾" brass flathead wood screws no. 91Z05.04X, \$6.60 for a package of 10 (2 packages). Call Lee Valley, 800/871-8158, or go to [www.leevalley.com](http://www.leevalley.com).

**Upper cabinet hardware.** Add two of the ¾" brass knobs listed above; 2½x1¾" brass ball-tip hinges no. 00D06.02, \$16.90 pr. (2 pairs); #6x¾" brass flathead wood screws no. 91Z06.04X, \$6.60 for a package of 10 (3 packages); 1½" brass ball catches no. 00W12.01, \$1.50 (4); #4x¾" brass flathead wood screws no. 91Z04.04X, \$5.55 for a package of 10 (2 packages); brass shelf supports no. 63Z06.04, \$4.50 for a package of 20 (1 package). Lee Valley, see above.

**Rail and stile bits.** Round-over profile rail and stile router bit set no. WL-1361, \$59 for the set of two bits. Woodline, Inc. Call 800/472-6950, or go to [www.woodbits.com](http://www.woodbits.com).

**Veneer.** ½"x12x36" curly maple veneer (3 pieces). Bob Morgan Woodworking Supplies, Inc. Call 502/225-5855, or go to [www.morganwood.com](http://www.morganwood.com) for a current price.

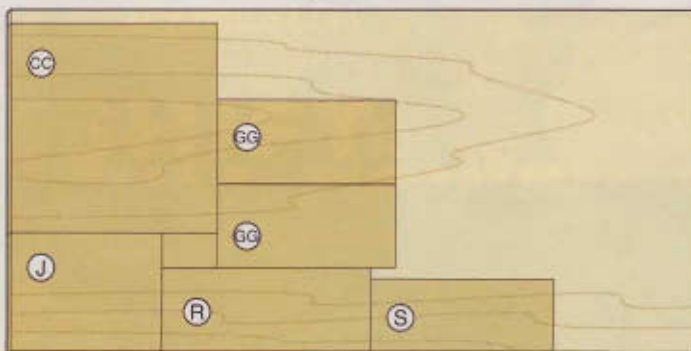

¼" x 48" x 96" Cherry plywood



½" x 12" x 36" Curly maple veneer



½" x 24" x 48" Hardboard

See more . . .

...furniture plans at

<http://woodstore.woodmall.com/furniture.html>







Turn the corner to  
**perfect miters**

**There's more than one way to cut and assemble  
air-tight miters; we'll show you how.**

**W**hen you make a picture frame or place solid-wood edging around a plywood panel, you want perfect, gap-free miters. Anything less detracts from the whole project.

In this article, we'll show you several ways to cut 45° angles, and help you achieve right-angle miter joints that practi-

cally disappear. And we'll do it through five common approaches, moving from low-tech, low-cost methods to those that rely on power tools.

No single approach satisfies everyone's needs. Some woodworkers don't have a tablesaw, some workpieces are too long to cut comfortably on a tablesaw, and some

jobs call for mitering away from the workshop. So we looked into a whole range of tools to serve every mitering purpose. We found that you can get respectable results from all of them, but that occasionally you'll need to do some fine-tuning. Don't worry, we'll show you three ways to handle that task by shaving or sanding.

## First, two simple approaches

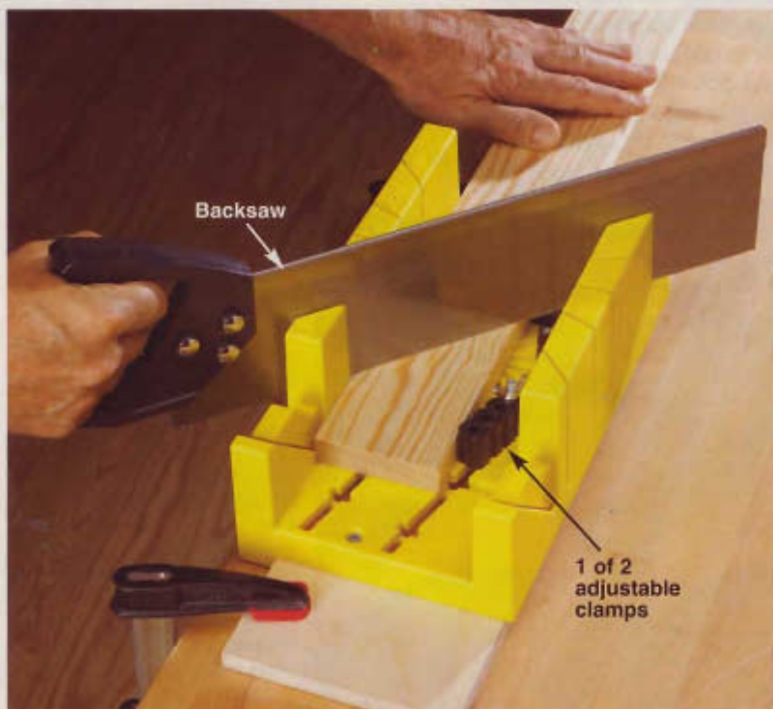

### Pre-formed miter box

#### Miter quality: Good to poor

For \$10 or so, you can buy a plastic miter box and a backsaw. The one we used gave acceptable results on narrow molding. However, with the provided saw, which has 11 teeth per inch (tpi), cutting a larger workpiece proved to be slow going. A slight amount of slop in the molded slots caused miter accuracy to vary from cut to cut. We also noticed that the cut surfaces were slightly rough.

#### PROS:

- ◆ Super safe—no chance of injury or kickback.
- ◆ Very inexpensive.
- ◆ Very portable.
- ◆ You can substitute a higher-quality backsaw.

#### CONS:

- ◆ Stock width limited by size of miter box.
- ◆ No provision for fine-tuning the 45° settings.
- ◆ Clamping workpiece is awkward.
- ◆ No provision for workpiece support or stops.
- ◆ You're restricted to short saw strokes; the blade easily can slip out of the guide slot.
- ◆ Time-consuming.

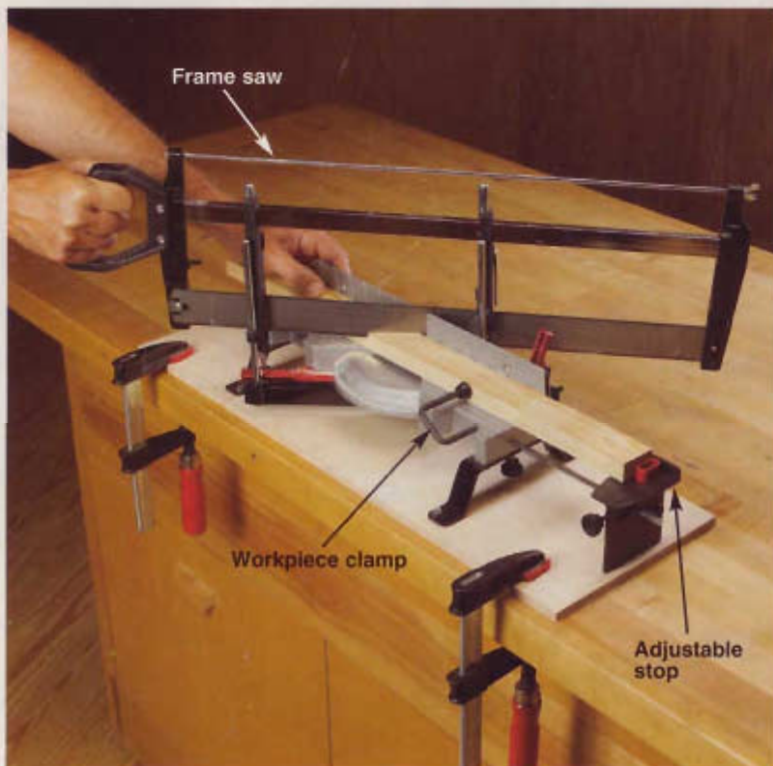

### Adjustable miter box

#### Miter quality: Good to fair

You can buy several models of miter saw boxes that allow the saw to pivot from one 45° detent setting to the other. They come with backsaws or frame saws. We tried out a frame-saw model priced at about \$85. It's easier to use than the plastic miter box, and the saw (24 tpi) cut slightly smoother. However, it provides no way to lock the saw at non-detent settings, and no way to fine-tune the detent settings. If you decide to buy a similar miter box, check for those options.

#### PROS:

- ◆ Safe to use.
- ◆ Reasonably priced.
- ◆ Portable.
- ◆ Detents at both 45° settings.
- ◆ Clamp and stop included, but both have limited range.

#### CONS:

- ◆ No provision for fine-tuning the 45° settings.
- ◆ Blade can flex enough to affect cut quality.
- ◆ Time-consuming.

# Now, let's add power

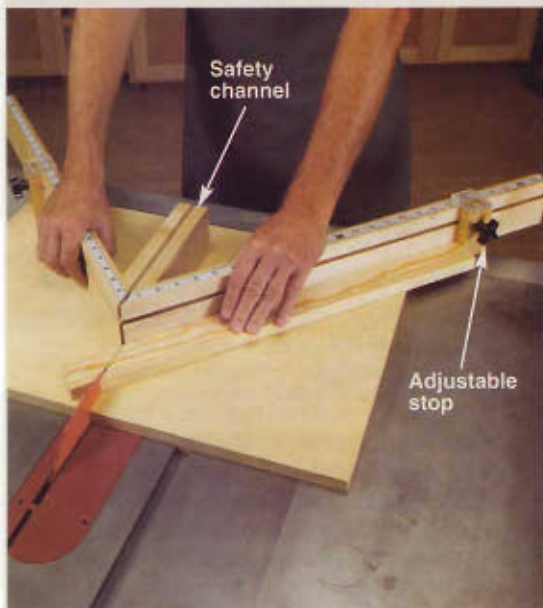

## Shopmade miter sled teamed with a table saw

### Miter quality: Excellent

This miter-cutting sled offers a dual-rail guidance system that rides in the miter-gauge slots of your table saw and smooth-acting stops that ride in tracks. It also features a safety channel down the middle to keep your hands away from the table saw blade.

To build the jig, see the drawing at bottom for the dimensions. We used Baltic birch for the base and hard maple for the other parts. Refer to the photos *below left* and *below* for building tips that guarantee an exact fit on your saw and a pair of perfectly aligned miter fences. Use an 80-tooth crosscut blade for smooth, ready-to-glue surfaces.

To make two workpieces of equal length, start by measuring and marking your first workpiece. Miter one end of the workpiece as

marked, using the appropriate fence, and then transfer the workpiece to the opposite fence. Line up the mark with the blade, slide the stop against the already mitered end, tighten it, and make the second cut. Leave the stop in place, and miter the second workpiece in the same sequence. Remember to stop your cut when the blade's highest point passes through the fence to avoid weakening the sled base.

### PROS:

- ◆ Fast cuts, even in thick, hard materials.
- ◆ Combination of table saw and jig provides accurate, consistent, and smooth cuts.
- ◆ Makes fine trimming cuts.
- ◆ Inexpensive to build.

### CONS:

- ◆ Hard to handle long workpieces.
- ◆ Dedicated to 45° cuts only.



To fit the guide bars to your miter sled, place two stacks of two pennies in each miter-gauge slot on your table saw to serve as shims. Place a bar in each slot, and apply double-faced tape to the top of each bar. Mark the center of the sled base, and locate the rip fence to place that mark over the blade. Press the base against the bars, remove the assembly from the saw, and permanently attach the bars with screws.

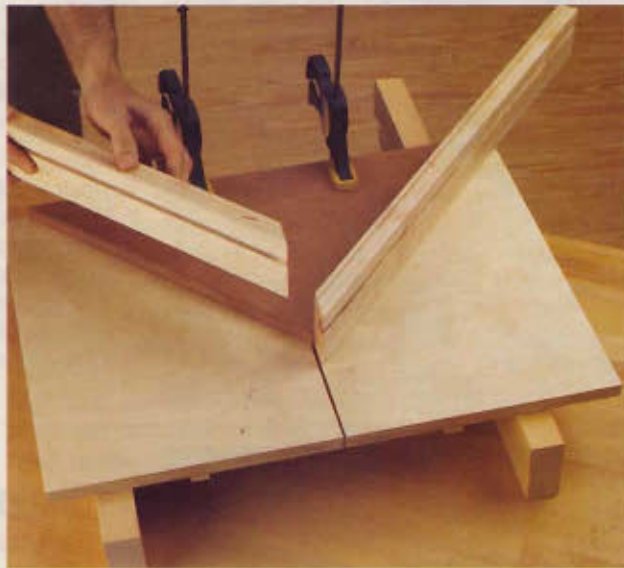

Place the sled on your table saw, and cut a kerf about 6" long to serve as a visual guide for placing the fences. Now, cut a right triangle measuring 21½" on its long edge to fit on the miter sled base as shown. Place it flush with the back edge of the sled, centered from side to side, and clamp it in position to serve as a guide for installing the miter fences. Apply double-faced tape to the bottom of each fence, and press them into place. Remove the clamps and triangle guide, and make test cuts in scrap to check your sled's accuracy. When it's dead-on, permanently attach the fences with screws, making sure that they sit perpendicular to the sled base.

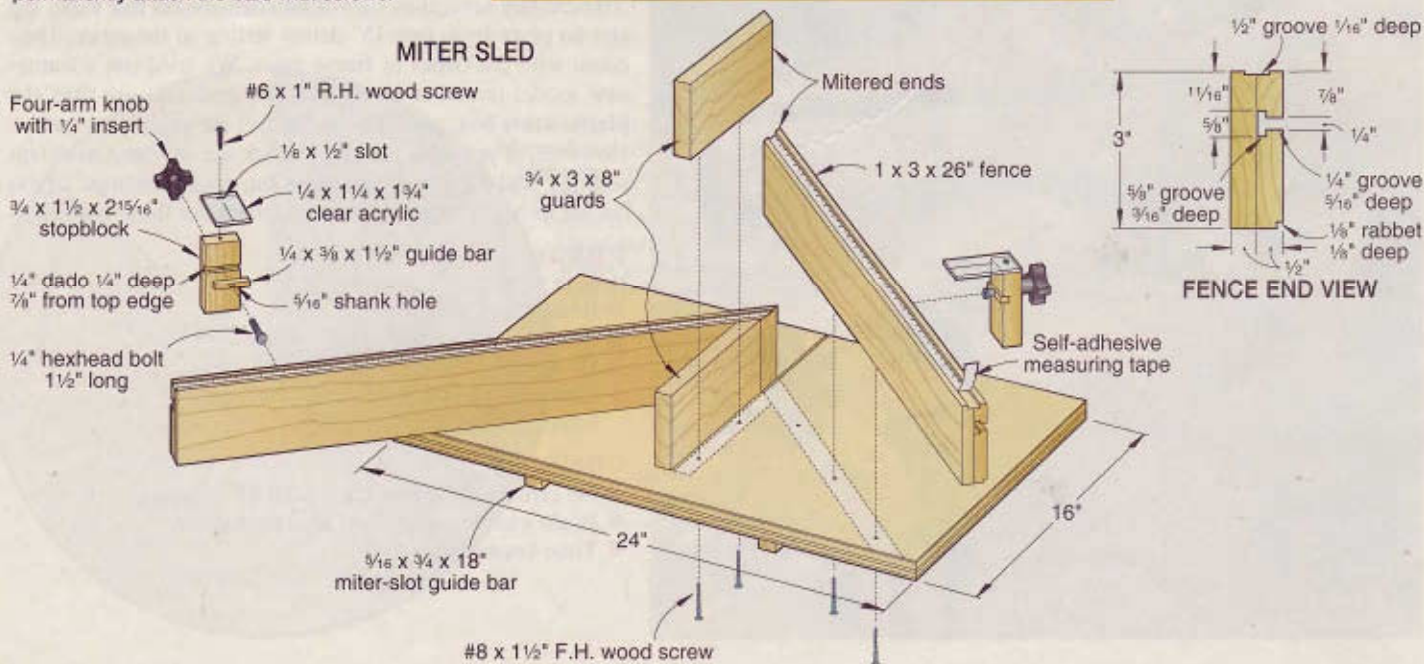

## Power mitersaws

### Miter quality: Excellent to good

Mitering long pieces is much more convenient on a power mitersaw, such as the one shown at left. As with the tablesaw, your first step should be to make sure the tool is aligned properly. (See issue 143, page 96, for tune-up tips.) Next, construct a permanent or temporary work support, making it as long as necessary on each side of the saw, and flush with the saw table. (See the "On-the-mark mitersaw station" article on page 14.) Install a sharp mitersaw crosscut blade, preferably one with 60 teeth and a negative hook angle. Then, with the workpiece held or clamped firmly in place, lower the blade through the workpiece slowly for a smooth cut.

#### PROS:

- ◆ Fast cuts, even in thick, hard materials.
- ◆ Adjustable to any angle, as well as having 45° detents.
- ◆ Good for long workpieces and repeatable cuts, if provided with suitable workstation.
- ◆ Removes tiny amounts of material if needed to fine-tune miters.
- ◆ Portable.

#### CONS:

- ◆ Can be awkward to cut long stock without dedicated support and fence system.
- ◆ Throws a lot of hard-to-collect sawdust into the air.
- ◆ More blade runout than a well-tuned tablesaw.



## Radial-arm saw

### Miter quality: Excellent to fair

If you own a radial-arm saw, you face the same issues as just discussed: Accurate set-up and adequate workpiece support. As with the power mitersaw, the radial-arm saw's main advantage over the tablesaw is in the handling of long workpieces. Place your workpiece flat on the table and butted against the fence, with the saw head pivoted to 45°.

#### PROS:

- ◆ Fast cuts, even in thick, hard materials.
- ◆ Handles long workpieces if surrounded by a flush support surface.
- ◆ Removes tiny amounts of material if needed to fine-tune miters.

#### CONS:

- ◆ Takes up a lot of room.
- ◆ Limited capacity when cutting 45° to the left because blade is located left of saw arm center.
- ◆ Many models have a tendency to move off the 45° setting, resulting in an imperfect cut.



## Our top recommendation for cutting 45° angles

You might need another tool now and then, but we suggest that you build the miter-cutting sled shown *opposite*, and rely on your tablesaw (tuned up as shown in issue 152, of course) for most of

your mitering work. This method offers accuracy, consistency, and control, and it's how we prefer to miter flat workpieces and molding in the *WOOD*® magazine shop.

## 3 ways to trim to a perfect fit

Despite your best efforts, it's likely that you'll need to trim one or more miters to make a perfectly fitted frame. Check each 45° cut as you work, as shown in the photo at *right*. When you fit all of the miters together, check each joint for inaccuracies like those shown on the drawings at *far right*. Problems result when one or more miters are slightly more or less than 45°, when a workpiece is slightly longer than its mate, or when the cut isn't at 90° to the workpiece face. Turn the page for three ways to trim a miter.

A well-made combination square, such as this Starrett tool, quickly shows you whether your miters are a true 45°. And yet, you still might have to trim those cuts slightly to produce a frame with four tight miter joints because the workpiece might vary slightly in length or your miter cuts might not be 90° to the workpiece face.



### TO FIX THESE GAPS

Increase the angle setting

Decrease the angle setting

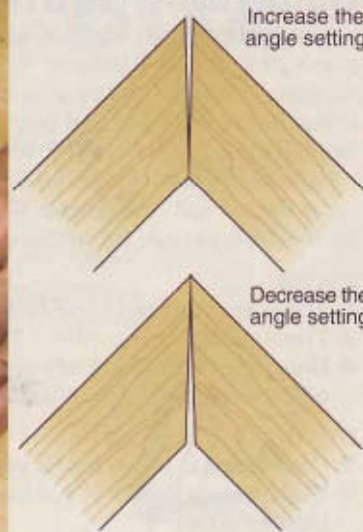

## Shooting board

You can trim a miter quickly and accurately with nothing more than a sharp hand plane and a simple jig, like the one shown in the drawing at *far right*. We built the jig out of medium-density fiberboard (MDF), making sure that all of the cut edges were perpendicular to the faces.

Clamp the jig in your vise, and then place the workpiece against the appropriate guide, allowing the mitered end to protrude just slightly beyond the plane guide. Set your plane for a light cut, place it on its side as shown in the photo at *right*, and make a pass across the miter.

As with any method for trimming miters, this one calls for frequent testing of the results. Depending on how much material you need to remove, test the fit after one or several passes.

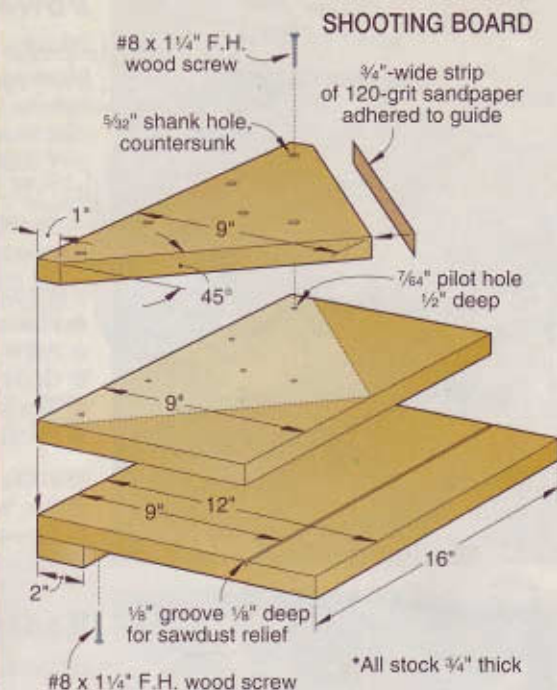
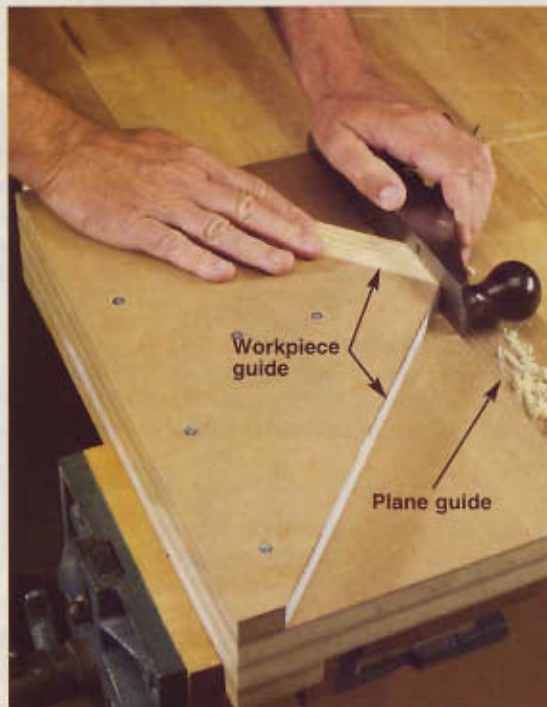

### PROS:

- ◆ Inexpensive.
- ◆ Easy to control the amount of material removed.

### CONS:

- ◆ Time-consuming.
- ◆ Jig requires precise construction for accurate mitering results.



## Disc sander

It's quicker and easier to use a disc sander, if you own one. Set your miter gauge to 45°, and place it in the horizontal slot of your disc sander table. Now, choose a piece of MDF or solid wood for an auxiliary miter-gauge fence, hold it against the miter gauge, and form a long miter at one end by pressing it into the spinning disc. Use screws to attach the auxiliary fence so that it lightly contacts the sanding disc.

Equip the disc sander with a fine-grit disc (180 grit would be a good choice) to produce a smooth gluing surface and avoid removing more material than you intended. Now, it's a simple matter of holding the workpiece against the auxiliary fence, and lightly pressing the miter against the spinning disc. As you work, move the miter gauge and workpiece back and forth slightly to achieve the smoothest possible surface.

### PROS:

- ◆ Trims quickly.
- ◆ Requires little physical effort.

### CONS:

- ◆ It's easy to remove more material than you intended.

## Guillotine-style trimmer

If you're into mitering big time, it might make sense to own a guillotine-style trimmer. A long lever, substantial gears, and large, sharp knives allow you to remove minuscule slices of material from any miter. Models range in price from about \$180 to \$300.

The lever works in either direction, allowing you to cut at the left end or right end. Cam-action inserts in the tool table provide for precision adjustment.

### PROS:

- ◆ Makes very fine and controlled cuts.
- ◆ Trims quickly.
- ◆ Once adjusted, you can rely on it for on-the-money cuts time after time.

### CONS:

- ◆ Cost is hard to justify unless you use it frequently.
- ◆ Blades pose a danger as you move and handle the tool. ⚠



See more . . .

...shop-tested techniques at

<http://woodstore.woodmall.com/dov.html>



Better Homes and Gardens®

# WOOD PATTERNS®

DECEMBER 2003

For your woodworking convenience

Issue 153

Dear Reader: As a service to you, we've included full-size patterns on this insert for irregular-shaped and intricate project parts. You can machine all other project parts using the Materials List and the drawings accompanying the project you're building.

**Children's Bookcases Page 84**  
**Picture Frame Page 112**

**BONUS PROJECT**  
**National Flag of Canada**  
(Instructions and pattern on  
this insert)

**Page 112**



**Page 84**



**On this insert**

© Copyright Meredith Corporation, 2003. All rights reserved. Printed in the U.S.A. Meredith Corp., the publisher of *WOOD Patterns*®, allows the purchaser of this pattern insert to photocopy these patterns solely for his/her own personal use. Any other reproduction of these patterns is strictly prohibited.

**NATIONAL FLAG OF CANADA  
FULL-SIZE PATTERN**

1R

Baltic birch backer held back  
 $\frac{1}{8}$ " from flag edge

2W

$\frac{1}{16}$ " round-overs on edges  
of individual pieces

$\frac{1}{16}$ " blade-star

5G

Baltic birch backer held back  
 $\frac{1}{8}$ " from flag edge

Baltic birch backer  
(dashed lines)

COLOR KEY: R-Red W-White DR-Dark Red G-Gray

# SPECIAL PULL-OUT POSTER AND PLAN

Made possible through support from **freud**



Build the cabinet, then add the poster for a winning workshop combination



## full-service router-bit cabinet

Tough, good looking, with plenty of room for your router bits and related accessories, this handy cabinet nicely complements the other wall-storage components of the Idea Shop 5 wall storage system.

**T**his accommodating shop cabinet can be hung in either of two ways. You can employ the beveled cleat approach used in Idea Shop 5 for maximum flexibility, or omit the cleat and screw it

to any shop wall. Case and door joinery consists of simple dadoes, rabbets, and grooves that you can cut on your tablesaw or table-mounted router. A handy drawer-lock router bit speeds the drawer construction.



## 1a CLEAT DETAIL

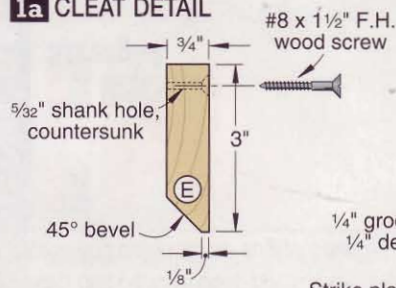

## 1 EXPLODED VIEW

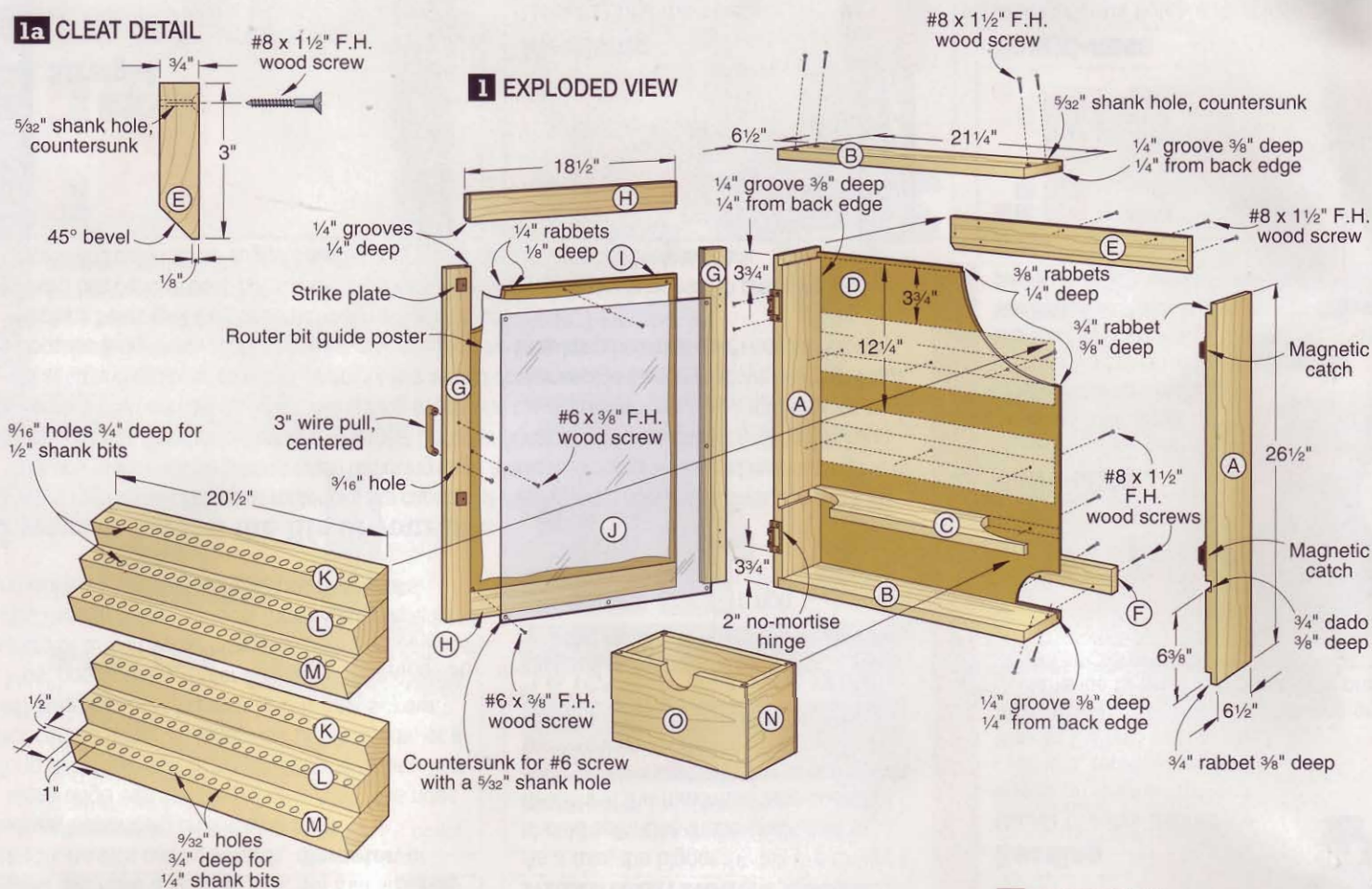

## Start with the case

**1** Cut the sides (A), top and bottom (B), and the shelf (C) to the sizes listed in the **Materials List**. Cut  $\frac{3}{4}$ " rabbets  $\frac{3}{8}$ " deep in the sides (A), where shown on **Drawing 1**. To prevent chipout, back your cuts with an auxiliary extension attached to your miter gauge. Then, using your rip fence as a stop, cut the  $\frac{3}{8}$ "-deep dados, where dimensioned. Cut  $\frac{1}{4}$ " grooves  $\frac{3}{8}$ " deep in the sides, top, and bottom for the back (D). When cutting the grooves in the sides, make sure you have mirror-image parts. Finish-sand the parts.

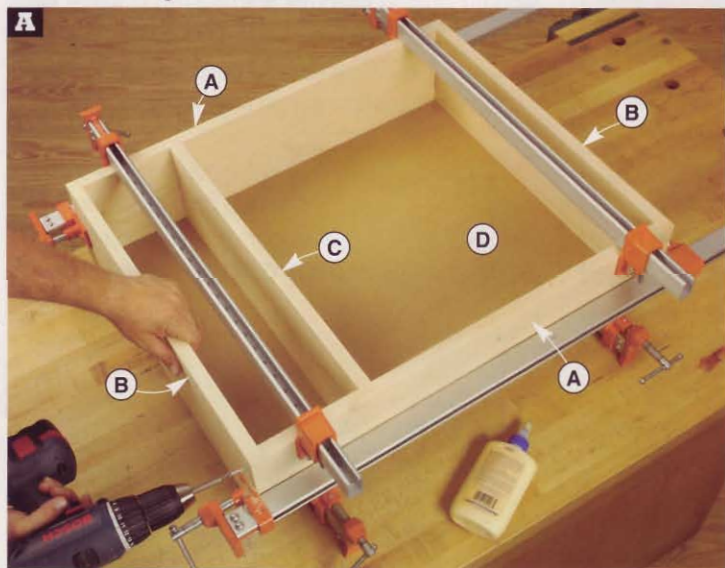

Glue and clamp the case together. Then drill angled countersunk screw holes through the top and bottom (B), and into the sides (A). Drive  $\#8 \times 1\frac{1}{2}$ " flathead wood screws.

## 2 DOOR DETAIL

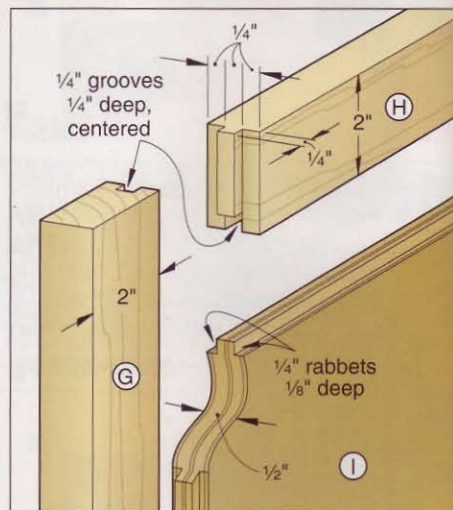

**2** From  $\frac{1}{2}$ " medium-density overlay plywood (MDO), cut the back (D) to size. Form a  $\frac{1}{4}$ " tongue around the back's perimeter by cutting  $\frac{3}{8}$ " rabbets  $\frac{1}{4}$ " deep along its back edges, where shown on **Drawing 1**. Finish-sand the back.

**3** Apply glue to the grooves, dados, and rabbets, and assemble the case, as shown in **Photo A**. Check to make sure the case is square and flat.

**4** For those adding this cabinet to the Idea Shop 5 wall-storage system, cut the cleat (E) and spacer (F) to size. Bevel the cleat, where shown on **Drawing 1a**. Clamp the cleat and spacer to the case, where shown on **Drawing 1**, drill countersunk screw holes, and screw the parts to the case.

## Build and hang the door

**1** Cut the stiles (G) and rails (H) to size. With a dado blade, cut centered  $\frac{1}{4}$ " grooves  $\frac{1}{4}$ " deep in the parts, where shown on **Drawing 2**. Then form the mating tenons on the ends of the rails.

**2** From  $\frac{1}{2}$ " MDO plywood, cut the panel (I) to size. Form a centered tongue, shown on **Drawing 2**, around the panel's perimeter by cutting  $\frac{1}{4}$ " rabbets  $\frac{1}{8}$ " deep along its front and back edges.

**3** Apply glue to the grooves, and clamp the door together. Check to make sure the door is square and flat.

**4** Lay the case on its back, and position the door on it. Mark hinge locations on the side (A) and the edge of the stile (G), where shown on **Drawing 1**, and as shown in **Photo B**. Remove the door, and transfer the location lines onto the door's back face and side's front edge. Position the hinges on the case, as shown in **Photo C**. Then position the hinges on the door, as shown in **Photo D**. Fasten the hinges to the door, as shown in **Photo E**.

**5** Attach the door to the case by driving screws through the countersunk holes in the hinges' large leaves. Fasten the magnetic catches to the opposite side (A), where shown on **Drawing 1**. Align the strike plates with the catches, and attach them to the door stile (G). Center the pull on the stile's length and width, and mark the screw locations. Drill the holes, and fasten the pull.

**6** Cut  $\frac{1}{8}$ " acrylic to size for the poster cover (J). Drill  $\frac{5}{32}$ " shank holes, where shown on **Drawing 1**, and countersink them for #6 flathead wood screws. Lay the poster cover on the inside face of the door panel (I), and using the holes in the cover as guides, drill pilot holes in the panel.

### Now for the bit holders

**1** Plane  $1\frac{3}{4}$ "-thick stock to  $1\frac{1}{2}$ " thick, and cut the top, middle, and bottom bit holders (K, L, M) to size. You also can laminate two layers of  $\frac{3}{4}$ "-thick stock for these parts. Based on your needs, drill  $\frac{5}{32}$ " (for  $\frac{1}{4}$ " bits) and/or  $\frac{9}{16}$ " (for  $\frac{1}{2}$ " bits) holes in the holders, where shown on **Drawings 1** and **3**. (For clean-edged holes, we used a  $\frac{5}{32}$ " brad-point bit and a  $\frac{9}{16}$ " Forstner bit.) To accommodate future changes in your bit-storage needs, see the **Shop Tip**, above right.

## SHOP TIP

### Make it easy to enlarge the holes in your bit holders

Many woodworkers start out with  $\frac{1}{4}$ "-shank router bits, and then, after upgrading their routers, gradually replace them with  $\frac{1}{2}$ "-shank bits. You can enlarge an existing hole in your bit holders with a regular twist drill, but it may not stay centered, and you risk chipout around the hole. A Forstner bit bores a nice clean hole, but in this case, there's nothing to center the bit. To make it easy to enlarge your  $\frac{5}{32}$ " holes in the future, first drill a  $\frac{9}{16}$ " counterbore  $\frac{1}{8}$ " deep with your Forstner bit, as shown above. Then drill the  $\frac{5}{32}$ " hole, centered in the counterbore. Should you need to enlarge the hole later, the counterbore centers your Forstner bit for chip-free drilling.

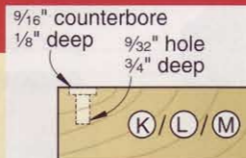

**2** Tilt your tablesaw blade to  $20^\circ$ , and bevel the bit holders' back edges, where shown on **Drawing 3**. Finish-sand the holders, and assemble them by first gluing and clamping the top and middle bit holders (K, L) together, and then with the glue dry, adding the bottom bit holders (M). Keep the holders' beveled faces flush, where shown.

### 3 BIT HOLDERS

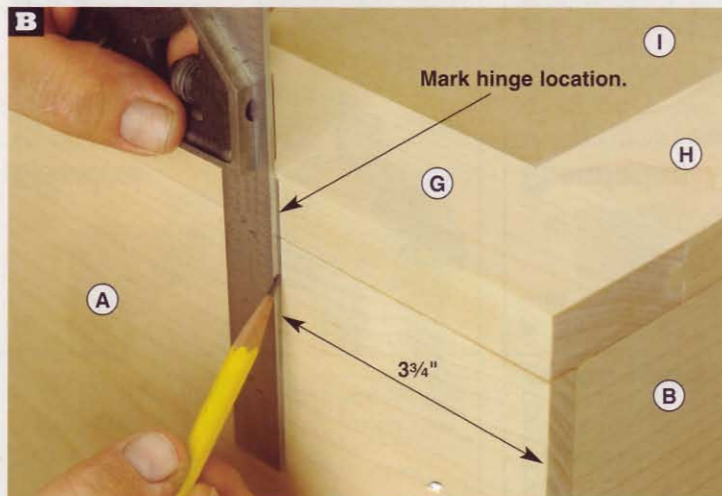
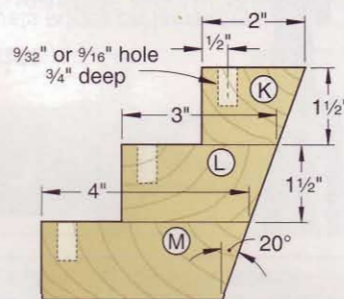

Position the door flush with the cabinet's top, bottom, and sides, and clamp it in place. Then mark the location of the top of the top hinge and the bottom of the bottom hinge.

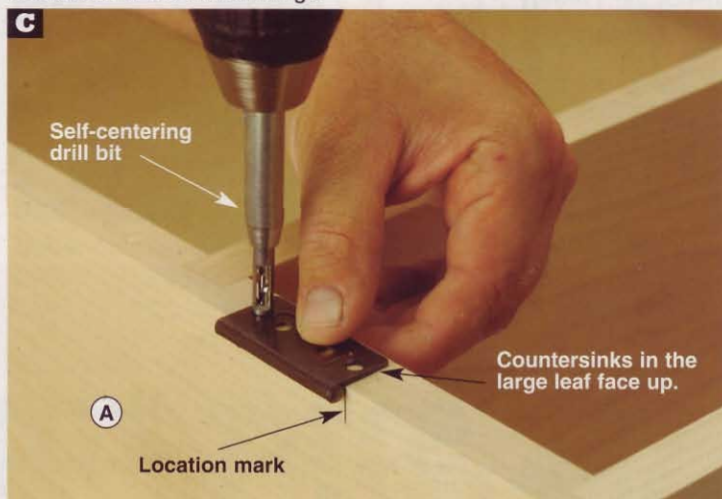

With its barrel tight against the side (A), align each hinge with its location mark. Using the holes in the hinge's large leaf as guides, drill screw pilot holes.

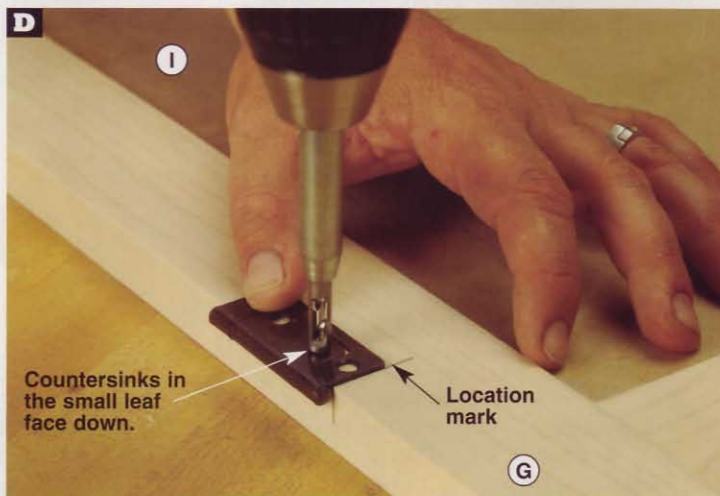

With its barrel tight against the door stile (G), align each hinge with its location mark. Using the holes in the hinge's small leaf as guides, drill screw pilot holes.



Turn each hinge over so its barrel and the countersunk holes in the small leaf face up. Fasten the hinge to the door stile using the screws supplied with the hinge.

## Add the drawers

**1** Plane stock to  $\frac{1}{2}$ " thick, and cut the drawer sides (N) and drawer fronts and backs (O) to size. Set aside scrap pieces to test the drawer-lock joint router bit's setup.

**2** Referring to **Drawing 4**, set up a drawer-lock router bit in your table-mounted router. Designating scrap pieces as front/back and side, make test cuts, adjusting the bit and fence as necessary to achieve a tight joint. Then cut the joints in the sides (N), holding their inside faces against the fence, and the fronts and backs (O), holding their inside faces against the tabletop.

**3** Mark the  $\frac{1}{4}$ "-radius cutouts in the drawer fronts (O), where shown on **Drawing 5**, and bandsaw and sand them to shape. Then, with a dado blade, cut the  $\frac{1}{4}$ " grooves  $\frac{1}{4}$ " deep in the sides, fronts, and backs for the bottoms (P). From  $\frac{1}{2}$ " MDO plywood, cut the bottoms to size. Then cut  $\frac{1}{4}$ " rabbets  $\frac{1}{4}$ " deep along their bottom edges, forming a  $\frac{1}{4}$ "-thick tongue around their perimeters. Finish-sand the parts, and glue and clamp the drawers together. Check to make sure they are square and flat.

## Apply the finish and assemble

**1** Remove all the hardware. Sand away the hinge layout lines, and resand the other parts where needed. Apply three coats of satin polyurethane, sanding between coats with 220-grit sandpaper.

**2** Apply double-faced tape to the backs of the bit holder assemblies, and adhere them to the back (D), where shown on **Drawing 1**. Drill countersunk screw holes through the back and into the holders, and drive the screws.

**3** Apply double-faced tape to the poster along its top back edge, and center it on the panel (I). Position the cover, and drive the screws so the heads are snug, not tight, in the countersinks. The combination of the oversized shank holes and snug screwheads prevents the acrylic from cracking around the screw holes.

**4** Rehang the door, and remount the pull, catches, and strikes. Slide the drawers into place. Hang the cabinet by its cleat (E), or by drilling countersunk holes through the back (D), and screwing it to the wall. Now arrange your bits in the holders, and start plotting to fill any empty spaces with those new bits you need. 🌱

Written by **Jan Svec**  
Project design: **Kevin Boyle**  
Illustrations: **Roxanne LeMoine**

## 5 DRAWER (2 required)

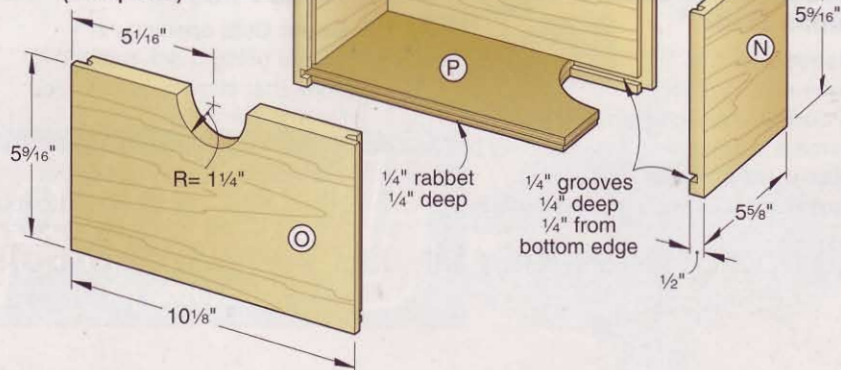

## Cutting Diagram

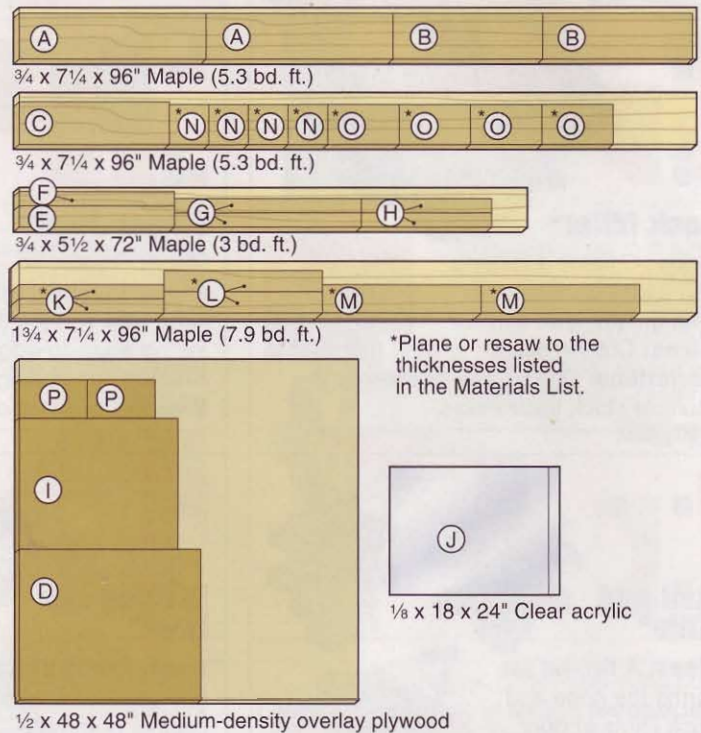

\*Plane or resaw to the thicknesses listed in the Materials List.

$\frac{1}{8}$  x 18 x 24" Clear acrylic

$\frac{1}{2}$  x 48 x 48" Medium-density overlay plywood

## 4 DRAWER-LOCK JOINT

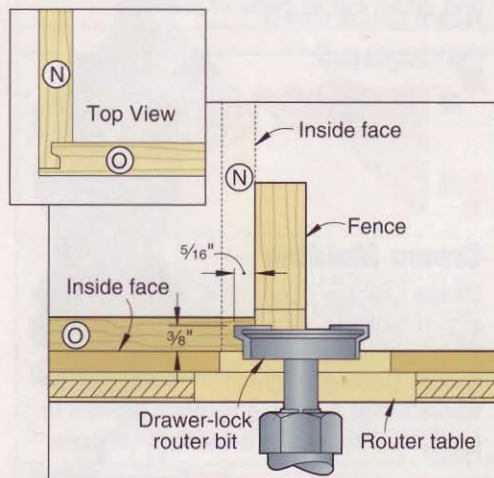

## Materials List

Case	FINISHED SIZE			Matl.	Qty.
	T	W	L		
A sides	$\frac{3}{4}$ "	6 $\frac{1}{2}$ "	26 $\frac{1}{2}$ "	M	2
B top and bottom	$\frac{3}{4}$ "	6 $\frac{1}{2}$ "	21 $\frac{1}{4}$ "	M	2
C shelf	$\frac{3}{4}$ "	6"	21 $\frac{1}{4}$ "	M	1
D back	$\frac{1}{2}$ "	21 $\frac{1}{4}$ "	25 $\frac{3}{4}$ "	MDO	1
E cleat	$\frac{3}{4}$ "	3"	22"	M	1
F spacer	$\frac{3}{4}$ "	2"	22"	M	1
<b>Door</b>					
G stiles	$\frac{3}{4}$ "	2"	26 $\frac{1}{2}$ "	M	2
H rails	$\frac{3}{4}$ "	2"	18 $\frac{1}{2}$ "	M	2
I panel	$\frac{1}{2}$ "	18 $\frac{1}{2}$ "	23"	MDO	1
J poster cover	$\frac{1}{8}$ "	18"	22 $\frac{1}{2}$ "	A	1
<b>Bit holders and drawers</b>					
K top bit holders	1 $\frac{1}{2}$ "	2"	20 $\frac{1}{2}$ "	M	2
L middle bit holders	1 $\frac{1}{2}$ "	3"	20 $\frac{1}{2}$ "	M	2
M bottom bit holders	1 $\frac{1}{2}$ "	4"	20 $\frac{1}{2}$ "	M	2
N drawer sides	$\frac{1}{2}$ "	5 $\frac{9}{16}$ "	5 $\frac{9}{16}$ "	M	4
O drawer fronts and backs	$\frac{1}{2}$ "	5 $\frac{9}{16}$ "	10 $\frac{1}{8}$ "	M	4
P drawer bottoms	$\frac{1}{2}$ "	5 $\frac{9}{16}$ "	9 $\frac{9}{16}$ "	MDO	2

**Materials key:** M—maple, MDO—medium-density overlay plywood, A—acrylic.

**Supplies:** #8 $\frac{1}{2}$ " flathead wood screws, #6 $\frac{3}{8}$ " flathead wood screws, double-faced tape.

**Blades and bits:** Stack dado set, drawer-lock router bit,  $\frac{3}{32}$ " brad-point drill bit,  $\frac{1}{16}$ " Forstner bit.

## Buying Guide

**Hardware.** 2" no-mortise hinges no. 28688, \$1.89/pair; 3" polished chrome wire pull no. 39834, \$1.29; magnetic catches no. 26559, \$1.49 (2). Call Rockler Woodworking and Hardware, 800/279-4441, or go to [www.rockler.com](http://www.rockler.com).

**Drawer-lock bit.** Freud no. 99-240  $\frac{1}{2}$ "-shank drawer-lock router bit. To locate a Freud dealer in your area, call 800/472-7307, or visit [www.freudtools.com](http://www.freudtools.com).

**Drill bits.**  $\frac{3}{32}$ " brad-point bit no. 120-275, \$4.49;  $\frac{1}{16}$ " Forstner bit no. 828-881, \$3.69. Woodworker's Supply. Call 800/645-9292 or go to [woodworker.com](http://woodworker.com).

# WOOD ® guide to rou

## What you need to know about bits

Router bits come in a wide variety of styles and sizes, but all fall into one or more of the four broad categories accompanying each bit on this chart:

- **Edge** bits cut profiles on the edges of boards, and are often guided by a pilot.
- **Grooving** bits cut anywhere on a board, when the router is guided by a template or straightedge.
- **Joinery** bits cut one or both parts of an interlocking joint.
- **Specialty** bits include all that don't neatly fit into the other categories.

All router bits share some common features, highlighted at *right*. For example, all bits have a 1/4"- or 1/2"-diameter **shank**. Large, heavy-duty bits come only with sturdier 1/2" shanks.

Most bits have a specific size. But that size may refer to the bit's cutting **length**, **diameter**, or **radius**, depending on the type of bit.

Many edge bits are guided by a pilot. This rides along the workpiece or an attached template. The pilot can be either an extension of the shank, or a **ball bearing** held in place with a **cap screw**.

Most good-quality router bits today have carbide cutters or are, in some instances, made of solid carbide. Though these bits cost more, they outperform and outlast inexpensive high-speed-steel bits.

## 5 ways to extend the life of your bits

- 1) While high-quality, balanced router bits are capable of making large cuts in one pass, we suggest that you make multiple passes when removing large amounts of material to avoid overloading the bit.
- 2) Use a bit with the shortest cutter and largest diameter possible to reduce chatter and heat buildup.
- 3) Remove pitch and debris, which dull cutting edges and cause overheating. Use a mild cleaner, such as soap and water, or soak bits overnight in a sealed container of kerosene (remove bearings first).
- 4) Because a dry or stuck bearing will overheat a bit in no time, keep bearings clean and lubricated. Replace bearings if they become frozen or hard to turn.
- 5) Sharp bits perform best, but sharpening them yourself can be tricky business. To preserve the profile and balance, we suggest having your router bits resharpened professionally.

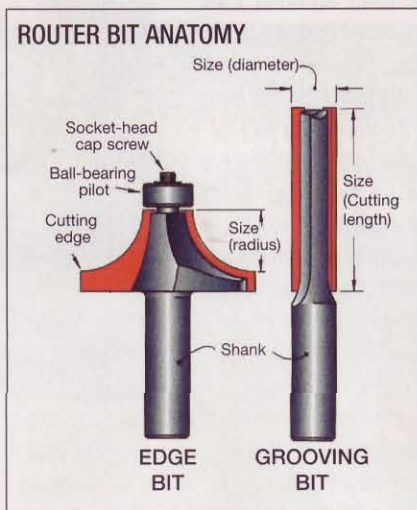

## Maximum Router Speeds:

As a rule, the bigger the bit, the slower it should spin. Use these guidelines to determine the maximum safe speed:

Bit Diameter	Max. Speed (rpm)
Up to 1"	Up to 24,000
1 to 1 1/4"	6,000 to 18,000
1 1/4 to 2 1/4"	12,000 to 16,000
2 1/4 to 3 1/2"	12,000

## EDGE BITS

### Round-over

**Uses:** Relieves sharp edges; creates profiles on tables, shelves, and other projects; makes dowels.  
**Sizes:** Cutting radius: 1/16-1 1/2"  
**Variations:** Cuts bullnose profiles, and creates beading using a smaller bearing.

### Beading

**Uses:** Creates decorative edges on drawer fronts, cabinets, molding, and trim.  
**Sizes:** Cutting radius: 1/16-1 1/2"  
**Variations:** Use with larger bearing or a guide fence to produce round-over profiles.

### Half-round

**Uses:** Rounds both corners of an edge in one pass to create profiles on stair treads, shelves, etc.  
**Sizes:** Cutting radius: 3/32-5/8"  
**Variations:** Also available with a guide bearing and in variable-radius styles.

## MOVING BITS



### Straight

**Uses:** Cuts dados, grooves, rabbets, box joints, inlays, mortises, and flush-trims when used with a guide bushing.

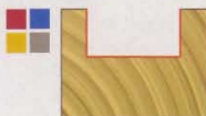

### Mortising

**Uses:** Forms mortises, dados, and rabbets when used with an edge guide.

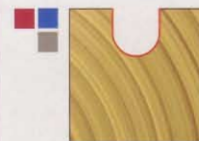

### Round-nose

**Uses:** Forms flutes and veins, makes signs, and cuts coves when used with an edge guide.

# ter bits



Sponsored by  
**freud**®

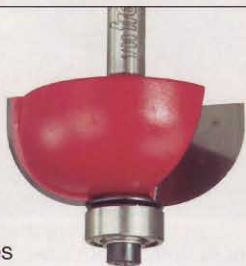
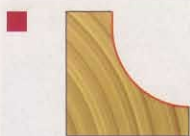

## Cove

**Uses:** Forms edges on drawer fronts, furniture, and molding.

**Sizes:** Cutting radius:  $\frac{1}{16}$ – $\frac{3}{4}$ "

**Variations:** Use along with a round-over bit to produce drop-leaf table edges.



## Rabbeting

**Uses:** Cuts square-cornered rabbets and lap joints.

**Sizes:** Cutting width:  $\frac{1}{8}$ – $\frac{1}{2}$ "

**Variations:** Some rabbeting bits include interchangeable bearings that allow one bit to produce rabbets of multiple widths.



## Ogee

**Uses:** Creates decorative edges on tabletops, plaques, and moldings.

**Sizes:** Cutting radius:  $\frac{5}{16}$ – $\frac{1}{2}$ "

**Variations:** Available in standard and "Roman" ogee styles.



## Classical

**Uses:** Creates decorative edges on furniture, shelving, and molding.

**Sizes:** Cutting width:  $\frac{3}{8}$ – $\frac{1}{2}$ "

**Variations:** Comes in both cove-and-bead and cove-and-round styles.



## Chamfering

**Uses:** Forms bevels on edges, creates staved joints, and produces edge miters.

**Sizes:** Cutting length:  $\frac{1}{2}$ – $1$ "

**Variations:** A 45° bevel is most common, but bevels range from 11¼° to 45°.

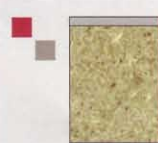

Plastic laminate  
Substrate



## Flush-trim

**Uses:** Trims surfaces flush with substrates, and cuts pieces to match patterns (pattern on bottom).

**Sizes:** Cutting diameter:  $\frac{1}{4}$ – $2$ "

**Variations:** Also can use in table-mounted router with pattern on top of workpiece.



## Fluting

**Uses:** Forms decorative beads on doors, frames, and molding.

**Sizes:** Bead diameter:  $\frac{1}{4}$ – $\frac{3}{4}$ "

**Variations:** Multi-flute bits cut several flute profiles in one pass.

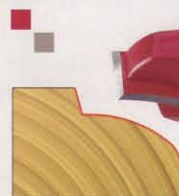

## Table Edge

**Uses:** Creates decorative edges on tabletops and shelves.

**Sizes:** Cutting width:  $\frac{7}{16}$ – $1\frac{1}{8}$ "

**Variations:** Also useful for producing top profiles on handrails.



Plastic laminate  
Substrate



## Bevel-trim

**Uses:** Bevels edges on laminates, banding, and veneers while it cuts the lower portion of the bevel flush with the substrate.

**Sizes:** Cutting radius:  $\frac{1}{8}$ – $\frac{3}{4}$ "

**Variations:** Available in solid carbide, shown, and in bearing-guided styles.



## V-groove

**Uses:** Creates decorative accents, makes signs and letters, and produces veining and chamfers.



## Spiral

**Uses:** Cuts dados, grooves, mortises, and rabbets when used with an edge guide.

**Sizes:** Cutting diameter:  $\frac{1}{8}$ – $\frac{1}{2}$ "

Up spiral  
Down



## Decorative Groove

**Uses:** Cuts dados and grooves with profiled edges in panels to create decorative accents.

**Sizes:** Cutting diameter:  $\frac{1}{2}$ – $2$ "

**Sizes:** Cutting diameter:  $\frac{1}{8}$ –2"  
**Variations:** Available in many lengths and diameters, including plywood-specific.



### Dovetail

**Uses:** Creates half-blind dovetail joints when used with a jig, plus sliding-dovetails. Produces through dovetails when used in conjunction with a straight bit.  
**Sizes:** Cutting diameter:  $\frac{1}{4}$ – $1\frac{3}{16}$ "  
**Variations:** Angle ranges from 7° to 14°.

**Sizes:** Cutting diameter:  $1\frac{1}{32}$ – $1\frac{1}{4}$ "  
**Variations:** Flush-trims when used with a guide bushing.



### Slot Cutting

**Uses:** Forms tongue-and-groove joints, plus slots for splines, T-molding or biscuits.  
**Sizes:** Slot depth:  $\frac{1}{4}$ – $\frac{1}{2}$ "  
**Variations:** Stackable sets use several cutters to produce slots of multiple widths.

**Sizes:** Cutting diameter:  $\frac{1}{8}$ –2"  
**Variations:** Available with top-mounted bearing for template routing.



### Reversible Glue Joint\*

**Uses:** Forms a locking, self-aligning joint for edge-glued panels.  
**Sizes:** Cutting height:  $\frac{1}{2}$ – $1\frac{1}{4}$ "  
**Variations:** One bit size handles multiple stock thicknesses.



### Drawer Lock\*

**Uses:** Forms a locking rabbet-style joint that increases gluing surface and locks drawer boxes together.  
**Sizes:** Cutting height:  $\frac{1}{2}$ "  
**Variations:** Available with  $\frac{1}{4}$ " or  $\frac{1}{2}$ " collet.



### Window Sash and Rail\*

**Uses:** Creates rails, sash bars, muntins, and frames for true divided-lite windows.  
**Sizes:** Cutting radius:  $\frac{1}{4}$ "  
**Variations:** Two bits work together to cut interlocking profiles.



### Biscuit Joining

**Uses:** Cuts a slot that matches the thickness of biscuits used in joinery.  
**Sizes:** Slot depth: 8.5–12.5mm  
**Variations:** Multiple bearings accommodate various biscuit sizes.



### Dish Carving

**Uses:** Forms trays and shallow bowls, makes signs, creates decorative edges when used with an edge guide.  
**Sizes:** Cutting diameter:  $\frac{7}{16}$ – $1\frac{1}{8}$ "  
**Variations:** Available with top-mounted bearing for template routing.



### Pattern

**Uses:** Recreates template shapes using a top-mounted bearing. Also works as a straight bit and flush-trimming bit.  
**Sizes:** Cutting diameter:  $\frac{5}{16}$ –2"  
**Variations:** Also can use in table-mounted router with pattern below workpiece.



### T-Slot

**Uses:** Cuts a wide, T-shaped channel to receive hanging hooks or backing plates for display/storage walls.  
**Sizes:** Cutting diameter:  $1\frac{1}{8}$ – $1\frac{3}{8}$ "  
**Variations:** Also useful for creating hold-down slots in jigs and shop fixtures.



### Raised Panel\*

**Uses:** Forms raised-panel profiles on cabinet and passage doors. Panel lays flat while cutting.  
**Sizes:** Cutting diameter:  $2\frac{3}{4}$ – $3\frac{1}{2}$ "  
**Variations:** Many styles available to produce panels with varying profiles.



### Vertical Raised Panel\*

**Uses:** Forms raised-panel profiles on cabinet and passage doors. Panel stands vertically while cutting.  
**Sizes:** Cutting diameter:  $1\frac{1}{2}$ "  
**Variations:** Many styles available to produce panels with varying profiles.



### Raised Panel with Backcutter\*

**Uses:** Forms a raised panel and relieves back face to form a tongue on  $\frac{3}{4}$ " stock.  
**Sizes:** Cutting diameter:  $3\frac{1}{2}$ "  
**Variations:** Several styles available; backcutters are replaceable.

\* Use with table-mounted router only.

\*\* Plunge router recommended.

**Sizes:** Cutting diameter: 1/4-2"  
**Variations:** Available with top-mounted bearing for template routing.

**Variations:** Up spiral clears chips efficiently for fast cutting. Down spiral leaves a top edge free from tear-out.

**Variations:** Available in several profiles, and with a top-mounted bearing for template routing.



**Lock Miter\***  
**Uses:** Creates a locking, self-aligning miter joint with greater glue surface.  
**Sizes:** Cutting height: 1/2-1 1/4"  
**Variations:** One bit size handles multiple stock thicknesses.



**Finger Joint\***  
**Uses:** Creates an interlocking joint with a large glue surface area for strong edge-to-edge or end-to-end joints.  
**Sizes:** Cutting height: 3/8-1 1/2"  
**Variations:** Variable-height style available.



**Adjustable Tongue and Groove\***  
**Uses:** Cuts tongue-and-groove joints for panels, and breadboard ends, plus stub tenon-and-mortise joints.  
**Sizes:** Tongue and groove widths: 7/32-3/8"  
**Variations:** Adjustable to cut multiple widths.



**Rail and Stile\***  
**Uses:** A two-bit set forms the cope and stick joints in door frames, and cuts the door-panel groove.  
**Sizes:** Cutting height: 1 1/16-7/8"  
**Variations:** One-piece bits also available.



**Divided Lite Door\***  
**Uses:** Forms the cope and bead profiles on cabinet door rails, stiles, and muntins.  
**Sizes:** Major radius: 1/8"  
**Variations:** Two-bit set plus a drill bit and chisel cut all parts of joinery.



**V-Panel**  
**Uses:** Cuts the tongue-and-groove joint and chamfers to create V-groove panels.  
**Sizes:** Cutting height: 1/2-1"  
**Variations:** Set of two bits includes spacers to cut multiple tongue thicknesses.



**Keyhole\*\***  
**Uses:** Bores a large-diameter hole for screw or nail head, and then cuts sideways to produce a T-shaped slot. Used for hanging plaques/frames.  
**Sizes:** Cutting diameter: 25/64"  
**Variations:** Also useful for creating hold-down slots in jigs and shop fixtures.



**Crown Molding**  
**Uses:** Creates decorative crown molding. Changing bit height alters profile.  
**Sizes:** Cutting height: 1 1/4"  
**Variations:** Available in many profiles to produce moldings in a variety of shapes.



**Face Molding**  
**Uses:** Creates decorative molding for furniture and cabinet trim.  
**Sizes:** Cutting height: 7/8-1 5/8"  
**Variations:** Several profiles available to produce trim in a variety of shapes.



**Multi-profile**  
**Uses:** Cuts many profiles by using only a portion of the bit or by making multiple passes.  
**Sizes:** Cutting height: 51/64-1 59/64"  
**Variations:** Available in several styles that allow production of many different profiles.



**Recoverable-bead Glass Door \***  
**Uses:** Cuts the cope and stick joints in door frames, and simultaneously forms a removable glass-retaining bead.  
**Sizes:** Major radius: 7/32-1 5/64"  
**Variations:** Several profiles available.



**Panel Pilot\*\***  
**Uses:** Cuts openings in panels using a drill-through point that eliminates the need for a starter hole.  
**Sizes:** Cutting radius: 1/8-3/4"  
**Variations:** Pilots at tip and shank allow use for template routing.

more information on choosing the appropriate router bit, visit [www.freudtools.com](http://www.freudtools.com)

Location of sawtooth hanger on back side

1/4" poplar flag (solid lines)

10"

6R

3R

t hole

4DR

See the reverse side of this insert for building and painting instructions.

5"

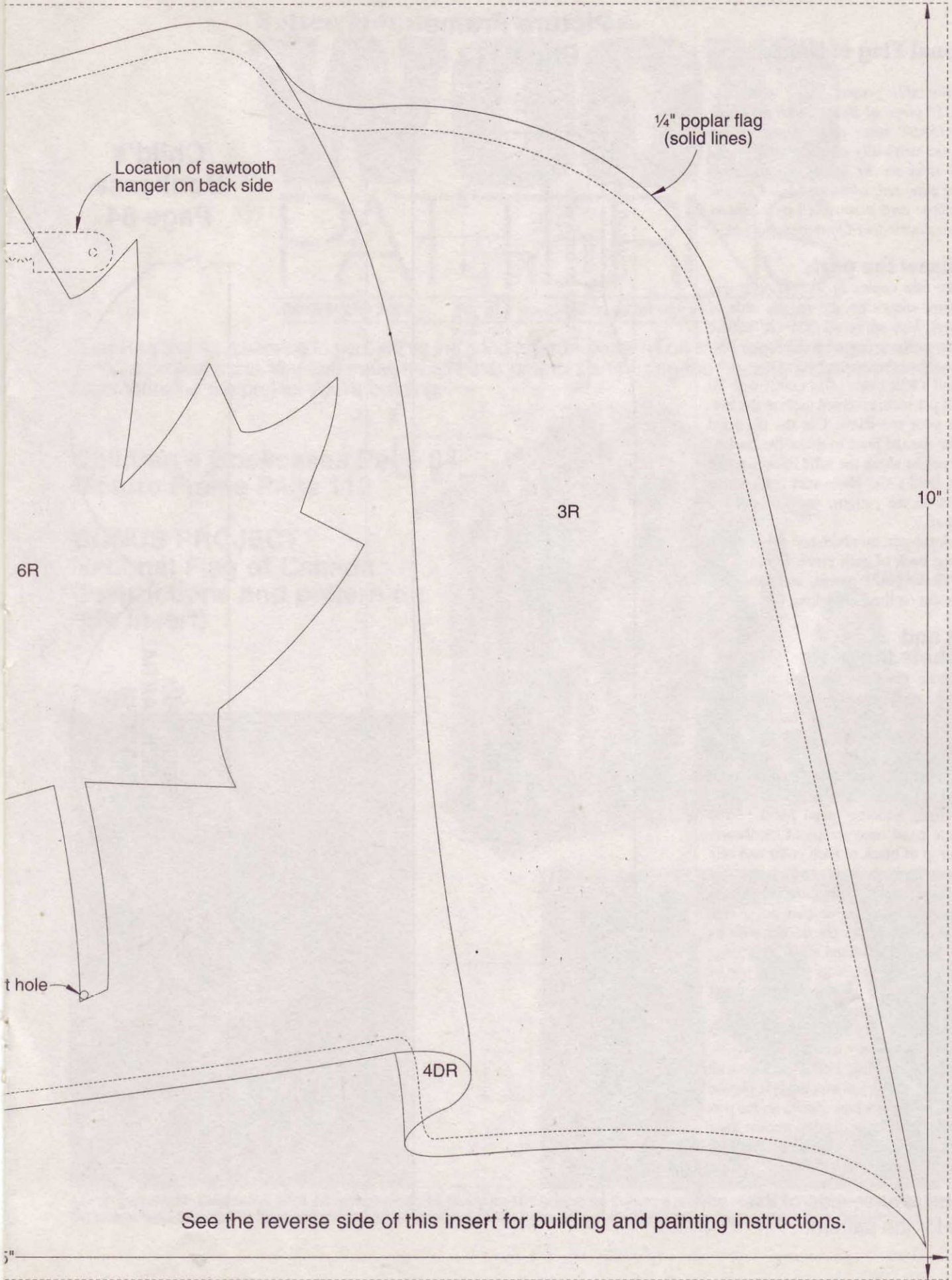



## National Flag of Canada

*Note: For this project you'll need one 1/8x10x15" piece of Baltic birch plywood; one 1/4x15x10" piece of solid poplar (the grain runs vertically on the flag to avoid a weak stem on the maple leaf); water-resistant glue; red, white, and black acrylic craft paints; and a sawtooth-style picture hanger or double-faced foam mounting tape.*

### Scrollsaw the parts

**1** Make two copies of the full-size flag pattern, shown on the reverse side of this insert. Use spray adhesive to adhere one copy to the piece of Baltic birch plywood and the other to the poplar.

**2** Install a #2R blade (.014x.032" with 20 teeth per inch, reversed teeth at the bottom) in your scrollsaw. Cut the plywood along the dashed lines to make the backer, and the poplar along the solid lines to make the flag. Drill a 1/16" blade-start hole, where indicated on the pattern, and saw out the maple leaf.

**3** Mark the part numbers and color letters on the back of each piece. Remove the pattern from all the pieces, and sand 1/16" round-overs on the front edges.

### Paint and assemble the parts

**1** Separate the parts into red and white groups, and paint the fronts and edges using a foam brush. Paint the back and edges of the backer white. To make a small amount of dark red for part no. 4DR (the "back" of the red stripe) and a small amount of gray for part no. 5G (the "back" of the white stripe), squeeze small pools of red and white paint onto scraps of cardboard. Add a drop of black to each color and mix it in. Paint the parts, fronts and edges.

**2** With the paint dry, organize the parts in numerical order. Glue part no. 1 (the left-hand red stripe) to the backer with its top, bottom, and left-hand edges overhanging the backer by 1/8". Now glue the rest of the parts in place. Use a water-resistant glue. (We used Titebond II.)

**3** With the glue dry, apply a couple coats of clear satin spray lacquer.

**4** Display your flag. For an indoor wall hanging, attach a sawtooth-style picture hanger to the back where shown on the pattern. For a front-door display, mount your flag with double-faced foam tape. (We used 3M Scotch mounting tape.)

See the reverse side of this insert for the pattern.

## Picture Frame Page 112



## Child's Bookcase Page 84



Corrections  
#153

slant-front secretary

2 GUIDES AND RAILS

P.52

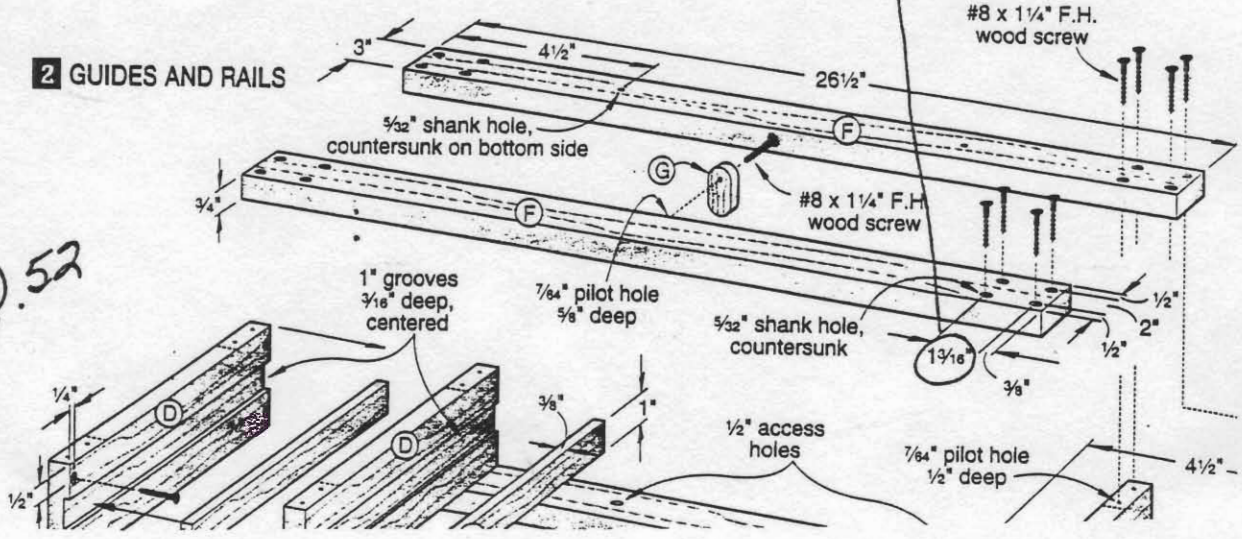

P.55

5 DESK CASE SECTION

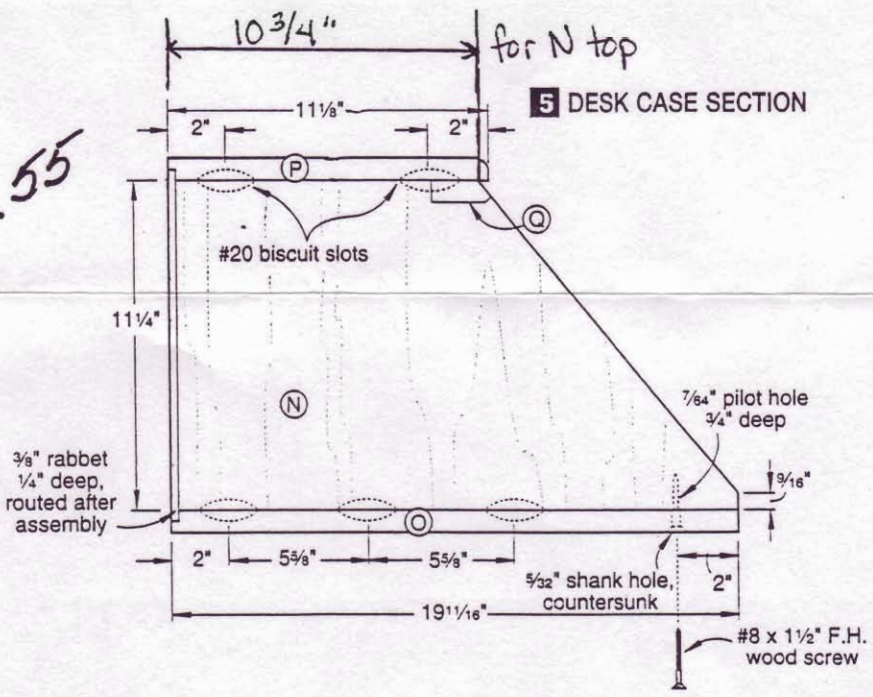

What a pyramid point tool can do for you (issue 153, page 122): Here is the correct image for Photo B:

Cyclone dust collectors (issue 153, page 94): Additional information for the "Report Card" chart on pages 98-99:

Brand	Model	Inlet Diam. (inches)
Bridgewood	BW-CDC3	8
Grizzly	G0525	8
Oneida	Comp-Sys 1.5EXT35	6
	Comp-Sys 2EXT35	7
	2 Commercial	7
Penn State	Tempest	5
	Tempest142CX	6
Woodsucker	Woodsucker II	6



# How to mix & match woods

## An essential guide

**W**hat separates a really good project from a great one? Though joinery skills, tool selection, and design savvy help, it often comes down to the wood itself.

Why? Because knowing how to select, cut, and assemble your stock to best match the wood's grain and color gives your projects a professional look. Here, you'll learn to choose and use wood to achieve consistency and to create flair in your projects. And it may be easier than you think.

The slant-front desk, *right*, and on *page 50*, shows the results of skillful wood usage: All of the cherry parts share a similar color. Grain patterns blend to create attractive panels with barely visible joints. The curly maple adds contrast yet remains complementary.

Check out the photos on these two pages that show key wood-selection strategies. Then, read on for tips on why the appearance of wood varies how to match grain figure, and how to combine species to achieve striking effects.

### It all starts at the lumberyard ...

When you go shopping for wood, don't be afraid to bring along hardware, fabric samples, or, as we did, veneer. Compare these items with boards you are considering to make sure they work well together. In our case, both cherry and walnut looked great with the curly maple, but we chose cherry to lend the piece an overall lighter appearance.



### How do you make your projects look this good?

Creating an heirloom-quality piece, such as this slant-front desk, requires more than a good plan. To get great results, you need to understand how to select and combine woods, a process that starts long before the building begins.





Once you've chosen the species, don't randomly pull boards from the rack. Take your time, keep your materials list in mind, and consider which parts each board may yield. Look first for boards with similar color and grain patterns, and set aside the ones that you think you can use.

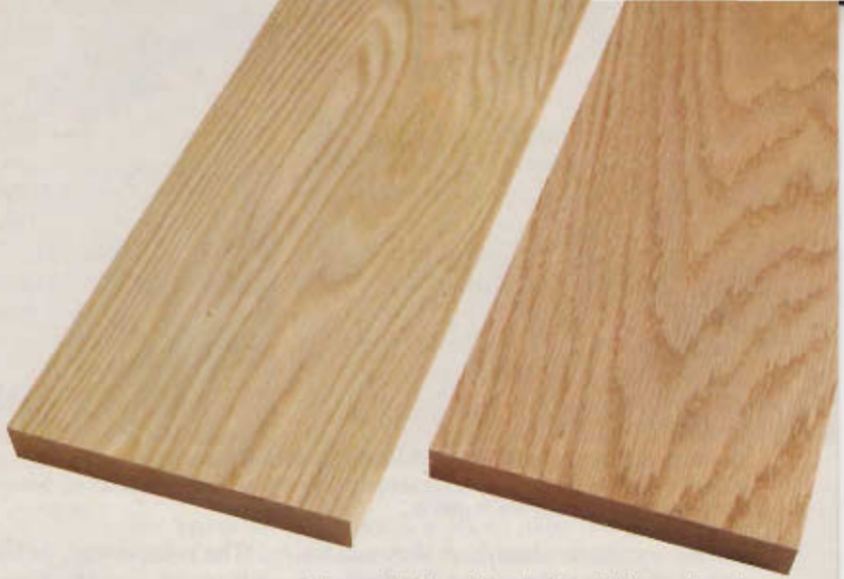

Though both sold as "red oak," these boards exhibit dramatic differences in color, grain pattern, and even cell size. Making them match in a project would prove difficult.



Place boards that pass your preliminary inspection next to one another in a brightly lit area. This allows you to closely compare color and grain from board to board. If a board stands out markedly, reject it and find a better match.

### The name game and other causes of inconsistent looks

When looking through the lumber bin, we all regularly find boards of the same name with varying grain and color. Why?

For starters, trees of the same species often take on different appearances because of where they grow. Northern trees grow slowly, leading to tighter growth rings than found in southern trees. Trees from open fields grow faster than woodland trees, and branch out lower, yielding more knots and wilder grain patterns.

Remember, too, that as trees pull in water through the soil they also draw in minerals that will color the wood. The mixtures of those minerals may vary widely in different types of soil.

Sometimes, woods sold under one name are actually different species. Red oak, for example, may include "true" red oak, live oak, black oak, pin oak, and hybrids. So you'll often find inconsistencies in their color and grain, as shown *above*.

If you buy directly from a small sawmill, you may be able to request lumber from one tree or from trees harvested together. At volume retailers, though, you'll likely have to compare color and grain to match boards that were cut from different trees.

### Mate boards carefully to get the best appearance

In the shop, you'll soon realize that carefully selecting boards simplifies the process of laying out parts. Joining those boards, though, still requires careful attention. With straight-grained boards, you may be able to match grain to create a seamless-looking panel. Matching wild grain proves tougher, but can be done.

### ... and culminates in the shop

Cutting diagrams are handy for calculating lumber needs, but they don't account for grain irregularities and defects. Use them as a guide, but break down your boards by examining each one to determine where to harvest parts based on size, grain patterns, and part locations in the project.

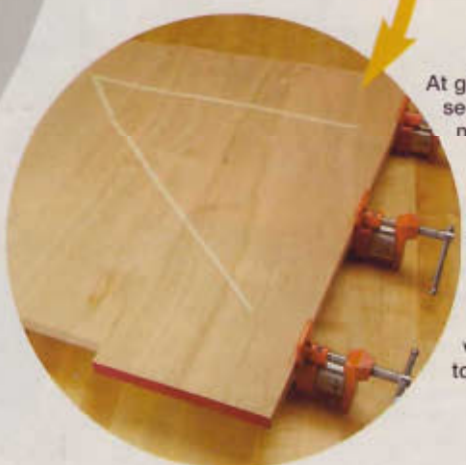

At glue-up and assembly, you'll see the results of careful planning. This side panel contains three pieces, selected from two different boards, that flow together naturally and downplay the joints between them. Once you have the boards laid out in the best sequence, mark them with chalk, as shown. This prevents you from gluing them together in the wrong order.

## Our builders' advice for a good mix

The *WOOD* magazine project designers and builders have years of experience selecting woods. Here are their insights on successfully mixing species.

**Kevin Boyle, Senior Design Editor:** "I'm a fan of strong contrast when I mix woods, but I make sure to use a much higher percentage of one wood than the other. Remember, too, that when you surround one wood with another, you'll draw attention to the wood at the center, even if there's only a little bit of it.

"I enjoy mixing maple with cherry or mahogany, and like blending walnut with cherry. For exotic woods, I often combine wenge with either lacewood or bubinga."

**Chuck Hedlund, Master Craftsman:** "On traditional projects, subtle color differences work well. I'll go for sharper contrast on contemporary styles. In addition to color, I pay attention to grain. If one wood has coarse grain, so should the other. By the same token, fine-grained woods usually pair best with other fine grains.

"My favorite combinations are cherry with maple, and mahogany with maple.

**Jeff Mertz, Design Editor:** "I use woods with a lot of contrast as accents on smaller projects, and woods that contrast subtly on larger pieces. When using highly contrasting woods, I make sure that neither one has a grain pattern that's overbearing.

"Like Kevin and Chuck, I'm a big fan of maple—either figured or regular—paired with cherry or mahogany."

*above*, for more insights from *WOOD* magazine's on-staff designers and builders.

In the end, beauty lies in the beholder's eye. So if you think two woods look great together, pair them up and enjoy. ♣

Written by David Stone



These boards share similar grain and color, making them good mates. But joining them as shown at *left* yields conflicting grain patterns. Flipping one board end for end, as shown at *right*, blends the patterns together.

When joining two boards, as shown in the photos *above*, turn them over, flip them end for end, and try mating different edges until you find the best combination.

Sometimes, you can even achieve success matching woods of different species. For example, woods with similar hues or grains, such as maple and birch or oak and ash, often can be paired with little visible difference. Just be sure to use them on different surfaces, say a cabinet face and side. Don't edge-glue them in the same panel. You can even stain some similarly grained woods to serve as substitutes. Ash, for instance, mimics oak, and stained birch can pass as cherry.

### What to do when you want woods to look different

Sometimes, projects call for woods to contrast rather than conform. The curly maple panel on the slant-front desk, for example, transforms a great-looking project into a knockout. When it comes to mixing species, there are fewer hard-and-fast rules than are used in matching. Again, examining grain and color remain important, but in different ways.

The color wheel, *below left*, contains a variety of popular domestic species that you've likely used, but may have never thought of mixing. Notice how some look great together, while other combinations just don't work.

On the second color wheel, *below right*, we've grouped some easy-to-find exotics, along with several varieties of figured maple, a perennial favorite.

When creating contrast or highlights, "complementary" takes on a different meaning. Light colors are usually paired successfully with darks. You can pair woods with prominent grains, as long as the patterns are different, so that they don't compete or cause oddly intersecting lines.

Specific numbers do not exist regarding what percentage of each wood should be used, though a 50-50 split rarely works well. One wood should dominate. Usually, the wood that dominates will be the one used in the highest percentage, but not always. Even when used in small quantities, contrasting woods that are vividly toned or strongly figured can easily overpower muted, fine-grained woods. Read "Our builders' advice for a good mix,"

Color and grain-figure variety abound in domestic hardwoods and other readily available species. This offers you opportunity to creatively blend favorite woods and make your projects stand out from the crowd.

Rarity and price keep many of us from using exotic woods on a large scale. Used in small quantities, though, these dramatic woods make great accents when combined with contrasting domestic species.

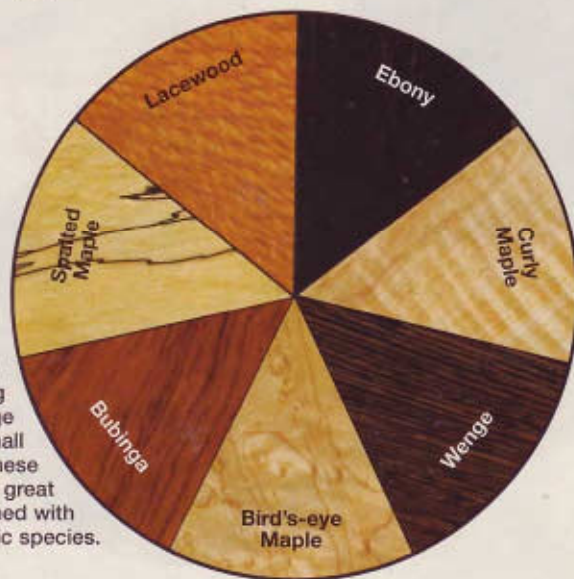
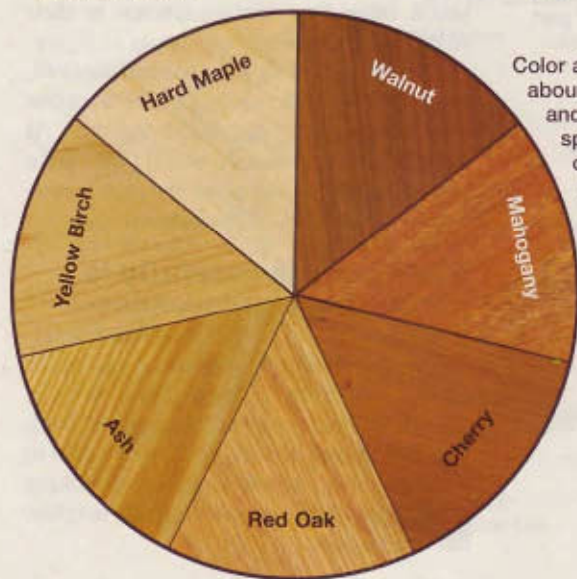



From one simple case plan, build either the dollhouse or castle bookcase shown here. Just add the needed roof or trim to customize the design.



# storybook storage

**B**righten a child's room and provide an imaginative place to keep books and treasures with this colorful dollhouse or castle design. For ease of assembly, the bookcases have identical base and case construction. Just add a few simple details to complete the desired style, and paint. The units are made of medium-density fiberboard, plywood, and poplar. You can build either structure for about \$60.

## Build the cases

**1** From  $\frac{3}{4}$ " medium-density fiberboard (MDF), cut the window and door sides (A, B) and the tops and bottoms (C) to the sizes listed in the **Materials List**. Label the side pieces "window" and "door," and mark their inside and outside faces.

**2** Using a stacked dado set adjusted to the thickness of the MDF, cut a  $\frac{3}{8}$ "-deep rabbet along each end of the sides (A, B) on their inside face, where shown on **Drawings 1** and **2**. Then, cut  $\frac{3}{8}$ "-deep dadoes on the inside face of the window sides (A) and on the inside and outside faces of the door sides (B), where dimensioned.

**3** Adjust the dado set and cut a  $\frac{1}{4}$ " groove  $\frac{3}{8}$ " deep along the back edge on the



With the back (E) captured in the grooves in the sides (A, B) and top and bottom (C), glue and clamp the case together. Check for square.



Scrap brace  
34½" long

Glue the shelf (F) between the door sides (B). Screw scrap 34½"-long braces to the cases' bottoms to keep the assembly square.



Create this entertaining castle-style bookcase by adding easy-to-make turret trim and quoins to the cases.

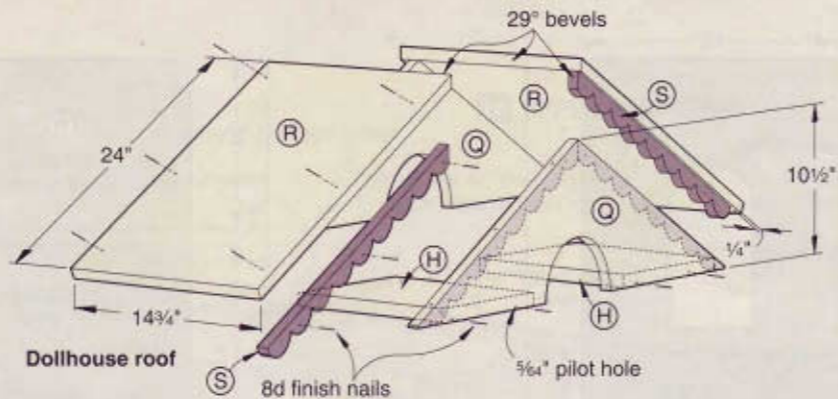

$\frac{5}{32}$ " shank hole, countersunk on bottom face of part (C), with a  $\frac{3}{32}$ " pilot hole  $\frac{1}{2}$ " deep in part (H)

$\frac{1}{4}$ " groove  $\frac{3}{8}$ " deep  
 $\frac{1}{4}$ " from back edge

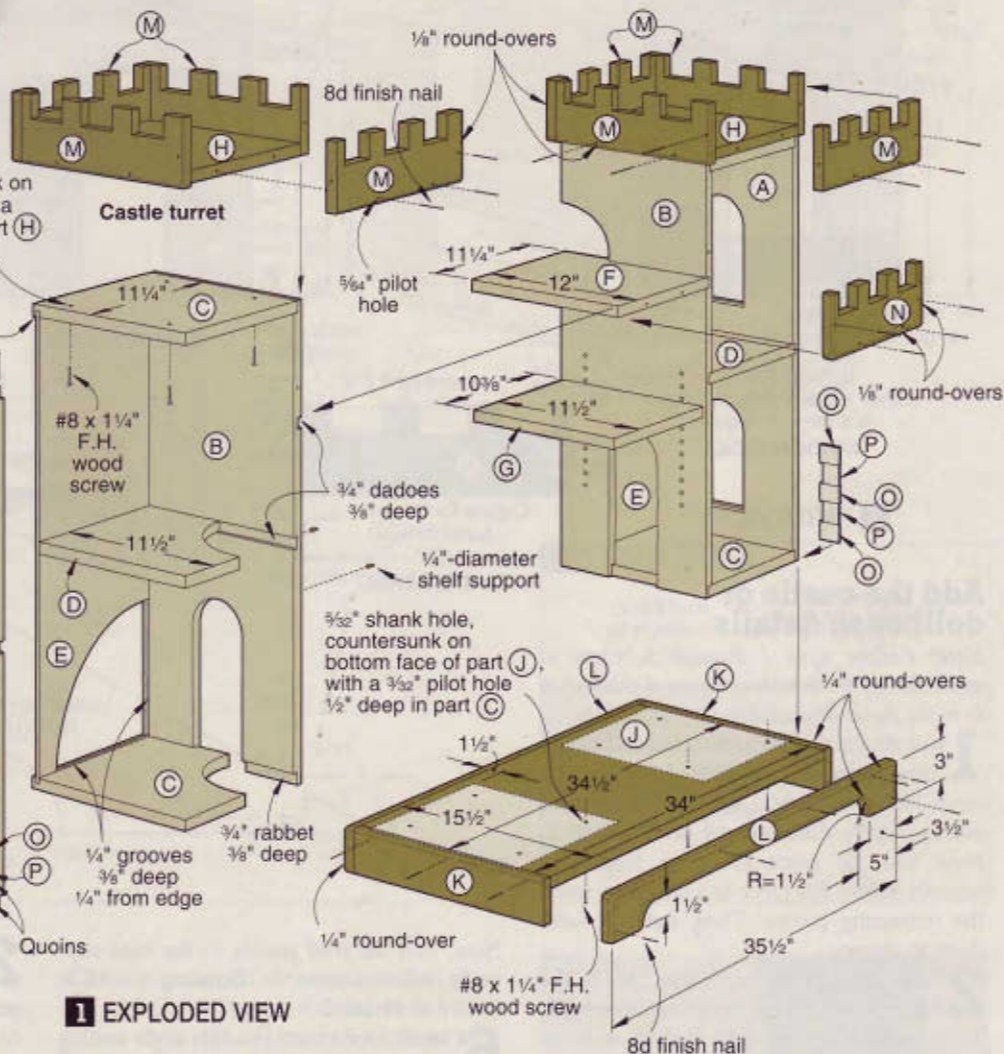

## 1 EXPLODED VIEW

For the board feet of lumber and other items needed to build this project, see page 87.

inside face of the sides (A, B) and tops and bottoms (C) for the backs (E), making sure you have mirror-image door sides.

**4** Lay out the window and door openings in the sides (A, B), where dimensioned on **Drawing 2**. Drill a  $\frac{3}{8}$ " start hole inside the window openings. Then, using a jigsaw with a 10-teeth-per-inch blade, cut all of the openings to shape. Smooth the openings using a half-round file followed by 180-grit sandpaper.

**5** Make the drilling guide shown on **Drawings 3** and **3a**. Using the guide and a stop collar on your  $\frac{1}{4}$ " drill bit, drill  $\frac{3}{8}$ "-deep holes in the door sides (B) for the shelf supports, where dimensioned on **Drawing 2**.

**6** Cut the shelves (D) and the backs (E) to size. Then, assemble the two cases by gluing together the sides (A, B), tops and bottoms (C), shelves, and backs, as shown in **Photo A**. Make sure each case has a window side (A) and a door side (B).

**7** Cut the center fixed shelf (F) to size. Then, glue it between the cases, as shown in **Photo B**.

**8** Cut the adjustable shelf (G) and supports (H) to size. From  $\frac{1}{2}$ "-thick poplar, cut a  $\frac{1}{2}$ "x22" blank for the window trim (I). Set the shelf, supports, and trim blank aside.

## Make the base

**1** Cut the base panel (J), side trim (K), and front and back trim (L) to size. Lay out the cutout on the front and back trim, where dimensioned on **Drawing 1**. Jigsaw the cutouts to shape, and sand smooth.

**2** Glue and nail the trim pieces to the base panel, where shown. When the glue dries, rout  $\frac{1}{4}$ " round-overs along the trim's top edges, corners, and cutouts.

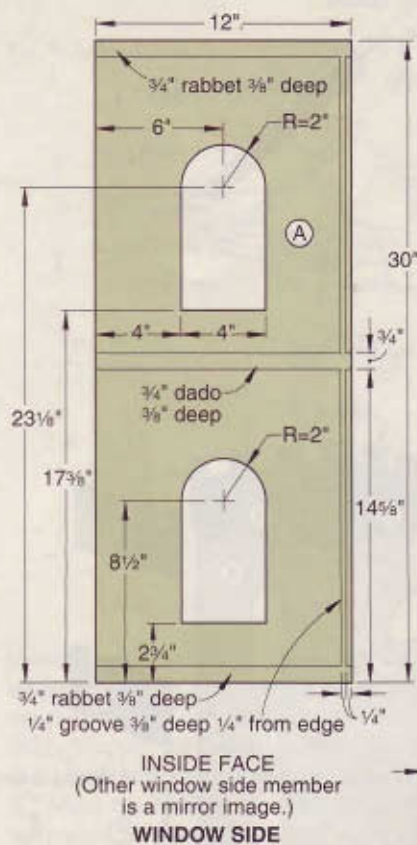

## 2 PARTS VIEW

### Add the castle or dollhouse details

*Note:* Follow steps 1 through 3 below to make the castle details or steps 4 through 6 to make the dollhouse details.

**1** Cut the castle turret trim (M) and center turret trim (N) to size. Lay out the crenellations (notches) on one of the trim pieces, where dimensioned on **Drawing 2**. Now, cut the piece to shape, and sand smooth. Using this piece as a template, mark the remaining pieces. Then, cut and sand them to shape.

**2** Glue and nail the turret trim (M) to the supports (H), where shown on **Drawing 1**. To prevent splitting, drill 3/64-inch pilot holes before driving the nails. Then, rout 1/8-inch round-overs on the turret-trim assemblies and center turret trim (N), where shown.

**3** Cut a 1/4x1 1/4x21-inch blank for the thick quoins (O) and a 3/16x1 1/4x14-inch blank for the thin quoins (P). Set the blanks aside.

**4** Cut the dollhouse roof supports (Q) to size. Lay out the angled top and radius cutout on each support, where dimensioned on **Drawing 2**. Jigsaw the parts to shape, and sand smooth.

**5** Cut the roof panels (R) to size, bevel-ripping one end of each panel, where shown on **Drawing 1**. Then, nail the roof supports (Q) to the supports (H), locating the supports (H) where shown on **Drawing 2**.

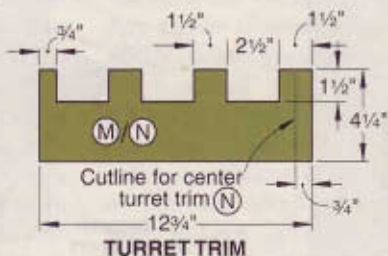

TURRET TRIM

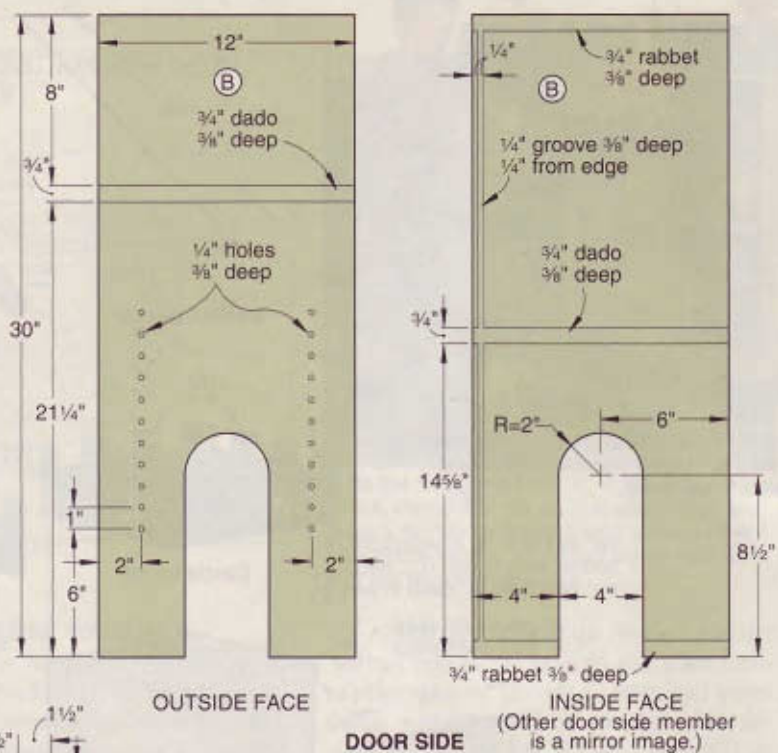

OUTSIDE FACE

DOOR SIDE

INSIDE FACE  
(Other door side member is a mirror image.)

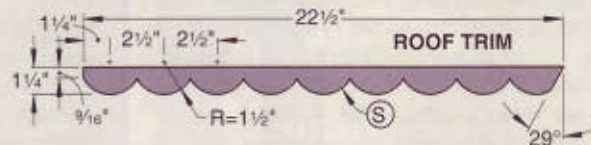

ROOF TRIM

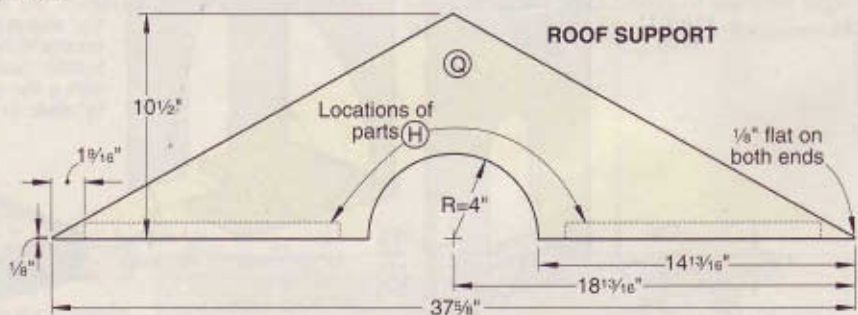

ROOF SUPPORT

Now, nail the roof panels to the roof supports, where shown on **Drawing 1** and as shown in **Photo C**.

**6** Cut the roof trim (S) to size, angle-cutting one end of each piece, where shown on **Drawing 2**. From 1/4-inch hardboard, cut a 2x7 1/2-inch piece for a marking template. Photocopy the full-size partial roof-trim pattern in the *WOOD Patterns* insert. Spray-adhere the pattern to the hardboard, jigsaw or bandsaw to the pattern lines, and sand smooth. Using the template, and beginning at the square end of each roof-trim piece, mark the contour along its complete face, where shown. Then, cut and sand the trim pieces to shape.

### Coloring time

**1** Fill all the nail holes with a paintable wood putty. (We used Durham's Rock Hard Water Putty.)

**2** Sand any areas that need it, ease any sharp edges, and remove the dust. Then, prime all the parts, window-trim and quoin blanks, and assemblies with a stain-blocking latex primer. Lightly sand when dry.

**3** Apply two coats of latex paint to the primed surfaces. The "Bookcase Paint Schemes" table, *opposite page*, lists the brand and colors we used.

**4** From the blanks, cut the window trim (I) and thick and thin quoins (O, P) to the listed lengths. Then, prime and paint the parts' ends.

### Final assembly

**1** Using a small amount of latex caulk adhesive and #18x1-inch brads, attach the window trim (I) to the window sides (A), where shown on **Drawing 1**. For the castle bookcase, attach the center turret trim (N)





With the roof panels (R) positioned so they overhang the roof supports (Q) 1" in the front and 1/4" at the back, drill pilot holes, and nail the panels to the supports.

using adhesive and 8d finish nails and quoins (O, P) using adhesive and #18x3/4" brads, alternating the quoins in the orientation shown. For the dollhouse bookcase, apply adhesive to the back face of the roof trim (S). Then, using 8d finish nails, fasten the trim, with the bevel-cut ends together, to the front roof support (Q). Fill the nail holes, and touch up with paint.

**2** Place the case assembly faceup on your workbench on spacers, as shown in **Photo D**. Remove the braces from the assembly's bottom. Then, position the base assembly (J/K/L) on your workbench, and center it on the case assembly. Drill mounting holes, where shown on **Drawing 1**, and drive the screws.

**3** With a helper, stand the bookcase upright. As applicable, position the castle's turret-trim assemblies (H/M) or the dollhouse's roof assembly (H/Q/R/S) on the case assembly, aligning the supports (H) with the tops (C). Drill mounting



With the case assembly supported on 1 1/2"-thick spacers, center the base assembly (J/K/L) side-to-side on the case assembly's bottom, and fasten with screws.

Bookcase Paint Schemes	
Behr Disney-series paint color*	Bookcase part
<b>Castle Bookcase</b>	
Christopher Robins Swing DC4C-40-2	Case (A through G)
100 Acre Trees DC4C-40-4	Supports (H), base (J,K,L), turret trim (M, N)
Skipping Stones DC4C-40-1	Window trim (I), quoins (O,P)
<b>Dollhouse Bookcase</b>	
Pooh Bear Yellow DC1A-30-2	Case (A through G)
Hums in the Sun DC1A-30-1	Supports (H), window trim (I), roof supports and panels (Q, R)
Moonlight Waltz DC3A-10-2	Base (J,K,L), roof trim (S)
*Premium Plus Interior Semi-Gloss Enamel paints, available at Home Depot.	

holes through the tops and into the supports, and drive the screws. Paint the screw heads to match the tops' color.

**4** Finally, install the shelf supports and the adjustable shelf (G). Then, place the bookcase in a child's room, and watch the fun begin. 🍷

## Cutting Diagram

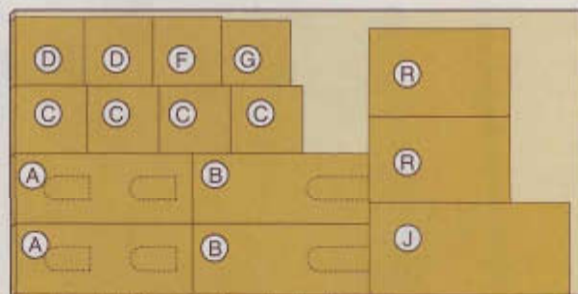

3/4 x 48 x 96" Medium-density fiberboard

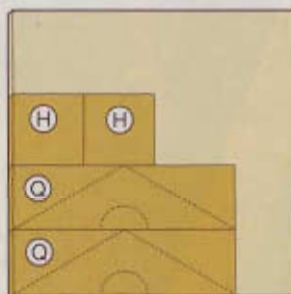

3/4 x 48 x 48" Medium-density fiberboard



3/4 x 7 1/4 x 96" Poplar (5.3 bd. ft.)

\*Plane or resaw to the thicknesses listed in the Materials List.

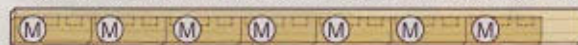

3/4 x 5 1/2 x 96" Poplar (4 bd. ft.)



1/4 x 24 x 48" Birch plywood

## 3 DRILLING GUIDE

Use these holes to drill shelf support holes in sides (B).

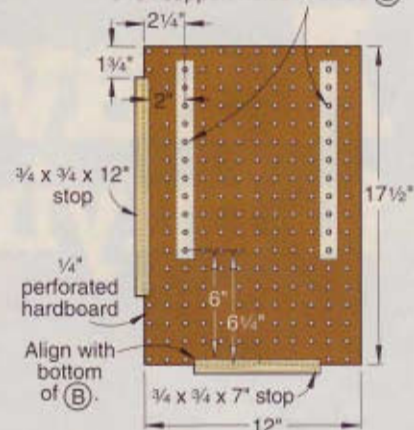

## 3a STOP DETAIL

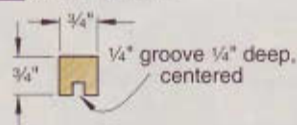

Written by Owen Duvall with Jeff Mertz

Project design: Kevin Boyle

Illustrations: Roxanne LeMoine

## Materials List

Cases	FINISHED SIZE			Matl.	Qty.
	T	W	L		
A window sides	3/4"	12"	30"	MDF	2
B door sides	3/4"	12"	30"	MDF	2
C tops and bottoms	3/4"	11 1/4"	12"	MDF	4
D shelves	3/4"	11 1/4"	11 1/2"	MDF	2
E backs	1/4"	11 1/4"	29 1/4"	BP	2
F center fixed shelf	3/4"	11 1/4"	12"	MDF	1
G adjustable shelf	3/4"	10 3/8"	11 1/2"	MDF	1
H supports	3/4"	12"	12"	MDF	2
I* window trim	1/2"	1/2"	5"	P	4

Base					
J base panel	3/4"	15 1/2"	34"	MDF	1
K side trim	3/4"	3"	15 1/2"	P	2
L front and back trim	3/4"	3"	35 1/2"	P	2

Castle Details					
M turret trim	3/4"	4 1/4"	12 3/4"	P	8
N center turret trim	3/4"	4 1/4"	12"	P	1
O* thick quoins	1/4"	1 1/4"	1 1/2"	P	12
P* thin quoins	3/8"	1 1/4"	1 1/2"	P	8

Dollhouse Details					
Q roof supports	3/4"	10 1/2"	37 3/8"	MDF	2
R roof panels	3/4"	14 3/4"	24"	MDF	2
S roof trim	3/4"	1 1/4"	22 1/2"	P	2

\*Parts initially cut oversize. See the instructions.

**Materials key:** MDF—medium-density fiberboard, BP—birch plywood, P—poplar.

**Supplies:** 8d finish nails, latex caulk adhesive, spray adhesive, paintable wood putty, #18x3/4" and #18x1" brads, #8x1 1/2" flathead wood screws (16), 1/4"-diameter shelf supports (4).

**Blades and bits:** Stacked dado set, 1/8" and 1/4" round-over router bits.

# A sawyer's secrets to buying better hardwood

Want to learn what makes great lumber? Take a sawmill tour and find out firsthand.



Jim Pierce, owner of Pierce Lumber Company, has spent a lifetime learning how to turn a stack of logs, such as these red oak behemoths sitting in his mill yard, into the top-quality lumber he stands alongside.

**M**ost woodworkers buy wood already milled into boards, ready to cut up and make into projects. But a surprising few understand the complex processes used to create those boards. Learn how it's done, though, and you'll get higher-quality stock every time, and be able to spot deals, whether you buy from a retailer or directly from a mill.

To get the full story, we recently visited Pierce Lumber Company in Belle Plaine, Iowa. In this high-tech operation, owner Jim Pierce and his employees produce about 350,000 board feet of top-quality hardwood lumber monthly. Jim grew up in the mill business, and knows that creating great lumber requires careful attention to detail at every stage of production.

Although many smaller operations occur in a sawmill, four key areas warrant close examination: log selection, efficient milling, drying techniques, and proper grading. Let's see how Jim ensures that his mill makes the most of every board. Also check out *page 92* for Jim's top 5 tips for buying hardwood.

### Great boards come from good trees

Creating top-quality boards requires a top-notch tree. Jim and his buyers can judge a specimen quickly, before it's ever cut down, to determine whether it's worth

making into lumber, or if it's destined to become pallet stock. So just how do they know this, and why should you?

You need this knowledge because the tree's location, condition, and size all combine to determine the quantity and quality of lumber it will yield and, therefore, the price that you'll ultimately pay. Plus, if you own a tree that you've considered processing into lumber—perhaps one from your yard that was damaged in a storm—you'll be able to evaluate whether it's worth sawing up.

The most desirable trees grow in rural areas, preferably in large stands, and distanced from roads or fencerows. Those growing in urban areas or near homesteads may contain metals that can destroy a sawmill's expensive blades. The same metal stains wood and invites damaging viruses and bacteria that can cause a raft of problems with milling and drying.



This roughly circular interruption in the bark's straight lines marks the former location of a branch. Though no visible branch butt remains, the wood below will contain knots.

A buyer looks also for straight trees, and not just because they yield longer boards. A curved trunk contains "reaction wood" that has uneven distribution of the wood cells and fibers. This wood will likely warp, bow, or twist over time.

Curves are easy to see, but many indicators are tougher to see, until you learn to "read" the bark. "Learn to do this, and you'll know what's inside the log," Jim says. These subtle cues include remnants of long-overgrown branches. Called "cat's faces," shown in the photo *above*, these

## A run through the mill

When a log slips into the mill at Pierce Lumber Company, it enters a high-tech, high-power world. Taking every inch of a 27,000-square-foot building, the mill and its two main bandsaws are immense. The whole works sits elevated 10' above the concrete floor so that workers can move underneath to clear jams and perform maintenance. Logs and boards travel on conveyors that run in all directions, while catwalks allow the twelve workers who run this monster machine to travel between stations. Let's follow a log through to see how it's processed.



From the log yard, a log travels by skid loader to the debarker. In less than 30 seconds, this monster strips away most of the bark along with dirt, rocks, and other foreign objects. Once stripped clean, the log passes through a metal detector to ensure it contains no blade-damaging metal.



Next, the log lands at the headsaw, where a carriage moves the log back and forth during the cutting process. With its 200-hp electric motor and 49'-long bandsaw blade, the headsaw works quickly. Most often, it makes just a few cuts to either flatten one side, create a square cant, or section the log for quartersawing.

areas disappear only after years of growth—ring layering over the branch site.

Jim can even differentiate between related trees by examining the bark on cut logs. The logs seen in the photo on *page 88*, for example, all are classified as “red oak.” Jim points out, though, that the pile contains true red oak, black oak, pin oak, and hybrids.

Each of these logs will produce oak with slightly different color and grain characteristics. Some sawmills lump it all together, which means you may get hard-to-match boards. Jim’s employees sort milled oak boards by color and appearance.

A tree’s health also ranks as an important indicator of its lumber value. Dead sections, splits, and discolored leaves may indicate rot or infection. These conditions reduce the yield, produce discolored boards, or boards that won’t dry properly. Jim also warns against “over-mature” trees that often have internal problems that remain invisible on the surface.

Only after the tree is cut can some internal problems be diagnosed, usually by looking at the log’s butt end.

The tree in the photo *above right*, for example, shows several typical problems. First, checks (splits radiating from the center) are forming. “It needs to be milled soon before those advance, or we’ll only be able to produce shorter boards,” Jim notes.

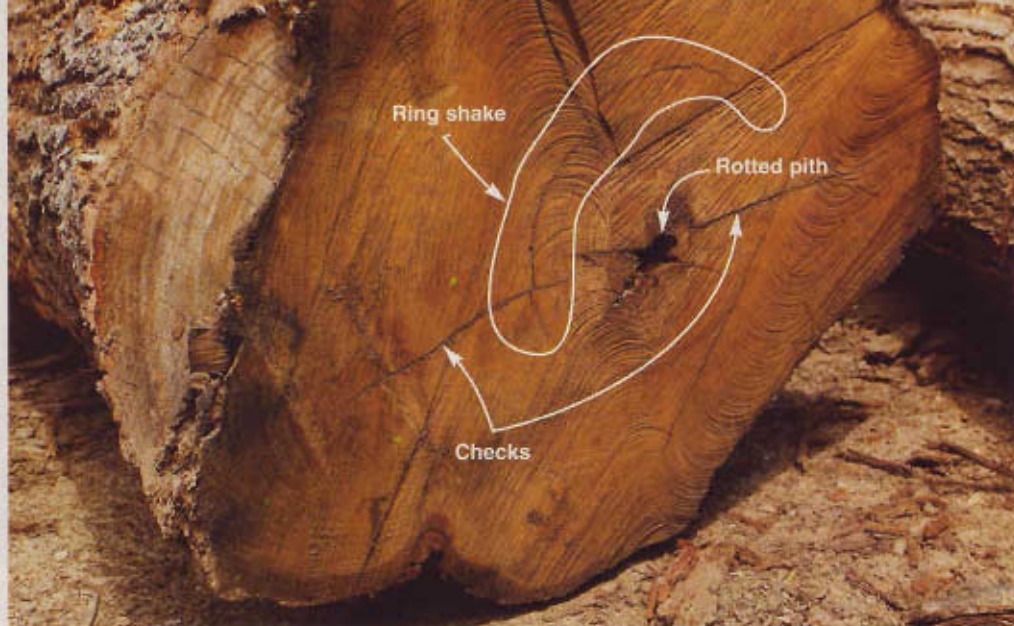

The butt of this log shows a few ills, but an experienced eye can tell the log remains suitable for milling. If these conditions progress, though, much of the wood will go to waste.

The log also has a rotted pith (center portion), and a condition known as “ring shake.” This occurs when a tree that has been weakened by infection gets flexed enough by wind, or another force, to break apart cells between the growth rings.

Once a log lands in the yard, Jim tries to mill it as soon as possible. “People are often told to let a log sit on the ground and season for six to twelve months before milling. But that’s a bad idea,” he says. “During warm months, I don’t keep logs in the yard for

more than 60 to 90 days.” Heat causes more problems than moisture because it encourages growth of fungus, bacteria, and insects.

### Proper milling produces lovely lumber

Examining the exterior of a log gives a good idea of what lies inside, but nobody knows for sure until the log enters the sawmill. Read “A run through the mill,” starting on *page 89*, to see firsthand how the high-tech mill at Pierce Lumber Company operates.

## A run through the mill (cont.)



From the headsaw, logs and cants travel—all under the control of photo eyes that trigger the conveyors—to the resaw. Here, the operators use their experience as well as laser sighting guides to determine the best way to slice the cant into the greatest number of high-quality boards.



A 12" wide bandsaw blade tracks true, while pinch rollers and guides push the log through the resaw. Once a board gets sliced free, it may move directly on to crosscutting and grading or to the edger for straight-line ripping. The remainder of the log travels back for another run through the resaw.

## The yield factor

Even the most-perfect log won't get milled entirely into the boards you buy for projects. Jim Pierce says that as little as 60 percent of many logs meets standards for the highest grades. So, the mill owner only makes top dollar on a portion of the wood, but has to purchase and process the entire log. This means the mill has to charge more for top-grade lumber to recover its costs.

The other 40 percent of the log, which includes the unstable center (called the pith) and areas with unworkable defects, doesn't go to waste, though. Much of it goes to manufacturers of pallets, crates, and railroad ties. The remainder gets chipped up to fuel the sawmill's kilns and furnaces.

Every mill employee needs to understand the lumber-production process. The head-saw operator, for example, has to rotate the log to decide how to best saw it for maximum yield. The resaw operators (two at this mill) then judge the log's figure and appearance, and slice the log to garner the best yield.

Should anybody misjudge the log, the boards they produce won't be as large or look as good as they could. In the end, that means you'll find fewer superior boards in your lumber retailer's bins.

## Wringing out the water

The process of drying the wood to a workable level (usually between 6 and 10 percent moisture content for hardwoods) represents the final phase of lumber production. Moisture must be removed at just the right rate—which varies by species and board thickness—to prevent problems.

"Drying is a balancing act," says Jim. "If boards dry too quickly, checks (cracks parallel to the grain) appear." Some checks are inevitable at the ends of boards. Checking can become severe, though, if a board's exterior dries too rapidly. In many cases, the exterior wood shrinks, but the still-wet core doesn't, causing the surface to tear open. Occasionally, the exterior stays together and crushes the cells of the interior wood.

If you find boards that show excessive cracking on their faces, put them back. They'll cause such problems as splitting, warping, difficulty machining, and even inability to successfully accept glue, stain, and finish.

The drying process begins by stacking the boards on  $\frac{3}{4}$ "-thick spacers called stickers. These allow air to flow through the stack so that the boards dry evenly.

The stickered boards then head for a building called a predryer, *above right*. "We expose boards to 80° temperature and circulate air through them for 30 to 45 days. This



Large fans near the roof of the predryer circulate air through the 91 stickered boards. Baffles positioned between the stacks direct the airflow to ensure even drying.

process gently takes the boards from green (where they retain all of their moisture) to a moisture content of 15 to 20 percent."

Walnut boards actually make one extra stop between the mill and the predryer. Read "Getting steamed about walnut," *page 92*, to learn why.

Once predried, boards head for the dry kiln, shown on *page 92*. Jim runs four kilns to increase capacity and because different woods require varying combinations of time, airflow, temperature, and humidity to dry properly. The process takes 10 to 12 days. Samples are pulled daily to check their appearance and moisture content.



The lumber grader looks down on this sloped platform, where he examines the appearance of one face of each board, then flips it and looks at the opposite face. At the same time, he checks the board's width, and sends the board to be automatically crosscut to final length and stamped with a grade mark.



After leaving the grading and crosscutting station, the freshly milled boards fall back into human hands in the load-out area. As the boards travel down this long conveyor, workers inspect each one by hand, and then sort the boards according to grade and length. Finally, the boards get stacked to await drying.

# Getting steamed about walnut

Some samples get cut into two-pronged wafers that are dried in an oven to check for internal tensions in the wood, *middle right*. After checking the samples, the operator adjusts kiln settings accordingly.

## Making the grade

As freshly milled boards exit the mill, they arrive at the first of two grading stations, shown on *page 91*. There, the boards are quickly judged by width and length, and examined for knots or other defects that will reduce their yield of clear lumber.

Because grading ranks so critically in determining the price the mill will receive for its stock, Pierce Lumber Company, and many other mills, grade the boards again after kiln drying, *bottom right*. They measure

## Jim's top 5 tips for buying hardwood

- 1 Know the wood color, grain figure, dimensions, and quantity you want so you're not left guessing while selecting stock.
- 2 Purchase No. 1 Common stock if you can get it. You can work around the defects, and you'll save up to 30 percent.
- 3 Closely examine each board for checks, cracks and uneven surfaces, which may be signs of improper drying.
- 4 Buy your boards from a sawmill that sells directly to the public. You may have to purchase a minimum quantity (100 or more board feet), and you won't be able to select your stock by hand. But, if you clearly communicate what you need, and you're knowledgeable and easy to work with, you'll get good stock at a great price.
- 5 Whether purchasing from a retailer or a sawmill, make sure the dealer is reputable and stands behind their product.

Walnut ranks as one of the most expensive, desirable hardwoods. "Unfortunately, walnut logs are smaller in diameter than many others, and always contain a thick layer of white sapwood," Jim Pierce explains.

Because of this, mill operators place the milled walnut boards inside a chamber and pump in hot steam for four to five days. This causes a chemical reaction that darkens the sapwood to a color that mimics the heartwood, as seen at *right*, and produces more usable lumber in each board. On the downside, many feel the process dulls the natural variations in tone and purple hues that are common in the heartwood.

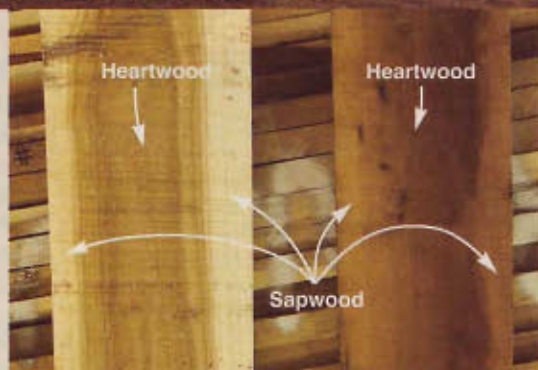

Straight out of the mill, the walnut board at left has colors quite different from the deep brown we're accustomed to on the board at right. But the right-hand board looked just the same, sapwood and all, before it made a stay in the steamer.

the width of each board to check for shrinkage, and again look for knots and defects.

One key thing to remember is that grades aren't determined by appearance, only by yield. As grade-level increases, a board's size and its percentage of clear (knot- and defect-free) area increase.

In fact, you'll often find lower-grade boards—No. 1 or No. 2 Common for example—that look just as good as those bearing the highest grades of Selects or FAS (Firsts and Seconds). You may also find completely clear boards graded as No. 1 Common only because they're smaller than needed to achieve Selects or FAS status. What's the payoff for the extra effort of working with this stock? A cost savings of 30 percent or more over FAS-grade stock.

After receiving their final grade, boards are either bundled for shipping in rough form, or surfaced and edged before they get shipped to become cabinets; flooring; furniture; or, the stock at your lumber dealer. ♣

Written by **David Stone**  
Photographs: **Jay Wilde, Blaine Moats**

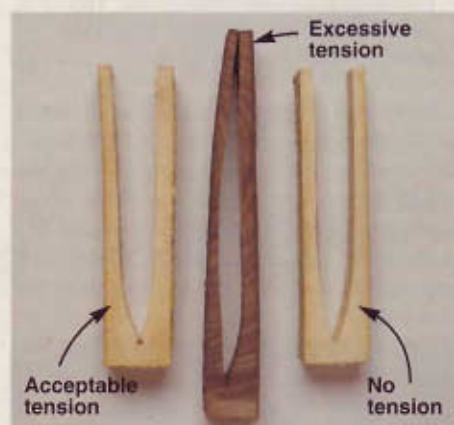

The kiln operator cuts test wafers into these tuning-fork shapes, then dries them in a small oven. If the forks bend, especially if they do so differently, the operator adjusts the kiln temperature, humidity, airflow velocity, or all three to alleviate the tension.

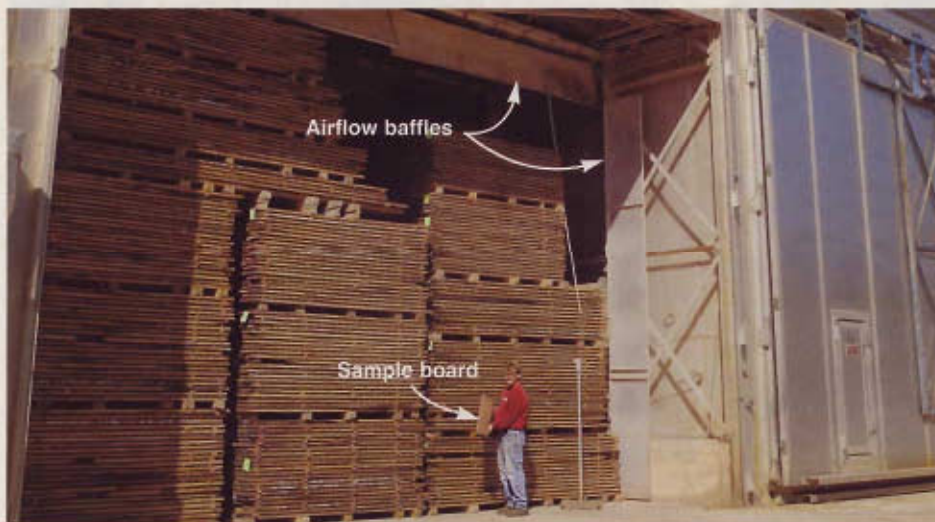

Inside these kilns, careful manipulation of airflow, temperature, and relative humidity dries the wood to a stable four-percent moisture content. Then, moisture gets reintroduced to stabilize the wood and bring it back up to about six percent.



Standing atop a stack fresh from the kiln, a lumber grader calculates the board footage of each board using his grader's stick, examines one face, and then flips the board to examine the other. He marks the board with its final grade, and finally tallies the information as helpers carry the board away.

# twister

We tested eight cyclone dust-collectors to

**I**n the beginning, the woodworking world was covered in sawdust. Slowly we evolved from broom-and-dustpan to shop vacuum, and eventually to bigger, more capable dust collectors with the suction to carry away wood chips as well as fine sawdust. These days, with the health hazards of wood dust making front-page news, you're about as likely to see a dust collector in a woodworking shop as a table saw.

In *WOOD* magazine issue #140, we tested single-stage collectors best suited to gathering dust from one tool at a time. (You can go to [www.woodmagazine.com/dcreview](http://www.woodmagazine.com/dcreview) to download that review.) This time, we focus on cyclone systems capable of pulling dust through a whole-shop duct system.

## How cyclones differ from single-stage dust collectors

The bag-type dust collectors most of us know and use today are basic, single-stage units. They suck wood dust and chips through an impeller that deposits the entire mess in a lower container bag, while the air—and some dust—exhausts back into the shop through an upper filter bag. Most units can be wheeled from tool to tool and then connected directly to whatever power equipment you're using.

Cyclonic-type collectors are larger, fixed units, generally more powerful, with most requiring 220-volt service. They suck wood chips and dust into a funnel-shaped chamber (as shown at left and described in the caption below) where heavier particles—the chips and the more substantial grains of sawdust—fall into a separate drum for disposal.

Numerous advantages give cyclone collectors an edge over single-stage

units. Because cyclones separate out and dispose of virtually all the debris before it passes through the impeller, engineers can design the impeller for maximum airflow, not for its ability to withstand the impact of a stray chunk of wood. The impellers of single-stage collectors, on the other hand, not only have to create suction, they also have to transport the debris passing through them, which can bog them down and clog them under heavy workload.

Cyclones also can be built with bigger impellers and motors, which create greater airflow volume (rated in standard cubic feet per minute, or SCFM), and with larger inlet ports to allow large-diameter, multi-duct runs. With the proper setup, a cyclone may be able to serve several woodworking machines operating at the same time without sacrificing performance.

## Five comparison points for cyclone collectors

To ensure that our testing would be fair across a range of units with different specifications and options, we enlisted the assistance of Dr. Greg Maxwell, an airflow expert from Iowa State University. (Although our test numbers may vary from the manufacturers' quoted specs, all of the cyclones were tested in the same manner, so our results give you a fair head-to-head evaluation of each machine.)

Three key criteria define the performance of a cyclone dust collector: airflow, filtration, and debris separation. In addition, we think the overall size of the unit, and what exactly you get for your money are important to your buying decision, so we'll touch on those subjects as well.

■ **Airflow.** Generally speaking, your dust collector must pull a high volume (SCFM)

**SEPARATING BY CYCLONE.** When dust and debris enters the cyclone collector through the inlet (1), it begins a spiral descent along the inside wall (2), which slows its speed. As the particles slow, larger debris falls from the air stream and into the storage drum (3). Small dust continues to flow upward through the outlet tube (4), into the impeller (5), and finally is exhausted out to the filter (6), which removes nearly all of the fine dust before returning cleaned air to the shop.

# test

separate hype from reality.

of air at the tool despite static-pressure (SP) loss caused by ductwork between the tool and the collector. (See "What is static-pressure loss?" on page 97.) Using a pitot tube and manometer, we recorded SCFM readings at a series of SP levels in ductwork matching each unit's inlet diameter. The Cyclone Performance Curves chart, on the next page, plots the airflow through each inlet as we gradually dialed in a funnel-shaped plug (shown in the photo above) to increase SP. All models used their factory-supplied filters, which were seasoned with 30 gallons of wood dust and then emptied prior to the test, to provide real-world results.

Reading the chart from right to left, you see that as static pressure climbs, airflow drops. Oneida's 2 Commercial System pulled the highest volume of air across a wide range of SP, with Grizzly's G0525 second best.

However, at very high static pressures, the Penn State TEMP142CX delivered higher airflow. So, if the SP loss on your shop's ductwork is less than about 7", the 2 Commercial and Grizzly perform best; ductwork with greater than 8" SP loss (a pretty extreme condition) would be better served by the Penn State cyclone. Most stationary woodworking power tools require at least 350 SCFM to adequately evacuate dust, so at over 9" of SP even the TEMP142CX becomes ineffective.

Remember, too, that opening the ductwork to two machines at a



Pleated cartridge filters pack more filter surface area into a small package. Oneida's (left) cleans easily by blasting it with compressed air; Penn State's filter has five times the surface area, but its closely spaced pleats take more time to clean.

time requires twice the airflow and can nearly double the SP, depending on the configuration of your ductwork.

■ **Filtration.** When it comes to filters—the cyclone's last line of defense against fine dust—consider both the level of filtration and the filter media itself. All of the manufacturers represented in this test have switched to high-efficiency cartridges (see photo, above) or bags that capture virtually all of the dust particles most harmful to your respiratory system—particles that range in size from 0.5 to 10 microns.

Besides protecting your lungs, these high-efficiency filters also can improve airflow through the system. For example, Bridge-wood and Grizzly first sent 30-micron bags (common on single-stage dust collectors) with their cyclones, and then changed to high-efficiency bags midway through our test. Retesting these machines with their new bags gained them an average of 175 SCFM and 1" of static pressure.

As for the filtration media itself, cellulose or paper-type cartridge filters perform as well as more costly spun polyester filters—although the synthetics have the edge in moisture- and puncture-resistance. A steel mesh protects Penn State's cellulose filters from projectiles, such as a miter-saw-flung offcut. Cartridge filters also provide a larger surface area for filtration than cloth bags. That means they restrict the exhausted air less and take up less space in your shop.

■ **Debris separation.** To test how well each cyclone separates heavier dust and debris from fine dust, we diligently mixed and weighed equal piles of wood chips and sawdust, and then fed the same amount at the same rate to each of the collectors. Ultimately, we found negligible differences in the way each cyclone separates materials.

But what do you do with that drum when it gets full? Units that collected the debris in 55-gallon drums went longest between emptyings, but those drums are awkward and heavy to lift and dump (although both 55-gallon models in our test come with a



wheeled drum dolly to ease transportation). Smaller drums are easier to manage but must be emptied more often.

■ **Overall size.** Cyclone collectors are necessarily tall, and manufacturers have to work hard to make their units fit under an 8' ceiling (the Bridgewood and Grizzly crowded even the 10' ceiling in our test facility). Also, because space often is tight in a workshop, it helps to know a cyclone's footprint before you buy. Those dimensions are shown in the chart on page 98.

Some units offer space-saving options, such as the internal filter that fits inside the cyclone on the Oneida Comp-Sys models. The trade-off, however, is about a 10-percent drop in airflow compared to the external filter, and more difficult—and more frequent—cleanings. Penn State's cartridge filter can be suspended from the ceiling to save floor space.

If noise reduction is more important to you than size, Penn State's optional exhaust muffler increases the cyclone's overall footprint, but decreases noise by 5 to 10 dB.

■ **Extras.** None of the units in our group was complete and ready to run "out of the box." They required assembly, and we found that some key components may or

may not be included in the purchase price. For example, collection drums add cost to all but the Oneida systems. Most also came without power cords and plugs, so we had

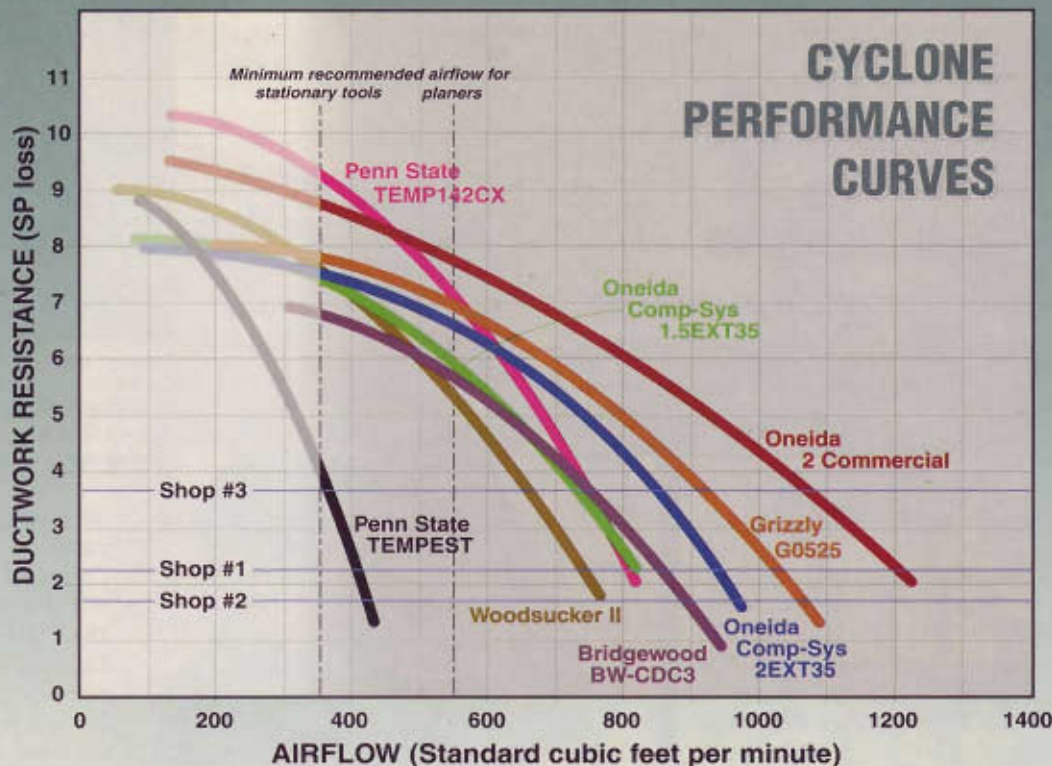

Tests were conducted using pilot tube and manometer at dust-collector inlet, and ductwork the same diameter as the inlet. Duct length was 10 times its diameter to stabilize airflow for accurate measurements. Filters were seasoned, emptied, and tapped clean before test to simulate workshop conditions.

After calculating the static-pressure loss of your ductwork (see sidebar at right), find the number along the left side of this chart. Now follow that horizontal line across the chart. (We plotted the three "typical" shops from the sidebar as examples.) The dust collector you choose must have a performance curve above your horizontal line and to the right of the 350-SCFM mark recommended for most stationary woodworking tools.

## How the cyclones stack up

**Bridgewood BW-CDC3, \$695**  
www.wilkemach.com, 800/235-2100



### High points

- ◆ Three-way adapter instantly reduces 8" inlet to three 4" inlets, or can be left off for a full 8" main.
- ◆ Rolling drum dolly makes haul-away easier, and large drum size eliminates frequent emptying.
- ◆ Fairly easy assembly.

### Low points

- ◆ 10' height means it won't fit under a standard 8' ceiling.
- ◆ Owner's manual doesn't list some assembly steps at all, and lists others that are no longer necessary.

### More points

- ◆ 55-gallon drum not included.
- ◆ Bridgewood also sells a 5-hp version (model BW-CDC5), requiring 30 amps at 220V for \$1,095.

**Grizzly G0525, \$725**  
www.grizzly.com, 800/523-4777



### High points

- ◆ The second-highest airflow and a comparatively low price make this cyclone our Top Value.
- ◆ Three-way adapter instantly reduces 8" inlet to three 4" inlets, or can be left off for a full 8" main.
- ◆ Drum dolly makes haul-away easier, and large drum eliminates frequent emptying.

### Low points

- ◆ 10' height means it won't fit under a standard 8' ceiling.
- ◆ Owner's manual doesn't list some assembly steps at all, and lists others that are no longer necessary.

### More points

- ◆ 55-gallon drum not included.
- ◆ Although this unit appears similar to the Bridgewood BW-CDC3, its impeller pulled higher airflow.

# What is static-pressure loss?

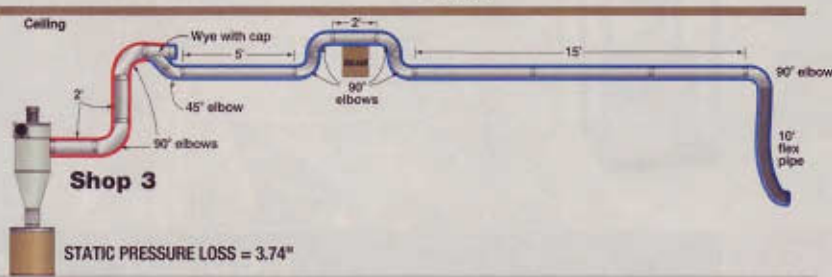
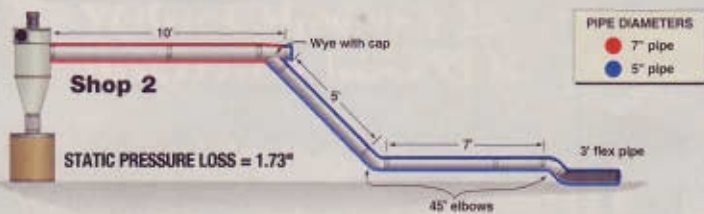
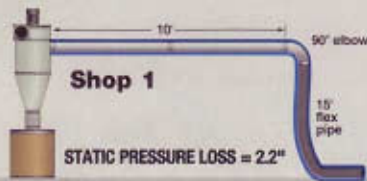

Static-pressure loss is resistance to airflow created by "upstream" factors, such as duct length and diameter, and the number—and even the angle—of intersections, bends, and elbows. There's a real science to minimizing SP loss (thus maximizing the performance) of dust-collection ductwork, and some of the manufacturers represented in our test provide assistance in planning or analyzing your system, for free or a nominal fee. We heartily recommend taking advantage of these services before buying a cyclone.

To help you make a meaningful comparison of the cyclones in the test, we came up with the three "typical" shop scenarios shown at left. (Note: Although there's more ductwork in Shop #2 than Shop #1, this system's SP loss is actually lower because of the 7"-diameter main and a shorter run of flex hose.)

It's unlikely that any of these scenarios will match your shop exactly, but you can use them to "ballpark" the SP on your ductwork. Remember that adding length, elbows, and flexible hose will add to SP loss; removing them will reduce the loss. Collecting from two tools at once also will increase SP loss and require twice the airflow.

You can calculate more precisely the static pressure of your existing or planned ductwork by following the instructions in *WOOD* magazine issue #119 (page 16), or by visiting [www.woodmagazine.com/spcalc](http://www.woodmagazine.com/spcalc) for a handy worksheet.

to buy those as well. (Check the list of standard and optional accessories for each model in the chart on page 98.)

Sales tax and shipping also add cost, which can be considerable on large, heavy equipment, particularly with units shipped by a trucking line. Cyclones that are broken

down for shipping by UPS can save you shipping hassles and costs, but you pay with extra assembly time. It's worth your while to call the manufacturers or check out their Internet sites to find out, in advance, exactly what you're getting for your money, and what shipping methods are available.

Finally, it may be important to have help when you're setting up your system. Design information or assistance is available from Grizzly, Oneida (for a \$50 fee, which can be applied toward the purchase of one of their systems), and Penn State, but not from Bridgewood or Woodsucker.

## Oneida Comp-Sys 1.5EXT35, \$875

[www.oneida-air.com](http://www.oneida-air.com), 800/732-4065



### High points

- ◆ The included 35-gallon drum mounts to and dismounts from the cyclone easily.
- ◆ Canister-filter clean-out at bottom of unit makes emptying it a snap.
- ◆ The only cyclone in the test that can easily run on a 110-volt circuit.
- ◆ Easy assembly and excellent manufacturer support, including design assistance and a complete line of filters, ductwork, and accessories.
- ◆ Packaged for shipping via UPS.

### Low points

- ◆ A small pinhole leak on the exhaust plenum allowed some dust to leak into the shop air. We patched it with a dab of silicone sealant.

### More points

- ◆ For small shops, this cyclone's optional internal filter reduces its footprint, but knocks about 10 percent off airflow, and makes clean-out more of a chore.

## Oneida Comp-Sys 2EXT35, \$975

[www.oneida-air.com](http://www.oneida-air.com), 800/732-4065



### High points

- ◆ Canister-filter clean-out at bottom of unit makes emptying it a snap.
- ◆ Easy assembly and excellent manufacturer support, including design assistance and a complete line of filters, ductwork, and accessories.
- ◆ Packaged for shipping via UPS.

### More points

- ◆ For small shops, optional internal filter reduces its footprint, but knocks about 10 percent off performance, and makes clean-out more of a chore.

## Oneida 2 Commercial System, \$1,070

www.oneida-air.com, 800/732-4065



### High points

- ◆ The highest airflow numbers in the test.
- ◆ Pleated-polyester canister filter is an efficient dust-catcher, and a clean-out at bottom of unit makes emptying it a snap.
- ◆ Easy assembly and excellent manufacturer support, including design assistance and a complete line of filters, ductwork, and accessories.

### Low points

- ◆ The highest-priced cyclone in the test.
- ◆ Large size of components requires they be shipped by trucking line, which may or may not deliver to a home address.

### More Points

- ◆ Hands down, this machine tested best, so we named it our Top Tool.

## Penn State TEMPEST, \$495

www.pennstateind.com, 800/377-7297



### High points

- ◆ The lowest-priced cyclone in our test.
- ◆ A clean-out zipper on the filter bag makes dust removal fast and easy.
- ◆ Optional 26-gal. drum is small, but it mounts to and dismounts from the cyclone quickly and handles easier than larger drums.
- ◆ Wall-mounting brackets come with the cyclone.
- ◆ Packaged for shipping via UPS.

### Low points

- ◆ This unit pulled the lowest SCFM in the test.
- ◆ Lots of assembly work, and the manual is disorganized and confusing.

### More points

- ◆ Also available with .5 micron canister filter (TEMPESTCX) for \$645.

## Penn State TEMP142CX, \$795

www.pennstateind.com, 800/377-7297



### High points

- ◆ Started in the middle of the pack for airflow, but outsucked all the other cyclones at SP levels greater than about 8".
- ◆ Ceiling-mounting the cartridge filter saves on floor space.
- ◆ The largest filter surface area—452 sq. ft.—of any cyclone in the test, means less-frequent cleanings.
- ◆ Power cord, switch, and wall-mounting brackets included in purchase price.
- ◆ Packaged for easy shipping via UPS.

### Low points

- ◆ Clean-out drum is permanently affixed to the filter, so it must be vacuumed out through an access door.
- ◆ Closely spaced pleats inside the filter require patience to clean.

### More points

- ◆ The photo shows a steel filter-clean-out drum, but Penn State changed to a fiber clean-out drum (and lowered the price) just before this issue went to press.
- ◆ Options abound on this cyclone, including a 5-micron bag filter that reduces unit cost to \$645, an excellent value.
- ◆ We tested the 3-hp version (TEMP143CC, \$995) and found its performance curve identical because the impeller and motor speed are the same as the 2-hp model. However, the 3-hp motor should last longer.
- ◆ System-design assistance is available.

## REPORT CARD

BRAND	MODEL	MOTOR		
		HORSEPOWER	AMPS (220V)	FAN IMPELLER DIAMETER (INCHES)
BRIDGEWOOD	BW-CDC3	3	18	13
GRIZZLY	G0525	3	18	13
ONEIDA	Comp-Sys 1.5EXT35	1½	8.5	12½
	Comp-Sys 2EXT35	2	11.4	12½
	2 COMMERCIAL	2	11.4	14
PENN STATE	#TEMPEST	2	8	12
	#TEMP142CX	2	10	14
WOODSUCKER	WOODSUCKER II	2	11.4	13

### NOTES:

- Height may vary according to distance between drum and cone.  
(\* ) Alternative mounting method lowers height to 85½".
- (S) Leg stand  
(W) Wall mount  
(S/W) Can be mounted either way
- (B) Bag filter  
(C) Cartridge filter  
(CC) Cartridge filter with cleanout
- (C) Cellulose with steel mesh  
(P) Spun-bond polyester

### Share your opinion

of these cyclones in our Interactive Tool Review at

[www.woodmagazine.com/cyclones](http://www.woodmagazine.com/cyclones)



**Woodsucker II, \$800**  
www.woodsucker.com, 866/366-3878



**High points**

- ◆ Unique exhaust design captures the .5-micron cartridge filter inside a clear plastic bag so you can see when the filter needs cleaning.
- ◆ Well-written manual made bolt-together setup easy and relatively quick.
- ◆ Wall-mounting brackets, power cord, and switch included in price.

**Low points**

- ◆ Large size requires shipping by trucking company.
- ◆ Noticeably the loudest in the test at 91 dB.
- ◆ Not much in support services provided by the manufacturer.

**Our pick of the litter gobblers**

The Oneida 2 Commercial has the most impressive overall performance of all the cyclones in the test, with the highest peak SCFM readings and the ability to sustain that airflow well above 6" of static pressure. This, plus effective fine-dust filtration and fast, easy clean-out earned this sucker Top Tool honors.

For about \$300 less, though, Grizzly's G0525 performed remarkably well, with a high-efficiency filter bag and airflow second only to the Oneida 2 Commercial, so we named it the Top Value. The only drawback is its towering height, which, at 10', may be too much for many home shops. If your shop can't handle that height, take a good look at the Penn State TEMP142. It's the same machine as the TEMP142CX we tested but comes with a less-efficient 5-micron bag instead of the .5-micron cartridge filter, and costs only \$645. And, at only 94" tall, it fits under an 8' ceiling. ♣

Written by Michael Morris with Dave Campbell and Jeff Hall  
Illustrations: Tim Cahill

**FOR EIGHT CYCLONE DUST-COLLECTORS UNDER \$1,100**

CONSTRUCTION				FILTER (AS TESTED)		PERFORMANCE GRADES (6)						ACCESSORIES (9)		WARRANTY (YEARS)				COUNTRY OF ASSEMBLY (10)		WEIGHT (POUNDS)		SELLING PRICE (11)	
DIMENSIONS (HxWxD, INCHES) (1)	MOUNTING STYLE (2)	DRUM CAPACITY AS TESTED (GALLONS)	STYLE (3)	MEDIA (4)	FILTER EFFICIENCY (MICRONS) (5)	AIRFLOW	EASE OF EMPTYING FILTER	EASE OF EMPTYING DRUM	EASE OF ASSEMBLY	OWNER'S MANUAL CLARITY	NOISE LEVEL (dB) (7)	CORD LENGTH (FEET) (8)	STANDARD	OPTIONAL	WARRANTY (YEARS)	COUNTRY OF ASSEMBLY (10)	WEIGHT (POUNDS)	SELLING PRICE (11)					
																			DD, P, S	D	1	T	246
120 x 68 x 40	S	55	B P	5	B	A-	C	B	C	82	12	DD, P, S	D	1	T	246	\$695						
120 x 68 x 40	S	55	B P	1	A-	A-	C	B	C+	89	12	DD, P, S	D	1	T	246	725						
85 x 48 x 28	S/W	35	CC P	.2-2	C	A	B	A	A	81	N/A	C, D, O, W	P, R, S	2	U	219	875						
89 x 48 x 28	S/W	35	CC P	.2-2	B+	A	B	A	A	83	N/A	C, D, O, W	P, R, S	2	U	238	975						
96 x 54 x 28	S/W	35	CC P	.2-2	A	A	B	A	A	81	N/A	C, D, O, W	P, R, S	2	U	350	1,070						
88 x 46 x 25	W	26	B P	5	D	B+	A	B	C	81	5	P, W	C, D, M, O, R, S, U	2	T	125	495						
94 x 44 x 28	W	26	CC C	.5	C+	B+	A	B	A-	83	6	C, O, P, W	D, M, R, S, U	2	T	217	795						
93" x 40 x 23	W	35	C P	.5	C	C	B	A-	A	91	6	C, W	D	2	U	165	800						

5. From manufacturer's specifications. We were not able to verify this in our testing.

6. A Excellent  
B Good  
C Average  
D Below average

7. Measured 8' from machine at 5' height.

8. (N/A) Cord not included.

9. (C) Cartridge filter  
(D) Drum  
(DD) Drum dolly  
(M) Muffler  
(O) Cleanout  
(P) Power switch  
(R) Remote power switch  
(S) Leg stand  
(U) Ceiling-mounting brackets for filter  
(W) Wall-mounting brackets

10. (T) Taiwan  
(U) United States

11. Prices current at time of article's production and do not include shipping, where applicable.

# Winners all! America's top woodworking mentors



Is America's youth interested in woodworking? Absolutely! But they need a helping hand from you to get started.

**I**n today's busy world, finding a few moments (and the energy) to help aspiring woodworkers isn't easy. With that in mind, I set up a contest to recognize and reward those readers who volunteer their time and talents to teaching tomorrow's woodworkers. As you may recall, in the May 2003 issue I announced that Laguna Tools was partnering with us in this effort by contributing six heavy-duty, European-style workbenches for the top mentors.

Of course, choosing six winners from the many deserving entries was no easy task. And as their experiences outlined here attest, the ways to be a mentor vary greatly. Who knows, one of their ideas may inspire you to do some mentoring too.

*Bill Krier*

Editor-In-Chief



## Grand prize winner (7' Laguna workbench)

### **F**red Sotcher, San Jose, California

What caught the judges' attention about retired electrical engineer Fred Sotcher was his sheer determination. He persisted in starting his mentoring program long after most of us would have thrown in the shop apron.

Wanting to spend more time with his six-year-old granddaughter, Sotcher approached her school's principal with a proposal: He would make anything the school wanted if they would simply allow him to conduct a woodworking program for the students. So, for two years Fred built desks, training aids, bookshelves, and anything else the school needed. He kept asking about his woodworking program, and finally, in 1998, school officials accepted his idea.

"The deal we made was that I would work as a volunteer teacher, provide all the necessary tools, build the workbenches, and furnish all materials at no cost to the school. They provided a classroom, and allowed me to hold a six-week woodworking class twice a week during lunch-time," says Fred.

Over a five-year period, Fred estimates he taught 150-200 students, devoting about 600 hours in the process. "I've enjoyed every minute," he says.



Remember when you first learned to drive a nail? Here, Fred Sotcher helps a young student assemble a shelf project.

## Runners-up (5' Laguna workbench)

### William Townsend, Austin, Texas

Since taking on violin-making as a part-time pursuit in 1999, William has shown one to three middle and high school students each semester how to make the stringed instrument. He typically works with his students two nights a week. He also shares his knowledge via e-mail, digital video, and digital photos with several restorers and a Florida student, who plans to enter violin-making school.

In his program, the kids work with only hand tools, learning their use and maintenance. Students also learn about different types of wood and their properties, finishing, and acoustics.

William was nominated by Joey Bein, one of his students, who has gone on to study instrument-making in Italy. "I first met Joey when he was mowing my yard," says William. "His father had passed away, and he was looking for direction. When he carved his first scroll and held it up for my inspection, the look of accomplishment on his face was priceless."



Amanda Morris discusses her approach to finishing the violin she built under the mentoring of William Townsend.

### Ray Heidtke, Jackson, Wisconsin

Numbers alone speak volumes about Ray's mentoring activities. In 17 years as a volunteer 4-H woodworking project leader, he's taught close to 300 kids, some of whom have repeated his program several times. For the past six years he's served as the woodworking superintendent at the local county fair.

Ray's woodworking program occupies most of his Monday and Wednesday evenings between January and June. During that time, his woodworking shop is abuzz with 20-30 youths, ages 8-19, designing and building their projects for that summer's state fair. To accommodate this enthusiastic crew, Ray, who owns a residential construction company, recently put up a 24x36' shop building with in-floor heating.



Ray Heidtke, right, helps 4-H youth leader Joe Herther build an oak version of the heirloom hutch in issue 147. Heidtke built an 864-square-foot shop to accommodate his students.

### Jack Grube, Derry, New Hampshire

By day Jack Grube teaches woodworking to youth in grades 9-12 at Pinkerton Academy in Derry; but it's what he's done outside of the classroom that earned him our prize. In 2001 he founded the New England Association of Woodworking Teachers (NEAWT) and today serves as its president.

In 2002 he developed a program for the NEAWT in conjunction with the American Association of Woodturners (AAW) called "Turning To Teens." Through this program, 50 teachers and students, representing 15 schools, attended an AAW-sponsored workshop with woodturning expert David Ellsworth (see photo right).

Jack also volunteers his time overseeing an after-school woodworking program at Pinkerton and is active in the Guild of New Hampshire Woodworkers.



Woodworking instructor Jack Grube (front row) and his students did a workshop with acclaimed woodturner David Ellsworth (back row).

## Portage County RSVP Program, Stevens Point, Wisconsin

The Retired and Senior Volunteer Program (RSVP) is national in scope and aimed at making a positive impact on communities through the services of people age 55 and over. Through RSVP, 14 woodworkers in Stevens Point have conducted a woodworking workshop the past three years at Emerson Alternative School.

"A total of 35 kids in 7th–12th grades have gone through the workshop," says volunteer Joe Murin, who nominated his group. "These kids are at risk for dropping out of school and in need of a different learning experience than schools typically provide. When a student with no previous experience with tools, and very little self-esteem, actually produces something that he is proud of, it's a very fulfilling experience for him and us."

To learn more about getting involved in your local Retired and Senior Volunteer Program, contact Senior Corps at 800/424-8867, or go to [www.seniorcorps.org](http://www.seniorcorps.org).



RSVP volunteers (foreground) Charles Fernandez and Joe Murin guide students Tom Baltzell and Nate Garski in safe and effective use of the tablesaw and palm sander.

## Ken Waltz, Anaheim Hills, California

Ken's mentoring sprouted from another good deed he was doing. "I was making braille letters for the Hadley School for the Blind in Chicago. There's a lot of repetitive work involved, so I needed help for that. I found a teenager who was interested in woodworking, and things took off from there," the retired business owner says.

"Over the past three years, I've mentored four local kids who find out about me through word of mouth. They can't drive, so I pick up and deliver them with fast food enroute. We start the mentoring process with the braille letters and then move on to building projects they want, such as jewelry boxes, bookcases, birdhouses, or cutting boards.

"They stay with me an average of six months, but one young man has been with it 18 months, and now he's taking woodworking courses at Cerritos College. All of them become like adopted kids to my wife and me."



Ken Waltz recently mentored siblings Kevin and Melina Svenson.

## Some more great mentoring ideas

Looking for ways to get involved as a mentor? Try one of these ideas from other entrants in the mentoring contest.

### ■ Woodworking birthday party

**The idea:** Instead of traveling to a migraine-inducing pizza parlor/arcade, have a woodworking party for your children or grandkids. Let the kids assemble something simple from parts you premake.

**Sent by** Michael Tobin, Franklin, Wisconsin.

### ■ Woodworking as art

**The idea:** Teach woodworking skills as part of an art class, perhaps making presents, such as ornaments or candleholders, prior to the holidays. Even if you're not a teacher, you can offer to help an art teacher with ideas for projects.

**Sent by** Jack Smalldon, a grade-school teacher at Bertie Public School in Ridgeway, Ontario.

### ■ Woodworking instead of the mall.

**The idea:** Help your grandkids build Christmas gifts for their

parents instead of purchasing something at a store. You'll have a great time together, and the recipients will be thrilled.

**Sent by** Bill Lotter, Kennett Square, Pennsylvania.

### ■ Helping the challenged

**The idea:** Brighten the life of someone who faces physical or mental challenges. Invite him over for a few hours of conversation and creativity.

**Sent by** Bert Simoneau, Livermore Falls, Maine, who spends Saturday mornings in the shop with Dylan Driscoll, a 12-year-old with muscular dystrophy.

### ■ Fund-raisers

**The idea:** Find a worthy charity and teach its supporters how to make things that can be sold. Stress that woodworking skills will be learned, not required.

**Sent by** John Weber, Richmond, Indiana, who showed some stay-at-home moms how to make birdhouses for a women's shelter fund-raiser. ♣



# stately, yet simple architectural clock

**W**hen *WOOD* magazine senior design editor Kevin Boyle was asked to create an easy-to-make, classical-style clock, he delivered—big time! His novel design, accented with basic edge profiles and a four-segment bird's-eye maple face, has just eight parts and no complex joinery. Better yet, you need only a tablesaw, router, and bandsaw or jigsaw to complete it. You don't have to buy a special-size Forstner bit to bore the opening for the movement.

## Build the case

**1** Cut the face (A) and backer (B) to the sizes listed in the **Materials List**. Then, glue the backer to the face's back, keeping their edges and ends aligned. (The added 1/4"

thickness of the backer ensures the clock movement securely engages the face.)

**2** On the face, mark the locations for the 1/8" saw kerfs and draw a circle with a 1 1/16" radius, where dimensioned on **Drawing 1**. Rip and crosscut the face/backer assembly (A/B) at the marked kerf locations, separating it into four pieces. Then, cut the arc on each piece by bandsawing and sanding to the line.

**3** Cut the sides (C) and back (D) to size. Glue and clamp the face/backer pieces to the sides (C), as shown in **Photo A**, making sure you have mirror-image assemblies. When the glue dries, sand the assemblies to 220 grit. Then, glue and clamp the assemblies to the back (D), as shown in **Photo B**.

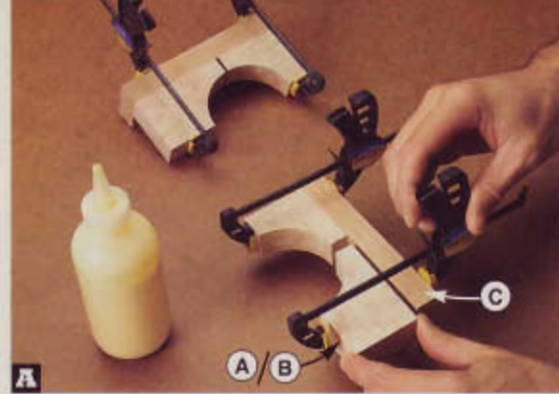

**A** Glue the mirror-image pair of face/backer pieces (A/B) to each side (C), aligning the pieces with the side's ends and front edge.

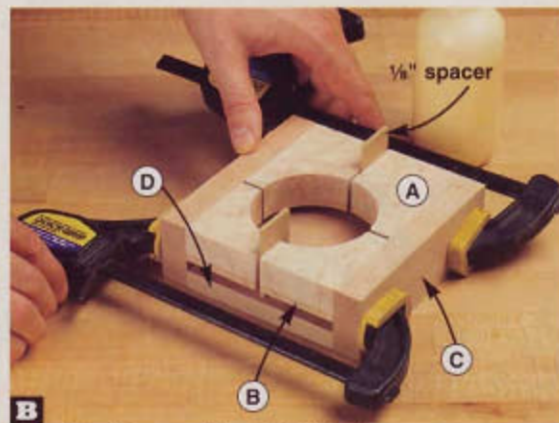

**B** Glue the side assemblies (A/B/C) to the back (D), inserting 1/8" spacers between the assemblies to keep them square.

**4** Cut the sub top and bottom (E) to size. Rout a 1/4" cove along the ends and one edge of each piece, and sand smooth. Mark centerpoints on the pieces for countersunk shank holes, where dimensioned on **Drawing 2a**, and drill the holes. Now, posi-

*Continued on page 106*

## 1 FACE/BACKER LAYOUT

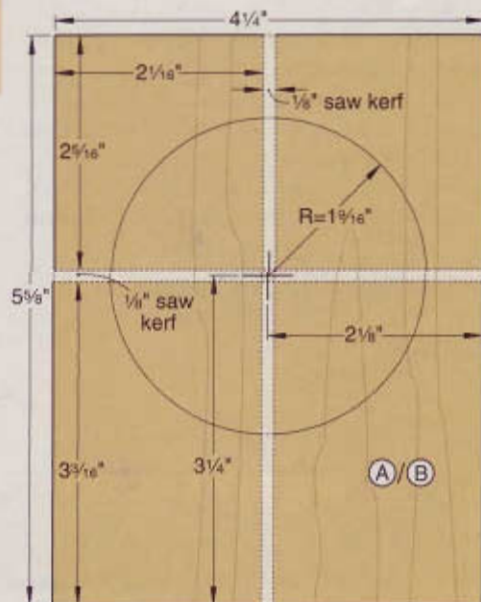



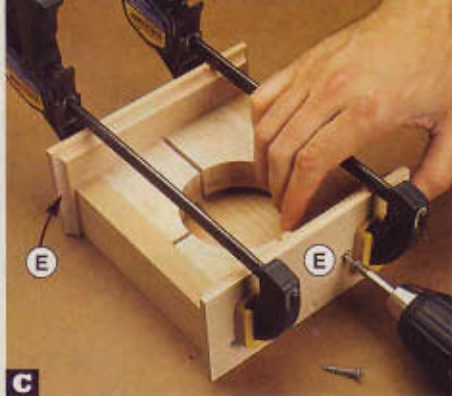

**C** Center the sub top and bottom (E) side-to-side on the clock case. Drill pilot holes, and drive the screws.



tion, clamp, and screw the pieces to the clock case, as shown in **Photo C**.

**5** Cut the top and bottom (F) to size. Rout a  $\frac{1}{4}$ " round-over along the ends and one edge of each piece, and sand smooth. Apply glue to the sub top and bottom (E). Then, clamp the top and bottom (F) in place, flush with the back (D) and centered side-to-side on the sub top and bottom.

**6** From  $\frac{1}{2}$ "-thick stock, cut a  $\frac{7}{8} \times 10$ " workpiece for the capitals (G). Rout a  $\frac{1}{4}$ " cove along an edge of the workpiece. Then, crosscut four  $\frac{3}{4}$ "-long capitals from the piece. Glue the capitals to the sides (C) and sub top and bottom (E), where shown on **Drawing 2**.

**7** From  $\frac{1}{2}$ "-thick stock, cut a  $\frac{3}{4} \times 10$ " workpiece for the pillars (H). Rout a pair

## Cutting Diagram



$\frac{3}{4} \times 5\frac{1}{2} \times 12$ " Bird's-eye maple (.5 bd. ft.)



$\frac{3}{4} \times 5\frac{1}{2} \times 48$ " Cherry (2 bd. ft.) \*Plane or resaw to the thicknesses listed in the Materials List.

## 2 EXPLODED VIEW

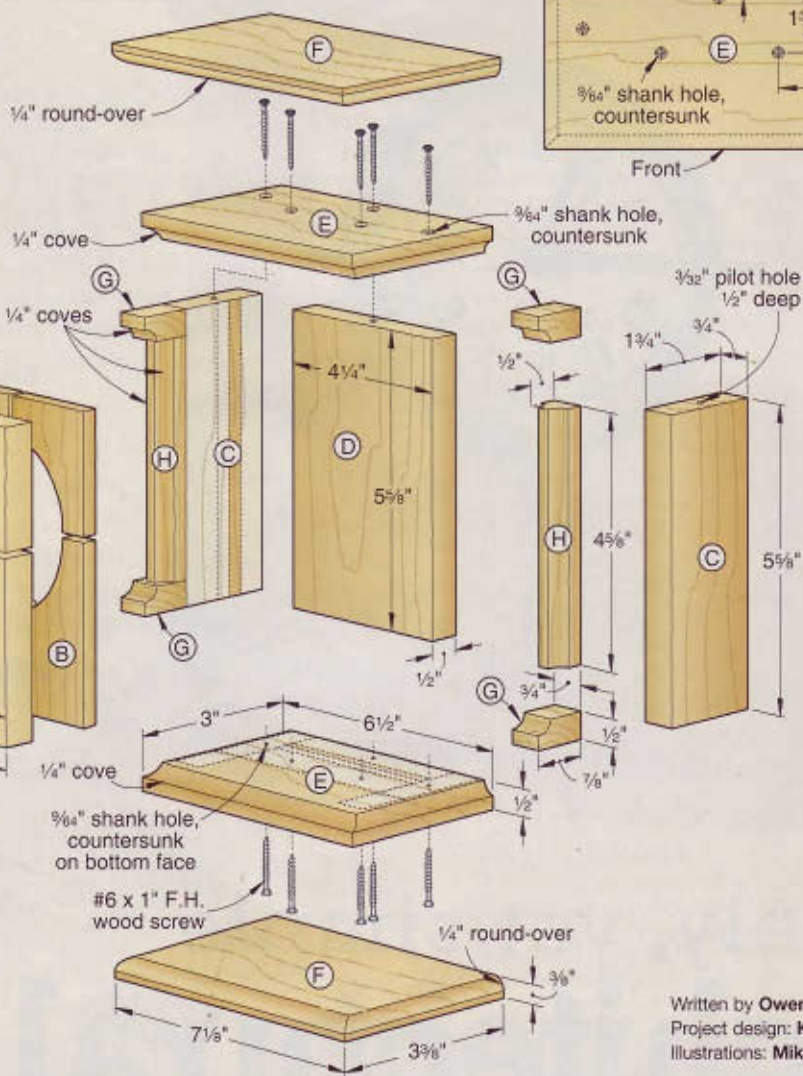

## 2a SCREW LOCATION DETAIL

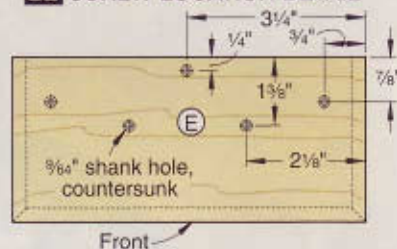

of  $\frac{1}{4}$ " coves on the workpiece, where shown. Then, crosscut two pillars to length to fit snugly between the capitals (G). Glue the pillars to the sides (C).

## Now finish up

**1** Sand any areas that need it, and remove the dust. Then, apply two coats of a clear finish. (We used ZAR Semi-Gloss Polyurethane, sanding to 220 grit between coats.)

**2** Install a 1.5V AA battery in the clock movement, set the time, and press the movement into the face. Finally, take a few moments to enjoy your handiwork. 🌲

## Materials List

Part	FINISHED SIZE	Matl.	Qty.
	T W L		
A face	$\frac{3}{4}$ " 4 $\frac{1}{4}$ " 5 $\frac{5}{8}$ "	BEM	1
B backer	$\frac{1}{4}$ " 4 $\frac{1}{4}$ " 5 $\frac{5}{8}$ "	C	1
C sides	$\frac{3}{4}$ " 1 $\frac{3}{4}$ " 5 $\frac{5}{8}$ "	C	2
D back	$\frac{1}{2}$ " 4 $\frac{1}{4}$ " 5 $\frac{5}{8}$ "	C	1
E sub top and bottom	$\frac{1}{2}$ " 3" 6 $\frac{1}{2}$ "	C	2
F top and bottom	$\frac{3}{8}$ " 3 $\frac{3}{8}$ " 7 $\frac{1}{8}$ "	C	2
G* capitals	$\frac{1}{2}$ " $\frac{7}{8}$ " $\frac{3}{4}$ "	C	4
H* pillars	$\frac{1}{2}$ " $\frac{3}{4}$ " 4 $\frac{5}{8}$ "	C	2

\*Parts initially cut oversize. See the instructions.

**Materials key:** BEM—bird's-eye maple, C—cherry.

**Supplies:** #6 $\times$ 1" flathead wood screws (10), 1.5V AA battery.

**Blades and bits:**  $\frac{1}{4}$ " cove and  $\frac{1}{4}$ " round-over router bits.

## Buying Guide

**Clock movement.** Clock no. 200260, \$10.90 ppd. Add \$6.95 for each additional movement. Call Schlabaugh and Sons Woodworking, 800/346-9663, or go to [www.schsons.com](http://www.schsons.com).

# crown-molding shelf



High in style but inexpensive and easy to build

What can you make from a scrap length of crown molding and a piece of 1x8? How about this stylish go-anywhere accent shelf.

**C**omplete this project, from rummaging for materials to mounting it on the wall, in a weekend, and still have time for a round of golf. A simple, concealed hanging system gives the shelf a built-in look. The **Materials List** shows parts for shelves 25" and 37" long, but you can make a shelf of almost any length.

## First, make the shelf frame

**1** Cut the top (A) and bottom (B) to the sizes listed in the **Materials List**. Install a  $\frac{5}{32}$ "-radius roman ogee bit in your table-mounted router. Adjust it as shown on **Drawing 1**, and rout the profile along the

### 1 TOP PROFILE

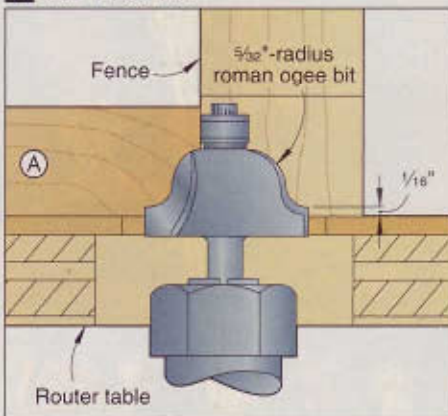

top's ends and front edge, where shown on **Drawing 2**. Now lower the bit as shown on **Drawing 3**, and rout the partial profile along the bottom's ends and front edge.

**2** Cut the back (C) to size. To provide for concealed attachment to the wall, chuck a keyhole bit in your table-mounted router, and adjust it so the top of the bit is  $\frac{3}{8}$ " above the table. Attach an auxiliary extension to your miter gauge, and clamp a stopblock to it to position the back's keyhole slot centers where shown on **Drawing 2**. Rout the slots. Now install a dado blade in your tablesaw, and cut a  $\frac{1}{2}$ " groove  $\frac{3}{8}$ " deep, where shown on **Drawing 4**.

### 3 BOTTOM PROFILE

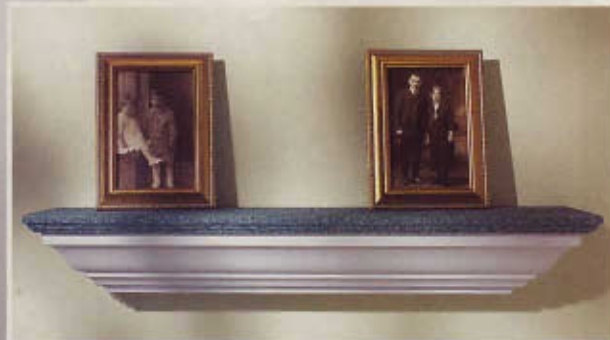
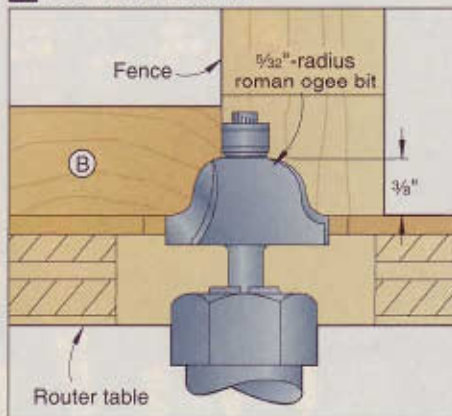

The large photo, left, shows the shelf painted all one color. Here, the shelf's top is finished with an aerosol faux-stone paint.

**3** Glue and clamp the top (A) and the bottom (B) to the back (C), where shown on **Drawing 4**. Keep the ends flush.

## Add the crown molding

**1** Purchase standard (no. 49)  $1\frac{1}{16}$ "x $3\frac{7}{16}$ " crown molding for the crown front (D) and crown sides (E). (You'll need a 36" length for the 25"-long shelf, and a 48" length for the 37" shelf.) Miter one end of the piece for the crown front, mark its exact length, as shown in **Photo A**, and then miter-cut it to length. Cut the remaining piece of crown molding in half, and miter one end of each piece, for the mirror-image crown sides (E). Clamp the crown front in place, and then fit the crown side pieces, marking their exact lengths flush with the back (C). Trim the crown sides to length.

**2** Aligning the heels of the miters of the crown front (D) with the front corners of the bottom (B), glue and clamp it in place. Then glue and clamp the crown sides (E) in place. Make sure the flat bearing surfaces of the molding mate with the bottom surface of the top (A) and the front edge of the bottom (B), where shown on **Drawing 4**.

*Continued on page 110*

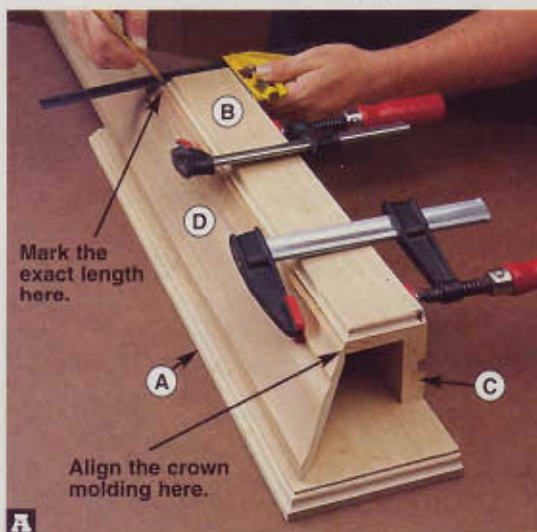

**A** Align the heel of the crown molding's mitered end with one corner of the bottom (B). Using a straightedge, mark the exact length flush with the bottom's opposite end.

## On the mark drilling for keyhole slot screws

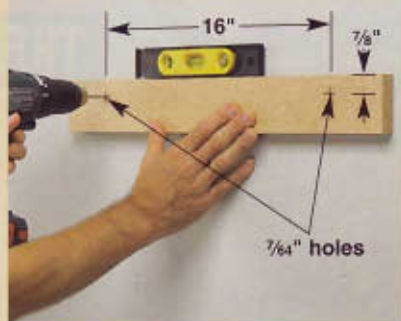

The keyhole slots used for hanging this shelf require driving a pair of #8 panhead screws into the wall spaced exactly 16" apart and dead level. The photo, above, shows you how to accomplish this feat.

First, drill a pair of holes in a scrap of 3/4"-thick stock 16" apart and 7/64" down from its top edge. Drill 7/64" holes for fastening into studs, as shown, or holes sized for wall anchors for fastening between studs. Use your drill press and its fence for accuracy.

Apply a couple small pieces of double-faced tape to the back of the scrap, position its top edge where you want the top of the shelf to be, level it, and press it against the wall. Now, using the holes in the scrap as guides, drill holes in the wall. Remove the scrap, and drive screws into the wall studs, or insert wall anchors and drive the screws into them.

## 2 EXPLODED VIEW

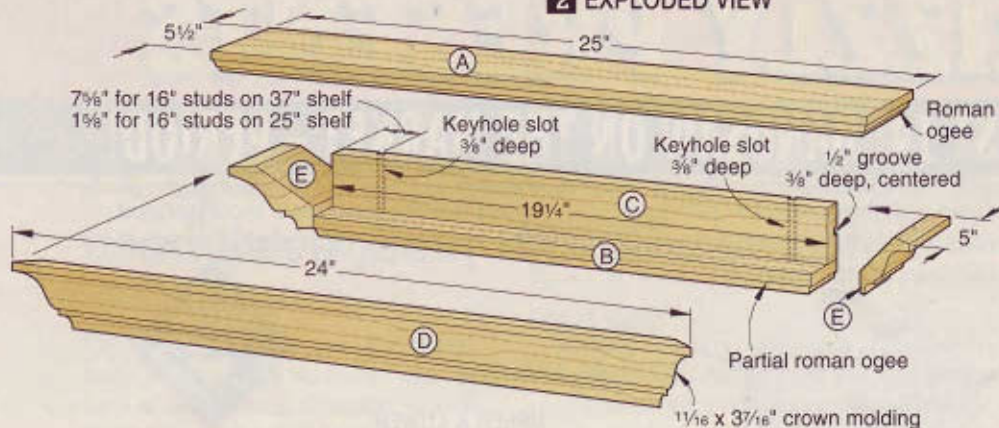

## 4 SIDE SECTION VIEW

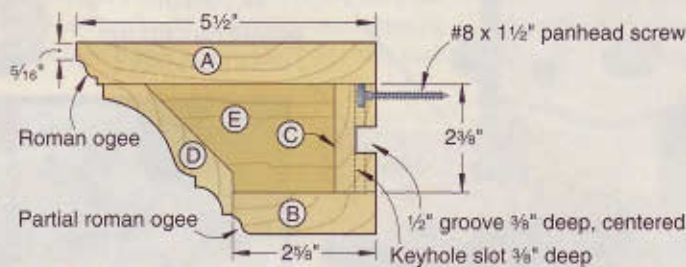

## Apply a finish, and hang the shelf

**1** Finish-sand the shelf to 220 grit. Apply primer, and sand lightly after it dries. Apply the finish color of your choice. (We sprayed on an aerosol all-purpose white primer, and then sprayed both shelves with Rust-Oleum American Accents no. 7930 Blossom White. Then on the 25" shelf we masked the crown and bottom and sprayed the top with Rust-Oleum American Accents Stone Creations no. 7993 Green Marble, following the directions on the can. Finally, to protect the Green Marble paint, we top-coated it with Rust-Oleum American Accents clear matte finish.)

**2** Mark the shelf's location on the wall, and drill pilot holes into wall studs, or install wall anchors 16" on center. To

ensure accurate spacing and dead level alignment, see the Shop Tip, right.

**3** Drive #8x1 1/2" panhead screws, leaving about 3/16" between the wall and the screwheads. Place the groove in the back (C) over the protruding screwheads, and move the shelf sideways until the keyhole slots drop onto the screwheads. Push down on the shelf until the screwheads contact the bottom face of the top (A). You may have to adjust the amount the screwheads protrude to get a snug—but not too tight—fit. Now rescue those old family photos from the trunk in the attic, and proudly display them for all to see. 📌

Written by **Jan Svec** with **Jeff Mertz**  
Project design: **Jim Heavey**  
Illustrations: **Roxanne LeMoine**

## Cutting Diagram (25" shelf)



3/4 x 7 1/4 x 48" Poplar (2.7 bd. ft.)



1 1/16 x 3 3/16 x 36" Crown molding (no.49)

## Cutting Diagram (37" shelf)

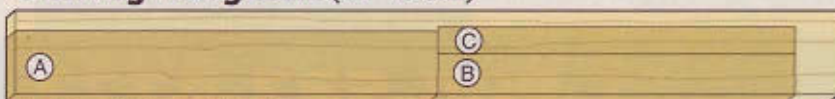

3/4 x 7 1/4 x 72" Poplar (4 bd. ft.)



1 1/16 x 3 3/16 x 48" Crown molding (no. 49)

## Materials List

25" shelf	FINISHED SIZE			Matl.	Qty.
	T	W	L		
A top	3/4"	5 1/2"	25"	P	1
B bottom	3/4"	2 3/8"	19 1/4"	P	1
C back	3/4"	2 3/8"	19 1/4"	P	1
D* crown front	1 1/16"	3 3/16"	24"	PC	1
E* crown sides	1 1/16"	3 3/16"	5"	PC	2
37" shelf					
A top	3/4"	5 1/2"	37"	P	1
B bottom	3/4"	2 3/8"	31 1/4"	P	1
C back	3/4"	2 3/8"	31 1/4"	P	1
D* crown front	1 1/16"	3 3/16"	36"	PC	1
E* crown sides	1 1/16"	3 3/16"	5"	PC	2

\*Parts initially cut oversize. See the instructions.

**Materials key:** P—poplar, PC—poplar crown molding.

**Supplies:** #8x1 1/2" panhead screws, double-faced tape.

**Blades and bits:** Stack dado set, 3/32"-radius roman ogee and keyhole router bits.

## Buying Guide

**Router bits.** Freud 3/32"-radius roman ogee bit no. 38-100 (1/4" shank), \$28.99, or no. 38-104 (1/2" shank), \$29.99; Freud keyhole bit no. 70-104, \$17.99. Woodworker's Supply. Call 800/645-9292, or go to woodworker.com.

# era-inspired picture frame

Subtle "cloud-lift" rails and square-peg ornamentation capture the styling of famed architects Greene and Greene.



## Who were Greene and Greene?

More than just brothers, Charles and Henry Greene were prominent California architects who embraced the English Arts and Crafts style that began to take root in America around 1870. From about 1900 to the mid-1930s, the Greenes created a distinctive look that can be seen in both their residential designs and complementary interior furnishings.

*Note: This project's frame will accept a 5x7" photo. For larger photos, just make the length of the rails and stiles 3 1/2" longer than the width and height of your photo, and adjust the size of the back (F) accordingly. For a photo larger than 8x12", we recommend that you omit the supports (E), and wall-mount the frame using a suitable hanger.*

## Cut the frame parts

**1** From 3/4"-thick stock, cut the top rail (A) and bottom rail (B) to the size listed in the **Materials List**. From 1/2"-thick stock, cut the stiles (C) to size.

**2** Make two photocopies of the full-size rail pattern in the *WOOD Patterns*® insert. (If you're making several frames, we suggest you make a hardboard template of the pattern, and use it to mark the details on the rails.) Using spray adhesive, attach a pattern to the front face of each rail. On one rail, transfer the locations for the 1 1/4" dados, shown on the pattern, onto the rail's edges. Clamp the rails together with their edges aligned, and extend the lines on the marked rail onto the other rail. Separate the pieces. Then, on the bottom rail (B), transfer the centerpoints for the two 1/4" holes for the frame support dowels (E) onto the back of the rail.

*Note: If you are making a larger frame, cut each pattern in half, and glue the pieces in position at the ends of the rails. Then, transfer the dado and hole locations onto the rails.*

**3** With a dado blade installed in your tablesaw, cut the 1/2"-deep dados in the back of the rails. Bandsaw the two cloud-lift details in each rail, where shown on the pattern, and sand smooth. On the back of the bottom rail (B), drill a 1/4" hole 3/8" deep at the two marked centerpoints.

**4** Place a 1/2"-thick scrap piece in one of the dados in the top rail (A) to prevent tear-out when forming the 3/8"-square mortise. Drill an 1 1/32" hole, centered in the mortise location, where shown on the pattern. Then, square the mortise. (See the **Shop Tip**, on page 114.) Repeat this process to form the remaining mortise in the top rail and the two mortises in the bottom rail (B).

*Continued on page 114*

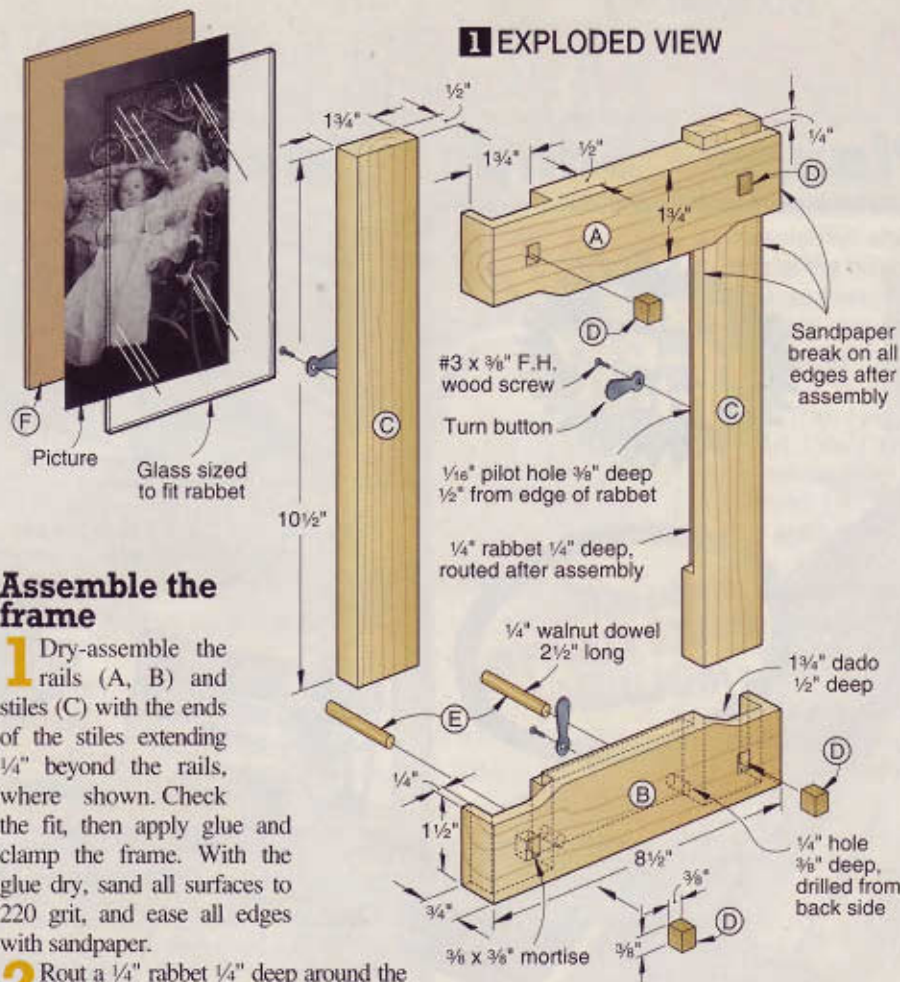

## Assemble the frame

**1** Dry-assemble the rails (A, B) and stiles (C) with the ends of the stiles extending 1/4" beyond the rails, where shown. Check the fit, then apply glue and clamp the frame. With the glue dry, sand all surfaces to 220 grit, and ease all edges with sandpaper.

**2** Rout a 1/4" rabbet 1/4" deep around the opening on the back of the frame. Square the corners of the rabbet with a chisel.

**3** Cut a piece of walnut to 3/8" x 3/8" x 12" for forming the corner pins (D). Apply glue to the inside of one of the 3/8" mortises, and insert the pin blank, bottoming it in the hole. Trim the blank, as shown in **Photo A**, leaving the pin projecting approximately 3/32" above the rail's surface. Repeat this at the other three corners of the frame.

**4** Hand-sand the top of each pin, gently rounding the surface toward the corners. Do not sand the pins flush. The final pin height should be approximately 1/16".

**5** Cut the frame supports (E) to size. Then, glue them into the holes in the back of the bottom rail (B). Cut the back (F) to size from 1/8" hardboard. Have a piece of 1/8"-thick glass cut to the same size.

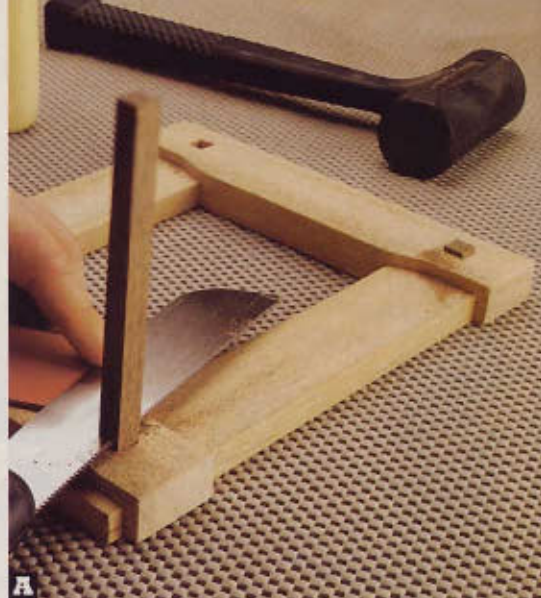

**A** With a 3/32" spacer placed under a flush-cutting saw, trim the corner-pin blank, leaving the pin proud of the rail's surface.

**6** Drill 1/16" pilot holes 3/8" deep in the back of the frame for the turn button mounting screws. Locate the holes 1/2" away from the frame opening.

## Finish up

**1** Sand any areas that need it, and remove the dust. Apply three coats of a clear finish (we used Minwax Antique Oil), sanding between coats. Apply extra oil to thirsty end-grain areas.

**2** Now, place the glass, a favorite picture, and the back (F) into the frame, and install the turn buttons. ♣

Written by **Owen Duvall**  
Project design: **Jeff Mertz**  
Illustrations: **Mike Mittermeier**

## Materials List

Part	FINISHED SIZE			Matl.	Qty.
	T	W	L		
A top rail	3/4"	1 3/4"	8 1/2"	M	1
B bottom rail	3/4"	1 3/4"	8 1/2"	M	1
C stiles	1/2"	1 3/4"	10 1/2"	M	2
D* corner pins	3/8"	3/8"	5/16"	W	4
E frame supports	1/8" diam.		2 1/2"	WD	2
F back	1/8"	4 15/16"	6 15/16"	HB	1

\*Parts initially cut oversize. See the instructions.

**Materials key:** M—mahogany, W—walnut, WD—walnut dowel, HB—hardboard.

**Supplies:** Spray adhesive, 1/8" x 4 15/16" x 6 15/16" glass, turn buttons (4), #3 x 3/8" flathead wood screws (4).

**Blades and bits:** Dado blade, 1/4" piloted rabbeting bit, 3/8" mortising chisel, flush-cutting saw.

## SHOP TIP

### Square mortises the easy way

You can use a handled chisel to square the mortises in the picture frame's rails, but for greater ease and consistent results, try a 3/8" mortising chisel with the bit removed. Just drill an 1 1/32" hole, center the chisel over the hole, and tap the chisel a few times with a dead blow hammer. These chisels sell for less than \$25.



## See more . . .

...gift and decorative accessory plans at

<http://woodstore.woodmall.com/gifts.html>



# get "bar top" tough with epoxy

When the situation calls for a super-thick tabletop finish, pour it from a pair of bottles.

**I**f you want a thick finish that has no trouble standing up to spilled water and alcoholic drinks, and can absorb a lot of physical punishment, epoxy does the job. However, it calls for much different application techniques than traditional wood finishes, and perfect results can prove tricky to achieve. Follow this advice for quality results.

Epoxy comes in two parts: Resin and hardener. Some brands call for 1:1 mixing; others, two parts of resin and one of hardener. For this article, we used System Three Mirror Coat, a 2:1 product from System Three Resins. It's available from Woodcraft in a 1½-pint kit, item 143153, priced at \$24.99. With 1½ pints, you can cover nearly 5 square feet with a coating ¼" thick. A 1½-quart kit that covers 9½ square feet, item 143154, costs \$39.99. Call 800/225-1153 to order, or visit [www.woodcraft.com](http://www.woodcraft.com).

Your workshop should be well ventilated and between 70° and 85° while you work with epoxy. Use eye protection and gloves. If necessary, clean uncured epoxy from your skin with soap and water or vinegar.

For best results, take care to mix the two parts accurately, and prepare no more than you'll use in 30 minutes. Place your project on cardboard or a tarp to catch any drips, and make sure the surface to be coated is level. A single thick coat can result in trapped bubbles as air rises out of the wood pores, so plan to apply two coats. A thin first coat allows the air to escape through the epoxy before it cures, paving the way for the second coat to go on more smoothly. Allow the first coat to dry, and then apply the second coat within 72 hours of the first application to ensure proper bond-

*Continued on page 120*



**A** Along with a two-part epoxy product, you need a mixing container; gloves; masking tape for the underside of the surface; a leveling tool, such as the plastic spreader shown here; and an inexpensive brush that you'll throw away after coating the edges.



**C** Use a measuring spoon or small cup to measure out the resin and hardener into your mixing container, and then stir it steadily for two minutes with a stick. Scrape it off the sides as necessary, but don't mix vigorously enough to introduce air bubbles.



**B** Apply masking tape flush with the edge of the surface to be coated. We placed short strips all the way around the table, each one protruding slightly, and then trimmed them with scissors. After you pour the epoxy, allow it to set up, and then peel away the tape. Any epoxy "stalactites" will come with it.



**D** Pour the epoxy mixture onto the surface, and spread it with your plastic spreader. After applying your first thin coat, wait 30 minutes, and then use this same tool to scrape off the excess. Pour the second coat up to ¼" thick, and again use the spreader to assist the self-leveling process.

# ROUTERSHOP

by HAWK Woodworking Tools.

"The router tool with a brain"

- No fancy bits required - with a simple bit you can create a complete set of cabinets
- Patented tilting table - set your cutter vertically & horizontally for a safe, new way to make cuts
- No time consuming set-ups, the calibrated crossfeed system does it automatically with its built-in "brain"
- Solid steel work surface - no flimsy chipboard to warp
- Factory Direct Savings



Ask for a **FREE** Demonstration VIDEO and FACT KIT

E038

Discover how the Hawk RouterShop™ can help you unlock your woodworking potential.

Call 1-800-487-2623

www.hawkwoodworkingtools.com

© 2003 rbindustries, inc.

Circle No. 1676

Adams Wood Products™ LTD., LP.

STOCK ITEMS  
NO MINIMUM ORDERS  
-OR-  
WE WILL MAKE PRODUCTION RUNS OF YOUR PART

By American Craftsmen

ACR108  
913 LEGS

CHAIR LEGS

AM100B

BUN LEGS  
A0556

FR STYLE QUEEN ANNE LEGS

FINIALS  
A0851

113 REEDED BASE W/206 LEG

404 CHAIR KITS

P.O. Box 728, Dept. M52  
Morristown, TN 37815-0728  
Phone 423-587-2942 • Fax 423-586-2188  
www.adamswoodproducts.com

FREE COLOR CATALOG

Circle No. 1831

## finishing school



Use a brush to coat the edges with any epoxy that overflows the top. Dip into the mixing container if you need more material to produce an even layer. Expect to leave a thinner coat on vertical surfaces than you did on horizontal ones.



Continue to inspect the surface for several minutes after you finish spreading the thick coat. Blow gently on any air bubbles to make sure they pop. As an alternative, use a blow dryer set to its lowest blower speed. Be careful to hold it well away from the surface, and keep it moving to avoid putting ripples into the finish. Or, do the job with a heat gun held 6 to 12 inches from the surface.



If your cured epoxy finish contains craters and bubbles, you can rub out all or most of them. Begin with 320-grit wet/dry sandpaper, water, and dish soap. Continue on to higher grits until you're satisfied with the results. We left the right half of the table untouched, while working up to 4,000 grit on the left half with abrasive pads on a random-orbit sander. Most of the flaws disappeared, as did the high gloss. To restore glossiness, continue with finer rubbing compounds.

ing. If you want to apply epoxy on both sides of a surface, turn the project facedown and do the underside first.

To embed pictures or other objects in the finish, place them in the thick coat while it's wet. Cover them with subsequent coats. ♣



See over 260 JET tools online.  
www.amazon.com/jet

Most woodworkers are looking for the most efficient dust collection system they can find. The new JET canister filter dust collector filters down to 2 microns, and delivers the superior dust collection today's woodworkers demand.

- Powerful 1-1/2 horsepower motor
- Canister filter traps particles down to 2 microns
- V-weave filter design offers 12,052 square inches of filtering surface area
- Easy clean filter eliminates clean-out mess
- Clear plastic collection bags for easy dust disposal

**\$100 COUPON OFFER**

\$100 coupon by mail toward the purchase of any other qualifying Jet, Powermatic, or Performax machine over \$349. Coupon effective 9-1-03 through 4-30-04.



\*We will match our competitors price plus beat it by 10% of the difference. Find out more at www.amazon.com/price-match.



#708626CK  
Dust Collector  
with Filter  
Canister

Call for your FREE Tool Crib catalog  
1-800-635-5140

amazon.com  
tools & hardware

# what a pyramid point tool can do for you

"I wish someone had shown me one of these when I first tried to turn beads."

— Phil Brennon, professional woodturner

The pyramid point tool has been in English turners' tool boxes for generations, and was typically shop-made from a triangular file. We found one made from 1/2" round high-speed steel in the Craft Supplies USA catalog, where it claimed, "...the three-sided pyramid point tool is excellent for turning perfect beads and spheres.... It is not a scraping tool but is used for shearing or planing surfaces, much as a skew is used. However, the pyramid point tool is more forgiving and doesn't produce the catches of a skew." Needless to say, that last part piqued our interest.

To test the claims, we sent the tool to professional turner and *WOOD* magazine consultant Phil Brennon of Chino Valley, Arizona, for his evaluation. We asked Phil to

answer the following four questions. Trying the tool out turning willow, box elder, and ash, here's what he discovered.

## What's it good for?

The pyramid point tool performs many of the same functions as a skew chisel, but with minimal potential for the nasty kickback often associated with a skew. As easy to use as a scraper, it cuts with a shearing action to produce beads and spheres with much less demand for advanced technique. You easily can accomplish sharp detail, especially where you find a gradual transition into the detail. But because of the tool's 30° pyramid tip, it cannot form deep, narrow cuts. The tool is great for forming tenons, and although you can make planing cuts and tapers with it, the

bevels' short edges make it difficult to get smooth surfaces on long cuts.

## How do I use it?

Unlike a skew chisel, you'll immediately be comfortable with the pyramid point tool. It takes a little time to develop the technique required to use it to its fullest potential, but even a novice can soon turn beads and other convex surfaces with few problems. As you use the tool, you'll discover more things you can do with it, and more than one way to make the same cuts. When using the pyramid point tool, position the tool rest about 1/2" below the center of your workpiece so the tool cuts at or above center.

To form a bead, first mark the center and both sides of the bead with a pencil. Make V-grooves to define the bead, as shown in **Photo A**.

## The pyramid point tool excels at beading cuts...

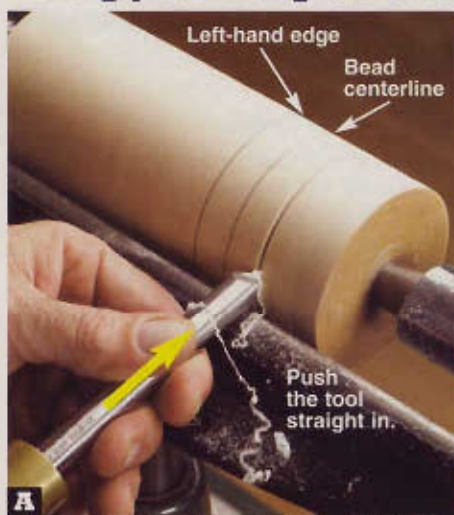

To cut a bead, position the tool at 90° to the workpiece with one bevel facing up and the handle slightly down. (The handle's downward angle produces a shearing action.) Push the tool into the workpiece, forming V-cuts to define the bead.



With one of the tool's bevels up, position its edge parallel to the axis of the workpiece and the point toward the left-hand groove. Starting at the bead's center, swing the handle to the left as you steer the point into the groove. Repeat on the right-hand side.

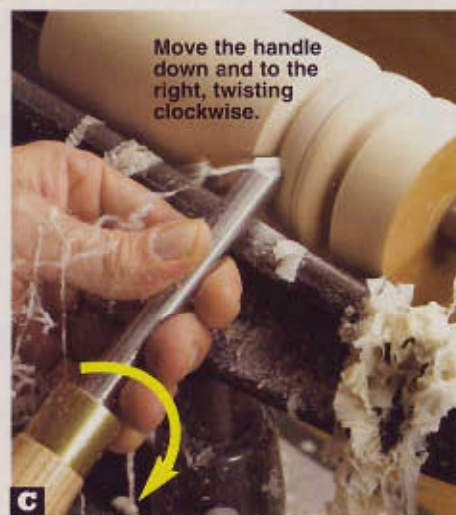

With the tool in the left groove, simultaneously move the handle down and to the right while twisting it in a clockwise direction until you arrive at the top of the bead. Repeat from the right groove with the opposite handle swing and twist.

*Continued on page 124*



Three bevels and three sharp edges on the end of a 1/2" round shaft make a versatile tool you'll want to take for a spin.



...and it's pretty good for planing and end-grain cuts, too.

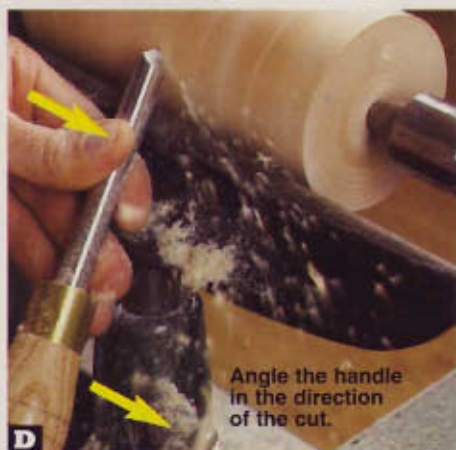

**D** Position the tool with one of its bevels riding flat on the workpiece, with the handle angled in the direction of the cut. Slightly rotate the tool, engaging the half of the cutting edge closest to its heel. Now advance the tool along the length of the workpiece.

Rough out the bead, as shown in **Photo B**. Cutting downhill from the bead's center to the groove removes stock quickly, and avoids pulling chips out of the grain.

To finish the bead, start with the tool in the groove, and cut uphill from the groove to the bead's center, as shown in **Photo C**. This gives you ultimate control for smoothing your beads. With most of the waste already removed, chipping is eliminated.

Make planing cuts on cylinders or long



**E** To dress end grain, position the tool with one bevel up and tilted slightly toward the work surface. Engage the workpiece, advancing the tool from edge to center, using the whole cutting edge on flat surfaces and the middle of the cutting edge on convex surfaces.

tapers using the half of the cutting edge closest to its heel, as shown in **Photo D**. Finally, dress end grain, as shown in **Photo E**.

As one cutting edge dulls, simply rotate the tool to the next one. With this tool, you have three edges to dull before sharpening.

**How do I sharpen it?**

For surface quality close to that produced by a skew chisel, you'll need to keep this tool sharp. To sharpen the tool, lay it on a

platform-type tool rest, adjusting its angle so the bevel makes full contact with the grinding wheel. Switch on the grinder, and lightly touch the bevel to the wheel, checking to make sure its entire surface is ground. Pay close attention to keeping the bevel straight when contacting the wheel, and avoid any rolling motion. Rotate the tool to the next bevel and repeat, keeping the point centered on the tool. To grind bevels exactly 120° apart, see the **Shop Tip**, below.

**Should I buy one?**

The pyramid point tool's great attraction is its ability to make cuts normally reserved for a skew chisel, such as forming beads and spheres, with very little potential for the catches and spiraling digs associated with a skew. The tool's rather short, three-bevel tip allows for fairly aggressive removal of wood from your workpiece. Although not capable of deep detail, it performs most jobs well, and with a little practice, leaves clean, smooth surfaces. While not likely to make you throw away your skew chisel, the pyramid point tool just might make it collect dust, rather than make it. ♣

**Buying Guide**

**Pyramid point tool.** Pyramid point tool no. 988-1023, \$25.99, or unhandled no. 088-2023, \$22.99. Craft Supplies USA, 800/551-8876, or go to [www.woodturnerscatalog.com](http://www.woodturnerscatalog.com).

**SHOP TIP**

**Make this simple grinding guide for foolproof sharpening**

Although the sharpening geometry of the pyramid point tool is simple (three 30° bevels on the end of a round bar), keeping the tool steady while grinding and the bevels even is a challenge. Here's a simple hardware-store solution from Dave Collier of Nashville, Tennessee.

Buy a hexnut that fits closely over the tool's shaft, and a socket-head setscrew. (We found a 3/16" hexagonal lock nut and a 1/4"-20 setscrew 3/16" long in our local hardware store's specialty fasteners aisle.)

Drill a hole centered on one of the nut's faces, and tap threads for the setscrew. (See photo, above.)

Thread the setscrew into the nut, and slip the nut over the tool shaft. Align one of the nut's faces with one of the tool's bevels, and tighten the setscrew with an Allen wrench. Lay the tool on your grinder's platform rest with one hexnut face on the rest and one bevel on the

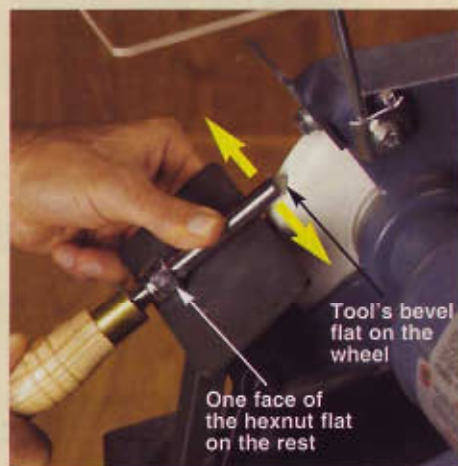
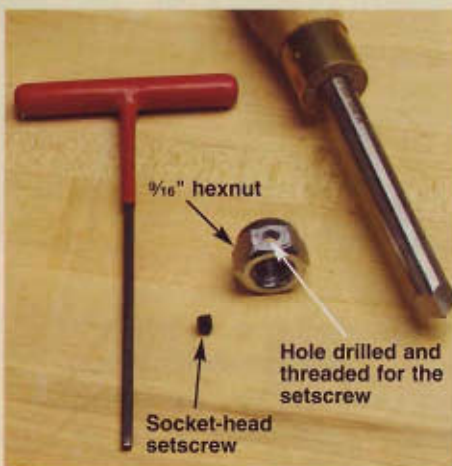

grinding wheel. Adjust the platform's angle so the tool's bevel rests flat against the wheel, as shown in the photo, above. Switch on the grinder, and lightly touch the bevel to the wheel, moving it side-to-side by pivoting the tool on the nut. When the bevel is ground toe to heel, rotate the tool to its next bevel, and repeat.

# 6 steps to perfect stock

Save money by buying rough-sawn lumber, and then turn that stock into ideal boards with your jointer, planer, and tablesaw using this simple method.

**E**ver wind up with a cabinet door that won't rest flat against its frame? Or do you find yourself sanding, sanding, and sanding a joint that you just couldn't make flush? To avoid these frustrations, I recommend you take the time to make your lumber flat, straight, square, and of uniform thickness before you start each project. Follow the steps shown here even if you buy wood with two straight edges and a surfaced thickness of  $\frac{25}{32}$ ", as sold by

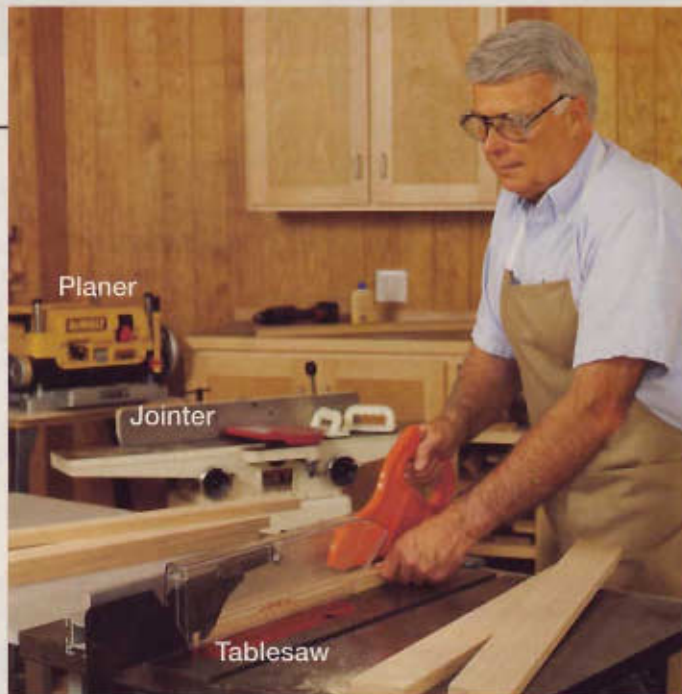

many home centers. Or, use this procedure to even greater benefit when you buy rough-sawn or skip-planed stock at a sawmill. Take advantage of the lower price per board foot, then surface it yourself.

*CHUCK HEDLUND*

WOOD® Magazine Master Craftsman

## 1 Bring home the best.

No matter where you buy your lumber, sort through it relentlessly. Look down the edge of each board to spot bowing, and sight along the face to find cupping. You don't have to come away with absolutely perfect stock, but buy the best you can find. At a sawmill, you might come across rough-sawn boards or skip-planed boards. You can work with either type; skip-planed boards give you a better idea of the wood's true color. Always keep the stack neat so the sawmill will welcome you back the next time.

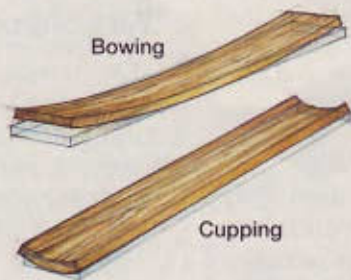

## 2 Start breaking it down.

Back in your shop, remove any staples, and crosscut at least  $\frac{1}{8}$ " from each end of each board. It's likely to have grit embedded in the end grain after all the hauling and stacking it's been through, and that material will dull your sharp tools. Cut off more, as necessary, to get rid of checked or discolored ends.

Next, figure out how you're going to use each board. Mark the basic outline of project parts in chalk, avoiding knots and other flaws while showing off the grain to best advantage. A cardboard "window," cut to the approximate shape of a given part, helps you select good-looking grain.

Crosscut the pieces a couple of inches longer than needed; crosscutting makes it easier to deal with bows and other imperfections in the following steps than if you left the boards long. Finally, rip the pieces  $\frac{1}{4}$ " over width.

*Continued on page 128*

### 3 Flatten one face at the jointer.

Study each workpiece to determine the best feed direction for preventing tear-out. Orient the edge-grain lines, as shown at *right*, so that the jointer knives slice through the fibers instead of prying them up. However, ray lines, which are less prominent than grain lines, sometimes run in a different direction and in some cases can determine the smoothness of a jointed or planed surface. For this reason, check the results after the first pass, and flip the workpiece end for end if you find tear-out. If the piece has a slight bow, place the concave face down, and use pushpads to apply pressure at the ends only. Also put the concave face down if the workpiece is cupped. Set your jointer for a light cut (about  $\frac{1}{32}$ "), and work on one workpiece at a time, making as many passes as necessary. When you hear a consistent cutting sound all the way through a pass, lay the jointed face on a flat surface, such as your tablesaw, and check it for flatness.

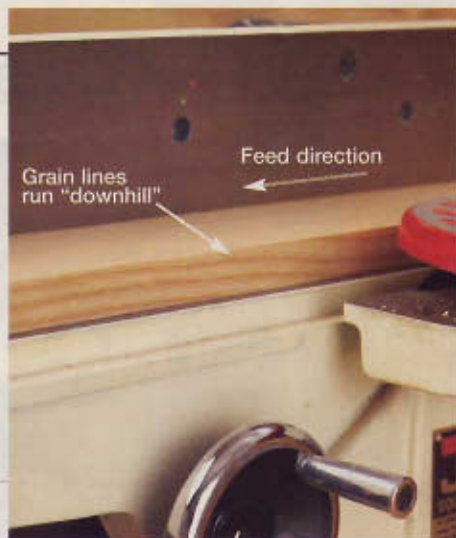

### 4 Now, head to the planer.

The jointer produces a flat face, but it takes a planer to make the opposite face parallel to the jointed one (jointing both faces could produce a tapered workpiece). Again, examine the edge grain of each workpiece to find the best orientation. Stack the sorted boards next to the planer, arranged so that you'll naturally pick them up in the correct orientation. Keep organized with a second stack for the boards as they come out of the planer.

Set your planer to remove no more than  $\frac{1}{32}$ " from the thickest workpiece in your stack, and send each workpiece through the machine at that setting. Check the results for tear-out, and flip the workpiece end for end if necessary. Reset the planer and repeat the process until the upper faces are flat. If the workpieces are still thicker than  $\frac{3}{4}$ ", continue to plane them, but flip each workpiece end for end between passes; removing equal amounts of material from each face helps to keep wood stable. For most purposes, make your stock  $\frac{3}{4}$ " thick, a dimension that looks good and keeps calculations simple.

### 5 Square up one edge.

Now it's easy to joint one edge  $90^\circ$  to both faces. First, check your jointer with a square or drafting triangle to make sure that the fence sits at a right angle to the outfeed table. Then, check face-grain direction instead of edge grain, orient your boards correctly in a stack, and proceed to joint one edge of each workpiece with light passes.

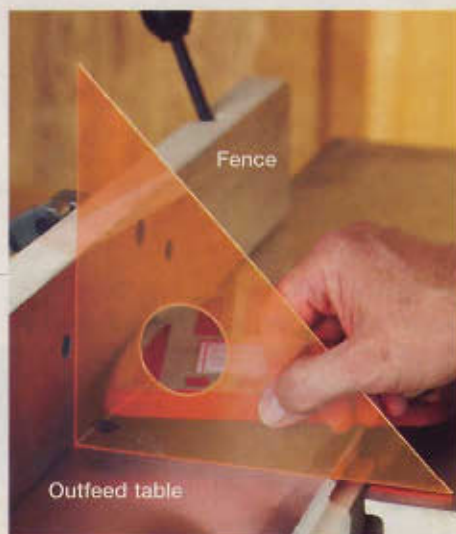

### 6 Rip, joint, and you're done.

It's time to bring each piece to its finished width. Install a sharp blade in your table-saw, and for each piece set the fence to the finished width plus  $\frac{1}{32}$ ". Make the rip cut, and then return to the jointer to clean up the saw blade marks. Set the jointer to remove  $\frac{1}{32}$ ", and make one pass on the sawn edge. This pass produces the desired width and a smooth surface at the same time. Now you're ready to start building; just cut each piece to length when you need it. 🛠️

# shop-proven products

These woodworking wares passed our shop trials

## Compact compressor kit packs a punch

When Senco's PC0947/FP18 air compressor and brad nailer kit landed on my bench, I thought, "Isn't that cute?" I mean, this tiny compressor fits in my chair with room to spare—how serious can it be? Then I put it to work and found out this little guy means business.

First, I carried the compressor into my house to finish up trimming out a room. At 20 pounds, it weighs only about a third as much as typical 4-gallon "portable" pancake- or hot-dog-style compressors, yet it has all of the amenities of the big boys. The gauges are well-located and easy to read, and it's surprisingly quiet for an oil-free unit.

The 18-gauge brad nailer that came with the kit drives fasteners from  $\frac{5}{8}$ " to 2" and has all of the features you'd expect these days—soft-grip handle, a "fuel gauge" to show when you're getting low on fasteners, and a removable no-mar tip. I also like the belt hook to keep the tool close at hand, and the depth-of-drive control for setting brads perfectly below the surface.

Teamed together with a coiled air hose, the three make a great package for woodworkers who need a compressor primarily for use with a nailer. I punched ten 2" brads quickly into thick hard maple, just bang-bang-bang, and each nail set to the same depth without starving the compressor of air. But the small tank means the compressor will have to run more often, so it's better suited to the home shop or punch-list guy, rather than all-day use by a trim carpenter.



### Senco PC0947/FP18 air compressor/brad nailer kit

Performance ★★★★★  
Price \$200

Senco  
800/543-4596, www.senco.com

—Tested by Kevin Boyle

## Save money, fingers, and lungs with overarm blade guard and dust hood

Most woodworkers know about the health benefits of good dust collection. But a table saw's collection system often consists of only a dust port beneath the saw, where the debris falls harmlessly anyway. The fine dust that flings off the blade on top of the table, however, enters the air to become a breathing hazard.

Penn State answers the problem with an economical overarm blade guard/dust collector that protects both fingers and lungs. The concept isn't new, but the TSGUARD costs from \$90 to \$300 less than other similar devices. For the price difference, you get some good features and a few minor annoyances. (As with all overarm guards, you should still use a splitter behind the blade to reduce the chance of kickback.)

The floor-standing TSGUARD mounts to the end of the saw's extension table, so it doesn't interfere with most rear fence rails, with a height-adjustable leg. You also can ceiling-mount the boom, and Penn State includes the hardware to do so. The molded plastic hood that constitutes the guard provides an unobstructed view of the blade,

and replaceable inserts at the rear of the hood can accommodate a splitter or anti-kickback pawls.

As I tested the TSGUARD, I found myself adjusting the hood side-to-side more than I expected. Usually, I centered it over the blade, but sometimes I shifted it to one side to clear my miter-gauge extension. The telescoping dust-collection boom makes these adjustments pretty easy, but instead of a special grommet to seal between the inner and outer tubes of the boom, a rubber O-ring rolls up and down the inner tube to create a somewhat imperfect seal. Still, I found that the accessory captured nearly all of the tabletop dust I generated, whether the O-ring was in place or not. (The boom accepts both 4" dust-collection hose and 2½" vac hose.)

The instructions provided should more rightly be called "rough guidelines," as they were

incomplete, and required a good dose of intuition to complete the assembly, which took about two hours. In fact, I learned more about how the TSGUARD goes together—and even found an assembly that came wrong from the factory—by looking at the photo in the Penn State catalog.

—Tested by Jan Svec



### Penn State TSGUARD overarm blade guard/dust hood

Performance ★★★★★  
Price \$218 (ppd.)

Penn State Industries  
800/377-7297, www.pennstateind.com

Continued on page 132

Why should I use System Three on my projects?

**“Because Woodworking Built Our Company.”**

**Kern Hendricks -**  
Chemical Engineer & Founder

Get a rebate coupon for \$5.00 off your next purchase\* at: [systemthree.com](http://systemthree.com) click: Rebates & Coupons! Visit our new website!



Pourable, self-leveling, topcoating. Scratch & stain resistant as well as alcohol & water proof.

**We Understand Specific Woodworking Applications.**

For over 2 decades we've been working with woodworkers to formulate the highest quality epoxy adhesives and coatings for their specific applications. We specifically designed MirrorCoat to create a high gloss, decorative coating on wood and other materials.

**Pourable Perfection.**

MirrorCoat is specially formulated to create glossy, high build resin surfaces on bars, counters and tabletops. Pour a perfect durable, smooth, glossy finish on many surfaces such as wood, ceramics, plaster and masonry.

**SYSTEMTHREE**

Find a dealer near you: 1.800.333.5514

©2003 System Three Products, Inc. All Rights Reserved.  
Circle No. 117

**shop-proven** products

**One bit countersinks and drives the screw**

For those speedy woodworkers who find today's quick-change drill accessories too slow, Craftsman offers a single driver bit that both countersinks a screw hole and drives the fastener that goes in it. (See photos.) The trick is in the tip, which has cutting flutes on each of its four "wings."

Although the Craftsman Countersinking Phillips Bit doesn't drill a pilot hole, I had little trouble with splitting—even in hardwoods—unless I was near the end of a board. And, I found the countersink created by this bit fit the screw better than the dedicated countersinking bits in my shop. I also compared this technique with some self-sinking screws, and found that conventional screws countersunk with the Craftsman bit seated flush or a bit below the wood surface better than those specialized screws.

I found an unexpected benefit when using the Countersinking Phillips Bit to drive brass screws. The fluted tip seemed to "bite" into the screw slots better than an ordinary driver bit, so I shredded far fewer screw heads.

You'll find these bits sold in two different configurations in Sears stores and catalogs. One set (#25820) includes eight double-ended bits in a plastic case; the other (#25824) comes with six such bits, a quick-release chuck, and a screw-starting sleeve. Both sets include bits for #1, #2, and #3 Phillips screws.

**Craftsman Countersinking Phillips Bits**

Performance	★★★★★
Price	\$15, #25820; \$20, #25824

Craftsman  
Visit your local Sears, [www.sears.com/craftsman](http://www.sears.com/craftsman)

—Tested by Jeff Hall

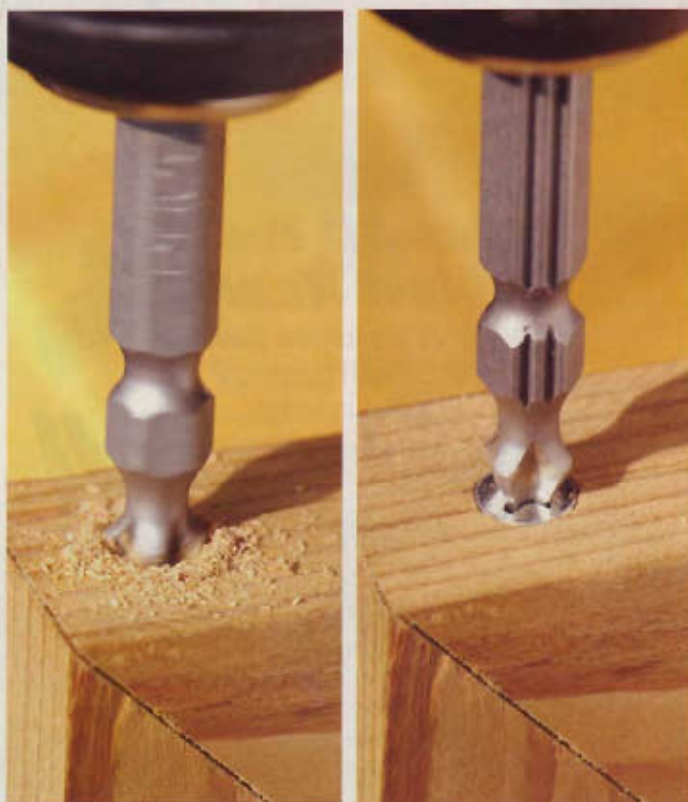

**SIMPLE WOODWORKING SOLUTIONS THAT WORK EVERY TIME!**

**POCK'IT JIG KIT**

- KIT CONTAINS:**
- Pocket Jig with Clamp
  - 3/8" Step Drill Bit
  - Stop Collar for Drill Bit
  - Hex Wrench for Collar
  - Square Drive Screws
  - 6" Square Drive Bit

TAKE IT HOME AND MAKE JOINTS - NOTHING MORE TO BUY.



**DOWL SIMP'L KIT**

OUR DOWELING JIG COMES WITH EVERYTHING NEEDED FOR EDGE TO EDGE AND RIGHT ANGLE DOWELING.

- IN THIS KIT:**
- Doweling Jig/Clamp
  - 3 Brad Point Bits
  - 3 Drill Bushings
  - Supply of Dowels
  - Tube of Wood Glue



\$39.95\*

\$19.95\*

**SANTA'S CHOICE FOR DAD!**

**JOINT'R CLAMP KIT**

(2 clamps per kit)

Now you can straight line rip a crooked board on any table saw with this versatile kit.

\$16.95\*

\* SOLD ONLY THRU DEALERS. SEND FOR OUR LIST

**SIMP'L PRODUCTS Inc.**

21 Bertel Avenue, Mount Vernon, NY 10550  
Web Site: [woodjigs.com](http://woodjigs.com) E-Mail: [info@woodjigs.com](mailto:info@woodjigs.com)

Circle No. 665

Continued on page 134

## BUILD YOUR BEST WITH THE NEW MILLER DOWEL

Miller® Dowels are currently offered in multiple sizes and are intended for use with a corresponding TruFit Drill Bit. Available in Birch, Cherry, Red Oak and Black Walnut.



### SUPERIOR FASTENERS FOR SOLID WOOD JOINERY

- **SIMPLE** – fast and easy to use
- **STRONG** – solid, longer-lasting joints
- **ECONOMICAL** – minimal tools required
- **VERSATILE** – use in any woodworking project
- **UNIQUE** – the only natural fastener designed for insertion from the outside
- **EXCELLENT RESULTS** – an appealing and durable alternative to metal fasteners

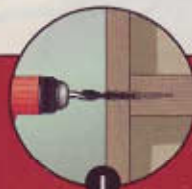

1 DRILL STEPPED  
PILOT HOLE

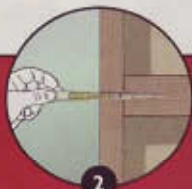

2 ADD GLUE & INSERT



3 TAP &  
FINISH



1-866-WOODPEG WWW.MILLERDOWEL.COM

## shop-proven products

### Finally, a quick-change mount for dust hoses

Lacking a central dust-collection system in my home shop, I've simply rolled my dust collector from tool to tool for years. I just keep a length of flexible hose on each dust-producing tool and slip the other end of the hose over the collector's inlet. But a hose that slips on, also sometimes slips off, and that's a nuisance.

Since I installed Fazlok fittings on my dust-collection hoses and collector, I've not had that problem. The male coupler mounts to the hose with ordinary hose clamps, while the female portion installs on the collector with a sheet-metal screw or two. (A bead of silicone here helps seal against air leakage.) Align the pins on the hose coupler into the slots on the collector coupler, push down, twist, and the hose is locked and ready for action.

Convenience isn't its only advantage. Before Fazlok, I couldn't always tell when dust and debris had clogged the collector inlet until the backup became significant. Because of the clear acrylic construction of the couplers, I can spot a clog at the inlet with a quick glance.

The starter kit includes two male and two female Fazlok couplers, enough for one power-tool hookup. For each additional tool you want to connect to the hose, just buy an individual coupler.

—Tested by Dave Campbell



### Fazlok Quick-Disconnect Fittings (part no. 960805)

Performance ★★★★★  
Price \$25, starter kit; \$7 additional fittings

Woodworker's Supply  
800/645-9292, www.woodworker.com

### About our product tests

We test hundreds of tools and accessories, but only those that earn at least three stars for performance make the final cut and appear in this section. Our testers this issue include: high-school industrial arts and woodworking teacher **Jeff Hall**, and *WOOD* magazine staff members **Kevin Boyle** (senior design editor), **Dave Campbell** (products editor), and **Jan Svec** (projects editor). All are avid woodworkers. ♣

# what's ahead

A sneak peek at projects and other articles in the March issue (on sale January 20)

## FEATURED PROJECT



**One shelving unit, three smart styles**  
Build this basic bookshelf to suit your preferences by simply changing its wood type, top, and base.

## Traditional oak chair

This comfortable and sturdy project matches the style of the dining table featured in the November 2003 issue.



## GETTING KIDS INVOLVED



## Stackable CD storage

Here's the perfect project for teaching woodworking to youths. The stackable box system assembles easily, and can be added to as the CD collection grows.



## Weather station

Three affordable gauges give you a quick read of temperature, humidity, and barometric pressure in this striking weekend project.

## Something for everyone . . .

### TOOL TEST



## Sliding mitersaw review

See how seven 10" saws (including one with all-up-front controls) survived our punishing in-shop tests.



## Toning and shading

Use aerosol stains to match new finishes to old ones, as well as blend together different color woods.



## Secrets of shelf making

No matter what needs or space your shelving must fulfill, you'll find the tips necessary to build with confidence.



## Master of moving parts

Go inside the ingenious mind of Mike Jagielo, a repeat winner in *WOOD* magazine woodworking competitions.