

Better Homes and Gardens®

WOOD

13
SUREFIRE TIPS
for cutting plywood p.70

NOVEMBER 2003
ISSUE 152

The Shop-Proven Woodworking Magazine

41

TOOLS & ACCESSORIES
TESTED

- orbital-sander discs
- pocket-hole jigs
- tenoning jigs
- wood fillers
- sharpening jigs

Build this expandable family dining table

p.46

plus 10 more projects

for your home and shop

finish oak to perfection!

Tips and tricks begin on p.96



p.86

ORGANIZE YOUR WORKSHOP'S WALLS

This adaptable system changes as your storage needs grow!

www.woodmagazine.com

Display until November 25, 2003



U.S.A. \$6.99

0 92567 14072 5

WOOD®

November 2003, Issue 152

PROJECTS

- 12 **dual-purpose sanding center**
Gain floor space by teaming up two benchtop power tools with these mobile cabinets.
- 46 **traditional oak dining table**
- 66 **lighted showcase**
- 74 **3-drawer mobile utility cabinet**
- 78 **slice & serve bread knife**
- 86 **super-flexible shop storage**
Build any or all of the pieces of this simple wall system for holding tools, hardware, and more.

TECHNIQUES

- 16 **quick-and-easy mitered half laps**
Make strong, seamless joints in eight steps.
- 22 **kerf bending**
Learn to curve solid-wood project parts using a form and special cutting process.
- 26 **time-saving pocket-hole joinery**
Try this speedy, clamp-free way of joining wood. You may become hooked.
- 54 **tune your tablesaw to perfection**
Improve the quality of your cuts with fine adjustments that make a big difference.
- 70 **13 tips for flawless plywood cuts**
Whether using a tablesaw or circ saw, try these tricks to trim plywood cleanly.
- 92 **surefire lathe tool sharpening**
- 96 **how to fill open-grain wood**
Create smooth finished surfaces with a shop-made slurry or store-bought paste.

TOOLS & MATERIALS

- 10 **wise buys: tablesaw tenoning jigs**
- 62 **shop-tested pocket-hole jigs**
Choose one that fits your budget and needs from 18 models in four price ranges.
- 72 **sanding-discs compared**
- 100 **5 shop-proven products**

FEATURES

- 80 **Greene & Greene's modern master**
See how one top-notch professional crafts furniture in this beloved style.

DEPARTMENTS

- 4 **editor's angle**
- 6 **sounding board**
- 31 **wood words**
- 32 **shop tips**
- 40 **short cuts**
- 42 **ask WOOD**
- 120 **what's ahead in our next issue**



74



92



72

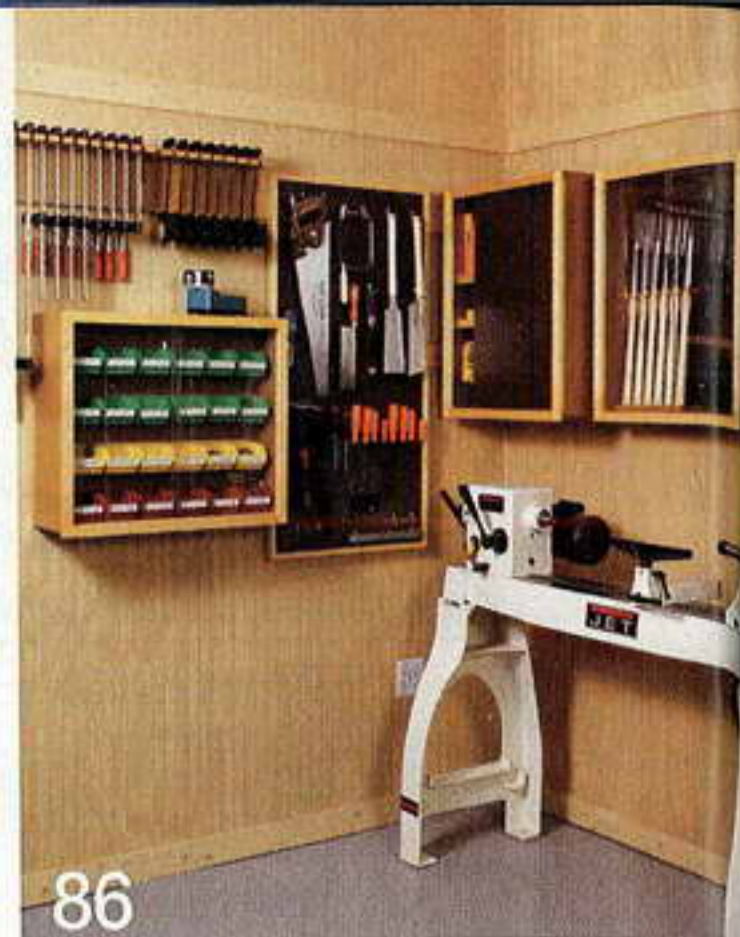

86



66

46



This seal is your assurance that we build every project, verify every fact, and test every reviewed tool in our workshop to guarantee your success and complete satisfaction.

sounding board

Our bulletin board for letters, comments, and timely updates

Manufacturer says use diamonds to hone a stone

In "Ask WOOD" in the May 2003 issue, you correctly advised a reader to flatten a dished sharpening stone by lapping it on a diamond whetstone. However, you said that doing this could prematurely wear the diamond stone.

Actually, as long as you use an extra-coarse (220 diamond/60 grit) diamond whetstone, you can successfully flatten almost any water stone or oil stone with virtually no wear on either the diamond or on the nickel it's bonded to.

*David G. Powell, President Emeritus,
Diamond Machining Technology, Inc.*



An extra-coarse diamond stone effectively flattens a waterstone or oilstone.

A woodworking mentor reaps multiple rewards

Thank you for selecting me as a runner-up in your mentoring contest. I commend what you and Laguna Tools are doing to promote woodworking skills in our teenagers.

Many kids today are left to their own devices, which often leads to problems. Every young person needs to learn skills that they can be proud of, and what could teach them better than woodworking? I am pleased to be part of this activity, and enjoy watching kids develop as they work in my shop.

Rest assured that the beautiful workbench that you and Laguna awarded me will be put to good use by all of the kids I teach in the future.

Dr. Kenneth Waltz, Anaheim Hills, Calif.

We appreciate all that you do to help kids, Ken. Enjoy the bench, and keep up the great work!

Be sure to check out the next issue of WOOD® (issue 153) to learn more about the mentoring efforts of Ken and our other five contest winners.

Project updates

Adirondack Chair and Footrest (issue 149, page 74):
The slats (M) should be 2½" wide.

Pizza Peel (issue 150, page 86):
Here's the full-size handle end for the pizza peel.

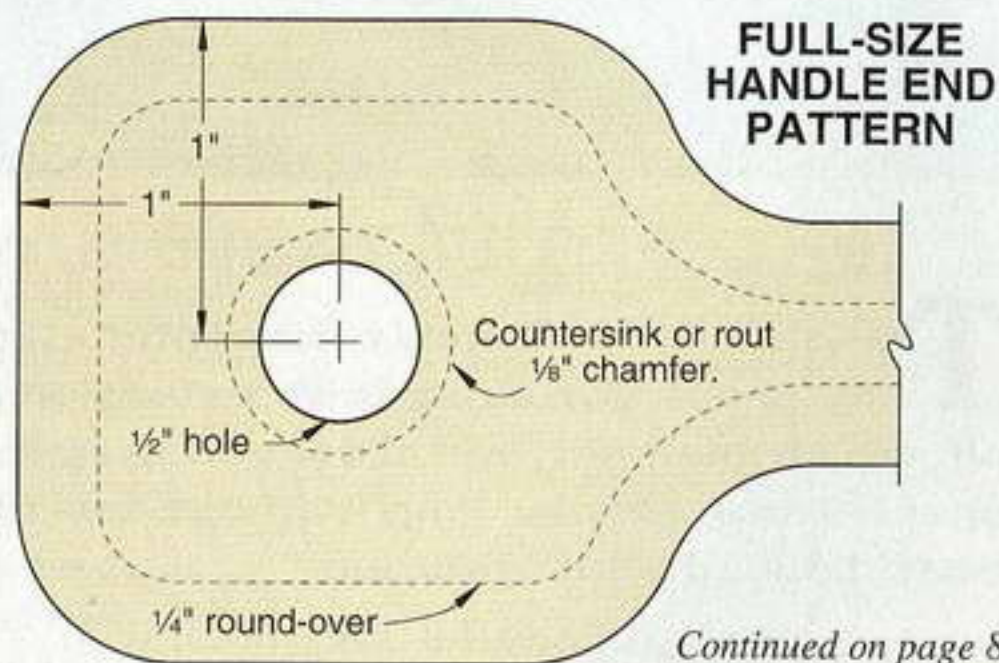

HOW TO REACH US

■ Editorial questions and feedback:

E-mail woodmail@woodmagazine.com; call 800/374-9663 and press option 2; or write to WOOD magazine, 1716 Locust St., GA-310, Des Moines, IA 50309-3023.

■ Subscription assistance:

To notify us of an address change, or to get help with your subscription, go to woodmagazine.com/service; call 800/374-9663 and press option 1; or write to: WOOD magazine, P.O. Box 37439,

Boone, IA 50037-0439. Please enclose your address label from a recent magazine issue.

■ To find past articles:

Go to our continuously updated online index at woodmagazine.com/index.

■ To order past issues and articles:

Order past issues of WOOD magazine and our newsstand specials at woodstore.woodmall.com, or by calling 800/346-9663. Be aware that many early

issues are sold out. For reprints, send \$5 per article (no phone orders), including the article name and issue number, to: WOOD Article Reprint Service, P.O. Box 349, Kalona, IA 52247; make check or money order payable to WOOD magazine.

■ Updates to previously published projects:

For a complete listing of known changes in dimensions and buying-guide sources from issue 1 through today, go to woodmagazine.com/editorial.

Soldier shares patriotism through woodworking

I ordered wood and started building the Patriot's Plaques (issue 139, page 74) as soon as the issue arrived. I live in Germany as part of the United States Army's 130th Engineer Brigade, and had to put my woodworking on hold for Operation Iraqi Freedom. Now that I'm able to work in the shop again, I wanted to show you the plaques I make, which combine the American and German flags, as gifts for soldiers departing our base.

—Robert Nowicki, Hanau, Germany



Amateur appreciates achievable articles

Thanks for including small projects that amateurs like myself can build. Here's a photo, below, of the Chef's Bookshelf (issue 148) that I made, with some modifications. I made mine from pine and oak (instead of maple and cherry) because it's readily available to me, and I painted a stencil design on the ends because I didn't have tools to make the onlay. I enjoyed the project, and think it looks great.

Doug Stone, Woodbridge, Va.



Bunk bed plan arrives just in time for a new baby

Thanks for publishing the best woodworking magazine available! I have subscribed since my sophomore year in college, and have almost every issue back to 1989.

Last fall, my wife, Laura, and I found out she was pregnant with our third child. Then, she reminded me that we really needed bunk beds so our first two daughters could share a room. Believe it or not, that same day my new WOOD® magazine arrived (issue 144) with plans for a great-looking set of beds! That's what I call timing!

I did alter the design slightly. Instead of the banded plywood panels in the headboards, footboards, and guardrails, I built mine with slats, as shown below. I also left off the post caps, and filled the holes with temporary plugs. When my oldest daughter gets a little bit bigger, we'll stack the beds and add the ladder.

As you can see in the photo, below, the project is a hit. I'm sure that when another need arises, WOOD will be there to save the day once more.

Thomas Bates, Hilbert, Wis.



Amelia, left, and Lydia Bates love their new beds, and their talented woodworker dad!

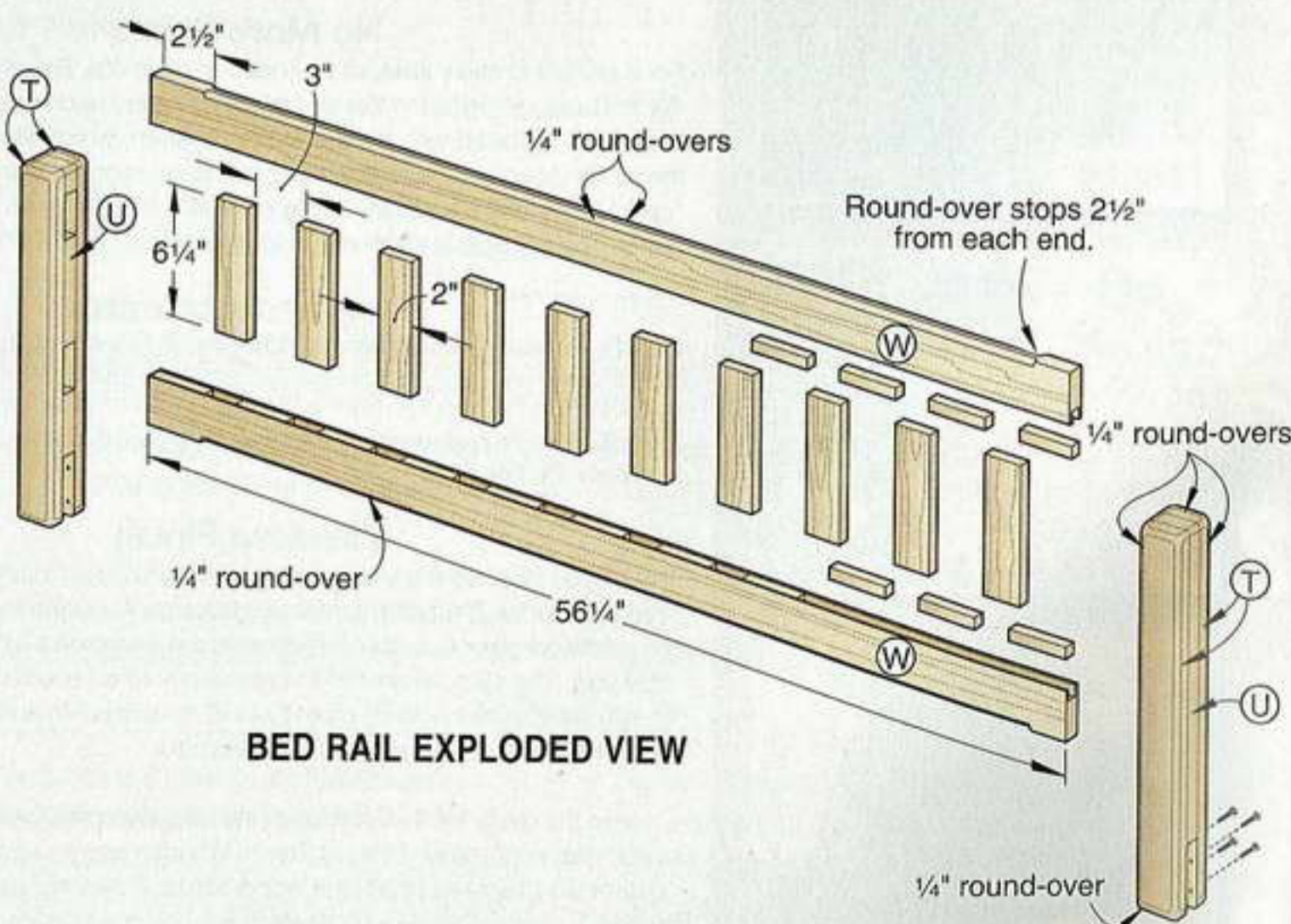

our editors test

tablesaw tenoning jigs

You don't need a high-priced dado set to cut clean, precise mortise tenons, stub tenons, and half-lap joints. A tenoning jig firmly supports your workpiece while you make the tricky cheek cuts with an ordinary saw blade.

Delta 34-183, \$90

Tested by Chuck Hedlund, Master Craftsman

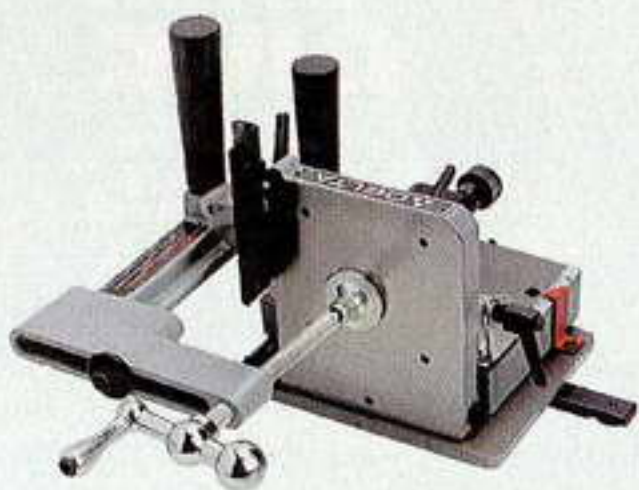

Delta 34-184, \$100

Tested by Kevin Boyle, Senior Design Editor



Jet JTG-10, \$110

Tested by Marlen Kemmet, Managing Editor

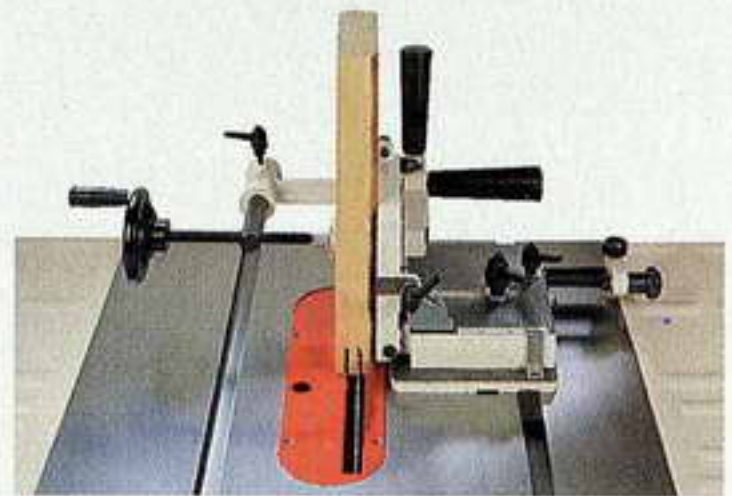

Why buy?

This updated incarnation of Delta's classic design adds a width-adjustable miter-slot guide bar that you can tweak to fit your saw perfectly. T-slot washers also have been added at each end of the bar to prevent the jig from lifting off the table during use. Out of the box, it works on right-tilting saws; it switches for left-tilting saws with some effort.

Why buy?

It has everything the Delta 34-183 has, and more. After the initial setup and alignment, no tools are needed for any of the routine adjustments, including moving the clamp location. A quick-release push-button mechanism allows fast positioning of the jig for both cheek cuts without a lot of tedious knob turning to get from one cheek to the other.

Why buy?

Like the Delta 34-184, adjusting the Jet tenoning jig after setting it up requires no tools, and a quick-release mechanism (in this case, a ratcheting knob) speeds positioning for the cheek cuts. The JTG-10 also has a T-slot-style guide bar but, unlike the Delta jigs, it's not adjustable to custom-fit your saw.

Editor test-drive:

We've had the older version of this tenoning jig in the *WOOD* magazine shop for years, and the improvements are welcome. Delta added an adjustable stop on the backstop to ensure its return to 90° without having to resquare to the tabletop. Cheek cuts I made using the 34-183 were super smooth. The jig slides easily and I liked the large handles that gave me a good grip and kept my hands well away from the blade.

Editor test-drive:

The assembly and setup instructions are clear, and, from opening the box to cutting tenons in 3/4" stock, it took less than five minutes on my right-tilting tablesaw. After using the quick-release button to position the workpiece close, the fine-adjustment knob helps adjust the location to perfection. The knob shows .004" increments, with one full turn equaling 1/16". My only beef is the cursor on the scale, which hides the 1/16" graduations.

Editor test-drive:

Once I filed a little off the sides of the miter-slot guide bar to fit my saw, the Jet tenoning jig performed well, sliding easily and cutting smoothly. The combination of one horizontal and one vertical push handle feels comfortable—like using a power drill with a side handle. The guide bar has a washer on only one end to engage the T-slot, but I had no trouble keeping the jig flat on the saw table while cutting the cheeks.

To learn more:

800/438-2486, www.deltamachinery.com

To learn more:

800/438-2486, www.deltamachinery.com

To learn more:

800/274-6848, www.jettools.com

quick-and-easy mitered half laps

Team up a half lap with a basic miter, and you instantly create a handsome joint that also provides plenty of strength.

Miters look great, but in many applications they need reinforcement from wood splines or metal fasteners for strength. But as you can see in the photos *above*, there's a better way to add beef to a miter: by combining it with a half lap. Why's that? Because of the joint's ample face-grain gluing surfaces.

To create this reliable joint, you'll need a tablesaw equipped with a dado set that produces flat, smooth cuts. You'll also need a scrapwood stop that attaches to your rip fence, an accurate miter gauge equipped with an auxiliary

fence, and a simple plastic guard that we'll tell you how to make.

To get started, use a straight piece of solid wood or plywood to make the stop for your tablesaw's rip fence. Cut the stop about 12" long, and narrower than the height of your rip fence. Clamp it to the rip fence with the front end slightly back from the dado blade.

Check your miter gauge for accuracy at both 45° settings, and then add an auxiliary miter-gauge fence that's narrower than the height of your rip fence. Make it more reliable by adding self-adhesive, 120-grit sandpaper to its face

to keep the workpiece from slipping. Be sure to place the sandpaper away from the business end of the fence to prevent the abrasives from contacting the dado set and making it dull.

Some of the cuts you'll make tend to throw chips straight up in the air. That's why we put together a safety guard from scraps we had in the shop.

To make the guard, attach a piece of 1/8"×8"×16" acrylic to a 3/4"×2"×30" board with 1" panhead screws. The dimensions aren't critical; size your guard so that it extends past the dado set when you cut.

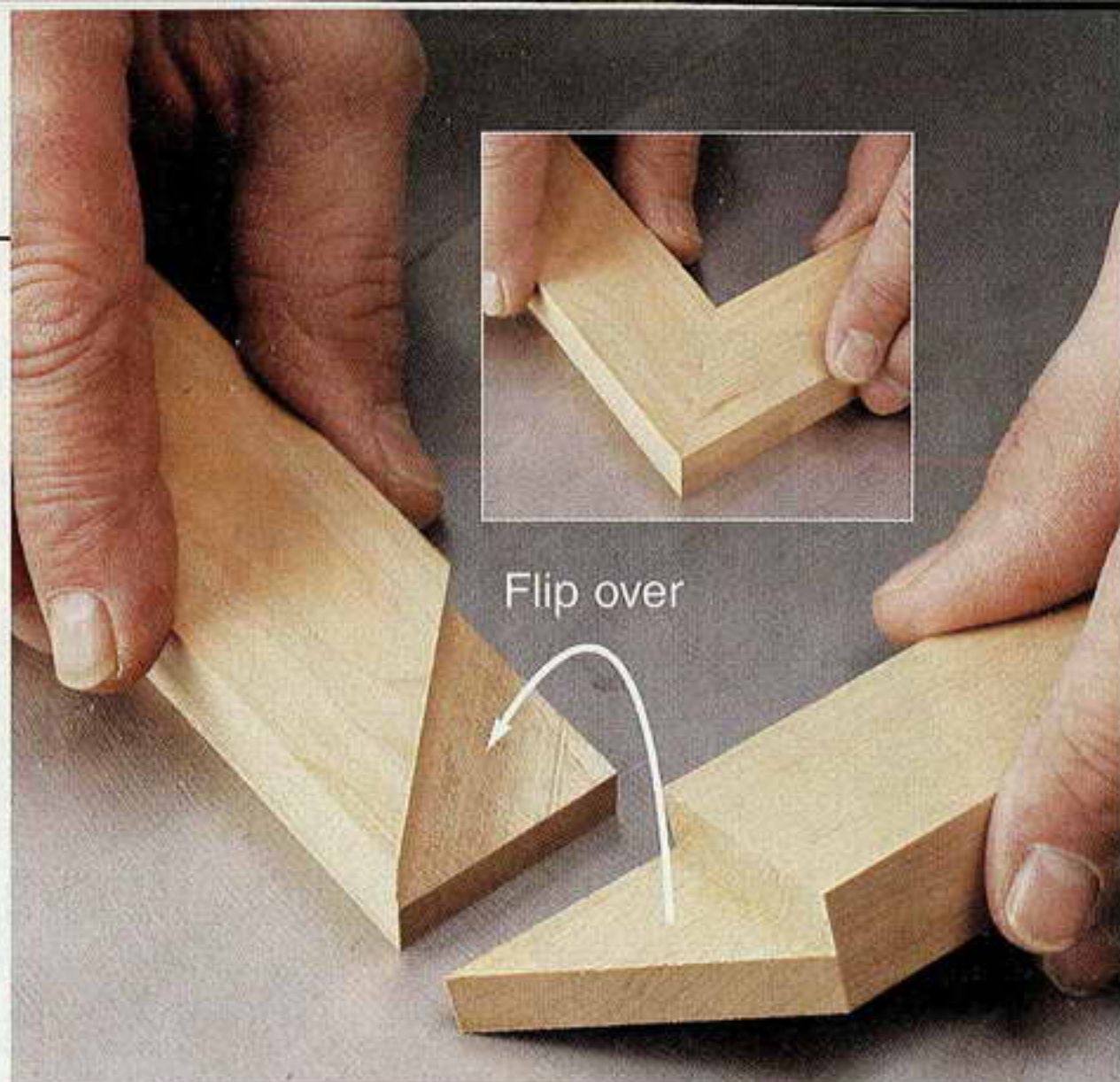

A mitered half-lap joint consists of two parts like the ones shown here. Just flip the piece at right, and the mating miters form the completed joint, inset. We placed the exposed end grain at the top and bottom of the frame.

8 EASY STEPS TO MITERED HALF LAPS

1 A tight miter joint begins with precise equipment. Make sure your tablesaw table sits square with the blade, using the method described on *page 56*. Then set your miter gauge as shown on *page 58*, or use this trick. Insert tight-fitting 3/4" scrap in the right miter-gauge slot, and place your miter gauge in the left slot. Slide an accurate 45° angle against the scrap, and place a steel rule against the miter gauge, *left*. Then line up the angle, the rule, and the miter gauge. To double-check the accuracy of your setup, cut miters on two pieces of scrap, hold them together at a right angle, and check them with a reliable square, *right*. They should fit with no gaps.

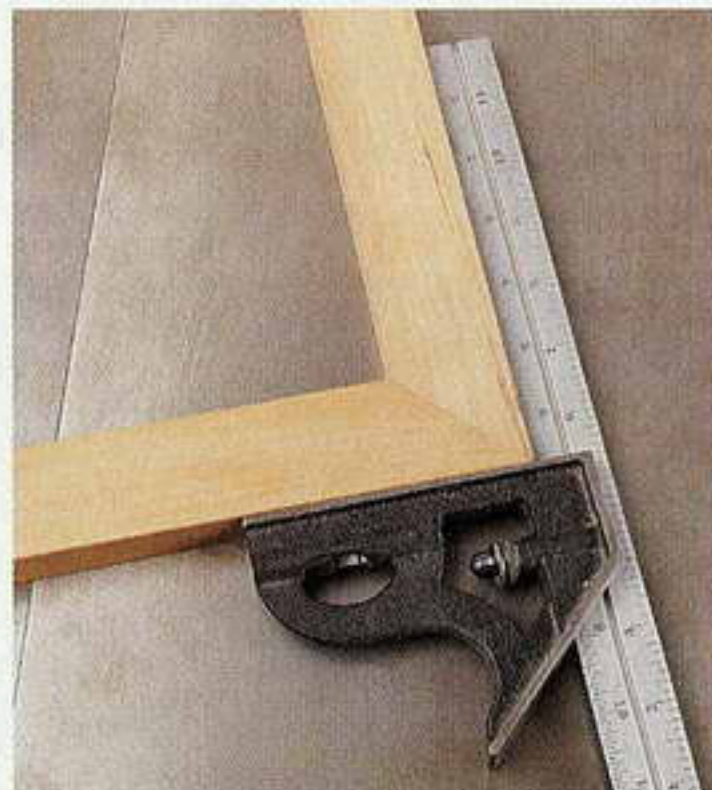

Continued on page 18

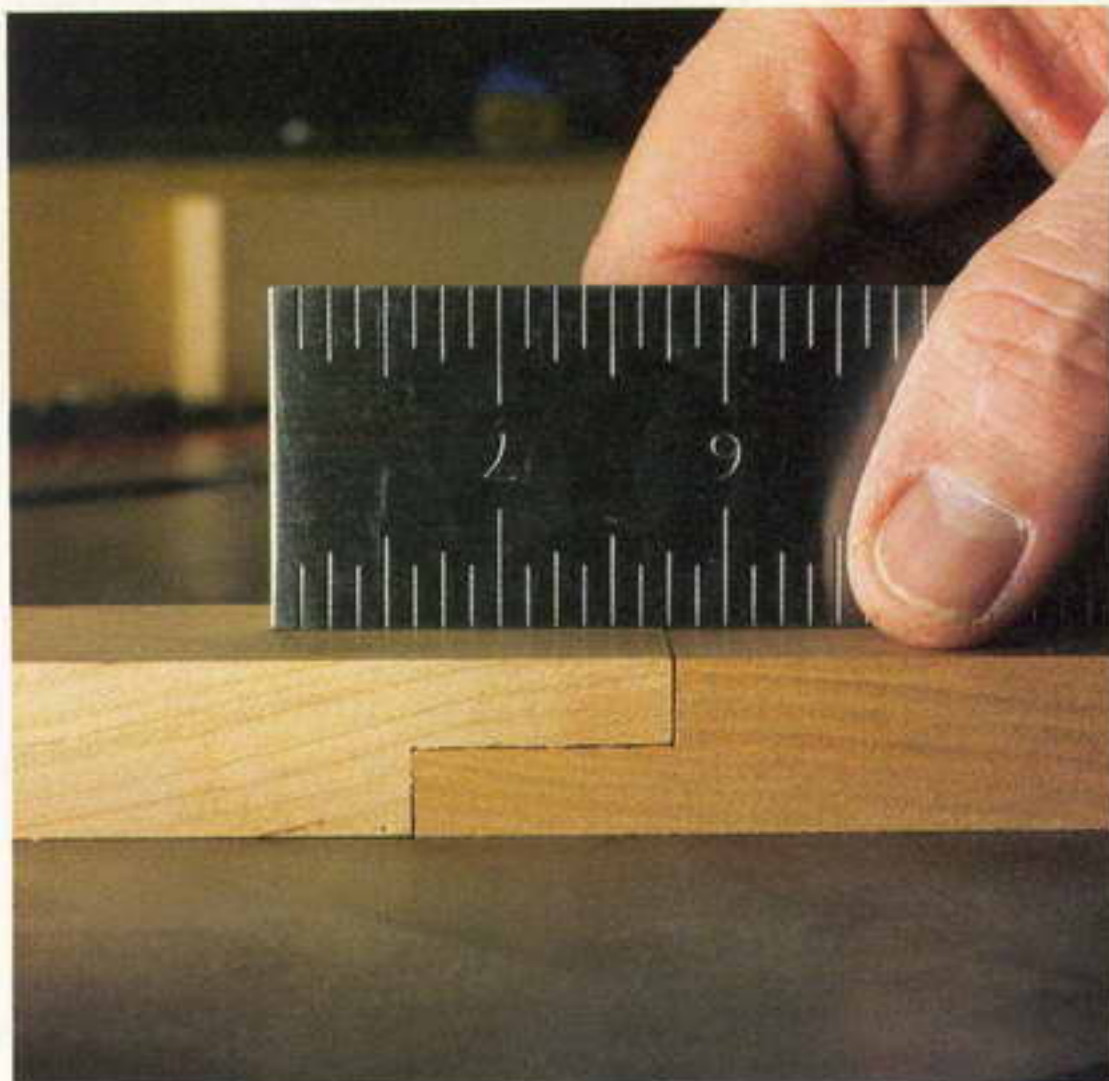

2 Install a full-width dado set, and raise it to cut exactly half the thickness of your workpiece. (If your dado set produces rough surfaces, see issue 150 for our dado set test.) Make test cuts on scrap pieces of the same thickness as your workpieces. Mate the two pieces, and use a rule or other straightedge to check for a flush fit, as shown. Cut your stiles and rails to finished length.

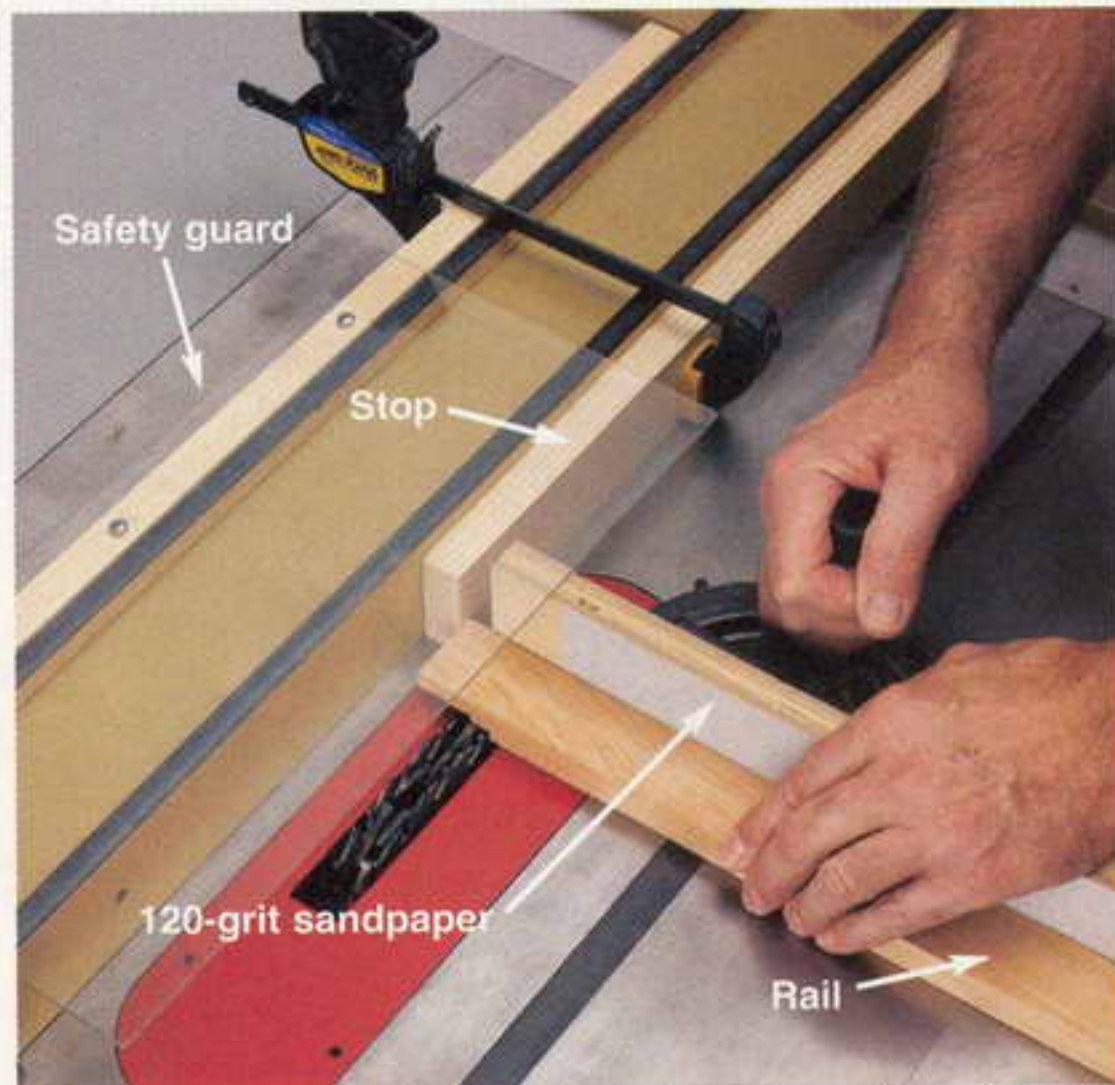

3 Clamp your safety guard and stop in place, as shown. Adjust the rip fence so that the distance from the stop to an outside tooth of your dado set equals the width of your workpiece. Set your miter gauge at 90°, and cut away the underside of each rail at each end. Make two or three passes, as necessary. For the final pass, butt the end of the rail against the stop.

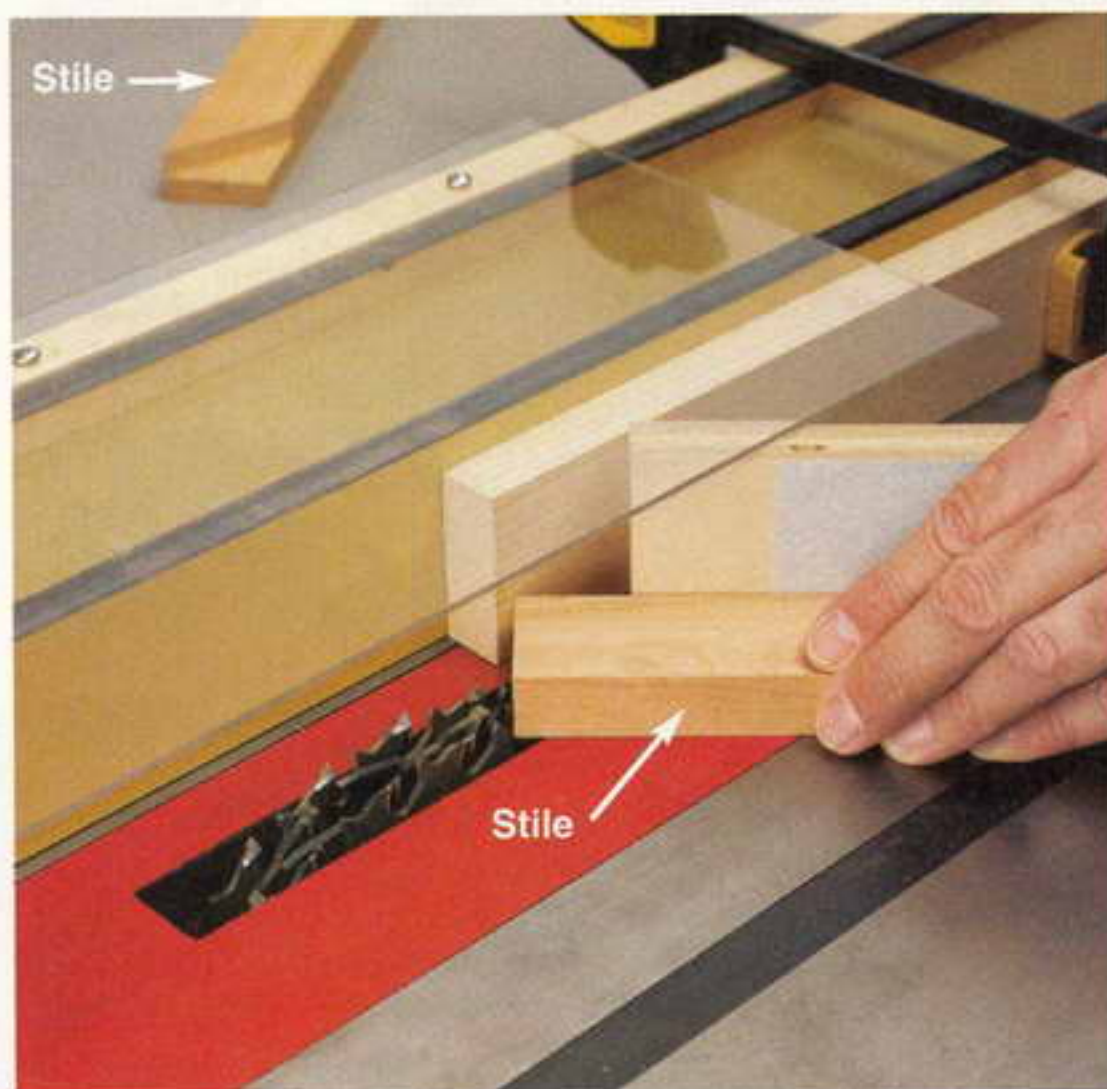

4 Set your miter gauge at 45° as shown, and place a stile face-down against it. Align the leading corner with an outside tooth on the dado set. Adjust your rip fence so that the opposite corner of the stile contacts the stop. Lock the fence in place, and leave it there for the remaining cuts. Make the needed passes to form a mitered recess on the underside of the stile.

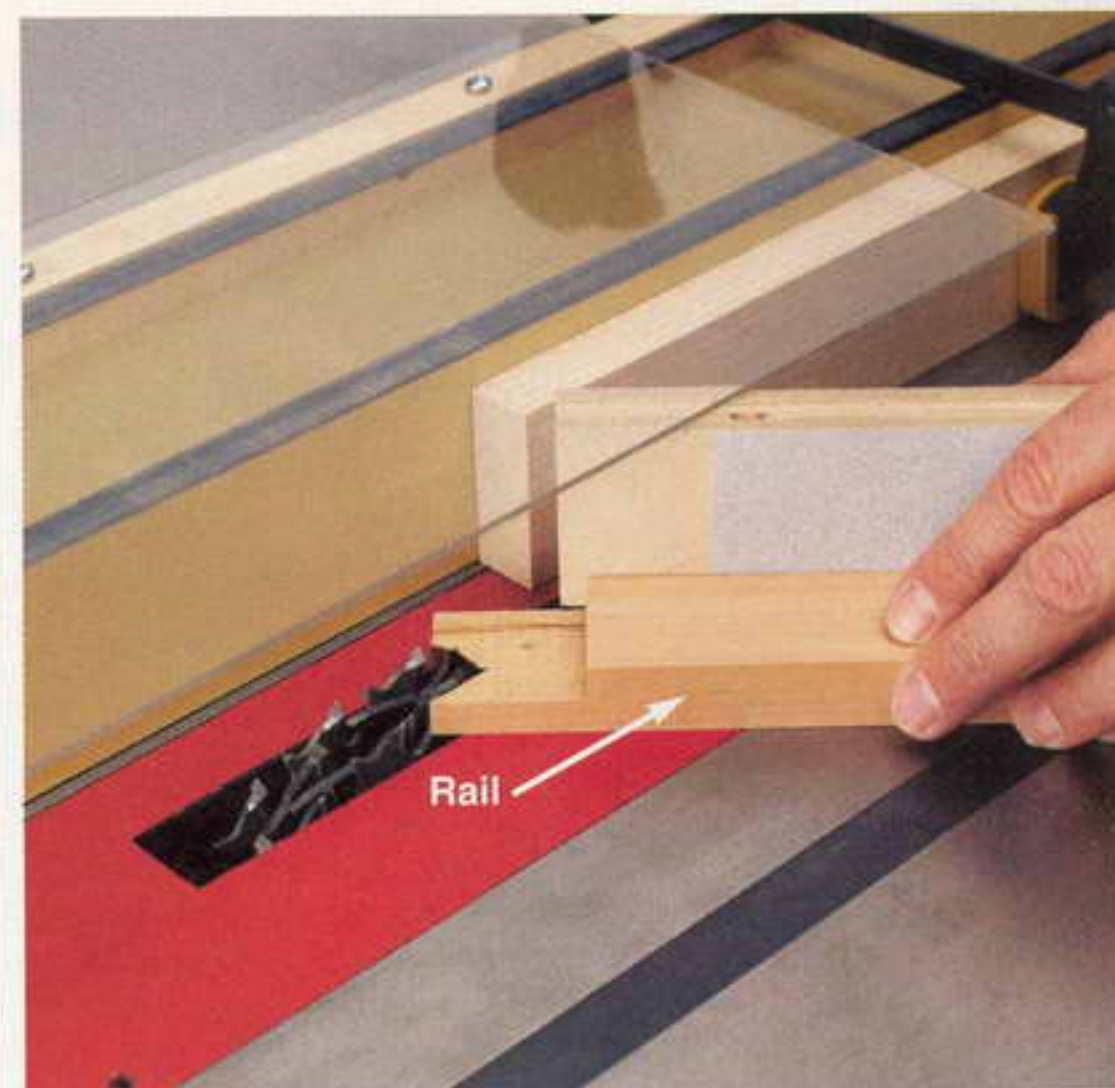

5 Place your rail on the tablesaw with its inside corner butted against the stop. Miter-cut this half lap with just one pass. The inside corner drops away as you complete the cut.

Continued on page 20

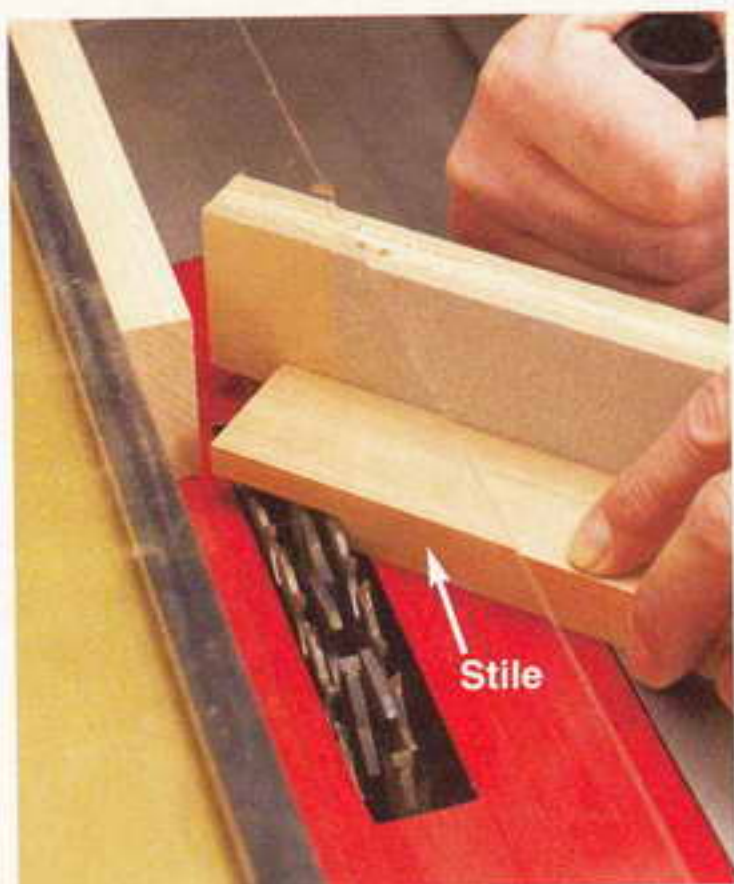

6 Now, swing your miter gauge to the opposite 45° setting, again using the procedures from Step 1. (**Shop tip:** Buy extra miter gauges so you can leave them set at 90° and both 45° settings.) Now, butt the inside corner of the stile against the stop, and cut each of the remaining two stile ends, as shown.

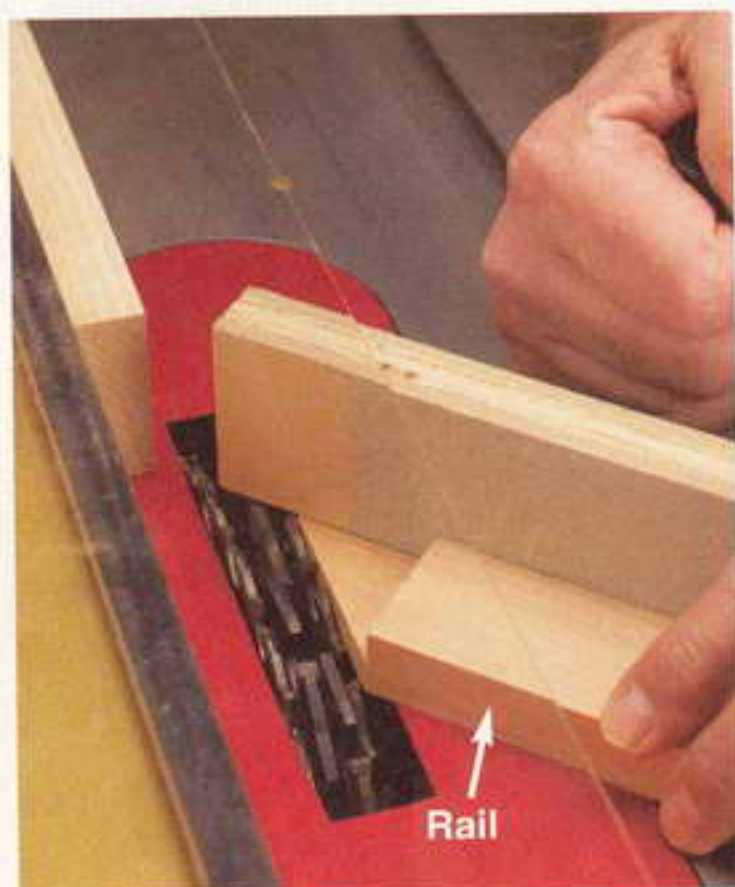

7 Complete the cuts for your frame by mitering the remaining two rail ends, as shown. Again, place the inside corner of the workpiece against the stop to line up each cut.



8 A type of glue with longer open time, such as Titebond Extend, comes in handy when you assemble mitered half-laps. Lay the frame on a pair of bar clamps, and make them snug. Now, add a small clamp vertically at each joint to apply face-to-face pressure. Finally, add two bar clamps on top of the frame and perpendicular to the first pair. (We've left one off for clarity.)

save time with pocket holes

You won't find a faster way to build basic cabinets, and they're handy for assembling tricky joints, too.

With all of the great woodworking joints at our disposal, most of which don't require hardware of any kind, a woodworker has to wonder: Why use a pocket-hole joint? The answer is simple: Pocket holes offer the quickest way imaginable to build a face frame, assemble a cabinet, or join parts that would be difficult to clamp. And they provide plenty of holding power, too.

Of course, you could try to drill the pocket holes freehand, but a commercial jig helps you do it far more accurately and efficiently. Let us show you the basics, using a Kreg K2000 jig as our main example. (Kreg's Mini jig is represented in the drawing below.) To learn more about pocket-hole jigs, see page 62.

1 USING THE JIG

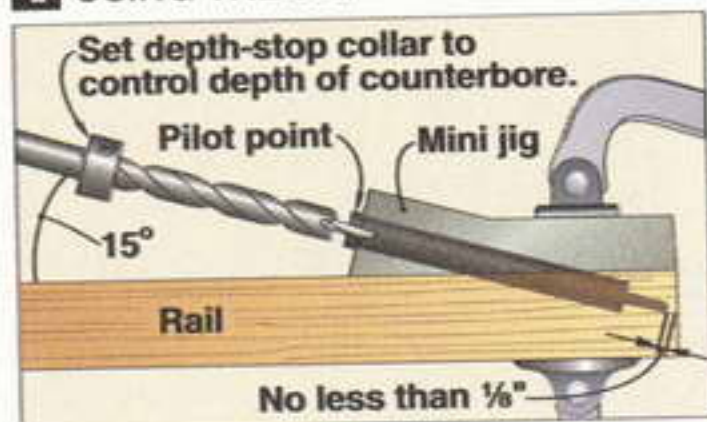

2 DRIVING THE SCREW

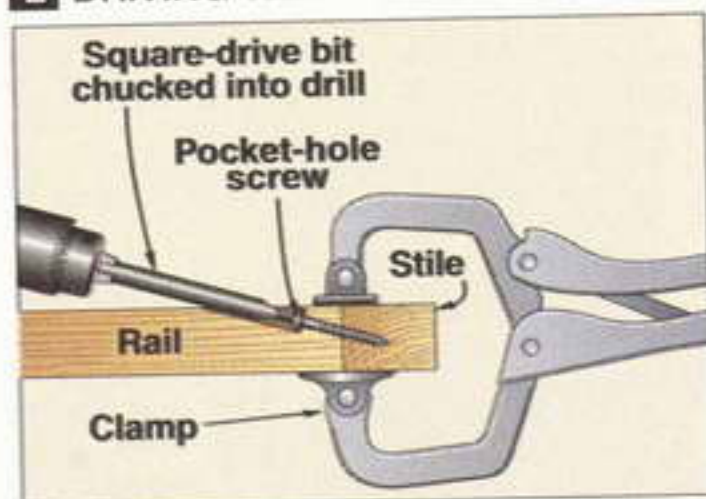

When using a jig like this one, take a minute to mount it on a plywood panel. Then, you can easily clamp the unit to your workbench.

A pocket-hole joint at a glance

A pocket hole enters wood at an angle of about 15° to the workpiece surface, allowing you to drill toward the end or edge of a project part as shown in the photo above. A specially designed drill bit equipped with a stop collar (**Drawing 1**) creates a hole large enough to accept the head of a screw, while also drilling a small hole for the shank.

Use screws with coarse threads to join softwood, plywood, or medium-density fiberboard (MDF), and fine threads for hardwoods (see photo below). Pocket-hole screws have a self-tapping auger point. This point, combined with the untapered profile of the screw, allows you to drive the screw into the adjoining part without a pilot hole. Even dense woods, such as oak, should not split.

The screws also feature a round washer head (so named because it has extra bearing surface built into the bottom of the head). This design, which prevents the head from being pulled into the wood, guarantees a tight connection.



Drill at least two holes to resist twisting. Add glue to the mating surfaces if you don't intend to disassemble the parts later. Use clamps to ensure flush surfaces, as shown in **Drawing 2**. Now, insert the screws, and drive them to full depth, drawing the two parts together.

Let's put it to use

Face frames come together quickly with pocket-hole joinery, as shown in **Photo A**.



A A clamp, such as this specialized version, keeps the joint members flush while you drive the pocket-hole screws. Use 1 1/4" pocket-hole screws for 3/4" stock.

Continued on page 28

develop your shop skills

As you can see, we built a support platform out of 2x4s to make the process go even more smoothly. The platform holds your workpiece up off the bench, creating space for clamps.

Pocket holes save a lot of time when you build basic cabinets, as shown in **Photos B** and **C**. Pocket-hole joinery also stands out as a way to assemble angled, hard-to-clamp joints, like the ones found in a multiple-sided frame. See **Photo D** for an example.

Pocket-hole joinery creates long, unsightly surface holes at each joint. That's not a problem for concealed surfaces. For sometimes-seen surfaces, you might decide to fill the holes with commercially available plugs, as shown in **Photo E** (or make your own plugs from dowels). The result might not be acceptable on highly visible project surfaces, though. In such cases, another joint type, say biscuits, might give better results. 🪵

Written by Jim Pollock

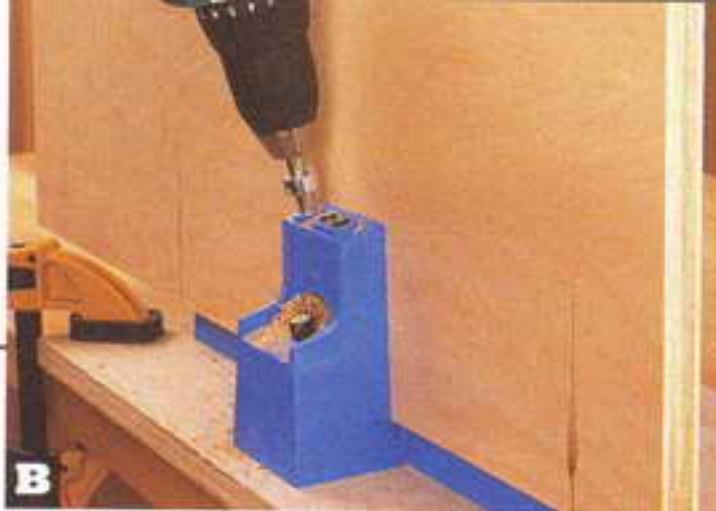

B You can drill into panels of any size; just make sure to provide level support. If your jig doesn't include accessories for that purpose, cut scraps of wood to suit. Drill on the inside face of each panel if the outside will be visible; for a cabinet that will be part of a row of attached cabinets, drill on the outside face.



C Pocket holes make cabinet construction quick and easy. Use them not only to attach a cabinet's face frame, as shown here, but also to join sides, back, and bottom. Clamps help you keep large pieces aligned as you drive the screws.



D Rather than struggling to hold these joints in place during glue-up, we used pocket holes. Drill holes from opposite sides of each joint for extra strength.



E If you choose to use plugs, brush glue on each one, and tap it in place with a wood block and hammer. You have to plane or sand the plugs flush, which eliminates some of the timesaving advantage of pocket-hole joinery.

A quick guide to must-know terms used throughout *WOOD*® magazine

Ease: To slightly relieve, or “soften,” a sharp edge on a piece of wood. This is generally accomplished by sanding, planing, or rounding the edge with a 1/8" round-over router bit.

Magnetic starter: A type of power switch, often used on tablesaws and other large stationary machines. Typically, it contains contact points that are held closed—when the switch operates in the “on” position—by electromagnetic attraction. In the event of a power interruption, the attraction stops, allowing a spring to pull the contacts apart, turning the switch off. This prevents an accidental restart when electrical power returns.

Rough-cut: To cut a workpiece slightly oversize in thickness, width, and/or length, prior to trimming it to final dimensions.

Stopblock: Commonly, this is a small block, clamped or temporarily-affixed to a fence or machine surface. It either holds a workpiece firmly in position, or limits the distance it can travel during machining operations. Stopblocks also can be attached to a workpiece to limit the movement of a tool, such as a router.

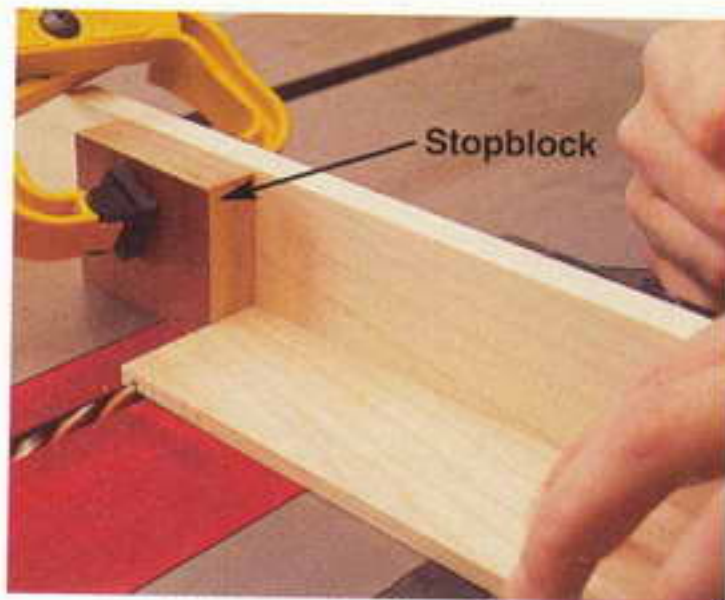

Green wood: Stock, usually in rough-cut lumber or log form, that has been cut but not dried, and retains a high moisture content. Woodturners often use green stock because of its workability.

Moisture content: The total amount of water in a piece of wood, expressed as a percentage of the wood's oven-dry weight. The content can be determined using a moisture meter. For kiln-dried stock, moisture content generally runs from 4 to 10 percent.



shop tips

Helping you work faster, smarter, and safer

Maximize storage with “vertical drawers”

I have a bunch of those big plastic multi-bin organizers that I use for storing small parts and hardware, but they hogged up a lot of benchtop space. My solution: drawer slides.

I installed full-extension slides inside my workbench, as shown in the drawing, with one side of the slide (the side nor-

mally attached to the drawer) mounted to a plywood panel. Next, I attached the organizer to the panel, as shown. The keyhole mounting slots on the back of the organizer allow me to quickly bring it to benchtop level when needed. For the center panel, I added a pair of mounting cleats for the drawer slides, and then put organizers on both sides of the panel.

—John Vail, Somerset, Calif.

top shop tip

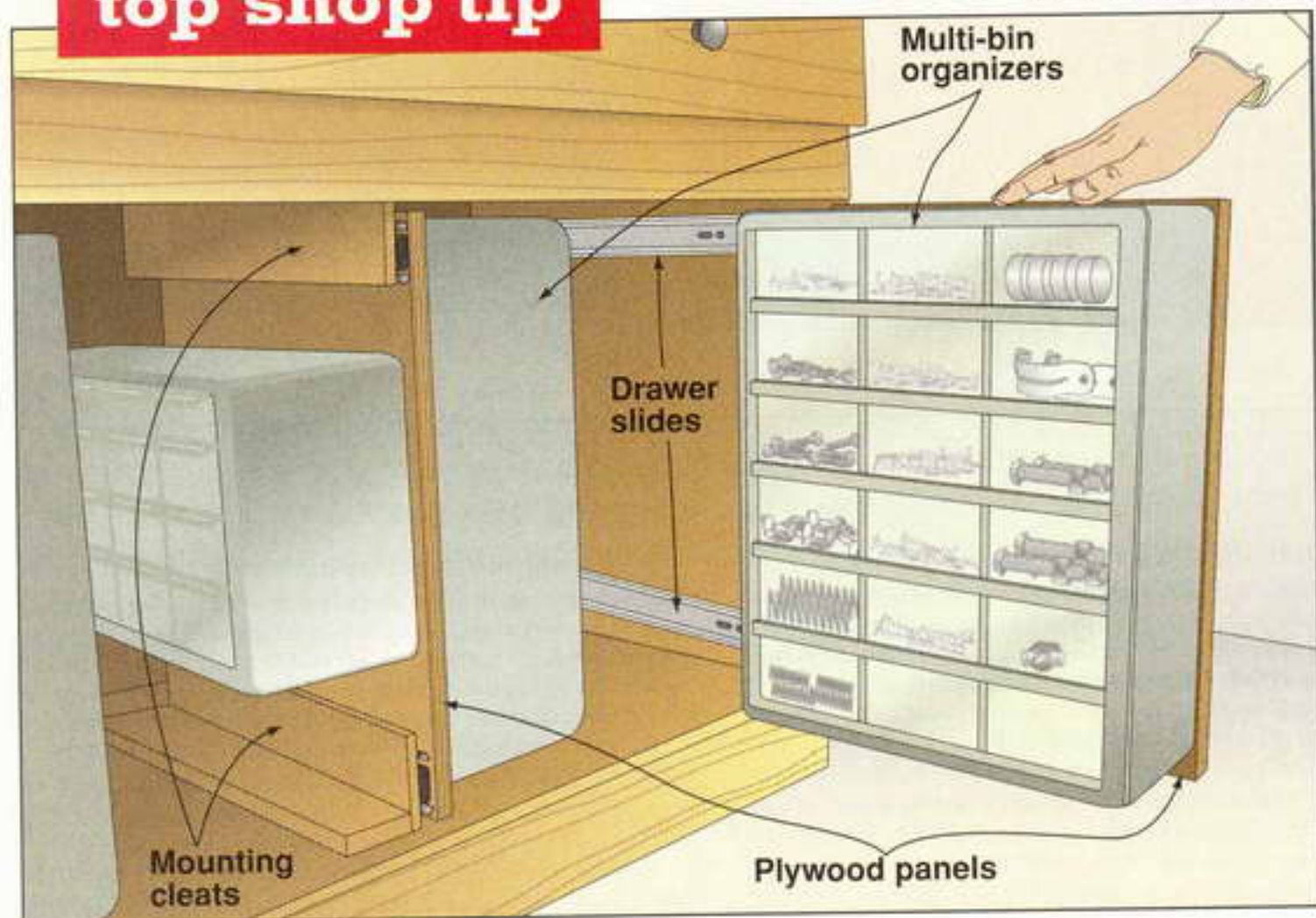

Drywall scrap saves tiny turnings

When I do small, delicate turnings, I used to mount them to a wooden waste block screwed to the lathe's faceplate.

But I damaged too many pieces trying to remove them because the waste block was stronger than the turning.

Instead, I now glue a piece of $\frac{1}{2}$ " drywall to the waste block, and then my workpiece to the drywall, as shown, using contact cement or hotmelt glue. When I'm done turning the piece, I simply cut through the drywall's paper "skin" to dismount the turning, and then remove the skin from the workpiece with a little solvent.

—Duane Herzig, Brier, Wash.

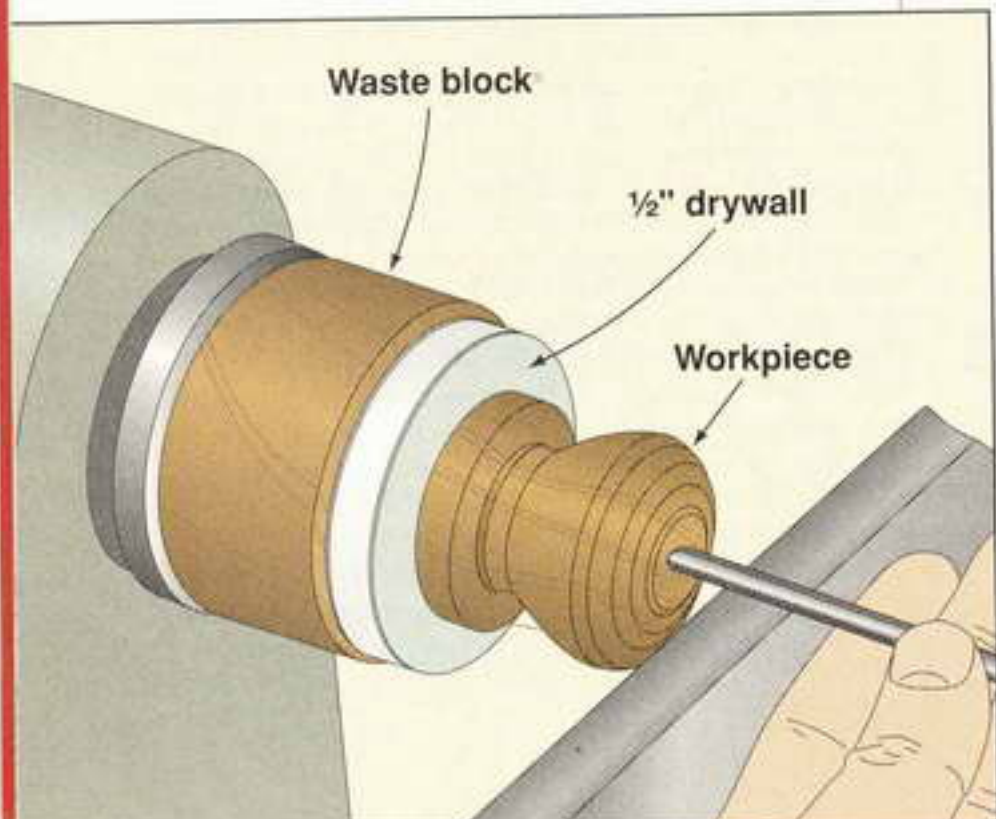

Continued on page 34

Pipe clamp makes a nice vise

I enjoyed your "Buyer's Guide to Woodworking Vises" (issue 147), but can't afford the \$100 price tag for a really nice vise like those shown in the article. My economical "vise," shown at *right*, costs about the same as the inexpensive subpar model shown in that article, but offers the reliability and holding power of a good old pipe clamp.

I mounted the business end of a $\frac{3}{4}$ " pipe clamp to the front of my bench using a cut-off floor flange and a short length of pipe, as shown in the drawing. (The top of the jaw is about 1" higher than the benchtop.) Next, I drilled two rows of evenly spaced $\frac{3}{8}$ " holes in the benchtop to accept the dog's $\frac{3}{8}$ " bolts. The bolts don't thread into these holes; they just pin the dog in place in whatever pair of holes best suits the size of my workpiece.

To distribute the clamping pressure over a wider area than the narrow face

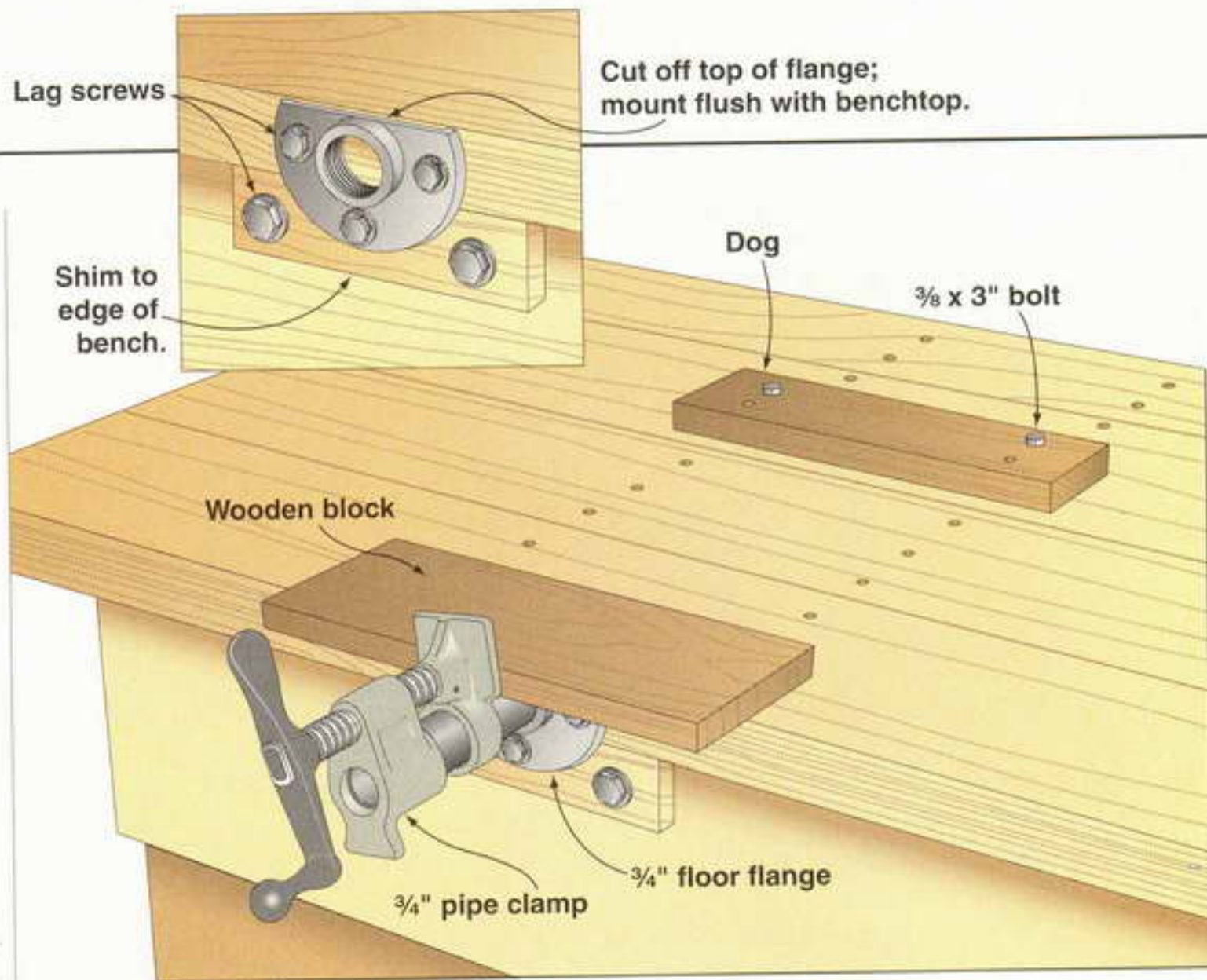

of the clamp jaw alone can provide, I insert a wooden block between the jaw and my workpiece. I also keep a variety of thin scraps around that don't interfere

when I power-sand a workpiece held in my "vise."

—George Roskopf, Pewaukee, Wis.

Good fence makes a better cyclone collector

After adding a garbage-can chip separator to my dust-collection system, I decided it would be easier to take the chips to the curb if I put a trash-can liner in the can. Oops! The first time I turned on the collector, it sucked the liner into the hose, rendering the system useless.

To remedy this situation, I fashioned a sleeve out of 2×4" welded fencing that fits inside the trash-can liner. I made mine an inch or so smaller in diameter than the bottom of the can to keep from damaging the liner as I insert the sleeve. When it comes time to empty the can, I lift the sleeve out, wiggling it from side to side. Then, I just pull out the bag, tie it up, and take it to the curb.

—John Rieger, Worthington, Ky.



Continued on page 38

Teach a new trick to your dogless vise

If your bench vise lacks one of those handy pop-up dogs for holding a workpiece flat on the bench, here's an easy remedy. Unbolt the wooden face from the vise's movable jaw, then extend the mounting holes downward about 1" to make them into recessed slots, as shown in the drawing *below*. (Use a $\frac{1}{2}$ " straight bit in your router to create the recess.)

Now, remount the jaw face using machine screws inside and washers and wing nuts outside. The wooden jaw face can now be quickly raised and, being softer and wider than the steel dogs on dog-equipped vises, is easier on your workpieces.

—Syl Helminiak, Bozman, Md.

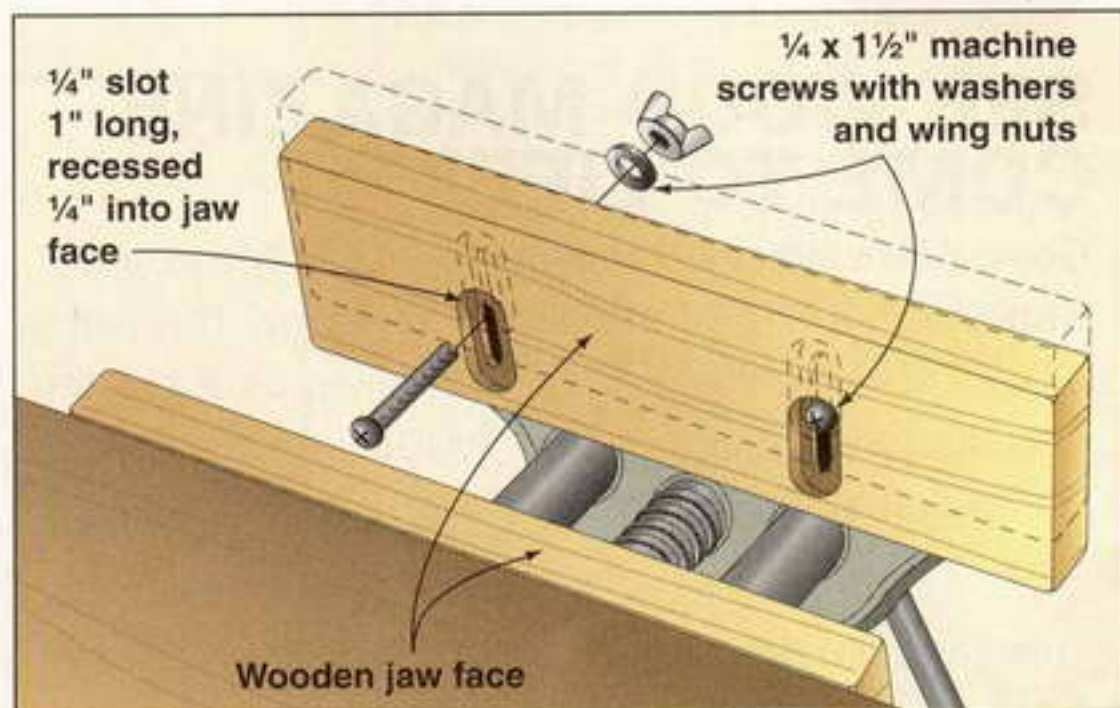

Finally, a use for that free sample of dental floss

After sanding a piece of scrollwork, the fine veining can fill with sawdust that not even my shop vacuum or a blast of compressed air can clear. In these cases, I insert a piece of flat, unwaxed dental floss into the pilot hole of the vein, and floss away the dust. You may find it easier to thread the floss if you stiffen the end with a pinch of yellow or white glue.

—Charles Flynn, Fort Smith, Ark.

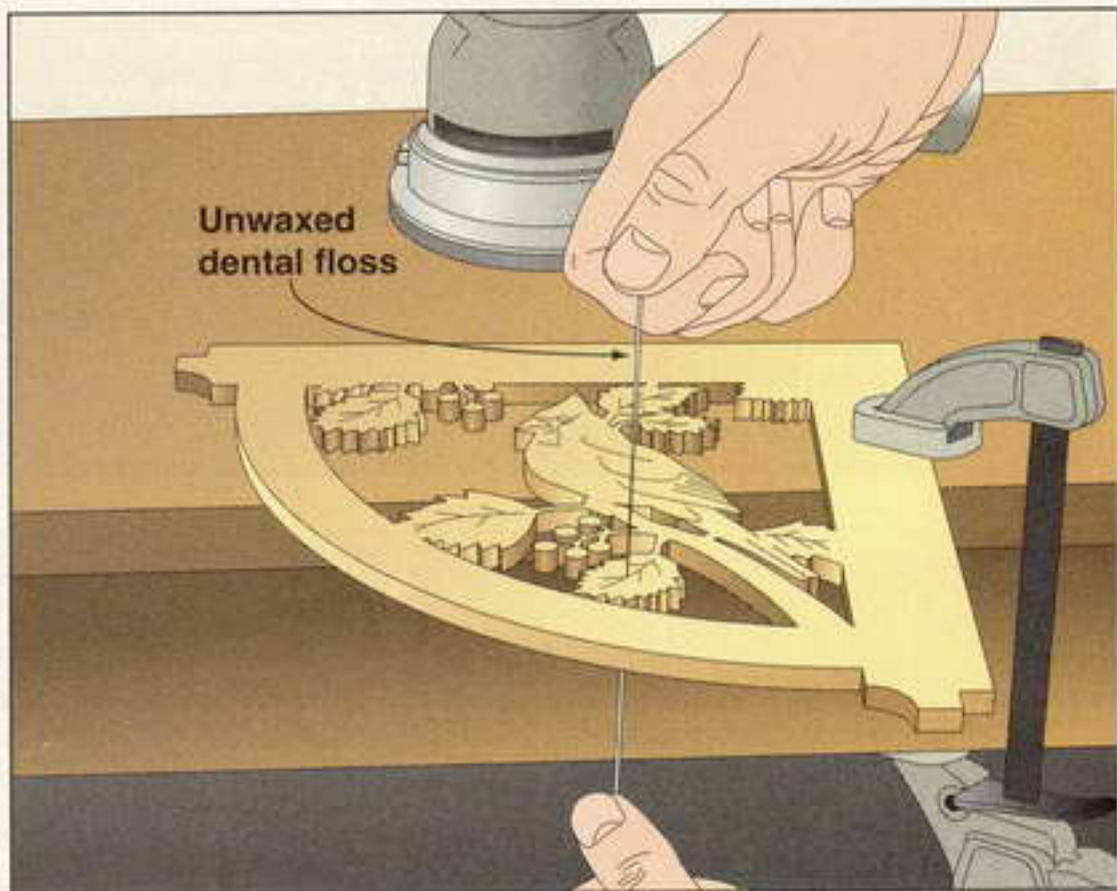

Board jack keeps workpieces hanging around

Call me a Neanderthal woodworker, but I still enjoy jointing boards in my vise using a hand plane. To support the other end of long boards, I made a board jack that hangs from the bench instead of resting on the floor.

My vise has 1½"-thick jaw faces, and the fixed face stands proud of the edge of the bench, so I made my jack out of 1½"-thick maple. This keeps the jaw face and jack on the same plane. And, for extra strength, I dovetailed the joint in the jack.

Depending on the length of the board I'm working with, I can position the jack anywhere along the length of my bench, using a bench stop to pin it into a dog hole. The ¾" dowel pin that supports the board fits through any one of the staggered holes on the face of the jack to work with various-width boards.

—Bob Pearlman,
Birmingham, Ala.

HOLE PATTERN

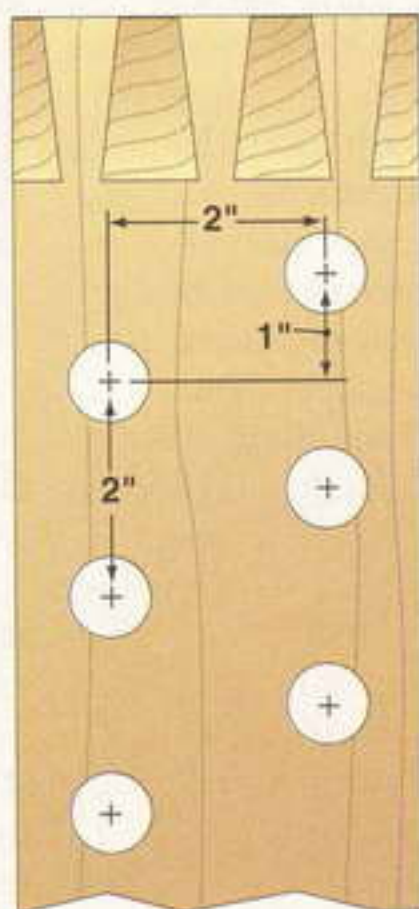

See a new . . .

...shop tip daily at

www.woodmagazine.com/tips

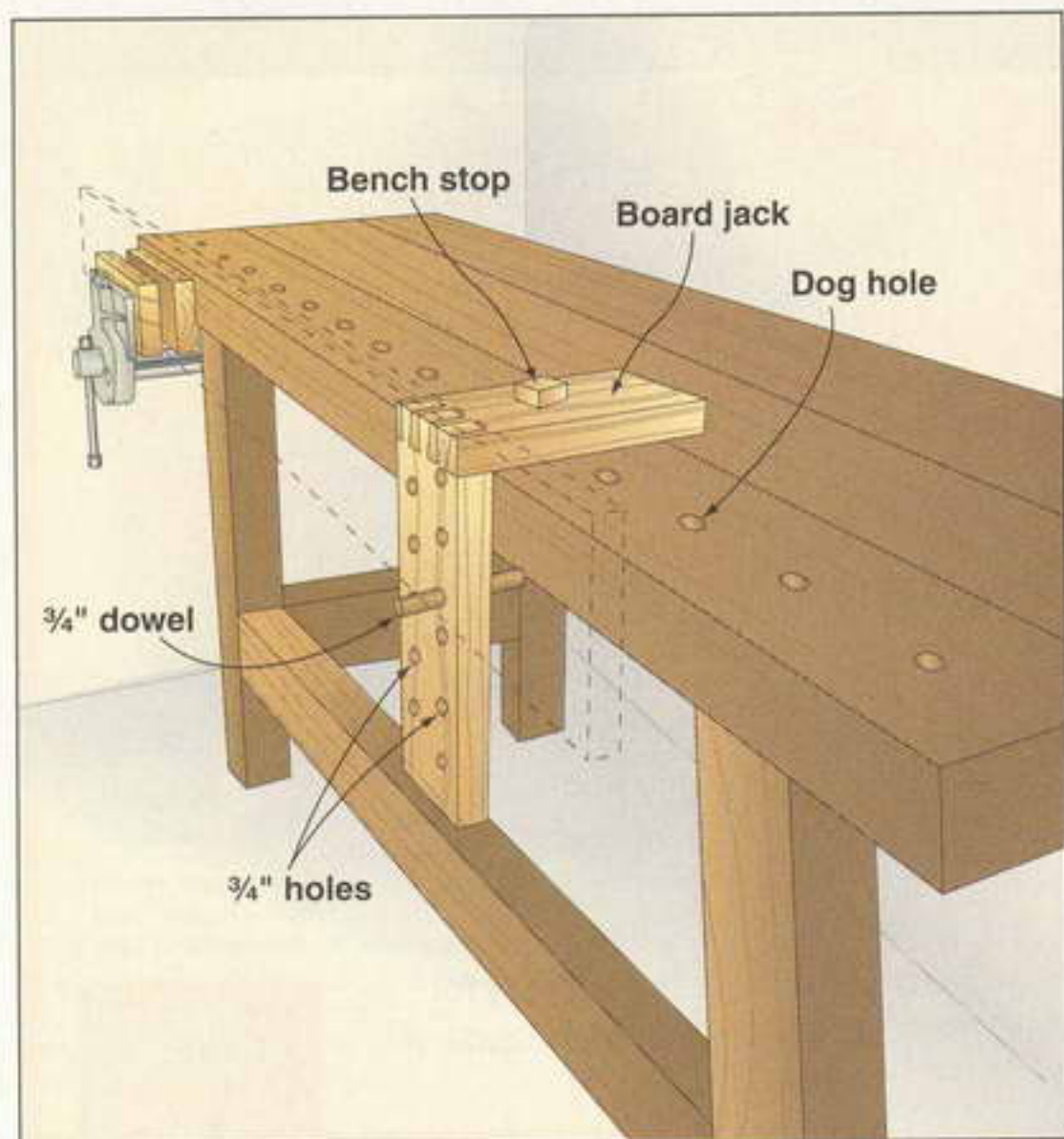

short cuts

News and notes from the woodworking world

Del Mar's judgment day



On June 7–8, 2003, Managing Editor Marlen Kemmet served as a woodworking judge at the 22nd annual Design in Wood exhibition at the San Diego County Fair in Del Mar, California. It's one of the premier woodworking competitions found in North America.

The exhibition, hosted by the San Diego Fine Woodworkers Association, showcased more than 320 pieces of

This graceful, long-legged cherry cabinet by Randy Miller won *WOOD* magazine's "Excellence in Workmanship" award at the Design in Wood competition.

handcrafted furniture, turnings, carvings, and intarsia. Marlen's task was to select the winner for the *WOOD*®-magazine-sponsored "Excellence in Workmanship" award, worth \$500. His choice: the upright cabinet, at left, by Randy Miller of Aliso Viejo, California, the same woodworker who had won the award the previous year. Says Marlen, "This piece exemplifies what the show is all about—finely crafted furniture and accessories with exceptional attention to detail. I liked the graceful, flared legs, well-executed joinery, and precisely installed hardware."

The exhibition also offers how-to demonstrations on woodturning, carving, model building, scrollsawing, and chairmaking. It's a must-see event for area woodworkers. For more, visit www.sdfwa.org/diw.htm

Photograph by Andrew Patterson

Test your workshop smarts

Waiting for glue joints or fresh finish to dry? Why not wash up, pour a cup of java, and take a few minutes to answer these fun questions. You'll find the answers in the next issue of *WOOD*® magazine Short Cuts; or, to find the answers fast, go to www.woodmagazine.com/shortcuts

■ What's the wood commonly found in particleboard?

■ What state contains the largest number of champion trees?

■ Does blueing negatively affect the quality of high-speed steel during sharpening?

ask wood

Answers to your questions from letters, e-mails, and WOOD Online®

Perfect positioning for drawer fronts

Q When you build drawers with false fronts, what's the best way to hold each front in place while you adjust its fit?

—Richard Kulesa, Springfield, N.J.

A Rich, you usually get the best results with cloth-backed, double-faced tape. Place a wood block inside the cabinet behind the drawer so the drawer box protrudes about $\frac{1}{16}$ " from the cabinet. Apply a 6" strip of double-faced tape to the box, carefully position the false front, and press it against the box. Gently pull the assembly out far enough so that you can clamp the drawer front to the box with a pair of sliding-bar clamps to prevent slippage. Now, pull the drawer to its full extension, reach inside the drawer box, drill two screw pilot holes through the box at diagonally opposite corners,

and screw the box to the front. Remove the clamps, and reinstall the drawer to check the reveal at all four edges. If it needs adjustment, remove the screws, pull the front away from the box, and repeat the process. This time, place screws at the other two corners. If the fit is right, leave those screws in place, and reinstall the original two screws, too—in most cases, the adjustment will be so slight that you won't have to drill new pilot holes. You can leave the tape in place permanently.

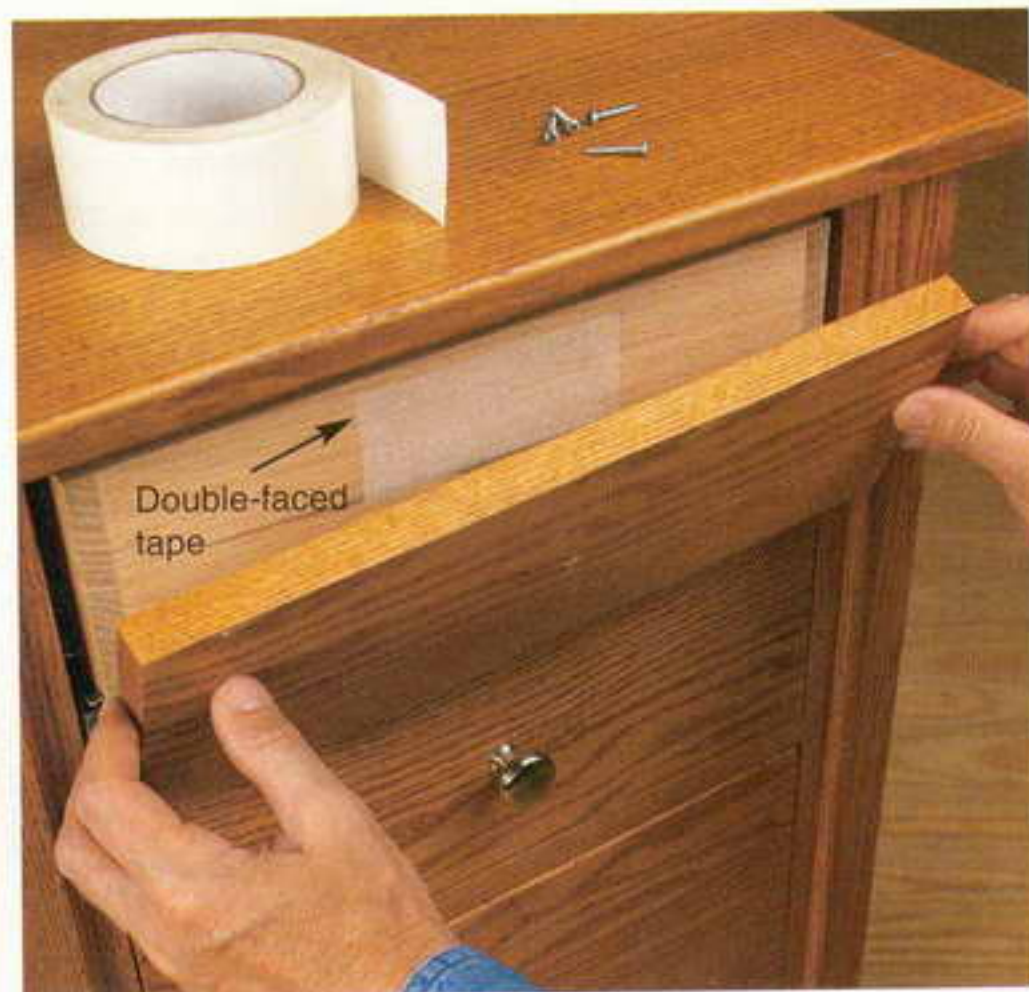

Double-faced tape holds a drawer front tightly enough so that you can pull the drawer out, and attach the front permanently. And if the first effort is slightly off, you can release the front from the tape and try again.

Locate bench dog holes for infinite variability

Q I'm building a workbench, and wondering about where to space the holes for the bench dogs. Is there a rule of thumb?

—Jon Rossing, Kansas City

A Coordinate the bench dog hole spacing with the jaw opening of your vise, Jon, for a system that covers every possibility. First, line up the planned row of holes with the pop-up stop in your vise. As long as the space between holes is less than the maximum jaw opening, you can adjust the vise to coordinate with any point in that row.

So where should you place your vise? In most cases, a right-handed woodworker chooses to put the vise at the near right-hand corner of the bench. That location makes planing, scraping, and sanding convenient. Left-handers can use a more natural stance if they pick the near left-hand corner.

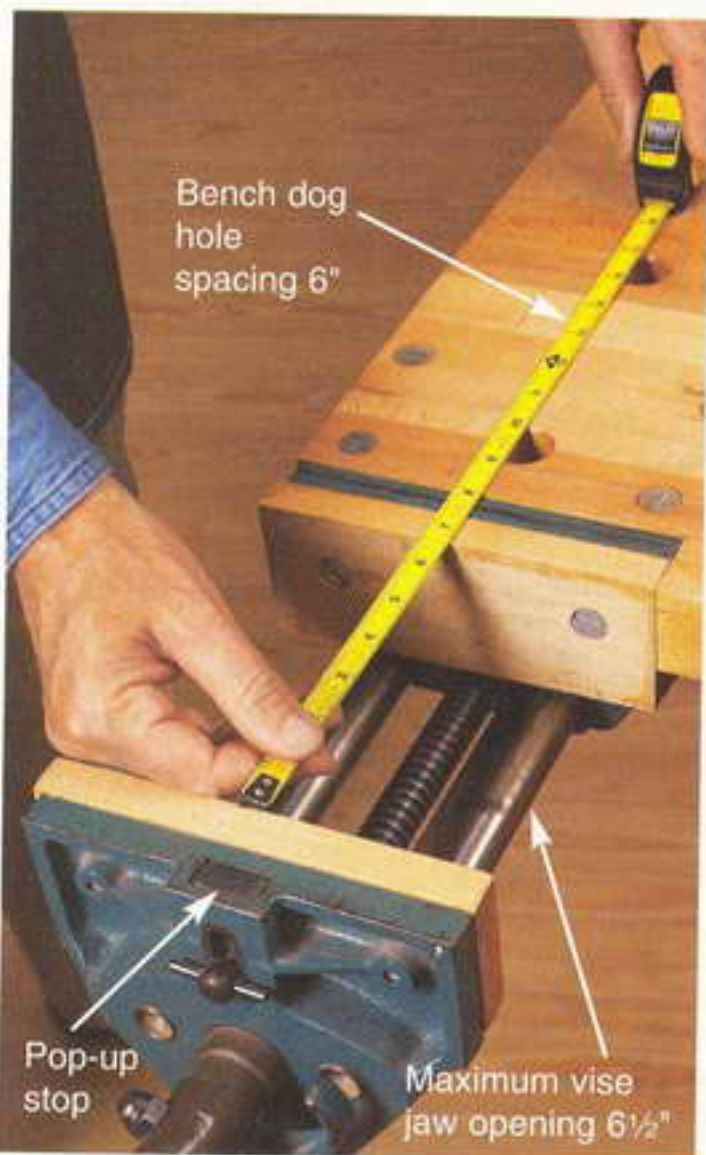

Our workbench vise opens to 6½". Because the bench dog holes were drilled with 6" spacing, we can secure a workpiece of any length between the vise's pop-up stop and a bench dog.

Continued on page 44

Color holds the key to abrasive pads

Q What is the color-grading system for nonwoven abrasive pads? I'm never sure which color is the best choice for a particular job.

—Bill Rood, Boston

A We can't speak for every single manufacturer, Bill, but here's the basic industry code: A white pad is extra-fine, approximately equivalent to 600-grit sandpaper; gray compares to 220-grit; maroon, 150-grit; and green, 100-grit. The difference among them relates to the coarseness of grit that's impregnated in the plastic strands, not the thickness of those strands.

Nonwoven abrasive pads offer a couple of advantages over steel wool, especially when you use water-based finish. They don't contain oil, which would adversely affect the bonding of the finish, and they don't leave behind bits of steel that can rust, ruining the appearance of a finish. Even when you're using a solvent-based finish, these pads work well for leveling and smoothing between coats. Hold your hand flat on the pad, or back it with a wood block, and exert even pressure throughout each stroke. When it comes to rubbing out the final coat, experiment to find out what you like best. Pads work well for a glossy finish, but 0000 steel wool might be your best choice for a satin finish because of its more uniform scratch pattern.

Compared to sandpaper, pads do a better job of conforming to tight curves and narrow grooves. That helps when you need to smooth moldings and carvings.

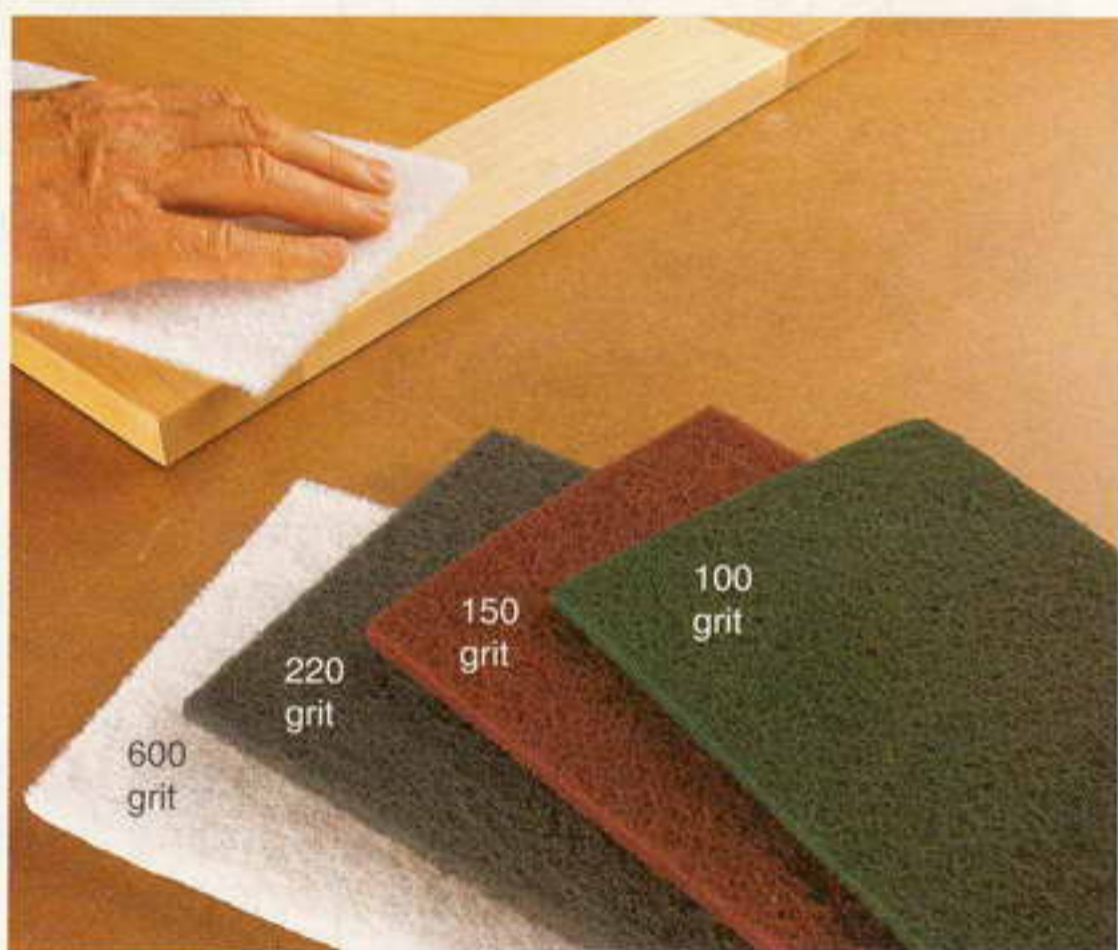

Some abrasive pads are labeled individually with a coarseness designation, but these aren't. Memorize the sequence, or make a simple container with a labeled compartment for each color.

Got a question?

If you're looking for an answer to a woodworking question, write to **Ask WOOD**, 1716 Locust St., GA-310, Des Moines, IA 50309-3023, or send us an e-mail at askwood@woodmagazine.com. For immediate feedback from your fellow woodworkers, post your question on one of our forums at www.woodmagazine.com.



If you're interested in building the table's matching cushioned chairs, you'll find the plans for them in the March 2004 issue.

traditional oak dining table

Looking for a round classic dining table that will serve your family's needs for a lifetime? Let this 48"-diameter, pedestal-style design fill the bill. While it typically seats four, you can expand its capacity to six by adding two leaves, as shown *above*. Doing this lengthens the table to 72".

You'll find its simple construction appetizing—just 10 parts, a notch joint for the feet, and patterns to shape the legs and feet. And, you'll also learn our secret for building round tables—kerf-bent aprons.

For the board feet of lumber and other items needed to build this project, see page 52.

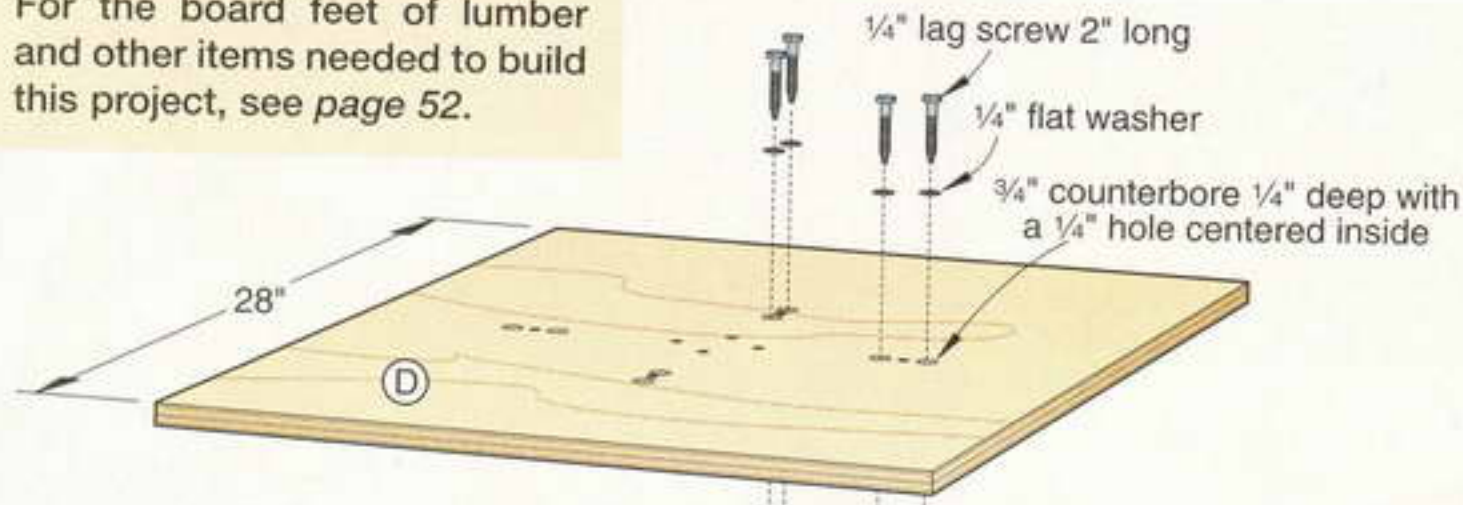

1 BASE ASSEMBLY

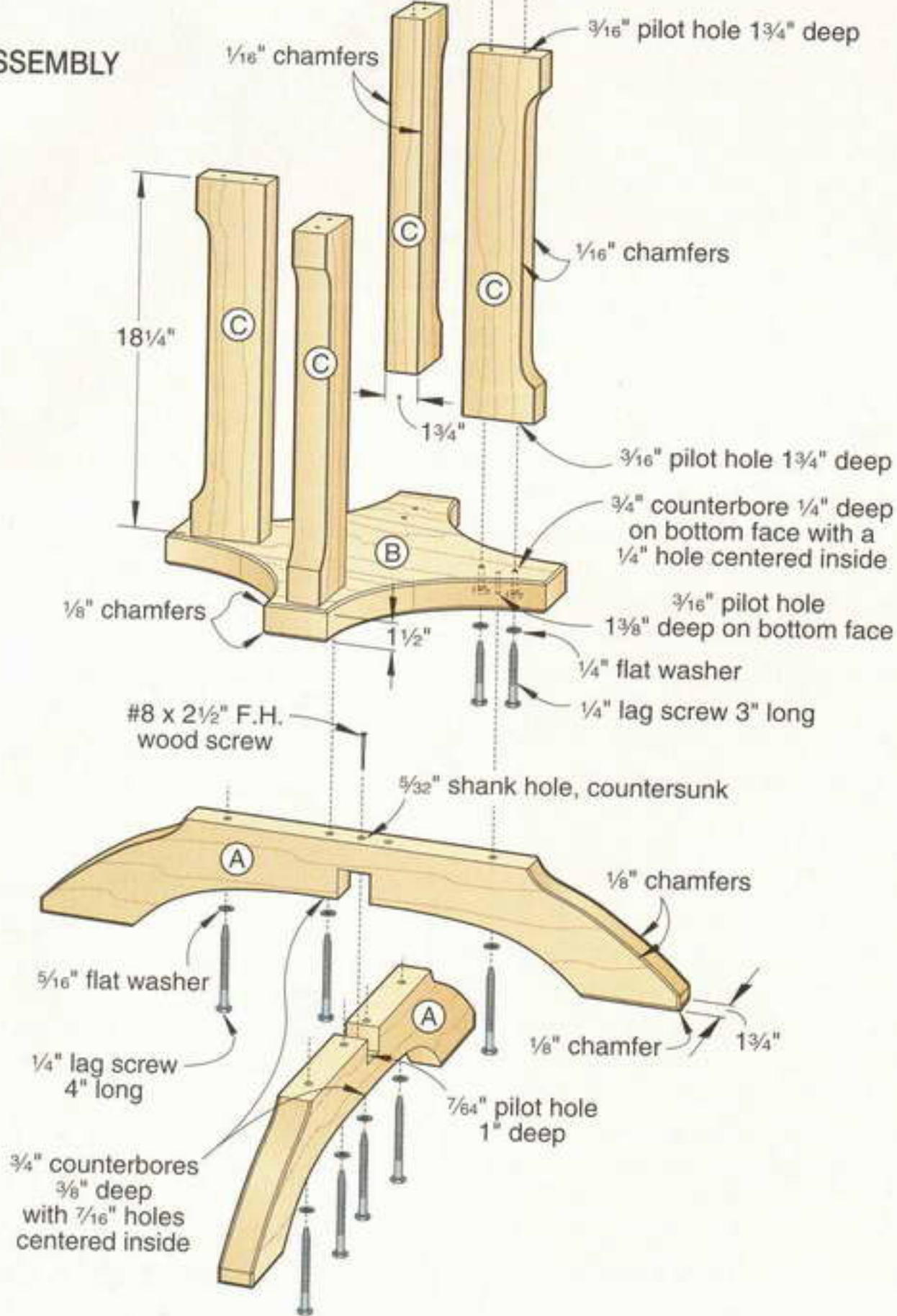

SHOP TIP

Let cutoffs be your guide

Want to get some mileage from your cutoffs? To cut the notch in the feet (A), you'll need to use a handsaw. Master Craftsman Chuck Hedlund used the odd-shaped foot cutoffs as saw guides to get exact-width notches in both feet. The photos, below, show you how to do it.

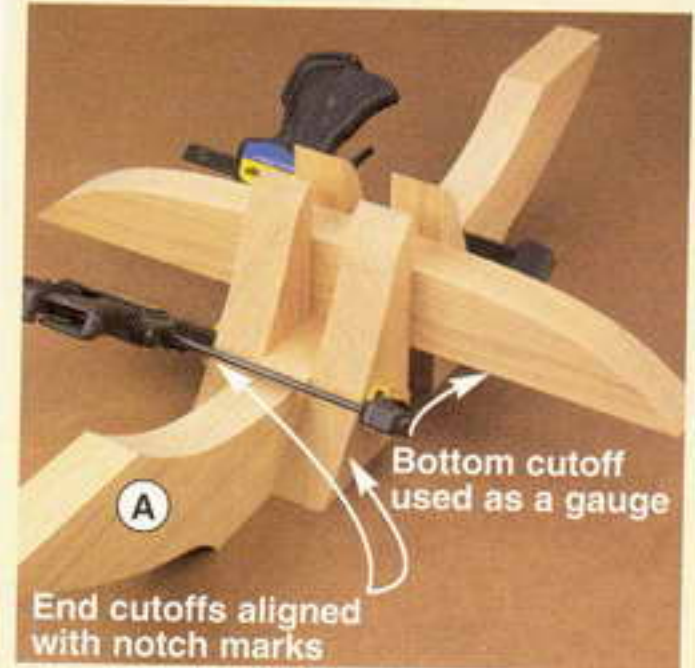

End cutoffs aligned with notch marks

Align the end cutoffs with a foot's notch marks, place the bottom cutoff between them as a gauge, and clamp the end cutoffs to the foot.

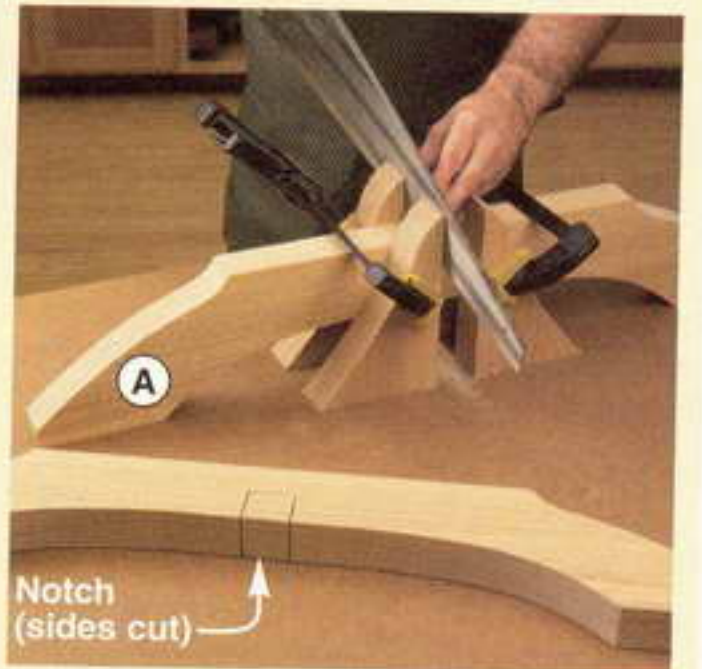

With the bottom cutoff removed, cut the sides of the notch, keeping the saw tight against the end cutoffs.

Get moving on the feet

1 From 1 3/4"-thick oak, cut the feet (A) to the size listed in the **Materials List**. As an alternative, you can laminate thinner stock, and plane it to 1 3/4" thick.

2 Make four copies of the full-size foot end pattern on the *WOOD Patterns*® insert. Spray-adhere the patterns to the feet, where shown on the

pattern's diagram. (Flip the pattern over at one end of each foot.) Draw a straight line connecting the patterns' bottom lines together. Now, lay out the notches on the feet, where dimensioned on the pattern.

3 Bandsaw and sand the feet to shape, saving the cutoffs. Using a handsaw and the cutoffs as a guide, as explained in

the **Shop Tip**, above, cut the sides of the notches. Then, chisel out the waste.

4 Chamfer the feet's edges, where shown on the pattern. Then, remove the patterns, and sand the feet to 220 grit. Glue and assemble the feet; drill the countersunk shank hole through the notch joint, where shown on **Drawing 1**; and drive the screw.

2 BASE (Bottom view)

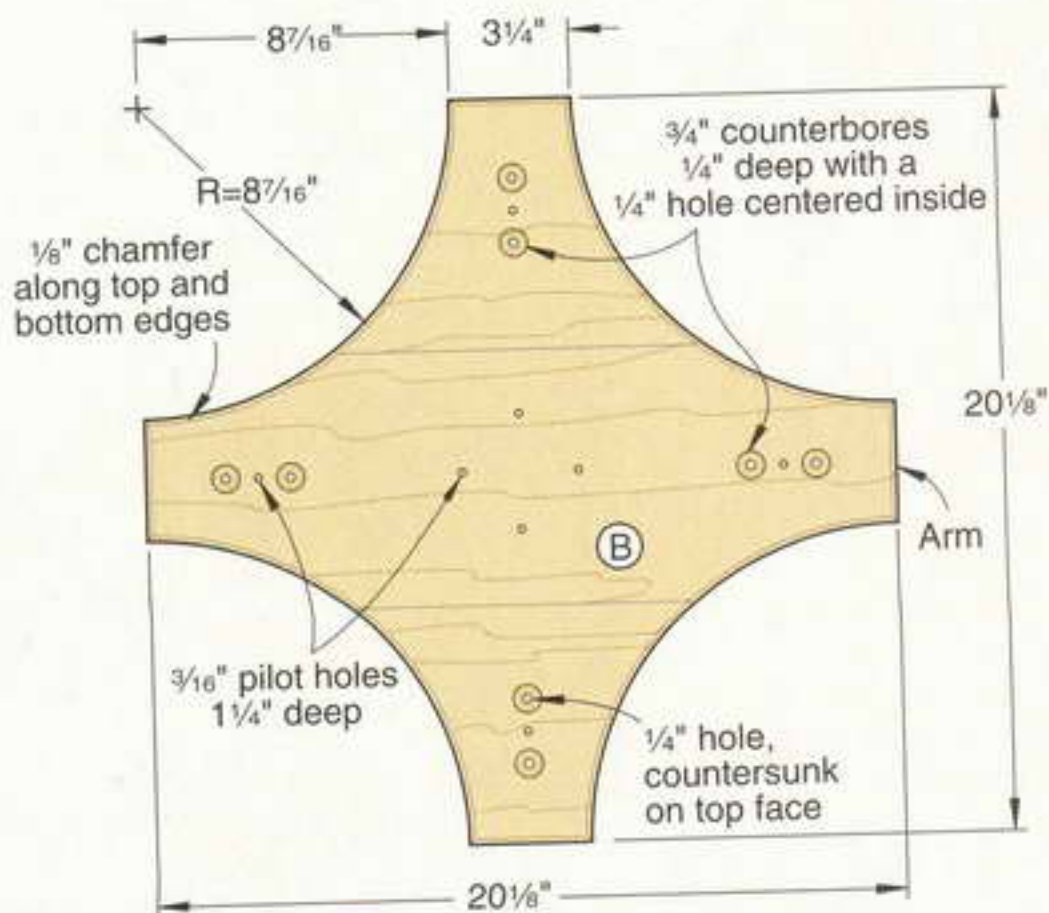

3 SLIDE PLATFORM (Bottom view)

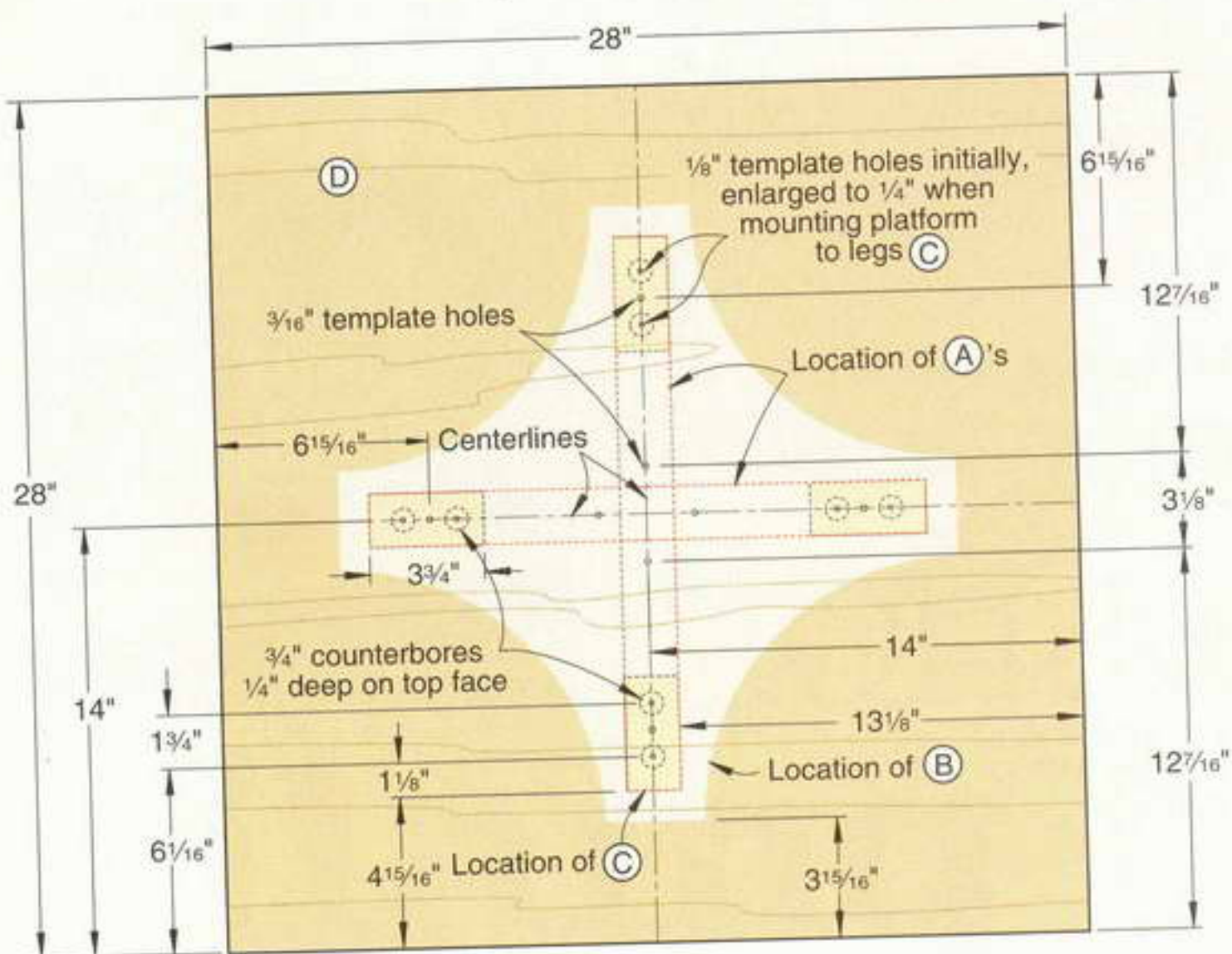

Next up: the base, legs, and slide platform

1 Edge-joint enough 1 1/2"-thick oak to form a 21x21" workpiece for the base (B). Then, trim the base to finished size.

2 Mark the four radii on the base, where dimensioned on **Drawing 2**. Bandsaw and sand the base to shape. Now, rout 1/8" chamfers along the base's top and bottom edges.

3 Next, cut the legs (C) to size. Make two copies of the full-size leg end pattern, and spray-adhere them to the ends of a leg. Draw a line to connect the patterns together. Now, bandsaw and sand the leg to shape, and remove the patterns. Using this leg as a template, mark the other legs, and cut and sand them. Then, rout 1/16" chamfers along the legs' edges.

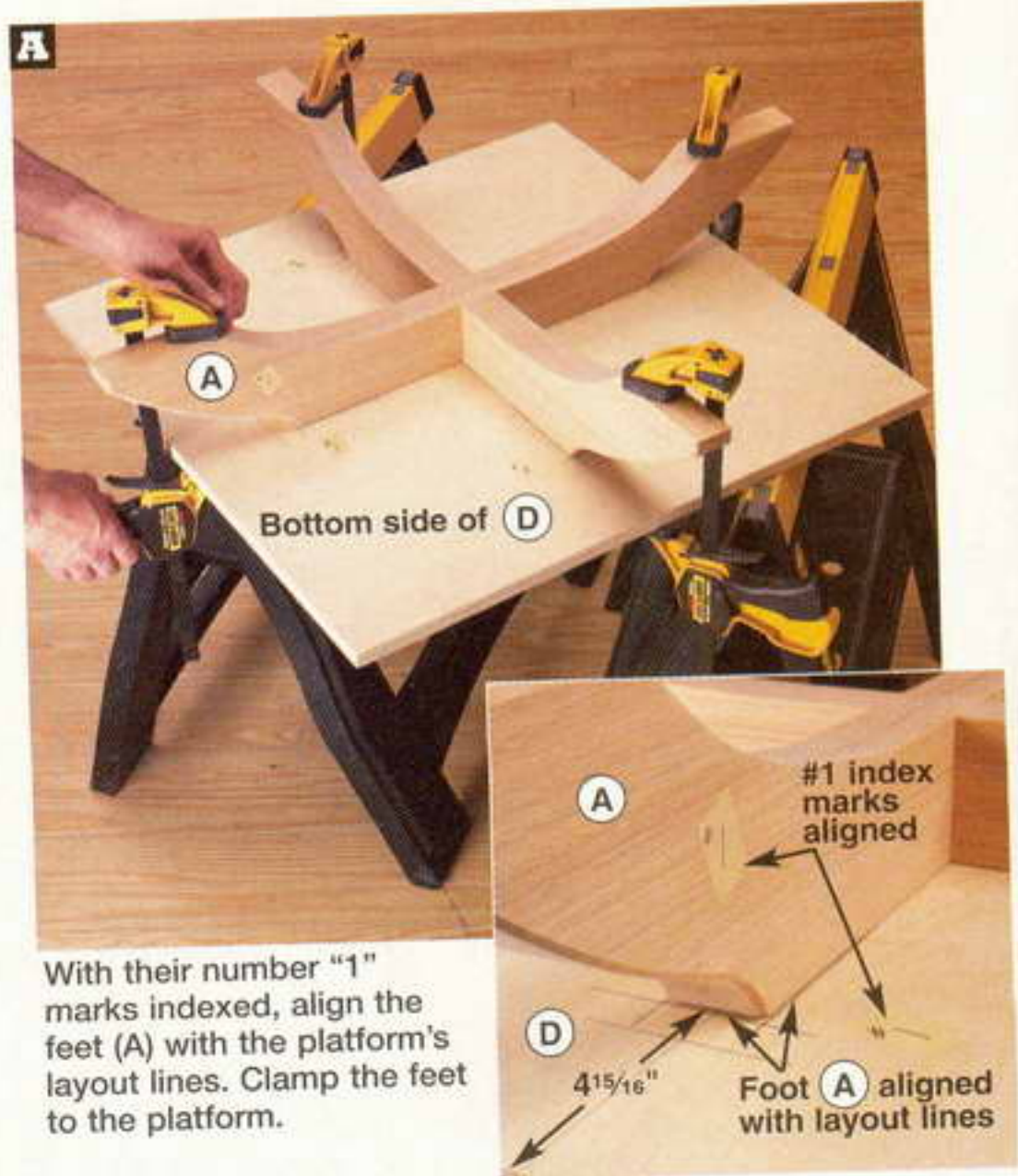

With their number "1" marks indexed, align the feet (A) with the platform's layout lines. Clamp the feet to the platform.

4 Cut the slide platform (D) to size. From scrap 3/4" plywood, cut another piece to the same size. (You'll use it when assembling the table's base.)

5 To prepare the slide platform for use as a drilling template, draw a pair of centerlines on its bottom; lay out the locations for parts A, B, and C; and mark the hole locations, where dimensioned on **Drawing 3**. Then, drill 1/8" and 3/16" holes through the platform, where shown. Turn the platform over, and counterbore the 1/8" holes.

6 For matching purposes, number the leg (C) locations (the order is not important) on the platform's bottom, and number the legs. Also, mark a "1" on a foot (A) and on an arm of the base (B) to index these parts to the platform.

Drill lag-screw holes, and assemble the base

Note: To successfully do the operations in this section, you need to pay close attention to the orientation of parts and the applicable sets of holes in the slide platform (D) that you'll use as drilling guides. To ensure success, read through the section first, and make sure you understand all of the steps before proceeding.

1 To drill the counterbored holes in the feet (A) for lag screws, where shown on **Drawing 1**, place the slide platform (D)

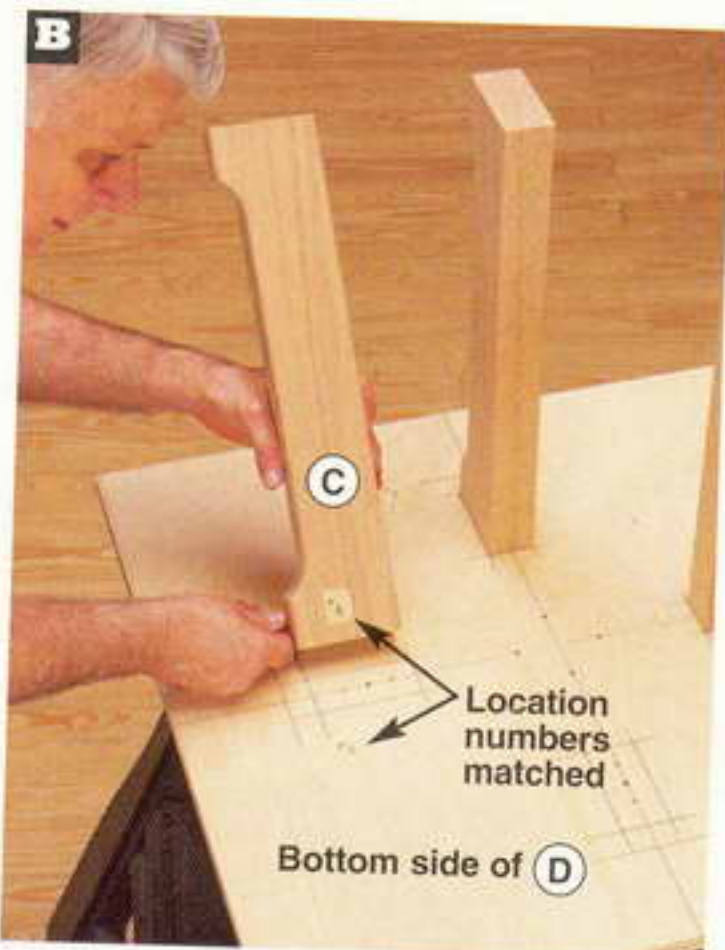

Match the legs (C) to the numbered locations on the slide platform (D). Align the legs with the layout lines.

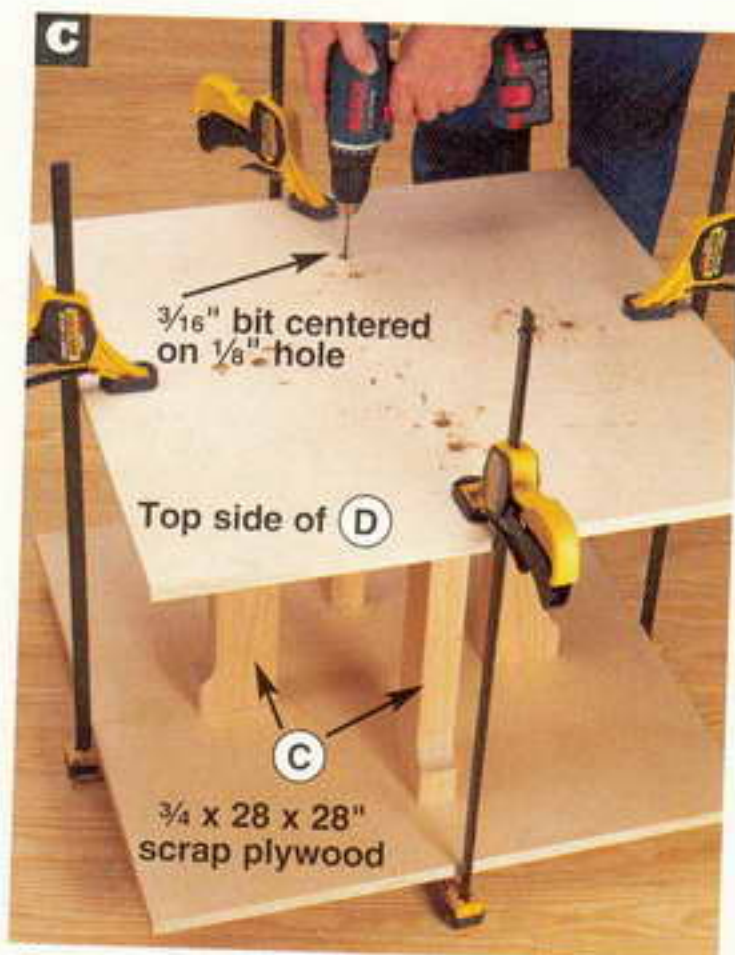

Centering a $\frac{3}{16}$ " bit on the platform's $\frac{1}{8}$ " holes, drill a pair of $1\frac{3}{4}$ "-deep pilot holes in each leg (C).

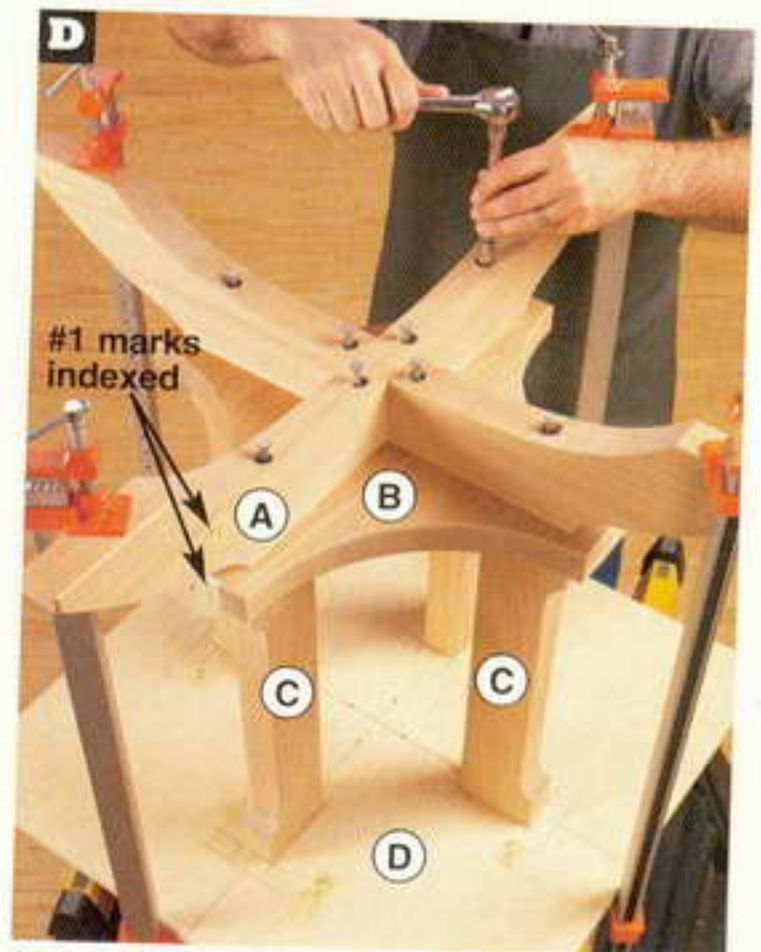

Index the feet (A) on the base (B), and align their mounting holes. Clamp the assembly, and drive the lag screws.

on sawhorses with the bottom side up. Then, align and clamp the feet to the platform, as shown in **Photo A**.

2 Turn the clamped assembly over. Using the eight $\frac{3}{16}$ " holes in the platform as guides, drill $\frac{3}{16}$ " holes as deep as you can into the feet. Remove the platform. Now, redrill the holes with a $\frac{7}{16}$ " bit, boring through the feet.

3 Place the feet on your drill-press table with the bottom face up. Using a $\frac{3}{4}$ " Forstner bit, counterbore the four inner holes $\frac{3}{8}$ " deep. Set the depth stop to ensure a consistent depth. Without changing the setting, counterbore the four outer holes.

4 To align the base (B) on the platform for drilling, mark centerlines across the grain on the ends of the base's arms. Apply a few pieces of double-faced tape to one face of the base. Indexing the base to the platform, align their centerlines, and press the base firmly against the platform.

5 Turn the assembly over. Using the $\frac{3}{16}$ " holes in the platform as guides, drill $\frac{3}{16}$ " pilot holes $1\frac{1}{4}$ " deep in the base's bottom. See **Drawing 2**. Then, using the $\frac{1}{8}$ " holes in the platform as guides, drill $\frac{1}{8}$ " holes through the base. Remove the base from the platform.

6 Using the $\frac{3}{4}$ " Forstner bit in your drill press, counterbore the $\frac{1}{8}$ " holes in the base's bottom $\frac{1}{4}$ " deep. Then, enlarge the $\frac{1}{8}$ " holes to $\frac{1}{4}$ ". Now, countersink the $\frac{1}{4}$ " holes on the base's top, where shown. This will ensure a tight fit when the base is attached to the legs (C).

7 To drill the pilot holes in the ends of the legs, place the platform on the sawhorses, bottom face up. Align the legs on the platform, as shown in **Photo B**. Then, place the $\frac{3}{4} \times 28 \times 28$ " piece of scrap plywood on top of the legs, in line with the platform, and clamp the assembly together. Double-check the alignment of the legs on the platform.

8 Place the clamped assembly on the floor with the platform on top. Using the $\frac{1}{8}$ " holes in the platform as a guide, drill pilot holes in the legs, as shown in **Photo C**. Unclamp the assembly, turn the legs over end for end, reclamp with the legs aligned as before, and drill the pilot holes. Now, centering on the $\frac{3}{16}$ " holes you just drilled, drill $\frac{1}{4}$ " holes $\frac{3}{4}$ " deep in the platform for shank holes.

9 Drive $\frac{1}{4}$ " lag screws 2" long with $\frac{1}{4}$ " flat washers through the platform and into the legs. To ease installation, lubricate the threads with paraffin.

10 Place the assembly back on the sawhorses with the scrap plywood on top. Remove the plywood. Index and position the base (B) bottom face up on the legs, aligning the base's and legs' holes. Now, clamp the assembly together, and drive $\frac{1}{4}$ " lag screws 3" long with $\frac{1}{4}$ " flat washers through the base and into the legs.

11 Unclamp the assembly. Mount the feet (A) on the base (B), as shown in **Photo D**, and drive the $\frac{1}{4}$ " lag screws 4" long with $\frac{5}{16}$ " flat washers.

Make the tabletop and leaves

1 Edge-join enough $\frac{3}{4}$ "-thick boards to make two 25×49 " workpieces for the tabletop halves (E) and two 13×49 " workpieces for the leaves (F). Rip the leaves to their finished width of 12".

2 Using a square, mark a centerline across the width of the tabletop halves and leaves on their bottom faces. Then, place the tabletop halves (not the leaves) bottom face up on your workbench with the centerlines aligned. Apply two pieces of duct tape across the joint to keep the parts tight together and aligned.

3 From scrap, make a pivot block for marking (and later routing) the tabletop's diameter, as shown on **Drawing 4**. Mark centerlines across the block's face and down its edges, where shown.

4 Center the block on the tabletop's bottom face, aligning the block's centerlines with the tabletop's centerline and joint line. Fasten the block to the tabletop with four $\#8 \times \frac{1}{2}$ " flathead wood screws. Then, using a trammel, and

4 PIVOT BLOCK

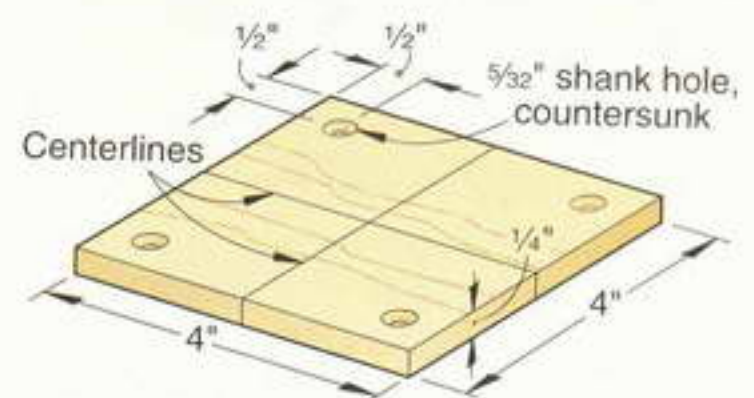

5 TABLETOP
(Bottom view)

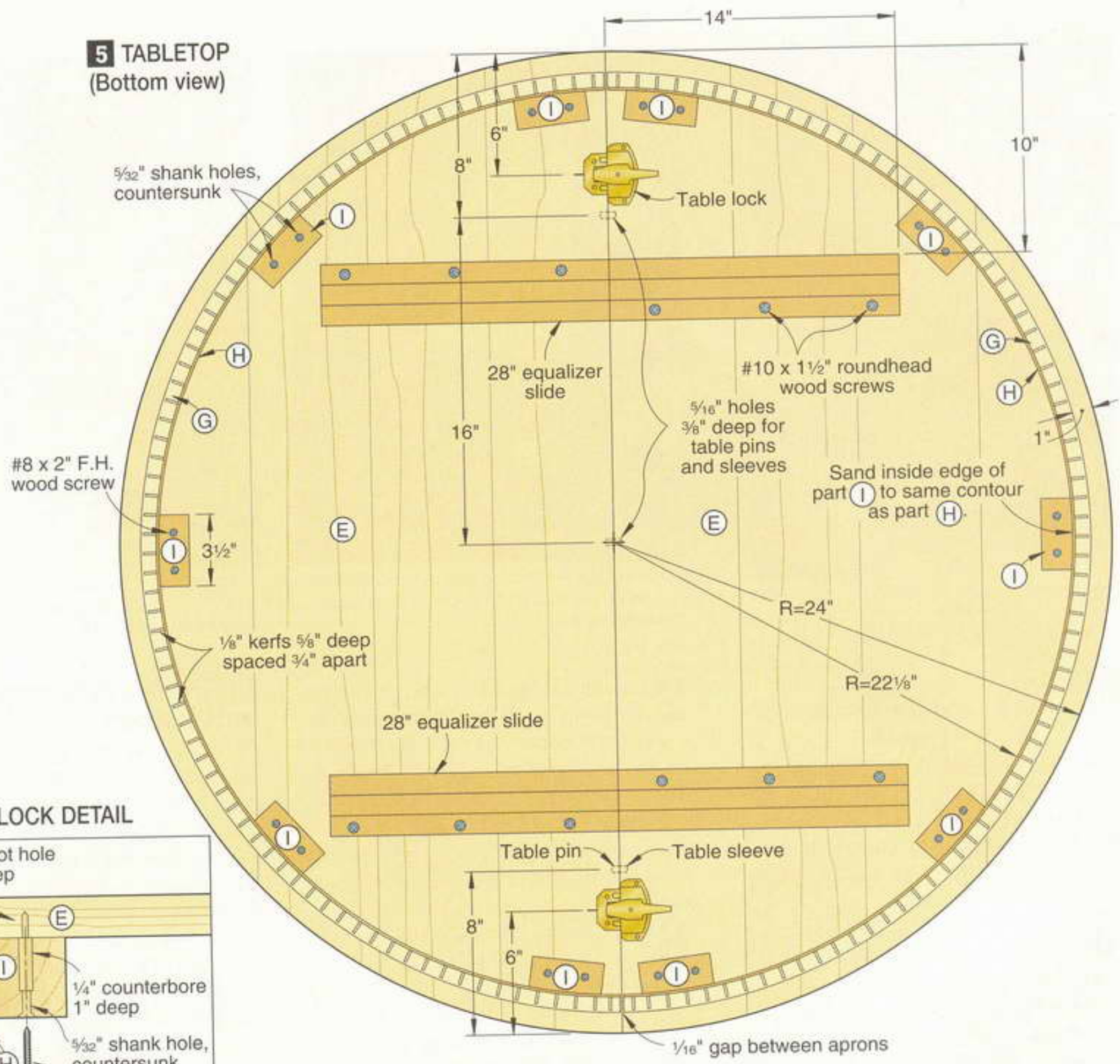

5b GLUE BLOCK DETAIL

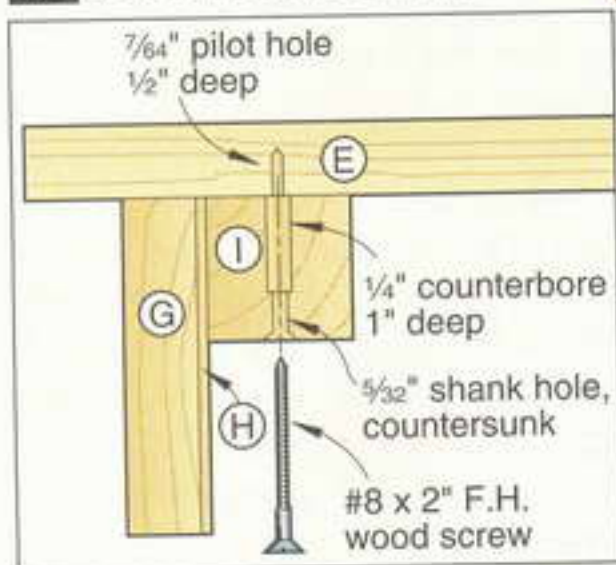

5a TABLE LOCK DETAIL

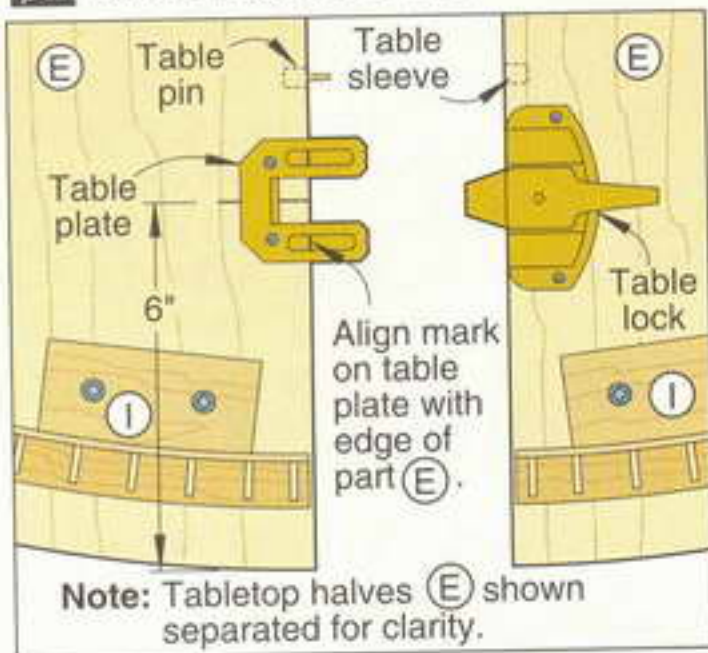

locating its pivot pin on the block's center, draw a circle with a 24" radius for the top's outer edge and another circle with a 22 1/8" radius for locating the glue

blocks (I), where shown on **Drawing 5**. Remove the pivot block.

5 Using a straightedge, draw lines across the tabletop's joint to mark the locations for the outer tabletop pins/sleeves and the table locks, where dimensioned. (The center pin and sleeve align with the tabletop's centerline.)

6 To mark the locations for the leaves' pins and sleeves, position the leaves between the tabletop halves, align the parts' centerlines, and tape across the joints. Then, align a straightedge with the marked lines on the tabletop halves for the outer pins and sleeves, and draw lines across the leaves' joints. To ensure correct pin installation, mark "pin" on the right side of the left tabletop half and leaves. Separate the parts.

7 Using a doweling jig, drill 5/16" holes 3/8" deep in the parts' edges at the marked

locations, as shown in **Photo E**. Then, install the pins and sleeves in the applicable holes, using a mallet to drive them in.

8 Using a helper, bandsaw and sand the tabletop halves to within 1/8" of the outer line. Then, join them together, bottom face up, and tape across the joint. Now, using a 1/2" straight bit in your router and a router trammel, trim the top to the line. For help on doing this, see the sidebar, *opposite page, far right*.

9 To trim the leaves' lengths, position the leaves tight between the top halves. Now, using a straightedge aligned flush with the tabletop halves' edges, draw lines across the leaves. Cut and sand the leaves to the lines.

10 To install the table locks, join the tabletop halves (E) together, bottom face up. On the tabletop half with table pins, position the table-lock plates,



Align a doweling jig's $\frac{5}{16}$ " guide hole with the marked line for a pin or sleeve. Adjust the jig to center the guide hole on the part's edge, and drill the hole.



Clamp a $\frac{3}{4} \times 3\frac{1}{2} \times 18$ " scrap to the tabletop half, $\frac{1}{32}$ " back from its straight edge and tight against the apron. Using the scrap as a saw guide, trim the apron's end.

where shown on **Drawing 5a**, centering them on your marks. Mark the mounting hole locations, drill pilot holes, and drive the supplied screws. Then, position the mating table locks on the other top half, and engage them with the plates. Mark the table locks' mounting holes, drill the holes, and drive the screws.

11 Place a leaf (F), bottom face up, between the tabletop halves. Then, position table locks and plates on the leaf, and engage them with the mating parts on the tabletop halves. Screw the parts to the leaf. Insert the remaining leaf, and install its lock hardware in the same way. Remove the leaves, and join the tabletop halves together.

Add the aprons

*Note: As an alternative to forming the tabletop's curved aprons (parts G and H, shown on **Drawing 5**), you can use preformed parts. (See the **Buying Guide** at the end of this article for our source.) These parts have predrilled pocket holes, so you'll screw them directly to the tabletop halves (E) without using glue blocks (I).*

1 Cut the kerfed aprons (G) to the listed width but to a length of $75\frac{5}{8}$ ", and cut the apron backers (H) to width but to a length of 73". Then, referring to the article on page 22, kerf the aprons, assemble the backers to them, and form the assemblies to the radius shown on **Drawing 5**.

2 Cut the glue blocks (I) to size, and drill the blocks' countersunk shank holes, where shown on **Drawings 5** and **5b**. Turn the blocks over, and counterbore the holes. Set eight of the 18 blocks aside for the leaves (F). To radius an edge of the remaining 10 blocks so they fit tight against the curvature of the apron/backer assemblies (G/H), use an apron as a template, and scribe its contour on a block's face. Sand the block to the line. Now, using this block as a template, mark the other blocks, and sand them to shape.

3 Position the blocks (I) on the tabletop halves (E), where shown, aligning their curved edges with the inner radius line. Using the shank holes in the blocks as guides, drill pilot holes in the tabletop halves. Then, screw (no glue) the blocks in place.

4 To trim the apron/backer assemblies to finished length, position one on a tabletop half (E) against the glue blocks and supported on $\frac{1}{8}$ " spacers. Align the apron's and tabletop half's centerlines, and clamp the apron to the blocks.

5 Using a square, draw a line, located $\frac{1}{32}$ " inside the tabletop's straight edge, across the apron's outside face at each end. (The $\frac{1}{32}$ " setback provides clearance so the tabletop halves will close together tightly.) Now, trim the apron's ends, as shown in **Photo F**, and smooth them with a flat bastard file. Repeat the process to trim the other apron on its tabletop half.

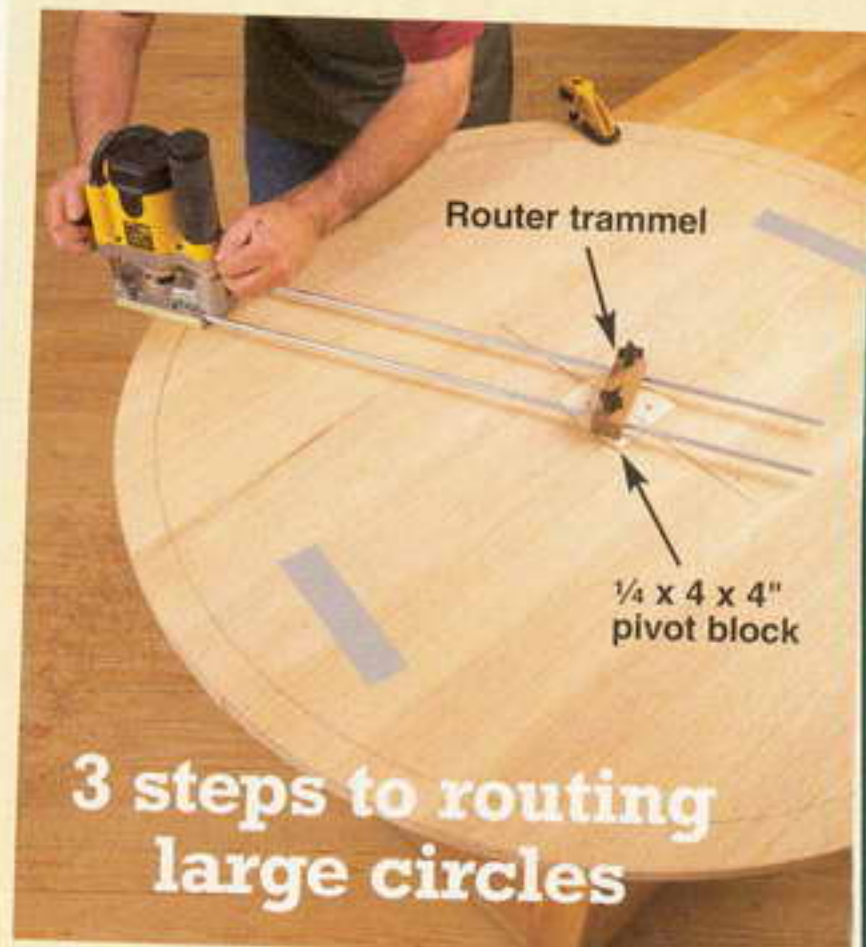

3 steps to routing large circles

With just a router, a straight bit, and a router trammel, you can easily form large, perfectly circular parts, such as this project's tabletop. No trammel? Don't worry. In a flash, you can make the one shown in the drawing, *below*, that will let you cut circles up to 72" in diameter. Here's how to put the setup to work.

STEP 1

Insert and fasten the trammel's rods in your router's edge-guide mounting holes. Then, set the radius of the circle by measuring from the inside of the straight bit's cutting edge to the center of the trammel's pivot pin. Now, lock in the radius by tightening the trammel's knobs.

STEP 2

Drill a hole, sized to suit the trammel's pivot pin, in the center of the workpiece's bottom. Make the hole at least $\frac{1}{4}$ " deep but not through the workpiece. Or, for this project's tabletop, which has a joint between the halves (E), drill a hole through the scrap pivot block's center, and reattach the block to the tabletop's bottom.

STEP 3

With the workpiece rough-cut to within $\frac{1}{8}$ " of the finished diameter, insert the jig's pivot pin into the drilled hole. Now, plunge the router bit, and slowly rout the workpiece, as shown in the photo, *above*.

ROUTER TRAMMEL

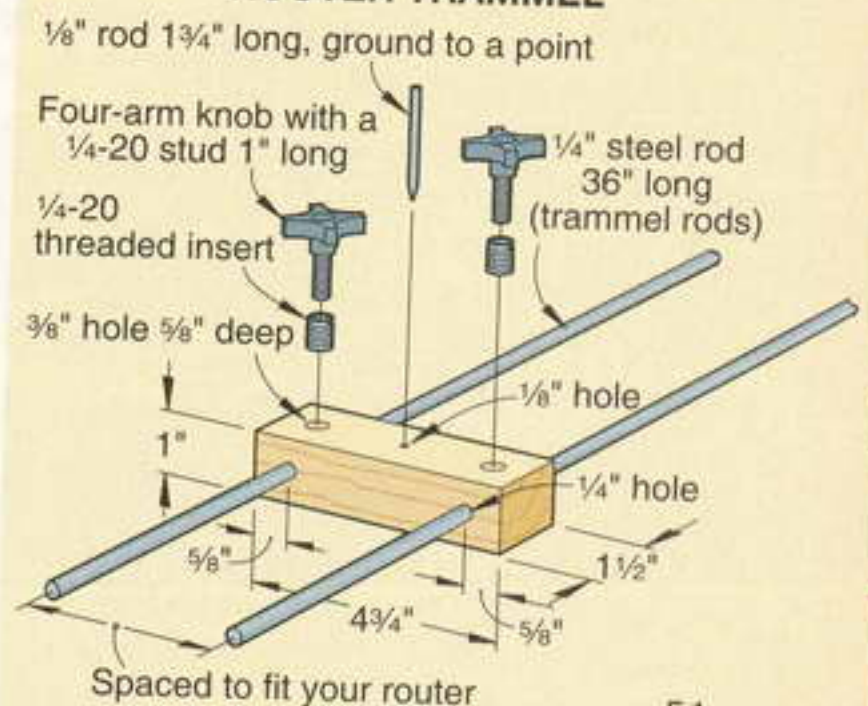

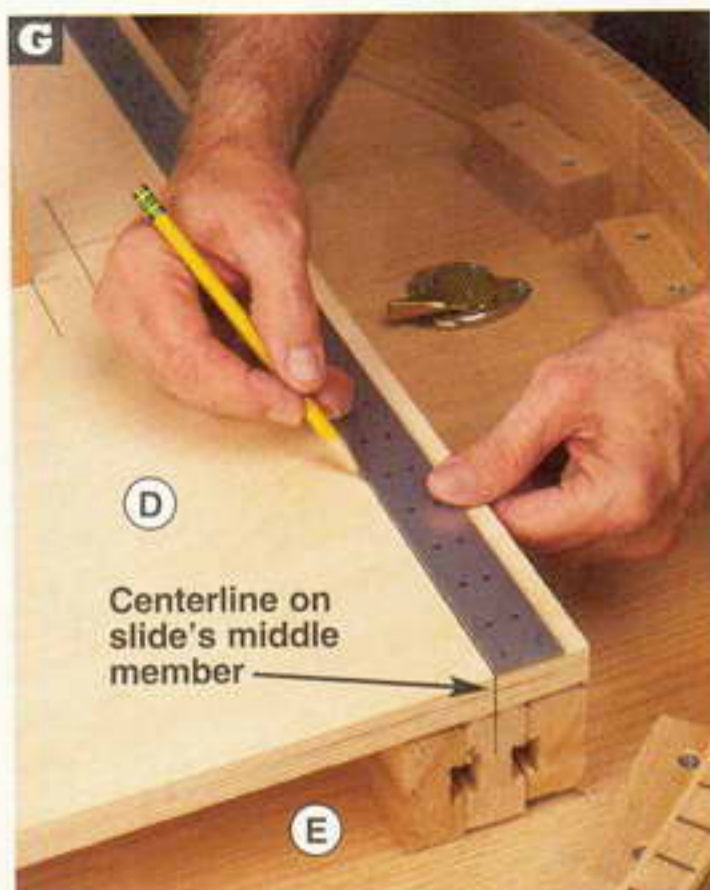

Mark the center of each slide's middle member on its ends. Draw lines across the platform, connecting the marks.

6 Remove the aprons. Apply glue to the glue blocks' curved faces. (We used Titebond Wood Molding Glue, which sets quickly and helps to fill any gaps between the parts.) Clamp the aprons to the blocks.

7 Cut the leaf aprons (J) to size. Then, glue the blocks (I) to the aprons, flush with their ends, where shown on Drawing 6.

8 Position the tabletop-half assemblies (E/G/H/I), with the leaves (F) between them, bottom face up. Then, along each side of the table, place a straightedge against the aprons (G/H), and draw a line across the leaves. Align the block/apron assemblies (I/J) with the lines, and center them side-to-side on the leaves. Drive the screws through the blocks and into the leaves.

9 Rout a $\frac{1}{16}$ " chamfer along the outside edge of the table's aprons. Then, remove the leaves, and rejoin the top.

Complete the assembly, and finish up

1 To install the 28" equalizer slides, where shown on Drawings 5 and 7, make marks on the bottom face of the tabletop halves (E) 10" in from the ends of their straight edge. Then, using a square, extend a 14" line from each mark.

2 With the predrilled, countersunk holes in the slides' outer members faceup, position and align the slides on the inside of the marked lines, where dimensioned on Drawing 5. Then, using an awl, mark the slides' hole locations

6 TABLE LEAF

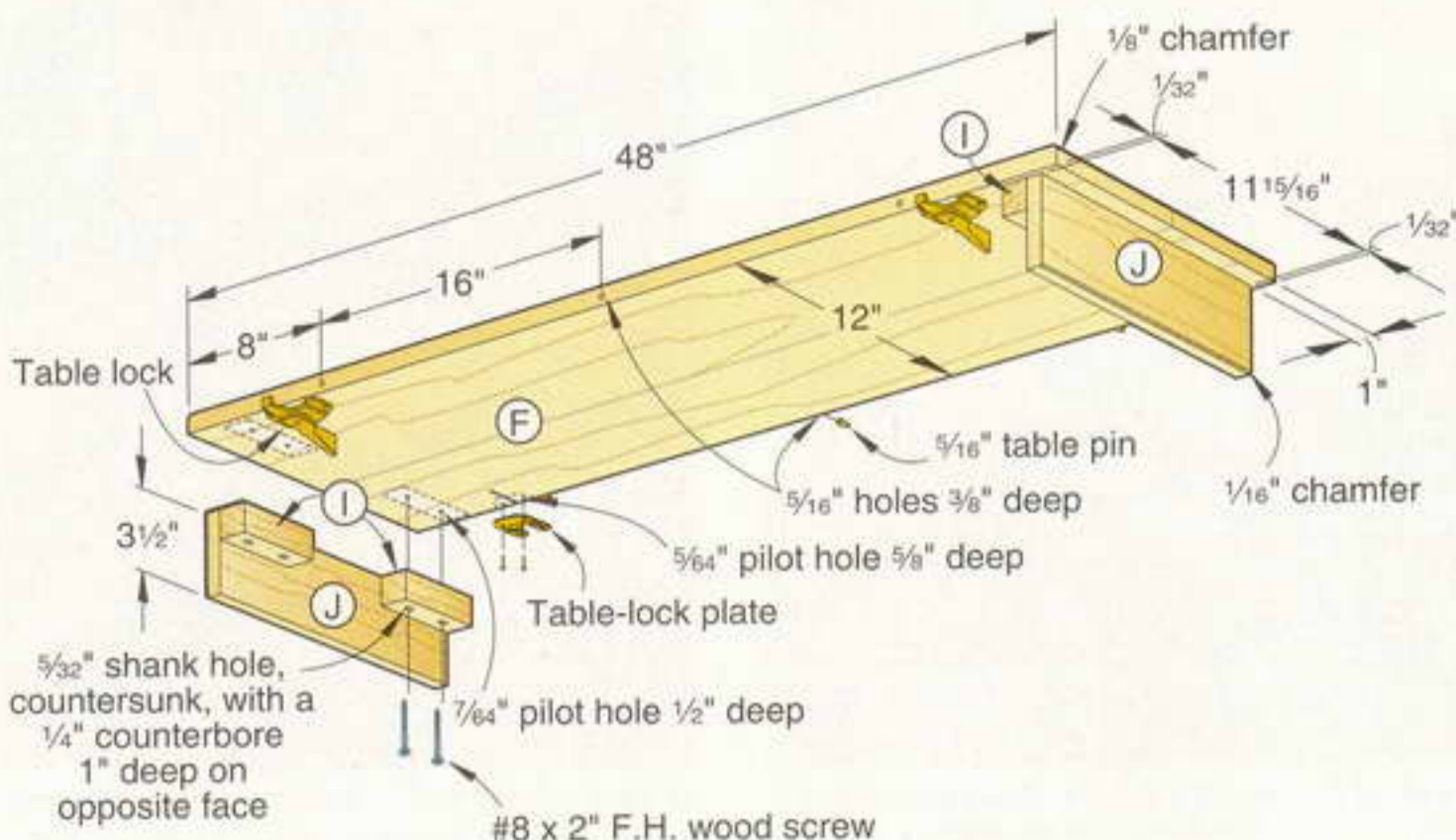

Cutting Diagram

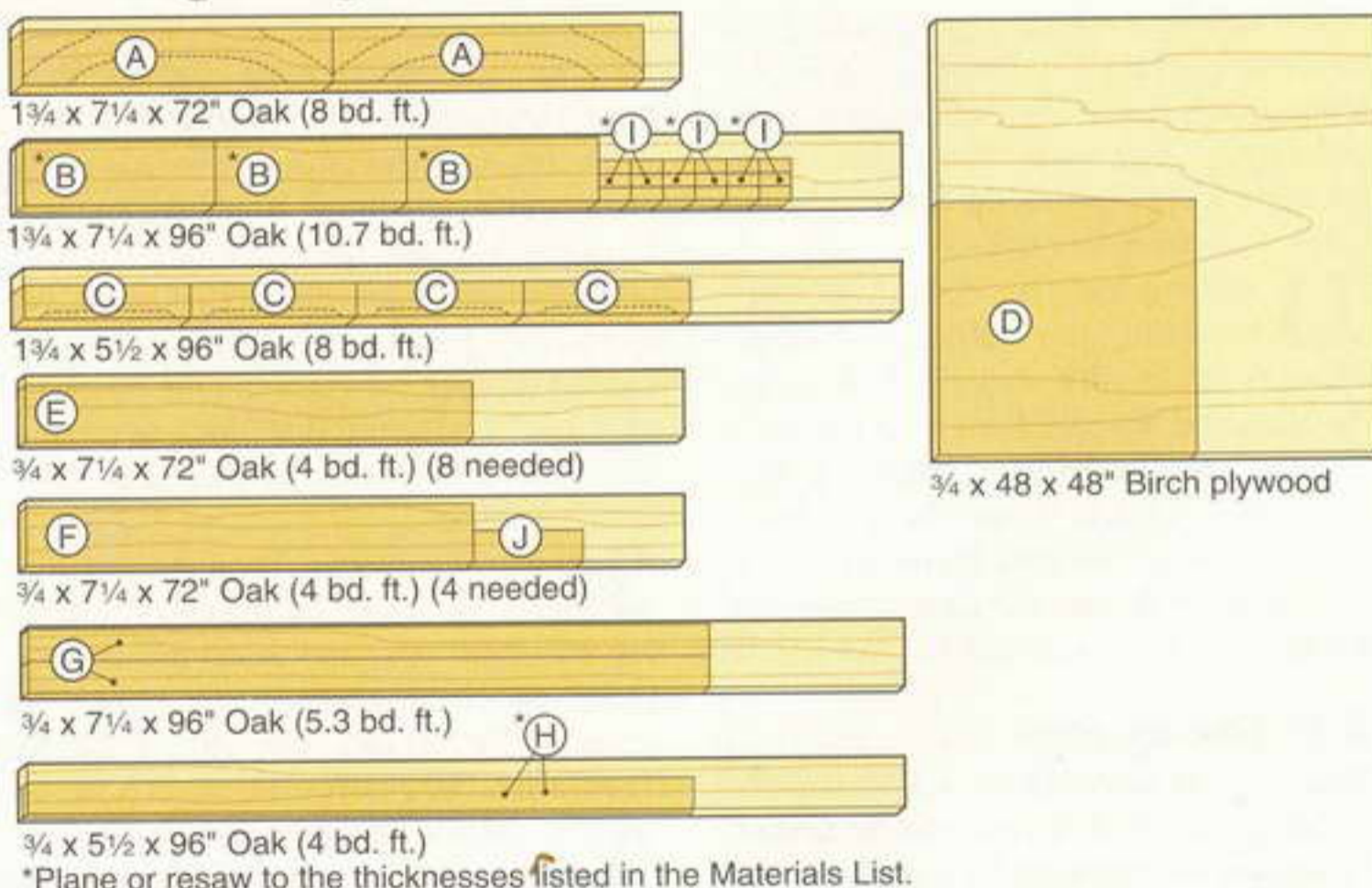

on the tabletop. Remove the slides, and drill a $\frac{1}{8}$ " pilot hole $\frac{5}{8}$ " deep at the marked locations. Now, realign the slides, and drive the screws.

3 Position the base assembly (A/B/C/D) on the slides, aligning the slide platform (D) with the slides' edges and ends. Next, mark lines on the platform centered over the slides' middle members, as shown in Photo G. Drill mounting holes along the marked lines, and drive the screws through the platform and into the slides. Now, with

a helper, set the table on its feet, insert the leaves, and rout a $\frac{1}{8}$ " chamfer along the top edge.

4 Finish-sand the table and leaves to 220 grit. Apply a stain if you wish. (We used ZAR Oil-Based Stain, no. 110 Salem Maple.) Then, apply two coats of a clear finish. (We sprayed on AquaZAR Water-Based Clear Satin Polyurethane, sanding to 320 grit between coats.) Now, get ready to make the matching chairs in the March 2004 issue, and take time before your next project to enjoy some fine dining. 🍴

pocket-hole jigs

With models starting at \$10, you have to give this joinery method a try.



If there's a faster, simpler, and stronger joinery method than pocket holes and screws, we'd like to see it. Using pocket-hole joinery, glue-ups are virtually clamp-free whether you're edge-joining boards for a tabletop, assembling a face frame, or building a drawer. (If you're not familiar with the technique, check out the pocket-hole primer on *page 26*.)

So, what about the jigs that make pocket holes possible? We gathered 18 models selling for \$10 to \$800, put them to the test, and found what characteristics—besides price—separate them. Now, we're prepared to name the Top Tools and Top Values in four price ranges.

What makes a good pocket-hole jig?

Drill guides. These steel tubes guide the drill bit at an angle as you cut the pocket hole, and the constant reaming by a sharp bit can take its toll. Several jigs showed signs of scoring inside the guides after boring about 40 pocket holes, suggesting they'll wear faster than those without scoring. And, although some steel shavings from the guides are acceptable for the first few holes while the bit and guide break in together, the Rockler 21296 (*above right*) continued to spit out metal well into our tests.

Pocket holes usually are made in pairs, so a jig with two drill guides saves you time if you can drill both pockets with only one setup. For making 1½" face frames, we find ⅞" spacing between the holes to be perfect, and most of the two-guide jigs deliver.

Several jigs are adjustable to increase the spacing for wider workpieces, but only two—the Task Pro Center 06250 and Kreg K2—can go narrower. Of course, for spacing above or below the ranges shown in the chart on *page 64*, you simply move the jig, and drill the pockets individually.

Portability. A less-portable jig isn't necessarily a bad thing; it's merely a question of whether you bring the jig to the workpiece (as you would do for a large or built-in project), or the workpiece to the jig. Low-cost jigs without built-in clamps tend to work better on large projects: They're smaller and easier to clamp in tight spaces



The guides on Rockler's 21296 didn't hold up well in our test. Even after boring more than 50 pocket holes, we still found steel shavings among the wood chips.

than the more-expensive benchtop jigs. However, most are awkward to use on a benchtop (except for Pock'It, which, with its flat bottom and built-in clamp, is similar to the more-expensive benchtop jigs).

When you can bring the work to the jig, most benchtop jigs (priced \$70 and up) have built-in clamps that make positioning and securing the workpiece fast and easy. These jigs also typically have a stop to positively locate the workpiece on the jig.

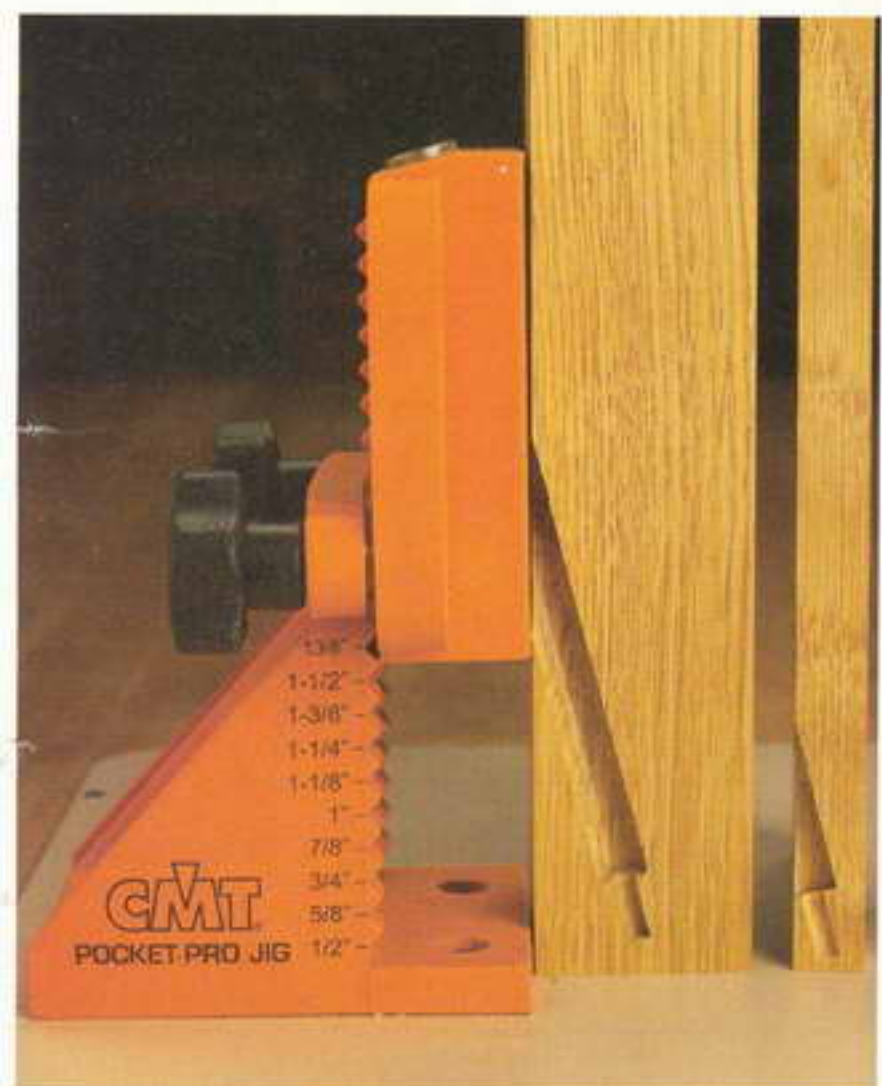

Whether you're making pocket holes in 1/2"-thick drawer sides (right), 1 5/8"-thick bed rails (left), or something in between, the Pocket Pro easily adjusts to any 1/8" increment within that range.

Adjustability for stock thickness.

All of the pocket-hole makers in our test are designed to center the screw-exit hole in 3/4" stock. Can you work thinner or thicker pieces? Sure, within about 1/8" or so, but the screw won't be centered in the end or edge of the workpiece—it isn't a problem, but it's not ideal, either.

A few readily adjust to bore centered holes in 1/2" stock, a common thickness for drawer sides. The Kreg Rocket and ProPack come with spacer blocks that change the placement of the holes to accommodate 1/2"- and 1 1/2"-thick stock. They're easy to install, but also easy to misplace. CMT's Pocket Pro (see photo *below left*) is the only jig with positive stops for ten thicknesses of material from 1/2" to 1 5/8".

"Pluggability." Although most pocket holes will be hidden inside cabinets and beneath tables, there may be times when they show. You can plug them with dowels, and some manufacturers sell specially cut dowel segments, or you can make them yourself.

To help the plugs blend in, you want a pocket hole free of tear-out, and most of the jigs delivered acceptable results when boring with the grain. Cross-grain cuts (such as you might make when edge-joining a panel or tabletop) were a different story, especially for the \$20-and-under crowd. The Kreg Mini, shown at *lower right*, and the Pock'It were the only low-cost jigs that left us with a pluggable pocket across the grain.

Two of the most expensive pocket-hole makers cut unpluggable holes, but for different reasons. Because the Porter-Cable 552 creates a curved pocket (see photos, *above right*), a dowel won't do the trick. FaceMaker 500 leaves the pocket screw slightly proud of the workpiece, so you can't hide it with a plug.

Top-dollar jigs uniquely suited to production pros

Once you try pocket-hole joinery, you might find yourself addicted to the ease and speed of assembling projects. (Some pocket-hole-obsessed craftsmen actually boast about the number of pocket holes in their projects!) The \$330+ jigs are designed for high-productivity shops with budgets to match, but we thought you might like to know about them in case you're ready to take the next step.

Kreg's two entries in this price category bore pockets in the same basic manner as the least expensive jigs, but they automate



Porter-Cable's 552 swings a straight router bit up into the workpiece to create an arch-shaped pocket (top). Then, a drill bit plunges into the end to create the screw pilot hole (bottom).

at least part of the process. The K200 consists of a drill chuck and bit guided by a pair of spring-loaded plunge rods, and a pedal-activated pneumatic clamp. Mount your own power drill to the K200's chuck, position your workpiece on the jig, and step on the pedal to clamp it in place. Then drill the pocket as usual.

The Kreg Foreman, on the other hand, is an automatic, entirely pneumatic pocket-hole machine. Position the workpiece flat on the Foreman's table (two flip stops provide excellent repeatability), and pull the lever forward. In a flash, a clamp secures the workpiece, and the step drill bit bores the pocket from below. The whole process takes less than 2 seconds.

Porter-Cable's 552 takes an unusual two-step tack to pocket holes. After manually clamping the workpiece to its tabletop, you push a lever forward, and then pull it back. Each action creates part of the pocket hole, as shown *above*.

Expect longer bit life from the automated and semi-automated jigs from Kreg and P-C. Machine-guided bits drill straighter and with less stress on the cutting flutes than human-guided bits.

FaceMaker, designed specifically for face-frame construction, is more an



The close-fitting bit-exit hole of the Kreg Mini (left) prevents tear-out in cross-grain cuts better than the wide-open back of the Task Pro Center 06200 (right).

Our picks of the pocket makers

assembly jig than a true pocket-hole jig. Insert two frame pieces to be joined, and self-centering clamps position them for drilling. After drilling the pocket holes, you drive the screws right through the guide holes without unclamping the assembly. The process works well, but seems antiquated by the standards of other pocket-hole jigs in this price range.

Sometimes, the original is still the best, and Kreg Tools pulled off an amazing, unprecedented sweep of our top recommendations in all four price categories.

■ **\$10-\$40.** The Kreg Mini cut the cleanest pocket holes and comes with a step drill bit and a lifetime replacement warranty on the guide, so we named it the Top Value. Nothing else comes close in this price range.

POCKET-HOLE SCORECARD: HERE'S HOW 18 JIGS FARED IN OUR TESTS

BRAND	MODEL	BODY MATERIAL (1)	POWER SOURCE (2)	WORKPIECE THICKNESS RANGE (INCHES)	CLAMP STYLE (3)	DRILL GUIDES (4)				PERFORMANCE GRADES (7)							ACCESSORIES (8)		WARRANTY (9)	COUNTRY OF ASSEMBLY (10)	SELLING PRICE (11)	FOR MORE INFORMATION	
						NUMBER OF GUIDES	GUIDES REPLACEABLE (YES, NO)?	GUIDE MATERIAL (5)	GUIDE-HOLE SPACING RANGE (INCHES) (6)	QUALITY OF POCKET, CROSS-GRAIN CUT	QUALITY OF POCKET, WITH-GRAIN CUT	GUIDE DURABILITY	EASE OF CLAMPING TO PORTABLE WORKPIECE	EASE OF CLAMPING TO FIXED WORKPIECE	EASE OF PLUGGING POCKET HOLES	ADJUSTMENTS FOR DIFFERENT MATERIAL THICKNESS	INSTRUCTIONS	STANDARD					OPTIONAL
MODELS PRICED \$10-\$40																							
KREG	Mini	G	UD	3/4	N/A	1	N	HS	N/A	A	A	A	C	B	A	C	B	B	D6, FC, S	30/L	U	\$20	800/447-8638 www.kregtool.c
ROCKLER	21296	A	UD	3/4	N/A	2	N	S	7/8-3	D	B	D	C	B	C	C	N/A		B, D6, FC, S	LIFE	T	13	800/279-4441 www.rockler.co
SIMP'L PRODUCTS	Pock'it PJ-5K	A	UD	1/2-1 1/2	S	2	N	HS	1	B	A-	C	B	B+	B	C	D	B, D6, FC, S		LIFE	U	40	914/662-2820 www.woodjigs.c
STEELEX	D1060	A	UD	3/4	N/A	2	N	S	7/8-3 3/4	C	B	C	C	B	C	C	D		B, D6, FC	1 yr.	T	10	800/840-8420 www.shopfox.b
TASK PRO CENTER	06200	A	UD	3/4	N/A	1	Y	HS	N/A	C	B	B	C	B	C	C	D		B, D6, FC	LIFE	U	12	269/795-7146 www.task-usa.c
	06250	A	UD	3/4	N/A	2	Y	HS	3/4-2 3/8	C	B	B	C	B	C	C	D		B, D6, FC	LIFE	U	20	
WOODWORKER'S SUPPLY	28084	A	UD	3/4	N/A	2	N	HS	7/8-3	C	B	C	C	B	C	C	D		B, D6, FC, S	1 yr.	T	13	800/645-9292 www.woodworker
MODELS PRICED \$65-\$80																							
KREG	Rocket	G	UD	1/2, 3/4, 1 1/2	F	2	N	HS	7/8	A	A	A	C+	A	A	A-	A	B, D6, FC, S		30/L	U	65	800/447-8638 www.kregtool.c
PENN STATE	#PHJIG	A	UD	3/4	P	2	N	S	1 1/4-2 1/2	B	B	B	B+	C	B	C	C		S	LIFE	U	80	800/377-7291 www.pennstateind
ROCKLER/KREG	31995	A	UD	3/4	P	2	N	HS	7/8	A	A	A	A-	B	A	C	C	B, CC, D3, D6, S		2 yr.	T	70	800/279-4441 www.rockler.co
TASK PRO CENTER	06270/06250	A	UD	3/4	P	2	Y	HS	1 1/4-2 1/2	C	B	B	B+	C	B	C	C			LIFE	U	70	269/795-7146 www.task-usa.c
MODELS PRICED \$100-\$150																							
CMT	Pocket Pro PPJ-001	P	UD	1/2-1 1/2	P	2	N	HS	7/8	A	A	A	A-	D	A	A	B	B, CC, D3, D6, FC, S		LIFE	I	150	888/268-2487 www.cmtusa.c
KREG	K2	A	UD	3/4	P	2	N	HS	9/16, 7/8, 1 1/16	A	A	A	A-	B	A	C	A	B	S	30/L	U	100	800/447-8638 www.kregtool.c
	ProPack	G	UD	1/2, 3/4, 1 1/2	P	3	N	HS	7/8	A	A	A	A-	A	A	A-	A	B, CC, D3, D6, FC, S		30/L	U	140	
MODELS PRICED \$330-\$800																							
FACEMAKER	500	CI	UD	3/4	SC	2	Y	S	1 1/2-6 1/2	A	A	B	B	N/A	D	C	A	BP, D6, S		LIFE	U	395	800/533-5000
KREG	K200	A	CA, UD	3/4	A	1	N	HS	N/A	A	A	A	A	N/A	A	C	A	B	S	30/L	U	330	800/447-8638 www.kregtool.c
	Foreman (DKDB)	S	CA	3/4	A	1	N	HS	N/A	A	A	A	A	N/A	A	C	A	B	S	30/L	U	800	
PORTER-CABLE	552	S	110v	1/2-9/16	P	N/A	N/A	N/A	N/A	A	A	N/A	A-	N/A	D	D	A	D6		1 yr.	U	700	800/487-8663 www.porter-cable

NOTES: 1. (A) Aluminum (CI) Cast iron (G) Glass-filled nylon (P) Plastic (S) Steel 2. (CA) Compressed air (UD) User's drill (110v) 110-volt AC 3. (A) Pneumatic clamp (F) Face clamp (P) Push clamp (S) Screw clamp (SC) Self-centering screw clamp (N/A) No clamp provided 4. (N/A) This model doesn't use drill guides. 5. (HS) Hardened steel (S) Steel 6. (N/A) Workpiece or jig must be moved for every new pocket hole. 7. A Excellent B Good C Average D Below average N/A Does not apply to this model. 8. (B) Step drill bit (BP) Brad-point drill bit (CC) Carrying case (D3) 3"-long square drive (D6) 6"-long square drive (FC) Face clamp (S) Pocket screws

in four price ranges



Kreg Mini



■ **\$65–\$80.** The Kreg Rocket combines the portability of lower-priced jigs with the capacity and performance of more expensive models to earn Top Tool honors in this price category.

Kreg Rocket



COMMENTS

- The best of the low-dough pocket-hole makers with clean entry holes even across the grain.
- Cross-grain cuts tore out badly, and the drill guides enlarged every time we used them. No instructions included.
- Functions like a benchtop model at a portable-model price, and made the second-cleanest cuts in the price range. Setscrew on the stop collar stripped after a few uses; Simp'L's Burt Weinstein says they've upgraded it and will replace defective screws.
- The least expensive pocket-hole jig in the test, and it delivered results about equal to other similarly priced jigs.
- Comes with interchangeable drill guides, 3/8" for drilling the pocket, and 1/8" for the pilot hole. We just used the 3/8" guides with a step drill bit. The guides are replaceable, though, should they wear excessively.
- This is actually two of the Task 06200 units connected by a slotted bar to adjust the distance between pocket holes.
- Similar in design and function to the Task 06250, but without replaceable drill guides.
- The only jig in this price range that can be clamped easily to a fixed workpiece, it's also the only "portable" jig with stops to locate it perfectly on 1/2", 3/4", and 1 1/2" material.
- It's like a portable guide mounted to a clamping fixture. In fact, the guides come off the fixture for portability if necessary. Three different hexhead wrenches come with it for the different adjustments—one size would be easier.
- Essentially, this is a Kreg Rocket on the jaw of a toggle clamp mounted to an aluminum insert plate that fits Rockler's router table. The Rocket comes off the clamp to go portable when needed.
- Similar to the Penn State #PHJIG, but with the Task 06250 jig mounted to the clamping fixture. Drill guides thread out for easy replacement when worn.

- Adjustable to work 10 different material thicknesses from 1/2" to 1 1/8". Sturdy phenolic base fits in CMT router-table insert hole. Also available without the phenolic plate (model PPJ-002) for \$70.
- The original solid-aluminum Kreg jig. It's less versatile than the Kreg Rocket, costs \$35 more, and comes with fewer accessories.
- The K200 jig has three drill guides: Use whichever pair best suits the width of your workpiece. Step blocks reposition the guides for 1/2" and 1 1/2" stock, but CMT's PPJ-001 adjusts easier. Also comes with Rocket and Mini jigs for versatility.

- Designed specifically for face-frame construction; you clamp, drill, and screw the joint without removing the jig. Uses a brad-point bit instead of a step bit to create the pocket, but we experienced no splitting without a pilot hole.
- You power this plunging-chuck mechanism with your own drill. Pneumatic stock clamp automatically adjusts for stock thicknesses, but requires an air compressor. In a production setting, it isn't as fast as the P-C 552 or Kreg Foreman.
- Fully pneumatic machine clamps and bores with one pull of a lever. Flip stops along the back fence help positively locate workpieces in production settings. For the price you should expect a lot, and this machine definitely delivers.
- This electric pocket-hole maker's internal router cuts the pocket, then an internal drill bores the pilot hole, so it's noisy. Also, the resulting pockets are long and difficult to plug. Works well on 3/4" stock, but requires shimming for 1/2" material.

9. (LIFE) Lifetime warranty against factory defects. (30L) 30 days, with lifetime warranty on drill guides. 10. (I) Italy (T) Taiwan (U) United States 11. Prices current at time of article's production and do not include shipping, where applicable.

■ **\$100–\$150.** Got a little more money in the budget? The Kreg ProPack earned high marks in our test, and comes with everything you need to put a pocket hole almost anywhere (including the Mini, Rocket, and K200 benchtop model). So, the ProPack is our Top Tool in this price range.

Kreg ProPack



■ **\$330–\$800.** Of the high-dollar models, we'd take the Kreg Foreman, which couldn't be easier to use. This Top Tool, however, is also at the top of the price range, and requires an air compressor that can deliver 5.3 cfm at 90 psi. 🌲

Kreg Foreman (DKDB)



Written by Dave Campbell with Paul McClannahan

shining showcase



Bring your special glassware, china figures, or other prized collectibles out of the closet and into the light. This easy-to-build project showcases their beauty *and* your craftsmanship.

Here's a visually high-impact piece of furniture that you can build for only a moderate investment of time and materials. Its three glass-insert shelves let light from a concealed halogen fixture stream from top to bottom.

To discover how to beef up frame corners on this project and others, see the mitered half-lap joinery article on *page 16*. This joint hides the frames' exposed end grain within the project's legs.

For the board feet of lumber and other items needed to build this project, see *page 69*.

Laminate four legs

1 Cut eight $\frac{3}{4} \times 1\frac{5}{8} \times 55$ " blanks for laminating the legs (A). To form a channel to conceal the light fixture's cord, install a dado blade in your table saw, and plow a centered $\frac{1}{2}$ " groove $\frac{1}{4}$ " deep in two of the pieces, where shown on **Drawing 1a**.

2 Glue and clamp four pairs of laminations, keeping the ends and edges flush. The grooved pair forms the right rear leg. Remove any excess glue, and joint $\frac{1}{16}$ " off one edge of each lamination. Plane the opposite edges to form four $1\frac{1}{2} \times 1\frac{1}{2}$ " legs. Trim the legs to the length listed in the **Materials List**.

3 Mark the tops of the legs with their final orientations. Indicate the face to be drilled for shelf supports. Position the leg with the centered cord channel at the right rear, where shown on **Drawing 2**. Referring to **Drawing 1**, lay out the shelf-support hole centers on the right rear leg.

4 To drill the legs' shelf-support holes, chuck a $\frac{1}{4}$ " bit in your drill press. Attach a 5'-long fence $\frac{3}{4}$ " back from the bit's center, with about 1' of the fence extending to the right of the bit. Drill the $\frac{3}{8}$ "-deep holes, as shown in **Photo A**.

5 Adjust your biscuit joiner's fence to center a slot $\frac{1}{2}$ " from the legs' outside faces, and cut slots for #20 biscuits, where dimensioned on **Drawing 1**.

6 To provide electric cord access to the hole in the right rear leg, make a V-block from 2×4 scrap. With a $\frac{1}{2}$ " straight bit in your table-mounted router, and a stopblock clamped to the fence, form a $\frac{1}{2}$ "-long

1 LEG (Right rear shown)

1/2" notch 1/2" deep (right rear leg only)

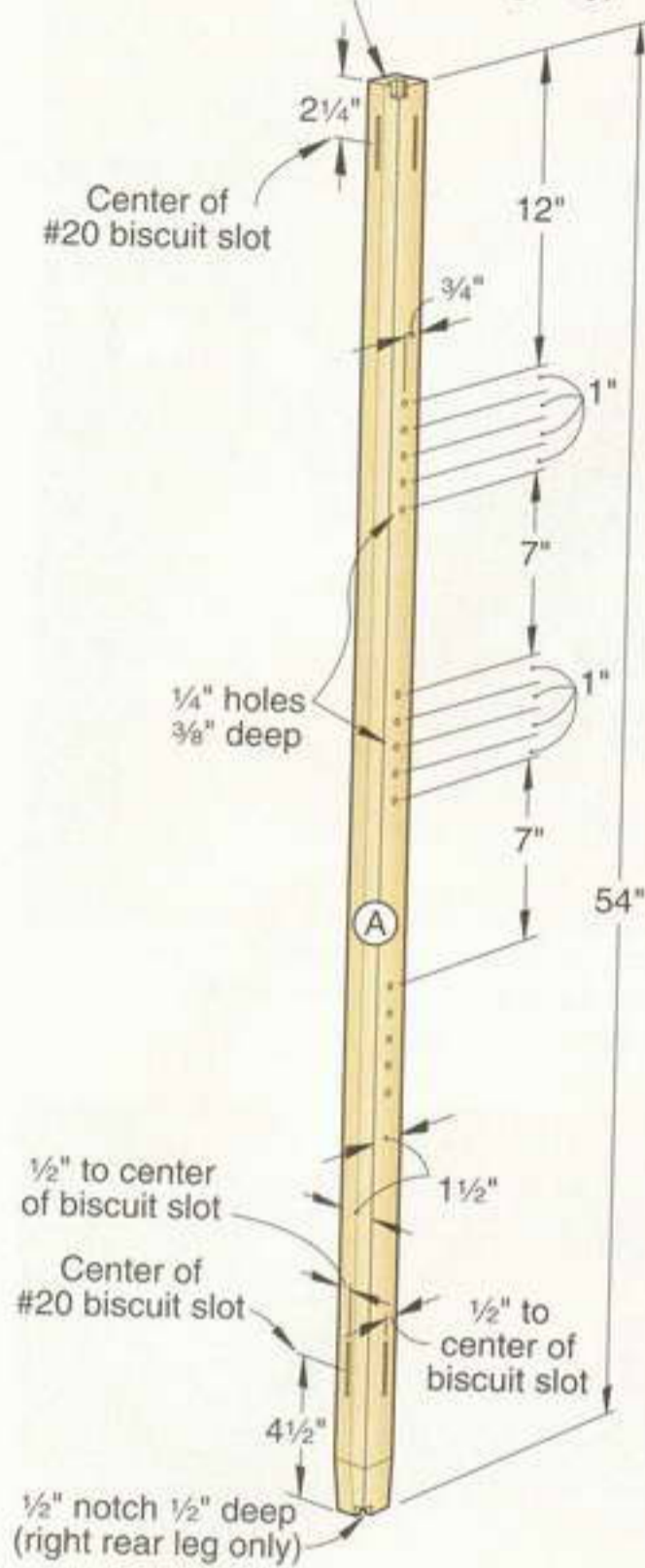

1a LEG DETAIL (Top view shown)

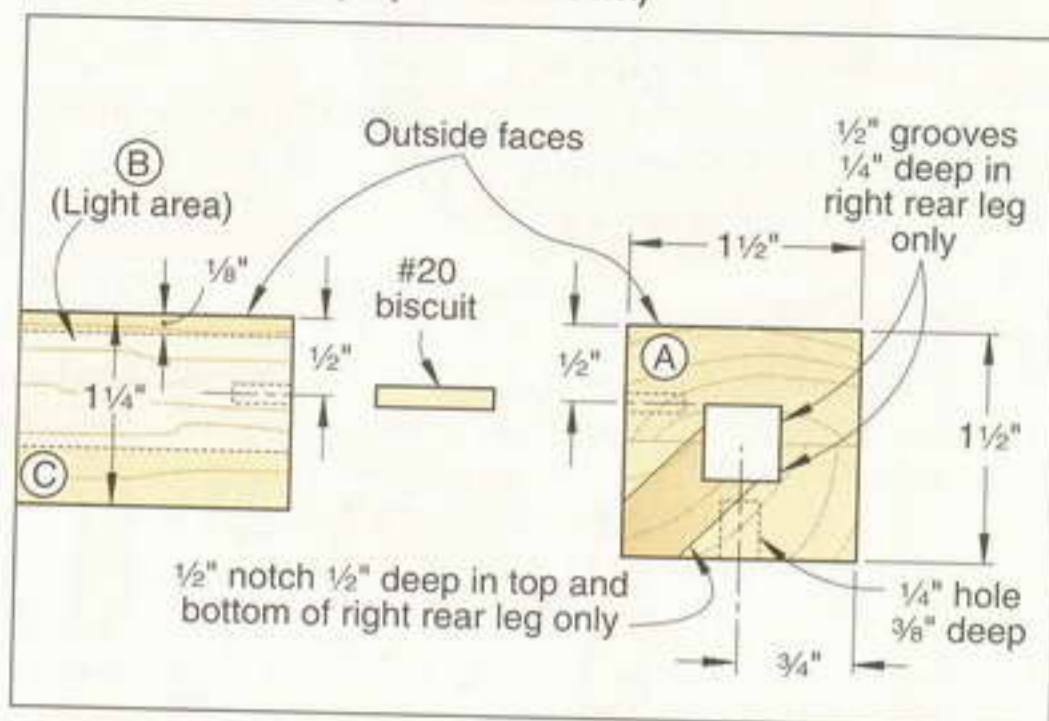

1b LEG TAPER DETAIL

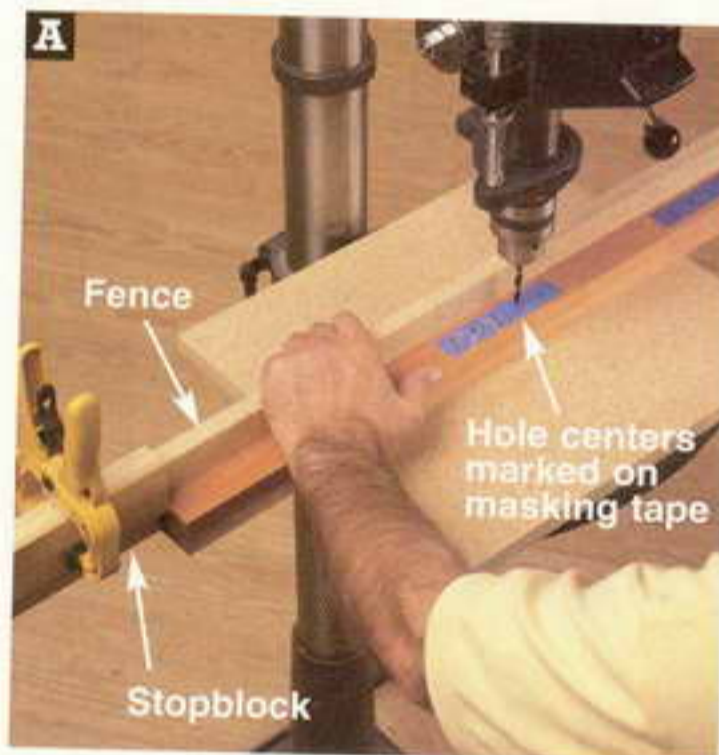
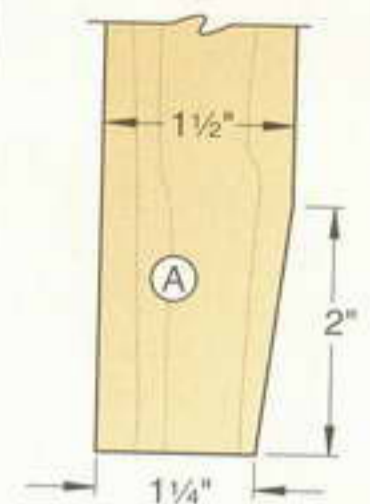

Mark the right-rear leg shelf-support hole centers on masking tape. Align each mark with the bit, and position a stopblock. Drill all four legs at each stopblock position.

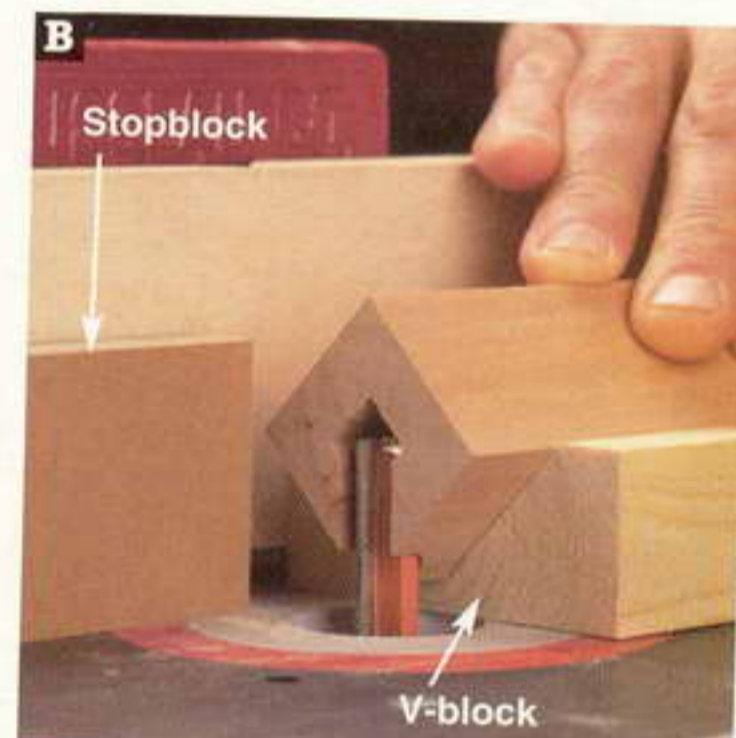

With the right rear leg cradled in a V-block, rout the top and bottom 1/2"-long notches in progressive 1/8" increments. Clamp a stopblock to the fence to control the depth.

notch in the leg's top and bottom inside corners, where shown on **Drawings 1** and **1a** and as shown in **Photo B**. Cut the notches in steps, first positioning the bit to cut 1/8" into the leg's corner, and then raising the bit in 1/8" increments until the notches are complete.

7 Mark the bottom tapers on each leg's two inside faces, where shown on **Drawing 1b**. Bandsaw and sand to the lines. To ensure uniform tapers, see the **Shop Tip** at *right*. Sand the legs to 220 grit.

Form the rails and caps

1 Cut the rails (B, D) and caps (C, E) to size. To ensure that the rails and caps are identical lengths, use a stopblock clamped to an auxiliary miter-gauge extension.

2 Adjust your biscuit joiner to center a slot in the thickness of the rails. Then plunge slots for #20 biscuits in the rail ends, centered in their width.

SHOP TIP

Sand perfect leg tapers quickly with a simple scrapwood jig

To sand uniform tapers on all four legs (A), tack together the scrapwood jig shown in the drawing, *below*. Leave the nailheads protruding so you can easily disassemble the jig and return the parts to your scrap bin. Clamp the jig to your disc- or belt-sander table 1/8" from the face of the sanding disc. Slide each leg along the fence, as shown in the photo, *right*, until its end contacts the stop.

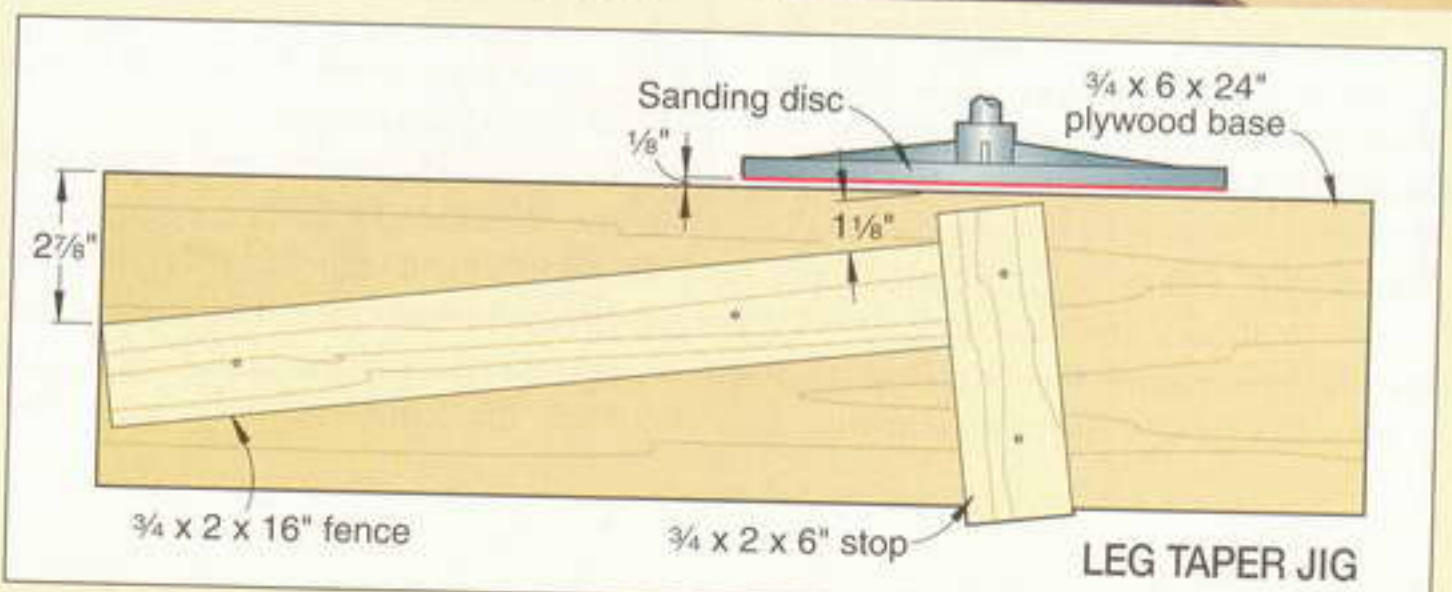

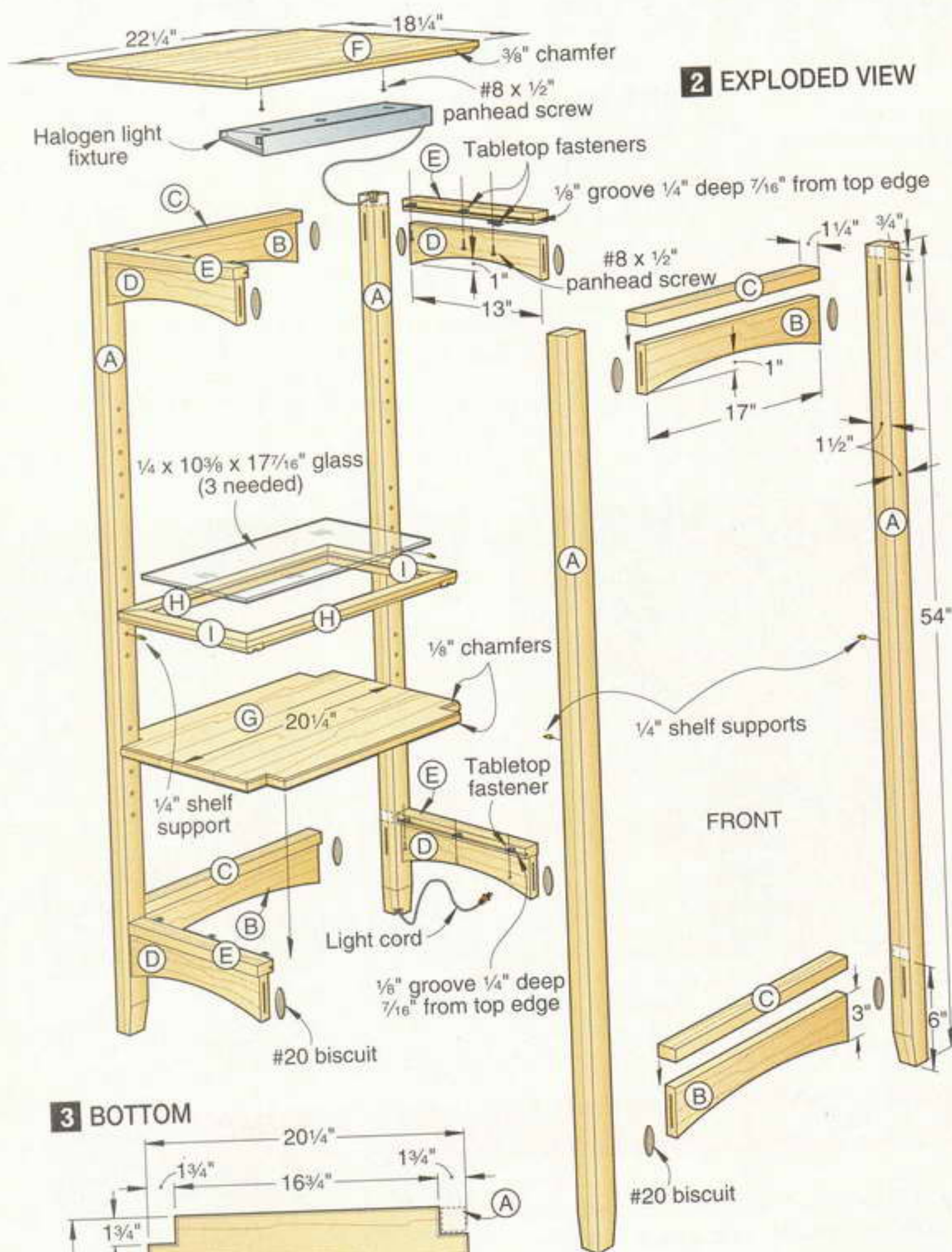

2 EXPLODED VIEW

3 BOTTOM

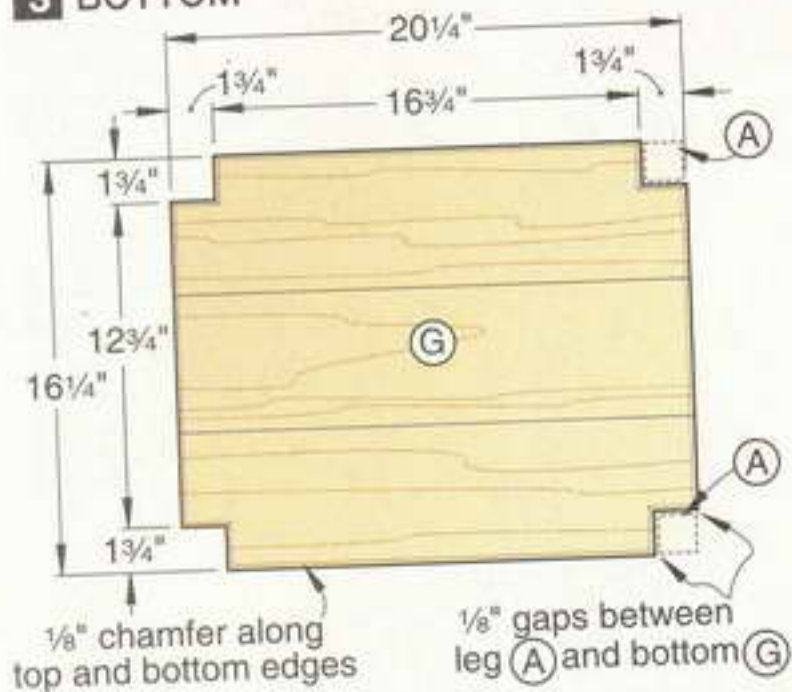

3 Using a fairing stick, draw arcs on the rails (B, D), where shown on **Drawing 2**. Saw and sand them to shape.

4 Cut $\frac{1}{8}$ " grooves $\frac{1}{4}$ " deep for the tabletop fasteners in the side caps (E), where shown on **Drawing 2**.

Note: Before cutting the grooves, check the offset of your tabletop fasteners. It

may be different from the $\frac{7}{16}$ " dimension shown on the drawing.

5 Finish-sand the rails and caps. Mark the locations of the top edges of the rails (B, D) on the legs (A), where shown on **Drawing 2**. Glue, biscuit, and clamp the front and back rails (B) between the front and back legs. Then

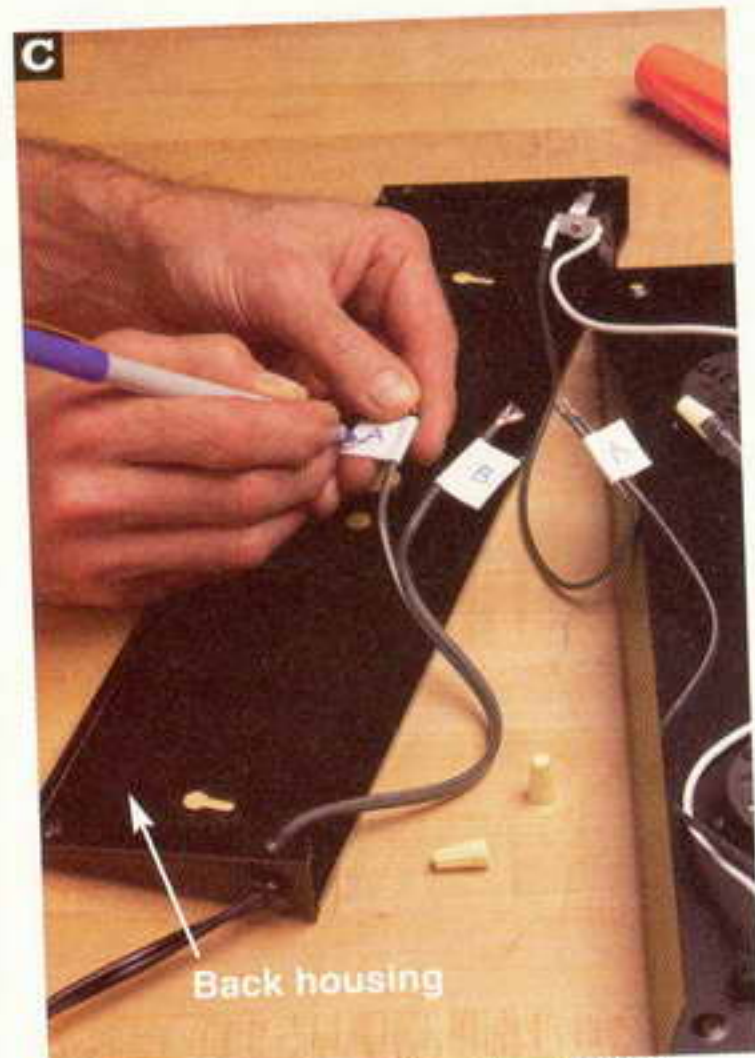

Disconnect the cord from the internal wiring by removing the wire nuts. Mark the wires for proper reassembly.



Grasp and squeeze the cord grommet with pliers to release the cord from the housing. Pull the cord out of the housing, and remove the grommet.

join the front and back leg/rail assemblies (A/B) together by gluing and clamping the side rails (D) in place. Glue and clamp the rail caps (C, E) to the rails. The caps' front edges are flush with the legs' outside faces. Finally, ease the corners of the completed assembly with a sanding block.



Bold markings on the Woodcraft disc (left) clearly show the grit; seven out of ten Kling-On discs (center) in one package didn't include the grit at all; and Porter-Cable's markings (right) are so faint, they're hard to read, especially after sanding dust accumulates.



The discs that tested best

Klingspor's uncoated Kling-On discs lasted longest and removed the most material in our testing, so we named them the Top Disc, despite their sometimes-absent grit markings. But they don't represent the best value, as you can see by the "More Sanding for Your Money" chart, below. Top Value honors go to Klingspor's Stearate Kling-On discs that cost you less for every gram of material removed. You can change these discs more often and still be money ahead.

Written by Dave Campbell with Dean Fiene

Cost per gram of wood removed (cents)	MORE SANDING FOR YOUR MONEY									
	1.0¢	1.1¢	1.2¢	1.2¢	1.6¢	1.6¢	1.9¢	2.0¢	2.4¢	3.3¢
	Klingspor Stearate Kling-On	Mirka Gold	Norton A290	Klingspor Kling-On	WW Supply Regis Royal Plus	Porter-Cable Red Phenolic	3M 232U	DeWalt	Woodcraft	3M SandBlaster
*Cost per disc	\$0.28	\$0.30	\$0.31	\$0.38	\$0.46	\$0.39	\$0.53	\$0.52	\$0.65	\$0.99
**Grams removed	28.87	28.10	26.83	32.70	28.67	24.10	27.73	26.07	27.30	30.10

*Based on 5", 5-hole, hook-and-loop discs, purchased in quantities of 25-50. If such quantities are not available, we used the largest-quantity package offered. Prices current at time of article's production and do not include shipping, where applicable.

**After 20 minutes of sanding. Average of three boards.

THE NITTY-GRITTY ON RANDOM-ORBIT SANDING DISCS

BRAND	MODEL	GRIT MATERIAL (1)	DIAMETERS AVAILABLE (INCHES)	HOLE PATTERNS AVAILABLE (2)	PERFORMANCE GRADES (3)					COUNTRY OF MANUFACTURE (4)	PHONE	INTERNET
					AGGRESSIVENESS	FINISH QUALITY	HOOK-AND-LOOP GRIP	READABILITY OF DISC				
3M	232U	AO	4 1/2, 5, 6	0, 5, 6, 8	C+	B+	B	A-	C	800/999-3552	www.3m.com	
	SandBlaster	CA	5	*	B	B+	B	A	C			
DEWALT		AO	5	8	C-	A	B	A	S	800/433-9258	www.dewalt.com	
KLINGSPOR	Stearate Kling-On	AO	4 1/2, 5, 6, 8	0, 5, 6, 8, 9, 16	B	A-	B	A	G	800/228-0000	www.woodworkingshop.com	
	Kling-On	AO	4 1/2, 5, 6, 8	0, 5, 6, 8, 9, 16	A	A-	A-	D	G			
MIRKA	Gold	AO	5, 6	0, 5, 8	C+	A-	A-	A	F	800/843-3904	www.mirka-usa.com	
NORTON	A290	AO	4 1/2, 5, 6	0, 5, 8	C	A-	B	A	C	800/543-4335	www.nortonabrasives.com	
PORTER-CABLE	Red Phenolic	AO	5, 6	5, 8	C-	B+	A	C	U	800/487-8665	www.porter-cable.com	
WOODCRAFT		AO	5, 6, 8	5, 8	C	B+	B	A	U	800/225-1153	www.woodcraft.com	
WOODWORKER'S SUPPLY	Regis Royal Plus	AO	5, 6	0, 5, 6, 8	B-	A-	B+	A	F	800/645-9292	www.woodworker.com	

NOTES: 1. (AO) Aluminum oxide (CA) Ceramic aluminum oxide 2. (*) "Universal" hole pattern fits 5- and 8-hole sanders. 3. A Excellent B Good C Average D Below average 4. (C) Canada (S) Switzerland (F) Finland (U) United States (G) Germany

easy-to-make 3-drawer utility cabinet



Floor Cabinet System



See page 12 to learn how to combine this three-drawer cabinet with a flip-top cabinet and a mobile base to create the multifunction work center, above.

Inexpensive materials and basic joinery make for speedy construction of this hardworking shop cabinet. Even the drawers won't slow you down. With their special side/slide hardware, they practically build themselves.

If saving time and money is important to you, you'll really appreciate the drawer hardware used in this project. Costing little more than standard slides, this epoxy-coated steel hardware combines both drawer side and slide in one piece. For more on this innovative hardware, see "Make the fastest drawers in the west (or east)" on page 76.

Start with the case

- 1** Cut the stiles (A), side rails (B), front rails (C), and back rail (D) to the sizes listed in the **Materials List**. With a dado blade adjusted to match the thickness of the $\frac{1}{2}$ " plywood side panels (E), cut centered grooves in parts A, B, and D, where shown on **Drawing 1**. Then cut the $\frac{1}{4}$ "-deep rabbet along the top edge of the lower front rail (C) and the $\frac{1}{2}$ " notches $\frac{3}{4}$ " deep in both front rails. Now cut the rabbets in the stiles (A). Finish-sand all the parts to 180 grit.
- 2** Cut the side panels (E) to the size listed. Glue and clamp the stiles and rails (A, B) to the side panels, checking the assemblies for square.
- 3** Cut the bottom (F) and back (G) to the sizes listed. Cut the $\frac{1}{4} \times \frac{1}{2}$ " notches in the back's top corners.

- 4** Retrieve the lower front rail (C), and glue and clamp it to the bottom (F), keeping the ends flush. Retrieve the back rail (D), and glue and clamp it, centered, on the back (G). Now, clamp the back to the bottom as shown, and drill screw holes through the back and into the bottom. Drive the screws.
- 5** Place the first side assembly (A/B/E) flat on a horizontal surface. Squeeze a bead of glue on the side panel along the rear stile and the lower side rail. Place the bottom/back assembly (C/F/D/G) on the side assembly, and clamp it in place. Now drill angled countersunk screw holes through the bottom and back and into the rear stile and the lower side rail. Drive the screws.
- 6** Apply glue to the upward-facing edges of the bottom and back panels. Position the second side assembly, and clamp it in place. Turn the cabinet over. Then, as before, drill angled countersunk screw holes, and drive the screws.

1 EXPLODED VIEW

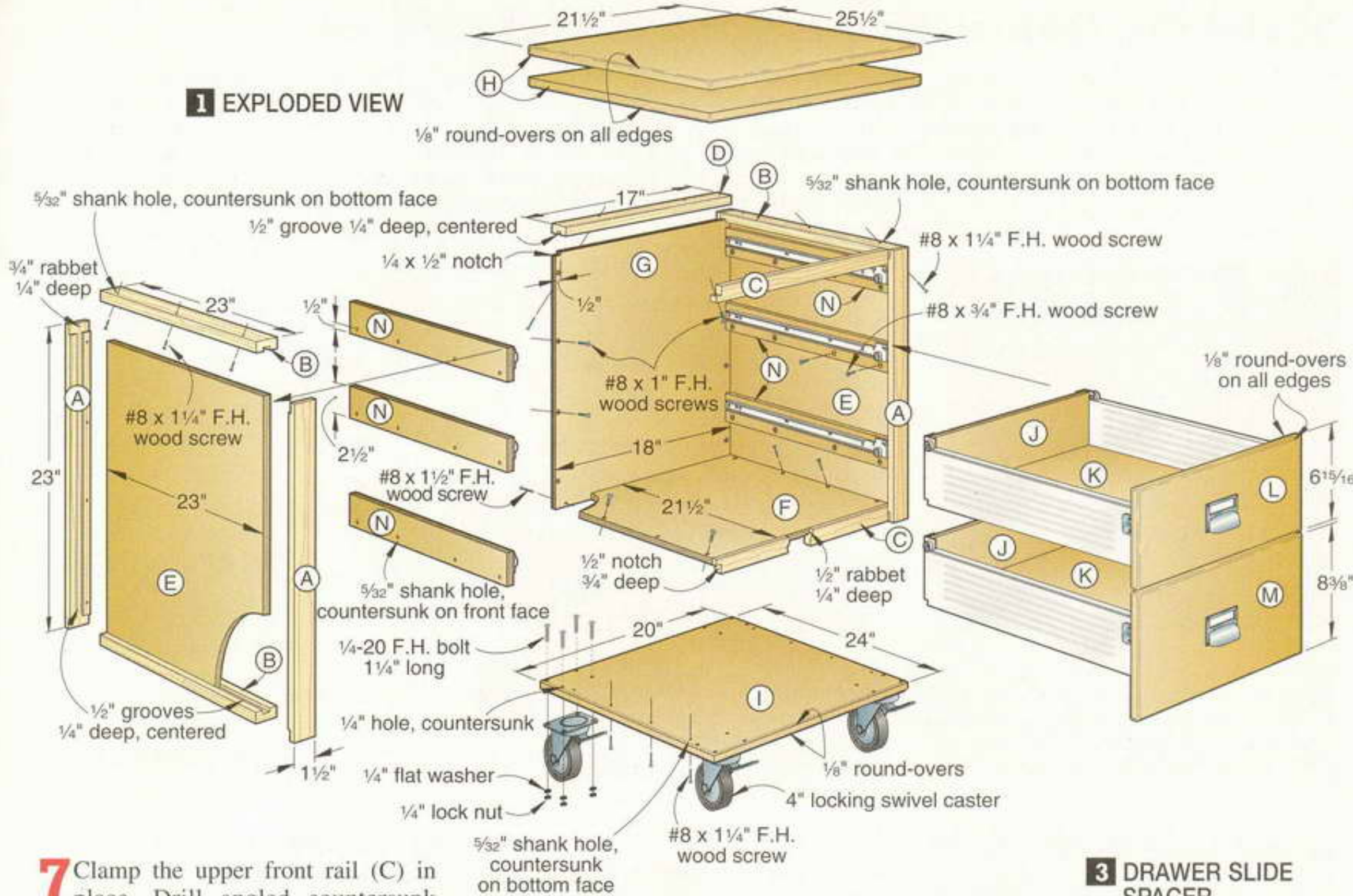

7 Clamp the upper front rail (C) in place. Drill angled countersunk screw holes through the front rail and into the side rails (B). Drive the screws.

8 Cut two 3/4x21 1/2x25 1/2 inch pieces of medium-density fiberboard (MDF) for the top (H). Glue and clamp them together, keeping the ends and edges flush. Sand the edges smooth, and rout 1/8 inch round-overs along all the edges.

9 Cut the mobile base (I) to size, and rout 1/8 inch round-overs along the top and bottom edges. Using a caster's mounting plate as a guide, mark mounting-hole locations at all four corners. Drill 1/4 inch holes and countersink them on the panel's top face.

2 DRAWER FRONTS PARTS VIEW (Inside face shown)

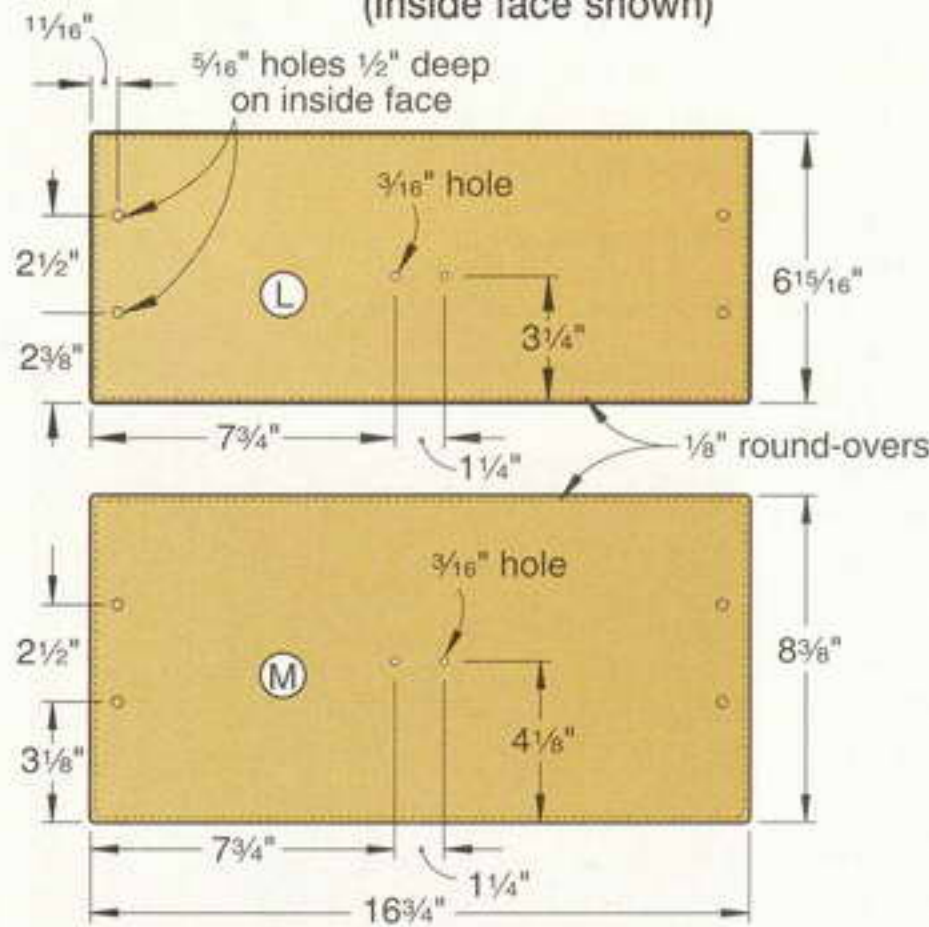

Add the drawers

1 Cut the drawer backs (J), drawer bottoms (K), and drawer fronts (L, M) to size. Ease the edges of the bottoms and backs with a sanding block. Rout 1/8 inch round-overs along the front and back edges of the drawer fronts. Drill the screw holes for the pulls, where shown on Drawing 2. Finish-sand the parts.

3 DRAWER SLIDE SPACER END VIEW

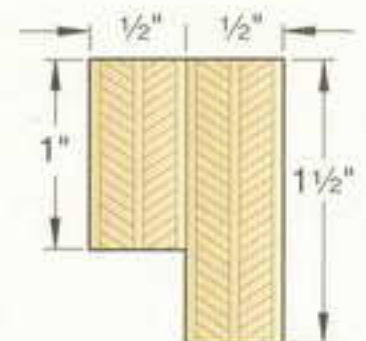

Apply two coats of satin polyurethane to the bottoms and backs and three coats to the fronts, sanding between coats. Now, to assemble the drawers using the metal side/slides, see the sidebar on pages 76 and 77.

2 With the drawers made, cut the cleats (N) to size. Mark the bottom front corner of each cleat, making sure you have three mirror-image pairs.

Drill countersunk screw holes through the cleats 1/2 inch up from their bottom edges, where shown on Drawing 1.

3 Make the drawer slide spacer shown on Drawing 3 from 12 inch-long scraps of 1/2 inch plywood. Using the holes in the drawer slides' cabinet members as guides, drill pilot holes in the cleats, as shown in Photo A.

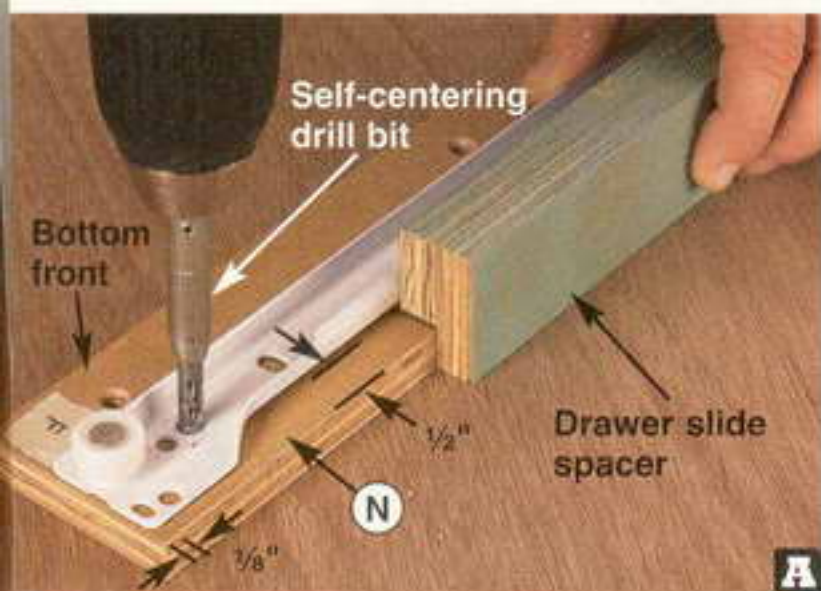

Use a spacer to position the drawer slide 1/2 inch down from the cleat's top edge. With the slide's front end 1/8 inch from the cleat's front edge, drill the pilot holes.

Make the fastest drawers in the west (or east)

Initially developed for the commercial kitchen-cabinet trade, the all-in-one metal drawer side/slide hardware used in this project allows you to build sturdy drawer boxes in record time. But that's not its only advantage. The side/slide hardware costs about the same as regular drawer slides alone while eliminating the wood for drawer box sides and fronts. And, adjustable brackets attach the finished drawer fronts

to the sides, allowing you to fine-tune the gaps between drawers during final cabinet assembly. Here's how to build a drawer using this time- and money-saving hardware. **Note:** The metal sides have a pair of raised tabs (see drawing below) used for positioning in mass-production applications. Clip off these tabs before assembling your drawers.

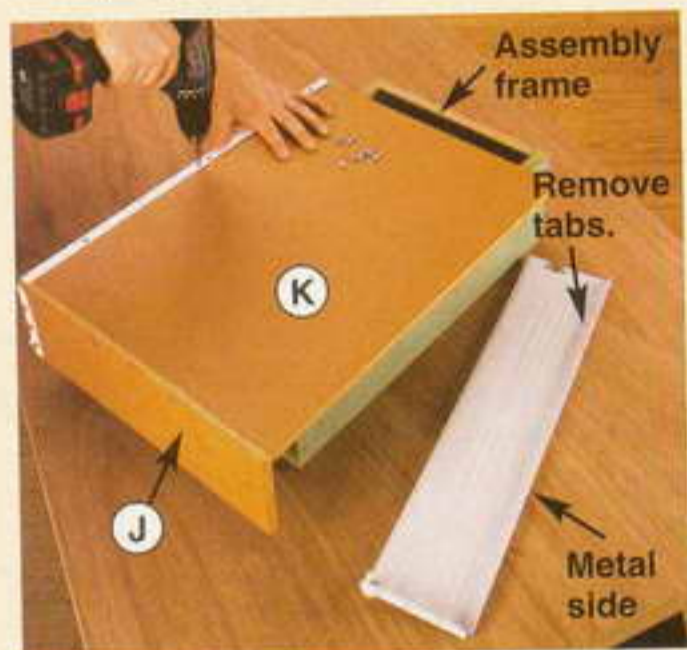

Step 1

Drill screw holes and fasten the drawer back (J) to the drawer bottom (K), where shown on the drawing, right. Position the metal sides on the back/bottom assembly, drill pilot holes, and screw them in place, as shown in the photo, above. For easy assembly, a 12x18" scrapwood assembly frame 6" high holds the back and sides clear of your worktop.

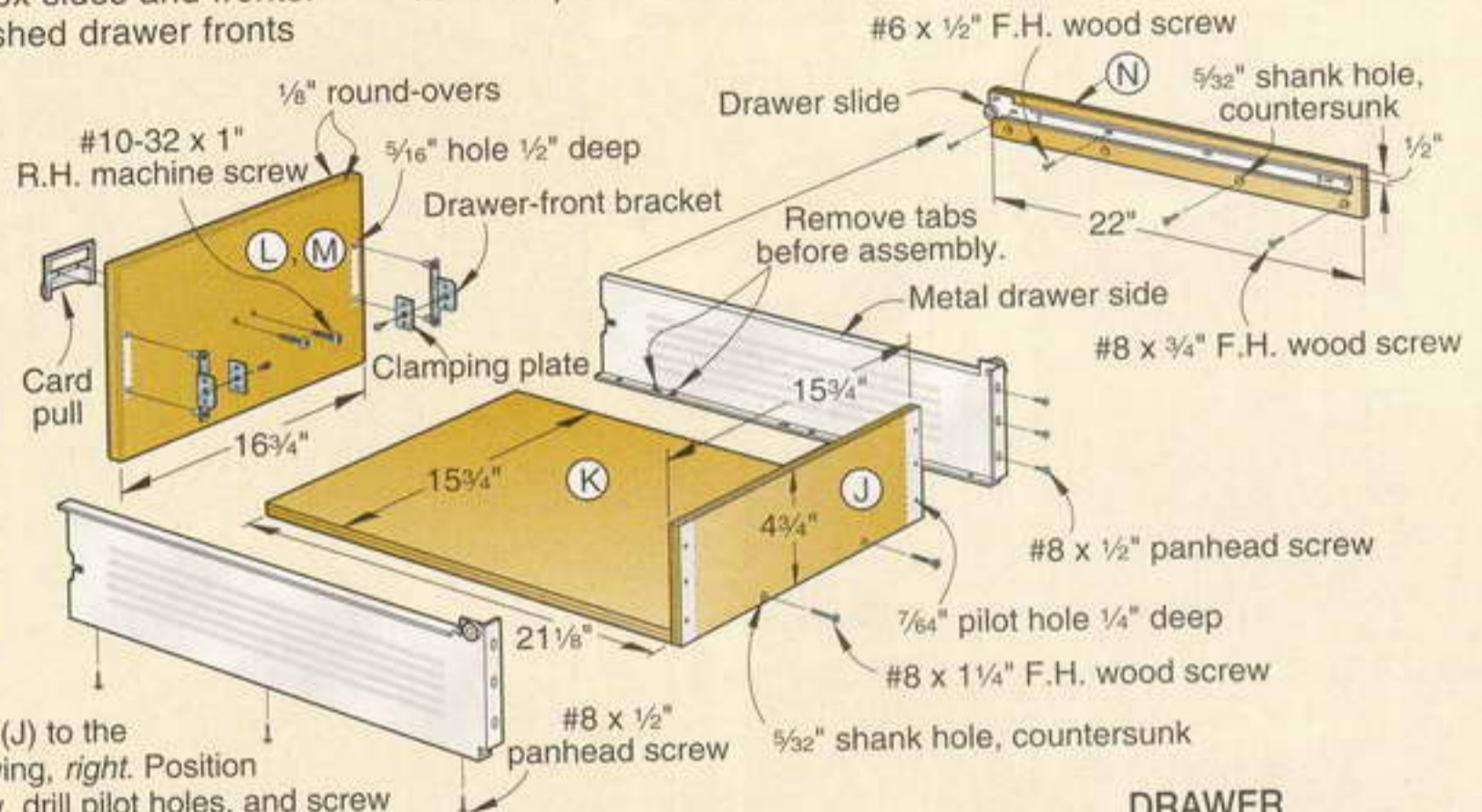

DRAWER
(Viewed from the back)

4 Cut two 2x18" pieces of scrap for cleat positioning spacers. Use them to position the top pair of cleats (N), as shown in Photo B. Now trim the spacers to 10 7/8", and then 3 1/8" to mount the middle and bottom pairs of cleats, where shown on Drawing 4.

Finish and assemble

1 Finish-sand the case and the top. Apply two coats of satin polyurethane to the case and three coats to the top, sanding between coats.

2 Place the top (H) upside down on a pair of sawhorses. Turn the cabinet upside down, center it on the top, and clamp it in place. From the outside of the cabinet, drill angled countersunk screw holes through the side rails (B) and back rail (D) and into the top. Drive the screws.

3 With the hardware shown on Drawing 1, bolt the casters to the mobile base (I). Place the base on the cabinet, drill countersunk screw holes through the base and into the lower side rails (B). Drive the screws, and place the cabinet right side up on the floor.

4 Attach the drawer slides' cabinet members to the cleats (N), driving the screws into the previously drilled holes. Fasten the pulls to the drawer fronts, and slide the drawers into the cabinet. Adjust the drawer fronts to leave 1/4" between the top (H) and the top

drawer front, and 3/16" between drawer fronts, leaving 1/8" between the bottom drawer front and the mobile base.

5 Center your benchtop tool on the top, and mark the locations of the mounting holes. Drill the holes, and bolt the tool to the top. Roll the cabinet out of the way, set the caster brakes, and round up some stuff to fill its drawers. 🐘

Written by **Jan Svec**
Project design: **Jeff Mertz**
Illustrations: **Roxanne LeMoine**



B With their ends against the cabinet's bottom, use a pair of 18"-long spacers to position the top cleats. Then glue and screw the cleats in place.

4 DRAWER SLIDE CLEATS FRONT SECTION VIEW

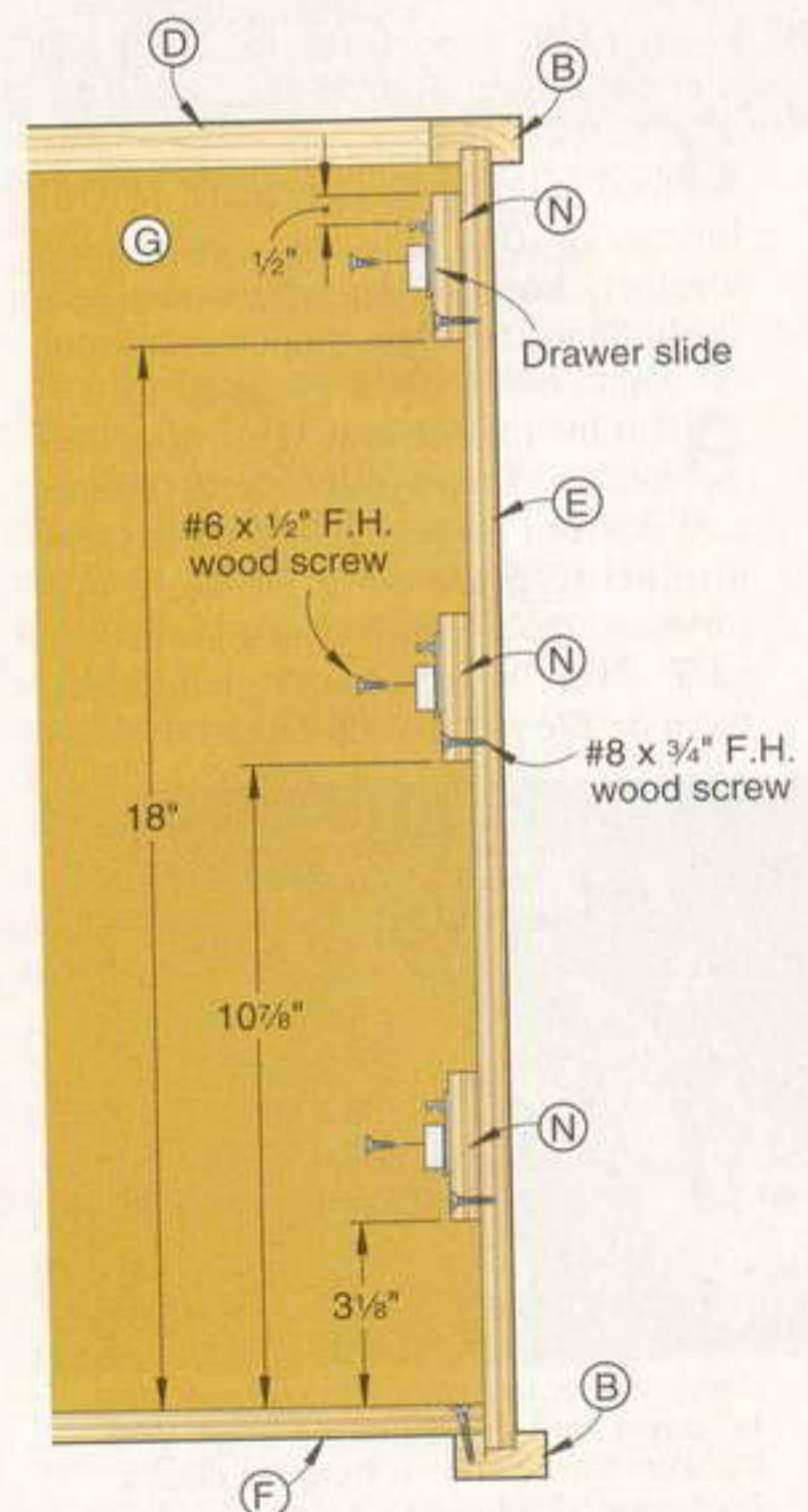

Step 2

To accurately place the drawer-front brackets on both the small drawer fronts (L) and the large drawer front (M), make the drilling guide according to the drawing, *far right*. To avoid confusion, draw brackets on both of the jig's faces to connect the pairs of holes for parts L and M, as shown. Mark the door front's centerline on its back face. Place the guide's cleat against the front's bottom edge, align the guide's edge with the marked centerline, and clamp it in place. Drill $\frac{5}{16}$ " holes $\frac{1}{2}$ " deep, as shown in the photo, *right*. Flip the jig, and repeat at the drawer front's other end.

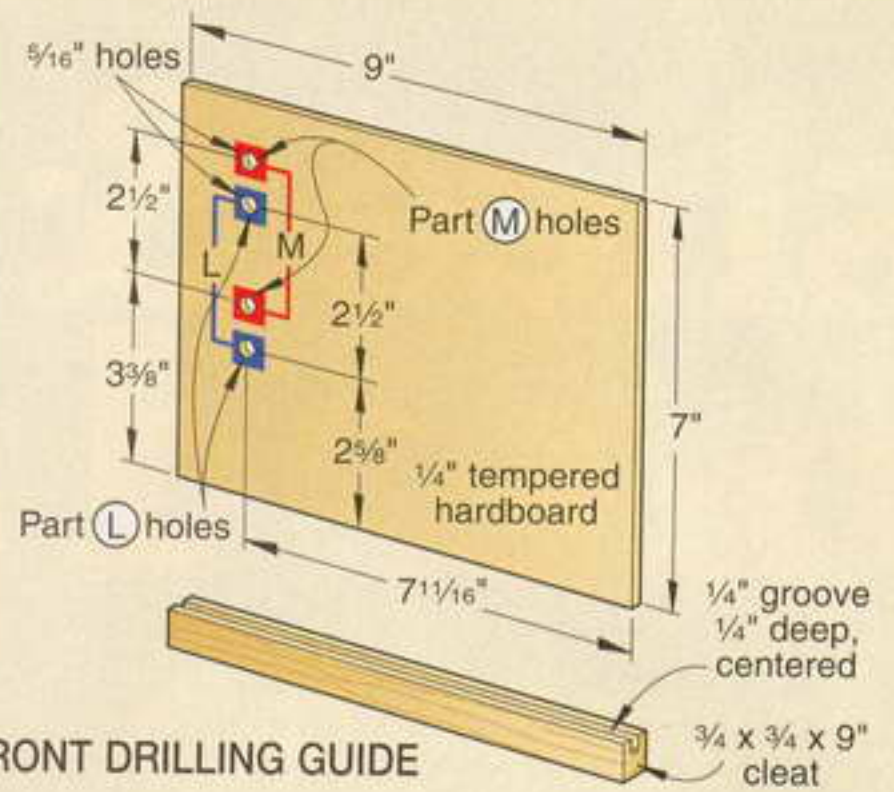
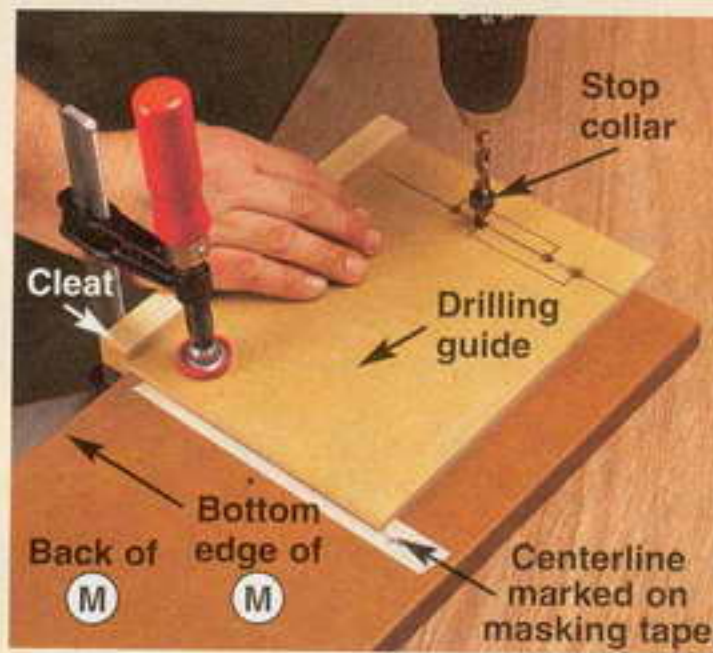

DRAWER FRONT DRILLING GUIDE

Step 3

With the bracket's drawer-side flange to the outside, drive its plastic inserts into their holes, as shown, *right*. Use a scrap of wood to evenly distribute the force. Loosely fasten the clamping plates to the brackets with the provided machine screw. Slide the drawer sides between the brackets and the clamping plates, as shown, *far right*, and tighten the screws.

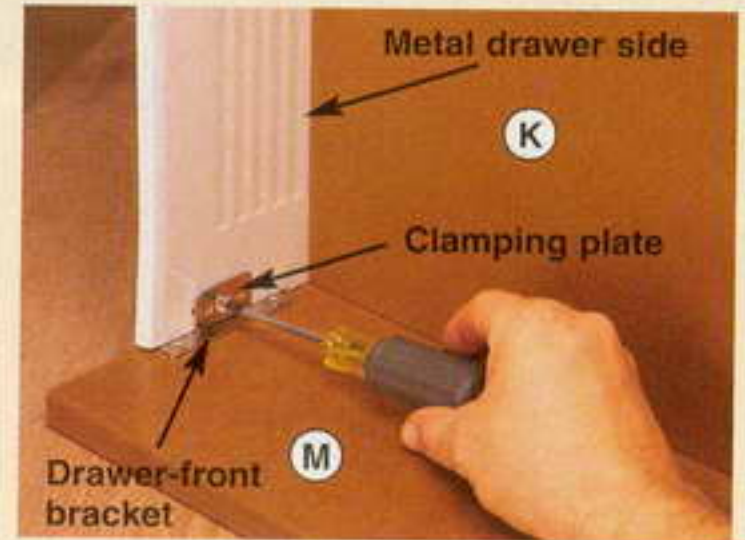
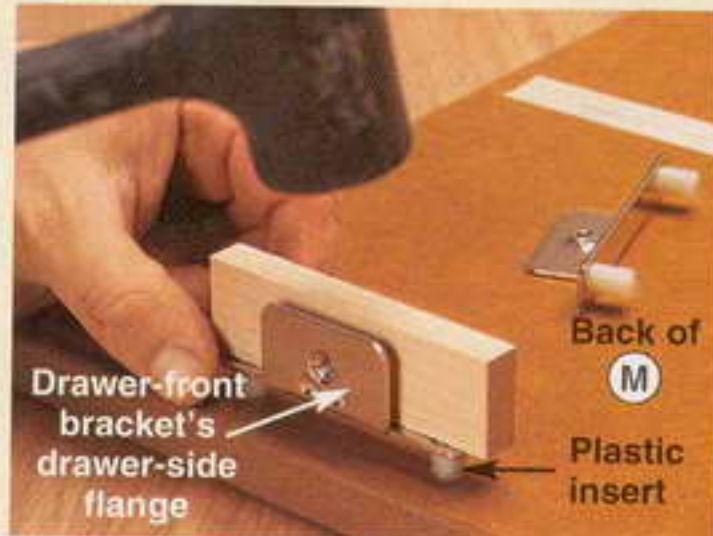

Cutting Diagram

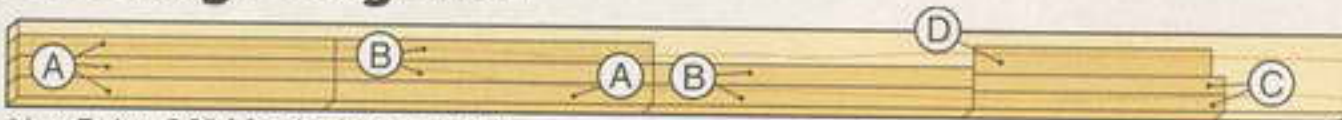

$\frac{3}{4}$ x $5\frac{1}{2}$ x 96" Maple (4.0 bd. ft.)

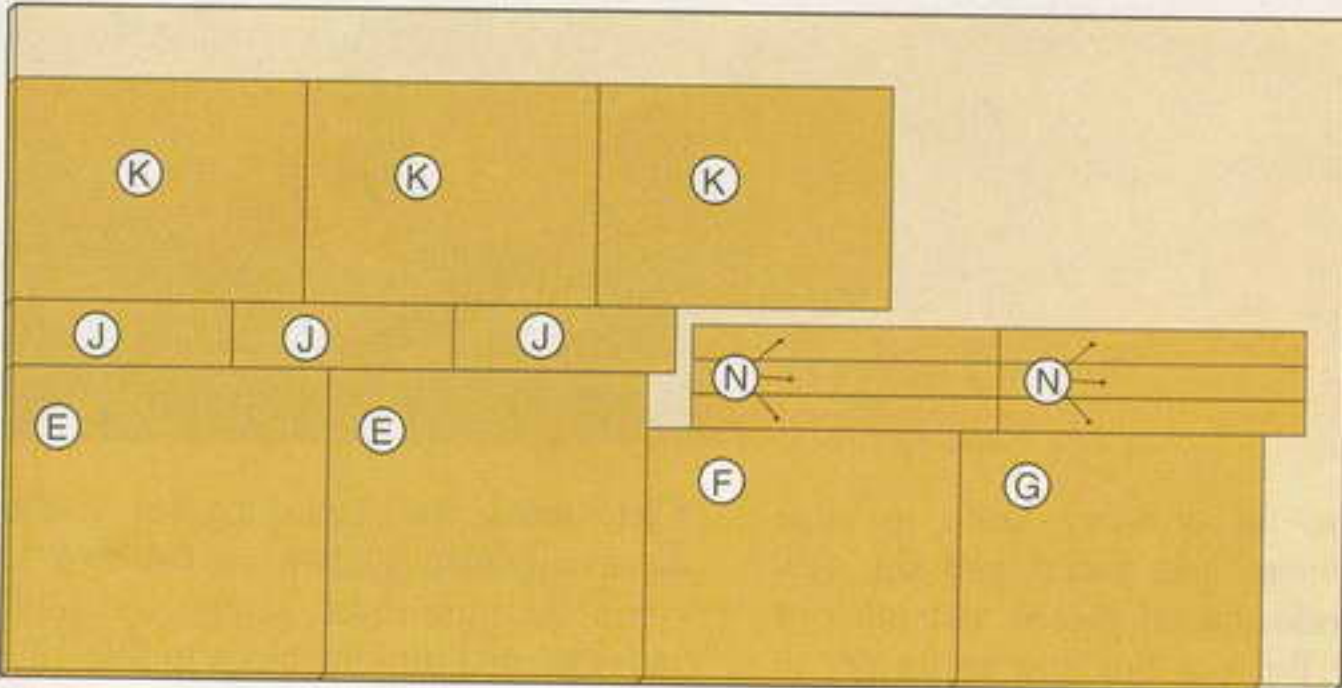

$\frac{1}{2}$ x 48 x 96" Medium-density overlay plywood (MDO)

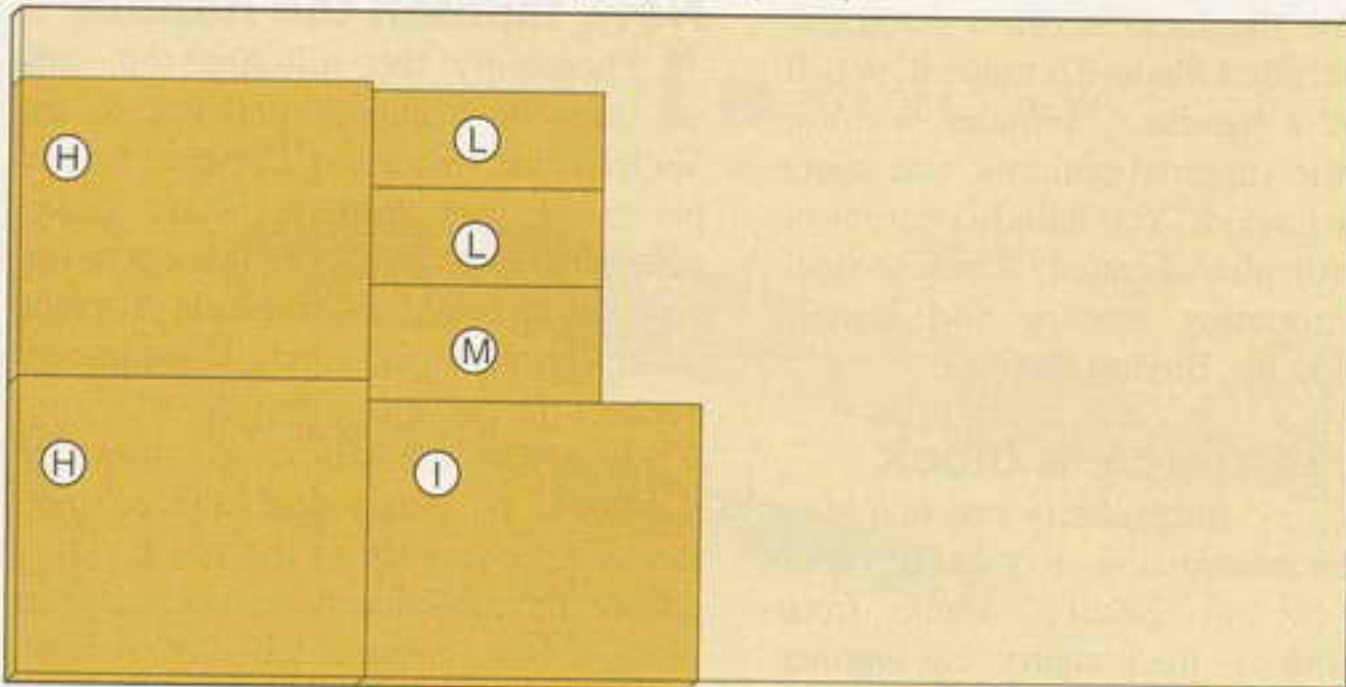

$\frac{3}{4}$ x 48 x 96" Medium-density fiberboard (MDF)

Materials List

Cabinet	FINISHED SIZE			Matl.	Qty.
	T	W	L		
A stiles	$\frac{3}{4}$ "	$1\frac{1}{2}$ "	23"	M	4
B side rails	$\frac{3}{4}$ "	$1\frac{1}{2}$ "	23"	M	4
C front rails	$\frac{3}{4}$ "	$1\frac{1}{4}$ "	18"	M	2
D back rail	$\frac{3}{4}$ "	2"	17"	M	1
E side panels	$\frac{1}{2}$ "	22"	23"	MDO	2
F bottom	$\frac{1}{2}$ "	18"	$21\frac{1}{2}$ "	MDO	1
G back	$\frac{1}{2}$ "	18"	$21\frac{1}{4}$ "	MDO	1
H top	$1\frac{1}{2}$ "	$21\frac{1}{2}$ "	$25\frac{1}{2}$ "	LMDF	1
I mobile base	$\frac{3}{4}$ "	20"	24"	MDF	1
Drawers					
J drawer backs	$\frac{1}{2}$ "	$4\frac{3}{4}$ "	$15\frac{3}{4}$ "	MDO	3
K drawer bottoms	$\frac{1}{2}$ "	$15\frac{3}{4}$ "	$21\frac{1}{8}$ "	MDO	3
L small drawer fronts	$\frac{3}{4}$ "	$6\frac{1}{16}$ "	$16\frac{3}{4}$ "	MDF	2
M large drawer front	$\frac{3}{4}$ "	$8\frac{3}{8}$ "	$16\frac{3}{4}$ "	MDF	1
N cleats	$\frac{1}{2}$ "	$2\frac{1}{2}$ "	22"	MDO	6

Materials key: M—maple, MDO—medium-density overlay plywood, LMDF—laminated medium-density fiberboard, MDF—medium-density fiberboard.

Supplies: #8x $\frac{3}{4}$ ", #8x1", #8x $1\frac{1}{4}$ ", #8x $1\frac{1}{2}$ ", and #6x $\frac{1}{2}$ " flathead wood screws; #8x $\frac{1}{2}$ " panhead screws; $\frac{1}{4}$ -20x $1\frac{1}{4}$ " flathead bolts, $\frac{1}{4}$ " flat washers, and $\frac{1}{4}$ " lock nuts (16 of each); #10-32x1" roundhead machine screws (6); $\frac{1}{4}$ " hardboard and solid stock for the drawer front drilling guide.

Blades and bits: Stack dado set, $\frac{1}{8}$ " round-over router bit.

Buying Guide

Hardware. 4 $\frac{5}{8}$ "-deep 22"-long drawer side/slides no. 12K38.55, \$8.20/pr. (3 pairs); card pulls no. 01A57.65, \$2.80 ea. (3); 4" locking swivel casters no. 00K20.01, \$11.50 ea. (4). Lee Valley Tools Ltd. Call 800/871-8158 or go to www.leevalley.com.

slice & serve bread knife

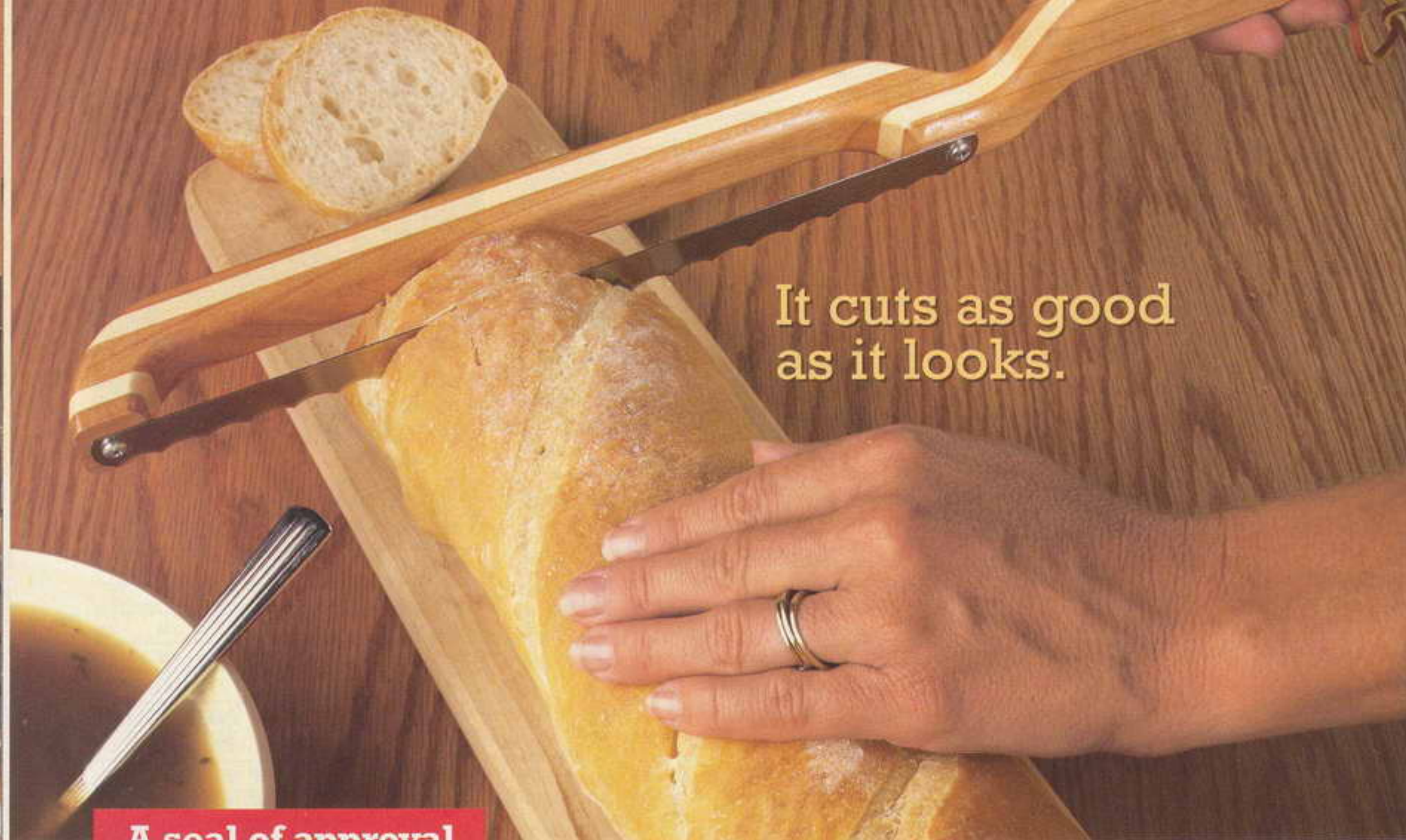

It cuts as good
as it looks.

A seal of approval from the pros

Before presenting this project to you, senior design editor Kevin Boyle consulted with the world-renowned Better Homes and Gardens® test kitchen staff of home economists for their input and approval. The result is this cutting-edge bread knife that produces perfect slices time after time with ease.



Use an ordinary knife to slice bread and you'll end up with odd-shaped pieces and piles of crumbs. But put this star performer to work and you'll get evenly sliced pieces every time, thanks to its offset shape and special serrated blade. To make it, you'll need just a bandsaw, a router, a drum sander, the supplied patterns, and some contrasting woods. You'll find a convenient source for the serrated stainless-steel blade, mounting screws, and leather bootlace in the **Buying Guide**.

First, laminate a block

1 Using ¼"-thick cherry and maple or other contrasting woods of your choice, cut two 2⅝×17" blanks from each. From ½"-thick cherry, cut another blank of the same size.

2 Laminate the blanks together in the arrangement shown on **Drawing 1**. When the glue dries, scrape and joint one edge, and trim the block to 2¼×16".

Now, fashion the handle

1 Photocopy the full-size top- and front-view handle patterns in the *WOOD Patterns*® insert. Cut apart the two pieces of each pattern. Then, spray-adhere the top-view pattern pieces to one edge of the laminated block, aligning them with the block's ends. Draw lines to connect the patterns.

2 Bandsaw the block, as shown in **Photo A**. Using double-faced tape, reattach the cutoffs to the block. Then, adhere the front-view pattern pieces to the block's face, connect the pattern lines, and bandsaw again, as shown in **Photo B**.

Make the entire set

The bread knife is the latest member of our maple-and-cherry kitchen accessories. See issue 147 for a matching pastry board and rolling pin, issue 148 for a chef's bookshelf, and issue 150 for a pizza peel and cookbook holder (right). Or go to <http://www.woodmagazine.com/kitset>



3 Drill a $\frac{1}{4}$ " strap hole through the handle, where shown on the front-view pattern. Then, using a countersink, form $\frac{1}{8}$ " chamfers on the hole's edges. Remove the patterns.

4 Smooth all of the handle's surfaces using a 150-grit sanding drum. Then, rout $\frac{1}{4}$ " round-overs along the handle's edges, where shown on **Drawing 2** and the patterns. Round over areas that the router bit could not reach with a round file and sandpaper, starting with 80-grit and working up to 220-grit sandpaper.

5 Clamp the handle in a wood vise with a scrap board against its bottom, as shown in **Photo C**. Using a small piece of double-faced tape at each end, adhere the serrated blade to the handle, positioning the blade with its cutting edge tight against the scrap and its front end $\frac{1}{8}$ " back from the handle's end, where shown on **Drawing 2**. Now, using a $\frac{3}{32}$ " drill bit, drill $\frac{1}{2}$ "-deep

pilot holes in the handle for the mounting screws, as shown in **Photo C**. Remove the blade from the handle, and peel off the tape.

Finish up

1 Sand the handle to 320 grit. Then, apply two coats of a finish. (We used Watco Clear Danish Oil Finish.) When the finish cures, screw the blade to the handle.

2 Finally, insert an 8"-long piece of leather bootlace through the handle's $\frac{1}{4}$ " hole, and knot the ends together. Now, get a fresh loaf of bread, and enjoy some fine slicing. 🍞

Buying Guide

Blade kit. Stainless-steel serrated blade, $10\frac{1}{2}$ " long; #6x $\frac{1}{2}$ " stainless-steel panhead screws (2); leather bootlace, 8" long. Order kit no. 300BK, \$12.95 ppd. Add \$9.00 for each additional kit. Call Schlabaugh and Sons Woodworking, 800/346-9663, or go to www.schsons.com.

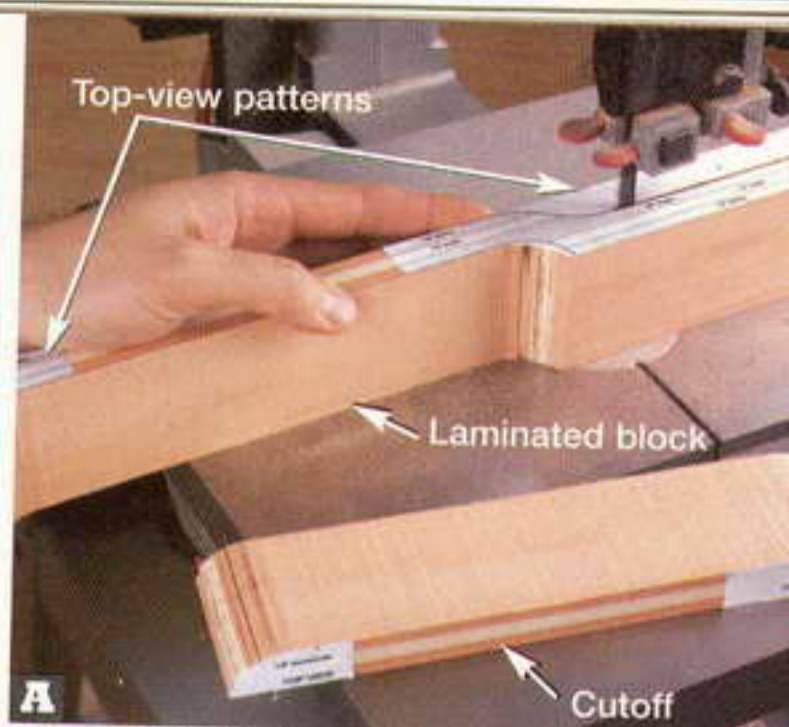

A Bandsaw the laminated block, staying just outside the top-view pattern lines. Save the cutoffs for reattachment to the block.

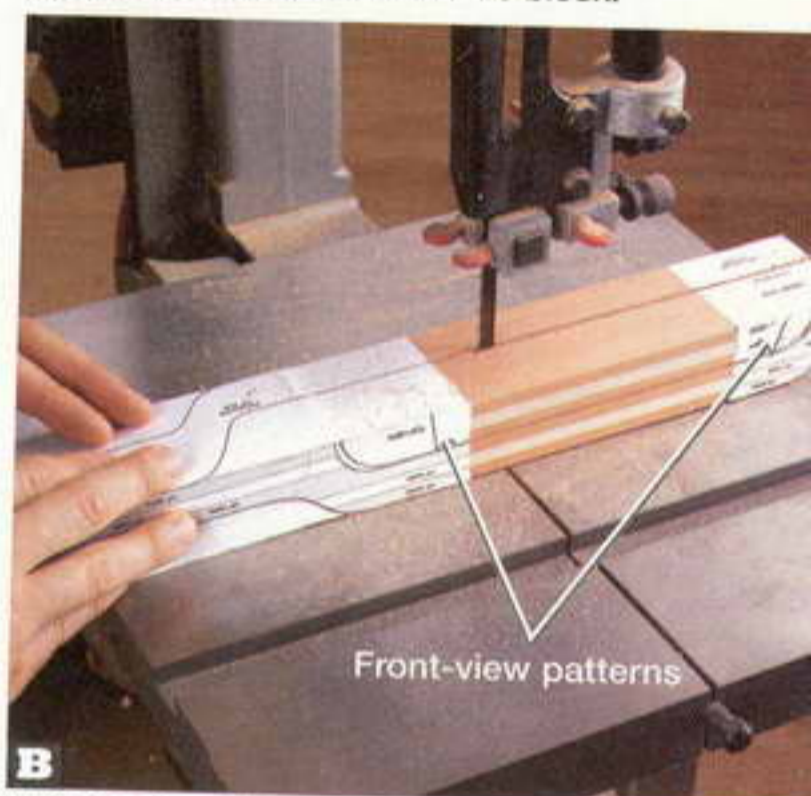

B With the front-view patterns adhered where shown, bandsaw just outside the pattern lines to complete the handle's shape.

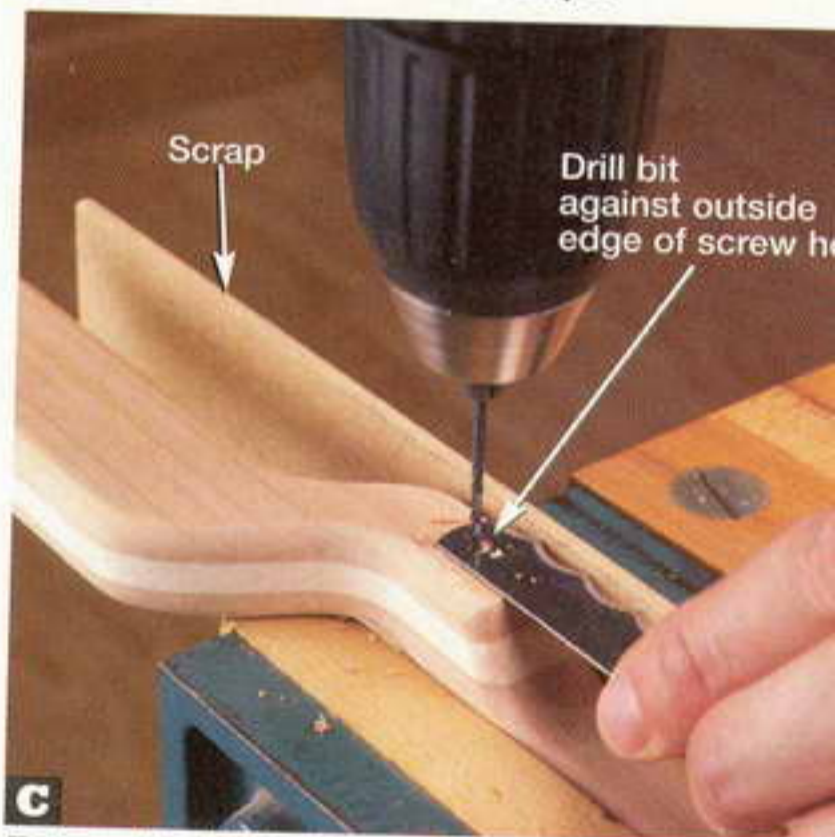

C To keep the blade tight between the screws, drill pilot holes against the outside edge of the blade's screw holes.

1 LAMINATED BLOCK

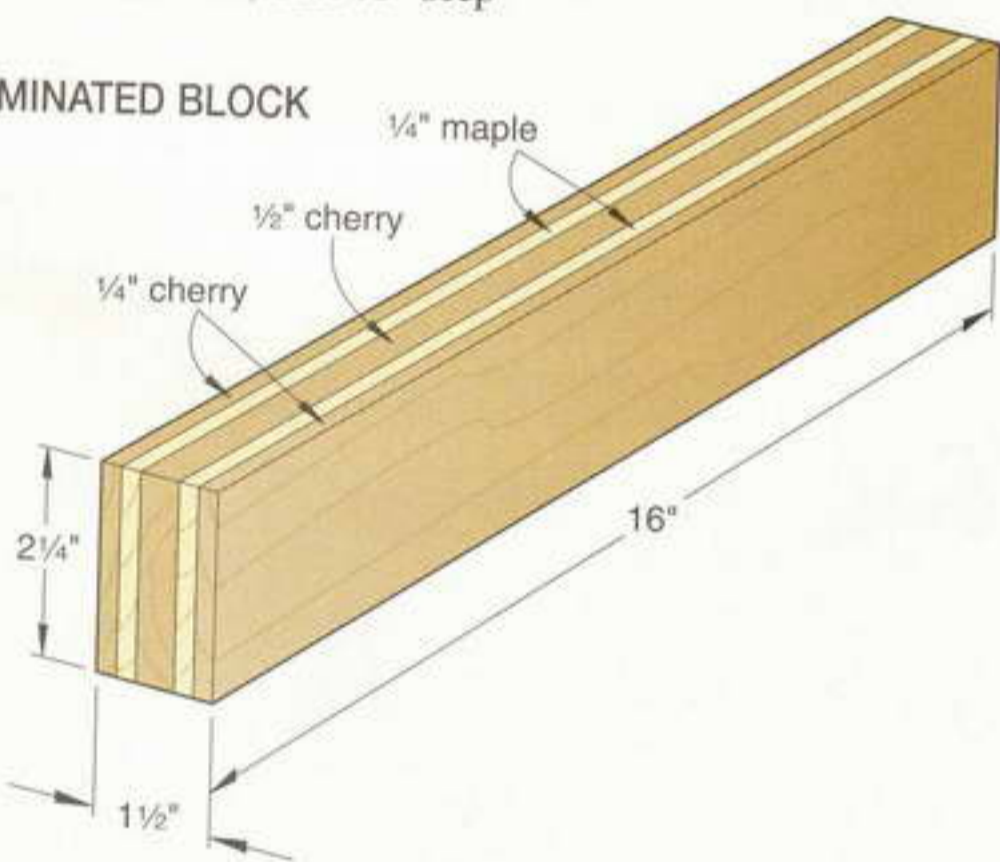

2 EXPLODED VIEW

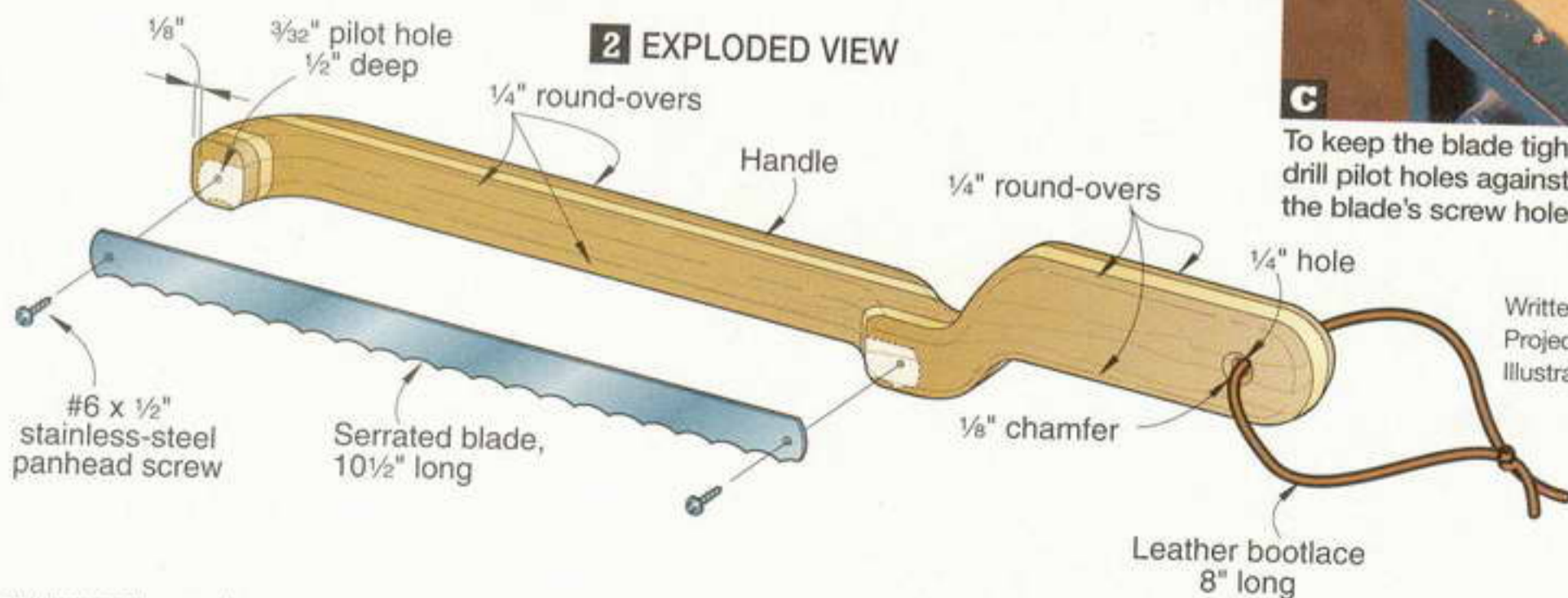

Written by Owen Duvall
Project design: Kevin Boyle
Illustrations: Roxanne LeMoine

Greene and Greene's

modern master

Seattle craftsman Tom Stangeland takes a beloved furniture style to new heights.

“Don't skimp on materials. When creating something beautiful, your time will be your greatest expense.”

— Tom Stangeland

Tom Stangeland's introduction to the Greene and Greene style, an offshoot of the Arts and Crafts movement, came in 1981. That's when someone handed him a photo of an armchair and asked if he could build one. Viewing the intricate joinery, curves, and inlay work, Tom replied, "If I can build that chair, I can build any chair." The replica, *below*, is just one of many chairs of this design that Tom has built since reaching that turning point.

Already a professional woodworker versed in the Art Deco style, Tom soon found himself immersed in this style, named for Charles Sumner Greene and Henry Mather Greene. These California brothers were prominent architects involved in the Arts and Crafts movement. Like others from the era, they often designed not just their clients' homes, which were built to glorify wood, but the furnishings to go in them, as well.

"This furniture is very tactile. It begs to be touched and handled."

"I immediately took to the style," Tom says, "because it's beautiful, but very accessible. And it fits in nicely with a wide variety of furniture and architectural styles, from old to new."



The "Blacker House" chair, named for the home of the original, presents a feast for a woodworker's senses: exposed, floating tenons and pegs made of ebony; inlays that contrast with the mahogany body; and satin-smooth surfaces.

Expanding on a classic style

These days, many regard Tom as one of the premier Greene and Greene-style furniture makers around. But he's not content to make replicas. "I take the principles of their design and expand on them," he says. "I want to play with the style, adjust it, do new things with it."

The "reverse-taper" legs Tom uses on some of his pieces exemplify what he means. "Those have become a hallmark of my work. But I've never seen them in Greene and Greene's designs." (See "Creating the reverse taper" on page 82 to learn how it's done.)

So how does Tom create new furniture that stays faithful to the Greene brothers' beloved originals? He keeps what he views as the key elements of the style in mind as he designs. They include:

- **Fine, but not overstated, materials:**

Mahogany and ebony contrast nicely, and carry a look of quality. But both feature subtle grain. Even the fine veneers he uses on tabletops, *below*, draw your eye without distracting you from the overall piece.

- **Relief and texture:**

Pegs used to reinforce joints protrude beyond surrounding surfaces; tabletops feature chamfered joints and exaggerated breadboard ends; and inlays and interesting shapes abound.

- **Softness:**

"My furniture has no sharp edges that can catch you if you, say, brush against the corner of a dining table as you walk by. The textures are friendly to touch."

- **Subtle Asian influences:**

Though not immediately apparent, elements, such as Tom's reverse taper and the "cloud lift" design, *right*, appear on many of his pieces and further define the style.



The edge of this server's top could be flat, and likewise the drawer front. Instead, both are alive with texture. The "cloud lift" bracket connecting the stretcher adds shape and a bit of flair to an otherwise ordinary joint, as well.



When sitting in the armchair, your hand naturally falls right on the exposed parts of the joint. This might, at first blush, seem odd, until you realize they're a pleasure both to feel and to see.

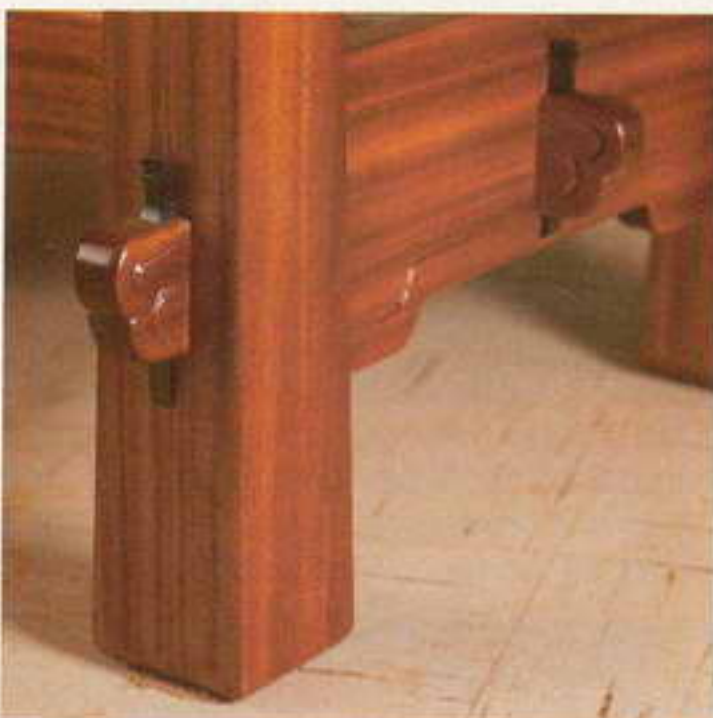

The cloud lift profile on the bottom edge of the stretcher, as well as the through tenons' shape and carvings, allow this dining table to echo Asian style without making it the driving force in the design.



To help clients choose the appearance of their tabletop, Tom uses this sample board. It showcases different veneers, all from mahogany or related species, that carry grain figures with names as interesting as their appearances.

Creating the reverse taper

Several of Tom's furniture pieces, including his dining table, *right*, glass-topped coffee table (*page 80*), and Arts and Crafts bench (*page 84*), feature a leg he calls a reverse taper. Though it might look complex, the leg actually is easy to build.

Tom starts with 16/4 mahogany, trimming it down to the proper thickness, width, and length. He cuts mortises for stretchers and aprons next. Now for the tapering.



1 Tom's taper jig couldn't be much simpler. The fence consists of two layers of 1/2" particleboard with a cleat attached at one end. Two cleated spacer blocks—one 1/2" thick, the other 1" thick—screw to the fence face to support the top end of the leg blank.



2 Tom butts the bottom end of the leg blank against the fence cleat, and rests the top end against the 1/2" spacer. Pushing the whole assembly past the blade rips a wedge off one edge. He then rolls the leg 90° to taper the adjoining face.



3 The two remaining faces get tapered using the 1"-thick spacer. The process leaves the leg 1" smaller at the top than at the bottom. The taper stops shy of the bottom of the leg, yielding a shape that's subtly more bulbous and massive.



4 To give the leg a more sculpted look, Tom routs a 1/2" round-over on the base. This simple step dramatically alters the leg's final appearance compared to the plain version also shown, plus creates softened edges that are less prone to chipping.

A diamond makes a gem of a detail

Diamond-shaped inlays, *right*, create a subtle yet striking detail at each corner on the breadboard ends of Tom Stangeland's dining tables. He precisely crafts each diamond from a thin strip of ebony, and fits each one by hand to ensure a tight, gap-free fit. Here's how he does it.

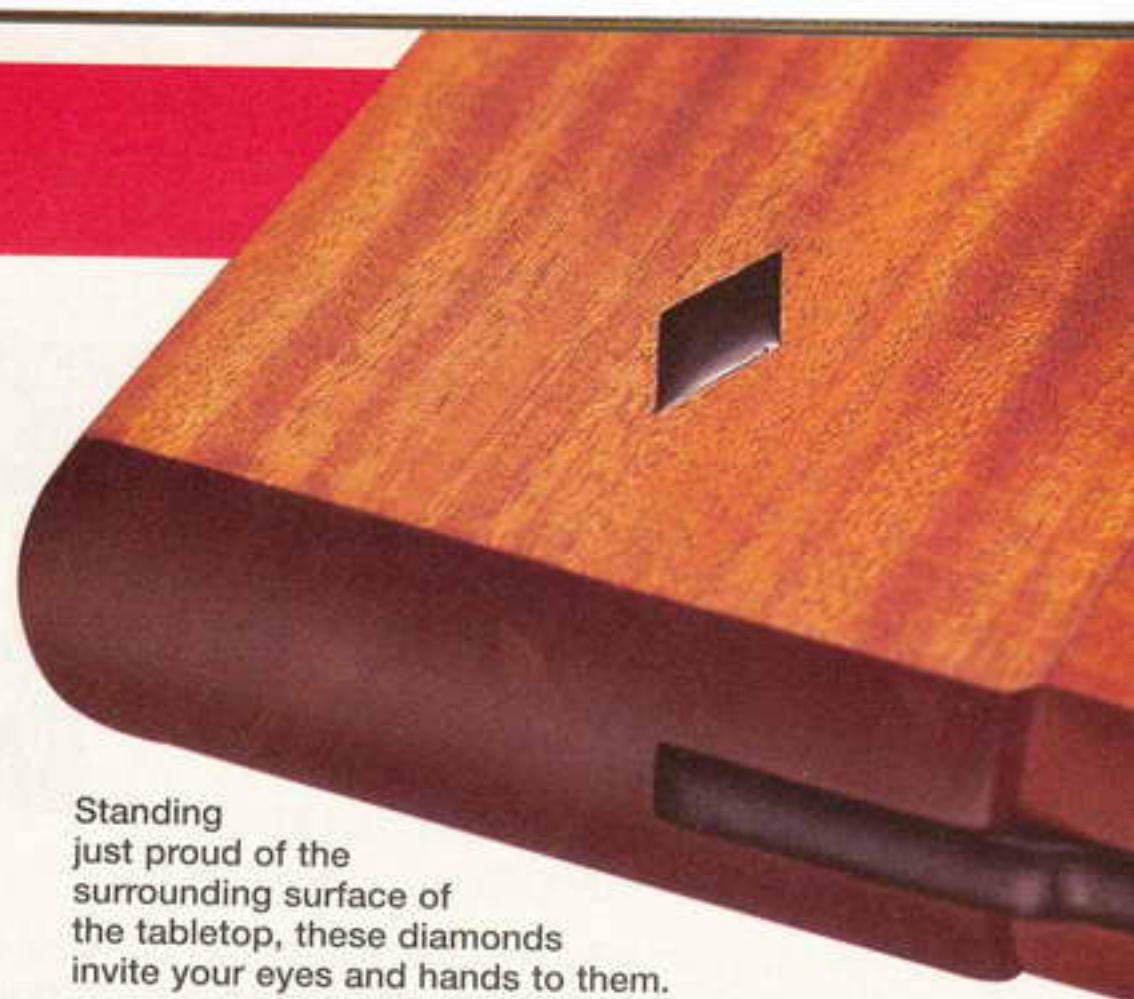

Standing just proud of the surrounding surface of the tabletop, these diamonds invite your eyes and hands to them.



Tom starts by ripping $\frac{1}{8}$ "-thick ebony into narrow strips. Placing the wood at an angle orients the grain parallel to the long axis of the diamond. A thin piece of particleboard clamped to the saw acts as a zero-clearance insert.



A homemade jig holds the ebony strips at the correct angle for cutting diamond shapes. Tom cuts just through the ebony stock, then pulls the jig back from the blade. As in **Photo 1**, he uses a pencil eraser to hold the diamond as he cuts.

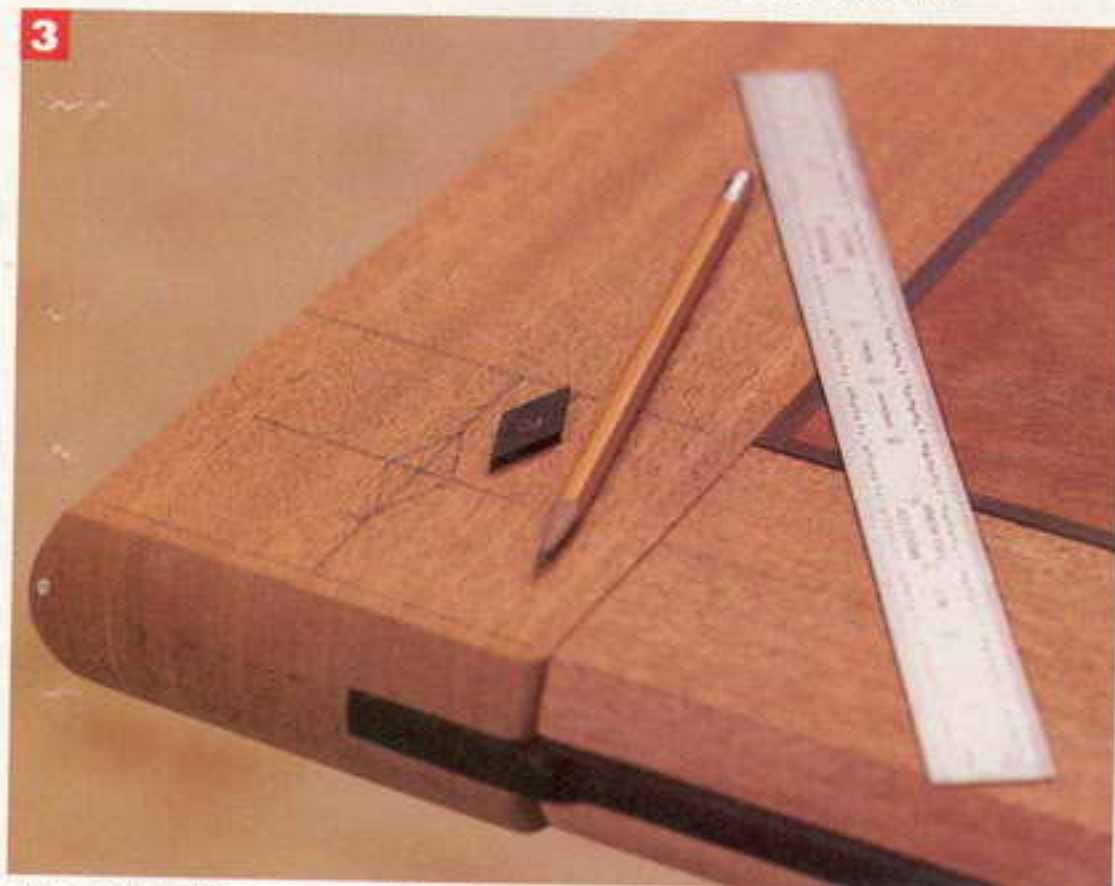

At each table corner, Tom lays out lines for the mortise. He marks intersecting lines centered on the width of each joining piece. Then he places the diamond's points on those lines and traces its shape using a sharp pencil to create a fine line.



Tom cuts away most of the recess to a depth of about $\frac{1}{16}$ " using a handheld router equipped with a $\frac{1}{8}$ " straight bit. A sharp chisel and steady hand finish the cut. Once it's fitted, Tom glues the diamond in place and carefully hand-sands it.

Tom's top seven success tips

- 1** Make good and accurate layout marks, and then trust them.
- 2** Be thorough and decisive. Second-guessing leads to confusion and mistakes.
- 3** Have a good plan and design on hand before you start cutting. You want to know where you're going to avoid arriving at a dead end.
- 4** Always use good materials, and don't be wasteful. There are only so many beautiful boards.
- 5** Don't be tentative when operating equipment or hand tools. Stay focused and make sure you've sorted out any questions or uncertainties about the operation before you turn on a machine.
- 6** Select the wood you use personally and carefully. Don't leave it to someone who isn't sure what you're after.
- 7** Get to know your wood supplier really well. Having a good relationship at the lumberyard leads to better material in your shop because the supplier will know your desires, and may notify you when stock you'll like arrives.



While six out of ten people might not pick up on these subtle styling cues, Tom insists that they're critical to good design, and make up a large part of what separates fine furniture from the run of the mill. In "A diamond makes a gem of a detail" you'll see how he creates this signature inlay.

Close examination of the dining table base reveals more subtle details: The center stretcher sports a slight chamfer, plus a thin cap on top with half-round edges.

"That detail takes a lot of time," Tom says, "and you don't necessarily notice that it's there. But it catches the light, creating an accent that you will see, whether or not you know why it happened."

Design that works

While design is obviously important in Tom's works, he's quick to point out that function comes first. "When designing a piece of furniture, always start by figuring out why it needs to exist and what it has to accomplish."

A partially finished custom display case on his shop floor illustrates the point. Were he designing it for himself, he would have made this piece either taller or slightly narrower to make the proportions a little more pleasing. But it's designed to tuck into a niche in the client's dining room, and has to be

wide enough to properly fill the space. Because the client is short, a taller cabinet would have made it hard for her to see a treasured piece of art that will reside on top.

Making those kinds of decisions lends an extra challenge to furnituremaking, which answers why Tom produces more stock pieces than custom ones these days. "When working on special orders, I have to stand around thinking a lot while I fig-

ure it out. And it's hard to charge people for that part of the process."

So does he ever tire of making similar pieces multiple times? Not really. Of the dining table he says, "I get really excited when I finish one. It's a design I never tire of. And I really enjoy building beautiful things that will last a long, long time. It's a little piece of immortality." 🌲

Written by **David Stone**
Photographs: **Richard McNamee**



Like all of Tom Stangeland's furniture, this sideboard is built to withstand daily use. The finish looks like natural oil but is really a durable catalyzed lacquer. The drawers feature hidden ball-bearing glides for smooth operation.

super-flexible shop storage



Clamp racks

Perforated hardboard panel

General storage cabinet

Clamp rack

Wall cleat

Wall cleat

Hardware cabinet

Tool cabinet

Wall cleat

Interlocking cleats

All of the wall system's components hang by hooking the downfacing bevels of their cleats over the upfacing bevel of a cleat fastened to the wall, as demonstrated here with the perforated hardboard panel.

Mitersaw workstation, coming in issue 153

Work light holder, coming in issue 155

Wall Storage System

Presto chango! With this simple system, adding to or rearranging your workshop wall storage is (almost) as easy as waving your hand.

Adding new tools or supplies to your workshop is always a good thing. But sometimes, finding a place to set up a tool or store more supplies means juggling the existing layout of wall cabinets or tool racks. With its interlocking hanging cleats, shown in the inset photo, *far left*, this Idea Shop 5 system transforms a major hassle into a minor task accomplished in minutes.

Here, you'll learn how to build racks for bar and pipe clamps, a perforated hardboard panel for hanging hand tools, and wall cabinets with either clear acrylic or hardboard doors for see-through or covered-up storage. Featured in three handy sizes—12¼" deep for general storage, 8¾" deep for hardware, and 7½" deep for tools—all the cabinets share identical construction details. The inset photos, *left*, show even more ways to make your wall system work for you.

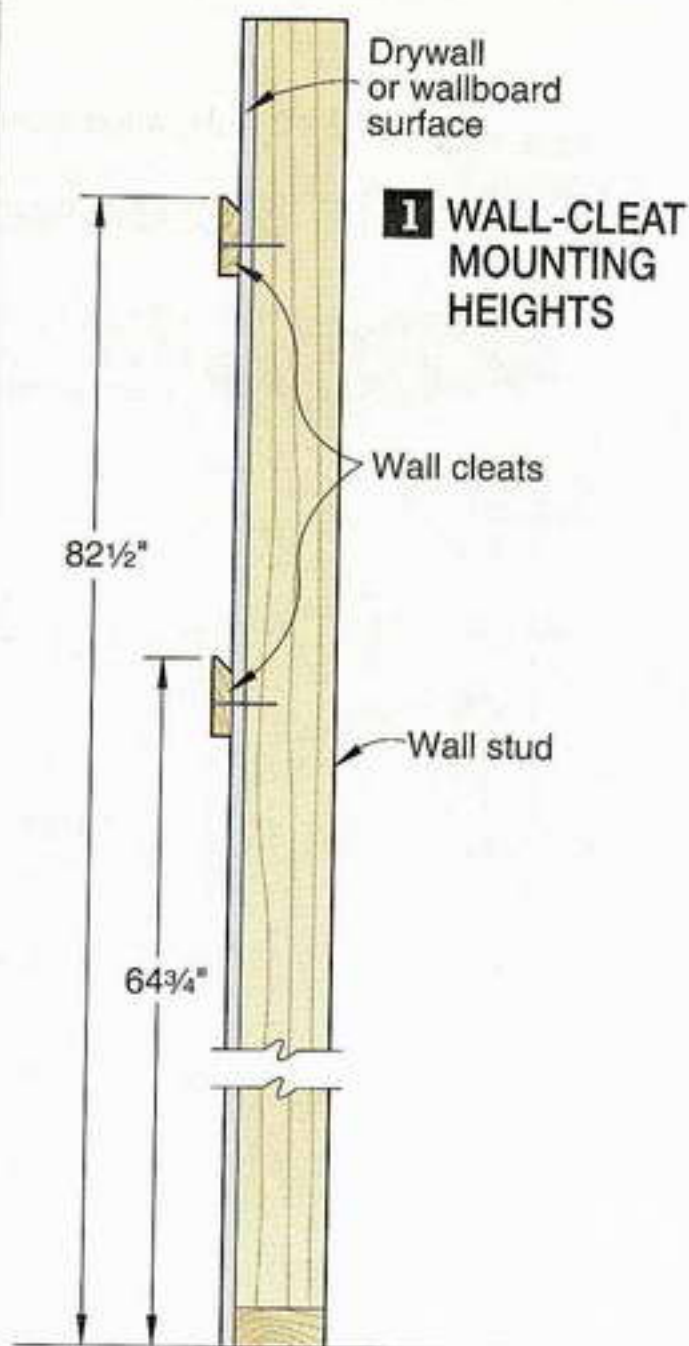

2 CLEATS

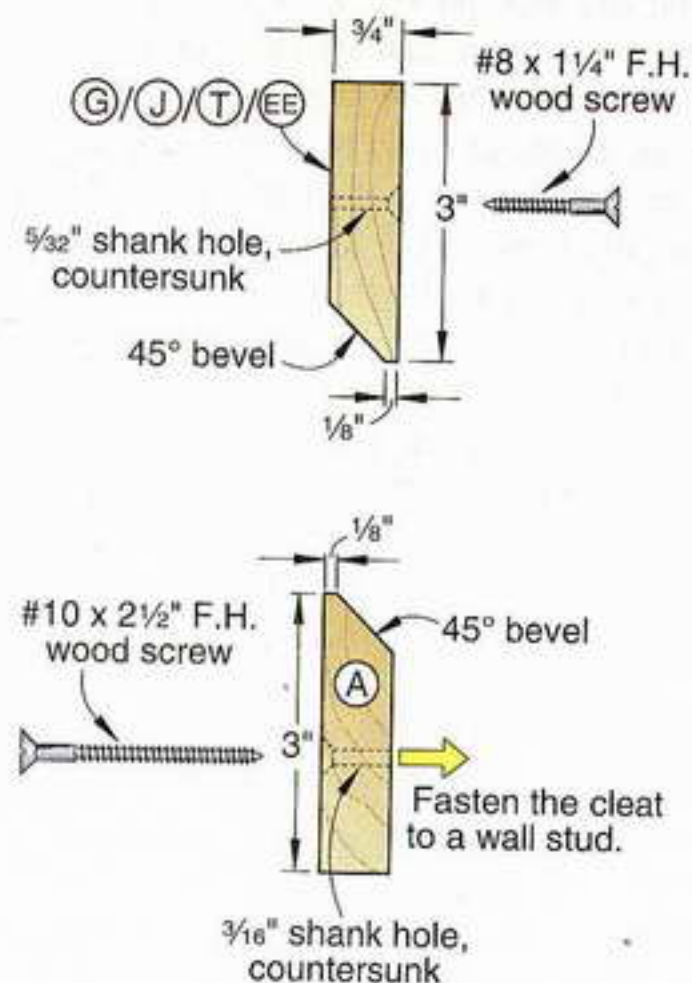

Start with the wall cleats

1 Measure your shop for the total linear feet of wall cleat (A) you'll need. The Idea Shop has cleats at the levels shown on **Drawing 1**, although not necessarily on every wall. Plan your wall-cleat mounting heights according to your needs. Joint one edge of your

boards straight, rip them to 3" wide, and then bevel one edge, where shown on **Drawing 2**. Sand the cleats, and apply two coats of satin polyurethane.

2 Locate the wall studs, and drill countersunk shank holes in the cleats at these locations. Leveling the cleats, drill pilot holes, and drive the screws.

Add a perforated hardboard panel

1 Cut the frame sides (B) and frame top and bottom (C) to size. With a dado blade, cut ¼" grooves ⅜" deep in the sides, top, and bottom, where shown on **Drawing 3**. Then cut the ¾" rabbets ⅜" deep in the ends of the sides.

2 Cut the panel (D) to size. Squeeze glue into the frame members' grooves, and clamp them to the panel.

3 Cut the back rail (E) and spacer (F) to size. Glue and clamp the rail to the back of the panel (D). Clamp the spacer in place, drill screw holes through the spacer and into the frame bottom (C), and drive the screws.

4 Cut the cleat (G) to size, and then bevel one edge, where shown on **Drawing 2**. Glue and clamp it in place, flush with the top of the frame top (C). Drill screw holes, and drive the screws.

3 PERFORATED HARDBOARD PANEL

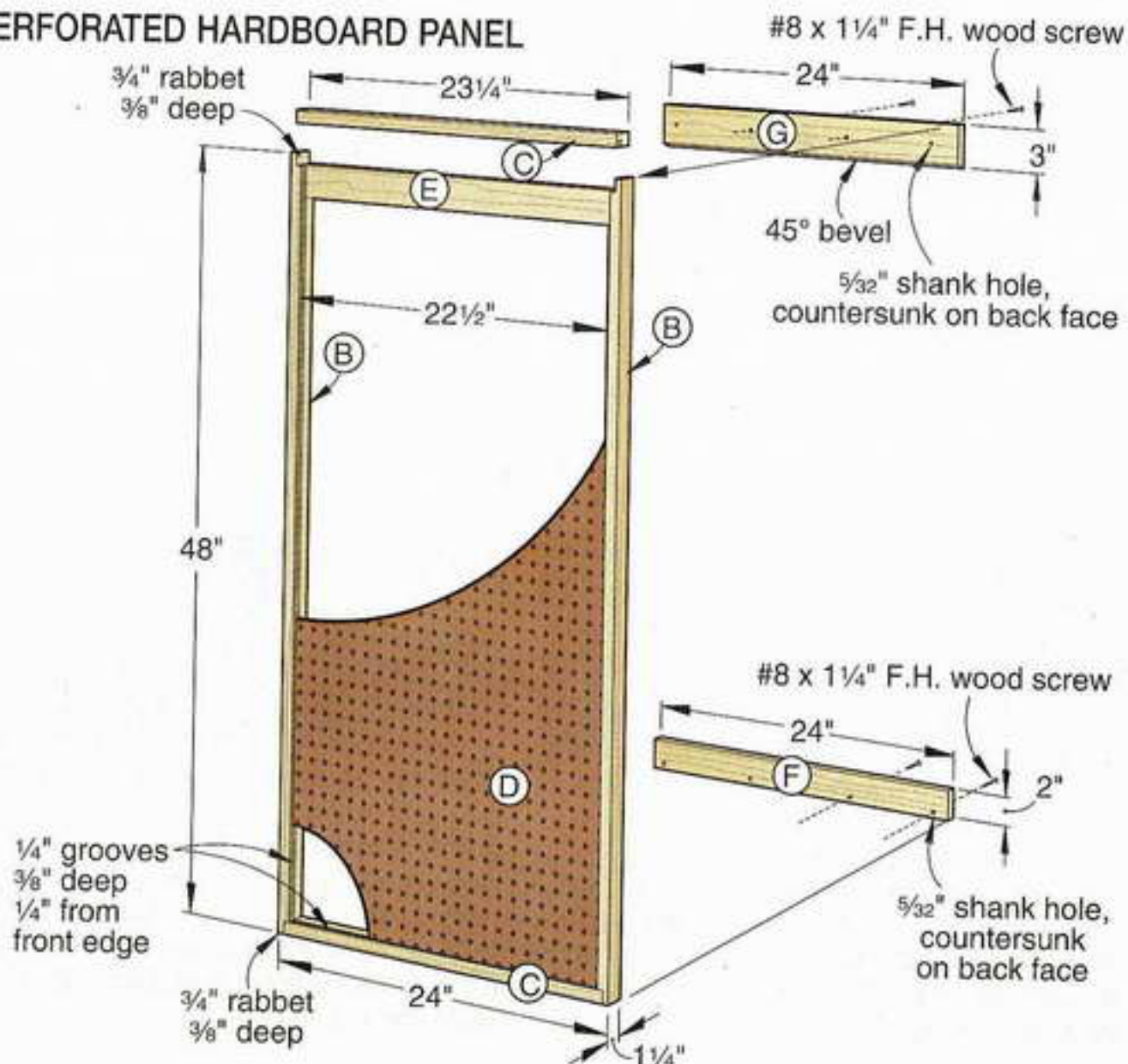

Now make clamp racks

1 To determine the size of the holder (H), shown on **Drawing 4**, and the size and spacing of the notches for the bar or pipe clamps that you have, see the six steps shown on **Drawing 5**. Cut the holder (H) to size. Then cut the upright (I) and cleat (J) to the widths listed in the **Materials List** and the same length determined for the holder. Cut 2° bevels on all the parts, where shown on **Drawing 4a**. Then cut the 45° bevel on the cleat. To lock the completed rack onto the wall cleat, drill a countersunk screw hole centered in the length of the upright, where shown on **Drawing 4**.

2 Lay out the notches on the holder (H). With a dado blade in your tablesaw, and an auxiliary extension attached to your miter gauge to prevent chip-out, cut the notches. For a method of cutting the notches that avoids tedious layout, see the **Shop Tip, below**.

3 Glue and clamp the cleat (J) to the upright (I) with their top edges flush, where shown on **Drawing 4a**. Drill screw holes, and drive the screws. Then glue and clamp the holder (H) to assembly I/J, keeping the back edge of the holder flush with the back face of the cleat. Drill screw holes, and drive the screws.

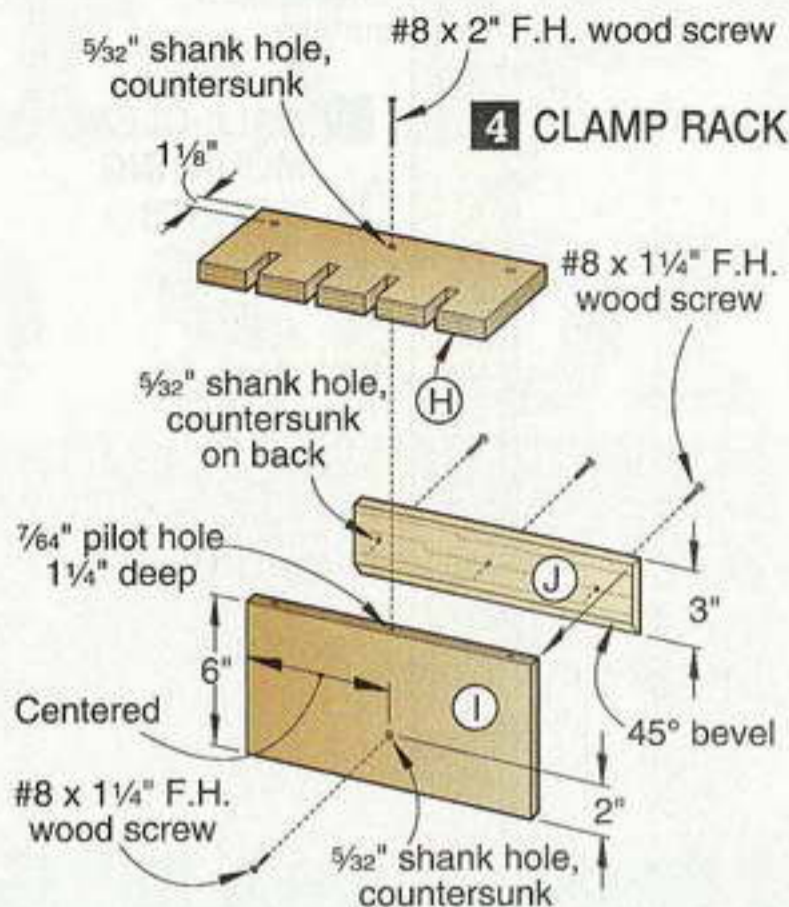

4a SIDE SECTION VIEW DETAIL

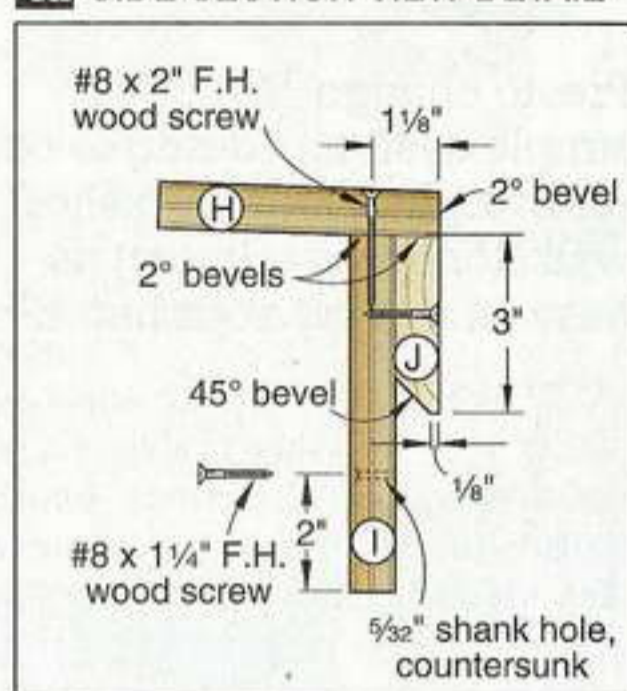

5 SIZING THE CLAMP HOLDER

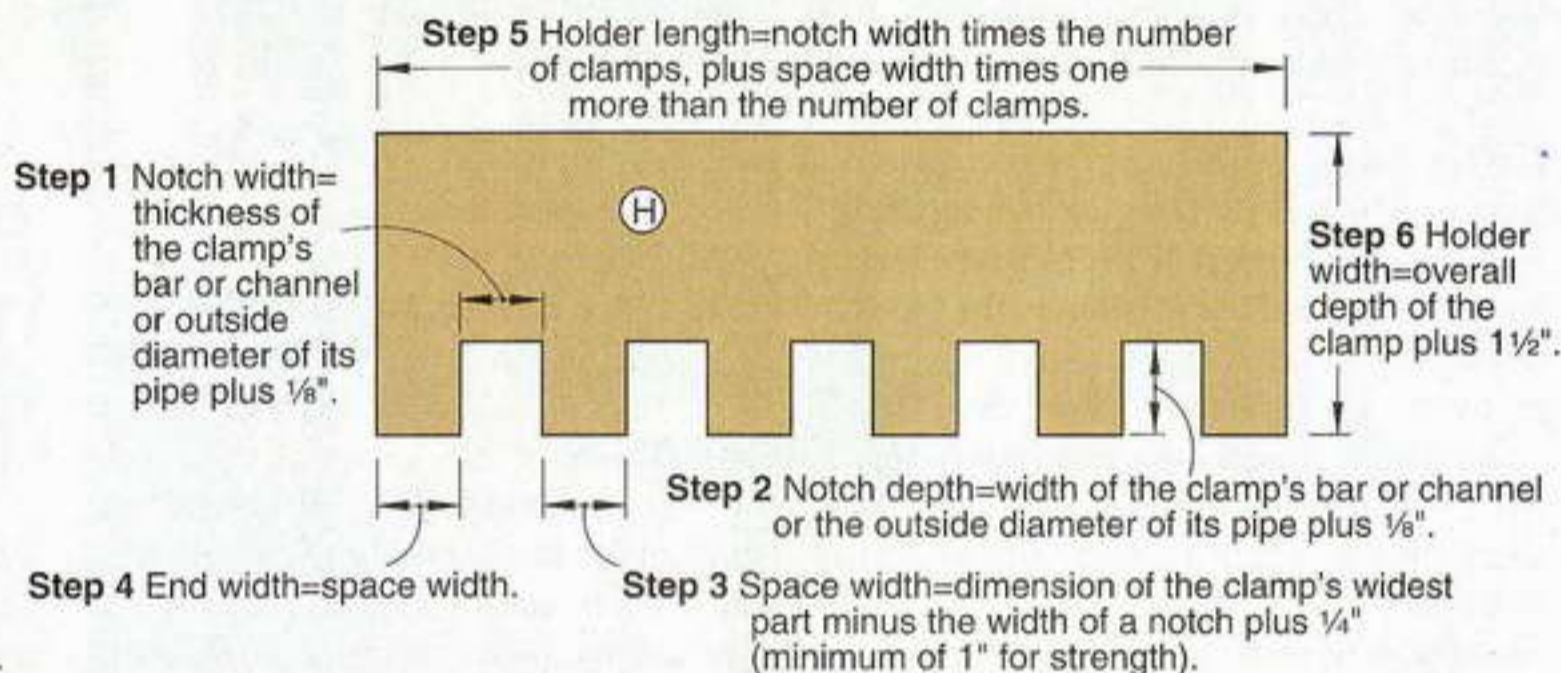

SHOP TIP

Save time notching with a simple step-and-repeat jig

When making several clamp racks, speed things up by adding an indexing pin the same width as the notches you wish to cut to a miter-gauge auxiliary extension. Then use it just like a box-joint jig to cut the notches.

When making racks that call for notches of more than one width, make your jig for the narrowest notch, and cut these holders first. Then use the same jig to cut the wider notches. The photos, *below*, show you how to cut 1" notches with a jig originally made to cut 1/2" notches.

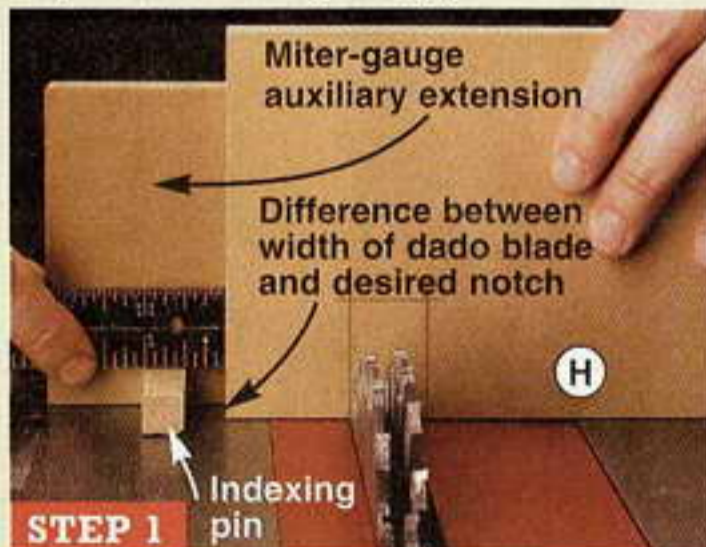

Lay out the holder's first notch, and align it with the dado blade. Adjust the auxiliary extension so the distance between the indexing pin and the end of the holder is the same as the difference between the width of the dado blade and the width of the desired notch. Secure the extension to the miter gauge, and make the first cut.

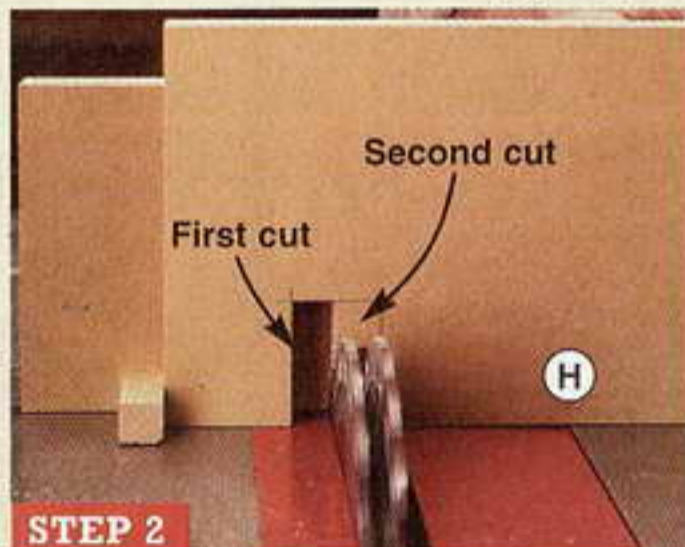

Slide the holder over against the indexing pin, and make another cut. In this case, the notch is formed in two cuts because the dado blade is half the width of the desired notch. When the dado blade's width is less than half the desired notch's width, you'll have to make more than two cuts to complete the notch.

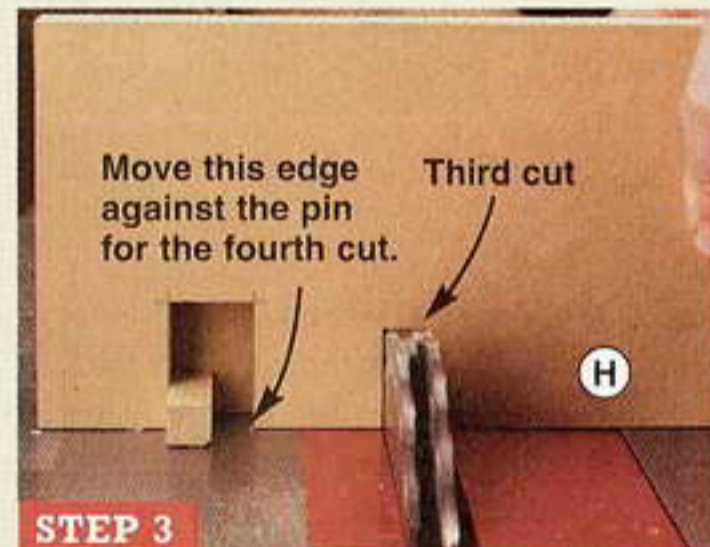

Place the notch just cut over the indexing pin with one side against the pin, and make the third cut. Push the notch's other side against the pin, and make a fourth cut. Once again, if using a narrower dado blade, clean out between the two cuts with additional passes. Now repeat these steps until all the notches are cut.

8 HARDWARE CABINET

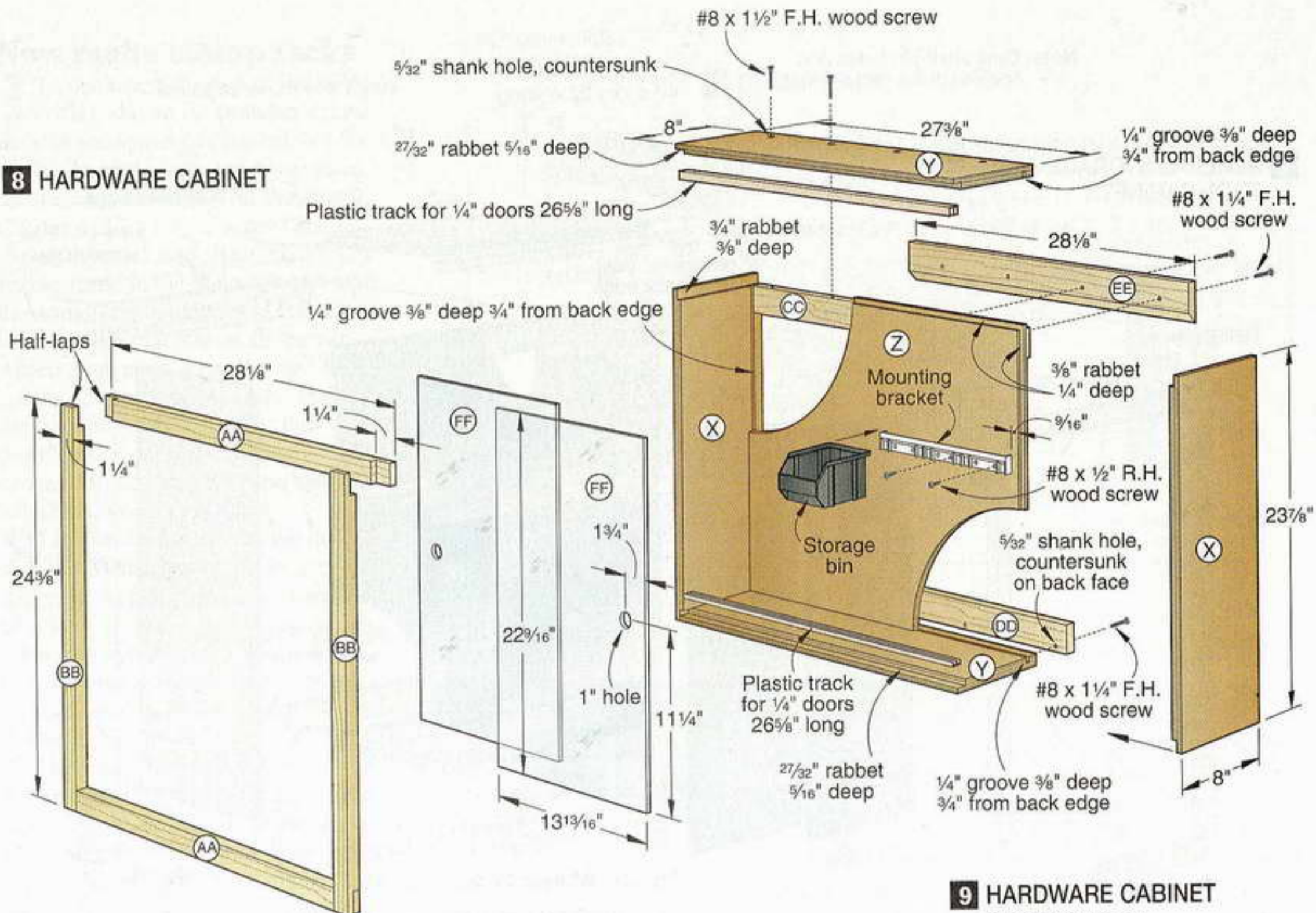

Now measure the exact length of the stiles (Q, BB), and cut them to size. Cut half-lap joints in the ends of the parts, and glue and clamp them in place.

5 Cut the rear rails (R, CC), spacers (S, DD), and cleats (T, EE) to size. Bevel the cleats, where shown on **Drawing 2**. Glue and clamp the rear rails to the backs (O, Z), and the spacers to the bottoms (M, N, Y), where shown on **Drawings 6, 7, 8, and 9**. Drill screw holes, and drive the screws. Then glue and clamp the cleats in place, drill screw holes, and drive the screws.

6 Cut the doors (U, FF) $\frac{1}{16}$ " larger in length and width than the sizes listed. Depending on what you wish to store in the cabinets, choose either tempered hardboard or clear acrylic. (We used both hardboard and acrylic for general storage cabinets, and acrylic for the tool and hardware storage cabinets.) Clean up the edges by jointing off $\frac{1}{32}$ ", and then ease the sharp corners with a sanding block. Chuck a 1" Forstner bit in your drill press, and drill the finger holes. Chamfer their edges with sandpaper. When drilling finger holes in acrylic doors, run your drill press at 250 rpm.

7 For a general storage cabinet, cut the shelves (V) and the shelf edges (W) to size. Glue and clamp the shelf edges to the shelves.

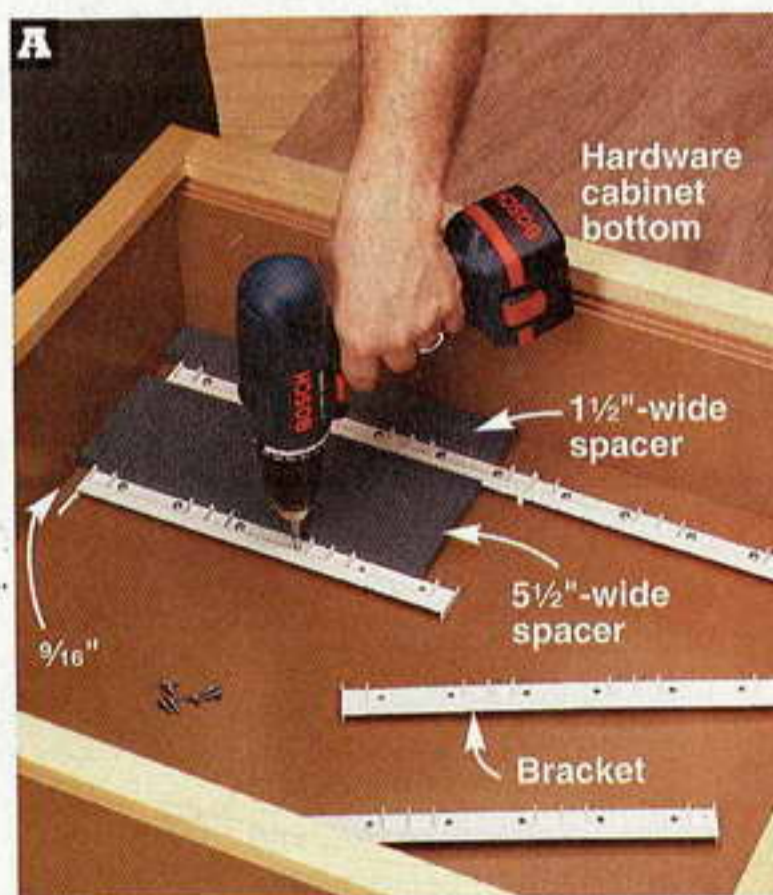

Place the 1 1/2" spacer between the cabinet's bottom and the first bracket, and align it with the mark. Drill pilot holes, and drive the screws. Slide the spacer over, and mount the second bracket. Now, using the 5 1/2" spacer, mount the remaining brackets.

9 HARDWARE CABINET SECTION VIEW

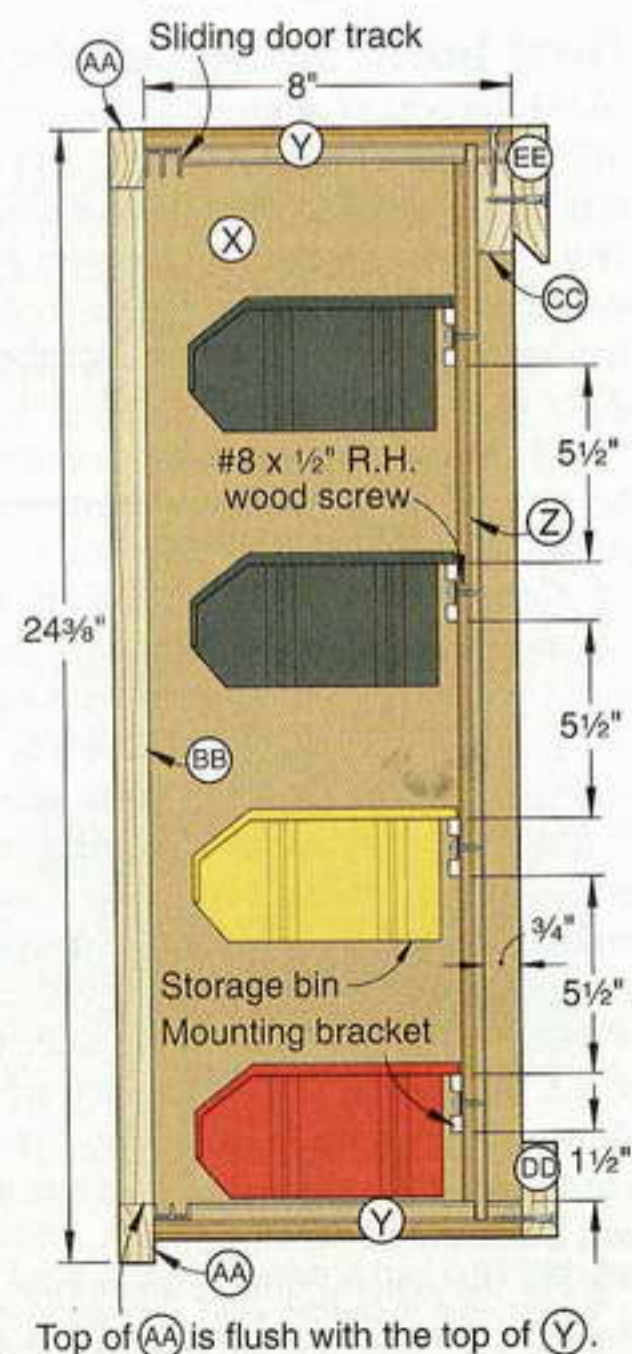

Finish and hang

1 Sand the exposed plywood edges of the clamp racks smooth, and ease all the corners with a sanding block. Sand the perforated hardboard panel frame, cabinet frames, and shelf edges, and ease their corners with a sanding block. Apply two coats of satin polyurethane to all the parts, sanding between coats.

2 Cut sliding door tracks to fit between the cabinet sides, apply a 1/8" bead of construction adhesive, and clamp the tracks in place.

3 Lay the hardware storage cabinet on its back. Cut 1 1/2"- and 5 1/2"-wide spacers from scrap, and make bracket-alignment marks 1/16" from one end. Fasten the bin-mounting brackets, where shown on **Drawing 9**, and as shown in **Photo A**.

4 Lay the perforated hardboard panel on its back, and arrange your tools on it. Once you work out an efficient arrangement, attach perforated hardboard hooks and tool holders.

5 Hang the clamp racks, perforated hardboard panel, and cabinets on the wall cleats. To keep from accidentally dislodging the clamp racks, use the hole drilled in the rack's upright as a guide to drill a pilot hole in the wall cleat. Drive the screw. Install the shelf pins, shelves, and plastic bins in their respective cabinets, and then add the doors. Now, hang up your clamps, refill the perforated hardboard, and arrange your other tools and supplies in the cabinets. 🐿

Materials List

Part	FINISHED SIZE			Matl.	Qty.
	T	W	L		
A wall cleat	3/4"	3"	†	M	†
Perforated hardboard panel					
B frame sides	3/4"	1 1/4"	48"	M	2
C frame top/bottom	3/4"	1 1/4"	23 1/4"	M	2
D panel	1/4"	23 1/4"	47 1/4"	PH	1
E back rail	3/4"	2"	22 1/2"	M	1
F spacer	3/4"	2"	24"	M	1
G cleat	3/4"	3"	24"	M	1
Clamp rack					
H holder	3/4"	†	†	MDO	1
I upright	3/4"	6"	†	MDO	1
J cleat	3/4"	3"	†	M	1
General storage and tool cabinets					
K storage cabinet sides	3/4"	11 1/2"	30"	MDO	2
L tool cabinet sides	3/4"	6 3/4"	30"	MDO	2
M storage cabinet top and bottom	3/4"	11 1/2"	23 1/4"	MDO	2
N tool cabinet top and bottom	3/4"	6 3/4"	23 1/4"	MDO	2
O backs	1/4"	23 1/4"	29 1/4"	PH	2
P rails	3/4"	1 1/4"	24"	M	4
Q stiles	3/4"	1 1/4"	30 1/2"	M	4
R rear rails	3/4"	2"	22 1/2"	M	2
S spacers	3/4"	2"	24"	M	2
T cleats	3/4"	3"	24"	M	2
U* doors	1/4"	11 3/4"	28 1/16"	H/A	4
V shelves	3/4"	8 3/4"	22 3/8"	MDO	2
W shelf edges	3/4"	1 1/4"	22 3/8"	M	2

Written by **Jan Svec**
Project design: **Kevin Boyle** and **Frank Polimene**
Illustrations: **Roxanne LeMoine**

Hardware cabinet					
X sides	3/4"	8"	23 7/8"	MDO	2
Y top and bottom	3/4"	8"	27 3/8"	MDO	2
Z back	1/2"	23 1/8"	27 3/8"	MDO	1
AA rails	3/4"	1 1/4"	28 1/8"	M	2
BB stiles	3/4"	1 1/4"	24 3/8"	M	2
CC rear rail	3/4"	2"	26 5/8"	M	1
DD spacer	3/4"	2"	28 1/8"	M	1
EE cleat	3/4"	3"	28 1/8"	M	1
FF* doors	1/4"	13 13/16"	22 9/16"	A	2

†Determined by measurement. See the instructions.

*Parts initially cut oversize. See the instructions.

Materials key: M—maple, MDO—medium-density overlay plywood, PH—perforated hardboard, H—tempered hardboard, A—acrylic.

Supplies: #8x1 1/4", #8x1 1/2", #8x2", and #10x2 1/2" flathead wood screws; #8x1 1/2" roundhead wood screws; construction adhesive.

Blades and bits: Stack dado set, 1" Forstner bit.

Buying Guide

Hardware. 48" brown plastic sliding door track no. KV241748, \$5.57, 1/4" shelf pins no. G401BN, \$2.40 for 20. Woodworker's Hardware. Call 800/383-0130, or order online at www.wwhardware.com.

Storage bins. Six-pack of plastic storage bins with mounting bracket nos. BINS6000R (red), BINS6000Y (yellow), BINS6000G (green), \$6.50. McFeely's. Call 800/443-7937, or order online at www.mcfeelys.com.

See more ...

... Idea Shop 5 projects and tools at

<http://www.woodmagazine.com/ideashops>



Cutting Diagram

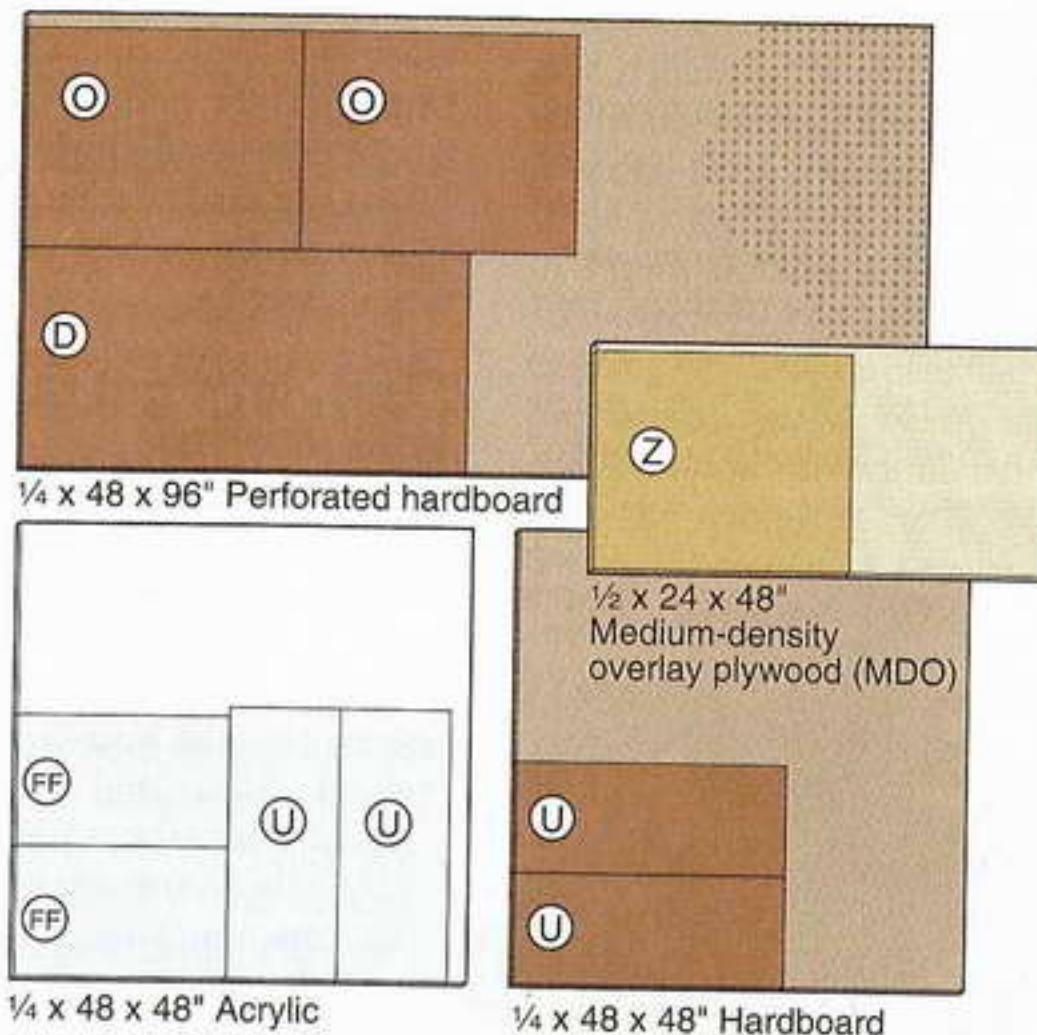
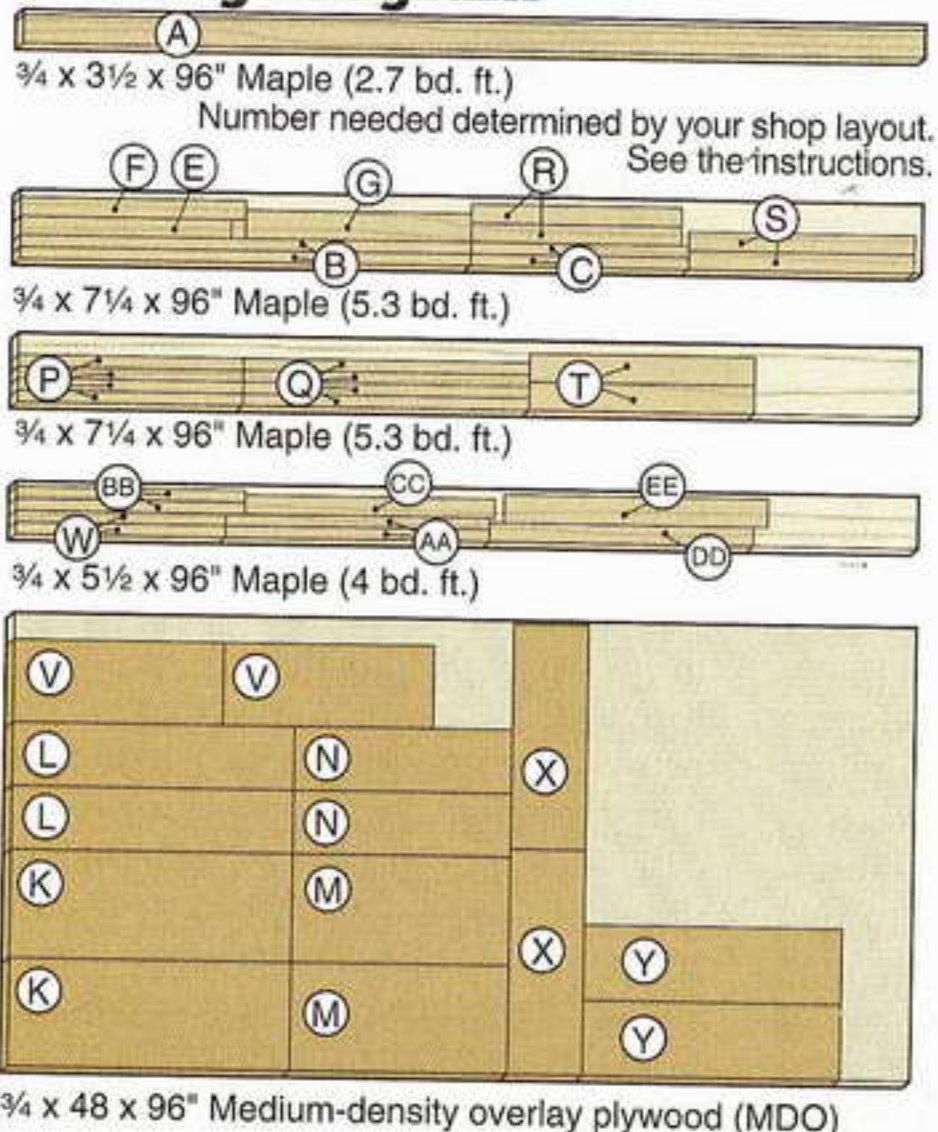

Note: Parts H and I are made of 3/4" medium-density overlay plywood, and part J is made of maple. To determine their dimensions and the quantity of materials needed, see the instructions.

surefire lathe tool sharpening

A nifty jig slays
the sharpening dragon.

To help avoid tool catches, torn grain, and other turning snafus, it's essential that your tools be properly sharpened. So how do you do that? We asked three professional turners (see page 95 for more on them), and their answers were unanimous: "Get a Wolverine Grinding Jig." All three felt that next to a solid lathe and a good set of

tools, the Wolverine Grinding Jig by Oneway is the best investment an amateur or occasional turner can make.

Next, we asked our pros how to put the Wolverine Jig to best use. Here's what they showed us.

First, let's get familiar with the jig

The complete sharpening system, shown left, includes the Wolverine Grinding Jig, consisting of two locking bases, a V-arm rest, and an adjustable platform rest (about \$80), and two accessories: the Vari-Grind Attachment (about \$48) and Skew Grinding Attachment (about \$27).

Use the V-arm rest by itself to sharpen your roughing gouge and parting tool. It also supports the Vari-Grind Attachment, used for putting the popular side grind on bowl gouges and fingernail grind on spindle gouges. To sharpen your

skew chisel, clamp the Skew Grinding Attachment to the V-arm rest. The platform rest accommodates the sharpening of scrapers, and also makes an excellent rest for sharpening other edge tools, such as plane irons and chisels.

Adjustable locking bases secure the rests for proper tool positioning. This also allows you to grind on either wheel with both rests. The bases mount directly under the grinding wheels, as shown on Drawing 1, so make sure your grinder accommodates them. To elevate the center of the grinding wheels to the height shown, insert a spacer block between the grinder and its platform.

You may find the prospect of spending \$160 for a jig to sharpen your lathe tools daunting. That's about the cost of five mid-priced M2 high-speed steel tools. But if they're not sharpened properly, even the most expensive tools aren't much good. The Wolverine Jig allows

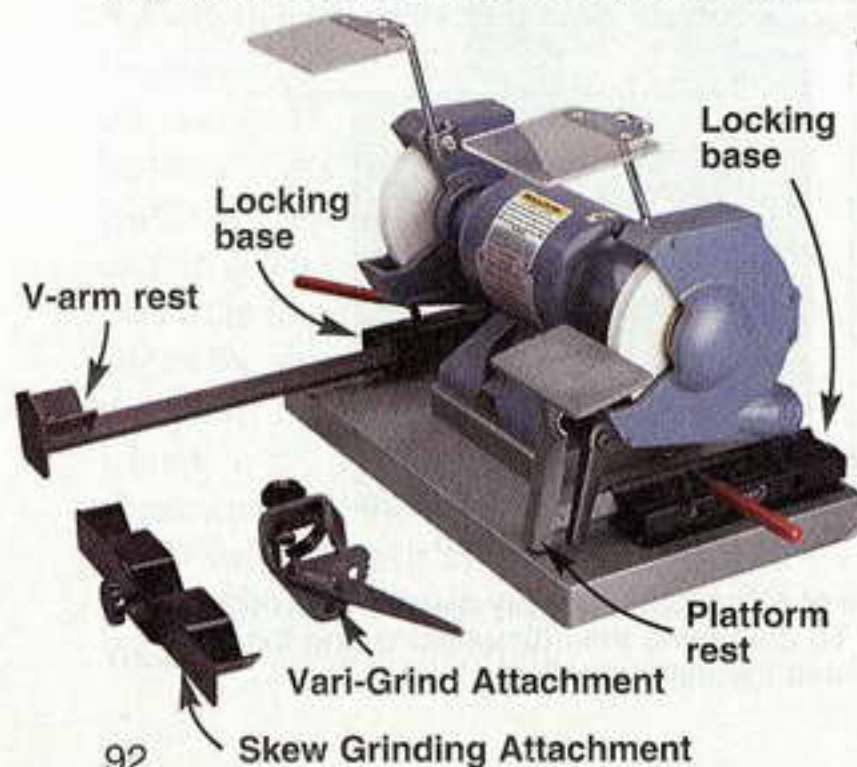

SHOP TIP

How to ensure perfect tool-to-grinding-wheel alignment

Accurate alignment of a tool's bevel with the grinding wheel means less metal removed when sharpening. You'll also avoid a gradual drift away from that perfect bevel you've established. Aligning the bevel to the wheel by eye doesn't always get perfect results. Here's a trick that will.

Blacken the bevel of the tool with a permanent felt-tip marker. Adjust the tool rest, and align the tool's bevel with the wheel by sight. Switch on the grinder, and barely touch the tool's bevel to the wheel. In the photo, right, the shiny spot shows that the bevel's heel contacted the wheel first. Readjust the tool rest so the wheel removes the marker all the way from the bevel's heel to the cutting edge.

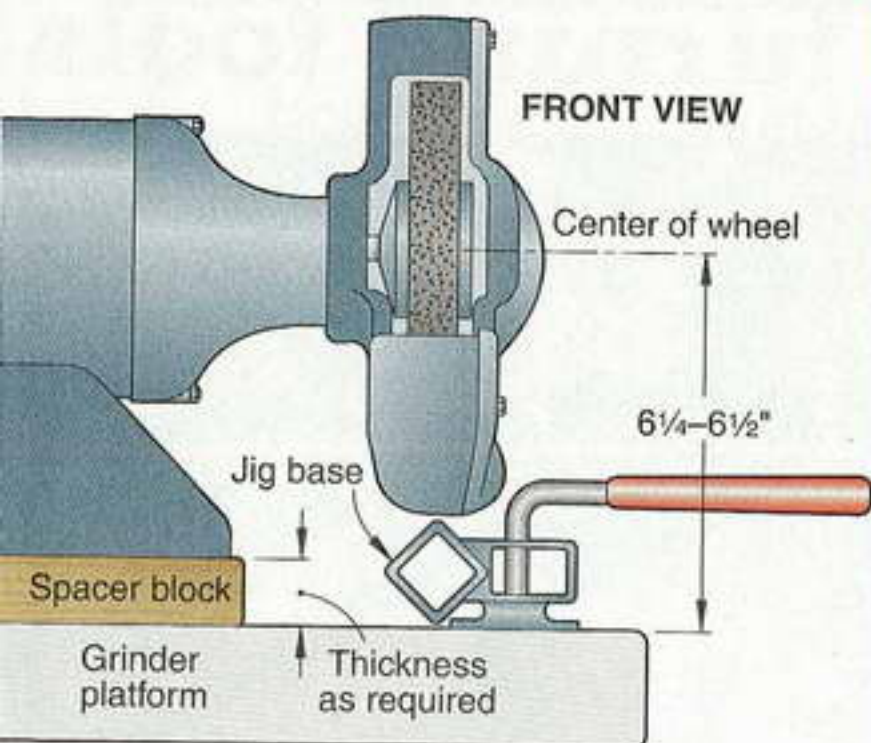
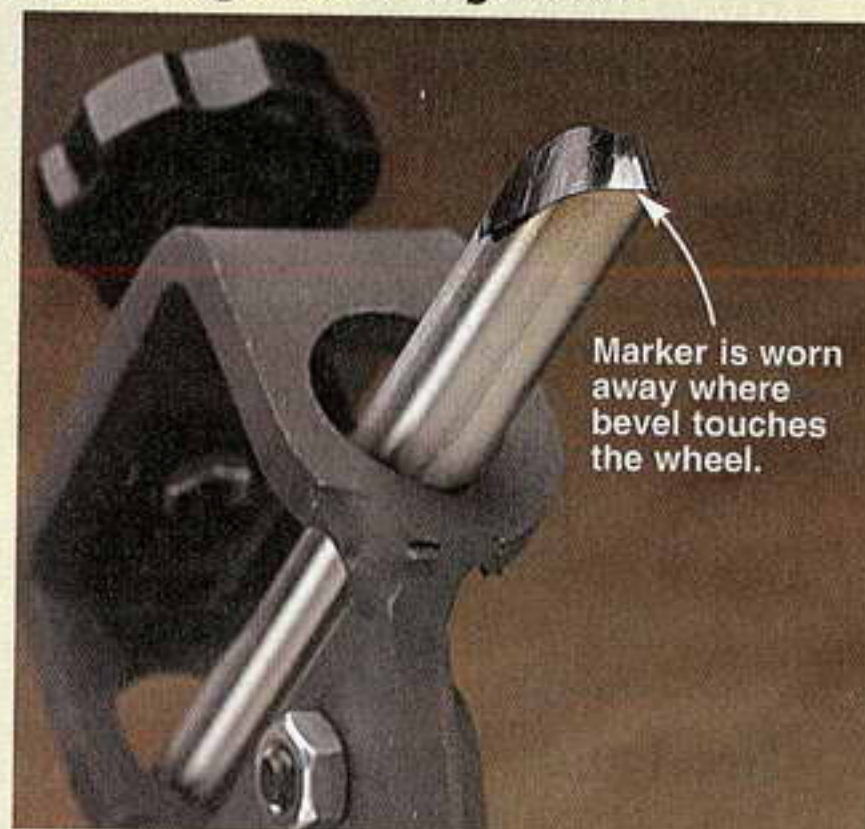

1 JIG SETUP

you to do what most people can't do by hand: grind smooth, consistent bevels to precise angles without the multitude of facets typical of freehand attempts.

What you need to know about grinders and wheels

Most general-purpose grinders run at 3,450 rpm and come equipped with gray utility wheels. This combination of high speed and hard wheels easily overheats lathe tools, leading to short edge life. Our experts recommend an 8" slow-speed grinder (1,725–2,000 rpm) equipped with white aluminum oxide wheels. These wheels are designed to wear away during sharpening, constantly exposing new cutting particles. This results in cooler, more efficient grinding. Fit your grinder with one 60-grit wheel for rough shaping your tool profiles when needed, and one 100-grit wheel for routine sharpening.

If you already have a 3,450-rpm grinder you don't have to replace it; fitting it with white aluminum oxide wheels is more important than slow speed. Also, a 6" grinder is acceptable, but no matter which size grinder you use, replace the wheels when they wear down to about 5" in diameter.

You'll need to keep the wheels dressed to remove metal particles and maintain flat surfaces. Oneway offers the Wolverine Dressing Jig (about \$65), and most woodworking and turning supply catalogs offer inexpensive diamond wheel dressers (\$16 to \$40).

For best results, use light grinding pressure, and move the tool from side-to-side to avoid wearing furrows in the wheels. For safe operation when using the V-arm rest, keep the tool's contact point well above the grinding wheel's centerline. When using the platform

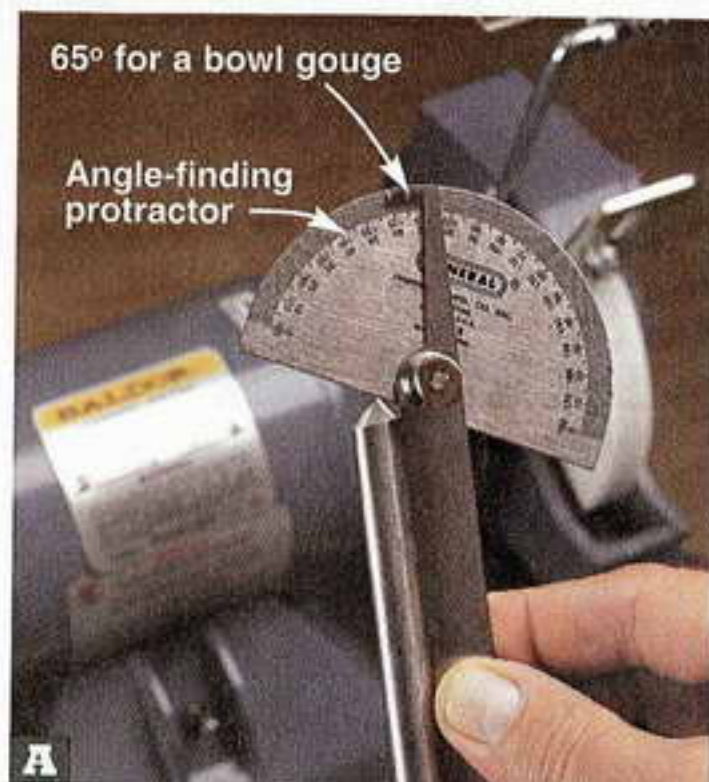

rest, position its leading edge about 1/8" from the wheel. Make all jig adjustments with the grinder stopped.

Setting up the jig

Note: Drawing 2 shows the various parts of a bowl gouge tip. Although the geometry of spindle and roughing gouges is different, the parts have the same names. Adjusting the Wolverine Jig to help you grind the angles described in the next section is easy. First, set an angle-finding protractor to the desired angle, and compare the tool's existing bevel to it, as shown in **Photo A**. This helps you form a mental picture of where to grind away metal. Then position the tool in the appropriate rest with its bevel contacting the grinding wheel. Adjust the rest to grind the bevel to the desired angle, and grind just enough to start forming a bevel. Check the angle with the protractor, and adjust the rest as necessary. With a couple of tries, you'll be right on the mark.



Once you've established the proper bevels on your tools, you'll be able to match them to the grinding wheel when adjusting the jig, greatly speeding the process. Simply touch the bevel to the wheel, sight it from the side, as shown in **Photo B**, and make the necessary adjustments. To perfectly match an existing bevel to the grinding wheel, see the **Shop Tip**, above. Occasionally check your bevels with the protractor to keep the cutting edges within 2–3° of the angles shown on **Drawings 3–9**.

2 PARTS OF A BOWL GOUGE TIP

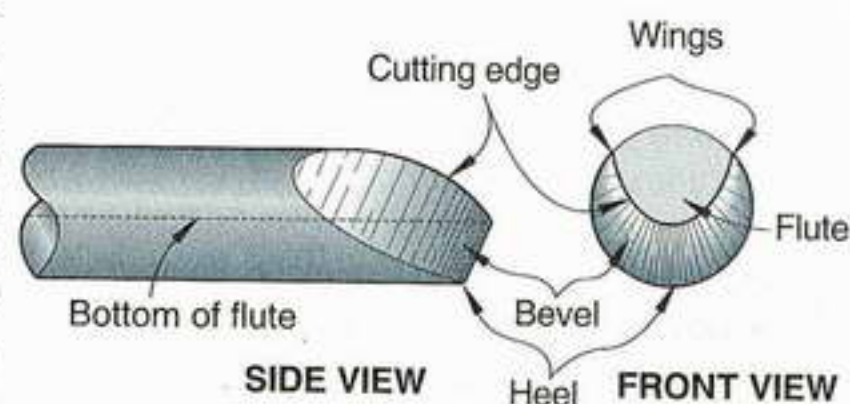

How to sharpen 6 basic turning tools

Roughing gouge

Position your roughing gouge with the end of its handle in the V-arm rest and its bevel on the grinding wheel. Adjust the V-arm to grind a 45° bevel, where shown on **Drawing 3**. Touch the roughing gouge's bevel to the wheel starting at the wing on one side of the flute. Roll the bevel across the grinding wheel all the way to the opposite wing in a continuous motion, as shown in **Photo C**. Maintain the 90° tip shown on the drawing.



3 3/4" ROUGHING GOUGE

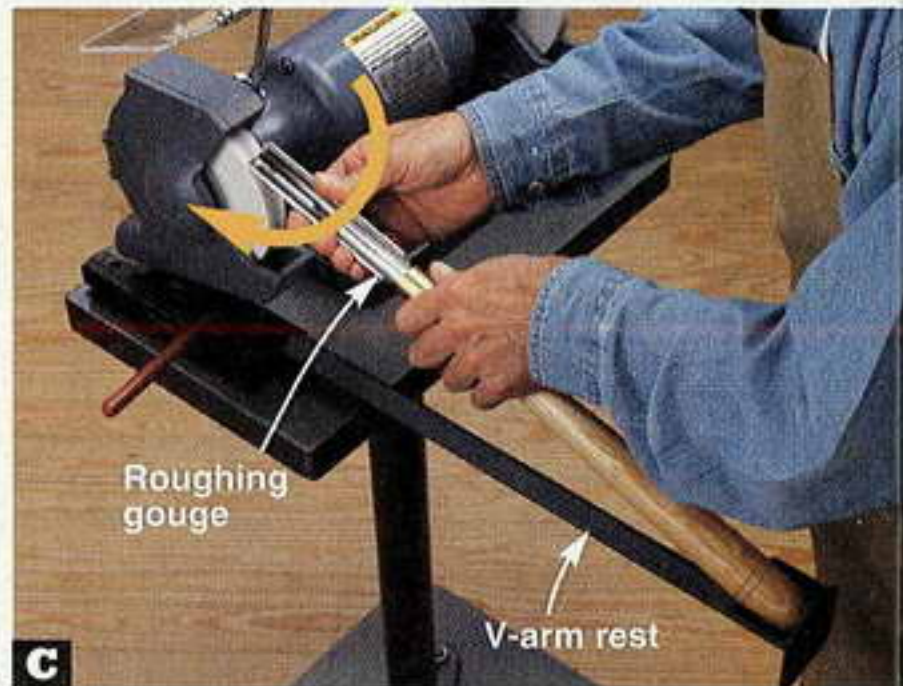
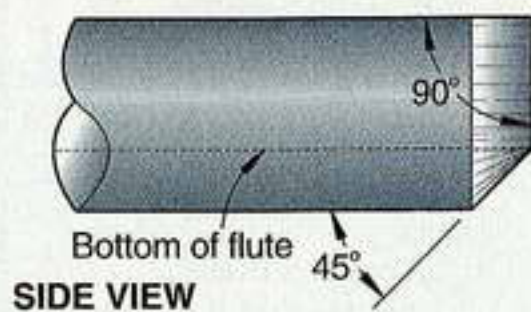

Bowl and spindle gouges

Bowl and spindle gouges come from the factory with a variety of grinds, some with limited uses and others not usable at all until they are reground. With more cutting edge and less chance of catching, a side grind on these gouges is becoming very popular. (In a side grind, the bevel extends back from the tip along the tool's side, in contrast to the "straight around" bevel on a roughing gouge.) Because of the wide range of motion required, this grind takes a lot of practice to execute freehand. Fortunately, the Vari-Grind Attachment for the Wolverine Jig makes it possible with little practice.

To sharpen bowl and spindle gouges, clamp the tool in the Vari-Grind Attachment with 1 3/4" protruding, as shown in **Photo D**. Place the attachment's leg in the V-arm rest, and touch the tool's tip to the wheel. Adjust the rest and the angle of the leg to grind the bevels shown on **Drawings 4** and **5**. With the grinder off, touch the tool's bevel to the wheel, and practice moving the tool from side to side to get comfortable with the motion needed to successfully sharpen your gouges. Now switch on the grinder, and gently touch the tool to the wheel, rolling it from side to side, as shown in **Photos E** and **F**.

Roll the bowl gouge far enough to each side to grind the flute's wings back about 1/2-3/4" from the tool's tip, as shown on the drawing. Examine the bevel from the side. Look for a smooth, slightly convex profile, shown on **Drawing 6**. A slightly concave profile leaves the flute's wings protruding beyond the center of the cutting edge, making the gouge prone to catching in your work. Correct a concave profile by removing more material from the wings and the heel.



4 1/2" BOWL GOUGE

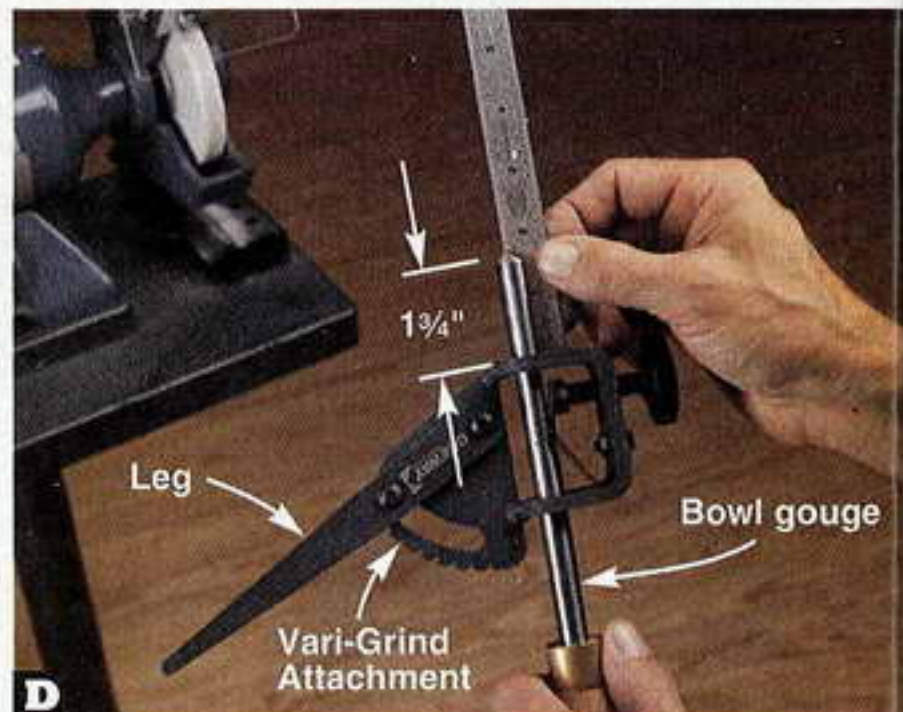
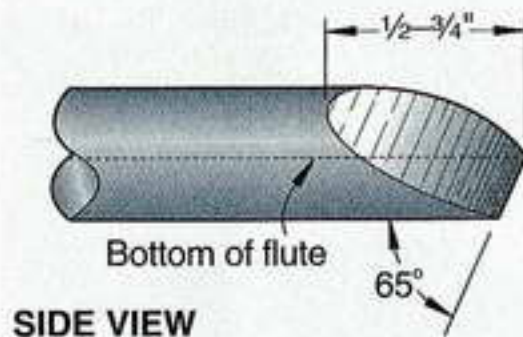

5 3/8" SPINDLE GOUGE

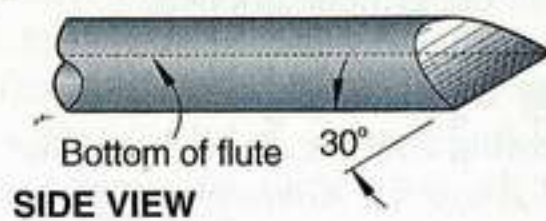

6 BEVEL SHAPE

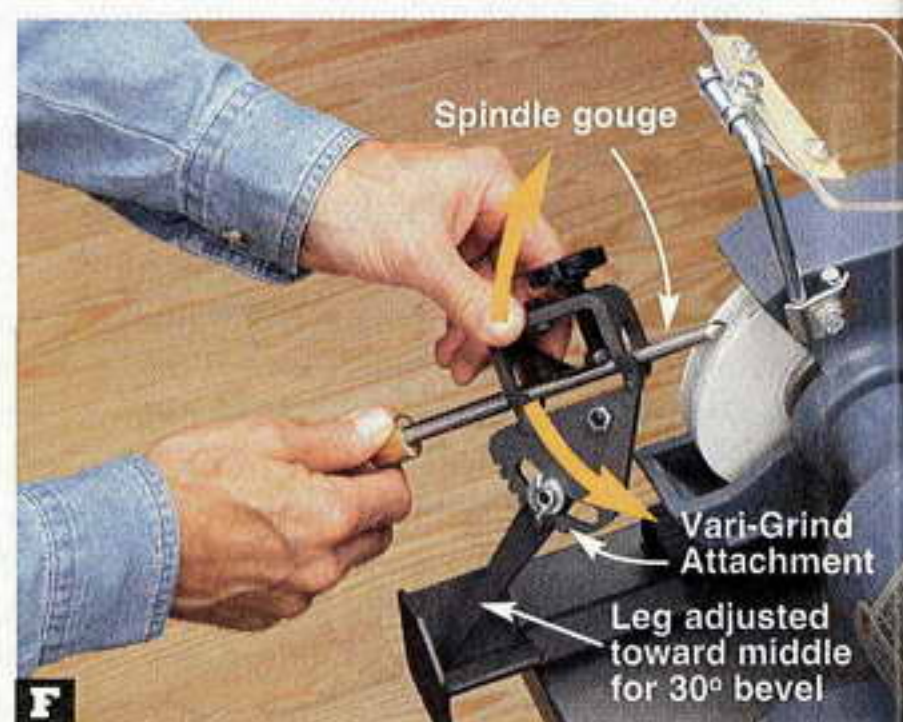
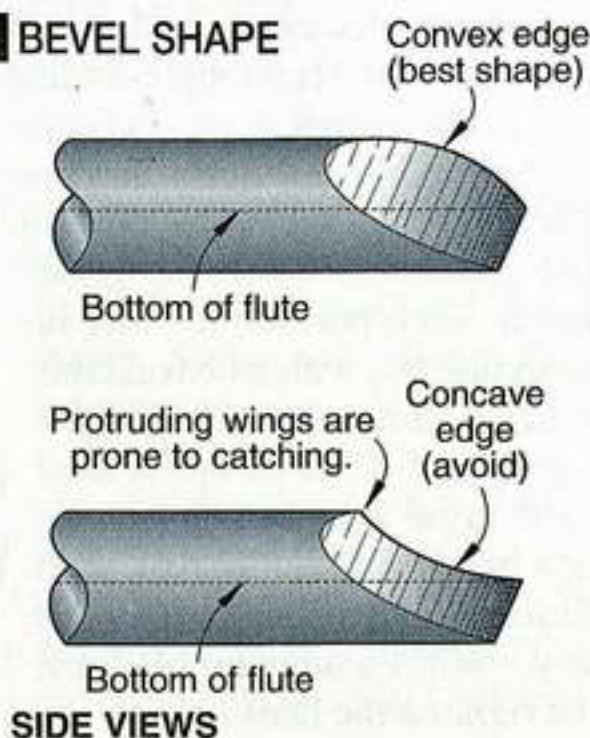

shop-proven products

These woodworking wares passed our shop trials

DeWalt challenges Forrest saw blades

A couple of years ago, DeWalt engineers set a goal to topple the king of clean tablesaw cuts—Forrest Manufacturing's Woodworker II 40-tooth general-purpose blade—and to do it for half the price. After testing the new DeWalt DW7657 blade, I can tell you that they hit their price goal but fell just a little short on the performance side.

Starting with a brand-new blade from each manufacturer, I established a baseline for smoothness by ripping a 2' length of 1¾"-thick maple with each blade. Out of the box, the Forrest produced a very smooth cut, ready for gluing; DeWalt's cut wasn't quite as smooth, and I would still joint it before gluing.

Next, I wanted to see how each blade would cut after losing some of its factory sharpness, so I accelerated the dulling by ripping ipe—a tough-as-nails exotic wood. Alternating between the maple and

ipe, I gauged the sharpness by observing changes in the amount of feed pressure I needed to apply.

The Forrest blade seemed to dull a bit faster than the DW7657, requiring more feed pressure with each subsequent cut. However, the cuts made in maple by the Forrest blade felt slightly smoother at each equivalent cut than those made by the DeWalt.

When crosscutting red oak, it was a dead heat between the two blades—tear-out on the bottom of the board and at the blade exit was minimal. In oak plywood, the DW7657 caused a little more fuzzing along the cut edge than the Forrest.

Still, I was impressed with the DeWalt DW7657's performance, especially given its \$52 price tag (about half the cost of

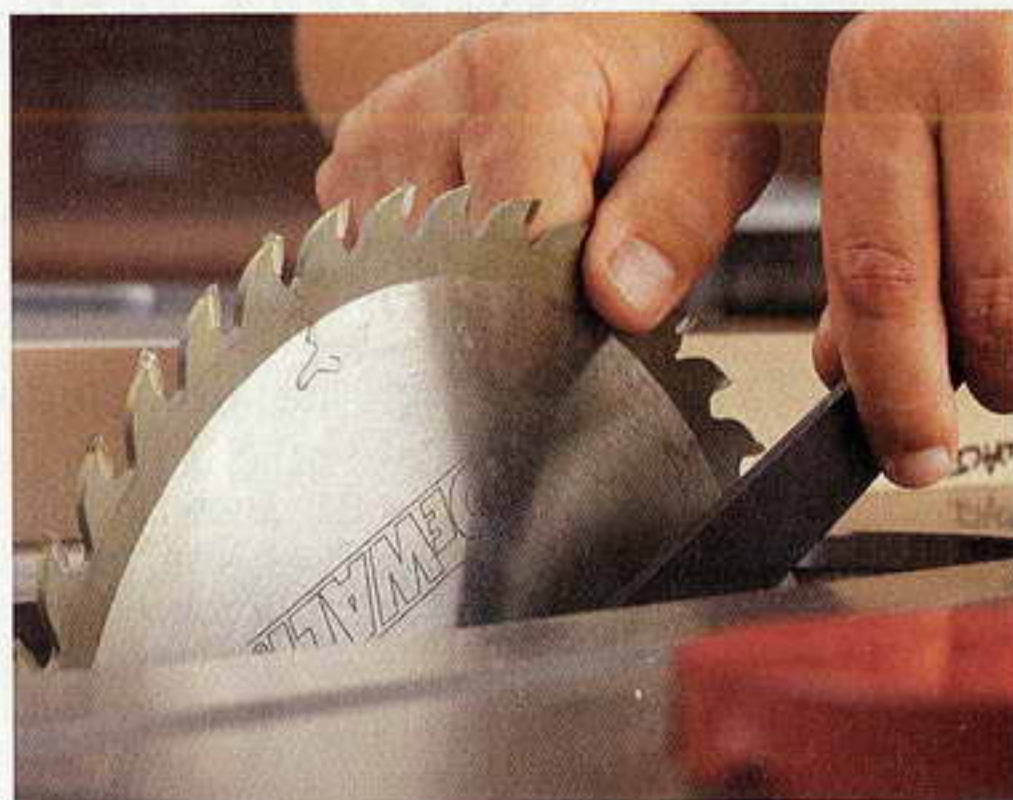

the Forrest Woodworker II). I've used blades that cost much more that didn't equal the cuts of this blade.

—Tested by Jeff Mertz

DeWalt DW7657 40-tooth general-purpose tablesaw blade

Performance ★★★★★
Price \$52

DeWalt
800/433-9258, www.dewalt.com

Two-bit Gizmo32 bores shelf-pin holes fast

If you've ever bored shelf-pin holes for adjustable shelving in a bookcase or cabinet, you know how difficult it is to keep those holes aligned and consistently spaced. One hole, misaligned just a fraction of an inch, makes the difference between a tippy shelf and one that's rock solid. Gizmo32 idiot-proofs the process.

When chucked into a handheld drill, Gizmo32 bores two 5mm holes at a time, 32mm (about 1¼") apart. Before drilling the first pair of holes, I adjusted the tool's fence for the proper setback from my case front, and then set the internal depth stop to ½" to prevent drilling all the way through the case side.

After drilling the first pair of holes, I slid Gizmo32 down the workpiece until the retractable index pin dropped into the last hole. With the fence still snug against the workpiece, I bored another pair of holes, slid down to the last hole again,

and repeated, working my way all the way down the case side. All of the holes were perfectly spaced and perpendicular, as if they'd been drilled on a drill press with a step-and-repeat jig.

Gizmo32 works just as well in cases and cabinets that are already assembled, thanks to its completely reversible fence and adjustable height locators (not shown). If needed, the fence moves around to the end of the jig, where it can be used to consistently locate mounting holes for drawer slides.

If you're wondering about the metric dimensions, this accessory was designed to work with European-style cabinet hardware, which is based on 32mm spacing. Here in America, ¼" shelf pins are more common than 5mm pins. Gizmo32 converts to ¼" drill bits, if you prefer to go that route.

—Tested by Kevin Boyle



Gizmo32

Performance ★★★★★
Price \$70

Allen Field Companies
631/756-0810, www.allenfield.com

Continued on page 102