

8 PROJECTS FOR YOUR HOME AND SHOP

Better Homes and Gardens®

WOOD

SEPTEMBER 2003 ISSUE 150

The Shop-Proven Woodworking Magazine

9 PROVEN WAYS TO BUILD FURNITURE THAT LASTS p. 80

MAKE PERFECT CUTS EVERY TIME

Our review of alignment tools shows you how p. 74

CRAFT THIS HEIRLOOM CURIO CABINET p. 58



HOW TO MASTER WIPE-ON FINISHES p. 12

www.woodonline.com

Display until September 2, 2003



U.S.A. \$6.99

WOOD®

September 2003, Issue 150

PROJECTS

- 10 on-wall saw-blade rack
- 44 scrollsawn bears puzzle
Use our full-size patterns and your scrapwood to bring this charming family to life.
- 52 bird's-eye maple occasional table
- 58 lighted showcase
Learn four valuable techniques while building this handsome sliding-door display cabinet.
- 70 turned keepsake box
- 86 cook's kitchen combo
Make one or both of these problem solvers that include the oven-tested pizza peel and matching spatterproof cookbook holder, p.88

TECHNIQUES

- 12 wipe-on finishes
Discover the secrets for topcoating projects using these oil and varnish products.
- 38 glass-smooth polyurethane finish
- 40 fancy flutes in five steps
- 42 just-right joinery: haunched tenons
- 54 two ways to make perfect circles
- 80 how to win over wood movement
Discover nine strategies for keeping projects intact when wood expands and contracts.

TOOLS & MATERIALS

- 66 display lighting lowdown
Before building another display cabinet, check out these illumination options.
- 74 precision tune-up tools
Align the cutters, fences, and gauges of power tools for better workshop results.
- 92 dado set showdown
Cut crisp dados, grooves, and rabbets with one of these 15 shop-tested models.
- 96 5 shop-proven products

FEATURES

- 16 regional woods
Find a new woodworking wood where you live.
- 26 lasered enhancements
Let light cut and engrave your next project.
- 46 hollywood spin
Learn along with actor William H. Macy as he turns thin-walled bowls with a pro.

DEPARTMENTS

- 4 editor's angle
- 6 sounding board
- 20 shop tips
- 30 ask WOOD
- 35 short cuts
- 36 wood words
- 112 what's ahead in our next issue



58



70



88

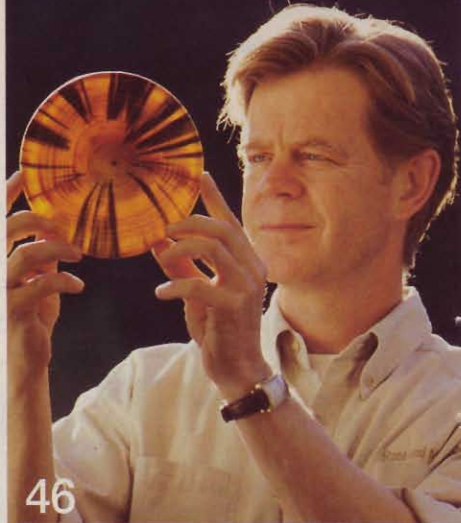

46



52



54



This seal is your assurance that we build every project, verify every fact, and test every reviewed tool in our workshop to guarantee your success and complete satisfaction.

Visit our Web site at www.woodonline.com for free woodworking plans, tips, shop tours, and more.

solving woodworking's deepest mysteries

Woodworking, by its nature, is a journey of discovery. We start with a stack of boards, follow a plan, and learn a great many things as we transform that rough stock into something beautiful, functional, and appreciated. Making this issue of *WOOD* was much like that, as we tackled a number of woodworking quandaries. Here are just a few.

Like you, our staff enjoys a woodworking challenge, one that really gets the creative juices flowing.

Take for example the following:

Mystery 1. *How do you design a full-size curio cabinet with an unobstructed view and easy access to its contents?* For Senior Design Editor Kevin Boyle, the answer was a sliding, full-view glass door, as shown on page 58.

Of course, many solutions create new mini-mysteries. For example, how do you mount the curio cabinet's three mechanical slides perfectly parallel to each other? And where do you find a supplier willing to sell three slides? Master Craftsman Chuck Hedlund and Projects Editor Owen Duvall solved both questions.

Mystery 2. *What's the best type of lighting for a cabinet?* Until now, the answer was "Who knows?" That's why Projects Editor Jan Svec took it upon himself to test nine cabinet lights. As you'll see on page 66, Jan found big differences in the performance of the various products. Consider his article a must-read before you buy another cabinet light.

Mystery 3. *What can you do with all of those wood scraps that build up in your shop?* To help out, we've developed a new column called "Scrapwood Projects." See the first installment on page 44.

Mystery 4. *What do Hollywood stars do when they're not making movies?* Okay,

so maybe this isn't a woodworking mystery, but we nevertheless thought it would be fun to visit with actor William H. Macy, who freely admits to going into his workshop at times and not coming out for 12 hours. So, Features Editor Dave Stone, turning wiz Phil Brennon, and I spent a day with Macy in his shop. See Dave's report on page 46.

I've always been a big fan of Macy's movies, so I'm happy to report that in person he's a humorous, down-to-earth, family-man kind of guy. In other words, just another woodworker, much like you and me.

Bill Krier



Making shavings: From left, me, Phil Brennon, William H. Macy, Dave Stone, and Charlie Hulien (Macy's friend) solved a few turning mysteries in our day together.

Editor-in-Chief **BILL KRIER**
Executive Editor **JIM HARROLD**
Managing Editor **MARLEN KEMMET**
Features Editor **DAVID STONE**
Products Editor **DAVE CAMPBELL**
Projects Editor **JAN SVEC**
Projects Editor **OWEN DUVALL**
Techniques Editor **JIM POLLOCK**
Senior Design Editor **KEVIN BOYLE**
Design Editor **JEFF MERTZ**
Master Craftsman **CHUCK HEDLUND**
Production/Office Manager **MARGARET CLOSNER**
Administrative Assistant **SHERYL MUNYON**
Illustrators **LORNA JOHNSON, ROXANNE LeMOINE, TIM CAHILL, MIKE MITTERMEIER**
Technical Consultants **JEFF HALL, GARRY SMITH, JOHN CEBUJAR**
Contributing Craftsman **JIM HEAVEY**
Proofreaders **JIM SANDERS, BARBARA KLEIN**
Art Director **KARL EHLERS**
Associate Art Director **GREG SELLERS**
Assistant Art Director **CHERYL A. CIBULA**
Publisher **MARK HAGEN**

Advertising Office: 333 N. Michigan Ave., Suite 1500, Chicago, IL 60601 Phone: 312/853-2890 Fax: 312/580-7906
Sales and Marketing Assistant **NEILLE MORRIS**
Account Executive **BON GOLMINAS**
Direct Response Manager **CAROLYN DAKIS**
Direct Response Sales Representative **SANDY ROBINSON**
Account Executive **JOHN THORNBURGH**
Detroit, Phone: 248/356-1149 Fax: 248/356-8930
Account Executive **PAT TOMLINSON**
Northeast, Phone: 212/551-7043 Fax: 212/551-7192
Southeast: Lagomarsino, Dempsey & Dennis, Inc. 2951 Piedmont Rd., NE, Suite 100, Atlanta, GA 30305
Phone: 404/261-5400 Fax: 404/261-5404

Group Marketing Director **CATHY E. SMITH**
Senior Marketing Services Manager **ALEXANDER D. CLARKSON**
Phone: 212/551-7090 Fax: 212/551-7192
Senior Promotion Designer **SARAH DIBELLA**
Group Publisher **STEPHEN B. LEVINSON**
Associate Business Director **CRAIG FEAR**
Advertising Operations Manager **PAT HENDERSHOTT**
Consumer Marketing Director **JULIE MARTIN**
Vice President/Publishing Director **WILLIAM R. REED**

MEREDITH PUBLISHING GROUP

President **STEPHEN M. LACY**
Magazine Group President **JERRY KAPLAN**
Group Sales **MICHAEL BROWNSTEIN**
Creative Services **ELLEN DELATHOUDER**
Manufacturing **BRUCE HESTON**
Consumer Marketing **KARLA JEFFRIES**
Finance and Administration **MAX RUNCIMAN**



WILLIAM T. KERR, Chairman and Chief Executive Officer
In Memoriam — E.T. Meredith III (1933-2003)

©Copyright Meredith Corporation 2003
All rights reserved. Printed in the U.S.A.

Better Homes and Gardens® *WOOD*® magazine (ISSN-0743-894X) is published seven times a year in March, May, June/July, September, October, November, and December by Meredith Corporation, 1716 Locust St., Des Moines, IA 50309-3023. For subscription questions call 800/374-9663. Letters to Editor: *WOOD* magazine, 1716 Locust St., GA-310, Des Moines, IA 50309-3023, or woodmail@mdp.com. Periodicals postage paid at Des Moines, Iowa, and additional mailing offices. *Better Homes and Gardens* trademark registered in Canada and Australia. Marca Registrada en México. **ONE-YEAR SUBSCRIPTION PRICES:** U.S. and its possessions, \$28; Canada, \$41; other countries, \$49. Canada Post Publications Mail Sales Product Agreement No. 40069223. Canadian BN 12348 2887 RT. **CANADIAN RETURN ADDRESS:** *Better Homes and Gardens* *WOOD* magazine, 2744 Edna Street, Windsor, Ontario, N8Y 1V2. **POSTMASTER:** Send address changes to *Better Homes and Gardens* *WOOD* magazine, P.O. Box 37439, Boone, IA 50037-0439.



sounding board

Our bulletin board for letters, comments, and timely updates

Another round of woodworking witticisms from "the rookie"

At the end of his first year as a woodworker, Scott Spencer of Rochester, N.Y., shared his insights on the hobby in issue 145, page 6. Now at the end of his second year, Scott is still learning the ins and outs of woodworking. We got a kick out of his latest observations, and thought that you would, too. Here they are:



Woodworker Scott Spencer develops his skills designing and building projects for his family.

- Advising another "newbie" increases my knowledge of woodworking, but not necessarily theirs.
- Five cheap tablesaw blades cost about the same as one good blade, but they sure don't cut as well.
- Five cheap tablesaw blades cost a lot more to sharpen than one good blade, and they still don't cut as well.
- My second tablesaw should have been my first tablesaw.
- I need "downtime" after "relaxing" in the shop.
- You can more easily justify the cost of a dust collector if you factor in the savings on tissues.

- Sawdust is no longer a novelty.
- A measurement of $\frac{1}{16}$ " sounds small but looks really big on furniture.
- I learn a new word with every woodworking technique.
- A belt sander equipped with 60-grit paper can create a divot faster than a golf club.
- All tape measures definitely are not created equal.
- Obtaining some tools is worth incurring the wrath of my spouse.
- Many woodworkers will tolerate criticism of their hand tools, but most get pretty defensive about their tablesaw.
- On average, every other project I complete is for the shop or storage of woodworking reference material.
- I can produce a curve in a perfectly straight board by running it across a perfectly tuned jointer.
- I spend the vast majority of my time in the shop either rubbing my chin or scratching my head.
- Sometimes I peek into the shop just to look at the tools.
- Three sheets of cheap sandpaper last about as long as one good sheet.
- There is no "payback" for kickback.
- Murphy must have been a woodworker before he became a lawmaker.
- I go through "postpartum depression" when a project is done.

Accolades for the Arts & Crafts lamp

I liked the looks of the Arts & Crafts lamp in issue 148 so much that I made two, and ordered the hardware kits to complete them. I built mine just like yours, except that I put some leftover veneer on two faces of each post so I'd have quartersawn grain showing on all four faces.

Our front room is full of Gustav Stickley reproduction pieces, and the lamps look like they belong there. I am very pleased with the way they turned out, and wanted to let you know. ♣

Ron Warman, Topeka, Kan.



HOW TO REACH US

■ Editorial questions and feedback:

Send e-mail to woodmail@mdp.com; call 800/374-9663 and press option 2; or write to WOOD magazine, 1716 Locust St., GA-310, Des Moines, IA 50309-3023.

■ Subscription assistance:

To notify us of an address change, or to get help with your subscription, go to woodmagazine.com/service; call 800/374-9663 and press option 1; or write to: WOOD magazine, P.O. Box 37439,

Boone, IA 50037-0439. Please enclose your address label from a recent magazine issue.

■ To find past articles:

Go to our continuously updated online index at woodmagazine.com/index.

■ To order past issues and articles:

Order past issues of WOOD magazine and our newsstand specials at woodstore.woodmall.com, or by calling 800/346-9663. Be aware that many early

issues are sold out. For reprints, send \$5 per article (no phone orders), including the article name and issue number, to: WOOD Article Reprint Service, P.O. Box 349, Kalona, IA 52247; make check or money order payable to WOOD magazine.

■ Updates to previously published projects:

For a complete listing of known changes in dimensions and buying-guide sources from issue 1 through today, go to woodmagazine.com/editorial.

protect-and-serve blade rack

Keep your blades sharp, safe, and ready for action with this wall-mounted system.



This accommodating holder keeps saw blades easily accessible, separated, and protected from damage. In addition to storage slots for standard blades, it also makes room for a complete 8" stacked-dado set. Dowel pins provide a place for dado shims, a blade stabilizer, wrenches, and throat plates. The rack handles blades from 7 1/4" to 10" in diameter.

Start by cutting the 3/4 x 7 1/2 x 29 1/2" back to size. (If you want to store more blades, add 2" to the length for each additional slot.) Now drill the screw and dowel holes.

Next, cut the 3/4 x 3 x 29 1/2" sides. Using double-faced tape, temporarily join them together face-to-face. This lets you lay out and machine both pieces identically.

Drill a 1/2" hole through both sides to hold the dowels you'll add later. Lay out and cut the radiused corners. Mark the locations of the 1/4" starter holes for the slots, and then mark the slot locations. Drill the starter holes, and cut the slots using a bandsaw or jigsaw. Cut just inside the lines, and then sand the slots smooth using a piece of 1/8" hardboard wrapped in 100-grit sandpaper. Also sand off the sharp points on each slot, where shown.

To complete the rack, screw the sides to the back, and glue in the dowels. Add a coat of clear finish, and mount the holder to the wall by driving 3" screws into a stud. 🐿

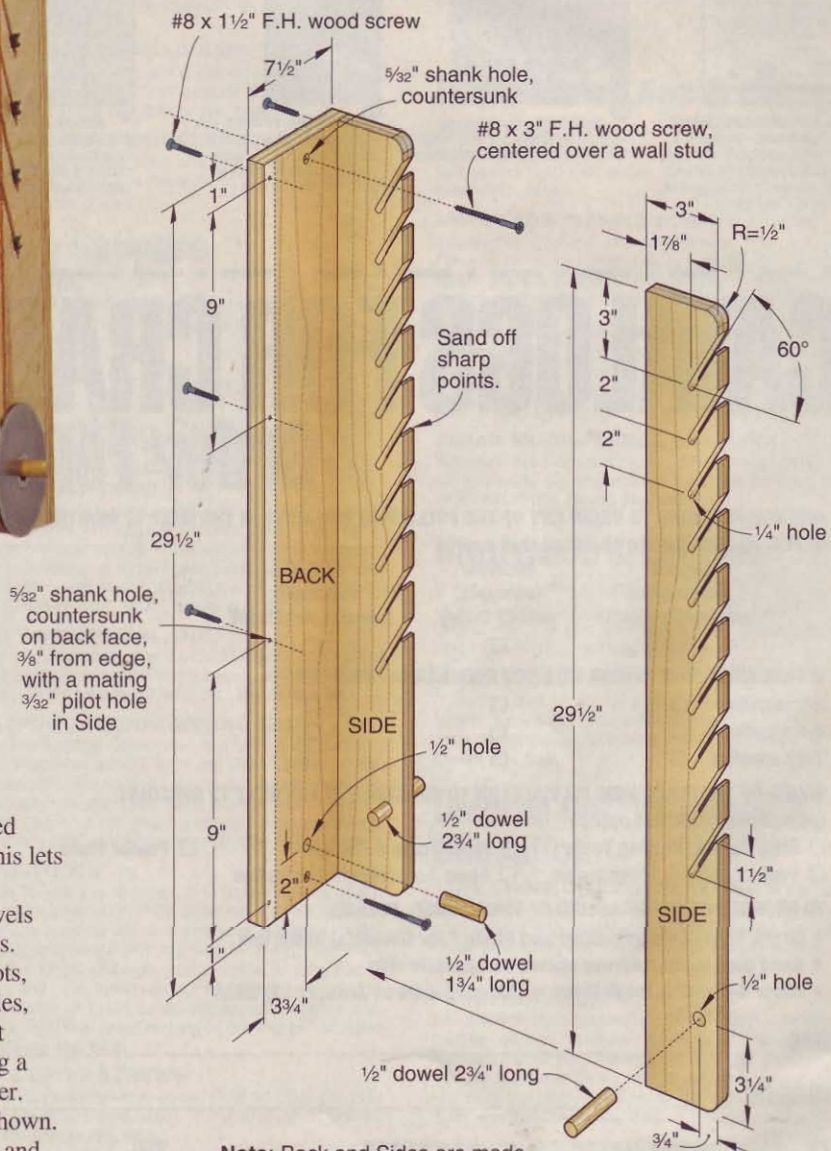

Note: Back and Sides are made from 3/4" birch plywood.

wipe-on finishes

an easy way to a great-looking topcoat

To create a surface free of runs, sags, and brush marks, consider wipe-on finishes. Once you get comfortable with them, you may never clean a brush again. Here's what you need to know.

Understand the breed

When you shop for these finishes, you'll find only a few labeled as "wipe-on." Examples include Minwax Wipe-On Poly and Wipe-On Arm-R-Seal from General Finishes. But other products apply the same way, though you'd never know it without closely examining the label.

Many of these others bear names that imply they are oils, such as Watco Danish Oil Finish, Minwax Antique Oil, and Deft Deftoil. None of these finishes, however, is 100 percent pure oil.

No matter how they're named, you'll find by reading the label that all of these products wipe on, and all do contain either tung or linseed oil. They combine oil with other ingredients to create either an "oil/varnish blend" or a "wiping varnish." Read "Wipe out confusion," on page 14, to learn how they're blended.

Identify what you have

Before you use a wipe-on finish, you need to determine whether the product is an



Pour a few drops of the finish in question onto a piece of glass, and then let it dry overnight. If the finish wrinkles, left, it's an oil/varnish blend. A smooth surface, right, indicates a wiping varnish.



oil/varnish blend or a wiping varnish. A simple test, *below left*, will tell you.

If you're shopping for a finish, check the label. It won't likely say what type it is, but clues exist. Oil/varnish blends are labeled "finish" most of the time. Also, the "Danish" oils are all oil/varnish blends.

The words "wipe-on" or "varnish" often identify a wiping varnish, as does the presence of mineral spirits as an ingredient or as the recommended solvent.

Preserve a natural feel

Most woodworkers strive to maintain wood's natural texture. Oil/varnish blends do this especially well because their oils penetrate the wood fibers. In fact, blends look and feel almost like a pure-oil finish.

A wiping varnish builds to a thicker, glossier film. This will mask the wood's natural texture if you build up enough coats (more than about six), but also gives the wood a greater amount of protection against damage and moisture.

Note: Beware of pure-oil products, such as raw tung oil or raw linseed oil. They give wood a natural feel, but never dry, and can remain tacky for weeks and even months. Pure tung oil may turn white if you apply too many coats. Boiled linseed oil contains metallic driers, but doesn't build well with successive applications.

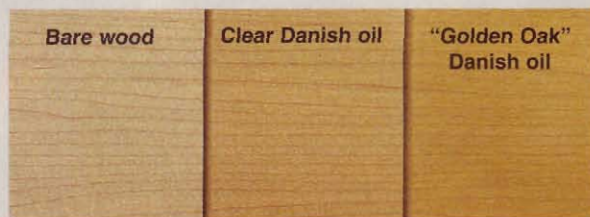

This maple board shows clearly Danish oil's natural amber tone, and the results of adding pigments with the oil.

Create the perfect color

Many times, of course, you'll want to accentuate wood's natural color. Wipe-on finishes impart a warm amber tone that brings vibrancy to the grain, as seen in the photos *top* and *below*. The wood's color does change slightly, but in a familiar, inviting way.

To add color to the wood, use an oil/varnish blend premixed with pigments, such as Watco Danish Oil, as shown, *above*. Or, make a custom color by adding an oil-base stain to an untinted finish.

Continued on page 14



Bring walnut instantly to life with deep color and eye-popping grain by applying a coat of wipe-on finish. On large surfaces, a foam brush works better than a rag.

Add layers to build luster

Applying wipe-on finishes is easy. For either type, start by saturating the bare wood using a rag or, on large surfaces, a foam brush. Let the finish stand, and check after a few minutes for areas that have dried. Recoat where needed to dampen the entire surface.

With an oil/varnish blend, wipe off any excess finish after about 15 minutes. Check in a couple of hours and wipe off any finish that bleeds out of the pores. Let the finish dry for 12 to 24 hours.

Recoat an oil/varnish blend only after the first coat dries thoroughly, and stop adding coats when another application no longer improves the sheen (the shininess of the surface). Usually two or three coats will do.

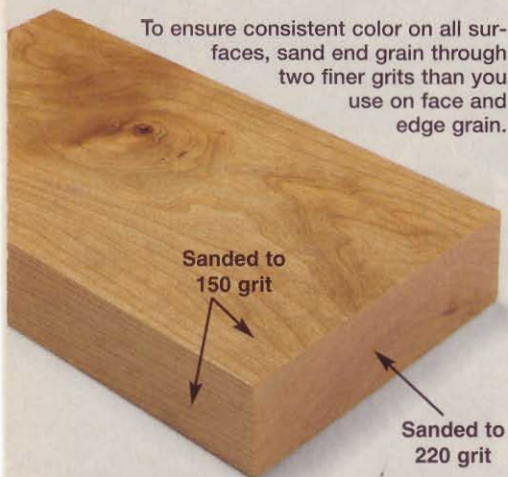

Applying the first coat of wipe-on finish brings wood to life, but don't be disappointed when it dries and goes flat. Adding another coat or two builds sheen and color.

If you're using a wiping varnish, start by saturating the surface, as previously discussed. Spread any excess finish evenly, and then let it dry (usually 6 to 10 hours) rather than wiping it off. Lightly roughen the finish using 220-grit sandpaper, 0000 steel wool, or a fine synthetic steel wool pad. Then add two to three more coats (sanding between coats), stopping when you achieve the sheen you desire.

End grain requires special attention when using wipe-on finishes. Because the pores are open, end grain can soak up more finish, causing it to take on a darker color than edge and face grain. Prevent this by sanding end grain to a finer grit than you use on the other surfaces, as shown, *left*.

When you should not use a wipe-on finish

A wipe-on finish isn't ideal for every situation. Oil/varnish blends look great, but offer little protection against scratches, dents, and moisture. Wiping varnishes combat damage better, but build up in

very thin coats. That means they require many applications to create a surface that will stand up to wear and tear.

For tabletops, dining chairs, floors, or other heavily used surfaces, opt for a brushed- or sprayed-on varnish, such as polyurethane. You'll get a thick, durable film in just two or three coats. 🌲

Written by David Stone

Wipe out confusion

You'll commonly find four types of wipe-on finishes. Here's a look at each one:

■ **Raw linseed oil:** One of the oldest wood finishes around, raw linseed oil offers little protection because it remains soft after curing, which takes several days. Adding metallic driers creates "boiled" linseed oil, which cures in about a day, but imparts no more protection.

■ **Raw tung oil:** This finish offers a natural look, some water resistance, and darkens the wood less severely than linseed oil. Tung oil cures in a couple of days but remains soft. Tung oil remains a woodworkers' favorite, but performs best when used as an ingredient in varnish (see the note, *below*), or when blended with varnish.

■ **Oil/varnish blends:** This is a mixture of conventional varnish and pure oil. The oil reduces the glossiness of the sheen, and makes the finish easier to apply than varnish, thanks to the slower drying time of the oil.

■ **Wiping varnish:** This type is simply conventional varnish thinned with mineral spirits for easy application.

Note: Varnish and wiping varnish contain oil, but only as an ingredient. Varnish combines oil (tung, linseed, or safflower) with natural or synthetic resins, such as polyurethane. Heating the mixture causes the oil and resin to combine chemically, creating a new substance: varnish.

Make a home brew

With so many wipe-on finishes to choose from, you'll probably find one you like right off the shelf. But you can easily make your own.

To make an oil/varnish blend, mix equal parts of oil-base varnish, tung or boiled linseed oil, and mineral spirits, as shown, *left*. You can alter the mixture to suit your need. More oil increases penetration and color, and slows drying. Additional mineral spirits speeds drying and decreases the thickness of the film. Increase the quantity of varnish to create a thicker film.

Making a wiping varnish is even simpler. Just mix conventional varnish with an equal amount of mineral spirits.



Combine your ingredients in a glass jar, working in a well-ventilated area. Keep your mixture stirred as you use it.

regional woods

Too often, we rely on commonly available woods to build projects when great local species may grow as close as our own backyard!

Want to make your next project really unique? Instead of relying on common species, such as oak or pine, look around your neck of the woods. You'll find many species, both hardwoods and softwoods, that offer great woodworking properties. To locate them, inquire at local sawmills and tree services, or stroll around your property.

If you find a tree or log, but don't have a way to saw it, call Wood-Mizer at 800/553-0182, or send an e-mail through its Web site: www.woodmizer.com. You'll be supplied with the name of someone in your area who can bring a portable sawmill to the log's location.

We hunted up several uncommon but worthy regional woods you might want to try. Many more exist, of course, but, for now, we'll leave that discovery up to you.

Species roundup

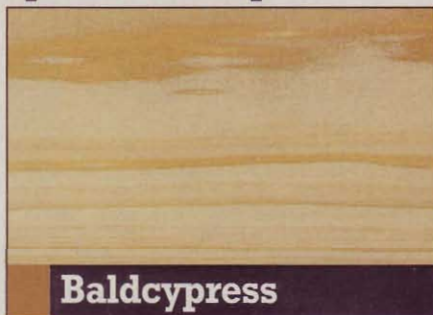

Baldcypress

Along the Gulf Coast, up the Eastern Seaboard, and through the Mississippi River valley, the baldcypress (*Taxodium distichum*) thrives, with trees reaching heights of more than 100'. Their broad, buttressed trunks produce great quantities of lumber. Some outlets even stock sinker

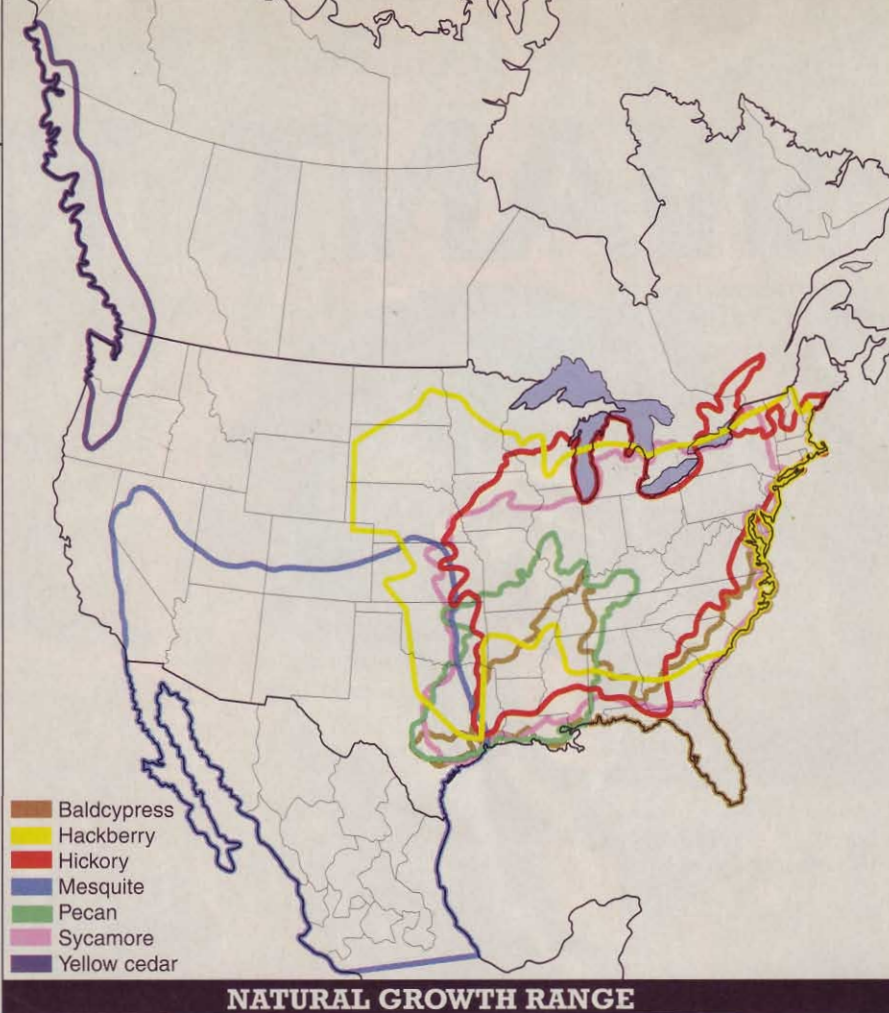

cypress—boards milled from fallen old-growth logs that have been salvaged from rivers and swamps.

If you're building outdoor projects, cypress is a great choice, thanks to its natural resistance to decay. It offers superb workability, too. And don't overlook the wood for furniture. It has a prominent but appealing grain, and features a beautiful yellow to medium-brown color. In its range, cypress carries a reasonable price.



Hackberry

Growing across much of the eastern United States and southeastern Canada, the hackberry (*Celtis occidentalis*) grows to about 50' tall, with a 2-3' trunk. It yields a pale-yellow to greenish-yellow

sapwood and heartwood that's light brown with dark brown and yellow streaks.

The wood's coarse but straight grain sometimes exhibits cross-grain rays. It machines and carves well, glues effectively, finishes easily to an attractive color, and takes stain well.



Hickory and Pecan
(HICKORY SAMPLE SHOWN)

Like many nut-bearing trees, hickory and pecan (*Carya* spp.) draw their reputations more from the food they produce than from their wood. These close cousins, which are relatives of the walnut, though, produce similar-appearing lumber that is renowned for its excellent strength, elasticity, and toughness. Both woods feature

Continued on page 18



WOODCRAFT
UNIVERSITY

There's a
Woodcraft University
location near you

Alabama

Birmingham Area

Arizona

Tempe
Tucson

California

Sacramento
San Francisco Bay Area
Santa Rosa

Colorado

Colorado Springs
Denver

Connecticut

Hartford Area
New Haven Area

Florida

Clearwater
Casselberry

Georgia

Atlanta Area

Hawaii

Honolulu

Idaho

Boise

Illinois

Palatine
Peoria

Indiana

Evansville
Indianapolis

Iowa

West Des Moines

Kansas

Lenexa

Kentucky

Louisville

Maryland

Towson

Massachusetts

Woburn

Michigan

Canon
Sterling Heights

Minnesota

Bloomington

Missouri

St. Louis Area

New Hampshire

Portsmouth Area

New Mexico

Albuquerque

New York

Rochester

North Carolina

Charlotte Area
Raleigh

Ohio

Cincinnati Area
Cleveland Area
Columbus Area
Dayton

Oklahoma

Tulsa

Oregon

Eugene
Portland Area

Pennsylvania

Harrisburg
Philadelphia Area
Pittsburgh Area

Rhode Island

East Greenwich

South Carolina

Charleston

Tennessee

Knoxville

Texas

Austin
Dallas Area
Fort Worth
Houston
San Antonio

Utah

Salt Lake City Area

Virginia

Richmond
Washington D.C. Area

Washington

Seattle

West Virginia

Parkersburg

Wisconsin

Appleton/Fox Cities Area
Madison
Milwaukee Area

Woodworker's Club:

Connecticut

Norwalk

Maryland

Rockville

WOODCRAFT[®]

For your local woodcraft store,
visit www.woodcraft.com,
or for a free catalog, call
800 542-9115

Dept.03WI09BE

Circle No. 927

wide world of **wood**

straight and coarse grain. A medium-brown hue marks hickory, while pecan sports a lighter tone.

Two types of hickory grow in a broad range across the eastern United States, while pecans grow in the lower Midwest and South, through Texas. All varieties can grow to around 100' tall. Some pecans produce 6'-diameter trunks.

Of the two, hickory ranks as a top choice for makers of wooden handles, and, increasingly, for cabinetmakers. Pecan trees undergo far less commercial milling because they hold more value as producers of nuts.

These woods dull tools, so keep an eye on your cutting edges and sharpen as necessary to maintain clean cuts. Patience and effort yield rewards, though, of beautiful color and a lustrous shine.



Mesquite

Unless you hail from Texas or the Southwest, you may know mesquite (*Prosopis glandulosa*) only as a wood that flavors your charcoal-grilled food. In fact, this scraggly tree, which rarely reaches beyond 20–50' tall, bears beautiful wood.

Naturally durable mesquite has long been used for fence posts and even railroad ties. In recent years, though, woodworkers have begun taking notice. Cocoa-brown hues color mesquite heartwood; the sapwood is creamy yellow. Coarse, interlocking grain filled with black flecks accentuates these colors, producing a rustic but refined look.

Most mesquite boards are short and narrow, and often bear bark inclusions and worm infestations. These areas, though, provide character, according to some woodworkers, who fill them with black epoxy rather than cut them out. The wood can be stubborn to machine, but glues well; finishes to a high shine; and takes on a deep, mellow look over time.

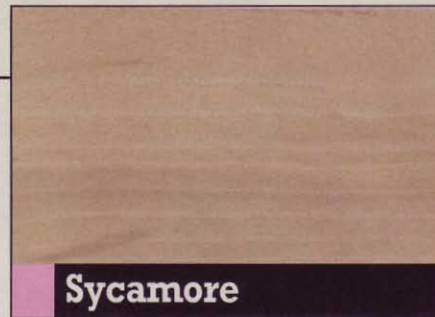

Sycamore

From the Atlantic coast westward into Nebraska, sycamore (*Platanus occidentalis*) trees are common. They vary in size from 60' to 120', with shaggy-barked trunks up to 5' across.

The wood has long been a favorite for producing butcher blocks, and finds its way into boxes and baskets, too. Its tan to medium-brown color and irregular grain give it an attractive appearance. While it has some tendency to tear out, the wood turns reasonably well. Woodworkers are beginning to discover this wood's beauty, especially the eye-catching quartersawn variety, which they snatch up for showy parts of some projects.

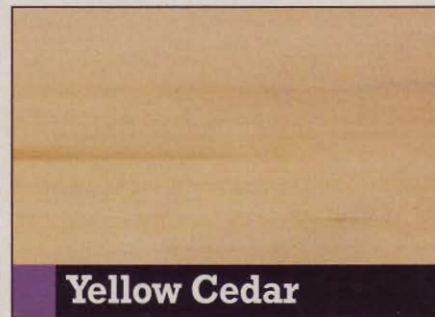

Yellow Cedar

Also known as Alaska cedar, this wood (*Chamaecyparis nootkatensis*) grows in the Pacific Northwest, from Oregon through British Columbia, and into Alaska. The trees reach 80–100' tall, often with no branches for 30' or more. Though a softwood, it is hard and dense, with tight rings indicative of its slow growth. Little of the wood gets harvested live—most of the supply comes from deadfalls and driftwood.

Native Americans of the region understood yellow cedar's value, using it to produce many things, including strong, lightweight, and decay-resistant canoe paddles. Today, instrument makers and boatbuilders prize the wood. Yellow cedar's color ranges from creamy white to sulfur yellow, with occasional dark streaks. The wood machines beautifully, glues and stains well, and develops a satiny sheen. 🌲

shop tips

Helping you work faster, smarter, and safer

Two steps to perfect-size dados

If you use a stacked dado set on your table-saw or radial-arm saw, you know the nuisance: You install what you hope is the perfect combination of blades, chippers, and shims. Then, on your test cut, you find the fit isn't quite right with the mating workpiece so you have to do it all over again—perhaps several times—to get a perfect fit. Here's how to get an accurate dado the *second* time, every time.

First, stack the blades and chippers to get close to the right width without going over. Next, insert enough dado shims to ensure that you'll make an oversize cut. Then, cut a test dado in scrapwood.

Now, test the fit with the mating workpiece or a scrap of the same thickness. (The fit should be loose.) Remove the dado set from your saw, keeping close

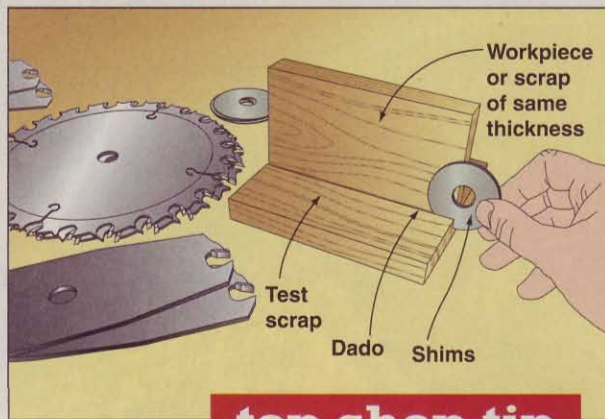

top shop tip

track of the shims that you remove from the stack. Insert some of those shims between the workpiece and one wall of the test dado, as shown above, until you get a satisfactory fit.

Finally, reassemble the stacked set, this time without the shims that you used to "tighten up" the test cut. The dados you cut now will fit the workpiece perfectly.

—Joe Hurst-Wajszczuk, Westminster, Colo.

A woolly tip from Down Under

Before applying a French-polish finish to a gate-leg drop-leaf table, I buffed the



top with 000 wire (steel) wool. Although I blasted off the leftover bits of wire wool with compressed air, I wanted to be absolutely sure I'd removed it all before applying the finish.

So, I found a big magnet from an old radio speaker and waved it over the table just a few millimeters above the surface. To my surprise, the magnet pulled heaps of wire bits off the tabletop that could have ruined my finish.

—Syd Rostron, Perth, Australia

Editor's note: You'll spend less time picking steel-wool fibers off the magnet if you use a releasing-canister magnet like the one shown in the drawing. Pulling the handle on top of the canister releases the fibers so they simply drop off. You'll find such a magnet at home centers for about \$10.

Continued on page 22

Our Winner

So, you think it's a struggle getting things done in your shop? Joe Hurst-Wajszczuk's shop shares a single 20-amp circuit with three other garages in his townhouse complex. Not only that, but this is the third garage he's occupied since moving to the complex a few years ago. "My neighbors kept complaining about all the noise," Joe chuckles. In spite of the hassles, he seems like a happy guy, and a pretty clever woodworker if his Top Shop Tip, at left, is an indication.

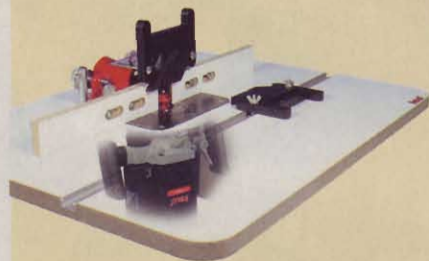

For submitting this issue's Top Shop Tip, Joe Hurst-Wajszczuk wins a Freud router-table kit that includes a 3-hp router and fence. Way to go, Joe!

Top tips win top tools!

Describe how you've solved a workshop dilemma, and you'll earn \$75 if it appears here. And, if your tip garners Top Shop Tip honors, you'll also win a tool prize worth at least \$250.

Send your best tips, along with photos or illustrations and your daytime telephone number, to: **Shop Tips, WOOD® Magazine, 1716 Locust St., GA-310, Des Moines, IA 50309-3023.** You also can e-mail tips to shoptips@woodmagazine.com, or post them on the Top Shop Tip forum at www.woodonline.com.

Because we try to publish only original tips, please send your tips only to WOOD magazine. Sorry, but submitted materials can't be returned.

Quick-change system for benchtop tools

Benchtop real estate in my shop is at a premium, so I can't afford to dedicate permanent space to tools that I use infrequently, such as a grinder, mortiser, or belt/disc sander. Yet, when I do use those tools, I want them securely mounted for safety. So, I came up with a quick-change system that addresses both concerns.

I first found a common mounting-board size that works with all of my benchtop tools, and then cut a 3/4"-thick piece of plywood for each tool. On one of these boards, I test-fit each tool to determine the best locations for the three mounting slots, and used a 3/8" straight bit to rout the slots leading to each location in each board.

Next, using one of the slotted mounting boards as a guide, I marked the locations for the mounting holes on my benchtop, drilled holes for each 5/16"-18 brass threaded insert (part no. 3607-BI from McFeely's, 800/443-7937 or

www.mcfeelys.com), and installed the inserts. You also can buy the studded T-knobs (part no. JKD-3114) from McFeely's.

—Scott Warnecke, Findlay, Ohio

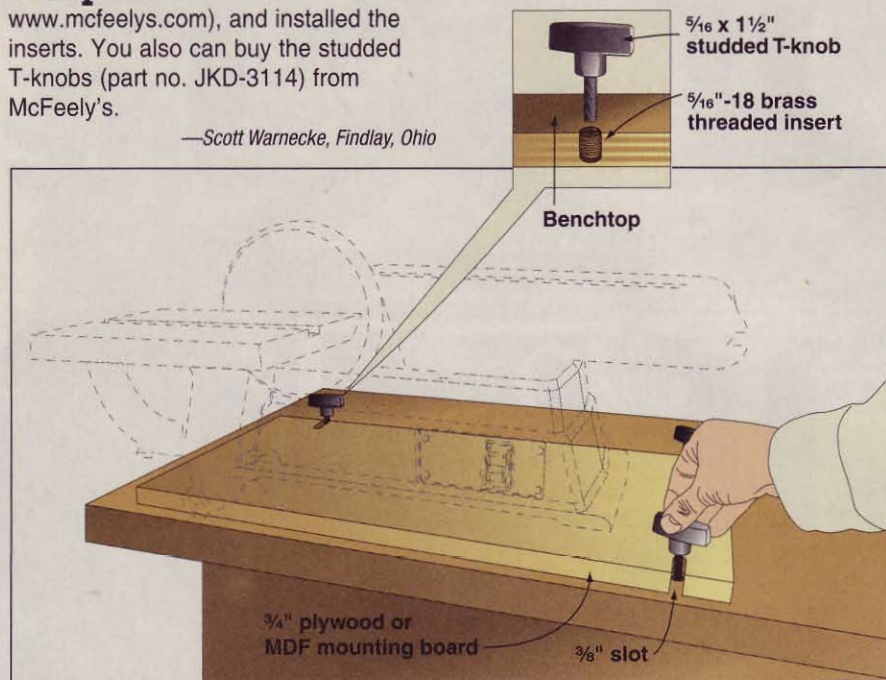

Quality, performance & value set us apart!

CMT's most popular bit sets are the perfect choice for your fall projects



Set with cove profile: 800.515.11 • Set with ogee profile: 800.520.11



Cove profile: 800.517.11
Ogee profile: 800.521.11

All sets include a Raised Panel Bit with Back Cutter

You don't have to make your living working with wood to demand professional performance and quality from your tools. And with CMT's value-packed Sommerfeld Cabinetmaking and Raised Panel Sets, you can put the finest router bits in your shop no matter how you make your living! These sets include CMT's famous orange* Teflon®-coated bits, with super-sharp, super-durable micrograin carbide edges, perfectly balanced shanks and bodies, and complete instructions that let you start on your project right away. Visit a CMT Distributor today for great deals on the world's finest router bits, and learn first hand what sets CMT apart from the crowd!

*the orange color on tool surfaces is a registered trademark of CMT Utensili, S.p.A.

Circle No. 180

Get the full story about CMT bits, blades, cutters and more. Ask your CMT distributor for your free 2003 catalog, or contact CMT for a catalog and the name of a distributor in your area.

CMT USA, Inc. • 307-F Pomona Drive • Greensboro, NC 27407 • 888-268-2487 • www.cmtusa.com



World's longest hook rule

Hook rules (precision rulers with a hook on one end similar to a retractable tape) make it easy to measure accurately from the end or edge of a workpiece. However, I've not seen a hook rule that will work across a 48" sheet of plywood, so I made my own.

I plugged one end of a 4' length of aluminum square tubing with a block of wood and attached a fender washer, as shown below. I then applied a pair of self-adhesive measuring tapes to the sides of the tube: one reads from left to right, and the other from right to left. (\$10 each, part nos. 08Y41 and 08Y42, from Woodcraft. Call 800/225-1153, or visit www.woodcraft.com.)

My new super-long hook rule is absolutely flat and makes a great straightedge for laying out long cuts, slots, and dados

—Harry Dubetz, Alexandria, Va.

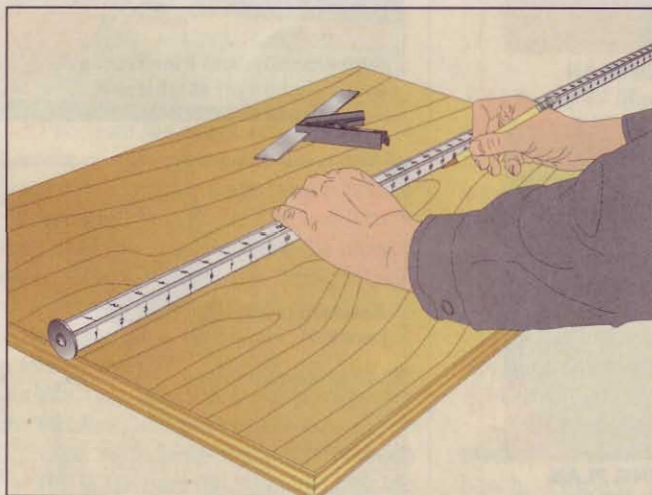
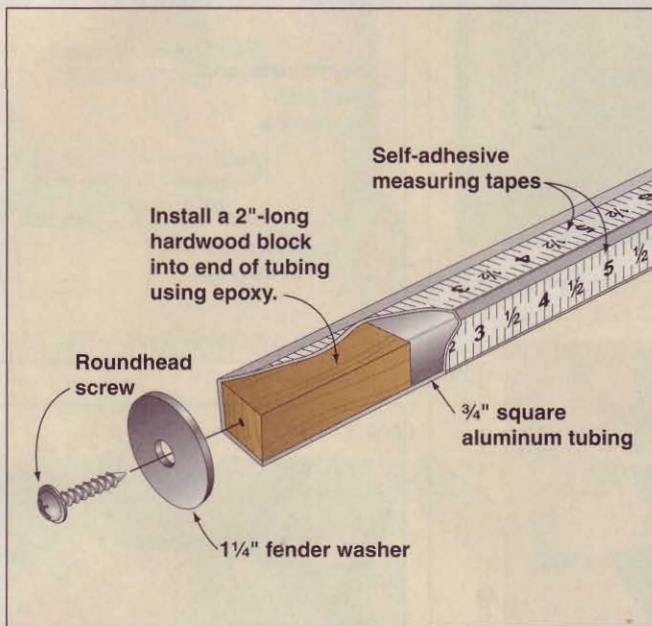

Continued on page 24



MY WAX... BRIWAX

YOUR PROJECTS DESERVE
THE FINEST FINISH IN THE WORLD!

BRIWAX can be used as a convenient one-step finishing process to make all your projects look their best. With 8 colors from which to choose, once you discover the BRIWAX difference you will join countless other professionals who declare "My Wax... BRIWAX".

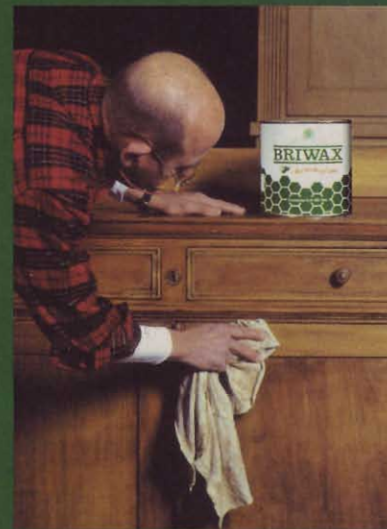
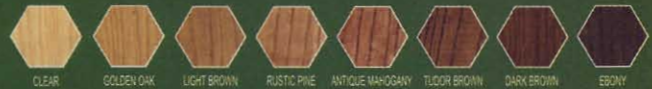

A Natural Blend of
Carnauba Wax
and Beeswax

Perfect for
Furniture
Antiques
Cabinets
Flooring
Paneling
And More...

AVAILABLE IN
CLEAR & 7 SHADES

Call For A Free Sample



www.briwax.com

or Call: 1-800-5BRIWAX

ASK ABOUT OUR SPECIAL OFFERS

Circle No. 55

Unique Woodworking Kits

800-847-4947



Authentic Wagon
\$109.00*
*(58.00 shipping, USA)



Buckboard Bench
\$49.00*
*(56.00 shipping, USA)



Wheelbarrow
\$59.00*
*(55.00 shipping, USA)

We offer many build-it-yourself kits: buckboard bench, irish mail handcar, wheelbarrows, halltree, sleigh, baker's cart, garden cart, & park bench. All kits come with complete hardware, detailed instructions and full size patterns.

Items shown:

1901 Buckboard Wagon

Measures 36"x16"x18" Tall

Build your 1901 wagon with these authentic looking plastic wagon wheels, which are very sturdy and look great.

Buckboard Bench

Measures 42"(long) x 22"(wide) x normal seat height

Authentic reproduction seats two adults comfortably. Great for indoors or on the patio.

Antique Wheelbarrow

Measures 56"(long) x 24"(wide) x 29" Tall

Build this nostalgic Antique Wheelbarrow, for use in your backyard or a display piece.

- All Items Shipped UPS
- All Items US currency required
- Indiana Sales add 6% sales tax

Many More Items Available!
Call for Catalog: 800-847-4947

The Roundbush Company
PO Box 348

Star City, IN 46985

Visa & Mastercard Accepted

www.woodkitsandplans.com

The Radial Arm Mill Router (RAMR)

For radial arm molding
 * Architectural window moldings
 * Round and oval picture frames
 Perfect dados
 Louvers
 Mortise and Tenon
 Milling soft metals
 Pin routing
 And a coaxial mounted table router

Think
 safety



PLEASE visit our large web site dedicated to Radial Arm Milling Routers:
www.tenfingerscorp.com

Pricing:
 Upper Radial Arm Mill Router and table top: \$750, with table but no elevator \$850. Same as above with the table router elevator: 1,095.

ROUTERS NOT INCLUDED



Ten Fingers Corp.™
 1-866-458-9673 (toll Free)
www.tenfingerscorp.com

Patents Pending

shop tips

Man on a mission-style mission

One of the factors that distinguishes a quality piece of mission furniture from another is the joint between the slats and rails. Typically, you'd cut a groove in the rails, then install the slats in the groove with spacers in between, then sand like the dickens to flush the spacers to the rails. The result often isn't very pretty.

But it doesn't have to be that way. If you follow the three-step process shown below, you'll find yourself sanding less and enjoying building mission furniture more.

—Michael Hendricks, Colorado Springs, Colo.

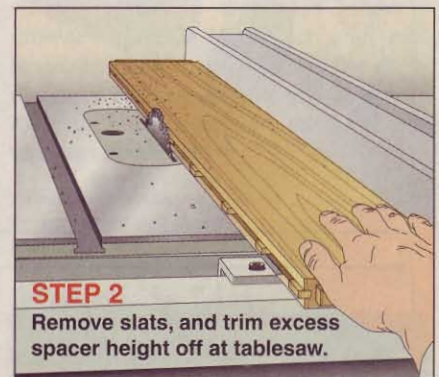
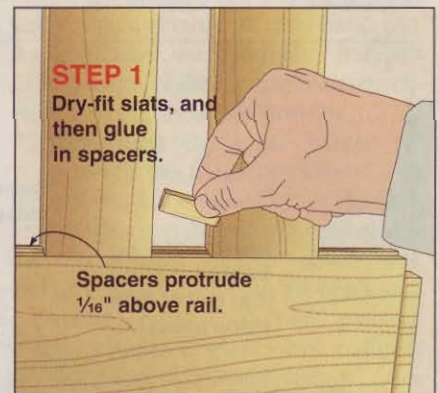

Better Homes and Gardens.

WOOD PLANS

from the editors of **WOOD** magazine
 Circle No. 459



WACKY WITCH PLAN
 47" tall OFS-1055, \$13.95



WAYWARD WITCH PLAN
 48" tall OFS-1065, \$13.95



GHOSTLY GATHERING PLAN
 32" tall OFS-1057, \$13.95

TO ORDER, CALL TOLL FREE: 1-888-636-4478

Detailed woodworking plans tested in the WOOD® magazine shop. WD150

Have a Coke and a dust shield

My router didn't come with a dust shield around the base, so every handheld routing operation created a blizzard of chips on my clothes. When I sat down with a soft drink to ponder a solution, I suddenly found it right before my eyes.

I sliced a 2"-wide strip of clear plastic from near the bottom of the 2-liter soda bottle, cut it to cover the opening in my router, and secured it to the machine with a stout rubber band, as shown. (It helps if you first make a paper pattern, especially if you have to fit the new "window" around handles or other obstructions.)

—Russell Dieter, Omer, Mich.

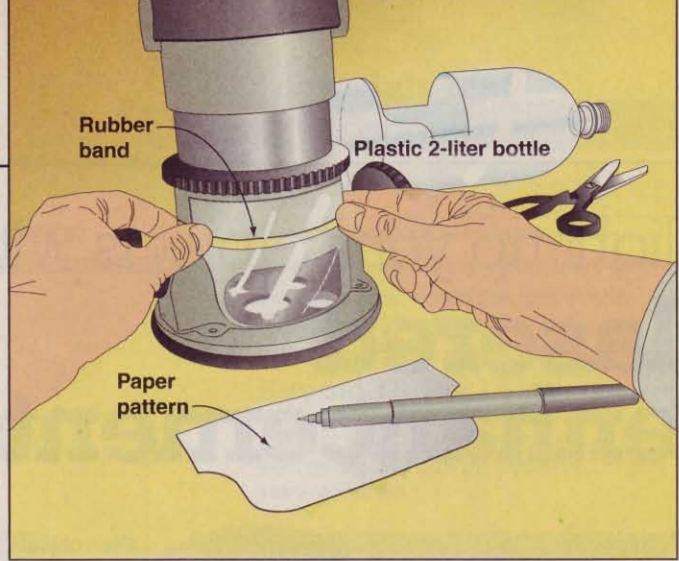

Raised-panel cleanup cuts made easy

When routing raised panels using a large-diameter bit, you'll cut safer and cleaner if you remove the bulk of the waste in one roughing pass, then make a dead-on cleanup cut. Typically, you do this by moving the fence back or raising the bit between cuts, but here's a simpler way that even works with curved or arch-topped panels.

Using a starting pin in your router table and the bearing that comes with your raised-panel bit, perfect the cutting depth in scrapwood. Now, without changing anything else, replace the bearing with a slightly larger bearing and make the roughing cut on your workpiece. Reinstall the original bearing and make your final cleanup cut.

—Warren Johnson, Matthews, N.C.

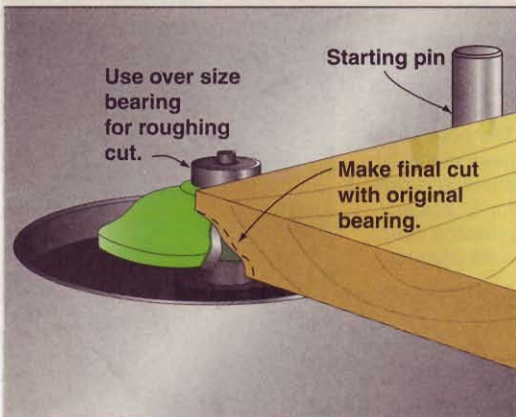

See a new . . .

...shop tip daily at
www.woodmagazine.com/tips



Dust-Free Sanding

Eliminate hazardous dust BEFORE it becomes airborne

Airborne dust is now being recognized as a major health hazard. Imagine sanding in a dust-free environment, where 98% of the dust created by sanding is contained.



How It Works

Dust produced by sanding is immediately sucked away through holes located in the sandpaper, the bottom of the sanding pad, AND around the outside edge of the pad (a FEIN exclusive). The extracted dust is contained by a powerful vacuum.

Unbeatable Finishes

When you sand with normal sanders, your sander ends up riding on a bed of dust and broken abrasive. With the FEIN Sanding System, this "bed" of dust doesn't exist. Your paper cuts faster, cleaner, and lasts up to 10 times longer.

Automatic Vacuum

When you turn your FEIN sander on, the vacuum starts. When you switch your sander off, the vacuum stops....automatically. The FEIN Turbo II Vacuum is built to handle large amounts of super-fine dust.



For more information and a dealer near you, call 1-800-441-9878 or visit us on the web at www.feinus.com

light up your projects with lasered enhancements

You've probably seen laser-engraved or laser-cut wood in gift shops and on signs, but have you ever considered including such laser work into your projects? The good news is you don't have to own an expensive laser to do so.



Even objects as small as drawer pulls can undergo customized laser-engraving.

company's laser engraver. The end result: dead-on replicas of the patterned part, as shown *below left*.

On other occasions, Josh had Mike engrave an heirloom crib and wood pulls (*left*) to give drawers he had made a distinctive, personalized look. For him, contracting laser-engraving and -cutting had become a habit.

Work for hire

Because owning a low-end laser-engraving machine like the one in "No ordinary copier" (*page 28*) will set you back \$14,000 or more, we thought we'd look into Josh's approach of contracting customized laser piecework. We quickly discovered that you can find laser-engraving and -cutting services widely available in every state. We found 38 in Iowa alone. (Go online to ARA.org, and click "Locate a dealer" to contact the laser engraver nearest you.) Most, but not all, cut and engrave wood, as well as other materials such as glass, plastic, and metal.

We also found the cost for a single engraving or cutout quite reasonable. According to Mike, "An 8x10" engraving from a cleanly rendered illustration, or a 4x6" photo, which we would scan into the laser engraver, runs \$30."

Laser-cutting costs depend on the number of pieces required; the thickness of the wood and overall dimensions of the pieces; and the intricacy of the design, especially if it needs additional setup time. Mike's charge for a 1/4x3x12" applique, such as the Victorian samples, runs \$5, with the price per piece dropping with increased volume.

WOOD® magazine reader Josh Brower of Burbank, South Dakota, wrote to us proclaiming his joy over incorporating laser-engraving and laser-cutting into his arsenal of woodworking wizardry. Josh's business, The Wood Works, specializes in architectural design and restoration. When faced with the task of recreating 50 identical applique's for a high-Victorian home in Denison, Iowa, Josh contracted with a business friend, Mike Driscoll of Lamars, Iowa, to cut out the applique's using his

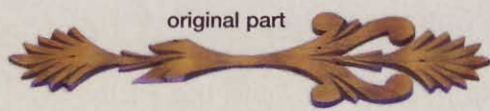

original part



laser-cut blank (above) and duplicate part



Rather than scrollsaw 50 identical applique pieces for a home restoration, Josh Brower saved time by having them laser-cut. He carved the new pieces to match the originals.



Laser-cut precision marquetry in contrasting woods helped create this veneer assembly, making it ideal for adhering to box lids or tabletops.

Now that you know about it, what do you do with it?

Applications for laser-cutting and laser-engraving run the gamut from adorning small objects to embellishing cabinet doors (depending on the machine's capacity), and everything in between. For tips on achieving stellar results, see "Laser pointers" on *page 28*.

As demonstrated by the examples sprinkled throughout this article, laser work excels at both decorating and personalizing woodworking. Among this bounty of accent work are adding words in a desired

Continued on page 28

As a test, we had this photo laser-engraved on red alder. The precise likeness and 3-D shading make for a unique, pleasing keepsake plaque.



typeface; precise duplication of graphic images (either illustrations or photos); the creation of fancy inlays and appliqué's (onlays); and the cutting of marquetry pieces, box joints, scrollsaw patterns, and super-accurate router templates. Machines with an optional rotary attachment can also cut and engrave cylindrical objects, such as turned pens and vessels.



A photo keepsake box lid becomes more meaningful with an attractive, laser-engraved palm tree and place name.

When you meet with a laser-engraving service, provide your workpieces, which can be a length of solid wood, an edge-joined panel, a mitered frame, a lid, or some other piece of woodworking. Discuss your design interest, which may include images you bring, artwork the service may already have on hand, or something entirely new that you develop together. Finally, settle on a price and production deadline, and wait with anticipation for the finished product. Chances are, you'll come away impressed. 🌲



Laser engravings—both small and shallow, and large and deep—adorn this raised-panel door.



No ordinary copier

Like a copy machine, a laser engraver, *above*, duplicates a graphic image in wood, acrylic, plastic, leather, and other materials by either cutting or engraving it with a laser beam. The basic model shown here, Epilog's Legend 24TT, can engrave or cut an area up to 12×24". (More expensive Legend models go up to 20×32".) Graphic images, clipart, CAD files, or photos are first scanned into a Windows-based computer connected to the laser engraver. Software allows the operator to size and locate the image on the workpiece using grid coordinates. Adjustments made to the power and speed of the laser beam, along with the contrasts in the image, determine the depth of the cutting and engraving. For more on this machine, call 888/4EPILOG, or visit www.epiloglaser.com.

Laser pointers

Ready to incorporate laser engravings in your projects? Keep these important pointers in mind:

- **Tight and light-grained woods work best.** Common engraving woods include red alder, cherry, birch, maple, and sometimes walnut, an exception to the rule. Avoid engraving or cutting common plywoods because of voids and the reactions of some glues when laser-heated.
- **When planning an engraving**, take into account the wood-grain patterns and joint lines of the workpiece, working around them so they don't detract from the end result.
- **The maximum thickness of wood cut with a laser beam** depends on the wattage of the engraver. A 25-watt laser

can cut stock up to 1/4" thick, whereas a 100-watt laser can cut stock up to 1/2". The slower the cut due to thickness, the greater likelihood the wood will catch fire. An air-assist pump, an accessory on some machines, helps cool the cutting area, thereby limiting this problem significantly.

■ **Ensure that the graphic content you supply** your professional engraver is an uncluttered, well-composed illustration or photo. Clipart works fine, though the best results come from pen-and-ink drawings because of their high contrast. In many cases, the engravers will have in-house images that their own graphic designers developed for client use. Both high-contrast black-and-white photos and color photos reproduce well. With color photos, however, images are converted to a gray-scale likeness prior to engraving. It's in gray-scaling where a professional engraver can create subtle contrasts and depth for a 3-D look in some projects.

■ **Laser resolution, measured in dpi (dots per square inch)**, affects the engraved image's detail level. Go with low dpi for a grainier, more textured look; high dpi, for finer detail. Both have their place. Low-end engravers range from 150 to 1,200 dpi, giving you a wide choice.

- **Consider a laser over a scrollsaw for complex pattern cutting.** It executes cleaner, more accurate duplications, making it ideal for elaborate filigree work and puzzle designs.
- **Laser-cut wood, unless later painted**, will show a burn residue along the edges. You can remove it by sanding if you find it undesirable, but this can be a lot of work. You also can lighten an edge with a water-dampened cloth. To avoid soot from smudging surrounding wood surfaces during cutting operations, your engraver can mask over the work area using wet newspaper or easy-release painter's tape. In addition, he can focus the engraver's lens to reduce the laser-beam line thickness, resulting in more efficient cutting and less burning. A finer line also can provide you with tighter-fitting puzzle parts or precision clock gears.
- **Consider using colored wood fillers**, such as acrylic paint, particularly with dark woods like walnut, to enhance an engraving and to create a different look.
- **Apply clear finishes** to the workpiece prior to turning it over to a professional engraver. This eliminates the problem of soot getting into the finish. Lacquer yields the best results.

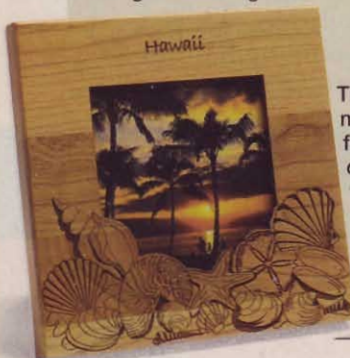

This seashore-motif picture frame consists of a slab of wood and a laser-engraved and -cut opening and place name.

ask wood

Answers to your questions from letters, e-mails, and WOOD ONLINE®

Grain holds the key to flat panels

Q: I need to glue up an oak tabletop, and want to make sure it not only looks good, but also stays flat. Should I use the widest boards I can find? And will it look better if they're all the same width?

—Steve Dee, Durham, N.C.

A: The key to a flat, stable oak panel, Steve, is not the width of the boards, but the orientation of their grain. In the photo at *right*, you see two 6" white oak boards. To build a tabletop, you would rip them as indicated, and use only the pieces with straight "rift" grain, which tends to be stable.

If you have a wide board that's all rift grain, rip it into 4" widths to relieve any internal tension. If the pieces remain reasonably straight, joint the sawn edges, and glue them together again.

The areas with more random markings contain flat grain, also identifiable by arcs in the end grain. It's much more likely to warp in a wide panel, but you can use it for smaller parts without problems. The narrower the part, the less you have to worry about wood movement.

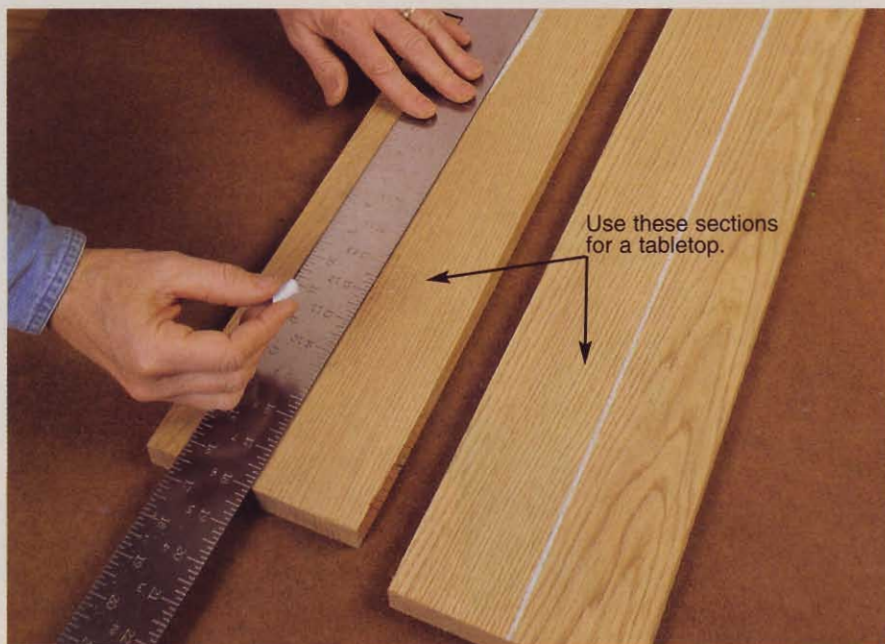

No matter how carefully you select lumber, you often need to rip a board to get the most out of it. To build a tabletop that will never warp, use only the straight-grain portions.

As you prepare to glue up your tabletop, take time to match the grain and color of your boards as closely as possible. When you make the joints nearly invisible, differences in board width don't affect the tabletop's appearance.

When you're using a species that rarely offers large areas of straight face

grain, such as cherry, maple, or walnut, the appearance of the face grain is likely to be your main concern. However, it's worth checking out the end grain for vertical lines, especially if you're building a hinged chest lid or some other kind of panel that won't be captured in a frame or held flat by fasteners.

When pieces slip, cut back on glue

Q: I've been trying to glue small pieces of wood, and they always slide out of position as I try to clamp them. How can I make them stay put?

—Larry Tkaczyk, Charlotte, Mich.

A: Larry, the key to this problem is to use the minimum amount of glue to do the job. Apply yellow glue to both of the mating surfaces, but only a thin coat. It doesn't take much glue to provide adhesion, and excess glue creates a cushion that allows the wood to slide.

After spreading the glue, rub the two pieces together quickly and firmly. This speeds the glue to its tacky stage, and produces a bond strong enough to hold small pieces in position as you proceed.

Now, use masking tape, rubber bands, or clamps to add light pressure to the joint. Avoid screw-type clamps, which can twist a small piece out of alignment as you tighten the screw.

You can get a good bond on a small, easily controlled area with just enough glue to coat both surfaces. You'll see little or no squeeze-out from this joint.



Continued on page 32

YOUR GARAGE IS YOUR CASTLE.

Give it the royal treatment with a **\$10,000 MAKEOVER.**

It's America's Ultimate Garage Contest. Win a \$10,000 garage makeover courtesy of Rust-Oleum® EPOXYShield®. Describe what your garage means to you, why you deserve a garage makeover, and what makes for an ideal garage, in 300 words or less. Then, include a color photo of the interior of your garage. The winner will receive "An Ultimate Garage Makeover" from a Home Depot® approved contractor. Included in your new look will be a showroom-quality floor protected with EPOXYShield Garage Floor Coating.

ONE GRAND PRIZE
\$10,000 Garage Makeover

ONE SECOND PRIZE
Trip to a continental US city

25 SEMI FINALIST PRIZE PACKAGES
EPOXYShield Garage Floor Coating Kits



RUST-OLEUM®

stopping rust is just the start.™

No purchase necessary. Contest is open August 1 - October 15, 2003, to legal U.S. residents ages 18 and over. Enter online at epoxyshield.com, rustoleum.com, homedepot.com, or mail entries, including first and last name, date of birth, address (including zip code), telephone number, color photograph of the interior of your garage and a description, in 300 words or less, of your ideal/ultimate garage and why you are most deserving of your dream garage. Mail entry in a stamped envelope to: America's Ultimate Garage Contest, P.O. Box 39101, Chicago, IL 60639. Entries must be postmarked by Wednesday, October 15, 2003. Void where prohibited. For official contest rules visit epoxyshield.com or homedepot.com.



You can do it.
We can help.

ask wood

How to take off old veneer . . .

Q: I'm replacing damaged, peeling veneer on an antique daybed, and one area refuses to come off. What's the best way to remove it?

—Ray Stigge, Mt. Pleasant, Iowa

A: To avoid creating new problems, Ray, it's usually best to rely on a sharp, wide chisel or scraper, as shown below, and lots of patience. Slice under the veneer bit by bit, leaving the substrate intact, smooth, and ready for new veneer. Always try this method first.

We have used another method that requires less elbow grease, but carries the risk of damaging the substrate. Dampen a

cloth, lay it on the veneer, and leave it there overnight. Then, your chisel or scraper should peel the veneer off much more easily. If that proves too slow, you can further loosen old hide glue with an iron on top of a damp cloth pad. (Most furniture made before the 1950s was made with hide glue.) Heat won't help if you're dealing with yellow glue, so if you're not sure about the type of glue, it's wise to experiment on a small spot before going further.

But remember: If too much moisture soaks through the old veneer, the substrate will warp if it's solid wood, or delaminate if it's plywood. Then you'll have to repair that damage before laying down new veneer.



Mark the damaged area of veneer, cut along the lines with a utility knife, and then scrape away the glue and veneer. The clean, smooth, squared-off area is ready for new veneer.

. . . and the best way to cut veneer

Q: Someone told me that a veneer saw is the right tool for cutting veneer. I've never heard of such a thing. What is it, and how is it used?

—Dave Findley, Omaha, Neb.

A: Shown at right is a veneer saw in action, Dave. Notice the offset handle, fine teeth with little set, and reversible blade. Add up those features, and you have a handy tool for making straight cuts in any thin veneer you might buy. Rely on a metal straight-edge, such as the rule shown here, to keep it on course. Veneer saws are more likely to produce a rough edge than a knife, but less likely to ruin your straight cut by following a grain line when cutting with the grain. To buy



Cut veneer on a piece of scrap so you don't damage your workbench. When the teeth on one edge of the blade get dull, remove the screws, reverse the blade, and reattach it to the handle.

veneer saws, other veneering tools, and veneer, too, contact Van Dyke's Restorers at 800/558-1234, or log on to www.vandykes.com.

Continued on page 34



www.amazon.com/hitachi

See over 200 Hitachi tools online.

Includes an extra 10" x 72 tooth carbide blade, a \$59.99 value.



#C10FSH
10" Dual Bevel
Slide Compound
with laser



Top quality product. Could not have asked for anything better! The laser sight makes cutting parts for my projects so much easier.

-An Amazon.com customer from Wilkes-Barre, PA

- New laser cut guide delivers highly accurate cuts
- New high flip fence design for extra support
- Frontal bevel scale makes reading angles
- Soft-start, belt-driven, 12-amp motor reduces vibration for superior results



*We will match our competitors price plus beat it by 10% of the difference. Find out more at www.amazon.com/price-match.

Call for your FREE Tool Crib catalog

1-800-635-5140

amazon.com
tools & hardware

ask wood

Remove auxiliary fence after using

Q: I'd like to install an auxiliary fence on my tablesaw for rabbeting. How should I make the fence, and can I leave it there permanently?

—Scott Larson, Nashville, Tenn.

A: Scott, use 3/4" plywood, medium-density fiberboard, or a flat, straight piece of hardwood for an auxiliary fence. Cut it slightly longer than your tablesaw's rip fence, and about the same height. Drill and counterbore two holes in the auxiliary fence, matching them to existing holes in your rip fence or locating them to each side of the blade and centered on the auxiliary fence's height. Add a T-nut in each hole on the outer face. If your rip fence doesn't have mounting holes, drill a pair to match your auxiliary fence holes. Mount the auxiliary fence with hexhead bolts, or use threaded rod and wing nuts. If you don't want to drill into your rip fence, hold the auxil-



This auxiliary fence shows marks left by various types of operations. You might choose to make a new fence each time you need to cut rabbets at a different depth.

iary fence in place with clamps, making certain they won't interfere with the rabbeting operation.

Install a dado set in your tablesaw, and lower it below the table. Mark the planned depth of your rabbets on the auxiliary fence, then adjust the fence to cut the rabbet width. Double-check to make sure that the dado set won't contact your rip fence. Now, turn on the saw, and gradually raise the dado set into the auxiliary fence until the cut reaches your mark. You're ready to rabbet.

Don't leave the auxiliary fence in place permanently, though. The recesses left behind are likely to snag workpieces as they slide along the fence.

Southern yellow pine can be hard to find

Q: How do you know if you're buying Southern yellow pine (that's what I want for some indoor projects) or another kind of pine? I've found that most home centers don't label the different species.

—Gary Thurm, Readlyn, Iowa

A: Gary, the photo at right should help you identify Southern yellow pine when you find it. Also look for the initials "SYP" stamped on the boards or on paper labels.

However, you might have to find a new outlet to get what you want. In most parts of the U.S., the only Southern yellow pine carried at home centers is pressure-treated. That's the green-colored wood intended for outdoor use. Contact lumber outlets that cater more to woodworkers, and ask if they carry untreated Southern yellow. Or visit www.southernpine.com, and click on the "Where to buy" button.

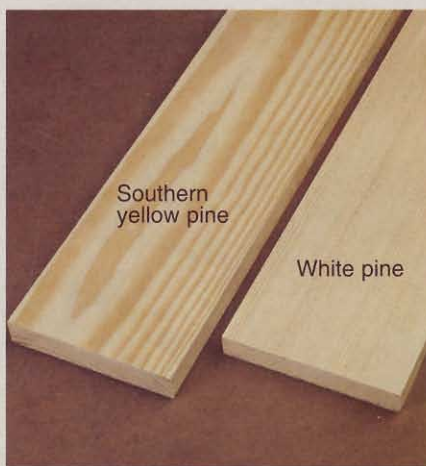

Strongly contrasting grain lines and a yellow tone make it easy to identify Southern yellow pine, as you can see here.

Got a question?

If you're looking for an answer to a woodworking question, write to Ask WOOD, 1716 Locust St., GA-310, Des Moines, IA 50309-3023 or send us an e-mail at askwood@mdp.com. For immediate feedback from your fellow woodworkers, post your question on one of our woodworking forums at www.woodonline.com.

short cuts

News and notes from the woodworking world

Ridgid tool shakeup

Emerson Electric, the maker of the Ridgid power tool line sold exclusively at The Home Depot, recently announced that it will no longer manufacture Ridgid benchtop and stationary woodworking tools. It will, however, continue making the Ridgid wet/dry vacuums, drill press, hand tools, and other products for The Home Depot.

According to Karen Powers, a Home Depot public relations manager, "The Home Depot will continue to fully support the Ridgid woodworking tools in stores. Likewise, it will continue its efforts to enhance the line through power tool innovations and the introduction of new products."

What this means, in effect, is that several of the Ridgid woodworking power tools will be made by a company other than Emerson. What if you own a Ridgid woodworking power tool or two and need a part, accessory, or technical help? Call 800/4-RIDGID (800/474-3443) and your needs will be met. Regardless of who made the tool, model numbers will remain the same. 🌲



This 16-gallon wet/dry vac, model WD1735, is just one of the Ridgid power tools still made by Emerson Electric and sold at The Home Depot.

WOODLINE USA™ OFFERS YOU MORE... LIFETIME WARRANTY / GUARANTEED LOWEST PRICE

30 Piece PROFESSIONAL SET



Includes:
5 Straight Bits
6 Roundovers
3 Dovetails
3 Core Box
3 Cove Bits
2 Flush Trim, 1 Panel Bit
2 Roman Ogee, 2 Slot Cutters, 1 "V" Groove
1 Chamfer and 1 Bevel Trim Bit

SUPER BUY
WL-2010 **OUR PRICE ONLY \$109** set

15 Piece 1/2" SHANK SET

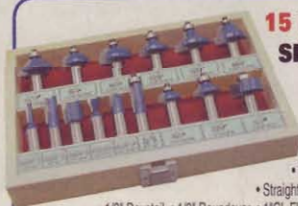

Includes:
• Chamfer • Cove = 1/2"R, 3/8"R, 1/4"R
• Roundover = 1/2"R, 3/8"R, 1/4"R
• Roman Ogee = 1/4"R
• Straight Bits = 3/4", 1/2", 1/4"
• 1/2" Dovetail • 1/2" Roundover • 1" CL Flush Trim • Rabbet Bit

WL-2022 for 1/2" or WL-2021 for 1/4" SHANK SET
OUR PRICE ONLY \$59 each set

5 Piece MOULDING SET



1/2" Shank Router Bits WL-2011 \$175 VALUE
OUR PRICE ONLY \$99 set

5 Piece DOVETAIL SET



• 14 3/4" • 14 5/8"
• 8 1/2" • 14 1/2"
• 14 3/8"
1/2" Shank Router Bits
WL-2017
\$30 VALUE
OUR PRICE ONLY \$19 set



6 Piece CABINET DOOR SET

1/2" Shank Router Bits
• 2-pc Rail & Stile (Roman Ogee) • Drawer Lock
• 3 1/4" D Panel Raiser (Ogee) • Door Lip • Glue Joint

WL-2020-1 \$175 VALUE
OUR PRICE ONLY \$119 set

9 Piece MASTER DADO SET

Includes Undersize for Plywood, Standard for Hardwood and Oversize for Melamine or Veneered Materials, In 3 Popular Sizes: 1/4", 1/2" and 3/4".



WL-2030 \$89 VALUE
OUR PRICE ONLY \$39 set

3 Piece CABINET DOOR SET

1/2" Shank Router Bits
• 2-pc Roman Ogee Rail & Stile • 3 1/4" Panel Raiser

WL-2019-1 \$129 VALUE
OUR PRICE ONLY \$69 set



Other Profiles Available.

8 Piece PICTURE FRAME SET

Perfect for making great looking picture frames. Bits can be combined to form complex mouldings or simple decorative frames.



WL-2008 \$189 VALUE
OUR PRICE ONLY \$75 set

LASER CUTTING GUIDE

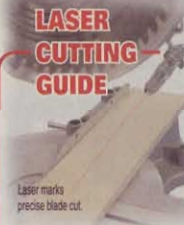

WOODLINE USA's NEWEST PRODUCT

MOUNTED LASER CUTTING GUIDE
Quality made. Precision cutting accuracy. Economical battery operated. (included) Versatile, easily mounts to your chop saw, compound miter saw, radial arm saw, or drill press.

Quality • Precise • Economical • Versatile

WL-LAZ \$69 VALUE
OUR PRICE ONLY \$39

PREMIUM CARBIDE

- Euro Anti-Kickback Design
- Super-Slick Non-Stick Finish
- Super Low Prices

FREE CATALOG

See our great selection of Bits and Cutters
1-800-472-6950



GREAT ROUTER BITS AND SHAPER CUTTERS
BEST SELECTION / BEST PRICE!

ORDER TOLL FREE

1-800-472-6950

WOODLINE USA • P.O. BOX 298 • TEMECULA, CA 92593

Visit us at our **WOODBITS**

Web site: www.woodbits.com

E-mail: woodline@woodbits.com

- INDIVIDUAL BITS ALSO AVAILABLE • ALL MAJOR CREDIT CARDS
- SAME DAY SHIPPING

QUALITY Guaranteed

A quick guide to must-know terms used throughout *WOOD*® magazine

Board foot: The standard unit of measure for hardwood lumber. Because hardwoods often sell in random widths and lengths, a board foot measures thickness, width, and length to determine the total volume of wood in the board. One board foot is a piece 1×12×12". Use the following formula to calculate the board foot measurement of any piece of lumber:

$$\frac{T" \times W" \times L"}{144} = \text{board feet}$$

Flush-trim router bit: A straight bit with a bearing mounted at the tip, as shown, *right*. Typical use includes trimming workpieces—wood or plastic laminate, for instance—to conform to a template or substrate.

Kerf: The slot or opening produced in a workpiece by a saw blade as it cuts through the material. A standard tablesaw blade cuts a 1/8"-wide kerf.

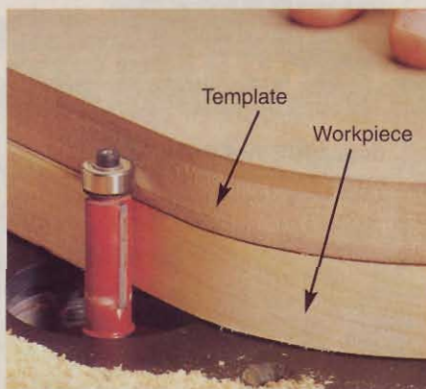

Squeeze-out: The small bead of glue that gets pushed out of a joint under clamping pressure. Remove this glue by wiping it away, being careful not to spread it, before the glue dries. Or, scrape it off using a chisel or other blade after the glue skins over.

Throat: Most often, the opening in a tablesaw, bandsaw, or router table where the bit or blade protrudes. The throat is usually covered by a removable piece called a throat plate or table insert.

Zero-clearance insert: A throat plate, used in a tablesaw, with an opening cut by raising a spinning blade or dado set through it. Because the opening matches

LAGUNA TOOLS

*Simply
the Best!*



Call for FREE Video!

1.800.234.1976

mail@lagunatools.com

The new Laguna TS table saw is setting a new high standard by which all others will be measured. With all the features of a traditional cabinet saw, the TS also comes with its own line of bonus 'Laguna' features.

The X31 multi-task machine has a lineage second to none. This third-generation combination machine is a best seller, with updated fences and increased cutting capacity.

Meet our latest award-winning machine, the LT 14 bandsaw. Packed with outstanding features for powerful performance. 1.7 HP motor - 13 1/4" throat - 1/16" to 1" blade - 8" resaw.

www.lagunatools.com

17101 Murphy Avenue
Irvine, CA 92614

the cutting width of the blade, it reduces chip-out by providing maximum workpiece support. It also prevents small pieces from dropping into the throat opening.

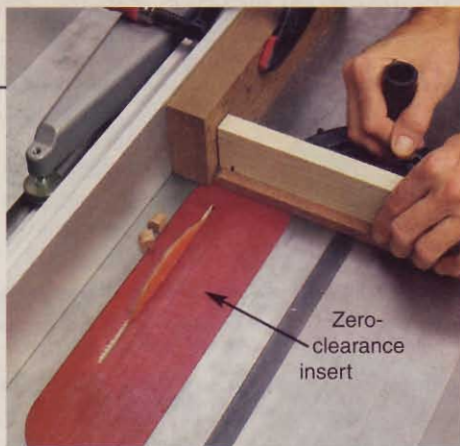

Counterbore: A stopped hole in a workpiece that allows you to set a screw-head below the surface of the wood. You can plug the counterbore to hide the head.

Countersink: A shallow, conical hole in a workpiece that matches the shape of a flathead screwhead. When used without a counterbore, it positions the head flush with the surrounding surface.

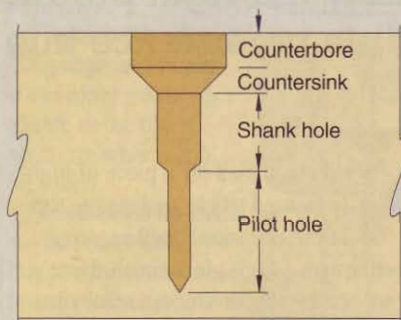

Shank hole: A hole drilled in a workpiece to receive the unthreaded portion of a wood screw's shank. The hole is just slightly larger than the shank diameter.

Pilot hole: A hole drilled in a workpiece to receive the threaded portion of a screw. The pilot hole is just slightly smaller than the screw's thread diameter.

Crosscut: A cut across the wood grain.

Rip: A cut parallel to the wood grain.

Resaw: Slicing a length of wood with the blade running parallel to the workpiece faces to create thinner pieces. Usually done on a tablesaw or bandsaw.

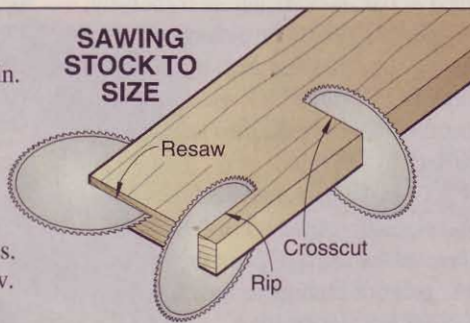

Dado: A square-cornered channel cut across the wood grain, typically using a dado set or a straight router bit.

Groove: A square-cornered channel similar to a dado, but cut parallel to the wood grain.

Rabbet: An L-shaped channel cut along the edge or end of a workpiece, typically using a rabbeting bit or dado set.

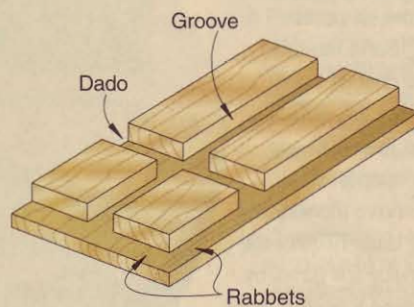

The Toughest Glue On Planet Earth

Gorilla Brand Premium Glue is the all purpose, interior/exterior glue ideal for most repair and bonding needs. It's great for indoor/outdoor furniture repair, woodworking projects, as well as general repairs around the house. Bonds wood, stone, metal, ceramic and more! Incredibly strong and 100% waterproof.



for retailers near you:
www.gorillaglu.com
 1-800-966-3458

Circle No. 50

A new look FOR LESS.



YOU CAN give your outdoor metal furniture and accessories a truly distinctive look with Rust-Oleum Stops-Rust aerosol paints. The chip resistance and color retention you've come to expect from Rust-Oleum are now available in exciting finishes such as Metallic, Hammered, Satin and Textured. Don't need to repaint the furniture? Try it on outdoor light fixtures. In fact, Rust-Oleum works wonders on wood, concrete or masonry. And remember, Rust-Oleum paints are always at home on interior projects, too.

HOW TO paint previously painted metal and/or partially rusted surfaces:

1. Sand or wire brush to remove all loose rust and/or chipping paint.
2. Rinse and dry thoroughly. A clean, dry surface is essential.
3. Prime rusted areas with Rust-Oleum® Rusty Metal Primer. For all other areas, prime with Rust-Oleum® Clean Metal Primer. For lightly rusted areas, you can use Rust-Oleum Rust Reformer® which neutralizes rust and creates a surface that can be topcoated.
4. Paint, and take pride in your improvement!

Visit www.rustoleum.com for information on the entire portfolio of Rust-Oleum top-quality paints and surface coatings.



stopping rust is just the start.™
Circle No. 115

4 easy steps to a smooth-as-glass finish

Parlay the right products and a little persistence into lustrous results.

Nothing shows off a piece of highly figured stock, such as the top of the occasional table on *page 52*, better than a high-gloss finish. Here's how we achieve super-smooth results in the *WOOD*® magazine shop.

1 For tight-grained woods, such as the maple shown in this project, sand the surface to 220 grit, and you're ready to apply the finish. An open-grained wood, such as oak, ash, walnut, or mahogany, requires the use of a matching-color paste grain filler. Pack the grain by working the filler cross grain with a wide putty knife. Let the filler dry, and then sand the surface to 220 grit.

2 To make polyurethane finish flow out smoothly without brush marks, add three tablespoons of paint thinner to one quart of high-gloss finish. Do not use fast-drying polyurethane. Brush on three coats, sanding with 220-grit sandpaper between coats.

3 Sand the third coat of finish with 320-, 400-, and then 600-grit sandpaper. Remove the sanding dust. Inspect the surface for flaws by wiping it with thinner,

and shining a light across the surface at a low angle. Spray on a fourth coat of gloss polyurethane from an aerosol can, uniformly wetting the whole surface. Let the finish cure for a week.

4 Remove any dust motes with 1,500-grit sandpaper. Make a pad with a soft cotton rag, and buff the surface to a high sheen with 3M Finesse-it II Finishing Material (available at auto-paint supply stores, or buy it online at www.proper-autocare.com/3mfiniimacpo.html). ♣



fancy flutes, simple setup

Add an impressive detail to your finest work, using a router and these tips.

The curio cabinet on *page 58* offers a prime example of the classic look you can create with parallel, round-bottomed grooves called flutes. Because these grooves do not exit at the ends of the workpiece, we call them “stopped” flutes. As a design element, they set your work apart from the ordinary, yet they’re not difficult to make, as you’ll soon discover.

Successful fluting starts with careful planning and layout. For a stile $2\frac{3}{4}$ " wide, like those in our curio cabinet, we used a $\frac{1}{4}$ " core-box bit to make four flutes approximately $\frac{1}{4}$ " wide and $\frac{1}{16}$ " deep, leaving $\frac{1}{4}$ " of flat surface between flutes, and a $\frac{1}{2}$ " border along each edge. Pieces of different dimensions might call for more or fewer, wider or narrower flutes. Whatever the plan, keep the flat intervals equal to or less than the flute width. Draw full-scale samples on paper to arrive at a handsome design.

For best results with stopped flutes, you’ll need a plunge router so you can smoothly lower and raise the bit at the beginning and end of each flute. You’ll also need an adjustable edge guide. Keep each set of stopped flutes aligned at the ends with a startblock and a stopblock. ♣

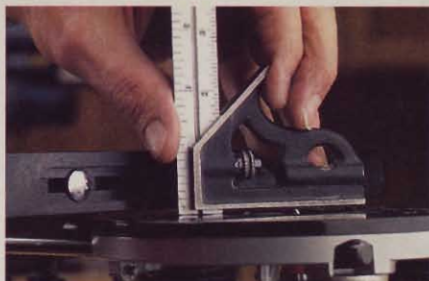

1 First, set the depth of your cut. To do this, extend the blade of a combination square $\frac{1}{16}$ ", and lock it in place. With the router in its plunge mode, hold the blade end on the router base, and adjust the bit to make contact with the square’s head. Now, set the router’s depth stop.

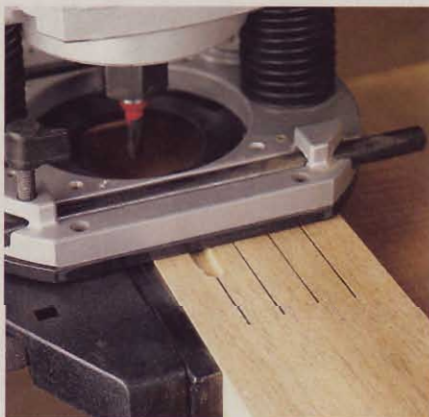

3 On a piece of scrap the same width as your workpiece, lay out and mark the locations of your flutes. Now, set your router’s edge-guide fence to make the first flute. The distance from the fence to the bit’s center equals the distance from the scrap edge to the nearest mark ($\frac{5}{8}$ " for the curio cabinet). Test the setting by routing into the scrap piece, as shown. When it’s centered on the mark, rout the first flute in your workpiece. (If your router’s base is round, and your block-to-flute distances are equal, you can flip your workpiece around, and rout the flute nearest the opposite edge.)



2 Mark the ends of your planned flutes on the workpiece. Place a rule on the router base, and measure from the bit to the edge of the base. Measuring to the leading edge tells you how far to set your stopblock from the top mark. Measuring to the trailing edge determines the distance from the bottom mark to your startblock. If your router’s base is round, these measurements will be equal. Place the workpiece at the edge of your workbench, and clamp the blocks and workpiece in place.



4 Cut a wood spacer to match the gap between marks on your scrap template ($\frac{1}{2}$ " for the curio cabinet). Clamp the router to your workbench. Loosen the edge-guide fence, and slip the spacer between it and the workbench. Tighten the fence, remove the spacer, unclamp the router, and then double-check the setting on your scrap. Rout the second flute on your workpiece. Repeat this step for each flute, using the same spacer. (If your router has a round base, and you cut two flutes in Step 3, flip the workpiece after cutting this third flute, and rout the fourth one.)

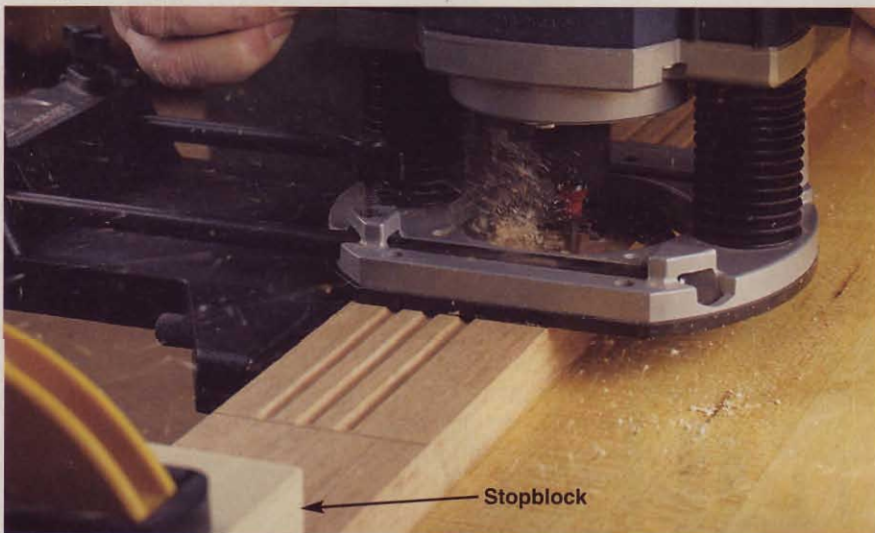

5 When you rout a flute, butt the router base against the startblock, plunge to the preset depth, and immediately move the router forward. Rout until the base contacts the stopblock, and immediately allow the plunge mechanism to pop up. Quick entry and exit prevents hard-to-remove burn marks on the wood.

haunched tenons

Strengthen and simplify rail-and-stile framework with this easy variation on the classic mortise and tenon.

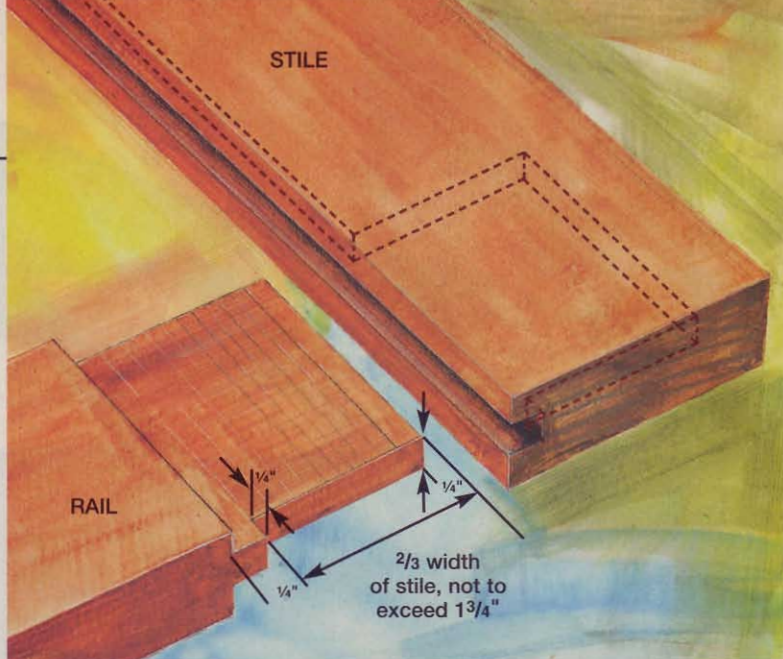

You can go a long way with the basic mortise-and-tenon joint, but sometimes a variation comes in handy. The curio cabinet on *page 58*, for example, features haunched tenons on the top and bottom rails. With a haunched tenon, you can cut a groove the length of each stile's inside edge, then automatically fill the exposed end of the groove with the haunch as you assemble the joint. A haunched tenon looks like a standard tenon, but adds a shoulder that extends to the edge of the rail, as shown in the drawing *above, right*.

Making the tenon is simple. All you need is a tablesaw and dado set, as shown here.

First, cut the rails and stiles to their final dimensions, with the rail length including the planned tenons. Plow a $\frac{1}{4} \times \frac{1}{4}$ " centered groove along the inside edge of each part to receive a panel.

Now, lay out a mortise to be cut into the groove on the stile.

Locate the mortise $\frac{1}{4}$ " from the end of the stile, and make its length $\frac{1}{2}$ " less than the width of the rail; our mortises measured $2\frac{1}{4}$ " long. We made the curio cabinet mortises $1\frac{13}{16}$ " deep to receive $1\frac{3}{4}$ " tenons, allowing $\frac{1}{16}$ " of extra space for glue. Each mortise is $\frac{1}{4}$ " wide, matching the groove in the stile. Now, you're ready to form both parts of a haunched tenon joint following the steps shown *at right*.



1 Choose your method for forming mortises—a drill press equipped with a standard twist bit or a hollow chisel attachment, a plunge router and centering jig, or a mortising machine (our choice). When using this tool, bore at each end of the mortise layout with a $\frac{1}{4}$ " hollow chisel bit, then bore a series of holes in between, leaving a wall between adjacent holes. Finally, bore out the walls.

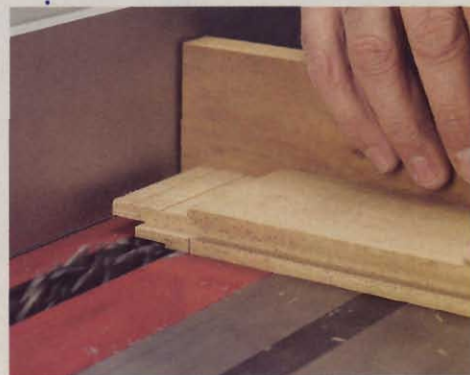

2 Mount a dado set on your tablesaw and raise its height to $\frac{1}{4}$ ". Make a test cut on both faces of a scrap piece, and test the fit in one of your mortises. Set your rip fence so that the distance from the fence to the left side of the dado set equals the depth of the mortise as measured from the stile edge, minus $\frac{1}{16}$ ". With an auxiliary fence on your miter gauge, make passes on each face to form the tenon.

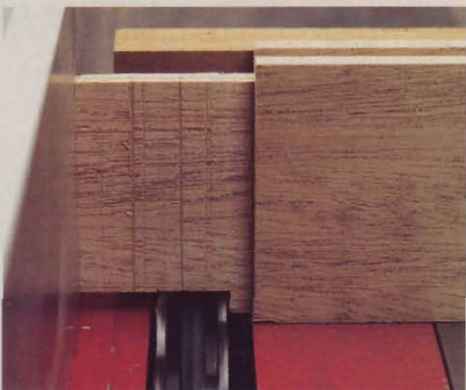

3 Move the rip fence $\frac{1}{4}$ " closer to the dado set and lock it in place. Place the rail against the miter gauge with the grooved edge up. Make a series of passes to form the haunched shoulder of the tenon. You should be able to butt the end of the workpiece against the rip fence for the final pass, but test the fit before making that pass.

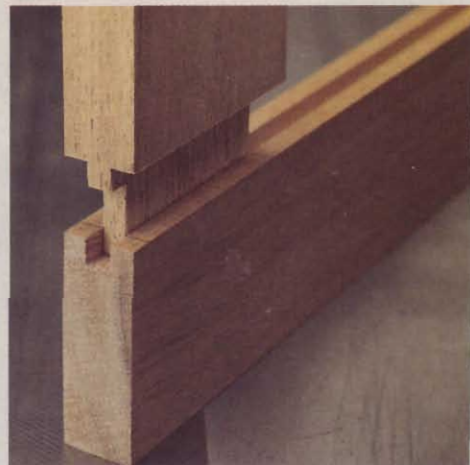

4 Test the joint's fit by checking for gaps at the visible joint lines. Then, apply glue to all of the mating surfaces. Place the panel in the grooves as you slide the four joints of your frame together, and clamp the assembly. ♣

scrollsawn bears puzzle

This group just loves hanging around.

In no time at all, you can make this adorable, four-piece display puzzle from scraps of any type of $\frac{3}{4}$ "-thick wood. (We used poplar.) Wee ones will have "bear-rels" of fun putting it together, and showing it off on a dresser or shelf. You can even involve kids in the scrollsawing, painting, or both.

Cut out the bears

1 Make two copies of the bear pattern on the *WOOD PATTERNS*® insert. Cut the patterns, where shown, to separate the large group of bears, which have a horizontal grain direction, from the dangling bear, which has a vertical grain direction. Using spray adhesive, attach the patterns to your stock, aligning their grain-direction arrows with the wood's grain.

2 Form the bears' eyes by drilling $\frac{3}{32}$ " holes where shown. Scrollsaw the

bears and their body details to shape, as shown in **Photo A**, using a no. 7 crown-tooth blade. To form the inside details, drill $\frac{1}{16}$ " blade start holes where needed, insert the blade through the holes, and cut.

3 Remove the patterns, and sand the parts to 220 grit.

Add the colors

1 Prime and paint the bears. We first used Rust-Oleum gray spray primer. Then we sprayed on Rust-Oleum quick-drying American Accents satin-finish paints in these colors: *Heirloom White* for the three small bears, *Canyon Black* for the large bear on the left, and *Nutmeg* for the large bear on the right, as shown in the photo above. Apply two coats of paint to all parts.

2 With the paint dry, use a small artist's brush to paint the bears' faces and noses with contrasting colors, where shown on the pattern and as shown in **Photo B**. We used Winsor & Newton acrylic artists' paints, choosing *Raw Sienna* for the large bears' faces, and *Ivory Black* for all of the bears' noses. A two-ounce tube of paint sells for about \$3 at art supply stores. 🌲

Written by Owen Duvall with Kevin Boyle
Project design: Lee Gatzke

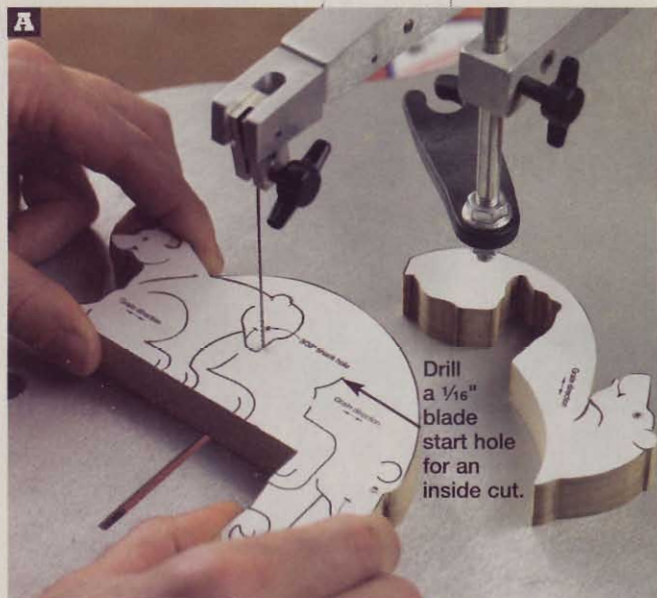

Scrollsaw down the center of the pattern lines to separate the bears and create their face, arm, and leg details.



Using an artist's brush, paint the bears' faces and noses with acrylic paint. Apply additional coats as needed.

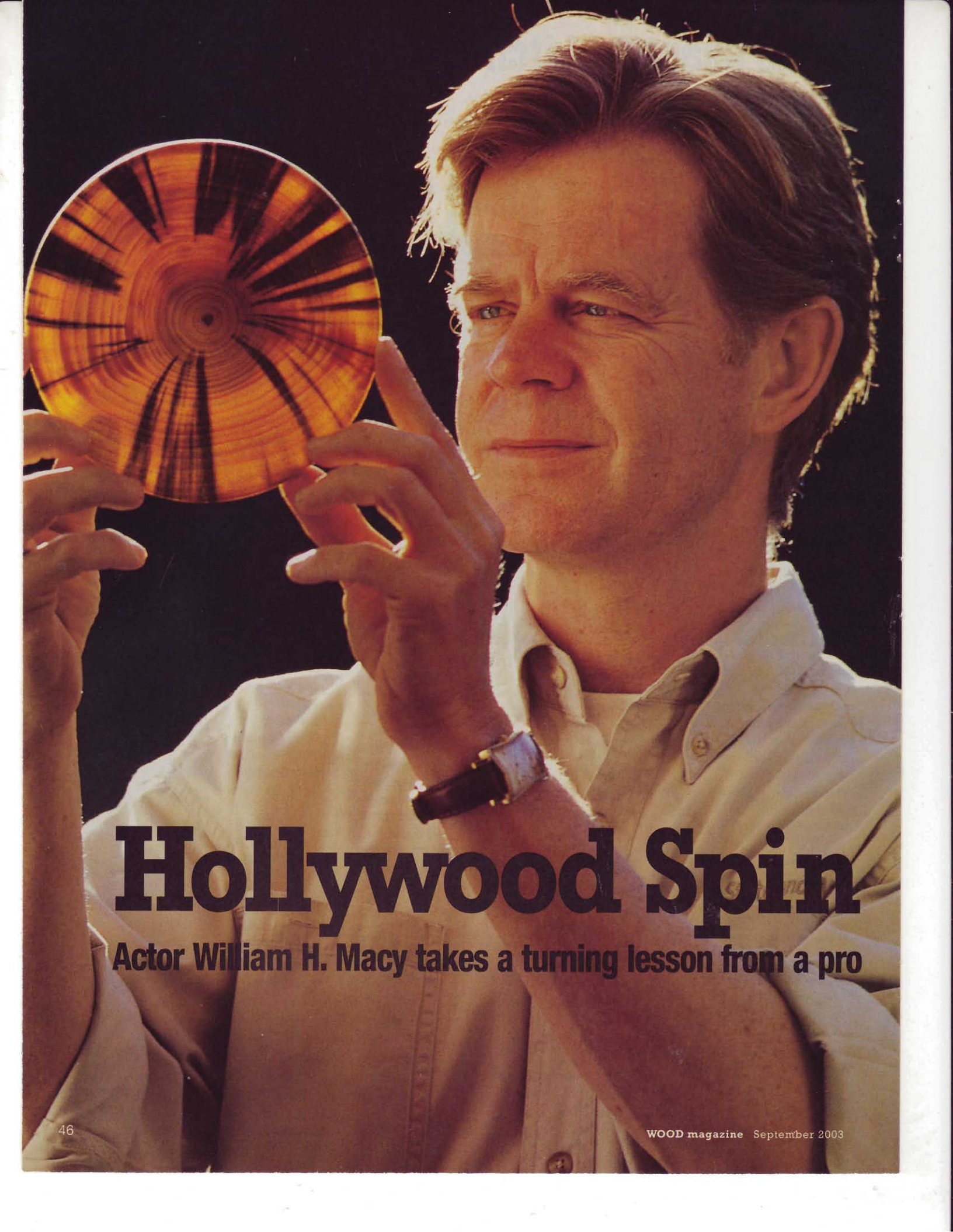

Hollywood Spin

Actor William H. Macy takes a turning lesson from a pro

Performing in the movie *Fargo* changed William H. Macy's life. For starters, his role in the film earned him an Academy Award nomination in 1996, and established him as one of Hollywood's premier character actors. In addition, while filming in Minnesota, Macy began woodturning. He took lessons from a local turner, and even bought a lathe and had it shipped to the set so that he could practice his new hobby between scenes.

What sparked his decision to turn? "I have the mind of a chimpanzee. Turning fits the attention span," Macy says with a laugh. Then, more seriously, he adds, "I've always been nuts about containers. And bowls are practical. I just love giving them away, knowing they'll be used." He says that "people just like the shape of bowls, the tactile sensation of holding them. They pick them up, rub them, and smile."

Once we learned of Macy's passion for turning, we thought it would be fun to let you share a day in his shop as he takes a lesson from a master woodturner. So we traveled with woodworking wiz Phil Brennion to the actor's residence in suburban Los Angeles. By the end of the day, Macy successfully

turned his first thin-walled, translucent bowl (the one in the photo, *left*). Now stay tuned for the tips and techniques that helped him along the way.

Setting the stage: Choose the right wood and tools

Turning a translucent bowl requires a special piece of stock. It has to be light colored, tough enough to turn super-thin, and have character marks to give it visual interest. When Brennion pulled a gnarly, sap-oozing, bug-infested, 8"-diameter hunk of ponderosa pine, *right*, from a plastic bag, we questioned whether this was it. But with this wood, ugly was only bark deep.

The piece came from a tree killed by bark beetles. These nasty little buggers are wreaking havoc throughout the West, as they feed on the cambium (the live-wood layer just below the bark) of trees weakened by drought. When the beetles move out, fungus sets in, creating the radiating dark blue streaks.

Even if you can't find a unique workpiece like this one, you can create a bowl that the light shines through, too. Choose a light-colored wood, such as soft maple. And make sure it's green, not dried, so it will carve away cleanly.



This log didn't look like much at first, but stripping away the bark revealed the makings of a beautiful bowl: ponderosa pine infested with bark beetles.

Note: This blank is longer than necessary for the task. Our intrepid turners used the extra to experiment with turning a hollow vessel after completing the bowl. To create a bowl similar to this one, a blank about 6" long works nicely.

Craftsman PROFILE

Occupation: Actor

Specialties: Portraying intriguing characters and turning "useful" bowls.

Most Notable Roles: Jerry Lundegaard in "Fargo," which garnered an Academy Award nomination for Best Supporting Actor; Bill Porter in "Door to Door," a role that earned him a Screen Actors Guild Award. He cowrote that movie.

Shop Specs: His 24x24' shop sits above a 2-car garage, with a Powermatic Model 4224 lathe as its star. Other tools play supporting roles, helping to prepare turning stock. Macy outfitted his Vermont shop with an identical lathe.

Woodworking Background: His father was a woodworker, and built the family's home, so tools have always been around. He became intrigued by the woodturner's close connection with the wood, gave it a try, and got hooked.

Most Used Tools: His lathe, turning tools, and sharpening system.

Favorite Wood: Hophornbeam, which is durable, attractive, and easy to find near his Vermont cabin; and walnut because of its beautiful color.

Finish of Choice: Behlen Salad Bowl Finish; it's easy to apply and replenish.

Best Advice: "Learn how to sharpen your tools, and understand how they and your lathe work. And always be careful—safety is key. I find it valuable in my line of work to have all of my fingers and few scars."

William H. Macy



For turning tools, you need just two: a $\frac{3}{8}$ " bowl gouge and a $\frac{3}{16}$ " parting tool, well-sharpened for delicate work. See the **Shop Tip**, right, for Brennon's insight on this subject.

Turning a thin-walled bowl also requires a block of time (Macy needed about 3 hours to learn the process). Once you start turning, Brennon advises, try to complete the bowl without stopping. Why? The green wood, especially as it gets thinned down, will dry out quickly, and will likely crack or warp if left unattended. "If you have to stop," he says, "gather up your shavings, put them in a plastic bag, and place the bag over the workpiece. Squeeze out the air and tape the bag tightly closed. This helps equalize moisture and may prevent splitting."

SHOP TIP

Keep 'em sharpened

Phil Brennon says it simply: "Turning tools are like a woodturner's sandpaper. You wouldn't keep sanding with worn-out paper, but turners will avoid sharpening to 'preserve' the tool. Frankly, turning tools are disposable. They have long flutes that let you keep regrinding the tip. When it's too short to use, buy another one." High-speed-steel turning tools sell for as little as \$30-\$40 each, and can last for years.

His best advice: "Grind a consistent bevel from side to side on the tool, and remove projections that can catch in the wood. Make it easy by using a sharpening jig."

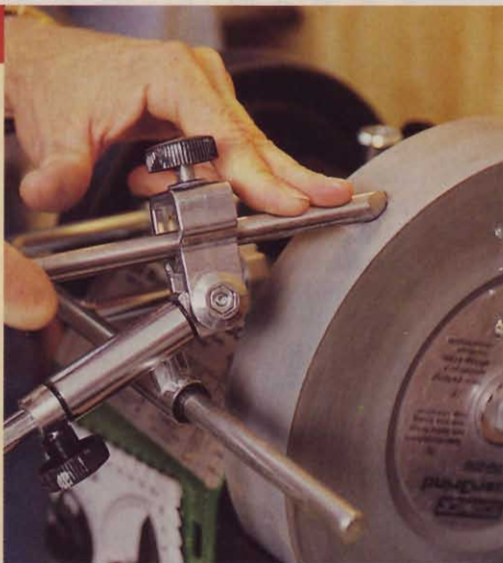

How to become a star of thin-wall turning

Scene one: Prepare the blank

After removing the bark and brushing off the workpiece, Macy mounted it on the lathe between centers. He turned it by hand to ensure that it was balanced and securely held. Then, he turned the blank round using a bowl gouge, **Drawing 1** and **Photo A**. (This tool's small profile reduces the likelihood of it catching in an out-of-round workpiece. If your piece is fairly round, you could use a $\frac{3}{4}$ " roughing gouge to speed up this task.)

Next, using the bowl gouge then a parting tool, he trued the ends of the blank by paring away the wood down to the drive centers, **Photo B**.

Then, Brennon and Macy removed the blank from the lathe, and secured a faceplate to one end using panhead sheet-metal screws, centered on the pith. (In this case, the short tenon fit within a hole centered in the faceplate.) Here, the two took extra care to ensure that the faceplate was well-secured.

Next, Macy mounted the faceplate onto the lathe, and supported the opposite end of the blank with the tailstock. Then he trued the blank again to make sure it spun smoothly between the centers.



A With the lathe's speed at about 500 rpm and the tool rest about 2" below center-line, Macy trues the blank using a gouge.

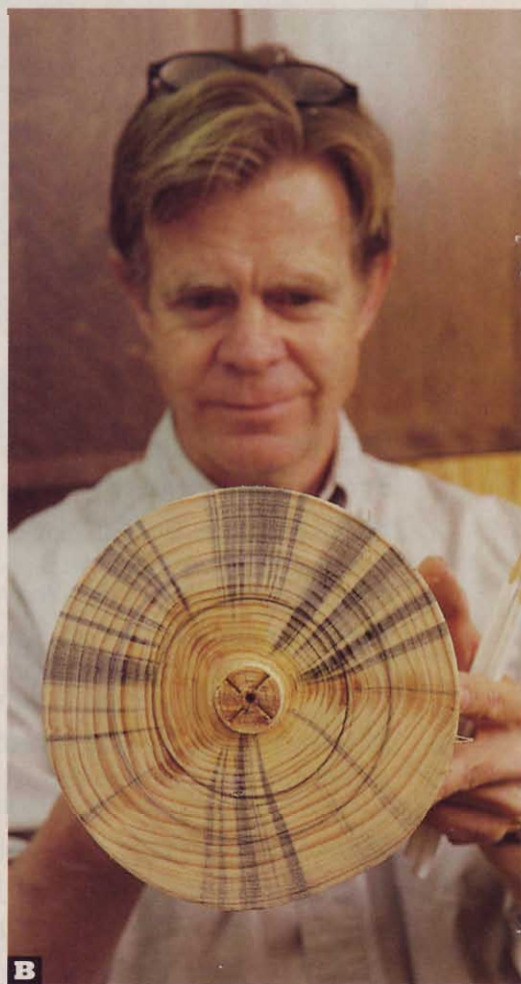

B Macy shows the results of flattening the ends of the blank with a parting tool. This smooths the ends and prepares the piece for faceplate-mounting. The tenon at the center can be chiseled away if necessary.

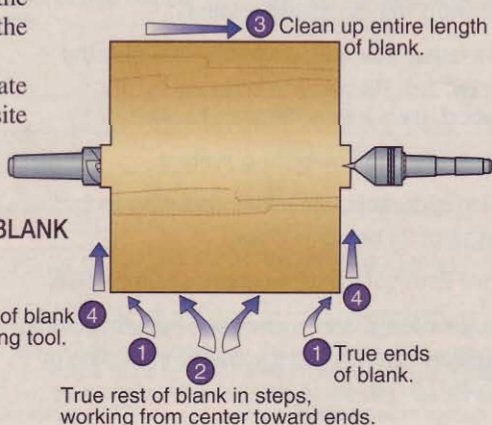

2 FORM THE OUTER PROFILE

Scene two: Rough out the bowl

Creating a translucent bowl, Brennon advises, requires a lot of surface area for the light to shine through. A conical shape with relatively flat walls and a narrow base works well.

To create this shape, Brennon had Macy crank the lathe's spindle speed up to about 1,000 rpm; then, using the bowl gouge, begin shaping a cone, **Drawing 2** and **Photo C**. He didn't worry, at this time, about creating the exact outside profile. And he left a sturdy base to support the lateral pressure that he would put on the blank as he turned. His

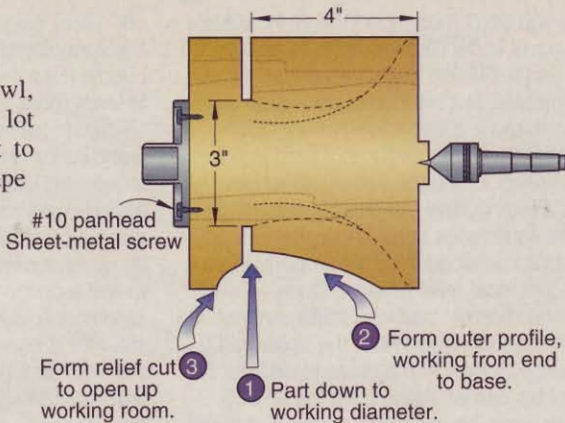

Form relief cut to open up working room.

1 Part down to working diameter.

2 Form outer profile, working from end to base.

bowl had, when complete, a base about 2" in diameter. Brennon advised that he leave about 3" at the center until almost done turning.



C

Stopping periodically to check the contour, Macy begins shaping the bowl between centers. The tool rest sits perpendicular to the tool's cutting direction.

Scene three: Shape the inside contour

To turn the interior of the bowl, Macy backed the tailstock out of the way, and made sure the blank was still secured to the faceplate. Positioning the tool rest parallel to the end of the blank, he bored into the center using the gouge, **Drawing 3**. (Or, you can mount a drill chuck in the tailstock and create the hole using a drill bit.) "Bore to the full depth of the bowl now," Brennon advised, "before the bowl gets thin and fragile."

Turning a thin-walled bowl in end grain, Brennon says, requires working in a way different than normal. "You typically work from the outer rim toward the center when flat-grain turning. When turning the interior of this type of bowl, though, you work from the center outward," **Photo D**. This offers better control, he says, and lessens the risk that you'll accidentally shove your tool right through the bowl's thin wall if you slip.

Brennon recommended caution as the bowl walls got thinner. Green wood can warp as it thins, which can push the rim slightly out of round. Light cuts and a sharp tool help ensure control.

After rough-shaping the inside, Macy again worked the outside of the bowl, **Photo E**. With that shape finalized, he made his remaining cuts only in the interior. Brennon notes that this minimizes warping of the thinning walls.

To create the translucent effect, Brennon says, the bowl wall needs to be no greater than 3/16" thick, and consistent.



D

The bowl's interior begins taking shape as Macy mimics the contour of the exterior. The tool rest sits close to the rim, and about 1 1/2" below center.

Any thin or thick areas will set up tension in the wood that could split it apart.

Our turners used two methods to determine when they'd reached the proper wall thickness. First, they held a small lamp in front of the bowl, and checked from the back side for light coming through. Second, they used their hands to feel the wall of the spinning bowl. Feeling the thickness proves more accurate than looking, and less risky than measuring with wing dividers.



E

Macy moves the tool rest as necessary to keep it roughly parallel to the bowl's surface. He positions the tool rest at centerline for outside cuts, and about 1" below centerline on the interior.

3 FORM THE INNER PROFILE

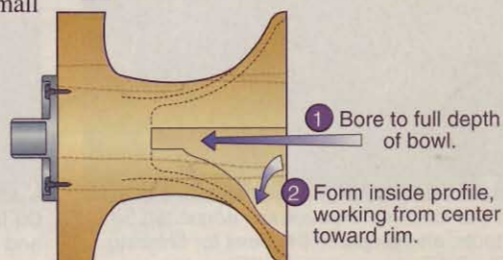

1 Bore to full depth of bowl.

2 Form inside profile, working from center toward rim.

Meet our cast of woodturning characters



Even if you don't recognize William H. Macy's name, you'll know his face. With more than 70 movie and television roles, he's as prolific as he is versatile. But his talents don't stop with acting. He owns a cabin in Vermont that he has worked on extensively, including building his own shop. "I bought a book called *How to Build a Building*, and just did it," he says. "I'll go there sometimes and turn for days." Macy harvests some wood from his property there, and scours local mills for good stock.

When he recently built his Craftsman-inspired home in the Hollywood Hills, the shop was a big priority. It offers him a place to escape the rigors of his career. Aside from the \$3,500 lathe, his tools—a contractor's saw, drill press, mitersaw, and a couple of grinders—are similar to those found in most home shops.

Movie stars often have the reputation for being aloof and self-important, but not William H. Macy. This could very well be the most down-to-earth guy in Hollywood. "I spent 20 years on stage paying my dues, I married very well [his wife, Felicity Huffman, is an actor, too], and I have young kids. They keep you ground-

ed," Macy says. Hanging out in his shop was like spending the day with any woodworking buddy. (See the "Craftsman Profile," page 47, to learn more about the man.)

You can tell immediately that Macy is a true woodworker. He's eager to learn, happy to share, and generous with what he builds. "I've turned hundreds of bowls," he says, "and given almost all of them away." In fact, to show us his handiwork, he had to scrounge around to find a dozen or so bowls.

Mentoring Macy that day was woodturning star Phil Brennon. He serves on the board of the American Association of Woodturners; teaches turning at Yavapai College in Prescott, Arizona; gives seminars; and sells his works in galleries. We regularly tap Phil for advice on turning articles, for assistance with project designs, and recently to test mid-size lathes (see issue 147).

Macy's friend and fellow woodworker Charlie Hulien dropped by, too, to join in showing off the shop he helped Macy build, and to take in Phil's advice. See the photo of the whole gang on page 4.

Scene four: Sand, finish, and make the final cut

Once Macy shaped the bowl from base to rim, he sanded it smooth, starting with 120-grit paper, and working through 220, **Drawing 4** and **Photo F**. Hand-sanding works fine, but Macy uses a "sanding drill" to speed the process.

To bring out the wood's translucence, Macy wiped on a generous coat of Danish Oil finish, **Photo G**. This finish soaks through the wood and helps transmit the light. Film-building finishes, such

as lacquer or polyurethane, don't offer the same effect.

Though the wood started out green and wet, the heat generated while turning made it dry enough to accept the oil. Had he left the bowl unfinished, it might have cracked and warped in just minutes.

Finally, Macy cut the bowl free using a parting tool. After sanding and finishing the underside of the base, he inspected it under the warm L.A. sun. 🌞

Written by **David Stone**
Photographs: **Michael E. Garland**

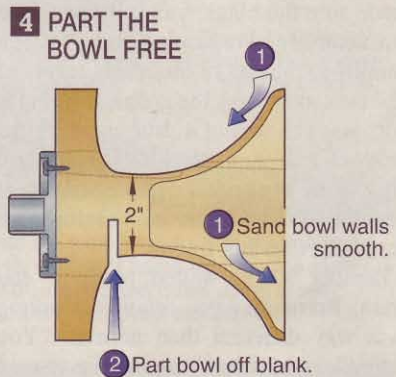

F Final sanding removes any ridges left by tools, and prepares the bowl for finishing.



G Oil finish brings the almost-complete bowl to life, highlighting the contrast between dark and light, and adding an amber glow.



occasional table

with uncommon good looks

This 22"-diameter table in bird's-eye maple and cherry has all the right stuff: appealing design, traditional joinery, and ease of construction.

One warning: It'll look so good you won't want to put anything on it.

For the board feet of lumber and other items needed to build this project, see [page 55](#).

It's not often that you can make a great-looking piece of furniture, such as this table, in just one weekend (plus maybe a couple weekday evening hours to apply the finish). And if you've been saving a special highly figured board for the right project, you'll find the top of this table the perfect place to show it off.

Mortise and bandsaw four shapely legs

1 Cut four leg blanks (A) to the size noted on the **Materials List**. Lay out the mortise locations, where shown on **Drawing 1**. Chuck a $\frac{3}{8}$ " brad-point bit in your drill press, adjust the fence to center the legs' thickness on the bit, and form the mortises by drilling overlapping holes. Square the ends of the mortises and smooth the sides with a chisel.

2 Make four copies of the leg partial pattern on the **WOOD PATTERNS®** insert. Adhere the patterns with spray adhesive to the leg blanks, where shown. Complete the leg layouts as in **Photo A**. Bandsaw and sand the legs to shape. Rout $\frac{1}{8}$ " round-overs on the bottom ends of the legs.

3/4" counterbore
1/8" deep with a
7/64" pilot hole
5/8" deep centered
inside (upper
stretchers only)

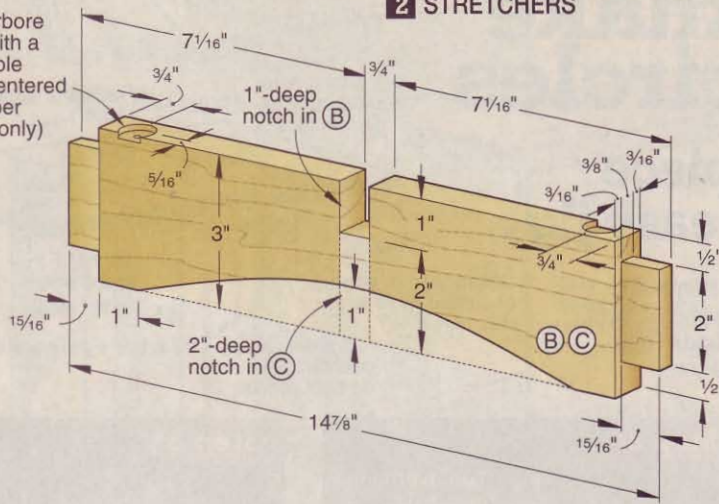

1 LEG

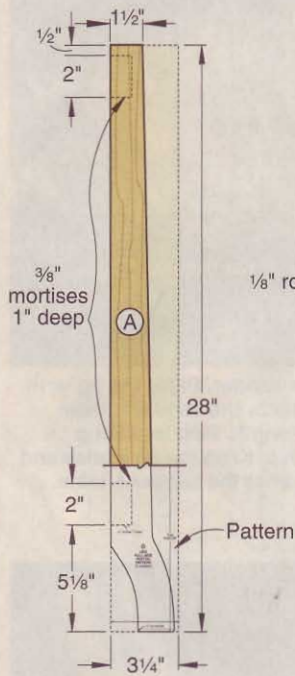

3 EXPLODED VIEW

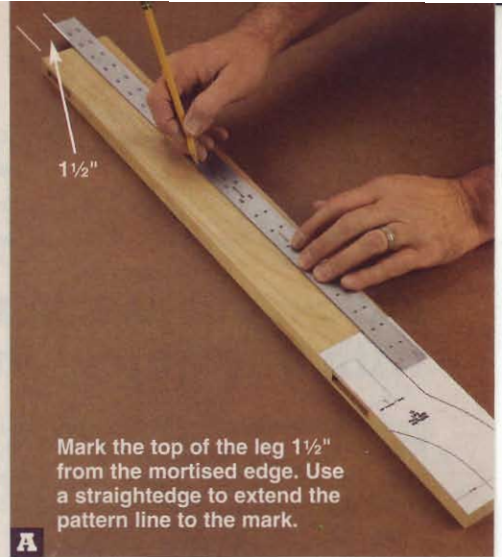
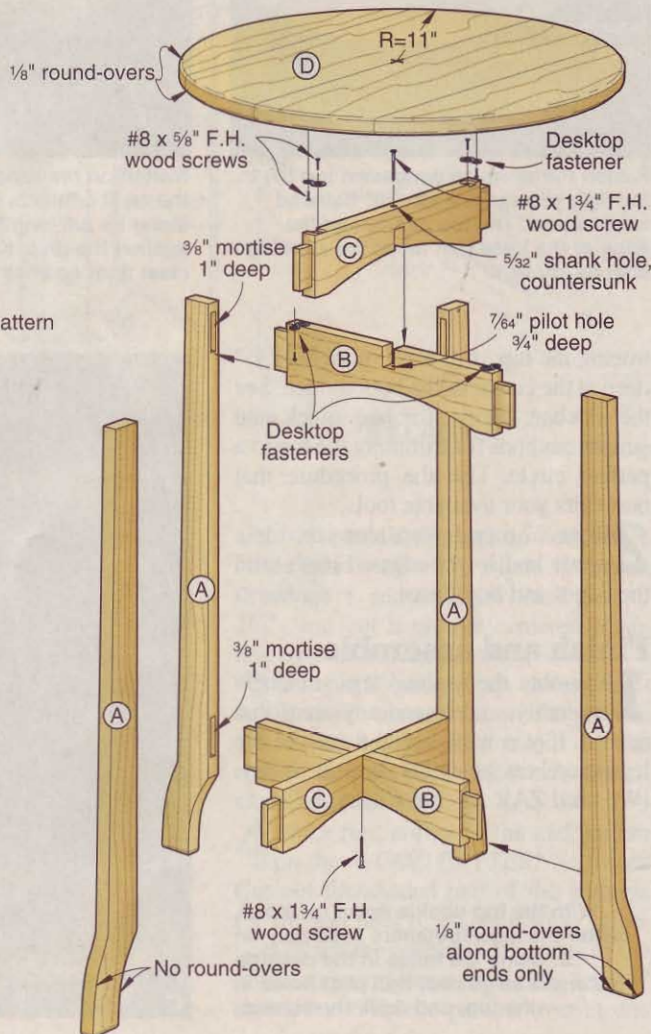

Mark the top of the leg 1 1/2" from the mortised edge. Use a straightedge to extend the pattern line to the mark.

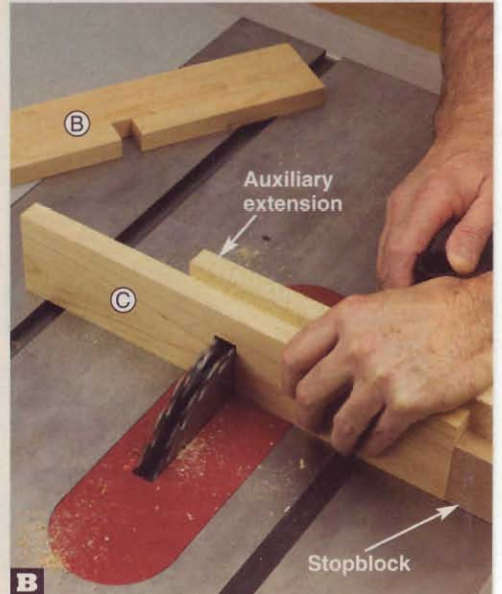

Cut 1"-deep notches in parts B. Then raise the blade and cut 2"-deep notches in parts C. To prevent chip-out, back the cuts with an auxiliary extension.

Form two pairs of interlocking stretchers

1 Cut the stretchers (B, C) to size, and then cut their centered, interlocking notches, where shown on **Drawing 2** and as shown in **Photo B**. The parts should make a snug fit without having to be forced together. Their top and bottom edges should be flush.

2 With the dado blade still in your tablesaw, form the tenons on the ends of the stretchers (B, C). Before cutting the parts, make test cuts in scrap the same thickness as the stretchers.

3 On the *upper* stretchers (B, C) only, mark the centers of the counterbores for the desktop fasteners, where shown on **Drawings 2** and **3**. Drill the counterbores and centered pilot holes.

2 ways to make perfect circles

Disc-sand the workpiece with this quick-and-easy jig ...

Here's a circle-sanding jig you can make in no time flat. First, screw together the jig, shown in the drawing at right, from a couple pieces of particleboard or plywood. Then follow the three steps shown in the photos, below.

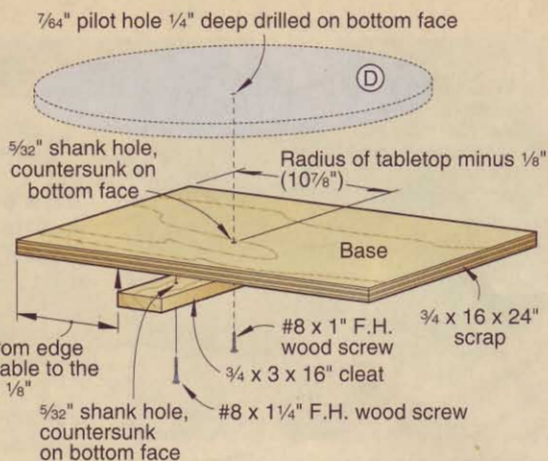

Step 1
Position the jig on your disc sander's table with the cleat contacting the table's right-hand corner, but about 2" away from its left-hand corner. With a single clamp, secure the jig's base to the table.



Step 2
Fasten the oversize bandsawn top (D) to the jig's base with a #8x1 1/4" flathead wood screw. The top overhangs the edge of the base that faces the sanding disc by about 1/4".

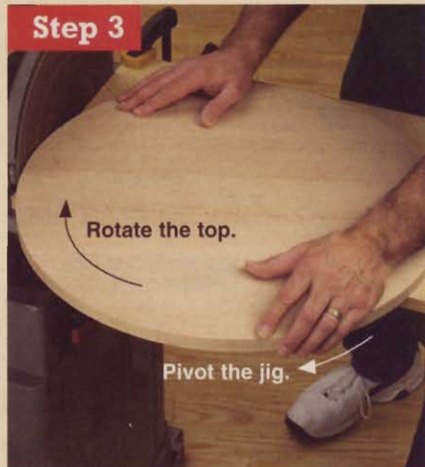

Step 3
Switch on the sander. Pivot the jig until the cleat contacts the sander's table along its full length. Rotate the top against the disc. Keep the jig's base and cleat tight against the sander's table.

4 Mark the ends and centers of the stretchers' arcs. Bend a thin strip of wood to connect each set of three points, and draw the arcs. Bandsaw and sand to the lines.

5 Interlock the upper and lower pairs of stretchers (B, C). The upper stretcher pair has the desktop fastener counterbores. Drill pilot and countersunk shank holes where the parts interlock, shown on Drawing 3, and drive the screws.

6 Spreading glue in their mortises, clamp the legs to the interlocked stretcher pairs. With the glue dry, sand the leg-to-stretcher joints smooth, and then finish-sand all parts to 220 grit. Ease all the edges with a sanding block.

Add the top

1 Edge-join an oversize blank for the top (D). Using a compass, draw an 11"-radius circle on the blank's bottom face. Bandsaw the top about 1/8" outside the circle. To provide a pivot point for

trueing the top, drill a 7/64" pilot hole 1/2" deep at the center of the bottom face. See the sidebar, above, for two quick and simple methods for trimming the top to a perfect circle. Use the procedure that best suits your available tools.

2 Rout 1/8" round-overs along the top's upper and lower edges. Finish-sand the edges and both faces.

Finish and assemble

1 Examine the top and legs/stretchers assembly, and resand any areas that need it. If you wish, apply a stain to the legs/stretchers assembly, and let it dry. (We used ZAR no. 116 Cherry.)

With the top upside down on a pad, center the legs/stretchers assembly on it. Using the holes in the desktop fasteners as guides, drill pilot holes in the top, and drive the screws.



... or try a scrapwood router trammel

If you don't have a disc/belt sander, a simple trammel for your plunge router does the trick. Because using a straight flute bit may cause tear-out in two quadrants, where shown in the drawing at *right*, trim the circle in a series of $\frac{1}{8}$ "-deep cuts. Avoid chatter by using a $\frac{1}{2}$ "-shank bit. To trim the circle without tear-out in a single pass, use a $\frac{1}{2}$ " upcut spiral flute bit.

To make the trammel, drill a 1" hole at one end of a 16"-long piece of $\frac{3}{4}$ " particleboard that is wide enough to accommodate your router's base. Screw the router to the particleboard with the bit centered in the hole. Now follow the three steps *below*.

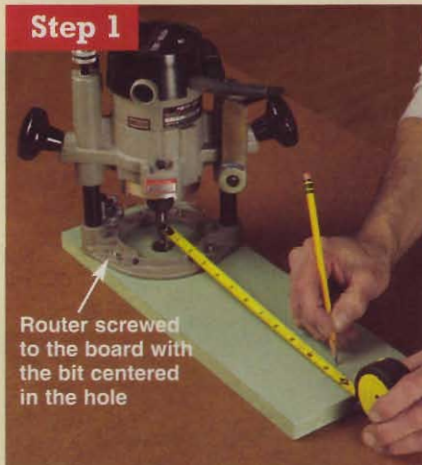
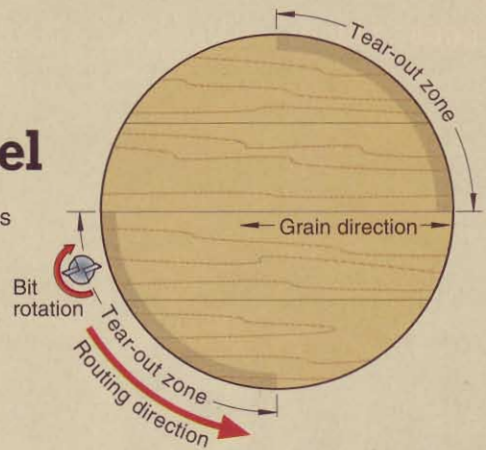

Step 1
Router screwed to the board with the bit centered in the hole. Measuring from the edge of the router bit, mark the radius of the circle on the trammel. Drill a $\frac{5}{32}$ " countersunk hole for a #8 flathead wood screw on the mark, centered on the trammel's width.



Step 2
To provide clearance for the router bit, stick three scrap blocks to your workbench with double-faced tape, then stick the top (D) to the blocks with more double-faced tape, top face down.



Step 3
Screw the trammel to the center of the bottom face of the top with a #8x $\frac{1}{4}$ " flathead wood screw. Plunge the bit into the top's edge, and rout. Raise the bit before switching off the router. Start routing where the grain is tangent to the edge. Bottom face (good face down)

2 Apply a clear finish. (We brushed two coats of satin polyurethane on the legs and stretchers, sanding between coats with 220-grit sandpaper.) For instructions on applying a flawless gloss finish to the top, see *page 38*.

3 Place the desktop fasteners in the counterbores in the top stretchers (B, C), and screw them in place.

4 Fasten the legs/stretchers assembly to the top, as shown in **Photo C**. Give your project a final dusting, carry it into the living room, and enjoy your beautiful new occasional table. 🍷

Written by **Jan Svec** with **Chuck Hedlund**
Project design: **Kevin Boyle**
Illustrations: **Roxanne LeMoine**

Cutting Diagram



$\frac{3}{4}$ x $7\frac{1}{4}$ x 96" Cherry (5.3 bd. ft.)

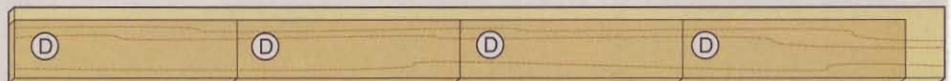

$\frac{3}{4}$ x $7\frac{1}{4}$ x 96" Bird's-eye maple (5.3 bd. ft.)

Materials List

Part	FINISHED SIZE			Matl.	Qty.
	T	W	L		
A leg blanks	$\frac{3}{4}$ "	$3\frac{1}{4}$ "	28"	C	4
B stretchers	$\frac{3}{4}$ "	3"	$14\frac{7}{8}$ "	C	2
C stretchers	$\frac{3}{4}$ "	3"	$14\frac{7}{8}$ "	C	2
D* top	$\frac{3}{4}$ "		22" diam.	EM	1

*Part initially cut oversize. See the instructions.

Materials key: C—cherry, EM—edge-joined bird's-eye maple.

Supplies: Spray adhesive, #8x $\frac{5}{8}$ " flathead wood screws, #8x $\frac{1}{4}$ " flathead wood screws.

Blades and bits: Stack dado set, $\frac{1}{8}$ " round-over router bit, $\frac{3}{8}$ " brad-point drill bit.

Buying Guide

Hardware. Desktop fasteners no. 866-826, \$5.99 for a package of 10. Call Woodworker's Supply, 800/645-9292 or go to woodworker.com.

See more . . .

...furniture plans at

<http://woodstore.woodmall.com/furniture.html>



lighted **showcase**

with unobstructed views



Display your collectibles and craftsmanship with this heirloom-quality, mahogany masterpiece. A sliding door makes access easy.

For the board feet of lumber and other items needed to build this project, see [page 65](#).

This spacious cabinet, measuring 18×37×83", includes a full-view, sliding glass door; an easy-to-make built-up crown; and halogen accent lights with three output levels. Of course, there's a lot of glass in this project, and it will run you a little more than \$200. Lights and hardware add \$80. Although we built this one from mahogany, you could use any number of less-expensive woods, including oak. But, keep in mind that a comparable store-bought piece will run you \$1,500 to \$2,200. Savings aside, no amount of money can replace the satisfaction you'll get by building this beauty yourself.

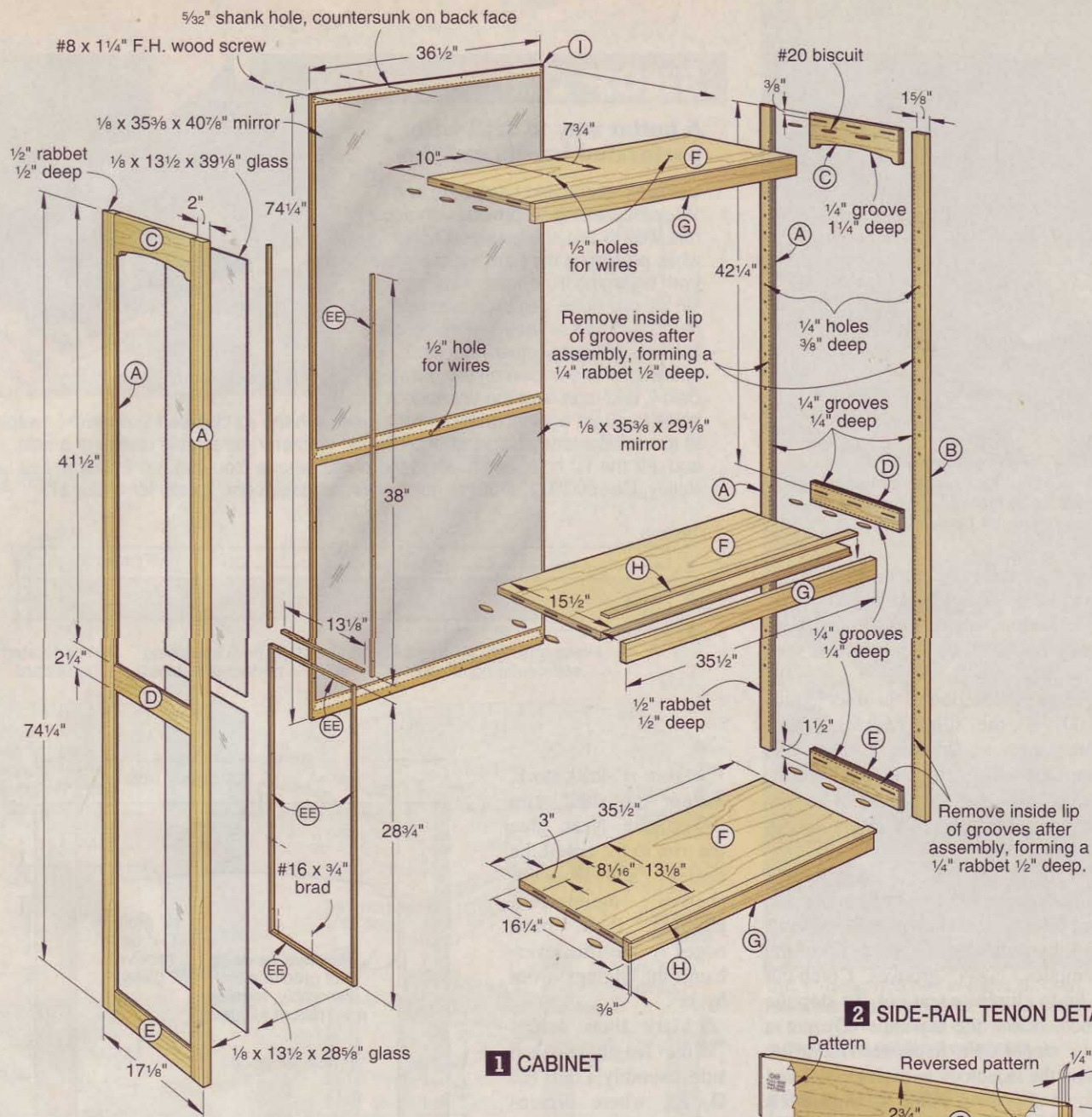

1 CABINET

2 SIDE-RAIL TENON DETAIL

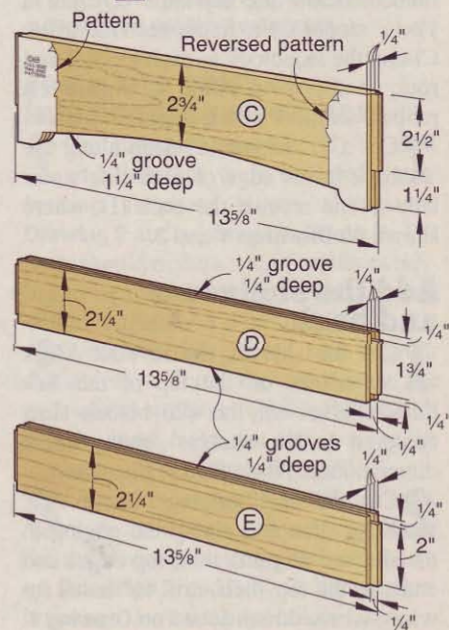

Note: This article describes how to build the curio cabinet with a right-sliding door. To build it with a left-sliding door, switch the positions of the wide and narrow stiles (A, B) at the front of the cabinet; reverse the orientation of the cabinet's full-extension slides; and attach the door edge (DD), shown on **Drawing 7**, on the opposite side of the door.

Start with the sides

1 Cut the wide stiles (A), narrow stile (B), top rails (C), middle rails (D), and bottom rails (E) to the sizes listed in the **Materials List**.

2 Cut a 1/4" groove 1/4" deep centered along one edge of the stiles (A, B)

and bottom rails (E), and on both edges of the middle rails (D), where shown on **Drawings 1** and **2**. Raise the blade to 1/4", and cut a groove centered along one edge of the top rails (C).

3 Using a 2"-wide scrap, cut and test-fit a 1/4" tenon in a stile's groove. When satisfied, cut the tenons on the ends of the rails (C, D, E), where dimensioned on **Drawing 2**.

4 Make four copies of the end pattern on the **WOOD PATTERNS**® insert. Cut out the shaded part of the patterns for the top rails (C). Using spray adhesive, attach the patterns to the ends of the rails, aligning them with the tenons' shoulders. (Flip the pattern over at one

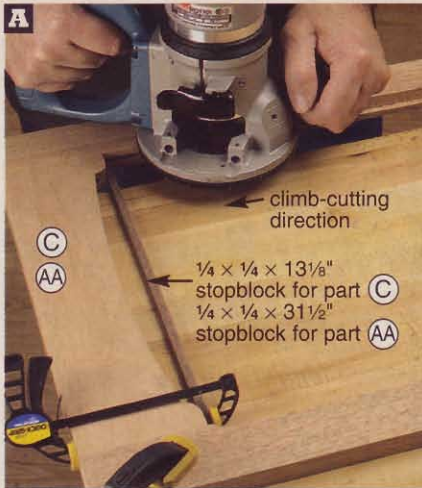

A $\frac{1}{4} \times \frac{1}{4}$ " stopblock clamped against the outside lip of the top rail's groove stops the rabbeting bit below the rail.

end of each rail.) Using a $\frac{1}{8}$ "-thick wood fairing strip 16" long, lay out the rails' curved bottom, where dimensioned, connecting the patterns. Bandsaw and sand to the lines.

5 Mark the location of the middle rails (D) on the stiles (A, B), where dimensioned on **Drawing 1**. Glue and clamp the stiles and rails (C, D, E) together, checking for square. When the glue dries, sand the side assemblies to 220 grit.

6 Form $\frac{1}{4}$ " rabbets $\frac{1}{2}$ " deep for the glass and glass stops (EE) in the side assemblies, where shown on **Drawings 1** and **3**, by removing the inside lip of the assemblies' $\frac{1}{4} \times \frac{1}{4}$ " grooves. Climb-cut the lip to eliminate tear-out. To stop the rabbets below the top rails (C), cut a $\frac{1}{4} \times \frac{1}{4}$ " stopblock to fit between the stiles. Clamp the stopblock to each top rail and rout, as shown in **Photo A**. Square the rabbets' corners with a chisel.

7 Cut a $\frac{1}{2}$ " rabbet $\frac{1}{2}$ " deep along the back inside edge of each side's rear stile (A) to receive the back (I), where shown on **Drawings 1** and **3**.

Add the shelves and back

1 Cut the shelves (F) to size. Mark centerlines on the top of the $\frac{3}{4}$ "-thick shelves for the #20 biscuit slots centered in the shelves' ends, where dimensioned. Now, plunge the slots.

2 Cut the shelf edging (G) to size. Now, glue and clamp the edging to the shelves, aligning their top edges and ends. In the top shelf, drill $\frac{1}{2}$ " holes for wires, where dimensioned on **Drawing 1**.

SHOP TIP

A better way to drill with perforated hardboard jigs

Using $\frac{1}{4}$ " perforated hardboard and a $\frac{1}{4}$ " self-centering bit provides an accurate way to drill shelf-support holes while protecting the hardboard's holes from enlarging from wear. First, using a $\frac{3}{8}$ " bit, drill holes centered over the hardboard jig's $\frac{1}{4}$ " holes. (For the curio cabinet, drill every other hole for 2" spacing, where shown on the drawing, *below*, and tape over the unneeded holes to guard against drilling error.) Next, with the jig clamped in position, switch to the self-centering bit, insert the bit's $\frac{3}{8}$ "-diameter retractable sleeve in a hole, and drill the $\frac{1}{4}$ " hole, as shown in the photo, *above*. You can find the bit at Lee Valley. Call 800/871-8158, or go to www.leevalley.com. It sells for under \$7.

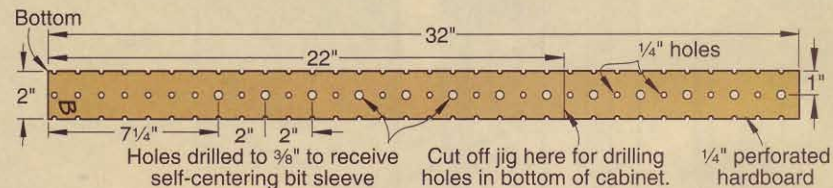

3 From $\frac{1}{4}$ "-thick stock, cut the shelf trim (H) to size. Next, glue the trim to the top of the center and bottom shelves' edging (G), aligning their back edges so the trim overhangs the edgings' front by $\frac{3}{8}$ ".

4 Mark lines across the length of each side assembly's rails (C, D, E), where dimensioned on **Drawing 1**, to locate the horizontal centers of the mating biscuit slots. Mark the vertical centerlines of the biscuits across these lines at the same dimensions as for the shelves, measuring from the rabbeted edge of the rear stiles (A). Plunge the slots.

5 Glue, biscuit, and clamp the side and shelving assemblies together, checking for square.

6 Set the cabinet on one side on a large, flat surface. Mark centerlines for the $\frac{1}{4}$ " shelf-support holes along the stiles (A, B), where dimensioned on **Drawings 3** and **4**.

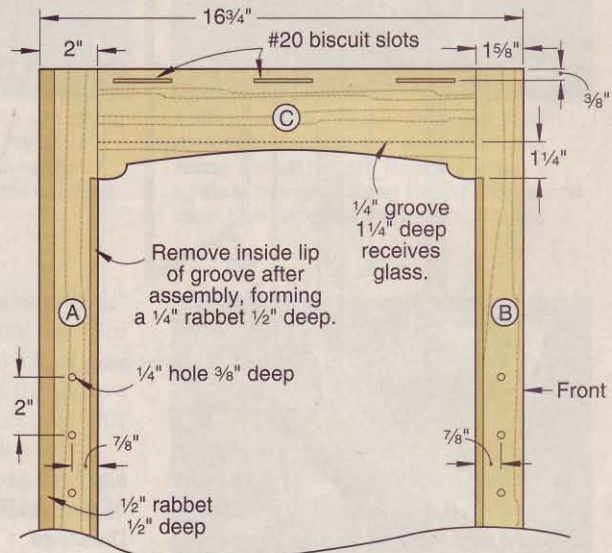

3 RIGHT SIDE ASSEMBLY

7 Make a hole-drilling jig, as shown in the **Shop Tip**, *above*. Center the jig's holes over one shelf-support centerline in the top of the cabinet, and position its bottom end against the middle shelf (F). Clamp the jig to the stile. Now, drill the shelf-support holes, repeating the process for the other stiles in the top of the cabinet. Then, cut the jig where shown, and drill the holes in the bottom of the cabinet.

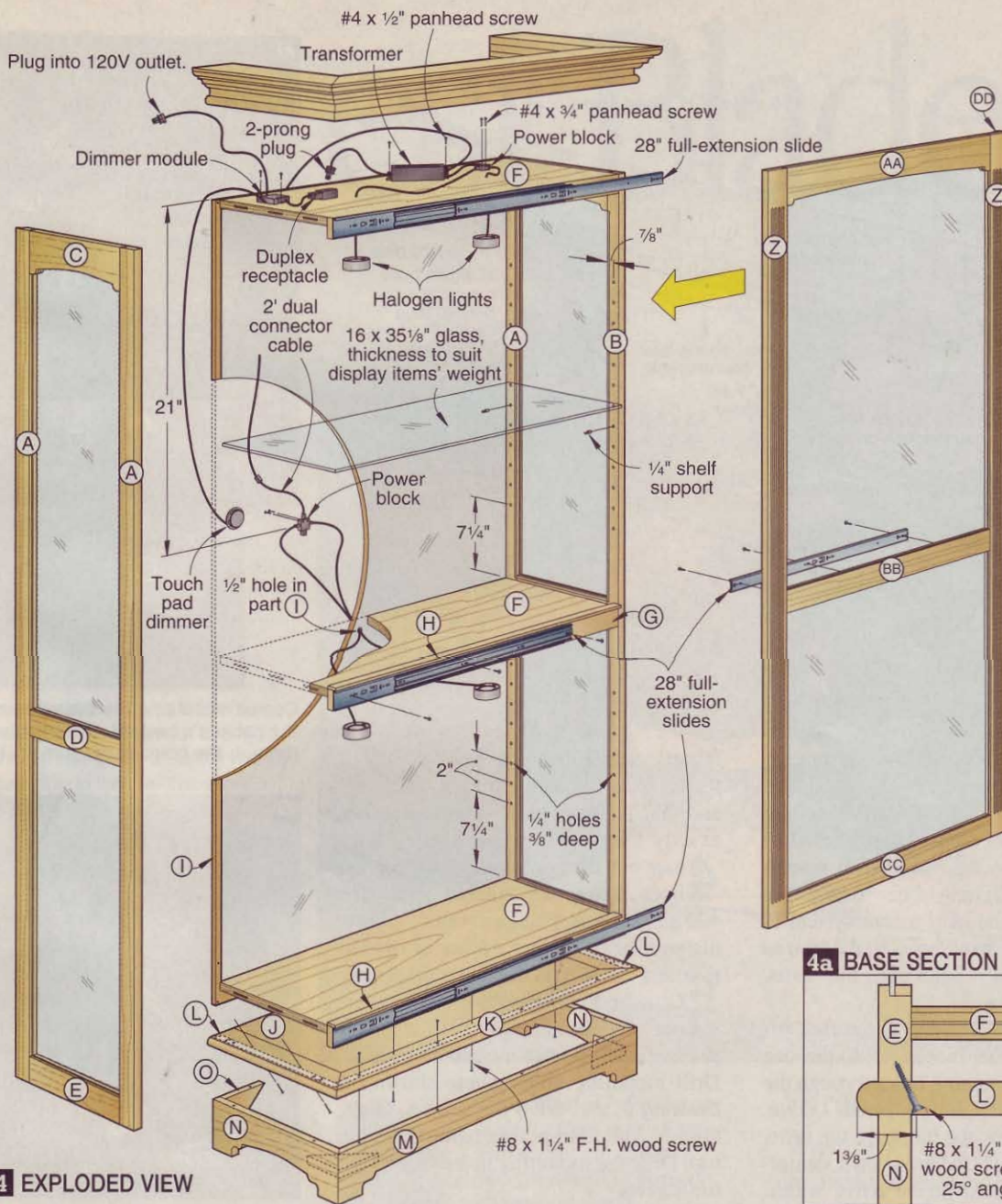

4 EXPLODED VIEW

4a BASE SECTION DETAIL

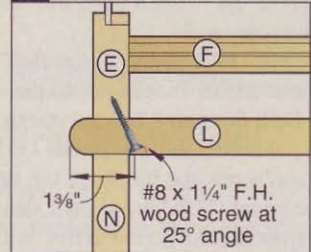

8 Position the cabinet facedown on your work surface. Cut the back (I) to fit in the rabbeted opening. Drill mounting holes through the back, where shown on **Drawing 1**. Locate the holes $\frac{3}{8}$ " from the back's top and bottom edges and $\frac{1}{4}$ " from its sides. Drive the screws. Drill a $\frac{1}{2}$ " hole for wires through the back where shown, countersinking its edges.

Build a sturdy base

1 Cut and miter-cut the base panel (J), front trim (K), and side trim (L) to size, where shown on **Drawing 5**.

2 Rout a $\frac{3}{4}$ " bullnose along the outside edge of the trim pieces, where shown. (We did this by routing a pair of round-overs using a $\frac{3}{8}$ " round-over bit.)

3 Mark a centerline across the trims' miter joints for the #20 biscuit slots. Plunge the slots, centering them on the trims' thickness.

4 Glue and clamp the trim to the base panel, inserting the biscuits in the slots in the trim's miter joints. Sand the trim flush to the panel. Now, drill mounting holes through the top and bottom of the trim, where dimensioned on **Drawings 4a** and **5**.

5 Cut the front skirt (M) and side skirts (N) to size, miter-cutting their ends, where shown on **Drawing 5**. Make six copies of the end pattern, but do not cut off the patterns' shaded area. Attach the patterns to the skirts' ends. Lay out the curve on each skirt's bottom, where dimensioned on **Drawing 5**, connecting the patterns. Bandsaw and sand the curves to the lines.

6 Mark centerlines on the outside face of the skirts at the mitered corners for #20 biscuit slots. Plunge the slots in the skirts' ends, where shown, offsetting them toward the skirts' inside face

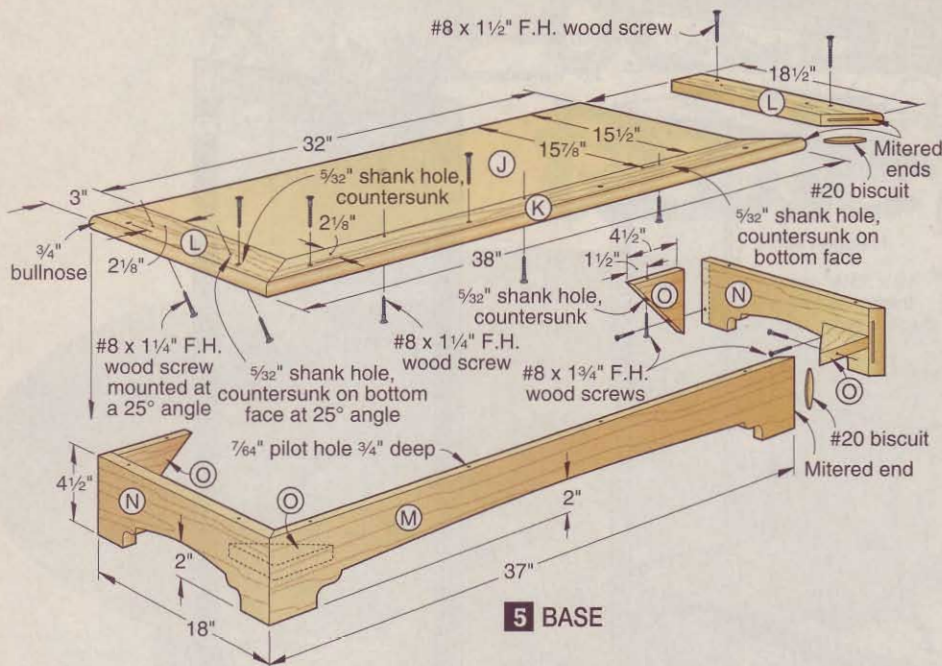

5 BASE

to ensure the slot cutter does not go through the outside face.

7 Glue and biscuit the skirts together. Then, glue and clamp the skirt assembly to the base panel/trim assembly (J/K/L), aligning their back edges and centering the skirt assembly end to end. Using the shank holes in the trim as guides, drill pilot holes into the skirts. Drive the screws.

8 Referring to **Drawing 5**, cut four triangular corner blocks (O) to the size shown. Drill mounting holes through the blocks, where dimensioned. Glue, clamp, and screw the blocks to the skirts and base panel (J), where shown, centering the front blocks on the skirts' width.

9 Place the cabinet on its back. Attach the base assembly to the cabinet as shown in **Photo B**.

Crown the cabinet

1 Cut the crown parts (P through Y) to size but 1" longer than listed.

2 Using your router table, rout the 3/4" bullnose on parts P and Q, the 1/2" round-over on parts T, U, X, and Y, and the 1/2" cove on parts V and W, where shown on **Drawing 6**.

3 Miter-cut the ends of the parts to the dimensions shown, making sure you have left and right (mirror image) pieces for the side parts. Cut the front parts P, R, T, V, and X so their back

(short) edges measure exactly 32" in length. Cut the side parts Q, S, U, W, and Y so their back edges measure exactly 15 1/2".

4 Lay out the parts, and mark centerlines across the mitered joints for #20 biscuit slots. Plunge the slots, adjusting your biscuit joiner's fence as needed to center the slot on the part's thickness.

5 Glue and clamp part P to the cabinet's top, centering it end to end and placing it 15 1/2" from the cabinet's back. Drill mounting holes where shown on **Drawing 6**, and drive the screws. Glue, biscuit, and clamp side parts Q to the top. Drill the mounting holes, and drive the screws.

6 Using the same method, install the remaining crown parts R through Y, as shown in **Photo C**.

Add a door with a view

1 Cut the stiles (Z) to size but 4" longer than listed. Make marks on a face of each stile 4 1/4" from the bottom and 5 7/8" from the top to identify the flutes' length. Now, chuck a 1/4" roundnose bit in your handheld router. Attach an edge guide to the router. Clamp stopblocks to the ends of the stiles where appropriate for your router to stop the flutes at the marks. For more on this, see *page 40*.

2 Adjust the router bit to cut a 1/16"-deep flute. Adjust the edge guide as

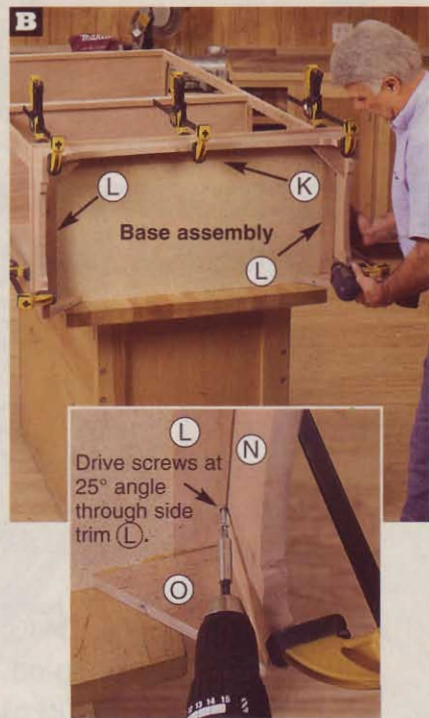

Center and clamp the base assembly to the cabinet's bottom. Drive the screws through the holes in the trim (K, L).



Align the back edges of the crown's parts as you assemble it. Offset each part's screw locations to avoid striking the screws below.

needed, and cut the flutes, where dimensioned on **Drawing 7a**.

3 Trim the bottom of each stile (Z) 2 1/4" below the ends of the flutes. Then, trim the top of the stiles to their finished length of 74 1/8".

4 Cut the top, middle, and bottom rails (AA, BB, CC) to size. Next, cut 1/4" grooves in the rails, and stiles (Z), where shown on **Drawings 7 and 8**.

5 In the grooves in stiles Z, lay out the 1/4" mortises 1 13/16" deep. Drill out the mortises using a 1/4" brad-point bit

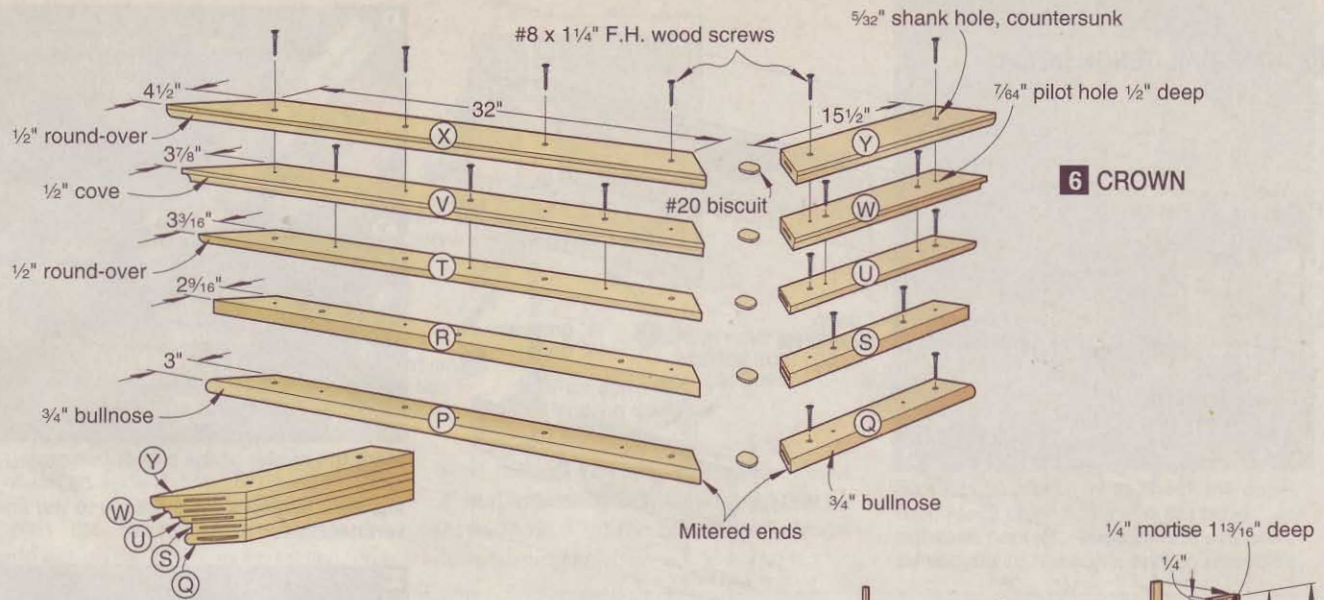

6 CROWN

in your drill press. Square the ends of the mortises and straighten their sides with a chisel. (For an easier way to form the mortises, and for help on forming the mating door-rail tenons in the next step, see the article on *page 42*.)

6 Cut the 1/4" tenons on the ends of the rails (AA, BB, CC), where dimensioned on **Drawing 8** on *page 64*. Note that the tenons for the top rail (AA) and bottom rail (CC) are haunched (notched).

7 Make two copies of the end pattern, and cut out the shaded part. Attach them to the ends of the top rail (AA). Mark the arch on the rail where dimensioned. Bandsaw and sand to the line.

8 Dry-assemble the stiles (Z) and rails (AA, BB, CC). When the parts fit together correctly, glue and clamp them together, checking for square. Later, sand the assembled door smooth.

9 As in **Photo A**, rout 1/4" rabbets 1/2" deep for the glass in the door's back, where shown on **Drawing 7**, by removing the inside lip of its 1/4x1/4" grooves. Square the rabbets' corners.

10 Cut the door edge (DD) to size. Glue and clamp it to the back of the door where shown, flush with the outside edge of the stile (Z).

Install the door

1 Using a helper, place the cabinet faceup on sawhorses. Separate the cabinet slide and matching door slide parts of the full-extension slides by pressing the slide release tab shown in **Photo E** on *page 64*. Screw the cabinet slides (the larger pieces) to the shelf

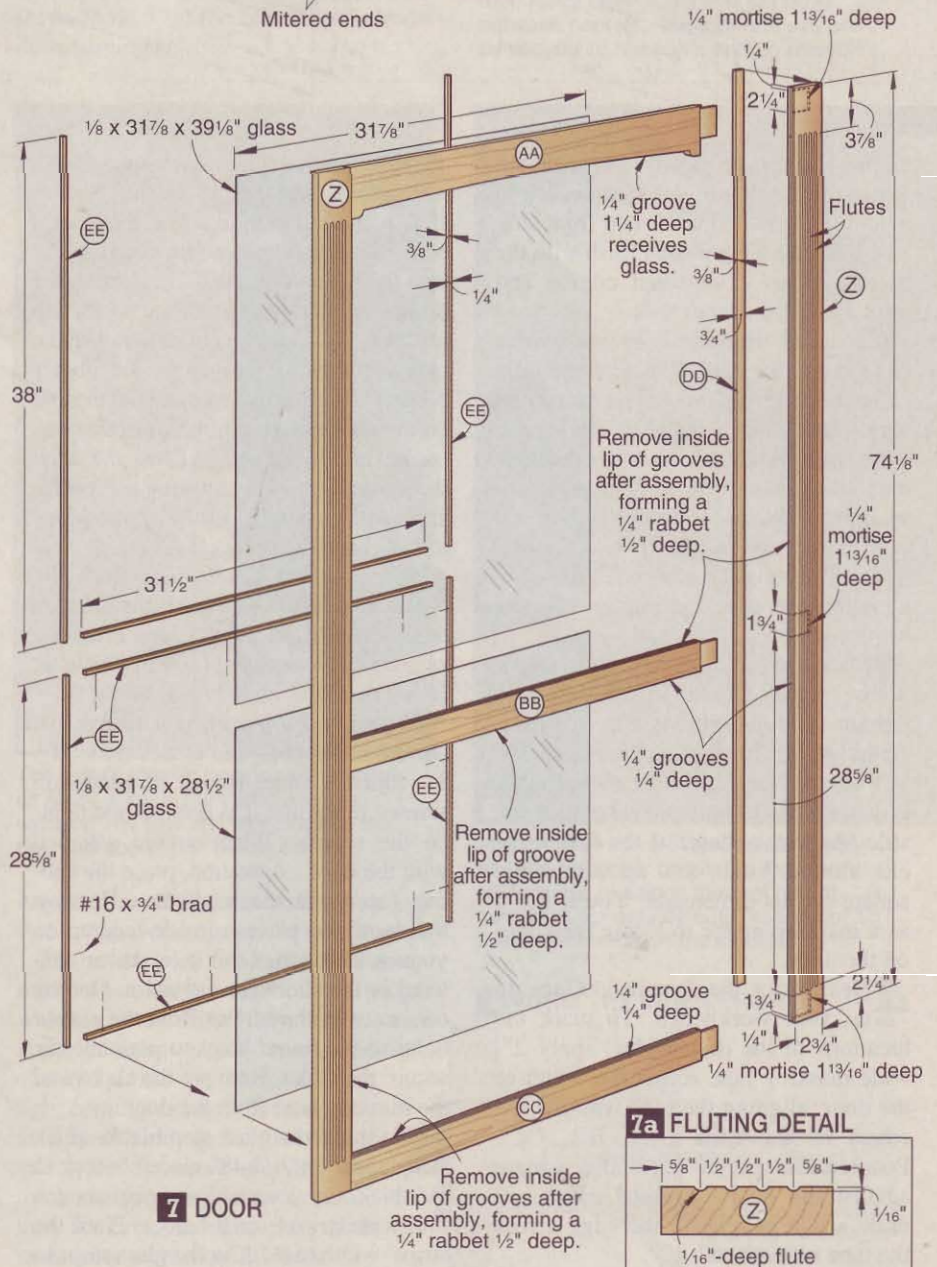

7 DOOR

7a FLUTING DETAIL

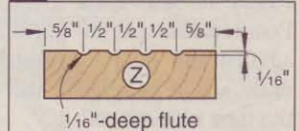

8 DOOR-RAIL TENON DETAIL

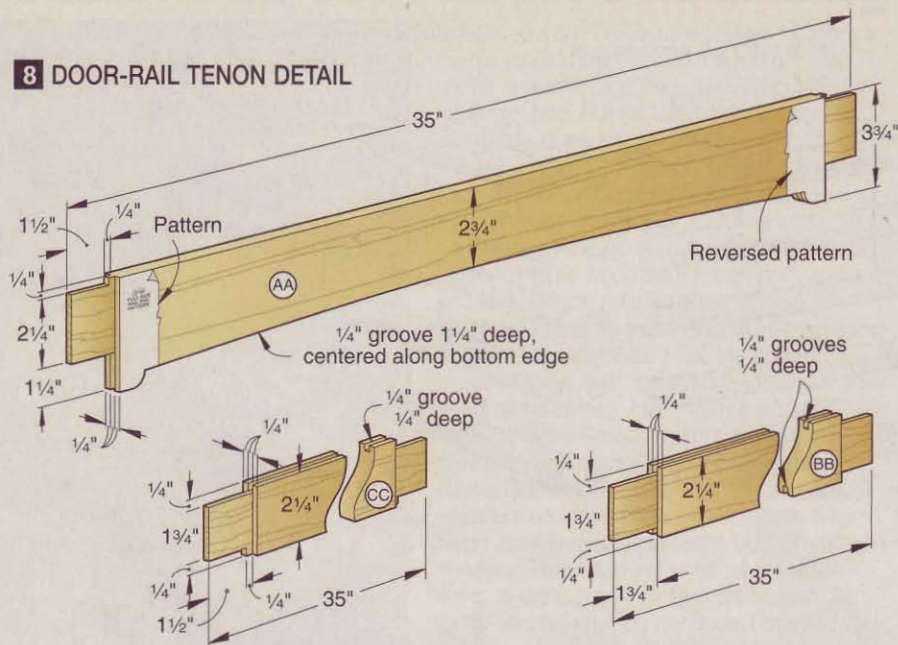

edging (G), where shown on **Drawing 4**. Position the lower two slides tight against the shelf trim (H) and front stile (A). Position the top slide flush with the bottom edge of the shelf edging and tight against the front stile.

2 To locate the door slides, reassemble them to the cabinet slides, and fully close them. Position the door faceup on the cabinet with its bottom flush against the front trim (K). Measure the reveal at the top of the door. Now, adjust the door so approximately one-third of the reveal is at the top and two-thirds is at the bottom. (The reveals will equalize after mounting the door and setting the cabinet upright.)

3 Slide the door open 4", and clamp it in place. Make sure the slides remain fully closed. Mark each slide's centerline on the door's edge, as shown in **Photo D**. On one slide, measure the distance from the outside face of the front stile (A) to the center of the first *vertical* slotted hole. Set an adjustable square to this dimension. You'll use it as a marking gauge to locate the slides on the door.

4 Next, place the door inside face up on your workbench. To mark the locations of the door slides, apply 2"-wide masking tape across the width of the door, aligning the tape with the top edges of the rails (AA, BB, CC). Position the preset adjustable square against the door's marked edge, and draw a line parallel to the edge across the tape on each rail.

5 Position the square against the door's bottom, and set it to the bottom slide's centerline marked on the door's edge. Transfer the centerline across the tape on the bottom rail (CC). Repeat this process to mark the centerline on the top rail (AA). To mark the middle rail (BB), measure the distance from the door's bottom to the middle slide's centerline on the door's edge. Mark this dimension on the middle rail at both ends, and draw the centerline. (This ensures the center slide will be parallel to the top and bottom slides.)

6 Separate the door slides from the cabinet slides. Align the slides on the door, drill pilot holes, and drive the supplied screws, as shown in **Photo E**. Install the door, as shown in **Photo F**.

7 Stand the cabinet upright. Check that the door opens and closes smoothly. To adjust a slide, loosen its mounting screws, reposition it as needed, and tighten the screws. When you're satisfied with the door's operation, place the cabinet faceup on the sawhorses. Remove the door, and place it inside face up on your workbench. Drill pilot holes centered in the slides' *round* holes. One by one, transfer the screws from the *slotted* holes to the *round* holes to permanently secure the slides. Remove the slides and the masking tape from the door.

8 To make the glass stop blanks (EE), plane a 1/2x7 1/4x48" piece of stock to 3/8" thick. On your tablesaw, rip sixteen 5/16"-wide strips from the stock. Plane the strips' width to 1/4". Cut the glass stops to

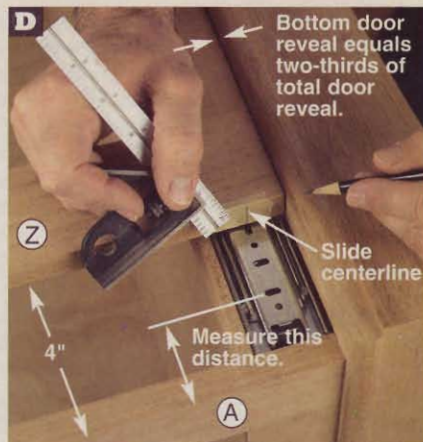

Mark the center of the slide's horizontal slotted hole on the door's edge on masking tape. Measure the distance to the first vertical slotted hole.

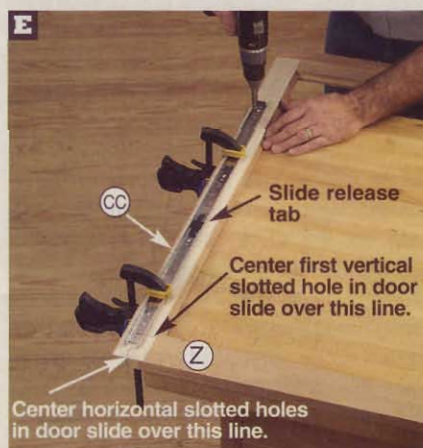

With the slide aligned with the marked lines, drill pilot holes through the slide's horizontal slotted holes using a self-centering bit. Drive the screws.



Using a helper, align the door's and cabinet's slides, and slide the door in place.

fit the openings in the cabinet's sides and door, where dimensioned on **Drawings 1** and **7**. Set the stops aside.

Put on a fitting finish

1 Sand any areas on the cabinet and door that need it. Remove the dust.

2 Apply a stain if you wish. (We used ZAR Oil-Based Wood Stain #118 Dark Mahogany.) To ensure adequate adhesion of the mirrors, stain (and finish) only a 1½"-wide strip around the mirror mounting areas on the cabinet's back (I).

3 Apply three coats of a clear finish, sanding to 320 grit between coats and removing the dust. (We sprayed on DEFT Satin Lacquer Clear Wood Finish.)

Add the lighting

1 Surface-mount a pair of halogen lights under the top and middle shelves (F), as directed in the manufacturer's instructions. Route the wires from the upper lights through the ½" holes in the top shelf. Feed the wires from the lower lights through the ½" hole in the back (I).

2 Referring to **Drawing 4**, screw the transformer, dimmer module, and a power block to the top of the cabinet. On the back side of the cabinet, screw another power block to the center of the back (I) 21" from the cabinet's top. Connect the lights' and transformer's wires to the power blocks, where shown.

3 Plug the wire from the touch pad dimmer into the dimmer module. Using cloth-backed, double-faced tape, mount the pad in a convenient place, such as on the cabinet's back or inside the cabinet under the middle shelf.

4 Trim the transformer's power cord, attach its plug, and insert it into the dimmer module's receptacle, as directed in the manufacturer's instructions.

Install the glass

1 Place the cabinet on its back. Apply mirror mastic (from your local glass shop) to the back of the mirrors, and press them onto the cabinet's back (I). Let the mastic cure for 24 hours.

2 Install the glass and glass stops (EE) in the cabinet's sides and door. Attach the stops with #16x¾" brads. To prevent splitting the stops, drill holes in them using a brad with its head snipped off.

Cutting Diagram

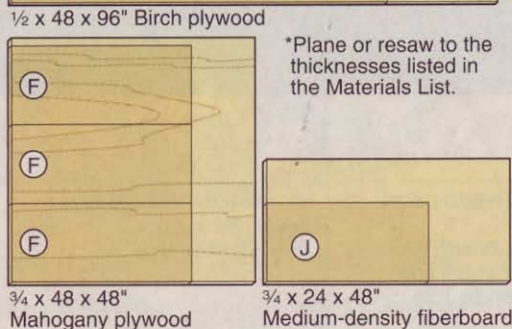
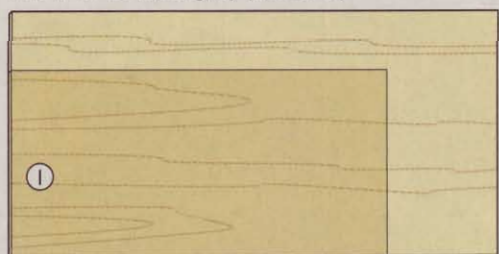
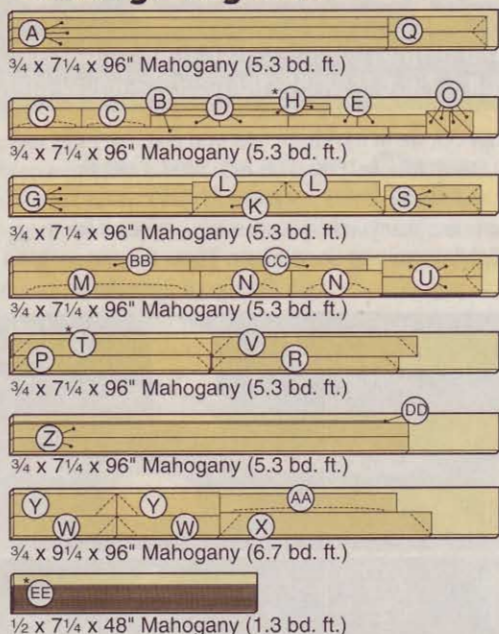

*Plane or resaw to the thicknesses listed in the Materials List.

3 Reinstall the door slides and the door. Set the cabinet upright, and move it to its final location. Install shelf supports and glass shelves. Use a suitable glass thickness to safely support your display items. For the 35½" span of the shelves, the maximum load ratings per square foot are: 5.3 pounds for ¼" glass; 17.5 pounds for ⅜" glass; and 32.6 pounds for ½" glass.

4 Plug the module's power cord into a 120V outlet. Place your collectibles on the shelves, press the three-level touch pad dimmer to set the desired light level, and enjoy the beautiful display. ♣

Written by **Owen Duvall** with **Chuck Hedlund**
 Project design: **Kevin Boyle**
 Illustrations: **Roxanne LeMoine**

Materials List

Cabinet	FINISHED SIZE			Matl.	Qty.
	T	W	L		
A wide stiles	¾"	2"	74¼"	M	3
B narrow stile	¾"	1⅝"	74¼"	M	1
C top rails	¾"	3¾"	13⅝"	M	2
D middle rails	¾"	2¼"	13⅝"	M	2
E bottom rails	¾"	2¼"	13⅝"	M	2
F shelves	¾"	15½"	35½"	MP	3
G shelf edging	¾"	1⅞"	35½"	M	3
H shelf trim	¼"	1⅞"	35½"	M	2
I back	½"	36½"	74¼"	BP	1

Base

J base panel	¾"	15½"	32"	MDF	1
K front trim	¾"	3"	38"	M	1
L side trim	¾"	3"	18½"	M	2
M front skirt	¾"	4½"	37"	M	1
N side skirts	¾"	4½"	18"	M	2
O corner blocks	¾"	4½"	4½"	M	4

Crown

P* bullnose front	¾"	3"	38"	M	1
Q* bullnose sides	¾"	3"	18½"	M	2
R* flat front	¾"	2⅞"	37⅞"	M	1
S* flat sides	¾"	2⅞"	18⅞"	M	2
T* middle front	½"	3⅞"	38⅞"	M	1
U* middle sides	½"	3⅞"	18⅞"	M	2
V* cove front	¾"	3⅞"	39¾"	M	1
W* cove sides	¾"	3⅞"	19⅞"	M	2
X* cap front	¾"	4½"	41"	M	1
Y* cap sides	¾"	4½"	20"	M	2

Door

Z* stiles	¾"	2¾"	74⅞"	M	2
AA top rail	¾"	3¾"	35"	M	1
BB middle rail	¾"	2¼"	35"	M	1
CC bottom rail	¾"	2¼"	35"	M	1
DD door edge	⅝"	¾"	74⅞"	M	1
EE* glass stop blanks	¼"	⅝"	48"	M	16

*Parts initially cut oversize. See the instructions.

Materials key: M—mahogany, MP—mahogany plywood, BP—birch plywood, MDF—medium-density fiberboard.

Supplies: Spray adhesive; #20 biscuits; #8x1¼", #8x1½", and #8x1¾" flathead wood screws; #4x½" and #4x¾" panhead screws; #16x¾" brads; mirror mastic; ⅞x13½x28⅞" glass (2); ⅞x13½x39⅞" glass (2); ⅞x31⅞x28½" glass (1); ⅞x31⅞x39⅞" glass (1); ⅞x35⅞x29⅞" mirror (1); ⅞x35⅞x40⅞" mirror (1); 16x35⅞" glass for shelves (3), ¼", ⅜", or ½" thick to suit load-support needs; cloth-backed, double-faced tape.

Blades and bits: Dado-blade set; ¼" and ½" rabbeting, ⅝" and ½" round-over, ¼" roundnose, and ½" cove router bits; ¼" brad-point drill bit.

Buying Guide





Hardware. Halogen light set, includes four 20-watt lights with brass finish, transformer, and two power blocks; three-level touch pad dimmer; 2' dual connector cable; ¼" shelf supports, polished brass, white-vinyl coated (12); 28" full-extension slides (3). Kit no. KIT0903, \$79.95 ppd. Price reflects a discount for WOOD® magazine readers. Woodworker's Hardware. Call 800/383-0130, or go to www.wwhardware.com.

display lighting lowdown

Built-in lighting can transform a display cabinet from dark to dazzling, provided you choose the right type of lighting fixture. Here's what you need to know about 9 lighting options.

When designing the curio cabinet on page 58, we lit it with low-voltage halogen "puck" lights, available in pre-packaged kits at hardware stores and home centers everywhere. But, as the chart below shows, there are many other choices. Use this information to choose your next lighting product. See page 68 for a list of sources.

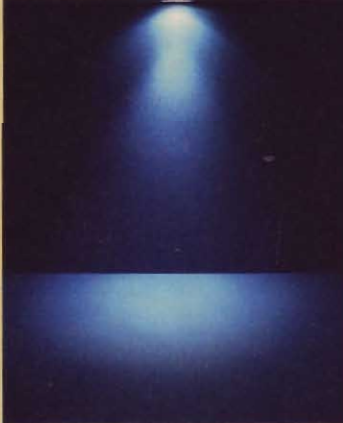
As you pore over the various fixtures, note that we arranged them in the order of brightness, with the brightest first in our chart. When making your choice, keep in mind that all recessed fixtures require an open-top cabinet, with the minimum overhead clearance listed in the chart. These fixtures are ideal when crown molding creates a recess at the top of the cabinet, hiding the electrical components from view.

Light fixture	1	2	3
			
	120V halogen canister	120V swivel eyeball	120V under-cabinet halogen (only one bulb switched on in light-pattern photo)
Light pattern			
Vertical Surface	30"		
Horizontal Surface	32"		
Cost with bulb	\$23	\$20.50	■ 2-light, \$24.50 ■ 3-light, \$35
Installation	Two versions, both recess-mount with trim: ■ Flathead screws through the trim ring, 3½"-diameter hole ■ Clip-in, 3¾"-diameter hole	Recess-mount, flathead screws through the trim ring, 4¼"-diameter hole	Surface-mount
Minimum overhead clearance	4"	4"	None required
Minimum cabinet dimensions per fixture or bulb	12x12x18"	12x12x12"	12x12x12"
Electrical configuration	Maximum of six fixtures may be linked together.	Maximum of six fixtures may be linked together.	Two or three lights in a single housing with a high/low intensity switch
Bulb watts	50W	50W	25W
Bulb life	500 hours	2,000 hours	2,000 hours
Replacement bulb cost	\$12.50	\$5.50	\$6.25
Wiring system	Modular	Modular	Plug-in or hard-wire
Accessories (footnote 1—see page 68)	D2, D3, DF, PS, RS, SS	D2, D3, DF, PS, RS, SS	None
Comments	Although the bulb for this fixture is the most expensive to replace, it throws the brightest light the longest distance. This is the best fixture to use for a tall display case that can be lit only from the top.	Slightly less bright than fixture no. 1, this fixture throws a softer, more diffuse light. For improved lighting of objects, mount the fixture toward the front of the cabinet, and aim it slightly toward the back.	This surface-mounted halogen fixture doesn't need a transformer. Use it where the cabinet's design hides it from view. The two-position switch gives you a choice of brightness levels.

Also, recess-mounting 12-volt halogen puck lights requires that the mounting hole be bored through the cabinet's top for ventilation.

No, you don't have to be an electrician to install these lights. The fixtures either plug directly into an outlet, or gang together via "modular" wiring. In this case, each component has a short cord or cords with molded-on connectors. Simply mount the fixture, plug the connectors together, add your choice of modular switches or dimmers, and then plug the whole system into a wall outlet.

To sort out the choices, we purchased the various cabinet lights available through catalogs and local retailers. Then we photographed their lighting patterns against a dark background. The drawings, right, show how the lights were set up for comparison.

Continued on page 68

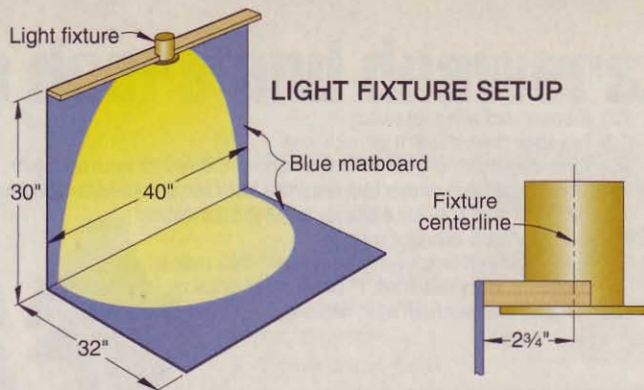

Light fixture	4 12V halogen puck	5 120V incandescent canister	6 120V mini-swivel eyeball
Light pattern			
Vertical Surface	30"		
Horizontal Surface	32"		
Cost with bulb	<ul style="list-style-type: none"> ■ 3-light set, \$26.25 ■ 4-light set, \$44 ■ Extra lights, \$7 	<ul style="list-style-type: none"> ■ Bracket-mount, no trim, \$12 ■ Screw-mount or clip-in, with trim, \$15 	\$17
Installation	Two options, both require a transformer that must be concealed by the cabinet's design, or remotely mounted: <ul style="list-style-type: none"> ■ Surface-mount ■ Recess-mount in a 55mm-diameter hole 	Three versions, all recessed: <ul style="list-style-type: none"> ■ Bracket-mount, no trim, 3 1/2"-diameter hole ■ Flathead screws through the trim ring, 3 1/2"-diameter hole ■ Clip-in with trim, 3 3/4"-diameter hole 	Recess-mount, flathead screws through a flange covered by a trim ring, 2 7/8"-diameter hole
Minimum overhead clearance	Through hole for recess-mounting	4"	4"
Minimum cabinet dimensions per fixture or bulb	12x12x12"	12x12x18"	12x12x12"
Electrical configuration	<ul style="list-style-type: none"> ■ 60W transformer, maximum of three 20W or six 10W lights ■ 120W transformer, maximum of six 20W or twelve 10W lights 	Maximum of six fixtures may be linked together.	Maximum of six fixtures may be linked together.
Bulb watts	10W, 20W	40W	40W
Bulb life	4,000 hours	500 hours	500 hours
Replacement bulb cost	\$2.70	\$3.25	\$3.25
Wiring system	Modular	Modular	Modular
Accessories (footnote 1)	D3P, PS	D2, D3, DF, PS, RS, SS	D2, D3, DF, PS, RS, SS
Comments	Some puck-type fixtures are available with xenon bulbs. These bulbs cost twice as much to replace as ordinary halogens, but they create about 10 percent less heat and last more than twice as long.	This fixture combines a wide angle of light distribution with good downward projection. Available with or without trim. The trim version mounts the same as fixture no. 1; the no-trim version mounts similar to no. 7.	A compact version of fixture no. 2, this model uses the same 40-watt bulb as no. 5. With its open housing, it leaks some light upward. The cabinet design must shield this errant light from view.

Notes:







1. (CS) 6' power cord with a roll switch
- (D2) Two-stage dimmer switch (off, high, low)
- (D3) Three-stage touch dimmer (connect to cabinet hardware for touch operation)
- (D3P) Three-stage touch dimmer (supplied with a touch pad, or connect to cabinet hardware for touch operation)
- (DF) Full-range dimmer switch with a stem for 3/4"-thick material
- (EX) Fixture-to-fixture extension cord
- (PS) Push on/push off switch with a stem for 3/4"-thick material
- (RS) Two-circuit rotary switch (off, 1st circuit on, 2nd circuit on, both circuits on)
- (SS) Spring-loaded switch (on when released)

Sources

Rockler Woodworking and Hardware. Call 800/279-4441 for a catalog, 877/762-5537 for the location of the nearest retail store, or go to www.rockler.com.

Woodworker's Hardware. Call 800/383-0130 for a catalog, or go to www.wwhardware.com.

Woodworker's Supply. Call 800/645-9292 for a catalog, or go to www.woodworker.com.

Light fixture	7 120V incandescent mini-canister 	8 120V curio light (only one bulb switched on in light-pattern photo) 	9 120V strip light 	
Light pattern				
Vertical Surface	30"			
Horizontal Surface	32"			
Cost with bulb	\$8.50	Double, \$11.50 Single, \$7.25	10", \$13.50 20", \$17.75 30", \$24	10", \$25 20", \$30.75 30", \$36.50
Installation	Recess-mount with bracket, no trim, 2 1/2"-diameter hole	Surface-mount	Surface-mount	
Minimum overhead clearance	4"	None required	None required	
Minimum cabinet dimensions per fixture or bulb	12x12x12"	12x12x12"	12" width, 22" width, 32" width	
Electrical configuration	10' power cord with a roll switch	10' power cord; switch(es) on bulb socket(s)	67" power cord with a roll switch; multiple fixtures cannot be linked.	Link multiple fixtures up to a total of 300W.
Bulb watts	25W	25W	6W, 12W, 18W	
Bulb life	1,500 hours	1,200–1,500 hours	40,000 hours	
Replacement bulb cost	\$4	\$2.50	Replace entire fixture.	
Wiring system	Plug-in	Plug-in	Plug-in	Modular
Accessories (footnote 1)	D2, D3, DF, PS, RS, SS	D2, D3, DF, PS, RS, SS	N/A	CS, EX
Comments	With a smaller mounting hole than the no-trim version of fixture no. 5, this is the least conspicuous model in the group. It mounts from the top with a plastic ring-shaped bracket that screws in place.	The granddaddy of all cabinet lights, this surface-mounted fixture comes in double- and single-bulb versions. The fixture's open construction requires cabinet design suitable to hide it.	Intended for exposed mounting, this fixture is more an accent than a display light, and works best for lighting a single shelf. You must replace the entire fixture when the individual bulbs start to burn out.	

double-take

keepsake box

A foolproof technique makes fitting the lid to the base a snap.



Turn this beautiful box from any wood you have on hand. The three examples shown here (from top): cherry, walnut, and hackberry. Although it appears to be a Southwest-style vessel—thanks to the black-painted recess at its top—it's really a lidded bowl for holding jewelry and other small items. The illusion is further assisted by three decorative grooves; the center one conceals the joint between the lid and base.

1 Create the templates

Make a copy of the six templates on the *WOOD PATTERNS*® insert, and adhere them with spray adhesive to 1/8" tempered hardboard. Bandsaw or scrollsaw, and sand the templates to shape.

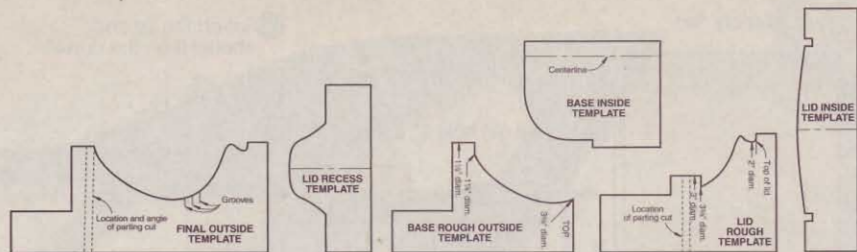

2 True the blank, and bore a hole

Find the center of a 4x4x5" bowl blank by drawing diagonals on one end. Use a compass to draw a 3"-diameter circle around the center. Screw your 3" faceplate to the blank, centered in the circle, and then mount the blank on your lathe. Use your roughing gouge to turn it to a 3 3/4"-diameter cylinder. True the blank's end with your spindle gouge.

Install a drill chuck in the lathe tailstock, and chuck in a 3/4" Forstner bit. Bore a 3/4" hole 1/2" deep in the blank's end.

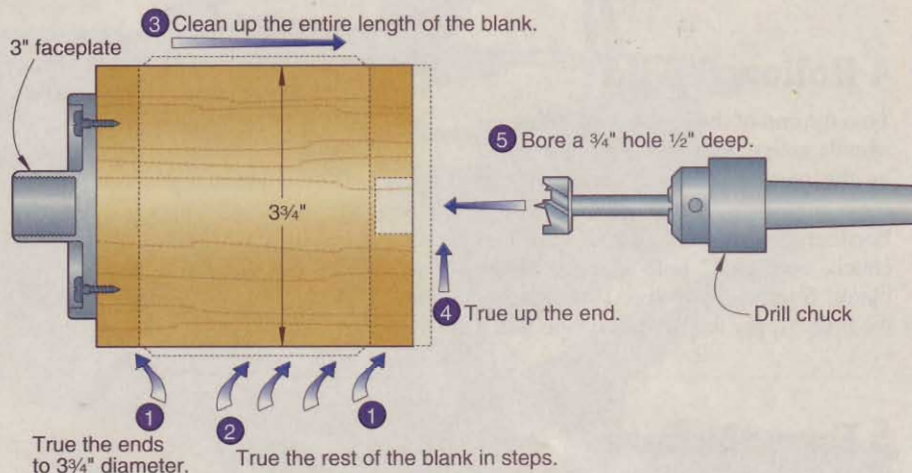

Tools: 3/4" roughing gouge, 3/8" spindle gouge, 3/4" Forstner bit.

Tool rest: Roughing gouge, center; spindle gouge, slightly below center.

Speeds: Roughing gouge, 600–800 rpm; spindle gouge, 800–1,200 rpm; Forstner bit, 500 rpm.

3 Rough-shape and part the lid

Align the top mark on the **Lid Rough Template** with the blank's end, and mark the critical diameters on the blank, as shown in **Photo A**. Then to avoid accidentally hitting them with your turning tools, mark a safety line 1/4" beyond the tips of the faceplate screws. With your parting tool, make gauging cuts to the diameters indicated on the template, checking your cuts with outside calipers. Make overlapping cuts to clean out the 1/2"-wide groove that separates the lid from the base.

Use your spindle gouge to form the lid's rough profile, checking it with the template. Part the lid from the blank with your parting tool, where indicated on the template, and as shown in **Photo B**, leaving a 1/8"-long tenon on the lid.

Tools: Parting tool, 3/8" spindle gouge.

Tool rest: Parting tool, center; gouge, slightly below center.

Speed: 800–1,200 rpm.

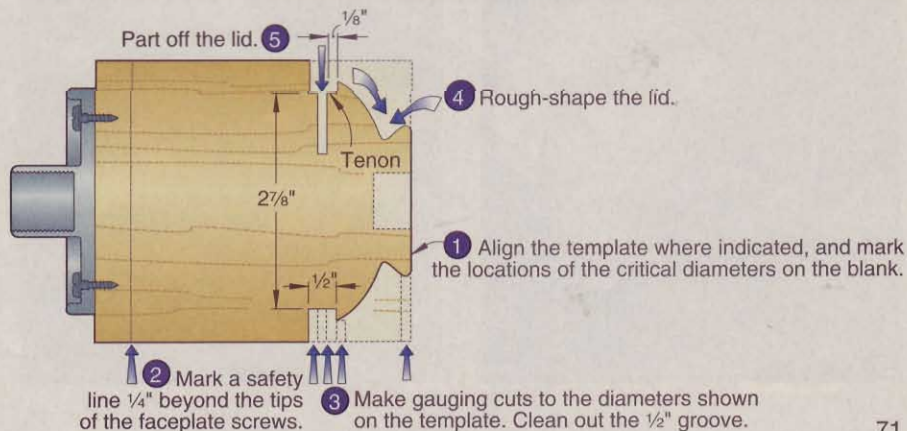

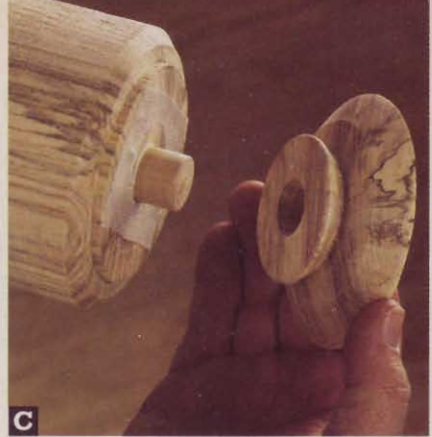
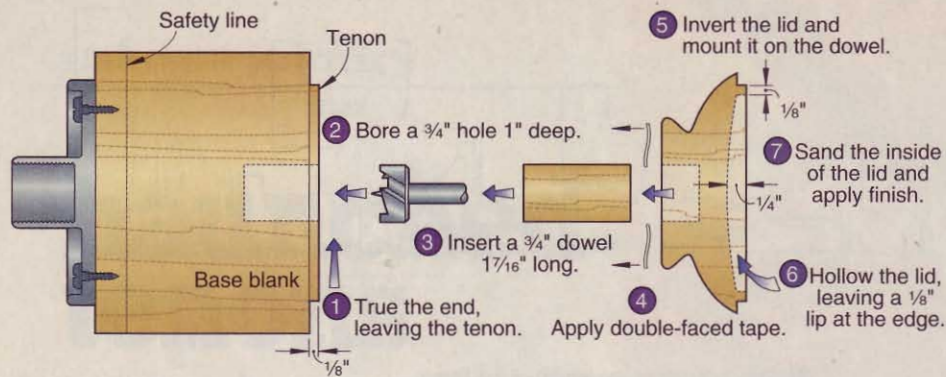

4 Hollow the lid

True the end of the base blank with your spindle gouge, leaving the tenon formed by the portion of the $\frac{1}{2}$ "-wide groove remaining after parting the lid. With a Forstner bit in the tailstock-mounted chuck, bore a $\frac{3}{4}$ " hole 1" deep in the blank. Insert a $\frac{3}{4}$ " dowel $1\frac{7}{16}$ " long in the hole. Apply double-faced tape to the

base blank. Invert the lid, and mount it on the dowel's protruding end, as shown in **Photo C**. Make certain the lid's top is firmly seated against the base blank's end. Use your spindle gouge to hollow the inside of the lid, leaving a $\frac{1}{8}$ "-thick lip at the perimeter. Check the profile with the **Lid Inside Template**.

Sand the inside of the lid, and apply a clear finish. We used Mark VI poly-oil

finish, a fast-drying friction finish you apply with the lathe running at slow speed. See the **Buying Guide** for our source for the finish. Remove the lid, dowel, and double-faced tape from the base blank.

Tools: $\frac{3}{8}$ " spindle gouge, $\frac{3}{4}$ " Forstner bit.
Tool rest: Slightly below center.
Speeds: Gouge, 800–1,200 rpm; Forstner bit, 500 rpm.

5 Form the base

Align the top of the **Base Rough Outside Template** with the base blank's shoulder, and mark the critical diameters. Then, make gauging cuts with your parting tool and outside calipers to the diameters indicated on the template. Make overlapping cuts to clean out a $\frac{3}{8}$ "-wide groove at the base's bottom. Form a recess for the lid's lip, aligning your parting tool's edge with the edge of the base's tenon, where shown on the **Lid Recess Detail**, and as shown in **Photo D**.

Hollow the base with your spindle gouge, checking it with the **Base Inside Template**. Smooth the interior with a roundnose scraper, as shown in **Photo E**, and check the lid's fit on the base. The fit should be snug, but not forced. Use your spindle gouge to form the base's rough outside profile, as shown in **Photo F**. Check the profile with the **Base Rough Outside Template**. Sand the inside of the base, and apply the finish.

Tools: Parting tool, $\frac{3}{8}$ " spindle gouge, $\frac{1}{2}$ " roundnose scraper.
Tool rest: Parting tool, center; gouge and scraper, slightly below center.
Speed: 800–1,200 rpm.

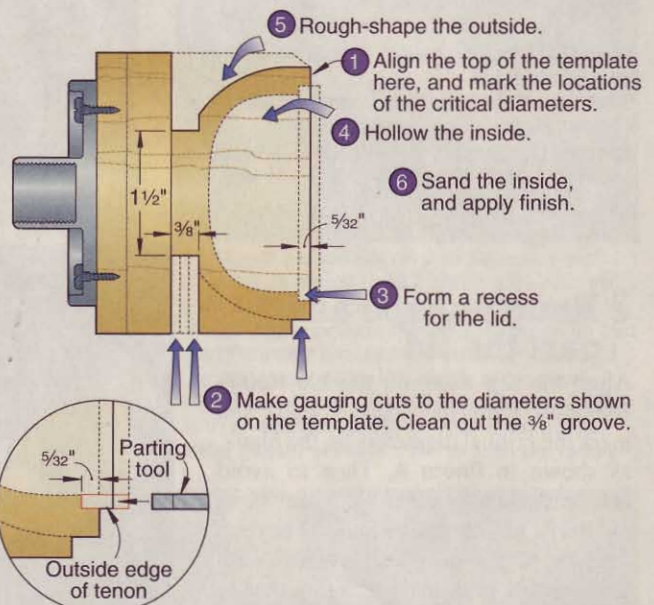



G



H

6 Refine the shape, and cut the grooves

Install a live center in the lathe tailstock, and fit the lid on the base, holding it in place with the live center. To remedy a loose fit, see the **Shop Tip**, top right. Clean up the outside profile, removing

SHOP TIP

How to tighten a loose lid for smooth turning

When your box is complete, you'll want the lid to fit loosely enough so it won't stick in the base. But to turn the outside profile, the lid must fit snugly and stay on. If your fit is a little loose at that stage, simply sandwich a layer or two of tissue between the lid and base.

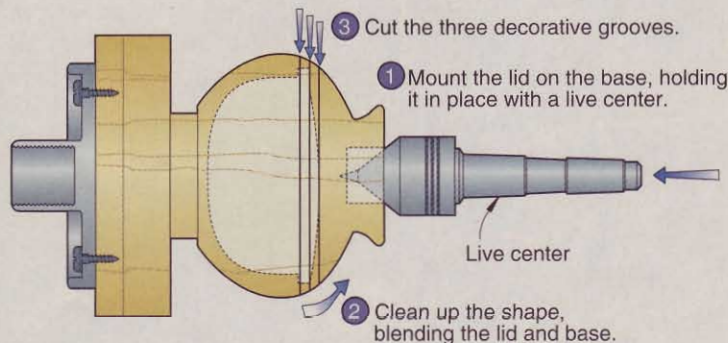

about $\frac{1}{16}$ " from the surface with your spindle gouge. Smoothly blend both base and lid together. Check the profile with the **Final Outside Template**.

Mark the locations of the decorative grooves with a sharp pencil. The center groove aligns with the joint between the lid and base, as shown in **Photo G**, hid-

ing it to make the box look like a hollow vessel. Use the toe of your skew chisel to cut grooves just wide enough to remove the pencil lines, as shown in **Photo H**.

Tools: $\frac{3}{8}$ " spindle gouge, skew chisel.
Tool rest: Gouge, slightly below center; skew, slightly above center.
Speed: 1,200–1,600 rpm.

7 Form the lid's recess, finish, and part

Move the tailstock and live center out of the way. Secure the lid to the base with masking tape. Use your $\frac{3}{8}$ " spindle gouge to form a recess in the top of the lid, as shown in **Photo I**. Check the profile with the **Lid Recess Template**.



I

Remove the masking tape, sand the box to 320 grit, and apply the finish. With the finish dry, paint the top recess with flat black acrylic craft paint. To remove any errant paint, dampen a clean rag with water, and wipe the rim of the recess while you turn the lathe by hand. Remove the lid, and use your parting tool to part the base from the waste. To make sure your box sits flat, angle the cut slightly into the base's bottom, where shown on the **Final Outside Template**. Finally, pare away the "nub" at the center with your gouge. Now, display your "hollow vessel," and watch its admirers' surprise as they discover its secret. ♣

Tools: $\frac{3}{8}$ " spindle gouge, parting tool.
Tool rest: Gouge, slightly below center; parting tool, center.
Speed: 800–1,200 rpm.

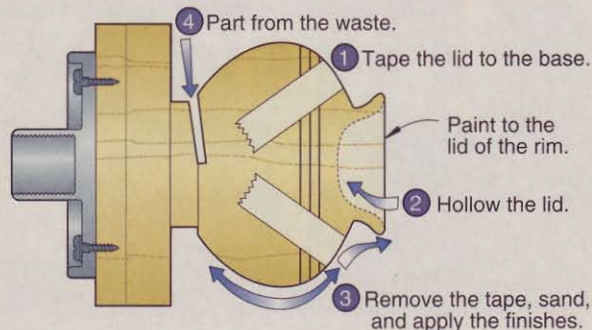

Written by **Jan Svec** with **Jeff Mertz**
 Project design: **Phil Brennon**
 Illustrations: **Roxanne LeMoine**

Buying Guide

Turning blanks. Set of four 4x4x5" Keepsake Box blanks, one each of walnut, cherry, hackberry, and butternut, \$27 ppd. Iowa residents add sales tax. Send a check or money order to Johnson Wood Products, 34897 Crystal Rd., Strawberry Point, IA 52076. For additional information, call 563/933-6504.

Clear finish. Mark VI poly-oil finish no. 123201, \$9.95 for one pint. Call Packard Woodworks, 800/683-8876, or shop online at www.packardwoodworks.com.

A close-up photograph of a person's hand adjusting a precision gauge on a circular saw blade. The gauge has a circular dial with a needle and is mounted on a metal frame. The saw blade is partially visible, showing its teeth. The background is a solid blue color.

precision tune-up tools

Get top-notch results from your power tools by keeping them properly aligned and running true. We'll tell you how and show you which gauges do the job best.

A well-tuned cutting tool practically sings as it slices and saws its way through the wood. However, tools such as your tablesaw, radial-arm saw, planer, and jointer need regular maintenance and tweaking to keep them running at that peak performance. Without periodic tune-ups, tools don't cut up to snuff, putting your safety and the quality of your workmanship at risk.

A handful of manufacturers sell accessories specifically designed to help align your power tools properly. To see how accurate and easy to use they really are, we gathered fourteen such devices with prices ranging from \$10 to \$330, and put them to the test.

Tune-up steps and the gauges that did them best

Tuning up your power tools should be a hassle-free experience as long as you adjust the right things in the right order. (Owning the right tune-up tool helps, of course, too.) Here are the steps to take when tuning up your tablesaw, radial-arm saw, miter saw, jointer, and planer.

Because the methods of making the actual adjustments vary from machine to machine, consult your owner's manuals for specifics. (For more detail about tuning up power tools, see *WOOD* magazine issues 82 and 91. Or visit www.woodmagazine.com/tooltuneup to download our tool tune-up seminars.) For safety's sake, make sure you unplug any tool before performing a tune-up.

Tuning your tablesaw

1 Parallel the blade and miter slot. A poorly aligned blade has to work harder, and can cause burning and dangerous kickback.

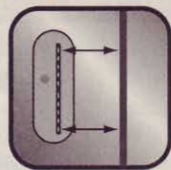

2 Set the 0° bevel stop. This ensures that your tablesaw blade cuts square edges. After setting the stop, adjust the bevel cursor to read 0°.

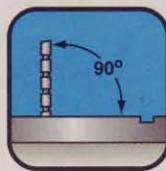

3 Set the 45° bevel stop. Likewise, you want to make sure you can quickly and accurately hit this common angle.

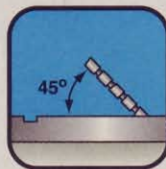

4 Square the miter gauge and blade. If the miter gauge isn't square to the blade, your crosscuts won't be, either.



5 Parallel the rip fence and miter slot. Despite the widespread practice of setting a fence slightly more open (.015-.030") at the back of the table to prevent work-

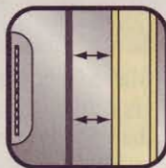

piece burning and kickback, we suggest setting it dead-on. Dado sets cut cleaner with the fence set parallel.

6 Square the fence face to the tabletop.

The least critical of the tablesaw tasks, it matters most when ripping stock on edge (for example, grooving frame parts to accept a panel).

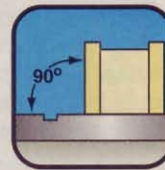

Tested best for tablesaws

TS-Aligner and MasterGage Classic both ranked high here, as you might expect from gauges costing \$330 and \$260 respectively. Opt for the MasterGage and spend some of your leftover money on a machinist's 45° angle block and you're set. On the value side, just couple the A-Line-It Basic kit with a 45° drafting triangle (about \$5 from an office-supply store), and you'll get good tune-ups for under \$65.

Continued on page 76

The alignment-gauge lineup

Accu E-Z, \$10

800/760-2700 or e-mail AccuEZ@aol.com

What it does:

Helps align various machinery components, such as blades, fences, and miter gauges, to make them square or parallel.

High points:

- ◆ The magnetic back of this machined medium-density fiberboard (MDF) block fixes it firmly in place on the tabletop.
- ◆ The kerf in the cutout holds a bandsaw blade still while you adjust the guides.
- ◆ Low cost.

Low points:

- ◆ It's not perfect (we measured .002" out of square on the short side), but plenty accurate for righting crosscuts on a miter saw and squaring a miter gauge.
- ◆ The lack of a miter-slot guide bar makes Accu E-Z inconsistent for paralleling a tablesaw blade to the miter slot.



TS-Aligner, \$330

Edward J. Bennett Co., 800/333-4994, www.ts-aligner.com

What it does:

Performs every alignment we tested on five major power tools, using accessories that come with it.

High points:

- ◆ Custom-fits to your table saw's miter slot with three ball-bearing guides below its base.
- ◆ Dial indicator mounts vertically or horizontally.
- ◆ Dial indicator rides up and down on parallel steel bars for precise blade-height measurements.
- ◆ Comes with a machinist's square and a gauge rod (the shiny circle shown under the dial-indicator carriage in the photo, *opposite page*) to quickly calibrate the gauge for setting a 45° bevel angle.

Low points:

- ◆ Guide bearings must be removed for use on jointer, planer, and miter saw, which is a bit of a nuisance. They also must come off for radial-arm saw use unless you buy the optional RS-Aligner accessory (\$175).
- ◆ Relatively expensive.

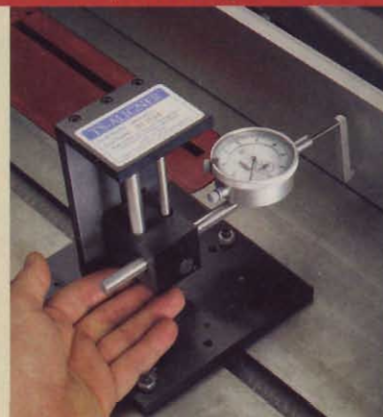

Make your mitersaw right

1 Square the fence and blade.

Perfectly square cross-cuts start here. With your saw's turntable firmly locked in its 0° miter detent, make sure the fence is perfectly square to the blade and adjust the fence or head (motor and blade) if not.



2 Square the blade to the tabletop.

Non-compound mitersaws may or may not accommodate this tune-up task, which ensures that the blade travels straight down through your workpiece. Adjust the



Tested best for mitersaws

Simple is better when it comes to miter-saw alignments. With TS-Aligner Jr. Lite's angle-attachment gauge calibrated using an accurate square from your shop, your mitersaw will be ready to roll in no time. And the Lite helps you set virtually any bevel or miter angle accurately. Nothing else comes close at any price.

0° bevel stop and dial in the bevel-scale cursor to the 0° mark.

3 Set the 45° bevel stop. Lay the motor and blade over to the left 45°, and adjust the stop and bevel scale if necessary. On dual-bevel machines, repeat for the right side.



Aligning your jointer just so

1 Align the tables "coplanar."

That's fancy talk for making sure the infeed and outfeed tables are parallel on both the long and short dimensions. A long straightedge helps with the lengthwise alignment; almost any dial-indicator gauge can do the short dimension.

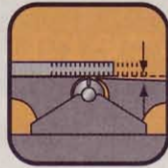

2 Square the fence to the tabletop.

This adjustment task ensures crisp, square edges on your work-

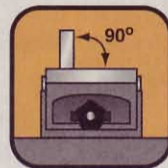

pieces. On a jointer, it's more critical than on a tablesaw as a slight inaccuracy multiplies itself over and over when you're edge-gluing a wide panel.

3 Level the knives to the outfeed table.

If the knives are set too low, your workpiece catches on the outfeed table; too high, and the outfeed table won't properly support the workpiece, resulting in a curved cut. The cutterhead needn't be perfectly parallel to the outfeed table as long as the knives are.

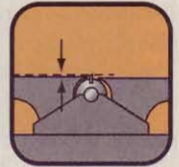

Tested best for jointers

MasterGage Classic and Oneway's Multi-Gauge both performed very well here with the nod going to Multi-Gauge because it costs only \$75 (compared to MasterGage's \$260 price tag). For setting knives alone, though, we love the Jointer Pal because it actually holds the knives at the correct height, virtually guaranteeing perfect alignment.

Continued on page 18

MasterGage Classic, \$260

888/893-8300, www.mastergage.com



What it does:

Every alignment task we tested, but some alignments require a 45° angle block (such as the head of a combination square) that you supply.

High points:

- ◆ Perpendicular "knife edge" proved perfectly square whether referenced from the top or bottom edge.
- ◆ The expand-to-fit miter-slot guide dismounts quickly for nonslotted tabletops, such as those on a mitersaw, jointer, planer, and drill press.
- ◆ Dial indicator raises, lowers, and easily switches from horizontal to vertical for measurements such as blade height.

Low points:

- ◆ 45° angle block, required for setting bevel stops, doesn't come with gauge.

More points:

- ◆ The upscale MasterGage Pro (\$460, not tested) sets bevel angles without a conversion table.



SuperBar, \$70

MasterGage. 888/893-8300, www.mastergage.com

What it does:

Measures parallelism of components, such as fences and blades to miter slots.

High points:

- ◆ Checks the two most common tablesaw alignments: blade and rip fence parallel to the miter slot.

Low points:

- ◆ Limited in tune-up tasks it performs.

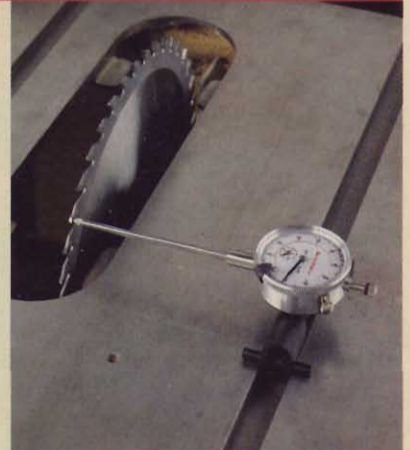

Share your opinion of these tools in our Tune-Up Tools forum at

www.woodmagazine.com/tunetools



Strive for planer perfection

1 Parallel the cutterhead and table.

A misaligned cutterhead makes boards thinner on one edge than the other. And, because every method of aligning the knives—from self-aligning knives to springs, jackscrews, and three-legged gauges—only sets the knives parallel to the cutterhead, this alignment is critical.



2 Parallel knives to the cutterhead.

If the cutterhead is parallel to the table, but the knives aren't parallel to the cutterhead, you'll still end up with wedge-shaped boards. You could combine Steps 1 and 2, and just set the knives parallel to the table; but it's awfully hard to tighten the gib bolts while holding the knives in place as they hang from the bottom of the cutterhead.

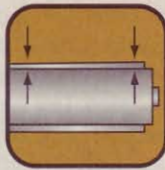

Tested best for planers

Get a set of Mini Planer Pals for setting knives in your portable planer, and then use any one of the dial-indicator gauges that help you set the cutterhead parallel according to the chart, *opposite*. If you have a stationary planer, the price goes way up for the full-size Planer Pals, so you may want to just stick with the three-legged gauge that came with your machine.

Now, the overall top tune-up tools

MasterGage Classic performed at the top of the class in nearly every measurement it's capable of doing, so we named it the Top Tool. Our only knock is that it can't help you set the 45° bevel stop on your tablesaw, but an inexpensive drafting triangle can help with that. The same could be said of the A-Line-It Basic, which performed well at making things parallel, but needs the help of a triangle to set things at 45° and 90°. It costs only \$60, so it's one of our Top Values.

On the other hand, TS-Aligner Jr. Deluxe helps set not only the 45° stop, but also any bevel angle in between,

making it a tool you'll use more often than just at tune-up time. It sells for \$120 less than MasterGage Classic, making it, too, a Top Value. TS-Aligner Jr. Deluxe is accurate and easy to use, but lost points overall because it must be calibrated with an accurate square and, for most non-tablesaw uses, you have to remove the guide bearings or base.

For tools with cutterheads, Jointer Pal and Planer Pals do only one thing—help you set knives. But they do it so well, and for so little cost, we couldn't help but name them Top Values. ♣

The alignment-gauge lineup (continued)

Multi-Gauge, \$75

Oneway, 800/565-7288, www.oneway.on.ca

What it does:

Helps to square machine components, and excels at jointer setup.

High points:

- ▲ Accurately machined: Cast-iron gauge is less than .001" off from perfectly square and parallel, and on par with the most expensive tools in this test.

Low points:

- ▼ Without a miter-slot guide, you have only the length of the gauge instead of the length of the tablesaw's miter slot to check parallelism.



Jointer Pal W1210, \$30

Woodstock International, 800/840-8420, www.shopfox.biz

What it does:

Strong magnets hold the jig to a jointer's out-feed table, and the knives level to the table, while you tighten the gib bolts.

High points:

- ▲ Sets knives so accurately, you can toss out your jointer's jackscrews, springs, and knife-setting gauge.

More points:

- ▶ This polycarbonate version works with high-speed steel knives 4–8" long; other Jointer Pal models go up to 16" long, and also work with carbide knives.



TUNE-UP TOOLS: WHAT THEY CAN DO, AND HOW WELL THEY DO IT

BRAND	MODEL	PERFORMANCE GRADES (1)															COUNTRY OF ASSEMBLY (8)	SELLING PRICE (9)				
		TABLESAW (2)					RADIAL-ARM SAW			MITERSAW		JOINTER (3)			PLANER							
		BLADE PARALLEL TO MITER SLOT	SET 0° BEVEL STOP	SET 45° BEVEL STOP	MITER GAUGE SQUARE TO BLADE	FENCE PARALLEL TO MITER SLOT	FENCE SQUARE TO TABLETOP	ARM PARALLEL TO TABLETOP (3)	BLADE SQUARE TO TABLETOP (3)	ARM SQUARE TO FENCE (4)	BLADE SQUARE TO FENCE (4)	FENCE SQUARE TO BLADE (5)	BLADE SQUARE TO TABLETOP (3)	SET 45° BEVEL STOP (6)	TABLES COPLANAR	FENCE SQUARE TO TABLETOP			KNIVES LEVEL TO OUTFEED TABLE	CUTTERHEAD PARALLEL TO TABLE (3)	KNIVES PARALLEL TO CUTTERHEAD	WARRANTY (7)
ACCU E-Z	Magnetic Alignment Jig	C	B		A	C-	A		C+		C+	A	B		A	C			90D	US	\$ 10	
EDWARD J. BENNETT CO.	TS-Aligner	A	A	A	B	A	A	B*	A*	B**	B**	B*	A-	C	A-	A*	A*	A*	C	1 yr.	US	330
	TS-Aligner Jr. Deluxe	A	A*	A**	B*	A	A	B**	B+**	B**	B**	B**	B**	B+*	A-	B+**	A*	A*	C	1 yr.	US	140
	TS-Aligner Jr. Lite	A-	B*	B**	C*	A-	A-		B**			A*	B+**	A***		B**	B+			1 yr.	US	70
IN-LINE INDUSTRIES	A-Line-It Basic	A			B*	A		B+		B*	B*				A	A	A	A	C	1 yr.	US	60
	A-Line-It Complete	A			B*	A		B+		B*	B*				A	A	A	A	C	1 yr.	US	140
MASTERGAGE	MasterGage Classic	A	A	B**	A	A	A	A	A	B*	A	A	A-	C**	A	A	A	A	C	LIFE	US	260
	SuperBar	A				A		A		B*	B*									LIFE	US	70
ONEWAY	Multi-Gauge		C				B	A	C+		C	A	B		A	A	A	A	C	2 yr.	CA	75
WOODSTOCK INTERNATIONAL	Jointer Pal															A				1 yr.	US	30
	Mini Planer Pals																	A		1 yr.	US	30
	Rotocator															A	A	C		1 yr.	US	100

NOTES:

- ☐ A blank cell means tool cannot perform this task.
 - A** Excellent
 - B** Good
 - C** Average
- (*) Requires accurate 90° square (not included).
 - (**) Requires accurate 45° angle gauge (not included).
- (*) Guide bearings must be removed.
 - (**) Requires accurate 90° square (not included), and guide bearings must be removed.
- (*) Requires sliding gauge along an accurate square.
 - (**) Requires sliding gauge along an accurate square, and guide bearings must be removed.
- (*) Guide bearings may need to be removed.
 - (**) Requires accurate 90° square (not included), and guide bearings must be removed.
- (*) Requires accurate 90° square (not included), and guide bearings or guide must be removed.
 - (**) Requires accurate 45° angle gauge (not included).
 - (***) Requires accurate 90° square (not included).
- (90D) 90 days
 - (LIFE) Lifetime warranty against factory defects.
- (CA) Canada
 - (US) United States
- Prices current at time of article's production and do not include shipping, where applicable.

Mini Planer Pals W1226, \$30/pair

Woodstock International, 800/840-8420, www.shopfox.biz

What it does:

Similar to the Jointer Pal, magnets hold a planer knife parallel to the cutterhead while you tighten the gib bolts.

High points:

- ◆ As with Jointer Pal, setting knives is a no-muss, no-fuss operation.

Low points:

- ◆ You still need a dial indicator to ensure that the cutterhead is parallel to the table.

More points:

- ◆ For 15–20" planers, you'll need full-size Planer Pals (\$160 per pair, more for the carbide-knife versions).



Rotocator W1218, \$100

Woodstock International, 800/840-8420, www.shopfox.biz

What it does:

Measures distances up to 1" with dial-indicator precision, for checking cutterhead-to-table parallelism in jointers and planers.

High points:

- ◆ Dial indicator and its stylus rotate on the face of the base to lock in at 90° angles to measure up, down, or sideways.

Low points:

- ◆ With no miter-slot bar and no square reference edges or faces, Rotocator is limited in the tune-up tasks it can perform (see chart).

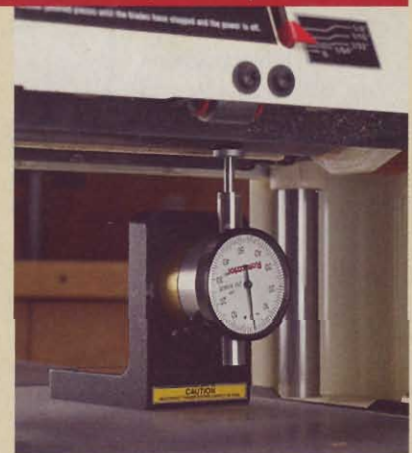

Written by Dave Campbell with Garry Smith

how to win over

9
proven
strategies

TOP: Install fasteners that allow a wide top to move freely.

DOORS:
Learn to control solid-wood panels in frame-and-panel construction.

TRIM MOLDING:
Discover a clever, classy method for attaching molding without restraining the cabinet side.

DRAWERS:
Honor tradition with a solid-wood bottom, and size the parts to avoid sticking.

DRAWER DIVIDERS:
Create drawer supports that allow for expansion and contraction of solid-wood sides.

wood movement

FINISH PROTECTION:

Avoid warping through proper finish application.

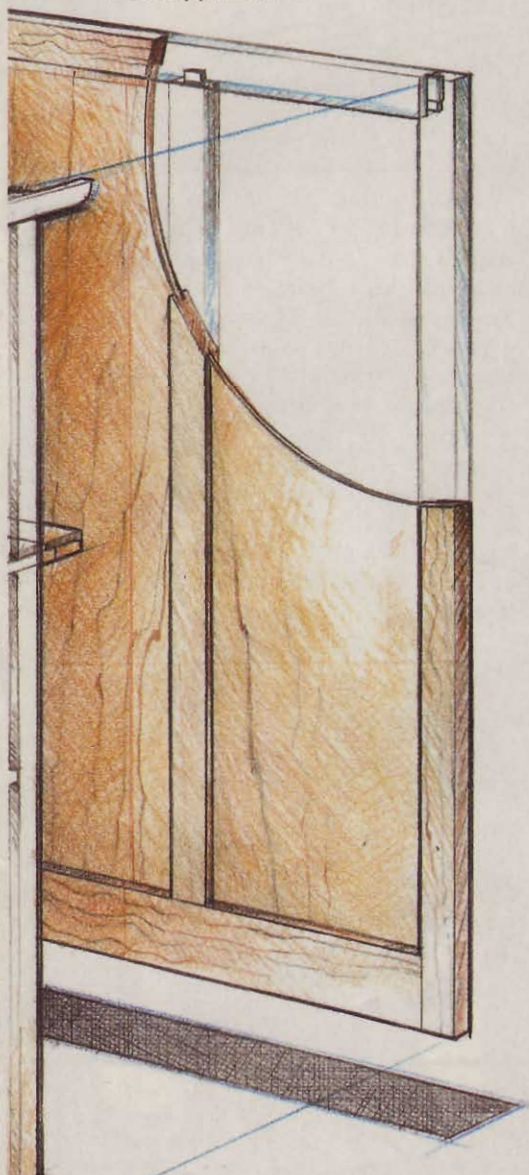

BASE MOLDING:

Keep molding joints intact with a time-tested trick.

Build projects that last for generations with time-tested joinery techniques.

Wood never stops moving. Your projects shrink in dry conditions, swell when the air turns humid, and always will. As moisture passes into and out of the wood's cells, the changes cause enough movement to create gaps in joints, warped panels, and splits along grain lines. You can't stop this motion, but you CAN plan for it to prevent damage. You just need the right building techniques.

Strategy 1: Buy smart, then acclimate your project stock

Ignore the minuscule change in dimension along the grain; a board hardly changes in length. The thickness of a board stays steady, too. Instead, focus on movement across the grain.

The width of a board changes radically as it goes from fresh-cut to room-dry. For this reason, stick with kiln-dried or thoroughly air-dried lumber for your projects, and you reduce your wood movement concerns tremendously.

Once you find your lumber source, spend plenty of time on stock selection. Look at the end grain to classify each board, as illustrated in the drawing on page 84. When using oak, choose quartersawn or riftsawn (where the grain lines run somewhat perpendicular to the board's face), unless you want figure that appears only on flatsawn stock.

Boards that are riftsawn or quartersawn move less than flatsawn ones, as you can see in the "How much will it move?" chart on page 84. Some popular species, such as cherry, maple, and walnut, rarely appear as quartersawn stock. When working with them, you'll probably choose your stock on the basis of face-grain appearance.

The chart also gives you an idea of how much movement you can expect from the most common woodworking woods commercially available.

When you take your stock home, let it sit for a few days, stacked with stickers (wood spacers) between the boards, before you use it. That delay allows the wood to adjust to the humidity in your workshop, so parts won't change dimensions after you cut them to size.

Strategy 2: Plan joints to avoid stress

Always follow the cardinal rule of solid-wood construction—when it's necessary to glue together pieces that measure more than 3" wide, design the

joint so that the grain runs in the same direction on both pieces. Cross-grain assemblies constantly pull in different directions, weakening the joint.

Strategy 3: Allow tops to move freely

A wide, solid-wood top needs lots of room to move. If it's restrained, ugly splits eventually occur. The top also requires a sturdy connection to the cabinet because you just know that people will use the top to pick up and move the entire piece.

Solve both problems with clips that engage a groove near the upper end of the cabinet and are screwed into the top. Make your own from hardwood, or buy metal ones, such as those carried by Woodcraft. Ask for item 27N10, a bag of 10 fasteners, for \$1.99. Call 800/225-1153 to place an order, or visit www.woodcraft.com.

Use a router or tablesaw to cut $\frac{1}{8}$ "-wide, $\frac{3}{8}$ "-deep slots inside the cabinet

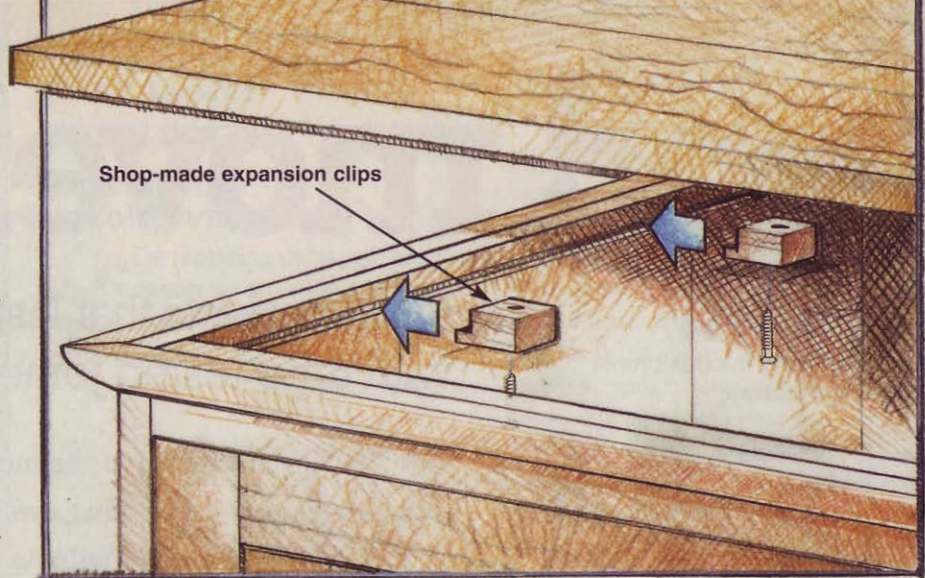

sides before assembly. Locate them $\frac{1}{4}$ " from the end if you're using the metal clips. If you make your own clips, use $\frac{3}{4}$ " stock to make blanks $1\frac{1}{4}\times\frac{3}{4}$ ". Cut a $\frac{1}{4}\times\frac{3}{8}$ " tongue at one end of each blank. Note that you'll need to make the carcass slots $\frac{1}{4}$ " wide if you choose to use this style of expansion clip.

Finally, glue the top to the cabinet front, and install two clips along each end, using panhead screws that penetrate more than halfway into the top. When the top shrinks or expands, the front overhang remains constant, the top remains in contact with the sides, and the clips slide in the slots.

Strategy 4: Use sliding dovetails to grip moldings

When you apply molding to a face frame, you can nail it or glue it on without considering wood movement because it sits on a rail with grain running in the same direction. But molding across the grain of a solid-wood side has to allow that side to slide beneath it.

To counter this challenge, use a sliding dovetail. (Refer to issue 148, page 90, for details on making sliding dovetails.)

Mount a $\frac{3}{8}$ " dovetail bit in a table-mounted router, and raise it $\frac{1}{4}$ " above the table. Set the fence to center the bit on your molding, or locate it slightly toward the thickest part. Rout a groove in the back side of the molding.

Next, make a matching tenon that you'll fasten to the carcass. To begin, select a workpiece longer than the width of the carcass, and about as wide as the height of your router-table fence. Use scrap of equal thickness to set up the operation. With the dovetail bit projecting slightly out from the fence, rout along one edge of the scrap, flip it edge for edge, and rout the opposite edge to produce a dovetail tenon. Adjust the fence and rout as needed until the tenon

slides smoothly into the molding groove. Now, form the tenon on your workpiece.

Rip the tenon away from the workpiece with your tablesaw. Cut the tenon to a length 1" less than the width of the cabinet side, and mark it into 3" sections. Working from the wide face of the tenon, drill and countersink two screw holes in the front section, skip the next section, drill two holes in the third section, and continue to alternate. Now, use a handsaw to cut halfway through each of the section lines from the narrow face of the tenon.

Insert the tenon into the groove in your molding, leaving the front section exposed. With the tenon held back 1" from the front of the cabinet, clamp the molding flush with the top of the cabinet. Drive $\frac{3}{4}$ " flathead screws through the front section and into the cabinet side. Unclamp the molding, slide it back to expose the next screw holes, reclamp, and add those screws. Continue until you complete the tenon installation. Carefully saw the rest of the way through your section lines, as shown in the circled drawing, to remove the sections that contain no screws. You're left with perfectly aligned tenon sections. Apply

glue to the front tenon section only. Slide the molding into place from the rear. The tenon sections allow movement of the cabinet side, while keeping the molding in place.

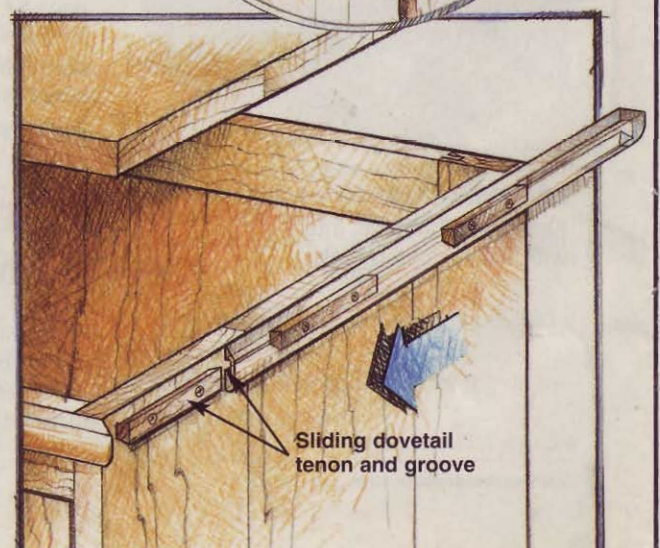
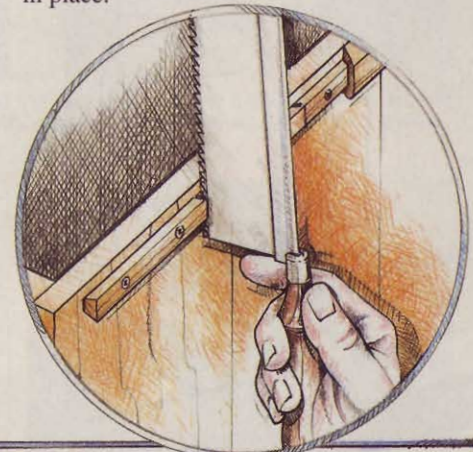

Strategy 5: Employ the classic molding trick, too

If you want a quicker way to attach molding, as compared to the sliding dovetail approach, use screws and slots. From inside the cabinet, drill a standard shank hole for the screw nearest the cabinet front. For each of the other screws, rout a slot through the cabinet side, about an inch long and slightly wider than the shank of the screw. If you prefer, you can drill a series of overlapping holes, and clean out the remaining waste with a chisel. Temporarily clamp the molding in place. From inside the cabinet, drill a pilot hole through the cabinet side and into the molding at the center of each slot. When you permanently attach the molding, apply glue on the mitered end, and on the front third of the molding. The joint will remain intact while the rear two-thirds of the molding allows movement in the cabinet side.

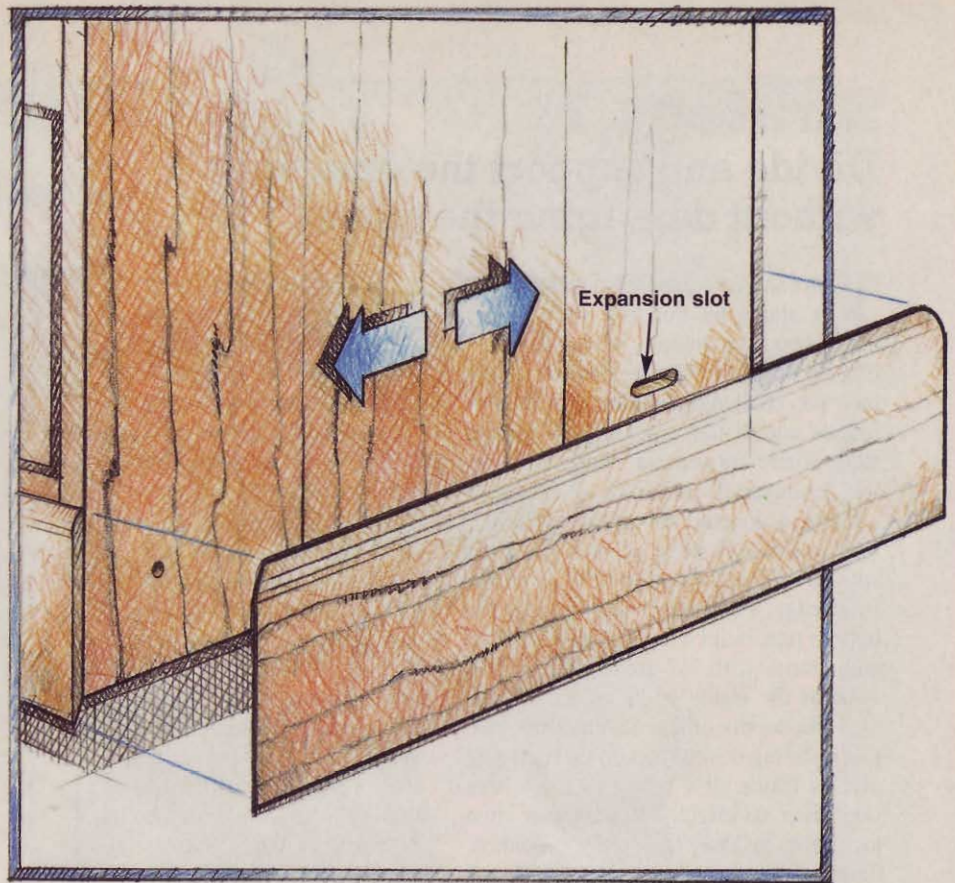

Strategy 6: Add class with floating panels

Frame-and-panel components look fine with flat plywood panels, but solid wood allows you to shape a raised field on each panel for a more refined appearance. However, you have to allow room inside the grooves for panel movement. Here, cut a $\frac{3}{8}$ " groove into the inside edge of each frame member. Size the panel to allow for a $\frac{1}{8}$ " gap inside the groove on each side and $\frac{1}{16}$ " at top and bottom. Shape the raised panel with at least $\frac{3}{8}$ " of flat surface along each edge to allow for movement.

Loose panels in a door tend to rattle when you close the door. To eliminate that problem, glue a $\frac{1}{2}$ " spot at the center of the panel, top and bottom, during assembly. This step holds the panel in a fixed position while still allowing expansion and contraction to each side. For more details about building a raised-panel door, see "Raised-panel doors made easy" in issue 144, page 42.



Strategy 7: Divide and support the drawers without damaging the sides

You can avoid expensive metal drawer slides by building web frames that support the drawers while also serving as visual dividers. However, you face the challenge of running the web frames across the grain of the cabinet side, where movement occurs. To fix this, let dovetails provide a solution.

Using a dovetail bit and your router, start at the back edge of each side, and cut dovetail dados stopped 1" from the front edge. For each drawer except the bottom one, build a mortise-and-tenoned web frame with 3/4" stock. Make it as wide as the inside width of the cabinet plus the depths of the dovetail grooves. Cut a sliding dovetail tenon on each side of this frame. It's better to make this joint ever so slightly loose rather than too tight, to avoid assembly problems. Trim off the front 1 1/4" of each dovetail tenon. The extra space provides a spot for glue to pool, easing assembly.

To install each web frame, apply glue to the front 3" of the dovetail grooves. Slide the web frame into the dados from the rear of the cabinet until it's flush at the front. The dovetail holds the assembly firmly in place, glue keeps the front flush, and the unglued portion allows the cabinet side to expand and contract. To make the drawer slide smoothly, apply self-adhesive strips of ultra-high molecular weight (UHMW) plastic to the web frame for the drawer sides to ride on. (A 10 1/2' roll of UHMW costs \$5.99 from Woodcraft. Call 800/225-1153, and order item 16L64.)

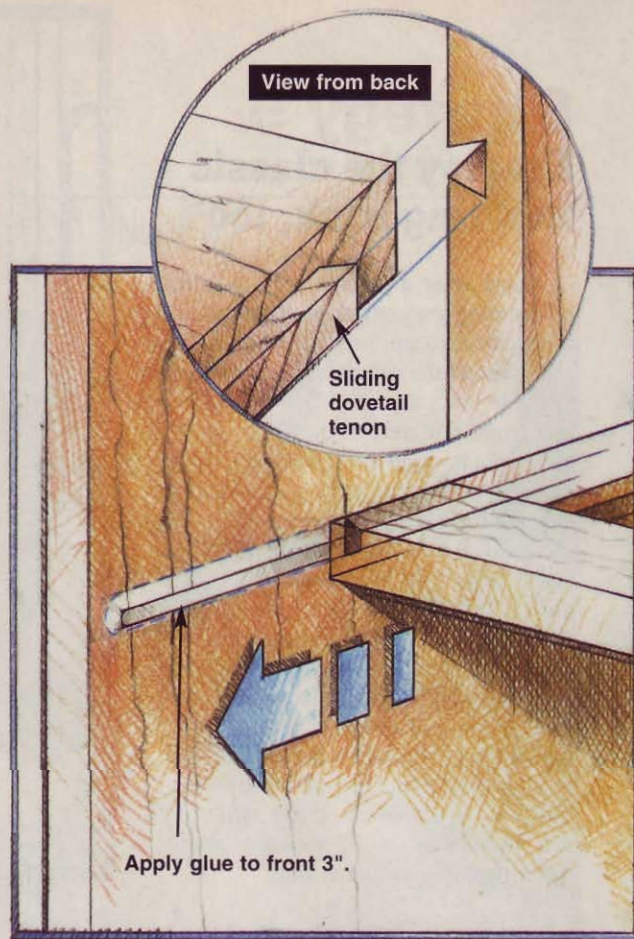

How much will it move?

Here's a sampling of movement information for often-used woods. Use the "Change per unit" columns to calculate the amount of swelling or shrinking to allow for when sizing project parts.

	Width (inches) at 14 percent moisture content	Width at 6 percent moisture content		Change per unit*	
		Quartersawn	Flatsawn	Quartersawn	Flatsawn
Ash, white	12	11.84	11.74	.0017	.0027
Birch, yellow	12	11.75	11.64	.0026	.0034
Cedar, western red	12	11.89	11.77	.0011	.0023
Cherry, black	12	11.88	11.76	.0013	.0025
Mahogany	12	11.83	11.77	.0017	.0024
Maple, sugar	12	11.84	11.66	.0017	.0035
Oak, red	12	11.85	11.65	.0016	.0037
Oak, white	12	11.83	11.65	.0018	.0037
Pine, ponderosa	12	11.87	11.79	.0013	.0022
Teak	12	11.9	11.82	.001	.0019
Walnut, black	12	11.82	11.74	.0019	.0027

*Multiply "change per unit" by width of board to find out how much it will shrink or swell per 1 percent change in moisture content.

Source: U.S. Forest Service's Forest Products Laboratory

Quartersawn



Flatsawn



On the left, you see the vertical lines of quartersawn grain; on the right, flat grain. For a general guideline, assume that flat grain will shrink and swell about twice as much as quartersawn grain in response to changes in moisture content.

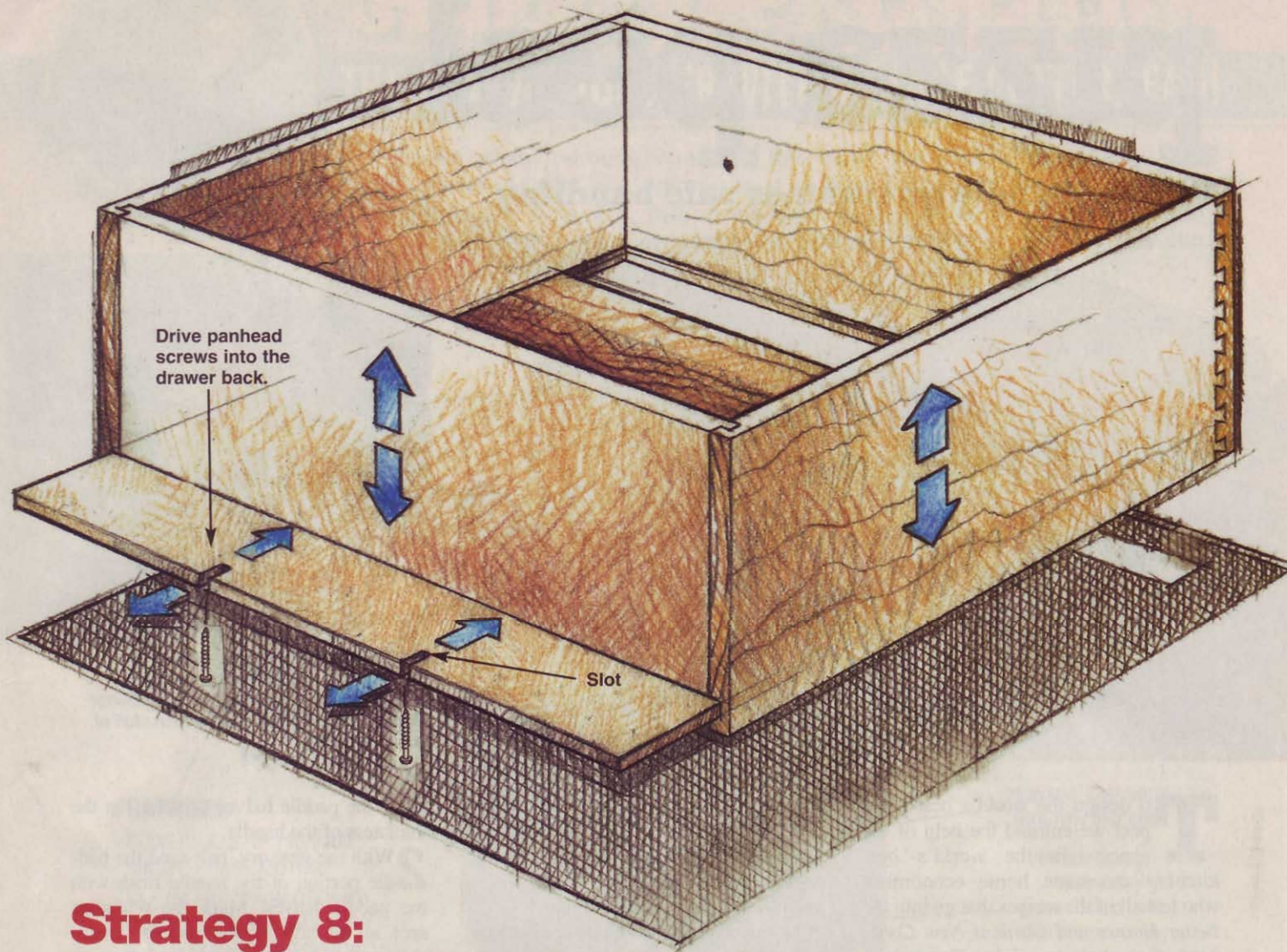

Strategy 8: Pay attention to the drawer details, inside and out

A solid-wood bottom is a traditional feature of a well-made drawer. Here's how to make and install a bottom that won't push the rest of the drawer apart.

Resaw and plane stock to $\frac{1}{4}$ " thickness, and edge-glide the boards to make an oversize panel for the drawer bottom. Cut a $\frac{1}{4} \times \frac{1}{4}$ " groove on the inside of the drawer front and sides, $\frac{1}{4}$ " from the bottom edge. The back sits in dadoes cut into the sides, and its bottom edge aligns with the top of the groove.

Plan for the grain of your drawer bottom to run from side to side so that wood expansion won't force the sides apart. Trim the drawer bottom panel to fit into the drawer side grooves with $\frac{1}{16}$ " to spare on each side. Now, seat it in the drawer front groove, and

mark it flush with the back end of each drawer side. Remove it from the drawer assembly, and cut it to this dimension on the tablesaw.

Rout through slots at the back edge of the bottom, as shown in the drawing. Make them 1" long and slightly wider than the shank of the screw. Slide the drawer bottom into its grooves, and drive screws through the slots and into the bottom edge of the drawer back. Tighten the screws, and back them off one-quarter turn to allow the bottom to move. One more note about solid-wood drawers: If you don't allow room for maximum expansion of the drawer sides, front, and back, you'll wish you had during humid weather. Swelling wood can make the drawer stick. Also consider current conditions when you size your

drawer parts. If you live in a climate of extremes, and you're building during a cold, dry winter, leave enough room for expansion during the hot, humid summer.

Strategy 9: Control the motion with proper finish

Once your project is complete, apply finish to slow down the movement of water vapor into and out of the wood. Apply an equal number of coats to all surfaces to equalize that movement. ♣

Written by Jim Pollock with Kevin Boyle
Illustrations: Mike Mittermeier

pizza peel

Its long handle guarantees safe handling.



IT'S A WINNER! Before presenting this project to you, design editor Jeff Mertz sought input and approval from the Better Homes and Gardens® test kitchen staff of home economists.

To design the world's best pizza peel we enlisted the help of the experts in the world's best kitchen—the same home economists who test all of the recipes that go into the *Better Homes and Gardens New Cookbook*. (See photo top right.) These chefs liked the end result so much, they had us make a second peel to leave with them.

This pizza peel and the cookbook holder on page 88 wrap up our maple-and-cherry kitchen accessories. See issue 147 for a matching pastry board and rolling pin, and issue 148 for a chef's bookshelf.

Form the paddle and handle blanks

1 Plane six $\frac{3}{4} \times 2\frac{1}{16} \times 14$ " maple boards to $\frac{3}{8}$ " thick for the paddle halves (A). Joint $\frac{1}{32}$ " off each edge of all six pieces for a finished width of 2". Edge-join two sets of three boards each, using a water-resistant glue. (We used Titebond II.) To help the paddle flat, alternate the grain orientation of adjacent boards, as shown on **Drawing 1**. Set the halves aside.

2 Cut a $\frac{3}{4} \times 2\frac{1}{16} \times 32$ " piece of cherry for the handle (B). Joint the edges for a finished width of 2". Make a copy of the handle end pattern on the *WOOD PAT-*

TERNS® insert. Adhere it to one end of the handle blank with spray adhesive. Drill the $\frac{1}{2}$ " hole. Chamfer around the hole on both faces of the handle with a chamfer bit in a handheld router.

3 Use a combination square or a marking gauge to extend the pattern lines down the handle, marking the $\frac{3}{4}$ "-wide shaft, shown in the Front View on **Drawing 2**. Draw the $\frac{1}{2}$ " radii where the handle widens from $\frac{3}{4}$ " to 2".

Turn the handle blank on its edge. Mark lines in $\frac{3}{16}$ " from each face on the bottom 14" of the blank where it narrows to $\frac{3}{8}$ " to match the thickness of the paddle halves (A), shown in the Side View on **Drawing 2**.

4 With the handle blank on its edge, bandsaw close to the marked lines on the paddle portion. Turn the blank flat, and bandsaw close to the lines on the upper portion of the handle, including the handle end. Sand to the pattern lines only on the handle's upper portion.

Assemble and shape the peel

1 Retrieve the two $\frac{3}{8} \times 6 \times 14$ " paddle halves (A), and edge-join them to the handle (B), where shown on **Drawing 2**.

Keep the paddle halves centered on the thickness of the handle.

2 With the glue dry, belt-sand the paddle portion of the handle flush with the paddle halves. Mark the 6"-radius arcs at the top of the paddle, where shown, and bandsaw and sand them to the lines.

3 Clamp the peel to a plywood carrier board. Raise your tablesaw blade to its maximum height, and tilt it 5°. Position the fence to leave a $\frac{1}{8}$ " flat edge on the paddle, where shown on **Drawing 2**, and cut the taper, as shown in **Photo A**.



For a safe, stable cut when forming the end taper, clamp the peel to a $\frac{3}{4}$ "-thick plywood carrier board.

Cutting Diagram

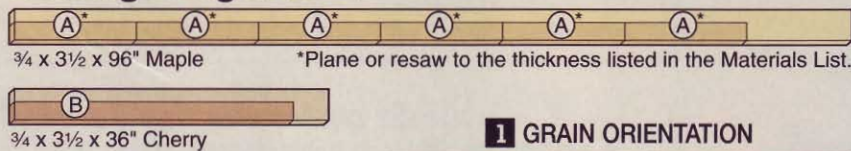

1 GRAIN ORIENTATION

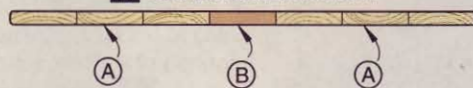

2 FRONT AND SIDE VIEWS

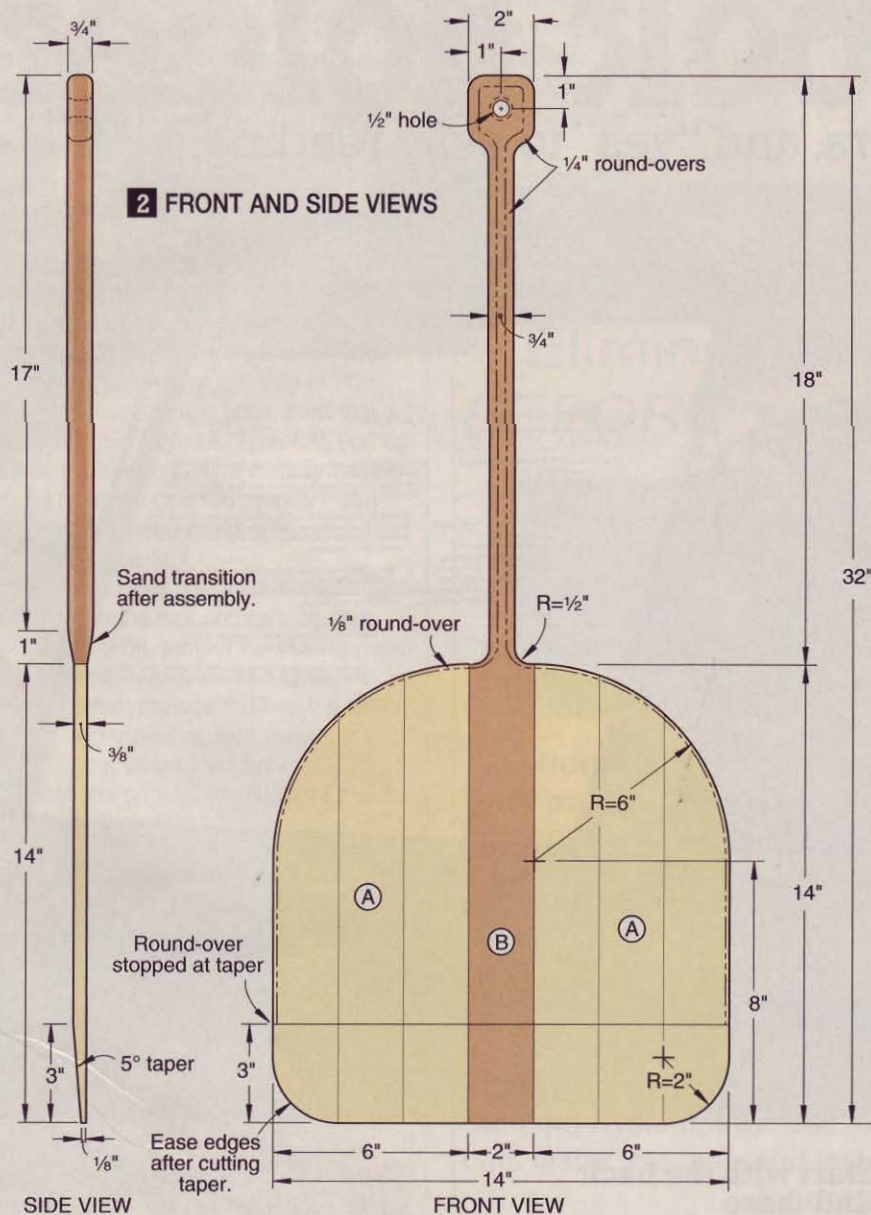

4 Mark the 2"-radius arcs at the bottom of the paddle, and bandsaw and sand to the lines.

5 Chuck a 1/4" round-over bit in your handheld router, and rout the handle's edges, stopping at the 1/2" radii where the handle merges with the paddle. Switch to a 1/8" round-over bit, and rout the paddle's top and side edges.

6 Smooth the transitions from the paddle's tapered end to its flat surface and from the paddle to the handle with your random-orbit sander and a 100-grit disc. Finish-sand the peel to 220 grit.

7 Finish the peel with a food-safe finish. (We applied four coats of General Finishes Salad Bowl Finish, following the instructions on the can.)

Materials List

Part	FINISHED SIZE			Matl.	Qty.
	T	W	L		
A paddle halves	3/8"	6"	14"	EM	2
B* handle	3/4"	2"	32"	C	1

*Part initially cut oversize. See the instructions.

Materials key: EM—edge-joined maple, C—cherry.

Supplies: Water-resistant glue, spray adhesive, 12" length of leather bootlace.

Bits: Chamfer router bit, 1/4" and 1/8" round-over router bits.

Buying Guide

Finish. General Finishes Salad Bowl Finish no. 125374, \$9.50/pint; or no. 125375, \$13.99/quart. Visit your local Woodcraft store, call 800/225-1153, or go to www.woodcraft.com.

Test your pizza peel with a great recipe

Although you won't be able to use the Better Homes and Gardens® test kitchen to test your pizza peel, you can make the same great pizza we did.

For the recipe, go to: www.woodonline.com/editorial/150pizza.html. Or, if you don't have Internet access, we'll mail you a copy of the recipe. Just send a stamped, self-addressed business-size envelope to:

Pizza Recipe
WOOD magazine
1716 Locust St., GA-310
Des Moines, IA 50309-3023



8 Cut a 12" length of leather bootlace for a hanging loop. Thread it through the hole in the head, and tie a knot. For a suggestion on testing your pizza peel, see the sidebar, *above*.

Written by Jan Svec
Project design: Jeff Mertz
Illustrations: Roxanne LeMoine

cookbook holder

Just say "no" to spatters, and "yes" to easy reading.



For the board feet of lumber and other items needed to build this project, see *page 90*.

Your favorite chef will appreciate this holder's heavy, tempered-glass shield that wipes clean and holds pages open for viewing. Its 3"-wide base holds any cookbook, even the large ring-binder types. And, after the meal's prepared, the holder folds up for storage.

Start with the back and base

1 Edge-join $\frac{1}{2}$ "-thick stock to form an $11 \times 17\frac{1}{2}$ " blank for the back (A). Trim it to the size listed in the **Materials List**.

2 Bevel-rip the bottom edge of the back at 20° , where shown on **Drawing 1**. Lay out the back's curved top, where dimensioned, using a $\frac{1}{8}$ "-thick wood fairing strip 20" long. Mark the $\frac{3}{8}$ " radii at the top corners. Bandsaw the top to shape, and sand smooth.

3 Rout a $\frac{1}{4}$ " partial round-over along the back's top and side edges, where shown on **Drawing 1**, using the setup shown on **Drawing 1a**.

4 Cut the base (B) to the size listed. Photocopy the full-size base patterns on the **WOOD PATTERNS®** insert. Attach them to the base's ends using spray adhesive. Now, bevel-rip the edges, cutting them in the sequence indicated. Peel off the patterns, and sand the part smooth.

1 EXPLODED VIEW

1a 1/4" PARTIAL ROUND-OVER SETUP

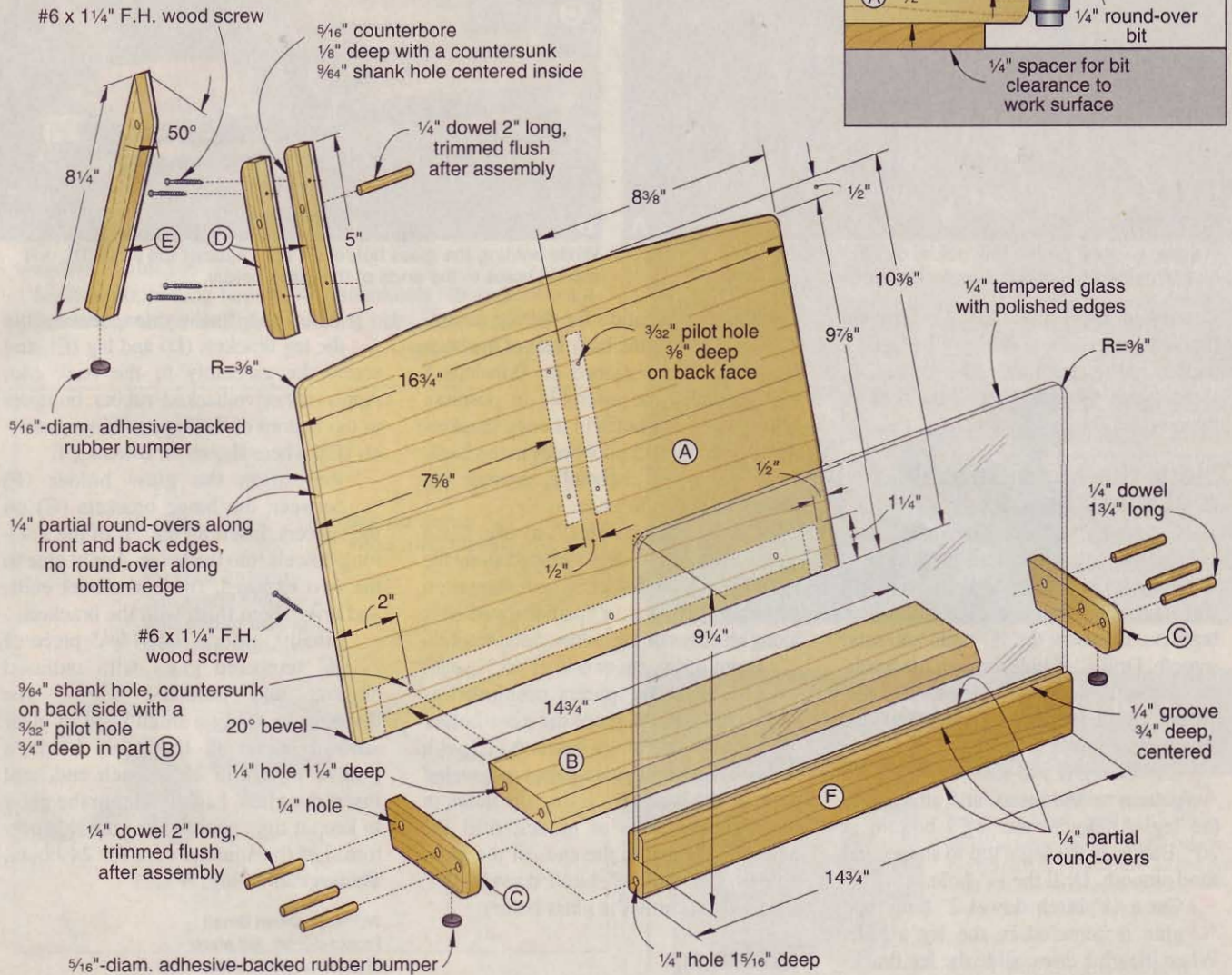
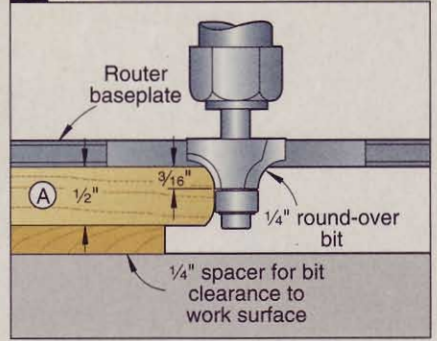

5 Cut the hinge brackets (C) to size. Face-join the hinge brackets (they'll become mirror-image parts) using double-faced tape. Copy the hinge bracket pattern on the insert, and attach it to one face of the joined brackets. Bandsaw the marked radii; then, angle-cut the brackets' 20° end. Drill 1/4" holes through the brackets at the marked centerpoints. Rout a 1/4" partial round-over along the edge on the outside face of each bracket. Separate the brackets, and sand smooth.

6 Glue and clamp the hinge brackets (C) to the base (B), aligning their top and angled back edges.

7 From a 1/4" birch dowel, cut four 2"-long pieces. Drill 1/4" holes 1 1/4" deep in the base, where shown on **Drawing 1**, using the holes in the brackets (C) as guides. Glue the dowels in the holes. Later, trim the dowels, and sand them flush.

8 On the back side of the back (A), mark centerpoints for the three screws for attaching it to the base (B), where dimensioned on **Drawings 1** and **1b**.

9 Cut a 3/4 x 13/16 x 15" piece for use as a drill guide. Clamp the base/hinge brackets assembly (B/C) to your workbench. Position the back (A) where shown. Using the drill guide as shown in

1b SIDE VIEW

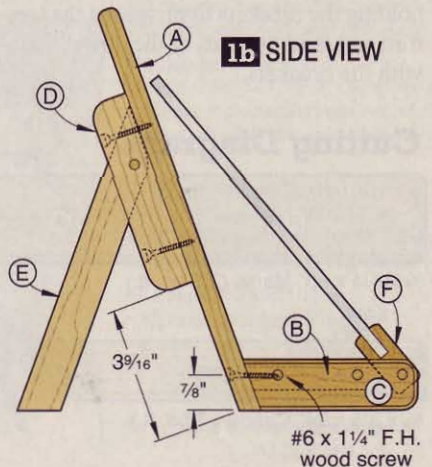

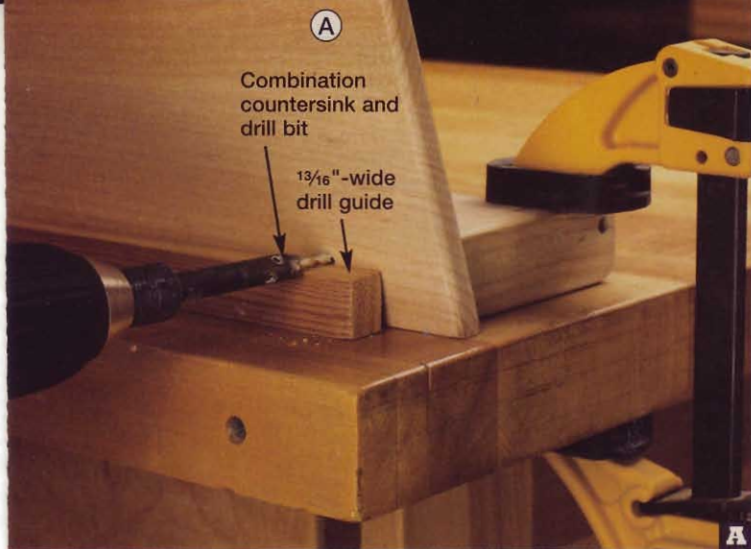

Resting your bit on the drill guide, drill into the back (A), stopping before the bit's countersink contacts the guide.

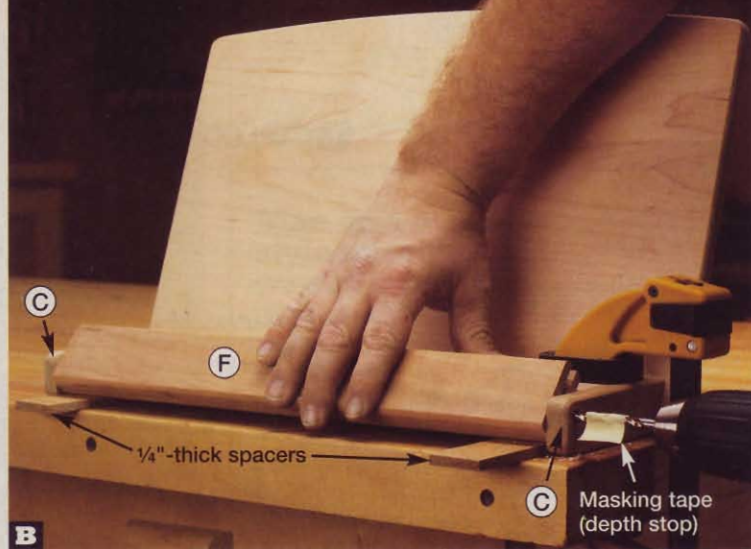

While holding the glass holder (F) tight against the base (B), drill the 1/4" holes in the ends of the glass holder.

Photo A, drill $\frac{3}{32}$ " holes in the back at the marked centerpoints. Remove the guide, and complete the pilot and countersunk shank holes. Glue and screw the back to the base and brackets.

Now, the leg assembly and glass holder

1 Cut the leg brackets (D) to size. Face-join the parts with double-faced tape. Copy the leg bracket pattern on the insert, and attach it to one face of the joined brackets. Bandsaw the $\frac{1}{2}$ " radii, and sand smooth. Drill a $\frac{1}{4}$ " hole through the brackets, and drill mounting holes centered on the brackets' edges where shown. Separate the parts, and sand smooth.

2 Cut the leg (E) to size. Copy the leg pattern on the insert, and attach it to the leg. Angle-cut the leg's bottom at 20° . Bandsaw the leg's top to shape, and sand smooth. Drill the $\frac{1}{4}$ " hole.

3 Cut a $\frac{1}{4}$ " birch dowel 2" long, and glue it centered in the leg's hole. When the glue dries, slide the leg brackets (D) onto the ends of the dowel in the orientation shown on **Drawing 1**. While holding the brackets tight against the leg, trim and sand the ends of the dowel flush with the brackets.

4 Mark the location for the leg assembly (D/E) on the back side of the back (A), where dimensioned on **Drawings 1** and **1b**. Place the assembly in position. Using the shank holes in the leg brackets (D) as guides, drill pilot holes in the back. Remove the leg assembly, separate the parts, and set them aside.

5 Cut the glass holder (F) to size. Cut a $\frac{1}{4}$ " groove $\frac{3}{4}$ " deep centered along the top edge of the holder, where shown on **Drawing 1**. Rout a $\frac{1}{4}$ " partial round-over along all edges of the holder. Sand smooth.

6 From scrap, cut two $\frac{1}{4} \times 1\frac{1}{2} \times 3$ " spacers. With the spacers positioned as shown in **Photo B**, place the glass holder (F) between the hinge brackets (C) with its back face tight against the top beveled edge of the base (B). Using the holes in the hinge brackets as guides, drill $\frac{1}{4}$ " holes $1\frac{5}{16}$ " deep in the ends of the glass holder. Cut two $\frac{1}{4}$ " birch dowels $1\frac{3}{4}$ " long for attaching the glass holder.

Finish up

1 Finish-sand the project. Then, apply two coats of a clear finish (we used satin polyurethane) to all parts, including one end of each of the $1\frac{3}{4}$ "-long dowels. Sand between coats to 220 grit.

2 When the finish dries, reassemble the leg brackets (D) and leg (E), and screw the assembly to the back (A). Apply adhesive-backed rubber bumpers to the bottom of the leg and hinge brackets (C), where shown on **Drawing 1**.

3 Reposition the glass holder (F) between the hinge brackets (C) on the spacers. Insert all but $\frac{1}{2}$ " of the $1\frac{3}{4}$ "-long dowels into the holes. Apply glue to the two exposed, finished dowel ends, and drive them flush with the brackets.

4 Finally, order a $9\frac{1}{4} \times 14\frac{3}{4}$ " piece of $\frac{1}{4}$ " tempered glass with radiused corners and polished edges. See **Drawing 1**. Apply a small bead of clear silicone caulk in the glass holder's groove to within 2" of each end, and insert the glass. Lightly clamp the glass to keep it tight against the groove's bottom. Let the silicone cure for 24 hours. Then, get cooking! 🍲

Written by **Owen Duval**
Project design: **Jeff Mertz**
Illustrations: **Mike Mittermeier**

Materials List

Part	FINISHED SIZE			Matl.	Qty.
	T	W	L		
A* back	$\frac{1}{2}$ "	$10\frac{3}{8}$ "	$16\frac{3}{4}$ "	EM	1
B base	$\frac{3}{4}$ "	$3\frac{1}{2}$ "	$14\frac{3}{4}$ "	M	1
C hinge brackets	$\frac{1}{2}$ "	$1\frac{1}{4}$ "	$4\frac{3}{8}$ "	C	2
D leg brackets	$\frac{1}{2}$ "	1"	5"	M	2
E leg	$\frac{1}{2}$ "	1"	$8\frac{1}{4}$ "	M	1
F glass holder	$\frac{3}{4}$ "	$1\frac{3}{4}$ "	$14\frac{3}{4}$ "	C	1

*Part initially cut oversize. See the instructions.

Materials key: EM—edge-joined maple, M—maple, C—cherry.

Supplies: Spray adhesive; double-faced tape; $\frac{1}{4}$ " birch dowel 16" long; #6 \times 1 $\frac{1}{4}$ " flathead wood screws (7); silicone caulk; $\frac{1}{4}$ " tempered glass, $9\frac{1}{4} \times 14\frac{3}{4}$ "; $\frac{5}{16}$ "-diameter adhesive-backed rubber bumpers (3).

Blades and bits: Dado-blade set, $\frac{1}{4}$ " round-over router bit.

Cutting Diagram

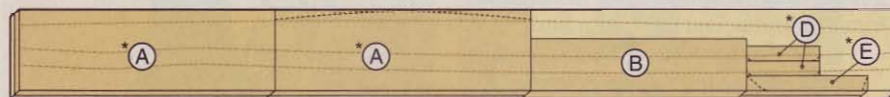

$\frac{3}{4} \times 5\frac{1}{2} \times 60$ " Maple (2.5 bd. ft.)

*Plane or resaw to the thickness listed in the Materials List.

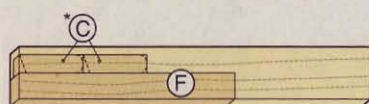

$\frac{3}{4} \times 3\frac{1}{2} \times 24$ " Cherry (.7 bd. ft.)

dado set showdown

We cut a quarter mile of dados and grooves to find the best of the best of 15 sets.

When a woodworking project calls for a dado, groove, or rabbet, a dado set is frequently your best option. Although a router and straight bit will also do the job, you'll often find that they require multiple passes to achieve the necessary width or depth, with each additional pass inviting error. On the other hand, with a dado set installed in your tablesaw, you can cut most slots precisely with only one pass using your saw's rip fence instead of setting up a straightedge.

But, with dado sets ranging from \$30 to \$300, how do you know which one is right for the work you do? To find out, we put a pile of carbide-toothed sets—both stacked and adjustable—to the test. We quickly learned that nearly all adjustable sets (sometimes called “wobble” blades) simply don't make cuts clean enough for cabinet-grade woodworking. (See “How a ‘wobbler’ works,” *opposite*.) So, we eliminated those models, leaving us with the final 15 we rated for this article.

Here's what to look for

Woodworkers demand four key performance characteristics from their dado sets: clean edges, square shoulders, ridge-free bottoms, and minimal scoring (V-shaped grooves in the corners of the dado created when the outside blades cut deeper than the chippers). However, perfection in all of the areas is rarely required. Depending on how you use a dado set, you might be able to save money by purchasing one that performs best in only the ways you're most likely to use it. So, for example, if you work mostly in solid woods, don't pay the extra money for the sets that cut well in plywoods and laminates.

To help you sort it all out, we'll show the four primary dado uses, the critical performance characteristics for each use, and tell you which sets tested best for that job. And, as always, we'll give you our picks for Top Tool as well as Top Value—the set that gives good grooves at a great price.

About our test

We used each dado set on a 3-hp tablesaw—with the fence set perfectly parallel to the blade—to make a series of with- and cross-grain cuts in solid red oak, pine, oak-veneered plywood, and melamine-coated particleboard. Then, we repeated the cuts using a zero-clearance insert in the saw's throat plate to see how that would affect performance. (In every case, the quality of the cut improved dramatically with an insert.) Finally, we stacked up the outside blades and appropriate chippers (without shims) to make 1/4"-, 1/2"-, and 3/4"-wide dados, and then made the cuts to see how close each measured to those dimensions.



Share your opinion
of these sets in
our Dado Sets
forum at

www.woodmagazine.com/dadoes

WOOD
ONLINE

The top 4 dado uses and the sets that excel in each

Shelf dadoses in plywood or melamine

Getting a clean edge is the top priority for these cuts. The outer veneers on today's plywoods are thinner than ever, making them more brittle and subject to severe tear-out, especially when cutting across the grain. Brittleness also factors in with melamine-coated particleboard, which tends to chip out badly when cut with a dado set having fewer than 46 teeth per outside blade.

Less critical is the depth of the scoring grooves. In most cases, solid-wood edge banding will hide any imperfections.

The top sets for dadoing plywood: CMT 230.024.08 and Freud SD608. Two other dado sets cut more-difficult melamine cleanly: Amana 658040 and the identical Lee Valley 15W02.02. Both are specially designed for the task.

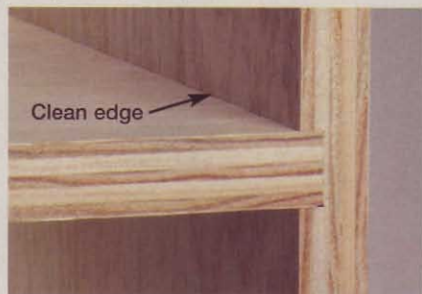

Rabbets and dadoses in solid stock

With no brittle veneer to be concerned about, you can achieve clean edges in solid wood with most of the tested sets. However, because most rabbets and dadoses (and box-joint fingers, for that matter) in solid stock remain visible on the finished project, flat bottoms and shallow scoring cuts take on high significance. The Forrest Dado King and the Freud SD508 get the nod for this task.

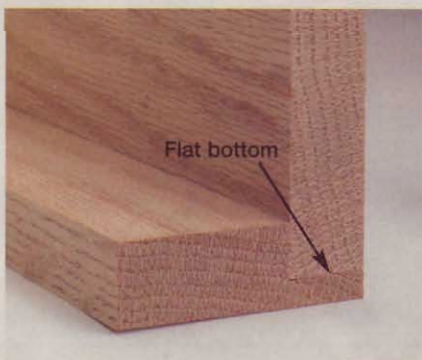

Tenons

Square shoulders and clean edges are key to first-rate tenons. Scoring in the corners means little, because the cut surface will be completely hidden with the joint assembled. (Some woodworkers argue that a little scoring is actually a good thing here, as it provides a place for excess glue.)

Ridges on a tenon can be a bit more problematic, creating less surface area for adhesion within the joint. But in the *WOOD*® magazine shop we like to cut tenons just a hair oversize, then sand them to a good fit. This process lessens the importance of flat-bottomed dadoses. The Freud SD508 and Lee Valley 15W01.04 proved best in the test for tenoning.

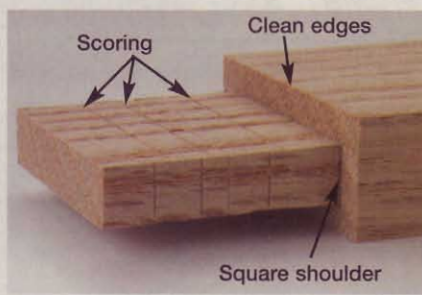

Half-lap joints

Arguably, half-lap joints provide the ultimate test of a dado set because without square shoulders, flat bottoms, and clean edges, the joint looks bad at best, and lacks strength at worst. Rippled bottoms mean less gluing surface and, unlike with tenons, sanding isn't a good solution. Scoring grooves show up on both exposed edges of the joint, so you can't hide them. Two sets did well enough in our testing to get a recommendation for this joint: the Forrest Dado King and the Freud SD508.

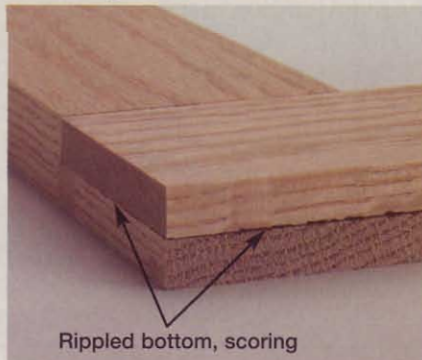

How a "wobbler" works

Instead of having two outside blades and multiple chippers, a wobbler has just one or two blades. That blade sits cockeyed on the saw arbor, so it cuts a side-to-side path as it spins.



The distance between the extremes of the blade path, shown above, is the width of the dado. In our tests, we found these designs—with one exception, noted below—inadequate for quality woodworking, because they leave tattered edges on plywood and ridges in the bottom of the dado.

That's not to say that adjustable sets don't have a place in your shop. For instance, most are inexpensive—in the \$25-\$40 range. And, they work fine for noncritical applications, such as tenoning for fence rails or half-laps in construction materials. Save your expensive dado set for precision work, and use an adjustable or other low-cost set for rough work.

(Freud's SD608 "Dial-A-Width" dado set is shimless, yes, but does not qualify as a wobbler. Rotating a hub on the outside blade merely pushes that blade straight out, .004" per click, much like inserting an actual shim between chippers.)

More findings from our tests

- More than half of the tested sets have chippers with four or more teeth. (Two teeth per chipper used to be standard.) These sets balance better when more than one chipper is installed. On two-tooth chippers, distribute the chipper teeth evenly around the hub when using more than one chipper.

- When we stacked up the sets to cut 1/4", 1/2", and 3/4"-wide dadoses, we were surprised to learn that most of them made those cuts oversize. For example, two outside blades (1/8" each) and two 1/8" chippers should yield a 1/2" dado, but about half of the dado sets made cuts wider than that. (See the chart at the end of this article.) It's simple to add a shim or two to widen an undersize cut, but a nuisance to remove a chipper and use lots of shims.

- Six of the tested sets include a 3/32" chipper to more readily cut dadoses to fit

plywood, which is typically 1/32" thinner than its stated thickness. You just substitute this special chipper for a 1/8" chipper in your stack. Again, it's quicker (and cleaner) than adding 3/32" of shims.

■ If mishandled, steel shims can become inaccurate—a careless bend will never flatten out completely. Plastic shims and Freud's tempered-steel shims resist such accidental damage. Forrest's magnetic shims stay in place on the blade or chipper without fear of dropping them into the saw while installing the set.

■ We looked only at 8" dado sets for this article. But, the 1"-depth capacity of a 6" set may be plenty for the kind of work you do, and many manufacturers also offer 6" versions of the sets we tested. Although you can't assume equal results with the smaller-diameter blades, we've found over the years that a company that makes a quality 8" set also makes a quality 6" set. As you might expect, the smaller sets cost a little less, too.

■ Make sure your saw's rip fence is set perfectly parallel to the blade, and keep

it there. Some woodworkers like to set the back of their fence a little farther from the blade to reduce the likelihood of kickback, but we have found that the practice contributes to poor cuts with a dado set.

Here's what we'd buy for our shop

Without question, Forrest's Dado King ruled in nearly every category of our tests, so we named it our Top Tool. But, at \$260 for the set, it doesn't fit into

HOW TODAY'S 8" DADO SETS STACKED UP

BRAND	MODEL	OUTSIDE BLADES		CHIPPERS				PERFORMANCE GRADES (3)																	
		NUMBER OF TEETH PER BLADE	HIGH TOOTH-BEVEL ANGLE? (YES/NO)	HOOK ANGLE (POSITIVE OR NEGATIVE)	ANTI-KICKBACK DESIGN?	NUMBER OF TEETH PER CHIPPER	3/32" CHIPPER INCLUDED? (YES/NO)	SHIM MATERIAL (1)	ACTUAL WIDTH OF 1/4" (.250"), 1/2" (.500"), 3/4" (.750") STACK (WITHOUT SHIMS) (1) (2)	CLEANNESS OF CUT EDGES (4)															
										WITHOUT ZC INSERT								WITH ZC INSERT							
										ABSENCE OF RIDGES IN BOTTOM	ABSENCE OF SCORING IN CORNERS	SQUARENESS OF CORNERS	OAK PLYWOOD, RIPPING	OAK PLYWOOD, CROSSCUTTING	SOLID OAK, RIPPING	SOLID OAK, CROSSCUTTING	SOLID PINE, RIPPING	SOLID PINE, CROSSCUTTING	MELAMINE-COATED PARTICLEBOARD	OAK PLYWOOD, RIPPING	OAK PLYWOOD, CROSSCUTTING	MELAMINE-COATED PARTICLEBOARD			
AMANA	658030-AK	24	Y	POS	Y	2	N	P	.251, .509, .763	B	A-	A-	A	C	A	B	A	B	D	A	A	A			
	658040	46	Y	NEG	N	2	N	P	.251, .510, .755	A	A	A	A	B	N/A	N/A	N/A	N/A	A	A	A	A			
AVENGER	10026	42	N	POS	N	6	N	B	.258, .499, .745	C+	A-	C	A	F	A	C	A	B	D	A	A-	A			
	10031	30	N	POS	N	5	Y	B	.259, .478, .708	C+	A-	B	C	F	A	C	A	C	F	A	A-	A			
CMT	230.024.08	24	N	NEG	Y	4	Y	P	.256, .499, .737	B	B	B	A	B+	A	D	A	A	C	A	A-	A			
DELTA	35-535	24	N	POS	Y	2	N	C	.245, .508, .759	A-	B	B	A	F	A	A	A	B	D	A	B	A			
FORREST	Dado King	24	Y	NEG	N	4	Y	M	.244, .488, .735	A	A	A	A	B	A	B	A	A	C	A	A	A			
FREUD	SD208	12	N	NEG	Y	2	N	T	.234, .494, .737	C+	A	A-	B	B-	A	A	A	C	F	A	B	A			
	SD508	24	N	NEG	Y	4	Y	T	.245, .499, .753	A-	A	A	A	C	A	A	A	B	C	A	A	A			
	SD608	24	N	NEG	Y	4	Y	N/A	N/A	A	A	A	A	B+	A	C	A	C	C	A	A	A			
JESADA	108-240S	24	N	NEG	Y	4	Y	P	.268, .492, .738	B	A-	A-	B	B	B	B	B	B	D	A	A-	A			
LEE VALLEY	15W01.04	24	Y	POS	Y	2	N	P	.251, .512, .766	B	A-	A-	B	F	A	A	A	B	D	A	A-	A			
	15W02.02	46	Y	NEG	N	2	N	P	.254, .509, .755	A	A	A	A	B	N/A	N/A	N/A	N/A	A	A	A	A			
SYST-MATIC	37155	22	N	POS	N	2	N	N	.274, .504, .769	D+	A-	C	B	F	B	C	B	C	D	A	B	A			
	37160	42	N	POS	N	6	N	N	.261, .508, .767	B	A	A	A	C	A	B	A	B	D	A	B	A			

NOTES: 1. (B) Brass (N/A) Shimless design (C) Cardstock (P) Plastic (M) Magnetic (T) Tempered steel (N) None provided 2. Red numbers indicate undersize cuts, which can be shimmed to the full width. Oversize cuts require removing a chipper and adding lots of shims. 3. A Excellent D Below average B Good F Poor C Average N/A Not tested in solid wood, as manufacturer recommends use only in melamine.

every woodworker's budget. Freud's SD508 costs \$60 less and delivered comparable results, but didn't do as well when crosscutting oak plywood without a zero-clearance insert.

Freud's SD208 and Delta's 35-535 earned Top Value honors. Both did a good job in most cuts, but have some shortcomings, as you can see in the chart. At \$95 and \$100, respectively, neither will bust your budget.



Forrest Dado King



Freud SD508



Written by Dave Campbell with George Granseth



Delta 35-535



Freud SD208



WARRANTY (5)	COUNTRY OF MANUFACTURE (6)	SELLING PRICE (7)	OTHER DIAMETER AVAILABLE/SELLING PRICE (7)	COMMENTS	PHONE, WEB SITE
L	IS	\$150	6"/ \$120	Thick carbide teeth will withstand many sharpenings so this set should last a lifetime. The pin that holds the outer blade in the plastic storage case broke off early in our tests, and the chippers sometimes stick in the lid when opening.	800/445-0077, www.amanatool.com
L	IS	190		A good choice for melamine, and a smooth running set. Flat-ground chippers left ridge-free bottoms, but high bevel angle and negative hook angle of outside blades will dull quickly. It's identical to the Lee Valley 15W02.02, which is recommended for use only in melamine, so we didn't test it in solid wood.	
L	CH	100		This copy of the Systi-Matic 37160 sells for less than half the price and performed half as well. Cardboard storage box with foam inserts won't hold up with repeated use. Thicknesses are marked on the shims—a nice touch.	805/983-0039, www.avengerproducts.com
L	CH	50	6"/ \$40	A zero-clearance insert helped this inexpensive set achieve pretty clean edges, even in oak plywood. While not suitable for most woodworking tasks, it's a good "second" set for rough work. Same storage box as Avenger 10026. Thicknesses are marked on shims.	
L	IT	190	6"/ \$180	The only set in the test with a Teflon coating to reduce heat buildup. This set cuts cleaner than most across oak plywood and in melamine, but we'd still use a zero-clearance insert. Two-piece storage case proved clumsy.	888/268-2487, www.cmtusa.com
2 yr.	NZ	100	6"/ \$90	"Permanent" shims on both outside blades detached from the blades after only a few uses. The smallest carbide teeth in the test means you won't get many trips to the sharpener before it's time to replace the set.	800/438-2486, www.deltamachinery.com
30D,L	US	260	6"/ \$245	The Top Tool in our tests, this set cuts at or near the top of the pack in every material. All three stacked-without-shims cuts were undersize, which we like. Magnetic shims work well with minimal fuss, but only go .010" at smallest. The high bevel angle and negative rake angle of the outside blades will cause them to dull quickly.	800/733-7111, stores.yahoo.com/forrestman
L	IT	95	6"/ \$85	This set doesn't come with a 3/32" chipper, but all three stacked-without-shims cuts were undersize, which we prefer. An inexpensive set best suited for solid woods. Shims aren't marked or color-coded.	800/472-7307, www.freudtools.com
L	IT	200	6"/ \$185	A middle-priced set that cuts flat-bottomed dados with little scoring in the corners. Excellent storage case provides ready access to both blades and chippers. It cuts too wide at the 3/4" stack, but the included 3/32" chipper minimizes shimming. Shims are neither marked nor color-coded.	
L	IT	300	6"/ \$290	Similar performance-wise to the Freud SD508. Instead of shims, you adjust the width of the set by rotating a hub in the center, and each click widens the cut by .004". However, stacked to its 1 3/16" capacity, the nut on our tablesaw's 1 1/8"-long arbor grabbed fewer than half of the threads.	
L	IT	180	6"/ \$140	Although it underperformed the CMT set in most materials, the two sets look as though they were made in the same plant (except for the absence of the Teflon coating on the Jesada). A middling set for a middling price.	800/531-5559, www.jesada.com
90D, L	IS	140	6"/ \$115	Appears identical to the Amana 658030-AK, but fared worse in oak plywood. Foam-lined case provides better protection to blades and cutters than the Amana case.	800/871-8158, www.leevalley.com
90D, L	IS	150		Not tested in solid wood, because the manufacturer recommends it only for melamine, and it did a fine job in that material. Identical to Amana 658040 but with a nicer case.	
1 yr.	US	130	6"/ \$120	For \$130, we expect better performance and shims, and something more substantial than a cardboard storage box with foam.	800/426-0035, www.systimatic.com
1 yr.	US	240	10"/ \$280	Solid performance in most materials, especially when used with a zero-clearance insert. But it wasn't as good as the Freud SD508 that costs \$40 less and includes a 3/32" chipper and shims.	

4. ZC=Zero clearance 5. (30D) 30-day return policy. (90D) 90-day return policy. (L) Lifetime warranty against factory defects. 6. (CH) China (IS) Israel (IT) Italy (NZ) New Zealand (US) United States 7. Prices current at time of article's production and do not include shipping, where applicable.

shop-proven products

These woodworking wares passed our shop trials

Spindle sander for under a hundred bucks

Ryobi continues its rollout of low-priced woodworking tools with the OSS500—a benchtop oscillating spindle sander priced at \$99. (If you're not up to speed on these tools, the sanding drum spins while also moving straight up and down. This action slows sawdust loading on the drum and reduces workpiece burning.)

Internally, the OSS500 closely resembles Ryobi's previous spindle sander (OSS450). In fact, the machine specs out exactly the same: $\frac{3}{8}$ " vertical stroke, 58 oscillations per minute, and a somewhat whiny 3.5-amp universal motor. To test power, I sanded into 3"-thick red oak, pushing pretty hard, and bogged down the motor. Working with $\frac{3}{4}$ " material, though, I had no trouble sanding cleanly to a line.

On the outside, Ryobi switched from MDF to cast iron for the tabletop, nearly doubling its weight and helping dampen

vibration. It seems odd to me, though, that the OSS500's power switch is on the same end of the machine as the short side of the table. I had to either reach around the spindle when sanding large workpieces, or turn the sander around and fumble behind it for the power switch.

The sander comes with drums, abrasives, and throat inserts for six diameters ($\frac{1}{2}$ " through 3"), with on-tool storage provided for all. A standard 2 $\frac{1}{2}$ " vacuum hose fits nicely on the OSS500's dust port, and with a vac connected I captured 95 percent of the dust the tool generated.

I've had an OSS450 in my high-school woodshop for about six years, and it's held up pretty well despite the abuse adolescent woodworkers can dish out. I suspect the OSS500 will last at least that long given its new heavy-duty table.

—Tested by Jeff Hall



Ryobi OSS500 oscillating spindle sander

Performance	★★★★☆
Price	\$99

Ryobi Technologies
800/525-2579, www.ryobitools.com

Southpaws rejoice over Ridgid drill press

Let's face it: Left-handed woodworkers often are left behind by the engineers who design power tools. Miter saws, circular saws, and drill presses all require a strong right arm for easy operation.

Ridgid engineers have helped correct that injustice with the DP1550—a drill press with a quill-feed handle that can be switched to the left-hand side. It takes about 20 minutes to make the move, and although the job isn't complicated, you'll probably only do it when you first assemble the tool.

Regardless of which side of the plate you bat from, you'll find lots of other nice touches on this 15", 12-speed drill press. For example, a column-mounted parts tray stores individual bits in holes from $\frac{1}{8}$ " to $\frac{5}{8}$ " (by $\frac{1}{16}$ " increments), and still has room for a tape measure, sanding drum, or other small accessories. You won't need to put the chuck key there, though, because it has its own home: clipped to the side of the head.

Features alone don't drive this drill press. The DP1550's $\frac{1}{2}$ -hp motor seems

Ridgid DP1550 drill press

Performance	★★★★☆
Price	\$300

Ridgid
866/539-1710, www.ridgidwoodworking.com

more powerful thanks to the poly-vee belt drive that didn't slip a lick in my tests. And, with 12 speeds ranging from 250 to 3,100 rpm, you can choose the best speed for virtually any bit or material.

When I first pulled the DP1550 out of the box, I was disappointed to see a dial-style depth stop on this machine. (Generally speaking, I prefer threaded-rod depth stops.) But this dial stop proved rock solid and reliable, slipping only about .008" after drilling one hundred holes.

—Tested by Jeff Hall

Continued on page 99



shop-proven products

Shop Strop a keen addition to your shop

A well-honed chisel is pure joy to use, and a whole lot safer than a dull one. With a Shop Strop in your drill press, you can quickly touch up already sharp tools, and clean up those with dinged or ragged cutting edges.

The Shop Strop configuration I tested (#1) consists of a 4" leather-covered wheel (shown in use in the photo below) on a hex shank, three aluminum discs, and three grits of adhesive-backed sanding discs that mount to the aluminum discs. Slip an abrasive-covered disc over the shank, chuck the wheel into your drill press, set the drill-press speed to about 800 rpm, and you're ready to roll.

To grind out some bad dings on a chisel, I started with the 150-grit abrasive disc, stepping up a grit whenever I achieved a wire-edge burr on the back of the chisel. Each change in grit required removing the Shop Strop wheel, and replacing the abrasive disc. Still, by the time I got down to the leather-covered wheel itself, I'd put a mirror edge on the chisel. Only about five minutes had elapsed.

Without any kind of tool guide, you're on your own for achieving a specific sharpening angle, so the Shop Strop isn't a precision tool. But I found it put a quick edge on all of the chisels in my shop without my having to buy (or find a place to store) a bench grinder.

—Tested by Garry Smith

Shop Strop Sharpening System

Performance	★★★★☆
Price	\$30, #1 (complete system) \$20, #2 (honing system)

Pacific Rack & Machine
877/220-2699, www.bigleg.com



Continued on page 100

SUPERSHOP 10-IN-1 WOOD & METAL SHOP

Own a Complete, **PRO-QUALITY WOOD SHOP** In Just **12 SQUARE FEET!**

Stand-alone machines take TOO MUCH ROOM!



All the **QUALITY** of premium "stand-alone" shop machines in **LESS FLOOR SPACE... and at LOWER COST!**

10 TOOLS IN JUST 12 SQ. FT.!

- Equal or **BETTER QUALITY** than one-function shop equipment.
- **COSTS LESS** than buying several one-function machines.
- **10 MOST-USED TOOLS IN 1:** table saw, lathe, drill press, router, sander, more!
- **Rock solid, 2½ times MORE MASSIVE** than other combo machines.
- State-of-the-art **ELECTRONIC SPEED** controls, powerful DC motor.
- Perfect for both **HOME & PROFESSIONAL** woodworkers.
- **30-Day RISK FREE** Buy-Back Offer & Industry-Leading Warranties.

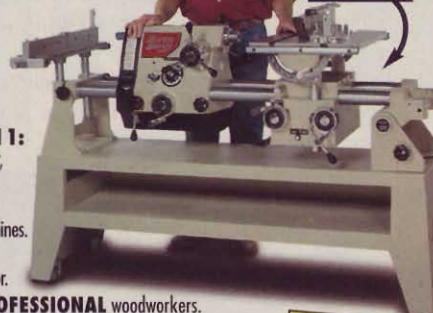

Get complete details & SAVINGS OFFER:

ON SALE FOR A LIMITED TIME ONLY!

CALL TOLL FREE
1-800-476-4849

Or this Mail to: **SuperShop®** Dept. WOOD, P.O. Box 1517, Ann Arbor, MI 48106-1517

YES! RUSH me all the details on the HIGH QUALITY, AFFORDABLE alternative for TIGHT SPACE wood shops!

Name _____

Address _____

City _____

State _____

Zip _____

Circle No. 1766



Furniture Medic has ALL the tools

"Furniture Medic furnished the tools needed to build my own business. With continuous training plus time-saving tools, products and processes, I mastered wood repair as well as on-site restoration. Their comprehensive business support and software — and strong marketing materials — have allowed me to grow my business beyond my expectations."

- ▶ Variety of customers including offices, hotels, restaurants, homeowners, moving and storage companies, and insurance companies
- ▶ Over 600 franchises worldwide
- ▶ Recognized as the #1 brand for on-site furniture repair and restoration for a decade
- ▶ Division of The ServiceMaster Company, ranked among the Fortune 500

Check out our toolbox!
Call **1-800-RUN-YOURS** or
visit furnituremedicfranchise.com



FURNITURE MEDIC®

Circle No. 895

No-drill screws: No splitting? No kidding

Predrilling screw holes is a time-consuming but necessary task. SplitStop High-Performance Wood Screws can be driven without a pilot hole, without splitting your precious stock.

Like other self-tapping screws, SplitStop's tip cuts threads as it bores into the wood. In addition, knurling on the shank,

(shown in the inset photo) plows just enough breathing room for the shank. This feature improves the screw's draw-down capability, especially on slightly cupped or bowed lumber.

I drove a dozen #6x2" SplitStop screws very near the end of a piece of pine in less than 4" of space, without a single split. In

red oak, I drove several screws within 1/4" of the end of the board, and experienced only one minor split. In medium-density fiberboard (MDF), a material notorious for splitting, they split less than regular wood screws without predrilled pilot holes, but about as often as wood screws with pilot holes.

SplitStop screws come in three varieties: MACroBrite and Stainless Steel (with a lifetime corrosion warranty for outdoor applications), and Zinc-Yellow for interior use.

—Tested by Jeff Hall

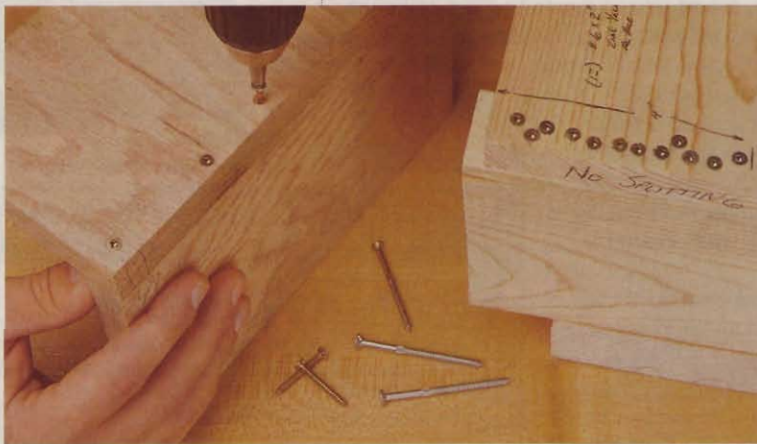

SplitStop High-Performance Wood Screws

Performance	★★★★☆
Price	\$6.70, 155 ct. Zinc-Yellow #6x1 5/8"; \$8.00, 85 ct. MACroBrite #8x2 1/2" (other sizes also available)

Titan Metal Werks
888/578-3273 www.splitstop.com.

Who Raises Your Router?

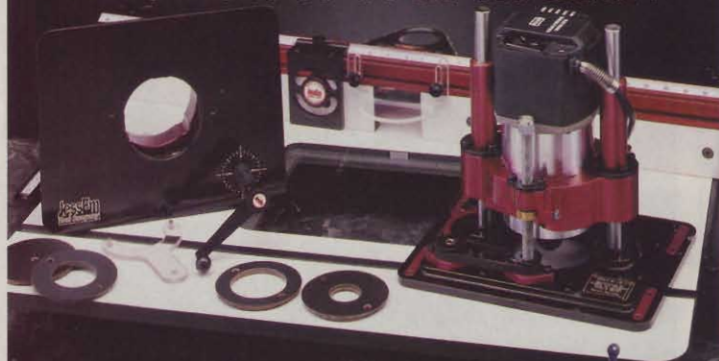

Take the guess work out of your router table set-ups. Just crank it up 1/64 of an inch, or tweak it .002" at a time. From the makers of the original Rout-R-Lift and the all new Mast-R-Lift, JessEm helps get it done faster with pure accuracy. Look to JessEm for innovative solutions for those who put the "work" into woodworking!

JessEm
Tool Company

Barrie, Ontario
Canada, North America

For additional product information call 866-272-7492 or visit us online at www.jessem.com email: jessem@jessem.com

Distributor inquiries are highly recommended



Over 120 Flavors of Wood Turnings



8116 Highway 123 North • Toccoa, GA 30577
Call for a catalog: 1-800-746-3233
Order line: 1-800-849-8876 • Español: 1-877-445-6034
email: turn@alltel.net

www.osbornewood.com

shop-proven products

Convertible drill/driver gets you into tight spaces

As a professional woodworker for more than 30 years, I wouldn't be without my cordless drill. I also know its limitations, and working inside a cabinet installing drawer slides and hinges is where the tool's bulkiness shows its shortcomings. It's for people like me that Festool's TDD12FX 12-volt cordless drill was designed to get us into, and out of, those situations.

At first blush, it looks like an ordinary cordless drill. But the three-jaw chuck pops off to reveal a 1/4" hex drive that shortens the tool by nearly 2 1/2". (Driver bits with 1/4" hex shanks are available almost everywhere—that's the industry standard for quick-release drill bits and accessories.)

Other space-saving features include an optional right-angle chuck (for working inside narrow cabinets) that accepts hex-drive bits or the three-jaw chuck, and an offset chuck (for using hex-drive bits close to obstructions, such as a shelf). Both attachments snap onto the body of the drill in place of the three-jaw chuck, and of the two, I liked the offset chuck better. In right-

angle mode, the TDD12FX is still bulkier than a dedicated right-angle drill.

I drove and removed 220 1 1/4" screws on a single charge of the 1.7-amp-hour NiCd battery. The fast 15-minute charger topped off that battery long before I used up the charge in the second battery.

Make no mistake: Festool's TDD12FX is a well-crafted European tool, and you'll pay a premium for that quality. But if you buy one accessory chuck and figure what it would cost you for two dedicated tools, it makes more economic sense.

—Tested by
George Granseth

Festool TDD12FX cordless drill

Performance ★★★★★
Price \$395 (includes three-jaw chuck);
right-angle chuck, \$70; offset chuck, \$70

Festool USA
888/337-8600, www.festool-usa.com



About our product tests

We test hundreds of tools and accessories, but only those that earn at least three stars for performance make the final cut and appear in this section. Our testers this issue include: high-school woodworking teacher **Jeff Hall**, machinist **Garry Smith**; and **George Granseth**, who heads the architectural millwork department at a community college. All are avid woodworkers. 🌲

ROCKLER®

WOODWORKING AND HARDWARE



Pre-drilled holes to mount pads, cauls and jigs

Exceptionally stable, just won't tip during glue-ups!

A taller base —no more knuckle knocks...

This isn't your father's pipe clamp!
Introducing the innovative
Sure-Foot™ pipe clamp.

Code 14001

Call or go online to get your **FREE** catalog today!

1-800-403-9736 -or- **rockler.com/go/V4302**

Circle No. 661

COMPARE!

See our Competition Comparison on our website at www.oneida-air.com

Collect Dust!

Leeson Industrial U.S. Motors
1.15 S.F. - F Class Motor Windings

1.5 - 20hp Systems

Captures 99.9% of test material
between 0.2 - 2.0 microns @
11 FPM face velocity

Wide Pleats for easy cleaning. Made
specifically for wood dust

Heavy Gauge /
Up to 2x the Metal Gauge of Imports

Backward Incline Fan Wheel / Super
Efficient / No Vibration

Quiet - Silencer included
w/ Filter Cartridge on
1.5 - 3hp Systems

Buy Factory Direct and Save!

Buy the Best!

100% Quality
Made in USA

FREE Catalog! 1.800.732.4065

Oneida Air Systems, Inc. 1001 W. Fayette St. Syracuse, NY 13204

Circle No. 2039

what's ahead

Don't miss the October issue of *WOOD*® magazine on sale September 2

Here it comes: Idea Shop 5

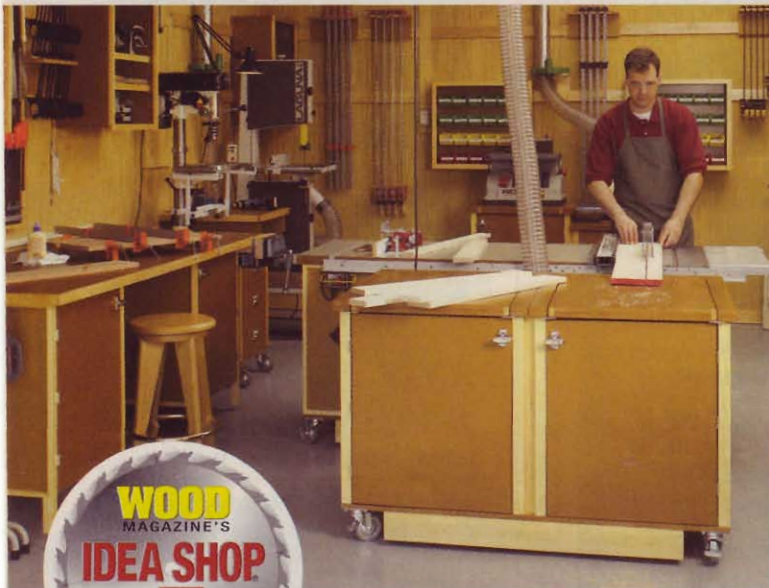

Make the most of your workshop space

Interested in making some improvements to your workshop? Then come along as we convert a one-stall garage into a full-function workshop. You'll find tons of ideas for building multipurpose tool bases and wall cabinets from inexpensive materials. Everything is mobile, and adapts to serve your woodworking needs today *and* in the future.



2-in-1 mobile work center

At the heart of Idea Shop 5 is this easy-to-build dual-cabinet base with built-in dust collection for its tablesaw and router, a shared fence system, and storage for your saw blades, router bits, and other accessories.



Flip-top tool base

All of the floor cabinets and tool bases in Idea Shop 5 start with the same case design. Simply build that case, team it with identical cases, and adapt it in ways that suit your needs, choosing from a range of options. In this project, you add a pivoting top that holds a woodworking machine. It's perfect for heavy, occasionally used benchtop tools.

More Projects, Tools, and Techniques



2 quick-and-easy projects

Build a three-columned holder for a Galileo thermometer, or an out-of-this-world child's mobile, in no time flat.



Traditional display case

Lights, style, and storage—this exquisite wall-hung cabinet has it all.



Bad boy tablesaws

Ready to step up to a saw that has the guts to cut any workpiece with power and precision, time after time? We test and rate today's most popular 3-hp models.

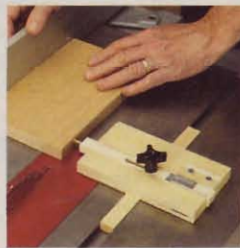

4 must-have tablesaw jigs

Get maximum use and accuracy out of your tablesaw with these shop-made helpers. Build a pocket-size height gauge, taper jig, thin-strip ripper, or crosscut sled with adjustable stop.