

# WOOD

**FULL SIZE  
PULL-OUT PATTERNS**

## build this heirloom hutch

p. 62

**HOW TO  
WORK WITH  
PINE**  
p. 70



**8 PROVEN  
PROJECTS**  
for home & shop

**space-saving**



**MOBILE TOOL  
CABINET**

**SHOP-TESTED SKILLS  
PRECISION  
RESAWING**

**TOOL TESTS:**

**mid-size lathes** p. 98

**bench vises** p. 88

[www.woodonline.com](http://www.woodonline.com)

Display until March 25, 2003





TM  
This seal is your assurance that we build every project, verify every fact, and test every reviewed tool in our workshop to guarantee your success and complete satisfaction.

# contents

WOOD® magazine

March 2003, Issue 147

## PROJECTS

- 18 hassle-free clamp blocks
- 50 baker's pastry board, rolling pin, and wall rack
- 58 colorful fish puzzle
- 62 heirloom pine hutch
- 80 intarsia teddy bear
- 92 mobile tool cabinet



62

## TECHNIQUES

- 14 instant patina for brass hardware
- 16 how to mark smooth curves
- 20 intarsia tips and tricks
- 42 quick fix for a failed chair rail
- 46 tight-fit wraparound moldings
- 70 working with pine  
Discover the secrets for buying, machining, and finishing this beautiful, but finicky, wood.
- 84 mastering resawing  
Improve your precision for cutting thin stock on both your bandsaw and tablesaw.

58

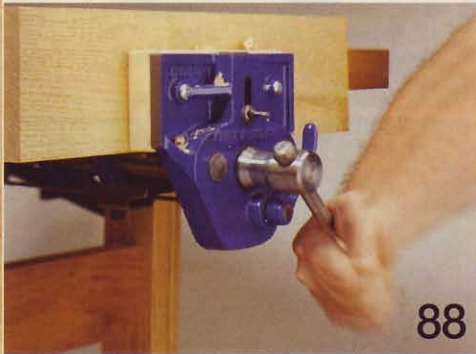

88



80

## TOOLS & MATERIALS

- 32 shop-proven products
- 88 a guide to woodworking vises  
Learn what's available and what you need to know to make a smart purchase.
- 98 mid-size lathes  
Get the spin on eight tools, and find out which ones take top honors in our test.



92

## FEATURES

- 44 problem-solving solvents
- 74 country furniture in the making  
Craftsman Bill Draper reveals the keys to building great-looking pieces.

50



## DEPARTMENTS

- 4 editor's angle
- 6 sounding board
- 12 at your service
- 22 shop tips
- 34 ask WOOD
- 40 short cuts
- 120 what's ahead in our next issue



84

# editor's angle

The world is full of opportunities for using your woodworking skills to benefit others in need. If that sounds like something you're interested in, let me tell you how our staff recently applied its collective talents to better the lives of others. You can do the same in your local community.

**R**arely a week goes by when I don't hear from a reader who's done a good deed for others. From time to time, someone from a woodworking club writes to say how the members mass-produced a line of toys for disadvantaged kids, or that they auctioned club-made projects to benefit a charity. We often get calls from individuals who just volunteered to make, for example, a podium for a civic group or a nativity scene for a church, and need to find a set of construction plans ASAP!

I think that's just great. Now here's another way to help others. As you may recall, in the October issue I mentioned that our company was celebrating its centennial. As a part of those festivities, more than 1,000 employees volunteered to rehabilitate 40 homes from coast to coast, through a program called Rebuilding

Together. The goal of this national, non-profit agency is simple: to make the homes of low-income, elderly, or disabled homeowners safe, warm, and dry. Typically, the local chapters of this organization assign crews to homes, working with materials donated to, or purchased by, Rebuilding Together. The crew does as much work as can be accomplished in 8 hours. And you would be amazed at how much work a team of 25 or so dedicated volunteers can do in that time.

Much of the work on these homes is relatively unskilled—painting, cleaning, and roofing are common tasks. But there is a great demand for talented folks like you, with woodworking, carpentry, and other home-repair skills. If you can install a door, replace rotted trim, build a wheelchair ramp, fix a wobbly railing, or do simple framing, Rebuilding Together needs you!

I'm proud to say that nearly all of our staff lent their much-appreciated woodworking skills to a number of homes. For all, it was a truly gratifying experience.

To find out how you can become involved in your local Rebuilding Together chapter, or if you know a homeowner in need of assistance, give the national office a call at 800/4-REHAB-9, or go to [www.rebuildingtogether.org](http://www.rebuildingtogether.org)

*Bill Krier*



**Rebuilding Together™**



This industrious crew (yours truly at far right) painted the exterior of a home, trimmed trees, cleaned a basement, added ceiling fans, fixed screens, and patched a sub-floor—all in less than 8 hours!

Kathryn Morgan, lucky homeowner

Editor-in-Chief **BILL KRIER**  
Executive Editor **JIM HARROLD**  
Managing Editor **MARLEN KEMMET**  
Features Editor **DAVID STONE**  
Products Editor **DAVE CAMPBELL**  
Projects Editor **JAN SVEC**  
Projects Editor **OWEN DUVAL**  
Techniques Editor **JIM POLLOCK**  
Senior Design Editor **KEVIN BOYLE**  
Design Editor **JEFF MERTZ**  
Master Craftsman **CHUCK HEDLUND**  
Production/Office Manager **MARGARET CLOSNER**  
Administrative Assistant **SHERYL MUNYON**  
Photographer **MARTY BALDWIN**  
Illustrators **LORNA JOHNSON, ROXANNE LeMOINE, TIM CAHILL, MIKE MITTERMEIER**  
Technical Consultants **RICH BRIGHT, JEFF HALL, PHILLIP GOODWIN, GARRY SMITH**  
Contributing Craftsman **JIM HAEVEY**  
Proofreaders **JIM SANDERS, BARBARA KLEIN**  
Art Director **KARL EHLERS**  
Associate Art Director **GREG SELLERS**  
Assistant Art Director **CHERYL A. CIBULA**  
Publisher **MARK HAGEN**

**Advertising Office:** 333 N. Michigan Ave., Suite 1500, Chicago, IL 60601 Phone: 312/853-2890 Fax: 312/580-7906  
Sales and Marketing Assistant **LARA KALLAL**  
Mail Response Manager **CAROLYN DAKIS**  
Account Executive **RON GOLMINAS**  
Account Executive **NEIL KIRBY**  
Account Executive **JOHN THORNBURGH**  
Detroit, Phone: 248/356-1149 Fax: 248/356-8930  
Account Executive **PAT TOMLINSON**  
Northeast, Phone: 212/551-7043 Fax: 212/551-7192  
**Southeast:** Lagomarsino, Dempsey & Dennis, Inc. 2951 Piedmont Rd., NE, Suite 100, Atlanta, GA 30305  
Phone: 404/261-5400 Fax: 404/261-5404

Group Marketing Director **CATHY E. SMITH**  
Senior Marketing Services Manager **ALEXANDER D. CLARKSON**  
Phone: 212/551-7090 Fax: 212/551-7192  
Senior Promotion Designer **SARAH DIBELLA**

Group Publisher **STEPHEN B. LEVINSON**  
Associate Business Director **CRAIG FEAR**  
Senior Product Manager **RICK GROW**  
Advertising Operations Manager **PAT HENDERSHOTT**  
Consumer Marketing Director **JULIE MARTIN**  
Consumer Marketing Manager **DAVE HONOLD**

Vice President/Publishing Director **WILLIAM R. REED**  
**MEREDITH PUBLISHING GROUP**  
President **STEPHEN M. LACY**  
Magazine Group President **JERRY KAPLAN**  
Group Sales **MICHAEL BROWNSTEIN**  
Creative Services **ELLEN DELATHOUER**  
Manufacturing **BRUCE HESTON**  
Consumer Marketing **KARLA JEFFRIES**  
Finance and Administration **MAX RUNCIMAN**

**Meredith CORPORATION**  
**WILLIAM T. KERR**, Chairman and Chief Executive Officer  
**E.T. MEREDITH III**, Chairman of the Executive Committee

©Copyright Meredith Corporation 2003  
All rights reserved. Printed in the U.S.A.  
Better Homes and Gardens® WOOD® magazine (ISSN-0743-894X) is published seven times a year in March, May, June/July, September, October, November, and December by Meredith Corporation, 1716 Locust St., Des Moines, IA 50309-3023. For subscription questions call 800/374-9663. Periodicals postage paid at Des Moines, Iowa, and additional mailing offices. Better Homes and Gardens trademark registered in Canada and Australia. Marca Registrada en México. **ONE-YEAR SUBSCRIPTION PRICES:** U.S. and its possessions, \$28; Canada, \$41; other countries, \$49. Canada Post Publications Mail Sales Product Agreement No. 40069223. Canadian BN 12348 2887 RT. **CANADIAN RETURN ADDRESS:** Better Homes and Gardens WOOD magazine, 2744 Edna Street, Windsor, Ontario, N8Y 1V2. **POSTMASTER:** Send address changes to Better Homes and Gardens WOOD magazine, P.O. Box 37439, Boone, IA, 50037-0439.

# sounding board

Our bulletin board for letters, comments, and timely updates



## Readers put new spins on the tool carousel

The tool carousel project (issue 144) is a great idea. As I began mine, I made a few changes. First, to fit the space available in my shop, I made my carousel smaller than yours. I modified the panels by making them pivot on the left side, rather than rotate in the middle (as shown on the drawing at right). The core is a hexagon with 3½"-wide sides. Both of these changes beef up the storage capacity, and allow easy access to the items found within.

*John Wolf, Phoenix, Ariz.*

I recently built the tool carousel featured in issue 144, and made a few changes to suit my needs. I used perforated hardboard (PegBoard) for the panels, and made the bottom cleats from 1×3 stock, with ⅜" holes for drill bit storage (as shown on the drawing, right). I had fun with this project, and I already have a request to build one for a friend.

*Jack Powers, Corpus Christi, Texas*

- John Wolf's modifications
- Jack Powers' modifications

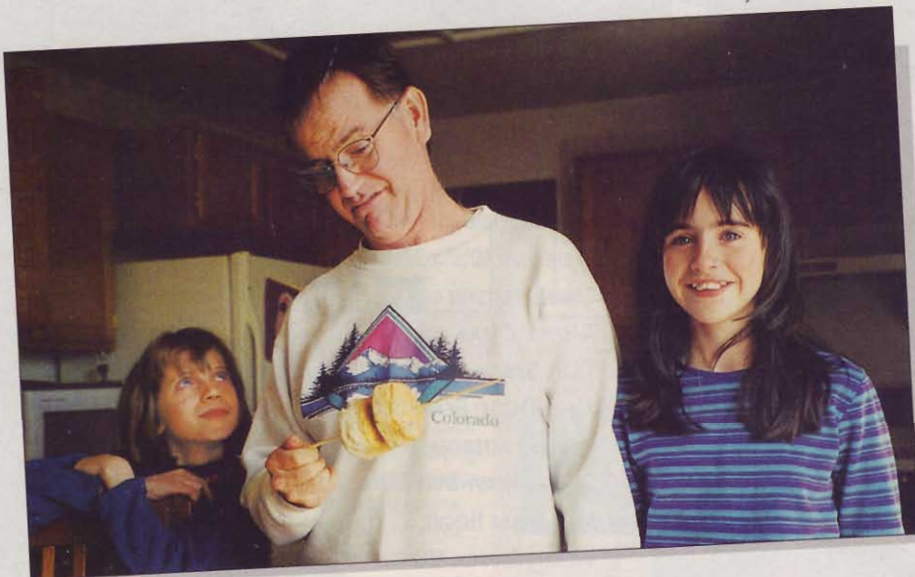
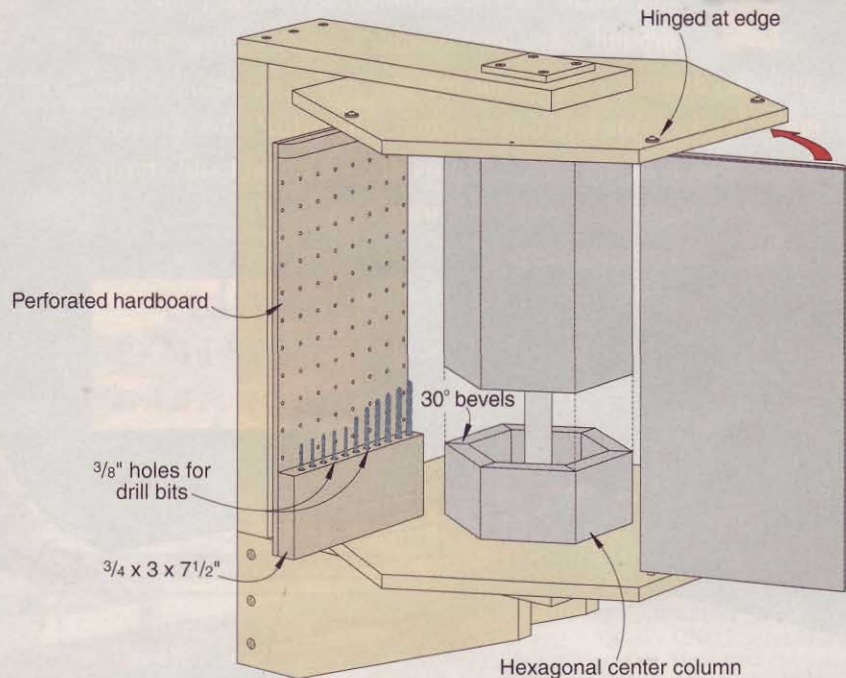

## Daughters reward woodworking dad

For our dad's birthday, we got him a woodworking tool he'd been wanting. When he opened it up, he was confused. We had to tell him it was a biscuit joiner.

*Christine and Lindsey McNulty, Westminster, Colo.*



## The skinny on locating thin lumber

A couple of readers wrote to us about the "Scrollsawn Tree Trimmers" and "Reindeer in Flight" projects (issue 145) looking for sources for the ⅛", ¼", and ½" stock we used.

We resaw thicker stock to make our thin material. But if you don't have access to a bandsaw or planer to make your own thin stock, try a specialty wood supplier, such as Heritage Building Specialties (800/524-4184), listed in the Buying Guide on page 77 of that issue. To find a list of more thin-wood dealers around the nation, check out the Web site of the Scrollsaw Association of the World at [www.saw-online.com](http://www.saw-online.com).

*Continued on page 11*

## Mobile storage cart gets rolling quickly

Thank you much! My October issue wasn't in my hands for more than four hours when I began to build the mobile storage rack (page 72). For several years, wood storage has been a problem for me because my shop space is limited. I stored wood in the garage, next to my wife's car, which made it difficult for her. Plus, the board I needed was always on the bottom of the stack.

After building the rack and equipping it with heavy-duty casters, we loaded it with everything that was on the floor. We reclaimed some valuable floor space and made everything more accessible.

*John Hofeling, Williamson, Ga.*



Heavy-duty casters and simple, sturdy construction make this mobile cart a perfect cure for a cluttered workshop.

## Cypress lumber, round two

We at the Southern Cypress Manufacturers Association thank you for the cypress profile that appeared in your April 2002 issue. We appreciate your building awareness of this distinctive, beautiful, and affordable wood.

You can learn more about cypress on our Web site: [www.cypressinfo.org](http://www.cypressinfo.org). Here you'll find source information and a highly informative questions-and-answers section.

*John F. Millea, Communications Manager,  
Southern Cypress Manufacturers Association*

## Stanley Adjustable Sawhorse update

Since we ran our review of stowable sawhorses (issue 142, page 70), we've heard from several readers who either had trouble locating the horses, or wanted to pick up a second pair of the Stanley "Smart Grooves," right.

Our contact at Stanley says that the Stanley Adjustable Sawhorses are now available exclusively through Home Depot. If your local store doesn't stock the horses, you can ask them to place a special order for you.

As a goodwill gesture, Stanley will send Adjustable Sawhorse owners another set of Smart Grooves. Just call 888/628-4455 and order the Smart Grooves directly from The Stanley Works/ZAG. You will have to pay the \$5 shipping charge.



Removable Smart Grooves on Stanley's Adjustable Sawhorses hold sacrificial 2x4 beams so you can cut without damaging the horse, and feature rollers to support odd-shaped stock.

## More hints for working with plastic

Thank you for your recent "Working with Plastics" article (issue 144). It never occurred to me to use a cabinet scraper to clean up the edges, as you advise. I tried it, and it works well.

I recently tried the bonding technique you suggested, as well, while I was making acrylic organizers for kitchen and craft drawers. What a quick and easy way to make them; no cutting dadoes, or wood finishing needed!

While I was at the plastics store picking up my supplies for that project, I bought some Novus Plastic Polish No. 1 ([www.noscratch.com/novus](http://www.noscratch.com/novus)). I've worked

with acrylic before, and my main objection to it has always been its tendency to hold a static charge and attract dust. The Novus polish has an antistatic element that works very well at repelling dust.

Thank you for the great articles in *WOOD* magazine. Every month you bring me something that I can put to immediate use.

*Elaine Carlson, Agawam, Mass.*



Methylene-chloride solvent bonds acrylics or polycarbonate plastic by dissolving a layer of material on adjoining surfaces.

## Write Us!

Do you have comments, criticisms, suggestions, or maybe even a compliment specifically relating to an article that appeared in *WOOD* magazine? Please write to:

Sounding Board  
WOOD magazine  
1716 Locust St., GA-310  
Des Moines, IA 50309-3023

or, if you prefer, you can send us an e-mail at [soundingboard@woodmagazine.com](mailto:soundingboard@woodmagazine.com).

*Due to the volume of letters and e-mails we receive, we can respond to and publish only those of the greatest interest to our readers.*

## Project update

•Salt and Pepper Shakers (issue 144, p. 18):

The bungs listed in the Buying Guide are item #123-0148, \$.99 each.

## Article information online

Do you have a question on a project? You'll find a complete listing, from issue 1 through today, of all known updates to past *WOOD* magazine projects on our Web site at [www.woodmagazine.com](http://www.woodmagazine.com). Just click on *WOOD* magazine on the left side of the screen. Then select Editorial Extras from the options on the next screen.

at your **service**

# WOOD<sup>®</sup> assistance

## Help is just a click, or call, away

### • Learn a woodworking trick each day

Hungry for a proven woodworking tip? Visit our illustrated tip of the day at [woodmagazine.com/tips](http://woodmagazine.com/tips). And for even more shop tips, or to post your own tried-and-true shop-helper advice, visit the Top Shop Tips forum at [woodmagazine.com/tipsforum](http://woodmagazine.com/tipsforum). We review all the tips posted for publication, and all are eligible to win a Top Shop Tip tool prize worth at least \$250, awarded in each issue of *WOOD*.

### • Looking for just the right shop project plan?

Search through dozens of free shop project plans for help with your work area at [woodmagazine.com/wbprojects](http://woodmagazine.com/wbprojects). For more in-depth plans, check out our over

200 downloadable project plans at [woodstore.woodmall.com/index.html](http://woodstore.woodmall.com/index.html)

### • Get past issues and articles here

Order past issues of *WOOD* magazine at [woodstore.woodmall.com](http://woodstore.woodmall.com) or by calling 800/346-9663. Be aware that many early issues are sold out. For article reprints, send \$5 per article (no phone orders), including issue and name of article, to *WOOD* Article Reprint Service, P.O. Box 349, Kalona, IA 52247; check or money order made payable to *WOOD* magazine.

### • Subscription assistance

Need to notify us of an address change, or get help with your subscription? Visit us at [woodmagazine.com/service](http://woodmagazine.com/service), call 800/374-9663 and press option 1, or



write to *WOOD* Magazine, P.O. Box 37439, Boone, IA 50037-0439. Please enclose your address label from a recent issue.

### • We welcome your comments

E-mail your suggestions and criticisms to [woodmail@mdp.com](mailto:woodmail@mdp.com), call 800/374-9663 and press option 2, or write: Editor-in-Chief, *WOOD* Magazine, 1716 Locust St., GA-310, Des Moines, IA 50309-3023. ♣

## Cabinetmaking in your future? Your CMT Distributor has the tools to put you in the picture

### Sommerfeld Cabinetmaking Set

CMT's ideal cabinetmaker's set; including Raised Panel, Rail & Stile, Ogee, Drawer Front and Super Duty Flush Trim Bits  
Cove: #800.515.11 Ogee: #800.520.11



### Sommerfeld Raised Panel Set

Perfect for any doormaker, with matched Rail & Stile and Raised Panel Bits  
Cove: #800.517.11 Ogee: #800.521.11

### Sommerfeld Glass Panel Set

Elegant glass doors give your work a distinctive touch, and this 3-bit set makes them easy. 855.803.11



### Sommerfeld Junior Raised Panel Set

Build door panels as small as 2-3/4" square with this set. Includes a Junior Raised Panel and matched Rail & Stile bits.  
Cove: #800.518.11 Ogee: #800.522.11



Master cabinetmaker Marc Sommerfeld and a few of his recent creations

If you're ready to build cabinets (and what woodworker isn't?), then CMT has the router bit sets you need. All of our Marc Sommerfeld boxed sets were carefully selected by Marc and CMT to suit the needs of cabinetmakers and furniture builders. They're packed with the finest carbide tipped, Teflon<sup>®</sup> coated bits, all in 1/2" shank.

To put yourself in the cabinetmaking picture visit a CMT Distributor today! For a distributor in your area, call 888-268-2487, or visit us online at [www.cmtusa.com](http://www.cmtusa.com)



# instant patina for brass

Age bright brass hardware in hours, not years.

**I**n searching for the hardware for the pine hutch on page 62, we came across hinges and door catches in just the style we wanted. The only problem: The hinges are black for the rustic look we want, but the catches are available only in bright brass. If you ever find yourself in a similar pickle, the solution is only five easy steps away. You already may have everything you need to put an antique patina on brass hardware. Here's how.

## STEP 1

Soak the hardware overnight in lacquer thinner to remove any protective coating. Bend hooks onto both ends of a 2½"-long piece of coat-hanger wire, and use it to fish the hardware out of the lacquer thinner. Blot the hardware dry with a clean rag.



## STEP 2

Dissolve two table-spoons of salt in one cup of water. Pour ½" of household ammonia into a one-pound coffee can. Punch a hole in the can's lid to accept one end of the double-ended hook. Using the hook, dip the hardware in the saltwater solution.



## STEP 3

Hang the hardware on the can lid, and snap the lid onto the can, suspending the hardware inside the can. Don't let the hardware touch the ammonia.



*Note: This technique works only on solid-brass hardware. Thin plating may be entirely removed by this process.*

## STEP 4

Heat the can with a hair dryer for two minutes. Dip the hardware in salt water again, and repeat the ammonia fuming. Dip and fume until you obtain the desired patina. We got good results with 6 two-minute treatments.



*Note: Because the salt water flows to the bottom edge of the hanging part, the patina concentrates there. Even the patina by inverting the hardware for each fuming.*

## STEP 5

Remove the hardware from the coffee can, rinse it thoroughly in running water, and let it dry. Wipe off any surface powder with a soft cloth. Spray on two coats of satin lacquer.

## SHOP TIP

### Don't forget the screws

Make a small basket from aluminum screen for dipping and fuming the mounting screws. Check the screws with a magnet to make sure they are solid brass, not brass-plated steel. For an even patina, dump the screws out of the basket and mix them up between successive treatments.



**Before:**  
bright brass

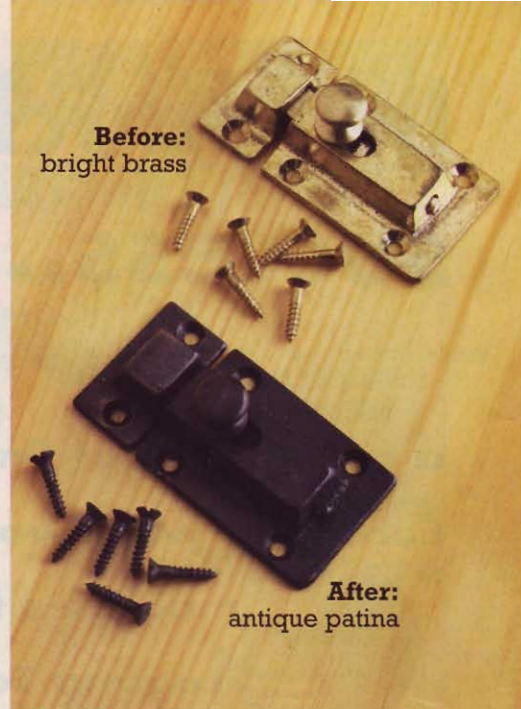

**After:**  
antique patina

a short course on

# marking curves

**You don't need fancy equipment to turn away from straight lines.**



**M**ost woodworking projects rely on straight lines and right angles, but sometimes you need a nicely formed curve to give your project a more stylish look. So how do you make a curve when you're modifying a project plan or designing a piece from scratch? Study the curved shapes in good furniture to develop your eye. Then try the techniques shown here.

When you're tinkering with a curve, trying to get it just so, draw on a full-size piece of plywood, medium-density fiberboard, cardboard, or paper instead of putting it directly on your stock. You can tape together brown paper bags from the grocery store to make a template as large as necessary. Transfer the curve to the workpiece by cutting out the template and tracing along its edge.

For symmetrical shapes with multiple curves, draw exactly half of the shape on plywood, hardboard, or paper. Cut out that piece and use it as the template for the other half.

Remember that you already own an array of templates for simple shapes. For example, anything from a five-gallon bucket to a small washer can serve as the pattern when you need a round corner. And once you've made a nice template, save it. Put it in a drawer, or hang it on perforated hardboard, because you just might need it again someday.

## **Big curves are simple with a trammel**

A simple radius, like those found on some Shaker furniture, calls for nothing more complicated than a wooden trammel and a pencil. Without a measured radius from a plan or a computer-aided drawing, however, it does take some guesswork. Establish the width at each end of the pattern, then experiment with different lengths for the trammel until you have a good-looking curve. Make the trammel handier to use by drilling several holes along its length for different radii. Place the pivot end on a scrap piece equal in thickness to your pattern piece, as shown.

## **String and pins make a quick ellipse**

Here's a neat way to draw an ellipse for tabletops, trays, and the like. Use a square to mark intersecting perpendicular lines on pattern material, such as this piece of medium-density fiberboard.

Place pushpins on the long axis, equal distances from the centerpoint. Tie a piece of string into a loop, put it around the pins, and place a pencil inside the loop. Keep the string taut as you move the pencil clockwise or counterclockwise, and you'll draw an ellipse. Adjust the position of the pins and the length of the loop to vary the size and proportions of the figure.

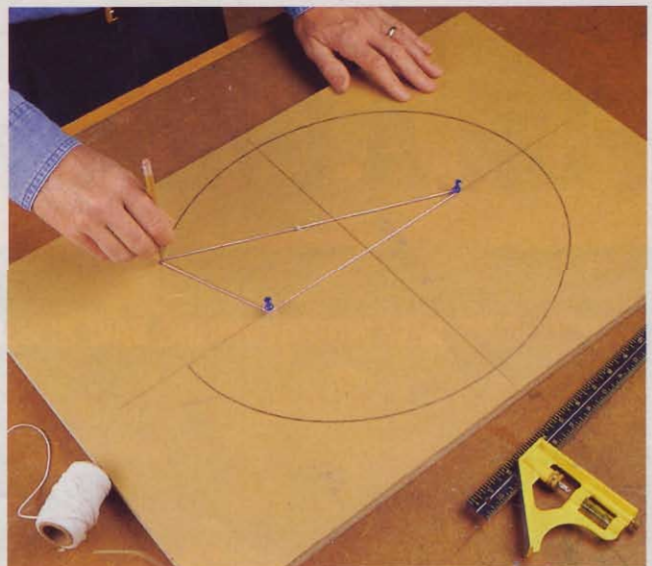

*Continued on page 17*



### 3 easy steps to compass-drawn radii

STEP 1

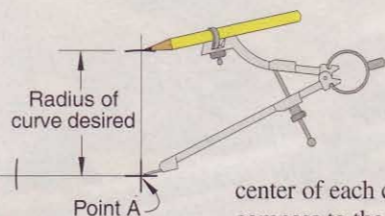

STEP 2

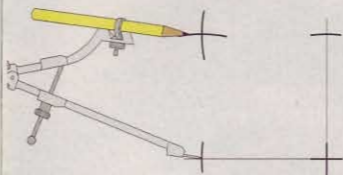

STEP 3

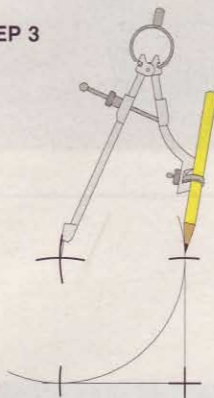

The curved edge of this shelf bracket consists of three 1" radii. It's an example of a seemingly complicated design that you can draw quickly with a compass. To make such a pattern, decide on its length and width, then use those boundaries to locate point A for the center of each curve, as shown in the drawings. Set the compass to the desired radius, place its pivot point on each mark and draw the curves, as shown.

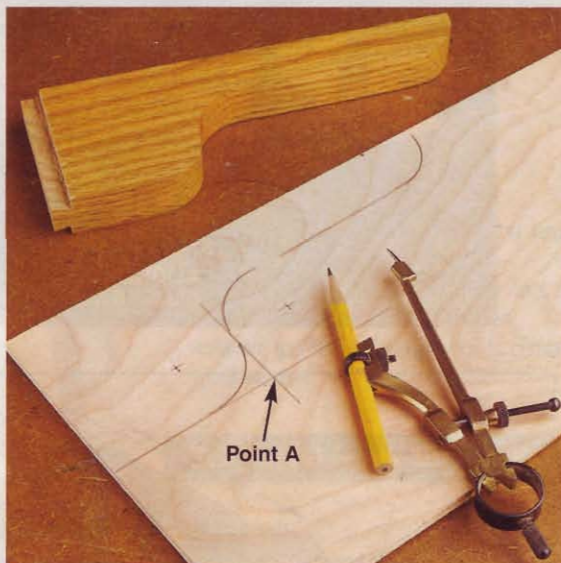

### Say "oui" to the French curve

You probably ran into a French curve at some point in school, but maybe you forgot all about it. This is a reminder that it can come in handy for designing furniture and other woodworking projects. The simplest application of this plastic tool is to draw a corner that isn't a radius, as shown here. If you'll need to repeat the shape, put masking tape on the French curve to mark the beginning and ending points. You can buy a set of four French curves, covering a wide variety of shapes, for \$8.99 from Woodcraft. Call 800/225-1153 and order item number 01P11.



### A flexible curve bends to your will

Rely on a flexible curve to create the exact shape you have in mind, as shown here, or use it to transfer curves from plans or existing pieces. A plastic surface encloses a lead core, which holds almost any shape. Woodcraft sells a 24" model for \$9.99. Call 800/225-1153 to order item number 16M32. If you need to duplicate this curve on the other half of a workpiece, cut out the pattern with your band-saw. Trace the pattern at one end of the workpiece, flip the pattern over, and trace the other end, as shown in the inset. 🌲

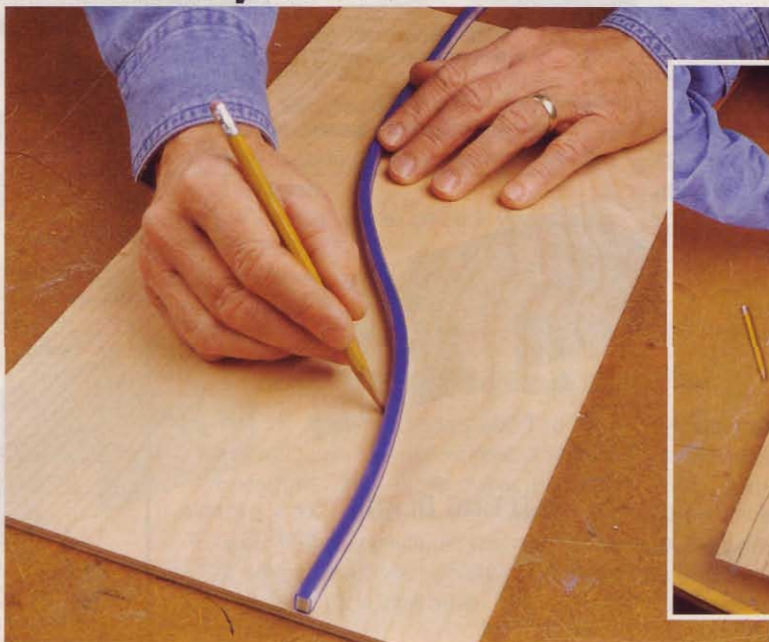

great ideas  
for your shop

# pipe- and bar-clamp blocks

Let a few scraps of hardwood and hardboard remove the hassle from gluing up panels.

**T**hese easy-to-make shop aids really simplify edge-gluing boards. The clamp blocks spread each clamp's pressure over a wider area, and feature hardboard "outriggers" that keep the blocks in place while you position the clamps. They also prevent the clamp's pipe or bar from touching the panel's surface and creating a glue stain on your project.

The blocks without outriggers, called alignment blocks, bridge across the faces of mating boards, keeping their surfaces flush during assembly and as the glue dries. Cutouts prevent accidentally gluing the blocks to your workpieces.

To make a set of blocks, start by cutting a 2½"-wide blank from ¾"-thick stock, as shown. Make the blank as long as you wish, working in multiples of 4⅞". Next, lay out and drill a series of 1" holes through the blank, centered on its width, where dimensioned on the drawing. Now rip and crosscut the blank as dimensioned.

Cut a pair of ½" bevels on each block, using a bandsaw. For now, set aside the pairs you plan to use as alignment blocks. Complete the clamping blocks by adding ¼" hardboard outriggers.

Add a couple of coats of clear finish to all the blocks to prevent glue from sticking to them. Finally, apply ¾" self-adhesive cork pads (available in hardware stores) to the edges of the clamping blocks to prevent workpiece marring. ♣

Project design: Jeff Mertz

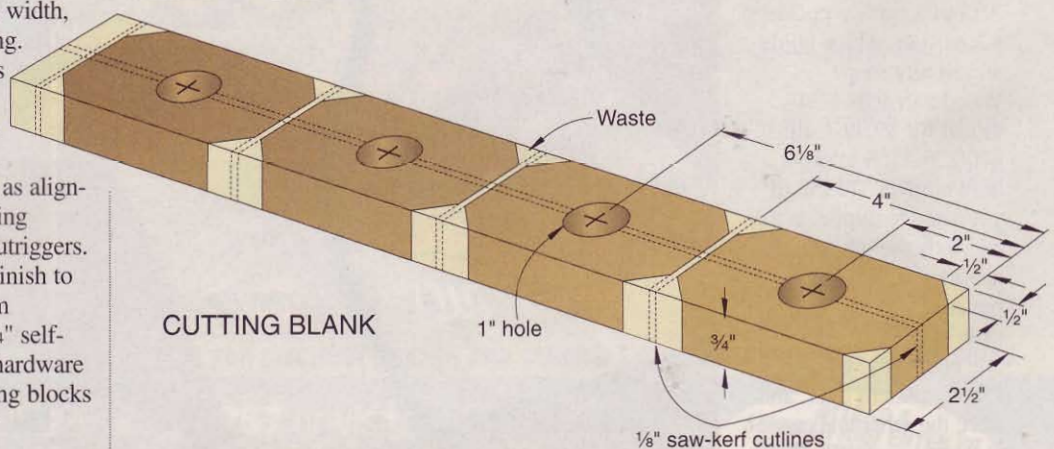
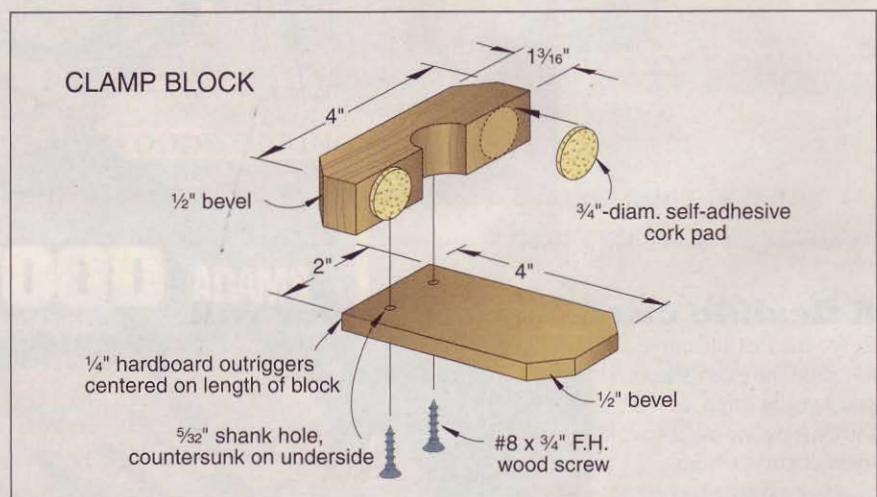
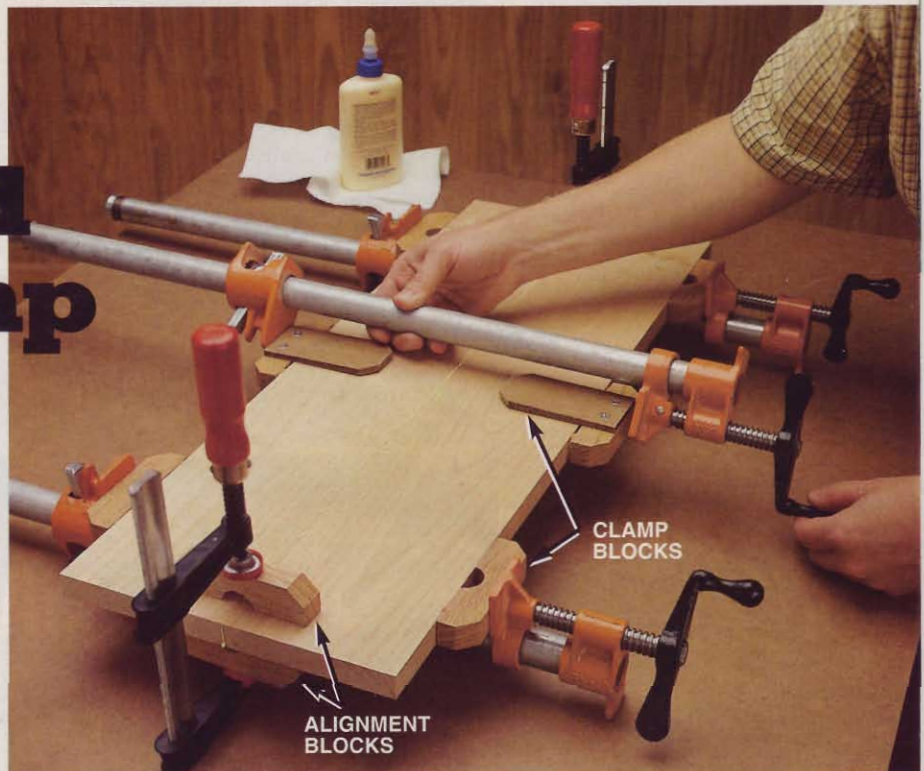

the pros **know**

# intarsia tips and tricks

From the team that reinvented intarsia in North America

**F**or intarsia projects to look their best, the parts need to fit together tightly. Besides sawing right down the middle of the pattern lines, what else can you do to prevent gaps? These surefire pointers from Judy Gale Roberts and Jerry Booher could improve your results dramatically.

## 1 Use the right blade

For scrollsawing softwoods and hardwoods up to 1" thick, Judy and Jerry recommend you use a no. 5 reverse skip-tooth blade (12 teeth-per-inch minimum) like the one shown on **Drawing 1**. With its set of reverse teeth at the bottom, the blade cuts on both the up and down strokes, leaving a smooth finish and minimizing bottom splintering. The blade's quick cutting action also allows you to scrollsaw slower for better control. For cutting woods up to 1 $\frac{3}{4}$ " thick, use a more aggressive no. 7 blade (10 teeth-per-inch minimum).

### 1 NO. 5 REVERSE SKIP-TOOTH BLADE

Skip-tooth gullet speeds waste removal.

Reverse teeth at bottom of blade provide clean cuts.

## 2 Square your table

After tensioning the blade in your scrollsaw, check that the table is square to it, as shown in **Photo A**. Adjust the table's tilt as necessary to square it.

## 3 Set the right speed for control

To cut accurately, you need to set a speed that gives you good control. As a general guideline, Jerry suggests setting the speed at 60–70 percent of your saw's maximum speed. The optimum speed, though, will vary depending on the density of the material. So, make test cuts in scrap first to find the right setting.

## 4 Plan before cutting

Before you rush into cutting parts, plan how you can cut them from larger

pieces for safe handling. Aim for rough-cutting parts or groups of parts into hand-size pieces, and shape and separate the small parts from the group first, as shown in the photo above.

## 5 Check the bottom of parts for splintering

Even when using the right blade, you can still get splintering. Those splinters can lead to out-of-square workpiece edges by preventing your stock from lying flat on the table. So, frequently check the bottom for splinters, and sand them off. ♣

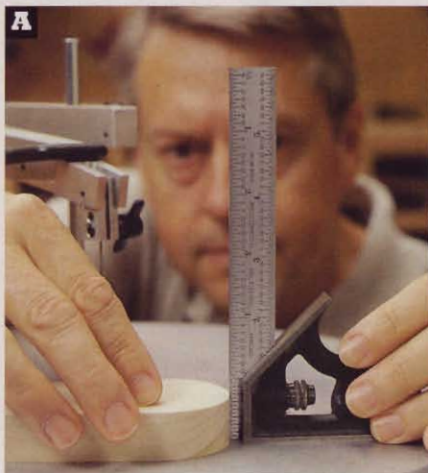
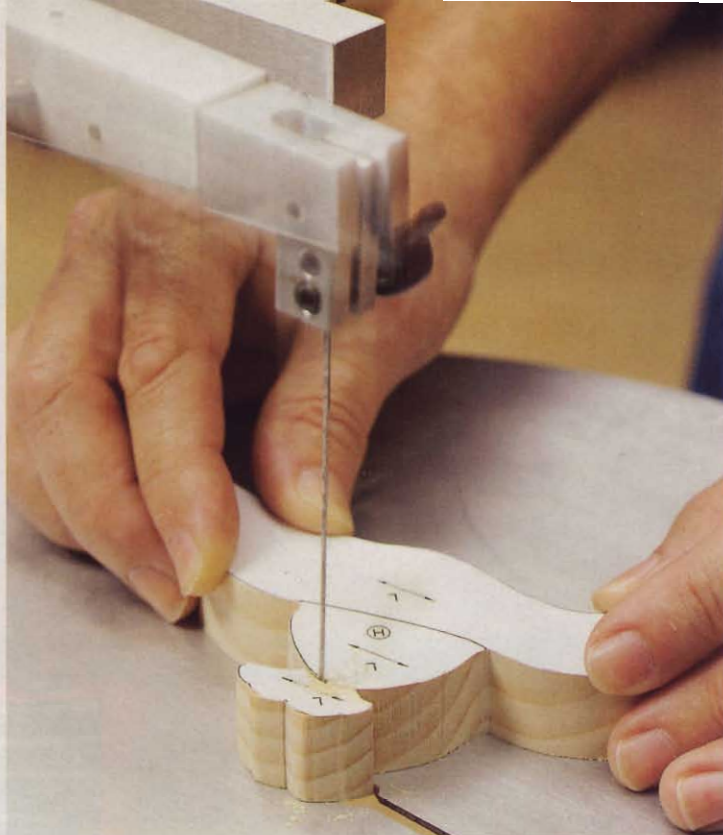

Cut a curve in 1"-thick scrap, and check the edge for square. The curve makes it easy to see any light between the square and the edge.



No two persons in recent times have done more to educate the world about intarsia than the designer/craftsman team of Judy Gale Roberts and Jerry Booher. They currently offer classes at their studio in Sevierville, Tennessee.

# shop tips

Helping you work faster, smarter, and safer

## Revive your zero-clearance insert

The zero-clearance throat insert on my tablesaw wasn't doing a good job at preventing tear-out anymore because its slot had become enlarged from years of use with different blades. Rather than make or buy a new insert, I decided to try to fix the old one.

I started by removing the insert from the saw and cleaning the slot thoroughly with acetone. Next, I applied a strip of clear packaging tape over the slot from the top of the insert. After mixing up a little two-part epoxy, I flipped the insert

over and drizzled the epoxy into the front of the slot, as shown *below*. (It's not necessary to fill the whole slot, only as far back as the teeth are likely to come while using the insert.)

After the epoxy cured, I lowered the saw blade, reinstalled the insert, then turned the saw on and raised the blade up through the newly repaired slot.

—Harold Pinder, Key Largo, Fla.

### top shop tip

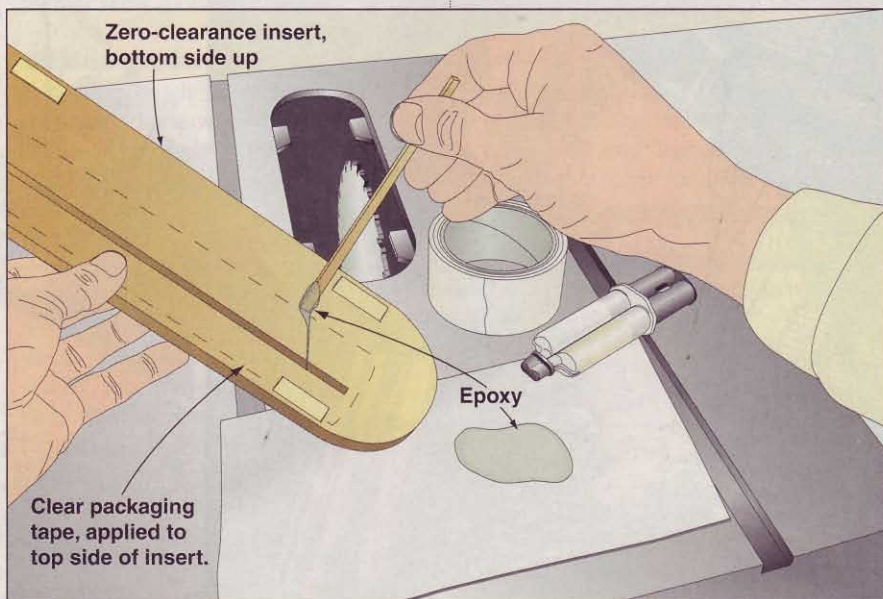

## Know the true grit at a glance

Take a quick look at your random-orbit sander. Can you tell what grit of abrasive is on it right now? If you have hook-and-loop paper, you can pull it back and take a look, but with peel-and-stick sanding discs you just can't tell.

That's why I mark the grit right on the abrasive side of my sanding discs with a permanent marker. The abra-



sive in the middle of the disc doesn't wear very fast, so I've never had the marking wear off to where I couldn't read it anymore; nor has any of the ink ever transferred to a workpiece.

Dropping the "0" at the end of the grit number means less writing, but still tells me what I need to know.

—Erv Roberts,  
Des Moines, Iowa

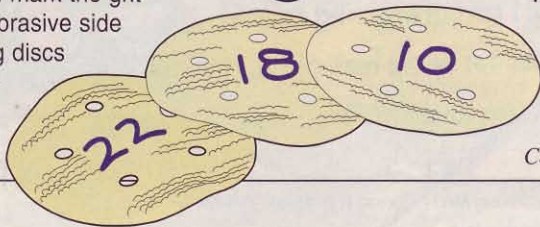

Continued on page 24

OUR winner

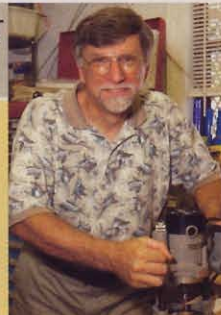

During the dot-com bust a few years ago, electronic engineer Harold Pinder opted for early retirement and moved from Fort Lauderdale to Key Largo, Florida. What our Top Shop Tip winner gained in ambience, he lost in work space, moving from a garage to his current 15x15' shop. "It's not so bad," he chuckles. "Most of my tools are always within reach." Good things come from small shops, though. In fact, Harold used his to build a full set of mission-style furniture.



Ryobi's "six-pack" of cordless tools (model MK618K3) should fit nicely in Harold Pinder's small shop. We're shipping him the whole kit for sending us this issue's Top Shop Tip. Thanks, Harold!

## You can win a free tool, too!

Describe how you've solved a workshop dilemma, and you'll earn \$75 if it appears here. And, if your tip garners Top Shop Tip honors, you'll also win a tool prize worth at least \$250.

Send your best tips, along with photos or illustrations and your daytime telephone number, to: **Shop Tips, WOOD® Magazine, 1716 Locust St., GA-310, Des Moines, IA 50309-3023.** You can also e-mail tips to [shoptips@woodmagazine.com](mailto:shoptips@woodmagazine.com), or post them on the Top Shop Tip forum at [www.woodonline.com](http://www.woodonline.com).

Because we try to publish only original tips, please send your tips only to *WOOD* magazine. Sorry, but submitted materials can't be returned.

# WOODLINE USA™ OFFERS YOU MORE... LIFETIME WARRANTY / GUARANTEED LOWEST PRICE

All Woodline USA Products Feature  
Tough Micro Grain Carbide

## 30

### Piece PROFESSIONAL SET

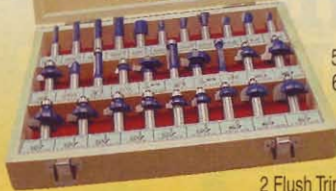

- Includes:  
5 Straight Bits  
6 Roundovers  
3 Dovetails  
3 Core Box  
3 Cove Bits  
2 Flush Trim, 1 Panel Bit  
2 Roman Ogee, 2 Slot Cutters, 1 "V" Groove  
1 Chamfer and 1 Bevel Trim Bit

**SUPER BUY**

WL-2010 **OUR PRICE ONLY \$109** set



### 6 Piece CABINET DOOR SET

- 1/2" Shank Router Bits  
• 2-pc Rail & Stile (Roman Ogee) • Drawer Lock  
• 3 1/4" D Panel Raiser (Ogee) • Door Lip • Glue Joint

WL-2020-1 \$175 VALUE  
**OUR PRICE ONLY \$119** set



WL-1505 \$279 VALUE  
**OUR PRICE ONLY \$179** set

### 5 Piece MOULDING SET



WL-2011 \$175 VALUE  
**OUR PRICE ONLY \$99** set

### 13 Piece DOVETAIL SET



WL-2014 \$125 VALUE  
**OUR PRICE ONLY \$49** set

### 9 Piece MASTER DADO SET



WL-2030 \$89 VALUE  
**OUR PRICE ONLY \$39** set

### 5 Piece COVE SET



WL-2015 \$99 VALUE  
**OUR PRICE ONLY \$49** set

### 15 Piece 1/2" SHANK SET

Includes:  
• Chamfer • Cove = 1/2" R, 3/8" R, 1/4" R  
• Roundover = 1/2" R, 3/8" R, 1/4" R  
• Roman Ogee = 1/4" R  
• Straight Bits = 3/4" R, 1/2" R, 1/4" R  
• 1/2" Dovetail • 1/2" Roundover • 1" CL Flush Trim • Rabbet Bit

WL-2022 for 1/2" or WL-2021 for 1/4" SHANK SET  
**OUR PRICE ONLY \$59** each set

### 5 Piece DOVETAIL SET

• 14° 3/4" • 14° 5/8"  
• 8° 1/2" • 14° 1/2"  
• 14° 3/8"

1/2" Shank Router Bits  
WL-2017 \$30 VALUE  
**OUR PRICE ONLY \$19** set

### 8 Piece PICTURE FRAME SET

Perfect for making great looking picture frames. Bits can be combined to form complex mouldings or simple decorative frames.

WL-2008 \$189 VALUE  
**OUR PRICE ONLY \$75** set

### 3 Piece CABINET DOOR SET

1/2" Shank Router Bits • 2-pc Roman Ogee Rail & Stile  
• 3 1/4" Panel Raiser

WL-2019-1 \$129 VALUE  
**OUR PRICE ONLY \$69** set

**WOODLINE USA™**

GREAT ROUTER BITS AND SHAPER CUTTERS  
BEST SELECTION / BEST PRICE!  
ORDER TOLL FREE  
**1-800-472-6950**  
WOODLINE USA • P.O. BOX 298 • TEMECULA, CA 92593

• INDIVIDUAL BITS ALSO AVAILABLE • ALL MAJOR CREDIT CARDS  
• PRIORITY SHIPPING: \$3.75 FOR UP TO \$99, / \$4.75 FOR \$100.+  
• MOST ITEMS IN STOCK • SAME DAY SHIPPING

PREMIUM CARBIDE

- Tough Micro Grain Carbide
- Euro Anti-Kickback Design
- Super-Slick Non-Stick Finish
- Super Low Prices

FREE CATALOG  
See our great selection of Bits and Cutters  
1-800-472-6950

ALL WOODLINE USA SETS ARE PACKAGED IN BEAUTIFUL WOOD BOXES

**QUALITY Guaranteed**

## shop tips

### Grinder drain no longer a pain

I dreaded draining the water out of my benchtop wet/dry grinder because it emptied all over my bench. To solve this messy problem, I redrilled the drain hole to 7/16", tapped it with my 1/4" pipe tap, and threaded in a 1/4" nylon male hose barb.

Next, I slipped a piece of 5/16" clear vinyl tubing (just long enough to hang over the edge of my bench) onto the hose barb. Finally, I bent a short piece of coat-hanger wire into an "S" shape, with one end of it wrapped around the end of the vinyl tubing, and the other end free to hang in an open hole at the back of the reservoir.

When it comes time to drain the grinder, I unhook the free end of the tubing and drape it over the edge of my bench where the contents run into a waiting waste bucket. After the draining, I return the hook to the hole and refill the reservoir with fresh water. Because water seeks its own level, I can read the water level inside the reservoir by looking at the water level in the tubing.

—Donald Plahn, Marshalltown, Iowa

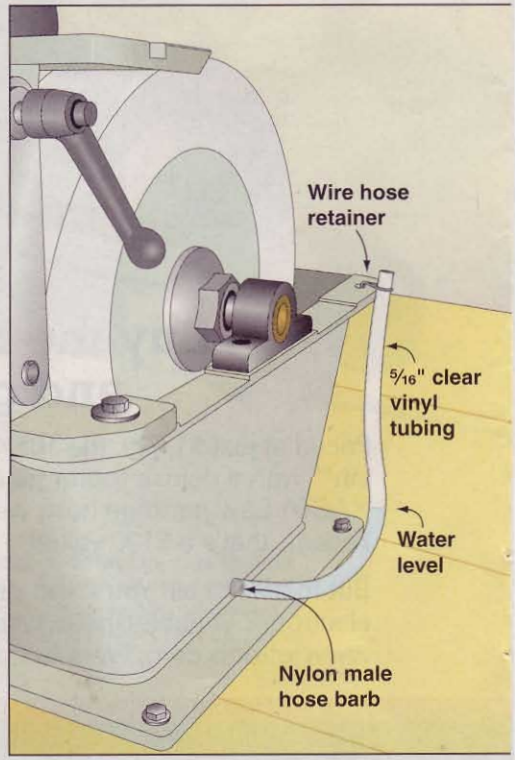

Continued on page 26

# The Delta Edge

New from the company on the cutting edge of innovation.



## Delta Industrial 12" TwinLaser™ Compound Miter Saw

Bright TwinLaser™ cut lines clearly indicate both sides of the blade kerf for faster and more accurate cuts. Plus a powerful 15 amp motor provides power for any job.



## Delta Industrial 1/2 HP Mortiser

Featured with easy and open access to the drill chuck, adjustable fence and hold-down, and a large cast-iron base with center through hole make this mortiser perfect for any shop.



## Delta Industrial 14" Band Saw

Feature-packed with a powerful 1 HP, 120V motor, enclosed stand, 9-spoke wheels, large 16" x 16" tilting cast-iron table, and quick-release tension lever.

For complete product specifications on these and other Delta innovations visit [deltamachinery.com](http://deltamachinery.com).

**DELTA**

Your achievement. Our tools.

Circle No. 1501

## shop tips

### Inset doors just two blocks away

Inset doors help give a traditional-style cabinet, such as the Pine Hutch on *page 62*, its finely crafted look. But the demand for dead-on alignment can make installation difficult. Here, along with the right hardware, is a no-hassle way to tackle the task.

First, use an adjustable non-mortise hinge, such as the one shown in the photo at *right* (from Lee Valley, 800/871-8158, or [www.leevalley.com](http://www.leevalley.com)). These hinges automatically leave a  $\frac{1}{16}$ " hinge-side gap. Slotted screw holes in the hinges allow fine-tuning of the door's horizontal and vertical position after installation.

Before you install the hinges, cut a gauge block whose length is the same as the dimension from the door's corner to the edge of the hinge leaf ( $\frac{3}{16}$ " in the case of the Pine Hutch). Clamp the block to the door and flush with its edge, butt the hinge against the block, and drill pilot holes at the centers of only the slotted holes, as shown in the *bottom left* drawing.

Now, cut a second gauge block  $\frac{1}{16}$ " longer (to match the hinge-side gap) than the first. Use this block to position the hinges on the carcass, as shown in

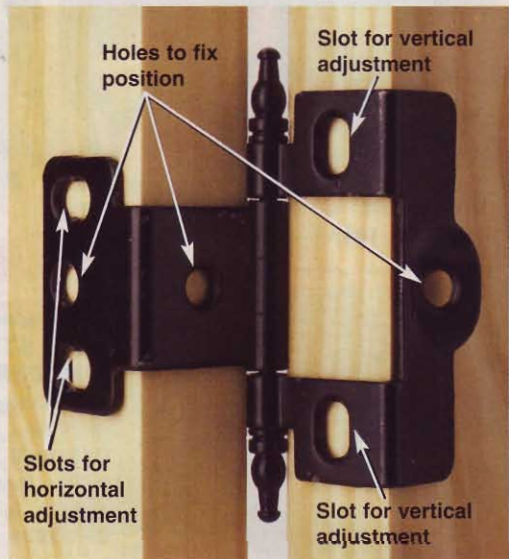

the *bottom right* drawing, once again drilling pilot holes centered in the slots.

Finally, mount the hinges and test-fit the doors—you should have a  $\frac{1}{16}$ " gap around all four sides of the door. Each hinge leaf has a hole or holes to permanently fix the hinge's position once the door is aligned. When you're satisfied with the fit, drill pilot holes and drive screws in these holes.

—Chuck Hedlund, *WOOD® magazine*  
master craftsman

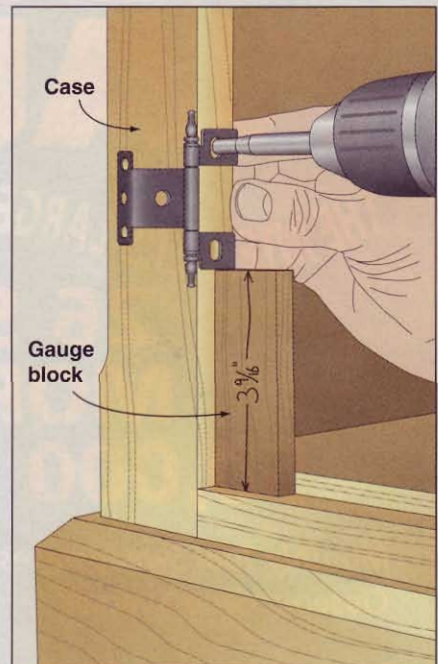
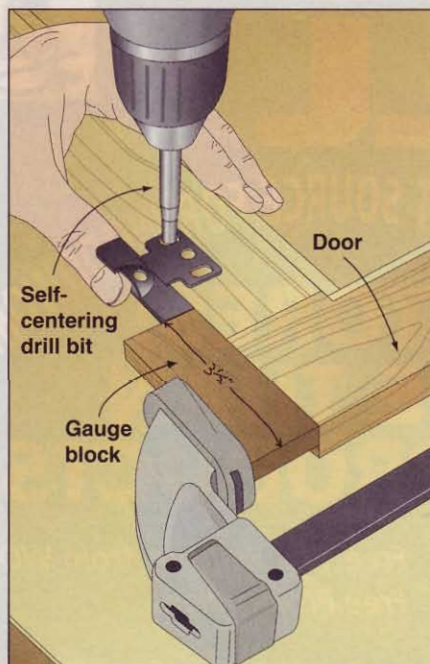

Continued on page 28

## Quality Pen Kits and Other Turning Kits



- Designers & Manufacturers
- Wholesale & Retail

**THE Berea Hard Woods** CO. Inc.

Manufacturer of quality writing instruments, components and kits.

CALL FOR FREE CATALOG

6367 Eastland Rd. • Brookpark, Ohio 44142 U.S.A.  
Ph: 440-234-7949 • Fax: 440-234-7958 • bereahard@aol.com

Circle No. 947

## shop tips

### Pull the plug, undo the screw

When repairing a project, you'll often need to get at a screw hidden beneath a wooden plug. It's tough to remove the plug without damaging the wood around it, but the drawings, *below*, show how to do it. When the drywall screw hits the buried screw, much of the plug climbs right up the threads and out of the hole. If it doesn't pull the plug completely, the rest of the plug comes out when I back out the buried screw.

—George Rowe, St. Helens, Ore.

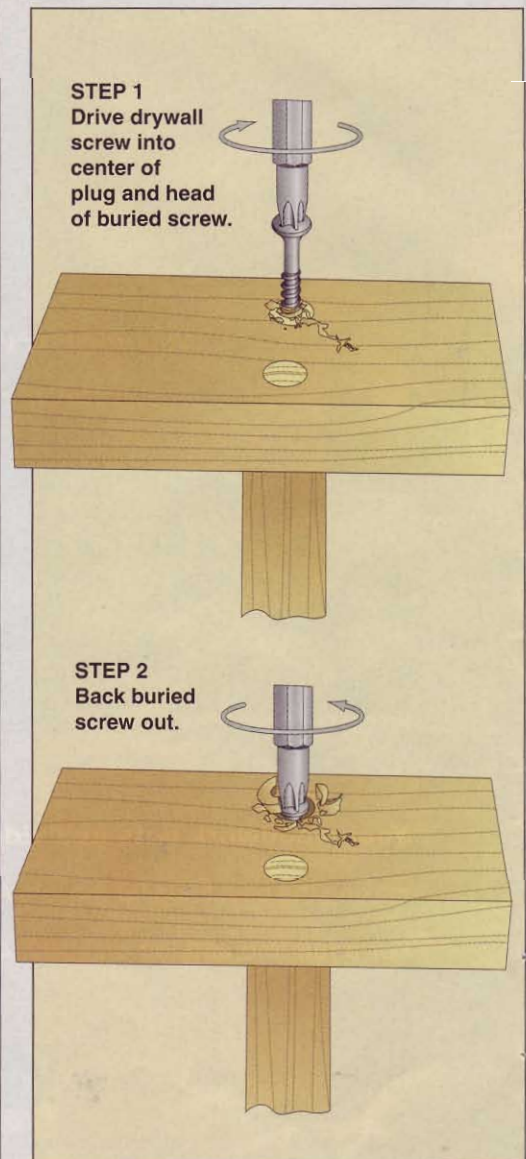

## When the Sawdust Settles... Premium Quality ZAR® Rises Above the Rest!

Whether you're creating your own masterpiece or want to give new life to a treasured family heirloom only the best wood stain will do. ZAR Wood Stain is formulated using only the finest ingredients. ZAR Wood Stain's controlled penetration formula allows you to work at your own pace. ZAR wipes on easily and penetrates evenly for uniform color tone without streaks, lapmarks or blotches. ZAR Wood Stain's extra rich formula makes it ideal for all types of wood; from Oak to Aspen to Poplar to Pine with beautiful results every time. So whether you're a professional or just want professional looking results - use ZAR Wood Stains and Clear Finishes.

**CONTROLLED PENETRATION**  
YOU CONTROL THE STAIN IT DOESN'T CONTROL YOU!



ZAR Wipes on Evenly!

Other Brands Leave Uneven, Blotchy Color Tone.

Match Color Tone on Different Kinds of Woods.

# ZAR®

The Best Thing That Ever Happened to Wood!

For a free brochure and the name of your nearest dealer call 1-800-272-3235, or visit us at [www.ugl.com](http://www.ugl.com).

## Here's one low-down storage solution

After many good years of use, I finally decided to replace the crude shop cabinets I built when I first got started in woodworking. One of my goals for the new cabinets was to squeeze every last bit of storage space out of them.

While pondering the design of the cabinets, I realized that their bases would be the perfect place to keep the tool manuals, reference books, magazine articles, and project plans that I'd accumulated. The result is the toe-kick drawer shown at *right*. You can make your own wheels; use bed-box rollers (part no. 71597, about \$7 per set from Rockler, 800/279-4441 or

[www.rockler.com](http://www.rockler.com)); or just let the drawer ride on the shop floor.

You may be able to use this tip even if you're not building your own cabinetry. On many commercially made base cabinets, the toe-kick panel is just stapled to the case and simple to remove.

—Gary Cawn, Buffalo Grove, Ill.

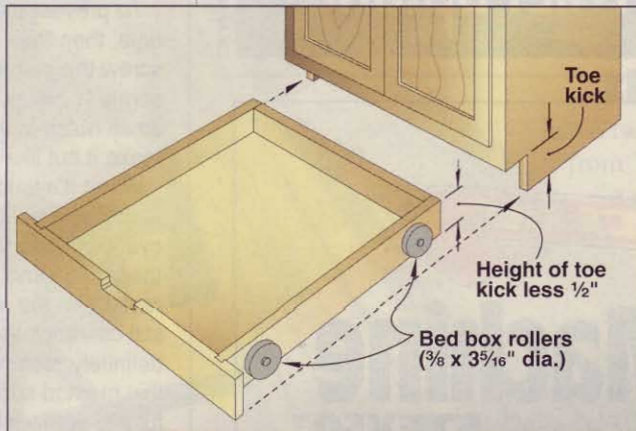

## Pipe-clamp clips prevent rollover

The small bases on pipe clamps make them prone to rolling over at the most inconvenient times, such as when gluing up a large panel. To hold them steady, I made about a dozen pipe-clamp holders from scraps of  $\frac{3}{4}$ " plywood and 1" PVC pipe, as shown in the drawing *below*.

On my bandsaw, I cut twelve 2" lengths of PVC pipe, using a miter gauge to keep the cut as square and

straight as possible. Next, I cut a  $\frac{15}{16}$ " opening in the side of each pipe segment, leaving just enough of the PVC on both sides of the cut to grip the pipe clamp when inserted.

When I'm ready for a glue-up, I simply snap a couple of these holders on each clamp and set them on my assembly table. After the job is done, they snap off just as easily.

—Jim Dutcher, Nuevo, Calif.

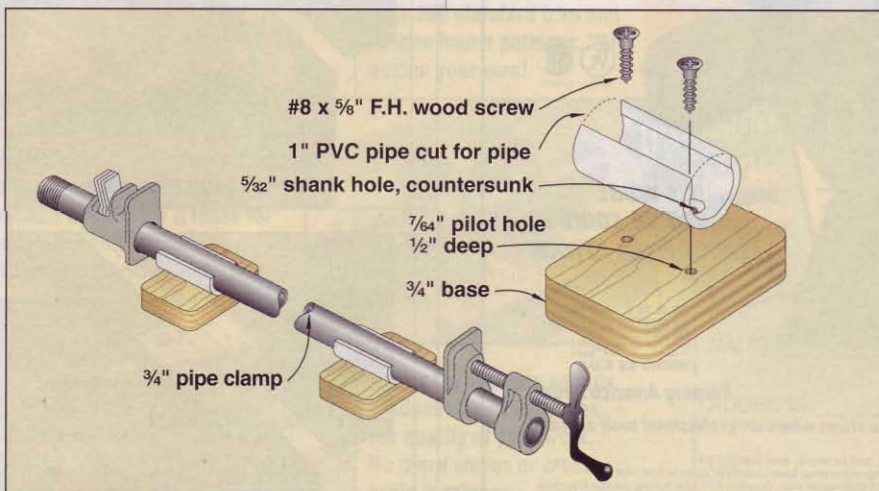

Continued on page 30

# FASTER

30 Second Set Time

No Clamping or Bracing

Improves Productivity

**HiPURFORMER™**  
ADVANCED BONDING SYSTEM



1-800-347-4583  
[www.titebond.com](http://www.titebond.com)

**Titebond®**  
Glues & Adhesives



# NO MORE DUST



Introducing Microplane® Rotary Shaper Power Tool Attachments for low-speed shaping. The razor-sharp teeth create tiny shavings that fall to the surface instead of clouding your air.

Call 501-968-5455 or

**1-800-555-2767**

\* dealer inquiries encouraged

www.microplane.com email: info@microplane.com

**Microplane**  
A Product of Grace Manufacturing

Circle No. 505

## The **ARROW** Machine **X** ETFX50™



**XTRA HEAVY DUTY**  
Professional

**XCEPTIONAL COMFORT**  
Cushioned Grip

**XPERT PERFORMANCE**  
Drives 6 Different Size  
Staples+Nails

**XTRAORDINARY POWER**  
14 Amps of Surge Power

**XCITING DESIGN**  
New Ergonomic Styling



... It's what  
you've come to  
**XPECT** from Arrow!

MADE IN  
**USA**  
HECHO EN E.U.A.

Keeping America Strong

Available at home centers, lumberyards, and fine hardware stores wherever professional tools are sold!



Arrow Fastener Co., Inc., 271 Mayhill Street, Saddle Brook, New Jersey 07663  
Canada: Jardel Distributors, Inc., 6505 Metropolitan Blvd. East, Montreal, Quebec H1P 1X9  
Arrow Fastener (U.K.) Ltd., Unit 5 2K Park, 23 Commerce Way, Croydon CR0 4Z5, Surrey, United Kingdom  
www.arrowfastener.com ©2002 Arrow Fastener Co., Inc. Rev 702

## shop tips

### Use a little glue, hold a little screw

Two things I love to do in the woodshop are carving small figures and building small treasure or jewelry boxes. I get frustrated when attaching hinges to a box (or a basswood figure to its base) because the screw can strip or split the wood.

To prevent this, I first drill a pilot hole, then "tap" the hole with a steel screw the same size as the brass screw I'll install permanently. (I file a small notch in the screw threads to make it cut like a self-tapping screw.)

When it's time to install the brass screws, I first add a drop or two of cyanoacrylate (CA) glue to the hole, then insert and tighten the screw. This really sets the screws in place. I find I still can back the screws out, but it's definitely more work. I've also used this method successfully to screw into the edge of plywood.

—Ed Twilbeck,  
Ocean Springs, Miss.

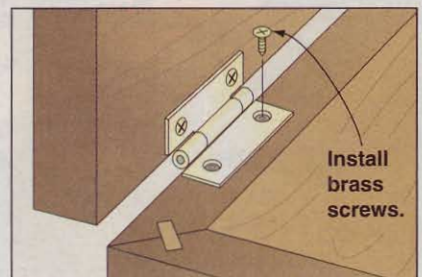
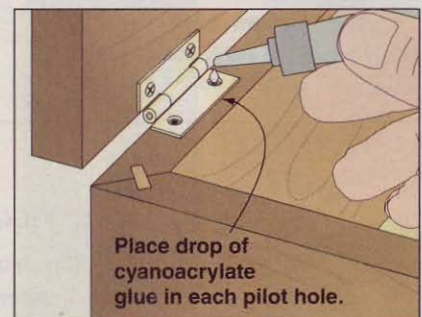
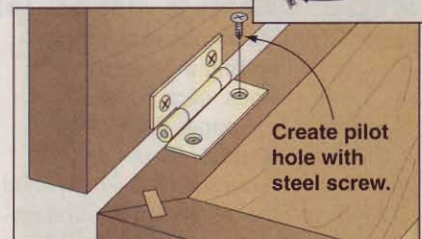
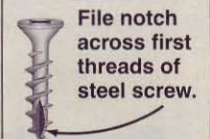

## Improve the leverage of an allen wrench

To loosen a stubborn hexhead screw, head for the laundry room and grab an old-fashioned springless clothespin. The slot fits a wide range of allen-wrench sizes, and increases your mechanical advantage while protecting your hand.

This trick is especially good when you have to work with the short end of the wrench, but also gives you a useful extension when you have space to swing the long end of the wrench.

—R. B. Himes, Vienna, Ohio

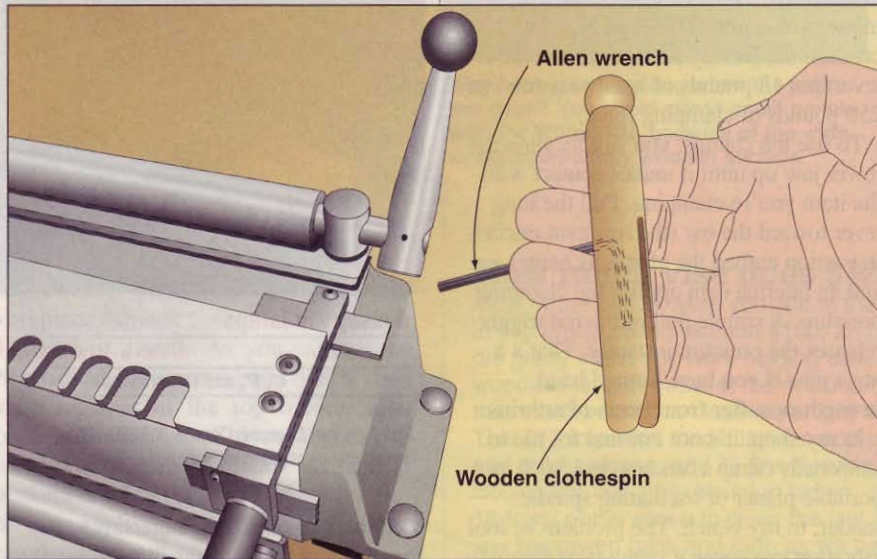

## Plug-cutting jig is flush with success

If you've ever used a power saw to cut a dowel into short plugs, you already know that the saw will eat six plugs for every clean one. With a simple jig and a flush-cut saw, I use every plug I make and enjoy precise length control as well.

Make the jig from scrapwood as thick as the intended length of your plugs. As soon as you drill a few holes into it (for mass production), you're ready to clamp the jig to your workbench. Insert your plug stock in the hole until it bottoms on the bench. Then, slice off the plugs, as shown in the drawing above right, and pop them out of the jig.

—Tom Peters, Midland, Mich., via WOOD ONLINE®

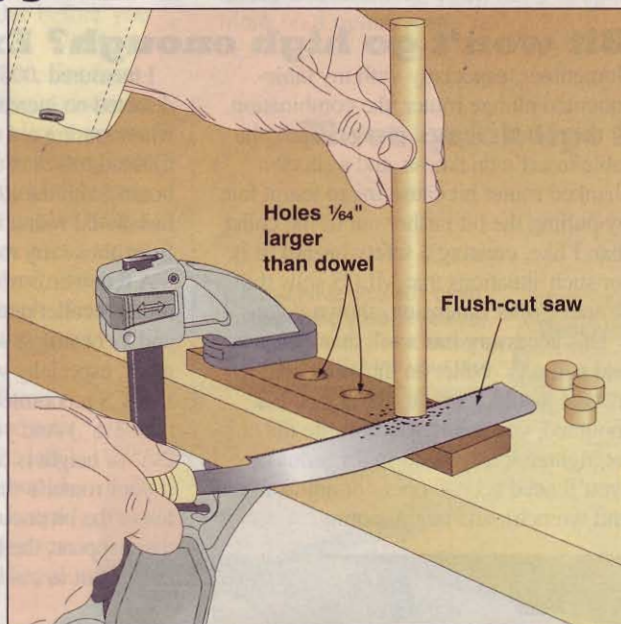

See a new ...

...daily shop tip at  
[www.woodmagazine.com/tips](http://www.woodmagazine.com/tips)

# STRONGER

Superior Strength

Eliminates Nails & Staples

Permanent Bond

**HIPURFORMER™**  
ADVANCED BONDING SYSTEM



1-800-347-4583  
[www.titebond.com](http://www.titebond.com)

**Titebond®**  
Glues & Adhesives

The Best Place to Buy Over 700 Delta Tools Online at the lowest prices guaranteed



#46-715

14" Ironbed Wood Lathe

- Heavy duty 3/4 horsepower induction motor
- Extra long tool rest base control handle for easy positioning
- Complete with steel stand for stability and ease of use
- 40 inches between centers for turning spindles

Shop at [www.amazon.com/delta](http://www.amazon.com/delta)



\*We will match our competitors price plus beat it by 10% of the difference. Find out more at [www.amazon.com/price-match](http://www.amazon.com/price-match).

Call for your FREE Tool Crib catalog  
1-800-635-5140

TOOLS & HARDWARE  
**amazon.com**

shop-proven products

These woodworking wares passed our shop trials

Clamps convert modest hand pressure to monster force

Leave it to the folks at American Clamping Corporation (the same people who brought us the Bessey K-body parallel-jaw clamps) to come up with another innovative clamp. They call their latest creation the Bessey KliKlump, and it leverages 18 pounds of hand pressure into 250 pounds of clamping force.

To use the clamps, you simply slide the lower jaw up until it makes contact with the item you're clamping. Pull the long lever toward the bar (the resultant ratcheting action earned the clamp its name), and an internal cam applies the clamping pressure. A simple pull of the red trigger releases the pressure instantly. That's a huge plus if you have limited hand strength or suffer from bouts of arthritis.

In my shop, it's not unusual for me to temporarily clamp a benchtop tool, such as a portable planer or oscillating spindle sander, to my bench. The problem is, tool vibration can cause a screw-type clamp to loosen, and the tool to wander. The Bessey KliKlumps didn't budge when I



Bessey KliKlumps

Performance	★★★★★
Price	4", 8", and 12", priced \$20-\$24
Value	★★★★☆

Call American Clamping Corp. at 800/828-1004, or visit [www.americanclamping.com](http://www.americanclamping.com).

used them to clamp my miter saw to my bench. They worked equally well for other clamping tasks around the shop.

—Tested by John Cebuhar

Bit won't go high enough? Extend it

Sometimes, especially with my table-mounted plunge router, the combination of the router's limited plunge depth, the table insert's thickness, and a short-shanked router bit cause me to tempt fate by pulling the bit farther out of the collet than I like, creating a safety hazard. It is for such situations that MLCS sells the Router Collet Extension, shown below.

This accessory has a 1/2" shank on one end and a 1/2" collet on the other, and it installs just like a router bit. Once it's mounted, you insert your bit into the collet, tighten it as you normally would (you'll need a 1/16" open- or adjustable-end wrench), and begin routing.



I measured .006" of runout (wobble), but detected no increase in vibration or chatter when routing red oak (the router itself contributed less than .001" of runout). As a bonus, with the Router Collet Extension installed, I found it was easy to change bits from above my router table.

A few words of caution: Extending your router's collet puts extra stress on the tool and its bearings, so take multiple passes on stock, especially with large-diameter bits. (MLCS recommends using bits no larger than 3 1/2".) And you may find that the extra 2 1/4" of height is too much of a good thing, if your router's vertical travel won't let you lower the bit enough to cut properly. When that happens, the Router Collet Extension comes out as easily as a bit.

—Tested by Ben Von Ruden

Router Collet Extension (#9464)

Performance	★★★★☆
Price	\$25
Value	★★★★☆

Visit MLCS at [www.mlcswoodworking.com](http://www.mlcswoodworking.com), or call 800/533-9298.

## Build a workshop in a weekend or over years

Tool Dock beats the piecemeal approach to setting up shop with a system of sturdy, 18-gauge steel cabinets. They give you the flexibility to add one piece at a time, but still keep that built-all-at-once look.

A large hole in each Tool Station and Multi-Station (*top right photo*) accepts Tool Dock's 1/2"-thick high-density particleboard inserts, to which you attach your benchtop tools. Beneath the hole is a shallow pan with a dust-collection port to the outside of the cabinet. A perforated insert turns the Tool Station into a downdraft table, which captured most of the dust in my tests.

With several tools mounted to different inserts, you can load and lock only the insert/tool you need, and leave the others stored in the Tool Rack or Tool Crib. I was concerned about sagging, but after several weeks in my humid garage with a bench grinder in the middle, its insert had deflected less than 1/8".

The Tool Dock Router Station appeared promising with its 1 1/2x30x28" melamine-coated particleboard top, external power switch, and copious storage area below. The plastic fence, though, was hard to move because of rubber feet on the bot-



tom. I had a hard time nudging the fence to fine-tune it for a perfect cut.

That aside, all Tool Dock cabinets have leveling legs to compensate for an uneven shop floor, and the height-adjustable tops can be set to your comfort level. The Mobile Station comes equipped with four swivel casters; on others, you can get them as an option. The Router Station and lowboy Multi-Station come with drop-down rear wheels for when you want to go mobile.

If you had enough money to buy everything shown in the photo *below* (about \$1,800 worth), you could assemble the Tool Dock and have your shop set up in a weekend. There's a lot more to this system than I can describe here, so I recommend you visit the information-packed Web site.

—Tested by David Stone

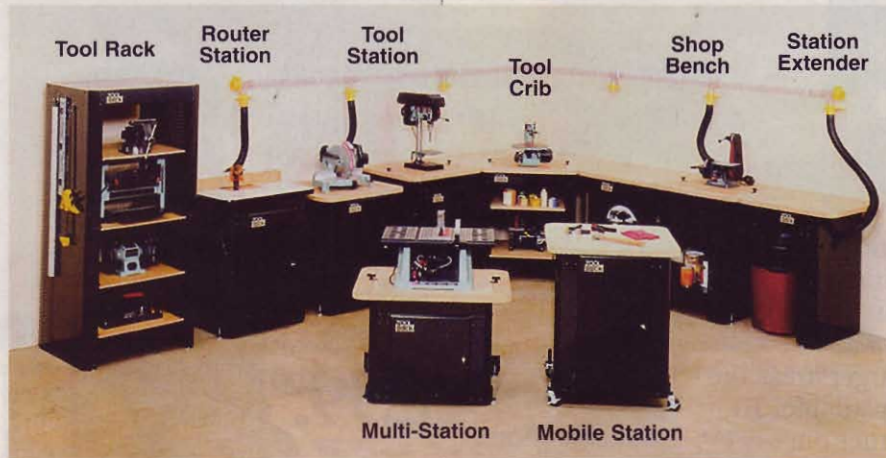

### Tool Dock Modular Workshop

Performance	★★★★☆
Price	Station Extender, \$90; Tool Crib, \$150; Tool Rack, \$180; Multi-Station, Tool Station, Mobile Station, \$200; Router Station, \$300; Shop Bench, \$310
Value	★★★★☆

Call Waterloo Industries toll-free at 866/866-5362, or visit [www.tooldock.com](http://www.tooldock.com).

### About our product testers

David Stone is WOOD® magazine's features editor. John Cebuhar is a former industrial-arts teacher. Ben Von Ruden helps restore antique jukeboxes. All are avid woodworkers.

# BETTER

Bonds Most Anything

20 Minute Cordless Use

100% Waterproof

**HiPUR FORMER™**  
ADVANCED BONDING SYSTEM



1-800-347-4583  
[www.titebond.com](http://www.titebond.com)

**Titebond®**  
Glues & Adhesives

# ask wood

Answers to your questions from letters, e-mails, and WOOD ONLINE®

## Wide tenons need special treatment

**Q:** What's the best way to handle the wide through tenons that are common in Arts and Crafts furniture? It seems as if expansion of the tenon could wind up cracking the wood around the mortise.

—Joe Darmofal, Mead, Colo.

**A:** You're wise to consider wood movement in a joint like that, Joe. Here's how furnituremaker Darrell Peart, host of WOOD ONLINE's Arts and Crafts forum, handles the situation in one of his bed designs. For a 7" tenon, he cuts a 7 1/8" mortise, leaving 1/16" at top and bottom for the tenon to expand. Then he drills a hole through the middle of the joint to accept a dowel, glues only the middle 4" of the tenon, assembles the joint, and pins it with the dowel. "I've produced several of these beds over the years, and haven't had any problems with the joint,"



Darrell reports. Try his method for any tenons more than 6" wide.

—WOOD® magazine

A wide tenon provides lots of resistance to racking, but presents wood movement challenges. Glue and pin the middle for strength and flexibility.

## JDS AIR-TECH and Dust-Force

When only the **Best** will Do!



**\$289.00**

**Model 750-ER**

JDS, the leader in quality air filtration products, introduces the ultimate air cleaner for your shop (**Model 750-ER**). This remote controlled unit will clean the air in a 30'x30'x8' shop once every ten minutes. For larger areas the models 8-12, 10-16, and 2400 are available. To remove odors, fumes and smoke, order our optional charcoal filter.

**Model 750-ER**

When only the **Best** will Do!

- LCD Remote Control with speed and timer function
  - Highest Maximum Air Flow in its Class 1,050 CFM (750 CFM Filtered Air)
  - 95% ASHREA Tested main filter (91% Efficiency at 1 micron - 99% at 5 microns)
  - Washable Electrostatic Pre Filter
- With ten year manufacturer's warranty



Put the force to work in your shop...

Our new 1.5 HP **Dust-Force** is the perfect addition to our award winning line of air filtration units. Powerful, portable, and ready to work for you, the **Dust-Force** will make your shop a cleaner, healthier, more productive environment.

**\$299.00**

### Specifications

Motor.....	1.5 HP
Max CFM.....	1250
Fan.....	11"
Inlet Dia.....	1-5"/2-4"
Bag Capacity.....	42 gallons
Decibels.....	67-77
Electrical.....	110/220
↳ Switch Prewired for	110V



Another quality product from



To place an order or for the dealer nearest you call us toll free. 1-800-480-7269

[www.thejdscompany.com](http://www.thejdscompany.com)

**Lauan looks lovely, with a little help**

**Q:** I'm building a mahogany cabinet, and having trouble finding the right plywood for the back, which will be partly visible through glass doors. I want a 1/2" back for rigidity, but 1/2" mahogany plywood is awfully pricey. Can I get acceptable results by laminating two pieces of inexpensive 1/4" lauan plywood?

—Sandy Grefner, Chicago

**A:** Yes, you can, Sandy. Laminate the plywood with either yellow glue or water-based contact cement. Then, after staining or clear-coating your solid mahogany, experiment with scrap lauan to find a matching color. Follow the sequence described below, substituting tints in the final step as needed, and you'll also add interest to the bland grain.

Here's how you can start with unfinished lauan plywood, shown at the bottom of the stack in the photo, and produce results like those on the other two samples. (1) Wipe on honey amber TransTint dye, mixed in denatured alcohol; (2) seal in the dye with a thin coat of super-blond shellac; (3) wipe on a layer of paste filler tinted with reddish brown TransTint and burnt umber Japan color. (Japan colors consist of finely ground pigments mixed in a varnish binder; they're similar to artist's oils and compatible with oil-based finishing materials.)

The lighter sample received relatively little burnt umber, while more went onto the darker sample. Removing the excess filler produced the results you see.

You can buy a range of TransTint dyes from Woodcraft. Call 800/225-1153 to order 2-ounce bottles for \$16.99 apiece. Honey amber is item number 128481, and reddish brown, 128483.

Call Woodworker's Supply at 800/645-9292 to order Japan color. A half-pint can of burnt umber is item 848-320, priced at \$9.99. Woodworker's Supply also carries paste filler. A quart can of the natural color, item 843-826, costs \$14.99.

—WOOD® magazine



Finishing materials can be expensive, but they allow you to save a bundle on wood. This cheap lauan can substitute for high-grade mahogany in cabinet interiors.

Continued on page 37



"I enjoyed woodworking but never saw it as a business!"

Bret Hall, Furniture Medic owner  
Greenwich, CT

**Furniture Medic has ALL the tools**

"Furniture Medic furnished the tools needed to build my own business. With continuous training plus time-saving tools, products and processes, I mastered wood repair as well as on-site restoration. Their comprehensive business support and software — and strong marketing materials — have allowed me to grow my business beyond my expectations."

- ▶ Variety of customers including offices, hotels, restaurants, homeowners, moving and storage companies, and insurance companies
- ▶ Over 600 franchises worldwide
- ▶ Recognized as the #1 brand for on-site furniture repair and restoration for a decade
- ▶ Division of The ServiceMaster Company, ranked among the Fortune 500

Check out our toolbox!  
Call 1-800-RUN-YOURS or  
visit [furnituremedicfranchise.com](http://furnituremedicfranchise.com)

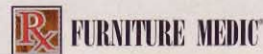

Circle No. 895

**SUPERSHOP 10-IN-1 WOOD & METAL SHOP**

**Own a Complete, PRO-QUALITY WOOD SHOP In Just 12 SQUARE FEET!**

Stand-alone machines take TOO MUCH ROOM!

10 TOOLS IN JUST 12 SQ. FT.!

**All the QUALITY of premium "stand-alone" shop machines in LESS FLOOR SPACE... and at LOWER COST!**

- Equal or **BETTER QUALITY** than one-function shop equipment.
- **COSTS LESS** than buying several one-function machines.
- **10 MOST-USED TOOLS IN 1:** table saw, lathe, drill press, router, sander, more!
- **Rock solid, 2 1/2 times MORE MASSIVE** than other combo machines.
- State-of-the-art **ELECTRONIC SPEED** controls, powerful DC motor.
- Perfect for both **HOME & PROFESSIONAL** woodworkers.
- **30-Day RISK FREE** Buy-Back Offer & Industry-Leading Warranties.

**Get complete details & SAVINGS OFFER:**

**ON SALE FOR A LIMITED TIME ONLY!**

**CALL TOLL FREE 1-800-476-4849**

Or this Mail to: **SuperShop®** Dept. WOOD, P.O. Box 1517, Ann Arbor, MI 48106-1517

**YES!** RUSH me all the details on the HIGH QUALITY, AFFORDABLE alternative for TIGHT SPACE wood shops!

Name \_\_\_\_\_  
Address \_\_\_\_\_  
City \_\_\_\_\_ State \_\_\_\_\_ Zip \_\_\_\_\_

**FREE!**

Circle No. 1766

### Dirty boards make dull planer knives

**Q:** I acquired some old barn boards, and ran one through my thickness planer to check the appearance. Two passes, and the knives were dull. Do you have any suggestions?

*Steve Der-Garabedian, Mississauga, Ont.*

**A:** Steve, barn boards commonly contain enough dirt to give high-speed steel knives a tough time. After you have checked carefully for nails and other metal, clean the boards with compressed air and a wire brush. We don't recommend pressure washing, which injects a lot of water into the wood, or sandblasting, which leaves behind a new batch of abrasive particles.

Next, do some heavy-duty sanding. If you have a drum sander, install 60-grit sandpaper and connect your dust collector before running the barn boards through. A belt sander can do the job, too, but be sure to wear a dust mask, and work outside if possible.

Now it's time for planing. Install carbide knives if they're available for your planer. Carbide is harder than high-speed steel, and remains sharp much longer.



**Old lumber saves you money, but expect to spend a fair amount of time on preparation. Dirt and paint can take the edge off the knives of planers and jointers.**

*Note:* Be cautious when cleaning paint from old barn boards. Such paint is likely to contain lead, a significant health hazard, so avoid turning the paint into dust with your sander or planer. Remove the paint with a hand scraper, if possible, or use a chemical stripper and properly dispose of the resulting material.

—WOOD® magazine

### If you can't joint it, rip it

**Q:** I often need to face-joint boards that are too wide for my 6" jointer. What's the best way to get around that problem?

*—Russ Harvig, Davenport, Iowa*

**A:** Russ, we recommend that you rip wide stock into pieces narrow enough for your jointer to handle. We've tried methods that allow you to keep the board intact, but we find this technique to be quicker, easier, and less wasteful. Run one face of each piece across the jointer, glue them back together with the jointed faces flush, and plane the unjointed face. Of course, if the original board also was too wide for your planer, you should go through both the jointing and planing steps before regluing.

—WOOD magazine



**We've tried various methods of face-jointing a board that's too wide for the jointer, and found that the simple way is best. Rip the board, joint the pieces, and glue them back together.**

*Continued on page 38*

# The Toughest Glue On Planet Earth

Gorilla Brand Premium Glue is the all purpose, interior/exterior glue ideal for most repair and bonding needs. It's great for indoor/outdoor furniture repair, woodworking projects, as well as general repairs around the house. Bonds wood, stone, metal, ceramic and more! Incredibly strong and 100% waterproof.

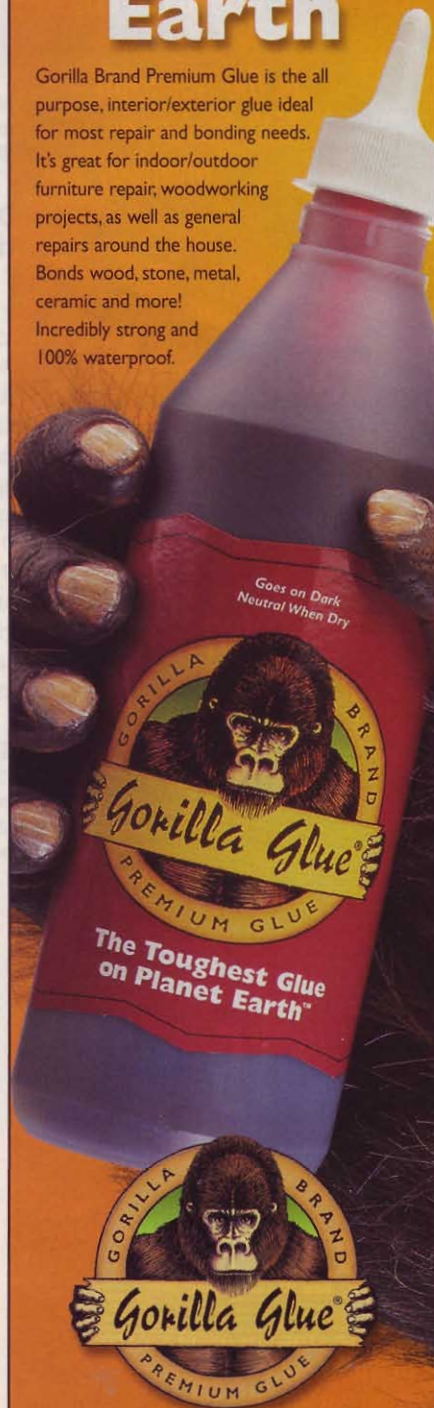

for retailers near you:  
[www.gorillaglu.com](http://www.gorillaglu.com)  
 1-800-966-3458

**WIN**  
a New 2003  
Pickup Truck &  
a Shop Full of  
Porter-Cable Tools  
In The Woodcraft  
75th Anniversary  
Giveaway

75th Anniversary Sweepstakes  
**TRUCK & TOOLS!**  
WOODCRAFT JET PORTER-CABLE

Enter  
Online  
at [www.woodcraft.com](http://www.woodcraft.com)  
for your chance to win

Void where prohibited by law,  
complete rules and regulations  
are available online.

75<sup>th</sup>  
SINCE 1928  
anniversary

**WOODCRAFT**  
Helping You Make Wood Work

For the store nearest you,  
or for a free catalog visit  
[www.woodcraft.com](http://www.woodcraft.com),  
or call 800 542-9115

Dept.03WI03BA

Circle No. 700

## ask wood

### Drill the pilot hole, then the shank

**Q:** When I need to join two pieces of wood with screws, I first drill a shank hole through one piece, countersink it, then use a smaller bit to make a pilot hole in the second piece. But the pieces don't always line up correctly when I drive the screw. What should I do differently to get more accurate results?

—Don MacKenzie, via WOOD ONLINE®

**A:** Just change your sequence, Don. Clamp the pieces securely together, preferably on your drill press, then drill the smaller pilot hole through the top piece and to the appropriate depth in the bottom piece. Without changing your setup, chuck the correct bit in the drill press for the shank hole, and drill through the top piece only. The larger bit will follow the smaller hole. Finish with the countersink. Now a screw will join the two pieces just as they were clamped. When you drill the large hole first, it's hard to center the smaller hole precisely. If it's slightly off, you force the pieces out of alignment when you drive in the screw.

A quicker, one-step solution to the problem is to use a countersink mounted on a

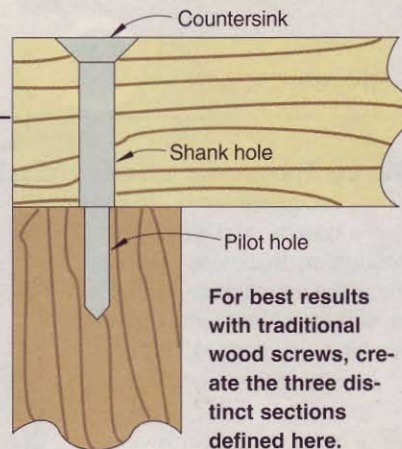

For best results with traditional wood screws, create the three distinct sections defined here.

tapered bit. The tapered bit produces a hole that's small in diameter at the bottom and bigger at the top, matching the shape of a standard wood screw. It's expensive to buy a complete set of these bits and countersinks, good for every size of screw, but not too costly if you buy one or two for the sizes you use most often. For example, Woodcraft carries a tapered bit sized for #8 screws (item number 06J44), priced at \$6.99, and the corresponding countersink attachment (item number 06J34) for \$7.99. Call 800/225-1153.

For untapered production screws, you usually need to drill just one hole the same diameter as the shank. Clamp the pieces tightly together, however, so the screw doesn't spread them apart.

—WOOD® magazine

### How do you glue wood to melamine?

**Q:** I need to attach small wood blocks to melamine for a project. Will Titebond II do the job? Or should I use another type of glue?

—Steven Myers, Shelburne, Vt.

**A:** You can use Titebond II, Steve, especially if you scuff the melamine first

with sandpaper. But you'd get the best results with glues developed specifically for bonding wood to melamine. Franklin International's Titebond Melamine glue or Roo Products' Roo Clear will do the trick. They're thick, so the wood doesn't absorb them completely before they dry. You can order Titebond Melamine glue—\$7.99 for 16 ounces, item number 922-293—from Woodworker's Supply, 800/645-9292, or call Roo Products at 877/766-4583 to find a local source for Roo Clear.

—WOOD magazine



### Got a question?

If you're looking for an answer to a woodworking question, write to Ask WOOD, 1716 Locust St., GA-310, Des Moines, IA 50309-3023 or send us an e-mail at [askwood@mdp.com](mailto:askwood@mdp.com). For immediate feedback from your fellow woodworkers, post your question on one of our woodworking forums at [www.woodonline.com](http://www.woodonline.com).



# short cuts

News and notes from the woodworking world

## You already may be a wood collector

**If you plead guilty to setting wood scraps aside because you like the way they look, the International Wood Collectors Society may be for you.**

**F**ormed in 1947, the International Wood Collectors Society (IWCS) dedicates itself to individuals interested in collecting wood both as an academic pursuit and as a hobby. With members in more than 35 countries, IWCS fulfills a variety of needs. Some of these include wood sample collecting and trading; classification of specimens; shar-

ing information about wood, trees, and forests; and crafting with identified wood.

While it all sounds somewhat formal, collecting wood can be a lot of fun, and you can begin by gathering samples of local species. IWCS recommends making samples that measure  $\frac{1}{2} \times 3 \times 6$ ". As a member, you'll quickly come to know those wanting to sell and trade samples, allowing you to build up your collection.

Members with woodworking tools and skills sometimes represent their species collections through items they've made—

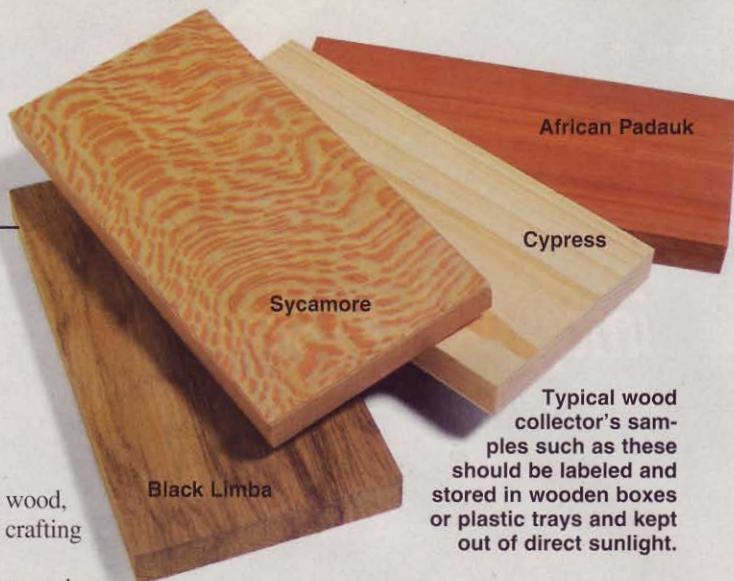

Typical wood collector's samples such as these should be labeled and stored in wooden boxes or plastic trays and kept out of direct sunlight.

gavels, eggs, pens, bowls, carvings, even gunstocks.

The biggest highlight of the year for IWCS is its annual meeting. At this function, wood collectors from around the globe attend lectures, tour forests, trade samples, display their woodworking, and meet new friends.

Yearly membership in IWCS runs \$30. For information, call 765/653-6483, or visit [www.woodcollectors.org](http://www.woodcollectors.org).

## WOOD® recognized for excellence

For the first time in its history, *WOOD* magazine was honored with an Editorial Excellence Award at the 2002 Celebration of Excellence. The event, held in New York on October 29, is a highlight of the Folio:Show, the premiere conference and exposition for the magazine publishing industry.



*WOOD* magazine was a Gold Winner in the Hobbies category of consumer magazines. The annual competition is judged by a panel of

professionals from throughout the publishing industry and major journalism schools. The judges evaluate a magazine on how well it fulfills its mission, the quality of its content, and its overall design and production. Other winners in the Hobbies category included *Fine Woodworking*, *Toy Fare*, and *Watch Time*.

## On the road with WOOD

For the past 21 years, the San Diego Fine Woodworkers Association has hosted the Design in Wood competition. It's held in June at the San Diego County Fair in Del Mar, California. The event allows craftsmen and craftswomen from across the country and beyond to submit works in a full range of woodworking categories in the hope of winning one of many great prizes. Such categories include contemporary and traditional furnituremaking, model building, woodturning, and carving—to name a few.

Not only does *WOOD* magazine regularly provide the \$500 prize for the Excellence in Workmanship award, but Editor-in-Chief Bill Krier also traveled to Del Mar to judge the 2002 entries in this category. His pick: the seven-drawer chest shown *above*, crafted by Randy Miller of Aliso Viejo, California. Says Bill about the piece, "I gave it the award because of its perfect handmade joinery, hand-planed stock,



*WOOD* magazine Editor-in-Chief, Bill Krier, (left) and the Design in Wood Show Coordinator, Bob Stevenson, spend time admiring this year's winner of the Excellence in Workmanship award, a seven-drawer chest that stands 36" high.

and attention to detail. The drawers fit precisely and slid smoothly without mechanical slides."

For more on the competition, write to the San Diego Fine Woodworkers Association, P.O. Box 82323, San Diego, CA 92138-2323. ♣

# quick fix for a failed rail

You can do the job without disassembling the chair; all you need is a scarf joint.

**T**he chair you see at *right* suffered from a common problem: a broken stretcher rail. If the chair's joints were loose, we would have disassembled it, and made a solid replacement stretcher. This chair's joints were sound, however, so we wanted to repair the stretcher without taking the chair apart. Here's how we did just that.

## Match the wood

First, decide what species of wood you need for the new stretcher. Although the seat and back of our chair are oak, the stretchers are maple. We measured the diameter at  $\frac{5}{8}$ ", as shown in **Photo A**, and bought a standard maple dowel as our workpiece. (To replace a nonstandard size,

**A long scarf joint, with a good coat of glue, provides all the strength you need. As a bonus, it's nearly invisible.**

you can make a dowel on a router table, as described on page 55 in issue 138.)

Remove the old stretcher, measure the space between the legs, and add the depths of the tenon holes. Subtract  $\frac{1}{8}$ " to make installation easier. Cut the dowel to that length.

Next, install a  $\frac{1}{4}$ " core-box bit in your table-mounted router, and use a tenon on the old stretcher as a gauge to set the bit's height. The setup shown in **Photo B** serves as a quick way to shape the new tenons. Set the router-table fence to act as a stop that determines the length of the tenon. Secure an auxiliary fence to your miter gauge, locate the gauge so that your dowel is centered on the bit, and clamp it to the table.

## Cut the scarf joint

After making the tenons, go to the band-saw, and cut a long, sharply angled scarf joint across the dowel. Ours was a  $15^\circ$  cut  $2\frac{1}{4}$ " long. Cut as straight as possible, making sure not to rotate the dowel, and then smooth the sawn surfaces on 150-grit sandpaper, as shown in **Photo C**.

Now, coat the tenons with yellow glue, insert them into the holes, apply glue to the scarf joint, and fit it together, as shown in the photo *top right*. Wrap it with masking tape to serve as a clamp. After the glue dries, sand the joint.

All that remains is to match the replacement piece to the chair's finish. Clean the chair, then use a dowel scrap to test stains until you find the color you want. ♣



**A** Fixing a round stretcher rail isn't as difficult as it might look. Start by measuring the diameter and length of the piece.

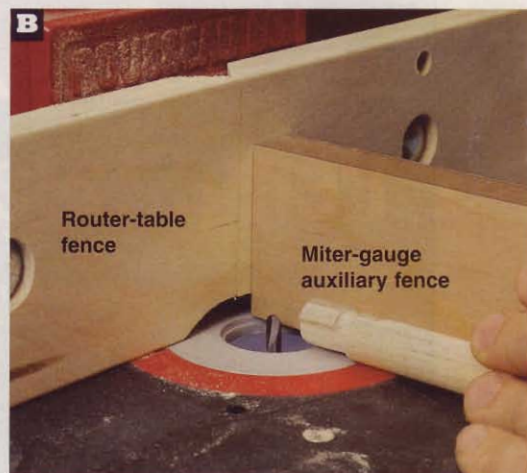

**B** Push the stock all the way to the fence, and rotate it once counterclockwise. Then nibble away the rest of the waste.



**C** Place self-adhesive sandpaper on a flat surface, such as your workbench, and carefully smooth the scarf joint.

# problem-solving solvents

When you're cleaning, refinishing, or thinning, pour out the right chemicals to get the job done.

**T**he chart below sorts out the most common workshop solvents and their uses. While all of these liquids commonly are called solvents, note that they're also used as thinners. A solvent dissolves certain solids. A thinner mixes with a liquid and dilutes it.

Take precautions when using these substances because overexposure in liquid or vapor form can cause a range of short-term and long-term health problems. Toluene, for example, is considered a probable cause of cancer.

Protect your skin with rubber gloves, and wear goggles to protect your eyes.

Provide adequate ventilation for the sake of your lungs and to eliminate the risk of an explosion if your shop contains a pilot light or other open flame.

Rags soiled with solvents should be stored temporarily in metal, self-closing containers, or taken outdoors immediately and allowed to dry. Once the solvent smell dis-

appears, you can throw them in the trash. Store containers of solvent behind closed doors in a metal cabinet. Take unwanted solvents to a recycling center. ♻️



## Here's how to use them

Solvent	What it dissolves	What it thins	Comments
Mineral spirits (paint thinner) Naphtha	Wax	Wax, oil, varnish, polyurethane	"Paint thinner" is essentially the same as mineral spirits. Use a product with either label to clean varnish or oil-based paint from brushes.
Toluene Xylene (xylol)	Wax, water-based finish, white glue, yellow glue	Wax, oil, varnish, polyurethane, conversion varnish	These very toxic chemicals can be used to soften and remove dried yellow glue.
Denatured alcohol	Shellac	Shellac, lacquer	Denatured alcohol is poisonous. It's made that way so that it can be sold without a liquor tax.
Lacquer thinner	Lacquer, shellac, water-based finish	Lacquer, catalyzed lacquer, shellac	"Lacquer retarder" is a special form of lacquer thinner that evaporates more slowly; add it to lacquer when working in hot or humid conditions.
Acetone	Lacquer	Lacquer	Removes adhesives, including contact cement, and resins. However, it can damage plastics.

# tight-fit wraparound moldings

Maintaining clean, gap-free corner joints when installing moldings around three or even four sides of a carcass or panel can be tricky. Here's a fail-safe method that'll handle both situations.

## Fitting moldings around three sides

### STEP 1

Cut the moldings 2" longer than their finished lengths, and miter one end of each. Make sure the side moldings mirror each other. Dry-fit the front molding and a side molding around the first carcass corner, holding the joint tightly together with masking tape.



*Note: Fitting the moldings is easier when gravity holds them in place. Whenever possible, instead of working overhead, invert the carcass on your workbench.*

### STEP 2

At the other corner, hold a straightedge flush with the carcass side. Using a sharp pencil, mark the miter's heel onto the front molding's unmitered end. Remove the front molding. Using a combination square and pencil, draw a 45° cutline intersecting the heel mark.



### STEP 3

Attach a scrapwood auxiliary fence that is 1" taller than the molding in its installed orientation to your miter saw's fence with double-faced tape. Make a 45° cut through it. Hold the front molding against the auxiliary fence, angled in its installed orientation. Align the 45° cutline with the saw kerf, and miter-cut the molding to length.



To make this cut on your tablesaw, attach an auxiliary extension fitted with a 1/8"-hardboard sled to your miter gauge. Fasten a cleat to the sled to hold the molding in its installed orientation. Cut through the extension's end at 45°. Align the molding's marked cutline with the saw kerf in the extension, and cut the molding to length.

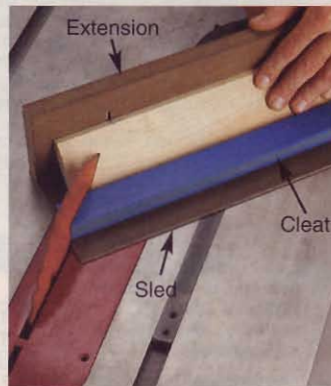

### STEP 4

Dry-fit all three moldings on the carcass, taping the corner joints together. Holding the moldings snug to the carcass, make marks on the side moldings flush with the back edges of the carcass sides. Remove the side moldings, and cut them to length.

### STEP 5

Glue and nail the front molding to the carcass, using wire brads. (A pneumatic brad nailer works wonders here.) When fastening side moldings to a solid-wood carcass, allow for seasonal wood movement using slots, as in Step 3, page 66. On a plywood carcass, which moves insignificantly with changes in humidity, simply fasten the side moldings with glue and brads.

Continued on page 48

## Fitting banding around four sides

### STEP 1

Cut the bands about two inches longer than their finished lengths. Miter one end of bands 1 and 3, making *mirror-image* parts, and one end of bands 2 and 4, making *identical* parts. Dry-fit bands 1 and 2 at the first corner, taping the parts together. Using a straightedge and sharp pencil, mark the miter heels on the unmitered ends of both bands. Remove the bands, mark 45° cutlines, and miter-cut the bands to length.

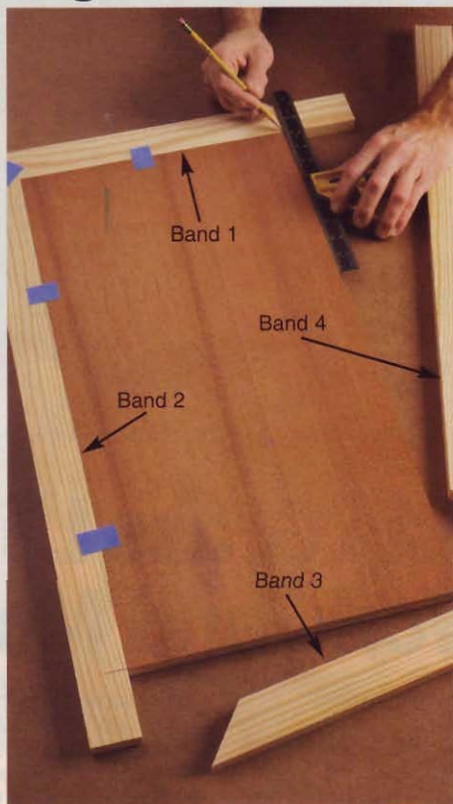

### STEP 2

Tape together the mitered ends of bands 2 and 3 at the second corner. Tape the bands to the panel. Make the miter heel mark on the unmitered end of band 3. Remove the band, mark a 45° cutline, and miter-cut the band to length.

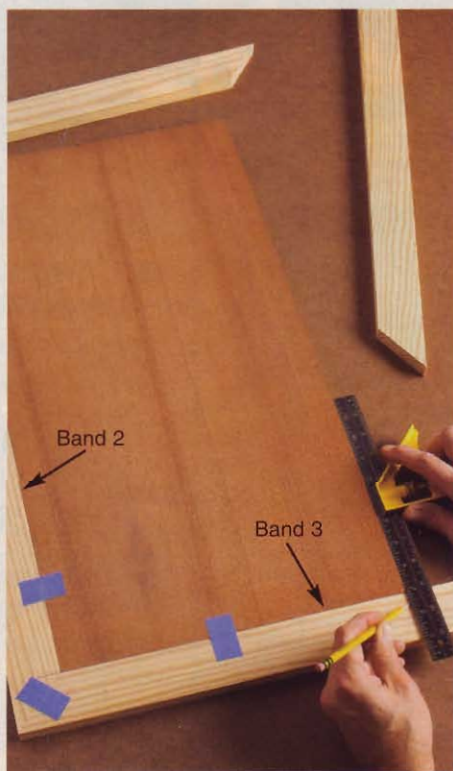

### STEP 3

Tape bands 3 and 4 to each other and to the panel. Once again using a straightedge and sharp pencil, mark the miter heel on the unmitered end of band 4. Remove the band, and mark a 45° cutline. Miter-cut band 4 about 1/16" longer than the marked length.

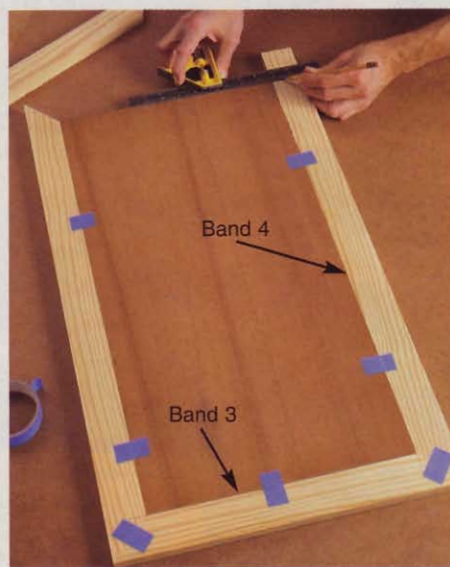

### STEP 4

Tape band 1 in place. Check the miters at the first two corners, making sure the joints are tight. Test-fit band 4, and recut the miter, shaving off a little at a time while sneaking up on a perfect fit.

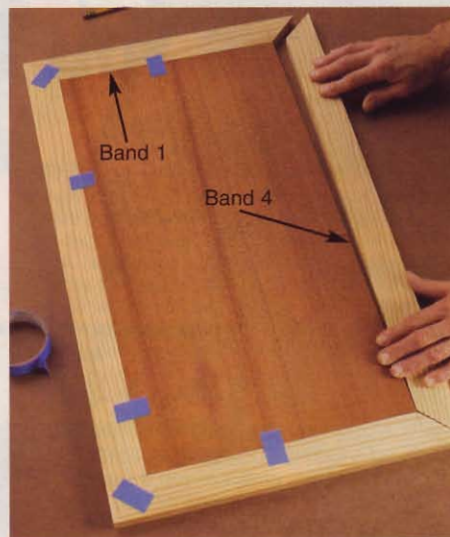

### STEP 5

Glue and clamp the bands to the panel, using bar clamps in an over and under configuration, as shown. Concentrate on getting the bands flush with the panel's surface. The bands should fit perfectly, so apply only moderate clamping pressure.

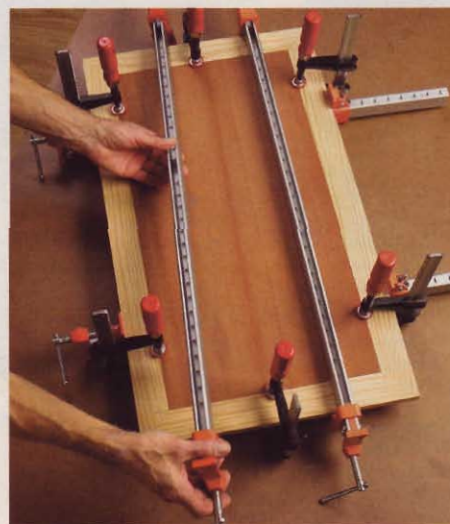

# baker's trio

Build one or more pieces of this set that includes a pastry board, rolling pin, and wall rack.



**B**efore starting design work on our pastry set, we asked the world-renowned chefs in the test kitchen of our sister publication, *Better Homes and Gardens*®, for advice. We took their dream for pastry perfection and turned it into a wood-working reality in our shop. Now, you can do the same.

At the heart of this set is a pastry board with dotted circles that help you roll out dough to uniform sizes. To chop vegetables simply flip the board to the other side. Either way, cleats hook over your countertop's edge to keep the board in place. Our experts prefer a French-style rolling pin, and we'll show you how to turn one.

To store and display both the pastry board and rolling pin, we designed a matching wall-mounted rack, *above right*.

## First, let's make the pastry board

### Start with the panel

**1** To make the panel (A), cut 15 pieces of maple to  $\frac{3}{4} \times 1\frac{5}{16} \times 20$ ". Joint  $\frac{1}{32}$ " off both edges of each piece for a finished width of  $1\frac{1}{4}$ ". To make the glue-up easier, first edge-join one group of seven pieces and one group of eight, carefully

aligning the pieces. Use a water-resistant glue, such as Titebond II. To keep your panel flat, alternate the end-grain orientation, as shown on **Drawing 1**. With the glue dry, scrape off any glue squeeze-out, then edge-join the two groups.

### 1 SECTION VIEW

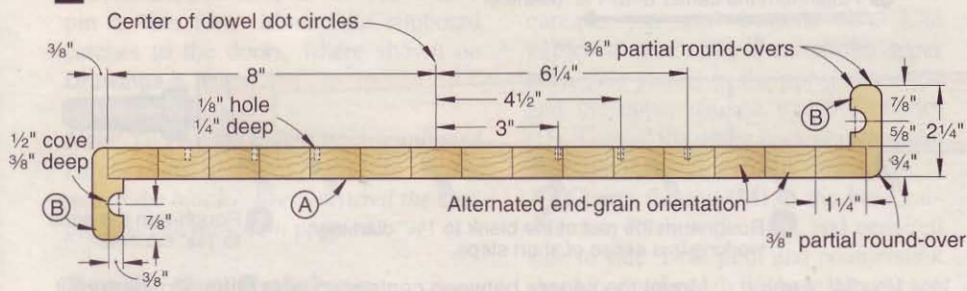

### 2 PASTRY BOARD

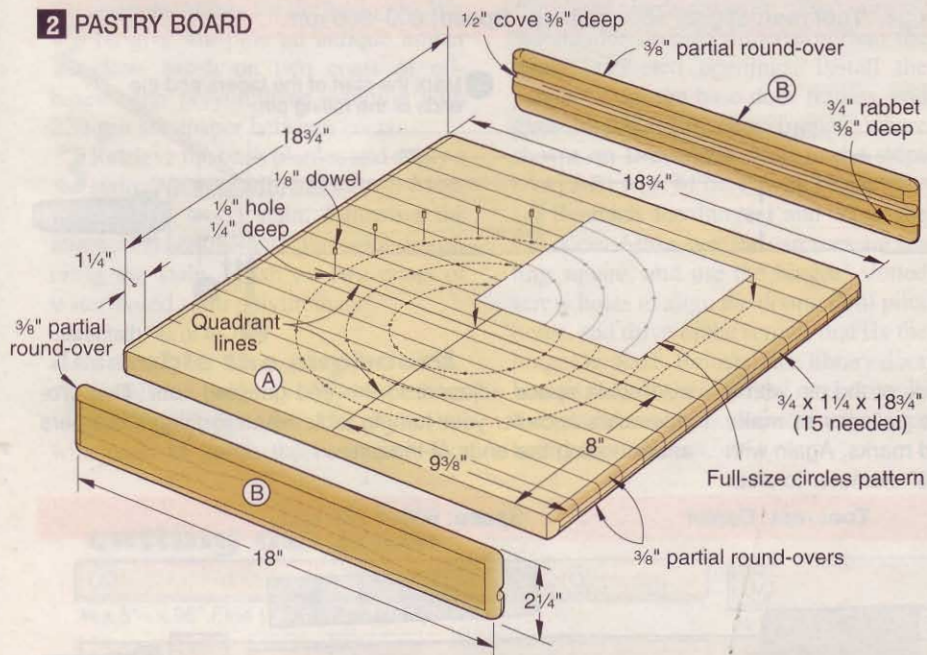

**2** Sand the panel flat. Trim both ends to cut it to finished length.

**3** Mark the center of the circles, where dimensioned on **Drawing 2**. Divide the panel into quadrants by drawing 16"-long lines through the center. Make a copy of the circles pattern on the *WOOD PATTERNS*® insert, and cut it along the quadrant lines. Tape the pattern to the panel, and mark the 1/8" hole centers, as shown in **Photo A**. Reposition the pattern, and repeat until the holes in all four quadrants are marked.

**4** Chuck a 1/8" brad-point bit in a hand drill. Attach a masking tape "flag" to the bit 1/4" from its end. Drill 1/4"-deep holes at the marked locations. Glue 1/8" walnut dowels in all the holes, and trim them flush, as shown in **Photo B**. With the glue dry, sand the dowels flush.

**5** Chuck a 3/8" round-over bit in your table-mounted router, and adjust it as shown on **Drawing 3**. Rout the ends

of the panel (A), where shown on **Drawing 2**. Sand the panel to 220 grit.

### Add the cleats and finish

**1** Cut the cleats (B) to the size listed. With the same setup used for the panel, rout partial round-overs on the cleats' edges and ends, where shown on **Drawings 1** and **2**. Switch to a 1/2" roundnose bit, and rout the 3/8"-deep coves, where shown on **Drawing 1**.

**2** Install a dado blade in your tablesaw, and cut the 3/4" rabbets 3/8" deep, where shown.

**3** Glue and clamp the cleats (B) to the panel (A). For best results, attach the cleats one at a time, centering them on the panel.

**4** Resand any areas that need it. Apply three coats of a penetrating-oil finish, following the instructions on the can. Let the finish cure for a week before using the pastry board.

### 3 PARTIAL ROUND-OVER

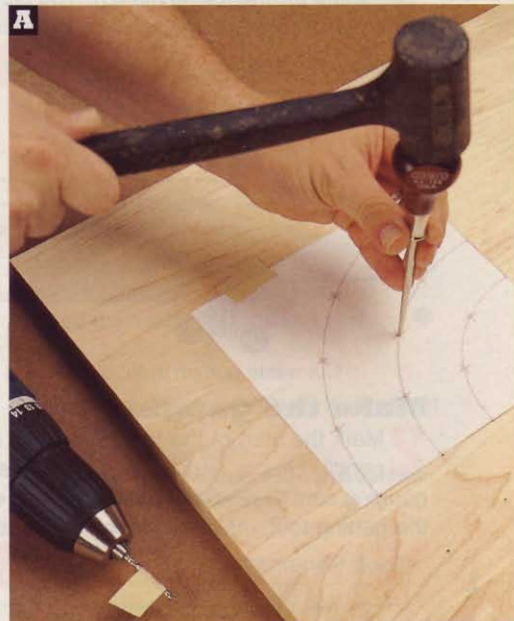
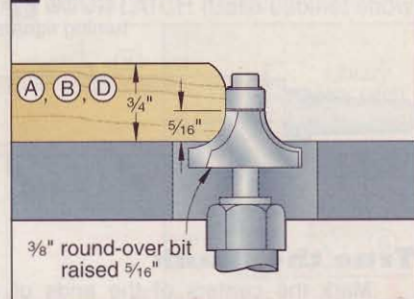

Align the pattern with the quadrant lines, and secure it with masking tape. Use an awl to mark the hole centers.

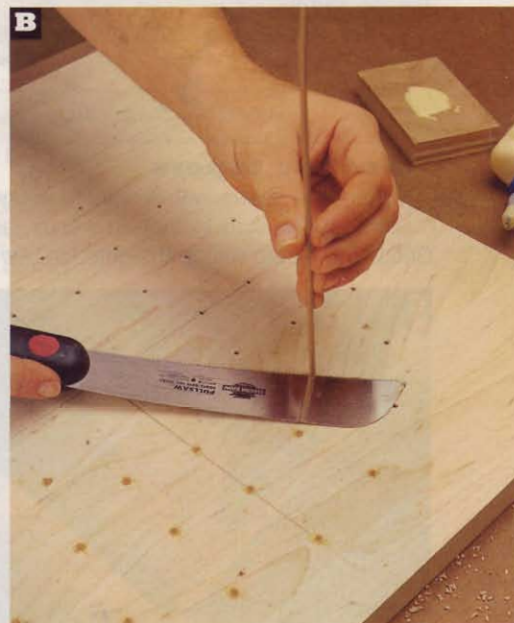

Dip the end of a 1/8" walnut dowel in glue, and then insert it in a hole. Trim the dowel flush. Repeat until all holes are filled.

## Try your hand at turning the rolling pin

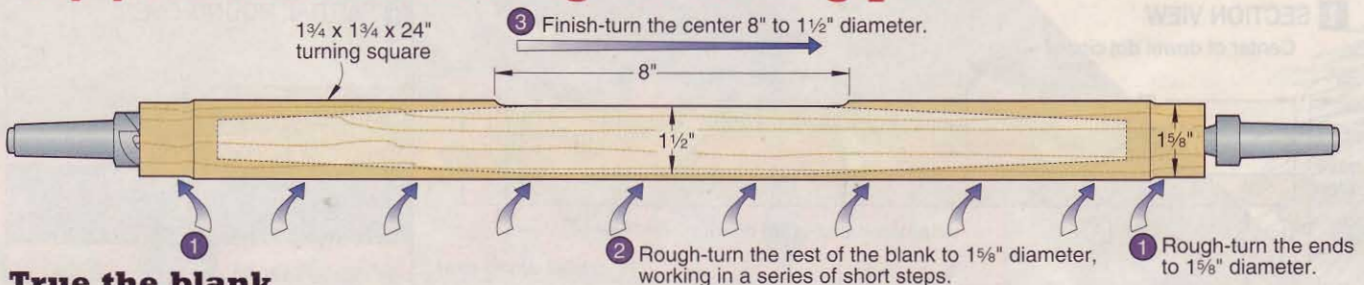

### True the blank

**1** Mark the centers of the ends of a 1 3/4 x 1 3/4 x 24" turning square for the rolling pin (C). You can make your own turning square from 8/4 material, or by laminating thinner stock.

Mount the square between centers on your lathe. Rough-turn it to 1 5/8" diameter with a roughing gouge, and then use a spindle gouge to finish-turn the middle 8" to 1 1/2" diameter.

**Tools:** 3/4" roughing gouge, 3/8" spindle gouge. **Tool rest:** Slightly above center. **Speed:** 600–800 rpm.

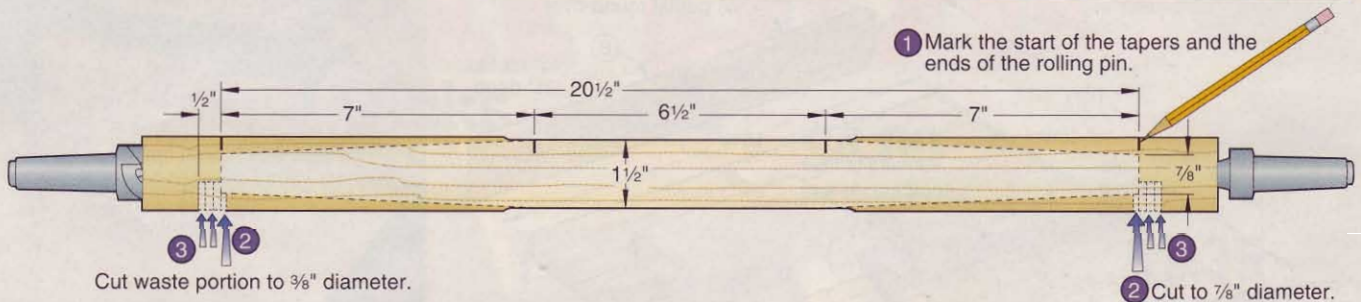

### Make the gauging cuts

**2** Mark the start of the tapers and the ends of the pin with a pencil. Use a parting tool and outside calipers to make gauging cuts to 7/8" diameter at the pin's end marks. Again with the parting tool, make overlapping cuts to 3/8" diameter to clear

a 1/2"-wide space adjacent to the end gauging cuts. This provides clearance for your turning tools when forming the tapers and rounding the ends of the pin.

**Tool:** Parting tool.

**Tool rest:** Center.

**Speed:** 800–1,200 rpm.

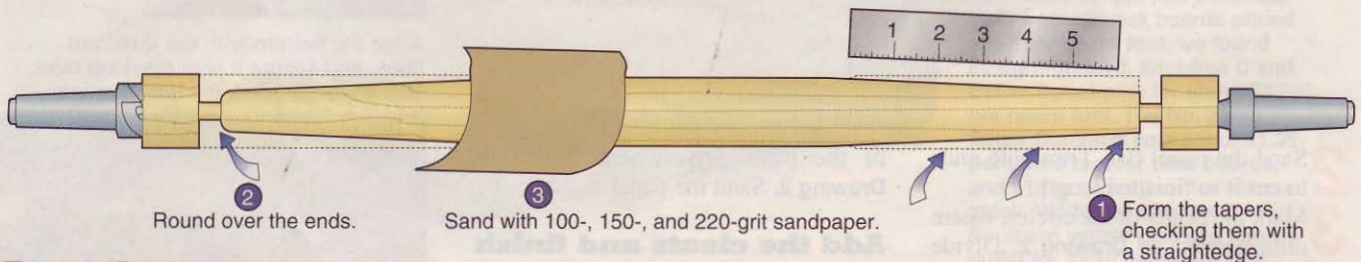

### Form the tapers

**3** Form the tapers with a spindle gouge. Cut downhill, from the tapers' start to the pin's ends, as shown in **Photo C**. Check the tapers with a straightedge. Switch to a skew chisel,

and form 1/8" round-overs at the ends. Sand the pin to 220 grit, easing the transition from the flat center portion to the tapers.

**Tools:** 3/8" spindle gouge, 3/4" skew chisel.

**Tool rest:** Slightly above center.

**Speed:** Gouge, 600–800 rpm; skew, 800–1,200 rpm.



### Finish up

**4** Remove the rolling pin from the lathe, and separate the waste with a fine-tooth saw. Sand the ends smooth. Apply three coats of a penetrating-oil finish, following the instructions on the can. Let the finish cure for a week before using the rolling pin.

*Continued on page 54*



# Build a wall rack to organize your set

## Make the back and rolling pin brackets

**1** Edge-join  $\frac{3}{4}$ "-thick stock for the back (D), and cut it to the size listed. Mark the back at its top center and  $\frac{3}{8}$ " down from the top on the ends, where shown on **Drawing 4**. Connect the three points with a flexible ruler or thin wood

strip, and draw the top arc. Draw  $\frac{3}{8}$ " radii at the ends of the arc and at the back's bottom corners, where shown. Bandsaw and sand to the lines. Using the same table-mounted router setup shown on **Drawing 3**, rout a partial round-over on the back's front edges and ends. Sand the back to 220 grit.

**2** Plane a  $\frac{3}{4} \times 2\frac{1}{2} \times 30$ " board to  $\frac{1}{2}$ " thick, and from it cut a  $2\frac{1}{4} \times 10$ " blank for the brackets (E). Set the rest of the board aside to make part G later. Lay out the bracket profiles, and mark the  $\frac{1}{4}$ "-diameter hole centers, where shown on **Drawing 5**. Bore the holes with a Forstner bit, and then rip the

*Continued on page 56*

**4 BACK**

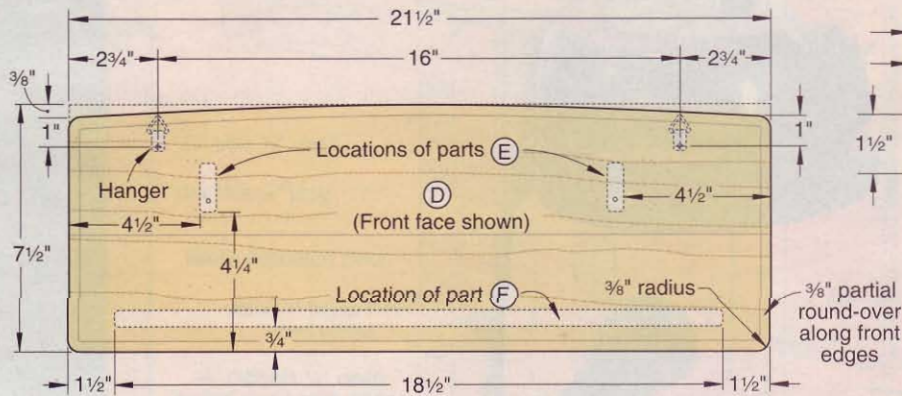

**5 BRACKETS**

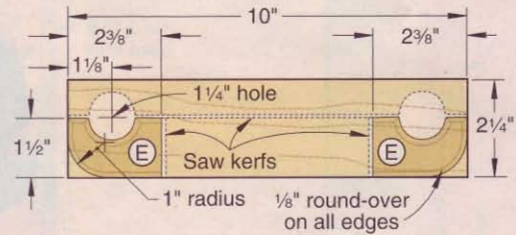

**6a HANGER CLEAT**

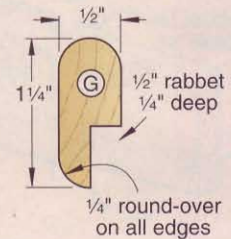

**6 WALL RACK EXPLODED VIEW**

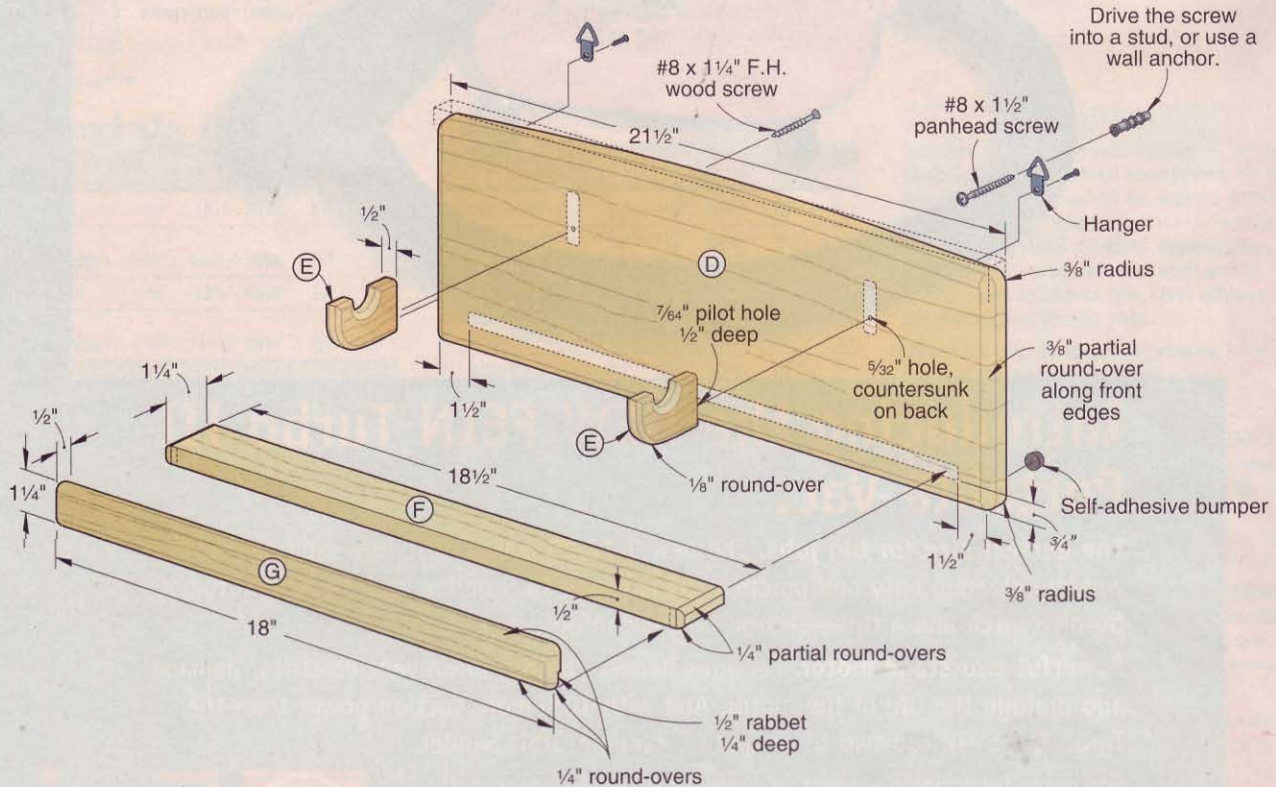

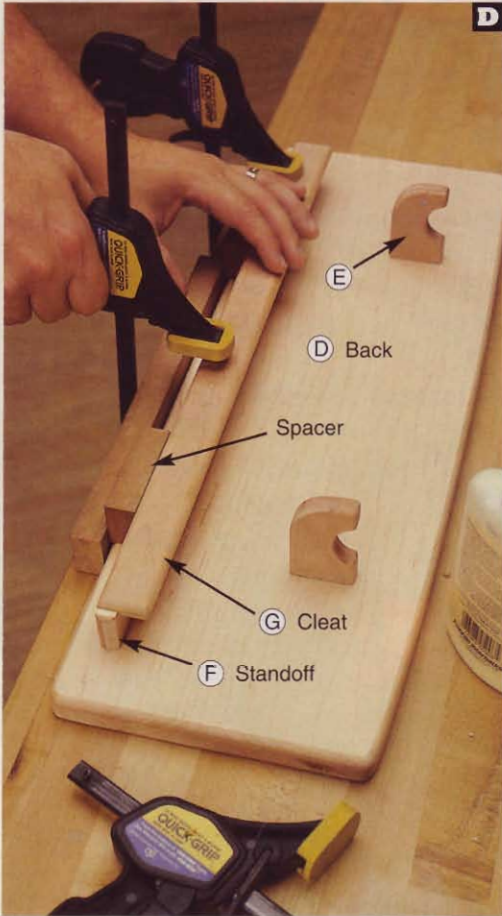

Using 3/4"-thick spacers to position the standoff/cleat assembly, glue and clamp it in place, centered on the back's length.

blank to 1 1/2" wide, where indicated. Bandsaw and sand the corners. Install a 1/8" round-over bit in your table-mounted router, and rout the edges of both sides of the blank. Sand the brackets to 220 grit, then crosscut the blank where indicated to separate the two 2 3/8"-long brackets (E).

3 With masking tape, mark the locations of the bottoms and outside edges of the brackets (E) on the back (D). Apply a couple small dots of glue to each bracket, and clamp them in place. With the glue dry, drill pilot and countersunk shank holes through the back into the brackets, where shown on Drawing 6. Drive in the screws.

### Add a hanger for the pastry board

1 Plane stock to 1/2" thick, and cut the standoff (F) to the size listed. Install a 1/4" round-over bit in your table-mounted router, and adjust it as shown on Drawing 7. Rout partial round-overs

on the standoff's ends, where shown on Drawing 6. Sand it to 220 grit.

2 Retrieve the set-aside 1/2" stock, and cut the hanger cleat (G) to size. Raise the 1/4" round-over bit in your table-mounted router to form a full round-over. Rout the cleat's edges and ends, where shown on Drawings 6 and 6a. With a dado blade in your tablesaw, cut the 1/2" rabbet 1/4" deep, where shown. Sand the cleat to 220 grit.

3 Glue and clamp the cleat (G) to the standoff (F), centering the cleat on the standoff. With the glue dry, cut two 3/4x1 1/4x2" and one 3/4x1 1/4x12" scrap-wood spacers. Glue and clamp the standoff/cleat assembly to the front face of the back (D), as shown in Photo D.

4 Check the wall rack's surfaces, and resand areas that need it. Apply two coats of satin polyurethane, sanding between coats with 220-grit sandpaper. With the finish dry, drill pilot holes, and screw the hangers in place, where shown on Drawing 4. Adhere self-adhesive bumpers to the back's bottom corners, where shown on Drawing 6.

5 Install two #8x1 1/2" panhead screws, 16" on center and level, in your wall. Locate your rack so the screws can be driven into studs, or use wall anchors. Let the screws' heads protrude 1/8" from the wall. Hook the rack's hangers on the screw heads, and set the pastry board and rolling pin in place. 🍪

Written by Jan Svec with Jeff Mertz  
Project design: Jeff Mertz  
Illustrations: Mike Mittermeier; Roxanne LeMoine; Lorna Johnson  
Photographs: Marty Baldwin

### 7 1/4" PARTIAL ROUND-OVER

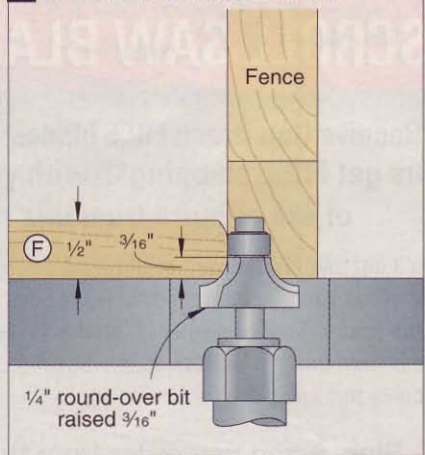

### materials list

Pastry board	FINISHED SIZE			Matl.	Qty.
	T	W	L		
A* panel	3/4"	18 3/4"	18 3/4"	EM	1
B cleats	3/4"	2 1/4"	18"	C	2
Rolling pin					
C* rolling pin	1 1/2" diam.	20 1/2"		M	1
Wall rack					
D back	3/4"	7 1/2"	21 1/2"	EM	1
E* brackets	1/2"	1 1/2"	2 3/8"	C	2
F standoff	1/2"	1 1/4"	18 1/2"	M	1
G hanger cleat	1/2"	1 1/4"	18"	C	1

\*Parts initially cut oversize. See the instructions.

Materials key: EM—edge-joined maple, C—cherry, M—maple.

Supplies: Water-resistant glue, 1/8" walnut dowel 14" long, #8x1 1/4" flathead wood screws (2), #8x1 1/2" panhead screws (2), wall anchors (2).

Bits and blades: 1/8", 1/4", and 3/8" round-over router bits, 1/2" roundnose router bit, 1/8" brad-point drill bit, stack dado set, 1/4" Forstner bit.

Lathe tools: 3/4" roughing gouge, 3/8" spindle gouge, parting tool, 3/4" skew chisel.

### Buying Guide

Wood and hardware. 2x2x30" maple turning square no. 50W62, \$8.99; hangers no. 27K04, \$2.99 (bag of 10 with screws); self-adhesive bumpers no. 02S82, \$6.50 (sheet of 56). Call Woodcraft, 800/225-1153, visit a Woodcraft store near you, or go to www.woodcraft.com.

### cutting diagram

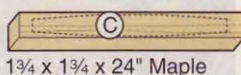
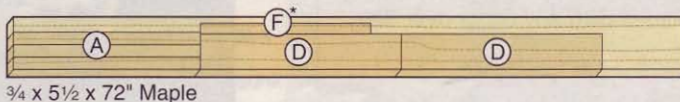
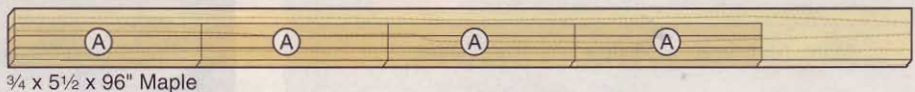

\*Plane or resaw to thickness listed in the Materials List.

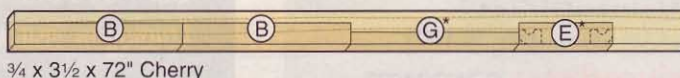

# fishy puzzle

kids will love it to pieces

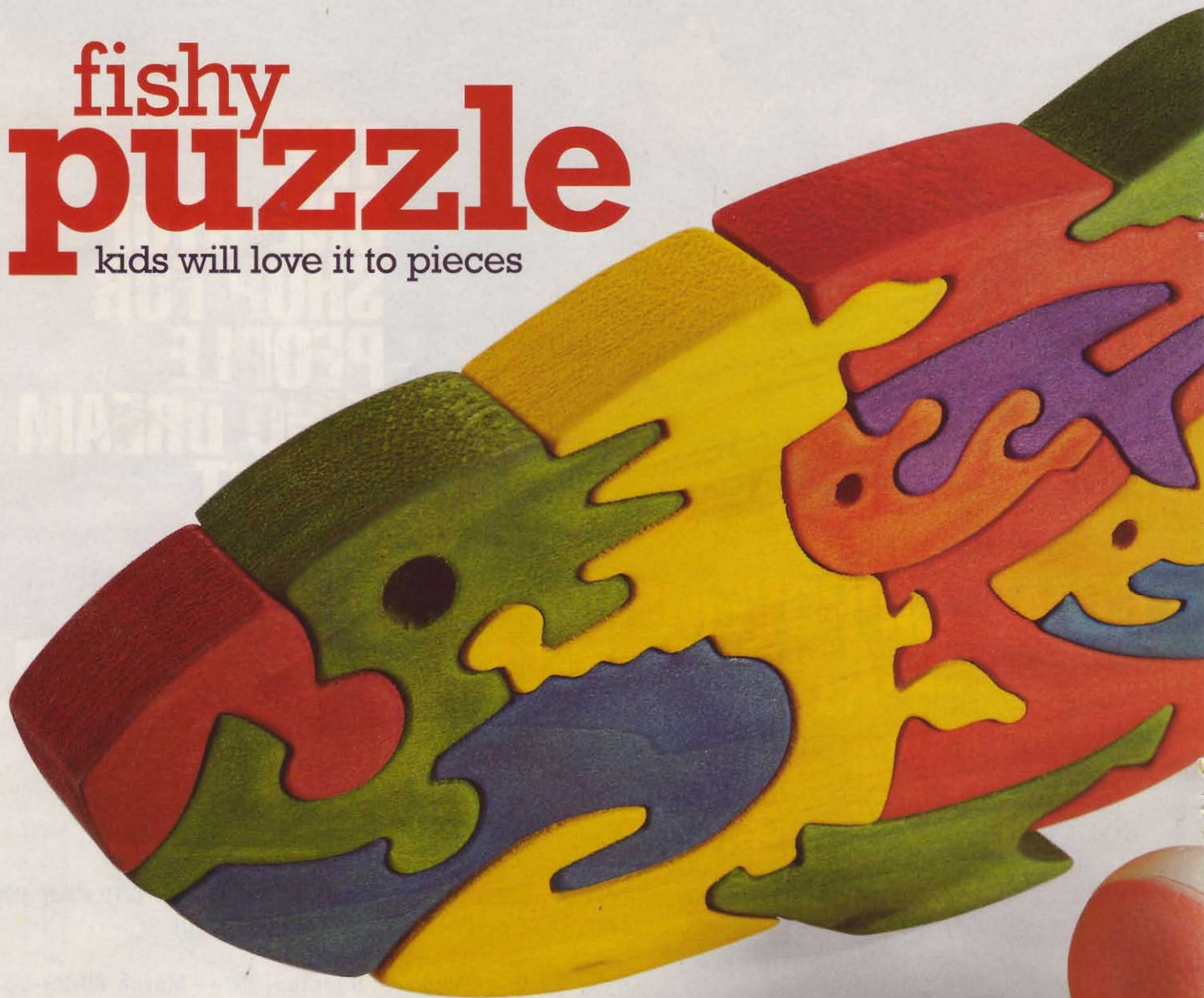

Scrollsawers and kids will appreciate the clever design and eye-popping colors of this Russell Greenslade original. Look closely and you'll spot not one but three bright fish going for a swim.

## Let's make the puzzle

**1** Start by cutting a  $\frac{3}{4} \times 5 \times 14$ " blank for the puzzle. We used poplar but pine, basswood, or soft maple also would be suitable.

**2** Photocopy the full-size "fishy puzzle" pattern in the *WOOD PATTERNS*® insert. Trim the pattern, and attach it to the blank with spray adhesive.

**3** Drill a  $\frac{3}{8}$ " hole for the big fish's eye and two  $\frac{3}{32}$ " holes for the small

fishes' eyes through the blank, where shown on the pattern.

**4** Fit your scrollsaw with a no. 5 blade (16 teeth per inch). Cut around the outside pattern line first; then, cut the puzzle into parts, as shown in **Photo A**.

**5** Remove the patterns and any residual adhesive. (A cloth moistened with paint thinner works well.)

**6** Using 220-grit sandpaper, lightly round over the edges of each piece, and sand their surfaces smooth. Avoid sanding the interlocking surfaces as doing so will result in loose-fitting parts.

*Note: Russell Greenslade colors his puzzles with water-soluble aniline dyes. His color choices for this puzzle are identi-*

*fied on the pattern's color key by numbers, which correspond to those shown on the pattern pieces. (See the Buying Guide on the opposite page for a source of dyes.) For a less-expensive approach, try all-purpose dyes sold in drug and variety stores for fabric coloring. Avoid paints as they can prevent parts from sliding together easily.*

## Add brilliance

**1** Mix the prescribed aniline dyes according to package instructions.



For this puzzle, Russell reduces the intensity of the “green peacock blue” color (key item 3) by adding about 10 ounces of water to the mixed dye. Also, to make the blended “green peacock blue/lemon yellow” color (key item 2), he starts with the lemon yellow dye and very slowly adds the reduced green peacock blue dye to it to get a bright green color. Similarly, to make the “brilliant scarlet/lemon yellow” color (key item 6), he slowly adds brilliant scarlet dye to lemon yellow dye to get an orange color.

**2** Color the parts by applying the dyes with a brush or cloth or by dipping them. After the dyes dry, lightly sand the parts with 400-grit sandpaper to smooth the grain, which will have been



**A** Working from the big fish’s mouth to its tail, cut out each puzzle piece as you come to it, sawing right down the middle of the pattern lines.

raised by the water-base dye. Dye the parts again.

**3** With the dye dry, apply a non-ambering penetrating oil to the pieces. (Russell recommends Minwax Antique Oil Finish.) Wipe off the excess after 10–15 minutes. Allow the oil to cure before you assemble the parts of the puzzle. 🌲

Written by **Owen Duvall**  
Project design: **Russell Greenslade**  
Photographs: **Marty Baldwin; William Lewis**

### Buying Guide

**Aniline dyes.** Woodworker’s Supply catalog numbers for the colors used follow each color. Ruby (W1800), green peacock blue (W1720), lemon yellow (W1850), brilliant scarlet (W1790), violet (W1760), orange golden yellow (W1810), and magenta (W1750). The dyes cost \$6.99 each for one ounce, which makes one quart of stain. Call 800/645-9292, or go to [woodworker.com](http://woodworker.com).

## Make a frame, and the puzzle becomes a game

Although this friendly fish stands upright just fine on a display shelf, you may want to put him in a frame to help children assemble the puzzle and keep its parts together.

To make the frame, cut a 7×15" piece from 1/8" and 1/4" plywood. Center the fish on the 1/4" plywood, and trace around its outside. Drill a 1/4" starter hole through the plywood inside the marked outline; then scrollsaw just outside the outline to form the fish’s opening. Face-glue the 1/4" plywood to the 1/8" plywood backer. Spray-paint the frame a color of your choice, and let it dry. To give children a guide for assembling the puzzle, photocopy the puzzle pattern in the insert; trim the pattern to fit the opening; and glue it inside the opening to the backer with spray adhesive.

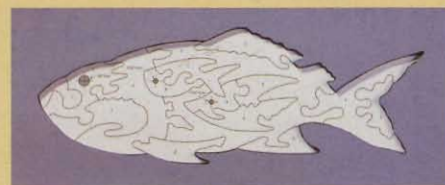

### Find more ...

...great projects for kids at  
[www.woodstore.woodmall.com/kidfurtoy.html](http://www.woodstore.woodmall.com/kidfurtoy.html)



### Meet the designer



From his shop in Girard, Ohio, Russell Greenslade crafts cleverly designed and brightly colored toys and puzzles, treasured both by children as play toys and by adults as collectibles.

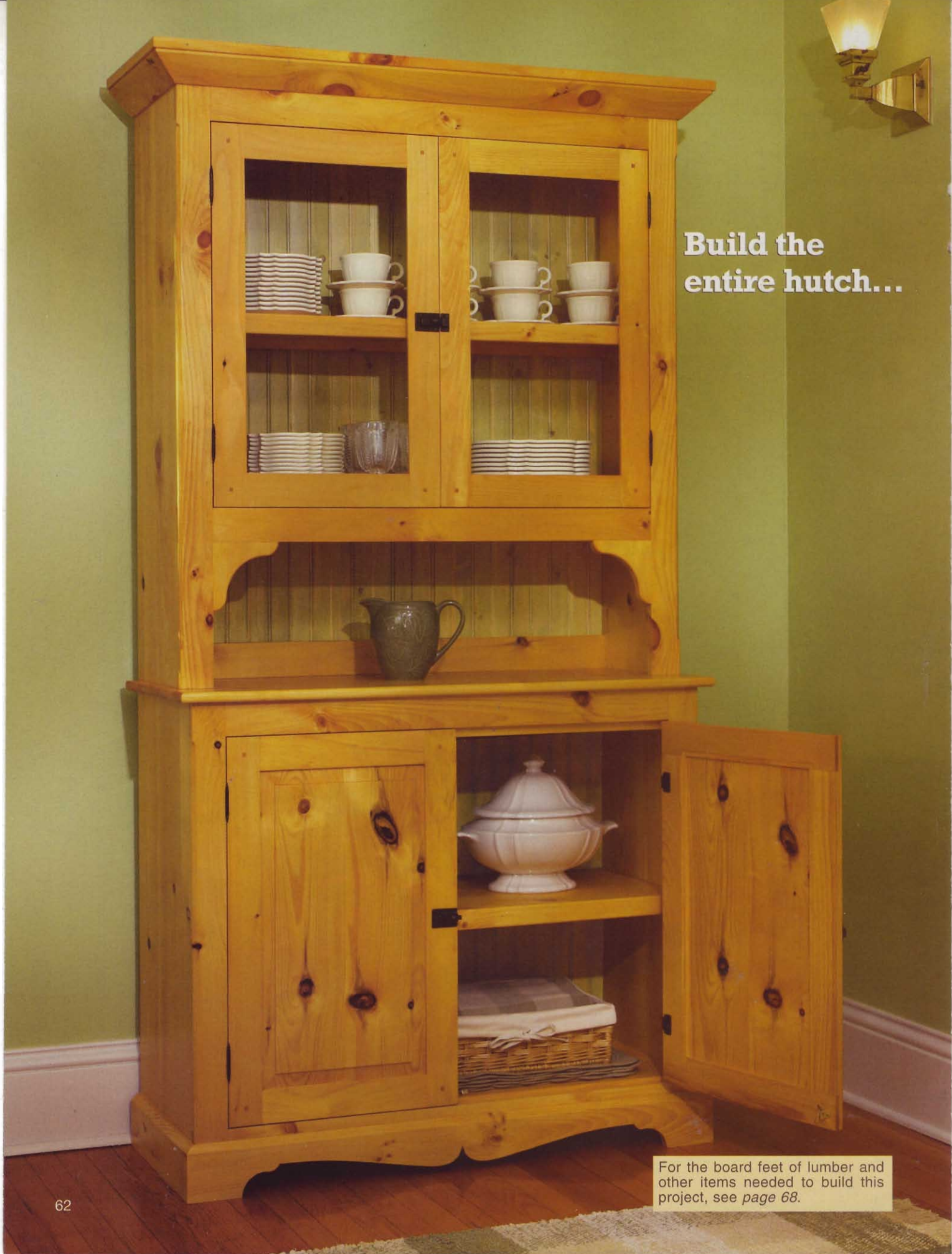

**Build the  
entire hutch...**

For the board feet of lumber and other items needed to build this project, see *page 68*.

an instant heirloom

# pine hutch

Create this classic furniture piece for your home, and in the process, learn a super-simple way to make doors with glass inserts or raised panels using just your tablesaw.

**M**ade entirely of affordable  $\frac{3}{4}$ "-thick knotty pine lumber and  $\frac{5}{16}$ "-thick beaded planking, this handsome piece has a classic country look that's enhanced by such details as its pegged doorframes and antique glass. If you're not used to working with knotty pine, find helpful hints in the article "Working With Pine" on page 70. And, by all means, don't try to hide the knots—they're a big part of this piece's rustic appeal!

*Note: If you wish to build only the sideboard base, we've made doing that simple. Just skip any part of the instructions that has a green tint behind it. These sections cover making the upper cabinet.*

## Edge-join the part blanks

**1** Select boards to edge-join into blanks for the base sides (A), base carcass top and bottom (B), upper sides (C), upper carcass top and bottom (D), top (M), base shelf (R), and upper shelf (S). Match them for grain and color, and use boards that will make blanks slightly longer and wider than the part sizes listed in the **Materials List**.

**2** Joint the mating edges, and glue and clamp the boards. Mark the part letters on the ends. With the glue dry, sand the blanks to 220 grit.

## Make the carcasses

**1** Cut the base sides (A), base carcass top and bottom (B), upper sides (C), and upper carcass top and bottom (D) to size. Cut the rabbets and dados across the width of the sides, and the rabbets along the sides' inside rear edges, where shown on **Drawing 1**. Make sure you have mirror-image parts.

...or make just the sideboard base.



**2** Glue and clamp together the base carcass (A/B) and the upper carcass (C/D). Square the assemblies, and toenail the tops and bottoms to the sides with finish nails, where shown on **Drawings 1 and 1a**.

**3** Drill shelf-pin holes in the sides (A, C), where shown, using the method suggested in the **Shop Tip**, below.

## Add the face frames

**1** Cut the base stiles (E), frame rails (F), upper stiles (G), and upper top rail (H) to the sizes listed. Install a dado blade in your tablesaw, and cut the half laps, where shown on **Drawing 1**.

*Sideboard base builder's note: Make only two frame rails (F).*

## SHOP TIP

### Drill shelf-pin holes quickly and accurately

Rather than laboriously marking the locations of shelf-pin holes, make a simple, dead-on drilling guide from  $\frac{1}{4}$ " perforated hardboard scrap. To avoid a mistake, mark the jig's bottom and the holes used as drill guides, as shown in the photo.

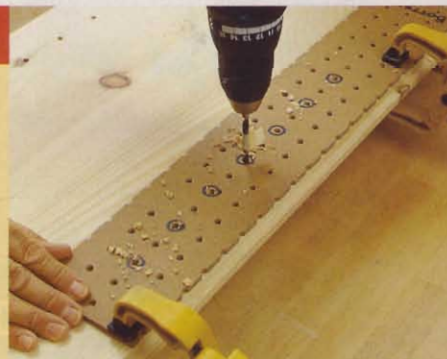

# 1 CARCASSES AND FACE FRAMES

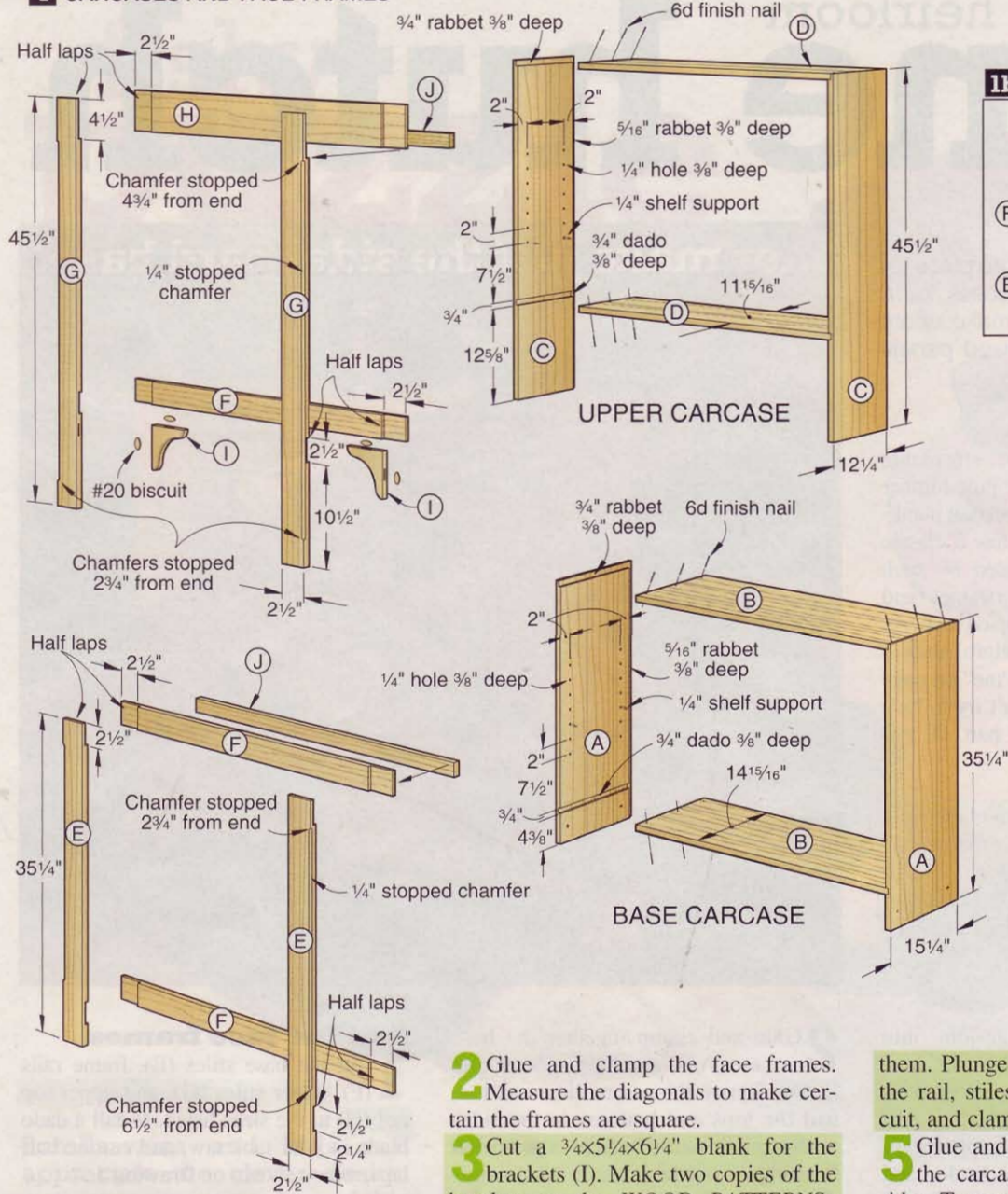

## 1b DOOR STOP

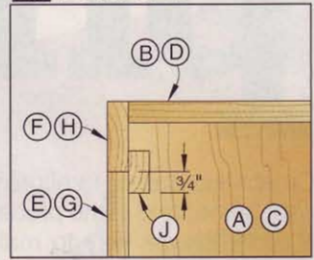

## 1a TOENAILING

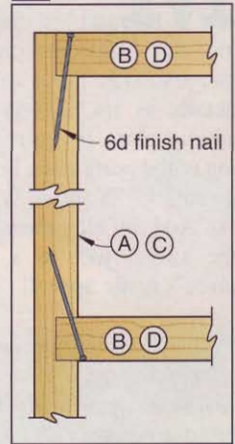

**2** Glue and clamp the face frames. Measure the diagonals to make certain the frames are square.

**3** Cut a  $\frac{3}{4} \times 5\frac{1}{4} \times 6\frac{1}{4}$ " blank for the brackets (I). Make two copies of the bracket on the *WOOD PATTERNS*® insert. Cut the patterns to the lines, and adhere them to the blank with spray adhesive in the orientation shown on the **Cutting Diagram**. Bandsaw and sand the brackets to shape. Rout round-overs on the edges, where shown.

**4** Positioning your biscuit joiner tight into the upper frame's lower corners, transfer the joiner's centering mark to the frame rail (F) and upper stiles (G). Position the brackets where shown on **Drawing 1**, and transfer these locations to

them. Plunge slots for #20 biscuits into the rail, stiles, and brackets. Glue, biscuit, and clamp the brackets in place.

**5** Glue and clamp the face frames to the carcasses, flush at the tops and sides. To provide a lower door stop, the top surfaces of the base and upper carcass bottoms (B, D) sit  $\frac{3}{8}$ " above the top edges of the lower frame rails (F), as shown in **Photo A**. Sand the frames' top and side edges flush with the carcasses' tops and sides.

**6** Rout the  $\frac{1}{4}$ " stopped chamfers on the base and upper stiles (E, G), where shown on **Drawing 1**.

**7** Checking the inside widths of your carcasses, cut the door stops (J) to size. Glue and clamp them to the face frames, where shown on **Drawing 1b**.

**When clamping the face frames in place, make certain the carcass bottoms protrude evenly above the bottom rails.**

*Sideboard base builder's note: Make only one door stop (J).*

## Make the skirts and top

**1** Cut the front skirt (K) and the side skirts (L) to width, but 1" longer than the lengths listed. Set the side skirts aside.

**2** Miter-cut the front skirt to finished length. Make two copies of the end pattern and one copy of the center pattern on the pattern insert. Cut the patterns to the lines, and use spray adhesive to adhere them to the skirt, where shown on **Drawing 2**. You'll flip the pattern for the right end and apply it facedown.

**3** Use a fairing strip to draw gently curving lines connecting the patterns' ends, as shown in **Photo B**. Bandsaw and sand the skirt to shape.

**4** Rout  $\frac{1}{2}$ " chamfers along the top edges of the front and side skirts (K, L), where shown on **Drawing 3**. Glue and clamp the front skirt in place.

**5** Miter one end of each side skirt (L), making a mirrored pair. Fit them in

place, mating their miters with those on the front skirt (K). Mark the side skirts flush with the back edges of the base sides (A), and trim them to length.

**6** Drill holes and slots in the base sides, where shown on **Drawing 3**. Apply glue to the miter and front 2" of the side skirts, and clamp them in place. Using the holes and the slots' centers as guides, drill  $\frac{3}{32}$ " pilot holes in the skirts. Drive  $\#8 \times 1\frac{1}{4}$ " flathead wood screws through the countersunk holes, and  $\#8 \times 1\frac{1}{4}$ " roundhead wood screws fitted with  $\#8$  flat washers through the slots.

**7** Retrieve the edge-joined blank for the top (M), and cut it to finished size. Round over the top's ends, then edges, as shown on **Drawing 3a**.



**Bend a thin strip of wood to form a shallow arc, and draw curved lines connecting the end and center patterns.**

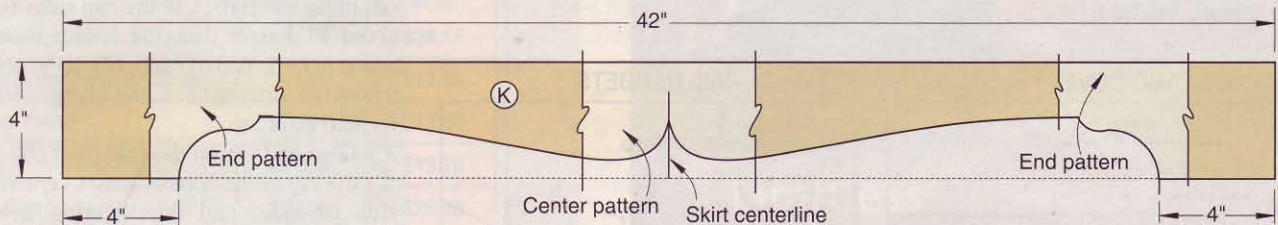

**2 FRONT SKIRT**

### 3a TOP PARTIAL ROUND-OVER

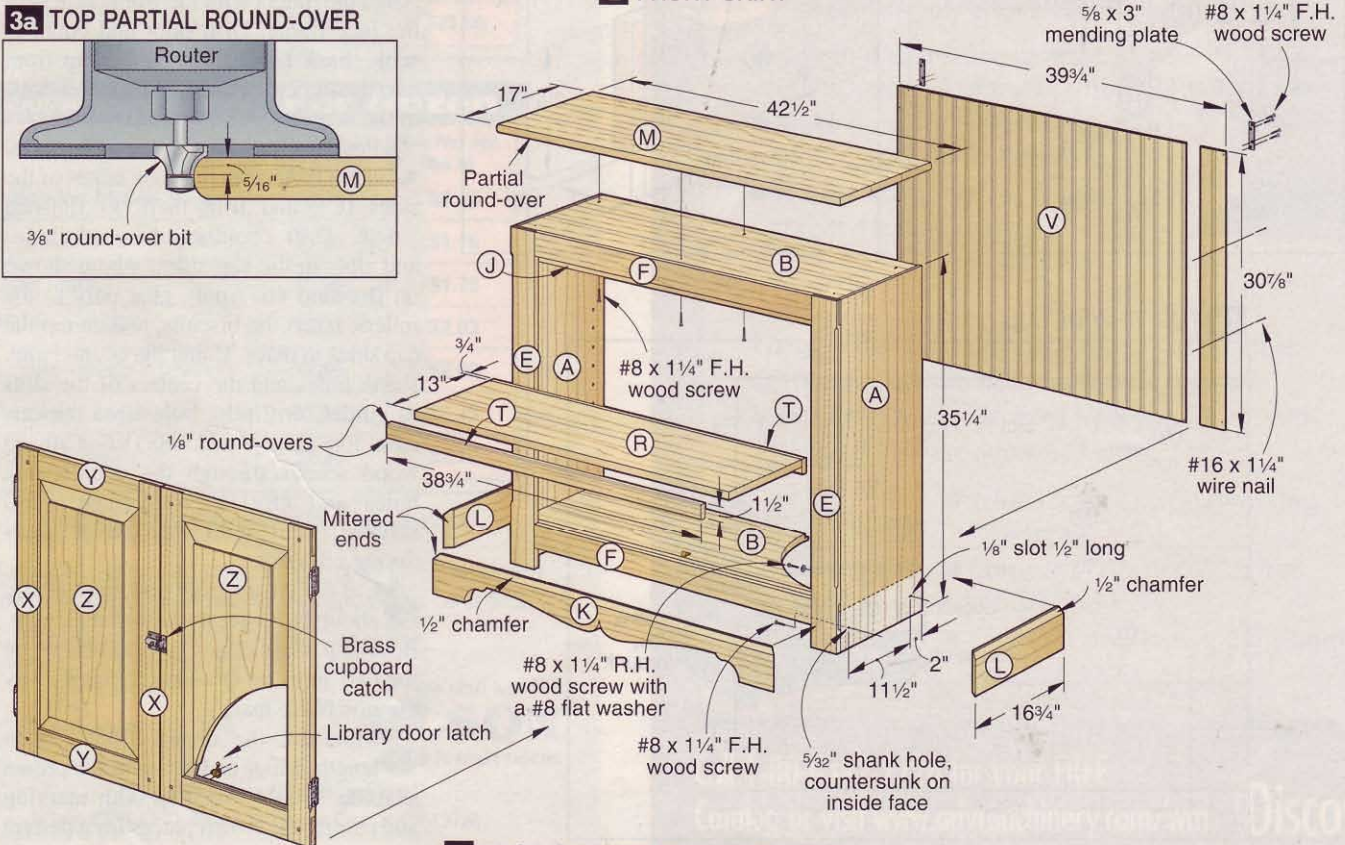
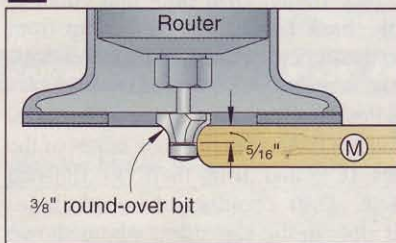

**3 BASE CABINET EXPLODED VIEW**



#### 4 UPPER CABINET EXPLODED VIEW

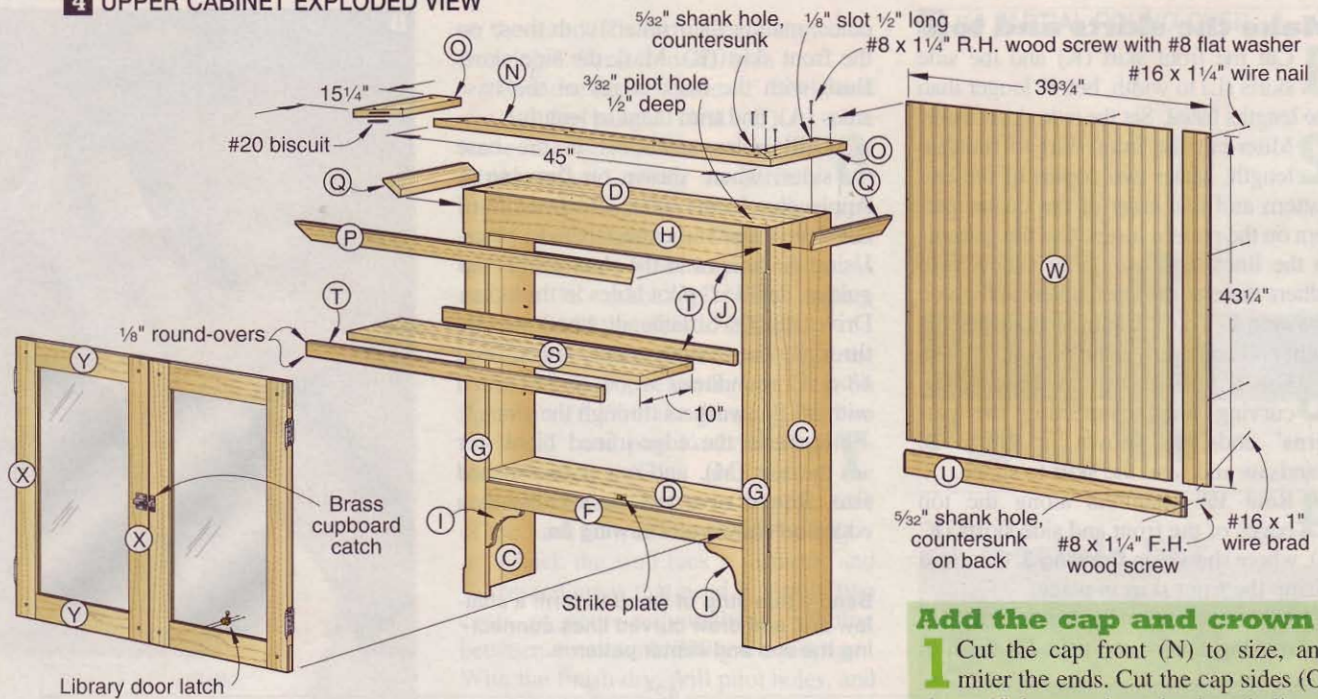

#### 4a CROWN AND COVE

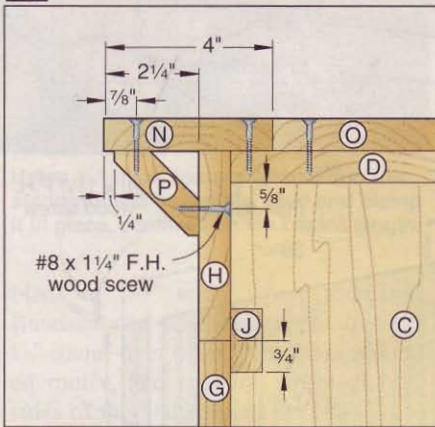

#### 4c BACK RAIL RABBETS

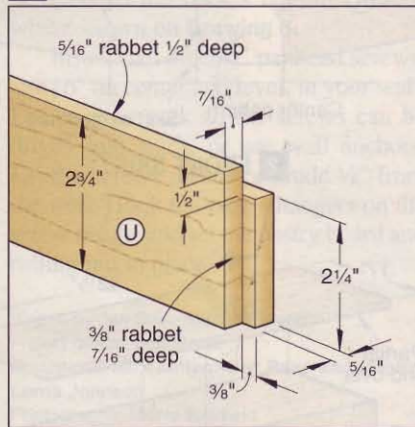

#### 4b TOP VIEW DETAIL

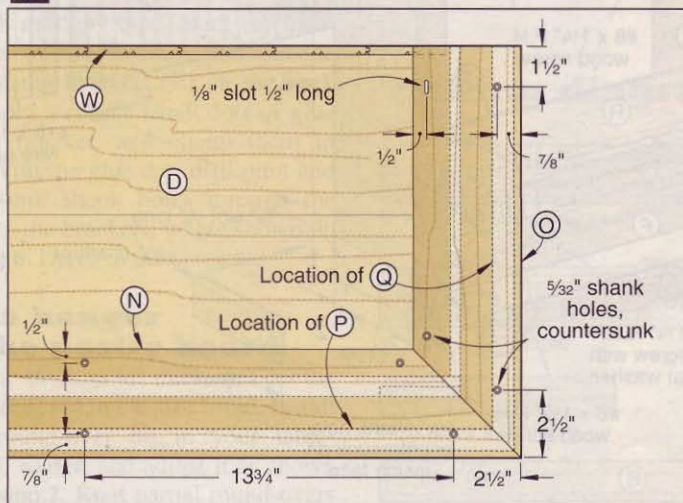

#### Add the cap and crown

**1** Cut the cap front (N) to size, and miter the ends. Cut the cap sides (O) about 1" longer than the length listed, and miter one end of each. Mark the centers of the mitered ends, and plunge slots for #20 biscuits.

**2** Glue and clamp the cap front (N) to the top of the upper cabinet, centered side to side, and overhanging 2 1/4", where shown on **Drawings 4, 4a, and 4b**. Align the miters with the front corners of the face frame. Drill pilot and countersunk shank holes through the cap front into the upper carcass top (D), and drive in the screws.

**3** Position the cap sides (O), mark them flush with the back edges of the sides (C), and trim them to finished length. Drill countersunk shank holes and slots in the cap sides, where shown on **Drawing 4b**. Apply glue only to the miters, insert the biscuits, and clamp the cap sides in place. Using the countersunk shank holes and the centers of the slots as guides, drill pilot holes into the carcass top (D). Drive #8x1 1/4" flathead wood screws through the countersunk holes and #8x1 1/4" roundhead wood screws fitted with #8 flat washers through the slots.

**4** Cut the crown front and sides (P, Q) about 2" longer than finished length. Bevel-rip their edges, where shown in the two steps on **Drawing 5**. Sand away the saw blade marks.

**5** Miter-cut the crown front (P) to length. Miter and crosscut the crown sides to length. For help with marking and cutting the crown pieces for a perfect

fit, see "Tight-fit wraparound moldings" on page 46.

**6** Glue and clamp the crown front to the upper top rail (H) and cap front (N), where shown on **Drawing 4a**. Drill pilot and countersunk shank holes through the upper top rail and the cap front into the crown front, where shown. Drive in the screws. Apply glue only to the miters and top edges of the crown sides (Q), and clamp them in place. Drill pilot and countersunk shank holes only through the cap sides into the crown sides. Drive in the screws.

### Make the shelves and fit the backs

**1** Retrieve the blanks for the base shelf (R) and upper shelf (S), and cut them to finished size. Cut the shelf trim (T) to size. Glue and clamp the trim to the shelves, as shown on **Drawings 3 and 4**. Sand the trim flush with the tops of the shelves. Chuck a  $\frac{1}{8}$ " round-over bit in your handheld router, and rout the shelf trim edges. Set the shelves aside.

*Sideboard base builder's note: Make only two shelf trims (T).*

**2** Cut the back rail (U) to size. With a dado blade in your tablesaw, rabbet the ends and one edge, where shown on

### 5 MAKING THE CROWN

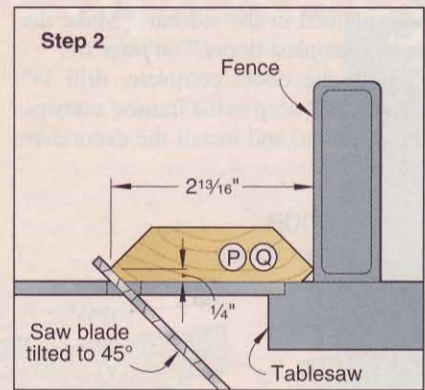
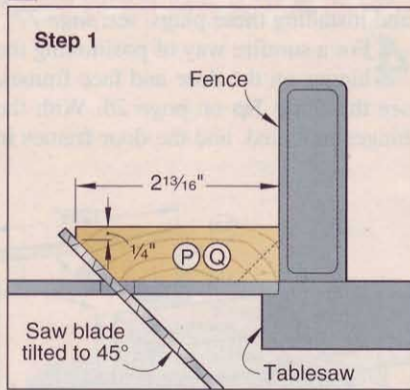

**Drawing 4c.** Apply glue and clamp the rail in place flush with the bottom of the upper sides (C). Drill pilot and countersunk shank holes through the rail into the sides, and drive in the screws.

**3** From  $\frac{5}{16}$ "-thick, 8'-long beaded tongue-and-groove planks, cut 12 pieces each for the base back (V) and upper back (W) to the lengths listed. Lay one set of planks on your workbench, fitting the tongues and grooves together. Measure the rabbet-to-rabbet width of one carcass, and center this measurement on the assembled planks. Trim equal amounts off the first and last planks of both back assemblies so they will be centered in their openings. Set the planks aside.

### Now for the doors

**1** Measure the face frame openings. The length of the stiles (X) should be  $\frac{1}{8}$ " less than the height of the openings. The sum of the lengths of two rails (Y) should be  $\frac{1}{4}$ " less than the width of the openings. Make any necessary adjustments to the lengths of the parts, and cut the stiles and rails to size. Edge-join oversize blanks for the panels (Z). Resaw and plane  $\frac{1}{4} \times \frac{3}{8}$ " stock for the vertical stops (AA) and the horizontal stops (BB), making the parts about 1" longer than the lengths listed.

*Sideboard base builder's note: Make only four stiles (X), four rails (Y), four vertical stops (AA), and four horizontal stops (BB).*

## Make the world's simplest doors

Using only your tablesaw with a blade and a dado set, you can make sturdy, good-looking raised-panel or glass-insert doors for this, or any project. Here's how.

**1** Lay out the doorframe parts the way they will be assembled, and mark their inside back edges. Install a dado blade in your tablesaw, and cut  $\frac{3}{8}$ " rabbets  $\frac{1}{2}$ " deep along the marked edges. Then cut laps in the ends of the stiles and rails, where shown on **Drawings 6 and 6a**.

**2** Apply glue to the laps, and clamp the door frames. Check them for square by measuring their diagonals. Set the frames on a flat surface to dry.

**3** Cut the panels (Z) to finished size. Each panel should be  $\frac{1}{8}$ " narrower and  $\frac{1}{16}$ " shorter than its rabbeted opening. Set up your tablesaw, as shown in **Step 1**, below, and cut saw kerfs around the perimeter of the face of each panel. Cut the bevels, as shown in **Step 2**. Install a dado blade, and rabbet the backs of the panels, as shown in **Step 3**. Sand the saw blade marks from the bevels and rabbets.

**4** Cut the vertical and horizontal stops (AA, BB) to fit the rabbeted openings. Clip the head off a #17 $\times$  $\frac{3}{4}$ " wire brad, and use it to drill pilot holes through the stops.

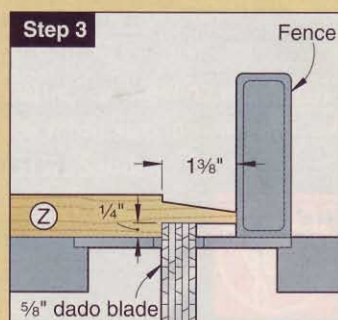
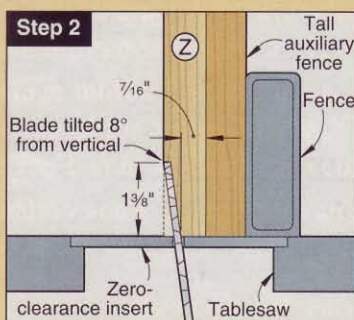
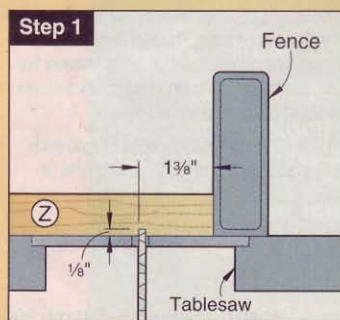

**2** Build the door frames and panels, as explained in the sidebar, "Make the world's simplest doors," on page 67.

**3** With the doors complete, drill  $\frac{1}{4}$ " holes  $\frac{5}{8}$ " deep in the frames' corners, where shown, and install the decorative

square plugs. For instructions on making and installing these plugs, see page 77.

**4** For a surefire way of positioning the hinges on the door and face frames, see the **Shop Tip** on page 26. With the hinges mounted, and the door frames in

place, center and install the library door latches, where shown on **Drawings 3, 4, and 7**. Each latch strike has one slot and one hole. Position the strike, and drill a pilot hole at the center of the slot. Secure the strike with a roundhead screw, as

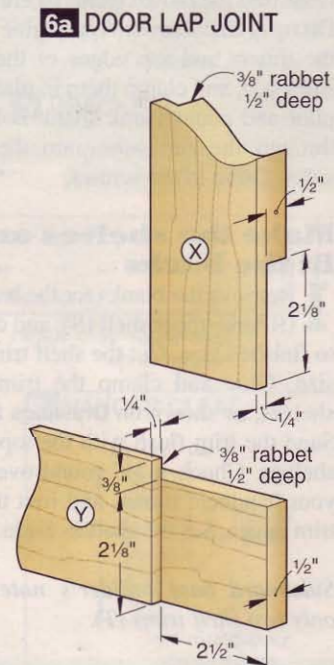
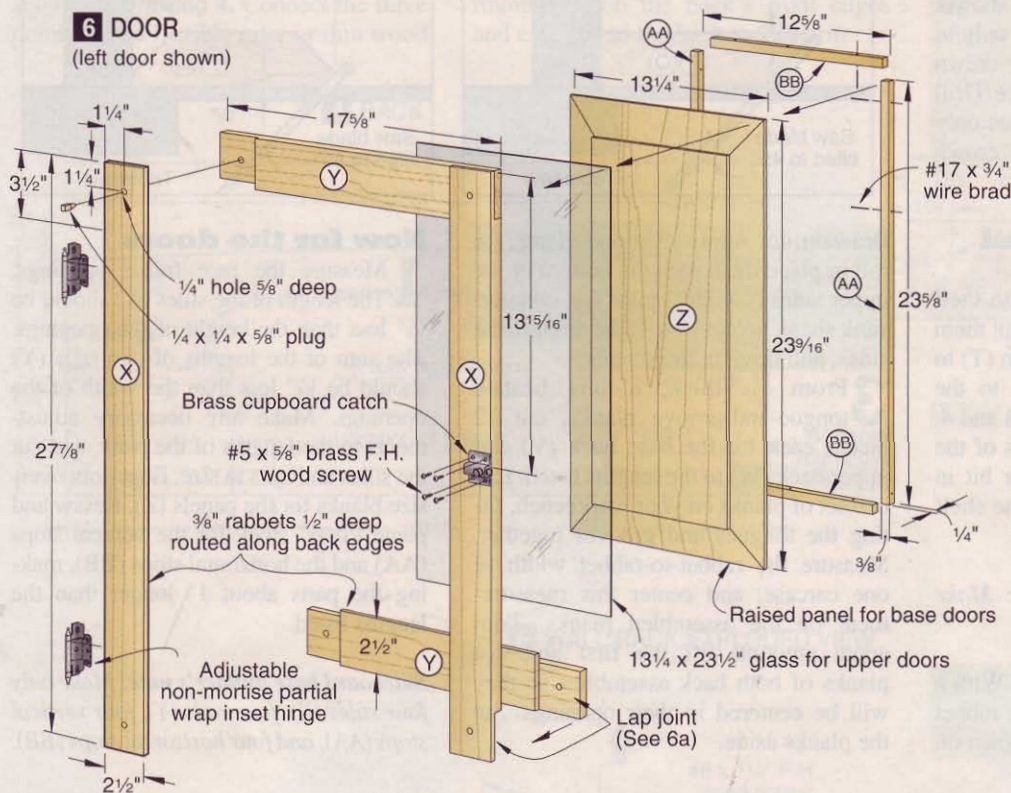

## materials list

Carcases	FINISHED SIZE			Mati.	Qty.
	T	W	L		
A* base sides	$\frac{3}{4}$ "	15 $\frac{1}{4}$ "	35 $\frac{1}{4}$ "	EP	2
B* base top and bottom	$\frac{3}{4}$ "	14 $\frac{15}{16}$ "	39 $\frac{3}{4}$ "	EP	2
C* upper sides	$\frac{3}{4}$ "	12 $\frac{1}{4}$ "	45 $\frac{1}{2}$ "	EP	2
D* upper top and bottom	$\frac{3}{4}$ "	11 $\frac{15}{16}$ "	39 $\frac{3}{4}$ "	EP	2
<b>Face frames</b>					
E base stiles	$\frac{3}{4}$ "	2 $\frac{1}{2}$ "	35 $\frac{1}{4}$ "	P	2
F frame rails	$\frac{3}{4}$ "	2 $\frac{1}{2}$ "	40 $\frac{1}{2}$ "	P	3
G upper stiles	$\frac{3}{4}$ "	2 $\frac{1}{2}$ "	45 $\frac{1}{2}$ "	P	2
H upper top rail	$\frac{3}{4}$ "	4 $\frac{1}{2}$ "	40 $\frac{1}{2}$ "	P	1
I* brackets	$\frac{3}{4}$ "	5"	5"	P	2
J door stops	$\frac{3}{4}$ "	1 $\frac{1}{2}$ "	39"	P	2
<b>Trim</b>					
K* front skirt	$\frac{3}{4}$ "	4"	42"	P	1
L* side skirts	$\frac{3}{4}$ "	4"	16 $\frac{3}{4}$ "	P	2
M* top	$\frac{3}{4}$ "	17"	42 $\frac{1}{2}$ "	EP	1
N cap front	$\frac{3}{4}$ "	4"	45"	P	1
O* cap sides	$\frac{3}{4}$ "	4"	15 $\frac{1}{4}$ "	P	2
P* crown front	$\frac{3}{4}$ "	2 $\frac{13}{16}$ "	44 $\frac{1}{2}$ "	P	1
Q* crown sides	$\frac{3}{4}$ "	2 $\frac{13}{16}$ "	15"	P	2

Shelves	FINISHED SIZE			Mati.	Qty.
	T	W	L		
R* base shelf	$\frac{3}{4}$ "	13"	38 $\frac{3}{4}$ "	EP	1
S* upper shelf	$\frac{3}{4}$ "	10"	38 $\frac{3}{4}$ "	EP	1
T shelf trim	$\frac{3}{4}$ "	1 $\frac{1}{2}$ "	38 $\frac{3}{4}$ "	P	4
<b>Backs</b>					
U back rail	$\frac{3}{4}$ "	2 $\frac{3}{4}$ "	39 $\frac{3}{4}$ "	P	1
V* base back	$\frac{5}{16}$ "	39 $\frac{3}{4}$ "	30 $\frac{7}{8}$ "	PP	1
W* upper back	$\frac{5}{16}$ "	39 $\frac{3}{4}$ "	43 $\frac{1}{4}$ "	PP	1
<b>Doors</b>					
X stiles	$\frac{3}{4}$ "	2 $\frac{1}{2}$ "	27 $\frac{7}{8}$ "	P	8
Y rails	$\frac{3}{4}$ "	2 $\frac{1}{2}$ "	17 $\frac{5}{8}$ "	P	8
Z* panels	$\frac{3}{4}$ "	13 $\frac{1}{4}$ "	23 $\frac{9}{16}$ "	EP	2
AA* vertical stops	$\frac{1}{4}$ "	$\frac{3}{8}$ "	23 $\frac{5}{8}$ "	P	8
BB* horizontal stops	$\frac{1}{4}$ "	$\frac{3}{8}$ "	12 $\frac{5}{8}$ "	P	8

\*Parts initially cut oversize. See the instructions.

**Materials key:** EP—edge-joined pine, P—pine, PP—beaded tongue-and-groove knotty pine planking.

## Find more ...

...on country furniture at  
<http://woodstore.woodmall.countfur.html>

**Supplies:** 6d finish nails, #20 biscuits,  $\frac{1}{4}$ " perforated hardboard, #8x $\frac{1}{4}$ " flathead wood screws, #8x $\frac{1}{4}$ " roundhead wood screws, #8 flat washers, #17x $\frac{3}{4}$ " wire brads, #16x1" wire brads, #16x $\frac{1}{4}$ " wire nails,  $\frac{5}{8}$ x3" mending plates (2), #5x $\frac{5}{8}$ " flathead brass wood screws, #4x $\frac{1}{2}$ " roundhead brass wood screws, #18x $\frac{1}{2}$ " brass escutcheon pins, spray adhesive, single-strength or antique glass.

**Blades and bits:** Stack dado set; chamfer,  $\frac{1}{8}$ " round-over, and  $\frac{3}{8}$ " round-over router bits.

## Buying Guide

**Hardware.** Brass cupboard catches no. 01G50.03, \$10.90 ea. (2); adjustable non-mortise partial wrap inset hinges with screws no. 01H31.60, \$3.10 ea. (8); library door latches no. 00W11.03, \$0.50 ea. (2); brass shelf supports no. 63Z06.04, \$4.50 (package of 20). Call Lee Valley, 800/871-8158, or go to [www.leevalley.com](http://www.leevalley.com).

**Water-based stain.** Look for Minwax Winter Moss custom-mixed water-based stain at local hardware stores, paint stores, and home centers that carry Minwax finishes. These stains are available in 60 custom-mixed and six premixed colors and wood tones.

**Planking.** Look for  $\frac{5}{16}$ x $\frac{3}{8}$ x96" beaded tongue-and-groove knotty pine planking at local lumberyards or home centers.

shown. Do not drive in the escutcheon pin at this time. Mount the cupboard catches to the doors, where shown on **Drawings 3, 4, and 6.**

*Note:* To give the bright brass cupboard catches an antique patina to better match the black hinges, we used the simple process shown on page 14.

### Apply the finishes

**1** Remove the hardware. Finish-sand all parts and assemblies to 220 grit. Set aside the planks for the backs (V, W).

**2** To give the pine an antique amber glow, brush on two coats of oil-based satin polyurethane, sanding with 220-grit sandpaper between coats.

**3** Retrieve the back planks, and apply a stain. We used Minwax Winter Moss water-based wood stain, following the instructions on the can. To avoid discoloring the stain, brush on two coats of water-based satin polyurethane.

### Assemble the cupboard

**1** Install the backs (V, W) in the base and upper carcasses. Use #16x1¼" wire nails to fasten the base back (V)

planks to the base sides (A) and the base carcass top and bottom (B). Use #16x1¼" wire nails to fasten the upper back (W) planks to the upper sides (C) and the upper carcass top and bottom (D). Toenail the upper back planks to the back rail (U) with #16x1" wire brads.

**2** Clamp the top (M) to the base carcass, flush at the back and centered side to side. Drill pilot and countersunk shank holes through the base carcass top (B) into the top (M), where shown on **Drawing 3.** Drive in the screws.

**3** Have single-strength glass cut ⅛" smaller in each dimension than the doors' rabbeted openings. Install the panels (Z) in the base door frames, and glass in the upper door frames, where shown on **Drawing 6.** Nail in the stops (AA, BB) with #17x¾" wire brads.

**4** Reattach the hinges, and hang the doors. Make sure the carcasses are sitting square, and use the hinges' slotted screw holes to align the doors. Drill pilot holes, and drive in the screws that fix the hinges in place. Reinstall the library door latches, adjust their strikes, and drive in the escutcheon pins. Remount the cupboard door catches.

### 7 DOOR LATCH (Base cabinet shown)

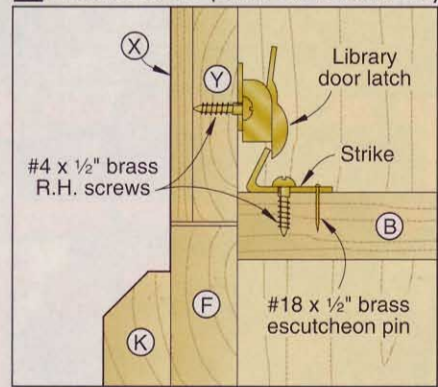

**5** Center the upper cabinet on the base. Drill pilot holes, and screw the mending plates to the cabinets' backs, securing the upper cabinet to the base. Install the shelf supports and shelves. 🛠️

Written by Jan Svec with Chuck Hedlund and Kevin Boyle

Project design: Kevin Boyle

Illustrations: Roxanne LeMoine; Lorna Johnson

Photographs: Marty Baldwin

## cutting diagram

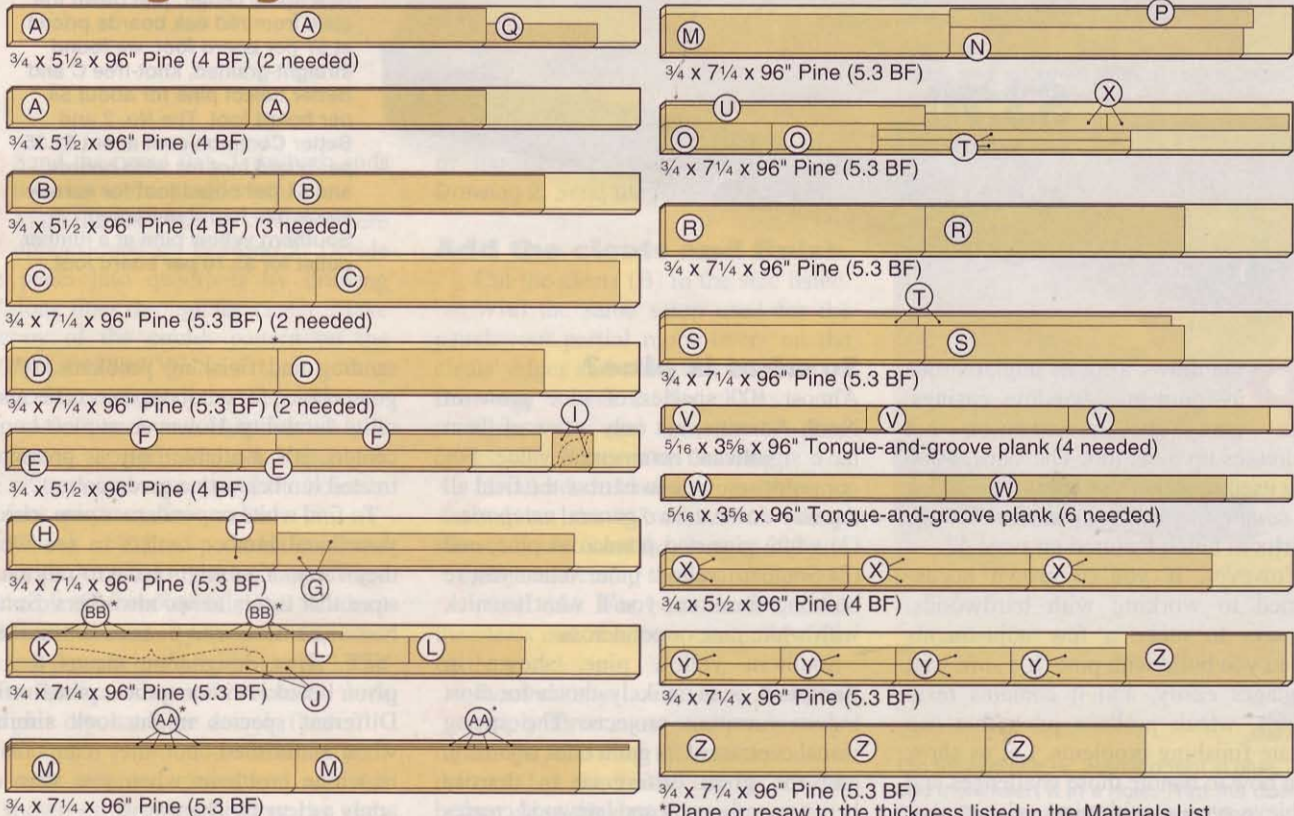

\*Plane or resaw to the thickness listed in the Materials List.

# working with pine

tips and tricks  
for success

**\$4.00**  
per board foot

2

**\$1.35**  
per board foot

3

Building with this softwood calls for extra care and the right finishing techniques.

**\$3.70**  
per board foot

1

At a home center, just down the aisle from red oak boards priced at \$7 per board foot, we found straight-grained, knot-free C and Better Select pine for about \$4 per board foot. The No. 2 and Better Common cost about \$1.35 per board foot for wide boards, and \$1 per board foot for narrow stock. We found untreated Southern yellow pine at a lumber outlet for \$3.70 per board foot.

**P**ine draws a lot of unglamorous assignments—window casings, garage shelves, and so on—but it dresses up nice, too. The same wood you used in shop class lends a nice look to country-style furniture, such as the heirloom hutch featured on *page 62*.

However, if you've grown accustomed to working with hardwoods, it pays to make a few adjustments when you build with pine. It's soft, so it damages easily, and it contains resin canals, which produce pitch that can create finishing problems. Let us show you how to handle those challenges and achieve success with pine.

## So what is pine?

Almost 100 species of pine grow in North America, but only a few of them have significant commercial value. For our purposes, we can narrow the field all the way down to two general categories: (1) white pine and ponderosa pine, and (2) Southern yellow pine. When you're building furniture, you'll want to stick with white pine or ponderosa.

Southern yellow pine, shown in **Sample 1**, is an unlikely choice for most indoor furniture projects. The strong visual contrast of its grain lines is jarring, and the great difference in density between earlywood and latewood creates

sanding and finishing problems. It's a good choice for outdoor projects because of its durability. However, at most home centers, it's available only as pressure-treated lumber with a green color.

To find white or ponderosa pine, check your local lumber outlets to see what they carry. You might have to rely on a store that caters to woodworkers. Some home centers carry boards marked "SPF." That designation means that a given board is either spruce, pine, or fir. Different species might look similar when unfinished, but they can create matching problems when you stain or apply a clear finish.



### Putting knots in their place

You don't see many knots in hardwood boards at most lumber outlets. When you go pine shopping, however, you see plenty. The chart below describes the basic grades of softwood lumber, largely classified on the basis of the size, number, and quality of the knots. Practically speaking, your choices are simple. For indoor furniture projects, you can buy medium-priced C and Better Select, as shown in **Sample 2**, or inexpensive No. 2 and Better Common, with numerous large knots, as shown in **Sample 3**.

Home centers carry wide pine panels, glued up from narrow boards. They're time-savers, but in most cases they include **sawn-through knots** that detract from your project's appearance. You get better-looking results by gluing up wide boards, taking care to keep the knots intact.

4

Sawn-through knot

As you see in **Sample 4**, a panel made up of edge-joined narrow boards is likely to include **sawn-through knots**, which give a cheap look to your work. Wider boards, such as **Sample 5**, look better in a big project.

5

### Pine requires TLC

Pine is a relatively stable wood, with a low tendency to warp as it dries. But it's

also soft, so it dents easily. To prevent dings, remove the wood chips, dried glue, and other hard objects from your workbench before beginning a pine project. Step up to an even higher level of protection by laying a nonslip pad on the bench, as shown in **Photo A**.

As for the knots, it pays to inspect them closely before you purchase your

## Shopping for pine

The grading system for pine can be somewhat confusing, especially because different sources use different categories. The chart below gives you the essential points of reference.

For most of us, however, buying pine is a matter of sorting through what's available at a home center. Take your time, consider how you plan to use the lumber, and choose each board by its appearance. When price is a major factor, remember that a board with significant flaws can produce usable stock. In your shop, lay out the needed pieces on the clear parts of the board, and cut out the knots. With a little extra planning and sawing, you can save money and still build with clear pine.

### Basic grading categories

GRADE	DESCRIPTION
<b>C and Better Select</b>	A combination of the two highest recognized grades, allowing only minor imperfections, including small, tight knots on the better side.
<b>D Select</b>	Numerous small knots and blemishes that cover smoothly with paint.
<b>No. 2 and Better Common</b>	Small to moderate-sized knots. Takes paint fairly well, but knots may need to be sealed. Used for siding, molding, shelving, and paneling.
<b>No. 3 Common</b>	Contains splits and loose knots. Does not take paint well. Used for crates, sheathing, subflooring, and secondary furniture components.



It's much easier to prevent dents and gouges in soft pine, rather than trying to fix them later. Before you start a project, take a minute to clean up your working surfaces. Then place a soft pad on the workbench to protect the wood.



You want this ...

**B**

lumber. Red, solid knots will stay in place throughout the building process and thereafter. You should avoid dark, “dead” knots with noticeable cracks or gaps, because they’re likely to loosen up and even fall out as you work with the lumber.

If you find a dead knot here and there after you begin your project, lock each one in place with clear, five-minute, two-part epoxy. With that done, you can saw, joint, or plane the wood without a problem. See **Photos B** and **C** for a precaution.



... not this

**C**

Lock knots in place, and create a smooth surface for finishing, with epoxy. Use the kind that looks clear in its applicator tube; it dries clear, so the knot retains its natural look, as in the top sample. The epoxy shown in the bottom photo is white and opaque when dry.

Pine mills easily with sharp blades and bits. However, it contains pitch, which tends to gum up sandpaper and can build up on planer rollers. To clean drum sanders and thickness sanders, use a rubber cleaning stick, as shown in **Photo D**. Consult your owner’s manual before inspecting your planer rollers, and then remove any residue with lacquer thinner.

Clean pitch buildup on saw blades by soaking them in kerosene overnight. You can clean router bits in the same fashion, just remember to remove any pilot bearings prior to soaking. Solvents can rob bearings of their lubricants.



**D**

Pine tends to load up sanding belts and drums, so use a rubber cleaning stick occasionally to remove the residue. The sandpaper will cut better, stay cooler, and last longer with regular cleaning.



Liquid Stain

Expect blotching when you apply pigmented stain to raw pine, as shown with two samples on the board above.

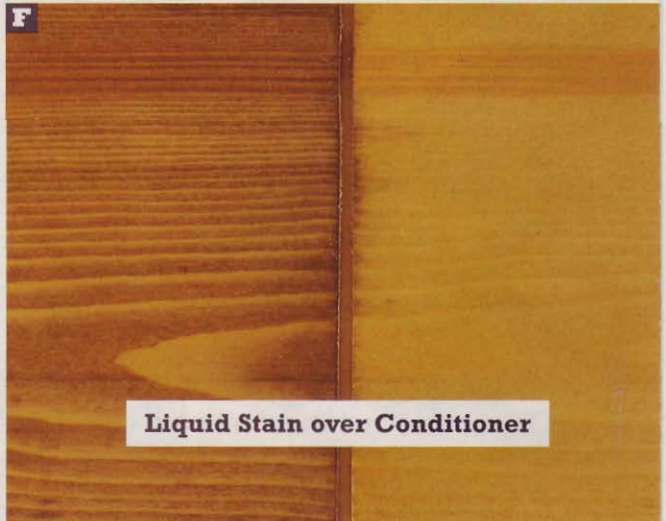

Liquid Stain over Conditioner

Begin with a conditioner, or mineral spirits, and you get the more even results shown on this board. Note that dark stains present more problems than light ones.

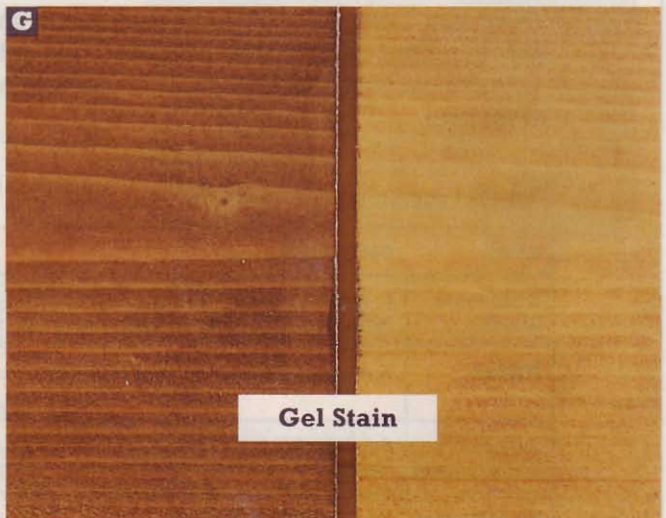

Gel Stain

Gel stains produce a fairly even color across most samples of pine, as shown here. The lighter tones, in particular, do away with any significant blotching.

## How to eliminate blotching

Pine looks so clean and white after sanding—then you add stain, and it blotches, like the samples in **Photo E**. Why? Because the large pores of its earlywood soak up pigment like a sponge; the latewood isn't nearly as receptive.

You can significantly reduce blotching problems by using dye instead of stain. But if you prefer to use stain, begin by sanding the wood thoroughly. If you bought surfaced boards, or have jointed and planed rough-cut lumber, start the sanding sequence with 120-grit paper on your random-orbit sander. Switch to 150 grit, then 180 grit. If you plan to apply pigment stain, stop there. When using dyes, go on to 220 grit, then stop.

Now seal up the pores of the wood to keep the color in a uniform layer. The best choices are to use a pre-stain conditioner, a wash coat of shellac, or a gel stain. Let's look at them one by one.

■ **Conditioner:** You can use a product specifically labeled for this purpose, as we did on the samples in **Photo F**, or you can simply use paint thinner or mineral spirits. The goal is to fill the pores with solvent, then apply your stain

before the solvent evaporates. The stain will stay on the surface of the wood instead of penetrating unevenly.

■ **Shellac:** Make a very thin wash coat to seal the pores with shellac. Using a typical can of premixed shellac from the hardware store or home center, pour one part of the premix into a glass or plastic container, and add five parts of denatured alcohol. Brush this blend onto the wood, allow it to dry, and sand it lightly with 220-grit sandpaper. Sanding removes the shellac from the high spots, while leaving it in the pores.

■ **Gel stain:** Available in a variety of colors from several manufacturers, these thick stains remain on the surface of the wood, producing results like those in **Photo G**. Gel stains are basically thinned paint, but they allow most of the grain and figure to show through.

If you prefer to skip the staining step, you can use any clear coat to finish pine



**H** Traditional orange shellac over unstained wood creates a nice color for country-style pine projects. Apply it with a foam brush, as shown, or go with a bristle brush.

without problems. Most clear finishes impart a warm, amber tone that improves the appearance of pine. Try orange shellac for an old-fashioned country look, as shown in **Photo H**.

To make the amber color darker, add burnt sienna colorant to varnish. This colorant can be a solvent-based dye or a Japan color, which consists of finely ground pigment in a varnish binder. 🐭

### See more ...

...country furniture projects at

<http://woodstore.woodmall.com/counfur.html>

## The shellac solution

For blotch-free results and great color, here's a tip from Ohio furniture builder and finisher Steve Mickley. He uses several shellac-based recipes that produce beautiful colors on pine.

Begin with a generous application of boiled linseed oil, available at any hardware store or home center. Brush it on, and allow it to soak into the wood for about 30 minutes, and then wipe away the excess. This step adds depth to the finish, and emphasizes the subtle grain and figure of the pine.

Let the oil dry for at least five days, then proceed with the steps outlined in the caption to **Photo I**. For the final step, Steve recommends a water-based varnish to add protection without altering the color.

Written by **Jim Pollock** with **Steve Mickley**  
Photographs: **Marty Baldwin**



Steve Mickley with his own version of a pine country cupboard.

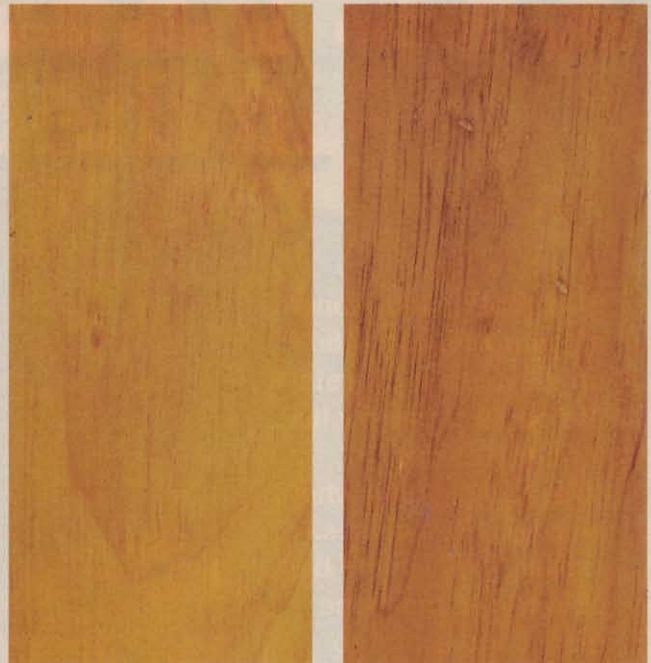

To achieve the color on the left, start with linseed oil, then apply a 2-pound-cut coat of garnet shellac, followed by a water-based topcoat. The sample on the right received linseed oil, a 1-pound-cut coat of super-blond shellac tinted with burnt sienna dye, a coat of 2-pound-cut garnet shellac, and finally a water-based topcoat.



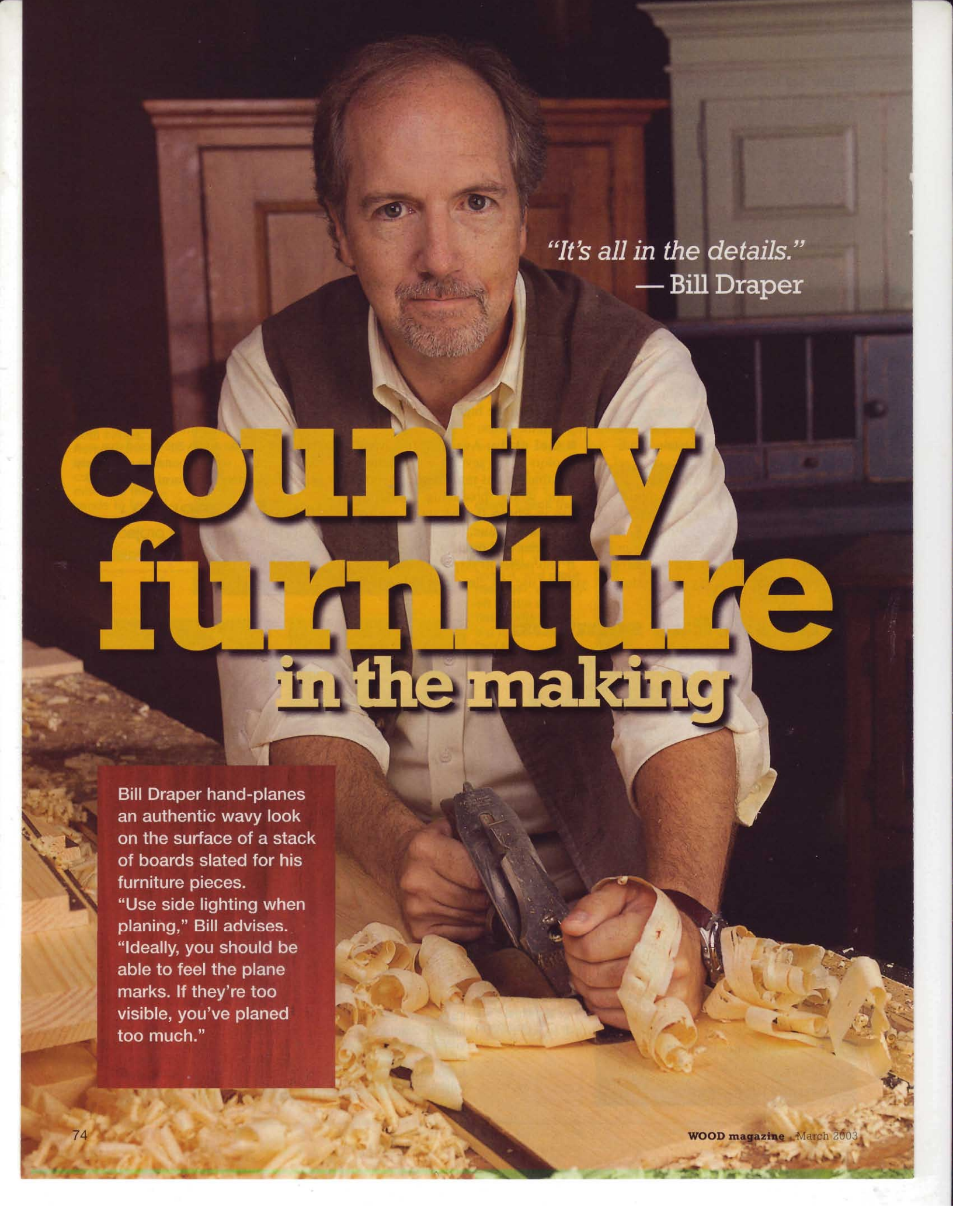

*"It's all in the details."  
— Bill Draper*

# country furniture in the making

Bill Draper hand-planes an authentic wavy look on the surface of a stack of boards slated for his furniture pieces.

"Use side lighting when planing," Bill advises.

"Ideally, you should be able to feel the plane marks. If they're too visible, you've planed too much."

# elements of country style

Bill Draper imparts an authentic 18th-century look to his furniture with touches like these.



In Bucks County, Pennsylvania, people still have the original land grants, made of sheepskin and signed by William Penn in the late 1600s and early 1700s. The farmhouses are 200 to 250 years old, with thick stone walls; every now and then a workman opens up a wall to find logs from an original log cabin peeking out at him.

And in a small town in the heart of the county, Bill Draper, cabinetmaker, builds furniture that would have been at home in those farmhouses and cabins when they were new. Bill, and the cabinetmakers who work for him, build in the old tradition—pegged mortises and tenons, raised-panel doors, and hand-planed surfaces.

"The whole aura of 18th-century woodwork is fascinating to me," he says. "I'd love to be transported back in time to see what it looked like when it was new, modern. They didn't want crude. They were tired of the frontier look. I try to learn what the originators knew, how they learned and proceeded. I ask myself if I had been there at the beginning of this style in 1710, what would I do?"

## From shop hand to entrepreneur

His love of things ancient is, in part, an accident of location. Though he grew up in Connecticut, he moved to rural Bucks County, northwest of Philadelphia, when in his mid-twenties. "I needed a job, and, for no particular reason, went to work for a one-horse carpenter; I was the horse. I did restoration work, and saw a lot of old wood. I got a real affection for old, beat-up, chipped paint—what I call my 'depraved love of the decrepit.'"

A housing downturn, a stint as a cabinetmaker, and a job at a shop that ran out



A large-scale molding built up from three simpler moldings lets cabinetmakers create elaborate crowns.

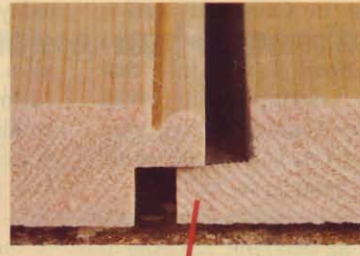

Beaded boards with rabbet joints form the cabinet back.

A beaded face frame dresses up the edge of the door opening. (See the bead above right.)

Carved wooden latches keep doors closed without the need for store-bought hardware. (See page 76.)



Cut nails serve as fasteners.

Hand-planed shelves re-create the look of handmade furniture.



Panels in doors rise 1/4" beyond the surrounding frames for an exaggerated, decorative look.

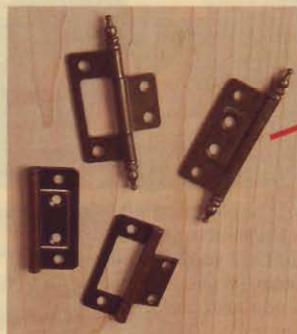

Flush doors swing out on easy-to-install surface-mounted metal hinges.

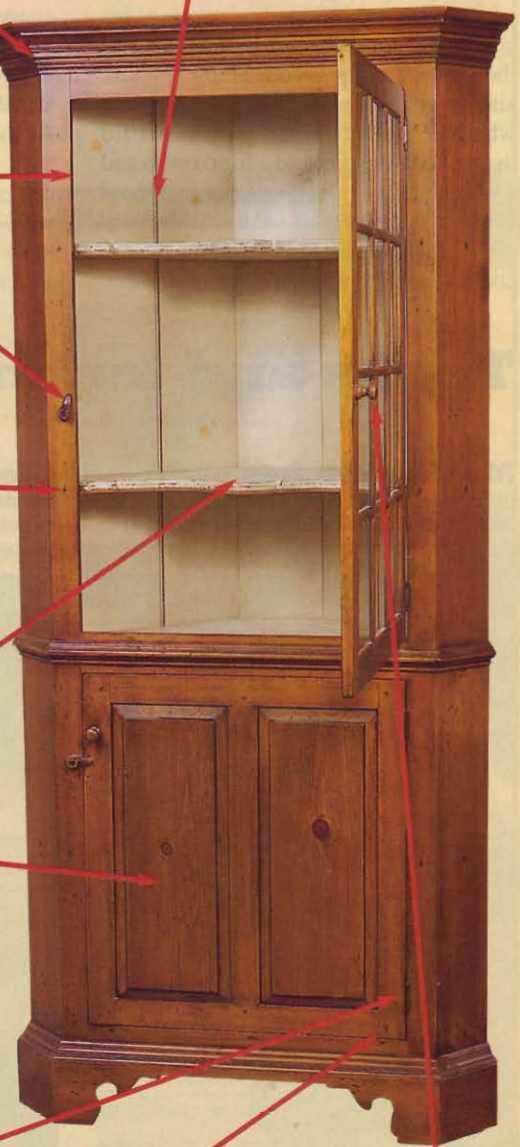

Pegs reinforce mortise-and-tenon joints on the frame-and-panel door. (See page 77.)

Purchased turned wooden knobs look at home on a handcrafted country cabinet.

## country furniture in the making

of work left Bill unemployed. With no jobs on the horizon, Bill began making furniture in his basement shop. "I really had an interest in California stuff—Krenov, Maloof, natural wood, clean contemporary lines. I was into that whole aesthetic. Looking for the perfect edge, the perfect contour, getting very mystical. Except I'm in Bucks County, where it's rural, antique, rustic."

He built a jelly cupboard, using a shop-made mortising jig (see page 78). And in taking what he'd learned from one of his clients, he created a finish that imitated the look of worn wood, chipped paint, and layers of color. It looked so good when he tried it on the jelly cupboard that he took the piece to a friend who had a store. Not only did it sell, but his friend sold similar pieces as soon as Bill completed them. His friend told him that he could judge the popularity of each piece

by the squeal of brakes as passing motorists pulled over to take a closer look.

It was the beginning of a business that today has grown to two buildings, 75 employees, and \$6 million a year in sales. Much of that lies in his kitchen cabinet business, located in a modern building outside of town. Not far away, however, in an old three-story cigar factory in Perkasio, Bill employs a small crew of woodworkers who turn out two or three dozen country furniture pieces every week.

### Choosing wood with the right look

At the cigar factory/furniture shop, Bill tries to build furniture pieces the way they were originally built, beginning with wood selection. The hardwoods he uses are mostly cherry and walnut, which grow like weeds in Pennsylvania.

They arrive at the shop planed, clear, and ready to work. The softwood—pine—is mostly No. 2 Common, planed to  $\frac{3}{4}$ ". "It's the same sort of stuff you get at the lumberyard—a bit knotty, and a bit crooked. It's perfect," Bill says, "for the old look of country furniture, where cabinetmakers worked around knots, and where time caused a few surfaces to bow in or out."

### The elements of country style

What gives Draper furniture its special look? Bill borrows as many elements from his predecessors as he can to craft his brand of country styling, as seen in the corner cabinet on page 75.

Hardware includes surface-mounted hinges, turned wooden knobs, and hand-carved wooden latches to hold doors shut. Molding is kept simple because in

## Tricks and techniques for a country look

### Making latches

Bill carves latches from whatever wood the cabinet is made of, saving a few bucks in the process.



During shaping, the front of the latch butts against a stop screwed to the bench. Bill holds the back end down with one hand, while the other hand shaves the workpiece with a butt chisel.

### Cleaning an edge

Bandsaws leave fuzzy surfaces on cut edges. Bill removes them the traditional way—with a spokeshave.

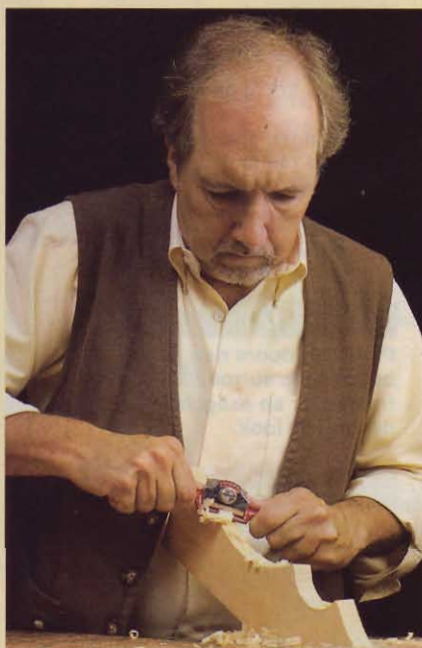

"The secret [to cleaning an edge]," Bill says, "is a razor-sharp blade. Shave from the highest to the lowest points along the curved edge or the grain will grab the blade and cause tear-out."

### Routing a bead

Colonial woodworkers formed beads using a beading plane. Today, Bill achieves the same look with a router and beading bit.

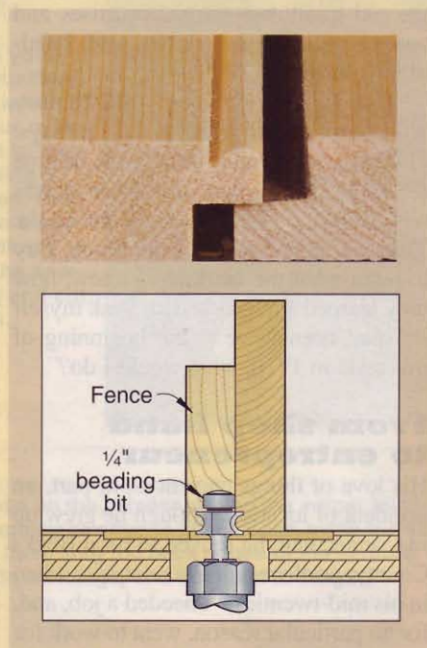

Bill uses a  $\frac{1}{4}$ " beading bit to detail rails, stiles, and the boards used to line the cabinet backs. Beads soften the edges on these parts while adding style and visual interest.

the old days each piece had to be hand-planed. If a piece had more elaborate molding, it was made by stacking simpler moldings on top of each other.

Joinery on these pieces remains true and basic as well, but strong. Door frames receive mortises and tenons; drawers, dovetails and rabbets. Shelves and bottoms sit in grooves and are nailed in place with cut nails. (Today's cut nails replicate the blacksmith's square nails.)

### Hand versus power tools

Cabinetmakers in the old days didn't have the luxury of machinery. Bill does, but he doesn't want to use it at the expense of authenticity. Almost any operation that begins with a power tool, he finishes with a hand tool.

Practically the first step in any project is to hand-plane the surfaces of his cabi-

net stock to remove the washboard marks left by the planer. His plane is usually an old No. 4 Stanley or Record with a razor-sharp blade set just high enough to peek over the surface of the sole. A slight curve ground into the edge keeps the corners from digging in. (See page 74.) Bill starts on one side of a board, and makes a slow, firm pass. It removes the machine marks. The surface underneath shines like glass. The gentle waves left by the curved blade may be harder to see than feel with your fingers. Once finished, the plane marks remain barely visible under several layers of paint.

If the power tools keep him competitive, the hand tools serve as Bill's signa-

### Drawer joints with staying power



Two types of joints can be found in Bill's drawer-front construction: vertical sliding dovetails, left, and the more common half-blind dovetails, right.

ture. He cuts curved cabinet parts with a bandsaw, but he removes the marks with a spokeshave. He cuts his shelf joinery on the tablesaw, but reinforces it with cut nails driven through the cabinet's sides. He raises door panels on a shaper, but hand-planes their surfaces and carves latches for the doors.

### Add character with a pegged mortise-and-tenon joint

In earlier times, a country cabinetmaker pegged his tenon joints. Pegs add strength, and back then, when glues were less reliable, it was good insurance. Bill pegs joints today as part of his interest in capturing an authentic country look. Note that the process described below works well in a softwood like pine, but could cause splitting in a dense hardwood such as maple. Here's how he does it.



Once the joint is glued and clamped, Bill drills a  $\frac{1}{4}$ " hole that travels through the mortise-and-tenon door frame. Use a block of scrap on the underside to prevent chip-out.



Bill rounds one end of a  $\frac{1}{4} \times \frac{1}{4}$ " square peg by tapping it into a Corian pad that has a countersunk recess machined into it. Doing this prevents the peg from splintering when he drives it.



Finally, Bill drives the peg through the joint. As he does, the square corners grab the edges of the round hole, helping to anchor it in place. Excess wood is then cut and sanded off.

## How to create beaded mortise-and-tenon joints

The beaded mortises and tenons that Bill uses on most of his door face frames combines two joints. The beaded part is mitered; the rest receives common mortise-and-tenon machining. The cutting sequence stays fairly standard, except for the fancy footwork at the end of the process.

Bill starts by routing a 1/4" bead along both the rails' and stiles' inside edges. (See the drawing on page 76.) Then he cuts a 1/4" mortise in the stiles, as shown in **Step 1**. He uses a slot mortiser, which leaves a mortise with rounded ends. He cuts the mortise long enough to accept a squared tenon, avoiding the need to chisel the mortise square.

Next, he cuts the 1/4" tenons as shown in **Step 2**. He starts by putting a dado set in the saw, setting the blade height to cut away enough stock to leave a 1/4" tenon in the center. Then, he sets the fence so that the distance from the fence to the far side of the dado head is the needed length for the tenon. He cuts a test piece, guiding it along the fence with the miter gauge. He flips the piece, cuts away stock on the opposite face, and tests the fit in the mortise. After raising or lowering the dado set as necessary to get a good fit, he machines the rails.

Following this, Bill turns his attention to mitering the rails' beads. He replaces the dado head with a crosscut blade, angling it at 45°. He lowers the blade so it just cuts through the bead as in **Step 3**.

Mitering the mortised stile is pretty much the same, except for the location of the cut. In order for the joint to fit snugly, the miter is offset from the end of the stile by the width of the tenoned rail. Bill sets the fence so that he can guide the piece against it with the miter gauge, as shown in **Step 4**, to position the first cut. (Always test this setup on scrap first.)



**Step 1:** With a horizontally mounted router, lay the workpiece on the table and ease it against a centered 1/4" straight bit. Use pencil marks and a stopblock to determine the start/stop locations of the mortise.



**Step 2:** Cut the tenon with a dado set, using both the miter gauge and fence to guide the stock.

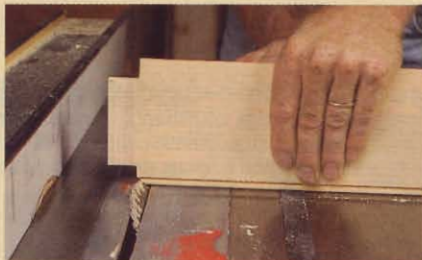

**Step 3:** Miter-cut just the bead on the tenoned rail, using the miter gauge.

Once the miter is cut, Bill makes repeated passes to remove the remaining bead waste at the end of the stile.

When making the cutting list for his door-frame parts, he takes the effect of this last cut into account. By cutting away the bead, you effectively make the

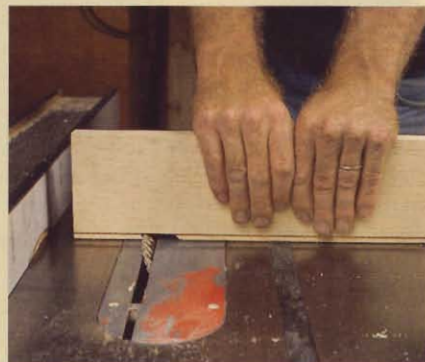

**Step 4:** With the stile against the fence, miter-cut the stile's bead, removing the remaining waste with repeated passes.

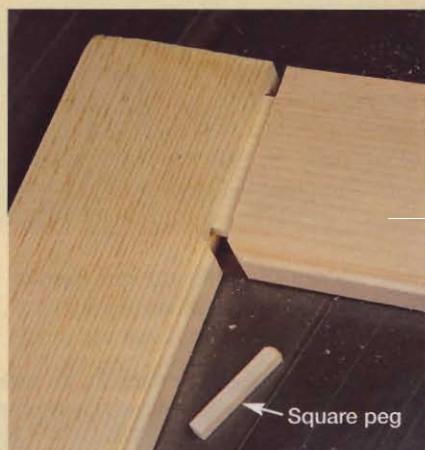

The beaded mortise-and-tenon is a country classic design element that is practical as well as decorative. It draws the eye away from gaps between the door and frame caused by contraction of the wood in dry months.

stile narrower at the joint by one bead width, and this happens at each mortise. To compensate, therefore, you have to make the rails longer by twice the width of the bead from shoulder to shoulder. Doing this will guarantee a good fit and a frame that measures the desired width.

## A timeworn finish? Not exactly

The finish Bill applies to his country classics mimics a centuries-old antique. Wear at corners, along edges, and on shelf surfaces exposes several layers of paint, topped with a coat of lacquer. It's not unusual to see one layer in oil, another water-based, and a third coat in lacquer. To add authenticity, the surface is "distressed"—banged with keys or hit with a worn brick to create the inevitable gouges a piece receives over time. Small sections of finish are sometimes flaked



Bill's finish, though it may look old, is the end result of a painstaking process.

off with a razor to imitate paint failure. (The actual finish is quite durable, even if the layers are made of supposedly

incompatible materials.) As the process nears the end, one layer of paint is sanded through to reveal another. It can take up to five days to create a Draper trademark painted finish. 🐿

## Find more ...

...on country furniture at  
<http://woodstore.woodmall.counfur.html>

Written by Jeff Day  
 Photographs: Donna Charelli  
 Illustration: Roxanne LeMoine



*Note: Project shown  
5/8" shorter than full  
size to fit on page.*

# intarsia teddy

This Judy Gale Roberts wall plaque bears looking into.

**N**o matter if you're a novice at intarsia or a seasoned pro, here's an eye-catching project you'll enjoy building, and one that any child will adore. You'll find full-size patterns for cutting out all of Teddy's parts (including spacers for raised parts). Each pattern piece has labels that identify the wood color, grain orientation, and grouping for easier contouring of parts. Now, get ready to put your paws to work.

*Note: You'll need a selection of 3/4"-thick wood scraps of dark, medium-dark, medium, and light tones. We used pine for the light-toned wood and western red cedar (which Judy prefers due to its color variety) for all of the other tones.*

## First, cut out the parts

**1** Start by making at least five copies of the full-size bear pattern in the **WOOD PATTERNS**® insert. The bear's parts are identified on the pattern with uncircled letters indicating the wood tones. Look over a pattern to find areas where you can cut out groups of adjacent parts that have the same wood tones. Cut apart the grouped and individual pattern pieces.

**2** For each pattern piece, align the arrow on the pattern with the grain on your stock, and move the pattern around until you find the area with the best color and grain figure for the piece. Adhere the patterns to the stock with spray adhesive. See the **Shop Tip, right**.

**3** Scrollsaw the parts, as shown in **Photo A**. (For tips to help you scrollsaw more accurately, see the article on *page 20*.) To form the opening in the muzzle for the nose, make a cut through the bottom of the muzzle into

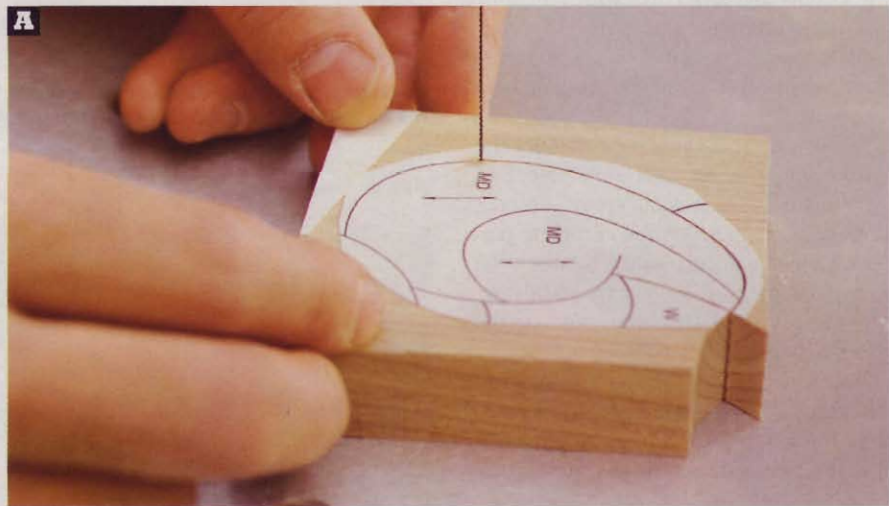

For tight-fitting parts, scrollsaw right down the middle of the intarsia pattern lines.

the nose area, then remove the waste for the nose.

**4** Drill a 3/8" hole 1/4" deep in each of the face pieces to receive Teddy's eyes, where shown on the patterns.

Then, using a 3/8" plug cutter, cut two 3/8"-long plugs for the eyes. (We cut them from dark cedar.) Or, cut these pieces from a 3/8" walnut dowel. Set the eyes aside for now.

## SHOP TIP

### Working with light-tack spray adhesives

For applying patterns, use a spray adhesive, such as 3M Spray Mount Artist's Adhesive, that lets you easily remove and reposition the paper. If patterns stay attached for several days, though, or you apply too much adhesive, they can become difficult to remove. Should this happen, apply a little heat to the top of the paper with a hair dryer, as shown at *right*. This will soften the adhesive so you can cleanly peel off the paper. Keep the heat low to avoid burning. Later, remove the adhesive with a solvent.

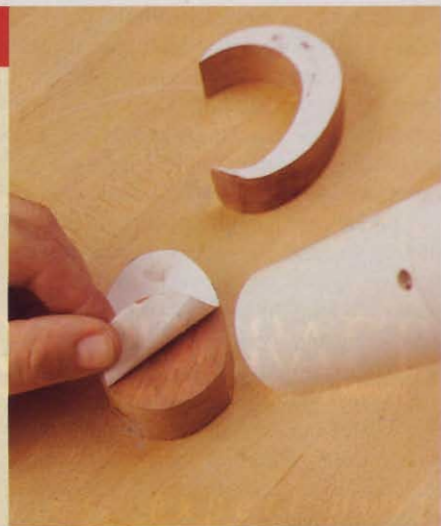

# Contouring guide

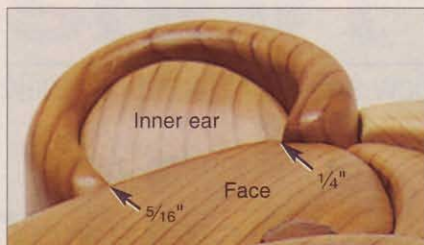

Contour the inner ear piece so it slopes toward the face and angles slightly from top to bottom. Aim for a face-to-ear depth of about  $\frac{1}{4}$ " at the top to  $\frac{5}{16}$ " at the bottom.

## Now, for the contouring

**1** Group together parts with the same circled letter. The parts in these groups have a continuous contour across them, so you'll save time by sanding them as groups.

**2** Using double-faced tape, adhere the groups of parts to a  $9 \times 12$ " piece of  $\frac{1}{4}$ " plywood, with each group's pieces arranged as shown on the complete pattern. Leave a  $\frac{1}{4}$ " clearance between the groups; then cut them out by scrollsawing the plywood to within  $\frac{1}{16}$ " of the groups' perimeters.

**3** Referring to the "Contouring guide," above and right, mark contour reference lines along the edges of the grouped and nongrouped parts.

**Note:** For best results, practice contouring scrap pieces first to get used to the technique. If you don't feel comfortable doing this, it's perfectly fine to just gently round the top edges of parts and leave their faces flat.

**4** Using 100-grit sandpaper, contour the parts as shown in **Photo B**. We used a 3"-diameter pneumatic drum sander mounted in a drill press, which is ideal. (See the Buying Guide on the opposite page for our source.) But an oscillating spindle sander, drill-press drum sander, or disc sander also would be suitable. Be careful not to sand completely around the edges to the back surface, which will leave gaps between parts. We found it easiest to start with the bear's feet and work to its head.

**5** After contouring the bear's face pieces, glue the  $\frac{3}{8}$ "-long plugs into the  $\frac{3}{8}$ " eyeholes. Then hand-sand the eyes, gently rounding their edges and leaving them approximately  $\frac{1}{16}$ " proud of the face pieces.



Contour the top of Teddy's belly to about  $\frac{1}{8}$ " below the scarf. Slope the scarf toward the face and the right paw down into the scarf.



Round the belly's bottom to about  $\frac{3}{16}$ " below the feet. Angle the raised paw toward the face and hat. Sand the bottom scarf pieces to sit about  $\frac{1}{16}$ " below the belly.

**6** As your contouring progresses, frequently place adjacent parts together and check for the desired transition between them, as shown in **Photo C**.

**7** When you have finished rough-sanding the parts, finish-sand their contoured surfaces by hand to 150 grit, then 220 grit.

**8** Cut out the full-size muzzle and nose spacer patterns from one of your photocopied patterns. Adhere the spacer patterns to a  $2 \times 3$ " piece of  $\frac{1}{4}$ "-thick plywood; then scrollsaw the pieces to shape.

**9** Remove the double-faced tape from all of the grouped parts. Now assem-

ble the bear on a  $9 \times 12$ " piece of  $\frac{1}{4}$ " plywood, raising the muzzle and nose parts with the spacers, where shown on **Drawing 1**, and as shown in **Photo D**. Check the fit and transition between all of the parts, and make final adjustments where necessary by sanding or trimming.

**10** When you're satisfied with the fit and look, trace around the perimeter of the bear with a pencil. Carefully slide the bear off the plywood backer, keeping the pieces together. Cut the backer to shape, scrollsawing just inside the marked line. Sand the edges smooth.





When contouring the parts, use light pressure and keep them moving to prevent burning the wood.

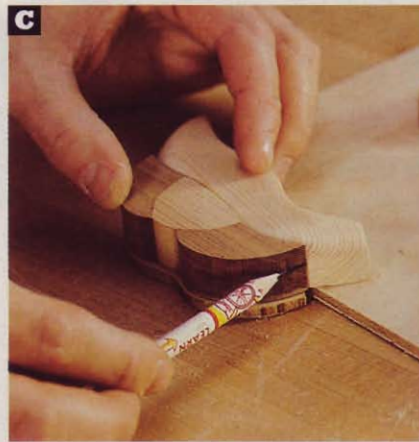

Check the transition between adjacent parts as you contour them. Re-mark and continue sanding as necessary.

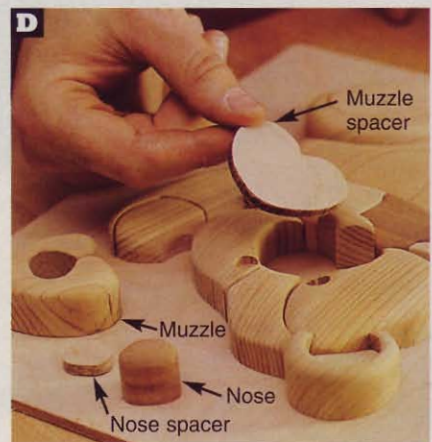

Install the muzzle spacer followed by the muzzle. Then insert the nose spacer and the nose into the muzzle opening.

**1 EXPLODED VIEW**

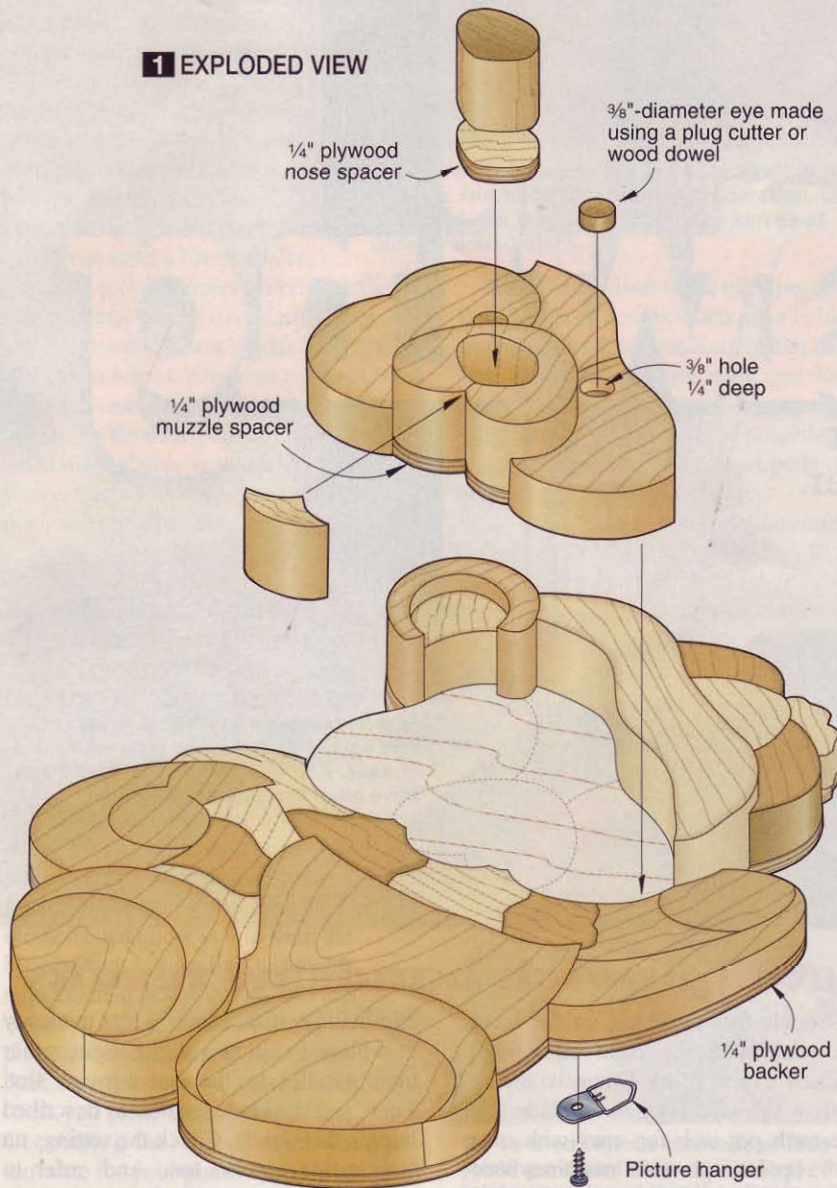

**Glue the bear to the backer, and add the finish**

**1** Spray-paint the back face and edge of the backer with glossy black enamel paint.

**2** With the paint dry, carefully slide the bear onto the unpainted side of the backer. Center the bear so there's an even overlap all around the backer. Now, glue each piece onto the backer using a couple of drops of yellow woodworking glue.

**3** Remove all of the dust. Then, apply three coats of a clear finish, sanding to 400 grit and removing the dust between coats. (We used Watco aerosol satin lacquer.) Finally, attach a hanger to the backer.

**Buying Guide**

Drum sander and adapter. 3"-diameter pneumatic drum sander no. 09M32, \$57.99; drill-press adapter no. 14072, \$14.99. Woodcraft, call 800/225-1153, or go to [www.woodcraft.com](http://www.woodcraft.com).



**Want to know more about intarsia?**

To receive a free newsletter chock-full of intarsia tips, books, videos, classes, and patterns (including the two bear companions shown above), visit Judy Gale Roberts' Web site at [www.intarsia.com](http://www.intarsia.com), or call 800/316-9010 in the U.S. or 865/428-8875 if outside the U.S.

Written by Owen Duvall Project design: Judy Gale Roberts Illustrations: Roxanne LeMoine; Lorna Johnson Photographs: Marty Baldwin



# resawing

Save money making your own thin stock and veneer. Here's how... one slice at a time.

When you resaw to make thin veneer, this jig's high, flat fence puts your mind at ease. Add the feather board, and you have all of the support you need.

**Y**our lumber may measure  $\frac{1}{16}$ " or  $\frac{3}{4}$ " thick when you bring it home, but it doesn't have to stay that way. Maybe you need  $\frac{1}{2}$ " pieces for drawer sides, or you want to slice a beautifully figured board into veneer for a jewelry box. No problem. With your bandsaw or tablesaw, you can resaw a board quickly to any thickness that you want. We'll cover both methods here, with an emphasis on the bandsaw.

## Get top-notch bandsaw results

For trouble-free resawing on the bandsaw, start with the right equipment. Bandsaw expert Mark Duginske recommends a  $\frac{1}{2}$ "-wide hook-tooth blade with three teeth per inch for saws with more than  $\frac{1}{2}$  hp. Less-powerful machines benefit from a blade with four teeth per inch.

If your blade is dull, buy a new one. A sharp blade goes a long way toward

eliminating drift, which is the tendency of a blade to cut at a slight angle, rather than parallel to the miter-gauge slot. Then, test the blade tension as described later in this article. Check the settings on your guide blocks, too. And, refer to "10-step tool tune-up: bandsaws" on page 80 of issue 144 for more information about making bandsaw adjustments.

## RESAW JIG

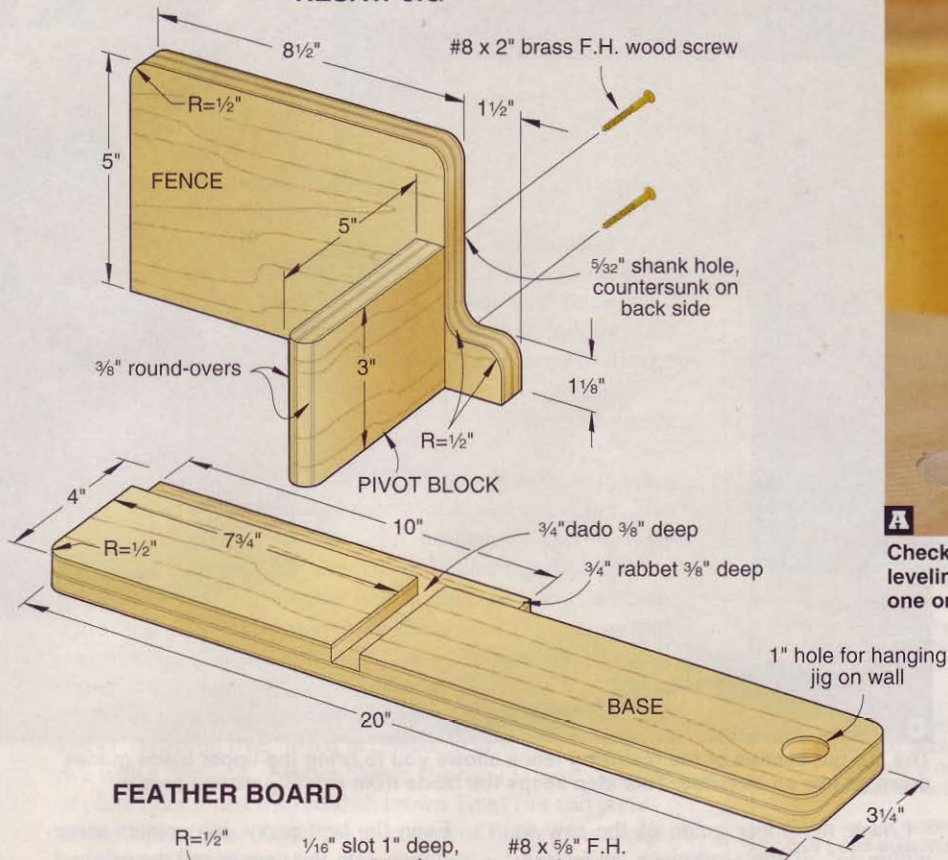

## FEATHER BOARD

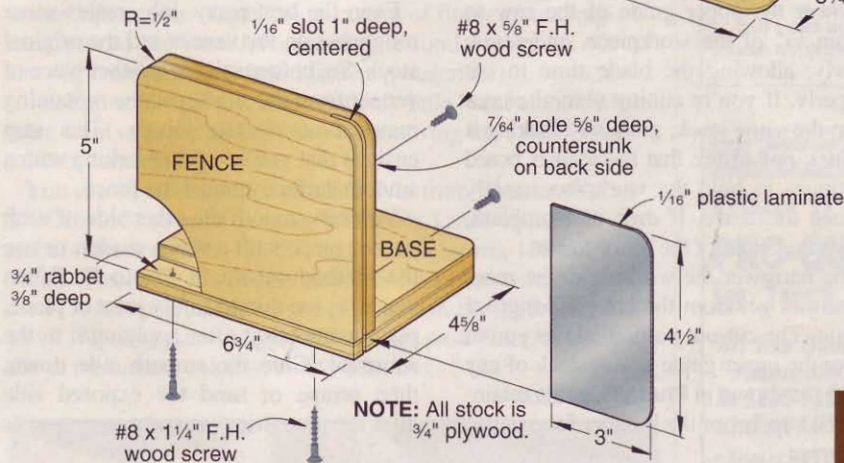

## Make it easy with jigs

We've built and tested more than one resawing jig for the bandsaw, and they all produced good results. But recently we sat down and developed a simple version that we like best of all.

The unique shape of the fence allows you to keep the bandsaw's blade guides as close together as possible during every cut. That support minimizes any twisting and flexing in the blade, resulting in the truest cut possible.

The two-piece jig that you see in the drawing *above* is built from 3/4" birch plywood. Start by making the base of the long unit by cutting a 4x20" piece of ply-

wood. Cut a 3/4" rabbet 3/8" deep along the top edge where shown. Next, cut a dado 7 3/4" from the left end. Measure 10" from the left end, and mark the rabbet. Go to the bandsaw, and trim off the portion of the rabbet to the right of the mark. Drill a 1" hole at the right end of the base, just to make the jig easy to hang on the wall when it's not in use.

Cut the pivot block to size. Rout 3/8" round-overs on one edge, where shown.

For the fence, begin by cutting a piece 10" long and narrow enough



**A**

Check your owner's manual for instructions on leveling the table. In most cases, you'll loosen one or two knobs, and adjust the 0° stop bolt.

to fit between your bandsaw table and the upper wheel housing, while resting on the base rabbet. (We made ours 5" wide.)

At the bandsaw, shape the leading end of the fence, as shown in the drawing. Cut 1/2" radii on the corners of the fence and base, where shown.

Glue and clamp the three pieces together, and allow the glue to dry. For added strength, drive two brass screws through the fence and into the pivot block, as shown.

Finally, make the simple feather board from plywood and plastic laminate. Cut the base to the dimensions shown, and rabbet one edge. Cut the fence, then put a 1"-deep kerf in one end with the bandsaw. Cut a 1/2" radius on each of the top

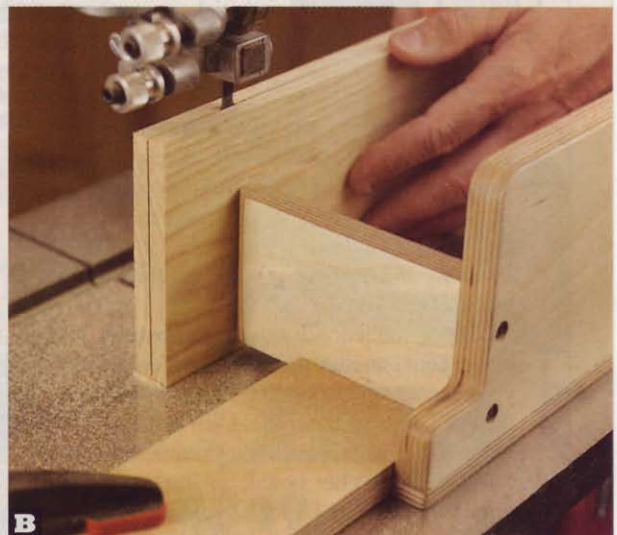

**B**

You can use the jig's pivot block for most resawing jobs except making veneer. The rounded end makes it easy to adjust for blade drift.

corners. Cut the plastic laminate, slip it into the kerf, and fasten it with two  $\frac{3}{8}$ " screws. Attach the fence to the base with glue and a couple of screws driven from below. Brush three coats of polyurethane on both jigs to protect the wood.

### Set up and resaw

Check that your bandsaw table is set at  $90^\circ$  to the blade, as shown in **Photo A**. Now put the jigs to work.

You need adequate tension on your bandsaw blade to get top results. To adjust the tension, set the upper guide 6" above the table. Push on the side of the blade with your little finger about 3" above the table. If the blade deflects more than  $\frac{1}{4}$ " under moderate pressure, increase the tension.

To resaw a board in half, or simply cut a slab from a thicker piece, set up the pivot block on your resaw jig. Mark a guideline on the top edge of your stock with a pencil. Use that line to position your resaw jig. Clamp the jig on the left side of the blade, as shown in **Photo B**. Use an adjustable bar clamp at each end of the base, and locate the pivot block alongside the blade, leaving a gap equal to the distance between your stock's left face and the outline.

Set the upper guide of the bandsaw  $\frac{1}{4}$ " above the upper edge of your stock. Hold the left side of your workpiece tightly against the pivot block, and slowly feed it into the blade. The rounded end of the block allows you to slightly adjust the angle of the board as you saw, compensating for any blade drift.

Use a scrapwood pushstick as you complete the cut. That step keeps your hands safely away from the blade.

### Let's make some veneer

When you resaw very thin layers of wood, it helps to have plenty of support on both sides of your stock. You can get that support by using the fence of the resaw jig and the feather board, as shown in the photo on *page 87*.

Position the fence at a distance from the blade equal to the desired thickness of your veneer, and extending about  $\frac{1}{2}$ " past the back edge of the blade. Clamp the jig to the bandsaw table, front and back.

Angle the feather board, as shown on *page 87*, with the laminate wing on the near side of the blade and slightly closer to the fence than the width of your stock. Secure it to the table with two clamps.

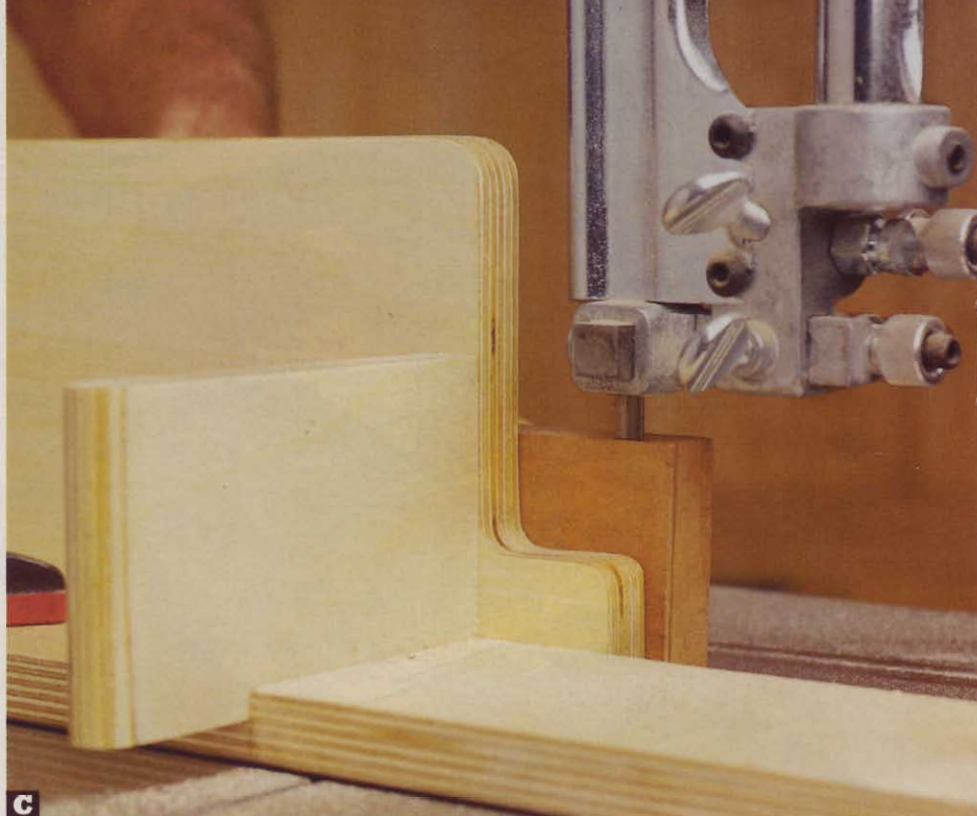

**C** The cut-out section of the resawing fence allows you to bring the upper blade guides down as low as possible. This step keeps the blade from twisting as you resaw.

Lower the upper guide of the saw to within  $\frac{1}{4}$ " of the workpiece, and resaw slowly, allowing the blade time to cut properly. If you're cutting several pieces from the same stock, gradually making it thinner, make sure that the feather board continues to hold the workpiece snugly against the fence. If drift is a problem, adjust the angle of the fence to suit.

The narrower the workpiece, the more value you get from the unique design of the jig. The cut-out portion allows you to lower the upper guide to suit stock of any width, as shown in **Photo C**, while retaining the support of the broader fence side.

Even the best resaw job creates some roughness on the veneer and the original stock. So, before sawing another piece of veneer from the stock, run the remaining material across the jointer. This step ensures that you're again working with a smooth surface against the fence.

You can smooth the other side of each veneer piece with a drum sander, or use the method shown in **Photo D**. When veneer is too thin to safely joint or plane, plan to smooth it after applying it to the substrate. Glue the smooth side down, then scrape or sand the exposed side after the glue dries.

You can smooth veneer as thin as  $\frac{1}{8}$ " by using a carrier board along with your thickness planer. Attach the veneer to particleboard with double-faced tape.



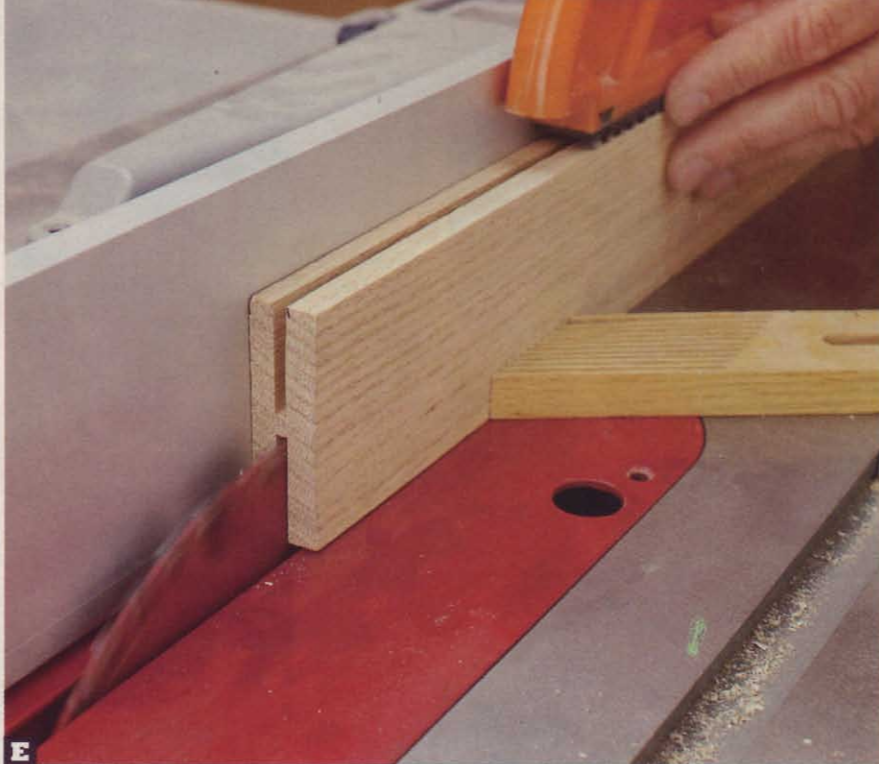

**E**

Be prepared for the blade's tendency to lift the workpiece when you cut a kerf. Your pushstick should extend well onto the board to counteract that force.

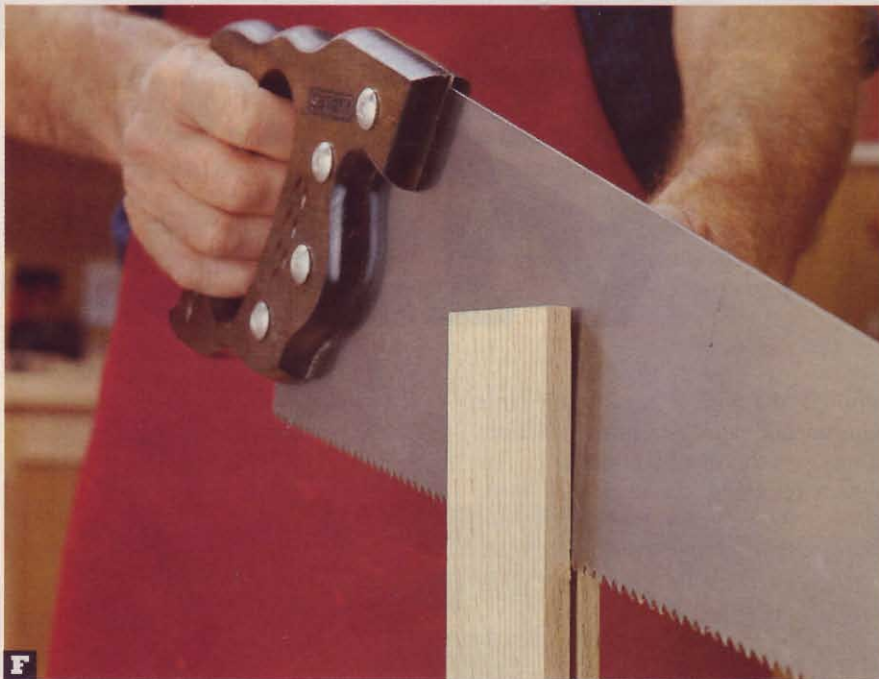

**F**

If you don't have a bandsaw, start with your tablesaw and finish the job with a sharp rip saw. Clamp the workpiece in your bench vise to hold it firmly.

## In a pinch, use the tablesaw

If you don't have a suitable bandsaw, you can rely on the tablesaw for resawing narrow workpieces, but plan to spend a bit more time and effort. For safety's sake, you shouldn't cut completely through the stock on the tablesaw, so reach for the handsaw to finish the job.

Mount a rip blade with 24 or fewer teeth on your tablesaw. Set the blade no more

than 1" high, and adjust the fence for the desired cut thickness. Hold the workpiece tightly against the fence with a feather board, and guide it through the cut with a well-made commercial or shopmade pushstick. Flip the workpiece end-for-end, keeping the same face against the fence, and cut a kerf into the other edge, as shown in **Photo E**. Raise the blade and

## Find beauty in book-matching

Resawing allows you to book-match the two halves of a single board. Slice the board open, edge-glue the pieces, and you create a great-looking panel. You're sure to get striking results with a material like the spalted maple seen *below*. However, it can be difficult to predict what you'll find in the middle of a board with less dramatic figure. Check both faces to see if the pattern carries through the board. Then cut the board longer than the planned panel, giving yourself extra room to adjust the design for best effect.

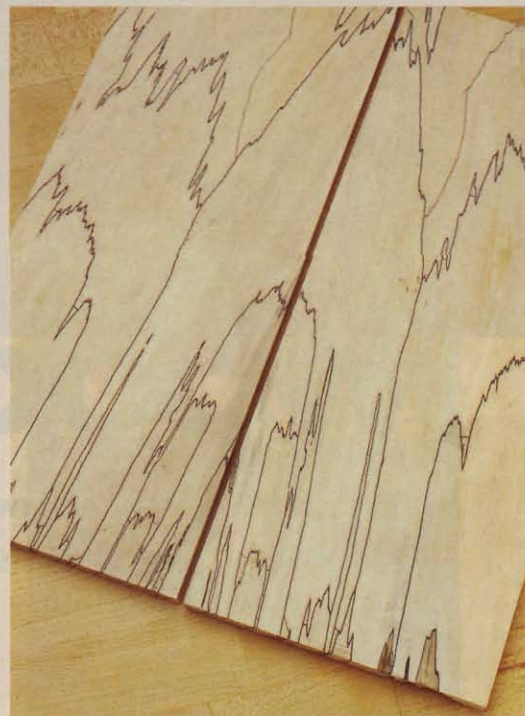

This piece of spalted maple looked great before resawing. Opening it up lets you create a symmetrical design that's even more impressive.

repeat as necessary, but leave at least 1/4" of material between the two kerfs.

Clamp the workpiece in a vise, and complete the cut, as shown in **Photo F**. Saw half the length with a rip saw, flip the workpiece end-for-end, and finish the cut. Clean up the two sawn surfaces with the thickness planer or a sander.

You also can combine the double-kerf method with a finishing cut on the bandsaw. This technique pays benefits when you're handling wide stock that would require a lot of hand sawing. 🌲

Written by **Jim Pollock** with **Chuck Hedlund** and **Jeff Mertz**  
 Photographs: **Marty Baldwin**  
 Illustrations: **Roxanne LeMoine**; **Lorna Johnson**



## A buyer's guide to

# woodworking vises

**What's the difference between a \$12 vise and one costing \$400? Plenty, as we'll explain.**

**Y**ou can spend just a few dollars or several hundred bucks on a woodworking vise, but both are designed to do the same thing: hold a workpiece solidly without marring it. Vises come in many sizes and types, but the most popular vise for home woodworkers is a bench vise, shown *above*.

This style of vise mounts easily to most workbenches and requires only the addition of hardwood faces to the metal jaws. Figure about an hour's work before the vise can go to work for you. Unless you're working with very wide pieces or want to clamp large glue-ups (see "The classic wooden-jaw vise," on page 90), a good-quality bench vise will handle most of your work-holding demands.

### Three "must-have" bench-vise features

**1 Quick-release jaw.** To spare you the annoyance of tediously turning (and

turning) the vise's handle for large adjustments, a quick-release mechanism allows you to instantly position the jaw anywhere along its range. A *lever release*, shown in **Photo A**, disengages the threads from the screw when you actuate the lever, then reengages them when released.

More convenient is a *gravity release*, which disengages with a mere counterclockwise half-turn of the screw; turning it clockwise reengages the threads. You'll especially like this style of quick release if you have limited hand strength.

**2 Pop-up dog.** You'll find this feature on all but the most bare-bones vises. When used with bench dogs this device will help hold a benchtop workpiece in place for sanding or scraping.

A thumbscrew locks most vise dogs in place; precious few, such as the spring-loaded dog on the Jorgensen 40709

shown in **Photo B**, stay in the up or down position without having to be locked. The Wilton 78A, shown in

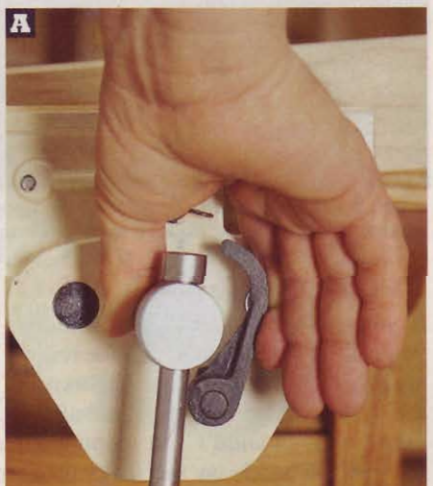

Pressing the quick-release lever toward the screw allows the movable jaw to travel freely for speedy positioning.

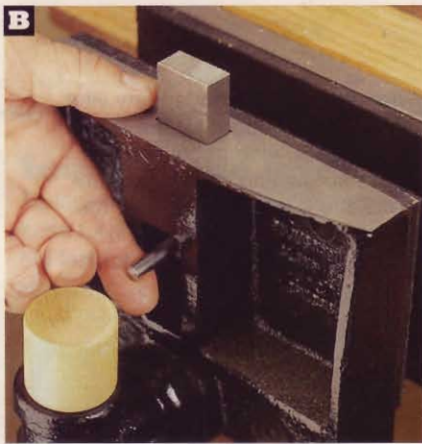

**B** Jorgensen's pop-up dog rises to the occasion with a simple lift lever. Spring steel in the jaw eliminates the need for a locking thumbscrew.



**C** Why have a pop-up dog when the entire jaw rises? You could clamp small panels with the Wilton 78A because of the wide, workpiece-friendly wooden surface.

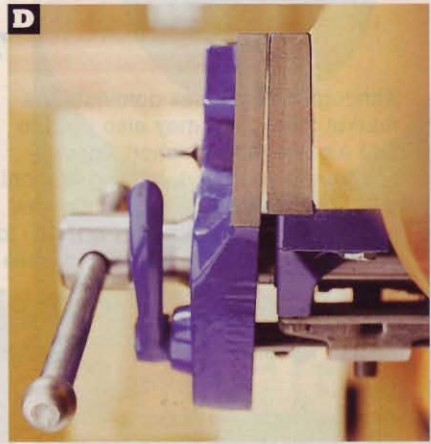

**D** Toed-in jaws, shown on the Record 52ED, meet at the top first, then become parallel as you tighten them. (Wooden jaw faces removed for clarity.)

**Photo C**, adds an interesting twist to the pop-up dog: The entire jaw rises to provide holding power while minimizing workpiece damage.

**3 Toed-in jaws.** As you can see in **Photo D**, the jaws of a good bench vise come together at the top before they touch at the bottom. This arrangement, called *toe-in*, helps equalize clamping pressure across the jaws. Without *toe-in*, the jaws apply more pressure at the bottom than at the top.

### Mounting tips

Thinking of buying a bench vise? Here are a few things to consider before you install it:

**1 Front, but not center.** For front-of-bench mounting, install your vise near one end or the other. This allows you to hold short workpieces for cutting off with a handsaw without fear of cutting into your benchtop. You can also hold a workpiece or assembly that goes around a corner, such as a portion of a frame. Don't forget to allow enough clearance behind the vise for the screw when the jaws are closed.

**2 Righties, go left.** If you're right-handed, mount the vise near the left end of your bench; left-handed woodworkers should install on the right. This keeps your "power arm" directly over the workpiece for hand-tool tasks, such as planing.

**3 Flush those jaws.** The tops of the wooden jaws should be flush with or slightly lower than your benchtop. You may need to shim between the vise and the bottom of the benchtop before installing it.

**How much vise does \$12 buy?** Most of the bench vises you see in the photos in this article sell for around \$100, and will handle pretty much any work-holding task a home woodworker can throw at them. But are they that much better than less-expensive vises? This \$12 imported model lacks a pop-up dog and quick release, and its fine threads make closing the jaw an exercise in tedium. (It takes 16 turns of the screw to close the jaw 1".) The jaw seesawed back and forth as we turned the screw, and the skimpy handle felt as though it would bend if we overtightened it. It might be fine for a second vise, but if you're serious about woodworking, you'll need to spend a bit more on a quality vise.

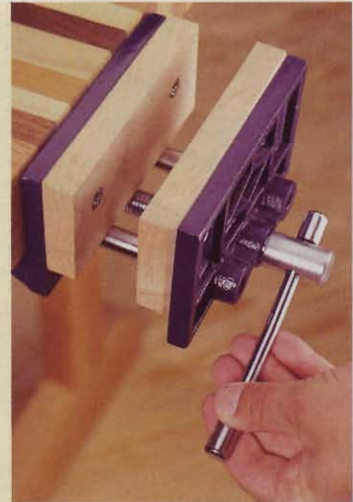

## Three quick tips for vise installation

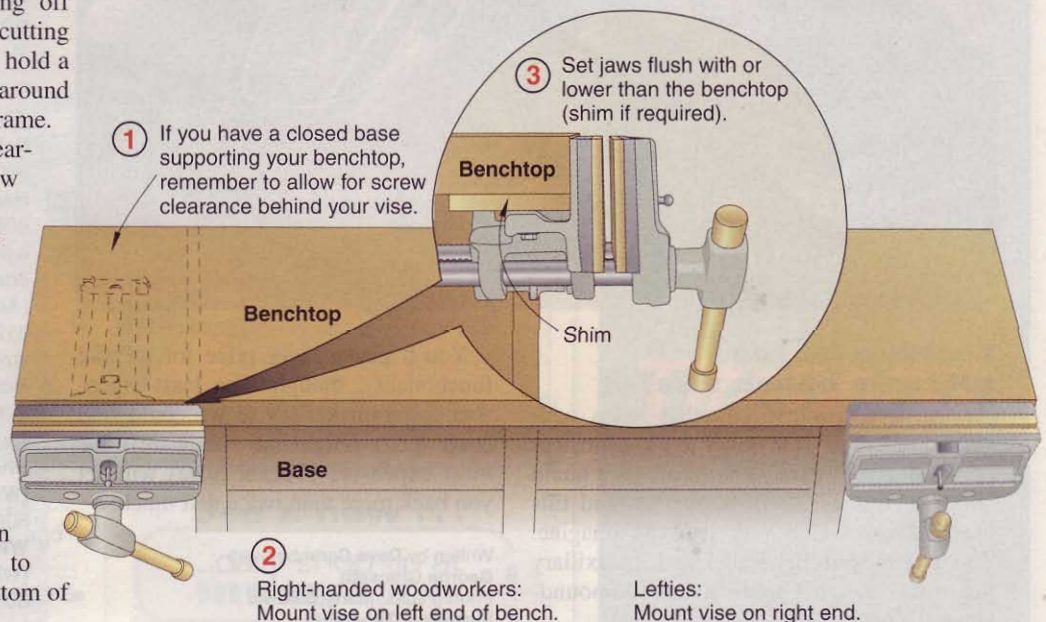

## The classic wooden-jaw vise

Although bench vises dominate the market today, you may also want to add a good old-fashioned wooden-jaw vise to your work-holding arsenal. Like a bench vise, most wooden-jaw vises use a single screw (Photo E) to open and close the jaws. Some have

two screws (Photo F) connected by a timing chain to keep the jaws parallel.

A wooden-jaw vise typically mounts across the end of your bench to hold or clamp long workpieces or wide assemblies. But you can also mount it on the front like a bench vise.

When you buy a wooden-jaw vise, don't forget to budget for the jaws. The \$60–\$150 vise price includes only the screw and mounting hardware. Set aside plenty of time, too. Making the hardwood jaws and installing the vise can take hours.



The wide jaws you make for a wooden-jaw vise provide excellent grip on long workpieces.



A twin-screw vise, such as this Veritas model, distributes pressure more evenly across its jaws than a single-screw vise.

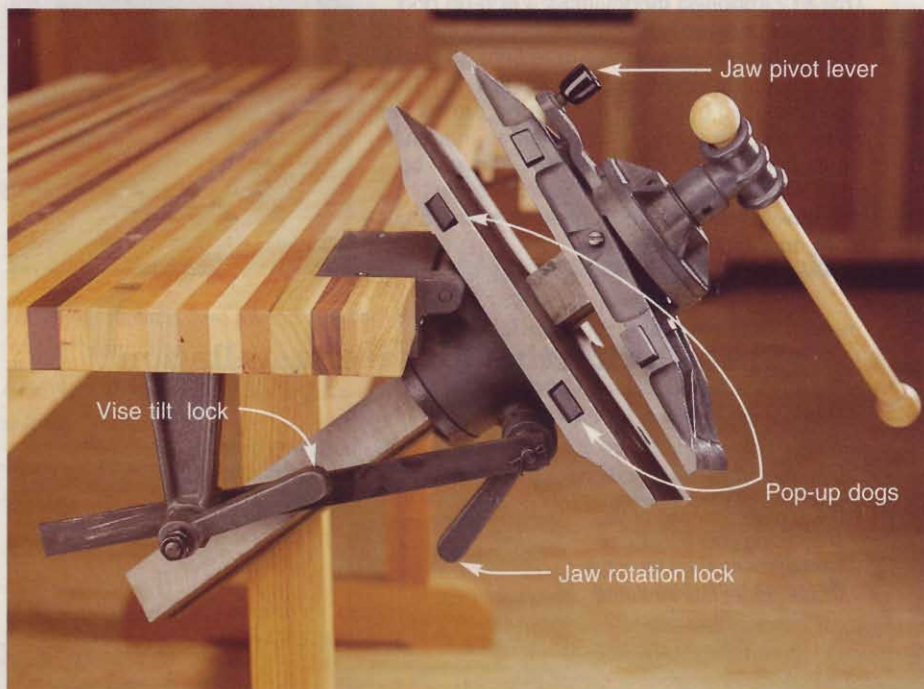

### Looking for the ultimate bench vise?

If you need a super vise that holds odd-shaped pieces at even odder angles, consider purchasing a patternmaker's vise. (See photo above.) This vise swivels, rotates, and tilts nearly every which way you can imagine. The jaws pivot from parallel, and an auxiliary jaw (not shown) holds even compound-tapered workpieces.

You'll pay a hefty price for all that functionality, though. The least-expensive patternmaker's vise we could find costs \$220 (Highland Hardware); the most expensive (Tucker Vise) will set you back more than twice that much. ♣

Written by **Dave Campbell** with **George Granseth**  
Photographs: **Marty Baldwin**  
Illustration: **Tim Cahill**

### Sources

#### Patternmaker's vises:

##### Highland Hardware

800/241-6748, [www.highlandhardware.com](http://www.highlandhardware.com)

##### Lee Valley & Veritas (Tucker Vise)

800/871-8158, [www.leevalley.com](http://www.leevalley.com)

##### Woodcraft

800/225-1153, [www.woodcraft.com](http://www.woodcraft.com)

#### Wooden-jaw vises:

Those listed above, plus

##### Garrett Wade

800/221-2942, [www.garrettwade.com](http://www.garrettwade.com)

##### Rockler

800/279-4441, [www.rockler.com](http://www.rockler.com)

#### Bench vises:

Those listed above, plus

##### Grizzly Industrial

800/523-4777, [www.grizzly.com](http://www.grizzly.com)

##### Harbor Freight Tools

800/423-2567,  
[www.harborfreight.com](http://www.harborfreight.com)

##### Jorgensen/Pony

(Adjustable Clamp Company)

312/666-0640,  
[www.adjustableclamp.com](http://www.adjustableclamp.com)

##### Record (American Tool)

800/838-7845,  
[www.americantool.com](http://www.americantool.com)

##### Shop Fox

(Woodstock International)

800/840-8420, [www.shopfox.biz](http://www.shopfox.biz)

##### Wilton/Columbian

(WMH Tool Group)

800/519-7381, [www.wiltontool.com](http://www.wiltontool.com)



the wheel deal

# mobile tool cabinet

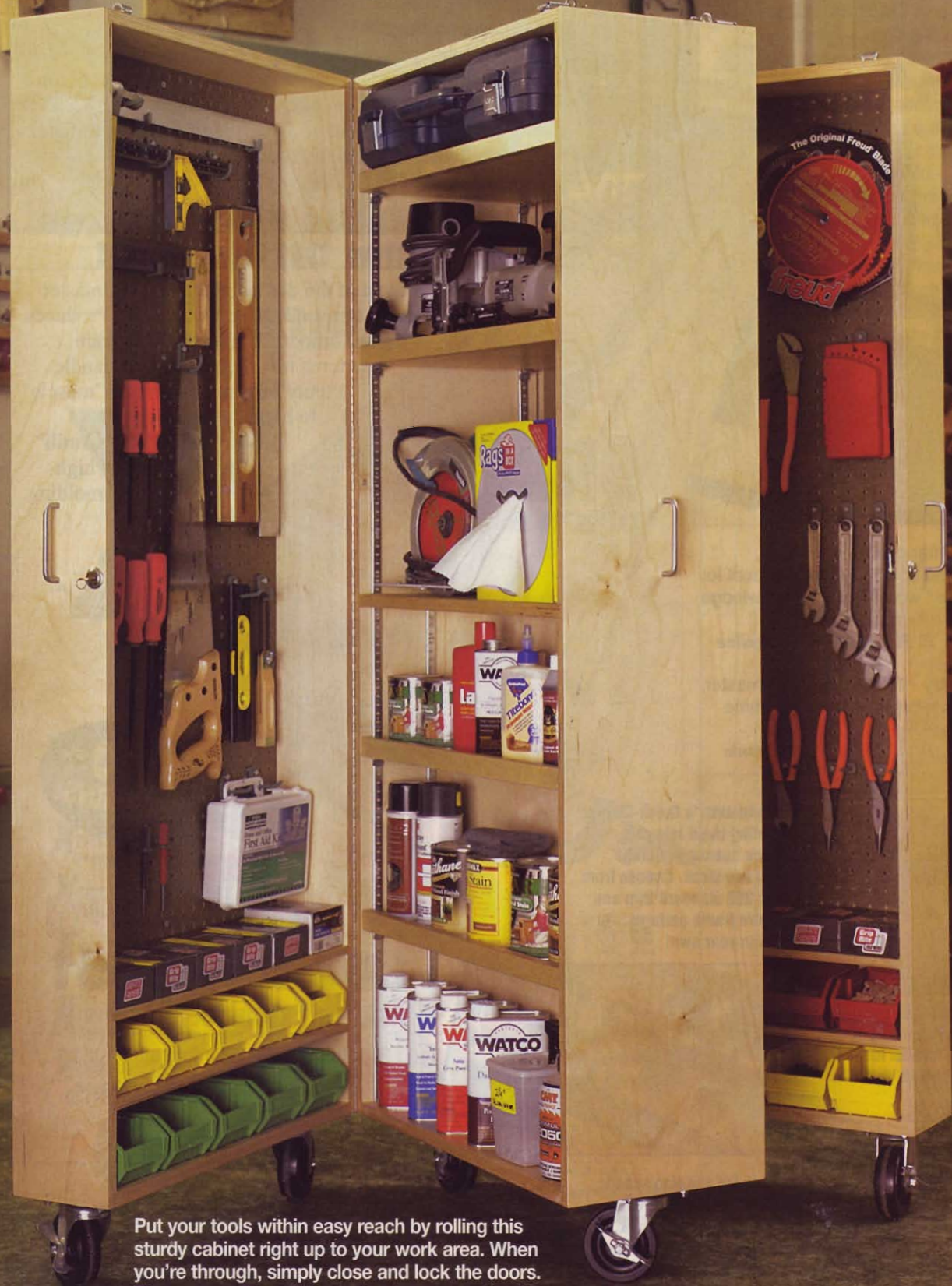

Put your tools within easy reach by rolling this sturdy cabinet right up to your work area. When you're through, simply close and lock the doors. Then return the cabinet to its storage spot — it occupies only 2x2' of floor space.

# 1 DOOR EXPLODED VIEW

(Two doors needed)

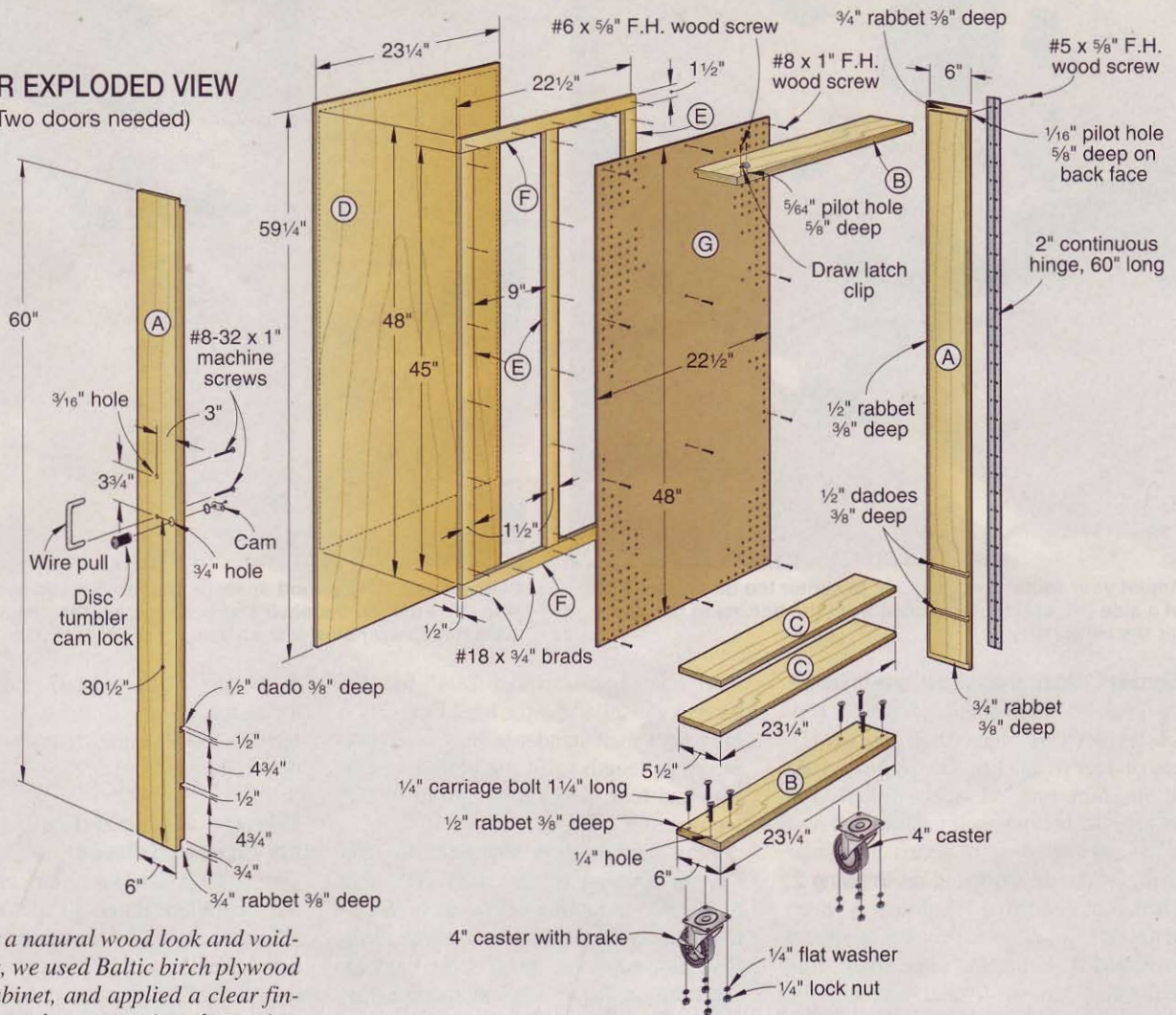

**Note:** For a natural wood look and void-free edges, we used Baltic birch plywood for our cabinet, and applied a clear finish. But, as a less expensive alternative, you also can use type AC or BC plywood, particularly if you plan to paint the cabinet.

## Start with the doors

**1** From 3/4" plywood, cut the door sides (A) and tops and bottoms (B) to the sizes listed in the Materials List. From 1/2" plywood, cut the shelves (C) to size.

**2** On the inside face of the side pieces, rout 1/2" dados 3/8" deep to receive the shelves, where dimensioned on **Drawing 1**. Then, rout 3/4" rabbets 3/8" deep across the ends of the sides to accept the tops and bottoms. Now, rout a 1/2" rabbet 3/8" deep along the back edge of the sides, tops, and bottoms, to receive the back (D).

**Note:** To rout the 1/2" and 3/4" rabbets and dados in this project, we used 1/4" and 1/2" straight bits, respectively, making two passes to size the joints exactly to fit the mating plywood parts.

**3** Glue and assemble a door's sides, top, bottom, and shelves, as shown in

**Photo A**, using squaring braces to keep the assembly square. With the glue dry, sand the door frame's surfaces and edges to 220 grit. Repeat to assemble the other frame.

**4** From 1/2" plywood, cut the backs (D) to size. Sand them to 220 grit, and remove the dust. Glue a back in the rabbeted opening in each door frame, and clamp it securely all around the frame.

**5** From 1/2" plywood, cut the vertical spacers (E) and horizontal spacers (F) to size. Glue and nail the spacers inside each door to the back (D), where shown on **Drawing 1**.

**Note:** Because actual plywood thicknesses vary from their nominal dimensions, measure all inside dimensions of the tool cabinet and cut the spacers, and later the upper and lower shelves (L, M) and shelf edging (N), to the necessary length for the best fit.

**6** Brush or spray the inside and outside of the doors with a finish of your

choice. (We brushed on three coats of Minwax satin polyurethane, sanding to 220 grit between coats.)

**7** Cut the perforated hardboard panels (G) to size. Screw them to each door's spacers, where shown.

**With the edges of the door-frame members flush, clamp the assembly together with squaring braces. You can make simple braces from scrap 3/4" plywood.**

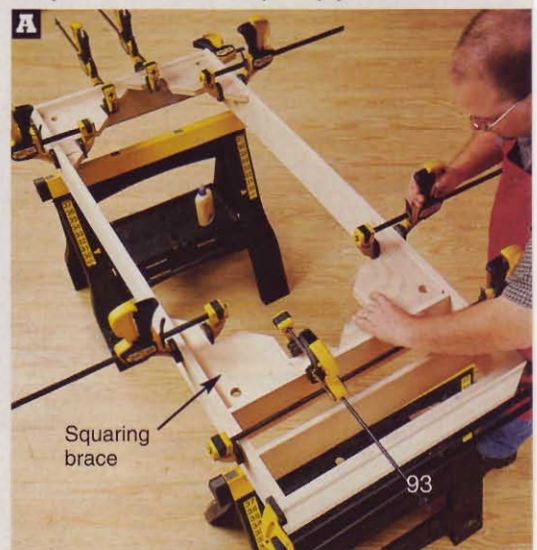

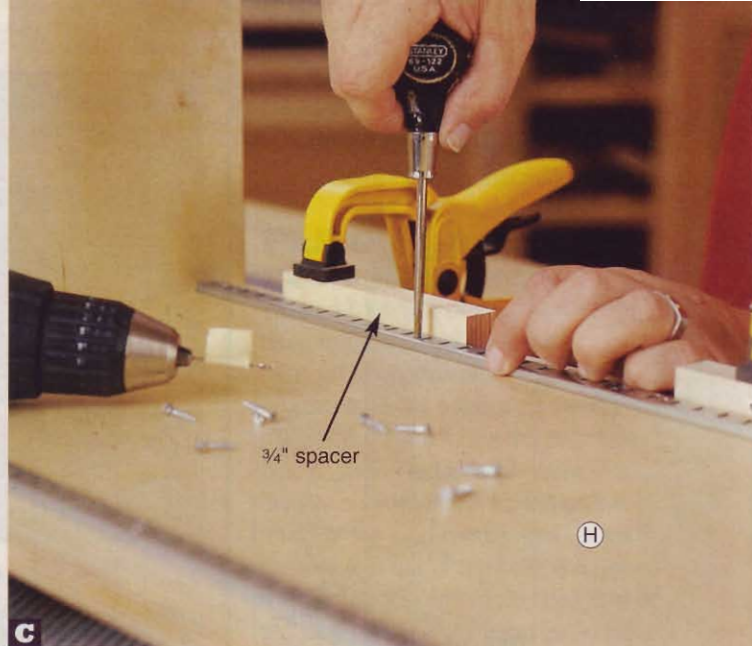
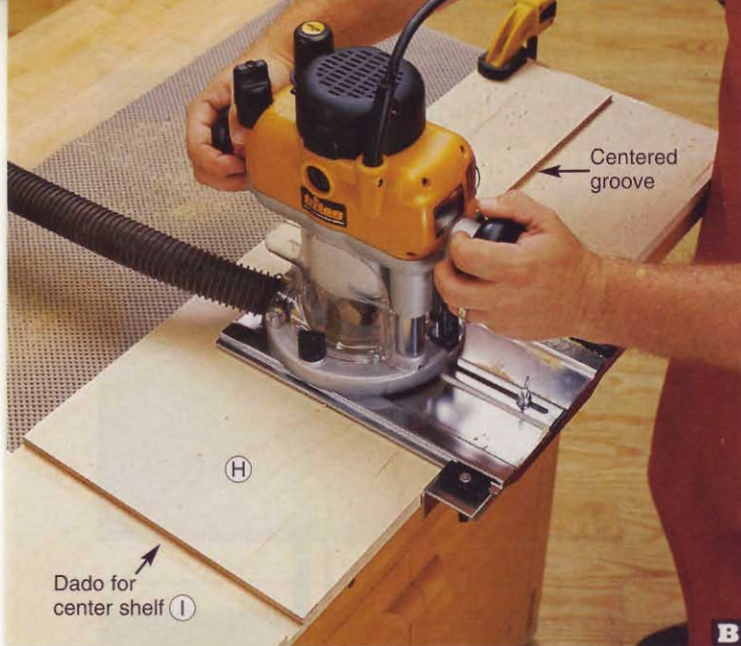

Adjust your router's edge guide to center the bit on the width of a side (H), and rout a groove from the bottom to the dado for the center shelf (I).

Clamp scrap 3/4" plywood spacers flush to the edges of each side (H). Position the shelf standard against the spacers, and mark the screw holes with an awl.

### Build the center cabinet

**1** From 3/4" plywood, cut the sides (H), bottom and center shelf (I), top (J), and divider (K) to size. On the inside face of the sides, rout 3/4" rabbets 3/8" deep to receive the bottom shelf and top and rout a 3/4" dado 3/8" deep to accept the center shelf, where dimensioned on **Drawing 2**. Then, rout a centered 3/4" groove 3/8" deep in the sides to accept the divider, as shown in **Photo B**. Using the same setup, rout the mating grooves for the divider in the bottom and center shelf.

**2** Sand the parts to 220 grit, dry-assemble them, and verify they fit correctly. Then, glue and clamp the parts together, again using squaring braces to keep the assembly square. When the glue dries, apply the finish.

**3** Measure the openings between the bottom and center shelf (I) and between the center shelf and top (J).

(Our openings measured 28 1/2" for the bottom and 29 1/4" for the top.) From 30"-long steel shelf standards, hacksaw eight pieces to length to fit the bottom openings and four pieces to length to fit the top opening.

**4** Position the four standards for the top opening on the sides (H), and mark the mounting-screw hole locations, as shown in **Photo C**. Then, drill 1/16" pilot holes 7/16" deep at the marked locations, and screw the standards to the sides. Following the same process, mount the four outer standards in the bottom openings. Then, mount the four inner standards to the sides, using the 3/4" spacers to position them parallel to the divider (K).

**5** Position 4" casters on the bottoms (B, I), where dimensioned on **Drawing 3**. Mark the centers of the casters' mounting-bolt holes, and drill 1/4" holes through

the bottoms at the marked locations. Bolt the casters to the bottoms, as shown, making sure to locate the casters with a brake where shown.

### Hinge the doors to the cabinet

**1** Using a hacksaw, cut two 2x72" continuous hinges to a length of 60". Align the doors and the center cabinet on a flat surface with the back side facing up, and clamp them together. (See the **Shop Tip**, below left.)

**2** Center the hinges along the door/center-cabinet joints. Drill 1/16" pilot holes 5/8" deep in the center of the hinge screw holes, and drive the screws. Now, set the tool cabinet upright on the casters.

### Add the shelves

**1** From 3/4" plywood, cut the upper shelves (L), lower shelves (M), and edging (N) to size. (Again, it's a good idea to measure the inside width of the cabinet, both between the sides (H) for the edging and the shelf standards for the shelving, and cut the parts to the exact length for a snug fit.)

**2** Glue and clamp the edging to the upper and lower shelves, where shown on **Drawings 2** and **4**. Center the edging so it overhangs the shelves by 1/8" at each end. When the glue has dried, sand the shelves and trim to 220 grit, and apply the finish. With the finish dry, clip the shelf supports in the standards at the desired locations, and install the shelves on the supports.

### SHOP TIP

#### How to install continuous hinges

When attaching doors with continuous hinges, such as for the tool cabinet, leave a 1/16" gap between the members to be hinged. The gap will prevent potential hinge binding due to wood movement, which could keep the parts from closing together tightly. To establish the gap, place 1/16"-thick wood spacers between the parts as needed, and then clamp the parts together.

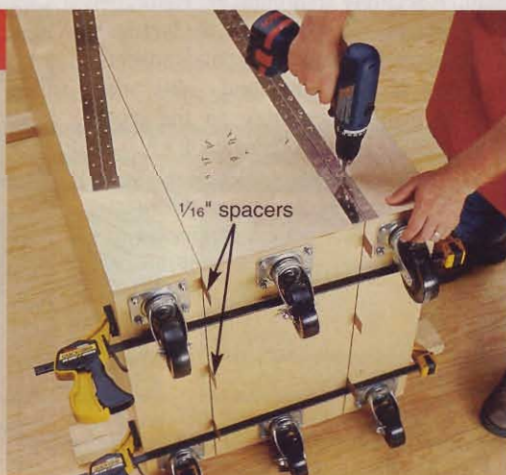

## 2 CENTER CABINET EXPLODED VIEW

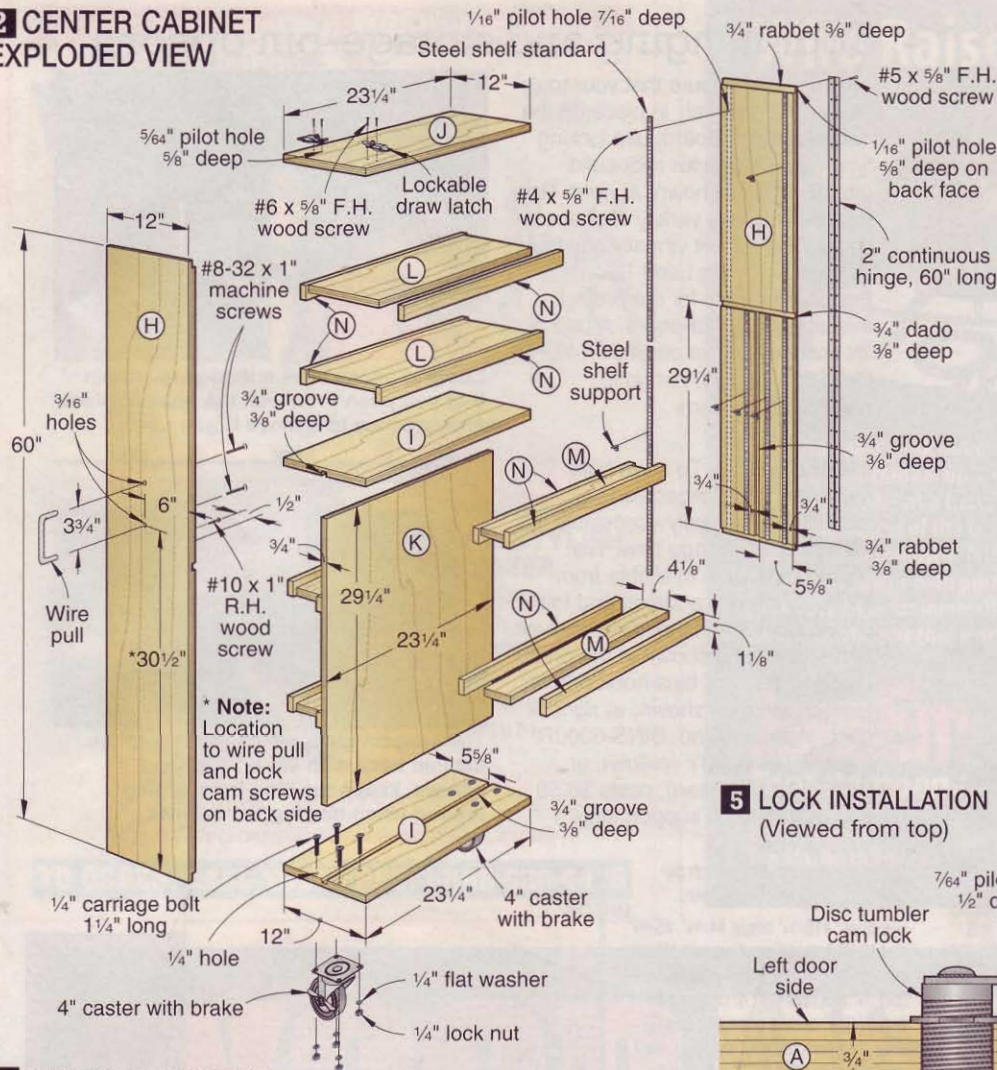

## 3 CASTER PLACEMENT (Viewed from bottom)

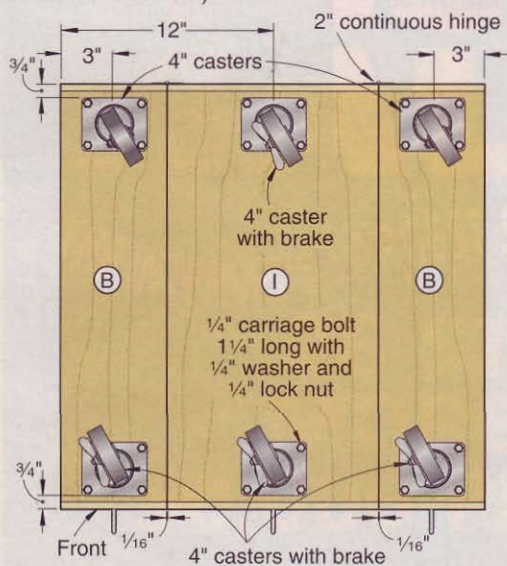

See more ...

...shop projects at

[www.woodstore.woodmall.com/shoptoolac.html](http://www.woodstore.woodmall.com/shoptoolac.html)

## 4 SHELVING DETAIL

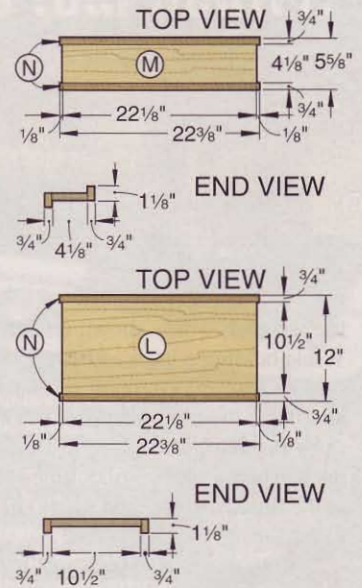

## 5a CAM DETAIL

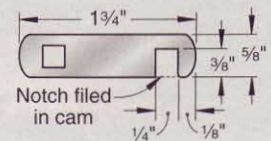

## 5 LOCK INSTALLATION (Viewed from top)

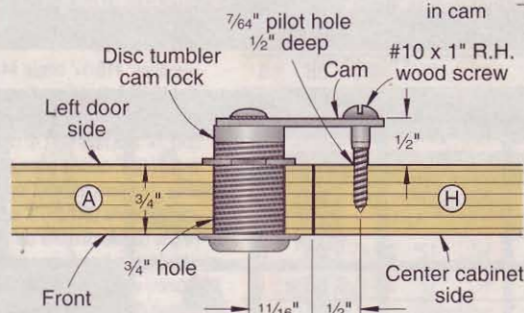

## Install the locks and handles

**1** On the front of each door, mark the center-point for a 3/4" hole to receive a disc tumbler cam lock, where dimensioned on **Drawings 1** and **5**. (Note that the two lock installations are mirror images of one another.)

**2** Using a 3/4" Forstner bit and a backer board to prevent tear-out, drill the lock holes through the doors. Remove the screw attaching the cam to the back of each lock, and remove the cam. Install the locks in the holes as directed in the manufacturer's

instructions. File a notch in each cam where dimensioned on **Drawing 5a**. Then screw the cams to the locks.

**3** On the back of the center cabinet's front side (H), mark the centerpoints for #10x1" roundhead wood screws that engage with the locks' cams, where dimensioned on **Drawings 2** and **5**. Drill 7/64" pilot holes 1/2" deep at the centerpoints. Then, drive in the #10x1" roundhead wood screws to the depth shown.

**4** On the front of the doors and center cabinet, mark the screw-hole locations for attaching the wire pulls, where shown on **Drawings 1** and **2**. Drill 3/16" holes at the marked locations, and mount the pulls using the supplied screws.

**5** Clamp the doors snug against the center cabinet at the front. Engage the lockable draw latches in the mating clips, and position the pieces on top of the

## 6 DRAW LATCH INSTALLATION (Viewed from top)

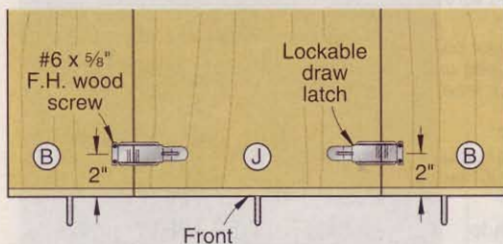

tool cabinet, where shown on **Drawing 6**. While holding a latch and clip against the cabinet, carefully release the latch lever and mark the mounting-screw hole locations in each piece. Repeat for the other latch. Then, drill  $\frac{5}{64}$ " pilot holes  $\frac{5}{8}$ " deep at the marked spots, and screw the pieces to the top.

**6** Now, to mount your tools and organize hardware in the cabinet, see the sidebar, at *right*, for ideas. 🌱

### materials list

Doors	FINISHED SIZE			Matl.	Qty.
	T	W	L		
A sides	$\frac{3}{4}$ "	6"	60"	BB	4
B tops and bottoms	$\frac{3}{4}$ "	6"	23 $\frac{3}{4}$ "	BB	4
C shelves	$\frac{1}{2}$ "	5 $\frac{1}{2}$ "	23 $\frac{3}{4}$ "	BB	4
D backs	$\frac{1}{2}$ "	23 $\frac{3}{4}$ "	59 $\frac{1}{4}$ "	BB	2
E vertical spacers	$\frac{1}{2}$ "	1 $\frac{1}{2}$ "	45"	BB	6
F horizontal spacers	$\frac{1}{2}$ "	1 $\frac{1}{2}$ "	22 $\frac{1}{2}$ "	BB	4
G perforated panels	$\frac{1}{4}$ "	22 $\frac{1}{2}$ "	48"	PH	2
<b>Center cabinet</b>					
H sides	$\frac{3}{4}$ "	12"	60"	BB	2
I bottom and center shelf	$\frac{3}{4}$ "	12"	23 $\frac{3}{4}$ "	BB	2
J top	$\frac{3}{4}$ "	12"	23 $\frac{3}{4}$ "	BB	1
K divider	$\frac{3}{4}$ "	23 $\frac{3}{4}$ "	29 $\frac{1}{4}$ "	BB	1
L upper shelves	$\frac{3}{4}$ "	10 $\frac{1}{2}$ "	22 $\frac{1}{8}$ "	BB	2
M lower shelves	$\frac{3}{4}$ "	4 $\frac{1}{8}$ "	22 $\frac{1}{8}$ "	BB	4
N edging	$\frac{3}{4}$ "	1 $\frac{1}{8}$ "	22 $\frac{3}{8}$ "	BB	12

### cutting diagram

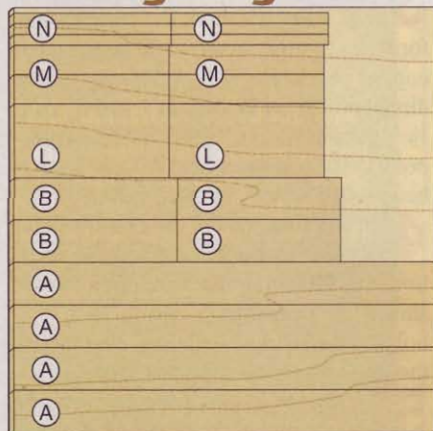

$\frac{3}{4}$  x 60 x 60" Baltic birch plywood

## Tool-hanging and storage-bin options

■ **Hooks.** To ensure that your tools' hooks stay securely in place on the perforated hardboard, use locking-type nylon hooks for rock-solid attachment, as shown, at *right*. The hooks come in a variety of shapes, so you can mount virtually any tool or accessory. We used Talon Perfboard Hooks for our project, available from McFeely's. A bag of 32 assorted hooks costs \$17.49. Call 800/443-7937, or go to [www.mcfeelys.com](http://www.mcfeelys.com).



Locking hooks have a dual-purpose pin that you push in to lock the hook in place and unscrew to remove it.

■ **Storage Bins.** To keep bulk hardware items organized, identified, and easily accessible, it's hard to beat storage bins. We placed bins, also available from McFeely's (Web address and telephone *above*), on the lower shelves of the doors, as shown in the photo on *page 92*. The bins hook onto a support strip, as shown, at *right*. A pack of six bins, no. BINS-6000R (red), BINS-6000Y (yellow), or BINS-6000G (green), costs \$6.50 and includes the support strip.



The support strip, which mounts to the cabinet back with #8x $\frac{3}{8}$ " panhead screws, keeps the bins from sliding around when moving the cabinet.

**Materials key:** BB—Baltic birch plywood, PH—perforated hardboard.

**Supplies:** #18x $\frac{3}{4}$ " brads; #4x $\frac{5}{8}$ ", #5x $\frac{5}{8}$ ", and #8x1" flathead wood screws;  $\frac{1}{4}$ " carriage bolts 1 $\frac{1}{4}$ " long (24);  $\frac{1}{4}$ " flat washers (24);  $\frac{1}{4}$ " lock nuts (24); 4" casters with brake (4); 4" casters without brakes (2); steel shelf standards 30" long (12); steel shelf supports (24); 2x72" continuous hinges (2); disc tumbler cam locks (2); #10x1" roundhead wood screws (2); 3 $\frac{3}{4}$ " (96mm) wire pulls with #8-32x1" machine screws (3); lockable draw latches (2) with #6x $\frac{5}{8}$ " flathead wood screws.

**Blades and bits:**  $\frac{1}{4}$ " and  $\frac{1}{2}$ " straight router bits,  $\frac{3}{4}$ " Forstner bit.

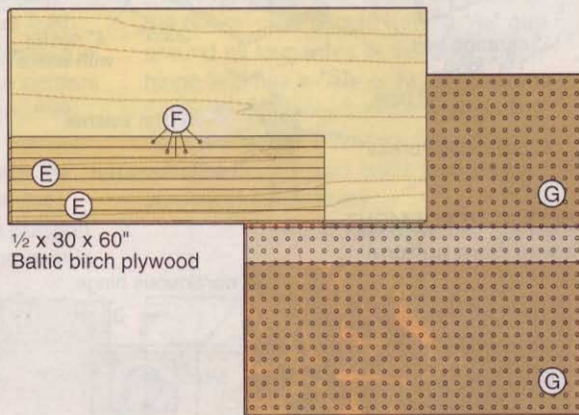

$\frac{1}{2}$  x 30 x 60" Baltic birch plywood

$\frac{1}{4}$  x 48 x 48" Perforated hardboard

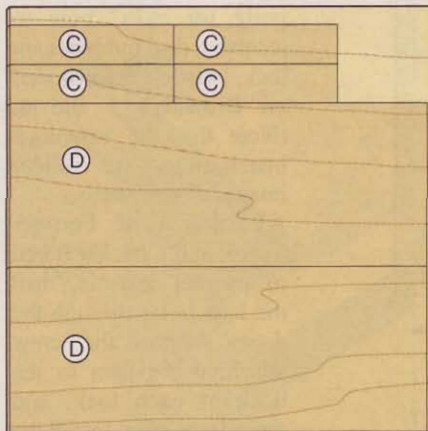

$\frac{1}{2}$  x 60 x 60" Baltic birch plywood

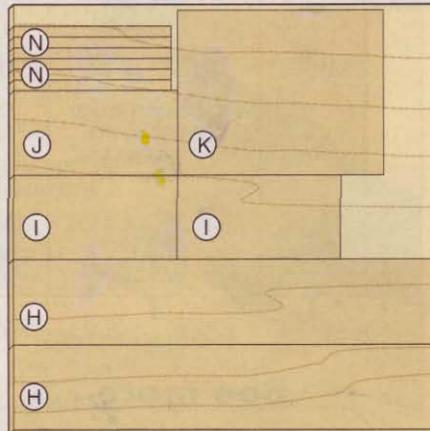

$\frac{3}{4}$  x 60 x 60" Baltic birch plywood

Written by **Owen Duvall** Project design: **Burdette Heikens**, Carefree, Arizona, with **Jeff Mertz**  
Illustrations: **Mike Mittermeier**; **Lorna Johnson** Photographs: **Marty Baldwin**



# mid-size lathes

We take eight models for a spin to see which deserves a turn in your shop.

See more ...

...tool reviews at

[www.woodstore.woodmall.com/reviews.html](http://www.woodstore.woodmall.com/reviews.html)

A dial indicator measures the side-to-side movement in each lathe as a turning blank spins, showing how well each machine dampens vibration. See the chart on *page 100* for the test results.

**P**rofessional woodturners may spend thousands of dollars on a lathe. But the rest of us, even those who turn fairly often, probably don't need that much tool. So, we wondered: What kind of lathe can you get for less than \$1,000? To find out, we brought in eight mid-size models from six manufacturers. Then, an expert turner put them through their paces. (See "A hired gun takes a turn" at bottom right.)

### Your top five demands for lathe performance

Here's how the tested lathes performed in the areas most important to turners:

**1 Power.** Small turning jobs, such as pens, don't require gobs of power. But tackling big cylinders or bowls does. An underpowered lathe makes large-scale projects frustrating if not impossible to accomplish.

To gauge the outright strength of these eight models, we made repeated, timed plunge cuts in maple cylinders, see "Parting power," below. We also turned 8"-diameter green-wood bowl blanks to gauge power for faceplate turning.

The Ridgid and the Grizzly G1067Z both offer just ½ horsepower, and were the most difficult to keep from stalling or slowing. They required the most time—twice as long as the four fastest lathes in the Grizzly's case—to make these aggressive cuts.



To change speeds on the Ridgid, left, and the Teknatool Nova (not shown), you stop the tool, and then move the belt on the stepped pulleys. The Craftsman, shown right, and the other tested lathes use shive pulleys. These pulleys expand and contract in diameter with just the turn of a knob or lever, increasing or decreasing the spindle speed.

**2 Speed range/ease of changing speeds.** Turning on a lathe requires a wide range of speeds. Roughing out a 10" bowl blank might best be accomplished at 450 rpm, while a finish cut on a spindle may require 2,000 rpm. Plus, varying the speed helps control vibration.

All of the lathes in this test offer multiple speeds, but the Teknatool Nova and the Ridgid both require you to stop the machine and move the drive belt by hand. The process is inconvenient on the Nova, and downright cumbersome on the Ridgid, **Photo A**, which has no tension release to ease the task.

We prefer models that let you adjust spindle speed with the tool running. The other six tested lathes do this with just a twist of a knob or lever, thanks to their shive-pulley drive systems, **Photo B**.

**3 Tool rest/tailstock security.** Turning anything but small projects means you'll move the tool rest and its base often to properly support the cutting tool near the workpiece. So, these assemblies must move quickly and easily. On the other hand, the rest and base have to lock firmly in place.

Positive locking is crucial for the tailstock, as well. If it moves, a piece turned between centers (mounted between the headstock and tailstock) may dislodge.

All of the assemblies on the tested models locked securely. Both Grizzly models, though, required constant adjustment because the nuts that hold them in place worked loose. A Grizzly representative told us they will cure the problem on both the G1067Z and G1495 by equipping them with nylon locking nuts.

### PARTING POWER

To test power, we measured how many seconds it took to cut a maple cylinder from 3" in diameter down to 1¾". For consistency, all eight maple blanks came from the same tree limb, and we sharpened the

3/16" parting tool after testing each lathe. We pushed the parting tool as hard as we could without slowing or stalling the lathe's motor. The machines with shorter times showed less tendency to bog, indicating more power.

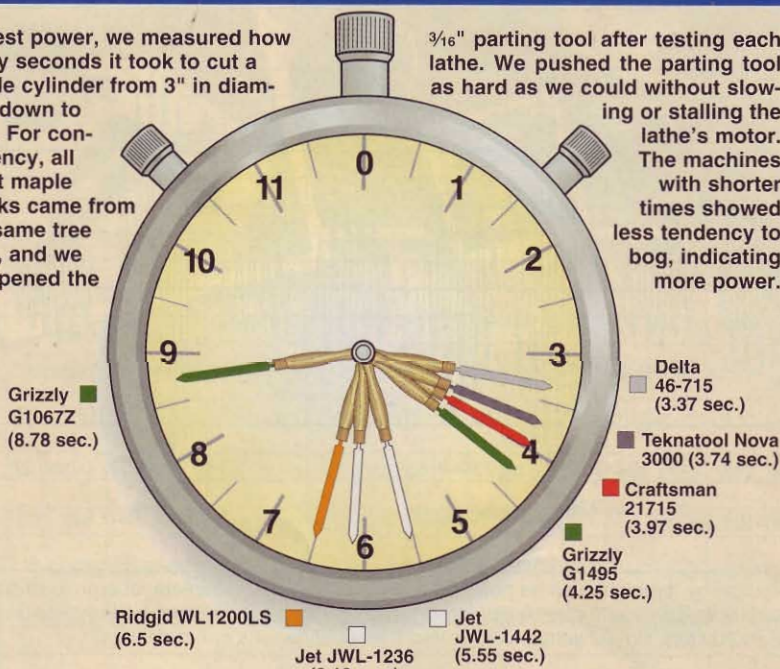

Tested at a no-load spindle speed of approximately 1,350 rpm. Time is the average of five cuts.

### A hired gun takes a turn

Our tester, Phil Brennon, knows a thing or two about lathes. He is a professional woodturner who teaches college-level woodturning and sculpting courses, and conducts workshops around the nation. Phil also serves on the board of the American Association of Woodturners ([www.woodturner.org](http://www.woodturner.org)), and hosts our woodturning forum at [www.woodonline.com](http://www.woodonline.com).



Phil helped devise our procedures, offering his insights into what hard-core turners demand from a lathe. Then, he translated it all into terms anybody can understand.

mid-size lathes

**4 Vibration.** Lathe vibration is inevitable, though it can be controlled. Contributing factors include the size, shape, weight, balance, and speed of the spinning workpiece.

Sheer mass serves as one of the best ways to combat vibration. A hefty machine or one that allows you to add weight works to dampen vibration. The heavier lathes in this test vibrated less, in general, though the second-lightest—the Craftsman—performed well, as shown in “Vibration Dampening,” at bottom.

Oftentimes, you can calm a vibrating workpiece by lowering or raising the spindle speed. But you can't always do that and still work the piece effectively.

**5 Headstock-tailstock alignment.** We assumed that after assembling all the lathes, we'd have to align the headstocks and tailstocks. We were pleasantly surprised, though, to find that all of the tested lathes were aligned within a few thousandths of an inch.

**Other points to ponder**

If turning bowls is among your goals, consider a lathe with a swiveling headstock, as shown in Photos C and D. Rotating the headstock to the outboard position (either at 45° or 90° from the spindle-turning position) offers two advantages. First, you can work on a faceplate-mounted workpiece without having to constantly reach over the lathe bed. Second, you can turn larger objects than would fit over the lathe bed. You'll see the manufacturers' over-bed and outboard turning capacities on the chart at the end of the article.

With the headstock rotated in the outboard position, you may need additional accessories, such as a tool-rest extension, Photo E.

The headstocks also slide along the full length of the bed on three of the eight tested lathes. This could be a handy feature if you turn heavy bowl blanks, as you can center the headstock on the length of the bed for better balance.

Consider also the space available in your shop. You can buy the Craftsman, Jet



C



D

With the headstock in standard position, left, the distance to the lathe bed restricts turning diameter. Rotating the headstock outboard, right, allows you to turn larger pieces attached to a faceplate. (Grizzly model G1067Z shown.)

JWL-1442, and Teknatool Nova 3000 without the stand for use on a benchtop. All of the lathes in this test, though, should be considered stationary unless mounted on a rolling base. They are all too heavy to move around by lifting.

All the tested models have indexing spindles. This feature allows you to lock the spindle in a preset position (from 12 to 36 stops, depending on the model) for carving or layout work. The Jet and Grizzly lathes use a removable pin for this operation. The others all lock into their stops using a permanent, spring-loaded pin. To access this pin on the Craftsman and Ridgid lathes, though, you have to open the pulley cover.



Included with some of the tested models, a simple extension positions the tool rest for outboard turning. (Delta 46-715 shown.)

**VIBRATION DAMPENING**

Any lathe will vibrate when turning an out-of-balance workpiece. Some, though, squelch this vibration better than others. The Jet JWL-1442, for instance, barely moved during our tests. The Grizzly G1067Z and the Ridgid, on the other hand, both shook noticeably.

Craftsman	Delta	Grizzly	Grizzly	Jet	Jet	Ridgid	Teknatool
21715/22249	46-715	G1067Z	G1495	JWL-1236	JWL-1442	WL1200LS	Nova 3000
(+/- .003")	(+/- .002")	(+/- .009")	(+/- .004")	(+/- .003")	(+/- .0015")	(+/- .0085")	(+/- .002")

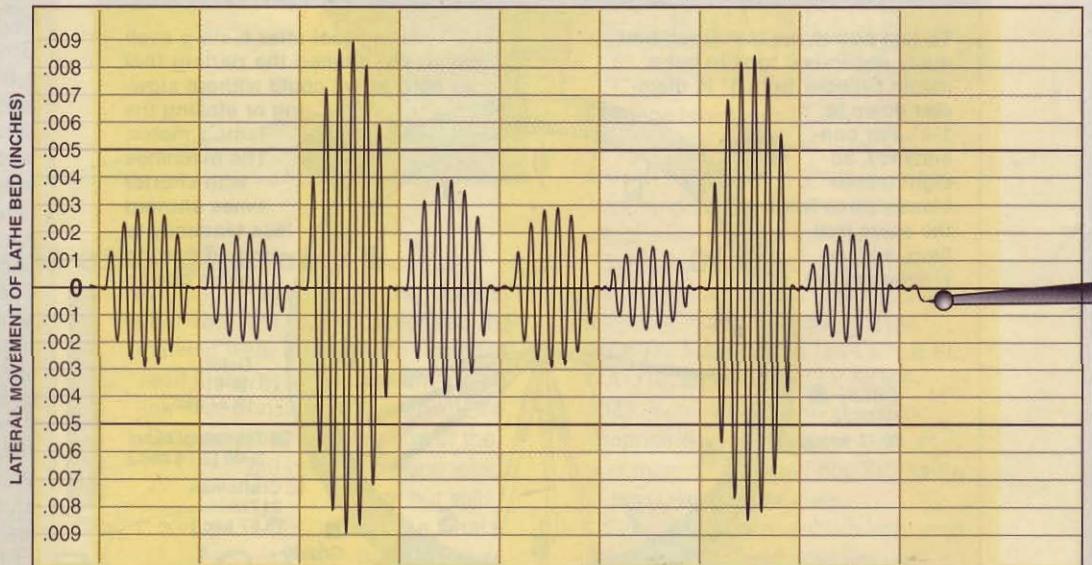

Tests conducted by turning the same bowl blank, mounted between centers, at a no-load spindle speed of approximately 1,400 rpm. A dial indicator, placed against the lathe bed and in line with the blank, measured vibration. All lathes were tested freestanding on a concrete floor.



# A closer look lathe by lathe

For consistency, all of our spindle blanks came from one tree, and all of our bowl blanks came from another. We made all of our cuts with the same tools, sharpening them between rounds.



**Craftsman 21715, \$450 without stand, \$550 with stand (model 22249),**  
[www.sears.com/craftsman](http://www.sears.com/craftsman) or visit your local Sears store

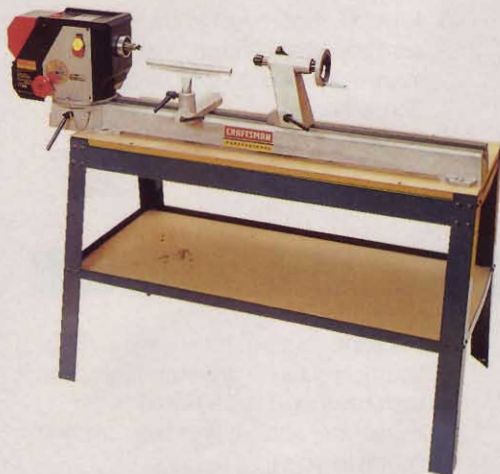

### High points

- ⤴ Great power for spindle and faceplate turning.
- ⤴ Positive tool-rest and tailstock lockdown with large levers.
- ⤴ The beefy headstock gives the feeling of a heavy-duty lathe, even with the use of some plastic components.
- ⤴ Swiveling headstock.

### Low points

- ⤴ Ventilation hole in motor housing produces an irritating whistling sound.

- ⤴ Accessing the indexing mechanism requires unscrewing a plastic pulley cover.
- ⤴ Plastic speed control knob proved uncomfortable and stiff to turn compared to a lever.
- ⤴ Tool rest won't go low enough to allow larger tools, such as a roughing gouge, to contact the workpiece at its centerline.
- ⤴ The optional stand went together slowly and had one MDF panel that was too long.

### More points

- ⤴ Stand has a large (54×28") footprint.

**Delta 46-715, \$650, [www.deltamachinery.com](http://www.deltamachinery.com) 800/438-2486**



### High points

- ⤴ Heavy, large headstock adds heft.
- ⤴ Thick bed casting with wide ways helps squelch vibration.
- ⤴ Great power in all turning conditions.
- ⤴ More spindle-speed stops (13) than any other model tested (others have 4 to 8), offering a multitude of control options.
- ⤴ Big, easy-to-use handles on the tool rest, tailstock, and headstock.
- ⤴ Comes with a tool-rest extension for outboard turning.
- ⤴ Quietest machine tested, at 69 db.

### Low points

- ⤴ Accessing the on/off switch requires a long reach, though it is large and easy to find.
- ⤴ Tailstock lockdown not as secure as some other models, though adequate.

### More points

- ⤴ Motor is located well clear of headstock, out of the way of large faceplate turnings.
- ⤴ Feels substantial and solid, even with a bolt-together metal stand.
- ⤴ Lathe comes preassembled, and the stand goes together quickly.

**Grizzly G1067Z, \$450, [www.grizzly.com](http://www.grizzly.com) 800/523-4777**



### High points

- ⤴ Swiveling and sliding headstock.
- ⤴ Smooth and easy speed control.
- ⤴ Comes with a tool-rest extension.

### Low points

- ⤴ Tool-rest and tailstock locking nuts work loose and require retightening often to achieve positive lockdown. Future models will sport nylon locking nuts to cure this problem.
- ⤴ The 1/2-hp motor offers too little power for a lathe of this size and capacity.

- ⤴ Lathe stands too low and needs to be raised for operator comfort.
- ⤴ Inconvenient on/off switch position.
- ⤴ Considerable vibration.

### More points

- ⤴ Offers all the features of the bigger lathes (except horsepower) at a low price.

Grizzly G1495, \$695, www.grizzly.com 800/523-4777

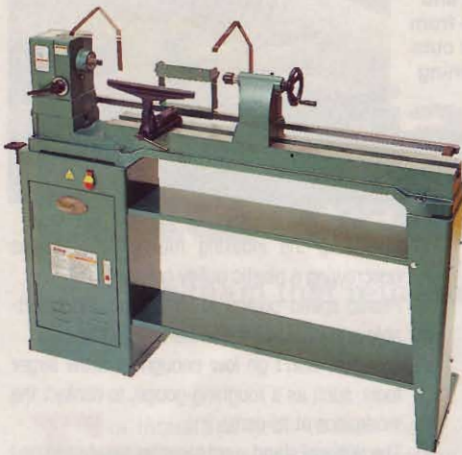

- High points**
- ⬆ Good power.
  - ⬆ Enclosed cabinet offers storage, and shelves accommodate added weight for stability.
  - ⬆ Comes standard with a chip guard and a disc/drum sanding attachment with table, shown at right.
  - ⬆ Easy spindle speed adjustment.
- Low points**
- ⬇ Gap-bed design doesn't allow locating the tool-rest base close to the spindle.
  - ⬇ The tool-rest base and tailstock nuts vibrated loose, and required readjustment, though this will be changed on future models.

The G1495 does double duty with its included sanding center that mounts to an outboard spindle.



- ⬇ A narrow stand magnifies the lathe's top-heaviness. Metal outriggers allow bolting the machine down, and should be used.
- More points**
- ⬆ Can be wired for 110- or 220-volt service.

Jet JWL-1236, \$600, www.jettools.com 800/274-6848

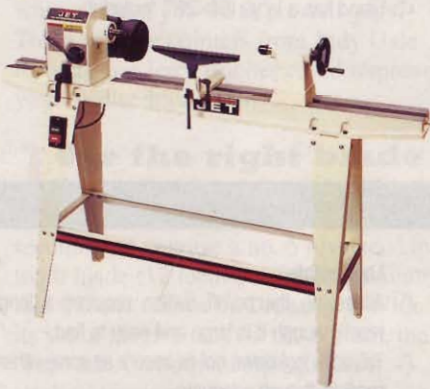

- High points**
- ⬆ The 3/4-hp motor offers adequate, though not overabundant, power for spindle and bowl work.
  - ⬆ Stable machine with little vibration.
  - ⬆ Comes with a tool-rest extension.
  - ⬆ Positive tool-rest and tailstock lockdown.
  - ⬆ Smooth operating speed control.

- Low points**
- ⬇ Machine height is low for average-height users.
  - ⬇ Inconvenient on/off switch location.
  - ⬇ Inboard and outboard gap beds can limit tool rest positioning.
  - ⬇ Noisiest lathe tested, at 85 db.
- More points**
- ⬆ Gap-bed design seems unnecessary because of the swiveling headstock.
  - ⬆ Motor location crowds the spindle area.

### LATHE PERFORMANCE: THE FINAL TURNOUT

BRAND	MODEL	VOLTS (1)	MOTOR		CAPACITY (INCHES)				HEADSTOCK		SPINDLE				TAILSTOCK				PERFORMANCE REPORT CARD (5)										
			RATED HORSEPOWER	BED TYPE (2)	FOOTPRINT (LxW, INCHES) (3)	GAP BED (YES/NO)	SWING OVER BED	OUTBOARD/OVER GAP (4)	BETWEEN CENTERS	MORSE TAPER	SWIVELING HEAD (YES/NO)	NUMBER OF INDEXED STOPS	SLIDING HEAD (YES/NO)	SPEED RANGE (RPM)	SPEED-CHANGING METHOD	DIAMETER (INCHES)	THREAD (THREADS PER INCH)	MORSE TAPER	QUILL TRAVEL (INCHES)	THROUGH HOLE (INCHES)	SELF-EXTRACTING TAILSTOCK (YES/NO)	EASE OF ASSEMBLY	POWER	VIBRATION	TOOL-REST/BASE LOCK	TOOL-REST LOCK	TAILSTOCK LOCK	EASE OF CHANGING SPEEDS	NOISE LEVEL
CRAFTSMAN	21715	110/220	2	FCI	54x28	N	15	20	38	#2	Y	24	N	360-2,400	Knob	1	8	#2	1/4	Y	N	C	A	B	B	A	A	B	D
DELTA	46-715	110	3/4	FCI	60x20	N	14	19	40	#2	Y	24	Y	500-2,500	Lever	1	8	#2	3	Y	Y	A	A	A	C	B	B	A	A
GRIZZLY	G1067Z	110	1/2	FCI	51x20	N	14	17	40	#2	Y	12	Y	600-2,100	Lever	1	12	#2	1/4	Y	Y	B	C	D	D	C	C	A	C
GRIZZLY	G1495	110/220	3/4	FCI	57x18	Y	14	17	40	#2	N	12	N	500-3,070	Lever	1	12	#2	1/4	Y	N	B	B	C	D	C	C	A	C
JET	JWL-1236	110	3/4	FCI	60x17	Y	12	16 1/2	34 1/2	#2	N	12	N	500-3,000	Lever	1	8	#2	1/4	Y	Y	B	B	B	B	B	B	A	D
JET	JWL-1442	110	1	FCI	57x20	N	14	*	40	#2	Y	12	Y	450-3,000	Lever	1	8	#2	4	Y	Y	A	A	A	A	B	A	A	B
RIDGID	WL1200LS	110	1/2	TS	58x30	N	12	N/A	36	#1	N	36	N	875-3,450	Pulley	3/4	16	#1	1/4	N	N	D	C	D	B	B	B	D	B
TEKNATOOL	Nova 3000	110	1	FCI	40x10	N	16	29	24	#2	N	24	N	215-3,630	Pulley	1 1/4	8	#2	1/4	Y	Y	B	A	A	A	B	A	C	C

**NOTES:**

1. All lathes come wired for 110-volt service.
2. (FCI) Flat cast iron (TS) Tubular steel
3. Dimensions refer to base size; lathe bed and motor may overhang.
4. \*No outboard capacity given. See "more points" at top of page 103.
5. **A** Excellent **B** Good **C** Average **D** Below average
6. (AR) Auxiliary tool rest (CG) Chip guard (D) Duplicator (DC) Drill chuck (FP) Faceplate (HW) Handwheel (KB) Knock-out bar (SA) Sanding accessories (SC) Scroll chuck (TE) Tool-rest extension
7. (Life) Lifetime warranty against defects.
8. (C) China (NZ) New Zealand (T) Taiwan (U) United States

Jet JWL-1442, \$750 without stand, \$830 with stand, www.jettools.com 800/274-6848



**High points**

- ⤴ A true heavy-duty lathe with big, meaty components at a medium price.
- ⤴ 1-hp motor offers plenty of power for spindle and outboard turning.
- ⤴ Sliding and swiveling headstock.
- ⤴ Handwheel allows manual stock rotation for marking, layout, and indexing.
- ⤴ Minimal vibration.

**Low points**

- ⤵ Motor position crowds the spindle area.
- More points**
- ⤴ According to John Otto from Jet, the outboard capacity for this lathe equals the distance from the spindle to the floor. We're comfortable saying that this lathe should at least equal the Teknatool Nova's 29"-diameter outboard capacity (with the use of an outboard tool rest).

Ridgid: WL1200LS, \$300, www.ridgidwoodworking.com 800/474-3443



**High points**

- ⤴ Affordably priced.
- ⤴ Tenacious tailstock grip.
- ⤴ Second-quietest tested, at 73 db.

**Low points**

- ⤵ Lacks power and capacity for turning large-diameter bowls.
- ⤵ A small spindle and #1 Morse taper limit the availability of aftermarket accessories.
- ⤵ Awkward tool-rest adjustment due to cumbersome handles.

- ⤵ Changing speeds requires removal of plastic cover to expose step pulleys, and there's no tension release for the belt.
- ⤵ Excessive vibration, attributable in part to the machine's light weight.
- ⤵ The 58x30" footprint is the largest in the test.

**More points**

- ⤴ Though adjustments are cumbersome, this lathe functioned well considering its low price and light-duty design.

Teknatool Nova 3000, \$900, www.teknaatool.com 866/748-3025

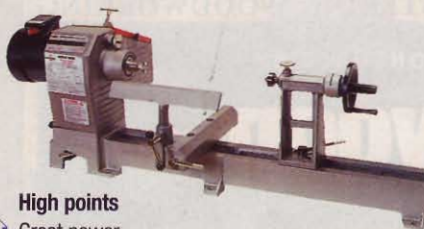

**High points**

- ⤴ Great power.
- ⤴ Very little vibration.
- ⤴ Large over-bed capacity plus swiveling headstock adds versatility in a small package.
- ⤴ High-quality machining and good fit and finish.

**Low points**

- ⤵ 24" capacity between centers is the shortest in the test.
- ⤵ Price doesn't include stand.

- ⤵ Cumsome speed changing requires stopping the lathe and manually moving belts (though a tension release helps).
- ⤵ On/off switch is small and inconveniently located for quick access.
- ⤵ Quill screw protrudes out the rear of tailstock and gets in the way when operating handwheel.

**More points**

- ⤴ Optional 24" bed extensions (\$150) increase spindle-turning capacity.
- ⤴ A benchtop tool, but made for heavy-duty work.
- ⤴ Teknatool offers an optional metal stand (\$100) and is developing a cast-iron version.
- ⤴ Heavy motor and narrow bed mean the lathe has to be bolted to a sturdy bench or stand.

ACCESSORIES		WARRANTY (YEARS) (7)	COUNTRY OF ASSEMBLY (8)	WEIGHT (POUNDS)	SELLING PRICE (9)
STANDARD (6)	OPTIONAL (6)				
AR, FP, KB	AR, D, DC, SC	1	T	175	\$550
FP, KB, TE	AR, D, DC	2	U	300	650
FP, KB, TE	AR, D, DC, SA, SC	1	T	180	450
CG, FP, KB	AR, D, DC, SC	1	T	250	695
FP, KB, TE	SC	2	T	185	600
FP, HW, KB, TE	SC	2	T	240	830
AR, FP, KB	AR, DC	Life	C	135	300
AR, FP, KB	AR, HW, SC, TE	5	NZ	220	900

9. Prices current at time of article's production and do not include shipping, where applicable.

Craftsman 21715 and Jet JWL-1442 prices include optional stand (as tested).

**Which lathes found their ways to our hearts?**

The Jet JWL-1442 takes our Top Tool award thanks to its great power, smooth operation, and large capacity. This lathe's \$830 price is the icing on the cake. With this machine, you won't have to worry about your ability outgrowing your lathe for a long time.

Delta's 46-715 earned our Top Value award, and was a strong contender for Top Tool honors, as well. At \$650, it offers rock-solid stability and refinement. Plus, the Delta brings plenty of power to play, boasting the fastest time in our Parting Power test. 🌟

Written by David Stone with Phil Brennon

Photographs: Marty Baldwin

# what's ahead

A sneak peek at some of the articles in the May issue of *WOOD*® magazine (on sale March 25)

## Great projects for your home and garden



### Gardener's gateway

It takes more than flowers, fruits, and vegetables to create a beautiful garden, and this trellised treasure is just the project, transforming your landscape from ordinary to extraordinary.



### 4-piece desk set

Make multiple sets of these smart desk accessories in no time, thanks to their shared parts and construction techniques.



### Pretty planter

This handsome housing holds a flower pot up to 16" in diameter.

Build one or more, then stay tuned for the June/July issue where you'll find plans for a trellised tuteur (see inset) that sits on the ground or rests atop the planter.



### Arts & Crafts table lamp

Mica shade panels accented with scroll-sawn, copper pine-cone motifs make this a glowing attraction.

## Tools, Techniques, & Features



### Portable planer showdown

What's the best portable planer today? Which offers the best value? We tested 10 popular models to find the answers.



### Pen-turning primer

Here's a great way to break into turning. With only a minimal investment in time, tools, and supplies, you can enjoy instant success making pens.



### Made in Utah

Craftsman Dale Peel makes a line of furniture in the "Mormon pine" style. In this article, he shows you a method for using power tools to make dovetails that appear handmade, and how to finish pine to look like an exotic wood.