

**SUCCESS GUIDE TO CLEAR FINISHES**

Better Homes and Gardens®

# WOOD

**FULL-SIZE  
PULL-OUT PATTERNS**

JUNE/JULY 2002  
ISSUE 142

Tips, Tools, Techniques, and Projects for the Home Woodworker

build this heirloom  
**hope chest**

**MORE GREAT  
PROJECTS:**

- ultimate tool chest
- built-in storage
- high-styled gate and fence

**HOT NEW TOOL  
8 ROUTER-LIFTS  
COMPARED**

[www.woodonline.com](http://www.woodonline.com)

Display until July 23, 2002

U.S.A. \$6.95



07>

© 72440 14072 1



# contents

WOOD® magazine

June/July 2002, Issue 142

## P R O J E C T S

- 14 sanding-disc organizer**  
Create simple storage that helps you install random-orbit discs quickly and easily.
- 42 ultimate tool chest**  
Show off your woodworking skills while providing a home for your favorite hand tools.
- 58 grand-entrance garden gate**  
Let this inviting structure welcome guests to your backyard living spaces.
- 64 good-neighbor fence**  
Spice up borders with a builder-friendly design that features durable plastic lattice.
- 74 heirloom hope chest**  
Learn basic frame-and-panel construction when you make this handsome project.
- 86 space-saving built-ins**  
Add style and storage to interior walls with this between-the-studs remedy.
- 94 kids' horseshoe set**  
Put on your game face and make something geared for outdoor fun.

## T E C H N I Q U E S

- 38 sign your work in brass**  
Show pride and class in your handcrafted projects with shop-made nameplates.
- 52 guide to clear finishes**  
Get the lowdown on topcoat choices, including application.



Cover Photograph: Baldwin Photography

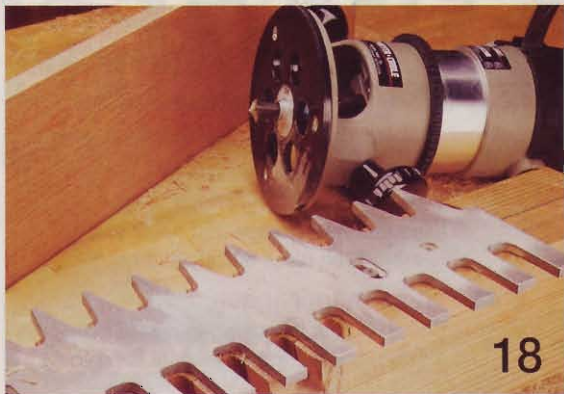

# contents

June/July 2002, Issue 142

## TOOLS AND MATERIALS

- 16 what makes a great brush**  
Discover what finish brushes work best for different topcoats and why.
- 18 price-busting dovetail jigs**  
Check out two new router accessories that combine ease of use with a great price.
- 70 tool test: stowable sawhorses**  
See which of the 12 tested models lead the pack in features and versatility.
- 80 tool test: router lifts**  
Quickly adjust bit height in table-mounted routers with one of these eight accessories.
- 98 products that perform**  
Check out the world's first cordless router, and beef up your router table with a shaper-type fence.

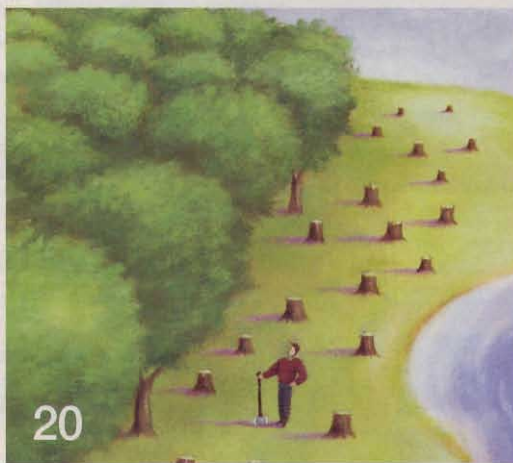

## FEATURES

- 20 where will the wood come from?**  
Find out the supply status of softwoods and hardwoods worldwide.
- 50 update on treated lumber**  
The days are numbered for wood with chromated copper arsenate. Catch up on the latest developments.

## DEPARTMENTS

- 6 editor's angle**
- 10 short cuts**
- 12 talking back**
- 22 shop tips**
- 33 ask WOOD**
- 112 what's ahead in our next issue**

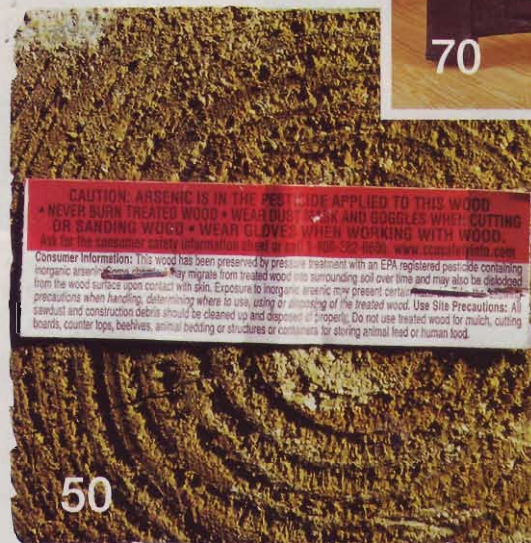

Better Homes and Gardens® WOOD® magazine (ISSN-0743-894X) is published seven times a year in March, May, June/July, September, October, November, and December by Meredith Corporation, 1716 Locust St., Des Moines, IA 50309-3023. Periodicals postage paid at Des Moines, Iowa, and additional mailing offices. Better Homes and Gardens trademark registered in Canada and Australia. Marca Registrada en México. **ONE-YEAR SUBSCRIPTION PRICES:** U.S. and its possessions, \$28; Canada, \$41; other countries, \$49. Canada Post Publications Mail Sales Agreement No. 40069223. Canadian BN 12348 2887 RT. **CANADIAN RETURN ADDRESS:** Better Homes and Gardens WOOD magazine, 2744 Edna Street, Windsor, Ontario, N8Y 1V2. **POSTMASTER:** Send address changes to Better Homes and Gardens WOOD magazine, P.O. Box 37439, Boone, IA 50037-0439.

# Walking the walk

What, exactly, are readers like yourself looking for in a wood-working magazine? At *WOOD* we give that question a lot of thought every day. Fortunately, thousands of you have supplied us with answers through letters, e-mails, and face-to-face meetings. Here's how we plan to live up to your high expectations.

Just as you devote your full energy and talents to every project that comes out of your shop, our staff prides itself on putting our very best effort into each issue of *WOOD* magazine. We make no bones about wanting to bring you a woodworking publication that is absolutely unmatched in every way.

To achieve that, we have to do a lot more than produce easy-to-read and insightful articles, complete with great photos and detailed illustrations. What we strive to do, more than anything, is capture your unreserved confidence in the accuracy and achievability of everything you see in the magazine. It is this level of confidence, we believe, that creates a quality difference among woodworking publications in today's marketplace.

We consider it essential that you can build a project from *WOOD* without fear that you'll be slowed by errors or stymied by missing steps. You can put your trust fully in the techniques and tips shown here, knowing that you won't waste materials or time. And, we want you to march into tool retailers with the unwavering certainty that you'll get a good buy based on the recommendations in our tool reviews.



From now on, you'll find this seal in every issue of *WOOD* magazine. It serves as a reminder of our central mission: to serve you with a woodworking magazine of unparalleled quality.

How do we deliver this quality difference? It's not easy, and it's not cheap, but there's no getting around it: We have to build every project, painstakingly prove every dimension, redesign and rebuild projects if necessary, then double- or triple-check every detail. We verify the effectiveness and safety of every woodworking technique here in our shop by an in-house staff of designers, builders, and writers. Each staffer takes ownership of every article he is involved with, and proudly places his name at the end of each story. When it comes to tools, we never write up a product until it proves itself worthy of a place in your shop by passing our intensive tests first.

It's called walking the walk, not just talking the talk. Of course, I want you to tell me how well we're succeeding. Just drop me a letter at the editorial mailing address at *right*, or send an e-mail to me at wood-mail@mdp.com.



Bill Krier

Editor-in-Chief **BILL KRIER**  
Executive Editor **JIM HARROLD**  
Managing Editor **MARLEN KEMMET**  
Features Editor **DAVE STONE**  
Products Editor **DAVE CAMPBELL**  
Projects Editor **JAN HALE SVEC**  
Projects Editor **OWEN ØJVALL**  
Techniques Editor **JIM POLLOCK**  
Senior Design Editor **KEVIN BOYLE**  
Design Editor **JEFF MERTZ**  
Master Craftsman **CHARLES I. HEDLUND**  
Production/Office Manager **MARGARET CLOSNER**  
Administrative Assistant **SHERYL MUNYON**  
Illustrators **LORNA JOHNSON, ROXANNE LeMOINE, TIM CAHILL, MIKE MITTERMEIER**  
Contributing Photographer **MARTY BALDWIN**  
Technical Consultants **RICH BRIGHT, JEFF HALL, PHILLIP GOODWIN, GARRY SMITH**  
Contributing Craftsman **JIM HEAVEY**  
Proofreaders **JIM SANDERS, BARBARA KLEIN**

Art Director **TIM ALEXANDER**  
Associate Art Director **KARL EHLERS**  
Assistant Art Director **CHERYL A. CIBULA**  
Publisher **MARK HAGEN**

Advertising Office: 333 N. Michigan Ave., Suite 1500, Chicago, IL 60601 Phone: 312/853-2890 Fax: 312/580-7906  
Sales and Marketing Assistant **LARA KALLAL**  
Mail Response Manager **CAROLYN DAKIS**  
Account Executive **RON GOLMINAS**  
Account Executive **NEIL KIRBY**  
Account Executive **JOHN THORNBURGH**  
Detroit, Phone: 248/356-1149 Fax: 248/356-8930  
Account Executive **PAT TOMLINSON**  
Northeast, Phone: 212/551-7043 Fax: 212/551-7192  
Southeast: Lagomarsino, Dempsey & Dennis, Inc. 2951 Piedmont Rd., NE, Suite 100, Atlanta, GA 30305  
Phone: 404/261-5400 Fax: 404/261-5404  
Group Marketing Director **CATHY E. SMITH**  
Senior Marketing Services Manager **ALEXANDER D. CLARKSON**  
Phone: 212/551-7090 Fax: 212/551-7192  
Senior Promotion Designer **SARAH DI BELLA**

Group Publisher **STEPHEN B. LEVINSON**  
Associate Business Director **CRAIG FEAR**  
Senior Product Manager **RICK GROW**  
Advertising Operations Manager **PAT HENDERSHOTT**  
Consumer Marketing Director **KATHI PRIEN**  
Consumer Marketing Manager **DAVE HONOLD**  
Vice President/Publishing Director **WILLIAM R. REED**

**MEREDITH PUBLISHING GROUP**  
President **STEPHEN M. LACY**  
Magazine Group President **JERRY KAPLAN**  
Group Sales **MICHAEL BROWNSTEIN**  
Creative Services **ELLEN DELATHOUDER**  
Business Development **TINA GEORGEOU**  
Manufacturing **BRUCE HESTON**  
Consumer Marketing **KARLA JEFFRIES**  
Finance and Administration **MAX RUNCIMAN**

**Meredith CORPORATION**  
**WILLIAM T. KERR**, President and Chief Executive Officer  
**E.T. MEREDITH III**, Chairman of the Executive Committee

©Copyright Meredith Corporation 2002  
All rights reserved. Printed in the U.S.A.  
**Customer Service Information:** For service on your subscription, including change of address, contact us at [www.woodmagazine.com/service](http://www.woodmagazine.com/service) or call 800/374-9663.  
**Subscription mailing address:** Better Homes and Gardens WOOD magazine, P.O. Box 37439, Boone, IA 50037-0439. Please enclose your address label from a recent issue.  
**Editorial mailing address:** The Editor, WOOD magazine, 1716 Locust Street, GA310, Des Moines, IA 50309-3023. For questions on editorial, questions about how to reach an advertiser, or to place an advertisement in our magazine call 800/374-9663.  
**To order back issues call 800/346-9663.** Article reprints, send \$5 per article (no phone orders), include issue and name of article, to WOOD Article Reprint Service, P.O. Box 349, Kalona, IA 52247, check or money order made payable to WOOD magazine.



amazon.com. VIEW CART | WISH LIST

WELCOME | BROWSE PRODUCTS | LAURA'S STORE | BROWSE BRANDS | BOOKS | TOP SELLERS | ELECTRONICS | DVD | HEALTH & BEAUTY | TRAVEL | COMPUTER & VIDEO GAMES | MUSIC | TOOLS & HARDWARE | INFO CENTER | FREE CATALOG | COMPANY ACCOUNTS | YOUR DESK

All results for: routers

Search: Tools & Hardware in routers

Most popular results for routers:

1. Makita RT1010 2-1/4 HP VS Router Kit includes Fluorocarbon Guide, Larger Hole Base Plate, and 8-Piece Carbide Router Bit. \$139.00 Value. Our Price: \$79.99
2. Freud FT200EP 2-1/4 HP Electronic Variable Speed Router Kit includes Edge Guide, a \$24.99 Value. Our Price: \$199.99

Freud #FT200EP



Freud #FT200EP



Fein #RT-1800

**THE BEST PLACE TO BUY HUNDREDS OF ROUTERS ONLINE**

[www.toolcrib.amazon.com](http://www.toolcrib.amazon.com)

Call for your FREE Tool Crib catalog  
**1-800-635-5140**

**TOOLS & HARDWARE**  
**amazon.com**

# short cuts

News and notes from the woodworking world

## A mahogany look-alike makes its debut

Any woodworker who has purchased the premium hardwood Honduras mahogany has experienced sticker shock firsthand. We found it for over \$5 a board foot at our local lumberyard. Recognizing the need for a lower-priced substitute, industry giant Weyerhaeuser recently introduced a comparable product that sells for around \$4 a board foot.

Called Lyptus, a hybrid of *Eucalyptus grandis* and *Eucalyptus urophylla*, this hardwood grows in mammoth sustained-forest plantations in Brazil, as pictured at right. Harvested in just 10 to 12 years, Lyptus is then brought into the U.S. and Canada and sold on a special-order basis through lumber retailers carrying Weyerhaeuser products. You can purchase it surfaced on four sides (S4S) in 4/4 and 5/4 thicknesses, and in random lengths and widths.

Weyerhaeuser's new hybrid hardwood Lyptus serves as a less-costly substitute for mahogany.

With the product being so new, some dealers may not know of it. And while its intended use includes furniture, cabinets, and architectural millwork, Weyerhaeuser has not yet manufactured a Lyptus-veneered plywood to support the hardwood end of the business.



A sprawling, well-managed plantation of Lyptus trees thrives in the South American jungle climate.

## Give batteries a safe retirement

Thanks to the nonprofit, public-service organization Rechargeable Battery Recycling Corporation (RBRC), you now have an environmentally friendly way to dispose of all your worn-out rechargeable batteries. These include cells from portable power tools, laptop computers, cell phones, and camcorders.

Partnering with The Home Depot, and receiving assistance from



DeWALT Industrial Tools, RBRC has installed collection boxes, above, in participating Home Depot

stores in the U.S. and Canada. Also, countless other retailers, such as hardware stores, have joined in the campaign. To find the collection outlet nearest you, call 800/8-BATTERY or log onto [www.rbrc.org](http://www.rbrc.org).



# talking back

Our bulletin board for letters, comments, and timely updates

## More panel designs offer new tales to tell for the storybook lamp

We wanted to let you know that we are now offering more laser-cut side panels—26 new designs plus your original four—for the “Storybook Lamp” you featured in issue 135, September 2001. The new panels include more with kids’ storybook themes, as well as some geared more toward grown-ups. These include the sailboat and patriotic-themed panels shown at right.

—Mike and Joan Driscoll,  
Drico Products, Inc.

For more information about the new panel designs and their prices, call Drico Products at 888/577-3257.



“Hideout” woodworkers Carolyn Barnes (top) and Andy Mihok helped kids build birdhouses during a junior woodworker’s day.



## Mentoring works great for kids and the kids-at-heart

In reference to Bill Krier’s editor’s letter on mentoring (issue 139), I am writing on behalf of a group of woodworkers who reside in “The Hideout,” a 3,200-home recreational community located in the Pocono Mountains of Pennsylvania. We now have over 100 men and women in our woodworking club. Last summer we held the grand opening of a new 36×80’ woodshop facility.

We also sponsored our first junior woodworker’s day, inviting kids of the community, ages 8 through 12. We had two sessions, each attended by 20 children. Each junior woodworker received a shop apron (made by our ladies auxiliary), safety glasses, and pre-cut wood for a birdhouse. The kids worked at centers with club members until their projects were complete.

“The Hideout” woodworkers are trying to promote interest in woodworking to everyone in our community. We’re planning to hold another junior woodworker’s day sometime this summer.

—Kenneth Wenz, Lake Ariel, Pa.

## Titebond II gets a new lease on shelf life

I would like to respond to a reference made about the shelf life of Titebond II glue in the article “Double take on woodworking” in issue 137, November 2001, of *WOOD* magazine.

On page 82, Robert Meier is quite complimentary of Titebond II, but his opinion that the glue “must be fresh” and that it “gets old in six months and loses some strength,” concerns me. Titebond II has been on the market for 10 years and millions of gallons have been sold. Our comprehensive testing,

coupled with extensive customer feedback, gives us ample evidence and resounding confidence that the shelf life of Titebond II extends well beyond six months.

We are very conservative in our published shelf life of 12 months. Experience shows that the product maintains its integrity and bonding characteristics for a substantially longer period of time.

—Mark Schroeder, Marketing Manager,  
Franklin International

## Write Us!

Do you have comments, criticisms, suggestions, or maybe even a compliment specifically relating to an article that appeared in *WOOD* magazine? Please write to:

Talking Back  
WOOD magazine  
1716 Locust St., GA-310  
Des Moines, IA 50309-3023

or e-mail us at [talkingback@mdp.com](mailto:talkingback@mdp.com)  
Due to the volume of letters and e-mails we receive, we can respond to and publish only those of the greatest interest to our readers.

# sanding-disc organizer

A simple system to keep abrasive discs flat and at the ready for quick mounting

**E**ver been frustrated trying to align the holes in a sanding disc with the holes in a random-orbit sander's pad? If so, then you'll appreciate this simple storage and organizing system designed by *WOOD*® reader and professional woodworker Tom Frazier. This fixture stores three grits of 5" hook-and-loop discs on short pieces of dowel that index with the holes in the sander, making alignment foolproof.

To use the organizer, place the sanding discs over the dowels grit side down. Then just press the sander onto the dowels for surefire alignment. Each section holds about a dozen discs. A cap keeps them flat and clean.

Building a disc dispenser is easy. Cut a base to the size shown from scrap  $\frac{3}{4}$ " stock. (Tom used MDF because it stays flat.) Then rout the top edges with a  $\frac{1}{4}$ " round-over bit. Next, cut a  $\frac{1}{4}$ " hardboard cap, center it on the base, and temporarily tape it in place.

Mounting the dowels accurately is no problem. Use a sanding disc as a guide, and follow the three steps shown in the drawing at right. Whether your sander accepts 5-hole or 8-hole discs, three dowels hold each disc securely in place. ♣

Written by **David Stone**  
Project design: **Tom Frazier**  
Illustration: **Roxanne LeMoine; Tim Cahill**  
Photograph: **Baldwin Photography**

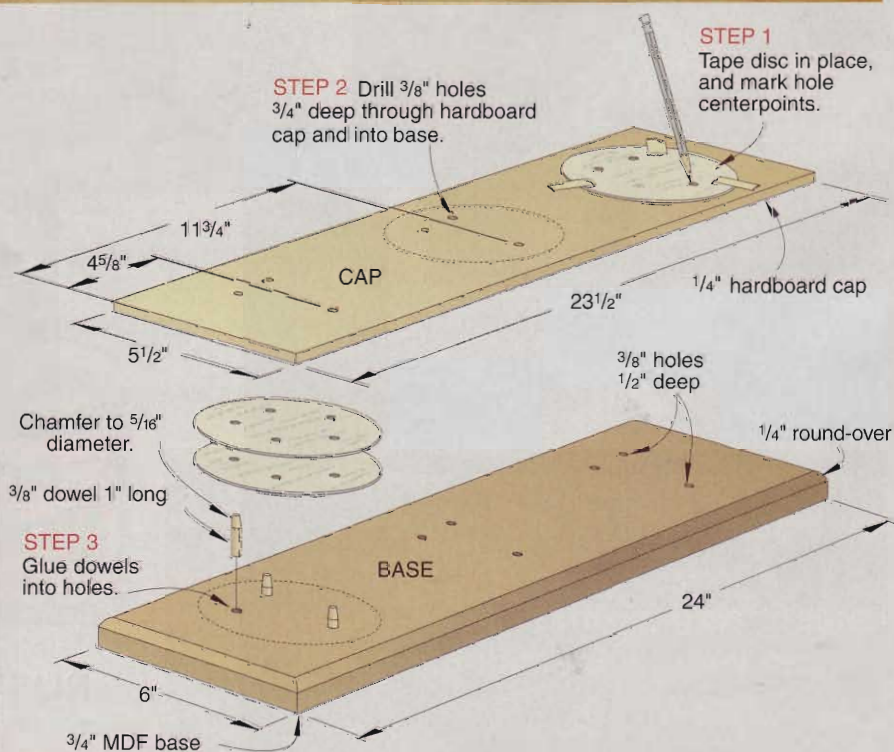
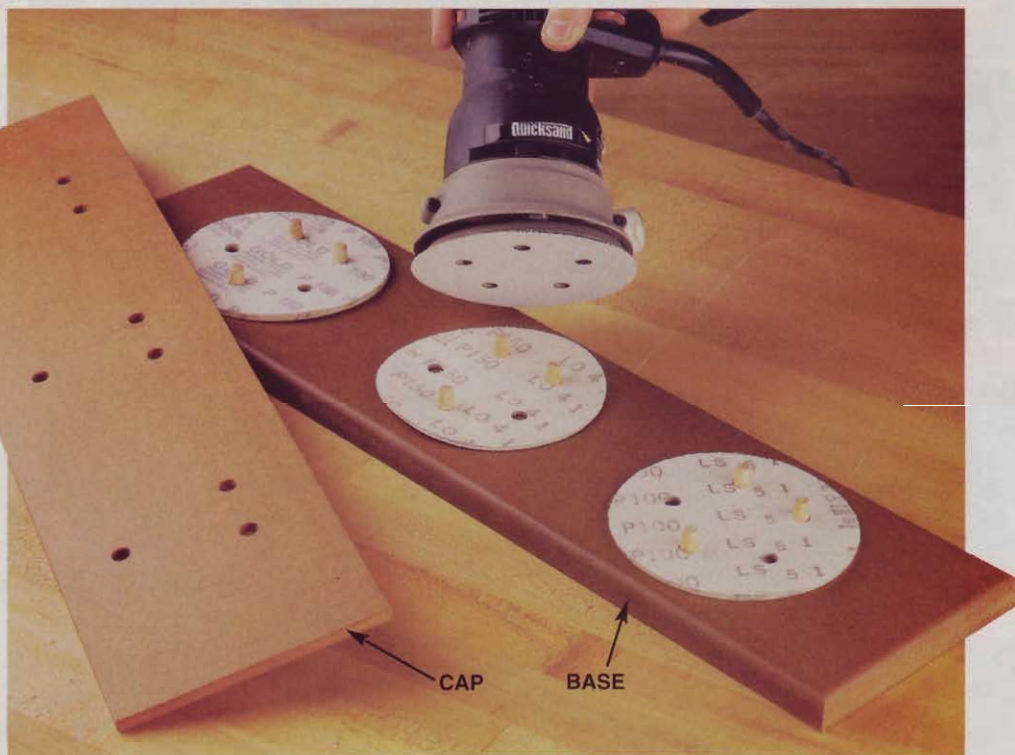

# a brush with greatness

Brushes may look alike, but they're not all equal. Choose wisely, then handle them with care.

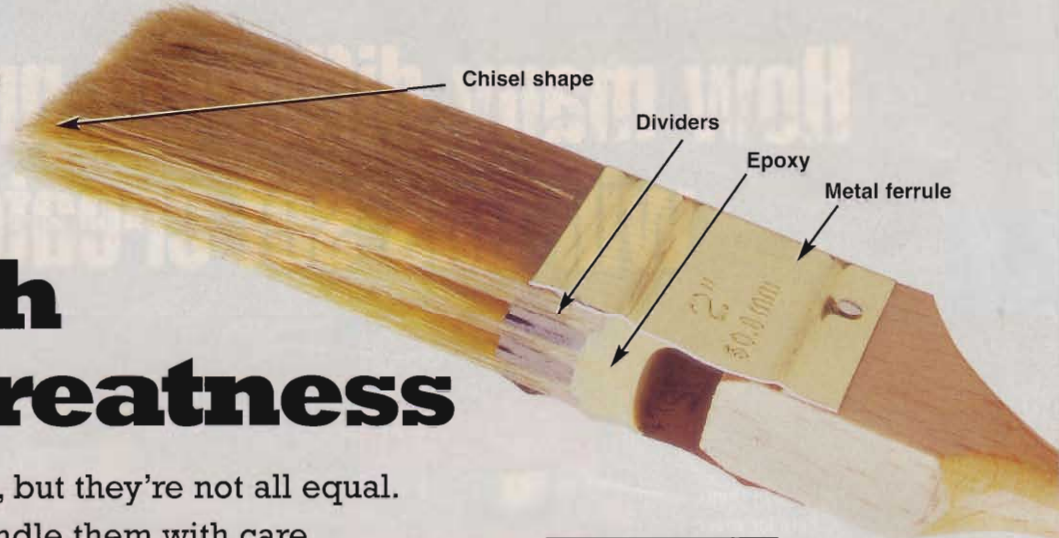

**W**hen you apply a clear finish, your brush makes a difference. A cheap, throwaway model can cause problems, while a quality brush that suits your particular finish will help you achieve first-class results. You'll spend more up front, but that's not a decisive factor; take care of it properly, and a good brush will last much longer than a cheap one.

The photo *above* provides a cutaway view of a finishing brush made by the Elder & Jenks company, brushmakers since 1793. The bristles are set into a slightly convex base of epoxy, then trimmed to complete the chisel shape. Double dividers give the bristles extra support. They also create reservoirs that hold a small amount of finish, feeding the brush as you use it.

When you apply varnish or brushing lacquer, opt for a "China bristle" brush made with hog hairs from China. These bristles, as shown in the drawing *above right*, have a natural taper that provides strength while putting more bristles in contact with the surface. Their "flagged" ends hold more finish than pointed ones, and dispense it more evenly.

For water-based finishes, use synthetic bristles. Nylon bristles are softer and more flexible than polyester, or you can buy a combination of the two. Golden nylon gives great results with shellac. Some synthetic bristles also are tapered and flagged.

Once you have a top-notch brush, keep it in working order. It takes only a couple of minutes to clean and store it properly.

When you're done applying a coat of finish, brush out as much finish as possible onto paper or a piece of scrap. Put on protective gloves, soak the bristles in the appropriate solvent, and work it in with your fingers. If you used the brush with varnish, clean it with mineral spirits, then lacquer thinner. If you applied lacquer, clean with lacquer thinner. A shellac brush benefits from a bath in ammonia and hot water. Use water to clean out water-based finishes. When the bristles feel clean, shake the brush to remove most of the solvent, or hold the handle between your palms and rub your hands to spin it.

Finally, no matter which solvent you started with, finish cleaning the brush with soap (shampoo works well) and water, as

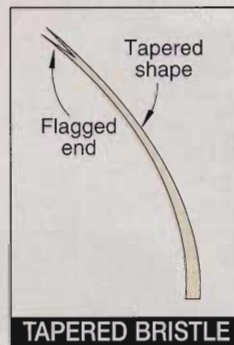

**TAPERED BRISTLE**

Tapered bristles are strong, but capable of laying down a smooth finish. Flagged ends also help finish flow out evenly.

shown in **Photo A**. Rinse out the soap, then spin the brush to remove the water. Before it dries completely, place the brush in its original cardboard jacket, or wrap it with paper from a grocery bag, as in **Photo B**, to keep the bristles straight and clean. The next time you need it, your brush will be as good as new. ♣

Photographs: **Baldwin Photography**  
Illustration: **Roxanne LeMoine**



**A** Use the appropriate solvent to clean your brush after each use, then complete the job with soap and water. Work the lather into the bristles, then rinse.



**B** Cut your paper long enough so you can fold it back to the ferrule without bending the bristles. Wrap it tightly, fold it, then hold it in place with a rubber band.



# price-busting dovetail jigs

Pins and Tails jigs deliver through dovetails for the price of a half-blind jig.

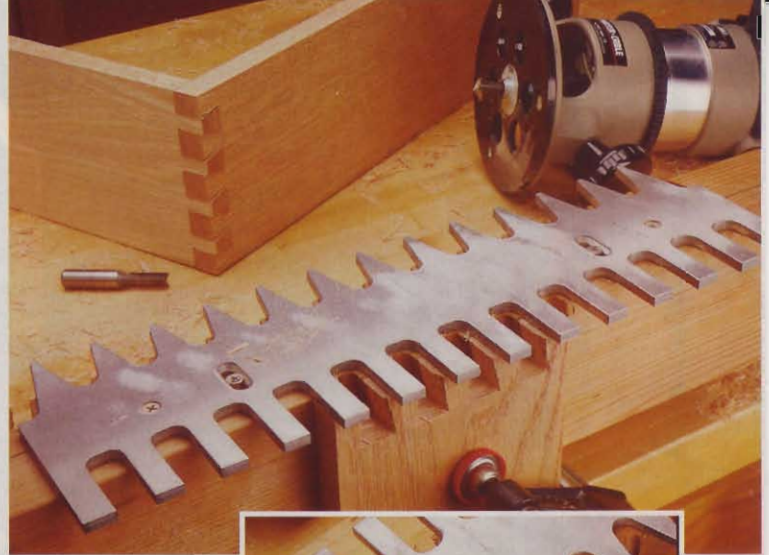

We were careful to mark the waste areas to make sure that we routed away the sockets, not the pins.

**W**oodworkers are drawn to dovetail joints like college students to free pizza. Now, for about the price of dinner and a movie for two, you can cut precise through dovetails with the Pins and Tails Traditional Through-Dovetail Jigs from MLCS.

These templates came on the market just as our review of through-dovetail jigs (August 2001, issue 134) hit the newsstand. Although they borrow many of the better attributes of the jigs in that test, Pins and Tails jigs (\$80 each) cost only about half as much as the least-expensive model originally reviewed.

## Imitation is flattery

In setup and operation, the Pins and Tails jigs resemble the Keller 2401. You mount the template to a 2 $\frac{7}{8}$ "-thick wooden fence that you provide. (We resawed, then planed down, a 4x4 cedar post to make this odd-size fence.) After clamping your stock to the fence and routing the tails, you use the tails to mark the pin board.

Because the Pins and Tails jigs use a  $\frac{5}{8}$ " guide bushing instead of a bearing-guided bit, you can't simply align the pin side of the template to those marks, as you can with the Keller 2401. After we made our first set of pin cuts, we found we could use the actual cut in the fence to align the template for future cuts, as shown in the *inset photo*. As with the Keller 2401, you can manually vary the pin spacing by cutting pins and tails one at a time.

Adjusting the fit of the joint is pretty straightforward: Cut a test joint by temporarily mounting the template to the fence, using the elongated screw slots. Then shift the template forward or back to adjust the fit. In our tests, we achieved a perfect-fitting joint on our third test cut. We then locked in that fit with a pair of screws in round holes on the template.

## Any downside?

Although many of the templates in our recent test make 7° dovetails, these templates cut 14° tails. It's a strong joint, but the steeper angle makes the tips of the tails more prone to breakage. As the bit exited the cut, several of the tails in our red-oak test pieces lost a small chip at the very tip.

MLCS sells two jigs: Model 8701 (shown *above*) comes with  $\frac{1}{2}$ "-shank bits, and cuts  $\frac{3}{4}$ " tails on  $1\frac{1}{8}$ " centers; model 8702 makes 1" dovetails 2" on-center. You can also get either model with  $\frac{1}{4}$ "-shank bits instead of  $\frac{1}{2}$ ". The \$80 price

doesn't include the  $\frac{1}{4}$ "-long  $\frac{5}{8}$ "-diameter guide bushing required to make the cuts.

Our jigs didn't come with setup and operating instructions, but we found them in an online instruction book. The setup procedure is clearly described, although the directions for actually cutting the dovetails were vague. At our suggestion, Bill Goldman of MLCS said the company would immediately beef up the operating instructions and include a copy with every Pins and Tails template shipped.

Written by Dave Campbell with Dave Henderson  
Photographs: Baldwin Photography

MLCS THROUGH-DOVETAIL JIGS, IN A NUTSHELL																					
BRAND	MODEL	BITS INCLUDED (YES/NO)	BOX JOINTS POSSIBLE (YES/NO)	GUIDE-TEMPLATE MATERIAL (1)	ROUTER-GUIDING SYSTEM (2)	CAPACITIES						PERFORMANCE RATINGS (4)				WARRANTY	COUNTRY OF ASSEMBLY (6)	SELLING PRICE (7)			
						MINIMUM THICKNESS USING INCLUDED BITS	MINIMUM THICKNESS USING OPTIONAL BITS	MAXIMUM THICKNESS USING INCLUDED BITS	MAXIMUM THICKNESS USING OPTIONAL BITS	MINIMUM STOCK WIDTH (3)	MINIMUM CENTER-TO-CENTER WIDTH	MINIMUM PIN WIDTH	EASE OF ASSEMBLY	EASE OF TUNING FIT OF JOINT	MANUAL CLARITY				EASE OF USE	EASE OF SETUP	OPTIONAL ACCESSORIES (5)
MLCS	8701	Y	Y	AL	G	$\frac{1}{2}$ "	N/A	$\frac{7}{8}$ "	N/A	15**	$1\frac{1}{8}$ "	$\frac{3}{4}$ "	E	G	F	G	E	G	90 days	T	\$80
	8702	Y	Y	AL	G	$\frac{1}{2}$ "	N/A	$\frac{7}{8}$ "	N/A	16**	2"	1"	E	G	F	G	E	G	90 days	T	\$80

NOTES:

1. (AL) Aluminum  
2. (G) Guide bushing  
3. (\*) Can be repositioned along board for wider workpieces.  
4. E Excellent  
G Good  
F Fair  
5. (G) Guide bushing  
6. (T) Taiwan  
7. Prices current at time of article's production.

For specifications on other types of tools, click on "Tool Comparisons" at [www.woodmall.com](http://www.woodmall.com).

# where will the wood come from?

As the world's population grows, demand for wood increases. Can global forests provide it? Here's a brief look at today's reserves, and a peek into the future.

**E**conomists and other researchers that take a hard look at the world and the pressures on it most often tie their projections to population growth. As the population expands, it automatically demands more of the world's natural resources, and that includes wood. The following facts and figures offer a glimpse at what the future holds for this remarkable resource.

## How much wood do people use?

As of April 2000, the United States' population was 282,421,906. It's calculated that in this nation that ranks as the world's largest consumer of wood products, each person uses in some way the equivalent of 960 board feet of wood annually. That translates into a 36"-diameter log about 32' long. And the U.S. population grows by about 2.5 million annually.

In the next 50 years, the United Nations expects the world population to expand from 5.95 billion to 9.36 billion. Most growth will occur in developing

countries, where wood is used for cooking and heating (fuelwood). Currently, 56 percent of the world's consumed wood sees such usage. The rest (44 percent) becomes lumber, paper, and engineered wood products.

## Will there be enough wood to meet demand?

Although the need for fuelwood will increase in developing countries, demand for wood products also will increase in developed countries. For instance, in the United States, the average home size is now 2,120 square feet (up 600 square feet since 1971). That home size requires 15,000 board feet of lumber and other wood products.

Thankfully, forests account for one-third of the U.S.—about 737 million acres. Commercial forests (where trees are harvested for further processing) make up 490 million acres of that. Individuals own 59 percent of the commercial forests. The government owns 27 percent, while the forest industry owns the last 14 percent.

## Hardwoods, the woodworker's choice

Global wood and forest statistics don't differentiate between hardwoods and softwoods. To them, it's all just wood. As a woodworker, though, your usual preference likely includes hardwoods, such as maple, oak, and walnut. That's where the Hardwood Forest Foundation comes in. They track them. And the future looks good:

- Hardwood forests cover about 269 million acres in the United States, mostly east of the Mississippi River.
- Today, there's 102 percent more hardwood growing than in 1950. Projections show that by 2040, hardwood volume will expand by another 70 percent.
- Hardwood forests annually grow 80 percent more than is harvested, lost to fire, insects, and disease combined.

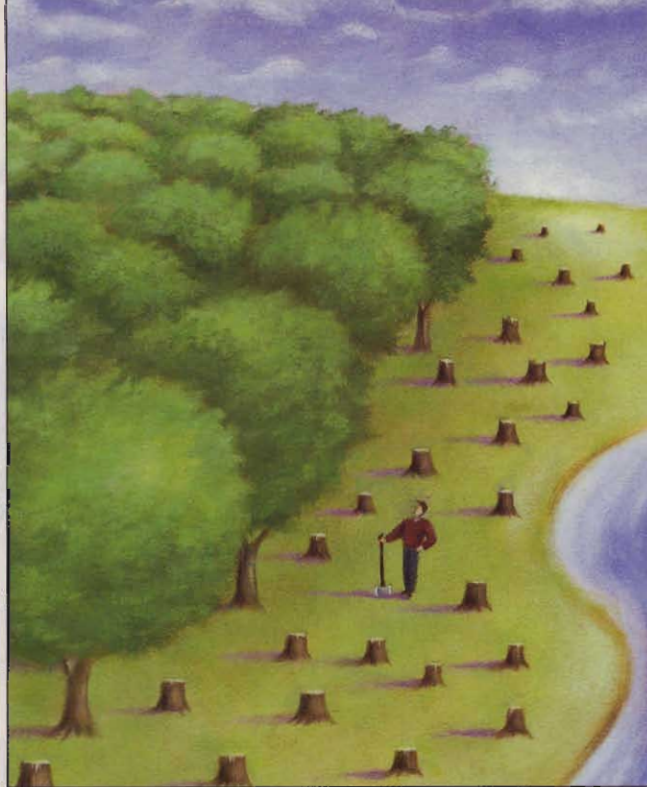

In these commercial forests, annual growth exceeds harvest and losses to insects and disease by 33 percent. In fact, the U.S. has 30 percent more timber volume now than 50 years ago. Combined, the U.S. and Canada produce 40 percent of the world's wood.

Given current statistics and future projections, analysts believe that any wood-supply crisis will occur in developing countries. That's because forests there decreased by 494 million acres between 1980 and 1995. But in the same period, developed-world forests increased by 49.4 million acres.

At this point, predictors see no trouble meeting the demand for wood in developed countries. That outlook assumes that the forest products industry continues its ongoing efforts to reduce sawmill waste and increase recovery in manufacturing and that everyone recycles more paper and paperboard.

Two other factors help meet demand. First, tree plantations in the United States, Canada, Australia, New Zealand, Indonesia, and South America produce wood products at sustainable rates. Second, commercial forests keep getting more efficient. In the U.S., alone, forest-industry land (again, just 14 percent of commercial forests) produces one third of the annual harvest. ♣

Written by **Peter J. Stephano**

Illustration: **Brian Jensen**

Sources: **Temperate Forest Foundation, The Hardwood Forest Foundation**

# shop tips

Helping you work faster, smarter, and safer

## top shop tip

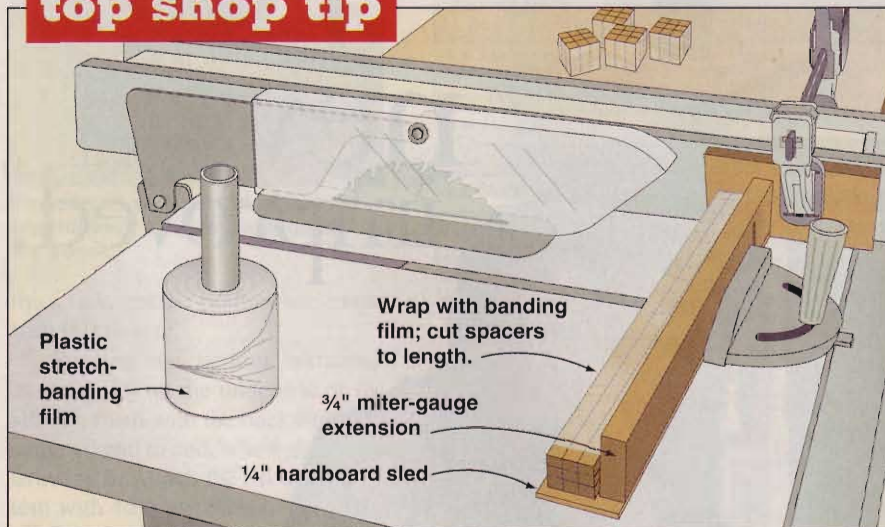

## Make a bundle before cutting a pile of parts

Since the time I built the Sweet Dreams Cradle in *WOOD*® magazine issue 85 for the arrival of our daughter Terra, I've made four more for friends. Although each was a very rewarding project, the only part I didn't like was cutting all those slat spacers—68 for each cradle!

So, for the last cradle I built, I cut several long spacer blanks to width and thickness, then wrapped them with plastic stretch-banding film (sometimes called "flat twine"). Using a narrow sled

and extension temporarily attached to my tablesaw's miter gauge, I crosscut the entire bundle of blanks until I had enough spacers for the cradle.

Wrapped in this manner, I get less tear-out because the blanks back each other up. And, I don't need to worry about individual spacers getting kicked back at me by the blade. As a bonus, I can quickly count bundles instead of spacers to know when I'm done.

—Dan Wallace, Lomita, Calif.

## See if this pushblock tip floats

Over the years, I've found that most of the pushblocks that come with jointers and shapers provide little grip on the stock. Instead, I use a couple of molded sponge-rubber floats, such as Goldblatt part no. 03295 (call 866/465-3252), that seem to hold on to the wood better than ordinary pushblocks. The broad aluminum bases on these masonry tools won't damage a cutter if hit, and they keep my hands well away from the cutters of a jointer or shaper.

—John Crouse, Wolcott, N.Y.

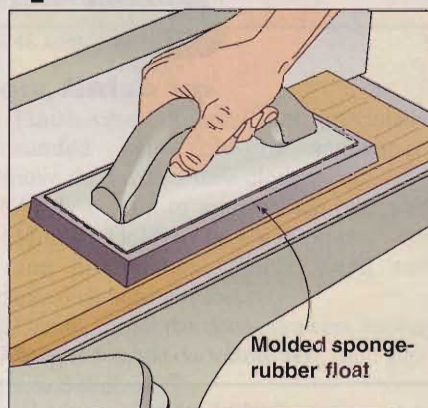

Continued on page 27

our winner

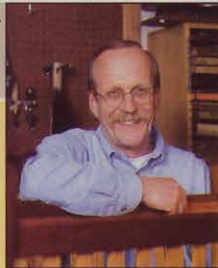

When the aerospace industry went a little soft around 1989, Dan Wallace, then a 20-year veteran of that field, looked for a fallback career. So, our Top Shop Tip winner pursued with vigor something he'd just dabbled in previously: woodworking.

Fortunately, Dan survived the aerospace slump (he now has 33 years in at Boeing), and he became a darned good woodworker, too, completing hundreds of projects for both himself and paying customers. These days, Dan and his wife are restoring their Craftsman-style home, and he's pursuing yet another vocation: becoming a deacon.



For submitting this issue's Top Shop Tip, at left, Dan Wallace wins a Delta 6" jointer (37-195). Attaboy, Dan!

## You can win a free tool, too!

Tell us how you've solved a workshop dilemma, and we'll send you \$75 if we print your solution. And, if we choose your tip as the Top Shop Tip, you'll also win a tool worth at least \$250.

Send your best tips, along with photos or illustrations and your daytime telephone number, to: **Shop Tips, WOOD® Magazine, 1716 Locust St., GA-310, Des Moines, IA 50309-3023.** You can also e-mail tips to [shoptips@woodmagazine.com](mailto:shoptips@woodmagazine.com), or post them on our Top Shop Tip discussion group at [www.woodonline.com](http://www.woodonline.com).

Because we try to publish only original tips, please send your tips only to *WOOD* magazine. Sorry, but we can't return your materials.

### Block self-centers holes in dowel ends

While building a bird feeder recently, I needed to center a hole in the end of a 1" dowel. The centering block I came up with to do the job accurately works with three different dowel diameters, and is shown *below*.

I started by marking three straight index lines across a 1x1¼x9" hardwood scrap. Using a ¼" brad-point bit in a self-centering doweling jig, I poked a dimple in the block at each line. I then bored ½", ¾", and 1" holes with Forstner bits at each of the marks, respectively. Finally, I cut a saw kerf where shown so the block expands to accept dowels, and can be clamped to hold them solidly.

To drill a ¼" hole in the end of a 1" dowel, for example, I first insert the dowel in the 1" hole in the centering block. Next, I clamp the centering block in the doweling jig, aligning the index lines with the jig's ¼"-hole index marks, and drill the dowel.

—Oscar Eli, Milaca, Minn.

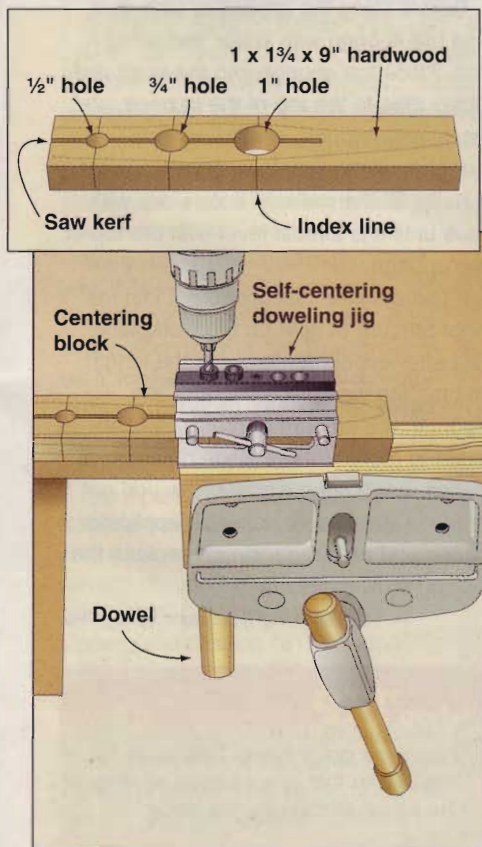

### Level-headed idea hits the bull's eye

I loved the Garden Footbridge project in *WOOD* magazine issue 133, but I came up with an easier way to drill the spindle

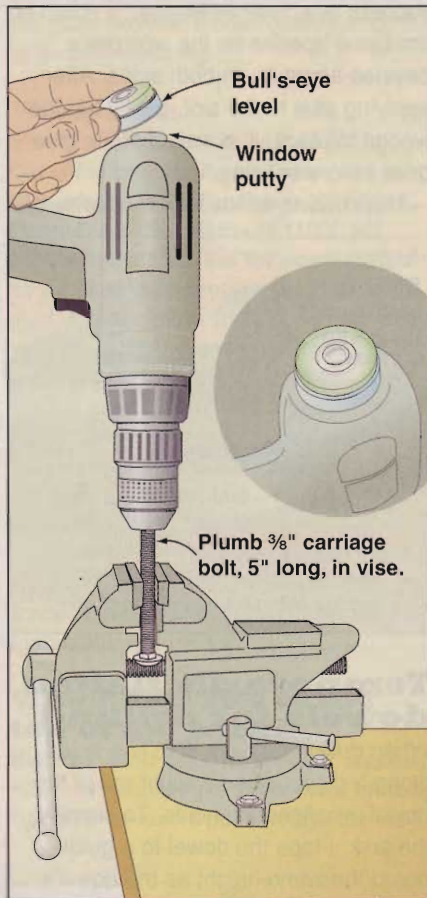

holes. I bought a bull's-eye level at the hardware store for under \$3, then affixed it to the butt of my drill using a blob of window putty.

The key to making this tip work is to calibrate the level. To do this, I clamped a ¾x5" bolt into my vise, as shown *below*, using a level to make sure it was perfectly plumb. (If your vise's jaw faces aren't plumb, you may need to shim them or the base of the vise.)

Next, I chucked the threaded end of the bolt into my drill, and mounted the bull's-eye level. The window putty allowed me to shift the level until the bubble was centered precisely in the bull's eye.

—Dick Brown, Mitchell, Ore.,  
via WOOD ONLINE®

Continued on page 28

# Convert your Router into the most precise tool in your shop

**ROUTERSHOP**  
by **HAWK** Woodworking Tools.

- ▶ Patented **split table design**, use your cutter vertically or horizontally for safety and versatility
- ▶ **Crossfeed adjustment system** calculates and keeps track of tedious measurements for you
- ▶ **Control** the movement of your **cutter position** in increments as small as 1/64"



**New!**  
**CALL NOW for a FREE Catalog**  
**1-800-487-2623**  
[www.rbiwoodtools.com](http://www.rbiwoodtools.com)



**JointABILITY**  
by **HAWK** Woodworking Tools.

- ▶ **More precise and easier** to use than a traditional jointer
- ▶ **Create invisible joints** the entire length and thickness of your workpiece
- ▶ **Easily cut sheet materials** to size, perfect fitting dados, rabbets, and more
- ▶ **Use with** a router or circular saw

# MORE PRESSURE EQUALS BETTER PERFORMANCE

Compressor Comparison	CRAFTSMAN®	CAMPBELL HÄUSFELD®	PORTER CABLE®
	150 PSI (30 Gal.)	130 PSI (30 Gal.)	135 PSI (25 Gal.)
Operating Time (seconds)			
3/8" Air Ratchet	71	33	48
3/8" Drill	59	25	39
Random Orbit Sander	65	29	43
1/2" Impact Wrench	65	29	43
Number of Roofing Nailers (60 nails each)	5	3	4

Actual performance may vary on a unit-to-unit test.

Just \$329.99

Ask for #16731  
Hose and tools sold separately

Available at Sears and  
Sears Hardware stores

800.437.9686

www.sears.com/craftsman

**SEARS**  
Where else?™

© 2002 Sears, Roebuck and Co.

## shop tips

### Smooth rough joints with a wedge

Here's a trick I've used over the years to improve the appearance of less-than-perfect edge-to-edge joints. The key to success is a "feather wedge," a scrap of the same species as the workpiece, beveled about 3° on both sides. After applying glue to the slot, gently tap the wedge in place, and wait until the glue dries before sanding.

—Chuck Hedlund, WOOD® magazine shop manager

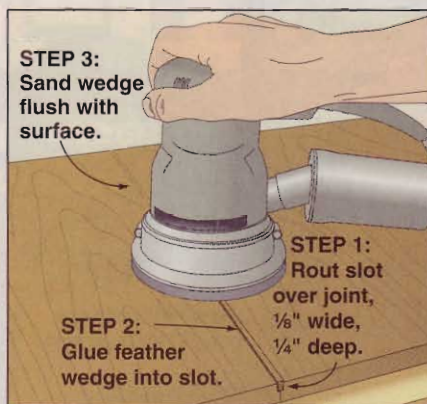

### Temporarily flatten dowels for drilling

When drilling a series of in-line holes along a dowel, even a slight roll of the dowel misaligns the holes. To simplify the task, I tape the dowel to a guide board the same height as the dowel's diameter, as shown in the drawing below. With the guide board held against the fence, the dowel can't rotate.

—Mary Wing, Kingfield, Maine

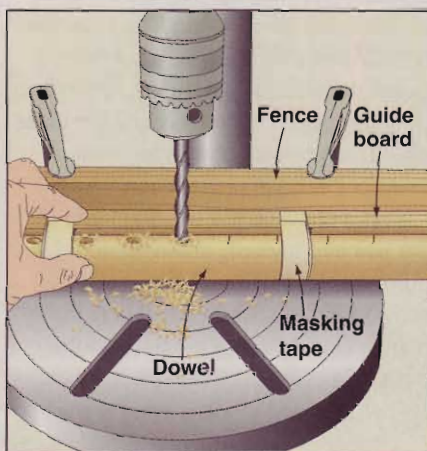

### Soap dish makes tiny glue-ups tidy

Almost all of the woodworking I do is segmented turnings, and I use all manner of methods to apply glue to the segments—brush, roller bottle, and of course, my finger on occasion. For small pieces, I like to use my soap-dish-and-sponge applicator.

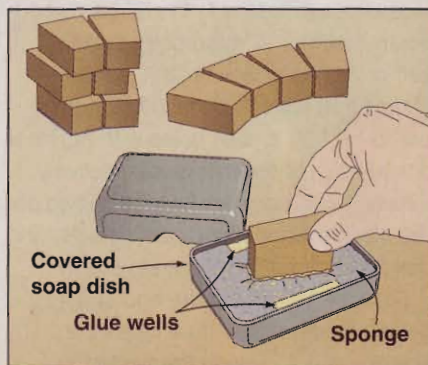

The applicator consists of a covered soap dish and a sponge cut to fit inside it. In both long edges of the sponge, I cut small glue "wells," where shown in the drawing above.

Before filling the applicator with glue, wet the sponge with water and wring it out. Place the sponge into the soap dish, apply glue to the top of the sponge, and let it soak through, continuing until you get glue all the way through the sponge. Finally, fill the wells on both sides with glue until it is almost level with the top of the sponge.

It takes a little practice to get just the right amount of glue on the workpiece. But after experimenting with the length of time the workpiece contacts the sponge, the amount of pressure used, and the motion of the piece during application, you'll soon wonder how you got along without your soap-dish applicator. At the end of the job, simply replace the lid and stow the dish.

—Bob Uding, Homosassa Springs, Fla.

### shop TIP

For more great Shop Tips, look for boxes like this one nestled among the other articles in this issue.

# ask wood

Answers to your questions from letters, e-mails, and WOOD ONLINE®

## Make straight edges without a jointer

**Q** I'm trying to joint a straight edge on a piece of oak for a kitchen tabletop, but the board is too long, heavy, and awkward for good results on my jointer. What's a better way to produce a smooth surface for edge-gluing?

—Mike Payeur, via WOOD ONLINE

**A** Mike, a router outfitted with a straight bit will do the job quite nicely. For a long straightedge, just use the factory edge of a sheet of medium-density fiberboard or hardwood plywood. Mark that edge, rip a piece about 8" wide to eliminate flexing, and you have an 8' piece that, in our experience here in the WOOD® workshop, is always perfectly straight.

Place your workpiece so that its edge slightly overhangs your workbench. Locate your straightedge on top of the

workpiece so that the router base rides against the straightedge and the bit lightly contacts the narrowest spot on the workpiece. Make sure the bit extends slightly past the bottom face of your workpiece, and you're ready to go. A two-flute, spiral-cut bit will give you the smoothest surface. Or, if you prefer, clamp the straightedge underneath the workpiece within 1/8" of its edge, install a flush-trim bit in your router, and allow the pilot bearing to ride against the straightedge. A large-diameter bearing works better than a small one.

If your workpiece has a significant bow in it, cut it as straight as possible before you start jointing. Using the narrowest width for a measurement, snap a chalk line the length of the board. Cut to that line with a circular saw, bandsaw, or jigsaw, then finish the job with your router as described above.

—WOOD magazine



The factory edge of a sheet of MDF or plywood makes a fine straight-edge for edge-jointing with a router. Mark it and save it for future use.

Continued on page 34

## The Toughest Glue On Planet Earth

You're beyond simple yellow glues and you don't want a different bottle of glue for every project. You want Gorilla Glue®. Bonds wood, stone, metal, ceramic, plastics and more. Incredibly strong and 100% waterproof.

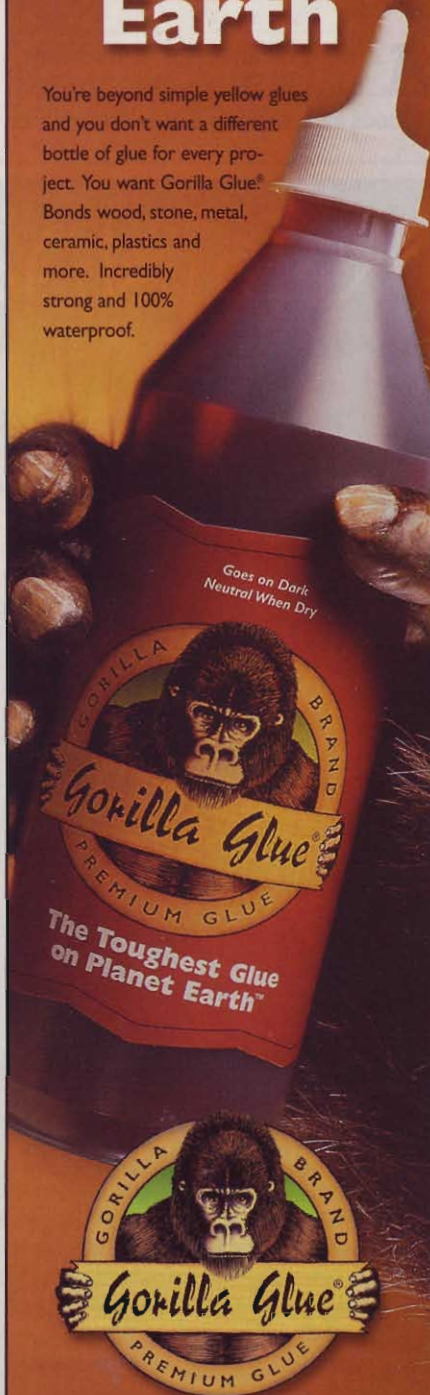

for retailers near you:  
[www.gorillaglu.com](http://www.gorillaglu.com)  
1-800-966-3458

## Rails, stiles, and wood movement

**Q** I know you're supposed to avoid cross-grain glue-ups because of wood movement, but what about rail and stile assemblies? How wide can the rail be without creating movement problems?

—Phil Peterson, via WOOD ONLINE

**A** The short answer is, don't worry too much about it, Phil. All wood expands and contracts across the grain as

it absorbs and releases moisture, but the percentage of change isn't great enough to affect typical rails and stiles, which are about 2" wide. Kelly Mehler, who makes solid-wood furniture in Berea, Kentucky, says that the movement of wood usually won't cause trouble in rails less than 6" in width. In addition, yellow glue has some "give" in it even after curing, which allows for a bit of movement, and Kelly likes to leave very

Allow for wood movement on tabletops and other large pieces, but don't worry about rails and stiles. Small pieces don't move enough to create problems.



slight gaps at each edge of a tenon (not on the cheeks) to provide still more breathing room.

For pieces that are wider than the norm, note that a plainsawn board will move about twice as much as a quartersawn board of the same species. And, among the most popular furniture woods, plainsawn white oak moves significantly more than red oak, cherry, or walnut, and twice as much as mahogany.

If you want to delve even more deeply into the subject, follow Kelly Mehler's example. "As a furniture maker working only in solid wood, I have to *know* how wood will behave," Kelly says. "I can't go by hearsay." So he refers to the kind of data that you find in *Understanding Wood*, by R. Bruce Hoadley (available for \$27.96 through Amazon.com). There you'll find a table listing shrinkage values for most of the woods you'll ever use, and a formula for calculating the effects of shrinking and swelling.

—WOOD® magazine

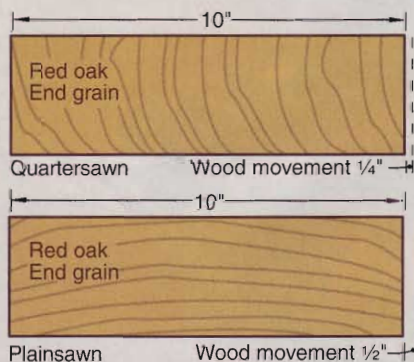

Quartersawn lumber, identifiable by its nearly vertical end grain, shrinks and swells much less than plainsawn.

Continued on page 36

# Refinish Your Future.

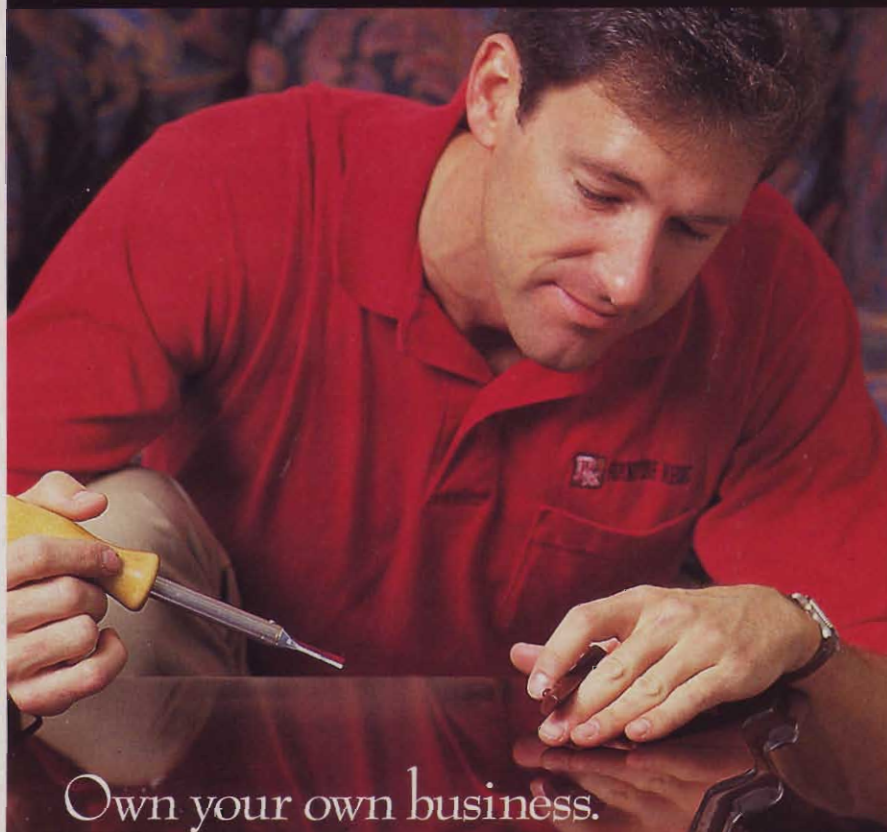

## Own your own business.

Let your passion for furniture lead you into a new business with a Furniture Medic franchise. We're a complete on-site repair and restoration-refinishing business servicing homes and companies as well as handling moving and insurance claims. We offer extensive training and support with a low initial investment and manageable overhead. Financing is available to qualified candidates and franchises are offered nationwide. Call today to brush up on the details.



**FURNITURE MEDIC**  
"the prescription for damaged furniture"

www.furnituremedicfranchise.com



**1-800-RUN YOURS**

WOODLINE ARIZONA, INC. OFFERS YOU MORE...

# Super Sets AT Great Prices!!!

ask wood

## Which is better, red oak or white?

**Q** I want to build a wall unit out of oak. The local building supply store only has red oak. Should I drive an extra hour to check out white oak?

—Phil Peterson, Crown Point, Ind.



**A** You didn't say what style you're using. Arts and Crafts or mission style, for example, might require quartersawn white oak. This type of cut in white oak has a stunning ray flake and is quite eye-catching. I've built several pieces from this type of wood, and all have turned out wonderfully. Most white oak has a high content of tannic acid, and can be darkened with ammonia by a process called fuming, which also is something to consider.

—Robert Phillips, San Antonio, Texas

**A** The grain on red oak is more open. When I use red oak, I like to fill the grain with thinned wood putty. If I don't, stain will fill the grain and will take much longer to dry completely, a must before you put on your clear finish. White oak seems harder than red and has straighter grain.

—Dave Lehnert, Milford, Ohio

## Got a question?

If you're looking for an answer to a woodworking question, write to Ask WOOD, 1716 Locust St., GA 310, Des Moines, IA 50309-3023 or send us an e-mail at [askwood@mdp.com](mailto:askwood@mdp.com). For immediate feedback from your fellow woodworkers, post your question on one of our discussion groups at [www.woodonline.com](http://www.woodonline.com).

**30-Piece Professional Set**

**SUPER SPECIAL BUY**

Includes:  
5 Straight bits  
3 Dovetails  
3 Core Box  
3 Cove Bits  
6 Roundovers  
2 Flush Trim  
1 Panel Bit  
2 Roman Ogee  
2 Slot Cutters  
1 "V" Groove  
1 Chamfer  
1 Bevel Trim Bit

1/2" Shank Router Bits

WL-2010 **OUR PRICE ONLY \$109 set**

**5-Piece Cove Set**

1/2" Shank Router Bits  
1/4"R, 3/8"R, 1/2"R,  
5/8"R, 3/4"R

A \$89 VALUE

WL-2015 **OUR PRICE ONLY \$49 set**

**5-Piece Roundnose (Core Box) Set**

1/2" Shank Router Bits  
3/8"D, 1/2"D, 3/4"D, 1"D, 1 1/2"D

A \$80 VALUE

WL-2012 **OUR PRICE ONLY \$49 set**

**13-Piece Dovetail Set**

1/2" Shank Router Bits  
3 Straight bits  
10 Dovetail bits

A \$115 VALUE

WL-2014 **OUR PRICE ONLY \$49 set**

**6-Piece Bullnose Set**

1/2" Shank Router Bits  
1/4"D, 3/8"D, 1/2"D,  
5/8"D, 3/4"D, 1"D

A \$115 VALUE

WL-2013 **OUR PRICE ONLY \$89 set**

**15-Piece 1/2" Shank Set**

Includes:  
Chamfer  
Cove -  
1/2"R, 3/8"R, 1/4"R  
Roundover -  
1/2"R, 3/8"R, 1/4"R  
Roman Ogee -  
1/4"R  
Straight Bits -  
3/4"R, 1/2"R, 1/4"R  
Roundover -  
1/2"R, 3/8"R, 1/4"R  
1/2" Dovetail  
1/2" Roundover  
1"CL Flush Trim  
Rabbit Bit

1/2" Shank Router Bits

WL-2022 **OUR PRICE ONLY \$59 set**

**15-Piece 1/4" Shank Set**  
same as WL-2022 except 1/4" shank

WL-2021 **OUR PRICE ONLY \$59 set**

**3-Piece Cabinet Door Set**

1/2" Shank Router Bits  
2-Piece Roman Ogee Rail & Stile  
2 3/4" Ogee Panel Raiser

A \$100 VALUE

WL-2019 **OUR PRICE ONLY \$65 set**

**5-Piece Cabinet Door Set**

Includes:  
3/4" Bore Shaper Cutter  
1-pc Rail & Stile (Roman Ogee)  
4 5/8" Panel Raiser (Ogee)  
Door Lip  
Glue Joint  
Drawer Locker

A \$279 VALUE

WL-1505 **OUR PRICE ONLY \$179 set**

**5-Piece Moulding Set**

1/2" Shank Router Bits

A \$175 VALUE

WL-2011 **OUR PRICE ONLY \$99 set**

**All Woodline Arizona Sets are packaged in a beautiful wood box (a \$10.00 value).**

**6-Piece Cabinet Door Set**

Includes:  
2-pc Rail & Stile (Roman Ogee)  
2 3/4" D Panel Raiser (Ogee)  
Door Lip  
Glue Joint  
Drawer Locker

A \$175 VALUE

WL-2020 **OUR PRICE ONLY \$119 set**

**5-Piece Carbide-Tipped Forstner Bit Set**

3/8" Shank for Drill Press  
35mm, 1 1/4", 1", 3/4", 5/8"

A \$89 VALUE

WL-2018 **OUR PRICE ONLY \$39 set**

**8-Piece Classical Set**

Includes:  
2 Classical - 5/32"R & 1/4"R, 1 Wavy  
2 Ogee - 5/32"R & 1/4"R, 1 Filet  
2 Roman Ogee - 5/32"R & 1/4"R  
(1/2" Shank Router Bits)

A \$150 VALUE

WL-2016 **OUR PRICE ONLY \$99 set**

**5-Piece Dovetail Set**

1/2" Shank Router Bits  
8" - 1/2"  
14" - 3/8", 1/2", 5/8", 3/4"

A \$30 VALUE

WL-2017 **OUR PRICE ONLY \$19 set**

**WOODLINE ARIZONA, Inc.**  
P.O. Box 298 • Temecula, CA 92593  
**Great Router Bits & Shaper Cutters!**  
*Best Selection...Best Price*

**Order Toll Free**  
**1-800-472-6950**

Most items in stock • All major credit cards accepted  
Same-day shipping!! • Shipping \$3.75/\$100 + \$4.75

WOODLINE's Quality Bits and Cutters feature:  
• Tough Micro-Grain Carbide  
• Euro Anti-Kickback Design  
• Super-slick Non-stick finish  
• **Super Low Prices**

Check our website for new products:  
[www.woodbits.com](http://www.woodbits.com)

Get your FREE catalog and see our great selection of Bits and Cutters



develop your **shop skills**

# sign your work— in brass

You don't need artistic talent to etch a nifty nameplate. What you need is ferric chloride.

**Y**ou've just built a fine piece of furniture, you're proud of it, and you want to put your name on it. You could grab an ink pen and sign your autograph or buy a custom-made branding iron, but we have another suggestion. Let us show you how to create a maker's mark that will add a distinctive touch of quality to your best projects.

With a sheet of brass and readily available chemicals, you can produce truly handsome nameplates in an endless variety of designs. Personalize them however you please. For example, you might choose your initials, your name, or the name of your business, and spruce it up with the image of a woodworking tool or any shape that strikes your fancy.

## It's easy to learn

We picked up the process from Ron Coleman, a woodworker in Columbus, Ohio. It's only one of many ways to etch



Make a round nameplate from brass, drill a shallow recess with a Forstner bit to house it, and you've added a real touch of class to your project.

brass, copper, and other soft metals. We like this one because it's effective, anyone can learn to do it, and the results look great.

You'll need a small, brass sheet of whatever thickness you prefer. We used brass about .05" thick, which is available at hobby stores and some home centers, and is easy to work with. You'll also need transparency film, available at office supply stores; access to a printer; photo emulsion, which is carried by art stores (we used Hunt Speedball Screen Printing Photo Emulsion); ferric chloride etchant, available at our local Radio Shack in a 16-ounce bottle for \$3.49; a small pane of glass in any thickness; a plastic or glass tray; and a 300-watt light bulb.

Smaller bulbs will do the job, too, but the process takes longer.

Artwork holds the key to a nice nameplate, and it's easy to produce with a computer, clip-art software, and a laser-jet or ink-jet printer. We located woodworking images on our software, blended them with lettering to make designs that look good on our

woodworking projects, and printed the results on transparency film.

Make your design in the standard black-on-white format, then print it out as a reversed negative. That means the letters are printed backwards, all letters and objects are clear, and the background is black. Because the image is reversed, the printed side will go against the brass during the next step. This gives you the sharpest possible results.

A raised lip around the background adds a nice framing effect for most designs. Make the lip at least one full point wide.

Set your printer for transparency film, and load it with film that's made for printers. Print it out and check for crisp edges and dense black areas.

Put a fine jeweler's blade in your scroll-saw, and cut the brass slightly bigger than the image you've created. Or, if you know you're going to want several nameplates, save time by printing them on one piece of film, and size the brass to match.

Now, clean the brass thoroughly with water and 400-grit wet/dry sandpaper. Hold the workpiece by the edges, to keep

oily fingerprints off the flat surface. Dry it with a lint-free towel.

### See what develops

Putting an image onto the surface of brass is similar to developing a photograph on paper. As in a photo darkroom, you'll work in subdued lighting.

Following the manufacturer's directions, mix the two-part photo emulsion. Brush an even, fairly thick layer onto the brass. Place the workpiece in a drawer and let it dry in darkness for an hour. Check it for a uniform, hole-free coating.

Now, let's make the exposure. Place the brass on a flat surface, put the transparency film on top so that it reads correctly, and lay a clean pane of glass on the film. Position your light bulb, equipped with a reflector, about 12 inches above the glass. We used a 300-watt bulb that cost about \$5, and made the reflector by cutting a hole in an aluminum pie pan, as shown in the drawing, *right*.

Turn on the light and let it shine on the workpiece for 45 minutes. Ultraviolet light from the bulb will reach the emulsion through the clear areas and cause it to harden. The emulsion under the black areas will remain soft enough to wash off.

Take the brass to a sink, and rinse it in room temperature tap water, as shown in **Photo A**. The uncured areas will wash away, leaving the desired image behind in

**Rinse off all of the photo emulsion after an adequate exposure to light. Use a soft brush, if necessary, but be careful not to damage the hardened resist.**

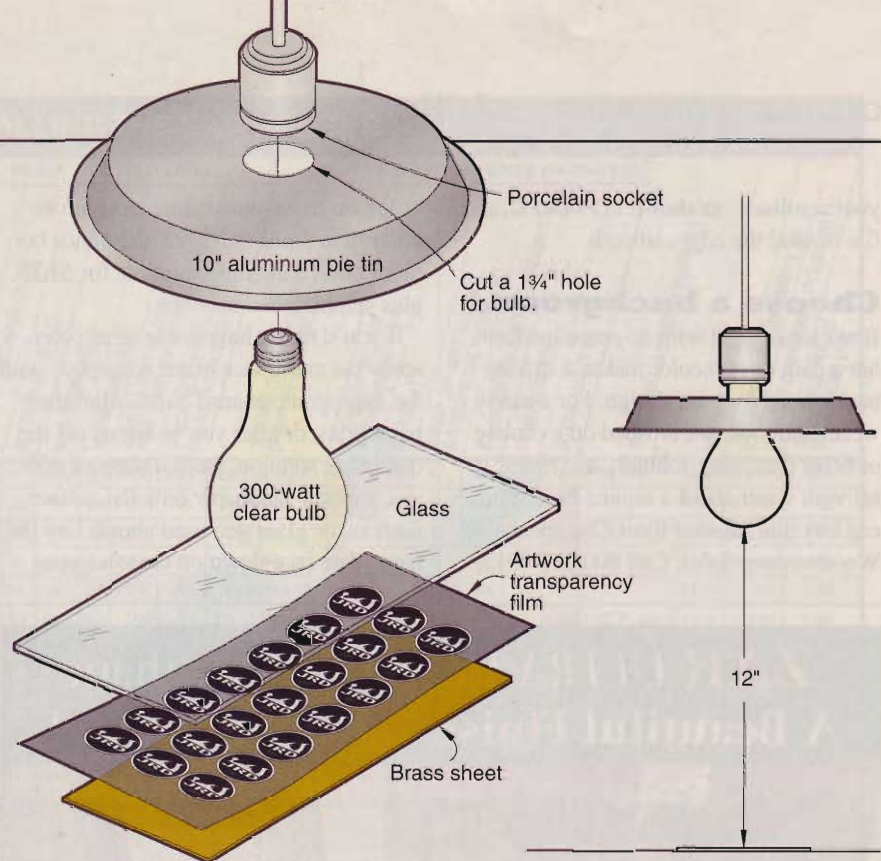

the form of a chemical-proof "resist." Set the brass aside for an hour to dry and to let the resist harden.

### Move some metal

You don't want to etch the back of the nameplate, so seal it with packing tape. Or, you can apply a coat of clear lacquer on the back. Now, it's time for the ferric chloride. Wear old clothes, rubber gloves, and safety glasses. This brown liquid permanently stains just about anything it con-

**Some patience is required for the actual etching. You'll start to see results quickly, though, as dark lines of sediment flow away from the unprotected areas.**



tacts, such as skin and clothes, and etches most metals, including stainless steel.

Put the brass sheet in the tray, then pour in enough ferric chloride to cover it. You can accelerate the process slightly if you warm the ferric chloride to about 100° F. before starting to etch. Agitate the liquid by rocking the tray gently in every direction. We found that nearly constant motion produces the best results. As you keep the ferric chloride moving, it eats into the brass and washes away the residue at the same time. The process moves even faster when you brush the surface occasionally with an inexpensive paint brush, as shown in **Photo B**.

Stay at it for about 45 minutes. Check the nameplate occasionally by lifting it out of the ferric chloride with your gloved hands or plastic tongs. When the etching looks right, remove the nameplate and rinse it with water. Be sure to follow the directions on the container to dispose of the used ferric chloride.

Remove the tape from the back and edges, or clean the brass with lacquer thinner if you used lacquer. Wash the face of the workpiece with bleach to remove the photo resist, or simply peel it off. Cut out the nameplates with a jeweler's blade on

*Continued on page 40*

## develop your **shop skills**

your scrollsaw, as shown in **Photo C**, and file or sand the edges smooth.

### Choose a background

Brass looks great with no embellishment, but a dark or rich color makes a striking background for your design. For a nicely weathered look, we brushed on a coating of brass darkening solution, and rinsed it off with water about a minute later. You can buy this solution from Chesapeake Woodworkers Sales. Call 800/287-4012,

or log on to [www.woodmatters.com](http://www.woodmatters.com) to order item number J-3492, a 2-ounce bottle of brass darkening solution, for \$1.75, plus shipping and handling.

If you'd rather have some other color, spray the entire face of the nameplate with the appropriate enamel paint. After the paint dries, or after you've rinsed off the darkening solution, place a sheet of 600-grit, wet/dry sandpaper on a flat surface, such as the glass you used above. Lay the nameplate face-down on the sandpaper

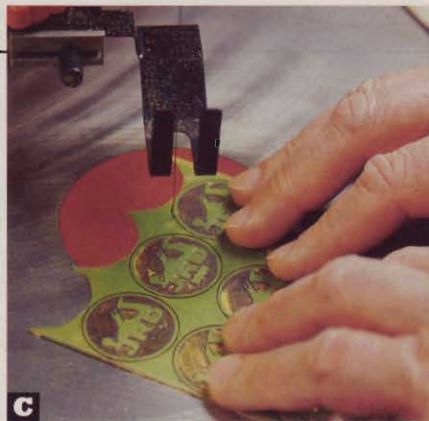

**C** With a very fine jeweler's blade in our scrollsaw, and good lighting, we were able to cut out our round nameplates smoothly and accurately.

and rub it lightly, as shown in **Photo D**, to remove the paint from the raised areas.

Roll a piece of tape, sticky side out, and put it on the back of the nameplate if you find the brass slipping away from you. Work slowly and carefully, to avoid removing color from the recessed areas.

For a higher polish, repeat the sanding process with 1,000-grit paper. When you're satisfied with the nameplate's appearance, dry it off, and coat it with clear lacquer to prevent tarnishing.

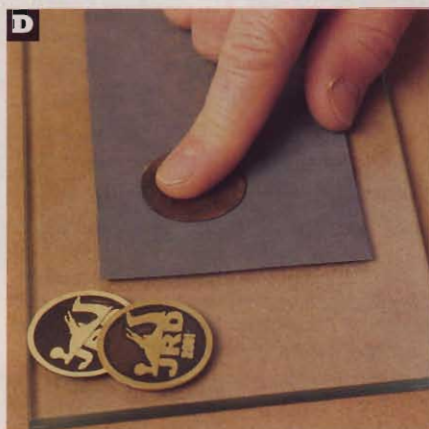

**D** Tape 600-grit wet/dry sandpaper onto the piece of glass used earlier. A rolled-up piece of tape on the back of the nameplate keeps your finger from slipping.

We made our nameplates to a 1¼" diameter, matching the size of a Forstner bit. Drill a shallow hole in the bottom or back of a project, apply epoxy, and fit the nameplate into place. Or, include blank spaces in your design, where you can drill holes for small, brass screws. ♣

Photographs: D.E. Smith Photography; Baldwin Photography

## ZAR<sup>®</sup> ULTRA Interior Polyurethane A Beautiful Finish in *half* the Time!



Great for Floors,  
Dries in 2 Hours!

If waiting for a finish to dry just won't fly – we have just the right product for you – ZAR<sup>®</sup> ULTRA Oil-Based Interior Polyurethane. ZAR ULTRA provides a beautiful, smooth finish in just 2 hours. ZAR's extremely durable formula makes it ideal for high usage areas, such as floors, cabinets, furniture and doors.

*ZAR ULTRA, the fastest way to a beautiful finish!*

For a free brochure and dealer nearest you, call 1-800-272-3235 or visit [www.ugl.com](http://www.ugl.com)



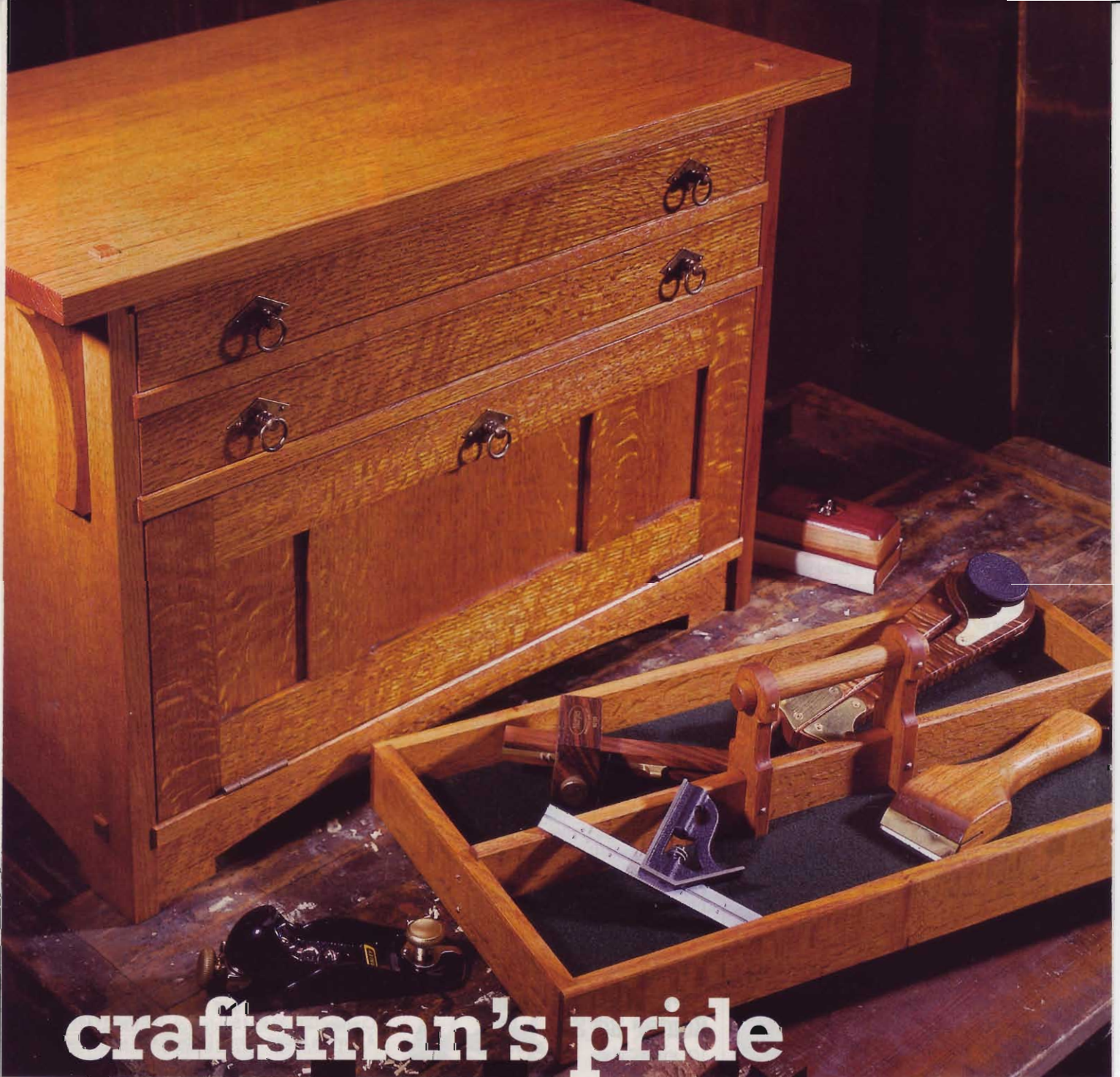

craftsman's pride

# tool chest

Your best tools deserve a top-drawer storage box.

**E**very woodworker has some treasured tools that deserve the ultimate in protected storage. They may include a marking gauge that belonged to your great-grandfather or a set of carving gouges you purchased this morning. Whatever their vintage, precision tools and sharp edges will last longer and work better when protected. The felt-lined trays of our Arts and Crafts design meet that need. And the removable tool tote lets frequently used tools travel first-class.

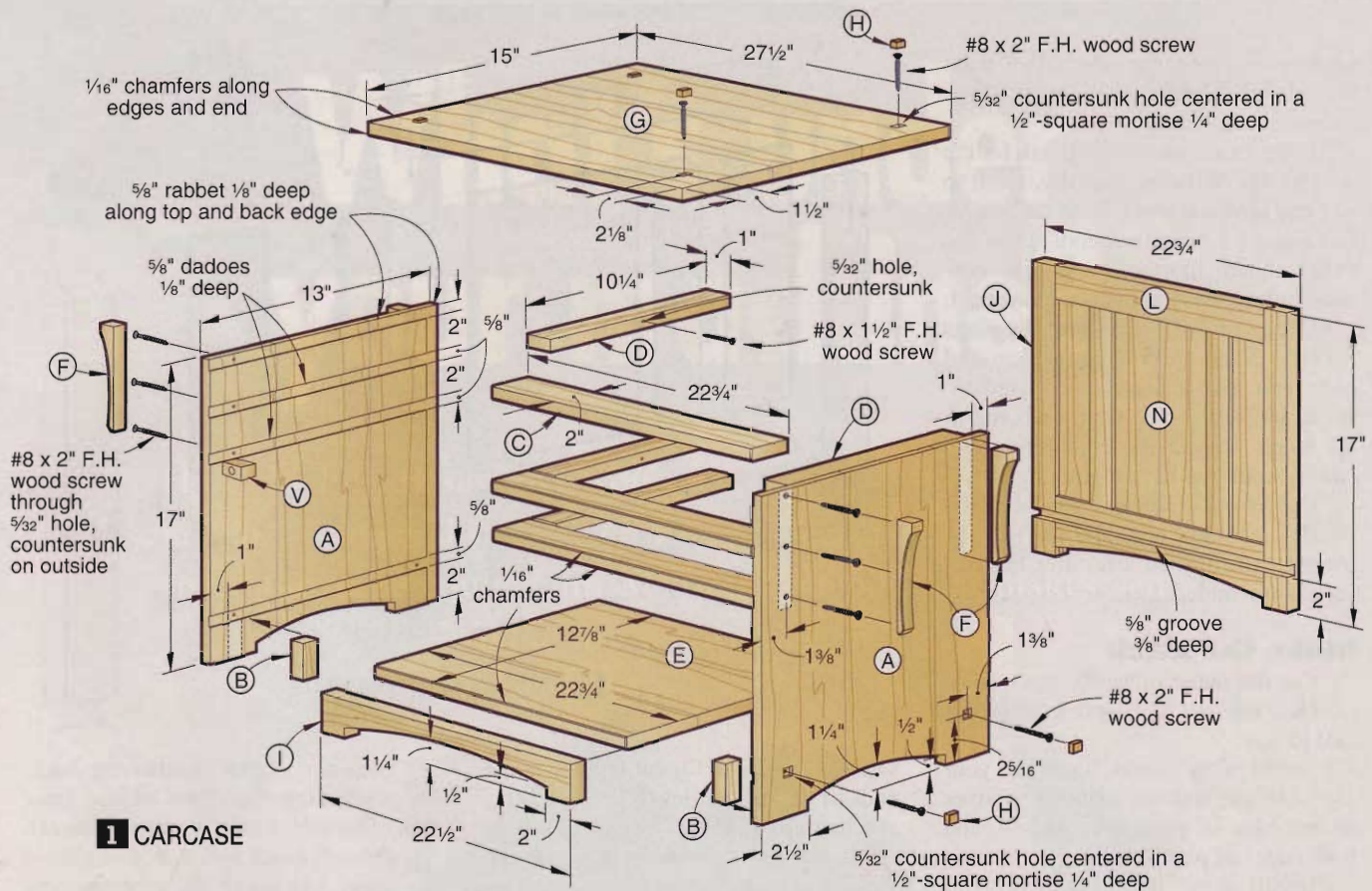

## Begin with the sides

*Note: Throughout this project, sand all the parts to 220 grit before assembly.*

**1** Edge-join a  $\frac{3}{4} \times 14 \times 36$ " blank for the sides (A). With the glue dry, sand it smooth, and cut the sides to the size shown in the Materials List.

**2** Install a  $\frac{5}{8}$ " dado blade in your table-saw, and cut the dados and rabbets, where dimensioned on **Drawing 1**. Note that the sides are mirror images of each other, not identical.

**3** Mark the ends and midpoint of the curved cutout at the bottom of each side (A). Flex a thin strip of wood to connect the three points of each curve, and mark the curve with a pencil. Bandsaw just to the waste side of the line, then sand to the line as shown in **Photo A**.

**4** Mark the centers of the two square mortises on the outside face of each side (A). The mortises are centered on the width of the dados for the bottom (E). Remove most of the waste with a  $\frac{1}{2}$ " Forstner bit, then square the corners with a chisel. Drill a  $\frac{5}{32}$ " countersunk hole centered in each of the mortises.

**5** Drill  $\frac{5}{32}$ " countersunk holes centered in the rail/drawer runner rabbet and dados of each side, where shown on **Drawing 1**.



**Make a custom sanding block by sticking adhesive-backed 120-grit sandpaper to a piece of the curve's waste.**

**6** Cut the two glue blocks (B), and glue and clamp them to the front inside faces of the sides (A), where shown on **Drawing 1**.

## Make the remaining carcass components

**1** Plane  $\frac{3}{4}$ " stock to  $\frac{5}{8}$ " thick for the rails (C) and the drawer runners (D). Check the stock's fit in the dados in the sides (A). Cut the parts to size.

**2** Chuck a chamfering bit in your table-mounted router, and rout  $\frac{1}{16}$ " chamfers around each rail's front edge. Keep this router-table setup for chamfering other parts.

**3** Plane enough lumber to  $\frac{5}{8}$ " thick to edge-join a  $\frac{5}{8} \times 14 \times 24$ " blank for the bottom (E). With the glue dry, cut the bottom to size. Rout  $\frac{1}{16}$ " chamfers around the front edge.

**4** Cut four  $\frac{3}{4} \times 1\frac{1}{4} \times 5\frac{7}{8}$ " blanks for the corbels (F). Make four photocopies of the full-size corbel in the *WOOD PATTERNS*® insert in the center of the magazine, and use spray adhesive to adhere them to the blanks. Bandsaw and

sand the corbels to the pattern line. Rout  $\frac{1}{16}$ " chamfers along the edges, where shown on the pattern.

**5** Edge-join a  $\frac{3}{4} \times 16 \times 29$ " blank for the top (G). With the glue dry, cut it to size and sand it smooth. Rout  $\frac{1}{16}$ " chamfers along the edges and ends. Drill and chisel square mortises, and drill centered holes, where shown on **Drawing 1**.

**6** Cut a  $\frac{1}{2} \times \frac{1}{2} \times 10$ " blank for the plugs (H). Sand  $\frac{1}{16}$ " chamfers around each end. Use a fine-toothed handsaw to cut a  $\frac{3}{8}$ "-long plug from each end of the blank. Repeat the chamfering and cutting until you have eight plugs.

**7** Cut a  $\frac{3}{4} \times 2 \times 23$ " blank for the apron (I), and set it aside. It will be trimmed to finished size after the carcass is assembled.

**Make the back**

**1** Cut the outer stiles (J), inner stiles (K), top rail (L), and bottom rail (M) to size.

**2** Install a  $\frac{1}{4}$ " dado blade in your tablesaw, and cut centered grooves in one edge of parts J, L, and M, and both edges of part K.

**3** Install a  $\frac{3}{8}$ " dado blade in your tablesaw, and adjust it to cut  $\frac{1}{4}$ " deep. Screw an auxiliary extension to your tablesaw's miter gauge. Clamp a stopblock to the extension to control the cuts. Using a test piece the same thickness as the stiles and rails, form a  $\frac{3}{8}$ "-long tenon. Test the fit in the stile and rail grooves, and make any necessary adjustments. When you are

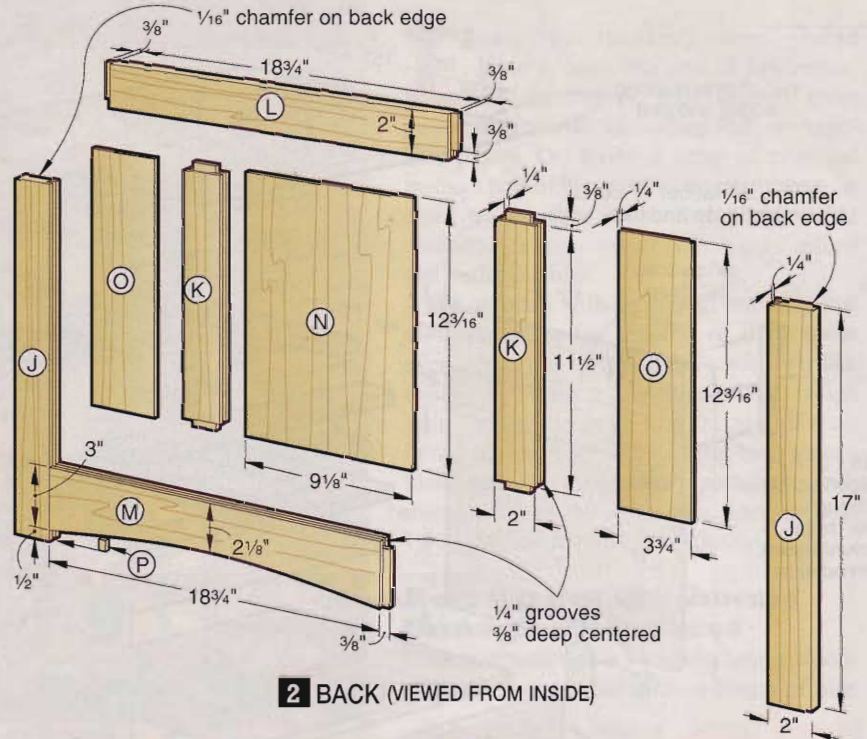

**2** BACK (VIEWED FROM INSIDE)

satisfied with the fit, cut tenons on the ends of the inner stiles (K), top rail (L), and bottom rail (M).

**4** Referring to **Drawing 2**, mark the cutout on the lower edge of the bottom rail. As with the cutout in the sides (A), cut and sand it to shape.

**5** Resaw  $\frac{3}{4}$ "-thick stock, then edge-join and plane a  $\frac{1}{4} \times 10 \times 26$ " blank for the center panel (N) and outer panels (O). Cut the panels to size. To allow for wood movement, the panels are  $\frac{1}{16}$ " shorter and  $\frac{1}{8}$ " narrower than the maximum groove-to-groove dimensions.

**6** Glue and clamp together the back, positioning the edges of the inner stiles (K)  $\frac{3}{8}$ " from the outer stiles (J). Secure each panel with a drop of glue in the upper and lower rail grooves, centered on the width of each panel. Make certain that the assembly is square and flat. Rip a  $\frac{1}{4} \times \frac{3}{8} \times 10$ " strip for the fillers (P), and cut them to length. Glue them into the grooves, where shown on **Drawing 2**.

**7** Install a  $\frac{5}{8}$ " dado blade in your tablesaw, and cut a  $\frac{3}{8}$ "-deep groove in the inside face of the back, where shown on **Drawing 1**. Rout  $\frac{1}{16}$ " chamfers on the outside back edges of the outer stiles (J) and bottom rail (M).

**Assemble the carcass**

**1** Apply glue to the vertical rabbets at the rear inner edge of each side (A), and clamp the back in place, aligning the dados and groove that receive the bottom (E). Slide the bottom into position, check that its front edge is  $\frac{1}{8}$ " proud of the front edges of the sides, and clamp it in place. Using the holes in the square counterbores as guides, drill pilot holes and drive in the screws.

**2** To position the no-mortise hinges on the bottom (E), measure the distance between the sides (A), and cut a  $\frac{3}{4} \times 1 \frac{1}{2}$ " piece of scrapwood to this length. (Ours is  $22 \frac{1}{2}$ ".) Tape the large

**SHOP TIP**

**How to cut a perfectly centered groove**

It's easy to make a perfectly centered groove in the edge of a board. Set your rip fence by careful measurement, then make a test groove in scrapwood that matches the thickness of your stock. Turn off the saw, and put the opposite face of the scrapwood against the fence. If the blade aligns perfectly with the groove just cut, you're centered. If the blade doesn't line up, as shown at right, adjust your fence, and repeat the test with a new piece of scrap.

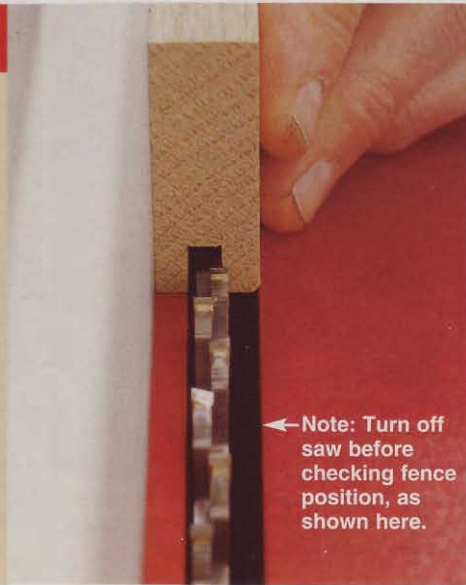

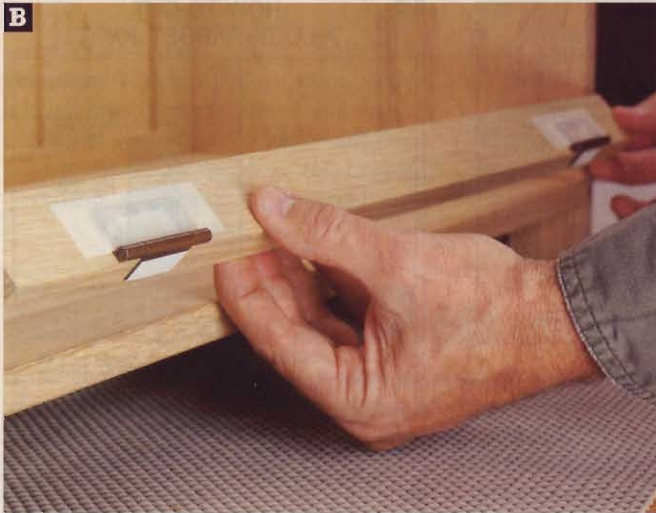

**To position the hinges on the bottom (E), tape their large leaves to a spacer. Apply double-faced tape to the small leaves. Press them in place, keeping the spacer flush with the sides' edges.**



**With the back panel glued and clamped between the sides and the bottom screwed in place, drill pilot holes, and drive in the screws that fasten the rails.**

leaf of each hinge  $2\frac{1}{16}$ " from each end of the scrapwood, and apply double-faced tape to the other leaf, as shown in **Photo B**. Position the scrapwood flush with the front edges of the sides, and press down, adhering the double-faced taped leaves to the bottom's front edge. Pivot the scrapwood forward, exposing the hinge leaves. Drill pilot holes, and remove the hinges.

**3** Position the rails (C) in the dadoes and rabbets in the sides with their front edges  $\frac{1}{8}$ " proud of the sides' front edges. Using the countersunk holes in the sides as guides, drill pilot holes and drive the screws as shown in **Photo C**.

**4** Referring to **Drawing 1**, drill countersunk  $\frac{5}{32}$ " holes centered in the length of each drawer runner (D). Center the runners in the dadoes and rabbets in the sides (A), leaving a  $\frac{1}{8}$ " gap at the front and back. Using the holes in the runners as guides, drill pilot holes in the sides. Applying glue only at their centers, screw the runners to the sides.

**5** Center the top (G) on the carcass assembly, and using the holes in the counterbores as guides, drill pilot holes in the upper end of each side (A). Drive the screws to fasten the top.

**6** Place a drop of glue in the counterbores in the sides (A) and the top (G), and tap in the plugs (H).

**7** Check the dimension between the sides (A), retrieve the apron (I) blank, and cut it to finished length. Referring to **Drawing 1**, mark the ends and midpoint of the curve on the apron.

Following the same procedure you used for the sides and back, mark, saw, and sand the cutout to shape.

**8** Turn the carcass assembly upside down on your workbench, and glue the apron (I) to the bottom (E) and the glue blocks (B). While the carcass is still upside down, glue the corbels (F) into place, where shown on **Drawing 1**. The front corbels hide the rail-screw heads. Apply glue only to the corbels' long edges. Use masking tape to hold them in place while the glue dries.

### Make the paneled door

**1** The door is  $\frac{1}{8}$ " smaller in length and width than the carcass opening.

Our opening is  $8\frac{1}{2} \times 22\frac{1}{2}$ ". If yours is different, make the necessary adjustments to the door parts. Cut the outer stiles (Q), rails (R), and inner stiles (S) to size. Referring to **Drawing 3** and following the same procedure you used for the back assembly, cut the grooves and tenons in the door parts.

**2** Resaw  $\frac{3}{4}$ "-thick stock, then edge-joint and plane a  $\frac{1}{4} \times 10 \times 12$ " blank for the center panel (T) and outer panels (U). Cut the panels to size. Dry-assemble the door parts to check their fit. As with the back, the panels are undersized. Position the edges of the inner stiles (S) 3" from the outer stiles (Q). When you're satisfied with the fit, glue

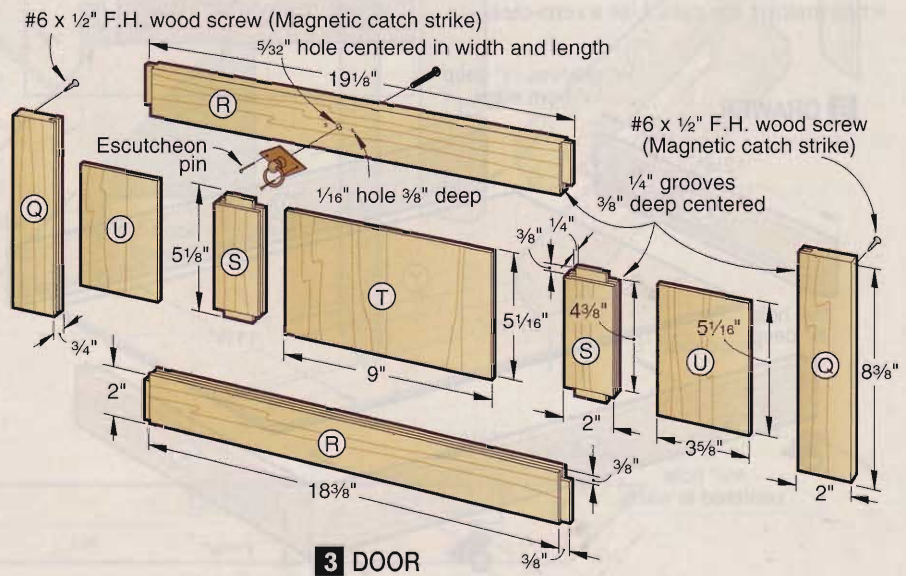

**3 DOOR**

**4 DOOR CATCH**

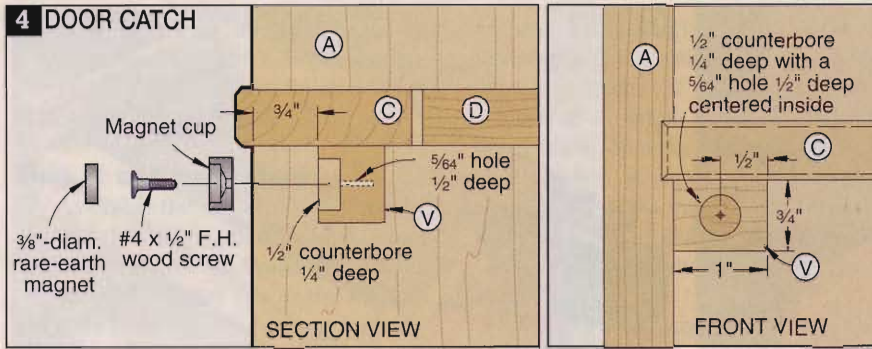

and clamp the door together in the same manner as the back. Make sure the door is flat and square. With the glue dry, drill a centered pull hole in the top rail, and set the door aside.

**3** Cut a 3/4x3/4x10" blank for the stops (V). Referring to **Drawing 4**, drill counterbores and pilot holes 1/2" from each end, then cut the stops to size. Screw the magnet cups in place, but do not insert the magnets. Glue the stops to the underside of the lower rail (C), where shown.

**Make a pair of drawers**

**1** Plane 3/4" stock to 1/2" thick for the drawer fronts/back (W) and the drawer sides (X). Cut the parts to size. Cut a 1/4" groove 1/4" deep in parts W and X for the drawer bottom (Y), where shown on **Drawing 5**.

**2** Form the lock-rabbit joint shown in **Drawing 5a** by following the four-step sequence shown in **Drawing 6**. Use a 3/4x6x6" follower block to prevent chip-out and to steady the narrow parts when making the cuts. Use a zero-clear-

ance insert for your tablesaw when making the cuts in **Step 1**. Drill holes for the drawer pulls, where shown on **Drawing 5**.

**3** Cut the bottoms (Y) to size, and dry-assemble the drawers to check the fit of the parts. Glue and clamp together the drawers, making certain they are flat and square.

**Craft a handy tool tote**

**1** Plane 3/4" stock to 1/2" thick for the sides (Z), ends (AA), divider (BB), and brackets (CC). Cut the sides, ends, and divider to size. Cut the groove in the sides and ends for the bottom (EE), where shown on **Drawing 7**.

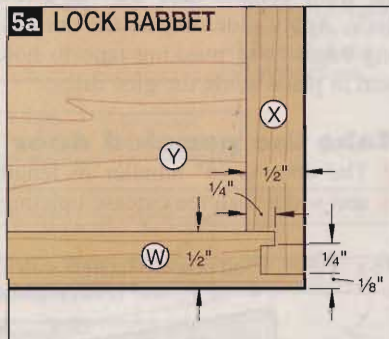

**5 DRAWER**

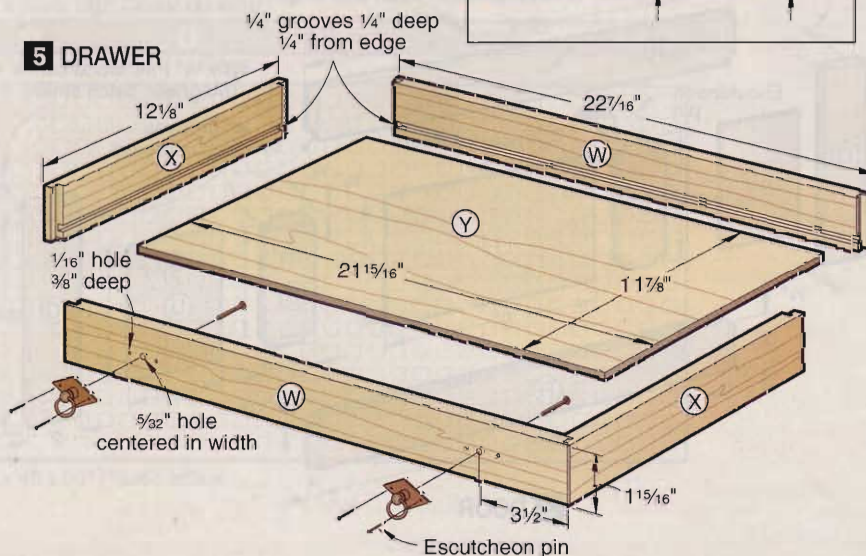

**6 HOW TO CUT A LOCK-RABBIT JOINT**

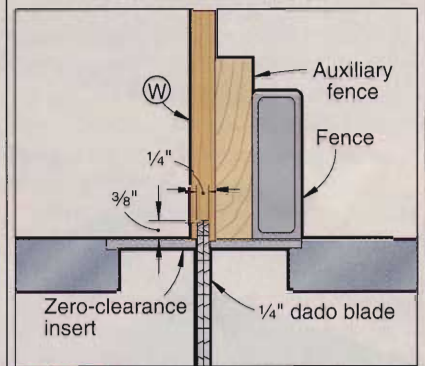

**STEP 1:** Cut centered grooves in both ends of the fronts and backs.

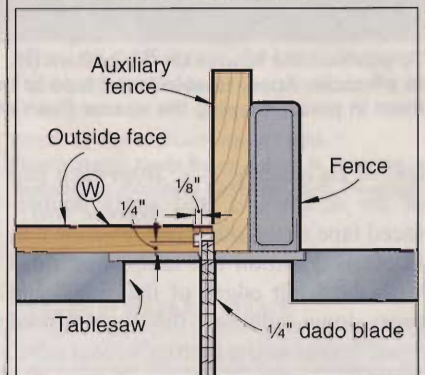

**STEP 2:** Remove part of the inside lip of the grooves just cut.

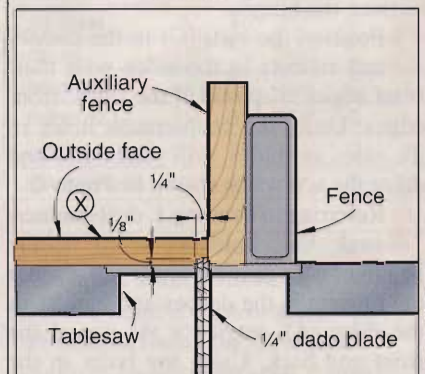

**STEP 3:** Cut 1/8"-deep rabbets in the ends of the drawer sides.

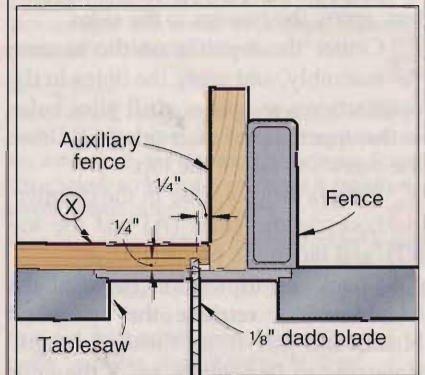

**STEP 4:** Cut a 1/8" saw kerf to form the interlocking notch.





**Now apply the finish and assemble**

**1** Apply the stain. (We used Zar Salem Maple.) With the stain dry, brush on two coats of satin polyurethane, lightly sanding with 220-grit sandpaper after the first coat.

**2** Fasten the pulls with their machine screws. Align the escutcheons, as shown on **Drawings 3** and **5**. Using the holes in the escutcheons as guides, drill pilot holes for the escutcheon pins. Drive in the pins.

**3** Screw the hinges to the bottom (E), and flip them open. Pull the chest to the edge of your workbench. With the door held straight down, position the hinge leaves on its bottom edge. Centering the door on its opening, drill pilot holes and drive in the screws.

**4** Press magnets into the cups. To position the screws that act as catch strikes, stick #6x1/2" flathead wood screws to the centers of the magnets. Press the door against them, marking their positions. Drill countersunk pilot holes and drive in the screws.

**5** To line the bottom of the drawers and the tote, cut pieces of poster board 1/8" smaller in length and width

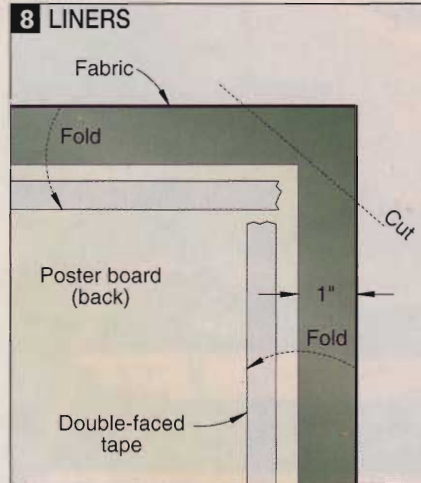

than the inside dimensions of the drawers and tote. Apply double-faced tape to the bottom of the poster board around its perimeter. Cut fabric 2" larger in length and width than the poster board. We used green felt. Center the poster board, top down, on the fabric, and trim the corners, where shown on **Drawing 8**. Fold the fabric onto the tape. Place the liners in the drawers and tote. Slide the divider assembly into the dadoes in the tote's ends. Drill pilot holes, and drive in the copper nails. ⚡

**cutting diagram**

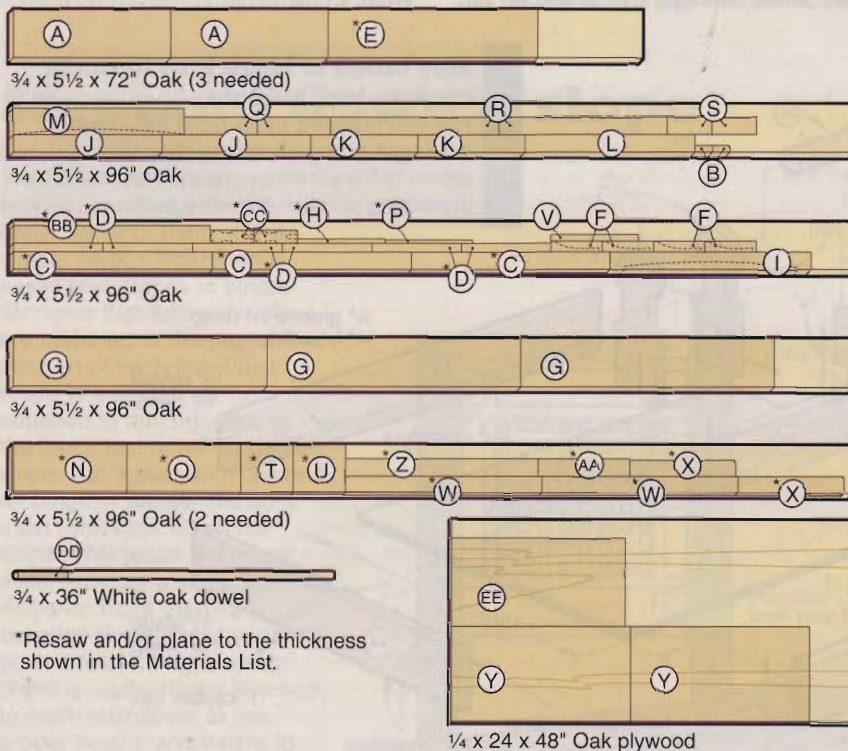

**materials list**

Carcase	FINISHED SIZE			Matl.	Qty.
	T	W	L		
A* sides	3/4"	13"	17"	EQO	2
B glue blocks	3/4"	3/4"	2"	QO	2
C rails	5/8"	2"	22 3/4"	QO	3
D drawer runners	5/8"	1"	10 1/4"	QO	6
E* bottom	5/8"	12 7/8"	22 3/4"	EQO	1
F corbels	3/4"	1 1/4"	5 7/8"	QO	4
G* top	3/4"	15"	27 1/2"	EQO	1
H* plugs	1/2"	1/2"	3/8"	QO	8
I* apron	3/4"	2"	22 1/2"	QO	1
<b>Back</b>					
J outer stiles	3/4"	2"	17"	QO	2
K inner stiles	3/4"	2"	12 1/4"	QO	2
L top rail	3/4"	2"	19 1/2"	QO	1
M bottom rail	3/4"	3"	19 1/2"	QO	1
N* center panel	1/4"	9 1/8"	12 3/16"	EQO	1
O* outer panels	1/4"	3 3/4"	12 3/16"	QO	2
P* fillers	1/4"	3/8"	1/2"	QO	2
<b>Door</b>					
Q outer stiles	3/4"	2"	8 3/8"	QO	2
R rails	3/4"	2"	19 1/8"	QO	2
S inner stiles	3/4"	2"	5 1/8"	QO	2
T* center panel	1/4"	9"	5 1/16"	EQO	1
U* outer panels	1/4"	3 5/8"	5 1/16"	QO	2
V* stops	3/4"	3/4"	1"	QO	2
<b>Drawers</b>					
W fronts/backs	1/2"	1 1/16"	22 7/16"	QO	4
X sides	1/2"	1 1/16"	12 1/8"	QO	4
Y bottoms	1/4"	11 7/8"	21 15/16"	OP	2
<b>Tote</b>					
Z sides	1/2"	2"	22"	QO	2
AA ends	1/2"	2"	10 1/2"	QO	2
BB divider	1/2"	1 5/8"	21 1/2"	QO	1
CC* brackets	1/2"	1 1/2"	5"	QO	2
DD handle	3/4" diam.		6 1/4"	WO	1
EE bottom	1/4"	10 1/2"	21 1/2"	OP	1

\*Parts initially cut oversize. See the instructions.

**Materials Key:** EQO—edge-jointed quartersawn white oak, QO—quartersawn white oak, OP—oak plywood, WO—white oak dowel.

**Supplies:** #4x1/2" flathead wood screws (2), #8x1 1/2" flathead wood screws (6), #8x2" flathead wood screws (14), #8x1/2" flathead wood screws (2), 22x28" poster board (2), double-faced tape, fabric.

**Buying Guide**

**Hardware.** 7/8" tapered ring pulls no. 01A63.01, \$1.70 ea. (5); 2x1 1/16" plain-end no-mortise hinges no. 00H51.02, \$.70 ea. (2); 3/8" rare-earth magnets no. 99K32.03, \$.43 ea. (2); magnet cups no. 99K32.52, \$.45 ea. (2); 1" copper rose-head boat nails no. 91Z30.03, \$9.50 for a 1-lb. box. Lee Valley Tools, P.O. Box 1780, Ogdensburg, NY 13669. Call 800/871-8158, or go to [www.leevalley.com](http://www.leevalley.com).

Written by **Robert J. Settich** with **Kent Welsh**  
 Project design: **Kent Welsh**  
 Illustrations: **Mike Mittermeier**; **Lorna Johnson**  
 Photographs: **Baldwin Photography**

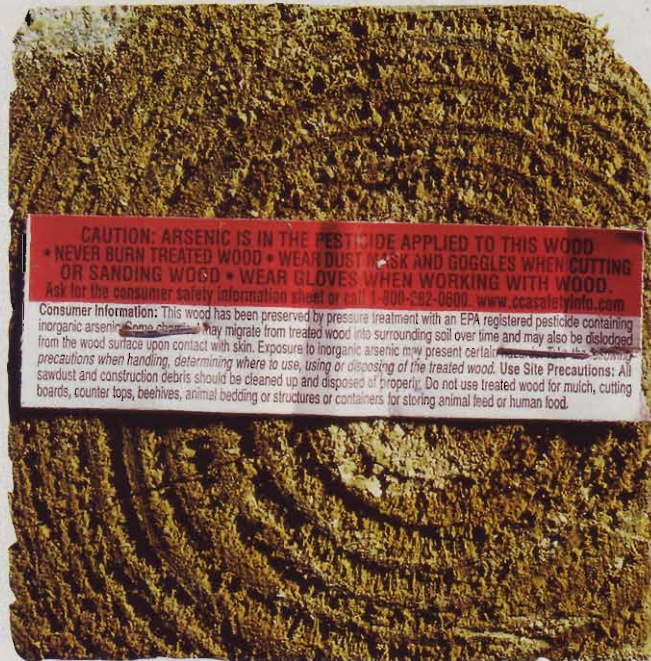

# treated lumber gives in to pressure

**It's official:** Lumber treated with Chromated Copper Arsenate (CCA) won't be available after the year 2003. What chemicals will take its place? Will they cost extra? And what should you do with CCA structures you already have?

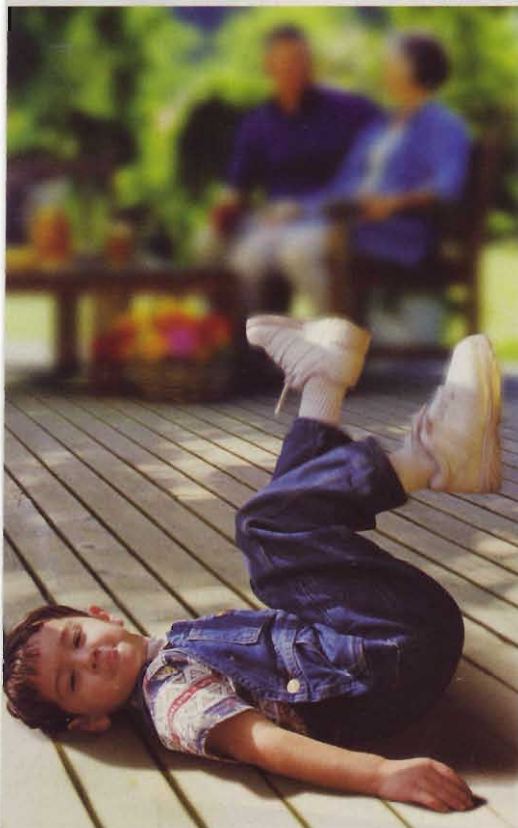

Possible health risks, especially for children, associated with arsenic in CCA-treated wood have led to new products treated with safer chemicals.

**I**t's hard to deny the advantages of pressure-treated lumber for backyard decks, play sets, and other outdoor structures. Its low cost, availability, strength, and durability, even in direct contact with the ground, make it a good material for building lasting outdoor projects.

These days, about 90 percent of the treated wood sold for residential use gets its protection from chromated copper arsenate (CCA). See the sidebar at *right* for more about how CCA works.

In recent months, arguments over the safety of CCA have heated up. The result was an agreement between manufacturers and the United States Environmental Protection Agency (EPA) to phase out CCA lumber as a residential-use product by no later than December 31, 2003.

### The problems

Fears with CCA center around the arsenic component. Classified by the EPA as a restricted-use pesticide and a hazardous material, arsenic is also a known carcinogen, but has long been deemed safe in this application.

We now know that some arsenic leaches back out of treated wood over time. Exactly how much leaches out is a hot debate. Regardless, the arsenic can

### What is chromated copper arsenate?

**Chromium:** Acts as a fixative to bind the copper and arsenic to wood fibers.

**Copper:** Makes the wood decay-resistant and stops some insects.

**Arsenate:** This powerful pesticide is a derivative of inorganic arsenic.

contaminate soil or groundwater or be ingested by people and animals. (Arsenic can't be absorbed through the skin.)

Manufacturers and the EPA consider the amounts too small to cause undue risk. Opponents of CCA, such as the Environmental Working Group, say that significant risks exist, especially for children playing on treated structures. Whichever side of the argument you're on, evidence of illness or deaths directly attributable to CCA exposure seems in short supply.

### Upcoming options

With CCA going away, what alternatives do you have for building lasting outdoor wood structures? See the chart at the *top* of the *following* page for a quick overview of options.

## Outdoor woods compared

TYPE	DURABILITY		COLOR		PRICE	AVAILABILITY
	ABOVE GROUND	GROUND CONTACT	NEW	WEATHERED		
CCA pine	excellent	excellent	green	gray	low	excellent
ACQ pine	excellent	excellent	green	gray	moderate	limited*
Copper Azole pine	excellent	excellent	green	brownish	moderate	limited*
Cedar	good	fair	tan	gray	moderate	good
Redwood	excellent	good	brown	gray	high	limited**
Cypress	good	fair	tan	gray	moderate	limited**

\*Availability will improve as manufacturers/retailers switch products.

\*\*More prominent in some parts of country: redwood on West Coast, cypress in south and southeast

**Note:** You may see copper-azole lumber listed as copper boron azole (CBA). New formulations won't contain borates, though, because they are water soluble and offer only short-term protection.

The naturally resistant woods come from slow-growing trees. Readily-available, fast-growing southern yellow pine, therefore, likely will remain the wood of choice for outdoor use. But two newer, safer chemicals will be used to treat it instead of CCA.

Amine Copper Quat (ACQ) currently gets the most press as an alternative. It relies on copper as a main ingredient, but replaces arsenic and chromium with solutions of ammonia. None of these chemicals are known or suspected carcinogens. ACQ-treated lumber looks similar to CCA, with a slightly more brown color.

ACQ-treated products, currently sold under the Preserve and Preserve Plus names, have been around for about seven years, mainly on a special-order basis. As ACQ lumber moves to regular stock, look for prices 10-25 percent higher than current CCA prices. This increase stems from the higher cost of the chemicals.

Copper-azole represents the newest chemical. Used in Japan and Europe for some time, it has been produced in the United States for about a year.

Like ACQ, copper-azole contains no EPA-listed hazardous chemicals, or any known or suspected carcinogens. In fact, azole is used to treat swimming pools and commercially-grown fruit.

Copper in the mix gives this lumber a greenish tint similar to ACQ or traditional CCA lumber, but copper-azole will weather to a brownish tone instead of gray. At least for the time being, copper-azole lumber will be marketed only under the Wolman's NaturalSelect name at a price about 15-20 percent higher than equivalent CCA products.

Though ACQ and copper-azole both have a short track record, they look

promising. In standard industry tests, both perform with effectiveness similar to CCA. Expect to see lumber treated with these chemicals showing up on store shelves soon. Depending on consumer demand, you still may see CCA products on shelves, too.

### Can you live with existing CCA lumber?

Do fears of arsenic exposure mean you should tear down CCA-lumber structures you've already built? No, says everyone but the more-extreme groups.

The majority of leaching seems to occur within the first year, so older structures aren't of much concern. However, if you want to add an extra measure of protection, the EPA recommends sealing CCA lumber every year or two with either exterior-grade polyurethane finish or exterior paint.

What about newly built CCA structures, or those you have under way? Even amid current concerns, manufacturers stand behind the safety of CCA-treated lumber. They stress following the use and handling guidelines, at *right*.

The guidelines hold importance because manufacturers often ship CCA-treated lumber to retailers right after treatment, with little time for drying. Liquid may even pool around screw heads as you drive them, or seep from the ends of cut boards. After you build a structure with CCA lumber, allow it to dry for several weeks before applying finish or paint. In the meantime, wash your hands, and especially children's hands, thoroughly after contact with fresh CCA lumber. 🌲

Written by **David Stone**  
Photographs: **Baldwin Photography; Arch Wood Protection, Inc.**

## CCA lumber use and handling guidelines

**Note:** The EPA hasn't yet established guidelines for ACQ or copper-azole. For now, we suggest following the same guidelines as those established for CCA lumber.

### Use Site Precautions

- Clean up and dispose of all sawdust and construction debris.
- Do not use treated wood where the preservative may become a component of food or animal feed. Prohibited uses include use of mulch from recycled arsenic-treated wood, cutting boards, counter tops, animal bedding, and structures or containers for storing animal feed or human food.
- Use only treated wood that is visibly clean and free of surface residue for patios, decks, and walkways to avoid overexposure to excess chemicals.
- Do not use treated wood for portions of beehives which may come into contact with honey.
- Do not use treated wood where it may directly or indirectly contact drinking water, except for uses involving incidental contact, such as docks and bridges.

### Handling Precautions

- Dispose of treated wood by ordinary trash collection. Never burn treated wood in open fires or in stoves, fireplaces, or residential boilers. The smoke and ashes may contain toxic chemicals.
- Avoid frequent or prolonged inhalation of sawdust from treated wood. When sawing, sanding, and machining treated wood, wear a dust mask. Whenever possible, perform these operations outdoors to avoid indoor accumulations of airborne sawdust from treated wood.
- When power-sawing and machining, wear goggles to protect your eyes from flying particles.
- Wear gloves when working with treated wood. Wash exposed areas thoroughly before eating, drinking, using the restroom, or using tobacco products.
- Because preservatives or sawdust may accumulate on clothes, they should be laundered before reuse. Wash work clothes separately from other clothing.

### To learn more, visit these Web sites:

[www.ccasafetyinfo.com](http://www.ccasafetyinfo.com)  
[www.preservedwood.com](http://www.preservedwood.com)  
[www.epa.gov](http://www.epa.gov)  
[www.fpl.fs.fed.us](http://www.fpl.fs.fed.us)  
[www.naturalselect.com](http://www.naturalselect.com)  
[www.treatedwood.com](http://www.treatedwood.com)

The **WOOD** magazine  
guide to finishing  
**PART 3**

# clear choices

Protect and beautify your projects  
with a durable topcoat.

**W**hen it comes to clear finishes, or topcoats, for your woodworking projects, many products vie for your attention. However, you really have only a few basic choices. In this article, we'll cover six types of clear finishes. These products separate themselves in terms of ease of application, skill level, durability, repairability, safety, and appearance.

## FINAL INSTALLMENT OF A START-TO-FINISH SERIES

We discussed wood preparation in issue 139 and staining in issue 140; now it's time for the final step in finishing your projects—applying a clear topcoat. You'll make the wood look great while protecting it from spills, heat, dirt, scratches, and wear.

### For an easy finish, try oil

Oil-based finishes are the most widely available of the consumer finishing products, and by far the easiest to apply. Simply wipe on a generous coat, as shown in **Photo A**, let it soak in for several minutes, wipe off the excess, and let it dry.

Unfortunately, no true oil finish offers much in the way of water or heat resistance. But it does a terrific job of bringing out the color and grain characteristics of the wood. Add protection with a topcoat that builds a film on the surface—such as lacquer or varnish—and you have the best of both worlds.

Boiled linseed, tung, and soya are the most common oils used in finishing. Boiled linseed and tung serve as straight oil finishes and soya appears as an ingredient in other finishes.

### Oil plus varnish gives a hand-rubbed look

Blend oil, varnish, and thinner, and you have a “Danish oil,” “tung oil finish,” “antique oil finish,” or almost anything else that's labeled as an oil finish. A side-by-side comparison of these products reveals few, if any, differences among them.

To determine whether a given product is an oil/varnish mix or a wiping varnish—a finish we'll discuss shortly—follow the procedure shown in **Photo B**.

You easily can create your own oil/varnish mix with equal parts of boiled linseed oil, thinner, and varnish.



Alter this ratio to suit your tastes. If you increase the oil, you slow down the drying time. If you increase the varnish, you make the mix more resistant to water, heat, and abuse. If you increase the thinner, the mix penetrates better and dries faster, but requires more coats to provide protection.



Some commercial oil/varnish mixes contain an added color. Or, you can tint any of the clear oil/varnish mixes by adding oil-based stain or a compatible dye. Be aware that if you add a stain to either a commercial product or your own recipe, you're adding oil, too. Adjust your ratio accordingly.

Oil/varnish mixes do not provide a high degree of protection, and can't give you a glossy finish, but they're easy to apply and repair. A couple of coats of an oil/varnish mix followed by a paste wax coat produces a wonderful, hand-rubbed, satin appearance.

Apply an oil/varnish mix like a true oil finish. Flood it on, let it soak in, then make sure to wipe off any excess. On some woods, especially large-pored species such as oak, this finish tends to "bleed back" and pool on the surface. Keep wiping to remove these spots until the finish has dried. Left untouched, the excess finish skins over and produces a scaly effect; then you'll have to sand the finish back or remove it completely.

Oil/varnish mixes dry slowly, especially in high humidity. Don't build them up beyond two coats.

You can repair most surface damage with sandpaper and more oil/varnish mix. If the surface has been waxed, remove the wax with mineral spirits before you apply another oil/varnish coat.

### Varnish: The king of durability

Varnish reigns as the most resistant and durable film finish among those that are generally available to the home woodworker. Manufacturers combine oil and resin, cook the mixture, and produce a finishing material that's very tolerant of heat and water. However, all varnish finishes are difficult to repair.



*continued*



**A**

**Y**our top choices for oil finishing are boiled linseed oil and tung oil, but remember that they won't stand up to hard use. Both give wood a "glow," and are somewhat amber. Over time, linseed will darken and/or amber more than tung. Linseed offers a glossier appearance and builds far better and easier than tung.

Tung oil is clearer and more water-resistant than linseed oil. However, it costs more, dries more slowly, and tends to turn white as you build coats.

You also can buy linseed and tung oils that the makers have altered chemically by heating them to high temperatures in an oxygen-free environment. They're identified with the word "polymerized" on the label. Polymerized oils dry faster, cure much harder, and develop more water resistance. Because of their faster drying characteristics, polymerized oils are difficult to apply to a large surface. They build well but tend to crack.

**B**



**Y**ou can't always rely on the label to tell you what kind of finish is inside the container. For example, "tung oil" shows up on the label of various finishes that may or may not contain tung oil as an ingredient. And many products with "oil" in their name actually are varnishes that have been thinned with mineral spirits, making them easy to wipe on. The biggest area of confusion comes in determining whether a product is an oil/varnish mix or a wiping varnish. To test, pour a bit of the finish on a piece of glass, and let it dry overnight. If it appears wrinkled, like the one at left, it's an oil/varnish product. If it dries smooth, it's a wiping varnish.



**C**

**W**hen you brush on varnish, use a good-quality brush. Buy a China bristle with a chisel shape and split ends. (See the article on *page 16* for more about brushes.)

You'll encounter two major problems in brushing—brush marks and bubbles. Most brush marks result from going back over the surface too often. Most varnish starts to skin over very soon after it hits the surface, and further brushing creates flaws. Bubbles come from a variety of sources, including a poor-quality brush and careless brushing habits. Also, don't create bubbles by shaking the can; stir its contents gently.

If you still have trouble, thin the varnish so the bubbles have time to pop before the varnish dries. Start with about 10 percent naphtha and gradually increase the ratio, if needed.



Depending on the type of oil and the resin, varnish varies in color from clear to a deep amber. Most varnishes combine an alkyd resin with oil—either linseed or one of

the less expensive oils, such as soya. The amount of oil in the varnish determines its hardness. “Long oil” varnishes, such as spar varnish, contain a high percentage of oil. This high oil content makes the varnish more flexible and able to withstand the rigors of weather. A “short oil” varnish, such as those labeled for interior use, tends to be harder. This makes it more susceptible to chipping, but allows for a glossier surface.

You can buy varnish in many forms. The only difference between a polyurethane and any other kind of varnish is the addition of a bit of polyurethane resin. This resin makes the varnish slightly more scratch-resistant.

Brushing is the most common method of applying varnish, but it takes practice to do a top-flight job. See **Photo C** for the tips you need.



When you brush on varnish, gently scrape the surface between coats to remove any bumps. Take the blade from a utility knife, hold it nearly vertically between your forefinger and thumb, and keep the pressure light.

Buff down the surface with gray Scotch-Brite, 0000 steel wool, or 320-grit sandpaper before applying your final coat. This may sound like a lot of work, but it really isn't. None of the steps takes very long. It's the waiting between steps that takes time.

It's a pleasure to apply varnish by wiping it on, but this works best with the addition of thinner to the varnish. You can buy a wiping varnish, like the one we're using in **Photo D**, or make your own by mixing equal parts of varnish and thinner. Naphtha makes a good thinner because it dries faster and clearer than mineral spirits.

You can spray varnish, but you'll run into some significant drawbacks. Whatever your spray method, the overspray winds up everywhere. Because varnish is a



**D**

**P**aper towels or the cotton cloth from a T-shirt works wonderfully for applying a wiping varnish. Wipe on each coat quickly, as if you were wiping down a tabletop with water. Don't go back over the surface or you'll drag the varnish and create lines. If you see that you missed a spot, ignore it. You'll get it on the next coat. Allow the varnish to dry for a couple of hours, then test it with a touch of your finger. If you don't leave a print, it's ready for another coat. Apply at least six additional coats of wiping varnish for added depth. Allow the finish to dry overnight, then scrape it gently with a utility knife blade before applying the final coat.

slow-drying product, it becomes a dust magnet, and can soon create a crust on everything in your garage or workshop. However, you'll find that varnish in an aerosol spray can does come in handy for small projects.

A few companies make a gel varnish, a thick product designed to be wiped on. It is strictly a surface film and offers little penetration. Gel varnishes are susceptible to chipping and very difficult to repair.

### Professionals like lacquer

Furniture manufacturers and woodworking pros choose lacquer for most of their finishing work. It dries quickly, saving valuable production time. Lacquer presents problems for the home woodworker, however. The volatile fumes are unhealthy to breathe, and also pose a risk of fire or explosion. You need adequate ventilation while applying most finishes, and this requirement becomes even more critical when you use lacquer.



Most lacquer gives the best results when sprayed (see **Photo E**). Brushing lacquers contain additives to retard the drying speed.



**E**

**L**arge projects, or frequent use of lacquer, might lead you to invest in a spraying set-up, including a high-volume, low-pressure (HVLP) gun like the one shown here. Always wear a vapor mask when spraying lacquer, and never spray where there is any risk of explosion. And remember, you can spray small projects with a handy, inexpensive aerosol can of lacquer.

Don't bother sanding between coats of lacquer, unless you find rough spots. Each coat will soften the preceding coat and create an excellent bond. Most lacquer turns amber over time, much like varnish. Lacquer offers a reasonable degree of durability and resistance to heat, water, and cleaners. It's easy to repair because a fresh coat dissolves into the existing coat.

You can buy lacquer in a few colors, or tint it yourself with a variety of colorants, including dyes. The hardness of lacquer makes it ideal for rubbing out with fine abrasives to a mirrorlike finish.

*continued*

**N**atural shellac is orange-brown, but you have choices when it comes to the refined product. Darker shellac, such as buttonlac and seedlac, does a wonderful job of replicating antique finishes. Here you see the difference in color between amber (orange) shellac, on the left, and clear shellac, on the right. Orange, or amber, shellac adds a wonderful tone to darker woods, such as walnut. Clear shellac adds almost no color and yellows very little over time.

Shellac can be sprayed, brushed, or wiped on. Because it dries fairly rapidly, spraying works well. You can buy shellac as flakes or as a pre-mixed liquid. The premixes tend to be about a 3-pound cut, which describes a ratio of 3 pounds of flakes per gallon of alcohol. A thinner 1-pound cut makes all forms of application easier, but requires more coats to achieve the same result as a heavier cut.

**F**







**I**f you need a finish that adds no color to the wood, consider water-base. However, this clearness also presents a disadvantage. Apply a clear coat to a dark wood or a wood that has been stained dark, and it acquires a washed-out appearance. The amber quality of some oil-based finishes brings out the color and grain characteristics better in these cases. You can overcome the washed-out look of water-base by adding just a touch of color to the finish, as shown here. Dyes and universal tinting colorants work well for this procedure. Don't add much. It just takes a touch.

### Don't forget shellac; it's safe and tough

Shellac is neither an oil-based finish nor a water-based finish. Shellac comes from the secretions of the lac bug. These secretions are a resin that's formed into flakes and then dissolved in alcohol. Different grades produce different colors; see the examples in **Photo F**.



Shellac ranks as the most environmentally friendly of the finishing products. Manufacturers use the resin to coat candies, glossy pills, and even fruit. It reigned as the finish of choice prior to the development of lacquer. If you find a film finish on furniture made before about 1920, it's probably shellac. The survival of such furniture, with the original finish still intact, proves the durability of shellac. However, it offers relatively poor resistance to water, alcohol, heat, and cleaners that contain alkali.

Once mixed, shellac starts to deteriorate, and finally reaches a point where it won't dry. You can't predict when that will happen. Some premixes claim a 3-year life span, which starts on the day the shellac is mixed by the manufacturer. The can could sit on a shelf somewhere for most or all of that time, so check the date on the bottom of the can to see either the manufacturing date or the 3-year expiration date.

For the most dependable results, buy shellac in flake form, mix the flakes with denatured alcohol to make the amount you need, and dispose of any that's left over when you're done finishing your project. This may seem wasteful, but the most expensive finish is one that has to be removed because it is old and will not dry.



If you do save some shellac, or have a premixed can, test it before you commit to its use. Put a coat on some scrap to see how well it dries.

### Test the water-base before you dive in

Water-based finishes, such as the one we're tinting in **Photo G**, possess much different strengths and weaknesses than the oil-based finishes. The situation constantly changes, as manufacturers modify their oil-based products to be more environmentally friendly, and reformulate water-based finishes to stand up better to heat, water, and cleaners. As a result, oil-based finishes are becoming slower to dry and more difficult to apply, while water-based finishes become easier to apply.



Apply water-based finish with a spray gun or aerosol can, if possible. Some water-based finishes are formulated to be applied with a brush—check the label to make sure. If it's suitable for brushing, you also can wipe it on.

Most water-based finishes are acrylic mixtures. Some of them also contain polyurethane resin, added to make the finish more scratch-resistant. These additives also tend to make the water-based finish somewhat opaque and slightly blue.

Water-based finishes exhibit extreme sensitivity to heat and humidity during application. High humidity can cause a white haze known as "blush," and can slow the drying time. If the blush does not go away, you'll have to strip the finish and start over.

Heat speeds drying and makes application tougher. During hot weather, take care not to overwork the finish. Water-based finishes are tough to strip, and tend to be sensitive to certain cleaners. Also, you'll have a hard time removing white rings caused by water.

*This concludes our series on the basics of finishing, but keep watching for information on more advanced methods. In our next finishing article, we'll give you the details on how to rub out a finish.*

Written by Jim Kull with Jim Pollock  
Photographs: D.E. Smith Photography; Baldwin Photography



Author Jim Kull also monitors the discussion group on wood finishing at our [www.woodonline.com](http://www.woodonline.com) Web site.

**GREAT  
OUTDOOR  
PROJECTS**



# grand entrance

Build an inviting approach to your backyard with this arched garden gate.

Nothing adds more to the allure (and privacy) of your backyard "secret garden" than a stately garden gate. For this project, we borrowed the construction of the overhead arbor from the pergola in the previous issue of *WOOD* magazine, and the look of the shingled posts from the railing planter box columns also in that issue. Build this gate along with the fence on page 64, or as an addition to your existing fence. Either way, walking into your backyard will never be the same.

### Plant a pair of posts

**1** Once you determine your gate's location, dig two 10"-diameter holes with their centers 50 $\frac{3}{4}$ " apart. The article "Be a post master" on page 66 of issue 141 shows you how to accurately locate and temporarily brace your posts. To properly support the gate, the posts must extend at least 36" below grade. Because of the frost line in our location, our posts extend 42" below grade. Check with your local building code enforcement official. Dig holes deep enough to allow for a 6" layer of gravel at the bottom for drainage, where shown on **Drawing 1**.

**2** With the gravel in place, position two 6x6x12' (5 $\frac{1}{2}$ x5 $\frac{1}{2}$ " actual) pressure-treated posts (A) in the holes, plumb them, and brace them in place. Make sure that the 45 $\frac{1}{4}$ " distance between the posts is uniform top to bottom. Set them in concrete, as shown on **Drawing 1**.

*Note:* Our gate is 38 $\frac{1}{2}$ " wide. When the posts are boxed and trimmed there will be  $\frac{3}{8}$ " gaps between the gate and the posts' corner battens (K, L).

**3** When the concrete hardens, remove the bracing from the posts. To trim the posts to finished height, make a mark 95 $\frac{3}{4}$ " up from grade on one post. Using a straight board and a level, transfer this top mark to the other post. Measure the offset on your portable circular saw between the edge of its base and the blade. Measure this offset distance down from the marked top line, and draw a level line around all four sides of each post. Temporarily nail a short board to one side of the first post with its top edge at this lower line. Setting your circular saw to its maximum depth, use the board to guide your saw as you make the cut. In this manner, work your way around the post's other three sides. Finish cutting through the post with a handsaw. Repeat this procedure on the other post, making them even in height.

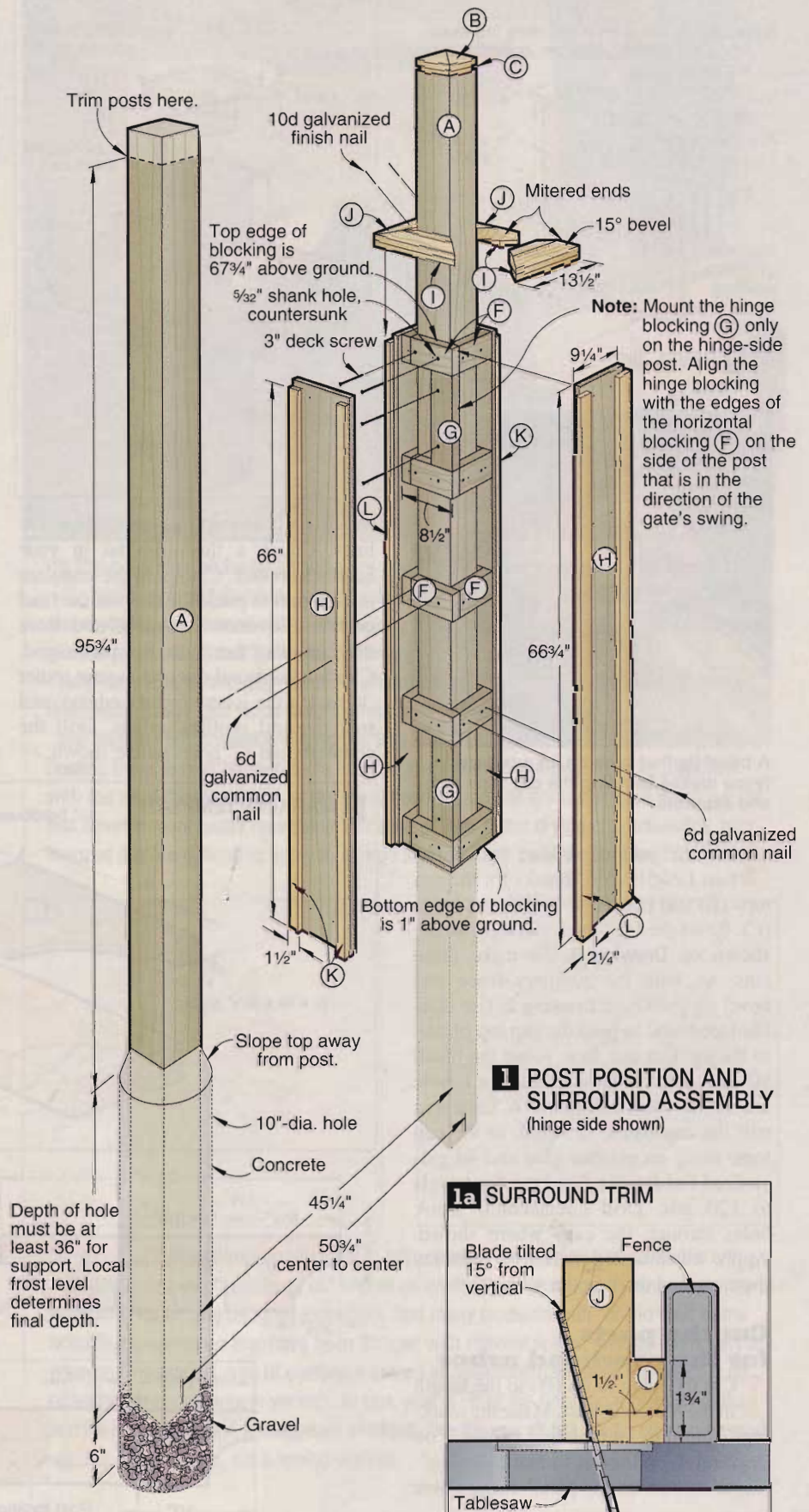

## garden gate

**Note:** Jig shown is for a left-tilting tablesaw. For a right-tilting tablesaw, build the mirror image of this jig.

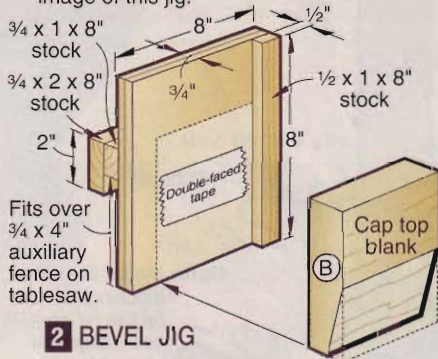

**2 BEVEL JIG**

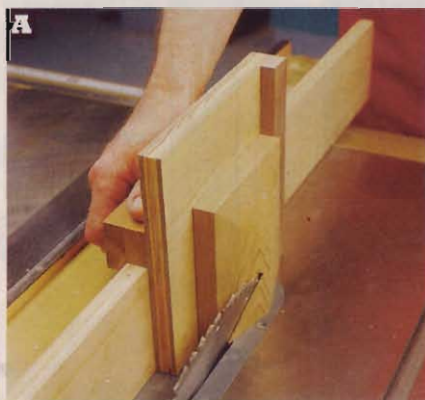

**A** A bevel jig that runs on an auxiliary fence makes beveling the cap tops safe and accurate.

**4** For the post caps, start by cutting two  $1\frac{1}{2} \times 5\frac{1}{2} \times 5\frac{1}{2}$ " blanks for the cap tops (B) and two  $\frac{3}{4} \times 4\frac{1}{2} \times 4\frac{1}{2}$ " cap bases (C). Bevel the  $1\frac{1}{2}$ "-thick cap tops, where shown on **Drawing 3**. To make these cuts, we built the auxiliary fence and bevel jig shown on **Drawing 2**. Use double-faced tape to hold the cap top blanks to the jig. Cut one face, rotate the blank  $90^\circ$ , cut, and repeat until all four bevels are cut, as shown in **Photo A**. Glue and nail the cap bases, centered, to the cap tops, using an exterior glue and 4d galvanized finish nails. Sand the cap bevels to 120 grit. Drill countersunk shank holes through the caps where shown. Apply construction adhesive, position the caps, and drive in the screws.

### Cut the parts for the overhead arbor

**1** Cut the main joists (D) to the length in the Materials List. Make the marking/trimming template shown on **Drawing 4**, and use it to mark the  $3\frac{1}{2}$ "-radius cutouts on the parts' ends, where

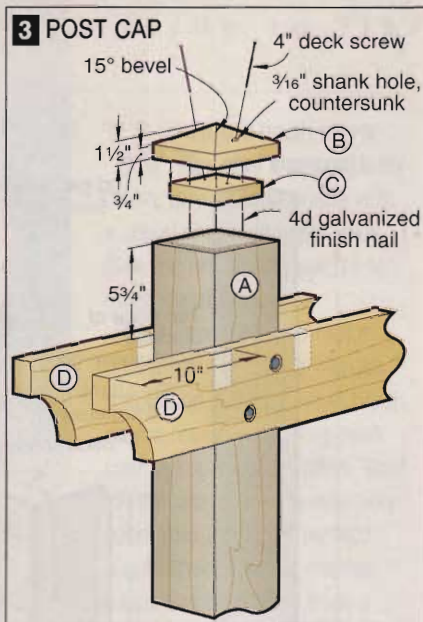

shown on **Drawing 5**. Jigsaw close to the lines. Chuck a flush-trim bit in your handheld router. Clamping the template to each part to guide the bit, rout the final profile. For smooth routing, rout from the cutout's "heel" to the part's end. Chuck a  $\frac{1}{8}$ " round-over bit in your router (to match the joists' factory edges), and rout the end profiles' edges. Drill the counterbored  $\frac{3}{8}$ " holes where shown.

**2** Cut the cross joists (E) to the length in the Materials List. Form the end cutouts, shown on **Drawing 5**, in the same manner as those in the main joists.

**3** Turn the cross joists upside down on a pair of sawhorses, and clamp them together with their ends and top edges flush. Using a square, draw lines across the parts' bottom edges for the  $1\frac{1}{2}$ "-wide notches, where dimensioned on **Drawing 5**. Adjust your portable circular saw to cut  $2\frac{1}{4}$ " deep. Guided by a straightedge clamped to the cross joists, make two cuts to define the notches' sides. Then cut a series of closely spaced kerfs through the waste between these two cuts. Finally, clean out the notches with a 1" chisel. Check the fit of your  $1\frac{1}{2}$ " stock in the notch. For good appearance and easy assembly, you'll want a close, but not tight, fit.

**Note:** Check the actual dimension of your 6x6 posts. The spaces between the notches in the cross joists (E) must match this dimension.

**4** Sand all your arbor parts with 120-grit sandpaper. Prime the parts, including the top 36" of the posts, with an exterior-grade latex primer. Take special care to coat the end grain and the notches.

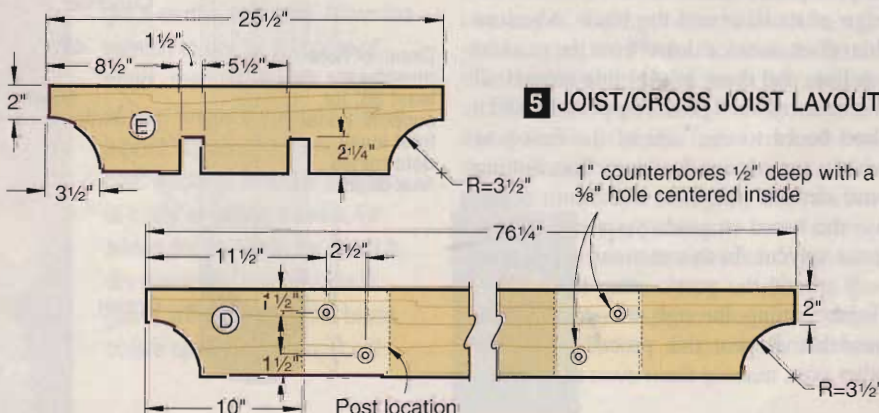
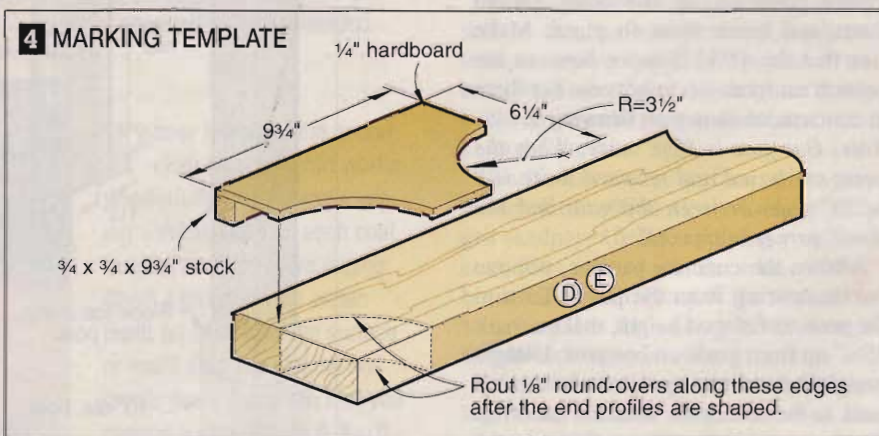

**5 JOIST/CROSS JOIST LAYOUT**

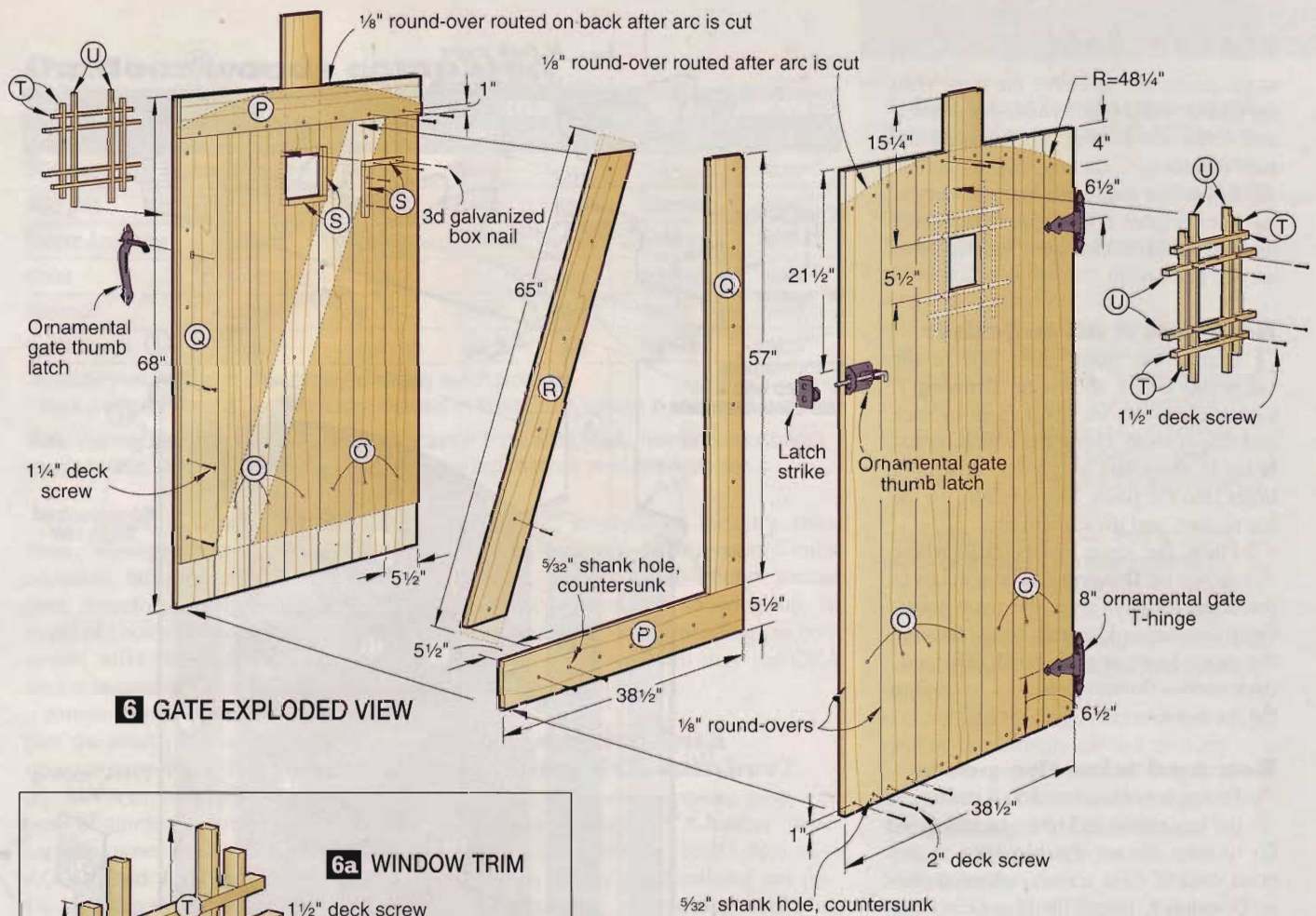

**6 GATE EXPLODED VIEW**

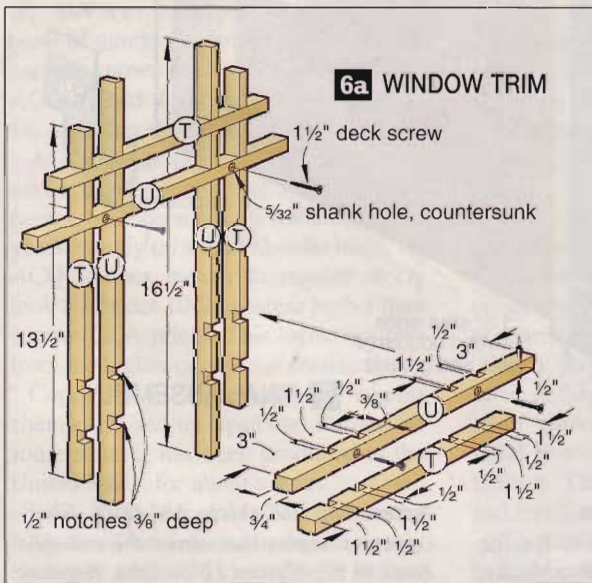

**6a WINDOW TRIM**

When the primer dries, lightly sand with 220-grit sandpaper. Finish the parts with two coats of exterior latex paint.

### Build a sturdy gate

**1** Cut 1x6 boards ( $\frac{3}{4} \times 5\frac{1}{2}$ " ) to length for the slats (O). Chuck a  $\frac{1}{8}$ " round-over bit in your handheld router, and rout their outside ends and edges. Pick out two center slats, and crosscut them for the window,  $15\frac{1}{4}$ " from the top end, where shown on **Drawing 6**.

cut them to this length. Cut the stiles (Q) to the length in the Materials List.

**3** Glue and clamp the bottom rail (P) in place. (We used polyurethane glue.) Drill countersunk shank holes, centered on the rail's width and on each slat, where shown on **Drawing 6**. Drive in the screws. Glue, clamp, drill, and screw the stiles (Q), then the top rail (P), in place. When drilling the shank holes in the top rail, once again center each hole on a slat, but drill them 1" from the rail's bottom edge.

**2** Clamp together seven slats (O) edge to edge, facedown, positioning the long portion of one of the cut slats in the center. Make sure the bottom ends are flush and the assembly is square. Insert the short portion of the center slat, leaving a  $5\frac{1}{2}$ "-long space for the window, where shown on **Drawing 6**. Measure the width of the assembly for the exact length of the rails (P), and

**4** Cut the brace (R) to the length shown in the Materials List. Lay it diagonally across the assembly with its top end at the hinge side. Mark and cut the end angles, as shown on **Drawing 6**. Drill countersunk shank holes, and glue and screw the brace in place.

**5** Cut the window cleats (S) to size, apply glue, and nail them in place around the window with 3d galvanized box nails.

**6** Apply glue to the rails, stiles, brace, and cleats. Clamp the remaining slats in place with the cut slat in the center. Using a thin wood strip bent to the curve shown on **Drawing 6**, mark the door's top arc. Drill countersunk shank holes in the slats where shown. Drive in the screws and remove the clamps. Cut the top arc with a jigsaw, and sand it smooth. Rout  $\frac{1}{8}$ " round-overs on both edges.

**7** Cut the long and short window trim (T, U) to size. Install a  $\frac{1}{2}$ " dado blade in your tablesaw, and raise it to cut  $\frac{3}{8}$ " deep. Attach an auxiliary extension to your miter gauge and, form the notches, where shown on **Drawing 6a**. Apply glue

## garden gate

to the joints, and assemble the trim. With the glue dry, drill countersunk shank holes, and screw the trim in place around the gate's window.

**8** Prime the gate with exterior acrylic latex primer, taking care to fully coat the end grain. Finish with two coats of acrylic latex paint.

### Now put it all together

**1** Clamp the main joists (D) to the posts, where shown on **Drawing 7**. Check the joists for level front-to-back and side-to-side. Using the counterbored holes in the joists as guides, drill pilot holes into the posts. Slip washers on the lag screws, and drive them in.

**2** Place the cross joists (E), where shown on **Drawing 7**. The notches in the cross joists fit over the main joists. Drill countersunk shank holes through the cross joists at each notch. Drive 4" deck screws through the cross joists into the main joists.

### Box and trim the posts

**1** From pressure-treated 2x4 stock, cut the horizontal and hinge blocking (F, G) to size. Fasten the blocking to the posts with 3" deck screws, where shown on **Drawing 1**. Install the hinge blocking (G) on only the hinge-side post, flush with the corner that is in the direction of the gate's swing.

**2** From pressure-treated plywood, cut the surround sides (H) to size. Using construction adhesive and 6d common galvanized nails, attach the sides to the blocking. Keep the top edges of the sides and the top blocking flush.

**3** Cut eight  $\frac{3}{4} \times 1\frac{3}{4} \times 14\frac{1}{2}$ " pieces of cedar for the trim base (I), and eight  $1\frac{1}{2} \times 4 \times 14\frac{1}{2}$ " pieces of cedar for the beveled trim (J). Glue and clamp blanks for the surround trim (I/J), keeping one edge of the assembly flush, as shown on **Drawing 1a**. Use an exterior glue. (We used polyurethane glue.) With the glue dry, cut the bevels, where shown.

**4** Miter-cut the surround trim (I/J) to fit around the tops of the surrounds. Gluing the corners together, nail the surround trim to the blocking (F) with 10d galvanized finish nails.

**5** Cut the narrow battens (K) and wide battens (L) to size. Nail them to the corners of the post surrounds with 6d galvanized finish nails, where shown on **Drawing 7**.

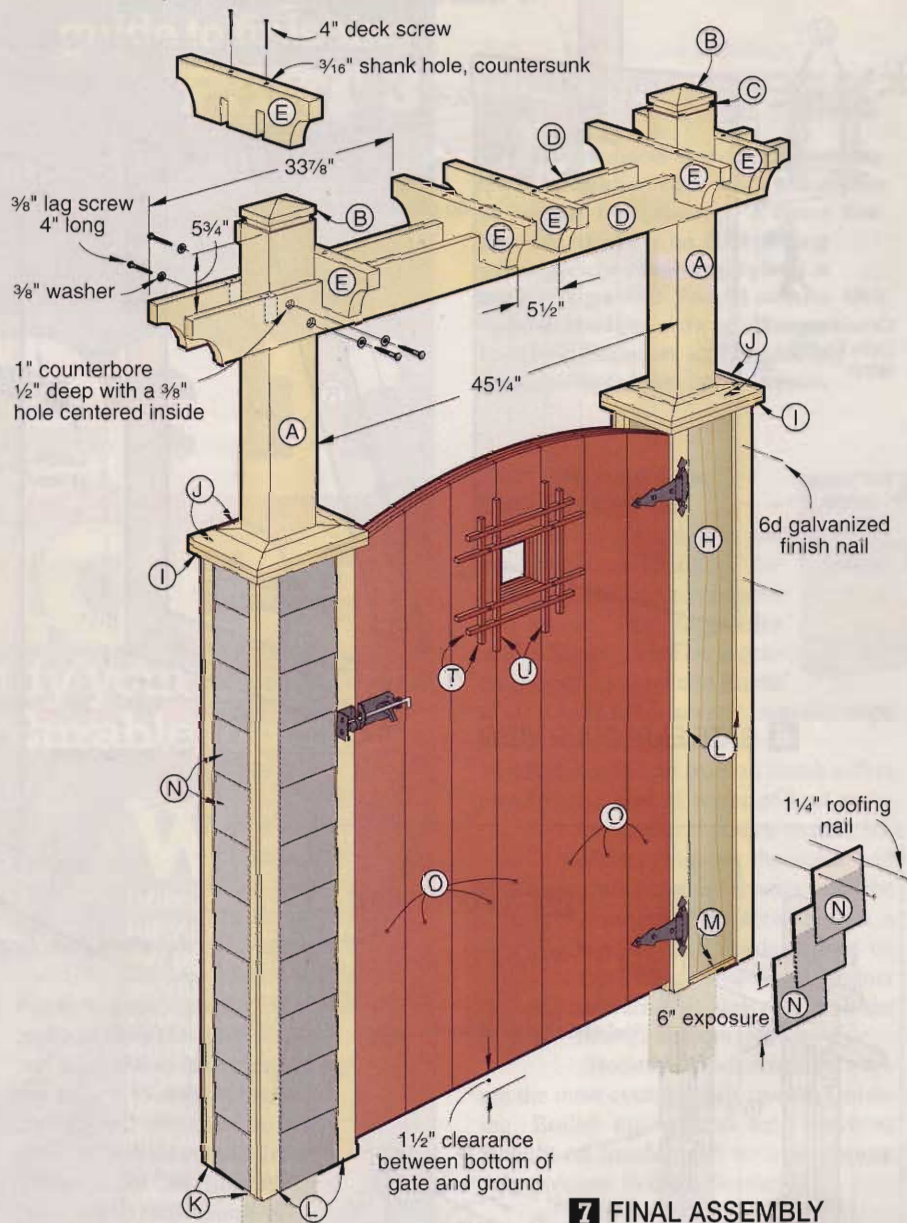

**7** FINAL ASSEMBLY

### Apply the shingles

**1** Rip two  $\frac{7}{16} \times \frac{3}{4} \times 30$ " blanks for the starter strips (M). From these blanks, cut pieces to fit around the bottom of each post surround. Nail them in place with 4d galvanized box nails.

**2** Using an inexpensive  $7\frac{1}{4}$ " carbide-tipped blade in your tablesaw, trim 18"-long fiber-cement shingles (N) to width, then cut the lengths in half, making  $8\frac{1}{2}\frac{1}{16}$ "-long shingles. You'll get two  $8\frac{1}{2}\frac{1}{16}$ "-long shingles out of each 18"-long one, so for the 88 shingles needed, you'll have to purchase at least 44 of the 18"-long shingles. See the Buying Guide for fiber-cement shingle information.

*Note: The  $\frac{1}{4}$ "-thick 18"-long fiber-cement shingles that cover the columns come in 6", 8", and 12" widths. Because the between-the-battens width of our sides is 7", we used only 8"-wide shingles.*

**3** Fasten the shingles with a couple dabs of construction adhesive and  $1\frac{1}{4}$ " roofing nails, maintaining the 6" exposure, where shown on **Drawing 7**. Keep the course lines even all around each post box. Because nothing overlaps the top course, trim these shingles to 6" before nailing them in place.

*Note: If a fence is to be attached to the gate post surrounds, you may want to attach it before applying the shingles.*

Then fit the shingles around the fence members. The fence we built (shown in the opening photo) is featured on page 64.

**4** Caulk the joint between the surround trim (I/J) and the post. Fill any nail holes. Prime and paint the shingles, battens, and trim. Touch up the paint on the posts and arbor where needed.

## Hang the gate, and you're finished

**1** Position the gate between the shingled post surrounds, flush with the corner battens, as shown on **Drawing 7**. Raise it 1½" off the ground with scrap-wood blocks, and insert shims between the gate and the corner battens so the gaps at both sides are equal.

**2** Position the hinges, where shown on **Drawing 7**, and mark the screw locations. (We used black-painted 8" ornamental gate T-hinges, available at hardware stores and home centers.) Drill pilot holes, and fasten the hinges to the gate, then the post surround, as shown in **Photo C**. Use the 1½"-long lag screws provided with the hinges to fasten the hinge to the gate, but use 4"-long lag screws for fastening into the post surround. Locate the T-ends of the hinges so the pilot holes for the 4" lag screws go through the corner batten and side into the hinge blocking (G).

**3** Remove the shims and blocking. Install the latch according to the instructions that come with it. (We used an ornamental gate thumb latch that matches the hinges.)

## materials list

Posts	FINISHED SIZE			Matl.	Qty.
	T	W	L		
A* posts	5½"	5½"	†	PT	2
B cap tops	1½"	5½"	5½"	C	2
C cap bases	¾"	4½"	4½"	C	2
<b>Pergola</b>					
D main joists	1½"	5½"	76¼"	C	2
E cross joists	1½"	5½"	25½"	C	6
<b>Post Surrounds</b>					
F horizontal blocking	1½"	3½"	7"	PT	40
G hinge blocking	1½"	3½"	12½"	PT	2
H sides	¾"	9¼"	66¾"	PP	8
I* trim base	¾"	1¾"	13½"	C	8
J* beveled trim	1½"	4"	13½"	C	8
K narrow battens	¾"	1½"	66"	C	8
L wide battens	¾"	2¼"	66"	C	8
M*starter strips	7/16"	¾"	7"	C	8
N* shingles	¼"	7"	81½"	FC	88
<b>Gate</b>					
O slats	¾"	5½"	68"	C	14
P rails	¾"	5½"	38½"	C	2
Q stiles	¾"	5½"	57"	C	2
R* brace	¾"	5½"	65"	C	1
S window cleats	¾"	¾"	6¼"	C	4
T short window trim	½"	¾"	13½"	C	8
U long window trim	½"	¾"	16½"	C	8

\*Parts initially cut oversize. See the instructions.

†Length varies. See the instructions.

**Materials Key:** PT—pressure-treated lumber, C—cedar, PP—pressure-treated plywood, FC—fiber-cement shingles.

**Supplies:** Gravel; concrete mix (approximately 3 cubic feet); 3d galvanized box nails; 4d galvanized box nails; 4d galvanized finish nails; 6d galvanized finish nails; 10d galvanized finish nails; 6d galvanized common nails; 1¼" roofing nails; 4" deck screws (16); 3" deck screws;

2" deck screws; 1½" deck screws; 1¼" deck screws; ¾" lag screws 4" long (8); ¾" flat washers (8); ¾" lag screws 4" long (4); 8" ornamental gate T-hinges (2); ornamental gate thumb latch; exterior glue; construction adhesive; caulk; exterior wood filler; sandpaper; exterior primer; exterior paint; wood shims. For the bevel jig: ¾x8x8" plywood, ¾x1x8" stock, ¾x2x8" stock, and ½x1x8" stock. For the marking/trimming jig: ¼x6¼x9¾" hardboard and ¾x¾x9¾" stock.

### Buying Guide

**Fiber-cement shingles.** For Hardie Shingleside Heritage Single Shingle product and dealer information, call James Hardie Building Products, 800/942-7343, or go to [www.jameshardie.com/shingleside.htm](http://www.jameshardie.com/shingleside.htm).

Written by **Jan Svec** with **Kevin Boyle**

Project design: **Kevin Boyle**; **James R. Downing**

Illustrations: **Roxanne LeMoine**; **Kim Downing**;

**Lorna Johnson**

Photographs: **Baldwin Photography**



**First, mount the hinge's strap on the gate. Then, using the holes in the hinge's T as guides, drill pilot holes in the surround and drive in the lag screws.**

## cutting diagram

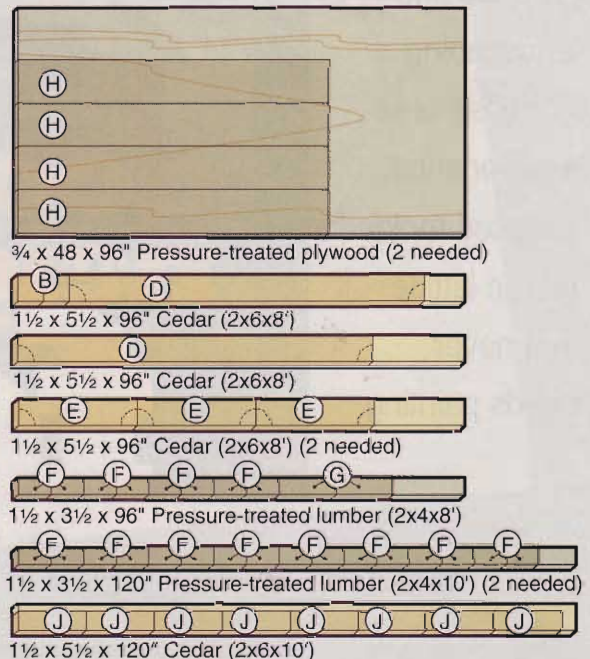
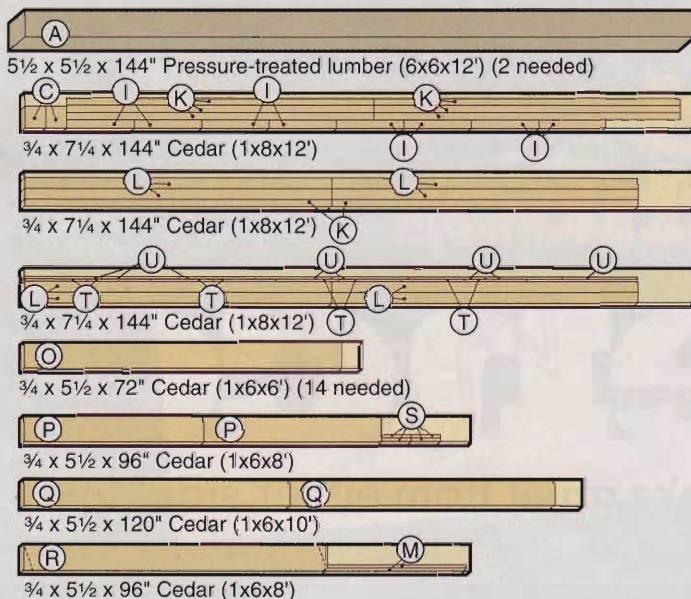

**GREAT  
OUTDOOR  
PROJECTS**

Simple to build, yet striking in appearance, this fence makes the perfect backdrop for your flower gardens and landscaping. For ease of maintenance, we used molded plastic lattice that never needs painting.



**good-neighbor  
fence**

It looks great from either side!







**Check the post on adjacent sides for plumb. Fasten 2x4 braces to the stakes and the post with screws.**

treated posts of the next standard length. For example, if your posts extend 24" below ground, use 8'-long posts. If they extend 42", buy 10' ones. Position the posts (A) in the holes, plumb them in two directions, and brace them in place, as shown in **Photo A**. Make sure that the distance between the posts is 35" from top to bottom.

**3** If your fence is on level ground, make a mark 59 $\frac{3}{4}$ " up from the ground on the end posts. Stretch a string

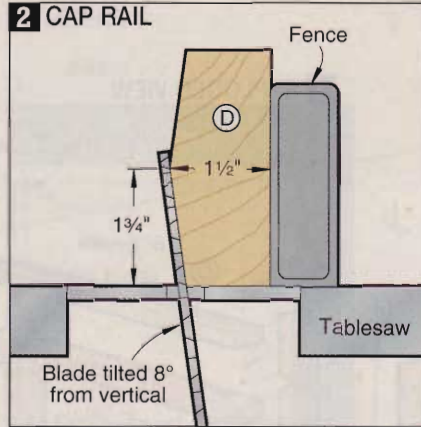

line between these marks. (Mason's line, available at hardware stores, lumberyards, and home centers, can be stretched very tightly without breaking to give you the straightest line possible.) Check your string line with a level, and make any adjustments necessary. Mark the posts and trim them to finished height using the method explained in the article "Grand Entrance" on page 58. If your fence is on a slope, see the sidebar "Stepping down a slope," below.

**4** Make a cap (B/C) for each post, as explained on page 60 of the article "Grand Entrance." Set them aside.

**Make the panel parts**

**1** From 2x4 stock, cut four lengths for the cap rail (D), lattice rails (E), and

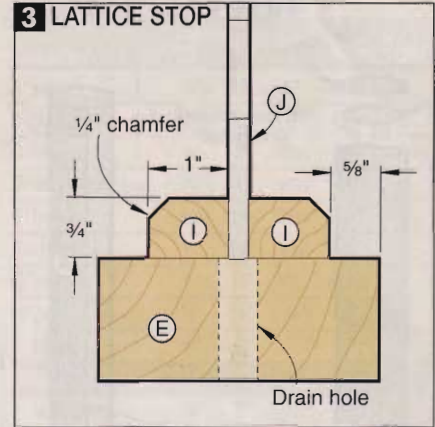

bottom rail (F). With the table saw blade tilted 8°, bevel-rip the cap rail, where shown on **Drawing 2**. Set the cap and bottom rails aside.

**2** Tape the lattice rails (E) together with their ends flush. Lay out the notch locations, where shown on **Drawing 1**. Install a 3/4" dado blade in your table saw, and raise it to cut 1 3/4" deep. Using the miter gauge fitted with an auxiliary extension to reduce chip-out, cut the 1 1/2"-wide notches, making at least two passes over the blade. Check the fit of your 2x4 stock. For good appearance and easy assembly, the fit should be close, but not too tight.

Cut the uprights (G) to length, and repeat the above procedure to form their mating notches. Select one of the lattice

**Stepping down a slope**

Not every fence is on flat ground, and different types of fences handle slopes differently. Some of them, like a simple vertical board fence, easily take slopes in stride. Stringers that follow the slope are attached to the posts. The position of each individual board is adjusted as it is attached to the stringers so the fence just flows down the slope. But fences with discrete rectangular panels like ours must "stairstep" down the slope. This fence will easily accommodate a slope that drops no more than 12" between posts. Once your posts are set, the five-step drawing, right, shows you how to mark your posts at the proper height, and where to position the fence panels.

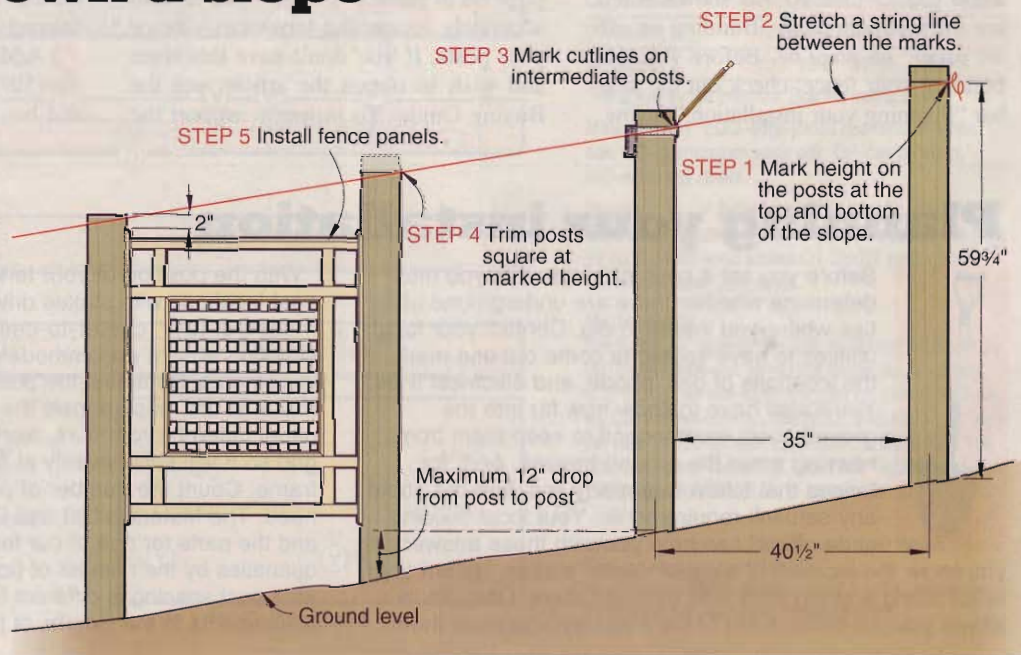

rails (E) as the lower one, and drill centered drain holes, where shown on **Drawings 1 and 3**. (The lattice stops, applied later, form a channel that would trap water on the bottom lattice rail.)

**3** Cut the mounting plates (H) to size. Chuck a 1/4" cove bit in your hand-

held router, and rout coves on the plates' edges, where shown on **Drawing 1**.

**4** Cut eight 3/4x1x24" blanks for the lattice stops (I). Install a chamfer bit in your table-mounted router, and cut 1/4" chamfers on the edges, where shown on **Drawing 3**.

### Finishing now saves time later

**1** Sand all the parts to 120 grit. Prime the post caps and all the panel parts, including the lattice stop blanks, with exterior acrylic latex primer. Double-prime the notches and all end grain.

## Building an offset panel

**Note:** Our fence makes an angled jog, as shown in the opening photo on page 64. Although an unusual situation, we found this offset handy in solving a tricky landscaping problem. Should you find yourself in a similar pickle, here's how to handle it.

**Step 1** After bracing the posts in their holes and trimming them to finished length, cut a 2x4 long enough to lay across the tops of the posts, where shown on **Drawing 4**. Using a piece of 3/4"-thick stock to represent the mounting plates (H), mark cutlines on the underside of the 2x4, where shown on **Drawing 5**. Miter-cut the 2x4 to length. Trim the points of the mitered ends, where shown on **Drawing 6**. Using this 2x4 as a template, mark and trim three more rail blanks.

**Step 2** Referring to **Drawing 2**, bevel the top of one blank for the cap rail (D). Lay out the notch locations on two blanks for the lattice rails (E), where shown on **Drawing 6**. Cut the notches, then drill drain holes in one, where shown on **Drawings 3 and 7**.

**Step 3** Form the uprights (G), mounting plates (H), and lattice stops (I) in the same manner as for a standard panel. Sand, paint, and assemble the angled panel, as shown on **Drawing 7**. Measure and cut the lattice stops and lattice insert to fit.

**Step 4** Finally, as you work your way along the fence fastening the panels in place, simply screw the angled panel to its posts.

### 7 OFFSET PANEL ASSEMBLY

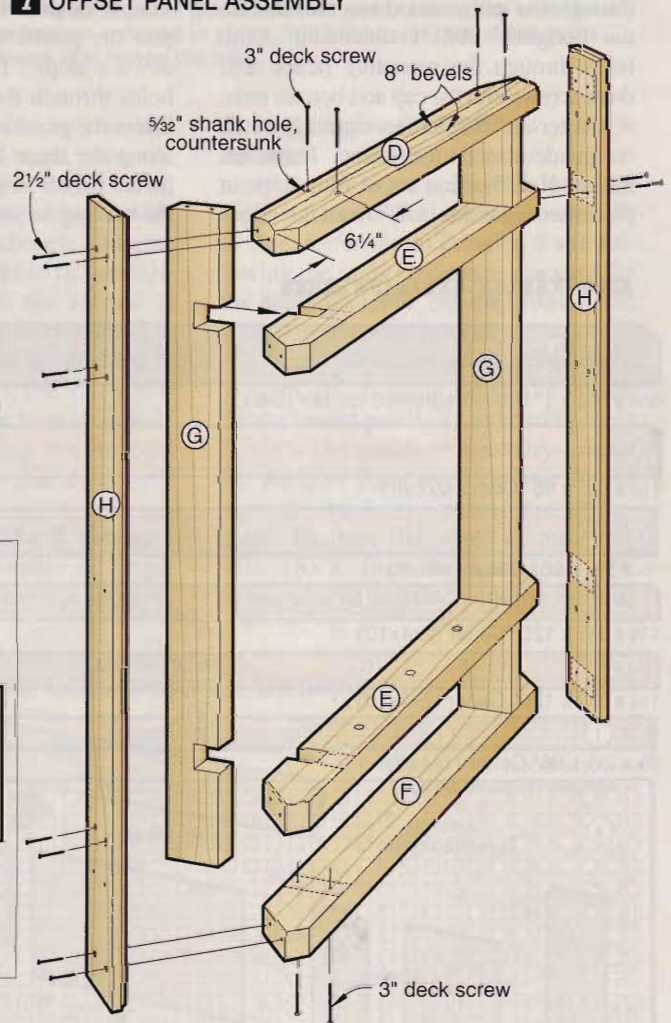

### 4 OFFSET PANEL

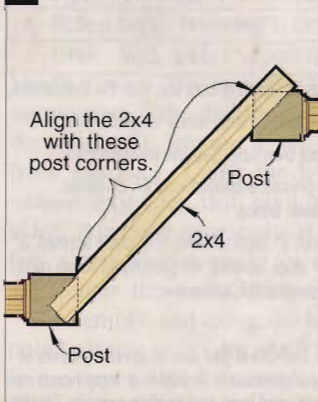

### 5 MARKING THE RAIL

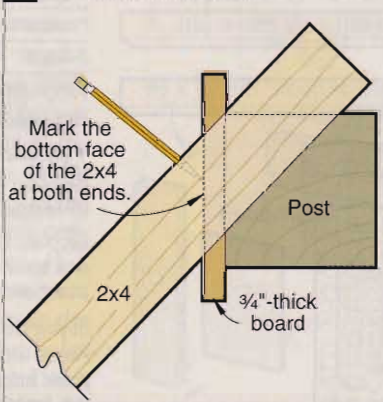

### 6 OFFSET RAILS

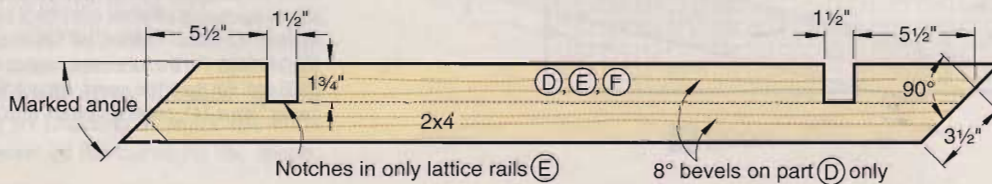



# stowable sawhorses

We test 10 supports that stand strong and stow small.



Every woodworker's shop should have at least one pair of sawhorses. By themselves, they support sheet goods and boards for cutting into manageable pieces. Or, throw a scrap of plywood across a pair of horses and instantly create an extra worksurface. Some height-adjustable sawhorses even convert into handy infeed and outfeed tables.

The problem with shop-built horses is that they take up a fair amount of floor space even when not in use. That's why we like today's commercial sawhorses that weigh little and knock down to a fraction of their in-use size for easy storage. Big-time capacities come in these small packages, with most of the tested sawhorses rated to hold 1,000 pounds or more per pair.

## How we put the 'horses through their paces

If the sawhorses didn't already have a wooden beam, we attached one—a length of pine

2x4, in most cases—and began our testing. (This sacrificial beam protects both the horse and your saw from cut-through damage.) To test for stability, we dragged a sheet of 3/4" plywood every which way we could atop each pair of horses, much as you might do when positioning a sheet before cutting. Next, we placed more than 600 pounds of weight on each pair and looked for any sag in the legs or beams. Finally, we spent several weeks using the sawhorses in and out of the shop to get better acquainted with each product's features.

## Two methods of downsizing

Stowable sawhorses "get small" in one of two ways: Most break down or fold so that they basically become flat versions of their set-up selves (thin, but wide); the others have collapsible legs that swing up and store inside the beam. We found no advantages or disadvantages to either style when it comes to sag, stability, or weight capacity.

Fold-flat sawhorses set up in a heartbeat, and can hang on a wall for storage, as shown at left, or stand under one end of your bench. Collapsible sawhorses take an extra couple of setup steps, but break down into a compact package that can be tucked away on a shelf or in the trunk of the car.

# A model-by-model look at the horses in this race



## Clyde & Dale's 32100

800/390-5303, [www.clydeanddales.com](http://www.clydeanddales.com)

These lightweight leg sets can't splay, because they're manufactured as a single, heart-shaped loop of tubular aluminum. That's a big reason why Clyde & Dale's Sawhorses have the highest weight-capacity rating in the test (3,000 pounds per pair).

You provide your own wooden beam, and that presents advantages and a disadvantage. On the plus side, you can make the horses practically any length you want. And, you can adjust the height of the horses by using different widths of 2x lumber. To store the sawhorses, merely slip the leg sets off the ends of the beam. The leg sets nest together nicely for storage, but you still have to store the beams separately.



## HandyHorse TS-21

Fulton Corporation, 800/252-0002

[www.fultoncorp.com](http://www.fultoncorp.com)

Made entirely of stamped 20-gauge galvanized steel, the TS-21 is by far the lightest of all the collapsible sawhorses, weighing only 20 pounds per pair. But the thin steel tended to cut into our hands when we carried the horses by their ends. The TS-21 also flexed and twisted along its beam until we added a sacrificial 2x4.



## Tote-A-Horse TS-501

Fulton Corporation

In some ways, the TS-501 is twice the sawhorse the TS-21 is—twice the load limit; twice the weight; twice the price. Its 14-gauge, stamped-steel construction reduces the twisting tendency of the beam, and accounts for the weight difference, but built-in carrying handles make lugging the pair easier.

The TS-501 is one of only three tested sawhorses where the beam can be set to different heights, but we found it the most cumbersome to change, as shown in the "Beam up, Scotty" section, on the next page. And those legs must be returned to their lowest height before folding and storing, or they won't fit inside the beam.



## Maverick

Genesee Metal, 716/968-6000

[www.genesee-metal.com](http://www.genesee-metal.com)

The highlight of this tubular-steel sawhorse is its infinitely height-adjustable beam, which means you can set it for table saw infeed or outfeed support, or as an extension to your workbench or assembly table. But the downsides—a \$140 per-pair price tag and a mere 500-pound load rating—outweigh that benefit, in our opinion. For storage, the leg sets rotate 90° to fold against the beam, making the sawhorses flat but about 20" longer stored than when set up.

## Mounting the beam

In most cases, attaching the sacrificial beam is a simple matter of driving a couple of screws through the horse's beam into a 2x4. We found three noteworthy exceptions to this rule, as shown below.

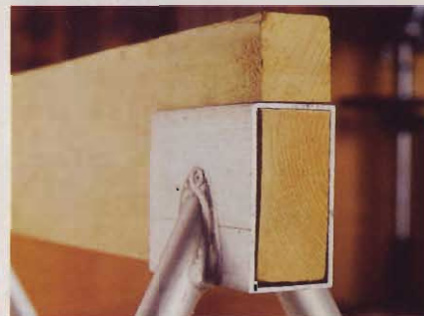

The box tubing of the Clyde & Dale's Sawhorses fits a 2x4 like a glove, but leaves the metal exposed to a saw blade. Instead, we cut a kerf in a 2x6 (above) to provide cut-through protection.



The vaguely X-shaped "Smart Grooves" fit snugly over the ends of the Stanley Adjustable Sawhorse's plastic beam. The 2x4 sacrificial beam friction-fits into the notches on edge (as shown above), or flat, using the top notches.



Storehorse's V-shaped "Sawbucks" accept a 2x4 or 2x6 sacrificial beam laid flat. However, the fit isn't snug to either the sawhorse or the wooden beam, so the beam slides in the Sawbucks, and the Sawbucks slide on the sawhorse.

## Beam up, Scotty

For maximum versatility, we like a sawhorse with a height-adjustable beam. Three tested horses have such capability but, as shown *below*, they vary in their ease of use.



**GOOD:** Changing the beam height of the Tote-A-Horse TS-501 requires removing a wing nut, carriage bolt, and the bottom portion of each leg. Replace the leg bottom in a new set of 4"-spaced locking slots, then replace the nut and bolt.



**BETTER:** With no fixed increments, Maverick's beam can be set literally anywhere from 28" to 38" high. You first release the knurled locking knob, then a clutch (like that on a pipe clamp), and adjust one end at a time.



**BEST:** When folded flat, you can lift or lower the Stanley's beam in 1" increments. Opening the horse to its in-use position locks in the beam height. At full height, the load limit is reduced from 1,000 to 800 pounds per pair.



### Port-A-Mate

HTC Products, 800/624-2027

HTC's tubular-steel Port-A-Mate is the only sawhorse that comes with a wooden (2x6) beam, so we didn't need to add one. Because of the scissors-style legs, you could bolt a pair of these sawhorses to a sheet of plywood to create an easy-to-fold temporary table. Or, add HTC's optional miter saw platform, and you have a solid, stowable, miter saw stand. Port-A-Mate comes in two heights: The HP-328-2 stands 26" tall, and the HP-333-2, 33".



### StableMate

Iowa Manufacturing, 800/882-4422

[www.stablemateonline.com](http://www.stablemateonline.com)

One of our favorites, this 16-gauge, galvanized-steel sawhorse edges out the

Fulton TS-501 for "heaviest horse" honors (at 38 pounds per pair), and proved rock solid in our tests. Spring-loaded ball catches keep the legs locked in both set-up and stored modes.

If there were a "best accessorized" award, StableMate would win that, too. Add enough options, and you can turn it into a full-blown miter saw stand, complete with workpiece supports and wheels. Choose from the 35"-tall SH-4236-2, or the 29" SH-4230-2 (for about \$10 less per pair).



### Rugged Buddy Folding Legs

Target Precision, 310/527-7844

Like the Clyde & Dale's sawhorses, Rugged Buddy doesn't come with a beam, but each leg set's mounting plate attaches to a 2x4 laid flat, or bolts beneath a tabletop for a temporary table. Rubber feet provided good purchase on our concrete test floor, making it one of the more stable sawhorses in the test. The legs lock when in the set-up orienta-

tion, but releasing them requires a fair amount of force, and might be difficult if you have limited hand strength.



### Stanley Adjustable Sawhorse

The Stanley Works, 888/628-4455

[www.thestanleyworks.com](http://www.thestanleyworks.com)

Although made entirely of plastic, these horses didn't sag or deflect any more than the metal horses in our test. Besides being height adjustable, the Stanley Adjustable Sawhorse adjusts widthwise as well: Pull on one end of the beam, and both ends extend out to as much as 47" wide—a perfect width for cutting sheet goods.

Ingenious "Smart Grooves" allow you to instantly add or remove a sacrificial beam. (See the *middle* photo on the *previous page*.) Flip these pieces over and the V-groove holds dowel, pipe, or even dimensional lumber for cutting—as long as it's at least 29" long (the length of the beam). We just wish there were on-board storage for the Smart Grooves: They're easy to misplace.

## CORRALLING THE SAWHORSES

MANUFACTURER/BRAND	MODEL	BEAM			LEGS			STORED DIMENSIONS (PAIR OF HORSES, INCHES) (1)	EASE OF SETUP AND BREAKDOWN	STABILITY	PERFORMANCE RATINGS (5)				OPTIONAL ACCESSORIES (7)	WARRANTY (8)	COUNTRY OF ASSEMBLY (9)	WEIGHT (PER PAIR, POUNDS) (1)	SELLING PRICE (PER PAIR) (10)	
		HEIGHT RANGE (INCHES) (1)	LENGTH (INCHES) (2)	MATERIAL (2) (3)	WIDTH (INCHES)	MATERIAL (3)	LOAD LIMIT (POUNDS, PER PAIR OF HORSES) (4)				FOOT MATERIAL (PLASTIC/RUBBER)	EASE OF ATTACHING SACRIFICIAL BEAM (6)	EASE OF ADJUSTING HEIGHT	PORTABILITY						STOWABILITY
CLYDE & DALE'S	32100	33 3/4*	*	*	27 3/4	T	3,000	N/A	8 x 28 x 36	E	E	G	N/A	F	G		Life	U	6	\$80
FULTON	HandyHorse TS-21	29 1/4	32 1/2	GS	24	GS	1,000	N/A	8 x 32 1/2 x 12	E	G	G	N/A	F	E		Life	U	20	28
	Tote-A-Horse TS-501	25-40	38	SS	18 3/4	SS	2,000	N/A	4 x 38 x 5	G	G	G	F	G	E		Life	U	37	65
GENESEE METAL	Maverick	28-38	32	SS	25 1/2	TS	500	R	5 x 52 x 27	G	G	G	G	G	G	M, RS	Life	U	30	140
HTC	Port-A-Mate HP-328-2	33	29 3/4	W	19 1/4	TS	1,000	P	9 x 29 3/4 x 37	E	G	E	N/A	G	G		Life	U	30	78
IOWA MANUFACTURING	StableMate SH-4236-2	35	42 1/4	GS	25 1/2	GS	1,000	P	5 3/4 x 42 1/4 x 6 1/2	E	E	G	N/A	G	E	C, E, R, SB, W	1 yr	U	38	80
STANLEY	Adjustable Sawhorse	30-37	29-47	P	19 3/4	P	1,000*	P	5 x 29 1/2 x 32	E	E	E	E	E	E		6 yrs	i	14	50
STOREHORSE	XL	30	30	P	17 1/4	P	1,000	N/A	4 x 30 x 31	E	E	F	N/A	E	G	H, P, S	1 yr	U	20	40
	XT	36	30	P	20	PA	1,000	N/A	4 x 30 x 38	E	E	F	N/A	E	G	H, P, S	1 yr	U	26	50
	Series II	30 3/4	27	P	17 1/2	P	1,000	N/A	4 x 28 x 30	E	E	F	N/A	E	G	H, P	1 yr	U	18	30
TARGET PRECISION	Rugged Buddy	34 1/2**	*	*	24 1/2	SS	2,000	R	7 x 24 1/2 x 33	E	E	G	N/A	G	G	M	2 yrs	U	12	35
WOODCRAFT SUPPLY	Portable Saw Horses	31 3/4	39 1/2	SS	15	SS	1,500	R	3 1/2 x 39 1/2 x 3 1/2	E	G	G	N/A	E	E		1 yr	T	27	60

**NOTES:**

- |                                                                              |                                                                                                                                                                             |                                                                             |                                                   |                                                 |                                                                                                                                                                                                                        |                                                      |                                                  |                                                                                                   |
|------------------------------------------------------------------------------|-----------------------------------------------------------------------------------------------------------------------------------------------------------------------------|-----------------------------------------------------------------------------|---------------------------------------------------|-------------------------------------------------|------------------------------------------------------------------------------------------------------------------------------------------------------------------------------------------------------------------------|------------------------------------------------------|--------------------------------------------------|---------------------------------------------------------------------------------------------------|
| 1. Not including sacrificial beam.<br>(*) With 2x6 beam<br>(**) With 2x beam | 3. (GS) Galvanized steel<br>(P) Plastic<br>(PA) Plastic with tubular-aluminum reinforcement<br>(SS) Stamped steel<br>(T) Tubular aluminum<br>(TS) Tubular steel<br>(W) Wood | 4. Rating from manufacturer.<br>(*) Limit reduced to 800 lb. at full height | 5. <b>E</b> Excellent <b>G</b> Good <b>F</b> Fair | 6. (*) Supplied with attached sacrificial beam. | 7. (C) Tool-mounting clamps<br>(E) Extension wings<br>(H) Hobby top<br>(M) Miter saw platform<br>(P) Power strip<br>(R) Work supports<br>(RS) Roller supports<br>(S) Sawbricks<br>(SB) Shelf brackets<br>(W) Wheel kit | 8. (Life) Lifetime warranty against factory defects. | 9. (U) United States<br>(I) Israel<br>(T) Taiwan | 10. Prices current at time of article's production, and do not include shipping where applicable. |
|------------------------------------------------------------------------------|-----------------------------------------------------------------------------------------------------------------------------------------------------------------------------|-----------------------------------------------------------------------------|---------------------------------------------------|-------------------------------------------------|------------------------------------------------------------------------------------------------------------------------------------------------------------------------------------------------------------------------|------------------------------------------------------|--------------------------------------------------|---------------------------------------------------------------------------------------------------|

For specifications on other types of tools, click on "Tool Comparisons" at [www.woodmall.com](http://www.woodmall.com).



### Storehorse

The Lehigh Group, 800/523-9382  
[www.lehighgroup.com](http://www.lehighgroup.com)

Although similar to the Stanley Adjustable Sawhorse in construction, capacity, stability, and stowability, Storehorse lacks the versatility and reliable sacrificial-beam-mounting system. Still, even if you cut into the plastic beam cap, you wouldn't damage your tools or hurt the integrity of the horse. On two models—the XT and Series II—the removable beam cap has a V-groove for cutting small or round stock.

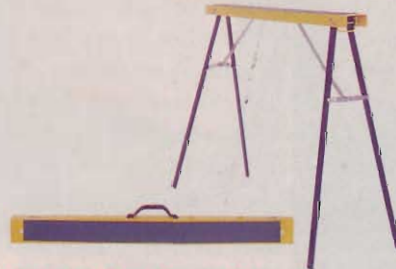

### Portable Saw Horses

Woodcraft Supply, 800/225-1153  
[www.woodcraft.com](http://www.woodcraft.com)

Made of heavy-gauge steel, these sawhorses are among our favorites, in large part because they store the smallest of all the models in the test. Like other collapsible horses, the legs fold up inside the beam. Then, both beams lock together into one dense but portable package (see photo, above right) for maximum mobility. Though compact, a pair of Portable Saw Horses provides 1,500 lb. of load capacity.



When was the last time you carried two sawhorses in one hand? Woodcraft's Portable Saw Horses snap together when stored to keep the other hand free.

### Which horse is right for your house?

Three models tripped our trigger: Iowa Manufacturing's StableMate lives up to its name, offering self-storing legs in a rugged body, with few moving parts and plenty of add-on options. Need something that stores a little smaller and is a little more portable? Try Woodcraft's Portable Saw Horses. On the other hand, Stanley's flat-folding Adjustable Sawhorse combines versatility, light weight, and height adjustability into an easily manageable sawhorse. 🐾

Visit [www.woodmall.com](http://www.woodmall.com) to talk about stowable sawhorses with other woodworkers.

Written by Dave Campbell with Phillip Goodwin  
Photographs: Baldwin Photography



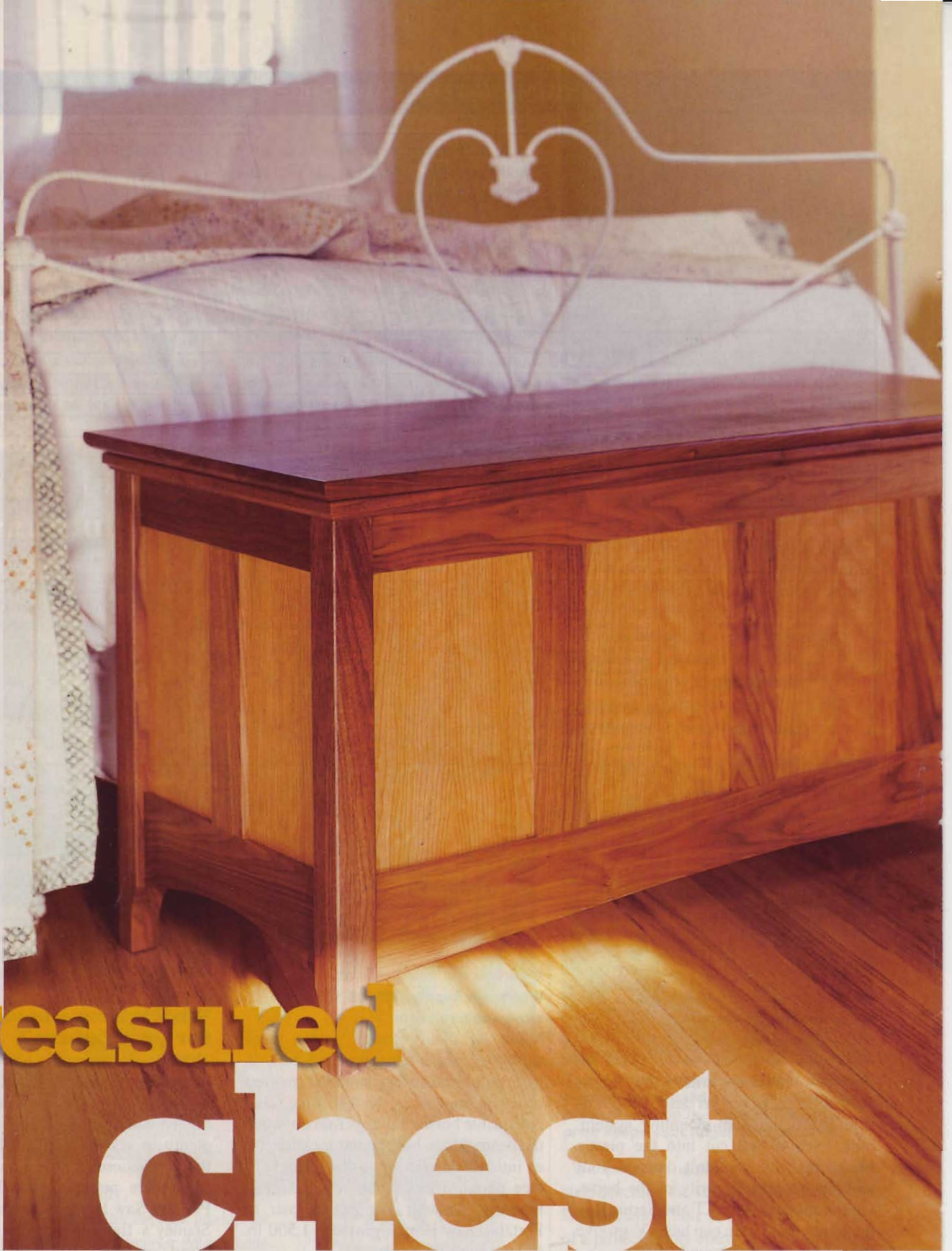

# treasured chest

**Frame-and-panel construction with contrasting woods lend good looks to roomy storage**

**L**ooking for a handsome, functional project that won't overtax your woodworking skills?

Here's one, and it makes a wonderful storage or hope chest. You'll find the construction of this piece strictly straightforward, with groove-and-tenon joints you cut with only a tablesaw. Blankets, toys, or family keepsakes will never have a more beautiful home.

**Start with the carcass parts and top cleats**

*Note: For the best fitting joints, surface-plane at the same time all materials that require the same finished thickness.*

**1** From 8/4 walnut, cut the legs (A) to the size listed in the Materials List and set aside. You also can make the legs by laminating three 3/4"-thick boards and surface-planing to the listed dimensions.

**2** From 5/4 walnut, planed to 1" thick, cut the side top rails (B), side bottom rails (C), stiles (D), front/back top rails (E), front/back bottom rails (F), front/back cleats (G), side cleats (H), and top cleats (I) to the sizes listed.

**3** Cut a 3/8" notch in both ends of the side cleats (H), where shown on **Drawing 1a**.

**4** Lay out and cut a 3/4" radius on the ends of the top cleats (I), where shown on **Drawing 1**. Then rout a 1/8" round-over on the outer edges of the cleats.

**5** To form the 1/2"-thick side panels (J) and front/back panels (K), first cut

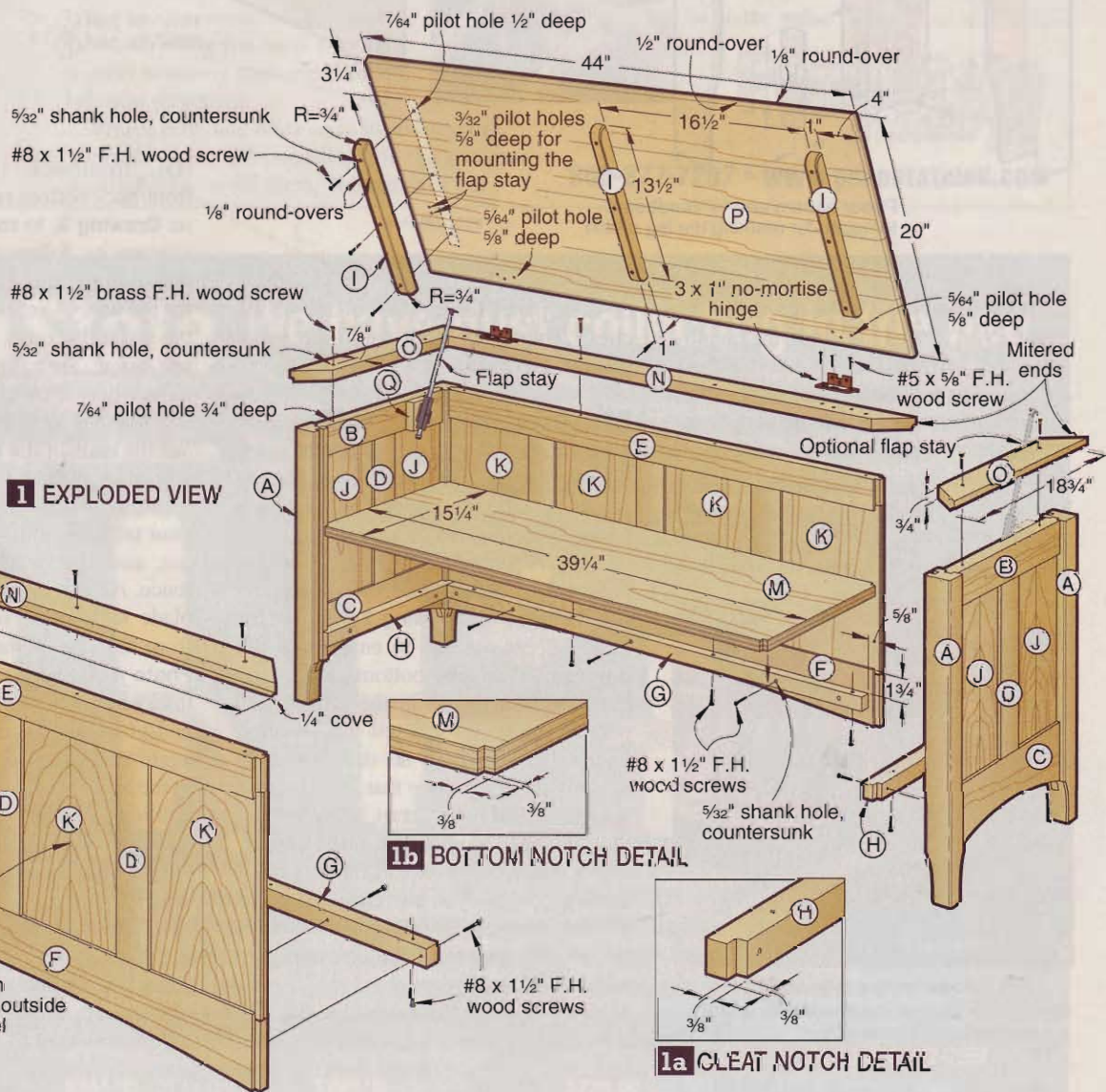

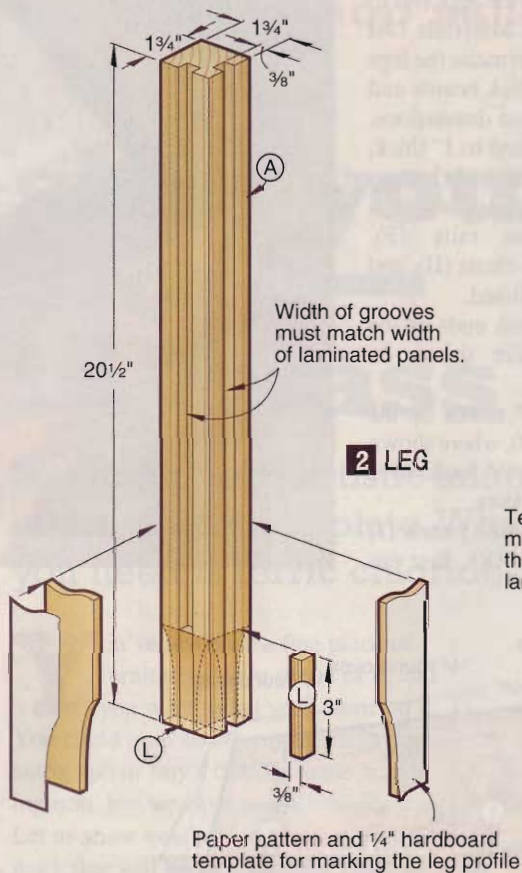

2 LEG

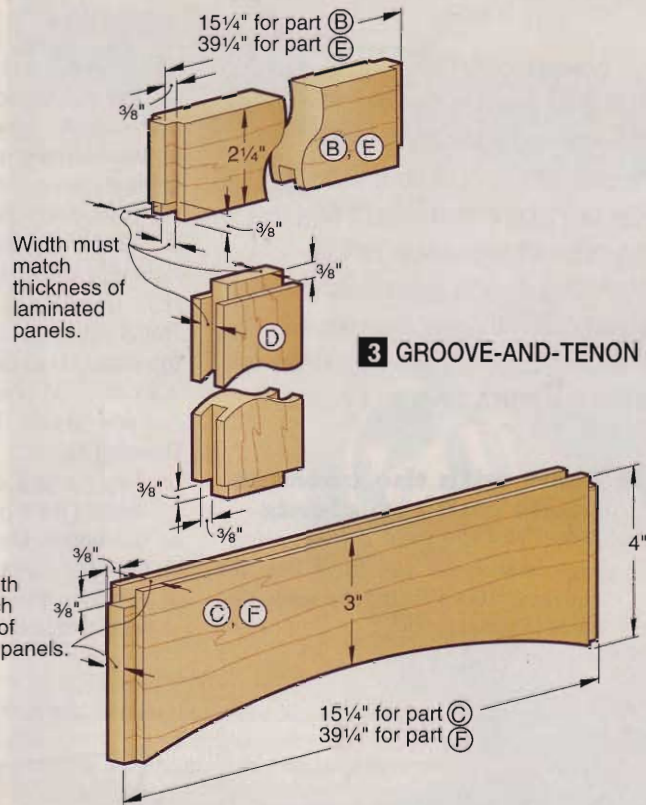

3 GROOVE-AND-TENON JOINERY

1/4"-thick cherry plywood to the sizes listed. (You'll need to double the quantity in the Materials List.) For the best appearance, cut the panels so that the veneer lamination line will be in the center of each panel, where shown on **Drawing 1**. Determine which panels—when placed side by side—offer the best overall look, and which can be joined back to back. You'll want the best face



Cut the tenons on the rails and stiles using a stopblock, as shown, to ensure a consistent tenon length.

of each panel facing the outside of the chest. Then, glue and clamp the panel sets back to back.

**Machine the details on the carcass parts**

**1** To cut the grooves in the legs (A) to receive the side panels (J), front/back panels (K), and the tenons of the rails, install a 3/8" dado blade in your table saw. Adjust it to cut 1/32" deeper than the 3/8" depth shown on **Drawing 2** to allow for glue squeeze-out and to ensure that the rail tenons do not bottom out in the grooves. Using a scrap the same thickness as the legs for a test cut, position your table saw fence so that the dado blade will cut a groove that is just shy of being centered in the scrap. Make the cut, turn the piece around, and make another cut to widen the groove. Test-fit a panel in the groove. Adjust the fence and repeat the test cut, as necessary, until the panel fits in the groove. Then, cut the two grooves in each leg.

**2** To cut the grooves in the side top rails (B), side bottom rails (C), stiles

(D), front/back top rails (E), and front/back bottom rails (F), where shown on **Drawing 3**, to receive the panels and stile tenons, follow the same process that you used for adjusting the fence position for the legs (A) except use a scrap that is the same thickness as the rails for your test piece. Then, cut the grooves in the rails, where shown.

**3** Now, to form the 3/8"-long tenons on the ends of the rails (B, C, E, F) and stiles (D), where shown on **Drawing 3**, begin by attaching an auxiliary fence to your table saw miter gauge to avoid chip-out, and also attach a stopblock to the fence. Adjust the height of your 3/8" dado blade to 1/4" and set the stopblock 3/8" from the side of the blade, as shown in **Photo A**. Using a scrap that is the same thickness as the rails and stiles, cut one end of the piece, turn it over, and cut it again to form a tenon. Test-fit the tenon in the leg groove. Adjust the blade height and test-cut, as necessary, until you get the proper fit of the tenon. Then, cut the tenons on the ends of all of the rails.

**4** Lay out the arch in the side bottom rails (C) and front/back bottom rails (F), where shown on **Drawings 4** and **5**. Refer to the **shop tip, An easy way to lay out smooth arches**. Now, bandsaw the arches and sand to remove saw marks.

#### 4 SIDE PANEL (outside face shown)

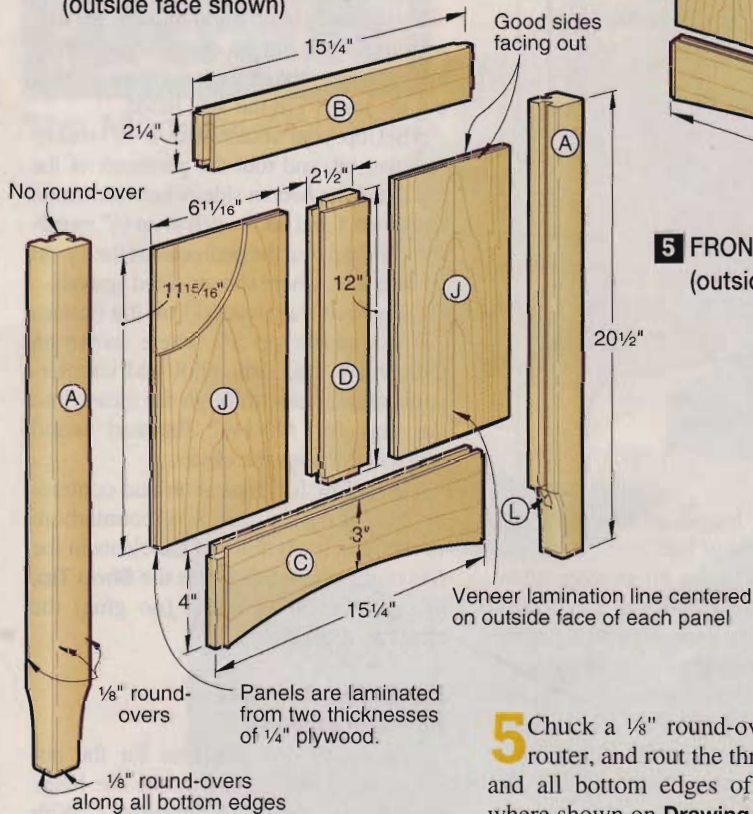

#### 5 FRONT AND BACK PANEL (outside face shown)

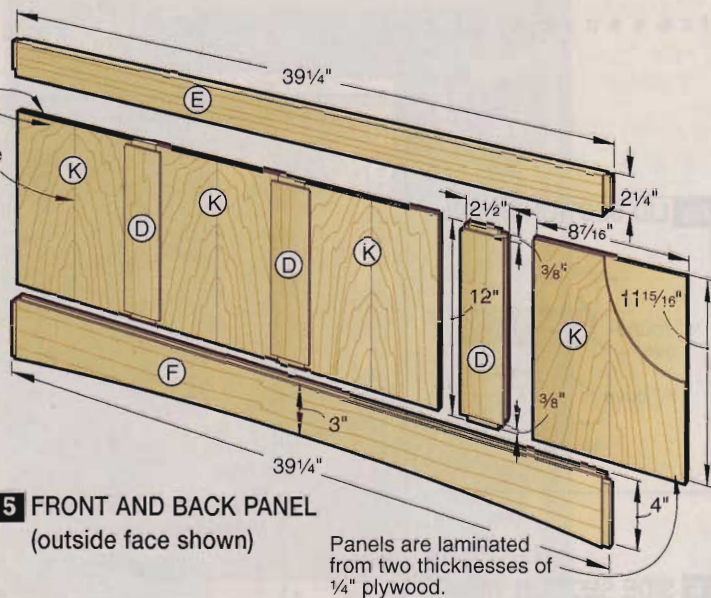

#### Complete the legs

**1** Cut the filler strips (L), which fill the bottom of the grooves in the legs (A). Cut the strips slightly proud of  $\frac{3}{8}$ " thick.

**2** Glue and clamp the filler strips (L) in the legs (A), where shown on **Drawing 2**. When the glue is dry, sand the strips flush with the legs.

**3** To cut the curves in the bottom of the legs (A), first make a photocopy of the leg full-size pattern in the *WOOD PATTERNS*® insert. Then, using spray adhesive, adhere the pattern to a piece of  $\frac{1}{4}$ " hardboard to make a template. Cut and sand the hardboard to the pattern line.

**4** Using the template, lay out the curves on each leg (the curves are on the two sides with the grooves). Bandsaw and sand the curves to the layout lines.

**5** Chuck a  $\frac{1}{8}$ " round-over bit in your router, and rout the three outer edges and all bottom edges of the legs (A), where shown on **Drawing 4**.

#### Let the assembly begin

**1** To form each side of the chest, first dry-assemble the legs (A), side top rails (B), side bottom rails (C), stiles (D), and side panels (J). See **Drawing 4**. Check for correct fit and for square. Then, glue up and clamp each side-panel assembly.

**2** To form the front and back panel assemblies, dry-assemble the stiles

(D), the front/back top rails (E), the front/back bottom rails (F), and front/back panels (K). See **Drawing 5**. To keep the stiles evenly spaced, use masking tape to mark their locations on the face of the rails. Check for square; then, glue up and clamp.

**3** Unclamp and sand all the panel assemblies. Then, place each assembly outside face down and, referencing **Drawings 1** and **6**, measure  $1\frac{3}{4}$ " down from the top edge of the side bottom rails (C) and front/back bottom rails (F) for the location of the top edge of the side cleats (H) and front/back cleats (G). Because the front/back cleats (G) fit between the side cleats (H) when the panel assemblies are joined together, you must center the front/back cleats (G) on the rails, where shown in the drawings.

**4** With the cleats correctly positioned on the rails, drill pilot and counter-sunk shank holes through the cleats into the rails, where shown on **Drawings 1** and **6**.

#### SHOP TIP

#### An easy way to lay out smooth arches

Mark arches of nearly any length or curvature using this simple method. Clamp three stopblocks to the workpiece, two at the ends of the arch and one at its middle (this block should come to a point) as shown. Rip a  $\frac{1}{8}$ "-thick fairing strip of wood, position it between the blocks, and mark the arch.



**6a LID SECTION DETAIL**

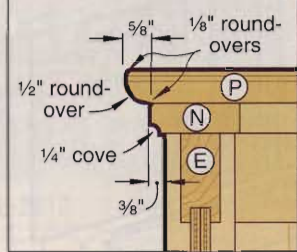

**6 SIDE SECTION VIEW**

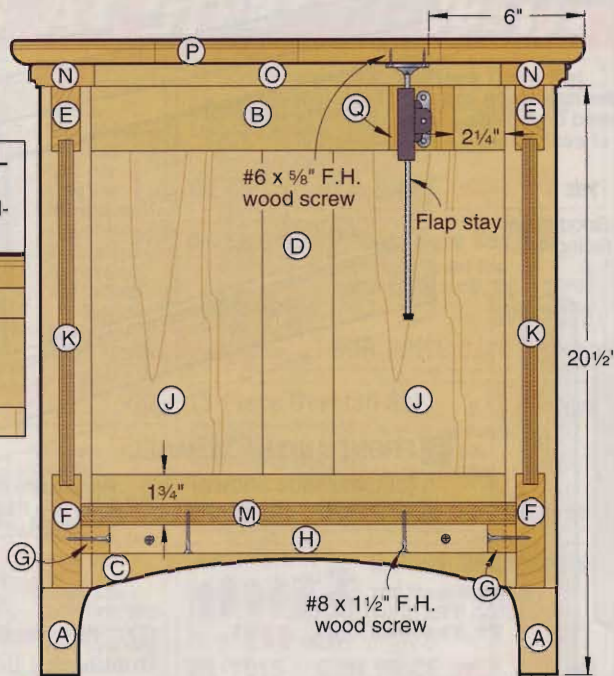

Then, attach the cleats to the rails with glue and #8x1 1/2" flathead wood screws.

**5** On a flat surface, glue and clamp the end-panel assemblies to the front- and back-panel assemblies to form the chest. Check for square.

**6** From 3/4" cherry plywood, cut the bottom (M) to the size listed. Then form the 3/8" notch in the corners, where shown on **Drawing 1b**.

**7** Place the bottom (M) on the cleats and drill pilot and countersunk shank holes through the cleats into the bottom, where shown on **Drawings 1** and **6**. Attach the bottom to the cleats with #8x1 1/2" flathead wood screws.

**Now add the trim**

**1** From 3/4"-thick walnut, cut the front/back top trim (N) and side top trim (O) to the sizes listed except make

the lengths 1" longer to allow for the ends to be miter-cut later.

**2** Chuck a 1/4" cove bit in your table-mounted router and rout a 1/4" cove along the outer bottom edge of all of the trim pieces, where shown on **Drawings 1** and **6a**. Switch to a 1/8" round-over bit and rout the top outer edge of all of the pieces.

**3** Miter-cut all of the trim pieces to the finished length. Then, position the front/back top trim (N) and side top trim (O) on the chest, where shown on **Drawing 1**, so that the outer edge of the trim overhangs the legs (A) by 3/8", where shown on **Drawing 6a**. Glue and clamp the trim in place.

**4** Drill pilot and countersunk shank holes through the front/back and side trim into the rails, where shown on **Drawing 1**, and drive the #8x1 1/2" brass flathead wood screws.

**Time to top it off**

**1** Cut enough 3/4"-thick random-width walnut boards for the top (P). Cut the boards so that when placed edge to edge they exceed the top's finished width and length by 1".

**2** Joint the edges of the boards; then glue and clamp them to form the top, keeping it as flat as possible. Remove any squeeze-out. When the glue is dry, cut the top (P) to the size listed.

**3** Set up your router with a 1/2" round-over bit, and rout the perimeter of the top (P) on its *bottom* side, where shown on **Drawings 1** and **6a**. Switch to an 1/8" round-over bit, and rout the perimeter of the *top* on its face side, where shown. Sand smooth.

**4** Position the cleats (I) on the bottom face of the top (P), where shown on **Drawing 1**, and drill pilot and countersunk shank holes through the cleats into the top for #8x1 1/2" flathead wood screws. Remove the cleats.

**5** To allow for expansion and contraction of the top, drill a 3/8" counterbore 5/8" deep in the bottom of the cleats in the two outer screw holes (see the **Shop Tip**, below left). Now, screw (no glue) the cleats to the top.

**Attach the lid to the chest**

**1** To locate the positions for the no-mortise hinges, first make the hinge locating jig, shown on **Drawing 7**. With the top (P) face down, position the jig on the back edge of the top (as viewed from the back) flush with its right end. Place a hinge in the opening in the center of the jig with the barrel up (to keep the hinge flat for marking) and against the jig. Mark the locations for the hinge screws in the small leaf part of the hinge. Now, move the jig and hinge to the left end of the top, flush with the edge of the top, and again mark the screw hole locations in the hinge. Drill pilot holes in the marked locations, and attach the hinges to the top with #5x5/8" flathead wood screws.

**2** To locate the hinge positions on the back top trim (N) of the chest, see **Photo B** for set-up. With the top (P) positioned as shown and the top centered end-to-end with the chest, mark the screw locations on the trim. Attach the hinges to the trim with #5x5/8" flathead wood screws in pilot holes.

**3** To install the flap stay, cut the filler block (Q) (or two blocks if you want

**SHOP TIP**

**Low-tech trick gives solid-wood panels room to move**

There's no getting around it: wood contracts and expands with changes in seasonal humidity. If you don't allow for that movement, wide panels of solid wood will bow, cup, or split. So, when you screw cleats to solid panels, counterbore the screw holes in the cleat as shown. That allows the screw to move back and forth as the panel moves. Never glue cleats to wide, solid-wood panels.

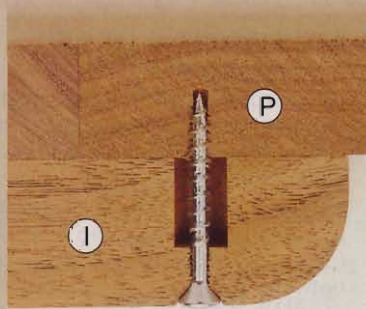



**To locate the hinge positions on the back top trim (N), set the chest on 1½"-high support blocks (we used 2x4s). Position the top (P) as shown.**

to install a second flap stay) from ½"-thick walnut to the size listed. (We installed one flap stay and found this to be adequate. However, if you prefer additional resistance to lid closure for safety reasons, install the additional flap stay.) Glue and clamp the block to the side top rail (B), where shown on **Drawing 6**.

When the glue is dry, secure the block by driving a screw in the center into a pilot hole. Attach the flap stay to the block and to the top (P), where shown, by driving screws into pilot holes.

### Sand and finish it up

- 1 Remove the flap stay and hinges.
- 1 Finish-sand the entire chest with 220-grit sandpaper.
- 2 Apply a clear finish of your choice, sanding between coats and removing dust with a tack cloth. We suggest using a penetrating oil, such as Watco Danish Oil, for the chest portion to highlight the grain and enhance the colors of the woods. For the top, we recommend a Zar polyurethane finish to provide more durable protection for this piece. Because multiple coats of satin polyurethane have a potential to cloud the finish, we recommend that you first apply two coats of high-gloss polyurethane followed by a final coat of satin polyurethane. Sand and remove dust between all coats.

### 3 Install the hardware and start filling the chest.

Written by **Owen Duval**  
 Project design: **Kent Welsh**  
 Illustrations: **Roxanne LeMoine; Lorna Johnson**  
 Photographs: **Baldwin Photography; Douglas E. Smith**

### materials list

Part	FINISHED SIZE			Matl.	Qty.
	T	W	L		
A legs	1¾"	1¾"	20½"	W	4
B side top rails	1"	2¼"	15¼"	W	2
C side bottom rails	1"	4"	15¼"	W	2
D stiles	1"	2½"	12"	W	8
E front/back top rails	1"	2¼"	39¼"	W	2
F front/back bottom rails	1"	4"	39¼"	W	2
G front/back cleats	1"	1"	37¼"	W	2
H side cleats	1"	1"	15¼"	W	2
I top cleats	1"	1"	13½"	W	3
J side panels	½"	6¼"	11½"	LCP	4
K front/back panels	½"	8¼"	11½"	LCP	8
L* filler strips	¾"	½"	3"	W	8
M bottom	¾"	15¼"	39¼"	CP	1
N* front/back top trim	¾"	2¼"	42¾"	W	2
O* side top trim	¾"	2¼"	18¾"	W	2
P* top	¾"	20"	44"	EW	1
Q filler block	½"	2¼"	2¼"	W	1

\*Parts initially cut oversize. See the instructions.

**Materials Key:** W—walnut, CP—cherry plywood, EW—edge-joined walnut, LCP—laminated ¼" cherry plywood.

**Supplies:** #8x1½" flathead wood screws, #8x1½" brass flathead wood screws, #5x5/8" flathead wood screws, ¼" hardboard, spray adhesive, glue, clear finish.

### Buying Guide

**Hardware.** 3x1" no-mortise hinges no. 00H51.04, \$2.50 per pair; flap stay no. 00U06.01, \$11.90 per stay. Order from Lee Valley, 12 East River St., Ogdensburg, NY 13669, call 800/871-8158, or go to [www.leevalley.com](http://www.leevalley.com).

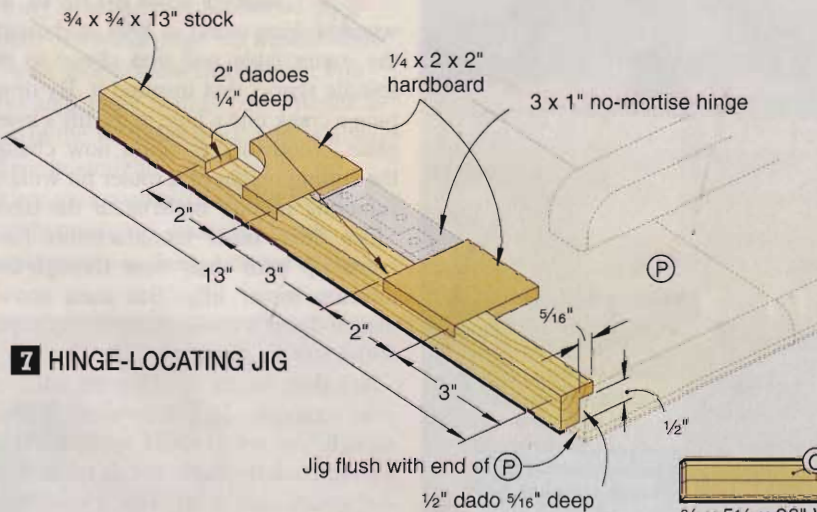

**7 HINGE-LOCATING JIG**

### cutting diagram

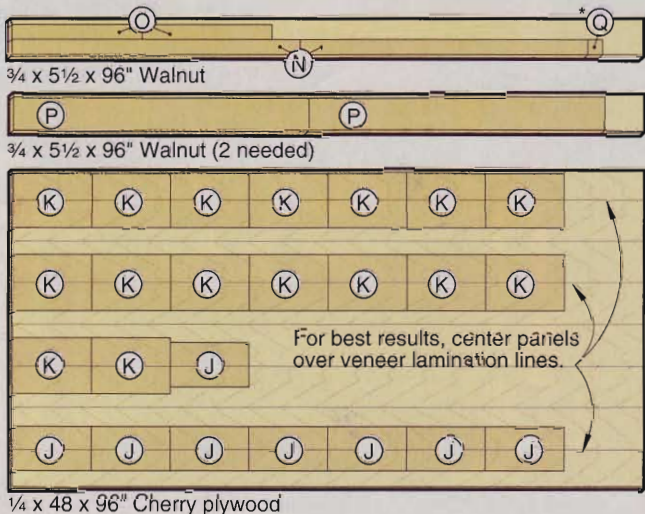
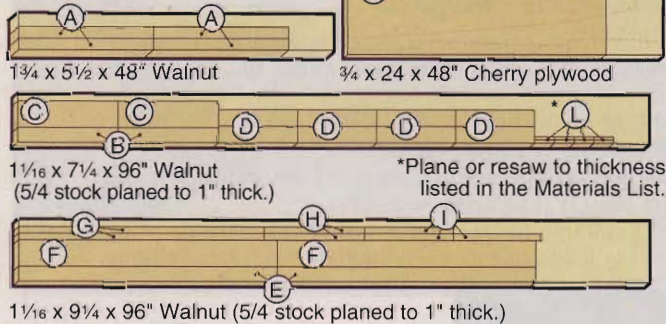

# router-lift roundup

**Need a lift?  
We shop-test  
eight mechanisms  
that promise  
to raise your  
table-mounted  
router with  
precision and  
convenience.**

**W**hen Canadian machinist Darrin Smith introduced the JessEm Rout-R-Lift to the woodworking world in 1999, he brought the router table one step closer to the spindle shaper that inspired it. By dropping a crank into a hole in the lift's insert plate, woodworkers could now change the cutting height of a router bit without fumbling around underneath the table. Since then, other manufacturers have come up with their own through-the-tabletop router lifts. But such convenience doesn't come cheap—you'll pay \$90–\$360 for a router lift.

Are they worth it? That depends on your situation. If you're starting from scratch, you could easily spend \$800 on a commercially made router table, mid-size router, and a lift. That's more than you might spend on a shaper with similar power and capabilities. But if you

*WOOD*® magazine tool tester Garry Smith uses a 12" race shaft to determine how well JessEm's Mast-R-Lift keeps bits perpendicular to the table.

## Readers' top 5

We asked woodworkers on our Web site, [www.woodonline.com](http://www.woodonline.com), what they want to know most about router lifts. Here's what they told us:

1. Will it fit my router?
2. Will it fit in my router table?
3. How quickly and accurately can I set the bit's height?
4. How easy is it to change bits?
5. Can I still use my router for handheld tasks?

We answer these questions starting on the *opposite page*.

already have a table, router, and bits, adding a lift could be as simple as mounting your router to an insert plate and dropping it in.

### Gauging success: How we tested the lifts

Any good router keeps the bit perpendicular to its base, but do these lifts maintain that perpendicularity throughout their full elevation range? Using a precision-ground race shaft in the mounted router's collet, as shown *opposite*, we found that they do.

To test the accuracy of the height-adjustment mechanism, we raised and lowered the router to specific heights by counting turns of the crank, then measuring the actual cutting depth. Next, we routed 100' of 1/2"-deep dado in plywood, and measured the difference in depth from the start to the end of the cut. After this messy test, we examined each lift for dust-related difficulties. Finally, we used each lift in our daily shop duties for more than a month to give us a good feel for how easy it is to change bits, remove and remount the router to the table, and use the fine-adjustment scales.

### Answers to your questions about router lifts

**1. Will it fit my router?** The model-by-model summaries, beginning on the *next page*, give more specifics, but here's the scoop in a nutshell: Virtually any popular fixed-base or plunge router will mount to Rout-R-Lift or XACTA-Lift. And Router Raizer works with most plunge routers.

The rest of the lifts are fairly finicky about their partners. Three of the fixed-base-only lifts are designed for a Porter-Cable 7518, but will also accept midsize routers from Bosch, Makita, and Porter-

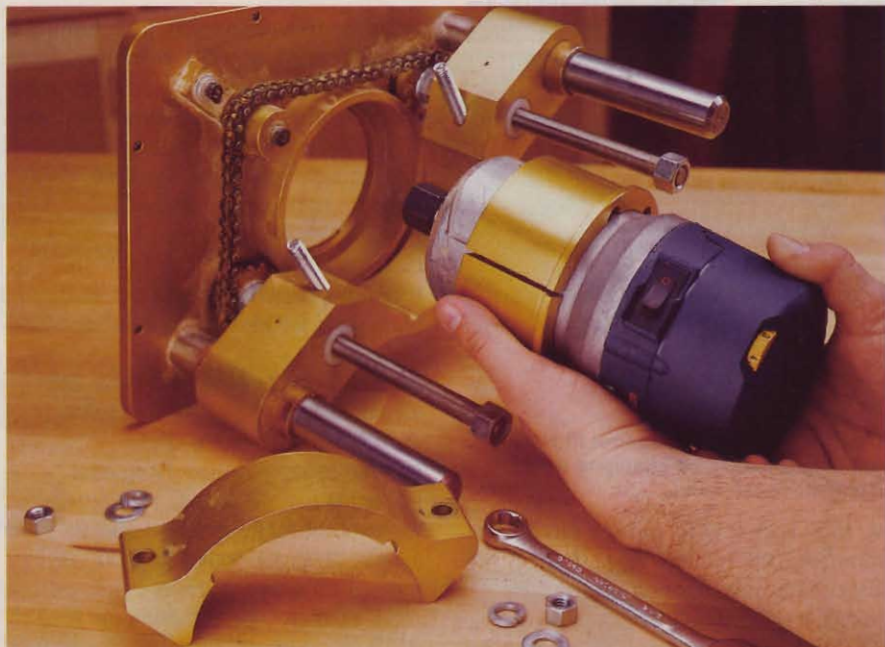

Adapter collars make midsize routers fit the ProLift Ni28, Mast-R-Lift, and Precision Router Lift (PRL), shown *above*. The ProLift AI13 fits these routers out of the box.

Cable, using optional adapters like that shown *above*. PlungeLift currently mounts to only five plunge routers, with more promised in the future.

**2. Will it fit in my router table?** That depends on the size of your existing insert plate, so check the Insert Plate Sizes chart, *below left*. If your current insert is smaller, you can enlarge the hole to fit. Half of the lifts provide insert-plate levelers; the rest, you'll have to shim yourself.

On the other hand, if you have a cast-iron or steel tabletop, machining an opening to accept the insert plate isn't an option. Your only choice in such cases is Router Raizer, which works with any router table you can drill a hole through.

**3. How quickly and accurately can I set the bit's height?** That depends on how many crank turns it takes to raise the bit. (See the chart, at *right*.) The more turns required, the easier it is to make fine adjustments; the fewer turns, the less time it takes to make large changes.

Except for Router Raizer and both Woodpecker lifts, all of the lifts have an anti-backlash mechanism. (See *Dealing with Backlash* on the *next page*.) With this, you can adjust for wear between the leadscrew and the carriage—a big plus if you'll use the lift a lot.

Once set, all of the lifts held their ground well, varying less than 1/64" after routing 100' of dado. The Bench Dog lifts have a thumbscrew lock on the carriage for holding the height, but we didn't find them any more or less accurate in this test than the models without a lock.

Speaking of locks, you'll have to deal with the router's own plunge lock if you use Router Raizer or PlungeLift. If your plunge router locks on release, such as on Porter-Cable plunge routers, you'll have to reach under the table to hold the lock open while you adjust the lift from above, negating one of the lifts' key benefits.

All of the insert-based lifts have a fine-adjustment scale, but only the Bench Dogs and the Precision Router Lift scales can be "zeroed" to your bit height to measure only the change in height.

INSERT PLATE SIZES		
BENCH DOG	ProLift AI13	8 1/4" x 11 1/4"
	ProLift Ni28	8 1/4" x 11 1/4"
JESSEM	Mast-R-Lift	9 1/4" x 11 1/4"
	Rout-R-Lift	11 3/4" x 14 3/4"
JET	XACTA-Lift	11 3/4" x 14 3/4"
ROUTER TECHNOLOGIES	Router Raizer	(no plate)
WOODPECKER	Precision Router Lift	9 1/4" x 11 1/4"
	PlungeLift	9 1/4" x 11 1/4"

TURNS REQUIRED TO CHANGE ELEVATION 1"		
BENCH DOG	ProLift AI13	8
	ProLift Ni28	8
JESSEM	Mast-R-Lift	16
	Rout-R-Lift	20
JET	XACTA-Lift	20
ROUTER TECHNOLOGIES	Router Raizer	16
WOODPECKER	Precision Router Lift	32
	PlungeLift	32



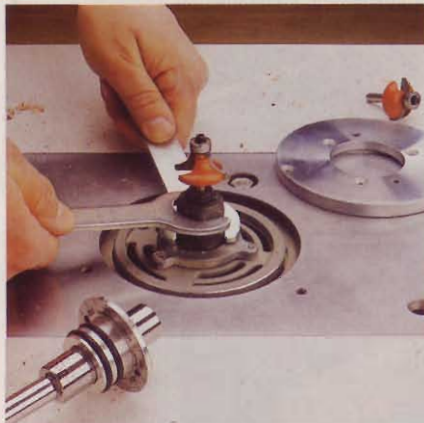

Cranking the BenchDog ProLift Ni28 to full height makes bit changing easy from above the table.

**4. How easy is it to change bits?** After removing the reducer ring, if used, the fixed-base-only models allow you to raise the collet above the table, as shown above, for easy bit changes. Changing bits on the rest of the models is about the same as changing bits in the same table-mounted router without a lift.

**5. Can I still use my router for handheld tasks?** Sure, but some lifts make the switch easier than others. Reverting to handheld use with Router Raizer is as simple as dismounting the router from your table—the device stays on the router and functions even handheld. PlungeLift requires reinstalling the plunge router's depth-stop rod.

On the fixed-base-only lifts, turning a few screws loosens the motor clamp enough to remove it and remount it in the router's original base. However, with XACTA-Lift and Rout-R-Lift, plan on dedicating a router to the table. Why? Because to revert to handheld, you must first remove the carriage plate from the carriage, then the router from the carriage, and finally the universal mounting plate from the router. It's cumbersome.

### A lift-by-lift look at the tested models

#### Bench Dog ProLift A113

800/786-8902, [www.benchdog.com](http://www.benchdog.com)

Out of the box, fits: Bosch 1617/1618, DeWalt DW610, Porter-Cable 690. With adapter (\$16), fits: Makita RF1100/1101.

Instead of a hex-shanked crank to turn the leadscrew, the all-aluminum ProLift A113 uses a 1/16" deep-well socket (provided), so you don't have to keep track of a special tool to use the lift. The fine-adjustment scale fits over the socket, as shown above right.

To accommodate slight variations in router-motor diameters that could cause the carriage to bind on its guide posts, you calibrate the posts to fit your router. And the carriage has cooling fins to dissipate motor heat.

We like almost everything about this lift except bit changing. The leadscrew



O-rings inside the Bench Dog fine-adjustment scale hold the socket shaft firmly, yet allow you to zero the scale to the index mark on the insert plate.

moves the router fast, but to raise the collet through the tabletop, you must first remove the reducer ring, which is secured to the insert with three socket-head Allen screws. And, because the insert plate is designed to fit Bench Dog's router table (with its integral plate-leveling mechanism), this plate has no levelers.

*continued*

## Dealing with Backlash

Backlash is the amount the leadscrew turns before the lift starts to move when changing directions, and it's a fact of life in leadscrew-driven machines like these lifts. (Your tablesaw's height- and bevel-adjustment cranks also have some backlash.) Let's say you need to raise the bit .010", but you accidentally raise it .012". If there's .001" of backlash in the system, turning the crank back down to .010" will only lower the bit to .011". (The first .001" is lost to backlash.) To compensate, turn the crank down to a few thousandths below the .010" mark, then back up to .010".

**Step 1**



**Step 2**



**Step 3**



**How we measured backlash:** After calibrating the height of a gauge pin (in the router collet) to "0" on the fine-adjustment scale (Step 1), we raised the router at least one-half turn of the crank (Step 2). We then turned the crank back to "0" (Step 3), where the dial indicator shows the amount of backlash.

# Ups and Downs of the Tested Lifts

Although we tested eight router lifts, we found that they operated in the four ways shown here.

## FIXED-BASE-ROUTER-ONLY LIFTS

Bench Dog ProLift AI13 (shown) and ProLift Ni28, JessEm Mast-R-Lift, and Woodpecker Precision Router Lift

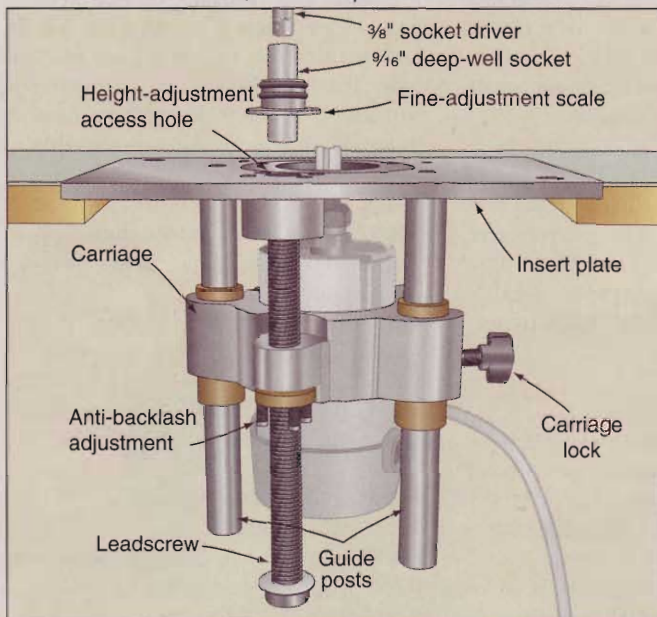

The four fixed-base-only lifts operate in essentially the same way: Remove the router's base and mount the motor to the carriage. Both Bench Dog units use direct drive (as shown here). Mast-R-Lift uses a belt and pulleys to link the crankshaft to the leadscrew; Precision Router Lift uses a chain and sprockets.

## UNIVERSAL LIFTS

JessEm Rout-R-Lift and Jet XACTA-Lift

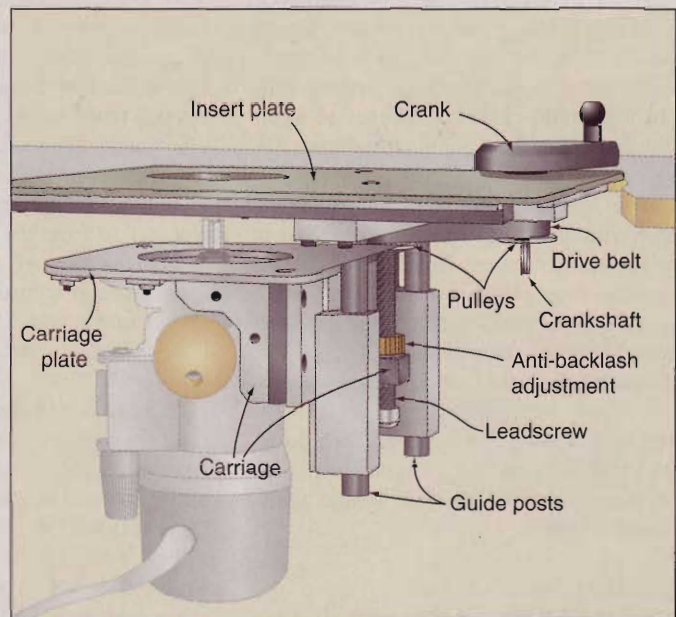

Universal lifts—the nearly identical JessEm Rout-R-Lift and Jet XACTA-Lift—accept virtually any router, fixed- or plunge-base, because the router mounts, base and all, to the carriage plate. This additional thickness can limit the cutting depth, depending on the router.

## PLUNGE-ROUTER-ONLY LIFTS

Router Technologies Router Raizer

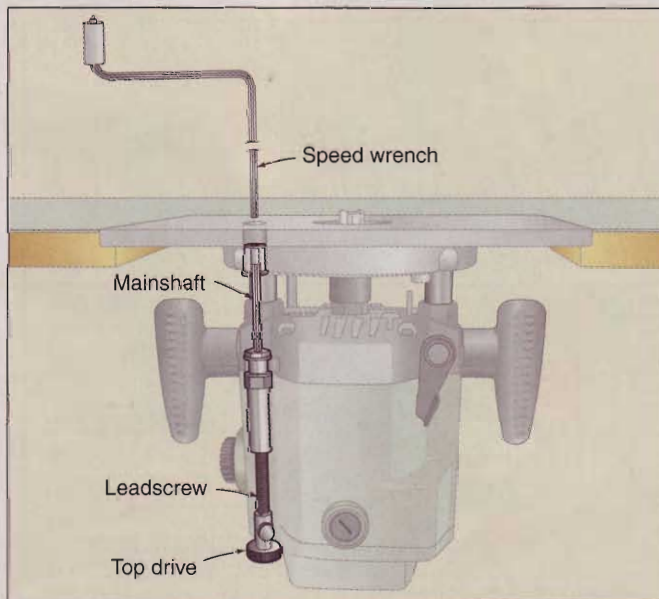

Woodpecker PlungeLift

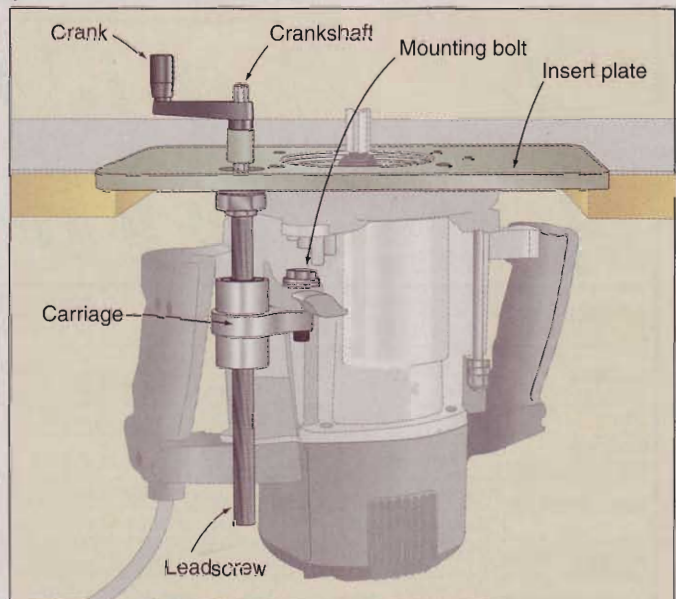

The plunge-router-only models—Router Raizer (left) and PlungeLift (right)—rely on your router's built-in posts to guide the router through its up-and-down travel, making them only as accurate as the router you use them with. (The fixed-base-only and universal designs virtually eliminate the router from the accuracy equation because the elevation action happens outside the router.)

**Bench Dog ProLift Ni28**

Out of the box, fits: Porter-Cable 7518.  
With adapter (\$20), fits: Bosch 1617/1618, DeWalt DW610, Porter-Cable 690, Makita RF1100/1101.

The beefy ProLift Ni28 is the cast-iron version of the A113, with a one-piece carriage casting and a nickel-plated insert plate that should last a lifetime. This thing is so massive, it comes with an aluminum-channel stiffener to keep your tabletop from sagging under its 34-pound weight (not including router).

The heavyweight reducer rings stay put without being fastened to the insert plate in most cases. But on the unit we tested, they stood as much as .007" proud of the plate, catching on stock as we worked. Bench Dog's Norston Fontaine suspects that our plate's rabbet may not have been machined deep enough, adding, "We've sold hundreds of these units without a single complaint. If there's a problem, call us and we'll make it right."

**JessEm Mast-R-Lift**

800/436-6799, www.jessem.com  
Out of the box, fits: Porter-Cable 7518.  
With adapter (\$20), fits: Bosch 1617/1618, DeWalt DW610, Porter-Cable 690, Makita RF1100/1101.

Our first impression when we pulled the Mast-R-Lift out of the box was, "Wow, that's pretty." Its beauty isn't just skin deep, though, as this lift's performance backed up that impression in spades.

Although similar to the ProLift A113, Mast-R-Lift improves on that model in a couple of ways. First, removing a reducer ring to change bits requires only a simple flick of the wrist using a spanner wrench that comes with the lift.

Secondly, Mast-R-Lift's insert plate has a leveling system for flushing the plate to your tabletop. However, the levelers adjust from the bottom, so we spent a fair amount of trial-and-error time installing and adjusting it. Mast-R-Lift's 3"-tall crank easily clears most router-table fences.

**JessEm Rout-R-Lift**

Out of the box, fits: Bosch 1450, 1604, 1611, 1613, 1617; Craftsman 3- and 4-hole bases; DeWalt DW610, DW615, DW621, DW624, DW625; Elu 2721, 3337-9; Freud FT2000; Hitachi M12V, TR12; Makita 1100/1101 series, 3600, 3621, 3612B; all Milwaukee; Porter-Cable 100, 518, 520, 536, 690 series, 7518/19, 7538/39; Ryobi 180, 500/501, RE-600.  
Rout-R-Lift fits more routers than any other in the test, and its mounting plate

comes predrilled for all of the routers listed. Unfortunately, it doesn't hold a candle to Mast-R-Lift (although they both share the same under-the-insert-plate leveling system).

You can't raise the collet high enough to change bits from above, but a finger hole helps when removing the lift to change bits. And, the insert plate is about twice the size of the other lifts' plates—something to consider if you have a miter slot in your existing router table.

**Jet XACTA-Lift**

800/274-6848, www.jettools.com  
Out of the box, fits: Same models as JessEm Rout-R-Lift.

This lift is virtually identical to the JessEm Rout-R-Lift with a couple of notable exceptions. First, it comes with a nice aluminum fence, shown *opposite*; and the insert plate lacks levelers.

**Router Technologies Router Raizer**

866/266-1293, www.router technologies.com  
RZ100 kit fits: Craftsman 27505, 27506, 27510, 27511; DeWalt DW625; Elu 3337, 3338, 3339; Freud FT2000, FT2000E; Hitachi M12V, TR12; Makita 3612BR, 3612B, 3612C; Porter-Cable 693, 6931 base, 7529, 7538, 7539; Ryobi RE600.

RAISING YOUR EXPECTATIONS OF 8 ROUTER LIFTS																						
MANUFACTURER/BRAND	MODEL	INSERT PLATE				CARRIAGE			PERFORMANCE RATINGS (3)					ACCESSORIES (7)		WARRANTY (YEARS)	COUNTRY OF ASSEMBLY (8)	WEIGHT (POUNDS)	SELLING PRICE (9)			
		MATERIAL (1)	PRIMARY THICKNESS (INCHES)	MAXIMUM BIT OPENING (INCHES)	REDUCER-RING DIAMETERS (INCHES)	MATERIAL (1)	TOTAL ROUTER TRAVEL (INCHES) (2)	SCALE INCREMENTS (INCHES)	INSERT LEVELING EASE TO INSERT (4)	PERPENDICULARITY TO INSERT (4)	SCALE/CRANK ACCURACY (5)	BIT CHANGING EASE	BACKLASH (6)	EASE OF RETURN TO HANDHELD MODE	STANDARD					OPTIONAL		
BENCH DOG	ProLift A113	AL	1/2	3 3/8	2, 2 1/8	AL	6 3/8	0.0025	F	E	E	E	E	G	E	G	S	A, G, P, Z	2	U	12	\$280
	ProLift Ni28	CI	1/2	3 3/4	2, 2 1/8	CI	6	0.0025	F	E	E	E	E	E	E	G	S	A, G, P, Z	2	U	34	370
JESSEM	Mast-R-Lift	AL	2 1/32	3 3/8	1 1/8	AL	3 1/2	0.0020	G	E	E	E	E	E	E	G	S	A, R	2	C	14	270
	Rout-R-Lift	AL	3/16	3 3/8	1 1/2	AL	2 9/16	0.0050	G	E	E	G	G	E	F	S	S	R	2	C	13	200
JET	XACTA-Lift	AL	1/4	3 3/8	1 1/8	AL	2 9/16	0.0050	G	E	E	G	G	E	F	F, S	R	R	2	C	14	280
ROUTER TECHNOLOGIES	Router Raizer	N/A				S	2 3/4	N/A	N/A	*	G	N/A	G	G	E			C	2	U	0.5	90
WOODPECKER	PlungeLift	AL	3/8	3 3/8	1, 1 1/16, 2 1/2	AL	3"	0.0010	E	*	G	F	F	G	G	S	C, Z	LIFE	U	4.5	150	
	Precision Router Lift	AL	3/8	3 3/8	1, 1 1/16, 2 1/2	AL	4 3/16	0.0010	E	E	G	E	G	E	G	S	A, C, Z	LIFE	U	14	250	

NOTES: For specifications on other types of tools, click on "Tool Comparisons" at www.woodmall.com.

1. (AL) Aluminum (CI) Cast Iron (S) Steel  
 2. (\*) May vary depending on router used.  
 3. **E** Excellent **G** Good **F** Fair  
 4. (\*) Accuracy dependent on plunge router used.  
 5. (\*) Scale cannot be zeroed.  
 6. (\*) Backlash adjustment provided.  
 7. (A) Adapter collar for mid-size fixed-base routers (C) Extended-height crank (F) Router-table fence (G) Freehand routing guard with dust-collection port (P) Porter-Cable guide-bushing adapter (R) Reducer-ring set (S) Starting pin for freehand routing (Z) Zero-clearance insert  
 8. (C) Canada (U) United States  
 9. Prices current at time of article's production, and do not include shipping, where applicable.

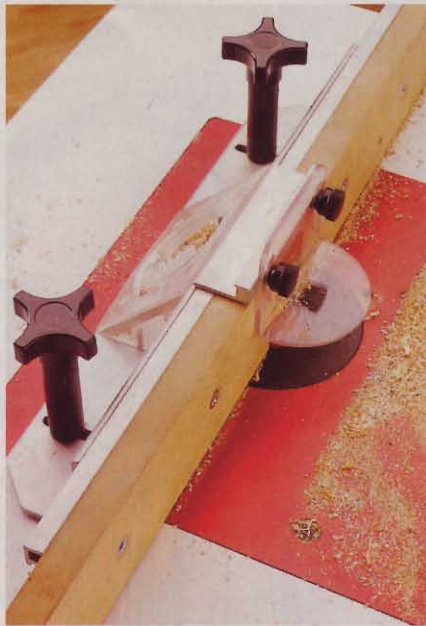

**XACTA-Lift's fence features movable medium-density fiberboard (MDF) faces, a bit guard, and dust-collection port.**

*RZ200 kit fits:* Bosch 1617/18, 1619; Fein RT1800; Makita RP1100/01 and RF1100/01 plunge base.

Fitting most plunge routers on the market today, Router Raizer is the only tested lift priced under \$100. With no insert plate, it works in almost any router table.

Installing Router Raizer can take a couple of hours, and in some cases requires disassembly, removal, and/or drilling of the router's parts. Before you buy, we recommend you visit the manufacturer's Web site to preview the process for your router to make sure you're comfortable with the task.

With no fine-adjustment scale, you'll have to use your ruler to set the cutting height, then tweak it by trial and error. But the 16 turns-per-inch leadscrew strikes a nice compromise between adjustment speed and fine-tuning.

### Woodpecker PlungeLift

800/752-0725, [www.woodpeck.com](http://www.woodpeck.com)

*Five separate lifts, fitting:* DeWalt DW625, Freud FT2000, Hitachi M12V, Makita 3612C, Porter-Cable 7539.

*Coming soon:* Bosch 1613, 1615, 1619, DeWalt DW621.

Each PlungeLift fits only one model of router, so it mounts to that router quickly and easily. However, once you've invested in the lift, you probably won't want to

change routers. PlungeLift's carriage replaces the router's depth-stop rod, so returning to handheld mode requires reinstalling the rod.

As for the insert plate, we like the eight set-screw levelers that adjust from the top of the plate. And, a pair of spring-loaded ball bearings in adjacent edges of the plate provide a comfortably snug fit in its table opening.

### Woodpecker Precision Router Lift (PRL)

*Out of the box, fits:* Porter-Cable 7518.

With adapter (\$30), fits: Bosch 1617/1618, Porter-Cable 690, Makita RF1100/1101.

PRL's insert plate has the same attributes we liked in its brother, the PlungeLift. And, like the other fixed-base-only lifts, you can raise the router collet above the table for changing bits. But we downgraded both Woodpecker lifts' ratings for bit-changing ease because of the 32-turns-per-inch required to raise the collet through the insert plate.

When routing with the bit partially captured in the fence, as shown *below*, we found that the crank handle hits the fence. You can purchase an optional 8"-high crank rod for \$15.

### Which lifts rise to the top of the pack?

Because most lifts fit specific models, you may simply have to choose a lift that fits your router. Undoubtedly, the cast-



**PRL's crank handle extends past the bit opening's center line and bumps the fence.**

iron Bench Dog ProLift Ni28 is as tough and accurate a lift as you'll find, bringing near-shaper qualities to the router table. But for \$100 less, we'd opt for JessEm's Mast-R-Lift. We think it's worth the savings unless you're in a professional cabinet shop.

If you're on a budget and already own a plunge router, go with Router Raizer (if it fits your router). You'll still be able to use your router for handheld tasks with a minimum of hassle. 🌲

Written by **Dave Campbell** with **Garry Smith**

Illustrations: **Tim Cahill**

Photographs: **Baldwin Photography**

**Visit [www.woodmall.com](http://www.woodmall.com) to talk about router lifts with other woodworkers.**

### The lift within: Milwaukee's new fixed-base router

If you don't already have a router to table-mount, consider Milwaukee's 5615-20 (\$155), shown *below*. Its built-in leadscrew depth adjuster can be accessed through the base and turned with an ordinary speed wrench and socket, making it a good candidate for table-mounting. Currently, this router is a single-speed machine, but Milwaukee's Chris Berg says a variable-speed version is due out "later this year."



space-saving

# modular built-ins

**Yes, you can salvage those unused areas behind your walls!**

**Y**ou can always use more storage space, right? Here's a simple way to get it by tapping into those roomy pockets behind the walls of your home. No matter what your available space, you can mix and match these boxes, drawers, doors, and shelves to fit under a stairwell or into a kneewall or dormer.



# Create a plan that suits your space

We designed our adaptable built-ins around two box sizes—a 14"-high "short" box and a 28"-high "tall" box—to accommodate different wall areas, storage needs, and looks. Typical installation areas for these units include a sloping stairwell wall (opening photo, *left*), a dormer area (drawing, *right*), or a kneewall (drawing, *below*). The width of our boxes is 14", which allows them to fit between common wall stud spacing of 16" on center. If the spacing between your studs is not 16" on center, don't worry. Simply adjust the width of your boxes and size the other parts as necessary to fit the space.

Before starting this project, make sure for safety's sake that there are no electrical outlets in the wall and that the wall cavities are free of water or gas pipes, air ducts, and pass-through wiring. For a staircase wall installation, also check the location of the stair stringer to see if it will interfere with a cabinet. If so, you may be able to avoid the interference by locating the cabinets closer to the floor. (We set ours at 8" above.)

After completing your inspection, prepare a sketch of your layout to determine the number of short and tall boxes that you need and your total material requirements for the project. Now, get ready to transform an "ordinary" wall into a hardworking storage masterpiece.

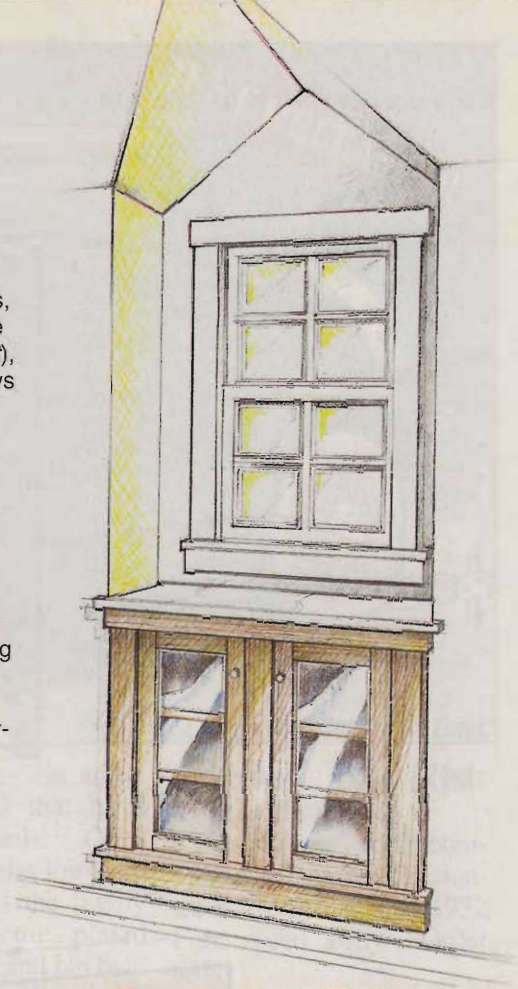

## Dormer installation

Transform unused space in a dormer area into useful storage with these units. This drawing shows two tall boxes with shelves and doors installed in the dead space between sidewalls.

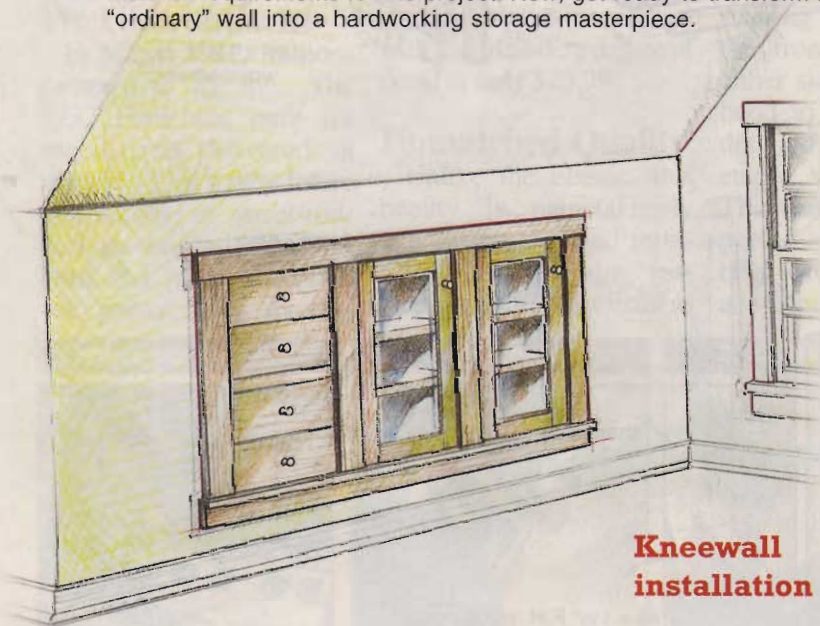

## Kneewall installation

Gain storage and good looks by installing units in a kneewall. This drawing shows two tall boxes with shelves and doors located next to two short boxes (stacked) with drawers.

### Lay out and prepare the box openings

**1** Refer to "Create a plan that suits your space," *above*, for general layout guidelines.

**2** Locate your wall studs using a magnetic or electronic stud finder or by driving a 6d finish nail into the wall at various points. Your studs should be 16" on center, leaving approximately 14½" of space between them. Draw the outline of the studs on the wall.

**3** Using a level and a straightedge, draw a line on the wall for the location of the bottom of the boxes. From this line, measure up a distance equal to the height of the boxes plus ¼", and draw a line for the top of each box opening. The added ¼" will give you room to maneuver and adjust the boxes. The gaps will be covered by trim.

**4** Using a drywall saw, cut out the openings for the boxes. See **Photo A**.



With the box locations marked on the wall, cut out the openings with a drywall saw.

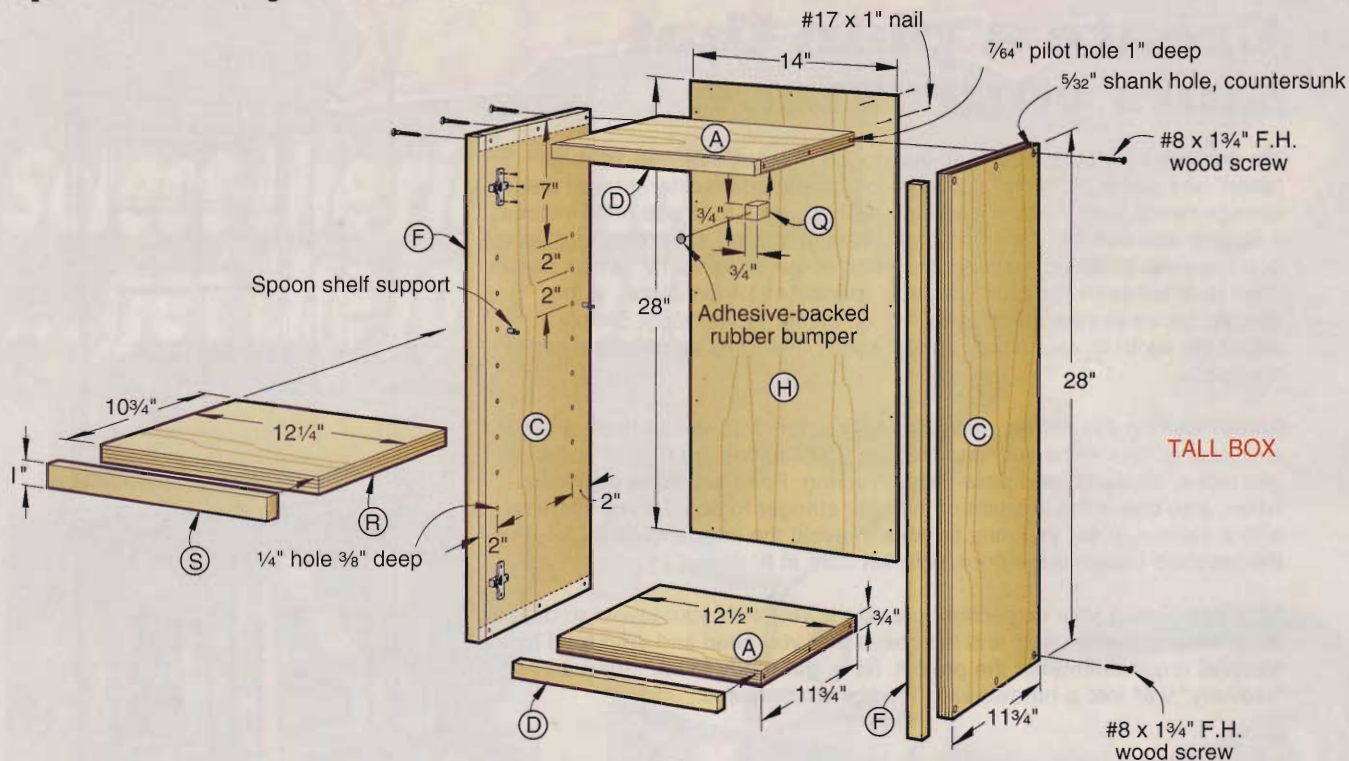

TALL BOX

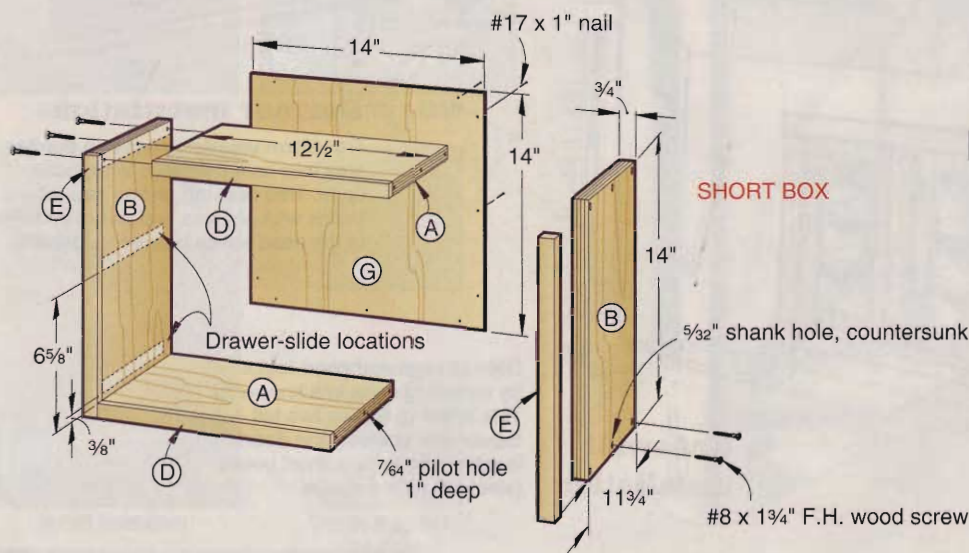

SHORT BOX

**1** CARCASSES

**Make the box parts and assemble**

**1** From 3/4" oak plywood, cut the box tops and bottoms (A), short sides (B), and long sides (C) to size.

**2** From 3/4"-thick stock (we used oak for all edging, trim, and face parts), rip six 3/4x83" blanks to form the top and bottom edging (D), short side edging (E), and long side edging (F). Each strip provides enough edging for one box.

**3** Crosscut the blanks, where shown on the Cutting Diagram, to make

edging pieces (D, E, F) to fit all of the mating box panels. Then, glue and clamp the edging to the panels, where shown on **Drawing 1**.

**4** Assemble and clamp up the two short boxes using a top and bottom (A) and two short sides (B) for each. Check for square. Then, drill pilot and countersunk shank holes through the short sides into the tops and bottoms for screws, where shown. Drive the screws.

**5** From 1/4" oak plywood, cut the short backs (G) to the size listed and

attach them to the back of the short boxes with #17x1" nails, where shown. *Note: We found it easiest to finish the boxes and the backs before attaching the backs.*

**6** To ensure equally spaced holes for the shelf supports in the long sides (C), make the hole-drilling jig, **Drawing 2**. Chuck a 1/4" bit in your drill, and set a depth stop (we used masking tape) 5/8" from the end of the bit. (This depth allows for the 1/4" thickness of the jig and the 3/8" depth of the hole.) As shown in **Photo B**, place the jig on the inside face

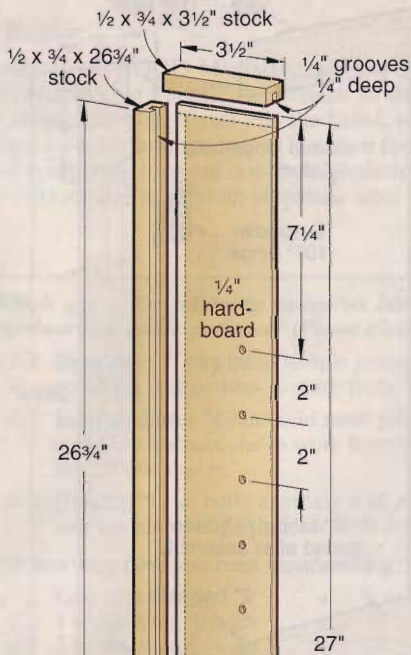

**2** HOLE-DRILLING JIG

of a long side panel against the top edge and a long edge, and drill the first row of holes. Then, reposition the jig against the opposite long edge of the panel and drill the second row of holes. Repeat this procedure on all long sides (C).

**7** Referring to **Drawing 1**, assemble and clamp up the four tall boxes using a top and bottom (A) and two long sides (C) for each. After checking for square, drill pilot and countersunk shank holes through the long side panels into the top and bottom panels for the screws, where shown. Drive the screws.

**8** From 1/4" plywood, cut the long backs (H) to the size listed, and attach them to the back of the tall boxes with #17x1" nails, where shown.

**Next, make the drawers**

**1** From 1/2"-thick stock of your choice (we used poplar), cut the drawer

sides (I) and front and back pieces (J) to the sizes listed.

**2** From 1/4" plywood, cut the drawer bottoms (K) to size.

**3** Referring to **Drawings 3** and **3a**, cut the 1/4" groove in the sides (I) and front and back pieces (J) to receive the drawer bottoms (K). Using the same setup, cut the two 1/4" dados in the drawer sides (I) to receive the rabbeted ends of the drawer front and back (J).

**4** Referring to **Drawing 3b**, attach an auxiliary fence to your tablesaw fence and position the fence adjacent to your 1/4" dado blade. Now, cut the rabbets in the ends of the drawer fronts and backs (J).

**5** Dry-assemble the drawers (I, J, K), and check that the parts fit together correctly. Then, glue and clamp the drawer assemblies, checking for square.

**6** From 3/4"-thick oak, cut the drawer faces (L) to the size listed.

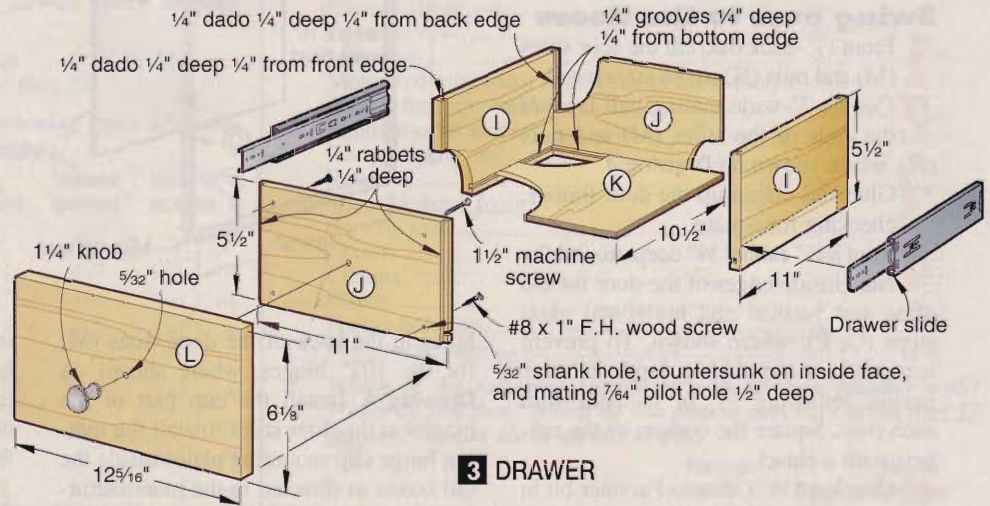

**3** DRAWER



To drill uniformly spaced shelf support holes in the box long side panels, use a hole-drilling jig and a depth stop.

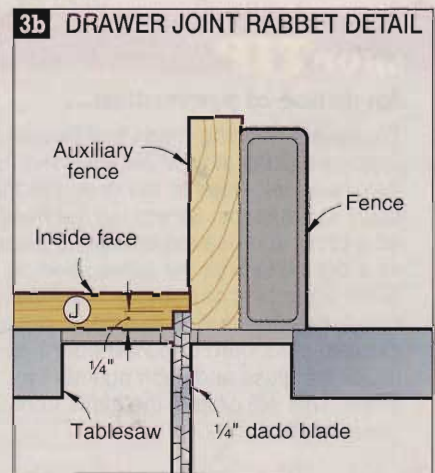
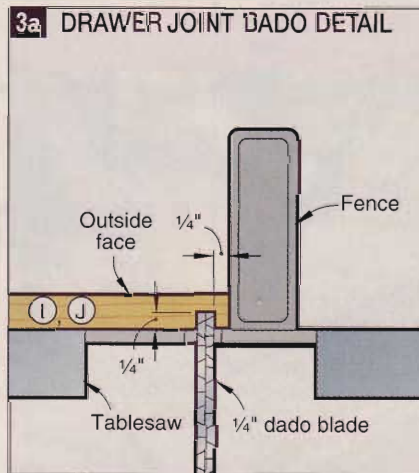



## space-saving built-ins

**7** Place a drawer face on the front (J) of a drawer assembly, and center it side-to-side and top-to-bottom with the front. Clamp the face to the drawer, making sure that the face does not move. Now, drill four pilot and countersunk shank holes through the drawer front into the face for the mounting screws, where shown on **Drawing 3**. Drive the screws. Also, in the center of the drawer face, drill a  $\frac{5}{32}$ " hole for the knob attachment screw (you will need a  $1\frac{1}{2}$ "-long machine screw) through the face and the drawer front. Install the knob. Assemble the drawer faces and knobs to the other drawers.

**8** Position the drawer slides against the sides (I), flush to their front and bottom edges. Attach the slides using the screws supplied with the slides. Disconnect the outer part of the slides from the drawer-mounted part, and attach these pieces to the short box sides, where shown on **Drawing 1**.

### Swing over to the doors

**1** From  $\frac{3}{4}$ "-thick oak, cut the door stiles (M) and rails (N) to the sizes listed.

**2** Cut the 2"-wide mating half laps on the ends of the stiles (M) and rails (N), where shown on **Drawing 4**.

**3** Glue and clamp up the door frames, checking for square.

**4** Rout a  $\frac{1}{4}$ " rabbet  $\frac{3}{8}$ " deep around the back inside edges of the door for the glass and vertical and horizontal glass stops (O, P), where shown. To prevent tear-out, cut the rabbet depth in three passes, removing  $\frac{1}{8}$ " of material with each pass. Square the corners of the rabbets with a chisel.

**5** Chuck a  $1\frac{3}{8}$ " (35mm) Forstner bit in your drill, and bore the two  $\frac{1}{2}$ "-deep

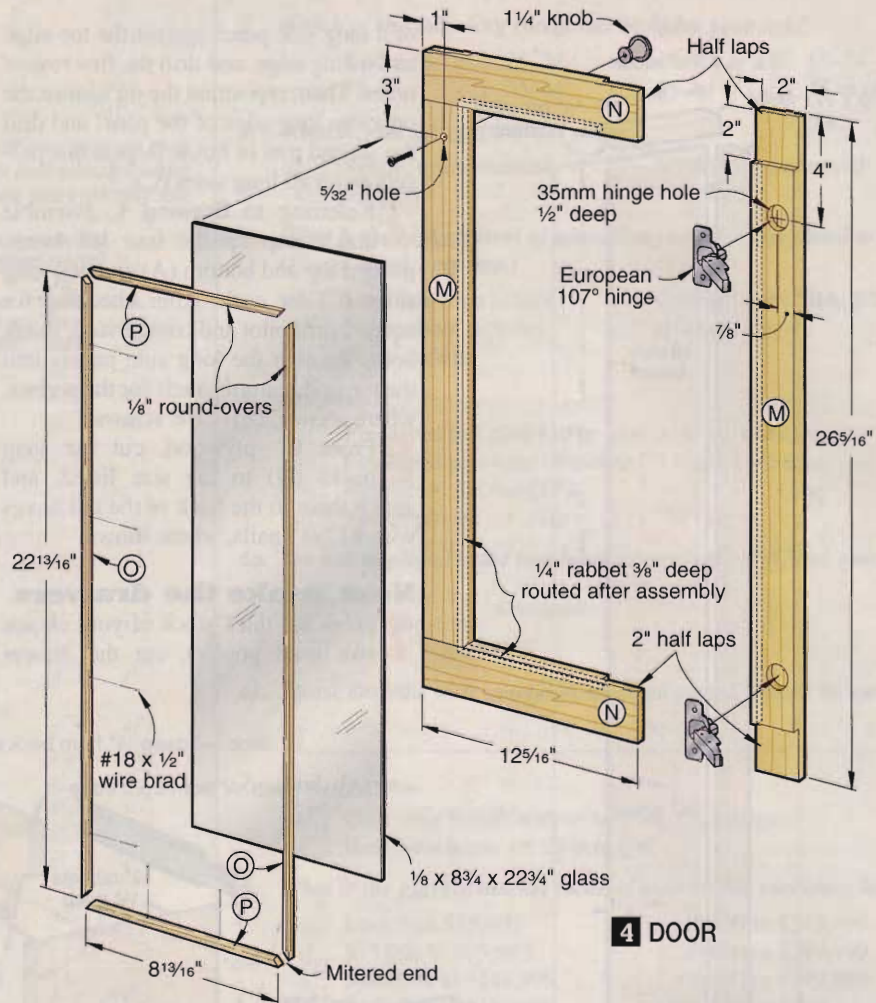

**4** DOOR

holes in the back of the door stiles (M) for the 107° hinges, where shown on **Drawing 4**. Install the cup part of the hinges in the door stiles. Install the mating hinge clip mounting plates inside the tall boxes as directed in the manufacturer's instructions. When locating the

mounting plates, make sure that the front face of the door frame is flush with the front of the box edging (D, F) and that there is an equal reveal all around. Remove the door frames after mounting.

**6** To form the vertical and horizontal glass stops (O, P), shown on **Drawing 4**, thickness-plane a  $\frac{1}{2}$ " $\times$ 2 $\times$ 68" oak blank to  $\frac{1}{4}$ ". With a  $\frac{1}{8}$ " round-over bit chucked in your table-mounted router, rout the two long edges of the blank; then, rip a  $\frac{1}{4}$ "-wide strip from each side of the blank. Repeat this process to make a third strip. Each strip makes all of the glass stops for one door. Now, miter-cut the strips to make the glass stops fit the openings in the back of the doors.

*Note: We finished the doors before we installed the glass and glass stops.*

**7** Place a  $\frac{1}{8}$ " $\times$ 8 $\frac{3}{4}$ " $\times$ 22 $\frac{3}{4}$ " piece of glass in a door opening. Secure the glass by installing glass stops (O, P) using #18 $\times$  $\frac{1}{2}$ " wire brads. (See the **Shop Tip**,

### SHOP TIP

#### An ounce of prevention...

To prevent bending brads and possibly splitting a glass stop when attaching the thin, hard-oak stops to the door, predrill holes in the stops. Simply cut the head off a brad, and use the remaining piece as a drill bit to bore the holes. Also, to avoid scratching or possibly breaking the glass when nailing the stops, put a piece of cardboard or poster board on top of the glass and flush against the stops. This will protect the glass from hammer slips.



opposite page.) Repeat this procedure for the remaining doors.

**8** Drill a  $\frac{5}{32}$ " hole through the door styles (M), where shown on **Drawing 4**, for the knob. Attach all knobs using the screws provided.

**9** From  $\frac{3}{4}$ "-thick oak, cut the door stops (Q) to size. Glue and clamp the stops to the top (A) and long side (C) of the tall boxes, in the corner opposite the door-hinge side of the box, where shown on **Drawing 1**. Position the stop back from the front of the edging (D, F) a distance equal to the thickness of the door plus a rubber bumper (an adhesive-backed bumper of your choice).

### Time for the shelves

**1** From  $\frac{3}{4}$ " plywood, cut the shelves (R) to the size listed.

**2** From  $\frac{3}{4}$ "-thick oak, cut the shelf edging (S) to size. Then, glue up and clamp the edging, making it flush with the top front edge of the shelves, where shown on **Drawing 1**. (The edging overhangs each shelf's bottom face.)

### Install the boxes

**1** Position a box in its wall opening, resting it on the bottom of the opening. As shown in **Photo C**, insert shims along the sides of the box to fill the gaps and make it plumb. Also, using a straightedge, check that the front edge of the box is flush with the face of the wall. Then, secure the box by driving  $\#8 \times 1\frac{3}{4}$ " wood screws through the box and shims into the studs.

**2** Using the same alignment process, install the remaining boxes. Between adjacent boxes, also check that the distance between the outer edges of the boxes (ours was 2") remains constant from top to bottom. This also shows that the boxes are plumb.

### Add the trim

*Note: We finished the trim before installing it, and touched it up after installation, where necessary.*

**1** From  $\frac{3}{4}$ "-thick oak, cut the sill (T) to the size listed. Also, from  $\frac{1}{2}$ "-



**To make the box plumb in its wall opening, insert shims between the box and wall studs.**

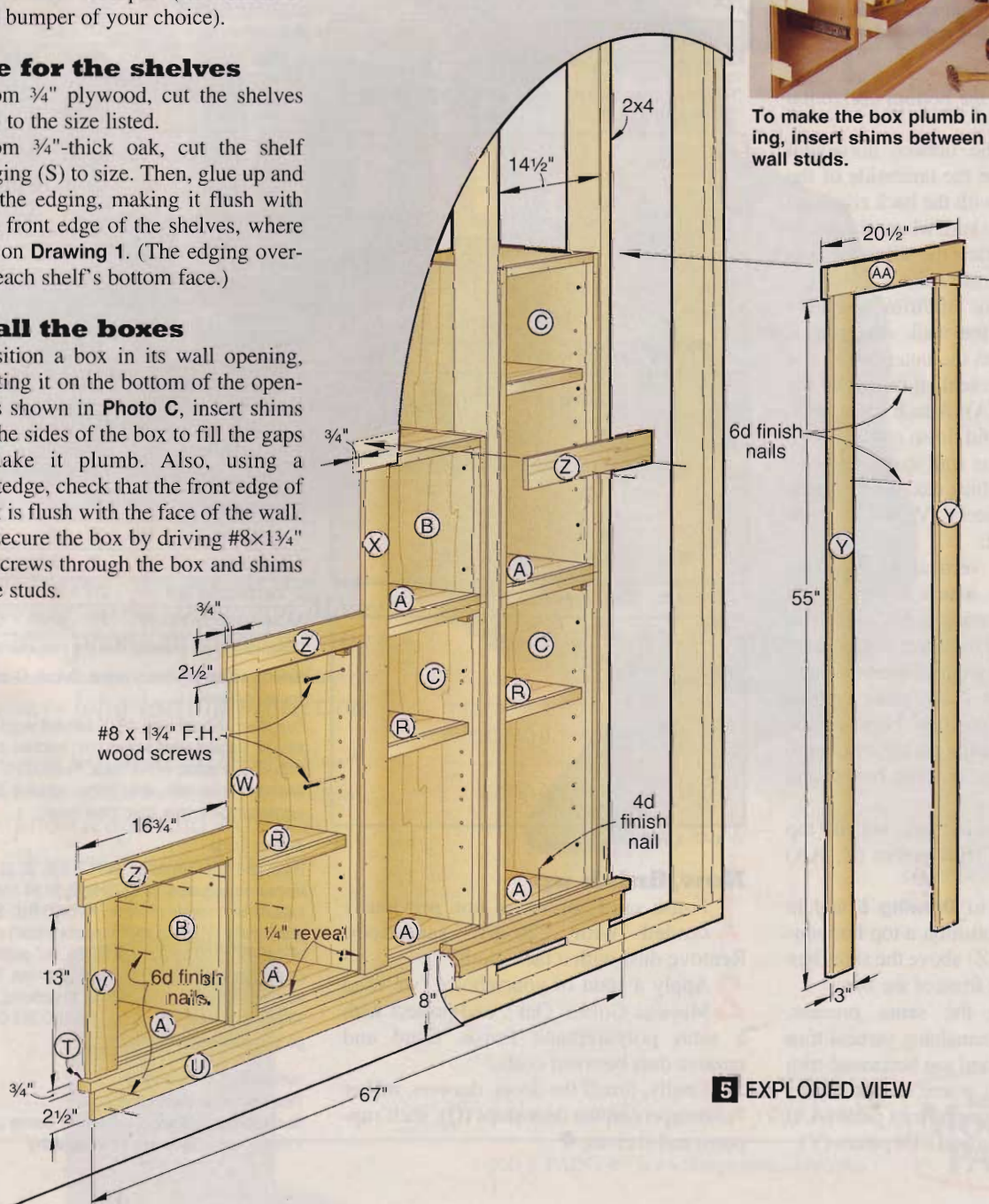

**5** EXPLODED VIEW

**D**



Position all vertical and horizontal trim to leave a 1/4" reveal around the boxes.

thick oak, cut the bottom horizontal trim (U) to size.

**2** Position the bottom horizontal trim (U) on the underside of the sill (T), flush with the back edge and centered end to end, where shown on **Drawing 5**. Attach the sill to the bottom with 4d finish nails.

**3** Position the sill/trim assembly (T/U) on the wall, centering it end to end with the outer boxes and leaving a 1/4" reveal at the top of the box bottoms (A). Attach the assembly by driving 6d finish nails through the trim into the wall studs.

**4** From 1/2"-thick oak, cut the vertical trim pieces (V, W, X, Y) to the sizes listed.

**5** Place the vertical trim (V) in position, where shown on **Drawing 5**, leaving a 1/4" reveal on the left side of the short box. Attach the trim to the front of the box using 6d finish nails. Now, place vertical trim (W) in position between the short box and adjacent tall box, leaving a 1/4" reveal on both boxes, and nail in place.

**6** From 1/2"-thick oak, cut the top horizontal trim pieces (Z, AA) to size.

**7** Referring to **Drawing 5** and to **Photo D**, position a top horizontal trim piece (Z) above the short box and nail to the front of the box.

**8** Following the same process, install the remaining vertical trim pieces (X, Y) and top horizontal trim pieces (Z, AA), where shown. Center the last top horizontal trim piece (AA) over the two vertical trim pieces (Y).

### cutting diagram

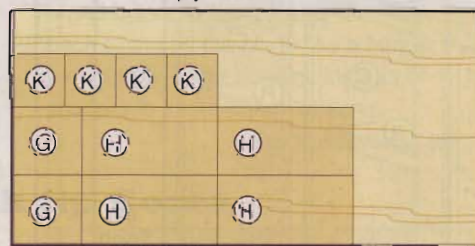
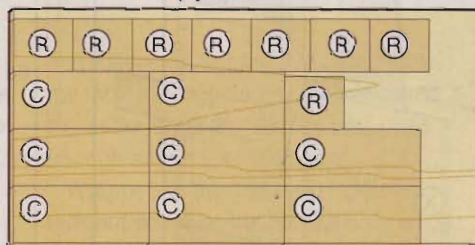
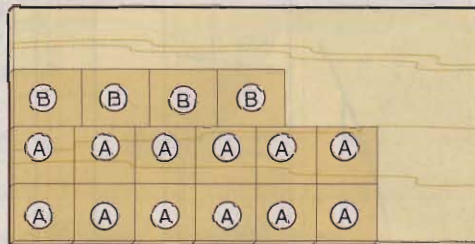
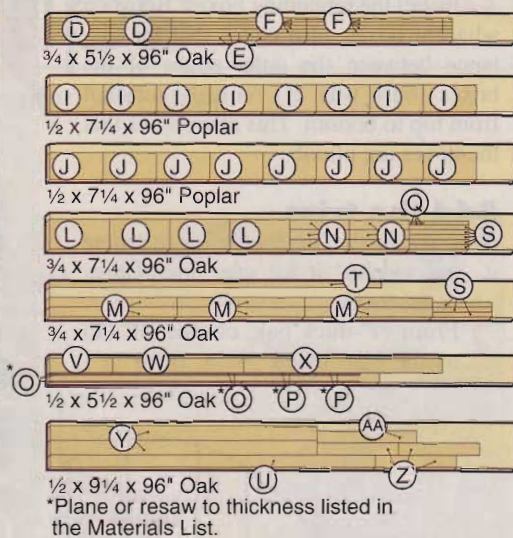

### Now, finish up

**1** Finish-sand all areas not previously sanded with 220-grit sandpaper. Remove dust with a tack cloth.

**2** Apply a stain of your choice (we used Minwax Golden Oak), and protect with a satin polyurethane finish. Sand and remove dust between coats.

**3** Finally, install the doors, drawers, rubber bumpers on the door stops (Q), shelf supports, and shelves. 🍄

### materials list

Boxes	FINISHED SIZE			Matl.	Qty.
	T	W	L		
A tops and bottoms	3/4"	11 3/4"	12 1/2"	OP	12
B short sides	3/4"	11 3/4"	14"	OP	4
C long sides	3/4"	11 3/4"	28"	OP	8
D* top and bottom edging	3/4"	3/4"	12 1/2"	O	12
E* short side edging	3/4"	3/4"	14"	O	4
F* long side edging	3/4"	3/4"	28"	O	8
G short backs	1/4"	14"	14"	OP	2
H long backs	1/4"	14"	28"	OP	4
<b>Drawers</b>					
I sides	1/2"	5 1/2"	11"	C	8
J fronts and backs	1/2"	5 1/2"	11"	C	8
K bottoms	1/4"	11"	10 1/2"	OP	4
L faces	3/4"	6 1/8"	12 5/16"	O	4
<b>Doors</b>					
M stiles	3/4"	2"	26 5/16"	O	6
N rails	3/4"	2"	12 5/16"	O	6
O* vertical glass stops	1/4"	1/4"	22 3/16"	O	6
P* horizontal glass stops	1/4"	1/4"	8 1/16"	O	6
Q door stops	3/4"	3/4"	1"	O	3
<b>Shelves</b>					
R shelves	3/4"	10 3/4"	12 1/4"	OP	8
S edging	3/4"	1"	12 1/4"	O	8
<b>Wall Trim</b>					
T sill	3/4"	1 1/4"	68 1/2"	O	1
U bottom horizontal trim	1/2"	2 1/2"	67"	O	1
V vertical trim	1/2"	3"	13"	O	1
W vertical trim	1/2"	3"	27"	O	1
X vertical trim	1/2"	3"	41"	O	1
Y vertical trim	1/2"	3"	55"	O	2
Z top horizontal trim	1/2"	2 1/2"	16 3/4"	O	3
AA top horizontal trim	1/2"	2 1/2"	20 1/2"	O	1

\*Parts initially cut oversize. See the instructions.

**Materials Key:** OP—oak plywood, O—oak, C—choice of poplar or maple.

**Supplies:** 1/4" hardboard, #8x1" flathead wood screws, #8x1 3/4" flathead wood screws, 1 1/2" machine screws, #18x1/2" wire brads, #17x1" nails, 1/8x8 3/4x22 3/4" glass (3), 4d and 6d finish nails, wood shims, adhesive-backed rubber bumpers, glue, stain, clear finish.

### Buying Guide

**Hardware:** 107" hinges no. B075T1650, \$2.22 each (6); hinge mounting clips no. B175H919, \$1.54 each (6); 10" full-extension drawer slides no. KV8400 B10, \$10.22 pair (4 pair); 1/4" spoon shelf supports (nickel) no. HB28C25, \$3.00 each box of 20 (2); 1 1/4" polished chrome knobs no. A04271 26 with 1" screws, \$1.96 each (7). Order from Woodworker's Hardware, PO Box 180, Sauk Rapids, MN 56379, call 800/383-0130, or go to [www.wwhardware.com](http://www.wwhardware.com).

Written by **Owen Duvall**

Project design: **Kevin Boyle**

Illustrations: **Roxanne LeMoine; Lorna Johnson**

Photographs: **Baldwin Photography**

# horseshoes anyone?

Looking for a project kids will love? This one's a ringer.

**T**oo many kids these days don't recognize the word "game" unless it's preceded by "video." With this horseshoe set, however, today's youngsters can have fun with a throwback to simpler times. The shoes and stakes are made from light but strong plywood finished in bright aniline dyes.

## On with the shoes

**1** Make four copies of the full-size horseshoe pattern found in the *WOOD PATTERNS*® insert, and cut the paper patterns to rough shape. Use spray adhesive to adhere the patterns to a sheet of 1/2" plywood, where shown in the **Cutting Diagram**.

*Note: We used a special thin-veneer birch plywood that offers high strength and stability. See the Shop Tip on page 96 for more information. You can substitute standard birch plywood if you prefer.*

**2** Cut blanks for the horseshoes (A) to rough shape using a bandsaw, scroll-saw, or jigsaw. Make your cuts about 1/16" outside the layout line on the pattern.

**3** Set three of the rough-cut horseshoes aside for now. Sand the remaining one up to the line to create the final horseshoe shape. You'll use it as a template for the others.

**4** Temporarily affix one of the rough-cut horseshoes (A), using small pieces of double-faced tape, to the template shoe you just sanded. Now chuck a flush-trim bit in your table-mounted router, and trim the rough-cut shoe to match the shape of the template shoe, as shown in **Photo A**. Repeat these

*continued on page 96*

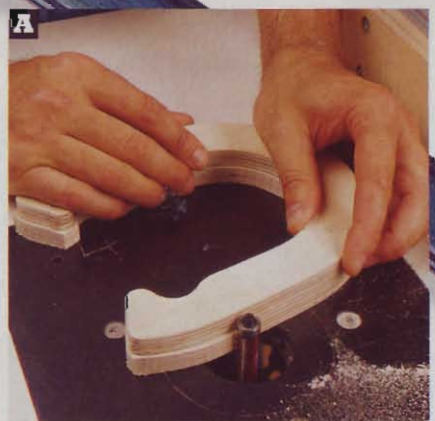

**Rout the rough-cut horseshoes to shape using a flush-trim bit and template horseshoe. Take it slow, and keep a firm grip as you rout around the ends.**

## horseshoes anyone?

steps for the two remaining horseshoes. This pattern-routing technique is faster than shaping each horseshoe by hand, and it ensures that each of the horseshoes is an exact duplicate.

**5** Now chuck a  $\frac{3}{16}$ " round-over bit into the table-mounted router, and relieve the edges of all four horseshoes, where shown in **Drawing 1**.

**6** Rip a 2x21" strip from the birch plywood to create the center cleats (B) and end cleats (C). (Though the cleats are small, the following operations will be much easier and safer if you start with an oversized piece.) Resaw the piece to  $\frac{1}{4}$ " thick, then rip the resawn piece down to create a  $\frac{1}{4}$ x $\frac{1}{4}$ x21" strip.

**7** Crosscut the strip to create four center cleats (B) and eight end cleats (C) at the sizes shown. To give the cleats their final shape, adhere a quarter-sheet of 80-grit sandpaper to a flat surface and sand  $\frac{1}{16}$ " tapers on the edges and ends of all the cleats.

**8** Glue one center cleat (B) and two end cleats (C) to one face of each horseshoe, where shown on the full-size horseshoe pattern.

### Add the stakes, finish

**1** Rip four 1x21" strips from the  $\frac{1}{2}$ "-thick birch plywood. Face-glue two strips together using a water-resistant adhesive to create each stake (D), as shown in **Drawing 2**.

**2** After the glue sets, remove any excess and sand the edges smooth. Now rout a  $\frac{3}{8}$ " round-over on all four edges of each stake.

**3** Mark a line around each stake 4" up from the bottom, where shown in **Drawing 2**. Then form a point on each stake using a disc sander. (A rasp, followed by sandpaper, also works.)

**4** Finish the stakes and horseshoes. You can create pairs of shoes for each of two players by using different colors. (We chose colorful red, green, and blue aniline dyes. See the Buying Guide for more information.) Now apply a couple coats of exterior polyurethane to provide long-lasting protection. 🍄

Written by **David Stone** with **Kevin Boyle**  
Project design: **Robert Allen**  
Illustrations: **Mike Mittermeier**; **Lorna Johnson**  
Photographs: **Baldwin Photography**

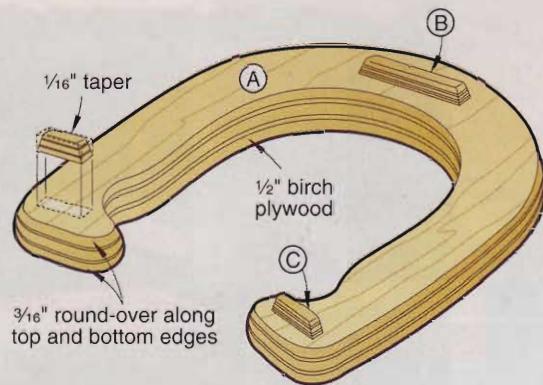

**1** HORSESHOE

### materials list

Part	FINISHED SIZE			Matl.	Qty.
	T	W	L		
A horseshoes	$\frac{1}{2}$ "	6 $\frac{1}{16}$ "	7 $\frac{1}{2}$ "	BP	4
B* center cleats	$\frac{1}{4}$ "	$\frac{1}{4}$ "	1 $\frac{1}{2}$ "	BP	4
C* end cleats	$\frac{1}{4}$ "	$\frac{1}{4}$ "	$\frac{3}{4}$ "	BP	8
D stakes	1"	1"	21"	LBP	2

\*Parts initially cut oversize. See the instructions.

**Materials Key:** BP—birch plywood, LBP—laminated birch plywood.

**Supplies:** Spray adhesive, exterior glue, and finish.

### BUYING GUIDE

**Finnish Birch plywood.** Woodcraft no. 50Y06,  $\frac{1}{2}$ x24x30", \$18.99. Available from your local Woodcraft store, or order from Woodcraft, 560 Airport Industrial Park, Parkersburg, WV 26102. Call 800/225-1153, or shop online at [www.woodcraft.com](http://www.woodcraft.com).

**Aniline dyes.** Homestead Transfast water-soluble aniline dyes, no. 123835 Cardinal Red, \$9.50; no. 126305 Toymaker's Blue, \$11.50; no. 126308 Toymaker's Green, \$11.50. Woodcraft, see above.

**Alternate plywoods.** For Baltic birch order no. 300BB27,  $\frac{1}{2}$ x24x30", \$11.50, from Schlabaugh & Sons, 720 14th Street, Kalona, IA 52247; 800/346-9663; [www.schsons.com](http://www.schsons.com). To locate an ApplePly dealer near you, contact States Industries at 800/626-1981; [www.statesind.com](http://www.statesind.com).

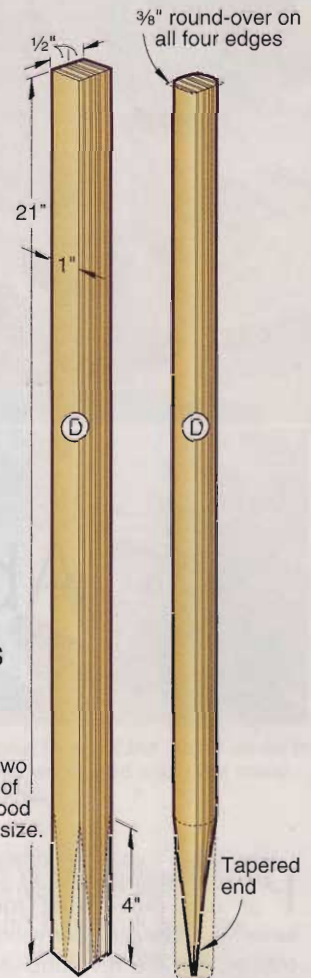

**2** STAKES

Laminate two  $\frac{1}{2}$ " pieces of birch plywood and cut to size.

Tapered end

### cutting diagram

\*Plans or resaw to thickness listed in the Materials List.

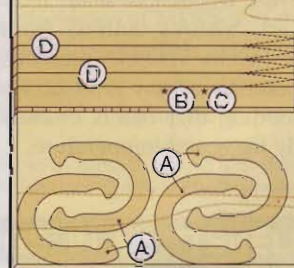

$\frac{1}{2}$  x 24 x 30" Birch plywood

### SHOP TIP

#### Plywood with more plies

Baltic birch and Finnish birch plywoods both have a greater number of plies than standard domestic plywood. A  $\frac{1}{2}$ " sheet, for example, has nine plies, as opposed to the five plies usually found in standard  $\frac{1}{2}$ " plywood. These imports are made from slow-growing (and therefore tight-grained) birch trees harvested in the cool Baltic regions of Finland and Russia. Gluing thin, void-free veneers together results in a rigid, neutral-grained plywood that looks great, even on the edges. Baltic birch, the better-known of the two, works well for indoor use. Finnish birch plywood looks similar, but uses exterior-grade glue, making it suitable for use outdoors. An American-made version called ApplePly is also available for indoor projects. See the Buying Guide, above, for sources.

# products that perform

These woodworking wares passed our shop trials

## Carefree cutting with a cordless router

Until I tested Porter-Cable's 9290 Cordless Router, I didn't really notice the hassle of handling a router's power cord. Based on Porter-Cable's classic 690-series router, the 9290's direct-current motor runs off a P-C 19.2-volt battery pack, which mounts to the top of the motor. Yes, it looks top-heavy, but I was surprised at how well-balanced this machine really is (and quiet, at 78 decibels).

To see how much work the 9290 could do on a single battery charge, I went to work cutting a 1/2" round-over in red oak. After 103 linear feet of cutting, the battery still had some life, but the quality of cut was beginning to deteriorate. Performing the same test in pine, I exhausted the battery after 155 linear feet.



So, should you buy one? Well, that depends. The 9290 comes with a 1/4" col-

let, discouraging the use of 1/2"-shank bits to maximize battery life. (However, this machine is so closely related to the 690 series that my 690's 1/2" collet, plunge base, and D-handle base all fit it perfectly.) And the \$279 price tag includes only one battery pack, which isn't a big problem if you own other Porter-Cable 19.2-volt tools. If not, you'll cool your heels for an hour while the battery recharges.

—Tested by Rich Bright

### Porter-Cable 9290 Cordless Router

Performance	★★★★★
Price	\$279
Value	★★★★☆

Call Porter-Cable at 800/487-8665, or visit [www.porter-cable.com](http://www.porter-cable.com).

Continued on page 102

Suggested list \$299.  
**ON SALE \$269**  
NOW FOR ONLY

## The Precision Router Lift

Total control for table mounted routers.

The PRL (Precision Router Lift) fits a PC 7518 directly and is available with adapter collar's for other fixed base routers.

- Change bits above the table.
- Includes (3) aluminum twist lock rings.
- Adjustable index scales.
- Elevated crank handle.
- Includes threaded starting pin.

**1.800.752.0725 • [www.woodpeck.com](http://www.woodpeck.com)**

## FREE FREE INFORMATION WORTH WRITING FOR

*A Moment of Your  
Time for a Wealth of  
Information!*

Top-quality catalogs and brochures from the nation's leading woodworking companies; the easy way for those who enjoy *woodworking* to explore products and services that will enhance the entire experience. Before you start your next project, turn to the back of this magazine, complete the order card and receive a wealth of...

## INFORMATION WORTH WRITING FOR

**See Page 104**

## Shaper-like fence for your router table

Although I never felt compelled to drop a lot of money on a stationary shaper, I've always been enamored with the precision and versatility of a shaper fence. Freud's SH-5 Router Table Adjustable Fence System brings many shaper-fence features to the router table.

For example, the separate infeed and outfeed fences adjust independently with micrometer-style knobs. Each full turn of a knob yields .050" (about 3/4") change of

fence position, and every .001" increment is clearly marked on the knobs. I found I could effortlessly tweak the fence to perfection. Setting the SH-5's outfeed fence a little proud of the infeed fence, I used a straight bit in my router table to joint the edges of 3/4" stock more precisely than I can on my jointer.

The travel on these fences is only 7/8", and that's fine for probably 90% of my work. But for wider workpieces or large

panel-raising bits, I had to add an extra pair of threaded inserts to mount the SH-5 farther back on my tabletop. (Threaded inserts are the preferred mounting method; none come with the fence system.)

The 10" spacing of the SH-5 mounting bolts fits Freud's BF-3 router table, but is too narrow for most commercial insert plates, which run about 12" wide. For those situations, Freud sells an adapter (\$18) with mounting holes 14" on center.

With my shop vacuum hooked up to the SH-5's dust port, I captured about 80% of the chips produced. That port and a safety guard mount to the cast-aluminum fence body, which proved plenty solid.

—Tested by Phillip Goodwin

**The new standard has arrived:**

## CMT's Industrial Thin-Kerf Blades



CMT's new ITK blades give you all the advantages of a thin kerf blade, like reduced drag on your saw and less wasted material, plus the latest in design features:

- Laser Cut plate, arbor, and expansion slots
- Anti-kickback design
- Tri-Metal brazing, precision balancing & more!

Best of all, these blades are yours at prices that set the competition on its ear! Easy on your wallet, easy on your saw and easy to remember - the new standard of cutting performance is as simple as ITK.



Visit your CMT Distributor for the finest woodcutting tools: bits, blades, shaper cutters & more

CMT USA, Inc. • 307-F Pomona Drive • Greensboro, NC 27407  
888-268-2487 • Visit our website at [www.cmtusa.com](http://www.cmtusa.com)

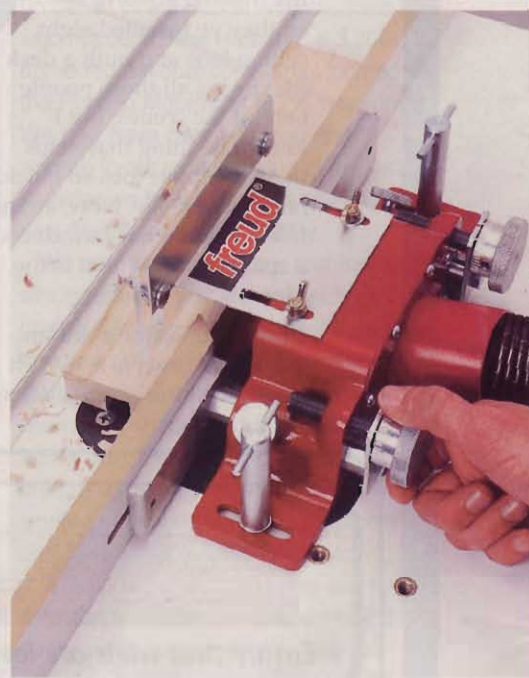

### Freud SH-5 Router Table Adjustable Fence System

Performance	★★★★☆
Price	\$109
Value	★★★★☆

For more information, call Freud at 800/334-4107, or visit [www.freudtools.com](http://www.freudtools.com).

### About our testers

Phillip Goodwin is a programmer/analyst by day. Rich Bright teaches woodworking and other technical skills to high-school students. Both are avid woodworkers.

# what's ahead

in our next issue

## Projects



### Mix-and-match modular storage

It's a shelving system! No, it's a dresser! A sideboard! A nightstand! A curio display stand! It's all of these and other furniture forms, depending on how you assemble its separate pieces using knock-down hardware.



### Keepsake box

Contrasting woods and wraparound tapered legs distinguish this deceptively easy-to-make project.



### Blooming mailbox

Who says your roadside mailbox has to look ordinary? Make it enhance your landscape with this durable design.



### Chaise lounge

Build this pleasing project in mahogany or other weather-resistant wood, then add a comfy cushion for backyard R and R.

## Tools, Techniques, & Features



### 10" miter saws

We tested 10 machines for power, accuracy, and convenience. And we now know which model you should buy. And—get this—we even came across a *cordless* 10" miter saw.



### Intro to knock-down hardware

Learn how and when to use hardware that lets you quickly take apart and reassemble furniture, cabinets, and shelving.



### James Krenov up front and personal

One of the most widely respected woodworkers of our time just retired. Here he shares his best pearls of furniture-design wisdom.