

Better Homes and Gardens®

WOOD

7 1/4" CIRC SAWS
AND PICK THE BEST

APRIL 2002
ISSUE 141

Tips, Tools, Techniques, and Projects for the Home Woodworker

SPECIAL!

5 great outdoor projects

PLUS:

- TV stand
- Kid's speedboat
- Turned snack tray

10 ways to get the most from your table saw



www.woodonline.com

Display until May 21, 2002

USA \$5.95

0 72440 14072 1

04 >

contents

WOOD® magazine

April 2002, Issue 141

PROJECTS & TECHNIQUES

- 46 contemporary TV stand**
Let this project provide a handsome home for your electronics.
- 50 model speedboat**
Expect waves and raves with this rubber-band-powered runabout.
- 60 build-to-suit pergola**
Shade your deck, patio, or yard with this pleasing architectural structure.
- 66 how to install posts**
Learn the tricks builders use to locate and set posts in the ground.
- 68 arbor/swing combo**
Plan for a relaxing summer with this freestanding outdoor project.
- 72 deluxe deck-railing system**
Planter-box columns and tough materials make for lasting beauty.
- 80 on-wall trellis**
Combine 2x2s and lattice to create a great framework for climbing plants.
- 92 glass-domed snack tray**
Serve up style by turning this plate, cheeseboard, and knife handle.
- 96 10 ways to tablesaw success**
Make your tablesaw the best it can be with these shop-smart tricks.



Cover Photo: Baldwin Photography

**GREAT
OUTDOOR
PROJECTS**

68

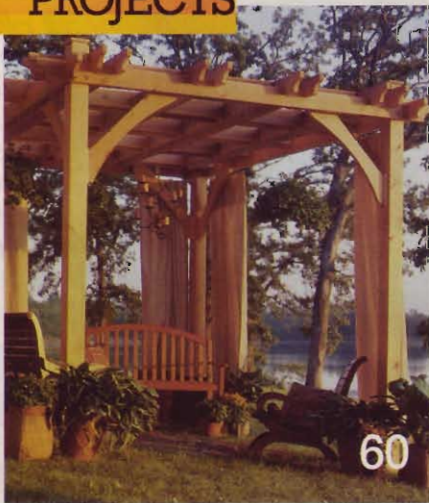

60



72



46



50



92

contents

April 2002, Issue 141

TOOL REVIEW

84 **7¼" circular saws**

We test the power, performance, and features of eight competing models.



84

FEATURES

44 **wood close-up: baldcypress**

54 **how to craft cutlery handles**

Check out the results of three staffers who used mail-order knife kits.

90 **who built Lady Liberty?**

See the role wood played in the construction of our most famous statue.

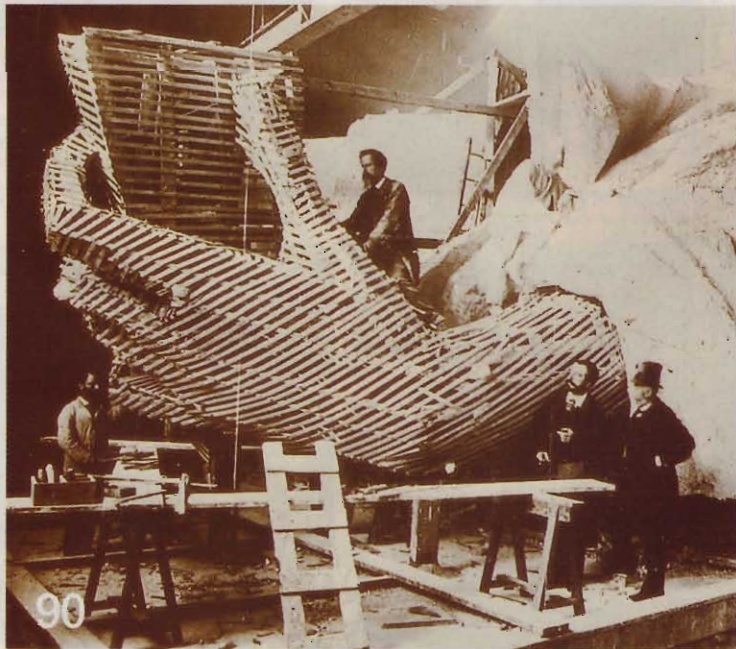

90

DEPARTMENTS

6 **editor's angle**

8 **talking back**

12 **great ideas: rip-fence saddle**

Machine bridle joints, open mortises, and tenons with this handy jig.

14 **short cuts**

16 **shop skills: step-building**

Learn the guidelines when working on outdoor projects.

22 **joinery: mark with precision**

24 **talking shop: glass shelving**

See what your options are, and how they impact price.

26 **how dry should wood be?**

32 **ask WOOD**

36 **shop tips**

42 **WOOD ONLINE®**

100 **outdoor products resource guide**

101 **products that perform**

111 **wood anecdote: coffeetree**

112 **what's ahead in our next issue**



54

Better Homes and Gardens® WOOD® magazine (ISSN-0743-894X) is published nine times a year in February, March, April, May/June, July/August, September, October, November, and December by Meredith Corporation, 1716 Locust St., Des Moines, IA 50309-3023. Periodicals postage paid at Des Moines, Iowa, and additional mailing offices. Better Homes and Gardens trademark registered in Canada and Australia. Marca Registrada en México. ONE-YEAR SUBSCRIPTION PRICES: U.S. and its possessions, \$28; Canada, \$41; other countries, \$49. Canada Post Publications Mail Sales Product Agreement No. 40049562, Canadian BN 12348 2887RT. CANADIAN RETURN ADDRESS: Better Homes and Gardens WOOD magazine, 2744 Edna Street, Windsor, Ontario, N8Y 1V2. POSTMASTER: Send address changes to Better Homes and Gardens WOOD magazine, P.O. Box 37439, Boone, IA 50037-0439.

Some special people you ought to know

If you've visited our online discussion groups you know how much woodworking wisdom can be gained by tuning in to them. That exchange of information wouldn't be possible without the help of these dedicated readers.

I think I speak for everyone on the staff when I say that the best part of working at *WOOD* magazine is producing a publication for readers who are so passionate about a subject matter. If there's a group of people who enjoy their craft and pursue it with more zeal than woodworkers, I'd like to meet them.

So it's no surprise that thousands of woodworkers share their knowledge, and seek it from others, by actively participating in our Internet discussion groups at www.woodonline.com. The 11 groups cover every area of woodworking, and the talk can get rather lively, the viewpoints pretty strong. I've always found it fun and informational.

The discussions are hosted by a corps of dedicated volunteers from across North America. They monitor the conversations, lend a helping hand to needy woodworkers, and yes, they step in from time to time to keep things civil. If a participant raises a concern that requires the immediate attention of one of our editors, they alert us to it. They do these things because they love woodworking and sharing information. For that, I would like to acknowledge them here. Some of these folks have expertise in specific areas, and I've listed those after their hometown.

Don Sindledecker, Ketchikan, AK,
host at large

Jim Frye, Toledo, OH, host at large
Jim Becker, New Hope, PA, tool buying
Willy Driscoll, Surrey, BC,
woodworking plans finder

Jamie Downing, West Des Moines, IA,
downloadable plan support

Jim Kull, McKinney, TX,
finishing and refinishing

Phil Brennon, Chino Valley, AZ,
woodturning

Kathy Hutton, Dubuque, IA,
scrollsawing

Ross Canant, Greenville, TX, old tools
Russell Floyd, Jericho, VT,
woodworking plans finder

Doug Mount, Peachtree City, GA,
home improvement

Tim Rundall, Des Moines, IA,
woodcarving

To learn more about these enthusiastic woodworkers, and see their pictures, go to www.woodonline.com and click on WOOD TALK. And while you're there, don't forget to add your two cents to one or more of the discussions. We'll be expecting you.

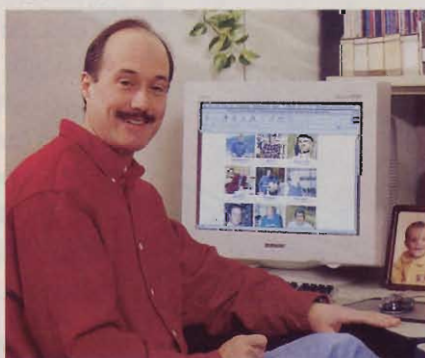

Bill Krier

Editor-in-Chief **BILL KRIER**
Executive Editor **JIM HARROLD**
Managing Editor **MARLEN KEMMET**
Features Editor **DAVE STONE**
Products Editor **DAVE CAMPBELL**
Projects Editor **JAN HALE SVEC**
Projects Editor **OWEN DUVALL**
Techniques Editor **JIM POLLOCK**
Senior Design Editor **KEVIN BOYLE**
Design Editor **JEFF MERTZ**
Master Craftsman **CHARLES I. HEDLUND**
Production/Office Manager **MARGARET CLOSNER**
Administrative Assistant **SHERYL MUNYON**
Illustrators **LORNA JOHNSON, ROXANNE LeMOINE,**
TIM CAHILL, MIKE MITTERMEIER
Contributing Photographer **MARTY BALDWIN**
Technical Consultants **RICH BRIGHT, JEFF HALL,**
KIRK HESSE, GARRY SMITH
Contributing Craftsman **JIM HEAVEY**
Proofreaders **JIM SANDERS, BARBARA KLEIN**
Art Director **TIM ALEXANDER**
Assistant Art Director **CHERYL A. CIBULA**
Publisher **MARK HAGEN**

Advertising Office: 333 N. Michigan Ave., Suite 1500,
Chicago, IL 60601 Phone: 312/853-2890 Fax: 312/580-7906

Sales Assistant **LARA KALLAL**

Mail Response Manager **CAROLYN DAKIS**

Account Executive **RON GOLMINAS**

Account Executive **NEIL KIRBY**

Account Executive **JOHN THORNBURGH**
Detroit, Phone: 248/356-1149 Fax: 248/356-8930

Account Executive **PAT TOMLINSON**

Northeast, Phone: 212/551-7043 Fax: 212/551-7192

Southeast: Lagomarsino, Dempsey & Dennis, Inc.

2951 Piedmont Rd., NE, Suite 100, Atlanta, GA 30305

Phone: 404/261-5400 Fax: 404/261-5404

Group Marketing Director **CATHY E. SMITH**

Phone: 212/551-7178 Fax: 212/551-7192

Senior Marketing Services Manager **ALEXANDER D. CLARKSON**

Group Publisher **STEPHEN B. LEVINSON**

Associate Business Director **CRAIG FEAR**

Senior Product Manager **RICK GROW**

Advertising Services Manager **PAT HENDERSHOTT**

Consumer Marketing Director **KATHI PRIEN**

Consumer Marketing Manager **DAVE HONOLD**

Vice President/Publishing Director **WILLIAM R. REED**

MEREDITH PUBLISHING GROUP

President **STEPHEN M. LACY**

Magazine Group President **JERRY KAPLAN**

Group Sales **MICHAEL BROWNSTEIN**

Creative Services **ELLEN DELATHOUDER**

Business Development **TINA GEORGEOU**

Manufacturing **BRUCE HESTON**

Consumer Marketing **KARLA JEFFRIES**

Finance and Administration **MAX RUNCIMAN**



WILLIAM T. KERR, President and Chief Executive Officer

E.T. MEREDITH III, Chairman of the Executive Committee

©Copyright Meredith Corporation 2002

All rights reserved. Printed in the U.S.A.

Customer Service Information: For service on your subscription, including change of address, contact us at www.woodmagazine.com/service or call 800/374-9663.

Subscription mailing address: Better Homes and Gardens WOOD magazine, P.O. Box 37439, Boone, IA 50037-0439.

Please enclose your address label from a recent issue. **Editorial mailing address:** The Editor, WOOD magazine, 1716 Locust Street, GA310, Des Moines, IA 50309-3023. For questions on editorial, questions about how to reach an advertiser, or to place an advertisement in our magazine call 800/374-9663.

To order back issues call 800/346-9663. Article reprints, send \$5 per article (no phone orders), include issue and name of article, to WOOD Article Reprint Service, P.O. Box 349, Kalona, IA 52247, check or money order made payable to WOOD magazine.

MPA

MPA

talking back

Our bulletin board for letters, comments, and timely updates

Increase the performance of your cyclone

I downloaded the plans for the cyclone dust collector from your Web site, and built it pretty much as shown. My only departures were a 2-hp blower and felt filter bags.

At the end of a 4' length of duct connected to the cyclone's inlet, I measured an air flow of 350 cfm. After installing a "neutral vane" inside the cyclone, shown on **Drawing 1**, the flow increased to 525 cfm. This is a significant increase in performance for such a simple modification, and is well worth trying out.

—John Dillbeck, Shell Knob, Mo.

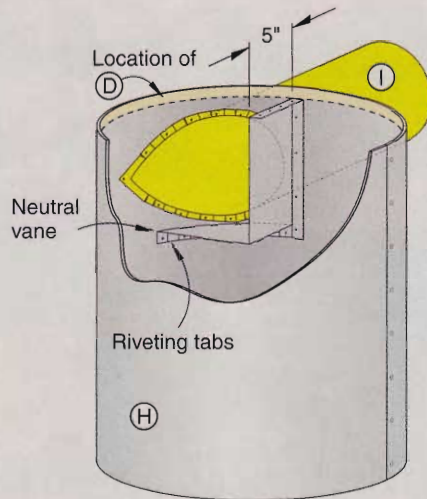

1 MODIFICATION

Another reader recently called us for advice on building the cyclone, and described the same sort of deflector inside an old cyclone that was once part of a piece of farm machinery. Perhaps they knew something we didn't when we designed our cyclone.

It wouldn't be too difficult to retrofit an existing cyclone in this manner. But better yet, incorporating a similar detail in a new cyclone would simplify its construction. When forming the teardrop-shape cutout in the cyclone's cylinder (H), leave three tabs around its perimeter, where shown on **Drawing 2**. Bend the tabs into the cylinder, and trim the end of the inlet duct (I) at an angle so it clears the outlet duct. Insert the inlet and pop-rivet the tabs to it, where shown on **Drawing 3**. Seal around the inlet/cylinder joint on the outside with caulk.

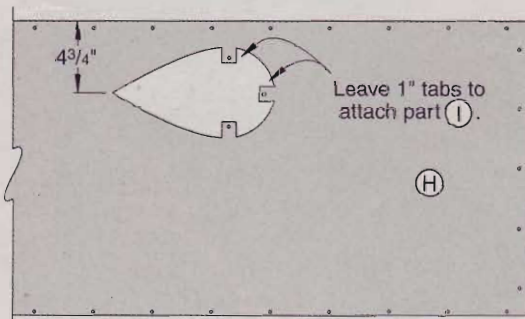

2 CYLINDER—NEW OPTION

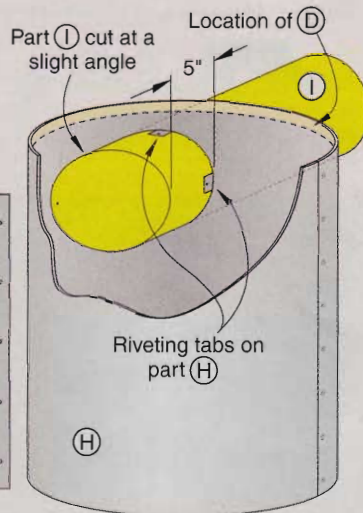

3 INLET—NEW OPTION

Drilling for quarters

Your framed display case for commemorative state quarters is a drop-dead project that I'm sure lots of people will want to make ("Our Country in Quarters" in issue 131).

You specify using a 1" Forstner bit to drill the 1/16"-deep holes for the quarters. And because this results in a loose fit, you say to use a removable adhesive underneath to keep the quarters nice and aligned. Well, this will work, but why not save yourself the trouble? I used a 1 5/16" Forstner bit to drill my holes and then "punched" the quarters in place with a 3/4" dowel. The fit is perfect. No adhesive required!

—Tom Epps, Denver



Thanks, Tom, for your suggestion, but we would sound a note of caution. Force fitting a quarter into a 1/16" hole might split one of the states like West Virginia or Tennessee where the coin recess comes very close to its edge. Even if you got a quarter into Texas or Arizona without splitting it, seasonal wood shrinkage would probably do the job.

What may be the perfect solution comes from Rockler Woodworking and Hardware. Anticipating a need for displaying these commemorative quarters, they are selling a special quarter-size (.995") carbide-tipped Forstner bit (catalog no. 26057) for \$21.99. To order one, call 800/279-4441.

Continued on page 10

Footbridge is short a couple of spindles

I just finished making the garden footbridge featured in issue 133, and am extremely happy with the way it turned out. It's better looking than the pictures.

There are, however, a couple of corrections that should be noted. The Rail Holes drawing on page 43 shows holes for 16 spindles on each side. The photographs and Bridge Sides drawing on page 46 show 18 spindles. Also, the Rail End and Center Mounts drawing on page 44 implies that the bottom ends of both the end mounts (I) and the center mounts (J) have a 15° bevel. Only the end mounts need the bevel. The center mounts are cut square.

Aside from these two items, your instructions and

drawings were very accurate and easy to follow. I'm a rookie at this sort of thing, and I want to thank you for the wonderful, constructive hours I spent on this project. This bridge is the centerpiece of my backyard.

—Tom Mateer, Naperville, Ill.

Thanks for your compliments, Tom, and you're right about the spindle holes and the center mounts. See the drawings, below and right, for the corrections.

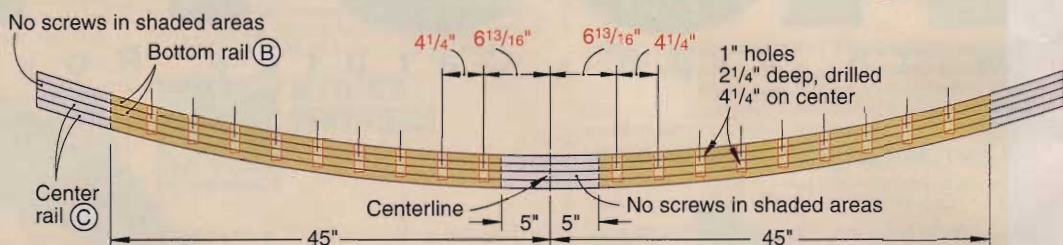
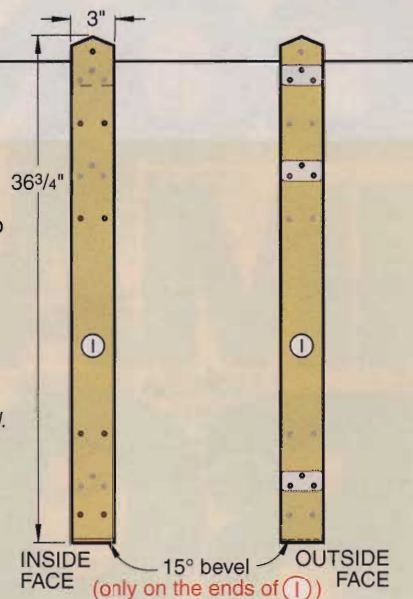

Buying guide revised for the arched-top clock

Please note the revisions, indicated below in red type, to the Buying Guide for the arched-top clock in issue 138.



Buying Guide

Brass knobs no. 39500, \$1.25 each (4); 5/8"-diameter press-in clock movement no. 15343, \$11.95. Order from Klockit, P.O. Box 636, Lake Geneva, WI 53147, or call 800/556-2548, or go to www.klockit.com.

Don't let your dream home go up in smoke

I'm a regular reader of WOOD®, and I have read your frequent cautions about the right way to store potentially combustible staining materials and supplies. But your good advice never really hit home with me.

Not until recently. Some good friends of mine were about to move into their dream retirement home, which was almost two years in the building and on which they were putting the finishing touches. The weekend before they were to move in, fire totally destroyed their new home. The cause? A pile of wet staining rags accidentally left on the wood floor.

I hope this letter will hit home with your readers and save someone else from such a tragic accident.

—John R. Good, Kewanee, Ill.



We hope so too, John, and thanks for writing. Just to underscore the point, staining rags aren't the only potential problem. Rags soaked with drying oils, such as boiled linseed oil and Danish-oil finishes, are just as prone to spontaneous combustion if not handled properly.

Don't take chances. Never rely on "air-tight" containers. Lay out (or hang up to dry as shown, left) any rags or paper towels you've used to apply these finishes.

Write Us!

Do you have comments, criticisms, suggestions, or maybe even a compliment specifically relating to an article that appeared in WOOD® magazine? Please write to:

Talking Back
WOOD magazine
1716 Locust St., GA310
Des Moines, IA 50309-3023

or e-mail us at talkingback@mdp.com. Due to the volume of letters and e-mails we receive, we can respond to and publish only those of the greatest interest to our readers.

great ideas for your shop

rip-fence saddle

An inexpensive, shop-built jig for top-notch machining and joinery

Build this auxiliary wood fence and mating saddle to bevel-cut the post caps for the pergola on page 61, or build it for supporting stiles and other workpieces as shown in the photo at right. Use one hand to push the saddle and workpiece across the blade, and your other hand to keep the saddle riding firmly on the auxiliary fence. Wax the mating pieces if necessary for easy sliding.

Positioned to center the workpiece over the dado blade, the jig is the perfect setup for machining bridle joints or open mortises and the mating tenons.



Note: Our auxiliary fence is screwed securely to our metal tablesaw rip fence, with the top edge of the fence sitting 1" above the top edge of the metal fence. The auxiliary fence must be 90° to the saw table. Size your wood fence so the saddle rides smoothly, without free play, along the top edge of the auxiliary fence.

Illustration: Roxanne LeMoine; Tim Cahill
Photograph: Baldwin Photography

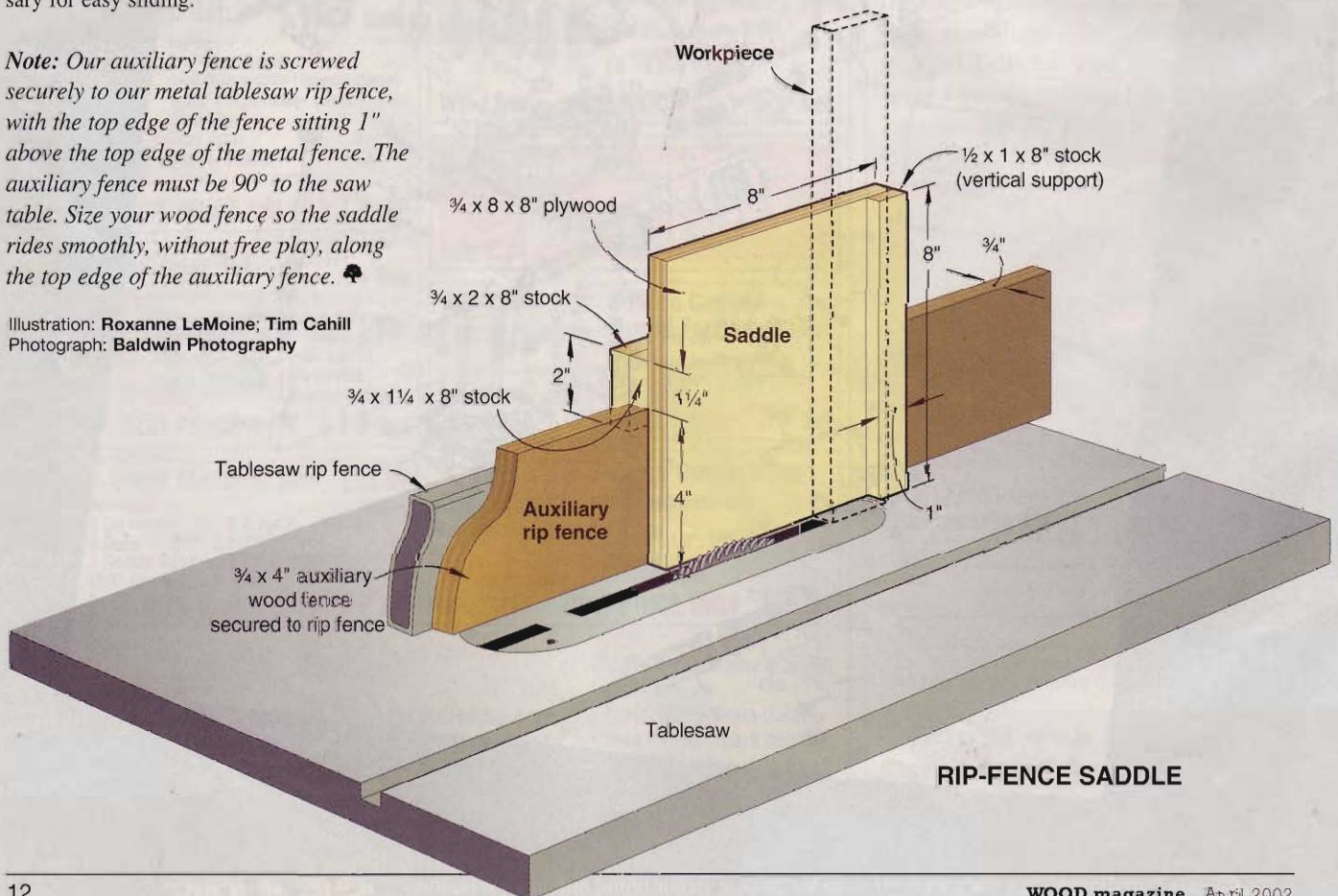

short cuts

News and notes from the woodworking world

A touching tribute from America's woodworking clubs

After the tragedies of September 11, 2001, people across the country asked what they could do to help. In San Ramon, California, just east of San Francisco, a woodworker named Phil Cullen hatched an idea that took hold in several woodworking clubs across America. The idea: build flag cases for the families of police officers, firefighters, and others who lost their lives from the terrorists' acts.

At that point, Phil e-mailed his idea to several woodworking clubs to see if they were up to building the needed number of flag cases. As Phil describes it, the response was both instant and impressive. "George DuBois from the Guild of Oregon Woodworkers volunteered to be the national coordinator of the effort. He

Seen here with Diablo woodworking club members, founder of WUFA Phil Cullen (middle row, second from right) has received the nod to make the flag case for the chief of the FDNY who lost his life on September 11.



contacted key officials at the Pentagon and spoke with members of other woodworking clubs." In no time, the idea grew into a nationwide organization that is referred to as Woodworkers United for America (WUFA).

Phil's local Diablo woodworking club, *above*, pitched in and made 60 cases; other clubs, such as the Des Moines Woodworkers Association, *right*, and other Iowa clubs made more than 50 cases. Clubs from practically every state in the country, including Alaska and Hawaii,



Members of the Des Moines woodworking club show off their flag cases. This batch is slated for the families of those lost in the Pentagon. Dick Meuler (center right) headed up the effort in Iowa.

volunteered their woodworking talents and time. And because of the task size, the work continues. And that's to say nothing of the distribution logistics. Solicited companies from around the country also are doing their part by donating glass, wood, and flags to help the woodworking clubs.

Though the construction of the triangular cases varies from club to club, the basic plan (found on the Internet at www.woodworkersunitedforamerica.org) calls for sides that measure $\frac{3}{4} \times 3\frac{3}{4} \times 18\frac{3}{4}$ " and a $\frac{3}{4} \times 3\frac{3}{4} \times 26\frac{1}{2}$ " base. Side ends are mitered at $22\frac{1}{2}^\circ$ and 45° , and held together with splines. Grooves in the sides and base keep the glass in place, while a plywood back fits into rabbeted edges and screws off to hold a folded flag inside (typically, one that is $5 \times 8'$ or $5 \times 9\frac{1}{2}'$).

If you, too, would like to help WUFA, whether you are a woodworking club member or not, contact the nearest regional representative using the map at *left*. For more info, log onto their Web site. 🌲

Photographs: Chris Kammeyer; Baldwin Photography

Want to help? Contact the WUFA regional representative nearest you.

- | | |
|---|---|
| <p>1 George DuBois, 503/365-7636
gdubois@woodworkersunitedforamerica.org</p> <p>2 Bill Tarleton, 925/939-8052
btarl@attbi.com</p> <p>3 Dick Meuler, 515/967-7686
dmeuler@woodworkersunitedforamerica.org</p> <p>4 Earl Ashurst, 972/727-3542
eashurst@woodworkersunitedforamerica.org</p> | <p>5 Larry Rine, 815/577-1307
lwrine@execpc.com</p> <p>6 Mickey Hudspeth, 770/441-9202
mhudspeth@mindspring.com</p> <p>7 Al K. Spitzer Jr., 603/669-3416
alspitzer@woodworkersunitedforamerica.org</p> <p>8 John E. Mielcarski, 315/476-6571
SLICKROVER@aol.com</p> <p>9 Mr. Ray Taylor, 703/490-8103
yar_rolyat@hotmail.com</p> |
|---|---|

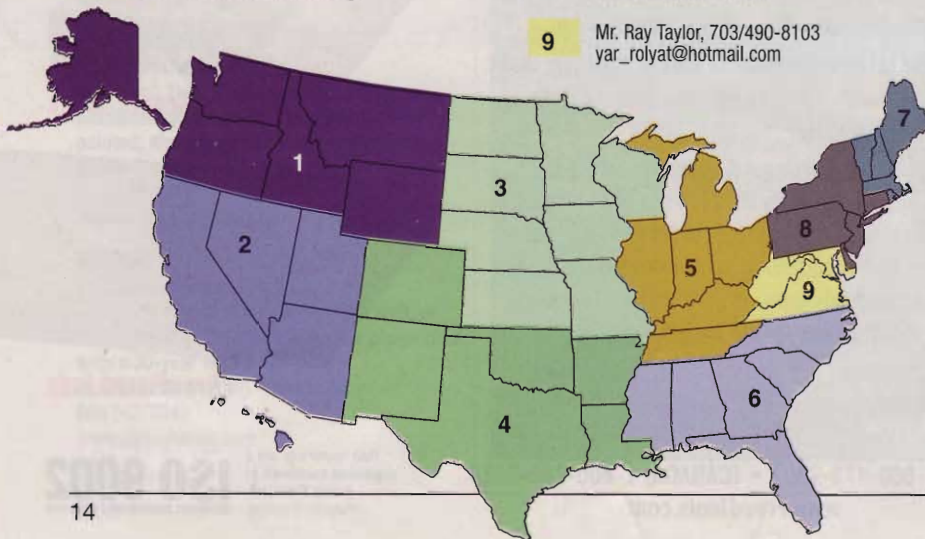

develop your **shop skills**

simple step building

Get off the ground one step at a time with a framing square and these tricks of the trade.



A deck built close to the ground, like the one shown *above*, gives you an excellent chance to learn the skills of step building. You'll use the same principles that apply to any run of steps, but you can practice them with small, easily handled pieces.

We'll show you how to build steps with open stringers, which support the treads from underneath. Laying out these stringers requires accurate measurements and a bit of arithmetic. After that, it's just a matter of making basic cuts.

Figure the rise

Take a look at the drawings *below* to get familiar with step-building terminology. Now let's get to the construction details.

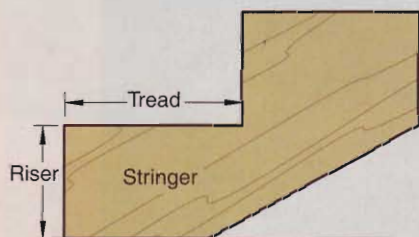

Measure from the top of the deck surface to the ground. This number is the total "rise" of the steps.

Now, you need to make sure that each of the individual steps has an equal rise. If one or more are off, your feet will feel the difference.

Divide the total rise by the preferred rise of each step in inches—either 6 or 7 will give you a comfortable step. The result probably will include decimals, so round it to the nearest whole number to determine how many steps you'll build. Now, divide the overall rise by the number of steps to get the actual rise per step. See the box at *right* for a typical calculation.

Figure the run

The total "run" is the horizontal distance from the edge of the deck to the bottom end of the stringers, as shown in the drawing. The run of an individual step equals the width of the tread—11" is typical.

Continued on page 18

The total run of a set of steps equals the distance from the edge of the deck to the point where the stringers rest on a pad. The total rise is the distance from pad to deck top. Each step consists of a riser and tread.

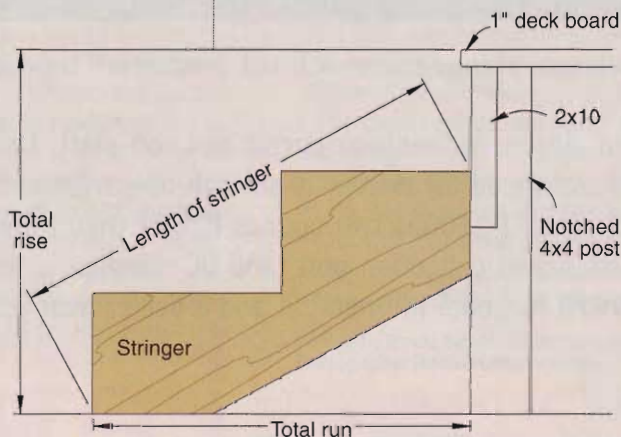

Step building by the numbers

Here's an example of how to figure a stair run for a low deck. In this case, the top of the deck is 26" above the ground.

1. Divide the total rise by your chosen riser height of either 6" or 7" (26 divided by 6 = 4.33).
2. Round up or down to the nearest whole number to get the actual number of steps (4).
3. Divide the total rise by the number of steps to get the actual rise per step (26 divided by 4 = 6.5, or 6½").

You can add or subtract a step and divide that number into the total rise if you're not satisfied with the riser that you calculate the first time. If you end up with a riser number that's not a whole number or standard fraction, one riser will be slightly different than the rest. Make it the first one at the bottom end of the stringer.

As for tread width, consider 11" the standard. As you make your plans, allow for one less tread than the number of risers. Because the stringer attaches to the deck joist below the level of the deck surface, the deck itself serves as the top tread.

Before you buy or rough-cut stringer boards, calculate the approximate length you'll need. Add up all of the tread widths to find the total run of the steps. Use a tape measure to mark that point on the ground, then measure from there to the highest point where the stringer will contact the deck joist. This number is the stringer length.

The tread can be one wide board or several narrower boards with equal gaps in between. We used a pair of 1¼×5¾" composite decking boards to make each tread, or you can use pressure-treated 2× lumber. To match the deck design, we attached a board to each set of riser cuts so that its top edge serves as part of the tread, as seen in the lower right photo on page 20. It's

Lay out the stringers

Now you're ready to lay out your stringers for a two-step assembly, as shown in the drawings below. Choose straight pressure-treated 2×12 lumber, and draw your lines so that any significant knots will lie in the waste areas.

step 1 Tighten one stair gauge on the outside edge of the square's long leg at the number equaling the run. The other gauge goes on the outside of the short leg, at the number equaling the rise.

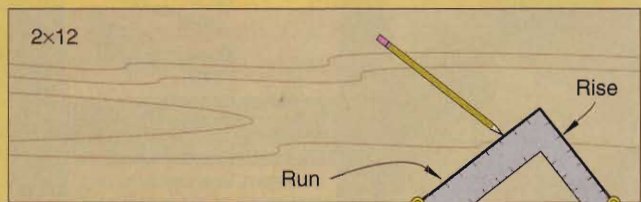
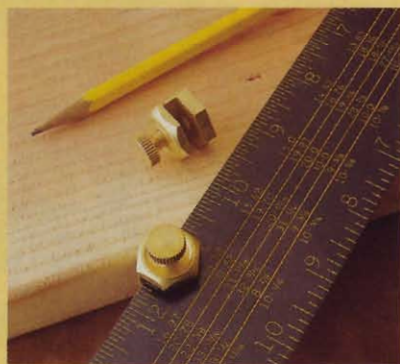

step 2 Starting near one end of the board, use your framing square to mark the rise and run. This will be the top end of your stringer.

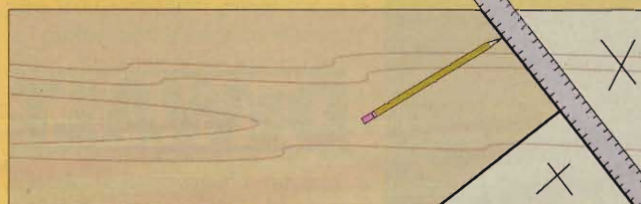

step 3 Use a straightedge to extend the riser line across the board; you'll cut along that line later. Draw Xs to mark the waste areas, shown here in a lighter color.

more common to fit that riser board under the tread, leaving a 1" overhang.

Figure the approximate length of your stringers, as described in the box on page 16, and mark the spot where they will sit on the ground. Install a 4"-thick concrete pad on a 4" gravel base to support the steps.

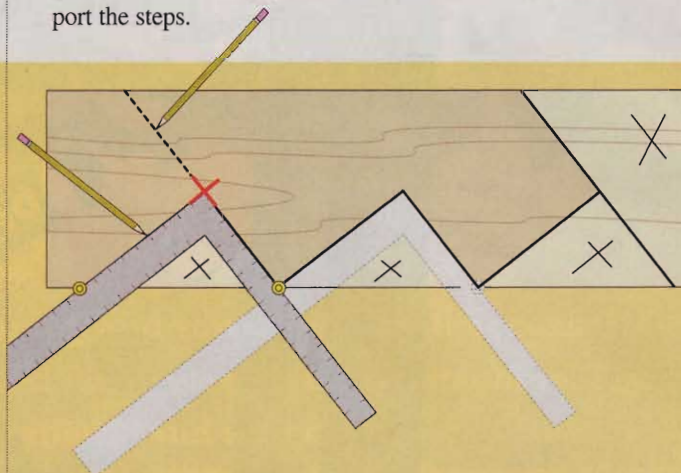

step 4 Draw a second set of rise and run lines, with the rise line intersecting the previous run line at the edge of the board. Draw a third rise line, mark its end point, then extend the line across the board.

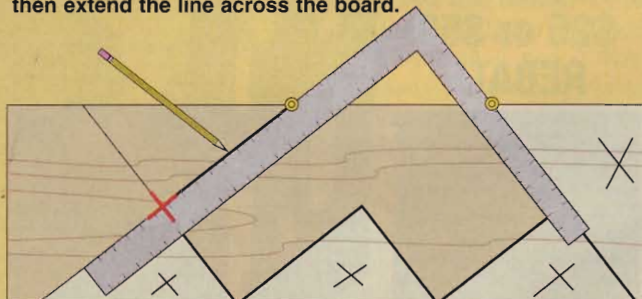

step 5 Move your square to the other side of the board, and draw a line perpendicular to the final rise line, starting from the end point.

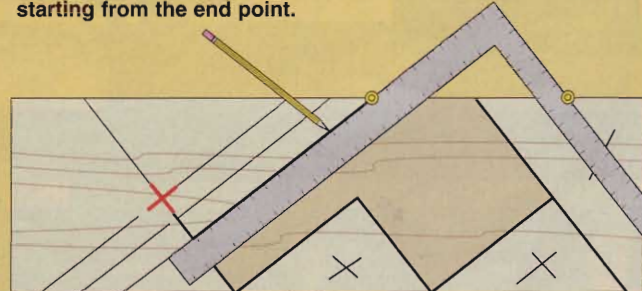

Thickness of bottom plate
Thickness of tread

step 6 Subtract the thickness of the base plate that supports the stringers, and subtract the thickness of the first tread. Then, mark the stringer's bottom end. Write "pattern" on your first stringer, and trace around it to lay out each of your other stringers.

Continued on page 20

Cut and assemble the steps

Follow the techniques outlined *below* to complete the steps. Use stainless-steel screws throughout to avoid rust or corrosion problems. Make your steps at least 3' wide for safety, and use at least three stringers, evenly spaced for full support underfoot. For wider steps, you'll need to use more stringers. Make the spacing 24" or less.



step 7 **CUT THE STRINGER:** Mount a coarse-toothed blade in your circular saw, then cut carefully along your layout lines. Always keep the blade on the waste side of the line. At the inside corners, stop when the leading edge of the saw blade reaches the perpendicular line. Use a handsaw or jigsaw to finish the cuts.



step 8 **ASSEMBLE THE STRUCTURE:** Attach a 2x12 base plate to the bottom ends of the stringers with screws. Then, locate a 2x12 backing plate at the top ends of the stringers, where it serves as the final riser, and attach it with screws. Set the assembly squarely in place atop your concrete pad. Secure the entire unit in place with several 3" deck screws through the backing plate and into the rim joist.

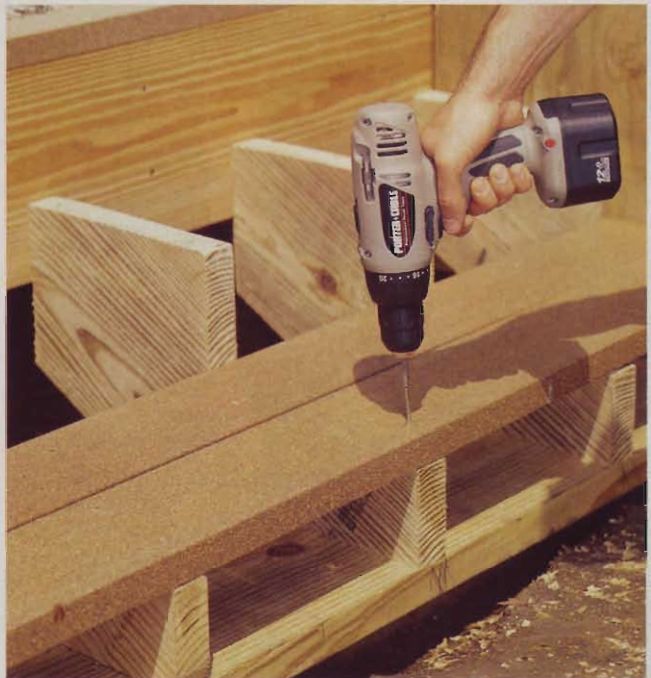

step 9 **INSTALL THE TREADS:** Our steps sit between two planter boxes, so we cut the treads to that length. For open steps, let the treads overhang the stringers by about 1" at each end. We made each tread with two boards of the same composite material that covers the deck. Attach each board with two screws in each stringer.



step 10 **SHIM THE RISERS:** Riser boards create a nicely finished look, and make the steps less likely to cause tripping accidents, too. A single board nearly covered the gap in our steps. We used shims to coax the top edge flush with the next step, then fastened the board in place with a pair of screws into each stringer.

Photographs: Baldwin Photography
Illustrations: Roxanne LeMoine

mark with precision

Top-quality joints depend on layout lines that are accurate, sharp, and easy to follow. Try these tips in your workshop.



Measure by holding your rule on edge, and fit the pencil point into the incised line. This method eliminates the slight inaccuracy that can result from looking across the thickness of a rule lying flat on your workpiece.

Sure, you should measure twice and cut once, but don't ignore the crucial step in between. Mark those measurements precisely in your quest for perfect joints. Here are a few basic tools that will help you do just that, along with some tips about how to use them.

Use a pencil for most marking jobs, but make sure it's an accurate one. Don't settle for a flat carpenter's pencil, or even a standard writing pencil. Their lines get wider and wider as you use them. Get a good mechanical pencil, instead. We chose a model that uses 0.5 mm lead, which produces a narrow, consistent mark.

Marking knives come in handy at times because a sharp knife makes the finest line possible. However, remember that the cut can pose a problem if it's visible in your finished project.

Finally, equip your shop with steel rules and squares that have incised measurement lines. They'll be much more accurate than tools with painted-on lines. Also, the increments on your various marking tools should match one another exactly, so you can switch tools without losing accuracy. Compare them to make sure. 🐿

Photographs: Baldwin Photography



Make your mark with an arrow shape, like the one shown here. When you take the rule away, you'll still know the exact point that matched your measurement. The longer leg denotes the waste side of the cut to be made through this point.



To draw a line after measuring a dimension, hold the pencil point on the tip of the arrow, then slide your square or rule until it contacts the pencil. This method ensures that your line will match the point. Now, pull the pencil along the square.

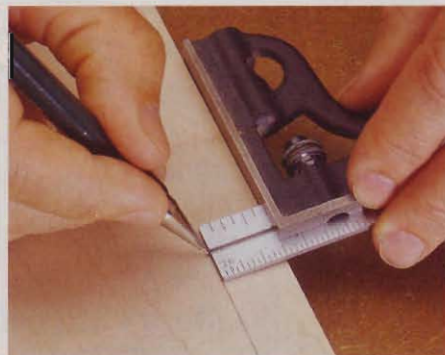

For a line parallel to an edge, place the pencil at the correct spot, then adjust your combination square to match. Put the grooved side up, so the pencil won't slip into the notch. Hold the pencil against the square as you slide it along the edge.

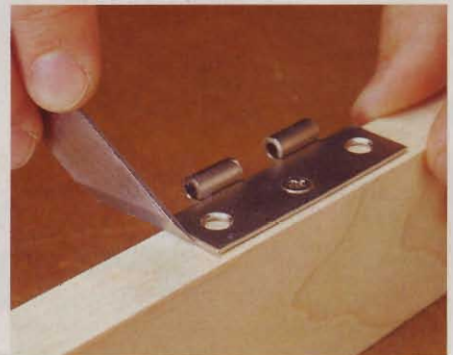

Use a knife that's flat on one side and beveled on the other to define a recessed area, such as a hinge mortise. The line will guide your chisel. This marking knife, item number 127680 in the Woodcraft catalog, costs \$11.99. Call 800/225-1153.

buying glass: a clear view

Size, price, options—
what you need to know to be a smart shopper

When we designed the television stand on *page 46*, we wanted a glass top to complement its clean, crisp lines and to highlight the beautiful maple and mahogany. Once that decision was made, a whole range of issues came into play.

Design with price and availability in mind

In our original plan, we sized the glass to fit the project. But, we were surprised by the almost \$100 price tag from our local supplier for the ½×26×36" top piece that the TV rests on. We also planned to make the stand's adjustable shelf from ½" glass. Though smaller, this piece was almost as expensive. The high price, we learned, was because both pieces had to be custom-cut to size.

We turned to a mail-order glass supplier that offered a ½×24×36" piece of glass at a much lower price: \$66. So we modified the stand for the 2"-narrower piece. The lesson: Just as with hardware, it's critical to determine the glass you'll use *before* finalizing the design or cutting wood.

Norm Levine of Wholesale Glass Brokers (see the Buying Guide *below*) says many local glass suppliers stock relatively small glass sheets. Often, the cut-offs from these sheets are too small to be used as tabletops, so you may end up essentially paying for the waste.

Large glass retailers, such as his, buy very large glass sheets. This results in lower cost, as one sheet can yield many smaller pieces with less waste.

Keep in mind, also, that thicker glass always costs more than thin glass. We could have used ¾" glass and saved about 10% of the cost, but we felt the ½" glass looked better. Glass tabletops are also available in ¼", ¾", and 1" thicknesses. Tell your supplier what weight the glass must hold and the span between supports to determine the proper thickness.

Hold your temper

Glass, of course, can break, and the thought of a television or Grandma's china smashed atop shards of broken glass isn't pleasant. That leads many people to believe they need tempered glass for a tabletop. Tempered glass is four to five times stronger than standard, but more expensive. Standard glass will bear a surprising amount of weight—a ½" piece supported every two feet will bear about 80 pounds per square foot. See *Ask WOOD* in issue #137 for more information. Also, tabletops seldom are subject to heavy impacts, so use standard glass. Save the tempered glass for doors, room dividers, and areas subject to impacts.

Add life to the edge

Glass edges can be finished in a variety of ways. Some of the common profiles are shown *above*. We chose a flat-polished edge for our television stand. This style, or a flat-ground profile (similar but with a frosted appearance), is often the



Flat Polished



Pencil Polished



Ogee



1" Bevel



Chamfer

"standard" profile for a tabletop. Most suppliers can produce the custom edge designs shown, and sometimes more. Expect to pay at least 50% more for a custom edge than the standard-edge cost. Our ½×24×36" piece with a 1" bevel would have been \$118.

Depending on where your tabletop will be located, you may want to consider radiused or cut corners, like those shown *below*. Most suppliers offer this service, with or without a custom edge profile, and can trim the corners anywhere from 1" to 6" for added safety.

If these options aren't enough, round and oval tops are available, too. For a price, you can get glass cut in almost any shape imaginable. ♣

Illustrations:
Tim Cahill

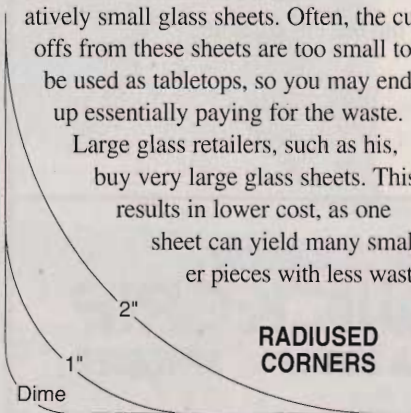

RADIUSED
CORNERS

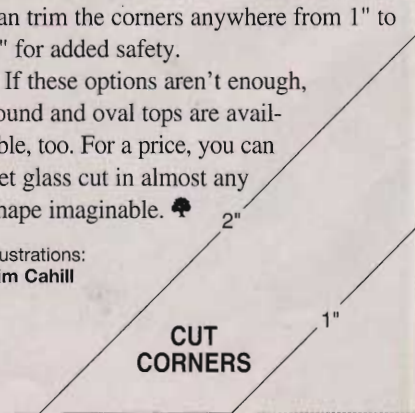

CUT
CORNERS

Buying Guide

For more information on glass tabletops, write Wholesale Glass Brokers, 19785 W Twelve Mile Road, Ste. 357, Southfield, MI 48076, or call 800/288-6854.

How dry should your wood be?

How dry is dry when it comes to woodworking stock? That depends on what you're planning to build, as well as where you'll build it.

Wood freshly cut from a log, called green wood, can contain a lot of water. And the amount often varies between the heartwood and the sapwood. (See the chart on page 28 for the green moisture content of some commonly used woods.) That's because wood is actually a network of close-knit cells—like microscopic open barrels—with spongelike walls. These cells hold and transport the tree's sap, also known as *free water*. Some of the free water also gets absorbed, saturating the cell walls and becoming *bound water*.

Why moisture matters

As wood dries, it first loses the free water to the atmosphere. The bound water, though, takes longer to escape. (Think of a sponge. Wringing it out gets rid of the free water, but the sponge stays damp until all the water escapes from its cell walls.)

Moisture in the air influences how quickly and completely wood dries. The lower the relative humidity, the more water the wood loses and the drier it gets. Wood never dries out completely, but eventually reaches an equilibrium point based on the humidity of the air around it. Given the average relative humidity of the United States, air-dried wood can reach a minimum moisture content of only about 12–15 percent. That's good enough for boards utilized in building construction and outdoor projects.

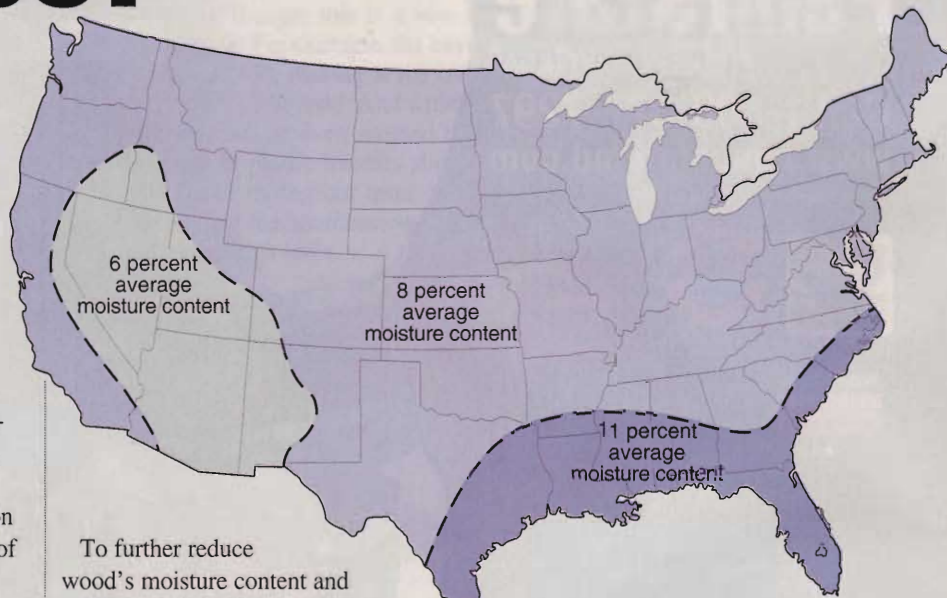

To further reduce wood's moisture content and make it fit for indoor use, say for furniture, manufacturers dry it in an oven-like facility called a kiln. The dry heat slowly brings the wood's moisture content down to anywhere from 6 to 9 percent (typical for hardwoods only). Those percentages are more in line with the relative humidity found in modern heated and dehumidified buildings.

Where you live makes a difference

According to data compiled by the U.S. Forest Products Laboratory (FPL) in Madison, Wisconsin, the recommended moisture content for wood destined for interior use varies across the nation, as shown in the map above. For maximum stability, the moisture content of such wood should vary only about 1 percent from those limits. Wood that's too dry may expand and make drawers hard to open, or even push assemblies apart. Wood that's too moist, a much more common problem,

The advisable moisture content of wood used for interior projects varies due to changes in relative humidity. Let wood acclimate to its surroundings before cutting or assembly.

may shrink and check, split, warp, or cause joints to fail as it dries.

Commercial processors delivering wood to the furniture and flooring

Continued on page 28

A hand is shown holding a black pin-style moisture meter against a piece of reddish-brown wood. The meter has two metal pins inserted into the wood. The device has a digital display and several buttons.

Pin-style moisture meters measure electrical conductivity between two metal sensors pressed into the wood, then convert this data to create a percentage readout.

industry generally dry wood to a moisture content slightly lower than it will finally encounter. This practice assumes that the wood will take on some moisture during further processing and construction stages.

For projects that last, care for your wood

If you're suspicious of the moisture content of the wood you are buying, ask the supplier to check it for you. It might pay for you to buy a moisture meter (from \$70 to \$150), especially if you buy air-dried or rough-milled stock. With a meter, you can check wood's moisture content before you buy, and then track it at home.

Most moisture meters work by passing a small electrical current between sensor pins inserted about 1/4" into the wood. More moisture transfers more current, resulting in a higher percentage reading. For the most accurate reading, check several locations along the board's edge or

face, or cut a few inches from one end and check the end grain. Ask first; suppliers may frown on poking holes in their stock. Pinless meters are also available.

Always let your wood acclimate to the relative humidity where it will be used, remembering that dry wood will pick up moisture from the atmosphere. If it's for your home, sticker the wood (stack it with wood spacers) for a week or more in an area with the same relative humidity before machining it. (Check a piece of furniture in your home and compare it to your stock for a benchmark.) You also can store stock standing straight up, but never put dry stock directly on a concrete floor.

Don't think that wood movement stops once boards are machined and assembled

into a project. As relative humidity changes, wood still absorbs and sheds moisture. The best way to minimize this is to seal all surfaces of the completed project, not just the exterior or exposed parts, with a few coats of finish. 🌿

Written by **Peter J. Stephano**
 Illustration information provided by the U.S. Forest Products Laboratory
 Photograph: **Baldwin Photography**

Average green moisture content (%) of some common woods		
hardwood species	heartwood	sapwood
Ash, white	96	113*
Hickory	70	52
Maple, sugar	65	72
Oak, red	80	69
Walnut, black	90	73
softwood species	heartwood	sapwood
Cedar, red	58	240*
Fir, Douglas	37	115*
Redwood	86	210*

* Because moisture content is defined as the weight of the water expressed as a percentage of the wood's dry weight, not the total green weight, it often exceeds 100 percent.

Talented Creator. Skilled Hobbyist.

BUSINESS OWNER.

You're already two. With Guardsman FurniturePro®, you can become all three!

Guardsman FurniturePro is a network of franchises specializing in furniture-related services. Guardsman FurniturePro has available territories throughout North America.

- Restaurants and Hotels
- Professional office buildings
- Moving and storage companies

TRAINING AND SUPPORT PROGRAMS:

- Comprehensive initial training
- Ongoing regional workshops
- Web-based support programs
- 24-hour technical assistance
- Access to fellow FurniturePro franchisees

GUARDSMAN FURNITUREPRO CUSTOMERS:

- Homeowners
- Furniture retailers

NOT TO MENTION:

- Protected territories
- Affiliation with the most established and respected name and presence in the marketplace
- The support of a \$2.2 billion company, and the largest manufacturer of furniture finishes in the world.
- Affordable franchise entry fees, as low as \$9,500
- Home based with low overhead!



For Franchise Information Call
 800.496.6377
www.guardsmanfurniturepro.com.

GUARDSMAN FurniturePro
The most trusted name in furniture repair.

Profit Centers



Furniture Repair - gouges, scratches, burns, water marks, dents and more



Leather Cleaning and Repair - stain removal, recoloring, and more



Upholstery Services - spot cleaning, panel replacement, seat re-upholstering



Cabinet Refurbishing - cleaning, degreasing, repairing and polishing



Refinishing - complete stripping and refinishing using an eco-friendly, water-based system

ask wood

Answers to your questions from letters, e-mails, and WOOD ONLINE®

Cut no tree before its time

Q About 20 walnut trees will be taken out for a highway project in our area, the largest being about 12" in diameter. Are these trees too young to salvage for lumber?

—Steve DiServio, via WOOD ONLINE

A You might get a few boards out of them, Steve, but they're a long way from their prime as lumber sources. According to Joey Gallion, a forest products specialist with the Indiana Department of Natural Resources, a 12"-diameter walnut tree will contain a high proportion of light-colored sapwood, and the heartwood will have a large number of knots. "Hardwood trees have a lot of limbs in the beginning, then as those limbs get shaded out and die, knots remain," Joey says. "As the tree grows bigger, you get good-quality wood

Small walnut trees produce boards like this one. Instead of clear, dark heartwood, you get knots and white sapwood.

Heartwood
Sapwood

forming over the knots. Generally, a sawmill doesn't saw boards out of the middle of a big tree because the knots start to show up."

Dan Johnson, with the U.S. Forest Service in Indiana, says federal hardwood grading categories don't go below an 11" diameter. He says the best time to harvest most hardwood trees—including walnut, oak, hickory, and cherry—is when they measure 24" to 28" in diameter at breast height. Growth slows after that.

—WOOD® magazine

Removing a chuck takes more than luck

Q Now I know what the "immovable object" really is—it's the chuck on my drill press. I tried to remove it so I could install a mortising accessory, and had no luck whatsoever. What's the secret?

—Dave Goodman, Carmichael, Calif.

A Amazing how tight a Morse-taper connection can be, isn't it, Dave? Here's the right way to remove the typical drill-press chuck. Lower the quill, exposing the slot in its side. Inside the slot, you'll see daylight through a gap. You should have received a tapered piece of steel with your drill press, a tool that we've seen referred to as a wedge or drift key. If you don't have that tool—it's the kind of item that tends to disappear over the years—ask your dealer to get a replacement from the manufacturer. Or, go to a machine shop and have one made. Make sure the



It doesn't take much force to drive the chuck out of your drill press with a wedge and a hammer.

machinist includes a hole at the wide end, then run a string or plastic tie through that hole, and hang the tool somewhere out of the way on your drill press.

Raise the table until it almost touches the chuck, or have someone hold the chuck. Insert the narrow end of the tool into the gap, and tap the wide end with a hammer, as shown in the photo above. That should force the chuck to drop out.

To reinstall the chuck, slide it firmly back into the quill, place a board on the table, and raise the table until the board contacts the chuck. Open the belt housing on top of the drill press, place a block of hardwood on the exposed end of the spindle, and tap it with a hammer to set the chuck's Morse taper in place.

—WOOD magazine

What's the key to staining end grain?

Q I am building an Arts and Crafts mirror frame out of quartersawn white oak. I plan to use a Watco dark walnut finish. How do I prepare the end grain? My experience with other woods is that the end grain tends to soak up lots of stain and get much darker than the face grain.

—Kevin Herber, Austin, Texas

Continued on page 34

Let's Clear the Air...

JDS AIR-TECH 2000™

Model 750, Still the Best!

- Variable Speed Control for unlimited air flow settings
- Highest Maximum air flow in its class - 1,050 CFM
- Convenient On/Off pull chain
- Ultra Quiet
- 1/4 H.P. Motor for heavy duty performance
- Antimicrobial 1 Micron Internal bag filter
- UL Listed
- Lifetime Warranty

The National Institute for Occupational Safety and Health (NIOSH) recommends limiting wood dust exposures. The JDS Air-Tech 2000 will dramatically improve the quality of the air you breathe. Our new model 750 variable speed allows you to dial in your desired air flow, from a whisper quiet 200 cfm to an ultra performance 750 cfm. This will clean the air in a 30'x30'x8' shop every ten minutes. For larger areas our models 8-12, 10-16 and 2400 are available. The JDS systems will remove 99% of particles as small as five microns and 80% of particles as small as one micron. For the removal of odors, fumes and smoke, our optional charcoal filter is available. To place an order or for the dealer nearest you call us toll-free.

\$259.00

Model 750

Another quality product from

1-800-382-2637

Manufactured in the U.S.A.

www.thejdscompany.com

JDS
COMPANY

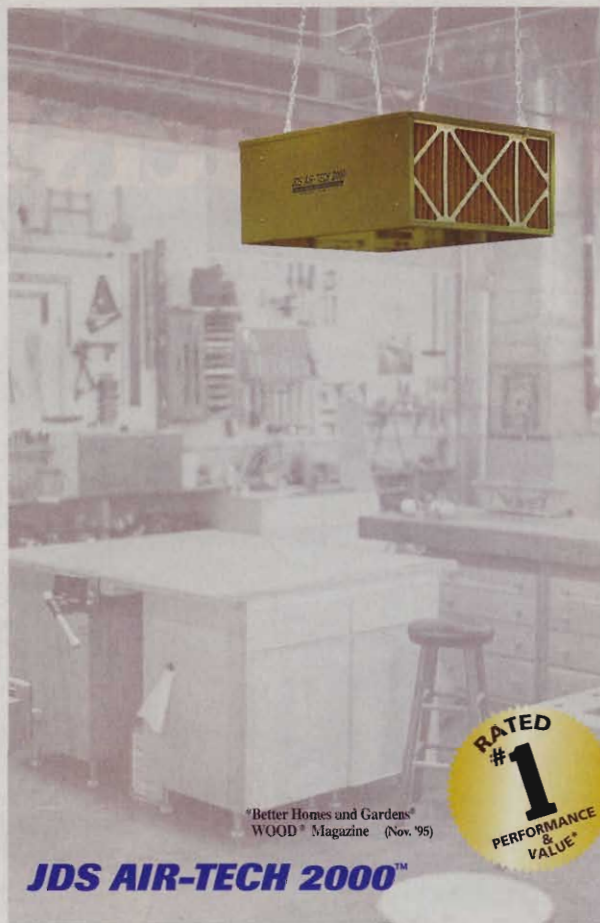

*Better Homes and Gardens
WOOD Magazine (Nov. '95)

JDS AIR-TECH 2000™



ask wood

A I apply a one-pound cut of shellac on the end grain. Another good way is to use white glue mixed with water and apply it on the end grain.

—Michael De Bonis, Yardley, Pa.

A Take a piece of scrap and sand the end grain with sandpaper a couple of grades finer than the sandpaper you used on the face grain. Test stain it to see how well it matches with the face.

—Jim Green, Placentia, Calif.

To burnish or not to burnish ...

Q Some woodturners talk about using a handful of shavings to burnish their work on the lathe. I've just finished a spalted-maple bowl, and I'm wondering, what are the pros and cons of that technique?

—Ron, via WOOD ONLINE®



Use sandpaper on your turnings, rather than burnishing with shavings. Hold the paper like this, to keep your fingers safe in case the paper catches on the wood.

A We've heard that too, Ron, but it's an old-time method that's been made obsolete by today's materials. Professional woodturner Alan Lacer says, "Turners used to do that to give the wood some luster, but that was before we had 320-grit sandpaper." Out of curiosity, Alan experimented with a couple of samples, one pine and one hard maple. On each piece, he rubbed shav-

ings on one portion and used 320 paper on the rest. "The results with sandpaper were far superior to the shavings," Alan reports. He found that the shavings cut little grooves in the pine. They didn't groove the maple as noticeably, but they didn't do much to improve it, either.

If you really want to burnish a turning, you could use a round bar of steel. However, Alan points out that any bur-

nished look disappears the moment you apply a liquid finish. "And if you burnish it really hard, some stains won't 'take' very well," he says. Our advice: Forget the burnishing, and just concentrate on doing a thorough job of sanding.

—WOOD® magazine

Didn't like the dent, really hates the spot

Q While building a table of hard maple, I accidentally dented the top. I ironed out the dent with a warm iron and damp cloth, sanded through all the grits again to 220, and saw no evidence of scorching. But when I applied a colonial maple stain, a black spot appeared where the dent had been. I've tried sanding and bleaching, but can't get the spot out. What caused this, and is there anything else I can do to fix it?

—Ed Cloonan, Cincinnati

A Sounds like you took all the right steps, Ed, but the resulting defect is not uncommon. Finishing expert Bob Flexner says that steaming out a dent "stretches" the wood fibers and makes that spot softer than the surrounding wood. When you apply stain, sometimes the repaired area soaks up more colorant and becomes darker. It's impossible to predict, however, so all you can do is sand thoroughly after fixing the dent,



You can steam out small dents in wood with an ordinary household iron, but staining might leave a dark spot.

then go ahead with staining—if you're set on using a stain. (Skipping the stain and going directly to a clear topcoat of varnish or lacquer would eliminate the risk of a dark spot.)

When such a spot appears, it's difficult to eliminate. You would have to sand the entire surface below the extent of the damage, or hide it with fairly sophisticated touch-up techniques. The good news, according to Bob, is that the spot will appear to be a natural characteristic of the

wood after you apply a smooth, consistent film finish to the table.

—WOOD magazine

Got a question?

If you're looking for an answer to a woodworking question, write to Ask Wood, 1716 Locust St., GA 310, Des Moines, IA 50309-3023 or send us an e-mail at askwood@ndp.com. For immediate feedback from your fellow woodworkers, post your question on one of our discussion groups at www.woodonline.com.

Inkra
MITER1000



- ◆ 41 Indexed Angle Stops over ± 90° range
- ◆ 18" Inkra Track Fence with Slide Stop
- ◆ Steel GlideLOCK™ Miter Bar with 6 Width Adjustment Points

SALE
\$89



Inkra
MITER3000



- ◆ 364 Indexed Angle Stops over ± 90° range
- ◆ 27" Miter Fence + Dual-Flip Stop
- ◆ Steel GlideLOCK™ Miter Bar with 8 Width Adjustment Points

SALE
\$219



Inkra
MITER5000



- ◆ 364 Indexed Angle Stops over ± 90°
- ◆ 36-64" Miter Fence + Dual-Flip Stop
- ◆ Steel GlideLOCK™ Miter Bar with 10 Width Adjustment Points
- ◆ Integral Hold-down Clamping System
- ◆ Renewable Zero Clearance Right Panel

SALE
\$299



Produce perfect gap-free hairline glue joints on the mitered corners of any multi-sided object on your first try without trial-and-error setups.

Woodpeckers Inc.
The Inkra Tool Source
www.woodpeck.com

All models include: Adjustable GlideLOCK Miter Bar, Inkra Specified Fence with Stop Positioner, and FREE Video Brochure. 1-800-752-0725

shop tips

Helping you work faster, smarter, and safer

top shop tip

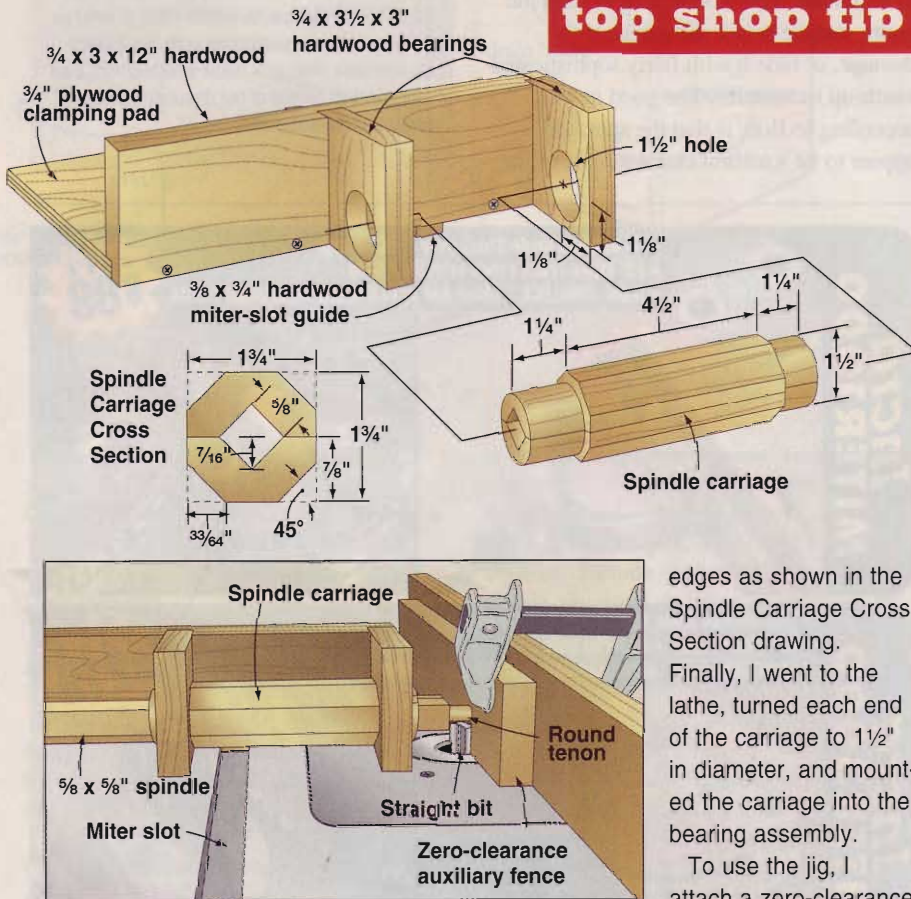

Solved: Square peg in round hole

While building an Arts and Crafts-style bed recently, I didn't exactly relish the thought of chiseling the 54 round spindle holes into square mortises. Yet the rails were too wide to fit into my benchtop mortiser. So, I made the router-table jig, shown *above*, to cut round tenons on the square rails.

The heart of the jig is the spindle carriage, which I made by first cutting a right-angled V-groove in a 14½"-long piece of 7/8" hardwood. After crosscutting the grooved piece into two 7" lengths, I glued them together and beveled the

edges as shown in the Spindle Carriage Cross Section drawing. Finally, I went to the lathe, turned each end of the carriage to 1½" in diameter, and mounted the carriage into the bearing assembly.

To use the jig, I attach a zero-clearance auxiliary fence to my router-table fence, and set a straight bit to cut the length and diameter of the tenon. Next, I position the jig in my router table's miter slot so that the spindle carriage is centered on the router bit, and clamp it to the tabletop. Then, I fire up my router, insert a scrap of spindle stock into the carriage, and gently plunge it into the spinning bit until the stock touches the auxiliary fence. One complete clockwise rotation of the carriage rounds off the spindle.

Finally, I test-fit the round tenon in a rail hole, and adjust the bit height, if necessary, to fine-tune the fit. Once satisfied, I switch to the actual spindles and start cranking out round tenons.

—Tom Freyer, Phoenix

our winner



They say the longer a couple stays together, the more they become like each other, and that seems to be true in the case of Tom Freyer and his wife of 45 years, Samantha. Our Top Shop Tip winner loves steam engines, and Samantha enjoys the old machinery, too.

You'll often find husband and wife, side by side, working with wood as well. "Sometimes, she does my finishing," Tom says, "and when I built new cabinets for our kitchen, Samantha punched the brass inserts for the upper cabinet doors." Tom seems to have been a pretty good catch himself, judging from his Top Shop Tip, at *left*.



For sending this issue's Top Shop Tip, Tom Freyer receives a Tool Dock TD300CH Router Station from Waterloo Industries. Terrific tip, Tom!

You can win a free tool, too!

Tell us how you've solved a workshop puzzler, and we'll send you \$75 if we print your solution. And, if your tip is chosen as the Top Shop Tip of the issue, you'll also win a tool prize worth at least \$250.

Send your best tips, along with photos or illustrations and your daytime telephone number, to: **Shop Tips, WOOD® Magazine, 1716 Locust St., GA-310, Des Moines, IA 50309-3023.** Or post your suggestions on our Top Shop Tip discussion group at www.woodonline.com.

Because we try to publish only original tips, please send your tips only to *WOOD* magazine. Sorry, but we can't return your materials.

Good to the finish

Here's an age-old problem: applying finish to all sides of a project in one session. My solution: the portable finishing rack, shown *below*. Building the rack is pretty straightforward—just make sure you align the holes in the top and bottom

pieces of perforated hardboard. Insert the sharpened dowels where they best support your project. If you break or dull the fine points, you can touch them up again with a quick trip to the pencil sharpener.

—David Luttrell, Xenia, Ohio, via WOOD ONLINE®

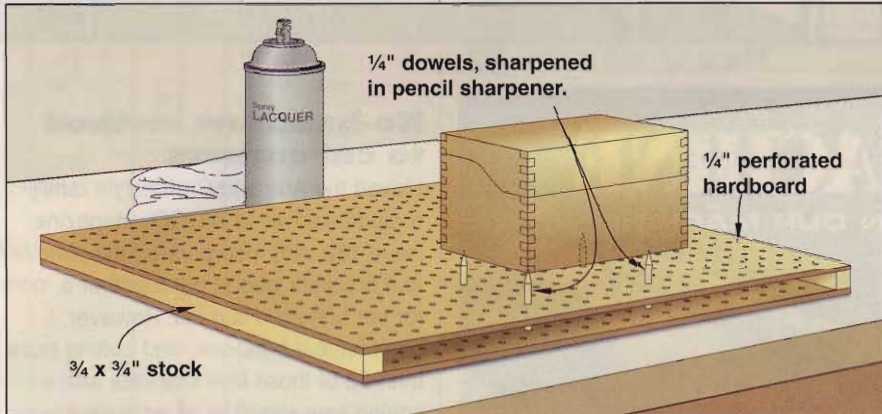

An "attractive" idea for dust hoods

I recently outfitted my shop with a dust-collection system, including a lathe dust hood (Woodcraft, 800/225-1153, part no. 141207). Instead of permanently mounting the hood to the lathe bed, I attached a round magnet that I found in

the tool section of my local home center for less than \$5. The surprisingly strong magnet holds fast to the cast-iron lathe bed, yet I can reposition the dust hood instantly anywhere along the bed.

—Bob Goulding, Wright City, Mo.

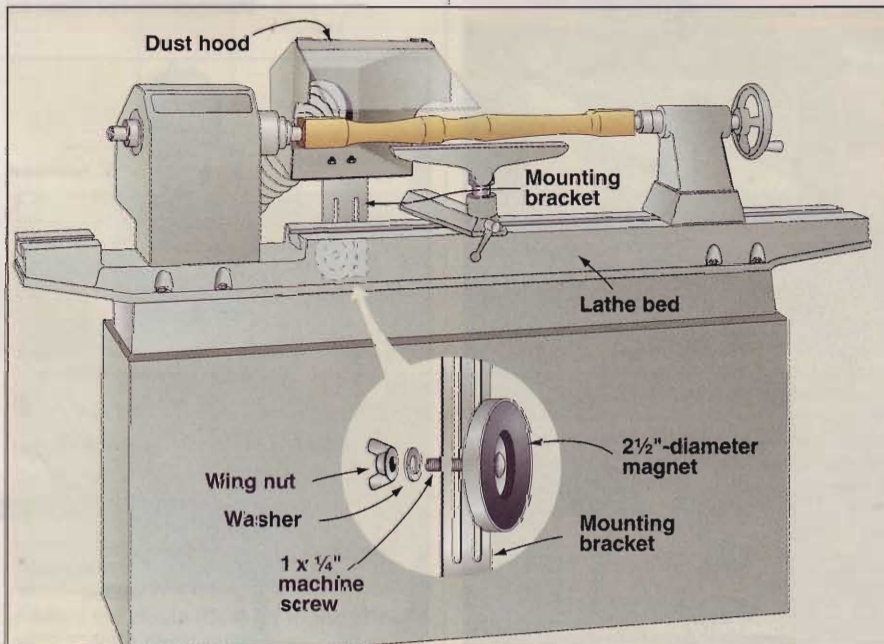

Continued on page 38



THE BEST PLACE TO BUY PORTER-CABLE TOOLS ONLINE

#743-K
Blade on Left



#347K
Blade on Right

www.amazon.com/portercable

Call for your FREE Tool Crib catalog
1-800-635-5140

TOOLS & HARDWARE
amazon.com

shop tips

Need a temporary table? Pipe up!

I have a small shop, so benchtop space is always an issue, especially when it comes time to finish my projects. To gain the extra real estate, I make a temporary table out of a piece of plywood and four 3' pipe clamps. When assembled, as shown at right, it's at a perfect working height, and when disassembled, it only takes up as much space as the plywood.

—Darin Wallace, via WOOD ONLINE®

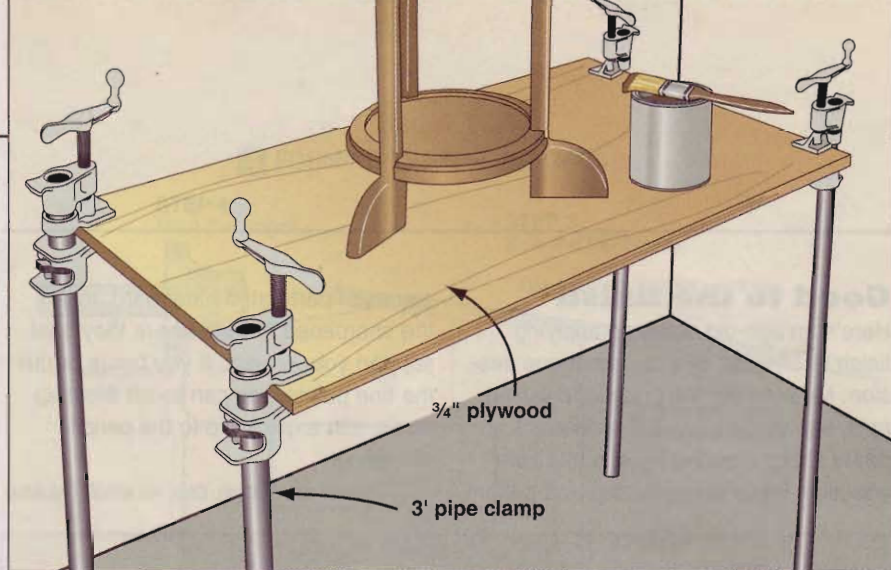

DREAM MACHINE

PUT YOUR ROUTER IN OUR MACHINE

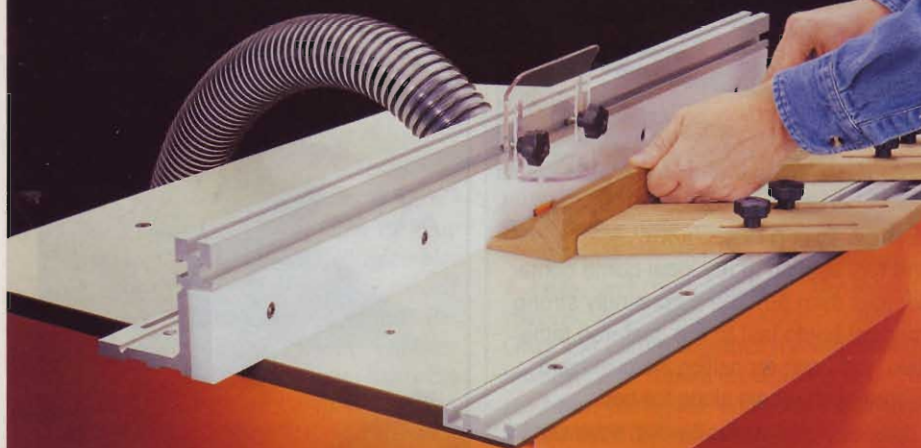

Check out our demo at www.woodshopdemos.com

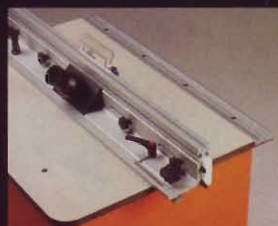

CMT INDUSTRIO™
PIVOTING FENCE



CMT INDUSTRIO™
ROUTING SYSTEM



REPLACEABLE ZERO
CLEARANCE INSERTS

Imagine the ultimate routing system for all your woodworking pleasures. Picture a spacious table top made of solid phenolic that will never warp and will provide you with many years of reliable service. Add on a heavy-duty anodized aluminum fence that pivots in both directions and makes set-ups fast and easy. Yes, and a split sub-fence with zero clearance inserts made of slick UHMW that your prized wood glides across almost effortlessly.

Imagine your shop with CMT's New Industrio™ Routing System designed by Marc Sommerfeld. This system will make all your routing dreams real!

MADE IN ITALY

Router, feather boards, dust hose and denim shirt not included.

CMT
the only ORANGE one™

CMT USA, Inc. • 307-F Pomona Drive • Greensboro, NC 27407 • 888-268-2487

Check out our NEW website at www.cmtusa.com

No-bandsaw method to cut corners

I loved the Arts and Crafts-style family-room makeover in WOOD® magazine issue 132, and incorporated the plate rail and brackets when I put together a room for our first child last fall. However, I don't have a bandsaw, and cutting more than 30 of those little brackets with a coping saw wasn't at all appealing.

Instead, I turned to my drill press and a 5" holesaw, as shown below. After removing the half-moon-shaped waste piece, I cut the bracket blank where shown and netted two brackets. This technique sure made the job go quickly, and I was surprised at how little sanding I had to do on the curves.

—Matthew White, Fort Wayne, Ind.

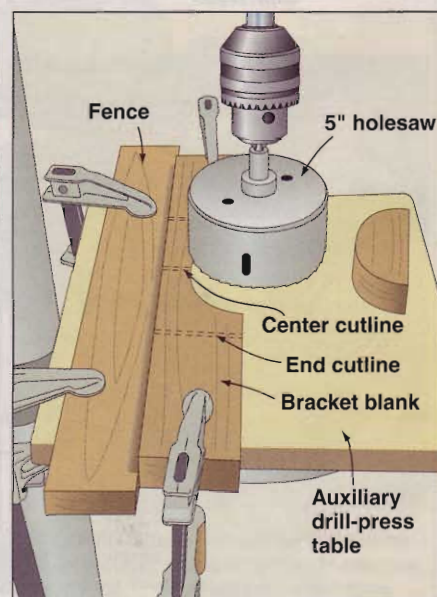

Zero-clearance extension makes a mini-mill

While building a scale model recently, I needed to rip some $\frac{1}{2}$ " stock to $\frac{1}{8}$ " wide to make miniature lumber. Ripping pieces that small against my tablesaw fence was just begging for big trouble, so I made a zero-clearance fence extension from a piece of $\frac{1}{8}$ x 6 x 24" hardboard and an equal length of $\frac{3}{4}$ " stock, as shown below.

After installing an 80-tooth crosscut blade in my tablesaw, I lowered the blade below the tabletop. Next, I clamped the zero-clearance fence extension to my tablesaw's fence, set the fence so that the hardboard hung over the blade by about $\frac{1}{2}$ ", then cranked the spinning blade up through the hard-

board. (Press the hardboard down to the tabletop with a piece of scrap wood during this operation, keeping well clear of the emerging blade.)

To rip my $\frac{1}{2}$ x $\frac{1}{8}$ " strips, I start with a $\frac{3}{4}$ "-thick blank. Using a straight bit in my router table, I create a $\frac{1}{4}$ " rabbet $\frac{3}{4}$ " deep in the edge of the blank. Taking the blank back to the tablesaw, I place the rabbet face down and against the edge of the hardboard, which guides the blank through the cut. With a little trial and error, I can adjust the router bit's cutting depth to where the rabbet leaves me with a precise $\frac{1}{8}$ "-thickness. After each rip, I re-route the rabbet for the next rip. Once set up, I never have to readjust the bit's cutting depth.

—Dan Myers, Kelso, Wash.

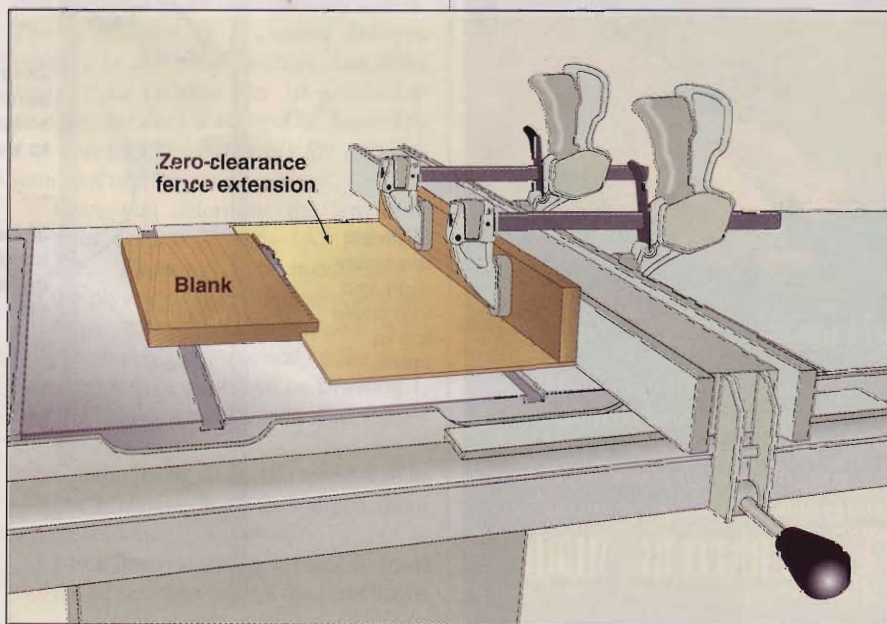
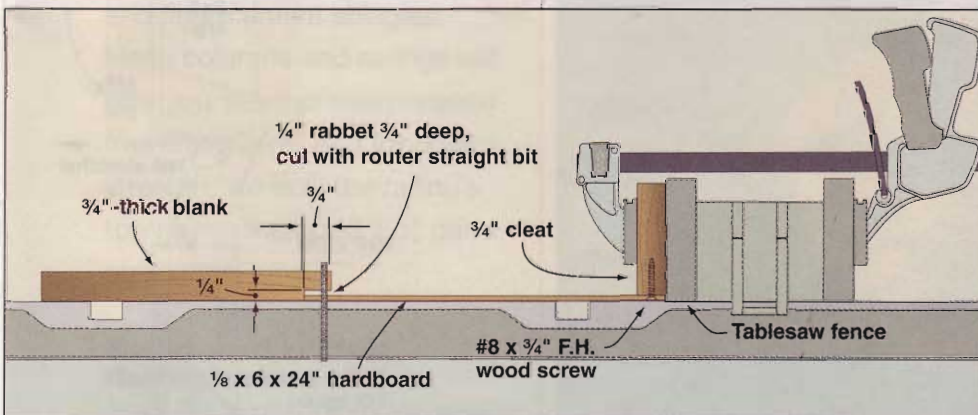

Continued on page 40

The Toughest Glue On Planet Earth

You're beyond simple yellow glues and you don't want a different bottle of glue for every project. You want Gorilla Glue®. Bonds wood, stone, metal, ceramic, plastics and more. Incredibly strong and 100% waterproof.

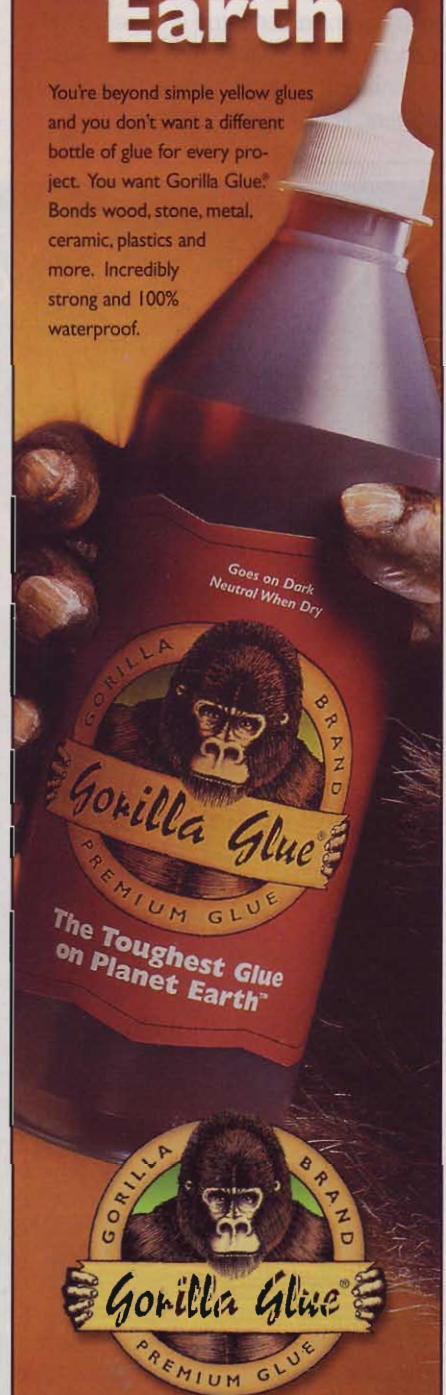

for retailers near you:

www.gorillaglu.com

1-800-966-3458

Stow the bench, and save the storage

I read with interest your Fold-Down Workbench project in *WOOD* magazine issue 139. When I designed a similar bench 24 years ago, I made it so I could keep frequently used items, such as glue bottles and fasteners, at the ready, even with the main benchtop dropped. That bench, made mostly of 2x4 stock with a laminated 1½"-thick plywood top, shown at right, is still in use today.

The 6"-wide permanent portion of the benchtop is bolted to my garage wall. I used butt hinges to make the leg set swing out of the way to stow the bench. Using my left hand to lift the front edge of the benchtop slightly, I grab the front apron with my right hand and swing the leg set flat against the wall, then lower the top.

—Jack Turnage, Shawnee, Kan.

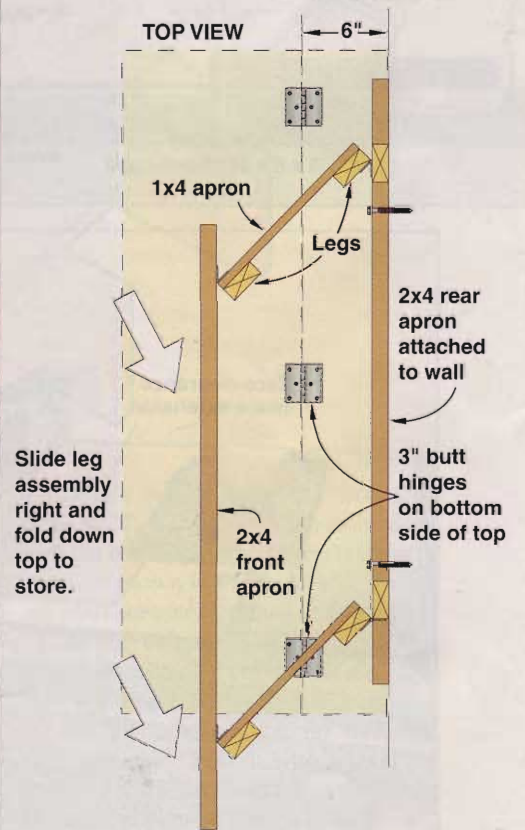
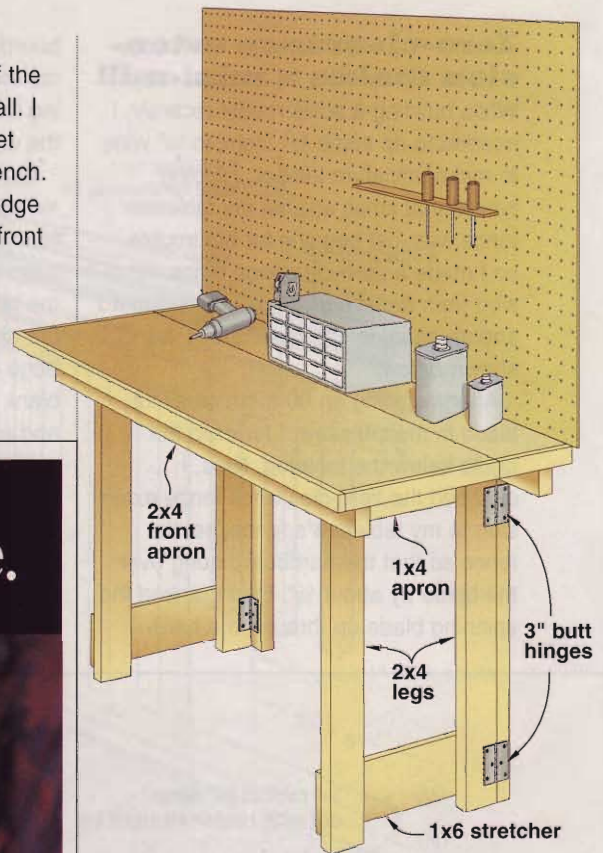

Refinish Your Future.

Own your own business.

Let your passion for furniture lead you into a new business with a Furniture Medic franchise. We're a complete on-site repair and restoration-refinishing business servicing homes and companies as well as handling moving and insurance claims. We offer extensive training and support with a low initial investment and manageable overhead. Financing is available to qualified candidates and franchises are offered nationwide. Call today to brush up on the details.

FURNITURE MEDIC
"the prescription for damaged furniture"

www.furnituremedicfranchise.com **1-800-RUN YOURS**

Stretch 18×18" of space into 4×6" of storage

Here's a way to squeeze a lot of storage into a small amount of floor space: a rotating tool kiosk. Start by ripping the perforated hardboard to width, joining the three pieces with plastic cable ties, as shown *below*, then cutting and fitting the triangular plywood top and bottom. Don't attach the ends to the sides just yet, though.

Drill a 1" hole in the center of each triangle, and attach a 3" lazy-Susan bearing (part no. 28951, Rockler Hardware, 800/279-4441) to the bottom. Now, center a 15/16" hole 1/2" deep in the plywood floor anchor. Position the bottom's 1" hole over the anchor's hole, and attach the other side of the lazy-Susan bearing

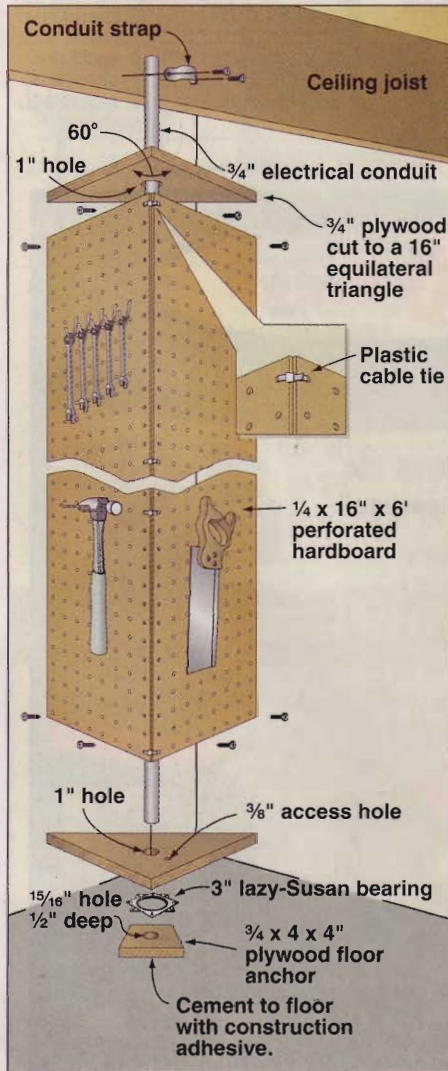

to the floor anchor. (You'll need to drill an access hole in the bottom to drive the screws into the floor anchor.)

Using construction adhesive, cement the floor anchor to the floor at least 18" from the wall, and let cure. Attach the top and bottom triangles inside the perforated-hardboard sides with screws, run a length of 3/4" conduit through the holes, then slip the conduit into the anchor hole as you stand up the kiosk. When the conduit is plumb, secure it to

a ceiling joist with a conduit strap. Finally, hang storage hooks in the peg holes, and your tools on the hooks.

—Louis Grivetti, Latonia, Ky.

shop TIP

You'll find more great Shop Tips throughout every issue of *WOOD*® magazine. Look for boxes like this one nestled among the project and technique articles.



ET100™
Nail Master™

- Ergonomic Design
- Durable
- Powerful

10 Amps

Removable
Non-Marring
Bumper

Heavy Duty Electric Brad Nail Gun



Shoots 3
Different
Length Brads

5/8"
(15mm)

3/4" (20mm)

1" (25mm)



ARROW
Wherever fine tools are sold.

Arrow Fastener Co., Inc., 271 Mayhill Street, Saddle Brook, New Jersey 07663
Canada: Jardel Distributors, Inc., 6505 Metropolitan Blvd. East, Montreal, Quebec H1P 1X9
United Kingdom: Arrow Fastener (U.K.) Ltd., 14 Barclay Road, Croydon, Surrey CRO 1JN
www.arrowfastener.com

©2000 ARROW FASTENER COMPANY, INC.

Rev.700

5 Great Reasons to Visit WOOD ONLINE!

1. 20 active woodworking discussion groups
2. Free seminars
3. Free home page software
4. WOOD® magazine searchable index
5. Shop tip of the day

Kudos for free classifieds

We recently received this e-mail from a WOOD ONLINE user:

I just wanted to pass along my thanks. I placed an ad in the WOOD ONLINE classified ad section to sell my old air compressor and sold it today. Not only that, I had the opportunity to meet a really nice woodworker and show off my shop to him. He was happy to get the compressor to take to job sites with him and I was happy that I do not have two air compressors taking up the space in my tiny shop that can barely accommodate one compressor. I promptly deleted my ad so that no one else will contact me about it.

Bill Boehme, Arlington, Texas

Improve your workshop today!

Time to revitalize your shop? Seldom a day goes by when we don't get a letter or e-mail from someone looking to upgrade or redo their workshop. If this describes you, help is only a click away. Just visit *WOOD* magazine's five Idea Shops®, complete with floor plans, shop projects, and hundreds of great ideas you can put to use. Best of all, we've built each shop to verify the results. 🌲

Get **FREE** tools, downloadable plans, gift registry & newsletter
Become a Member of **WOOD ONLINE!**

SHOPPING

WOOD MAGAZINE

- ▶ [WOOD Mag. Home](#)
- ▶ [Editor's Welcome](#)
- ▶ [Editorial Extras](#)
- ▶ [Handcrafted Home](#)
- ▶ [Shop Tours](#)
- ▶ [Shop Tip of the Day](#)
- ▶ [WOOD Index](#)
- ▶ [Wood Profiles](#)
- ▶ [Hall of Fame](#)
- ▶ [Back Issues](#)
- ▶ [FREE Charts](#)
- ▶ [Woodworking Basics](#)

SUBSCRIPTIONS

WOOD TALK

COMMUNITY

SOFTWARE

Search on [Welcome](#)

CLICK HERE

New at WOOD

Garden W Plan
Liven up your summer v pair. The 39" tall, us body patte fours, ma and quick change, s pulling ap

Rockler.com
WOODWORKING SUPERSTORE

JET

Win a Saw!

3 HP XACTA Saw™ with 50" Fence



Register to win at www.rockler.com/jet and receive Rockler's email newsletter for free!

No purchase necessary. See official rules at www.rockler.com/jet for details. Enter online at www.rockler.com/jet or send your name, address, phone and e-mail address on a postcard to: Rockler/ JET XACTA Saw Drawing, 4365 Willow Drive Medina, MN 55340. One entry per household. Void where prohibited by law. Entries must be received by April 30, 2002.

Kreg™



POCKET HOLE SYSTEMS

Have you discovered the Pocket Hole Advantage?

Experience the joinery technique everyone's talking about...

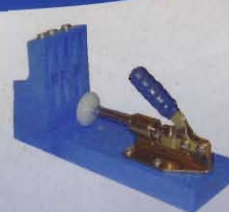
Kreg offers solutions to all of your joinery needs with Pocket Hole Systems from \$20 to \$3,000, including our most popular tool the **Kreg Jig® ProPack**.

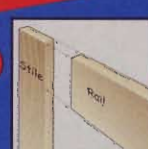

- 1  Cut wood square.
- 2  Drill pocket holes.
- 3  Clamp and drive self-tapping screws.

Visit our website to learn more. www.kregtool.com

wood
close-up

baldcypress

The buttressed
belle of the bayou

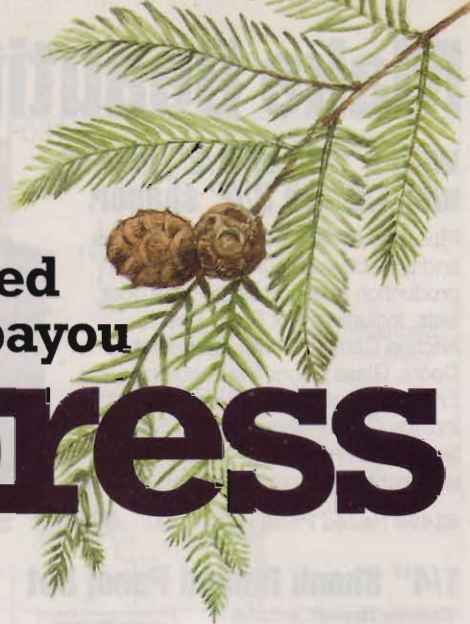

Growth range

The last remaining species of an ancient tree family that once ranged over North America and northern Europe, the baldcypress (*Taxodium distichum*) is truly unique. This tree is classified as a conifer and a softwood because it has needles rather than leaves. But, baldcypress isn't an evergreen like other conifers. It sheds its foliage as do deciduous (hardwood) trees, a trait shared only by the larch. And, baldcypress feels equally at home growing in water or on dry land.

In its Southern range, baldcypress once grew to immense sizes. Trees 150' tall with 12' diameters weren't uncommon. In the Louisiana swamps and other places where it grows in stands, an acre of old-growth baldcypress trees could yield 100,000 board feet of lumber. By the 1930s, trees of those grand proportions had all fallen to the saw, furnishing decay-resistant boards and timbers for countless docks, warehouses, and other structures.

From Florida to eastern Texas there's now an abundant supply of second-growth baldcypress. Although it isn't as resistant to decay as the old-growth wood, it's still an excellent choice for outdoor projects. Salvage operations also contribute to the supply. They provide "sinker cypress" old-growth logs dredged from lakes, rivers, and swamps. Too, as decrepit factories and warehouses are replaced, structural timbers of old-growth wood return to the saw.

Finding the tree afield

Swampy areas in the baldcypress' range provide the best environment for the

sapwood

heartwood

largest trees. There, they'll grow in stands, their thickly buttressed trunks providing storm-proof anchorage in the sodden footage. Baldcypress growing in water also feature above-water extensions of their roots called "knees," which provide added stability and air to the tree. On drier ground, baldcypress trees stand unaided by knees and have less buttressing.

Young baldcypress trees have a roughly conical shape with a thin layer of light brown bark. As baldcypress matures, it develops a thick, tapering trunk that approaches 120' in height and a diameter of 3-5'. Its irregular crown of foliage is frequently draped in Spanish moss. The reddish brown, ridged bark peels off in long strips about 2" thick.

Baldcypress' yellow-green needles (leaves) are 1/2-3/4" long and arranged spirally around the twig. Come fall, they turn yellow or brown before dropping to the ground. Scaly, purple-colored cones about 1" long follow the blooms of spring.

The wood and its uses

Baldcypress heartwood, because it's so durable in contact with the ground, long ago earned the title "the wood eternal." Approximating the weight of cottonwood or willow at 28 pounds per cubic foot air-dry, the wood is somewhat soft and even textured. Although it has a



Baldcypress is weather resistant and easy to work with, making it a good choice for outdoor projects, such as this potting bench found in issue 140.

Baldcypress at a Glance

Price: Baldcypress is priced reasonably in all parts of the nation, and downright cheap in its native regions. To get a range, we surveyed lumber dealers from around the country for their prices on select-and-better, 4/4, random-width-and-length boards. Costs were lowest in the South and Southeast, where the tree grows, at \$1.81 to \$2.40 per board foot (bf). Prices increased to \$3.20 in the Midwest, and \$3.95 in the Northwest.

Pros: Baldcypress resists rot, making it well-suited for outdoor projects. It machines and takes finishes well.

Cons: Limited in availability in some areas; boards with cathedral grain may stain unevenly.

Alternates: Both redwood and cedar offer similar decay resistance, with cedar being the softer of the two, making it less-suited to structural use. Redwood costs more due to its scarcity. Douglas fir offers strength similar to baldcypress, but is more prone to decay.

waxy feel, baldcypress contains no resin ducts.

The thin sapwood is much lighter in color than the pale- to reddish-brown heartwood, which carries an unpleasant odor. Baldcypress is also relatively strong, stiff, and stable for its weight. It occasionally can have attractive, although not outstanding, figure. A fairly rare architectural veneer made from baldcypress crotch wood, called faux satine, is quite beautiful, as well as expensive.

Traditional uses for baldcypress wood include docking and structural timbers, siding, posts, boat planking, flooring, water tanks, coffins, and shingles. Don't overlook it, though, for both indoor and outdoor furniture, as shown at left.

Some baldcypress trees are attacked by a fungus that causes pockets of decay. The resultant wood is riddled with small, shallow holes and is called "pecky cypress." Still durable, such wood is used for decorative paneling.

In its range, you'll find baldcypress relatively abundant. Elsewhere, it is becoming more available as an alternative to western red cedar and redwood. Baldcypress veneer is available from marquetry suppliers. You won't, however, find it available as plywood.

Baldcypress in the shop

Although fairly hard, baldcypress is easy to work with, behaving much like other softwoods, such as pine.

- You can work straight-grained baldcypress with hand or power tools. Though not prone to burn, use carbide cutters and blades for the best results.
- Tear-out isn't a problem when planing or machining straight-grained boards. Make lighter passes when working cathedral-grained boards.
- Baldcypress holds screws well. Pre-drill shank holes, pilot holes, and counter-bores to avoid splitting.
- Baldcypress' waxy feel won't hinder gluing. Use weatherproof adhesives for outdoor projects.
- Sand through 180- to 220-grit abrasives to impart a smooth finish for fine projects. Baldcypress can be left rough for use in construction or to provide a more rustic look on outdoor projects.
- If staining, avoid cathedral-grained boards. The dark latewood absorbs less stain, as shown below. 🌲

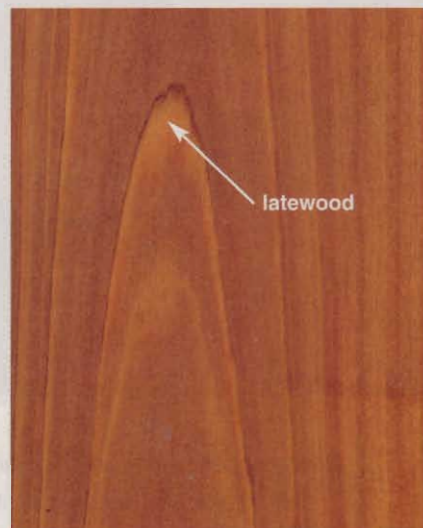

Stained with "Antique Cherry," this baldcypress board takes a lighter tone in the denser latewood. Use wood conditioner or gel stain to achieve consistent color.

Written by Peter J. Stephano
Illustration: Steve Schindler
Photographs: Baldwin Photography

stand that delivers

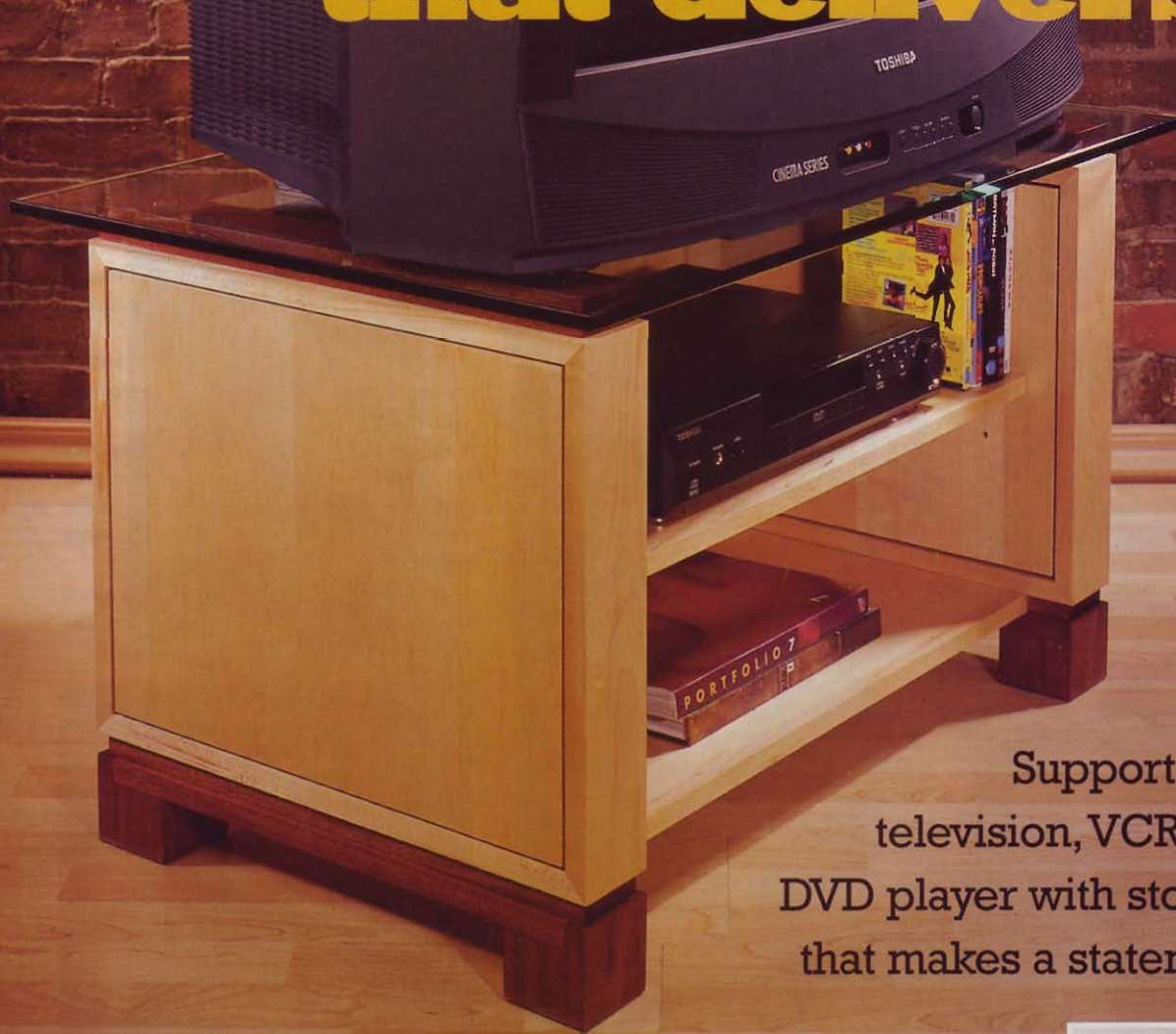

Support your television, VCR, and DVD player with storage that makes a statement.

Clean lines, sleek styling, and a touch of flair make this television stand the ideal place to set your set. Build it as a stand-alone piece or as part of a matching living room ensemble with the futon sofa/sleeper and modular knock-down shelving set, both shown at *right*. All three pieces share the same design style and simple approach to construction.



The futon sofa/sleeper *above* (issue 139) is great for sitting or snoozing. The modular shelving at *left* (issue 143) can be configured to match most any space or task thanks to special hardware.

1 BASE

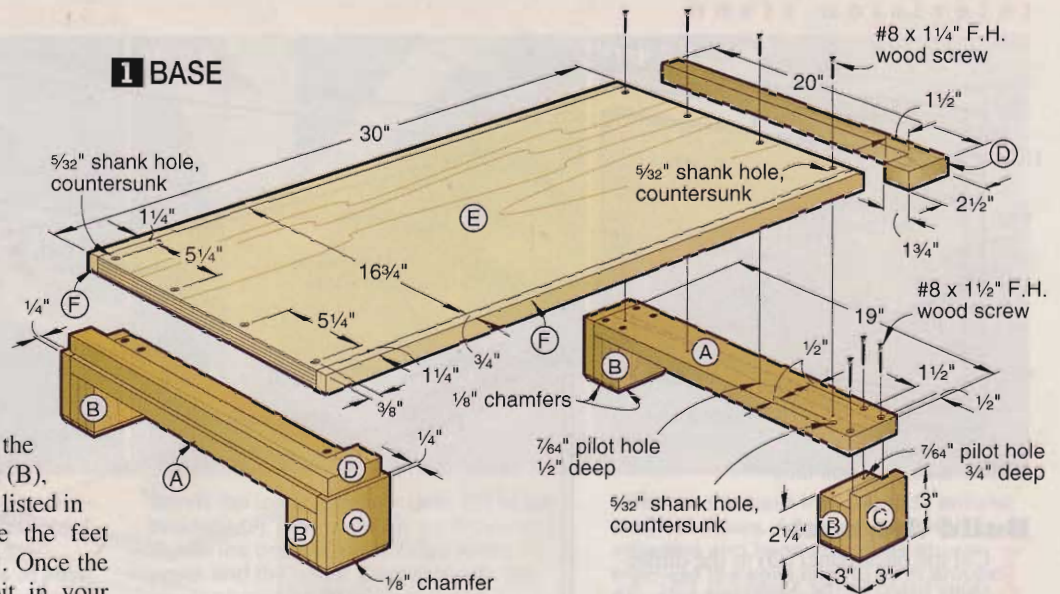

Start at the base

1 From $\frac{3}{4}$ " mahogany, cut the stretchers (A), foot bodies (B), and foot faces (C) to the sizes listed in the Materials List. Laminate the feet (B/C), as shown in **Drawing 1**. Once the glue dries, use a chamfer bit in your router to rout a $\frac{1}{8}$ " chamfer around the bottom of each foot. Then clamp the feet to the stretchers, and drill the pilot and countersunk shank holes where shown. Glue and screw the stretchers to the feet.

2 Cut the lower reveal trim (D) to $2\frac{1}{2} \times 20$ ". Then notch each piece where shown in **Drawing 1**. This can be done using a jigsaw or bandsaw. Just make sure the edges of the notch are square and straight.

3 Finish-sand the lower reveal trim (D) and the foot assemblies (A/B/C) to 220 grit. Then glue the reveal trim to each foot assembly to create two base assemblies (A/B/C/D), leaving a $\frac{1}{4}$ " reveal on the sides, front, and rear edges, where shown in **Drawing 1**. If you wish to stain the base assemblies (A/B/C/D), do so now. We used Bartley's Pennsylvania Cherry gel stain.

4 Cut the bottom panel (E) to size from $\frac{3}{4}$ " maple plywood. From $\frac{3}{4}$ " solid maple, cut the bottom panel edging (F) to size, as well. This is a good time to cut the adjustable shelf (G) and shelf edging (H) to size, too.

5 Glue the edging (F) to the front and back edges of the plywood bottom panel (E). Sand the edging flush with the faces of the bottom, taking care not to sand through the plywood's thin veneer layer. Also glue the shelf edging (H) to the shelf (G), sand them flush, then set this assembly (G/H) aside. Once the stand is assembled, you can perform one last operation on the shelf to help keep it in position. See the shop tip on *page 48*.

6 Next, glue and clamp the bottom assembly (E/F) to the base assem-

blies (A/B/C/D), then drill the pilot and countersunk shank holes, where shown in **Drawing 1**. Drive screws to join the assemblies together.

Add the ends

1 From $\frac{3}{4}$ " poplar, cut the frame tops/bottoms (I) and frame ends (J) to size. Glue and clamp the frames (I/J) together, keeping the ends flush, where shown in **Drawing 2**. Measure the frames' diagonals or use a framing square to check each for square, and place them on a flat surface while the glue dries. Once the glue sets, remove the clamps, drill pilot and countersunk shank holes, and drive in the screws.

2 Cut the four end panels (K) to size from $\frac{3}{4}$ " maple plywood, making sure they match the length and width of the assembled frames. Chuck a $\frac{1}{8}$ " rabbeting bit in your router and rout $\frac{1}{8}$ " rabbets $\frac{1}{4}$ " deep around the perimeter of the good faces of all four panels, where shown in **Drawing 2**.

3 Choose two panels (K) to be the insides of the end assemblies. Then lay out and drill the shelf pin holes in these two panels, where shown in **Drawing 2**.

Note: The dimensions shown for the shelf pin locations are measured from the edge of the panel, not from the edge of the rabbet.

4 To accentuate the reveal formed by the rabbets around the end panels, stain the bottom of the rabbet, as shown in **Photo A**. Use the same stain you applied to the mahogany parts earlier.

5 Glue and clamp the panels (K) to the frame assemblies (I/J). Make sure to apply one shelf-pin-drilled panel to each assembly and check that the panel's edges are flush with the frames.

6 Cut the top/bottom trim (L) and end trim (M) to width and about 1" longer than dimensioned in the Materials List. Fit the trim around the panel assemblies (I/J/K), miter-cutting each piece to length. Glue and clamp the trim pieces in place, where shown in **Drawing 2**. After the glue sets, finish-sand the end assemblies (I through M).

7 Cut the upper reveal trim (N) to size from $\frac{3}{4}$ " mahogany. Finish-sand the pieces, then stain the top face, edges, and ends with the same stain used earlier. Don't stain the bottom face. Glue the upper reveal trim to the end assemblies (unstained face down), leaving a $\frac{1}{4}$ " reveal on all sides.

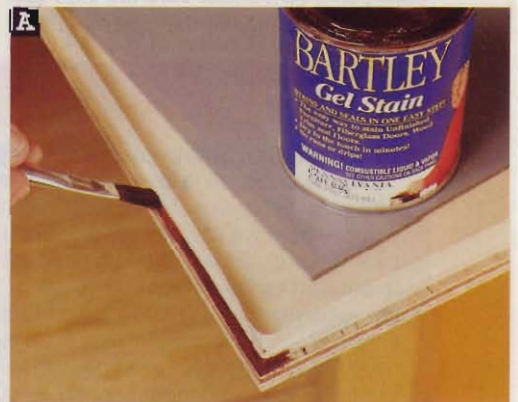

Mask the edge of the rabbet to keep stain from accidentally bleeding onto it or the panel's surface.

television stand

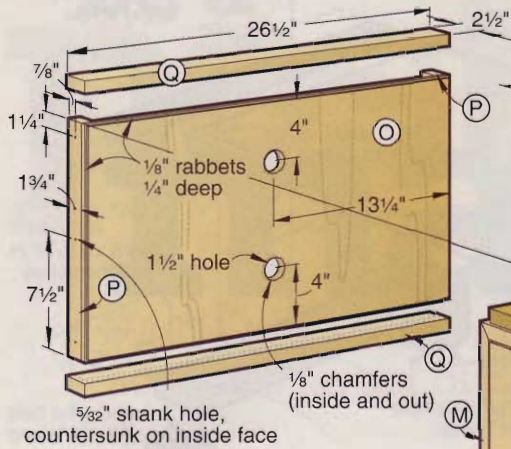

Build the back

1 Cut the back panel (O) to the dimensions listed in the Materials List. As you cut the panel, remember that the grain runs vertically. Rabbet the perimeter of the good face of the back panel, just as you did earlier with the end panels, and apply stain to the rabbets.

2 Use a Forstner or spade bit in your drill press to bore the 1 1/2"-diameter cord-access holes through the back panel (O), where shown in **Drawing 2**. (Once again, measure from the edges of the panel.) Chuck a chamfering bit in your router, and rout 1/8" chamfers around the holes on both faces of the panel. This eases the edges, which reduces the risk of chip-out when pulling wires through after the television stand is completed.

3 From 3/4" solid maple, cut the back side trim (P) and top/bottom caps (Q) to size. Drill countersunk shank holes through the back side trim, where shown in **Drawing 2**.

4 Clamp and glue the back side trim (P) and top/bottom caps (Q) to the back panel (O). Make sure the caps are flush with the face of the panel and that

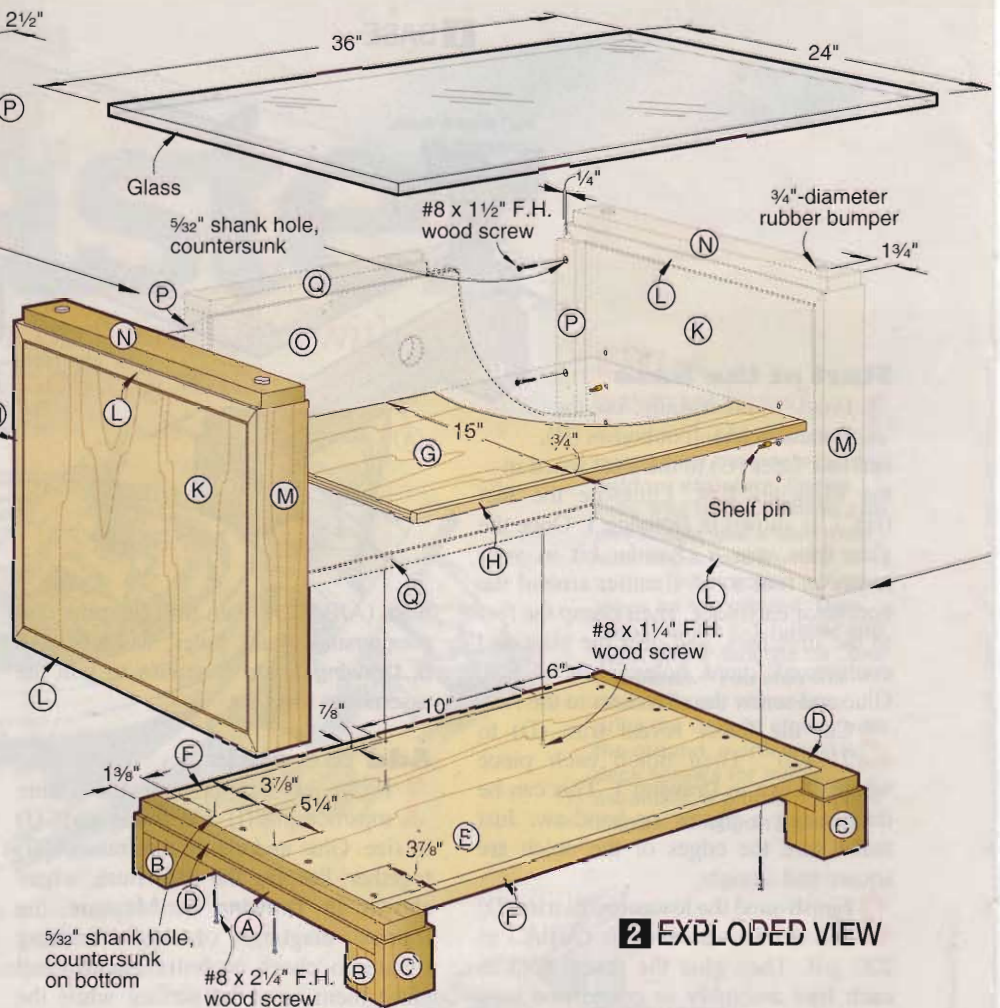

2 EXPLODED VIEW

the counterbores on the side trim face the inside. After the glue dries, finish-sand the back assembly (O/P/Q) to 220 grit.

Now finish and assemble your stand

1 The base, end, and back assemblies simply screw together, meaning you can break the stand down if it ever needs

to be packed away or moved. Lay out the locations of the mounting holes on the upper surface of the base assembly, where shown in **Drawing 2**. Then, from the top side, drill a 5/32" shank hole at each location. Turn the base assembly facedown, and countersink the underside of each of these holes.

2 Because there are no glue joints to worry about, go ahead and finish all the parts prior to assembly. We applied a coat of gloss polyurethane, then sanded lightly with 220 grit, and added two coats of satin polyurethane.

3 After the finish dries on all the assemblies, lay some cardboard on your benchtop and assemble the stand. The process is easier if you assemble the stand upside down. Start by placing the back assembly (O/P/Q) on a 3/4"-thick scrapwood spacer. Position the end assemblies (I through N) alongside, with the upper reveal trim (N) resting on the bench. Referring to **Drawing 2**, you'll see

SHOP TIP

Solution for stay-put shelves

To prevent the adjustable shelf from sliding forward when you need to access VCR or DVD player wires, we routed recesses for the shelf pins. After assembling the stand, put the shelf in position and mark around the pins. Transfer the centerlines to the end edges of the panel. Chuck a 1/2" straight bit in your table-mounted router, and raise it for a 1/8"-deep cut. Position the fence to center the bit on the layout mark. Clamp a stopblock to the fence, and rout a 5/8"-long recess at each pin location.

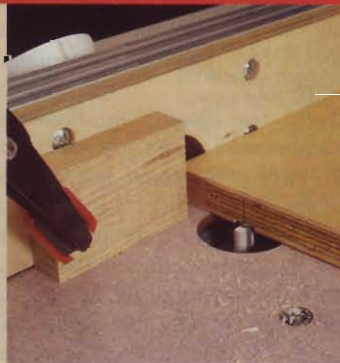

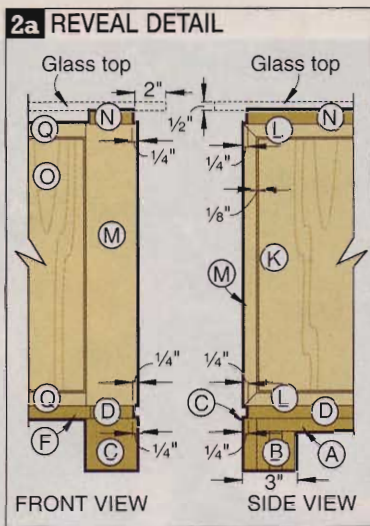
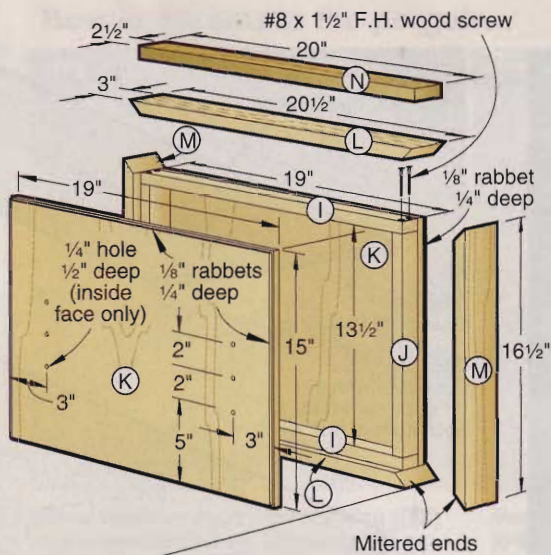

that the back assembly is positioned $\frac{1}{4}$ " forward of the rear edges of the end assemblies. Temporarily clamp these assemblies together.

4 Place the base assembly on the ends and back, aligning it so the feet are flush with the outer faces of the end assemblies, as shown in **Drawing 2a**. Note that the rear edge of the back bottom cap (Q) should be flush with the rear edge of the bottom panel edging (F). Once you have everything aligned, use the countersunk mounting holes you drilled through the base assembly as guides, and bore $\frac{3}{32}$ " pilot holes into the back and end assemblies. Then drive in the screws, as shown in **Photo B**. Using the shank holes in the back sides (P) as guides, drill pilot holes into the end assemblies and drive those screws.

5 Remove the clamps and turn the stand right side up. Adhere clear rubber bumpers to the upper reveal trim (N), where shown in **Drawing 2**.

6 Position the $\frac{1}{2}$ " glass plate on top of the stand. For more information on the types of glass available and purchasing options, see "Buying Glass: A

Clear View" on page 24. Finally, insert shelf-support pins and position the adjustable shelf. Now you're ready to install your television and components, and sit back to watch the tube or at least admire the stand it sits on. 🍷

Rest the stand on cardboard to protect the finish. Use clamps to keep the pieces aligned as you drill and drive the screws.

Written by David Stone with Charles I. Hedlund
Project design: Kevin Boyle
Illustrations: Roxanne LeMoine; Lorna Johnson
Photographs: Baldwin Photography

materials list

Base	FINISHED SIZE			Matl.	Qty.
	T	W	L		
A stretchers	$\frac{3}{4}$ "	3"	19"	MY	2
B foot bodies	$\frac{3}{4}$ "	3"	2 $\frac{1}{4}$ "	MY	12
C foot faces	$\frac{3}{4}$ "	3"	3"	MY	4
D* lower reveal trim	$\frac{3}{4}$ "	2 $\frac{1}{2}$ "	20"	MY	2
E bottom panel	$\frac{3}{4}$ "	16 $\frac{3}{4}$ "	30"	MP	1
F bottom panel edging	$\frac{3}{4}$ "	$\frac{3}{4}$ "	30"	M	2
Shelf					
G adjustable shelf	$\frac{3}{4}$ "	15"	26 $\frac{3}{8}$ "	MP	1
H shelf edging	$\frac{3}{4}$ "	$\frac{3}{4}$ "	26 $\frac{3}{8}$ "	M	1

*Parts initially cut oversize. See the instructions.

Materials Key: MY—mahogany, MP—maple plywood, M—maple, P—poplar.

Supplies: #8x $\frac{1}{2}$ " flathead wood screws (38), #8x $\frac{1}{4}$ " flathead wood screws (11), #8x2 $\frac{1}{4}$ " flathead wood screws (6), spoon-type shelf-support pins (4), $\frac{3}{4}$ "-diameter self-adhesive clear rubber bumpers (4), stain, polyurethane finish (gloss and satin).

Ends	FINISHED SIZE			Matl.	Qty.
	T	W	L		
I frame tops/bottoms	$\frac{3}{4}$ "	1 $\frac{1}{2}$ "	19"	P	4
J frame ends	$\frac{3}{4}$ "	1 $\frac{1}{2}$ "	13 $\frac{1}{2}$ "	P	4
K end panels	$\frac{3}{4}$ "	19"	15"	MP	4
L* top/bottom trim	$\frac{3}{4}$ "	3"	20 $\frac{1}{2}$ "	M	4
M* end trim	$\frac{3}{4}$ "	3"	16 $\frac{1}{2}$ "	M	4
N upper reveal trim	$\frac{3}{4}$ "	2 $\frac{1}{2}$ "	20"	MY	2
Back					
O back panel	$\frac{3}{4}$ "	26 $\frac{1}{2}$ "	15"	MP	1
P back side trim	$\frac{3}{4}$ "	1 $\frac{3}{4}$ "	15"	M	2
Q back top/bottom caps	$\frac{3}{4}$ "	2 $\frac{1}{2}$ "	26 $\frac{1}{2}$ "	M	2

Buying Guide

Glass: $\frac{1}{2}$ "x24x36" glass tabletop with flat-polished edge, \$66 plus shipping. Wholesale Glass Brokers, 19785 West Twelve Mile Rd., Ste. 357, Southfield, MI 48076; 800/288-6854.

cutting diagram

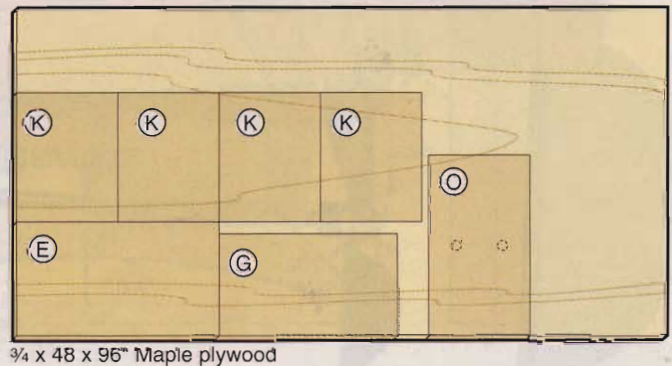
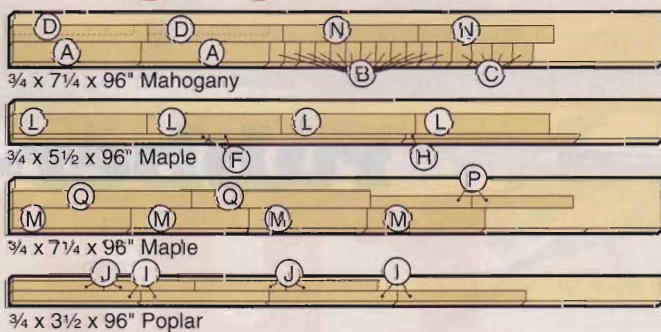

Some toys are for play, others for display. With this snazzy rubber-band-powered speed-boat, you have both. Modeled after a 1930s hydroplane racer, this fully-functional boat can whirl across a backyard pool or sit handsomely on its stand.

Constructed with scraps of cedar 2x6, straight-grained pine, and brass rod, tube, and sheet, it requires only a small investment in materials to complete. Happy motoring!

Note: The brass rod, tube, and sheet we used in this project are available at hardware and hobby stores, or see the Buying Guide for our source.



Form the hull first

1 Cut a 20"-long piece of cedar 2x6 for the hull (A). Cut a centered groove in the bottom of the hull, where shown in **Step 1** on **Drawing 1**.

2 Chuck a 1/2" straight bit in your table-mounted router, and, using a stopblock clamped to the fence to control the groove's length, rout a 3 3/4"-long stopped groove, shown in **Step 2**.

3 From a 20"-long piece of dark, straight-grained cedar 2x6, resaw two 3/8"-thick book-matched pieces for the deck halves (B). Rip them to the width in the Materials List. Cut a 1/8x3/8x20" pine piece for the center strip

(C). Edge-glide the deck halves (B) to both sides of the center strip (C), shown in **Step 3**. With the glue dry, plane this deck blank (B/C) to 1/4" thick.

4 Glue the deck to the hull, shown in **Step 4**, keeping the ends and edges flush. To spread the clamping pressure evenly, lay down waxed paper, and clamp the assembly, deck down, to a piece of 3/4" plywood. Remove any glue that squeezes into the 1/2x3/8" groove.

5 Scrape any excess glue from the sides of the hull/deck assembly. Sand the stern so the deck and hull are flush. Install a 3/4" dado blade in your tablesaw, and cut the

STEP 3
Edge-glide deck pieces.

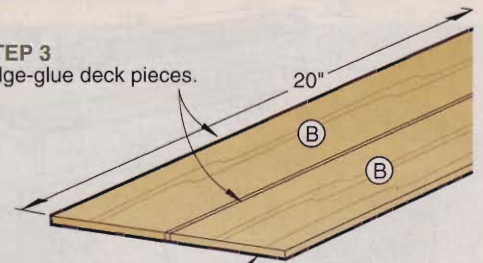

STEP 4
Glue deck to hull.

STEP 1
Cut a 1/8" groove 1/4" deep centered on bottom of hull (A).

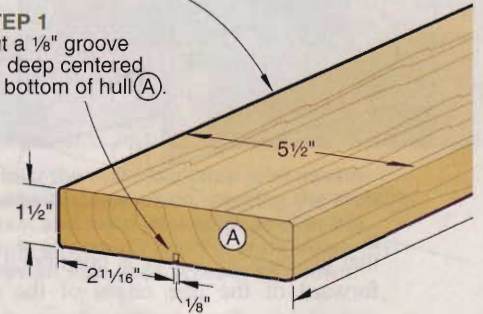

3"-wide cockpit, shown in **Step 5**. To avoid chipping the blank's side, back the cuts with an auxiliary extension attached to your miter gauge.

6 Copy the deck from the **WOOD PATTERNS**® insert. Adhere it to the deck/hull blank with spray adhesive. Tilt your bandsaw table 15°, and cut along the pattern lines, shown in **Step 6**. Save the cutoffs. Sand the saw marks from the hull assembly.

7 Select a piece of wood with straight grain, and resaw and plane the planks (D) to the size listed, book-matching the two sides. Glue and clamp the planks, one piece at a time, to the hull, shown in **Step 7**. Use the hull



rubber-b
run

1 FORMING THE HULL AND DECK

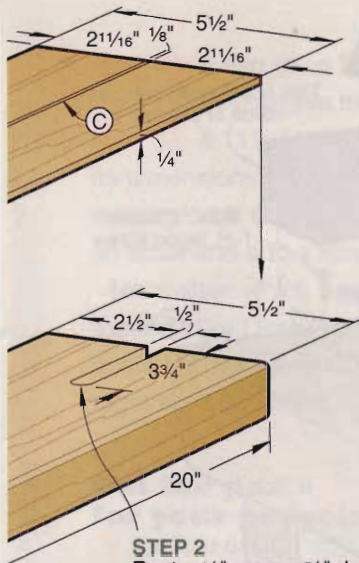

STEP 2
Rout a $\frac{1}{2}$ " groove $\frac{5}{8}$ " deep, stopped $\frac{3}{4}$ " from end.

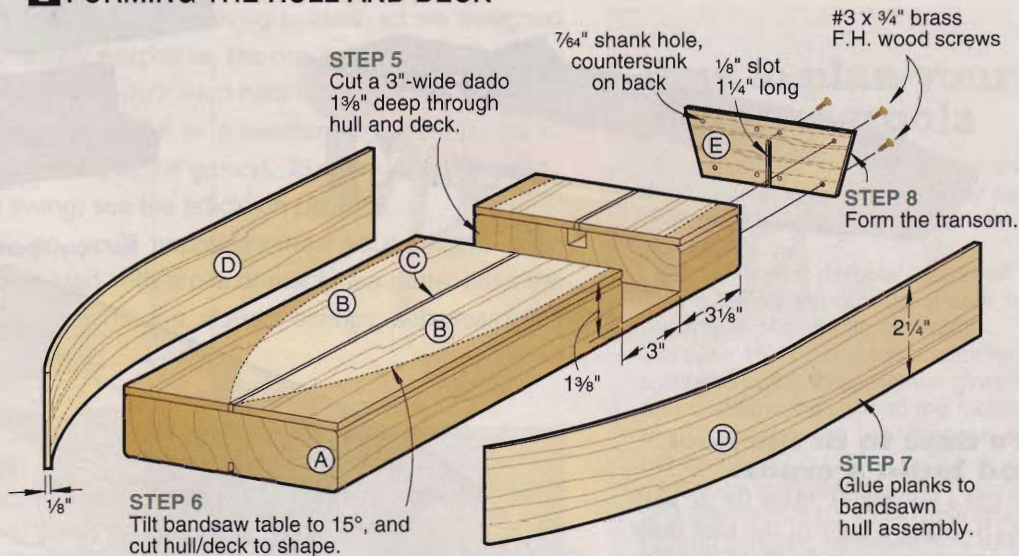

STEP 5
Cut a 3"-wide dado $1\frac{3}{8}$ " deep through hull and deck.

STEP 6
Tilt bandsaw table to 15° , and cut hull/deck to shape.

STEP 8
Form the transom.

STEP 7
Glue planks to bandsawn hull assembly.

cutoffs as clamp blocks. Make sure the planks protrude beyond the edges of the hull all around with at least $\frac{3}{16}$ " overhanging the stern. Trim the first plank where it overhangs the bow before gluing and clamping the second plank. When the glue dries, use a block plane and a sanding block to trim the planks flush with the deck and the bottom of the hull. Do not trim the stern.

8 Cut a $\frac{1}{8} \times 2 \times 4\frac{3}{4}$ " blank for the transom (E). Use your bevel gauge to transfer the planking's angle onto the transom, and trim the ends to shape. Fit the transom between the protruding planks (D), and sand it flush with the hull at the top and bottom. Then trim and sand

the protruding planks flush with the transom. Mark the screw hole locations, where shown on **Drawing 1a**, and drill $\frac{1}{16}$ " pilot holes through it, into the stern. Remove the transom, enlarge the holes to $\frac{7}{64}$ " for the screw shanks, and countersink them. Install a $\frac{1}{8}$ " straight bit in your table-mounted router. Using your miter gauge fitted with an auxiliary extension and a stopblock, cut the $1\frac{1}{4}$ "-long slot in the transom for the rudder, where shown. Set the transom aside.

9 Sand an angled flat at the bow where the planks come together, as shown on **Drawing 2**. Cut the bow stem (F) to size, and glue it to the hull, holding it in place with masking tape. When the glue dries, carefully sand it flush with the planks, deck, and bottom.

1a TRANSOM

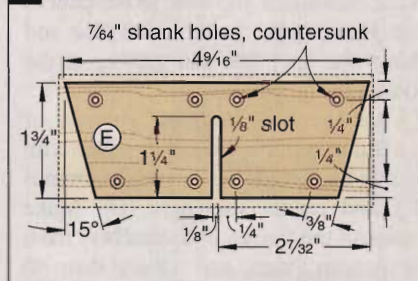

Now, outfit the cockpit

1 Cut a $1\frac{1}{4} \times 1\frac{3}{4} \times 10$ " blank for the seat (G). Make the two cuts shown on **Drawing 2a** to form the back and bench. Match the compound cuts at the seat's ends to the inside of the cockpit. (To get a good fit, we angled the miter gauge 3° and tilted the blade 15° .) Make the cuts on scrap to test the fit. After making any necessary adjustments, cut the seat to finished length. Sand the round-overs, where indicated. Set the seat aside.

2 Cut a $1 \times 1\frac{1}{4} \times 10$ " blank for the windshield (H). Bevel-rip the 45° angle, shown on **Drawing 2b**. Angle your miter gauge 30° , tilt the saw blade 30° , and cut the windshield to final length. Set the windshield aside.

3 Cut the rudder block (I) to size, and test-fit it in the rectangular hole formed in the stern by the $\frac{1}{2} \times \frac{5}{8}$ " groove and the deck. The fit should be snug, but still allow easy removal. Hold the block with a handscrew clamp, and drill the hole with your drill press, where shown on **Drawing 2c**. Drill and countersink the hole in the deck for the screw that holds the rudder block in place, where shown on **Drawing 2**.



and
about



It's time to fit the keel and build a cradle

1 Cut a $\frac{1}{8} \times 2\frac{1}{2} \times 20$ " blank for the keel (J). Make a copy of the keel from the pattern insert, and adhere it to the blank. Scrollsaw and sand to the pattern line. Remove the pattern, and glue and clamp the keel into the groove in the bottom of the hull.

2 Adhere two $\frac{1}{4} \times 6 \times 12$ " pieces of Baltic birch plywood together with double-faced tape for the cradle frames (K) and cradle stretchers (L). Make copies of the frames and stretchers from the pattern insert, and adhere them to the plywood. Scrollsaw and sand the parts to the pattern lines. Glue and clamp the frames to the stretchers, as shown on Drawing 2.

Apply varnish and paint, and build the running gear

1 Finish the hull assembly, transom, rudder block, and cradle with gloss polyurethane. To make sure the parts are well protected, we brushed on the first coat, sanded with 220 grit, then finished up with two light coats from a spray can. Prime and spray-paint the seat red and the windshield black.

2 Cut a 3"-long piece of $\frac{5}{32}$ " brass tubing for the propeller shaft sleeve. Cut a $2\frac{1}{4}$ "-long piece from a $.025 \times 2 \times 12$ " strip of brass sheet for the sleeve bracket. Bend it to fit around the sleeve, as shown on Drawing 2. Solder the tube to the bracket so $\frac{1}{2}$ " protrudes at each end. Polish away any discoloration from the soldering. Put a dab of silicone sealant on the keel's bottom edge, and slide the sleeve/bracket assembly onto the keel.

3 Make a copy of the propeller from the pattern insert, and adhere it to the brass strip. Drill the center hole and

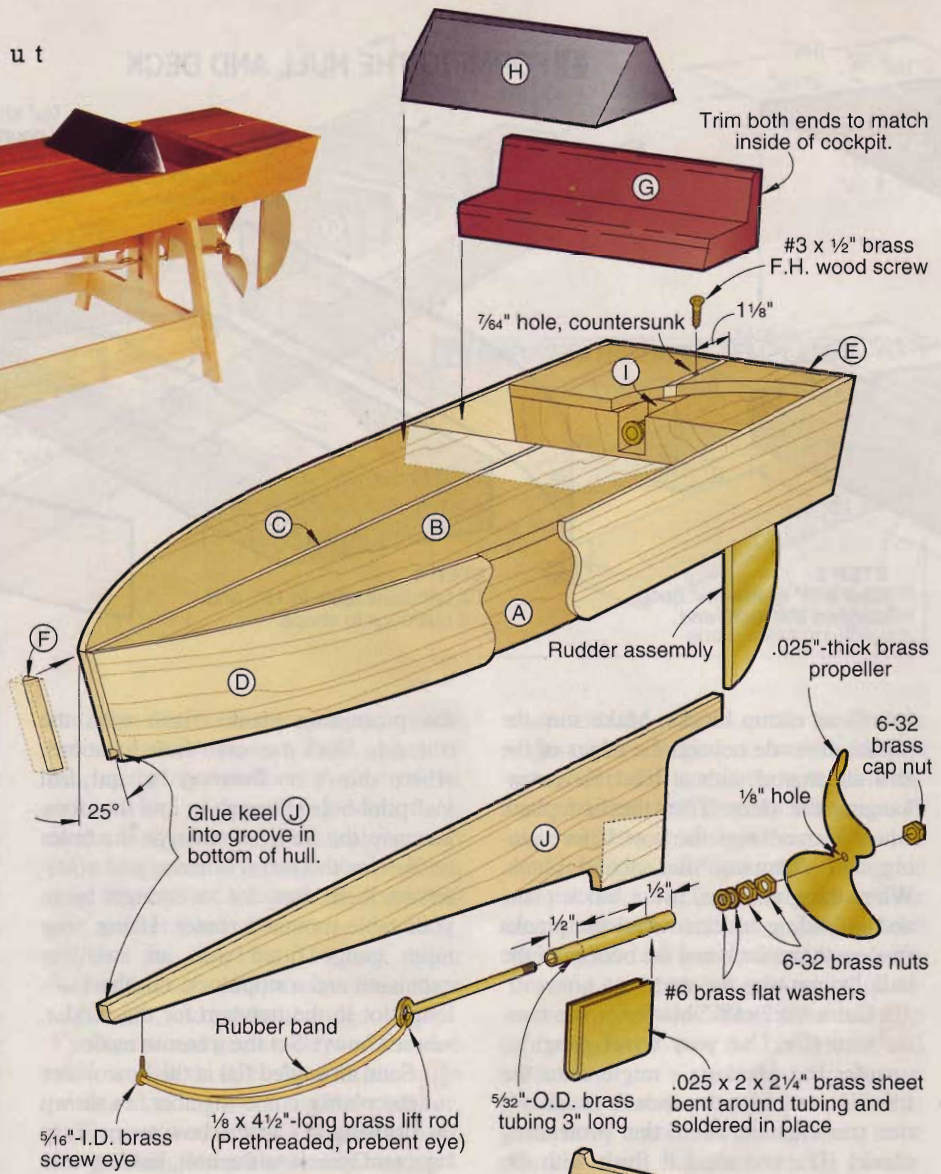

2 EXPLODED VIEW

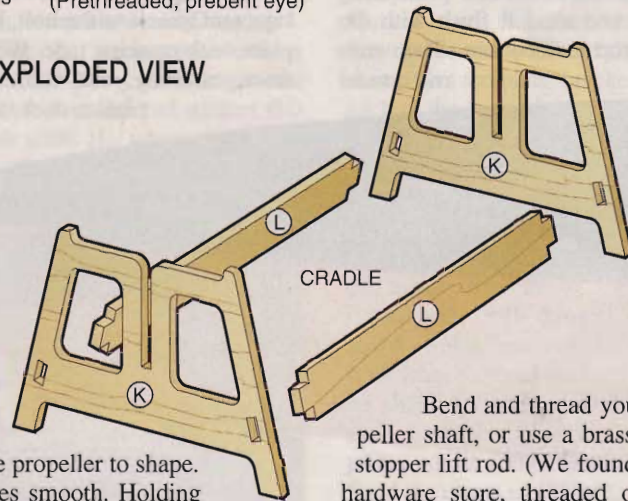

scrollsaw the propeller to shape. File the edges smooth. Holding it with a small C-clamp, shape the propeller, as shown in Photos A and B. Remove the pattern.

4 Slide the propeller shaft through the sleeve, and assemble the washers, nuts, propeller, and cap nut, as shown.

Bend and thread your own propeller shaft, or use a brass toilet tank stopper lift rod. (We found one at the hardware store, threaded on one end with an eye on the other.) Drive a brass screw eye into the keel at the bow, and string up a couple of sturdy rubber bands. We used loops of rubber strip from a hobby store (SIG Contest Rubber no. CR-825).

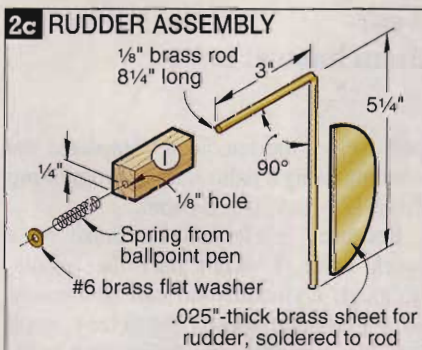
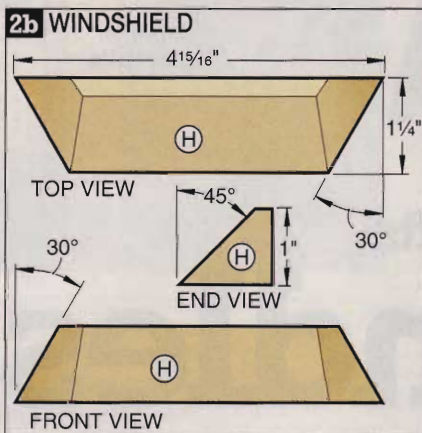
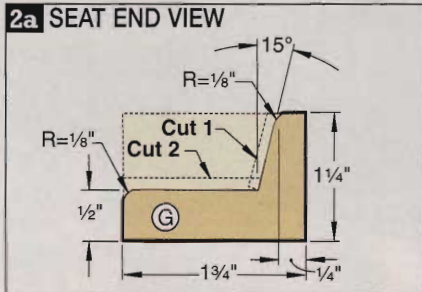

5 Make a copy of the rudder from the pattern insert, adhere it to the brass strip, scrollsaw it to shape, and file the edges smooth. Bend an 8 1/4" length of 1/8" brass rod for the rudder shaft, shown on **Drawing 2c**. Clamp the shaft in your vise, and solder the rudder to it, as shown in **Photo C**. Slide the shaft through the rudder block (I), spring, and washer. Compress the spring with the washer and

cutting diagram

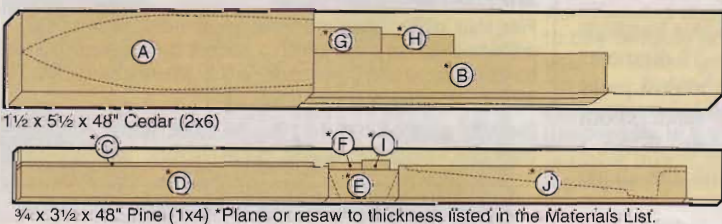

Twist each propeller blade, pushing down on the short lobe, and pulling up on the long one.

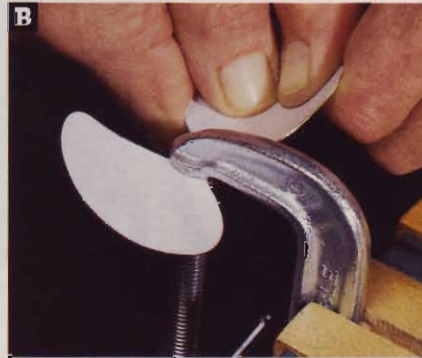

Now, maintaining the twist, bend an upward curl in each blade. The side with the pattern is the back of the propeller.

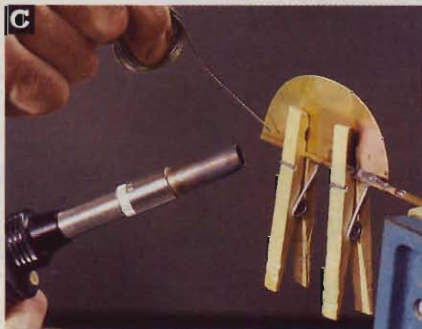

A pair of clothespins holds the rudder centered on the shaft while you solder it in place.



To wind the propeller, pull the rudder shaft out of the transom slot, and swing it out of the way.

hold it with pliers while you flatten the tip of the shaft with a hammer just enough to keep the washer from sliding off the end.

6 Slide the rudder assembly into the stern recess. Push the rudder block in to compress the spring 1/8", and drive the screw through the deck hole. Screw the transom (E) in place. Glue the seat and windshield in place with a couple of dabs of silicone sealant. Wind the propeller, as shown in **Photo D**, and let 'er rip. 🚤

Written by **Jan Svec**
 Project design: **James R. Downing; Jan Svec**
 Illustrations: **Kim Downing; Lorna Johnson**
 Photographs: **Hetherington Photography; Baldwin Photography**



materials list

Part	FINISHED SIZE			Matl.	Qty.
	T	W	L		
A* hull	1 1/2"	5 1/2"	20"	C	1
B* deck halves	1/4"	2 1/16"	20"	C	2
C* center strip	1/8"	1/4"	20"	P	1
D planks	1/8"	2 1/4"	21"	P	2
E* transom	1/8"	1 3/4"	4 9/16"	P	1
F bow stem	1/4"	1/2"	2 1/4"	P	1
G* seat	1 1/4"	1 3/4"	4 5/8"	C	1
H* windshield	1"	1 1/4"	4 15/16"	C	1
I rudder block	1/2"	5/8"	1 7/8"	P	1
J* keel	1/8"	2 5/16"	19 1/4"	P	1
K* cradle frames	1/4"	4 1/2"	7"	BP	2
L* cradle stretchers	1/4"	1"	10 1/4"	BP	2

*Parts initially cut oversize. See the instructions.

Materials Key: C—cedar, P—pine, BP—Baltic birch plywood.

Supplies: 4 1/2"-long brass toilet tank stopper lift rod, #6 brass flat washers (3), 6-32 brass nuts (2), 6-32 cap nut, 5/16"-I.D. screw eye, 5/32"-I.D. x 1" spring, #3 x 1/2" brass flat-head wood screw, #3 x 3/4" brass flat-head wood screws (8), solder, rubber bands, glue, gloss polyurethane, red and black spray paint, silicone sealant.

Buying Guide

Brass. .025x2x12" brass strip no. G7669, \$2.40; .125x12" brass round rod no. G7646, \$0.88; 5/32x12" brass round tubing no. G7612, \$1.00. Grizzly Industrial, Call 800/523-4777, or go to www.grizzly.com.



Marlen's
fillet knife

the **WOOD**® gang crafts
cutlery handles

Interested in making your own knives?
Three **WOOD** staff members were, so we let them have at it.

To create their cutlery pieces, all three staffers purchased items from mail-order suppliers. In each case, they received blades with pre-drilled tangs (the portion that fits into the knife's handle). Two of the builders ordered kits that came complete with scales (the handle slabs that fit on either side of the blade tang). Each of our intrepid builders took their own path to completion.

A fillet knife in a flash



By Marlen (Perkins)
Kemmet, Managing
Editor

Prior to any work on the handle, I taped the supplied cardboard sheath to the blade, then I wrapped the entire sheath with

masking tape. Without the tape, the paper sheath still tended to slide down accidentally as I worked, leaving the sharp blade exposed.

Because the fillet knife's tang had a nice handle shape, all I had to do was match the two Dymondwood (a "plasticized" wood made of birch veneer layers impregnated with resin) scales to it. I did this by tracing the shape of the tang onto each scale, then bandsawing each a bit oversize.

In my kit, the holes for the three brass rivets were already drilled in the blade tang and the scales. I just glued the scales in place with cyanoacrylate (instant) adhesive, making sure the holes lined up. Next, I used a hammer and nail punch to set the rivets in the handle.

I sanded the scales to rough shape using a 3"-diameter drum sander in the drill press and a 1" spindle sander, both with 80-grit paper. When I was satisfied with the shape

and feel of the handle, I completed the sanding using a palm sander, progressing from 120- to 220-grit paper.

Because I prefer a satin finish on a work knife, I didn't buff the handle, although Dymondwood can be brought to a glass-like sheen. Plasticized wood requires no protective finish, and holds up well to the abuse a fillet knife faces.



Buying Guide

Fillet knife kit: 7" polished and honed vanadium-steel blade pre-drilled for rivets; two prebored and countersunk Dymondwood handle blanks (rosewood color), three brass rivets for attaching handle. Kit, \$30 including postage. Leather sheath, \$14.

Easley Knives, 638 N. 14th Ave., Blair, NE 68008. 402/426-2481. crickettpms@aol.com. Send SASE for free brochure.



10-step steak knives



By Kevin (the carnivore) Boyle, Senior Design Editor

When I received my order, I discovered that I really didn't care for the color of the handle scales I'd selected, so I made my own scales from scraps of bubinga. To get started, I taped on the cardboard sheathes that came with each sharp blade. This protected me and the blades.

After performing each of the steps in fashioning the first handle, I brought all the other knives along to that step before moving to the next one. That helped keep all the handles consistent.

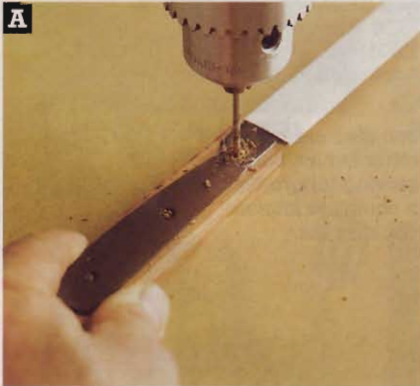

A Predrilled holes in the tang guide the drill bit to create holes for pins that, along with epoxy, attach the scales in place.

With double-faced tape, I fastened the two scales together, then taped them to one side of the blade's tang. I drilled the pin holes in the scales at the drill press, as shown in **Photo A**.

Keeping the scales in the same orientation, I pulled them away from the blade tang. I cut three pins from the mosaic-patterned brass pin stock, making them slightly longer than the combined thickness of the scales and blade's tang.

I applied two-part epoxy to the back side of the scales and placed them onto the tang, lining up their holes. Next, I tapped the three pins into the holes, as shown in **Photo B**, and clamped the scales down tightly.

After the epoxy cured, I sanded the pins flush with the scale surfaces. Next, I sanded the scales with an 80-grit drum sander in the drill press to the outline of the knife's tang.

A custom shape

I personalized the handles with a double taper on top that ran each way from the



B The pins help hold the scales to the tang, and add decoration, with stainless rods arranged inside a brass tube.

middle. This left the middle of the handle a little thicker for a hand-hold. I shaped the tapers with a drum sander mounted in the drill press.

Using 80-grit paper, I rounded over the handle edges slightly. Then I moved on to 120-grit and finished with 150-grit.

Holding the protected blade in a vise, I wiped on three coats of polyurethane, sanding between coats with 600-grit wet/dry sandpaper. After the finish dried, I applied a coat of paste wax and buffed the handles at the benchtop grinder with a buffing wheel.



Buying Guide

Knife Supplies. Blades: hollow ground stainless steel, pre-drilled for pins, with satin finish: (6 ea.) 4 3/4" blade with 2 1/2" of serrations at tip, 9"-long overall, #BL477, \$5.25; Mosaic pins: 1/8"x12", brass and stainless steel, #MPP200-12, \$16; 1/8"x6", brass and stainless steel, #MPP200-06, \$9; Scales: Dymondwood, pair, each approx. 3/8"x1 1/2"x5", #DW41S, \$3.25. Shipping and handling extra.

Texas Knifemaker's Supply, 10649 Haddington, #180, Houston, TX 77043. 888/461-8632 (orders). www.texasknife.com. Catalog, \$6.95.



Kevin's steak knives

Cut-above cutlery

By Jan (Ginsu man)
Svec, Projects
Editor



Rather than following the traditional method of letting the shape of the tang dictate the handle profile, I made my handles from 3/4"-thick blanks glued up from granadillo and redheart scraps. This allowed me to make a handle wider than the tang, a design inspired by the fins on a late 1950s Chrysler.

Creating a prototype

I began by tracing the outline of the knife blade's tang on 1/8" hardboard, then drew the handle design around this outline, keeping the top edges of the handle and tang flush. I cut out this hardboard template, and traced the pattern onto 3/4"-thick scrap, which I cut and sanded to the pattern lines to act as a prototype.

When I was satisfied with the feel, I installed a thin-kerf blade and a zero-clearance insert in my tablesaw, and cut a groove in the prototype's top edge to accept the tang, as shown in **Photo C**.

Note: Because the blade tangs are set in epoxy when they're riveted to the handles, the tang's fit in the groove should be slightly loose. Epoxy needs a thick glue layer to develop any strength.

Hands-on handle work

I glued up, using epoxy, a blank long enough to accommodate all the handles



Unlike the two-part handles of most knives, Jan's one-piece design allows for more grip area (prototype shown).

I needed. I sawed a tang slot in this blank, then used the hardboard template to trace the individual handle outlines onto the blank. Next, I cut the blank into individual handles, and sanded and sanded them to final shape.

Using the rivet holes in the tangs as guides, I drilled all the way through the handles, as Kevin did. I counterbored each hole so the rivet heads would protrude just a hair from the surface, then drilled holes for the rivets. Next, I routed a partial round-over on the handles' edges. To avoid chipping, I sanded the end-grain round-overs.

After dry-fitting the blades in the handles, I masked the blades where they met the handles. To install the handles, I applied slow-set epoxy, making sure the epoxy filled any void at the slot's bottom. With that done, I inserted the rivet halves and drove them together with a hammer.

When the epoxy cured, I filed and sanded off any excess, then refilled any voids. I let the epoxy again cure, then sanded the rivets flush with the handles.



Soaking the handles lets the tung oil penetrate deeply, beautifying and protecting the wood.

Jan's cook's knife



To finish the handles, I soaked them in tung oil for an hour or so, as shown in **Photo D**. I let the finish dry, then buffed each one with a cotton cloth. ♣

Photographs: Baldwin Photography

Buying Guide:

Knife Supplies. Blades, heat-treated, pre-punched for rivets, polished, and hollow ground from 440-C stainless steel: 8" cook's, #SS821, \$10.02; 6" cook's, #SS820, \$6.50; 5 1/2" boner, #SS823, \$6.58; 8" carver, #SS822, \$7.43; carving fork, SS825, \$6.49; Rivets: 5/16x1/2" brass, (pkg of 25) #RV125, \$3.95; 3/16x3/8" brass, (pkg of 25) #RV325, \$3.95. Plus shipping and handling.

Jantz Supply, 309 W. Main, Davis, OK 73030. www.jantzsupply.com. 800/351-8900. e-mail: jantz@brightok.net. Catalog, \$5.

Jan also crafted three other knives and a serving fork to create a complete kitchen cooking set.



GREAT OUTDOOR PROJECTS

Summer will be here before you know it, so now's the time to start thinking about projects that will help transform your outdoor living spaces into inviting get-aways. To help out, in this issue we'll show you how to build the pergolas, trellis, and planter box/railing system shown *here*. The garden gate and fence, also shown, are coming up in the next issue. We designed all of these projects with versatility in mind so that they'll fit with most homes, backyards, and gardens. To give you a sense of how they look grouped together, we built all of

them in the backyard of the home shown at *left*.

Now, you don't have to do such a total transformation. You'll find that any outdoor area will greatly benefit by adding just one of these projects. Each is designed to mini-

mimize maintenance by appropriately combining long-lasting synthetic materials with

durable natural woods. To learn more about the outdoor-tough products we chose, see the article "Outdoor products resource guide" on *page 100*.



Versatile, durable planter box and railing system, *page 72*

High style meets low maintenance with this deck railing system. Built from expanded polyvinyl chloride (PVC) lumber, these rails and balusters won't warp, split, or splinter. Topped with a coat of paint, the material appears just like wood. And you can work it just like wood, with basic skills and a few common tools.

The railing sections are joined by columns with built-in planter inserts. The columns are made from economical exterior plywood, and sheathed with fiber-cement shingles that hold paint for years. More PVC trim dresses out the columns' corners and the inserts.



Tempting trellis, *page 80*

Big impact with little expense or effort: That's what you'll get with this trellis. The western red cedar frame will hold up for years, and surrounds accents made from plastic lattice that wears like iron. It never needs painting, won't pop apart when cut, and doesn't split or warp like wood lattice can when exposed to the elements.

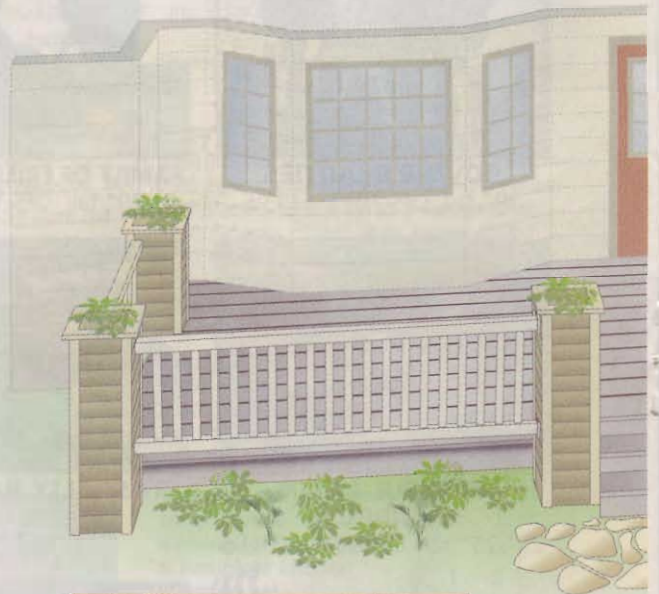



**A graceful garden gate,
June/July issue**

We'll show you how to create this dramatic entrance to your yard or garden. The main structure matches the pergolas and railing system, just in case you want to build all of them. The hefty cedar gate features ornate (but easy) trim around its "window."

**Fanciful fencing,
June/July issue**

This fence defines the boundaries of your yard while enhancing your landscaping. Whatever the size or contours of your outdoor spaces, you can build the fence to fit, with its pressure-treated posts and panels made of cedar and plastic lattice. Construction goes quickly, but the beauty lasts for years.

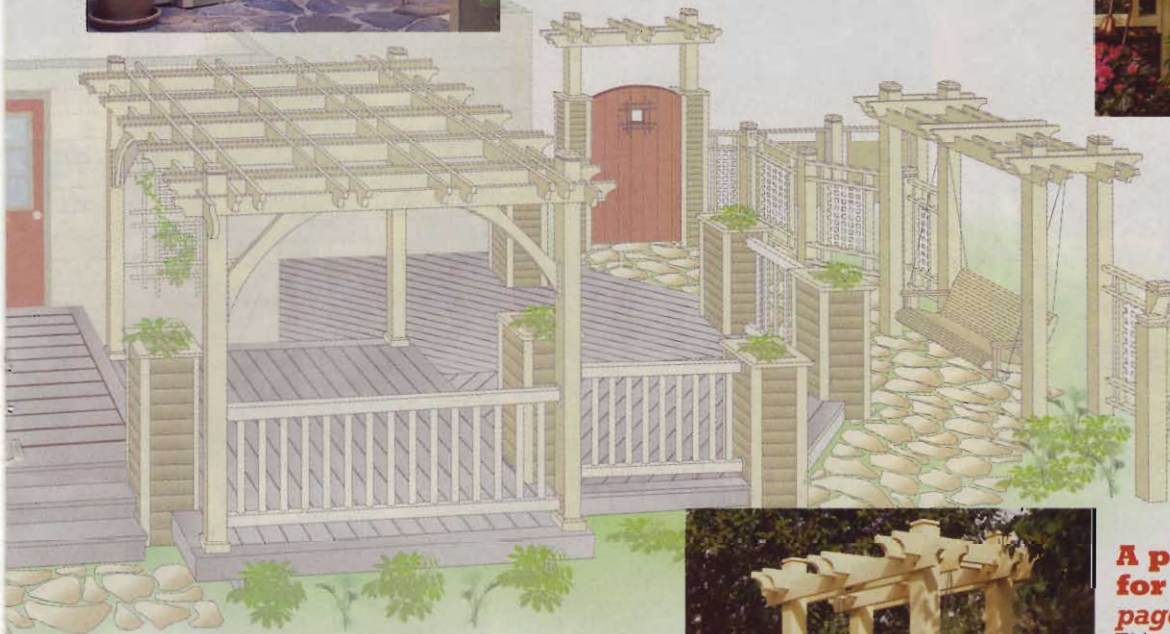

**A pergola fit
for a swing,
page 68**

This scaled-down version of the large pergola makes the perfect place to hang a swing. To build the swing, follow the instructions available from WOOD PLANS® (no. WP-OFS-1002, \$10.95). To order go to www.woodstore.woodmall.com or call 888/636-4478.



Pretty pergola, page 60

Add dappled shade, classic styling, and a sense of defined space to any outdoor area with this pergola. The design is flexible, so you can dress up an existing deck, as shown *here*, or create an "outdoor room," as seen on *page 60*. (Check out *page 66* to see proper techniques for setting the posts into the ground.) Building the pergola is a straightforward process, employing a few portable power tools and hand tools. For longevity, it's made of high-quality, rot-resistant western red cedar.



build-to-suit pergola

**GREAT
OUTDOOR
PROJECTS**



Add elegance to your outdoor living with this airy pavilion. Easily sized to fit any space, this versatile pergola will enhance your deck, patio, or yard.

No two of us have the same outdoor living spaces, so we designed this pergola to be infinitely adaptable. The one shown here occupies a 111x148" "footprint," but you'll learn how to increase or decrease its dimensions as needed. You can build it as a freestanding structure on an existing deck or patio or set its posts in the ground. To shrink it to the size of an arbor and add a relaxing swing, see the article on page 68.

No matter which way you go, you'll appreciate how your pergola goes together like Lincoln Logs. You start with a pile of machined parts, raise the posts, construct the frames, then fit the slotted canopy subassemblies together. It's that easy.

Cut the parts for your pergola kit

1 Cut four 6x6 (5½x5½" actual) posts (A) to the length in the Materials List. To get a square cut, mark your cut-line on all four sides. Using a crosscut guide, cut all around the post to the full depth of your portable circular saw. Finish off the cut with a handsaw. Sand the posts to 120 grit, and set them aside.

2 For the post caps, start by cutting four 1½x5½x5½" cap tops (B) and four ¾x4½x4½" cap bases (C). Bevel the 1½"-thick cap tops, where shown on **Drawing 1**. To make these cuts, we used the auxiliary fence and sliding saddle

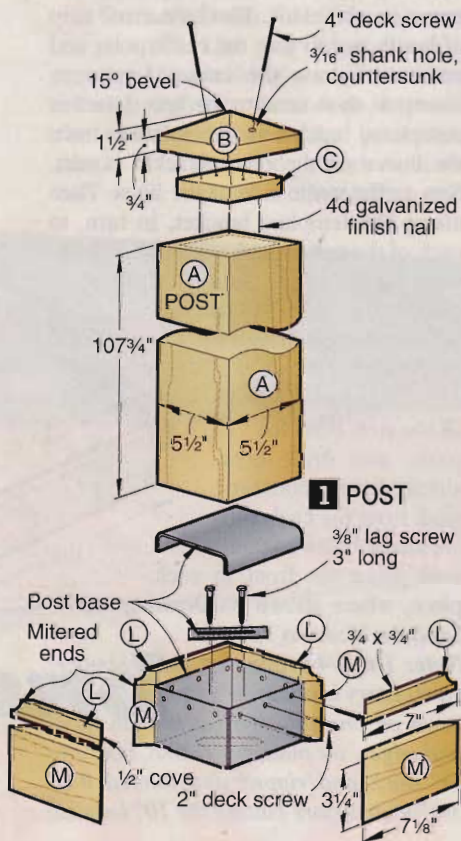

Use your jigsaw to cut the joist and girder ends to shape before smoothing the final profile with your router.

shown in "Great Ideas for Your Shop" on page 12. To hold the blank, drive a wood screw through the back of the jig into the blank's center. Cut one face, rotate 90°, cut, and repeat until all four bevels are cut. Glue and nail the cap bases, centered, to the cap tops, using an exterior glue and 4d galvanized nails. Sand the caps to 120 grit and set them aside. (We installed the caps after the pergola was completely assembled.)

3 Cut the 2x6 main joists and side girders (D, E) to length. Make the marking/trimming template shown on **Drawing 2a**, and use it to mark the 3½"-radius cutouts on the parts' ends, where shown on **Drawing 2**. Cut close to the lines, as shown in **Photo A**. Chuck a flush-trim bit in your handheld router. Clamping the template to each part to guide the bit, rout the final profile. For smooth routing, rout from the cutout's "heel" to the part's end. Chuck a 1/8" round-over bit in your

How to plan your perfect pergola

Using these instructions and the drawing below as a guide, you easily can customize a pergola to fit your needs. Here's how.

Start with your pergola's footprint. This is simply the outside-of-post to outside-of-post length and width. Because 16' is the longest commonly available cedar 2x6, and the girders and joists extend beyond the footprint by 10" at each end, your footprint cannot exceed 172x172".

Although you can orient the main joists and side girders (D, E) in either direction, for planning purposes we'll refer to

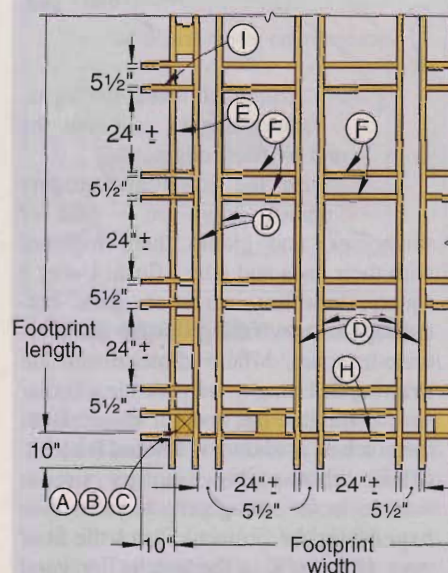

the outside-of-post to outside-of-post dimension parallel to these members as the footprint length. To find the length of the main joists and side girders (D, E), add 20" to the footprint's length. To find the length of the end girders (H), add 20" to the footprint's width.

Position the main joists (D) across the end girders (H), keeping the distance between the close-spaced pairs at 5½". Adjust the number of pairs and/or the length of the blocking (F) to evenly fill the distance between the pairs. (We tried to keep the interval between adjacent joist pairs in the neighborhood of 24".) The interval between the pairs is the length of the blocking (F).

Now, using the same spacing method (though not necessarily the same spacing), position the blocking and the stub joists (I) along the main joists.

2 MAIN JOIST/BLOCKING ASSEMBLY

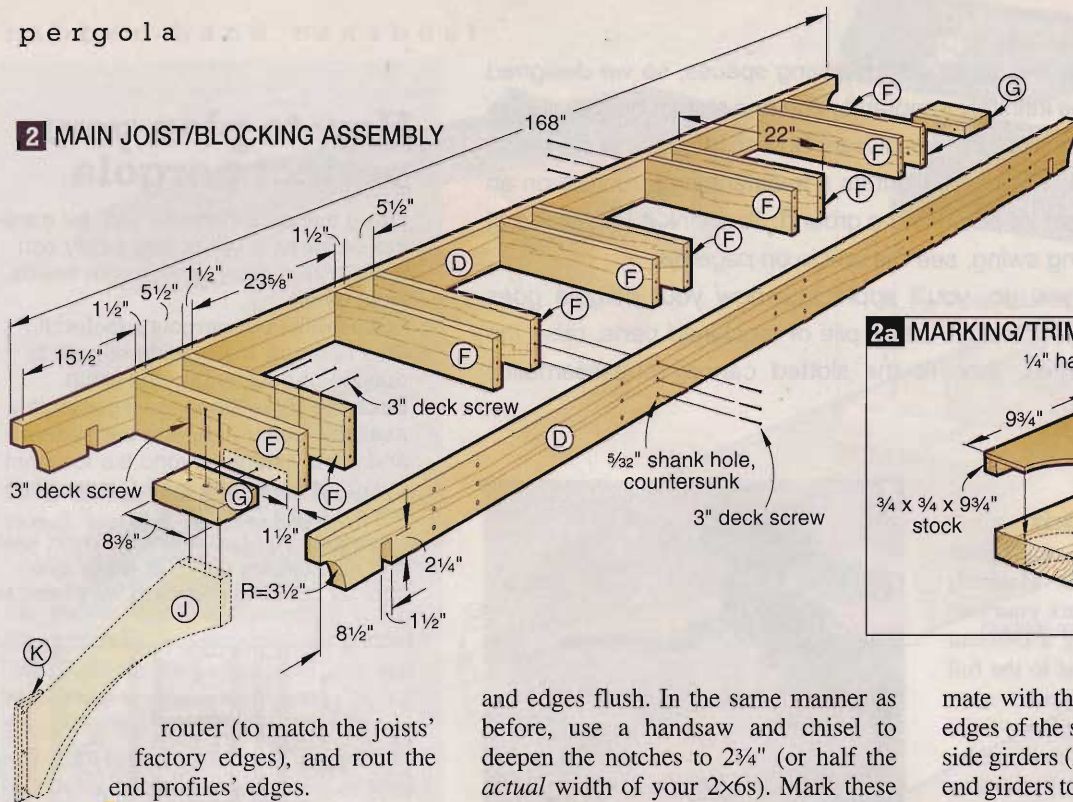

router (to match the joists' factory edges), and rout the end profiles' edges.

4 Turn the joists and girders upside down on a pair of sawhorses, and clamp them together with their ends and edges flush. Using a square, draw lines across the parts' bottom edges (now facing up) for the 1 1/2"-wide notches, where dimensioned on **Drawing 2**. Using your portable circular saw, a straightedge, and a 1" chisel, form the notches, as shown in **Photos B and C**. (These photos show cutting similar notches in the swing pergola joists. See *page 68* for this project.) Check the fit of your 1 1/2" stock in the notch. For good appearance and easy assembly, you'll want a close but not tight fit.

5 Take two of the parts just notched, and clamp them together, with ends



Set your saw to cut 2 1/4" deep. Clamp a straightedge to the joists, and cut a series of kerfs to define the notches.

and edges flush. In the same manner as before, use a handsaw and chisel to deepen the notches to 2 3/4" (or half the actual width of your 2x6s). Mark these as the side girders (E) that, along with the end girders (H), form the pergola's outer frame. Sand the parts (D, E) to 120 grit, and set them aside.

6 Cut the blocking (F) and upper bracket cleats (G) to size. Sand them to 120 grit, and set them aside.

7 Cut the end girders (H) and the stub joists (I) to size. As with the main joists and side girders, use the template, jigsaw, and router to mark and form the end cutouts, where shown on **Drawing 3**.

8 Following the same procedure as with the main joists and side girders, form the notches in the end girders (H) and the stub joists (I), where shown on **Drawing 3**. Note that the notches in the end girders are cut in their top edges to

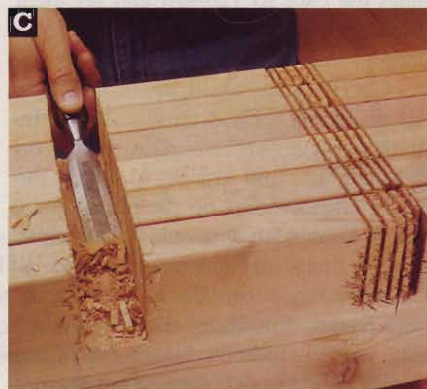

Use a chisel and hammer to clean out the notches, smoothing their bottoms to a uniform depth.

mate with the notches cut in the bottom edges of the side girders. As with the two side girders (E), extend the notches in the end girders to 2 3/4" deep. Sand the parts H and I to 120 grit, and set them aside.

9 Cut eight 2x8 blanks 41 7/8" long for the brackets (J). Using your circular saw or tablesaw and miter gauge, make the angled end cuts, where shown on **Drawing 4a**. Mark the centerpoint of the curve on one blank. Bend a narrow strip of hardboard to join the centerpoint and ends, and draw the curve. Jigsaw or bandsaw, then sand to the line. Use this completed bracket as a template to trace the curve on the other bracket blanks. Saw to the waste side of the lines. Then clamp the template bracket, in turn, to each of the sawn blanks, and use a flush-trim bit in your handheld router to smooth the curves. Finish up by routing 1/8" round-overs where shown.

10 Cut the lower bracket cleats (K) to size. Rout the 1/4" cove, and drill three shank holes countersunk from the back and six shank holes countersunk from the front in each piece, where shown on **Drawing 4**. Sand the cleats to 120 grit.

Note: The 4/4 cedar that many lumberyards carry is about 7/8" thick and rough-sawn on one side. To get smooth faces and edges, we planed a 1x6x8' board to 3/4" thick and ripped and jointed it to 3 1/2" wide before cutting the 10" lengths.

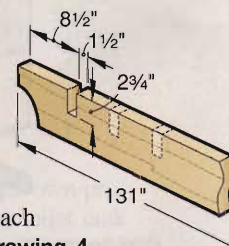

step 1



Screw together main joist/blocking (D/F) subassemblies, where dimensioned on **Drawing 2**. Fasten the upper bracket cleats (G) to the subassemblies where shown on **Drawings 2 and 5**.

step 2



Screw together the two main joist/stub joist (D/I) subassemblies, where dimensioned on **Drawing 3**. Fasten the upper bracket cleats (G) to the main joists, where shown on the drawing.

step 3



Lay out your pergola's footprint, and lag-screw four post bases to the deck. Take diagonal measurements to check your layout for square. The post bases allow you to fine-tune their locations.

11 For the cove caps (L) and base trim (M), plane two 1x6x6' cedar boards to 3/4" thick, as noted above. Joint one edge of each board. Rout a 1/2" cove in the jointed edges, and rip off a 3/4"-wide strip for the cove caps (L). Joint the sawn edges of the remaining boards, and rip them to 3/4" wide for the base trim (M). Sand the base and cap stock to 120 grit. You'll miter-cut the cove caps and base trim to fit around the posts after the pergola is in place.

12 Prime all the pergola parts with an exterior-grade latex primer. Apply two coats to the end grain and the notches. When the primer dries, lightly sand with 220-grit sandpaper. Finish the parts with two coats of exterior latex paint.

Put it all together and voilà, pergola

1 Now that you have all your pergola parts made, primed, and painted, you're just an afternoon away from transforming your yard's personality. Referring to the nine-step sequence of photos that starts above and ends on page 65.

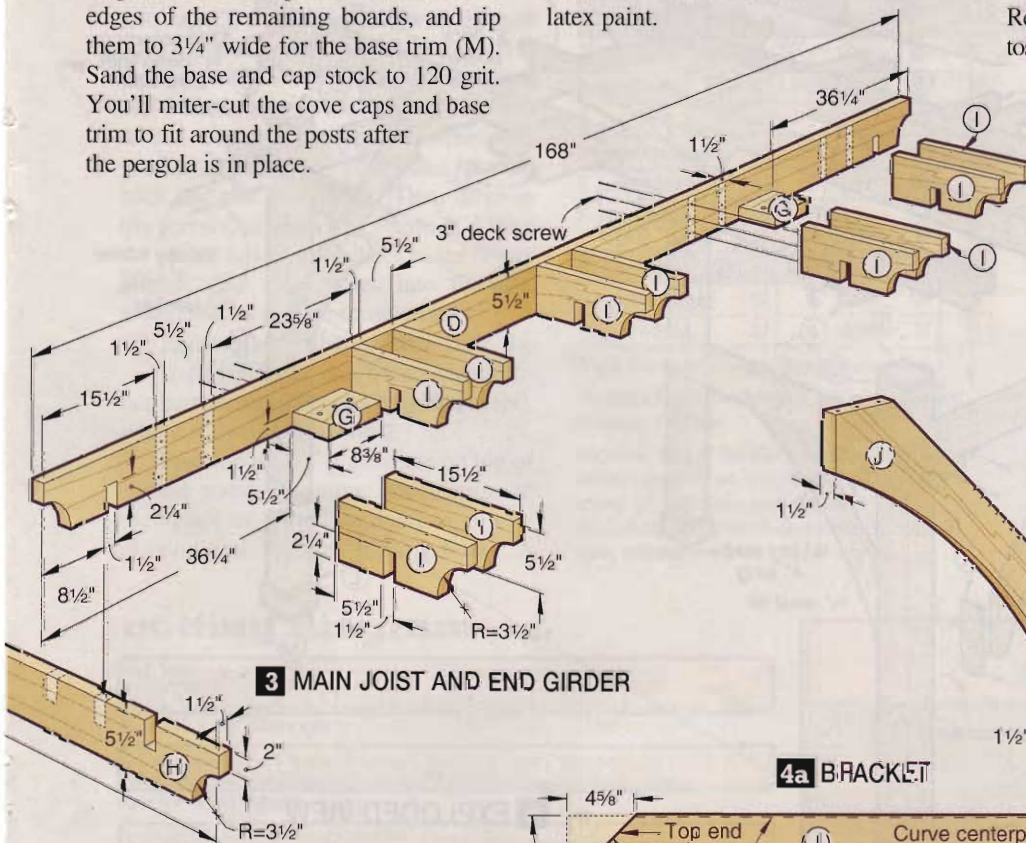

3 MAIN JOIST AND END GIRDER

4a BRACKET

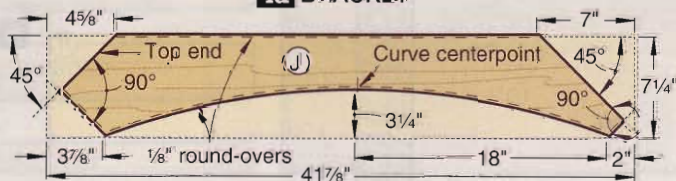

4 BRACKET MOUNTING

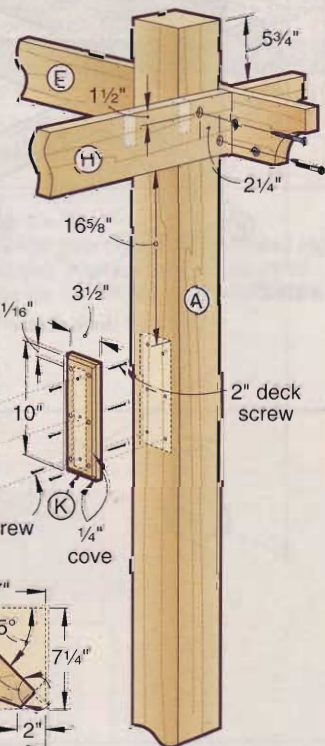

How to assemble the pergola (continued)

step 4



Lag-screw each end girder to two posts, where shown on **Drawing 4**. Stand these assemblies up in the post bases, plumb, and brace them in place. Screw the bases to the posts, as shown on **Drawing 1**.

step 5



Slip the end notches of the side girders (E) into the notches of the end girders (H). The tops of both girders are flush. Drill $\frac{1}{4}$ " pilot holes, and lag-screw the side girders to the posts.

step 6



Hoist the main joist/stub joist assemblies (D/I) into place, slipping the stub joist and main joist notches over the side girders (E) and the end girders (H). Fasten with deck screws, as shown.

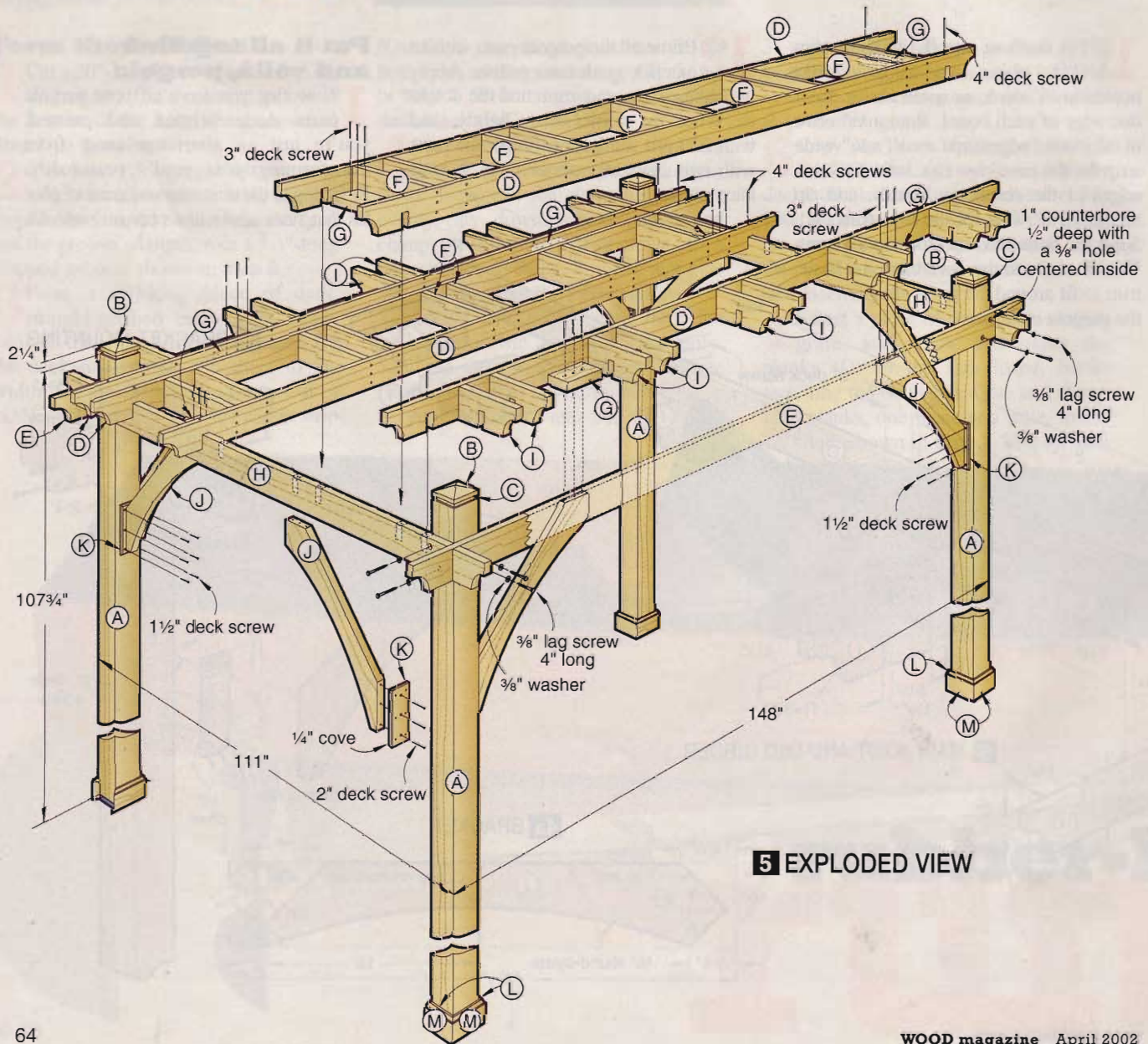

step 7



Position the main joist/blocking assemblies (D/F), slipping the main joist notches over the end girders. Leave 5½" spaces between the main joists of adjacent assemblies. Fasten with screws.

step 8



Screw the lower bracket cleats (K) to the brackets (J), where shown on Drawing 4. Screw the bracket assemblies to the posts and the upper bracket cleats (G), where shown on Drawings 4 and 5.

step 9



Miter-cut the base trim (M) to fit around the post bases. Apply construction adhesive and band-clip, as shown. Miter-cut the cove cap (L) to fit around the post, and nail it in place.

make up the subassemblies, erect the posts and girders, and assemble the canopy and braces. All you'll need is some basic hardware: deck screws, lag screws, and steel post bases (Simpson Strong Tie no. AB66). To give us secure anchorage for the post bases, we added blocking underneath the deck. When lag-screwing the girders to the posts, drill counterbored shank holes through the girders and ¼" pilot holes into the posts. When fastening parts with deck screws, drill only countersunk shank holes. The deck screws drive into the cedar without pilot holes.

2 Finish off your pergola by driving 3" deck screws through the side girders (E) and the end girders (H) into the upper bracket cleats (G). Remove the temporary braces from the posts. Drill countersunk shank holes through the post caps (B/C). Apply construction adhesive to the bottoms of the caps, and screw the caps to the tops of the posts. Touch up the paint where needed. 🌳

Written by Jan Svec with Kevin Boyle
Project design: Kevin Boyle; James R. Downing
Illustrations: Roxanne LeMoine; Kim Downing; Lorna Johnson
Photographs: Baldwin Photography

materials list

Part	FINISHED SIZE			Matl.	Qty.
	T	W	L		
A posts	5½"	5½"	107¾"	C	4
B cap tops	1½"	5½"	5½"	C	4
C cap bases	¾"	4½"	4½"	C	4
D main joists	1½"	5½"	168"	C	8
E side girders	1½"	5½"	168"	C	2
F blocking	1½"	5½"	22"	C	30
G upper bracket cleats	1½"	5½"	8¾"	C	8
H end girders	1½"	5½"	131"	C	2
I stub joists	1½"	5½"	15½"	C	20
J* brackets	1½"	7¼"	40¾"	C	8
K lower bracket cleats	¾"	3½"	10"	C	8
L* cove caps	¾"	¾"	7"	C	16
M* base trim	¾"	3¼"	7½"	C	16

*Parts initially cut oversize. See the instructions.

Material Key: C—cedar.

Supplies: 1½" deck screws, 2" deck screws, 3" deck screws, 4" deck screws, ¾" lag screws 3" long, ¾" lag screws 4" long, ¾" flat washers, 4d galvanized finish nails, steel post bases (4), construction adhesive, primer, paint.

cutting diagram

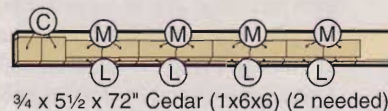
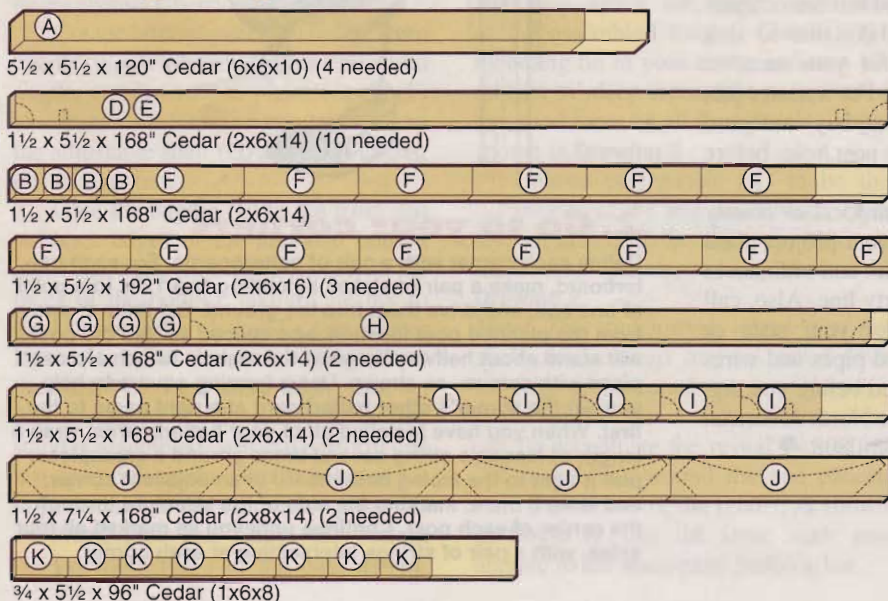

be a post master

Well-built outdoor projects start with accurate layout of post locations.

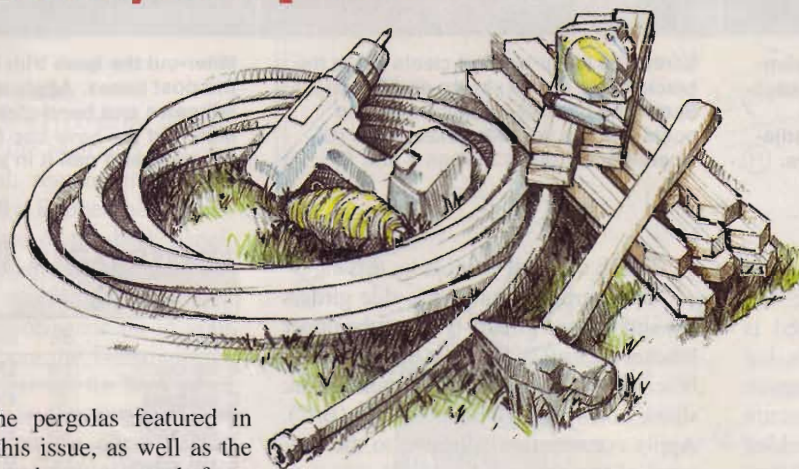

The pergolas featured in this issue, as well as the garden gate and fence

projects still to come, call for posts set in straight lines and with square corners. A few 1×2s, a length of mason's string, and simple arithmetic will get you to that goal.

The illustrations and captions on these pages show you the essential steps in locating and lining up the posts you'll need. Posts set in the ground, and anchored with concrete, are the best way to support a gate, a fence, or a pergola with an attached swing.

Use posts made of pressure-treated lumber or foundation-grade (heartwood) cedar. Make sure to sink them deeper than the frost line for your area, to counter the effects of frost heaving. For a neater job, and added protection against heaving, buy cardboard tubes at your home center to line the post holes before filling them with concrete.

Before you go too far, check with local or county government officials to make sure your project plans are in compliance with building codes and ordinances regarding setback from your property line. Also, call the "One Call" phone number for your state or province, and ask to have the buried pipes and wires on your property located and marked before you dig. If you can't find the number, call the North American One Call Referral System at 888/258-0808. ♣

Illustrations: Mike Mittermeier

1. Get organized

You don't need much equipment to lay out posts for an outdoor structure. For an easy way to visualize its size and shape, use a tape measure and a garden hose to outline your project's dimensions on the ground. Then gather some 1×2 lumber and cut it into 3' lengths for "batterboards." You also will need a heavy hammer to drive the upright stakes into the ground, a drill and 1½" deck screws for quick assembly, a plumb bob, and a spool of mason's string.

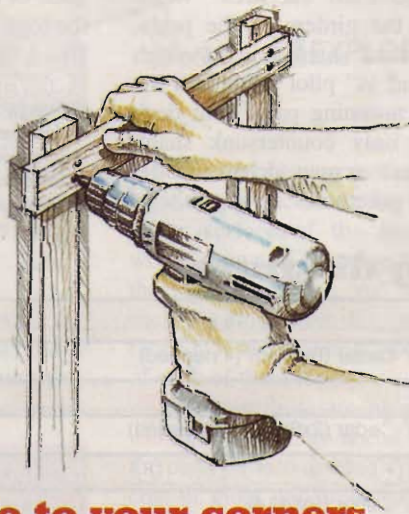

2. Go to your corners

Define each corner with a pair of batterboards. For each batterboard, make a pair of stakes by cutting two 1×2s to a point at one end, and drive them into the ground. Set them 2' away from the planned post location, and spaced so that the post will stand about halfway between the stakes. Attach a crosspiece with screws, as shown. Use a framing square to help you set the corner's other batterboard at a right angle to the first. When you have installed all of your batterboards, wrap a length of mason's string several times around a crosspiece, pull it tight to the facing batterboard at an adjacent corner, and wrap it there, marking the side of the structure through the center of each post. Continue until you've marked all four sides, with a pair of strings intersecting at each corner.

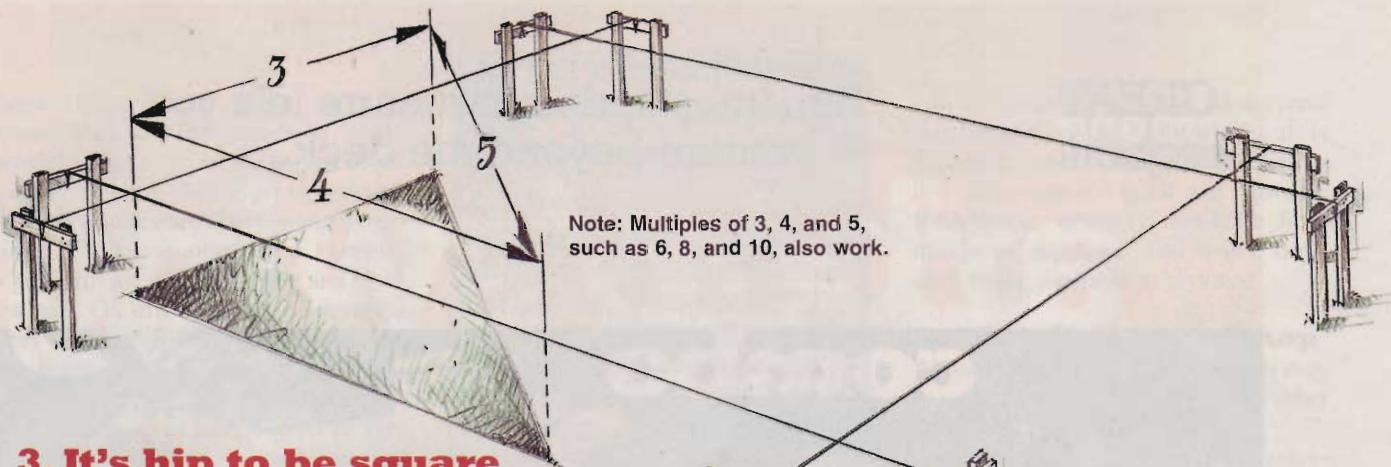

Note: Multiples of 3, 4, and 5, such as 6, 8, and 10, also work.

3. It's hip to be square

At one corner of your planned structure, measure from the corner to a point 3' away on one string, and mark the spot on a piece of masking tape folded over the string. Then, measure the perpendicular string 4' out from the corner, and mark that point. Now, measure between your two marks. If the distance equals 5', the strings lie at right angles to one another. If the distance is less than or greater than 5', relocate the string on your batterboard until it's right on the money. Mark the correct spot on the board with a nail, or a handsaw kerf, in case the string gets moved by accident. Check the adjacent corners for square, and finish up at the opposite corner.

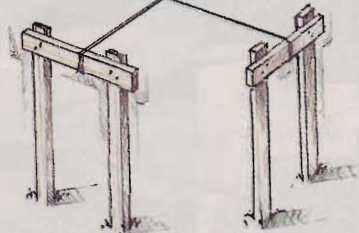

4. X marks the spot

At each corner, transfer the strings' intersection down to the ground with a plumb line. You can find an inexpensive plumb bob at a home center, and a camera or telescope tripod makes a handy holder. Keep the plumb line about 1/8" away from the strings, so that you're not pushing them out of position. The plumb bob locates the spot for the center of the post. Mark that point, then remove the strings to make room for digging.

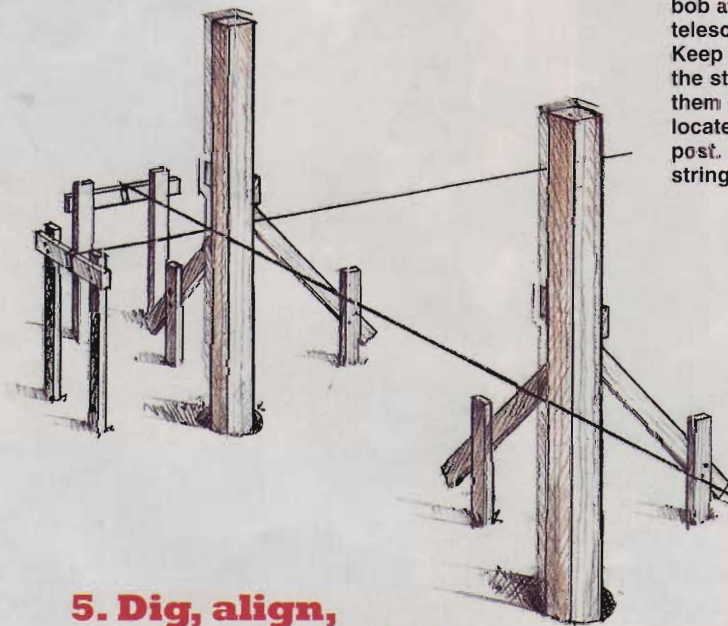
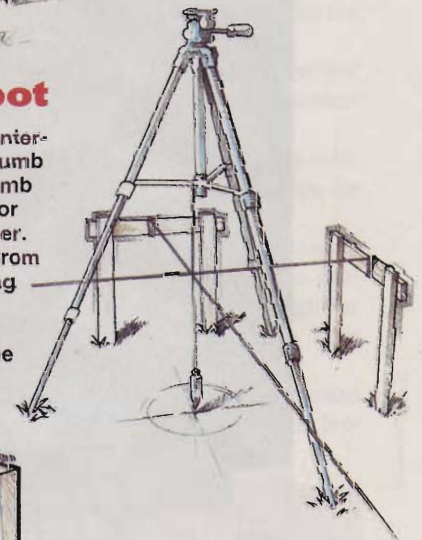

5. Dig, align, and finish the job

Dig an 8"-diameter hole at least 6" deeper than your area's frost line for each 4x4 post, using a power auger, hand auger, or post-hole digger. A 6x6 post requires a 10"-diameter hole. Shovel a 6" layer of gravel into the hole to provide drainage. Now, put the strings back on the batterboards, but move them toward the outside of the layout by one-half the post thickness. Set each post in its hole, and move it until the outside edge lines up with the string. Attach two braces to adjacent sides of the post with screws, and drive a stake next to each brace. Use a level to make sure the post is plumb—check adjacent sides—and fasten the braces to the stakes with screws. When everything lines up, add water to premixed concrete, and fill the holes.

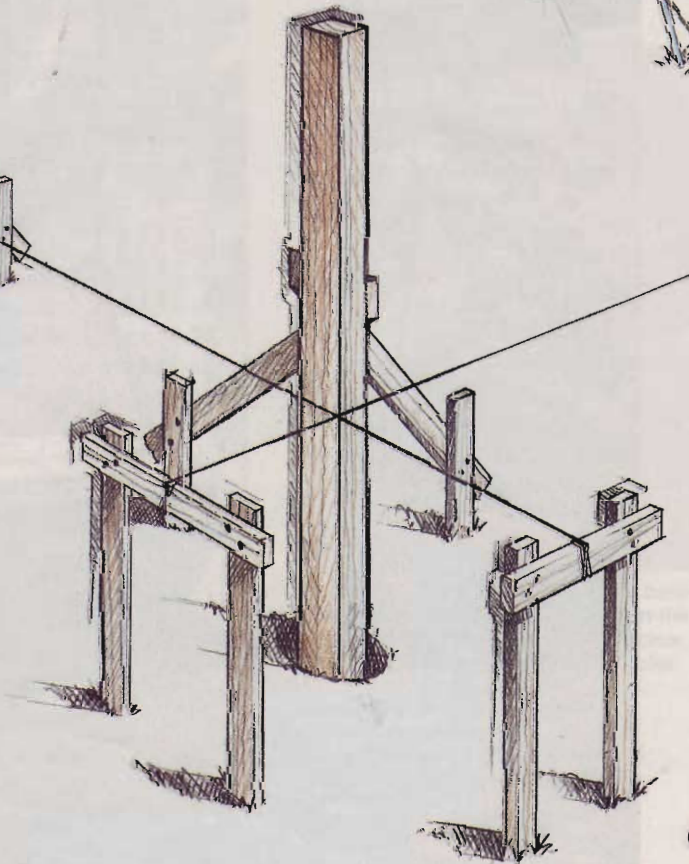

**GREAT
OUTDOOR
PROJECTS**

This freestanding structure lets you
venture beyond the deck.

arbor/swing combo



The construction method used in the previous article for the deck pergola is very versatile. With a little imagination and planning, it adapts to any number of outdoor applications.

We combined a porch swing from our library of WOOD PLANS® with a reconfigured pergola. The result is a great place to relax and watch the world go by. See the Buying Guide for the swing plan. (We made our swing out of cedar.) Here's how to build the swing's pergola.

Plant four posts on a level spot

1 Dig four 10"-diameter holes spaced where shown on **Drawing 1**. The article "Be a post master" on page 66 shows you how to accurately locate and temporarily brace your posts. To support the swing, the posts extend at least 36" below grade. Because of the frost line in our location, our posts extend 42" below grade. Check your local requirement. Dig holes deep enough to allow for a 6" layer of gravel at the bottom for drainage, as shown on **Drawing 2**.

Note: Our swing is 58½" wide. The pergola is sized to leave about 8" of clearance at each end between swing and posts. If you use a different swing, you may have to modify the pergola to maintain this clearance.

2 Position four 6x6x12' (5½x5½" actual) pressure-treated posts (A) in the holes, plumb them, and brace them in place. Make sure that the distance between the posts is the same at the top as at the grade. Set them in concrete, as shown on **Drawing 1a**.

3 When the concrete hardens, remove the bracing from the posts. Make a mark 95¾" up from grade on one post. Using a straight board and a level, transfer this top mark to the other posts. Measure the offset on your portable circular saw between the edge of its base and

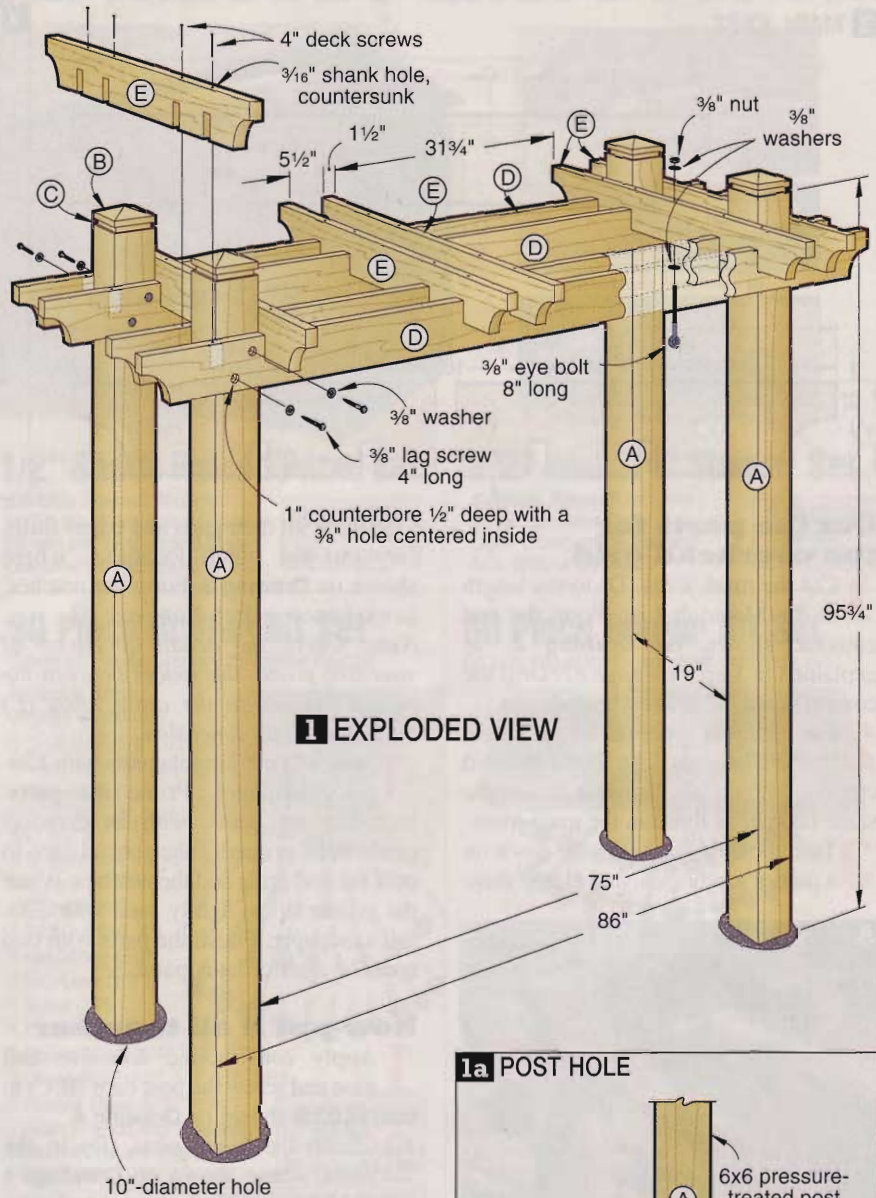

1 EXPLODED VIEW

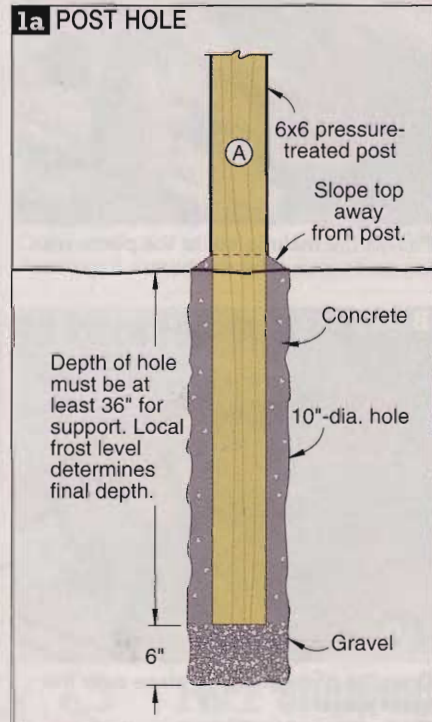

the blade. Measure this offset distance down from the marked top line, and draw a level line around all four sides of each post. Temporarily nail a short board to one side of the first post with its top edge at this lower line. Setting your saw to its maximum depth, use the board to guide your saw as you make the cut. In this manner, work your way around the post's other three sides. Finish cutting through the post with a handsaw. Repeat this procedure on the other three posts, making them even in height.

4 Make four post caps (B/C), as explained in *Step 2* on page 61. Set them aside.

2 MAIN JOIST

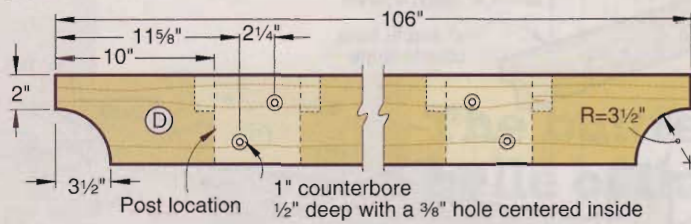

3 CROSS JOIST

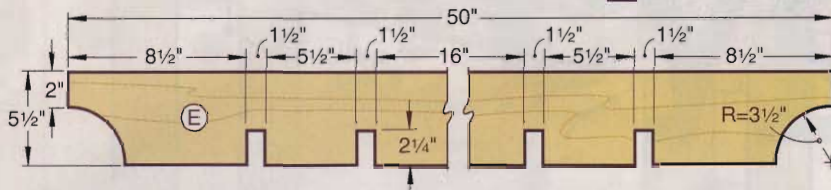

Cut the parts for the overhead grid

1 Cut the main joists (D) to the length in the Materials List. Form the end cutouts, shown on **Drawing 2**, as explained in *Step 3* on page 61. Drill the counterbored 3/8" holes where shown.

2 Cut the cross joists (E) to the length in the Materials List. Form the end cutouts, shown on **Drawing 3**, in the same manner as those in the main joists.

3 Turn the cross joists upside down on a pair of sawhorses, and clamp them

together with their ends and edges flush. Lay out the notch locations, where shown on **Drawing 3**. Form the notches, as explained in *Step 4* on page 62.

Note: Check the actual dimension of your 6x6 posts. The spaces between the paired notches in the cross joists (E) must match this dimension.

4 Sand all your pergola parts with 120-grit sandpaper. Prime the parts, including the posts, with an exterior-grade latex primer. Take special care to coat the end grain and the notches. When the primer dries, lightly sand with 220-grit sandpaper. Finish the parts with two coats of exterior latex paint.

4 POST

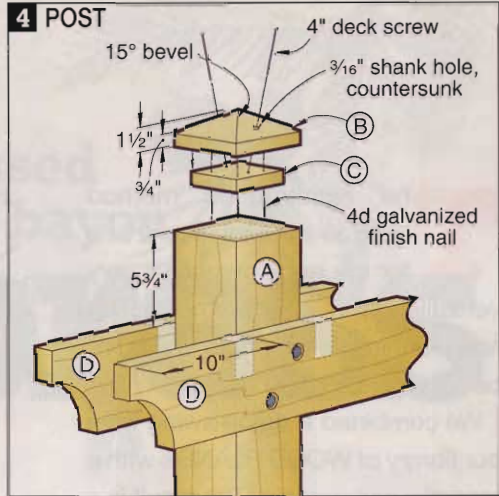

shank holes through the cross joists at each notch. Drive 4" deck screws through the cross joists into the main joists.

4 Drill 3/8" holes for the eye bolts, centered between the posts and in the thickness of the cross joists, where shown on **Drawing 1**. Touch up the paint where needed. With the paint dry, install the eye bolts, and hang the swing.

Written by Jan Svec with Kevin Boyle
Project design: Kevin Boyle; James R. Downing
Illustrations: Roxanne LeMoine; Kim Downing; Lorna Johnson
Photographs: Baldwin Photography

materials list

Part	FINISHED SIZE			Matl.	Qty.
	T	W	L		
A posts	5 1/2"	5 1/2"	†	PT	4
B cap tops	1 1/2"	5 1/2"	5 1/2"	C	4
C cap bases	3/4"	4 1/2"	4 1/2"	C	4
D main joists	1 1/2"	5 1/2"	106"	C	4
E cross joists	1 1/2"	5 1/2"	50"	C	6

†Length varies depending on depth of frost line. See the instructions.

Materials Key: PT—pressure-treated lumber, C—cedar.

Supplies: 3/8" lag screws 4" long (16), 3/8" flat washers (20), 4" deck screws (32), 4d galvanized finish nails, 3/8" eye bolts 8" long (2), 3/8" nuts (2), construction adhesive, primer, paint, gravel, concrete mix (approximately 5 cubic feet).

Buying Guide

Swing plan. Order porch swing plan no. WP-OFS-1002, \$10.95, by calling 888/636-4478, or go to WOOD PLANS® at www.woodstore.woodmall.com.

Now put it all together

1 Apply construction adhesive and glue and screw the post caps (B/C) to the posts, as shown on **Drawing 4**.

2 Clamp the main joists (D) to the posts, where shown on **Drawings 1** and **4**. Make sure the joists are level side-to-side and that the front pair of joists is level with the back pair. Using the counterbored holes in the joists as guides, drill pilot holes into the posts. Drive in the lag screws, as shown in **Photo A**.

3 Place the cross joists (E), where shown on **Drawing 1**. The notches in the cross joists fit over the main joists, as shown in **Photo B**. Drill countersunk



Fasten the main joists to the posts with lag screws and flat washers.



Drop the cross joists in place over the main joists.

cutting diagram

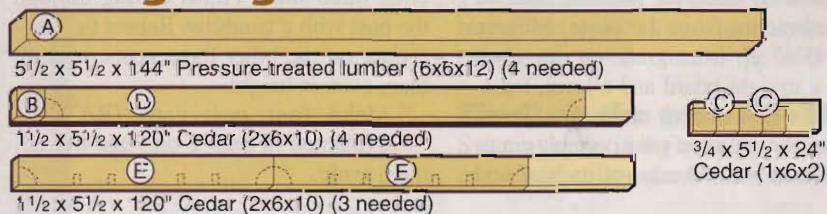

**GREAT
OUTDOOR
PROJECTS**

Go from plain to pleasing
with new railings and
planter-box columns

high-style deck railing



Replace wimpy corner posts with shingled columns, and give your deck a solid structural look and architectural flair. Then, add planter inserts in the columns' tops to brighten your deck with flowering greenery.

Constructed with pressure-treated plywood, PVC lumber (see the sidebar on *page 74*), and fiber-cement shingles, these columns and railings will give you years of maintenance-free enjoyment. And for added strength, we built the railing's top member around 1½" galvanized steel pipe.

Build and install the columns

Note: This section covers the installation of a column at the corner of a deck. The installation of a column between corners is the same, except that three sides of the column must be notched to fit over the deck's edge. The Materials List specifies the materials for one column and one length of railing.

1 Once you determine the length of your columns' sides (A) (see the sidebar, "Planning your installation"), cut the plywood, and glue and screw the columns together. (We glued with polyurethane construction adhesive.) Lap the corners, as shown on **Drawing 1**, making boxes whose inside dimensions are 15×15".

2 Cut the insert cleats (B) to the size in the Materials List, and attach them where shown.

3 Mark lines on the deck 11½" in from the edges, then extend the lines down

1 COLUMN CARCASE

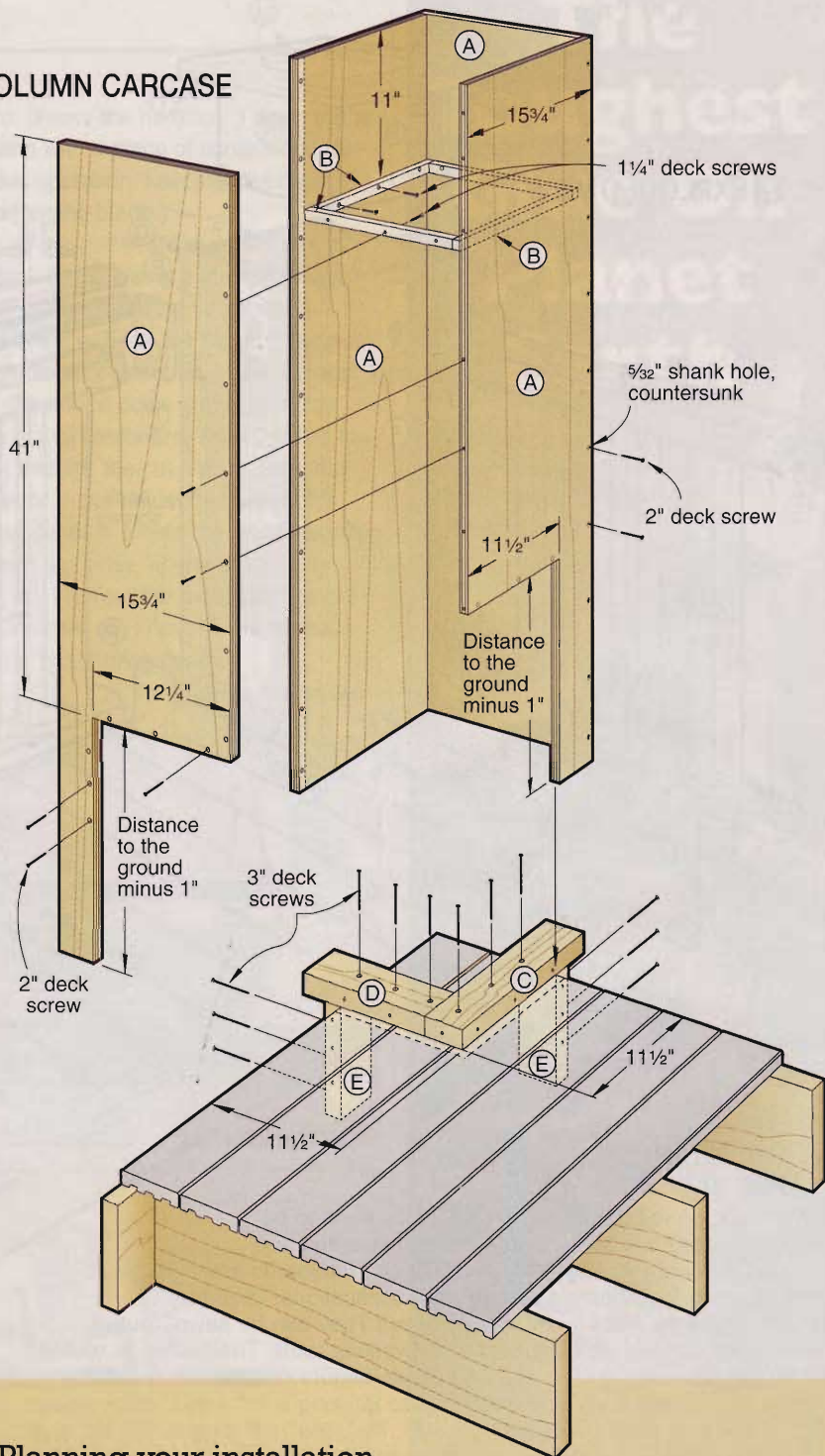

Planning your installation

We located planter-box columns at the deck's outside corners, where the railings terminate next to the house, and alongside the steps that descend to the yard. Also, if a length of railing would exceed 12', we added a column to shorten the span.

The columns are notched so their outside faces extend almost down to ground level. This gives them the appearance of supporting the deck. To determine the overall length of your columns' sides (A), measure from the deck surface to the ground, and subtract 1". Add this dimension to 41" (the columns' height above the deck). Our deck surface is about 18" above grade, so we cut our sides 58" long. To fit the columns to our deck, we then cut 17"-long notches out of the column carcasses, shown on **Drawing 1**. Once your columns are in place, measure between them for railing lengths.

2 EXPLODED VIEW

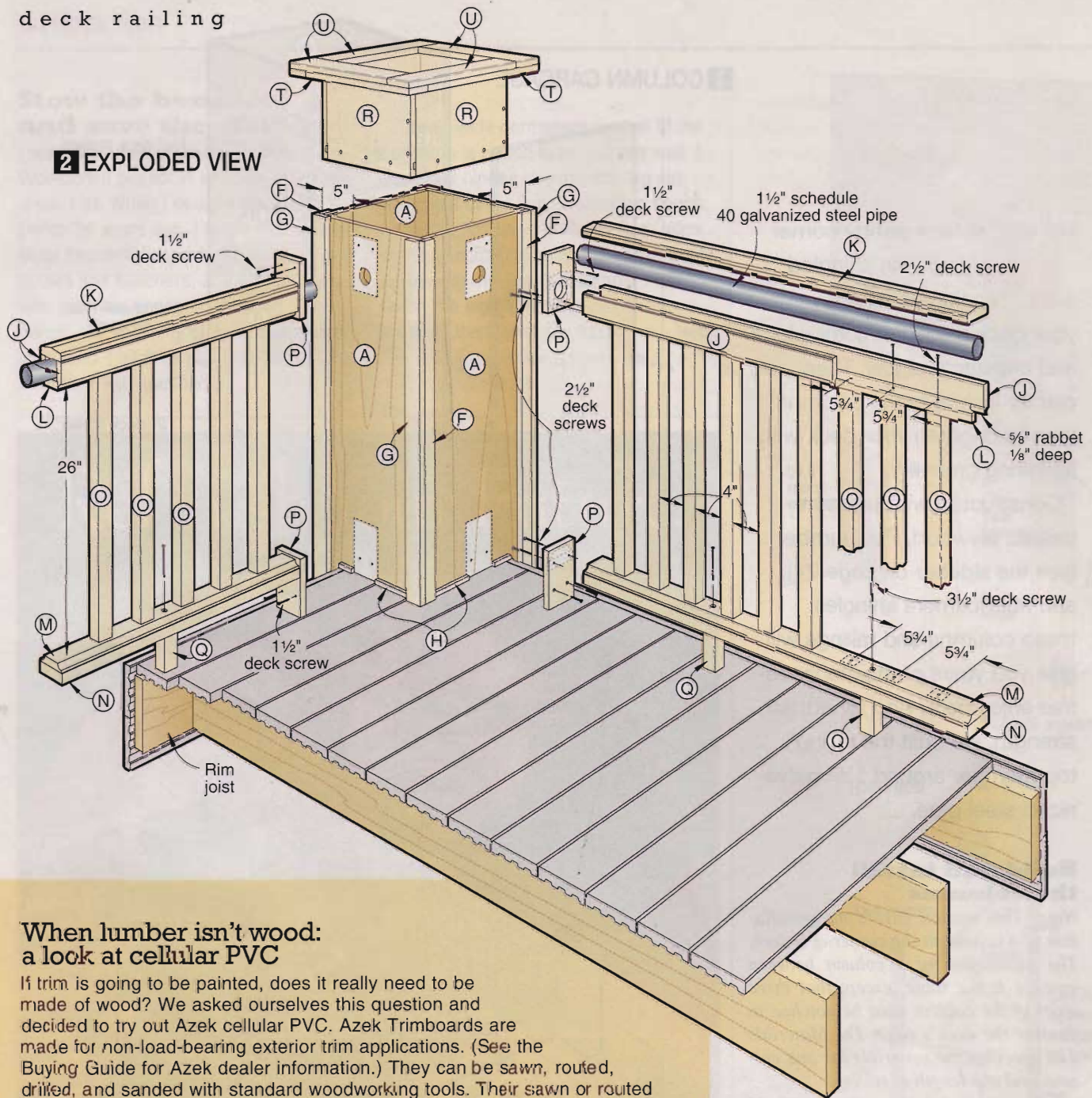

**When lumber isn't wood:
a look at cellular PVC**

If trim is going to be painted, does it really need to be made of wood? We asked ourselves this question and decided to try out Azek cellular PVC. Azek Trimboards are made for non-load-bearing exterior trim applications. (See the Buying Guide for Azek dealer information.) They can be sawn, routed, drilled, and sanded with standard woodworking tools. Their sawn or routed edges are void free and have a fine dense texture comparable to MDF.

Azek is available in 4'-wide sheets up to 20' long in 3/4" and 1" thicknesses, and in nominal lumber widths (3 1/2", 5 1/2", 7 1/4", 9 1/4") 18' long in 5/8", 3/4", and 1" thicknesses. Some prefabricated components, such as the 1 3/4 x 1 3/4 x 26" balusters used in the railings, are also available.

Azek can be screwed, hand-nailed, or nailed with a nail gun. Glue it to other materials using standard construction adhesives. Bond it to itself with PVC cement. (The manufacturer recommends Gorilla PVC, a nonflammable cement that provides adequate working time. See the Buying Guide for our Gorilla PVC cement source.)

Although the material is white throughout, and has a smooth semigloss surface, the texture of cut or routed edges will look dull, so you may want to paint it. For best results, use high-quality 100% acrylic latex primer and paint. Because it absorbs no moisture and is impervious to water vapor, Azek has superior paint-holding characteristics, is insectproof, and will never rot.

the deck's outside face. Cut 2x4 cleats (C, D, E) to size. Align their edges with the marked lines, and screw them in place, as shown in **Photo A**.

4 Mark the cutout, shown on **Drawing 1**, on the column. Guiding your saw with a straightedge, cut out the notch, as shown in **Photo B**.

5 Set the notched column over the cleats, and check it with a level for plumb. Secure it with deck screws driven through the plywood and into the cleats.

3 RAIL SECTION

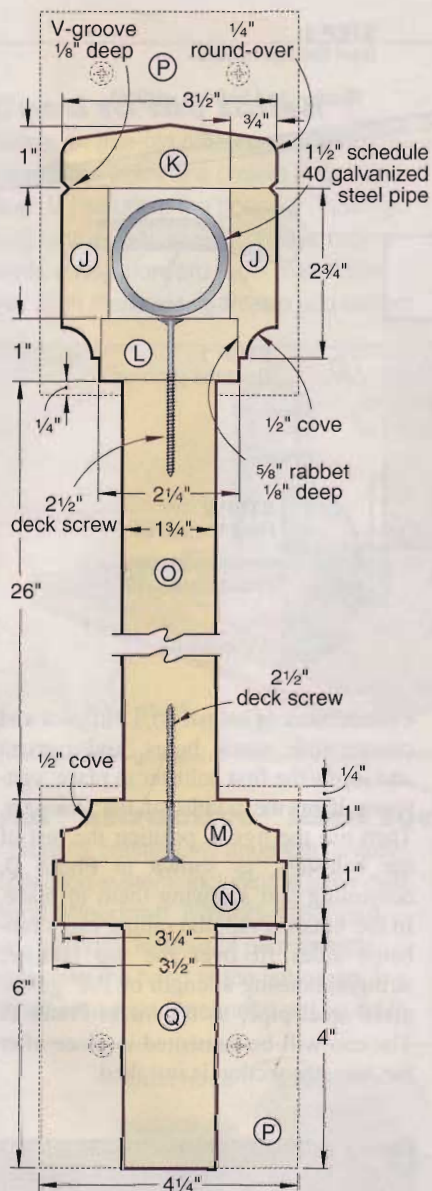

3a UPPER RAIL BRACKET

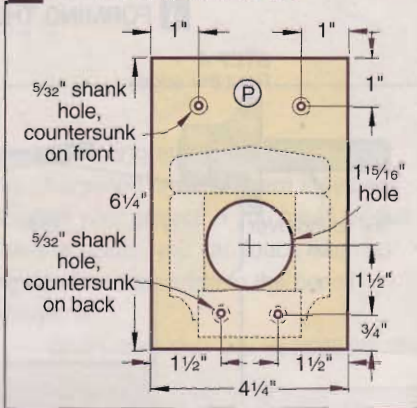

3b LOWER RAIL BRACKET

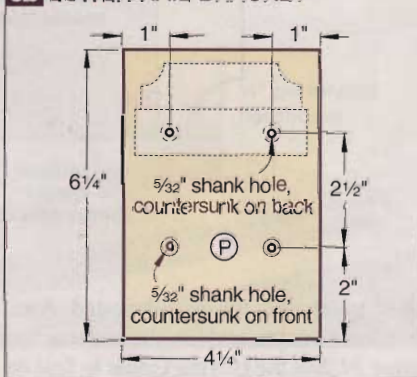

Fabricate the railing cap

With the column carcasses in place, measure the distance between them, and subtract 2" for the thickness of the two rail brackets (P), as shown on **Drawing 2**. Cut the upper rail sides (J), upper rail top (K), upper baluster stringer (L), lower baluster stringer (M), and lower rail (N) to this length. Rout the coves in the lower baluster stringer, where shown on **Drawing 3**. Set the



A Fasten the cleats (C, D, E) to the deck with 3"-long deck screws.



B To guide your saw, temporarily nail a short, straight board to the column.

materials list

Column	FINISHED SIZE			Matl.	Qty.
	T	W	L		
A sides	3/4"	15 3/4"	†	PTP	4
B insert cleats	3/4"	3/4"	14 1/4"	A	4
C deck cleat 1	1 1/2"	3 1/2"	15"	PT	1
D deck cleat 2	1 1/2"	3 1/2"	11 1/2"	PT	1
E deck cleat 3	1 1/2"	3 1/2"	8 1/2"	PT	2
F narrow battens	3/4"	1 1/2"	†	A	4
G wide battens	3/4"	2 1/4"	†	A	4
H* starter strips	7/16"	3/4"	54"	A	1
I shingles	1/4"	††	††	FC	†
Railing					
J upper rail sides	3/4"	2 3/4"	†	A	2
K upper rail top	1"	3 1/2"	†	A	1
L upper baluster stringer	1"	2 1/4"	†	A	1
M lower baluster stringer	1"	3 1/4"	†	A	1
N lower rail	1"	3 1/2"	†	A	1
O balusters	1 3/4"	1 3/4"	26"	A	†
P rail brackets	1"	4 1/4"	6 1/4"	A	4
Q blocking	1 3/4"	1 3/4"	4"	A	†
Planter insert					
R sides	3/4"	11 3/4"	14"	A	4
S bottom	3/4"	13 3/4"	13 3/4"	A	1
T trim base	3/4"	2 3/4"	17 1/2"	A	4
U trim	3/4"	3 1/2"	16 3/4"	A	4

*Part's initially cut oversize. See the instructions.

†Lengths or numbers of parts determined by your deck's requirements.

††Cut to fit. See the instructions.

Materials Key: PTP—pressure-treated plywood, A—Azek Trimboards cellular PVC, PT—pressure-treated lumber, FC—fiber-cement shingles.

Supplies: 1 1/2", 1 1/2", 2", 2 1/2", 3", and 3 1/2" deck screws; 4d galvanized finish nails; 4d galvanized box nails; 1" roofing nails; 1 1/2" schedule 40 galvanized steel pipe; polyurethane construction adhesive; masking tape; latex wood filler; acrylic latex primer; acrylic latex paint; packing peanuts; potting soil. For the baluster-spacing jig, you'll need two 1/4x4x5" pieces of hardboard and eight 3/4x3/4x7 1/2" wood cleats.

Buying Guide

Bits. 1/2" cove bit with 1/2" shank, no. 8643, \$16; 1 15/16" Forstner bit no. 9228, \$13.95. MLCS, PO Box 4053, Rydal, PA 19046-6053. Call 800/533-9298, or go to mlcswoodworking.com.

Cellular PVC. For Azek Trimboards information, call Vycom at 800/235-8320, or go to www.azek.com. For balusters and deck components, go to www.deckandporchsupply.com.

PVC cement. 32-ounce can Gorilla PVC cement, no. R-3200, \$16.95. Gorilla PVC Cement LLC, PO Box 873969, Hollywood, FL 33084, or call 888/367-4583.

Fiber-cement shingles. For Hardie Shingleside Heritage Single Shingle product and dealer information, call James Hardie Building Products, 888/542-7343, or go to www.jameshardie.com/shingleside.htm.

upper baluster stringer (L), lower baluster stringer (M), and lower rail (N) aside.

2 Chuck a $\frac{3}{4}$ " straight bit in your table-mounted router, and rout $\frac{5}{8}$ " rabbets $\frac{1}{8}$ " deep in the upper rail sides (J), where shown on **Drawing 3**. Clamp the upper rail sides together, separated by temporary 2x2" spacers, as shown in **Photo C**. Make sure the rabbets face inward and the ends of the rail sides are even.

3 Spread PVC cement on the top edges of the rail sides. Slide the upper rail top (K) under the clamps, and secure it to the sides with masking tape. Make sure the ends and edges are flush.

4 With the cement set, remove the tape. Using your table-mounted router and tablesaw, follow the four steps shown on **Drawing 4** to form the upper rail. Sand the saw blade marks from the top bevel, and blend the round-overs into the beveled surfaces. Remove the spacers, and set the railing cap aside.

Assemble a sturdy balustrade

1 To figure the number of balusters (O) you need, make a "story pole" about 1' longer than the length of your railing, and mark it off in $5\frac{3}{4}$ " intervals. (The maximum allowable space between the $1\frac{3}{4} \times 1\frac{3}{4}$ " balusters is 4".) Shift the pole back and forth on one baluster stringer until you can locate balusters equally spaced no more than 3" from each end. (3" plus the 1"-thick rail bracket equals the 4" maximum spacing.) Count the number of needed balusters.

4 FORMING THE RAILING CAP

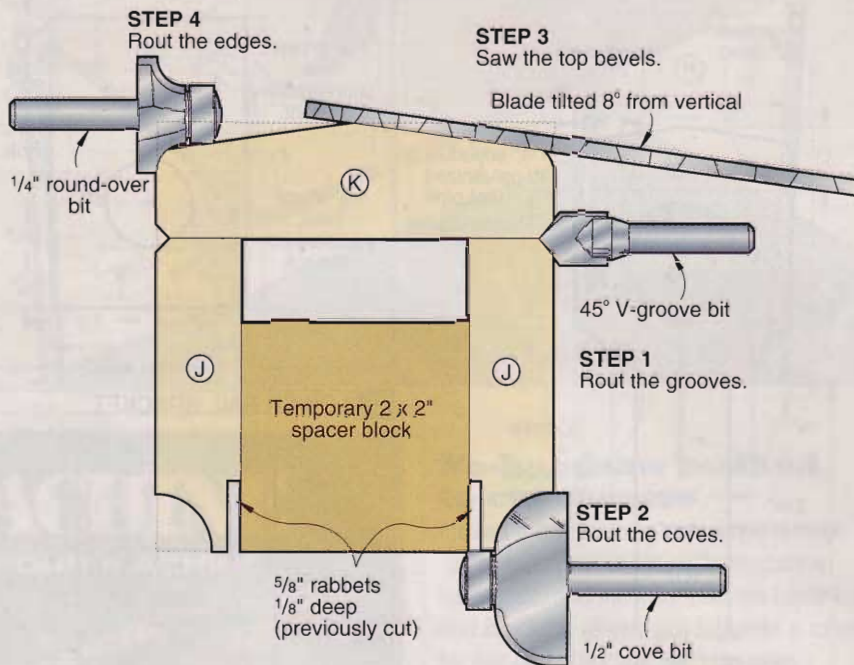

(We purchased the prefabricated Azek balusters mentioned in the sidebar on page 74. See the Buying Guide to find an Azek dealer near you.)

2 To make baluster spacing/centering jigs, cut two $\frac{1}{4} \times 4 \times 5$ " hardboard spacers and eight $\frac{3}{4} \times \frac{3}{4} \times 7\frac{1}{2}$ " cleats. Glue and clamp together the upper and lower jigs, as shown on **Drawing 5**.

3 Mark the upper and lower baluster stringer (L, M) centers (if you have an odd number of balusters), or $2\frac{7}{8}$ " to one side of the centers (if you have an

even number of balusters). Drill pilot and countersunk shank holes, and cement and screw the first baluster in place, centering it on the widths of the stringers. Then use the jigs to position the rest of the balusters, as shown in **Photo D**, cementing and screwing them in place. In the finished rail, the railing cap's rabbeted sides fit over the top baluster stringer, housing a length of $1\frac{1}{2}$ " galvanized steel pipe, as shown in **Photo E**. The cap will be cemented in place after the baluster section is installed.

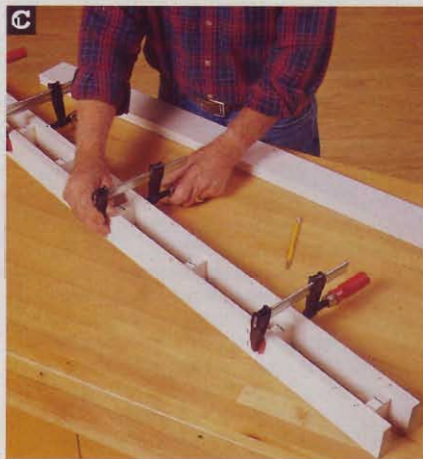

Clamp 2x2" scrap blocks between the upper rail sides (J) to keep them properly spaced and parallel.

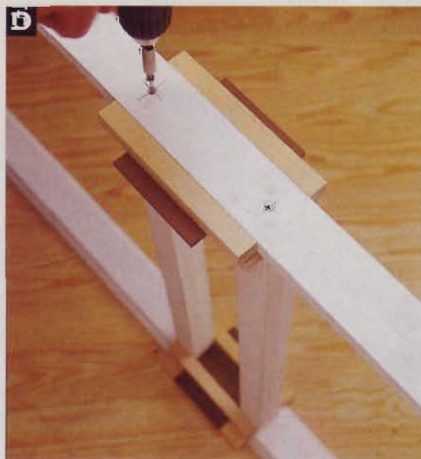

Use the spacing jigs to maintain 4" spaces between balusters and keep them centered on the stringers.

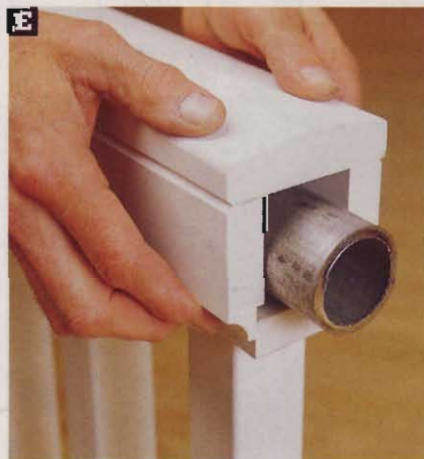

The hollow space formed by the railing cap and upper baluster stringer houses a length of $1\frac{1}{2}$ " galvanized steel pipe.

Install the railing

1 Cement and clamp the lower rail (N) to the lower baluster stringer (M). Cut four rail brackets (P) for each section of railing. With a Forstner bit, drill $1\frac{1}{16}$ " holes in the upper pair, where shown on **Drawing 3a**. (See the Buying Guide for a bit source.) Then drill countersunk shank holes, where shown on **Drawings 3a** and **3b**. Cement and screw the brackets to the ends of the upper and lower baluster stringers, where shown on **Drawing 3**.

2 Slide the railing section between the previously installed columns. With the bottom rail brackets resting directly on the deck, screw the brackets to the columns, where shown on **Drawing 2**.

3 Using the hole in the upper rail bracket (P) as a guide, drill a $1\frac{1}{16}$ " hole through the column side, as shown in **Photo F**. Mark a corresponding centerpoint on the corner column's opposite side, and drill another hole.

4 Measure the distance between two columns. Add the thickness of two column sides. Cut $1\frac{1}{2}$ " galvanized steel pipe to this length. Feed it through the first column, over the baluster assembly, and into the second column, as shown in **Photo G**. The pipe must engage the columns' plywood sides at both ends of the railing.

5 Cut pieces of baluster stock for the blocking (Q), and center them under every fourth baluster space. Drill countersunk shank holes through the lower stringer/rail assembly, and drive in the screws, as shown in **Photo H**.



Guided by the hole in the upper bracket, drill a $1\frac{1}{16}$ " hole through the column. Repeat at the railing's other end.



A hole in the column face opposite the railing facilitates the installation of the $1\frac{1}{2}$ " galvanized steel pipe.



To prevent sagging install 4"-long pieces of baluster stock between the deck and bottom rail assembly.

5 SPACING/CENTERING JIGS

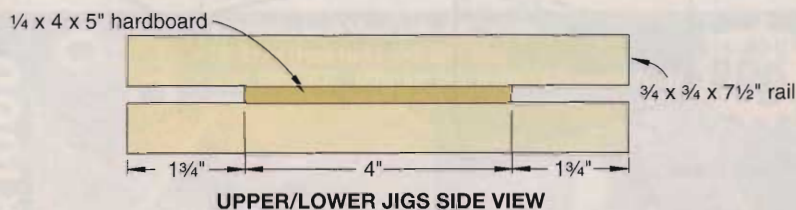
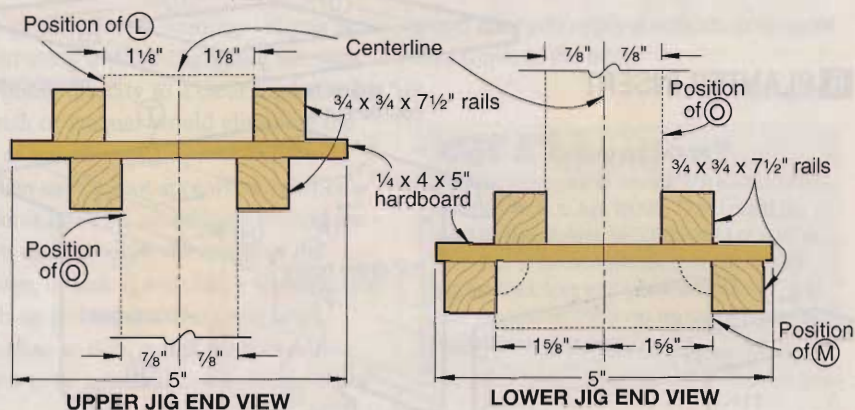

6 Center the pipe so its ends are flush with the insides of the columns. Spread PVC cement on the railing cap's bottom inside rabbets and slide the cap over the pipe, seating it on the upper baluster stringer.

Shingle the column

1 Measuring the column's corners for their lengths, cut the narrow and wide battens (F, G) to size. Glue and clamp them together, forming L-shaped assemblies. Nail them to the columns with 4d galvanized finish nails.

2 Rip one 54" length of starter strip (H) for each column. From this strip, cut pieces to fit around the bottom of the column. Nail them in place with 4d galvanized box nails. Where the column is notched around the deck, install the strips on the horizontal portions. Leave $\frac{1}{4}$ " between the strips and the decking.

3 Now, calculate your shingle needs. The $\frac{1}{4}$ "-thick 18"-long fiber-cement shingles that cover the columns come in 6", 8", and 12" widths. Because the width of our sides is $13\frac{1}{2}$ ", we used only the 6" and 8" widths. (See the Buying

6 PLANTER INSERT

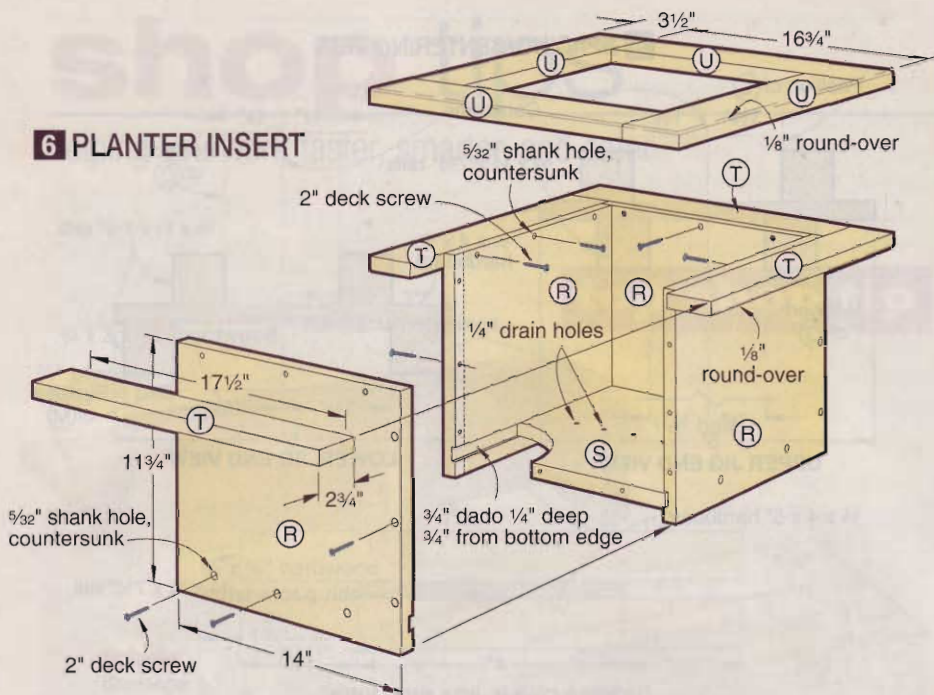

The planter inserts in the top of each column lift out for easy maintenance.

Guide for shingle information.) Using a 7/4" carbide-tipped blade in a tablesaw, we cut the lengths in half, making 8 1/16"-long shingles.

First you'll need to figure out the shingle course spacing, then count the total number of courses on all the columns. To do this, divide the column's total height by 7 1/2" (the optimum exposure), then stretch or shrink the exposure to obtain consistent courses top to bottom. Try to maintain a 7 1/4"-7 3/4" exposure (1 1/4"-1 3/4" course overlap). Keep the course lines even all around each column

and from column to column. To keep the courses even where the columns notch over the deck, you may have to cut short courses of shingles. When counting the courses, include any short ones. Now, divide the total number of courses by two. (You're getting two 8 1/16"-long shingles out of each 18"-long one.) Finally, divide this number by two, and purchase this many each of the 6x18" and 8x18" shingles.

4 Use one 6"- and one 8"-wide shingle per course, trimming the 6" shingle to fit. Fasten them with construction adhesive and 1" roofing nails, maintaining the proper exposure, as shown in Photo 1. Stagger the joints in successive courses. As you shingle the column, notch the shingles around the rail brackets. Keep the shingles 1/4" off the deck. Because nothing overlaps the top course, trim these shingles to the exposure length.

Make the planter inserts

1 Cut the planter sides (R) and the planter bottom (S) to the sizes listed. Install a 3/4" dado blade in your tablesaw, and cut the 1/4"-deep dadoes in the sides, where shown on Drawing 6. Drill a half-dozen 1/4" drain holes in the bottom. Clamp the bottom and sides together, and drill pilot and countersunk shank holes, where shown. Disassemble the box, apply PVC cement to the mating surfaces, and screw it together.

2 Cut the trim base (T) and trim (U) to size. Clamp the trim base to the insert sides, butting the corners, as shown on Drawing 6. Drill pilot and countersunk shank holes through the sides (R) into the trim base. Remove the trim, apply PVC cement to the mating surfaces, and screw the parts in place.

3 Spread PVC cement on the trim base (T), and clamp the trim (U) in place. To add strength, overlap the corners in the opposite direction, as shown. When the cement cures, sand the edges of T and U flush, then rout the 1/8" round-overs on the top and bottom edges.

Finish up with a coat of paint and add plants

1 Apply a coat of acrylic latex primer to the railings and columns. Prime only the planter insert's trim base (T) and trim (U). Finish with an acrylic latex top-coat. We painted the columns to match the house's siding and trim colors, then painted the railing a warm off-white.

2 To ensure good drainage, place about 3" of plastic packing peanuts in the bottoms of the planter inserts, then fill them to about 1" from the top with potting soil. Lower them into the columns, and put in your plants. 🌱

Written by Jan Svec with Kevin Boyle
Project design: Kevin Boyle; James R. Downing
Illustrations: Roxanne LeMoine; Kim Downing;
Lorna Johnson
Photographs: Baldwin Photography



Starter strips nailed to the bottom of each column side give the first course of shingles the appropriate slope.

one terrific trellis



This wall- or fence-hung trellis dresses up any outdoor area, providing an attractive background for a climbing plant. But the real beauty is in its simple construction.

Lay out and shape the uprights and crossbars

Note: Begin your project at the lumberyard by selecting stock carefully. All the parts for the trellis frame come from two 10'-long cedar 2x4s. Look for boards with straight grain; with no warp or twist; and with no knots or small, tight knots that won't pop out. Also pick up a 4' cedar 1x4, and a 24x48" sheet of lattice. (We used plastic lattice in a square 1½" pattern, available in home centers.)

1 Rip two 10' 2x4s into 1½x1½"-wide strips. Then crosscut the strips to the lengths listed in the Materials List and **Drawing 1a** to create the uprights (A, B) and crossbars (C, D).

2 Lay out and mark the locations of the dadoes in each piece, where dimensioned in **Drawing 1a**. Mark the area to be removed with an "X" to prevent confusion when you machine the dadoes.

3 Install a ¾" dado blade in your table saw, and clamp a ¾"-thick setup block to the fence, about 3" ahead of the blade. Also, attach an auxiliary extension to your miter gauge to help support the long workpieces.

Now cut the first dado in one of the long uprights (A). To do this, position the fence so the setup block is the appropriate distance from the blade (7" for part A). Butt the end of the workpiece against the setup block, then make one pass over

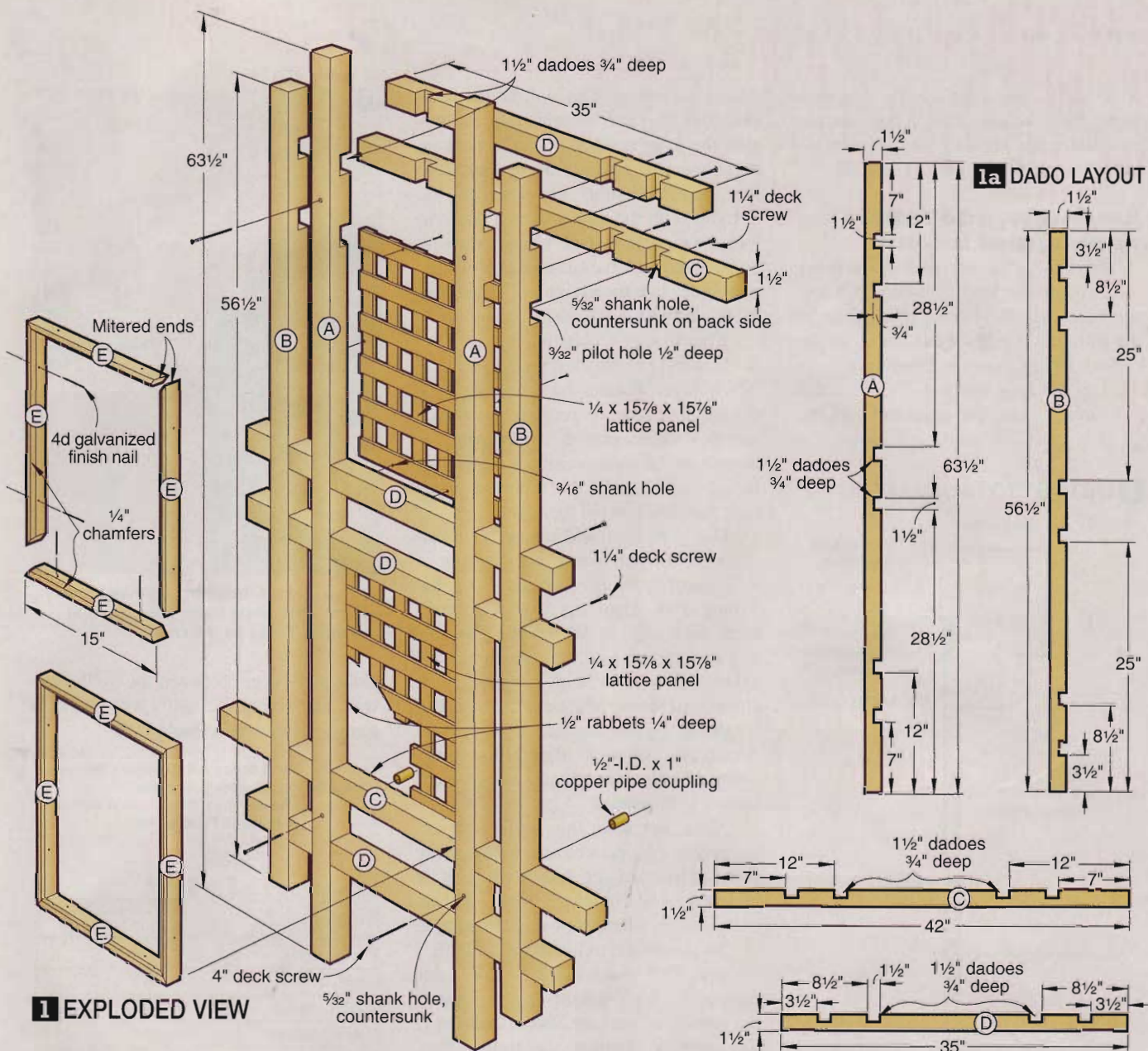

1 EXPLODED VIEW

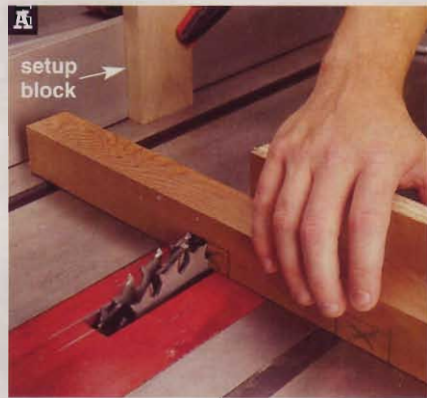

Butt the workpiece against the setup block, holding it securely against the miter gauge. Then make the first cut.

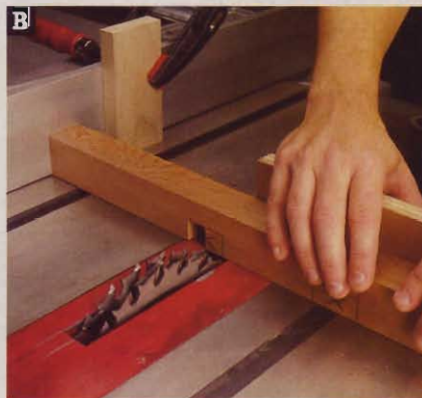

For the second pass, butt the workpiece against the fence. This doubles the dado width without a setup change.

the blade, as shown in **Photo A**. Pull the workpiece and miter gauge back, slide the workpiece against the fence, and make another pass to complete the dado, as shown in **Photo B**. Flip the piece end-for-end and repeat the process. Then cut the matching dados in the other long upright using the same setup.

4 Reposition the fence/setup block and cut the rest of the dados in the long uprights (A) using the same procedures. Then dado the short uprights (B), long crossbars (C), and short crossbars (D).

Note: The locations of the first two dados in the long uprights (A) match those in the long crossbars (C). Cut

these pieces consecutively to eliminate extra fence setups. The dadoes in the short uprights (B) and the short crossbars (D) match one another as well.

Assemble, add lattice panels, and mount

1 Predrill $\frac{5}{32}$ " countersunk shank holes through the long crossbars (C) and short crossbars (D) before gluing them to the uprights. Center these holes in the dadoes, where shown in **Drawing 1**.

2 Lay the long uprights (A) on a flat surface, about 16" apart and with the

dadoes facing up. This will be the back side. Lay the short uprights (B) just outside the long uprights. Now spread an exterior-grade glue in the dadoes. Join the long and short crossbars to the uprights with the dadoes facing down to lock the pieces together. Using the shank holes in the crossbars as guides, drill $\frac{5}{32}$ " pilot holes into the uprights. Then secure each joint with a $1\frac{1}{4}$ " deck screw.

3 Chuck a $\frac{1}{2}$ " rabbeting bit in your handheld router, and set it to make a $\frac{1}{4}$ "-deep cut. Rabbet the square areas of the trellis frame to receive the lattice panels, where shown in **Drawing 1**. Square up the corners using a chisel. Cut lattice panels to fit the rabbeted openings, but don't install them yet.

4 Use your handheld router, equipped with a chamfering bit, to rout a $\frac{1}{4}$ " chamfer along each edge of the 4'-long 1x4. Then rip a 1"-wide strip from each edge of the board. Chamfer and rip one edge of the remaining 1x4 again so you end up with three $\frac{3}{4}$ "x1x48" chamfered strips. Miter-cut the strips to length to create the lattice stops (E). Attach the stops to the trellis frame using 4d galvanized finish nails, where shown in **Drawing 2**.

5 Stain or paint the trellis as you prefer. (We painted ours to match the exterior trim on the house where it is installed.) Then mount the lattice panels to the frame, where shown in **Drawing 2**.

6 To mount the trellis to the wall, first drill $\frac{5}{32}$ " countersunk shank holes through the long uprights for the mounting screws, where indicated in **Drawing 1**. Temporarily position the trellis, then push an awl or long nail through the pilot holes to mark the locations of pilot holes on the wall. To hold the trellis away from the wall, we used spacers made from standard copper plumbing-pipe couplings ($\frac{1}{2}$ " inside diameter x 1" long) purchased at the local hardware store.

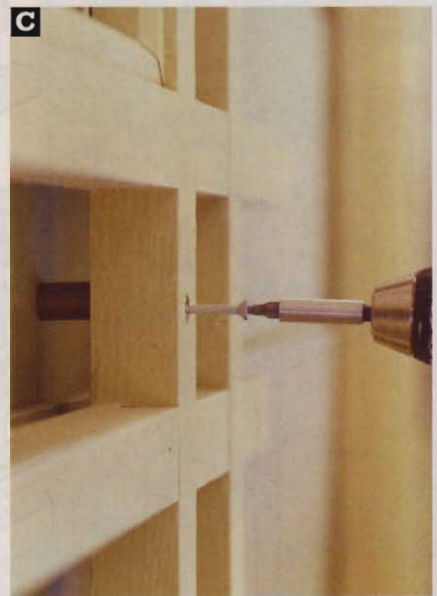

Attach all four mounting screws loosely at first, then snug them down to hold the trellis firmly to the wall.

Hold the spacers between the trellis and wall, and secure the trellis with 4" deck screws, as shown in **Photo C**.

Written by **David Stone** with **Charles I. Hedlund**
Project design: **Charles I. Hedlund**
Illustrations: **Roxanne LeMoine**; **Lorna Johnson**
Photographs: **Baldwin Photography**

materials list

Trellis	FINISHED SIZE			Matl.	Qty.
	T	W	L		
A* long uprights	1½"	1½"	63½"	C	2
B* short uprights	1½"	1½"	56½"	C	2
C* long crossbars	1½"	1½"	42"	C	2
D* short crossbars	1½"	1½"	35"	C	4
E* lattice stops	¾"	1"	15"	C	8

*Parts initially cut oversize. See the instructions.

Material Key: C—cedar.

Supplies: Exterior wood glue, exterior paint or stain, $15\frac{7}{8}$ "x $15\frac{7}{8}$ " lattice panels (2), 4d galvanized finish nails (16), $1\frac{1}{4}$ " deck screws (24), 4" deck screws (4), #6x $\frac{3}{4}$ " panhead sheet-metal screws (12), $\frac{1}{2}$ "-I.D.x1" copper pipe couplings (4).

2 LATTICE/STOP INSTALLATION

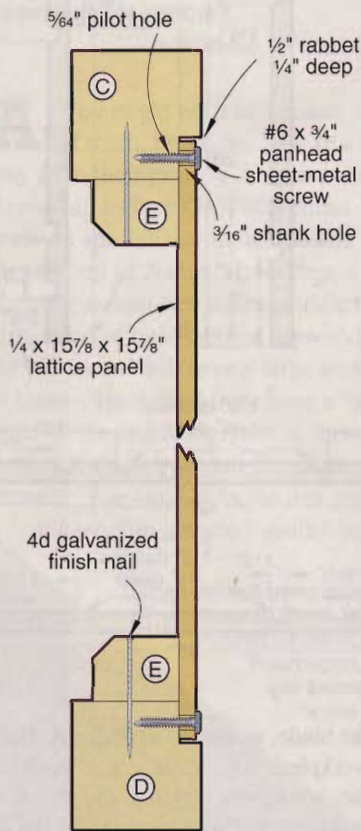

cutting diagram

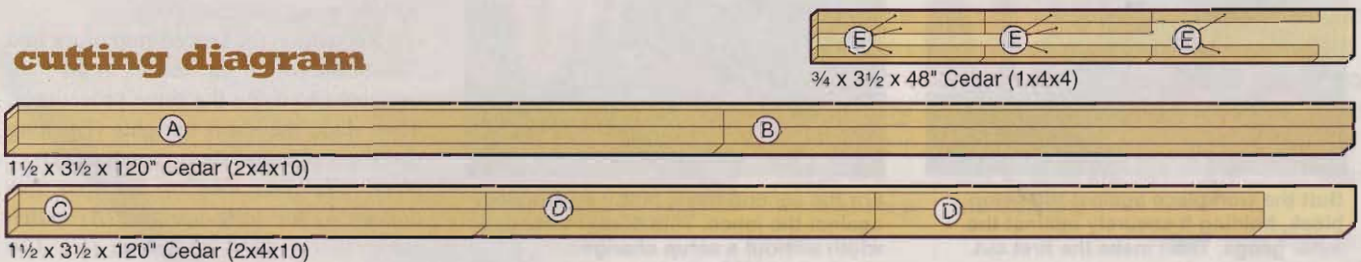

7 1/4" circular saws

You won't find many circular saw tasks more taxing than ripping pressure-treated lumber. We timed each saw's performance to determine its power.

They came, we sawed. Which will conquer?

Readers' top 5

We posted a question on our WOOD ONLINE® (www.woodonline.com) discussion groups asking what you, our readers, find most important when choosing a circular saw. Here's what you told us:

1. Power
2. Ease/accuracy of adjustments
3. Ease of following a line
4. Foot (base) quality
5. Weight and balance

Sometimes, it's easier to take the tool to the work than the other way around. That's why we have a well-worn portable circular saw in our shop, and we'll bet you do, too. For large built-in-place projects, such as the outdoor projects in this issue, a circ saw is worth its weight in gold. Meanwhile, in the shop, it earns its keep by helping break down sheet goods into tablesaw-manageable sizes.

Circular saws come in two basic varieties—helical-drive models (sometimes called “sidewinders”) and worm drive—with blades ranging from 4” to 16” in diameter, and costing anywhere between \$30 and \$700. For this test, we focused on saws with 7¼” blades and drawing 13 to 15 amps. These tools provide the best balance of power, price, portability, and versatility. Also, you’ll find the widest selection of specialty blades in this size, for cutting non-wood materials, such as concrete, tile, and metal pipe.

Tough testing for tough tools

To make certain we evaluated the saws and not the blades that came with them, we first set aside each saw’s supplied blade and installed identical 24-tooth, carbide-tipped Freud Diablo blades.



We bevel-cut thin strips of medium-density fiberboard to test each saw’s lower blade guard for hang-ups.

After a short motor break-in, we got to work ripping pressure-treated 2x8s, as shown in the photo *opposite*—a demanding task for any saw. While pushing the saw to the point that it was under heavy load, but not ready to stall, we timed a 5’ rip. This test was performed three times with each saw, and the cutting times averaged.

Next, because the blade guards on circular saws have a reputation for hanging up when cutting bevels, we made several ½”-wide cuts in ¾” medium-density fiberboard (MDF) at both 22.5° and 45° (Photo A). We’re happy to report that

none of the guards hung up in this test or in general use.

To see how dust would impact the saw’s workings, we made 50 crosscuts with each saw in 8”-wide cement-and-cellulose siding, a notoriously dusty material. Again, all of the saws passed this test with no apparent effect on motors, bearings, or blade guards.

Finally, we spent a month just using the saws; sometimes with the supplied blade, sometimes with the Diablo blade; cutting freehand and guided by a straightedge. We even made pocket (plunge) cuts in oriented-strand board (OSB) and oak plywood. This month of “playing” gave us a good feel for the settings, adjustments, and how easy it is to follow a cutline.

What to look for in a good circular saw

•**Powerful motor.** A circular saw’s ampere rating tells you how much electrical current the motor uses, but it can’t tell you how well the saw uses it. The First to the Finish Line chart on the *next page* does. For example, the 13-amp Bosch 1657 made a 5’ rip cut in pressure-treated lumber faster than all of the 15-amp models in the test except the Milwaukee 6390-21.

What about worm drives?

Unlike the helical-drive models in our test, worm-drive saws, such as the Skil 77 shown *below right*, put the motor more behind the blade than beside it. The name “worm drive” comes from the worm gear on the motor shaft that transfers the power to the blade arbor.

These saws are popular with contractors because their slower speed (usually around 4,000 rpm, compared to the 5,000–5,800 rpm of a helical-gear saw) means higher torque. The long, narrow body of the tool

also gives the operator a longer reach and allows the saw to get into spots too tight for a sidewinder, where the motor sticks out one side.

However, worm-drive saws weigh 3–8 pounds more than the saws in our test. And their price tags are no lightweights either, starting at about \$165 and running as high as \$250 (our tested helical-gear saws range from \$80 to \$165). All in all, a sidewinder makes more sense for woodworking and occasional remodeling.

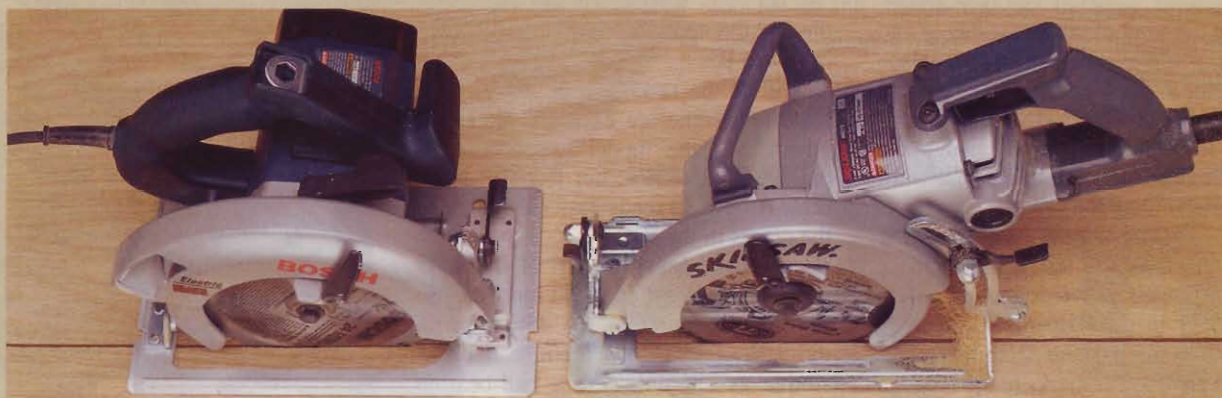

With its motor shaft perpendicular to the blade arbor, rather than parallel to it, a worm-drive saw (*right*) is longer and narrower than a helical-gear saw (*left*).

FIRST TO THE FINISH LINE

Rip-cutting speed reveals power
(average of 3 cuts in pressure-treated 2x pine)



If you use your circular saw day in and day out, you'll eventually need to replace the motor's brushes, and the Hitachi C7BD, Makita 5007NHK, and Porter-Cable 347K allow you to change the brushes from the outside of the case without disassembling the saw.

•**Easy cutting-depth adjustments.** Although all of the tested mechanisms worked smoothly, we found plenty of differences in the ease of using them. First, the location of the depth locks varied. We gave lower marks to the Hitachi, Makita, and Ryobi CSB130K, where the locking lever is between the saw's han-

dle and the upper blade guard, as shown in **Photo B**.

Most of the saws have a depth-of-cut scale, but some are easier to read than others. See the model-by-model summaries for specifics, but Ryobi's depth scale (**Photo C**) reads easier than any of the others in the test.

•**Convenient beveling.** All of the saws will bevel at least 45°, and most can go beyond. Getting past the 45° stop, on those saws that have them, can be as simple as slipping past a ball-bearing detent on the DeWalt DW369, or as clunky as the bevel-stop sleeve on the

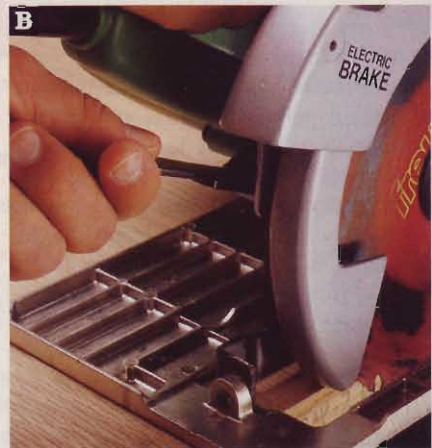

Depth-locking levers located between the handle and blade guard are awkward to operate with the left hand while holding the saw in your right.

Porter-Cable (**Photo D**). And, although you can adjust the 0° bevel stop on all of the saws, only two—Makita and Porter-Cable—provide calibration screws for the 45° stops.

As for the bevel locks, we prefer levers to thumbscrews, which often put your fingers into tight spots. Bosch, DeWalt, Makita, and Milwaukee use lever locks.

•**Stamped foot.** The base of a circular saw is called its "foot" (or sometimes, "shoe"), and most of these feet have gone high-tech. Only Ryobi still uses a steel foot, while the other models sport a foot of stamped aluminum, cast aluminum, magnesium, or composite plastic.

When dropped, a stamped foot may bend, but a cast or composite foot is more likely to break. A bend can be straightened; a broken foot must be replaced, which could mean downtime on a project.



Clearly marked graduations make setting the correct cutting depth easy with the Ryobi CSB130K. This saw also had the most marked graduations.



D Porter-Cable's bevel-stop sleeve rotates to open the bevel scale above 45° and below 0°. However, there are no markings to indicate whether the stop is in place or not.

- **Safe blade guard.** The lower blade guard should retract automatically in most situations, but some procedures, such as pocket cuts, and thin-strip bevels and rips, require that you manually retract the guard. Bosch's unique remote lift lever (**Photo E**) keeps your hand well away from the blade when pulling back the guard. Four of the tested saws—Bosch, DeWalt, Milwaukee, and Ryobi—have mechanisms that automatically retract the guard slightly when the foot is tilted to 45° or beyond, reducing the risk of the guard hanging up on such cuts.

- **Good sightlines.** The blade mounts on the right side of the motor on all of the tested saws, so right-handed users must sight the cutline through a gap between the body of the saw and the blade guard.

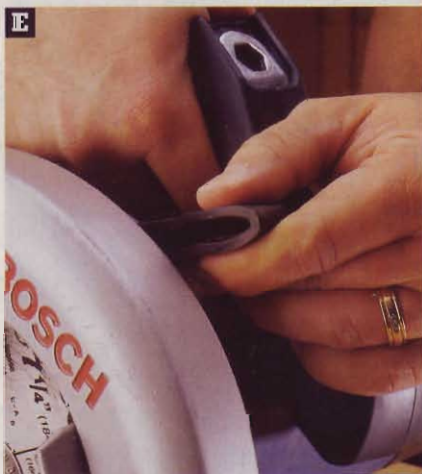

E This lever retracts the lower blade guard of the Bosch 1657 so you don't have to reach down around the blade when making pocket cuts.

Some saws also come in a left-bladed configuration that allows an unimpeded view of the blade and cutline (see the chart on page 88). However, this configuration places the wide part of the foot and the weight of the tool on the waste piece during cutting instead of the "keeper" piece, which can contribute to inaccurate cuts.

DeWalt and Milwaukee score high marks here, partly due to large openings in the foot, and partly because their front handles don't interfere with your line of sight at 0° or 45° bevel. Ryobi's viewing window (**Photo F**) allows you to get closer to the sight line while minimizing the splatter of dust in your face.



F Instead of an open space, Ryobi incorporates a dust-deflecting window for viewing the cutline. It remained surprisingly clear throughout our tests.

A saw-by-saw look at the tested machines



Bosch 1657

877/267-2499

www.boschtools.com

Besides ranking as one of the most powerful saws in the test, the 1657 also offers nice features, such as its remote guard lift, an electric blade brake that stops the blade within two seconds of releasing the trigger, and handy on-board storage for the blade-changing wrench. The spring-steel 45°-bevel stop feels positive and is easy to defeat when necessary.

Two sets of markings on the depth-of-cut scale let you set either the actual cutting depth, or the thickness of material you're cutting. However, the scale is hard to read from the back of the saw because the markings face the handle. We had to look through the handle to use the scale.

At 12.3 pounds, the Bosch 1657 is almost half a pound heavier than the next-heaviest, the Craftsman. It's also the loudest in the test, tied with Ryobi.

Craftsman 27108

Visit your local Sears store or www.sears.com/craftsman

There's an awful lot to like about this circular saw, starting with its price: \$100. The comfortable soft-grip material on the handle, and the large, well-placed, loop front handle (like those found on worm-drive saws) gave us good control of the tool, in spite of its 11.9-pound heft.

The 27108 could be improved, though, by changing the bevel and depth-of-cut locks from thumbscrews to levers. Also, although the depth scale is numbered from 2 3/8" to 1 3/4", there are no numbered markings from 1 1/2" on down, making it more difficult to set the depth for thinner stock. A 1/4" dust port comes with the 27108, but the weight of our vac hose often detached the port from the saw.





DeWalt DW369

800/433-9258

www.dewalt.com

This saw covers all the angles when it comes to beveling, with its 56° capacity (the most in the test) and 1° increments on the bevel scale. (Most scales offer only 5° markings.) Ball-bearing detents mark 22.5° and 45° bevels, and we found it easy to override them. We also like the substantial locking levers on both the bevel and depth mechanisms.

The plastic composite foot keeps the weight of the tool down, making the DW369 the second-lightest saw in the test. And, as we mentioned earlier, the tool provides good visibility of the cutline at all angles. Like the Bosch, this saw has an electric blade brake.

Hitachi C7BD

800/546-1666

www.hitachi.com/powertools

We really like the way this saw helped us follow a line. With most of the other tested saws, we were able to hold the line well enough with a little attention. But the C7BD tracks a straight cutline almost effortlessly.

Beyond that, though, this is a saw in need of updating. For example, the bevel angle maxes at 45°, making it the only saw that doesn't go beyond. And without soft-grip material, or even molded texture, the smooth plastic handles slipped in sweaty hands during our tests. We'd also like to see the thumbscrew bevel lock replaced with a lever.

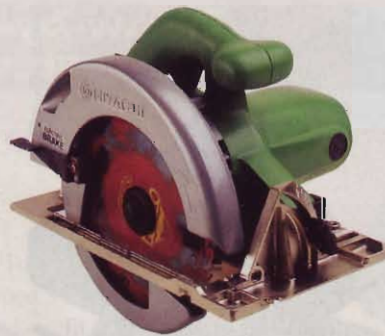

You do get an electric blade brake, though. And our Canadian readers will appreciate the depth-of-cut scale marked in both metric and English.



Makita 5007NHK

800/462-5482

www.makitatools.com

This saw turned in the second-best time in our 5'-rip test, and the second lowest weight. The 5007NHK boasts beefy locking levers and a fine-adjustment screw for the 45° stop. And, going past the 45° stop is easy, thanks to a simple knob that you turn to open the way to the full 50° bevel scale. The factory-equipped blade is coated with a nonstick material that reduces the amount of gunk

EIGHT PORTABLE CIRCULAR SAWS UNDER THE MAGNIFYING GLASS

MANUFACTURER	MODEL	MOTOR		CONSTRUCTION		MAXIMUM CUTTING DEPTH (INCHES)		BEVEL		MAXIMUM BEVEL ANGLE	KERF THICKNESS (INCHES)	FACTORY BLADE		PERFORMANCE RATINGS (3)							CORD	
		AMP RATING	SPEED (RPM, NO LOAD)	BLADE BRAKE? (YES/NO) (1)	FOOT MATERIAL (2)	FOOT SIZE (W x L) (INCHES)	0° BEVEL	45° BEVEL	BEVEL STOPS (DEGREES)			NUMBER OF TEETH	CUTLINE VISIBILITY FROM LEFT OF SAW	DEPTH-GAUGE READABILITY	EASE OF DEPTH ADJUSTMENT	EASE OF BEVEL ADJUSTMENT	EASE OF BLADE CHANGING	DUST CONTROL EFFECTIVENESS	TOOL BALANCE	NOISE LEVEL (dB, NO LOAD) (4)	LENGTH (FEET)	MATERIAL (5)
BOSCH	1657	13	5,500	Y**	SA	6½ x 11½	2¾	1¾	45	50	0.082	24	F	G	E	E	E	G	G	99	9	R
CRAFTSMAN	27108	15	5,500	N	SA	6½ x 11¾	2¾	1¼	45	51.5	0.070	24	G	G	G	F	E	E	G	93	10	P
DEWALT	DW369	15	5,800	Y**	C	6½ x 11¾	2¾	1¼	45, 22.5	56	0.076	24	E	G	E	E	E	G	E	95	9	R
HITACHI	C7BD	13	5,500	Y**	CA	6¾ x 11¾	2½	1¼	45	45	0.068	18	G	G	G	G	E	G	E	98	8	R
MAKITA	5007NHK	15	5,800	Y	SA	6¾ x 11¾	2¾	1¾	45	50	0.071	24	G	N/A	G	E	E	G	E	98	9	R
MILWAUKEE	6390-21	15	5,800	N*	SA	6½ x 12½	2¾	1¼		50	0.062	24	E	G	E	E	E	G	E	94	9	R
PORTER-CABLE	347K	15	5,800	N*	M	6½ x 11¾	2¼	1¼	45	48	0.061	18	F	G	G	F	G	E	G	95	10	R
RYOBI	CSB130K	13	5,000	N	SS	5¾ x 11	2¾	1¼		51.5	0.086	24	G	E	G	F	E	E	G	99	10	P

For specifications on other types of tools, click on "Tool Comparisons" at www.woodmail.com

- NOTES:
- 1. (*) Electric-brake model also available. (**) No-brake model also available.
 - 2. (CA) Cast aluminum (SA) Stamped aluminum (C) Composite (SS) Stamped steel (M) Magnesium
 - 3. E Excellent G Good F Fair
 - 4. Measured 24" from saw equipped with standard blade.
 - 5. (P) Thermoplastic PVC (R) Rubber
 - 6. (R) Rip fence (D) Dust-collection port Case
 - 7. (LIFE) Lifetime warranty against factory defects.

building up on the blade and causing friction, a plus if you do much work with pressure-treated lumber.

We were surprised to find that the 5007NHK doesn't have a depth-of-cut scale. Although we didn't think we'd use these scales much, we quickly came to rely on them, and we missed the convenience on this saw. The 5007NHK also comes in a left-bladed version.



Milwaukee 6390-21

877/279-7819

www.mil-electric-tool.com

From its excellent power, to its heavy-duty locking levers, to its middling \$155 price tag, we liked almost everything about the 6390-21. Like the Hitachi, this

saw tracked nice and straight with virtually no effort on our part. The 6390-21 also comes in a blade-on-left configuration. The model we tested doesn't have an electric blade brake, but a sister model (6394-21, \$190) does.

The unique Tilt-Lok handle can be locked in any of eight positions to keep your hand at approximately the same angle for any cutting depth. As much as the tilting ability, though, we like the comfortable soft-grip material found on both the front and rear handles. Although the 6390-21 has no bevel stops, its scale is marked in 1° increments like the DeWalt. And it's the only scale in the test that's marked on the back, so it can be read from the normal operating position.



Porter-Cable 347K

800/487-8665

www.porter-cable.com

Perhaps the most notable feature of the 347K is the dust-collection tube, which accepts a standard 1/4" vacuum hose, sprouting from the top front of the upper blade guard. Where a vac isn't convenient, the tube directs debris anywhere you want, which we found handy when working outdoors on breezy days.

The 347K is also the only saw in the test with a bypassable stop at 0° bevel, as well as the typical 45° stop. With the bevel stop rotated out of the way, you can back-bevel as much as -3°, or bevel up to 48°. Although similar in function to the stop on the Makita, it's less intuitive and requires 2½ turns of the locking thumb-screw to rotate it in or out of position.

All of the tested saws have spindle locks for changing blades, but the 347K's is in a tight spot between the front handle and the upper blade guard, making it more difficult to access than the others. However, we'll give P-C credit for including onboard storage for the blade wrench.



Ryobi CSB130K

800/525-2579

www.ryobitools.com

The CSB130K is everything you expect in an \$80 circular saw, and a little bit more. As we mentioned before, we like its depth-of-cut scale and cutline-viewing window. However, in our 5'-rip test, this saw took nearly twice as long to make the cut as the top performers in our test (which, not coincidentally, cost nearly twice as much).

This tool shares some features of the more expensive saws in the test, such as a dust port (with an odd 1/8" diameter), a blade guard that retracts slightly at 45° bevel, and onboard wrench storage. Unfortunately, the CSB130K also shares some of their foibles, such as noise (Bosch), smooth handles (Hitachi), and the absence of bevel stops (Milwaukee).

A round of applause for the top circ saws

Milwaukee's 6390-21 offers almost everything we're looking for in a circ saw: lots of power, straight-as-an-arrow tracking, and a boatload of performance-enhancing features at a reasonable price. DeWalt's DW369 trades a little power for bevel stops at 22.5° and 45°, and does it for about \$20 less.

If you don't think you'll use a circular saw often enough to justify the cost of the DeWalt or Milwaukee, the Craftsman 27108 will fill the bill nicely for you. For occasional use, we can overlook the thumbscrew locks. ♣

Written by **Dave Campbell** with Kirk Hesse
Photographs: **Baldwin Photography**

Visit www.woodonline.com to talk about circular saws with other woodworkers.

STANDARD	ACCESSORIES (6)		WARRANTY (7)	COUNTRY OF ASSEMBLY (8)	WEIGHT (POUNDS) (9)	SELLING PRICE (10)	LEFT-BLADED MODEL/PRICE (10)
	C, R	D, R					
	C, R		1 yr.	U	12.3	\$155	N/A
	C, D		1 yr.	C	11.9	100	N/A
	C		1 yr.	U	11.2	135	N/A
	C	D, R	1 yr.	S	11.1	165	N/A
	C	R	1 yr.	U	11.2	160	5007NLK/\$160
	C	R	LIFE	U	11.6	155	6391-21/\$155
	C, D	R	1 yr.	U	11.1	130	743K/\$130
	C, D		2 yr.	C	11.5	80	N/A

8. (U) United States
(C) China
(S) Singapore

9. All saws weighed with identical blades installed.

10. Prices current at time of article's production.

the woodworkers who built Lady Liberty

Look beyond the Statue of Liberty's metal exterior and you'll find the handiwork of skilled woodworkers.

It was a grand day that Fourth of July in 1884 when the Statue of Liberty was presented to the United States in a ceremony held at the Gaget, Gauthier et Companie foundry outside Paris. There, for eight years under the direction of sculptor Frédéric-Auguste Bartholdi, nearly 200,000 pounds of copper had been meticulously formed into the panels that would become Lady Liberty.

Though all the attention may have gone to the shiny metalwork—then as bright as a new penny—it was the scores of French woodworkers and carpenters behind the scenes that made it all possible. On these shores, it took American woodworking know-how before the statue could take its place of honor in New York Harbor.

A statue like no other

Because the statue is constructed almost entirely of copper and steel, it may be

difficult to see why woodworking skills were critical in its construction. To understand why, it's helpful to know a bit about the properties of that most malleable metal—copper.

Copper was the ideal material for the Statue of Liberty. It can be shaped and bent without breaking, making fine contours possible. Pure copper won't rust, and actually gains protection as the surface oxidizes, forming the greenish patina that shields the metal underneath, providing built-in protection against salt air and dampness.

Through an ancient metal-forming technique known as repoussé, raw copper sheets were carefully hammered against intricate wooden forms (possibly built from pine or ash) until the copper was just 2.5 millimeters thick—about $\frac{3}{32}$ ". See the photo below. The resulting thin contoured copper plates—some 310 of them—formed the three-dimensional jigsaw puzzle that would become the statue.



Some 310 huge sheets of copper were hammered into shape against intricate wooden molds to shape the skin of the Statue of Liberty.

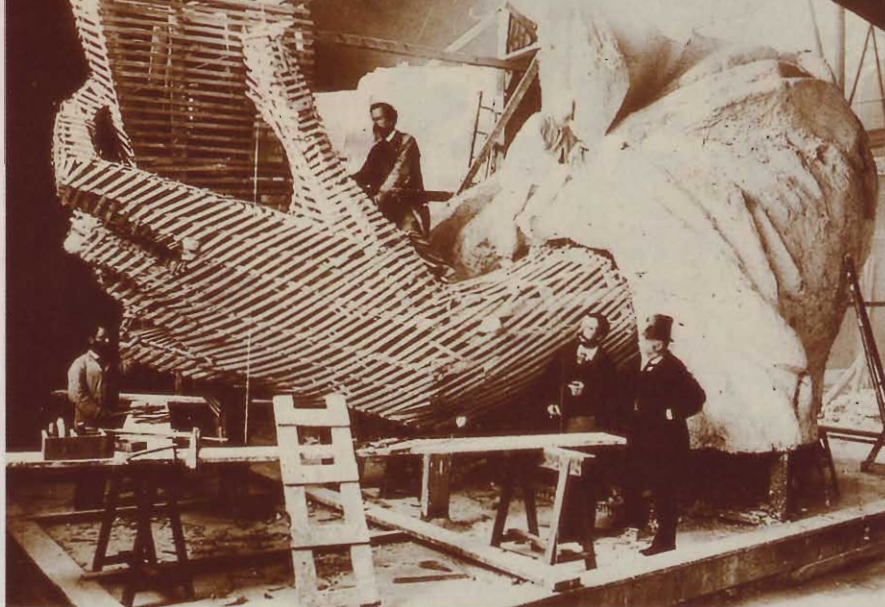

Before the final wooden molds could be constructed, it was necessary to make actual-size replicas of the statue's components out of wood lath and plaster.

Three separate statues

To create the molds, woodworkers first built three progressively larger wood-lath-and-plaster enlargements of Lady Liberty. The first stood just over 9' tall. The second version—about 36' tall—was sectioned off, and each section was measured some 9,000 times in order to enlarge it yet again. These enlarged sections, shown *above*, were assembled into a 151' colossus that was used to create the final statue.

The real work begins

More than 300 full-size wooden forms were modeled from the contoured plaster sections of the final enlargement. On these forms, workers shaped the copper plates that make up the statue's skin. This was delicate work, partly because of the intricate contours of the sculpture and the thinness of the copper skin, and because the wooden molds weren't solid. As shown in the photo at *right*, many curved sections of the wooden molds were an open matrix, which required extreme care with the wooden mallets and implements used to shape the copper. For the most detailed sections, the copper sheets had to be heated to give them maximum flexibility before they were formed.

Eventually it came time to put the elaborate planning and construction techniques to their ultimate test—a complete assembly in Paris before disassembly and shipment to America. Again, wood was key to the ultimate success.

To assemble the statue, workers built an elaborate wooden scaffolding that

gave them safe access to the exterior skin while, inside, other workers (who were able to enter through an access in Liberty's right foot) assisted.

Working from outside and within, workers affixed the outer skin panels to a 96' iron pylon inside the structure. The pylon was designed by Alexandre-Gustave Eiffel, who had yet to begin work on the tower that bears his name. Sprouting out on all sides from the pylon is a network of flat metal bars. Bolted to the pylon at the center, this armature is affixed to the copper skin with some 2,000 steel brackets called saddles that provide elasticity in the face of winds and changes in temperature.

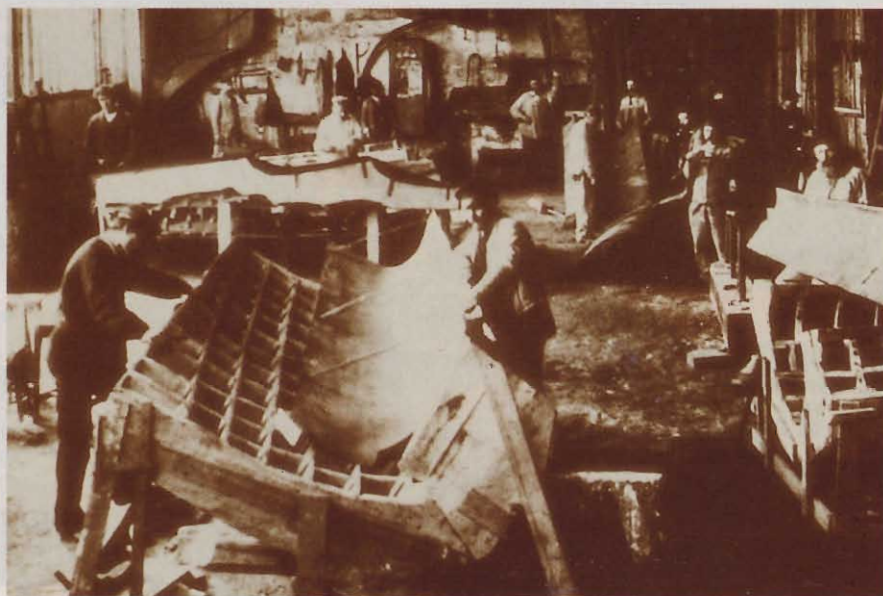

The workshops at the Gaget, Gauthier et Compagnie foundry were filled with activity, and with hundreds of wooden forms, such as this one, used to shape the copper.

INDUSTRIAL

A foundation for Liberty

The French had pronounced the statue completed on Independence Day 1884, but it took more than two years before she could stand in New York Harbor. First, American workers had to build a fitting pedestal atop the pyramid-shaped concrete foundation that had just been completed. That foundation weighed an incredible 23,500 tons and rose more than 52 feet above the ground. At the time, it was believed to be the largest mass of solid concrete in the world.

The pedestal, designed by architect Richard Morris Hunt, was crafted from concrete and granite, and stands another 89' tall. It incorporates a balcony and 40 escutcheons bearing the coats of arms of each state then in the Union.

In May of 1886, the statue at last began to take shape over the new edifice. On October 28, 1886, more than a million people turned out for the dedication ceremony to unveil this new symbol of freedom and democracy to the world. ♣

Written by **Dave Kirchner**
Photographs: Courtesy of **National Park Service: Statue of Liberty National Monument**

More about Lady Liberty

Write: The Superintendent, The Statue of Liberty National Monument, Liberty Island, New York, NY 10004. You will receive information about the Statue of Liberty and Ellis Island.

domed snack set

Serve cheese and crackers on this terrific turned tray.



A maple cheeseboard graces the center of this domed mahogany tray, making an ideal service for all kinds of snacks. A knife with a turned bird's-eye maple handle completes the set.

Note: See our Buying Guide sources on page 95 for the glass dome, knife blade, finishes, and mahogany and bird's-eye maple turning blanks. Check the special kit pricing for WOOD® readers.

Start with the cheeseboard

1 Prepare the blank.

Cut a $\frac{3}{4} \times 6\frac{1}{4} \times 6\frac{1}{4}$ " bird's-eye maple blank for the cheeseboard. Draw diagonal lines to locate the center on the side of the blank that will be the bottom. Draw $\frac{1}{2}$ " and $3\frac{1}{8}$ "-radius circles around the center. Bandsaw just outside the large circle.



2 Attach an auxiliary faceplate.

Use your 3" faceplate to trace a circle onto a piece of 1½"-thick scrap, and bandsaw to the line. The disc doesn't need to be perfect, but get it as close as you can. Apply cloth-backed double-faced tape or hotmelt glue to this auxiliary faceplate, and fasten it, centered in the 1½"-radius circle, to the cheeseboard blank. If you use double-faced tape, squeeze the two parts together with a clamp, or in your bench vise.

3 Turn the cheeseboard.

Screw your 3" faceplate to the auxiliary faceplate, and mount the cheeseboard blank on your lathe. Use a bowl gouge to true the blank's edge. Turn the cheeseboard to fit within the glass cheese dome. The dome should slip over the board easily without being too loose.

Form a ⅛" round-over on

the front edge. Sand the cheeseboard to 320 grit.

Separate the cheeseboard from the auxiliary faceplate, and set it aside.

TOOL: ½" bowl gouge.

TOOL REST: Slightly below center.

SPEED: 600–800 rpm.

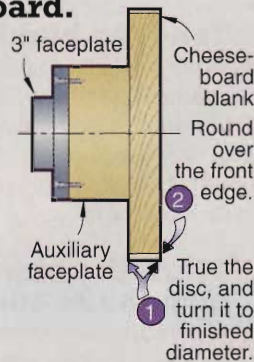

4 True the blank.

Mount the tray blank on your lathe. Use a bowl gouge to true the blank's edge and turn it to a 12" diameter. Repositioning the tool rest parallel to the blank's face, turn it almost to finished thickness. Then true the face with one continuous cut from rim to center.

TOOL: ½" bowl gouge.

TOOL REST: Slightly below center.

SPEED: 600–800 rpm.

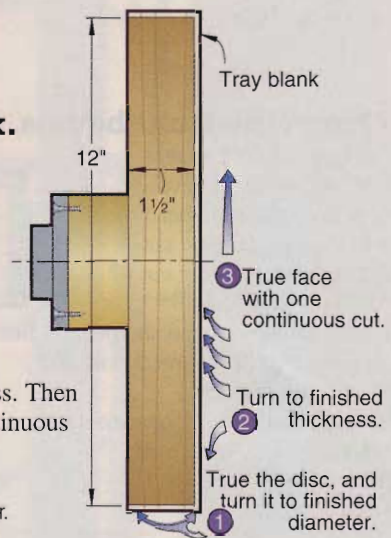

5 Make the gauging cuts.

With the lathe at slow speed, and referring to your tray front and back templates, mark the 3" radius for the cheeseboard recess and the 3⅝" radius for the bottom of the rim bevel on the blank's face. Measuring from the blank's edge and front face, mark the platter's ⅜" edge bead. Again measuring from the edge, mark the end of the back bevel and the beginning of the bottom recess.

Using a parting tool, make the four gauging cuts, where shown on the drawing, to the depths indicated.

TOOL: Parting tool.

TOOL REST: Center.

SPEED: 800–1,200 rpm.

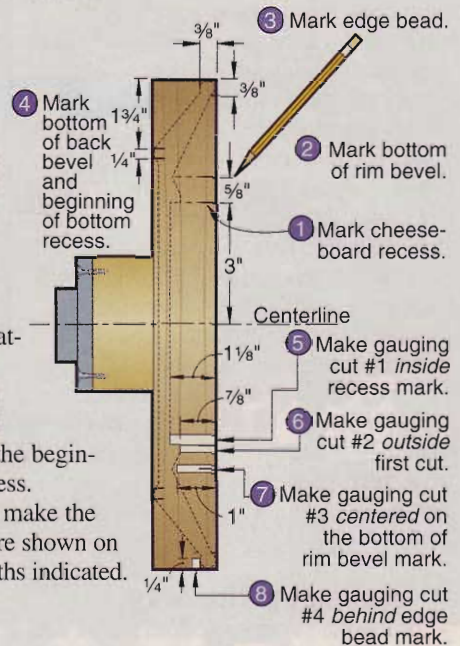

Now, on to the tray

1 Create a pair of templates.

Make a copy of the tray full-size half patterns from the *WOOD PATTERNS*® insert at the center of the magazine. Use spray adhesive to adhere them to ⅛" hardboard. Cut and sand the front and back templates to the pattern lines.

2 Prepare the blank.

Start with a piece of 84 mahogany 12¼" square. If you can't find a piece this size, glue up narrower stock to make one. (The blank listed in the Buying Guide is glued up from color-blended stock.) Draw the square's diagonals on the bottom of the blank to locate its center. Draw 1½"- and 6⅛"-radius circles around the center. Bandsaw just outside the large circle.

3 Attach an auxiliary faceplate.

With the auxiliary faceplate you used to turn the cheeseboard still mounted to the faceplate, clean off any double-faced tape or hotmelt glue residue. Using regular woodworking glue, glue and clamp the auxiliary faceplate, centered in the 1½"-radius circle, to the tray blank. Let the glue dry thoroughly.

6 Form the back bevel and edge bead.

Using a bowl gouge, rough out the back bevel, cutting away the corner until you connect the bottom of gauging cut #4 with the marked bottom of the back bevel. Change to a skew chisel and roll the bead. Smooth the bevel with a squarenose scraper.

TOOLS: ⅜" bowl gouge, ¾" skew chisel, ¾" squarenose scraper.

TOOL REST: Slightly above center.

SPEED: 800–1,200 rpm.

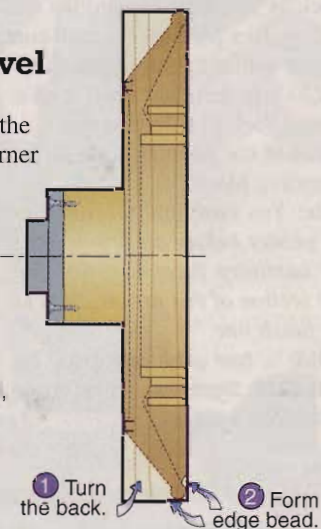

7 Form the front bevels.

Using a bowl gouge, rough out the front bevels. Work from the edge bead to the bottom of gauging cut #3, then from gauging cut #2 to the bottom of cut #3.

Smooth the bevels, and sharpen the line where the two bevels meet with a squarenose scraper.

TOOLS: $\frac{3}{8}$ " bowl gouge, $\frac{3}{4}$ " squarenose scraper.

TOOL REST: Slightly above center.

SPEED: 800–1,200 rpm.

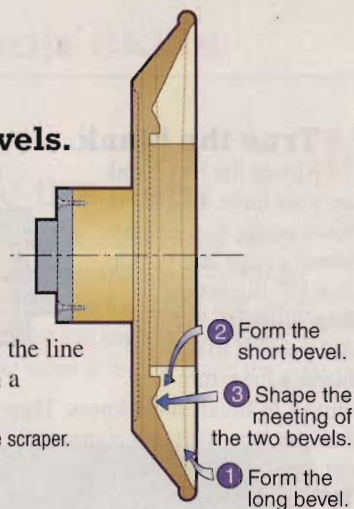

8 Fit the cheeseboard.

Hollow out the tray's center to the depth of gauging cut #1 with a bowl gouge. As you near the bottom of the cut, stop the lathe periodically and use a straightedge to check the bottom of the recess for flatness. With the bottom flat, switch to a squarenose scraper, and, while smoothing the recess, cut the center about $\frac{1}{16}$ " deeper than the edge. This will ensure that the cheeseboard doesn't rock. Check the cheeseboard's fit in the recess. The diameter of the recess should be about $\frac{1}{16}$ " larger than the cheeseboard. Use the scraper to enlarge the recess, if necessary. Flatten the lip where the glass dome sits.

TOOLS: $\frac{3}{8}$ " bowl gouge, $\frac{3}{4}$ " squarenose scraper.

TOOL REST: Slightly above center.

SPEED: 800–1,200 rpm.

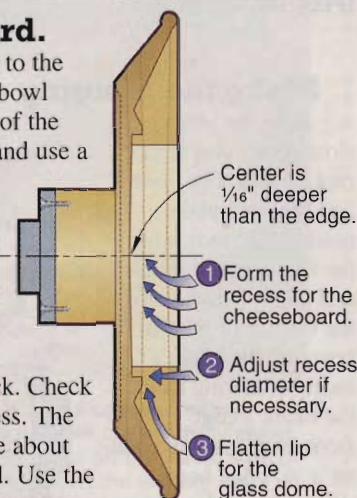

9 Finish up the tray.

Form the $\frac{1}{8}$ "-deep bottom recess with a bowl gouge, cutting slightly into the waste block as you work toward the center. Change to a parting tool, and continue cutting to within $\frac{1}{2}$ " of center. Sand the platter to 220 grit, then part it off with a parting tool. Finish-sand the center of the bottom recess with a sanding block.

Note: You can apply a finish to the platter before parting it from the auxiliary faceplate. See the last section of this article, "On to the finish line."

TOOLS: $\frac{1}{2}$ " bowl gouge, parting tool.

TOOL REST: Slightly above center (gouge), center (parting tool).

SPEED: 800–1,200 rpm.

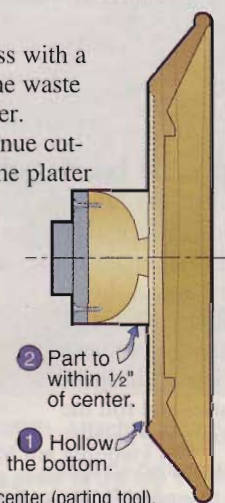

Get a handle on the knife

1 Prepare and mount the blank.

To make the knife handle, *right*, mark the center on each end of a 1×1×8" blank. Drill a $\frac{3}{16}$ " hole 2" deep at the center of one end. Centerpunch the other end. Install a drive center on the lathe headstock and a revolving cone center in the tailstock. (See the Buying Guide for a cone center source.) Mount the blank between centers, engaging the hole in the end on the cone center.

2 True the blank.

Using a spindle gouge, round down the blank to $\frac{3}{4}$ " for a distance of 6" from the tailstock end. Leave the 2" portion at the headstock end square.

TOOL: $\frac{3}{8}$ " spindle gouge.

TOOL REST: Slightly above center.

SPEED: 600–800 rpm.

3 Mark the blank and turn the beads.

Draw guidelines on the blank. Mark the first bead $\frac{1}{4}$ " from the blank's end, where shown on the knife handle full-size pattern on the pattern insert. Then mark the other beads and the stepped finial. Use a skew chisel to form the beads and finial. Turn the finial only as far as the end "button." Do not part off the turning. Finally, make index marks on the blank and drive center so you can remount the turning in the same position after removing it to sand the grip recesses in the next step.

TOOL: $\frac{3}{4}$ " skew chisel.

TOOL REST: Slightly above center.

SPEED: 800–1,200 rpm.

4 Sand the grip recesses.

Referring to the knife handle full-size pattern on the pattern insert, mark the length of the grip recesses. Dismount the workpiece. Sand the concave grips on opposite sides of the handle with a drum sander. To keep the grips parallel, keep the square end of the workpiece flat on your spindle-sander or drill-press table.

5 Remount the turning.

Finish-sand the handle to 220 grit. Trim it at the tailstock end, cutting in as close to the cone center as possible without disengaging it. For the cleanest cut, cut straight in at the guideline with the long point of a skew chisel. Use the skew to finish forming the finial as you part off the handle. Touch up the finial's tip with sandpaper, and sand the handle's blade end smooth.

TOOL: $\frac{3}{4}$ " skew chisel.

TOOL REST: Slightly above center.

SPEED: 800–1,200 rpm.

Note: You can apply a finish to the knife handle before parting it from the waste. See "On to the finish line."

On to the finish line

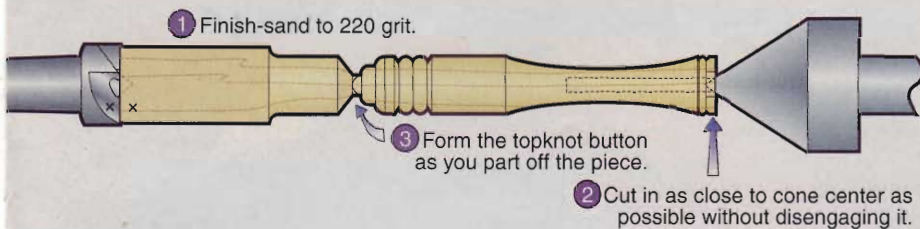
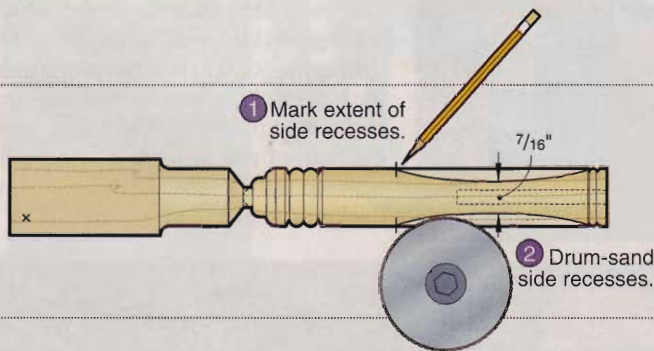
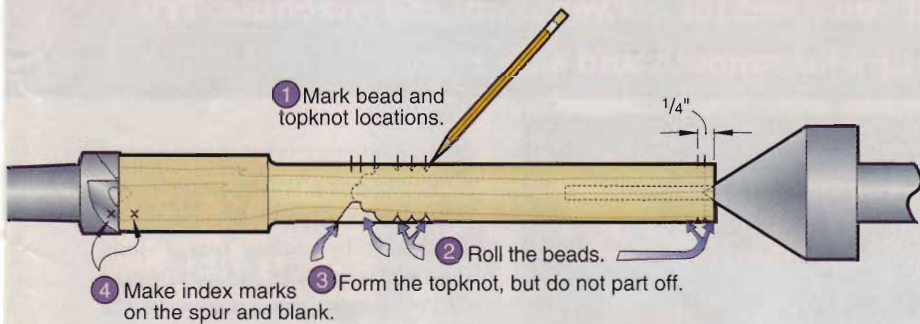
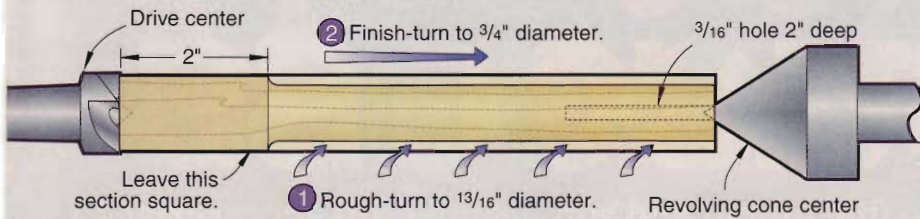
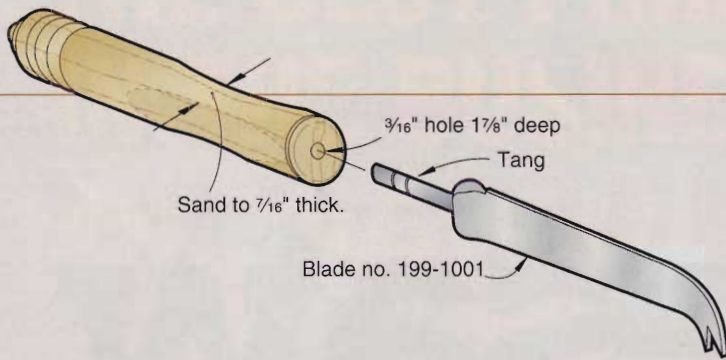

1 Apply a clear finish to the platter and the knife handle. To withstand the rigors of occasional washing, spray on three coats of gloss polyurethane from an aerosol can. Rub out the finish between coats with 0000 steel wool or an ultra-fine (gray) Scotch-Brite pad.

As an alternative, you can apply the finish while the part is still on the lathe. Although it ties up your lathe for additional time, it is easier to get good results when finishes are applied in this manner. Simply slow your lathe to about 300 rpm, and follow the directions on the finish container. See the Buying Guide.

2 Because the cheeseboard will be subject to knife cuts, do not use a film finish. Apply an oil finish, reapplying periodically as needed. See the Buying Guide for a finish source.

3 With the finishes dry, epoxy the blade tang into the handle. Place the cheeseboard in the platter's recess, and cover it with the glass dome. 🌲

Written by **Larry Johnston** and **Jan Svec** with **Ray Wilber**

Project design: **Ray Wilber**

Illustrations: **Roxanne LeMoine**; **Lorna Johnson**
Photographs: **Baldwin Photography**

Materials

Supplies: 1/2"-thick stock for auxiliary face-plate, hotmelt glue or double-faced tape, woodworker's glue, finish, epoxy.

Buying Guide

Turning blanks. 1 3/4x12 1/4x12 1/4" mahogany (edge-joined from color-blended stock); 3/4x6 1/4x6 1/4" bird's-eye maple; 1x1x8" bird's-eye maple. Kit no. W-141, \$19.95 ppd., Minnesota residents add sales tax. Heritage Building Specialties, 205 N. Cascade, Fergus Falls, MN 56537. Call 800/524-4184.

Cone center. Cone center no. 914-0001 (#1 Morse taper) or no. 914-0002 (#2 Morse taper), \$39.99 ppd. Craft Supplies USA, 1287 E. 1120 S., Provo, UT 84606. Call 800/551-8876, or go to www.woodturnerscatalog.com.

Dome and knife. 6" glass dome no. 011-0120, \$7.99; deluxe cheese knife no. 199-1001, \$6.50. Craft Supplies USA.

Finishes. Mylands Friction Polish (4 oz.) no. 949-400, \$5.50; butcher block oil (16 oz.) no. 076-0830, \$6.99. Craft Supplies USA.

WOOD® special kit. Glass dome, knife, friction polish, butcher block oil, kit no. 900-9000, \$26.99 ppd. Craft Supplies USA.

10 ways to tablesaw success

A little fine tuning and some shop-built accessories are all you need for a sweet-running machine. Try these tips for smooth and safe cuts.

1 Get blade height right.

Everyone has a different idea on how far saw-blade teeth should protrude above the stock. As a general rule, raise the blade $\frac{1}{2}$ " above the surface of softwood stock to reduce heat buildup. For hardwoods, raise it to $\frac{3}{4}$ " above the surface. You want the blade to eject waste from the gullets between the teeth. That means that the bottom of the blade's gullets should be almost flush with the surface of the stock, as shown *above*.

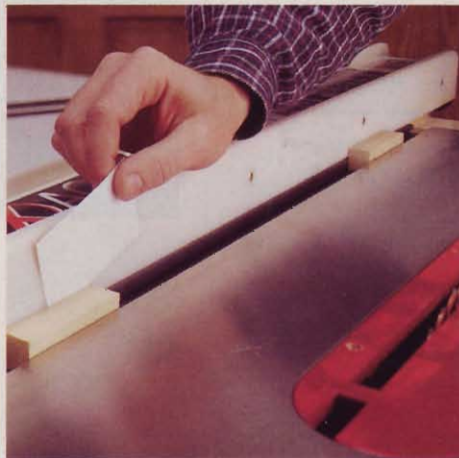

3 Finesse the fence.

To set the fence parallel to the blade, start by cutting two 2"-long blocks to fit snugly in one miter gauge slot. Position the fence against them, and use a thin shim to check for an equal gap at both ends, as shown at *left*. Setting the fence exactly parallel yields the best results, especially with dados. If the workpiece burns or binds, cant the outfeed end away from the blade between .010" and .030" (about the thickness of a business card).

2 True the blade and table.

For straight, burn-free cuts, the saw blade must run parallel to the miter-gauge slots and the fence. To align the blade, mark one blade tooth and measure, at the front of the throat opening, from one miter gauge slot to it using a combination square, as shown at *right*. Then rotate the blade and measure to the same tooth at the back of the throat opening. If the distances vary, reposition either the trunnions or the saw table. Check your owner's manual to see which method applies. Also check and adjust the blade's 45° and 90° bevel stops. Procedures for this vary widely, so check your owner's manual.





4 Cover the angles. To ensure accurate crosscuts, make sure the miter gauge is accurate at 90° and 45°. Rest one edge of a plastic drafting triangle on the blade body—not on the teeth. Loosen the miter gauge knob, slide the head against the triangle, and lock the knob, as shown *above*. Do the same at 45°. These triangles are available in artist's supply stores and are very accurate. Adjustable models also are available.

5 Get proper clearance. The standard throat plate on most saws has a wide opening to allow tilting the blade. This leaves the underside of the workpiece unsupported and susceptible to chip-out, and can allow thin wood strips to drop into the gap. To minimize these problems, make a zero-clearance insert. Just trace your insert onto plywood of the proper thickness (you may have to plane it down) and cut it to rough shape. Plywood is better than solid stock, which may warp. Either sand the insert to exact shape, or attach it to the throat plate using double-faced tape and shape it using a pattern-routing bit in your table-mounted router, as shown *below*. You also can use thinner plywood and drive short flathead screws into the bottom face to act as levelers.

Lower your saw blade all the way and check the insert's fit. If the blade doesn't retract far enough to allow the insert to sit flush with the table surface, reinstall the standard throat plate and cut a kerf in the underside of the zero-clearance insert. Recheck the fit, then clamp the insert in place using a long board. Turn on the saw and slowly raise the blade to full height to cut through the plate, as shown at *right*. Use the same procedures to make a dado insert.



6 Add function to the fence. For some operations, such as when cutting tenons with a dado blade or cutting with the blade against the rip fence, you'll appreciate having an auxiliary fence face. Easy to make, this accessory prevents damage to the fence, and can support a tall face for cutting wide workpieces on edge.

For general use, cut a 3/4" plywood face 4"-wide by the length of your fence. How you attach the face depends on your fence. If your fence has holes through it, attach the face with bolts. Just counterbore the holes in the face so the bolt heads sit below the surface. Or make a "saddle" that slips over the fence, as shown at *right*. Clamp it at the out-feed end, or mount a pair of T-nuts in the saddle's back "leg," and use short bolts as setscrews to secure the saddle.

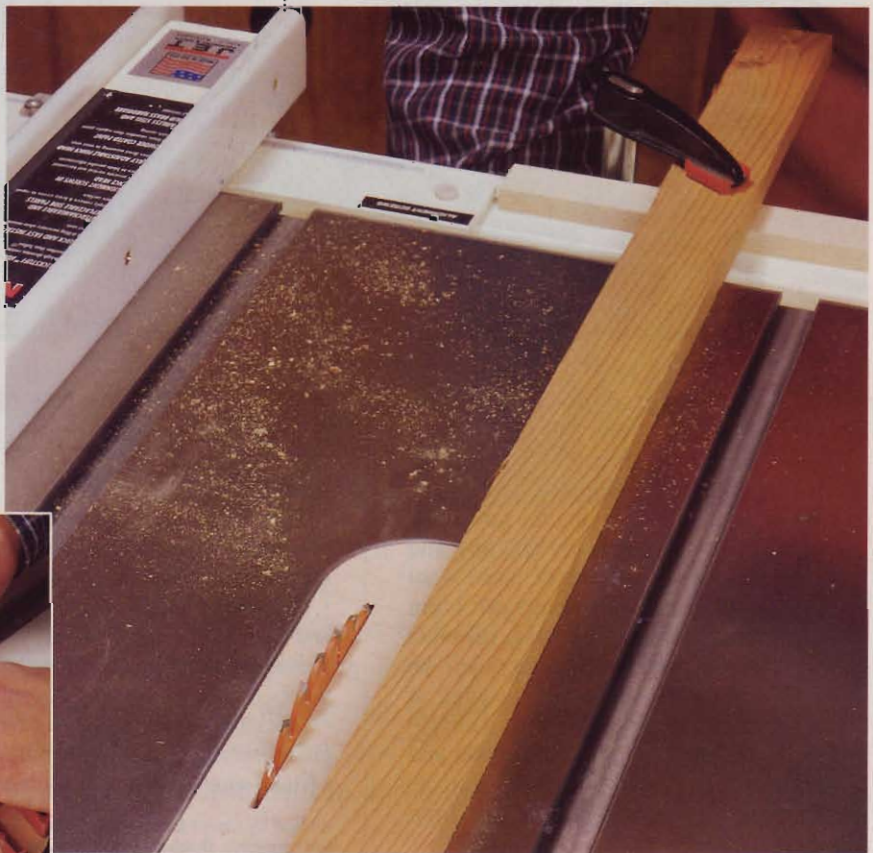
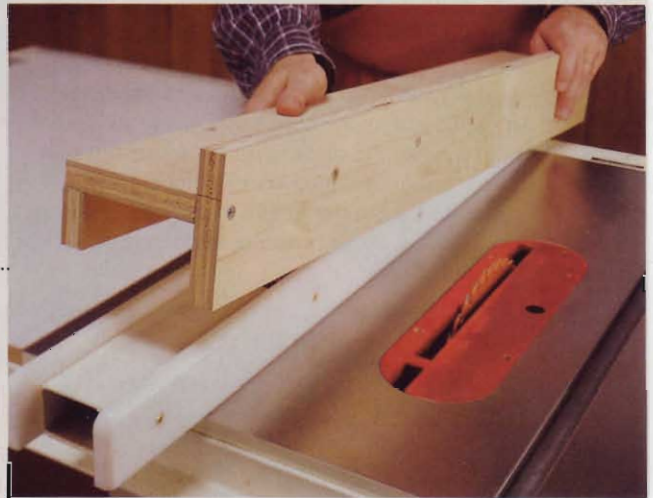

7 Create a mightier gauge. When crosscutting long boards or cutting multiple pieces to the same length, an auxiliary extension board for the miter gauge is a must. Make one from scrap $\frac{3}{4}$ " plywood, about 3" wide and up to 36" long, such as the one shown at *right*. For even greater accuracy, give the extension a grip on the workpiece by covering the face with adhesive-backed sandpaper. Screw the extension to the miter gauge so it protrudes beyond the blade, then cut a kerf through it. Next, make a clamp-on stopblock about $\frac{1}{4}$ " shorter than the fence height to prevent sawdust from building up and causing inaccurate cuts.

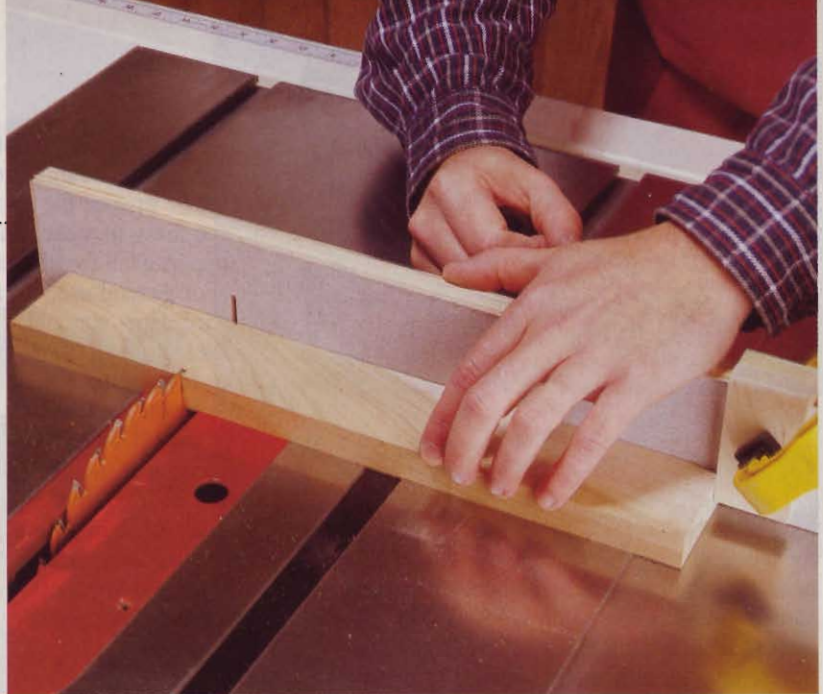

8 Make sacrificial guides. Any time you are ripping pieces narrower than 6", use a pushstick to guide your stock while keeping your hands safely away from the blade. Make your own by simply cutting a birdsmouth notch in one end of a $\frac{3}{4}$ "x2x12" piece of stock. If you have to rip pieces narrower than 1", make a wide pushblock from a 2x4 and a piece of hardboard, as shown at *left*. The blade will cut into the pushblock, but the hardboard "heel" pushes both the workpiece and waste safely past the blade. Rather than getting fancy, make your pushsticks from scrap stock, and sacrifice them to the blade instead of your fingers.

9 Wax for smooth sliding. Cast-iron saw tables will rust if left bare, which prevents workpieces from sliding freely. You can get rid of rust by spraying the table with penetrating oil (such as WD-40) and scrubbing with a synthetic steel-wool pad or 220-grit wet/dry sandpaper. Form a barrier to new rust by coating the table with a commercial product such as Top-Cote (available from Woodcraft at 800/225-1153), or by applying a couple coats of paste wax to the table and buffing it out well. Recoat the table every few months to prevent rust from coming back.

10 Take time for regular maintenance. Your saw will run better and last longer if you take care of it on a regular basis. Do the following every month or two:

- Wipe sawdust and debris from the saw table. Spray protectant or polish the table with wax several times per year.
- Vacuum, blow, or brush sawdust from the trunnions and lubricate per the manufacturers instructions.
- Turn blade-height and bevel handwheels through their full range of motion, and check 45° and 90° stops.
- Use blade-and-bit cleaner to remove pitch from your saw blade. Oven cleaner works, but is caustic. Try Formula 409-brand cleaner for minor cleanups.
- Check the condition of drive belts, and replace them if cracked or worn. Check pulley setscrews, and tighten if necessary.
- Make sure all electrical cords and connections are in good condition. 🌲

Written by David Stone with Robert Settich
Photographs: Baldwin Photography

outdoor products resource guide

When we designed and built the projects for our outdoor living area featured on pages 58 and 59, we selected products that met our rigorous criteria. We combed the market for materials and hardware that are maintenance-free and resistant to weather's worst abuses. We also chose products that offer convenience, ease of installation, and great looks. Now let's review these nationally available products and how you can learn more about them.

CEDAR LUMBER

Weyerhaeuser CedarOne Western Red cedar
Comment: Cedar is a rot-, warp-, and crack-resistant wood that holds up well in above-ground outdoor applications.
Weyerhaeuser Building Products
866/233-2766
www.cedarone.com

DECKING

Weyerhaeuser ChoiceDek Plus
Comment: These wood fiber/plastic composition boards won't rot, crack, or warp; they need no finish and offer great wet-traction due to their grooved surface.
Weyerhaeuser Building Products
877/235-6873
www.choicedek.com

PVC LUMBER

Azek Expanded Rigid PVC
Comment: This plastic-based product machines like wood and looks like it once painted; it's impervious to rot and insects.
Vycom Corp.
570/346-8254
www.azek.com

SHINGLES

Shingleside Heritage Single Shingle
Comment: Single Shingle won't rot, split, or curl. It takes paint well and comes pre-primed with a 30-year warranty.
James Hardie Building Products, Inc.
888/542-7343
www.jameshardie.com



Weyerhaeuser
ChoiceDek Plus



Malibu Lighting



Poly-Planar Speakers



Tehema Patio Pavers

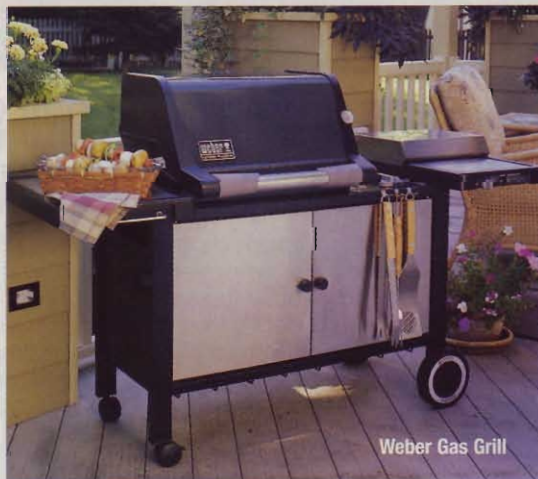

Weber Gas Grill

LATTICE

Tuff-Bilt Classic Privacy Square plastic lattice in Honey-Almond

Comment: This fully-fused lattice product imitates the look of wood. It is sold in a variety of colors and patterns, and does not require paint.

Plastics Research Corp.
810/235-0400
www.tuffbilt.com

FASTENERS

ProMax Optimized Thread Length screws

Comment: This square-drive fastener offers great holding power with shank lengths sized to match wood thickness.

McFeeley's Square Drive Screws
800/443-7937
www.mcfceelys.com

SYNTHETIC STONE

Tehema Water Wash Patio Pavers TC-3407

Comment: Providing a real-stone look with better color consistency, this lighter-weight building material is easy to install due to its consistent thickness and flat bottom side.

Cultured Stone—A Division of Owens-Corning
800/255-1727
www.culturedstone.com

LOW-VOLTAGE LIGHTING

Malibu Architectural Grade CL900 and CL902 recessed lights; CL131 flood lights

Comment: Easy to install, these energy-efficient lights come in many styles and feature protective, durable, metal housings.

Intermatic, Inc.
815/675-2321
www.intermatic.com

STEREO SPEAKERS

MA905 panel speakers and one MS150 10" subwoofer waterproof speakers

Comment: With its high-fidelity stereo sound, this waterproof audio system attaches to your home's audio system for convenient use.

Poly-Planar, Inc.
215/675-7805
www.polyplanar.com

CONCRETE AND FORMS

10x42" Quik-Tube concrete forms and Quikrete 5000 Concrete Mix

Comment: While the easy-to-use forms give shape to your footers, the quick-mixing concrete mix fills the forms with lasting strength.

The Quikrete Companies, Inc.
800/282-5828
www.quikrete.com

GAS GRILL

Weber Genesis Platinum gas grill

Comment: This may be the last grill you ever buy. It has long-wearing stainless steel components, and a 12' quick-disconnect hose that lets you hook up to your home's gas supply so you never have to run out to fill a propane tank.

Weber-Stephen Products, Co.
800/446-1071
www.weber.com

products that perform

These woodworking wares passed our shop trials

Portable planer finishes the job

Consider what you dislike about your portable planer and, chances are, Delta's 22-580 Two-Speed Finishing Planer has addressed them. The 22-580's disposable and self-aligning 13" knives make knife changing a snap. But one of its best attributes is one you might never have thought you needed: dual feed speeds.

At "dimensioning" speed, this planer delivers about 60 cuts per inch and leaves a relatively smooth surface. I was surprised at how quickly I planed away 1/2" of walnut in multiple passes. For the final pass, though, I switched to "finishing" speed, which slows the feed rate and leaves a silky-smooth 90 cuts per inch. The difference in surface quality was clearly visible.

Snipe a problem? Not with the 22-580. The cutterhead lock and 35" long (com-

bined) infeed and outfeed tables virtually eliminate detectable snipe, even on my 8'-long test workpieces.

Delta engineers added a unique "blade zero" device for quickly zeroing the cutterhead to your workpiece's starting thickness. After using the blade-zero on a piece of 4/4 rough-sawn cherry, the cutterhead just barely skimmed the top of the board, proving it to be an accurate starting point.

I've always found thickness scales on portable planers hard to read—on top of the machine is too high; on the cutterhead is too low. The 22-580's scale is on the face of the case, near the top, and angled for good viewing.

Many portable planers have a cutting-depth stop that ensures uniform thickness to one or a few fixed dimensions, up to 3/4" or 1". The 22-580's stop can be set



**Delta 22-580
Two-Speed Finishing Planer**

Performance	★★★★★
Price	\$450
Value	★★★★★

Call Delta Machinery at 800/438-2486, or visit www.deltamachinery.com.

anywhere along the full 6 1/2"-thickness capacity of the machine.

—Tested by Garry Smith

Continued on page 102

www.woodonline.com

101

SOMMERFELD'S
TOOLS FOR WOOD

8 East Third Street Remsen, IA 51050

CMT's New
Industrio™
Routing System

Designed by
Marc Sommerfeld





This system combines the performance and design of a shaper with the versatility of a router.

Check out our complete
on line catalog at
www.sommerfeldtools.com

ORDER TOLL-FREE 1-888-2BUY-CMT

1-888-228-9268

Trade in your
coat & tie
for a shop apron.

Call us, we'll tell you how!





Woodcraft
Franchises
Available!

Premium locations
are limited!

Please contact:
Bill Carroll
Director of Franchise Operations
Woodcraft Franchise Corp.

304-422-5412

or e-mail:
bill_carroll@woodcraft.sbrinc.com



560 Airport Ind. Park, PO Box 1686, Parkersburg, WV 26102-1686 Dept. F02WI04Q

Circle No. 1366

WOODLINE ARIZONA, INC. OFFERS YOU MORE...

Super Sets AT Great Prices!!!

products that perform

This pair of diamonds wins hands down

Monocrystalline diamonds are a cutting tool's best friend. Virtually wearproof, they impart a consistently flat, sharp edge on chisels, knives, or even other sharpening stones. But that precision usually comes with a high price tag. That's why I did a double take when I saw DuoSharp monocrystalline stones for under \$100.

DuoSharp stones have different grits on each side with color-coded dots on each stone to give a quick visual reference to which grit is up. Using the fine/extra fine 8" stone (shown in the optional molded base, below), I tuned up my bench chisels and found the fine grit aggressive, but not grabby. I then flipped the stone to extra-fine and, with a few strokes, honed it razor-sharp.

After sharpening everything but the pencil over my ear, I simply rinsed the DuoSharp stone clean with water, and wiped it off. The diamond crystals are set in a nickel surface to prevent rusting.

Flatness is always a concern on sharpening stones, and again, DuoSharp excelled. I checked three different stones using a surface plate and found them to vary less than .003" from perfect.

—Tested by Garry Smith

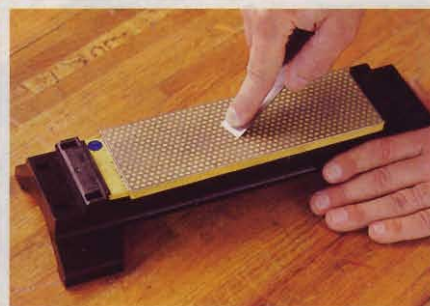

DMT DuoSharp Sharpening System

Performance	★★★★★
Price	\$80, 8"; \$110, 10"; \$18, molded base
Value	★★★★☆

Call Diamond Machining technology at 800/666-4368, or visit www.dmtsharp.com

About our product tester

Garry Smith is a tool-and-die maker and avid woodworker.

30-Piece Professional Set



- Includes:
5 Straight bits
3 Dovetails
3 Core Box
3 Cove Bits
6 Roundovers
2 Flush Trim
1 Panel Bit
1 Roman Ogee
2 Slot Cutters
1 "V" Groove
1 Chamfer
1 Bevel Trim Bit

WL-2010 OUR PRICE ONLY \$109 set



- ### 5-Piece Cove Set
- 1/2" Shank Router Bits
1/4"R, 3/8"R, 1/2"R,
5/8"R, 3/4"R

WL-2015 OUR PRICE ONLY \$49 set

5-Piece Roundnose (Core Box) Set



- 1/2" Shank Router Bits
3/8"D, 1/2"D, 3/4"D, 1"D, 1 1/2"D

WL-2012 OUR PRICE ONLY \$49 set

13-Piece Dovetail Set



- 1/2" Shank Router Bits
3 Straight bits
10 Dovetail bits

WL-2014 OUR PRICE ONLY \$49 set



- ### 6-Piece Bullnose Set
- 1/2" Shank Router Bits
1/4"D, 3/8"D, 1/2"D,
5/8"D, 3/4"D, 1"D

WL-2013 OUR PRICE ONLY \$89 set

3-Piece Cabinet Door Set



- 1/2" Shank Router Bits
2-Piece Roman Ogee Rail & Stile
2 3/4" Ogee Panel Raiser

WL-2019 OUR PRICE ONLY \$65 set



- ### 5-Piece Moulding Set
- 1/2" Shank Router Bits

WL-2011 OUR PRICE ONLY \$99 set

All Woodline Arizona Sets are packaged in a beautiful wood box (a \$10.00 value).

15-Piece 1/2" Shank Set



- Includes:
Chamfer
Cove -
1/2"R, 3/8"R, 1/4"R
Roundover -
1/2"R, 3/8"R, 1/4"R
Roman Ogee -
1/4"R
Straight Bits -
3/4"R, 1/2"R, 1/4"R
Roundover -
1/2"R, 3/8"R, 1/4"R
1/2" Dovetail
1/2" Roundover
1"CL Flush Trim
Rabbit Bit

WL-2022 OUR PRICE ONLY \$59 set

15-Piece 1/4" Shank Set

same as WL-2022 except 1/4" shank

WL-2021 OUR PRICE ONLY \$59 set

5-Piece Cabinet Door Set



- Includes:
3/4" Bore Shaper Cutter
1-pc Rail & Stile (Roman Ogee)
4 5/8" Panel Raiser (Ogee)
Door Lip
Glue Joint
Drawer Locker

WL-1505 OUR PRICE ONLY \$179 set

6-Piece Cabinet Door Set



- Includes:
2-pc Rail & Stile (Roman Ogee)
2 3/4" D Panel Raiser (Ogee)
Door Lip
Glue Joint
Drawer Locker

WL-2020 OUR PRICE ONLY \$119 set



- ### 5-Piece Carbide-Tipped Forstner Bit Set
- 3/8" Shank for Drill Press
35mm, 1 1/4", 1", 3/4", 5/8"

WL-2018 OUR PRICE ONLY \$39 set



- ### 5-Piece Dovetail Set
- 1/2" Shank Router Bits
8" - 1/2"
14" - 3/8", 1/2", 5/8", 3/4"

WL-2017 OUR PRICE ONLY \$19 set



- ### 8-Piece Classical Set
- Includes:
2 Classical - 5/32"R & 1/4"R, 1 Wavy
2 Ogee - 5/32"R & 1/4"R, 1 Filet
2 Roman Ogee - 5/32"R & 1/4"R
(1/2" Shank Router Bits)

WL-2016 OUR PRICE ONLY \$99 set

WOODLINE's Quality Bits and Cutters feature:

- Tough Micro-Grain Carbide
- Euro Anti-Kickback Design
- Super-slick Non-stick finish
- Super Low Prices

Check our website for new products:
www.woodbits.com
E-mail:
cutteraz@cybertrails.com



WOODLINE ARIZONA, Inc.
P.O. Box 1530 • Payson, AZ 85547
Great Router Bits & Shaper Cutters!
Best Selection...Best Price

Order Toll Free

1-800-472-6950

Get your FREE catalog and see our great selection of Bits and Cutters

Most items in stock • All major credit cards accepted
Same-day shipping!! • Shipping \$3.75/\$100 + \$4.75

Kentucky coffeetree

Its beans were once better than nothing

As the only species of its genus in North America, the sparsely appearing Kentucky coffeetree (*Gymnocladus dioica*) was a welcome sight to early explorers and pioneers traveling into the wilds west of the Allegheny Mountains. Not that it's an attractive tree—it leafs out in late spring and sheds early, causing it to stand naked for at least half of the year. In fact, because it often looks so stark, the French called it *chicot* or “dead tree” while to Southerners it became “stump tree.” Rather than its eye-appeal, the attraction was its bean-laden pods.

Lacking coffee beans for their travels, frontiersmen ground and brewed

the beans of the Kentucky coffeetree as a stimulating replacement. The result was a bitter imitation at best, but they made do.

Reaching heights of 100' and diameters to 4' in its range from southern Canada to Kentucky and west to Nebraska, the Kentucky coffeetree has so wide a distribution and so single a growth pattern that it has never reached commercial importance. Although, farmers always have used the coarse-grained yet durable wood for fence posts and barn timbers. Light brown to reddish brown in color, the heavy and hard wood machines easily and takes a high polish. Pioneers no doubt crafted it

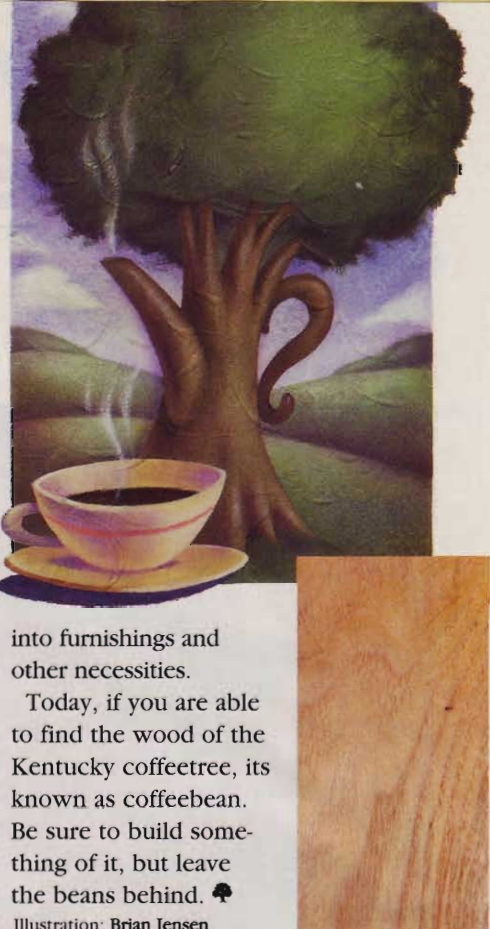

into furnishings and other necessities.

Today, if you are able to find the wood of the Kentucky coffeetree, its known as coffeebean. Be sure to build something of it, but leave the beans behind. ☿

Illustration: Brian Jensen

FREE TOOL CATALOG!

Your Best Work Starts With Us...

With over 8,000 of the finest woodworking tools in the world, Woodcraft can help you work more efficiently and skillfully than ever. Call for your Free copy today.

1-800-542-9115



WOODCRAFT
Helping You Make Wood Work®

www.woodcraft.com

Visit one of our stores located nationwide! Call us for the store nearest you.



Proud sponsor of “The American Woodshop” hosted by Scott Phillips on PBS.

560 Airport Ind. Park,
Dept. 02WI040,
PO Box 1686,
Parkersburg, WV
26102-1686

Stainless Deck Screws from the Source

- Square Drive Stops Driver Bit Slippage!
- 305 or 316 Stainless for Extra Corrosion Resistance
- Deep Thread for Exceptional Holding Power
- Self-Drilling Point for Drives Easily
- Sizes from #6 x 1-1/4 to #10 x 3-1/2

Write for FREE Catalog!

McFEELY'S
SQUARE DRIVE SCREWS

PO Box 11169 • Dept WD04C • Lynchburg • VA • 24506
Toll Free 1-800-443-7937 or at www.mcfelys.com

what's ahead

in the June/July issue

Projects



Timeless tool box

Looking for a place to store your tools that shows off your woodworking skills? This Arts & Crafts-inspired chest has two drawers and a pull-out tool tray, all with protective felt liners.



Heirloom chest

Build this as a gift, and you're sure to make someone's day. Contrasting woods lend an air of distinction to its traditional design.

It's a ringer

This easy-to-make horseshoe set will give kids hours of safe fun.



Built-in storage for unused places

Make use of space beneath stairs and behind kneewalls with this modular, in-wall system. Two cabinets of different heights fit between studs set on 16" centers.



One gorgeous gate

The classy looks of this sturdy entry create a pleasing invite to spaces beyond. Weather-resistant materials give it long life.

Tools & Techniques

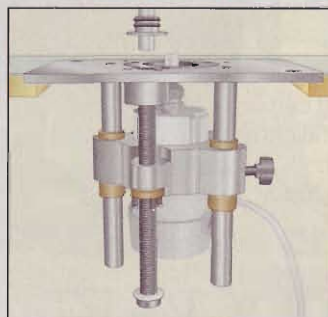

Tool test: router-elevation systems

These new gizmos make router-table work much more convenient. No wonder they've recently exploded on the marketplace. We put eight models through their paces to see which work best.



WOOD's guide to finishing, part 3

Previous articles in this series covered wood preparation and staining. Here, we focus on clear finishes and how best to apply them.