

Better Homes and Gardens®

WOOD

WE TEST
DUST COLLECTORS
\$300 AND UNDER

March 2002
ISSUE 140

Tips, Tools, Techniques, and Projects for the Home Woodworker®

hideaway computer center

SPECIAL!
GUIDE
TO
WOOD
STAINING

MORE GREAT PROJECTS:

- Gardener's potting bench
- Shelving stand with flair
- Retro TV desk clock
- Mission CD case

www.woodonline.com

Display until March 5, 2002

U.S.A. \$5.99



contents

WOOD® magazine

March 2002, Issue 140

projects & techniques

34 **gardener's potting bench**

Let your green thumbs play in the dirt with this easily constructed mobile workstation.

40 **finishing guide: staining**

Color wood to bring out its beauty using this comprehensive look at dyes and pigments.

46 **electronic media storage**

Organize CDs and DVDs with this adjustable Arts & Crafts design.

52 **hideaway home office**

Build a handsome cabinet that transforms into a deluxe computer center.

68 **contemporary shelves**

Display art, picture frames, and more with this stylish home accent.

78 **novelty desk clock**

Craft this early-days TV timepiece, complete with a specially designed mail-order face.

Cover Photo: Baldwin Photography



contents

March 2002, Issue 140

tool review

62 110-volt dust collectors

See which of the nine models from our test sweeps up top honors.

features

72 workshop contest winners

You'll be impressed by the problem-solving ideas of these eight entries.

departments

6 editor's angle

8 talking back

12 safety: how to avoid kickback

Learn the precautions for cutting with a table saw, circ saw, and chainsaw.

14 WOOD ONLINE®

16 router bits: keyhole cutter

Use this bit and our template to rout perfect slots for hanging frames.

20 ask wood

22 repair shop: fixing an heirloom

Five restoration tricks show you how to give an antique new life.

24 great ideas: crosscut sled

Improve the accuracy of your table saw with this zero-clearance jig.

26 shop tips

32 workshop savvy: glues

Refer to our chart when choosing and using any of seven popular adhesives.

82 short cuts

96 what's ahead in our next issue

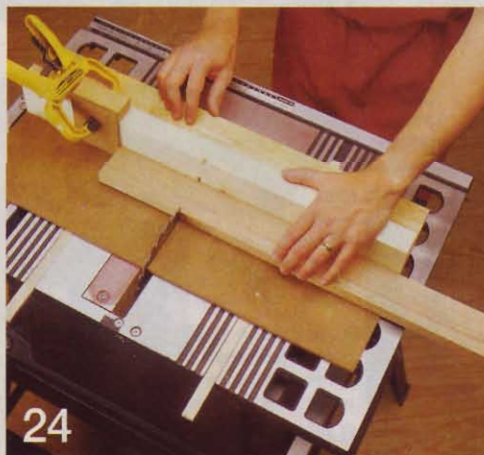
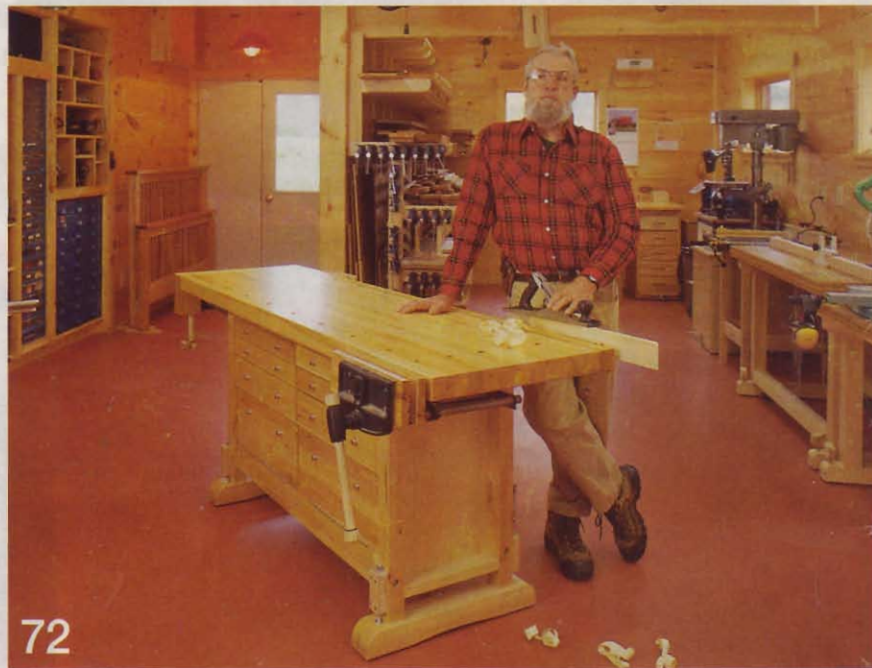
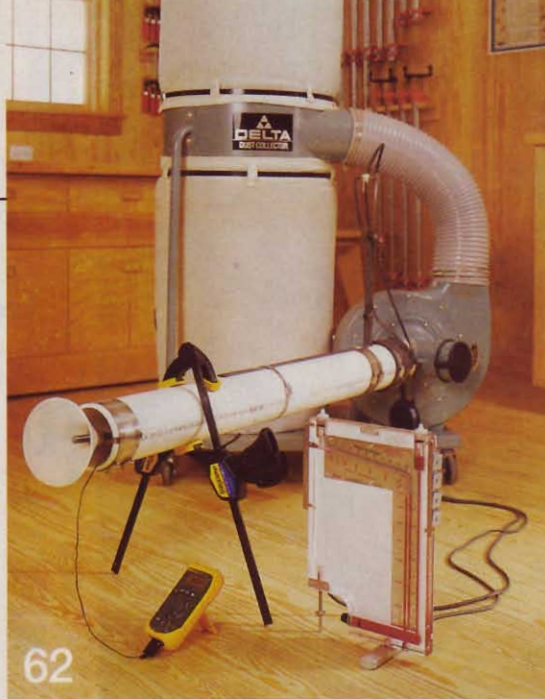

Better Homes and Gardens® WOOD® magazine (ISSN-0743-894X) is published nine times a year in February, March, April, May/June, July/August, September, October, November, and December by Meredith Corporation, 1716 Locust St., Des Moines, IA 50309-3023. Periodicals postage paid at Des Moines, Iowa, and additional mailing offices. Better Homes and Gardens trademark registered in Canada and Australia. Marca Registrada en México. **ONE-YEAR SUBSCRIPTION PRICES:** U.S. and its possessions, \$28; Canada, \$41; other countries, \$49. Canada Post Publications Mail Sales Product Agreement No. 40049562. Canadian BN 12348 2887RT. **CANADIAN RETURN ADDRESS:** Better Homes and Gardens WOOD magazine, 2744 Edna Street, Windsor, Ontario, N8Y 1V2. **POSTMASTER:** Send address changes to Better Homes and Gardens WOOD magazine, P.O. Box 37439, Boone, IA 50037-0439.

'Twas the last day of the shop contest...

...and all through the land, many readers were wishing: "Let me win the grand." Their photos were packaged and mailed so fine, with the hope that their entries might meet the deadline.

Excuse me for taking liberties with "An Account of a Visit From Saint Nicholas," also known as "The Night Before Christmas," by Clement Clarke Moore. I was reminded of that classic holiday poem as I wrote this column on the entry deadline day for our Great American Workshops Contest. You see, events on that day were lending a festive atmosphere to our shop and offices.

First, the mailman dropped off a much-larger-than-usual load of packages—nearly all of them overnight deliveries from contestants. Minutes later, a Minnesota reader stopped in after a three-hour drive to hand-deliver his entry—even the overnight services couldn't help him get the package here on time. Then, the phone rang. On the line was an Oregon reader saying that the overnight services weren't flying on schedule, so would it be okay if we received her entry the next day?

Now, mind you, the contest was announced a full five months before the final entry due date. So, I couldn't help but chuckle—I know how we woodworkers can put things off. I've given my share of holiday presents that smelled of barely cured varnish. Still, I wondered why so many entries came in at the last minute when only photos and a floor plan were required. Well, the grand-prize winner, Jacques Jodoin, whose entry arrived on the final day, provided me with some



Fellow judges (front to back) Chuck Hedlund, Dave Stone, and Marlen Kemmet pored over hundreds of entries to choose eight winners.

insight. "It took me three months to clean up the shop for taking photos," he admitted in a phone call. And when you see Jacques's shop on *page 74*, you'll understand why it took him that long.

We received more than 400 entries in the eight contest categories, and I think I speak for all of the judges when I say that we were absolutely blown away by the ingenuity and resourcefulness shown by the entrants. The hardest part of the selection process, of course, was narrowing it down to one winner in each category.

My thanks to all of the entrants, winners and nonwinners alike, who made this contest a success. In future issues we hope to show you how to implement many of the best ideas submitted in your own shop.



Bill Krier

Better Homes and Gardens®

WOOD®

March 2002 • Vol. 19, No. 2 • Issue No. 140

Editor-in-Chief **BILL KRIER**
Executive Editor **JIM HARROLD**
Managing Editor **MARLEN KEMMET**
Products Editor **DAVE CAMPBELL**
Projects Editor **JAN HALE SVEC**
Projects Editor **OWEN DUVAL**
Features Editor **DAVE STONE**
Techniques Editor **JIM POLLOCK**
Senior Design Editor **KEVIN BOYLE**
Master Craftsman **CHARLES I. HEDLUND**
Production/Office Manager **MARGARET CLOSNER**
Administrative Assistant **SHERYL MUNYON**
Illustrators **LORNA JOHNSON, ROXANNE LeMOINE, TIM CAHILL, MIKE MITTERMEIER**
Contributing Photographer **MARTY BALDWIN**
Technical Consultants **RICH BRIGHT, JEFF HALL, KIRK HESSE, GARRY SMITH**
Contributing Craftsman **JIM HEAVEY**
Proofreaders **JIM SANDERS, BARBARA KLEIN**

Art Director **TIM ALEXANDER**
Associate Art Director **JOHN MEEK**
Assistant Art Director **CHERYL A. CIBULA**

Publisher **MARK HAGEN**

Advertising Office: 333 N. Michigan Ave., Suite 1500, Chicago, IL 60601 Phone: 312/853-2890 Fax: 312/580-7906

Sales Assistant **THERESA COOKS**

Mail Response Manager **CAROLYN DAKIS**

Account Executive **RON GOLMINAS**

Account Executive **NEIL KIRBY**

Account Executive **JOHN THORNBURGH**

Detroit, Phone: 248/356-1149 Fax: 248/356-8930

Account Executive **PAT TOMLINSON**

Northeast, Phone: 212/551-7043 Fax: 212/551-7192

Southeast: Lagomarsino, Dempsey & Dennis, Inc.

2951 Piedmont Rd., NE, Suite 100, Atlanta, GA 30305

Phone: 404/261-5400 Fax: 404/261-5404

Group Marketing Director **CATHY E. SMITH**

Phone: 212/551-7178 Fax: 212/551-7192

Senior Marketing Services Manager **ALEXANDER D. CLARKSON**

Group Publisher **STEPHEN B. LEVINSON**

Associate Business Director **CRAIG FEAR**

Senior Product Manager **RICK GROW**

Advertising Services Manager **PAT HENDERSHOTT**

Consumer Marketing Director **KATHI PRIEN**

Consumer Marketing Manager **DAVE HONOLD**

Vice President/Publishing Director **WILLIAM R. REED**

MEREDITH PUBLISHING GROUP

President **STEPHEN M. LACY**

Magazine Group President **JERRY KAPLAN**

Group Sales **MICHAEL BROWNSTEIN**

Creative Services **ELLEN DELATHOUDER**

Business Development **TINA GEORGEQU**

Manufacturing **BRUCE HESTON**

Consumer Marketing **KARLA JEFFRIES**

Finance and Administration **MAX RUNCIMAN**

Meredith
CORPORATION

WILLIAM T. KERR, President and Chief Executive Officer

E.T. MEREDITH III, Chairman of the Executive Committee

©Copyright Meredith Corporation 2002

All rights reserved. Printed in the U.S.A.

Customer Service Information: For service on your subscription, including change of address, contact us at www.woodmagazine.com/service or call **800/374-9663**.

Subscription mailing address: Better Homes and Gardens WOOD magazine, P.O. Box 37439, Boone, IA 50037-0439. Please enclose your address label from a recent issue.

Editorial mailing address: The Editor, WOOD magazine, 1716 Locust Street, GA310, Des Moines, IA 50309-3023. For questions on editorial, questions about how to reach an advertiser, or to place an advertisement in our magazine call **800/374-9663**.

To order back issues call 800/346-9663. Article reprints, send \$5 per article (no phone orders), include issue and name of article, to WOOD Article Reprint Service, P.O. Box 349, Kalona, IA 52247, check or money order made payable to WOOD magazine.

♻️

MPA

talking back

Our bulletin board for letters, comments, and timely updates

Thanks for a charitable article

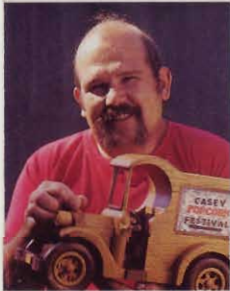

Richard Gard

I was taking a break from a music-box project and thought I'd just sit and relax for a spell. While doing so, I wondered if I ever thanked *WOOD*® magazine for what you've done to help me in my woodworking endeavors.

Back in June 1991 (issue 43), you featured me in an article about the music boxes I build and donate to local charity fund-raising activities. That article opened doors and allowed me to interact with woodworkers all over the world. And my music boxes have generated over \$40,000 for charity.

These things would never have been possible without your help. I truly appreciate everything you've done to help me realize my dream.

—Richard Gard, Casey, Ill.

This heart-shaped box, one of Richards designs, was featured in issue 43.



Give 'em the ol' flush-cutting one-two punch

I enjoyed "Copycat cutters," the article on router flush-trim and pattern bits in issue 136. I belong to Worthington Woodworkers,

and we make 300–400 toys each year for community Christmas baskets.

Using a template and flush-trim bit to make identical parts, we always have trouble when the bit runs against the grain. Marv Rall, one of our members, suggested also using a pattern bit. Now, when the flush-trim bit starts running against the grain, we stop, turn the workpiece over, and finish up with a pattern bit. With the template on the bottom, running against the pattern bit's bearing, we're once more routing with the grain.

—Kern Schwartz, Worthington, Minn.



Pattern bit Flush-trim bit

Into thin wood

I look forward to each issue of *WOOD* that shows up in my mailbox, and issue 133 did not disappoint. But when I read the Tool Buyers' Update about portable planers (page 16), I came away scratching my head.

You see, I just bought the Craftsman no. 21713 you talked about. And even though you say its depth-stop turret has five thicknesses down to $\frac{3}{8}$ " , I know from personal experience that mine will surface to less than $\frac{1}{8}$ ". In the accompanying chart, you shortchange this planer even further, saying its minimum cutting thickness is $\frac{1}{2}$ ".

—Ed Maze, Malabar, Fla.

Sorry for the confusion, Ed. We took the 1/2" spec directly from Craftsman's most recent catalog (and a Craftsman represen-

tative verified it when he reviewed our chart prior to publication). Compounding matters, the planer's manual and the labeling on its infeed table specify a 3/8" minimum thickness. But you're right. Checking the turret stop on the same machine reveals six stops down to 1/8".

Take another look at the display stand

I'd like to call attention to a misplaced dado in the display stand in issue 135. On Drawing 3, Step 3, and again on Drawing 4b, the centered dado in the divider (E) is shown $3\frac{1}{2}$ " from the end. The correct dimension is $3\frac{3}{4}$ ", as shown in the drawings, below.

—Ryan McGuire, South Euclid, Ohio

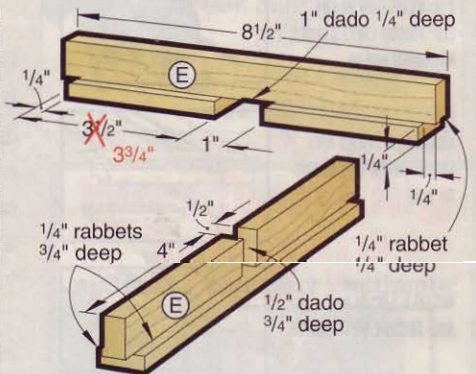
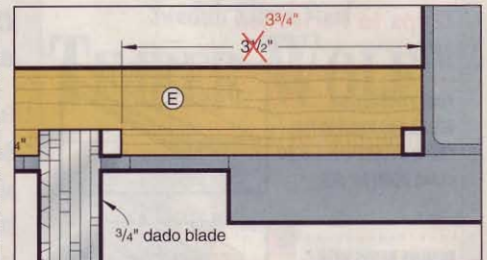

Is Douglas fir really as thick as a brick?

I am very perplexed by "If a wood truck could truck wood" in Talking Back on

Continued on page 10

CRAFTSMAN

MAKING A PERFECT CUT IS AS EASY AS LINING YOUR MARK UP TO THE LASER TRAC!

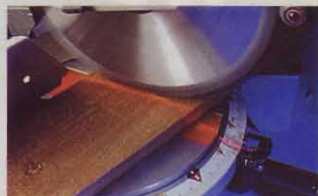

Craftsman Exclusive Laser Trac
The guesswork is over. So is wasteful, inaccurate cutting. Now you'll know exactly where the blade will intersect with your workpiece. Perfect for all types of straight and bevel cutting.



5,000 rpm no-load speed for fast and smooth cutting
15-amp universal motor with externally accessible brushes has power needed for all types of cuts.

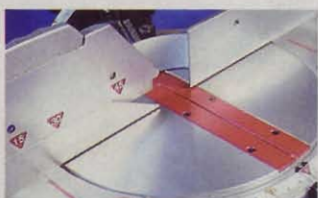

Sliding fence with built-in bevel indicators for fast, accurate setups
With our new easy-to-read controls, even the tricky cuts can be set up and made with confidence.



Extensions provide capacity for projects both large and small
From ornate crown molding to a huge backyard deck, make precise adjustments with ease & confidence.

Available at Sears, Sears Hardware, and the Craftsman Catalog at 800-437-9686

SEARS
Where else?™

talking back

page 8 of issue 135. You state that the weight of green Douglas fir is 8.216 pounds per board foot. If this were true, then a cubic foot of green Douglas fir would weigh 98.59 pounds, about the same as a cubic foot of bricks, and would float just about as well.

The *Textbook of Wood Technology* lists the average weight of green Douglas fir as 38 pounds per cubic foot or 3.16 pounds per board foot. An 8' diameter 32' log containing 14,560 board feet would weigh 46,009 pounds, a fairly easy load for an 18-wheel logging truck.

—Herm Finkbeiner, Executive Secretary,
Northeastern Woodworkers Association, Rexford, N.Y.

Nettlesome nets

We've had several calls alerting us to inconsistencies in the net bag listed in the Buying Guide for the landing net featured in issue 133. Our pattern shows locations for 44 net bag loop holes in the frame. Readers have received nets with

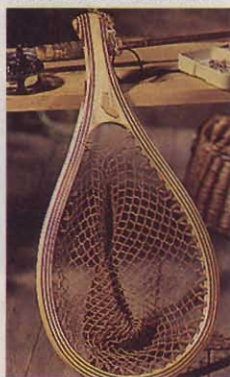

anywhere from 43 to 48 loops. The supplier has no control over this situation, so readers are advised to count the loops on their net bags, and adjust the number and location of the loop holes.

An amps oops

In the issue 136 drill-press review, we misstated the amperage of the Jet JDP17-MF as 14/7 amps at 110/220 volts. The correct rating is 9/4.5 amps at 110/220 volts.

A blast from the past

This is the first time I've ever written to a magazine, but I just had to congratulate you on the great idea for using magnetic switches (instead of toggle switches) on your dust-collector blast gates (issue 120,

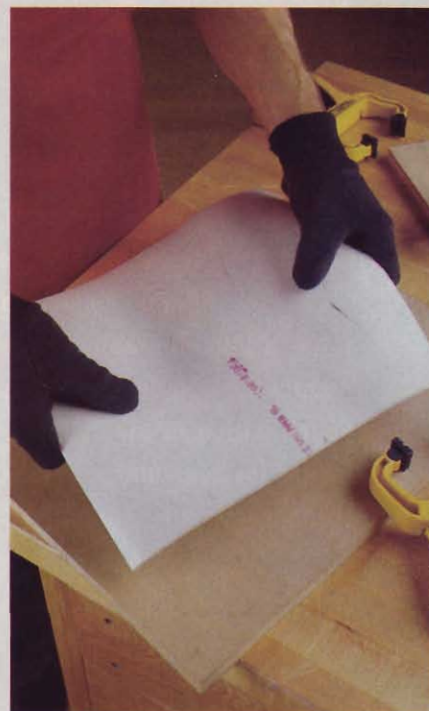

Tips from Your Shop and Ours). It really deserved the prize for Top Shop Tip.

But I think I've done it one better. Instead of making part of the blast gates out of 1/4" plywood, mine are made completely from inexpensive PVC pipe. I slit a short section, heated it to about 280° F in our kitchen oven, then simply flattened it into sheets. After that, it was easy to cut the sheets to size, and glue them together to make my gates.

—Steve May, Prairieville, La.

Thanks, Steve, for reminding us what a malleable material PVC pipe really is.

Write Us!

Do you have comments, criticisms, suggestions, or maybe even a compliment specifically relating to an article that appeared in *WOOD* magazine? Please write to:

Talking Back
WOOD magazine
1716 Locust St., GA310
Des Moines, IA 50309-3023

or e-mail us at talkingback@mdp.com.
Due to the volume of letters and e-mails we receive, we only can respond to and publish those of the greatest interest to our readers.

where **safety** begins

stay on guard **against kickback**

Simple strategies
help you play it safe.

All spinning saws can kick back. And, boy, does it happen quickly! To protect yourself, learn the causes of kickback and counter them with safe work habits. You'll reduce the chances of kickback happening—but if it does, you'll be out of harm's way.

What causes kickback?

Pinching is the most common culprit. If the saw kerf closes in on the blade so that it can't spin freely, something has to give. Depending on what kind of tablesaw you're using, either the tool jumps or the wood flies in the direction of the saw blade's rotation.

On a tablesaw, the wood's direction is straight back at you. On a radial-arm saw, it's straight at you when ripping and away from you when crosscutting. When using a handheld circular saw or a chainsaw, the saw itself can leap toward you.

Serious injuries can result in these situations. Avoid that danger by following these safety rules.

Stationary saw safety strategies

Always stand slightly to the outside edge of the board when you're ripping on a tablesaw. That keeps you out of the direct line of kickback. If you're feeding the workpiece by hand, your hand can slip forward toward the blade when the board kicks out. So use a pushstick made of soft plastic, or a properly shaped piece of

wood, and keep it out of the blade's path. Don't pull the workpiece from the back side of the tablesaw—a kickback can yank your hand right into the blade.

To avoid tablesaw kickback, keep the kerf open with a splitter—either a commercial version or one built into a homemade table insert. Most tablesaws also come with anti-kickback pawls, those metal teeth that prevent the workpiece from sliding backward. Keep them installed on the saw. Make sure each piece of wood, whether it's a long board, wide sheet, or something in between, has adequate support all the way through the sawblade. When making a bevel cut, keep your miter gauge or pushstick on the opposite side of the blade's high point.

When you're using a radial-arm saw, again, don't stand in line with the board when ripping. Keep your hands out of the line of cut at the infeed side, and don't reach around the blade.

Be patient with portable saws

Kickback often occurs when you're cutting large sheets of material. If you let the sheet droop down, the kerf can close and pinch the blade as you near the end of the cut. Keep your hands and body out of the line of cut. Always maintain a firm grip



This is the way to play defense against tablesaw kickback. Stand at the outside edge of the board, use a proper pushstick and featherboard, and keep your splitter and anti-kickback pawls in place.

on the saw. And don't stretch so far over the workpiece that you're left in an awkward, unbalanced position.

Remember, too, that big sheets need wide, solid support all the way around, in the form of a workbench or well-made stands with rollers. Don't replace such support with a human helper. You won't find a helper who can keep your work as steady as a workbench.

Don't let a chainsaw loose

When you cut with the bottom edge of the chain bar, the saw pulls away from you. That's good. But when you cut with the top edge the saw wants to come at you. The most hazardous cutting spot of all is the top curve of the bar's nose. Using that point almost guarantees a kickback.

Hold the chainsaw with both hands, and wear safety glasses or goggles. A full face shield is even better. 🛡️

How you benefit by going to www.woodonline.com



Free seminars just one click away

Every issue of *WOOD*® magazine is packed full of tips, projects, and techniques to help you become a better woodworker. Whether you subscribe or buy the magazine off the newsstand, you get a lot of information for a little bit of money. But at *WOOD MALL*® we have a deal that's even better: FREE woodworking seminars.

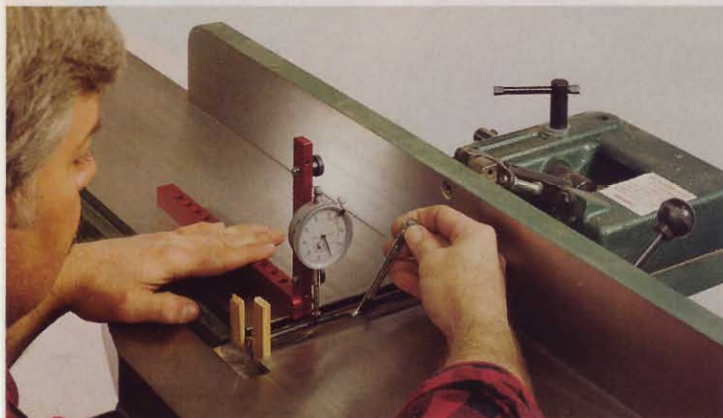

Free woodworking seminars at *WOOD MALL* will help improve your skills in many areas, such as setting up your machines for peak performance.

Just point your browser to www.woodmall.com and click on Free Seminars. You'll find a new seminar every month on subjects ranging from tool tuning to carving. Clear photos and easy-to-understand text help you learn something new or brush up on old skills. While you're there, take a look at our selection of other seminars you can download for just a few bucks each.

Discussion groups offer answers and advice

When woodworkers aren't in their shops, they spend a lot of time talking about woodworking. That's the idea behind the *WOOD Talk* section at *WOOD ONLINE*®. Here, you'll find a dozen discussion groups where you can ask questions and offer your advice on woodworking topics, such as finishing, woodturning, and tool buying.

Go to www.woodmagazine.com, click on *WOOD Talk* in the left-hand navigation bar, then on *WOOD Talk Home* in the drop-down menu.

Learn more about lumber

Pick the right wood for every project and calculate how much you need using our free Lumber Sizing Chart at www.woodmagazine.com. It contains valuable information on the uses and characteristics of 21 common woods. Plus, there's a handy chart that explains the basics of lumber grading and shows the board-foot content for a wide range of board sizes.

From the magazine site (*above*) click on *WOOD MAGAZINE*, and on *FREE Charts* in the menu.

YOUR GUIDE TO COMMON WOODWORKING WOODS

Printed by which wood to use for what? Much of the wood comes down to personal use. Use your analysis, the answers provided can be confusing. Use the chart below. See the cost and availability. Set with you know the quantities that help you choose. To acquaint you with the woods in common usage.

WOOD SPECIES	PRICE (1)	MOISTURE (%)	DENSITY	TEXTURE	GRAIN	RATINGS (2)											USE/COMMENTS						
						STABILITY	WORKABILITY	TURNABILITY	JOINABILITY	STAINABILITY	PAINTABILITY	GLUEABILITY	SCREWABILITY	NAILABILITY	DRILLABILITY	PLANING		SMOOTHING	FINISHING				
ALDER, RED	22	8	Medium	Shine	Light	G	F	F	G	G	F	G	F	G	F	G	F	G	F	G	F	G	Cabinets, furniture, interior
ASH, WHITE	33	8	Hard	Shiny	Heavy	G	F	G	E	F	P	G	G	E	G	F	G	F	G	F	G	Cabinets, furniture, interior	
BASSWOOD	15	8	Soft	Shiny	Light	G	P	G	E	P	G	G	E	G	E	G	E	G	E	G	E	Best for carving	
BIRCH, YELLOW	28	8	Hard	Shiny	Heavy	G	F	G	E	G	P	G	G	F	G	F	G	F	G	F	G	Cabinets, furniture, interior	
BUTTERNUT	108	8	Soft	Shiny	Light	E	F	P	F	G	G	G	G	F	G	F	G	F	G	F	G	Carving, furniture	
CEDAR, RED	38	8	Soft	Shiny	Light	G	E	P	F	P	F	G	P	F	G	P	F	G	P	F	G	Outdoor furniture, interior	
CHERRY	8000	8	Hard	Shiny	Medium	G	F	F	E	E	G	E	E	G	E	G	E	G	E	G	E	Price furniture, interior	
CYPRESS	15	8	Medium	Medium	Medium	G	E	F	P	P	G	F	F	G	F	F	G	F	F	G	F	Outdoor furniture, interior	

Behind the screen: Don Sindledecker, *WOOD Talk* Host-at-Large

A lot of the credit for the success of our online discussion groups goes to our hosts. These experienced woodworkers offer advice and direct visitors to information available on our various sites, in *WOOD* magazine issues, and other sources. They also monitor each discussion group to help us ensure the postings are appropriate and relevant.



When he's not working with wood or on the web, Don Sindledecker enjoys spending time on the water.

Go to www.woodmagazine.com, click on *WOOD Talk*, and on *WOOD Talk Home*. Click the *Meet Our Hosts* link to learn about people like Don Sindledecker, *Host-at-Large*.

Don is Service Manager for a marine service company in Ketchikan, Alaska. Because dried hardwood is scarce there, he builds a lot of small projects, and pursues other hobbies, such as sailing, fishing, and computers. Don enjoys his hosting duties and helping people find the woodworking information they need. He thinks the free exchange of information is the best part of the discussion groups. "I have found that there are usually several ways to come to the same end," Don says. "Most of the time I find others' posts and answers to be answers to many of my own questions."

keyhole bit

Go wireless when hanging pictures and plaques. With the right bit, a plunge router, and our simple-to-use template, you'll master keyhole slots in minutes.

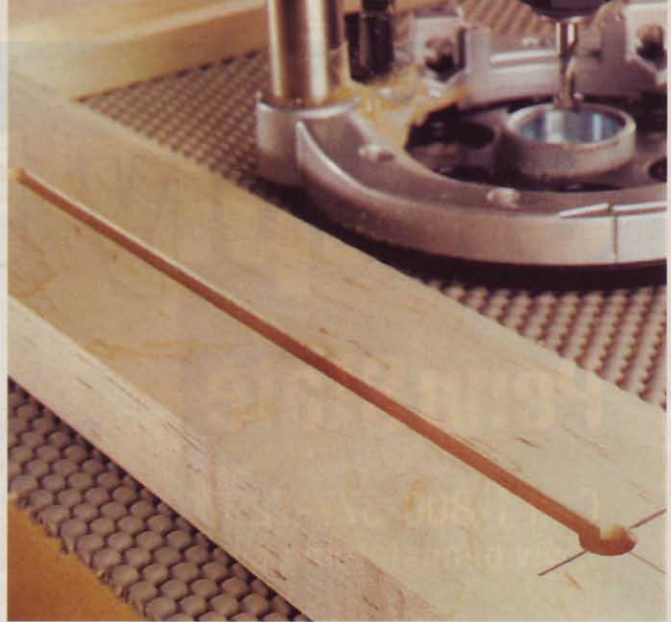

Our simple router template helps you make long keyhole slots, such as the slot shown above, or short slots, as shown below.

If it's made of wood, and you want to wall-mount it, call on a keyhole bit for the job. Unlike sawtooth hangers or the old wire-over-nail method, keyhole slots capture the head of a screw driven part way into the wall, so you can firmly affix a picture frame, plaque, clock, or bracketed shelf without fear of it falling. And, without eyelets or hangers to get in the way, your workpiece hugs the wall.

A typical keyhole bit has a major diameter (the size of the screw-entry hole) of $\frac{3}{8}$ ", and a minor diameter (the width of the visible slot) of $\frac{3}{16}$ ". For heavy workpieces requiring larger screws, some manufacturers also sell a $\frac{1}{2}$ " major-diameter bit that leaves a $\frac{1}{4}$ " visible slot.

As you plunge the bit into your workpiece, it first creates the screw-

entry hole. Moving the router with the bit lowered plows an inverted T-shaped slot to capture the screw head.

Up and down or side to side?

Depending on the size and nature of the wall-hanging, you can cut keyhole slots either vertically (with the screw-entry hole at the bottom) or horizontally. As a rule of thumb, use a horizontal slot for small, flat items that require only one screw for hanging. That allows you to slide the item side to side until it balances and hangs straight. Cut the slot near the top of the workpiece and $\frac{1}{2}$ -1" on both sides of the center line.

Small weight-bearing pieces, such as the shelf shown at right, benefit from a short, vertical

slot. Make certain your slot is perfectly centered, though, or the piece may not hang level.

For larger and heavier workpieces, use two or more slots. A picture frame hung from the center of its top rail tends to sag under its own weight, but a vertical keyhole slot in each stile of the picture frame places the burden on these vertical frame members. To ensure that the frame hangs straight, both keyhole slots must end the same distance from the top of the frame, and the screws in the wall must be both level and the exact same distance apart as the slots in the frame.

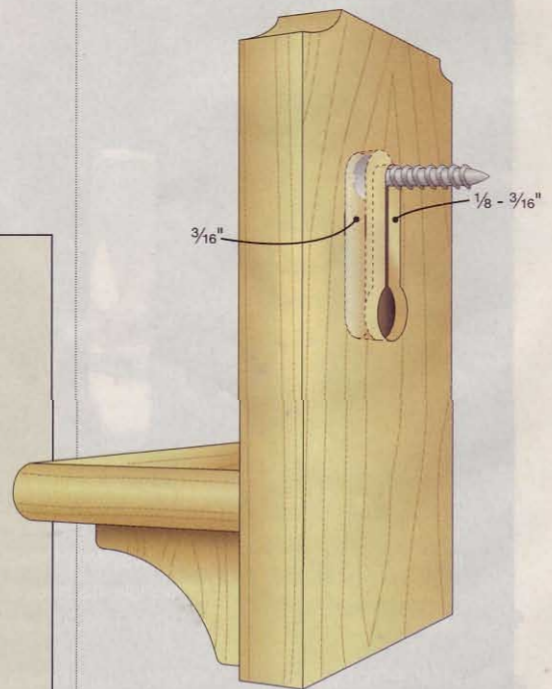
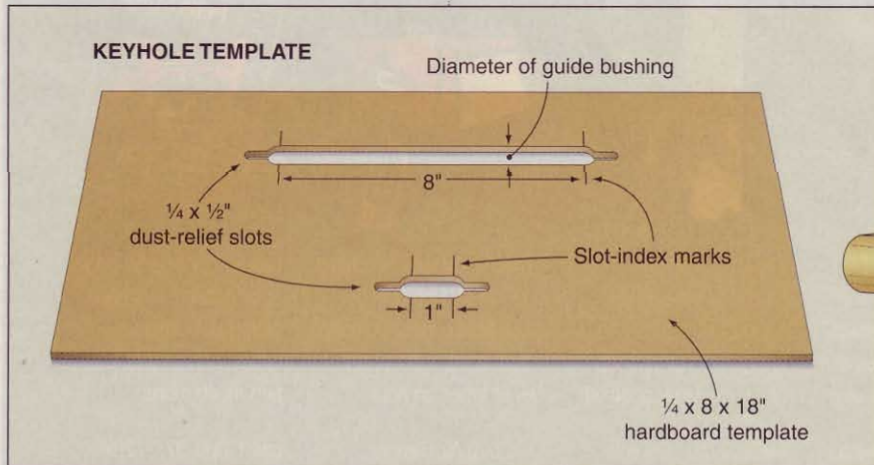

Continued on page 18

For long wall hangings, such as a bracketed shelf, where you want to make sure your mounting screws bite into a wall stud, we recommend a pair (or more) of long horizontal slots. Find the mounting location, drive the screws into the wall, then mark the screw locations on the back of the workpiece. Roughly center a long keyhole slot at each screw location, with all slots pointing in the same direction. With 8"-long slots, you can shift the workpiece up to 4" in either direction until it looks right.

Keep it straight, keep it even

If a horizontal keyhole slot runs downhill, or if a pair of vertical slots don't start and stop on the level, your workpiece will be out of kilter. So we came up with a simple template, shown on page 16, to make sure that doesn't happen.

Our template requires a 5/8" guide bushing (Porter-Cable part no. 42046), but you can use a different size. Just adjust the slot width accordingly. If your bushing protrudes more than 1/4" beyond the router's base, you'll have to file or grind it down to length.

To make the template, first lay out the start and end points (the slot-index marks) of your slots on the hardboard with long, bold lines. You'll use these index marks for alignment purposes later. With a 5/8" Forstner bit loaded in your drill press, and a fence set 2" from the center of the chuck, bore a hole centered on each of your layout lines. Don't move the fence when you're done.

Now remove the waste between the holes. For the short slot, we drilled a series of overlapping holes with the Forstner bit, then filed the edges of the slot smooth; for the long slot, we used a 5/8" straight bit in our router table.

Finally, chuck a 1/4" bit in your drill press, then bore and clean out the dust-relief slots. To use the template, follow the photos and instructions at right. ♣

Written by **Dave Campbell** with **Chuck Hedlund**
 Illustrations: **Tim Cahill**
 Photographs: **Baldwin Photography**

Master keyhole slots in four easy steps

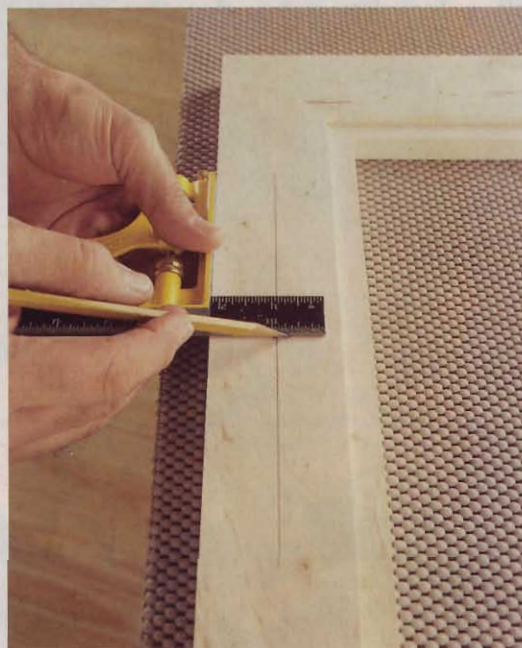

1 Mark the slot
 Locate the keyhole slot by drawing a long center-line on your workpiece. Measure and mark the bottom end of the keyhole slot, as shown, with a short perpendicular line.

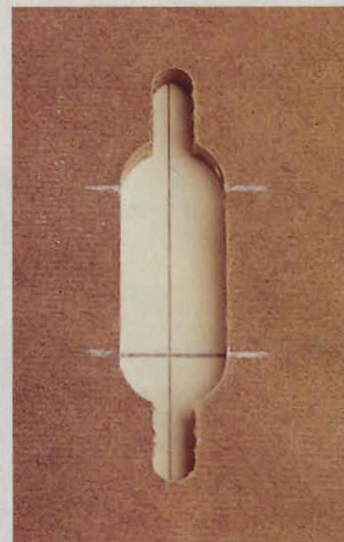

2 Index the template
 Align the short line with the slot-index marks on the template, and center the long line in the dust-relief slots. Clamp the template to the workpiece, and set your plunge router's depth stop so the bit will leave a 1/8-3/16"-thick shoulder above the keyhole slot.



3 Rout the slot
 With the guide bushing at the bottom of the slot (as the workpiece will hang) and the router on, plunge the bit into the workpiece. Guide it to the other end, backing the bit out frequently to clear dust.



4 Remove the template
 After finishing the cut, turn the router off and back it completely out of the cut. If you're going to hang the piece from two fasteners, mark the other slot and repeat the process.

ask wood

Answers to your questions from letters, e-mails, and WOOD ONLINE®

Don't let good varnish go bad

Q What's the best way to store leftover polyurethane or shellac between coats and between projects?

—Paul Johnson, via woodonline.com

A Paul, every woodworker hates to reopen a can of finish and find that it has “skinned over.” Fortunately, it's not difficult to make your finishing products last longer. Gene Hoyas, brand manager for clear finishes at William Zinsser and Company, says the key is to keep oxygen away from the liquid, and to store it in a cool place. A high-



tech way to solve the oxygen problem is to use Bloxygen, a spray product that replaces air with nitrogen, carbon dioxide, and argon. One container will handle 75 one-quart cans, and costs \$8.95 from the Woodworker's Supply catalog. Call 800/645-9292 and order item number 914-785.

Some other options cost almost nothing. For example, cut a piece of wax paper into a circle the same diameter as the inside of the can, and float it on the remaining liquid. Or, pour the leftover liquid into the smallest available jar or bottle—made of glass or a plastic that's not affected by solvent—or use a collapsible plastic container, and make it as small as possible. Woodworker's Supply carries 32-ounce collapsible bottles, priced at \$9.99 for a package of three (item number 910-207). Store the container in a cool, dry, dark place. Sunlight harms shellac by heating it, while the light itself can affect some types of varnish.

—WOOD® magazine

Osage orange is a wood of extremes

Q I soon will receive a quantity of Osage orange lumber, and I have no experience with this kind of wood. What can I expect when I work with it?

—Dean St. Clair, Salesville, Ohio

A Expect an extremely hard wood that's tough on your tools' cutting edges, Dean. However, it's also extremely resistant to insects, decay, shrinking, and swelling.

We checked with someone who has a boatload of first-hand knowledge about Osage orange's characteristics—Drew

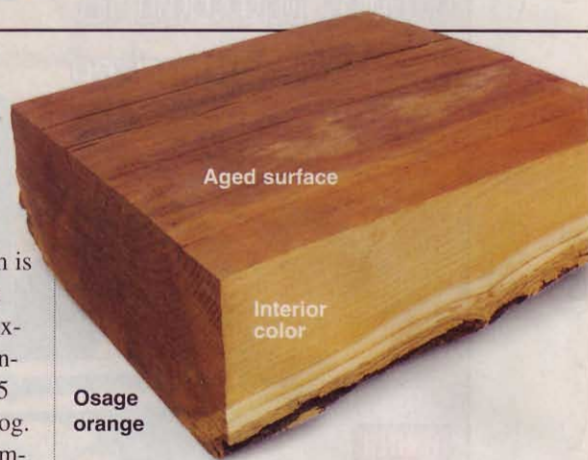

Osage orange

McMullen of Chestertown, Maryland, who directed the building of the Sultana, a 97' replica of an 18th-century schooner. Drew told us that the builders went out to the Osage orange hedgerows of Maryland and harvested trees that matched the curve they needed for the ship's ribs. They found the logs difficult to work because of cracks in the middle and because it was so hard on the sawblades. “We ran a piece through a band-saw after dark, and you could see sparks because the silica content is so high,” Drew said.

You'll also have to cut precise joints and clamp carefully if you glue Osage orange because its density prevents glue from “grabbing” easily. On the other hand, you can form crisp details if you turn Osage orange on a lathe.

Finally, if you receive freshly-cut Osage orange, you'll find nice yellows and oranges in the heartwood—but expect the wood to fade to a nondescript brown in a matter of months.

—WOOD magazine

For a smooth finish, here's the rub

Q I sometimes get dust nibs in the lacquer or urethane finishes that I spray on my projects. I've heard that a final rubbing with #0000 steel wool and a lubricant will remove those nibs without affecting the semi-gloss sheen. Which lubricant should I use for the best results?

—William Young, Wynndel, B.C., Canada

A Choosing a lubricant is easy, Bill, but you can't rub a finish without losing some of the sheen. Finishing expert Bob Flexner says you can use mineral spirits, mineral oil, or soapy water as the lubricant—experiment with them and pick the one you prefer. You'll cut quickly with water, more slowly with oil or mineral spirits. But when you remove those nibs with sandpaper, steel wool, or any other abrasive that's aggressive enough to do the job, you dull the sheen by putting tiny scratch marks into the finish. You can return to the sheen you want by rubbing with finer and finer abrasives.

Bob recommends this sequence for rubbing out your finish: Get rid of the nibs by sanding very lightly with 600-grit wet/dry sandpaper, lubricated with mineral oil. Then rub with #0000 steel wool and mineral oil to produce a satin sheen. If you want a glossier look than that, use a sequence of rubbing compounds, and stop when you reach your goal. Many woodworkers rely on pumice and rottenstone for rubbing out, but rubbing compounds give you more choices. You can order J.E. Moser's coarse (item number 957-909), medium (957-916), and fine (957-923) rubbing compounds from the Woodworker's Supply catalog by calling 800/645-9292. They come in 1.65-pound cans, priced at \$14.99 apiece.

Or, you could use Abralon abrasive pads instead of rubbing compounds. Manufactured by Mirka, these pads



come in a range of fine grits, and are designed to be used on a random-orbit sander without lubricants. They're also available from Woodworker's Supply, at grits from 180 (item number 928-165) to 4,000 (number 928-154). The price is \$16.79 for a single-grit pack of five 6" hook-and-loop pads.

—WOOD® magazine

Got a question?

If you're looking for an answer to a woodworking question, write to **Ask WOOD, 1716 Locust St., GA 310, Des Moines, IA 50309-3023** or send us an e-mail at askwood@mdp.com. For immediate feedback from your fellow woodworkers, post your question on one of our discussion groups at www.woodonline.com.

When the Sawdust Settles... Premium Quality ZAR® Rises Above the Rest!

Whether you're creating your own masterpiece or want to give new life to a treasured family heirloom only the best wood stain will do. ZAR Wood Stain is formulated using only the finest ingredients. ZAR Wood Stain's controlled penetration formula allows you to work at your own pace. ZAR wipes on easily and penetrates evenly for uniform color tone without streaks, lapmarks or blotches. ZAR Wood Stain's extra rich formula makes it ideal for all types of wood; from Oak to Aspen to Poplar to Pine with beautiful results every time. So whether you're a professional or just want professional looking results - use ZAR Wood Stains and Clear Finishes.

ZAR
The Best Thing That
Ever Happened to Wood!

For a free brochure and the name of your nearest dealer call **1-800-272-3235**, or visit us at www.ugl.com.

YOU CONTROL THE STAIN IT DOESN'T CONTROL YOU!

<p>ZAR Wood Stain wipes on evenly. Its controlled penetration gives you a uniform color tone without streaks or lap marks.</p> <p>Before After</p> <p>ZAR Wipes on Evenly!</p>	<p>ZAR's controlled penetration allows you to apply the same stain to different species of wood and get matching color tones.</p> <p>Before After</p> <p>Other Brands Leave Uneven, Blotchy Color Tone.</p>
<p>Match Color Tone on Different Kinds of Woods.</p> <p>Pine Birch Oak Maple</p>	



THE BEST PLACE TO BUY DELTA TOOLS ONLINE



www.amazon.com/delta

Call for your FREE Tool Crib catalog
1-800-635-5140

TOOLS & HARDWARE
amazon.com

furniture **repair shop**

from **junk** to **jewel**

Start-to-finish, here's how one heirloom was saved.

Senior Design Editor Kevin Boyle found this ideal restoration candidate in his parents' basement. It's a marble-topped, Eastlake table that had been charred, broken, and generally mugged by the passage of time.

The photos here show what Kevin did to restore its original glory. The work required a few hours, and an assortment of woodworking skills, but not many specialized tools or materials.

With a nod to Public Television's *The Antiques Roadshow*, we'll caution you against using epoxy or sanding away the wood's patina if you're dealing with a valuable antique. But most old pieces of furniture, such as the one shown here, don't have any great monetary value. Fix them up, and enjoy them.

1 Kevin disassembled the table (for details on taking apart dowel joints, see issue 132, page 24). Then he tackled the center post, which had split in two. He sanded both halves of the break on adhe-



After



Before

sive-backed sandpaper pressed flat on the workbench. He

reassembled it, using Titebond Dark Wood Glue so that the glue line would blend in with the walnut. To hold the assembly while the glue dried, he clamped a bicycle inner tube on the squared end, wrapped the tube tightly around the post, and clamped the other end. He sanded the old finish off of the pieces as thoroughly as possible.

2 One leg was split at the bottom end where fire damage had weakened the wood. Kevin chiseled the area flat and square, then smoothed it with sandpaper. To avoid rounding the inside corner, he put two pieces of self-adhesive sandpaper on adjoining faces of a wood block, rather than wrapping sandpaper around it. He found a piece of walnut similar to the leg in grain and color, cut it slightly larger than the opening, as shown here, glued it



in place with dark glue, and clamped it. Later, he bandsawed the patch to shape, and matched the coves on the front of the leg by filing and sanding.

3 When it came time to re-drill the cast-er hole in the repaired leg, Kevin got good results with this Stanley doweling jig. He adjusted it to match the remaining portion of the original hole, and installed a bushing of the needed diameter. The appropriate twist bit and an electric drill created a new hole without wandering off course. Any good doweling jig will serve the purpose.

4 Again relying on dark glue, Kevin re-attached the legs to the center post with new dowels. He made sure it was sitting squarely on all four feet, then

clamped the assembly with band clamps. After a couple of coats of General Finishes' Satin Royal Finish, four new casters completed this phase of the restoration. The casters were part number AG-02002612 from Van Dyke's Restorers, priced at \$6.99 apiece. Call 800/558-1234.

5 A good rubbing with wet/dry sandpaper and water cleaned rust stains and smoke residue from the white marble top. Kevin started with 400 grit, worked through a couple more stages, and finished up with 1,200 grit. Finally, he applied a coat of Minwax paste wax to the marble, as shown in **Photo 5a**. ♣

Photographs: Baldwin Photography; D.E. Smith Photography

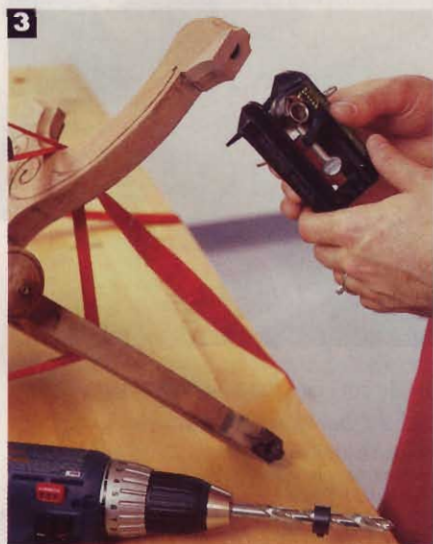

The Toughest Glue On Planet Earth

You're beyond simple yellow glues and you don't want a different bottle of glue for every project. You want Gorilla Glue®. Bonds wood, stone, metal, ceramic, plastics and more. Incredibly strong and 100% waterproof.

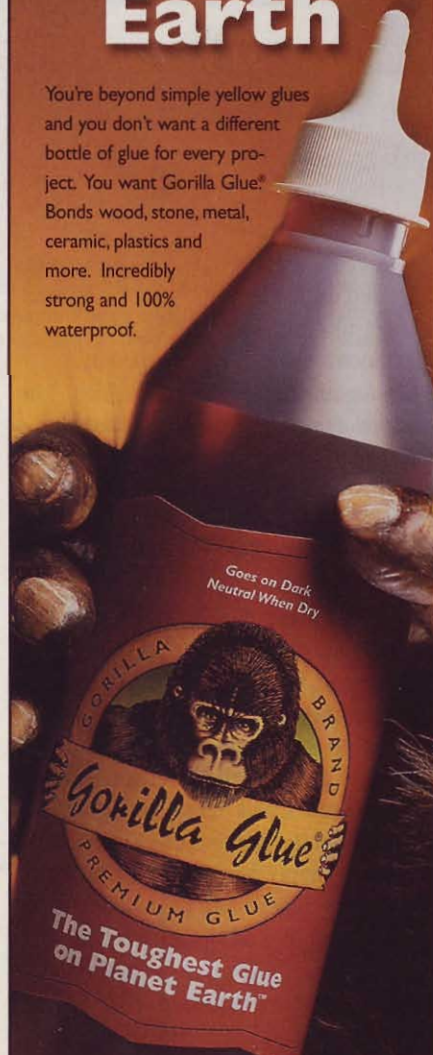

for retailers near you:
www.gorillagluue.com
1-800-966-3458

zero-clearance crosscut sled

Ditch the miter gauge to increase the accuracy of your benchtop tablesaw.

If you have zero tolerance for tear-out and inaccurate cuts, you'll enjoy the results you get with this zero-clearance crosscut sled designed by **WOOD**® magazine reader Dan Pacht. He uses the sled to increase the precision of his benchtop tablesaw. It replaces the wobbly miter gauge, and reduces tear-out by closing the gap in the saw's wide-open throat plate. You also could modify the sled for use with a stationary tablesaw.

Start by cutting a 1/4" hardboard base to size. Now square the edges of a pine 2x4, ripping it to 3" wide. From it, cut two 24"-long pieces, and glue and screw them together to form an L-shaped fence assembly. Then glue it to the hardboard base.

Next, make a pair of hardwood runners to fit your miter-gauge slots. The runners should fit snugly but still be able to slide.

Place the runners into their slots and run a small bead of glue along each one where the sled's base will cover them. Center the base/fence assembly side-to-side on your saw's table. Square the sled's fence to the saw blade by placing a framing square against the fence face and along the face of the blade. Allow the glue to dry.

Drill countersunk pilot holes in the base, and drive screws through it into the runners. Turn the sled over, and screw each runner into the base/fence assembly. Add a screw eye at one end of the fence so the sled can hang when not in use.

Note: This sled is designed for 3/4"-thick stock. To safely cut thicker stock, add a 1 1/2"x3"x4" block behind the fence, aligned with the saw kerf, to encase the blade.

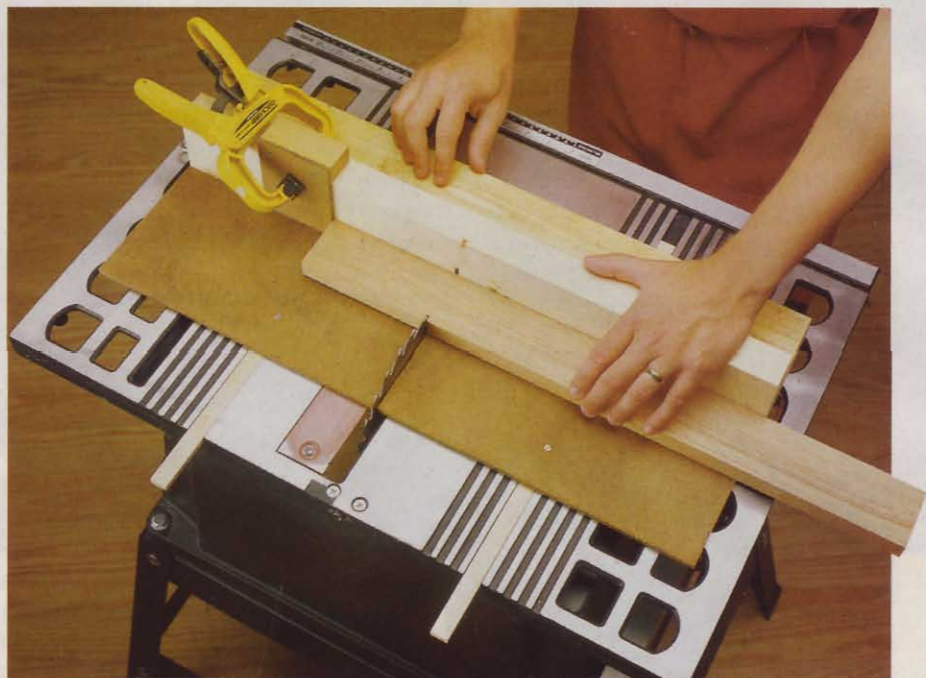

Finally, make the optional stopblock if you wish, and you're ready to go. Simply place the runners into the slots, and raise your blade 1/4" above the saw table. Glide the sled forward until the top of the

blade cuts into the fence, then back out of the cut. Now crosscut your workpiece. 🪚

Written by **Robert Settich**
Project design: **Dan Pacht**
Illustration: **Roxanne LeMoine; Lorna Johnson**
Photograph: **Baldwin Photography**

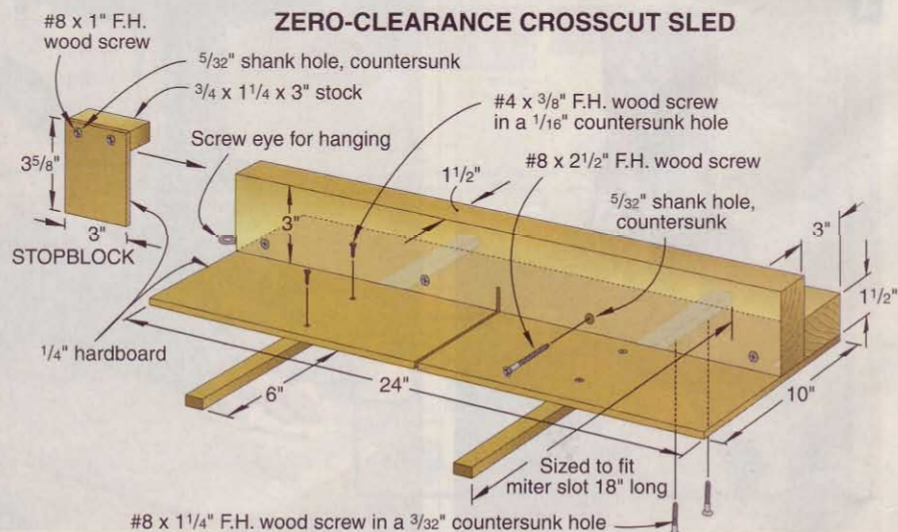

shop tips

Helping you work faster, smarter, and safer

Multiple stops for instant setups

Even though I'm retired, I still make die boxes for the printing company I used to work for. These boxes store the label-cutting dies, and making them requires a lot of repetitive drilling and machining. So I came up with a fence-and-stopblock system that works on my drill press and other machinery.

I built an auxiliary table for my drill press with T-slots, as shown in the *bottom* drawing, to adjust the fence forward and back. In my shop-made fence, I drilled a series of $\frac{1}{4}$ " holes spaced at 1" intervals along the entire fence. The cen-

top shop tip

ter hole aligns with the center of the drill-press chuck.

Each stopblock is made from a scrap of hardwood into which I've inserted a carriage bolt. The $\frac{1}{4}$ " dowels mate with the fence holes, so if I need a hole in a workpiece $4\frac{3}{4}$ " from the end, I install the stopblock in the appropriate fence holes and turn the carriage bolt until it's $4\frac{3}{4}$ " from the center of the bit. Tightening the wing nut against the T-nut locks the carriage bolt firmly in place.

Those are the basics, but now here's where it gets good. I make a separate

adjustable stopblock for each drilling operation, and write the part and fence-hole location on each stopblock. That way, I can set up a stopblock instantly for any of the holes I drill regularly.

I've now adapted this system all over my shop, using similar task-specific stopblocks and indexed fence holes on my miter saw, router table, radial-arm saw, and panel-cutting sled. These simple little stops have saved me a lot of setup time.

—Jim Maw, Kleinburg, Ont.

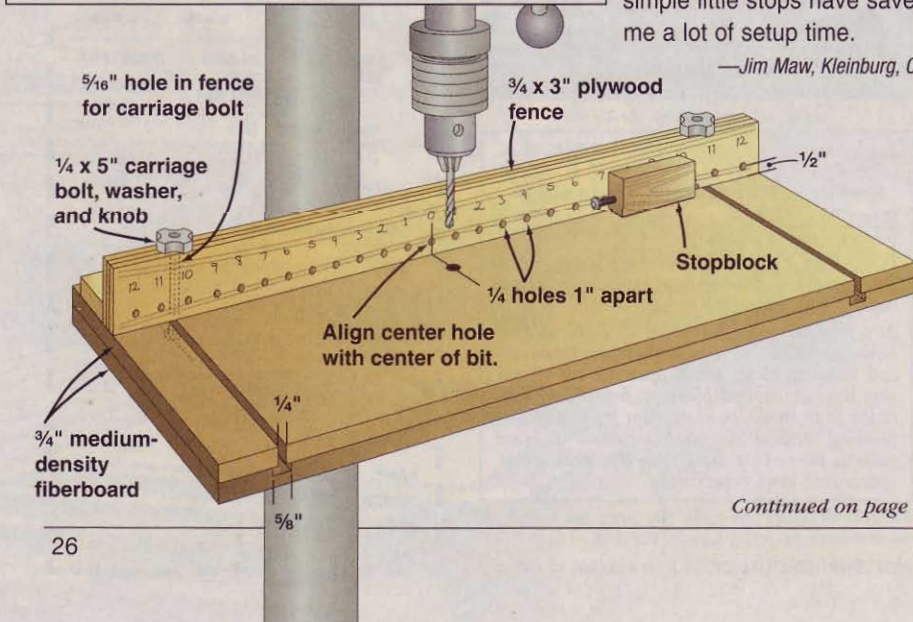
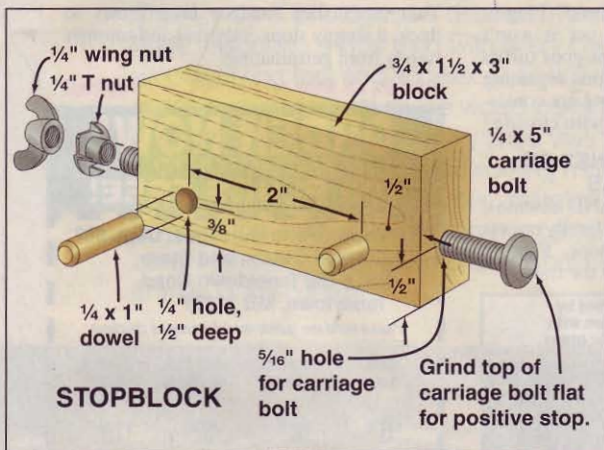

our winner



You won't catch Jim Maw resting on his laurels in retirement. You're more likely to find our Top Shop Tip winner gardening, kayaking, bicycling, or hiking. In fact, Jim and Orma, his wife of 47 years, recently spent some time hiking in Costa Rica.

Between adventures, Jim also squeezes in a little woodworking. "I don't consider myself a great craftsman," he says modestly. "I think I spend more time coming up with ideas than actually working." Well, Jim, if they're all as good as your Top Shop Tip, at left, keep sending 'em in, and we'll keep printing 'em.

For sending in this issue's Top Shop Tip, Jim wins a DeWalt DW987K-2 18-volt drill/driver kit. Thanks for your help, Jim!



You can win a free tool, too!

Tell us how you've solved a workshop puzzler, and we'll send you \$75 if we print your solution. And, if your tip is chosen as the Top Shop Tip of the issue, you'll also win a tool prize worth at least \$250.

Send your best tips, along with photos or illustrations and your daytime telephone number, to: **Shop Tips, WOOD® Magazine, 1716 Locust St., GA-310, Des Moines, IA 50309-3023.** Or post your suggestions on our Top Shop Tip discussion group at www.woodonline.com.

Because we try to publish only original tips, please send your tips only to WOOD magazine. Sorry, but we can't return your materials.

Continued on page 28

Quality Pen Kits and Other Turning Kits



- Designers & Manufacturers
- Wholesale & Retail

THE BereaHardWoods CO. Inc.

Manufacturer of quality writing instruments, components and kits.

CALL FOR FREE CATALOG

6367 Eastland Rd. • Brookpark, Ohio 44142 U.S.A.
Ph: 440-234-7949 • Fax: 440-234-7958 • bereahard@aol.com

Circle No. 510

Inkra
MITER1000

- ◆ 41 Indexed Angle Stops over $\pm 90^\circ$ range
- ◆ 18" Incra Track Fence with Slide Stop
- ◆ Steel GlideLOCK™ Miter Bar with 6 Width Adjustment Points

Inkra
MITER3000

- ◆ 364 Indexed Angle Stops over $\pm 90^\circ$ range
- ◆ 27" Miter Fence + Dual-Flip Stop
- ◆ Steel GlideLOCK™ Miter Bar with 8 Width Adjustment Points

Inkra
MITER5000

- ◆ 364 Indexed Angle Stops over $\pm 90^\circ$
- ◆ 36-64" Miter Fence + Dual-Flip Stop
- ◆ Steel GlideLOCK™ Miter Bar with 10 Width Adjustment Points
- ◆ Integral Hold-down Clamping System
- ◆ Renewable Zero Clearance Right Panel

Produce perfect gap-free hairline glue joints on the mitered corners of any multi-sided object on your first try without trial-and-error setups.



Woodpeckers Inc.

The Incra Tool Source

www.woodpeck.com

All models include: Adjustable GlideLOCK Miter Bar, Incra Specified Fence with Stop Positioner, and FREE Video Brochure. **1-800-752-0725**

shop tips

Don't waste caulk, wrap that rascal!

Over the years, I've tried every trick known to mankind to preserve a partially used tube of caulk: plugging the tip with a screw or nail, capping it with a wire nut, even using the caps that sometimes come with the tube. None of these methods seal well enough to preserve the contents for more than a few days. So, here's my contribution to mankind.

Go to an electronics store, and ask for a roll of coaxial-connector sealant tape (Radio Shack part no. 278-1645, www.radioshack.com). After wiping the excess caulk from the tip of the tube, pinch a short length of this gummy, pliable tape over the tip, as shown below.

The tape is elastic enough to provide a good seal and tacky enough to keep its grip on the tube's plastic tip. I've even reused a piece of tape on occasion. (Although, at only \$3 for a 5' roll of the stuff, it's really not necessary. I've more than recovered that cost after only a tube or two of caulk saved.)

—Nick Orth, Hartford, Wis., via WOOD ONLINE®

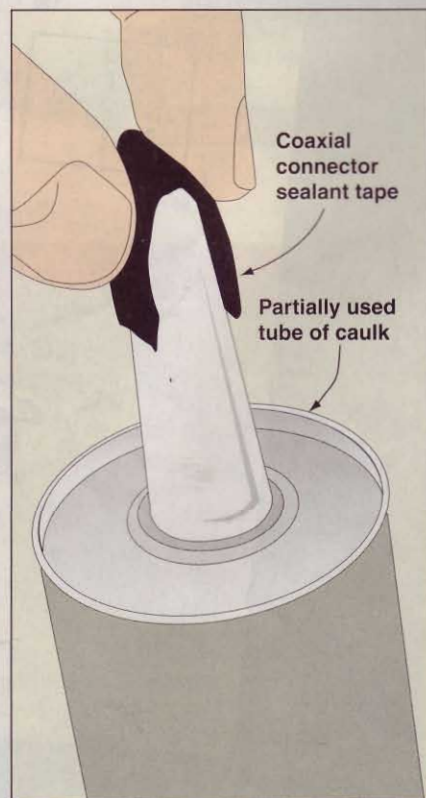

Filing system for files

In my tool chest, I have one drawer that I have dedicated to files and rasps. Unfortunately, every time I opened the drawer, the tools tended to rub against one another, making them dull.

To prevent this, I made a simple storage rack, shown *below*, from a scrap of

1x4 stock. The rack stands the tools up on edge so that the abrasive faces can't touch each other. And, by alternating the direction of the handles, I found that the files and rasps take up half the space they did before.

—Paul Neuman, Hanover, Ont.



Hang 'em high and let 'em dry

During a recent remodeling project, I had 22 pieces of 8'-long molding to clear-finish. Instead of laying them out on sawhorses to dry, which has previously left me with dust nibs in the polyurethane finish, I decided to hang it up for the day (the molding, that is).

I started by making a drying rack from a 3/4x3" strip of scrapwood about 4' long. Using my tablesaw, I cut a 1/4" groove 1/8" deep along the length of the rack, as shown in the drawing at *right*. I then set my tablesaw blade for a 1 1/4"-deep cut, and cut kerfs spaced every inch along the rack. Finally, I screwed the drying rack to a ceiling joist in my shop.

Before applying finish to the molding, I tacked a 3d box nail into the end of each piece. I then brushed on the finish and hung the molding strips on the drying rack. (The shank of the nail fits into the kerf on the drying rack, and the groove holds the nailhead to keep the molding from sliding out.)

Hanging the molding while it dries leaves no horizontal surfaces to catch dust, and I ended up with very few nibs in the finish. As a big bonus, all of that molding took up little space in my shop while it dried.

—Dan Theisen, Racine, Wis.

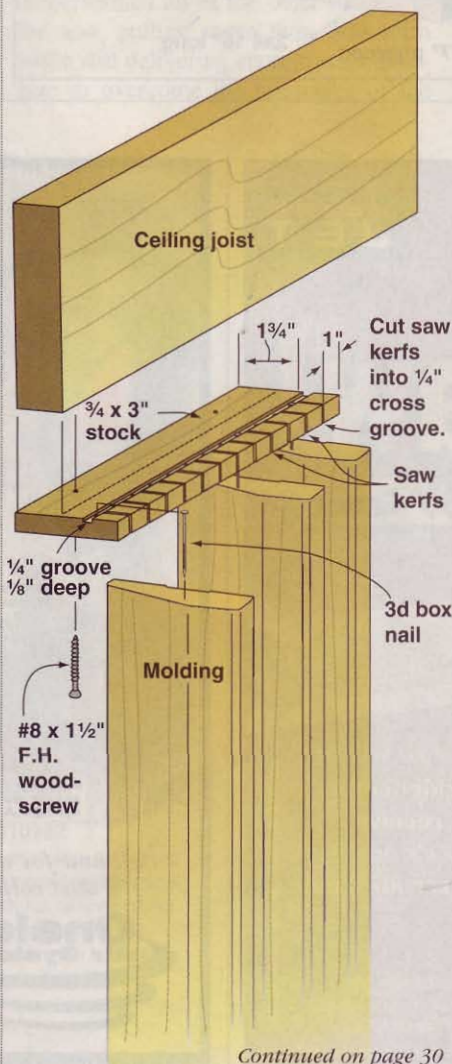

THE BEST PLACE TO BUY JET TOOLS ONLINE



www.amazon.com/jet

Call for your FREE Tool Crib catalog

1-800-635-5140

TOOLS & HARDWARE
amazon.com

Like having an extra set of hands

Woodworkers usually work alone, but there are times—such as when trying to assemble large casework—when we just need someone (or something) to help

hold things together. I made a set of scrapwood work holders, shown *below*, that have proved invaluable in my shop. Essentially, they're small versions of a

doormaker's jig, with a base and two uprights. Prop a panel up on edge in the middle of a base, and slide the uprights together to hold it while you align, glue, and screw.

Reversing and centering the uprights on a holder gives you a 90° cradle that is 45° off-perpendicular. I use a set of the holders in this configuration when working on the face of a corner cabinet, as they keep the cabinet in a front-up position.

—James LeMaster, Martinsburg, W.Va.

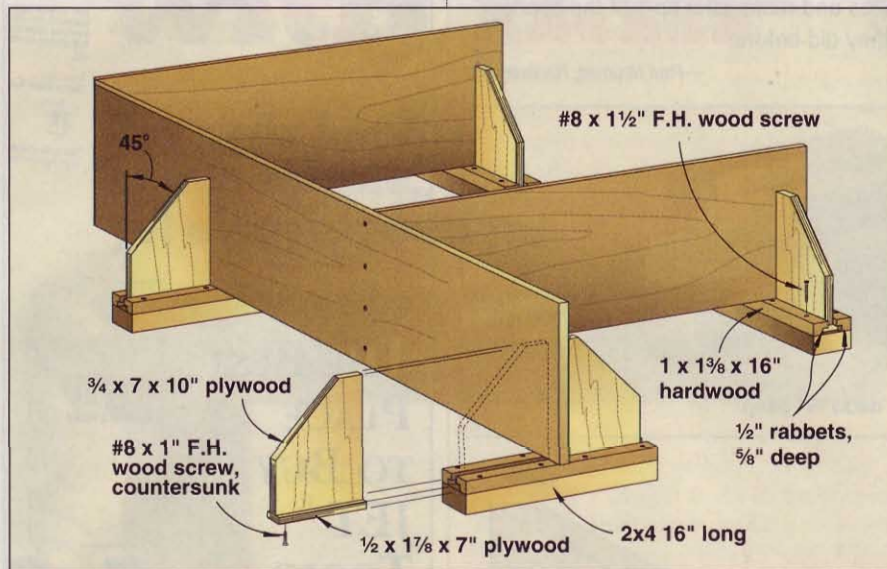

shop TIP

You'll find more great Shop Tips throughout every issue of *WOOD*® magazine. Look for boxes like this one nestled among the project and technique articles.

Rockler.com
WOODWORKING SUPERSTORE

JET

Win a Saw!

3 HP XACTA Saw™ with 50" Fence

Register to win at www.rockler.com/jet and receive Rockler's email newsletter for free!

No purchase necessary. See official rules at www.rockler.com/jet for details. Enter online at www.rockler.com/jet or send your name, address, phone and e-mail address on a postcard to: Rockler/ JET XACTA Saw Drawing, 4365 Willow Drive Medina, MN 55340. One entry per household. Void where prohibited by law. Entries must be received by April 30, 2002.

Eliminate 99% of potentially hazardous airborne dust!

- 99% filtration efficiency with .2 - 2.0 micron test material
- Features internal filter cartridge - compact and space efficient
- Flexible design options - perfect for the small shop
- Engineered ductwork design & parts list provided

Call now for more information and let us design a dust collection system to fit your needs.

Oneida Air Systems 1-800-732-4065
www.oneida-air.com
1001 W. Fayette St.
Syracuse, NY 13204

Dust collection systems & components 1.5 hp & larger.

choose the right glues

Building an outdoor project? Using an oily type of wood? Check this chart before you reach for the adhesive.



The kindergarten teacher started you off with paste. You moved on through rubber cement and all-purpose white glue. By now, you probably have tried several other adhesives—but it isn't always easy to figure out which type is best for a particular job.

To help you choose the right glue, we developed the chart below. Stock these

basic types of adhesives in your workshop, or most of them, learn their characteristics, and you'll be ready for anything.

To keep your glues fresh and effective, buy quantities that you'll use up in 12 months and write the purchase date on the label. Also, keep them out of temperature extremes. 🐼

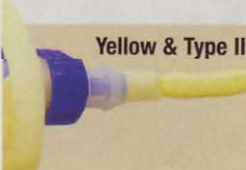
Photographs: Baldwin Photography

	Use it for . . .	At assembly time . . .	Open time	When it comes to finishing . . .	Approximate price	You also should know . . .
	Yellow & Type II Use standard yellow glue for most indoor projects, Type II for most outdoor projects	Both types: Solids can settle to the bottom, so stir or shake before using	Standard: 3 to 5 minutes Type II: 3 minutes	Both types: Dried squeeze-out left on wood will show up under stains and topcoats	Standard: \$4.50 for 16 oz. Type II: \$5.50 for 16 oz.	Titebond's "Extend" versions offer longer assembly time; Type II is water-resistant, not waterproof
	Polyurethane Oily woods, outdoor projects, or joining non-porous materials	Cures faster with moisture added, so lightly mist or wipe the surfaces with water before gluing	20 minutes	Amber-colored types produce a tan glue line that blends well with most woods	\$10 for 8 oz.	Water-resistant, not waterproof; shelf life is relatively short after you open the container
	Hot-melt polyurethane Joints that are difficult to clamp; joints with slight gaps	Hold the joint for 30 to 60 seconds, depending on type used; no clamping needed	30 to 60 seconds	Can react with lacquer to "blister" at the glue line	\$100 for Titebond system; \$6 to \$8 for refills	You can machine the joint immediately, but avoid stressing it for 24 to 48 hours
	Two-part epoxy Joining different materials, or filling gaps without losing strength	Spread in a thick layer, use light clamping pressure	Slow type: 1 hour Fast type: 1 minute	Resists stains, but will take paint and other film coatings	Slow type: \$25 for 1 quart of resin, \$17 for 1 pint of hardener Fast type: \$11 for one-half pint	Slow versions develop much more strength than fast ones
	Contact cement Bonding laminates to large, flat surfaces	Pieces adhere immediately and can't be adjusted	30 minutes to 3 hours	Don't use for veneer; finishing solvents will break it down	\$13 for 1 quart	Made from synthetic rubber, never becomes as hard as glues
	Cyanoacrylate (CA), or "super glue" Assembling small, hard-to-clamp pieces; filling small cracks (along with sawdust)	Starts to harden immediately, so hold the parts in place instead of clamping	5 seconds	Will resist stains and finishes, so clean up the joint carefully	\$10 for 2 oz.	Thicker types are more versatile; wear goggles to protect your eyes, use acetone to remove CA from skin
	Liquid (cold) hide glue Authentic restoration of antiques, or making joints that will be reversible with water or alcohol	You'll have several minutes to make adjustments and set clamps	30 minutes	You can tint it with aniline dye before using to match the color of the finished wood	\$5 for 8 oz.	You can make your own with granular hide glue, water, and a pot that will heat the mixture to 140 degrees

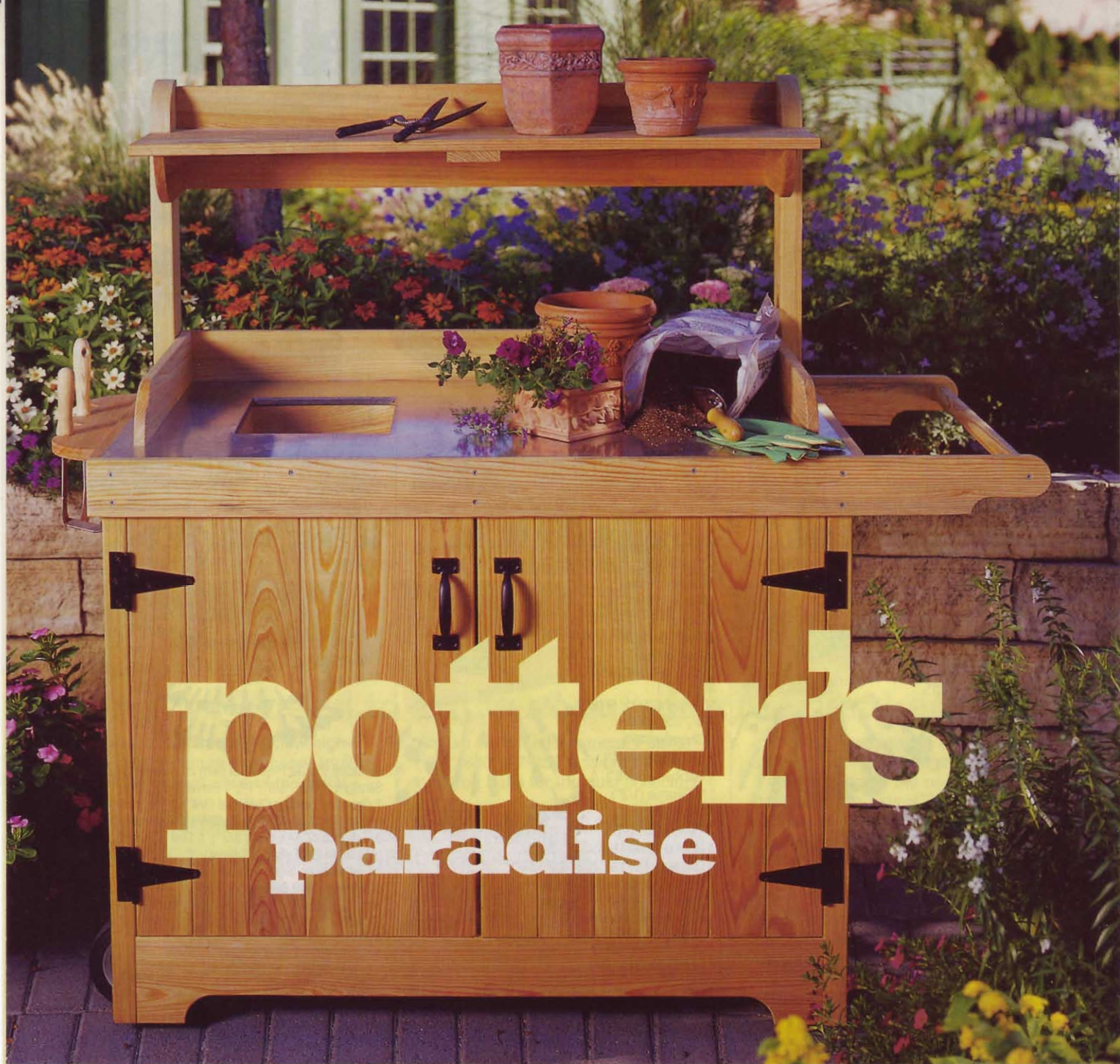

potter's paradise

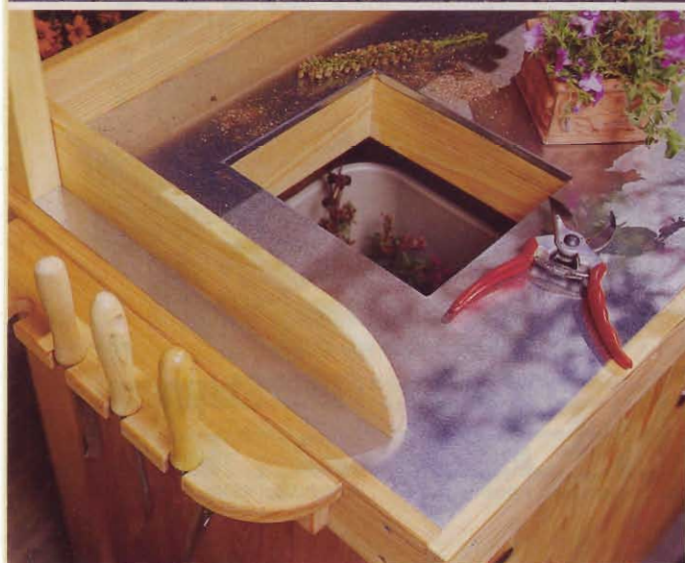

**The
perfect
place
to play
in the
dirt**



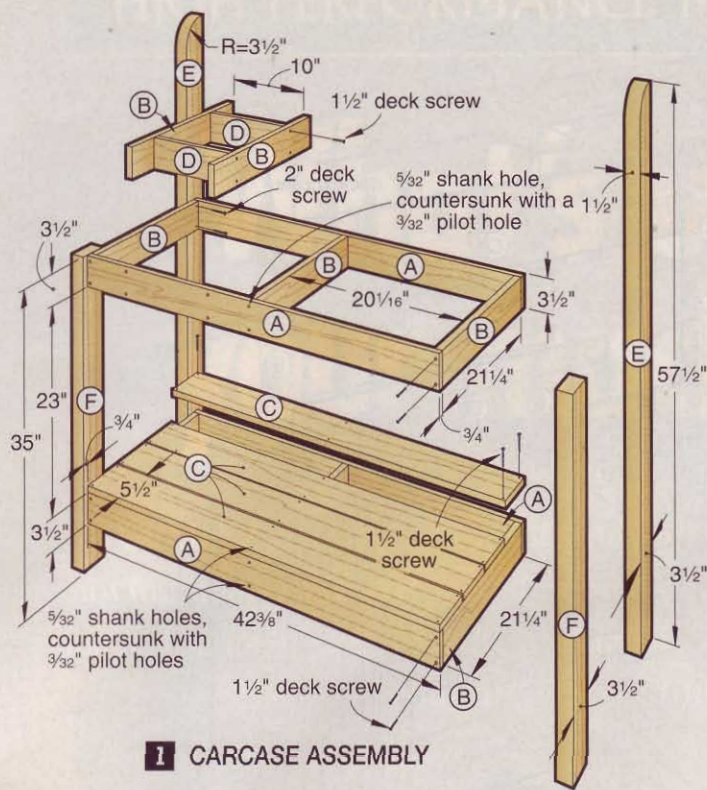

1 CARCASE ASSEMBLY

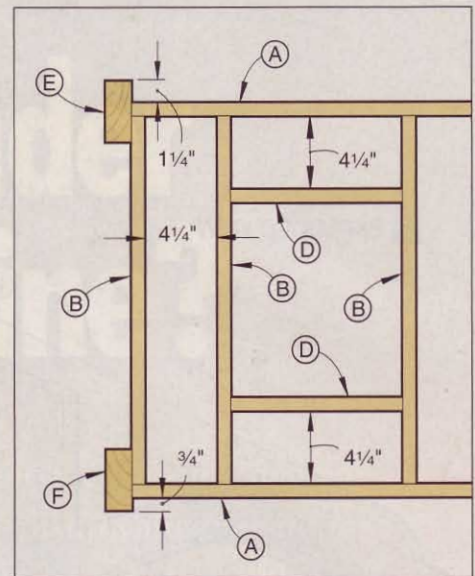

1a CARCASE DETAIL TOP VIEW

Before designing this project, we turned to the horticulture experts at our sister publication, *Better Homes and Gardens*® magazine. They told us what gardener-friendly features to build into the potting bench. A tough top and easy waste disposal were priorities, so we incorporated a galvanized-metal work surface with a handy waste disposal opening over a plastic garbage can. We also added plastic storage bins concealed by doors, a tool rack and overhead shelf, plus wheels and a handle to make the whole setup mobile. You can see these features in the photos and in **Drawing 5** on page 38.

We built our bench from rot-resistant cypress, purchasing random-width 4/4 and 8/4 boards and cutting them to the sizes listed. We chose cypress because we found clear, defect-free boards at our local lumber supplier for about the same price as western red cedar. But, to give you options, we sized the parts so you can build the bench from cedar or pressure-treated lumber available in standard dimensional sizes (1× and 2× stock).

Begin by building two frame assemblies

1 Cut the four frame fronts/back (A) and the eight frame cross members (B) to the lengths listed in the Materials List and shown on **Drawing 1**.

Note: If you use dimensional lumber, crosscut these pieces to length. Otherwise, you'll need to rip pieces to width, as well. To avoid splitting the lumber, drill holes for all screws.

2 Form two frame assemblies (A/B) by driving 1 1/2" deck screws through the frame fronts/back (A) into the cross members (B), where shown in **Drawing 1**. Set aside one of the assemblies and the two extra frame cross members for now.

3 Cut four pieces of frame decking (C) to the size shown in the Materials List. Then align two pieces of the decking (C) with the front and back edges and the ends of one frame assembly (A/B), and screw the pieces in place. Add the remaining two pieces of frame decking with equal gaps between their edges. This assembly (A/B/C) will become the lower carcass frame.

4 The upper carcass frame gets additional bracing around the waste disposal opening. Cut two supports (D) to size. Screw the two remaining frame cross members (B) to the supports, where shown in **Drawing 1a**. Don't mount this assembly (B/D) to the upper frame (A/B) yet.

Make some sturdy legs

1 Mark the length of the back legs (E) and use a compass to lay out the 3 1/2" radius at the upper end of each leg, where

shown in **Drawing 1**. Cut the radius on each leg using a jigsaw, then sand to the line. Then cut the front legs (F) to length.

2 Mark the vertical and horizontal location of the upper and lower frame assemblies on the legs, where shown on **Drawing 1**. Referring to **Drawing 1a**, you'll see that the edge of the back legs extends 1 1/4" past the rear of the frames and that the front legs are 3/4" forward of the frames.

3 To make assembly easier, cut two scrapwood spacers to 3/4×1 1/4×36". Lay the spacers on edge on the floor so they support the upper and lower frames (A/B). Align frames with the marks on the legs, and clamp them into place. Attach the legs as shown in **Photo A** to make the carcass assembly.



Drill countersunk shank and pilot holes, then drive 2" deck screws through the frame assemblies into the legs.

2 EXPLODED VIEW

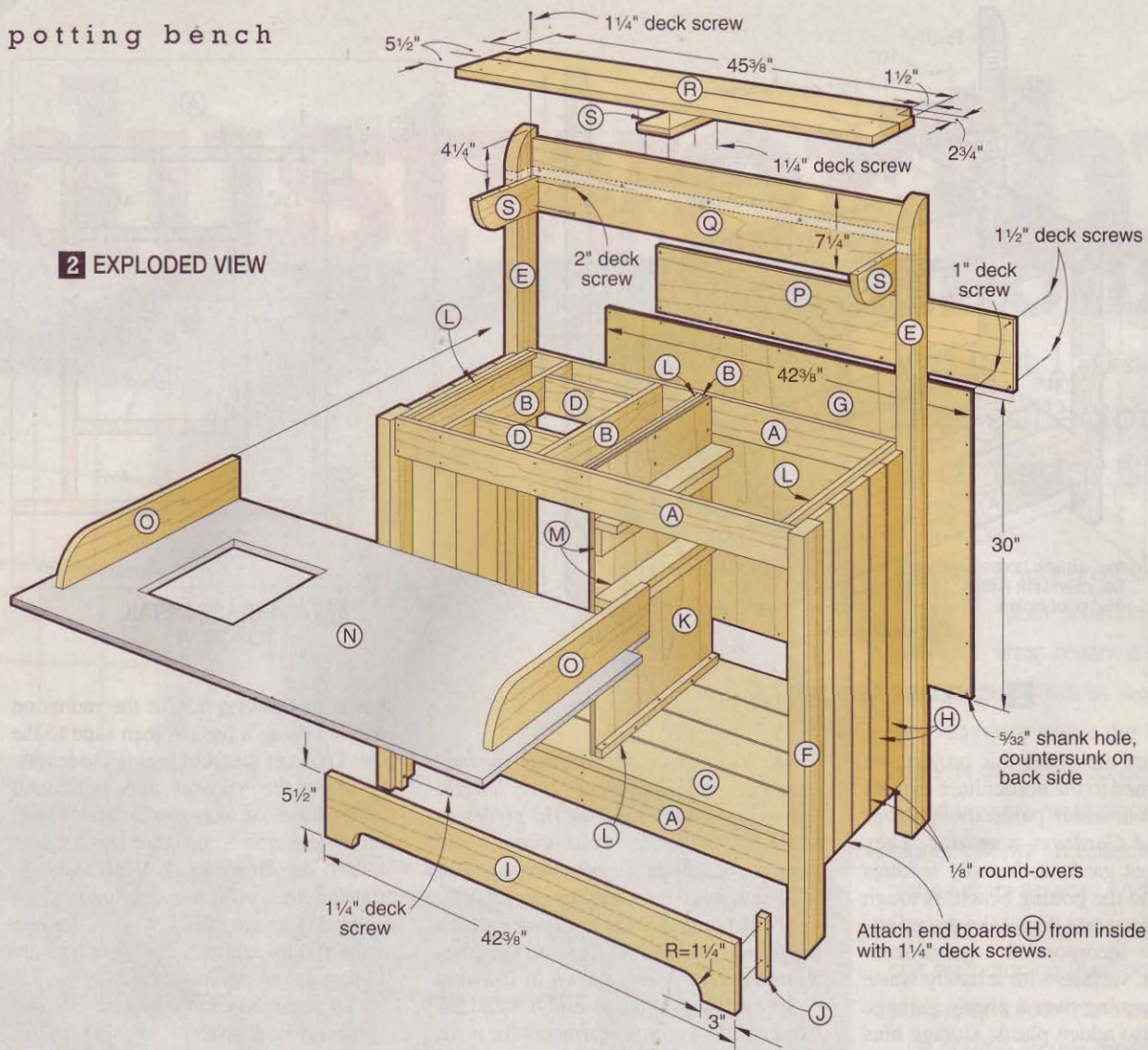

Add the back, ends, and bottom skirt

1 Cut the plywood back (G) to size. Place the carcass assembly face-down on the floor, and align the edge of the back (G) with the edge of the frame back (A) in the upper frame assembly. Using 1" deck screws spaced about 6" apart, attach the back to the frame assemblies, where shown in **Drawing 2**.

2 Cut the 10 end boards (H) to size, then ease their outer edges with sandpaper or a 1/8" round-over bit. Align the end boards' upper ends with the top of the upper frame assembly (A/B), and leave equal spaces between them. Attach the end boards, as shown in **Drawing 2** and **Photo B**. Rest the carcass on its end to drive screws into the lower ends.

3 Attach the support assembly (B/D) you set aside earlier to the upper frame, where shown in **Drawing 1a**.

4 Cut the bottom skirt (I) to size, and mark the radius near each end, where shown on **Drawing 2**. Connect the tops of the radii with a straight line. Cut the opening, staying just to the waste side of the line, then sand it smooth.



To give the bench a clean appearance, drive the 1 1/4" deck screws into the end boards from inside the carcass.

5 Cut the two corner blocks (J) to size. Screw the corner blocks to the front legs (F) where shown. Next, screw the bottom skirt (I) to the corner blocks.

Next, the divider panel and drawer guides

1 Cut the plywood divider panel (K) to size. Rip and crosscut the four cleats (L). Screw three of the cleats to the top frame assembly (A/B) where shown on **Drawing 2**. (They provide a mounting surface for the top assembly that you'll add later.) Now drill countersunk holes for 1 1/4" deck screws through one of the cleats, and mount it flush with the edges and bottom end of the divider panel (K), where shown in **Drawing 3**.

2 Cut the eight drawer guides (M). Glue pairs of the drawer guides together to make four L-shaped drawer

guide assemblies, as shown in **Drawing 3**. Screw two drawer guide assemblies to the divider panel (K).

3 Place the divider panel assembly (K/L/M) inside the carcass and screw it into the center frame cross member (B), where shown in **Drawing 2**. Use a framing square to position the divider on the frame decking (C), and drive screws through the cleat (L) into the decking. Now fasten the two remaining drawer guide assemblies inside the carcass, aligning them with the drawer guide assemblies on the divider.

Craft a metal-clad top

1 Cut the plywood top (N) to size, and notch the back corners, where shown on **Drawing 4**. Test-fit the top onto the carcass assembly, and use a pencil to trace the perimeter of the supports (B/D) onto the underside of the top. Drill $\frac{1}{2}$ " holes near the corners of the layout, and cut the opening with a jigsaw.

2 Go to a local heating contractor or sheet-metal supplier, and purchase a sheet of 28-gauge galvanized steel cut to $26 \times 47\frac{3}{8}$ ". This size is 2" larger than the top (N) to allow 1" of metal to wrap around the edges and ends of the top.

3 Lay the sheet of steel facedown on your workbench, and center the top (N) on it. Mark the notches for the back legs (E) and the perimeter of the waste opening using a permanent marker. Lift

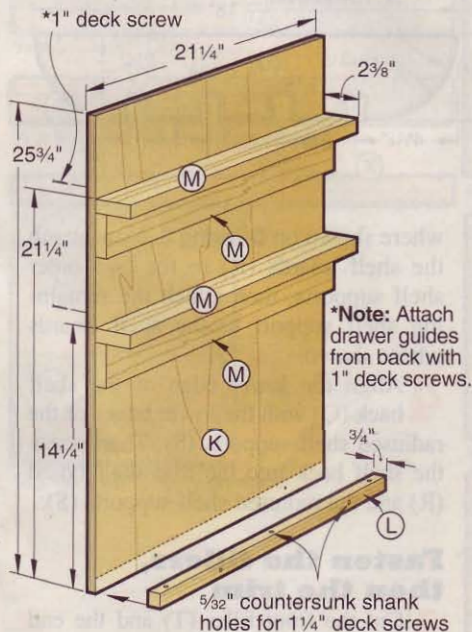

3 DIVIDER PANEL

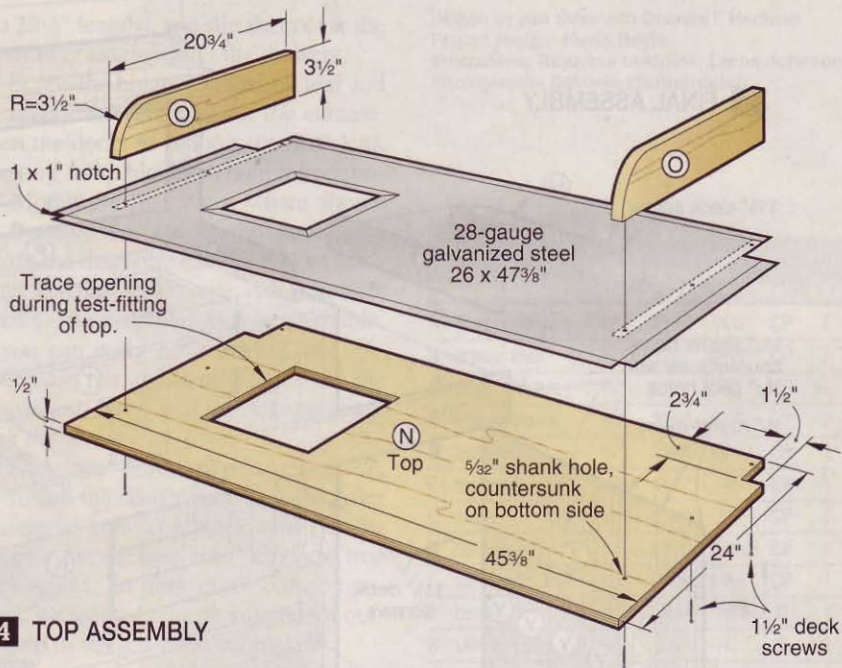

4 TOP ASSEMBLY

off the plywood top, and set it aside. Draw another rectangle on the steel whose sides are 1" inside the perimeter of the opening you just marked.

Now drill $\frac{1}{2}$ " holes within the inner rectangle, where shown in **Photo C**, to serve as starting points for your tin snips. Drill $\frac{1}{8}$ " holes in the corners of the outer rectangle. Wear heavy gloves as you cut the perimeter of the inner rectangle, and make diagonal cuts from each corner of the inner rectangle to the $\frac{1}{8}$ " hole. Also cut notches for the back legs, and small notches at the front corners that allow the metal to bend around the plywood.

4 Place the steel sheet facedown on your workbench, and apply a bead of clear silicone caulk to the metal near the perimeter of the hole and the cutouts for the rear legs, and put small dots of sili-

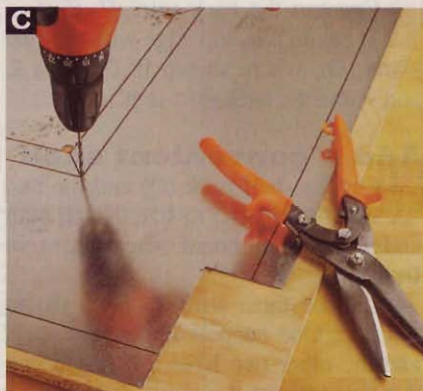

Support the metal top on a sheet of scrap plywood as you drill the holes at the corners of the rectangles.

cone in a 6" grid pattern in the field of the metal. (Don't use all of the caulk; you'll need some later.) Position the top (N) on the metal, as shown in **Photo D**, and let the silicone cure.

5 Using a dead-blow mallet and wood scraps, wrap the metal around the edges of the waste opening and the perimeter of the top, as shown in **Photo E**.

6 Cut the side skirts (O) to the length shown in **Drawing 4**, then cut the radius at one end of each. Drive screws through the top (N) from underneath to attach the side skirts.

7 Wipe a thin layer of silicone onto the notches for the back legs in the top (N) to seal the edges of the plywood. Then position the top on the carcass assembly, and drive $1\frac{1}{4}$ " screws up through the cleats (L) and into the top.



Align the plywood top and sheet metal, then place weights on the top. Let the silicone cure before bending the metal.

5 FINAL ASSEMBLY

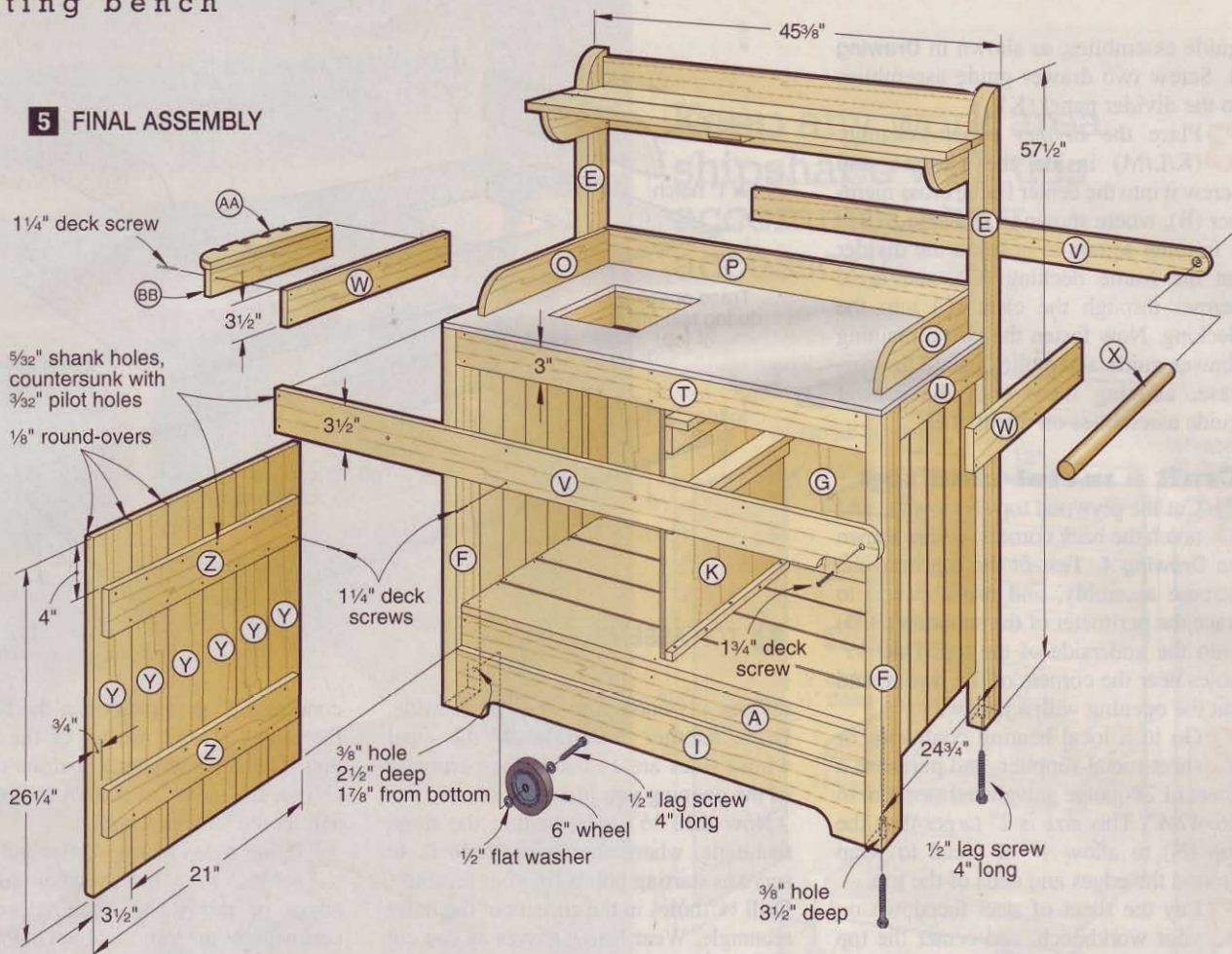

5a FRONT/BACK TRIM DETAIL

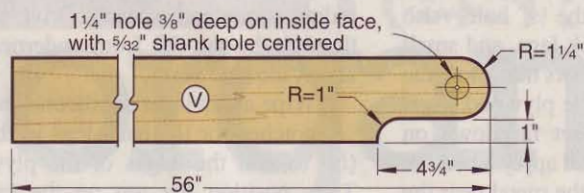

5b TOOL-RACK DETAIL

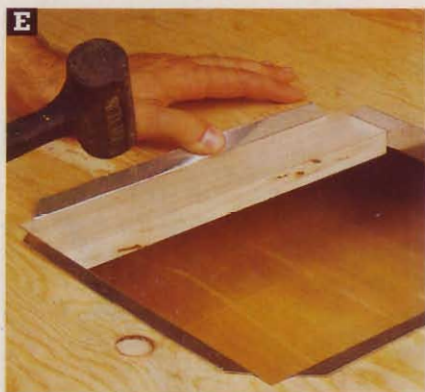
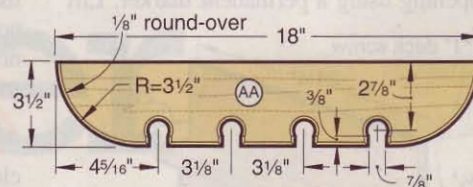

Wrap the metal around the perimeter, then form the cut-out opening. The hardwood scrap keeps the metal from rising.

8 Crosscut the back skirt (P) to size. Then align its top edge with the side skirts (O), where shown in **Drawing 2**, and screw the back skirt in place.

Add a convenient shelf

1 Cut the shelf back (Q) and the two shelf boards (R) to size. Notch both ends of one shelf board, where shown in **Drawing 2**.

2 Cut the three shelf supports (S) to size. One support has square ends and the other two have a radiused end that you cut with a jigsaw.

3 Screw the two radiused-end shelf supports (S) to the back legs (E),

where shown on **Drawing 2**. Now attach the shelf boards (R) to the two outer shelf supports, then attach the remaining shelf support to the shelf boards where shown.

4 Align the lower edge of the shelf back (Q) with the lower edges of the radiused shelf supports (S). Then screw the shelf back into the rear shelf board (R) and the radiused shelf supports (S).

Fasten the fillers, then the trim

1 Cut the front filler (T) and the end fillers (U) to size. Fasten these parts where shown in **Drawing 5**.

2 Cut the front/back trim (V) to length. Then lay out and cut the shaped ends on both pieces, where shown in **Drawing 5a**, and bore the stopped holes that will receive the handle (X). Cut the end trim (W) to length. Now attach both pieces of end trim and the front trim.

3 Cut a length of 1/4"-dia. fir closet pole to length for the handle (X). Position the handle into the holes in the front/back trim (V), and screw the back trim into place with the handle captured between the front and back trim.

The doors make it an open-and-shut case

1 Crosscut twelve door boards (Y) and four door battens (Z) to size. Ease the edges on the the door boards using your router and an 1/8" round-over bit. Butt six of the door boards edge to edge, facedown on your workbench. Square up the boards, and attach the door battens (Z), where shown on **Drawing 5**. Repeat for the other door.

2 Mount the hinges to the carcass, referring to the **Opening Photo** to see their locations. The rectangular plates of the T-hinges are spaced 2 1/4" from the bottom skirt (I) and front trim (V). Then attach the doors, leaving approximately a 1/8" gap between them. Mount each door pull centered on the width of the innermost door boards (Y) 2 1/2" from the top of the door. To hold the doors closed, we

mounted roller catches inside the doors and carcass.

You're ready for the finishing touches

1 Lay the potting bench on its back, and drill 3/8" holes into the inner edges of the left-hand front leg (F) and back leg (E), where shown on **Drawing 5**. Place the washers and wheels onto the lag screws, and drive the screws into the legs, leaving enough clearance for the wheels to spin freely.

2 Drill holes into the ends of the other two legs, where shown on **Drawing 5**. Drive lag bolts into these holes to act as leveling feet and to prevent moisture from wicking into the ends of the legs.

3 Cut the tool rack (AA) to size, then shape the radiused ends and the hole centerpoints, where dimensioned in **Drawing 5b**. Bore the holes using your drill press, and cut the opening from each hole to the edge. Sand the edges smooth, then rout a 1/8" round-over on the edges of the tool rack.

4 Crosscut the mounting plate (BB), and glue and clamp it to the tool rack, forming the L-shaped assembly shown on **Drawing 5**. When the glue dries, screw the assembly to the end of the potting bench.

5 Before applying finish, use sandpaper to ease the remaining exposed edges on any bench parts you may come

in contact with. Apply your choice of finish to the potting bench. We used two coats of an exterior oil finish. To help prevent water from wicking under the metal top, run a bead of silicone around the seams where metal meets wood. ♣

Written by **Robert J. Setlich** with **Kevin Boyle**
Project design: **Kevin Boyle**
Illustrations: **Mike Mittermeier**; **Lorna Johnson**
Photographs: **Baldwin Photography**

materials list

Part	FINISHED SIZE			Mati.	Qty.
	T	W	L		
A frame fronts/back	3/4"	3 1/2"	42 3/8"	C	4
B frame cross members	3/4"	3 1/2"	21 1/4"	C	8
C frame decking	3/4"	5 1/2"	42 3/8"	C	4
D supports	3/4"	3 1/2"	10"	C	2
E back legs	1 1/2"	3 1/2"	57 1/2"	C	2
F front legs	1 1/2"	3 1/2"	35"	C	2
G back	1/2"	42 3/8"	30"	P	1
H end boards	3/4"	3 1/2"	30"	C	10
I bottom skirt	3/4"	5 1/2"	42 3/8"	C	1
J corner blocks	3/4"	3/4"	5"	C	2
K divider panel	1/2"	21 1/4"	25 3/4"	P	1
L cleats	3/4"	3/4"	21 1/4"	C	4
M drawer guides	3/4"	2 3/8"	21 1/4"	C	8
N top	1/2"	24"	45 5/8"	P	1
O side skirts	3/4"	3 1/2"	20 3/4"	C	2
P back skirt	3/4"	7 1/4"	42 3/8"	C	1
Q shelf back	3/4"	7 1/4"	42 3/8"	C	1
R shelf boards	3/4"	5 1/2"	45 5/8"	C	2
S shelf supports	3/4"	3 1/2"	10 3/4"	C	3
T front filler	3/4"	3"	42 3/8"	C	1
U end fillers	3/4"	3"	17 3/4"	C	2
V front/back trim	3/4"	3 1/2"	56"	C	2
W end trim	3/4"	3 1/2"	24 3/4"	C	2
X handle	1 1/4"	1 1/4"	25 1/2"	F	1
Y door boards	3/4"	3 1/2"	26 1/4"	C	12
Z door battens	3/4"	3 1/2"	19 1/2"	C	4
AA tool rack	3/4"	3 1/2"	18"	C	1
BB mounting plate	3/4"	3 1/2"	17"	C	1

Materials Key: C—cypress; P—plywood; C/D exterior grade; F—fir closet pole.

Supplies: 1" deck screws; 1 1/4" deck screws; 1 1/2" deck screws; 2" deck screws; tube of clear silicone caulk; 28-gauge galvanized steel 26x47 3/8"; 20" plastic trash can; 7-gal. plastic bins (2) (Rubbermaid no. 2221); exterior glue; exterior finish.

Buying Guide

Hardware: 6"-dia. wide metal-rimmed wheels with rubber tires, 1 3/8" wide with 1/2" axle bore (2); 4" T-hinges (black) with screws (4); double roller catches (2); 6" black door pulls (2); 1/2" lag screws 4" long (4); 1/2" flat washers (4). Order kit WDPB2, \$49.95 from Miller's Hardware Inc., 1300 M.L. King Jr. Pkwy, Des Moines, IA 50314, or call 515/283-1724.

cutting diagram

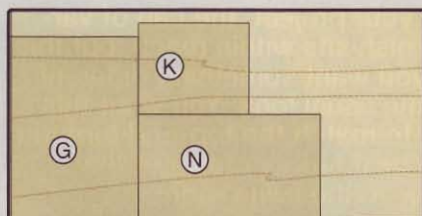

1/2 x 48 x 96" Exterior plywood

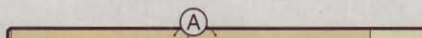

3/4 x 3 1/2 x 96" Cypress (1x4) (2 needed)

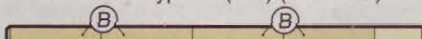

3/4 x 3 1/2 x 96" Cypress (1x4) (2 needed)

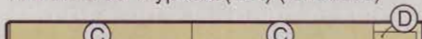

3/4 x 5 1/2 x 96" Cypress (1x6) (2 needed)



1 1/2 x 3 1/2 x 96" Cypress (2x4) (2 needed)

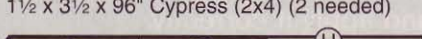

3/4 x 7 1/4 x 96" Cypress (1x8) (2 needed)

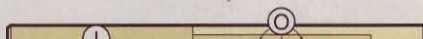

3/4 x 5 1/2 x 96" Cypress (1x6)

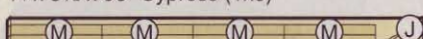

3/4 x 7 1/4 x 96" Cypress (1x6)

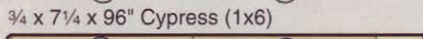

3/4 x 7 1/4 x 96" Cypress (1x8)

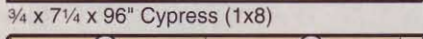

3/4 x 5 1/2 x 96" Cypress (1x6)

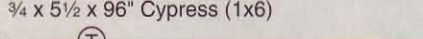

3/4 x 3 1/2 x 96" Cypress (1x4)

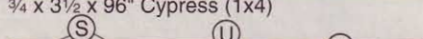

3/4 x 3 1/2 x 96" Cypress (1x4)

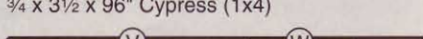

3/4 x 3 1/2 x 96" Cypress (1x4) (2 needed)

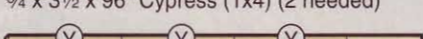

3/4 x 3 1/2 x 96" Cypress (1x4) (4 needed)

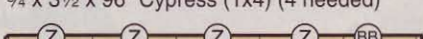

3/4 x 3 1/2 x 96" Cypress (1x4)

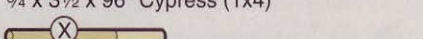

1 1/4"-dia. x 36" Fir closet pole

staining

**DYES,
PIGMENTS,
AND THE
SECRETS
TO CREATING
THE COLOR
YOU WANT**

You've assembled and sanded your project, the can of varnish sits within reach, but this time you want something different than the usual look. You want this piece to match the top-end furniture in the best store in town or the antique in the living room.

Or maybe you want to even out the varying colors of different boards that you've used, make a common wood look exotic, or add richness and depth to your project's appearance. If you have any of these goals in mind, it's time to do some staining.

Staining relies on two types of colorants: pigment and dye. We'll help you choose the right product for the job, and apply it correctly.

We began our series in February with a look at wood preparation. In a future issue, we'll delve into clear topcoats.

A multiple-choice test

Which type of colorant should you select? You have plenty of choices, like those in the photo at right. Your decision depends on the look you want to achieve, the type of wood you're using, and the final topcoat you plan to apply.

For general staining, use either a pigmented stain or a dye. These two types work differently, as shown in the drawings below right, and produce noticeably different results, as you can see. Most paint or hardware stores carry pigmented stain. You might have to visit a wood-working specialty store, or go the mail-order route, to find dyes. For example, the Woodcraft catalog carries Trans-Tint dyes in several colors, priced at \$15.99 for a 2-ounce bottle that will make about 2 quarts of colorant. Call 800/225-1153.

Pigmented stains tend to blotch on woods with uneven density, such as maple, birch, cherry, and pine. Dyes tend to penetrate evenly all over the wood, regardless of their density.

As you strive for the perfect hue, be aware that all color products will fade. Pigmented stains fade the least

continued



Pigmented stains offer the most flexibility in your choice of a topcoat. Once the stain dries, you can apply almost any finish over it. For example, you can use an oil-based or water-based finish over either a water-based or oil-based stain.

The stain must be dry before you proceed with finishing. Temperature, humidity, and moisture content of the wood all affect drying time, so don't rely on the can instructions. Use your nose. If you can smell the solvent, the stain isn't dry.

Dyes are a bit more dicey. If you brush or wipe on a finish containing the same dissolving solvent, you can cause streaking and will partially lift the dye into the finish. This can create a wonderful depth to the color, but might lighten it, too. If you have the necessary equipment, you can spray on the topcoat without causing any problems.

Here, you can see the difference between dyes and pigmented stains. The oak board at right received a coat of golden oak dye, while the other board, lower right, was tinted with a golden oak stain.

Like paint, a pigmented stain goes on the surface of the wood and penetrates very little. Paint contains enough pigment to make it opaque. Stain has similar pigments, but in lesser amounts, so that it is relatively transparent.

Pigments are suspended in a binder—an additive that dries, and creates a seal between the stain and the wood. The most common oil-based binder is linseed oil. Water-based stains employ a non-oil binder. All pigmented stains have to be stirred thoroughly to mix the pigments with the binder, or you will get streaky coloring.

Dyes differ greatly from pigmented stains. Dyes are transparent, penetrate into any kind of wood, and give it an even tone all over.

You can buy dyes pre-mixed, powdered, or as liquid concentrates. Manufacturers design each powdered dye or liquid concentrate to dissolve with a particular solvent: water, alcohol, or a petroleum product, such as paint thinner. You must use the proper solvent with each type of dye. A dye intended to be dissolved in water usually can't be dissolved in alcohol.

Concentrated liquid dyes will work with more than one solvent. Alcohol-based dyes dry the fastest—perhaps too fast for general use. Water-based dyes are the easiest to apply and the safest to use.

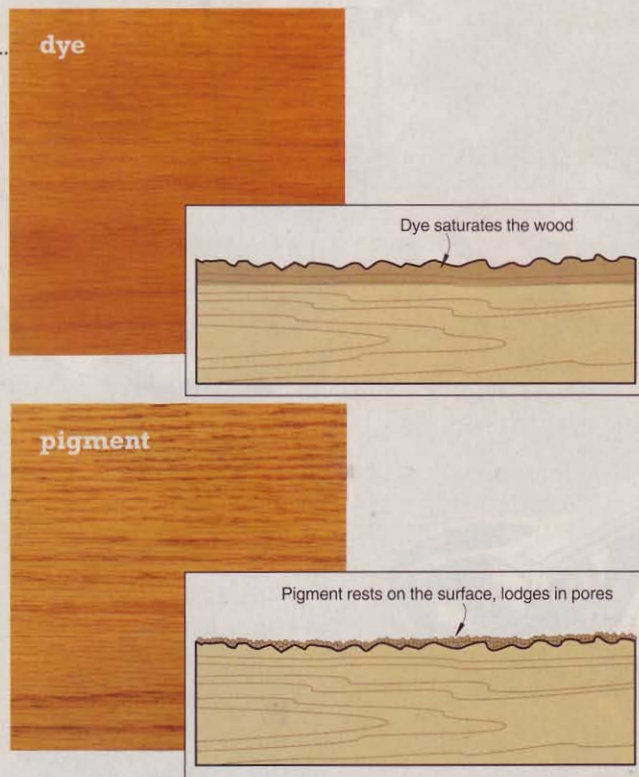



One of the keys to staining is learning how to allow for changes in color from wet stain to dry. Often, a woodworker will notice the change, and decide that additional coats of stain are necessary—usually a mistake. If the wet color was correct, leave it alone. The wet color of the stain will return as soon as a coat of finish is applied, as shown here.

Some stains dry faster than others, and once the stain dries, you'll have more difficulty removing the excess. Water-based pigment stains tend to dry faster than the oil-based pigment stains. Often, the color will get a dry, powdery look when the stain dries. It's nothing to worry about.

and the slowest. Among the dyes, the oil-based and alcohol-based versions fade the fastest and the water-based fade the least. Don't use dyes in direct sunlight applications, because they'll fade quite rapidly in those conditions.

Application is easy

Applying a stain is essentially the same with either a pigment or a dye. Test the stain on a scrap piece, then flood the surface of your project, and wipe off the excess to even out the color.

After wiping, allow the stain to dry completely and wipe the surface again to remove any residue. Remember that the appearance changes when the stain dries, then changes again when you apply a clear topcoat, as shown in the photo at left.

You can use either liquid or powder when you choose to dye a piece of wood. Make sure to mix powdered dyes thoroughly, then filter them, as shown in the photo, lower left. Generally, the color you apply to a piece of wood will remain the same regardless of the number of coats. The color will darken but remain transparent. Pigmented stains become darker and more opaque with each application.



When you mix a powdered dye with water or alcohol, no matter how thoroughly you stir, some of the dye particles never will dissolve. After mixing, allow the dye to settle. Stir it again, and then filter the mixture through a coffee filter, cheesecloth, or nylon hose to remove those undissolved particles. Always wear a mask when working with dry dyes, which become airborne easily. They can cause respiratory problems and even allergic reactions in some people.

You can mix stains and dyes for a custom color, as long as they have the same solvent. For best results, mix the same type and brand of product. Also, mix each color separately before combining them. Don't add a powder or concentrate of one color to the mixed version of another.

Preventions and cures

Even though the actual application is easy, can things still go wrong? Yes, they can. But you can avoid most problems, once you know what to expect.

Raised grain. The biggest problem with water-based products is that they raise the grain of the wood. Go ahead and raise the grain intentionally, then carefully remove the resulting whiskers, as shown in the photo at *right*.

Uneven color. A perfectly good board might vary in color, and most stains won't cover up the differences. See the photo, *lower right*, for a discussion on evening out color.

Blotching. Some woods acquire an uneven look when stained. Apply a conditioner first, and you'll get a much more consistent result. Check the photo on *page 44, top*, for examples that illustrate the blotching issue.

Dark end grain. End grain absorbs more pigmented stain than the rest of the board. To compensate, sand end grain with one grit higher paper than you use on the other surfaces. Then, coat the end grain with a conditioner. A dye stain solves the uneven coloring problem with no conditioner needed.

Wrong color. Sometimes you won't be satisfied with the look of a stain on your project. If it's the right shade, but too light, apply another coat of the same stain. If it's the wrong shade, you can hide it with a darker stain.

If your stain is too dark, and still wet, you can remove much of it by scrubbing the surface with the appropriate thinning solvent. Use water for water-based stains, and rely on mineral spirits for oil-based stains.

If the stain already has dried, and it's water-based, you'll have to strip it all off with water and start over. You can remove some or all of a dried oil-based stain with lacquer thinner. If not enough comes off to suit you, remove it all with a stripping product, bleach out any remaining spots, and start over.

You can remove some of the color from a dry dyed surface by wiping it with the appropriate dissolving solvent. Be careful, though. You run the risk of creating streaks in the color.

continued

Water-based stains and dyes tend to "raise the grain" of wood. Tiny fibers swell up and remain standing like whiskers. If you apply a coat of finish over those whiskers, it will feel like sandpaper.

The easiest way to deal with raised grain is to make it happen before you apply a water-based stain or dye, then eliminate it. First, wet the wood with water from a spray bottle, and allow it to dry completely.

Then, sand or scrape off the fuzzy raised grain. For a simple and efficient scraper, just remove the blade from a utility knife. Hold the blade almost vertically, as shown here, and gently scrape the surface.

Wood varies in color, and no stain will even out those differences completely with one coat. The biggest problem occurs in such woods as cherry and walnut, in which the sapwood is a much lighter color than the heartwood.

If you want a dark color on the entire project, apply your stain just to the sapwood, as shown on this piece of cherry. After it dries, apply a coat of the same stain everywhere. If you want a natural finish, find a stain that's the same color as the heartwood, and use that stain to tint only the sapwood.

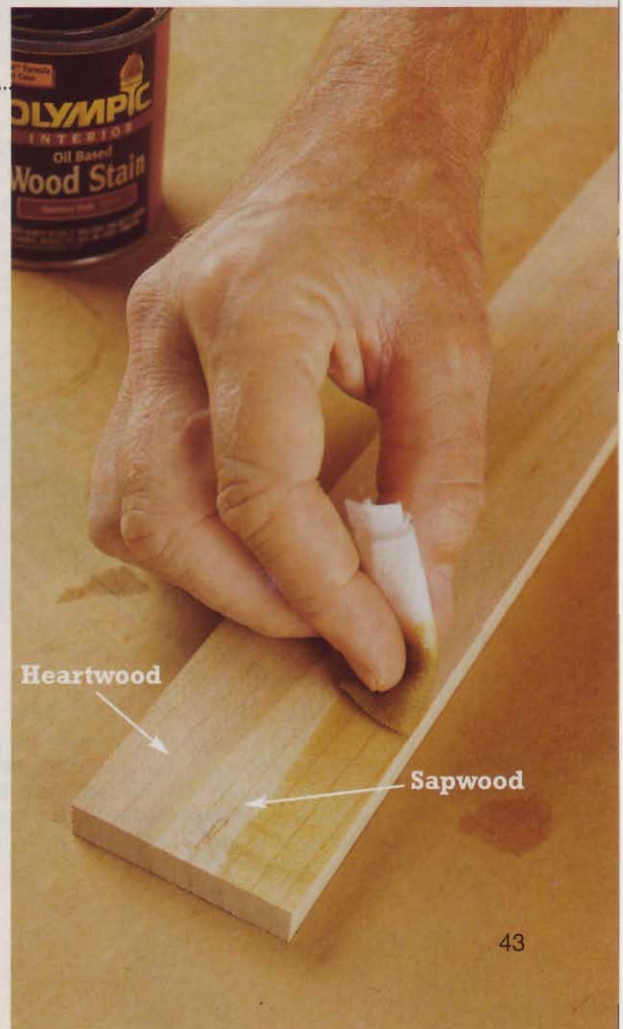
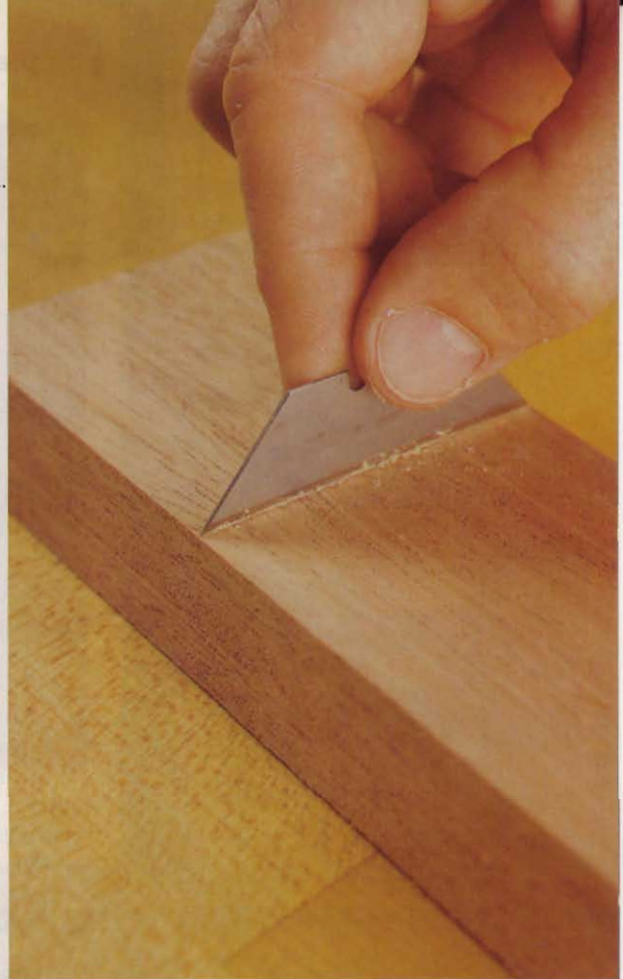

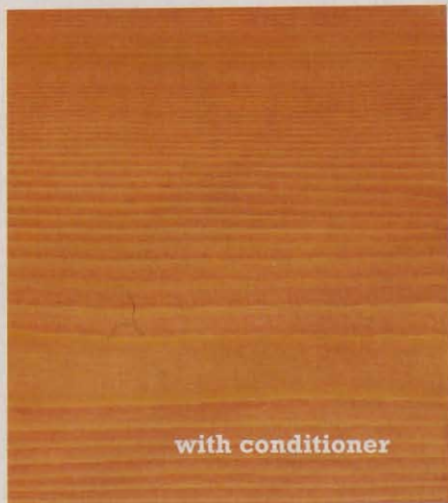

Woods such as pine, cherry, maple, and birch vary significantly in density within a single board. This inconsistency can create “blotch” when you apply stain. Softer areas absorb pigmented stain more readily than harder areas, making the soft spots darker and more opaque.

You can minimize or prevent blotching by using a conditioner before you stain. A conditioner is a coating that seals the pores of the wood, and makes the difference shown here. We applied Minwax conditioner, then red oak stain to the pine sample on the *left*, while the one on the *right* received only the stain.

You also can make your own conditioner. For example, if you’re going to finish with polyurethane varnish, make a conditioner from five parts thinner and one part poly. Apply this conditioner, allow it to dry, sand it gently with 220-grit sandpaper, remove the dust, and apply your stain.

Another world of colors to explore

Most woodworkers will find all the colors they need in the standard assortment of cans at a home center. But if you have a specific custom look in mind, or you just want to experiment, you can fine-tune those colors. One way is to mix the standard products, always making sure to combine only those with like solvents.

A more controllable approach is to add basic colors to the commercial products, or directly onto the wood. You can use Japan colors or artist’s oils if your stain and topcoat are oil-based, or mix acrylic

artist’s colors into a glazing medium if you’re using water-based products. Art stores and hobby stores carry artist’s oils, acrylic artist’s colors, and glazing medium. You can buy Japan colors from Woodworker’s Supply for \$9.99 per half-pint. Call 800/645-9292.

A color wheel will help you figure out how to arrive at the hue you have in mind. A traditional color wheel shows you how to use red, yellow, and blue to make all of the other colors. You can buy a 9¼” version for \$6.50 from The Color Wheel

Co. Call 541/929-7526 or log on to www.colorwheelco.com.

However, furnituremakers rely more on the earth-tone colors shown on the wheel pictured here. This wheel is available from Homestead Finishing Products for \$14.95. Call 216/631-5309. Various combinations of raw umber, burnt umber, raw sienna, burnt sienna, Van Dyke brown, white, and black will produce a range of beautiful furniture colors. Experiment on a storyboard—and write down the recipe as you go along.



We used a premixed glaze, available at home centers, plus acrylic colors to get the results shown here on oak. The *left* piece received a coat of raw sienna, the *middle* one got an application of burnt umber, and the sample on the *right* shows what happens when you blend the two colors together.



When you start dabbling in custom-look colors for your projects, here’s a basic approach that many woodworkers don’t consider. The acrylic colors at *left*, the artist’s colors at *right*, and the color wheel can help you create the exact color you need to turn a standard-issue project into something special.

Variations on a theme

We've concentrated on pigments and dyes, but five other types of staining products also deserve discussion. In certain situations, you might consider a dye/pigment stain, a colored oil/varnish mixture, a gel, an all-in-one product, or a non-grain-raising dye. The most versatile of these are the **dye/pigment** types, as shown in the photo at *right*. And, in some situations, a **gel** is the best way to get a beautiful result, as shown in the photo *below*.

Colored oil/varnish materials often are referred to as Danish oils. They combine oil, varnish, thinner, and a dye-like colorant. Easy to apply, they offer a fairly even penetration into the wood and a moderately durable binder that will serve as a finish.

All-in-one products are finishing materials, such as polyurethane varnish, with color added. They can be oil-based or water-based, and the colorant can be dye or pigment. They are designed to color and finish with a single application. These are generally surface products and perform much like paint. They can be tricky to apply because they tend to dry quickly and you can overwork them very easily. Successive coats make them darker and more opaque. Lap marks are very difficult to avoid. In short, avoid these products for general finishing.

Non-grain-raising dyes are water-based products that you thin with alcohol or lacquer thinner, making them compatible with oil-based finishing materials. They dry very quickly, which eliminates one of the advantages of a typical water-based dye. Most home woodworkers can get along just fine without them. ♣

Written by **Jim Kull** with **Jim Pollock**
Photographs: **Baldwin Photography**
Illustrations: **Roxanne LeMoine**



Author **Jim Kull** also monitors the discussion group on wood finishing at our www.woodonline.com Web site.



Dye/pigment stains contain both kinds of colorant, and usually have separated by the time you take them off the store shelf. The dye is in solution and the pigment has settled out. They require complete stirring to remix the pigment and achieve the intended color.

You can determine if you have a dye/pigment stain by inserting a stick into the unstirred can. If the stick has color along its body and a glob on the end, as shown here, it's a combination product. The dye penetrates the harder portions of a piece of wood, and the pigment settles into the grain and pores. A dye/pigment stain tends to soften blotching, but to really minimize blotch, use a conditioner first.

A dye/pigment stain offers you several staining options. Unstirred, the upper portion of the can will provide a dye type of stain. You can apply it as a stain or add it to a compatible finish to use in toning, which we'll discuss in the third part of this series.

Stir the can a bit, and you'll get a slightly different shade of the same color. Stir it completely for yet another shade. Finally, the settled pigment, left unstirred, works great for glazing, another topic for part three of this series.



Gels are pigments, dyes, or a combination of the two, combined with oil-based or water-based finishing materials. Essentially, a gel is paint, coating the surface without penetrating.

Gels tend to obscure the grain, but they do reduce blotching, as you see here. The sample board on the *left* received a standard stain, while the one on the *right* was coated with a gel.

Gel stains also work well for "glazing." The technique of glazing allows you to apply color between coats of finish, or to apply an artificial grain to literally any surface. For example, you can make two different woods look alike, or make cardboard look like oak. See Issue 129 for a thorough explanation of the "faux finishing" process.

showtime storage

**Stow CDs
or DVDs on
adjustable
shelves...
now that's
entertainment!**

We all have different storage needs for CDs, DVDs, or other electronic media. You can quickly reshuffle the glass shelves on this Arts & Crafts piece to hold any of them, with room left over for your favorite collectibles.

If the distinctive cut-out design in the side panels looks familiar, that's because we featured the same motif on eight matching living room pieces in previous issues of *WOOD*® magazine. For pictures of the pieces, and information on purchasing plans, see "Arts & Crafts furniture plans" on page 86.



2 FORMING A MORTISE

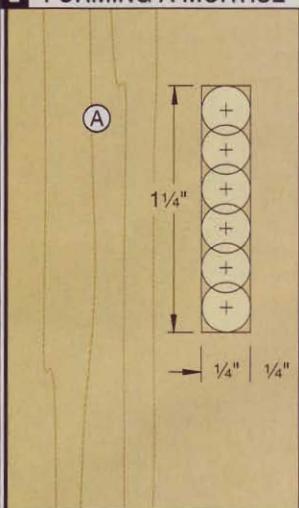

- STEP 1**
Mark mortise location on leg.
- STEP 2**
Drill 1/4" holes 1" deep at both ends of mortise.
- STEP 3**
Drill overlapping 1/4" holes 1" deep between holes drilled in Step 2.
- STEP 4**
Finish mortise with a chisel, cutting sides and ends square.

3 CUTTING THE RAIL TENONS

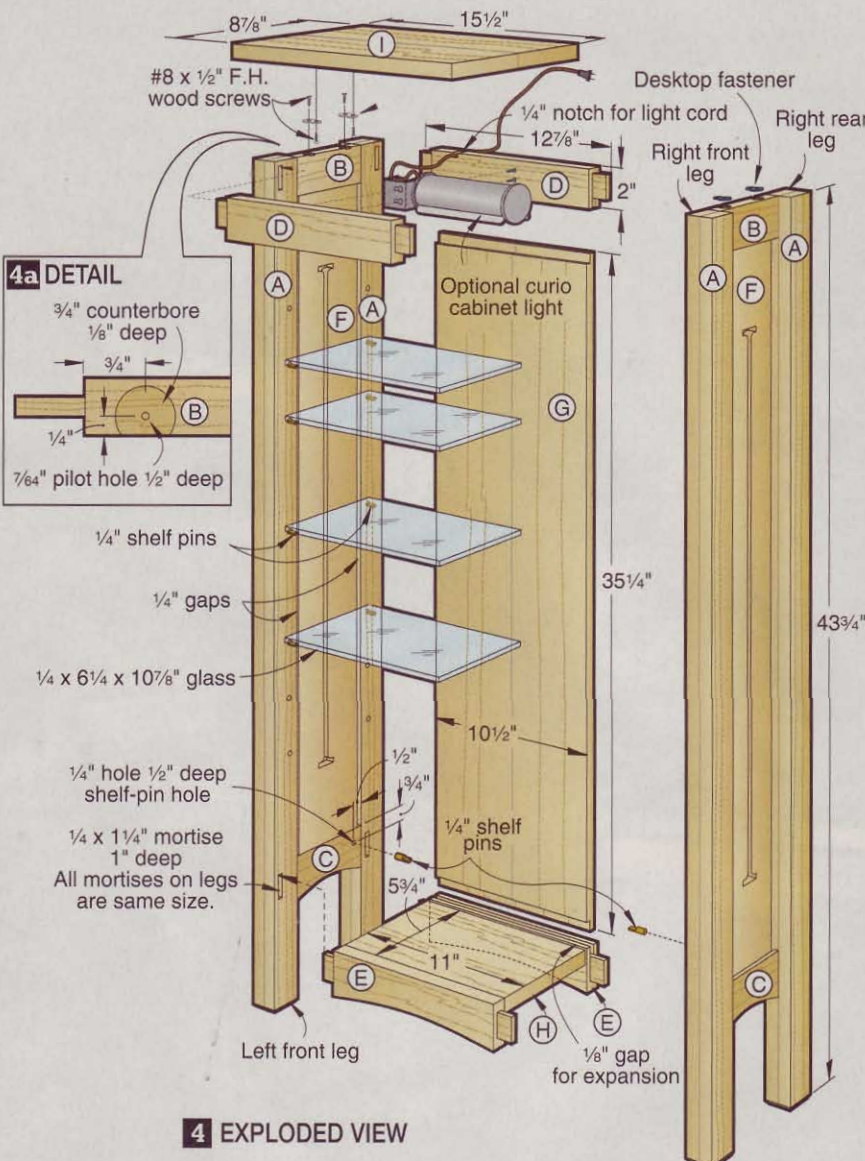
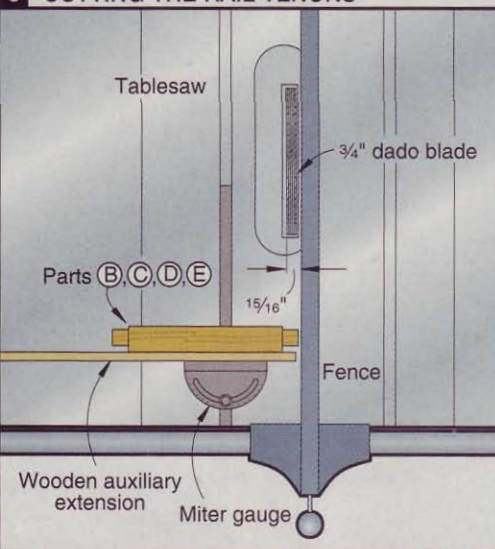

4 EXPLODED VIEW

SHOP TIP

Marking arcs in a pinch
You don't need fancy drafting equipment to draw a smooth arc like the one at the bottom of bottom rails (C, E). Simply rip a wood strip to 1/8x3/4x15" and pinch it in a clamp until it forms a smooth arc connecting the center height of the arc with the bottom ends of the rail.



3 Install a 1/4" dado blade in your table saw, raise it 1/2" above the table, and set your rip fence to cut the groove centered in the rails, where shown on **Drawing 1a**. Cut this groove in the lower edge of top rails (B, D), the upper edge of bottom side rails (C), and the back rail (E). The front rails (D, E) are not grooved. *Note: If you are installing the optional curio cabinet light, drill the mounting-screw pilot holes in the front rail and cut the cord notch in the back rail, where shown on **Drawing 5**. See the **Buying Guide** for the source of our light.*

4 Referring to **Drawing 1a**, mark the centerpoint of the arcs on the bottom rails (C, E). Connect that point to the bottom ends of the rail as shown in the shop tip, *left*. Bandsaw and sand to the line.



Put the bit through the side panel's start hole, and turn on the router. Move the panel to the stop hole, switch off the router, and remove the panel.

5 Drill the shelf-pin holes in the inner faces of the bottom side rails (C), where shown on **Drawing 4**.

6 Mark the centerpoints and drill the counterbores and pilot holes for the desktop fasteners on the top edges of the top side rails (B), where dimensioned on **Drawing 4a**. Use a $\frac{3}{4}$ " Forstner bit and a $\frac{7}{64}$ " twist drill in your drill press.

Make the panels, bottom shelf, and top

1 From $\frac{1}{2}$ "-thick stock, cut the side panels (F) to size, and edge-join an oversize blank for the back panel (G). From $\frac{3}{4}$ "-thick stock, cut the bottom (H) to size, and edge-join an oversize blank for the top (I). With the glue dry, cut parts G and I to finished size.

2 Install a $\frac{1}{2}$ " dado blade in your table-saw, and raise it $\frac{1}{4}$ " above the table. Cut the rabbets along the inside ends of the panels (F, G).

3 Make two copies of the Side Panel Full-Size Pattern on page 95. Use spray adhesive to adhere them to the side panels (F), $4\frac{1}{2}$ " from each end, as indi-

cated on the pattern. Drill the $\frac{3}{8}$ " start and stop holes through the panels.

4 Chuck a $\frac{1}{4}$ " straight bit into your table-mounted router, and clamp a fence behind the bit, $1\frac{15}{16}$ " from its centerpoint. Put the panel against the fence, and clamp another fence to the front of the bit, flush against the panel. Refer to **Photo B** to see this setup, and rout the slots in both side panels (F).

5 Install a #4 blade (.035x.015" with 18 teeth per inch) in your scrollsaw, and make the cutouts at the slots' ends.

Get squared away for the assembly

1 Before assembly, give all of the parts a final sanding with 220-grit paper, and soften any sharp edges. Glue and clamp the front bottom rail (E) to the bottom (H), flushing the top edges and the shoulders of the tenons.

2 Make the side assemblies by gluing up two legs (A), a top side rail (B), a bottom side rail (C), and a side panel (F). Secure the panels to the rails with a single drop of glue in the center of the rails' grooves. Center the panels between the legs. This construction keeps the panels centered, but still allows them to expand and contract. Check that each assembly is square and flat.

3 With the glue dry, join the side assemblies with the top rails (D), the front bottom rail/bottom (E/H), back bottom rail (E), and the back panel (G). Assemble the back panel and rails in the same manner as the side panels and rails. To support the back edge of the bottom, insert shelf pins in the holes previously drilled in the bottom side rails (C).

4 Drive #8x $\frac{1}{2}$ " flathead wood screws through the desktop fasteners into the top side rails (B). Adjust the top (I)

for an equal reveal on all sides, mark the fastener locations on the top, and drill $\frac{7}{64}$ " pilot holes $\frac{1}{2}$ " deep. Remove the top and the desktop fasteners.

You're ready for a durable finish

1 Using a sanding block and 220-grit paper, give the completed project a quick once-over to smooth grain that raised when wiping off glue squeeze-out.

2 After removing the dust with a tack cloth, we applied a coat of Minwax Provincial (no. 211) stain. Then we applied a coat of gloss polyurethane, followed by a coat of satin. Between coats, we sanded with 220-grit sandpaper.

3 With the finish dry, replace the desktop fasteners, top, and add shelf pins. Make a template for the shelves from $\frac{1}{4}$ "-thick plywood. Take the template to the glass shop to ensure that your shelves will fit. Have the shelves' edges ground with a pencil edge.

Note: If you are installing the optional curio cabinet light, fasten it to the front rail, and lay the cord in the rear rail's notch before replacing the top.

Written by **Robert J. Setlich** with **Charles I. Hedlund**
Project design: **Charles I. Hedlund**
Illustrations: **Roxanne LeMoine; Lorna Johnson**
Photographs: **Baldwin Photography**

materials list

Part	FINISHED SIZE			Matl.	Qty.
	T	W	L		
A* legs	1 $\frac{1}{2}$ "	1 $\frac{1}{2}$ "	43 $\frac{3}{4}$ "	LO	4
B top side rails	$\frac{3}{4}$ "	2"	6 $\frac{1}{4}$ "	O	2
C bottom side rails	$\frac{3}{4}$ "	2 $\frac{1}{4}$ "	6 $\frac{1}{4}$ "	O	2
D top rails, front/back	$\frac{3}{4}$ "	2"	12 $\frac{7}{8}$ "	O	2
E bottom rails, front/back	$\frac{3}{4}$ "	2 $\frac{1}{4}$ "	12 $\frac{7}{8}$ "	O	2
F side panels	$\frac{1}{2}$ "	3 $\frac{7}{8}$ "	35 $\frac{1}{4}$ "	O	2
G* back panel	$\frac{1}{2}$ "	10 $\frac{1}{2}$ "	35 $\frac{1}{4}$ "	EO	1
H bottom	$\frac{3}{4}$ "	5 $\frac{3}{4}$ "	11"	O	1
I* top	$\frac{3}{4}$ "	8 $\frac{7}{8}$ "	15 $\frac{1}{2}$ "	EO	1

*Parts initially cut oversize. See the instructions.

Materials Key: LO—laminated oak, O—oak, EO—edge-joined oak.

Supplies: #8x $\frac{1}{2}$ " flathead wood screws (8), $\frac{1}{4}$ " glass shelves (4), glue, stain, finish.

Buying Guide

Hardware. Desktop fasteners no. 130216, \$3.50 for a bag of 10; $\frac{1}{4}$ " spoon-style bronze shelf pins no. 27113, \$2.50 for a bag of 25; $\frac{5}{16}$ "-dia. x $\frac{1}{16}$ "-thick door bumpers no. 02S81, \$6.99 for a sheet of 75; optional curio cabinet light no. 09J81, \$9.99. Order from Woodcraft, 560 Airport Industrial Park, P.O. Box 1686, Parkersburg, WV 26102-1686, or call 800/225-1153.

cutting diagram

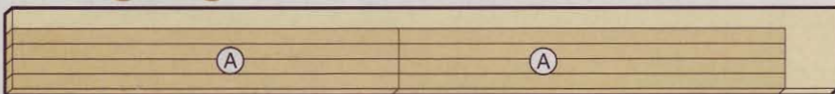

$\frac{3}{4}$ x 9 $\frac{1}{4}$ x 96" Oak

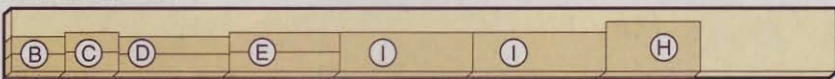

$\frac{3}{4}$ x 7 $\frac{1}{4}$ x 96" Oak

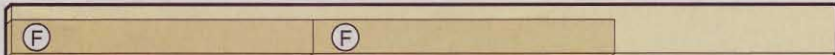

$\frac{1}{2}$ x 5 $\frac{1}{2}$ x 96" Oak

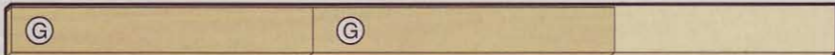

$\frac{1}{2}$ x 5 $\frac{1}{2}$ x 96" Oak

hideaway home office

conceal your components in this classy drop-leaf cabinet



Does a computer workstation look out of place in your traditional furnishing scheme? Hide its clutter behind the frame-and-panel front of this handsome cherry cabinet. The three-panel drop leaf gives you instant access and a spacious worktop. There's a pigeonhole to store your keyboard and mouse, and a shelf that holds a monitor up to 17¾" tall. The doors below hide a pair of file drawers and plenty of storage for your CPU and other supplies.

And speaking of clutter, we designed a matching pigeonhole unit to help you keep it under control. Even if you don't build the computer center, this is a great little organizer for anywhere from desktop to kitchen counter. See the instructions on page 60.



Form the carcass parts

1 Referring to the layout shown on the Cutting Diagram, cut the plywood parts A through I to the sizes listed in the Materials List.

2 Cut four strips of banding (J) to the size listed. From these lengths, cut bands for each of the parts A through E, and G through I. Glue and clamp the bands to the panels so they are flush at the edges and ends. The skirt (F) does not get banded. With the glue dry, sand the bands flush with the panels. Set the adjustable shelf (I) aside.

Note: For all parts, the length is always the dimension parallel to the grain.

3 Adjust your biscuit joiner to cut a slot centered in the thickness of your ¾" plywood. Mark the biscuit locations in the edges of parts B through F, and H, where indicated on Drawing 1. Plunge the slots. Mark the biscuit locations in the ends of the bottom face of the fixed shelf (A), the top of the drawer shelf (B), and the tops of the inside faces of the sides (G). Plunge the slots.

Note: Where three biscuits are shown, locate a biscuit 3" from each edge, and center the third one. Where two biscuits are shown, locate them at the one-third points.

4 Configure your biscuit joiner fence for vertical plunging. Using a straightedge offset from the biscuit centerlines and clamped to the workpiece as a guide, plunge the rest of the biscuit slots. The biscuit slots in the underside of the bottom (E) and the inside face of the sides (G) for the attachment of the front skirt (F) are centered 1⅜" from the front edges of the bottom and sides, as shown on Drawing 1b. When marking the locations of the biscuits that secure

the upper dividers (C) to the drawer shelf (B), remember that the dividers are 1" narrower than the shelf.

5 Drill the ½" wire-access holes in the fixed shelf (A), drawer shelf (B), and bottom (E), where shown on part B on Drawing 1. Drill the ¼" leveler adjustment holes in the bottom's corners, where shown. Drill the holes and slots in the carcass top (H) for the screws that fasten the top (O) to the carcass, where shown on Drawing 1a.

6 Install a dado blade in your table saw, and cut a ¼" rabbet ½" deep for the back (N) in the rear inside edges of the sides (G). Position the leveler brackets on the sides, where shown on Drawing 1b, and drill the screw pilot holes.

Note: The Buying Guide lists a source for the following hardware: levelers, hinges, magnetic catches, knobs, file drawer slides, hanging-file rail, flap stays, and shelf supports.

7 Mark the locations and drill ¼" holes for the shelf supports in the lower dividers (D), where shown on Drawing 1. See the shop tip on page 54.

8 Finish-sand the carcass parts to 220 grit. Take care not to round the edge bands. To keep your joints tight, ease the sharp edges with a sanding block after you assemble the carcass.

Assemble the carcass

1 Glue, biscuit, and clamp the upper dividers (C) between the fixed shelf (A) and the drawer shelf (B). Keep the back edges of the parts flush, and check the assembly for squareness. Make certain the two drawer recesses are 10⅛" wide and uniform front-to-back. Set this assembly aside until the glue dries.



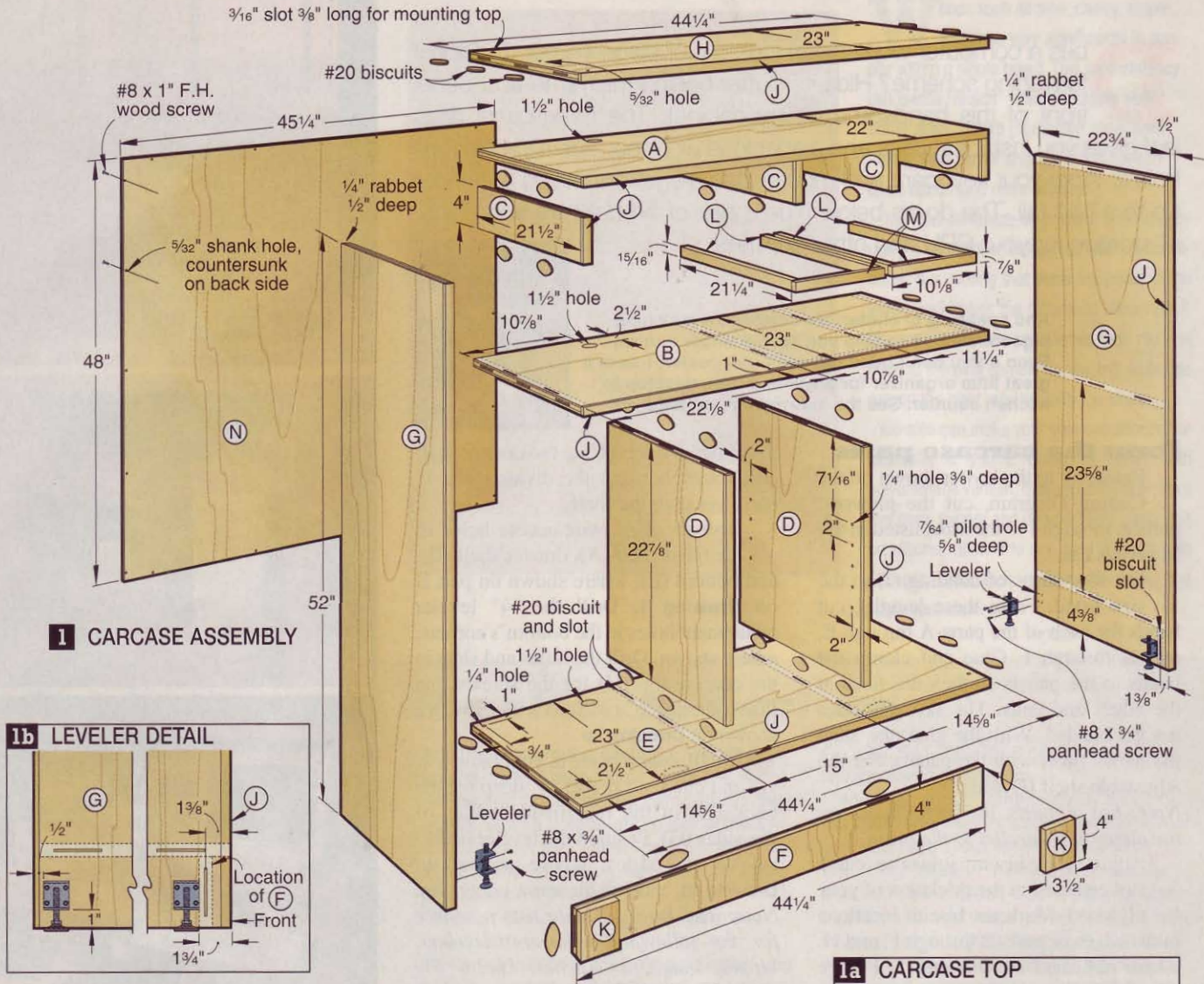

SHOP TIP

A jig that won't wear out

Making a hardboard guide for drilling shelf support holes is common practice. The drawback is that the same 1/4" bit is used to drill the holes in both the guide and the cabinet part. Repeated use enlarges the guide's holes, leading to inaccurate hole placement and wobbly shelves. Project builder Chuck Hedlund solved this problem by drilling 3/8" holes in the guide and using a 1/4" self-centering bit to drill the shelf support holes, as shown in the photo. This way, the bit's retractable centering sleeve, rather than the 1/4" drill bit contacts the guide hole, eliminating wear on the drilling guide. Self-centering bits are available from most woodworking supply catalogs.

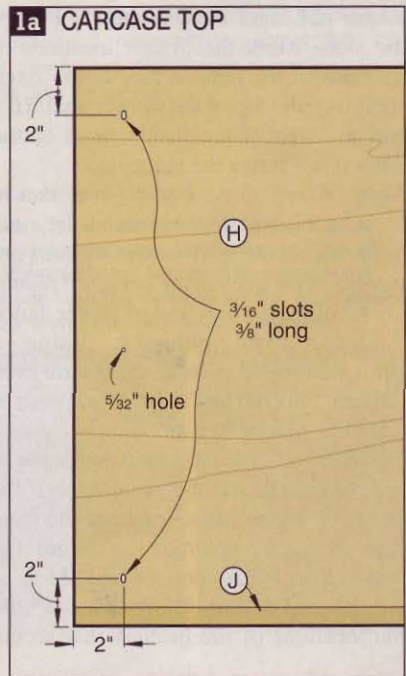

opening. Edge-join blanks about 1" oversize in length and width for the file drawer fronts/back (Q) and the file drawer sides (S). Cut parts P, R, and S to size. Cut parts Q to length, but make them 10⁷/₈" wide.

Note: Set aside scraps of drawer front and side stock for testing your tablesaw setup when cutting the lock-rabbit joints.

2 To accommodate the hanging-file rails, the file drawer fronts and backs are 1/2" wider than the sides. Rip 1/2" strips off the tops of the file drawer fronts/back (Q), where shown on **Drawing 2**. Mark these strips so they can be glued to their mating parts after the lock-rabbit joints are formed.

3 Install a 1/4" dado blade in your tablesaw, and attach a 6"-high auxiliary fence to your rip fence. Following the four steps of **Drawing 3**, cut the lock rabbets, shown on **Drawing 2a**, and the bottom grooves in the drawer parts P, Q, R, and S. Use a follower block to eliminate chip-out and to steady the narrow pencil drawer parts while making the cuts.

4 Retrieve the 1/2" strips cut from the file drawer fronts and backs. Glue and clamp them to their respective parts. With the glue dry, sand the joints flush.

5 Draw the finger recesses on the pencil and file drawer fronts, where shown on **Drawing 2**. Bandsaw, then sand the recesses.

6 Cut the drawer bottoms (T, U) to size. Glue and clamp the drawers together. Make sure they are square and flat. With the glue dry, sand the corner joints flush.

Create the drop leaf and doors

1 Cut the stiles (V), drop-leaf rails (W), and door rails (X) to size. Set aside some scraps of this stock to test your stub tenon and groove cuts.

2 With your regular tablesaw blade, cut 1/4"-deep, centered grooves for the 1/4"-plywood panels in the edges of the rails and stiles. To get perfectly-sized centered grooves, position the fence to roughly center your scrap stock on the blade. Make two passes over the blade, turning the scrap end-for-end between passes. Test the fit of your plywood. If necessary, nudge the fence toward the blade, and make two passes. Repeat this procedure until a good fit is achieved. Now cut all the grooves in the rails and

3 MACHINING THE DRAWER PARTS

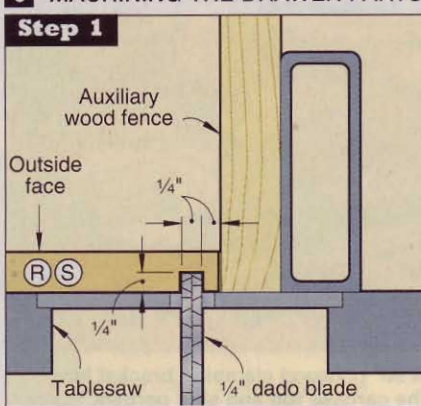

To make the drawer-side half of the lock-rabbit joint, cut dados across the drawer sides' ends.

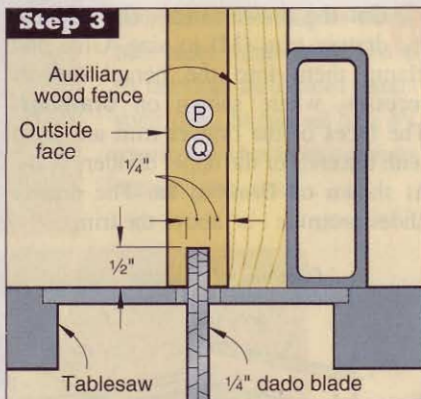

To make the drawer-front half of the joint, raise the dado blade and cut grooves in the fronts' ends.

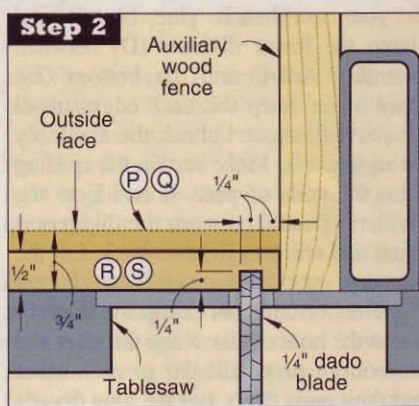

Without moving the blade or fence, cut the drawer-bottom grooves in the fronts and sides.

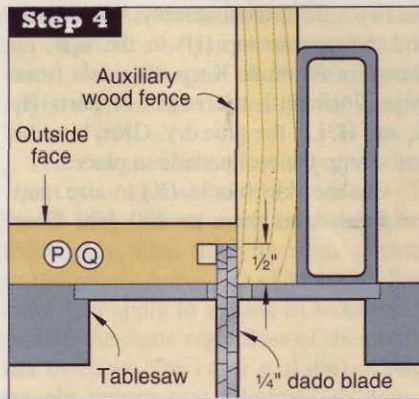

Reposition the fence, and finish the joint by cutting away part of the groove's inside lip.

stiles, where shown on **Drawings 4** and **4a**. The two center stiles (V) in the drop leaf get grooves along both edges.

3 To form the stub tenons on the ends of the stiles, shown on **Drawing 4a**, install a 1/4" dado blade in your tablesaw, and attach an auxiliary extension to your miter gauge. Cut stub tenons, as shown on **Drawing 4b**. To ensure a good fit of the tenons in the grooves, first test the blade and stopblock positions with your scrap stock.

4 Cut the drop-leaf panels (Y) and door panels (Z) to size. The panels are an exact fit in their respective frames, so dry-assemble the drop leaf and doors to make sure the parts go together properly. Glue and clamp the drop leaf and doors, check that they are square, and set them on a flat surface to dry.

5 Cut three 1/4x12³/₈x18³/₄" plywood blanks for the drop-leaf liners (AA), and three 12¹/₈x18¹/₂" pieces of plastic

laminate. (We used black matte-finish laminate.) Adhere the laminate to the liners with contact adhesive, keeping the laminate's edges inside the liners' edges. Check the stile-to-stile and rail-to-rail dimensions of the drop leaf's inside face, and trim the liners to fit, cutting through

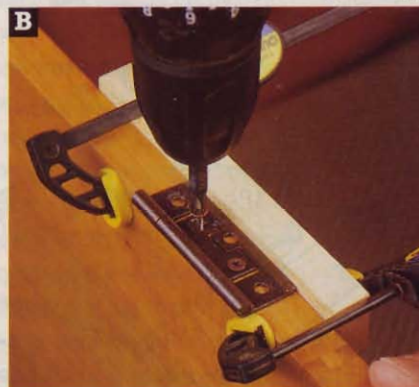

To help align them while drilling, push the no-mortise hinges, knuckle up, against a small scrap block.

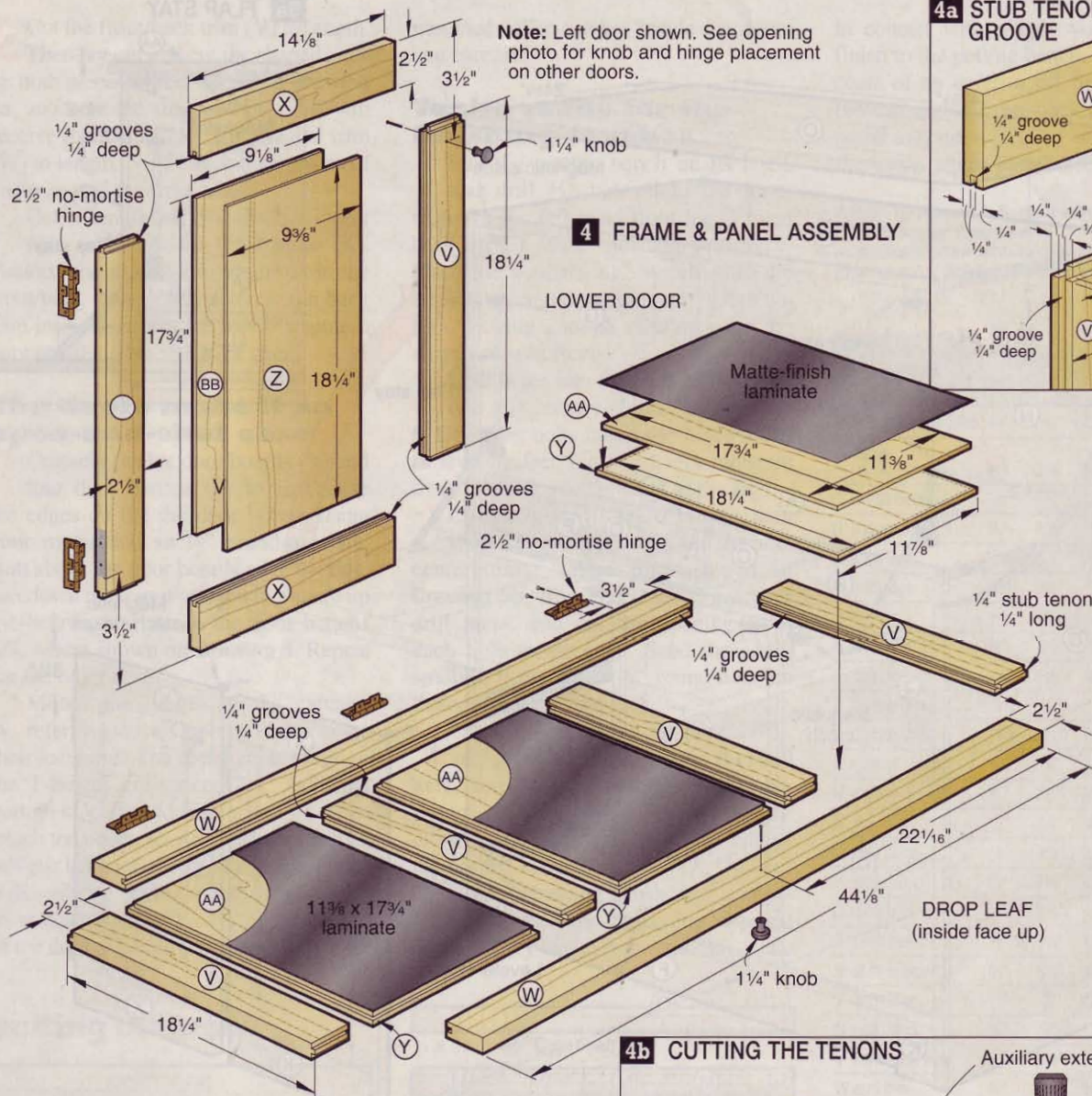

Note: Left door shown. See opening photo for knob and hinge placement on other doors.

4 FRAME & PANEL ASSEMBLY

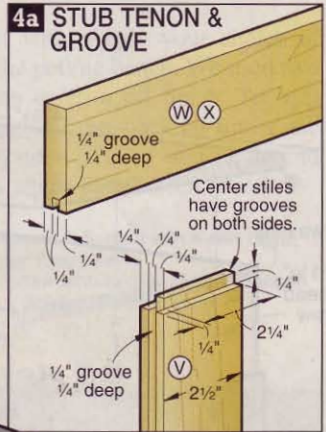

4b CUTTING THE TENONS

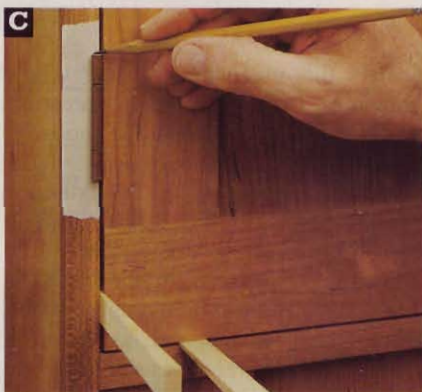
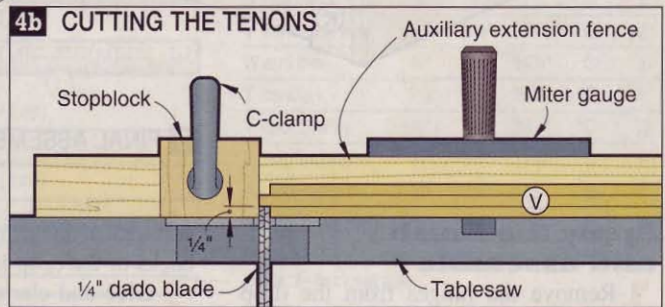

C Using wedges to hold the doors in place, mark the hinge locations on masking tape adhered to the carcass.

both the laminate and plywood. Set the drop-leaf liners aside. Measure the doors for the door liners (BB), and cut them to fit. Glue and clamp the liners to the doors' inside faces.

6 Mark the knob locations, centered on the drop-leaf rail and door stiles, where shown on **Drawing 4**. Drill the holes. Locate the hinges, and attach them to the drop leaf and doors, as shown in **Photo B**.

7 Transfer the hinge locations from the doors to the carcass, as shown in **Photo C**. Position an unmounted hinge on the marks, and use it as a guide to drill the screw pilot holes. Repeat with the drop leaf.

Note: Before fitting the doors, make sure the carcass is not racked. If necessary, adjust the levelers until the carcass openings are square.

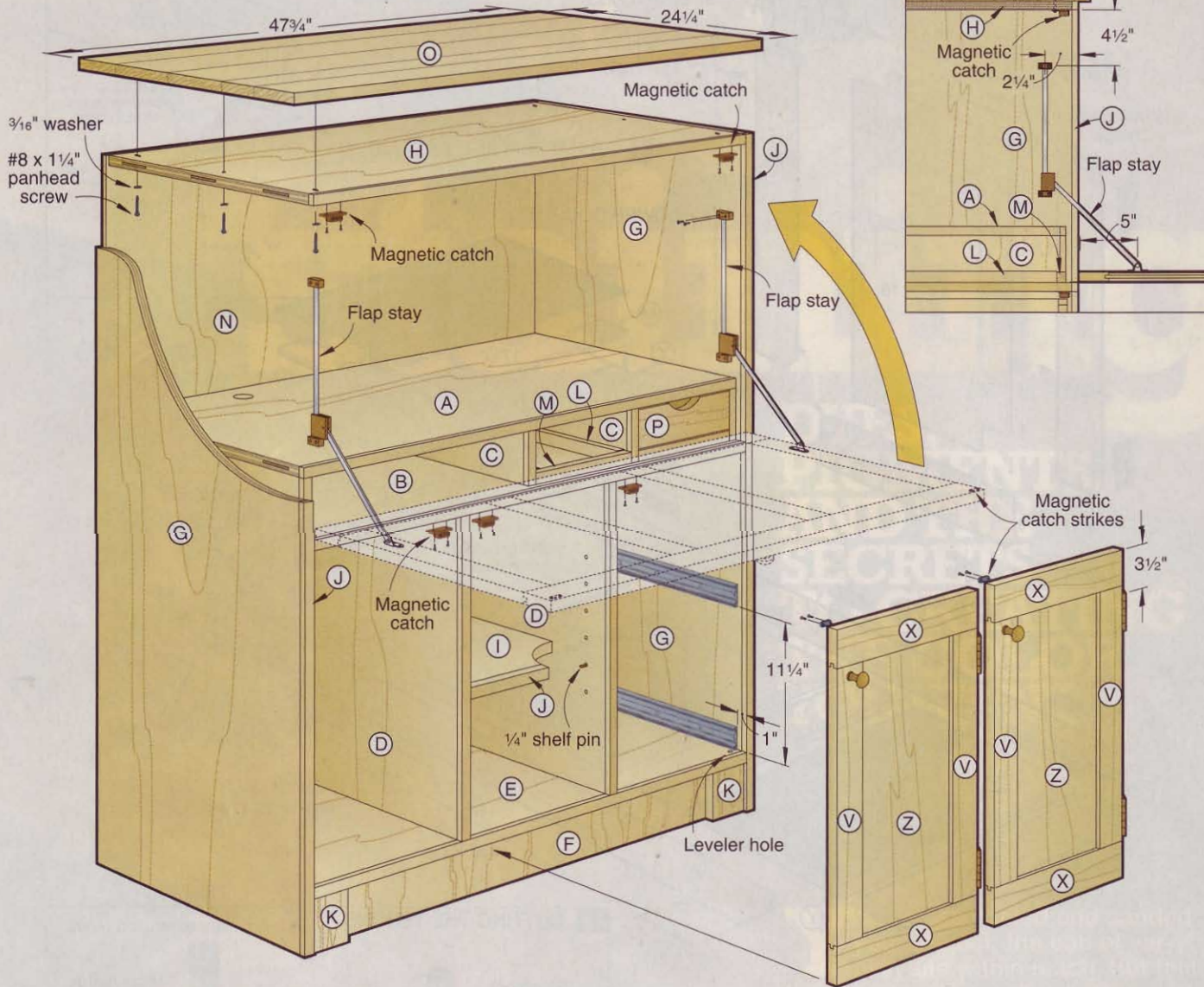

5 FINAL ASSEMBLY

Apply the finish and assemble

1 Remove the hinges from the drop leaf and doors. Finish-sand all the parts and assemblies to 220 grit. You do not need to sand the inside surfaces of the drop leaf's panels or the backs of the drop-leaf liners. Ease any sharp edges with a sanding block.

2 Apply two coats of clear finish, lightly sanding with 220-grit sandpaper between coats. We used gloss urethane for the first coat and satin urethane for the second. Do not finish the inside

surfaces of the drop leaf's panels or the backs of the drop-leaf liners.

3 Glue and clamp the drop-leaf liners in place. Use plywood scraps to evenly distribute the clamping pressure.

4 Place the top (O) on the carcass, flush at the back and centered side-to-side, and clamp it in place. Using the holes and slots in the carcass top as guides, drill pilot holes, and secure the top with pan-head screws and washers, as shown on **Drawing 5**. Remove the clamps.

5 Screw the hinges to the doors and hang the doors in their openings.

Install the magnetic catches, where shown on **Drawing 5**. Screw the strike plates to the doors. Mount the knobs.

6 Drill pilot holes, and screw the carcass members of the full-extension drawer slides to the carcass, where shown on **Drawing 5**. The slides' front edges are 1" back from the carcass' front edge. To position the upper slides, use an 11 1/4"-wide spacer, as shown in **Photo D**. The lower slides sit directly on the bottom (E). Mark pilot hole centerlines up 5/8" from the drawer sides' lower edges. Clamp the slides' drawer mem-



D To easily and accurately position the drawer slides, clamp an 1 1/4"-wide plywood spacer to the carcass.

bers to the drawers, flush at the front. Using the holes in the drawer members as guides, drill pilot holes along the centerlines, and screw the drawer members in place. Cut the plastic hanging-file rail

into 20 1/2" lengths, and slip them over the file drawer sides. Install the drawers.

7 Screw the hinges to the drop leaf and mount the drop leaf on the carcass. Open the doors to support the drop leaf, inserting scrap blocks to hold it horizontal. Mount the flap stays, where shown on **Drawing 5a**. Install the knob, and mount the magnetic catches and strikes. *Note: The flap stays come with mounting screws. The drop leaf foot is reversible, so you can make a right-hand and left-hand pair. To speed opening, turn the adjustment screw in; to slow opening, back the screw out.*

8 Slide the pencil drawers in place. Install the shelf pins and shelf. After you move your computer center to its location, use the levelers to level and true the carcass. To plug in all our components, we located a surge-suppressor outlet strip in the left-hand cabinet. 🌩

cutting diagram

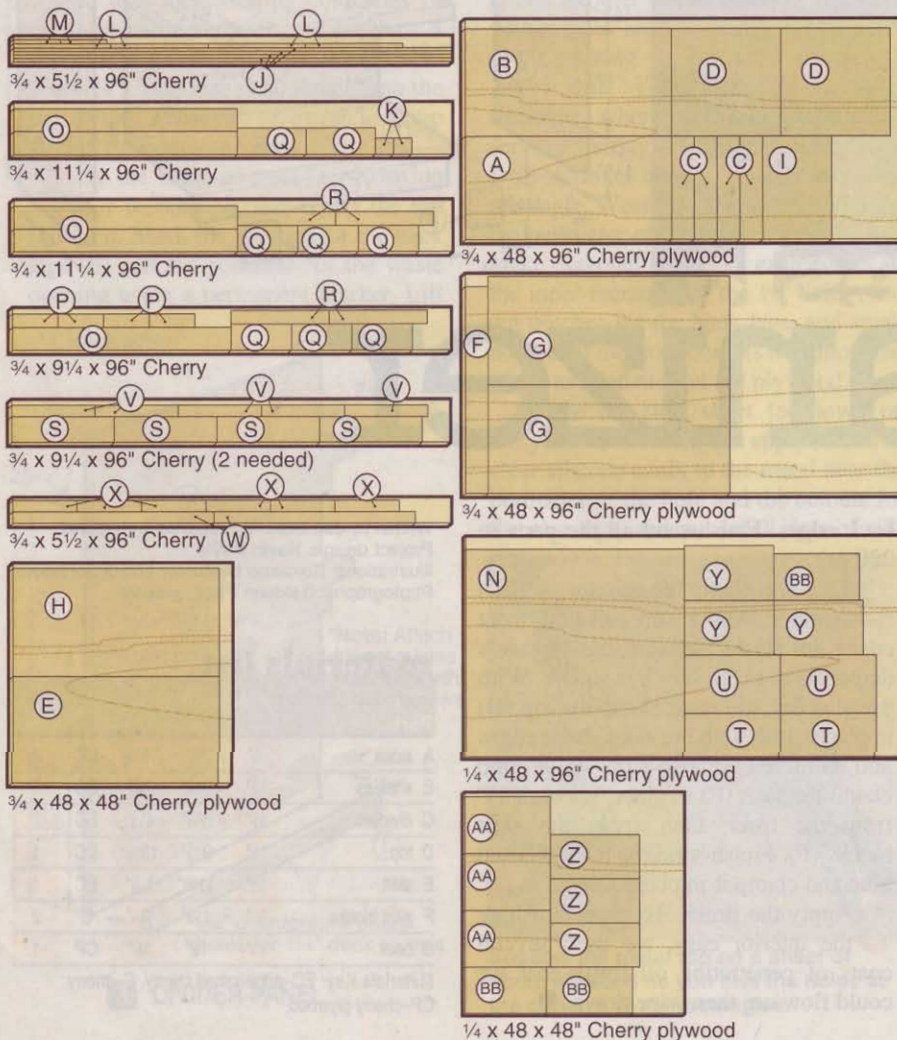

Written by **Jan Svec** with **Charles I. Hedlund**
Project design: **Kevin Boyle**
Illustrations: **Roxanne LeMoine; Lorna Johnson**
Photographs: **Baldwin Photography**

materials list

Carcass	FINISHED SIZE			Mtl.	Qty.
	T	W	L		
A fixed shelf	3/4"	21 1/2"	44 1/4"	CP	1
B drawer shelf	3/4"	22 1/2"	44 1/4"	CP	1
C upper dividers	3/4"	21 1/2"	4"	CP	4
D lower dividers	3/4"	22 1/2"	22 7/8"	CP	2
E bottom	3/4"	22 1/2"	44 1/4"	CP	1
F front skirt	3/4"	44 1/4"	4"	CP	1
G sides	3/4"	22 3/4"	52"	CP	2
H carcass top	3/4"	22 1/2"	44 1/4"	CP	1
I adjustable shelf	3/4"	21 1/2"	14 1/8"	CP	1
J banding	1/2"	3/4"	96"	C	4
K skirt blocks	3/4"	3 1/2"	4"	C	2
L drawer slides	3/4"	15 1/8"	21 1/4"	C	4
M drawer trim	3/4"	7/8"	10 1/8"	C	2
N back	1/4"	45 1/4"	48"	CP	1
O* top	3/4"	24 1/4"	47 3/4"	EC	1
Drawers					
P pencil drawer fronts/back	3/4"	3"	10"	C	4
Q* file drawer fronts/back	3/4"	10 3/4"	13 1/4"	EC	4
R* pencil drawer sides	1/2"	3"	21 1/2"	C	4
S* file drawer sides	1/2"	10 1/4"	21 1/2"	EC	4
T pencil drawer bottoms	1/4"	9 1/2"	21"	CP	2
U file drawer bottoms	1/4"	12 3/4"	21"	CP	2
Drop leaf and doors					
V stiles	3/4"	2 1/2"	18 1/4"	C	10
W drop-leaf rails	3/4"	2 1/2"	44 1/8"	C	2
X door rails	3/4"	2 1/2"	14 1/8"	C	6
Y drop-leaf panels	1/4"	11 7/8"	18 1/4"	CP	3
Z door panels	1/4"	9 5/8"	18 1/4"	CP	3
AA* drop-leaf liners	1/4"	11 3/8"	17 3/4"	CP	3
BB door liners	1/4"	9 1/8"	17 3/4"	CP	3

*Parts initially cut oversize. See the instructions.

Materials Key: CP—cherry plywood, C—cherry, EC—edge-joined cherry.

Supplies: #8x3/4" panhead screws (16), #8x1 1/4" panhead screws (6), 3/16" flat washers (6), #8x1" flathead wood screws (18), #20 biscuits, glue, 24x48" plastic laminate, contact cement, finish.

Buying Guide

Hardware: 2 1/2" no-mortise hinges w/screws (9), shelf supports (4), 22" full-extension drawer slides w/screws (2 pair), magnetic catches w/screws (5), flap stays w/screws (2), knobs (4), levelers with brackets (4) hanging-file rail (4 @ 2'). Order kit no. KIT0302, \$69.95. Woodworker's Hardware, P.O. Box 180, Sauk Rapids, MN 56379. Call 800/383-0130 or go to www.wwhardware.com.



Keep any work area shipshape with this accommodating accessory.

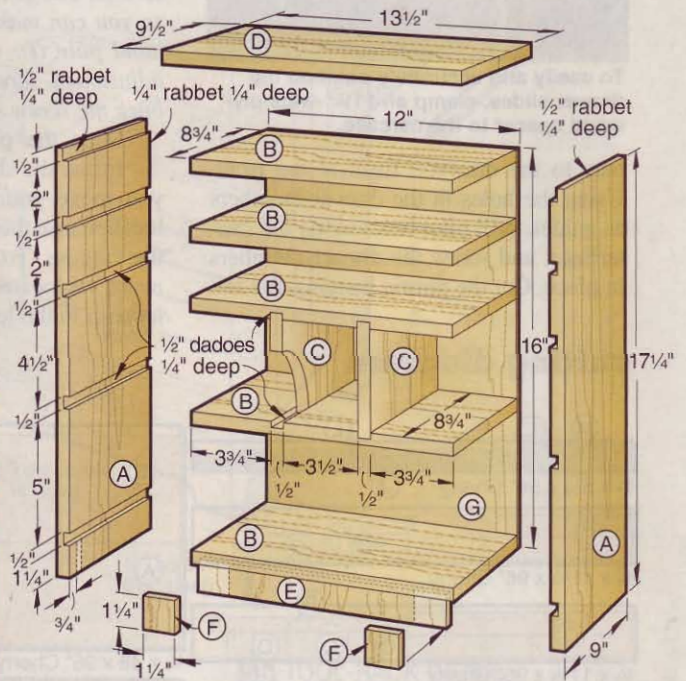

desk. organizer

To make this project, all you need is some 1/2" stock, a small piece of 1/4" plywood, your tablesaw, and a dado blade. For the 1/2" stock, we edge-joined four 3/4x5 1/2x72" boards in two pairs, then planed them down. We cut the 12x16" back out of plywood left over from the computer center's back and drawer bottoms.

1 Cut parts A, B, C, D, and F to size. You'll have to edge-join three pieces for the skirt (E). Install a 1/2" dado blade in your tablesaw, and cut the rabbets in the sides and the two shelves (B). Reset your fence, and cut the 1/4" rabbets 1/4" deep along the sides' inside

back edges. Finish-sand all the parts to 220 grit.

2 Glue and clamp the carcass (A/B/C) together. Make sure all the front edges are flush. Measure the carcass's diagonals to make sure it is square. With the glue dry, glue and clamp the top (D) in place, flush with the sides' back edges and centered side-to-side. Glue and clamp the skirt (E) in place, set back 3/4" from the front, then apply the skirt blocks (F). Finish-sand the back (G) and glue and clamp it in place.

3 Apply the finish. To make brushing the interior easy, we used several coats of penetrating oil finish that we could flow on, then wipe down.

Written by Jan Svec with Charles I. Hedlund
Project design: Kevin Boyle
Illustrations: Roxanne LeMoine; Lorna Johnson
Photographs: Baldwin Photography

materials list

Part	FINISHED SIZE			Matl.	Qty.
	T	W	L		
A sides	1/2"	9"	17 1/4"	EC	2
B shelves	1/2"	8 3/4"	12"	EC	5
C dividers	1/2"	8 3/4"	4 1/2"	EC	2
D top	1/2"	9 1/2"	13 1/2"	EC	1
E skirt	1/2"	11 1/2"	1 1/4"	EC	1
F skirt blocks	1/2"	1 1/4"	1 1/4"	C	2
G back	1/4"	12"	16"	CP	1

Materials Key: EC—edge-joined cherry, C—cherry, CP—cherry plywood.

dustworthy companions

We test 110-volt dust collectors at or under \$300

To your grandfather, “dust collection” in the shop meant a broom and dustpan. But, as we’ve learned more about the health hazards of workshop dust, woodworkers have placed a higher priority on collecting debris at its source. And, tool manufacturers have followed suit by including dust-collection ports on more of their products.

Of course, to use those ports, you need a dust collector. For this article, we put nine dust collectors—all with 110-volt motors—through their paces. These single-stage models, rated at 1 or 1½ horsepower, have enough suction to effectively pull dust from any home woodworking machine. And, at a top price of only \$300, you needn’t worry about sucking your bank account dry.

Airflow expert Dr. Greg Maxwell (background) records data while *WOOD*® magazine tool tester Jeff Hall adds resistance to the airflow during testing of the Delta 50-850.



Accurate ratings require sophisticated tests

After assembling the machines, we "seasoned" the filter bags twice by sucking up equal amounts of workshop dust, then emptying them and tapping them clean. This simulated workshop conditions in preparation for the airflow tests.

To ensure the validity of our testing, we enlisted Dr. Greg Maxwell, an airflow expert from Iowa State University. With his help, we built a test rig (shown *opposite*) consisting of 40" of 4"-diameter PVC pipe with a pitot tube at the dust-collector inlet and a manometer (to measure air velocity and static pressure). At the open end of the pipe, we mounted an adjustable restrictor, which we gradually closed to simulate specific static pressure (SP) losses. These SP losses represent the resistance caused by ductwork that you might add to the collector.

Using the data gathered at each SP interval from wide-open to closed, we built a performance curve for each model. The performance curve shows the volume of air the dust collector can move at various static pressures. While conducting those tests, we also measured

You chose the test criteria

Before we began testing these machines, we went to our WOOD ONLINE® (www.woodonline.com) discussion groups and asked readers to tell us the top three things they wanted to know about dust collectors. Here's what you asked for:

- 1 **SUCTION** "I don't care so much about the 'rated' CFM of a unit—only how well it performs." **Dave Hanke, Oshkosh, Wis.**
- 2 **BAG QUALITY** "Bags have a huge influence on dust-collector performance, just as a saw blade has on a saw." **Jim Halbert, Kimberling City, Mo.**
- 3 **KEEP IT FAIR** "Tests should be set up with identical environments.... Quality manometers, pitot tools, and ammeters should be used in identical configurations for all machines." **Jim Becker, New Hope, Pa.**

the maximum amperage of each motor at 110 volts. And, we took sound-level readings using a decibel meter mounted about 6' high and 8' from each collector.

Finally, to see how high-efficiency, 1-micron filter bags would affect airflow, we equipped each collector with 1-micron bags made to the same dimensions as the original bags. We then repeated the airflow test, and again built a performance curve for each model.

First, figure how much collector you need

Many woodworkers first buy a dust collector, then figure out how they'll connect it to their tools. However, it makes more sense to plan your ductwork (even if it's only a piece of flexible hose) before you purchase anything.

That's because every inch of duct diameter, every foot of length, and every elbow adds resistance (SP loss). As the resistance increases, the volume of air the dust collector can move through the ductwork (stated in standard cubic feet per minute, or SCFM) decreases.

Once you decide on what size ducting to run and where, you can calculate the total SP loss in your ductwork. In WOOD® magazine issue 119 (page 16), we give detailed instructions on figuring your dust-collection needs. (If you don't have that issue, you'll find the article on our Web site—www.woodonline.com. Under the WOOD magazine button, click on Woodworking Basics.)

Before you hunt for the article, though, let's look at a quick example of SP loss in 4" duct. A tablesaw requires 350 cfm of airflow. Hook it up to your dust collector with a straight 10' run of rigid duct and 5' of flexible hose, and your dust collector will have to draw 350 cfm at 1.75" of static pressure. Hook your tablesaw directly to the dust collector with 10' of flexible hose, and now the dust collector has to draw the same 350 cfm, but at 2.1" of static pressure.

These curves show real-shop performance

The air through a dust-collection system must move at a rate of at least 3,500 feet per minute to keep woodworking dust and debris suspended until it reaches the collector. In order to achieve that velocity through 4" round duct, a dust collector must pull no less than 305 scfm. As the Dust Collector Performance Curves With 4" Duct chart, at left, shows, all of the models achieved at least that level with our test rig attached.

But what happens when you add ductwork to the collector? The resistance added by the ductwork reduces the speed and volume of air moving through it. So,

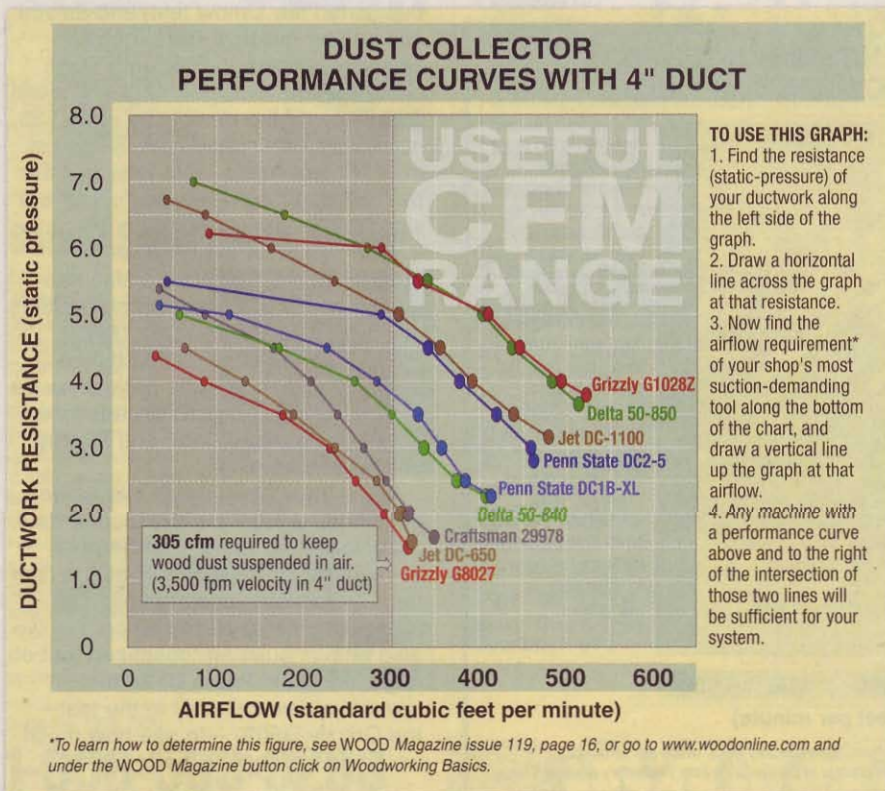

dustworthy companions

for example, if you add a 90° elbow and 1' of straight pipe (enough to increase the resistance to 2"), the Grizzly G8027 falls below the minimum airflow requirement. The Craftsman 29978 and Jet DC-650 performed only a little better. These machines are suitable for use only with a short run of flex hose on most woodworking tools.

On the other hand, you could increase the resistance on the Delta 50-850 and Grizzly G1028Z to nearly 6"—that's about 40' of 4"-diameter straight pipe and two 90° elbows—before their airflows would drop below 305 scfm, making them good candidates for a mid-sized central dust-collection system. The Jet DC-1100 and Penn State DC2-5 also fared well in this test.

Note: Due to differences in testing procedures, our cfm ratings may not match those quoted by the manufacturers. Because we tested all of the machines identically, our numbers provide a fair head-to-head comparison of the tested models. However, don't compare our

numbers to the published specs of dust collectors not in this test.

For most, "filter bag" is a misnomer

All of the dust collectors in our test have two bags. The top bag functions as a filter, separating dust particles from the air as it passes through the bag and back into the shop. The bottom bag, made from the same material as the top bag, stores the collected dust while also providing some filtration.

The bags on most of the tested collectors won't trap anything smaller than 30 microns. That disappoints us, because particles from .5–10 microns in size are the most hazardous to your respiratory system, and these bags don't come close to that filtration level. Only Penn State ships polyester/felt bags that filter down to 5 microns.

Even 5-micron bags allow hazardous dust through, however. Fortunately,



The release lever on the Grizzly G8027's bag clamp bent easily when closing it. Since our test, a Grizzly spokesman told us they would improve the clamps.

Delta, Grizzly, and Jet offer 1-micron bags as an optional upgrade, and we think they're worth the extra expense. (See What You Need To Know About Aftermarket Bags, below.)

Depending on the type and amount of work you do, the capacity of the storage bag may be an issue. The debris created by a tablesaw or sander won't quickly

What you need to know about aftermarket bags

We were curious to learn how high-efficiency, 1-micron filter bags would affect the performance of the collec-

tors, so we asked American Fabric Filter (800/367-3591) to craft a set of 1-micron bags for the dust collectors

in the test, made to the same dimensions as the factory bags.

After seasoning the new bags, we duplicated the airflow test, and as you can see by the How Performance Changes With High-Efficiency Bags chart, left, the 1-micron bags improved the airflow of the models by up to 133 scfm, while keeping all but the tiniest dust particles contained. How can this be? Although the 1-micron "holes" are significantly smaller than the 30-micron "holes" in the original-equipment bags, there are also substantially more of them, which explains the improved performance. (Penn State's performance didn't change much with the upgraded bags because their 5-micron bags are already more efficient than the others, and slightly oversized.)

AFF's Stan Wnukiewicz told us he could improve the performance of the collectors even more. For the best suction, he typically oversized the filter bag—sometimes even doubling its size—for optimal performance. So, we also let him build an "optimized" set of bags, shown in Photo C, for the lowest-volume collector in the test—the Grizzly G8027—to see how much we could increase its performance.

HOW PERFORMANCE CHANGES WITH HIGH-EFFICIENCY BAGS (4" DUCT)

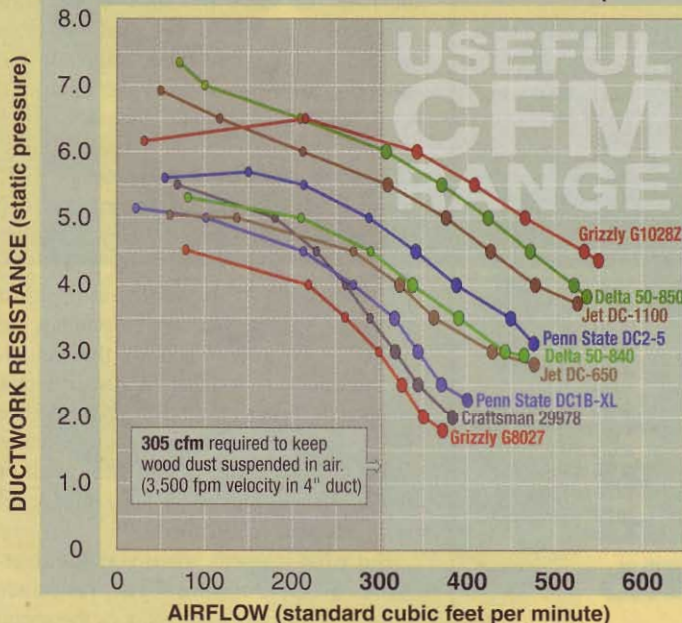

Test conducted using high-efficiency, 1-micron 10-ounce shaker-felt filter bag and 16-ounce polyester-felt storage bag, made by American Fabric Filter, to same size* as factory bags. Bags were dirtied twice, then tapped clean to simulate workshop conditions. Airflow measurements taken at dust-collector inlet with pitot tube inside 40"-long, 4"-diameter PVC drain pipe. Static pressures measured at same location with manometer.

* These high-efficiency bags are actually slightly smaller than Penn State's factory bags, which are 16-ounce polyester-felt. Therefore, the Penn State collectors showed little change in performance from the factory-equipped bags.

fill the small bags on the Craftsman, Delta 50-840, Grizzly G8027, and Jet DC-650. But the size and volume of chips produced by a planer or jointer can overwhelm those same bags. Delta's 50-850, with 6 cubic feet of capacity, nearly triples the capacities of those models. (Just as this issue went to press, Delta replaced the 50-840 with the 50-775. See the note under the 50-775 photo on page 66 for details.)

Incidentally, it's tempting to let that storage bag fill up completely before emptying it, but that's a bad idea for a couple of reasons. First, as the bag fills, it reduces the total filtration area, resulting in increased pressure inside the bags, and reducing suction. Second, that extra internal pressure forces larger dust particles through the bag and back into the shop air. Emptying the bag frequently relieves that pressure. Both Penn State models and the Jet DC-650 have clear plastic windows stitched into their storage bags to help you keep tabs on bag-changing time.

Reattaching the bags to the dust collector is a chore that hasn't changed much over the years. Most come with quick-release metal band clamps, which thread through belt loops around the bag opening. The quick-release clamps on the Delta 50-850 are easier to open than the others because the release lever isn't buried in the clamp when closed. The release levers on the Grizzly G8027 are made of a soft metal that bent easily (see Photo A). However, after learning of our findings, Grizzly's Bill Crofutt told us they would improve the clamp.

The Grizzly 1028Z improves on the belt-loop concept with a stitched pocket around the bag opening that captures the band and makes it easier to slip over the rim. The unit we tested used hose-clamp style bands that require a screwdriver to loosen and tighten, which we found a nuisance. Again, Crofutt responded by saying they would immediately switch to quick-release clamps.

Rather than a band clamp, the storage bags of the Craftsman and Jet DC-1100

have a springy hoop built in to the mouth of the bag. Collapse the hoop, as shown in Photo B, insert it inside the rim, and it snaps into place. Removal is just as easy,



Rather than a traditional bag clamp, the Jet DC-1100 has a spring-steel hoop stitched into the bag's mouth for effortless bag removal and reinstallation.

Case Study: Grizzly G8027 HOW OPTIMIZED FILTER BAGS AFFECT PERFORMANCE

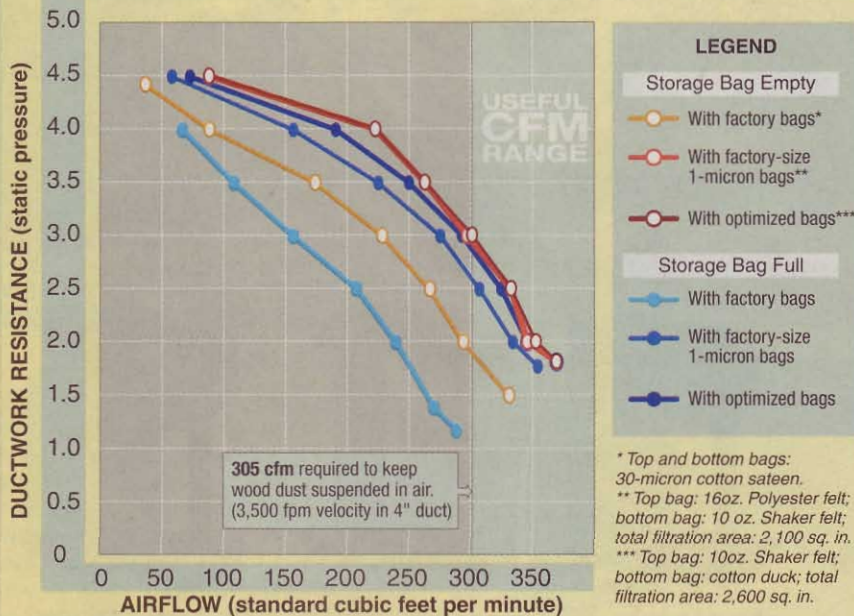

The Case Study chart, above, shows that with the optimized bags empty, we found virtually no suction difference between the factory-sized 1-micron bags and the optimized bags (although both outperformed Grizzly's

empty factory bag by 33 scfm). But look at the numbers when the storage bag is full. The optimized bags added nearly 80 scfm over the factory bags while also improving the machine's static pressure level.



The optimized bag set for the Grizzly G8027 performed better—even with the storage bag full—than the factory bags did when empty.

AFF's Wnukiewicz says the optimized bags he built for us, including a durable, non-breathable cotton-duck bottom bag, would cost in the neighborhood of \$100. But he can get the same performance by using a disposable 5-mil plastic bag on the bottom, cutting the cost to about \$55. All of AFF's bags are custom built, so they can tailor the bags to your space requirements and budget.

COLLECTION INSPECTION: 110-VOLT DUST COLLECTORS

MANUFACTURER/IMPORTER	MODEL (1)	MOTOR		BLOWER		BAGS			PERFORMANCE RATINGS (5)					ACCESSORIES (7)		CORD LENGTH	WARRANTY	COUNTRY OF ASSEMBLY (8)	WEIGHT (POUNDS)	SELLING PRICE (9)	
		VOLTAGE (2)	AMP DRAW (3)	INLETS (NUMBER @ DIAMETER)	IMPELLER DIAMETER (INCHES)	BOTTOM BAG CAPACITY (CUBIC FEET)	FILTRATION EFFICIENCY (MICRONS) (4)	HEIGHT WITH BAG INFLATED (INCHES)	BAG FILTRATION	BAG-CLAMPING SYSTEM	EASE OF CHANGING BAGS	MOBILITY	EASE OF ASSEMBLY	NOISE LEVEL (dB) (6)	STANDARD						OPTIONAL
CRAFTSMAN	29978	110	7.2	1@4"	10	2.4	30	60	F	G	G	E	E	78	A,H		6'	1 yr.	T	72	\$300
DELTA	50-840*	110/220	9.9	1@4"	10	2.1	30	60	F	E	E	E	E	72	H	M	6'	2 yr.	T	57	210
	50-850	110/220	12.1	2@4"	11 1/2	6.0	30	82	F	G	E	E	E	78	H	M	8'	2 yr.	T	100	300
GRIZZLY	G8027	110	5.0	1@4"	9	2.2	30	63	F	G	G	E	G	68		H,M,P	9'	1 yr.	C	79	130*
	G1028Z	110/220	13.9	1@6" or 2@4"	11	5.4	30	78	F	F	G	E	E	74		H,M,P	5'6"	1 yr.	T	116	240*
JET	DC-650	110/220	8.3	1@4"	9 1/2	2.1	30	57	F	G	E	G	E	74		A,H,M	10'	2 yr.	T	84	220
	DC-1100	110/220	10.7	1@6" or 2@4"	11	4.1	30	79	F	E	E	E	E	82		A,H,M	6'	2 yr.	T	110	300
PENN STATE	DC1B-XL	110/220	7.9	1@5" or 2@4"	10	4.7	5	60	G	G	E	E	E	72	H		5'6"	2 yr.	T	66	220*
	DC2-5	110/220	10.9	1@6" or 2@4"	10	5.6	5	78	G	G	E	G	G	78	H		5'6"	2 yr.	T	130	300*

For specifications on other types of tools, click on "Tool Comparisons" at www.woodmall.com.

- NOTES:
- 1. *50-840 replaced by 50-775. See note under photo of 50-775 below.
 - 2. All models come prewired for 110 volts.
 - 3. Amperage draw at 110 volts, measured with no ductwork attached to inlet.
 - 4. Smallest particle that filter can effectively remove from airflow.
 - 5. **E** Excellent
G Good
F Fair
 - 6. Measured 8' from blower at height of 5'6", with 5' of flex hose attached to inlet, and inlet facing away from meter.
 - 7. (A) 4"-to-2" adapter
(H) Hose
(M) 1-micron bags
(P) Plastic bottom
 - 8. (C) China
(T) Taiwan
 - 9. *Price does not include shipping charges.



Craftsman 29978
The convenient hooped storage bag makes removing and re-installing the bottom bag a breeze. But this machine's suction is well below similarly priced units. Visit your local Sears store. www.sears.com/craftsman

Delta 50-775
(Replaces 50-840 in tests)
Although this machine was unavailable at the time of our test, a Delta official told us that changes made to its predecessor did not change the performance of the unit. 800/438-2486 www.deltamachinery.com

Grizzly G8027
This unit costs \$90 less than any other machine tested, and not surprisingly had the lowest suction. You can hook it up to one machine with no ducting and get by. 800/523-4777 www.grizzly.com

Jet DC-650
On the low end of the suction scale with the original-equipment bags. However, high-efficiency bags netted us an extra 133 scfm, greatly improving airflow and static pressure. Windowed storage bag shows how full the bag is. 800/274-6848 www.jettools.com

Penn State DC1B-XL
This unit delivered the most suction of the 1-hp units, and did it while capturing dust as small as 5 microns. That combination makes it our favorite for the small shop. 800/377-7297 www.pennstateind.com

but does get more difficult as the bag becomes full.

Almost all of the bags stayed securely fastened to the rim, even with the increased back pressure caused by a full storage bag. The only exception was the Craftsman, which lacks a flange on the rim. In our tests, the filter bag popped off repeatedly and sent a cloud of dust drifting through the shop. Upon learning of this, Craftsman's Bryan Meyer told us that beginning in early 2002 they would replace the band clamp with an internal hoop like that found on the storage bag.

Mobility and more

•**Mobility.** Although we didn't have any major problems getting from place to place with these units, some are less maneuverable than others. Most have a wide base and four swivel casters, so we could move them easily in any direction without fear of tipping over. We downgraded both the Jet DC-650 and the Penn State DC2-5 because they have a pair of fixed casters and a pair of swivel casters, so steering them into a tight spot is akin to parallel parking your car.

Now at WOOD ONLINE®

- **Interactive Tool Review:** Talk about these dust collectors with fellow woodworkers (www.woodmagazine.com/woodmall/charts).
- **Calculate Your Dust Collection Needs** (www.woodmagazine.com, click on *WOOD*® magazine, then Woodworking Basics).
- **Build A Cyclone Dust Collector** (www.woodstore.woodmall.com/cycduscol.html).

The Craftsman and the Penn State DC1B-XL are the only units to provide an actual handle to help mobility. With the others, you grab the machine wherever you can, usually by the bag rim.

•**Noise.** Although these machines are plenty loud, they lack the annoying whine of a universal motor, so you may be tempted to take lightly the threat of hearing damage. However, most fell in the 72-78 decibel (dB) range, with the Grizzly G8027 the quietest at 68 dB, and the Jet DC-1100 the loudest at 82 dB.

Our collective opinion

For a small central-ductwork system, the Delta 50-850 and the Grizzly G1028Z outperformed all of the other models in the test, pulling more than 500 scfm while still delivering enough static pressure to overcome the resistance of the

ductwork. By the time you figure in shipping charges for the Grizzly, even the price is about a wash. If we were buying, we'd certainly spend the extra money for high-efficiency, 1-micron bags, whether from the manufacturer or an aftermarket provider.

If your plan is to move the collector from tool to tool, we think you'll be happiest with the Penn State DC1B-XL. It delivered the most airflow of the smaller machines in our test, and comes with the 5-micron bags. Delta's 50-840 and Jet's DC-650 deserve honorable mention here: When we equipped them with high-efficiency aftermarket bags, they both outperformed the DC1B-XL. ♣

Written by **Dave Campbell** with **Jeff Hall**
Photographs: **Baldwin Photography**



Delta 50-850

A voracious collector when it comes to airflow, and one of our top picks. The quick-release clamps on this model are the easiest to operate among those tested, and felt the most substantial. A good choice for a small central-collection system.

800/438-2486

www.deltamachinery.com



Grizzly G1028Z

A top performer, about on par with the Delta 50-850 in terms of airflow. Since our test, Grizzly has switched to quick-release bag clamps on this model.

Shipping costs bring this to about the same price as the Delta 50-850.

800/523-4777

www.grizzly.com



Jet DC-1100

Priced the same as the Delta 50-850, this collector doesn't perform up to the level of the Delta 50-850 or Grizzly G1028Z. We like the hooped storage bag that makes removing and reinstalling the bag a snap.

800/274-6848

www.jettools.com



Penn State DC2-5

Standard-equipment 5-micron bags provide the finest filtration in the test, but it doesn't pull numbers like the Delta 50-850 or Grizzly G1028Z.

Windowed storage bag shows when the bag is getting full.

800/377-7297

www.pennstateind.com

shelves with flair

Try your hand
at this simple,
yet elegant, design.



Every home can use another shelf unit, whether you fill it with prized collectibles, photos and artwork, display pieces, or even books. And this sturdy, yet highly stylish, design from the Meier brothers, Christian and Robert, of Santa Cruz, California, fits nearly anywhere. (For more information on the Meiers, see the November 2001 issue of *WOOD*® magazine.)

As an added bonus, you'll learn the ins and outs of the loose tenon, a joinery method that involves making mortises in two mating parts, then joining them with a third piece, the loose tenon. The name refers to the fact that the tenon is made from a separate piece of wood instead of being shaped as an integral part of a leg or rail. As you'll discover, loose tenons make rock-solid joints.

Start by building a pair of frames

1 Rip a 30" length of $\frac{3}{4}$ "-thick cherry $\frac{3}{8}$ " wide for the loose tenons. Chuck a $\frac{3}{16}$ " round-over bit into your table-mounted router, and rout all of the edges of the strip. Crosscut eight tenons $1\frac{5}{16}$ " long and four tenons that are $1\frac{1}{16}$ " long.

2 Cut four $\frac{3}{4}\times3\frac{1}{2}\times34$ " blanks for the legs (A). Referring to **Drawing 1**, draw the taper on each leg. Bandsaw the taper, cutting to the line's waste side.

3 Use double-faced tape to adhere a straightedge along the marked taper. Chuck a flush-trim bit into your table-mounted router, and adjust it so that the bearing contacts the straightedge. Referring to **Photo A**, trim the edge flush. Repeat for the other three legs (A).

4 Mark the location of the shelf-pin hole on the inner (untapered) edge of each leg (A), where shown on **Drawing 1**. Drill the hole with a $\frac{1}{4}$ " bit in a doweling jig to ensure that it is perpendicular and centered in the thickness of the leg.

5 Cut the lower rails (B) and the upper rails (C) to the sizes listed in the Materials List.



To avoid chipping, extend the straight-edge past the leg's end. Begin routing at the wider bottom portion, and move toward the narrower top.

6 Referring to **Drawings 1a** and **1b**, mark the hole centerpoints for the mortises in parts A, B, and C. Make certain that the mortise near the bottom of each leg (A) is on the untapered edge (same edge as the shelf-pin hole).

7 Mark the centerlines, and drill $\frac{3}{8}$ " holes to remove most of the waste in the mortises, as shown in **Photo B**. Use a chisel to smooth the side walls of each mortise, but leave the mortises' ends rounded to match the loose tenons.

8 Referring to **Drawings 1c** and **1d**, drill the counterbores and screw-shank holes in the face of the legs (A) and the upper rails (C).

9 To check the fit, dry-assemble the front and rear frames, each consisting of a pair of legs (A), a lower rail (B), an upper rail (C), and loose tenons. Glue and clamp the frames, measuring the diagonals. When the diagonals are equal, the frames are square. Make certain that the frames are flat. With the glue dry, finish-sand the frames to 220 grit.

Now for the slatted sides

1 Resaw and plane walnut lumber to $\frac{3}{8}$ " thick for the side slats (D), and cut them to size. Chuck a $\frac{3}{16}$ " round-over bit in your table-mounted router,

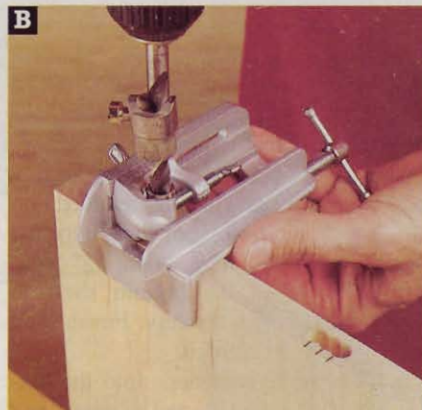

When drilling the mortises, use a doweling jig to keep your drill bit centered and vertical. The bit stop controls the depth as shown here with bottom shelf (G).

and rout the slats' edges, where shown on **Drawing 1**.

2 Cut the top side rails (E) and the bottom side rails (F) to size. Referring to **Drawing 1e**, use your drill press to drill the $\frac{1}{2}$ " counterbores and $\frac{1}{4}$ " holes in the top side rails (E).

3 Referring to **Drawings 1e** and **1f**, mark the centerpoints of the mortise holes. Following the procedure you used on the front and rear frames, drill and chisel the mortises.

4 Glue and clamp two side assemblies, each consisting of a top side rail (E), a bottom side rail (F), and two side slats (D), as shown in **Drawing 1**. To keep the rails (E, F) parallel and properly spaced when clamping the assembly, cut four pieces of scrapwood $29\frac{1}{4}$ " long, and insert two of these spacers between each pair of rails. Check that the side assemblies are square and flat.

Putting it all together

1 Edge-joint stock to make an oversize blank for the bottom shelf (G). Cut it



shelves with flair

to size. Referring to **Drawing 1g**, mark the centerpoints of the holes, then drill and chisel the mortises. You'll notice that the mortises in the bottom shelf are 1" long, but that the mortises in the bottom side rails are only $\frac{3}{4}$ " long. During assembly, the loose tenons are glued into the rails' mortises, but not into the shelf's mortises. This "floating" construction allows the bottom shelf to expand and contract freely. Finish-sand the shelf (G) to 220 grit.

2 Glue the loose tenons into the bottom side rails (F), and wipe off any glue that squeezes out.

3 Place one of the side assemblies (D/E/F) on edge on your workbench, and slip the mortises in the bottom shelf (G) onto the tenons protruding from the bottom side rails (F). Add the other side assembly to the opposite end and clamp, centering the shelf's width on the length of the bottom side rails.

4 To keep the side assemblies parallel to each other, clamp two 30"-long scrapwood spacers between the top side rails (E). Square the side/shelf assembly (D/E/F/G) by measuring the diagonals, and clamp it to your workbench. On top of this assembly, align the front frame (A/B/C), with the tops of the rails (B, F) flush. Using the holes in the counterbores as guides, drill $\frac{7}{64}$ " pilot holes 1" deep into the top and bottom side rails (E, F), and drive in the $1\frac{1}{2}$ " screws. Repeat for the back frame (A/B/C). Remove the clamps and spacers.

5 Cut 16 $\frac{1}{2}$ "-long plugs from a $\frac{3}{8}$ " walnut dowel, and glue one into each counterbore, where shown on **Drawing 1**. If you want to make your own dowels, see the shop tip, right.



Drill a $\frac{3}{8}$ " hole in the end of a $\frac{3}{16}$ "x2x6" board. Place the board over the protruding plug and saw and sand it flush.

6 After the glue dries, trim all of the plugs as shown in **Photo C**. We used a Japanese pull saw, but you could substitute a razor saw from a hobby shop.

7 Edge-join stock to make an oversize blank for the top (H). Cut it to size. Tilt your tablesaw blade, and cut the chamfer on the ends, where shown on **Drawing 1h**. Finish-sand it to 220 grit.

8 Edge-join stock to make an oversize blank for the center shelf (I). Cut it to size. To keep the shelf from sliding, use a $\frac{3}{8}$ " Forstner bit and chisel to make small recesses in its bottom surface to engage the shelf rests, where shown on **Drawing 1i**. Test-fit the center shelf, then finish-sand it to 220 grit.

Apply the finish, and you're finished

1 Using a sanding block and 220-grit paper, give the completed project a quick once-over, easing any sharp edges.

2 Remove the dust with a tack cloth, and apply a clear finish. We brushed on a first coat of gloss urethane. With the first coat dry, we lightly sanded with 220-grit sandpaper, then applied a final coat of satin urethane.

3 With the finish dry, center the top (H) side-to-side and end-to-end on the top side rails (E). Use the holes in the top side rails as guides to drill pilot holes into the top. Put the washers on the screws, and drive them in. Add the shelf pins and the center shelf (I). 🌲

Written by **Robert J. Settich** with **Charles I. Hedlund**
Project design: **Robert Meier**
Illustrations: **Mike Mittermeier**; **Lorna Johnson**
Photographs: **Baldwin Photography**

1a UPPER MORTISE DETAIL

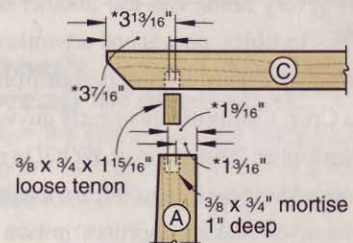

1b LOWER MORTISE DETAIL

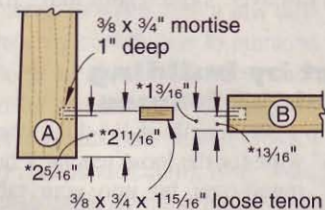

1c UPPER SCREW DETAIL

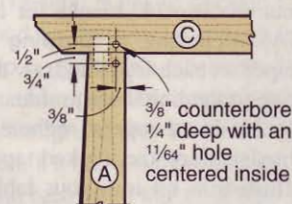

1d LOWER SCREW DETAIL

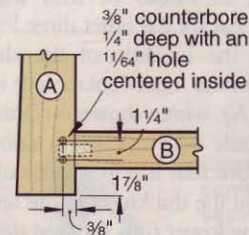

SHOP TIP

Getting 'round to making dowels

To make your own $\frac{3}{8}$ "-diameter dowels, start by ripping a 14" length of walnut to $\frac{3}{8}$ " square. Chuck a $\frac{3}{16}$ " round-over bit into your table-mounted router, and position the fence flush with the bit's pilot bearing. Make start and stop marks on the fence $1\frac{1}{4}$ " from the bit's center. By routing only between these marks, you'll keep the ends of the blank square to guide the cuts. Place the end of your blank on the start mark at the left of the bit with the other end angled away, clearing the bit. Pivot the blank into the running bit and move it to the left, as shown, until the blank's trailing end meets the stop mark to the right of the bit. Repeat on the remaining three sides of the blank. Cut off the square ends.



***Note:** Center the doweling jig at these points to form the mortises.

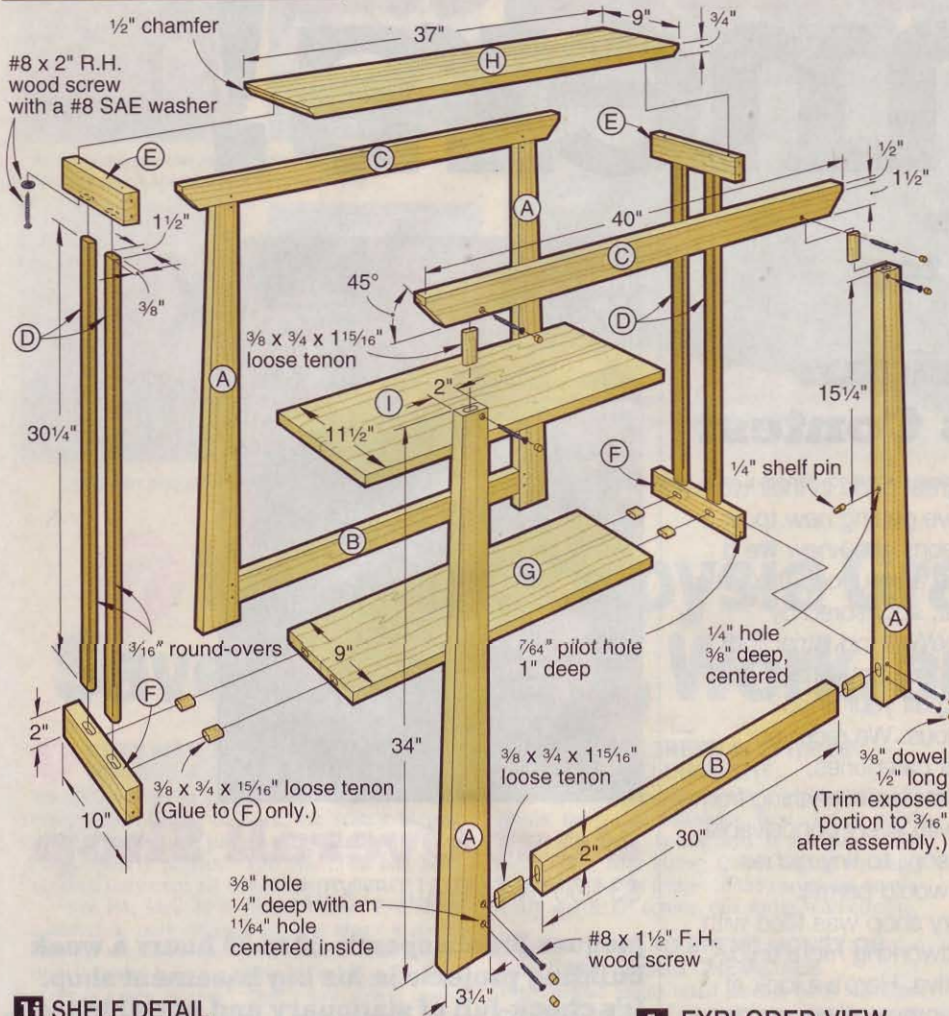

1 EXPLODED VIEW

1i SHELF DETAIL
(bottom side shown)

Step 1 Drill a $\frac{3}{8}$ " hole $\frac{1}{8}$ " deep.

Step 2 Chisel out to edge to form recess for shelf pin.

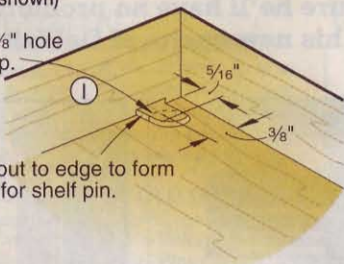

cutting diagram

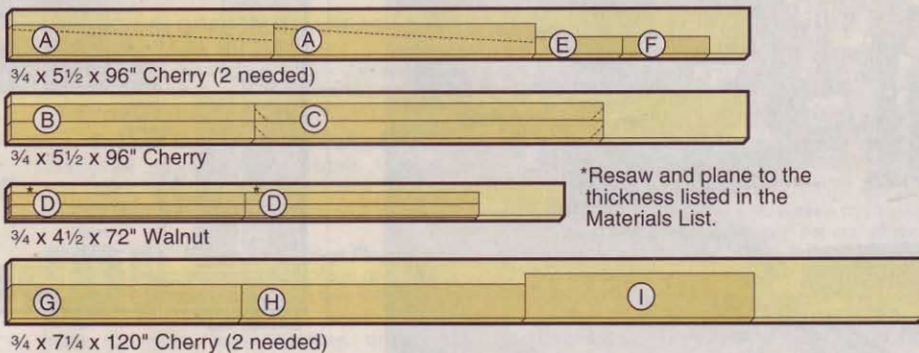

1e TOP SIDE RAIL DETAIL

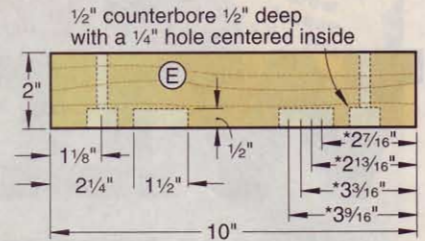

1f BOTTOM SIDE RAIL DETAIL

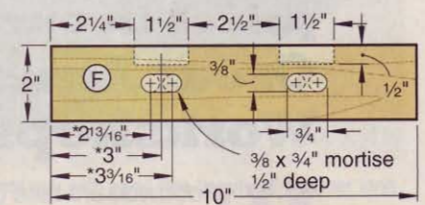

1g BOTTOM MORTISE DETAIL

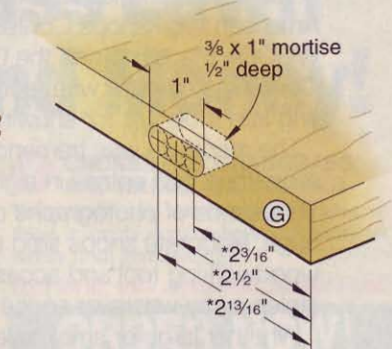

1h TOP DETAIL

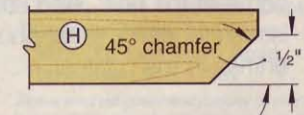

materials list

Part	FINISHED SIZE			Matl.	Qty.
	T	W	L		
A* legs	3/4"	3 1/4"	34"	C	4
B lower rails	3/4"	2"	30"	C	2
C upper rails	3/4"	2"	40"	C	2
D side slats	3/8"	1 1/2"	30 1/4"	W	4
E top side rails	3/4"	2"	10"	C	2
F bottom side rails	3/4"	2"	10"	C	2
G*bottom shelf	3/4"	9"	30"	EC	1
H* top	3/4"	9"	37"	EC	1
I* center shelf	3/4"	11 1/2"	29 7/8"	EC	1

*Parts initially cut oversize. See the instructions.

Materials Key: C=cherry, EC=edge-joined cherry, W=walnut.

Supplies: #8x1 1/2" flathead wood screws (16); #8x2" roundhead wood screws (4); #8 SAE flat washers (4); 1/4" shelf pins (4); 14" length of 3/8" walnut dowel.

• we have our winners!

These readers captured the top prizes in our Great American Workshops Contest

Woodworkers take great pride in their workshops, and they love getting new tools. For those very reasons, we knew we'd get a huge response when we announced the Great American Workshops Contest, sponsored by *WOOD* Magazine and the DeWalt Industrial Tool Company. After all, what could be better than getting free tools just for showing off your shop?

The response was tremendous. We received more than 400 entries in eight categories. Thousands of photographs detailed everything from huge, elaborate shops filled with every conceivable woodworking tool and accessory, to tiny niches stolen away wherever space would permit.

Whether large or small, every shop was filled with inventive ideas to make woodworking more enjoyable, safer, and more productive. Here's a look at some of the best. And keep an eye on upcoming issues for some great shop projects based on entries in the contest.

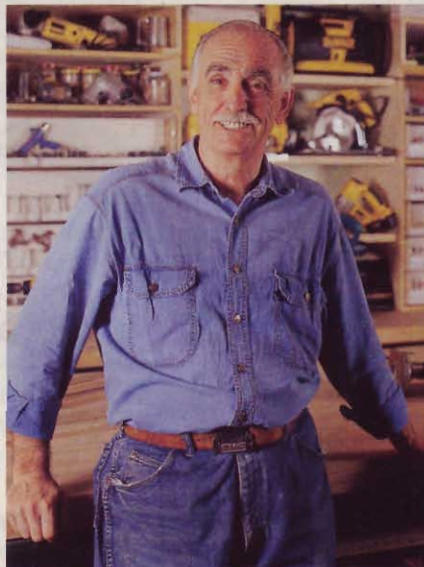

Best Overall Shop

\$3,000 IN DEWALT TOOLS

Jacques Jodoin spends 20 to 30 hours a week building projects in his big basement shop. It's chock-full of stationary and portable tools, but he's sure he'll have no problem finding space for his new cache of DeWalt equipment.

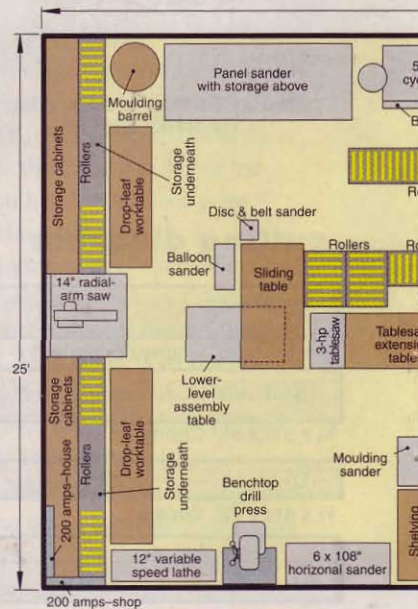
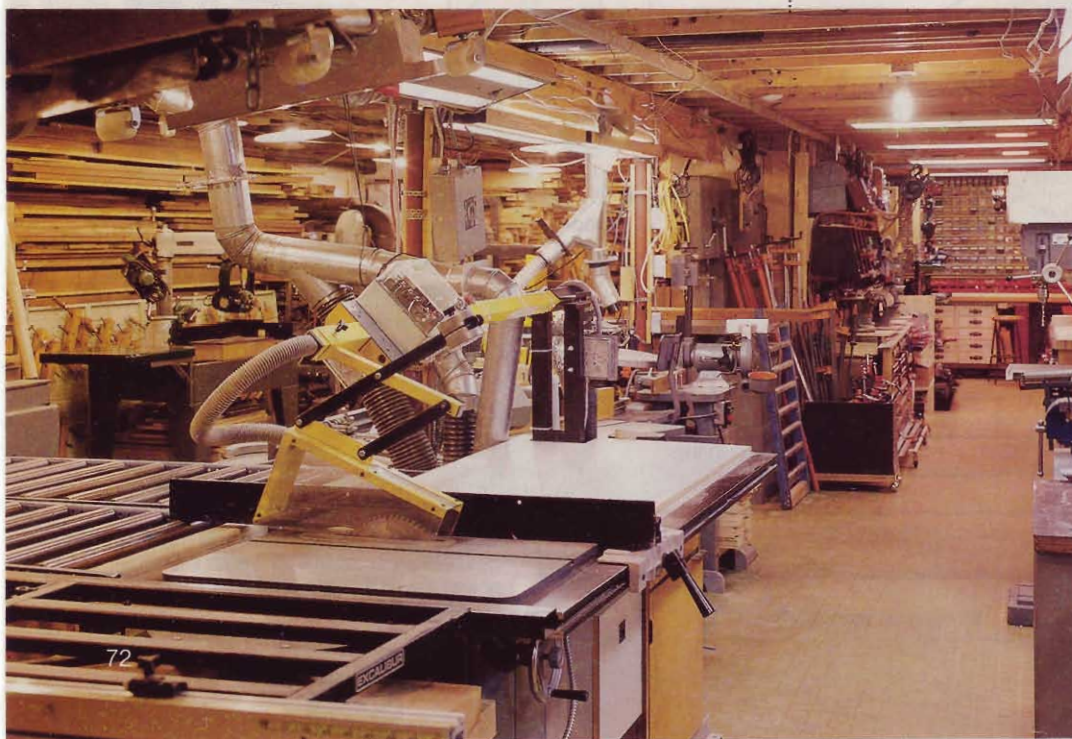

Jacques Jodoin of Cumberland, Ontario, doesn't have a typical cramped basement workshop. His basement is one 1,750-square-foot room, and it's all shop. As you can see in the photos, *below left and right*, and the floor plan *below*, Jacques filled every inch of the space with an impressive collection of tools that rivals many professional shops.

His arsenal includes almost every stationary machine imaginable, such as a 3-hp cabinet saw, a 20" planer, a 20" bandsaw, an 8" long-bed jointer, a panel saw, and many other industrial-grade machines. There's also space for an array of smaller machines and portable power tools.

Though Jacques' shop is crowded, it's organized into efficient work centers. The tablesaw, planer, shaper, radial-arm saw, and jointer, for example, are in one area, which lessens the need to move big boards around. Another area houses a large workbench/assembly table that is ringed by portable tools and clamps. A large dust collector and several smaller vacuums help keep the shop clean, and a dedicated 200-amp electric service supplies plenty of power.

Even with careful planning, getting the layout just right was a challenge. "I would just move a tool into position and try it as I was setting up. If it didn't work, I'd try another spot," he says.

Jacques spent more than 30 years with the Royal Canadian Mounted Police, and



Even in a shop this big, every inch of space counts. These slide-out, rotating platforms allow benchtop tools to be pulled out when in use and tucked away when not needed.

was transferred eight times. When he and his wife, Eileen, moved into their current home 18 years ago, it took two trucks and five or six men just to move the shop. Jacques even dug and cut an exterior doorway into the basement so the tools could be moved in.

Jacques took early retirement in 1990, and now spends time building furniture for his children, himself, and for friends. "They supply the lumber and I build what they want. I made a copy of a \$14,000 Shaker bedroom set for my daughter for \$2,000 worth of cherry," Jacques says. Hundreds of board-feet of

hickory are stacked in his garage now, waiting to be transformed into kitchen cabinets for a former co-worker.

For several years, Jacques also worked at a local Home Depot store as a tool demonstrator, instructor, and salesperson. That gave him extra money for tools, and allowed him to take advantage of a few "great deals" on merchandise.

So what does a guy with this much stuff plan to do with all his new DeWalt tools? He'll get a few tools he didn't have (believe it or not), replace a few old ones, and give some to his children. Here's hoping he can find space for it all.

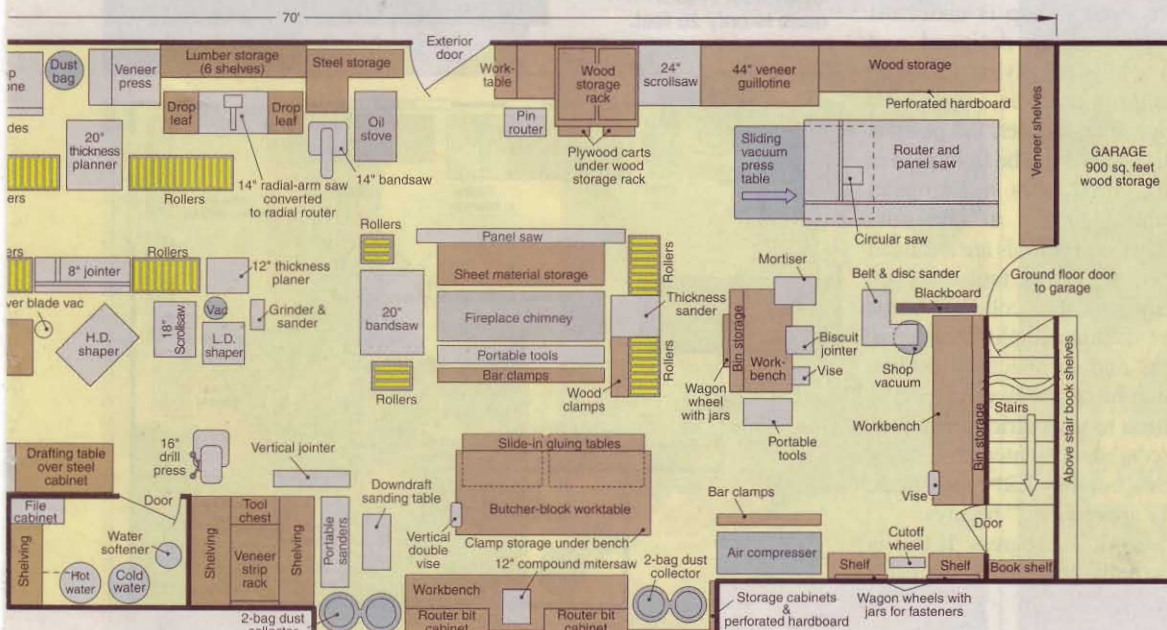

This basement shop is one large room, interrupted only by posts supporting a lengthwise beam. Tools are squeezed into the space in logical work stations. At far left, large stationary machines are grouped for breaking down stock. A central workbench area at bottom is flanked by portable tools, bits, and clamps. Storage and other tools occupy every remaining square inch.

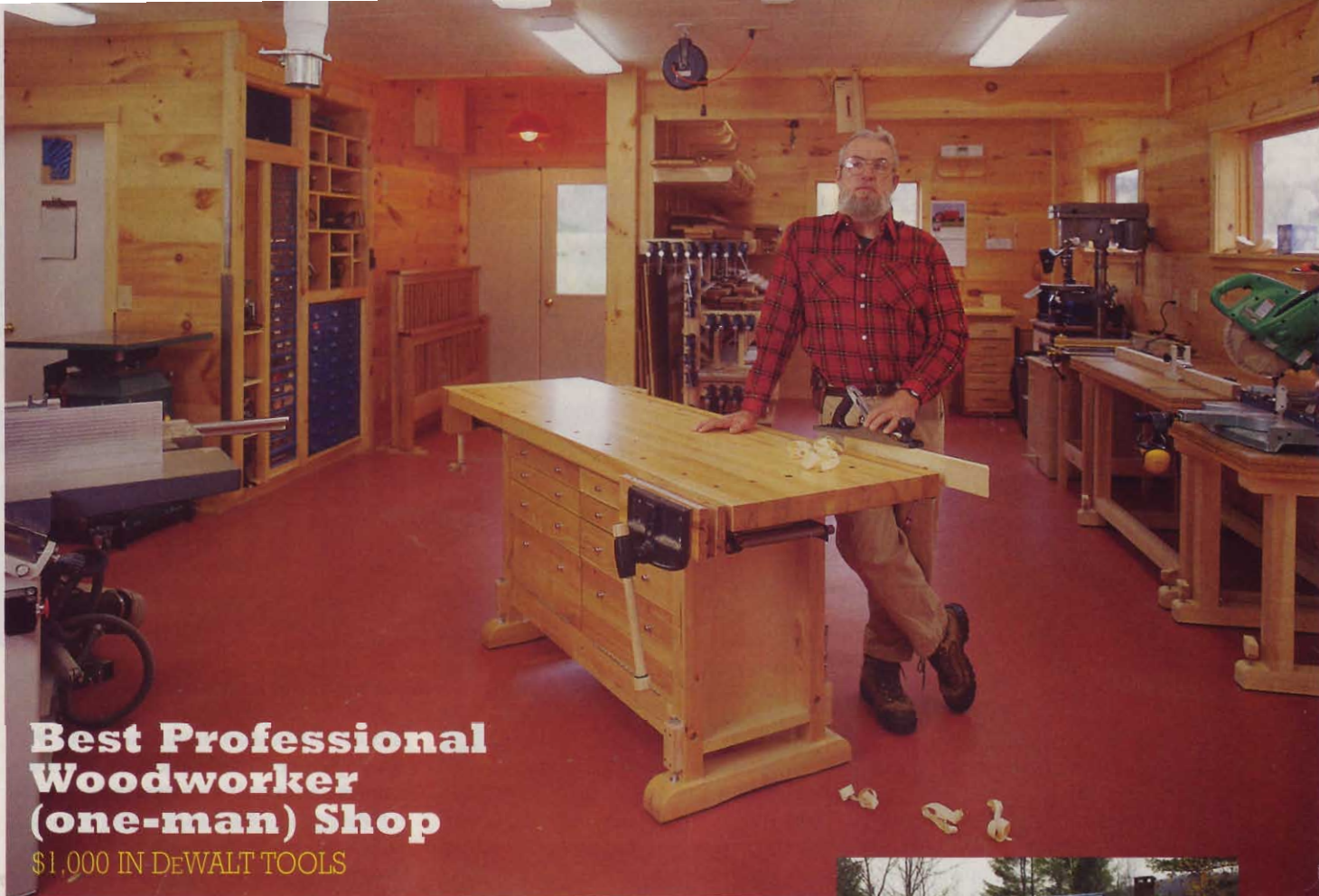

Best Professional Woodworker (one-man) Shop

\$1,000 IN DEWALT TOOLS

Almost every woodworker has dreamed of it: Building custom furniture for paying customers in a great shop. As long as you're dreaming, you might as well place the shop on a picturesque rural lot, surrounded by trees, and just a stone's throw from home.

This scene is reality for Frederick Collins of South Duxbury, Vermont, who became a professional woodworker after 30 years as a high-school woodworking and building trades teacher. Fred's shop is under his garage, a timber-framed structure he designed and built. The building sits on a hillside, giving the shop access on two sides and windows on three.

As you might expect from a shop teacher, the place is spotless and well-organized, as shown in the floor plan at right. To minimize clutter, Fred uses a European combination machine that includes a tablesaw, jointer/planer, and shaper. Other power tools are arranged around the shop's perimeter, and hand tools stay on shelves and in drawers. A cyclone dust collector keeps dust in check, while a central vacuum simplifies cleanup.

Along with original works and architectural details, Fred builds some reproduction furniture. Even on period pieces, he doesn't feel the need to stick strictly with traditional hand tools. "Seventeenth and eighteenth century builders didn't have machines, but they had apprentices. I look at the machines as my apprentices," he says.

Fred calls his workshop a work in progress. If this is what the shop looks like partially completed, we can't wait to see it when it's done.

Even on a cloudy fall day, Fred Collins' shop is warm and bright, thanks to lots of windows, radiant-slab heat, and wood paneling. With a workplace like this, it might be hard to go home at day's end. Of course, Fred's commute is only 20 feet.

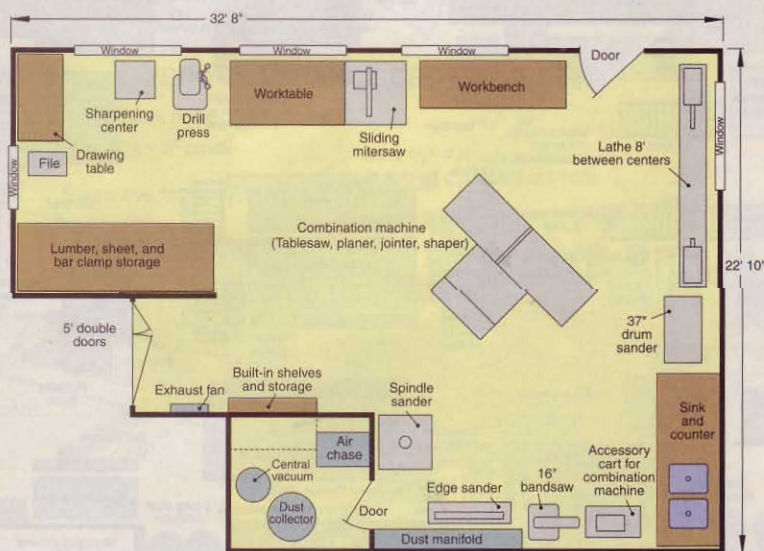

Best Shop Utilizing DeWalt Tools

\$1,000 IN DEWALT TOOLS

Tom Freyer's Phoenix, Arizona, workshop looks like a two-car garage. And when he and his wife, Samantha, bought the home, the garage "was the determining factor," Tom says. But cars aren't allowed here, it's a shop. The overhead doors are long gone, replaced by a wall and double 4'-wide, walk-in doors.

Inside, the shop is bright, with white walls and familiar yellow accents all around. But the yellow wasn't put there to better Tom's chances in the contest, it was there long before. Now retired, Tom spends a lot of time in his shop, and wanted it friendly and welcoming. "Yellow and white are pleasant colors," he says.

Tom likes his yellow shop accents, and his yellow DeWalt tools. "The DeWalt planer is second only to the [table]saw in importance. I designed the cabinet so that the tables fold down when not in use," he says. The planer helps Tom



This portable planer stand is customized down to the outfeed-table color. It's holds one of Tom Freyer's well-loved DeWalt tools.

thickness his stock, and an old model 925 DeWalt radial-arm saw handles crosscutting chores. "You can judge its age by the picture in the manual featuring dad doing the cutting with mom and son bearing their approval. Mom is wearing a frill apron," Tom says.

A DeWalt DW625 router sees action in a shop-built router table and, as Tom says, "the versatility of the [cordless] drill/driver has retired my corded drills."

With \$1,000 worth of new DeWalt tools, Tom may soon be an even bigger fan of yellow.

Best Original Workbench Design

\$1,000 IN DEWALT TOOLS

Like many of us, David Manning of Flushing, Michigan, has to share his shop with a couple of cars. That means mobility and compactness count. David's two-part workbench system provides a great solution.

The rolling bench features a 2"-thick top complete with a shoulder vise and a row of bench dogs. The end opposite the vise houses a router table. Underneath, David stashes his portable planer (on a roll-out shelf), plus has storage for hand and power tools, bits, and accessories of all sorts. Doors keep everything tucked safely away, and the whole bench slips beneath a mitersaw station built along one garage wall. With this setup, David's tools are kept handy, protected, and always ready for action.

Compact storage simplifies garage-shop woodworking for David Manning. The rolling bench has a switched power strip, making it easy to get plugged in.



Best Storage Solution or Organizer for One or More Portable Power Tools

\$1,000 IN DEWALT TOOLS

A shop in a one-car garage provides adequate space for Ron Robinson of Saskatoon, Saskatchewan. The problem was that he spent too much time dragging his tools into position, then storing them when he was done. To make set-up and tear-down a snap, he mounted a slew of benchtop tools on an ingenious mobile workstation.

The unit holds a tablesaw, router table, and compound miter saw, all positioned with their table surfaces at equal heights for stock support. A small drill press and a sanding center store underneath, while bins and drawers hold portable tools and accessories. Ron's workstation also has removable outfeed supports for the tablesaw and miter saw, a miter saw extension fence, and a benchtop he can place over the tablesaw and router table during project assembly or messy work. Leg levelers keep the 6'-long bench in place during use, and retract when he needs to roll it out of the way.



Ron Robinson's shop resides in a 6' mobile bench. It houses a benchtop saw, miter saw, and router table, plus storage for a drill press and portable tools.

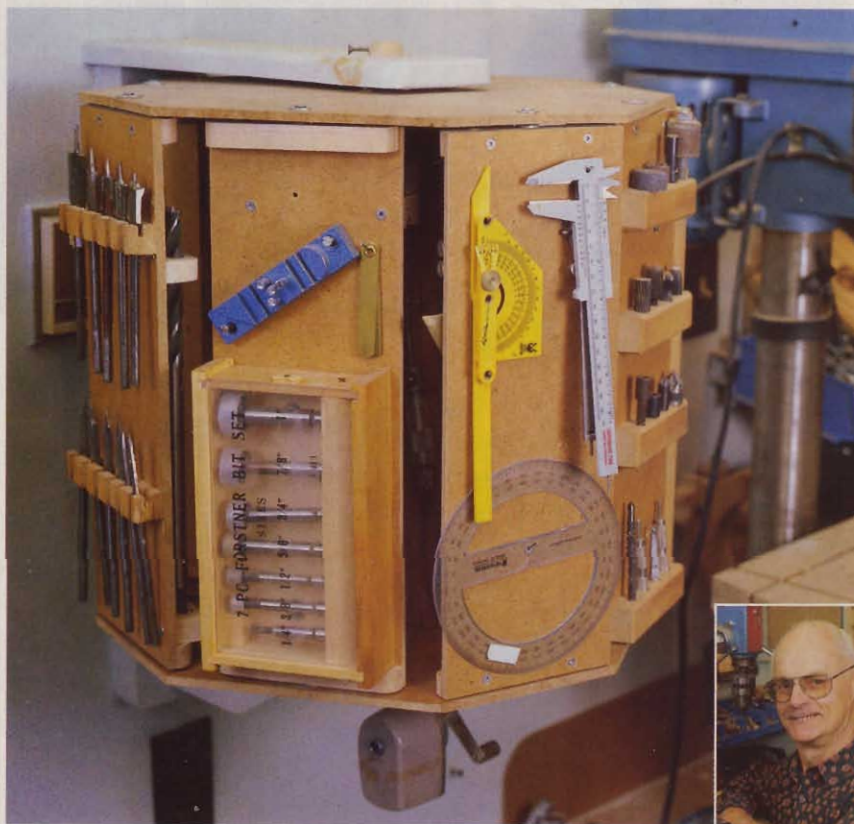

Best Storage Solution or Organizer for Power Tool Accessories (blades, bits, etc.)

\$1,000 IN DEWALT TOOLS

Keeping drill bits close by and protected is easy with this rotating organizer made by Jim Maw of Kleinburg, Ontario. The octagonal, wall-mounted unit rotates on a central column, allowing access to seven tool-and-accessory-filled outer panels. Each panel rotates independently for access to items stored on both sides. One side of the octagon is open so Jim can reach items stored on the central column.

In a space just 16" in diameter and 24" tall, the organizer lets Jim store loads of drill bits; layout tools; screwdrivers; wrenches; and, as he says, "everything but the kitchen sink." We liked the project so much, we'll feature plans for it in an upcoming issue.



Jim Maw's bit and accessory organizer proves that good things come in small packages. Mounted on the wall, it doesn't eat up floor space.



Best Storage Solution or Organizer for Hardware

\$1,000 IN DeWALT TOOLS

Storing all the hardware you need for shop projects and other needs can drive you, well, nuts. Kent Sibley of Keller, Texas had everything from coffee cans to small plastic drawer units, and still had trouble locating the items he needed. To solve the storage problem, he built an open cabinet that holds 16 lidded, plastic organizer trays (made by Zag) he picked up at his local home center.

The carcass and shelves are 1/2" birch plywood joined with simple dadoes. All exposed edges are banded with 3/4" oak for appearance and increased rigidity. Labels on each organizer make it easy to grab the desired tray. In Kent's case, the unit measures 34x41x15", and doubles as a work surface.



Kent Sibley stores hardware in plastic trays, but hated digging through the stack for the one he needed. His cabinet makes each tray easy to retrieve.

Best Original Workshop Safety Idea

\$1,000 IN DeWALT TOOLS

Cutting sheet goods safely on the tablesaw requires sturdy supports. But Ed Bawell of Washington, Pennsylvania, didn't have space to mount large extensions to his saw, and found temporary stands cumbersome. His solution is a pair of saw-mounted supports that slide into position when needed, and tuck out of the way when not in use. One support extends back as an outfeed support for long stock, the other extends to the left of the blade to hold wide sheets.

Each support is made up of two oak runners with a length of PVC pipe mounted in between. The pipe's heights are adjustable to align with the table surface. Ed bent 1/8x3/4" steel strap to make "J" shaped hangers that are bolted to the saw table for the runners to ride on. 🐿

Written by: David Stone

Illustrations: Roxanne LeMoine; Lorna Johnson

Photographs: Baldwin Photography; Kevin O'Connor; Gloria Markel; Terry Zemluch; Lisa Scale; Patty Recca; Sabrina Bawell



Ripping or cross-cutting long stock solo is no problem for Ed Bawell. His shop-built tablesaw extensions are always ready, but retract easily when not needed.

retro TV desk clock



actual size

You don't have to remember black-and-white television to enjoy this clock. The test pattern, rabbit-ear antenna, and retro styling are all you need to take you back to those thrilling days of yesteryear, when a man on a fiery horse and a hearty "Hi-Yo Silver" helped bring truth and justice across the land.

Turn up the tint on your retro TV.

Is clear-finished wood too tame for you? Try coloring the ash body with aniline dye. (Aniline dyes in dozens of colors ranging from flamingo pink to vivid green are available from most woodworking supply catalogs. See the Buying Guide.) Then top coat with spray lacquer. Spray-paint the sides and front panel black. With the finishes dry, use 5-minute epoxy to assemble the parts.

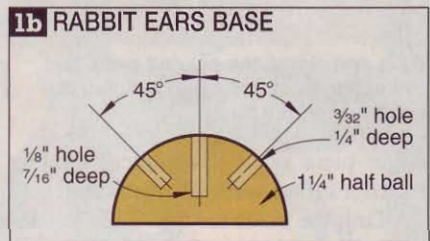
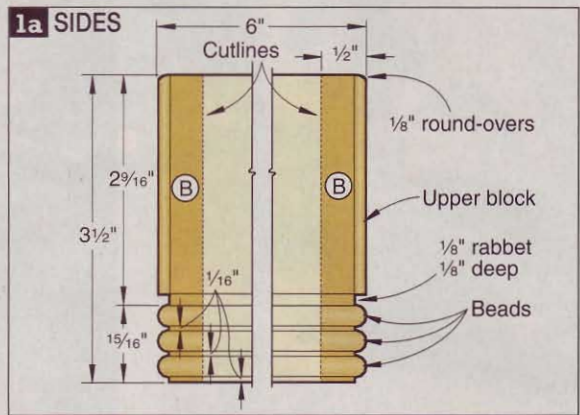
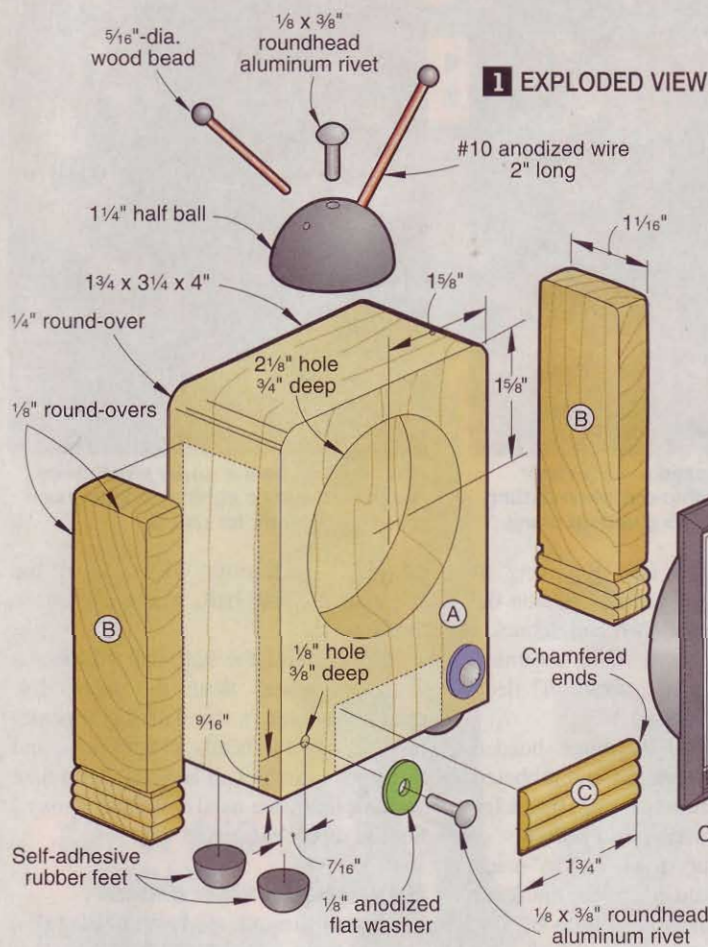

materials list

Part	FINISHED SIZE			Matl.	Qty.
	T	W	L		
A body	1 3/4"	3 1/4"	4"	A	1
B* sides	1/2"	1 1/16"	3 1/2"	W	2
C* front panel	3/16"	1 5/16"	1 3/4"	W	1

*Parts initially cut oversize. See the instructions.

Materials Key: A—ash, W—walnut.

Supplies: Gloss black spray paint, clear satin spray finish, glue, epoxy.

Buying Guide

Hardware. Clock movement, self-adhesive rubber feet (4), 1 1/4" half ball, 5/16" predrilled beads (2), 1/8x3/8" roundhead aluminum rivets (3), #10 anodized aluminum wires (2), 1/8" anodized aluminum flat washers (2). Order kit no. TV, \$18.95 ppd. for one kit or \$79.75 for five kits from Schlaubaugh and Sons Woodworking, 720 14th Street, Kalona, IA 52247, or call 800/346-9663.

Aniline Dye. Call Woodworker's Supply, 800/645-9292 for a catalog.

Note: For the movement, knobs, and rabbit ear parts, see the Buying Guide.

First, make the clock body

1 Cut the clock body (A) to the size listed in the Materials List. We made ours from 1 3/4"-thick stock. You also can glue up thinner stock.

2 Drill a 2 1/8" hole 3/4" deep in the body (A) for the clock insert, where shown on **Drawing 1**. We used a Forstner bit. If you don't have this size bit, cut the hole in a 3/4x3 1/4x4" blank with an adjustable circle cutter. Glue the blank to a slightly

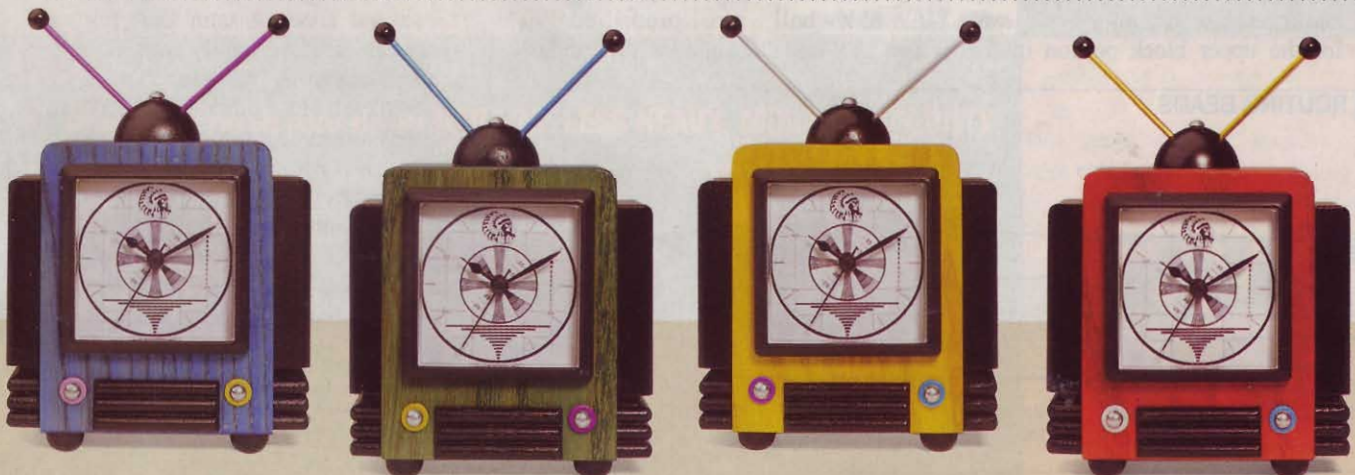



A Glue and clamp the beaded parts and the upper block together, keeping the ends and edges flush.

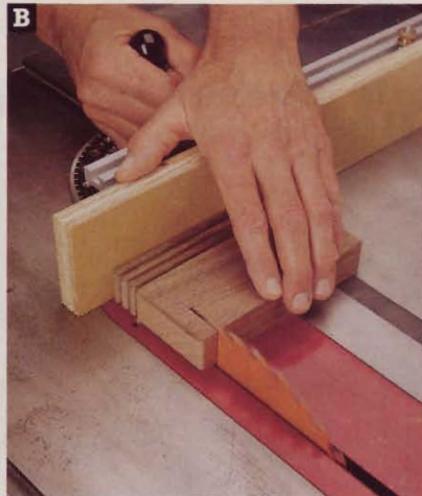

B An extension attached to your miter gauge eliminates chip-out when cutting the sides (B) from the glued-up blank.



C After separating the upper block from the beads, mark a cutline and bandsaw a $\frac{3}{16}$ "-thick blank for part C.

larger piece of 1"-thick stock, sanding the edges flush when the glue dries.

3 Drill the holes for the "volume control" and "channel changer" knobs, where shown on **Drawing 1**.

4 Mark the radii, and round over the top corners of the body (A) on your stationary disc sander. Finish-sand the body to 220 grit.

Now for some bead work

1 To form a blank for the beaded portion of the sides (B) and front panel (C), rip three strips of walnut $\frac{5}{16} \times 1\frac{1}{16} \times 6$ ". Chuck a $\frac{1}{8}$ " round-over bit in your table-mounted router, and rout the strips, where dimensioned on **Drawing 2**. Begin by rounding over the ends, then the edges of one side of all three pieces with the bit set so the round-over comes smoothly to the face of the stock. Then raise the bit $\frac{1}{16}$ " to create a small step below the round-over, turn the pieces over, and rout the remaining edges.

2 Rip a piece of walnut $1\frac{1}{16} \times 2\frac{9}{16} \times 6$ " for the upper block portion of the

blank for the sides (B). Referring to **Drawing 1a**, rout $\frac{1}{8}$ " round-overs on the top and side edges of each end. Chuck a rabbeting bit in your table-mounted router, and rout a $\frac{1}{8}$ " rabbet $\frac{1}{8}$ " deep around the bottom edges.

3 Glue and clamp the three beaded pieces and the rounded and rabbeted upper block together to form a blank for parts B and C, as shown in **Photo A**.

4 When the glue dries, cut $\frac{1}{2}$ "-wide pieces from each end of the blank for the sides (B), as shown in **Photo B**.

5 To make the front panel (C), take the remaining blank from Step 4 and cut the upper block from the beaded portion. Now, slice off a strip of beading about $\frac{3}{16}$ " thick, as shown in **Photo C**. Sand the back flush, then cut part C to length. Sand a slight chamfer on the ends.

Build a pair of rabbit ears

1 From the hardware kit, select the half ball, two predrilled $\frac{5}{16}$ " beads, a $\frac{1}{8} \times \frac{3}{8}$ " aluminum rivet, and two

anodized aluminum wires. Drill the holes in the half ball, where shown on **Drawing 1b**.

2 Spray-paint the half ball and beads gloss black. With the paint dry, epoxy the rivet in the half ball's center hole. Epoxy the beads to the wires, and the wires into the half ball. (To eliminate waiting time, we used 5-minute epoxy.) Set the rabbit ears aside.

Assemble the clock

1 Finish-sand the body (A), sides (B), and front panel (C) to 220 grit. Glue and clamp the sides to the body, where shown on **Drawing 1**. Make sure the bottoms of the sides are flush with the bottom of the body and that the sides are centered front-to-back.

2 Glue and clamp the front panel to the body, keeping it flush at the bottom and centered between the holes for the control knobs.

3 Apply a clear finish. We sprayed on several coats of satin Deft from a spray can, sanding lightly with 320-grit sandpaper after the first coat.

4 Slip each of the other two rivets from the hardware kit through an anodized washer, and epoxy them into the holes on the front of the body. Epoxy the rabbit ears in place.

5 Apply the self-adhesive rubber feet to the bottom of the clock, then insert the clock movement. 🐇

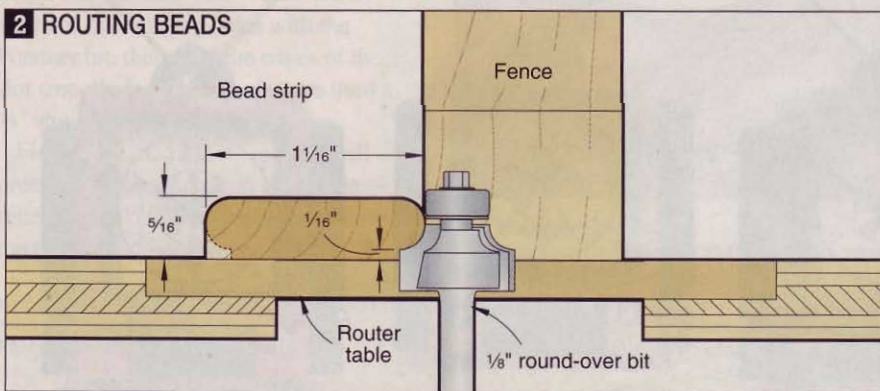

Written by **Jeff Day** with **Kevin Boyle**
Project design: **Schlabaugh and Sons**
Illustrations: **Mike Mittermeier**; **Lorna Johnson**
Photographs: **Baldwin Photography**

ADVERTISEMENT

Announcing the
Better Homes and Gardens®

2002
home
improvement
contest

You could win a share
of more than \$65,000
in cash and prizes!

To find out how to enter,
turn to page 83

Use these co-sponsors' products
in your project and you may
qualify to win special prizes

GOLD CO-SPONSORS



LONG LIVE THE HOME™



DUPONT

STAINMASTER
carpet



Profile

We bring good things to life.

What direction will you go?

KraftMaid
Cabinetry

SILVER CO-SPONSORS

HEAT-N-GLO

Horizons
by Marriott Education Club
OKLANDO

A better place™
LENNOX
HOME COMFORT SYSTEMS

MARVIN
Windows and Doors

MINWAX

short cuts

News and notes from the woodworking world

Distinctly extinct carving

Weekdays, Andy Serafin works in quality assurance for B.F. Goodrich near Seattle. Nights and weekends find him either carving in his home workshop or searching for raw material in the Cascade Mountains. In Andy's case, both of these leisure-time pursuits complement one another in a large way. Why is that?

It turns out that for his carving subjects Andy turns paleontologist and draws upon research to accurately reproduce in wood the skulls of long-extinct dinosaurs. Although he undersizes them, Andy takes pain to make them anatomically correct. He's done that so well that the skulls have been exhibited at a national paleontology convention and at both the Carnegie Museum and the American Museum of Natural History in New York. A 6'-long Tyrannosaurus rex that Andy crafted even shared space with dinosaur models from the popular movie *Jurassic Park* when they were displayed at Seattle's Pacific Science Center.

And although the western red cedar Andy uses for carving stock certainly isn't

rare in the Pacific Northwest, his is indeed special. Andy only carves wood from old-growth trees that he salvages from logged or burned areas. His interest in the extinct prompted his use of endangered old-growth stock.

Live oak for the future

Travel through the Deep South, and you can't help but admire the majestic live oaks you'll see gracing lawns. But 200 years ago, the trees meant much more than landscaping.

When American fighting ships were made of wood, the live oak (*Quercus virginiana*) was a tremendous contributor. Part of a wooden ship's frame were the "knees," the right-angled supports where the deck met the sides. They usually were made of live oak, cut from the junction of a large root with the trunk. This wood's continuous twisted grain proved far stronger than a similar piece cut from a straight timber.

To ensure such valuable wood for the Navy's future use, in 1799 the United States Congress purchased 350 acres of live oak timberland. By 1845, it had obtained and set aside over one-quarter million acres containing these

trees in five southern states. But after 1860, when ships were being fashioned of steel, the government gradually released most of the land for settlement.

However, it retained 30,000 acres of live oaks on the Santa Rosa peninsula near Gulf Breeze, Florida, and they're there today, preserved for continued enjoyment. 🌲



2'-long ceratosaurus skull carved by Andy Serafin

Photograph: Dean's Professional Photography, Inc.

our 2002 home improvement contest

More than \$65,000 in Cash and Prizes Offered!

There's No Better Time to Give Your Home a Fresh New Look. Whether you're redecorating a bedroom or starting a major remodeling job, your home improvement project may win a top award. Plus, your home could be featured in *Better Homes and Gardens*® magazine.

Pick your project

Two categories—
11 Divisions

Category I—Remodeling

Prizes for structural home improvements in each of the following eight divisions:
Exterior Fix-ups ■ Outdoor Improvements ■ Kitchen Shape-ups ■ Bathroom Remodelings ■ Interiors ■ Additions ■ Whole-house Remodelings ■ Restorations

Category II—Decorating

Solely cosmetic changes to your home's interior of the following three divisions:
■ Public rooms: living room, family room, kitchen, dining room, porch, sunroom
■ Private rooms: bedrooms, bathrooms, home offices
■ Whole-house redecorating

Home Improvement Contest

continued from page 83

2002 Awards

Best of Contest: \$10,000 cash plus an 8-day/7-night vacation for four* at Horizons by Marriott Vacation Club in Orlando, Florida. Horizons offers an action-packed and fun-filled vacation experience for the whole family.

*Airfare and meals not included.

Two runners-up: \$5,000 cash

1. Remodeling: Prizes given in each of the eight divisions for: Class A—large projects: \$1,500 ■ Class B—medium projects: \$750 ■ Class C—small projects: \$300. Three merit winners in classes A, B, and C of each division win \$100.

2. Decorating: Three awards in each of the three divisions: First Place: \$1,500 ■ Second Place: \$750 ■ Third Place: \$300

How to Enter

1. Right Now: To receive an official entry packet, call 1-866-509-1690 or mail the form (or a photocopy) below, postmarked by November 1, 2002 or order on line for free at www.bhg.com/hic2002. Get a head start by saving floor plans, before and after photos, and receipts that could help make your project a winner.

2. When Your Project is Finished: Send us the final entry form. All final entries must be postmarked by February 3, 2003.

Entry Judging

Entries will be judged on appearance, function, and cost-effective use of materials. Any home improvement/decorating project completed in 2002 is eligible, no matter how big or small. It's also eligible whether all the work was completed by yourself or by professional contractors. Entrants must be U.S. residents, 18 years of age or older. Judges' decisions are final. Void where prohibited. See page 95 for complete rules.

Winners

Better Homes and Gardens® magazine will select winners on or about June 2, 2003. Winners will be notified by mail. A selection of the top winners will be featured in upcoming issues.

You may qualify to win \$1,000 from each of these co-sponsors when you use their products and services: Ace Hardware ■ Andersen Windows® ■ DuPont Stainmaster® ■ GE Profile Appliances ■ KraftMaid Cabinetry ■ Heat-N-Glo ■ Lennox Industries ■ Marvin Windows and Doors ■ Minwax®

See page 95 for more Home Improvement Contest details, or visit our Web site at www.bhg.com/hic2002

THE OFFICIAL HOME IMPROVEMENT SURVIVAL KIT

presented by our gold co-sponsors:

Ace Hardware
Andersen Windows®
DuPont Stainmaster®
GE Profile Appliances
KraftMaid Cabinetry



Prioritize, organize, and get busy!

The Official Home Improvement Survival Kit will help keep your life in order from start to finish during your remodeling or redecorating project. Carry everything from fabric swatches to paint chips in this sturdy kit with handy pocket folders.

Plus:

You will also receive helpful tips and information from *BH&G* editors for every step of the home improvement process.

Special Offer:

The Home Improvement Survival Kit is just \$19.99 plus shipping and handling. Order information can be found on this page.

Please note: Do not send the Kit with any final entry submissions. Purchase of the Kit does not influence decision of Contest judges.

Better Homes and Gardens® 2002 Home Improvement Contest

Home Improvement Survival Kit and Entry Packet Order Information

Order online: Download the official entry packet, at no cost, at www.bhg.com/hic2002.

Order by phone: Call 1-866-509-1690 and use your MasterCard or Visa.

Order by mail:

- Please send only the official entry packet. Enclosed is a check or money order for \$3.00 for shipping and handling.
- Please send the Home Improvement Survival Kit and an official entry packet. Enclosed is a check or money order for \$23.49 (\$19.99, plus \$3.50 shipping and handling for both the Kit and entry packet).

Send this form to: *Better Homes and Gardens*®, Home Improvement Contest, P.O. Box 36197, Des Moines, IA 50315-0310. Must be postmarked no later than November 1, 2002.

Please print:

Name: _____

Address: _____

City: _____ State: _____ Zip: _____

Allow six to eight weeks for delivery. If ordering only the entry packet, the S&H charge is waived for residents of AZ, MD, CO, CT and VT. Please do not send photos or project plans with this order form. Send only one order form per family. See page 95 for complete rules.

Arts & Crafts furniture plans

The "Showtime Storage" shelving unit featured on *page 46* is the latest addition to a matching set of Arts & Crafts furniture that started with our lamp table/nightstand (issue 108). Since then we've featured a Morris reclining chair (issue 112), coffee table and Ottoman (issue 113), glass-door bookcase (issue 116), set of nesting tables (issue 121), and chair and sofa (issue 129). If you don't have these issues, go to woodstore.woodmall.com/misfur.html where you can purchase downloadable or paper plans for any of the pieces. You'll also see our entire gallery of plans for other Arts & Crafts furniture and accessories. ♣



DREAM MACHINE

PUT YOUR ROUTER IN OUR MACHINE

Check out our demo at www.woodshopdemos.com

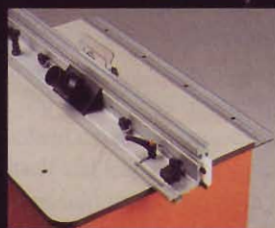

**CMT INDUSTRIO™
PIVOTING FENCE**



**CMT INDUSTRIO™
ROUTING SYSTEM**



**REPLACEABLE ZERO
CLEARANCE INSERTS**

Imagine the ultimate routing system for all your woodworking pleasures. Picture a spacious table top made of solid phenolic that will never warp and will provide you with many years of reliable service. Add on a heavy-duty anodized aluminum fence that pivots in both directions and makes set-ups fast and easy. Yes, and a split sub-fence with zero clearance inserts made of slick UHMW that your prized wood glides across almost effortlessly. Imagine your shop with CMT's New Industrio™ Routing System designed by Marc Sommerfeld. This system will make all your routing dreams real!

MADE IN ITALY

Router, feather boards, dust hose and denim shirt not included.

CMT

the only ORANGE one™

CMT USA, Inc. • 307-F Pomona Drive • Greensboro, NC 27407 • 888-268-2487
Check out our NEW website at www.cmtusa.com

showtime storage

Continued from page 51

Make two copies of this full-size pattern, and trim them to the $3\frac{7}{8}$ " width. Then cut the patterns apart between the center break lines. Use spray adhesive to adhere the patterns to the side panels. Position the tops of the I-shape cutouts $4\frac{1}{2}$ " from the panels' top edges, and the bottoms of the cutouts $4\frac{1}{2}$ " from the panels' bottom edges, as indicated on the patterns.

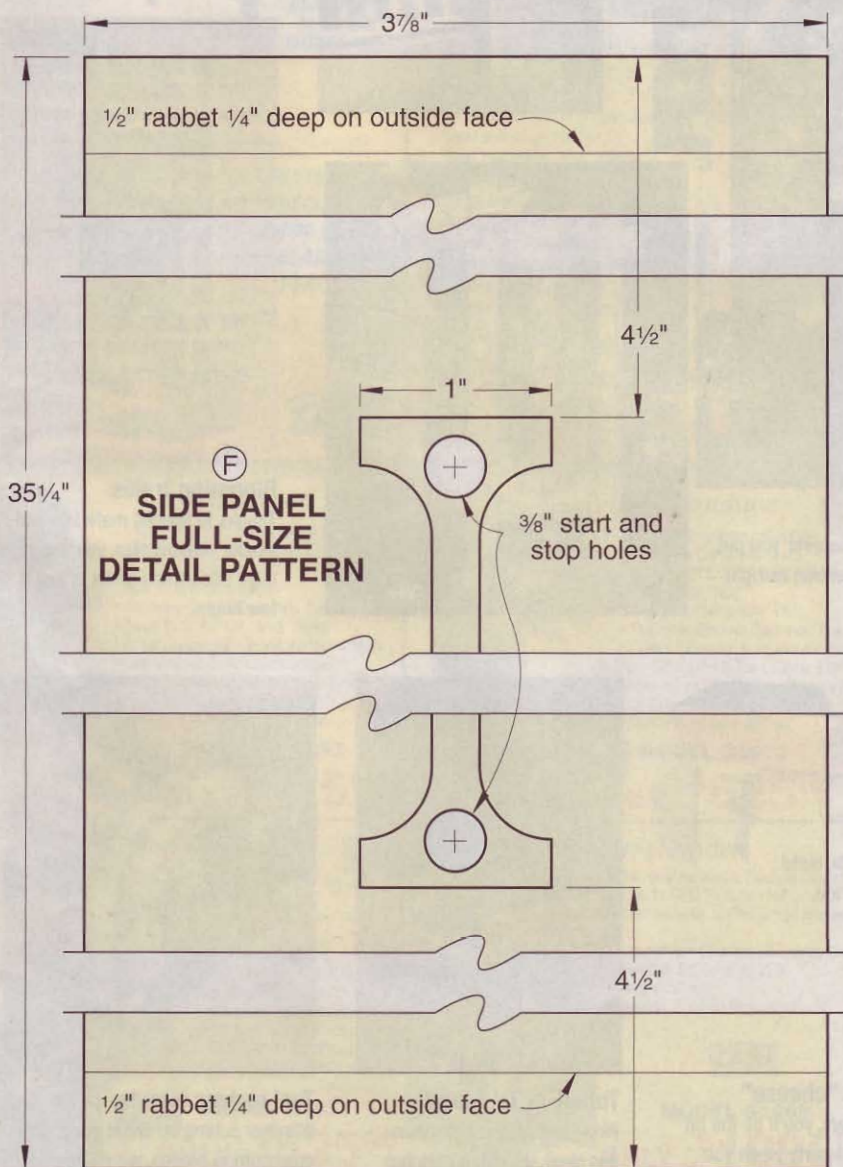

Better Homes and Gardens® 2002 Home Improvement Contest

OFFICIAL ENTRY RULES

NO PURCHASE NECESSARY TO ENTER OR WIN.

1. This contest is open to U.S. residents, 18 years of age or older who are homeowners of the property entered, except employees and their immediate families of Meredith Corporation, co-sponsors and their affiliates, subsidiaries, and advertising agencies. Preliminary entry blank must be postmarked by November 1, 2002, and received by December 2, 2002. Final entry form must be postmarked by February 3, 2003, and received by February 28, 2003. Final entry must include photos of project, written description of objectives, receipts for co-sponsor prizes, and floor plans (if applicable). Meredith Corporation not responsible for lost, late, misdirected, or illegible entries. 2. You may enter more than one project in the contest, but not the same project in two different categories. Projects may be do-it-yourself and/or those completed by professional contractors/architects/designers. Each project may be entered by only one person. Projects must be completed in 2002. 3. Entries will be judged on appearance, function, and cost-effective use of materials. In case of a tie, the entry with the highest score on appearance will be awarded the prize. Judging will be under the direction of *Better Homes and Gardens*® magazine. Co-sponsor awards are also judged by representatives of the co-sponsor. Decisions of judges are final. All winners except for co-sponsor awards will be chosen on or about June 2, 2003. Co-sponsor winners will be selected by August 1, 2003. Winners will be notified by mail. Winners will be required to sign an Affidavit of Eligibility, Assignment and a Release of Liability within ten days of notification or a new winner may be chosen. Travel companions of Grand Prize winner will be required to sign a release. 4. PRIZES: One Grand Prize includes \$10,000, plus an 8-Day Vacation for four at the Horizons by Marriott Vacation Club Orlando, FL, 7 nights lodging. Accommodations subject to advance notice, space availability, and black-out dates. Trip must be taken within one year from date of awarding. All other expenses not listed, including airfare, are the responsibility of the winner. Approximate retail value \$2,000. Eight Class A/Three First Place winners will receive \$1,500 each; Eight Class B/Three Second Place winners \$750 each; Eight Class C/Three Third Place winners \$300 each; 72 merit winners will receive \$100 each. 5. For a list of prize winners (available after August 1, 2003), send a separate self-addressed, stamped envelope to *Better Homes and Gardens*® Home Improvement Contest Winners' List, LS-253, 1716 Locust Street, Des Moines, Iowa 50309-3023. 6. Entries and entry materials become the property of Meredith Corporation and will not be returned. By acceptance of prize, winners agree that all rights, including copyright, in all entry materials, are assigned to Meredith Corporation. Submission of entry constitutes permission to use winner's name, hometown, likeness, and information regarding entrant, his/her family, and property by Meredith Corporation and co-sponsors in promotion of the contest, unless prohibited by law. The project submitted cannot have been previously published or photographed by, or committed to publication, in any other magazine or medium. 7. Contest is subject to all federal, state and local laws and regulations. All liability for federal, state, and other taxes are the sole responsibility of each winner. This contest is void where prohibited by law. Residents of AZ, CO, MD, CT, and VT are not eligible to win co-sponsor awards. No prize transfer or substitution. 8. PLEASE DO NOT SEND PHOTOS OR PROJECT PLANS WITH THE PRELIMINARY ENTRY FORM. SEND ONLY ONE PRELIMINARY ENTRY BLANK PER PROJECT. 🏠

what's ahead

in our next issue

With spring right around the corner, we designed a bevy of projects for your outdoor living areas.



Pair of showy pergolas

These versatile outdoor structures add shade and class wherever you put them—deck, patio, lawn, or garden. The smaller, painted version at *right* accommodates a comfy swinging bench.



Planter boxes with railing

Want to add lasting beauty to your existing deck? Just replace that plain-Jane railing with this system. It's made entirely of materials impervious to the elements.



Blooming trellis

Thanks to special materials and simple construction, you can build this stylish trellis in just a few hours.



Rubber-band runabout

Treat a youngster with this sleek and functional speedboat. Or, build one for yourself—it looks good enough to just sit on a shelf, too.



Say "cheese"

Turners, you'll be the hit of the party when you show off this cheese tray with glass dome.



Tuned-in TV Stand

Wood and glass combine in this sleek design. It matches the futon in issue 139 and an upcoming shelving unit.



Tool review: circular saws

Whether cutting up sheet goods or crosscutting boards, we all need a circular saw from time to time. We'll tell you which models make the cut.