

Better Homes and Gardens®

WOOD

November 2001
ISSUE 137

Tips, Tools, Techniques, and Projects for Woodworkers

we test the best
cordless kits

PLUS
17
SHOP-TESTED
TIPS

High-styled
entertainment
center

Great Gifts...

- **booklike keepsake box**
- **holiday candy dish**

www.woodonline.com

Display until November 6, 2001



contents

WOOD® magazine

November 2001, Issue 137



70

projects & techniques

- 44 divide and conquer with style**
Separate living spaces with showy, lighted, display cabinets.
- 54 create architectural art**
Partition rooms with pleasing columns and arches for a fresh open look. We'll guide you step by step.
- 66 a novel box**
Store photos or other favorite keepsakes in this booklike box.
- 70 entertainment center/armoire**
Build this handsome cabinet to store electronic components or clothing. We cover both options.
- 86 a bright idea for turners**
Add cheer to your holidays with this novelty turning. It's a decorative Christmas light that doubles as a lidded candy container.

Cover Photo: Baldwin Photography



86



54

44



66

contents

November 2001, Issue 137

tools & materials

- 60 dynamic duos**
See which cordless circ saw and drill kits get top honors in our test.

features

- 80 double take on woodworking**
Travel to Santa Cruz, California, to learn a few tricks from furnituremaking twins Christian and Robert Meier.
- 84 what makes wood beautiful?**
Color, luster, texture, and figure—all of these give a board its good looks.

departments

- 6 editor's angle**
- 8 talking back**
- 16 wood online®**
- 20 great ideas: bandsaw guide**
Correct blade drift by resawing with this adjustable jig.
- 22 talking shop: veneered tubing**
Use this hollow wood product for columns, kaleidoscopes, fly rod cases, and more.
- 24 ask wood**
- 30 cordless breakthrough**
Would you believe a battery-powered router? It's true.
- 32 shop tips**
- 92 products that perform**
- 103 what's ahead in our next issue**

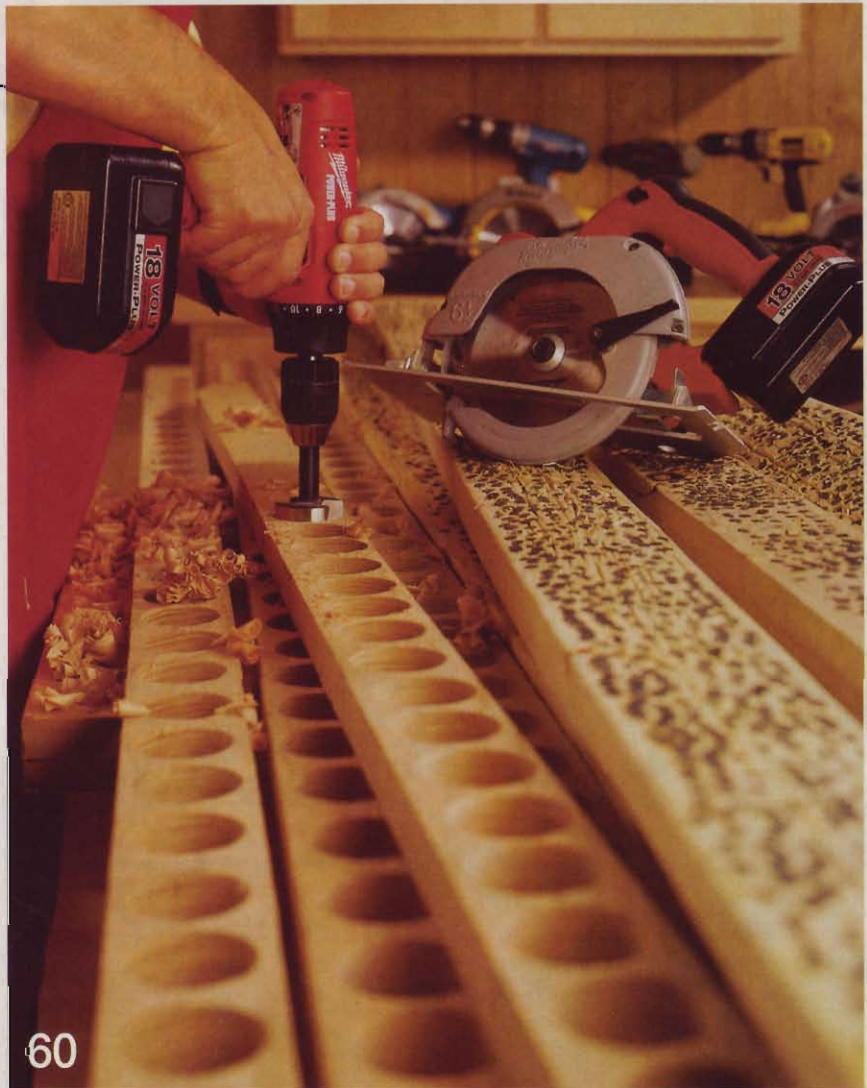

Better Homes and Gardens® WOOD® magazine (ISSN-0743-894X) is published nine times a year in February, March, April, May/June, July/August, September, October, November, and December by Meredith Corporation, 1716 Locust St., Des Moines, IA 50309-3023. Periodicals postage paid at Des Moines, Iowa, and additional mailing offices. Better Homes and Gardens trademark registered in Canada and Australia. Marca Registrada en México. **ONE-YEAR SUBSCRIPTION PRICES:** U.S. and its possessions, \$28; Canada, \$41; other countries, \$49. Canada Post Publications Mail Sales Product Agreement No. 40049562. Canadian BN 12348 2887RT. **CANADIAN RETURN ADDRESS:** Better Homes and Gardens WOOD magazine, 2744 Edna Street, Windsor, Ontario, N8Y 1V2. **POSTMASTER:** Send address changes to Better Homes and Gardens WOOD magazine, P.O. Box 37439, Boone, IA 50037-0439.

editor's angle

smart design— it's a labor of love

When asked what he considered to be his masterpiece, the famous designer and architect Frank Lloyd Wright often replied "The next one." And that, in three words, sums up how we approach the conception and design of the projects you find in *WOOD* magazine. No matter how good the projects were in past issues, we expect the next ones to be even better.

Fortunately, our talented staff of project designers is always up to the task. Issue after issue, they never fail to impress me with their creativity and resourcefulness.

Like real pros, they make project creation look easy. It's anything but that.

The design process begins with just an idea for a type of project. Through research, reader feedback, and simple instinct, we'll pinpoint a particular project, say a toolbox, for an upcoming issue. We do this up to a year or more before you see the project in the magazine. During that interval, the designers step in. It's up to them to turn that idea into a project you'll get excited about.

Typically, they come up with several concept drawings like the ones above. Then, everyone involved in the project design, building, and editing process meets to discuss the merits of each concept. This is where the designers need to have a thick skin, and they do.

We dissect each concept, determining which one functions best and has the most aesthetic appeal. Questions that need answers include: What's the best joinery? Does the project lend itself to teaching new tips and techniques? Are we making efficient use of materials? What wood is

best? Sometimes, the result of that meeting is a design combining elements of the various concepts.

Next, the designers produce a set of computer-generated drawings that go to the *WOOD* magazine shop. There, we prove the design by building the project. And we sometimes do that more than once, just to get everything right.

A new face on the staff

I chose the toolbox example for a reason. It was the first assignment we gave to the newest member of our design team, Kent Welsh, the fellow shown at right. Kent began his career doing cabinetry and finish carpentry, then managed a woodworking store. Following that, he spent the past nine years designing projects for *Shop Notes*, *Woodsmith*, and *Workbench* magazines. Kent's a talented designer and builder, and I think you'll appreciate his extensive background and creativity in the projects you'll find in upcoming issues.

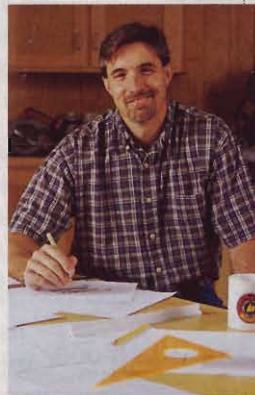

Bill Krier

Better Homes and Gardens®

WOOD®

November 2001 • Vol. 18, No. 8 • Issue No. 137

Editor-in-Chief **BILL KRIER**
 Executive Editor **JIM HARROLD**
 Managing Editor **MARLEN KEMMET**
 Products Editor **DAVE CAMPBELL**
 Projects Editor **JAN HALE SVEC**
 Projects Editor **DAVID STONE**
 Techniques Editor **JIM POLLOCK**
 Design Editor **KEVIN BOYLE**
 Design Editor **KENT WELSH**
 Master Craftsman **CHARLES I. HEDLUND**
 Production/Office Manager **MARGARET CLOSNER**
 Administrative Assistant **SHERYL MUNYON**
 Illustrators **LORNA JOHNSON, ROXANNE LeMOINE, TIM CAHILL, MIKE MITTERMEIER**
 Contributing Photographer **MARTY BALDWIN**
 Technical Consultants **RICH BRIGHT, JEFF HALL, KIRK HESSE, GARRY SMITH**
 Contributing Craftsman **JIM HEAVEY**
 Proofreader **JIM SANDERS**

Art Director **TIM ALEXANDER**
 Associate Art Director **JOHN MEEK**
 Assistant Art Director **CHERYL A. CIBULA**

Publisher **MARK HAGEN**

Advertising Office: 333 N. Michigan Ave., Suite 1500, Chicago, IL 60601 Phone: 312/853-2890 FAX: 312/580-7906

Mail Response Manager **CAROLYN DAKIS**
 Account Executive **RON GOLMINAS**
 Account Executive **NEIL KIRBY**
 Account Executive **JOHN THORNBURGH**
 (Detroit 248/356-1149)

Sales Assistant **THERESA COOKS**
 Southeast: Lagomarsino, Dempsey & Dennis, Inc.
 2951 Piedmont Rd., NE, Suite 100, Atlanta, GA 30305
 Phone: 404/261-5400 FAX: 404/261-5404

Group Publisher **STEPHEN B. LEVINSON**

Associate Business Director **CRAIG FEAR**
 Senior Product Manager **RICK GROW**
 Advertising Services Manager **PAT HENDERSHOTT**
 Consumer Marketing Director **KATHI HRIEN**
 Consumer Marketing Manager **DAVE ONOLD**

Vice President/Publishing Director **WILLIAM R. REED**

MEREDITH PUBLISHING GROUP

President **STEPHEN M. LACY**
 Magazine Group President **JERRY KAPLAN**
 Group Sales **MICHAEL BROWNSTEIN**
 Creative Services **ELLEN DELATHOUDER**
 Business Development **TINA GEORGEOU**
 Manufacturing **BRUCE HESTON**
 Consumer Marketing **KARLA JEFFRIES**
 Finance and Administration **MAX RUNCIMAN**



WILLIAM T. KERR, President and Chief Executive Officer

E.T. MEREDITH III, Chairman of the Executive Committee

©Copyright Meredith Corporation 2001
 All rights reserved. Printed in the U.S.A.

Customer Service Information: For service on your subscription, including change of address, contact us at www.woodmagazine.com/service or call 800/374-9663. **Subscription mailing address:** Better Homes and Gardens WOOD magazine, P.O. Box 37439, Boone, IA 50037-0439. Please enclose your address label from a recent issue. **Editorial mailing address:** The Editor, WOOD magazine, 1716 Locust Street, GA310, Des Moines, IA 50309-3023. For questions on editorial, questions about how to reach an advertiser, or to place an advertisement in our magazine call 800/374-9663. **To order back issues** call 800/346-9663. Article reprints, send \$5 per article (no phone orders), include issue and name of article, to WOOD Article Reprint Service, P.O. Box 349, Kalona, IA 52247, check or money order made payable to WOOD magazine.



talking back

Our bulletin board for letters, comments, and timely updates

Wood details warm up spaces

We came across the following thoughts in a newsletter from Susan Regan, executive vice president of the Hardwood Information Center. They sum up the philosophy of WOOD® magazine's new Handcrafted Home section so well that we'd like to pass them on. She writes:

"Architect Sarah Susanka urges her clients to ask themselves, 'Do we want a bigger house or a better house? An awful lot of people are building more space than they can use. The space that they do use ends up being very bland. It has no personality.'

"Susanka believes in investing more in good design, fine materials, details and craftsmanship, and less on the kind of cavernous, impersonal space characteristic of the 'McMansions' sprouting up in

suburbs. 'What defines the character of a house is the details, such as a beautiful stair railing, well-crafted mouldings around windows and doors, and useful, finely tailored built-ins,' she says."

We couldn't agree more with Susanka's comments, and we thank Regan for sharing them. There is no better material than wood to give a home character and personality, making it feel warm, welcoming, and inviting.

The Hardwood Information Center, a service of the Hardwood Manufacturers Association, is a source of non-commercial information about hardwoods, hardwood furniture, flooring, cabinetry, and decorative millwork. You can visit the web site at www.hardwoodinfo.com, or call its Hardwood Helpline at 800/373-WOOD. Susan Susanka is the author of "The Not So Big House," a best-selling book available from amazon.com.

The right classification for fungi

As an avid woodworker and a microbiologist, I noted that fungi were referred to as "simple plants" in the article "Decay—how it works and ways to foil it" in issue 131. As stated, fungi lack chlorophyll, but they are classified along with bacteria as microorganisms, not as plants. To me, this misclassification is like calling white pine a hardwood species. You are entire-

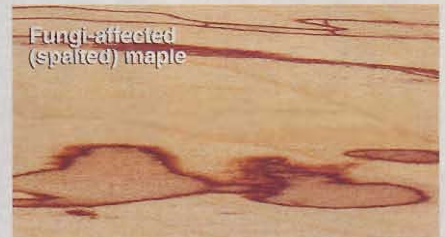

ly correct to identify fungi as the workhorse of wood decay. Many fungi contain enzymes that are able to break down lignin, a major component of wood that is fairly resistant to decay.

—Mark Strynar, Port Matilda, Pa.

Plastic rescues unusable burls

Your WOOD Forum piece in issue 130 on harvesting burls moved me to write about a coffee table I made from a cracked and deteriorated burl slab. I saved what probably would have been judged a worthless piece of firewood by filling its voids with clear polyester casting resin. Available at craft-supply stores under such brand names as Decapour, Craft-Cote, and Crystal-Sheen, they are two-part liquids that, when mixed, harden into clear plastic.

The slab I used measured 36" in diameter and 3" thick with many holes that went all the way through. After covering the holes on the bottom surface with masking tape, I poured in the resin, grad-

Continued on page 12



ually filling the holes over a period of days. I sanded the top and bottom smooth, then recoated the surfaces with more resin. In places, you can see right through the table.

For legs, I rough-turned some dry, but badly cracked firewood logs to within 1/2" of their final diameter, then filled the cracks with resin. With the resin cured, I finished the turnings. The cracks are fully visible, but completely filled with clear plastic.

Use this same method when working with knotty material. Simply pour the resin around the knot. When it cures, the knot will never loosen. Sanding the resin clouds the surface, but this disappears when a clear finish is applied.

—Howard Clements, Knox, Pa.

The many benefits of planting a tree

Thanks so much for featuring The National Arbor Day Foundation in the article, "Help for fire-ravaged forests" in *Finishing Touches* in issue 132.

Trees have a huge impact on the quality of the environment and on people's quality of life. They help clean the air, moderate temperatures, conserve energy, and provide wildlife habitat. Trees beautify our homes and neighborhoods, increase property values, conserve the soil, and help keep rivers and streams running clean.

Planting trees is something that everyone can do to make a positive contribution to a better future. Carrying information about the foundation's programs



makes it possible for your readers to become personally involved in this meaningful activity.

—Gary Brienzo, information coordinator,
the National Arbor Day Foundation

Foot lever enhances mortising on router table

I liked the looks of the All-Purpose Router Station in issue 129 so I built one for my shop. By adding an L-shaped foot lever (as shown in the photos and drawings), I can now form mortises by plunging the router bit into the workpiece rather than having to plunge the workpiece onto the bit. This machine works better than my hollow chisel mortiser.

To prevent it from flexing, the upright part of the lever that pushes

against the router is reinforced with two ribs. It is long enough to accommodate the router's vertical adjustment, and has a hole at the top for ventilation. To find the exact configuration for the triangular gusset at the bottom, hinge the upright arm to the leg stand's rear rail. Lock your router in the full-plunge posi-

tion, and temporarily tape the upright to it. Hold the flat plywood part of the horizontal portion of the lever in place, keeping its front end 1 1/2" off the floor. Measure the angle, and cut your triangle. Glue and screw the lever parts together.

—Louis Stephan, Greenwood, Ind.

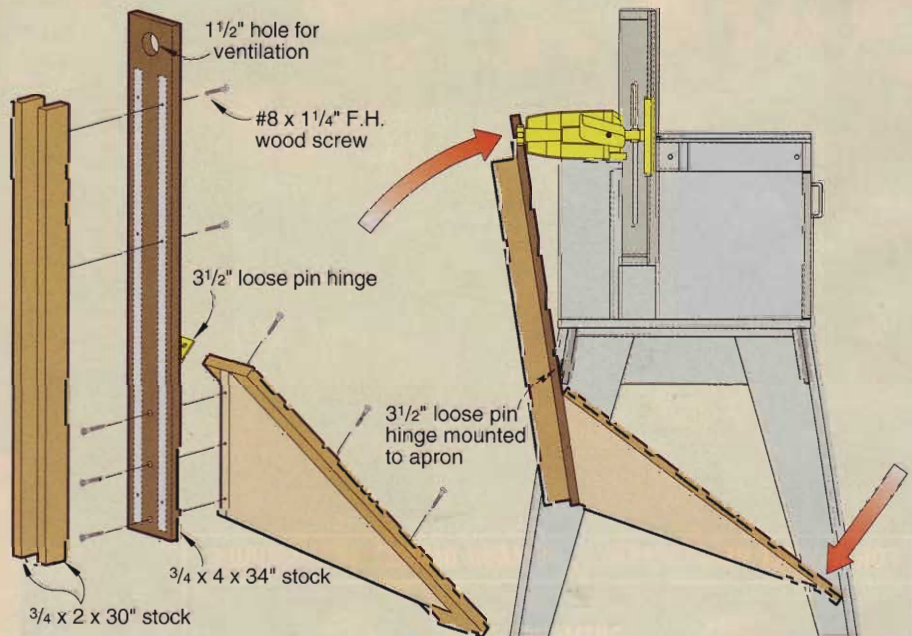

Continued on page 14

The Selection is Huge.

We Built a Porter-Cable Store to Show it all.

See the complete line-up of Porter-Cable products in the new Porter-Cable store. Over 1,000 items including pneumatics and cordless tools to the hard-to-find woodworking accessories. See the entire fleet of this year's new Porter-Cable products at the store that has it all.



Visit the Porter-Cable store at
[www.amazon.com/
portercable](http://www.amazon.com/portercable)

Call for your FREE Tool Crib catalog
1-800-635-5140

routers sanders cordless tools
generators the Porter-Cable store
nailers & staplers air compressors

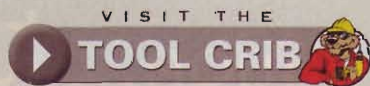

talking back

U P D A T E

Black & Decker, DeWalt battery chargers recalled

In cooperation with the U.S. Consumer Product Safety Commission, DeWalt Industrial Tool Company is voluntarily recalling for replacement DeWalt models DW9107 and DW9108 and Black & Decker Industrial and Construction models 97015 and 97016 power tool battery chargers. The chargers have date codes 9616 through 9752 located on their bottoms. They were sold either separately or with tools from May 1996 through August 2000.

These chargers can fail to automatically shut off after the battery is fully charged. This condition can cause the battery to burst, and poses fire, burn, and electrical shock hazards.

In addition, DeWalt model DW9116 chargers are being recalled for repair. These chargers have date codes, also on their bottoms, 9927EM through 9952EM and 0001EM through 0031EM. They were sold either separately or with tools from September 1999 through August 2000. Metal clips inside these chargers could come loose, stick through the charger's vents, and pose an electrical shock hazard.

Consumers should stop using these chargers immediately and take them to a DeWalt or Black & Decker service center for free replacement or free repair. To locate a service center or for more information, call DeWalt toll-free at 866/543-3401 between 8 a.m. and 4:30 p.m. ET Monday through Friday, or go to the service center locator at www.dewalt.com.

For a great shine, try toothpaste

For years, I've used a wet-sanding technique similar to the one you describe in Develop Your Shop Skills in issue 124. For a professional-looking finish I have not found anything that works better. For the final polish, I routinely use toothpaste and a few drops of distilled water. Toothpaste contains an ultra-fine abrasive grit and surfactants, both of which aid in obtaining a high gloss.

—Ramon Stoner, Villa Park, Ill.



Look to the links to drive really long holes

In WOOD Forum, issue 131, a reader was looking for a bit to drill holes in 34"-tall lamp bases. Long drill bits are used in golf club building and repair. Ralph Maltby's GolfWorks, 4820 Jacksontown Road, P.O. Box 3008, Newark, OH 43058-3008 sells a 7/32"x47" high-speed bit for \$17.50. Order catalog no. D4732 or call 800/848-8358.

—James Jansma, Hudsonville, Mich.

We found that a 7/32" hole is large enough for standard #18-2 lamp cord. You'll have to back the bit out of the hole often to clear the flutes. Then bore out the top few inches and epoxy in a standard lamp nipple for attaching the harp and socket.

Write Us!

Do you have comments, criticisms, suggestions, or maybe even a compliment specifically relating to an article that appeared in WOOD® magazine? Please write to:

Talking Back
WOOD magazine
1716 Locust St., GA310
Des Moines, IA 50309-3023

or e-mail us at talkingback@mdp.com.
Due to the volume of letters and e-mails we receive, we only can respond to and publish those of the greatest interest to our readers.



wood online®

How you benefit by going to www.woodonline.com

What's new for you at WOOD ONLINE®? Get the latest information

More than 55,000 woodworkers can't be wrong. That's how many folks subscribe to our free biweekly e-mail newsletter. Do they know something you don't? With all the valuable new information constantly being added to WOOD ONLINE, they most certainly could! But we'll have you up to speed in no time. And our "information—not sales hype" approach is a welcome breath of fresh air.

We invite you to review our latest issue at www.woodmagazine.com/newsletter/ and see what we mean.

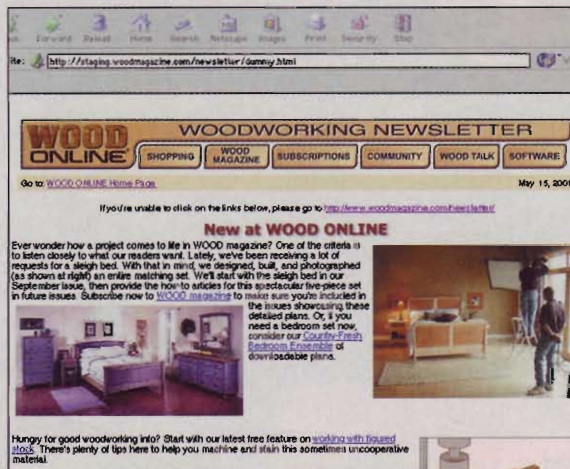

Tons of free stuff coming at you

Want "why didn't I think of that" woodworking tips? How about the latest news on manufacturers' special tool pricing? Throw in monthly product giveaways, skill-building seminars, downloadable woodworking plans, and, well, you get the idea. Those are just a few of the freebies you'll find day in and day out on WOOD ONLINE. And we add new ones every two weeks.

Don't wait a minute more! Go to www.woodonline.com, and click on the "Become a Member of WOOD ONLINE!" box at the top of the left-hand navigation bar.

- SHOPPING
- WOOD MAGAZINE
- SUBSCRIPTIONS
- WOOD TALK
- COMMUNITY
- SOFTWARE

Search our site: GO

Tip of the Day

The original "band" clamp

Although it's fairly routine to glue flat surfaces, you find it difficult to get even pressure on round, irregular, or otherwise out-of-the-ordinary surfaces.

TIP: For less than \$2 at most office supply stores, you can purchase an ordinary 1/2-lb. box of no. 107 rubber bands. The bands, which measure 1/16" thick, 5/8" wide, and 7" long before stretching, make great clamps. Smaller bands also can be useful in the shop. The glue pops off easily, and they never rust. (By the way, the bands will last a lot longer if you store them in a cool, dark drawer.)

—Mike Locke, Long Beach, Calif.

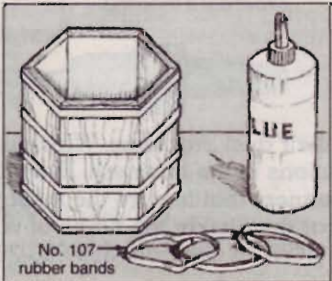

No. 107 rubber bands

WOOD STORE® affiliate program

Become a WOOD STORE® affiliate and make extra cash

Do you have an established woodworking or DIY Web site? Does it generate consistent, enthusiastic traffic? Then why not use it to generate some extra cash, too, by letting it showcase and promote the WOOD STORE®. Simply post images of the project plans we offer for sale. When your site visitor clicks on one of them, he's taken directly to the store. And if he purchases any of the 250-plus shop-proven products offered there, you earn an automatic 15 percent commission on every sale. Simply go to www.woodmagazine.com/affiliate/ for complete details.

But don't take our word for it...

"I have recently resubscribed to WOOD® magazine after an absence of several years and subscribed to your online newsletter. My initial reaction was that this was just another way to tout the different articles. But after visiting several of the links, I realized just how much the newsletter will simplify my woodworking. Not only does it allow me to print a specific article to file in a notebook, but I also can give each one a different name and store it in my computer. Your newsletter goes way beyond most I've seen. My only regret is that I didn't take advantage of it sooner."

—Terry Parker, Lakeland, Fla.

Thanks, Terry! We couldn't have said it better. We pride ourselves on the numerous free projects and features linked from each newsletter. Enjoy!

Marlen Kemmet
WOOD ONLINE Manager

fully adjustable bandsaw resawing guide

This resawing guide lets you correct for blade drift, and you can build it from parts you probably have lying around your shop.

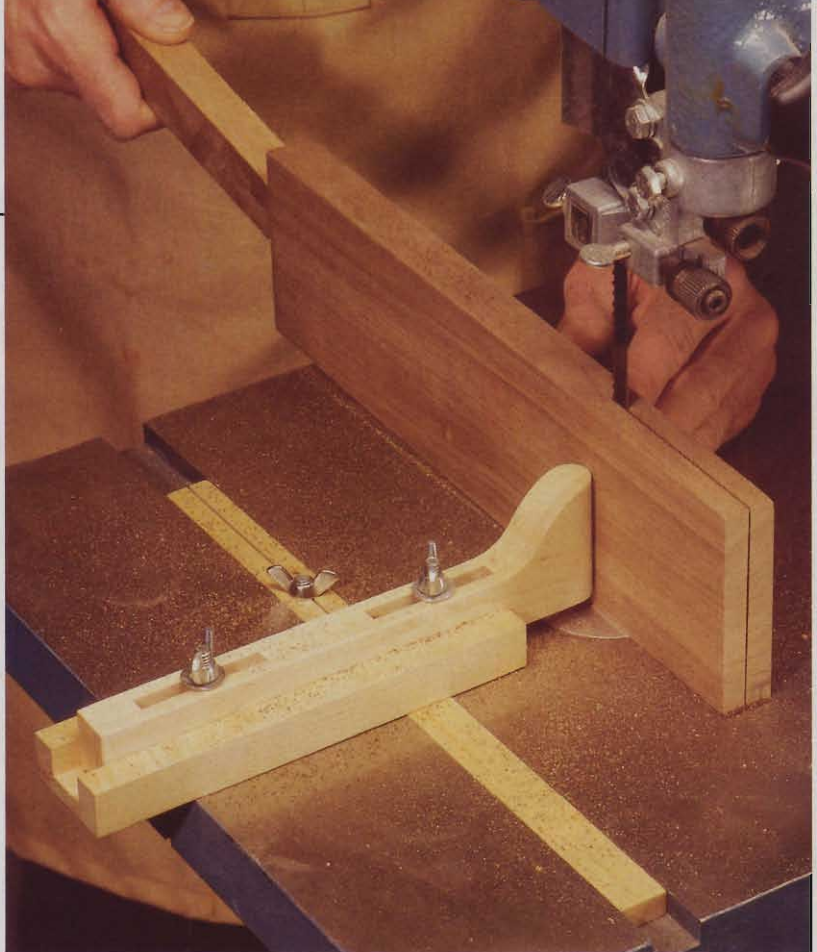

After struggling with his bandsaw fence, blocks, clamps, and a resaw guide, *WOOD*® magazine reader John Hodges of Kaufman, Texas, decided to design his own bandsaw resawing guide. You can build one just like it by gathering up some scrap stock and following the illustrations at right.

To use this guide, first mark a line along the top edge of the piece to be resawn. Adjust the center portion of the jig (A) until the bandsaw blade aligns with the marked line on the wood. Tighten the wing nuts that hold A securely to B. Tighten the wing nut in part C to secure it in the miter-gauge slot.

Because few bandsaw blades track perfectly straight (making a fence almost useless for resawing), the curved end of part A allows you to steer the board into the bandsaw blade and make adjustments to follow your marked line. We recommend using a 1/2"- to 3/4"-wide skip-tooth or hook-tooth blade for cleaner cuts. And, always use a pushstick for safety when resawing on a bandsaw. 🌲

Written by Tom Jackson
Illustrations: Kim Downing
Photograph: Hetherington Photography

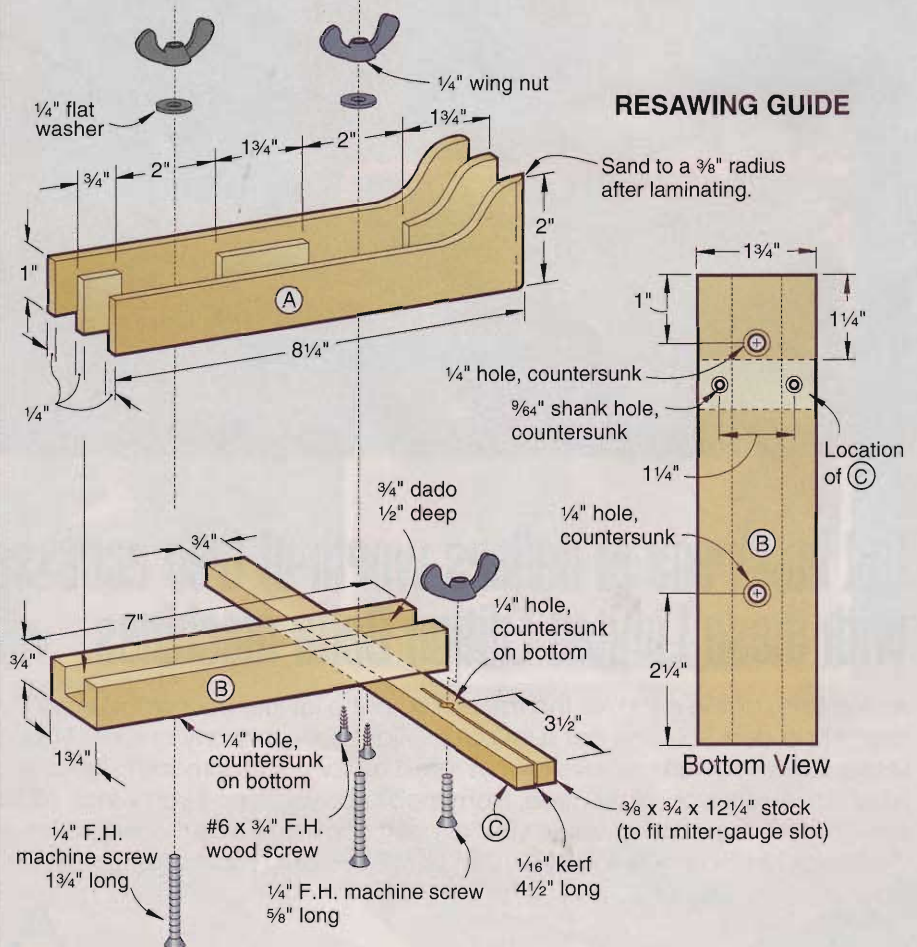

veneer in the round

What you need to know about working with Hollowood tubes

During the design stages of our room divider, featuring the arch and columns on *page 44*, we learned of a wood product that proved perfect for our columns. It was strong but light, and it matched the surrounding cherry cabinets. From the point of constructing columns from scratch, this substitute saved us time and money.

Called Hollowood by California manufacturer BrandNew, this veneered tubing consists of thin, bonded plies of poplar measuring anywhere from $\frac{1}{50}$ to $\frac{1}{16}$ " thick. Strong, waterproof, polyester resin adheres the plies together, creating a tube wall of $\frac{1}{8}$ to $\frac{1}{4}$ " thickness. The outside is wrapped with a $\frac{1}{32}$ " veneer of exotic or domestic hardwood.

The long and short of Hollowood

As cited in our story on arches and columns, we went with 6" diameter columns, but Hollowood comes in a variety of diameters, from 1 to 18". You can purchase tubes under 4½" diameter by the foot; you'll need to purchase tubes in 8' lengths for any order over that diameter. BrandNew offers more than 17 veneers, with prices varying according to tube diameters and veneer species. For instance, a 1"-diameter tube of maple costs \$4.17 per running foot; by contrast, a 1"-diameter tube of the exotic hardwood rosewood brings \$6.63 per foot. These prices don't include shipping. Still, you could not make a column for that money.

Idea starters

Though we used Hollowood in an architectural column application, there's no end to its uses. Some projects include bird houses, humidors, kaleidoscopes, furniture legs, drums, desk accessories, fly rod cases, kitchen canisters, and telescopes.

Making Hollowood work for you

To machine Hollowood, our builder Doug Guyer discovered a few secrets worth passing along. "When sawing the tubing, run tape around the perimeter where you have your cutline. Scribe your cutline on the tape. This will prevent chip-out.

"Also," Doug says, "make your cuts on a tablesaw, using a triple-chip blade with a 7° to 10° sawtooth bevel. Raise the blade $\frac{1}{8}$ " to $\frac{1}{4}$ " above the table/tube contact area [as shown *below*]. Fit your miter gauge with an auxiliary fence and stop. Locate the stop to cut the tube to the desired length. Then, turn on the saw, and move the gauge and tube over the blade. Rotate



Move the tube over the saw blade, then rotate it against the auxiliary fence and stop for an even 360° cut.



Use your drill press and a Forstner bit when making holes in Hollowood, easing the bit slowly into the wood to avoid tear-out.

the tube 360° to complete the cut. To drill Hollowood," Doug adds, "use a sharp Forstner bit mounted in a drill press and place the tube on a V-block to steady it while boring. [See photo *above*.] Don't force the bit through the wood or tear-out will result.

"Before applying a finish to Hollowood," Doug says, "sand the tube, working through a progression of 100- to 220-grit abrasives. Be careful not to sand through the thin veneer." 🌲

Photographs: Baldwin Photography

Buying Guide

For more on Hollowood, write to BrandNew Industries, Inc., 6326-B Lindmar Drive, Santa Barbara, CA 93117. Or, call 800/964-8251. Website at www.brandnew.net/hollowood.

ask wood

Answers to your questions from letters, e-mails, and WOOD ONLINE®



Limit the load on glass shelves

Q I want to install glass shelves in a cabinet. Each shelf will measure 43" wide and 21" deep and will be supported at the ends. I'll use them to display curios and small ceramic objects, so each shelf will carry only a few pounds. How thick should the glass be?

—Dick Van Zandt, Bellingham, Wash.

A Dick, we asked our local supplier, and got $\frac{3}{8}$ " for an answer. But if those display items start to multiply and the glass starts to bow, add support or remove weight. See the accompanying chart for glass shelving guidelines. While we're talking about glass shelves, consider edge treatments before you buy. A "seamed" edge remains slightly rough; a "ground" edge is smoother; and a "polished" edge offers a rounded, sleek look. If you don't want the greenish tint

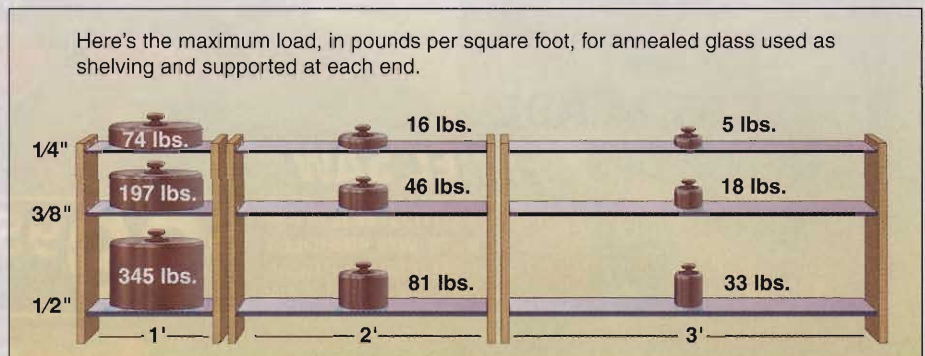
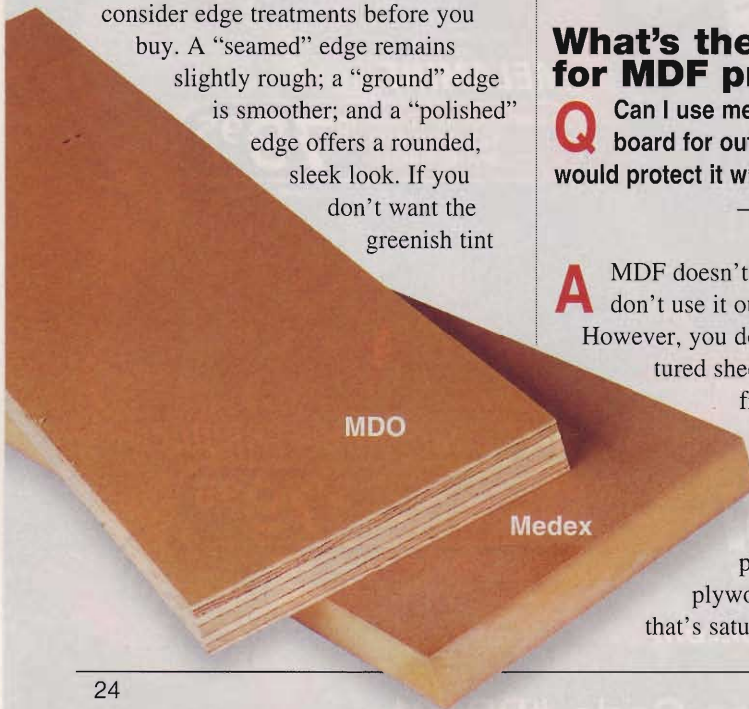

that's visible in the edge of a typical pane of glass, you can buy a clearer style with most of the iron removed. PPG Industries manufactures that product under the name Starphire.

—WOOD® magazine

What's the forecast for MDF projects?

Q Can I use medium-density fiberboard for outdoor projects? I would protect it with exterior paint.

—Terry Krueger, Alpena, Mich.

A MDF doesn't resist moisture, so don't use it outdoors, Terry. However, you do have other manufactured sheet goods to choose from, in addition to exterior plywood. Medium-density overlay, or MDO, consists of several plies of exterior-grade plywood, covered by paper that's saturated with resin. Also,

you can buy a fiberboard product that looks like MDF, but is engineered for exterior use. One example is Medex, from the Medite Corporation. These products cost more than MDF, however. Our local lumber company sells a $\frac{3}{4}$ " sheet of MDO for about \$46, and Medex goes for about \$37. These materials must be primed thoroughly and coated with top-quality exterior paint for maximum durability in the elements.

—WOOD magazine

What gouge size is best for turning?

Q I finally ground down my run-of-the-mill $\frac{3}{8}$ " gouge after turning many, many bowl blanks and whatnot. Now it's time to buy a higher-grade gouge from Robert Sorby or Henry Taylor. Am I thinking correctly about getting a $\frac{3}{4}$ " deep-fluted gouge I can use to turn all the little stuff and the larger bowls up to about 11" to 12" in diameter? I've been doing it all with

Continued on page 26

this little 3/8" tool, but I want to make heavier cuts with less vibration on deeper bowls. Will a 3/4" gouge be too big for smaller bowls?

—Mike Wurth, Coffee Creek, Calif.

A I think that you have been using the most appropriate all-around size. A 3/4" gouge is a hog—it really depends upon how much turning of the larger work you're going to be doing. The vibration dampening ability of the stouter gouges is nice for the larger work and for hogging a lot of wood, but in my opinion, control and the ability to finesse the gouge are most important. I consider the 1/2" gouge too large for 75 percent of the pieces I do. You can get used to working with any size tool, but if you can afford a larger gouge for roughing and a smaller one for controlled cuts, you're better off.

—Phil Brennon, Chino Valley, Ariz.

A I don't claim to be a master turner, but I really like my Ellsworth 1/2" gouge. I have used it from start to finish on bowls up to 14". You do need to buy the Ellsworth sharpening jig to get the proper grind angle, but it is very easy to sharpen once the jig is set up.

—Joseph Quesada, Schuylkill Haven, Pa.

What's the best glue for a cutting board?

Q A friend brought me a very old cutting board that had begun to come apart and asked me to rehabilitate it. What glue is most appropriate? This board will be used for all food-stuffs, including meats.

—George Davis, Macon, Mo.

A I have built a number of cutting boards over the years using Titebond II with good results. There are two cutting



boards in my kitchen that have been in use for over five years, and they show no sign of glue joint failure.

—Brian G. Hayek, St. Louis

Can walnut step up to the plate?

Q I suddenly acquired a supply of black walnut wood when a tree fell in my back yard. I'm thinking about

It's The World's Only Cordless Brad Nailer That's Also Pneumatic.

Cordless. Pneumatic. Our new cordless brad nailer gives you the option of both, using exclusive **TPS Technology™** (Twin Power Source System). It's cordless,



thanks to a mini-compressor powered by our rechargeable, interchangeable 12-volt battery. It's also pneumatic, courtesy of a 1/4" valve that allows you to use it with traditional

compressors. To get one of your own, visit your Porter-Cable dealer or call 1-800-487-8665

(519-836-2840 in Canada).



PORTER-CABLE
PROFESSIONAL POWER TOOLS

turning a baseball bat from one of the pieces. Can walnut stand up to hitting a baseball?

—Kerry Fagelman, Lewisberry, Pa.

A It sure would make a nice-looking bat, Kerry, but it probably would not last long in a ballgame. Juan Faxas, owner of baseball bat manufacturer Glomar Enterprises, says walnut just isn't tough enough to serve the purpose. Hickory ranks as the most durable wood for bats, but it's heavy and a bit difficult to obtain. So batmakers settled on white ash as the standard. Ash offers the weight-to-strength ratio they want, plus it's somewhat elastic. Of course, you can use walnut or any other wood to make a bat for display. Here are the typical specifications: the handle should be $\frac{15}{16}$ " to 1" in diameter; the barrel about $2\frac{1}{2}$ "; the weight in ounces about two digits less than the length in inches. If you turn

an ash or hickory bat to hit with, remember that a rapid taper from handle to barrel lets you swing the bat faster, but decreases its strength.

—WOOD® magazine

Planing knots? Try sanding instead

Q When I run rough boards through my planer, I have trouble with knots that come out and break up. On one pass, they're in there solidly; the next pass, they're broken and impossible to restore. What can I do about this problem?

—Sergei Burmenko, Stuart, Fla.

A A black, cracked knot has lost its resin and flexibility, Sergei, and there's not much you can do to hold it in place against the relentless impact of planer blades. However, if you really



want to use lumber with knots, you'll have better luck with a drum sander, which remains in constant contact with the workpiece. If you decide to buy a drum sander, see our comparison of four models in Issue 130. Call 800/346-9663 to buy a copy of that issue for \$6.95. Otherwise, check with commercial woodworkers or seri-

Continued on page 28

It's The World's Only Pneumatic Brad Nailer That's Also Cordless.



Pneumatic. Cordless. Our new cordless brad nailer gives you the option of both, using exclusive **TPS Technology™** (Twin Power Source System). It's pneumatic, courtesy of a 1/4" valve that allows you to use it with traditional compressors. It's also cordless, thanks to a mini-compressor powered by our rechargeable, interchangeable 12-volt battery. To get one of your own, visit your Porter-Cable dealer or call 1-800-487-8665 (519-836-2840 in Canada).

Proud sponsor of
THE NEW YANKEE
WORKSHOP on
Public Television



PORTER-CABLE
PROFESSIONAL POWER TOOLS

WWW.PORTER-CABLE.COM

ous hobbyists with drum sanders, and ask one of them to dimension your boards for you.

—WOOD® magazine

Matching color with wood filler

Q I despise using wood filler because I have never been able to get it to stain even close to the color of the wood. I recently built a large box out of oak, and I have a couple of 1/16" gaps. Does anyone know of a wood filler that will stain close to the color of the wood?

—Jason Barr, Copley, Ohio

A Force a little bit of polyurethane glue into the gaps, and let it foam out and dry. Then trim the foam, and sand flush and smooth. Poly will take stain but show no grain. Be warned that



the foamy stuff has absolutely no strength, so the joints must be strong to begin with. Also, always try new things on scrap to perfect your technique first.

—Robert Peterson, Ventura, Calif.

A I use my belt sander to make a pile of fine sawdust from the same type of wood that I'm filling. I mix in yellow wood glue until I have a paste that's a little softer than wood putty. Next, I work the paste into the voids and let it dry. Then I sand it flat. It will stain and paint just like the wood, but it will not

have any grain. A little practice and you'll never go back to wood putty.

—Tim D'Arcy, Richmond, Vt.

A What I like to do with very small gaps is to force some glue into the gap, and while it's still wet I run my sander over it for awhile. The dust will mix with the glue, and the heat from the sander will cure the glue relatively quickly. Try it in an inconspicuous area first to see how you like it.

—Gary Thomas, Fort Worth, Texas

Got a question?

If you're looking for an answer to a woodworking question, write to Ask WOOD, 1716 Locust St., GA 310, Des Moines, IA 50309-3023 or send us an e-mail at askwood@mdp.com. For immediate feedback from your fellow woodworkers, post your question on one of our discussion groups at www.woodonline.com.

I N T E R O D U C I N G

PC²

Gross Stabil Corporation, a leading manufacturer of woodworking clamps and accessories proudly introduces a new woodworking clamp product.

PC² is a revolutionary new Parallel Clamp for woodworking professionals. Manufactured in Germany of the highest quality materials and craftsmanship, the PC² will clamp wood pieces with up to 1100 lbs. of clamping pressure.

The PC² is made of polyamide 6.6 (nylon) grade 1A plastic, reinforced with 50% long-fiber fiberglass, malleable cast iron locking mechanism, and galvanized steel rail. The clamping jaws are wrapped around steel inserts for added strength and support. With a clamping area of 5-1/2" x 1-3/4" and clamping length from 12" to 100", the PC² will handle the largest of clamping projects. This easy to use clamp quickly and easily slides up and down its galvanized steel rail to accommodate virtually any size pieces of wood.

Woodworkers are assured of perfectly squared up clamping of wood products with this hand held unit.

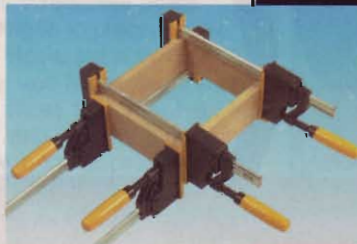

WOOD WORKER'S PARALLEL CLAMP



Introducing the
New Delta Store.

Tap into the Power of the Pros.

The new Delta store has over 1000 products from a complete line-up of unisaws to those hard-to-find machinery attachments. Extensive product information including customer ratings and reviews will help you choose the right tool for the job. We'll even deliver to your door for only \$5.99.



Visit the Delta store at
www.amazon.com/delta

Call for your FREE Tool Crib catalog
1-800-635-5140

table saws radial saws miter saws
scroll & band saws planers the Delta store
drifting machines jointers wood shapers



tool industry
insider

cordless takes a new rout

Battery-powered router turns heads

At first glance, Porter-Cable's new 9290 router, shown at *right*, looks much like its signature 690 series router. Closer examination, though, reveals something missing: the power cord. The 9290 couples P-C's 19.2-volt rechargeable battery with a direct-current (DC) motor to turn a bit at 23,000 revolutions per minute (no load).

So, does it really work? We haven't had a chance to put one through in-depth testing yet, but we did get our hands on a prototype for a few minutes recently, and the answer from that short trial is "yes."

With a 1/2" round-over bit chucked into the 9290's 1/4" collet (it also accepts P-C's accessory 3/8" and 1/2" collets), the router felt like it had power to spare when machining red oak. And to our ears, the router is noticeably quieter than a typical corded model.

Porter-Cable's Mark Woodlief says the tool specs at "about 1 horsepower," and can rout 100' of 1/2" round-over in oak or 200' in pine on a single battery charge. What about other bits? Woodlief says, "If you can run them in our model 100 1-hp router, the 9290 should have no trouble with them, either. We recommend 1/4"-shank bits to maximize run time."

Given the weight of cordless battery packs, we were surprised to find the 9290 to be a well-balanced tool. At 7 3/4 pounds, it actually weighs less than the corded 690. And, the cordless motor fits in all existing 690 bases, so you also could make it into a plunge or D-handle router.



With the 9290 router in the shop, you'll never worry about unexpectedly catching the cord on a workpiece and ruining an edge treatment, or having to stop a machining operation to move the cord out of the cutter's path. We also think it'll be handy for outdoor projects, such as building a deck, where electric outlets are few and far between.

As you might expect, convenience has its price. With one 19.2-volt battery, charger, and case, the 9290 is expected to sell for about \$250. Buying it in a kit with other cordless tools (it's currently available with a drill and jigsaw) reduces the per-tool price and gives you the benefit of an additional battery. 🔋

shop tips

Helping you work faster, smarter, and safer

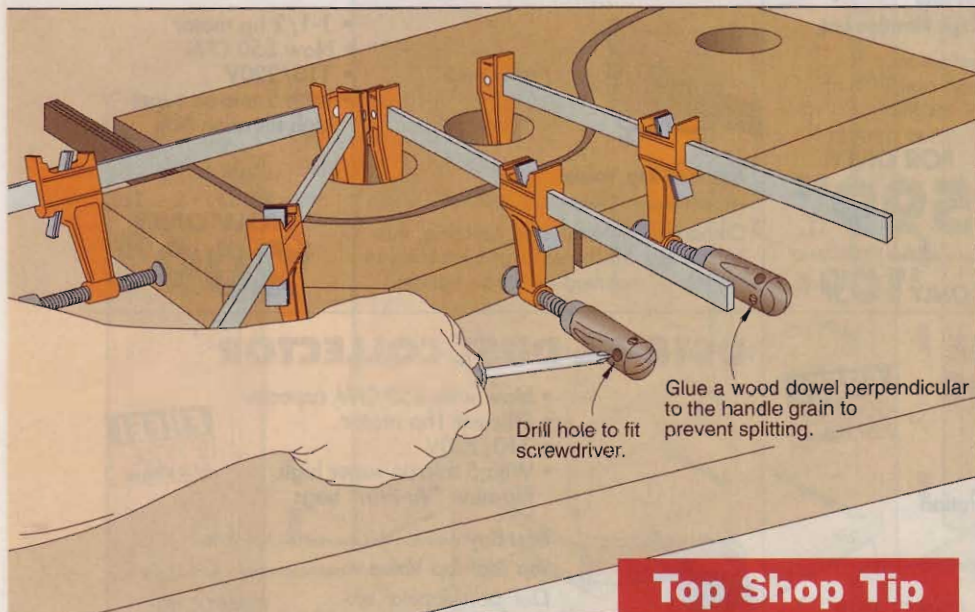

Oh, say, can you “C” your bar clamp handles?

While building the bentwood accent table in *WOOD*® magazine issue 131, my husband, Jim, and I used every large clamp in our shop. When we broke out the bar clamps to glue up the laminations, we found it hard to tighten them adequately. The handles rested so close to the tabletop we couldn't get a grip on them.

Thinking of the sliding barbell-shaped rod on a C-clamp, I suggested that Jim drill a hole in each handle and use a screwdriver to turn the handle, as shown above. It worked great. To keep from splitting the handle, you might want to first bore a hole perpendicular to the handle's grain, and glue a same-size dowel in that hole.

—Adelaide Kurtz, Kirkville, N.Y.

The job isn't done until the paperwork is filed

Let's face it guys: Our wives are likely to outlive us. If you suddenly passed away, how would your widow ever know what to do with all of your woodworking tools? Would she get a fair market value for them?

For each of my power tools, I've placed all of the paperwork, including the purchase price, in individual manila envelopes. On the outside of each envelope, I've written a code number that matches the code number I've written on the tool with a permanent marker. The envelopes are filed in a fire-safe file cabinet in my shop. These detailed records also would serve insurance purposes should my shop ever be burglarized or destroyed by fire.

—Brian Stanley, Yorba Linda, Calif.

Continued on page 34

our winner

Adelaide Kurtz shows off the *WOOD* magazine State Quarters Map she recently scrolisawed.



Several years ago, Adelaide Kurtz's husband, Jim, took her to a wood-working show. After watching a scrollsaw demonstration, our Top Shop Tip winner thought, "I can do that." She ended up buying a scrollsaw at that show.

Adelaide and Jim sometimes works on projects together (as with the table that inspired this issue's Top Shop

Tip at left), and sometimes separately. "I have my own tablesaw, sanders, and other tools," she says. "Of course, he can use them, too."



For sending in this issue's Top Shop Tip, Kurtz receives a Penn State DC2-5 dust collector. Attagirl, Adelaide!

How can I win a free tool, too?

Tell us how you've solved a workshop puzzler, and we'll send you \$75 if we print your solution. And, if we choose your tip as the Top Shop Tip of the issue, we'll also send you a tool prize worth at least \$250.

Send your best tips, along with photos or illustrations and your daytime telephone number, to: **Shop Tips, WOOD Magazine, 1716 Locust St., GA-310, Des Moines, IA 50309-3023**. Or post your best suggestions at www.woodonline.com on our Top Shop Tip discussion group.

Because we try to publish only original tips, please send your tips only to *WOOD* magazine. Sorry, but we can't return the items you send in.

Raise spindle sanding to new heights

After buying an oscillating spindle sander, I soon realized that the middle of the sanding sleeve doesn't contact the wood when I use 3/4" stock. Rather than waste part of the sleeve, I came up with a way to raise the workpiece.

I cut two pieces of 3/4" melamine-coated particleboard (you could use countertop sink cutouts from the bargain bin of your home center) to the same size and shape as my sander's table, then cut a hole for the largest sanding drum in each. I then routed a shallow rabbet around each hole to accept my sander's throat inserts as shown at right.

To ensure consistent alignment, I stacked the new tabletops on the sander, and drilled a 13/32" hole at each corner—completely through the new tables and 1/2" into the sander. From a 3/8" dowel, I cut eight pieces, each 5/8"

long, and glued them halfway into the holes of each of the new tabletops, as shown in the drawing below. When I start a sanding job, I stack both new tables in place and work my way down to the sander's original tabletop.

—Larry Gamache,
Windsor Locks, Conn.

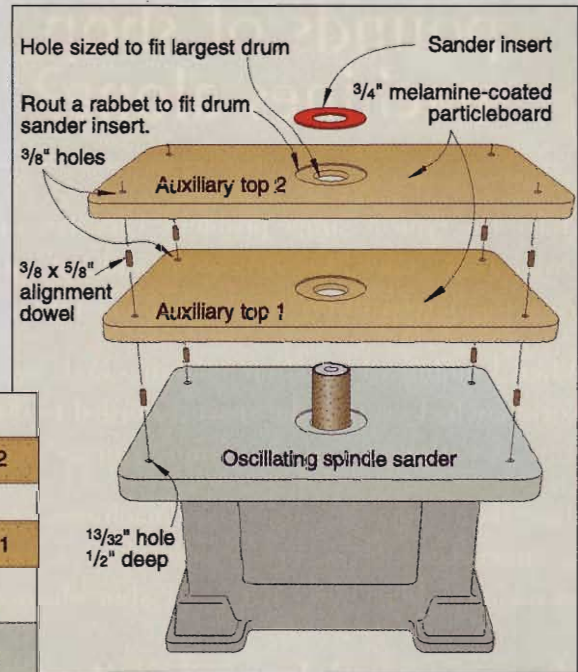
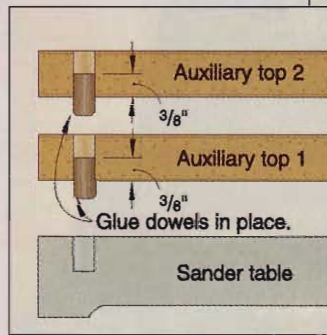

Continued on page 36

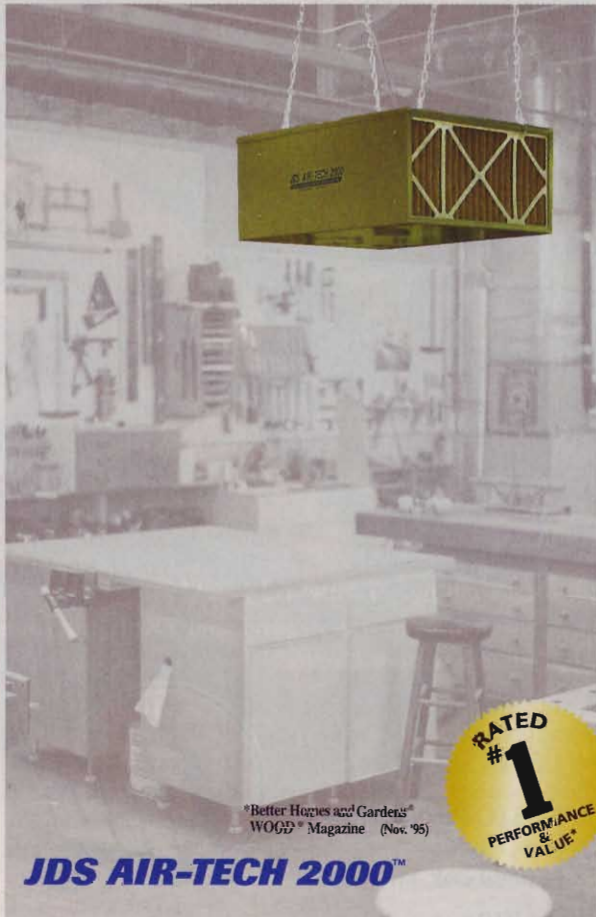

Let's Clear the Air...

JDS AIR-TECH 2000™

Model 750, Still the Best!

- Variable Speed Control for unlimited air flow settings
- Highest Maximum air flow in its class - 1,050 CFM
- Convenient On/Off pull chain
- Ultra Quiet
- 1/4 H.P. Motor for heavy duty performance
- Antimicrobial 1 Micron Internal bag filter
- UL Listed
- Lifetime Warranty

The National Institute for Occupational Safety and Health (NIOSH) recommends limiting wood dust exposures. The JDS Air-Tech 2000 will dramatically improve the quality of the air you breathe. Our new model 750 variable speed allows you to dial in your desired air flow, from a whisper quiet 200 cfm to an ultra performance 750 cfm. This will clean the air in a 30'x30'x8' shop every ten minutes. For larger areas our models 8-12, 10-16 and 2400 are available. The JDS systems will remove 99% of particles as small as five microns and 80% of particles as small as one micron. For the removal of odors, fumes and smoke, our optional charcoal filter is available. To place an order or for the dealer nearest you call us toll-free.

\$259.00

Model 750

Another quality product from
1-800-382-2637

Manufactured in the U.S.A.

www.thejdscompany.com



*Better Homes and Gardens®
WOOD Magazine (Nov. '95)

JDS AIR-TECH 2000™

Quality Pen Kits and Other Turning Kits



- Designers & Manufacturers
- Wholesale & Retail

THE BereaHardWoods CO. Inc.

Manufacturer of quality writing instruments, components and kits.

CALL FOR FREE CATALOG

6367 Eastland Rd. • Brookpark, Ohio 44142 U.S.A.
Ph: 440-234-7949 • Fax: 440-234-7958 • bereahard@aol.com

Circle No. 510



**ET100™
Nail Master™**

- Ergonomic Design
- Durable
- Powerful

10 Amps

Removable
Non-Marring
Bumper

**Shoots 3
Different
Length Brads**

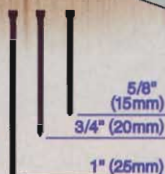

ARROW
Wherever fine tools are sold.

Arrow Fastener Co., Inc., 271 Mayhill Street, Saddle Brook, New Jersey 07663
Canada: Jardel Distributors, Inc., 6505 Metropolitan Blvd. East, Montreal, Quebec H1P 1X9
United Kingdom: Arrow Fastener (U.K.) Ltd., 14 Barclay Road, Croydon, Surrey CRO 1JN
www.arrowfastener.com ©2000 ARROW FASTENER COMPANY, INC. Rev.700

Heavy Duty Electric Brad Nail Gun



shop tips

An off-the-wall idea for benchtop storage

Like a lot of woodworkers, I have a small shop, so I need to utilize every bit of space I can find. When I ran out of shelf space for my benchtop tools, it drove me up a wall—my shop wall, to be precise.

I made a base for my miter saw, as shown *below*, with a beveled cleat along one edge and a clamping cleat on the bottom. The beveled piece mates with another that's securely attached to my shop wall. The other I use to clamp the plywood base into my clamping workstation. The system works so well I now have a wall full of bases, holding everything from my scrollsaw and belt/disc sander to my bench grinder.

—Bill Richardson, Greenwood, Nova Scotia

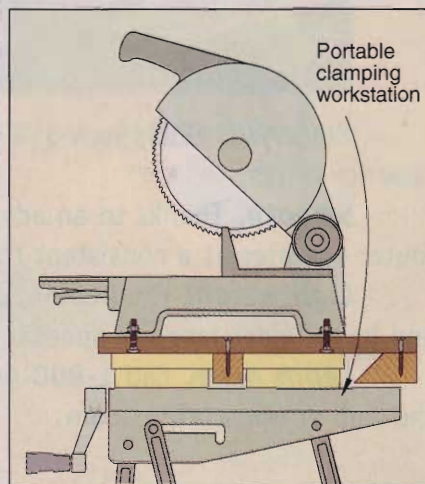
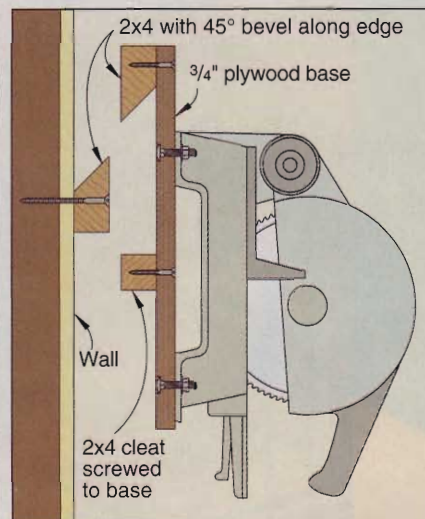

Put sheet storage on the fast track

To save precious shop space, I like to store sheet goods on end. (It's also easier to move a sheet that's standing tall, especially with super-heavy medium-density fiberboard (MDF) or MDF-core plywood.) But with the short edge on the

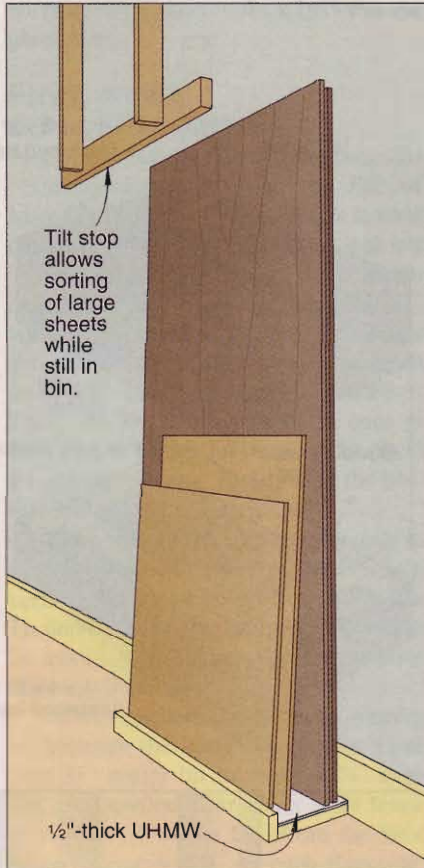

floor, it's hard to pull an individual sheet out—it always wants to tip, rather than slide out.

So, to reduce the drag, I built my plywood rack with a 1/2x12" sheet of slippery ultra-high molecular weight (UHMW) plastic for its "floor." Also, to help me easily sort through the full sheets, I hung a tilt stop from the joists overhead. It catches the outside sheets so I don't have to.

—Jeff Ament, Tigard, Ore.

Slotted box grabs the globs

When refinishing antique furniture, one of the messiest jobs is removing the old fin-

ish with a liquid stripping agent. The gloppy goo scrapes off with a putty knife, but then what do you do with it?

To contain the goo, I use a small cardboard box with slits cut in each side, as shown at *right*. I first dump the sludgy stuff in the box, then drag the putty knife through one of the slots to clean both sides of the blade in one pass before returning it to my project.

—Alyn Edmonston, Yakima, Wash.

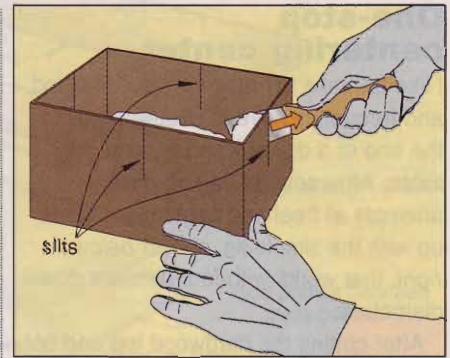

Continued on page 38



Viper® router bits are consistently cited as the finest quality woodworking tools, yet they are less costly than most. Recently reviewed by *The Woodworker*, the UK's leading woodworking publication, Viper was found to be "superior in every way"

when compared to Freud®, Bosch, CMT™ and other major brands.

Viper offers a full line of premium carbide router bits for all of your woodworking needs. Visit www.oldham-usa.com.

Viper® Carbide Router Bits



Make sure you buy the original yellow bit!



Oldham
American made since 1857

One-stop centering center

I like to make toy race cars out of wood, and frequently have to center a hole in the end of a dowel when making the axles. After several hit-and-miss attempts at freehand centering, I came up with the simple jig, shown *below right*, that works with four different dowel diameters.

After cutting the hardwood top and bottom to the sizes shown, I cut 1/4"-deep

dadoes 1/2" in from each edge. Next, I fashioned the splines, and glued them into place in the base.

With the top and base put together (there's a 1/8" gap between them when the jig is closed), I drilled holes for each size dowel I wanted to use. These holes go through the top and 1/2" into the base. Finally, I inserted metal dowel centers into the holes in the jig's base.

To use the jig, put both pieces together, insert a dowel in the appropriate

hole, and give it a tap. Flip the dowel, reinsert it, and head for the drill press. With the dowel still in the jig, position it under the bit, and drill the center hole. Using this jig, I've bored holes in dowels 4–6" long, drilling from both ends, that met perfectly in the middle.

—John Heide, Jacksonville, Fla.

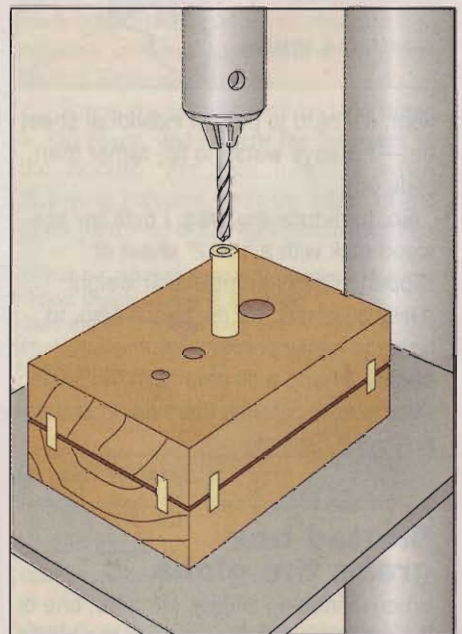
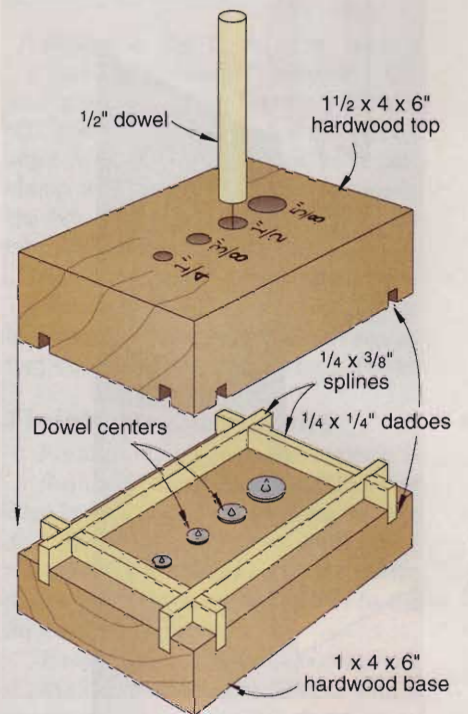

Measure Twice. Glue Once.

Hardwoods, softwoods, pressure-treated or exotics – Gorilla Glue® is tough enough to hold them all. Incredibly strong, nearly invisible glue lines, and 100% waterproof. Just the way serious woodworkers demand it. Call 800-966-3458 for a dealer near you, or visit www.gorillaglu.com to find out more.



The Toughest Glue on Planet Earth™

Instant drill-press fence and work stop

For a quick and accurate way to locate a hole in multiple workpieces, I clamp an ordinary framing square to my drill press table, as shown *below*. One tongue acts

as a fence, while the other acts as a stop. This worked exceptionally well while drilling the holes in the slats of the Arts-and-Crafts ottoman featured in *WOOD*® magazine, issue 113.

—Bill Van Gilst, Harwinton, Conn.

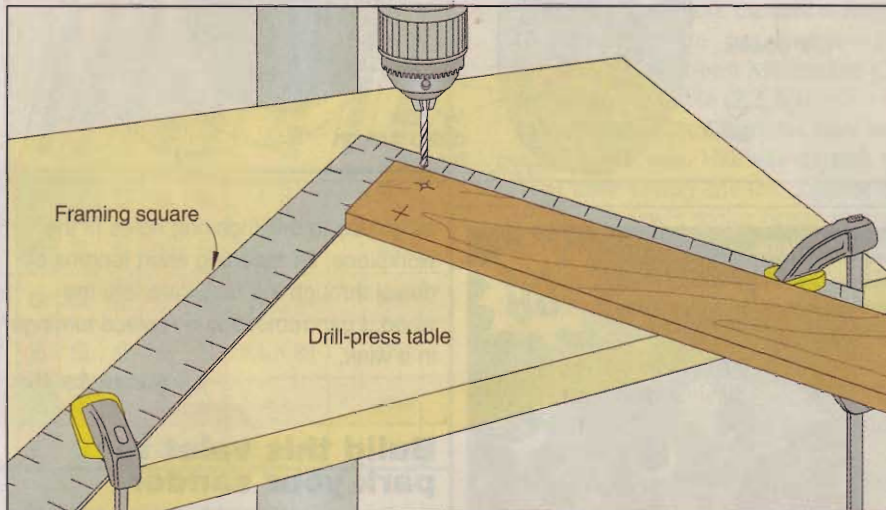

A new order in drawer-slide installation

I used to cuss up a storm when installing drawer slides in my projects. It seemed like there was never enough room to get my hand and drill/driver between the sides of the drawer opening. Sometimes, I even had to wedge my head in to see what I was doing. Then one day, I had a brainstorm.

After looking at the small openings in a desk I was building, I decided to install the drawer slides before gluing up the case. With the case sides laid out on my bench, I was able to accurately locate and mount the slides without obstruction. It worked like a charm, and the drawers fit perfectly when all was assembled.

—Don Eisenhardt, New Haven, Ky.

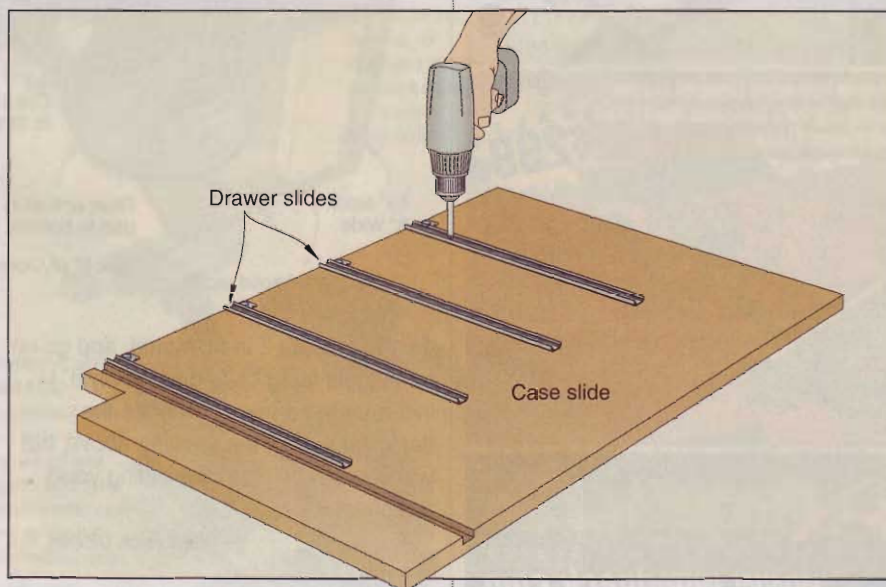

Continued on page 40

Heavy Duty, Rugged,
and Reliable.

A Web Site That's Built Like A DeWALT Tool.

The new DeWALT store has a complete DeWALT selection of over 1500 products. See the newest cordless tools and the hard-to-find woodworking accessories. Our heavy-duty product information including customer ratings and reviews will help you select the right products.



Visit the DeWALT store at
www.amazon.com/dewalt

Call for your FREE Tool Crib catalog
1-800-635-5140

chop saws drills grinders hammer
drills planers routers the DeWALT store
screw guns vacuums saw blades



On-again, off-again situation solved

Some lathe projects require you to remove the turning from the faceplate and later return it to the same position. To make that process easy, I drilled two holes through the faceplate, placing the holes at different distances from the faceplate's center to eliminate any risk of confusion. After screwing the faceplate to the workpiece (or auxiliary faceplate) in the usual manner, I use those holes

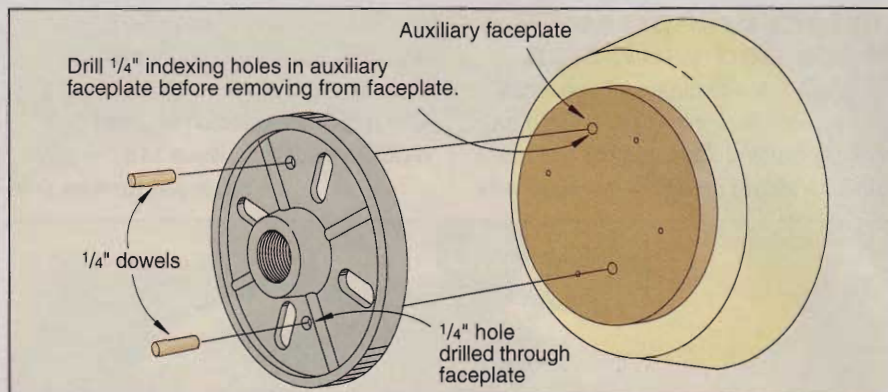

as guides to drill indexing holes in the workpiece. By inserting short lengths of dowel through the faceplate into the wood, I can remove and replace turnings in a wink.

—Lyle Granzow, Ray, Mich.

Incra MITER1000

- ◆ 41 Indexed Angle Stops over $\pm 90^\circ$ range
- ◆ 18" Incra Track Fence with Slide Stop
- ◆ Steel GlideLOCK™ Miter Bar with 6 Width Adjustment Points

SALE \$89

Incra MITER3000

- ◆ 364 Indexed Angle Stops over $\pm 90^\circ$ range
- ◆ 27" Miter Fence + Dual-Flip Stop
- ◆ Steel GlideLOCK™ Miter Bar with 8 Width Adjustment Points

SALE \$219

Incra MITER5000

- ◆ 364 Indexed Angle Stops over $\pm 90^\circ$
- ◆ 36-64" Miter Fence + Dual-Flip Stop
- ◆ Steel GlideLOCK™ Miter Bar with 10 Width Adjustment Points
- ◆ Integral Hold-down Clamping System
- ◆ Renewable Zero Clearance Right Panel

SALE \$299

Produce perfect gap-free hairline glue joints on the mitered corners of any multi-sided object on your first try without trial-and-error setups.

All models include: Adjustable GlideLOCK Miter Bar, Incra Specified Fence with Stop Positioner, and FREE Video Brochure.



Woodpeckers Inc.

The Incra Tool Source

www.woodpeck.com

1-800-752-0725

Build this valet to park your sander

Holding a random-orbit sander until it stops whirling was an annoyance that took some of the fun out of my time in the shop. But then I built a stand that acts like valet parking—I simply shut off

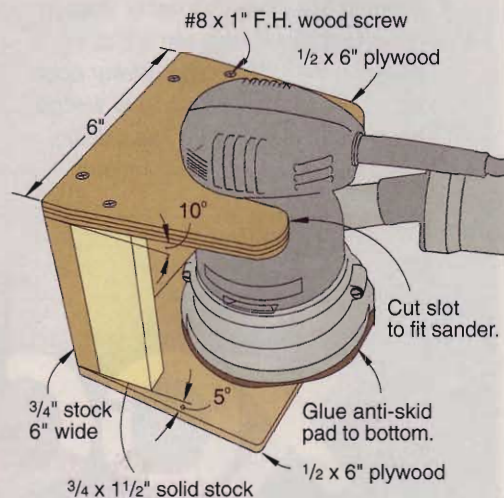

the sander, put it in the stand, and go on to my next task. To add some style, I incorporated a few angles into the design shown in the drawing above, but you could save time by building yours without them.

—Walter Feick, Oldwick, N.J.

Continued on page 42

Make legs four-of-a-kind and flush to the floor

If you've ever built a table or chair with splayed legs, you know how frustrating it

can be to cut those legs off so they stand flush on the floor. Here's a fool-proof technique that I've used with great success.

Put your project on a flat surface, such as your tablesaw top. In a piece of 1/4" plywood, cut a hole larger than the diameter of the leg. From the same stock, cut three more small shims.

Place one leg in the hole, as shown in the foreground of the drawing at left, and trim the leg using a flexible flush-cut saw. Move the hole jig to the next leg, shim the just-cut leg (as shown in the drawing), and repeat the cutting and shimming process for the remaining three legs.

—Marvin Aberle, Beulah, N.D.

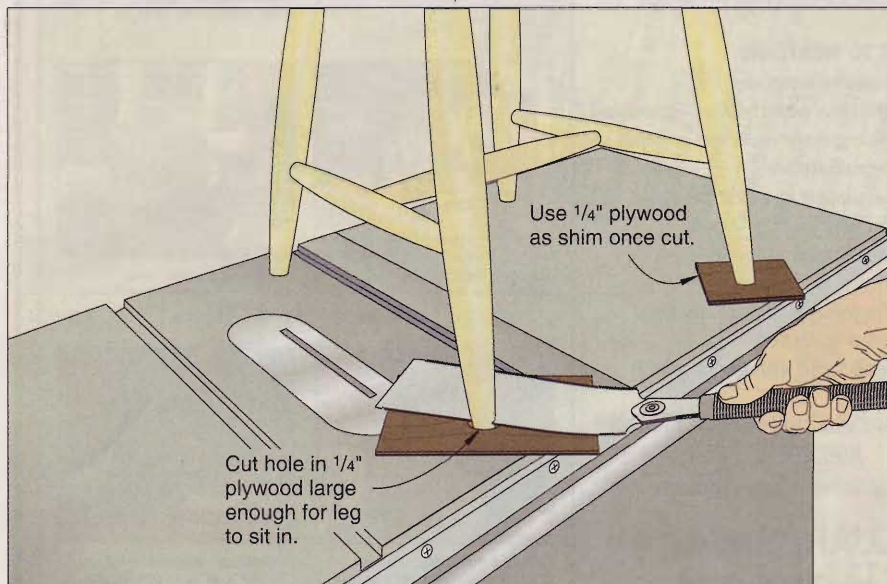

shop TIP

You'll find more great Shop Tips throughout every issue of *WOOD* magazine. Look for boxes like this one nestled among the project and technique articles.



The Boring Truth

From left to right: tapered drill/countersink, step drill, single-flute auger bit, saw drill, forstner bit, lipped brad-point drill, Veritas® Plugger, centering bit, Veritas® Snug Plug® cutter.

While the other guys duke it out over power tool specifications, we search for and manufacture the best selection of quality accessories. After all, it's the boring accessories that actually engage the wood and make the greatest difference in your work.

To see and read about our full collection of unique, high-quality power tool accessories, hand tools and woodworking supplies, visit our Web site or call to request our 252-page catalog - free with any purchase.

Contact us at: **1-800-871-8158**
or customerservice@leevalley.com
fax: **1-800-513-7885** and ask for catalog UTBT.

Shop online:
www.leevalley.com

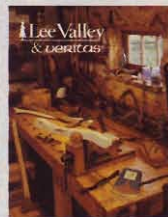

Lee Valley & veritas®

Lee Valley Tools Ltd., 12 East River St., Ogdensburg, N.Y. 13669



**NO 1940'S
QUONSET
TECHNOLOGY
HERE!**

Miracle Truss—THE WAY TO BUILD!

Add value to your property with a modern, ATTRACTIVE Workshop!



Why Miracle Truss??

- Easy to have side doors.
- Attractive colors available.
- Inexpensive to insulate, with more R-value.
- Simple concrete work.
- Readily satisfies building code requirements.

(Take immediate delivery — or defer it up to 12 mos. with our FREE Storage Program.)

—SPECIAL LIMITED OFFER—

**27' x 48' (a \$13,985 value)
NOW ONLY \$7,412**

Includes steel frames & endwalls, galv. sheeting, hardware, trim & complete assembly plans.

MIRACLETRUSS

1-800-663-0553

www.miracletruss.com

divide and conquer with style

Create
a pleasing
room
partition
with
handsome
cabinets.

When we planned our kitchen-renovation project for issue 136, we recognized that the wide-open space between the kitchen and the dining room was full of opportunities, both practical and dramatic. On the practical side, we wanted storage; on the dramatic, we wanted to maintain openness; our solution: cabinets with flair. Our design utilizes glass for the doors and shelves and includes lights inside the cabinet. The result functions to divide the space while letting you display favorite treasures.

After building the cabinets, give them the crowning touch by making an archway and a pair of columns as described in the article on [page 54](#).



The
Handcrafted
Home

***Note:** Back panel protrudes 2" past cabinet.
This will be scribed and sanded to match wall later.

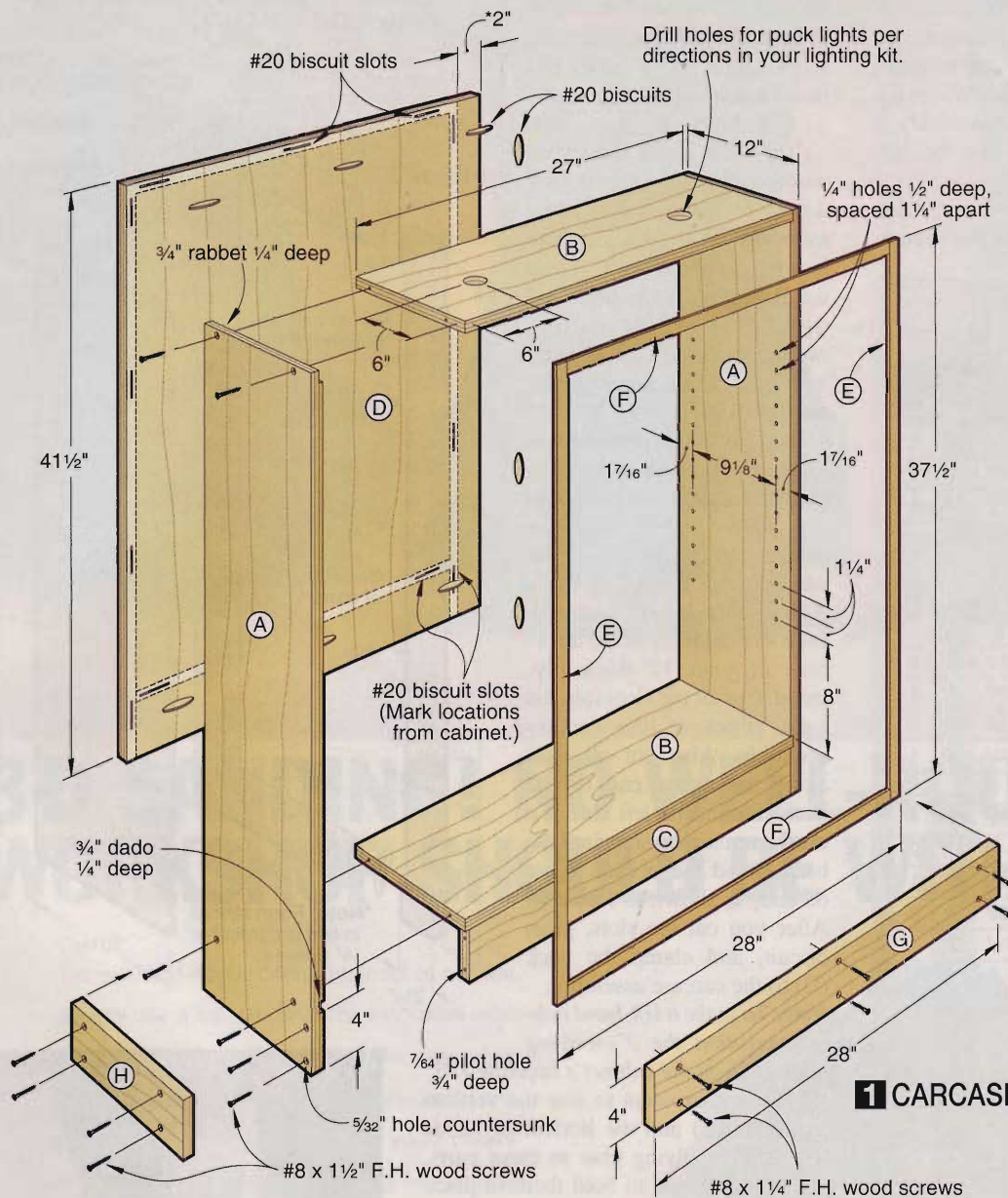

1 CARCASE EXPLODED VIEW

Note: The following directions cover the construction of the **right-hand** cabinet of the pair that we installed. If you build a pair, remember that the left cabinet is a mirror image, not identical. As you plan this project, you may want to change the width of these cabinets to suit your home. One key dimension: Be sure to leave a clear walkway of at least 36" between the cabinets.

Start by assembling the carcass

1 Referring to the Bill of Materials, rip and crosscut the sides (A) and the top/bottom (B) from cherry plywood. On these parts, the best-looking side faces the cabinet's interior. Using an adjustable circle cutter or a Forstner bit chucked into your drill press, and referring to **Drawing 1** and the directions furnished with your lighting kit, lay out and drill the holes for the halogen puck lights. (We purchased our two-light kits

at a local home center.) Lay out and drill the shelf-pin holes in the sides (A).

2 Install a 3/4" dado blade in your table-saw, and raise it for a 1/4"-deep cut. Screw a scrapwood face to your rip fence, and position it so the inner edge of the dado blade just touches the scrapwood face. Cut the rabbets at the top end of the sides (A), where shown on **Drawing 1**. Move the rip fence, and make the dado near the lower end of each side.

3 Glue and clamp the sides (A) and the top/bottom (B), flushing their edges.

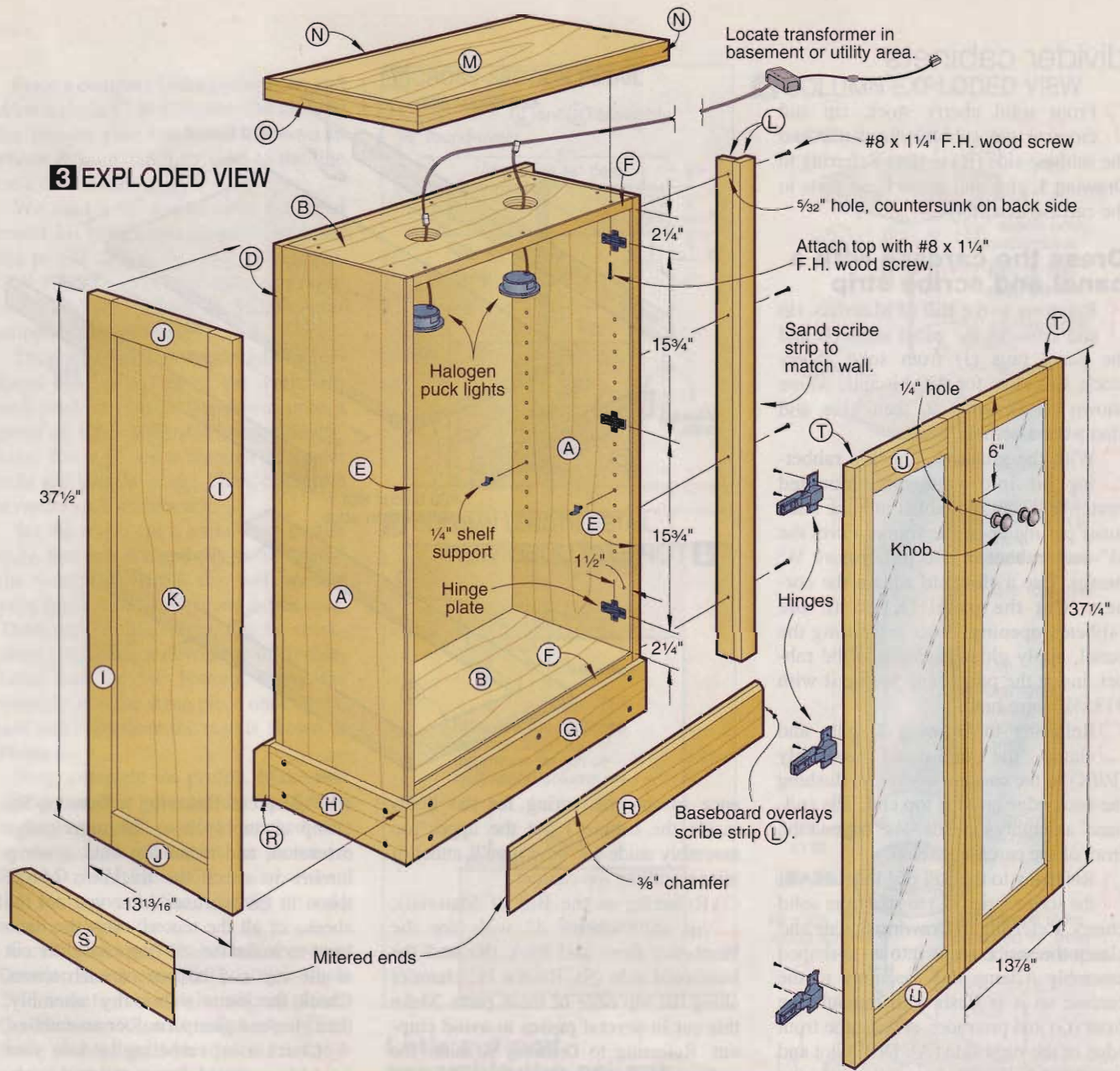

cutting diagram

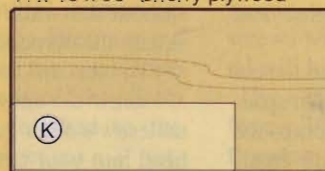
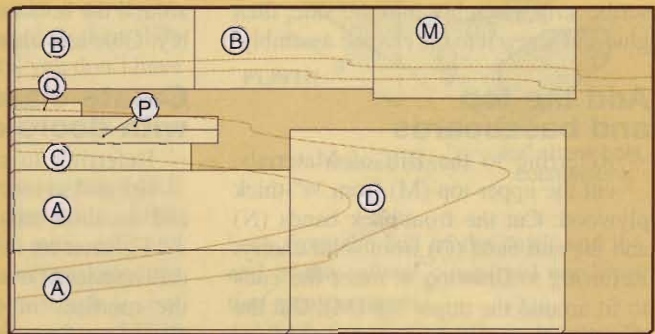
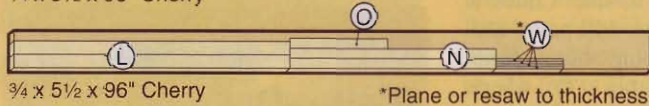
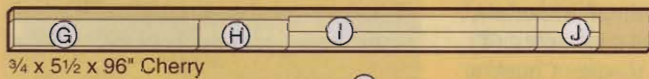

divider cabinets

Drill the pilot and countersunk shank holes in the sides (A), where shown on **Drawing 1**, and drive the screws. To check the assembly for square, measure the diagonals of the carcass. When the measurements are equal, the assembly is square. Also make certain that the carcass is flat.

4 Cut the stretcher (C) to size. Glue and clamp the top edge of the stretch-

er to the bottom (B), flushing the edges. Drill pilot and countersunk shank holes, and drive screws through the sides (A) into the ends of the stretcher.

5 Cut the back (D) to size. Lay the back on your workbench with its best face down. Position the carcass assembly on the back, where located on **Drawing 1**. Trace the inside of the bottom and right side of the carcass assembly onto the back, making light pencil lines in the position indicated by the dashed lines on **Drawing 1**. Mark the location of the biscuit slots on the back (D) and also mark mating locations around the perimeter of the carcass assembly (A/B/C). Adjust your biscuit joiner to cut a slot centered in the thickness of your 3/4"-thick plywood. Cut all the slots into the back edges of the carcass assembly. Also cut all slots along the upper end of the back (D) and its left side. To cut the remaining slots into the back, stand the biscuit joiner on end, as shown in **Photo A**. After you cut the slots, glue, biscuit, and clamp the back (D) to the carcass assembly.

Note: To make a left-hand cabinet, position the 2" scribing allowance on the cabinet's opposite end.

6 Rip and crosscut to size the vertical bands (E) and the horizontal bands (F). After applying glue to these parts, use masking tape to hold them in place while the glue dries.

2 END PANEL EXPLODED VIEW (VIEWED FROM BACK)

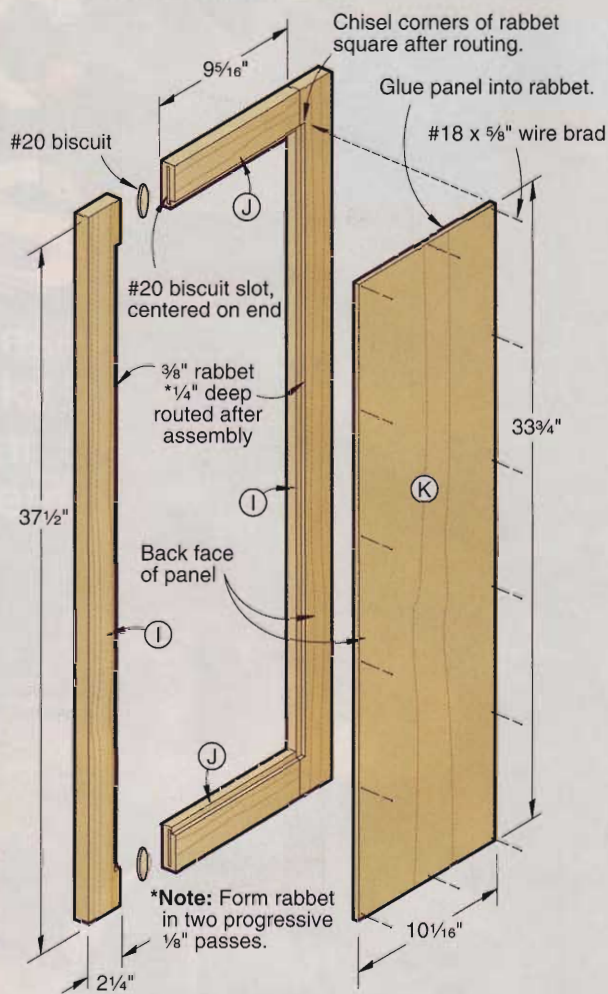

Clamping a straightedge to the back (D) creates a fence for positioning the biscuit joiner when cutting the biscuit slots along its bottom and right side.

bill of materials

Divider cabinets

Part	FINISHED SIZE			Matl.	Qty.
	T	W	L		
A sides	3/4"	12"	41 1/2"	CP	2
B top/bottom	3/4"	12"	27"	CP	2
C stretcher	3/4"	4"	26 1/2"	CP	1
D back	3/4"	30"	41 1/2"	CP	1
E vertical bands	1/4"	3/4"	37 1/2"	C	2
F horizontal bands	1/4"	3/4"	26 1/2"	C	2
G subbase front	3/4"	4"	28"	C	1
H subbase side	3/4"	4"	13 1/2"	C	1
I panel stiles	3/4"	2 1/4"	37 1/2"	C	2
J panel rails	3/4"	2 1/4"	9 5/16"	C	2
K panel	1/4"	10 1/16"	33 3/4"	CP	1
L scribe strips	3/4"	2"	41 1/2"	C	2
M upper top	3/4"	13 5/16"	30 1/2"	CP	1
N front/back bands	3/4"	1 1/2"	31 1/4"	C	2
O end band	3/4"	1 1/2"	14 13/16"	C	1
P side spacers	3/4"	2"	30 1/2"	CP	2
Q end spacer	3/4"	2"	9 5/16"	CP	1
R baseboards front/back	3/4"	4"	31 1/2"	C	2
S baseboard side	3/4"	4"	15"	C	1
T door stiles	3/4"	2 1/4"	37 1/4"	C	4
U door rails	3/4"	2 1/4"	11 19/16"	C	4
V vertical stops	1/4"	3/8"	33 1/2"	C	4
W horizontal stops	1/4"	3/8"	10 1/8"	C	4

Materials Key: C—cherry, CP—cherry plywood.

Supplies: (for a single cabinet) #8x1 1/4" flathead wood screws, #8x1 1/2" flathead wood screws, #20 biscuits, #18x5/8" wire brads, #17x1" wire brads, two-lamp halogen lighting kit, double-strength glass, 1/4"-thick glass.

Buying Guide

Hardware. (for a single cabinet) Blum 125° inset clip hinges with mounting plates, no. 02S60, \$8.99 per pair (3 pair); 7/8"-diameterx1/8"-thick door bumpers, no. 02S82, \$5.50/sheet of 56; shelf supports no. 27120, \$4.50/bag of 25. Order from Woodcraft, 560 Airport Industrial Park, Parkersburg, WV 26102, or call 800/225-1153. Amerock knobs no. BP-1590-FB (2). Amerock knobs are available at many home centers and hardware stores, or order no. AO-1590-FB, \$3.68 each (2), from Woodworker's Hardware 800/383-0130.

shop TIP

Easy on the power driver

Use a slow speed on your power driver when you're screwing into the edge of plywood so that you can stop as soon as the screw's head seats into its countersink. If you try to use too much speed or power, the screw's threads can spin after the fastener's head seats, chewing away the wood fibers. This dramatically reduces the screw's holding power.

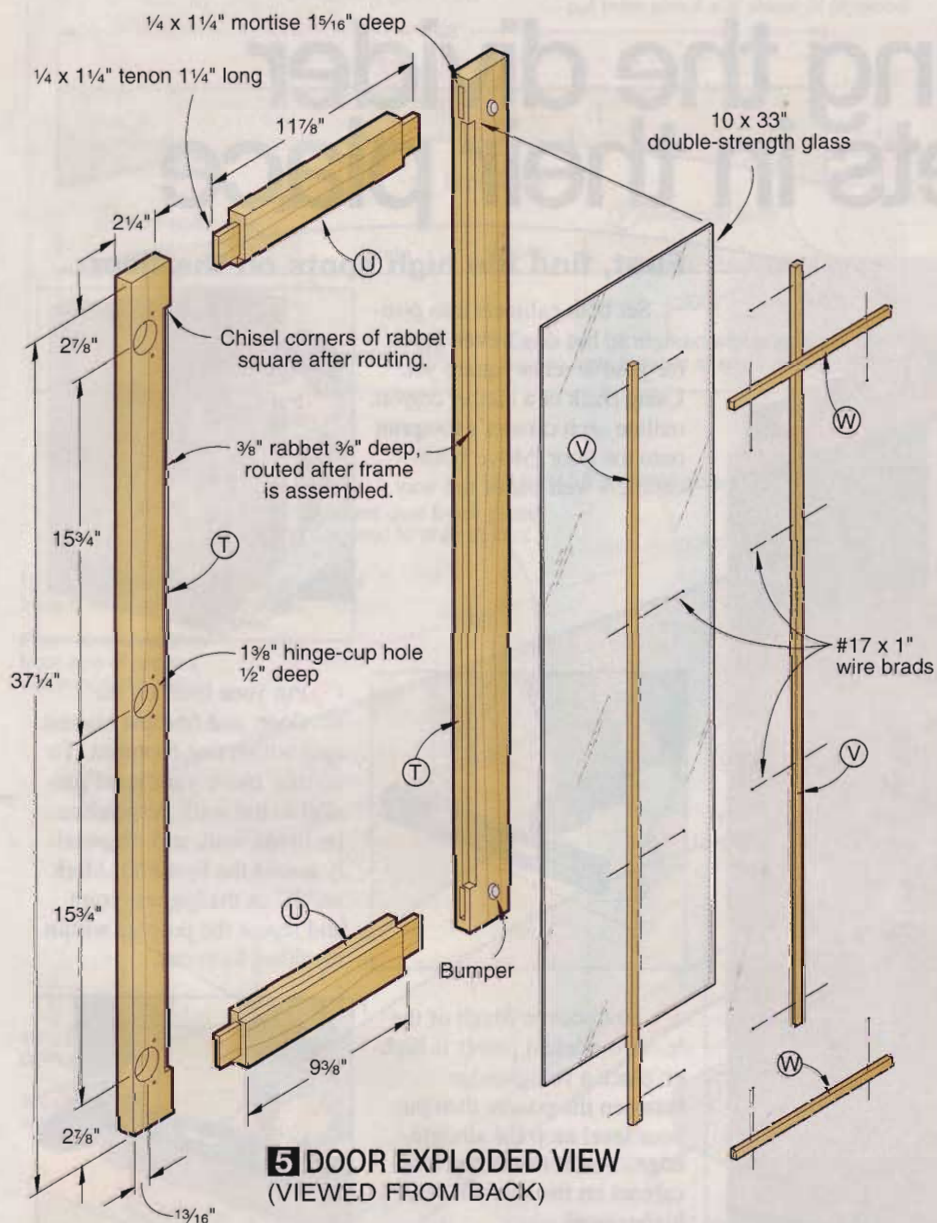

5 DOOR EXPLODED VIEW
(VIEWED FROM BACK)

5a MORTISE DETAIL

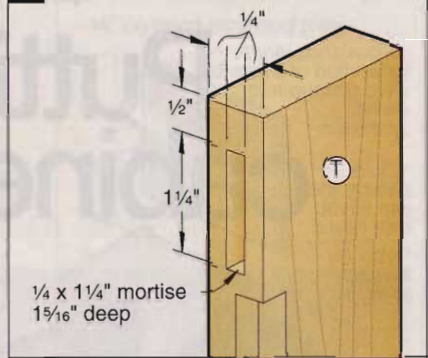

5b TENON DETAIL

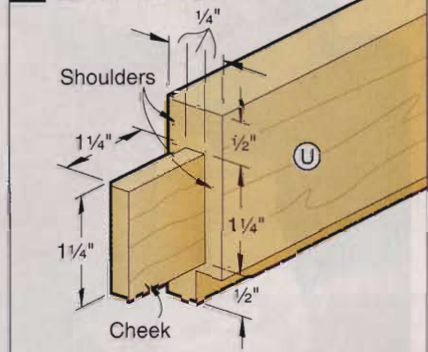

5c HINGE DRILLING DETAIL

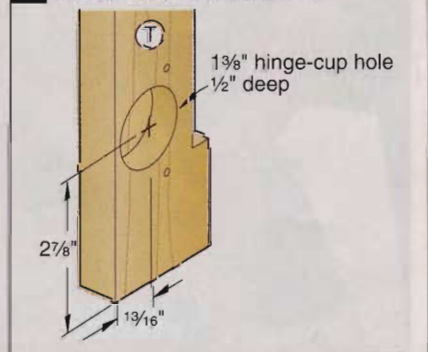

35mm or 1 3/8" Forstner bit, and install the hinges. Using the holes in the hinge-cup flanges as guides, drill pilot holes and drive the screws. Mount the plates in the carcass, where shown in **Drawing 3**, and test-fit the doors. Then remove the hinges and plates.

5 Take the completed door assemblies to a glass shop, and have double-strength glass cut about 1/8" smaller than the size of the rabbeted opening. (We had a local art-glass shop create the leaded-glass design shown in the photos.) Have the glass shop cut the 1/4"-thick

cabinet shelves, and have them seam the edges. When you get home, store the glass safely until after applying the finish. Cut and fit the vertical and horizontal glass stops (V, W), and drill holes for the brads. Set these parts aside for now. Referring to **Drawing 3**, drill the mounting holes for the knobs.

You're at the finish line

1 Apply your choice of clear finish to all of the wood parts. We first brushed on one coat of Minwax gloss polyurethane varnish, then, when dry,

sanded it with 220-grit sandpaper. After removing the dust with a tack cloth, we applied a second coat of Minwax satin polyurethane varnish.

2 You'll add the doors, bumpers, and top after you've installed the cabinet. For instructions on installing the cabinets, see the following article. 🌲

Written by **Robert J. Settich** with **Doug Guyer**
Project design: **Kevin Boyle**
Illustrations: **Kim Downing; Roxanne LeMoine; Lorna Johnson**
Photographs: **Baldwin Photography; King Au/Studio Au**

Putting the divider cabinets in their place



At first, the idea of installing the divider cabinets sounds easy enough. But when you check the installation site, you realize that the framing crew who built your house didn't own a level. And so many things happen over time to even the most carefully built house: Joists shrink, studs bow, and foundations settle. Fortunately, our installation procedure helps you overcome wavy floors and less-than-perfect walls.

First, find the high spots on the floor

1 Set both cabinets into position, but don't even reach for your level or square yet. Using chalk or a lumber crayon, outline each cabinet's footprint onto the floor. Move both cabinets well out of the way.

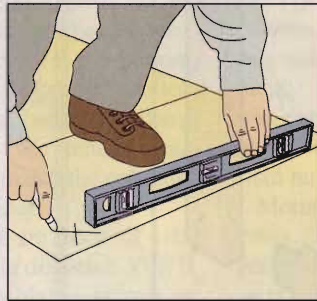

2 Put your level on the floor, and find the highest spot within one footprint. To do this, move your level parallel to the wall, perpendicular to the wall, and diagonally across the footprint. Mark an "X" at the highest point, and repeat the process within the other footprint.

3 To discover which of the two marked points is higher, place a straightedge between the points, then put your level atop the straightedge. You'll install the first cabinet on the side with the higher mark.

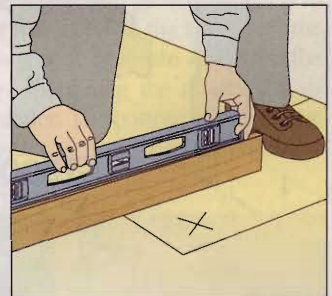

shop TIP

Leveling over a ridge

If there's a crown in your floor between the two high points, simply place a scrap block of 2x4 at each high point, then bridge your straightedge between the blocks.

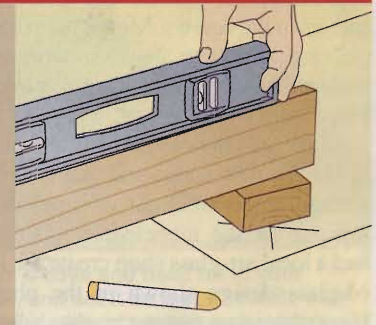

Prepare the cabinets for installation

1 Set the first cabinet onto its footprint, then level the cabinet from side to side by sliding tapered softwood shims below the base of the cabinet. Keep the cabinet snugly against the wall as you level it. After you level the cabinet side-to-side, check it from front to back, tapping in the shims until the cabinet is level in both directions.



2 Use a framing square to check that the front and back of the cabinet are square to the wall. If your wall is curved, adjust the cabinet so that the square has the same reading at the front and back. Use duct tape to secure the shims to the floor.

3 Set your scribe $\frac{1}{16}$ " larger than the biggest wall-to-cabinet gap. Run a strip of masking tape down each end of the cabinet that touches the wall. Run the scribe down the wall to mark along the tape.

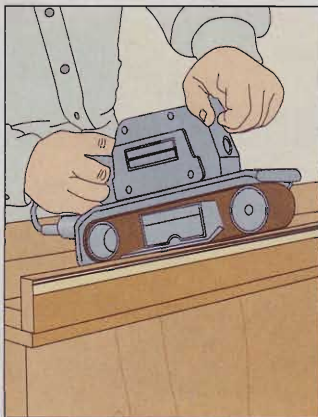
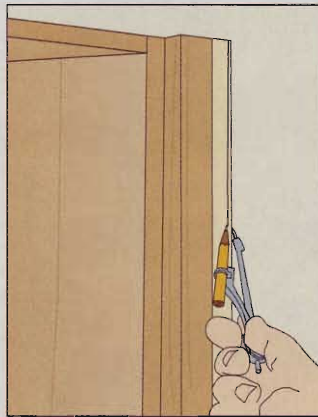

4 Recruit a helper, and lift the cabinet straight up and off the shims. Fasten the shims to the floor inside the cabinet's marked footprint with brads. Lay the cabinet on its paneled end and use a belt sander to remove stock to the scribed line. Slightly tilt the sander toward the center of the cabinet to undercut for a snug fit against the wall. Repeat for the line scribed along the back.

Secure the cabinets in place

1 Replace the cabinet on the shims, and push it against the wall. Run the wire for the lights through a hole in the wall that will be covered by the upper top. Drill angled pilot and counterbored shank holes close to the floor through the cabinet's baseboards. Toe-screw the cabinet to the floor, making sure the screwheads do not protrude. Trim the shims flush to the baseboards.

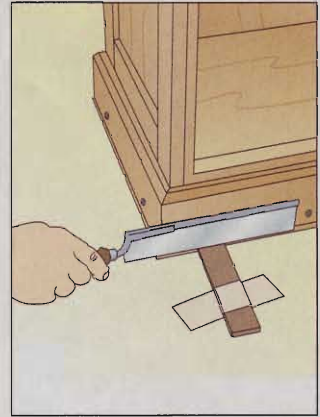

2 Span a level straightedge from the installed cabinet's top to the opposite wall, and make a mark. Shim the second cabinet so its top edge aligns with the line marked on the wall. Use a straightedge to align its front and back with the first cabinet. As with the first cabinet, secure the shims, scribe, and fasten the second cabinet in place.

3 Install the lights, following the manufacturer's instructions. Set the upper tops on the cabinets, centered front to back, with their ends against the walls. Apply tape, scribe the ends to the walls, and belt-sand to the scribed lines. Drive $\#8 \times 1\frac{1}{4}$ " flathead screws from inside the cabinets to secure the tops. Make molding with the same chamfered top as the baseboards, that is tall enough to cover the toe-screw heads. Miter-cut it to length and nail it to the cabinets' bases. Fill the nail holes, sand the filler smooth, and finish the molding. Put in the shelves, and attach the doors. 🌲



Written by **Robert J. Settich** with **Doug Guyer**
Illustrations: **Mike Mittermeier**; **Lorna Johnson**
Photographs: **Baldwin Photography**

Let there be light

Our electrician added an outlet in the basement, and plugged in the lights' transformers there. He then installed a wall switch in the kitchen to turn the outlet on and off, controlling the lights in both cabinets.

create architectural art

Introduce a classic look
with columns and arches.
We'll show you how.



The room divider cabinet described in the preceding article would look great in almost any setting. But in our Handcrafted Home kitchen renovation, we added a couple of special architectural features to help it shine even brighter. We installed ornamental columns atop the cabinets, and connected them to a gently arched soffit overhead.

Special features call for special techniques. How can you plan and build an arch? And what's the best way to form a column? Stick with us for the answers.

Fashion a sophisticated sweep

As we remodeled the kitchen, we added wall studs and blocking between ceiling joists to provide solid attachment points for the arch. If you don't plan to tear into the walls and ceiling as you remodel, consider placing the arch to take advantage of the existing framing.

Start with graph paper when you're laying out an arch. Draw the area to scale, then design a gentle, symmetrical curve that's pleasing to the eye. Ours flows from a 12" height at the ends to

6¼" at the middle of a 108" span, as shown in **Drawing 1**.

To transfer that curve to ¾" plywood or particleboard, mark the end points and centerpoint on the sheet goods with a pencil. Drive a nail halfway in at each point. Cut a ⅛" strip of scrapwood long enough to contact all three nails, and use it as a fairing stick. Place it against the end points, then push the middle up to the centerpoint. Mark the resulting curve with a pencil.

Cut the resulting line carefully with a jigsaw to form the upper arch (A). If your arch is longer than a single sheet, mark the curve on sheets butted together. Keep it as smooth as possible, but remember that minor flaws will disappear under the drywall that's still to come. Save the waste material to be used later.

If you make your arch in two pieces, join them with ¾" plywood about 12" long and slightly narrower than the center portion of the arch. Attach this glue block (B) with glue and screws, as shown in **Drawing 2**. Trim the ends so that the arched pieces fit perfectly in place between the walls. Then, cut two ¾" plywood end dividers (C) to fit between the arches ¾" from each end. Ours measured 12x14" squares. Add ¾" plywood dividers (D) between the sides, spaced approximately 2' apart. Screw the sides and dividers together to form the box-like structure shown in **Drawing 2**. Finally, attach a bottom (E) made with two layers of ¼" plywood.

We wanted our vertical columns to meet a horizontal surface, so we added the mini-soffits you see in **Drawing 2**. We formed the sides (F) from the scraps left by cutting the arches, so the curves match. Cut each ¾" plywood end (G) 10" long and wide enough to match the sides. Then, cut the bottom (H) 10" wide and 29⅞" long. Screw each mini-soffit together, and use a belt sander to bevel parts G and H to match the sides. Attach these units to the upright arch with screws from inside the upright arch.

To make the mounting plates shown in **Drawing 2a**, cut two pieces of ¾" plywood (I) to fit between the sides of the arch. Apply construction adhesive to both sides, then drive screws through the plates and into the studs. Find a helper, and slide the arch structure into place. Drive screws through

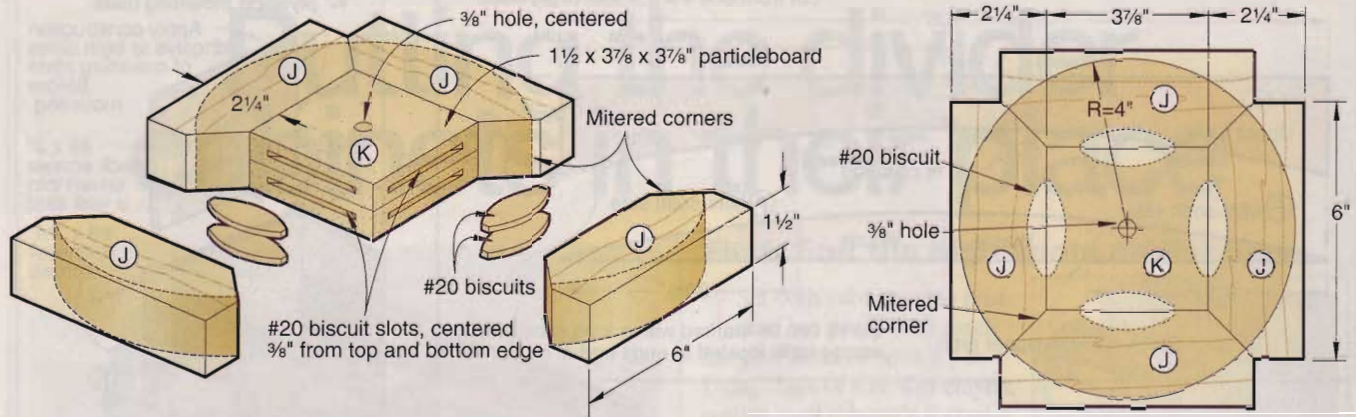

3 BASE AND CAPITAL BLANK ASSEMBLY

Thanks to a product called Hollowood, you can buy hollow columns 8' long, in a wide range of diameters and wood species. The manufacturer offers cherry, mahogany, maple, oak, walnut, and several exotics. We made our columns 45" tall, but you could use the same procedures to go from floor to ceiling. Don't plan for a pair of columns slightly over 4', if you could keep them shorter, because you'll waste most of an 8' piece.

The manufacturer uses several thin plies of poplar to make a tube. Then, a handsome, hardwood veneer goes on the outside, with the grain running the length of the column. The total wall thickness of the larger ones is about 1/4".

Our cherry columns, 6" in diameter, cost \$17.82 per foot from the BrandNew company. Call 800/964-8251 to get information. To learn more about this product, see Talking Shop on page 22.

Traditional trappings, top to bottom

The bottom end of each column nests inside a round, profiled, hardwood base 8" in diameter. An identical piece serves as a capital at the top of the column. Square, hardwood blocks at the bottom and top, respectively, are properly called the plinth and the entablature, and complete the assembly. We made these pieces from cherry to match the columns and room divider cabinets.

The base and capital are made of 1 1/2" stock and measure 8" in diameter. You'll shape them from the blanks shown in **Drawing 3**. Using 1 1/2"-thick hardwood of the same species as the columns, cut four sides 2 1/4" wide and 6" long (J). Cut a partial miter on all of the ends, making the short edge 3 7/8". Then, make a center square (K) from plywood or particleboard, laminated to a 1 1/2" thickness. Cut

it to 3 7/8" on each side. Using two biscuits per joint, glue and clamp the four sides and the center into a single block.

The groove that receives the column must be cut to the exact diameter of that column. A wing cutter works well for this task. If you don't have one of these handy accessories, Woodcraft carries one capable of cutting 8" circles, priced at \$27.99. Call 800/225-1153, and order item number 16N41.

Mount the wing cutter in your drill press, clamp a piece of scrap on the table, and make a test cut. When the column fits snugly into place, you've found the right cutter setting. Form a groove 3/8" deep in the top of the base and the bottom of the capital, as shown in **Photo A**. Widen the groove by shortening the cutting arc of the wing cutter. The bottom of the groove should be at least as wide as the column's wall thickness.

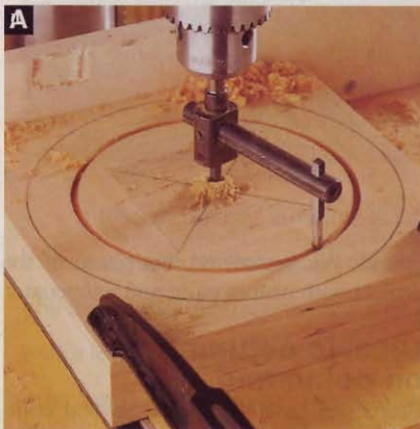

Keep your drill press speed low and make sure the workpiece is clamped securely when using a circle cutter.

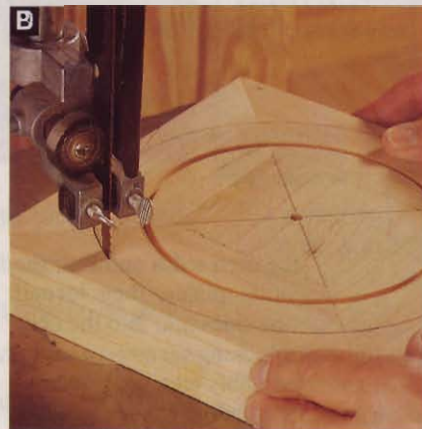

Leave the pencil line as you cut the workpiece into a rough circle. Take the piece to a disc sander to true it up.



Mount a cove and bead bit in your router, and set it so that it rounds over the edge without cutting a shoulder.

Place a compass in the center hole, and draw a circle 8" in diameter. Cut close to the line on your bandsaw, as shown in **Photo B**, then carefully sand to the line on a disc sander.

We used a $\frac{3}{8}$ " radius cove and bead router bit from Eagle America to make the profile around the base and capital. Call 800/872-2511 and order part number 178-3345, priced at \$65.99, plus shipping and handling.

Stick a piece of cloth-backed, double-faced tape on the top of the workpiece and press the piece, top-down, onto a piece of scrap at least 6" wide and 15" long. Run a 2" screw through the center hole and into the scrap. Then, clamp the scrap to your workbench.

Set the bit to cut a round-over profile only, and rout counter-clockwise around the workpiece. Hold the ball bearing pilot firmly against the wood as you rout. Then, remove the screw, flip the workpiece over, stick a new piece of double-faced tape on the bottom, screw the workpiece to the scrap piece once again, and you'll produce the results shown in **Photo C**.

Now, complete the profile. Make two or three passes, lowering the bit slightly each time, until you've reached the working depth of the bit, as shown in **Photo D**. A flat area will remain between the round-overs. Sand lightly to add some curvature there.

For the plinth and entablature, shown in **Drawing 4**, cut enough $1\frac{1}{2}$ "-thick stock $2\frac{3}{4}$ " wide to make eight mitered pieces (L), each one 9" on its longer edge. Glue these pieces into two squares, using a pair of biscuits at each corner.

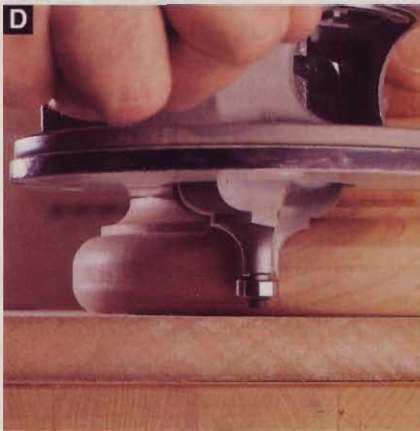

D Here, the final profile appears to the left. On the right side, you see the result of the previous, shallower pass.

4a CROSS-SECTION DETAIL

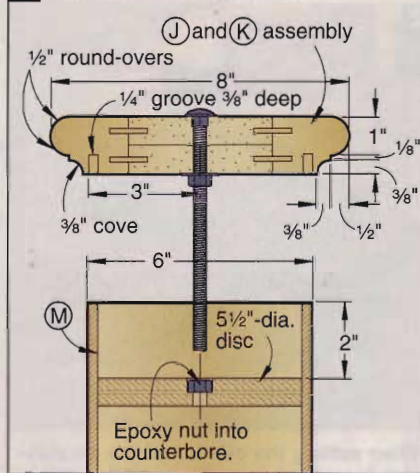

5 COLUMN LENGTH DETAIL

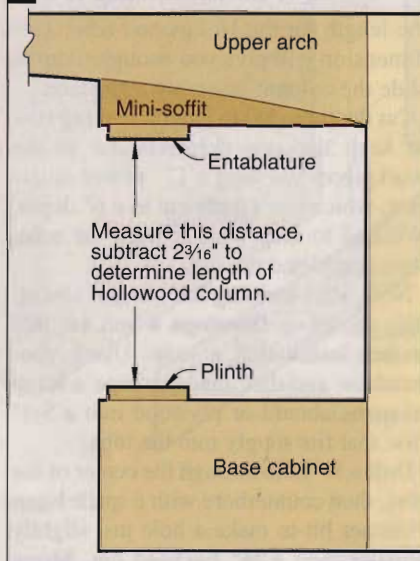

Let's cut and assemble the column

It would be tough to make a solid column the exact length needed, then slide it into place. Fortunately, you don't have to do that. The secret to a snug, secure placement lies hidden inside each of our finished columns.

But first, let's prepare a place for each column to stand. We dropped a plumb line from one side of the mini-soffit and made a mark on a piece of masking tape on the top of the cabinet, which is centered under the arch. We measured 1" in from the soffit edge and 1" in from the mark on the cabinet top to determine the location for one edge of the entablature and the corresponding edge of the plinth. The mini-soffit was designed to the same length as the cabinet, so a 1" set-

4 COLUMN EXPLODED VIEW

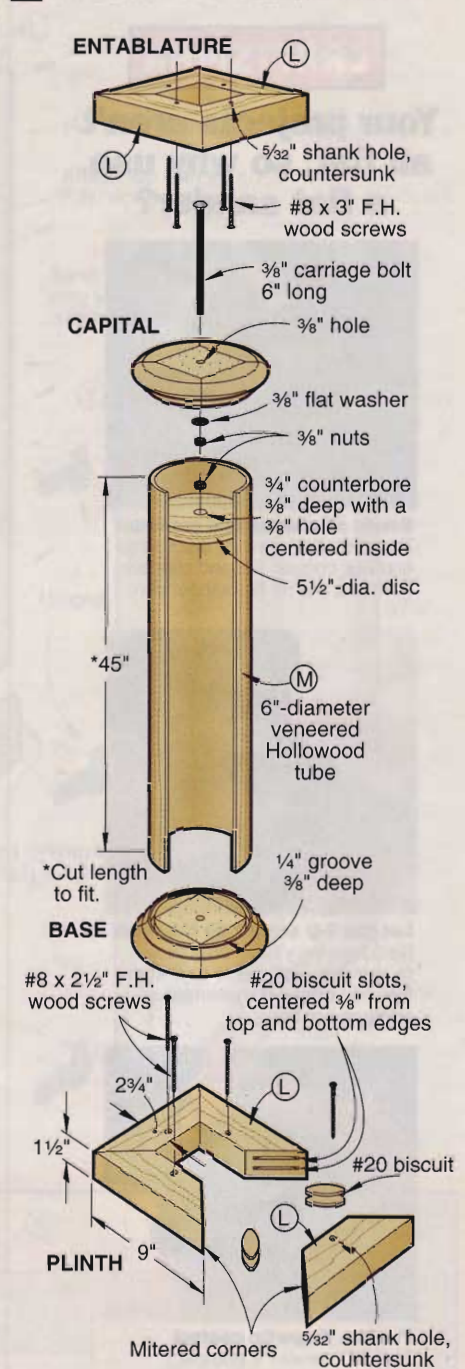

back from the end of the soffit and the end of the cabinet completed our location measurements.

Attach the plinth to the cabinet with screws, as shown in **Photo E**. Locate the screws where the column base and capital will hide them.

Use a tape measure to find the distance from plinth to entablature, as shown in **Drawing 5**. Subtract $2\frac{3}{16}$ " to determine

CRAFTSMAN

Your projects aren't all flat, so why use a flat sander?



Sands all shapes and contours
Three rotating sanding discs wrap and hug convex, flat and concave surfaces like no flat sander can.



Let the 3-D sander do the work
Requires very little pressure to remove rust, paint and stain from a variety of materials and surface contours.

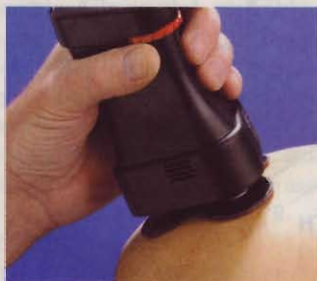

Precise fingertip control
The 3-D sander's compact design fits comfortably in your palm for one-hand operation. Turn the dial to adjust sanding speeds of 800 to 2600 rpm.

Available at Sears, Sears Hardware,
and the Craftsman Catalog
at 800-437-9686

SEARS

architectural art

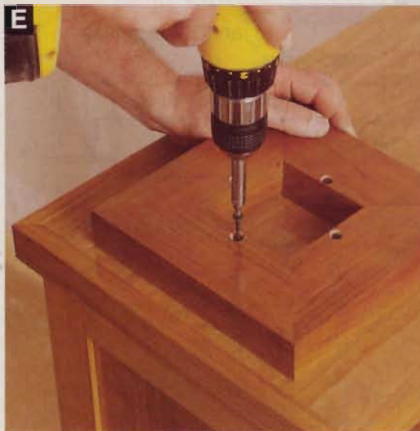

E
When setting the plinth and the entablature, locate the screws where they'll be hidden by the base and capital.



F
A long bolt allows you to adjust the height of the column. A shaped hole and epoxy prevent the nut from turning.

the length for the Hollowood tube. This dimension will give you enough room to slide the column assembly into place.

Cut the tube (M) to length, making sure to keep the saw perpendicular to the workpiece. We used a 12" power miter-saw, which can't quite cut to a 6" depth. We had to stop once to turn the tube, then completed the cut.

Now, start building the internal assembly, shown in **Drawings 4** and **4a**, that makes installation a snap. Using your bandsaw and disc sander, shape a scrap of particleboard or plywood into a 5½" disc that fits snugly into the tube.

Drill a ⅜" hole through the center of the disc, then counterbore with a spade bit or Forstner bit to make a hole just slightly smaller than a ⅜" hexhead nut. Shape this hole with a chisel to accept the corners of the nut, so that it fits snugly and won't turn. Spread epoxy around the

sides of the hole, and insert the nut, making sure to keep the adhesive out of the threads. Wait for the epoxy to harden.

Spread yellow glue around the inside of the tube, 2" below the rim. Slide the disc into place, and let the glue dry.

You could wait until after installation to apply a finish, but it's more easily done now. Finish-sand all of the components, and apply two or three coats of polyurethane varnish to all of the exposed surfaces, sanding lightly between coats with 220-grit sandpaper.

Now, set the column in its base on the floor. Run a ⅜" carriage bolt, 6" long, through the capital from above, and tighten it to the capital with a ⅜" nut and washer. Start the bolt into the disc inside the column, as shown in **Photo F**.

Turn the capital clockwise, as viewed from above, until the tube bottoms out in the groove. Apply a thin layer of 2-hour epoxy to the bottom of the base and the top of the capital. Set the assembly on the plinth, align the base joints with the plinth joints, and have a helper hold it in place. Turn the capital clockwise, as viewed from below, until it contacts the entablature. See **Photo G**. Make it snug, and align the miter joints.

Check to see if the finish needs any touch-up where the column moved against the base and capital. If so, sand that area lightly and apply another coat of finish to the entire column. 🌲



G
Apply epoxy at both ends, then slip the column assembly onto the plinth. Turn the capital to lock everything in place.

Written by **Jim Pollock** with **Doug Guyer**

Project design: **Kevin Boyle**

Illustrations: **Kim Downing**; **Roxanne LeMoine**;

Lorna Johnson

Photographs: **Baldwin Photography**; **D.E. Smith Photography**

dynamic duos

No energy crisis here—these cordless drill-and-saw kits work long and hard, anywhere you take them.





Cordless saws: Who needs 'em?

Some of us have had a cordless circular saw for years: the one in the bottom drawer with the accidentally severed cord. Frankly, when we decided to do this test, we wondered if we'd use a battery-powered saw in our shop more than that one. After all, we're never that far from an electrical outlet. (Of course, you can make the same argument about a cordless drill, which is now a staple in most shops).

Before we knew it, we were using those handy saws all over the place—breaking down sheet goods to make them more tablesaw-manageable, crosscutting hardwood pieces too long (or wide) to conveniently cut on the miter saw—and finding ourselves very satisfied with the results. (And we never had to worry about amputating that annoying power cord!)

Although impressive in their performance and convenience, these premium cordless saws come with a hefty price tag. But, when purchased in combination with another tool, the cost falls about in line with a good corded saw.

Cordless tools certainly have come a long way since Black & Decker introduced the first cordless drill 40 years ago. Voltages and run times have climbed to keep pace with the ever-growing number of tools using rechargeable batteries. From biscuit joiners to mitersaws to routers (see Tool Industry Insider on page 32), cordless technology is everywhere in the workshop. In fact, manufacturers tell us that cordless-tool combination kits containing at least two tools are selling like crazy, owing to their convenience and lower per-tool price.

But do these untethered tools belong in your shop? To find out, we gathered six high-powered cordless drill and circular saw kits and put them through a battery of tests. Most kits operate on an 18-volt platform, but two manufacturers, Panasonic and Porter-Cable, don't make an 18-volt tool, so we chose the next-closest voltage they offered (15.6V and 19.2V, respectively).

Incidentally, we opted not to include the rock-bottom priced kits in this test. In our preliminary research, we discovered that such low-dough models don't deliver the power or longevity of the tools in these premium-priced kits.

How we put the screws to the cordless corps

Before we began any testing, we ran all of the batteries through six charge/discharge cycles, allowing each charger to "top off" the battery in trickle mode for 30 minutes between cycles. This assured that all batteries were at full capacity for our tests.

Note: Due to differences in testing methods, our test results may vary from advertised ratings. Because we tested the tools in this article identically, our results accurately compare these tools to one another. However, don't compare our ratings to the advertised specs of tools not in this test.

First up: drills. To compare run times of the batteries in a real-world way, we drove 1½" drywall screws into pine until the drill could drive no more, then counted the number of screws per charge. Then we chucked a sharp 2" Forstner bit into each drill and bored holes through 5/4 red oak, again counting the number drilled before the battery drained. We performed both tests three times and averaged the results. (After driving more than 10,000 screws and boring more than

150 holes, you don't want to arm wrestle our tool tester!) Finally, using a shop-made adapter, we mounted a torque wrench to each drill's chuck, pulled the trigger, and after three tests recorded the average maximum torque produced.

Next, we put a fresh battery in each circular saw and ripped 5/4 red oak, ¾" pine, and ¾" hardwood plywood until the battery drained. After three tests in each material, we averaged the number of inches cut on each charge. To quantify the torque produced by the saws, we attached a torque wrench to the arbor nut of each, started the saw, and noted the average maximum torque of three trials.

Eventually, one of these tools is going to take a tumble, so we dropped all of them onto a concrete floor from a height of 35" to see how they handled the impact. All survived intact, except the Bosch and Porter-Cable circular saws, both of which suffered a minor bend on their shoes.

A bit about the drills

In our test of 12-volt cordless drills in issue 119, we found that few woodworking tasks require more than about 200

TEST RESULTS: DRILLIN' AND DRIVIN'

	2" holes bored through 5/4 red oak	1½" drywall screws driven in pine
BOSCH 3860CK	7	469
DEWALT DW987KS-2	11	393
MAKITA DK1016BL	8	390
MILWAUKEE 6310-26	13	536
PANASONIC EYC133	9	747
PORTER-CABLE 9884CS	10	529

dynamic duos

inch pounds of torque to complete. Only driving lag screws without a pilot hole and cutting with holesaws 1½" or larger needed more oomph. In this test of higher-voltage tools, we found that all had plenty of power, barely breaking a sweat performing those chores.

High torque comes at the expense of chuck speed, so we prefer a tool that can deliver enough power for the job without taking forever to finish it. In our tests, the Milwaukee drill provides the best combination of power and speed, followed by the Makita.

While most of the drills in our test have two gears, DeWalt's drill has three: low, high, and one called "Max." The low and high settings compare about equally to the other drills in the test, and we clocked "Max" at 1,840 rpm (no load).



A Milwaukee's battery mounts two ways: nose-forward (right) for better balance, or nose-backward (left) for close quarters drilling and driving.



B This dust-deflecting tube on the Porter-Cable circular saw rotates about 270° to redirect dust away from the operator.

This setting provides increased speed and enough torque to drive screws without pilot holes, and enough speed and torque for improved hole-quality with twist-drill bits up to ½".

We found a few more things not directly related to performance that you should think about before buying:

•**Chuck design.** Three of the drills in our test (Bosch, DeWalt, and Panasonic) have one-piece chucks. The motor arbor won't turn on these models unless the trigger is pulled, so you need only one hand on the chuck to tighten it on a bit. We prefer this to the two-piece design that requires both hands on the chuck to tighten it.

•**Size.** From the tip of its chuck to the back of its case, the Panasonic drill mea-



C We found the safety release button on the Porter-Cable saw difficult to reach with our hands in operating position.

sures only 8¼", making it a good choice for tight quarters. Milwaukee's drill, at nearly 12", is the longest in the test. However, its battery can be reversed, as shown in **Photo A**, to get the nose of the drill deeper into tight corners.

Let's go a few rounds with the circular saws

Unlike the low-voltage, small-bladed cordless saws of just a few years ago, these saws feel and act more like their corded counterparts. The saws from Milwaukee and Porter-Cable turned in average maximum torques of 80 and 87 inch pounds, respectively, and using them we felt as if we were cutting with corded tools. Makita turned in a 67 inch-pound

HOW THEY CUT IT: A CIRCULAR SAW ROUNDUP

Number of inches cut on a single battery charge. Average of three tests.

ripping 5/4 red oak
 ripping ¾" pine
 ¾" hardwood plywood

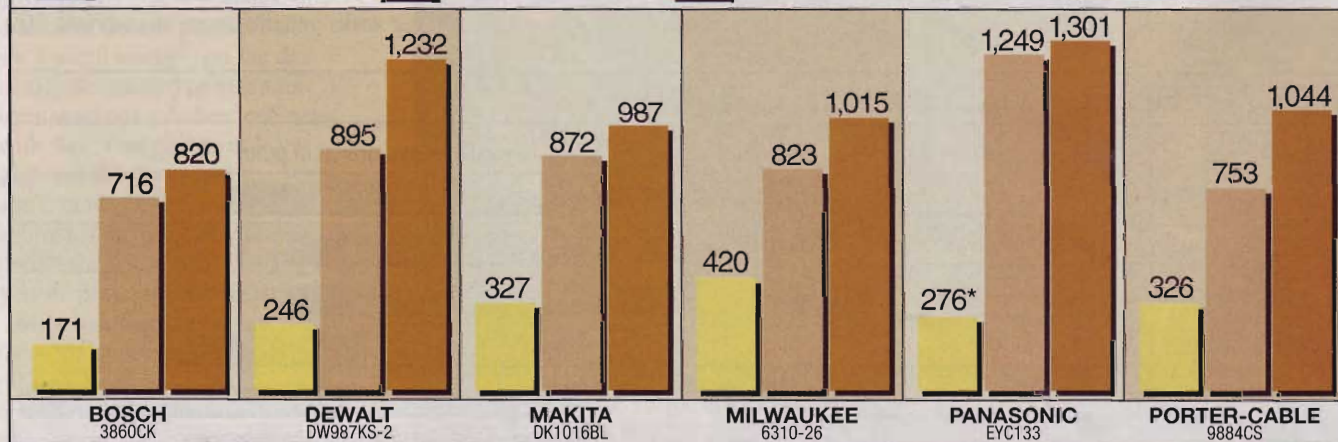

*In the first test, this saw cut 606", but the motor began smoking at 470". The motor was allowed to cool and three more tests were run. The average shown is for the last three tests.

we felt as if we were cutting with corded tools. Makita turned in a 67 inch-pound performance while Bosch, DeWalt, and Panasonic averaged about 50 inch pounds. Even so, we never felt at a loss for power when using these saws, even when ripping 5/4 red oak—a tough test for any tool.

As for the quality of the cut, we're fairly impressed, especially given that these tools were designed with carpentry, not woodworking, in mind. Guided by a straightedge, rips and crosscuts we made in solid-stock, and rip-cuts in plywood, were clean with only occasional tooth scratches on the sawn edge.

Plywood crosscuts are another story, but that's true of any circ saw, corded or not. Because the blade cuts from the bottom up, we found splintering and tearout as far as 3/4" from the kerf on the top of the workpieces. On the other hand, we found the underside of the cuts pretty much tear-out-free. Our advice: Leave yourself plenty of margin for tablesaw cleanup when crosscutting plywood, cut with the material face down, or cover the cutline with masking tape to prevent top-side tear-out.

Performance issues aside, we found some other differences in the saws that may affect your buying decision:

•**Dust control.** Bosch and Porter-Cable make provisions for dealing with the dust (which otherwise tends to be thrown in your face), both in different ways. Bosch engineers put a spring-loaded door for a vacuum hose on the top back of the saw's blade guard. With the Porter-Cable, you can direct the dust flow wherever you want using the included deflecting tube, shown in

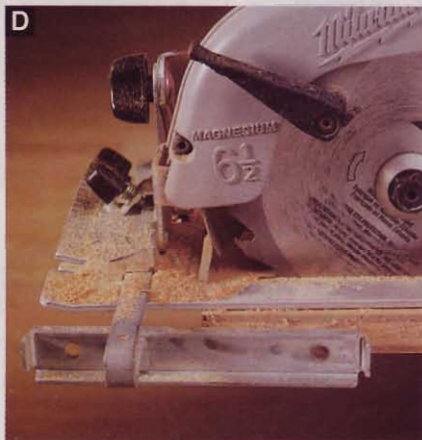

D The long rip fence on the Milwaukee saw kept the saw on track all the way to the end of the sheet.

Battle of the batteries: an industry-wide power struggle

Although nickel-cadmium (NiCd) is the seasoned veteran of cordless-battery technology, a young upstart—nickel-metal hydride (NiMH) has been turning heads in the last several years. But which is the better battery for high-drain applications, such as cordless power tools? That depends on who you ask.

NiCd proponents Bosch and DeWalt say that NiMH batteries cost more and offer fewer charge cycles than NiCd batteries. Bosch's Tom Schwalie says, "We've had NiMH in our lineup—we still do in Europe due to environmental regulations there—but we're going back to NiCd in the U.S.," because, he says, NiCd has more advantages than disadvantages, including a higher discharge rate, which makes it better for high-drain tools, such as circular saws.

Jason Gogert of DeWalt agrees. "After a great deal of testing in the lab and in the field, we've concluded that NiMH batteries are not ready for our customers." He cites research showing that the cycle life of NiMH batteries (the number of times a battery can be recharged) is about half that of NiCd.

Panasonic's Doug Bock says the limited life-cycle notion is outdated. "At first that may have been true because we were trying to use NiCd charging technology with NiMH batteries." However, using the correct charger, Bock says NiMH batteries should equal NiCd in the number of charge cycles. (Panasonic guarantees both their NiCd and NiMH batteries for 1,500 cycles.) As for NiMH's suitability for high-drain applications, Susan Gross of Moltech, maker of Makita's NiMH batteries, points to the Toyota Prius, a gas/electric hybrid car that uses 38 sealed NiMH modules as its power source.

Both camps can agree on a few points. First, NiMH is a denser technology, so you get longer run times out of same-sized cells, or similar run times out of smaller, lighter batteries. And, NiCd technology has just about reached its limit both in terms of power and run times, while NiMH has room to grow. Bock predicts you'll see 4.0 amp-hour NiMH batteries by 2003—nearly twice the run time of the current crop of NiCd batteries.

Photo B. The dust port also accepts Porter-Cable's optional dust bag.

•**Safety switches.** To prevent accidental startup, each saw has a safety release that you must trip before you trigger the switch. Except for the release on the Porter-Cable saw, which was nearly beyond the reach (see **Photo C**) of even the longest-thumbed *WOOD*® magazine staffer, all operate easily with either the left or right hand.

•**Rip fences.** Most of the saws, except for the Panasonic and Porter-Cable, come with a rip fence to guide the saw for narrow cutoffs. We especially liked Milwaukee's (**Photo D**) because it reached nearly to the center of the blade. Shorter fences cleared the end of the board before the blade, leaving the last couple of inches of the cut unguided.

•**Blade brakes.** This mechanism stops the blade rotation instantly upon release of the power trigger. We liked this safety feature, found on all of the saws except the DeWalt and Porter-Cable.

•**Depth of cut gauges.** Call it a nicety, rather than a necessity, but the Bosch and Milwaukee saws have a depth-of-cut scale built into their blade guards. Of the two, we found Bosch's scale (**Photo E**)

easier to read than the Milwaukee scale, which is partly blocked by the handle.

Battery matters

Ask a cordless-tool user what they would improve about the tool, and they'll likely answer "longer run time and more power." Truthfully, most of us just want enough power to do the job without running out of juice mid-project. Except for torque-hungry tasks, such as boring with big Forstner bits, any of the batteries in our test should allow a woodworker to go all day—possibly all week—without reaching for that second battery.



E Clear markings and good location make Bosch's depth scale the best in the test. The door on top of the blade guard opens to accept a dust-collection hose.

BATTERIED AND BRAVY: RATING KITS WITH A CORDLESS DRILL &

MANUFACTURER/ IMPORTER	MODEL	BATTERY				DRILL DRIVER							CIRCULAR SAW										
		VOLTAGE	AMP-HOURS	TYPE (1)	REPLACEMENT COST	MAXIMUM CHUCK SPEED (LOW/HIGH GEAR, RPMs) (2)	CHUCK DESIGN (1-PIECE OR 2-PIECE)	NUMBER OF TORQUE SETTINGS	WEIGHT (POUNDS) INCLUDING BATTERY	COUNTRY OF ASSEMBLY (3)	MAXIMUM TORQUE (LOW GEAR)	PERFORMANCE RATINGS (4)			BLADE DIAMETER (INCHES)	BLADE REPLACEMENT COST	ARBOR SPEED (RPMs) (2)	RIP FENCE INCLUDED? (Y)ES, (N)O	BLADE BRAKE? (Y)ES, (N)O	MAXIMUM DEPTH OF CUT INCHES, (0°/45°)	MAXIMUM BEVEL (DEGREES)	WEIGHT (POUNDS) INCLUDING BATTERY	COUNTRY OF ASSEMBLY (3)
												BATTERY RUNTIME	E	G									
BOSCH	3860CK	18	2	NiCd	\$85	396/1,411	1	16	5.6	S	E	G	G	E	5 3/8	\$15	3,791	Y	Y	1 5/8 / 1 1/4	50	8.9	M
DEWALT	DW987KS-2	18	2.4	NiCd	\$80	370/1,381*	1	22	6.1	U	E	E	F	E	6 1/2	\$10	3,941	Y	N	2 1/4 / 1 1/2	50	8.8	U
MAKITA	DK1016BL	18	2.2	NiMH	\$85	451/1,452	2	16	5.8	J	G	G	F	G	6 1/2	\$20	2,815	Y	Y	2 1/8 / 1 1/2	50	8.3	J
MILWAUKEE	6310-26	18	2.4	NiCd	\$85	481/1,531	2	20	6.3	G	G	E	G	E	6 1/2	\$12	3,400	Y	Y	2 1/8 / 1 9/16	50	9.8	U
PANASONIC	EYC133	15.6	3	NiMH	\$90	430/1,440	1	18	4.4	U	G	G	E	E	5 3/8	\$30	3,285	N	Y	1 13/16 / 1 3/16	45	6.7	J
PORTER-CABLE	9884CS	19.2	2.2	NiCd	\$80	430/1,290	2	21	5.9	T	G	E	G	E	6	\$10	3,120	N	N	2 / 1 1/2	45	9.7	U

NOTES:

- 1. (NiCd) Nickel cadmium (NiMH) Nickel-Metal Hydride
- 2. Measured with phototachometer. (*) This model has a third speed, called "max," whose maximum speed measured 1,840 rpm.
- 3. (G) Germany (J) Japan (M) Mexico (S) Switzerland (T) Taiwan (U) United States
- 4. **E** Excellent **G** Good **F** Fair
- 5. Damage resulting from 35" drop to concrete floor.
- 6. (*) Included in this kit (M) Miter saw (B) Biscuit joiner (BL) Blower (H) Hammer drill (J) Jigsaw (L) Work light (R) Reciprocating saw (RC) Radio/charger (RH) Rotary hammer (RL) Rotary laser level (RT) Router
- 7. (*) Selling price not yet established. Price shown is manufacturer's estimate.

FOR MORE INFORMATION:

Bosch
877/267-2499
www.boschtools.com

DeWalt
800/433-9258
www.dewalt.com

For specifications on other types of tools, click on "Tool Comparisons" at <http://www.woodmall.com>



Bosch 3860CK
A solid-performing drill, but the circ saw lacks the power and run time of other kits costing about the same.



Makita DK1016BL
The only kit in the test that comes with a work light. That and NiMH batteries make this kit a bit more expensive than others.



DeWalt DW987KS-2
Three-speed drill gear box provides higher speeds for better-quality holes in hardwoods. Lots of other products on the same battery platform.



Milwaukee 6310-26
Both drill and saw turned in top performances at a reasonable price. Our pick for best overall kit.

CIRCULAR SAW

		PERFORMANCE RATINGS (4)						
MAXIMUM TORQUE	BATTERY RUNTIME	BLADE/CUT QUALITY	DROP TEST (5)	BALANCE	OTHER PRODUCTS THAT USE SAME BATTERY (6)	WARRANTY (YEARS)	SELLING PRICE (7)	
F	F	G	G	E	L, R	1	\$420*	
F	G	G	E	G	B, H, J, L, R, RC, RH, RL	1	\$400*	
G	G	E	E	E	BL, H, J, L*, M, R	1	\$450*	
E	G	G	E	E	H, L, R, RH	1	\$380*	
F	E	E	E	E	H, L	1	\$380	
E	G	E	G	G	H, J, L, R, RT	1	\$340	

Makita
800/462-5482
www.makitatools.com

Panasonic
800/338-0552
www.panasonic.com/cordlesstools

Porter-Cable
800/487-8665
www.porter-cable.com

Milwaukee
877/279-7819
www.mil-electric-tool.com



Panasonic EYC133

3.0 amp-hour batteries gave us the longest run times in the test. However, our continuous testing took a toll on the circular saw's motor.



Porter-Cable 9884CS

This drill and circ saw performed well and are the least expensive kit in the test. The batteries also work in P-C's new cordless router.

Removing tool efficiency from the equation, power is a function of the battery's voltage, while run time comes from its amp-hour (Ah) rating. (A 1.0 Ah battery can deliver one amp of current continuously for one hour; a 2.0 Ah battery delivers one amp for two hours, etc.)

Witness the Panasonic kit: With the lowest voltage and highest amp-hour rating (3.0 Ah) in the test, the drill averaged 747 screws driven per charge—200 more than the next-best Milwaukee (2.4 Ah) and Porter-Cable (2.2 Ah).

In fact, Panasonic's batteries may well outperform its saw. Halfway through the first of three battery-life tests ripping 5/4 red oak, the saw's motor began to overheat and smoke, and numerous plastic shards fell out of the saw's body. Andy Mandanero of Panasonic told us our test was very severe. "The saw was not designed for continuous operation until the battery was depleted," he said. "The motor needs time in between operations to cool."

Allowing any cordless tool to "rest" periodically helps extend the life of both the battery and tool. So, unless you're using cordless tools exclusively on a large project, such as building a deck, you should be able to get an honest day's work out of any of the drills and saws in our test.

Before you commit yourself to a cordless kit, it makes good sense to see what other tools you can operate with the same batteries and charger. (A few examples are shown in **Photo F**.) Check the chart, *above left*, to find out what products use the same battery platform as the one you're considering. Often, three or more of these tools come packaged together with one charger and a pair of batteries, making a multiple-tool kit a better bargain in the long run.

For example, Porter-Cable's 9884 cordless drill with two batteries and a charger sells for \$200. P-C's 9845 6" Sawboss—the cordless circ saw in the kit we tested—sells for \$265 with the same two batteries and charger. Buy them separately, and pay \$465; buy the 9884CS kit that includes both tools and you save \$125.

Beyond saws and drills

Although we couldn't do a comprehensive test of every manufacturer's full cordless line, the samples of reciprocating



It's not uncommon to find other cordless tools, such as a jigsaw, work light, or reciprocating saw, bundled with drills and circular saws in kits.

ing saws and jigsaws we acquired demonstrated power and prowess equal to their corded cousins. We also like the work lights (Makita includes one with the kit we tested). Their broad, battered bases allow them to stand on their own, with pivoting heads, bright lights, and a spare battery always in the charger.

This fall, Porter-Cable introduced the first cordless router we've seen, operating on its 19.2-volt battery platform. We couldn't get one in time to test it for this article, but you can learn more about this revolutionary tool in the Tool Buyer's Update on *page 32*.

Our picks of the kits

Although all of the tools performed better than we expected, we'd put our money down for the Milwaukee 6310-26 kit. When using both the drill and the circular saw, it was easy to forget we were using cordless tools. Porter-Cable's 9884CS kit performed about as well for \$40 less.

If you're building for a complete wireless workshop, DeWalt's 18-volt system currently offers the most accessories, while Porter-Cable's lineup of 19.2-volt tools tends to target woodworkers. ♣

Sound off about cordless kits at WOOD ONLINE®

Are we on target with our evaluation of these kits? We've set up a special Internet discussion group where you can offer your opinion, ask more questions, or read the manufacturers' responses to our review. Just log on to www.woodmall.com, click on the Tool Comparisons tab, and speak your mind.



a novel box

for favorite photos

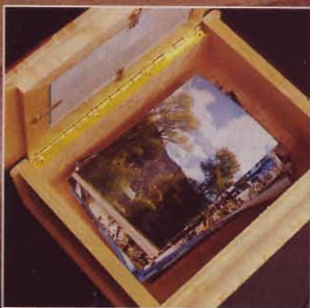

Build a tabletop tome
for storing and displaying
treasured mementos

How do you store your holiday or vacation photos? We like to show ours when friends or family stop by. Because the dog-eared processor's envelope never looks good lying about, we designed an attractive solution. Resembling a book, our box looks great on the coffee table. You can even display two photos at a time in the lid by sandwiching them back-to-back between the glass panes.

First, make a booklike box

1 Cut the bottom (A) and the back (B) to the sizes listed on the Bill of Materials. Chuck a $\frac{1}{2}$ " straight bit in your table-mounted router and adjust it to cut $\frac{1}{4}$ " deep. Using the fence to limit the cut, make multiple passes to rout the $\frac{1}{2}$ "-wide rabbet along the bottom's rear edge, and the $\frac{3}{4}$ "-wide rabbets along the front and ends, where shown on **Drawing 1**. Then rout the $\frac{3}{4}$ " rabbets on the ends of the back, as shown on **Drawing 1a**. Sand the rabbets smooth. Finish-sand the bottom and back to 320 grit.

2 Form the ends of the hinge notch in the back (B) by cutting $\frac{3}{8}$ "-deep kerfs in the top edge, $\frac{3}{4}$ " from each end. To prevent chip-out, back your cuts with an auxiliary extension attached to your tablesaw miter gauge.

3 Now, complete the notch by routing between the kerfs. To do this, raise your $\frac{1}{2}$ " router bit to make a $\frac{3}{8}$ "-deep cut, and position your router table fence to expose $\frac{1}{8}$ " of the bit. From the bit's center, measure $8\frac{1}{8}$ " in each direction, and clamp stopblocks to the fence. Rout a $\frac{1}{8} \times \frac{3}{8}$ " rabbet in the back, as shown in



With its right end against one stopblock, lower the back (B) onto the running bit. Then move the back to the left until it contacts the other stopblock.

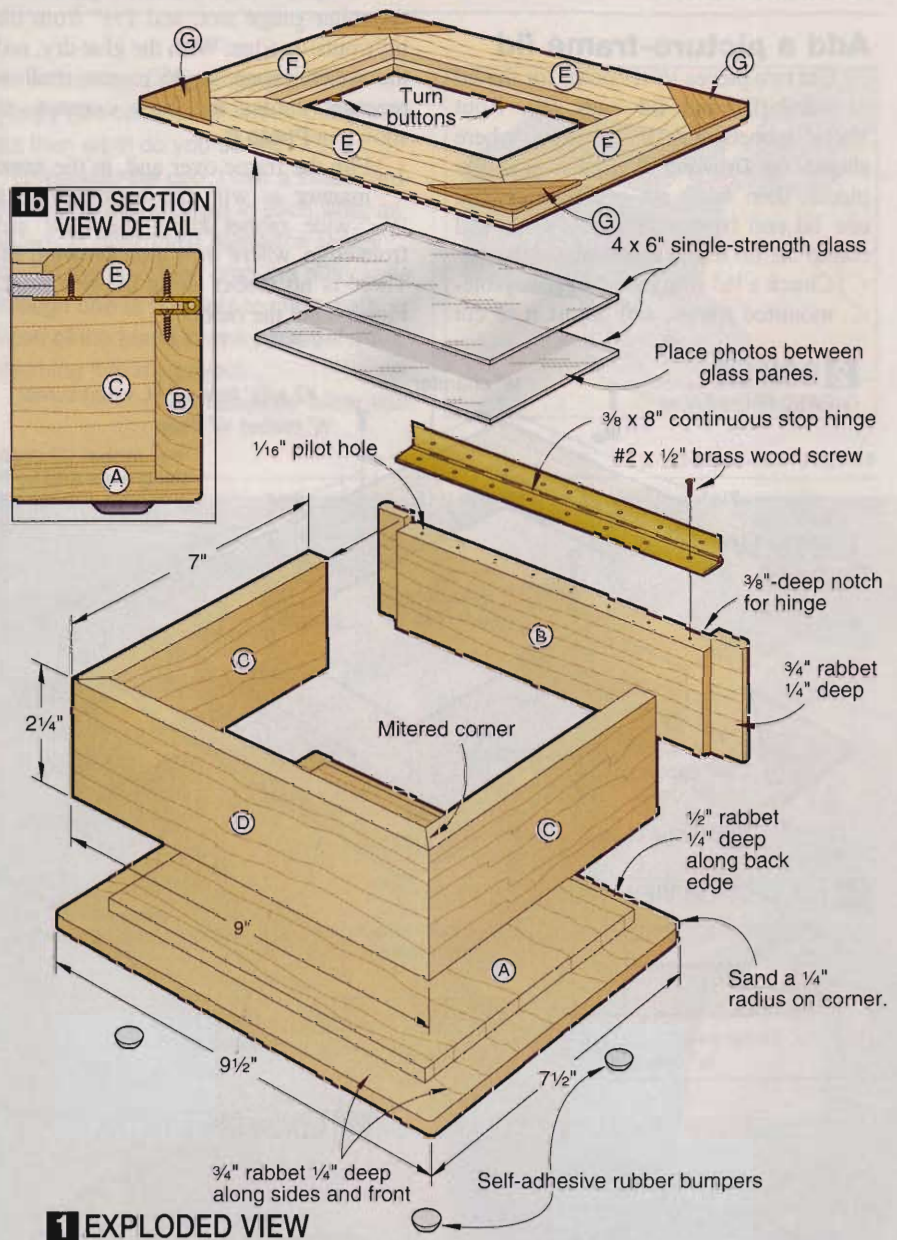

1 EXPLODED VIEW

Photo A. Turn the part over and repeat. Reposition the fence to expose $\frac{5}{16}$ " of the bit. With the back's inside face against the fence, make a final pass, completing the hinge notch. (Making the $\frac{1}{8}$ "-deep cuts first reduces the chance of chipping.) Clean up the ends of the cut with a chisel. Glue and clamp the back to the bottom, maintaining a 90° angle.

4 Cut stock $\frac{1}{2} \times 2\frac{1}{4} \times 25$ " for the ends (C) and front (D). (To resemble a book's pages, we selected a piece of straight-grained ash, cutting one edge parallel to the grain before ripping it to final width.) To get the grain to wrap

continuously around the corners, miter-cut the parts to length in the sequence end-front-end. Finish-sand the front and ends, then glue and clamp them into the rabbets in the bottom and back.

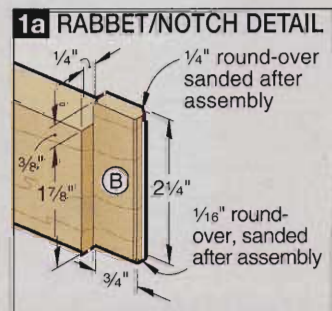

a novel box

Add a picture-frame lid

1 Cut two pieces $\frac{1}{2} \times 1\frac{7}{8} \times 20$ " for the lid sides (E) and lid ends (F). Rout $\frac{1}{8} \times \frac{1}{4}$ " rabbets and $\frac{1}{8}$ " chamfers, where shown on **Drawing 2**. Finish-sand the pieces, then miter-cut one lid side and one lid end from each piece. Glue and clamp the lid frame together.

2 Chuck a $\frac{1}{2}$ " straight bit in your table-mounted router, and adjust it to cut

$\frac{1}{16}$ " deep. Position the fence parallel to the miter-gauge slot, and $1\frac{1}{2}$ " from the bit's outside edge. With the glue dry, and the miter gauge at 45° , rout shallow recesses across the lid's corners, as shown in **Photo B**.

3 Flip the frame over and, in the same manner as with the bottom, rout a $\frac{1}{16}$ "-wide rabbet along the ends and front edge, where shown on **Drawing 2a**. There is no rabbet along the rear edge. Finish-sand the rabbet.



Rout the corner tab recesses, making multiple passes until the frame's corners ride against the fence.

2 BOX LID

(VIEWED FROM BACK)

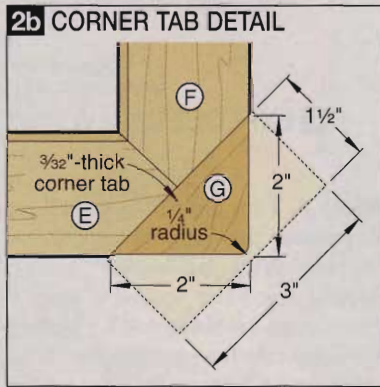
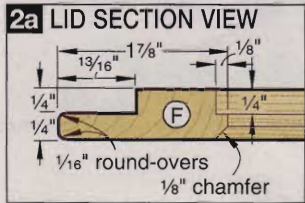
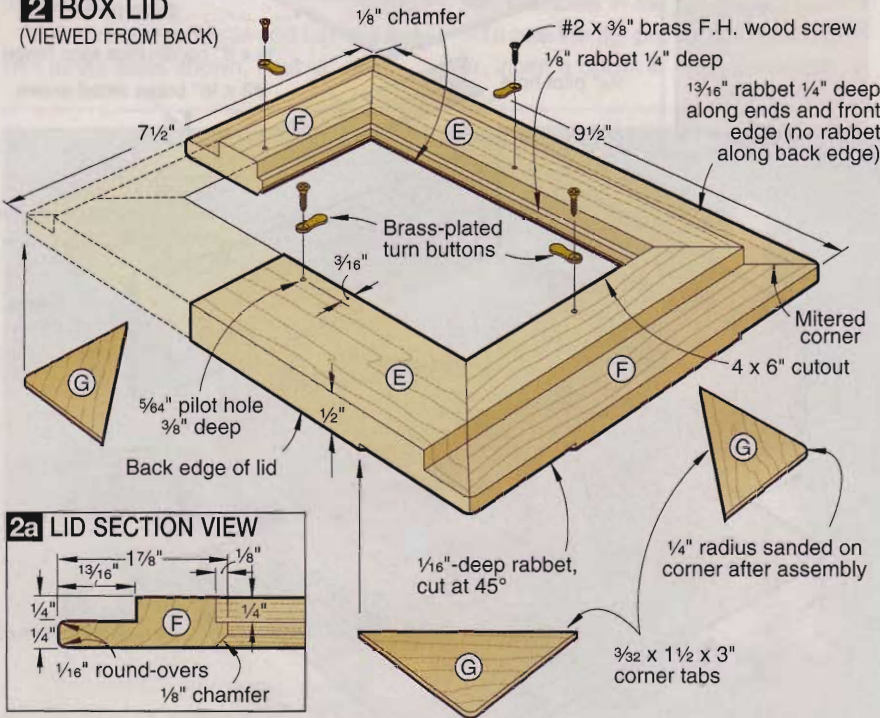

4 Resaw a $\frac{3}{32}$ "-thick strip from a $\frac{3}{4} \times 1\frac{3}{8} \times 12$ " piece of mahogany. Cut four oversize triangles for the corner tabs (G). Ease one top long edge of each triangle with a sanding block. Glue and clamp them into the corner recesses in the lid. When the glue dries, sand the tabs flush with the lid's edges.

5 Sand $\frac{1}{4}$ " radii on the lid's corners, as shown on **Drawing 2b**. Retrieve the box, and sand matching radii on the bottom's corners, including the back's ends.

Finish up the details

1 Position the hinge so the knuckle is flush with the back and the lid's rear edge, where shown on **Drawing 1b**, and drill the screw pilot holes. Drill screw pilot holes for the turn buttons. Cut two pieces of single-strength glass to fit the lid's rabbeted opening.

2 Ease the edges of the lid, bottom, and the inside ends of the back, with a sanding block, forming $\frac{1}{16}$ " round-overs. Apply two coats of a wiping varnish, such as Deftoil or Minwax Antique Oil, rubbing between coats with a very fine Scotch-Brite abrasive pad.

3 Screw the turn buttons and the hinge in place, and adhere the bumpers to the bottom. For safe handling when changing pictures, sand the edges of the glass panes with 320-grit sandpaper. 🌲

Written by **Jan Hale Svec** with **Charles I. Hedlund**
 Project design: **James R. Downing**
 Illustrations: **Kim Downing; Lorna Johnson**
 Photographs: **Baldwin Photography; Wm. Hopkins**

bill of materials

a novel box

Part	FINISHED SIZE	Matl. Qty.
	T W L	
A bottom	$\frac{1}{2}$ " 7 $\frac{1}{2}$ " 9 $\frac{1}{2}$ "	B 1
B back	$\frac{1}{2}$ " 2 $\frac{1}{4}$ " 9 $\frac{1}{2}$ "	B 1
C* ends	$\frac{1}{2}$ " 2 $\frac{1}{4}$ " 7"	A 2
D* front	$\frac{1}{2}$ " 2 $\frac{1}{4}$ " 9"	A 1
E* lid sides	$\frac{1}{2}$ " 1 $\frac{7}{8}$ " 9 $\frac{1}{2}$ "	B 2
F* lid ends	$\frac{1}{2}$ " 1 $\frac{7}{8}$ " 7 $\frac{1}{2}$ "	B 2
G* corner tabs	$\frac{3}{32}$ " 1 $\frac{1}{2}$ " 3"	M 4

*Parts initially cut oversize, see the instructions.

Materials Key: B—birdseye maple, A—ash, M—mahogany.

Supplies: #2 $\times\frac{3}{8}$ " brass flathead wood screws (4), glue, finish, single-strength glass.

Buying Guide

Hardware: $\frac{1}{16}$ " brass-plated turn buttons no. 6293, \$2.49/20; $\frac{3}{8}\times 8$ " stop hinge w/screws no. 9553, \$5.25; $\frac{1}{2}\times\frac{1}{8}$ " self-adhesive bumpers no. 8377, \$4.00/20. Call Meisel Hardware Specialties, 800/441-9870.

cutting diagram

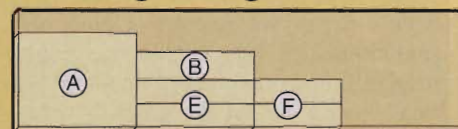

$\frac{1}{2} \times 9\frac{1}{4} \times 36$ " Birdseye maple

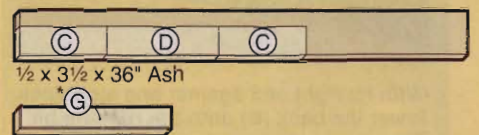

$\frac{3}{4} \times 1\frac{5}{8} \times 12$ " Mahogany

*Plane or resaw to thickness listed in the Bill of Materials.

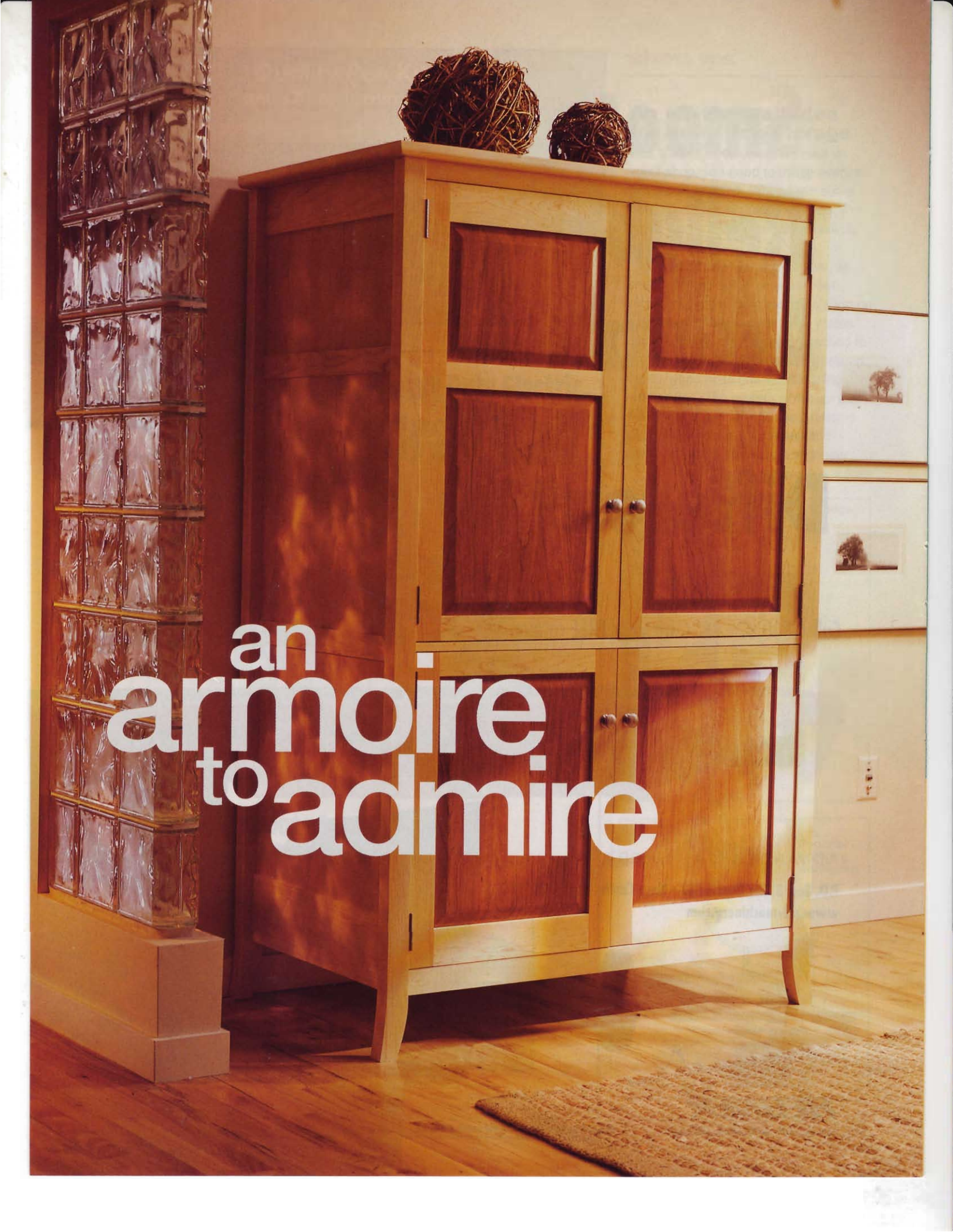
A photograph of a wooden armoire in a room. The armoire has a light-colored wood frame and four dark wood doors with a recessed panel design. Two decorative spheres made of twigs sit on top. To the left is a glass block wall, and to the right is a wall with framed pictures and an electrical outlet. The floor is wood with a rug.

an
armoire
to admire

build it as an **armoire**, or modify it to be an **entertainment center**, either way you get the same **stylish look**

Part III of our maple and cherry bedroom suite, this armoire matches the sleigh bed featured in issue 135 and the nightstand in issue 136. If your bedroom suite is already complete, we designed our armoire to easily transform into a handsome entertainment center.

Note: In addition to ease of assembly, the biscuit-joiner construction of this project makes finishing a breeze. We finish-sanded the parts before gluing up the various assemblies, then applied the finish to these flat assemblies before the final carcass glue-up.

Entertainment Center Builder's Note: To outfit the armoire with pocket doors for use as an entertainment center, see the sidebar "Completing the entertainment center" on page 78 before you hang the doors. Special instructions for building the entertainment center option are included in builder's notes throughout this article.

Shape the gracefully flared legs

1 Laminate two $\frac{1}{4} \times 2\frac{3}{4} \times 70\frac{3}{4}$ " pieces of hardboard to make a $\frac{1}{2}$ "-thick template blank for the legs (A). Joint one edge. Make a copy of the leg pattern from the **WOOD PATTERNS**® insert. Use spray adhesive to adhere the pattern to the template blank, aligning it with the jointed edge as indicated. Bandsaw and sand the template to the pattern line.

2 Prepare two $1\frac{1}{2} \times 5\frac{1}{2} \times 77$ " blanks for the legs (A). (We planed down $1\frac{3}{4}$ " stock. You also can laminate the blanks from $\frac{3}{4}$ " stock.) Joint both edges, then use the template to trace the leg outlines onto the blanks, aligning the template's and the blanks' jointed edges. To conserve lumber, nest the parts, as shown on

the Cutting Diagram. Bandsaw the legs from the blanks, keeping close to the pattern lines. Clean up the legs' bandsawn edges by drum sanding. We built the simple pattern-sanding jig shown on page 20 of issue 136 for this task, using double-faced tape to adhere the template to each leg.

3 With the four legs complete, arrange them for the best appearance, and mark their locations: front and back, left and right. Finish-sand the legs to 220-grit.

Make the carcass, gluing up the assemblies

1 Cut two $\frac{3}{4} \times 23\frac{3}{4} \times 65\frac{3}{4}$ " plywood blanks for the side panels (B). Resaw in half a $\frac{3}{4} \times 6\frac{1}{2} \times 72$ " maple board, and plane the two pieces down to $\frac{1}{4}$ ". From this stock cut blanks $4\frac{1}{2} \times 23\frac{5}{8}$ " for the upper trim (C), $2 \times 23\frac{5}{8}$ " for the center trim (D), and $5 \times 23\frac{5}{8}$ " for the lower trim (E). Finish-sand the panels and trim.

2 Glue and clamp the trim (C, D, E) to the side panels (B), where shown on **Drawing 1**, centering the trim on the panels. See the gluing tip, *below*. The trim's ends fall $\frac{1}{16}$ " short of the oversize panels' edges. This keeps the trim from interfer-



ing with the cut when the panel assemblies are ripped to final width.

3 With the glue dry, rip both edges of the side panel assemblies (B, C, D, E) to 23". Trimming panels and rails together ensures straight, flush edges and crisp, tight glue joints between the panels and the legs.

4 Adjust your biscuit joiner to cut a centered slot in the thickness of your $\frac{3}{4}$ " plywood. Mark the biscuit locations on both the legs and side panel assemblies, where shown on **Drawing 1**. Plunge the biscuit slots. Index your biscuit joiner on the *inside* surfaces of the legs and panels. Glue, biscuit, and clamp the legs to the sides.

5 To accommodate the back (U), rout stopped rabbets, shown on **Drawing 1a**, on the back inside edges of the rear legs, where shown on **Drawing 1**.

6 Cut the following $\frac{3}{4}$ " plywood blanks: one at $23\frac{1}{2} \times 41\frac{1}{2}$ " for the bottom (F), two at $24\frac{1}{2} \times 41\frac{1}{2}$ " for the center shelf/carcass top (G), three at

shop TIP

Avoiding glue squeeze-out

To avoid a tricky cleanup task, cut $\frac{1}{8}$ "-deep saw kerfs $\frac{1}{8}$ " from the edges of the rails.

Glue applied to the surface between the grooves squeezes into the grooves instead of out onto the panels.

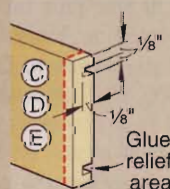

armoire

23 $\frac{3}{8}$ ×26 $\frac{1}{4}$ " for the lower dividers (H), four at 23 $\frac{3}{8}$ ×19" for the drawer shelves (I), one at 22 $\frac{3}{4}$ ×38" for the upper divider (J), and four at 22 $\frac{5}{8}$ ×20 $\frac{3}{8}$ " for the adjustable shelves (K). Mark the parts as you cut them.

Entertainment Center Builder's Note: Omit the upper divider (J) and the adjustable shelves (K).

7 Cut the following solid-stock blanks: two at 1×2×41 $\frac{3}{8}$ " for the bottom rails (L), one at $\frac{3}{4}$ ×1×41 $\frac{3}{8}$ " for the center shelf band (M), one at 1×1 $\frac{1}{2}$ ×41 $\frac{3}{8}$ " for the top rail (N), one at $\frac{3}{4}$ ×1 $\frac{1}{2}$ ×37 $\frac{1}{2}$ " for the door stop (O), two at $\frac{3}{4}$ ×1 $\frac{7}{8}$ ×26 $\frac{1}{8}$ " for the lower divider stiles (P), one at $\frac{3}{4}$ × $\frac{3}{4}$ ×26 $\frac{1}{8}$ " for the lower divider band (Q), four at $\frac{3}{4}$ × $\frac{3}{4}$ ×18 $\frac{7}{8}$ " for the drawer shelf bands (R), one at $\frac{3}{4}$ × $\frac{3}{4}$ ×37 $\frac{7}{8}$ " for the upper divider band (S), and four at $\frac{3}{4}$ × $\frac{3}{4}$ ×20 $\frac{1}{4}$ " for the adjustable shelf bands (T). Mark the parts as you cut them.

Entertainment Center Builder's Note: Omit the upper divider band (S) and adjustable shelf bands (T).

8 Glue and clamp the rails, bands, and stiles to their mating plywood panels, as shown on **Drawings 2** and **3**. Note that there is one right-hand and one left-hand assembly (H/P). As with the side panels and trim, the rails, bands, and stiles are $\frac{1}{16}$ " shorter at both ends than their mating plywood parts.

9 With the glue dry, cut the assemblies to finished length, trimming both ends. Glue and clamp the door stop (O) to the carcass top assembly (G/N), as shown on **Drawing 2a**. Finish-sand and set the adjustable shelf assemblies (K/T) aside. Mark the biscuit slot locations on the other assemblies' ends, where shown on **Drawing 2**, and plunge the slots, indexing your biscuit joiner on the top surfaces. Stagger the biscuit slot locations in the ends of the drawer shelves that mate with the center lower divider (H), as shown on **Drawing 2b**.

10 Mark biscuit slot locations, as shown on **Drawing 2c**, on the inside surfaces of the leg/side panel assemblies (A/B), where shown on **Drawing 1**. Mark the biscuit slot locations on the bottom (F/L), center shelf, (G/M) and lower dividers, (H/P, H/Q) where shown on **Drawing 2**. Stagger the slots on either side of the center lower divider to match the slot locations on the ends of the drawer shelves. Plunge the top row of

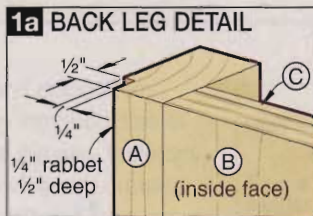

1 SIDE PANELS (RIGHT PANEL SHOWN)

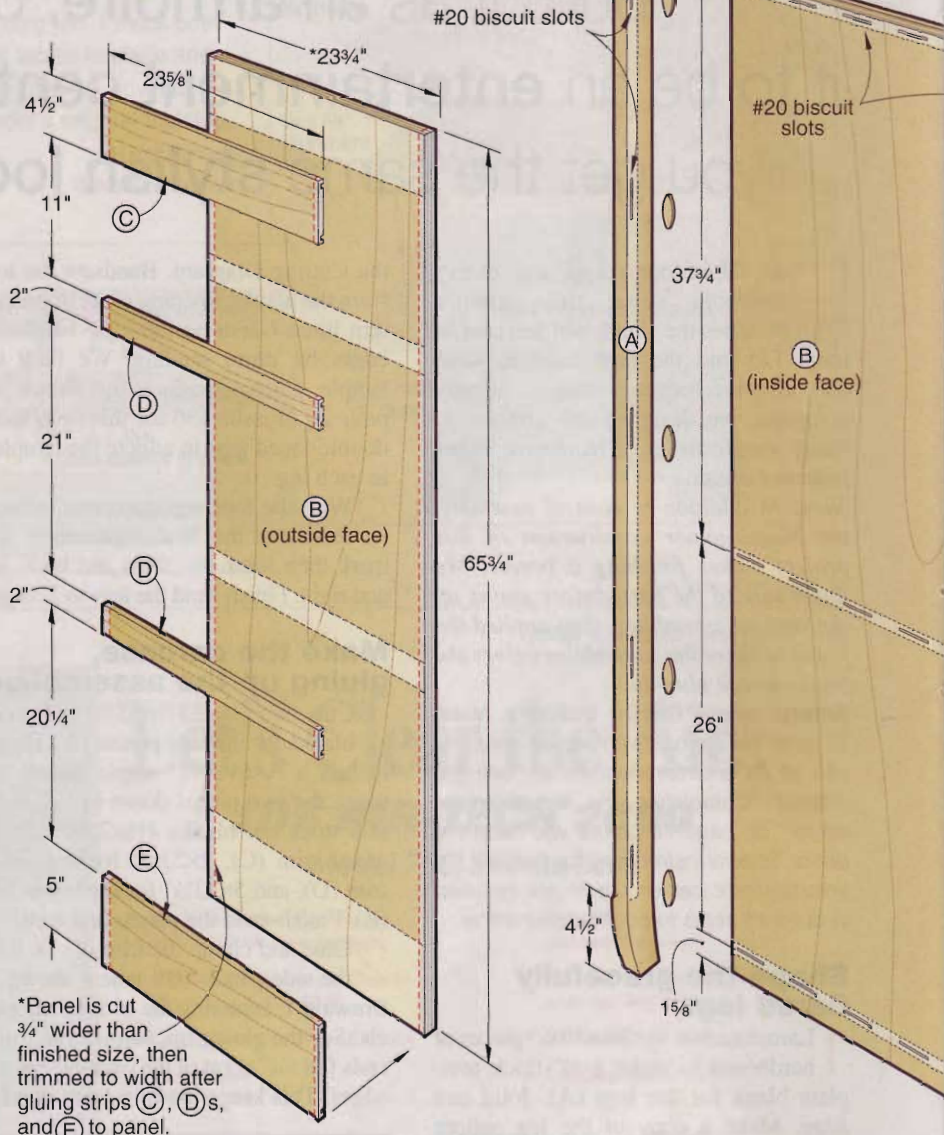

slots on the side panels (B), indexing your biscuit joiner on the panels' top edges. To guide your biscuit joiner when plunging the other slots, clamp a straight-edge to the panel, offsetting it so the biscuit slot falls on the marked horizontal centerline. Finish-sand all the panels.

Entertainment Center Builder's Note: Drill 1 $\frac{1}{2}$ " wire-management holes in the drawer shelves (I) and the center shelf (G), where shown on **Drawing 2**. Even if you are building the armoire, it easily can be

adapted to an entertainment center at a later date by removing the adjustable shelves (K/T), the upper divider (J/S), and as many drawers as needed to make room for your video components, so you may want to drill these holes anyway.

Finish the assemblies, then glue up the carcass

1 Mask off the mating ends, edges, and surfaces of the side and carcass assemblies that receive glue, as shown in

#8 x 2" F.H. wood screw



#20 biscuit slots

Apply all trim with #20 biscuits.

2a DOOR STOP DETAIL

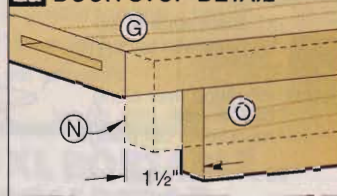

2b BISCUIT DETAIL

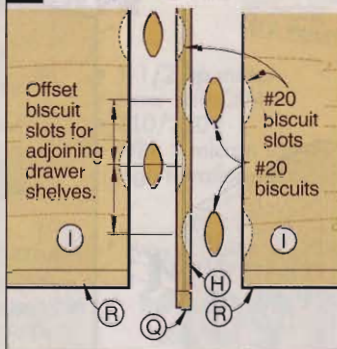

2 CARCASE

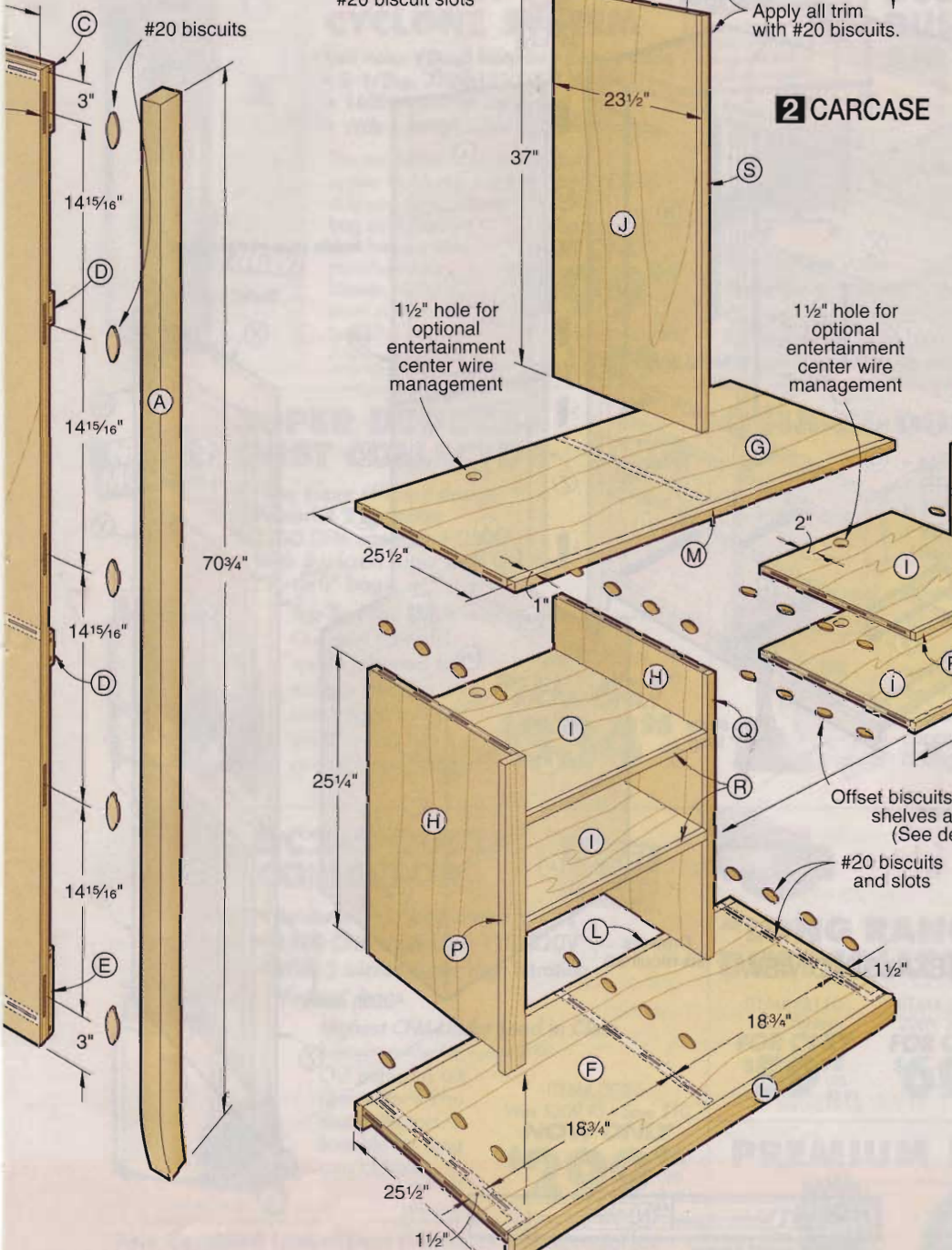

1 1/2" hole for optional entertainment center wire management

1 1/2" hole for optional entertainment center wire management

Offset biscuits slots in drawer shelves and divider. (See detail 2b.)

#20 biscuits and slots

2c MARKING BISCUIT SLOT LOCATIONS

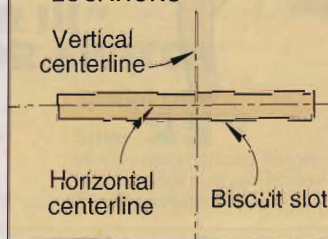

the shop tip, page 76. Apply a coat of gloss polyurethane to all the carcase parts. With the finish dry, sand lightly with 220-grit sandpaper. Remove the dust, and apply a coat of satin polyurethane. Remove the masking tape.

2To check the parts' fit, dry-assemble the carcase's drawer recesses with biscuits. Start with the center lower divider (H/Q), add the drawer shelves (I/R), then the right-hand and left-hand lower

dividers (H/P). Finish with the bottom (L/F/L) and center shelf (G/M). The back edges of all the parts are flush. Disassemble, then, using white glue for extended working time, apply glue to the slots and masked areas, and biscuit and

bill of materials

armoire

Carcase	FINISHED SIZE				Mtl. Qty.
	T	W	L		
A* legs	1½"	2½"	70¾"	M	4
B** side panels	¾"	23"	65¾"	MP	2
C† upper trim	¼"	4½"	23"	M	2
D† center trim	¼"	2"	23"	M	4
E† lower trim	¼"	5"	23"	M	2
F† bottom	¾"	23½"	40½"	MP	1
G† center shelf/ carcase top	¾"	24½"	40½"	MP	2
H† lower dividers	¾"	23¾"	25¼"	MP	3
I† drawer shelves	¾"	23¾"	18"	MP	4
J† upper divider	¾"	22¾"	37"	MP	1
K† adjustable shelves	¾"	22¾"	19¾"	MP	4
L† bottom rails	1"	2"	40½"	M	2
M† center shelf band	¾"	1"	40½"	M	1
N† top rail	1"	1½"	40½"	M	1
O door stop	¾"	1½"	37½"	M	1
P† lower divider stiles	¾"	17⁄8"	25¼"	M	2
Q† lower divider band	¾"	¾"	25¼"	M	1
R† drawer shelf bands	¾"	¾"	18"	M	4
S† upper divider band	¾"	¾"	37"	M	1
T† adjustable shelf bands	¾"	¾"	19¾"	M	4
U back	¼"	41½"	65¾"	BP	1
V† crown front	1"	4"	46¾"	M	1
W† crown sides	1"	4"	27"	M	2

Doors & drawers	FINISHED SIZE				Mtl. Qty.
	T	W	L		
X upper/lower door rails	1"	3"	16¾"	M	4
Y center door rails	1"	2"	16¾"	M	6
Z lower door stiles	1"	2"	25½"	M	4
AA upper door stiles	1"	2"	36½"	M	4
BB†† lower door panels	½"	16¾"	20¾"	EC	2
CC†† upper door lower panels	½"	16¾"	18¾"	EC	2
DD†† upper door upper panels	½"	16¾"	11½"	EC	2
EE†† upper drawer fronts	¾"	47⁄8"	177⁄8"	C	2
FF†† center drawer fronts	¾"	77⁄8"	177⁄8"	C	2
GG†† lower drawer fronts	¾"	105⁄8"	177⁄8"	C	2
HH upper drawer sides	½"	47⁄8"	23¾"	M	4
II center drawer sides	½"	77⁄8"	23¾"	M	4
JJ lower drawer sides	½"	105⁄8"	23¾"	M	4
KK upper drawer backs	½"	43⁄8"	173⁄8"	M	2
LL center drawer backs	½"	73⁄8"	173⁄8"	M	2
MM lower drawer backs	½"	101⁄8"	173⁄8"	M	2
NN drawer bottoms	¼"	173⁄8"	19½"	BP	6

*Parts nested in pairs on two blanks. See the Cutting Diagram.

**Parts initially cut wider.

†Parts initially cut longer.

††Multiple parts cut from a longer blank.

Materials Key: M—maple, MP—maple plywood, EC—edge-joined cherry, C—cherry, BP—birch plywood.

Supplies: ¼" hardboard, spray adhesive, #20 biscuits, #8x¾" flathead wood screws, #8x1¼" flathead wood screws, #8x1½" flathead wood screws, #8x2" flathead wood screws, #3x½" flathead wood screws, masking tape, glue, finish.

Buying Guide

Vertical raised-panel bit. Jesada no. 690-602, \$59.90, call Jesada at 800/531-5559.

Drawer lock joint bit. Use any one of the following bits: Freud no. 99-240 (order catalog no. 800-486), \$49.95, call Woodworker's Supply at 800/645-9292; Jesada no. 655-512, \$71.90, call Jesada at 800/531-5559; Katana no. 18850, \$39.00, call MLCS at 800/533-9298.

Hardware. Self-adhesive glide strip no. 464, \$4.55/10-foot roll (8 rolls). Call Meisel Hardware Specialties, 800/441-9870. Bullet catches no. KV0903, \$1.07 (4); shelf standards no. KV0255BRS36, \$1.82 (8); shelf supports no. KV0256BRS, \$.18 (16); pocket door slides no. KV8085Q22, \$28.05 (2); 1¼" satin chrome knobs no. A01466G10, \$4.83 (4); call Woodworker's Hardware, 800/383-0130. 3" no-mortise statuary bronze hinges no. 937-014, \$2.35/pair (4 pair); 40mm Forstner bit no. 913-945, \$6.85; call Woodworker's Supply, 800/645-9292.

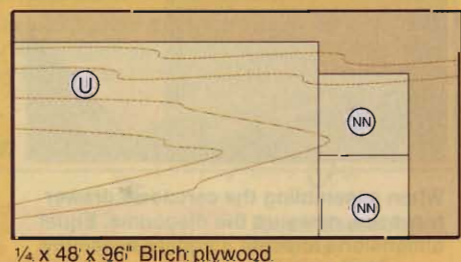
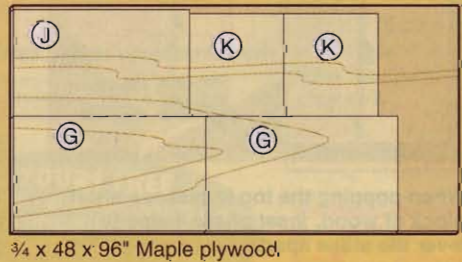
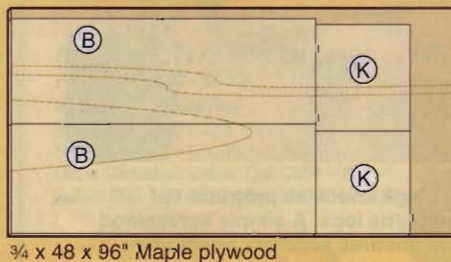
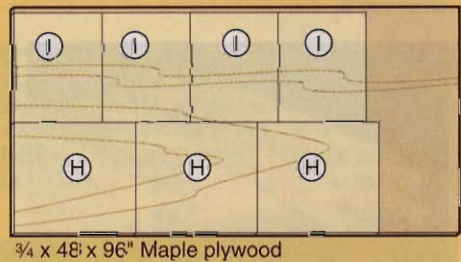
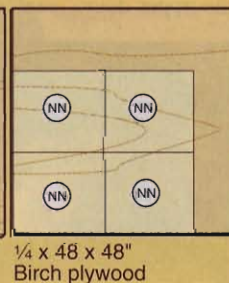
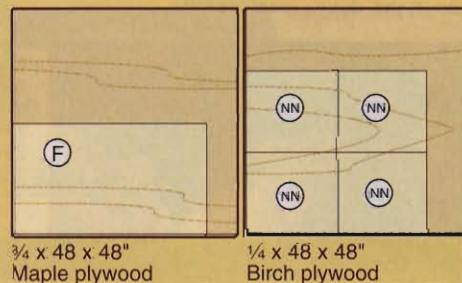
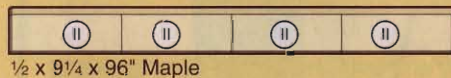
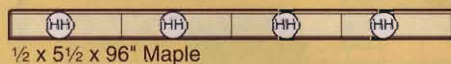
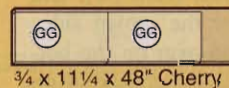
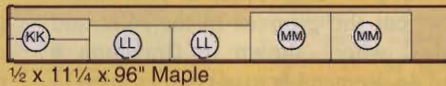
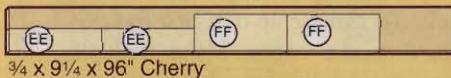

armoire

clamp the drawer recess subassembly, as shown in **Photo A**. Make certain it is sitting flat, and set it aside to dry.

3 Apply glue to the drawer recess subassembly's slots and edges. Glue biscuits into the corresponding slots in the side assemblies, and clamp them to the drawer recess subassembly. Align the back edges of the bottom (L/F/L) and the center shelf (G/M) with the leg rabbets. Glue biscuits into the sides' top slots. Apply glue to the slots and edges of the carcass top assembly (G/N/O), and pop it into place, as shown in **Photo B**. Clamp the top assembly in place. Make sure the cabinet is flat, and let the glue dry.

4 Measure the rabbet-to-rabbet width and the bottom-of-bottom-rail to top-of-carcass-top length for the back (U), and cut it to this size. Position the back on the carcass, and drill pilot and countersunk shank holes around the perimeter and into the center shelf (G/M) and center lower divider (H/Q). Screw the back in place.

Entertainment Center Builder's Note: Drill a 1½" hole for a power cord through the armoire back, centered in one of the drawer recesses.

5 Center the upper divider (J/S) in the cabinet, and drill pilot and countersunk shank holes through the top (G/N/O) and back (U) into the divider.

6 From 1"-thick stock, cut a 4×48" blank for the crown front (V), and two 4×28" blanks for the crown sides (W). Rout a ½" round-over on the bottom edges of the blanks, where shown on **Drawing 3**.



A When assembling the carcass's drawer recesses, measure the diagonals. Equal dimensions indicate a square assembly.

shop TIP

A big finishing job made smaller

Finishing the armoire is easier if you pre-finish some parts before final assembly. Use masking tape, as shown here on the nightstand from issue 136, to protect the mating surfaces.



7 Miter-cut to length both ends of part V and one end of each part W. Make sure you miter-cut one right-hand and one left-hand part W.

8 Cut biscuit slots in the miters and glue, biscuit, and clamp together the crowns (V, W). Make sure the crown is flat, and set it aside to dry. With the glue dry, clamp it in position atop the carcass, flush with the back and centered side-to-side. Drill pilot and countersunk shank holes, and screw the crown to the carcass.

Now build doors with contrasting raised panels

1 From 1"-thick stock, cut the upper/lower door rails (X), the center door rails (Y), the lower door stiles (Z), and the upper door stiles (AA) to size.

Note: Our doors are ⅛" shorter than the height of their openings and the pairs together are ¼" narrower than the width. Check the dimensions of your door openings, and make any necessary adjustments to your doors.

With a ¼" dado blade in your table-saw, cut the grooves in the rails and stiles, where shown in **Drawings 4** and **4a**. Remember to cut two grooves in the upper doors' center rails.

2 To cut the stub tenons on the rails, install a ½" dado blade in your table-saw. To avoid chip-out, attach an auxiliary fence to the miter gauge. Now, clamping a stopblock to the auxiliary fence to control their length, cut the tenons to fit the grooves in the stiles, as shown in **Drawing 4a**.

3 Edge-glue two ½×16¾×53" blanks for the door panels (BB, CC, DD). Cutting the two sets of panels in succession from these blanks makes the grain match continuously from top to bottom when the doors are assembled. Crosscut the panels to length, and mark their order. **Note:** To allow for wood movement, the panels are ⅛" narrower than their grooved openings, and are not glued into the door frames.

4 Chuck a vertical raised-panel bit into your table-mounted router, as shown in **Drawing 4b**. (See the Buying Guide for our bit source.) Feather boards positioned to bear on the panel above the bit ensure a consistent profile. Starting with about ⅛" of the bit exposed, raise the panels. To avoid chip-out, first rout the ends, then the edges. Make multiple passes, moving the fence back until the panels' edges fit the frame grooves.



B When popping the top in place, a short block of wood, inset photo, helps to lever the sides apart.



C The hinge knuckles protrude ⅛" beyond the legs. A simple scrapwood guide ensures accurate positioning.

4 UPPER DOOR

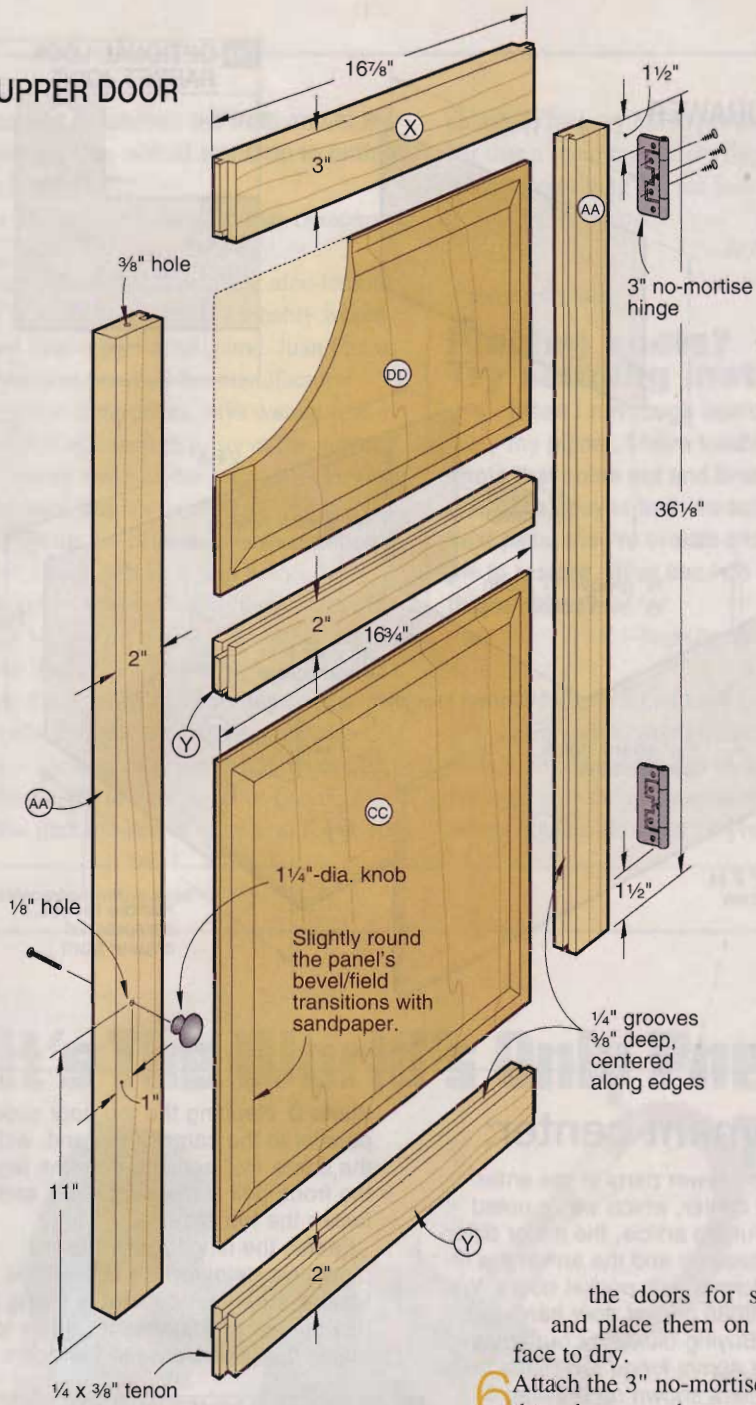

Finish-sand the panels. To give the raised-panel front a soft look, we slightly rounded the bevel/field transition as we sanded. Give the panels their first coat of finish.

5 Gather the rails, stiles, and panels together. Now apply glue to the rails' tenons, and clamp together the doors, in the configuration shown on **Drawings 3** and **4**. Remember, do not glue the panels in place. Measure diagonally to check

the doors for squareness, and place them on a flat surface to dry.

6 Attach the 3" no-mortise hinges to the doors, where shown on **Drawing 4**. See the Buying Guide for our hinge source. The hinge knuckles overlay and are tight to the face of the door stiles, as shown on **Drawing 4c**.

Note: The hinges we used for this project came only in an antique bronze finish. To match the knobs' satin nickel finish, we wire-brushed the hinges and sprayed them with satin lacquer.

Entertainment Center Builder's Note: Substitute pocket door hardware for two pairs of the no-mortise hinges. See the

4a STUB TENON & GROOVE DETAIL

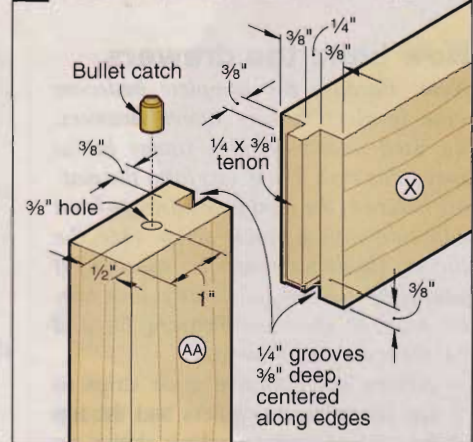

4b RAISED-PANEL DETAIL

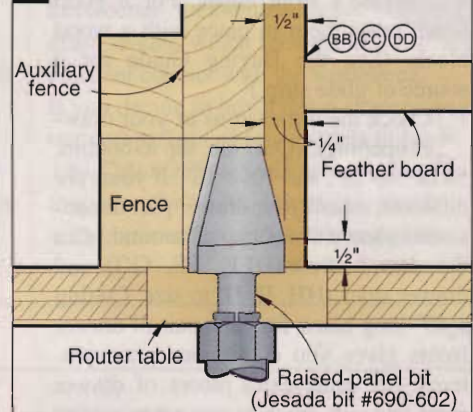

4c HINGE MOUNTING

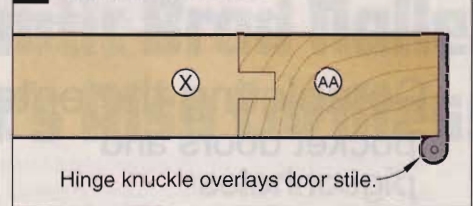

special instructions for mounting the pocket door hardware in the sidebar at the end of this article.

Making sure the carcass is sitting level, shim each door in its opening so the top and bottom spaces are equal. With a sharp pencil or a craft knife, mark the location of the top edge of each hinge on the front legs (A).

7 Remove the hinges from the doors. Cut a 1/4" dado 1/16" deep in a scrap-wood block, and use it to position the hinges at their marked locations while you drill the screw pilot holes, as shown in **Photo C**. Drill the knob holes, where shown on **Drawings 3** and **4**. Finish-sand the door frames, and set them aside.

Now build the drawers

Note: Because the complete bedroom suite involves making fifteen drawers, we used a drawer lock router bit to speed this task. These bits form the mating halves of the joint in the drawer front and side with a single setup. (See the Buying Guide for router bit sources.) If you wish, you can substitute a lock rabbet joint, as shown on **Drawing 5a**, and cut them on your tablesaw.

1 Adhere self-adhesive glide strips to the lower inside corners and the top of the drawer cavities, where shown on **Drawing 3**. Hold the strips 1/4" back from the carcass's front edges. For a good bond, press them in place with a wood block. (See the Buying Guide for a source of glide strip.)

2 Check the dimensions of your drawer openings. (Ours are, top to bottom, 5x18", 8x18", and 10 3/4x18". If yours are different, adjust your drawer part dimensions to leave a 1/16" gap all around.) Cut the drawer fronts (EE, FF, GG) and drawer sides (HH, II, JJ) to size. Cutting a 40"-long blank for each pair of drawer fronts gives you continuous grain patterns. Set aside extra pieces of drawer front and side stock to use when setting up the drawer lock bit.

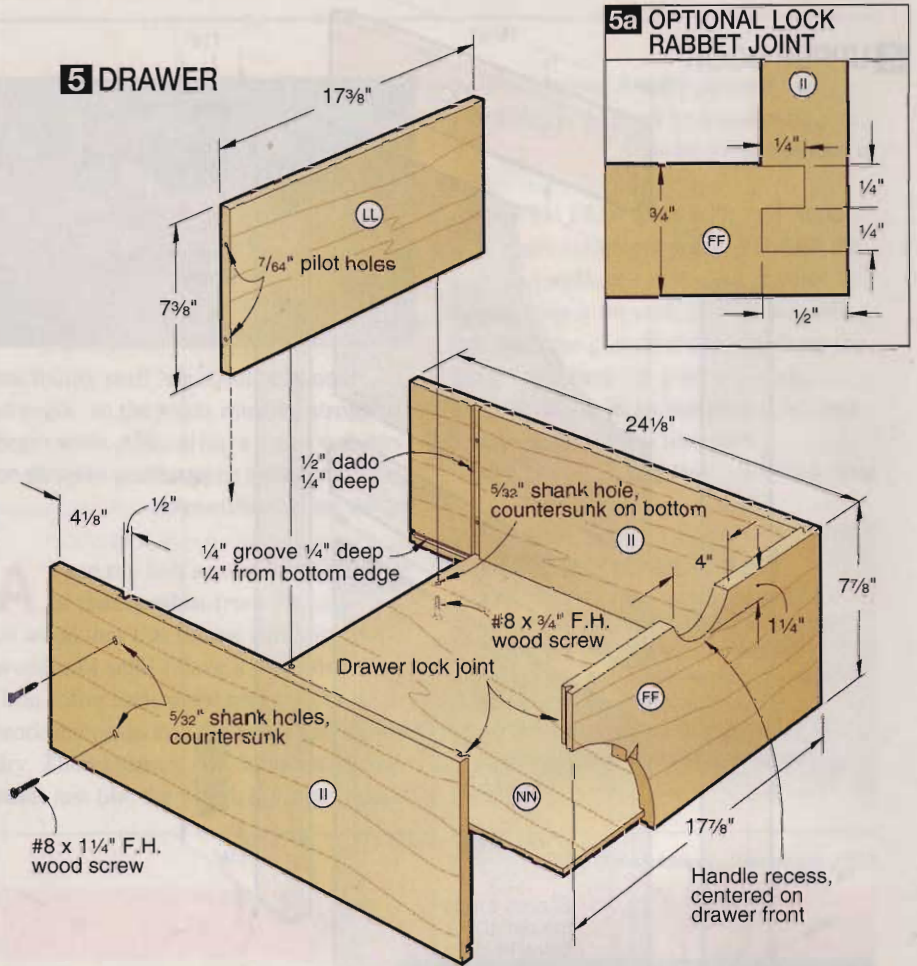

Completing the entertainment center: pocket doors and pigeonholes



Aside from fewer parts in the entertainment center, which we've noted throughout the article, the major difference between it and the armoire is fitting the former with pocket doors. We used KV8085 pocket door hardware. See the Buying Guide for our source.

Drill the 40mm hinge cup holes in the doors, where shown on **Drawing 6**. See the Buying Guide for a 40mm Forstner bit source. Position the hinges in the cup holes, and use the holes in the hinge cup flanges as guides to drill screw pilot holes. Fasten the hinges in place.

From solid stock, cut a 1/2x3x28 1/4" follower strip, and fasten the top and bottom door slides to it. Place a 1 3/4"-wide spacer strip under the bottom door slide. With the door slide end roller positioned 1 1/2" back from the leg's face, drill screw pilot holes, and screw the slide in place, as shown in

Photo D. Keeping the top door slide parallel to the carcass top and, with the same 1 1/2" setback from the leg at the front, drill screw pilot holes and fasten the top slide.

Fasten the hinged doors to the mounting plates on the door slides. Making sure your cabinet is sitting flat, use the hinge adjustment screws to adjust the gaps between the doors

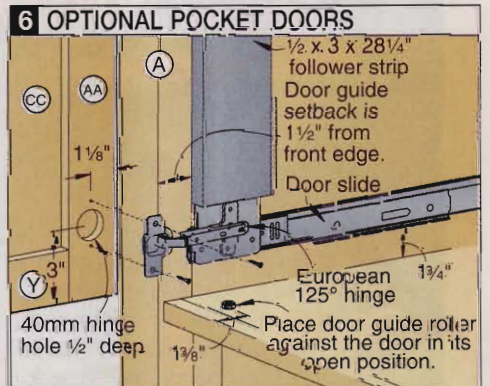

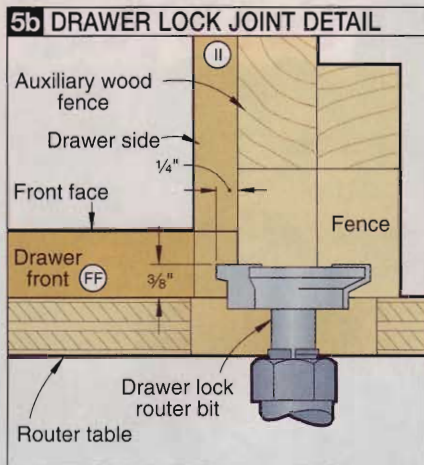

Entertainment Center Builder's Note: Eliminate drawers to make room for your VCR, DVD player, or other components, then reduce the number of drawer parts accordingly. Do not apply glide strip to the empty drawer recesses.

3 Chuck the drawer lock bit in your table-mounted router, and attach a tall auxiliary fence to the router table fence. Position the bit and fence as shown in **Drawing 5b**. Using the extra pieces you set aside, test your setup. Rout the front pieces flat on the router table with their outside faces up, and the side pieces upright with their inside faces against the fence. Make any necessary adjustments to get a tight joint. We let the

fronts protrude a hair beyond the sides, then sanded them flush after assembly.
Note: We used a Freud no. 99-240 bit. If you use another manufacturer's bit, your setup may differ slightly.

4 Now rout the ends of the drawer fronts (EE, FF, GG) and the drawer sides (HH, II, JJ) just as you did the setup pieces. Use a follower block to steady the parts and eliminate chipping.

5 Install a 1/2" dado blade in your table-saw and cut dadoes in the drawer sides (HH, II, JJ) to receive the drawer backs, where shown on **Drawing 5**. Change to your regular blade, and cut the drawer bottom grooves in the drawer front and sides. Match the thickness of your plywood by making two passes. Make certain you have left and right pairs.

6 Cut the drawer backs (KK, LL, MM) and drawer bottoms (NN) to size. Dry-assemble the drawers to check the parts' fit. Because the drawers fit closely in their recesses, make sure they are the same width front and back. Disassemble the drawers, and lay out the pull cutouts. Bandsaw and sand the cutouts to the layout lines, then finish-sand all the parts.

7 Glue and clamp the drawers together, gluing the bottom panel into the front and side grooves. Measure diagonally to check for squareness. Set the drawer on a flat surface until the glue dries.

Remove the clamps and drill pilot and countersunk shank holes through the sides and bottom into the back, as shown. Drive in the screws.

Finish the last batch of parts, and assemble

1 Remove and finish-sand the back. Retrieve the adjustable shelves, doors, and drawers. As with the carcass, apply two coats of polyurethane to the back, shelves, and drawers. Apply the first coat of finish to the door frames, then apply the second coat to both frames and panels.

2 With the finish dry, install the shelf standards and shelf rests. Fasten the back, set the shelves on the rests, and slide the drawers into place.

Entertainment Center Builder's Note: Omit the shelf standards and shelf rests.

3 Rehang the doors, and install the knobs. Install the bullet catches in the tops of the center stiles, where shown on **Drawing 4a**. Using the bullets to transfer their locations onto the bottom edges of the carcass top and center shelf, install the strike plates. 📌

Written by **Jan Hale Svec** with **Kevin Boyle**
Project design: **James R. Downing**
Illustrations: **Kim Downing; Roxanne LeMoine; Lorna Johnson**
Photographs: **Baldwin Photography; Douglas E. Smith; Andy Lyons**



A scrapwood spacer keeps the bottom door slide perfectly aligned.

and the carcass. Open the doors and slide them back into the cabinet. Position the door guide rollers so they keep the retracted doors parallel to the carcass sides, and are set back 1 3/8" from the front edge of the center shelf (G/M), as shown on **Drawing 6**. Screw the rollers in place. Position another pair of rollers to act as door stops to

keep the knobs from hitting the legs.
Note: Our KV8085 pocket door hardware came with excellent instructions, so you can double-check your installation against theirs.

If your television doesn't fill the entire upper portion of the entertainment center cabinet, you can build a component pigeonhole, shown in the photo **far left**, for your VCR or DVD player. This arrangement allows you to use your remote control without leaving one of the bottom doors open, or installing an auxiliary remote control sensor (available at your local electronics retailer).

Simply glue and clamp a 3/4x3/4x52" band to a 3/4x19 1/4x52" plywood panel. With the glue dry, cut the risers from one end, then biscuit and glue the risers to the panel, as shown in **Drawing 7**. Make sure the placement of the center riser accommodates your video player. Sand and finish the pigeonhole as you did the rest of the cabinet.

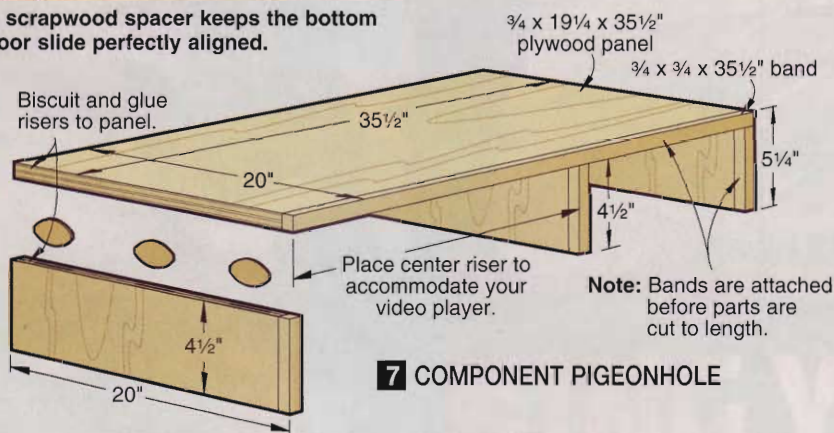

7 COMPONENT PIGEONHOLE

double take on woodworking

For high-quality furnituremaking, two heads prove better than one.

Enter the Meier brothers—twins who can teach you plenty about their craft.

At age 35, the Meier brothers are already climbing to the top of contemporary furnituremaking in California. In their hillside workshop on the edge of the Santa Cruz Mountains, Christian and Robert design and build unique, eye-catching pieces that find their way to clients all along the central coast and to galleries as far away as Seattle.

But what else would you expect from men that as children in their native Germany pleaded for nails to build crude furniture rather than toys. “I believe that we inherited our craftsman’s genes from our grandfather, who taught us some woodworking. When we went to the University of Munich to study mechanical engineering, we took extra classes in things like wood finishing and design,” says Robert.

“As graduates, we expected mechanical engineering to be creative,” Robert comments. “We thought we would be making things, but after a year we realized that the way the system worked we could only input at the start. Now, with our woodworking, we are creative to the end.”

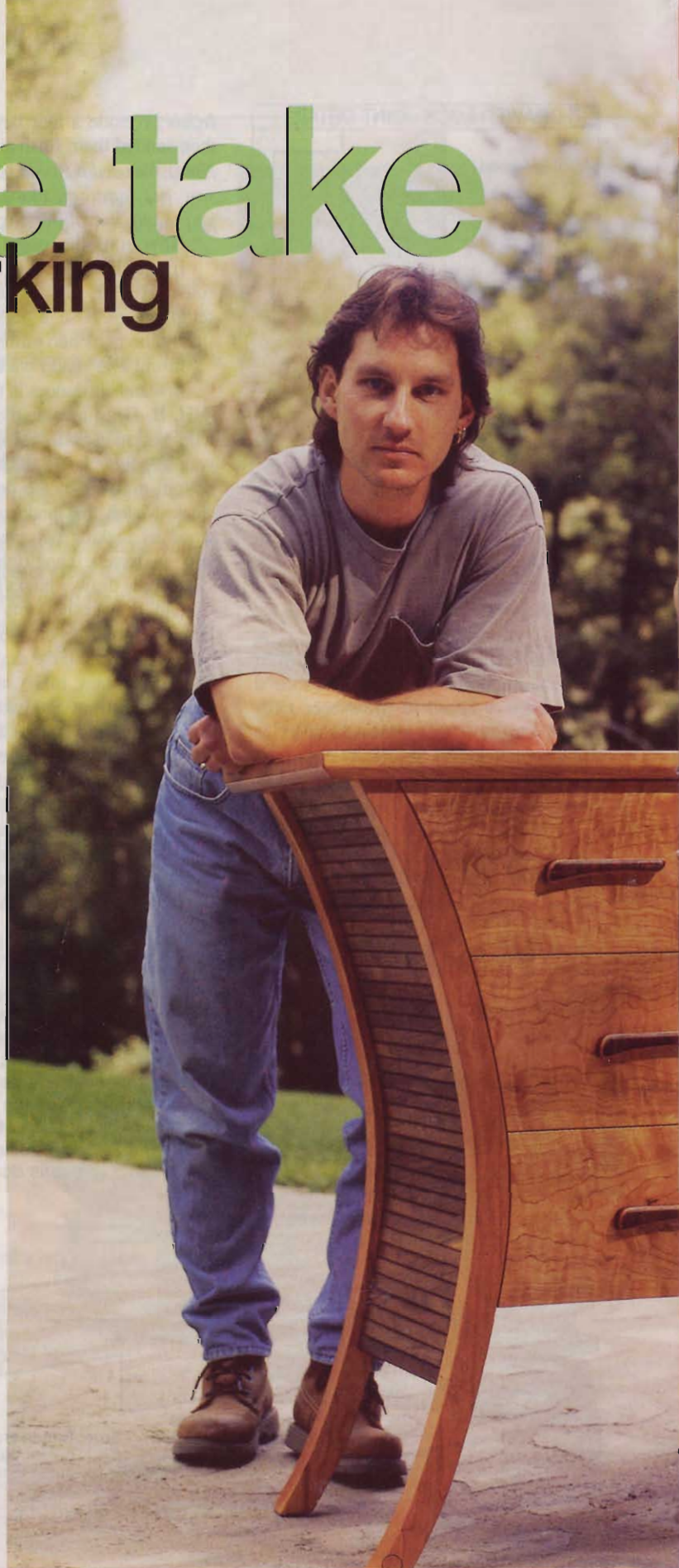



**Robert and Christian Meier
and their \$5,000 chest of drawers.**

An American adventure

In German-accented English, the twins explain their transformation from engineers to woodworkers. "We made furniture while we were in school, and after, in a little basement workshop," Christian says. "We built it for ourselves and friends with hand tools and small portable power tools—nothing like we have now."

After a 1988 visit to San Francisco, the brothers concluded that engineering was boring, and decided to move to the United States, selecting the city by the Bay as their new home. "We came to the United States with just two suitcases between us, and did anything to earn money," Christian remembers.

"We worked on cars and painted houses," Robert adds. "Meanwhile, we put together woodworking equipment, adding a few pieces here and there. It was hard because we were new and didn't yet have a woodworking reputation."

The young men persisted, though. They worked hard at pursuing their dream. Eventually, they were able to save enough to make a move down the coast to gain a larger shop. Then, in 1996, they made a final move to the Santa Cruz area.

Working with a focus

Today they're entirely focused on woodworking. Each has individual responsibilities for the success of their business, Meier Brothers Furniture Design.

Robert builds most of the furniture and Christian does the finishing as well as makes some of the special hardware. "But Robert and I together decide what we will build to sell," Christian notes. "Then, about 40 percent of our work is custom-designed for clients. And for large custom pieces Robert builds a full-sized prototype out of inexpensive wood just to give the client an idea of how it will look. Prototypes help us avoid unpleasant surprises."

The furniture designed and built by the brothers is freshly contemporary, yet the designs seem to have a familiar look. With study, you might arrive at the conclusion that their pieces mix in a bit of Shaker, some Stickley, and an oriental influence. But if there's any influence at all, it's nature.

"Everything I design has a curve because I think people find curves pleasing," Robert says. "That's right," Christian agrees. "Because nowhere in nature do you find straight lines."

If wood has figure, use it

The Meier brothers don't build a stick of furniture without figured wood, unless the client demands only straight-grained stock. "The material can transform a piece from Shaker to contemporary," Christian observes. "And highly contrasting woods always suggest contemporary."

If you want to use more figured stock in your projects, hardwood boards with figure are easy enough to spot at your local supplier. That's because they're usu-

double take on woodworking

ally planed or surfaced on four sides (S4S). It's a different story with rough-sawn lumber. Yet, there are some fairly simple tipoffs. **See Photos A and B.**

To get figured wood to final thickness, Robert turns to his Performax drum sander, a 37"-wide model with double drums. "This agile and well-designed machine is my favorite in the shop and is a must for small shops that need a powerful planer with a large capacity," he says. "On figured wood, you want to take wood off with abrasives to avoid tear-out," he advises. Robert also runs wood through at a slight angle to reduce the clogging of sanding dust in the abrasive, especially the finer grits.

The brothers' jointer plays a major machining role, too. Being the engineers that they are, the twins have modified the machine, boosting its power and making it more appropriate for figured woods. "We just beefed it up a little," Robert says. "It had a 1½-hp motor and made 15,000 cuts per minute. We switched to a 2-hp motor and changed the gearing. Now it makes 21,000 cuts per minute and we get smoother results."

Cut smoothness doesn't come from speed alone. "Before I edge figured boards, I dress up the knives with a diamond stone and finish with a leather strop," Robert notes. "Then, because it's hard to read grain direction in figured wood, I just feed it one way first, taking off 1/16". If the cut isn't satisfactory, I turn the board around and try it another way. One direction is always better than another."

Try fresh glue and looser joints

"Titebond II is excellent glue, but it must be fresh," Robert cautions. "It gets old in six months and loses some of its strength. You can extend its life to a year by keeping it in the refrigerator. But after a year, it's better to throw out your old glue and turn to fresh glue rather than ruin a project. I use Titebond II for all my gluing needs. It is strong, reliable, and waterproof. And, it cleans up with water."



A

Generally, you have to get the rough-sawn wood in good light and hold it at different angles to detect figure—it will reflect light differently than straight-grained wood," Robert advises. "Then, look at the edge of the board. If the surface looks slightly wavy, that means there's figure."

If the wood supplier will let you do it, wet a rag and wipe the edge and face of rough-sawn lumber. The figure will show up better,"

Christian says. "And dampening it will tell you how the figure is distributed. It may not run throughout the board. Of course, to really see the figure, have it planed, especially if the board has a hefty price tag."



B

The secret of the tablecloth table



For the Meier brothers, the highly figured tablecloth table has become a signature piece. Few of the ones they've made and sold are as playfully colorful as this purple-topped one.

The purple cloth is actually glued up from several pieces. Says Robert, "Gluing up the cloth keeps the movement and the possibility of cracking minimal. Christian dyed the redwood purple to highlight the quilted figure and to provide more contrast with the corner that's curly maple. The frame is plain maple."

To make a tablecloth table, Robert first roughly shapes the wooden cloth at the bandsaw. Then he finishes it up with chisels, a 4" angle grinder, and lots of hand sanding. He next cuts a 3/4" rabbet in the cloth to accept the maple part of the top. Doing this leaves the tablecloth part of the top 1/16" higher than the 3/4" maple to give the illusion of a cover. All maple parts are assembled first, then the cloth is fitted to them. (You can see all the parts in the underside view *above right*.) The top of the tablecloth is fastened to the apron with screws through oversize screw holes to allow for wood movement.



underside view

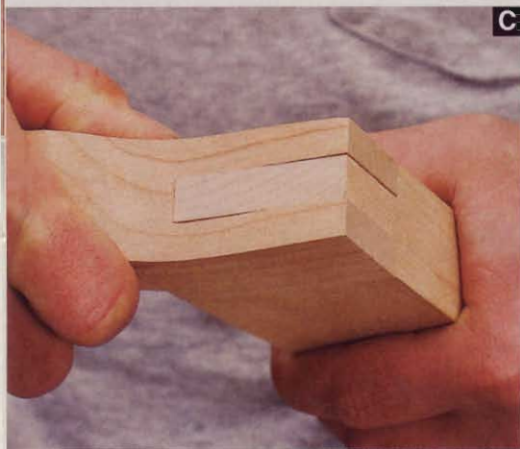

C I cut my joints with about $\frac{1}{32}$ " of slop," Robert says. "Otherwise you'll starve the joint. A film of glue should cover both surfaces, even when edge-joining for width," he adds, "such as for a tabletop. You don't want to clamp it too tight or you'll force out the glue. A good glue line is only a few thousandths of an inch wide with squeeze-out the size of a pencil lead."

To allow for wood movement, we simply lay our chair slats in dadoes in the framing members. And a small compression spring at the top holds them tightly in place. That way, the slats can expand and contract as much as they want,"

Robert says. "We also allow $\frac{1}{8}$ " of space on each side of drawers and doors.

You should always construct a piece to allow for wood movement in any humidity situation.



D



E After each of the three undercoats of tung oil dries, I rub it down with #0000 steel wool," Christian says. "I wait three days between coats. When the final coat has dried, I wax the entire piece. All in all, in a large piece such as the chest of drawers, I'll have about two weeks total finishing time." Due to temperature swings that can affect the finish's drying time and throw Christian off schedule, he tinkers with the oil. "I can add a drier, like mineral spirits, to speed the drying when it's colder."

There's another gluing aspect that many woodworkers overlook, the tightness of the joint. "Joints are frequently cut too tightly," Robert says. "I make mine less than tight." See Photo C.

Wood movement is another important factor that Christian and Robert must deal with. Besides monitoring the wood in their dehumidification kiln for the 10 percent moisture content suitable for coastal California, they also allow for movement in their designs.

"To slow down wood movement, I'd rather glue up thinner stock to thickness than use a solid piece," Robert explains. "For example, the slats in the back of our chairs are a three-piece lamination, which makes them more sturdy and keeps the movement minimal. The two runners framing the slats are a bent lamination, which is also much stronger than a solid cutout."

"The slats are more stable then," Christian points out. "And the glue keeps them bent, too."

To allow for movement, the slats on chair backs and the sides of case pieces, such as dressers, are not glued in place. See Photo D.

Finish makes the piece

The finish achieved by Christian is peerless. It showcases the wood and invites a touch. But it's not arrived at easily.

"I normally sand up to 400-grit before starting the finishing," Christian explains. "In between the sanding courses, I apply a coat of Wood Size by Franklin International [800/347-4583]. It seals end grain pores and prevents 'fuzzing' of wood fibers during sanding. It also helps stabilize the wood."

After careful preparation, Christian follows with up to four coats of penetrating tung oil. See Photo E.

Christian also makes his own paste wax. It's a combination of mineral, plant, and insect waxes with added driers and thinners. "Then I heat it in a double boiler until it all melts together. When cooled, it's ready for use. I also add color—artist's oil pigments from natural to dark—to enhance the wood. For instance, on maple, I use clear, but on walnut, I'll darken the wax. I apply the wax with cheesecloth."

For coloring wood, Christian turns to water-based aniline dye. "Water-based dye is more light resistant than the other types, which means the color won't fade," he explains. "Of course, the water raises the grain, but careful sanding after the dye has dried (using 400-600 grit) takes off the fuzz. For a more even absorption of the dye, dampen the wood first." ♣

Written by **Peter J. Stephano**
Photographs: **Tony Grant**

To see more of the Meier brothers' work

Go to www.mbfurnituredesign.com. In California, you can find Meier pieces on display at Made in Pescadero, Pescadero (650/879-9128) and at the Highlight Gallery in Mendocino (707/937-3132); or in Seattle, visit Northwest Fine Woodworking (206/625-0542). And watch for a Meier-designed bookcase in the February 2002 issue of *WOOD*® magazine.



colorful woods

what makes wood beautiful?

Wood technologists employ appearance characteristics to identify woods. These give a board its distinct look and beauty. Learn what makes up the look of wood, then turn to *page 103* to find the names of the species featured here.

If you've been working with wood for very long, you realize that each species has different characteristics and appeal. You probably know, too, that even a pair of boards taken from two logs of the same species may not look exactly alike. That's because color, luster, texture, grain, and figure all come into play for a species' visual appeal. And it's one or more of these characteristics that put a high value on the most favored hardwoods used for decorative purposes. Now you'll learn just what they are.

Color covers the palette

In hardwoods, color occurs naturally across a wide range. There are purples, yellows, oranges, almond tones, browns, cinnamons, and shades of red. And color plays a major role in determining the final use of the wood. East Indian rosewood's decorative color makes an attractive turned bowl. But a nearly

colorless wood, such as birch, makes a good mixing spoon.

Wood has color due to infiltrates that interact with the cellulose of its cell walls and the lignin that bonds them together. These infiltrates are soluble materials (sometimes called extractives) that a tree draws from the soil where it grows. Various species react to the infiltrates in different ways, thus creating contrasts among them. But that's also why even within a species the wood's color can vary.

Walnut harvested from the cool limestone bluffs of northeast Iowa, for instance, will differ in color from that grown in central Kansas.

Freshly sawn green wood from a tree also can change color when exposed to air and light, sometimes drastically. South American purpleheart turns from light brown to purple. Osage-orange is a bright yellow-orange when first cut or planed, but shortly turns brown. Some woods, such as teak, fade under strong light

but darken by moderate light. The moist heat of kiln drying will change a wood's color, too. As an example, the lighter color of walnut's sapwood evens out in a kiln to match the darker heartwood.

Luster in the light

A wood that has luster reflects light from its cell walls and appears to have a natural sheen. But any infiltrates in a wood's cell walls that give it color reduce its luster.

Because of this, light-colored hardwoods will have luster, as does the light sapwood of darker hardwoods. Lack of luster, however, does not mean that a wood won't take a high polish when finely sanded, then buffed. Finishing also adds luster.

In general, quartersawn wood has more luster than flatsawn, as with white oak. The ray flecks in white oak exposed by this manner of cutting reflect light. Too, woods with lots of figure, such as curly and fiddleback

lustrous woods



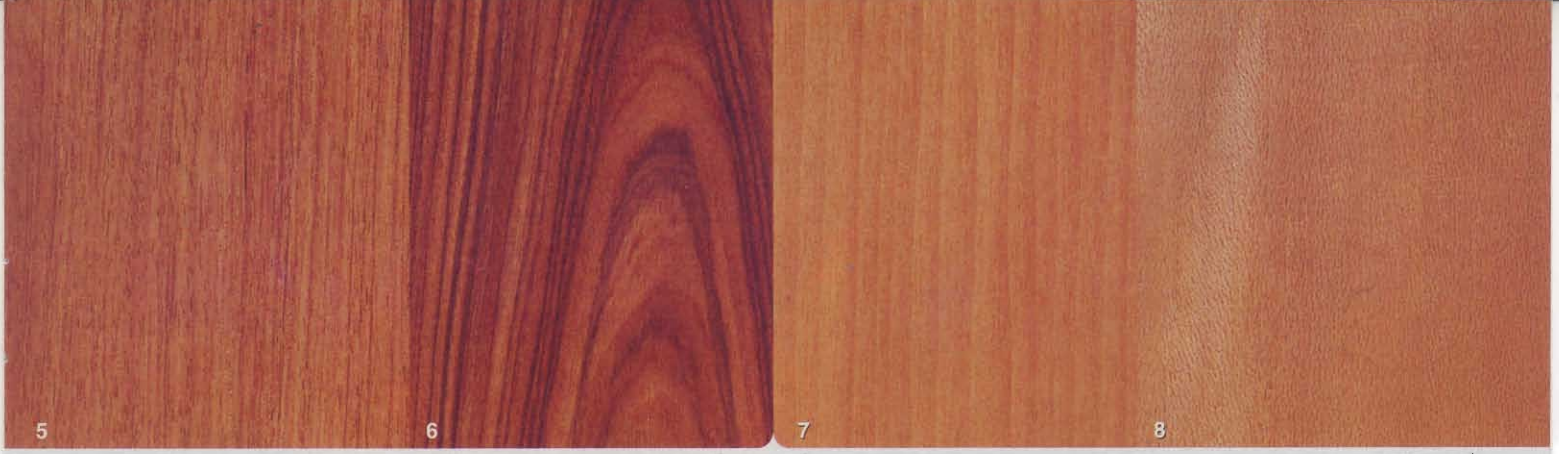

t e x t u r e d w o o d s

maple, display added luster due to the cell walls' changing angle to the light.

Texture to feel

When wood is said to be "coarse" grained or "fine" grained, it's a reference to its texture. And a wood's texture depends on the relative size and variation of size in its cells and the width and abundance of its rays. You actually can feel the difference between fine-textured wood with small cells and thin rays and coarse-textured wood with wide vessels and broad rays. Red oak, for example, rates as coarse-textured, while hard maple is fine-textured. Walnut, however, is moderately coarse-textured, while holly is very fine-textured.

Texture is only sensory. A wood's texture has little to do with how it saws or machines.

Grain follows direction

Grain is a term that's often misused. It does not refer to

the natural pattern seen on the surface of wood. That's figure. Technically, grain means the orientation of the wood cells. Under that definition, there are six general types of grain.

- Straight grain indicates that the cells and fibrous components run completely or nearly parallel to the vertical plane of the tree trunk and the log that came from it.
- Irregular wood grain implies irregular variations from the parallel orientation of the grain to the log. This most often happens around knots.
- Diagonal grain describes what results when an otherwise straight-grained log is not sawn parallel to its vertical axis—in other words, angled sawing.
- Spiral grain happens when the cells and fibers grow in a left or right twisted configuration around the trunk of a tree.
- Interlocked grain occurs when each successive layer of new growth on a tree runs in a different direction.

- Wavy grain is produced when the direction of the fibers alternate so that a board's surface looks like a washboard, as with the figure pattern of curly maple.

Figure in the patterns

Although some grain configurations in wood frequently do result in figure, the word describes the pattern that often occurs when several features interact, including irregular grain, rays, color deposits, and growth rings. Irregular grain in crotches and burls causes "feather" figure, "plum-pudding" figure, and others. Interlocked grain promotes "ribbon" figure and "bird's-eye." Wavy grain creates "fiddleback" or "tiger-stripe" figure.

Highly sought and expensive figured veneers are regularly manufactured by slicing or peeling a log with irregular or interlocked grain in a special manner. Changing the angle of cut enhances the irregularities

and yields special effects. It's the same with lumber; quarter-sawing a regular-grained wood sometimes results in figure pattern, again as with white oak and its ray flecks.

Another term used by woodworkers to describe what loosely could be called figure pattern is "character marks." This refers to naturally occurring ingrown knots, "tracks" left by insects in the living tree, "bird peck," and other signs that make the wood appear less than perfect. However, a skilled craftsman employing wood with character marks in a project can literally turn a sow's ear into a silk purse. 🌲

Written by **Peter J. Stephano**
Photographs: **Baldwin Photography**

Want to learn more about different woods, their uses and working properties? You'll find detailed info on more than 25 species at www.woodonline.com. Simply click on WOOD MAGAZINE in the left-hand column, then on Wood Profiles in the drop-down menu.

f i g u r e d w o o d s





a bright idea for turners

This Yuletide container will bring cheer twice: once from its novel lightbulb design, and again from the candy cached inside.

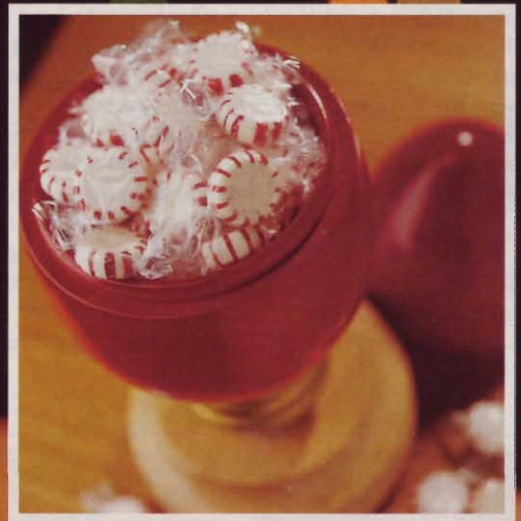

Make your templates, prepare your blank, and turn 'til you see the light.

1 Create the templates. Make a copy of the patterns from the *WOOD PATTERNS*® insert. Use spray adhesive to adhere them to 1/8" hardboard. Cut and sand the templates to the pattern lines. For critical dimensions, refer to the section view drawing on the insert.

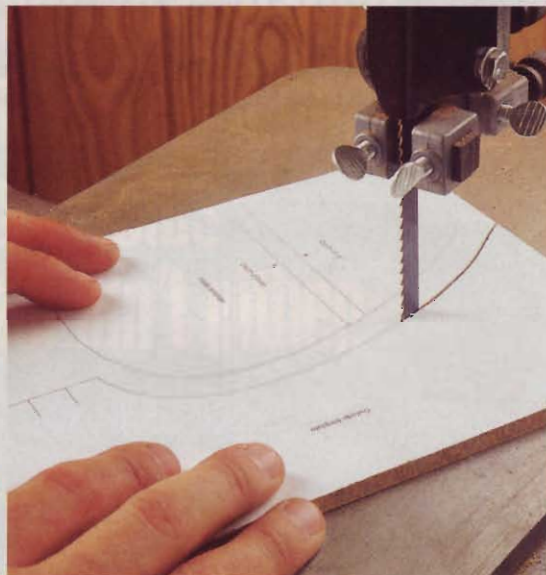
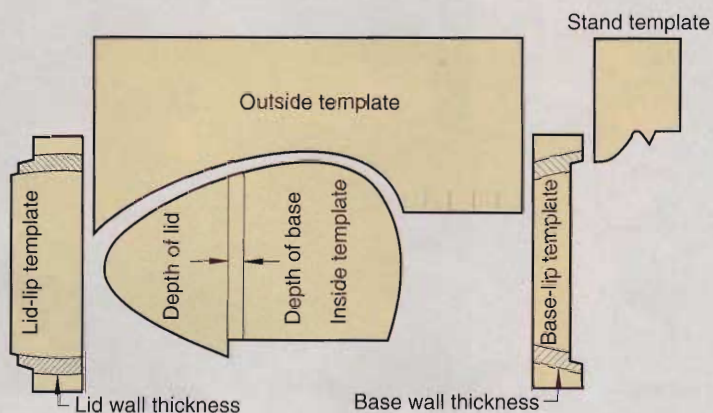

2 Prepare the blank. Glue up a 5 1/4 x 5 1/4 x 12" blank from 1 3/4"-thick poplar. Use a water-resistant glue, such as Titebond II, to avoid any damage from the water-based dye you'll use later. Mark the center of each end, and mount the blank between your lathe centers. Use your roughing gouge to turn it into a 5 1/4"-diameter cylinder.

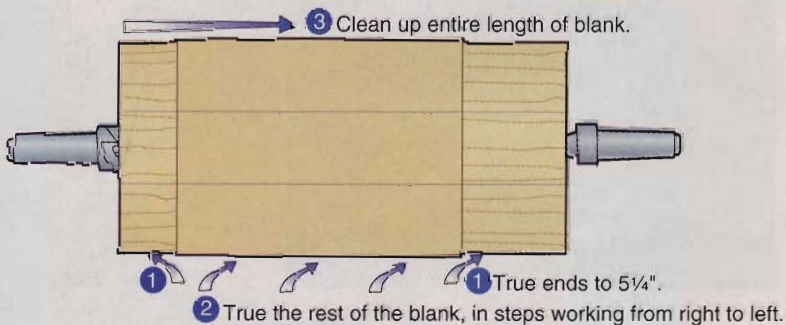

TOOL: Roughing gouge. **TOOL REST:** Slightly above center. **SPEED:** 600-800 rpm.

3 Form dovetail tenons. Using your skew chisel, turn dovetail tenons to fit your four-jaw chuck on each of the cylinder's ends. Remove the cylinder from your lathe. Measure 3 3/4" from one end, and bandsaw the cylinder into lid and base blanks.

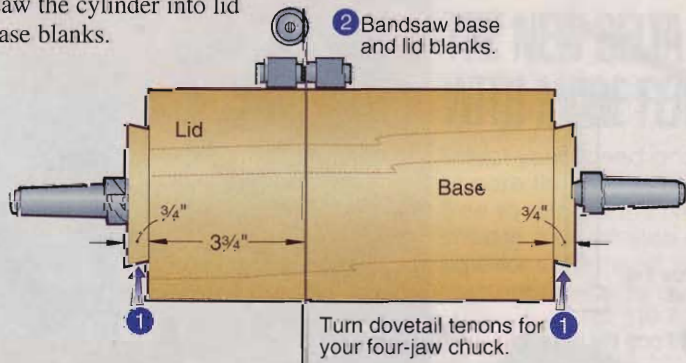

TOOL: Skew chisel. **TOOL REST:** Slightly above center. **SPEED:** 800-1,200 rpm.

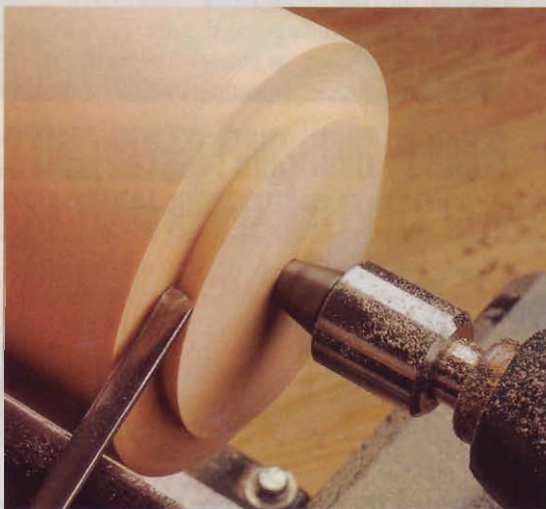

a bright idea

4 Hollow the lid. Chuck the lid blank into your four-jaw chuck. True the end with your bowl gouge. Using the lid-lip template as a gauge, mark the lid's wall thickness on the blank's end. Hollow out the lid with your bowl gouge, checking the depth and contour with the inside template, as shown. When you are close to the final shape, smooth the surface by making light passes. Finish-sand to 220 grit.

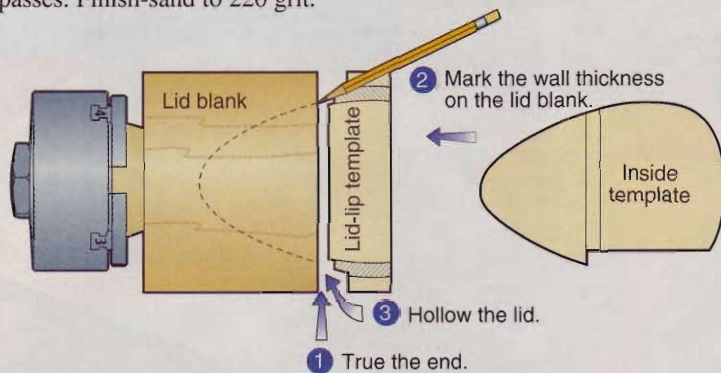

TOOL: Bowl gouge. **TOOL REST:** Above center. **SPEED:** 800-1,200 rpm.



5 Form the lid lip. With a square-end scraper, cut the lip on the inside of the lid, as shown. Use the lid-lip template as a guide. In case you need to remount it, make a mark on the lid to index it with one of your chuck's jaws. Remove the lid from the chuck.

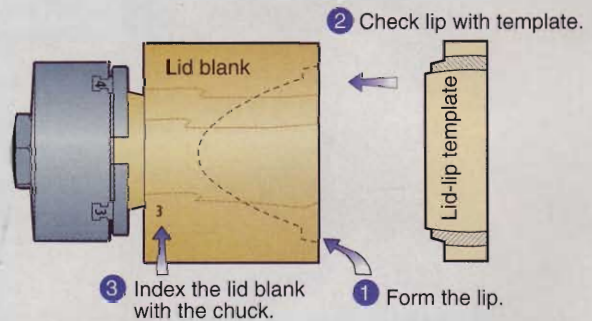

TOOL: Square-end scraper. **TOOL REST:** Above center. **SPEED:** 800-1,200 rpm.

6 Form the base lip. Mount the base blank in your chuck. True the end with your bowl gouge, and use the base-lip template to mark the wall thickness on the base blank's end.

Again, using your square-end scraper, cut the base lip that interlocks with the lid lip. Test the fit often, as shown. The fit should be just snug enough to keep the base and lid aligned when they are joined for forming the outside profile.

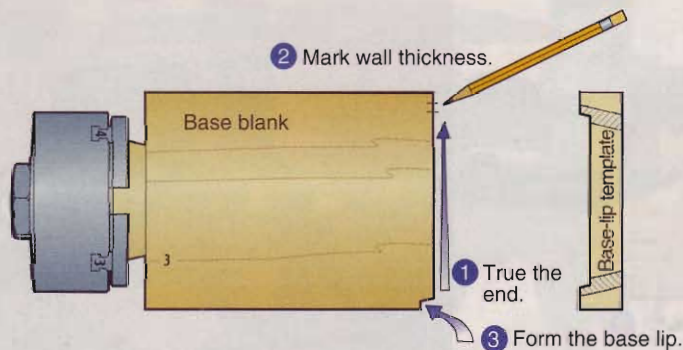

TOOLS: Bowl gouge, square-end scraper. **TOOL REST:** Above center. **SPEED:** 800-1,200 rpm.



7 Hollow the base. Hollow the base with a bowl gouge, then finish up with a heavy ($\frac{3}{4}$ " or 1") roundnose scraper, as shown. A heavy scraper absorbs some of the vibration that occurs when cutting deep into the base. As with the lid, the last passes should be light. Finish-sand to 220 grit.

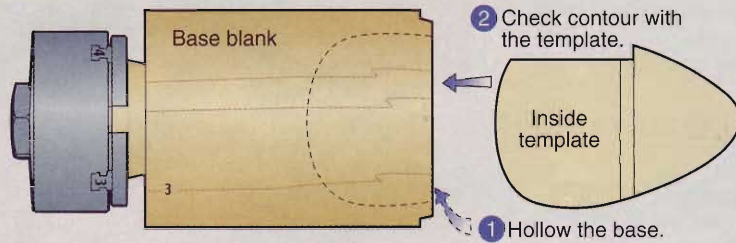

TOOLS: Bowl gouge, roundnose scraper. **TOOL REST:** Above center. **SPEED:** 800-1,200 rpm.

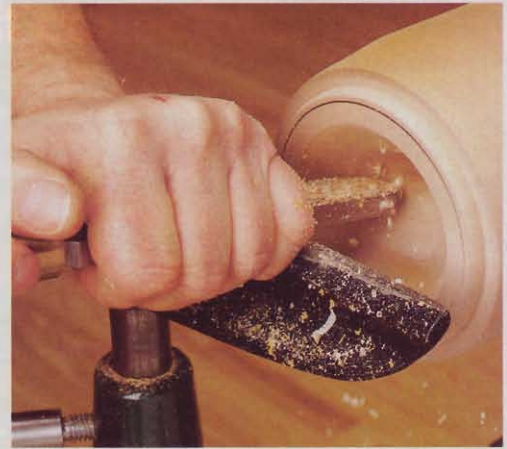

8 Shape the outside. Mate the lid to the base. Engage the tailstock to keep it in place. Using your bowl gouge, turn the outside close to its profile. Finish with your skew chisel, as shown. Check the profile with the outside template. Shape the lid end as far as you can with the tailstock in place, but don't part the waste.

Turn the base's threaded portion to a cylinder about $\frac{1}{8}$ " larger than finished diameter. Mark the threads' locations and cut narrow V-grooves with your skew chisel. Finish-sand the bulb to 220 grit. Back off the tailstock and remove the lid. Sand the base's lip to loosen the fit for finish buildup. Remove the base and chuck from the lathe.

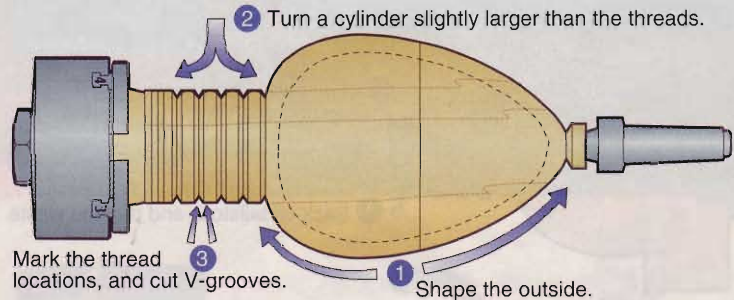

TOOLS: Bowl gouge, skew chisel. **TOOL REST:** Slightly above center. **SPEED:** 800-1,200 rpm.

9 Make a jam chuck and finish the lid. Make a jam chuck to hold the lid and base for final shaping, sizing the chuck first for the lid, then enlarging it for the base.

Bandsaw a 7" disc from $1\frac{3}{4}$ " scrap. Screw the disc to a 3" faceplate, mount it on your lathe, and true it up with your bowl gouge. Mark the lid's outside radius on the disc. Hollow the disc to a depth of about 1", staying $\frac{1}{8}$ " shy of the marked radius. Use your square-end scraper to form a 1° bevel on the jam chuck's inside lip, then work this bevel toward the rim until the lid simultaneously fits snugly and bottoms out in the chuck. With the lid firmly in the chuck, part off the waste with your skew chisel, as shown, and finish-sand the lid to 220 grit.

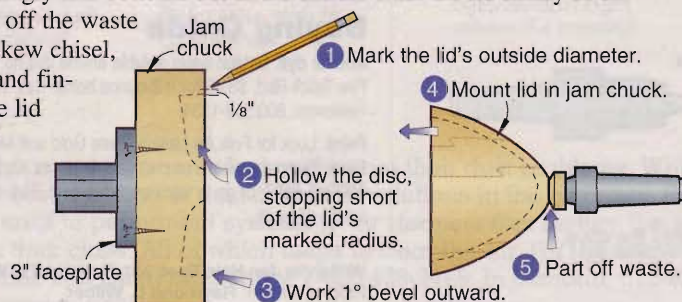

TOOLS: Bowl gouge, square-end scraper, skew chisel. **TOOL REST:** Above center. **SPEED:** 800-1,200 rpm.

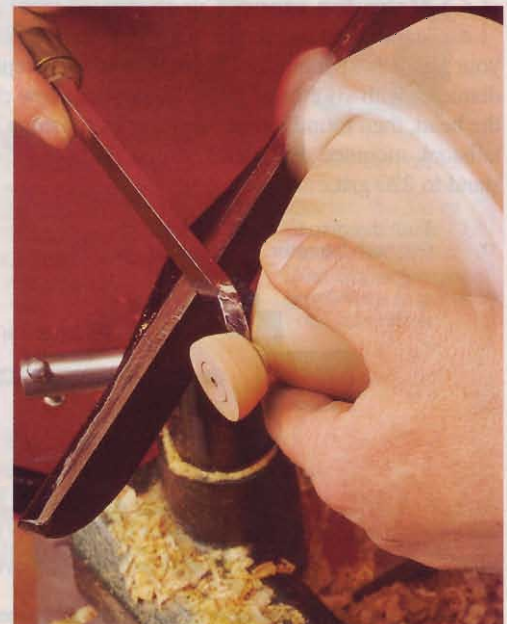

a bright idea

10 Finish the bulb's base. Slightly enlarge the jam chuck with your square-end scraper and mount the base. If you accidentally turn the jam chuck's opening too large to firmly grip the workpiece, insert layers of tissue paper until a tight fit is achieved. Engage the tailstock for support, and finish forming the threads on the base, rounding over their edges with your skew chisel, as shown.

Form the taper that represents the bulb's insulated tip. Finish-sand the base to 220 grit.

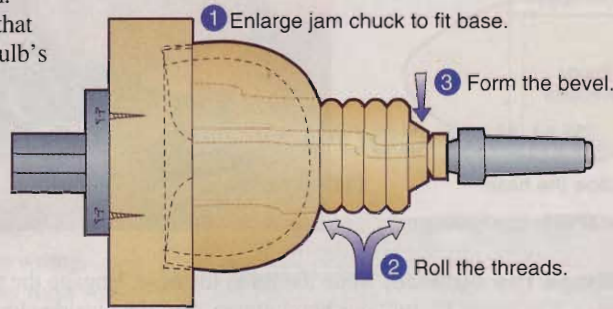

TOOLS: Square-end scraper, skew chisel. **TOOL REST:** Slightly above center. **SPEED:** 1,200-1,600 rpm.

11 Part the waste and drill the base. Back off the tailstock and part off the waste with your skew chisel, cutting into the base at a slight angle to create a small hollow. This hollow ensures a tight fit when the base is doweled to the stand. Mount your drill chuck in the tailstock and drill a $\frac{3}{8}$ " hole in the base, $\frac{1}{16}$ " deep.

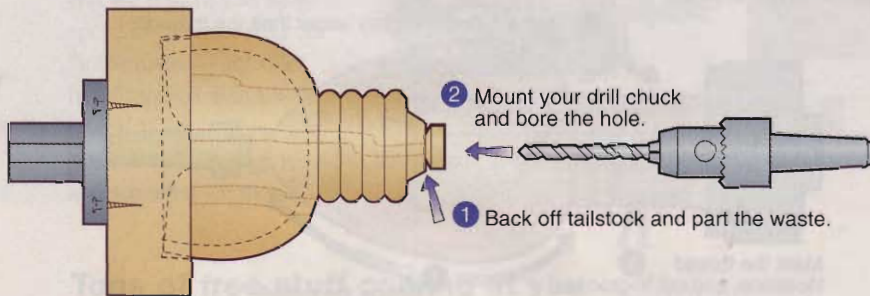

TOOL: Skew chisel. **TOOL REST:** Slightly above center. **SPEED:** 800-1,200 rpm.

12 Make the stand. Cut a $5\frac{1}{2} \times 5\frac{1}{2}$ " piece of $\frac{1}{4}$ "-thick maple for the stand. Find the center, draw a 5"-diameter circle, and rough-cut it on your bandsaw. Mount the blank to your 3" faceplate and turn it to the finished diameter with your bowl gouge. Use your skew chisel to cut a V-groove for the bead, then round it over, flowing its top edge into the cove. Using your tailstock-mounted drill chuck, drill a $\frac{3}{8}$ " hole $\frac{1}{16}$ " deep. Finish-sand the stand to 220 grit.

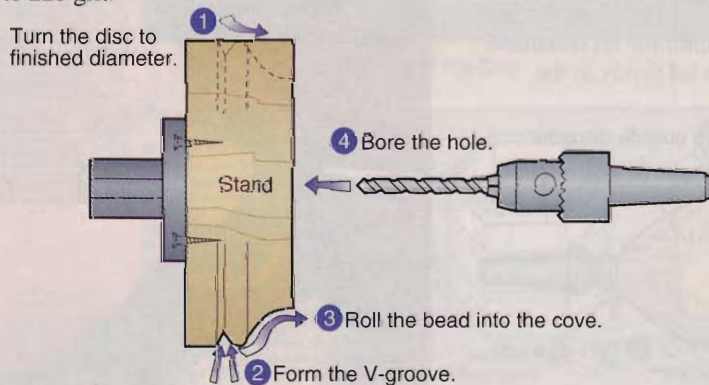

TOOLS: Bowl gouge, skew chisel. **TOOL REST:** Slightly above center. **SPEED:** 800-1,200 rpm.

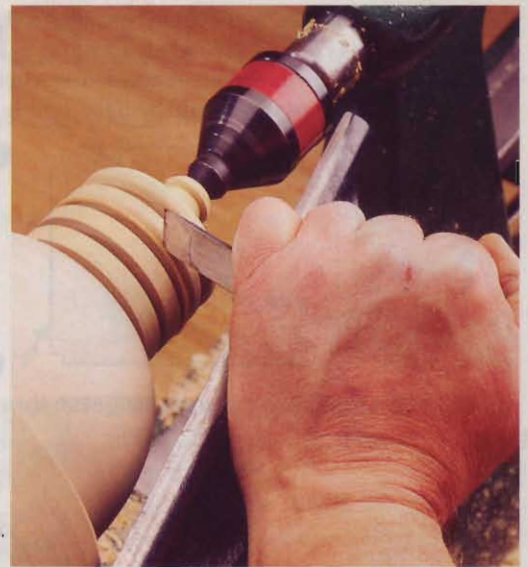

Finish up with aniline dye, paint, and lacquer

We used Behlen Fire Truck Red aniline dye to color the bulb. See the Buying Guide for our dye source. Wearing latex gloves while working with the dye, mix $\frac{3}{4}$ teaspoon of dye powder with $\frac{3}{4}$ cup of hot water. Brush it on the bulb, inside and out, saturating the surface to obtain an intense color.

With the dye dry, mount the base on the lathe using the jam chuck. Turning the lathe by hand, use an artist's brush to paint the threads gold and the insulated tip black. We used Folk Art paint. See the Buying Guide for our source.

With the base still in the jam chuck, glue and dowel the stand to the base. Use the tailstock to apply clamping pressure. (Five-minute epoxy will shorten your waiting time.)

Finish the project with several light coats of gloss aerosol spray lacquer. If needed, sand the bulb lightly with 320-grit sandpaper or a gray (ultra-fine) Scotch-Brite abrasive pad only when the lacquer builds enough of a film to protect the dyed surface. When the final coat of lacquer dries, glue felt to the bottom of the stand. ♣

Buying Guide

Aniline dye. Behlen water-soluble aniline dye no. AH-200648 Fire Truck Red, \$8.49 for a 2-ounce bottle. Call Van Dyke's Restorers, 800/558-1234.

Paint. Look for Folk Art Metallic Pure Gold and Metallic Sequin Black decorative paints at craft supply stores. Or call Artist Club, 800/845-6507; or go to www.artistclub.com. Two-ounce bottles are \$1.19 each.

Written by Jan Hale Svec with Raymond L. Wilber
Project design: Raymond L. Wilber
Illustrations: Raymond L. Wilber; Lorna Johnson
Photographs: Baldwin Photography

products that perform

These woodworking wares passed our shop trials

Low-cost scrollsaw with loads of features

When Black & Decker introduced its line of Firestorm cordless tools, it surprised many woodworkers with good performance at a great price. Those same qualities also can be found in B&D's BT4000 scrollsaw, right down to the bright-red color.

This \$170 unit sports features found on more expensive scrollsaws, such as a segmented air hose to blow dust away from your cutline. In addition, the BT4000 has a dust-collection port directly below the blade, which, when connected to a shop vacuum, gave me nearly dust-free cutting.



So, it must sacrifice power, right? Wrong. This machine has the ponies to saw 1½" material with no difficulty. Yet, the variable speed gave me the control to

make delicate cuts in thin material as well. The blade holder accepts both styles of blades, pinned and plain, and a slotted storage tray on top of the saw keeps those blades within easy reach.

In addition, the BT4000 offers an easy-to-read tilt scale and large knobs. One small gripe—to change blades, you need to tilt the table 45° to access the lower armature knob. But I do like how the blade and lower armature tilt forward to make threading the blade for inside cuts fast and easy.

—Tested by Kevin Boyle

Black & Decker BT4000 16" Scrollsaw

Performance	★★★★☆
Price	\$170
Value	★★★★☆

Call Black & Decker at 800/544-6986, or visit www.blackanddecker.com.

NEW!
Adjustable Bar!
Micro Adjusting
Flip-Stop

"All my tools should be this good!"

Accu-Miter® shown with optional manual clamp.

The Accu-Miter® is a professional miter gauge that makes perfect angles easily. Shot-pin action assures dead-on accuracy for common angles. Our new adjustable bar insures a perfect fit in your table saw's slot.

\$179
Model 18-34

Call or write for our free brochure.

JDS COMPANY

800 Dutch Square Blvd., Suite 200
Columbia, SC 29210
1-800-382-2637 www.thejdscompany.com

Econ-Abrasives

WE MAKE ABRASIVE BELTS ANY SIZE, ANY GRIT!

Standard Abrasive Sheets			ABRASIVE BELTS									
CABINET PAPER			Belts are resin bond cloth with a bi-directional splice, specify grits.									
	50/pk	100/pk	1X30 \$.81 ea	3X24 \$.93 ea								
60D	\$17.58	\$31.58C	1X42 .81 ea	3X27 .96 ea								
80D	\$16.42	\$29.26C	1X44 .81 ea	4X21 3/4 1.06 ea								
100 thru 150C	\$15.26	\$26.95C	2 1/2X16 .85 ea	4X24 1.10 ea								
FINISHING PAPER			3X18 .86 ea	4X36 1.35 ea								
80A	\$11.74	\$19.89C	3X21 .90 ea	6X48 3.50 ea								
100 thru 280A	\$10.50	\$17.58C	3X23 3/4 .93 ea	6x89 6.24 ea								
NO LOAD PAPER(white)			OTHER SIZES ON REQUEST									
100 thru 400A	\$12.90	\$22.40C	HEAVY DUTY SPRING CLAMPS									
"C" = 100 SHEETS			Clamps come w/PVC tips and grips.									
Velcro® Vacuum Discs			<table border="1"> <thead> <tr> <th>Size</th> <th>Price</th> </tr> </thead> <tbody> <tr> <td>4"</td> <td>\$1.75 ea</td> </tr> <tr> <td>6"</td> <td>2.25</td> </tr> <tr> <td>8"</td> <td>3.50</td> </tr> </tbody> </table>		Size	Price	4"	\$1.75 ea	6"	2.25	8"	3.50
Size	Price											
4"	\$1.75 ea											
6"	2.25											
8"	3.50											
8 Hole pattern for Bosch sanders			JUMBO ROUTER PAD(24" x 36")									
Dia.	Grit	Price	It will not allow small blocks of wood to slip out under router or sanding applications. ROUTER PAD ONLY \$8.95ea.									
5"	60	\$.48ea	JUMBO BELT CLEANING STICK ONLY \$8.80									
5"	80	.46										
5" 100 thru 320	.45											
* Available in 5 hole pattern *												
*Wide Belts*Rolls*Flap Wheels												
*Pump Sleeves*PSA Discs												
*Router & Wood Bits*Wood Glue												
*MasterCard, VISA, Discover, Am. Express			Econ-Abrasives									
*SATISFACTION GUARANTEED!!!			P. O. Box W1628									
*CALL FOR FREE CATALOG			Frisco, TX 75034									
-TX add appropriate sales tax			(972)377-9779									
-Call for shipping charges												
TOLL-FREE ORDERING LINE (800)367-4101												

The lowly sawhorse goes high-tech

Sawhorses used to be clunky, riddled with saw kerfs, and awkward to store. No more. There are a number of folding sawhorses on the market these days, but you'd be hard pressed to find any as versatile as Zag Adjustable Sawhorses.

These nifty, lightweight work supports can be set from 30" high (a good height for cutting sheet goods) to 37" high (easy on the back when working with smaller pieces). They also lengthen from 29" to 47" with a simple pull of the rail extension. I found the small rubber pads—built into the top rail to keep materials from marring or sliding around—a nice touch. Those features alone would probably earn Zag Adjustable Sawhorses a recommendation and a place in my shop. But there's more to these handy helpers.

Each sawhorse comes with a pair of "Smart Grooves"—vaguely X-shaped attachments that slip over the ends of the top rail. (See photo below.) With these, you can stand 2x stock on edge to act as a sacrificial top rail for cutting sheet goods.



Zag Adjustable Sawhorses

Performance	★★★★★
Price	\$50, pair
Value	★★★★☆

For more information, call The Stanley Works at 800/782-6539, or visit www.stanleyworks.com.

You can even crosscut long 2x4 stock, using only one Zag Adjustable Sawhorse and the Smart Grooves. I fit an 8' length of 2x4, lying flat, into the grooves and they held the stock securely during the operation. Invert the Smart Grooves and they work well for cutting round materials, such as steel or PVC pipe.

At their 30" height, each sawhorse is rated for 500 pounds. When raised to their

full height, the weight rating drops to 400 pounds each. That means you can safely load a pair of Zag Adjustable Sawhorses with 10 full sheets of medium-density fiberboard (MDF). Instead, I loaded mine with a more realistic four sheets of 3/4" plywood and, even at full height, detected little sway.

—Tested by Jeff Hall

Continued on page 94

All Fine Woodworking Demands The

WOODWORKER'S

Signature

ACCURATE

ULTRA-CLEAN

SMOOTH

COOLER CUTTING

T4 Silencer

INCLUDED TO PROVIDE THE HIGHEST QUALITY OF CUT FROM YOUR SAW BLADE.

All saw blades, even those with laser cut bodies, experience vibration caused by the saw motor, pulleys and arbor, especially when saw operates at maximum cutting rpm. The vibration resonates from the saw to the blade's perimeter, causing the rim to vibrate and flutter. This leads to inferior cuts and shortened blade life. The T4 Silencer dampens vibration and noise, providing smoother and quieter cutting.

UNITED STATES **SAW**
We Are Woodworkers



Sanding sponges speed surface prep

The advantages of sanding sponges are no big secret: They readily mold themselves to contoured surfaces, yet spring back to sand flat just as easily. And, when the abrasive clogs with dust or finish, they rinse clean with water. 3M SandBlaster sanding sponges and pads bring those pluses and more to the category.

The manufacturer claims these abrasives work three times faster than other sanding sponges. To test that boast, I applied equal weight to a 36-grit SandBlaster sponge and a new off-the-shelf 36-grit sponge. I then placed both sponges on an old painted shelf and counted the number of strokes it took to get

through the first layer of paint. It took me a little more than twice the number of strokes with the no-name sponge.

The folks at 3M also have taken some of the guesswork out of figuring out which abrasive to use where. SandBlaster products come color-coded based on their use—green for paint and varnish removal, violet for preparing wood or metal for finishing, and gold for sanding between coats of finish.

—Tested by Jeff Hall

3M SandBlaster sanding sponges

Performance	★★★★★
Price	\$3
Value	★★★★★

Available at Target and Wal-Mart stores.

About our product testers

Jeff Hall teaches woodworking and other technical skills to high-school students in Des Moines, Iowa.

Kevin Boyle is a design editor at WOOD magazine.

Square Drive Screws from the Source

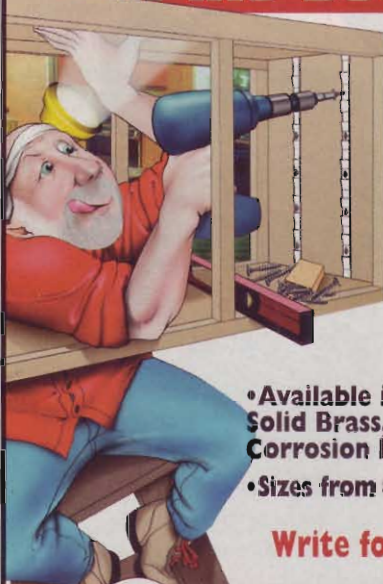

•Square Drive Stops Driver Bit Slippage!

•Hardened Steel for Extra Strength

•Deep Thread for Superior Holding Power

•Available in Stainless Steel, Solid Brass, Plated Steel, Corrosion Resistant and More!

•Sizes from #4 x 3/8" to #14 x 6"

Write for FREE Catalog!



McFEELY'S
SQUARE DRIVE SCREWS

PO Box 11169 • Dept WDKB • Lynchburg • VA • 24506
Toll Free 1-800-443-7937 or at www.mcfeelys.com

SOMMERFELD'S TOOLS FOR WOOD

8 East Third Street

Remsen, IA 51050

CMT's New Industrio™ Routing System

Designed by Marc Sommerfeld

CMT
the only ORANGE one™

This system combines the performance and design of a shaper with the versatility of a router.

We stock the full line of CMT cutting tools.

Check out our complete on line catalog at

www.sommerfeldtools.com

ORDER TOLL-FREE 1-888-2BUY-CMT

1-888-228-9268

what's ahead

in our next issue

Coming in December—

Arched-top cabinet clock

This unique timepiece was one of the finalists in our "It's About Time" Clock-Building Contest. You can build one just like it, and learn a few tricks about stave construction in the process.



Tabletop reindeer

Add a dash of festive cheer to your holidays with these 9"-tall decorations. You can make five deer from just two pieces of 1/8x12x30" birch plywood.



A feature-packed router table

Portable, easy to store, and capable of handling most routing tasks—that describes this benchtop workhorse. After you build one, we'll show you how to use it for template routing, biscuit joinery, making custom dowels, splining miters, and jointing edges.



Contemporary dresser and mirror
Our matching bedroom set concludes with a dresser and wall-mounted mirror. Check *page 70* of this issue for the accompanying armoire/entertainment center, issue 135 for the sleigh bed that kicked off this series, and issue 136 for the nightstand.

Window valance

This super-simple project will add elegance and soft lighting to any room. Dress it up with clear finish, paint, or wallpaper to match your home's interior perfectly.



Fixed-base routers

If you're looking for simple operation and maximum motor muscle for the money, try a fixed-base router. We test and review seven models sized from 1½ to 2¼ horsepower.



The answers from page 84

Color—1. padauk, 2. purpleheart, 3. black walnut, 4. tulipwood, 5. bubinga, 6. kingwood.

Luster—9. avodire, 10. satinwood, 11. obeche.

Texture—7. anegre, 8. sycamore.

Figure—12. myrtle burl, 13. madrone burl, 14. bird's-eye maple, 15. tiger maple, 16. elm burl.