

Better Homes and Gardens®

WOOD

DRILL PRESSES
See the best in our test

October 2001
ISSUE 136

Tips, Tools, Techniques, and Projects for Woodworkers

remake your **kitchen** one step at a time

LEARN TO...

- plan your space
- make and install cabinets
- craft a custom countertop
- add matching wood panels to appliances
- dramatize windows with faux transoms

More Projects:

- Chippendale accent mirror
- stylish nightstand

www.woodonline.com

Display until October 2, 2001

U.S.A. \$5.95



0 72440 14072 1 10 >

contents

WOOD® magazine

October 2001, Issue 136

projects & techniques

45

The Handcrafted Home



50



68



72



78



45 remake your kitchen

See all of the ways you can improve and update the hardest-working space in your home.

50 custom cabinetmaking

Learn how to plan, buy materials for, and build beautiful base and wall cabinets for all your storage needs.

60 installing cabinets

Use our guide for level placement of wall and base cabinets.

64 the integrated kitchen

Face your appliances with wood panels that match your cabinets.

68 crafting a countertop

Finish off base cabinets with an easy-to-clean plastic laminate top and your choice of attractive edge treatments.

72 adaptable display cabinet

Hung in the kitchen or another room, this lighted, glass-front showcase gives collectibles a stylish perch.

78 glass with class

Give an ordinary window extraordinary looks with a false transom.

Kitchen cover photo: King Au/Studio Au

80



90



80 chippendale mirror

Find the full-size patterns for this handsome antique design inside.

90 nightstand

Put your biscuit joiner to work on this one-drawer bedroom table.

contents

October 2001, Issue 136

tools & materials

- 84 meet the presses**
Bore into the body of research from our shop tests of six stationary drills.

departments

- 6 editor's angle**
- 8 wood online®**
- 12 talking back**
- 18 furniture repair shop**
Renew an old, dull, furniture finish with an oil-varnish blend.
- 20 great ideas: pattern sander**
Try a dead-on way to duplicate wood project parts.
- 24 be our guest expert**
Pick up tricks from scrollsaw guru Rick Hutcheson.
- 26 the buisness of woodworking**
Toot your horn in writing to help customers understand who you are.
- 28 perfect finish**
Let your furniture wax eloquent with these post-finishing products.
- 32 router bits: copycat cutters**
Make identical parts using templates and these piloted flush-trimmers.
- 34 ask wood**
- 38 shop tips**
- 96 products that perform**
- 102 wood anecdote: persimmon**
- 112 what's ahead in our next issue**

Better Homes and Gardens® WOOD® magazine (ISSN-0743-894X) is published nine times a year in February, March, April, May/June, July/August, September, October, November, and December by Meredith Corporation, 1716 Locust St., Des Moines, IA 50309-3023. Periodicals postage paid at Des Moines, Iowa, and additional mailing offices. Better Homes and Gardens trademark registered in Canada and Australia. Marca Registrada en México. **ONE-YEAR SUBSCRIPTION PRICES:** U.S. and its possessions, \$28; Canada, \$41; other countries, \$49. Canada Post Publications Mail Sales Product Agreement No. 40049562. Canadian BN 12348 2887RT. **CANADIAN RETURN ADDRESS:** *Better Homes and Gardens WOOD* magazine, 2744 Edna Street, Windsor, Ontario, N8Y 1V2. **POSTMASTER:** Send address changes to *Better Homes and Gardens WOOD* magazine, P.O. Box 37439, Boone, IA 50037-0439.

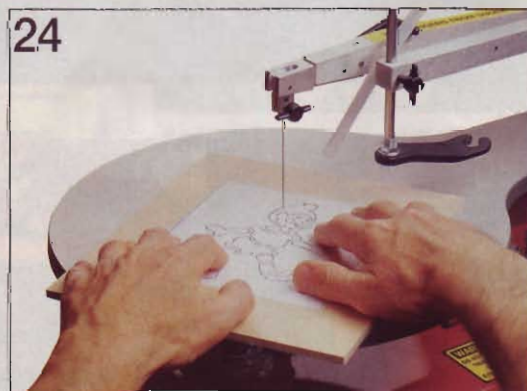

here's what's cookin'

As a woodworker, you've probably enjoyed the pleasure that comes from watching someone's face light up when he or she receives a gift of your handiwork. It's one of the best reasons to be a woodworker. And often, that lucky recipient is a spouse.

So imagine the reaction of your significant other when you share ideas for a kitchen improvement—say, a lighted display cabinet, new floor, fresh countertops, updated tile backsplash, or, if you're ambitious, all new cabinets.

Yes, building a set of kitchen cabinets is a big undertaking, but I think the benefits make it well worth the effort. By following the straightforward techniques on *page 50*, you can churn out cabinets far superior to what you'll buy off the shelves. And, by day's end, you'll have more pocket money—cash that could go toward tools or other toys.

Of course, the beauty of updating a kitchen is that you can do as little or as much as you like. Either way, domestic tranquility is virtually assured.

To help make you a kitchen-rehab hero, the staff and I gutted an existing kitchen and gave it a total woodworking face-lift. I think you'll find the results impressive—just remember that you don't have to take such extreme measures in your own home. We did a complete renovation because that's the best way to show you as many projects and techniques as possible. And, in the process, you can see how the cabinetry, countertops, appliances, flooring, and other kitchen elements come together in a unified whole. We made sure the information provided is as user-friendly and adaptable as you'll find anywhere.



Although we devoted a full 29 pages of this issue to kitchen improvements, plus part of our WOOD PATTERNS® insert, we still weren't able to show you every single skill that goes into a kitchen redo. So, as you'll see on *page 48*, we're featuring seminars on how to install the windows, the flooring, and wall tiling at our Internet site, www.woodonline.com. You'll even learn a thing or two about decorative painting.

Our expanded coverage also carries over to the next issue of WOOD. In November you'll learn how to build a room divider like the one at the end of the kitchen opposite the range. (See *page 112* for a photo.) By simply varying the length of the arched bulkhead, you can adapt the divider to fit your own home's interior. The columns are veneer-covered tubes you buy—no stave construction or turning necessary.

May you enjoy this special section as much as we did in putting it together. I hope our efforts will help bring a beaming smile to that special someone who spends time in your kitchen.

Bill Krier

Editor-in-Chief **BILL KRIER**
Executive Editor **JIM HARROLD**
Managing Editor **MARLEN KEMMET**
Projects Editor **JAN HALE SVEC**
Products Editor **DAVE CAMPBELL**
Techniques Editor **JIM POLLOCK**
Design Editor **KEVIN BOYLE**
Design Editor **KENT WELSH**
Master Craftsman **CHARLES I. HEDLUND**
Production/Office Manager **MARGARET CLOSNER**
Administrative Assistant **SHERYL MUNYON**
Reader-Contact Specialist **BEN VONRUDEN**
Illustrators **LORNA JOHNSON, ROXANNE LeMOINE, TIM CAHILL, MIKE MITTERMEIER**
Contributing Photographer **MARTY BALDWIN**
Technical Consultants **RICH BRIGHT, JEFF HALL, KIRK HESSE, GARRY SMITH**
Contributing Craftsman **JIM HEAVEY**
Proofreader **JIM SANDERS**

Art Director **TIM ALEXANDER**
Associate Art Director **JOHN MEEK**
Assistant Art Director **CHERYL A. CIBULA**

Publisher **MARK HAGEN**

Advertising Office: 333 N. Michigan Ave., Suite 1500, Chicago, IL 60601 Phone: 312/853-2890 FAX: 312/580-7906

Advertising Manager **JIM HUGHES**

Mail Response Manager **CAROLYN DAKIS**

Account Executive **RON GOLMINAS**

Account Executive **NEIL KIRBY**

Account Executive **JOHN THORNBURGH**
(Detroit 248/356-1149)

Sales Assistant **MARGARET TRAVIS**

Sales Assistant **THERESA COOKS**

Group Publisher **STEVE LEVINSON**

Associate Business Director **CRAIG FEAR**

Senior Product Manager **RICK GROW**

Advertising Services Manager **PAT HENDERSHOTT**

Consumer Marketing Director **KATHI PRIEN**

Consumer Marketing Manager **DAVE HONOLD**

Vice President/Publishing Director **WILLIAM R. REED**

MEREDITH PUBLISHING GROUP

President **STEPHEN M. LACY**

Magazine Group President **JERRY KAPLAN**

Group Sales **MICHAEL BROWNSTEIN**

Creative Services **ELLEN DELATHOUDER**

Business Development **TINA GEORGEOU**

Manufacturing **BRUCE HESTON**

Consumer Marketing **KARLA JEFFRIES**

Finance and Administration **MAX RUNCIMAN**



WILLIAM T. KERR, President and Chief Executive Officer

E.T. MEREDITH III, Chairman of the Executive Committee

©Copyright Meredith Corporation 2001

All rights reserved. Printed in the U.S.A.

Customer Service Information: For service on your subscription, including change of address, contact us at www.woodmagazine.com/service or call **800/374-9663**.
Subscription mailing address: Better Homes and Gardens WOOD magazine, P.O. Box 37439, Boone, IA 50037-0439. Please enclose your address label from a recent issue.
Editorial mailing address: The Editor, WOOD magazine, 1716 Locust Street, GA310, Des Moines, IA 50309-3023. For questions on editorial, questions about how to reach an advertiser, or to place an advertisement in our magazine call **800/374-9663**.
To order back issues call **800/346-9663**. Article reprints, send \$5 per article (no phone orders), include issue and name of article, to WOOD Article Reprint Service, P.O. Box 349, Kalona, IA 52247, check or money order made payable to WOOD magazine.

B

MPA

wood online®

How you benefit by going to www.woodonline.com



Access WOOD® subscription services

Forget about time-consuming letters and phone calls. Now you can access your personal magazine account instantly on the WOOD ONLINE® Customer Care page. We make it easy for you to check your account status, change your mailing or e-mail address, and now even pay your bill. Help is just a click away!

Simply go to www.woodonline.com and click on **SUBSCRIPTIONS** in the left-hand navigation bar and then on **Customer Service** in the drop-down menu.

Quickly locate any article WOOD has ever published

We know how frustrating it can be when you remember a favorite project or article you've seen in WOOD but you can't remember which issue it was in so you can look it up. Let our online index come to the rescue with its easy-to-use search engine. Just type in a descriptive word (such as "router") and click the Search button. You'll get an instant listing of articles from past issues that relate to your search.

To use, go to www.woodonline.com click on **WOOD MAGAZINE** in the left-hand navigational bar, then click on **WOOD Index** in the drop-down menu.

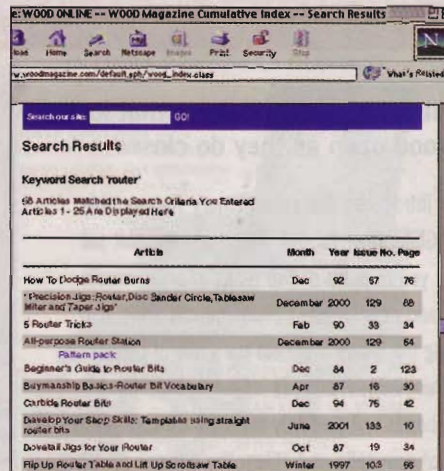

Brush up on the basics

And at WOOD ONLINE, we've got the basics covered. Every two weeks, we add a new project and a new feature to whet your woodworking appetite. Our newest entries? A nifty wall-mounted drafting reference center shown *below*, and info on how to use a bearing set to make your router's rabbeting bit do a few new tricks.



To access this new info, go to www.woodonline.com and click on **WOOD MAGAZINE** in the left-hand navigation menu, and then on **Woodworking Basics**. You'll find these two entries under the **Projects** and **Routing** headings. 🐿

Free classified ads? What's the catch?

There's no catch. Ads to sell your personal woodworking items can reach a gazillion woodworkers all over the globe 24/7, and they're absolutely free for a whole 60 days! (Sorry, ads from commercial companies and Internet-site advertisers are not accepted.)

Read all about it at www.woodmagazine.com/classifieds/



talking back

Our bulletin board for letters, comments, and timely updates

Add a lower vac port to your router station

I'm writing to thank you for the great design and excellent instructions for the all-purpose router station featured in issue 129. I built the project exactly as presented and everything fit perfectly. In addition to the leg stand for the router station, I

made two others, one for my bench drill press and one for my planer.

I decided to make frame-and-panel doors with raised panels instead of the plywood ones shown. In the process, I filled the cabinet with shavings. So I added a vacuum port under the auxiliary table, as shown in the drawing. I now capture nearly all of the chips.

—John Woodcox,
Kendallville, Ind.

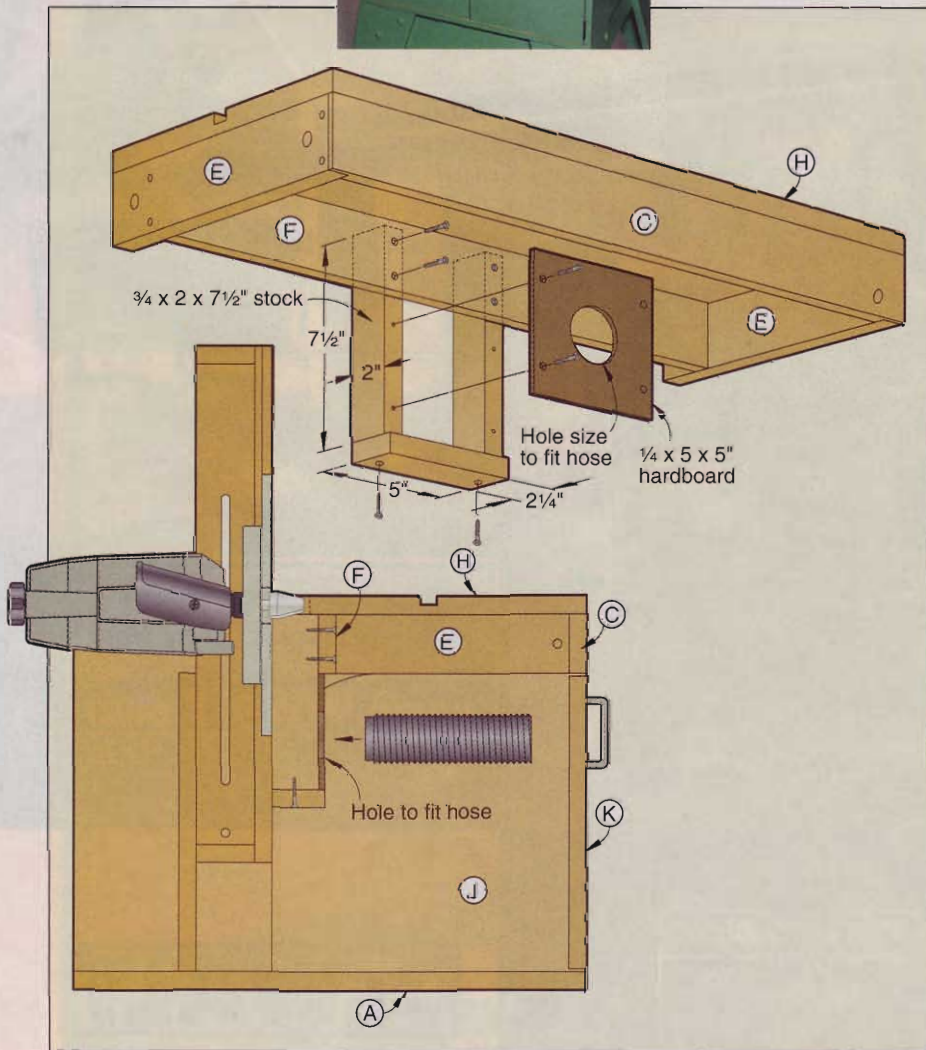

U P D A T E

Tree bark could help hold things together

The U.S. Department of Energy awarded Portland, Oregon-based Louisiana-Pacific Corporation and Boston-based Ensyn Group, Inc. a \$1.4 million grant to develop bark-based adhesives for use in the production of structural building materials, including oriented strand board (OSB) and plywood. The grant, announced last August, will be matched by funds from the two companies.

"Bio-based products can replace petroleum in chemicals and fuels instead of being put to some relatively low-value use or disposed of. Biomass has the potential to help reduce our dependence on imported oil if we can use it in place of petroleum in chemicals and fuels," said then-Secretary of Energy Bill Richardson.

According to Robert Graham, Ensyn president and CEO, "Bark holds great promise as a raw material for producing a less-expensive substitute to the petroleum-based adhesives traditionally used in building products."

"Ensyn is clearly a leader in demonstrating the commercial feasibility and cost-effectiveness of extracting chemicals found naturally in wood and using them to produce quality products," said Warren Easley, Louisiana-Pacific's vice-president of Technology and Quality. Easley noted that the bark Louisiana-Pacific currently generates is used predominately in landscaping and as a low-value fuel used at its facilities.

Continued on page 16

Show off your shop and win DeWalt tools

Do you have a shop-smart safety idea, original workbench design, problem-solving organizer, or just a great all-around workshop? Then you have a chance to share in \$10,000 worth of tool prizes. Just enter the first-ever Great American Workshop Contest™ sponsored by WOOD® magazine and DeWalt Industrial Tool Company.

There are eight categories to choose from. For complete details, see the contest rules on pages 24 and 25 of the August 2001 issue, or go to www.woodonline.com. The deadline for entries is October 1, 2001, so don't delay. We'll feature the winners in our March 2002 issue.

An easy adjustment for lift-up tool table latches

After working in construction all of my life, first as a shop teacher, then as the owner of a construction firm, I plan to retire in a couple of years. In anticipation of working with wood for fun, not just for profit, I recently built a 20x30' shop behind my home. After putting considerable thought into planning my dream shop, I decided that the lift-up tool tables from Idea Shop 3, detailed in issue 103, are the best solution to storing and using certain machines. My kudos to you on this great idea.

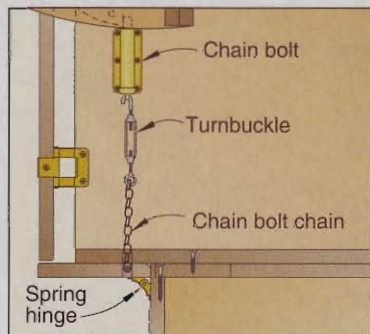

So, I built lift-up tables for my router, portable planer, and oscillating spindle sander. The tables work like a charm, but I had difficulty adjusting the length of the chains so that the spring-loaded chain bolts would consistently catch and release the latch blocks that hold up the

This cutting platform folds for storage

I made a slightly different version of the cutting platform shown in Great Ideas For Your Shop in issue 130. Because it folds instead of being taken apart, setting it up is a snap.

The platform is made of 4'- and 8'-long 2x2s bolted together, as shown in the drawings. The bolts are counterbored to keep them away from your saw blade. Tighten the locknuts enough to prevent the 2x2s from wobbling while still allowing them to pivot.

When ripping a sheet of plywood, place the platform on your saw horses with the 8'-long 2x2s on top. When crosscutting, orient the platform with the 4'-long 2x2s on top. When folded, the platform is about 10½' long.

—Greg Weller, Longmont, Colo.

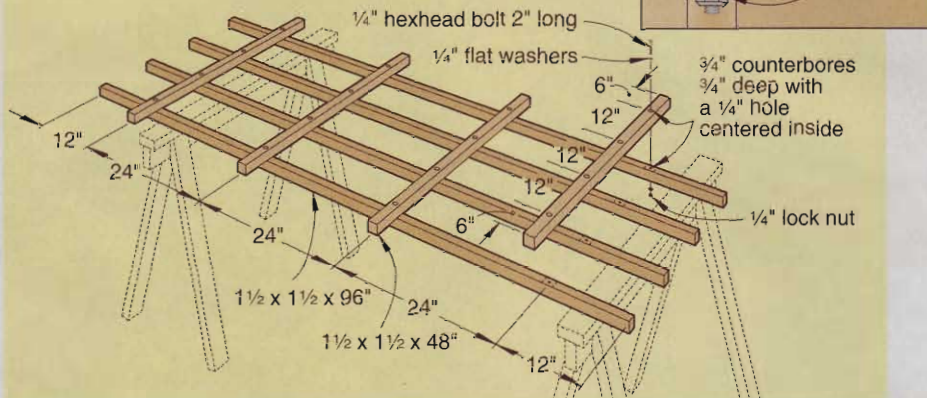

table. Even after I adjusted the chains, they seemed to stretch and go out of adjustment. My solution was to add a turnbuckle to each chain, as shown in the drawing. Voila—works like a charm!

—Lynn Lawrenz, Algoma, Wis.

DMT adds some TLC tips for router bits

The well-illustrated article, "TLC For Router Bits," in issue 126 points out some tips Diamond Machining Technology, Inc. (DMT) preaches. I would like to make these additional comments:

- About half the wear on carbide is chemical attack, caused by a reaction at high temperature between the cobalt binder and the tannic acid in wood, not mechanical wear. Promote cool running with frequent sharpening.
- Hand-sharpening carbide is more accurately described as lapping. You'll get finer results from 600-mesh, or even 325-mesh, diamond than the typical power grinding. The payoff to you is smoother profiles and less tearout. Hand lapping also conserves carbide because the alignment of the carbide's face to the

diamond surface is done before stroking.

- When you purchase a diamond sharpening stone, buy monocrystalline diamond. It is more durable than polycrystalline diamond.
- Use a large bench-type diamond stone for long stroking of open wing cutters. Use thin diamond files for the narrow gullets of anti-kickback bits. Lubricate your diamond stones with water to trap the carbide filings and keep them out of your lungs.
- Carbide doesn't rust, so it is not necessary to oil it for protection. Many router-bit bodies already are protected with various coatings.

—David Powell, President, DMT, Marlborough, Mass.

Write Us!

Do you have comments, criticisms, suggestions, or maybe even a compliment specifically relating to an article that appeared in WOOD® magazine? Please write to:

Talking Back
WOOD magazine
1716 Locust St., GA310
Des Moines, IA 50309-3023

or e-mail us at talkingback@mdp.com.

Due to the volume of letters and e-mails we receive, we only can respond to and publish those of the greatest interest to our readers.

oil-varnish blend **powerful potion for dull finishes**

An antique's finish often looks dull and lifeless. But stripping off the old and laying on a shiny new coating might rob the piece of both charm and monetary value. Here's an alternative.

Oil-varnish blend, often referred to as Danish oil or antique oil finish, offers an effective means of hiding minor surface flaws and restoring sheen to dull finishes. And it's an easy fix, too: Just clean the surface (a spray-on household cleaner works fine), rub the finish on as shown in the photo, then wipe off the excess. Rubbing off *all* the excess is the key to avoiding a smeary, sticky surface.

(Be careful with rags you use with oil-varnish; there's a danger of fire from spontaneous combustion. Spread the rags and hang them to dry evenly all over rather than wadding them up.)

In effect, going over an existing finish with an oil-varnish blend is similar to shining it up with paste wax (see *Paste wax*, *WOOD*® magazine issue 112, page 14). The difference is that an oil-varnish blend is more permanent. (You should wait about a year between reapplications. Unlike wax, oil-varnish will build up on



Bring a satin sheen to an old, dulled surface by applying an oil-varnish blend right over the existing finish. It's compatible with virtually all furniture finishes.

the surface.) In many cases, an oil-varnish product can color deeply scarred spots.

This technique works well on legs, doors, drawer fronts, cabinet sides, skirts, panels, and other such furniture parts. It could prove less successful on tabletops,

desktops, and other heavily used surfaces where the soft finish might not give enough abrasion resistance. You probably would be better off to shine up the surface with paste wax in these situations. 🌿

Photograph: Baldwin Photography

Mixing oil (often linseed or tung oil) with some varnish (polyurethane varnish, in some products) creates a finishing material with a blend of qualities. The varnish provides a higher gloss and offers more protection than oil alone. The oil in the mix slows curing—giving you more time for application—but makes the cured finish softer than varnish alone.

You probably won't find oil-varnish finish labeled as such in stores. It's usually billed as an oil finish; some popular brands are Deftoil Danish Oil Finish, Minwax Antique Oil Finish, Olympic Antique Oil Finish, and Watco Danish Oil Finish.

And don't expect the labeling to shed much light on which oil and varnish are in the mix, or in what proportions.

pattern sander

Let a template ensure safe, repeatable results

When it came to shaping the turned-out bottoms of the legs for the nightstand on *page 91*, Design Editor Jim Downing, Project Builder Chuck Hedlund, and Project Editor Jan Svec gathered around Chuck's workbench in the *WOOD*® shop for some communal head-scratching. For uniformity, we needed to guide a shaping tool along a template. But a flush trimming bit chucked in our table-mounted router caused chipping where the leg curves and the wood grain intersected the routed face. There was also the problem of safely holding on to the narrow workpiece. Our solution? A drill-press mounted jig that combines a "pilot-bearing" rub block with a sanding drum. Here's how to make it.



Cut the base from plywood or particle-board, and place it on your drill-press table, centered under the chuck. Mark the locations of your drill-press table slots, and drill counterbored holes for the mounting bolts. Drill holes for the dowel and the rub-block locking bolt. Glue the

dowel in place. Measure the diameter of your sanding drum. (You can make a rub block for each size of sanding drum you have. Ours are about $\frac{1}{16}$ " larger than their nominal sizes.) Cut a piece of $\frac{1}{4}$ " hard-board to this width, and bandsaw and sand the radius on one end. Rout or saw the slot, and drill the centered hole to clear the end of the sanding drum's shaft.

To use your pattern sander, fasten the base to your drill-press table with the carriage bolts. Install the rub block, and chuck up your sanding drum. Swivel the drill-press table to align the rub block side-to-side with the sanding drum, then lock the table in place. Slide the rub block on the dowel and locking bolt to align it front-to-back. Tighten the locking bolt. Make your pattern from $\frac{1}{2}$ "-thick material. (We laminated two layers of $\frac{1}{4}$ " hard-board.) Bandsaw your part to rough shape, and adhere your pattern to it with double-faced tape. Move the workpiece against the spinning sanding drum until the pattern contacts the rub block. ♣

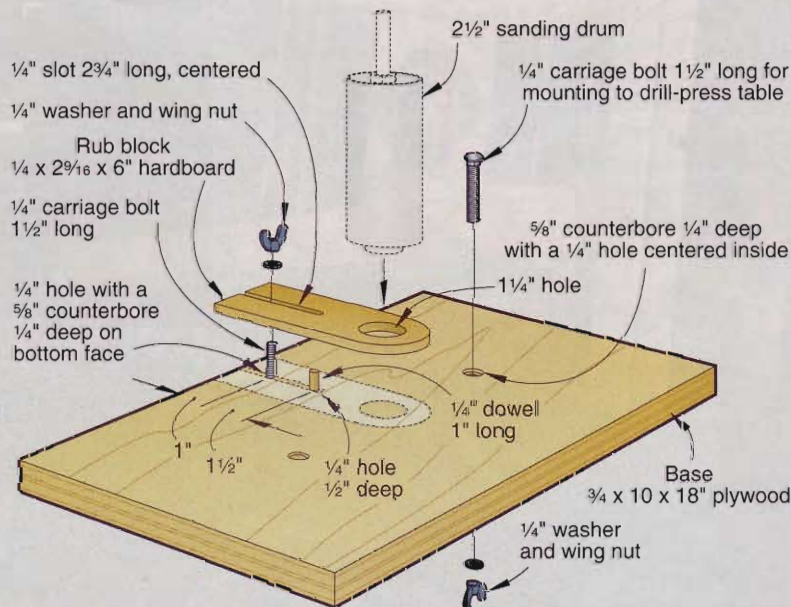

Illustration: Roxanne LeMoine; Lorna Johnson
Photograph: Baldwin Photography

always on a scroll



Lots of woodworkers own a scrollsaw, but **Rick Hutcheson** goes way beyond that. The first floor of his two-level workshop in

Grimes, Iowa, displays a row of newer scrollsaws that he'll readily evaluate for you, feature by feature. And upstairs, along with tables full of finished projects, you'll find a museum's worth of old, even antique, scrollsaws.

We asked Rick, our scrollsawing expert for the past decade, to pass along some tips for those new to the craft. To find out more, go to his Web site, www.scrollsaws.com, or buy his videotape, "Rick's Scrollsaw Video: Scrollsaw Basics." It's available as item number 1857 from Meisel Hardware Specialties (800/441-9870) for \$19.95.

Ease into it

- Cut at slow speeds** when you're learning. It's less stressful and more forgiving.
- Learn how your blades tend to cut.** Most will want to drift to your right, due to a burr that's created when they're stamped.
- When cutting a curve,** keep your eyes on a point $\frac{1}{16}$ " in front of the blade.
- Strive to stay on the line,** but don't worry when you veer off a bit. In most cases, it won't make enough difference to be noticeable.

Stay safe

- Wear safety glasses** to guard against flying wood chips or the pieces of a bro-

Buyers should consider....



1 Vibration and noise. A machine that runs smoothly helps you do better work and makes it easier to work for long stretches. Test variable-speed models at the same speed.



2 Location of the controls. You'll use the on/off switch and the tension control a lot. Are they in a convenient and safe spot?



3 Blade-changing. Different manufacturers have developed very different systems. Change the blade a couple of times to get a feel for it, and decide which system works best for you.



4 The blower. Does it truly get the dust out of your way? Look for a good-sized bellows and a nozzle that you can position as needed.



5 Cutting action. You'll find three arm types: C-arm, parallel arm, and parallel-link. Rick prefers the C-arm for its aggressive cutting action, but a casual user won't be as concerned with speed.

ken blade. •**Control dust** with a nearby dust filter or, better yet, take it right off the table with a collector. Some new models include attachments that accept a shop vacuum hose. •**Don't wear loose sleeves** or any jewelry that could get tangled in the blade. If you have long hair, tie it back.

Stock up on these

- A small assortment of blades** will handle any situation. Rick relies on very thin #2/0, #2, and #5 blades for most of his work, usually in a skip-tooth configuration. The skip-tooth style features a long, flat gullet between the teeth.
- Baltic birch plywood** serves as a great material for most scrollsawing projects. The edges look good and you won't run into voids, as you do with some plywood.

- Patterns** can come from downloadable Web sites, from computer software, or simply from children's coloring books. To make a permanent pattern, cut it out in plastic laminate.
- A magnifier light** helps you follow fine details, but can be tricky to use, so try it before you buy it. Rick recommends the kind with a fluorescent ring.

Photographs: **Baldwin Photography;**
Jim Kascoutas
Illustrations: **Brian Jensen**



make a case for your work

Artist information statements help woodworkers tell their stories to potential customers

Ever go to a craft show and see work in a booth that made you wonder how it was made and what materials were used? If so, you're not alone; a lot of customers and potential customers wonder the same things. That's why today there's a growing use of so-called "artist information statements." With these, you don't have to wonder anymore. And if you sell your work at craft shows, neither do the inquisitive folks who come to your booth.

Guidelines for your personal statement

The National Association of Independent Artists (NAIA) has developed a model Artist Information Statement that you can find on its Web site (www.naia-artists.org) as a way to foster dialog between craftspeople and their customers. (You also may obtain a copy by writing NAIA, P.O. Box 44008, Madison WI 53744-4008.) You can display the statement, which generally fits onto a standard 8½×11" space (8×10" if you want to frame it), in your booth. It should include the following, according to the NAIA:

- Name, contact information, and photo of the woodworker(s), preferably at work;
- Identification of techniques and processes used;
- A concise description of how collaborators, assistants, or apprentices are used, or a statement that none are used;
- Description of materials and methods of handling them;
- Whether or how outside sources, suppliers or contractors are used;
- Resume-type information, such as

awards, exhibitions, education, etc.

Let the NAIA model statement serve as a guide to help you develop your own.

Don't get puffy with philosophy

Although some statements you'll see include a discussion of philosophy or "creative vision," it's better not to get carried away, advises Ray Jones, an Asheville, North Carolina, wooden box-maker and NAIA member who has been using the statements in his booth for the past year.

"I personally get turned off by the statements when they get really, really deep," Ray says. "To my thinking, it sounds very pretentious."

The statement isn't necessarily all you need in the way of marketing materials, either, he notes. Ray also puts a business card in each box that cites information on how to care for the box as well as a one-paragraph biography.

"While it may take some time to prepare the statement the first time, the same one can be used from show to show, unless you add new items or techniques," says Ray. "People do read it and they make comments and ask questions that could only come from reading [the statement]," he says.

Privacy invasion or craftsmanship guarantee?

Some of the country's top-rated craft shows, including the Cherry Creek Arts



Festival in Denver and the St. Louis Art Fair, now require artist information statements as part of the application process. But even in shows that don't require the statements, they can be of value to woodworkers, believes Michael Hamilton, a Boise, Idaho, woodworker and also a NAIA board member.

"Some craftspeople do object to the statements as an intrusion on their independence or privacy," says Michael. But he doesn't believe a statement has to reveal any proprietary information.

The NAIA's not-so-subtle agenda in pushing the statements includes weeding out mass-production shops that pose as craftspeople at craft fairs and sell their wares as handcrafted. "Show officials are still reluctant to challenge credentials of suspect exhibitors during shows," the craftsman comments. But use of the statements did lead to at least one post-show challenge following the 1999 Cherry Creek Arts Festival in which organizers asked a metalworker to substantiate information he provided. Instead of providing it, the exhibitor chose not to re-apply for the 2000 show, according to Michael.

"I would say that the greatest majority of the artists and craftsmen are happy with the statement," he concludes. "And they're pleasantly surprised to see that the public enjoys reading them." ♣

Written by Jack Neff, a Batavia, Ohio, business writer and author of the book *How to Make Your Woodworking Pay for Itself*.
Photograph: Baldwin Photography

why wax wood?

When it comes to protecting that fine furniture you crafted, the final finish may not be enough.

The primary reason you apply a finish to wood is to seal and stabilize it. That is, you try to slow down its absorption and release of moisture, normally in the form of water vapor. If you don't, the wood will dimensionally change as it swells and shrinks, resulting in splits, checks, cracks, loosened joints, and other movement.

That's why experienced woodworkers always put the same number of coats on all exposed parts of the wood. If a tabletop gets three finish coats, so does its underside.

When that's accomplished, though, and the furniture goes in service, other attackers take over. (See the sidebar "The finish killers.")

The easiest added protection you can provide—at least against the accumulated effect of small scratches and abrasions—is a coat of wax. Wax provides a slick surface film that reduces traction of cups and other items coming in contact with it. It also fills the microscopic dents and other crevices in the surface that catch and hold light. This means light reflects better off wax, giving the finish added shine and a richer appearance.

Wax choices

At one time beeswax (taken from bee hives) was the only wax available. Today, though, manufacturers employ it as well as paraffin (from petroleum), carnauba (from palm tree leaves), and synthetic waxes in blends for their commercial paste waxes. That's because each of the natural waxes has its own characteristics.

Beeswax rates as medium-soft in hardness, easy to apply as polish, and results in a low semigloss appearance. Its melting point is about 150°.

Carnauba is a very hard wax and produces a higher sheen than beeswax, but when used alone, it's very difficult to buff out. It melts at about 180°.

Paraffin is even softer than beeswax and has a lower sheen. It melts at 130°, and is never used alone for polishing because it just doesn't do the job.

Manufacturers try to blend these waxes to arrive at a paste that's user-friendly, but that also produces a pleasing, protective gloss when buffed. About the only difference between brands comes from the amount of each type of wax used and the solvent that turns solid wax into paste. The latter results in different drying times—the length of time you wait before wiping off the excess.

Continued on page 30

Liquid furniture polishes come primarily from solvents of distilled petroleum. That's why they're oily. Manufacturers add a fragrance to douse the petroleum smell. Liquid polishes of this ilk add the same shine as paste waxes, yet it lasts only until the polish evaporates. And that could be in a few days.

Some liquid polishes do contain small amounts of wax or silicone oil, and sometimes both. When they do, they can perform almost as equally as paste wax. However, silicone polishes can pose refinishing problems. Penetrating into wood through finish nicks and cracks, silicone prevents reapplied finishes from flowing properly. All in all, though, most liquid polishes act better as furniture cleaners than as protectors.

Put it on and polish

Note here that if a wax lists toluene on the can as the solvent, don't use it on a water-based finish or damage will result. And remember that the solvent in all waxes can dissolve any finish if it hasn't cured completely. Too, forget about "wax buildup." If properly applied, there won't be any because you remove about 99 percent of it in the buffing. What does build up is the protection, and it's clear.

Applying paste wax isn't a cinch, but it's not a real chore either. And you should only have to do it every six months or less.

Before you start, make sure the furni-

ture is clean. If it looks dirty, clean it with a damp cloth and a mild soap (Murphy's Oil Soap or Ivory). Then dry the surface.

To apply, plop a marble-size blob of wax in the center of a soft, lint-free cotton cloth (part of an old diaper or T-shirt is good). Fold the cloth around the wax. If the wax feels hard, roll it around in your hands to soften it. What you want is to have the wax ooze through the cloth, dispensing just a little bit onto the surface as you wipe. (To level out and dull a glossy finish, apply paste wax with 0000 steel wool. Put it on with the grain to keep scratches from showing too much.)

Wipe in any direction on the surface to spread the wax. When it's completely covered, wait for the solvent to evaporate (the wax will turn hazy). Then, with a fresh piece of lint-free cotton cloth, begin wiping off the excess. When you can no longer make a smear in the wax with your finger, the excess has been removed.

Now buff the wax with another clean, lint-free cot-

ton cloth. The softer the cloth, the higher the sheen you'll achieve. (You can opt for a lamb's-wool pad in your power drill.)

When you've finished buffing, repeat the waxing process. Like spraying on a finish, it's best to apply two or more thin coats than one thick one. The second coat also covers any spots that you may have missed in the first application.

For maintenance, all that's necessary is an occasional dusting and wiping down with a damp cloth. You can rebuff, too. However, never apply liquid furniture polish atop a finish that's been paste-waxed. The solvent in the liquid polish will dissolve the wax.

Paste-wax brands

Here's a sampling of the paste waxes you'll find at woodworking suppliers and hardware stores: Antiquax, Black Bison, Briwax, Butcher's Wax, Johnson Paste Wax, Minwax Finishing Wax, Renaissance Wax, and Treewax.

Written by Peter J. Stephano
Photographs: Baldwin Photography



copycat cutters

Make identical parts—
even curvy ones—
with flush-trim
router bits

Flush-
trim bit



Pattern
bit

As the name suggests, a flush-trim router bit cuts the edge of one workpiece perfectly flush with the one to which it's attached. Those two workpieces could be plastic laminate and a countertop, edge banding and a cabinet, or a template and a rough-sized part. To accomplish this feat, the bottom-mounted bearing—so-called because of its orientation in a hand-held router—matches the cutting diameter of the bit.

Note: A pattern bit (bottom bit, above), sometimes called a "top-bearing flush-trim bit," also excels at duplicating parts. And, because the business end of the pattern bit is unimpeded by a bearing, it also can be used for dado-like cuts. However, this style of bit doesn't work for trimming laminate or edge banding.

Flush-trim bits come in $\frac{1}{4}$ – $\frac{3}{4}$ " diameters and lengths of $\frac{1}{2}$ –2". Better (and more expensive) bits have a slight shear angle to their cutting edges that imparts a much cleaner edge on your workpiece. That's especially important when working with solid-stock end grain or chip-prone plastic laminates.

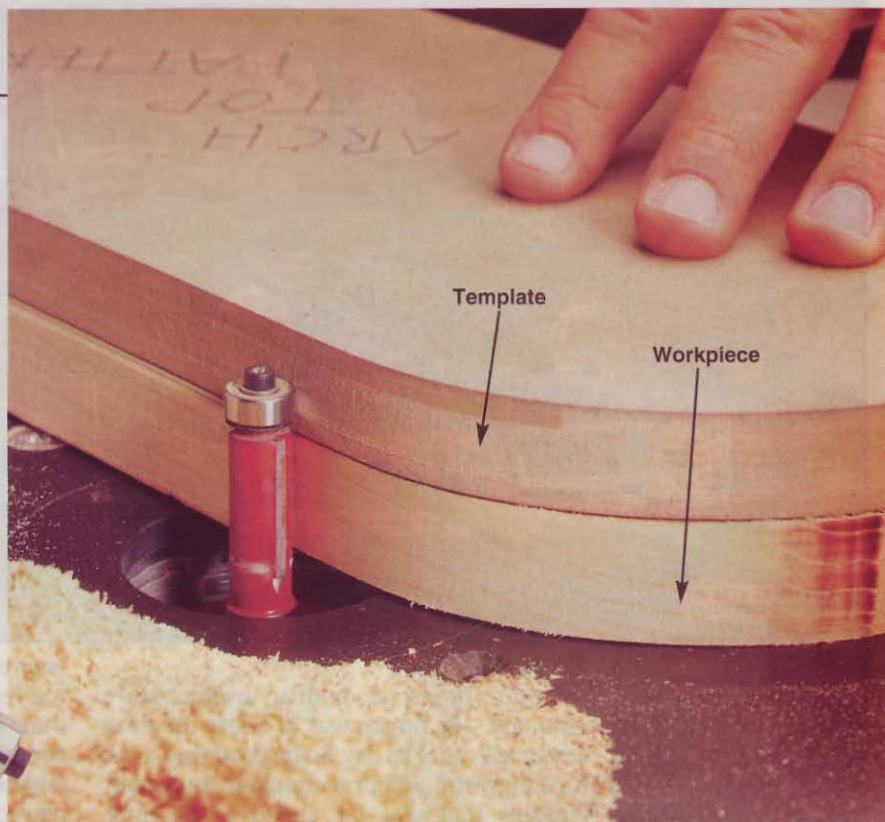

Cutting across the grain can cause the bit to become grabby and may result in burning. Bandsawing your rough workpiece close to the pattern line reduces the risk.

Copy right

When it comes to duplicating parts—especially curved parts—you just can't beat a flush-trim bit. That's because the bearing and bit precisely follow every curve of the template. But, before you can start reproducing, you need a part or pattern to reproduce.

If we need to make multiple matching parts in the *WOOD*® magazine shop, we'll often make a pattern or template out of hardboard or medium-density fiberboard (MDF). That way, we make our mistakes in less-expensive material and keep precious project stock from the scrap pile.

Once perfected, trace the pattern/template onto your workpiece. Cut the workpiece to rough shape on your bandsaw, cutting $\frac{1}{8}$ " or less outside the traced line. Bandsaw close to the line wherever you cross end grain. (Leaving less material here helps keep the bit's speed high and reduces fuzzing and burning.) Now, attach your template to the rough-cut workpiece using cloth-backed double-faced tape.

With a flush-trim bit in your table-mounted router, set the cutting depth a little deeper than the thickness of the workpiece, as shown in the photo above. Rout the template/workpiece assembly, template side up, cutting with the grain as much as possible.



Keep the bearing in light contact with the base material when routing. Too much pressure can mar the workpiece.

Patterns needn't be of your own making. When we need a zero-clearance throat-plate insert for our tablesaw, for example, we double-face tape the saw's factory-supplied insert to a wood scrap of the same thickness, and use the same method with one exception: We set the bit depth so that the cutters barely clear the workpiece. That keeps the cutters from making contact with the steel insert.

Trim talk

Whether you're fitting solid-wood banding or plastic laminate, the process starts with one slightly oversized piece attached to another workpiece. How much larger to make the oversized piece depends on the material. For plastic laminate or wood veneer, leave no more than the diameter of the bit overhanging; for solid-wood edge banding, such as that shown attached

to the shelf in the *top right* photo, leave $\frac{1}{16}$ " or less.

The actual cutting could hardly be more simple. Set your router's cutting depth to about $\frac{1}{16}$ " deeper than the thickness of the material you're trimming. Then rout the edge flush, working from left to right and keeping the bearing in contact with the base material below. Use a light touch to keep the bearing in contact, as too much pressure can mar the workpiece.

When working on the edge of a narrow workpiece, such as the MDF shelf in the *top right* photo, you'll want to give your router base some extra support. We mounted the shelf in our bench vise, then clamped a 2x4 to the shelf, flush with the face of the maple

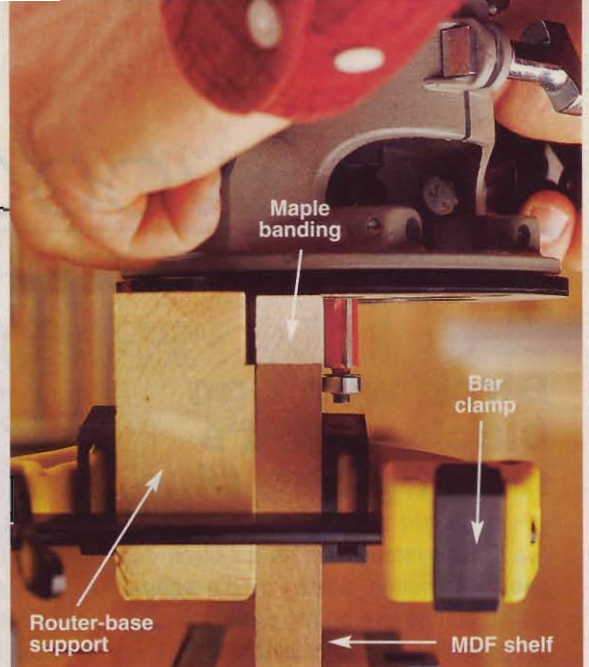

Cut a shallow rabbet in the 2x4 support piece to relieve the banding on the untrimmed side.

banding, to keep the router perpendicular while routing the long edge. 🪚

Written by Dave Campbell with Kevin Boyle
Photographs: Baldwin Photography

What a deal

Buy our best-selling band saw at our lowest price of \$1,695, and we'll give you 50% off our new European red beech work bench*. Our band saw features:

- Easy blade change
- 1.5 hp motor 220 volts
- Italian made
- All steel welded frame construction
- Cast-iron fence
- Electronically balanced cast-iron fly wheels
- 2 dust ports
- Large cast-iron table 16" x 19"
- Euro bearing guides
- Table tilt from -10 to 45 degrees
- Optional mobility kit.

Our new red beech workbench features cast-iron and steel vises, steel bench dogs, a tool tray and through joinery. Available in 5'

and 7' lengths with optional cabinet. 5' bench (pictured) list \$895. 7' bench list \$1,185. Call today for a free video or brochure.

Circle No. 615

*Excludes sales tax and freight. Limited offer, while supplies last.



Free Video

800-234-1976

17101 Murphy Avenue
Irvine, CA 92614

(949) 474-1200 • FX (F&E) 474-0150

LAGUNA TOOLS

Fine European Woodworking Machinery

E Mail: mail@lagunatools.com Web: www.lagunatools.com

800-234-1976

100 Central Avenue
South Kearny, NJ 07032

(973) 491-0102 • FX (973) 491-0591

ask wood original

Answers to your questions from letters, e-mails, and WOOD ONLINE®

Birch won't go black, and it's making him blue

Q I bought an ebonized home theater system, then built a birch cabinet to match. When I tried a water-based aniline dye on my project, it produced just a hint of black. Next, I tried an oil-based stain. I kept applying it until I achieved the right color, but it was hard to get an even texture and not much of the grain showed through. So what's the secret?

—Philip Morris, Katy, Texas

A Phil, we checked with finishing guru Bob Flexner. He says you should have stuck with the aniline dye. Keep adding coats of dye, letting each one dry before continuing, until you arrive at the desired result.



That's what we did to get the results shown *below*. Or, mix your dye stronger in the first place. "It's usually possible to mix the dye strong enough so one coat will do it," Flexner reports. "You shouldn't have any problem with birch." In this case, you'll have to remove the ebony finish before you go back to the dye, and that will take some work. You'll have to use paint stripper, or sand the wood, or both. Dye won't penetrate any spot where binder remains from the ebony finish.

—WOOD® magazine

In search of CAD software

Q I would like to find a computer-aided design (CAD) software program that's reasonably priced for a home woodworker. What do you recommend?

—Patrick Wagner, Slinger, Wis.

A Here at WOOD magazine, Pat, our designers use DesignCAD 3000. You can go to www.designcad.com to buy the newest, upgraded version, DesignCAD 3D MAX, for \$299.

—WOOD magazine

A I use DeltaCAD, which costs about \$40. It was the only one out of many that I found easy to use. You can download a free trial version, good for 45 days, at www.dcad.com.

—Bob Best, Niagara Falls, Ont., Canada

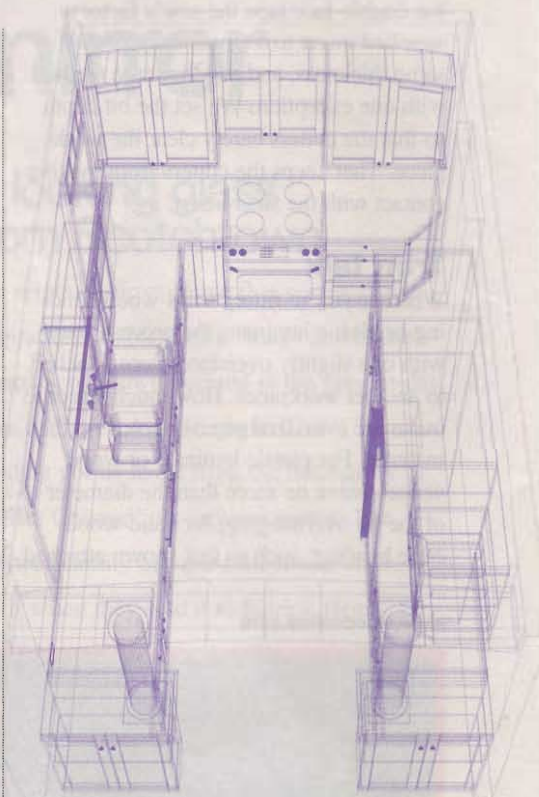

We used CAD technology to create the overhead view of the kitchen remodeling project featured in this issue of WOOD.

A Check out AutoCad Light. I use the full-blown version, but the light version is great and costs less—about \$650. There are several CAD programs out there, but I'm sold on AutoCad. You can find info at www.Autodesk.com.

—Ernie Stutz, Wichita Falls, Texas

How best to frame an ocean view?

Q I'm remaking some old wooden windows for a friend's beach house. He has some eastern red cedar, but I'm not so sure it's the best choice. Would a decking material, such as treated pine, be a good choice for salt spray, rain, and sun? If not, what's the

Continued on page 36

preferred wood for this project? I'd appreciate glue suggestions, too.

—Stan Smith, Pinehurst, Texas

A Stan, the cedar would give you a weather-resistant window, and so would cypress or Ponderosa pine. Treated lumber is best-suited for outdoor projects. You have to let it dry quite a while before you paint; and cutting and handling treated lumber, especially indoors, exposes you to potentially toxic

material. As for glue, go with a good polyurethane type.

Whatever wood you use, make sure to give it an extra durable paint job that will stand up to extreme weather. Apply a water-repelling preservative that's paintable—meaning that it doesn't contain wax—then an oil-based primer containing mildewcide, followed by a couple coats of top-quality, oil-based paint.

If you're willing to spend more, use a marine paint instead of a conventional

paint. For example, Valspar makes Marine Topside Polyurethane Enamel, which we found priced at \$10.94 per quart. You don't need a primer, you just need to be generous with the first coat, then add two or three more coats. The polyurethane makes it tough. However, this paint comes in only white, red, blue, and green, and Valspar doesn't recommend tinting.

—WOOD® magazine

Moving parts limit your finish choices

Q I made a locomotive of black walnut and maple, with fully operational parts, including the wheels, slides, and cylinders. Now I'd like to give it a matte finish that won't freeze up the moving parts. Would Salad Bowl Finish or Watco Danish Oil be the answer?

—Rich Palleschi, Bridgewater, Mass.



The All New T50PBN STAPLE + NAIL GUN



It Packs A One-Two Punch It Staples! — It Nails!

Meet the 21st Century ARROW T50 PBN

- **All Steel Construction** with long lasting chrome finish.
- **Easy Squeeze** double leverage mechanism for professional performance with no loss of driving power.
- **Cushioned Non-Slip Hi-Viz Handle.** Comfortable to use. Easy to locate.
- **Visual Refill Window** tells you when to reload.

ARROW tools and supplies are available at home centers, lumberyards and hardware stores.



© 1998 ARROW FASTENER CO., INC.

Packs a Double Wallop

- **The new T50PBN shoots 6 different size staples:** 1/4", 5/16", 3/8", 1/2", 9/16", and 17/32" Celltite staples. You can handle any job from upholstering a chair to insulating basements and attics.
- **It also drives a 5/8" nail** so you can decorate a door panel, build a picture frame, or create doll houses and toys for the kids.
- **ARROW T50PBN. Solid. Reliable.** Perfect for the handyman, the professional, and the hobbyist. You work hard for your money, spend it wisely.

ARROW FASTENER COMPANY, INC., 271 MAVHILL STREET SADDLE BROOK, N.J. 07663
 ARROW FASTENER (U.K.) LTD., 14 BARCLAY ROAD, CROYDON, SURREY CR0 1JN
 JARDEL DISTRIBUTORS, INC., 6505 METROPOLITAN BLVD. EAST, MONTREAL, QUEBEC H1P 1K9
 website: www.arrow-fastener.com



A The Watco oil should work fine, Rich, according to someone who knows all about making toys with moving parts. *WOOD* toy contest winner Mike Jagielo gives the thumbs-up to Watco, which penetrates wood rather than building a film on the surface. Mike suggests steering away from Salad Bowl Finish, which builds a bit and also would produce a glossy look. His own preference for moving parts is Minwax Antique Oil Finish. Whichever oil you choose, he says, the ideal procedure is to finish the parts before final assembly, and he recommends wiping off the oil before it becomes tacky.

—WOOD® magazine

What accessories suit a starter lathe?

Q I need help in getting the right accessories to use with an inexpensive lathe that I just bought. My plan is to buy a better lathe later when I have enough experience. I don't want to waste money on accessories if they aren't compatible with other machines.

—Pedro Castaneda, Torrance, Calif.

A If you need a chuck, get one with removable threaded inserts to allow adapting to any spindle size.

—Jeremy Kingry, Fort Walton Beach, Fla.

A I would hold off on purchasing high-dollar accessories, such as Nova or Oneway chucks and centers, until you see how serious you get about turning and what your demands of a lathe may be. Consider some less expensive, imported accessories that you won't feel bad about selling with your original lathe, if you decide to upgrade.

—Phil Brennon, Chino Valley, Ariz.

How can I take the sag out of shelves?

Q I am installing some shelves made from $\frac{5}{8}$ " maple plywood. They are 35" long, 21" deep, and they sag a little. My wife is not happy,

which means I am not happy. I know I can put a bullnose piece on the front, but I was wondering if anyone had any other suggestions for stiffening up these shelves?

—scottl@inmagic.com

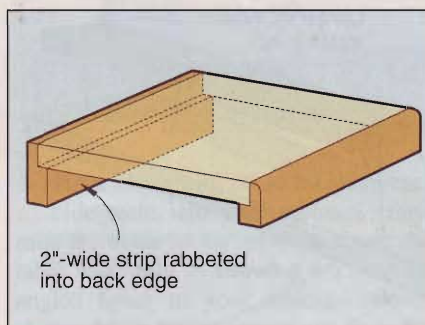

A You are correct with the hardwood edge, and $1\frac{1}{4} \times \frac{3}{4}$ " would be a good size. But $\frac{5}{8}$ " ply is marginal at best for a light-duty shelf, let alone one that is 21" deep. I would either glue two layers of that plywood together, or save the $\frac{5}{8}$ " plywood for a future project and make the shelf out of $\frac{3}{4}$ " material.

—Jack L. Little, Franklinville, N.Y.

A For myself, any shelf that is over 24" long gets a hardwood front edge with a rabbet and a 2" wide strip rabbeted into the rear edge so that the strip and the shelf form an L shape. With both of these members in place, I have never had any shelf sag under any reasonable load. The nice thing about the rear support is that it is neat, almost invisible, and can be attached to the cabinet back or wall if necessary. It doesn't have to be plain; you can dress it up real quick with a bandsaw or jigsaw.

—Robert Peterson, Ventura, Calif.

Got a question?

If you're looking for an answer to a woodworking question, write to **Ask WOOD**, 1716 Locust St., GA 310, Des Moines, IA 50309-3023 or send us an e-mail at askwood@mdp.com. For immediate feedback from your fellow woodworkers, post your question on one of our discussion groups at www.woodonline.com.

Introducing the New Delta Store. Tap into the Power of the Pros.

The new Delta store has over 1000 products from a complete line-up of unisaws to those hard-to-find machinery attachments. Extensive product information including customer ratings and reviews will help you choose the right tool for the job. We'll even deliver to your door for only \$5.99.



Visit the Delta store at
www.amazon.com/delta

Call for your FREE Tool Crib catalog
1-800-635-5140

table saws radial saws miter saws
scroll & band saws planers the Delta store
drilling machines jointers wood shapers



shop tips

Helping you work faster, smarter, and safer

top shop tip

A tapering jig from Walker: Texas Tipster

While building a pedestal table with a tapered, octagon-shaped center column recently, I fretted about getting the compound angles right. After all, the tapers and bevels on each edge of the eight staves had to match perfectly, or the project would be firewood. Here's the solution I came up with, and whether you make the bevel cuts or not, it's a handy way to make symmetrical tapered parts.

Start by ripping stave blanks to their widest width, and about 1" longer than their final length. At both ends of each blank, drill a 1/4" hole centered 1/4" from the end. (These holes fall in the waste area of the blank.) Starting 1/2" from one end, lay out your taper lines on one blank.

Now create a stock carrier by ripping a scrap of 3/4" plywood a little longer and wider than your blanks. After the cut is complete, don't move your tablesaw fence. Align the taper line you drew on your first workpiece with the edge you just cut and, using the holes in your workpiece as a guide, bore 1/4" holes in the carrier. Remove the blank and glue a 1/4x1" dowel into the holes you just drilled.

To cut the tapers, attach a blank to the carrier, registering it on the dowel pins, and cut the first taper. Then flip the blank over and cut the opposite taper.

Trim 1/2" off each end to remove the registration holes and size the stave. If you're going the extra step of beveling

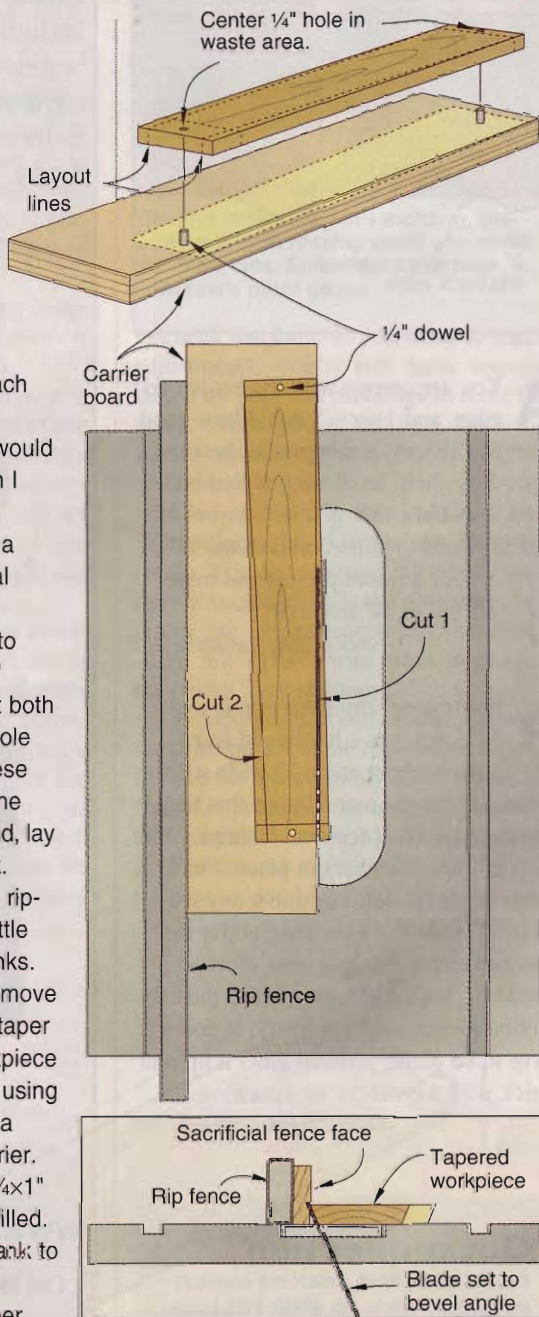

the edges, as I had to, you can make the bevel cuts using a sacrificial face on your rip fence, as shown above.

—Jim Walker, Tyler, Texas

Continued on page 40

top shop
tip winner

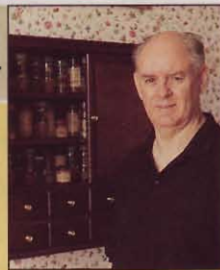

Jim Walker never lacks projects to build, such as the spice rack shown above. It seems like his three children are always approaching him with a catalog clipping, asking, "Can you build one of these?" One such request—for a mahogany pedestal table—left our Top Shop Tip winner scratching his head for a while because the center pedestal was a tapered, eight-sided column. Before long, though, the retired engineer found a way to tame the complex compound cuts, and his solution, at left, earned Jim this issue's Top Shop Tip accolades.



For sending in this issue's Top Shop Tip, Jim Walker receives an assortment of Ryobi tools, including a RE175 plunge router, BE321 belt sander, and HP1201MK2 drill/driver. Great job, Jim!

You can win a free tool, too!

Tell us how you've solved a workshop puzzler, and we'll send you \$75 if we print your solution. And, if we choose your tip as the Top Shop Tip of the issue, we'll also send you a tool prize worth at least \$250.

Send your best tips, along with photos or illustrations and your daytime telephone number, to: **Shop Tips, WOOD Magazine, 1716 Locust St., GA-310, Des Moines, IA 50309-3023.** Or post your suggestions on our Top Shop Tip discussion group at www.woodonline.com.

Because we try to publish only original tips, please send your tips only to WOOD® magazine. Sorry, but we can't send back the things you send in.

Jet...the Power to
Shape Your Ideas.
**And the Store
to Make
Them a Reality.**

The Jet store is now open with over 200 Jet products in stock, including best sellers and hard-to-find attachments. Complete product information including customer reviews make comparing products quick and easy. Visit the Jet store and see why Jet is one of the fastest growing brands in the industry.



Visit the Jet store at
www.amazon.com/jet

Call for your FREE Tool Crib catalog
1-800-635-5140

dust collectors jointers planers
saws wood lathes the Jet store
shapers sanders planer-molders



shop tips

**To keep legs level,
the play's the thing**

In addition to looking better than most store-bought leveling feet, my shop-made version has a "floating" feature that makes it work better, too. Many commercial feet are rigid, so only an edge touches an uneven floor. But I engineered some play into my design that keeps the entire bottom of the foot firmly planted.

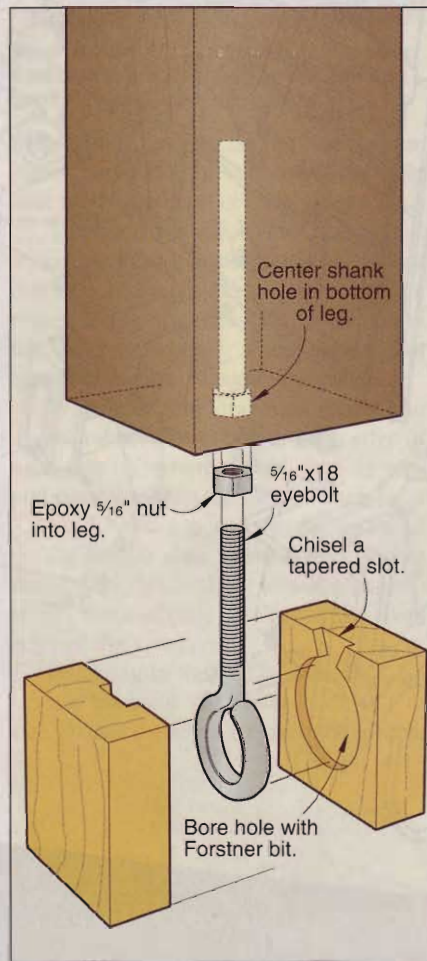

Referring to the drawing above, you'll see that making the blocks is a simple matter. To get the desired looseness into the finished block, drill each half slightly more than half the thickness of the eyebolt, and chisel a tapered slot for the shank. These feet work great for tool stands and tables in the shop, but you also could use the same idea for furniture throughout the house.

—Chuck Steeger, Bossier City, La.

**Forstner bit wins
a hollow victory**

To save time hollowing out bowls, I use a 4" Forstner bit (available from Woodworker's Supply, 800/645-9292).

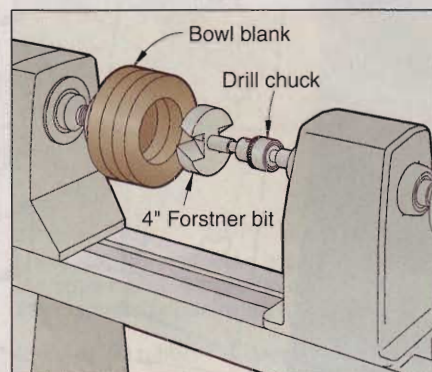

With this bit I can remove waste material from the full length of a bowl in less than three minutes. I keep the lathe moving at 750 rpm.

—James St. Clair, Colorado Springs, Colo.

**Here's a stock tip:
Resaw plywood**

For a recent project, I needed 3/4"- and 1/2"-thick oak plywood, but the plan required only a small amount of the thinner stock. Rather than buy a full sheet of 1/2" plywood and end up with a mess of scrap, I resawed the 3/4" ply.

First, I cut the parts slightly oversized, then resawed them with my bandsaw. Running the pieces through my thickness planer quickly reduced each one to 1/4" thick. Gluing and clamping the cut faces together finished the job. Besides

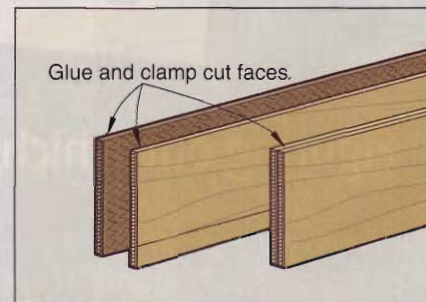

saving money, this method helped me build a better-looking project, with consistent color and matching grain pattern in all the plywood parts.

—Tom Halwachs, Taylor, Mich.

Comfort by the capful

Over the past several months, I've scrollsawn more than 30 Iwo Jima Flag Raising plaques for the guys in my Marine squadron. Each plaque has 132 internal cuts, so you can imagine the soreness in my thumb and index finger from loosening the blade for each cut.

While taking a break one day, it occurred to me that the twist-off cap on my plastic soda bottle fit my fingers better than the wing nut on the scrollsaw's blade holder. Inspired, I epoxied the

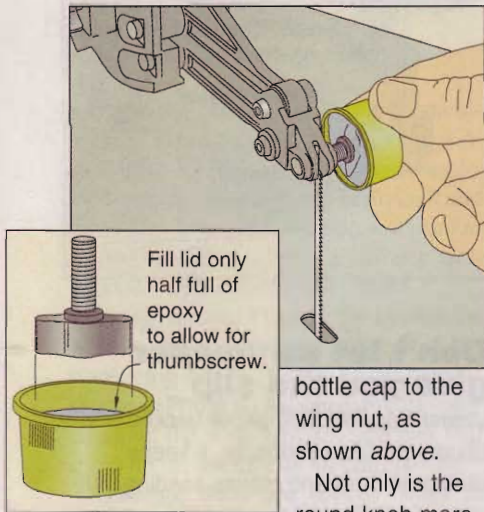

bottle cap to the wing nut, as shown above.

Not only is the round knob more

comfortable, its knurled edges give me a better grip. A month after installing it, my thumb and finger have healed quite nicely, and I'm back at full speed.

—Steve Manzo, Okinawa, Japan

With C-clamps, panel glue-ups will B-flat

When edge-gluing several narrow workpieces into a wide panel, I use C-clamps to keep the faces flush, as shown above right. For example, I had to glue eight 3"-wide boards together to make a tabletop. I applied glue to the mating edges of the first two boards and used pipe clamps to bring them just in contact with each other.

Then, starting in the center and working out to each end, I applied C-clamps with the clamping pad straddling the joint. (Your clamp must be at least as deep as the boards are wide.) Finally, I tightened the pipe clamps. After the glue

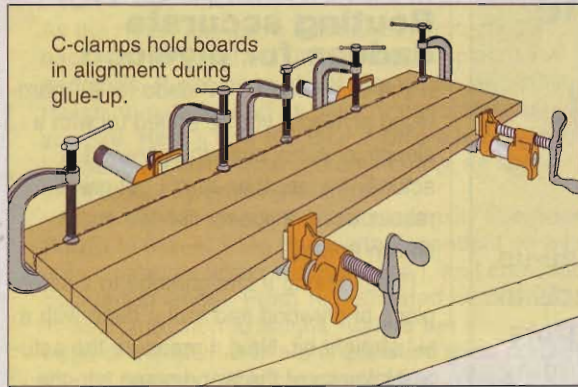

had set, I repeated the process until my eight boards were all joined.

Gluing one board at a time like this takes longer—about 20 minutes of drying time per joint. But my panels always come out flat and smooth with little sanding needed to even up the surface.

—Robert Bates, Beamsville, Ont.
Continued on page 00

Inkra
MITER1000

- ◆ 41 Indexed Angle Stops over $\pm 90^\circ$ range
- ◆ 18" Incra Track Fence with Slide Stop
- ◆ Steel GlideLOCK™ Miter Bar with 6 Width Adjustment Points

SALE
\$89

Inkra
MITER3000

- ◆ 364 Indexed Angle Stops over $\pm 90^\circ$ range
- ◆ 27" Miter Fence + Dual-Flip Stop
- ◆ Steel GlideLOCK™ Miter Bar with 8 Width Adjustment Points

SALE
\$219

Inkra
MITER5000

- ◆ 364 Indexed Angle Stops over $\pm 90^\circ$
- ◆ 36-64" Miter Fence + Dual-Flip Stop
- ◆ Steel GlideLOCK™ Miter Bar with 10 Width Adjustment Points
- ◆ Integral Hold-down Clamping System
- ◆ Renewable Zero Clearance Right Panel

SALE
\$299

Produce perfect gap-free hairline glue joints on the mitered corners of any multi-sided object on your first try without trial-and-error setups.



Woodpeckers Inc.
The Incra Tool Source

www.woodpeck.com

All models include: Adjustable GlideLOCK Miter Bar, Incra Specified Fence with Stop Positioner, and FREE Video Brochure.

1-800-752-0725

The Selection is Huge.
**We Built a
 Porter-Cable
 Store to
 Show it all.**

See the complete line-up of Porter-Cable products in the new Porter-Cable store. Over 1,000 items including pneumatics and cordless tools to the hard-to-find wood-working accessories. See the entire fleet of this year's new Porter-Cable products at the store that has it all.



Visit the Porter-Cable store at
[www.amazon.com/
 portercable](http://www.amazon.com/portercable)

Call for your FREE Tool Crib catalog
 1-800-635-5140

routers sanders cordless tools
 generators the Porter-Cable store
 nailers & staplers air compressors



shop tips

Routing accurate dados for plywood

If you've ever cut a $\frac{3}{4}$ " dado for $\frac{3}{4}$ " hardwood plywood, you've ended up with a sloppy joint, because the plywood is actually thinner than that. I get great results using a spacer like the one shown below.

First, I clamp a straightedge to a scrap piece of plywood and rout a dado with a $\frac{1}{2}$ " straight bit. Next, I measure the actual thickness of the wood going into the dado, and subtract $\frac{1}{2}$ ". I plane or rip a strip of wood to this thickness to make the spacer.

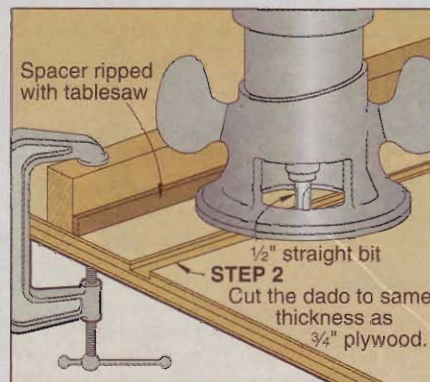
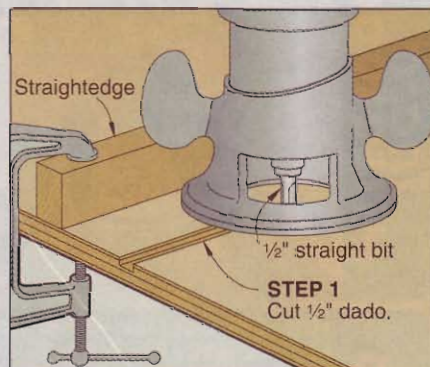

Laying the spacer next to the straightedge, I make another pass with the router and test-fit the joint. It should fit perfectly.

To rout the dado in the actual workpiece, I mark the critical edge of the dado (the edge that must measure exactly) on my workpiece. Then, I clamp the straightedge to the workpiece so that the first pass routs the critical edge. Finally, I lay the spacer in place and make the second pass.

—Jan Svec, *WOOD* magazine projects editor

Scrollsawyer gets grip with rubber fingers

To keep better control of my workpiece when scrollsawing, I purchased a handful of rubber fingers from an office supply store, and put one on the middle finger of each hand. Although my fingers get better traction, I can really spin the wood on my waxed saw table.

—Jim Friesen, Littleton, Colo.

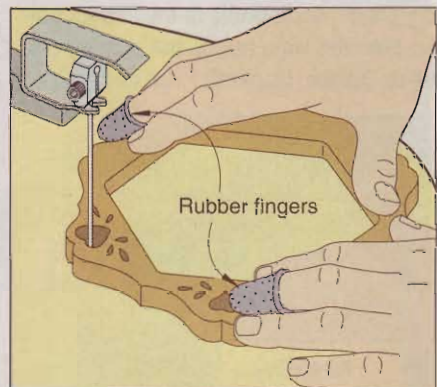

Don't let sandpaper give you the slip

Unless you fold thin, paper-backed silicon-carbide sandpaper, it keeps sliding on itself and makes sanding difficult, especially in corners. I cut sandpaper to double the size I want, then fold it in half and crease it. Then I open the sandpaper up, apply a light coat of spray adhesive to the back and press it back together.



If you don't have spray adhesive on hand, double-faced tape works, too. To stiffen the paper even more, sandwich a piece of cardstock between the folds before pressing them back together.

—Clair Mathabel, New Kensington, Pa.

Cord caddy keeps 'em close

To tame the power cord of my table-mounted router, I built a simple caddy from a few scraps of 1/4"-thick stock and mounted it to the tabletop, as shown below. I never have to blindly reach

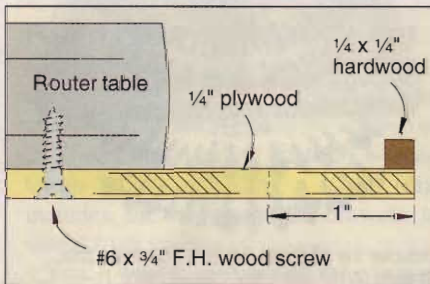
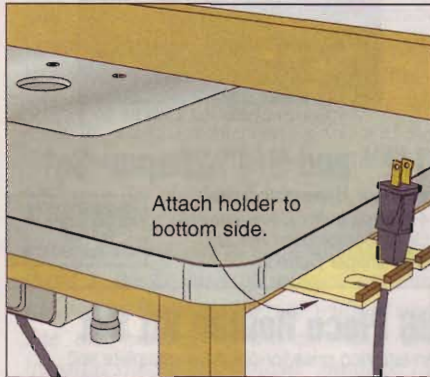

around under the table trying to find the cord. It works so well, I made another for my scrollsaw's foot switch to get it up off the floor when not in use.

—Max Taylor, Fort Worth, Texas

Collar on collet adapter stops the drops

It used to drive me nuts every time I used the 1/4" sleeve adapter in my table-

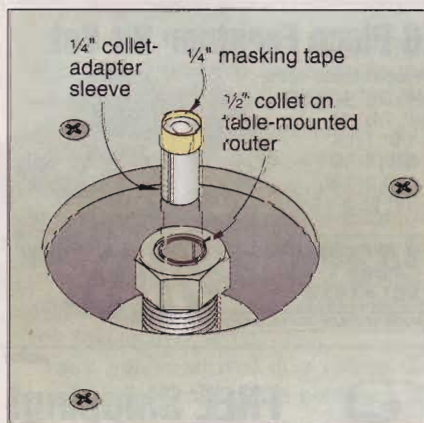

mounted router. Invariably, the darned thing would drop too low into the router's 1/2" collet, and I ended up upending the router or removing the 1/2" collet to fish out the adapter.

To save my sanity, I fashioned a narrow collar out of masking tape, as shown in the drawing below left. It only takes a few wraps of tape to keep the adapter from slipping through.

—Jim Downing,
West Des Moines, Iowa

A few more tips from our woodworking pros

- Chances are, the cabinets you make will be more perfect than the walls they hang on. Learn a trick to make them mate flawlessly in the Display Cabinet project on page 77.
- Curb glue squeeze-out by creating gutters on your workpiece, as we did with the Nightstand trim on page 91. ♣

Measure Twice. Glue Once.

Hardwoods, softwoods, pressure-treated or exotics – Gorilla Glue® is tough enough to hold them all. Incredibly strong, nearly invisible glue lines, and 100% waterproof. Just the way serious woodworkers demand it. Call 800-966-3458 for a dealer near you, or visit www.gorillaglu.com to find out more.



The Toughest Glue on Planet Earth™



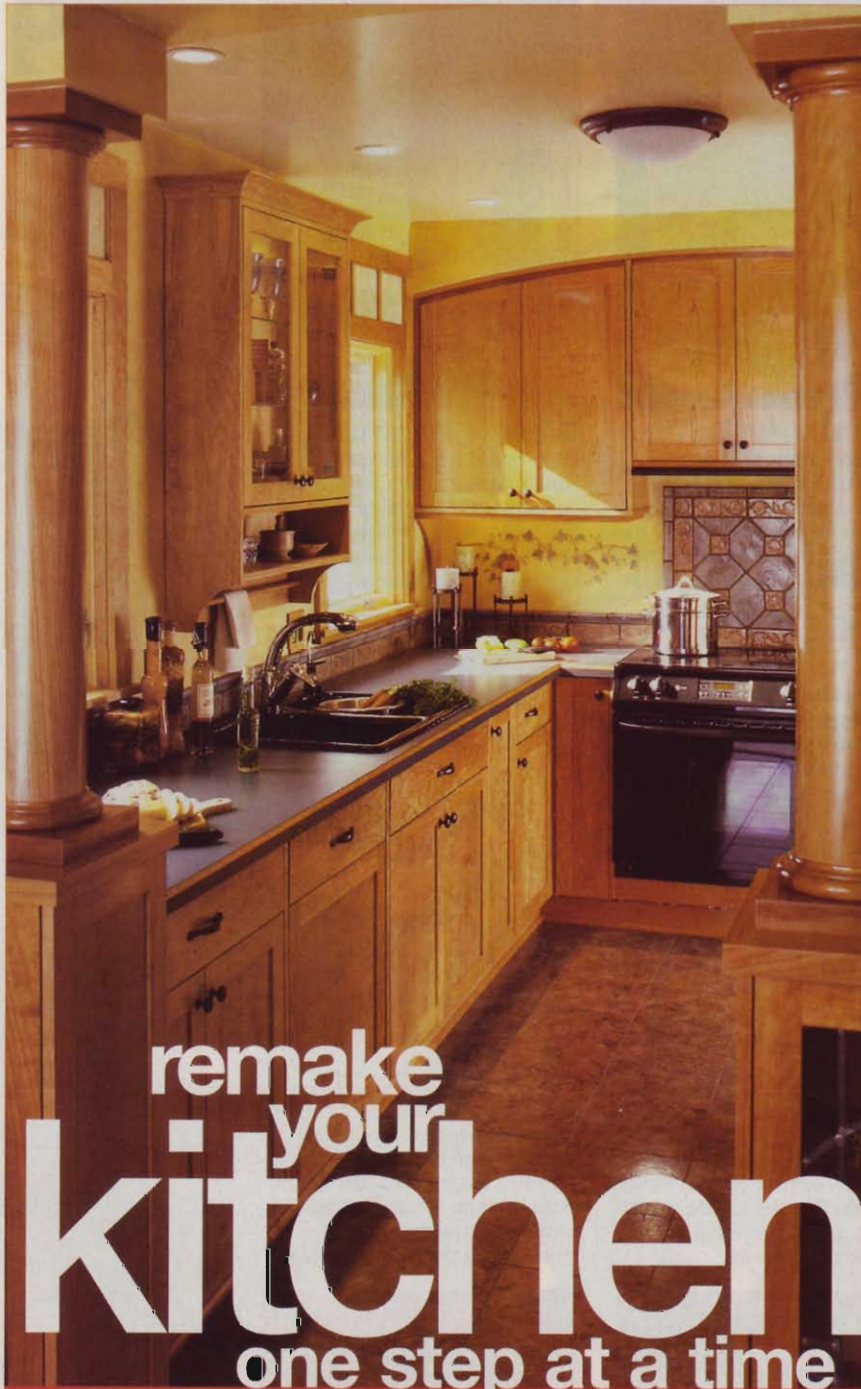

remake
your
kitchen
one step at a time

- planning pointers and product guide
- shop-tested cabinetmaking techniques
- building your own countertops
- installation techniques and tips
- achieving an integrated appliance look

Besides woodworking, all of us share another favorite pastime: eating. No wonder, then, that a kitchen serves as the most important room in the house. Whether you're an accomplished gourmet or the eat-and-run type, you want a space that offers lots of storage, makes meal preparation easier, and just plain looks great.

Fortunately, no other room in your home will benefit more from a woodworker's touch. Whether you want to upgrade the cabinets, install new countertops, add more lighting, or just spruce things up with new window trim, floor covering, or a tiled backsplash, we've got you covered. And we'll help you adapt these improvements to your spaces.



remake your kitchen



A GLASS ACT

This display cabinet makes a perfect place for your glassware or collectibles. To build one just like it, or a modified version for other rooms in your home, see *page 72*.



CREATIVE CORNER

Make the most of corner space by installing a blind corner shelf set for base cabinets by Rev-A-Shelf. (Find the manufacturer's phone number and Web Site on *page 49*).



CABINETS WITH STYLE

You can save a bundle by building your own high quality cabinets. Learn how on *page 50*. Behind these arched doors are square carcasses for ease of construction.



WINDOW TRANSOM

Trim complete with a faux transom makes squarish windows seem taller. To find out how to do the same in your home, see *page 78*.

just look at these features

CAMOUFLAGE APPLIANCES

Yes, there is a dishwasher hiding behind this wood panel (see the inset photo). To check how easy it is to blend a dishwasher into your cabinetry, go to *page 64*.



COUNTERTOPS

New countertops instantly update and beautify any kitchen—even if you do nothing else. Get the lowdown on building and installing countertops on *page 68*.



TRAYS FOR CONVENIENCE

Pull-out trays mounted in base cabinets make it easy to access large items. Build and install them much as you would a drawer, according to the instructions on *page 58*.

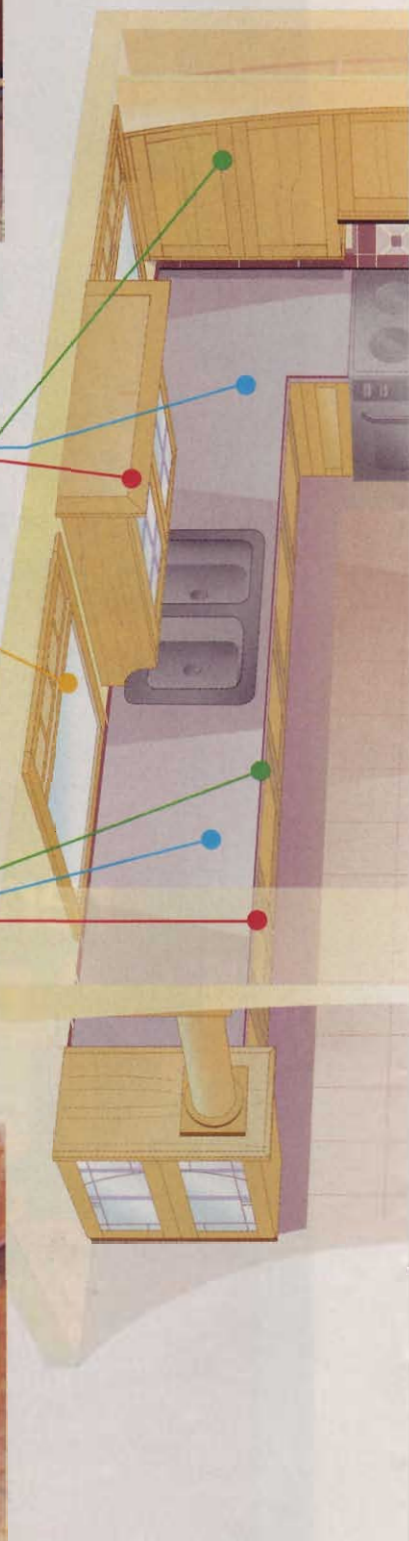



LIGHTED VENT HOOD

A slideout vent hood, like this GE model JV394SBB, is barely noticeable. For more info, contact the manufacturer at the phone number and Web address on *page 49*.



CERAMIC TILE

A classy hand-molded tile backsplash for the countertops and range is easy to install yourself. See www.woodonline.com for complete instructions.



PANTRY STORAGE

In only 18" of wall space, you can store plenty. Just install a pull-out pantry, such as this 8 $\frac{7}{8}$ "-wide model from Rev-A-Shelf. The outside of the pantry has 4 $\frac{1}{2}$ "-deep shelves covered by doors.

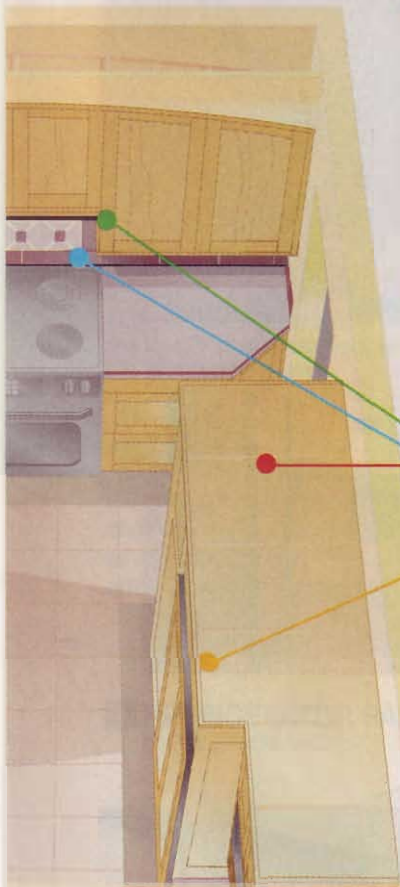

REFRIGERATOR REDO

Add wood panels to your refrigerator to make it match your cabinetry. Many reasonably priced refrigerators today come with trim kits that make this easy to do. See *page 65*.



Do as much, or as little, as you like. High-end looks and storage aplenty fall within your abilities and pocketbook—we'll show you how.

FOOD AND WINE TO GO

When you have little space for a microwave oven or wine bottles, store both in above-counter cubbyholes. A GE Spacemaker II takes only a 23 $\frac{25}{32}$ ×11 $\frac{1}{16}$ ×12 $\frac{9}{32}$ " space.



RECYCLABLES

To keep recyclables out of view, add a four-bin, slide-out wastebasket system, such as this one from Feeny Manufacturing. For a source, see *page 49*.



COMING NEXT MONTH!

Build a beautiful room divider anywhere in your home. We show you how in the November issue of *WOOD®* magazine. So stay tuned for this great project.



remake your kitchen

This view shows how dramatically the room divider provides separation, yet openness, between the kitchen and the dining room. Low-voltage lighting under the upper cabinets and in the toe-kicks adds nighttime flair (*inset photo*).



To show you the improvements outlined in this article, plus a few more, we performed all of them on the dated galley kitchen shown in the photos at *right*. After the dust settled, we doubled the kitchen's storage, multiplied its convenience features, and as far as eye appeal goes, well, you be the judge.

Accomplishing those goals was nice, but not enough. We also wanted to redo the kitchen on a budget that most of us can afford. So, we installed reasonably priced appliances, plastic-laminate countertops, and a do-it-yourself vinyl-tile floor. We think our final product compares favorably to any high-budget designer kitchen.

Yes, we did get slightly extravagant by using cherry for the cabinetry, but you'll have to cut us some slack for that. We just love cherry. If you like oak or another less-expensive wood, go that route and save yourself a bundle.

Whether you plan a complete overhaul or some touching up, you'll find what you need to know on the pages that follow, as well as on our Internet site (see full details at *right*). And, if you also require a little motivation to get started, remember this: We'll bet that your spouse will look more favorably on your next tool purchase if you can prove that you need it to improve your kitchen!



Two south-facing windows provide ample light to the kitchen, so we removed the far window in the photo *above* to gain extra cabinet space. The nonload-bearing wall and open doorway in the photo *right* was replaced by the room divider.



Learn more at www.woodonline.com

Although your woodworking skills will take you a long way in any kitchen remodeling, you will need to deal with some materials other than wood if you plan to do all of the work yourself. To give you a hand, we've developed a number of seminars that show you how we tackled these aspects of our kitchen remodeling:

- Enlarging a brick window opening.
- Installing an aluminum-clad casement window.
- Applying ceramic tiles above a countertop and range.
- Laying down a vinyl tile floor.
- Stippling and stenciling as ways of decorating walls with paint.

A few planning pointers

We're woodworkers, not kitchen designers, so we asked Ann Patterson, a certified kitchen planner in Eastsound, Washington, to help us. Here are some of Ann's best pearls of kitchen-design wisdom:

- Before you make any big changes, look at your home's architecture. The kitchen should blend with the rest of your home's interior. In the case of our Handcrafted Home kitchen, the arches above the range and room divider match other arches in the home.



- Never forget that function comes first in a kitchen, so work out your traffic pattern early in the planning process. Our new kitchen floor plan *below* incorporates a work triangle connecting the sink, stove, and refrigerator for convenience. In the tight quarters of such a galley kitchen, a side-by-side refrigerator works best because its doors don't entirely block the walkway. If you just can't make everything fit into your floor plan, it's best to plan for expansion now.

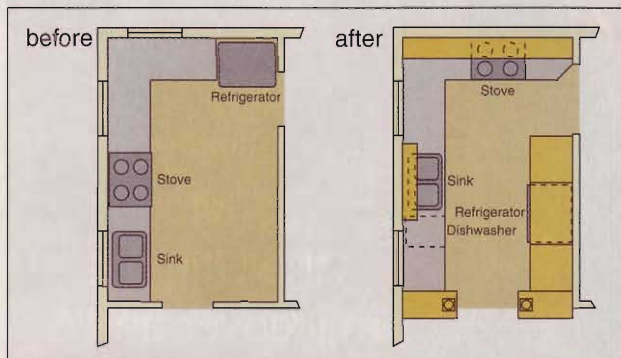

- Before you visit with an appliance salesperson, determine your refrigeration and cooking needs. As Ann told us, "Too many people buy appliances before they plan the kitchen. They often end up with appliances that are too large and expensive. Then, they have to cut back on cabinets and countertops."

- If the primary users of your kitchen are over 6' tall, it may make sense to install extra-high base cabinets that put your countertops at 38" or 39", but think long and hard before you do this. Appliances, such as dishwashers, are designed around standard kitchen dimensions, such as 36"-high countertops. It pays to consider how long you will be in the home—the next owners, or your children or grandchildren, may not benefit from extra-high counters.

For detailed information on kitchen planning, go to www.bhg.com. You'll even find an interactive feature that allows you to design your kitchen online.



A guide to the products in this kitchen

APPLIANCES

GE Profile Performance 23.7-cubic foot, CustomStyle, side-by-side refrigerator, model TPX24BPDBB; GE Profile 30" drop-in electric range, model JDP40BBBB; GE Profile 30" slide-out hood, model JV394SBB; GE Profile Spacemaker II .9-cubic foot microwave oven, model JEM31GA; GE SmartWater dual-stage drinking-water filter, model GXSV10C; GE continuous-feed disposer, model GFC800Y.
General Electric
800/626-2000
www.geappliances.com

Domco
800/227-4662
www.domco.com

HINGES AND DRAWER SLIDES

Inserta hinges and Tandem concealed drawer slides.
Blum
800/438-6788
www.blum.com

LEADED-GLASS ROOM-DIVIDER WINDOWS

Custom-made by Art Glass Creations. For full-size patterns, send \$5 and a stamped, self-addressed, business-size envelope to Art Glass Creations, 10417 Hickman Road, Urbandale, IA 50322. Call 515/276-3026.

LIGHTING

Ambiance low-voltage disk, recessed, and linear lighting systems.
Sea Gull Lighting
800/347-5483
www.seagullighting.com

BLIND-CORNER SHELF SET AND PANTRY HARDWARE

Various models available, differing in size and features.
Rev-A-Shelf
800/626-1126
www.rev-a-shelf.com

CERAMIC WALL TILES

Handmold Leaf Deco in pewter and sandalwood colors.
Seneca Tiles
800/426-4335
www.senecatiles.com

COUNTERTOP PLASTIC LAMINATE

Graphite grafix, matte finish, no. 515-58.
Formica Corporation
800/367-6422
www.formica.com

DISHWASHER

Model D1796FI.
Asko
800/367-2444
www.askousa.com

DOOR PULLS AND DRAWER HANDLES

Pulls, item BP-1950-NBZ; Handles, item BP-1590-FB.
Amerock
800/435-6959
www.amerock.com

FLOORING

Nafco Luxury Vinyl 12x12" tile in slate (MD-983) and brown slate (MD-783).

RECYCLING CENTER

Various models available differing in size and number of baskets.
Feeny Manufacturing
800/899-6535
www.feeny-mfg.com

SINK AND FAUCET

Marsala self-rimming black sink no. K-5922-2-7; Avatar single-control polished-chrome kitchen faucet no. K-6354-CP.
Kohler
800/456-4537
www.kohler.com

VENEERED WOOD COLUMNS

6"-diameter cherry
Hollowood
BrandNew
800/964-8251
www.brandnew.net

WINDOWS

Architect Series casement windows.
Pella
888/547-3552
www.pella.com

Give your
kitchen
the ultimate
makeover and
save!

custom cabinetmaking

Sure, you could go to the store and buy new cabinets when it's time to remodel your kitchen. But a woodworker with a bit of experience does have another choice, and a big advantage. Examine the quality of those factory-built units. Check the prices. You probably can beat the big manufacturers on both counts by building your own cabinets.



We asked Doug Guyer, a cabinetmaker in Des Moines, Iowa, to build the cabinets for our kitchen remodeling project. We also asked him to lay out the steps so that less experienced woodworkers can follow along.

You'll see that this project requires only basic woodworking tools and some special jigs that you can make yourself. Doug did all of the work in his shop, a converted two-car garage.

Still, there's no denying that it's a major undertaking. Make sure you have the time and patience to get it done in a reasonable fashion. Feeling confident on that score? Then here are the basics that will make the job go smoothly.

Plan to the last detail

This is not a project that you can jump into with a few rough sketches. You need to make precise measurements and drawings that are detailed enough to let you visualize both the construction procedures and the results. You can do it all on grid paper, but computer-aided design software is a great help.

Wheelchair access or just a strong personal preference for lower or higher countertops might enter into your planning. Otherwise, stick with standard specifications. The typical kitchen countertop is 36" off the floor; base cabinets are 24" deep; upper cabinets are 12" to 13" deep; and the upper cabinets perch 18" above the countertop. Plan for a 1/8" gap on each side of an appliance.

We're going to build boxes of manageable size and set them side by side, so you need to figure out logical widths for those boxes. For example, the sink base might be 42" wide, a standard storage unit might be 30", and a cabinet housing just a stack of drawers might be 18". Measure existing kitchens, and look into the cabinet manufacturers' brochures at home centers for examples.

We'll show you how to build slightly modified Euro-style cabinets. These

give you a contemporary look, and the absence of face frames makes them easier to build than more traditional styles.

Place hardware high on your planning list, too. If you can't find everything you need at your favorite home center, get a detailed catalog from a hardware supplier, such as Woodworker's Hardware. Call 800/383-0130 for a free catalog, or log on to www.wwhardware.com.

You have a huge array of pulls, hinges, and drawer slides to choose from, and those choices do make a difference. For example, standard drawer slides mount on the drawer sides, usually requiring 1/2" clearance on each side. However, we chose an undermount style, which is hidden from view, and allows for a slightly wider drawer, too.

Also, spend some time considering specialized hardware, such as pull-out trays, drawer inserts, wastebasket racks, storage baskets, and the like. Remember, you'll have to size some cabinets to accommodate those choices.

Material quality matters

Don't settle for common materials when you're aiming for top-notch results. It's worth the extra cost to go with professional quality when you select sheet goods, fasteners, and hardware.

You'll need enough solid-wood stock to build doors, drawers, and various trim pieces. We used cherry, a very popular cabinet wood these days. We made the door panels out of 1/4" cherry plywood, with two good faces.

You can buy melamine-coated sheet material at any home center, but we recommend that you go to a builder's supply outlet and buy "thermo-fused" melamine. It's a higher quality product with a shiny white coating that's more durable and easier to keep

clean than the dull kind that most home centers carry.

For our project, we used sheet goods with thermo-fused melamine on one face and a brown gluing surface on the other. Each sheet comes oversized at 49" by 97", allowing for space lost to saw kerfs, and you can expect to pay about \$30 per sheet.

You'll use 3/4" sheets for the sides and bottom of each base cabinet, and for the sides, top, and bottom of each upper cabinet. Buy enough 1/4" sheet stock, also with thermo-fused melamine on one side and a gluing surface on the other, for the backs of all the cabinets.

Also buy enough 3/4" sheet material with melamine on both sides to make shelves for all of your cabinets. You can use the two-sided type of sheet goods for the whole project, but you'll have to sand off the melamine coating on the bottom of each upper cabinet, so that veneer will adhere.

You'll cover the melamine's exposed edges with wood veneer tape. Look for it in 8' rolls at home centers, or you can order it in various species through Van Dyke's Restorers, 800/558-1234. Ask for part number 02280064,



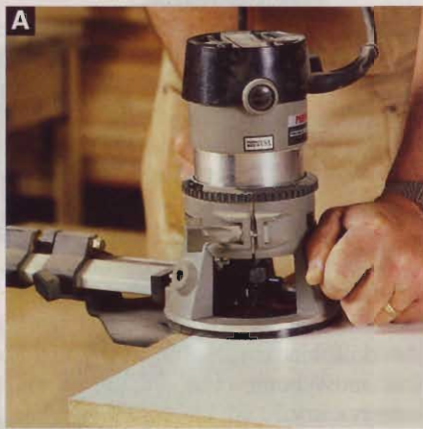

A Equip your router with a good edge guide before you start making grooves for cabinet backs. Set the guide, then do all the backs at once.

priced at \$4.49 per roll. Plan for some waste, because it's best to avoid using splices in your project.

Let's build a base cabinet

You need only basic woodworking skills to build the standard cabinet box. Let's start with a typical base cabinet, as shown in **Drawing 1**. Vary the dimensions and the number of drawers to make nearly any cabinet unit you want.

To avoid chipping the melamine, outfit your tablesaw with a sharp, 80-tooth blade. Then, cut a sheet in half lengthwise, and cut one half into three equal pieces, each approximately 24x32".

One piece at a time, clamp each sheet of melamine to your workbench, with the white face up. This surface will be visible inside the cabinet. Equip your router with an edge guide and a 1/4" straight bit, and rout a groove 3/8" deep and 1/16" from the edge, as shown in **Photo A** and the base cabinet assembly. This edge is going to serve as the back edge of the cabinet sides and bottom.

Now, cut the two sides to 23 1/4 x 30 1/2". Make the cabinet bottom 23 1/4" deep, and as wide as the finished width of the cabinet, minus 1 1/2". From the same material, cut two rails for the top, and a drawer divider, each piece 5" wide and as long as the bottom's width. Rout a groove in the back rail, sized and located to match the grooves in the sides.

Now, because they will show on the finished cabinet, put veneer tape on the front edges of the sides, bottom, and rails. We used cherry veneer to match

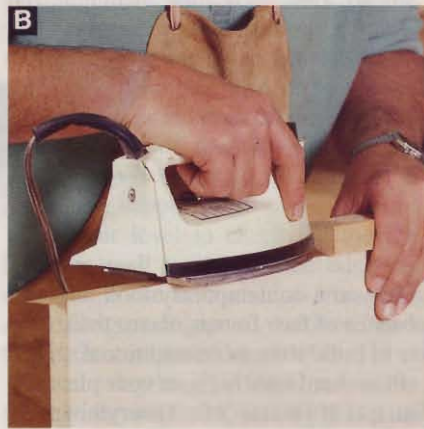

B All you need to apply veneer is an inexpensive household iron. If you plan to do a lot of cabinet work, you can buy veneer tape in 250' rolls.

the solid wood used for the doors and drawer fronts.

Apply veneer tape with a common household iron, as shown in **Photo B**. Secure the workpiece vertically in a vise or in a handscrew clamp that is, in turn, clamped to the top of your workbench. Cut enough tape to protrude beyond both ends of the piece. With your iron set at medium heat, run it along the length of the piece. This melts enough of the adhesive backing to hold the tape in place.

Then, go over the tape again, holding the iron in place for three or four seconds in each spot. Move an iron's length ahead, and also press a wood block on the previous spot. The wood absorbs some of the heat, and the pressure helps to set the veneer in place.

Score the tape from beneath at one end of the workpiece, using the wood block

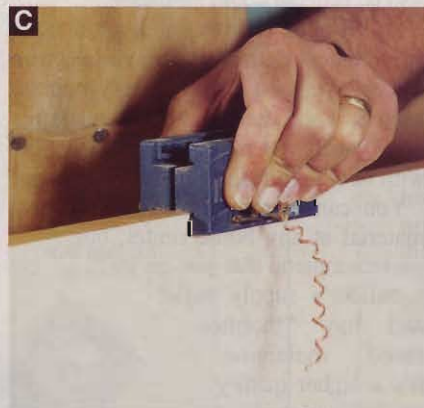

C A razor-sharp trimmer quickly cuts the lightweight veneer. This spring-loaded model handles both sides at once, and works on stock of various thicknesses.

as a backing surface. Snap off the veneer, then sand it flush with medium-grit sandpaper on a sanding block. Repeat at the opposite end.

Doug uses a handy little tool made by Virutex to trim both edges of the veneer at the same time, as shown in **Photo C**. You can find other styles, too, but this one is available from Van Dyke's Restorers, part number 02286821, for \$19.99. Or, you can shave the veneer flush with a sharp chisel.

See the sidebar, *page 59*, for details about making a drilling jig that you'll use to position shelf holes on the cabinet sides. Use this jig to drill a series of holes in each area where you want to place a shelf, to allow for some adjustment in shelf spacing.

Most factory-built cabinets have holes from the top of the cabinet clear down to the bottom, but there's no need to do that. Your cabinets will look better on the inside with fewer holes. In addition, you won't wind up with a hole, or half a hole, near the bottom, where liquids could splash into the particleboard core and cause damage.

Attach the sides to the bottom with #20 biscuits and #8x2" production screws. Keep it simple, and line up the edge of the biscuit joiner with the edge of the cabinet side, as shown in **Photo D**, then the edge of the bottom. That way, you don't even need to make pencil marks. Use four biscuits per edge.

Also, cut biscuit slots for the drawer divider. Doug uses a shopmade jig for this, consisting of a square piece of particleboard, 5" on each side, with wider



D Keep joinery simple and avoid measurements completely, when possible. Here, the biscuit joiner is lined up with the edge of the cabinet side.

1 BASE CABINET ASSEMBLY

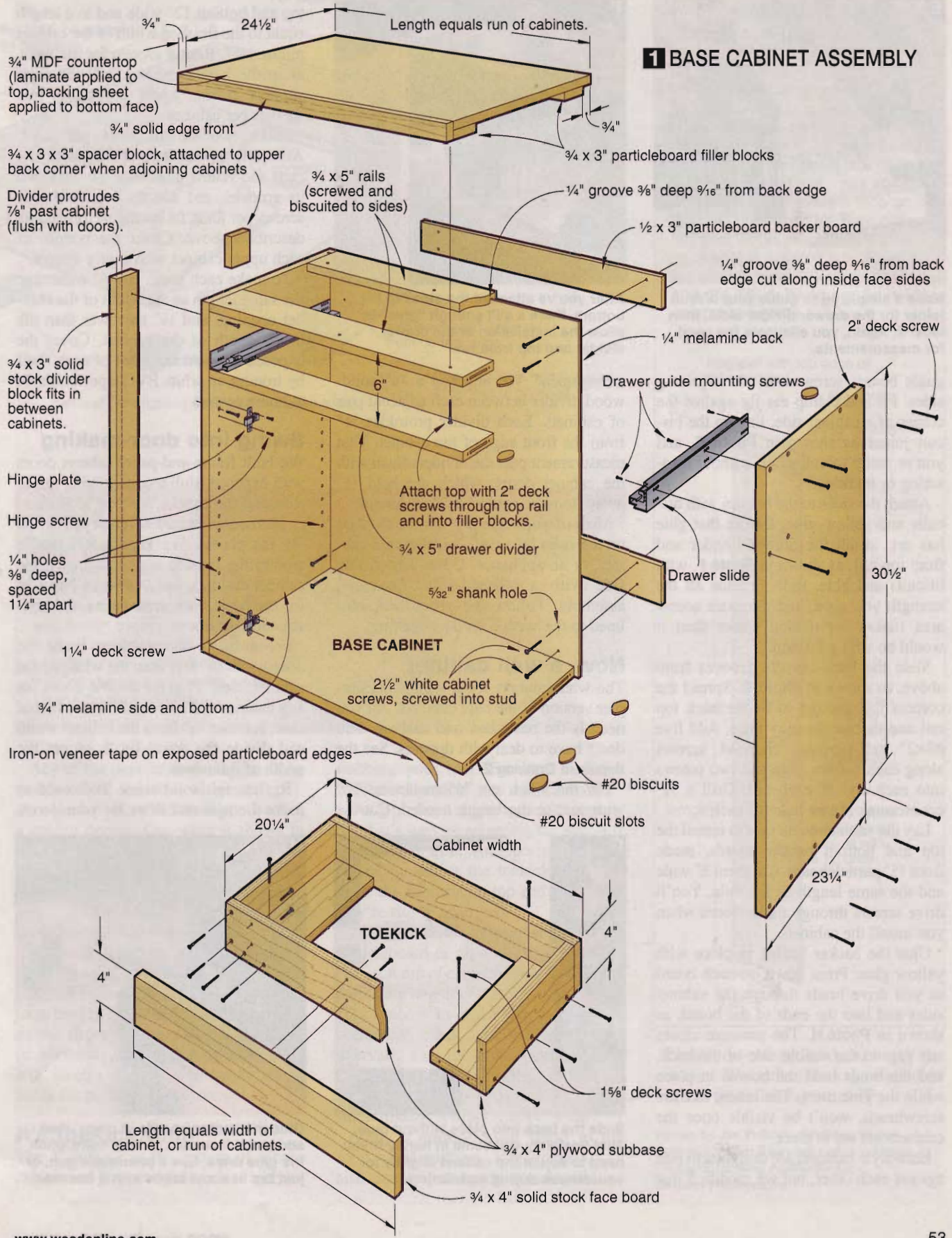

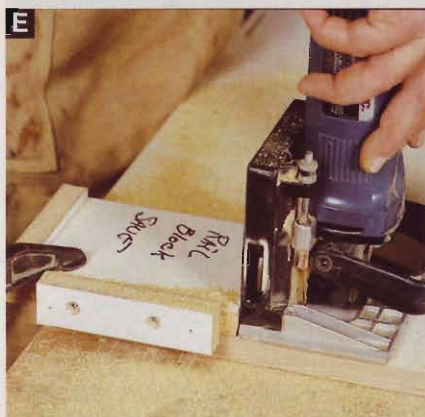

E Make a simple jig to guide your biscuit joiner for the drawer divider slots, then label it. Again, you eliminate the need for measurements.

guide boards screwed to two adjoining sides. Fit and clamp the jig against the corner of a cabinet side, line up the biscuit joiner as shown in **Photo E**, and you're ready to cut, again without measuring or marking.

Attach the sides to the bottom with biscuits and yellow glue. Before that glue has set, install the drawer divider and front top rail, as shown in **Photo F**, with biscuits and glue. Rails provide all the strength you need, and the extra access area makes installation easier than it would be with a full top.

Slide the back into its grooves from above, as shown in **Photo G**. Spread the corners just enough to fit the back top rail and its biscuits into place. Add five #8x2" self-tapping, flathead screws along each bottom edge and two screws into each end of each rail. Drill a 1/8" countersunk starter hole for each screw.

Lay the cabinet on its face to install the top and bottom backer boards, made from 1/2" particleboard. Cut them 3" wide and the same length as the rails. You'll drive screws through these pieces when you install the cabinets.

Glue the backer boards in place with yellow glue. Press down on each board as you drive brads through the cabinet sides and into the ends of the board, as shown in **Photo H**. The pressure closes any gap on the visible side of the back, and the brads hold the boards in place while the glue dries. The brads, like the screwheads, won't be visible once the cabinets are set in place.

Euro-style cabinets are designed to butt against each other, but we modified that



F After you've attached the sides to the bottom, there's still enough "give" to allow the installation of the drawer divider and top front rail.

arrangement. We attached a 3/4" solid-wood divider between each adjacent pair of cabinets. Each divider protrudes 7/8" from the front edge of the cabinet. That measurement puts the dividers flush with the cabinet doors, which are held 1/8" away from the cabinet by their hinges.

Most of your cabinets will be covered on the sides by a wall, an adjoining cabinet, or an appliance. Cover any visible side with a rail-and-stile, flat-panel assembly. Follow the procedures outlined in the section on door-making.

Now, a wall cabinet

The wall cabinets are a shallower, simpler version of the base cabinets. All you need is the basic box and shelves. You don't have to deal with drawers. See the details in **Drawing 2**.

For the sides, cut 3/4" melamine 12" wide and to the length needed. Cut the

top and bottom 12" wide and to a length equal to the finished width of the cabinet minus 1 1/2". Rout a groove for the back, as in the base cabinets. Drill the shelf support holes, again assuming two shelves per cabinet.

Make two biscuit slots per joint. Assemble the bottom and sides with biscuits and yellow glue, slide the back into its grooves, and add the top. Add four screws per joint, following the procedure described above. Cover the bottom of each upper cabinet with cherry veneer.

To make each shelf, cut 3/4" melamine the same length as the width of the cabinet opening, and 1/4" narrower than the inside depth of the cabinet. Cover the exposed edge on the front of each shelf by ironing on white PVC tape, available at home centers.

Swing into door-making

We built frame-and-panel cabinet doors with exposed, stub tenons joining rail to stile, and flat panels. We used solid cherry for the frames and 1/4" cherry plywood for the panels. We kept a 90° profile around the outside edges, to match the cabinet dividers. See **Drawings 2** and **2a** for the basic door dimensions and construction details.

For a single-door cabinet, make the door width 1/4" less than the width of the cabinet itself. Plan on double doors for any cabinet that's over 22" wide. In that case, subtract 3/8" from the cabinet width and divide the result by 2, to get the width of each door.

Rip enough solid stock 2 1/4" wide to make the rails and stiles for your doors.



G Slide the back into place without glue. That flexibility will come in handy if you need to adjust the cabinet slightly for squareness during installation.

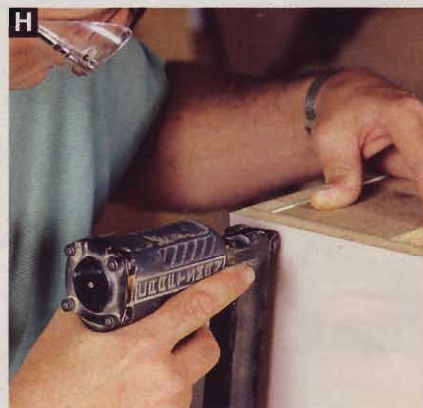

H Glue the backer boards in place, then add small fasteners to hold them while the glue dries. Use a pneumatic gun, or just tap in some brads with a hammer.

2 WALL CABINET ASSEMBLY

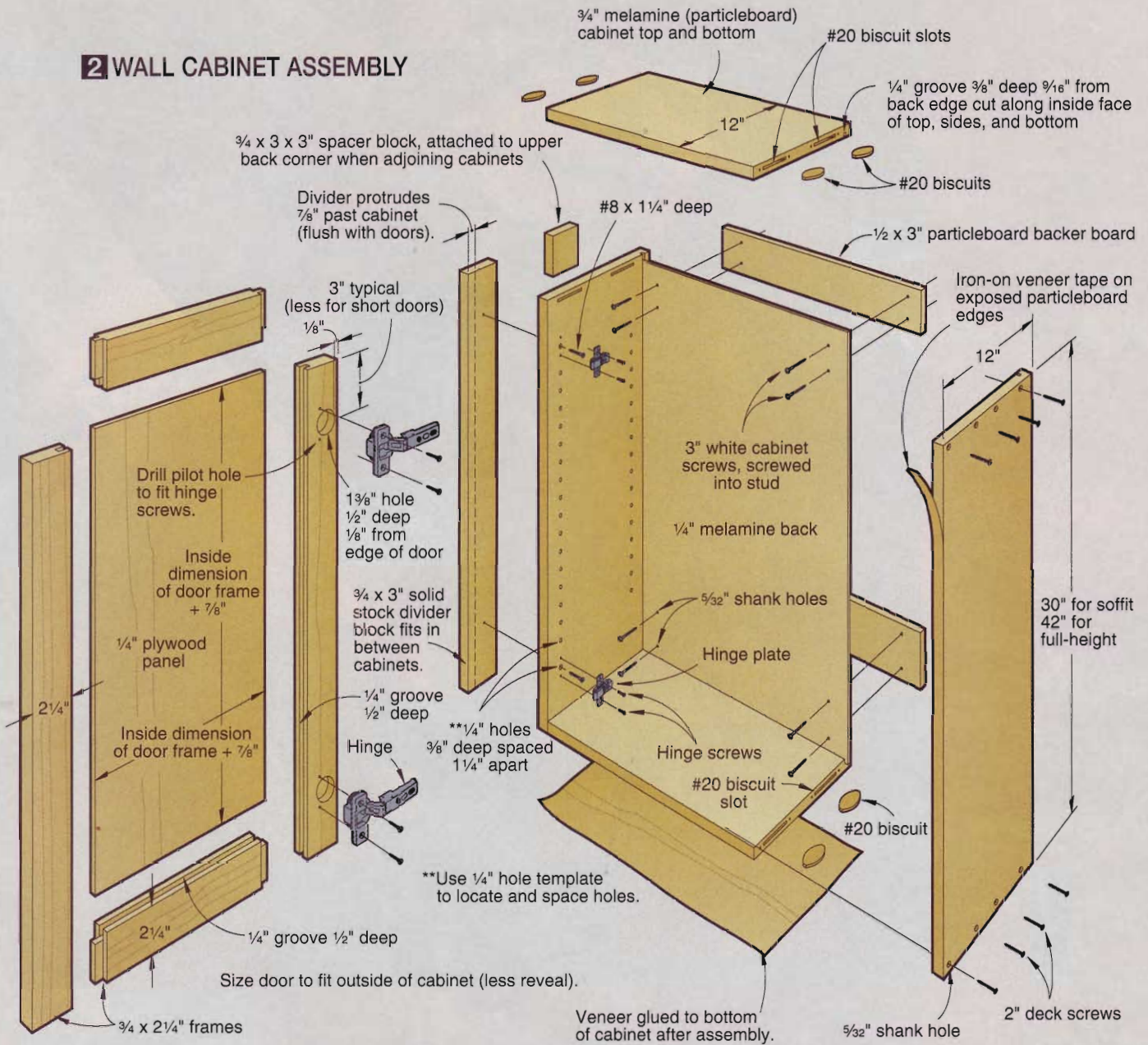

2a TENON DETAIL

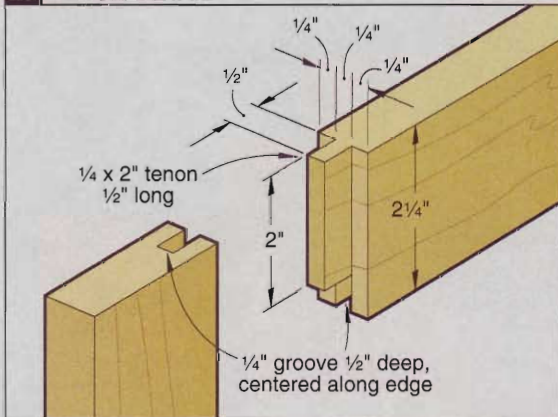

2b DOOR & DIVIDER DETAIL/TOP VIEW

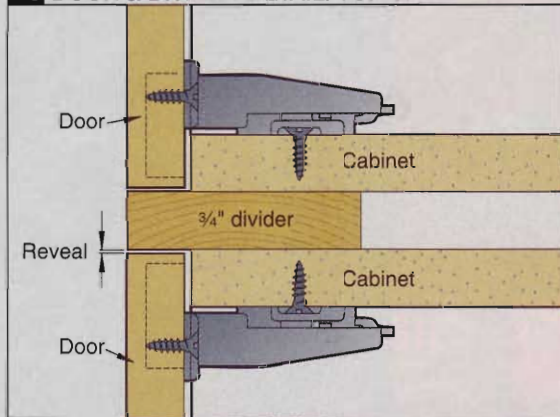



I A feather board adds a lot to your accuracy when you're cutting grooves on the edges of the door rails and stiles.

Then, take some time to choose the straightest pieces for the stiles. Straight stiles produce flat, good-fitting doors. Cut the longest stiles to length first, if you're making cabinets of various heights, then the remaining stiles, and finally the rails. To determine the length of the rails, subtract 4½" (the combined width of two stiles) from the finished door width, then add 1" to account for the tenons.

With a standard blade on your table-saw, cut a groove on the inside edges of the stiles and rails, as shown in **Photo I**. Make it ½" deep and just wide enough to accept the plywood. Usually, ¼" plywood won't measure exactly ¼", so run some test cuts on scrap pieces first. Cut the length of the piece, then flip the other face against the fence and cut in the opposite direction. This step centers the groove on the workpiece. Adjust the fence until the width is perfect.

Equip your table saw with a dado set and cut ½"-long tenons on both ends of each rail, sized to fit the grooves. We used a sliding carriage that rides in the miter gauge slots, and a hold-down clamp, as shown in **Photo J**.

Ease the inside edges of the grooves with 150-grit sandpaper on a block. The door will look nicer. Besides, a sharp edge doesn't take finish well.

Dry-fit the doors, measure for the panels, then cut the panels with a plywood blade mounted on the table saw. Allow for a ¼" gap at each side and each end to make for a smooth assembly. Ease the edges of this panel, too, with 150-grit sandpaper on a block. Rounded edges slip easily into the grooves without catch-

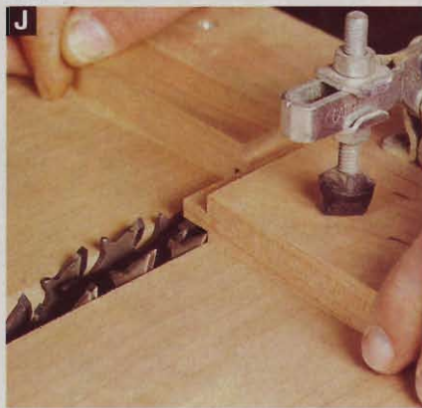

J This shopmade tenoning jig features a hold-down toggle clamp. Make your own carriage-style jig, or use a miter gauge.

ing and possibly damaging the veneer. When everything fits perfectly, glue the tenons in place with yellow glue and clamp each door with pipe clamps or bar clamps. Again, use 150-grit sandpaper to ease the exposed edges of the rails and stiles next to the panel. Check the door for square by measuring the diagonals, as shown in **Photo K**.

Drive two ⅝" brads into each tenon from the back side of the door and remove the clamps. Lay each door on a flat surface and weight it down with more doors, or boards, while the glue dries. Crisscross the doors as you stack them. Otherwise, squeeze-out at the joints could glue them together.

We recommend cup-style hinges, which are unseen when the doors are closed and allow adjustments, too. Home centers and hardware stores carry various brands, or check the Woodworker's Hardware catalog, which also describes the accessories that help you position the



K Before the glue sets, measure across the diagonals of each door. Equal measurements mean the corners are square.

3 DRAWER ASSEMBLY

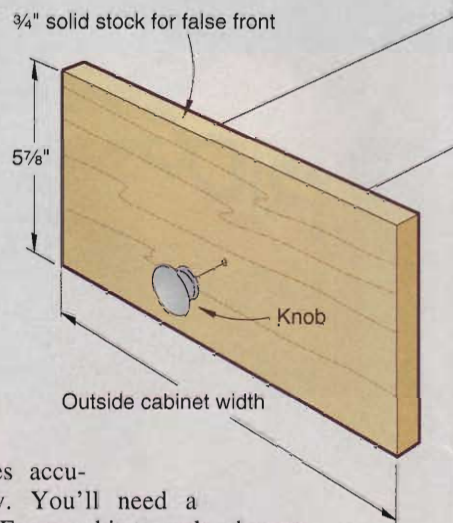

hinges accurately. You'll need a 1⅜" Forstner bit to make the cup holes in the doors.

Design the drawers

The typical cabinet drawer is 22" deep. Its width depends not only on the opening, but also on the kind of slides you choose. The height must be at least ¼" less than the height of the opening but might have to be reduced, again depending on the slides.

See **Drawing 3** for the dimensions and details of one of our typical drawers. Maple is always a good choice for the sides, front, and back of the drawer box.

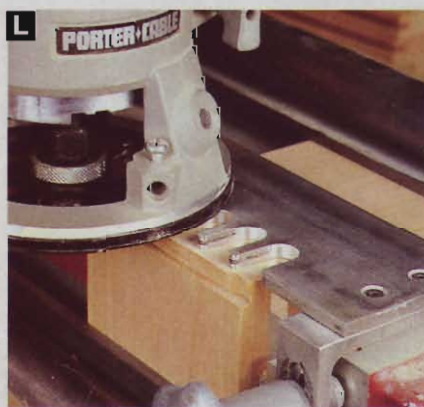

L Buy an affordable dovetail jig, practice with it, and you'll be able to make the drawer joints quickly.

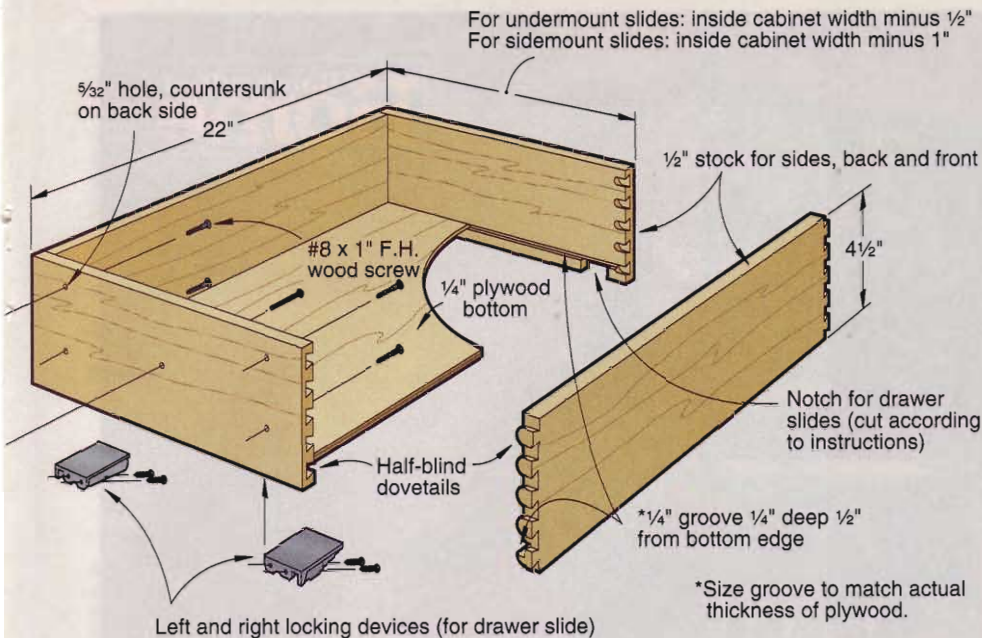

shop TIP

Skid control

As you complete each base cabinet, cut small pieces of particleboard scrap for skids, and fasten them underneath with a brad nailer. Now you can slide the heavy units around without damage while you work on the doors and drawers.



Any of the popular dovetail jigs, along with a router and dovetail bit, will produce the half-blind dovetails you want in a quality drawer. Our setup is shown in **Photo L**. Of course, you might choose another type of joint that's easier to make.

For a clean look, we installed undermount drawer slides, which don't show on the sides of the drawers. Following the manufacturer's directions, mount the guides on the 3/4" melamine divider rail that separates the drawer compartment from the rest of the cabinet. These undermount slides require just 3/16" clearance on each side. A good hardware catalog will specify the side and height clearances for each style of slide.

It's toekick time

The 3" setback at the bottom of a base cabinet lets you get right up close without

stubbing your toes. Furniture factories build this "toekick" into their cabinets.

Doug prefers a separate toekick assembly that's easy to adjust on the site, just in case the floor isn't perfectly level. Once you adjust the toekick, you can place the cabinets on top and know that they're sitting level, too.

To make the toekick, cut scraps of 3/4" particleboard or plywood to a 4" width. For each run of cabinets, you'll need two pieces the length of that run, and enough 18 3/4" pieces to make the vertical and horizontal cross members set at 16" intervals. Join the cross members into L-shaped structures with screws, as shown in **Drawing 1**, then screw on the sides, making a support 20 1/4" wide.

Apply a durable, clear finish to the solid wood surfaces. Polyurethane varnish stands up to handling and spills.

Make a shelf hole jig

To make sure your shelf holes line up accurately, you need a drilling jig. Make the simple one shown *below* out of scrap material, and you'll be all set to construct any standard cabinetry.

To use the jig, fit its guide boards against one top corner of a cabinet side. Mark the guide holes you want to use, set a depth stop on your 1/4" brad-point bit, then drill the shelf holes 3/8" deep. Flip the jig over to fit against the opposite top corner, mark the correct holes, and drill again, being careful not to enlarge the guide holes.

Register with top edge of side panels.

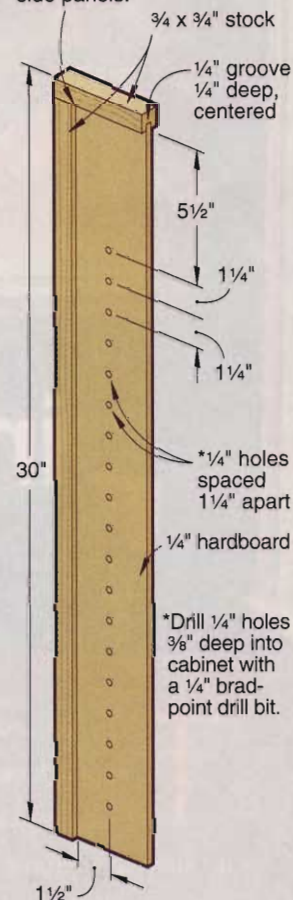

Now, you can get ready to install the cabinets. We outline the key installation steps in the following article. 📌

Written by **Jim Pollock** with **Doug Guyer**
Illustrations: **Kim Downing**; **Lorna Johnson**
Photographs: **King Au/Studio Au**;
Baldwin Photography

Careful
measurement
and planning make
for a trouble-free
placement.

installing cabinets step-by-step

The preceding article showed you how to build good-looking, durable kitchen cabinets. The next step is to install them dead-level and solid enough to survive anything your family can throw at them.

If you measured carefully during the building phase, you're halfway to a smooth installation. Pay the same attention to setting the toekicks, make sure the screws hit the studs, and your cabinets will give you years of satisfaction.



Remove the old cabinets and make any necessary repairs to the walls and floor. Take care of any electrical, plumbing, or heating and cooling work. Then, mark on the walls the height of your toe-kick, base cabinets, and wall cabinets, as shown in **Drawing 1**, to help keep everything on target during installation. Be sure to measure up from the floor's highest point. Work your way around the room with a 4' level to find that spot.

Start on the wall

Start the installation with the wall cabinets, rather than working over the base units. Enlist someone to help you hold each cabinet in place.

Your installation starting point depends on the room layout. Often, it's best to start with a cabinet that must be centered over a stove or sink. On our end wall, we started in the center, and aligned the stove-vent ductwork with the hole we cut in the cabinet top.

If your cabinets won't contact a soffit above, install temporary supports as shown in **Drawing 1**. Otherwise, locate the cabinets by holding them firmly against the soffit. Raise the first cabinet into place, and check it with a reliable level. Place shims between the wall and cabinet to make slight adjustments. Drill pilot holes into the wall studs, and attach

the cabinet to the wall with white 3" pan-head screws. Ideally, each cabinet is held by four screws in each stud, two near the top, and two near the bottom.

As noted in the cabinet construction article, we used a 3/4" divider made of cherry and positioned it to protrude 7/8". A 3/4" spacer between each pair of cabinets goes near the back edge and can be made from scrap, because it won't be seen. Refer back to **Drawing 1** in the cabinetmaking article.

Raise the second cabinet into place beside the first one, and drive two screws through its back and into the studs, but don't snug them tight yet. Clamp the two cabinets together with handscrews, as shown in **Photo A**.

Again, check the installation with your level. For a cabinet that's adjacent to a wall, place shims between the cabinet and the wall, as in **Photo B**, to help snug it into place. A piece of scrap material placed behind the shims protects the wall from damage.

While your assistant holds the cabinet in place, put two more panhead screws through the back and into the wall studs. Use a level along the front edge of the cabinet, and drive two 1 1/4" flathead wood screws, one near the top and one near the bottom, from the first cabinet into the second, as shown in **Photo C**.



A Use clean, smooth handscrew clamps to align cabinets. You can apply adequate pressure without damaging the wood.



B Protect the wall! with a board when you use shims like this. Remove the shims after screwing the cabinet to the wall.



C There's no need to clutter up the inside of a cabinet with lots of screwheads. Fasten adjacent cabinets with screws placed inside hinge or shelf holes.

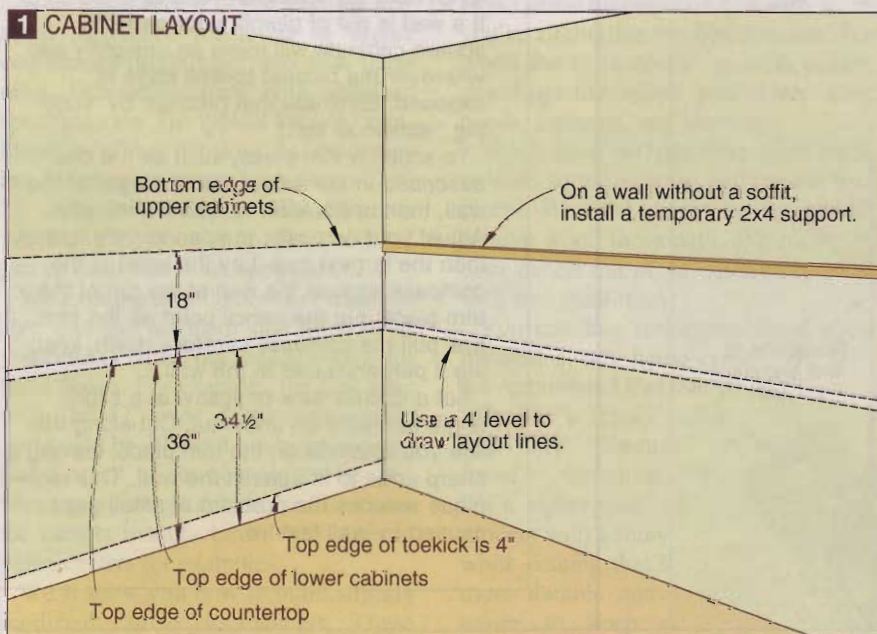

installing cabinets

Place these screws where they'll be hidden by the hinge plates. Now, tighten the screws in the cabinet back.

In many situations, your row of cabinets will run from one wall to another, as in the case shown here. We sized our cabinets to allow a 1/4" gap at each end of the installation, then covered it with trim as shown in **Drawing 2**.

From matching solid wood, cut two boards 1/2" wide and the length of the cabinet side. Temporarily attach the filler block with screws located inside shelf pin holes. Hold the trim piece vertically in place, and check to see whether it sits flush against the wall. If any gaps show, use a compass to scribe a line on the face of the trim, and cut it to fit. See the sidebar for scribing information.

After cutting the other side of the trim so that it sits flush with the outside edge of the cabinet, remove the filler block and glue the two pieces into an L shape. After the glue dries, screw this assembly in place so that it extends 7/8" beyond the cabinet side. That measurement will make it flush with the 3/4" doors after they're mounted on their hinges.

Build a foundation

Position the toekick frames on the floor, then use shims to bring any low spots

into alignment with your mark on the wall. To raise a given spot on a frame, start one shim under the nearest crosspiece with a hammer, then start a second shim on top of the first, driven from the opposite side of the crosspiece. Two wedge-shaped shims together create a flat, square support.

Use your level to check the toekick from the wall to the outside edge, as shown in **Photo D**. Use shims in several spots along each gap, so that there's no flex in the completed installation.

When everything is level, screw the frame to the wall studs with #10x3" pan-head screws. Finally, screw the toekick to the floor by driving two 3" screws through each horizontal piece. Wherever possible, locate the screws so that they also pass through shims.

Dress up the toekick

Cut a board from stock that matches your cabinets to the length of the toekick and wide enough to reach from the floor to the highest point on the toekick. Scribe a line on the back side of this board by running a pencil along the top of the toekick. Place the board on supports, and carefully cut along that line with a circular saw. Attach the board with #8x1/4" wood screws driven from inside the toekick frame.



Screw the toekick to the wall, then adjust it horizontally with a level and shims. Later, trim off any protruding ends of the shims with a handsaw.

You're likely to need a heating-and-cooling register somewhere within the toekick. To make the grille that you see in **Photo E**, we placed the board on a tablesaw, set a stop on the fence, raised the blade to make a slot, then repositioned the fence and repeated the procedure. We cut six 1/8" kerfs, with 1/4" spaces in between. Keep the kerfs 1" away from the top edge and 2" away from the bottom. The kerfs are longer on

2 WALL TRIM DETAIL

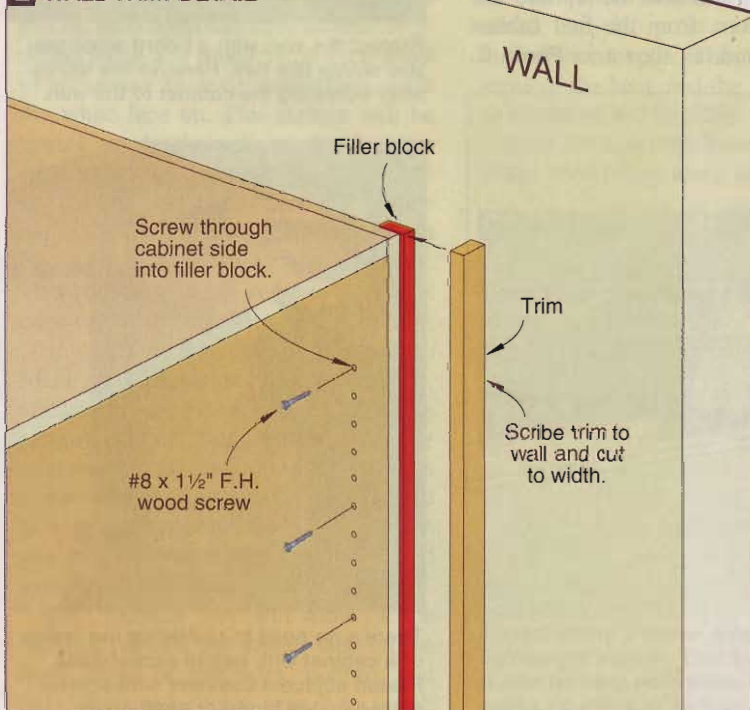

Scribing described

If a wall is out of plumb, your perfectly square cabinets will leave an unsightly gap wherever the cabinet-to-wall edge is exposed. Eliminate that problem by "scribing," shown at *right*.

To scribe a trim piece, such as the one described in the article, place it against the wall, then use a level to hold it vertically. Adjust your compass to span slightly farther than the largest gap. Lay the point of the compass against the wall at the top of the trim piece, put the pencil point on the trim, and pull the compass carefully down, keeping it perpendicular to the wall.

Set a circular saw or jigsaw at a slight angle to create an undercut. Cut along the line you've made on the trim piece, leaving a sharp edge to fit against the wall. This technique reduces the problem of small gaps caused by wall texture.



E Simple saw kerfs produce a clean-looking heating-and-cooling register. Seal the gap around the inside of the compartment with caulk.

the back side, due to the curve of the sawblade, but the appearance of the exposed side is all you have to consider.

Leave an open space in the toekick frame during assembly to allow for air flow, or cut it out now with a handsaw. After installing the face board, use construction adhesive to seal the bottom edge inside the toekick. This step makes sure the heated or cooled air flows directly into the room.

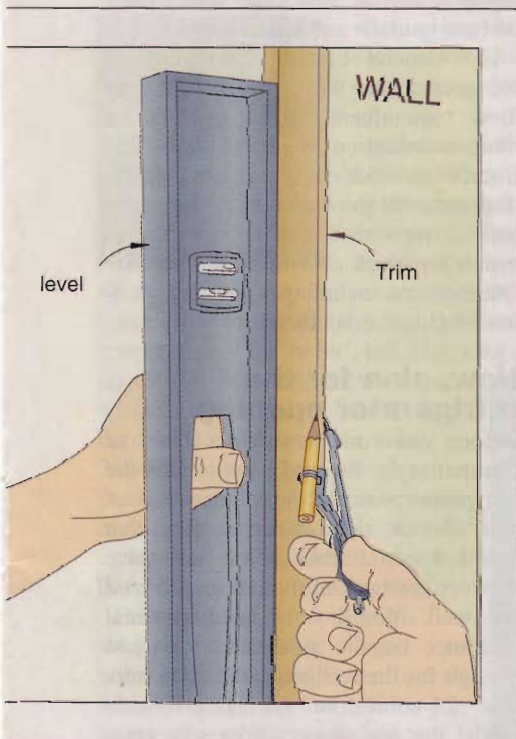

Place the base cabinets

Start placing your base cabinets with a unit that must line up with an architectural feature. For example, traditional kitchen design centers the sink cabinet under a window.

Speaking of the sink cabinet, you'll have to cut holes in the back of that unit to accept plumbing pipes. Mark the position of the cabinet on the wall, then measure from one end mark and the toekick to locate a given pipe. Measure from the same end on the cabinet and from the bottom. Cut the hole just slightly oversize with a jigsaw.

Place the first base cabinet on the toekick frame, and check it with your level. If it's off, adjust the frame.

Set the first cabinet in place. If the top edge sits flush against the wall, drive at least two 3" panhead screws through the backer board and into the studs. Because we left most of the top open on these base cabinets, you can work from a standing position and reach down into the cabinet to attach it to the wall. We'll add the countertop later.

If the bottom sits flush against the wall but the top shows a gap because the wall isn't plumb, insert shims over the wall studs. Then, drive screws through the cabinet back and the shims, and into the studs. The bottom of the cabinet must sit solidly on the toekick frame.

Clamp the adjoining cabinet to the first one with handscrew clamps, as shown in **Photo F**. Attach the rear spacer with



F If you build your base cabinets carefully, and set the toekicks perfectly level, this step is easy. Clamp adjoining units together, and attach them with screws.

screws from the inside of each adjoining cabinet. Again, place the screws where they'll be hidden by a hinge plate or inside one of the shelf support holes. Continue in this way to the end of the run.

Add doors and drawers

When all of the cabinets are set, install the drawers and doors. The doors are ready to snap into the hinges. However, we built the basic drawer boxes without their fronts, so we'll do that now.

First, locate the center of the drawer front. Place a piece of masking tape in the approximate center, then use a ruler to mark diagonal lines from opposite corners. Drill through the intersection of those lines to make a hole for the drawer knob screw.

Slip the drawer into its slides. Lay a 1/8" shim on top of the cabinet door below the drawer opening. Set the drawer front on the shim, align its ends with the door, then drill through the knob hole and drawer box. Install the knob, then drill four screw pilot holes from inside the drawer, making certain not to go clear through the front. Countersink the holes, and drive the four #8x1" flathead wood screws. Repeat that procedure with all of the drawers, and you're done.

Next comes the countertop. See the article on *page 68* for help with that.

Written by Jim Pollock with Doug Geyer
 Illustrations: Kim Downing, Lorna Johnson
 Photographs: King Au/Studio Art, Baldwin Photography



Believe it or not, there's a dishwasher behind the false door and drawer front at left. Although less disguised than the dishwasher, the side-by-side refrigerator below merges with its surrounding cabinetry thanks to matching wood panels.

the integrated kitchen

blend your appliances into the woodwork



Once you had to spend big bucks to buy kitchen appliances that harmonized with hardwood cabinets. Not anymore. Here's how to simply, and affordably, blend a refrigerator and dishwasher with all that beautiful wood.

If you're reading this, you probably have a passion for the warmth and beauty of wood. So, when it comes to your kitchen, don't you want the woodwork to dominate the appliances, and not the other way around? Fortunately, you can do a number of simple things to prevent appliances from overpowering your kitchen. As shown in the article beginning on page 45, you can hide a microwave in a cubbyhole, buy a slide-out vent hood, and install a drop-in range (one that rests on a wood base instead of on the floor). But what can you do about that enormous refrigerator and nondescript dishwasher? Plenty. Let's start with the refrigerator.

First, buy the right fridge

Most manufacturers of mass-produced refrigerators now offer reasonably priced models that accept wood panels. Make sure you buy one that advertises this feature, comes with a trim kit, and has an owner's manual with clear instructions on how to make and install panels.

The General Electric CustomStyle™ refrigerator that we chose meets all of those requirements. (See page 49 for more information on contacting GE.) Because the door edges, handles, and ice dispenser still show after installing wood panels, we chose a black version to match the black accents of the kitchen. Other colors, including white and stainless steel, are available.

Now, plan for the refrigerator opening

Before you build a single cabinet or countertop for the wall that houses the refrigerator, check the dimensions of your chosen fridge. Keep in mind that you'll need at least a 3/4" air space between the back of the refrigerator and the wall. You'll only need minimal clearance on the sides and top—just enough for the refrigerator to slide into. The 24-cubic-foot GE side-by-side model that we chose works with stan-



A First, loosen the screws that hold down the plastic panel retainers on the tops of the refrigerator doors.



B Then, slide in the panel, being careful to insert the refrigerator's panel-retaining lips in the panel's groove.



C Attach the trim kit's flange to the outside edges of the doors (double-faced tape holds them securely).

ward 24"-deep cabinets and 25"-deep counters. The refrigerator sticks out from the countertop by the thickness of the doors—enough clearance for the hinges to operate properly. Wheels help it slide effortlessly into its opening.

Build and install the panels—that's it!

We could have purchased wood panels supplied by the appliance maker, but we made our own that match the cabinet doors perfectly. Refrigerators designed

for accepting wood panels should have in their owner's manuals the necessary dimensions and instructions for building your own panels. **Drawing 1** shows how we made our panels according to the GE instructions. **Photos A, B, and C** show how the panels go into place.

1 REFRIGERATOR PANELS (VIEWED FROM BACK)

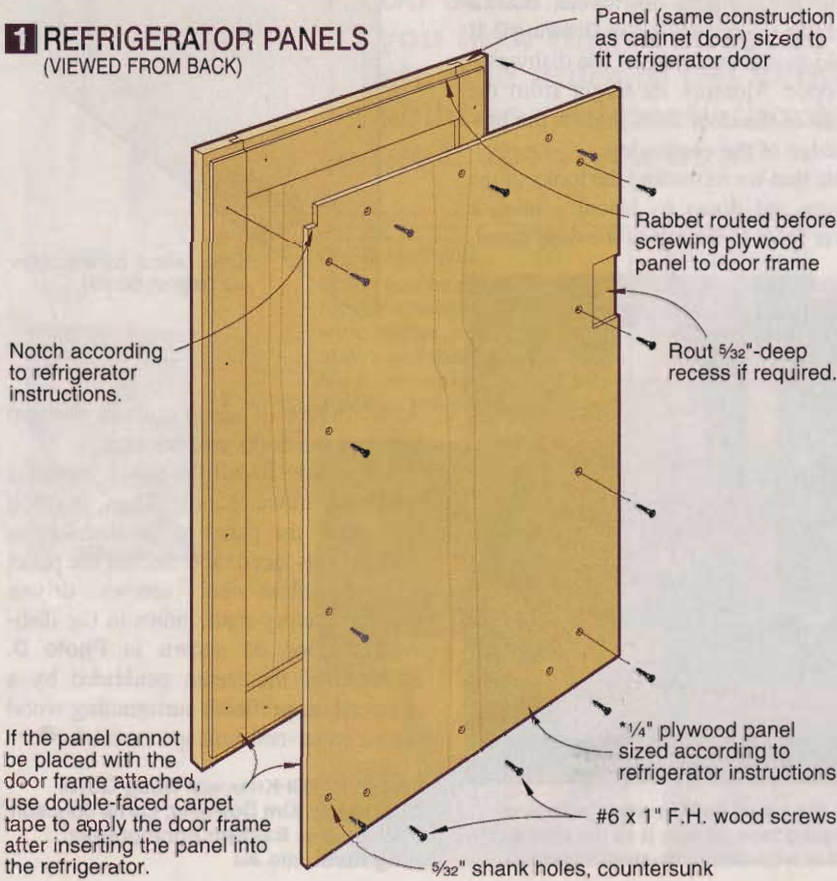

1a DOOR HANDLE REVEAL DETAIL

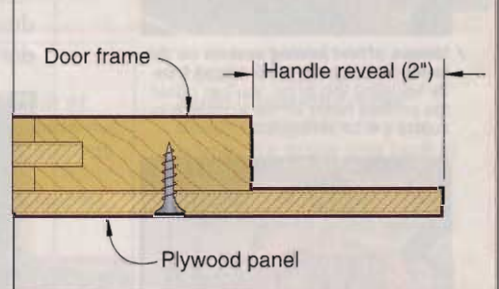

1b RABBET DETAIL

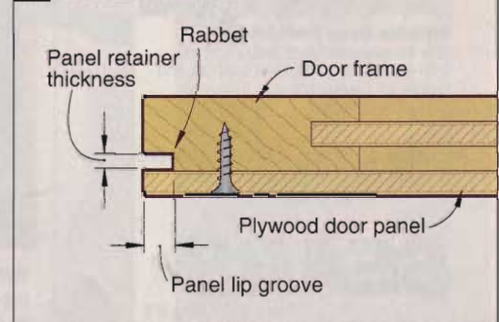

CRAFTSMAN

Advanced router table engineering made simple for your workshop!



Routers mount easily through an opening in the tabletop

No more fumbling underneath the table. Install your router thru the 11 3/8-in. x 9-in. opening on top. Mounting plate is keyed to ensure proper installation.



Innovative 3-piece fence adjusts, allowing you complete flexibility

The fence opening can be adjusted to match the varying diameters of your router bits.



Unique offset joining system on the fence helps make work edges true

By adjusting the fence, you can offset the outfeed fence so the workpiece is supported for joining cuts.



Includes three table inserts

The varying size inserts provide you with additional workpiece support and proper bit clearance.

Available at Sears, Sears Hardware, and the Craftsman Catalog at 800-437-9686

SEARS

THE GOOD LIFE
AT A GREAT PRICE
GUARANTEEDSM

the integrated kitchen

Make a dishwasher disappear—it's magic

Although visitors to your kitchen will have to look long and hard to find a paneled dishwasher, pulling off this disappearing act is an easy trick.

As with the refrigerator, you need to pick a dishwasher that accepts panels. We chose an Asko model D1796FI. See page 49 for information on contacting Asko. Although this European make costs a few hundred dollars more than most domestic models, we chose it for several important reasons. First, its touch-pad controls are on the top edge of the door. So, they are hidden when you close the door, and they don't interfere with installing a wood panel that covers the entire door. And, it's one of the quietest and most energy- and water-efficient dishwashers on the market.

Panel installation couldn't be simpler

The dishwasher we chose fits into a standard dishwasher opening, but to be on the safe side, be sure to buy your unit before planning the cabinetry around it.

After installing the dishwasher, build a panel like the one shown in **Drawing 2**. It should match the width of the dishwasher's door. Measure its height from the bottom of the door to 1/4" below the bottom edge of the countertop.

Note that we mimicked the looks of the drawers and doors by biscuit-joining a drawer front to the top of the door panel.



With the panel held in place with double-faced tape, attach it to the dishwasher door with stainless-steel screws.

2 DISHWASHER PANEL

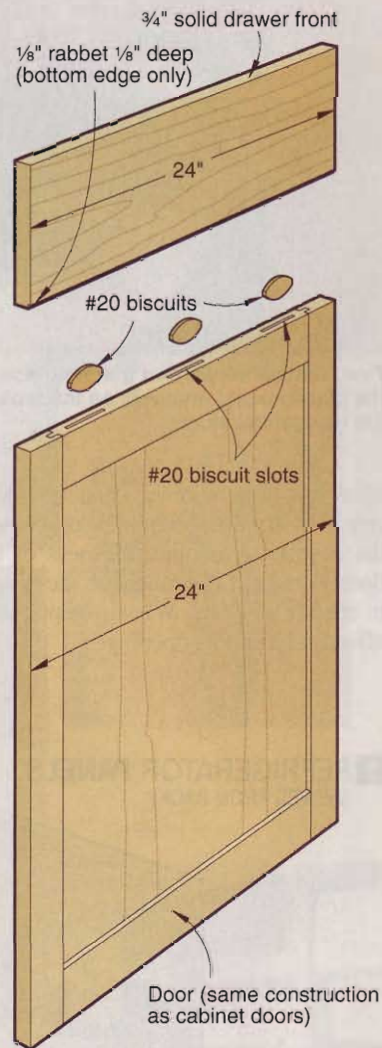

A 1/8" rabbet 1/8" deep imitates the gap between the doors and drawers.

Before you install the panel, mount a matching drawer handle. Then, position and attach the panel to the dishwasher with double-faced tape. Secure the panel with stainless-steel screws driven through factory-made holes in the dishwasher door, as shown in **Photo D**. Because of the steam generated by a dishwasher, prefinish surrounding wood with a water-resistant spar varnish. 🌲

Written by **Bill Krier** with **Doug Guyer**
Illustrations: **Kim Downing**; **Lorna Johnson**
Photographs: **Baldwin Photography**;
King, Au/Studio .Au

Whether capping off new or existing cabinets with a custom countertop, you'll find the process orderly and the results impressive.

crafting a countertop

You've probably walked the rows of mock-up kitchens at the home centers, marveling at the luscious cabinets with their gleaming countertops of differing colors, configurations, and materials. The choices seem endless.

When it comes to making your countertop, you'll find a similar story. You have all kinds of options in surface materials—from plastic laminate to marble, tile, and butcher block, to name a few. You also can customize the edge for a dramatically different look, or keep it plain and simple (see **Drawing 1**, Counter Edge Treatments on the *next page*).



For our kitchen redo, beginning on page 45, we opted for standard countertop construction, utilizing water-resistant $\frac{3}{4}$ " medium-density fiberboard (MDF) and plastic laminate (Formica brand Graphite Grafix #515 in matte finish). But we added a custom edge featuring a cherry reveal to match the cabinets. We built the cabinets (see page 50) and put them in place. Then we created the countertop in the shop and installed it. Read on to find out just how easy it is.

Note: Because our kitchen remodel featured a backsplash of molded ceramic tile, we built our countertop without one. See our sidebar "How to make and install a simple backsplash" on page 71.

Ready the underlayment

Kitchen-base cabinets are normally 24" deep. (Base cabinets for special task areas, such as baking, may be as deep as 29".) And the standard depth of a countertop is 25", providing a 1" lip (that includes the edging) over drawers to shield from spills.

You'll want to measure all the countertop area, then pencil a drawing on paper to help you maximize the sheet goods you'll use for the underlayment as well as the plastic laminate. (Remember that any joints in the countertop should not fall over a joint between cabinets.) To arrive at a 25" countertop depth, you must rip a 4x8' sheet lengthwise to 24 $\frac{1}{4}$ ". When you add the $\frac{3}{4}$ "-thick edging material, you'll have the 25". (If going with a plastic laminate edge, skip the $\frac{3}{4}$ " edging material and rip the underlayment to 25" wide.)

However, the kitchen wall against which the countertop will snuggle may not be flat. That's especially true in older construction. So, you have to leave a little excess material to accommodate scribing (removing countertop material to match the wall contour, a technique we'll show later). In most cases, leaving an extra $\frac{1}{8}$ – $\frac{1}{4}$ " should cover it. All those increments do add up to waste, though you will recover some.

Once you've arrived at a cutting diagram, rip and crosscut, as necessary, the



A Shimming up the biscuit joiner to cut the underlayment raises the slots $\frac{1}{32}$ ". This, in turn, raises the edging, allowing you to flush-sand it with the underlayment.



B A belt sander removes the excess from the wood edging, making it flush with the medium-density fiberboard (MDF).

underlayment to size. From the waste, also rip 3"-wide buildups as long as the countertop for the front and back (see **Drawing 1**). When fastened to the underside of the underlayment, the buildups raise it sufficiently for the necessary drawer clearance you need for the cabinet.

Now, using a water-resistant glue, such as Titebond II, adhere the buildups to the bottom of the underlayment; the one at front flush with the top, the rear one set in from the back edge $\frac{1}{2}$ – $\frac{3}{4}$ " to make later scribing easier. Then strengthen the bond by screwing down the buildups with wood screws along their length.

Next, rip the edging to 1 $\frac{1}{16}$ " wide from $\frac{3}{4}$ " solid stock. For a profile that highlights the wood, such as the design we used, you'll want to employ the same species as your cabinets. Crosscut the edging to length, and sand it smooth.

To attach the edging to the underlayment, first fasten a $\frac{1}{32}$ "-thick shim of

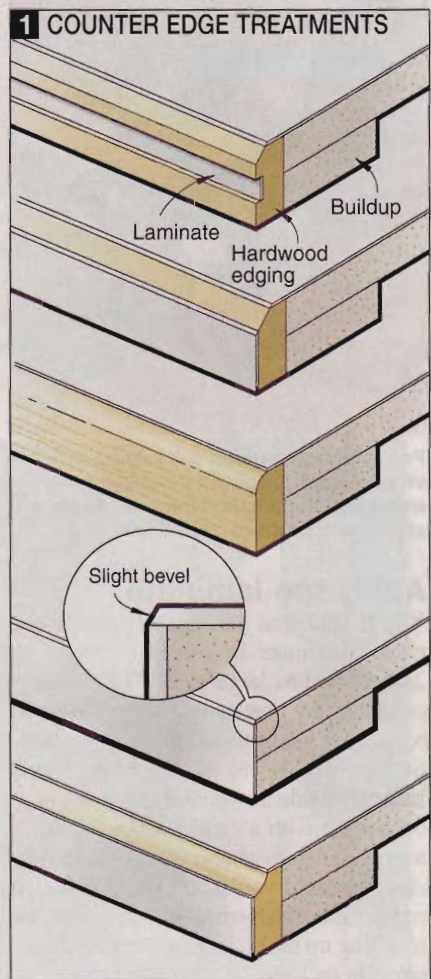

cardboard or other material to the bottom surface of your biscuit joiner's fence. This is only needed when slotting the underlayment. (If using a router and slot-cutting bit, adjust accordingly). As in **Photo A**, this raises the slots in the MDF and in the edging $\frac{1}{32}$ " to center the edging against the underlayment. Then, cut the biscuit slots in the underlayment and edging, glue (using water-resistant adhesive) and install the biscuits in the slots, and clamp the assembly until dry.

After the glue on your edging/underlayment joint has dried, use a belt sander (or random-orbit sander) outfitted with 80- to 100-grit abrasive to remove the $\frac{1}{32}$ " edging excess, as shown in **Photo B**. Sand it flush with the top of the underlayment. Be sure to keep the sander moving so you don't sand too deeply in any spot and create what would otherwise create voids between the laminate and the underlayment.



Polyurethane glue on the edging provides a waterproof bond between the wood and the plastic laminate. Apply it after the contact cement dries.

Apply the laminate

You'll find that you usually can order plastic laminate in pieces as small as 24x24" and as large as 60x144". When ordering, get one or two large sheets to reduce seams. And rough-cut your plastic laminate $\frac{3}{8}$ " to $\frac{3}{4}$ " oversize. Use a laminate blade on your table saw to cut it, or score it with a carbide-tipped scoring tool and snap it, as you would glass. Any chipped edges you'll take off later with a router and flush-trimming bit. But for touching up nicks, have a sharp mill bastard file on hand.

Then, vacuum the dust off the underlayment and edging before applying the contact cement, which you have to roll on the underlayment as well as the back of the laminate. But before you do, mask off the solid wood edging. Apply the contact cement, let it set up, then apply a polyurethane glue to the edging as in **Photo C**. It resists moisture better.

When the contact cement becomes dry to the touch, lay down some metal strips or scraps of laminate on the underlayment to help you position the plastic laminate without it prematurely bonding. When it's in position, pull out the strips. To form a butt-joint with the facing piece of laminate you'll add to the edging, let the top laminate extend over the edging about $\frac{1}{16}$ ". (Other edge treatments may require different positioning.) Then, starting at the center and working outward from there, roll or tap the entire laminate surface with a nonmarring deadblow hammer and a block of wood



A caul of scrap wood ensures even clamp pressure on the laminate adhered to the wood edging.

to ensure bonding. With a piece of scrap wood as a caul, apply clamps to the plastic laminate on the wood edging, as shown in **Photo D**.

After the glue has dried, remove the clamps. Clean up the edging face, apply polyurethane glue to it (again, for water protection), and add a facing piece of laminate that you've cut to size (slightly wider). Make sure that it butts tightly against the top surface laminate, then clamp in place.

Leave the clamps in place overnight to be sure the glue has cured. Then, remove the clamps, and with a piloted $\frac{1}{2}$ " flush trimming bit in your handheld router, trim off the excess laminate at the top and bottom of the wood edging, as in **Photo E**. If the edge treatment you've selected calls for exposed wood, now's



Scribing with a pencil transfers wall irregularities directly to masking tape on the countertop.



A piloted $\frac{1}{2}$ " flush trimming bit in a handheld router smoothly removes extra laminate from the edge joint.

the time to rout the reveal. For our edge treatment, we cut the $\frac{3}{8}$ " reveal with a 45° chamfer bit chucked into a handheld router, as you can see in **Photo F**.

To finish the countertop, we fine sanded the edge's wood reveal. Next, we taped off the plastic laminate, then sprayed on three coats of Minwax Helmsman spar polyurethane varnish. (To completely seal the cherry, we applied it to the exposed back and bottom of the edging as well.)

Scribe to fit the wall

With the cabinets leveled front and back and side to side, put down a strip of masking tape on the countertop at the back edge. Then lay the countertop in place on the cabinet, pushing it tightly against the back wall. If the countertop is



Sanding to the scribe line at a slight angle provides a tighter fit to the wall because the sharp edge cuts into it.



F To expose the cherry in the edging, cut the reveal with a 45° chamfer bit chucked into a handheld router.

going into a corner, add a strip of masking tape to the end, too. (*Note: If you plan on adding a backsplash after the countertop is installed, and the gap between it and the wall is under 1/8", you may not want to scribe. Instead, just apply a silicone sealer under the backsplash material.*)

To scribe, hold a pencil flat against the wall at one of the back corners of the countertop and rest the tip on the tape, as shown in **Photo G**. As you move the pencil along the wall, any irregularities will show up on the tape as an uneven line.

Although there are several ways to remove the material indicated by the scribe line, the fastest way is with a belt sander and 80-grit abrasive. Hold the sander at a slight angle, as shown in **Photo H**. This creates a bevel along the scribe line that allows only the top of the



I Fastening the countertop with wood screws through the cabinet spreaders allows later replacement if necessary.

How to make and install a simple backsplash

As the name implies, a backsplash protects the back wall behind the countertop from splashes and spills. It can be made of any water- and stain-resistant material and as plain or decorative as you like. Here's how to make a simple backsplash to match a plastic laminate countertop, as shown in the cutaway drawing at *right*.

Rip 3/4" water-resistant, medium-density fiberboard (MDF) to 3 1/2–4" wide (the width dependent on available clearance under windows, etc.), and crosscut to countertop length. From 1/8" tempered hardboard, rip a 1" strip and cut it to length. Adhere the strip to the top edge of the MDF with water-resistant glue, positioning the 1/4" excess to the back and clamp. When the adhesive has cured, remove the clamps.

Now, from plastic laminate that matches the countertop, rip a strip 1/4" wider and longer than the backsplash. From the same material rip another strip about 1/4" wider and longer than the tempered hardboard strip. Then, clean the backsplash face of any dust or glue, spread contact cement on it and its mating laminate, and let dry. When dry, carefully bond the laminate to the backsplash, leaving an overhang at all edges. Roll the laminate with a roller or tap down with a block of wood and a deadblow hammer. After the adhesive has cured, flush-trim with a handheld router. Now repeat the process with the top strip, but use a bevel trim bit at the top front edge.

You're then ready to scribe the top back edge of the backsplash to the wall. With the backsplash in place, this is done in the same way as with a new countertop.

Install the backsplash by applying spots of construction adhesive to the wall and a wide bead of silicone sealer to the countertop. Set in the backsplash and press it in place against the wall and into the silicone. You can rig scrapwood clamped to the front of the countertop to hold the backsplash in place until the adhesives cure. Be sure, though, not to apply pressure only at the base of the backsplash. That will force the top of it away from the wall.

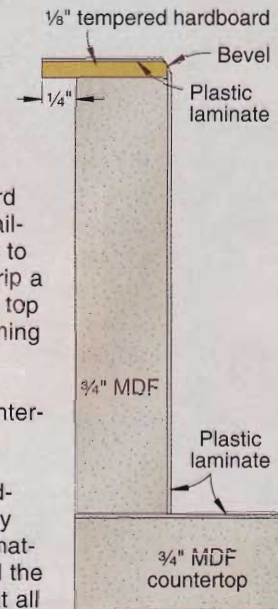

countertop to touch the wall. There's a two-fold reason for this.

First, by creating a bevel, only its leading edge follows the wall at the exact spot that the scribe line was taken. If the scribe line was sanded without a bevel, there would be a full 3/4" of thickness against the wall. And any imperfections in that 1 1/2" below the scribe line would prevent the countertop from fitting flush against the wall. A second reason is that the bevel permits a tight countertop/wall joint in new construction where drywall has been used. A few taps with a deadblow hammer along the front edge of the countertop will actually drive the back-edge bevel slightly into the wall.

Install the countertop

Installation is the easiest aspect of building a new countertop. To make later removal for possible replacement a sim-

ple chore, fasten the countertop to the cabinet(s) with 1 1/2" wood screws. First, though, make sure that the countertop is lined up with the cabinet front and it fits tightly to the back wall.

Screw directly through the spreaders at the front and back of the cabinet and into the countertop buildups, as shown in **Photo I**. If you used medium-density fiberboard, you won't have to drill pilot holes first. But solid wood or plywood will require them.

A cutout for a sink can be done with a jigsaw prior to countertop installation or after. But first be sure to carefully measure the sink and mark the laminate where it will go. Once it's out you can't put it back in! 🛠️

Written by Peter J. Stephano with Doug Guyer
Illustrations: Kim Downing, Lorna Johnson
Photographs: Baldwin Photography;
King Au/Studio Au

Cast a favorable light on your curios with this pleasing design

adaptable display cabinet

Is there one wall cabinet that meets all needs? If so, you may be looking at it. We designed this one with a cove top, halogen lights, and towel bar so it fits right into a kitchen or bathroom. But, leave off the towel bar, and this beauty looks perfect in a living, family, or dining room. You could even skip the lights, cove top, and radiused sides, and replace the glass with wood panels, to make utility cabinets for the laundry room or shop.



1 EXPLODED VIEW

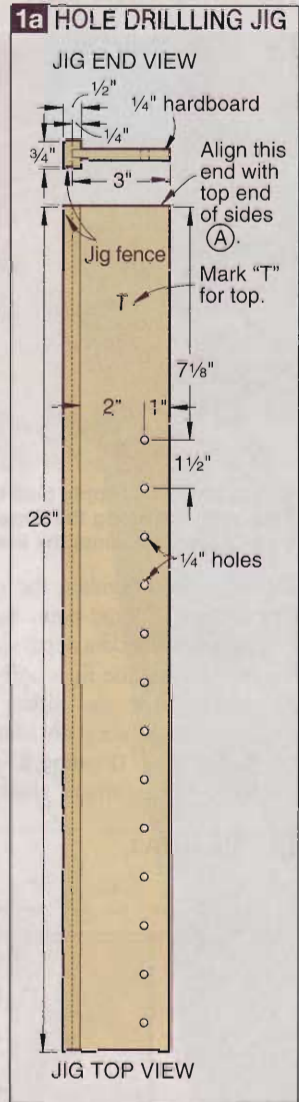
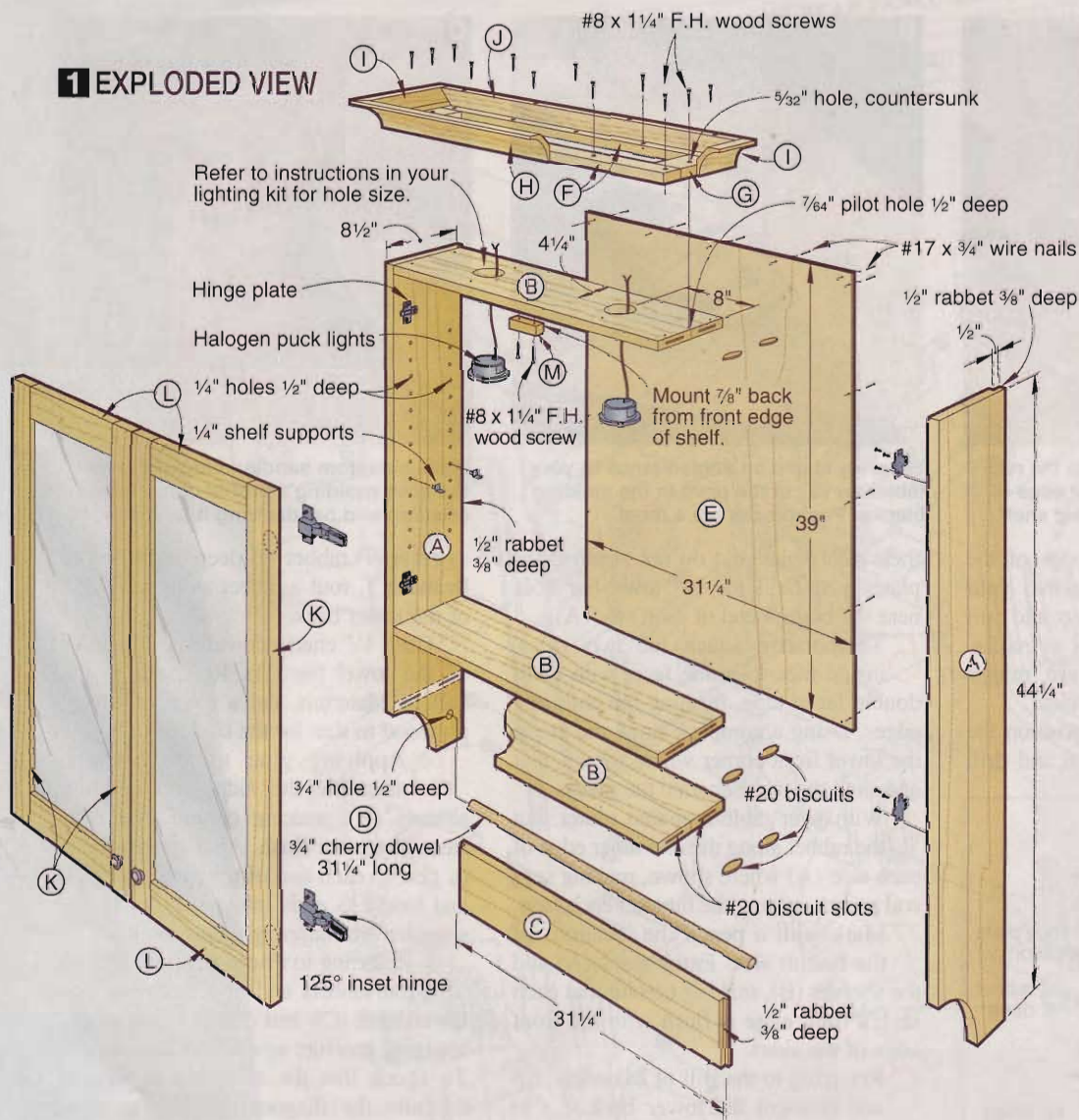

Start with the sides and shelves

1 Referring to the Bill of Materials, edge-join cherry lumber into slightly oversized blanks for the sides (A) and the shelves (B). Rip and crosscut these parts to size.

2 Following the installation instructions furnished with your halogen lights, use a Forstner bit or circle cutter in your drill press to make suitably sized holes into one of the shelves (B), where shown on **Drawing 1**.

3 Construct the jig shown in **Drawing 1a** to help you accurately drill the shelf-support holes into the inside faces of the sides (A). To use the jig, align its top end with the upper end of each side, and butt

shop TIP

A cardboard prototype helps with planning

Before we cut wood, we often build a full-scale prototype, using corrugated cardboard (available free from appliance stores) and clear packing tape. This technique lets us better visualize the project's proportions and scale in its intended location. After we hung this example on the wall for a few days, we trimmed several inches off its depth and rehung it a bit lower on the wall. Those changes produced the look we wanted, so we went ahead with construction. By the way, you don't have to make your cuts with a utility knife and straightedge. Use your tablesaw or bandsaw for fast and easy results.



display cabinet



A To fasten part C, apply glue to the rabbets and also along the upper edge of part C. Clamp against the lower shelf.

the jig's fence against the edge of the side. Chuck a brad-point bit into your hand-held drill, add a depth stop, and drill the holes using the jig's holes as guides. Remember that the sides are mirror images of each other, not identical.

4 Referring to **Drawing 2**, position the hinge plates where shown and drill

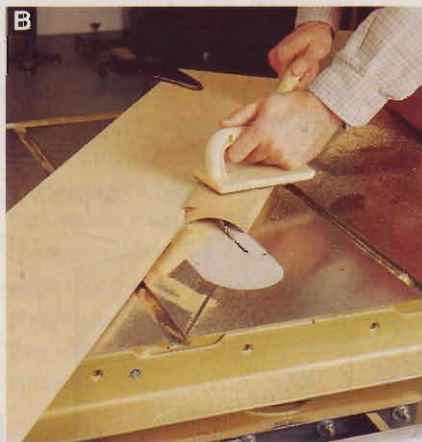

B Securely clamp an angled fence to your tablesaw to cut the cove in the molding blanks. Pushblocks are a must.

their pilot holes, but do not attach these plates yet. Drill the $\frac{3}{4}$ " towel-bar hole near the bottom end of each side (A).

5 Temporarily attach the two sides, inside face-to-inside face, with cloth double-faced tape, flushing the ends and edges. Using a compass, draw the arc at the lower front corner where shown. Cut and sand the arc. Separate the pieces.

6 With your table-mounted router, cut the rabbet along the rear inner edge of each side (A) where shown, making several passes, raising the bit after each pass.

7 Mark with a pencil the locations of the biscuit slots in the sides (A) and the shelves (B), making certain that each shelf's front edge is flush with the front edge of the sides.

8 Referring to the Bill of Materials, rip and crosscut the lower back (C) to size. Adjust the fence on your router table

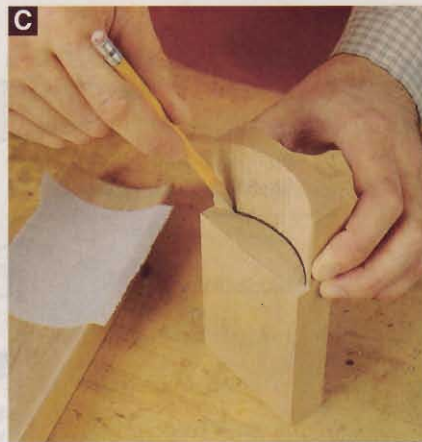

C Make a custom sanding block by tracing the cove molding's profile onto a piece of scrap and bandsawing it to shape.

to cut a $\frac{3}{8}$ " rabbet $\frac{1}{2}$ " deep. Referring to **Drawing 1**, rout a rabbet along each end of the lower back.

9 Cut a $\frac{3}{4}$ " cherry dowel $31\frac{1}{4}$ " long for the towel bar (D). Referring to the Bill of Materials, cut a piece of cherry plywood to size for the back (E).

10 Applying glue to the biscuits, assemble the sides (A) and the shelves (B), making certain that their front edges are flush. Also apply a drop of glue to each end of the towel bar (D), and insert its ends into the holes in the sides before clamping the assembly.

11 Referring to **Photo A**, apply glue to the rabbets and upper edge of the lower back (C), and clamp it into place, applying pressure against the lower shelf. To check that the assembly is square, measure the diagonals of the carcass. When the measurements are equal, the

2 SIDE DETAIL

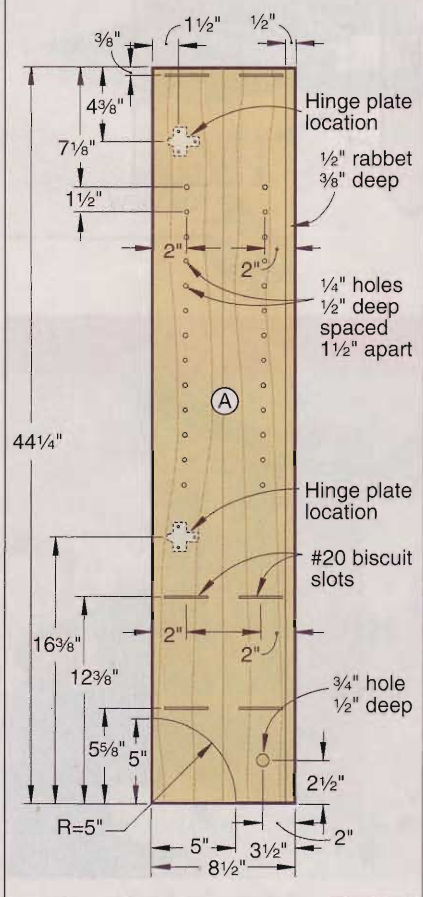

3 TOP ASSEMBLY

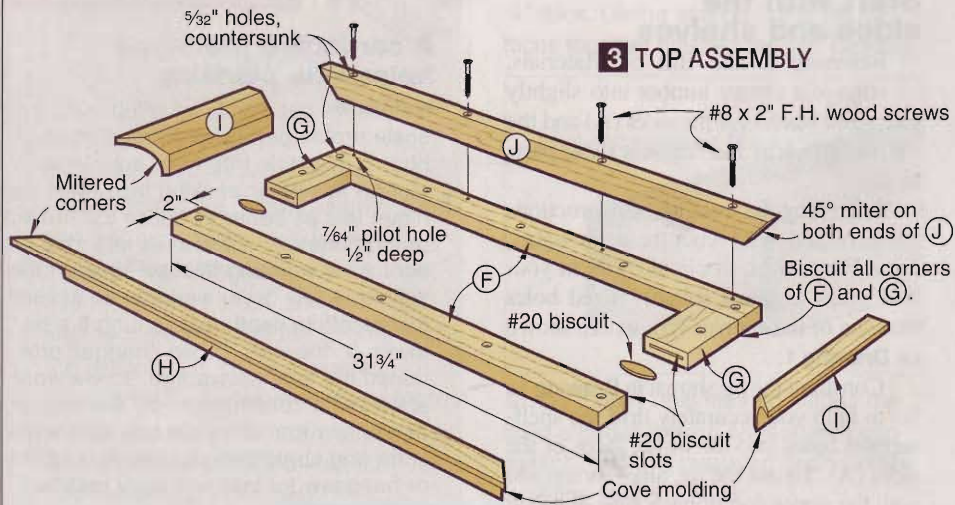

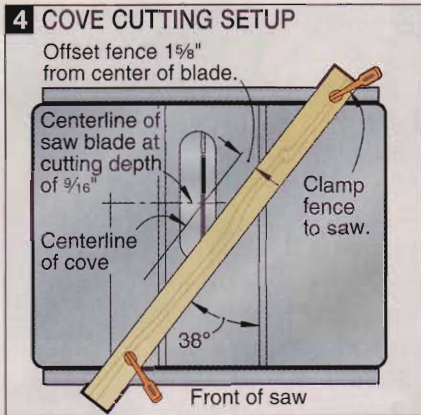

assembly is square. Remove any glue squeeze-out, and let dry overnight.

Build a sturdy top assembly

1 Referring to the Bill of Materials, rip and crosscut the front/back fillers (F), and the end fillers (G) to size.

2 Cut biscuit slots into the fillers (F, G), where shown on **Drawing 3**. Glue and clamp the assembly.

3 Unclamp when the glue is dry, and drill countersunk 5/32" screw-shank holes through the assembly where shown. Position the rear edge of the assembly flush with the rear edge of the top shelf, and center it side to side. Holding the assembly in position, use the holes as guides to drill 7/64" pilot holes 1/2" deep into the top shelf. Do not attach the assembly to the top shelf at this time.

Cut the cove molding

1 From 1"-thick cherry, rip blanks 3 1/4" wide for the front molding (H) and the end moldings (I). You'll cut these pieces to final length later, but for now, crosscut one blank to 40" and two at 12".

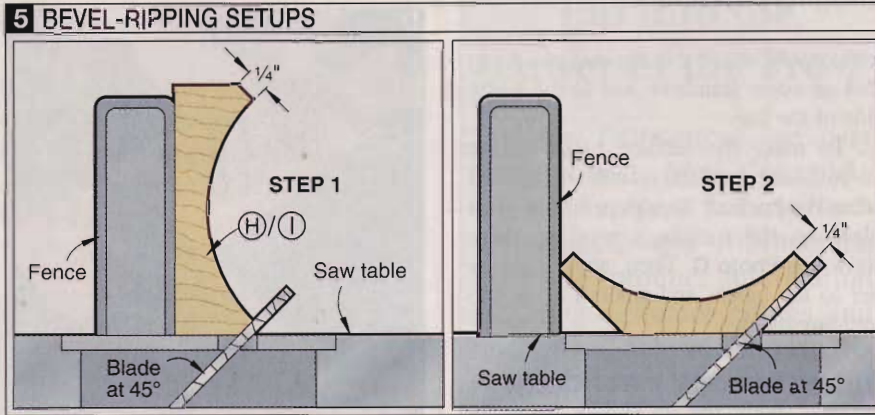

2 Put a blade with 60 to 80 sharp carbide teeth into your tablesaw, then raise the blade so 5/16" projects above the table. Referring to **Drawing 4**, clamp an angled fence to your tablesaw where shown. Make all measurements from the blade in its raised position. Before you lower the blade to make the first cut, make a note of the position of the handwheel's handle. Then count the revolutions of the handwheel as you lower the blade. This procedure eliminates guesswork as you raise the blade toward its final position.

3 Form the cove by making a series of cuts, raising the blade in 1/8" increments. Referring to **Photo B**, use push-blocks to move the molding blanks over the blade. Keep the edge of the blank against the fence, and advance it with both consistent downward pressure and steady forward motion. To reduce blade marks in the final pass, remove 1/16" or less with that cut, and make the pass non-stop at a slow but steady rate.

4 Referring to **Drawing 5**, make four cuts on each molding blank to complete its profile. Make two cuts with the

Step 1 setup, then change to the Step 2 setup for the final two cuts.

5 Crosscut a 1 1/2" piece from one of the front molding blanks as a pattern to make a sanding block. As in **Photo C**, trace the shape of the pattern onto the end of a 1x3 1/4x4 1/2" scrapwood block. To safely hold the block on end while band-sawing, we used double-faced tape to

bill of materials

display cabinet

Part	FINISHED SIZE			Matl.	Qty.
	T	W	L		
A* sides	3/4"	8 1/2"	44 1/4"	EC	2
B* shelves	3/4"	8"	30 1/2"	EC	3
C lower back	3/4"	5 1/4"	31 1/4"	C	1
D towel bar	3/4" diameter		31 1/4"	CD	1
E back	1/4"	31 1/4"	39"	CP	1
F front/back fillers	3/4"	2"	31 3/4"	C	2
G end fillers	3/4"	2 3/4"	4 5/16"	C	2
H* front molding	1"	3 1/4"	36 1/4"	C	1
I* end moldings	1"	3 1/4"	10 5/8"	C	2
J top back rail	3/4"	1 1/2"	34"	C	1
K door stiles	3/4"	2 1/4"	30 1/2"	C	4
L door rails	3/4"	2 1/4"	13 1/16"	C	4
M doorstop	3/4"	3/4"	2"	C	1
N* side stops	1/4"	3/8"	28 3/4"	C	4
O* top/bottom stops	1/4"	3/8"	11 5/16"	C	4

* Parts initially cut oversize.

Materials Key: EC—edge-glued cherry, C—cherry, CD—cherry plywood.

Supplies: #8x2" flathead wood screws, #8x1 1/4" flat-head wood screws, #20 plate-joiner biscuits, #17x9/4" wire nails, #17x3/4" wire brads, two-lamp halogen lighting kit, 1" knobs Amerock no. BP-1590-FB (2), 1/8" glass, 1/4" glass, glue, finish.

Buying Guide

3/4x36" cherry dowel, no. 50B04, \$3.50; Blum 125° inset clip hinges with mounting plates, no. 02S60, \$8.99/pair (2 pair); self-adhesive door bumpers, no. 02S82, \$5.50/sheet of 56; glass shelf supports, no. 27120, \$4.50/bag of 25. Order from Woodcraft, 560 Airport Industrial Park, Parkersburg, WV 26102, or call 800/225-1153.

cutting diagram

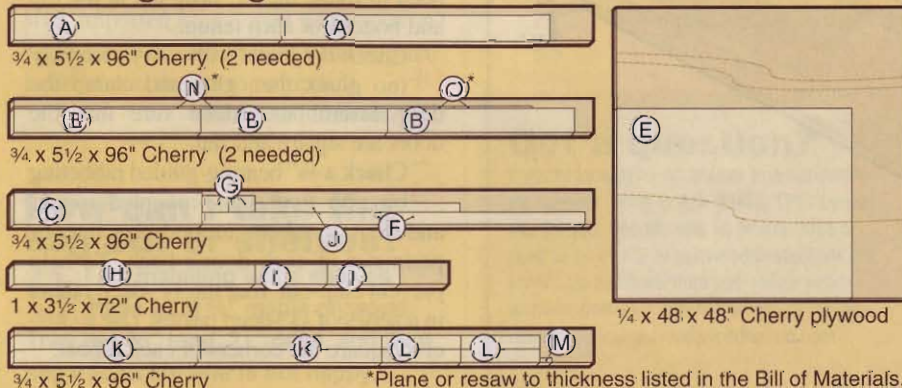

display cabinet

temporarily attach it to the end of a scrap 2x4 on edge. Bandsaw just to the waste side of the line.

6 To make the sanding block fit the molding perfectly, rub it against adhesive-backed sandpaper that you place on the molding's profile, where shown in **Photo C**. Then, apply sandpaper to the block, and smooth all of the molding blanks.

Miter the cove molding

1 First, build the jig shown below in **Drawing 6**. After screwing the jig to your table saw's miter gauge, angle the setup to miter an end of one of the blanks for the end moldings (I), as shown in **Photo D**.

Note: Photo D shows the mitering of the front molding (H); Use the same process for both parts H and I.

2 The molding is placed upside down in the jig. To avoid confusion, put a pencil mark on each blank to clearly identify the molding's upper edge. Let the square-cut end of the molding blank run long for now. Rotate your miter gauge to the opposite 45° setting, and miter-cut the other end molding (I).

3 Miter-cut one end of the front molding (H), then dry-clamp it and one of the end moldings (I) with a mating miter to the top assembly (F, G). After adjusting the pieces for a tight miter joint, use a sharp knife to mark the cutline for the opposite miter on the front molding, as shown in **Photo E**. Make the cut, then again clamp the front molding against the top assembly. Add the other end molding



The jig cradles the cove molding, preventing it from rocking while you make the miter cuts. Screw the jig to your table saw's miter gauge.

to check the joint. If you need to make adjustments, you'll still have enough length on both end moldings to recut the joints. When you're satisfied, mark the square-cut ends of the end moldings, and cut them to length.

4 Glue and clamp the front and end moldings (H, I) to the top assembly (F, G). You can use masking tape to hold the joints closed while the glue dries. We didn't use any fasteners, but you could add a few #17x1" wire brads to prevent the pieces from slipping.

5 Referring to the Bill of Materials and **Drawing 3**, cut the top back rail (J) to fit onto the top assembly. Drill the shank and pilot holes for the mounting screws, then glue and screw this part into position.

6 Position the top assembly on the carcase assembly, and drive screws



Want to know how pros get nearly invisible miters? Just use a sharp knife to transfer the cove molding cutline from the top assembly.

though the mounting holes. Make certain that the rear edge of the assembly is flush with the rear edge of the top shelf and is centered side to side.

Make a pair of glass-paneled doors

1 Referring to the Bill of Materials, rip and crosscut the door stiles (K) and the door rails (L) to size.

2 Chuck a 1/4" Forstner bit into your drill press, and drill a series of overlapping holes to form the mortises in the stiles (K), where shown in **Drawing 7a**. Use a chisel to smooth the walls of the mortises and to square the corners.

3 To set up for cutting the tenons, screw an 18"-long 1x4 extension to your table saw's miter gauge. Then, put a 3/4" dado head into your table saw, and raise it for a 1/4"-deep cut. See **Drawing 7b**. Clamp a stopblock to the miter-gauge extension, and make test cuts in scrap lumber to check the thickness of the tenon in the mortise. After you cut the cheeks of all the tenons, raise the dado head to make the 3/8"-deep cut at the top and bottom of each tenon.

4 Check the joints with a dry assembly (no glue), then glue and clamp the door assemblies. Make sure that the doors are square and flat.

5 Chuck a 3/8" bearing-guided rabbeting bit into your table-mounted router, and rout a rabbet around the interior perimeter of each door's back. To help prevent chip-out, rout the 3/8"-deep rabbet in a series of 1/8"-deep passes. Use a chisel to square the corners of each rabbet.

6 MITER JIG

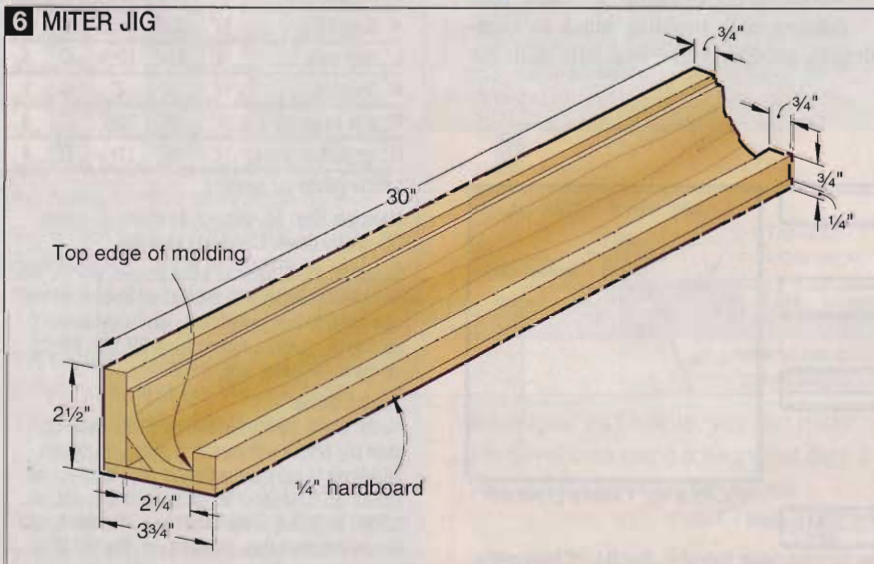

7a MORTISE DETAIL

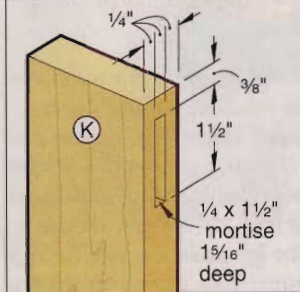

7 DOOR ASSEMBLY

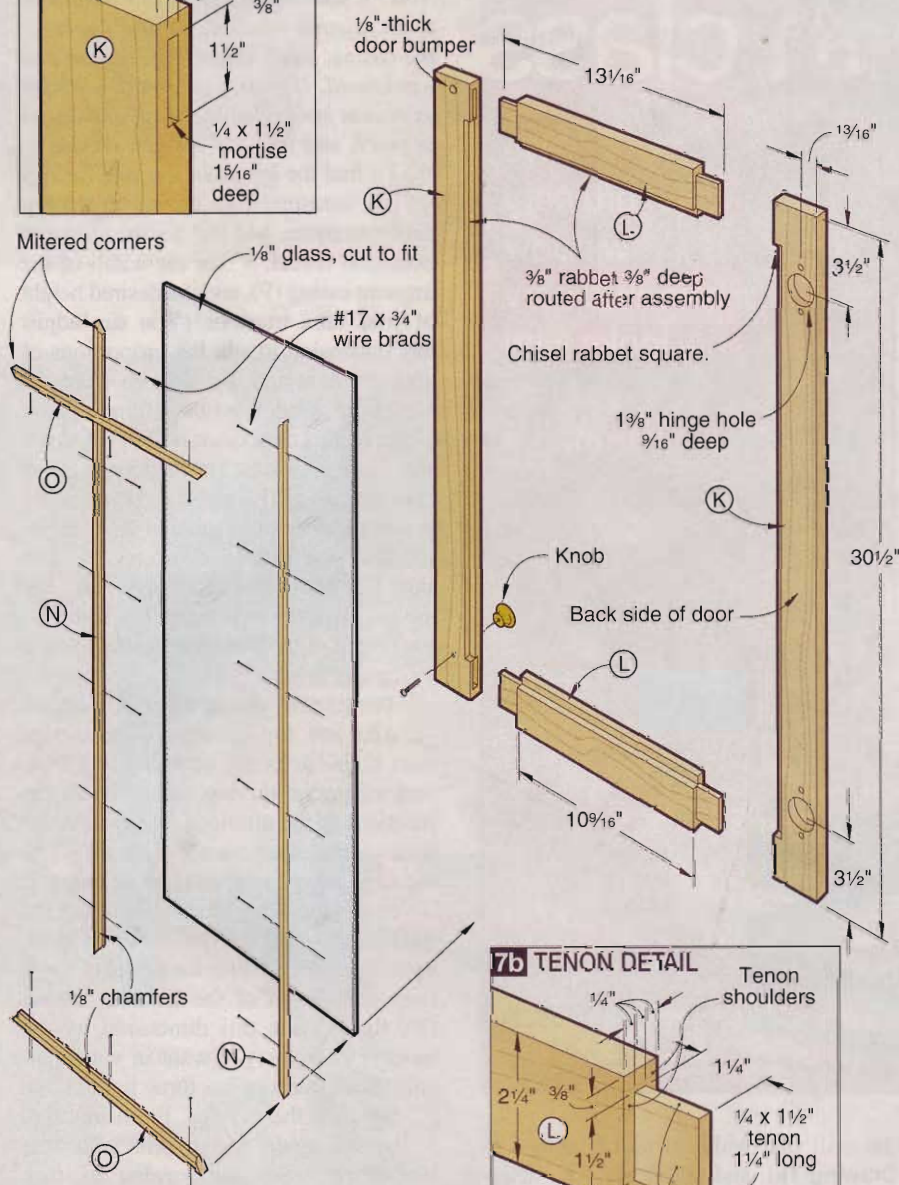

7b TENON DETAIL

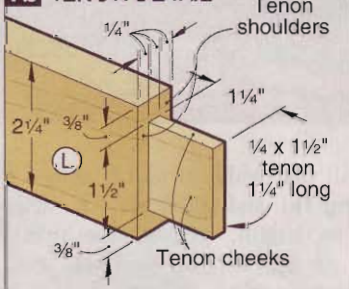

- 6 Rip and crosscut the doorstop (M) to size, then drill two $\frac{5}{32}$ " countersunk shank holes through it. Referring to **Drawing 1**, screw the doorstop to the underside of the top shelf (B), centering it.
- 7 Referring to **Drawing 7**, drill the hinge-cup holes, using a 35mm or $1\frac{3}{8}$ " Forstner bit, following the hinge maker's instructions. Install the hinges, test-fit the doors, and remove the hinges.
- 8 Take the doors to a glass shop and have $\frac{1}{8}$ "-thick glass cut $\frac{1}{8}$ " undersized for the openings.

- 9 Rip and crosscut four $\frac{1}{4} \times \frac{3}{8} \times 30$ " blanks for the side stops (N) and four $\frac{1}{4} \times \frac{3}{8} \times 13$ " blanks for the top/bottom stops (O). Chuck a chamfering bit into your table-mounted router, and rout a $\frac{1}{8}$ " chamfer along one edge of each blank. For safety, use featherboards and push-blocks when routing.
- 10 Miter the side stops (N) and the top/bottom stops (O) to fit the door openings. Set these parts aside for now.

shop TIP

Make your cabinet hug the wall

You'll notice that we cut a $\frac{1}{2}$ "-deep rabbet for holding a $\frac{1}{4}$ "-thick back. This time-honored cabinetmaker's trick eliminates contact between the back and the wall. Instead, the cabinet touches only around its perimeter, allowing a closer fit to less-than-perfect walls.

Finish before final assembly

- 1 Apply your choice of finish to all of the wood parts. We chose an oil/urethane wipe-on finish called Arm-R-Seal, manufactured by General Finishes. (For dealer information, call 800/783-6050, or go to www.generalfinishes.com.) We used a cloth to apply four coats of the satin finish. Between coats, we sanded with 600-grit wet/dry sandpaper, and removed the dust with a tack cloth.
- 2 Fasten the back (E) to the carcass assembly with #17x $\frac{3}{4}$ " wire nails.
- 3 Hold the glass in place by using #17x $\frac{3}{4}$ " wire brads to fasten the side stops (N) and the top/bottom stops (O) to the doors.
- 4 Referring to **Drawing 1**, drill centered mounting holes for the doorknobs, and attach them. (We used 1" Amerock knobs, no. BP-1590-FB. Amerock hardware is available at many home centers and hardware stores. To locate a dealer, visit the company's Web Site at www.amerock.com.) Reattach the hinges, and mount the doors.
- 5 Have $\frac{1}{4}$ "-thick glass shelves cut to size, and ask to have the edges seamed (sanded to remove sharpness). Don't forget to allow for the thickness of the inset doors when you measure for the shelves. Our shelves measure $7 \times 30\frac{1}{4}$ ".
- 6 Install the lights, following the manufacturer's instructions.
- 7 Hang the cabinet on your wall by drilling holes and driving two $\frac{1}{4} \times 3$ " lag screws through the top back rail (J) into wall studs. 🌲

Written by Robert J. Settich with Kevin Boyle
 Project design: Kevin Boyle
 Illustrations: Kim Downing; Lorna Johnson
 Photographs: Baldwin Photography;
 King Au/Studio Au

glass with class

Give
an ordinary
window
extraordinary
looks with
a false
transom



The Handcrafted Home

Our kitchen redo involved replacing two windows. Existing double-hung units were replaced with single-light casements, eliminating the meeting rails and opening up the view. To achieve a taller and narrower proportion without enlarging the existing openings, we added false opalescent-glass transoms. You can work this magic on any window in your house. Here's how.

Extend the jambs and apply a new frame

1 After the new window is in place, cut a $\frac{3}{4}$ "-thick blank for the sill (A). To determine its width, measure from the window's frame to the inside surface of

the wall (the width of part C shown in **Drawing 1a**), and add $1\frac{1}{16}$ ". To determine its length, measure the overall width of the window and add $6\frac{3}{8}$ ". Notch the sill's ends, as shown on **Drawing 1a**. Cut the 1"-wide apron (B) $1\frac{1}{2}$ " shorter than the sill. Finish-sand the sill and apron to 220 grit, and nail them in place, where shown on **Drawing 1**. Center the apron under the sill.

2 Add side and top jamb extensions (C, D) to bring the window frame flush with the surrounding wall. (We used cherry to match the new window casing.) Drill pilot and countersunk shank holes, and screw the extensions to the window frame.

Note: If you wish to apply this treatment to an existing window, carefully remove the casing, jamb extensions, apron, and windowsill. If your windows don't have extension jambs, leave the sill and apron in place, and just add the new casing.

3 To find the length of the side casings (E), measure from the sill to the top jamb extension, add $\frac{3}{16}$ " for the top jamb extension reveal, 3" for the width of the transom casing (F), and the desired height of your false transom. (You can adjust this dimension to suit the proportions of your window and the distance from the top of the window to the ceiling. In our example, this dimension is $7\frac{7}{16}$ ".) Cut the side casings to size. For the length of the transom casing (F), measure between the side jamb extensions and add $\frac{3}{8}$ " to allow for $\frac{3}{16}$ " side extension reveals on each side. Cut the transom casing to size. For the length of the top casing (G), add 6" to the length of the transom casing. Cut the top casing to size.

4 Temporarily clamp together the transom and top casings, edge-to-edge with their backs up, centering the transom casing on the top casing. Mark the locations of the mullions (H) on the transom casing, then transfer the marks to the top casing, as shown on **Drawing 2**. To determine your spacing, subtract the total width of all the mullions (we show two $\frac{3}{4}$ "-wide mullions for a total of $1\frac{1}{2}$ ") from the length of the transom casing (F), then divide this dimension by the number of lights you want in your transom. (Our transom has three lights.)

5 Separate the casings. Form mortises by drilling the casings with a Forstner bit, where shown on **Drawing 2a**, then squaring the sides with a chisel. Dry-assemble the frame face up on your workbench, and mark the biscuit locations. Plunge the biscuit slots, and glue and clamp the frame together.

6 Measure the distance between the transom casing (F) and the top casing (G), and add $1\frac{1}{2}$ ". Cut the mullions (H) to this length. Form rabbets in the ends so the mullions fit snugly between the casings, and round their ends to fit the mortises. With the mullions in place, drill pilot and countersunk shank holes. Remove the mullions, apply glue to the mortises, and screw the mullions in place.

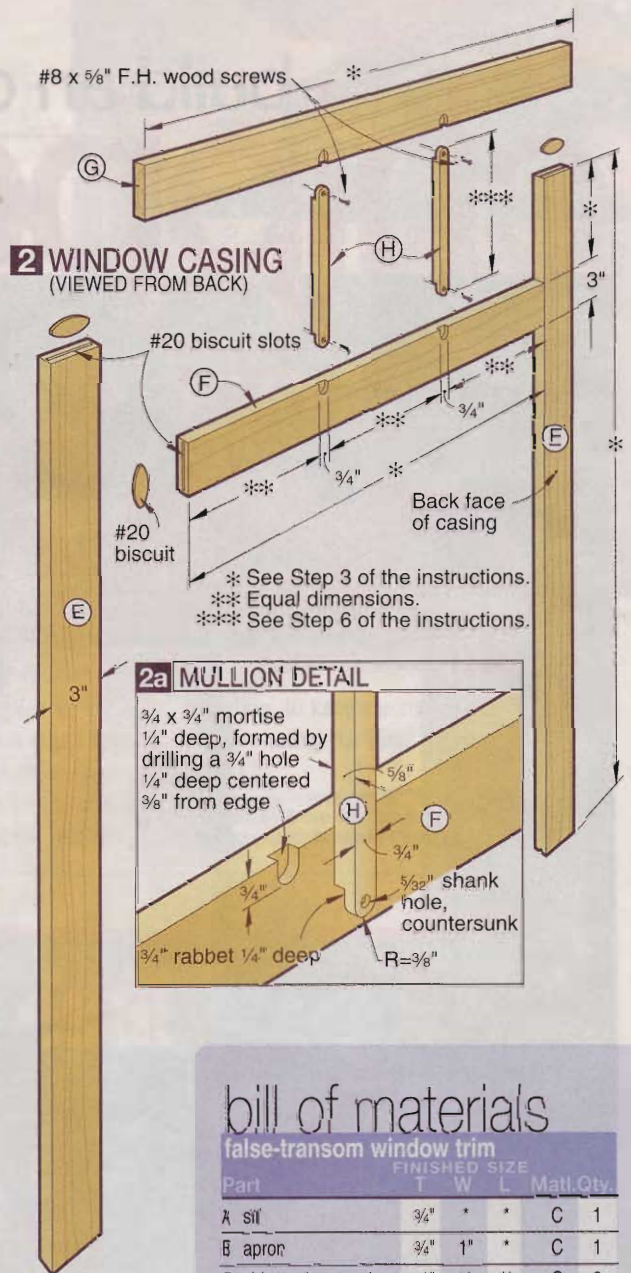
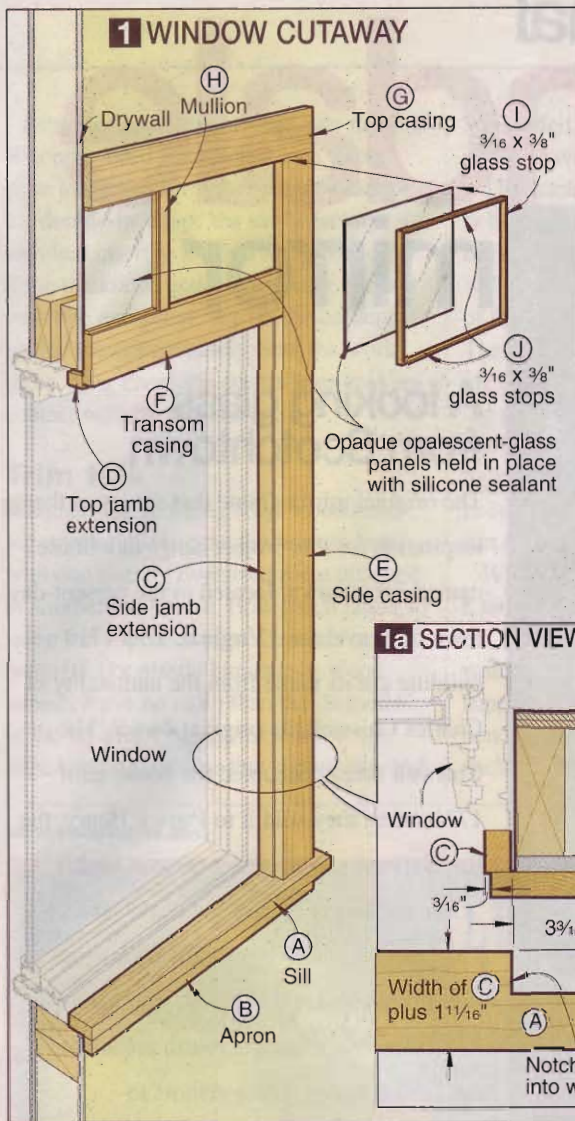

7 Resaw and plane stock for the vertical glass stops (I) and horizontal glass stops (J). Fit the vertical stops first, then cut the horizontal stops to fit between the vertical ones. Glue and clamp the stops in place, setting them $\frac{3}{16}$ " from the back faces of the casings and mullions.

8 Finish-sand the frame assembly to 220 grit. Select an opalescent glass and have panes cut to fit the transom openings. (For opalescent glass, look in your local Yellow Pages under Glass-Stained, Leaded, or check craft supply stores.) Insert the panes from the rear and secure them with a few dabs of silicone sealant.

9 With the silicone cured, stand the frame on the sill, check that the side

jamb extension reveals are equal, and nail the frame in place. Nail to both the jamb extensions and the wall framing. Fill the nail holes in the sill, apron, and frame. When the filler dries, sand it smooth.

10 Mask the window, the surrounding wall and the opalescent-glass panes. Apply two coats of clear finish, lightly sanding with 220-grit sandpaper between coats. We brushed on Minwax gloss polyurethane for the first coat, then, to eliminate brush marks, finished up with a coat of Minwax satin polyurethane from a spray can. 🐜

Written by **Jan Hale Sve c** with **Erw Roberts**
 Project design: **James R. Downing**
 Illustrations: **Kim Downing; Lorna Johnson**
 Photograph: **King Au/Studio Au**

bill of materials

Part	FINISHED SIZE			Matl. Qty.
	T	W	L	
A sill	$\frac{3}{4}$ "	*	*	C 1
B apron	$\frac{3}{4}$ "	1"	*	C 1
C side jamb extensions	$\frac{3}{4}$ "	**	**	C 2
D top jamb extension	$\frac{3}{4}$ "	**	**	C 1
E side casings	$\frac{3}{4}$ "	3"	***	C 2
F transom casing	$\frac{3}{4}$ "	3"	***	C 1
G top casing	$\frac{3}{4}$ "	3"	***	C 1
H mullion	$\frac{5}{8}$ "	$\frac{3}{4}$ "	†	C ††
I vertical stop	$\frac{3}{16}$ "	$\frac{3}{8}$ "	†††	C ††
J horizontal stop	$\frac{3}{16}$ "	$\frac{3}{8}$ "	††	C ††

* See Step 1 of the instructions.

** See Step 2 of the instructions.

*** See Step 3 of the instructions.

† See Step 6 of the instructions.

†† Depends on the number of lights in the transom. See Steps 4 and 7.

††† See Step 7 of the instructions.

Material Key: C—cherry.

Supplies: #20 biscuits (4), #8x $\frac{5}{8}$ " flathead wood screws, finish nails, glue, finish, opalescent glass.

build an original chippendale mirror



A looking glass from Scotchtown

The original mirror frame that serves as the inspiration for this project hangs in a house named Scotchtown, located in the present-day town of Beaverdam, Virginia. This 1719 building got its name from the nationality of Charles Chiswell, its original owner. The Chiswell family occupied the house until 1771, when they sold it to Patrick Henry, the Revolutionary War patriot famous for his "Give me liberty or give me death" speech. The house was also briefly the childhood home of a girl named Dolley, who later married James Madison, the fourth president of the United States. Some visitors to Scotchtown claim to have seen Dolley Madison's image in the original mirror. While we can't promise any paranormal experience with the reproduction you build, we can guarantee that this project will reflect your careful craftsmanship.

Scotchtown is presently a museum operated by the Association for the Preservation of Virginia Antiquities. You can visit Scotchtown at 16120 Chiswell Lane, Beaverdam, VA 23015, or find more information at the Web site www.apva.org.



Make the molding

1 To make the built-up frame molding shown in **Drawing 1**, rip and crosscut four pieces of stock $\frac{5}{16} \times \frac{1}{2} \times 15"$ for the inner profile, four pieces $\frac{1}{4} \times \frac{5}{8} \times 15"$ for the center profile, and four pieces $\frac{1}{16} \times \frac{3}{4} \times 15"$ for the outer profile.

Note: For safe and consistent results, use featherboards to hold the profile stock against the fence and table during all of the cutting and routing steps.

2 Now, to form the built-up frame profiles, follow Steps 1–4 of the six-step sequence shown in **Drawing 2**. Finish-sand the individual profiles. Glue and clamp together four sets of inner, center, and outer profiles, as shown in **Drawing 1**, keeping their backs flush. To minimize squeeze-out, use glue sparingly. Proceed with Steps 5 and 6 to complete

the blanks for the frame stiles (A) and frame rails (B).

Assemble the built-up molded frame

1 Referring to the Bill of Materials, miter the frame stiles and rails (A, B) to size. We cut the miters with the table-saw, screwing an auxiliary face to the miter gauge to minimize tearout where the blade exits the wood.

Use glue and a band clamp to assemble the frame. Make certain that the frame is square and flat.

Note: Tighten the band clamp just enough to pull the joints together. Excessive pressure weakens the joints by squeezing out nearly all the glue. In addition, you risk denting the corners or twisting the frame.

1 BUILT-UP MOLDING

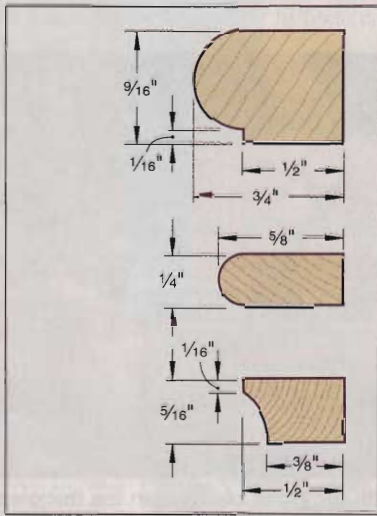
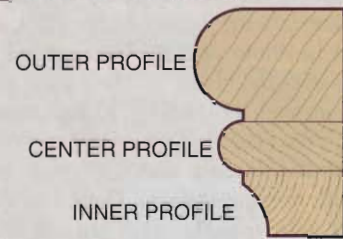

2 FORMING THE BUILT-UP MOLDING

<p>STEP 1 Rout a partial $\frac{1}{4}"$ cove along front edge of inner frame stock.</p>	<p>STEP 2 Rout $\frac{1}{8}"$ round-overs along front edges of center frame stock.</p>	<p>STEP 3 Rout a $\frac{1}{4}"$ bead with a $\frac{1}{16}"$ shoulder along the top edge of the outer frame stock.</p>
<p>STEP 4 Turn the stock over and rout a $\frac{1}{4}"$ round-over along the bottom edge.</p>	<p>STEP 5 To form the mirror rabbet, cut a $\frac{1}{8}"$ slot $\frac{3}{8}"$ deep, $\frac{1}{8}"$ from the fence.</p>	<p>STEP 6 With the saw blade flush with the auxiliary fence, cut another $\frac{1}{8}"$ slot $\frac{3}{4}"$ deep to form a rabbet for the back.</p>

chippendale mirror

2 To cut spline slots in the frame's corners, where shown on **Drawing 3**, build the jig shown in **Drawing 4**. Clamp the frame into the jig and cut the slots, as shown in **Photo A**. After you run each corner over the blade, lift the jig off the table instead of sliding it backward through the blade.

3 Cut and plane a $\frac{1}{8} \times 1 \times 10$ " piece of stock for the splines. Then, cut the splines into triangles that are slightly oversized in width and length. Glue the

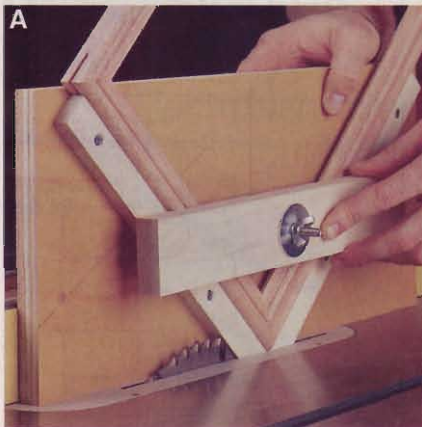

With the blade centered in the thickness of the frame, cut slots for the splines.

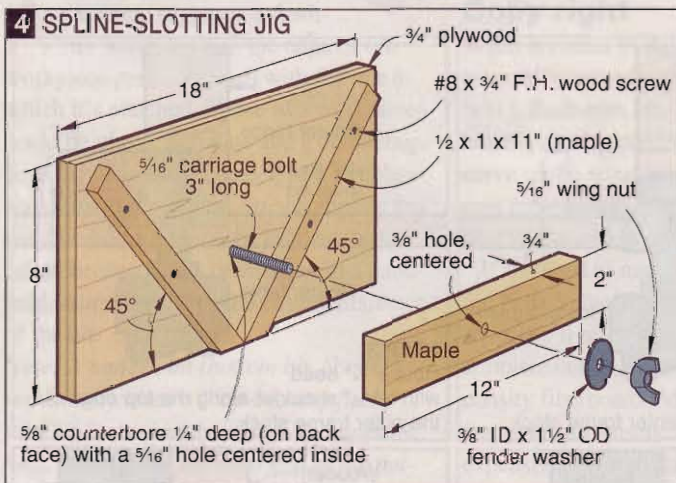

splines into position. Sand their edges flush to the frame after the glue dries.

Add the fancy trim

1 From $\frac{1}{4}$ "-thick mahogany, cut a 6×12 " blank for the crest (C), a $3\frac{1}{2} \times 12$ " blank for the bottom trim (D), and four 2×7 " blanks for the side scrolls (E).

2 Copy the patterns for the crest (C), the bottom trim (D), and the side

3 EXPLODED VIEW

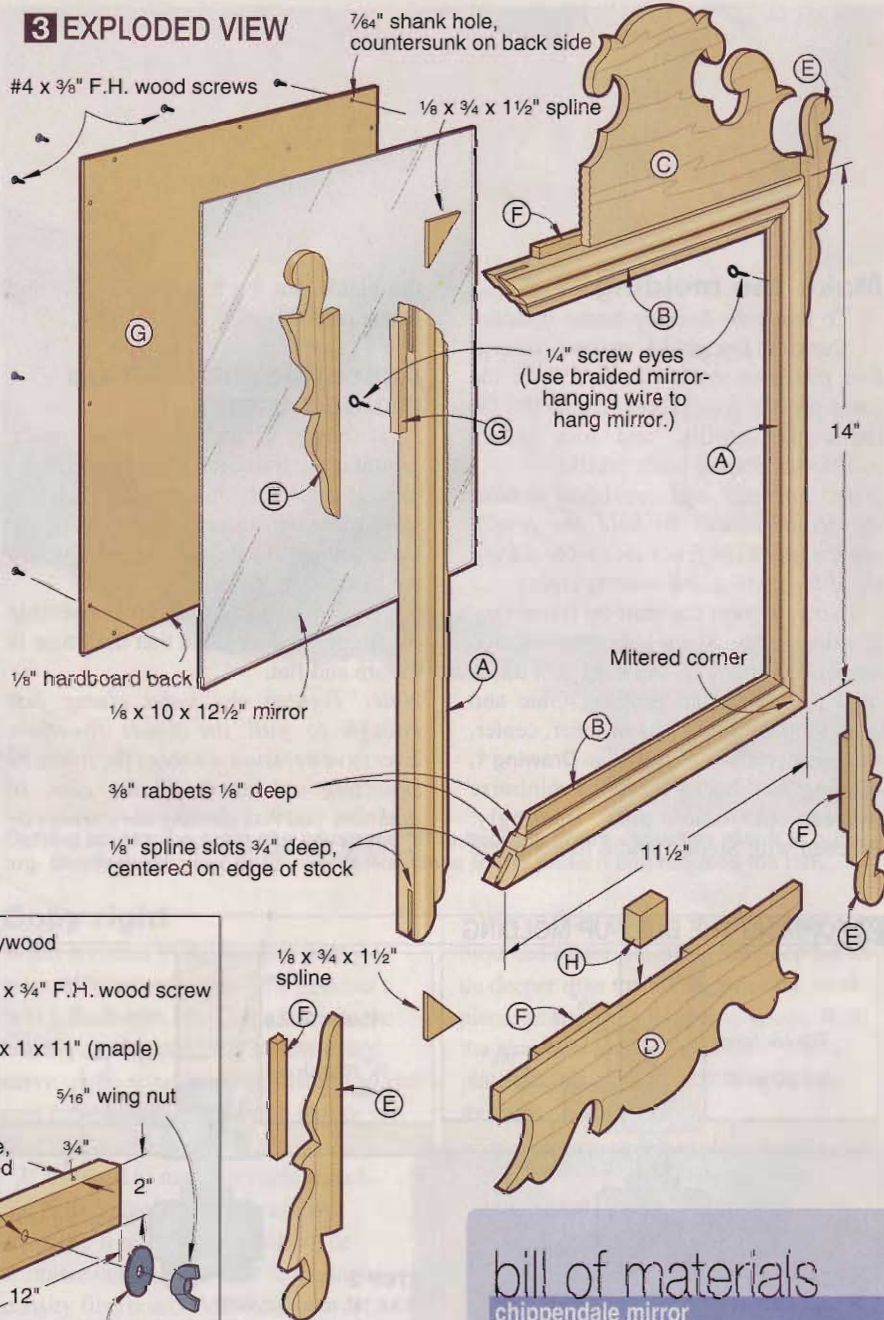

scrolls (E) on the **WOOD PATTERNS**® insert. Using spray glue or a glue stick, adhere each pattern to a piece of $\frac{1}{8}$ "-thick hardboard. Carefully align the straight edge of each pattern with a straight edge of the hardboard. Scrollsaw and sand the templates for C and D to the pattern lines. Don't cut the template for part E at this time.

3 Referring to **Photo B**, use the half templates to trace the crest (C) and

bill of materials

Part	FINISHED SIZE			Matl.	Qty.
	T	W	L		
A* frame stiles	$\frac{3}{4}$ "	$1\frac{1}{8}$ "	14"	M	2
B* frame rails	$\frac{3}{4}$ "	$1\frac{1}{8}$ "	$11\frac{1}{2}$ "	M	2
C* crest	$\frac{1}{4}$ "	$5\frac{1}{4}$ "	$11\frac{1}{2}$ "	M	1
D* bottom trim	$\frac{1}{4}$ "	$3\frac{1}{2}$ "	$11\frac{1}{2}$ "	M	1
E* side scrolls	$\frac{1}{4}$ "	$1\frac{1}{2}$ "	6"	M	4
F glue blocks	$\frac{1}{4}$ "	$\frac{1}{4}$ "	$2\frac{1}{2}$ "	M	8
G back	$\frac{1}{8}$ "	$10\frac{3}{4}$ "	$13\frac{1}{4}$ "	H	1
H kicker block	$\frac{5}{8}$ "	$\frac{3}{4}$ "	1"	M	1

* Parts initially cut oversize.

Materials Key: M—mahogany, H—hardboard.

Supplies: #4x $\frac{3}{8}$ " flathead wood screws (12), $\frac{1}{4}$ " screw eyes (2), braided mirror-hanging wire, $\frac{1}{8}$ "-thick mirror, glue, finish.

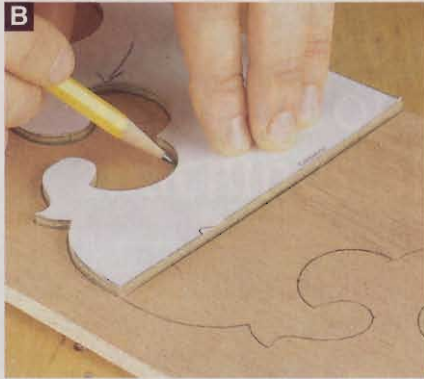

Working from a centerline drawn perpendicular to the edge, trace the outline of the template onto the blank.

the bottom trim (D) onto their respective blanks.

4 The pattern for the side scrolls (E) has the complete outline of the part, so instead of cutting the permanent pattern first, you'll make it at the same time that you cut the parts. Use double-faced

tape to join the four side scroll (E) blanks face to face. Then use one more piece of tape to add the hardboard pattern blank to the top of the stack. Now saw all of the side scrolls at once. Separate the parts after cutting and sanding, and save the pattern for future use.

5 Rip and crosscut the eight glue blocks (F) to the sizes listed in the Bill of Materials. Referring to **Drawing 5**, glue the blocks where shown. Make certain that the rear edge of each glue block is flush with the rear edge of the frame assembly.

6 Position the frame assembly face up on your workbench and glue the crest (C), bottom trim (D), and side scrolls (E) in place. Use 1/4"-thick scraps to support the scrollsawn pieces while the glue dries. Short strips of tape provide all the clamping pressure needed. As shown in **Drawing 5**, the curve of the crest and bottom trim continues into the shape of the

5 REAR VIEW

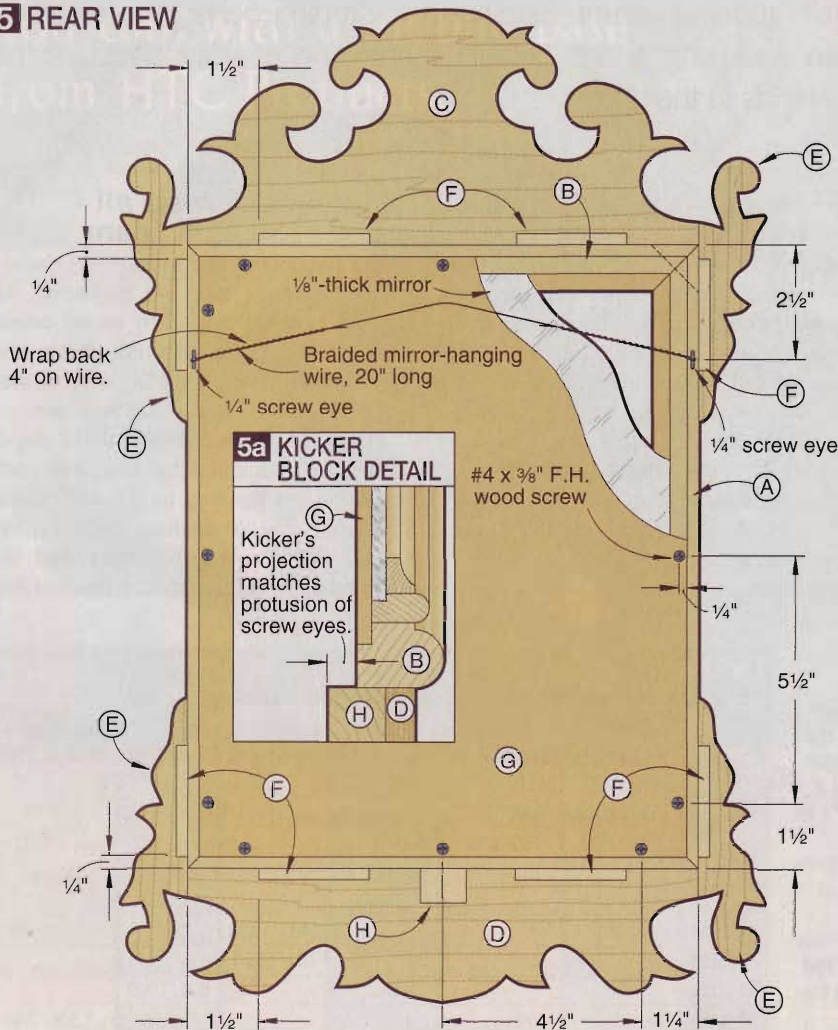

side scrolls. Align these parts as closely as possible during glue-up. After the glue dries, use 120-grit sandpaper to smooth the transition.

7 Cut the kicker block (H) to size. Glue and clamp it in place, where shown on **Drawings 5** and **5a**.

8 Cut a piece of 1/8" hardboard to size for the back (G). Mark the location of the screw holes where shown. Drill and countersink the 7/64" holes.

Apply the finish, and install the mirror

1 Apply your choice of finish to the project. We sprayed on three coats of aerosol semigloss Deft Clear Wood Finish. Between coats, we lightly sanded with 220-grit sandpaper, and wiped up the dust with a tack cloth.

2 Drill pilot holes for the screw eyes, where shown on **Drawing 5**, then drive in the screw eyes. Have a piece of mirror cut 1/8" smaller than the size of the rabbeted opening. Set the mirror in position, and screw the back (G) into place. Thread the braided mirror-hanging wire through the screw eyes, and wrap it back onto itself. 🌿

Written by **Robert J. Settick** with **Kevin Boyle**
 Project design: **Kevin Boyle**
 Illustrations: **Kim Downing; Roxanne LeMoine; Lorna Johnson**
 Photographs: **Baldwin Photography**

meet the presses

Six machines go head-to-head in a *WOOD*® magazine tool test

Although you might not think about it much, we're willing to bet you rely on your drill press more than you realize. Besides boring holes at exact angles with dead-on repeatability, a drill press also is the safest way to use large hole-makers, such as Forstner bits and circle cutters. You can even press it into service for mortising, drum-sanding, or clamping parts in a tough glue-up. Choose well, and a drill press can be one of your best and longest-lasting friends in the shop.

Benchtop or floor? Take a stand

We sought out floor-standing models for this test for a couple of reasons. First, because these machines are so durable, your first drill press may well be your last, so we think you should buy as much capacity as you can reasonably afford. While we admit that in the *WOOD*® magazine shop we rarely need more than about 8–12" between the chuck and the table—a table travel easily achieved by benchtop models—we like knowing we can drill into the end of a longer work-

piece, such as a lamp body or candlestick, if we need to.

Second, floor-standing presses tend to be more powerful than their bench-mounted counterparts. That means you can use bigger and longer bits with less stress on you and the machine.

So why would you want a smaller model? If benchtop real estate is hot property in your shop, you needn't dedicate work surface to a tool you use only on occasion. Just pull your benchtop press out of storage, bore, and store it when done.

How we learned all about the drill team

After unpacking and assembling the six models in our test, we measured for runout (wobble caused by an off-center or bent spindle) at the quill, chuck, and 2½" below the chuck using a precision-ground steel rod and a dial indicator.

To gauge the reliability of the depth stops, we chucked a twist bit into each machine, set the stop to ½", and drilled 100 holes into ¾" medium-density fiberboard (MDF). We then measured the difference in depth between the first and

The right rates

Quick survey: Raise your hand if you've never changed the speed on your drill press. Yep, we were afraid of that.

We're guilty, too, of not always using the correct spindle speed for the bit and material we're working. But if you choose the right speed for the task at hand, you'll be rewarded with cleaner holes and longer-lasting bits.

Here's a chart showing the best speeds for some common workshop applications, based on actual testing in our shop. You can download a free drill-press speed chart showing additional bits, accessories, and materials from our Web site. Just click on "Free Charts" under the "WOOD magazine" tab at www.woodonline.com, and follow the download instructions.

Drilling Dynamics						
Recommended speed (revolutions per minute, hardwood/softwood)						
	Twist Drill Bit	Brad-point Bit	Forstner Bit	Countersink	Plug Cutter	Hard-Rubber Sanding Drum
1/8"	3,000/3,000	1,200/1,800				
1/4"	1,500/3,000	1,000/1,800				
1/2"	750/1,500	750/1,800	500/2,400			
1"			500/1,500			
2"			250/500			
2-flute				1,400/1,400		
5-flute				750/1,000		
all sizes					500/1,000	
all sizes						1,500/750

last holes, and noted the difference.

Next, we observed the power of the press by setting it to its lowest speed, then boring with a 2" Forstner bit and a 2½" hole saw. Although the ampere ratings vary among the models, all of the drill presses handled the test without difficulty.

Finally, we put each machine through a month's worth of use, performing such tasks as drilling angled holes, drum-sanding, mortising, and more. During these tests we noted the ease of moving the drive belts to change speeds, as well as any difficulties in clamping a fence or workpiece to the table.

Quill, chuck, and spindle: Three as one

A sloppy fit between the quill and drill-press head, or between the spindle and quill bearings, affects the accuracy of a drill press. With all of those tolerances, you might expect relatively high runout readings. But all of these tools showed remarkably well here, with runouts ranging from only .002 (Craftsman and Delta) to .007" (Shop Fox), measured 2½" below the chuck, even after our testing. And, none of the machines we tested required adjustment between the quill and drill-press head. Shaking the chucks from side to side yielded no play.

When it comes to quill stroke—the maximum plunging distance of the bit—we prefer the capacities of the Delta 17-965 (47½") and Jet JDP-17MF (4¾"). Besides getting you deeper into a workpiece when drilling, the extra 1½–1¾" advantage over the other presses comes in handy if you use quill-mounted accessories, such as a mortising attachment or work hold-down. These accessories can rob you of up to ¾" of the machine's capacity.

The need for speeds

Most of the drill presses in our test offer 12 or 16 spindle speeds, and the more steps you have between the top and bot-



FAST FACTS

- The depth-stop system can make or break the drill press. In our tests, dial stops proved less reliable than threaded-rod systems.
- The diagonals of the smallest square tables are longer than the diameters of the round ones, so you can clamp wider jigs to them.
- One model in our test—the Grizzly G7946—is a radial drill press, meaning the head and table both tilt. This helps when boring angled holes in long stock. The head also slides forward and back on the column, so you can drill to the center of wider workpieces.

The inside story

To understand the important features of a drill press, it helps if you know more about the internal workings. This drawing explains the key parts and how they interact with each other.

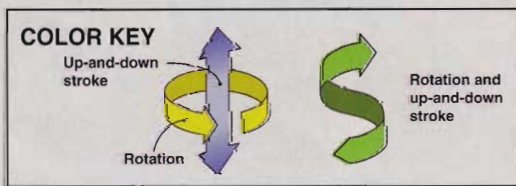
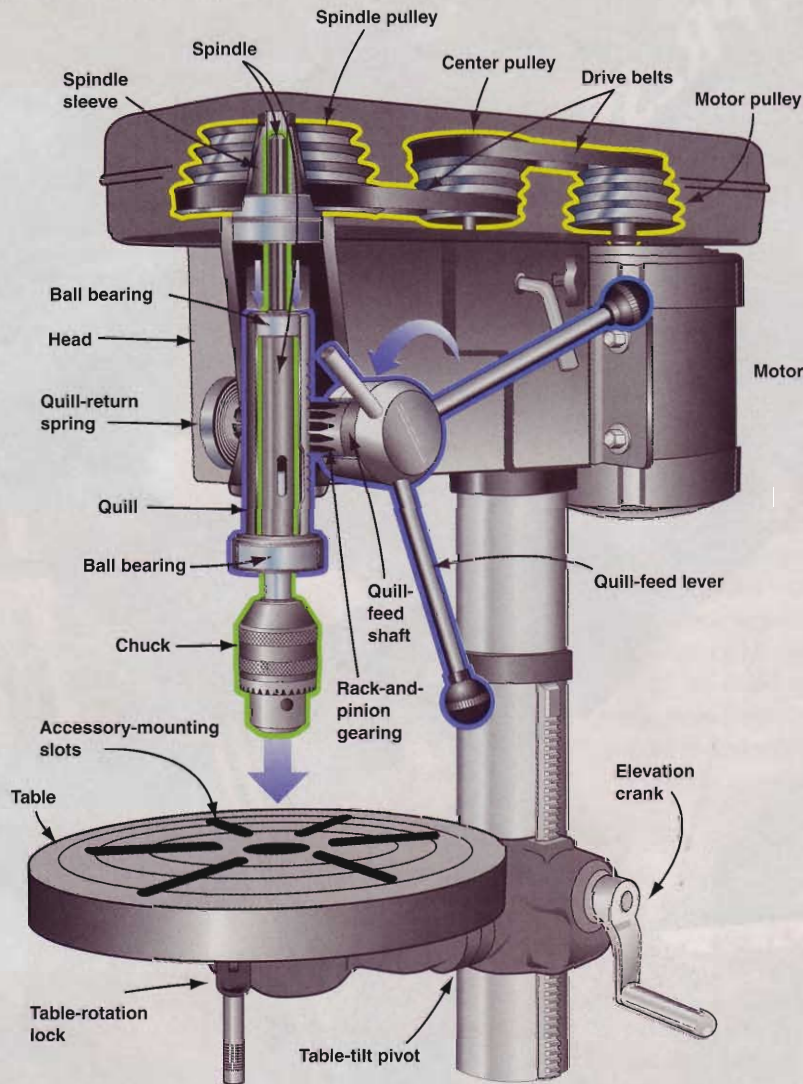

'ROUND AND 'ROUND. The motor turns the motor pulley at a constant speed. Like changing gears in a car, switching the V-belts up or down on the motor pulley, center pulley, and spindle pulley changes the spindle speed. **UP AND DOWN.** The spindle pulley turns the spindle, which moves up and down within the spindle sleeve. The spindle rotates inside the quill, isolated by ball bearings at the top and bottom

of the quill. Fitted to the lower end of the spindle, the chuck holds the bit. Turning the quill-feed shaft counterclockwise with a quill-feed lever lowers the quill in the head by means of rack-and-pinion gearing. As the quill lowers, the rotating spindle, chuck, and bit make their plunge toward the workpiece. Finally, the quill-return spring automatically raises the quill at the end of the operation.

tom speeds, the more control you have. As important as the number of speeds, though, is the range of those speeds. The Craftsman and Jet have the widest range, from a low of 200 rpm to a blistering 3,630 rpm. (See the chart at the end of the article for specifics on each machine.)

The chart on page 84 shows the best speeds to use for some common bits and accessories in both hardwoods and softwoods. Generally speaking, smaller bits and softer materials require higher speeds for the cleanest cuts. Large-diameter bits can dull and lose their temper at high speeds, so go slow with those.

To change speeds, you must first loosen a knob on each side of the drill-press head. This frees the motor's sliding mount, which moves forward and slackens the drive belts. A chart inside the pulley cover shows where to position each belt on each pulley for the speed you want. Changing belts was quick and easy on all of the machines, although we found the Jet press gave us a little less slack when loose than the others.

While we're on the subject of belts, the drill presses with wider belts—Craftsman, Delta, and Jet—slipped less in our large-cutter test than those with narrow belts. That's because wider belts make more surface contact with the pulleys and more effectively transfer the motor's power to the spindle.

Stop the presses

The most significant difference we found in the models in our test is with their depth-stop systems. Besides setting how deep you drill, the stop systems also can lock the quill in a plunged position for non-drilling chores, such as drum-sanding.

The Craftsman and Jet drill presses have three knurled nuts on a threaded rod, as shown in **Photo A**. The top two nuts limit the drilling depth, while the bottom nut rotates up or down to lock the quill in the down position. In our 100-hole test, this system proved the most reliable, with no change in depth between hole number one and hole number 100.

Delta's system also has a threaded rod, but instead uses a large, knurled stop nut, shown in **Photo B**, to limit the plunge of the quill. This quick-set stop has a spring-loaded half-nut mechanism

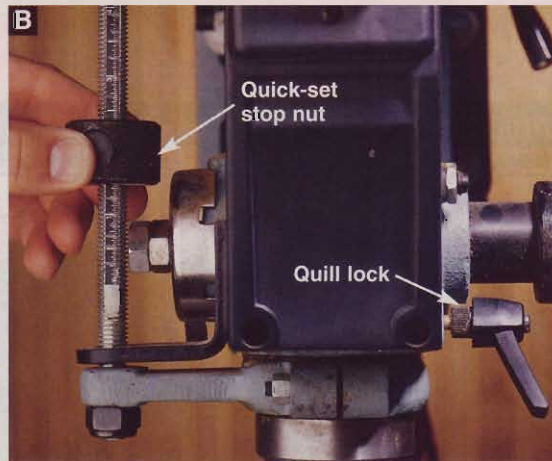
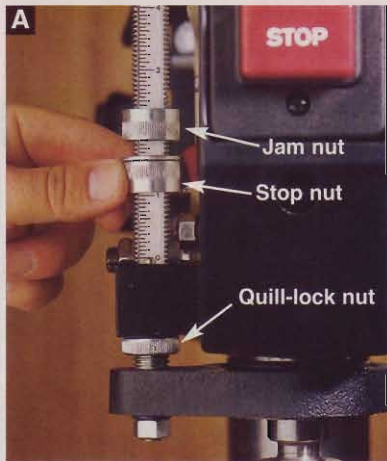

The stop nut of a three-nut system (Photo A) sets the drilling depth, the jam nut locks the stop nut in place, and the quill-lock nut fixes the quill's upward travel. Delta's stop system (Photo B) employs a quick-set stop nut and separate ratcheting-lever quill lock. In our tests, the models with dial stops on the quill-feed hub (Photo C) were easy to use but unreliable over the long haul.

inside it—push the button and slide the stop anywhere along the rod, then release the button to lock. You can still fine-tune the depth by turning the stop.

Delta's stop proved faster to set than the three-nut stops because little if any turning is required. And, the simple quill lock is a ratcheting lever on the opposite side of the head. After boring 100 holes, we couldn't measure any difference in depth between the first and last. However, we noticed that the stop had rotated slightly. This slippage shouldn't be a concern unless you're drilling several hundred holes at a time.

The Grizzly and Shop Fox drill presses use a dial stop (Photo C) on the quill-feed hub that limits the drilling depth and locks the quill. Although easy to set and use, we didn't find it as positive as the threaded-rod stops. In the Grizzly G7944's 100-hole test, the last hole drilled was a full $\frac{1}{8}$ " deeper than the first (Photo D); the G7946 fared slightly better with $\frac{1}{16}$ " slippage. Shop Fox fared best of the dial-stop models with only $\frac{3}{128}$ " difference from first hole to last.

In response to our findings, Grizzly's Bill Crofutt says most home woodworkers don't drill huge numbers of same-depth holes. "Our customers prefer the speed and convenience of a dial stop," he says, to the three-nut stop system.

Taking measure of the tables

In woodworking, you'll almost always want to use a fence, jig, or auxiliary wooden tabletop on your drill-press table. At the very least, you should

clamp the workpiece to the table while drilling. That's why we like a clamp-friendly table.

The shape of the table and the width of the rim around its bottom are the biggest factors in clamp-friendliness. We prefer the squarish tables of the Craftsman, Delta, and Grizzly G7944 tables to the round tables of the other models, because you can clamp wider stock to them. (Measured diagonally, the smallest square table in the test is 16"; the largest round table measures 14".) The tables on these three machines also have wide rims (Photo E) that provide a broad, flat surface for the clamp jaws.

Of course, the tables on all of the drill presses tilt to allow you to drill angled holes. Before tilting the table, you must first remove the indexing pin (most require a hex-head or open-end wrench) that ensures the table returns to exactly 90° after the tilt. That small pin can be

hard to remove and even harder to keep track of. Kudos to Delta for its long indexing pin that requires no wrenches and is secured to the table-support casting with a chain.

As we mentioned earlier, we rarely use more than 12" or so of our drill-press table's vertical travel, and all of the machines in this test had at least twice that. Before buying, though, check the "Table Travel" and "Distance from Chuck to Base" columns in the chart at the end of the article to ensure the press will handle your biggest jobs.

And, if you'll use your drill press for metalworking, consider the Craftsman or the Grizzly G7944. Both come with "wet" tables that have a reservoir rim to collect metal-cooling lubricants.

Less pressing concerns

•**Leverage and handling.** Manufacturers are beginning to place a higher priority

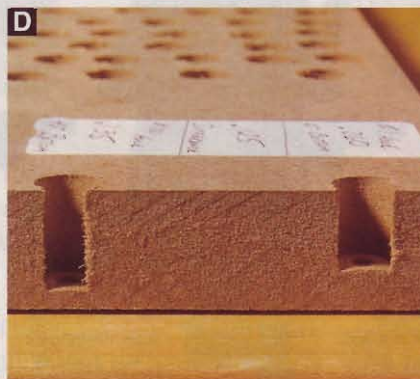

The 100th hole (left) we drilled with the Grizzly G7944 is $\frac{1}{8}$ " deeper than the first (right). By the 25th hole, we could see the depth difference without measuring.

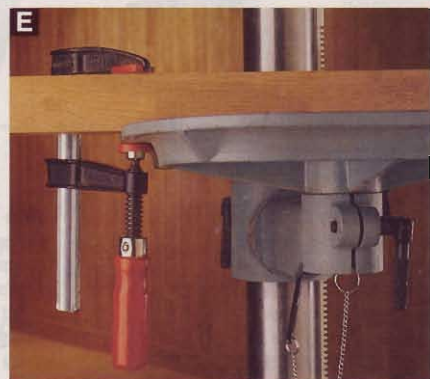

The wide rim around Delta's squarish table provides an excellent clamping surface for holding a workpiece or attaching a jig.

meet the presses

SIX DRILL PRESSES: THE HOLE-SHOOTIN' MATCH																											
MANUFACTURER/ IMPORTER	MODEL	STYLE	MOTOR		SPINDLE		QUILL		TABLE			PERFORMANCE RATINGS (4)						ACCESSORIES (5)		WEIGHT (POUNDS)	CORD LENGTH (FEET)	WARRANTY (YEARS)	COUNTRY OF ASSEMBLY (6)	SELLING PRICE (7)			
			VOLTAGE	AMPS (110/220v)	NUMBER OF SPEEDS	SPEED RANGE (RPMs)	STROKE (INCHES)	DEPTH STOP/QUILL LOCK STYLE (1)	SWING (INCHES)	SIZE (INCHES) (2)	TRAVEL (INCHES) (3)	DISTANCE FROM CHUCK TO BASE (INCHES)	DEPTH STOP	FEED-HANDLE LEVERAGE	CHANGING SPINDLE SPEEDS	DRIVE-BELT WIDTH	EASE OF CLAMPING TO TABLE	DRILLING WITH LARGE BITS	DRILLING ANGLED HOLES						DRUM SANDING	STANDARD	OPTIONAL
CRAFTSMAN	22917N	FLOOR	110	12	16	200-3,630	3/4	N	17	14 1/4 x 14 1/4	26	45 1/4	E	E	E	E	E	E	E	G	F, K, L	D	187	6.5	1	C	\$430
DELTA	17-965	FLOOR	110/220	10/5	16	215-2,720	4 7/8	Q	16 1/2	14 x 14	24 1/2	45	E	G	E	E	E	E	E	E		D, L, M	172	6.5	2	T	370
GRIZZLY	G7944	FLOOR	110	9	12	140-3,050	3/4	D	14	11 3/8 x 11 3/8	31 1/2	49	F	E	E	G	E	E	G	G	L	D, M	178	8.5	1	C	209
	G7946	RADIAL/ FLOOR	110	5	5	550-3,470	3/4	D	33 1/2	12 3/16*	30 1/2	51	G	G	E	G	G	E	E	E			150	6.5	1	C	180
JET	JDP-17MF	FLOOR	110/220	14/7	16	200-3,630	4 3/8	N	16 1/2	13 3/4*	29 1/8	49	E	G	G	E	G	E	G	E	L, M	D	178	6.5	2	T	400
SHOP FOX	W1680	FLOOR	110/220	10/5	12	140-3,050	3/4	D	17	14*	31 1/2	49	G	E	E	G	G	E	G	G	L		200	8.5	2	C	375

NOTES:

- (D) Internal dial
(N) Three nuts on threaded rod
(Q) Quick-set with lever lock
- (*) Diameter
- Maximum distance between table and bottom of chuck.
- E** Excellent
G Good
F Fair
- (D) Sanding drums
(F) Fence
(K) Key holder
(L) Work light
(M) Mortising attachment
- (C) China
(T) Taiwan
- Prices current at time of article's production, and do not include shipping where applicable.

For more information, contact:

Craftsman Jet
 Visit your local Sears store. 800/274-6848
www.sears.com/craftsman/ www.jettools.com

Delta Woodstock International (Shop Fox)
 800/438-2486 800/840-8420
www.deltamachinery.com www.woodstockint.com

Grizzly
 800/523-4777
www.grizzly.com

For specifications on other types of tools, click on "Tool Comparisons" at www.woodmall.com.



Craftsman 22917N
 A powerful, nicely featured model with excellent speed range. However, its short quill stroke doesn't suit it well for mortising. The only press in the test to include a fence and on-tool storage for the chuck key.

Delta 17-965
 Top speed doesn't reach 3,000 rpm—the best speed for the smallest bits. But we liked the lever-style quill lock. And, with the longest quill stroke in the test, it's a good candidate for mortising.

Grizzly G7944
 A lot of machine for the money, with a low, low 140-rpm bottom speed good for drilling hard metals. However, the dial stop slipped 1/8" while drilling 100 holes.

Grizzly G7946
 The only radial drill press in our test offers nearly twice the swing of the other models and makes drilling angled holes in long workpieces easier.

on user comfort, and it shows on some of the models in our test. We liked the better grip and felt less fatigued after long sessions with the soft feed knobs and handles on the Grizzly G7944 and the Shop Fox.

Although the knobs on the Craftsman and Delta are hard plastic, they felt better in our hands than the smaller knobs on Jet's quill-feed levers. Speaking of which, the levers on the Jet drill press are the shortest in this test, meaning we had to work a little harder while boring big holes because of their decreased leverage.

•**Let there be light.** Four of the models we tested—Craftsman, Grizzly G7944, Jet, and Shop Fox—have built-in work-lights under the head, and in many cases the extra illumination is welcome. But because they're behind the quill, the lights cast shadows forward, making it more difficult to center large bits in a workpiece.

•**One-of-a-kind features.** At the time of our test, Jet included a free mortising attachment, complete with three chisels, with the purchase of its drill press. Similar aftermarket devices sell for about \$70.

The Craftsman drill press comes with a couple of thoughtful features. The first is a simple sheet-metal fence complete with a work stop. Another nice touch: Craftsman also has a clip on the head for storing the chuck key.



Jet JDP-17MF
Powerful motor, long quill stroke, and included mortising attachment makes this an excellent choice if you do a lot of mortise-and-tenon joinery. We found the round table with deep gussets hard to clamp jigs and fences to.



Shop Fox W1680
The heaviest machine in the test. Similar to Grizzly G7944 in power and speed range, but with more swing and a round table.

Two models yet to come

At least two manufacturers—Ridgid and Shop Fox—have new 12-speed drill presses in the works. Although we're champing at the bit to put these uniquely featured units to the test, we couldn't get our hands on either model soon enough to include them in this article. When we do, we'll share our findings in an upcoming issue of *WOOD* magazine. Meanwhile, here's what the toolmakers say you can expect:



•**Ridgid DP1550.** Let's face it, most power tools are designed for right-handed people. However, the quill-feed hub of Ridgid's new 15" switch-hitting drill press (shown at left) can be moved to either side of the machine to give southpaws a fair shake. The DP1550 also has a column-mounted accessory tray to help you keep bits, clamps, etc., handy. Dave Hazelwood at Ridgid told us the machine will sell for under \$400 when it hits the streets early in 2002.

•**Shop Fox W1668.** Who needs an oscillating spindle sander when you've got a W1668 13" oscillating drill press? Its spindle can be set to oscillate $\frac{3}{4}$ ", so you don't have to raise and lower the quill manually when drum-sanding. The table even has an oversized hole (for sanding-drum clearance) with a dust-collection port attached. The benchtop machine (shown at right) sells for \$245 and includes 1", $1\frac{1}{2}$ ", and 2" sanding drums.



Our pick of the presses

Both the Craftsman 22917N and Delta 17-965 stood tall in our tests, but we give Delta the edge due to its longer quill stroke, quill-lock lever, table-

indexing pin, and lower price. If you do a lot of mortising, though, take a hard look at the Jet JDP-17MF. Besides coming with a mortising attachment, it offers the second-longest quill stroke in the test.

On the other hand, if you rarely drill large numbers of holes to the same depth, take a hard look at the Grizzly G7944. It gets the job done for about half the price of the other models in the test. 🌲

Written by **Dave Campbell** with **Jeff Hall**
Illustration: **Tim Cahill**
Photographs: **Baldwin Photography**

Log on and speak out about drill presses

You've read what we have to say. Now tell us what you think about the drill presses in our test. You know the drill: Log on to our Interactive Tool Reviews under the Tool Comparisons tab at www.woodmall.com. There, you'll find a drill-press discussion group along with comments from the manufacturers involved in the test.

nightstand

with a great
bedside manner



Part II of our maple-and-cherry bedroom suite, this nightstand is the perfect companion for the sleigh bed featured in issue 135. Its combination of traditional details and contrasting woods makes it a good fit in any setting. *Note: In addition to ease of assembly, the biscuit-joiner construction of this project makes finishing a breeze. We finish-sanded the parts before gluing up the various assemblies, then applied the finish to these flat assemblies before the final carcass glue-up. The Bill of Materials lists the parts for one nightstand. If you want to make a pair, you'll have to double the number of parts.*

Shape the gracefully flared legs

1 Laminate two $\frac{1}{4} \times 2\frac{1}{4} \times 25\frac{1}{4}$ " pieces of hardboard to make a $\frac{1}{2}$ "-thick template blank for the legs (A). Joint one edge. Make a copy of the leg pattern from the *WOOD PATTERNS*® insert. Use spray adhesive to adhere the pattern to the blank, aligning it with the jointed edge as indicated. Saw and sand the template to the pattern line.

2 Prepare two $1\frac{1}{2} \times 3\frac{1}{2} \times 32$ " blanks for the legs (A). (We planed down $1\frac{3}{4}$ " stock. You can also laminate the blanks from $\frac{3}{4}$ " stock.) Joint both edges, then use the template to trace the leg outlines on the blanks, aligning the template's and the blanks' jointed edges. To conserve lumber, nest the parts, as shown on the Cutting Diagram. Bandsaw the legs from the blanks, keeping close to the pattern lines. Clean up the legs' bandsawn edges with a drum sander chucked into your drill press. We built the simple pattern-sanding jig shown on page 20 for this task, using double-faced tape to adhere the template to each leg.

3 With the legs complete, arrange them for the best appearance and mark their locations, front and back, left and right. Finish-sand the legs to 220-grit.

Make the carcass parts, and glue up assemblies

1 Cut two $\frac{3}{4} \times 15\frac{1}{2} \times 20\frac{1}{4}$ " plywood blanks for the side panels (B) and one $\frac{3}{4} \times 17 \times 6\frac{1}{2}$ " plywood blank for the rear panel (E). Finish-sand the outside faces. *Note: The grain runs across the short dimension of part E.*

2 Resaw in half a $\frac{3}{4} \times 4\frac{1}{2} \times 36$ " maple board and plane the two pieces down

to $\frac{1}{4}$ ". From this solid-wood maple stock, cut blanks $\frac{3}{4} \times 15\frac{3}{8}$ " for the side upper rails (C), $1\frac{1}{2} \times 15\frac{3}{8}$ " for the side lower rails (D), $\frac{3}{4} \times 16\frac{7}{8}$ " for the rear upper rail (F), and $1\frac{1}{2} \times 16\frac{7}{8}$ " for the rear lower rail (G). Finish-sand the pieces.

3 Glue and clamp the rails to the panels, where shown on **Drawing 1**, centering the rails on the panels. The rails' ends fall $\frac{1}{16}$ " short of the oversized panels' edges. This keeps the rails from interfering with the cut when the panel assemblies are trimmed to final size. The spacing of the rear rails (F, G) is the same as that of the two side rails (C, D).

4 With the glue dry, trim both edges of the side panel (B) and rear panel (E) assemblies to the widths in the Bill of Materials. Trimming panels and rails together ensures straight, flush edges and crisp, tight glue joints between the panels and the legs. Set the back panel assembly (E, F, G) aside.

5 Adjust your biscuit joiner to cut a centered slot in the thickness of your $\frac{3}{4}$ " plywood. Observing the leg's previously marked positions, plunge the biscuit slots in them and the mating edges of the side and rear panel assemblies, where shown on **Drawing 1**. Index

shop TIP

Avoiding glue squeeze-out

To avoid a tricky cleanup task, cut $\frac{1}{8}$ "-deep saw kerfs $\frac{1}{8}$ " from the edges of the rails. Glue applied to the surface between the grooves squeezes into the grooves instead of out onto the panels.



your biscuit joiner on the inside surfaces of the legs and panels. Set the rear panel assembly aside. Glue, biscuit, and clamp the legs to the sides.

6 Cut two $\frac{3}{4} \times 15 \times 17$ " plywood blanks for the carcass top/drawer shelf (H) and one $\frac{3}{4} \times 15\frac{1}{4} \times 17$ " plywood blank for the lower shelf (I). Then cut a $\frac{3}{4} \times \frac{3}{4} \times 16\frac{7}{8}$ " blank for the upper band (J) and three $\frac{3}{4} \times 1\frac{1}{2} \times 16\frac{7}{8}$ " blanks for the lower bands (K). Glue and clamp the bands to the shelves, centering the bands on the shelves. As with the side panels and rails, the bands are $\frac{1}{16}$ " shorter than the shelves at both ends.

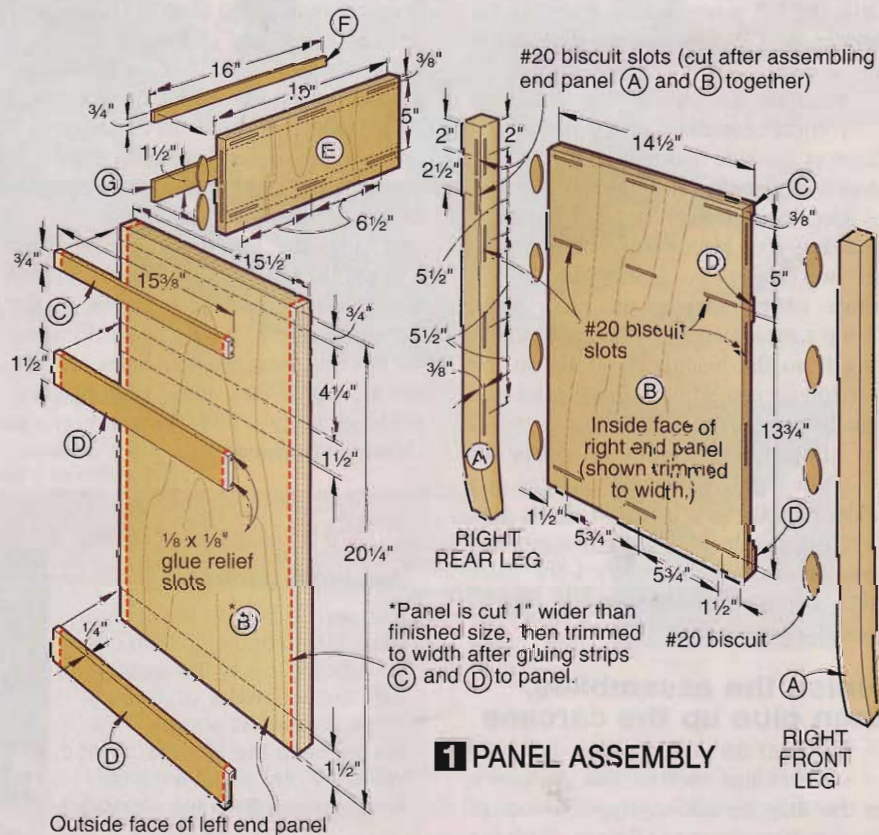

shop TIP

Prefinishing parts

Some projects are easier to finish if you do it before assembly. But how do you keep finish off the surfaces that will be glued? Use masking tape, as shown here, to protect the mating glued surfaces.

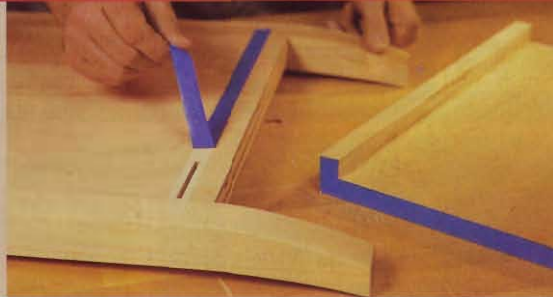

7 With the glue dry, cut the shelf/band assemblies to finish length, once again trimming both ends. Mark the biscuit slot locations on the carcase top's and the drawer shelf's ends and rear edges, and the lower shelf's ends. Plunge the slots, indexing your biscuit joiner from the top surface.

8 Lay out and drill the counterbored screw shank holes and slots in the carcase top (H), where shown on **Drawing 2**. To form the slots' counterbores, drill $\frac{3}{16}$ "-deep holes with your $\frac{1}{2}$ " Forstner bit, and chisel out the center, where shown on **Drawing 2a**. Then drill overlapping shank holes to form the slot. Drill the $\frac{1}{2}$ " screw access holes in the drawer shelf. Finish-sand the carcase top and shelves.

9 Mark the biscuit slot horizontal and vertical centerlines on the inside surfaces of the side and rear panels, where shown on **Drawing 1**. Plunge the top row of slots on the side and back panels, indexing your biscuit joiner on the panels' top edges. To guide your biscuit joiner when plunging the other slots, clamp a straightedge to the panel, offsetting it so the biscuit slot falls on the horizontal centerline. Finish-sand the panels' inside faces.

10 Edge-glide stock to form a blank for the top (L) about 1" longer and wider than the size listed. With the glue dry, trim the blank to size. Rout a round-over on the top's ends, then the front edge, as shown on **Drawing 2**. Finish-sand the top.

Finish the assemblies, then glue up the carcase

1 Mask off the mating ends, edges, and surfaces that receive glue, as shown in the shop tip above. Apply a coat of gloss polyurethane to all parts. With the

finish dry, sand lightly with 220-grit sandpaper. Remove the dust and apply a coat of satin polyurethane. With the finish dry, remove the masking tape.

2 Dry-assemble the carcase side, top, shelf, and rear assemblies with biscuits to check the fit. Disassemble, then place one side assembly on your workbench, inside face up. Using white glue for extended working time, apply glue to the slots and masked areas for the carcase top and shelves. In turn, glue biscuits into the ends of the carcase top and shelves, and position them on the side. Apply glue and biscuits, and position the rear panel assembly. Clamp this carcase subassembly, as shown in the shop tip below, and set it aside until the glue dries.

3 Apply glue to the carcase subassembly's slots and edges. Glue biscuits into the other side assembly and clamp it to the carcase subassembly. Place the completed carcase upright on a flat surface until the glue dries.

4 Clamp the top (L) in place, flush with the legs at the rear and centered side-to-side. Mark the locations of the mounting screws with an awl. Remove the top, drill the screw pilot holes, and fasten the top to the carcase with #8x $\frac{1}{4}$ " panhead screws and flat washers, as shown on **Drawing 2**.

shop TIP

Assembly assistance

Keeping large projects square while gluing and clamping can be difficult, to say the least. To help out, we make large right-angle braces, as shown. Two braces keep the shelves aligned, while the rear panel assembly keeps the carcase top aligned.

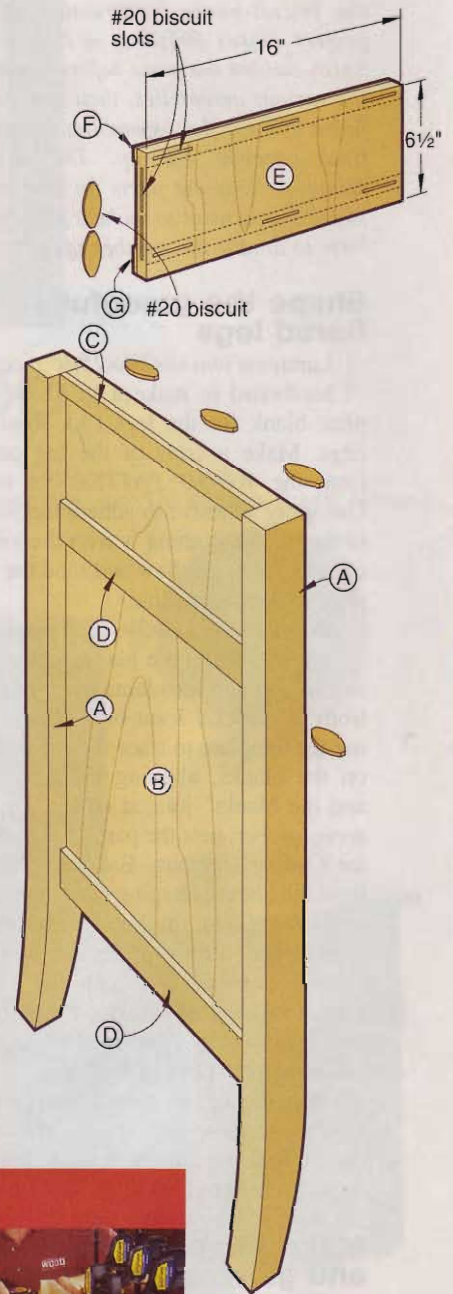

bill of materials

nightstand		FINISHED SIZE			Matl. Qty.
Part	T	W	L		
A* legs	1½"	2"	25¼"	M	4
B** side panels	¾"	14½"	20¼"	MP	2
C† side upper rails	¼"	¾"	14½"	M	2
D† side lower rails	¼"	1½"	14½"	M	4
E** rear panel	¾"	16"	6½"	MP	1
F† rear upper rail	¼"	¾"	16"	M	1
G† rear lower rail	¼"	1½"	16"	M	1
H† carcass top/ drawer shelf	¾"	15"	16"	MP	2
I† lower shelf	¾"	15¼"	16"	MP	1
J† upper band	¾"	¾"	16"	M	1
K† lower bands	¾"	1½"	16"	M	3
L†† top	¾"	18½"	21"	EM	1
M drawer front	¾"	4⅞"	15⅞"	C	1
N drawer sides	½"	4⅞"	15⅞"	M	2
O drawer back	½"	3⅞"	15⅞"	M	1
P drawer bottom	¼"	13½"	15⅞"	BP	1

*Parts nested in pairs on two blanks.

**Parts initially cut wider.

†Parts initially cut longer.

††Part initially cut oversize.

Materials Key: M—maple, MP—maple plywood, EM—edge-glued maple, C—cherry, BP—birch plywood.

Supplies: ¼" hardboard, spray adhesive, #20 biscuits, #10 flat washers, #8x1¼" panhead screws, #8x1¼" brass flathead wood screws, masking tape, glue, finish.

Buying Guide

Vertical raised-panel bit: Jesada no. 690-602, \$59.90. Call Jesada at 800/531-5559.

Drawer lock joint bits: Use any one of the following bits: Freud no. 99-240 (order catalog no. 800-486), \$49.95, call Woodworker's Supply at 800/645-9292; Jesada no. 655-512, \$71.90, call Jesada at 800/531-5559; Katana no. 18850, \$39.00, call MLCS at 800/533-9298.

Hardware: Self-adhesive glide strip no. 464, \$4.55/10-foot roll, call Meisel Hardware Specialties, 800/441-9870; 1¼" satin chrome knob, Amerock no. BP1466G10, check your local hardware store or home center or call Woodworker's Hardware, 800/383-0130, order no. A01466G10, \$4.83.

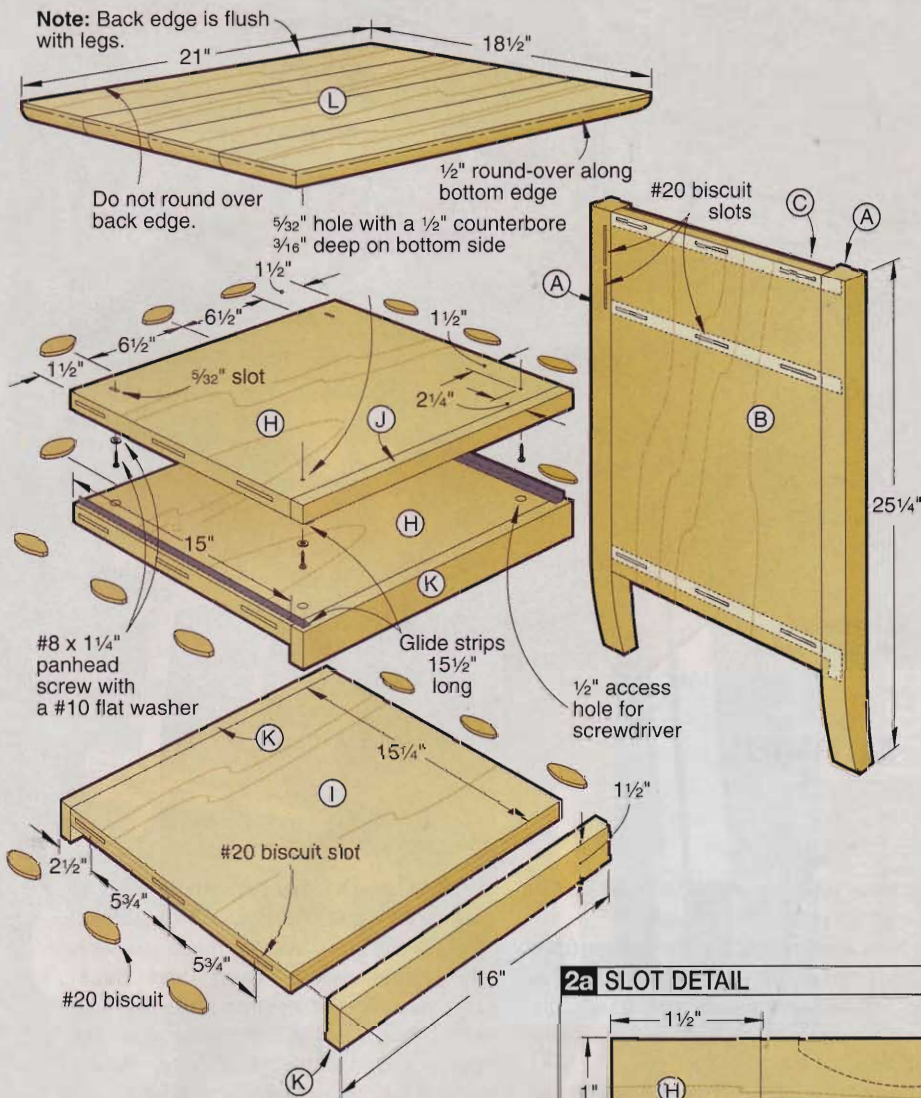

2 EXPLODED VIEW

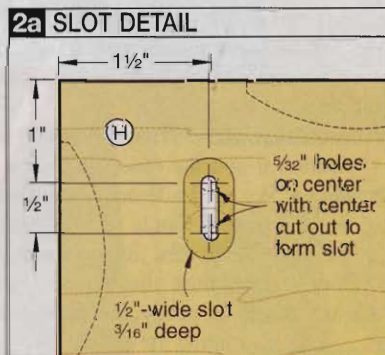

cutting diagram

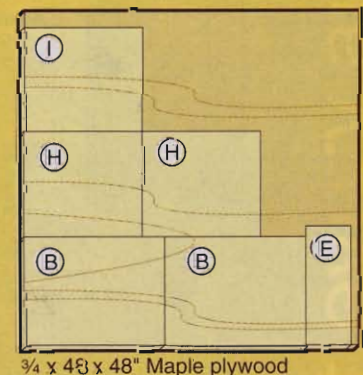
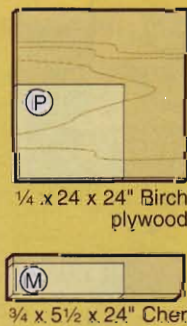
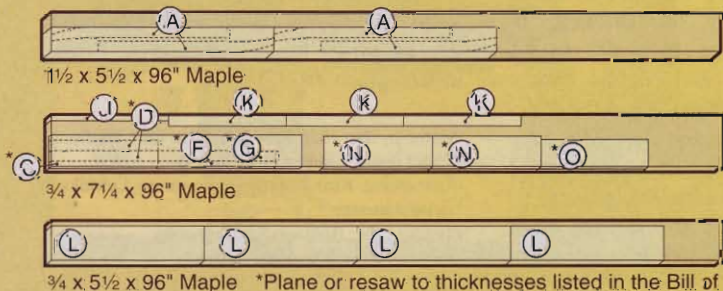

nightstand

5 Adhere self-adhesive glide strip to the lower inside corners and the top of the drawer cavity, where shown on **Drawing 2**. Hold the strips $\frac{1}{4}$ " back from the carcase's front edge. For a good bond, press them in place with a wood block. See the Buying Guide for a source of glide strip.

Now build a drawer with a contrasting front

Note: Because the complete bedroom suite involves making 15 drawers, we used a drawer lock router bit to speed this task. These bits form the mating halves of the joint in the drawer front and side with a single setup. (See the Buying Guide for router bit sources.) If you wish, you can substitute a lock rabbet joint, as shown on **Drawing 5a**, and cut them on your tablesaw.

1 Check the dimensions of your drawer opening. (Ours is $4\frac{1}{4} \times 16$ ". If yours is different, adjust your drawer part dimensions to leave a $\frac{1}{16}$ " gap all around.) Cut the drawer front (M) and drawer sides (N) to size. Set aside extra pieces of drawer front and side stock to use when setting up the drawer lock bit.

2 Chuck the drawer lock bit in your table-mounted router and attach a tall auxiliary fence to the router table fence. Position the bit and fence as shown in **Drawing 3**. Using the extra pieces you set aside, test your setup. Rout the front piece flat on the router table with its outside face up, and the side piece upright with the inside face against the fence. Make any necessary adjustments to get a tight, flush joint. We let the front protrude a hair beyond the sides, then sanded it flush after assembling the drawer.

Note: We used a Freud no. 99-240 bit. If

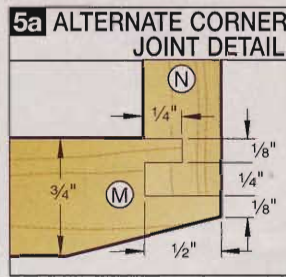

5 DRAWER

you use another manufacturer's bit, your setup may differ slightly.

3 Now rout the ends of the drawer front (M) and the drawer sides (N) just as you did the setup pieces. Use a follower block to steady the parts and eliminate chipping.

4 Switch to a vertical raised-panel bit and position it and the fence as shown in **Drawing 4**. We used a Jesada no. 690-602 bit. See the Buying Guide for a source of this bit. Rout the bevels, first on the drawer front's ends, then the edges. Use a follower block to steady the front when routing the ends.

5 Install a $\frac{1}{2}$ " dado blade in your tablesaw and cut dados in the drawer sides (N) to receive the drawer back (O), where shown on **Drawing 5**. Change to your regular blade and cut the drawer bottom grooves in the drawer front and sides. Match the thickness of your plywood by making two passes.

6 Cut the drawer back (O) and drawer bottom

(P) to size. Dry-assemble the drawer to check the parts' fit. Because the drawer fits closely in its recess, make sure it is the same width front and back. Disassemble the drawer, drill the centered pull hole, and finish-sand all the parts. To give the raised-panel front a soft look, we slightly rounded the bevel/field transition as we sanded.

7 Glue and clamp the drawer together, gluing the bottom panel into the front and side grooves. Measure diagonally to check for squareness. Set the drawer on a flat surface until the glue dries. Remove the clamps and drill pilot and countersunk shank holes through the sides and bottom into the back, as shown. Drive the screws.

8 As when prefinishing the carcass, apply two coats of polyurethane, sanding between coats. With the finish dry, install the knob, and slide the drawer into place.

Written by Jan Hale Svec with Charles I. Hedlund
Project design: James R. Downing
Illustrations: Kim Downing; Roxanne LeMoine; Lorna Johnson
Photographs: Baldwin Photography; Douglas E. Smith; Andy Lyons

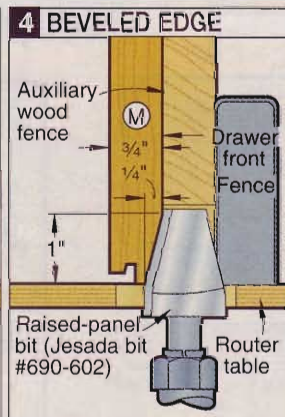
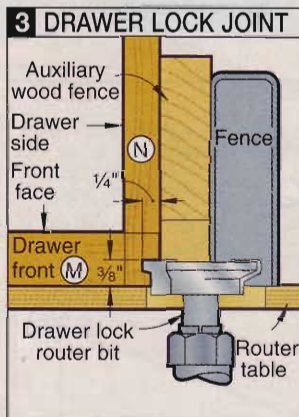

products that perform

These woodworking wares passed our shop trials

Makita plunges into midsized routers

When Makita introduced a new line of 2¼-hp fixed-base routers last year, woodworkers buzzed about the powerful, quiet motors. Now, Makita has put that same 11-amp, variable-speed motor into a new plunge router: the RP1101.



Makita RP1101 plunge router

Performance	★★★★☆
Price	\$260
Value	★★★★☆

Call Makita at 800/462-5482, or visit www.makitatools.com.

As on the fixed-base version, the RP1101's electronic speed control keeps the bit turning at a constant rate, without regard to the workload. I plowed a ¾" dovetail bit into a piece of red oak and, after a half-second slowdown, the motor recovered its speed nicely.

I was surprised to find that the router doesn't have an on-handle power switch

like other plunge routers. (The switch is on top of the motor.) However, I still felt safe holding the router with only one hand when I turned it on, because the soft-starting motor barely torques the router at startup.

To quickly set the cutting depth, the RP1101 has a half-nut mechanism on its threaded-rod stop. Engage the half-nut, and each turn of the rod changes the cutting depth by 1/16". My only beef with this system is the depth indicator—the yellow piece in the photo at left. With nearly 1/4" between the indicator and the depth-of-cut scale, I really had to eyeball the measurement.

The base readily accepts Porter-Cable guide bushings. And, with the base removed, you can run bits up to 3/4" in diameter (only in a router table, of course). The RP1101 comes with both 1/2" and 1/4" collets. It takes two wrenches to change bits, but both wrenches are the same size—a nice touch.

Here's good news if you already own one of Makita's 11-amp, fixed-base routers: Makita sells the plunge base separately for use with your existing motor.

—Tested by Rich Bright

DeWalt's "junior" miter saw shines

After designing and manufacturing one of the most popular 12" compound miter saws, DeWalt engineers turned their attention to those of us who don't need (or can't afford) a 12" saw. The result is the DW703, a 10" compound miter saw that shares many good qualities of its daddy.

Among the common family traits are a smooth-gliding turntable, a sliding left fence that

supports stock at virtually any bevel angle, a horizontal D-handle, and a large 3-spoke bevel lock. The powerful 15-amp motor and included 40-tooth blade sliced easily through 2x6s and 4x4s, with cuts clean enough for woodworking.

The youngster shows up the old man in a couple of ways, though. For instance, the DW703 miteres a full 50° both ways; the 12" DW705 only goes 48° left and right. And, the DW703 betters the DW705 with 11 positive miter stops—two more than the DW705—at 45°, 31.62° (for crown molding), 22.5°, 15°, and 10° both ways, and of course at 0°.

All in all, the DW703 compares well with other high-end 10" compound miter-saws you'll find on the market today. It's a fitting and welcome addition to the DeWalt miter saw family.

—Tested by Kirk Hesse



DeWalt DW703 compound miter saw

Performance	★★★★☆
Price	\$230
Value	★★★★☆

Call DeWalt at 800/433-9258, or visit www.dewalt.com.

Continued on page 98

Make your case without passing the bar (clamps)

While building a workbench recently, I had to jury-rig some bar clamps to get them to span the full 8' length of the bench case. I wish I'd had a Contact Clamp APS at the time; it would've saved me a lot of headaches.

As you can see from the photo above, this odd-looking clamp uses a pair of spring-loaded, rubber-faced cams as jaws to grab one workpiece (the shelf, in this photo). A threaded jaw on the other end pulls that workpiece lengthwise into the adjoining workpiece (the case side, here). I tightened that jaw as much as I could muster, and detected no slippage by the cam jaws.

So, for gluing up carcasses, face frames, mortise-and-tenon joints, or most any other 90° assembly, you no longer need to capture the entire workpiece within the jaws of a bar clamp. I even glued up a



Contact Clamp APS

Performance	★★★★★
Price	\$64
Value	★★★★☆

To locate your nearest dealer, call Gross Stabil Corporation at 800/671-0838.

biscuit-joined picture frame using the Contact Clamp APS. The only limitation I could find is the 2" maximum width that will fit between the jaws.

Convenience has its price, and in this case, it's \$64 apiece. That may be too

steep for the occasional user, but if you routinely find yourself pining for just a little more length out of your bar or pipe clamps, you might find these clamps well worth the money.

—Tested by Randy Zimmerman

Point-and-click marquetry and inlay

You decide to build dad an exotic checkerboard for Christmas. But you're fresh out of gaboon ebony and lacewood, and the holiday is just days away. Instead of panicking, you sit down at the computer, arrange photos of those exotic woods on the screen, and print a perfect checkerboard ready for veneering.

That seemingly futuristic solution is here today, thanks to SMartGRAIN veneer. The 8½×11" sheets of 10-mil paper-backed veneer have been treated to accept ink from your inkjet or laserjet printer without bleeding and blurring. Most print-

SOMMERFELD'S TOOLS FOR WOOD

8 East Third Street Remsen, IA 51050

CMT's New Industrio™ Routing System

Designed by
Marc Sommerfeld



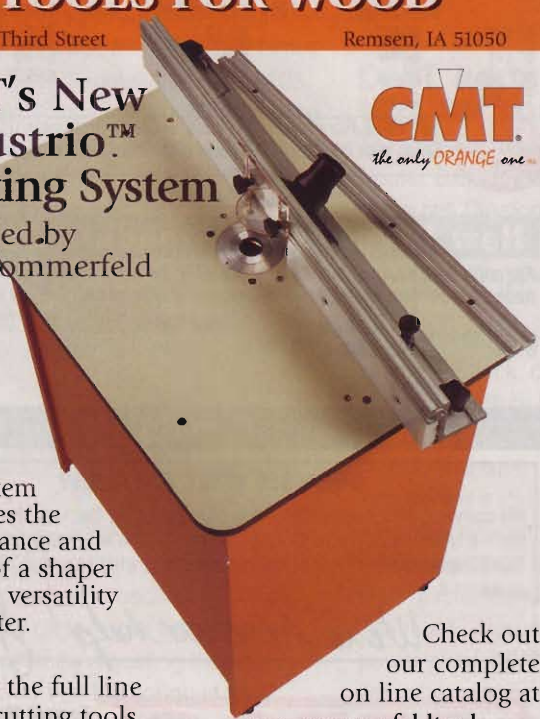

This system combines the performance and design of a shaper with the versatility of a router.

Check out our complete on line catalog at www.sommerfeldtools.com

ORDER TOLL-FREE 1-888-2BUY-CMT
1-888-228-9268

Need more shop time?

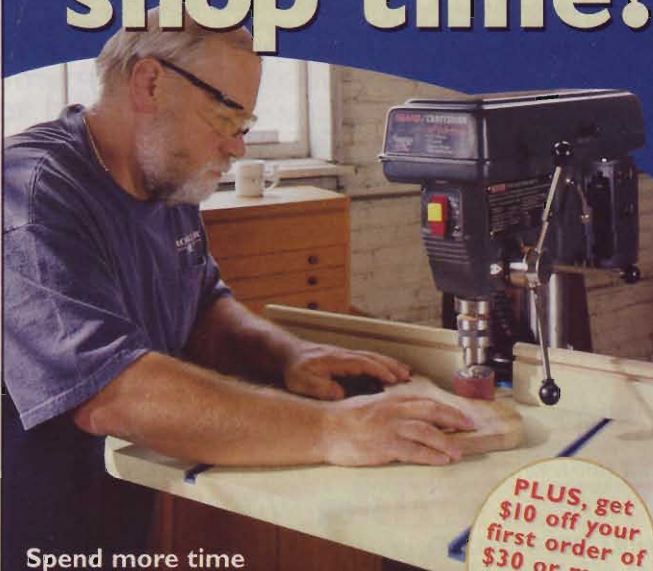

Spend more time in your shop and less time shopping – when you order your hardware, supplies, and tools on-line.

Rockler.com
WOODWORKING SUPERSTORE

PLUS, get \$10 off your first order of \$30 or more!
Just enter code V2304 at checkout

ers have an envelope or cardstock setting that can handle the thickness of the veneer. My old battle-hardened color inkjet printer did fine; my newer personal color inkjet, though, could not feed it.

Think of the possibilities: Using clip art and a word-processing program, create wooden plaques for all the kids on the soccer team. Scan your daughter's senior picture and commit it to wood on a keepsake box. Flip an image of crotch grain and create perfectly bookmatched panels for your project.

Plan to spend a lot of time, though (and a fair amount of money), getting the images just right. Because you're printing on maple veneer—not pure white paper—it's hard to know exactly how the colors on the printed image will compare to the colors on your computer screen.

For example, to create the ballerina picture *above right*, I blew through seven sheets of SMartGRAIN veneer, sizing the



SMartGRAIN printable veneer

Performance	★★★★☆
Price	\$7 per 8 1/2 x 11" maple sheet
Value	★★★★☆

Call Imaging Alternative at 651/275-1030, or visit www.imagingalternatives.com

image and getting the colors just so. The manufacturer suggests testing smaller portions of the image for color correctness, using parts of the same sheet to economize.

What about finishing? Spray finishes worked well in my test, but I found that

brushed or rubbed finishes can smear the image. If you insist on a brushed finish, spray a sealer coat first, then brush on a top coat.

Given the possible combinations of computers, software, and printers (not to mention your comfort level with computers), it's impossible to predict your success. However, the SMartGRAIN Web site offers helpful tips and one-on-one technical support to help you get the best results.

—Tested by Dave Henderson

Outfeed table holds up, then holes up

A tablesaw extension table can be your best friend in the shop, acting as an extra pair of hands to support wide or long workpieces as they pass the blade. When you're not using them, though, they're like your lazy brother-in-law: always

Continued on page 100



Econ-Abrasives

WE MAKE ABRASIVE BELTS ANY SIZE, ANY GRIT!

Standard Abrasive Sheets		
CABINET PAPER		
	50/pk	100/pk
60D	\$17.58	\$31.58C
80D	\$16.42	\$29.26C
100 thru 150C	\$15.26	\$26.95C
FINISHING PAPER		
80A	\$11.74	\$19.89C
100 thru 280A	\$10.50	\$17.58C
NO LOAD PAPER(white)		
100 thru 400A	\$12.90	\$22.40C
"C" = 100 SHEETS		
Velcro® Vacuum Discs		
8 Hole pattern for Bosch sanders		
Dia.	Grit	Price
5"	60	\$.48ea
5"	80	.46
5"	100 thru 320	.45
* Available in 5 hole pattern *		
*Wide Belts*Rolls*Flap Wheels *Pump Sleeves*PSA Discs *Router & Wood Bits*Wood Glue		
*MasterCard, VISA, Discover, Am. Express *SATISFACTION GUARANTEED!!! *CALL FOR FREE CATALOG -TX add appropriate sales tax -Call for shipping charges		

ABRASIVE BELTS

Belts are resin bond cloth with a bi-directional splice, specify grits.

1X30	\$.81 ea	3X24	\$.93 ea
1X42	.81 ea	3X27	.96 ea
1X44	.81 ea	4X21 3/4	1.06 ea
2 1/2X16	.85 ea	4X24	1.10 ea
3X18	.86 ea	4X36	1.35 ea
3X21	.90 ea	6X48	3.50 ea
3X23 3/4	.93 ea	6X89	6.24 ea

OTHER SIZES ON REQUEST

HEAVY DUTY SPRING CLAMPS

Clamps come w/PVC tips and grips.

Size	Price
4"	\$1.75 ea
6"	2.25
8"	3.50

JUMBO ROUTER PAD(24" x 36")

It will not allow small blocks of wood to slip out under router or sanding applications.

ROUTER PAD ONLY \$8.95ea.

JUMBO BELT CLEANING STICK

ONLY \$8.80



Econ-Abrasives

P. O. Box W1628
Frisco, TX 75034
(972)377-9779

TOLL-FREE ORDERING LINE (800)367-4101

SQUARE DRIVE GUTTER SCREWS!

- Square Drive for No-Slip Installation
- Screws Don't Back Out like Spikes, are Easier to Install
- Shank has Extra Thick Galvanized Coating for Long Life
- White or Brown painted Heads match Gutters
- Sizes for 4" or 5" Gutters





Call or Write for FREE Catalog!

PO Box 11169 • Dept WDKB • Lynchburg • VA • 24506
Toll Free • 1-800-443-7937 or at www.mcfeelys.com

Circle No. 1229

Circle No. 2450

products that perform

hanging around and taking up space. But Rockler's Table Saw Outfeed Table dismounts from your saw in a jiffy and stows easily when not needed.

The roomy 32x24" melamine-coated MDF table hangs on a pair of U-shaped steel brackets that bolt to the saw between its cast top and rear fence rail. On the far end, a pair of 2x2 legs supports the table. The kit includes the folding leg brackets and floor levelers; you provide the legs.

I installed the Table Saw Outfeed Table on four different tablesaws—my 20-year-old Craftsman saw, a new Craftsman tablesaw (22851), a Delta contractor's saw with a Unifence, and a DeWalt DW746 tablesaw. Except for the newer Craftsman saw, whose Align-A-Rip fence locks to the rear rail and required readjusting the fence, most installations took 20 minutes or less.

The mounting instructions are clear for the most part, detailing the methods for



Rockler Table Saw Outfeed Table (#23316)

Performance	★★★★★
Price	\$80, plus shipping
Value	★★★★★

Call Rockler Woodworking at 800/279-4441, or visit www.rockler.com.

different styles of fences and saws. The only shortcoming I found is that, while they acknowledge you'll probably have to machine a slot in the table to accommo-

date the saw's splitter and blade guard, they don't give any suggestions for how to do it.

For most of the panel cutting and ripping I did, the Table Saw Outfeed Table stood solidly. However, when ripping pieces longer than about 5', I found I still needed a roller stand. Most woodworkers will be well-served by both the size and price of this accessory.

—Tested by Jeff Hall

About our product testers

Rich Bright, Jeff Hall, and Kirk Hesse teach woodworking and other technical skills to high-school students in Des Moines, Iowa. Randy Zimmerman and Dave Henderson are avid woodworkers whose tool reviews have appeared in WOOD® magazine for several years.



Better Homes and Gardens®
WOOD PLANS

now available at

Michaels
THE ARTS AND CRAFTS STORE®

FOR THE STORE NEAREST YOU, PLEASE CALL OUR TOLL-FREE NUMBER, 1-800-MICHAELS OR VISIT WWW.MICHAELS.COM

persimmon

the all-American ebony that took to the links

One of the 200 members of the world-wide ebony family, but the only one in North America, the common persimmon (*Diospyros virginiana*) grows all the way from southern New York to Florida, west to Texas, and into Missouri. And just as with the ebonies of East India, Ceylon, and Africa, the heartwood of American ebony appears almost black in color and is dense, heavy, and hard. But it is small in diameter. The lighter colored sapwood, on the other hand, rates nearly the same density, hardness, and weight, but there's more of it.

A gnarly, small-diameter tree seldom found growing in stands, the persimmon sprouts in places other trees shun. You'll find it growing in played out strip mines

of coal, damp bottomlands, and trampled farmyards. In the best conditions, a persimmon tree might reach a 100' height, but less than half that would be normal.

Many people call persimmon "possumwood" due to that animal's liking of the tree's plum-like fruit. Yet, first-timers tasting it should beware. Ripe, it's orange pulp may be a true delight, but before then the pinkish-red globes possess enough tannic acid to keep you puckered for a full day.

Although always most well known for its puckery fruit, the persimmon's wood hasn't gone unnoticed. Lumbermen once sought it for the hard-working shuttles of textile looms. Only it and dogwood could

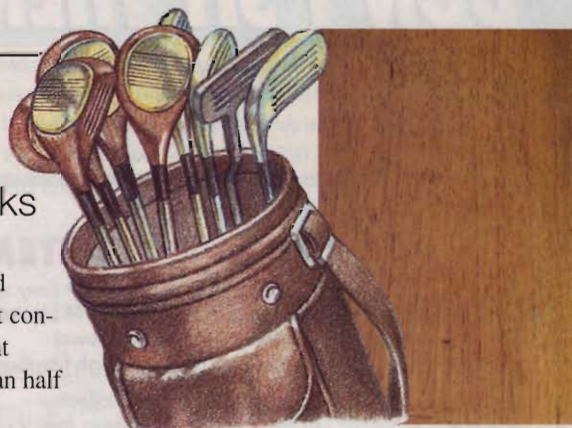

ILLUSTRATION: JIM STEVENSON

The heads of the drivers in your golf bag may well be persimmon, one of the hardest woods in the land.

stand up to thousands of hours wear before replacement. For its hardness, density, and resistance to splitting and splintering, persimmon long ago began showing up on the golf course as the highly polished head on a driver or "wood." Yet today, woods with persimmon heads have a loyal following on the links, even though they carry premium prices. ♣

Introducing, the **Kreg Jig**
K2000 ProPack...

NEW!

Featuring...

- Simple, three-step adjustability for nearly all material dimensions.

Pocket hole joinery, think outside the frame.

Kreg

Kreg Tool Company
201 Campus Drive
Huxley, IA 50124

www.kregtool.com
1-800-447-8638

TOP PICK in WOOD Magazine! June, 2001

The **OSBORNE**
by **Excalibur**
Miter Guide

ORDER TODAY
FOR ONLY \$179.99

COVERED BY EXCALIBUR LIFETIME GUARANTEE!

**So Simple...
So Stable...
So Accurate!**

OSBORNE EB-3 by Excalibur

THE GREATEST INNOVATION IN MITER GUIDE DESIGN IN OVER 100 YEARS!

Solid triangular configuration keeps the guide absolutely rigid, even at the outermost end of the fence. No movement in the fence, no movement in the work piece, no gaps in the miter joint.

Want more info? See our website...
www.osbornemfg.com

Want to own one? CALL 1-800-357-4113

EXCALIBUR • 940 BROCK ROAD, PICKERING, ONTARIO L1W2A1

what's ahead

in our next issue

Coming in November—

We've got an admirable armoire to adorn your master bedroom...it matches the sleigh bed you saw in September. You also can build it as an entertainment center.

Your own Great Divide

Split up spaces with these classic cabinets. We'll walk you through their building, and show how to add columns and an arched soffit, too.



Cordless kits corralled

Looking for convenience and cost savings? We test six cordless power tool kits that contain a high-voltage circular saw and drill.



Take a read on this book

You'll want to cache your family snapshots in this beauty of a book-like box. It's as easy to make as it is good looking.



Meet the Meier Brothers

We traveled to California so these master woodworkers could share with you their techniques for working with figured wood, joinery, finishing, and more.

