

Better Homes and Gardens

WOOD

February 2001 ISSUE 130

www.woodonline.com

tilt-top
oval
table

build it in a
weekend

for better living
full-service
laundry
center
for under \$250

tool review

**wide-abrasive
drum sanders**

technique

**hand scraper
how-to**

Display until February 6, 2001



this issue's highlights

WOOD® magazine

February 2001 Issue 130

www.woodonline.com



page 46

woodworking projects

22 knock-down-drag-out cutting platform

Six interlocking strips of $\frac{3}{4}$ " plywood fit snugly together to form a sizable support for machining large workpieces.

46 full-service laundry center

Create a functional and appealing wash-day work area with this wraparound storage unit. In the process, discover the tricks for working with melamine-laminated particleboard.

60 a classic tilt-top oval table

You don't have to be a woodturner to shape the pleasing pedestal of this weekend woodworking project. Simply mail-order the turning from our source, cut the parts, and assemble.

68 decorator's fireplace screen

Add an eye-catching accent to your home's hearth following the easy instructions for both the wood stand and fabric panel.

72 Nathan Hale pipe box

Construct a faithful replica of an authentic period piece found in the home of one of our nation's greatest patriots.

tools & materials



page 54

54 drum sanders for home workshops

Looking to avoid the tedious, time-consuming business of surface-sanding boards and wide, glued-up panels? Give one of these shop-tested workhorses a try.

82 products that perform

Check out the latest in the woodworking marketplace. The products include a saw-blade cleaner, a scrollsaw arm lift, wood-aging chemicals, a shop-vacuum hose lock, a quick-change tool-less collet for routers, a unique screw-driving system, and an aerosol that lets paint adhere to plastic and metal.



page 72



page 60

Continued on page 4

Cover photograph: Wm. Hopkins

tips & techniques

24 shop skills: cope and stick

Discover a low-tech, low-cost method for joining frame members for cabinet doors using dovetail and slot-cutting router bits.

28 tips from your shop and ours

One woodworker saves money using carpet tubes for dust collection; another employs a shelf support to fasten down a tabletop. See these and more workshop solutions inside.

76 learn the secrets of scraping success

No tool cleans up a woodworking project better than the simple metal hand scraper. Find out about the types of scrapers available, how to sharpen them, and how to put one to good use cleaning up joinery and glue lines.

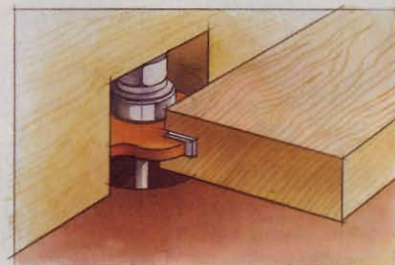

page 24

features

6 the editor's angle

10 talking back

14 WOOD ONLINE®

16 WOOD forum

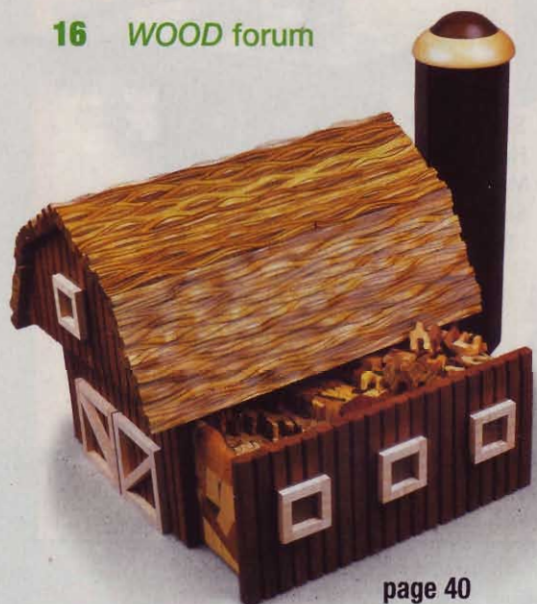

page 40



page 76

40 one very puzzling craftsman

Get to know Virginia woodworker Jerry Syfert and see how his intriguing boxes exhibit a whole new level of complexity, with some selling for over \$1,000.

66 back-to-basics caskets

Travel with *WOOD* magazine's Pete Stephano to the New Melleray Abbey in northeast Iowa where the Trappist monks supplement their monastery's lagging farm income with money made from a rather unique line of woodworking.

100 finishing touches

It's Here!

A new series of articles that will help you make the most of your woodworking skills in and around the house

We know that you take a lot of pride in your homes, yards, and gardens. With that in mind, we have decided to add a whole new dimension to the magazine—woodworking projects that improve the value and beauty of your home.

Starting now, we plan to cover some aspect of woodworking that enhances your home in every issue. For example, you'll find a nifty laundry storage center on page 46 that we designed to help bring order and good looks to an often-neglected area of the home. In the next issue, we'll bring you a bathroom cabinet that we think many of you will want to build and put in place of your standard medicine cabinet. This smartly designed project has built-in electrical receptacles; cord storage for shavers, blow dryers, or other appliances; and three mirrored doors.

But, we think you'll be really impressed by what we'll bring you in the April issue's "The Handcrafted Home" section. The coverage will include the complete overhaul of

a '60s-style family room into a high-style, woodworking-rich living space. We'll show you how to make and install paneled walls, built-in bookcases with doors, and matching light sconces. (See the drawing below.)

We'll do a major home-beautifying project, such as this family room, twice every year, in our April and October issues. So stay tuned as we tackle a complete kitchen remodel and a new deck in future issues. As always, we'll lead you step-by-step to the successful completion of each project. We'll include patterns, exploded-view drawings, precise instructions... everything you need for perfect results.

Larry Clayton



The Handcrafted
Home

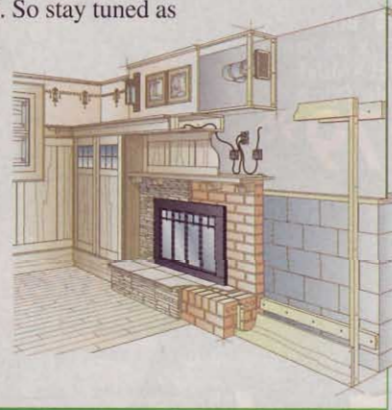

Better Homes and Gardens

WOOD®

FEBRUARY 2001 • Vol. 18, No. 1 • Issue No. 130

Editor **LARRY CLAYTON**
 Managing Editor **JIM HARROLD**
 Assistant Managing Editor/Features **PETER J. STEPHANO**
 Senior Design Editor **JAMES R. DOWNING**
 Projects Editor **BILL KRIER**
 Projects Editor **JAN HALE SVEC**
 Products Editor **DAVE CAMPBELL**
 Techniques Editor **JIM POLLOCK**
 Shop Manager/Project Designer **CHARLES I. HEDLUND**
 Assistant Design Editor/Project Builder **KEVIN BOYLE**
 Production/Office Manager **MARGARET CLOSNER**
 Administrative Assistant **SHERYL MUNYON**
 Reader-Contact Specialist **BEN VONRUDEN**
 Illustrators **KIM DOWNING, LORNA JOHNSON, ROXANNE LeMOINE, ERICH LAGE**
 Consultants **BOB McFARLIN, DAVE HENDERSON**
 Contributing Craftsman **JIM HEAVEY**

Creative Director **DANIEL MASINI**
 Associate Art Director **JOHN MEEK**
 Assistant Art Director **CHERYL A. CIBULA**
 Art Department Assistant **VICKIE JANSSEN**

Publisher **MARK HAGEN**
 Ancillary Sales and Internet Manager **MARLEN KEMMET**

Advertising Office: 333 N. Michigan Ave., Suite 1500,
 Chicago, IL 60601 Phone: 312/853-2890 FAX: 312/580-7906
 Direct Response Advertising **CAROLYN DAKIS**
 Account Executive **YUWEI LEE**
 Account Executive **RON GOLMINAS**
 Advertising Manager **JIM HUGHES**
 Marketing Manager **GERALLIE LEGASPI**
 Sales Assistant **MARGARET TRAVIS**
 Sales Assistant **THERESA COOKS**

Publishing Director **WILLIAM R. REED**

Advertising Services Manager **PAT HENDERSHOTT**
 Consumer Marketing Director **LIZ BREDSON**
 Associate Consumer Marketing Director **KATHI PRIEN**
 Assistant Consumer Marketing Manager **DAVE HONOLD**
 Business Manager **CRAIG FEAR**
 Senior Product Manager **RICK GROW**

MEREDITH PUBLISHING GROUP

President **STEPHEN M. LACY**
 President **JERRY KAPLAN**
 Vice President Publishing Director **JERRY WARD**
 Creative Services **ELLEN DELATHOUDER**
 Manufacturing **BRUCE HESTON**
 Consumer Marketing **KARLA JEFFRIES**
 Operations **DEAN PIETERS**
 Finance and Administration **MAX RUNCIMAN**

Meredith
CORPORATION

WILLIAM T. KERR, President and Chief Executive Officer

E.T. MEREDITH III, Chairman of the Executive Committee

©Copyright Meredith Corporation 2001
 All rights reserved. Printed in the U.S.A.

Better Homes and Gardens® WOOD® magazine (ISSN-0743-894X) is published nine times a year in February, March, April, May/June, July/August, September, October, November, and December by Meredith Corporation, 1716 Locust St., Des Moines, IA 50309-3023. Periodicals postage paid at Des Moines, Iowa, and additional mailing offices. Better Homes and Gardens trademark registered in Canada and Australia. Marca Registrada en México. ONE-YEAR SUBSCRIPTION PRICES: U.S. and its possessions, \$27; Canada, \$39; other countries, \$47. Canada Post Publications Mail Sales Product Agreement No. 1369350. Canadian BN 12348 2887RT. CANADIAN RETURN ADDRESS: Better Homes and Gardens WOOD magazine, 2744 Edna Street, Windsor, Ontario, N8Y 1V2. POSTMASTER: Send address changes to Better Homes and Gardens WOOD magazine, P.O. Box 37439, Boone, IA 50037-0439.

Customer Service Information: For service on your subscription, including change of address, contact www.wood-magazine.com/service or call 800/374-9663. **Subscription mailing address:** Better Homes and Gardens WOOD magazine, P.O. Box 37439, Boone, IA 50037-0439. Please enclose your address label from a recent issue. **Editorial mailing address:** The Editor, WOOD magazine, 1716 Locust Street, GA310, Des Moines, IA 50309-3023. For questions for our editorial staff, questions about how to reach an advertiser, or to place an advertisement in our magazine call 800/374-9663. To order back issues call 800/346-9663. For article reprints, write to the editorial address and enclose \$5 per article.

Letters, Comments & Updates

Knowing when to clean an air filter

How do you know when the filter on the *WOOD*® cyclone dust collector from Issue 100 needs cleaning? I added a simple air-pressure gauge called a manometer. Here's how.

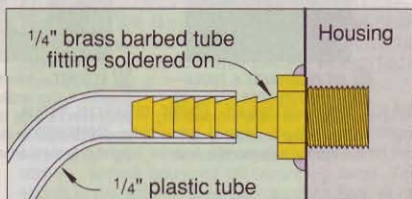

Mount a U-shaped loop of 1/4" i.d. clear plastic tube (available from hardware stores or home centers) on a board, and attach one end to the filter housing, as shown in the drawing. You can mount the board on a joist adjacent to the filter. Fill the tube about halfway up the U with colored water. Mark the level of the water with the cyclone off. This lets you keep tabs on the evaporation of water from the tube. I haven't tried it yet, but I hear

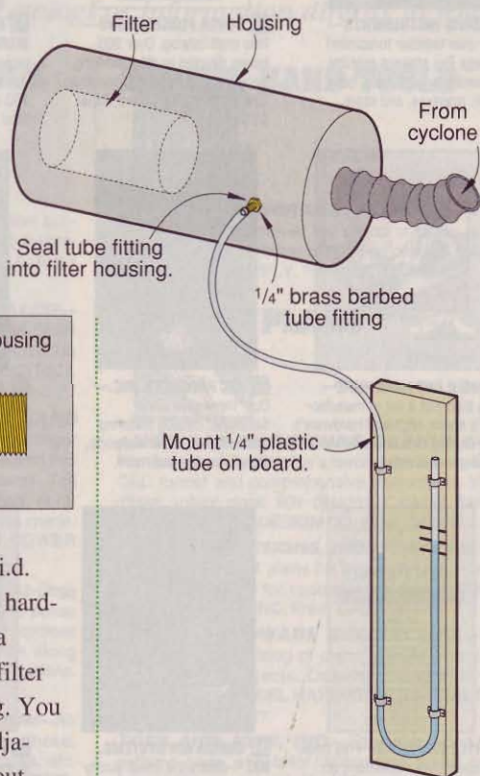

that you can eliminate evaporation by floating a small drop of light oil on top of the water on each side of the U.

With the filter clean, and one blast gate open, switch on the cyclone. The

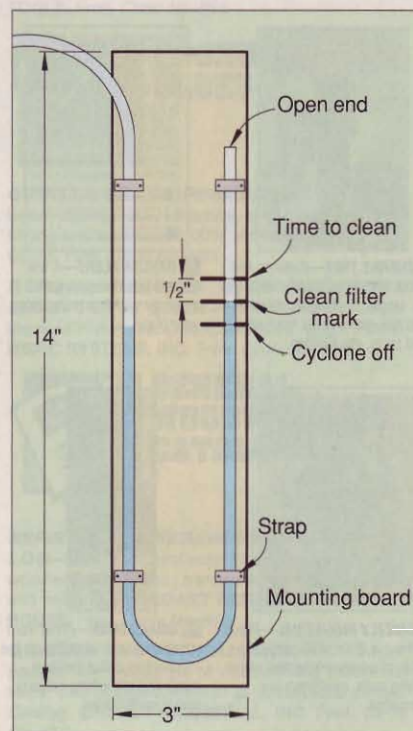

pressure backing up behind the clean filter will push the water a distance up the open leg of the U. Mark this level. Now, as the filter loads up, additional pressure pushes the water farther up the tube. With the same blast gate open, when the water level reaches 1/2" beyond the clean-filter mark, service the filter. I find that the *WOOD* cyclone loses about 100 CFM for each half-inch increase in the height of the water column.

—Rod Cole, Lexington, Mass.

Tablesaw trials appealed

The review of mid-priced tablesaws in Issue 128 incorrectly identified the Jet's fence-face material as melamine-coated particleboard. They are made of high-density polyethylene (HDPE).

Also, a cast-iron tablesaw top is much more flexible than one would expect. Because the open stand of a contractor saw lacks the rigidity of a cabinet saw base, its top flatness depends on the flatness of the floor.

—Dave Campbell, *WOOD* magazine

The complete guide to chair cane sizes

I just read the article on chair caning in Issue 123. Although medium and fine are the two most popular sizes, there are actually seven sizes of cane available. This is important information to know, especially when recaning an old chair. As shown in the chart, different hole diameters and spacing indicate the size of cane to use

—Vincent Tarantini, Ship Bottom, N.J.

Note: Vincent has taught chair caning and rush seating for 28 years. He currently teaches at the Southern Regional Adult School in Manahawkin, N.J.

Cane Size	Hole Dia.	Hole Spacing
carriage	1/8"	5/16-3/8"
superfine	1/8"	3/8"
fine fine	3/16"	7/16-1/2"
fine	3/16"	1/2-9/16"
narrow medium	1/4"	9/16-5/8"
medium	1/4"	5/8-3/4"
common	5/16"	3/4-7/8"

Continued on page 12

A production jig for wheel treads

The instructions for One Huge Hauler in Issue 122 call for filing the wheel-tread notches by hand. I made a jig to cut the notches on my router table with a straight bit. I thought some other WOOD® readers could use it.

—James Geary, Elk Point, S.D.

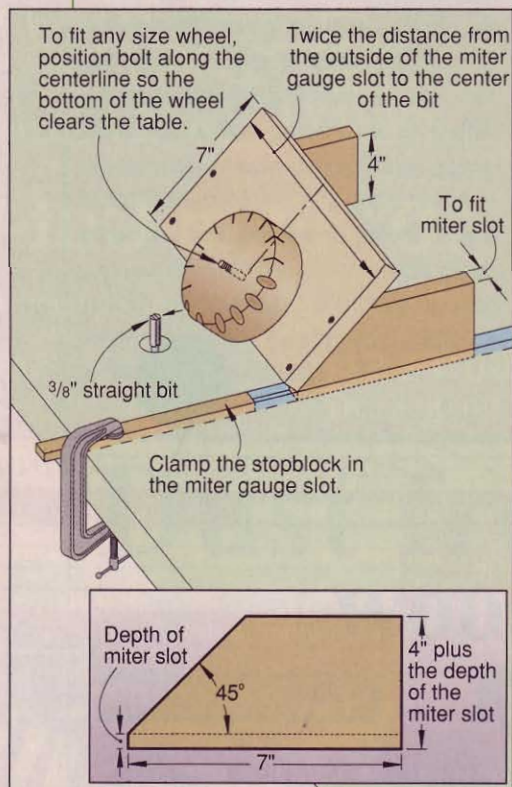

Great idea, Jim. We combined a couple of ideas from a recently published jig with yours, and here it is.

The American Chestnut and Elm: They're back!

The Wood Anecdote on American chestnut in Issue 125 elicited the response from several readers that, while the American chestnut is down, it is by no means out.

Chinese chestnuts are known to have chestnut blight resistance, but they lack the stature that makes the American species desirable for shade and lumber. Many decades of breeding research by the U.S. Department of Agriculture, the Connecticut Agriculture Experiment Station, and The American Chestnut Foundation (TACF) have shed light on the genetics of chestnut blight resistance.

TACF's goal is to introduce into the American chestnut the blight resistance of the Chinese tree, while preserving the other characteristics of the American species. The first line of blight-resistant American chestnuts will be ready for planting in 10–15 years. For information, contact The American Chestnut Foundation, 469 Main St., P.O. Box 4044, Bennington, VT 05201; phone, 802/447-0110; e-mail, chestnut@acf.org; or visit www.acf.org.

While we're on the subject of decimated species making a comeback, we feel obligated to mention the



American elm. The decline of the chestnut started in 1904; Dutch elm disease wiped out the elms in the 1960s. Many of us remember city streets and country roads arched over by elms.

The Elm Research Institute is a non-profit organization dedicated to the restoration of the American Elm. They market a preventative treatment for Dutch elm disease and the disease-resistant American Liberty elm. For information, contact the Elm Research Institute, 1 Elm Street, P.O. Box 150, Westmoreland, NH, 03467; phone, 800/367-3567; e-mail, eri@top.monad.net; or visit www.libertyelm.com.

Make that tablesaw insert safe to use

A shop tip in Issue 122 suggests making a zero-clearance tablesaw insert for both a full-width and a thin-kerf saw blade by turning the insert end-for-end. This is an excellent idea, with one addition to improve its safety. Original equipment inserts have some method to hold them down, keeping the blade from accidentally catching the insert and throwing it back at the operator. I would suggest a swiveling tab at both ends of the insert. The tab at the rear of the insert would engage the saw table while the one at the front would be rotated out of the way.

—Howard Acheson, Larchmont, N.Y.

Write Us!

We welcome your comments, criticisms, suggestions, and yes, even compliments. Please write to: **Talking Back, WOOD Magazine, 1716 Locust St., GA310, Des Moines, IA 50309-3023** or email us at talkingback@mdp.com.

We select and publish only letters of the greatest benefit to our readers.

Watch a masterful woodworking project unfold before your eyes



The Handcrafted Home™

If you're interested in customizing the interior spaces of your home with beautiful woodworking, check out the upcoming April issue of *WOOD*® magazine. In it you will find a spectacular renovation of a family room. But you don't have to wait until then to see how this exciting project is progressing. Just visit the web page *below*, and you'll get a behind-the-scenes sneak-peek at the construction, including the oak wall paneling, the application of wall stencils, and the installation of the

wood floor.

We'll give you new coverage of this ongoing renovation every two weeks up until the publication of the April issue, so stay tuned!

You'll even be able to take a 360° tour around the completed room.

www.woodmagazine.com/handhome

A mall loaded only with woodworking stores that stay open day and night

Sounds like a woodworker's dream come true, doesn't it? Not any more. This mall exists. You won't find it down the street, but you can get there in only seconds. Just click a computer mouse a few times and you'll be at the WOODMALL®, a 24-hour-a-day, 7-day-a-week cyberspace reality with 20-plus stores that cater exclusively to the product needs of woodworkers.

Shopping around, you'll find everything you require, from power and hand tools to hardware and wood. It's all there—over 40,000 items—with many on sale. You'll find special prices, closeouts, comparisons of over two dozen types of tools, and even a gift registry.

If you don't have the time to check out each store in the mall, you can survey all of them at once for a specific tool or product via our electronic search feature. Just plug in the name of a product, and we'll tell you where to find it in the mall. www.woodmagazine.com/woodmall

More free web offerings you don't want to miss

•The Design in Wood Show in San Diego features some of the most beautiful woodworking pieces you'll find anywhere. You can view 29 inspiring pieces and learn which ones took home the prize money.

www.woodmagazine.com/woodmall/sandiego/index.html

•Watch from design to finished masterpiece as a craftsman inlays an image of Sitting Bull in a cedar-strip canoe. Thirty-eight color images guide you every step of the way.

www.woodmagazine.com/woodmall/canoes/index.html

•The Northwest Fine Woodworking Furniture Gallery in Seattle is one of the finest handcrafted furniture stores in the nation. But you don't have to travel anywhere to visit 23 of the artists represented there—just check out this web page:

www.woodmagazine.com/woodmall/furn_gallery/index.html



You'll find Ken Richards' writing desk featured in the gallery mentioned above.

Answers to woodworking questions gathered from your letters and e-mails, and our WOOD Online® discussion groups.

How to harvest beautiful burls

Q I have acquired a walnut tree with several large burls. What's the best method for harvesting these burls to get the maximum yield?

—Jerry Tibbetts, Rockwall, Texas

A Jerry, we consulted with burl expert Tom Hutchinson, who owns Hut Products, Inc. He advises you to saw off each burl deep enough so that some of the non-burl wood remains with it. That should help avoid cracking and splitting. Store the burl in a relatively dry spot for six months before slicing it up or turning it. Or, you can speed up the process by coating or soaking the burl with Pentacryl. This wood stabilizer is available from Woodcraft, 800/225-1153, for \$14.99 per quart.

But before you spend six months dreaming about what beauty lies within, grab a sneak preview. Scrape off just enough wood to find out if it's an "eye" burl or an "onion" burl. If lots of round, eye-like features appear, as in the sample *above left*, that's a valuable burl. Slice across the eyes once the burl dries, and you can turn out some beautiful veneer or slabs. But if you find

only convoluted layers of wood, as in the one at *right*, don't count on veneer or slabs.

Tom says, "Most onion burls will literally fall apart" if you cut them into pieces.

—WOOD® Magazine

Ready, aim, blast?

Q I would like to sandblast some text into a piece of 1/4" walnut, using an inexpensive sandblaster and playground sand. When I sandblasted glass, long ago, I think I used contact paper to mask surfaces. Would that work in this situation?

—Joe Pasnik, Lewisville, Texas

A You can get some wonderful results by sandblasting wood, Joe, but using a low-end machine on walnut sounds like a formula for frustration. Jerry Stephens, who makes signs in California, says woods such as

walnut and teak are just too tough. Oak doesn't work well, either. Try cherry or maple for indoor projects and redwood or cedar for anything outdoors. And if you can get your hands on a heavy-duty blaster, the work will be much more rewarding.

As for the masking material, you'll get the best results with adhesive vinyl for light jobs. Try adhesive rubber, available at sign shops or from grave monument companies, for more serious work. Or you can get by with a couple of layers of duct tape, cut to shape with a sharp knife. Contact paper won't stand up in this application. Do the

blasting with silica sand, widely available at most home centers. Wear a good respirator, though, because prolonged exposure to silica sand leads to lung damage.

For more information about sandblasting equipment and supplies, call TP Tools and Equipment at 800/321-9260 and request a free catalog. You also could check the Yellow Pages, or do an Internet search for "sandblasting supplies."

—WOOD Magazine

Continued on page 18

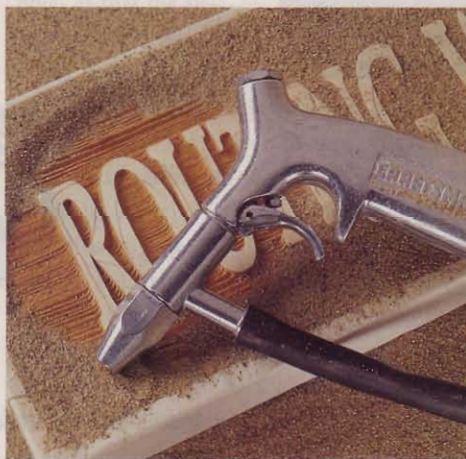



PHOTOGRAPHY: CLINT FARLINGER

Furniture from barn wood?

Q | A fellow here in eastern Pennsylvania is selling boards he has salvaged from old barns, mostly pine, with some hardwood mixed in. It's in random-width boards, some 12' or longer. I wonder whether these old barn boards are suitable for making furniture.

—WOOD Online® participant

A | Here in Kentucky most of the barn wood is oak and old. I made a small cabinet from it for a customer who supplied the wood. This stuff eats planer and jointer knives quickly, and there's a lot of waste, but it does make nice-looking stuff. I leave on some of the gray, weathered wood for looks.

—Don Eisenhardt, New Haven, Ky.

To me it's the greatest wood to work with. Most of the wood that I get from old barns and houses is 70 to 100 years old. That grade of wood just doesn't grow here anymore, and I don't plane or sand out all the defects. It's so cheap that most of the time I get it for doing the take-down. That's a little work, but worth it to build something from that age of wood.

—Mike Carlton, Newbern, Tenn.

There's an antique shop right near me that sells tables made exclusively from really old barn wood. The tables are new, but the wood is old. If I could get the prices they get, I could make a living working two hours a day.

—Wayne Van Coughnett, New Milford, Conn.

I use recycled wood all the time. Here in Ohio a lot of the old barns were made from red and white oak. The last I bought was about a buck a board foot. I just run it through my planer, taking light cuts. I do have a handheld metal detector, and it found a few nails I never saw. I usually find a couple of square cut nails and can pull them out in one piece. I made a harvest-type kitchen table and the tables in the living room. I leave small defects in the wood for character.

—WOOD Online participant

Got a question?

If you're looking for an answer to a woodworking question, write to: **WOOD Forum, 1716 Locust St., GA 310, Des Moines, IA 50309-3023**, or e-mail us at woodforum@mdp.com. For an immediate answer to your question, get help from fellow woodworkers by posting it on one of our Internet discussion groups at: www.woodonline.com.

Introducing, the Kreg Jig® K2000 ProPack...



Featuring...

-Simple, three-step adjustability for nearly all material dimensions.

Pocket hole joinery, think outside the frame.



Kreg Tool Company
201 Campus Drive
Huxley, IA 50124

www.kregtool.com
1-800-447-8638

TENRYU PRO SERIES

"The cuts were so quiet and effortless it felt like I forgot to raise the blade"

Hal Taylor, Museum Quality Works of Art, Hartwood, VA

Hal's comment is typical of the many we receive from craftsmen who have tried our Pro Series blades.

Each blade features:

- Expertly-tensioned, fully-hardened tool steel plates for true run
- Fine grit honing of carbide edge for clean, smooth, and easy cuts

- Resin bond-filled expansion slots for extremely quiet cuts
- High-grade, wear-resistant carbide tips for long life

Tenryu Pro Series blades are also available for cutting plastic and non-ferrous metals. So save your ears and make life easier with Tenryu blades. Ask for them at your favorite dealer or call 800-951-SAWS.

FOR YOUR SAFETY: Follow machine and manual safety instructions.

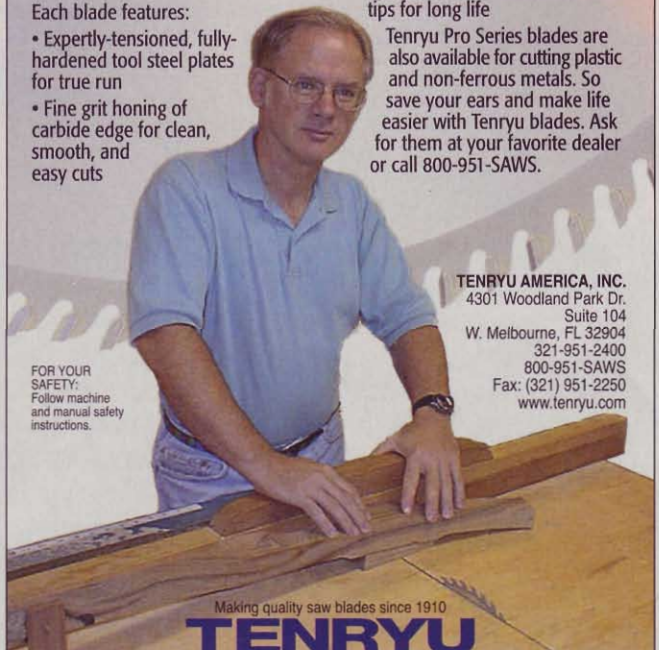

TENRYU AMERICA, INC.
4301 Woodland Park Dr.
Suite 104
W. Melbourne, FL 32904
321-951-2400
800-951-SAWS
Fax: (321) 951-2250
www.tenryu.com

Making quality saw blades since 1910

TENRYU

knock-down-drag-out cutting platform

Sheet goods often present a real challenge when it comes to cutting them down into project-sized pieces. Even if you have the room in your shop to maneuver a full sheet of plywood, singlehandedly balancing it on your tablesaw while cutting it can prove impossible.

After struggling with 2x4s and sawhorses, reader Richard Brunkow of Milligan, Nebraska, determined that it wasn't the sawhorses, but the shifting,

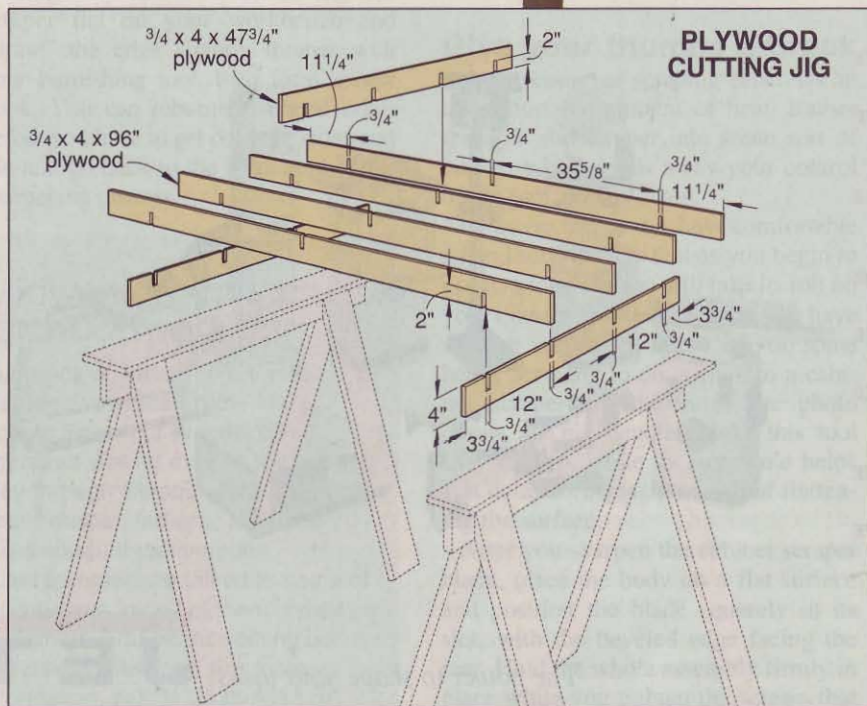

sagging 2x4s that were the problem. He sent us this idea for a knockdown platform that sets up quickly and easily.

Simply rip six 4x96" strips from a sheet of 3/4" plywood, then cut three 47 3/4"-long pieces from two of the strips. Cut the notches where shown in the drawing.

To use the platform, position your sawhorses so they support the two short end rails. Then drop the center rail in from the top. Adjust your saw to cut about 1/8" deeper than the thickness of the sheet being cut. When taken apart for storage, the pieces of the platform make a stack less than 5 1/4" thick that can easily be stored in the rafters of your shop or garage. 🌲

Project Design: Richard W. Brunkow
Photograph: Baldwin Photography
Illustration: Roxanne LeMoine

easy & quick **cope & stick**

Use a basic router bit in a new way to dress up those frame-and-panel doors.

Cope-and-stick joinery produces great-looking frames for cabinet doors, but you need specialized router bits or shaper cutters to do the job the traditional way. Those items don't come cheap. So we found a low-cost, low-tech alternative, based on a simple dovetail bit.

First, let's define some terms. "Stick" or "sticking" refers to the molded edge that's cut along the inside edge of the frame; pieces that meet that molding at a right angle must be "coped" to match the profile. Our technique replaces the usual round-over profile with a clean, simple bevel. It produces a subtle effect, not a dramatic one.

If you have a router, a router table, a dovetail bit, and a slot cutter, you can do it the way we show here. Begin by cutting the stiles to their final length.



Lay out the rails by adding 1" to the final inside width of the frame. That measurement will allow for a 1/2" stub tenon on both ends of each rail.

Bevel the edges. Install any dovetail bit with a 1/4" shank in your router, mounted in a router table. A 1/2" shank would rub against the middle of the workpiece and ruin your alignment. (Note: It's helpful to make several auxiliary fences with different-sized openings. For each bit, use a fence with an opening just big enough for that bit.)

Raise the bit so that it extends to the top surface of the workpiece. Set the fence to allow the bit to slice off just enough material to bevel the top half of

the inside edge, as shown in the drawing *below, left*. Make that cut, then flip the piece over and mill the other half of the same inside edge. Rout all the rails and stiles this way.

Cut slots for the panel. Switch to a 1/4" slot cutter in your router. You could use a 1/4" straight bit instead, but the slot cutter allows you to work with the pieces lying on their faces instead of balanced on edge. It's safer and more precise that way. Set the slot cutter to extend 1/2" from the router fence, as shown in the drawing *below*. Then, run the inside edge of each stile and each rail through the cutter to form a full-length slot.

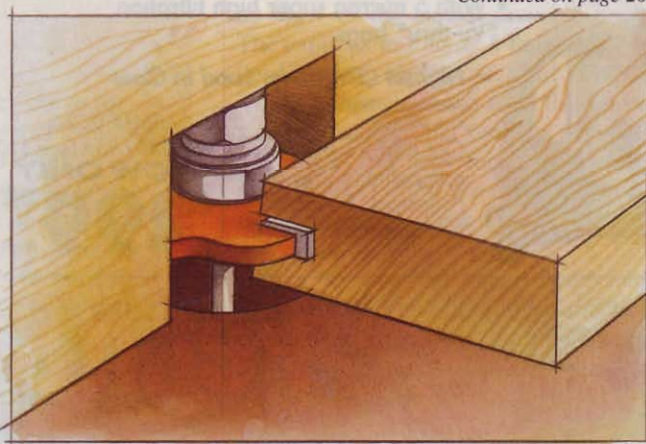
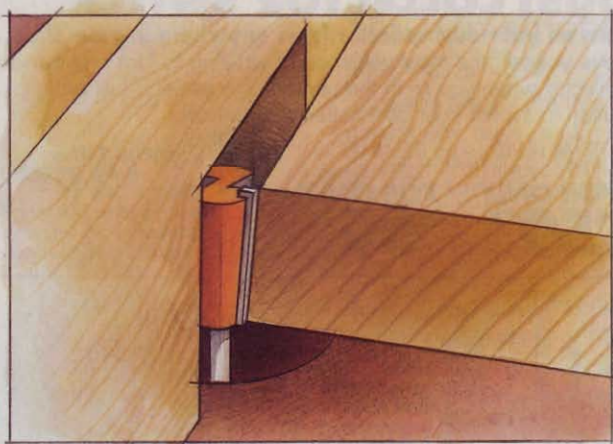

Continued on page 26

Start forming the tenons. Mount a dado blade on your tablesaw, and set it to cut a centered tenon $\frac{1}{4}$ " thick on the rails, as shown *below*. Support the workpiece with an auxiliary fence on your miter gauge. Run a test piece through first to make sure it fits snugly into the grooves made in the first step. Cut the tenons $\frac{3}{8}$ " long, just to get some of the waste out of the way. You'll finish cutting them to length on the router table.

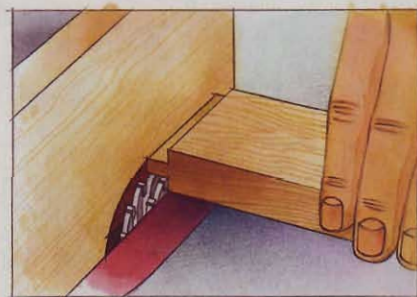

Finish the tenons. Go back to the router table and re-install your dovetail bit. Adjust the height of the bit to match the bottom surface of the tenon.

Now mark $\frac{1}{2}$ " from the end of one tenon to establish the completed length of the tenon. Set the router table fence so that the point of the dovetail bit hits the mark, as shown *below*. Rout the ends of the rails with this setup, finishing the top and bottom shoulder of each tenon.

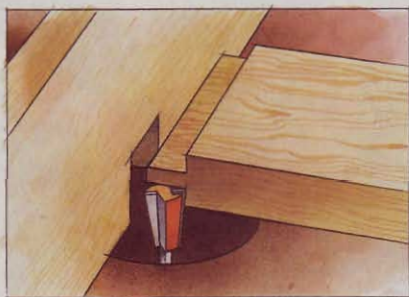

Assemble the frame. Now the rails and stiles fit together as shown *below*. Make standard panels with $\frac{1}{4}$ " sheet material or solid wood shaped to fit into the slots. We chose a third route and made raised panels out of the light-weight version of medium-density fiberboard. We glued the panels on all four edges and set them in the grooves. Glue plywood panels, too, but don't glue solid-wood panels in place. ♣

Written by **Jim Pollock** with **Chuck Hedlund**
Photograph: **Baldwin Photography**
Illustrations: **Brian Jensen**

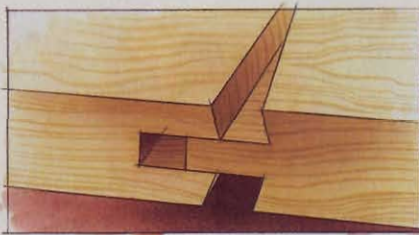

Free to a Good Home

\$131 Accessory Package

Accept no imitations! Buy the Performax 16-32 Plus Drum Sander, the industry's original drum sander, and receive the accessory package absolutely FREE!

Package includes:

- Infeed/outfeed tables
- Conveyor belt tracker set
- Box of ready-to-wrap sandpaper sized to fit

\$131 accessory package FREE



(Stand optional)

The power to shape your ideas **PERFORMAX**

JET, Performax and Powermatic — A Family Of Brands

Offer effective September 1, 2000 through March 31, 2001 • 800-334-4910 • www.PerformaxProducts.com

Circle No. 78

Introducing the New Delta Store. Tap into the Power of the Pros.



The new Delta store has over 500 products from a complete line-up of unisaws to those hard-to-find machinery attachments. Extensive product information including customer ratings and reviews will help you choose the right tool for the job. We'll even deliver to your door for only \$5.99.

Visit the Delta store at

www.amazon.com/delta

table saws radial saws miter saws
scroll & band saws planers the Delta store
drilling machines jointers wood shapers

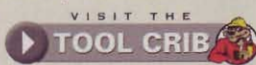



Top Shop Tip winner Jason Matthews stands in the custom kitchen he designed and built before he was old enough to vote.



For sending this issue's Top Shop Tip, Jason Matthews' shop will grow by one tool—a Porter-Cable 3807 sliding compound mitersaw. Thanks, Jason!

Call him a precocious woodworker, but by the tender age of 17, Jason Matthews already had a custom kitchen under his tool belt. Did he learn woodworking at his daddy's knee? "Actually, I got started with a scrollsaw when I was 13," our Top Shop Tip winner replies. "My mom did tole paintings, and I helped her by cutting the pine wood shapes that she painted on." Later, Jason parlayed Mom's request for a spice rack into a new tablesaw, drill press, and benchtop sander.

These days, Jason's shop takes up most of the family basement. That's where he designed and built a kitchen full of cabinets for a friend. It's also where he came up with this issue's Top Shop Tip, at right.

Have you come up with a solution for a workshop puzzler? Share it with us, and we may share it with the world. If we choose your tip for publication, you'll get \$75; if we deem it the best of the issue, you'll also get a tool prize worth at least \$250.

Send your tips, along with drawings or photos and your daytime telephone number, to:

Tips From Your Shop (and Ours)
WOOD® Magazine
1716 Locust St., GA-310
Des Moines, IA 50309-3023

Or post your suggestions on our Top Shop Tips discussion group at www.woodonline.com.

Because we try to print only original shop tips, please send them only to WOOD magazine. Sorry, but we can't send back your submissions. Thanks!

Dave Campbell

WOODWORKING PRODUCTS EDITOR



Rookie mistake, veteran solution

While building a small table recently, I realized I'd forgotten to cut a saw kerf inside the apron for the tabletop-mounting clamps. And, the table was small enough that I couldn't fit my biscuit joiner inside to make a slot.

While contemplating my dilemma, I stumbled across some 1/4" shelf supports like the ones shown in the drawing below. I drilled holes in the apron as shown, slipped a pin in each hole, then rotated each support into the position shown. Finally, I secured the shelf supports to the tabletop with screws. The technique worked so well, I now use it regularly in my projects.

—Jason Matthews, Ogden, Utah

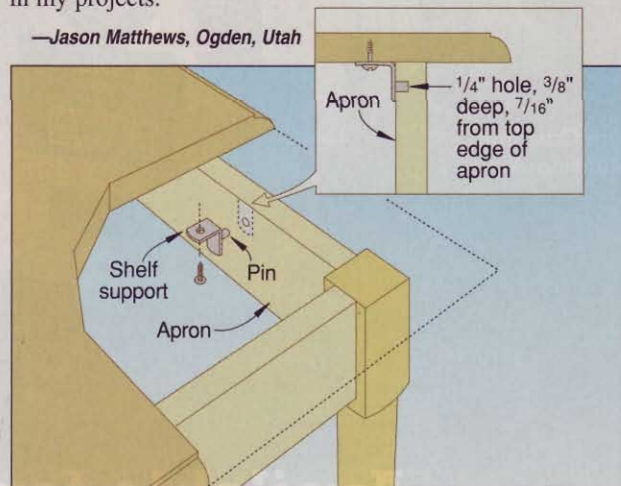

Carpet tubing makes thrifty dust duct

I recently purchased a dust collector for my shop and needed some ductwork to connect it to several machines. I'm always trying to be thrifty, so I trekked over to a local carpet shop and acquired—for free—several lengths of 4"×12" spiral-wound cardboard tubing used to roll carpeting on. These, I found, fit nicely into 4" PVC waste pipe fittings that you can buy at home centers.

I made several overhead runs, connecting the tubes with PVC elbows and wyes, shop-made blast gates, and varying lengths of flexible connector tubing. Gluing the joints with silicone caulk where shown makes a rigid, airtight fitting. A coat of paint made the entire installation barely noticeable.

—Jim Maier,
Joseph, Ore.

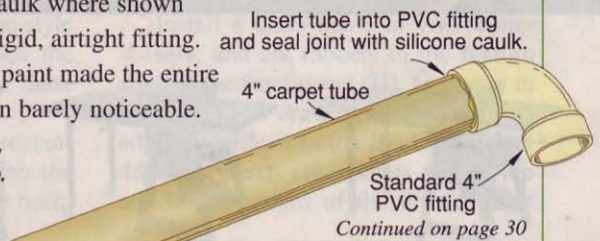

Continued on page 30

False tabletop makes space for long boards

In my small shop I can't dedicate a lot of space to miter saw stock-support tables, so my bench has to do the job. But when I need to cut long boards, my bolted-down benchtop tools were always in the way.

To solve my dilemma, I added a second top to the bench as shown at right, mounting it above the original surface so I have 3 1/2" of clearance between the tops. Now, I can slide long boards under the false top and cut them without interference.

I also hinged the false top so if I need to cut thicker stock, I simply block it up enough to clear the workpiece. My bench grinder, bolted to the second benchtop, goes along for the ride.

—Peter Lundebjerg, Greeley, Colo.

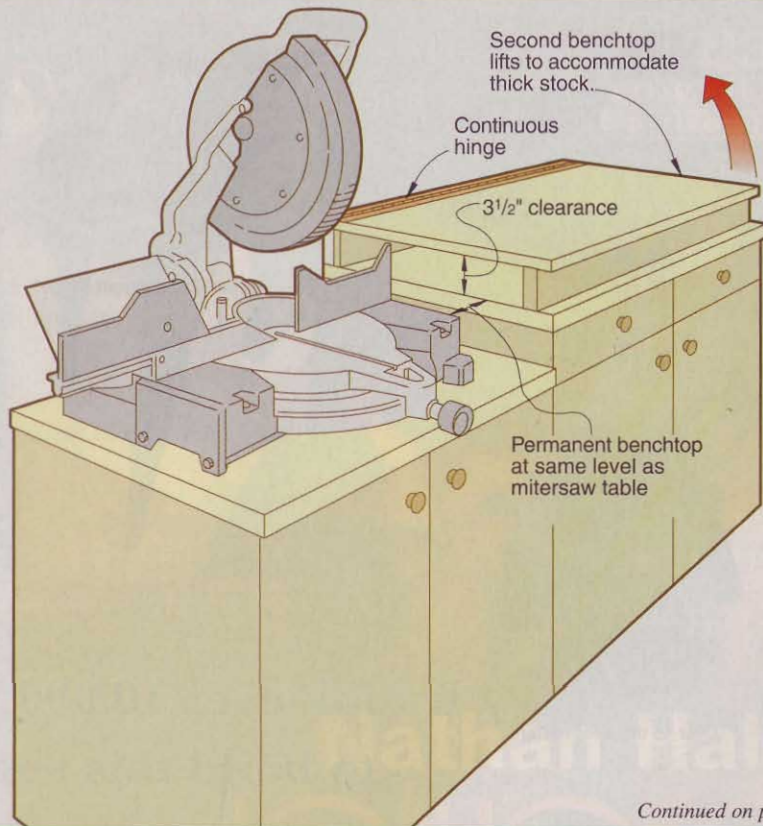

Continued on page 34

INCRA DOES IT AGAIN!



OUR ACCURACY GUARANTEE:

Produce perfect gap-free hairline glue joints on the mitered corners of any multi-sided object without trial-and-error setups.

1-800-752-0725

Woodpeckers Inc.
The Incra Tool Source

www.woodpeck.com

Incra Miter 3000

- ◆ 364 Indexed Angle Stops in 1/2° Steps
- ◆ Continuous Adjustability
- ◆ Full +/- 90° Range
- ◆ GlideLOCK™ Adjustable Miter Bar
- ◆ 27" Incra-LOCK™ FLIP Stop Miter Fence
- ◆ INCRA FLIP Shop Stop Positioner

The Selection is Huge.
We Built a Porter-Cable Store to Show it all.

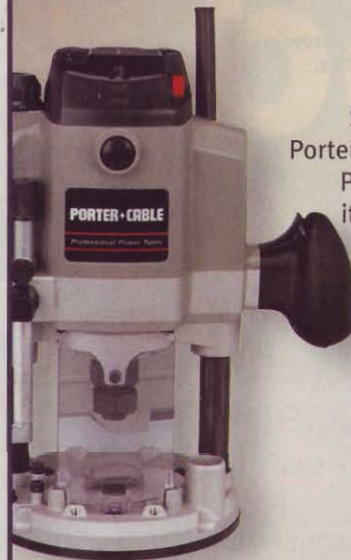

See the complete line-up of Porter-Cable products in the new Porter-Cable store. Over 500 items including pneumatics and cordless tools to the hard-to-find woodworking accessories. See the entire fleet of this year's new Porter-Cable products at the store that has it all.

Visit the Porter-Cable store at
www.amazon.com/portercable

routers sanders cordless tools
generators the Porter-Cable store
nailers & staplers air compressors



NO MORE DUST



Introducing Microplane® Rotary Shaper Power Tool Attachments for low-speed shaping. The razor-sharp teeth create tiny shavings that fall to the surface instead of clouding your air. Call 501-968-5455 or

1-800-555-2767

*dealer inquiries encouraged

www.microplane.com email: info@microplane.com

Microplane
A Product of Grace Manufacturing®

Circle No. 2145



**ET100™
Nail Master™**

- Ergonomic Design
- Durable
- Powerful

10 Amps

Removable
Non-Marring
Bumper



**Shoots 3
Different
Length Brads**

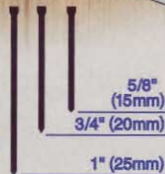

Arrow
Wherever fine tools are sold.

Arrow Fastener Co., Inc., 271 Mayhill Street, Saddle Brook, New Jersey 07663
Canada: Jandel Distributors, Inc., 6505 Metropolitan Blvd. East, Montreal, Quebec H1P 1X9
United Kingdom: Arrow Fastener (U.K.) Ltd., 14 Barclay Road, Croydon, Surrey CRO 1JN
www.arrowfastener.com ©2000 ARROW FASTENER COMPANY, INC. Rev.700

tips from your shop (and ours)

Check the cut before you make the cut

Using a scratch awl, I scribed a line on my tablesaw top, as shown *below*, to indicate exactly where my favorite blade will cut. I just mark my stock, then align my mark with the scribed line. Make sure you rest the ruler against the teeth, not between the gullets, when marking.

—Chuck Hedlund, *WOOD*® magazine shop manager

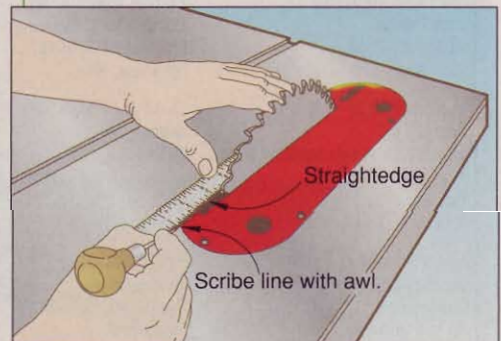

Maximize your tablesaw's rip capacity with support

My tablesaw's fence rails reach well beyond the extension table, but I found a safe way to use those rails to the max without letting the workpiece sag. I clamp a support strip to the bottom of the fence, as shown *below*. The support holds the end of the workpiece level with the table and ensures precise contact with the rip fence. When I'm not using it, it hangs on the wall near the tablesaw.

—Tom Hock, *Oconomowoc, Wis.*

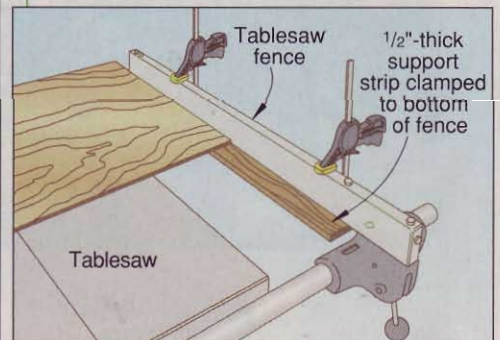

For a better grip, a dip'll do ya'

To get a better grip on clamp handles, dip them in heavy-duty flexible coating, such as "Plasti Dip" (800/969-5432). Let the coating cure and your clamps will be better than when they were new.

—Erv Roberts, Des Moines, Iowa



Board-stretching easier with shop-made clamps

To conserve material, especially on projects I plan to paint, I'll sometimes end-glue short pieces together to make up longer boards. I don't have clamps long enough to span these glue-ups (some measure 7' long) so I made several sets of the clamp shown below. One set spans each finger joint.

To use, I position the cross bars about equidistant from the joint, then tighten the four bolts at the ends of the crossbars. Next, I tighten both carriage bolts connecting the crossbars—this enables me to draw the pieces together with precise pressure, while ensuring their alignment.

Note: I drilled two sets of bolt holes through each crossbar to accommodate both wide and narrow boards. Also, gluing sandpaper to the inside faces of each crossbar helps reduce slippage on the boards.

—John Pugh, Haliborton, Ont.

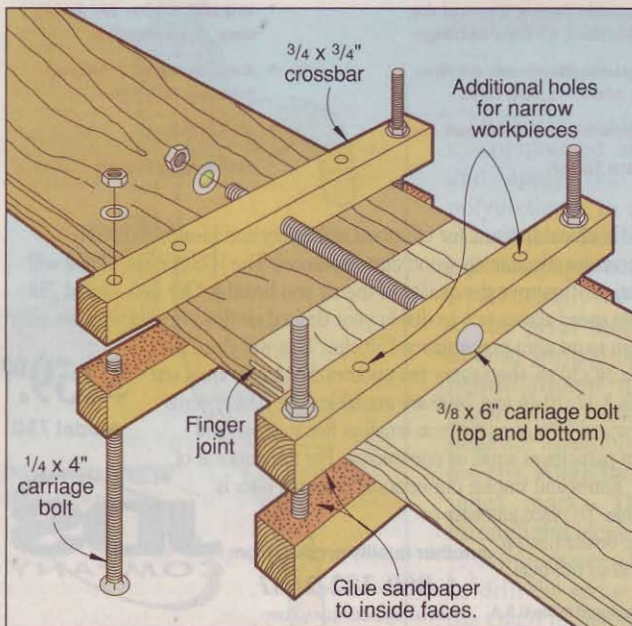

Continued on page 36

IMPORTANT SAFETY NOTICE

Craftsman® Radial Arm Saws
Model Nos. beginning with 113

Emerson Tool Company has announced the voluntary recall of certain 8, 8-1/4, 9 and 10 inch Craftsman radial arm saws manufactured from 1958 through 1992 (the 8-1/4 inch through 1995) in order to provide a retrofit guarding kit. If the saw is not retrofitable, Emerson Tool will pay \$100 for the return of the carriage/motor assembly. The saws were sold without a guard that covered the entire blade. Consumers have come into contact with the blade resulting in severe injuries.

Consumers should call Emerson Tool at 1-800-511-2628 or visit www.radialarmsawrecall.com to determine if their saw is subject to the recall and to ensure that they have proper safety and use instructions.

Location of radial arm saw's model and serial number nameplate

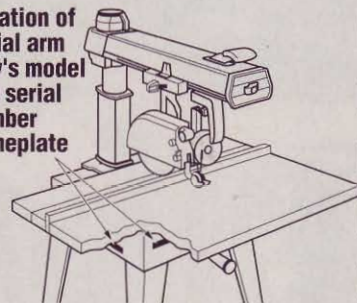

IMPORTANT SAFETY NOTICE

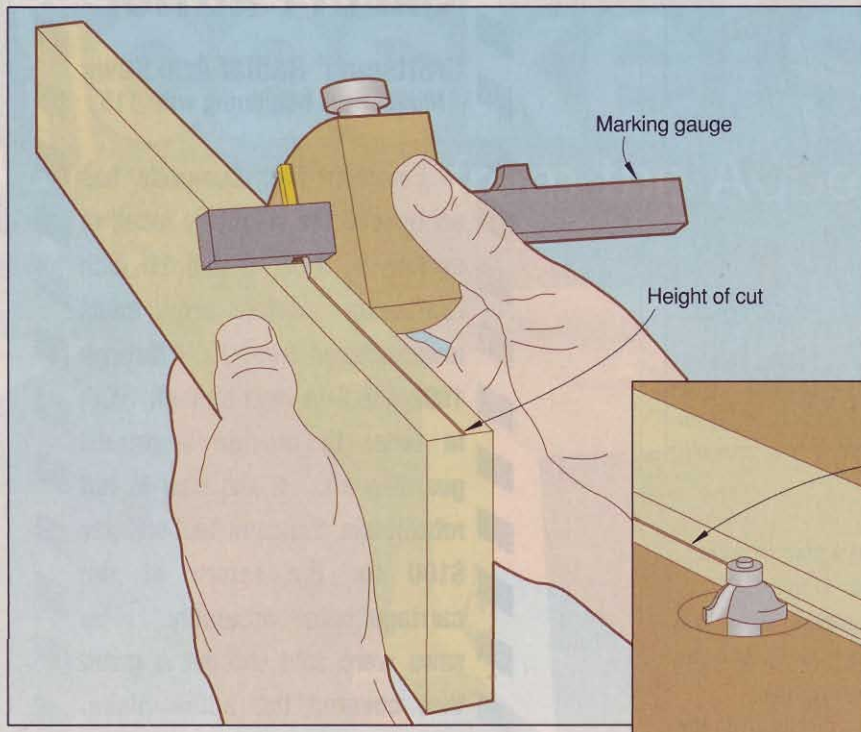

**Score one
for tearout reduction**

Routing an edge profile on delicate workpieces can cause bad tearout and even ruin valuable pieces. I head off this problem by using a technique borrowed from ripping plywood, where a scoring blade is sometimes used.

Before I even plug in my router, I scribe a line along the workpiece edge, as shown *far left*, scoring the material at a height to match the bit. A marking gauge fitted with a steel cutter (as opposed to a pin marker) makes the scoring task easy.

—Timothy England,
Breeding, Ky.

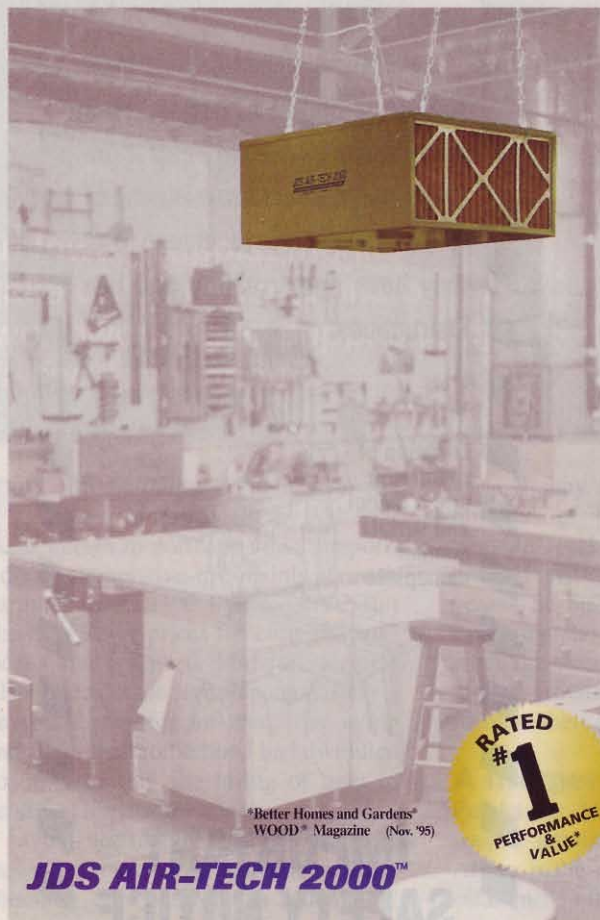

Let's Clear the Air...

JDS AIR-TECH 2000™

Model 750, Still the Best!

- Variable Speed Control for unlimited air flow settings
- Highest Maximum air flow in its class - 1,050 CFM
- Convenient On/Off pull chain
- Ultra Quiet
- 1/4 H.P. Motor for heavy duty performance
- Antimicrobial 1 Micron Internal bag filter
- UL Listed
- Lifetime Warranty

The National Institute for Occupational Safety and Health (NIOSH) recommends limiting wood dust exposures. The JDS Air-Tech 2000 will dramatically improve the quality of the air you breathe. Our new model 750 variable speed allows you to dial in your desired air flow, from a whisper quiet 200 cfm to an ultra performance 750 cfm. This will clean the air in a 30'x30'x8' shop every ten minutes. For larger areas our models 8-12, 10-16 and 2400 are available. The JDS systems will remove 99% of particles as small as five microns and 80% of particles as small as one micron. For the removal of odors, fumes and smoke, our optional charcoal filter is available. To place an order or for the dealer nearest you call us toll-free.

\$259.00
Model 750



Another quality product from
1-800-382-2637

Manufactured in the U.S.A. www.thejdscompany.com



*Better Homes and Gardens
WOOD® Magazine (Nov. '95)

JDS AIR-TECH 2000™

Sharpening tools? Hang one unit of H₂O, stat!

I don't use my wet grinding wheel often enough to keep water in the wheel bath all the time, but filling it every time I do is a messy proposition. I solved the dilemma by attaching one end of a hose to the drain plug hole at the bottom of the bath; the other I sealed to the cap of a water bottle.

When I want to work at the wheel, I hang the bottle from the ceiling, and the water drains into the bath. When I'm finished, I hang the bottle, still upright, beneath the grinder. The water then refills the bottle, ready for its next use.

—Tim Gant, La Maddalena, Italy

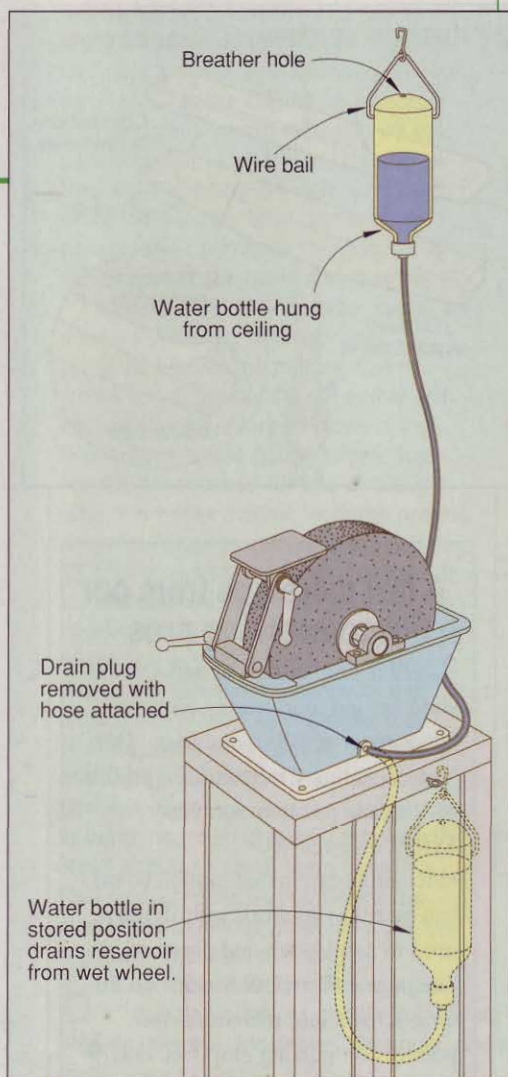

Continued on page 38

STEVE WALL LUMBER CO.

Quality Hardwoods and Woodworking machinery For The Craftsman and Educational Institutions

Ash	4/4	Select	2.35		\$ 80.00
Basswood	4/4	Select	1.95		\$ 68.00
Birch	4/4	Select	2.60		\$ 84.00
Butternut	4/4	1C	2.30		\$ 72.00
Cherry	4/4	Select	4.35		\$ 100.00
Hickory - Pecan	4/4	Select	2.50		\$ 78.00
Mahogany (Genuine)	4/4	Select	3.90		\$ 100.00
Maple (Hard)	4/4	Select	3.15		\$ 92.00
Maple (Soft)	4/4	Select	2.30		\$ 75.00
Poplar	4/4	Select	1.75		\$ 68.00
Red Oak	4/4	Select	2.50		\$ 83.00
Walnut	4/4	Select	3.55		\$ 98.00
White Oak	4/4	Select	2.40		\$ 80.00
Cedar (Aromatic Red)	4/4	1C+Btr.	1.75		\$ 69.00
Cypress	4/4	Select	2.30		\$ 77.00
White Pine	4/4	F.G.	1.20		\$ 58.00
Yellow Pine	4/4	Clear	2.00		\$ 70.00

Above prices are for 100' quantities of kilndried rough lumber sold by the Bd. Ft. FOB Mayodan, NC. Call for quantity discounts. Other sizes and grades available.

Above prices are 20 bd. ft. bundles of clear kilndried lumber 3"-10" wide • 3'-7' long (Random widths & lengths) Surfaced 2 sides or rough. Delivered UPS prepaid in the Continental U.S.

UPS
Specials

SEE OUR
CATALOG ON
THE WEB!

NOW AVAILABLE

Custom Made
Raised Panel
Cabinet Doors

4/4 Log Run
Walnut
100 bd. ft. \$160

Also Available
Exotic Lumber

STEVE H. WALL
LUMBER CO.

BOX 287
MAYODAN, N.C. 27027
336-427-0637
1-800-633-4062
FAX 336-427-7588

Email: wood@walllumber.com
Website: www.walllumber.com

Send \$1.00 For Lumber Catalog
Prices Subject to Change Without Notice

Circle No. 592

Measure Twice. Glue Once.

Hardwoods, softwoods, pressure-treated or exotics – Gorilla Glue® is tough enough to hold them all. Incredibly strong, nearly invisible glue lines, and 100% waterproof. Just the way serious woodworkers demand it. Call 800-966-3458 for a dealer near you, or visit www.gorillaglu.com to find out more.



The Toughest Glue
on Planet Earth™



Circle No. 650

Quality Pen Kits and Other Turning Kits



- Designers & Manufacturers
- Wholesale & Retail

The Berea Hard Woods CO. Inc.

Manufacturer of quality writing instruments, components and kits.

CALL FOR FREE CATALOG

6367 Eastland Rd. • Brookpark, Ohio 44142 U.S.A.
Ph: 440-234-7949 • Fax: 440-234-7958 • bereahard@aol.com

Circle No. 510



High Performance Router from Fein

This powerful new 3/4 horsepower plunge router will cut production time and give you a superior finish. Thanks to an advanced electronic feedback circuit, this state-of-the-art router operates at a consistent torque and speed for extremely smooth operation and a cleaner edge. It's lightweight for greater control, has a wider range of speeds, and includes soft start, dust collection port, and QC spindle. The new FEIN RT-1800 is designed for the cabinetmaker, solid surface fabricator and serious hobbyist. Call 1-800-441-9878 for more information and a dealer near you, or visit us on the web at www.feinus.com.

Finishing is just the beginning

Fein Power Tools, Inc. 1030 Alcon Street
Pittsburgh, PA 15220 1-800 441-9878

Fein

Circle No. 37

tips from your shop
(and ours)

Unroll your roller stand for better control

A roller stand works well for supporting stock coming off your tablesaw, but it can also “steer” your workpiece if it’s not properly aligned. To remedy the situation, I replaced the roller on my stand with a scrap of 2x stock and a strip of ultra-high molecular weight (UHMW) plastic, as shown *below*. This low-friction material supports the outfed stock without regard to its orientation, and can even be used to support a long, narrow piece for crosscutting.

—Jim Downing, *WOOD*® magazine
senior design editor

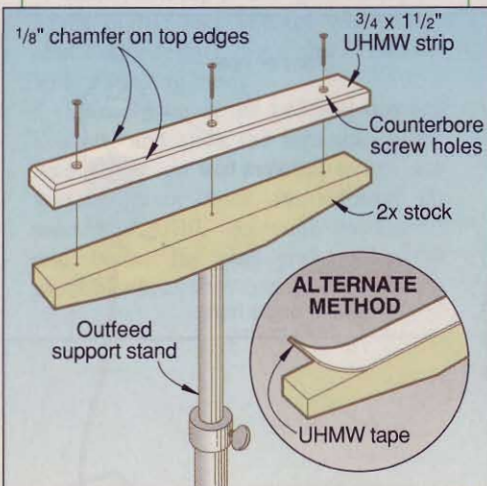

A few more tips from our woodworking pros

- Learn a simple trick to make wood slide around more easily on your bandsaw or scrollsaw table in “One Very Puzzling Craftsman,” a profile of Virginia puzzlemaker Jerry Syfert, on *page 40*.
- Melamine-laminated particleboard can be tricky to work with if you’re used to solid stock and plywood. See *pages 48 and 49* for tips on driving screws into melamine and pointers on making chip-free cuts. 🌲

one very

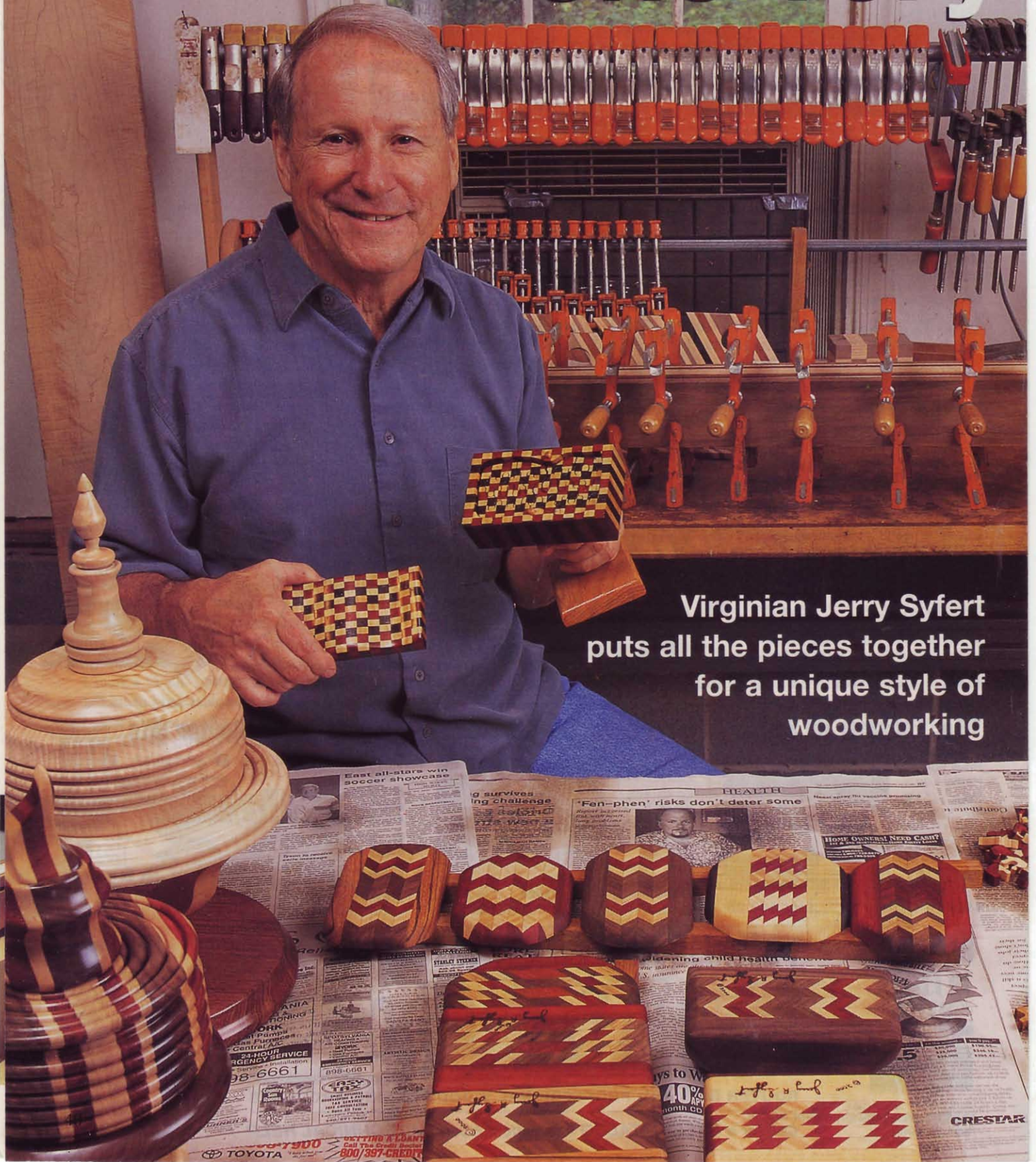

Virginian Jerry Syfert
puts all the pieces together
for a unique style of
woodworking

TOYOTA 1-800-337-7900 GETTING A LOAN? Call The Credit Doctor 800/397-CREDIT

40% month GO

CRESTAR

puzzling craftsman

Roy Underhill, woodworking author and host of public television's *The Woodwright's Shop*, believes that many people today begin woodworking as a diversion from technology. The switch to creating something by hand provides a satisfaction not found in the computer world. And that's exactly the way it was with Locust Grove, Virginia, craftsman Jerry Syfert.

"I worked for a large company in mainframe computer maintenance, and really enjoyed it because at first I could work with my hands and solve problems," says Jerry, now in his late sixties. "Then I was promoted into middle management. Suddenly, I had people above me to satisfy and people below me whose work I was responsible for. And I was no longer working with my hands. So, I took up woodworking as a hobby."

With seven children—and grandchildren starting to appear—Jerry built toys. He crafted large-scale trains, doll cradles, rocking horses, trucks, and cars, plus occasional pieces of furniture. He was infatuated.

When his company merged with another large firm about 12 years ago, Jerry opted to retire into full-time woodworking. "I thought that selling my work at crafts fairs with my wife, Anita, would be fun, and I'd really be working with my hands again," he recalls.

Jerry's toys sold well, but he was discovering that wooden toys were difficult to pack and bulky to move. So he began experimenting with bandsaw boxes

made of laminated native and exotic woods in a variety of colors.

The buying public's response was good. But always eager to try something new, Jerry began cutting the inside material of the boxes into simple jigsaw puzzles. He then made them more and more intricate, and their selling price rose with the difficulty level. Today, his puzzles might have as many as 1,200 pieces and sell for \$2,000 or more. Yet, he has many lesser-priced puzzles, too.

As he explains, he doesn't make and sell very many of the big ones. "At a crafts fair, people get overwhelmed with all there is to see, so I developed the

large, difficult puzzles as a 'hook' to get people into my booth. I set a big attractive piece out front to draw attention, maybe with a little sign telling how many pieces are in it. Usually, I put a large enough price tag on it so I won't lose my hook. But at one fair I put out a big puzzle priced at \$1,200 and a lady bought it the first day! It's usually puzzle collectors that buy those."



This barn puzzle has 640 pieces in eight layers. Jerry makes puzzles like this to draw customers to his crafts fair booth. It stands about 10" high and has a hefty \$2,500 price tag.

one very puzzling craftsman



Commonsense pricing

Although Jerry occasionally parts with one of his large puzzles, the majority of sales are generated from smaller ones priced under \$60. "My least expensive four-layer puzzle is \$35 in solid maple. Then they go up in increments of \$5," he notes. "So I think they're all reasonably priced."

Although much has been published about pricing items to sell, and Jerry's read all of it, he has developed his own theory. "You can read about pricing practices that deal with fixed costs,

Someone will spend \$2,000 for Jerry's 750-piece space-station puzzle made of figured maple and padauk. It's 18" tall.

such as overhead, materials, and all, but I don't do that," he says.

"I design a piece, which is really what I like doing, then figure out how to make it the most efficient way," Jerry continues. "Sometimes that requires changing something because it won't work readily. But when I've got the design down pat, and the process to make it ironed out, I ask myself, 'What am I willing to make that for?' Then, I ask, 'Would somebody be willing to pay that much for it?' Because if I made a puzzle and thought it should bring \$100, but no one would be willing to pay that much, why should I make it?"

Jerry tries to set reasonable prices for his pieces. And there's good reason for it. He sells the puzzles only at crafts fairs. And he only makes those he sells during seven months of the year. From December through April you'll find him and Anita in Florida, where Jerry doesn't have a shop. That makes outlets for his work, such as galleries and gift shops, out of the question. "In Florida, I can't

How to cut up a puzzle

1 Jerry laid up and sawed the maple and padauk for this 2 $\frac{5}{8}$ "-thick box blank so that the bands meet at 90° angles. But gluing it up required clamping blocks.

Nearly all of his puzzles begin as a laminated blank of contrasting wood.

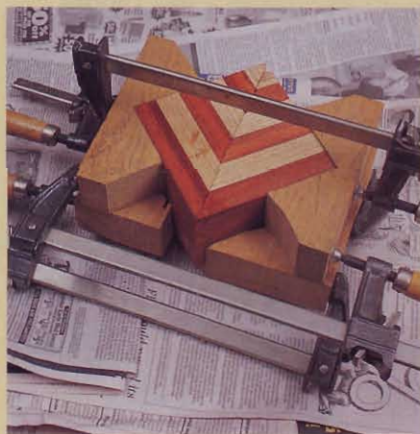

2 To cut the top and bottom off the box blank and to saw out the inside, Jerry installed a 10-teeth-per-inch $\frac{3}{8}$ " blade on his bandsaw. "I like to keep my puzzle thickness to about 1 $\frac{1}{2}$," he says. At this stage, Jerry uses a fence to



ensure straight cuts. The square of $\frac{1}{8}$ "-thick acrylic clamped to the bandsaw table provides a smooth, slick surface to guide the workpiece.

3 Puzzling the inside of the box calls for a 14-teeth-per-inch $\frac{1}{8}$ " bandsaw blade. "One of .025" thickness provides



take a phone call from a shop owner asking for some more puzzles right away because I couldn't deliver," he points out.

Design with bands of wood

A quick glance around Jerry's double-car garage shop hints at something missing. Drill press? Nope, there's one. Jointer? Yes, it's an ancient Craftsman Planer? There it is in the corner.

"I don't have a tablesaw. When I quit making toys and furniture, I sold it," Jerry replies to the questioning look. "I resaw on my bandsaw, then cut the workpieces up with either the miter saw or bandsaw."

In a few quick steps, Jerry approaches his workbench, the back of it a wall of clamps in various sizes. "I glued up these pieces of padauk and maple to demonstrate how to make different designs with laminated wood," he says, removing the array of clamps from a long block before him. "I removed the

glue squeeze out earlier, now I need to square up the block."

Jerry carries the workpiece to his jointer. "First I get one side perfectly flat," he explains, turning on the machine. After a few passes, he places the now-flat side against the fence and feeds the piece through two more times. "Now the block has two flat sides to ride on the planer bed."

The planer spews a colorful mixture of padauk orange and maple tan as Jerry completes the squaring. "Looks like confetti," he quips.

At the miter saw, the craftsman clamps to the fence a thin stopblock, set for "about half an inch." (After so many years, Jerry actually does little measuring.) Then, he sets the blade at 45°, and saws off a slab of the laminated block, as in the photo at right. "This Freud crosscut blade cost me about \$140," Jerry says, fingering the piece, "but it makes such a smooth cut that I don't have to sand. And with all these pieces, the less sanding the better!"

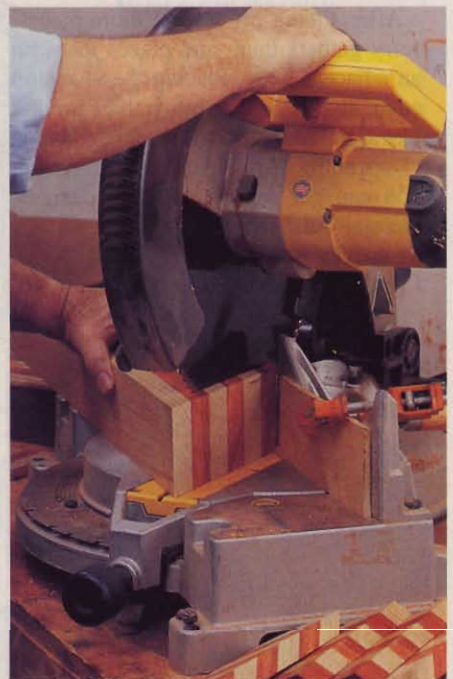

Jerry clamps a stop to his miter saw fence, then makes 45° cuts through the laminated block.

more stiffness," Jerry notes, as he begins guiding the wood—now turned on its side—against the blade. Quickly, wavy slices begin falling from the workpiece. "The thinner I saw the slices, of course, the more pieces the puzzle will have. These are about 1/2" thick for a five-layer puzzle." (Note the peg holes in the box at Jerry's left. The lid has

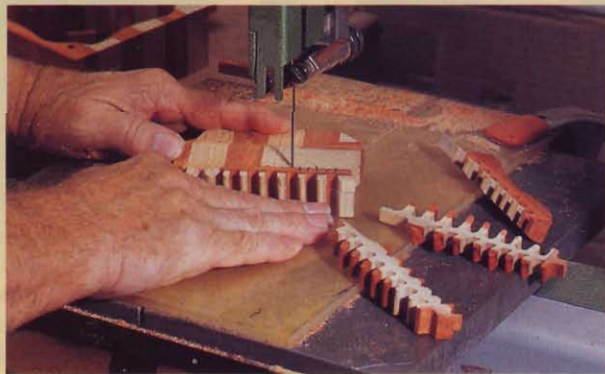

matching ones. He'll cut the heads off of two maple wheel axles and glue one in each of the box's holes to hold the lid in place.)

4 The puzzle pieces-to-be now cut into wavy slabs, Jerry once again begins feeding them into the bandsaw blade. "I've learned to keep my waves somewhat uniform, so the wood has a solid foundation as I saw," he says. Out from the blade come long, skeleton-like bands of wood. "Here, I could get as intricate as I want, but the finer the cutouts the weaker the pieces will be. So there's always a compromise to consider with puzzles."

5 Finally, Jerry starts the final step for a wood puzzle. His steady fingers move the wood to and from the blade as he crosscuts the skeletal bands into pieces, which begin to pile up on the table. "Usually, I end up with about 56 or so pieces per layer," he notes. "So this five-layer puzzle will have 280 pieces in all."

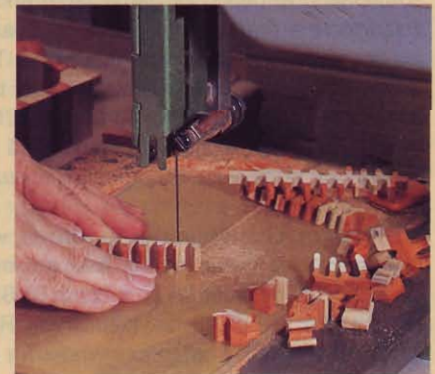

one very puzzling craftsman

After slicing off several more pieces, Jerry gathers them and places them on an adjacent table. Placing the slices on edge, he proceeds to move them around like dominoes, as in the photo below. "Depending on how you match them up, you can get several different designs. Here are just two possible," he says as he arrives at the configurations. "When I find ones I like, I'll glue them up into

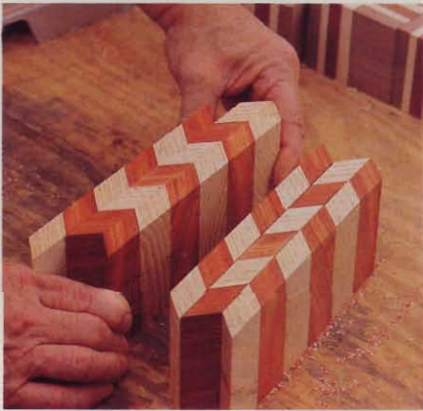

The angled slices done at the mitersaw can be glued up in several patterns to provide what will become eye-catching puzzle boxes.

box blanks," he adds. "Then, I'll cut them up at the bandsaw as I would a box, but I'll puzzle the inside." (You can see how Jerry puzzles a box in the sequence on the preceding pages.)

Pieces aplenty to play with

For a final finish on the box, Jerry puts on three coats of lacquer with his HVLP sprayer, sanding in between. "But in spraying the box, the top layer of the puzzle gets coated, too," he says. "So you can always identify the top layer's pieces. They always have one shiny side."

Prior to the final finish, though, the puzzle maker treats the box and the pieces with a sealer coat. "I've used a mixture of two parts linseed to one part turpentine for years," Jerry explains. "The pieces I just drop into a can, then pour in the mixture to cover them. After swishing it around, I pour it off. It primarily serves to rinse off the sawdust. I couldn't spray them with lacquer. I'd blow them all over the shop!"



These two puzzles show how plain or patterned puzzle boxes done following Jerry's technique can be.



Understandably, Jerry dare not mix the pieces from one puzzle with those of another in the finishing process. Nor will the pieces from one box blank fit into another. Seems like it all might become confusing somewhere along in the process.

"Not really," Jerry says. "I keep the pieces for one puzzle in a pile somewhere near the box they go in until everything is coated with finish. Then Anita assembles each finished puzzle in its box." He smiles. "My job is just to cut them out." ♣

Written by Peter J. Stephano
Photographs: Steve Uzzell

A real bear of a puzzle to make

Since the 1930s, versions of the table-and-chair puzzle have popped up here and there. You even may have owned one. But Jerry likes to tell the tale that sparked the idea for it back in a distant decade:

"Many, many years ago there was a family of bears who lived in the woods during the summer and in a cave during the winter. So every spring and every fall they had to pack up their furniture and move it.

"As the bears grew older, this became harder and harder to do. One winter night, a couple of the smarter bears got together and figured out that if they could construct their furniture to fit into one package, it would be a lot easier to move. That's how the now world-renowned table-and-chair puzzle came about."

According to Jerry, the large table and chairs belong to the grandma and grandpa bear. (They are up in years, and live with the "kids.") The next largest table and chair belong to mama bear and papa bear. The smallest table and chair belong to baby bear and the little girl with blond hair who sometimes visits. Fitted together, the puzzle measures 6x3x2½".

To order plans for Jerry's bandsawn version of the table-and-chair puzzle (stuffed bear not included), send a check or money order for \$6.95 ppd. (U.S.) to: Jerry Syfert, HC 76 Box 920/ 218 Sayers Creek Rd., Locust Grove, VA 22508. Please allow up to four weeks for delivery.





full-service laundry center

Now you can
add a world of
convenience
to all your
wash-day
chores.

Although doing laundry doesn't rank high on anyone's list of fun activities, this feature-packed project helps make wash-day work as pleasant and efficient as possible. It has storage aplenty, a rod for air-drying clothes, bulletin board, shelf, and a light to help spot stains. It ties all of these features, plus your appliances, into a tidy, hardworking assembly.

Let's build the large cabinet first

1 From $\frac{3}{4}$ " melamine-laminated particle-board (often referred to as just "melamine"), cut the two 24x80" side panels (A).

2 On both panels apply melamine edge banding to one long edge (the front edge in the assembled cabinet) and one short edge (the bottom edge of the cabinet). Use a clothes iron set on high heat to apply the banding as shown in *Photo A*. Be sure to keep the iron moving during application.

3 Mark one of the panels with dado and rabbet locations according to the Large Cabinet Left Side drawing. Repeat these



A
Apply the front banding edge last. That way, the joint between the front and bottom banding isn't visible from the front.

bill of materials

large cabinet

Part	FINISHED SIZE			Mati.	Qty.
	T	W	L		
A sides	3/4"	24"	80"	ME	2
B top	3/4"	23 1/4"	24"	ME	1
C fixed shelves	3/4"	23 1/4"	23 3/4"	ME	2
D* bottom cleats	1 1/2"	1 1/2"	4"	MA	4
E* upper front cleats	3/4"	3/4"	5 1/4"	MA	2
F upper back cleat	3/4"	1 1/2"	22 1/2"	MA	1
G top fixed panel	3/4"	6"	24"	ME	1
H bottom fixed panel	3/4"	4"	24"	ME	1
I back	1/4"	23 1/4"	75 1/4"	ME	1
J upper door	3/4"	24"	38 3/16"	ME	1
K lower door	3/4"	24"	31 7/16"	ME <td 1	
L shelves	3/4"	22 3/8"	23 1/2"	ME	2
M drawer front/back	3/4"	3"	20 3/4"	ME	2
N drawer sides	3/4"	3"	21 3/4"	ME	2
O drawer bottom	1/4"	21 3/4"	20"	ME	1
P drawer-slide filler	3/4"	1 1/2"	23"	ME	1

*Cut parts marked with * oversized, and trim to finished size according to instructions.

Materials Key: MA—maple, ME—melamine-laminated particleboard.

full-service laundry center

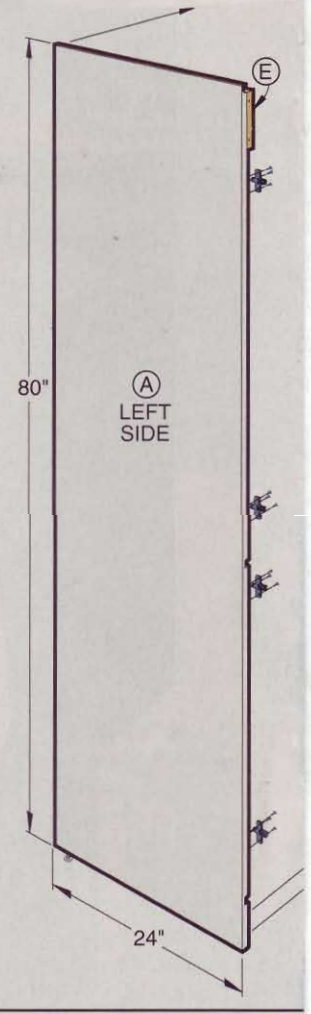
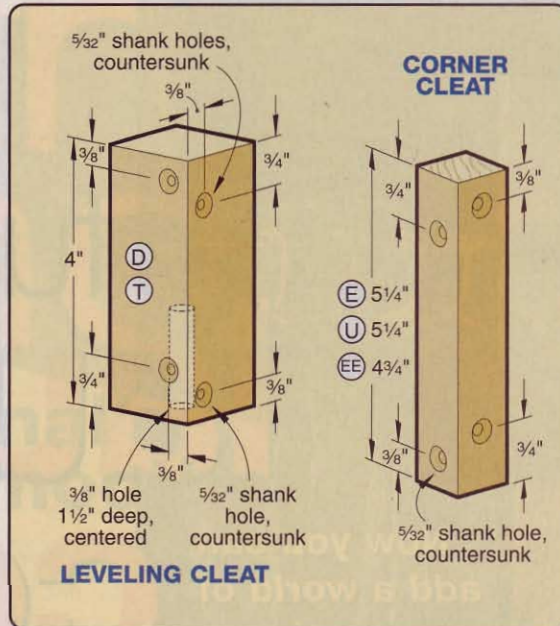

shop tip

Read this before you drive a single screw into melamine.

Unlike solid-wood fibers that tend to crush when you drive a screw into them, the glue and wood particles in melamine-laminated particleboard tend to bulge up at the point where the screw enters the surface.

To avoid this, always drill pilot holes into melamine. For the 1", 1 1/4", 1 3/4", and 2" deck screws used throughout this project, 7/64" pilot holes work well.

Also, in addition to drilling a countersink for the screw head, it helps to countersink the area where the pilot hole enters the second piece of material as shown at right. This gives the particleboard material a place to go so it doesn't bulge up and interfere with the pieces fastening tightly together.



DRAWING 1
Routing Dadoes and Rabbets

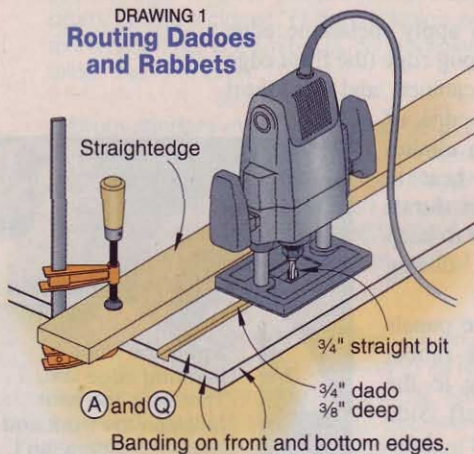

markings on the other panel (the right side of the cabinet), keeping in mind that the right side must be a mirror image of the left side.

4 Chuck a 3/4" straight bit in your router, and adjust it to cut 3/8" deep. Clamp a straightedge to your panel to cut the dadoes and rabbets as shown in Drawing 1.

5 Build the hole-drilling jig shown in Drawing 2. Next, drill the 1/4" shelf-support

holes 3/8" deep, where shown on the drawing. To do this, align the end of the jig with the center dado in the cabinet sides as shown in Photo B.

6 Cut the top (B) and the two fixed shelves (C) to size, according to the Bill of Materials. Band the front edges of all three panels.

7 Cut a 1 1/2 x 1 1/2 x 17" maple blank, and crosscut it into four 4" lengths for the bottom cleats (D). Drill the

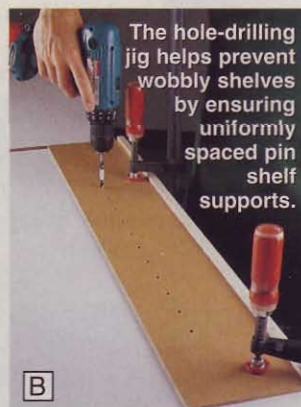

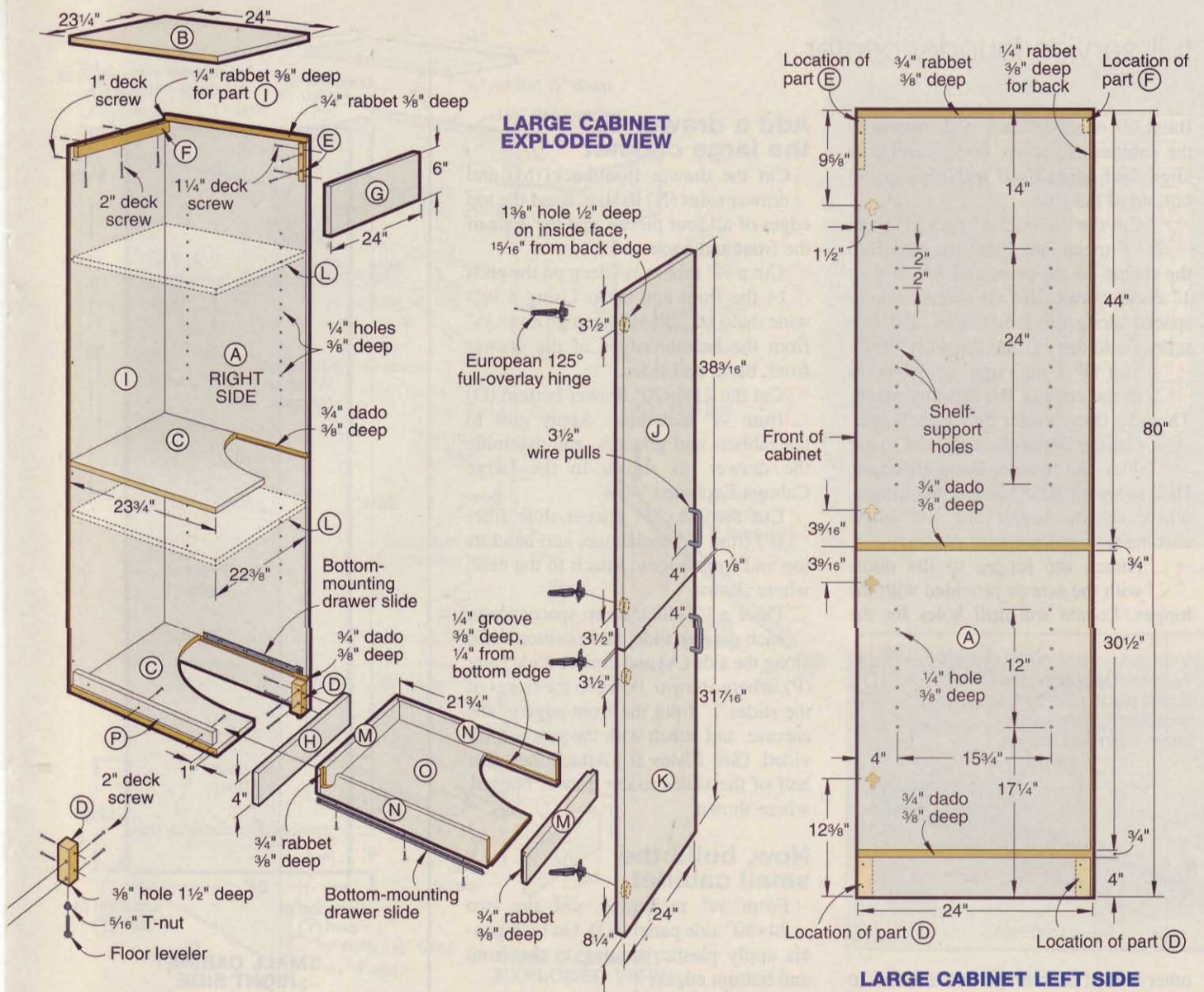

**DRAWING 2
Hole-drilling Jig**

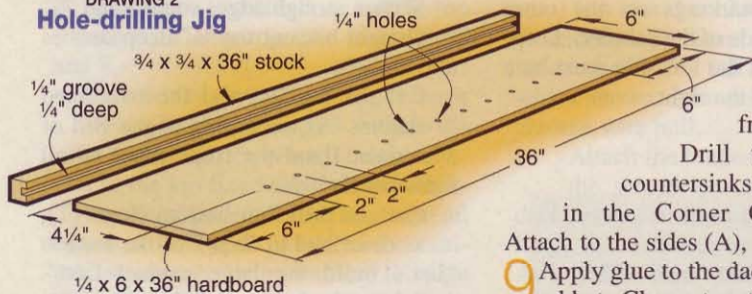

holes, and countersinks as shown in the Leveling Cleat drawing. Attach to the bottom of the sides (A), where shown in the Large Cabinet Left Side drawing and Large Cabinet Exploded View.

8 Cut a $\frac{3}{4} \times \frac{3}{4} \times 11$ " maple blank, and crosscut it into two $5\frac{1}{4}$ " lengths for

the upper front cleats (E). Drill the holes and countersinks, where shown in the Corner Cleat drawing. Attach to the sides (A), where shown.

9 Apply glue to the dados and the top rabbet. Clamp together parts A, B, and C, as shown in *Photo C*, and check for square.

10 Cut the $\frac{3}{4} \times 1\frac{1}{2} \times 22\frac{1}{2}$ " upper back cleat (F) from maple. Attach the cleat to the top (B), where shown.

11 Cut the top fixed panel (G) and bottom fixed panel (H) to size.



Tight-fitting dados and rabbets will help the carcass self-square during clamp-up. Check with a framing square.

full-service laundry center

Band all edges. Attach both panels to the cabinet as shown, being careful to align their edges flush with the top and bottom of the case.

12 Cut the $23\frac{1}{4} \times 75\frac{1}{4}$ " back (I) from $\frac{1}{4}$ " melamine. Place the back into the rabbet on the case, and attach with 1" deck screws. Use six screws evenly spaced along the long edges, and two screws into the top and fixed dividers.

13 Tap $\frac{1}{4}$ " T-nuts into the $\frac{3}{8}$ " holes in the ends of the leveling cleats. Thread a floor leveler into each T-nut.

14 Cut the upper door (J) and lower door (K) to size. Band all edges. Drill holes for 125° full-overlay hinges, where shown. Install the $3\frac{1}{2}$ " matte chrome wire pulls, where shown.

15 Attach the hinges to the doors with the screws provided with the hinges. Locate and drill holes for the

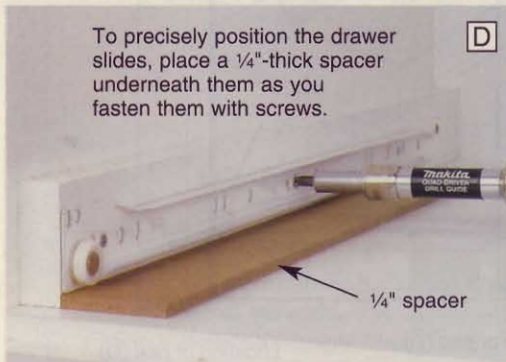

other half of each hinge that attaches to the carcass side, where shown on the Large Cabinet Left Side drawing. Attach the doors to the carcass, and adjust the hinges according to the instructions included with the hinges.

16 Cut two shelves (L) to size. Band the front edges only.

Add a drawer to the large cabinet

1 Cut the drawer front/back (M) and drawer sides (N) to size. Band the top edges of all four pieces, and the ends of the front and back.

2 Cut a $\frac{3}{4}$ " rabbet $\frac{3}{8}$ " deep on the ends of the front and back. Using a $\frac{1}{4}$ "-wide dado set, cut $\frac{3}{8}$ "-deep grooves $\frac{1}{4}$ " from the bottom edges of the drawer front, back, and sides.

3 Cut the $21\frac{3}{4} \times 20$ " drawer bottom (O) from $\frac{1}{4}$ " melamine. Apply glue to the rabbets and grooves, and assemble the drawer, as shown in the Large Cabinet Exploded View.

4 Cut the $1\frac{1}{2} \times 23$ " drawer-slide filler (P) from $\frac{3}{4}$ " melamine, and band its top and front edges. Attach to the case, where shown.

5 Place a $\frac{1}{4}$ "-thick scrap spacer under each drawer slide, and position them along the side (A) and drawer-slide filler (P), where shown. Position the fronts of the slides 1" from the front edge of the carcass, and attach with the screws provided. (See Photo D.) Attach the other half of the slides to the drawer bottom, where shown.

Now, build the small cabinet

1 From $\frac{3}{4}$ " melamine, cut the two 24×80 " side panels (Q). On both panels apply plastic banding to the front and bottom edges.

2 Mark one of the panels with dado and rabbet locations, according to the Small Cabinet Right Side drawing. Repeat these markings on the other panel (the left side of the cabinet), keeping in mind that the left side must be a mirror image of the right.

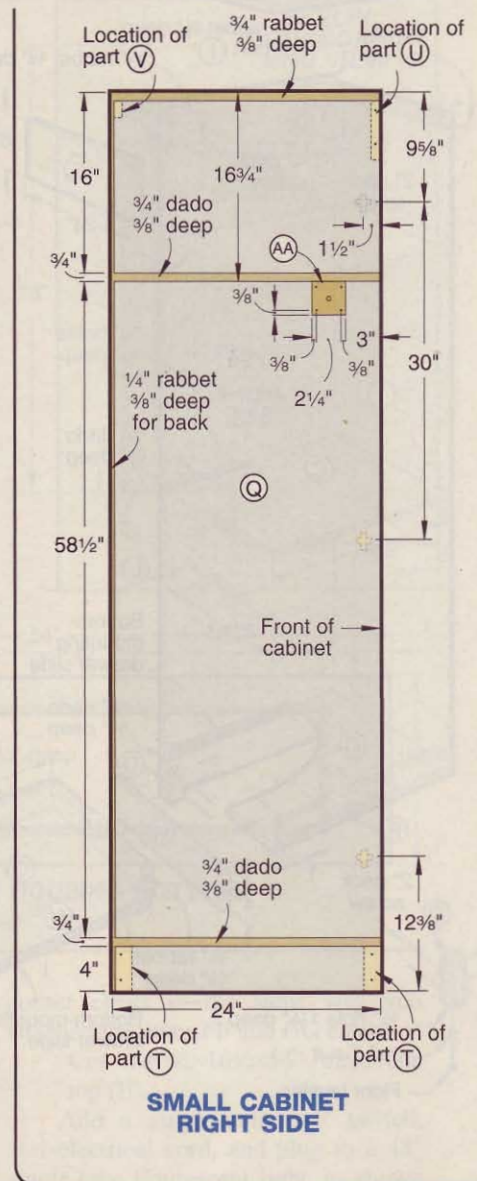

3 With a straightedge, router, and $\frac{3}{4}$ " straight bit, cut the $\frac{3}{8}$ "-deep dados and rabbets.

4 Cut the top (R) and the two fixed shelves (S), according to the Bill of Materials. Band the front edges of all three panels.

5 Cut and drill four bottom cleats (T), as described in Step 7 of the section "Let's build the large cabinet first." Attach to the bottom of the sides (Q), where shown in the Small Cabinet Right Side drawing and Small Cabinet Exploded View.

6 Cut and drill two upper front cleats (U) as described in Step 8 of the large cabinet section. Attach to the sides (Q), where shown.

shop tip

How to cut clean melamine edges. The thin plastic outer layers on melamine-laminated particleboard can chip easily when sawn, leaving unsightly edges. To minimize this chipping, do the following:

- Align your table saw's rip fence perfectly parallel with the blade.
- Use a sharp blade with plenty of teeth—10" carbide blades made especially for cutting melamine have 80 teeth.
- Orient the face side of the melamine sheet up when cutting it with a table saw.
- The previous rule is reversed for handheld circular saws and jigsaws—face side goes down when using these tools.

full-service laundry center

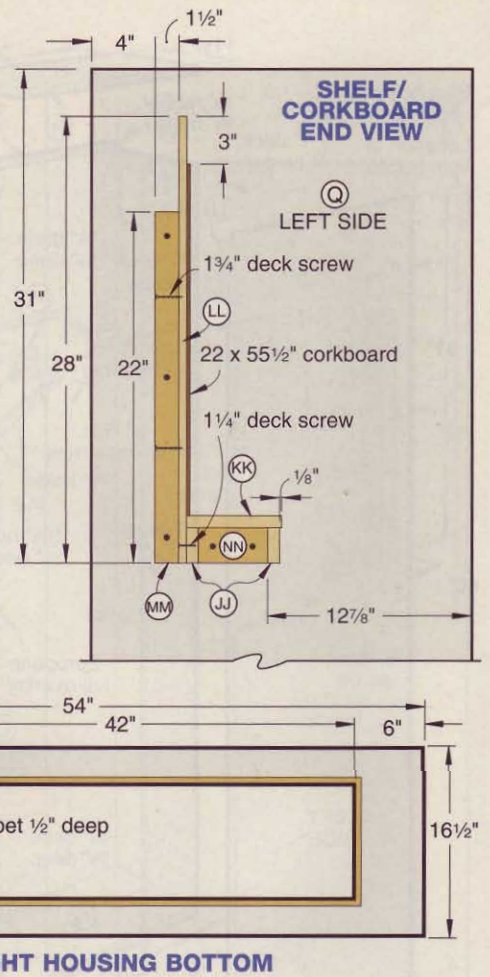
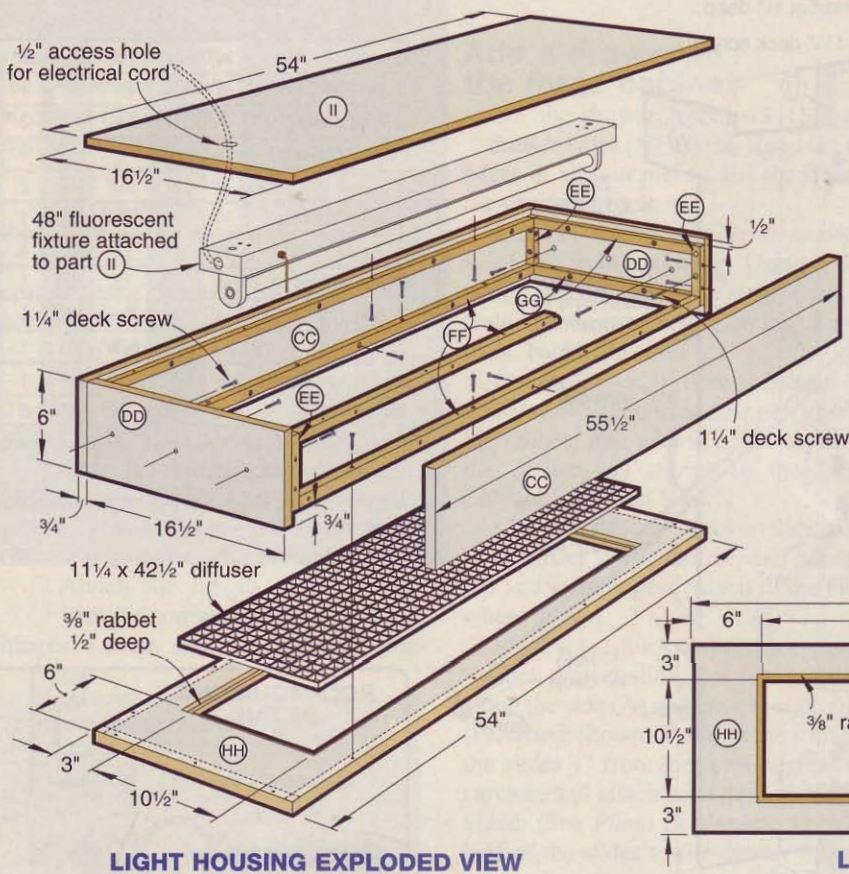

and ends of the front and back, and the bottom edge of the ends.

2 Rip a $\frac{3}{4} \times \frac{3}{4} \times 20$ " maple blank for the corner cleats (EE). Crosscut it into four pieces $4\frac{3}{4}$ " long. Drill each cleat, as shown in the Corner Cleats drawing. Attach the cleats to the ends with $\frac{1}{4}$ " deck screws, where shown in the Light Housing Exploded View.

3 Clamp the front, back, and ends together, being careful to align their ends and edges flush. Fasten them with $\frac{1}{4}$ " deck screws driven through the remaining holes in the corner cleats.

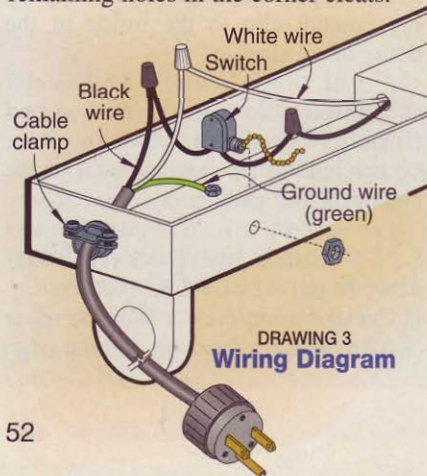

4 Rip four $\frac{3}{4} \times \frac{3}{4} \times 52\frac{1}{2}$ " maple front/back cleats (FF), and four $\frac{3}{4} \times \frac{3}{4} \times 15$ " maple end cleats (GG). Attach two FF cleats to the front and back, between the bottom ends of the corner cleats, where shown. Use five evenly spaced $\frac{1}{4}$ " deck screws. Follow the same procedure to attach two GG cleats to the ends, but use two screws. Set the unused FF and GG cleats aside for now.

5 Cut the $\frac{3}{4} \times 16\frac{1}{2} \times 54$ " melamine bottom (HH). With a jigsaw cut the opening, where shown, in the Light Housing Bottom drawing.

6 Rout a $\frac{3}{8}$ " rabbet, $\frac{1}{2}$ " deep around the edge of the opening using a piloted $\frac{3}{8}$ " rabbeting bit.

7 Place the bottom into the light-housing frame and screw it to the FF and GG cleats with $\frac{1}{4}$ " screws.

8 Cut a plastic light-diffuser panel to $11\frac{1}{4} \times 42\frac{1}{2}$ ". Place it into the rabbet in the bottom.

9 Attach the remaining FF and GG cleats between the top ends of the

corner cleats in the same way you attached the other FF and GG cleats.

10 Cut the $\frac{1}{2} \times 16\frac{1}{2} \times 54$ " melamine top (II).

11 Add a single-pole pull switch, electrical cord, and plug to a 48" single-tube fluorescent light, as shown in Drawing 3 at left. Mount the light to the center of the top (II). Drop the switch's chain pull through the grid of the light diffuser. Drill a $\frac{1}{2}$ " hole through the top (II), and feed the electrical cord through it.

Next up, the shelf/corkboard

1 Cut the shelf supports (JJ), and shelf (KK) to size. Glue and clamp these shelf-assembly parts together, using the Shelf/Corkboard End View drawing as a guide.

2 Cut the $28 \times 55\frac{1}{2}$ " back (LL) from $\frac{1}{2}$ " melamine. Clamp two $\frac{1}{4} \times 1 \times 60$ " strips of wood 3" from the edges, as shown in Drawing 4. Use a short-nap roller to apply contact cement between the strips.

bill of materials

light housing

Part	FINISHED SIZE			Mtl.	Qty.
	T	W	L		
CC front/back	3/4"	6"	55 1/2"	ME	2
DD ends	3/4"	6"	16 1/2"	ME	2
EE* corner cleats	3/4"	3/4"	4 3/4"	MA	4
FF front/back cleats	3/4"	3/4"	52 1/2"	MA	4
GG end cleats	3/4"	3/4"	15"	MA	4
HH bottom	3/4"	16 1/2"	54"	ME	1
II top	1/2"	16 1/2"	54"	ME	1

shelf/corkboard

JJ shelf supports	3/4"	2 1/4"	55 1/2"	ME	2
KK shelf	3/4"	6"	55 1/2"	ME	1
LL back	1/2"	28"	55 1/2"	ME	1
MM back cleats	1 1/2"	1 1/2"	22"	MA	2
NN ends	3/4"	2 1/4"	4 3/8"	MA	2

*Cut parts marked with * oversized, and trim to finished size according to instructions.

Materials Key: MA—maple, ME—melamine-laminated particleboard.

Supplies: 125° full-overlay hinges (7); 3 1/2" matte chrome wire pulls (3); 20" bottom-mounting drawer slides (2); 48" single-tube fluorescent light fixture, single-pole pull switch, grounded plug, 10'-long 16/3 insulated electrical cord; 1 1/4"x42 1/2" white 1/2"-grid dif-fuser panel; 1" chrome shower rod 42" long; 1" conduit clip; 5/16" floor levelers (8); 5/16" T-nuts (9); 1/4" pin shelf supports; 1", 1 1/4", 1 3/4", and 2" deck screws; 1/4"x22x58" corkboard; 5/16"x1 3/4" roundhead machine screw; 5/16" washer; white melamine edge banding.

Buying Guide: Hinges, wire pulls, and drawer slides available from Woodcraft, 560 Airport Industrial Park, P.O. Box 1686, Parkersburg, WV 26102-1686. Call 800/225-1153 or go to www.woodcraft.com. The following prices do not include shipping charges, which will vary depending on quantity ordered: 125° full-overlay hinges, item 02S60, \$8.99 per pair; 20" bottom-mounting drawer slides, item 01V09 \$5.50 per pair; 3 1/2" matte chrome wire pulls, item 130311, \$1.50 each.

cutting diagram

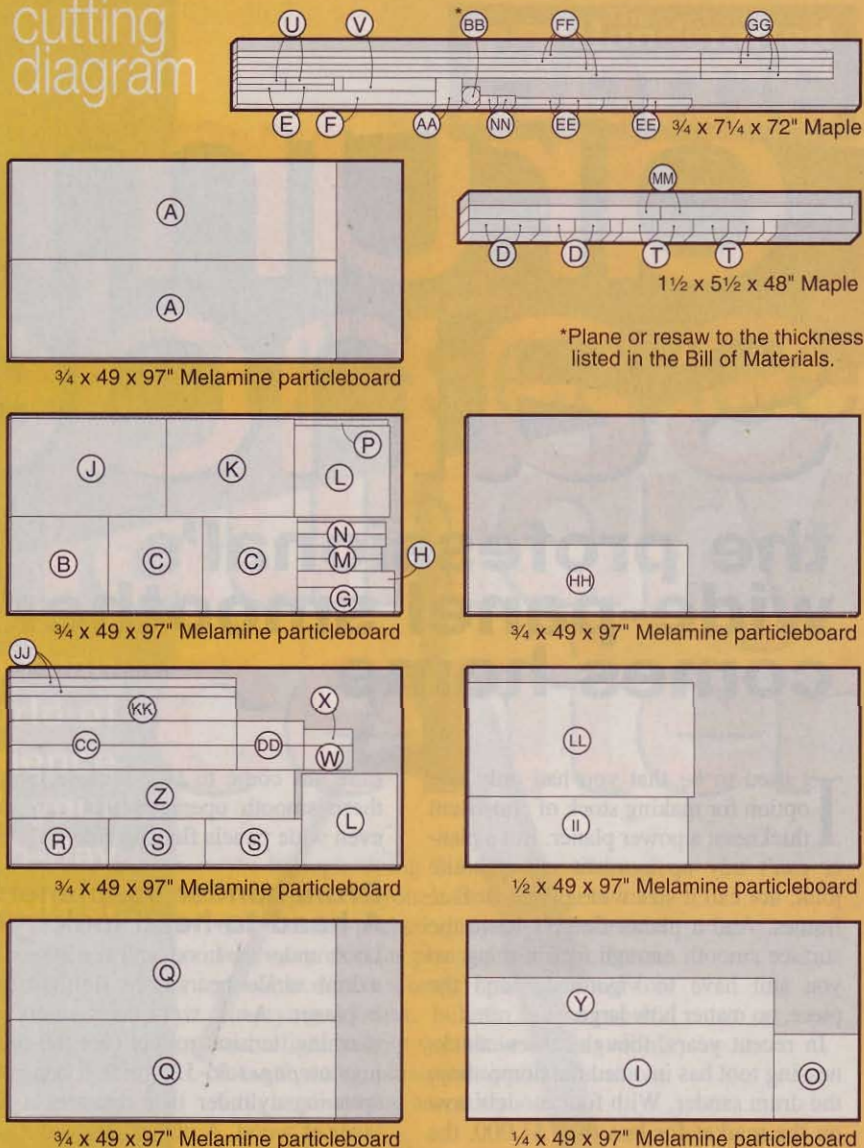

*Plane or resaw to the thickness listed in the Bill of Materials.

3 From 1/4" cork cut a 22x55 1/2" panel and apply contact cement to one face. Attach the cork to the back (LL), and remove the wood strips.

4 Attach the JJ/KK assembly to LL with six evenly spaced 1 1/4" screws.

Some final assembly and it's time for laundry duty

1 Cut the back cleats (MM) and ends (NN) to size. Attach to the sides of the large and small cabinets, where shown in the Small Cabinet Exploded View drawing.

2 Clamp the light housing between the two cabinets. It should be set back 3/4" from the front edge of the cabinets

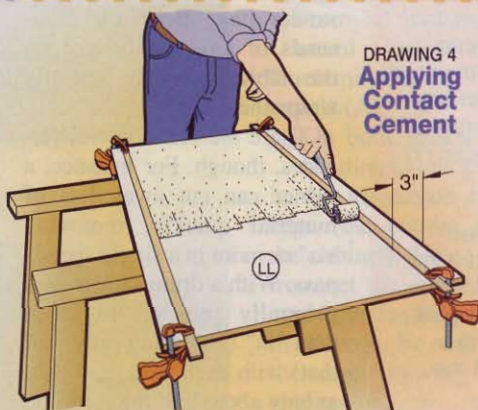

DRAWING 4
Applying
Contact
Cement

and flush with their tops. Screw to the sides with 1 1/4" deck screws.

3 Slide the shelf/corkboard unit between the cabinets and set down on the ends (NN). Drill two evenly

spaced holes through the back cleats (MM), and fasten the shelf/corkboard with countersunk 1 3/4" deck screws.

4 When placing the finished unit in your washing area, attach the cabinets securely to a wall to prevent them from tipping forward. Do this by driving fasteners through the upper back cleats (F, V) and into wall studs, concrete, or masonry block.

Now, grab your dirty laundry. It's time to clean some duds. 🌳

Written by **Bill Krier** with **Kevin Boyle**
Photographs: **Baldwin Photography**
Illustrations: **Roxanne LeMoine; Lorna Johnson**

drum sanders

the professional's wide-panel smoother comes home

It used to be that you had only one option for making stock of consistent thickness: a power planer. But a planer can't tidy up a misfit rail-and-stile joint, nor can it size wide panels or face frames. And a planer doesn't leave the surface smooth enough for finishing, so you still have to vigorously sand the piece, no matter how large.

In recent years, though, a new thickening tool has invaded the home shop: the drum sander. With four models now on the market for less than \$1,000, the

time has come to take a close look at these smooth operators that can sand even wide panels flat and fine.

Drum sander vs. planer: A head-to-head look

Look under the hood, and you'll see that a drum sander bears many similarities to a planer. As a workpiece enters the machine, tension rollers (see the drawings on pages 56-57) guide it beneath a spinning cylinder that removes a thin layer of wood. A planer may have two, three, or even four knives doing the cutting; a drum sander has, in effect, thousands of knives—the grit on the abrasive that spirally wraps the drum.

There are some key differences, though. For instance, a planer can cut away lots of material quickly, removing $\frac{1}{16}$ " or more in a single speedy pass. With a drum sander, you generally remove no more than $\frac{1}{64}$ " (and often only half that) with each pass, and then at only about half the feed rate of a portable planer. However, this slower feed speed and shallow cut leaves an exceptionally smooth surface on most woods.

A drum sander has other advantages as well. Because it doesn't slice away wood like a planer, you can sand end grain, and use it safely with thin or fragile stock, such as veneer and burls. And, you can abrade away a dirty or weathered surface, such as the maple benchtop, shown above, without dulling your planer knives.

Test talk

We began by assembling each of the four sanders in our test, noting any difficulties. The Grizzly G1079 and Ryobi WDS1600 sanders come with the table already mounted. It took us about 10 minutes to bolt on Delta's table, and less than 20 minutes to attach the Performax table. The Delta 31-250 and Grizzly come with leg stands, and the Performax 16-32 PLUS has extension tables, which we also assembled.

Next, we paralleled each machine's table and drum (or drums, in Grizzly's case). Although each of the four sanders differed in the method for making this adjustment, we found none of them difficult to align. On the Performax, we loos-

Fast Facts

- Three of the sanders in our test use a cantilevered design that allows you to smooth stock or panels up to twice the width of the sanding drum. Grizzly's closed, H-frame design proved extremely rigid, but limits you to workpieces no wider than the drum.
- Drum sanders excel at cleaning up glued joints. Angling the workpiece as you feed it into the sander prevents the glue from clogging the abrasive in one area. If you end up with a glue line on the abrasive, clean it off by holding a scrap piece of clear acrylic sheet against the spinning drum.
- The cloth-backed sanding strip, like any abrasive, wears out, but you can extend its life by periodically soaking it in paint thinner. After drying, wind it back onto the drum backwards (tail first), to use the opposite cutting face of the grit.

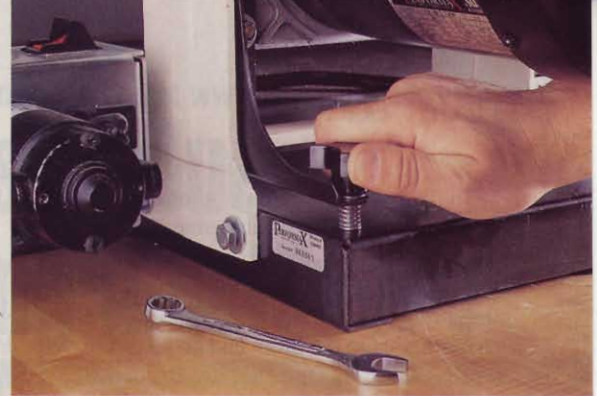

The fine-tune adjustment knob on the Performax 16-32 PLUS, above, allowed us to dial-in precise head-to-table alignment.

To make Delta's table, below, parallel to its drum, turn the outboard elevation screws an equal number of turns, then lock them in place with setscrews.



ened the four bolts that attach the shroud and motor/drum assembly to the table, tweaked the alignment with the fine-tuning knob (shown at *top right*), and tightened the bolts. Ryobi's process is similar, but lacks the fine-tuning knob. Instead, Ryobi provides two .010" shims that raise the outboard end of the table for fine-tuning. Larger adjustments are made by loosening four bolts and repositioning the shroud and motor/drum assembly where it fastens to the table.

Delta's system was our favorite. Changing the alignment is as simple as loosening a set screw atop each outboard table-elevation screw, and rotating both elevation screws with a 1/2" wrench. (See photo *above*.) Aligning Grizzly's table takes more work because with two drums you have to make it parallel both front-to-rear and side-to-side. Those adjustments are made with a jackscrew on each of the table's four posts, and the process is akin to leveling a washing machine or dryer.

Once aligned, we loaded an abrasive strip on each drum and went to work. Because of the open-ended design of the Delta, Performax, and Ryobi sanders, we wondered if the drums and tables of these units would stray from parallel under sanding load. So, armed with a dial indicator, we measured deflection at the outboard end of the drum while removing a healthy 1/32" from 5 1/2"-wide red oak boards. We also measured the actual difference in thickness across the test boards.

drum sanders

Finally, while running hundreds of board-feet of red oak and pine through each sander, we changed sanding grits frequently. This gave us a good feel for the process of replacing the abrasive strips that wrap the drum and do all of the work. During this test, we also examined the test workpieces for any signs of snipe.

Heads or tables? Going from thick to thin

Just as on a planer, you set the cutting depth of the abrasive by closing the gap between the sanding drum and the table. (See the box, *below*, for some great guidelines on stock removal.) To accomplish this, you either lower the head toward a fixed-height table (Performax and Ryobi) or raise the table toward a stationary head (Delta and Grizzly).

Performax and Ryobi employ a simple crank on a threaded rod to elevate the head within the shroud. This design demands some tolerance—no matter how small—between the motor-mount slide plate and shroud, or the head can't move. That small tolerance resulted in only .002" difference edge-to-edge on our 5½"-wide test pieces.

The tables of the Delta and Grizzly sanders elevate courtesy of four threaded posts. These posts, linked by either a cogged timing belt (Delta) or chain (Grizzly), simultaneously raise or lower

FIXED-HEAD SANDER

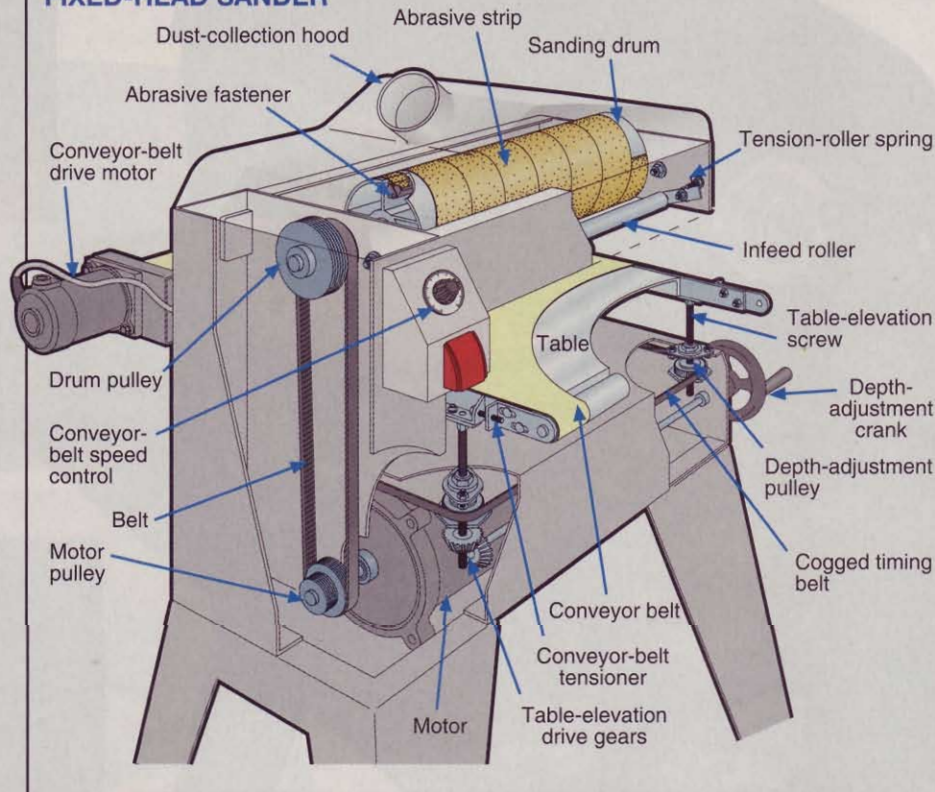

all four corners of the table. By fixing the head and moving the table in this manner, Delta engineers reduced deflection to .001" on our test pieces, even though the machine is open-ended like the Performax and Ryobi models.

One caution regarding Delta's timing belt: If the idler gear that takes up the belt slack is too loose (or if you take too deep a cut and jam your workpiece between the drum and table), this belt can skip when you try to change the table height. A couple of skips won't cause problems, but every "click" puts those four elevation screws farther out of sync, eventually causing them to bind, and the condition worsens rapidly. Delta engineers have prepared a flier describing how to re-align the table, should you encounter this situation. To get a copy, call 800/438-2486.

Sandpaper replacement: Cruising the strips

Once you get a drum sander, the task you'll perform most often is changing abrasives. Just as with hand-sanding, each workpiece must move through the whole range of grits from coarse to fine. Fortunately, it's a pretty simple job.

Rather than sliding a sleeve over the drum, like with an oscillating spindle sander, you attach a long abrasive strip to one end of the drum, and wrap it spiral-fashion to the other end. You can cut

Four tips for smoother sanding

Getting unbeatable results from a drum sander takes a fair amount of practice. But here are a few things you can do to get a jump start on sanding success:

•**Don't get greedy.** Using abrasive coarser than 100-grit, remove no more than 1/64" with each pass. For 100-grit or finer, reduce your take to 1/132" or less. Remember, each finer grit should only remove the scratches left by the previous grit.

•**Wanna drag?** An easy way to set the proper sanding depth is to place your workpiece between the drum and table. With the machine turned off, spin the drum by hand, and lower the head or raise the table until the abrasive just drags on the workpiece. If you can't turn the drum by hand, you'll sand too deep.

•**Flatten first.** Before you sand to thickness, make sure your workpiece has one flat face. Make a series of pencil lines across the grain, as shown *above left*, then make repeated shallow passes with the sander until the lines disappear. Sand crowned pieces crown-up.

•**The old reverse play.** After sanding to your final grit, rotate the workpiece 180° and, *without changing any settings*, run it through the sander again. Abrading from the opposite direction removes the "fuzzies" raised during the previous pass.



FIXED-TABLE SANDER

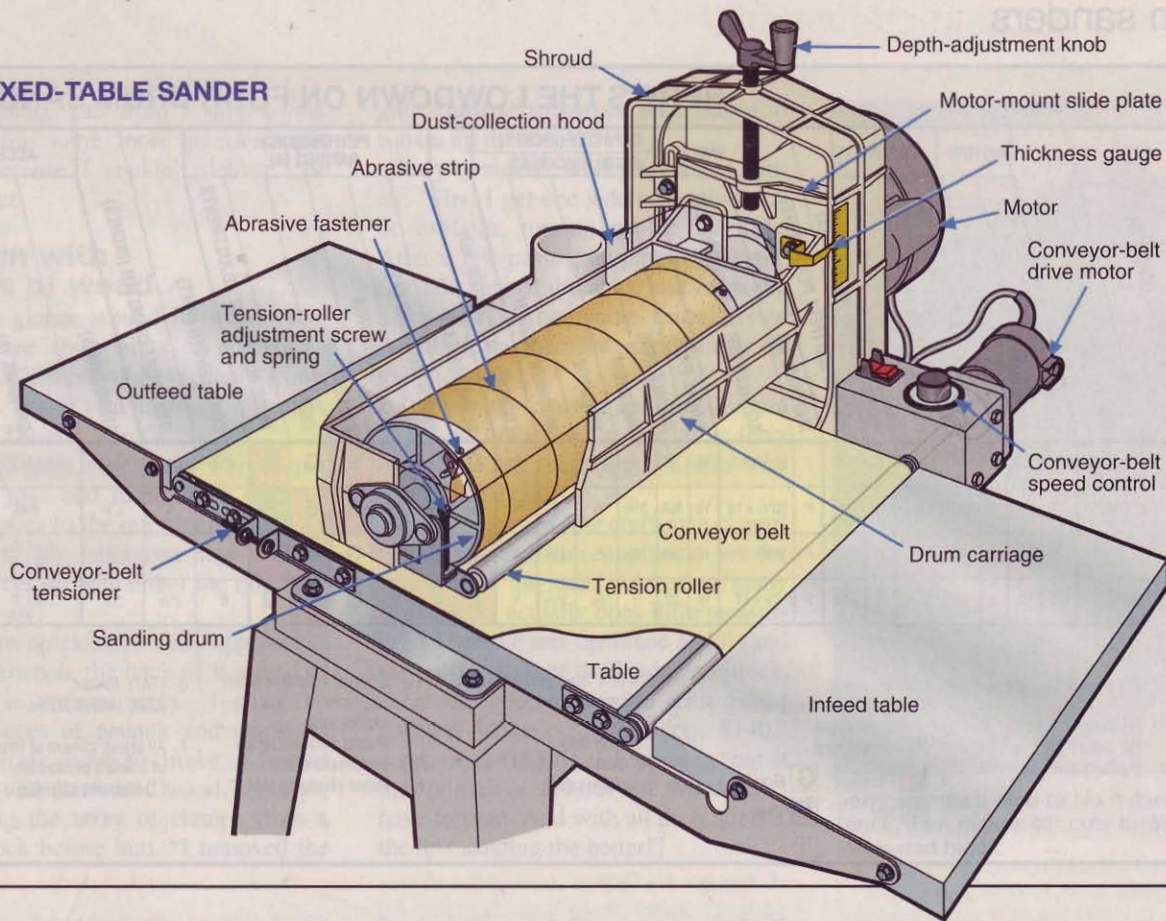

Let's buckle down and talk about belts

Drum sanders use a conveyor belt to move the stock at a steady rate beneath the spinning abrasive. For softwoods and narrow workpieces, a fast feed rate means less time spent sanding. But for hardwoods and wide workpieces, slow is the rule. Delta and Performax share a similar stock-moving system: a cloth-backed abrasive belt that you can dial from zero to its maximum speed. At 12 feet-per-minute (fpm), Delta bests Performax's 10 fpm top rate.

Grizzly and Ryobi use an embossed rubber belt, but Ryobi's feed rate can be adjusted only from 2–10 fpm—it can't be stopped completely without turning off power to the sanding drum. Likewise, Grizzly's feed rate is fixed at 11 fpm, and the belt starts and stops only with the main power switch. For safety reasons, we prefer a drive system that can be operated independently of the drum motor for cleaning the abrasive or setting sanding depth.

Any time you wrap a belt around two rollers, you must keep those rollers par-

LEFT: Performax's "TUF Tool" activates the tough-to-get-to spring clip on the inboard end of the drum to prevent finger-pinching while loading abrasive. **RIGHT:** The cutout on Delta's drum means you don't have to blindly feel for the take-up clip. However, it tended to pinch our fingers against the sharp edge as we released the clip.

your own from bulk abrasive, using the strip that comes with the machine as a template, or buy pre-cut strips in various grits. (Grizzly doesn't sell pre-cut strips for the G1079.)

Spring-loaded clips on both ends secure the strips and keep the abrasive taut should it stretch somewhat in use. Again, Grizzly differs by using a spring clip to attach the start of the strip, and duct tape to affix the end. It takes a bit longer, but was just as effective in use.

Operating the end spring clip requires some finger gymnastics in a tight spot on the Performax and Ryobi sanders, but Performax provides a tool (shown *above left*) to make the job easier. Delta engineers cut away a portion of the drum to make room for your fingers (see photo *above right*), but left an edge that's just sharp enough to be uncomfortable. Fortunately, there's plenty of room around the end of the drum to operate the take-up clip.

HERE'S THE LOWDOWN ON FOUR DRUM SANDERS

MANUFACTURER / IMPORTER	MODEL	MOTOR		DRUM			MATERIAL (3)	TABLE		CAPACITY (INCHES)		LOCKING SWITCH (YES, NO)	PERFORMANCE RATINGS (4)					CORD LENGTH (FEET)		DUST PORT DIAMETER (INCHES)		ACCESSORIES			
		VOLTS	AMPS	DIAMETER (INCHES)	SPEED (SURFACE FEET PER MINUTE) (1)	DRUM HOUSING MATERIAL (2)		FEED SPEED (FEET PER MINUTE)	SIZE (LENGTH X WIDTH, INCHES)	SINGLE PASS	DOUBLE PASS		MAXIMUM	MINIMUM	MINIMUM LENGTH	PAPER CHANGING EASE	DUST COLLECTION	DEFLECTION	SNIPES	TABLE ALIGNMENT ADJUSTMENTS	STANDARD (5)	OPTIONAL (5)			
DELTA	31-250	110	12.8	5	2,210/3,300	F	0-12	I	20 x 18 1/4	18	36	4	1/8	7	Y	G	E	E	E	G	E	6 1/2	4	L,P	D,E,I,M,P,PD
GRIZZLY	G1079	220	8	6	2,100	S	11	P	30 1/2 x 16	16	N/A	3 1/2	1/8	9	Y	G	G	P	E	E	F	6	4	L,P	B,M
PERFORMAX	16-32 PLUS	110	14	5	2,100	A	0-10	F	19 x 17	16	32	3	1/32	2 1/4	N	E	E	E	G	E	E	5 1/2	2 1/2	E,P,T	A,B,C,CS, D,L,P
RYOBI	WDS1600	110	10	5	2,100	A	2-10	F	19 x 17	16	32	3	1/32	2 1/4	Y	E	E	E	G	E	G	6	2 1/2	D,P	B,L,P

NOTES:

- (*) Dual drum speeds
- (F) Formed steel
(S) Solid steel
(A) Cast aluminum
- (I) Cast iron
(P) Particleboard with steel substructure
(F) Formed steel
- E** Excellent **G** Good
F Fair **P** Poor
- (A) 2 1/2 to 4" dust-port adapter
(B) Bulk abrasive
(C) Casters
(CS) Cleaning stick
(D) 90° dust-port elbow
(E) Extension tables
- (I) External inflatable drum
(L) Leg stand
(M) Mobile base
(P) Precut abrasive strips
(PD) Pneumatic drum
(T) Paper-changing tool
- (TAI) Taiwan
(USA) United States
- All prices current at time of article's production.
(* Includes shipping)

allel, or the belt will mistrack and wander off the end of the table. While it's simple to adjust belt-tracking on all of the machines, Performax brings a couple of nice features to the table. First, you can't lose the wrench because it's captured on the bolt it adjusts. And second, the sander comes with a pair of magnetic ceramic guides, called "Trackers," that cling to the bottom of the table and keep the conveyor belt from straying.

A few more things to mull over before you buy

•**Stunting snipe.** Overall, we were impressed with the lack of snipe we found in these sanders. Only the Delta dinged our test workpieces, about 2" from the end and .001" deep. We traced it to the 31-250's front pressure roller, which applied more downward pressure to the board than the other models in the test, and audibly snapped when it released the board. Performax and Ryobi allow you to adjust the roller tension to achieve the best results.

•**Go wide.** Delta wins the "mine's bigger than yours" battle. With its 18" drum and C-frame design, you can sand up to that width in one pass, and workpieces up to 36"-wide by rotating the workpiece end-for-end and feeding it through again. For many woodworkers, the 32" max of the Performax and Ryobi

sanders is plenty for panel and face-frame work. Grizzly's 15" capacity is better suited to narrow panels and individual workpieces.

Incidentally, the manufacturers of the C-frame machines suggest that you set the drum perfectly parallel to the table for sanding pieces in one pass, but a slightly different alignment for pieces wider than the drum. By setting the outboard end slightly more open, you reduce the likelihood of a ridge in the middle of your panel. (We settled on a compromise position—with the outboard end about .001" wider—that worked well with both narrow and wide stock, and kept us from constantly resetting the alignment.)

•**Smoothing short stuff.** Because a drum sander is ideal for smoothing fragile workpieces, it makes leveling marquetry a no-brainer. But the distance between the pressure rollers and drum limits how short a piece you can sand. Performax and Ryobi can handle stock as short as 2 1/4", a big plus if you sand a lot of small or fragile pieces.

•**On the drum beat.** One interesting note here about sanding drums: Grizzly has

True grit: Knowing what to use, and when

Choosing the right abrasive grit for the job at hand is half the battle when using a drum sander. As you get more comfortable with your sander, selecting abrasives will become almost second nature. Until then, use this reference chart as a guide.

TASK	GRIT									
	24	36	60	80	100	120	150	180	220	
Surfacing rough-sawn lumber										
Removing paint and glue										
Truing cupped and warped boards										
Removing planer ripples										
Light surfacing										
Finish sanding										

	WARRANTY (YEARS)	COUNTRY OF ASSEMBLY (6)	WEIGHT (POUNDS)	SELLING PRICE (7)	COMMENTS
2	USA	190	\$850		The new kid on the drum-sanding block, with the best performance and largest capacities. Price includes stand.
1	TAI	285	660*		Industrial machine for a small-shop price. Dual drums allow two-grit sanding in one pass. Requires high-volume dust-collector.
2	USA	95	870		A top performer with accessories galore, but the most expensive model in the test. Price includes extension tables.
2	TAI	105	600		This model delivers very good performance for comparatively little money. Takes a little more work to align. Stand is optional.

For more information, contact:

Delta 800/438-2486 www.deltamachinery.com	Grizzly 800/523-4777 www.grizzly.com
Performax 800/334-4910 www.performaxproducts.com	Ryobi 800/525-2579 www.ryobitools.com



Performax 16-32 PLUS



Ryobi WDS1600



Delta 31-250



Grizzly G1079

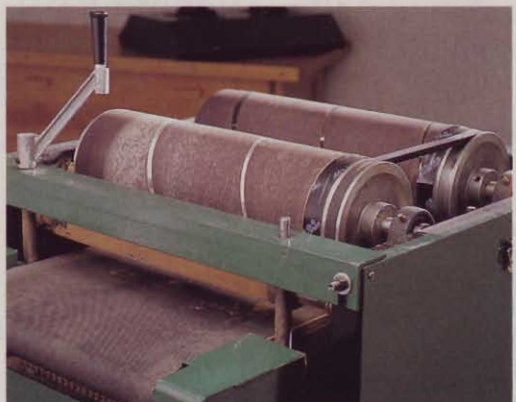

Grizzly's drum duet cuts your sanding time in half by allowing you to use different grits on each drum. Note that the height adjustment crank can be moved to another lug, such as the one in the foreground.

two of them, shown above. For production sanding, you can mount a coarse grit on the first drum and a finer grit on the second drum, and step up two grits of paper in one pass. A felt liner makes the second drum slightly larger than the first to sand just a smidgeon deeper.

•*Dealing with the dust.* Be it shop vacuum or dust-collection system, you must have some method of grabbing the fine

dust that quickly fills the air when using one of these machines. In our experience, one is as good as the other for most of the machines, but you may have to adapt the tool to fit your collector's hose. (See the chart above to learn the dust port size on each machine.)

The Delta 31-250 gets a slight edge here: The blow-molded drum cover mimics the shape of the drum and was almost spotless at the end of our testing. True to its industrial roots, the Grizzly G1079 has two 4" ports and a cavernous hood, which made it hard for us to capture much dust, even with our 750 cfm collector.

After the dust settled, which would we buy?

Honestly, it's a tough call. But Delta's engineers really did their homework when they designed the 31-250, and this machine's extra capacity, cast-iron table, dual drum speeds, and included leg stand nudge it past the Performax 16-32 PLUS for general use.

On the other hand, if you work with a lot of small pieces or veneers, it's a tough call between the Performax 16-32 PLUS and the Ryobi WDS1600. In the trenches, the two were virtually identical. Only you can decide whether the extra power and features on the Performax are worth the \$270 difference between the models.

Written by **Dave Campbell**
 Technical consultant: **Dave Henderson**
 Illustrations: **Kim Downing**
 Photographs: **Baldwin Photography**

We've had our say; now go online and have yours

If you've used one of the models in our test, we'd like you to sound off in our special Drum Sanders discussion group. Or, if you're still on the fence, go there for a second opinion.

To participate, simply log on to the WOOD ONLINE® home page at www.woodonline.com and click on "Interactive Tool Reviews." Besides hearing from other woodworkers, you'll also learn how the manufacturers responded to this article.



Grace and
craftsmanship
combine in
this traditional
table design.

classic oval table

Phillip Harmon restores and reproduces antiques in Duson, Louisiana. The original table, copied here, came through his shop some 20 years ago. A colonial period American piece, it probably originated in the Mid-Atlantic or New England region. Phillip was so taken by it that he made two for himself, and provided the documentation that allows us to present it to you.

Because this project is a copy of an antique, some of the parts have odd thicknesses. We used a 3" turning square for the pedestal, and were fortunate to find some 6/4 lumber for the legs and pivot block. If you can't find this thickness lumber, laminate the parts from 4/4 lumber, or plane down 8/4 lumber.

Note: For those of you who are interested in building this project, but don't want to turn the pedestal, see the *Buying Guide for a pretuned one*. For those up to the challenge, but needing a little help, see the turning instructions on page 63. Adept turners, go directly to the full-size pattern on the WOOD PATTERNS® insert. No matter which way you choose, once you have your pedestal in hand, you're ready to proceed.

Form the pedestal's sliding dovetails

1 Stick two 3/4x4x4" pieces of scrap material together with double-faced tape. We used MDF. Make a copy of the Pedestal Index Block on page 62,

and adhere it to the assembled pieces with spray adhesive. Band-saw, then sand to the pattern lines. Drill the screw shank holes, where indicated, then separate the blocks.

2 Drill screw pilot holes at the lathe center locations on the ends of the pedestal (A). Screw the blocks to the pedestal, using only the center holes. Fasten the block with the pattern on it to the bottom of the spindle with the pattern facing out. Lay the pedestal/index blocks assembly on a flat surface, aligning the blocks. Drill pilot holes in the pedestal, using the second hole in each block as a guide. Drive in a second pair of screws.

3 Outfit your router table with the auxiliary table and fence shown in Drawing 1: Router Table/Fence Extensions, on page 62. This set of extensions supports and guides the index blocks attached to the pedestal when forming the flats and dovetail slots at the bottom.

4 Chuck a 3/4" straight bit in your table-mounted router, and position the table extension over the bit so it is centered in the hole. Clamp the



classic oval table

DRAWING 1
Router Table/Fence Extensions

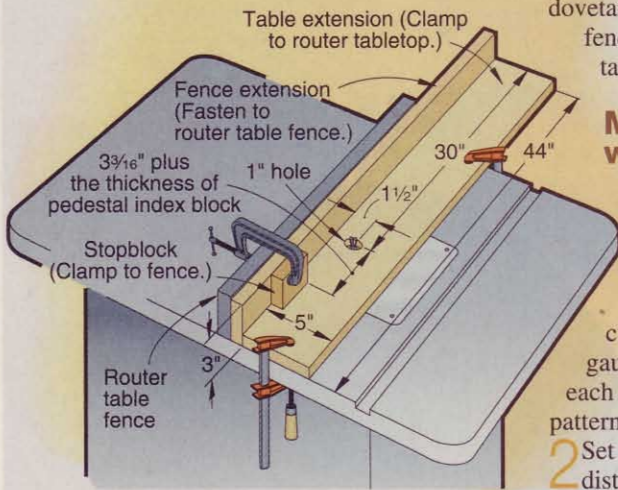

extension to your router table. Fasten the fence extension to your router table fence, and position it against the table extension. Clamp a stopblock to the fence, where shown on the drawing.

5 Place the spindle on the extension table, and raise the router bit to the height indicated on the bottom index-block pattern. With the index blocks against the extension fence, feed the pedestal through the bit until the index block contacts the stopblock. Turn the pedestal, and repeat on the remaining two faces. Reposition the fence, maintaining the spacing from bit to stopblock, and make a second set of cuts, as shown in *Photo A*. Reposition the fence, and repeat until the flats are completely formed.

6 Chuck a 1/2" x 8° (cutting angle) dovetail bit in your table-mounted router, and raise it to the height indicated on the pattern. See the Buying Guide for the bit we used. Adjust the fence to center the

bit on the pattern image. With the stopblock positioned the same distance from the center of the bit as before, rout the dovetail grooves. Remove the auxiliary fence and table, but leave the dovetail bit installed.

Make tapered legs with dovetail tenons

1 Plane a 1 1/4 x 4 x 60" board to 1 1/8" thick, and cut three 15"-long blanks for the legs (B), plus a couple of scraps for testing the setup of the dovetail cuts. Set your tablesaw miter gauge to 57°, and trim one end of each blank, where shown on the Leg pattern on the pattern insert.

2 Set your tablesaw rip fence so the distance from the left side of the blade to the fence is 1/64" less than the depth of the dovetail slots in the pedestal. Raise the blade to cut 3/8" deep. Place the first leg (B) blank with its angled end against the fence, and adjust your miter gauge to match the angle. Make the first shoulder cuts on all three of the leg blanks, supporting them with your miter gauge. Flip the legs over, readjust your miter gauge, and make the second set of shoulder cuts. Make the same shoulder cuts on your scrap pieces.

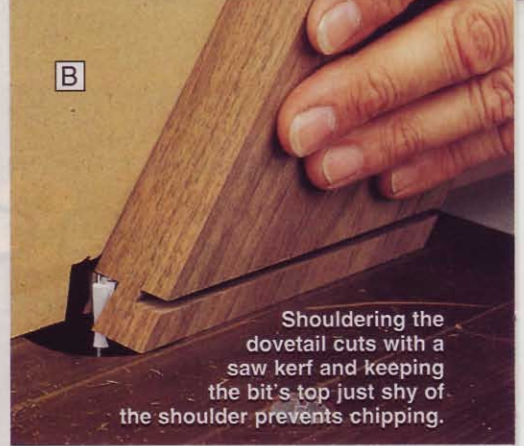

Note: Cutting the dovetail tenon slightly shorter than the depth of the groove keeps the tenon from bottoming out in the groove. This makes it easier to get a tight-fitting joint that will still slide together.

3 Using one of the scrap pieces previously cut as a gauge, adjust the height of the dovetail bit in your table-mounted router so it is just shy of the shoulders cut in *Step 2*. Position the fence so the bit is partially housed. Using the scrap pieces, make passes from both sides, adjusting the position of the fence until you form a dovetail that fits the slots in the pedestal. Now, cut the dovetails on the leg blanks, as shown in *Photo B*.

4 Remove the cutterhead guard from your jointer, and position the fence to

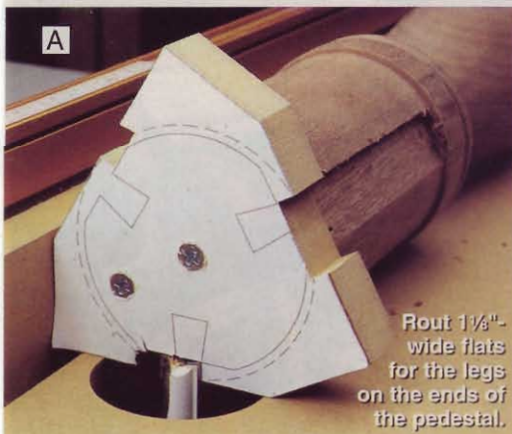

FULL-SIZE DRAWING
PEDESTAL INDEX
BLOCK

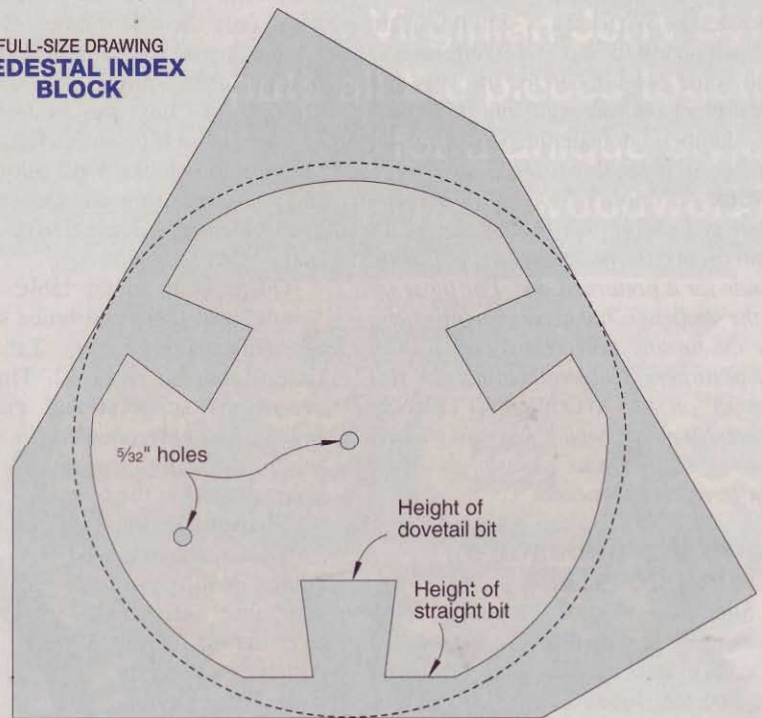

Turning the pedestal

1 Copy the full-size half-pattern of the pedestal from the *WOOD PATTERNS*® insert, and adhere it to a 1/8x3x23 1/4" piece of hardboard. Align the pattern centerline with one edge of the hardboard. Cut out the shaded portion of the pattern, leaving the negative image of the profile, as shown in Drawing 1. Use this template to check the progress of your turning.

2 Trim your 3" turning square to the length in the Bill of Materials, squaring the ends. Mark the centers of the ends. Mount the blank between the lathe centers. Use your 1" roughing gouge to round the blank to slightly greater than 2 7/8", as shown in Drawing 2. Stop the lathe often, and check your progress with calipers.

3 With a pencil, mark the locations of the critical diameters and beads on the blank, where indicated on the pattern. Cut grooves in the blank with your parting tool to the depths shown on your template, where indicated by your pencil marks, as shown in Drawing 3. Begin with the shallow cuts, and work to the deep ones. Shut off the lathe periodically, and check the diameters.

4 Rough out the basic shape of the pedestal with a 3/8" spindle gouge, as shown in Drawing 4. Check your progress against the pattern. Cut to within 1/16" of the depths set earlier with the parting tool. Work as close to the finer details as the gouge allows, leaving enough material for fine detailing later. For better control, work the profiles downhill (larger to smaller diameters).

5 Use your parting tool to true the narrow flats and inside corners, roll the beads and round-overs, and size the top tenon and bottom cylinder, as shown in Drawing 5. Start in the center of the beads, and work down to either side. Roll the parting tool over as you follow the bead profile. Work the round-overs downhill. Make multiple overlapping cuts to bring the tenon and cylinder close to finish size, then clean them up with a final light, continuous cut. Check the size of the top tenon carefully to ensure a good fit of the pivot block (C).

6 Smooth the broad profiles with your 3/8" spindle gouge, as shown in Drawing 6. As before, work the profiles downhill. Make very light cuts, and move the tool in long, continuous motions.

7 Slow the lathe to 800–1,200 rpm, and finish-sand the pedestal with a progression of 120-220-320-grit sandpapers. Do not sand the top round tenon.

1 Make the template

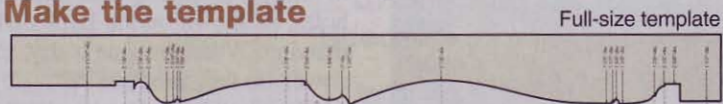

2 Prepare the blank

TOOL: roughing gouge **TOOLREST:** below center **SPEED:** 600-800 rpm

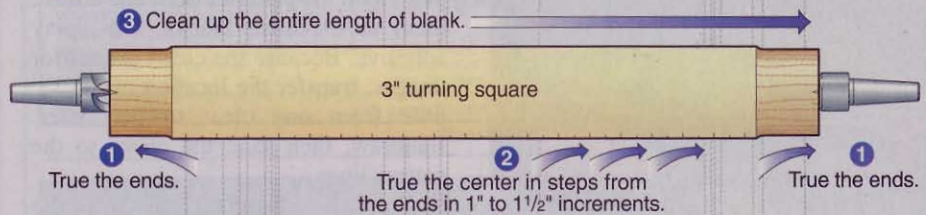

3 Mark and cut the diameters

TOOL: diamond parting tool **TOOLREST:** center **SPEED:** 800-1,200 rpm

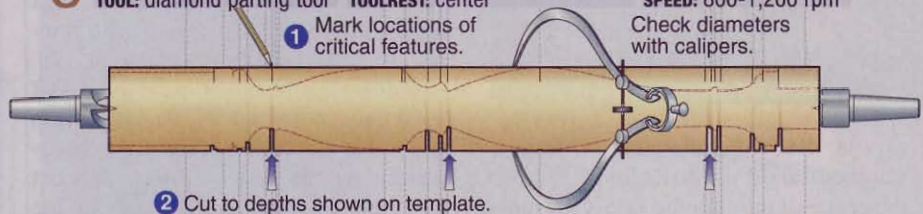

4 The shape emerges

TOOL: 3/8" spindle gouge **TOOLREST:** slightly below center **SPEED:** 800-1,200 rpm

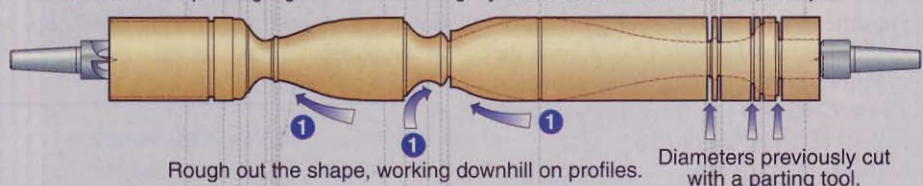

5 Refine the shape

TOOL: diamond parting tool **TOOLREST:** center **SPEED:** 1,200-1,600 rpm

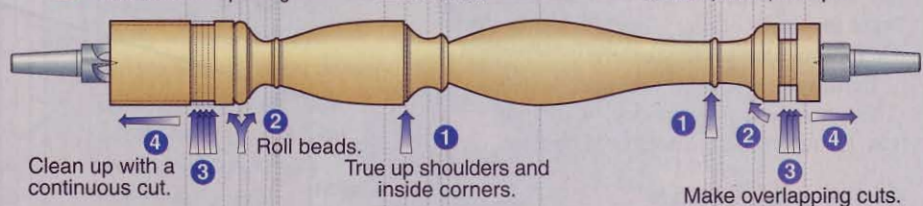

6 Finish up

TOOL: 3/8" spindle gouge **TOOLREST:** slightly below center **SPEED:** 1,200-1,600 rpm

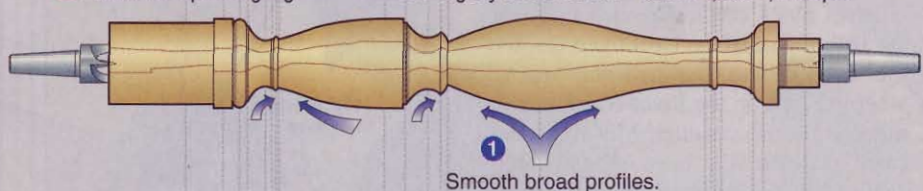

classic oval table



Face jointing the leg blanks tapers them from $1\frac{1}{8}$ " to $\frac{3}{4}$ ". The stopblock prevents kickback.

expose $4\frac{1}{8}$ " of cutterhead. Clamp a stopblock to the infeed table, $11\frac{1}{2}$ " from the center of the cutterhead. Set the jointer to cut $\frac{1}{16}$ " deep. Place the square end of a leg blank against the stopblock, while holding the dovetailed end off the cutterhead with a push stick. Switch on the jointer, and lower the blank onto the cutterhead, face-jointing it, as shown in *Photo C*. Repeat this three times on each side of all three leg blanks.

5 Make three copies of the Leg pattern, and adhere them to the leg blanks with spray adhesive. Bandsaw and sand the feet to the pattern lines. Trim the tops of the dovetail tenons, where indicated on the pattern.

6 Remove the patterns, and sand the feet to smooth the transitions at the top from the tapered to the untapered portions.

Build a top that tilts for storage

1 Cut a piece of $1\frac{1}{4}$ " stock for the pivot block (C) to the size listed in the Bill of Materials. Drill the holes for the dowels and the pedestal tenon, where shown on the Pivot Block drawing. Cut the $\frac{5}{8}$ " chamfer. Mortise in the catch plate for the brass tilt-top table catch, drill the screw pilot holes, then remove the plate. See the Buying Guide for our source for the catch.

2 Cut two 2"-long pieces of $\frac{1}{2}$ " dowel, chuck them in turn in your drill press,

and sand them down to fit the $1\frac{5}{32}$ " holes in the pivot block. Glue them in the holes, as shown on the Exploded View drawing. When the glue is dry, trim the dowels so they protrude $\frac{9}{16}$ ".

3 Cut two blanks for the cleats (D) to the size listed in the Bill of Materials. Make two copies of the Cleat pattern on the pattern insert, and adhere them to the cleat blanks with spray adhesive. Because the cleats are mirror images, transfer the location of the $\frac{1}{2}$ " hole from one cleat to the other. Bandsaw, then sand the cleats to the pattern lines.

4 Rout the chamfers, and drill the holes for the screws, where indicated on the pattern. Center the screw holes on the thickness of each cleat. Drill mirror-image holes for the pivot dowels. Remove the patterns.

5 Edge-glue three $\frac{3}{4}\times 7\times 27$ " pieces of walnut to form a blank for the top (E). Make four copies of the Top quarter-pattern on the pattern insert, and cut them out. Adhere the patterns to the bottom face of the blank with spray adhesive, forming a complete oval. (Two quarters of the pattern will be face down.) Bandsaw and sand the tabletop to the pattern line.

6 Place the top (E) on your workbench with the pattern facing up. This will be the tabletop's bottom surface. Assemble the cleats to the pivot block, inserting the pivot dowels in the holes in the cleats. Position the pivot block/cleat assembly on the top, aligning the cleats with their locations on the pattern. Clamp $\frac{1}{16}$ " spacers between the cleats and pivot block to keep the cleats parallel. Using the screw shank holes previously drilled in the cleats as guides, drill pilot holes into the top. Make a small chisel mark on a hidden portion of one cleat and the top to assist in reassembling the parts later. Remove the pattern.

Now finish and do final assembly

1 Finish-sand the legs, pivot block, cleats, and top to 220 grit. Break the edges of the legs (except where they abut the pedestal), pivot block, and top with a sanding block.

2 Spread glue in the pedestal dovetail slots, and slide the legs into place. Apply glue on the pedestal tenon, and seat the pivot block. Immediately lay assembly A/B/C on your workbench and, before the glue grabs, align the pivot block, as shown in *Photo D*.

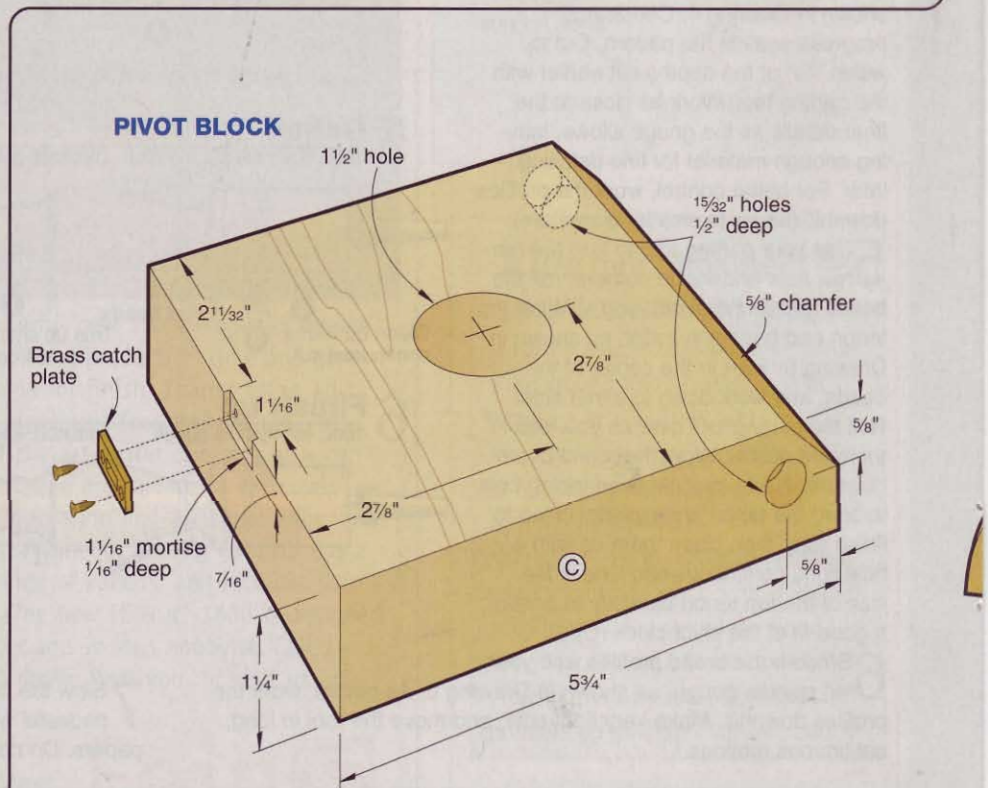

bill of materials

oval table

Part	FINISHED SIZE			Mater.	Qty.
	T	W	L		
A pedestal	2 7/8"	dia.	23 1/4"	W	1
B* legs	1 1/8"	4"	15"	W	3
C pivot block	1 1/4"	5 3/4"	5 3/4"	W	1
D cleats	7/8"	1 3/4"	20"	W	2
E* top	3/4"	18 1/2"	25 1/2"	EW	1

* Parts initially cut oversize. Trim to finished size according to instructions.

Materials Key: W—walnut, EW—edge-glued walnut.

Supplies: #10x1 1/2" brass flathead wood screws (6), 1/2" dowel, finish.

Buying Guide:

Dovetail bit: 1/2"x8" dovetail bit, Jesada #618-129, \$22.90 plus shipping. FL residents add tax. Call 800/531-5559 to order.

Catch: Spring-loaded tilt-top table catch #4720, Paxton Hardware, phone 800/241-9741. Item is imported from England. Please call for current price. MD residents must add tax.

Pedestal: A pre-turned walnut pedestal is available. Order item #OT, \$48.95 ppd., Schlabaugh and Sons Woodworking, 720 14th Street, Kalona, IA 52247 or call 800/346-9663. Other wood species available upon request. Ask for pricing and delivery time.

See the **WOOD PATTERNS®** insert for the full-size patterns.

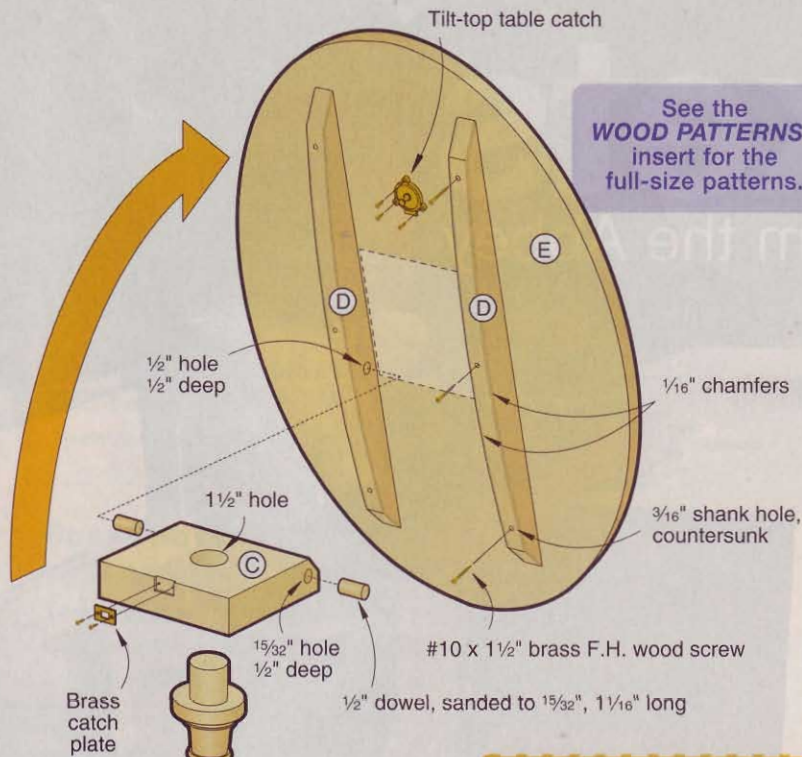

cutting diagram

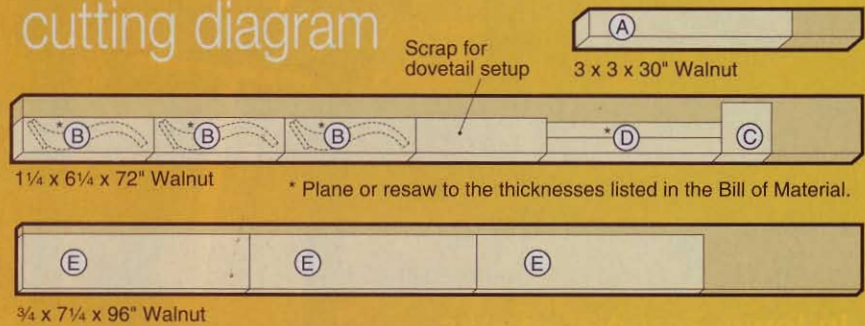

EXPLODED VIEW (viewed from behind)

3 Remove sanding dust with compressed air or a tack rag, and apply two coats of satin polyurethane to all the parts and assemblies. Sand lightly with 220-grit sandpaper between coats.

4 Reinstall the catch plate on the pivot block. Place the top, bottom surface up, on your workbench. Mount the cleats on the pivot block, and reposition the pedestal assembly A/B/C/D on the top (E). Align the previously made index marks. Drive the screws through the cleats and into the top.

5 Align the catch with the catch plate, drill the screw pilot holes, and screw the catch in place. 🌲



Written by **Jan Hale Svec** with **Charles I. Hedlund**
 Illustrations: **Roxanne LeMoine; Lorna Johnson**
 Photographs: **Baldwin Photography; Wm. Hopkins**

back-to-basics

caskets

from the Abbey

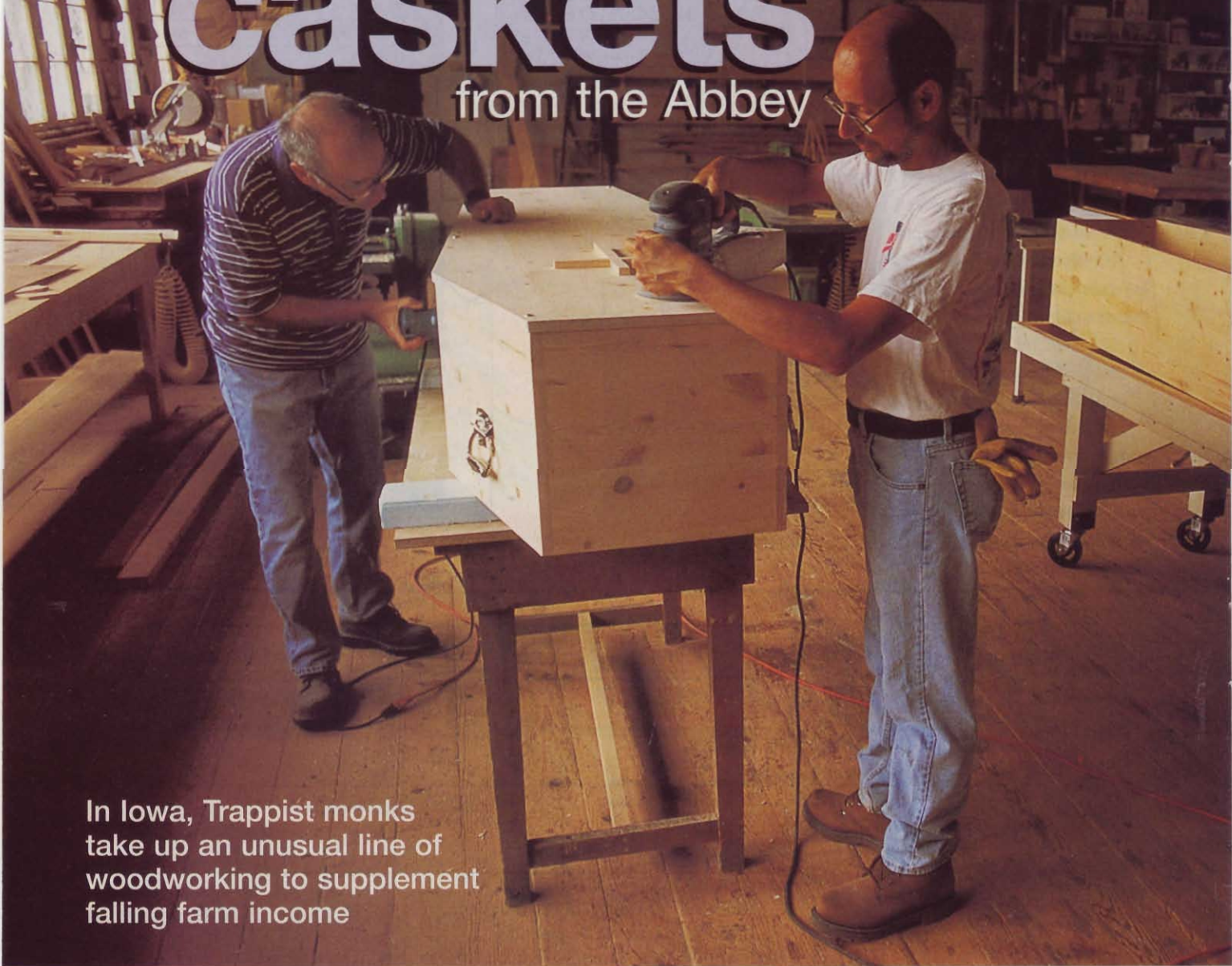

In Iowa, Trappist monks take up an unusual line of woodworking to supplement falling farm income

Until the fall of 1999, the Trappist monks of New Melleray Abbey at Peosta in northeast Iowa supported a contemplative life mainly through farming their 1,300 tillable acres. But the ever lower prices for corn and soybeans that plagued Midwest farmers also affected the agrarian monastery's revenues. On top of that, the aging monks in the brotherhood had dwindled to 36, requiring the hiring of help to tend and harvest the crops.

Living not too far away from them, however, was a possible answer to their dilemma. Sam Mulgrew, a Monmouth,

Iowa, hobby farmer, had developed a business of handcrafting and selling wooden caskets. Having acquainted himself with the Trappists over the years—he built his first casket in their carpentry shop—Sam wasn't surprised when the monastery asked about acquiring his growing casket business to supplement their sagging farm income.

A merger of resources

Purchasing Mulgrew's casket business was a natural move. New Melleray Abbey is the second largest private forest owner in the state, with mixed hard-

woods and pine covering 1,700 acres. And it already had a sawmill and drying facility, once relied upon to produce lumber for buildings and abbey furniture. All the monks needed was something to make and market, as well as someone like Sam with the knowledge and experience to direct the operation.

Sam, now general manager of Trappist Caskets, immediately realized the marketing value New Melleray could add to his line, and sold his company. "Where else could one buy a casket handcrafted by Trappist monks with wood from their own forest?" he asks rhetorically.

The Rule of Saint Benedict

The original Trappists of New Melleray Abbey came to Iowa from Ireland in 1849, the time of the Great Famine in that country. Then as now, the monks belong to the Cistercian tradition that adheres to the monastic Rule of Saint Benedict. In short, the rule says to follow God in a life of contemplative prayer, community liturgy, and manual labor to support themselves. Accordingly, the monks arise at 3:15 a.m. for prayer, work quietly through the day with stops for prayer in the chapel, then retire at 8:00 p.m.

"Besides, it took little investment in equipment because making caskets is not like making furniture. You don't need a lot of fancy tools. But you do need a few good ones, like a shaper and a tablesaw."

More than the basic pine box

Trappist Caskets now offers two designs in three grades. All display honest lines that reflect a simple dignity. First, there's the straight-sided, box-shaped casket in pine. The premium, shaped casket, available in walnut, ash, oak, and maple, features raised panels. There's a shaped pine casket, too, with a cross on its lid. (All lids are split crosswise so that

in place with stainless steel fasteners. Nickel-plated, trunk-type "D" handles embellish the pine models.

"We don't put any finish on caskets made of pine," notes Sam. "I've found that people like the feel and smell of the wood. For the raised-panel caskets in other woods, we use a lacquer finish."

In their first year, the Trappist monks made and sold 120 caskets, sending

they can afford on a loved one's funeral casket because there hasn't been an inexpensive, yet respectable-looking, option. Trappist Caskets fill that need. They're dignified, yet affordable, and funeral directors can still make a profit. Having a wooden casket that was carefully crafted by monks also adds a spiritual aspect.

However, some casket sales have taken a turn to interior design. Brother Felix Leja, in charge of orders, tells of a casket in wait as a wine rack. Another is on call as a coffee table. And a plain pine one was fitted with shelves for use as a bookcase until needed by the buyer. Unusual? Maybe, but there's at least one historical precedent. Frontier folklore has it that Daniel Boone made his casket out of buckeye wood, and in his later years actually slept in it. 🌲

Written by **Peter J. Stephano**
Photographs: **David Lee Hartledge**

 Sam Mulgrew, Trappist Caskets' general manager, checks inventory. The abbey operation sold 120 caskets in their first year.



 Pine caskets receive no finish because buyers like the feel and aroma of the wood. Through a funeral director, a casket like the one at left costs about \$900.

 A shaped, raised-panel casket, such as this one crafted of oak, measures 26½" at shoulders and 16" at head and foot and is 15" deep and 80" long. It has a split lid (no hinges), and a complete muslin lining with pillow.

the top half can be removed for viewing.) Each comes with a pillow and cotton muslin lining. Prices start at about \$600 and top out near \$1,400. Additionally, Trappist Caskets sells a cremation urn, a covered box with dove-tail joinery in walnut, ash, oak, or cherry.

When Mulgrew began making caskets at his farm, he used no metal parts. Tight-fitting lids snapped into place without hinges, and he offered wood or rope handles. The joinery was all dowels, splines, and glue. At New Melleray, though, the eight or so monks involved in casket making employ biscuit joinery to turn boards into panels and pocket-hole screws to mate the casket components. The unhinged, split lids are held

them to customers as far away as New Mexico and South Carolina (shipping costs within the U.S. are about \$150). Although sold only to funeral directors—and directly to members of the religious community—the caskets can be seen in a showroom at the abbey (888/433-6934) or viewed on New Melleray's website, www.trappistcaskets.com. By the way, they're accepted by all funeral homes and cemeteries in the United States.

Caskets for caring, and the home

According to Father Brendan Freeman, abbot of New Melleray, many people spend much more than



decorator's
fire screen



Here's a great project to complete in a weekend or two with the help of your favorite seamstress.

Few things impart ambiance like flames flickering atop a stack of firewood. But after the last embers go out, it sure would be nice to put a glow back on your fireplace. And that's what we had in mind in designing this screen. It radiates an inviting warmth, even when you don't have a log burning.

Note: You'll need at least 6 board feet of stock to build this project. We cut all of our parts from a clear $\frac{3}{4} \times 8 \times 96$ " piece of red oak.

Let's give this project some legs to stand on

1 Cut two $\frac{3}{4} \times 1\frac{1}{2} \times 32$ " blanks for the uprights (A) and two $\frac{3}{4} \times 2\frac{7}{8} \times 12$ " blanks for the feet (B).

2 Lay out and cut half laps at one end of both uprights as shown in Drawing 1 below. The auxiliary wooden fence minimizes chip-out on the edge of the upright where the dado blades exit the cut. Leave this setup as is for Step 5.

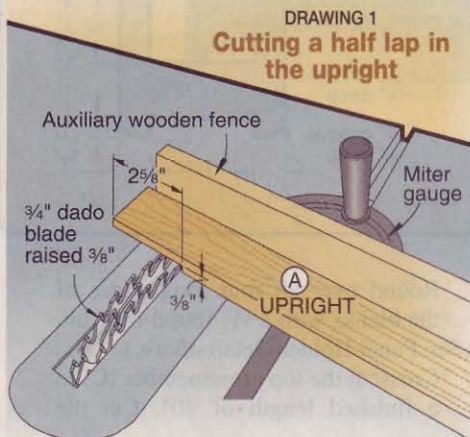

DRAWING 2
Cutting a half lap in the feet

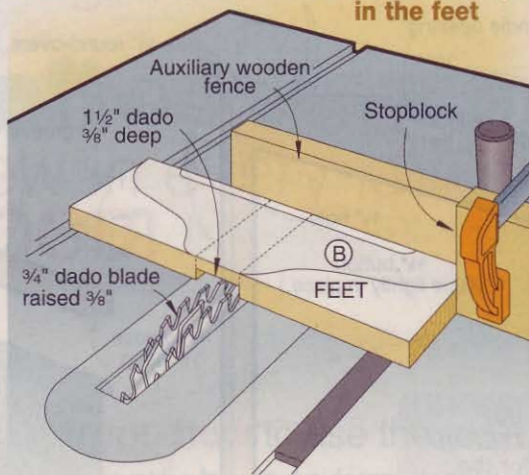

3 Measure up 29" from the shoulder of each half-lap and mark a 1" radius at the other end of each upright. We used a draftsman's circle template. Bandsaw and sand to the marked radius.

4 Make two copies of the Feet pattern found in the *WOOD PATTERNS* insert and apply one copy to each of the feet blanks. Crosscut the feet blanks to 11" long, cutting just up to the pattern lines at both ends of the feet.

5 Cut centered dados in the feet, where shown on the pattern. Use the setup shown in Drawing 2 above. Sneak up on the shoulders of the cut, testing its fit with the half laps cut into the uprights. Clamp a stopblock to the auxiliary wooden fence to help you quickly cut a matching half lap in the other foot.

6 Cut just outside of the feet pattern lines with a bandsaw, and sand up to the lines with a drum sander.

7 Glue and clamp together one upright to each of the feet. After the glue dries, sand the upright's protruding half lap end flush with the feet bottoms.

8 Rout $\frac{1}{8}$ " round-overs along all edges of the leg assemblies except for the feet bottoms, as shown on the Exploded View on the next page.

Now, make the cross-members, panel holders, and brackets

1 Cut a $\frac{3}{4} \times 4\frac{1}{2} \times 31$ " blank for the top crossmember (C). Make two copies of the top crossmember half-pattern found in the *WOOD PATTERNS* insert, tape them together, and cut to shape.

Making the fabric panel

At *WOOD* magazine we know a lot more about woodworking than sewing, so we enlisted the help of Jill Kemp of Bears Paw Designs in Westfield Center, Ohio, to design and stitch together the fabric panel. Anyone familiar with sewing techniques should be able to duplicate her design. To help out, we've included a full-size pattern in the *WOOD PATTERNS* insert. The photo above shows the stitching Jill used to sew the pattern pieces in place. Just make sure the finished panel measures $22\frac{3}{4}$ " high and $29\frac{5}{8}$ " wide, with loops at the top and bottom big enough to hold a $\frac{3}{8}$ "-diameter rod.

Jill used the following materials to put together the panel:

- Wool, navy blue— $\frac{1}{4}$ yards
- Wool, light gold, dark green, and light green— $\frac{1}{8}$ yard of each color
- Wool, red, caramel, pumpkin, peach, gold, medium blue, and rust—scraps
- Woven fusible interfacing— $1\frac{1}{2}$ yards
- Cotton backing fabric— $\frac{3}{4}$ yard
- Embroidery floss, #612—3 skeins
- Embroidery floss, a green compatible with your green wool—3 skeins
- Heat N Bond Lite— $1\frac{1}{2}$ yards
- Template plastic

All of the sizes given for the wool are prior to washing and drying—a process that felts the wool nicely, but causes it to shrink to about two-thirds of its original size.

To see a copy of Jill's detailed instructions for making the panel, go to: www.woodonline.com/editorial/130sew.html. Or, if you don't have internet access, we'll mail you a copy of the instructions. Just send a stamped, self-addressed, business-size envelope to:
Sewn panel instructions
WOOD Magazine
1716 Locust St., GA-310
Des Moines, IA 50309-3023



fire screen

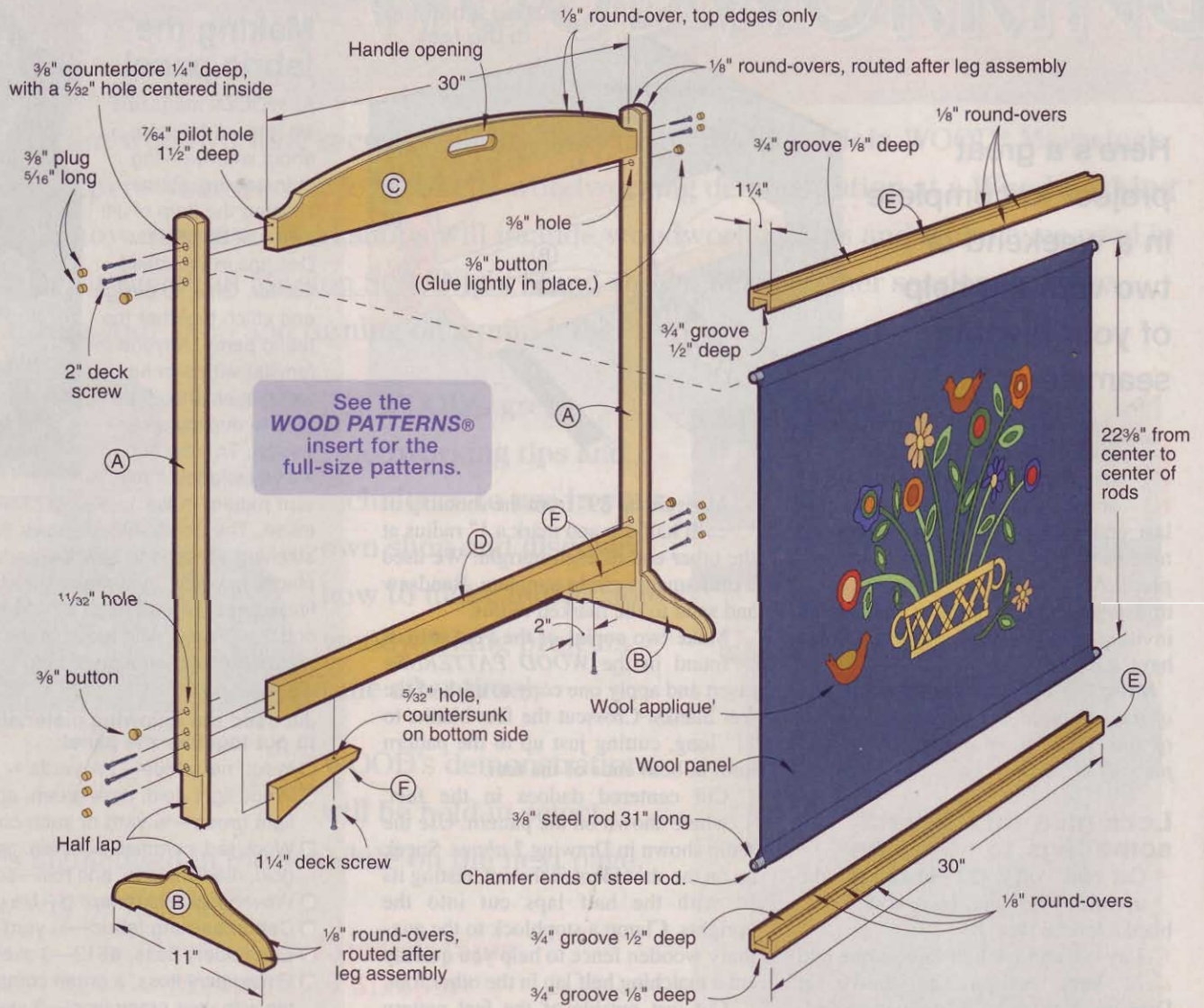

EXPLODED VIEW

PANEL HOLDER DETAIL

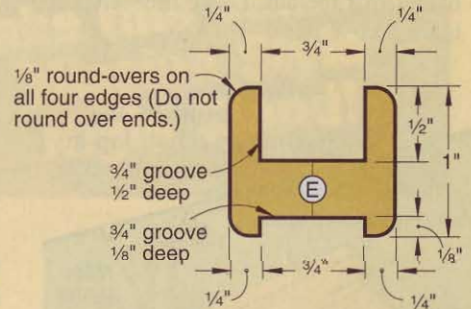

2 Adhere the pattern to the top cross-member blank. With a bandsaw or scrollsaw, cut just outside of the pattern, and sand to the line.

3 Drill two 1" holes, where marked on the pattern. Complete the handle opening with a scrollsaw or jigsaw, and sand smooth.

4 Rout a 1/8" round-over along the handle opening and the curved edges of the top crossmember, where shown on the Exploded View drawing.

5 Cut four 3/4x1x31" pieces. Group them in pairs and glue each pair face-to-face to make two 1 1/2x1x31"

blanks for the panel holders (E). Resaw or plane each blank to 1 1/4" thick. Keep the joint line centered on the thickness of these blanks.

6 Set up a dado blade to cut a 3/4"-wide groove for holding the crossmembers. Cut a centered groove, 1/8"-deep, along the length of both blanks where shown in the Panel Holder Detail drawing.

7 Raise the dado blade to cut a 1/2"-deep groove. Cut this centered groove on the edge of the panel holder blanks opposite the cut made in the previous step.

8 Round over all four long edges of the blanks with a 1/8" round-over bit. (See Panel Holder Detail above.)

9 Crosscut the top crossmember (C) to a finished length of 30". Cut the

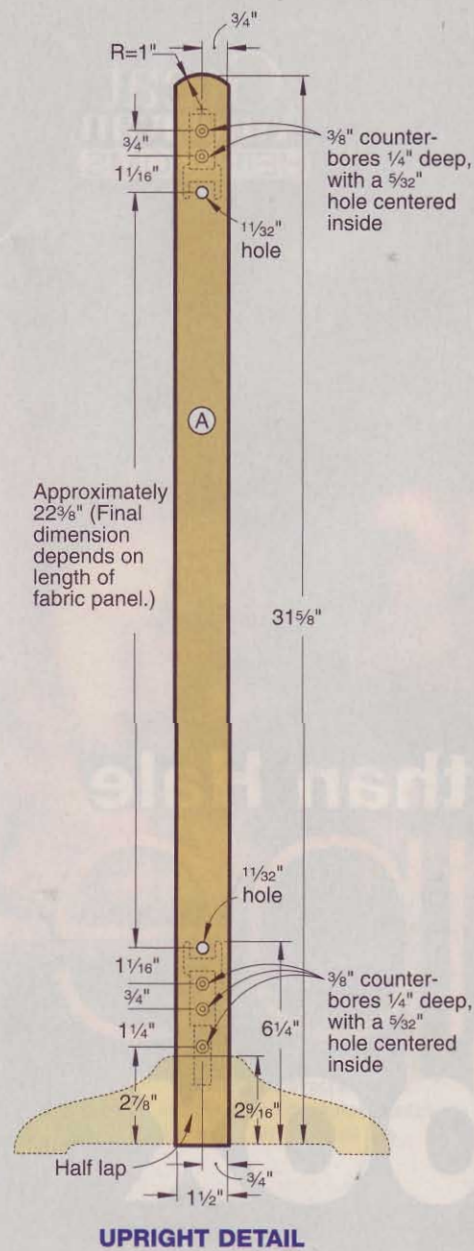

UPRIGHT DETAIL

Assemble, finish, and put your fabric in place

1 Mark the locations of the lower screw holes and the lower $1\frac{1}{32}$ " rod hole on each upright, where shown in the Upright Detail.

2 To find the locations of the screw holes and rod hole on the upper end, you will need your finished fabric piece. Insert a 31"-long $\frac{3}{8}$ " steel rod into each of the loops in the fabric, and pull the fabric taut, as shown in the photo below. Measure the center-to-center distance between the rods and use this figure to locate the upper $1\frac{1}{32}$ " rod hole. With that done, mark the upper screw holes, where shown on the Upright Detail.



3 Drill $\frac{3}{8}$ " counterbores $\frac{1}{4}$ " deep at each of the screw locations. Drill $\frac{5}{32}$ " holes centered in the counterbores. Drill the $1\frac{1}{32}$ " rod holes.

4 Locate the crossmember assemblies on the leg assemblies with the $\frac{1}{2}$ " grooves centered over the $1\frac{1}{32}$ " rod holes. Dry-clamp these assemblies.

5 Drill $\frac{5}{32}$ " screw holes about $1\frac{1}{8}$ " deep into the crossmembers using the $\frac{5}{32}$ " holes in the uprights as guides. Fasten the assemblies securely with 2" deck screws.

6 Apply glue to the long straight edge of each bracket (F), and clamp them centered on the ends of the lower crossmembers. Drill $\frac{5}{32}$ " screw holes about $1\frac{1}{8}$ " deep into the brackets, using the lowest $\frac{5}{32}$ " holes in the uprights as guides. Attach the brackets to the uprights with 2" deck screws, as shown in Drawing 3.

7 Mark a screw-hole location on the bottom of each bracket, centered and 2" from the narrow end of the bracket. Drill a $\frac{5}{32}$ " hole $1\frac{1}{8}$ " deep through the

bill of materials

fire screen

Part	FINISHED SIZE				Qty.
	T	W	L	Matl.	
A* uprights	$\frac{3}{4}$ "	$1\frac{1}{2}$ "	$31\frac{5}{8}$ "	O	2
B* feet	$\frac{3}{4}$ "	$2\frac{7}{8}$ "	11"	O	2
C* top crossmember	$\frac{3}{4}$ "	$4\frac{5}{16}$ "	30"	O	1
D* lower crossmbr.	$\frac{3}{4}$ "	$1\frac{1}{4}$ "	30"	O	1
E* panel holders	$1\frac{1}{4}$ "	1"	30"	O	2
F brackets	$\frac{1}{2}$ "	$1\frac{1}{4}$ "	6"	O	2

*Cut part oversized and trim to finished size according to the instructions.

Material Key: O—oak

Supplies: $\frac{3}{8}$ " steel rod 31" long (2), 2" deck screws (10), $1\frac{1}{4}$ " deck screws (2), $\frac{3}{8}$ " oak buttons (4), wool fabric, clear finish.

DRAWING 3
Fastening
the brackets

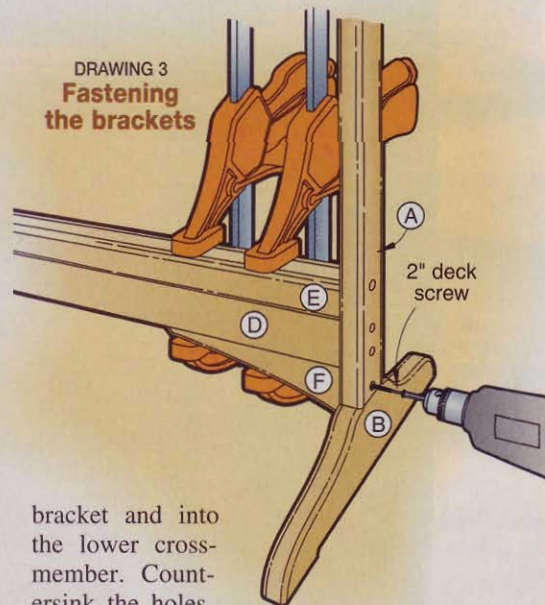

bracket and into the lower crossmember. Countersink the holes, and drive home the $1\frac{1}{4}$ " deck screws.

8 Plug the screw holes in the uprights with $\frac{3}{8}$ " face-grain plugs, and sand them smooth.

9 Sand smooth, and apply your finish of choice to the project as well as four $\frac{3}{8}$ " oak buttons. We chose General Finishes Wipe-On Satin Royal Finish.

10 Place the $\frac{3}{8}$ " rods through the fabric loops and install the fabric and rods in the assembled frame. Plug the rod holes with the $\frac{3}{8}$ " buttons—apply a light dab of woodworker's glue to the buttons so you can remove them later if need be. 🐿️

Written by **Bill Krier** with **Kevin Boyle**
Illustrations: **Kim Downing**; **Lorna Johnson**
Photographs: **Baldwin Photography**;
Wm. Hopkins

Great
American
HEIRLOOMS

Nathan Hale
pipe
box

Re-create
history by
making a
piece of it.

pipe box

Part	FINISHED SIZE			Matl. Qty.
	T	W	L	
A back	5/8"	6"	16"	P 1
B sides	5/8"	4 3/8"	12"	P 2
C bottoms	5/8"	3 3/4"	6"	P 2
D front panel	5/8"	6 5/16"	6 1/2"	P 1
E drawer front	5/8"	3 3/8"	6 1/2"	P 1
F drawer sides	7/16"	3 1/16"	3 1/16"	P 2
G drawer back	7/16"	3 1/16"	5 1/16"	P 1
H drawer bottom	7/16"	2 7/8"	5 1/16"	P 1

Material Key: P-pine.

Supplies: 5/8" diameter brass knob.

Buying Guide: 4d antique-style nails, item AG-02220672, \$5.75/lb.; barn red milk paint, item AG-200657, \$9.95/pt.; add shipping, SD residents add tax. Call Van Dyke's Restorers, 800/558-1234.

Lumber Guide: All the parts for this project are cut from one 3/4x7 1/4x96" pine board. Plane or resaw to the thicknesses listed above.

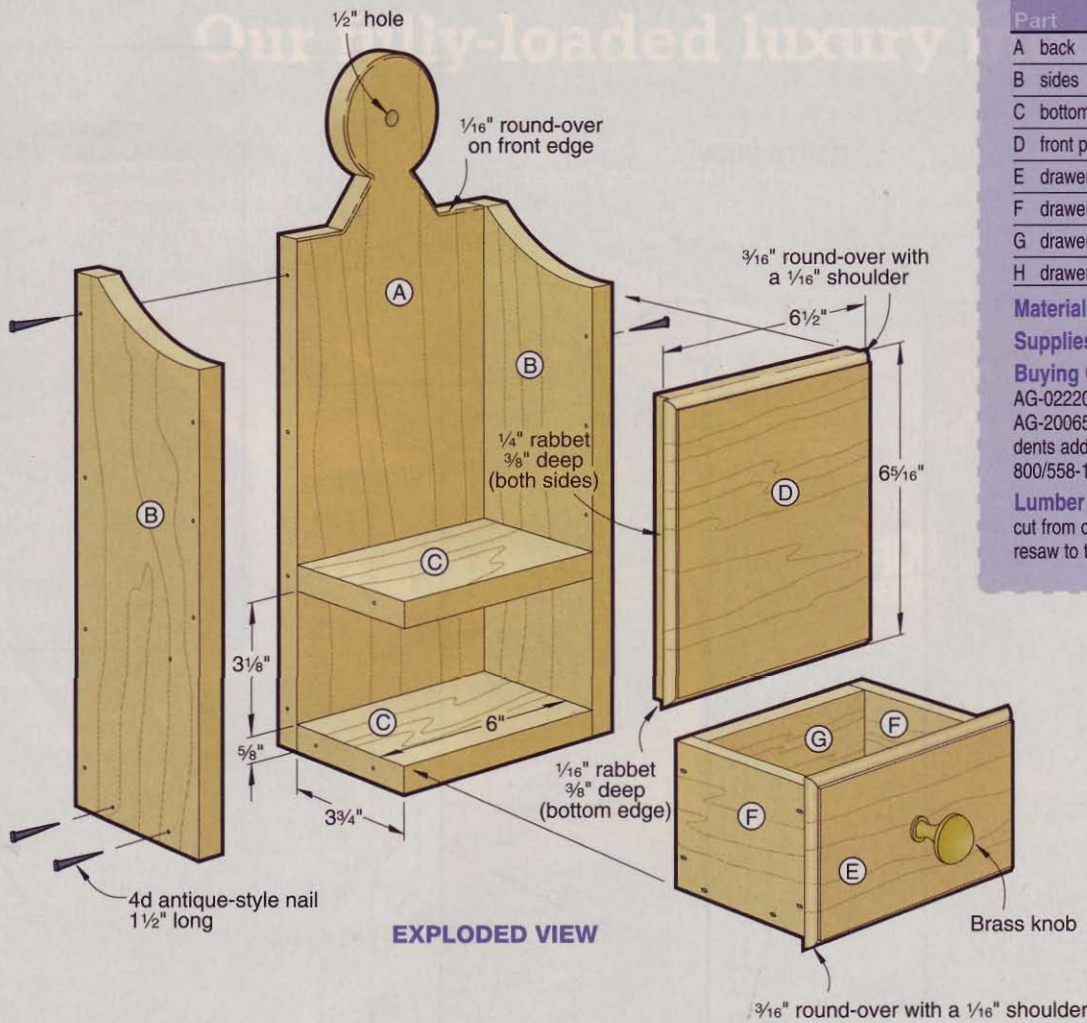

EXPLODED VIEW

Brass knob

3/16" round-over with a 1/16" shoulder

Available for purchase at

Originally used to hold clay smoking pipes in its top compartment and tobacco in its drawer, this country accent is based on an Early American classic design. (See the sidebar, right.)

Invest an evening or two in its construction, and you'll soon have pleasing storage for candles, matches, or anything else that suits your fancy.

Start with a two-compartment box

1 From a 3/4x7 1/4x96" pine board, cut a piece 72" long, and plane it to 5/8" thick for parts A-E. Set the rest of the board aside. Cut a blank for the back (A) to the size listed in the Bill of Materials. Referring to the Back on the

A hero's homestead

Richard Hale, a prosperous farmer, built a substantial house for his family at Coventry, Connecticut, during the spring of 1776. Later that year, on September 22, his 21-year-old son, Captain Nathan Hale, died a Patriot hero of the American Revolution. The house and property passed from the family in 1832. George Dudley Seymour, a wealthy New Haven attorney and noted antiquarian, acquired the house in 1914, and devoted the last 30 years of his life to restoring the homestead. Seymour eventually acquired all of the more than 300 acres of Hale land, and steadily collected family furnishings and period Connecticut pieces. At his death in 1945, Seymour bequeathed the estate to the State of Connecticut and the Antiquarian and Landmarks Society of Connecticut, which opened it to the public in 1948. When we visited the Nathan Hale Homestead, we found the pipe box hanging next to a fireplace.



Visitor Information: Nathan Hale Homestead, 2299 South Street, Coventry, Conn. Phone 860/742-6917. Open May 15–October 15, Wed.–Sun., 1–4 p.m. Admission: adults \$4, students \$1, preschool free. For information, write The Nathan Hale Homestead, P.O. Box 25, Coventry, CT 06238.

Nathan Hale pipe box

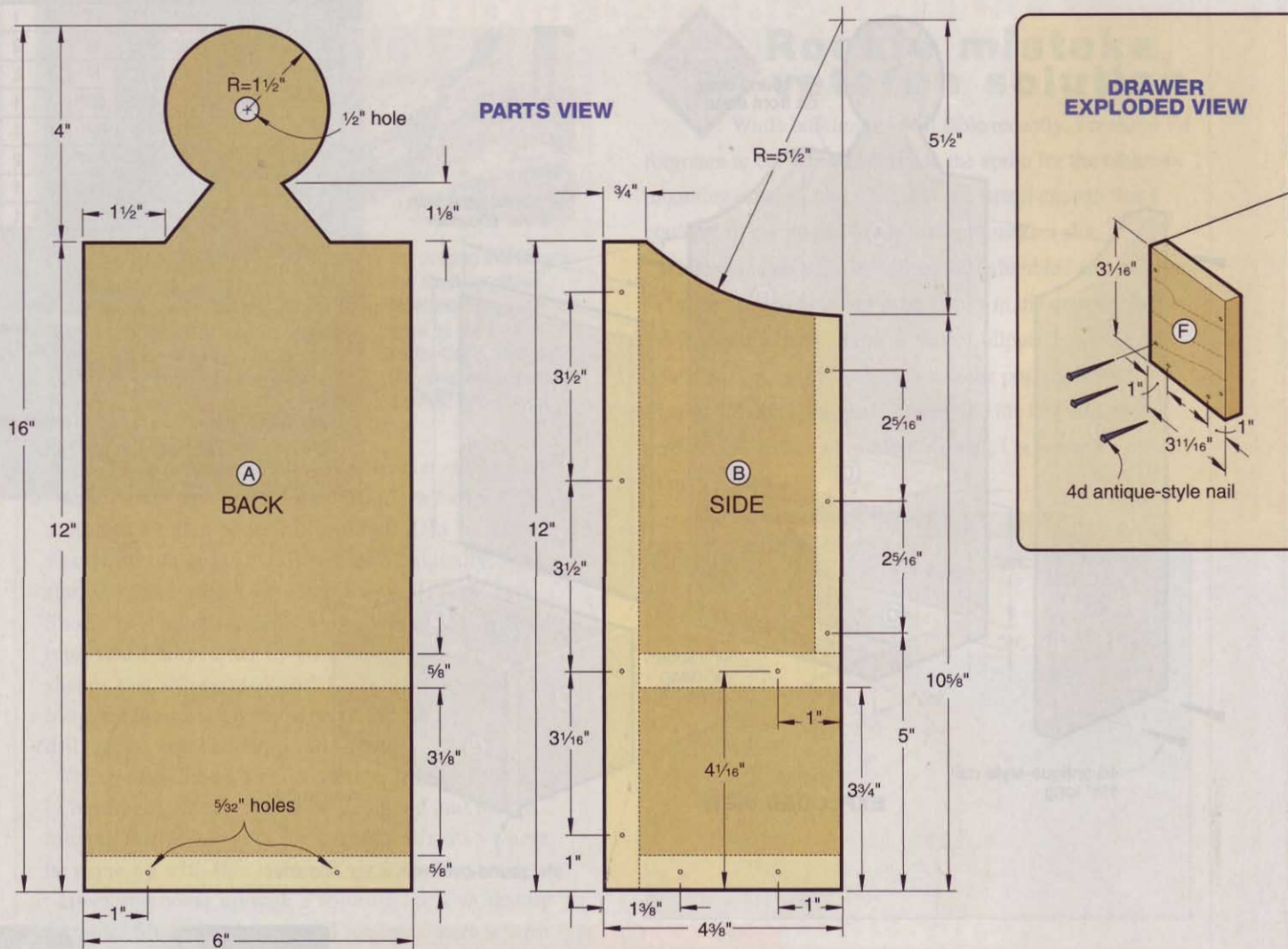

Parts View drawing *above*, lay out the top profile, and mark the locations of the 1/2" hanging hole and the 5/32" nail pilot holes. Scrollsaw or bandsaw the top profile, then sand to the layout lines. Drill the holes, where marked. Sand a 1/16" round-over, where shown on the Exploded View drawing.

2 Cut two blanks for the sides (B) to the size listed, and fasten them together with double-faced tape. Referring to the Side on the Parts View drawing *above*, lay out the top arc, and mark the locations of the 5/32" nail pilot holes. Saw and sand the arc to the layout lines, and drill the pilot holes, where marked, through both pieces. Separate the two sides.

3 Cut the bottoms (C) to size, then finish-sand parts A, B, C. Glue and clamp together the back (A), sides (B), and bottoms (C), as shown on the Exploded View drawing. Cut 3/8"-long spacers, and insert them between the bottoms to keep them aligned while gluing.

4 When the glue is dry, remove the clamps and, using the 5/32" holes previously drilled in the sides and back as guides, drill the pilot holes to a total depth of 1 1/2". Drive the antique-style nails, as shown in *Photo A*. (See the Buying Guide for our source of these antique-reproduction nails.)

Align the length of the roughly rectangular nail heads with the grain on the sides, and across the grain on the back.

Drive the heads slightly below the surface of the wood.

Now, make two panels and a drawer

1 Cut the front panel (D) and drawer front (E) to the size listed. Install a 3/16" round-over bit in your table-mounted router, and adjust it to make a bead with a 1/16" shoulder. Rout all four edges of both fronts.

2 Install a dado blade in your table-saw, and cut rabbets in the bottom edge of the front panel (D), as shown in the Side View drawing, and in the side edges, as shown in the Exploded View drawing. Next, cut rabbets in the top and bottom edges of the drawer front

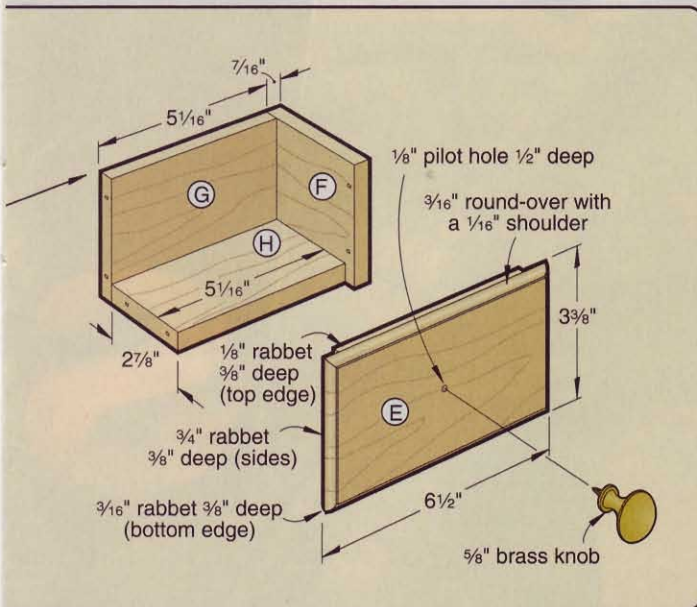

Hold the nails with needle-nose pliers to keep them from rotating when you drive them.

(E), as shown in the Side View drawing and in the side edges, as shown in the Drawer Exploded View drawing. Drill the knob pilot hole in the center of the drawer front. Finish-sand parts D and E.

3 Glue and clamp the front panel (D) in place. When the glue is dry, remove the clamps and, as before, drill the pilot holes, and drive the nails.

4 Plane the piece of pine previously set aside to $\frac{7}{16}$ " thick for the drawer sides (F), drawer back (G), and drawer bottom (H). Cut the parts to the sizes listed, and finish-sand them.

5 Glue and clamp the drawer together, as shown on the Drawer Exploded View drawing. When the glue is dry, drill the pilot holes and drive the nails. Align the length of the nail heads with the grain. Drive the nails deep so the heads do not protrude.

Apply a time-worn finish

1 Break the sharp edges of the drawer front and the edges and corners of the box with sandpaper to give them a well-used look. Apply a coat of stain

(we used Minwax Early American #230), and let it dry.

2 Mix up some milk paint, and apply it over the stain. (See the Buying Guide for our milk paint source.) When the paint is dry, rub through it on some of the corners and edges that would be subject to wear with steel wool or a Scotch-Brite pad until the stain shows through. Rub the lacquer coating off the brass knob and give it a dull sheen. It will darken with age and handling. Install the knob, and rub away some of the drawer front paint around it. 🌿

Written by Jan Hale Svec with Charles I. Hedlund
Illustrations: Roxanne LeMoine; Lorna Johnson
Photographs: Baldwin Photography;
Wm. Hopkins

SIDE VIEW

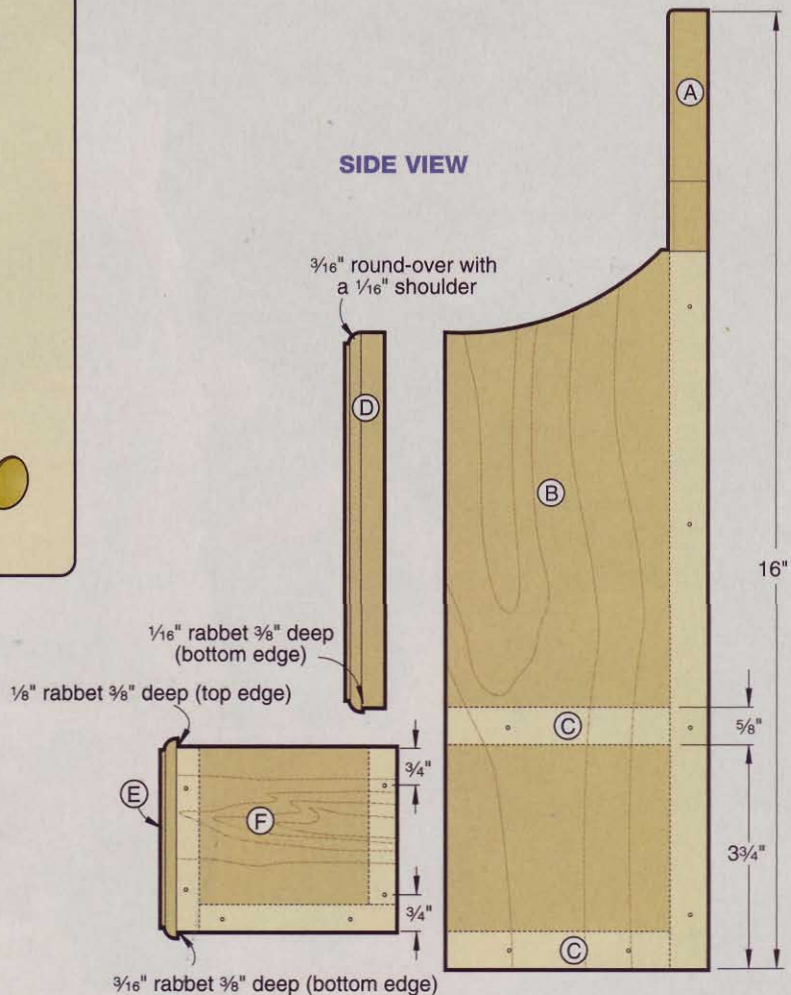



S

scrapers

tips for a close shave

Some say
the scraper
is difficult to
sharpen and
tricky to use.
Nonsense.
Here's how to
bend this little
gem to your
advantage.

Woodworking doesn't get any more basic than this. You pick up a rectangular piece of steel and make problems go away. Milling marks, joinery imperfections, glue lines, runs in a finish—they all bow before the simple hand scraper.

A well-tuned hand scraper, with a tiny "hook" of steel that you shape along its edge, smooths highly figured wood or burl without tear-out. If you start with a plane and run into tear-out trauma, your scraper comes to the rescue. It doesn't eliminate sanding, contrary to popular belief, but it does allow you to skip the coarser grits.

So what's the catch? It takes practice to use a scraper properly, and, just as important, it takes a honing technique that's nothing like sharpening your other tools. Don't worry. We'll guide you through all the steps with the help

of scraper expert Marc Adams, who runs the Marc Adams School of Woodworking in Franklin, Indiana.

Get your hands on one

If you don't own a hand scraper, buy a simple, rectangular model at a tool store or through a woodworking catalog. Most of them are either 5" or 6" long and 2" to 3" wide. Woodworker's Supply (800/645-9292) carries one for \$4.50, part number 813-756. Thickness and steel hardness vary from one brand of scraper to another, but you can ignore those factors for now.

You can't go wrong at that price, but you do have an alternative. A rectangle cut out of an old handsaw blade will work like a charm.

Once you've learned the ins and outs of scraping, you may decide to add a cabinet scraper, a small two-handled

If you want to get technical about it...

Scrapers range from about C-30 to about C-50 on the Rockwell hardness scale. The softer ones are easier to sharpen, but the harder ones hold a hook longer. Thickness varies from .020" to .030".

A thick scraper works best when you need to remove a great deal of material. Try a small, thin hand scraper for leveling a coat of varnish or making a delicate piece of inlay perfectly flush with the rest of the surface. Steel cut from a dull and inexpensive dovetail saw works well for this. Remember, you also can make small scrapers of any size and shape to suit particular tasks.

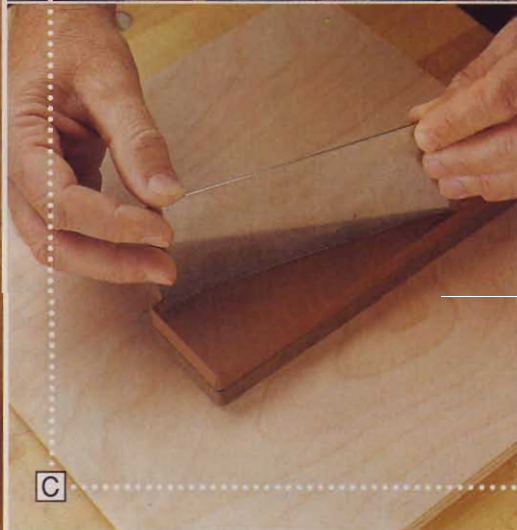
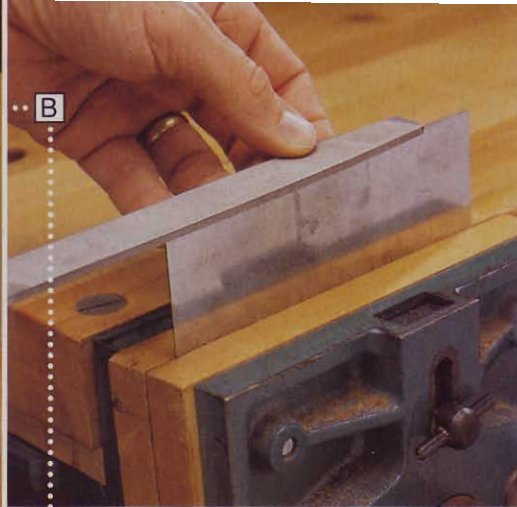
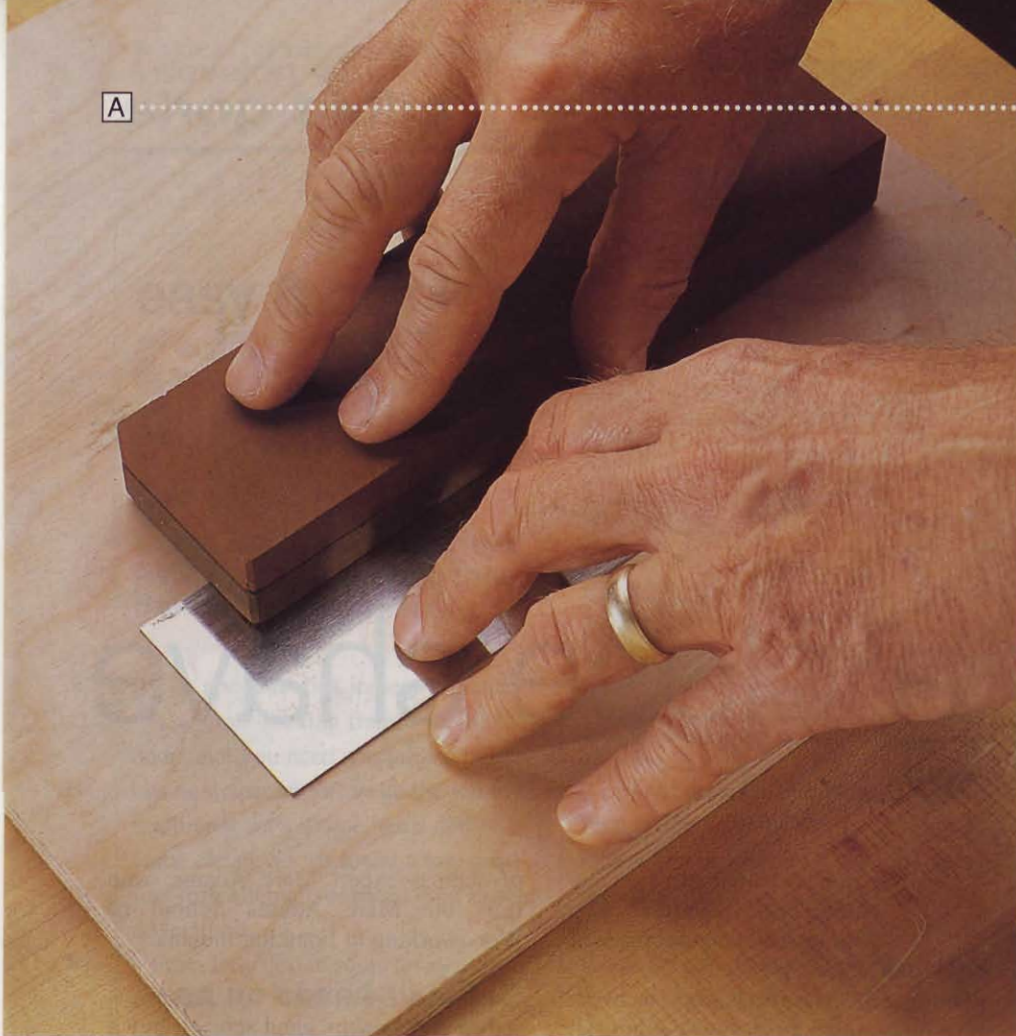

tool that clamps a scraper blade in place. It reduces the risk of ridges when you smooth a large surface, and it's a lot easier on you. A hand scraper stresses your thumbs and gets awfully hot.

Give it a keen edge

You can coax some sawdust off a piece of wood with an unhone

d scraper, but that's not what this tool is designed to do. Put the right hook on its edge and a scraper unfurls wispy curls of wood, finer than you could ever get with a plane.

Achieving that hook is no mystery; you just need the right technique. Learn to do it the simple way, and resist the urge to buy sharpening devices. Marc Adams says, "I've seen people struggle

with those accessories here at the school, and I've never seen one gadget that made me think, "This is what we need." In his opinion, "The less sophisticated a woodworker is, the more sophisticated tools he thinks he has to have."

A hand scraper and a cabinet scraper require slightly different procedures. Both, however, shave wood with a hook that you form along the edge. See the drawing (*opposite page, top*) for a close-up view of the almost invisible hook. The captions to *Photos A through F* tell you how to sharpen a hand scraper. You'll follow the same steps to sharpen a cabinet scraper, but keep the edge at a 45° angle and then turn the hook to match the drawing. We used a burnishing tool, but the shank of a good chisel works just as well.

Put a hook on both sides of both long edges so you won't have to reburnish as often. And if you want to get the absolute most out of your scraper, Marc points out that you can put as many as 12 hooks on one rectangular scraper. That's



You can smooth curves, too

Scrapers also come in a French curve, or gooseneck, style, and a model that's convex at one end and concave at the other.

Woodworker's Supply sells the ones shown at *left* for \$4.50 apiece. The gooseneck is part number 813-763 and the convex/concave model is 813-770. An \$11.95 package that includes these two and the rectangular style is part number 810-145.

It takes more practice to hone and hook a curved edge, but the steps remain the same. Marc Adams recommends working the edge an inch at a time.

Honing, step by step

STEP A: Lay your scraper on a piece of scrap, and rub a 1/2" strip along the edge with a medium-grit sharpening stone. Keep at it until you can see scratches all along the edge, then flip the scraper and repeat the process for a truly flat edge.

STEP B: Clamp the scraper in a vise, and file the edge level. Keep the file in contact with the length of the edge and perpendicular to the sides. A few strokes should do the job.

STEPS C & D: With the scraper's edge flat, smooth the milling marks with the stone. Push the scraper across the stone, carefully holding it upright and at a skew,

as shown in *Photo C*, then lay it flat on the stone and work it back and forth, as shown in *Photo D*.

STEP E: Hold the scraper flat near the edge of the bench, and pull the burnishing tool firmly across it several times. Flip the scraper over and do the other side, too. This flattens any wire edge that might remain, and slightly thins the steel.

STEP F: Hold the scraper in one hand. Applying moderate force, pull the burnishing tool along its edge at a very slight angle to push the steel down and out. Form the same slight angle toward the opposite side, too.

What's your angle?

Use the same steps to hone a cabinet scraper blade, but keep an eye on the different angles.

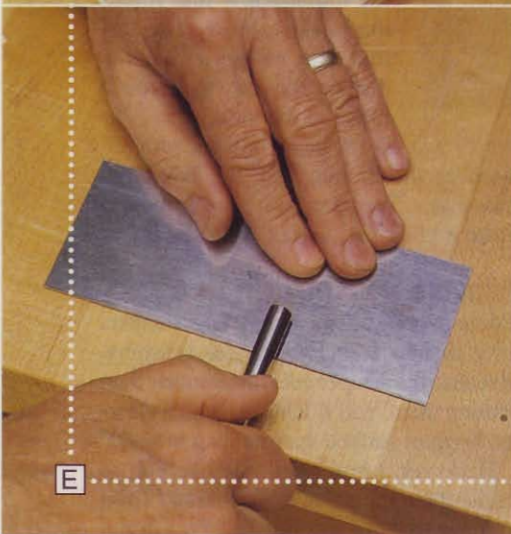
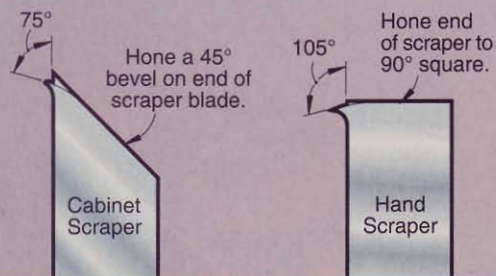

two on each side, two on each end, plus a 1/16"-wide hook at each corner that can handle tiny crevices and string inlay.

Put the little shaver to work

No matter how well honed, a scraper won't turn out feathery shavings until

you get the hang of using it. You have to flex it properly and hold it at the perfect angle to maximize its performance.

Of 20 students in one class, "Eighteen of them couldn't make their scrapers cut," Marc reports. "But I could, using the hooks they already had." Some people push a hand scraper and some pull.

Marc pulls, reasoning that "You can't hold it perfectly flat when you're pushing it, but you can when you pull it." He holds the scraper at a slight skew and varies the flex according to the job. This flexing concentrates the cutting power in one area and keeps the corners from digging into your workpiece.



Try pushing and pulling the scraper to get a feel for both methods. When you push, as shown at *left*, your thumbs bear the burden. The pull stroke, *below*, is a little easier on your hands.



The photos *above* and *above, right* show both methods. Ideally, you should hold the hand scraper just 10° to 15° from vertical, leaning in the direction that you're scraping. "If you've made the hook so that it cuts at that angle, it's easier to use," Marc says. "If you have to hold it at 45 degrees, for example, it's too sharp an angle for comfort."

The proper angle can change slightly from one honing to the next. Move the scraper until you can feel it cut and you see the shavings any more, reburnish. Lay the scraper flat on your workbench and "draw" the edge slightly thinner with your burnishing tool, then form a new hook. You can reburnish several times before you have to get out your stone and file and go back to the beginning of the sharpening process.



Use the cabinet scraper, *left*, when you want to work on a large surface. But remember that *bowing* the scraper blade out too far will cause noticeable hollows and ridges.

force the pressure bar against the blade. Then turn the thumbscrew that forces the blade to bow. The farther you nudge it out, the deeper the cut that you'll make in the wood.

A basic cabinet scraper, such as the Stanley No. 80, holds the blade at a fixed angle. It's up to you to form a hook that works at that angle.

Give your thumbs a break

A long session of scraping generates an uncomfortable amount of heat. Rather than put the scraper into some sort of holder, which steals away your control of the tool, wear gloves.

However, no matter how comfortable a hand scraper may feel as you begin to use it, a long session will take its toll on your thumbs and fingers. So if you have a large surface to clean up, or some heavy scraping to do, switch to a cabinet scraper, as shown in the photo *above*. Its big handles make this tool easy to grip, while its large sole helps you do a more consistent job of flattening the surface.

After you sharpen the cabinet scraper blade, place the body on a flat surface and position the blade squarely in its slot, with the beveled edge facing the rear. Hold the whole assembly firmly in place while you tighten the screws that

Marc's parting advice

Some woodworkers claim that scrapers give them a surface ready for finishing. Because the scraper cuts fibers rather than tearing them, you'll wind up with a clearer, brighter surface than sanding offers.

However, Marc would advise you to resist the temptation to go directly from scraper to finishing brush. "You're not going to eliminate sanding. That's fantasy," he says. "As soon as you try to make a tool do what it's not qualified to do, you'll have failure and become discouraged. But for certain jobs, a scraper is a tool you can't do without." 🍷

Written by Jim Pollock with Marc Adams
Photographs: Wm. Hopkins; Baldwin Photography
Illustration: Kim Downing

Midwestern mecca for woodworkers

Hundreds of woodworkers take classes every year at the Marc Adams School of Woodworking. Marc and visiting experts teach from May through October at his acreage near Franklin, Indiana, about 20 miles south of Indianapolis.

Last summer, we talked to some of his students, many of them repeat customers, and heard nothing but enthusiastic reviews. For more information, call 317/535-4013 or log on to www.marcadams.com

Orange tool cleaner is really quite green

Cleaning the accumulated gunk and grime off saw blades is a process that used to be almost as dangerous as using the saw itself. Caustic chemical cleaners and solvents remove the pitch and gum, true, but they also take off any markings on the blade, and can prove harmful to your health.

Now CMT has a cleaner that's biodegradable, nontoxic, and so safe you don't even need to wear gloves when using it. It's called Formula 2050 and, although it looks orange and smells orange, the manufacturer insists it's not a citrus-based product.

They say Formula 2050 doesn't dissolve the pitch and resin like chemical cleaners do. Instead, it penetrates it and breaks its bond with the metal tooling. Whatever. The stuff just plain works.

I started with a couple of 10" saw blades I didn't think were too dirty. I spritzed on the Formula 2050, waited a few seconds, and wiped with a paper

towel. The blades must have been dirtier than I thought because they shimmered and the paper towel was filthy. And all of the blades' original markings remained intact. A natural bristle brush helped me touch up between the carbide teeth and the posts.

Formula 2050 worked just as well on router bits. I soaked a cruddy bearing-guided bit for a week, with no apparent effect on the lubrication in the bearings. For disgustingly dirty tooling, I found that a pair of light applications worked better than one heavy dose.

I even had an old abrasive strip from my drum sander that was thick with packed pitch and gum. (Don't ask me why I saved it.) Previous attempts to clean it with solvents and mechanical



means had failed. Again, a couple of applications and a little scrubbing restored the abrasive.

—Tested by Raleigh Rubenking

PRODUCT SCORECARD

CMT Formula 2050

Performance	★★★★★
Price	\$12, 18 oz. bottle
Value	★★★★★

Call CMT USA toll-free at 888/268-2487, or visit www.cmtusa.com.

Attachment makes DeWalt scrollsaw arm weightless

If you own a DeWalt DW788 scroll-saw, you know it can be a nuisance doing a lot of inside cutting. Every time you release the blade to thread it



through your next starter hole, you have to juggle the saw's upper arm, the blade, and your workpiece. An extra hand would be nice.

The Easy Lift is just the hand, or rather arm, you need. This pivoting aluminum bar bolts to your DeWalt saw, using existing holes and replacement hardware provided with the Easy Lift. The spring at the rear helps to counterbalance the saw's arm, so it stays wherever you put it. You can even adjust the spring pressure to suit your saw by moving it to a different hole on the Easy Lift bar.

The assembly instructions are complete and thorough, and the Easy Lift required only about five minutes of my time for mounting. And, I recovered that downtime on my very next scroll-saw project.

—Tested by Kevin Boyle

PRODUCT SCORECARD

Easy Lift for DeWalt DW788 scrollsaws

Performance	★★★★★
Price	\$20, plus shipping
Value	★★★★★

Call Jim Dandy Products at 800/522-4717, or visit www.jimdandy.com.

Continued on page 84



Time in a bottle (two bottles, actually)

Human beings are funny: We spend a ton of money on products to make ourselves look younger, but we sometimes want our furniture to look old. Until recently, the art of aging new wood has been a job best left to Mother Nature or a finishing pro. Now, though, the folks at Old Growth Company are out to change that antiquated notion.

To call Old Growth a stain would be misleading because both parts of this water-based solution are as colorless as tap water. Part A—the activator solution—contains mineral compounds that soak deep into the wood fibers. Part B is an oxygen catalyst that crosslinks with Part A to instantly color the wood just as nature eventually would.

Want a fumed oak look for that freshly made Morris chair? Apply Part A

with a synthetic brush, wipe off any excess, and let it dry 15–20 minutes. When you brush on Part B, the color instantly transforms into a rich, deep hue. And unlike stain, which can muddy the grain with pigment, Old Growth makes the grain vibrant. In less than an hour, it's ready for a topcoat or two of clear finish.

You can adjust the color by diluting Part A with distilled water or adding additional coats before applying Part B. The color actually becomes a part of the wood, so test it on scrapwood to get the color just right before going whole hog on your project.

Besides Fumed Oak, shown *above right*, Old Growth comes in nine other formulas, including Instant Age (which weathers wood to silver), Aged Cherry,



PRODUCT SCORECARD

Old Growth Solutions

Performance	★★★★★
Price	\$11, 8 oz. kit; \$22, quart kit; \$55, gallon kit
Value	★★★★★

For product and ordering information, call Old Growth Company toll-free at 866/301-9663, or visit www.woodpatina.com.

Honey Brown, Whitewash/Blackwash and more. The 8 oz. kit, used full strength, should cover 25 square feet.

—Tested by Bob McFarlin

Continued on page 86



Laguna Tools Band Saw Now Only \$1,095*

No more excuses, you will never have a better time to purchase a Laguna Tools LT16 band saw. Due to the high volume of band saws that we sell, we can now give you the best band-saw value in the market. Manufactured in Italy exclusively for Laguna Tools, this powerful, swift piece of Italian ingenuity has high-quality, performance and your name written all over it.

Don't wait. Call today to get your free demonstration video.

- 12" resaw capability
- Easy blade change with 1/16 to 1" blade capacity
- 1.5 HP motor
- All-welded steel frame construction
- Cast-iron flywheels with snap on rubber tires
- Electrodynamically balanced
- Large 16" x 19" cast iron table
- Cast-iron rip fence
- 3/8" x 3/4" miter gage slot
- Two dust ports for excellent dust collection
- Blade tension indicator
- Table tilt from -10 to 45 degrees. Steel trunions
- Bearing Euro guides, both upper and lower
- Mobility kit, power feeder and 110-volt motor available

*Excludes sales tax and freight. Limited offer, while supplies last.

LAGUNA TOOLS
You Build With Wood, We Build With Trust.

800-234-1976

Circle No. 615

E Mail: mail@lagunatools.com Web: www.lagunatools.com
17101 Murphy Avenue Irvine, CA 92614 (949) 474-1200 • FX (949) 474-0150
100 Central Avenue South Kearny, NJ 07032 (973) 491-0102 • FX (973) 491-0591

NEW!
Adjustable Bar!
Micro Adjusting
Flip-Stop

**"All my tools
should be this
good!"**



Accu-Miter®
shown with
optional manual
clamp.

The Accu-Miter® is a professional miter gauge that makes perfect angles easily. Shot-pin action assures dead-on accuracy for common angles. Our new adjustable bar insures a perfect fit in your table saw's slot.



\$179
Model 18-34



Call or write for
our free brochure.

800 Dutch Square Blvd., Suite 200
Columbia, SC 29210
1-800-382-2637

www.thejdscompany.com

Fully automatic dust
collection
systems

ECOGATE

- Energy efficient, saves money
- Computer controls air flow with motorized blast gates
- Cleaner, quieter, and safer shop
- Fully scalable solutions: from one man shop to major manufacturing

Call 1-888-ECOGATE for a free
brochure. www.ecogate.com



products 
that perform

Tow your vacuum with a Pos-I-Lock

It's a safe bet that you've dragged your shop vacuum around by the hose at one time or another. You think you're saving steps, but invariably the hose pops off the vacuum and you have to go back for the vac. Craftsman's Pos-I-Lock vacuum hose puts an end to that frustration.

The aftermarket version, which works on Craftsman 12- and 16-gallon vacs built since 1990, consists of two parts: an adapter that snaps into the vacuum port and a 2½"-diameter hose. The adapter, once snapped in place, is a permanent part of the vacuum.

When you attach the hose, a spring-loaded catch (the red lever in the photo above right) grabs onto the adapter and won't let go until you release it. I dragged my vacuum around for 15

minutes—bumping into stationary tools, my workbench, the mini-van—nothing made that hose come off.

Another Pos-I-Lock "plus" is that the fittings on both ends swivel, reducing kinking. My old hose swiveled only on one end, and it seemed like no matter which end I put in the vacuum, it still kinked like crazy.

The Pos-I-Lock, and Ridgid's identical Tug-A-Long, come as standard equipment on Craftsman and Ridgid vacs built since 1999. Updating your vacuum will set you back about \$25 for the adapter and hose. If your vacuum is fairly new, this accessory is defi-



nately worth it, but on an older model, you might be wise to put that money toward a new vacuum.

—Tested by Dave Campbell

PRODUCT SCORECARD	
Craftsman Pos-I-Lock Hose	
Performance	★★★★★
Price	\$20, hose (17882), \$5, adapter (16917)
Value	★★★★★
Available at Sears stores. Call 800/377-7414 or visit www.sears.com/craftsman	

No wrenches required to change router bits? Call it one cool collet

Like the search for the Holy Grail, the quest for a truly tool-less router collet has been frustrating and mostly futile. But, while the hunt for the grail continues, engineers at Jacobs Chuck Company have quashed the collet crusade with the introduction of the PowerCollet. When installed in place of the original-equipment collet on your router, this gadget makes bit changing, literally, a snap.

Here's how the process works: Insert the bit shank in the collet and pull the locking ring toward the motor until it snaps. That's it—your bit is held firmly. To remove the bit, simply snap the ring back and pull out the bit. It does take a fair amount of strength to lock the mechanism, so you may have trouble with it if you're arthritic or have limited finger strength.

I have to admit I was skeptical about the gripping power of the ball-bearing collet mechanism, but after running everything from straight bits to panel-raisers in the PowerCollet, I was impressed. I couldn't even budge the bit with a pair of pliers! And I quickly grew to appreciate the speed and convenience of changing router bits in less than 10 seconds.

Because the PowerCollet is longer than the collet that came on your router, a set of aluminum spacers extend the reach of the router's base plate, as shown *below*. While the additional height felt funny at first, it didn't hinder my ability to control the tool. And, although I didn't do an endurance test, I suspect that the added lateral stress caused by the extended shaft may somewhat shorten the life of the router's bearings.

The PowerCollet is currently available for the Bosch 1615, DeWalt 625, Makita 3612, and Porter-Cable 690 and 7500

PRODUCT SCORECARD

Jacobs PowerCollet

Performance	★★★★☆
Price	\$45
Value	★★★★☆

Call Jacobs Company/Danaher Tool Group at 800/866-5753, or visit www.jacobschuck.com.

series routers. The assembly also comes with an adapter sleeve to use with 1/4" bits.

—Tested by
Bob McFarlin

Continued on page 90

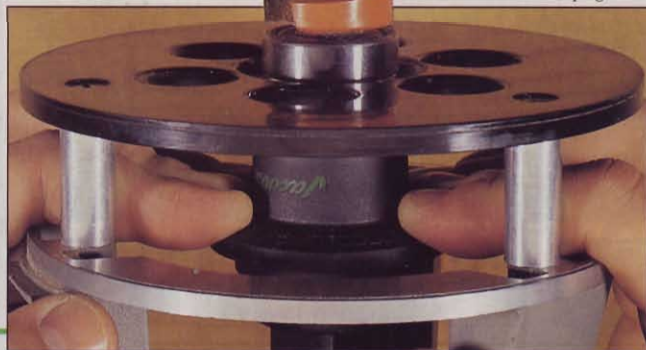

WHY ARE WE PRACTICALLY "GIVING AWAY"



"41 Birdhouse and Birdfeeder Woodworking Patterns for Only \$7.99?"

IF YOU LIKE TO CUT PATTERNS OUT OF WOOD, THIS IS THE SET FOR YOU! YOU'LL FIND A TREASURE HOUSE OF IDEAS INSIDE. 41 BIRDHOUSE AND BIRDFEEDER WOODWORKING PATTERNS AND DESIGNS.



(By Frank K. Wood)

FC&A, a Peachtree City, Georgia, publisher, announced today that it is practically "giving away" an all-new set of "41 Birdhouse and Birdfeeder Woodworking Patterns."

- Little thatched roof cottage, lovely Swiss chalets.
- Old red barn with silo, special holidays.
- Noah and the animals, birds of love and song.
- School days, slanted roof, snowman with his

- Picket fence birdbath, "Apple Cafe" feeder.
- Clever cats, Christmas tree, a cardinal with a treat.
- Decorative covered wagon, two-storied fun.
- One-of-a-kind birdhouse designs, hearts, and "Home Tweet Home."
- Southwestern adobe-style, spooky haunted house.
- Tailor shop, bakery, charming country church.
- Jack-in-the-box, pumpkin, lighthouse by the shore.
- Watermelons, daisies, sunflowers, and more!



Build all these wooden favorites. Illustrated plans include intricately detailed patterns and complete instructions. To order a set, just return this notice with your name and address and a check for \$7.99 plus \$3.00 shipping and handling, and we will send you "41 Birdhouse and Birdfeeder Woodworking Patterns." Or, for only \$9.99 plus \$3.00 shipping and handling, you can get both the basic set and an extra 100 assorted patterns.

Plus, you'll also get a free preview of companion sets of FC&A Woodworking Patterns, about every two months, on a 30 day free trial. You can keep only those sets you want and cancel any time.

Send your check along with your name and address to: FC&A, Dept. NWZ-2, 103 Clover Green, Peachtree City, GA 30269.

You get a no-time-limit guarantee of satisfaction or your money back.

You must cut out and return this notice with your order. Copies will not be accepted!

**IMPORTANT — FREE GIFT OFFER
EXPIRES FEBRUARY 20, 2001**

All orders mailed by February 20, 2001, will receive a free gift guaranteed. Order right away!



Ready, aim, Rapid-Fire!

If I drove a lot of screws for a living, I'd want a tool that would automatically load fasteners onto the end of my driver. Contractors have been able to get speedy self-feeding attachments for their drill guns that use strips of collated screws, and now you can, too.

Craftsman's Rapid Fire accessory, at *right*, mounts to any corded or 9.6-volt or greater cordless drill in less than two minutes, and comes off just as quickly. But once you put it on, you may never want to take it off.

Like professional attachments, Rapid Fire drives a Phillips or square-drive screw, then instantly readies a new fastener. You can drive screw after screw without reaching into a nail pouch and jamming a screw point under your fingernail (ouch!).

I sheet-rocked the vaulted ceiling in my living room using Rapid Fire, and drove more than 1,000 drywall screws without replacing the bit. But it's not a tool you'll find on the jobsite. Near the end of that run, I noticed that the mechanism started to hang up a little at the end of its travel. No big deal. A flick of my finger freed it every time.

And you won't have to worry about burying a screw too deep into your project or sheet rock. Instead of a clutch, the 11"-long Rapid Fire uses a three-position stop that repeatedly sinks the screws either flush, slightly proud, or slightly countersunk.

Currently the fasteners come in four styles and sizes: 1 $\frac{5}{8}$ " drywall, 2" general-purpose interior, 2" galvanized deck, and 2 $\frac{1}{2}$ " galvanized deck.



However, a box of five 30-screw strips will set you back from \$8-\$20, depending on type. We tried other brands of collated screw strips in Rapid Fire and found that strips from Quik Drive (888/487-7845) also work, and can be purchased in bulk quantities. That keeps the cost-per-fastener down.

—Tested by Bob McFarlin

PRODUCT SCORECARD

Craftsman Rapid Fire 28540

Performance	★★★★★
Price	\$50
Value	★★★★★

Available at Sears stores, or by catalog at 800/377-7414.

Continued on page 90



We take the guesswork out of starting your own business.

Turn your passion into profit! Furniture repair and refinishing is a multi-billion dollar industry, and Guardsman WoodPro® is ready to help you take advantage of this market opportunity. Guardsman WoodPro is a national franchise network specializing in furniture repair and refinishing, and the only

company of its kind backed by more than 130 years of industry experience. Your Guardsman WoodPro business comes with:

- Extensive training
- Ongoing support
- Protected territories
- Low overhead
- National accounts
- Financing package

GUARDSMAN
WOODPRO®

The most trusted name in furniture repair.™

Order your free info-video today!
Call: 800.496.6377
www.guardsmanwoodpro.com

Investment range: \$10,000 - \$20,000 • Offer by Prospectus only
Unit and Master Franchises available worldwide



Aerosol agent bonds paint to plastic, metal, and more

In my day job as an auto-body professional, I often have to make paint stick to hard-to-paint materials, such as plastic and galvanized steel. Because I'm in the business, I have at my disposal a number of bonding agents that do the trick. Now comes a product the average woodworker can use to make oil- and water-based paints stick better to metal, plastic, or pre-painted surfaces: Bond-Aid.

To test the manufacturer's claim that Bond-Aid makes paint stick to almost anything, I sprayed two coats on galvanized-steel and PVC rain gutter. Neither piece had held paint well before. I then top-coated both pieces with latex paint, and to my surprise, the paint bonded where previously I could have scratched it off with a thumbnail.



Then I moved to tougher material: glazed ceramic tile. I masked off the left side of the tile shown in the photo above and sprayed the right side with Bond-Aid. After painting the tile with latex paint, I easily scratched off the paint on the untreated side. The Bond-Aid-treated side held firm.

Adhesion to these surfaces isn't necessarily lock-tight: A purposeful scratch with a car key or screwdriver will still

remove the paint. But for metal, plastic, or other hard-to-paint accents, it's hard to beat Bond-Aid. 🐿

—Tested by Bob McFarlin

PRODUCT SCORECARD

Bond-Aid Adhesion Promoter

Performance	★★★★☆
Price	\$5, 12oz. aerosol
Value	★★★★☆

For a dealer near you, call Wm. Barr Branded Sales at 800/235-3546, or visit www.kleanstrip.com.

Dust free woodworking

Oneida Air 1.5 hp



Clean Air

Filter Inside

FOR ONLY

\$659⁰⁰

FOB
Syracuse
New York

Flex Hose & 35 gal. Barrel \$29⁰⁰
Optional wall mount brackets \$28⁰⁰

- 1400 cfm fan/blower
- 700 cfm @ 8" W/C system

Filter Efficiency

1-2 microns 99%
2-5 microns 100%
over 5 microns 100%



Free Ductwork Design



Call 1-800-732-4065

www.oneida-air.com

1001 W. Fayette St. Syracuse, NY 13204 Phone (315) 476-5151 Fax (315) 476-5044

Circle No. 1264

SUBSCRIBERS: PLEASE NOTE!

Many of our customers are mail-order buyers. These consumers are interested in receiving offers for other products and services from our company (Meredith Corporation) and for products and services offered by other reputable companies.

In order to promote our other products, we retain your name and address in a prospective customer file. We also provide that name and address to other reputable companies who offer products we consider to be of value and interest to our customers.

However, we also respect the rights of those customers who prefer not to receive additional mail-order offers.

Should you prefer to have your name restricted, please fill out the coupon (below), clip it out, and mail it to the address shown. Please be sure to indicate whether you wish to restrict all offers or just those from other companies.

- I will accept offers from Meredith Corporation only.
- I prefer not to receive any offers.

Include a current magazine address label with this coupon, and mail your request to:

Magazine Customer Service
P.O. Box 10263
Des Moines, IA 50336-0263

Termite-proof Habitat house goes up in New Orleans

To thwart the attack of voracious Formosan termites, the New Orleans' chapter of Habitat for Humanity teamed up with jazz musician Harry Connick, Jr. and pressure-treated southern pine to build an inedible house. The ambitious project, called "Harry's

House on Music Street," is the first Habitat house in the nation built completely of pressure-treated lumber.

Connick, a New Orleans native, donated the \$100,000 raised from a benefit concert to Habitat to help fund their home-building projects. Habitat brings together people with resources and people in need to build decent, affordable homes in an ongoing effort to eliminate poverty housing worldwide. The homes are built with volunteer labor, sold at no profit, and

financed with no-interest loans. To date, more than 80,000 houses have been built in this manner by Habitat in 67 countries.

The 8,500 board feet of pressure-treated southern pine in the New Orleans' home included rafters, floor joists, wall framing, plywood subfloor, and sheathing. The material was thought ideal for repelling the voracious Formosan termite, which chews up wooden buildings in New Orleans and other coastal cities in the South. More homes built of this material are planned.

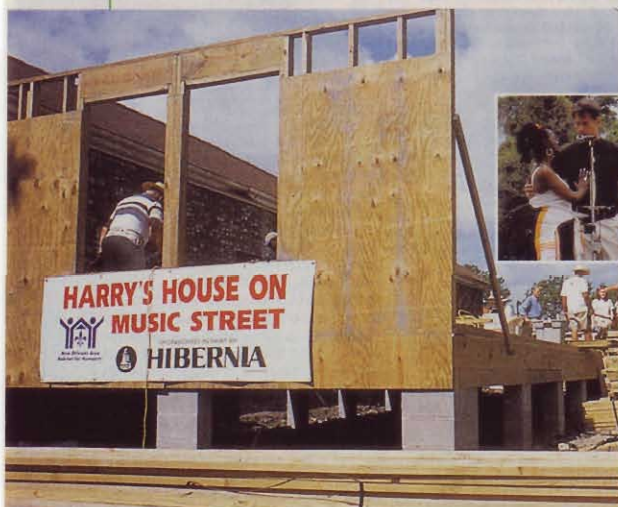

Musician Harry Connick, Jr. funded a Habitat for Humanity house in New Orleans built solely of treated southern pine.



No wood wasted

Russell Colbert lives kitty-corner from wood puzzlemaker Jerry Syfert (featured on page 40) in

Locust Grove, Virginia. Due to their proximity and Russ' fondness for beautiful wood, Jerry has little to worry about when it

comes to disposing of his scraps.

Russ, you see, in his 90 years, has mastered many things, including TV and radio repair, as well as stained-glass work. And in the last three years, he's picked up woodworking in a crafty way, primarily using Jerry's cast off bits and pieces of native and exotic stock.

With great care and artistic flair, this ex-marine (he fought the Sandinista guerrillas in Nicaragua in 1927 and also served in World War II) assembles the bright scrapwood into what he calls collages to hang on the wall. Does he sell them? "No, it's just for the fun of it," Russ says. "Gives me something to do."



At the desk in his extraordinarily orderly basement shop, 90-year-old Russ Colbert holds up one of his scrapwood collages.

Top trees for long-ago fencing

In early America, farmers were quite picky about the material for their rail fences. According to the late Eric Sloane in *A Reverence for Wood*, if locust, cedar, chestnut, walnut, or white oak (in that preference order) were not available locally, a farmer would travel several days by oxcart to find suitable wood to haul home. 🌲

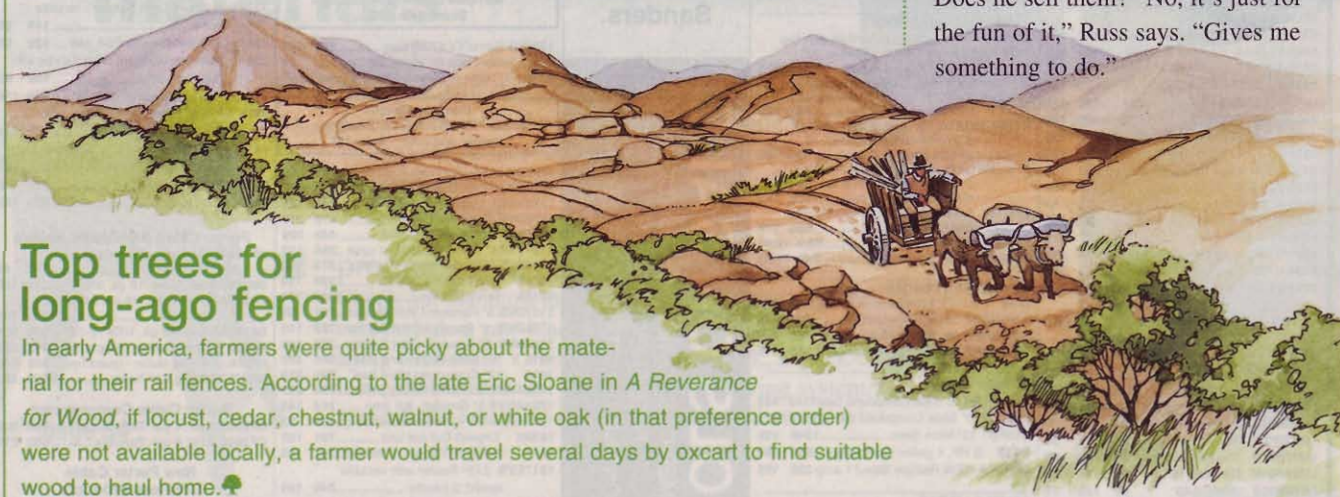

Illustration: Jim Stevenson Photographs: Jerry Syfert; Southern Pine Council