

Better Homes and Gardens®

# WOOD®

ISSUE 124 June 2000

## Brad Nailers

Choose from **12** shop-tested models  
page 70

You can master  
**Scrollsawn Marquetry**  
page 58

**5** EASY PROJECTS  
Including our patio plant stand

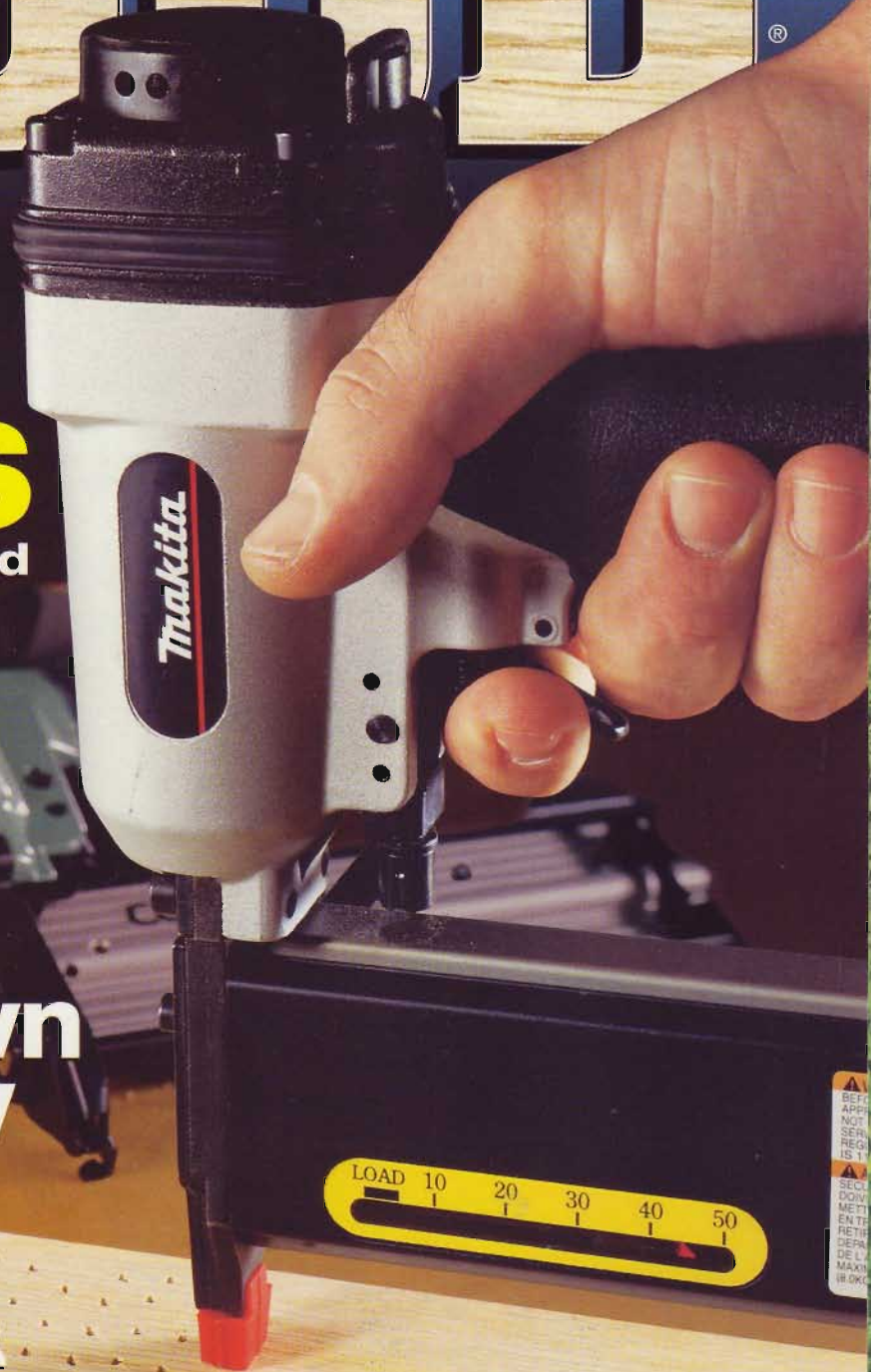

Display until June 6

U.S.A. \$5.95

www.woodmagazine.com

Better Homes and Gardens®  
**WOOD**

**CONTENTS**



Page 68



Page 43



Page 46

**39 Wet-sanding basics**

Learn the secrets to a phenomenal finish.

**51 WOOD index**

Find what you're looking for in issues 113-121.

**55 Spring cleaning**

Maintain your workshop with our timely guide.

**56 Real jobs for real woodworkers**

Apply your skills in one of these career choices.

**58 Scrollsawn marquetry**

Discover a fresh approach to this decorative skill.

**68 Brad nailers**

Pick from 12 shop-tested models, all under \$150.

**76 Woodworking associations**

Join a group that shares your special interest.

**84 Wood worldwide**

See how well our forest reserves are holding up.

**Woodworking projects**

**43 Pen box**

This desktop project keeps pens at the ready.

**46 Tree of life**

Show off your prized plants on a sturdy stand.

**64 Keepsake hand mirror**

Use your newly acquired marquetry skills to dress up this handsome design.

**74 Bright idea for a turning**

Our handy penlight project makes a great gift.

**80 Workshop rest stop**

Take a load off with this accommodating stool.



Page 64



Page 74



Page 80

**SHORT-SUBJECT FEATURES**

**4** The Editor's Angle

**6** Talking Back

**10** Hot Off The Internet

**16** Great Ideas: Pocket-Hole Routing Jig

**18** Need to Know: Straight Talk About Circles

**22** Business Side: How To Sell Your Work

**24** Furniture Repair: Making A Veneer Patch

**28** Wood Anecdote: Shagbark Hickory

**30** Ask WOOD

**32** Tips From Your Shop (And Ours)

**100** Products That Perform

**104** Finishing Touches

# Thanks a Lot, Dad!

As "dad" to two grown daughters, I halfway envy Bill Henwood. A few years ago, Bill's daughter Jan Tomlinson, a studio artist, wanted to add wood to her repertoire of media. And she knew exactly where to turn. "Dad has been working with wood for as long as I can remember," Jan told me.

Bill, it turned out, was delighted to share his shop with her for a month of intensive instruction. "We worked morning and afternoon every day except Sundays," Jan said.

Bill and Jan developed a hands-on curriculum that started at the lumberyard, where Jan learned how to select stock. Next, they drew up plans for a basic box, which enabled Jan to learn about squaring off material, cutting it, and making basic joints.

From there they went on to making picture frames, where Jan mastered rabbeting and mitering techniques. A miniature cabinet Jan built for her daughter taught her about fitting doors and drawers—a recipe box, about finger-jointing.

At the end of her crash woodworking course, Jan took her knowledge home and set up her own shop. She isn't entirely on her own, though.



Jan's gift, *WOOD* magazine's Cartoon Carpenter, slightly resembles Bill, though I think you'll agree that Bill, at 86, looks much more distinguished.

Photographs: Rinehart Photography

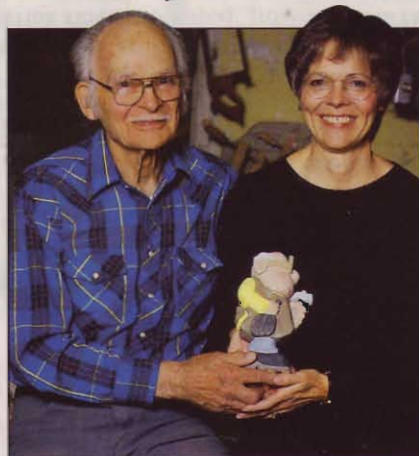

Jan Tomlinson presents her Dad, Bill Henwood, with a thank-you gift in the shop where he shared his woodworking expertise with her.

Help is just a short drive away because both Bill and Jan live in the same town—Bisbee, in southeastern Arizona, near the Mexican border.

Jan likes to combine woodworking with her mastery of painting techniques. She builds CD cases, for example, and adorns them with images of bears and coyotes, critters native to the Bisbee region.

"Since graduating from Dad's 'course,'" Jan says, "I had been trying to think of a thank-you project I could make for him. I wanted something he probably wouldn't make for himself."

A year or so ago, Jan took up chip carving, and when she came across the Cartoon Carpenter carving project and pattern featured in the January, 1996 issue of *WOOD*, Jan knew she'd found just the right gift for her dad. "Having settled on that, I decided I wanted the little guy to be 3-D, so I carved both sides of him. My version has two feet, two arms, two ears, and so forth. Daddy is very pleased with him." Way to go, Jan!

*Larry Clayton*

**CUSTOMER SERVICE 800/374-9663:** Use this number for subscription services, changes of address, billing questions, questions for our editorial staff, questions about how to reach an advertiser, or to place an advertisement in our magazine. **Subscription mailing address:** *Better Homes and Gardens WOOD* magazine, P.O. Box 55050, Boulder, CO 80328-5050. Please enclose your address label from a recent issue. **Editorial mailing address:** The Editor, *WOOD* magazine, 1716 Locust Street, GA310, Des Moines, IA 50309-3023. Reprints are \$5 per article. **To order back issues 800/346-9663.**

Better Homes and Gardens®

**WOOD**®

THE WORLD'S LEADING WOODWORKING MAGAZINE

MAY/JUNE 2000 • Vol. 17, No. 4 • Issue No. 124

Editor **LARRY CLAYTON**  
 Managing Editor **JIM HARROLD**  
 Assistant Managing Editor/Features **PETER J. STEPHANO**  
 Products Editor **DAVE CAMPBELL**  
 Projects Editor **BILL KRIER**  
 Projects Editor **JAN HALE SVEC**  
 Senior Design Editor **JAMES R. DOWNING**  
 Project Builder/Supervisor **CHARLES I. HEDLUND**  
 Senior Associate Art Director **PERRY A. MCFARLIN**  
 Assistant Art Director **CHERYL A. CIBULA**  
 Production/Office Manager **MARGARET CLOSNER**  
 Administrative Assistant **SHERYL MUNYON**  
 Art Business Office Secretary **BARBARA HELPS**  
 Reader-Contact Specialist **BEN VONRUDEN**  
 Contributing Editors **KIM DOWNING, LORNA JOHNSON, ROXANNE LeMOINE, CARSON ODE, BOB MCFARLIN, DAVE HENDERSON**

Publisher **MARK HAGEN**

Ancillary Sales and Internet Manager **MARLEN KEMMET**  
 Advertising Services Manager **PAT HENDERSHOTT**

Chicago Advertising Office: 333 N. Michigan Ave., Suite 1101, Chicago, IL 60601 Phone: 312/853-2890 FAX: 312/580-7906

Advertising Managers **JAMES N. FORD, WILL MURPHY**

Direct Response Advertising **CAROLYN DAKIS**

Marketing Specialist **GERALLIE LEGASPI**

Sales Assistant **MARGARET TRAVIS**

Des Moines Advertising Office: 1716 Locust St., GA204, Des Moines, IA 50309-3023 Phone: 515/284-3575 FAX: 515/284-3343

Direct Response Advertising **NATASHA KUCHERENKO**

Administrative Assistant **KRISTI HASEK**

Publishing Director **WILLIAM R. REED**

Consumer Marketing Director **LIZ BREDESON**

Associate Consumer Marketing Director **KATHI PRIEN**

Assistant Consumer Marketing Manager **DAVE HONOLD**

Business Manager **CRAIG FEAR**

Senior Product Manager **RICK GROW**

**MEREDITH PUBLISHING GROUP**

President **CHRISTOPHER M. LITTLE**

Vice President Publishing Director **JERRY WARD**

Creative Services **ELLEN DELATHOUER**

Manufacturing **BRUCE HESTON**

Consumer Marketing **KARLA JEFFRIES**

Group Sales **JERRY KAPLAN**

Integrated Marketing **BOB MATE**

Strategic Marketing **BILL MURPHY**

Consumer Marketing and Interactive Media **HAL ORINGER**

Operations **DEAN PIETERS**

Finance **MAX RUNCIMAN**

Licensing and New Media **THOMAS L. SLAUGHTER**

**Meredith**  
CORPORATION

**WILLIAM T. KERR**, President and Chief Executive Officer

**E. T. MEREDITH III**, Chairman of the Executive Committee

© Copyright Meredith Corporation 2000  
 All rights reserved. Printed in the U.S.A.

*Better Homes and Gardens*® *WOOD*® magazine (ISSN-0743-894X) is published nine times a year in February, March, April, May/June, July/August, September, October, November, and December by Meredith Corporation, 1716 Locust St., Des Moines, IA 50309-3023. Periodicals postage paid at Des Moines, Iowa, and additional mailing offices. *Better Homes and Gardens* trademark registered in Canada and Australia. Marca Registrada en México. **ONE-YEAR SUBSCRIPTION PRICES:** U.S. and its possessions, \$27; Canada, \$39; other countries, \$47. Canada Post Publications Mail Sales Product Agreement No. 1369350. Canadian BN 12348 2887RT. **CANADIAN RETURN ADDRESS:** *Better Homes and Gardens WOOD* magazine, 2744 Edna Street, Windsor, Ontario, N8Y 1V2. **POSTMASTER:** Send address changes to *Better Homes and Gardens WOOD* magazine, P.O. Box 55050, Boulder, CO 80328-5050.



## BUN FEET IN CHERRY WOOD AS WELL AS OAK AND MAPLE



A0552  
IN STOCK  
NO MINIMUM

A0556

A0553

Made in  
Tennessee

### FREE CATALOGUE



Adams Wood Products™ L.T.D., L.P.  
974 FOREST DR., DEPT. M45  
MORRISTOWN, TN 37814  
TEL 423-587-2942 • FAX 423-586-2188  
www.adamswoodproducts.com

Circle No. 1002

Better Homes and Gardens®

# WOOD Online®

at [www.woodmagazine.com](http://www.woodmagazine.com)

Proudly display one or a pair of prized quilts or blankets on this one-of-a-kind 36"-tall oak stand. A sturdy project, it features through mortises and slatted end panels reminiscent of the original and popular mission-style furniture. You can get this and over 90 other downloadable project plans from the WOOD STORE at [www.woodmagazine.com](http://www.woodmagazine.com). It's plan no. DP-00046, and it costs only \$5.95.



## TALKING BACK

### Heft helps portable planer

I read your well-written article on portable planers in issue #120 and want to clarify a few points about the Grizzly model G1017. First, while you saw its heavy weight as a negative, many of our customers have commented positively about that. When you plane a long or heavy piece of wood, the planer's weight keeps it from tipping. This planer also comes with a 700-pound capacity Shop Fox stand at no extra cost.

—Sbiraz Balolia, President, Grizzly Industrial, Inc., Bellingham, Wash.

### Planer changes color, but it's still the same

In the 12" portable planer comparisons in issue #120, you showed the JET JWP-12-4P in its former blue color. JET has changed its color to white and dropped the Shopline name. The unit is still carried by JET with the same model number but a new look. I feel that the photo of the planer as it once appeared may confuse your readers.

—Debi Schmid, JET Tools, Auburn, Wash.

### Looking for a woodworker who can design

WOOD® magazine seeks an enthusiastic, imaginative, hardworking project designer/builder who has proven woodworking project design and building abilities. This person will be responsible for producing top-notch, easy-to-build projects as assigned. Drafting experience is required, preferably using CAD software. Location: Des Moines, Iowa

If you feel qualified, please send a cover letter, recent resume, and examples of your work to: D. Neumann, Meredith Corp., Staffing Services, 1716 Locust St., Des Moines, IA 50309-3023. Fax: 515/284-2958. Equal Opportunity Employer.

### Spacers steady clamp extensions

I'd like to suggest an addition to your clamp extensions shown on page 16 of issue #117. By adding a scrap wood spacer block between the heads and above the bar, the extensions will stay parallel. Of course, this requires measuring the thickness of the piece being clamped and cutting the spacer to that exact length almost every time.

—Jerry Schnese, Appleton, Wis.

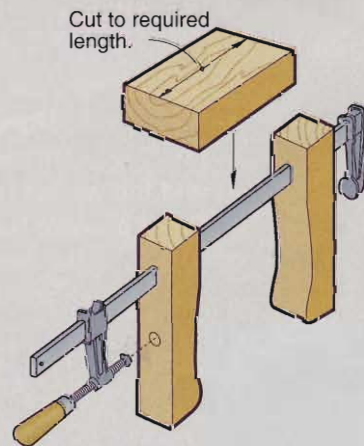

### Errant fraction

Please note that in the Bill of Materials for the cold frame on page 51 of issue #121 the width for the back panel (B) should be 17 3/16". The drawings, though, are all dimensioned correctly.

Bill of Materials					
Part	Finished Size			Mat.	Qty.
	T	W	L		
B back panel	3/4"	17 3/16"	38 1/2"	Ply	1

### We would like to hear from you

We welcome your comments, criticisms, suggestions, and yes, even compliments. We'll publish letters of the greatest benefit to our readers. Write to: Talking Back, WOOD Magazine, 1716 Locust St., GA310, Des Moines, IA 50309-3023

Continued on page 8

Continued from page 6

### Cutting diagram for nesting tables

Is there a cutting diagram for the nesting table project on page 46 of issue #121?

—John Legato, Anchorage, Alaska

Well, John, there wasn't a cutting diagram with the article, but there is one now. Hope this will help get you started.

#### LARGE TABLE

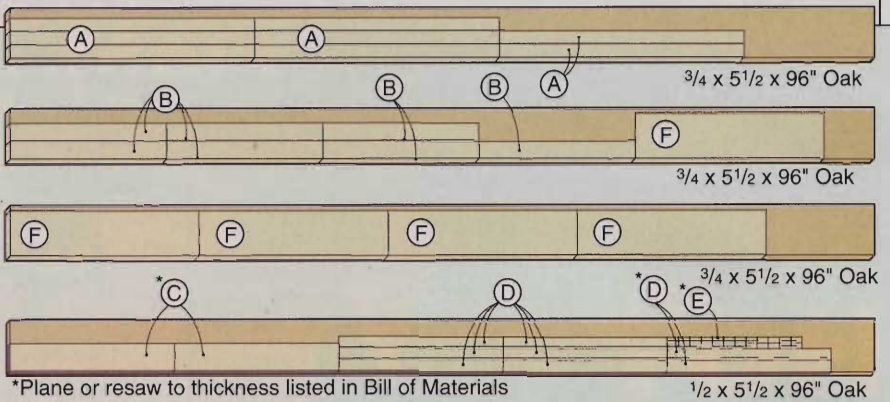

#### MEDIUM TABLE

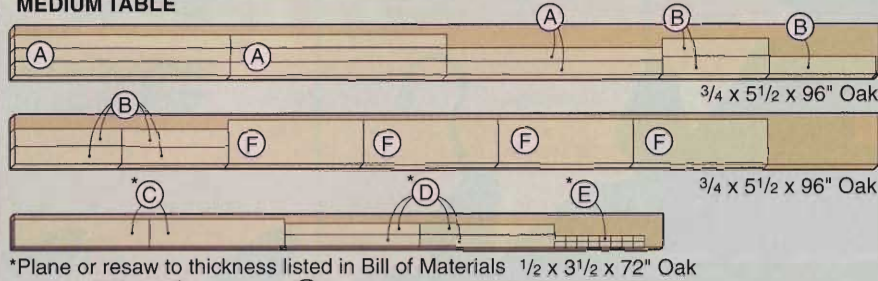

#### SMALL TABLE

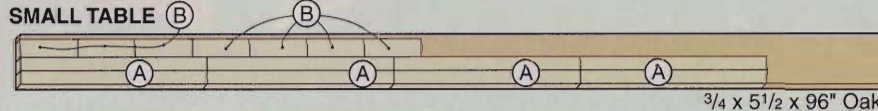

#### CUTTING DIAGRAM - NESTING TABLES

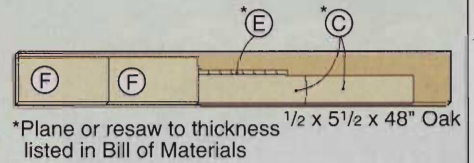

Continued on page 9



## Laguna Tools Band Saw Now Only \$995\*

No more excuses, you will never have a better time to purchase a Laguna Tools LT16 band saw. Due to the high volume of band saws that we sell, we can now give you the best band-saw value in the market. Manufactured in Italy exclusively for Laguna Tools, this powerful, swift piece of Italian ingenuity has high-quality, performance and your name written all over it.

Don't wait. Call today to get your free demonstration video.

- 12" resaw capability
- Easy blade change with 1/16 to 1" blade capacity
- 1.5 HP motor
- All-welded steel frame construction
- Cast-iron flywheels with snap on rubber tires
- Electro-dynamically balanced
- Large 16" x 19" cast iron table
- Cast-iron rip fence
- 3/8" x 3/4" miter gage slot
- Two dust ports for excellent dust collection
- Blade tension indicator
- Table tilt from -10 to 45 degrees. Steel trunions
- Bearing Euro guides, both upper and lower
- Mobility kit, power feeder and 110-volt motor available

\*Excludes sales tax and freight

**LAGUNA TOOLS**

You Build With Wood, We Build With Trust.

800-234-1976

E Mail: lagunatools@earthlink.net Web: www.lagunatools.com

2265 Laguna Canyon Rd., Laguna Beach, CA 92651 (949) 494-7006 • FX (949) 497-1346  
100 Central Ave., South Kearny, New Jersey 07032 (973) 491-0102 • FX (973) 491-0591

Circle No. 615

**WOODLINE ARIZONA, Inc.**  
 P.O. Box 1530 • Payson, AZ 85547  
 Great Router Bits and Shaper Cutters  
 FEATURING: Euro carbide - Anti-Kickback - Super-slick finish

• Shipping \$3.75 per order

• Same-day shipping!!

• All major credit cards

**1-800-472-6950**

or [www.woodbits.com](http://www.woodbits.com)

**NEW TONGUE & GROOVE for FLOORING/PANELING, ETC.**

1-piece Cutters. Easy to use, great fit. Just lower the cutter or shim the material for the matching pass.

Cuts round tongue for easy fit, with nail guide above the tongue for easy edge nailing.

For up to 13/16" material.

**only \$43**  
 1/2" shank Router Bit WL-1488-1  
**only \$65**  
 3/4" Bore Shaper Cutter WL-1584

For 3/8"-1/2" material (1/8" tongue)

2 bearings & 2 straight 1/4" cutters  
 1/2" shank Router Bit WL-1488-2  
**only \$33**

**REVERSIBLE "V" FACE T&G** provides 1/4" T&G, "V" groove on material face.

For up to 1-1/8" material.

1/2" shank Router Bit WL-1488  
**only \$33**

**CHECK OUR NEW CUTTERS** — chairrail, base cap, crown mouldings, and more!  
**1-800-472-6950**

**FREE Catalog** over 200 NEW Bits & Cutters

Circle No. 1395

# LOSE THE HASSLES

RBI GIVES YOU WOODWORKING MACHINERY THAT IS...

- Designed to be easy to use
- Over 70 years of building quality tools
- Backed with excellent customer service
- Covered by a great warranty
- All American Made

RBI gives you the best value for your woodworking dollar!

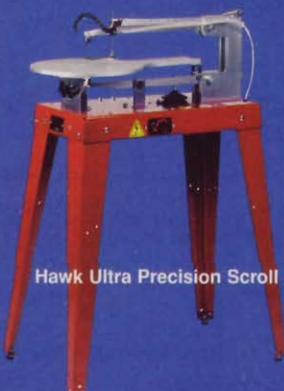

Hawk Ultra Precision Scroll Saws



RBI 4-in-1 Universal Planers



26" & 38" Drum Sanders



Panel Master II

**rbindustries, inc.**

1801 Vine Street • Harrisonville, MO 64701

[www.rbiwoodtools.com](http://www.rbiwoodtools.com)

**Call 1-800-487-2623 for your FREE fact kit!**

Copyright © 2000 Rbindustries. All rights reserved.

## TALKING BACK

Continued from page 8

### Here's the missing cutting diagram

Most of the projects published in *WOOD*® magazine include a cutting diagram to show you how to best get the parts you need from the wood you buy. However,

we omitted the cutting diagram for the Drop-front Writing Desk that appeared in issue #120. Thanks to those readers who let us know about our faux pas. 🙏

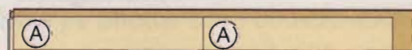

3/4 x 7 1/4 x 72" Pine



3/4 x 7 1/4 x 120" Pine

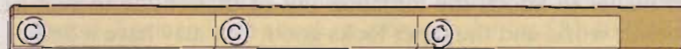

3/4 x 7 1/4 x 120" Pine

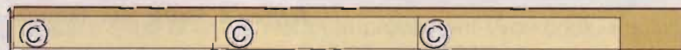

3/4 x 7 1/4 x 120" Pine



3/4 x 5 1/2 x 120" Pine



3/4 x 5 1/2 x 120" Pine



3/4 x 5 1/2 x 96" Pine

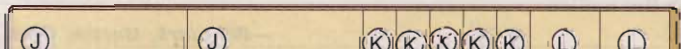

3/4 x 11 1/4 x 120" Pine

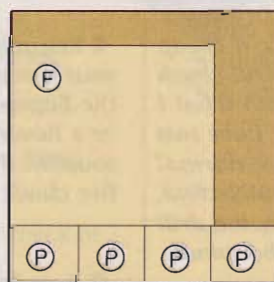

1/4 x 48 x 48" Pine/Fir Plywood

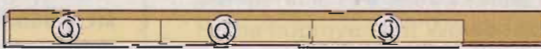

3/4 x 5 1/2 x 96" Pine

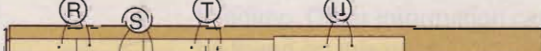

3/4 x 7 1/4 x 96" Pine

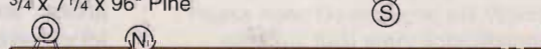

1/2 x 9 1/4 x 96" Pine

### CUTTING DIAGRAM DROP FRONT WRITING DESK

## WOODWORKERS TO THE RESCUE

Comments, answers, and ideas from our WOOD ONLINE® discussion groups

**Note:** If you would like more information on the woodworking-related subjects featured here, visit our WOOD ONLINE discussion groups at [www.woodmagazine.com](http://www.woodmagazine.com)

We have edited all entries in the interest of brevity and clarity while preserving the message. In addition, we have included our response to some questions.

## How can I keep tools from rusting?

*My garage doubles as my wood shop. It stays cool when the door is closed. When the door is opened, a rush of hot humid air comes in. The humid air condenses on the work surfaces of my tablesaw and other machines. The end result is rusty tools. Any suggestions?*

—Tony Trajkovich, Fontana, Wis.

● Clean all the rust off your saw table, and then put a coat of Johnson's paste floor wax on it. It will protect the surface from rust and make the wood glide much easier. I also use it on my planer bed. As for hand tools, I wipe mine off with a rag that has a small amount of WD-40 on it. Do not use auto wax on your tools because it contains silicone that can get onto wood and cause finishing problems.

—Jack Understeller, Cincinnati

## Why does my used saw start slowly?

*I just bought a second-hand Craftsman radial-arm saw in mint condition. It starts very slowly and then builds up to speed. Is this normal? Also, I'm looking for books on this saw and manuals for it.*

—Joe Romeo

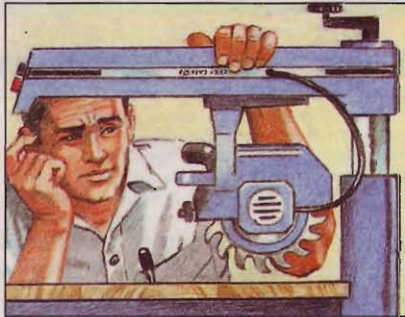

● What is the model number of your saw? Usually if it begins with 103 or 113, the saw was made by Emerson Electric Co., phone 800/325-1184. Also check [www.siamesedream.com/toolcorner/manu.htm](http://www.siamesedream.com/toolcorner/manu.htm). This should lead you to a web page for Craftsman Tools.

—Glynn Humphrey, Napa, Calif.

● Joe, we spoke with Vic Kluesner of Emerson Tool Company (formerly Emerson Special Products Division that manufactured Craftsman radial-arm saws up until 1998). Vic agrees that in all likelihood your saw is not getting enough voltage—any induction motor will start slowly if it's starved of voltage. He suggests that you not use extension cords, and that you check the voltage at the outlet with a meter. If the voltage is low, your circuit may be overloaded with too many other energy-eating lights and appliances. Try turning off some of those other juice gobblers. If that's not practical, you may want to remedy the problem by rewiring the saw for 220 volts. He added that while Emerson no longer supplies Craftsman woodworking machines or parts, they can provide old manuals if you call the phone number mentioned in Glynn Humphrey's post.

—WOOD magazine

## Chuck slips out of drill press

*I just bought a drill press, a cheap one made in China. The drill chuck attaches to the spindle with what I believe is a Morse taper. I have two questions. First, is this the normal set-up on drill presses? And second, when I use a circle cutter, the drill chuck comes loose from the spindle, what can I do to stop this?*

—Kirk Franks, Salisbury, Md.

● Regarding your first question, yes, it is a normal installation; and regarding your second, you've got to pound the chuck onto the taper soundly. Retract the fingers into the chuck so they're not being struck, and use a wood block or a heavy rubber mallet to knock the taper out of that chuck to seat it soundly. If that doesn't work, and the taper looks good, you may have a defective chuck.

—Jeffrey A. Smith, San Antonio

● If, as Jeff correctly suggests, you use a piece of wood, I would hit it with something harder than a rubber mallet, such as a 2-pound steel hammer. You are pounding upward, so your swing is not overly forceful. If you get it on tight, it should stay in place for a long time.

—Bill M., last name and address unknown

● I would add one more suggestion: While the chuck is off, clean all oil, grease, and debris off both the male and female surfaces of the taper. Then let'er have it with the mallet.

—Bill Clark, Marion, Ohio

Continued on page 13

Continued from page 10

**How to joint workpiece edges without a jointer**

*I want to be able to do panel glue-ups for doors, tabletops, case sides, and the like. I know the "right" way to true-up the workpiece edges is to use a jointer, but I don't have one. I thought about lining up the boards face-to-face and going along the edges with a hand plane, belt sander, or portable hand-held electric planer. I figure any deviation from square should offset each other. Does anyone have another plan? Would a router and straight bit work?*

—Arthur Allison, Jacksonville, Fla.

● Arthur, I use my router table with a split fence to prepare wood for making panels. So far, I have had good luck with it and have made numerous panels that I was satisfied with. I tried to make a split fence and finally decided to buy one after hours of fussing and not getting the results I wanted.

I bought an Inkra Intellifence (made by Taylor Designs, 972/243-7943) because eventually I plan to buy their positioning system. But Woodhaven (800/344-6657) sells a cheaper and just as effective alternative with 1/2" spacers for the outfeed side of its fence.

This method cannot completely replace a good jointer. The longest bit I have seen is 2 1/2", so if you plan on jointing anything bigger, you are out of luck.

—Bill Schreiber, Litchfield, N.H.

● I routinely use a router to straighten and joint stock too long for my 4" jointer and for highly figured grain that tends to chip out on the jointer. You will get good square edges ready for glueup.

The trick is to provide yourself with a very straight reference edge and to clamp everything solidly so nothing moves during a router pass. You can buy a good 8' straightedge (assembled from two 4' halves) made of aluminum, or you can buy a 6-12"-wide board and have someone joint it straight.

Since I use this method fairly often, I screwed aluminum angle stock to the edge of a 2x12. I use a 1/2" flush-trim bit with a bottom bearing. I position the stock on top of the straight-edge and adjust the bit so its pilot bearing rides against the aluminum edge.

I advise you to be fussy with the straightedge and the setup. I've had my aluminum edge bow slightly because of too much side pressure keeping the bearing in contact. That cuts a bow in the jointed edge. The gap between two such boards is double the amount of the bow—often too much to tolerate. ♣

—Ron Kent, Lenox Dale, Mass.

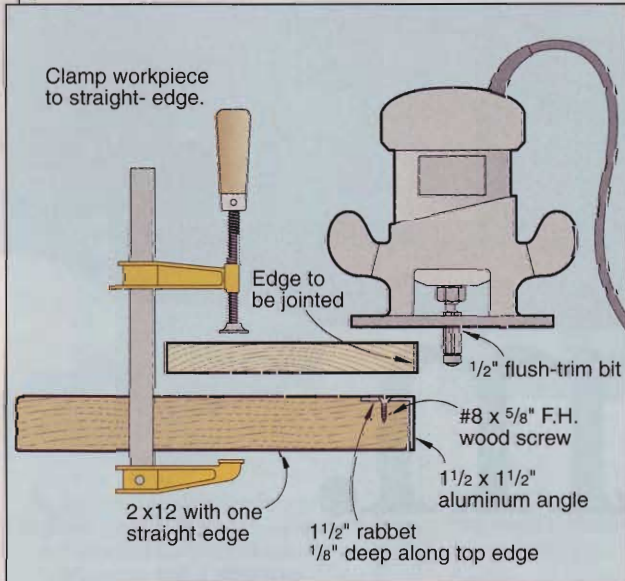

**The new Craftsman Professional line**



1. Hi-capacity sub C battery cells for rugged long life
2. Overload protection
3. Heavy-duty 2-speed gear box withstands tough drilling loads
4. Precise built-in level
5. Overmold grip on handle & trigger for comfort & control
6. 24-position clutch lets you match the torque precisely to the job



**SEARS**

THE GOOD LIFE  
AT A GREAT PRICE  
GUARANTEED™

\*Maximum torque



# A SIMPLE, NO-NONSENSE Pocket-Hole Routing Jig



Given how specialized the tools are for pocket-hole joinery, some woodworkers have balked at using the technique for projects. Nowadays, the dedicated jigs for drilling pocket holes are very affordable, but reader David Brunson of Loudon, Tennessee, came up with a router table jig for the same purpose. We tweaked his idea to get the design shown.

The jig is simply a plywood platform supported on wedge-shaped runners cut at a 15° angle. One runner has a bottom cleat that rides in the miter gauge slot of the router table and is controlled by a stop. This keeps the jig tracking in a straight line when routing, letting you make functional pockets. The hollow split-spring pin allows you to drill the centered pilot holes for screws.

On the jig's lower end, a wood fence acts as both a rest to locate the workpiece and a guide for drilling. Sandpaper and a toggle clamp grip the workpiece.

The pocket itself is cut with a 3/8" straight router bit. Simply raise the bit to 1/4" above the table surface, and slowly feed the jig, high end first, toward the cutter. It will plow into the underside of the platform and then emerge through the top. When the leading edge of the bit meets the index line marked 3/8" from the fence, shut off the router. Then clamp a stopblock in the miter gauge slot.

Before unclamping the workpiece, drill a 5/32" hole through the metal guide (the 1/4"-o.d. split-spring pin) in the fence, and into the workpiece. 🌲

Project Design: David Brunson; Jan Hale Svec  
Illustrations: Roxanne LeMoine  
Photograph: Jim Downing

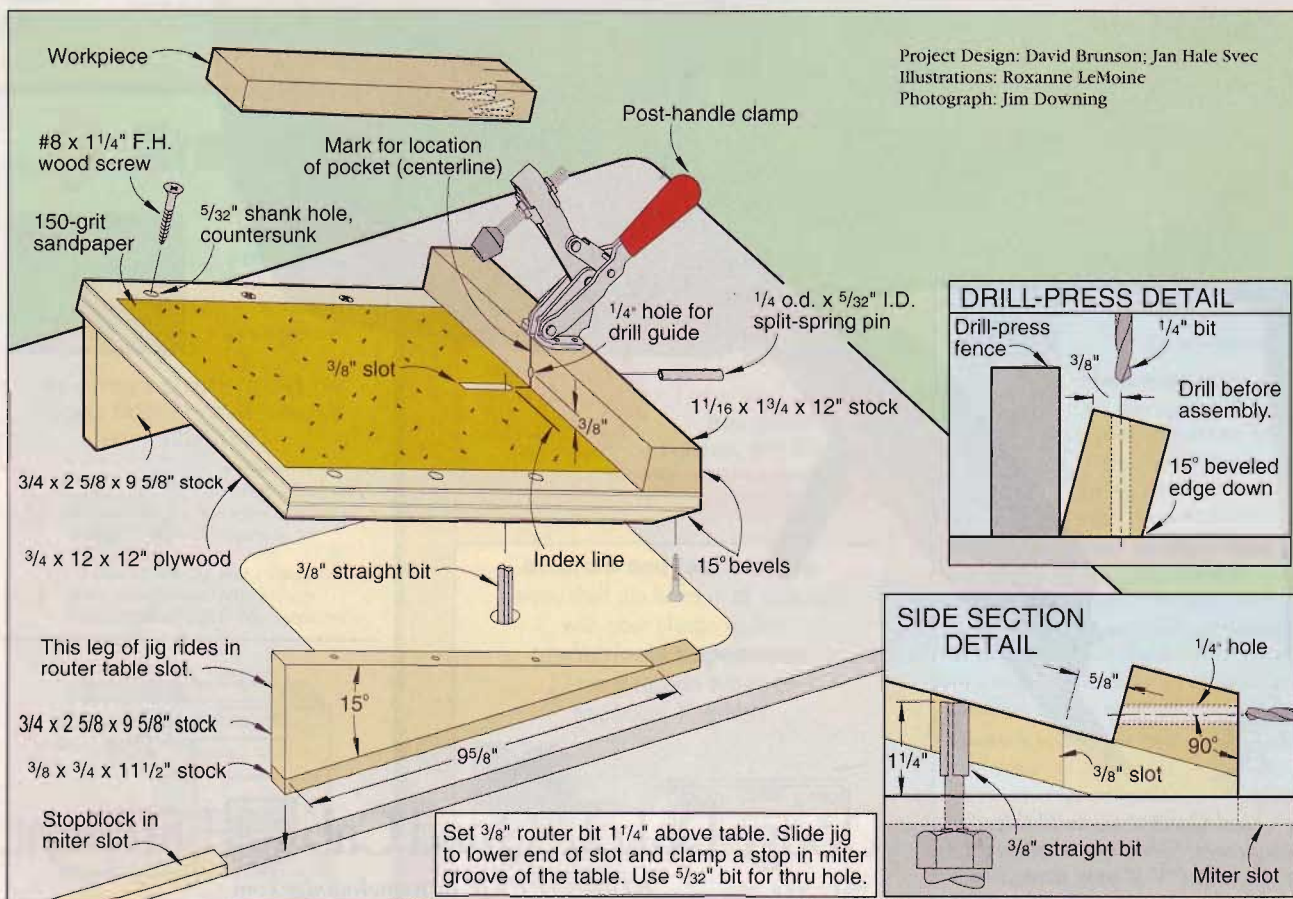

# Straight talk about Circles

Circles, or portions of them, often turn up in woodworking projects. Whether you're dealing with wheels for a toy or a round top for a table, here's how to work your way around a circle.

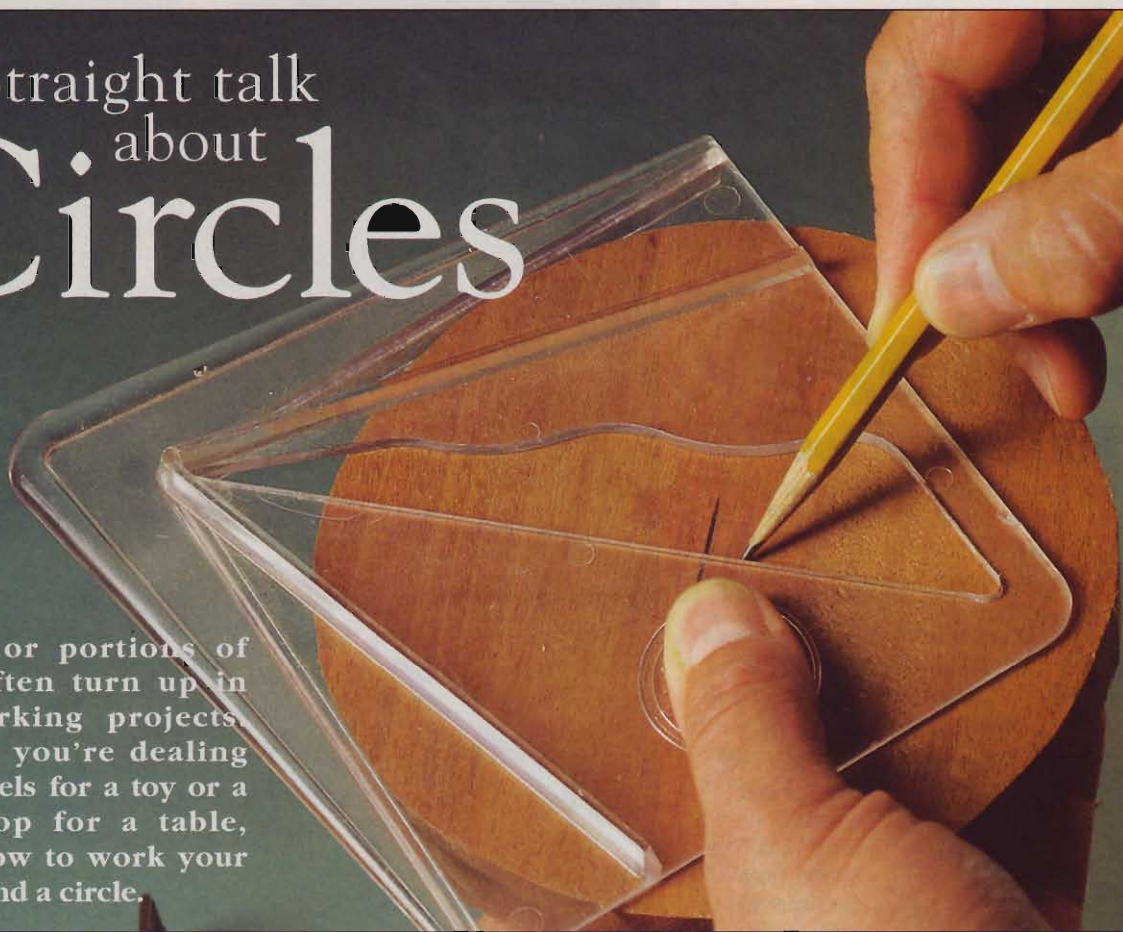

Quickly and accurately locate the center on a round piece using a center finder.

## First, have a little bit of Pi

If you're going to deal with round things, you need to know about  $\pi$  (Pi). Pi, a number you'll use often in circle calculations, represents the number of diameter lengths of a circle it would take to equal the same circle's circumference—about 3.14159. About, because  $\pi$  is always approximate—its value has been calculated to more than 2.2 billion decimal places without ending or repeating. (Many calculators have a  $\pi$  key to make figuring simple.)

## Handy circle calculations

In the box at *right* you'll find some formulas to help you solve workshop problems involving circles.

Using the circumference formulas, for instance, you can determine the length of veneer or laminate you'll need to edge a round tabletop. Or, if you know the distance required

**ANATOMY OF A CIRCLE**

- Diameter (D) is the distance across a circle, measured directly over the center.
- Radius (R) is the distance from a point on a circle to the center. Radius equals half the diameter.
- Circumference (C) is the distance around the circle. To calculate circumference, just multiply the diameter times  $\pi$ .
- Area (A) is the number of square inches (or feet or centimeters or whatever unit you're using) contained in the circle. To figure the area, square the circle's radius (multiply it by itself); then multiply the result times  $\pi$ .

To find Diameter $D=2 \times R$ $D=C \div \pi$	To find Radius $R=D \div 2$	To find Circumference $C=\pi \times D$ $C=2 \times \pi \times R$	To find Area $A=\pi \times R^2$ $A=\pi \times D^2 \div 4$ $A=C^2 \div (4 \times \pi)$
$\pi = \text{Pi (3.14159)}$		$R^2 = R \times R$	

around a circular table to provide certain seating capacity (the circumference), you can easily figure the table's diameter by dividing by  $\pi$ . Area calculations come in handy when you're estimating finish coverage or material quantities.

## Set your compass, and lay out some circles and arcs

Project plans and instructions ordinarily specify the diameter for circular parts. The radius usually is called out for corner rounds and other arcs (parts of circles).

*Continued on page 20*

Continued from page 18

You already know how to draw a circle of a certain size: Set the distance between your compass legs or trammel points to the *radius* of the circle (half the diameter), and draw

around the center. To avoid pricking the center with the compass point, stick on a piece of masking tape.

You can lay out a corner radius just as easily, once you locate the center.

To find the center and lay out a corner round in just three steps, first set your compass to the corner radius specified. Then, follow the steps in the photos *below*.

Lay out a corner round with your compass in three easy steps

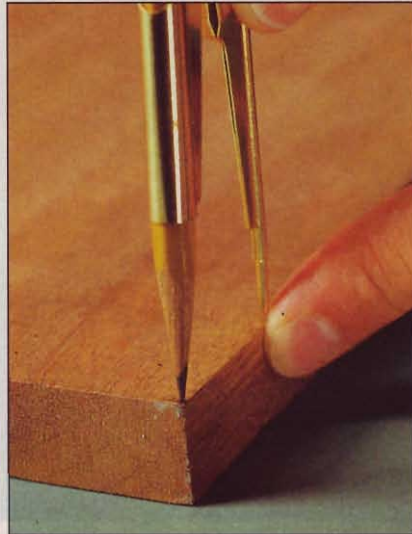

**STEP 1** Hold the compass point at the edge of the stock with the pencil point at the corner. Swing an arc.

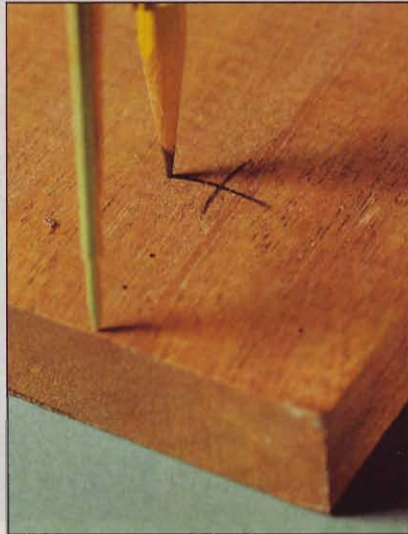

**STEP 2** Swing an arc from the adjacent side. The compass arcs intersect to form a cross at the centerpoint.

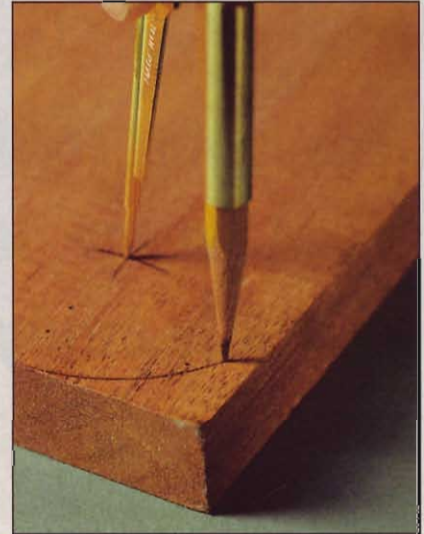

**STEP 3** Put the compass point at the center cross to lay out the corner radius.

Say you have a circle, and need to find the center . . .

Easy-to-use center-finding tools, such as the one shown in the *opening photo* or a centering head for a combination square, are readily available from woodworking-supply dealers. The devices work well on rounds up to 7" or 8" in diameter.

But you'll need to rely on layout methods to find the center on larger discs. The easiest way to do it (though a method prone to some

error) is to stretch your tape measure across the diameter of the circle, and make a mark at the middle, as shown *below*. Then, move 90° around the edge, and repeat. Extend the marks until they cross, pinpointing the center.

If you prefer greater accuracy, try this method. First, draw a chord on the circle, shown as line AB in the illustration *below right*. (A chord is

a straight line that extends from one point on a circle to another, but doesn't pass through the center.) Then, draw a perpendicular chord at each end of the first one, shown as lines AC and BD in the drawing.

Next, draw diagonal lines between the two perpendiculars, shown by the broken lines. The point where the diagonals cross marks the center of the circle. ♣

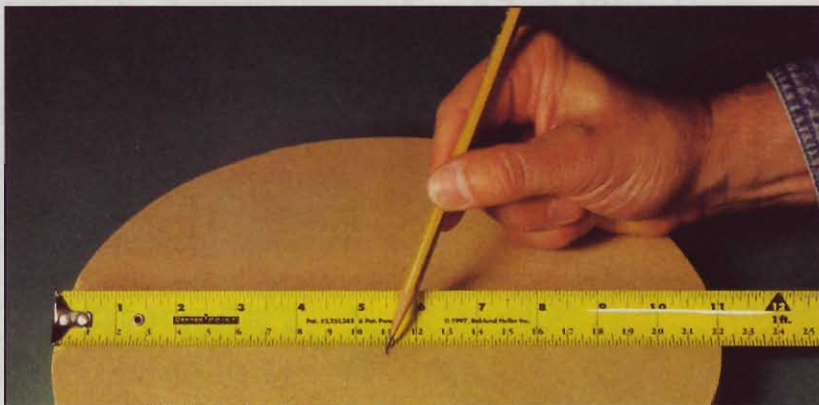

The longest measurement across a circle is the diameter. Mark the midpoint of two diameters 90° apart to locate the center.

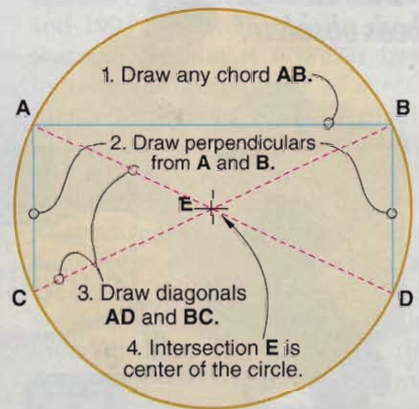

Photographs: Hetherington Photography Illustrations: Roxanne LeMoine; Lorna Johnson

# How To Sell Your Work Direct

**Selling work one-on-one to the public isn't for everyone, but the right approach can work wonders.**

**D**ave Monhollen was a corporate sales representative before he quit to take up woodcarving full time. The Crittenden, Kentucky, carver today makes more money than he ever did, proving in the process that woodcraft can be sold successfully direct to consumers—even if you don't have a store.

Selling direct has key advantages. By eliminating the gallery commission, consignment-shop cut, or retail markup that wholesaling entails, you pocket up to 100 percent more of your wholesale price.

Of course, craft merchants usually do earn their money. They're drumming up business and dealing with often demanding customers. When you sell direct to the public, you're doing your job *and* theirs, so you need a set of selling skills and strategies that have nothing to do with woodworking.

## **A specialized sales tactic that works**

Dave Monhollen was lucky. He brought sales experience with him to his carving. Yet, one of the sales tactics he regularly used you can easily apply to any kind of higher-end woodworking. Try this successful strategy of his:

Glean business newspapers or sections of your local paper for news about promotions or other milestones in executives' careers. They, or their associates and relatives, might want to commemorate the event with a memento of your woodworking.

Call and give a brief pitch to the executives mentioned in the paper,

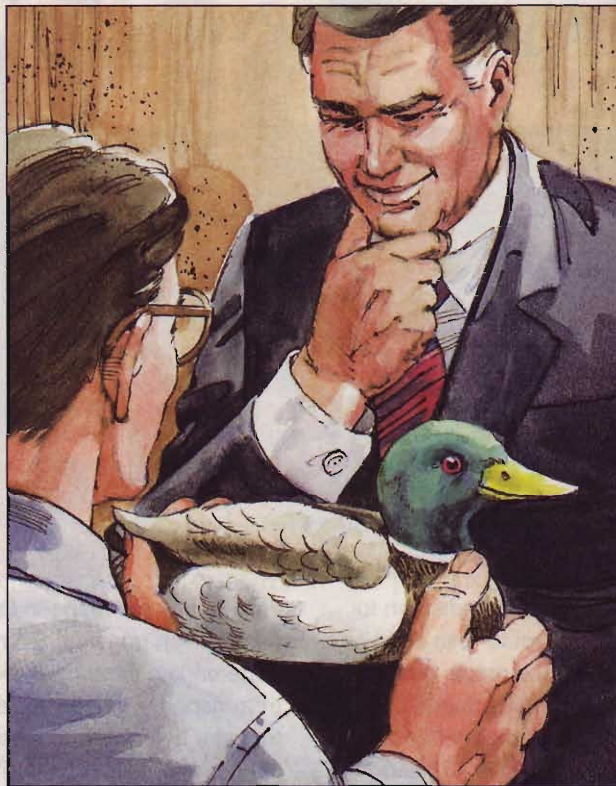

describing yourself and what you do. Then, ask for a 10-minute appointment. (Dave found that this was usually extended voluntarily once he started talking.)

Make sure, even when you're rejected on the phone or during a face-to-face call, that you try to come away with referrals to others who might be interested in your work.

## **Get your name and work out for people to see**

With substantial word-of-mouth and repeat business, Monhollen doesn't have to make those cold calls anymore. But to keep word of mouth working for you, it helps to leave a brochure or business card with every customer. That way, when your customer's friends and family admire what you've made, he or she can quickly refer them to the person who made it—you.

It also helps to take photographs of everything you make and keep them

in a photo album as a sort of catalog for future customers' reference, according to Jim Canfield. Jim's a Milford, Ohio, woodworker who only started his own shop at age 54 after being permanently laid off from a factory job.

Even more effective than photos are real samples of your work. And you can show off your work without the expense of a showroom. Former security manager Ray Murray built a thriving woodworking business by expertly crafting bunk beds and Adirondack chairs and putting samples of them on the lawn outside the small shop he owns along a busy highway near Cincinnati, Ohio.

Although it helps to live or work along a busy road with liberal zoning, a similar approach can succeed even if you don't have such access.

Try donating items to heavily trafficked stores, schools, or other places that can use them on the condition that your name and phone number be displayed with the item.

## **How you handle customers can decide your fate**

Once orders for your work come rolling in, you'll have another problem—managing demanding customers. The key here is to be honest and fair, says Murray.

Give consumers a realistic time range for delivery of custom work, and do your best to meet the deadline. When you can't meet a delivery date, warn the customer in advance and offer the deposit back. Though you might not be able to keep all of your customers happy, treating them fairly certainly increases the odds. ♣

Written by Jack Neff, a Batavia, Ohio, business writer and author of *Make Your Woodworking Pay for Itself*.  
Illustration by Brian Jensen

# How To Make A Veneer Patch Match

No matter how precisely you patch veneer or fix other furniture flaws, the repaired area will remain glaringly obvious unless you closely match its color and finish to the original. Here's how to blend new with old.

## Wouldn't you simply dye for a good color match?

The first choice to make is which colorants to use. Many furniture restorers prefer dyes rather than pigmented stains. Here's why:

- Dye colors are transparent, so they don't mask or muddy the wood's grain or figure.

- Dye imparts a uniform color to wood. Pigmented stain can collect in pores and scratches, giving a blotchy look or increasing grain contrast.

- Adjusting colors is easier with transparent dyes. You can dye wood that's already been dyed with a different color to achieve a special look or blend of the colors.

You won't need a lot of dye colors to start with. You can match most common wood colors successfully with just five dye hues—brown, black, red, green, and yellow. (We used inexpensive water-based all-purpose dyes from a discount store, shown in the photo above. More-expensive aniline woodworking dyes do a great job, and are available in many wood colors.)

## Consider how color works

Matching the color of an old furniture finish isn't a precise process—it strays way over into trial-and-error territory. A little knowledge of color theory can go a long way in helping you achieve a convincing match, though, so let's take a look at the color wheel (right).

The wheel's largest circles show the *primary colors* (or hues): red, yellow,



You can color wood with either liquid or powdered dyes. Mix powdered dyes according to package instructions.

low, and blue. Between them lie the *secondary colors*: orange, green, and violet. These are made by mixing the adjoining primaries in equal amounts (assuming equal color intensities). Beyond these hues, you can create countless *intermediary colors* by mixing primaries in unequal amounts. (The six innermost circles on our wheel show some of these.)

Want more colors? You can mix two secondary colors to obtain a *tertiary color*. (Olive, combining orange and green, is an example.)

Colors directly across the wheel from each other, such as red and green, are *complementary colors*. You can reduce any color's strength or intensity (its *chroma*) by adding some of its complement to it. When combined in equal parts (and, again, assuming equal color intensities), a color and its complement yield neutral, a grayish dark brown.

Color *value*—the measurement of lightness or darkness—spans a white-to-black scale. You can add white (the highest value) to any color to create a lighter *tint* of that color. (Adding extra solvent to the dye solution gives a similar effect.) Or, you can add black (the lowest value) to make a darker *shade* of the color. Brown, for instance, is a shade of orange—orange with black added. Tan is a tint of brown—brown with white added. Adding grey—equal parts of black and white—to a color creates a *tone* of that color.

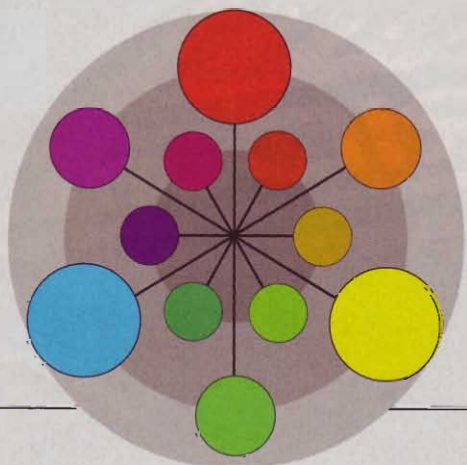

Continued on page 26

Continued from page 24

## How To Make A Veneer Patch Match

Realize also that while a color is constant, you may not always see it the same way. Color reaches your eye as light reflected by objects. Natural light contains all colors, whereas artificial light sources provide different, limited color spectrums. If a color is not present in the light, it cannot be reflected for you to see. So, a color may appear warmer (redder) when it's reflecting light from an incandescent bulb than when it's viewed under a fluorescent lamp. Likewise, a color match that appears perfect in your artificial shop lighting may be noticeably off when bathed in natural light from a living-room window.

### Let's make a match

The color-matching procedure is simple to describe, but getting the right results takes some experimentation. And you should do those experiments on a scrap of the veneer or

wood you used in the repair, not on the piece of furniture itself.

Start by comparing the color of the new wood to the finished wood you need to match. At first glance, the mahogany veneer used to patch the tabletop shown *below, left*, appeared both redder and lighter than the rest of the table. So, we tried two approaches to make a match.

One was to apply dark brown dye to one corner of a veneer scrap to darken it. On another corner, we added straight dark green, aiming to reduce the sample's redness and darken it, too. (Remember, the dyes are transparent, so the original color of the wood or veneer becomes an important part of the final color mix.) The green dye provided the closest match after the samples dried, as shown. (We also put some of the final clear finish material over the test spots.)

Based on our tests, we reduced the liquid dark green dye slightly with

water, and brushed it on the veneer patches, as shown in the photo *below, right*. (Because we were working with water-based dyes, we first brushed water on the veneer to raise the grain, let it dry overnight, then lightly sanded the veneer.) We rubbed the dye off after a few seconds, and let the surface dry. Then, we reassessed the color match. For final adjustment, we applied a slightly darker green dye. (If you get it too dark, you can undo some of the error with a rag dipped in common liquid laundry bleach.)

After you make your color match, allow the dye to dry thoroughly, then apply a finish over the repair to match the original. For the table shown—not a valuable antique—we sanded the top and applied semi-gloss polyurethane overall to make a practical piece of furniture. 🍷

Illustration: Ernie Shelton  
Photographs: Hetherington Photography



Green dye, applied to the pointed end of the test strip, took away some of the redness in the mahogany veneer, resulting in a close color match. Brown dye proved to be too dark.



You don't need a good brush to put on dye. You can even apply it with a rag—you may want to wear rubber gloves so you won't dye your fingers.

# SHAGBARK HICKORY

Wood that's hot, hard, strong, and tasty

Indians native to the Mississippi River bottomlands looked to the great shagbark hickory tree for bows and baskets, but they particularly valued its nuts. These they pounded into fine pieces, then boiled. After straining, the remaining liquid contained concentrated nut oil. This was used much like milk in the mixture for corncakes. Pioneer children liked the nuts as well, and ate them as fast they could be cracked.

Their elders, though, favored the shagbark's wood to produce smoked ham and bacon. Burned green, its smoke imparts an unmistakable taste and distinct aroma to the meat.

Besides smoke, hickory wood—that of the shagbark and 15 other species that lumbermen lump together—produces more thermal units of heat than almost any other hardwood. A

cord of it equals the heat output of 200 gallons of No. 2 fuel oil, making it one of the hottest woods around. And in native woods, only dogwood and Osage-orange are harder.

Hickory's hardness is only one of many qualities that still makes the wood a favorite for tool handles. That it also resists shock and flexes without breaking gives it a starring role. Few people know, though, that hickory rivals steel in strength (pound for pound), yet is more elastic, less heat conductive, and far less brittle.

With all these traits, it's no wonder that in times gone by craftsmen turned great amounts of hickory wood into the hubs and rims of wagon wheels, trotting-horse sulkies, and loom parts. Today, it has a growing popularity for kitchen cabinets. ♣



Nothing quite matches the great taste and aroma that smoldering green hickory gives to ham and bacon.

Illustration: Jim Stevenson



## No Matter How You Cut It, These Tenryu Blades Are Winning Combos

Tenryu Gold Medal 10" x 40t and Rapid-Cut 10" x 50t blades give you splinter-free cuts in all woods—even chip-free cuts in melamine. Both feature extra hard carbide teeth that stay sharp longer, even when cutting abrasive materials.

*Gold Medal: "A top performer offering a very smooth cut edge and glass-smooth feeding"... "the quietest-cutting blade in our test"*

*Rapid-Cut: "The smoothest cutting of all the ATB/R blades tested"*  
—WOOD Magazine, February 2000

For exceptionally clean and accurate cross, rip and miter cuts in all woods, ask for Tenryu Gold Medal or Tenryu Rapid-Cut blades at your favorite dealer.

Making quality saw blades since 1910

**TENRYU**

4301 Woodland Park Dr., Ste. 104 West Melbourne, FL 32904  
1-800-951-SAWS • 407-951-2400 • Fax: 407-951-2250 • www.tenryu.com



**NEW!**  
FROM  
MLCS

INTRODUCING...  
**KATANA™**

## The Cutting Edge Of Routing Technology

**Safety, performance, and durability.** NEW Katana™ router bits are manufactured using the highest quality materials on precision multi-axis CNC grinders. They feature: premium micro-grain carbide cutters, high hook and shear angles for clean cutting, anti-kick-back rounded shoulders, an anti-stick coating, a diamond honed 600 grit mirror finish, SAE 4140 solid steel bodies, plus our Safety Gauge Shank™ for easy set up. Katana™ brand bits come with a **lifetime guarantee**, backed by the MLCS reputation for customer service and product support.



**FREE CATALOG!**  
**1-800-533-9298**

**FREE SHIPPING**



**KATANA™** An MLCS Company  
2341 Hillmont Ave., Huntingdon Valley, PA 19006

3 PC. ROUND OVER  
BEADING BIT SET  
**\$65** Order Set  
#12305  
**WOOD BOX INCLUDED**

## Are You Stumped?

If you've got a question that you think would interest other readers, we would like to hear from you. Write to: Ask WOOD®, 1716 Locust St., GA310, Des Moines, IA 50309-3023. For an immediate answer to your question, try posting it on one of our 10 internet discussion groups at: [www.woodmagazine.com](http://www.woodmagazine.com)

## A guide for converting fractions to decimals and metric

*The drill bits I own are metric, and most plans I run across seem to be in U.S. inches. My question is this: If I need to drill a 7/8" hole, for example, what metric bit should I use?*

—Ray Cooper, Sante Fe, N.M.

Anytime you're converting a fraction to metric, Ray, you must first make the fraction into its decimal equivalent. Do this by dividing the numerator by the denominator, in this case  $7 \div$

$8 = .875$ . Now, to change any decimal to millimeters (mm), multiply the decimal by 25.4, i.e.,  $.875 \times 25.4 = 22.225$  mm.

You say you hate math? For commonly used fractions you need only consult the conversion table shown at left.

Fraction (inches)	Decimal (inches)	Metric (millimeters)
1/16	.0625	1.5875
1/8	.125	3.175
3/16	.1875	4.7625
1/4	.250	6.35
5/16	.3125	7.9375
3/8	.375	9.525
7/16	.4375	11.1125
1/2	.5	12.7
9/16	.5625	14.2875
5/8	.625	15.875
11/16	.6875	17.4625
3/4	.75	19.05
13/16	.8125	20.6375
7/8	.875	22.225
15/16	.9375	23.8125
1	1.0000	25.4

## Some tips on how to avoid tacky finishes on tropical woods

*A year ago I built a small project from bacote wood. I then sprayed on a clear finish from an aerosol can. Unfortunately, the finish remains tacky after all this time. What did I do wrong?*

—Mike Ciesiewsky, Ponchatoula, La.

Mike, many tropical woods, such as bacote, contain a lot of natural oil. This oil doesn't mix well with most finishes,

and hinders the curing process. For your clear finish to bond properly, the top layer of the oil has to go.

To remove the oil, wipe a fast-evaporating solvent, such as lacquer thinner, onto the wood. As soon as the solvent evaporates, apply your finish. The finish should have enough time to bond with the wood and cure before the next layer of oils can move up and mix in.

## Is there a woodworking glue for all seasons and reasons?

*What is the best all-purpose woodworking glue? I deal with the dry southwestern climate, and need something that won't set up too fast. Also, is there a disadvantage in using waterproof exterior glues for interior projects?*

Bill Culver, Phoenix

It seems like a simple enough question, Bill, but adhesives are tools just like router bits and tablesaws, so "one size fits all" doesn't apply. They're formulated for particular applications, with a set of properties they need to provide under certain circumstances.

The two most common woodworking glues—white and yellow—are both PVA formulas (*polyvinyl acetate*). Both qualify as "general-purpose" adhesives for interior use, but yellow glue (a variation called *aliphatic resin*) develops tack slightly faster, forms a harder glue line less prone to creeping under clamp pressure, and offers slightly better resistance to water. Exterior formulas have a "cross-linking" feature—strands of molecules form interwoven bonds—that helps them withstand exposure to moisture without dissolving. White glue usually offers the advan-

tage of a longer open time while you're assembling a project, but Titebond Extend is a yellow glue specially formulated to provide the same feature.

One-part polyurethanes allow even more working time and provide excellent resistance to water, making them ideal for exterior projects. They cost more, though, and contain isocyanates, which can trigger respiratory reactions in some people. Two bonuses—these glues expand to fill small gaps, and the dried residue cleans up easily.

You can get more specialized if you need to. It all depends on what you're asking the adhesive to do. Hide glue will soften or dissolve under moist heat, allowing for disassembly for repairs or modifications. Two-part adhesives (epoxies and resorcinol glues) undergo complex chemical reactions that make them impervious to water and many solvents. Urea resin glue, also a two-part formula, often gets the nod for veneer work. As long as the required mixing or higher cost of some high-performance adhesives doesn't bother you, Bill, there's no inherent problem with using them for interior projects—though it might be overkill. ♣







Rene Stebenne shows off his award-winning drill-press depth stop that works even when built-in stops fail.

Rene Stebenne formerly earned his living as a machinist, so it's not surprising that he likes to make his workshop run more smoothly with specially designed jigs and fixtures. But who could have guessed that he invents them in his dreams? That's how he came up with the Top Shop Tip at *right*.

Rene, 83, started to apply his creativity to wood instead of metal in 1981. He specializes in crafting wall clocks, mantel clocks, and cabinets in his retirement workshop, working mostly in pine.

Your creative solution to a workshop problem can earn you cash, but only if you write and tell us about it. If we print your tip in an upcoming issue, we'll send you \$75. And the person who sends our favorite tip of each issue—the Top Shop Tip—will also receive a tool prize worth at least \$250. So mail your best tips, along with photos or sketches and your daytime telephone number, to:

Tips From Your Shop (and Ours)  
**WOOD® Magazine**  
 1716 Locust St., GA-310  
 Des Moines, IA 50309-3023

Or e-mail them from our website at [www.woodmagazine.com](http://www.woodmagazine.com).

Sorry, but we can't return your submissions. We try to publish original tips, so please send your ideas only to **WOOD** magazine. Thanks!

*Dave Campbell*  
 WOODWORKING PRODUCTS EDITOR



## Shop-built stop keeps you from getting in too deep

While making a cribbage board recently, it seemed to take forever to drill all of those holes to the same depth. My drill press doesn't have a built-in depth-stop, so it was: check the drill press handle, check the hole—I wasn't getting anywhere.

Then I came up with this stop rod, and it made the job a whole lot easier. I cut the collar from poplar, and the threaded rod came from a toilet tank float, but any threaded rod will do. Size the collar to fit your drill press.

To use the stop, slip it on the quill and tighten it in place with the wing nut and carriage bolt. Adjust the length of the stop rod to suit the depth of hole you want to bore, then lock it

in place with the other wing nuts. When the job is finished, you can quickly remove the whole unit.

—Rene Stebenne, Whitinsville, Mass.

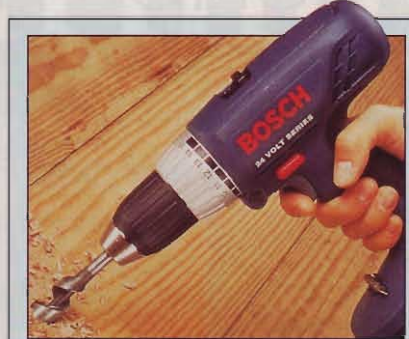

For excellence in tipping, Top Shop Tip winner Rene Stebenne will receive a Bosch 3960K 24-volt drill kit. Way to go, Rene!

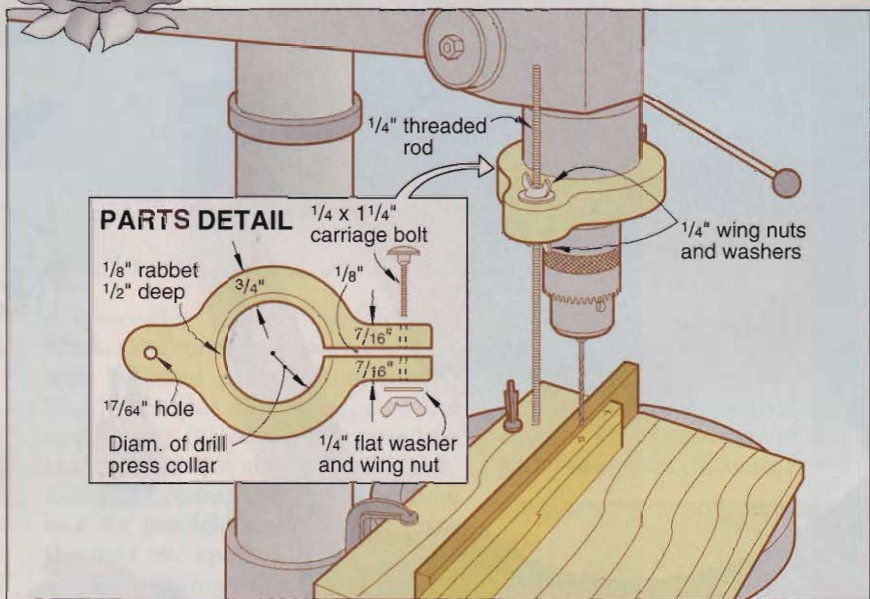

## Break out the tape and spare that pattern

Spray adhesive works great for attaching a paper pattern to a workpiece; but you're almost certainly going to tear the pattern when you try to peel it off. Try this instead: Trim your pattern close to the line, then use clear, wide, packing tape to stick it on the wood, as shown at *right*. It's inexpensive, it's not messy like the spray glue, and you can take the pattern off in one piece.

—Barry Kimble, Ropville, Ga.

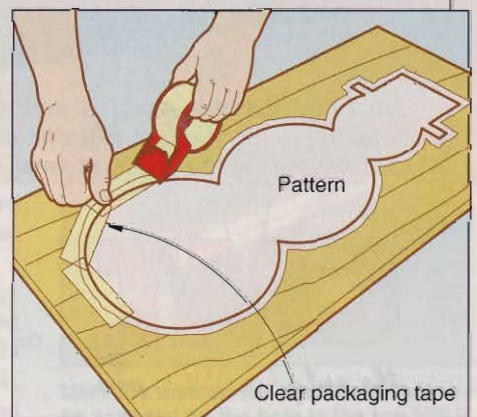

Continued on page 34

# NO MORE DUST

Introducing Microplane® Rotary Shaper Power Tool Attachments for low-speed shaping. The razor-sharp teeth create tiny shavings that fall to the surface instead of clouding your air.

Call 501-968-5455 or

**1-800-555-2767**

\* dealer inquiries encouraged

www.microplane.com email: info@microplane.com

**Microplane**  
A Product of Grace Manufacturing®

Circle No. 2145

## TIPS FROM YOUR SHOP (AND OURS)

Continued from page 32

### Storage system keeps scrollsaw blades orderly

Here's a simple jig and process I use to keep track of my scrollsaw blades. The system starts with the organizer shown *below* that I made from a scrap of 2x4. The 3"-deep holes allow the blades to fan enough for easy picking, and a tiny countersink at the top of each hole makes it easier to put blades in.

Now, you might wonder why I drilled a *pair* of holes for each type of blade. Well, I put used blades in one hole and new blades in the other. And because I can't always remember what type of blade is currently in my saw, I drop a thin dowel in the "used blade" hole for that type when I install it.

—Don Moffat, Corvallis, Ore.

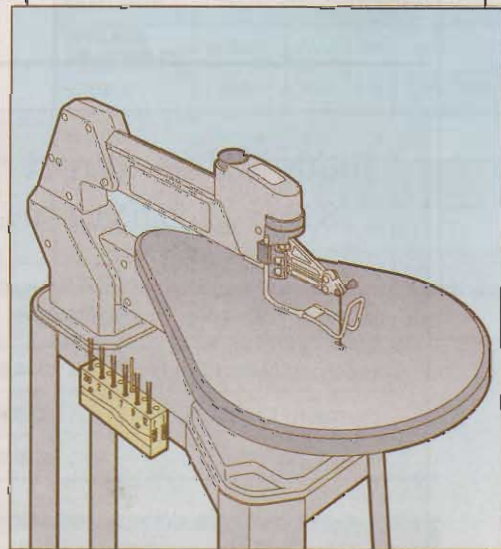
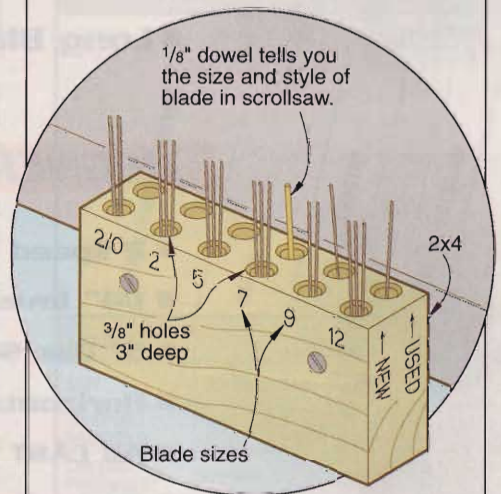

Continued on page 36

## Prototype



## Finished Product



**HEAVY DUTY ET100™**  
**Nail Master™**  
**ELECTRIC BRAD GUN**

Grab hold of the all-new ARROW ET100™ and experience the beauty of ergonomically designed comfort. Its non-slip cushioned grip and superb balance assures effortless work, even during long jobs.

In addition to performing routine nailing jobs, this powerful 10 amp brad nailer is specially angled to handle difficult corner, edging and framing jobs. No scratched or damaged surfaces.

The ET100™ provides nail driving muscle without the burden of an air compressor. It shoots 3 different size brads.

Solid state circuitry, a hardened carbon steel delivery system for jam-proof performance, and both trigger and surface contact safety locks combine to offer increased years of safe, accurate, trouble-free service.

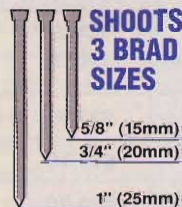

*The ET100™ is available wherever fine tools are sold.*

Arrow Fastener Co., Inc., 271 Mayhill Street, Saddle Brook, New Jersey 07663  
Canada: Jardel Distributors, Inc., 6505 Metropolitan Blvd. East, Montreal, Quebec H1P 1X9  
United Kingdom: Arrow Fastener (U.K.) Ltd., 14 Barclay Road, Croydon, Surrey CR0 1JN  
www.arrowfastener.com © 1999 Arrow Fastener Company, Inc.



TIPS FROM YOUR SHOP (AND OURS)

Continued from page 34

Your honor, I was framed, and I demand a recess

To hang a plaque or frame truly flat against the wall, recess the sawtooth hanger as shown *below left*. On

plaques or wide picture frames, you can use a Forstner bit; on narrower picture frames, rout the recess with a straight bit (*below right*).

—Erv Roberts, Des Moines, Iowa

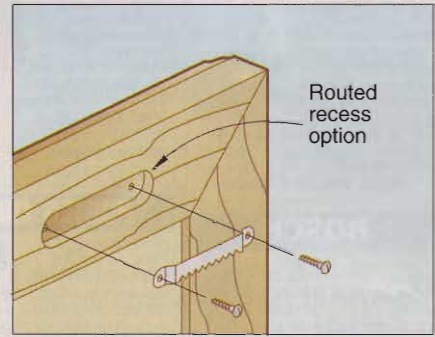
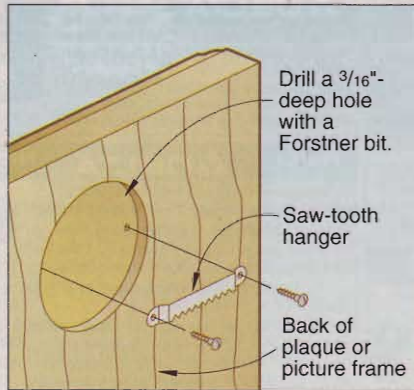

Router holder keeps you safe while the bit slows down

Call me impatient, but I don't like waiting for my router to come to a stop after I turn off the power. I know some guys just lay their router on its side during the wind-down, but that doesn't seem very safe—the spinning bit could catch part of a project or clothing, or me!

With this in mind, I built the simple router-holding jig shown *below* by gluing together two pieces of 3/4"-thick stock. The center hole goes through both pieces to give the bit plenty of room to spin, and the dowels keep the router from wandering off the holder.

—John Bachman, Crossville, Tenn.

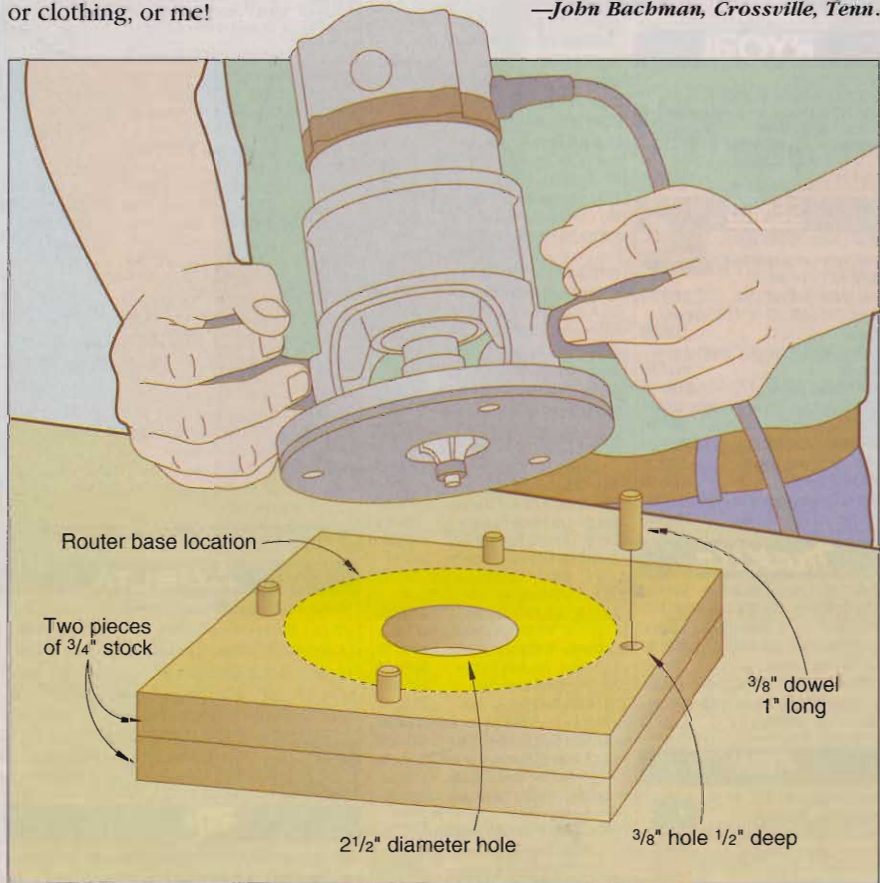

GROSS STABIL®  
PARALLEL CLAMPS  
VS. THE  
COMPETITION

	OURS	THEIRS
Clamping Depth	5-1/2"	5-1/8"
Clamping Width	1-3/4"	1-3/8"
Removeable Pads	Yes	No
15% Longer Spindle	Yes	No
Replaceable Pads	Yes	No
Metal Jaws	Yes	No
Nominal Throat Depth	4"	3.5"
Cast Iron Sliding Arm	Yes	No
Clamping Pressure	1100lbs.	1000lbs.
Tempered Steel Bar	Yes	Yes



(517) 278-6121 (800) 671-0838 Fax (517) 278-5523

Circle No. 2230

## Try the squint-free way to read drill bit sizes

It's tough to read the diameter sizes stamped on drill bit shanks, and it doesn't get any easier as the years roll by. Those numbers really stand out, though, if you dab some white correction fluid or paint on them and wipe off the excess.

—Allen Weiss, Fresh Meadows, N.Y.



## A FEW MORE TIPS FROM OUR WOODWORKING PROS

- You can get a glass-smooth finish without spray equipment. Starting on *page 39*, we'll teach you how to wet-sand your way to success.
- Looking for attractive, adjustable shelf brackets that are easy to make? You can adapt the brackets on our plant stand, *page 46*, to meet the need.
- Now is a great time to get the workshop shipshape for summer. Spring clean-up chores are detailed on *page 55*.
- Give your marquetry and inlay an amazing three-dimensional effect. Learn the simple art of sand-shading on *page 61*.
- Highlight your projects with an inlaid line of any color using the technique shown on *page 67*.

## STEVE WALL LUMBER CO.

Quality Hardwoods and Woodworking machinery For The Craftsman and Educational Institutions

Ash	4/4	Select	2.25		\$ 77.00
Basswood	4/4	Select	1.95		\$ 63.00
Birch	4/4	Select	2.50		\$ 81.00
Butternut	4/4	1C	2.20		\$ 69.00
Cherry	4/4	Select	4.20		\$ 98.00
Hickory - Pecan	4/4	Select	2.30		\$ 72.00
Mahogany (Genuine)	4/4	Select	3.70		\$ 98.00
Maple (Hard)	4/4	Select	2.80		\$ 72.00
Maple (Soft)	4/4	Select	2.20		\$ 72.00
Poplar	4/4	Select	1.55		\$ 64.00
Red Oak	4/4	Select	2.40		\$ 80.00
Walnut	4/4	Select	3.45		\$ 95.00
White Oak	4/4	Select	2.40		\$ 80.00
Cedar (Aromatic Red)	4/4	1C+Btr.	1.65		\$ 66.00
Cypress	4/4	Select	2.25		\$ 74.00
White Pine	4/4	FG.	1.15		\$ 55.00
Yellow Pine	4/4	Clear	1.80		\$ 65.00

### UPS Specials

SEE OUR CATALOG ON THE WEB!

Above prices are for 100' quantities of kilndried rough lumber sold by the Bd. Ft. FOB Mayodan, NC. Call for quantity discounts. Other sizes and grades available.

Above prices are 20 bd. ft. bundles of clear kilndried lumber 3"-10" wide • 3'-7' long (Random widths & lengths) Surfaced 2 sides or rough. Delivered UPS prepaid in the Continental U.S.

Circle No. 592

## \*NOW AVAILABLE\*

### Custom Made Raised Panel Doors

4/4 Log Run Walnut  
100 bd. ft. \$155

Also Available Exotic Lumber

## STEVE H. WALL LUMBER CO.

BOX 287  
MAYODAN, N.C. 27027  
336-427-0637  
1-800-633-4062  
FAX 336-427-7588

Email: wood@walllumber.com  
Website: www.walllumber.com

Send \$1.00 For Lumber Catalog  
Prices Subject to Change Without Notice

# Refinish Your Future.

Own your own business.

Let your passion for furniture lead you into a new business with a Furniture Medic franchise. We're a complete on-site repair and restoration-refinishing business servicing homes and companies as well as handling moving and insurance claims. We offer extensive training and support with a low initial investment and manageable overhead. Financing is available to qualified candidates and franchises are offered nationwide. Call today to brush up on the details.

**FURNITURE MEDIC**  
"the prescription for damaged furniture"

www.furnituremedic.com **1-800-WE SERVE**

# Wet Sanding

## Seven steps to a heavenly finish

**F**or most of us, finishing means applying varnish, polyurethane, or paint with a brush. The dream of a glass-smooth tabletop is always spoiled by brush marks and bits of dust and other debris. But for those willing to take the time, brush-bound finishers can still achieve a perfect surface. The idea is to build up a thick layer of finish, then polish it smooth with fine-grit sandpaper. Here's how.

**1** Sand the surface to 320-grit. Thoroughly remove sanding dust from the pores of the wood using compressed air or a shop vacuum and tack cloth.



Paste wood filler, top center, makes a smooth foundation for the finish. Wet-sand with a simple solution of liquid detergent and water, left, using a rubber sanding block, bottom center. Polish with an automotive wax, bottom right.

**2** When using open-grained woods, such as oak, ash, mahogany or walnut, fill the pores by applying a paste wood filler like J.E.Moser's Grain-Fil. See the Buying Guide at the end of the article. Use a plastic scraper, working across the grain, to pack the filler into the pores as shown in *Photo A*. Remove excess with a squeegee, once again working across the grain, as shown in *Photo B*, to avoid pulling the filler out of the pores. Let the filler dry overnight, then sand lightly with 220-grit sandpaper. Apply a second coat of filler, removing the excess with the squeegee as before. When the filler is dry, sand again with 220-grit sandpaper.

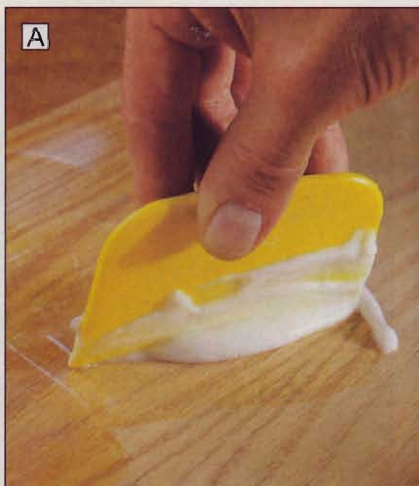

Continued on page 40

## DEVELOP YOUR SHOP SKILLS

Continued from page 39

**3** Apply a finish of your choice and let it dry overnight. We tested this technique on oil-based spar varnish, oil-based polyurethane, water-based polyurethane, and oil-based enamel paint. Any sheen—gloss, satin, or semigloss—will work. You can bring gloss finishes to the brightest sheen. The flattening agents in satin and semigloss finishes prevent them from being worked to attain a high gloss.



**Left to right:** You can work enamel paint to a bright automotive-style finish. Shown on white ash veneer, water-based poly goes on perfectly clear; oil-based poly and spar varnish add progressively more amber cast to the wood grain.

**4** Now it's time to "knock down" brush marks, drips, or dust flecks in the finish. Put about ½" of water in a shallow plastic tray and add a couple of drops of liquid detergent. The detergent, by reducing the surface tension of the water, allows it to more effectively wet the sandpaper and the tabletop and be a better lubricant. Dip 500-grit wet/dry paper (see box on wet-sanding) backed with a rubber sanding block (available at hardware stores and home centers) into the detergent solution and work the surface in a circular motion, as shown in *Photo C*. Be careful not to oversand the edges. Keep the sandpaper wet with clean detergent solution. Periodically wipe the surface dry to inspect it. When the surface has a uniform dull sheen, wipe it clean with a damp sponge and let it dry.



**5** Apply a second coat of finish and let it dry overnight. Wet-sand again as in *Step 4* and wipe dry. Now apply a third coat of finish, but this time, let it dry two days to make sure the entire film of finish is dry.

**6** Just as in *Step 4*, wet-sand the surface, this time starting with 1000-grit wet/dry sandpaper, progressing to 1500-grit and finally 2000-grit. Buff with a clean, soft cloth.

**7** Get out the car wax and apply and polish it, as shown in *Photo D*, according to the directions. (We used Turtle Wax, but any automotive cleaner/wax will do.)



### Why sand wet? Borrowing from the bodyshop.

Resin-impregnated sandpaper, in grits ranging from 320 to 2000, is available from auto-body paint and supply stores. The abrasive particles on these sandpapers are of a more uniform size than those of common woodworking sandpapers and are more securely bonded to the backing paper.

This wet/dry sandpaper can be used either dry, like common woodworking sandpaper, or wet, using a rubber sanding block and a solution of liquid detergent and water. Wet-sanding lubricates the surface being abraded, reducing scratches. The water also carries away loose pieces of abrasive as well as finish particles and prevents the sandpaper from loading up.

### Buying Guide:

**J.E. Moser's Grain-Fil**, available in quarts from

Woodworker's Supply  
1108 North Glenn Road  
Casper, Wyoming 82601-1698  
Phone: 800/645-9292.

Item no. 922-828, \$17.95 plus \$6.50 shipping. Residents of WY, NM, NC please add sales tax.

Written by Jan Hale Svec with Bob McFarlin  
Photographs: Baldwin Photography

# Flip-Up Pen Box

It stores a pair of pens, then hands them to you



Raising the lid lifts the pen and pencil right out of this handsome desktop box. It's perfect for turned wooden pens and pencils—you could even make the box from the same kind of wood as the writing instruments.

**Note:** The pen box shown accommodates two pens (or a pen and pencil) about  $\frac{1}{2}$ " in diameter and a little less than 6" long. You can adjust the dimensions for fatter or longer pens.

## Make three main parts to start:

**1** Trim a  $2 \times 1\frac{1}{8} \times 10$ " blank to  $6\frac{1}{4}$ " long. Keep the cut-off piece. We made our box of moradillo, but you could use any exotic or figured domestic hardwood. Draw index marks on one end of the blank, as in the Cutting the Box Top and Bottom drawing on page 44.  
**2** Saw a  $\frac{1}{4}$ "-thick slice off the top of the blank and a  $\frac{1}{8}$ "-thick piece off the bottom. Make the cuts with a bandsaw or on a tablesaw equipped with a thin-kerf blade in order to preserve grain continuity on the box as much as possible.

Plane or sand the saw marks off the mating surfaces, and set the top and bottom aside until later.

**3** Saw two deep dadoes across the body. See the Lid, Body, and Bottom drawing on page 45. To do this, install a  $\frac{3}{8}$ " dado blade on your table-saw, and set the cutting depth to  $1\frac{3}{8}$ ". Attach an extended fence to the miter gauge. Clamp stopblocks to the fence  $5\frac{1}{8}$ " from each side of the dado blade, and saw the dadoes, as shown in Photo A on the next page.

**4** Saw dadoes in the edge of the lid for the hinges, shown in the Lid, Body, and Bottom and Exploded View drawings on page 45. To saw them, change to a  $\frac{5}{16}$ " dado blade, and set the cutting depth at  $\frac{1}{4}$ ".

Install a new auxiliary fence on the miter gauge or move the used one

over so you'll have solid wood behind the lid when you cut the dadoes. This will help minimize tearout.

To locate the dadoes accurately, place the body against the fence, and center the dado in the body over the narrower dado blade. Clamp a stop-block to the fence at the opposite end of the body, as shown in Photo B. Repeat for the other dado. Verify which edge to cut by checking the index marks, then saw the dadoes in the lid.

## Rout the body and make the lid

**1** Rout a  $\frac{3}{16}$ " round-over along the top back edge of the body (the dadoed side). Do the job on a table-mounted router. To bridge the dadoes, set a fence flush with the router bit's pilot.

*Continued*

# Pen Box

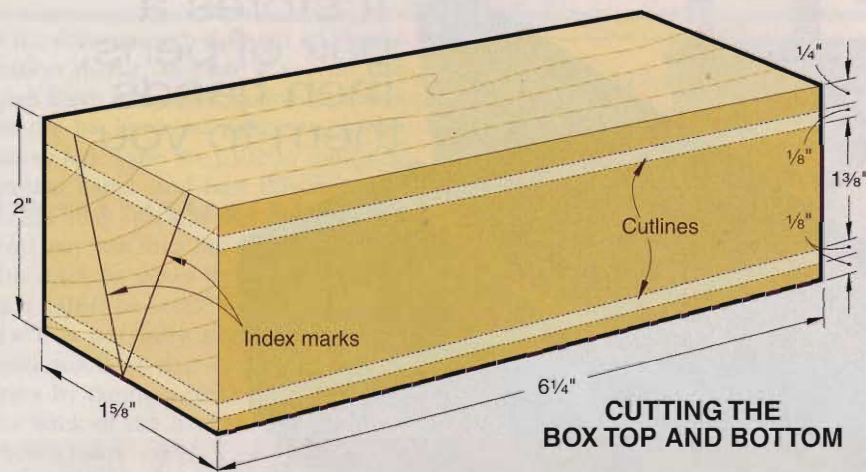

**CUTTING THE BOX TOP AND BOTTOM**

**2** Using a  $\frac{1}{2}$ " round-nose bit in the table-mounted router, rout the pen grooves in the body where shown. To rout them, position a fence on the router table  $\frac{1}{4}$ " from the bit. Clamp stopblocks to the fence  $5\frac{3}{8}$ " from each side of the bit. Clamp a straight-edged board to the table parallel to the fence, and  $1\frac{3}{8}$ " from it. This will help keep the body against the fence throughout the routing.

Rout the grooves in small depth increments—start at about  $\frac{1}{8}$ " deep and increase the depth by about that much each pass. Make a pass at each depth with each face against the fence to form the two grooves.

**3** Now, make the lid hinges. Start with two  $\frac{1}{4} \times \frac{5}{16} \times 1\frac{1}{16}$ " pieces of stock that match the rest of the parts. You can cut the hinge blanks from the cut-off end of the blank.

**4** Tape the pieces together edge to edge. Then, referring to the Hinge Full-Size Pattern in the *WOOD PATTERNS*® insert, sand pen recesses where shown. (We did this with sandpaper wrapped around  $\frac{1}{2}$ " dowel rod.)

**5** Glue the hinges into the lid dados. (We used epoxy.) Position the hinges perpendicular to the lid in both directions. (See the Exploded View and Side Section View drawings.)

**6** After the epoxy cures, sand off the squeeze-out on the top and back of the lid. You can pare away squeeze-out on the inside of the lid and sides of the hinges with a sharp chisel.

**7** Drill a  $\frac{3}{64}$ " hole  $\frac{3}{8}$ " deep at the middle of each hinge, centered on the edge of the lid. Enlarge the holes through the hinge arms to  $\frac{7}{64}$ ", and countersink them shallowly—shallow enough that the screw slot will be above the surface.

**8** Drive a screw into each hole, and file the heads flush with the arms, as shown in *Photo C*. Tape the tip of the file to keep it from gouging the wood.

## Write the last chapter

**1** Mark the location of the hinge pin on each end of the body. Refer to the Side Section View and Exploded View drawings for placement.

**2** Place the lid on the body, and slide a shim about  $\frac{1}{32}$ " thick between them. (We used cardboard from the back of

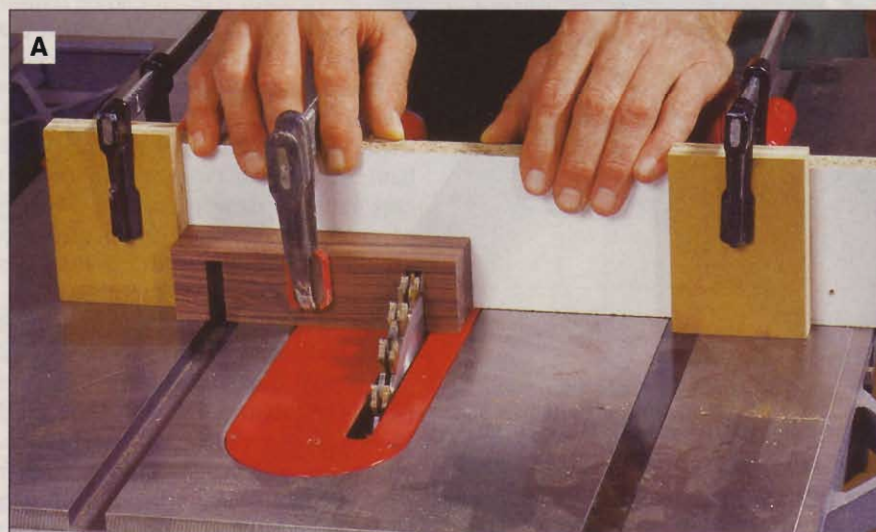

**A** Install an extended miter-gauge fence to saw the deep dados in the body.

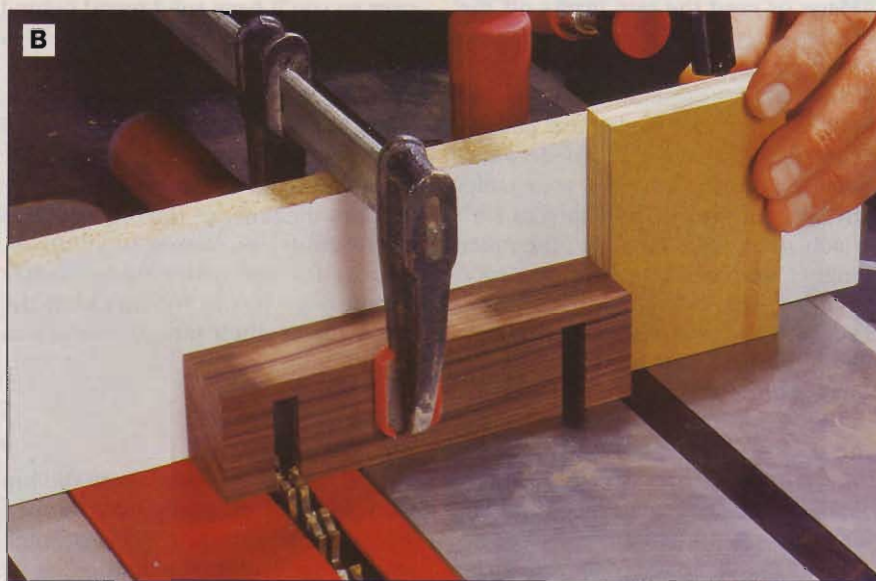

**B** The body dados help when setting stopblocks for sawing hinge dados in the lid.



a notepad.) Clamp the parts together, keeping the edges and ends flush.

**3** Drill the hinge hole on each end. Clamp the body/lid assembly to a fence on the drill-press table for accurate drilling, as shown in *Photo D*. Unclamp the assembly.

**4** Glue the bottom to the body. Double-check your alignment marks before gluing for the best grain match.

**5** Finish-sand the top and inside of the body, the underside of the lid, and the hinge arms. Clamp the lid to the



**C** Tape on the end of the file protects the lid when filing the screws flush.

body again, with the shim in place, and drive in the hinge pins. File the pin ends flush with the body. Unclamp, and remove the shim.

**6** Sand the sides and ends flush, and finish-sand all exterior surfaces. (We sanded with progressively finer grits, ending with 320.) Break the sharp edges slightly by block-sanding.

**7** Apply a clear oil finish overall. (We finished the box shown with Deftoil Danish oil finish, clear natural.)

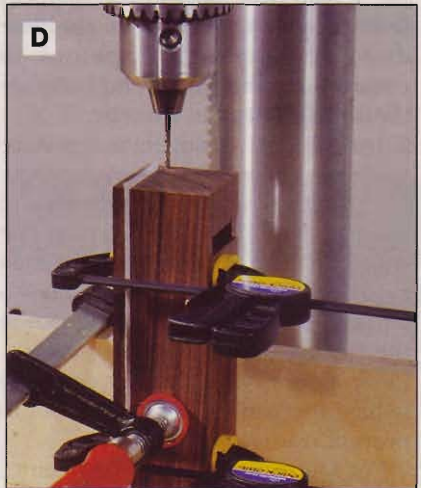

**D** Insert a cardboard spacer between the body and lid when drilling hinge holes.

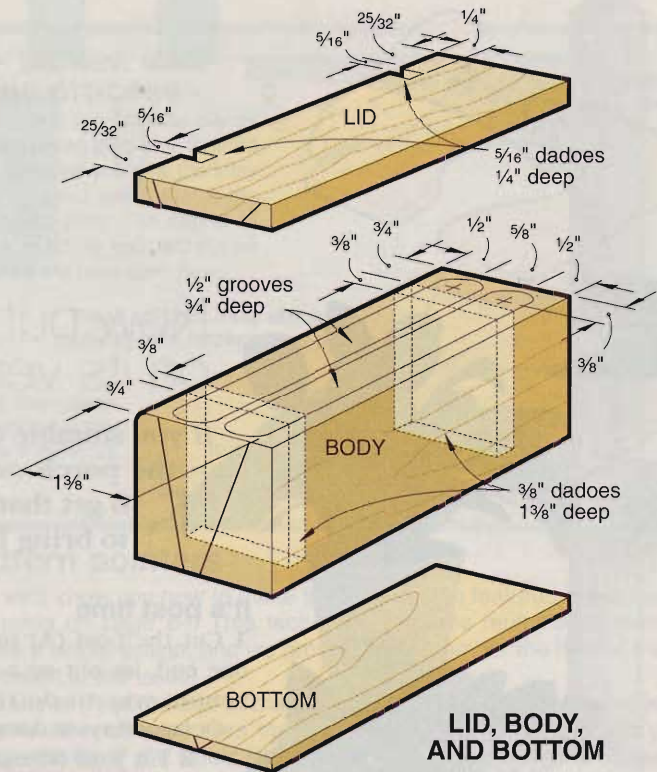

SEE THE  
WOOD PATTERNS®  
INSERT FOR  
FULL-SIZE PATTERN

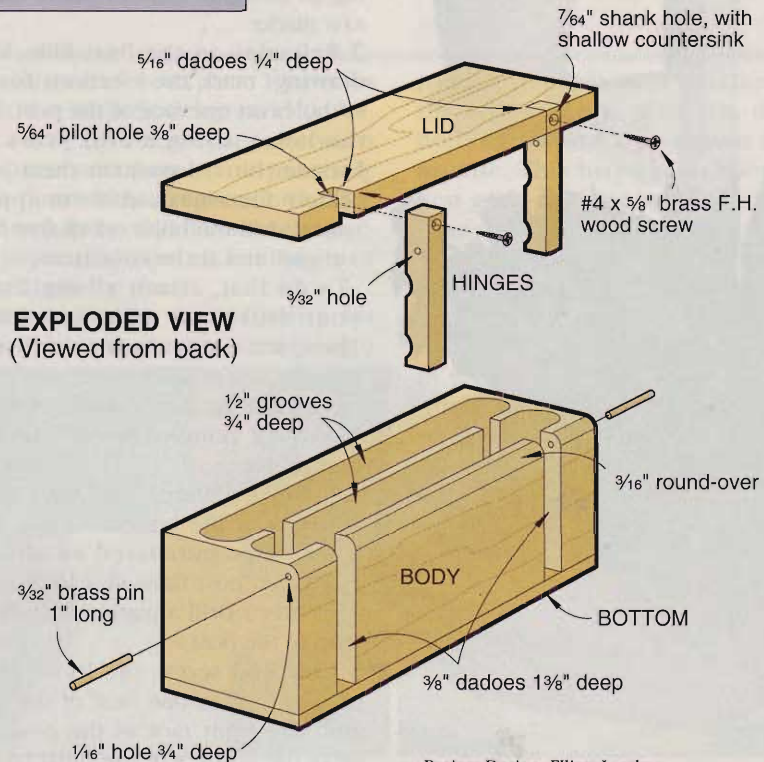

EXPLODED VIEW  
(Viewed from back)

Project Design: Elliott Landers  
Illustrations: Roxanne LeMoine; Lorna Johnson  
Photographs: Hetherington Photography

# Tree Of Life

Now put every blooming thing on its very own pedestal

If you stumble over potted plants every time you step onto the porch or patio, you should build this sturdy stand to get that flora off the floor. And, it's pretty enough to bring inside along with the plants for the winter.

## It's post time

**1** Cut the post (A) to length. On one end, lay out an octagon. For a simple way to do this, see the Octagon Layout drawing.

**2** Tilt your tablesaw's blade to 45°. Set the rip fence, and saw the four corners off the post, as shown in *Photo A*, forming an octagon. Sand or plane off the saw marks.

**3** Referring to the Post Side View drawing, mark the locations for the ¼" holes on one face of the post. Drill the holes, using a drill press and Forstner bit. To position them accurately for a neat, uniform appearance, drill the holes on all five faces on each tier at the same time.

To do that, attach a long 2×4 to your drill-press table as a fence. Then, set a stopblock to drill each tier of holes, as shown in *Photo B*.

After drilling the ¼" holes, go back and drill a centered screw pilot hole in each one.

**4** Drill a centered hole for a dowel screw in the bottom of the finial (B). (We purchased an already-shaped post finial at a local home center.) Drill a mating hole in the top of the post.

**5** Glue and screw the finial to the post top. Align one face of the finial with the front face of the post. Cut away the corners of the finial base to match the post, as shown in *Photo C*. Don't cut the top of the finial.

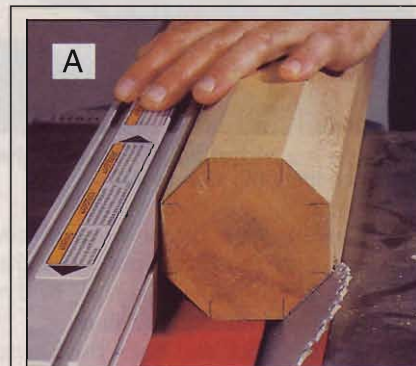

Saw the corners off a standard 4×4 cedar post to make the octagonal post (A) for the stand.

## Frame the base next

**1** Cut parts C, D, and E about ½" longer than the sizes shown in the Bill of Materials. Miter-cut the parts to finished length, referring to the Base drawing. Employ a stopblock to ensure that both Cs and both Ds are the same length. Cut F to size.

**2** Install a ¼" dado blade on your tablesaw. Then, using one of the miter-cut ends as a gauge, tilt the blade to saw the spline slots in the ends of parts C, D, and E. Attach a tall auxiliary fence to your tablesaw's fence, and saw the slots as shown in the Sawing the Spline Slots drawing. Push a scrapwood follower along behind the part as you cut the slot to prevent tearout.

**3** Cut four splines for the base joints. (We cut them from a scrap of 2×4, as shown in the Splines drawing.)

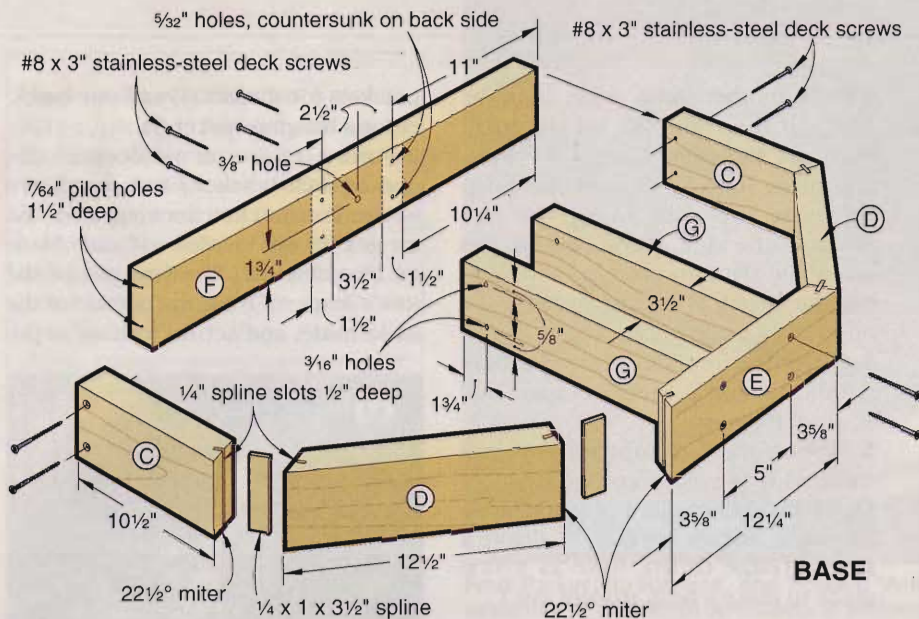

SEE THE  
WOOD PATTERNS®  
INSERT FOR  
FULL-SIZE PATTERN

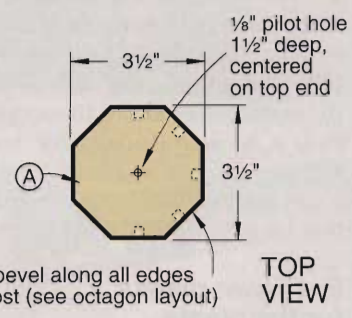

45° bevel along all edges of post (see octagon layout) **TOP VIEW**

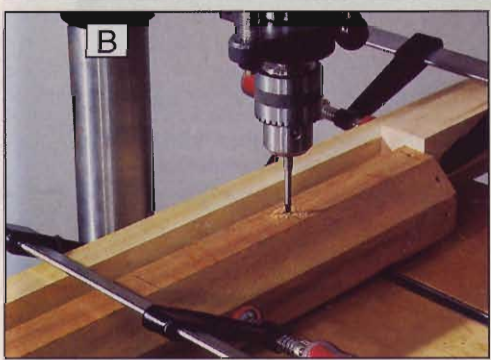

**B** Set a stopblock to drill holes at the same height in five faces of the post. Drill them straight with a drill press.

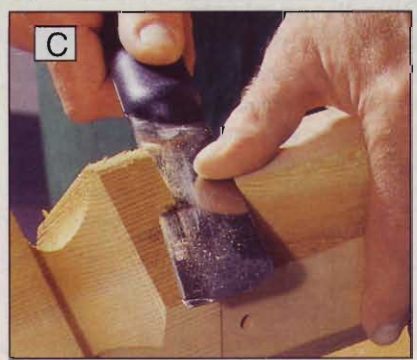

**C** Cut the square base of the ready-made finial to match the octagonal post. The top of the finial remains square.

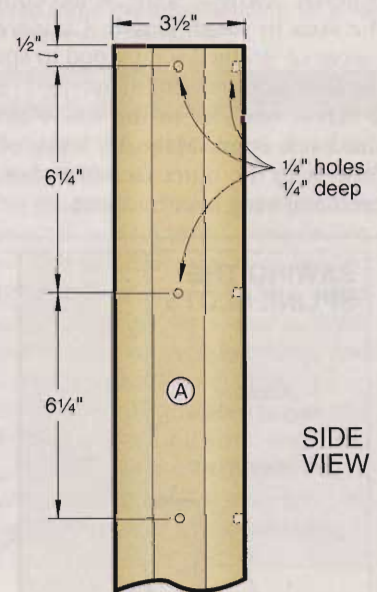

**SIDE VIEW**

**4** Without gluing, assemble and clamp parts C, D, E, and F. Check that the sides (C) are parallel; adjust the length of F if they aren't. Measure diagonally to check for square.

**5** Glue parts C, D, and E together with their splines. (We used polyurethane glue for moisture resistance.) Position part F between the tails of the sides (C), but do not glue or screw it in place yet. Measure for square, and clamp with a band clamp.

(To keep from gluing the band clamp to the base, we put masking tape at the base corners to contain glue squeeze-out.) Weight the clamped assembly down on a flat surface while the glue cures.

**6** After the glue cures, unclamp the assembly. Drill shank holes for the base back (F), and screw it into place.

**7** Cut the base rails (G) to size. Clamp the post between the rails, making sure the post stands at 90° to the top edge of the rails and the back face of the post lies flush with the back ends of the rails. The five faces with holes should be toward the front and sides.

**8** With the A/B/G assembly clamped together, drill shank holes through

*Continued*

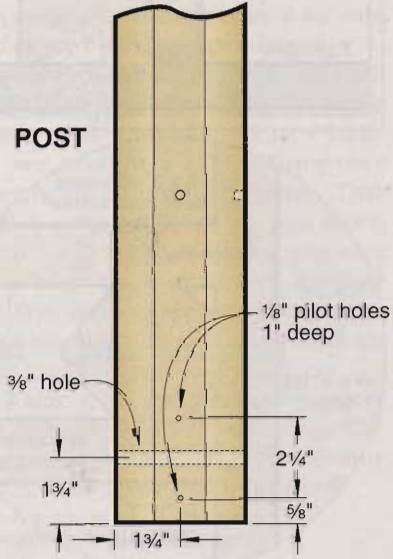
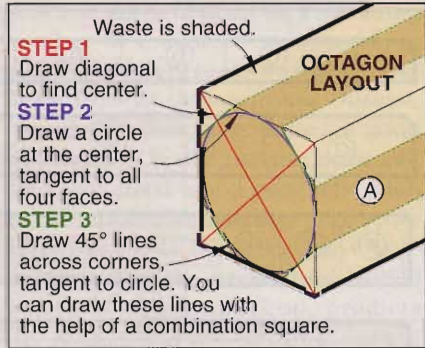

the rails and pilot holes into the post for lag screws, where shown in the Base and Exploded View drawings. Install the lag screws.

**9** Position the A/B/G assembly in the frame base (C/D/E/F). Drill and countersink shank holes in E and F, then drill pilot holes in the ends of the rails (G). Attach the rails to the frame base. Drill a  $\frac{3}{8}$ " hole through the back (F) and the post where shown, and install a carriage bolt. (We found a spade bit was long enough to do the job.)

**Put down planks for the plants**

**1** Rip the slats (H) from the edge of 2x material. Allow 2" extra when cutting the slats to rough length. Cut several pieces of  $\frac{1}{8}$ "-thick scrapwood to space the slats as you install them.

**2** Screw one slat to the frame along the back edge. Make its back edge flush with the outer face of F, but let each end hang over by about 1".

**3** Place another slat  $\frac{1}{8}$ " away from the first, on the right side of the post. Push the slat's end against the post, and mark it to fit around the post. Bandsaw the end. Space the end  $\frac{1}{8}$ " from the side of the post as you screw the slat into place, as shown in the Slat detail. Make and install a slat on the other side of the post.

**4** Cover the remainder of the base with slats. Space them  $\frac{1}{8}$ " apart and  $\frac{1}{8}$ " from the post.

**5** Saw off the overhanging slat ends flush with the sides and corners (C, D). (We did this with a portable circular saw, as shown in *Photo D*. Clamp a straightedge to the base as a saw guide to make a neat, straight cut.)

brackets for shelves (I) and one bracket for a hanging basket (J).

**2** Form a 1" groove  $\frac{1}{8}$ " deep in one end of each bracket blank, as shown in the Pot Bracket drawing. (To saw the grooves, we installed a  $\frac{3}{4}$ " dado blade on our tablesaw. We then placed the saw's fence  $\frac{1}{4}$ " from the outside of the dado blade, and set the cutting depth

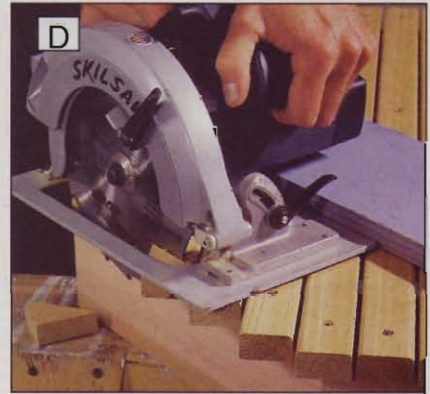

Install the base slats, then trim them to length with a portable circular saw.

**Give those plants some support**

**1** Cut 2x6 stock to length for the shelf and hanging-plant brackets (I, J). You can make as many of each as you want. For our stand, we made five

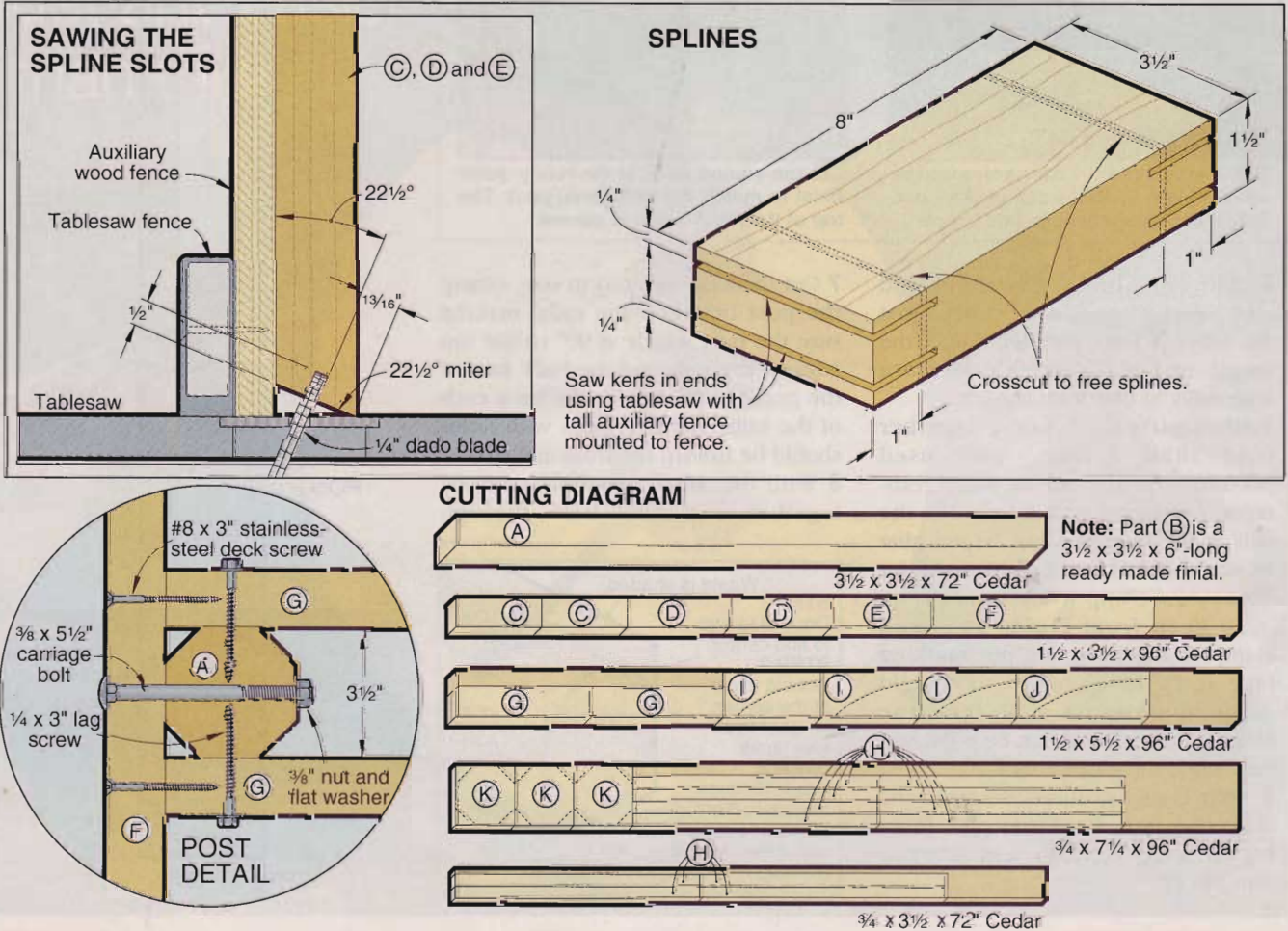

to 1/8". We sawed each groove in two passes, one with each face of the blank against the fence. To alleviate chipout, we pushed a scrapwood follower along behind each cut.)

**3** Photocopy the Full-Size Bracket Pattern in the *WOOD PATTERNS*® insert. Trace the appropriate outline onto each blank.

**4** Bandsaw the brackets. Saw slightly outside the line, and sand to it. Chamfer all edges by block-sanding.

*Continued*

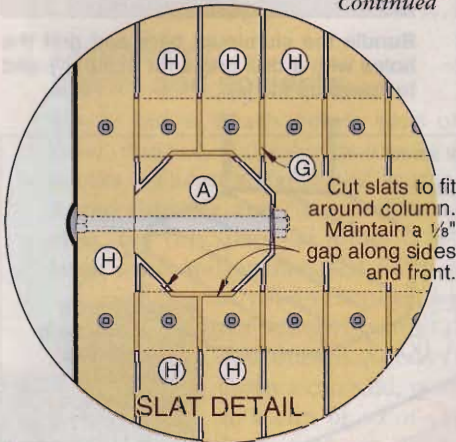

**Bill of Materials**

Part	Finished Size			Mati.	Qty.
	T	W	L		
A post	3 1/2"	3 1/2"	72"	C	1
B <sup>†</sup> finial	3 1/2"	3 1/2"	6"	C	1
C <sup>†</sup> frame side	1 1/2"	3 1/2"	10 1/2"	C	2
D <sup>†</sup> frame corner	1 1/2"	3 1/2"	12 1/2"	C	2
E <sup>†</sup> frame front	1 1/2"	3 1/2"	12 1/4"	C	1
F frame back	1 1/2"	3 1/2"	27"	C	1
G rail	1 1/2"	3 1/2"	16 3/8"	C	2
H <sup>f</sup> slat	3/4"	1 1/2"	30"	C	12
I pot bracket	1 1/2"	5 1/2"	12"	C	**
J plant hanger	1 1/2"	5 1/2"	16"	C	**
K shelf	3/4"	7 1/4"	7 1/4"	C	**

\* Make from commercial wooden 4x4 post cap, according to the how-to instructions.

† Make oversize initially, then trim to finished length according to the how-to instructions.

<sup>f</sup> Initial size shown; cut to length after installation, according to the how-to instructions.

\*\* Quantity optional; make as many as desired.

**Materials Key:** C—cedar

**Supplies:** #8x1", #8x1 1/2", and #8x3" stainless-steel deck screws, 1/4x3" lag screws with flat washers, 3/8x5 1/2" carriage bolt with nut and washer, 1/8x1" aluminum bar, brass screw eye.

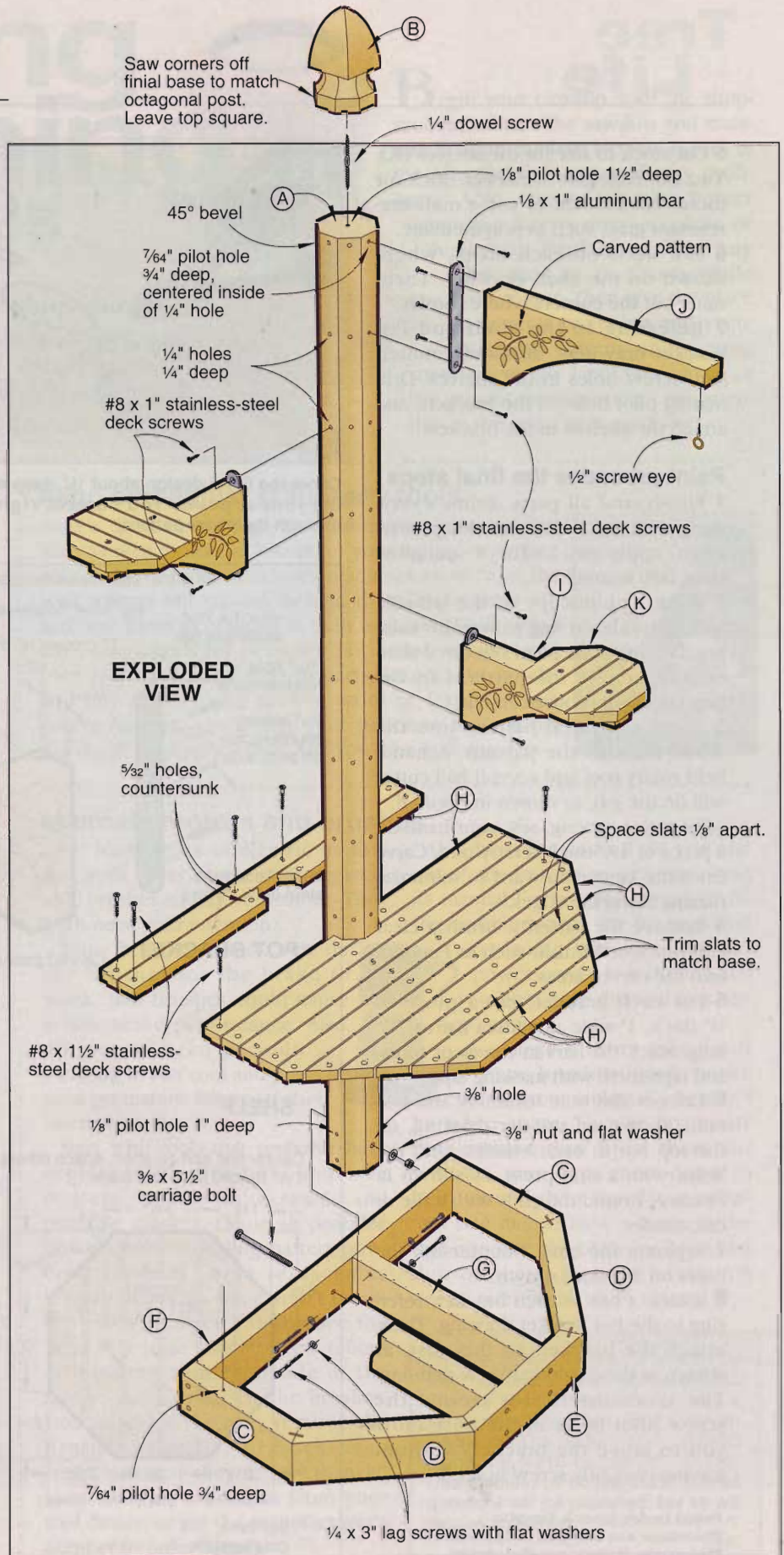

**5** Cut stock to size for the shelves (K). You can edge-glue narrower stock for these, but be sure to use a moisture-resistant glue, such as polyurethane.

**6** Saw kerfs on each blank, where shown on the Shelf drawing. Then, miter-cut the corners where shown.

**7** Referring to the Shelf and Pot Bracket drawings, drill and countersink screw holes in the shelves. Drill mating pilot holes in the brackets, and attach the shelves to the brackets.

### Paint precedes the final steps

**1** Finish-sand all parts. Prime everything with an oil-base exterior primer. Then, apply two coats of semigloss latex trim enamel.

**2** Make a photocopy of the left-side and right-side carving pattern for each bracket. After the paint has dried thoroughly, adhere the patterns to the brackets with rubber cement.

**3** Carve the floral pattern into the wood through the pattern. A hand-held rotary tool and a small ball cutter will do the job, as shown in *Photo E*.

For easier carving, rest your hand on a piece of 1½"-thick scrapwood. Carve from the center outward to minimize fuzzing along the edges.

**4** Remove the patterns. Brush a clear exterior wood finish, such as Penofin, into the carved areas.

**5** For each bracket, cut a piece of ⅛"-thick, 1"-wide aluminum bar to 7¼" long. Stack the bars in threes or fours, and tape them with masking tape.

**6** Lay out the hole locations and end radii, shown on the Bar drawing, on the top bar in each bundle. Drill the holes with a drill press, as shown in *Photo F*. Round the ends with a file or disc sander.

**7** Separate the bars. Countersink the holes on the sides shown.

**8** Attach a bar to each bracket, referring to the Pot Bracket drawing. Then, attach the brackets to the post, as shown in the Exploded View drawing. The ¼" counterbores around the screw pilot holes in the post allow you to move the brackets without leaving unsightly screw holes. 🌲

Project Design: James R. Downing  
Illustrations: Kim Downing; Lorna Johnson  
Photographs: Hetherington Photography



**E** Carve the floral design about ⅛" deep at the lowest point. You can cut right through the paper pattern.

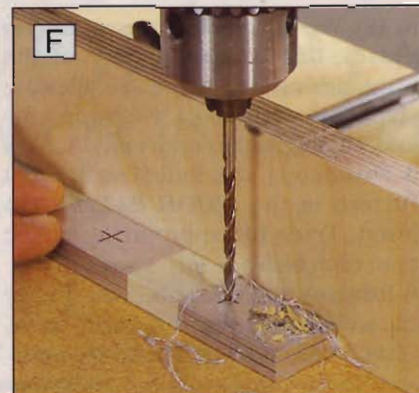

**F** Bundle the aluminum bars and drill the holes with a drill press for accuracy and to speed up the job.

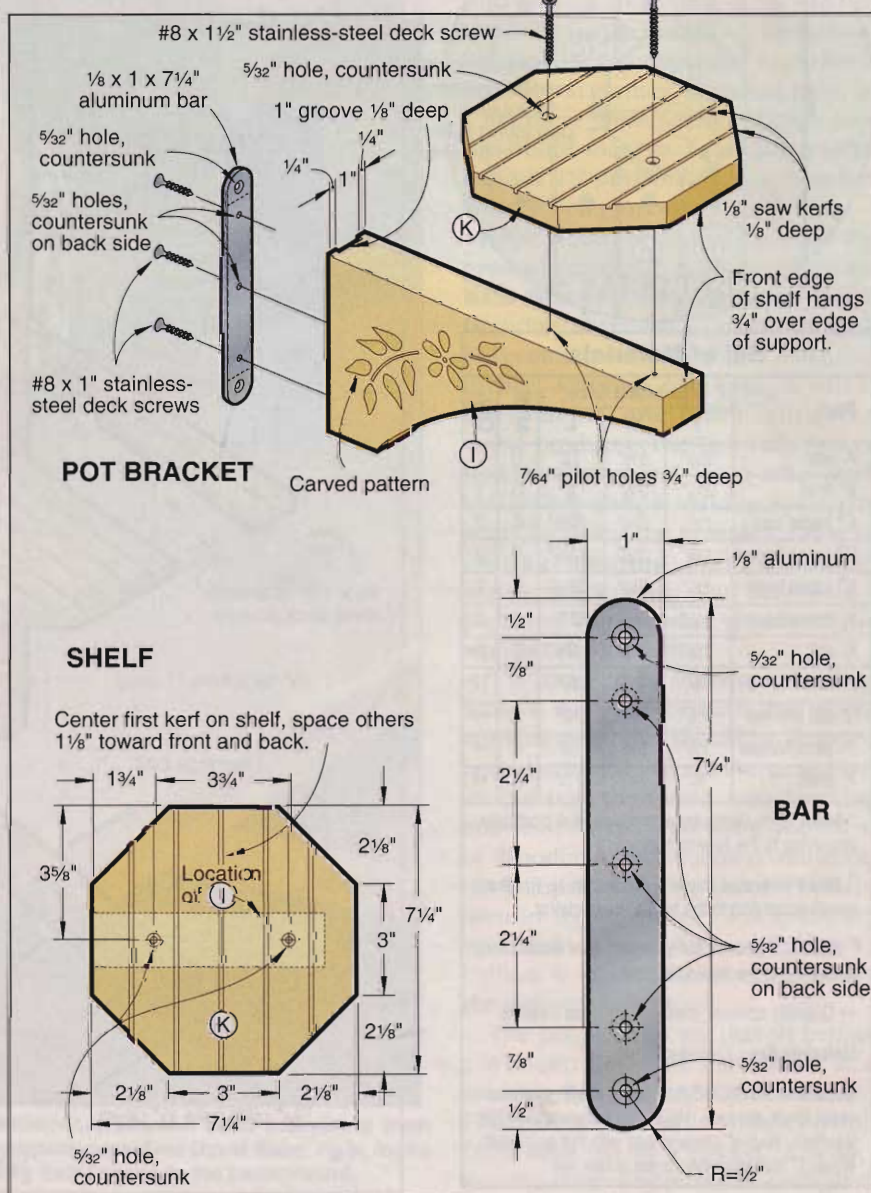

# WOOD Index

for issues  
113-121

The next time you're looking for a project or feature story in issues 113-121, use this handy reference to help you find it fast. We kept it simple. For instance, when searching alphabetically for an Alarm clock project story, you'll find "Alarm clock, 119:80-81." To locate the story, go to issue 119, page 80.



## A-C

Adirondack lawn chair, **115:72-77; 118:8**  
 Air-cleaning system, whole-shop, **120:70-73**  
 Alarm clock, **119:80-81**  
 Antique furniture. *See also* Repair, furniture. buying, **114:18** publications, **117:14**  
 Apothecary cabinet, **120:50-55**  
 Appliqué, **119:55**  
 Arbor, **116:52-57**  
 Arched doors, **113:104**  
 Arts and Crafts style. *See also* Mission style: bookcase, **116:62-69; 120:4** coffee table and ottoman, **113:52-59, 92** picture frame, **120:68-69**  
 Ash, black, **114:110**  
 Aspen, quaking, **115:110**  
 Banding, edge, **117:82-83** clamping, **113:14** trimming, **119:31**  
 Bandsaws: blade guides, **115:26** blade-welding jig, **115:30** boxes, **121:68-73, 74-75** fence, **113:16** multi-jig, **113:36, 38, 60-63; 120:4** resawing guide for, **121:100**  
 Bases, mobile, **117:112** mitersaw stands, **118:66-71**  
 Basswood, **116:115**  
 Batteries, NiMH, **119:88**  
 Bed, oak, **114:64-69**  
 Beetles, Asian longhorned, **116:119**  
 Belt sander, **116:114**  
 Bird feeders, **118:78-79**  
 Birds: carved, **117:55; 119:8** scrollsawn, **119:78-79; 120:37-38**

Biscuit joiners and joinery, **117:56-61** for corner braces, **117:30** glue used for, **116:98**  
 Boards. *See* Lumber.  
 Boats, Chris-Craft, **115:46-49; 119:104**  
 Bookcases: **114:54-57; 116:62-69, 120:4**  
 Bowls: blanks for, **113:70** of green wood, **115:92** Bows, maker of, **120:41-45**  
 Boxes: bandsawn, **121:68-73, 74-75** dovetail keys, **116:43-44** flocked lining, **119:35** lid latch, **113:12** nutcracker in, **118:84-88** veneered, **114:76-78**  
 Box joints, **113:90**  
 Brad nailer, **114:90**  
 Brushes, care of, **116:102; 117:20; 121:6** Buckeye, Ohio, **117:123** Build-A-Gift® contest, **117:66**  
 Business, woodworking: co-ops, **115:16** media publicity, **120:18**  
 Cabinets: apothecary, **120:50-55** banding, **113:14** corner braces, **117:30** doors, **113:104** hinge-hole jig, **113:10** drawer fronts, **115:33** ironing-board, **117:69-73** mitersaw, **119:60-65** tablesaw accessories, **118:62-65**  
 Canoes, maker of, **121:41-45**  
 Carving: duck decoy, **113:78-81** fish, **114:50-53** reef for, **114:22** power-carving, **117:52-55** shop figures, **121:76-78**  
 Casserole carrier, **116:82-83**

Caulk, smoothing, **114:33**  
 Cedar, red: aroma, **116:92**  
 Chairs: Adirondack, **115:72-77; 118:8** Morris (correction), **115:8** rocking, **121:53-59** seats, routing, **121:10-14** Chair seats, routing, **121:10-14** Chamfer bits, **118:34, 36** Chatterwork, **115:78-79, 86** Chisels, **116:76-81** Chris-Craft boats, **115:46-49; 119:104** Circle-cutting guide, **113:36, 38** Circular saws, **118:PP-4, -6, -10 (94, 96, 100)** Clamps and clamping, **118:PP-12 (102)** bar, overtightening, **121:18** caulking gun for, **116:22** of corner braces, **117:30** of edging, **113:14; 118:PP-8 (98)** extensions, **117:16** pads, **114:30** screws instead of, **117:28** of staved vase, **114:8** storage, **120:29**  
 Clocks: alarm, **119:80-81** contest, **119:4, 85** face layout, **115:32** handsaw, **113:82-85** octagonal, **115:42-45** schoolhouse, **117:45-51** Clothes, work, **117:114**  
 Coffee tables: Arts and Crafts, **113:52-57** sleigh, **118:72-77**  
 Contest: Build-A-Gift®, **117:66**  
 Coral reef, carved, **114:22**  
 Corner braces, clamping, **117:30**

Cove moldings, cutting, **116:38**  
 Craftsman Closeups: bows: Kent Ostrem, **120:41-45** canoes: Philip Greene, **121:41-45** furniture restoration: Dominick Coiro, **116:47-51** logging vehicles, model: Ed Carpenter, **113:47-51** period furniture: Lee Sawyer, **114:41-45** Windsor chairs: Bob Dillon, **118:51-55**  
 Crossword puzzles, **114:20; 116:16; 119:26**  
 Cupping of boards, **115:6; 120:4**  
 Cutting boards, **113:64-65; 120:46-49**  
 Cyanoacrylate (CA; instant) glue, as finish, **116:58-59**  
 Cyclone dust collectors, mini separator, **114:84**

## D-E

Decking materials, **115:66-68, 96**  
 Decoy, duck, **113:78-81**  
 Desks, **120:62-67**  
 Detail sanders, **116:31, 103**  
 Dolly, sheet-goods, **116:12**  
 Doors. *See also* Hinges. arched, **113:104** frame-and-panel, **116:39** hardware holes, **116:100**  
 Dovetail jig, **118:108**  
 Dovetail keys, **116:43-44**  
 Dowels: drilling, **114:28; 117:32** flattening, **119:28** router-made, **119:54** scoring, **117:28**

*Continued*

## Drawers:

- fronts, aligning, **115:33**
- hardware holes, **116:100**
- tool storage in, **116:29**
- Drill presses, **118:PP-14 (104)**
  - compound-angle jig, **121:60-61**
  - curves shaped on, **117:37, 116**
  - dowels drilled on, **114:28; 117:32**
  - dust collector, **119:70-71**
  - evenly spaced holes drilled on, **118:40**
  - pen blanks formed on, **114:92**
  - pin-routing jig for, **121:24**
  - spin control, **113:18**
  - as steady rest **115:29**
- Drilling, hints for, **117:38**
- Drilling guide, **116:100**
- Drills, cordless, **118:PP-6 (96); 119:40**
  - 12-volt, **119:72-77**
- Drying of wood, **113:70-71; 115:38; 118:PP-7 (97)**
- Duck decoy, **113:78-81**
- Duplicator, mini, **118:PP-7 (97)**
- Dust collectors. *See also* Vacuums.
  - air-cleaning system, whole-shop, **120:70-73**
  - calculating needs, **119:16, 18**
  - cyclone mini separator, **114:84**
  - drill-press, **119:70-71**
  - planers, **115:50; 120:56**
  - power-carving, **117:52**
  - safety issues, **119:24**
  - switches for, **113:110; 118:110; 120:26**
  - tablesaw, **119:66-69**
  - window in bag, **116:36**
- Edging banding, **117:82-83**
  - clamping, **113:14; 118: PP-8 (98)**
  - trimming, **114:29; 119:31**

## F-G

- Face shield defogger, **118:112**
- Feather boards, **119:22, 24**
- Finishes:
  - brushes, care of, **116:102**
  - cans, closing, **119:34**
  - cutting boards, **120:49**
  - drying, **114:30; 118:38**
  - heat rings on, **121:16**
  - identifying, **117:74-75**
  - milk paint (Craftsman Closeup), **114:45**
  - moisture resistance, **119:44**
  - outdoor projects, **116:70-75**
  - repairing, **115:18; 117:74-75**
  - shelves, **116:34**
  - small parts, **114:30; 116:40**
  - stains, **114:58-61**
  - turnings, small, **120:8-9**
  - instant glue, **116:58-59**
  - water marks on, **121:16**
- Fire extinguisher, **118: PP-10 (100)**
- Fire safety, **119:24**
- Fish, carved, **114:50-53**
  - reef for, **114:22**
- Flashlight, **118:PP-6 (96)**
- Flocker, mini, **119:35**
- Fog fighter, **118:112**
- Foot switches, **115:14**
- Forestry, modern-day, **121:37-38. See also** Lumber.
- Forstner bits, use of, **117:38**
- Found wood, **113:66-71**
  - salvaged wood, projects from, **121:104**
  - sunken, **114:80-82, 112**
- Frame-and-panel doors, **116:39**
- Frames:
  - mirror, **117:28; 119:48-51**
  - picture, **114:26; 117:80-81; 120:68-69**
- French finish, **120:8**
- Furniture. *See also* "Repair, furniture" and individual style names.
  - buying, **114:18**
  - reading about, **117:14**
  - reproduction (maker of), **114:41-45**
  - Shaker, **119:47**

Garden cold frame, **121:50-52**

Garden markers, **114:62-63**

Gel stains, **114:58-61**

Glue and gluing. *See also* clamps and clamping.

- cyanocrylate (CA; instant), as finish, **116:58-59**
- glue, **118:PP-12 (102)**
- hotmelt, for positioning parts, **115:33**
- outdoor projects, **116:72**
- panels, **121:32**
- veneer, **114:70-75**

Grain, wood, **113:43-44**

Gum, black, **113:40**

## H-J

Hall of Fame, **117:41-42**

Hardware, shop-made, **118:43-48, 122**

Hinges:

- hole-drilling jig, **113:10**
- positioning, **115:26**
- shop-made, **118:43-48, 122**

Home Improvement Guide:

- Moldings **117:HI 1-16 (89-104)**

Hooks, storage, **115:108**

Hotmelt glue, for positioning parts, **115:33**

HUT finish, **120:8-9**

Idea Shops:

- IDEA SHOP® 2000, **119: 56-59, 84**
- virtual tours, **119:82**

Inlays, decorative, **114:14**

Ipe wood, **115:66**

Irish Mail riding toy, **115:59-63; 118:6**

Ironing center, **117:69-73**

Jigs:

- bandsaw-blade welding, **115:30**
- bandsaw multi-jig, **113:36, 38, 60-63; 120:4**
- basket-handle, **114:6**
- dovetail, **118:108**
- dovetail key, **116:43-44**
- dowel-drilling, **114:28**
- drilling, **117:38**
- drill-press, compound-angle, **121:60-61**

## Jigs continued:

- drill-press, pin-routing, **121:24**
- hardware-hole, **116:100**
- hinge-hole, **113:10**
- interchangeable-dovetail router, **121:83**
- keyhole-cutting, **121:35**
- lathe accessory, **115:29**
- miter, **118:PP-4 (94)**
- panel-cutting **114:16; 116:22**
- pocket-hole, **113:12**
- T-slots for, **117:36**
- Jointers:
  - knives, sharpening, **117:34**
- Joints and joinery. *See also* Clamps and clamping.
  - biscuit, **117:30, 56-61**
  - dovetail jig, **118:108**
  - mitered corners:
    - chamfer bits for, **118: 34, 36**
  - dovetail keys for, **116:43-44**
  - mortise-and-tenon, **116:39**
  - pocket-hole, **113:12**
  - temporary, hotmelt glue for, **115:33**
  - wood movement and, **119:43-44**
- Keyhole-cutting jig, **121:35**
- Knobs, metal, **118:43-48**

## L-M

Laminate trimmers, **113:72-77**

Lamp, table, **118:56-61**

Lathes. *See* Turning

Lazy Susan, **116:84-87**

Letter holder, **117:84-86**

Lighting:

- table lamp, **118:56-61**
- work, **116:101**
- yard, **114:46-49**

Logging:

- backyard, **113:66-71**
- toy trucks, maker of, **113:47-51**

Logs, sunken, **114:80-82, 112**

Lumber:

- for exterior use, **115:66-69**
- forestry, modern-day, **121:37-38**



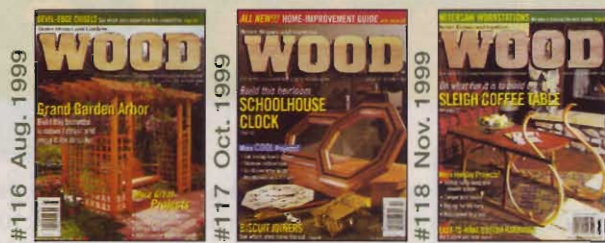

*Lumber continued:*

harvesting, **113:66-71**  
 movement in, **119:43-44**  
 redwood, waterproofed, **121:104**  
 straight edge on, **116:29**  
 sunken, **114:80-82**, **112**  
 Magazines:  
 labeling, **118:38**  
 shelf for, **114:54-57**  
 Magnetic starters, **115:14**  
 Marketing co-ops, **115:16**  
 Marking gauge, **115:64-65**  
 Media publicity, **120:18**  
 Metal:  
 hardware, **118:43-48**, **122**  
 steel bending, **115:12**  
 threading, **118:12**, **14**, **16**  
 Mirrors:  
 oval frame, **117:28**  
 Shaker, **119:48-51**  
 Mission style. *See also* Arts and Crafts style:  
 nesting tables, **121:46-49**  
 Miter jig, **118:PP-4 (94)**  
 Mitered corners:  
 chamfer bits for, **118:34**, **36**  
 gaps in, **121:20**  
 dovetail keys for, **116:43-44**  
 Mitersaws, **117:118**  
 compound, **120:33**  
 fence, **118:PP-8 (98)**  
 sliding compound, **120:10**  
 cordless, **118:PP-6 (96)**  
 stands for, **118:66-71**; **119:8**  
 mobile center, **119:60-65**  
 work supports, **119:28**  
 Mobile bases, **117:112**  
 mitersaw stands,  
**118:66-71**; **119:8**, **60-65**  
 Moisture content (MC) of wood, **115:37-38**  
 Moldings:  
 cove, cutting, **116:38**  
 Home Improvement Guide,  
**117:HI 1-16 (89-104)**  
 Morris chair (correction),  
**115:8**  
 Mortise-and-tenon joinery,  
**116:39**; **121:34**  
 Motors, kinds of, **120:14**

**N-P**

Nailer, brad, **114:90**  
 Nails, removing, **117:39**  
 Nightstand, **113:25-34**  
 Nutcracker (box), **118:84-88**  
 Oscillating spindle sanders,  
**116:114**  
 for curves, **114:35**  
 Ottoman, **113:58-59**, **92**  
 Outdoor projects  
 (building of):  
 Part 1, **115:66-71**, **96**;  
 Part 2, **116:70-75**  
 Outdoor projects:  
 Adirondack chair, **115:72-77**; **118:8** (correction)  
 anchoring, **116:18**, **20**  
 arbor, **116:52-57**  
 bird feeder, **118:78-79**  
 cold frame, **121:50-52**  
 garden markers, **114:62-63**  
 lighting, **114:46-49**  
 Paint, milk, **114:45**  
 Pallet wood, using, **115:91**  
 Panel-cutting jigs,  
**114:16**; **116:22**  
 Pattern-transfer tool, **121:85**  
 Pen blanks, **114:92**  
 Picture frames, **114:26**;  
**117:80-81**; **120:68-69**  
 Pine, sugar, **119:10**  
 Pinheads, making, **118:41**  
 Planers:  
 cordless, **118:PP-6 (96)**  
 knife setting, **117:122**  
 portable, **120:56-61**  
 snipe, **120:94**  
 stationary, **115:50-54**  
 Plastics for exterior use,  
**115:96**  
 Plywood: *See also* Sheet goods.  
 edging banding,  
**117:82-83**; **121:82**  
 clamping, **113:14**  
 trimming, **114:29**; **119:31**  
 mover for, **116:12**  
 Pocket-hole jig, **113:12**  
 Posts, setting, **116:18**, **20**  
 Product preview, **118:PP-1-14 (91-104)**  
 Project Showcase, **117:8**, **10**  
 Pulls, metal,  
**118:44-46**, **48**, **122**  
 Puzzles, bird, **119:78-79**

**Q-S**

Quail cutout, **120:37-38**  
 Quilt stand, **119:52-55**  
 Radial-arm saws,  
**118:PP-4 (94)**  
 work supports, **119:28**  
 Random-orbit sanders,  
**115:106**, **109**  
 disc organizer, **116:34**  
 Repair, furniture:  
 burning-in, **115:18**  
 expert (Dominick Coiro),  
**116:47-51**  
 finish renewal, **114:94**;  
**115:18**; **117:74-75**; **121:16**  
 Resawing, with bandsaw,  
**121:100**  
 Riding toy, Irish Mail, **115:59-63**; **118:6** (wheel source)  
 Rotary Shaper, **117:116**  
 Rotary tools, **120:34**  
 power carving with,  
**117:52-55**  
 Router bits,  
**118:PP-10**, **-14 (100, 104)**  
 chamfer, **118:34**, **36**  
 flush trim, **114:29**  
 for plywood edges, **121:82**  
 Routers:  
 auxiliary table, **120:30**  
 chair-seat jig, **121:10-14**  
 edging trimmed with,  
**114:29**  
 fence, two-wheel, **121:80**  
 interchangeable dovetail jig,  
**121:83**  
 jack for, **116:104**  
 pad, storing, **116:30**  
 pin-routing drill-press jig,  
**121:24**  
 pocket holes made with,  
**113:12**  
 template use with,  
**113:104**; **119:34**  
 Safety, **115:41**; **119:24**  
 cords, power-tool, **121:31**  
 drill-press, **113:18**  
 for "hot" tools, **121:28**  
 switches, **115:14**  
 thin-stock ripping, **115:28**

Salvaged wood.  
*See* Found wood.  
 Sanders:  
 belt, **116:114**  
 detail, **116:31**, **103**  
 drill press as, **117:37**  
 oscillating spindle,  
**114:35**; **116:114**  
 pads, adhering, **115:30**  
 random-orbit, **115:106**, **109**  
 disc organizer, **116:34**  
 Sawhorses, **115:20**  
 Screws:  
 for exterior use, **115:66-71**  
 loosening, **115:35**  
 storage, **113:14**; **115:34**  
 Scrollsaws, use of:  
 bird puzzles, **119:78-79**  
 blades, **114:26**  
 garden markers, **114:62-63**  
 letter holder, **117:84-86**  
 patterns, securing to work pieces, **121:26**  
 quail scene, **120:37-38**  
 Seat/step stool, **115:80-82**  
 Shaker style, **119:47**  
 mirror, **119:48-51**  
 quilt stand, **119:52-55**  
 Sharpening:  
 handsaws, **120:12**  
 jointer knives, **117:34**  
 Sheet goods.  
*See also* Plywood.  
 edge-banding, **117:82-83**  
 mover/lifter, **116:12**  
 Shelves:  
 adjustable, securing, **121:31**  
 bookcase, Arts and Crafts,  
**116:62-69**;  
**120:4** (correction)  
 book/magazine, **114:54-57**  
 finishing, **116:34**  
 Shop skills:  
 bandsawn boxes, **121:68-73**  
 dovetail keys, **116:43-44**  
 edge-banding, **117:82-83**  
 Sidewalk Speedster riding toy,  
**115:59-63**;  
**118:6** (correction)  
 Sleigh coffee table, **118:72-77**  
 Snipe from planers, **120:94**

*Continued*

# Index

for issues  
113-121



Solvent, for adhesive-backed stickers, **121:98**  
 Spreaders, **118:PP-12 (102)**  
 Stains, **114:58-61**  
 Steel bending, **115:12**  
 Step stool/seat, **115:80-82**  
 Storage, workshop:  
   clamps, **120:29**  
   in drawer, **116:29**  
   fasteners, **113:14; 115:34**  
   hooks for, **115:108**  
   router pad, **116:30**  
   sanding discs, **116:34**  
   tablesaw cabinet, **118:62-65**  
 Switches:  
   for dust collectors, **113:110; 118:110; 120:26**  
   for "hot" tools, **121:28**  
   magnetic starters, **115:14**

## T-V

Tables:  
   coffee, **113:52-57; 118:72-77**  
   nesting, mission-style, **121:46-49**  
   nightstand, **113:25-34**  
 Tablesaws,  
   **118:PP-7 (97); 120:14**  
   accessory cabinet, **118:62-65**  
   blade-changing tool, **118:PP-4 (94)**  
   blades, 10", **121:62-67**  
   cove moldings cut on, **116:38**  
   dust collector, **119:66-69**  
   edging trimmed on, **119:31**  
   feather boards, **119:22**  
   fences, **116:34; 120:16**  
   miter-gauge, adjustable-arm, **121:86**  
   miter jig, **118:PP-4 (94)**  
   mortises cut on, **116:39**  
   outfeed table, **117:62-65**  
   panel-cutting jigs for, **114:16; 116:22**  
   straighten stock on, **116:29**  
   thin stock ripped on, **115:28**  
   zero-clearance insert, **113:14**  
 Tack cloths, homemade, **116:36**  
 Tape measures,  
   **118:PP-4 (94); 119:38**  
   replaceable-tape, **121:80**

Templates, router, **119:34**  
   for arched doors, **113:104**  
 Tenon cutters, **118:PP-7 (97)**  
 Termites, Formosan subterranean, **121:104**  
 Thin stock, **118:24**  
   ripping, **115:28**  
 Threading of metal, **118:12-16**  
 Tool Reviews:  
   biscuit joiners, **117:56-61**  
   chisels, **116:76-81**  
   drills, 12-volt, **119:72-77**  
   mitersaw stands, **118:66-71; 119:8**  
   planers:  
     portable, **120:56-61**  
     stationary, **115:50-54**  
   routers, trim, **113:72-77**  
   stains, **114:58-61; 119:8**  
   tablesaw blades, 10", **121:62-67**  
   used machines, **116:88-90**  
 Toys:  
   jiggle eyes, for, **121:30**  
   Sidewalk Speedster, **115:59-63; 118:6 (correction)**  
   truck trailer, **118:80-83**  
 Travel guide, **120:74-78**  
 Trees. *See also* Wood species:  
   forests for the future, **121:37-38**  
   naming, **114:37-38**  
 Trim routers, **113:72-77**  
 Truck, toy, **118:80-83**  
 Turning:  
   bird feeder, **118:78-79**  
   chatterwork, **115:78-79, 86**  
   duplicator, **118:PP-7 (97)**  
   finishes, **120:8-9**  
   instant-glue, **116:58-59**  
   lazy Susan, **116:84-87**  
   pen blanks, **114:92**  
   steady rest for, **115:29**  
   workpiece removal, **119:30**  
 Used machines, **116:88-90**  
 Vacation stops, **120:74-78**  
 Vacuums, shop,  
   **118:PP-6,-8,-10(96,98,100)**  
   filter cleaning, **115:30**  
   muffler for, **115:107**  
 Veneers and veneering,  
   **114:12, 14, 70-75**  
   box, **114:76-78**  
   lampshade, **118:60-61**

## W-Z

Warping of wood, **119:43-44**  
 Waterlogged lumber, **114:80-82, 112**  
 Willow, black, **121:102**  
 Windsor chairs (maker of), **118:51-55**  
 Woodburning, **117:76-79**  
   photo frame, **117:80-81**  
 Wood movement, **119:43-44**  
 WOOD ONLINE®:  
   ([www.woodmagazine.com](http://www.woodmagazine.com))  
   home pages, **120:90**  
   IDEA SHOP® Tours, **119:82**  
   WOODMALL™, **118:106**

Wood species:  
   amazing, **114:24**  
   ash, black, **114:110**  
   aspen, quaking, **115:110**  
   basswood, **116:115**  
   buckeye, Ohio, **117:123**  
   gum, black, **113:40**  
   pine, sugar, **119:10**  
   willow, black, **121:102**  
 Woodworking Hall of Fame, **117:41-42**  
 Work supports, **116:31; 119:28; 121:32**  
 Wrench, locking, **118:PP-8 (98)**  
 Zero-clearance inserts, **113:14 ♣**

## BACK-ISSUE Ordering Service

If you would like to order one or more back issues of *WOOD*® magazine, write to the address below and include the issue number/s, your name, address, and phone number along with the payment. Send to:

**WOOD Back-Issue Sales**  
**Schlabaugh and Sons Woodworking**  
**P.O. Box 349**  
**Kalona, IA 52247**

To order using MasterCard or Visa, call 800/346-9663 (between 7 a.m.-5 p.m. central time). Please have order ready when calling. Prices are \$6.95 each. Price includes taxes, shipping, and handling. Allow 2-3 weeks for delivery.

### What's available in back issues\*:

7, 22, 24, 26, 28, 29, 30, 31, 32, 34, 36, 37, 39, 41, 42, 45, 47, 48, 49, 61, 62, 63, 64, 65, 66, 67, 68, 69, 70, 71, 72, 73, 74, 75, 76, 77, 78, 80, 81, 83, 84, 85, 86, 87, 88, 89, 91, 94, 97, 98, 99, 103, 104, 105, 107, 108, 109, 111, 113, 114, 115, 116, 117, 118, 119, 120, 121, 122, 123

\*Sorry, issues not included here are no longer available.

Index compiled by Barbara L. Klein and Dave Kirchner

# Spring Cleaning Strategies

For your shop

**For efficiency and safety your shop should get a thorough cleaning annually. So why not time it with spring? Do some basic power-tool maintenance, too. Well-maintained and adjusted tools work better. They're safer, too.**



**B**egin your cleanup with the shop-vacuum's filter. The sawdust and moisture buildup can lead to mold spores in the air. And they cause allergy problems. Also, the motor runs hotter when the filter's dirty, so clean or replace it. Replace or clean any other dust or air filters while you're at it. Then give the place a general sweeping and vacuuming, picking up and putting away as you go. Until you get rid of the general mess, you can't pay attention to the really important stuff.

## Dispose of paints and solvents

Divide old or nearly empty cans of paint, finishes, and solvents into two stacks: (1) latex paint and water-based finishes and (2) everything else. Try this disposal method for latex paint and water-based finishes as recommended by the Environmental Protection Agency: Open a can's lid, pour in a cup or so of cat litter, and mix. Leave the lid open. When it hardens, you'll have a landfill-safe package for the trash pick up.



The "everything else" isn't as easy, but at least your timing will coincide with most municipalities' "spring cleaning" hazardous-waste collection. Call city hall, your waste management agency, or trash hauler for dates. You'll have to haul to the site.

## Get rid of rust

All cast-iron surfaces, such as your table saw and jointer tops, will rust in the right conditions. And rust spots aren't smooth. Roughness can cause sudden slips and injury. If iron surfaces show rust, but no pits, they're simple to clean. Get rid of what rust you can with a wire brush. Remove what's left with naval jelly (from hardware stores), a product that darkens the metal but stops the rusting. Repeat both steps until you're satisfied, then protect the surfaces with a paste-type auto wax. It's as good as it gets for cast-iron surfaces.

## Align and adjust stationary tools

Now's the time to align your table saw and radial-arm saw, as well as set the knives on your jointer or surface planer. Move those stationary machines away from the wall, sweep and vacuum behind them, clean them off, and true them as outlined in their manuals. While doing that, also check for possible lubrication needs. Look over each machine for worn parts. Inspect drive belts and buy new ones if they're worn or frayed. When you've finished, you'll have your stationary tools in tip-top shape for another year. And you'll be in shape, too.



## Maintain motors and brushes

Two basic types of electric motors run your tools; those with replaceable brushes and those without. They both need your attention.

Many brush-type tools rely on the brushes for the brake to work. Bad brushes could cause erratic brake performance. Also, all motors need periodic cleaning to run cool and prevent premature failure of their internal wiring.

Start with tools that probably have replaceable brushes—mid-size routers, power mitersaws, and portable planers. (Most all portable power tools, including battery-powered versions, have replaceable brushes, although some aren't meant for you to replace.) If you see the head of a large plastic screw (about 3/4" diameter) on each side of the motor, you can access the brushes. Just unscrew them to remove the brushes. Usually, brushes need replacement if they're less than 1/2" long. (Buy new brushes from your tool dealer, or get the manufacturer's number to order them.)

Also, blow the dust off the tool and out of any louvers or air vents. Read its manual for instructions on cleaning and lubricating the bearings and replacing bad switches and power cords. If it doesn't tell you how, take the tool to a service center.

Large motors that don't have brushes, such as the one on your table saw, shouldn't be taken apart. They're not easily reassembled. Just blow them out with air, then wipe them down to help extend their life. Most radial-arm saw motors have a brake at the end opposite the blade, so blow the dust off there, also. For lubrication needs, refer to the tool's manual. ♣

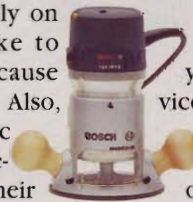

"Where Safety Begins" is written by Mike Gilliland, a safety consultant and lifelong woodworker. If you have a safety-related question, send it with an SASE to: The Safety Man, WOOD Magazine, 1716 Locust St., GA310, Des Moines, IA 50309-3023. Not all questions will be published, but all will receive an answer.

Real Jobs For

# Real Woodworkers

If you've got the skills, there's work to be had



At companies like Woodcraft Architectural Millwork, craftsmen build everything from conference tables to reception desks. Here, company president David Bahr, *right*, looks over plans with shop foreman Jon Dorman. Greg Baird sands in the background.

Despite the tendency of high schools across the nation to cut back and in some cases even eliminate their woodworking programs, woodworking jobs do exist nationwide. In fact, of the 20,000 or more occupational descriptions listed by the U.S. Department of Labor's Bureau of Labor Statistics (BLS) in their Dictionary of Occupational Titles, over 200 fall under woodworking. And according to that agency, in 1996 there were nearly 400,000 people filling those woodworking jobs. (About 10 percent of that number were self-employed.)

While woodworking jobs include the production ones in primary industries, such as sawmills and plywood manufacturing, they also include the work in secondary industries that make furniture, kitchen cabinets, musical instruments, and other fabricated wood products. The BLS calls "precision woodworkers" those who work in smaller shops making specialty items by doing the complete cycle of cutting, shaping, and assembling wood components. And becoming a precision woodworker requires basic woodworking training.

"I've listened to superintendents of schools voice the opinion that woodworking programs should be dropped because the jobs aren't there, and not all can start their own woodworking business," says David Bahr, president of Woodcraft Architectural Millwork. His company employs about 45 craftsmen in its Urbandale, Iowa, facility and 35 in Kansas City, and does \$7 million worth of woodwork annually throughout the nation.

"The people who say that sit behind a wooden desk and eat dinner at a wooden dining table," Bahr continues. "That desk and table didn't spring from seed out of a packet. A woodworker somewhere made each one."

## Make your router think it's a jointer

**Y**ou can equip your table with a split fence for edge-jointing, or you can take the low-tech route shown here. We simply clamped a piece of plastic laminate on the left-hand, outfeed end of the fence. Use sandpaper to ease the edge nearest the router bit, so it won't catch your workpiece as the board slides past. As seen in the photograph at *right*, we used a steel rule to align the laminate with the cutting edge of a straight bit mounted in the router.

Set the bit high enough to trim the entire edge of the board in one pass. Then, turn on the router, and move the board across the table from right to left. You'll remove  $\frac{1}{16}$ " with each pass, and leave a perfectly straight, square edge. Repeat the procedure with a second board, and the two pieces can be glued together without a gap anywhere. 🌲

Written by **Jim Pollock** with **Charles I. Hedlund**  
 Illustrations: **Roxanne LeMoine**  
 Photographs: **Baldwin Photography**

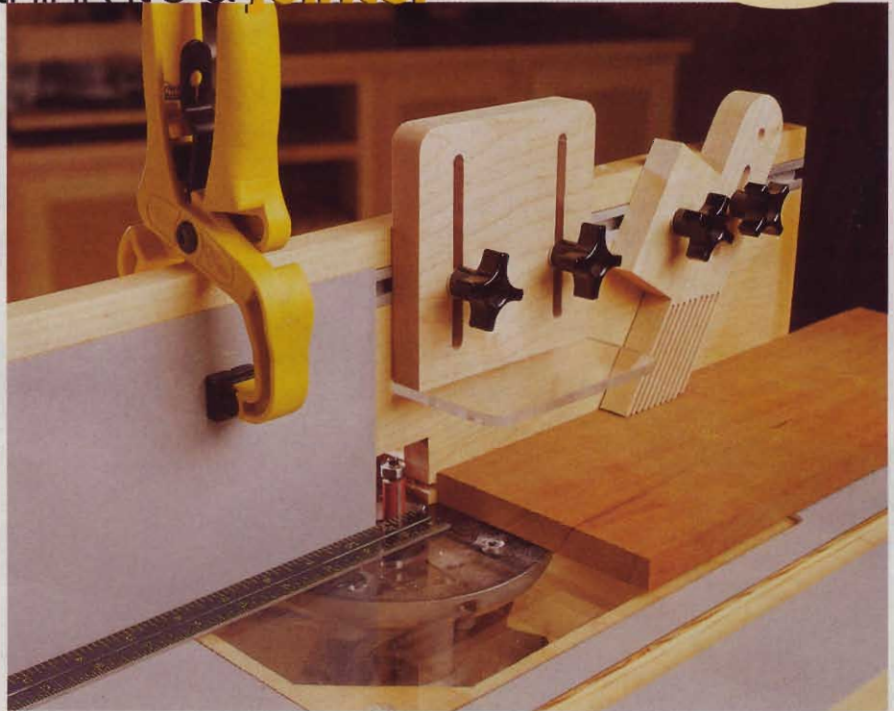

Place your laminate piece at the left-hand edge of the bit-clearance notch in the router table fence. The solid backing will keep it from flexing.



Clamp your insert-plate blank and a backer board to your drill-press table, centered under the bit of your holesaw. Drill slowly, and you'll get a clean cut.

### Set your table with custom plates

Router table work goes smoother and more safely when the hole in your insert plate is only slightly larger than the diameter of the bit. You can buy a plate with removable rings, which gets you close enough in most situations—or you can make a custom plate to match a bit exactly. Use Baltic birch plywood for the least expensive plate, or choose polycarbonate for a clear plastic plate. You can buy a 12×12" piece of  $\frac{3}{8}$ " polycarbonate for \$15.99 from Woodcraft. Call 800/225-1153 to order part number 16L72.

Place the insert plate faceup on a flat surface. Remove the subbase from your router, and adhere it to the plate, faceup, with double-faced tape. Be sure it's centered, and oriented so that your router will be convenient to operate once it's mounted under the table. Select a drill bit the same size as the holes in the subbase, and chuck it in your drill press. Using the holes in the subbase as guides, drill matching holes through the insert plate. Remove the subbase, and countersink the holes.

Now, attach the insert plate to your unplugged router and set it flat on your workbench. Chuck a  $\frac{1}{4}$ " drill bit in the router, and lower it until the bit touches the insert plate. Turn the collet by hand, mark the centerpoint.

Remove the insert plate from the router. Chuck a holesaw or adjustable circle cutter in your drill press to cut a center hole of the diameter needed, as shown at *left*.

Roy King  
and his

# Scrollsawn Marquetry

Great-looking  
inlays don't  
get any easier  
than this!



Like most of us, **WOOD**® magazine reader and scroll-sawyer extraordinaire Roy King has always found traditional marquetry methods, which require you to precisely cut and fit lots of tiny veneer pieces by hand, tricky and frustrating. Then he hit upon the idea of doing marquetry on his scroll-saw with beveled cuts in two 1/8"-thick pieces sandwiched together. Eureka! The technique yielded great-looking designs, and proved easy to master.

Of course, Roy, who was featured in our February 1993 issue, couldn't wait to share his newest results with us. We were so impressed that we recently got together with Roy in our shop for a session of scrollsawn marquetry. Here's what happened.

## Let's get started

The oval rose design is about 4x6" in size, so begin by resawing and thickness planing 1/8"-thick workpieces, each just larger than 4x6", in three woods: curly maple (for the background panel), chakte kok, also spelled chakte coc or called red heart (for the rose petals), and cherry (for the stem and leaves). See our Sources at the *end of this article* if your local supplier doesn't carry these woods.

Now, make an extra copy of plate 1 and set it aside for later. Tape the top

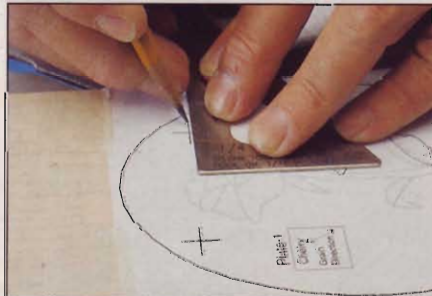

Use a straightedge and sharp pencil to accurately transfer the registration marks to the background panel.

edge of one of your plate 1 patterns onto the maple background panel, slip a sheet of carbon paper between the plate and panel, and precisely trace the cross-hair registration marks, as shown *below left*. Remove the tracing paper, and tape all four edges of the plate to the panel.

Place the inlay stock (cherry for plate 1) beneath the background

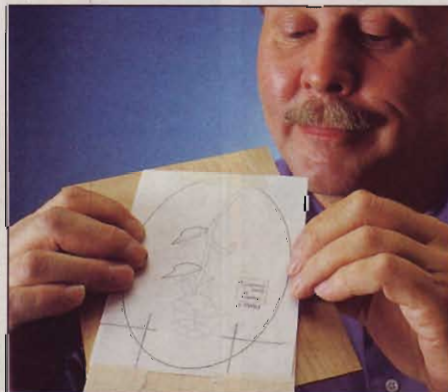

By carefully lining up the grain of your inlay pieces, your finished project will have a pleasing, natural look.

panel, aligning its grain direction with the arrow on the plate. Do this by holding the stack as shown *below middle*. This helps you choose the best grain direction and color for the inlay pieces marked with heavy lines.

Set down the stack and secure the background panel to the inlay stock with masking tape. Be careful to press the tape firmly into the corner formed by the edge of the panel and the inlay stock as shown *below right*. This prevents the stack pieces from shifting.



Firmly press the tape into position to prevent the background panel and inlay stock from shifting.

## A sneak preview into the basic process

With this technique you cut inlay pieces that fit like a tapered plug in a tapered hole. That's because you saw the inlay and the background panel that it fits into at the same time. The secret to success lies in tilting your scroll-saw table to produce the necessary bevel.

Piece cut from inlay stock fits tightly into the background panel.

Take note of the names of the parts shown in the drawing; we'll refer to them often.

Inlay stock (always positioned beneath the background panel)

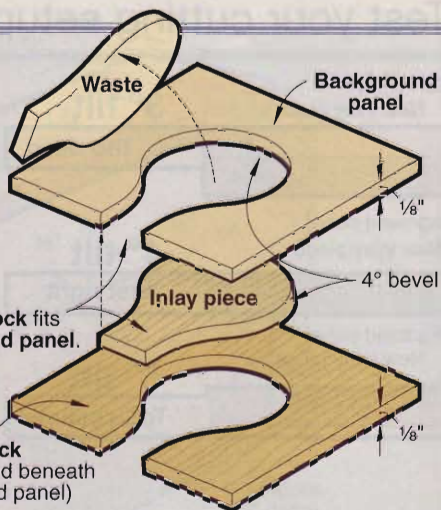

## A few pattern pointers

In this article we'll show you how to make the rose design featured in the hand mirror project beginning on *page 64*. This technique requires multiple patterns (called plates) to make a single design, and we provide all of them for the rose in the **WOOD PATTERNS**® insert in this issue.

If you would like to try your hand at making your own plates from line art you find in clip-art books or other sources, see the information titled "How to make your own plates" on *page 63*. Or, if you would like to purchase premade sets of plates for various designs, see our Sources at the *end of this article*.

*Continued*

# Scrollsawn Marquetry

## Test your cutting setup

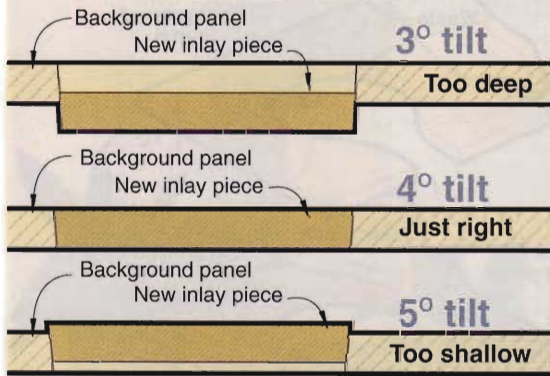

For proper-fitting inlay pieces, take a moment to check the angle of your scrollsaw table by making test cuts in two pieces of  $\frac{1}{8}$ " scrap stock taped together. First, tilt your table  $4^\circ$  to the left, install a 2/0 blade, and chuck a No. 67-72 wire size bit into a hand drill. Make a blade-start hole in the middle of this stack, thread your blade through it, and cut out a circular shape, being careful to cut in a *counterclockwise direction*. Keep the circle you cut from the bottom piece of

stock. Take the stack apart, place the top piece of stock front face down, and place the cutout from the bottom piece of stock into the hole in the top piece of stock. It should fit as shown in the  $4^\circ$ -tilt example illustrated at left. If the test piece slips too far through the hole, you need to increase the tilt angle. If the test piece goes into the hole but doesn't come flush with the face of the top piece of stock, you should decrease the tilt angle slightly.

## It's time to scroll

On every plate you will find three types of lines, as shown at right. This illustration tells you what you need to know about each type of line.

To get started, drill a hole through the stack at any point along both of the heavy dashed lines on the leaves, as shown below left. Thread the scrollsaw blade through either hole in your workpiece, and cut in a *counterclockwise direction* along the heavy dashed and heavy solid lines, as shown below right. Cut out the other leaf in the same fashion. Save the cutouts from the bottom (inlay) stock. For best cutting control, set your scrollsaw for slow speed.

### Grey lines:

These show the overall design for reference purposes only. Do not cut along these lines.

### Heavy solid lines:

You cut along these lines with your scrollsaw. Follow them carefully because these lines will show in the finished piece.

### Heavy dashed lines:

You cut along these lines as well, but this area will be overlapped by an inlay piece you cut later. Because of this, you can drill blade-start holes anywhere on these lines.



Drill straight down into the dashed areas on the plates to make start holes for your scrollsaw blade.

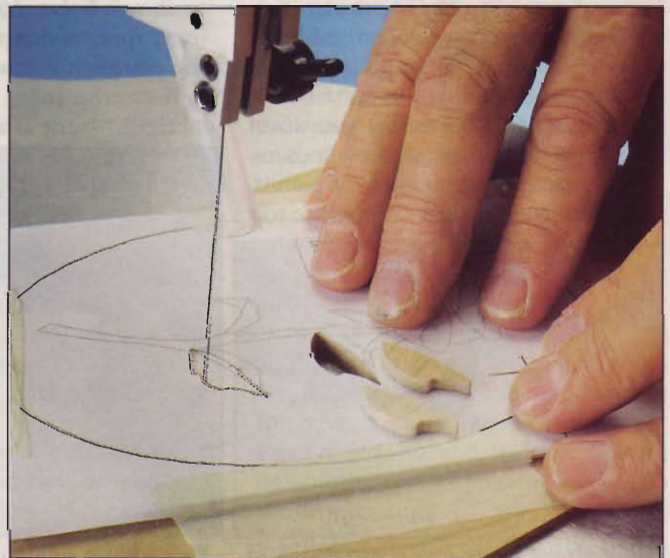

As you saw, save the inlay pieces and discard the waste pieces cut from the background panel.



## For a really hot look, toast the inlay pieces with sand

To give your project a realistic three-dimensional appearance, it pays to shade the inlay pieces with hot sand. First, pour a 1" layer of sand into a shallow pan (preferably one that's outlived its usefulness in the kitchen). Finer grades of sand work best; we purchased a bag of fine silica sand from a local home center.

Next, place the pan and sand on a burner set for high heat. The sand may take up to an hour to become hot enough. Test the temperature of the sand with  $\frac{1}{8}$ "-thick scrap; it should darken slightly after being in the sand for 15–30 seconds. Be careful not to touch the edge of the inlay piece to the pan; that will burn the edge but leave the rest of the piece unshaded.

To shade your inlay pieces, refer to the Shading Guide in the *WOOD PATTERNS*® insert. Then, use a tweezers to hold the pieces in the sand, as shown at *right*. It also works well to hold small pieces by stabbing the point of an X-acto knife into their edge. You will have to shade each piece just after sawing it and prior to placing it into the background, as described in the *next step*. The shading should show a light-toast color through the thickness of the piece so it won't sand away when you smooth the completed design later.



We used a scrap of wood to scrape away the top layer of sand and expose our work-piece to the hotter sand below.

## Glue the inlay pieces into the background panel

Discard plate 1, then remove the masking tape from the cherry inlay stock and set the stock aside. Lay the background panel front face down on a work surface, apply white glue to all edges of the inlay piece, and drop it into the matching hole in the background panel, as shown at *right*. For ease of application and neatness, Roy prefers to apply the glue with a glue injector (item 02130, two injectors for \$3.99, plus shipping, from Woodcraft, 800/225-1153 to order). Tap the piece

down firmly (a nail set comes in handy for small pieces) to seat it tightly in its hole.

Flip the background panel front face up and examine the inlay pieces for a tight and flush fit. Wipe away any excess glue with a rag or sponge dampened with water. If necessary, rub a drop of white glue into any tiny openings and lightly hand-sand these areas with 150-grit paper to mix sawdust into the glue. Again, wipe away excess glue.

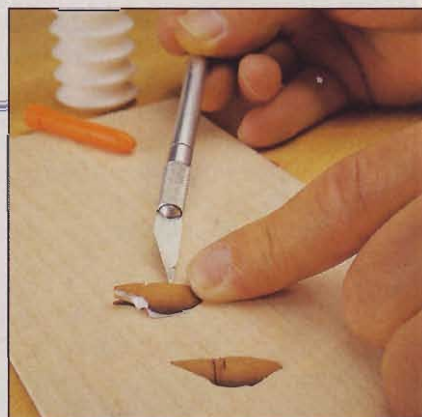

Apply glue to the edges of the inlay pieces and press them firmly into the background panel.

# Scrollsawn Marquetry

## And now, the rest of the plates

With scissors, cut through the registration marks on plate 2 so you can align them with the registration marks on the background panel, as shown *below left*. Tape the plate to the background panel, and tape this assembly to the inlay stock as described earlier. You may run into the situation where this stack becomes tipsy on the scroll-saw table because one side of the stack is not fully supported by the inlay stock. In that case, support the stack by taping a piece of  $\frac{1}{8}$ " scrap to the back of the background panel, as shown *below right*.

Repeat all of the previously mentioned steps for each plate in numerical order. As you cut and glue each inlay piece into position, notice how each piece overlaps the waste area of an adjoining piece you previously inserted into the background panel. Of course, you can't overlap the final piece on plate 14 with another succeeding piece, so you will have to treat this last inlay piece differently.

Because the last piece in the design has no waste area to drill the start hole into, you will have to drill it just inside the heavy solid line. To do this, hold your drill at an angle, as shown *above right*, with the bit angled away from the inlay piece. The bit should pass through the waste areas of both the background panel and inlay stock. Cut along the solid line as before.

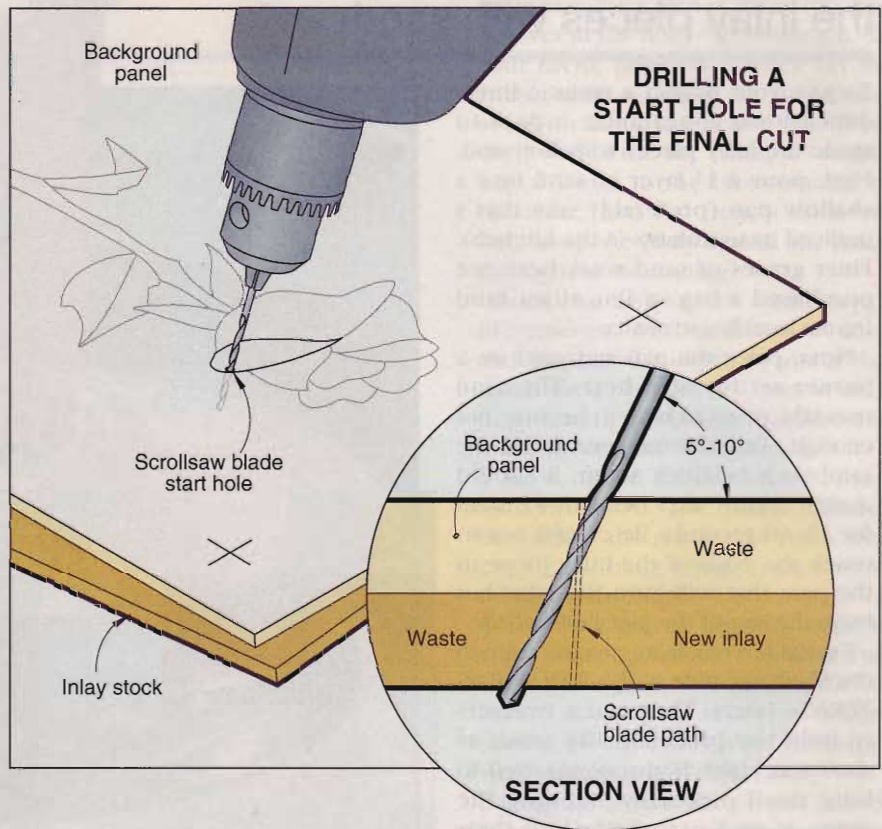

▶Tape small piece of scrap to the back of the background panel as necessary to keep it from tipping during cuts.

▼Align all subsequent plates with the registration marks transferred onto the background panel from plate 1.

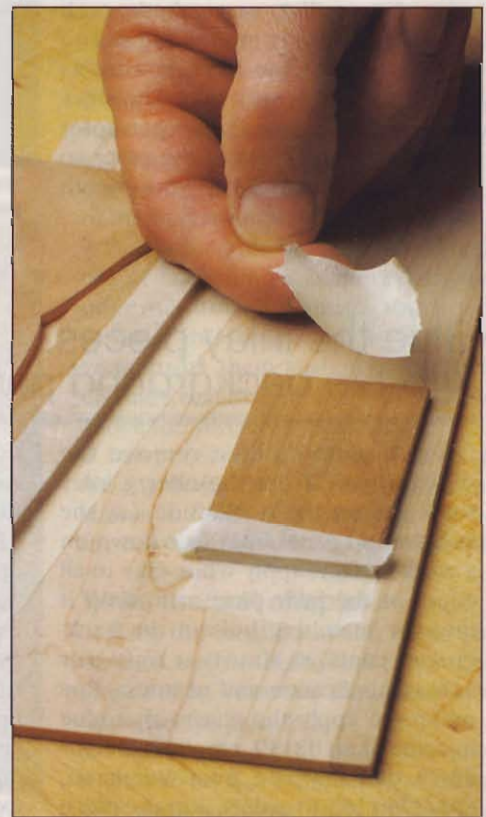
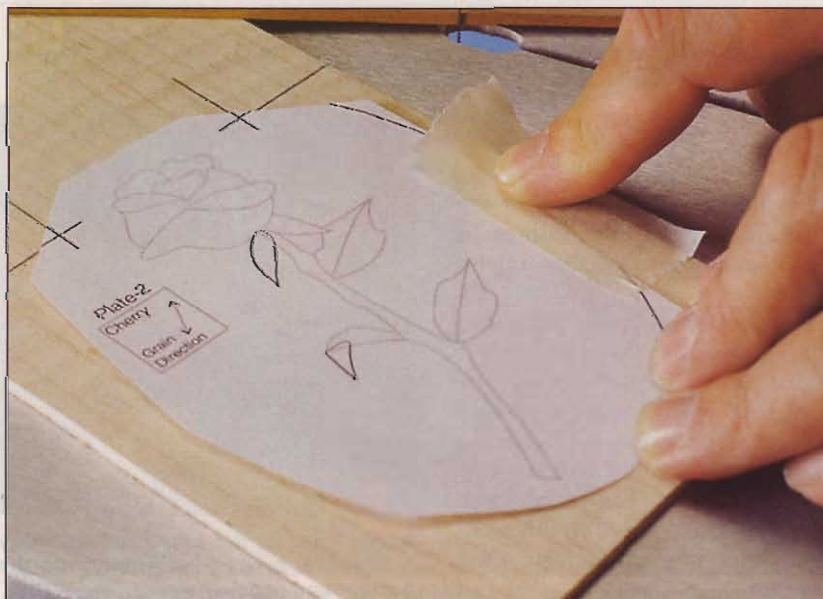

## The final touches

After you glue all of the inlay pieces into place, you'll find that they form an uneven surface slightly proud of the background panel. To flatten things out, Roy runs a random-orbit sander with 150-grit abrasive over the surface, as shown *below*. He then moistens the surface to raise grain hairs, allows the surface to dry, and goes over it again with a 150-grit disc.

Finally, use the extra copy of plate 1 to cut the background panel to an oval shape. Scissor a "window" roughly 2x3" in size out of the center of the plate. Use this window to align the pattern on the plate with the outline of your design, as shown in the *bottom* photo. Tape down the plate, adjust your scrollsaw table for a perpendicular cut, and saw along the oval. You're done!



A random-orbit sander and 150-grit disk remove the registration marks and flatten and smooth the workpiece.

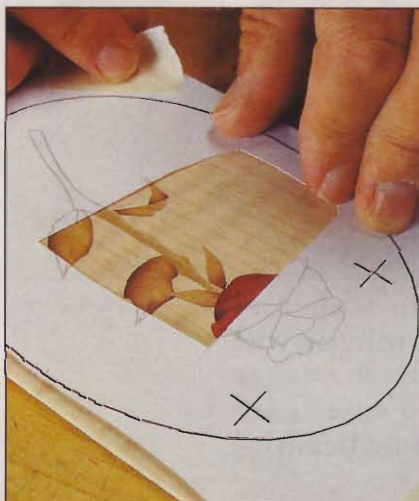

Tape the extra copy of plate 1 onto the workpiece after aligning the outlines of the rose pattern.

## How to make your own plates

Turning a piece of line art into a set of plates is simple once you get the hang of the general theory. In a nutshell, you need to plan the order of cuts so that each succeeding inlay piece overlaps the waste area of the piece cut before it. This typically means that you cut the pieces furthest in the background of the design first, then

work your way toward the foreground. As shown in this simple example, you cut the object furthest in the background (the sun) first. We positioned the waste area of the sun cut so that the next object you cut, the mountains, overlaps it. Finally, the cactus in the foreground overlaps the mountain waste area.



The original artwork at left is ideal for making an inlay because of the simple overlapping parts and easy shapes to cut out.

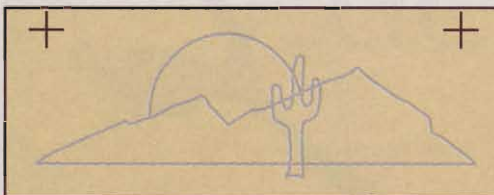

### STEP ONE

Start by tracing around all of the shapes with a pencil. Mark two registration crosshairs to ensure accurate part alignment later. Make photocopies for each of the inlay pieces.

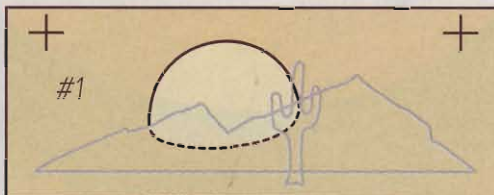

### STEP TWO

The moon is farthest back in the scene and will be trimmed by overlapping pieces cut in the next steps. Trace around its shape with a dark pen. Draw a dotted line behind the mountains as a place to start the scrollsaw cut. Label the plate as #1.

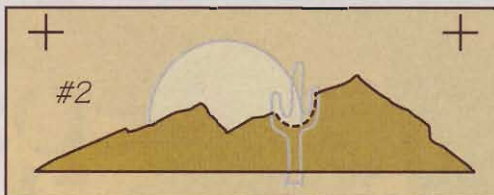

### STEP THREE

Trace around the next part you'll cut—the mountains. Note the dotted line behind the cactus, which you will trim away when cutting the cactus piece. Label the plate as #2.

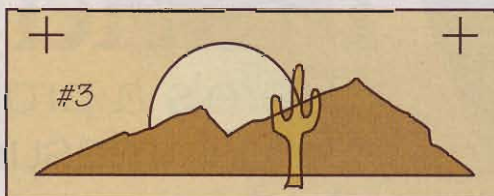

### STEP FOUR

Simply trace around the last inlay piece—the cactus, with a dark pen. Label the plate as #3.

### Sources

- Marquetry patterns with plates for double-bevel cutting, wire-size drill bits, and various woods planed to 1/8" thickness. For a catalog, send \$2 to The Artistic Inlay Company, 9033 S. Nashville, Oak Lawn, IL 60453.
- Exotic woods, most 3/4" thick. Woodworkers Source, 5402 S. 40th St., Phoenix, AZ 85040. Phone 800/423-2450. ♣

Written by Bill Krier with Roy King and Jim Downing  
Illustrations: Kim Downing; Lorna Johnson  
Photographs: Wm. Hopkins

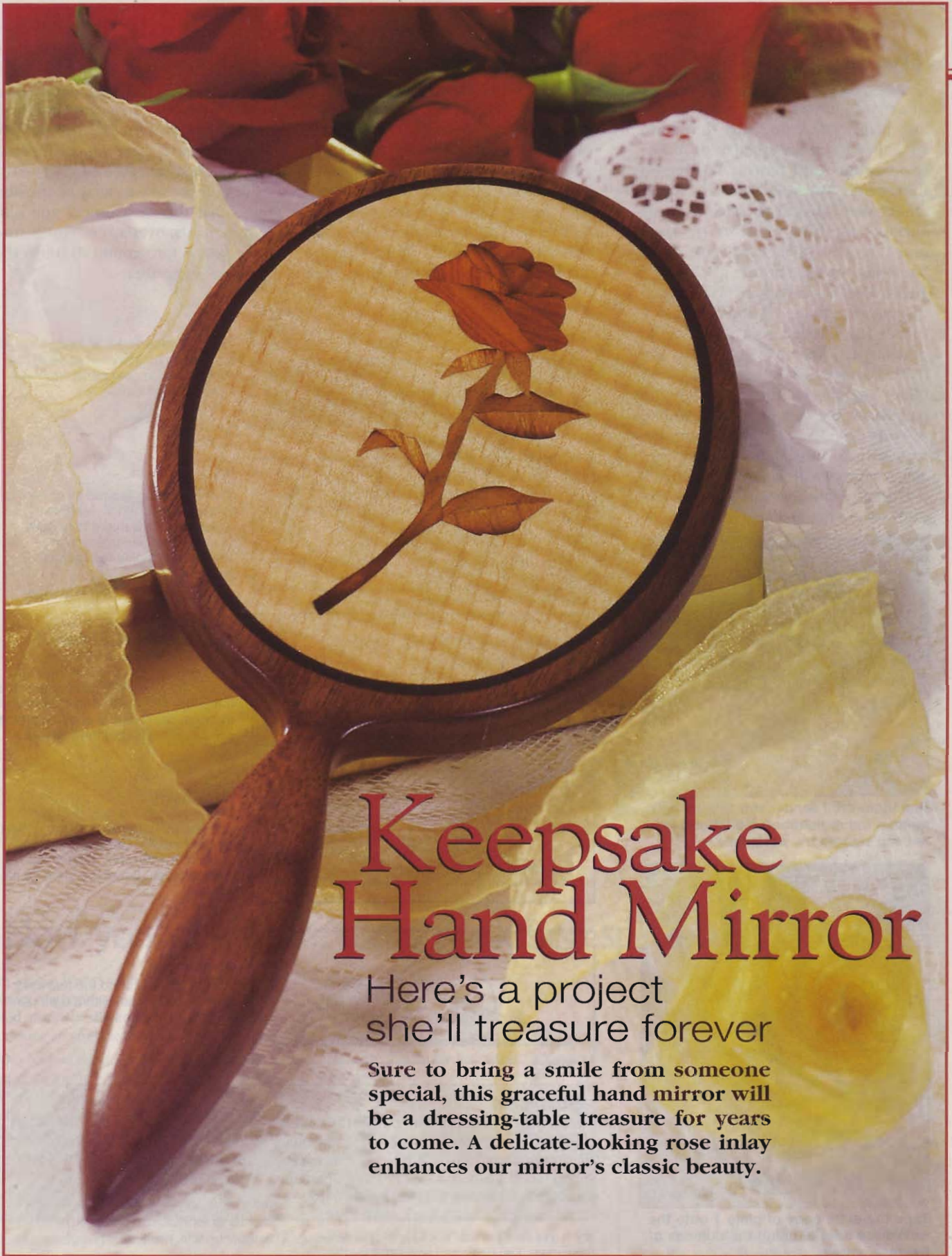

# Keepsake Hand Mirror

Here's a project  
she'll treasure forever

Sure to bring a smile from someone special, this graceful hand mirror will be a dressing-table treasure for years to come. A delicate-looking rose inlay enhances our mirror's classic beauty.

### A few notes before you begin:

• Before you make the mirror frame, buy a 4 x 6" oval mirror glass. (See the Buying Guide for the source of the one we used.) Then, verify that the size and shape of the mirror fits inside the line denoting the rabbet on the Mirror Full-Size Pattern in the WOOD PATTERNS® insert. Adjust the mirror, mirror insert, and routing template patterns as necessary.

• Make the inlaid rose design for the back by following the procedures in the article beginning on page 58. Before you build the hand mirror, complete the marquetry, and cut the insert to the shape shown by the Mirror Insert Full-Size Pattern. If you don't care to do the marquetry project, you can cut figured stock to shape for the back.

### Rout a rabbeted oval to start

**1** Photocopy the Mirror and Routing Template Full-Size Patterns in the WOOD PATTERNS insert. Adhere the mirror pattern to a 1/2 x 6 x 13" piece of walnut and the template pattern to a 1/4 x 6 x 13" piece of tempered hardboard or void-free plywood.

**2** Drill a 1/8" blade start hole inside the oval opening on each piece. Scrollsaw the openings, staying slightly inside the line on both pieces.

**3** Sand to the line on the template only. (We used a drum sander.) Make

sure you get the edge smooth—your router's guide bushing will ride against it. Remove the pattern from the template.

**4** Position the template on the patterned side of the walnut mirror blank. Align the ends and edges to center the template over the cutout

opening in the blank, as shown in *Photo A*. Hold the template in place with double-faced tape.

**5** Install a 5/8" guide bushing and a 1/2" straight bit in your router. The guide bushing needs to have a short nose, as shown in *Photo B*. (Project builder

*Continued*

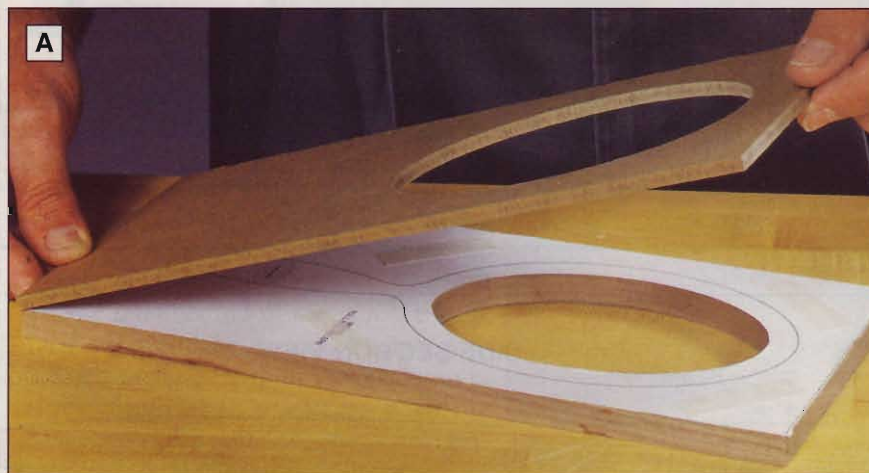
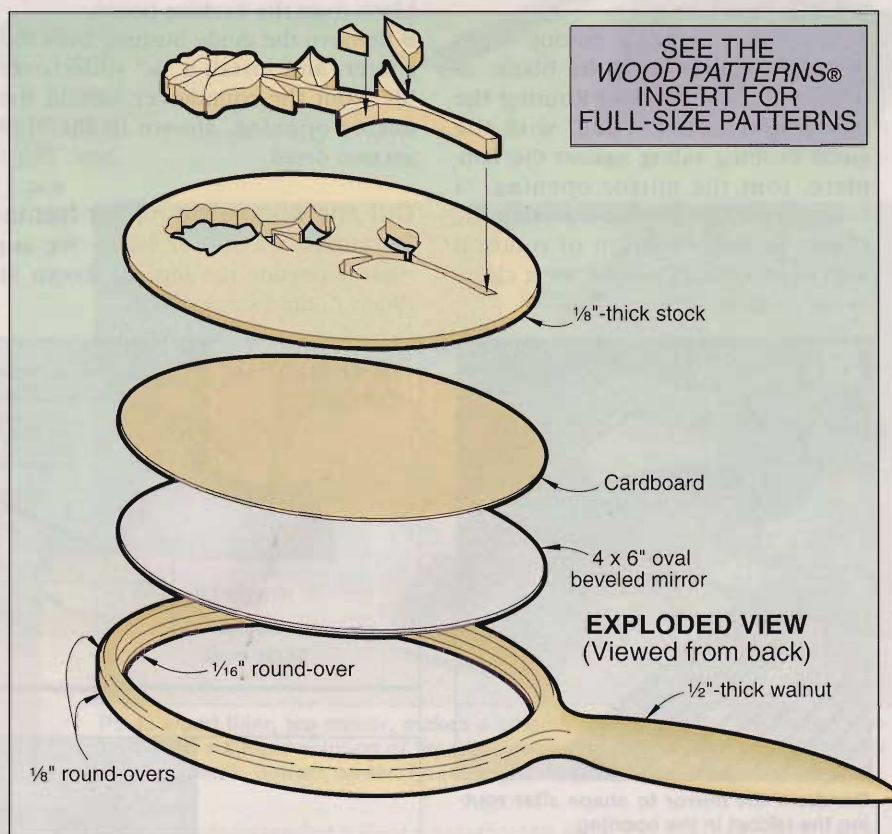

The hardboard template guides the router when forming the rabbet for the beveled mirror glass.

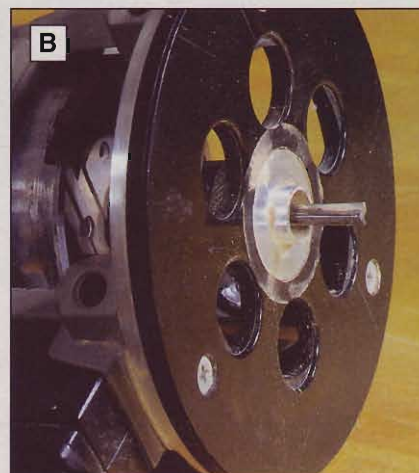

Shorten the nose of the router guide bushing to work with a thin template.

# Keepsake Hand Mirror

Chuck Hedlund cut the bushing shown to  $\frac{3}{16}$ " long. "The shortened nose makes the bushing more versatile—you can use it with thick or thin templates just as well," he says.)

**6** With double-faced tape, attach the blank to a larger piece of scrapwood, and clamp the scrapwood backing board to your benchtop.

**7** Adjust the router bit cutting depth to  $\frac{5}{16}$ " to cut  $\frac{5}{16}$ " into the blank, as shown in *Step 1* of the Routing the Opening drawing. Then, with the guide bushing riding against the template, rout the mirror opening. "I found that climb cutting—moving the router in the direction of rotation instead of against it—gave me a cleaner cut," Chuck says.

**8** Switch to a  $\frac{1}{4}$ " straight router bit. Set the cutting depth a little greater than  $\frac{3}{4}$ ", just deep enough to cut slightly into the scrapwood beneath the blank, as shown in *Step 2* of the drawing. Rout the opening, climb cutting again for a clean edge. Remove the template from the blank, and the blank from the backing board.

**9** Remove the guide bushing from the router, and install a  $\frac{1}{16}$ " round-over bit. Rout the round-over around the mirror opening, shown in the Side Section detail.

**2** Rout a  $\frac{1}{8}$ " round-over around the edge on both faces. (We did this with a table-mounted router.)

**3** Sand the handle to shape, referring to the Side Section View drawing. Form the cross-section shown by block-sanding with 100-grit sandpaper. Sand with the corner of the block to narrow the handle just below the mirror head, as shown in *Photo D*. Blend the contours together for a smooth, flowing shape. Finish-sand with 150- and 220-grit sandpaper and a sanding block.

## Cut and shape the mirror frame

**1** Bandsaw the mirror frame. We cut slightly outside the line, as shown in *Photo C*, then sanded to it.

## Add the inlaid back panel

**1** Cut a piece of light cardboard (the side of a file folder would work fine) to the shape of your mirror glass.



**Photo C** Bandsaw the mirror to shape after routing the rabbet in the opening.

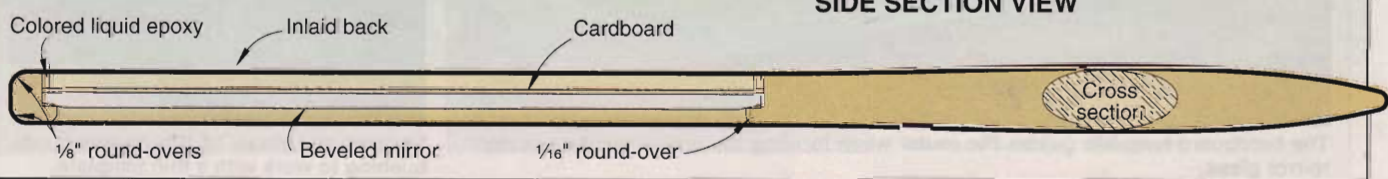
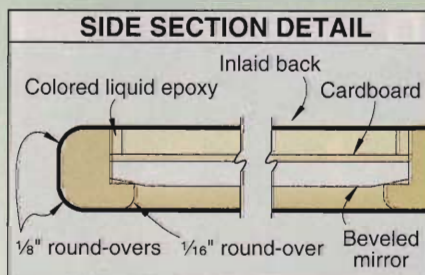
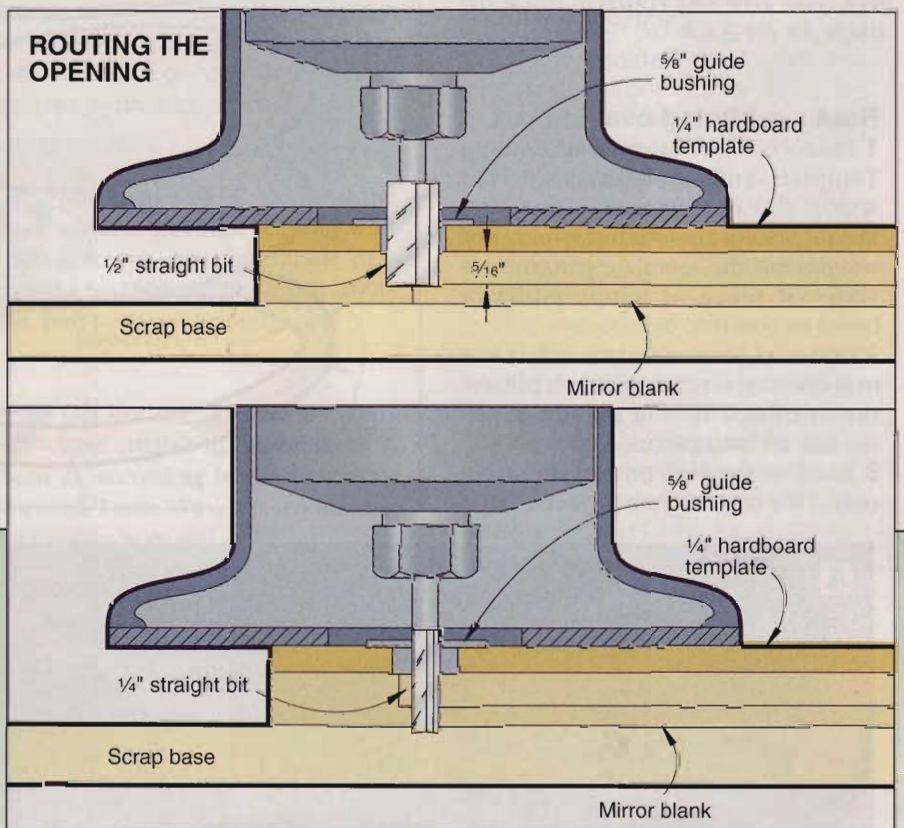

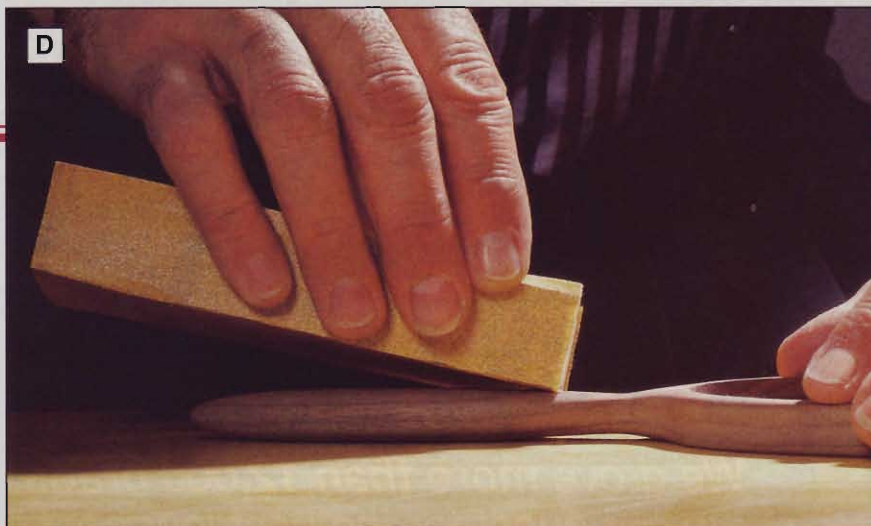

**D** Sand a hollow where the handle joins the mirror surround. The corner of a sanding block does the job.

**2** Place the mirror in the opening. Glue it into place with a small bead of silicone adhesive. Take care not to get silicone on the edge of the rabbet between the back of the mirror and the back of the frame—epoxy needs to bond to this area to hold the inlaid insert in place.

**3** After the silicone cures, spray the back of the mirror with spray adhesive, and press the cardboard oval onto it.

**4** Lay the inlaid panel in place. Cut four 1/8"-thick spacers, and place them around the panel to center it in the opening, as shown in *Photo E*. (You can adjust the thickness of the spacers, if necessary, to center the inlaid panel.) Remove the panel, apply spray adhesive to the back of it, and reposition the panel and spacers. Press down the panel to adhere it to the cardboard, and remove the spacers.

**5** Run clear packaging tape along the face of the panel, approximately centering the tape over the gap between the panel and the mirror frame. With a sharp knife, cut the tape away where it covers the gap, as shown in *Photo F*.

### Set off the inlay with a stripe

**1** Lay the mirror on a level surface. Then, in a plastic sandwich bag, mix enough 30-minute epoxy to fill the gap between the inlaid panel and the mirror frame. Add some black dye powder (we used Rit all-purpose dye) to the epoxy, and mix it in thoroughly for uniform color. (You need only add enough dye to color the epoxy—it won't take much.)



**E** You can center the back insert in the mirror frame by eye, but four spacers will do the job more accurately. Cardboard or scrapwood will suffice.

**2** Snip one corner off the bag to make about a 1/8" opening. Press the epoxy to the cut corner, and squeeze it into the gap, as shown in *Photo G*. Move the bag along the gap at a moderate, steady pace to allow the epoxy to flow out in the groove. Let the fill stand slightly above the surface.

**3** Allow the epoxy to cure fully. (We left ours overnight.) After it's cured, sand down any high spots with 150-grit sandpaper. Remove the tape, and block-sand the epoxy line flush, with 220- and 320-grit sandpaper.

**4** Mask the mirror glass with packaging tape or masking tape, and spray semigloss lacquer on both sides of the frame. (We applied several coats,

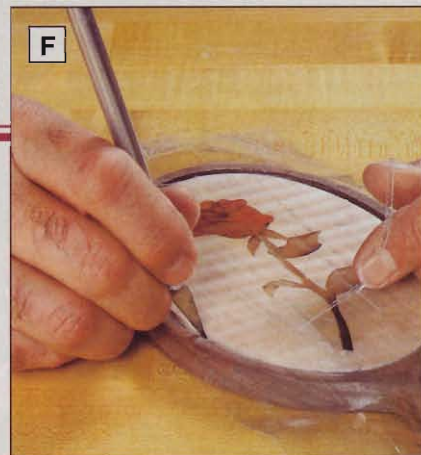

**F** Mask the back insert and the mirror frame with packaging tape. Apply a wide strip along the joint. Then, cut away the tape over the gap between the back insert and the frame.



**G** Borrowing a technique from cake-decorating, squeeze dyed epoxy from a bag into the gap between the back insert and the mirror frame.

sanding with 320-grit sandpaper between coats.)

After the final coat dries, polish the finish. (We did this with a white Scotch-brite pad.) Finally, apply a coat of paste wax, and buff it before unmasking the mirror. ♣

### Buying Guide

**Mirror glass.** Bevel-edge oval mirror glass, 4×6", Item no. 17T06, call for current price and shipping charges, Woodcraft, 800/225-1153.

Project Design: Roy King; James R. Downing  
Photographs: Hetherington Photography  
Illustrations: Roxanne LeMoine; Lorna Johnson

A close-up photograph of a person's hand operating a Makita pneumatic brad nailer. The tool is grey and black with a red trigger. The hand is wearing a blue denim shirt. The nailer is positioned over a piece of light-colored wood. The background is dark. The text 'LOW-COST Brad Nailers' is overlaid in the top right corner. Below the title, a testimonial reads: 'We drove more than 12,000 brads in our quest for the best low-cost pneumatic brad nailer'.

*LOW-COST*  
**Brad  
Nailers**

*We drove more than 12,000 brads  
in our quest for the best low-cost  
pneumatic brad nailer*



Previously considered a tool of finish carpenters and cabinet shops, brad nailers have become a hot commodity in home shops, thanks to the proliferation of low-dough, Taiwanese-made models. All the nailers in our test cost less than \$150 and require only a minimal compressor to bring fast fastening into your woodworking world.

## Fast facts

- A brad nailer makes clampless glue-ups a reality. Apply glue to the joint as normal, then pop a few brads in to hold it all together while the glue sets.
- The fine 18-gauge brads reduce splitting of hardwoods, while still packing plenty of holding power.
- Because you don't have to hold the brad to drive it, you gain a free hand to steady the joining parts. (And no more hammer-flattened fingers!)
- Electric brad nailers perform satisfactorily in softwoods like pine, but are no match for hardwoods. If you work in oak or maple, spring for an air-powered model.

### First, you should know how we tested these tools

Brad nailers have had a reputation for jamming if you look at them cross-eyed. We wanted to see how often that would happen with these low-cost nailers, so we started our test by driving 500 brads from each model into 2"-thick oak. Then, we drove 500 more into 2" pine. Much to our surprise, not a single one of the more

than 12,000 fasteners fired jammed in a nailer.

Still, in the unlikely event a nailer should ever get stuffed in the firing path, we wanted to know how difficult it would be to clear the wreckage. So, our jam session consisted of driving 1½" brads through ¾" plywood backed by ⅜" aluminum plate.

You'll learn about the results of our jam-clearing test a little bit later.

Finally, we put each nailer through a series of real-world applications, observing how well each performed in confined areas, and how accurately we could place a fastener. We also noted the comfort of handles and triggers throughout our tests.

### Driving lessons:

How a puff of air sinks steel

Knowing the basic parts of a pneumatic nailer and how they interact gives you a better understanding of the performance issues we'll discuss. The six steps shown here occur in half a heartbeat.

#### STEP 6

As the piston returns, air in the top of the cylinder is forced out through the exhaust port.

#### STEP 5

The piston bottoms against the rubber bumper, causing it to rebound slightly. Releasing the trigger routes compressed air into the bottom of the cylinder, forcing the piston back to its starting position.

#### STEP 4

The driver shears a fastener off the strip in the magazine, driving and countersinking it into the workpiece.

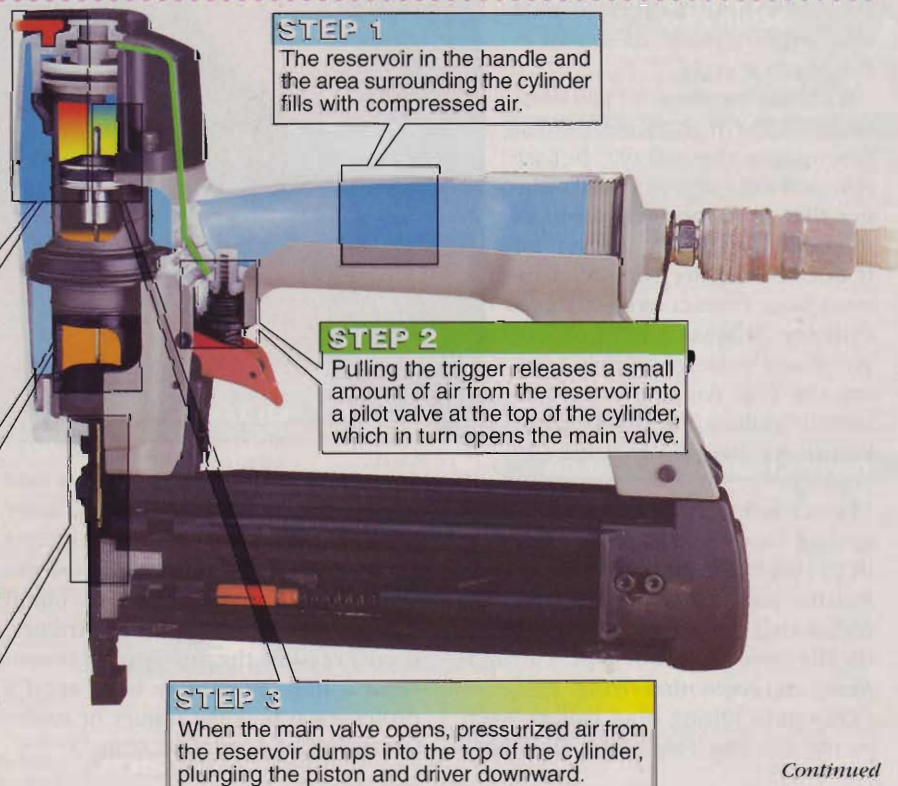

#### STEP 1

The reservoir in the handle and the area surrounding the cylinder fills with compressed air.

#### STEP 2

Pulling the trigger releases a small amount of air from the reservoir into a pilot valve at the top of the cylinder, which in turn opens the main valve.

#### STEP 3

When the main valve opens, pressurized air from the reservoir dumps into the top of the cylinder, plunging the piston and driver downward.

Continued

# Brad Nailers

## How's my driving?

Call 1-800-FILLHOLE

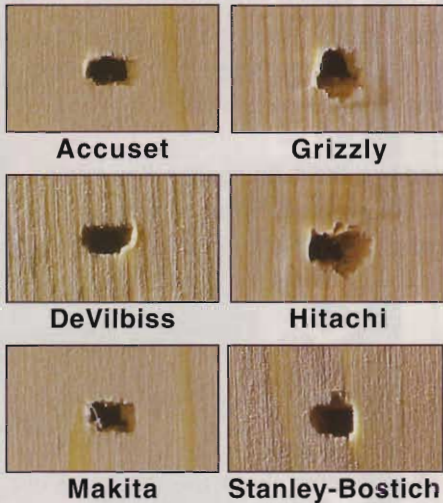

The beauty of pneumatic brad nailers is that they drive and set the fastener in one quick stroke, leaving you with a minimal entry hole to fill. Ideally, the tip of the protruding driver matches the brad, resulting in a  $\frac{1}{16}$ "-deep depression the same size and shape as the brad's head, such as those shown in the left set of photos at *left*. An improperly adjusted nailer can set a brad too deep, or it can also leave the head flush with or slightly proud of your workpiece.

The Airy, Central Pneumatic, Hitachi, and Makita nailers let you adjust the drive depth by loosening two hexhead screws and shifting the

nose plate up or down. Although less convenient than the thumbwheel depth-adjusters on the Accuset, Porter-Cable, and Stanley-Bostitch models, we found this mechanism no less accurate.

Even with models that have no on-tool adjustment mechanism, you can control fastener depth by varying the air pressure at your compressor's regulator. (See "Damage Control" box, *on the opposite page*.) When properly adjusted for the species of wood and length of fastener, the Accuset, Airy, Makita, and Woodtek nailers gave us the best results, with DeVilbiss and Porter-Cable close behind.

## Safety devices

Three types for trigger-happy woodworkers

All pneumatic nailers, large and small, have some manner of safety lockout to prevent you from accidentally firing a fastener. One type of safety, found on the Airy, Central Pneumatic, and Woodtek brad nailers, uses a *dual-trigger* system, as shown in the photo at *right*.

With this mechanism, you must first pull the rear trigger (which disengages the safety), before you pull the main (forward) trigger that fires the brad. Used as intended, this safety works, but it doesn't require the nailer-to-workpiece contact to discharge a fastener. It wasn't long before we found ourselves simply holding the rear trigger, and occasionally pulling the main trigger before we had the tool fully in position.

Better safety-lockout systems use a spring-loaded tip that must be depressed against the workpiece before you can drive a brad. We found two variations on this theme on the models in our test: *contact-firing* and *sequential-firing*.

On contact-firing brad nailers, such as the Campbell-Hausfeld, DeVilbiss,



Grizzly, and Hitachi, the safety and trigger can be activated in any order before firing a fastener. That means you can depress the tip, then pull the trigger, or if you wish, you can "bump fire" the tool, holding in the trigger, then pressing the tip wherever you want a nail. (You may have seen a professional building framer or roofer bump-firing a pneumatic nailer.)

What you gain in speed, though, you can lose in placement precision, so bump-firing is better suited for rough carpentry or areas of your project that won't be seen. One other caveat about contact-fire mechanisms: Sometimes, the recoil of the tool can raise the tip enough to reset the safety, and before you know it, you've fired a second brad in the same spot.

Sequential-fire nailers also utilize a spring-loaded tip, but that tip must be depressed before you pull the trigger. If you lift the nose off the workpiece, you have to release the trigger before the nailer will fire again, making it almost impossible to accidentally fire these models. This style of safety—our favorite—is found

on the Accuset, Makita, Porter-Cable, and Stanley-Bostitch.

You might have noticed that we haven't mentioned the Craftsman nailer yet, and here's why. This nailer switch-hits, allowing you to choose between contact-firing or sequential-firing (depending on the task at hand) simply by flipping a switch located above the trigger.

## In tight corners

Think inside the box



The design of the Airy (left) keeps it from getting in close, like the Stanley-Bostitch (right), when facing a head-on obstacle.

As you can see in the photo above, some brad nailers can drive a fastener very close to a vertical surface in front of them, while others can't. In fact, we found a wide disparity among the models in our nose-in test, with the Craftsman and Stanley-Bostitch nailers placing fasteners  $\frac{1}{4}$ " and  $\frac{3}{16}$ ", respec-

tively, from the "wall." The best we could do with the Airy, Central Pneumatic, and Woodtek models was from  $\frac{3}{4}$ "- $\frac{7}{8}$ ", while the rest fell somewhere between.

One word of caution here: The nailers that did well in this test have an angled magazine heel that helps get

the nose in tight. But, because we have a natural tendency to rest the nailer on its tip and heel, we had to make a conscious effort to keep the magazine parallel to the workpiece when driving a brad in the open. When we didn't, we frequently blew a brad out the side of the workpiece.

## Damage control

Fine-tune your brad nailer for the best results

You wouldn't just walk up to your tablesaw and start cutting up valuable wood without taking the time to make a couple of test cuts in scrap, would you? Neither should you punch brads into your project until you tune up your nailer for the task at hand. Here are a some things you can do to reduce the dings and divots:

•**Adjust air pressure for the species and fastener.** As you know from driving nails by hand, some species of wood are harder and denser than others. Those woods also require more air power to penetrate. Before taking the nailer to your project, take a few test shots into scrap of the same species and adjust your compressor's regulator until you're satisfied with the results. Likewise, the longest brads require more energy to drive than the shortest, so boost or reduce your compressor accordingly.

•**Lighten up.** The depressions shown around the nail holes shown below result from too much downward pressure on the tip of the nailer. After the



tool fires, even a slight recoil can lift it off the workpiece, and you unwittingly slam it back down onto the workpiece. Our advice: Press the tip down only hard enough to accurately locate the fastener and activate the safety tip. Also, models that come with a soft nose cover greatly reduce marring, even in soft woods like pine.

•**Curb side-blowout.** When an air-driven fastener takes a turn for the worse and shoots out the side of your workpiece, it's ugly and dangerous. A brad blows out the side when its chisel point follows the curve of the wood grain, especially in hardwoods like oak and maple. If you find blowout to be a problem, try positioning the nailer so that its body is perpendicular to the face grain. This allows the chiseled point of the fastener to slice across the grain, rather than be guided by it.

# Brad Nailers

## A few more points

to drive home before you decide

•**Jam-clearing.** As we mentioned at the beginning of this article, none of the models jammed during our 1,000-brad test. When we finally did succeed in balling up a brad in the drive path, we found clearing the debris a simple matter on most models.



Porter-Cable's flip-front worked fastest: Depress a spring-loaded lever and the hinged driver-guide cover swings open, freeing the gnarled fastener. Other models, such as the Campbell-Hausfeld, DeVilbiss, and Grizzly,

use a quick-release cover, shown above, that unlatches like the hasp on an old canning jar.

Airy, Central Pneumatic, Makita, and Woodtek require loosening a couple of hexhead screws to remove the driver-guide cover. To open the cover of the Accuset, Craftsman, and Stanley-Bostitch nailers, you must remove three or four screws, which makes clearing a bugged-up brad a pain. And, although Accuset provides a star-drive wrench for the job, it wasn't quite up to the task and contributed to stripping the screw heads.

•**Low/empty magazine indicators.** Besides the frustration of poking empty holes in your workpiece, "dry-firing" a brad nailer—driving when the magazine is empty—shortens its



life by prematurely wearing the bumper. All of the nailers in our test provide a small viewing

window near the front of the magazine so you can tell at a glance if the machine is loaded.

Likewise, most of them have a low-fastener indicator bar that blocks the viewing window as reload time nears. However, Makita's indicator, shown above, is our favorite not only because it counts down the remaining brads from 50-0, but also because, after driving the last brad in the maga-

zine and lifting the nose, it will not let you pull the trigger until you insert more fasteners.

•**Directional exhaust.** A brad nailer's exhaust sometimes contains small amounts of machine oil, which can soil your project. Several of the models we tested have a directional port at the top of the cylinder that rotates by hand to point this exhaust away from you and the workpiece. Although it's not positionable, we liked Accuset's rear-exit exhaust, at right, which directs the air harmlessly out the back of the nailer below the air fitting.



The deflecting plate at the top of the cylinder on the Airy, Central Pneumatic, and Woodtek nailers can be rotated to route exhaust to the front or either side. However, doing so means removing four screws, and repositioning the plate.

•**Extra features.** Although many of the brad nailers we looked at sacrificed bells and whistles for the sake of affordability, there are some exceptions. For example, Accuset's sleek design gives it virtually no hard edges that might ding a workpiece merely by setting down the tool. Campbell-Hausfeld, Makita, and Porter-Cable all use a square-cut O-ring on the driver piston that should last longer than round-cut rings. And Woodtek includes an extra piston and driver assembly should the need ever arise to replace it.

The Makita brad nailer is king of the hill when it comes to niceties. Besides its no-fire-when-empty magazine, you'll also find a one-piece piston and driver assembly (the others have a separate piston and driver), a no-mar rub-ring around the top of the head, and a hook for hanging the tool near your work area. And, because those soft protective tip covers can pop off and get lost, Makita includes an extra and on-tool storage for it.

## Our recommendations

It's time to nail down the winners

No matter what your needs or budget, we're sure there's a brad nailer for you in this group. Our favorite regardless of price is the Makita AF503, owing to its life-extending construction and handy features. Though not as well-featured as the Makita, we also like the Accuset A200BN and Porter-Cable BN200 in the same price range.

For \$100 or less, weekend woodworkers will be perfectly happy with either the DeVilbiss Air Power NB2002X4 or the Grizzly G6047. Both of these models provide single-trigger safety, directional exhaust, and easy jam-clearing. 🌱

MANUFACTURER/IMPORTER	MODEL	FASTENER LENGTHS	CAPACITY	
			MAGAZINE	MAX. AIR PRESSURE
ACCUSET	A200BN	5/8-2"	110	120
AIRY	ATA0249S	5/8-2"	100	100
CAMPBELL-HAUSFELD	NB004099	5/8-2"	100	110
CENTRAL PNEUMATIC	36570-2VGA	5/8-2"	100	100
CRAFTSMAN	18424	5/8-2"	110	100
DEVILBISS AIR POWER CO.	NB2002X4	5/8-2"	100	120
GRIZZLY	G6047	5/8-2"	100	110
HITACHI	NT50AE	3/4-2"	100	120
MAKITA	AF503	5/8-2"	100	115
PORTER-CABLE	BN200SA (kit)	3/4-2"	100	120
STANLEY-BOSTITCH	SB-1850BN	5/8-2"	100	100
WOODTEK	832-378	5/8-2"	100	100

### NOTES:

- (NP) Adjustable nosepiece  
(TW) Thumbwheel  
(\*) None on nailer
- (CF) Contact-fire (SF) Sequential-fire  
(DT) Dual trigger (SW) Switchable between CF and SF

For specifications on other types of tools, click on "Tool Comparisons" at [www.woodmall.com](http://www.woodmall.com).

Written by Dave Campbell Technical consultant: Dave Henderson Photographs: Baldwin Photography

TOP MODELS  
OVER \$100



Makita  
AF503

Accuset  
A200BN

Porter-Cable  
BN200

TOP MODELS  
\$100 OR  
LESS



Grizzly  
G6047

DeVilbiss  
Air Power  
NB2002X4

## 12 LOW-COST BRAD NAILERS GO HEAD-TO-HEAD

CONSTRUCTION				PERFORMANCE RATING (4)												STANDARD ACCESSORIES (6)	DIMENSIONS (HEIGHT X LENGTH, INCHES)	WARRANTY	COUNTRY OF MANUFACTURER (7)	WEIGHT (POUNDS)	SELLING PRICE (8)	COMMENTS
DRIVE-DEPTH ADJUSTMENT (1)	TYPE OF SAFETY SWITCH (2)	DISTANCE FROM VERTICAL OBSTRUCTION (INCHES)	DIRECTIONAL EXHAUST (3)	IN OAK		IN PINE		JAM CLEARING	LOADING/CHANGING FASTENERS	DEPTH-SETTING ADJUSTMENT	HANDLE COMFORT	TRIGGER COMFORT	LOW/EMPTY MAGAZINE INDICATOR									
TW	SF	5/8"	N	E	E	E*	E	E	E	F	E	E	E	E	E	C.G. O.W	8 3/4 x 10	2 yrs.	T	3.4	\$135	Comfortable handle and trigger, and thumbwheel depth-setting. Hard to disassemble in the rare event of a jam. Long warranty.
NP	DT	3/4"	Y*	G	E	G	F	E	E	G	G	G	G	G	P	C.O.W	8 1/2 x 9 3/4	1 yr.	T	3.1	95	Low-cost, no frills nailer. Does not come with air fitting.
*	CF	3/8"	Y*	E	E	G**	G	E	E	E	N/A	G	G	F		B.C.G. O.W	9 1/2 x 9 1/2	3 yrs.	T	2.8	129	Flip-front nailer allows easy removal of jammed fasteners. The longest warranty in the test.
NP	DT	3/4"	Y	G	G	F	F	E	G	G	G	G	G	F	F	W	8 1/2 x 9 3/4	2 yrs.	T	3.2	80	Least expensive nailer in the test, but adequate for most nailing tasks. Long warranty. Does not come with air fitting.
*	SW	1/4"	Y	E	E	G	G	E	E	G	E	N/A	G	E	F	O.W	9 3/4 x 9	1 yr.	T	2.7	125	Unique switchable safety mode offers flexibility in use. Angled magazine helps in tight spots and on moldings.
*	CF	5/16"	Y	E	G	G	E	E	E	G	N/A	G	F	F		B.C.G. O.W	8 1/4 x 9	1 yr.	T	2.8	99	Low-cost nailer with an angled magazine that gets in tight for nose-in applications.
*	CF	3/8"	Y	E	E	G	G	E	E	E	G	N/A	G	E	G	B.C.G. O.W	10 x 9 1/2	1 yr.	T	3.2	100	A long-time player in the low-cost nailer field, and a solid performer.
*	CF	1/2"	Y	E	E	G	G	E	E	G	G	G	G	G	G	B.C. G.O	9 3/4 x 10	1 yr.	T	3.2	110	Middle of the pack both in price and performance. Dated magazine design.
NP	SF	3/8"	Y	E	E	E*	E	E	E	G	E	E	E	E	E	C.G.O. T.W	9 3/4 x 9 3/4	1 yr.	T	3.2	139	Our favorite in the test, this feature-packed nailer includes such niceties as on-tool spare-tip storage and a belt clip.
T.M	SF	3/16"	Y	E	G	E*	E	E	E	E	E	E	E	E	E	B.C.G. O.W	10 x 10	1 yr.	T	2.8	149	The most expensive in the test, but a top performer with square-cut O-rings on the driver for durability.
TW	SF	5/16"	Y	E	G	E*	E	E	E	G	E	E	G	F	G	B.C.O	9 1/2 x 9 3/4	1 yr.	T	2.7	125	Angled magazine gets fasteners into tight spots.
NP	DT	13/16"	Y*	G	E	G	F	E	E	G	G	G	G	G	P	B.C.D. O.W	8 1/4 x 9 3/4	1 yr.	T	3.1	147	Identical to the Airy model. For the extra \$48, though, you get a spare driver (which you're not likely to ever need).

3. (\*) Adjustable only by removing and rotating top plate.

4. **E** Excellent  
**G** Good  
**F** Fair  
**P** Poor

5. (\*) Rubber tip reduced recoil.  
(\*\*) Nailer occasionally double-fired.

6. (B) Brads (G) Safety glasses  
(C) Case (O) Oil  
(D) Extra driver (T) Extra tip  
(W) Wrenches

7. (T) Taiwan  
8. Prices current at time of article's production. Shipping (where applicable) not included.

### FOR MORE INFORMATION CALL:

Accuset  
888/222-8144  
www.accuset.com

Airy  
888/835-2479  
www.airy.com

Campbell-Hausfeld  
800/543-8622  
www.campbellhausfeld.com

Central Pneumatic  
(Harbor Freight)  
800/423-2567  
www.harborfreight.com

Craftsman  
800/377-7414  
www.sears.com/craftsman

DeVilbiss Air Power Co.  
800/888-2468  
www.devap.com

Grizzly  
800/523-4777  
www.grizzly.com

Hitachi  
800/706-7337  
www.hitachi.com

Makita  
800/462-5482  
www.makitatools.com

Porter-Cable  
800/487-8665  
www.porter-cable.com

Stanley-Bostitch  
800/556-6696  
www.StanleyWorks.com

Woodtek  
(Woodworker's Supply)  
800/645-9292

# AYBILL®

LUNT-FONTANNE THEATRE

# Bright Idea For A Turning

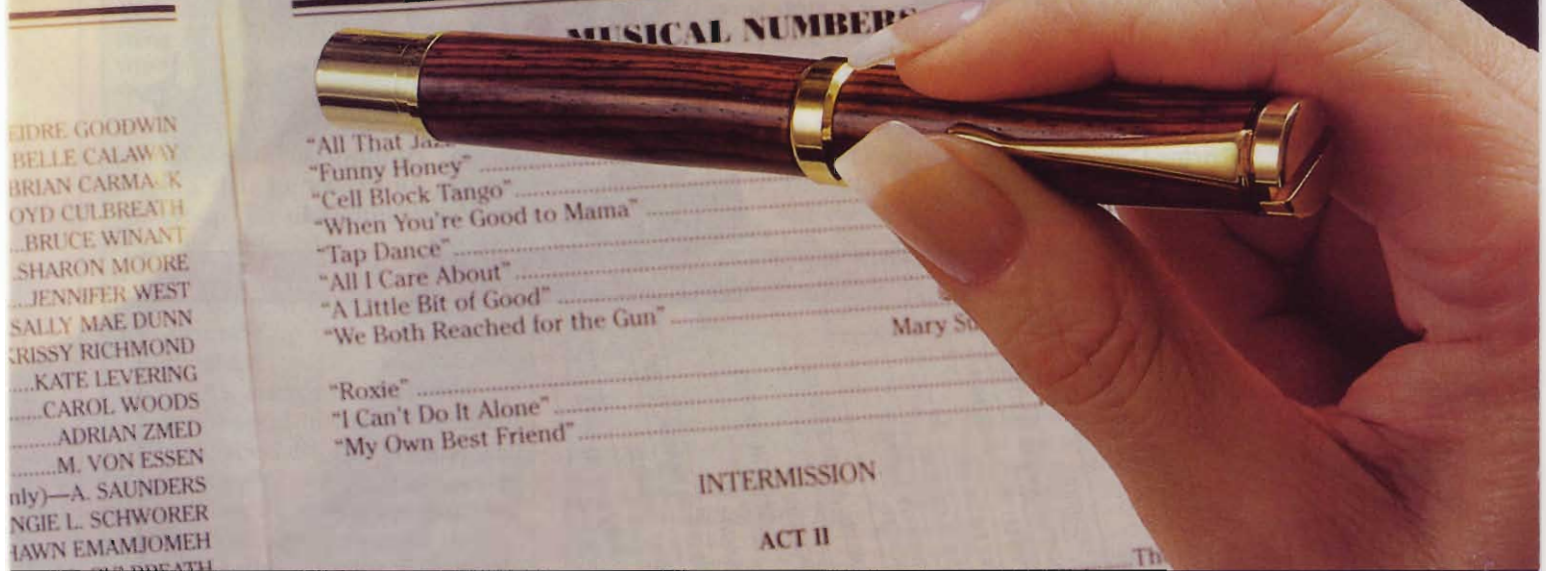

**You'll be able to turn this novel penlight in a flash. It's just one more shining example of the fun you can have with your lathe.**

### Prepare a pair of turning blanks

**1** The pocket penlight calls for two  $\frac{3}{4} \times \frac{3}{4} \times 2 \frac{1}{8}$ " blanks. Highly figured woods and exotic species that show striking grain or color make terrific-looking penlights. Laminated blanks and plastic pen-turning materials also give great results.

**2** Locate the center on one end of each blank. At the center, drill a  $\frac{3}{16}$ " hole lengthwise through each blank. (We did this on a drill press, clamping the blanks to a fence for stability.)

**3** On the blank that will become the top section of the body, draw the lengthwise hole's centerline along one face. Mark a center on the line  $1 \frac{1}{32}$ " from the top end of the blank. At the mark, drill a  $\frac{1}{4}$ " hole through the face into the lengthwise hole.

**4** Epoxy-gue a brass tube into each blank. (The tubes come with the flash-light kit listed in the Buying Guide.) Don't get glue on the area of the upper tube that will be exposed by the hole in the side of the blank. Electrical contact between the tube and the penlight's pocket clip turns the light on. Epoxy acts as an insulator, so covering the exposed area of the tube with glue would keep the light forever off.

Here's a way to glue the tube into the top blank that ensures unimpeded current flow. First draw a square around the contact point on the tube, as shown in *Photo A*. Then, with a toothpick, coat the lengthwise hole in the blank with epoxy—except spread none in the yellow area shown in the cutaway blank in *Photo B*.

Press the tube into the blank, keeping the marked area aligned with the hole in the blank. As the marked area slides into the bore of the blank, apply epoxy to the tube below it, and press the tube on in, until flush at the

top end of the blank. Clean any glue out of the tube ends. (Acetone is the solvent for epoxy.)

**5** After the epoxy cures, sand the ends of the blanks square and flush with the ends of the tubes.

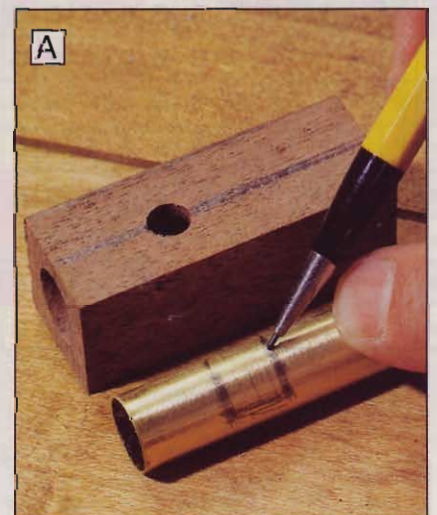

**Mark the area on the brass tube that will be exposed by the hole in the top blank. Allowing a little extra is a good idea.**

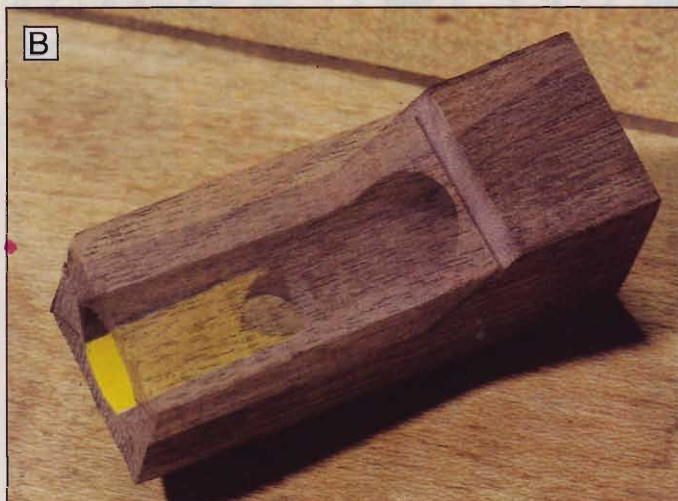

**B** When gluing the tube into the top blank, swab epoxy on the hole wall, except for the yellow-marked area.

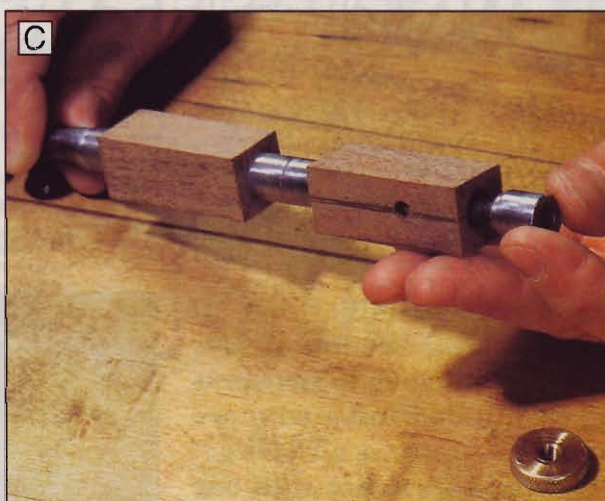

**C** Slide the blanks and sizing bushings onto a standard pen-turning mandrel.

### Turn two tubes for the body

**1** Slide the blanks onto a pen-turning mandrel with the correct sizing bushings (see the Buying Guide), as shown in *Photo C*. Mount the mandrel between centers on your lathe.

**2** With a gouge, rough-turn both blanks to a diameter slightly larger than the bushings. Then finish-turn the blanks to the bushing diameter. We made the final cut with a 1" skew. Check the turnings with a straight-edge to ensure straight sides.

**3** Finish-sand the turned tubes. (We sanded with 150-grit sandpaper with the lathe running; then turned off the lathe, and sanded in the direction of the grain to remove circumferential scratches. We repeated this with 220-grit sandpaper.) Sand with a block to keep the tube sides straight.

**4** Finish the tubes. A lathe-applied finish, such as turner's polish or HUT pen polish, makes the job easier. Clean finish off the exposed tube.

### Assemble the penlight

**1** Press the lamp head into one end of the bottom tube, using a bench vise.

**2** Press the black plastic insert into the top of the upper tube—the one with the hole. The insert goes into the end farthest from the hole, and the relief in it lines up with the hole, as shown in *Photo D*.

**3** Install the coupling ring into the upper tube. Join both tubes together.

**4** Put the coil spring onto the nib on the threaded end cap. Install the cap and clip, positioning the end of the clip over the hole in the upper tube.

To install the batteries (two AAA) and the bulb, unscrew the penlight tip.

Finally, adjust the pocket clip so it works as a press-to-light switch. To do this, bend the clip out slightly at the top. (We used needle-nose pliers to bend the metal, wrapping the jaws with tape to prevent marring.) This prevents the end from contacting the brass tube unless pressed down.

### Buying Guide

**Flashlight pen kit, bushings, mandrel.** Penlight kit includes all metal and plastic parts plus bulb (batteries not included), item 124665; bushing set for penlight, item 124580; pen-turning mandrel, item 06R01 (Morse taper #1) or 06R02 (MT #2). Woodcraft, call 800/225-1153 for current prices and to order. ♣

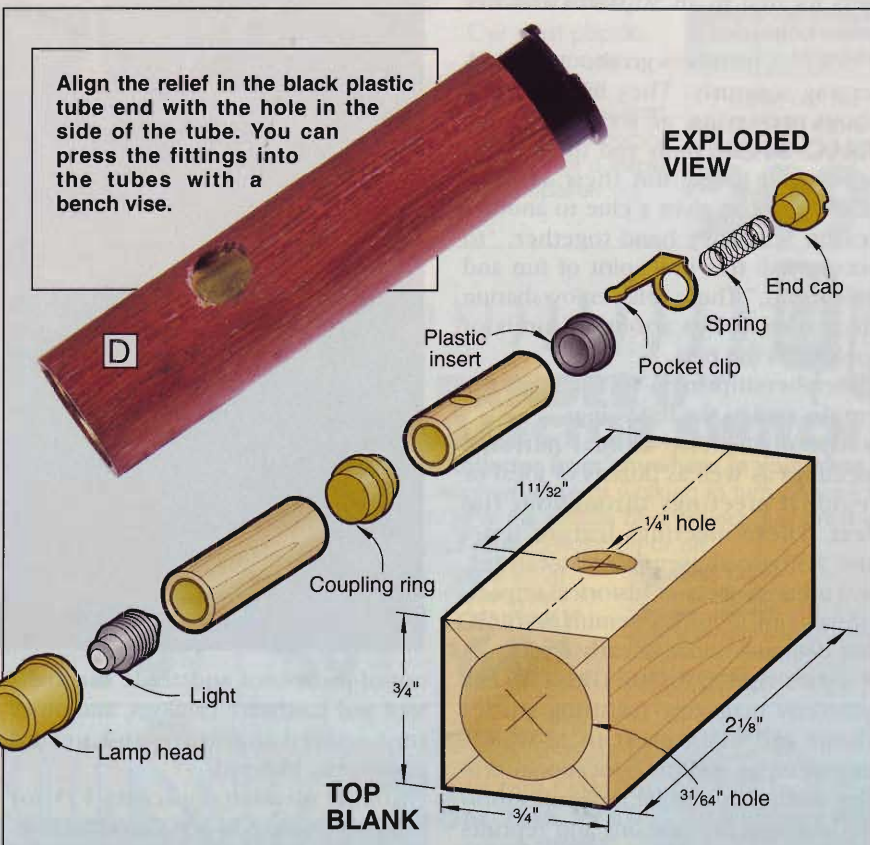

Project Design: Mark Tudor Photographs: Hetherington Photography Illustrations: Roxanne LeMoine; Lorna Johnson

# Woodworking Associations You Should Know About.....

The sweet satisfactions of woodworking needn't always be solitary, thanks to networks of like-minded folks who are eager to share knowledge, skills, and experience with one another. If you're seeking fellowship and camaraderie, you just might find it in one of these organizations.

## Mid-West Tool Collectors Association

The Mid-West Tool Collectors Association (M-WTCA) was started by 16 avid Chicago-area tool collectors in 1968. Now it numbers 4,000 members located in all 50 states and five other countries.

M-WTCA members go about tool collecting seriously. They feel strongly about preserving, as well as learning about, old-time tools and the artisans who used them. But their association's purpose gives a clue to another reason why they band together: "to accomplish this in a spirit of fun and fellowship." These folks enjoy sharing their discoveries about all kinds of tools from the past.

Membership in M-WTCA basically entitles you to the following:

- Attend the two annual national meetings as well as dozens of local or regional meetings throughout the year. These meetings feature tours and visits to museums, restorations, and other sources of historical impact, along with lectures, seminars, films, and demonstrations of early crafts.

- A subscription to *THE GRISTMILL*, a quarterly magazine featuring stories about and of interest to M-WTCA members, as well as educational articles written by and for tool collectors.

- Numerous publications and reprints prepared by the association, including



out-of-print tool and trade manuals, tool and hardware catalogs, and other tool-related literature and period advertising material.

Annual membership costs \$25 for U.S. residents, \$33 for Canadian residents, and \$40 for overseas members.

For more detailed information about M-WTCA and a membership application, write: John Wells, Mid-West Tool Collectors Association, P.O. Box 8016, Berkeley, CA 94707-8016. Or check out the M-WTCA website: <http://www.mwtca.org>.



ASSES THE NICKEL TEST. TURNS ON A TIME.



### The American Association of Woodturners

With 8,000 members and 135 local chapters, The American Association of Woodturners (AAW) boasts that it's the largest organization in the world dedicated to the advancement of woodturning. AAW's mission is to provide education, information, and organization to anyone interested in using a lathe to shape wood.

Benefits of membership in AAW include the following:

- A subscription to *American Woodturner*, a quarterly publication packed with a wide array of articles focusing on everything from basic woodturning techniques and special projects to innovative design ideas.

- The annual AAW Resource Directory, which lists the names and addresses of all members, also has sources of supply, contact information for local chapters and workshops, and a list of books and videos you can order.

- A network of local chapters across North America that offer monthly meetings, woodturning demonstrations, and a close-knit community of woodturning friends with lots of experience and free advice.

- A chance to attend the AAW National Symposium, which features dozens of renowned demonstrators who share their skills and insights.

Recent piece by Leon Lacoursier in an international show sponsored by AAW. Photograph: Larry Mart

Also, regional symposia and chapter-sponsored workshops are held throughout North America.

An individual AAW membership costs \$25 per year and includes the quarterly *American Woodturner*. For more information and an application, write: The American Association of Woodturners, 3499 Lexington Ave. N., Suite 103, Shoreview, MN 55126. Or you can visit the AAW website: <http://www.woodturner.org>.

### The Ward Foundation

Some people consider wildfowl carving and painting a craft, but to the members and staff of The Ward Foundation, it's an art—the only art form, they say, that really is native to North America.

Named in honor of Steve and Lem Ward, brothers considered pioneers of decorative bird carving, the foundation is dedicated to wildfowl carving and painting and to the historical, educational, and environmental aspects of the art.

The Ward Foundation sponsors international competitions, such as the World Carving Championships in Ocean City, Maryland, each April; exhibitions; seminars; workshops; and a museum program. New carvers—who design their work to “be a bird”—have picked up the skills of older masters, whose sole purpose was to create a decoy that would “catch a bird.”

The Ward Foundation supports the Ward Museum of Wildfowl Art, a Salisbury, Maryland, institution that tells the story of decoy and waterfowl



Photograph: Ernie Sparks, courtesy of the Ward Museum of Wildfowl Art

carving through displays of classic hunting decoys and works by today's carvers. Dioramas, videos, and interpretive exhibits re-create the world of wildfowl at the unique museum.

Individual memberships cost \$35 per year and include a subscription to *Wildfowl Art Magazine* (a well-done, colorful quarterly), free admission to the museum year-round, invitation to

members-only preview parties and events, a 10% discount on museum gift shop items, discounts for workshops and seminars, and a museum window decal. For more information and a membership application, contact: The Ward Museum of Wildfowl Art, 909 South Schumaker Drive, Salisbury, Maryland 21804. Website: <http://www.wardmuseum.org>.

*Continued*

## International Wood Collectors' Society

The 1,700 active members of the International Wood Collectors' Society (IWCS) have one thing in common—a reverence for wood. Many turn their wood into bowls, lamps, sculpture, jewelry, and other items. Others merely collect samples.

Founded in 1947, the society embraces professionals and novices worldwide. Among its members are scientists, botanists, dendrologists (those who study trees), craftspersons, educators, and folks who just enjoy wood.

The founders started IWCS with a strong emphasis on the academic collecting of species of wood from all over the world. The availability of this wide variety of woods and their inherent beauty quickly lead to crafting those woods. IWCS interests include:

- Academic wood collecting and sample trading.
- Harvesting wood from around the world for crafting and samples.
- Crafting with identified woods.
- Sharing information about wood around the world.
- Sharing information about trees and wood forests.
- Promoting good ecology and sound forest management.

In addition to IWCS's annual meetings, members hold regional events where wood is displayed and auctioned, ideas are exchanged, and wood samples are traded.

IWCS publishes the monthly *World of Wood* that tells members about events, craftspersons, and interesting developments. It also distributes an annual membership directory. Both publications are included in the IWCS annual membership fee of \$30. For information and a membership application, write: Bill & Myrtle Cockrell, Secretary/Treasurer, 2300 West Rangeline Road, Greencastle, IN 46135-7875. Or visit the society's web site: <http://www.woodcollectors.org>.

## National Wood Carvers Association

With the motto "Some carve their careers, others just chisel," a few whittlers, concerned that carving was dying out, founded the National Wood Carvers Association (NWCA) in 1953. Today, there are more than 56,000 members in each of the 50 states and in 47 countries all the way from Australia to Zimbabwe.

Unlike some organizations, NWCA is loose-knit and laid-back, with no formal national conventions, meetings, or tightly phrased bylaws. Election of officers, held every three years, is by mail-in ballot. But when NWCA promises to do "anything that aids the carver," they honestly try to deliver.

Within the pages of *Chip Chats*, NWCA's bimonthly magazine, readers find answers to carving questions, project designs, solutions to carving problems, craftsman profiles, hints on techniques, news of shows and events, lists of suppliers, and lots of personal attention.

*Chip Chats* offers 148 to 164 informative pages—many with color photographs—that are the lifeline that ties the NWCA members together. To carvers in the association's nearly 300 affiliated clubs, the magazine is NWCA.

For the \$11 annual dues (\$14 outside the U.S.), you receive *Chip Chats* and "rewarding and enriching" fellowship. For more information, a membership application, and a few sample pages from the magazine, write: National Wood Carvers Association, P.O. Box 43218, Cincinnati, OH 45243. You can also click on the association's website: <http://www.chipchats.org>



## Scrollsaw Association of the World

With just 600 members and a history that dates back to early 1998, the Scrollsaw Association of the World (SAW) is a new kid on the woodworking block. But it has all the attributes of an up-and-coming organization that can benefit scrollsawyers everywhere. Well, almost everywhere. Log onto SAW's website and you can immediately choose to view the pages in English, French, German, Italian, Portuguese, or Spanish!

SAW has a newsletter, too. *Saw Dust* comes out quarterly, and is loaded with tips, links to other web sites, and news about an ever-growing roster of local chapters. SAW also sponsors get-togethers, including an annual picnic.

Annual dues are \$20 for U.S. residents, \$25 for members in Canada and Mexico, and \$30 for overseas scrollers. Membership includes a subscription to *Saw Dust*, a copy of SAW's Resource Directory, and all the association's specialty pub-

lications. For an application, write: Scrollsaw Association of the World, 610 Daisy Lane, Round Lake Beach, IL 60073-2219. Also see SAW's website: <http://members.spree.com/saw-online/Join/Application.htm>.



## Early American Industries Association

You say you're interested in farm implements and dairy equipment; woodworking, metalworking, and leatherworking tools; textile machines; lighting devices; domestic utensils; hunting, fishing, or nautical equipment; medical and dental equipment; scientific instruments; weighing and measuring devices; industrial equipment; or vehicles? Then perhaps the more than 3,000 members of the Early American Industries Association (EAIA) can give you a helping hand.

Researching the old ways and sharing that research through publications is a primary activity of this group. In the *Chronicle*, the association's quarterly magazine, members describe past technology, current collecting, preservation techniques, and other related subjects. *Shavings*, a bimonthly newsletter, reports on meetings and activities. And, hot off the press, the association's 1,176-page *Directory of American Toolmakers* (the cost of



which is \$65) identifies more than 14,000 makers of tools who worked in Canada and the United States before the 1900s.

At EAIA meetings, members exhibit and view collections; add to them with tool sales and exchanges; and learn of bygone techniques and domestic industries through demonstrations, exhibits, and seminars.

Individual membership is \$30 per calendar year and includes the periodicals, plus an annual membership directory. For more information and a membership application, write: Early American Industries Association, c/o Elton Hall, Executive Director, 167 Bakerville Road, South Dartmouth, MA 02748-4198. Or visit the EAIA web site: <http://www.eaiainfo.org/>.

## The American Marquetarian, Inc.

Formed in 1997, this small but vibrant group of enthusiasts has banded together to promote marquetry, a woodworking technique from 13th-century Italy. They're also dedicated to helping marquetarians of all levels to further their skill and artistic talent.

Like most other woodworkers we know, the members of this organization love to share their knowledge and tricks of the trade, in this case by demonstrations and by articles in the 16-page quarterly newsletter.

The \$20 yearly membership, plus a \$5 new-member fee, entitles you to the newsletter, access to the group's expert marquetarians, participation in shows, a membership roster, a pattern library, and a listing of all sources of veneers and other supplies.

If you're interested in learning more about this society, write: Jim Sweet, AMI membership officer, P.O. Box 3502, Saratoga, CA 95070. Website: <http://www.bevcomm.net/~ami>.



# Workshop Rest Stop

Relieve tired legs with this sturdy stool



We call our craft woodworking, but for most hobbyists, being in the shop offers a chance to relax while they get immersed in a project. This custom shop stool can help you avoid the strain of being on your feet or bending over a workbench all day. And to help hone your skills, we'll show you step-by-step how to make the intersecting sliding dovetail joints that help lock the legs in place.

## Prepare stock, and start with the platform

**1** Start by edge-gluing two wide panels for the platform (A) and seat (C). (We chose 5/4 ash as the material for our shop stool.) After the glue cures, sand the joints, and trim the panels to rough blanks—13½" square and 16" square, respectively. (See the Bill of Materials for the finished sizes.)

**2** Mark a pair of intersecting diagonal lines (corner to corner) on the underside of the platform blank. Then use a compass to draw a 12½"-diameter circle, centered where the diagonals intersect. Drill a ⅛" hole at the center.

**3** Trim the corners off the platform blank to create a rough octagon (which makes for easier clamping and routing access); then set it upside down on the workbench.

## Rout sliding dovetails for sturdy leg connections

**1** The sliding dovetail joint, sometimes called a French dovetail, isn't complicated, but it does require that you fit the mating parts precisely. Cut a 12"-long setup block from ¾" plywood. The block's width should be equal to the router base diameter, and you'll need a centerline at each end.

**2** Align the block's centerlines with one of the diagonals on the underside of the platform; then clamp a pair of guide boards in place alongside it (*Photo A*). Remove the setup block.

**3** Rout a ½"-wide groove (⅜" deep)

along the first diagonal; then repeat the same setup and routing procedure for the second diagonal groove.

**4** Next, add two centered layout marks  $\frac{1}{2}$ " apart on the ends of the centering block, and reposition it over one of the grooves you just routed. Add a couple of  $\frac{3}{16}$ " spacers (drill bits work great) along each edge; then reclamp the outer guide boards in place again (*Photo B*). Then, once again, remove the setup block.

**5** Install a  $\frac{1}{2}$ "-diameter,  $14^\circ$  dovetail bit in your router, and adjust the cutting depth to  $\frac{7}{16}$ ". (See the Dovetail detail drawing). Start the cut at one end of the groove, keeping the router base up against one of the guide blocks. Make a return pass along the other guide block, making sure you don't lift the router during the cut. Then change the setup and follow the same procedure on the second diagonal. You now have two perpendicular dovetailed grooves intersecting at the center of the platform.

*Continued*

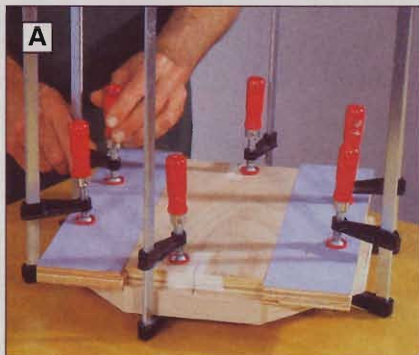

**A** Mark centerlines on each end of your setup block, align with the first diagonal, and clamp routing guides in place.

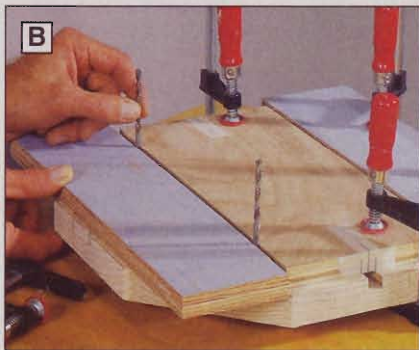

**B** After routing the rough grooves, reinstall the setup block and the guides, now spaced  $\frac{3}{16}$ " apart. Then remove the setup block and rout the dovetail slot.

### EXPLODED VIEW

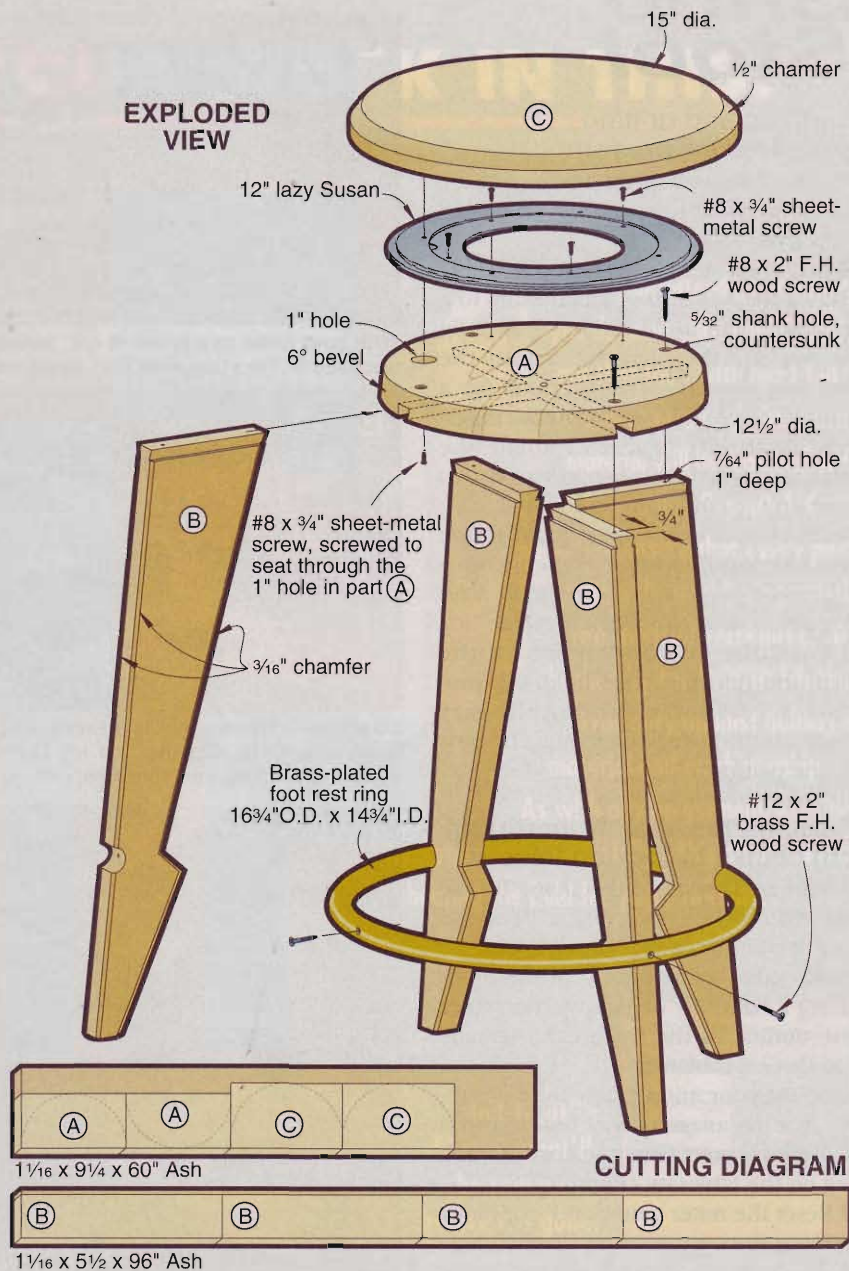

### DOVETAIL DETAIL

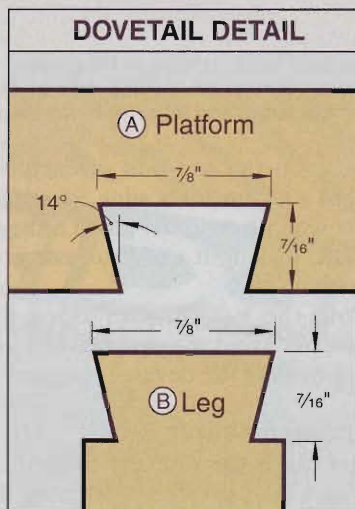

### Bill of Materials

Part	Finished Size			Mati.	Qty.
	T	W	L		
A platform	$1\frac{1}{16}$ "	$12\frac{1}{2}$ "	$12\frac{1}{2}$ "	EA	1
B leg	$1\frac{1}{16}$ "	5"	$23\frac{3}{4}$ "	A	4
C seat	$1\frac{1}{16}$ "	15"	15"	EA	1

**Materials Key:** EA—edge-glued ash, A—ash.

**Supplies:** #8x2" flathead wood screw; #12x2" flathead brass wood screws; #8x $\frac{3}{4}$ " panhead sheet-metal screws.

**Buying Guide:** Brass-plated foot-rest ring, #AD-S290, \$12.95; 12" lazy Susan bearing, #AD-S2149, \$6.45. Van Dyke's Restorers, P.O. Box 278, Woonsocket, SD 57385, or order by calling 800/558-1234.

along the first diagonal; then repeat the same setup and routing procedure for the second diagonal groove.

**4** Next, add two centered layout marks  $\frac{1}{2}$ " apart on the ends of the centering block, and reposition it over one of the grooves you just routed. Add a couple of  $\frac{3}{16}$ " spacers (drill bits work great) along each edge; then reclamp the outer guide boards in place again (*Photo B*). Then, once again, remove the setup block.

**5** Install a  $\frac{1}{2}$ "-diameter,  $14^\circ$  dovetail bit in your router, and adjust the cutting depth to  $\frac{7}{16}$ ". (See the Dovetail detail drawing). Start the cut at one end of the groove, keeping the router base up against one of the guide blocks. Make a return pass along the other guide block, making sure you don't lift the router during the cut. Then change the setup and follow the same procedure on the second diagonal. You now have two perpendicular dovetailed grooves intersecting at the center of the platform.

*Continued*

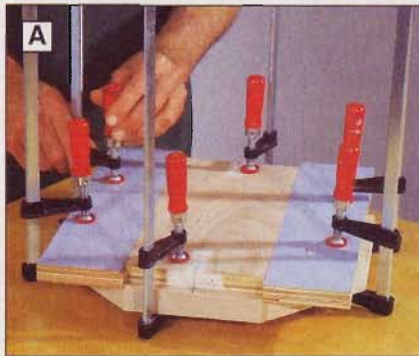

Mark centerlines on each end of your setup block, align with the first diagonal, and clamp routing guides in place.

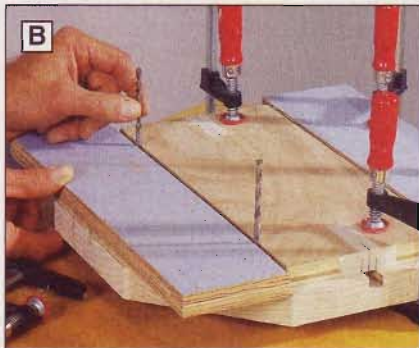

After routing the rough grooves, reinstall the setup block and the guides, now spaced  $\frac{3}{16}$ " apart. Then remove the setup block and rout the dovetail slot.

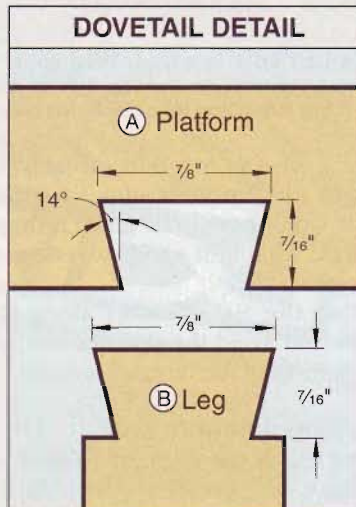
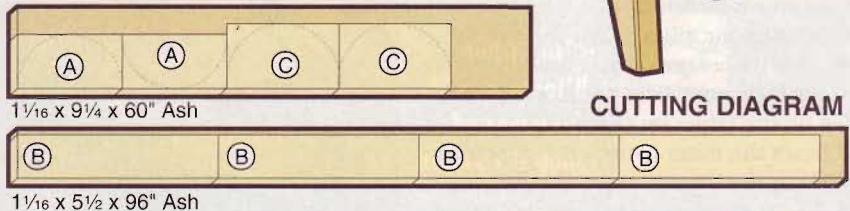
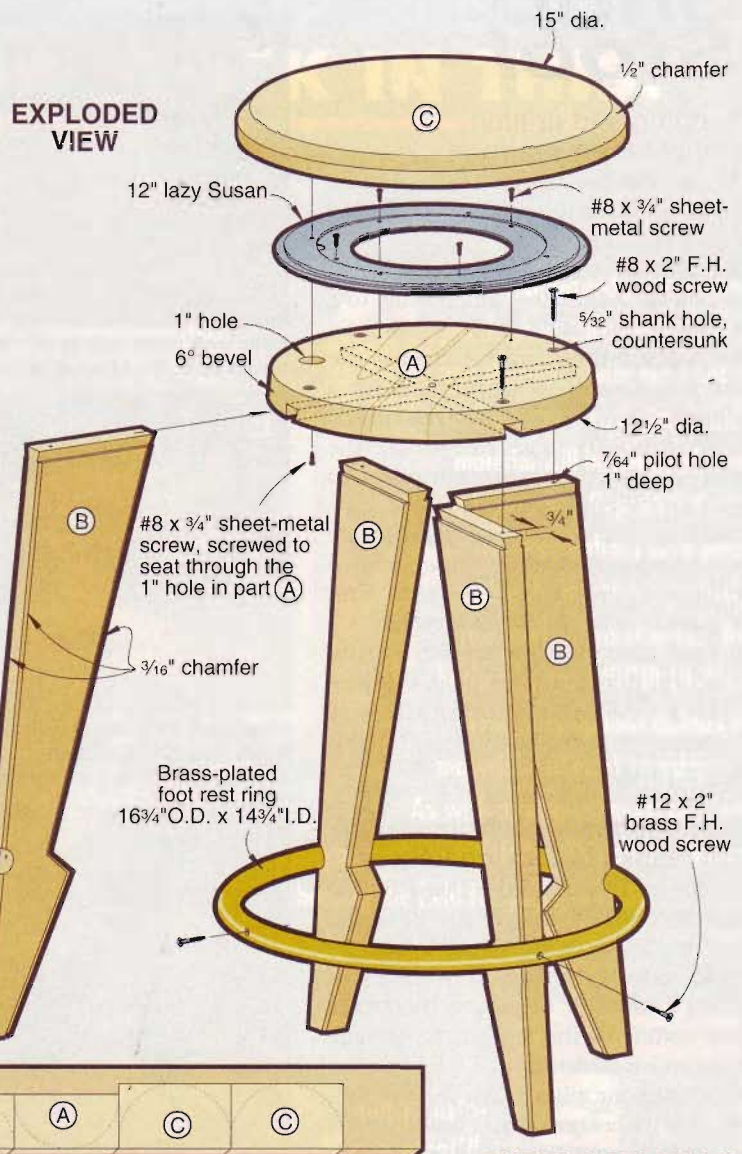

Bill of Materials					
Part	Finished Size			Mater.	Qty.
	T	W	L		
A platform	1 1/16"	12 1/4"	12 1/2"	EA	1
B leg	1 1/16"	5"	23 1/2"	A	4
C seat	1 1/4"	15"	15"	EA	1

**Materials Key:** EA-edge-glued ash, A-ash.

**Supplies:** #8X2 flathead wood screw; #12X2 flathead zinc-plated wood screws; #8X3/4 panhead sheet metal screws.

**Buying Guide:** Chrome-plated foot-rest ring, #200BAR \$11.95, Order 4 or more for \$9.95. 12" lazy-susan bearing, #300.S-12 \$5.85. Schleich & Sons, 720 14th Street, Katonah, IA 52247. Call 500-348-6883

# Shop Stool

## Sanding and drilling complete the platform

**1** Use a bandsaw or jigsaw to trim the platform blank to within  $\frac{1}{8}$ " or less of the circle outline.

**2** A disc sander works best for truing the circle. Adjust the sander table to a  $6^\circ$  angle, and use a circle sanding jig to position the platform against the sanding disc. (For instructions for a simple circle jig, see *WOOD*® magazine issue 110, page 28.) Rotate the platform on the jig's pivot point to true up the entire circumference.

*Note: If you don't have appropriate sanding equipment, a router with a trammel guide can be used to trim the circle to its finished diameter.*

**3** Drill the 1" hole shown in the Platform drawing. This hole will provide access for mounting the lazy Susan bearing that connects the seat to the platform.

## Forming the legs: from rough-cut blanks to locking joinery

**1** Start by laying out the shape of one leg (B) on a 24"-long blank. (See the Leg Profile drawing.) Rough-cut the inside edge to within  $\frac{1}{8}$ " of the lines, using a bandsaw or jigsaw; then trace the outline of the leg on the remaining three 24" blanks.

**2** Adjust your miter gauge for a  $6^\circ$  cut, fit it with an auxiliary fence and a stopblock, and trim the top of each leg on the tablesaw (*Photo C*).

**3** Reset the miter gauge and stopblock and cut the bottom angle on each leg.

**4** To clean up the cuts on the inside edges, use double-faced tape to adhere guides along the layout lines on the first leg. Install a flush-trim bit in your router table and trim the edge to shape (*Photo D*). Then use this leg as a template to trim the other three, again by adhering them to the pattern leg with double-faced tape.

**5** Next, clamp the legs together in pairs (outside edges back-to-back) and drill the 1" holes that create the notches for the foot ring (*Photo E*).

**6** Take the same dovetail bit you used earlier for the platform dovetail grooves and install it in your router table. After tuning the settings and test-cutting a scrap piece—one pass on each face—rout the dovetail



With your miter gauge set at a  $6^\circ$  angle, trim the top of each leg. Then reset the miter gauge to  $6^\circ$  the other direction, reset the stopblock, and cut the bottom ends.



Use tape-adhered guide blocks and a flush-trim bit to rout the first leg to final shape. Then use it as your template.



To make the half-round notches for the foot ring, clamp legs back-to-back and drill a 1" hole right on the centerline.



Make test cuts in scrap, then rout the dovetail "tenon" on the top end of each leg. A tall fence and follower block help.

tongue on the top end of each leg (*Photo F*). Aim for a snug fit—these joints won't have to be glued if the fit is tight, making it easier to assemble everything later.

**7** Rout the  $\frac{3}{16}$ " chamfer along the edges, but avoid the ring notches and the corners of the dovetail tongues.

## Fashion a simple seat

**1** The seat is the simplest component of the whole project. Start with the 16" square blank you glued up and cut



Two of the legs will have to be tapped in toward the center to make clearance for the foot ring, which installs from the top.

to size earlier. Draw diagonal lines on the underside to locate the center, and use a compass to mark the 15" diameter of the finished circle.

**2** If necessary, drill a shallow  $\frac{1}{8}$ "-diameter hole for the pivot pin on your circle-sanding jig.

**3** Use a bandsaw or jigsaw to rough-cut the seat blank close to the outline; then set up the circle jig again to sand to the finished diameter.

**4** Rout a  $\frac{1}{2}$ " chamfer around the top edge of the seat.

United States  
and Canada  
**13.7%**

# WOOD worldwide

## how much is out there?

Latin America  
**27.5%**  
(Mexico, Central  
& South America)

In the 1990s, public attention focused on forests perhaps more than at any other time in history. Media coverage of rainforest destruction disclosed what was going on in South America. In the United States, the concern to preserve endangered species, such as the spotted owl and the red cockaded woodpecker, slowed and sometimes even halted logging operations in areas of the Pacific Northwest and the South.

People began to realize that tropical rainforests and temperate old-growth forests represented much more than lumber. Ecological concerns began to grow larger than economic ones. And the forest products industry and other business interests began to recognize that, too. This report tells you what's happening to the world's wood today.

## Worldwide, where do the trees go?

For statistical purposes, in the global wood industry there are only two general use categories. **Fuelwood** means trees burned directly as firewood for heat and cooking. **Industrial roundwood** refers to trees sawn for lumber, peeled for plywood, or made into paper and other processed products. In the information boxes below you'll see how the world's wood was used in 1997, the latest available data at press time.

### Annual worldwide use of wood

- **Fuelwood**  
=1.87 billion cubic meters  
(If sawn into lumber, that would be roughly 790 billion board feet, not factoring in waste.)
- **Industrial roundwood**  
=1.48 billion cubic meters  
(approximately 628 billion board feet)

### Which country produces the most industrial roundwood?

•The United States and Canada combined account for approximately 40 percent of worldwide industrial roundwood. Here's the breakdown:

North America	40.4%
Europe	20.2%
Asia/Pacific	18.1%
Latin America	10.1%
Russian Federation	6.7%
Africa	4.5%

### FACT:

The United States ranks as the largest consumer of industrial roundwood around the globe. From baby food to diapers, football helmets to toothpaste, and rayon to cosmetics, tree fibers and paper-pulping residues contribute to more than 5,000 wood-based products.

## How are American forests doing?

Productive forests produce wood for products. Forests in national and state parks, monuments, and wilderness areas, where the law prohibits logging, don't. Some productive forests are *industrial*. They're owned and managed by large forest product companies. Others are *public* and belong to federal, state, or local governments. *Private* forests belong to individuals.

•The United States has a total of 490 million acres of productive forest. And it's classified by ownership as follows:

Industrial	14%
Public	27%
Non-industrial private forest	59%

•More than 50 percent of the U.S. wood supply originates on the 288 million acres of non-industrial private forest land. And it's that land that experts believe has the greatest potential for increased production. Properly implemented management plans could double the production.



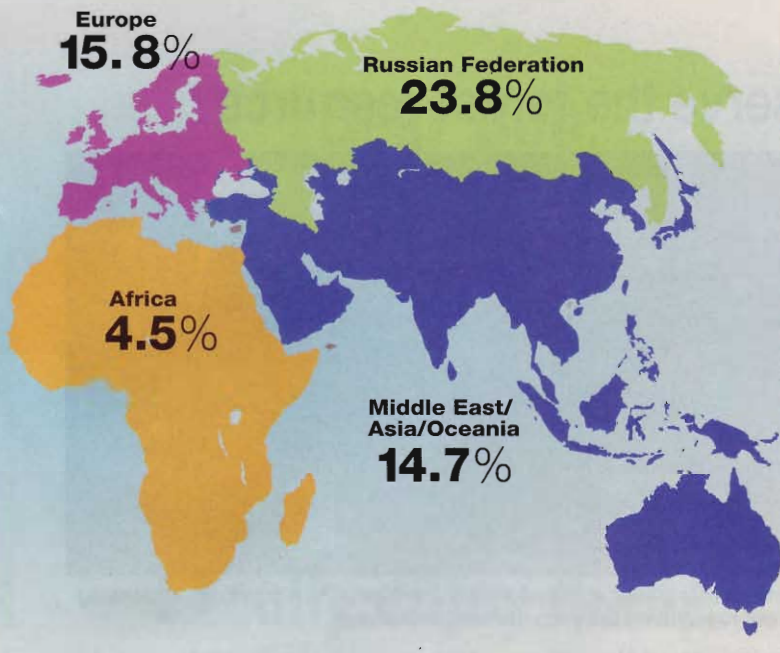

## Where you'll find the world's forests

- Worldwide, forests claim 8.5 billion acres, 52 percent of which are tropical and 48 percent temperate and boreal (far northern).

- The countries of the former U.S.S.R., Brazil, Canada, the United States, China, Indonesia, and Zaire contain the greatest amount of the world's forests by area. The illustration *at left* shows how world forest cover breaks down geographically.

- From 1980 to 1995, forest land decreased by 500 million acres in the developing world, but increased by 50 million acres in the developed world, for a net loss of 450 million acres.

- Current opinion has the rate of loss for worldwide forest land now slowing, but population growth in many developing countries is projected to cause the continued conversion of forest land to agriculture.

**FACT:** The Siberian *tiaga*, a vast evergreen forest twice the size of the Amazon rainforest, stretches 1.3 million square miles from the White Sea to Russia's Far East Pacific coast. It makes up nearly one quarter of the planet's timber reserves. (In Russia, though, logging remains unregulated, and it's anyone's guess how long such a huge forest can last without restrictions or management.)

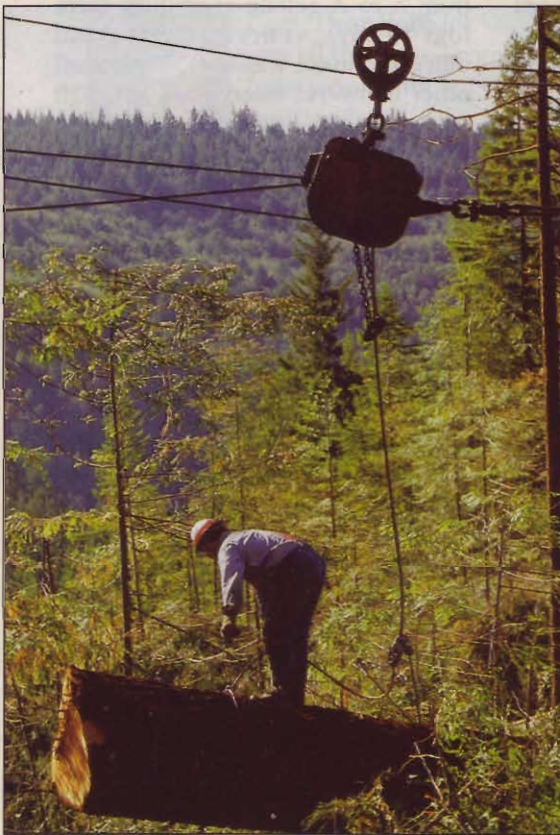

*Far left:* In California, a highline brings redwood logs down from the heights to a landing for loading onto trucks.

*Left:* Trees in forests managed for sustained yield, as in this one in Wisconsin, are cut selectively so that others grow.

*Below:* Hauling logs means new roads through the forest, as on this Oregon mountain scene.



## What's being done to conserve the forest resource?

National and local governments, even private landowners or groups, can remove forests from productivity by setting them aside as protected. This practice ensures the forest's future existence. But, it puts more pressure on the remaining productive forests, as well as other alternative resources, to meet growing consumer demands.

Unlike iron ore, coal, or petroleum, trees are a renewable resource. A forest can be harvested regularly of selected trees and still grow for centuries under a forestry practice called *sustainable* management. And more and more private forest owners have come to understand that the long-term adequacy of the world's wood supply depends on this practice.

In fact, beginning in the early 1990s, an environmental organization developed a way to promote sustainable management and still provide forest owners a profit incentive. The non-profit Rainforest Alliance, of New York, instigated a process called *certification*, which relies on a third party to verify a forest as being sustainably managed, taking into account the role it plays in local social, economic, and environmental issues. Owners of certified forests can then market their wood at a premium because it comes from a forest that's managed in an



In smaller private forests under sustained-yield management, horses are increasingly used to haul out logs, minimizing environmental damage.

environmentally friendly way. Processors and manufacturers that use certified wood also can stamp their products with the certified label.

Today, third-party certification comes from SmartWood, a Vermont headquartered division of the Rainforest Alliance, and Scientific Certification Systems, Inc., of Oakland, California. Both follow certification guidelines specified by the Forest Stewardship Council, an independent, international institution that develops standards for forestry certification worldwide. There are other certifiers in Europe and the United Kingdom as well.

- Figures from the Forest Stewardship Council, as of September 30, 1999, indicate there were 43,366,512 acres of certified forest land in the world. The United States accounts for 3,896,538 of those acres.

- The Oregon-based Certified Forest Products Council listed 165 certified North American suppliers with names from A to Z, selling everything from logs to toys, veneers, garden and office furniture, windows, doors, and other millwork. SmartWood lists 550 producers and distributors of certified products and more than 100 suppliers of certified logs and lumber worldwide. Both lists keep growing.

### FACT:

Sweden, a country with a land area one-twentieth the size of the United States, has 22,189,947 acres of certified forest land, more than any other nation. To learn more about certification and certified products, turn to *page 88* for sources.

### Major retailer takes environmental stance

Last August, Atlanta-based Home Depot's president and CEO, Arthur Blank, announced a sweeping policy change for the largest single retailer of lumber in the world: It would stop selling wood products that come from old-growth forests. And by the end of 2002, the company will eliminate from its nearly 900 stores any wood from endangered areas, including certain redwood, lauan (Philippine mahogany), and cedar products, and give preference to certified wood. Although certified wood traditionally has cost a bit more than uncertified wood, Home Depot pledged to hold the line on lumber prices, and urged other retailers to join the effort.

Written by Peter J. Stephano Photographs: Dan Sullivan; Peter J. Stephano  
World forest facts from Temperate Forest Foundation, based on 1997 statistics from the World Bank and other international organizations.

### Wood in the future

- Although the total forest area has shrunk, world consumption of wood increased 36 percent between 1970 and 1994. This consumption growth was somewhat offset, however, by the increase in the number of acres in plantations (commercially planted trees) in developing countries from 100 million acres to more than 200 million acres between 1980 and 1995.

- Increased processing efficiency, more recycling interest and effort, and greater use of wood and paper-making waste enables the forest products industries to significantly raise their output of processed products to meet demand. This also means they use fewer trees than in the past. ♣

## For All Your Woodcarving & Sign Carving Needs

Terrco provides a full line of machine carving and sign carving equipment. Beginning models are the T-110 single spindle bench carver and our CM614 single spindle sign carver.

Intermediate models include the K-Star, a two-spindle heavy duty bench model, and the Northstar, a heavy duty floor model available in one to eight spindles.

Our advanced model is our Master Carver series, which is an extremely heavy duty floor model with from eight to forty spindles.

Website: [www.terrco.com](http://www.terrco.com)  
E-mail: [info@terrco.com](mailto:info@terrco.com)

### Terrco, Inc.

222 1st Ave. NW  
Watertown, SD 57201  
USA  
(605) 882-3888  
Fax (605) 882-0778



Model T-110 Dupli-Carver



Model CM614 Sign Carver



Multi-Spindle Carving Machine

Circle No. 2175

## Buy Factory Direct and Save Thousands!

# Woodworkers Dreamshop

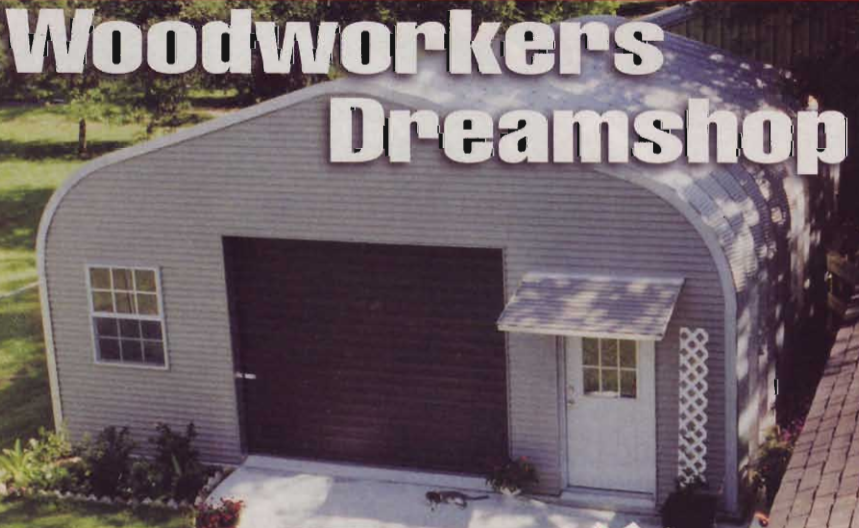

SAVE UP TO  
**\$5,000.00**  
ON STEEL  
BUILDINGS

**SAVE THOUSANDS  
ON SELECT SIZES**  
25x34 • 30x46 • 40x56 • 50x116  
*Additional sizes available.  
Proudly made in the USA.*

- 20 Year Guarantee
- Build it yourself
- Maintenance Free
- 100% Useable Space

**CALL TODAY  
1-800-463-6062**

**FREE PRODUCT CATALOG  
AND FACTORY PRICE LIST**

[www.us-buildings.com](http://www.us-buildings.com)



Circle No. 2030

## Concerned about the world's forests? Here's Help

See related article on page 86



The below-listed organizations can provide general information on forests around the world, certification, and certified products.

### Certified Forest Products Council

14780 SW Osprey Dr., Suite 285  
Beaverton, OR 97007-8424  
503/590-6600  
Fax: 503/590-6655  
[www.certifiedwood.org](http://www.certifiedwood.org)

### Forest Stewardship Council

Avenida Hidalgo 502, 68000 Oaxaca  
Oaxaca, Mexico  
52/951-46905  
Fax: 52/951-62110  
Email: [fscoax@fscoax.org](mailto:fscoax@fscoax.org)  
[www.fscoax.org](http://www.fscoax.org)

### Forest Stewardship Council—U.S.

134 29th St. NW,  
Washington, DC 20007  
877/372-5646  
Fax: 202/342-6589  
Email: [info@foreststewardshp.org](mailto:info@foreststewardshp.org)  
[www.fscus.org](http://www.fscus.org)

### SmartWood

61 Millet St.  
Richmond, VT 05477  
802/434-5491  
Fax: 802/434-3116  
Email: [info@smartwood.org](mailto:info@smartwood.org)  
[www.smartwood.org](http://www.smartwood.org)

### Scientific Certification Systems Forest Conservation Program

1939 Harrison St., Suite 400  
Oakland, CA 94612-3532  
510/832-1415  
Fax: 510/832-0359  
Email: [dhammel@scs1.com](mailto:dhammel@scs1.com)  
[www.scs1.com](http://www.scs1.com)



## Somewhere between dowels and tenons lies beadLOCK

I don't own a mortising machine or attachment for my drill press, so making mortise-and-tenon joints means boring a bunch of holes, then tediously squaring up and cleaning the mortise with a chisel. With the inexpensive beadLOCK Loose-Tenon Joinery System, I made strong joints with a minimum of equipment and cleanup.

This product consists of two parts: a drilling guide that works with any

portable drill, and tenon stock that looks like a handful of dowels glued together. In fact, that "bundle" of 3/8" or 1/2" dowels is actually milled from a solid hardwood blank.

The beadLOCK drilling jig makes it simple to bore the overlapping holes to accept the tenon stock without a drill press. Clamp the jig into position on your workpiece (a handscrew or vise will give you enough pressure), and bore the non-overlapping holes, using the guide block. Now, loosen the thumbscrews, slide the guide block (the jig doesn't move), and bore overlapping holes dead-center between the first set of holes. Bore a matching mortise in the other workpiece, cut the tenon stock to length, glue, and clamp.

Although the drilling guide automatically centers on 3/4"-thick stock, the manufacturer also provides shims for offset mortises or workpieces up to 1 1/4" thick. I had to completely

remove the guide block and thumbscrews to install the shims, which would get annoying if I worked with several different thickness of stock.

The unique shape of the beadLOCK tenon stock provides more gluing surface than either traditional dowel or mortise-and-tenon joinery, making the joint stronger. And, you can cut the tenon stock to whatever length you want and bore as deep as your drill bit will allow to further strengthen the joint.

—Tested by Bob McFarlin



### PRODUCT SCORECARD

#### BeadLOCK Loose-Tenon Joinery System

Performance	★ ★ ★ ★ ☆
Price	\$30, 3/8" or 1/2" kit; \$47, combo kit (inc. both sizes)
Value	★ ★ ★ ★ ★

For more info, call Journeyman Tool Company at 920/485-0350, or visit [www.beadlock.com](http://www.beadlock.com).

Continued on page 102

INTERNATIONAL



CORPORATION

"The Power Tool Specialists"

2590 Davie Road, Davie, Florida 33317  
Fax (954) 792-3560

- features online ordering for our full line of tools, machinery & accessories
- Hot Monthly Specials for extra low pricing on popular items
- Order our free catalog
- Ask the Tool Guru your tool-related questions
- Read the Tool Guru's Tip of the Month
- Serving your power tool needs for over 30 years
- Best selection & most knowledgeable staff in the industry

1-800-338-3384

LOWEST  
Guaranteed  
TOOL PRICES

• Free Freight & Same Day Shipping  
on most UPS orders over \$50 minimum purchase within the contiguous U.S.A.



ALL CHECKS WILL BE HELD 10 BUSINESS DAYS

Call for  
your  
FREE  
catalog!



Circle No. 49

[www.internationaltool.com](http://www.internationaltool.com)



Continued from page 100

## The price isn't the only healthy thing about these sliding tables

When I saw that Laguna Tools was selling a sliding crosscut table for table-saws, I suspected it would be substantial. I was right: The table, made by Robland, is big, long, and heavy, with a price tag to match.

It was a snap to mount this accessory in place of my cabinet-style saw's left extension wing. The sliding table's sturdy steel brackets support a 54-pound, 70"-long rail assembly that includes a pair of 1 3/16"-diameter solid-steel rails. You need that kind of length to safely cut sheet goods and wide panels.

And you need that kind of heft when you use cast iron for the table itself. You can choose a smaller table (shown at right) that measures 14 1/2 x 14" and weighs in at 32 pounds; or a larger 14 1/2 x 31 1/2" model weighing 70 pounds. If you crosscut a lot of full-sheet goods, go with the large table; the less-expensive small table works well with solid stock and sheet materials up to 24" wide.

For all its weight, the table feels like it's riding on glass thanks to sealed ball-bearing construction. I was disappointed, however, to find no locking mechanism that would allow me to fix the table and use it as an ordinary extension table.

The 4' extruded-aluminum fence is the longest I've seen, and comes with a flip stop and cam-action stock hold-down that unfortunately left a shallow dimple in my workpiece. The fence, hold-down, and sliding table team up for the safest crosscutting you can do on a table saw. ♣

—Tested by Dave Henderson



### PRODUCT SCORECARD

#### Laguna Sliding Table

Performance	★ ★ ★ ★ ☆
Price	\$795, small table; \$945, large table
Value	★ ★ ★ ☆ ☆
Call Laguna Tools at 800/234-1976, or visit <a href="http://www.lagunatools.com">www.lagunatools.com</a> .	

When Only The Best Will Do!



Superior Forstner Bits.  
Exacting Tolerances.  
Forged Special Steel.  
Available in 1/8" & 1/16th"  
Increments & Metric Sizes.  
Order Individually and in  
Sets of 4, 7 and 16.  
Lifetime Guarantee.  
Dealers are Welcome!

See us at the IWF Show  
Booth 6536

World Class Woodworking  
Tooling and Machinery

4632 Route 40 West, P.O. Box 644 • Claysville, PA 15323  
Ph: (724) 663-9072 Fax: (724) 663-9065

## Econ-Abrasives

WE MAKE ABRASIVE BELTS ANY SIZE, ANY GRIT!

### Standard Abrasive Sheets

#### CABINET PAPER

	50/pk	100/pk
60D	\$17.58	\$31.58C
80D	\$16.42	\$29.26C
100 thru 150C	\$15.26	\$26.95C

#### FINISHING PAPER

80A	\$11.74	\$19.89C
100 thru 280A	\$10.50	\$17.58C

#### NO LOAD PAPER(white)

100 thru 400A	\$12.90	\$22.40C
---------------	---------	----------

#### Velcro® Vacuum Discs

#### 8 Hole pattern for Bosch sanders

Dia.	Grit	Price
5"	60	\$.48 ea
5"	80	.46
5"	100 thru 320	.45

\* Available in 5 hole pattern \*

\*Wide Belts\*Rolls\*Flap Wheels  
\*Pump Sleeves\*PSA Discs  
\*Router & Wood Bits\*Wood Glue

### ABRASIVE BELTS

Belts are resin bond cloth with a bi-directional splice, specify grits.

1X30	\$.81 ea	3X24	\$.93 ea
1X42	.81 ea	3X27	.96 ea
1X44	.81 ea	4X21 3/4	1.06 ea
2 1/2X16	.85 ea	4X24	1.10 ea
3X18	.86 ea	4X36	1.35 ea
3X21	.90 ea	6X48	3.50 ea
3X23 3/4	.93 ea	6x89	6.24 ea

#### OTHER SIZES ON REQUEST

#### HEAVY DUTY SPRING CLAMPS

Clamps come w/PVC tips and grips.

Size	Price
4"	\$1.75 ea
6"	2.25
8"	3.50

#### JUMBO ROUTER PAD(24" x 36")

It will not allow small blocks of wood to slip out under router or sanding applications. ROUTER PAD ONLY \$8.95ea.

#### JUMBO BELT CLEANING STICK

ONLY \$8.80

\*MasterCard, VISA, Discover, Am. Express  
\*SATISFACTION GUARANTEED!!!

\*CALL FOR FREE CATALOG  
-TX add appropriate sales tax  
-Call for shipping charges



P. O. Box W1628  
Frisco, TX 75034  
(972)377-9779

TOLL-FREE ORDERING LINE (800)367-4101

### Check out this hardwood Harley

Philadelphia woodworker Sunia Reznik is awfully proud of his Harley Davidson motorcycle. But you won't find him riding it to the annual biker rendezvous in Sturgis, South Dakota. That's because his black walnut, oak, and maple Heritage Softail Classic with sidecar rendition measures only 29" long and stands 12" high.

The wooden bike does have a realistic, throaty roar, though, thanks to a battery-powered sound module that Sunia installed. It also has operational headlights, flashing turn signals, and brake lights. Leaving nothing to the imagination, the craftsman added a detailed engine, working gear shifter, operating drive belt, balanced spoke wheels, active suspension, and a host of other features on the 1:3.3 scale model. Brm. Brm.

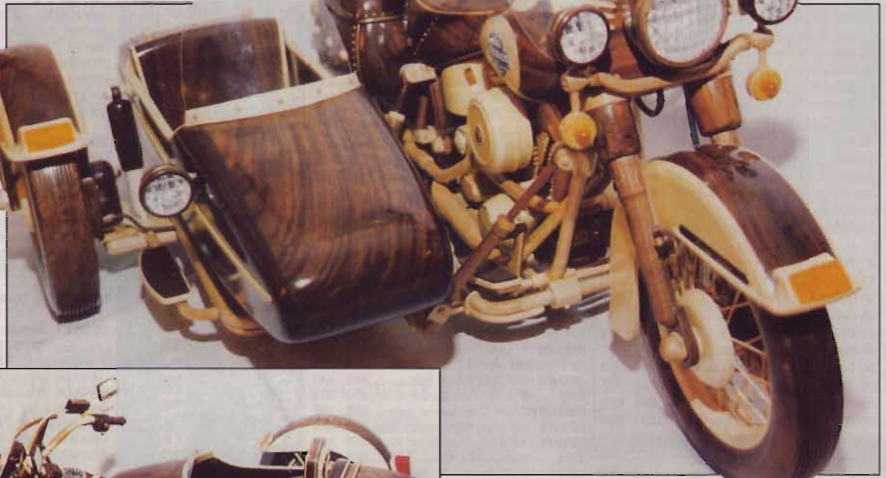

This Harley Davidson wooden scale model sports decorated saddle bags, working headlights and turn signals, a detailed engine, and much more.

### Trout snatches carving award

Ted Richmond of Wichita, Kansas, caught everyone's attention at last June's International Woodcarvers Congress, held in Davenport, Iowa. His stylized trout carving in driftwood, called "Flycaster's Dream," earned *WOOD*® magazine's People's Choice Award. Ted also could tuck away in his creel the \$500 that accompanied it. In addition, his piece took First Place in the Stylized Fish class and a top spot in Fishes and Other Aquatic Creatures.

For more than 30 years, the International Woodcarvers Congress has drawn nationally and internationally known carvers to the annual competition. Always held the third full week in June at Davenport's Putnam Museum, the Congress features special carving exhibits and seminars as well as entrants' work. It's sponsored by the Affiliated Wood Carvers, Ltd., and is open to the public. For event information, call 319/359-9684 (days) or 319/355-3787 (evenings). You also can write the Affiliated Wood Carvers, Ltd., P.O. Box 104, Bettendorf, IA 52722.



Measuring 36" high, this stylized trout snapped up *WOOD* magazine's People's Choice Award at the International Woodcarvers Congress.

### Forestry fund supports hardwood timber

Operating in low profile, the Hardwood Forestry Fund has, since 1990, sponsored 60 tree plantings and other hardwood-related projects in 15 states and four foreign countries. The Reston, Virginia-based non-profit foundation promotes hardwood timber growth, management, education, and environmentally sound uses of renewable forest resources. Here's one project example: Partnered with the Indiana Department of Natural Resources, the Hardwood Forestry Fund in 1998 planted 17,000 red oak, black walnut, white oak, and white ash seedlings in the Jackson Washington State Forest. The aim was to promote the restoration of an old field site to high-quality hardwood forest for the future.

Plantings of oak, white ash, walnut, maple, black cherry, and tulip poplar restore mining sites, reforest after fire and storm damage, and convert farmland to forest, as well as improve existing forest land. Supporters include individual woodworkers, small wood-related companies, and large corporations (including The Home Depot and LA-Z-BOY). For more information, call 877/433-8733 toll free. Or visit its website: [www.hpva.org/forestryfund.htm](http://www.hpva.org/forestryfund.htm).

Photographs: Courtesy of Sunia Reznik; Marc Featherly, International Woodcarvers Congress

**3 FENCE EXPLODED VIEW**

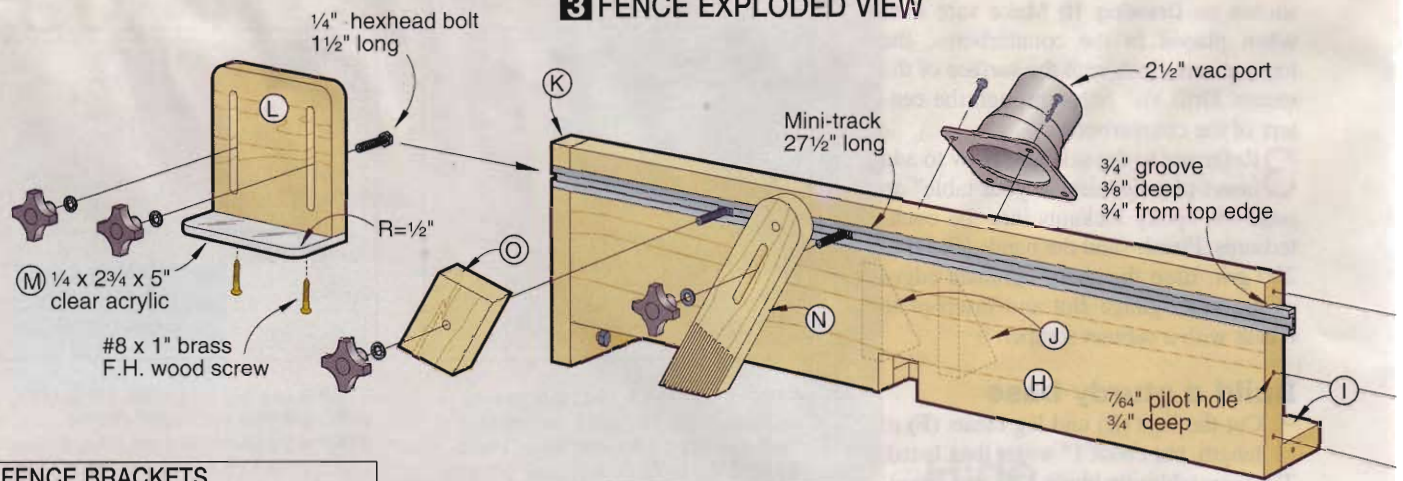

**3a FENCE BRACKETS**

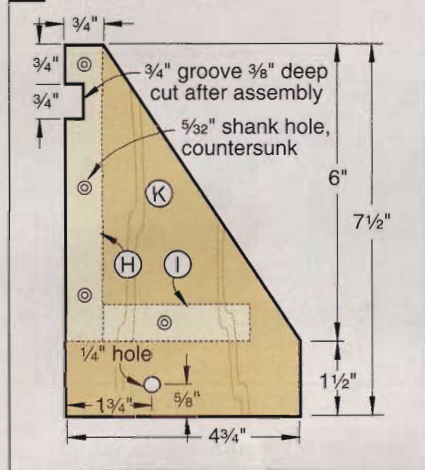

Mark the diagonal cut and the location of the 1/4" hole on the top blank, where shown on **Drawing 3a**. Bandsaw and sand to the marked line, and drill the hole. Separate the brackets.

**3** Glue and clamp the fence brackets (K) to the fence (H/I), making sure the brackets' edges are flush with the

**3c GUARD**

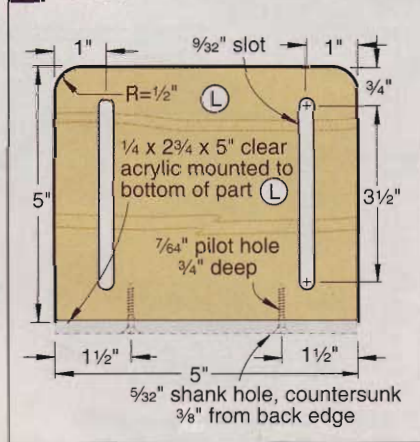

fence's face. Drill pilot and countersunk shank holes through the brackets into the fence, where shown, and drive in the screws. With your dado blade adjusted to the width of the mini-track, cut the dado in the fence (K/H/K), where shown on **Drawing 3**. Finish-sand the fence assembly to 220 grit.

**4** Cut the vac port mounts (J) to the size and shape shown on **Drawing 3b**. Dry-position the mounts and check their placement with your vac port. See the Buying Guide for our vac port source. Glue and

clamp the mounts in place. With the glue dry, use the port to mark the mounting screw locations. Drill screw pilot holes and set the vac port aside.

**Now, get your guard up**

**1** Cut the guard base (L) to size. Sand the 1/2" radii on the top corners, where shown on **Drawing 3c**. To form the mounting slots, drill 9/32" holes where shown, draw lines from hole to hole, and scrollsaw along the lines. Finish-sand the base to 220 grit.

**2** Cut 1/4" acrylic to size for the guard (M). Disc-sand 1/2" radii on the outside corners, where shown on **Drawing 3**. Adhere the guard to the base with double-faced tape, keeping the back edges flush. Drill pilot and countersunk shank holes through the guard (M) into the base (L). Remove the guard, and set it aside.

**Make the feather boards**

**1** Select a straight-grained piece of 3/4"-thick maple, and cut a 3/4x2x18" blank for the feather boards. Using your table-saw and miter gauge, trim 30° angles on both ends of the blank, where shown on **Drawing 4**. Mark angled lines across the

**shop TIP**

**Make a self-gauging feather board**

Here's a quick way to set your feather board to apply the proper pressure. Trim the first feather 1/8" shorter than the others, where shown on **Drawing 4**. When you use your feather board, place this short gauging feather on top of your workpiece. Now, keeping the other feathers parallel to the router-table top, tighten the mounting knob.

**4 FEATHER BOARDS & JAM BLOCKS**

