

Better Homes and Gardens

WOOD

THE WORLD'S LEADING
WOODWORKING MAGAZINE
ISSUE 123 April 2000

Build this
versatile

Garden Shed

page
50

Plus

3 Great Projects For your home

Tool Test

Random-Orbit Sanders

page 74

Display until April 4

U.S.A. \$6.95



<http://www.woodmagazine.com>

Better Homes and Gardens®

WOOD®

THE WORLD'S LEADING WOODWORKING MAGAZINE

CONTENTS



Page 43

- 39 A Look At Not-Quite-Perfect Stock**
Discover how nature creates defects in wood.
- 43 The WOOD Gang Builds Tall Clocks**
See what goes into making a big clock from a kit.
- 56 Plunge-Routing Basics**
Take your plunge-routing to a whole new level with the six simple jigs found here.
- 74 Random-Orbit Sanders**
Twelve popular models battle for supremacy.
- 80 Clever Ways to Recycle Wood Waste**
Turn sawdust and chips into something useful.
- 81 Chair Caning**
Make a chair seat in just seven easy steps.

Woodworking projects

- 46 Irrigation Island**
Keep your garden hose and sprayer off the ground with an attractive, stand-alone hanger.
- 48 Carve A Classic Shell**
Adorn furniture with an elegant ornament.
- 50 Mini Garden Shed**
Store rakes, shovels, and other yard-care items in this handsome outdoor structure.
- 62 All-Around Plunge-Router Jig**
Make precision grooves, dados, mortises, and curved cuts with this versatile shop aid.
- 68 Deluxe Day Bed**
Guests get a good night's rest with this project.



Page 50



Page 74



Page 62



Page 46



Page 68

SHORT-SUBJECT FEATURES

- | | |
|---|--|
| 4 The Editor's Angle | 22 Ask WOOD |
| 6 Talking Back | 26 Foot-Operated Tool Switches |
| 10 Business Side: Taxing Issues | 30 Tips From Your Shop (And Ours) |
| 12 Dial Indicator For Setting Jointer Knives | 86 Products That Perform |
| 14 Hot Off The Internet | 102 Wood Anecdote: Butternut |
| 18 How To Give Veneer Tops New Life | 104 Finishing Touches |

Cover photograph: Hetherington Photography

It's Off To The Races For WOOD® Magazine



I'll go anywhere to promote WOOD magazine, especially such fun places as the North Carolina Motor Speedway in Rockingham, N.C.

Before each race, all cars are inspected by NASCAR officials to ensure fairness.

You, the readers of WOOD magazine, are a loyal group, that's for sure. You renew your subscriptions at legendarily high levels and, by industry standards, you tend to stay with us for a long time. The staff and I greatly appreciate this show of support. And I want you to know that because of your allegiance, we feel a special obligation to provide you with a magazine you will look forward to receiving issue after issue. Here's to a long-lasting relationship between us.

As you might imagine, bringing large numbers of quality readers like yourself into our fold requires a lot of effort and money. And that's part of the cost of doing business. Thanks to our active circulation team, we currently have a subscription base of more than 550,000, the highest of any woodworking magazine. Usually, they create and mail direct-mail packages to good prospects in hopes that some of them will give us a try. And a fair number do.

Recently, though, we added a totally new twist to getting our name out. We purchased a small sponsorship for two races on NASCAR car number 17, the same vehicle that DeWalt

Industrial Tool Company underwrites. When I first heard about our plan, I had no idea how prominently our logo would be displayed. But as you can see in the photo above, we definitely got our money's worth.

Luckily, my wife Trudy, my youngest daughter Amanda, and I were on our way to South Carolina for a week's vacation, so we stopped by the North Carolina Motor Speedway in Rockingham, North Carolina, to see what all this NASCAR fuss is about. The whole thing can only be described as a mega-event. We were able to get up close to the car; meet driver Matt Kenseth; and watch the race, including pit stops, from the pit area. What a great time we had!

At this point, I don't know exactly how many subscribers we will be getting as a result of our sponsorship. But I am certain that lots of you NASCAR fans and several million television viewers saw us spreading our good name. And there's nothing wrong with that. ♣

Larry Clayton

Photographs: Amanda Clayton and Larry Clayton

Better Homes and Gardens®

WOOD®

THE WORLD'S LEADING WOODWORKING MAGAZINE

APRIL 2000 • Vol. 17, No. 3 • Issue No. 123

Editor **LARRY CLAYTON**
 Managing Editor **JIM HARROLD**
 Assistant Managing Editor/Products **BILL KRIER**
 Senior Editor/Features **PETER J. STEPHANO**
 Senior Editor/Special-Interest **LARRY JOHNSTON**
 General-Interest Editor **DAVE CAMPBELL**
 Senior Design Editor **JAMES R. DOWNING**
 Assistant Design Editor/Project Builder **JAN HALE SVEC**
 Shop Manager/Project Designer **CHARLES I. HEDLUND**
 Senior Associate Art Director **PERRY A. McFARLIN**
 Assistant Art Director **CHERYL A. CIBULA**
 Production/Office Manager **MARGARET CLOSNER**
 Administrative Assistant **SHERYL MUNYON**
 Art Business Office Secretary **BARBARA HELPS**
 Reader-Contact Specialist **BEN VON RUDEN**
 Contributing Editors **KIM DOWNING, DAVE HENDERSON,**
LORNA JOHNSON, ROXANNE LeMOINE,
BOB McFARLIN, CARSON ODE

©Copyright Meredith Corporation 2000
 All rights reserved. Printed in the U.S.A.

Better Homes and Gardens® WOOD® magazine (ISSN-0743-894X) is published nine times a year in February, March, April, June, August, September, October, November, and December by Meredith Corporation, 1716 Locust St., Des Moines, IA 50309-3023. Periodicals postage paid at Des Moines, Iowa, and additional mailing offices. Better Homes and Gardens trademark registered in Canada and Australia. Marca Registrada en México. ONE-YEAR SUBSCRIPTION PRICES: U.S. and its possessions, \$27; Canada, \$39; other countries, \$47. Canada Post Publications Mail Sales Product Agreement No. 1569550. Canadian BN 12348 2887RT. CANADIAN RETURN ADDRESS: Better Homes and Gardens WOOD magazine, 2744 Edna Street, Windsor, Ontario, N8Y 1V2. POSTMASTER: Send address changes to Better Homes and Gardens WOOD magazine, P.O. Box 37439, Boone, IA 50037-0439.

CUSTOMER SERVICE 800/374-9663: Use this number for subscription services, changes of address, billing questions, questions for our editorial staff, questions about how to reach an advertiser, or to place an advertisement in our magazine. To order back issues 800/346-9663. Subscription mailing address: Better Homes and Gardens WOOD magazine, P.O. Box 37439, Boone, IA 50037-0439. Please enclose your address label from a recent issue. Editorial mailing address: The Editor, WOOD magazine, 1716 Locust Street, GA310, Des Moines, IA 50309-3023. Reprints are \$5 per article.

MPA

Better Homes and Gardens®

WOOD Online®

at <http://www.woodmagazine.com>

"Design a doghouse? Sure, nothing to it!" At least that's what we thought before studying the material that the American Kennel Club sent on canine housing. We guarantee plenty of "creature comforts" for your pet for years to come. Download the plan, DP-00047, (and dozens of others) for only \$5.95 from the downloadable plans section of the WOOD STORE™.



For
that
"Special"
project



Table
Bases



Table Legs

IN STOCK
NO
MINIMUM
VARIOUS
WOODS



Kits Ready
to Assemble
& Finish

FREE
CATALOGUE



Adams
Wood
Products, LTD, LP

974 Forest Dr., Dept. M34, Morristown, TN 37814
423-587-2942 • Fax 423-586-2188
www.adamswoodproducts.com

Circle No. 1002

TALKING BACK

Of knives and men

During our recent test of portable planers (issue #120), we found the knives on the Makita 2012 to be harder than those on the other models. Curious, we contacted a Makita spokesperson, who told us the knives were made of carbide.

After a reader questioned the knife composition, we called Ken Hefley, president of Makita USA. Ken informed us that carbide knives have never been available for the 2012 portable planer. Carbide or not, the Makita knives were the sharpest and hardest in the bunch, and we stand

by our recommendations. Ken also says Makita's new portable planer will now be called the 2012BN.

While we're on the subject of planers, numerous reader calls and letters regarding the cover photograph on issue #120 prompt us to say "Safety first." To create a friendlier image, we chose not to have our model wear eye protection while running the planer. Bad choice. Even though planers have a shield on the operator side, eye protection should always be worn. We pledge never to err on the safety side again.

Save sanding time with this simple shingle jig

The Victorian-Style Bird Feeder in issue #109 was a pleasure to make. Whoever came up with the design should be commended. But, as in all projects, some little thing gets to me. In this one it was sanding the chamfers on the roof shingles [68 in all].

I made a simple jig [shown at right] and clamped it to my belt/disk sander. The sanding then went much faster, and making the shingles became an enjoyable task.

—Vincent Maida, Boca Raton, Fla

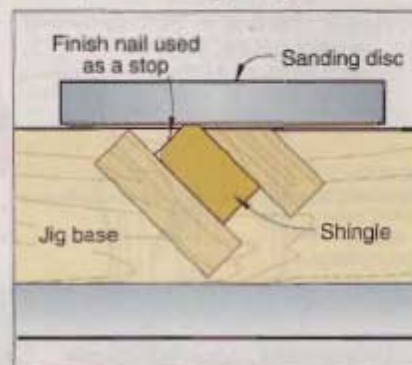

A clever alternative to making single shingles

Instead of cutting individual shingles for the Victorian-Style Bird Feeder, I used cedar closet liner, ripped to width and crosscut to roof length. With my bandsaw table fitted with an auxiliary wooden fence and tilted so that the blade would cut the strips vertically in half, I resawed each piece into two tapered roofing lengths.

Next, I marked score lines for individual shingles on each length and scored shallow grooves on those lines with the bandsaw blade. Then, again at the bandsaw, I notched the strips. This method has the visual effect of individual shingles.

—Wilbert R. Brown, Skowhegan, Maine

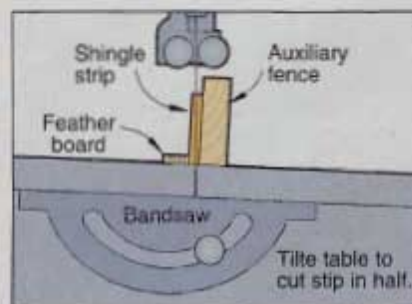
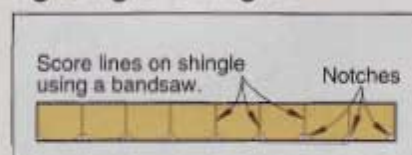

We would like to hear from you

We welcome your comments, criticisms, suggestions, and yes, even compliments. We'll publish letters of the greatest benefit to our readers. Write to: Talking Back, WOOD Magazine, 1716 Locust St., GA310, Des Moines, IA 50309-3023

Continued on page 8

Better Homes and Gardens
WOOD Advertising
& Marketing
THE WORLD'S LEADING WOODWORKING MAGAZINE

Publisher MARK HAGEN

Auxiliary Sales and Internet Manager MARLEN KEMMET

Advertising Services Manager PAT HENDERSHOTT

Chicago Advertising Office: 333 N. Michigan Ave., Suite 1101,

Chicago, IL 60601 Phone: 312/953-2890 FAX: 312/580-7908

Advertising Managers: JAMES N. FORD, WILL MURPHY

Direct Response Advertising CAROLYN DAKIS

Marketing Specialist GERALLIE LEGASPI

Sales Assistant MARGARET TRAVIS

Des Moines Advertising Office: 1716 Locust St., GA204,

Des Moines, IA 50309-3023 Phone: 515/284-3675 FAX: 515/284-3343

Senior Salesperson RICH RAINFORTH

Direct Response Advertising NATASHA KUCHERENKO

Administrative Assistant KRISTI HASEK

Classified Advertising: Phone 800/424-3090 FAX: 312/464-0512

Vice President JERRY WARD

Publishing Director WILLIAM R. REED

Circulation Director LIZ BREDESON

Associate Circulation Director KATHI PRIEN

Business Manager JANET DONNELLY

Senior Product Manager RICK GROW

MEREDITH PUBLISHING GROUP

CHRISTOPHER M. LITTLE, President

ELLEN DELATHOUER, Creative Services; BRUCE HESTON,

Manufacturing; KARLA JEFFRIES, Consumer Marketing;

JERRY KAPLAN, Group Sales; BOB MATE, Integrated Marketing;

BILL MURPHY, Strategic Marketing; HAL ORINGER, Consumer

Marketing and Interactive Media; DEAN PIETERS, Operations;

MAX RUNCIMAN, France; THOMAS L. SLAUGHTER, Licensing

and New Media

Meredith
CORPORATION

WILLIAM T. KERR, President and Chief Executive Officer

E. T. MEREDITH III, Chairman of the Executive Committee



Continued from page 6

Clamp extensions reach out

Your Long-reaching Clamp Extensions on page 16 in issue #117 looked so good that I made some for my bar clamps right away. I photocopied your pattern several times to use as cutting guides. While at the copier, I made some other copies at 115 percent to use for my pipe clamps.

Instead of using 1½"-thick stock and cutting mortises, though, I used two pieces of ¾" oak, cut a shallow dado in each, and glued them together. I reinforced the assembly with some #10 bolts and nuts. This didn't hurt their appearance, and they're really strong. To keep the pipe clamp extensions from turning on the pipe before the jaws lock, I use double-faced woodworker's tape.

Also note that I've replaced the original handles on my bar clamps with the shopmade handles you published for handscrew clamps in issue #35 [as shown below]. The square handles are a great improvement over commercial ones because they offer a firmer grip.

On another matter, I'm no expert on refinishing or antique furniture, but it seems to me that the article on antique restorer Dominick Coiro in issue #116 could lead the unwary into a trap. According to appraisers on the PBS television program *Antiques Road Show*, replacing the original finish should be approached with extreme caution. They consistently tell people that refinishing an antique could reduce its value.

—Barney Howard, Sisters, Ore.

Barney, nice job on your clamps. And regarding your refinishing question, we asked Dominick about your concern for refinishing antique furniture. Here's what he said: "The professional restorer must determine whether the finish on the piece before him is original, renewed, or new. An original finish in good shape must be preserved at all cost. If the original finish has been compromised, a different action may be advised."

"The original finish on North American furniture is very important to the overall value. However, European furniture usually has a high-gloss finish, called a French polish. This is a shellac finish that easily deteriorates. It is a standard practice to renew, and sometimes refinish, to maintain the value of the piece."



Gel stains can run hot but not cold

I enjoyed the article on stains in issue #114. But I'd like to add one thing about gel stains. In warm weather, gel stains can change to liquid. However, if you chill them in the refrigerator for a couple of hours, they'll return to gel form.

—Henry Douglas, Brockville, Ont.



Fisheye fouler found

I read with great interest the article "What finish is that anyway?" in issue #117. It mentions that if you know what finish is on a piece, you can recoat it with the same type. However, it doesn't mention "fisheye," the visual defect that occurs because of the incompatibility between the finish being applied and silicone, a major ingredient in many furniture polishes.

Silicone can actually penetrate a finish and go into the wood, making it almost impossible to adequately remove. To deal with fisheye, the finish needs to be modified with an additive I call "fisheye killer," such as Sherwin-Williams' Silicheck, so that it properly flows over the silicone. I spray a lot of lacquer, and treating it with Silicheck solves the problem.

—Richard Wiese, Glendale, Wis.

According to a Sherwin-Williams' spokesman, Silicheck (#V3K265) is primarily a lacquer additive sold through its automotive paint division. The company also sells a leveler (#V3K780) to use with urethane finishes that works the same.

Through-tenons hard to clean

I spent 47 hours each constructing and finishing two Morris chairs like the one in issue #112. I found no errors in any of the listed dimensions, and this is a credit to the WOOD® magazine staff. However, I do have a construction comment regarding the through tenons. The part of the tenons that extends through were a bear to clean up of glue after assembly and before finishing. The next time, I would stain and finish about ⅜" of the ends before assembly. Then, the clean up would become much easier. ♣

—William Springfield, Arden, N.C.

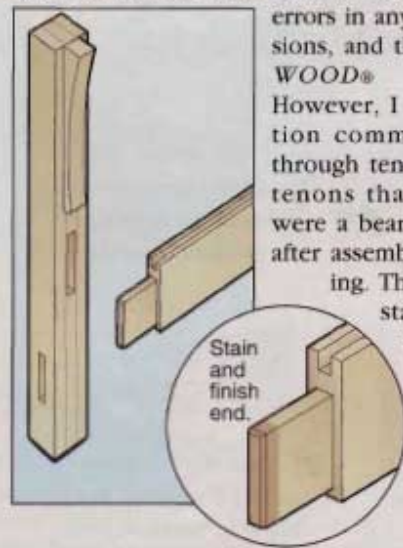

TAXING ISSUES

If you make something of wood, then sell it, revenue laws apply to you

Realistically, we all know wood-working hobbyists who sell a piece or two each year without reporting the extra income. But that doesn't make it right, or wise.

If you sell *any* of your work, you're subject to tax laws. Ignoring those laws puts you in peril should the Internal Revenue Service or state tax officials find out about it.

True, budget cutbacks and increasing congressional scrutiny have tamed IRS agents in recent years. State auditors, though, especially sales tax auditors, are more numerous and often keen on ferreting out the underground economy in crafts. And if the state catches someone, it can turn that person in to the IRS, too.

Honesty is the best policy, but...

Regardless of who's doing the most checking, honesty is always the best policy on your part. Trouble is, tax laws don't make honesty easy. Rules surrounding enterprises like wood-working—that frequently straddle the line between hobby and business—can seem confusing.

Having your woodworking treated as a business for tax purposes has two advantages. One, you're allowed to deduct costs for equipment and workshop space. And two, you also can deduct any losses from your wood-working business against income from your day job.

The IRS is wary, however, of part-time woodworkers who try to classify themselves as businesses. If you're actually clearing a profit and you're not writing off the cost of your wood-working equipment, this shouldn't be a problem. But if you've had a loss or you're writing off equipment costs, you could face closer scrutiny, including an audit of your income-tax records.

When woodworking becomes a business

Generally, the tax folks classify your woodworking as a business if:

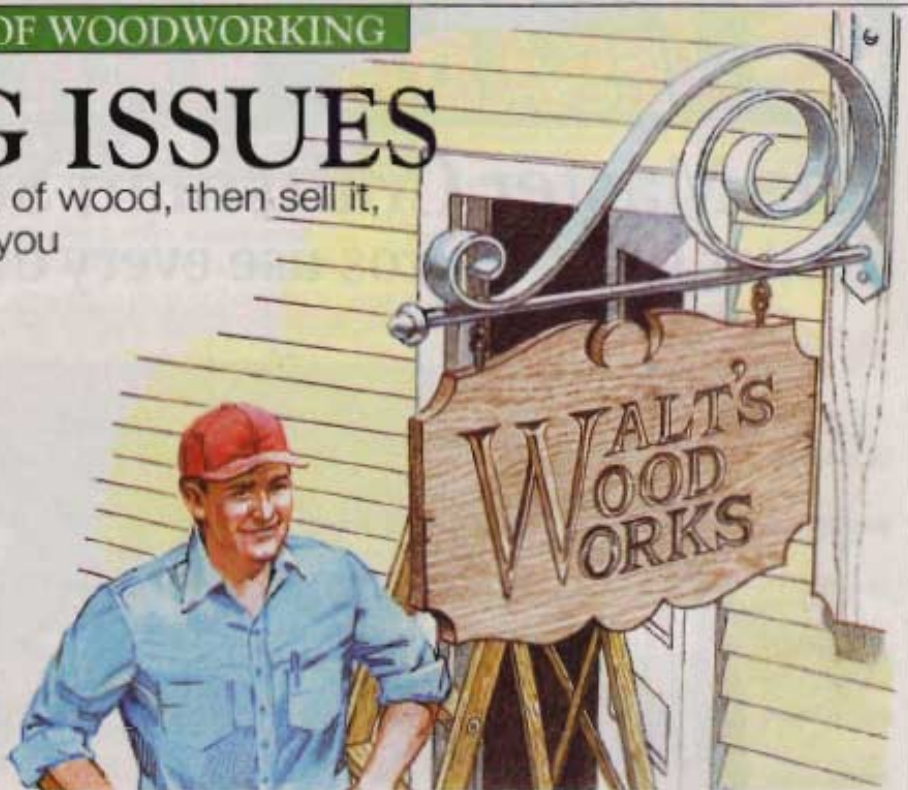

- You have made a profit from it in three of five consecutive years.
- You operate in a businesslike manner (for instance, by keeping complete financial records).
- Woodworking is your major source of income.

Sideline woodworking businesses, however, rarely meet all three standards. Yet, hobbyists still need to report income from sales, less the costs of materials that went into what they sold. But you can't deduct costs for running your workshop, such as electricity. And it's unlikely that you'll be able to deduct costs for equipment. If you do, you can deduct only the portion that exceeds two percent of your regular income, and you'll need to keep detailed records so you deduct only for the percentage of time you used the equipment for business (as opposed to hobby use).

Hobby woodworking has its advantages

Remaining a hobby woodworker isn't bad, though, tax-wise. Consider just this: You won't have to pay self-employment tax, which amounts to about 13 percent when income exceeds \$400. For example, let's say you're in the 28% tax bracket from your day job, sell \$2,000 worth of

furniture that you built (after deducting material expenses) and could deduct \$500 of equipment expenses under business tax rules. If taxed as a hobbyist, you'd pay \$560 in income taxes on that \$2,000. If taxed as a business, though, you'd pay \$615 in combined income and self-employment taxes. Tax forms for businesses are more complex, too, meaning you'll pay more for tax preparation.

Tax-time tips to help you out

Whether your woodworking qualifies as a hobby or a business for tax purposes, here are some things you should do:

- Keep records and receipts of all income and expenses associated with your woodworking activity.
- If you think your woodworking qualifies as a business, get form 1040-ES by calling 1-800-TAXFORM, and follow the instructions to pay quarterly estimated taxes so you aren't surprised or penalized come April.
- Contact your state's department of revenue for rules governing state and local sales taxes.
- Get advice from a tax preparer, accountant, or registered agent. ♣

Written by Jack Neff, a Batavia, Ohio, business writer and author of *Make Your Woodworking Pay for Itself*.

Poor Man's Dial-Indicator

SETS JOINTER KNIVES ACCURATELY

You don't need a fancy dial-indicator gauge to set the knives on your jointer; you simply want them set to the same height as the outfeed table. So, rather than buying an expensive gauge to do the job, *WOOD*® magazine reader Jim Murphy designed the magnetic jig shown at right, which helps align jointer knives precisely.

To make your own, start by shaping and machining the body of the jig from 1½" solid stock, as shown in the Parts View drawing. Counterbore two ¼"-deep holes in the bottom and epoxy a small round magnet in each hole. (We used a pair of ⅝×1" rare-earth magnets from Lee Valley, 800/871-8158.) Drill holes in a 1" dowel as shown in the Hub Detail and assemble the jig, leaving the hub loose enough to turn without being sloppy. Cut and bend two pieces of copper-coated welding rod or heavy coat-hanger wire to the shapes shown, and grind the end of the upper rod farthest from the hub to a point. Insert the rods in the small holes in the hub.

Before you use your gauge for the first time, calibrate it as shown in the Calibrating The Jig drawing. Now rotate the cutterhead so one knife is at its highest point, and position the jig on the outfeed table with the lower rod resting on the knife. When the knives are level with the outfeed table, the pointer will reach—but not rise above—the zero point on the masking tape.



EXPLODED VIEW

Epoxy magnets into counterbores, flush with bottom.

#8 x 2" panhead wood screw

1½" stock
Masking tape

¼" dowels 1½" long

⅛" welding rod, bent to fit

STEP 2 Mark zero location on tape.

CALIBRATING THE JIG

STEP 1
Zero the gauge on jointer outfeed table (bottom rod must lie flat on outfeed table).

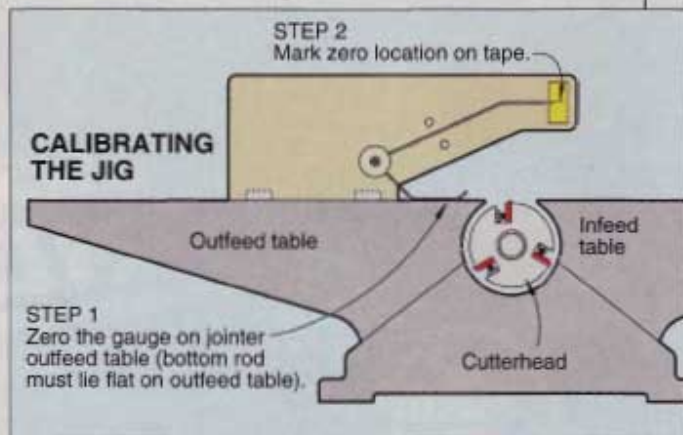
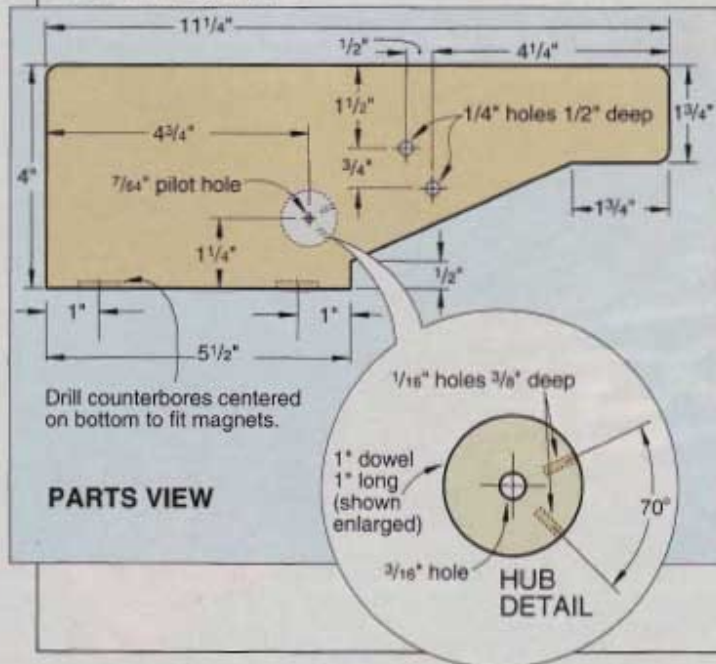

Project Design: James Murphy, Morgantown, W. Va.
Illustrations: Kim Downing
Photograph: Baldwin Photography

WOODWORKERS TO THE RESCUE

Comments, answers, and ideas from our WOOD ONLINE® discussion groups

What's the safest way for me to heat my shop?

I'm converting a two-car garage into a workshop and am thinking about using propane because of rapid heating and cost. My primary use of the shop is for general woodworking and furnituremaking.

I have read so much about explosion danger from dust and fumes. I am going to install a dust-collection system as soon as the drywall is taped and painted. Any advice?

—Eric Dickerson, Rainier, Wash.



● I have a 16x24' insulated shop not attached to the house. I heat it with a 25,000 Btu direct-vent propane heater made by Empire [Comfort Systems] that cost about \$650. It does not require electricity and has a thermostat. It vents and draws its combustion air through a common opening in the side wall and is very economical to operate. I set it back to about 55 degrees F. when I'm not using the shop, and the tools don't have any rust problems. [For more information or a catalog on Empire Comfort System's heating products, call 888/917-2244.]

—Mark Robey, Buffalo Junction, Va.

● You are absolutely right about dust being combustible and explosive. The ideal heating system for your shop would be a radiant heater or baseboard hot water system. Make sure you vacuum the baseboard from time to time to eliminate dust accumulation. Install your boiler in a separate room where vapors from finishes and solvents cannot enter. Many explosions and fires occur from these flammables. A fine-dust collector and ventilation system is very important. Take it from me—I am an OSHA inspector!

—Steven R. Myers, Shelburne, VT.

● Mark and Steven make several good points here. We covered workshop heating and ventilation in several past issues of WOOD® magazine. In our first IDEA SHOP™, issue #54, we heated a 14x28' dedicated workshop room with a standard 50,000 Btu forced-air Lennox gas furnace located in an adjacent two-car garage. In addition, we placed a 4"-thick pleated filter inside the furnace's cold-air return. For dust and volatile fume control, we included an explosion-proof, wall-hung room ventilator, a dust-collection system, and an air-filtration system.

In our second IDEA SHOP, issue #72, we went with a pair of direct-vent, wall-mounted heaters (model nos. ASV120RTN-T, 20,000 Btu, and ASV730RT, 30,000 Btu) made by Perfection-Shwank (706/554-2102) to heat a 24x24' two-car garage. Both units relied on outside air for combustion. A shop-vacuum dust-collection system and air-filtration system were also part of our approach for a cleaner, healthier shop. This same issue included an article on workshop heating options.

More recently, in issue #81, we ran a piece on a ceiling-mounted radiant heater (no. DBS 20-40, 40,000 Btu) by Detroit Radiant Products (800/222-1100). This unit also uses outside air and warms the shop via a heat-radiating pipe and reflection hood that runs the length of the shop. To order the above back issues, call 800/572-9350. We charge \$6.95 per issue.

—WOOD magazine

What's the best flooring for my shop?

I'm looking for ideas on how to finish the floor in my new second-story woodworking shop. I have installed a tongue-and-groove spruce subfloor, but nothing more. I've considered hardwood and tile, but they seem to have their drawbacks.

—Glenn Laidlaw,
Upper Stewiacke, N.S.

● I used a two-part epoxy paint on my wood floor and love it. It is really easy to sweep or wash. I got it from a local paint store, and they even used it on their own wood floor. You can get any color. I have had it down for 4 years, and it has held up great.

—Mike Elo, Longview, Wash.

● The vinyl composition tile I used in my workshop was relatively cheap—about 55 cents a square foot. It's easy to clean, durable, and in the event that you damage a section, you can easily replace the bad tiles.

—Allen Karantuk, South Attleboro, Mass.

Continued on page 16

Continued from page 14

Hot over saw-blade burn marks

I'm a relatively new woodworker. I have a Ridgid tablesaw with a Freud 50-tooth carbide blade. I just started ripping maple trim and got a lot of burning and blade marks on my pieces. I believe the saw is in correct adjustment. Any suggestions?

—Liam Dooley,
Rhinebeck, N.Y.



● If your tablesaw is tuned, your blade needs sharpening. Also, stock movement during the cut could be the problem. Try feather boards, especially on molding where the pieces tend to be thin and want to vibrate. If all else fails, cut the stock $\frac{1}{16}$ " wider than needed, then either clean up the edge with a jointer or adjust the tablesaw fence and just trim the edge.

—David Bronson, Apex, N.C.

● Liam, several problems can cause woodburning and saw marks. First, look at the cut. Are the burn marks predominantly or completely on one side of the cut? If so, your fence is most likely not parallel to the blade.

If the burn marks are pretty even, the wood is probably pinching in on the blade at the end of the cut. Are you using your splitter and blade guard?

With the Freud blade, you shouldn't have to worry about blade warp, so if both sides of the cut are rough, [with saw marks] the arbor on your saw may be loose, causing blade wobble.

Finally, your 50-tooth saw blade really isn't the best for ripping. You will definitely get better results with a 24- or 30-tooth ripping blade such as the Freud model LM72.

I have a newer Craftsman saw, similar to your Rigid, and am able to produce extremely smooth cuts consistently with a mid-quality rip blade, so don't settle for less!

—Jay Drew, Valparaiso, Ind.

● Liam, Jay, and David cover a lot of ground with their comments. And we concur with all of it. The consensus in our own workshop is that your saw may be underpowered, especially for hard maple. We use saws that have 3-hp motors and are on 220-volt circuits. That means the blade does not get bogged down and cause the feed rate to slow. When this happens, burning results.

—WOOD magazine

What finish for turned vessels resists all liquids?

I am looking for a finish for turned bowls and goblets that is not toxic and will withstand liquids, including alcohol and acidic food stuffs, such as salad dressings. The shortest drying time is preferable. I would also appreciate any tips about application.

—Robert Canfield, Sun Prairie, Wis.



● My preference is no finish because someday the water, or especially alcohol, will penetrate and in time make the finish fail. Nothing looks worse than a finish that comes apart when moisture gets under it.

The butter bowls, kitchen bowls, and mugs from the 18th through the early 20th century had no finish. They survived well and developed a patina that we could never achieve with any type of finish. I have used the no-finish approach for oak and ash beer mugs for many years, and it works very well. The beer has a natural taste, better than drinking from a glass. Try it. There is no question about it being nontoxic.

—Russ Fairfield, Tallahassee, Fla.

● Bob, there are a few things to keep in mind regarding a so-called "food-safe" finish, which in every case is some kind of oil finish. For starters, no such finish, including products marketed as "salad bowl finishes," have Food and Drug Administration (FDA) approval. However, such finishes are okay to eat off and drink from once the finish has completely cured. (For full curing, wait 30 days prior to use.)

Some such finishes include the varnish Waterlox, the catalysed lacquer Melamine, or any polyurethane varnish found locally. Apply these in several thinned coats, wiping them on with a rag. Two alternative oils you can use are walnut oil and mineral oil. Both of these oils are edible. While the former takes a long time to cure, the latter never cures. With regard to vegetable oils—don't use them. They could turn rancid. ♣

—WOOD magazine with Bob Flexner

Illustrations: Jim Stevenson

How To Give Veneer Tops New Life



Chipped veneer is only part of the damage to this table edge. The layer between the tabletop and the finish veneer has come unglued, too.

Veneer damage is a flaw you'll find commonly in old furniture, but one you can fix with surprisingly little trouble. "Veneer repair is an easy job for woodworkers of almost any skill level," according to San Francisco furniture repair and refinishing wizard Jim Kull. "It just takes a few tools and some care."

With Jim's encouraging words in mind and his advice close at hand, we decided to give it a try. It didn't take long to turn up the perfect subject—a little end table in a second-hand shop. The years had certainly taken their toll on the edges of the veneered top. Not only was the veneer itself loose, and even missing in spots, but the crossbanding—the thin layer beneath it—had delaminated from the tabletop, too, as shown in the photo *above, right*.

Provide a solid base first

Before we could repair the veneer, we had to get rid of the wrinkles in the crossbanding. We started that chore by cleaning out the old glue, dirt, and loose wood fibers between the crossbanding and the tabletop, using sandpaper, finishing scrapers, and a knife.

Then, using an old business card, we spread liquid hide glue between the layers, as shown at *right, middle*. With waxed paper and then a piece of scrapwood laid over the repair area, we next clamped the veneer and crossbanding to the top, as shown at *right*. We also added shims—pieces



Spread glue between the layers with thin cardboard or plastic. We scraped out the old glue and stuff with the tools on top of the table.

Clamp the edge layers. In spots where the veneer is gone, add shims to press the layer below the veneer solidly against the tabletop.

of some more of those old business cards—between the caul and the waxed paper to ensure contact between the crossbanding and the



Continued on page 20

Veneer Tops Continued from page 18



A simple guide and a router fitted with a straight bit make it easy to cut the old veneer back to a clean, straight edge.

tabletop in spots where the veneer was missing.

Cut away the bad veneer

For a nearly invisible repair along the edge, we needed to cut the damaged veneer back to a straight edge to match up with a new piece. We asked Jim for a foolproof way to make this cut accurately. "Use a router," he counseled.

With a router, a $\frac{3}{4}$ " straight bit, and a quick-to-make guide, shown in the photo *above*, it's easy to make the cut. This setup also mills the surface flat for a smooth repair.

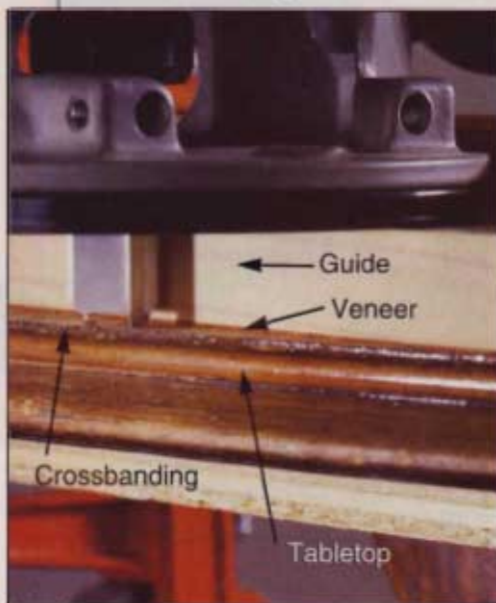

The router bit should just cut through the veneer to the crossbanding or other base material.

To make a guide like Jim uses, we cut a piece of $\frac{3}{4}$ " stock longer than the edge to be routed and about 2" wider than the distance from the center of the router base to its edge. We screwed a piece of straight $1\frac{1}{2}$ "-wide stock atop one long edge.

We then chucked in the router bit. "Any size straight bit will work," Jim advised, "but wider works faster." With the bit extended below the bottom of the guide and the router base riding along the screwed-on cleat, we routed off the edge of the guide base. This resulted in a straight edge that shows exactly where the bit will cut.

Then, we clamped the guide to the tabletop, just less than the bit's width from the edge, as shown in the photo. Normally, Jim suggests placing the guide parallel to the damaged edge. But because our tabletop featured a diagonal grain pattern, we decided to align the guide with the grain to simplify fitting the new piece. (See the box at the *bottom of the page* for another approach.)

With the bit set to just cut through the veneer and kiss the crossbanding, shown in the photo *below, left*, we made a pass along the guide. (If we had needed to remove a wider area, we would have moved the guide back for another cut, making enough passes to remove all of the damaged area.)

Fit and glue the new veneer

All that remained was to replace the missing veneer. Our replacement veneer was the same thickness as the original, so we simply matched up the grain as much as possible. New



Fit the replacement veneer to the routed area. Trim it to rough width before gluing it in place.

and old veneer thicknesses won't always match, though. In most cases, the new veneer will be thinner. To compensate, glue a layer of kraft paper under the new veneer.

Because the table's edge is shaped, we resorted to more handwork to fit the new piece. We marked the approximate contour of the edge on the new veneer, as shown in the photo *above*, and trimmed it.

Then, after gluing and clamping it in, we carefully sanded the edge of the new veneer to match the top. In a future installment, we'll take on the task of matching the color of the new veneer to that of the old.

Turn a repair into a decorative feature

Instead of matching veneer along straight, damaged edges, Jim sometimes likes to add a border of ready-made banding. Though this may not be appropriate for fine antiques, it can dress up old, everyday furniture.

"Make identical cuts along all edges so the area to be inlaid is exactly the same size all around," Jim advises. "Cut the inlay area slightly less wide than the banding," he adds. Then, glue the banding in, clamp or weight it down, and allow the glue to dry. "Trim off the edges with either a flush trimming bit in your router, or sand it flush with the edges," he says. "Then, sand the surface flat, and you are ready to finish." ♦

Written by Larry Johnston with Jim Kull Photographs: Hetherington Photography

Are You Stumped?

If you've got a question that you think would interest other readers, we would like to hear from you. Write to: Ask WOOD®, 1716 Locust St., GA310, Des Moines, IA 50309-3023. For an immediate answer to your question, try posting it on one of our 10 internet discussion groups at: www.woodmagazine.com

Benchtop planer on a "hunger strike"

I've been having a few problems with my Delta 12" benchtop planer (model #22-540) not feeding right. Sometimes I have to push the wood through. I did check to make sure the feed rollers are turning, and I installed new blades, but it didn't cure the problem. Hope you can help.

Arlyn Kastrup, La Vista, Neb.

Arlyn, you don't mention how much use the planer has had or which woods you plane most, but there are a few likely culprits. Unlike heavier industrial machines, benchtop planers have feed rollers made of urethane rather than steel, and they wear over time. The urethane has the density of hard rubber, and it compresses approximately 1-2 millimeters (about $\frac{1}{32}$ "- $\frac{1}{16}$ ") as the roller contacts the wood. If the wear to the rollers exceeds this range, they may not get enough grip on the stock to keep it feeding through without help. Remember, the blades are cutting *against* the infeed direction and so present some resistance to the feed rollers, possibly causing them to slip if their hold on the board is weak.

Engineers at Delta said taking heavier cuts is one way to minimize the problem, because it forces the rollers to compress more and get a firmer grip on the stock. If the wear is signifi-



cant, however, you may need new rollers. Before you go to that trouble, though, make sure the problem isn't something simpler, such as accumulated pitch on the planer bed. Small planers like yours don't have bed rollers, so you must keep the surface free of substances that can cause the wood to drag. Pine and other softwoods may produce a sticky buildup, so clean the bed regularly with acetone or mineral spirits; then apply a coat of paste wax to make the surface a little slicker. Also, clean the feed rollers so they don't accumulate a layer of slippery wood dust. Always keep the tool unplugged during any of these procedures.

If the problem persists, call Delta's technical assistance line at 800/223-7278. They can help you determine if new rollers or some other fix is necessary.

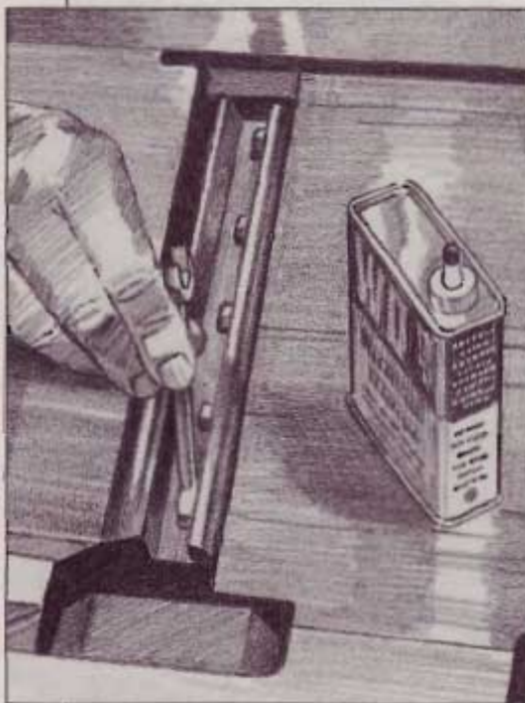

How to unstick stuck bolts

I have an older 6" jointer that needs new knives. Unfortunately, due to infrequent use and negligence on my part, I can't loosen the bolts that hold the knives. The bolts are rusted in place and won't move. Any ideas?

C.R. Dick,

Lake Jackson, Texas

To help you out we turned to Ken Pedersen, an authority on antique-tractor restoration who knows a thing or two about wrestling with rusty bolts. Ken's first

advice is overnight soaking with WD-40 or CRC56. This will work much of the time, especially if the bolt is on a top surface where the lubricant can penetrate the bolt hole and threads.

If soaking doesn't work, it's time to turn up the heat. Pedersen suggests heating the bolt with a butane torch. Before firing the area, be sure to wipe away any flammable oil. Heat the head of the bolt until it turns cherry red and work fast before the bolt cools. Tap on the head a few times with a hammer to break up the rust. Then use a socket wrench to loosen the bolt. Once the bolt starts moving, don't stop until it's out.

Be sure to clean the threads before reassembly. You can do this by scrubbing them with a wire brush, but a tap-and-dye set works much more effectively. ♣

Foot-Operated Tool Switches

A big step forward for safety and convenience



A real toe-tapper

Maybe this has happened to you:

You're drilling, scrollsawing, routing—doing some task that occupies both your hands. Then, you need to turn off the machine. But you're not quite sure what's going to happen when you let go of the workpiece with one hand. In situations like this, a foot-operated switch could save the day.

A foot switch is an easy add-on for many tools. You'll find two kinds generally available—the pedal switch shown *below* and the air-actuated variety, *bottom left*. The latter comes either as a continuous-action switch, which turns on with one step, off with another, or a momentary-contact switch, which stays on as long as you step on it. The pedal switch is a momentary-contact type. Which to use is a matter of preference—we like a momentary contact switch because it shuts off as soon as we lift our foot.

Stand by for some good advice

As handy as a foot switch may be, however, it doesn't suit all tools or situations. A foot switch works best with tools that don't require you to move or change your balance while using them.

A scrollsaw, for instance, is ideally suited to foot-switch use. You move

your feet little, if at all, while scrolling, and normally use both hands to control the work. Plus, you might risk breaking a delicate piece of fretwork if you let go of it with one hand to flip the switch.

With some other tools, such as a lathe, a foot switch doesn't serve as well in all instances. You could effectively use a foot switch on a lathe when turning small work between centers or for some faceplate work. But if you need to be able to move your feet to keep your balance when shaping longer spindle work or large vessels, the foot switch would prove more an impediment than a helper.

And connecting some tools to a foot switch just seems downright perilous. The table saw and radial-arm saw fall into this category.

We've listed some common tools and equipment in the chart *below*, along with our recommendations for hooking them up to a foot switch.

Continued on page 28



This air-actuated switch plugs into the wall outlet, and the tool plugs into it. Stepping on the red rubber dome operates the switch.



The cord from the tool plugs into the back of this typical foot-pedal switch.

Tool	Yes	Conditional	No
Bandsaw		X	
Disc sander		X	
Drill press	X		
Jointer			X
Lathe		X	
Mitersaw			X
Mortise machine	X		
Planer			X
Radial-arm saw			X
Rotary tool	X		
Router table	X		
Strip sander	X		
Scrollsaw	X		
Tablesaw			X

Get the "Pro Advantage"



Don't let your tools stand between you and truly professional results. Use Starrett tools, the choice of expert craftsmen for over 120 years.

Choose any or all of these **FREE**, attractive, full-color catalogs, packed with information on top quality Starrett tools.

Choose **Precision Tools; Saw Blades; and/or Measuring Tapes, Levels, and Tools.**

To order these Starrett Catalogs, see **Woodworker's Resource** on pages 96 & 97.

Starrett®

The L.S. Starrett Company,
121 Crescent Street Athol, MA 01331

Tel.: (978) 249-5330 • Fax: (978) 249-8495 www.starrett.com

Circle No. 175, 176, 1369



FREE CATALOGS

LOSE THE HASSLES

RBI GIVES YOU WOODWORKING MACHINERY THAT IS...

- Designed to be easy to use
- Over 70 years of building quality tools
- Backed with excellent customer service
- Covered by a great warranty
- All American Made

RBI gives you the best value for your woodworking dollar!



Hawk Ultra Precision Scroll Saws



RBI 4-in-1 Universal Planers



Panel Master II



26" & 38" Drum Sanders

rbindustries, inc.

1801 Vine Street • Harrisonville, MO 64701
www.rbiwoodtools.com

K106

Call 1-800-487-2623 for your **FREE** fact kit!

WHAT WOODWORKERS NEED TO KNOW

Continued from page 26

Foot-Operated Tool Switches

Current capacity counts

The pedal switch shown carries a 10-amp load rating, while the air-actuated one can handle 15 amps. Check the power consumption of any tool before you connect it to a switch. Some models of tools listed in our chart draw too much power to use with a 10-amp switch. For example, many high-horsepower routers (the type you might mount in a router table) draw 13 amps or more. These foot switches won't work on tools with magnetic switches, either.

Plug in and turn on

Here's good news: Plugging in a cord is the hardest thing you'll have to do to add a foot switch to a tool. It really is as simple as 1-2-3: 1 plug the tool cord into the switch; 2 plug the switch into the wall outlet; and 3 flip the tool switch on. Now, with a touch of your toe, you can control the tool. This easy installation means you can use one switch with several tools, too. Simply unplug one tool from the switch and plug another into it.

Don't step into harm's way

To prevent accidents, heed these precautions:

- Turn off the switch on the tool or disconnect the tool from the foot switch when you change blades or bits or adjust the tool.
- Whenever you aren't using the tool and it's still connected to a foot switch, turn off the tool switch to prevent accidental starting.
- When you disconnect a tool from a foot switch, remember to flip the tool switch off, in case someone plugs the tool directly into an outlet later.

Step right up!

You can buy pedal switches from many tool dealers, including Harbor Freight (800/423-2567) and Meisel Hardware Specialties (800/441-9870 in the U.S. or 612/471-8550). The air-actuated switch is available from Craft Supplies USA (800/551-8876) or Woodworker's Supply (800/645-9292). ♣



Ex-Navy quartermaster and current Top Shop Tip winner Sherwood Peppers shows his new idea of "basic training."

When Sherwood Peppers served in the U.S. Navy after World War II, he was in way over his head. Not that he couldn't hack the job, it's just that his duties included testing the seaworthiness of new submarines on their first deep dives. "We never really had any major problems," he says, "but we did have a couple of close calls."

These days, he immerses himself in woodworking. Whether building projects such as a cherry hutch and a grandfather clock for his grandsons, or a houseful of country furniture for his daughter, Sherwood is always on the lookout for ways to make things work better around the shop. Case in point: his Top Shop Tip at *right*.

If you've come up with an idea that makes life easier around your shop, tell us about it. Besides helping your fellow woodworkers, you'll also enjoy \$75 in folding money. And, if we deem your tip the Top Shop Tip for that issue, you'll also win a tool prize worth at least \$250.

Send us your tip, along with a photo or illustration, and your daytime phone number to:

Tips From Your Shop (and Ours)
WOOD® Magazine
 1716 Locust St., GA-310
 Des Moines, IA 50309-3023

Or, e-mail the same information to us from our homepage at www.wood-magazine.com.

Sorry, but we can't return your submissions. And, because we only print original tips, please send them only to *WOOD* magazine. Thanks!

Dave Campbell
 GENERAL-INTEREST EDITOR

No more beating around the bushings

I use guide bushings for template-routing, and I used to have difficulty tightening the ring nut that holds the bushing to the router subbase. Often, it would vibrate loose, which either spoiled the cut or damaged the guide bushing. I tried snugging them up with pliers, but found it too easy to distort the shape of the bushing.

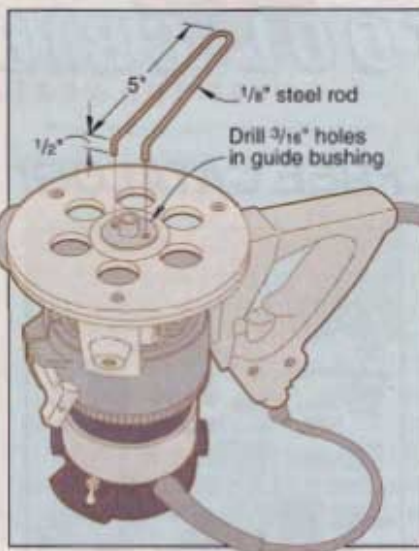

To solve this problem, I drilled a pair of holes in each bushing's flange, and formed a wrench out of 1/8" steel rod, as shown in the drawing *below left*. After hand-tightening the guide bushing, I drop the posts of the wrench into the holes in the bushing and give it one final turn.

—*Sherwood Peppers, Norwich, Conn.*



Top Shop Tip winner Sherwood Peppers will spice up his shop with a Delta 36-650 Professional Tablesaw. Way to go, Sherwood!

Stop cutterhead creep with this simple handle holder

My Delta 22-540 planer, like many portable 12" units, lacks a cutterhead lock, so I made my own. I cut an 8"-diameter disc from 3/4" plywood, and cut a notch in it to match the planer's height-adjustment handle.

After setting the cutterhead to the proper thickness for my workpiece, I slip the disc around the handle and clamp it to the body of the planer, as shown in the drawing *below*.

—*Paul Lonergan, Lancaster, Ohio*

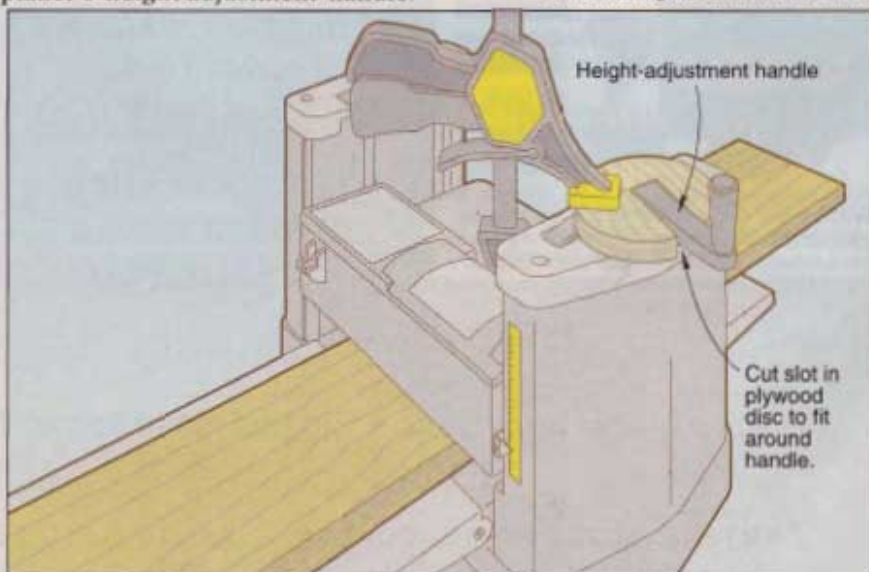

Continued on page 32

Continued from page 30

Dad comes to the rescue with pen-drilling jig

When a buddy and I were commissioned to make 150 wooden pens, we knew we needed an efficient way to bore the blanks. The handscrew-on-the-drill-press method just wasn't going to cut it. Thankfully, my dad came up with the jig shown at right.

He laminated pieces of $\frac{3}{4}$ " plywood to make the stop blocks, attached oak faces to them to prevent splintering, then glued and screwed them perpendicular to the plywood base and each other. He mounted a toggle clamp as shown, and I added the hardboard insert to reduce chip-out on the blanks.

Using the jig couldn't be simpler: I mark the center of a pen blank and clamp it in the jig, then position the jig so that the drill bit hits the center mark, and clamp it in place. I drill the hole, flip the toggle, pop in a new blank, and clamp. As long as my blank size doesn't change, I never need to mark another center hole.

—Tim Schubach, Miamisburg, Ohio

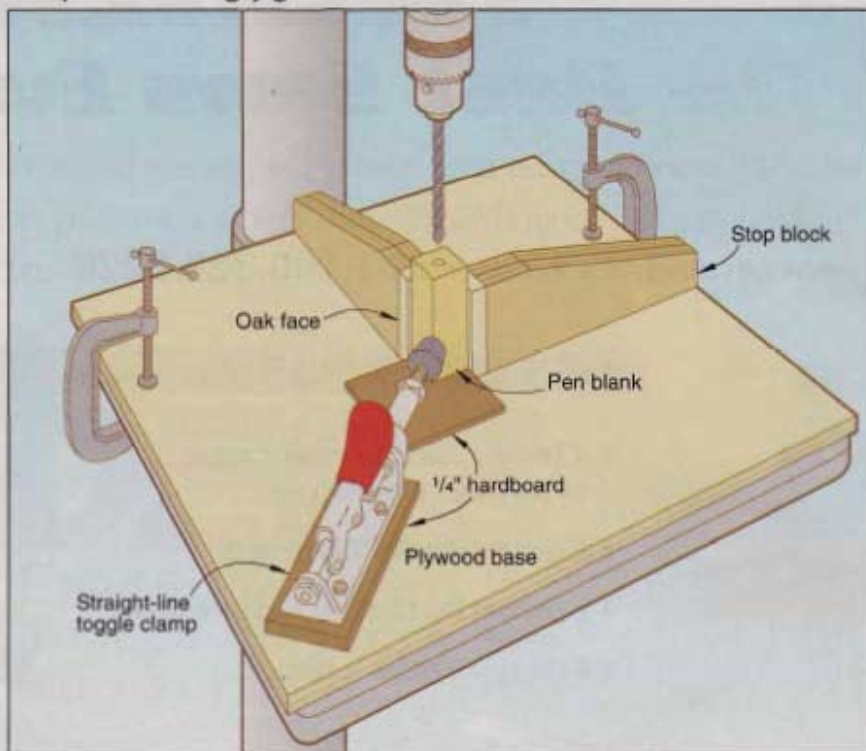

Continued on page 34

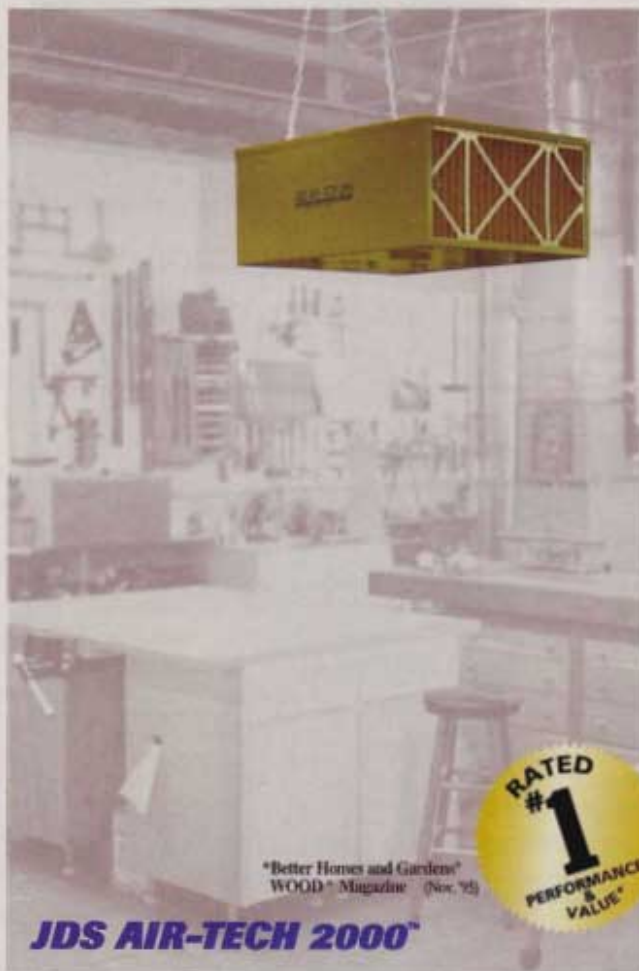

*Better Homes and Gardens®
WOOD® Magazine (Nov. '95)

JDS AIR-TECH 2000™

Let's Clear the Air...

Introducing The New Model 750 Simply The Best!

- Variable Speed Control (200 CFM to 750 CFM Filtered Air)
- Two Speed On/Off Pull Chain
- Ultra Quiet
- 95% ASHRAE Tested Main Filter
- Lifetime Warranty
- 30 Day Money Back Guaranty

The National Institute for Occupational Safety and Health (NIOSH) recommends limiting wood dust exposures. The JDS Air-Tech 2000 will dramatically improve the quality of the air you breathe. Our new model 750 variable speed allows you to dial in your desired air flow, from a whisper quiet 200 cfm to an ultra performance 750 cfm. This will clean the air in a 30'x30'x8' shop ten times per hour. For larger areas our models 8-12 and 10-16 are available. The JDS systems will remove 99% of particles as small as five microns and 80% of particles as small as one micron. For the removal of odors, fumes and smoke, our optional charcoal filter is available. To place an order or for the dealer nearest you call us toll-free.

\$259.00
Model 750

Another quality product from
Manufactured in the U.S.A.

**JDS
COMPANY**

www.thejdscompany.com

1-800-382-2637

Continued from page 32

Plastic protector corners the market on drawer slides

I needed drawer glides for a cabinet I was making, and all the stores were closed. Digging through my scrap pile, I stumbled across a length of clear-plastic outside-corner molding (the kind used to prevent damage to paint and wallpaper in the house). I glued the molding to the draw-

er sides, and it provided a great low-friction surface for the drawer to run on. If you don't want the molding to show, you could glue it into the corner of the case instead, as shown in the *bottom* drawing.

—Charles Szuch, Calgary, Alberta

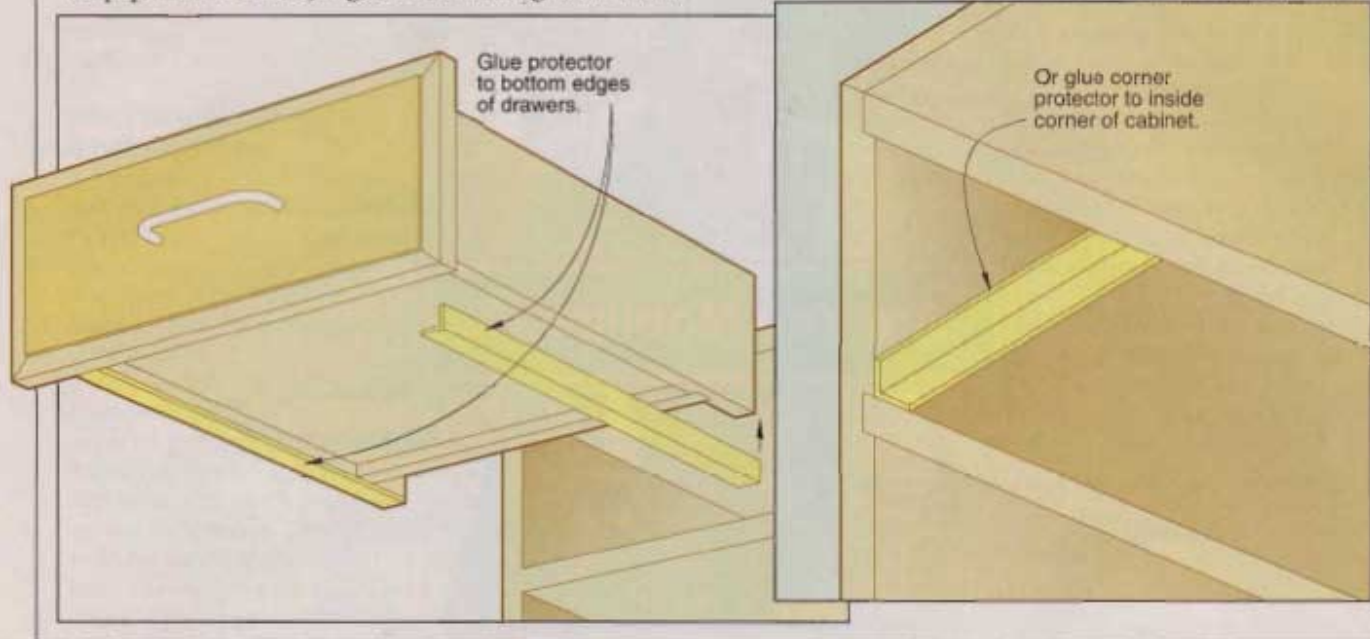

Taking Band Saws to New Levels

You've heard that they're the best, now its time to own one. Our band saws have won an Editors Choice Award and our customers rave about them. Call today and order a free demonstration video.

Designed by Laguna Tools and imported from Italy, we have the finest and largest selection of European band saws in the country.

- Best specifications in the industry
- Dynamically balanced cast iron flywheels
- Wider blades for straighter, smoother re-sawing
- Euro guides
- Conforms to the toughest dust standards
- Quiet and smooth with more power
- Robot welded steel frames
- More resaw height
- Rack and Pinion
- Easy blade change
- Mobility kit available
- Manufactured in Italy
- Order a custom made band saw to suit your needs.



LAGUNA TOOLS

You Build With Wood, We Build With Trust.

E Mail: lagunatools@earthlink.net

Web: www.lagunatools.com

800-234-1976

2265 Laguna Canyon Rd. Laguna Beach, CA 92651
(949) 494-7006 • FX (949) 497-1346

800-234-1976

100 Central Ave. So. Kearny, New Jersey 07032
(973) 491-0102 • FX (973) 491-0591

"Sticky stick" helps sand tiny parts on belt sander

To hold small parts, such as the wooden jewelry I make, for sanding on the belt sander, I made what I call my "sticky stick." This handy gadget keeps my fingertips well away from the abrasive belt.

Make your own by cutting a $\frac{1}{8}$ "-thick strip of $\frac{3}{4}$ " hardwood about 12" long. (It's best if the stick is somewhat flexible.) In one end of the stick, center a bandsaw kerf about $2\frac{1}{2}$ " long. Starting in the kerf, wrap the stick with 2" masking tape, sticky-side out, as shown below.

To use the sticky stick, press your tiny workpiece against the masking tape and, holding the opposite end of the stick, hold the piece against the moving sanding belt. When the tape gets dusty, simply tear off enough tape to expose a fresh tacky surface.

—Michael P. Locke,
Huntington Beach, Calif.

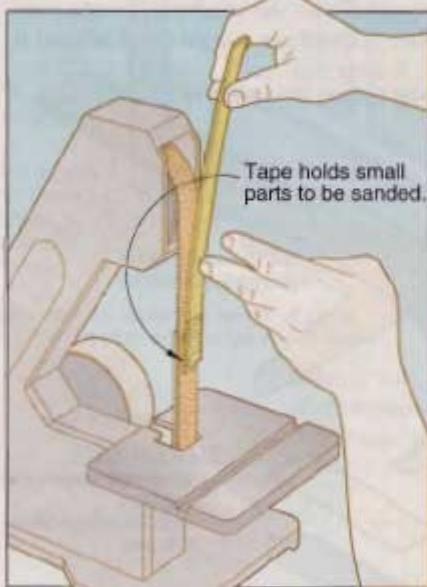
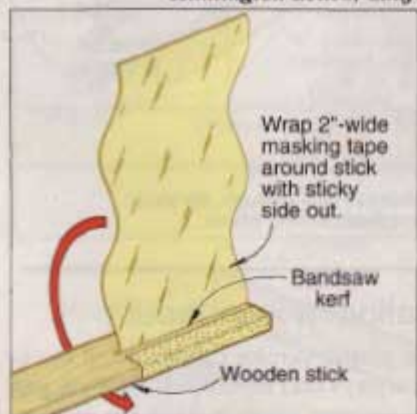

Continued on page 36

NO MORE DUST



Introducing Microplane® Rotary Shaper Power Tool Attachments for low-speed shaping. The razor-sharp teeth create tiny shavings that fall to the surface instead of clouding your air.

Call 501-968-5455 or

1-800-555-2767

*dealer inquiries encouraged

www.microplane.com

email: info@microplane.com

Microplane
A Product of Grace Manufacturing

Circle No. 2145

The most useful tool since the OPPOSABLE THUMB.



Gorilla Glue® is a serious woodworker's dream. It holds everything including hardwoods, softwoods, hard-to-glue exotics and pressure-treated lumber. Gorilla Glue joints are incredibly stable, and the glue lines are nearly invisible. Plus, it's 100% waterproof so it's perfect outdoors, too. Successful projects are within your grasp. Call 800-966-3458 for a dealer, or find out more at www.gorillaglu.com.



THE TOUGHEST GLUE ON PLANET EARTH™

4-WAY MONEY-MAKER!

● PLANES ● MOLDS
● SANDS ● SAWS



Turn a \$2 rough board into \$25 worth of finished trim right in your own shop! Make over 350 standard moldings, tongue & groove, picture frame stock, any custom design. QUICKLY CONVERTS from Planer/Molder to Drum Sander or power-feed Multi-Blade Rip Saw! Made in U.S.A. Choose from 12", 18" and 25" Models.

Variable Feed Makes The Difference!

Just a twist of the dial adjusts the Woodmaster from 70 to over 1,000 cuts per inch. Produces a glass-smooth finish on tricky grain patterns no other planer can handle. Plenty of American-made "muscle" to handle low-cost, "straight-from-the-sawmill" lumber. 5-Year Warranty. Easy Terms.

FREE FACT KIT

1-800-821-6651 ext. PW45

Woodmaster Tools, Inc.
1431 N. Topping Ave. Dept. PW45, Kansas City, MO 64120
www.WoodmasterTools.com

TIPS FROM YOUR SHOP (AND OURS)

Continued from page 35

Modified spade bit is the wheel deal

Your article about Ed Carpenter ("Logging on a Small Scale", *WOOD*® magazine issue 113) inspired me to share my method of making small wooden wheels. I ground a 1" spade-type drill bit to the shape shown below using a stone wheel in my high-speed rotary tool, then sharpened and honed the cutting edge to about a 5° angle. After cutting off the excess shank of my modified spade bit, I put it in place of the cutter in my circle-cutter.

To make wheels, I set my drill press stop so that the long edge of the bit goes half way into my 3/4" wheel stock, and bore through one side. I flip the stock over, repeat the process, and a toy wheel pops out!

—Fred Zurbuchen, Magalia, Calif.

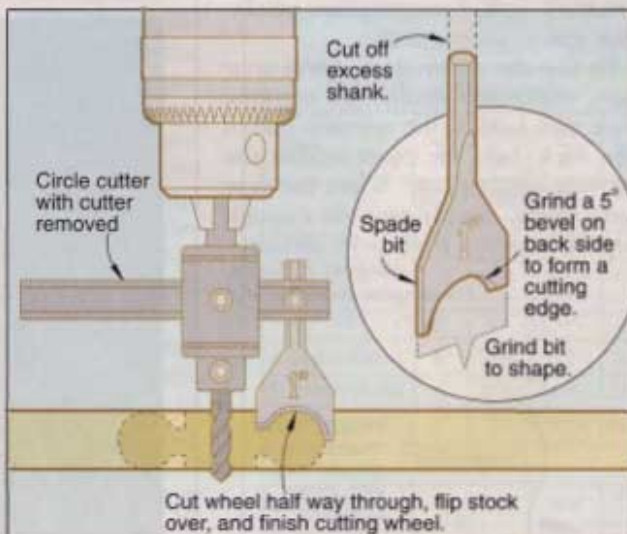

Quash your caliper's wanderlust

I use an inexpensive plastic vernier caliper when thickening stock, but I always find myself setting it on top of the planer when I'm not using it. To keep it from vibrating off and dropping into the machine, I cut a strip from a flexible rubber refrigerator magnet and affixed it to the caliper. Now, it stays put.

—John Goray, Monroe, Wis.

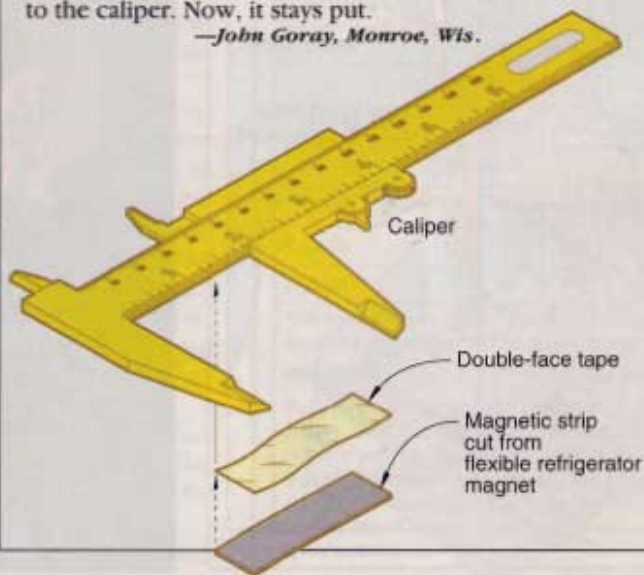

Visit us at www.vandykes.com



Featuring the industries largest selection of:

- Furniture Components
- Veneers, Carvings and Moldings
- Furniture Kits
- Hardware

Free catalog!

Call 1-800-558-1234

Or Write

Dept. 600.40 PO Box 278 Woonsocket, SD 57385

Circle No. 2077

Recycled packaging makes mini mixing tray

Whenever you buy hardware that comes packaged on a card with one of those clear plastic bubbles, discard the card and keep the bubble. It works as a handy mixing tray for making small quantities of acrylic paints or two-part epoxy.

—Larry Johnston, WOOD® magazine



Clear bubble removed from hardware package

A FEW MORE TIPS FROM OUR WOODWORKING PROS

• You can bore a hole in a spot too small for the drill chuck to fit into. Learn how we did it in the photo on page 47.

• Ever been frustrated trying to figure out how to clamp a small workpiece to your bench? On page 49, see one solution to the problem in the article about carving a shell ornament for furniture.

• Need a way to rout perfectly round circles and arcs? Cut all curves great and small with the help of two nifty jigs shown on pages 60 and 61.

• If you're the kind of woodworker who utilizes every last scrap of stock, check out page 80. You'll find a dozen different ways to put even your sawdust to good use.

STEVE WALL LUMBER CO.

Quality Hardwoods and Woodworking machinery For The Craftsman and Educational Institutions

Ash	4/4	Select	2.25		\$ 77.00
Basswood	4/4	Select	1.95		\$ 63.00
Birch	4/4	Select	2.50		\$ 81.00
Butternut	4/4	1C	2.20		\$ 65.00
Cherry	4/4	Select	4.20		\$ 96.00
Hickory - Pecan	4/4	Select	2.30		\$ 72.00
Mahogany (Genuine)	4/4	Select	3.70		\$ 96.00
Maple (Hard)	4/4	Select	2.80		\$ 85.00
Maple (Soft)	4/4	Select	2.20		\$ 72.00
Poplar	4/4	Select	1.55		\$ 64.00
Red Oak	4/4	Select	2.40		\$ 80.00
Walnut	4/4	Select	3.45		\$ 95.00
White Oak	4/4	Select	2.40		\$ 80.00
Cedar (Aromatic Red)	4/4	1C+8tr	1.65		\$ 66.00
Cypress	4/4	Select	2.25		\$ 74.00
White Pine	4/4	F.G.	1.15		\$ 55.00
Yellow Pine	4/4	Clear	1.80		\$ 65.00

UPS Specials

SEE OUR CATALOG ON THE WEB!

Above prices are for 100 quantities of kindred rough lumber sold by the bd. Ft. FOB Mayodan, NC. Call for quantity discounts. Other sizes and grades available.

Above prices are 20 bd. ft. bundles of clear kindred lumber 3'-10" wide x 2'-7" long (Random widths & lengths) Surfaced 2 sides or rough. Delivered UPS prepaid in the Continental U.S.

Circle No. 592

NOW AVAILABLE

Custom Made Raised Panel Doors

4/4 Log Run Walnut 100 bd. ft. \$155

Also Available Exotic Lumber

STEVE H. WALL LUMBER CO.

BOX 287
MAYODAN, N.C. 27027
336-427-0637
1-800-633-4062
FAX 336-427-7588

Email: wood@walllumber.com
Website: www.walllumber.com

Send \$1.00 For Lumber Catalog
Prices Subject To Change Without Notice

Take your hobby on the road.



As a Guardsman WoodPro franchise partner, you'll have confidence knowing you're backed by the largest producer of furniture finishes in North America, supplying over 500 furniture manufacturers. Your customers will also have peace of mind knowing that the same company who made the finish on their furniture is repairing and restoring it.



Finish Repairs

Waterbased Refinishing



Furniture Upholstery

Upholstery Repairs



Cabinet Refurbishing

Structural Repairs

Initial Advantages

- Low Overhead
- Exclusive Territories
- Inventory Packages
- Training Programs
- Marketing Programs

Ongoing Advantages

- Field Support
- Regional Workshops
- National Advertising
- National Service Accounts
- R & D on New Products and Services

GUARDSMAN
WOODPRO

The Best Wood Finishes for Furniture Repair™

For information, call:
(800) 496-6377

In Canada: (888) 966-3232
www.guardmanwoodpro.com

Target Markets

San Francisco • Portland • Albuquerque
Seattle • Chicago • Miami • St. Louis • San Diego
Las Vegas • Atlanta • Cincinnati • Los Angeles
Pittsburgh • Baltimore • New York City • Boston

Investment range: \$15,000 - \$25,000

Offer made by Prospectus only
Unit & Master Franchises available worldwide



A Business Unit of Lily Industries, Inc.

A Look At Not-Quite-Perfect Stock

Irregularities or variations in wood's structure that might make it unsuitable for a specific purpose are called natural defects. The most usual ones prove to be growth-related. Here's a rundown on some of the most common.

Trees have reactions, too

Trees grow best standing straight, so they work hard to upright themselves from leaning positions or correct the angle of their branches. Sometimes, the wood displays this reaction.

The reaction wood of hardwood trees is referred to as *tension wood* because it occurs on the side of the trunk away from the lean. The same type of wood in softwood trees gets the name *compression wood* due to the relatively compressed size of the growth ring's early wood where the fast growth appears.

In hardwoods and softwoods, reaction wood swells and shrinks (especially in length) more than normal wood, causing boards to warp and split. Although denser, reaction wood is also generally weaker. It machines differently than normal wood, too, dulling cutting edges faster and twisting away from or pinching blades when ripped.

Boards with reaction wood have wavy grain and feel heavier than other boards of the same species. They also may have checks in the grain along the length of the board from drying stresses.



Reaction wood represents the vigorous growth of wood on one side of the trunk that makes it lopsided.

When trees get shaken

Due to stresses that occur while a tree trunk grows, its wood may develop separations. *Wind shake* occurs between portions of the tree's annual growth rings and can be localized to a section of the trunk or run its entire length. Cracks running with a board's grain indicate shake. The wind shake may in time split the board lengthwise.

Heart shake shows up in the end grain of a board as a check or checks across or partially across the growth rings. And there's little reason to doubt that the checks eventually will get larger and split the board, too.



Wind shake causes the wood to separate parallel to the trunk.



Cracks extending from the pith of the trunk toward the bark represent heart shake.

Continued

Brash boards break

As a result of poor growing conditions, some trees develop wood with thinner than normal cell-wall structure, dubbed *brash*. The wood has a tendency to break under lower-level loads than would be normal.

Hardwoods are particularly susceptible to brashness. You can suspect brash wood in a hardwood board if it's lighter in weight in relation to other boards of the same species.



Brashness in boards causes them to fracture suddenly and sharply across the grain instead of splintering like normal wood.

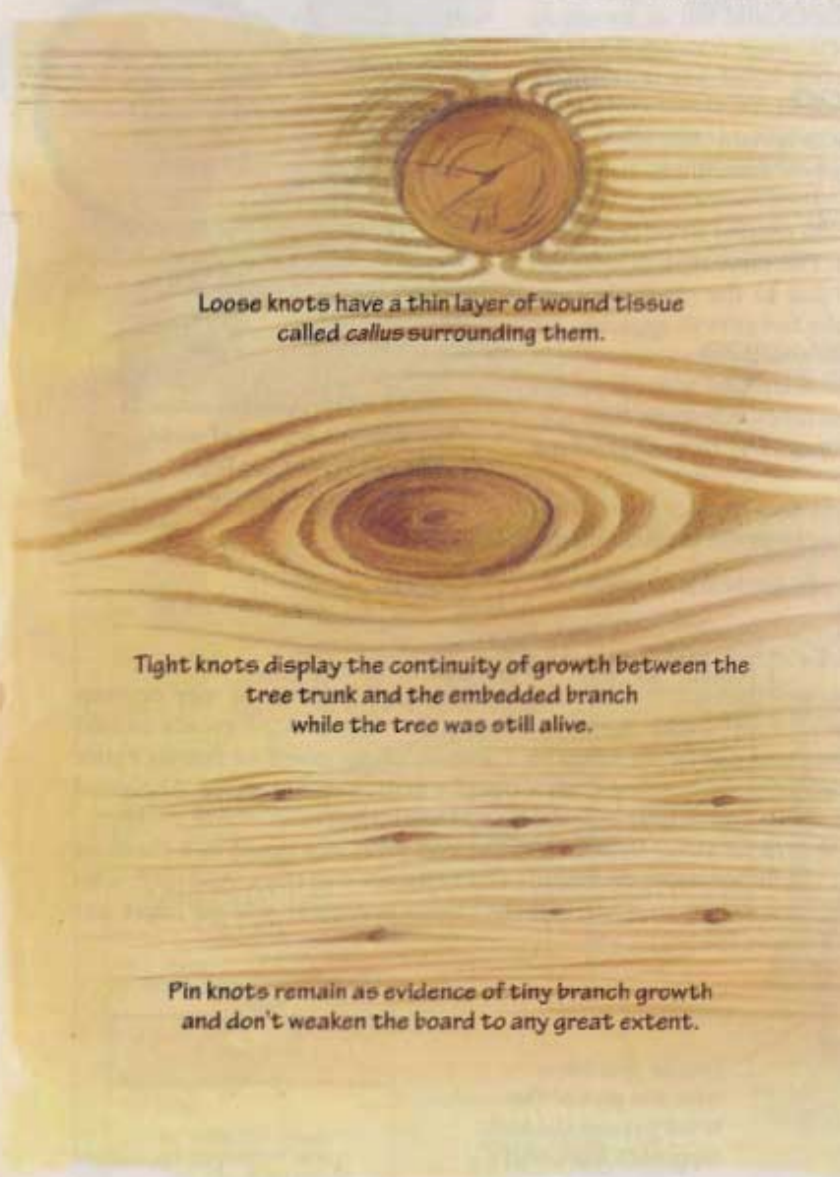

Loose knots have a thin layer of wound tissue called *callus* surrounding them.

Tight knots display the continuity of growth between the tree trunk and the embedded branch while the tree was still alive.

Pin knots remain as evidence of tiny branch growth and don't weaken the board to any great extent.

Knots weaken wood

Wood's most obvious structural defect is a knot. Nothing more than the bases of branches that once grew, knots tend to weaken boards because they cause otherwise normally straight grain to irregularly flow around them.

Loose knots normally detach from the board. As the stock dries, the knots tend to shrink away from the surrounding wood and fall out at the slightest touch.

Tight knots appear as dark spots of dense wood with irregular grain around them. This type of knot will stay in place, but it and the adjacent wood may split in time.

In some applications, knots add to wood's character and visual appeal, as with the *pin knots* in "knotty pine" paneling. However, when selecting boards always keep in mind their intended use and whether or not the presence of knots will affect that. Remember, too, that even tight knots represent harder, denser, and possibly more resinous wood that responds differently to machining, finishing, and relative humidity changes than the rest of the board's wood. ♣

Illustrations: Brian Jensen

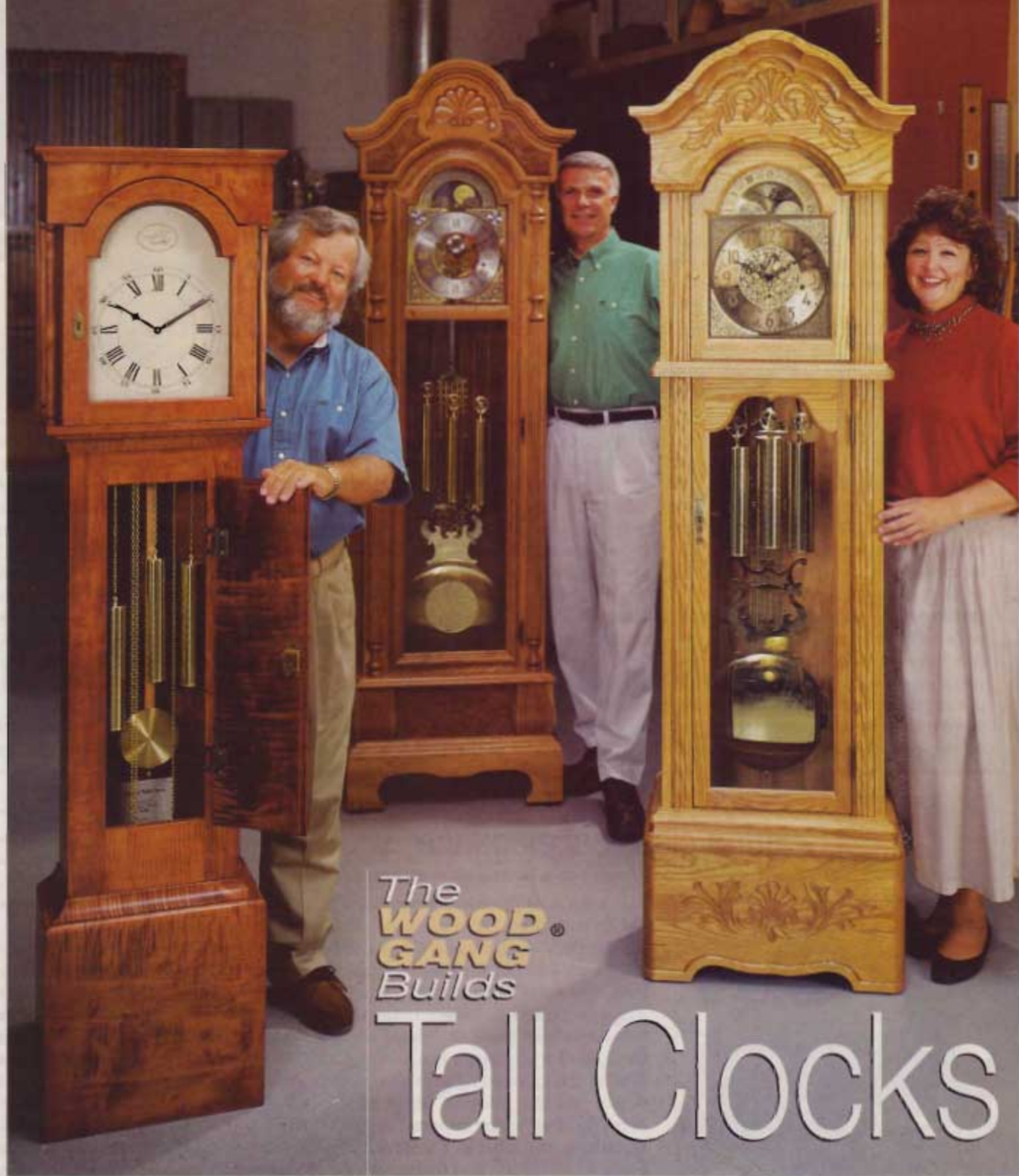

The
WOOD[®]
GANG
Builds

Tall Clocks

From left, Jim Downing with his Shaker tall clock, Chuck Hedlund and his cherry grandfather clock, and Sheryl Munyon with her version in white ash.

Tall clocks may be quite a woodworking challenge. But crafting one from a kit gives you a jump start—and some great satisfaction, too. Read what our *WOOD* magazine staff members have to say about building theirs.

Continued

Tall Clocks



Shaping up a Shaker tall clock

By James R. Downing, senior design editor

My kit came in three carefully packed boxes, yet a couple of delicate wooden parts were broken. I easily glued them. A parts list and diagram helped with the inventory, and all parts were there, the wood ones nicely machined for smoothness but not sanded. Some had to be adjusted for a perfect fit.

Although available in cherry, I wanted the maple version, hoping that it would have some figure. And it did. The wood also was blemish- and defect-free, but the grain in some pieces just didn't seem to match the rest. I requested that those parts be replaced, and the company complied without question.

Building the clock: The kit instructions were relatively clear. However, I did have to partially pre-assemble some parts to understand what the instructions were telling me. They were otherwise complete, and included step-by-step diagrams. More illustra-

tions, such as exploded views, would have been helpful. Despite that, I believe most intermediate-level woodworkers could build the clock. And for those who need help, Bartley has an 800 number.

I didn't substitute any of the parts, except for making a paper dial face on the computer. Bartley's duplicated the original, but to me, my design has better visual balance. That's one advantage of building from a kit—you can customize if you want to.

To get a dark, cherry-like color on the maple and bring out the figure as the Shakers would have, I mixed two TransTint water-based wood dyes (from WoodCraft). Before applying a thinned mixture, I sanded with 150-grit. The advantage of the thin coat was two-fold: It raised the wood grain so that I could sand it smooth, and it revealed any glue squeeze-out.

After the first application dried, I



sanded with 220-grit, then coated the clock with a full-strength dye mixture. When it was dry, I went over it with 320-grit. The finish is two coats of Olympic Antique Oil, followed by paste wax for added protection.

Last, I installed the clock works—a great Hermle movement, brass hands, weights, chains, pendulum, and chime rods. Instructions for assembling and installing it were quite complete. Learning more about mechanical movements was definitely a plus.

Summary: Overall, I spent about 24 weekend hours building the clock. I'm



Crafting classical elegance

By Charles L. Hedlund, project builder and shop supervisor



I've been a professional woodworker for better than 20 years now, but building this clock was my first experience with a kit. By the time I completed it, one thing became quite obvious: Anyone thinking about taking up woodworking should first build something from a kit. That's because, for a novice, the kit building provides confidence and the pride of accomplishment without buying expensive tools.

Building the clock: I ordered my clock kit in cherry, and found that the fit of parts was excellent, including accurate miters. On a scale of 1 to 10, the milling and machining was a 10.

I substituted cherry plywood for the birch plywood that was included for the case back and bottom, though, because I felt that the cherry would eventually darken, but the birch would not, even after staining. And I personalized the clock a bit by using some Carpathian elm burl veneer on either

side of the carving on the pediment and on the front of the base.

The instruction booklets were—unfortunately—not just specific to the clock kit received but also to variations of the model. I had to read all the booklets to discover any differences in instructions for the step that I was about to do. If they agreed, I proceeded. Sometimes I made a judgement call for what I thought would work, although I could have phoned the company for technical assistance using its 800 number.

I discovered some errors in measurement that would cause a person with no experience in building large woodworking projects to seek technical help. To an experienced woodworker, though, they'd only prove somewhat annoying. If the instructions could ever become as excellent as the machined parts, anyone could then assemble this clock kit easily.



proud of the result. It looks great with our other Shaker furniture. But friends say that I should install a glass door to display the beautiful weights and pendulum. I'm going to stick with the original Shaker design, though. After all, it's a replica.

Shaker tall case clock kit

Available in cherry or maple, the kit includes clock movement, glue, and sandpaper. Its finished size is 71x18x10". No. 0348, \$845 plus shipping. The Bartley Collection, Ltd., 65 Engerman Ave., Denton Industrial Park, Denton, MD 21629. 800/787-2800. www.bartleycollection.com. Free catalog.

F. Wm. Murray grandfather case kit

The case kit comes in either white ash or cherry. Its finished size is 85x25x14". No. F9SE C, \$849.95 (case only), plus shipping (from Niagara Falls, N.Y. for U.S. customers). Movement, Hermle 8-day triple chime cable drive, no. HCL3T, \$399.95; radial dial, no. DJ24TR, \$269.95; decorated pendulum, no. HLPD4, \$119.95; beveled glass, no. BGF 9, \$120. For all U.S. and Canadian mail orders, contact: Murray Clock Craft Ltd., 512 McNicoll Ave., Willowdale, ON. M2H 2E1. 800/268-3181. www.murrayclock.com. Catalog, \$2 (U.S.).

To tone the wood, I used Minwax Cherrywood Gel Stain. Several coats of spray Deft semi-gloss finished off my clock and enhanced its beauty.

Summary: Counting time spent customizing, the clock took about 20 hours. And as my first kit, I found it a highly enjoyable experience. Now, the grand-looking clock occupies a stately position in our living room.



Grandfather creates confidence

By Sheryl Munyon, administrative assistant

In the few years that I've been on staff, I've tried to learn wood-working techniques and pick up tips from other staff members. By doing so, I've improved my skills and actually built some items, but no fine furniture before this grandfather clock.

The kit clock gave me the assurance that I do have the ability to take on the next level of wood-working. It was a wonderful bridge, requiring me to assemble milled parts so that they fit exactly. Also, it gave me a greater understanding of the pride of accomplishment that comes after completing such a beautiful piece.

Building the clock: The difficult part of the kit was overcoming my fear that I lacked the needed skills to complete the clock. But the kit's difficulty level wasn't as high as expected. As long as I followed the orderly, straightforward, illustrated instructions—and dry-fit the parts—it went smoothly. The doors were pre-assembled, the glass was cut to size, the parts fit well together, and the holes were predrilled in the correct places. I found myself working ahead on one section while the glue was drying on another, and relishing my progress.

The instructions were wonderful. They provided general information first, then went through assembly step by step through the final installation of the clock works. Each numerical step was precise.

The only problem I had was fitting together the case's bottom molding. There was a $\frac{1}{8}$ " gap between the front moulding and the side pieces. When I called Klockit's 800 help line, the person there proved knowledgeable and had a solution: Glue another piece of wood onto the back of the



molding to bring it flush. Overall, I felt that the advisor cared about my project as if it was his own.

Because my clock was ash, but I wanted it to look like oak, I stained it with two coats of Minwax Golden Oak. The finish coats were Deft semi-

gloss, followed with Minwax Finishing Wax, which buffed out quite nicely.

Summary: I probably have 38-40 hours in my grandfather clock, from checking out the kit's parts to installing the works. And I'd do it again in a heartbeat! It would be well worth all the time and money spent. It's a wonderful heirloom to pass on

from generation to generation, and building it was definitely an exciting learning time. ♣



Cheyenne clock kit

The solid, white ash grandfather clock kit comes with carved base and crown, a cable-driven triple-chime movement, glue, and sandpaper. Finished size is 80x24x12 $\frac{1}{4}$ ". No. 34853, \$899.95 plus shipping. Four-piece glass, \$129.99 plus shipping. Klockit, P.O. Box 636, Lake Geneva, WI 53147-0636. 800/556-2548. www.klockit.com. Free catalog.

Photographs: Baldwin Photography

Irrigation Island

A handy hanger for a hose and sprinklers

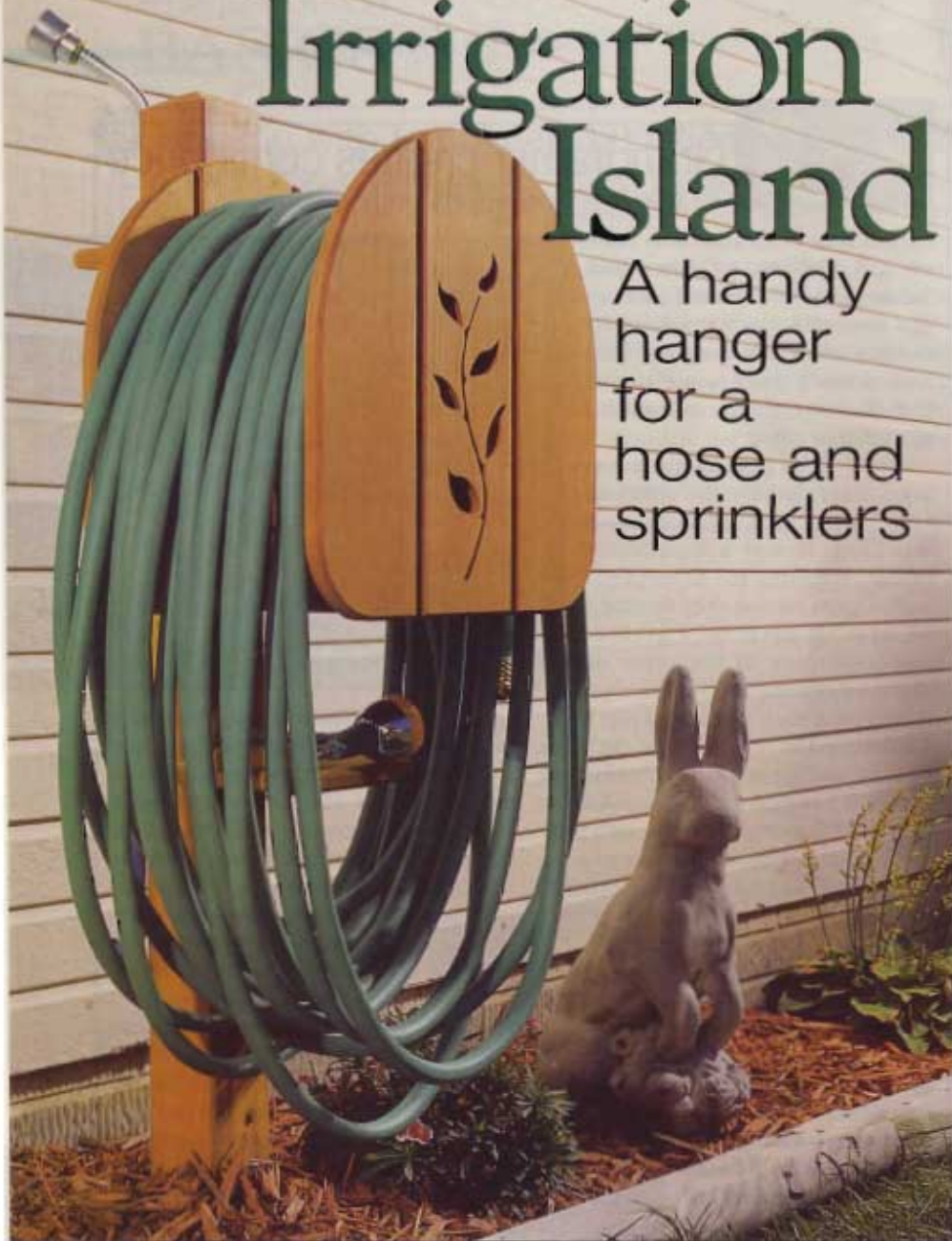

If, like so many homeowners, you frequently find your garden hose in a tangled heap, here's help. Our attractive cedar hanger will keep 100' or more of $\frac{1}{2}$ " hose and some watering accessories handy.

Note: You can build the freestanding hose rack as shown or build the rack assembly (parts B, C, D, E) alone to mount on a wall or fence. When building the post-mounted rack, first determine the length of the cedar 4x4 post (A). The 4' length listed in the Bill of Materials supposes installation with a Ground Tech anchor (inset photo, opposite page) or similar device. For a post that will be set in concrete, allow additional length.

Prepare a post to put it on

- 1 Cut the post (A) to length. (We cut it on a sliding compound mitersaw.) Tilt the saw blade to 25°, and saw a chamfer on each face at the top.
- 2 Form two $\frac{3}{4}$ x $\frac{3}{4}$ " dados in the post, where shown on the Side Section View drawing. You can saw them on a tablesaw equipped with a dado blade or rout them.
- 3 Rout a $\frac{3}{16}$ " chamfer along each edge of the post.

Build a pair of panels

1 Cut stock for parts B and C. (We cut six 18" lengths of 1x6 cedar.) Stack the pieces in pairs, aligning the edges and ends flush. Tape each set together with masking tape.

2 Make one photocopy of the full-size pattern for part B and two copies of the pattern for part C. (They're in the WOOD PATTERNS® insert.) Adhere the pattern for part B to the top of one stack; a pattern for part C to the top of each of the other two. Align the straight edges of the patterns with the boards' edges. Bandsaw the parts to shape, cutting slightly outside the pattern line. Sand to the line, and separate the pieces.

3 Scrollsaw the ivy design in the front center panel (B). Drill a $\frac{1}{16}$ " blade start hole inside each cutout area, and cut out the pattern on a scrollsaw fitted with a large blade (#9 or #11, for instance). Remove the patterns from all pieces.

4 Rout a $\frac{3}{16}$ " chamfer all around the edge on both sides of each piece.

5 Edge-glue stock to make two $\frac{3}{4}$ x $13\frac{1}{2}$ x 10 " blanks for the inside supports (D). (We glued up three pieces of 1x4 cedar for each blank, using polyurethane glue for moisture resistance. A 6'-long board yielded more than enough stock.) Stack the two blanks, and tape them together for stack-cutting.

6 Photocopy the Inner Support Full-Size Pattern. Adhere the pattern to the top of the stacked blanks, and bandsaw the two parts D. Saw outside the line; then sand to it. Drill eight $\frac{5}{32}$ " holes through both pieces where shown. Separate the parts, and drill the four holes for the post screws in the back piece. Countersink the screw holes on the appropriate side.

7 Attach the face panels (B, C) to the inside supports (D), where shown on the patterns. Space parts B and C $\frac{1}{4}$ " apart. (We put these parts together with stainless-steel deck screws.) To accent the cut-out ivy design, apply green paint (we used Krylon no. 2004 moss green) to the area of the inside support face behind the cutout before attaching the center panel (B).

8 Attach the back assembly (B/C/D) to the post (A) with 3"-long screws.

You can hang it up pretty soon

1 Cut the slats (E) to the size shown on the Bill of Materials. Set a stop-block on an auxiliary miter-gauge fence for accuracy when trimming the parts to length.

Cut several $\frac{1}{2}$ " scrapwood spacer blocks to ensure uniform spacing when you install the slats.

2 Drill and countersink a centered $\frac{7}{32}$ " shank hole $\frac{3}{8}$ " from each end of each slat. Set a fence and stopblock on your drill press to do this.

3 Attach the slats to the back panel (the one fastened to the post) first. Start with the slats at both lower corners and at the top center on part D. Guiding through the shank hole, drill a pilot hole into part D. (We filed a sharp end on a piece of coat-hanger wire to make a bit that would reach past the panel, shown below.)



A length of coat-hanger wire, or other stiff wire, serves as a drill bit to reach past the panel edge.

After you screw the three starting slats in place, position the slat next to one of the lower ones, drill the pilot hole, and screw it in place. Continue around to the top center slat. As you work around the curve, place the spacer blocks right at the face of the slats, as shown above, rather than pushing them all the way down to part D. Attach the slats on the other side, working from the bottom up.

4 Following the same procedure, install the front panel.

5 Cut out the front and back shelves (F, G), referring to the Front Shelf and Back Shelf drawings. Rout chamfers where shown.

6 Glue and screw the shelves into their dados.

7 Apply a clear outdoor finish. (We used Wolman Rain Coat water repellent with cedar toner.) Then, drive in the post anchor or dig a hole to set the post in concrete. 🍌

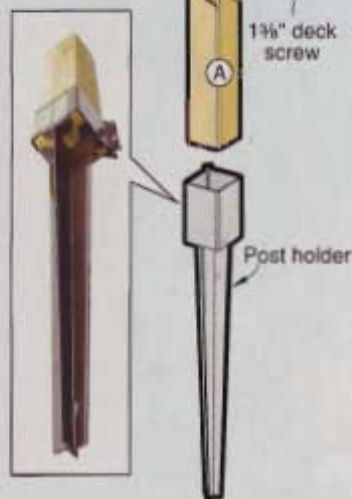
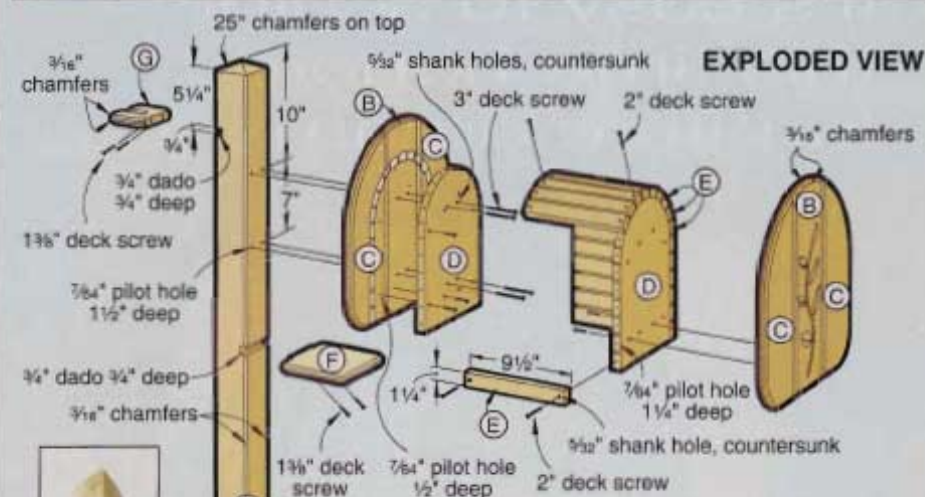
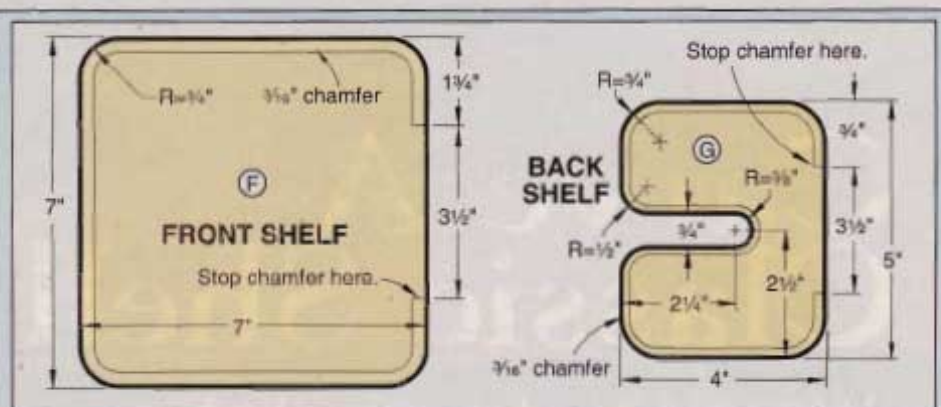

SEE THE
WOOD PATTERNS® INSERT
FOR FULL-SIZE PATTERN

Part	Finished Size			Mati.	Qty.
	T	W	L		
A post	3 1/2"	3 1/2"	48"	C	1
B center panel	3/4"	5 1/2"	17 1/4"	C	2
C side panel	3/4"	5 1/2"	16 3/4"	C	4
D inner support	3/4"	13 3/4"	9 1/2"	C	2
E slat	3/2"	1 1/4"	9 1/2"	C	23
F front shelf	3/4"	7"	7"	C	1
G back shelf	3/2"	5"	4"	C	1

*See Note at beginning of instructions.

Material Key: C—cedar

Supplies: #8x1 1/2", 2", and 3" deck screws, post anchor, finish.

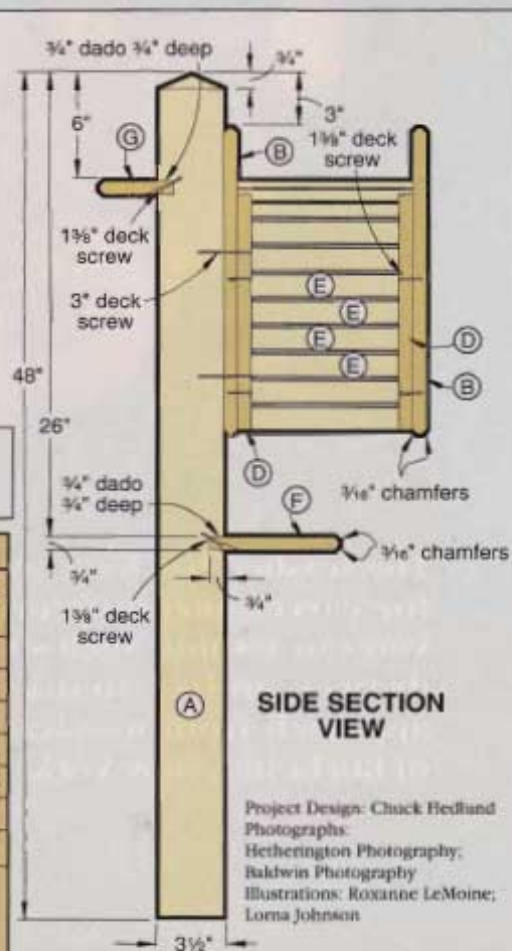

Project Design: Chuck Hedlund
Photographs:
Hetherington Photography;
Baldwin Photography
Illustrations: Roxanne LeMoine;
Lorna Johnson

Carve A Classic Shell

It's easy to sculpt this time-honored furniture ornament



The seashell has long been a popular design for carved furniture ornamentation. Now you can fashion shell-shaped ornaments or drawer pulls, thanks to this simple approach from woodcarver Keith Randich of Rochester, New York.

Cut out the shell blank, and mount it for carving

1 Photocopy the Full-Size Shell Pattern, and trace it onto a $\frac{3}{4}$ "x4"x4" blank. If you're carving a shell to match furniture wood, orient the grain to match that of the piece the shell will be fastened to. If the shell will be mounted on a table skirt or drawer front with horizontal grain, for instance, make the shell's grain run horizontally as well. You also can enlarge or reduce the pattern to size the shell to your furniture, if necessary. Changing the size may call for different tools than those listed.

2 Bandsaw the shell outline. If you're making the shell as a drawer pull, rabbet the backside $\frac{1}{2}$ " deep, extending about $1\frac{3}{8}$ " from the lobe end. Keith likes to carve this rabbet, but you could rout or saw it.

3 Glue the blank to a piece of scrapwood so you can clamp it to your workbench, as shown in *Photo 1*, opposite page. To allow easy removal of the carving later, first glue a piece of glossy magazine paper slightly larger than the blank to the scrapwood. Then glue the blank to the paper.

Leave plenty of room around the blank so your clamps won't be in the way when you're carving. (We cut the scrapwood close to the blanks shown to make tighter photos.)

Now, shape the shell

1 Draw a pencil line across the shell at the high point, shown about 1" from the wing end of the shell on the pattern. Working outward from that line, round over the ends of the shell. You can carve smooth curvatures with the inside (concave side) of the gouge, as shown in *Photo 2*.

A 20mm (or larger) no. 3 gouge works well on the lobed end; a 20mm (or larger) no. 5 on the winged end. You'll almost always be carving across the grain, so keep your tools sharp.

If you're carving a drawer pull with the rabbeted back, be careful at the unsupported edge on the lobe end. It's easy to chip out the wood when carving downward. To avoid that, stop a little short of the edge, then come back on it from the side, as shown in *Photo 3*.

Tools and materials

Keith used the tools listed below to carve the shell shown. Tools of similar size and sweep would work.

Nos. 3, 4, and 5 gouges, 20 mm (¾").

No. 6 gouge, 13mm (½").

No. 8 gouge, 10mm (¾").

V-tool, 10mm.

Carve the shell from stock that matches the grain and color of the furniture it will be mounted on. Or, you can select an easy-carving wood, such as basswood or jelutong, and paint or gold-leaf the carving.

2 Round over the sides with a 20mm (or larger) no. 4 gouge. Don't let the edges of the tool dig in. If they do, switch to a flatter gouge—swap the no. 4 for a no. 3, for example.

3 Work around the outside edges of the lobes. Clean them up and refine the contours. You can shape the spaces between the lobes uniformly with a 10mm no. 8 gouge. A 13mm no. 6 gouge will shape the tips nicely.

4 Cut the wings with a no. 5 gouge about 20 mm wide. You can draw a pencil line to guide your cuts, but let the tool's shape define the line's curve. Repeat chopping the stop cuts and cleaning out the wing areas (20mm no. 3), leaving a depth of ¼".

5 Draw a vertical centerline on the shell. Next, draw in the lobe lines shown on the pattern.

6 Using a V-tool, cut the lobe lines, as shown in *Photo 4*. Start the cuts going in both directions from the high spot so you're cutting downhill. Round the sides of the lobes down into the V-cuts, using a 13mm no. 6 gouge. Finish shaping the lobes in stages, alternately V-cutting and rounding.

7 When you're satisfied with the form of the shell, hone your tools and clean up all the cuts. Smooth and refine the curves, and cut several V-grooves into the wings where shown.

8 Push a large, flat chisel under the shell to break it free from the waste board. Clean off the paper and glue. Mount the shell either by gluing or by driving screws into the back. ♣

SEE THE
WOOD PATTERNS® INSERT
FOR FULL-SIZE PATTERN

Project Design: Keith Randlich
Photographs: Baldwin Photography;
James R. Downing

Illustrations: Roxanne LeMoine; Lorna Johnson



1 Glue the blank to a piece of scrapwood with a paper joint so you can hold it easily for carving. Tools shown are, from left, nos. 3, 4, and 5 gouges (all 20 mm wide), 13 mm no. 6 gouge, 10mm no. 8 gouge, and 10 mm V-tool. The gloves incorporate Kevlar fiber to minimize the chance of cuts.



2 After roughing out the curvature with a gouge, you can smooth the contour by carving with the inside of a gouge, such as the 20 mm no. 3 shown. (The wing end of the shell is shown here.)

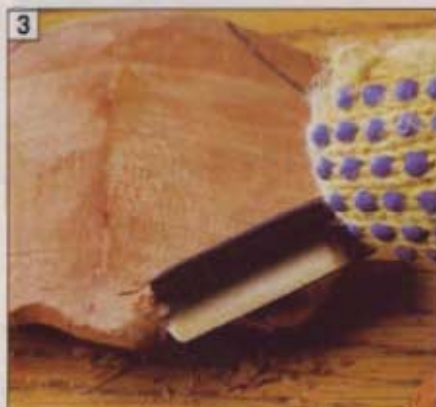

3 To avoid breaking out wood at the unsupported lobe ends, cut across the edge or upward on it as much as possible. This is a 10mm no. 8 gouge.



4 Carve the lobe lines with a V-tool, then round over the sides of the lobes to separate them. The wings have been cut to about ¼" thick.

Mini Garden Shed

There's no denying how useful backyard sheds are for organizing yard tools and outdoor supplies. But they require spare real estate not every yard has, and can't always be placed where the storage is needed most—next to a garden or flower-bed area. This post-mounted "mini" shed solves both problems with style and storage to spare.

Cut the carcass panels first

Note: We used a type 4 exterior plywood with 4-inch-on-center grooves. Sometimes this is referred to as "T 1-11." We also used dimensional lumber with each of these building materials. Be aware that the thickness and width may not be the dimension stated here. For instance, our 3/8" plywood measured 7/16" thick. Our 3/4" cedar was thicker than 3/4" and therefore required surfacing. Keep these inconsistencies in mind when cutting dados, grooves, and notches. In every case, measure the thicknesses of your workpieces.

- 1 Start with the shed's rear panel (A). Cut a sheet of siding to 81" long. For the front gable (B), cut a 21 1/2" section off the end of the second sheet of plywood siding. Then lay out the angled cuts for the roof peak on both pieces. (We laid these out on the backside.) Center the peak between the two centermost grooves in the plywood. See the Plywood Cutting Diagram and the Parts View in the pattern insert.) We placed masking tape along the cut lines, and used a straightedge and a circular saw to make the cuts (See *Illustration A*).
- 2 Making sure the peak stays in the center of the panel, trim the panel to width along the sides. Note that the front gable (B) is narrower than the rear panel.
- 3 Layout the notches for the ridge board in both A and B; then cut them with a jigsaw (See *Illustration B*).
- 4 Cut the side panels (C) to length and width. Note that the top edges are bevel-cut at a 35° angle and that the groove pattern again is centered.

Store shovels, rakes, grass seed, and other yard care items in this charming outdoor structure.

5 From $\frac{3}{4}$ " plywood, cut the floor (D), center divider (E), and three shelves (F).

Cut the frame corners

1 Select four reasonably clear and straight cedar 2x4s for the rear and front frame corners (G, H). On a jointer, tablesaw, or router table, straighten the edges and reduce the width to $3\frac{3}{8}$ ".

2 Using the Rear Frame Detail drawing as a guide, cut the $\frac{3}{4}$ "-wide rabbet along the inside corner edges of the two rear frame corners (G), to accept the rear panel. You can do this with a tablesaw and a standard or dado blade, but measure the plywood's actual thickness first. The $\frac{3}{4}$ " dimension is nominal, and the thickness is likely to be slightly less. Cut the rabbet depth so the plywood will lie flush with the edge of the frame.

3 Use the same technique as in step 2 to cut the $\frac{3}{4}$ "-wide rabbets for the side panels in the rear frame (G) and the front frame (H).

4 Cut the frame corners to length. Note that they get a 35° miter cut at the top to match the roof angle.

Getting the assembly underway

1 Drill a series of countersunk screw holes along the vertical edges of the side and rear panels, about $\frac{1}{2}$ " in from the edge. Put the end holes 2" in from the top and bottom edges of the panels, then space five more holes evenly between them. Also, drill a row up the center of the rear panel (A).

2 Glue and screw the rear frame corners to the rear panel. Lay this assembly flat on a pair of sawhorses, with the inside face up.

3 Attach the front frame corners to the side panels with glue and screws.

4 Glue and fasten the side panels to the other rabbets in the rear frame corners, and brace their front edges.

5 Next, drill more countersunk screw holes, this time along the bottom edges of the siding panels. Then glue and fasten the floor (D) in place.

6 Glue and fasten the center divider (E) to the floor and rear panel.

7 Now, cut the six shelf cleats (I) to size. Screw the shelf cleats to the center divider and the right side panel. We spaced ours at 24", 38", and 48" above the floor, but you can vary this. Don't install the shelves yet.

Continued

PLYWOOD CUTTING DIAGRAM

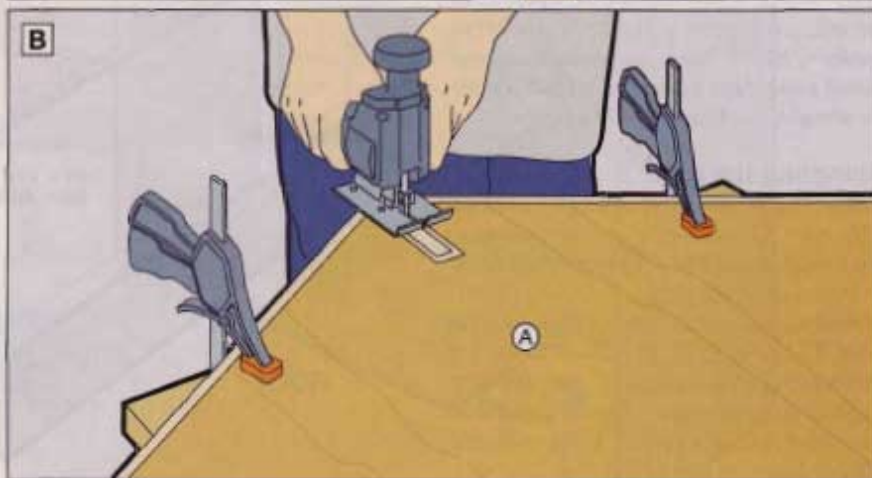
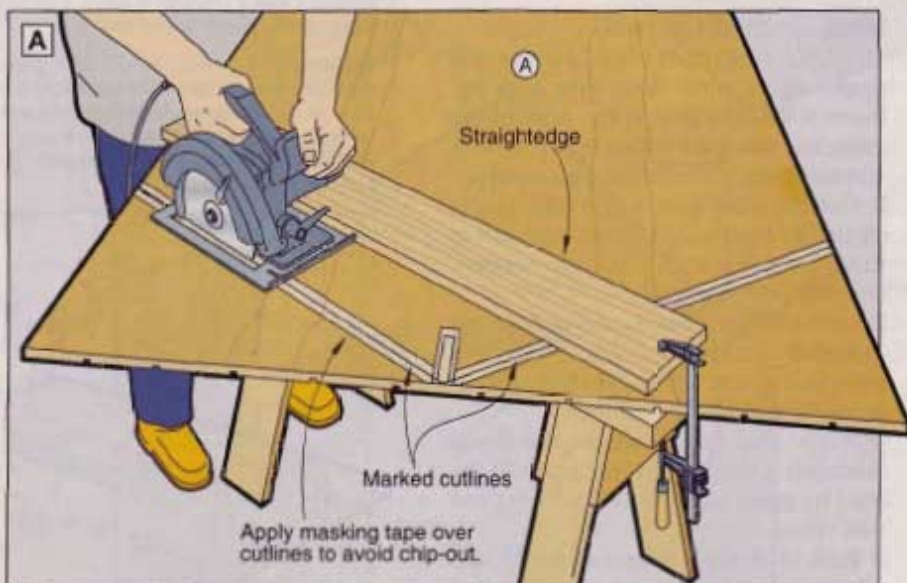
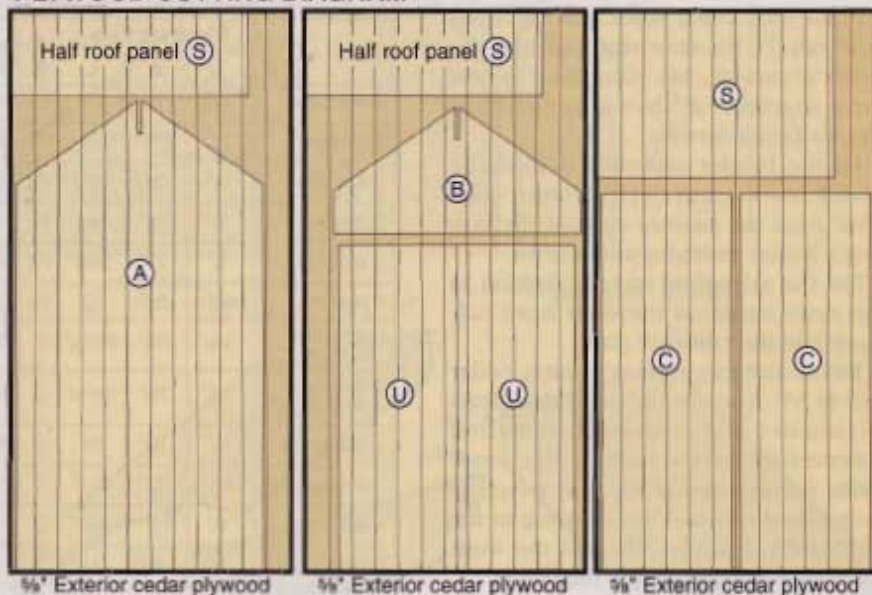

Garden Shed

Build the door header assembly

1 From solid cedar stock, cut the door head rail (J), the door stop (K), and the gable cleats (L, M). Glue and screw them together, as shown in the Door Header Detail drawing.

2 Fit the header assembly behind the front frame corners (with its lower edge 56 1/4" from the bottom ends of the corners). Fasten with glue and screws.

3 Cut the galvanized metal Z-flashing to the same length as the door head rail. Place it in the rabbet of part J.

4 Bevel one edge of an 8'-long cedar 2x4 to 35°, and cut the two ridge cleats (N) and two roof cleats (O) from it. Drill countersunk screw holes in the front frame corners and in the rear panel, as shown in the Parts View drawing in the *WOOD PATTERNS*®. Then fit the front gable, and glue and screw the cleats.

Next, up onto the roof

1 Cut the ridgeboard (P) to the size and shape shown in the Parts View drawing. Insert it into the slots at the peak of the gable and rear panel; then secure it with screws driven through the ridge cleats.

2 Cut the roof fascia (Q) and fascia cleats (R) to size and shape, and fasten them together with glue and screws. (See the Roof drawing.)

3 Refer to the plywood cutting diagrams to cut the roof panels (S). (Note that one panel is cut whole, but the other is pieced from two half-sections.)

4 Screw the roof panels to the fascia assemblies; then secure each one to the shed by fastening to the ridge cleats and roof cleats.

5 Tack or staple a length of metal drip edge along the bottom of each roof panel, and cover them both with roofer's felt. (This is an asphalt-impregnated paper that comes in a 15-lb. or 30-lb. weight—either one will do.)

Shingling the roof

Note: The first row of shingles is actually two layers—the starter course, then a top course staggered at least 1 1/2", to cover the gaps.

1 Nail the starter course shingles on with 3d hot-dipped galvanized nails. Let the bottom ends extend 1" past the drip edge. The side edges should extend 1" past the fascia boards. Then nail the double layer on top of the first.

Continued

Bill of Materials											
Part	Finished Size			Matl.	Qty.	Part	Finished Size			Matl.	Qty.
	T	W	L				T	W	L		
A rear panel	3/4"	42 3/4"	81"	PS	1	M gable cleat	3/4"	3/4"	6 1/2"	C	1
B front gable	3/4"	41 1/4"	21 1/2"	PS	1	N ridge cleats	1 1/2"	3 3/4"	21"	C	2
C side panels	3/4"	22 1/2"	64 1/4"	PS	2	O roof cleats	1 1/2"	3 1/4"	21"	C	2
D floor	3/4"	21"	46 1/4"	Ply	1	P ridgeboard	3/4"	8"	49"	C	1
E center divider	3/4"	21"	58 1/4"	Ply	1	Q roof fascia	3/4"	4 1/4"	41"	C	4
F shelves	3/4"	21"	23"	Ply	3	R fascia cleats	3/4"	3/4"	41"	C	4
G rear frame corners	1 1/2"	3 3/4"	66 1/4"	C	2	S roof panels	3/4"	28 1/2"	41"	PS	2
H front frame corners	1 1/2"	3 3/4"	66 1/4"	C	2	T ridge caps	1/4"	1 1/2"	32"	C	2
I shelf cleats	3/4"	1 1/2"	21"	C	6	U door panels	3/4"	20 3/4"	56"	PS	2
J door head rail	1 1/2"	3 3/4"	41 1/4"	C	1	V door stiles	3/4"	3 1/2"	56"	C	4
K door stop	3/4"	4"	46 1/4"	C	1	W door rails	3/4"	3 1/2"	20 3/4"	C	6
L gable cleat	3/4"	3/4"	41 1/4"	C	1	X hinge cleats	3/4"	3 1/2"	7"	C	4
Materials Key: PS—plywood siding, Ply—ACX fir/pine plywood, C—western red cedar.						Y posts	3 1/2"	3 1/2"	120"	C	2
Supplies: #8x1 1/4", #8x1 1/2", #8x2", #8x3" galvanized deck screws, 3d and 7d galvanized box nails, 1/4x1 3/8" lag screws, 1/4x8" lag screws with flat washers (2), metal drip edge (1-10-ft. length), 1/4" offset metal Z-flashing for plywood siding (1-10-ft. length).						Z cross brace	3 1/2"	3 1/2"	48"	C	1
Buying Guide: The following Stanley Hardware items (or appropriate substitutes) are also required for this project: ornamental spring T-hinge, (2 pr.), no. 76-0890/SP1296; ornamental pulls, (2), no. 1298; 3 1/2" safety hasp (1), no. 75-5201/CD917. Fasteners are supplied with each.											

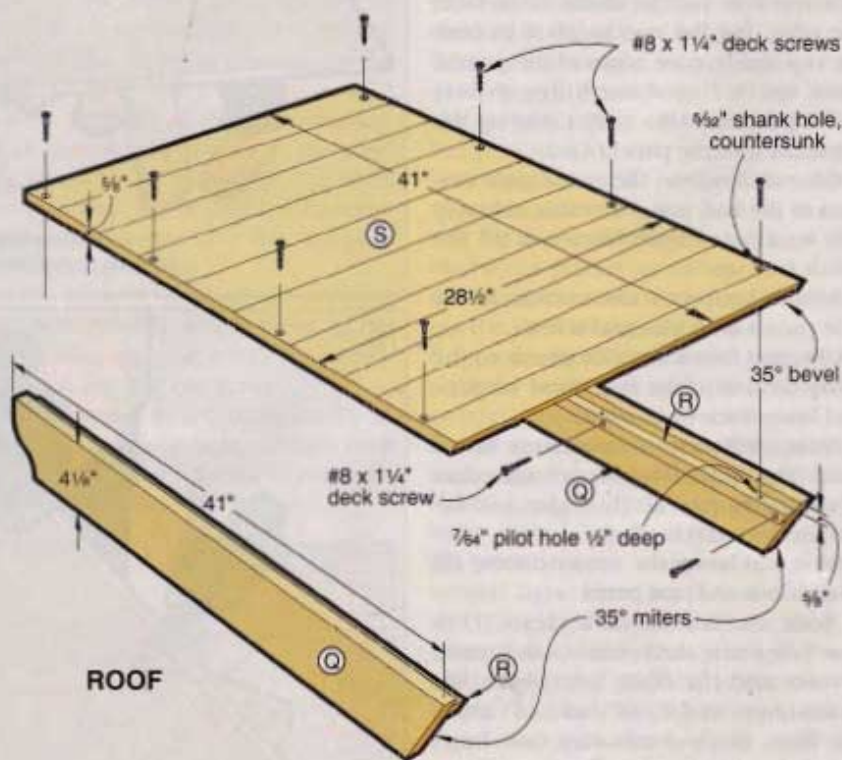

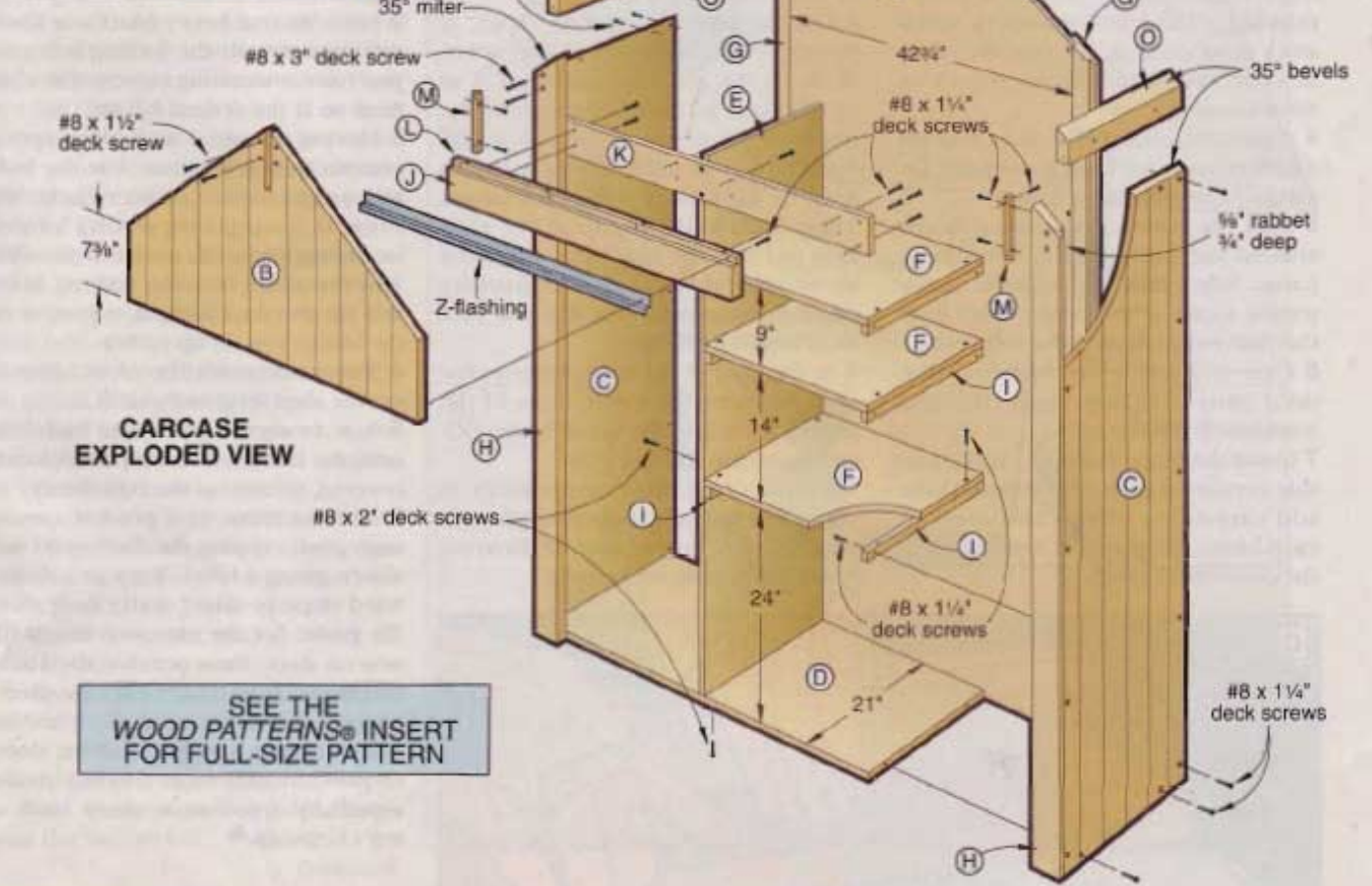
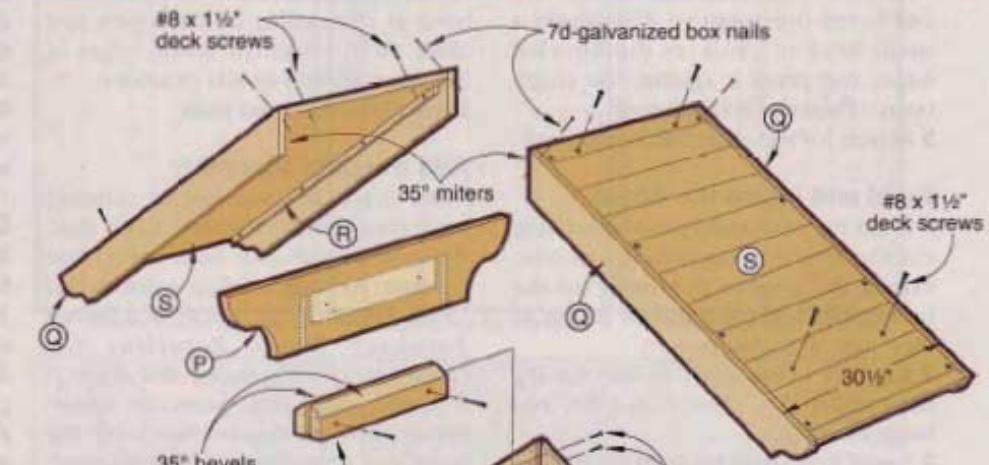
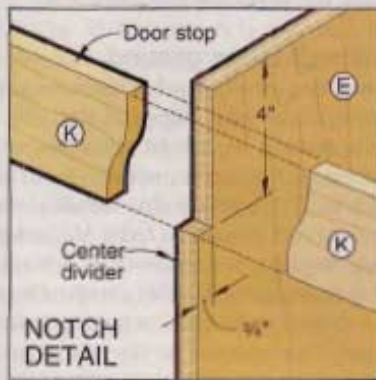
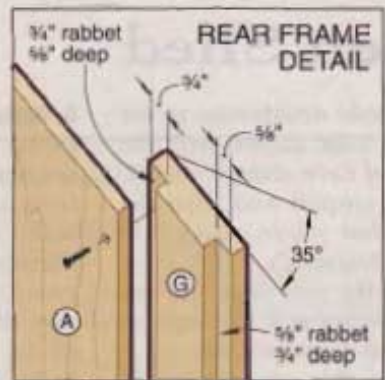
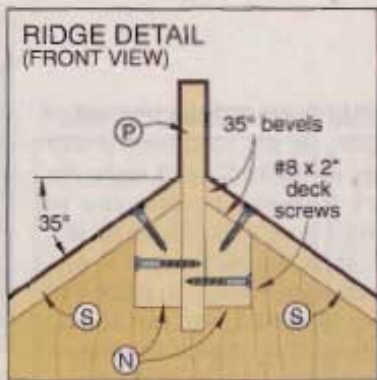
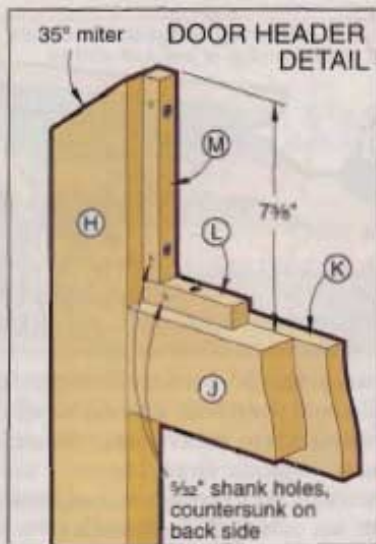

SEE THE WOOD PATTERNS® INSERT FOR FULL-SIZE PATTERN

Garden Shed

2 Clamp a 6"-wide straightedge to the roof, its lower edge aligned with the bottom edge of each shingle course, and use it to support and align the next course while you're nailing it in place (See *Illustration C*).

3 As you near the roof ridge, cut the tops of the shingles at a 35° angle so they butt against the ridgeboard.

4 Cut the ridge side caps (T) to size and bevel one edge to 35°. Apply a small bead of caulk to the beveled edge, and press it against the ridgeboard. Then nail it to the roof.

5 Repeat for the other half of the roof.

Build and install the doors

1 From the remaining plywood siding, cut the two door panels (U) to size. Check the groove positions on the front gable, and cut the door panels so they align with that pattern.

2 Cut 1×4 cedar stock to size for the door stiles (V), door rails (W), and hinge cleats (X).

3 Install a 3/4" dado blade in your table-saw and set the cutting height to 3/8" to cut the half-lap joints for the door frames. (See the Door Frame Detail drawing.) Make test passes in scrap stock to tune the fit; then cut the joints in your stiles and rails, as shown in *Illustration D*.

4 Glue and clamp the door frames together, and check each assembly for square before leaving it to dry.

5 Drill the countersunk screw holes around the perimeter of each door frame. Stay a little shy with the countersink so the screw heads won't bury themselves too deep in the soft cedar.

6 Glue and screw the frames to the door panels. Clamp them flat on a workbench top if you can.

7 Install the hinge cleats (X) at the outside corners of each door frame. These add support to handle the stress at each hinge. Then mount the hinges to the doors where shown.

8 With help from at least one other strong adult, lay the shed onto sturdy sawhorses on its back, and sight the front face from the bottom end to make sure there's no twist in the assembly. Shim the back edges if necessary, then set the doors in place and align them with a uniform gap around all the edges. Now, fasten the hinges to the front frame corners. If the doors bind at the center as you open and close them, bevel the inside edges of the frame slightly to add clearance.

9 Install the hasp and pulls.

Add the post assembly

Note: If you are painting or staining your shed, now is the time to do that. We used a solid color latex stain from Olympic for our trim (a color called "Faulkland"), and Wolman Raincoat Water Repellent (in Cedartone) for the siding and doors.

1 Apply your stain, paint, or water-preserved to the 4×4 stock for the posts and cross brace. We used western red cedar for its stainability, but pressure-treated fir or pine will work as well and may last longer.

2 Cut the posts (Y) at a 35° angle at the top ends. Now center and fasten them to the sides of the shed. Use #8×2" deck screws, driven from the inside of the plywood through to the posts. Keep in mind the post length must be the total of three dimensions. These include the length of the shed side (64 1/2"), the height of the shed above ground (12"), and the frostline depth for your area. (For this, ask your local building official.)

3 At the floor of the shed, measure the span between the inside faces of the posts. Then cut the cross brace (Z), and paint/seal the end grain.

4 Fit the cross brace temporarily in place, and drill a 3/8" hole through each post just into the end grain of the cross brace. Then remove the brace.

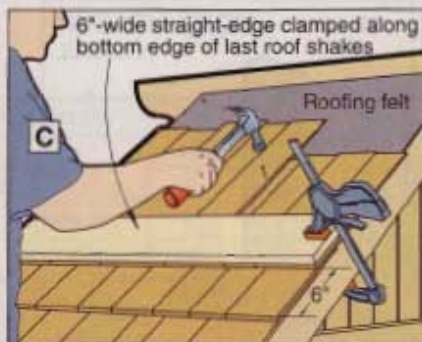

5 Switch to a 1/4"-diameter drill bit, and drill a 3-4"-deep hole into each end of the cross brace, where you "dimpled" it earlier with the larger bit.

6 Reinstall the cross brace, and drive a 3/8×8" lag screw through each post to secure the post/brace connection.

Getting it in the ground

1 First, dig two holes for the concrete footings that will support the shed. These should be 10-12" in diameter, spaced 46" apart center-to-center, down to the frostline. For stability, the posts should extend at least 30" below grade, so dig a minimum of 3' down to allow room for a layer of crushed rock (for drainage). Also, dig the holes slightly cone-shaped so they taper narrower toward the top.

2 Stack several heavy blocks or short timbers between the footing holes, so you have something to rest the shed floor on at the desired height.

3 Moving the shed into place isn't a complicated procedure, but the bulk and weight require plenty of help. We suggest having four strong adults, including yourself, on hand for this. Aim the posts into the footing holes and tilt the shed upright, resting it on the blocks you set up earlier.

4 Shim underneath the cross brace to get the shed level and plumb.

5 Pour crushed 3/4" rock into each hole until the bottom of each post is barely covered, then tamp the rock firmly.

6 Mix concrete, and pour it around each post, capping the footing off just above ground level. Trowel a downward slope to direct water away from the posts. Let the concrete set up for several days, then remove the shims and blocks from underneath the shed.

Install the shelves and that's it! One caution: Keep a padlock on the doors to prevent kids from getting inside, especially if you store sharp tools or any chemicals. ♣



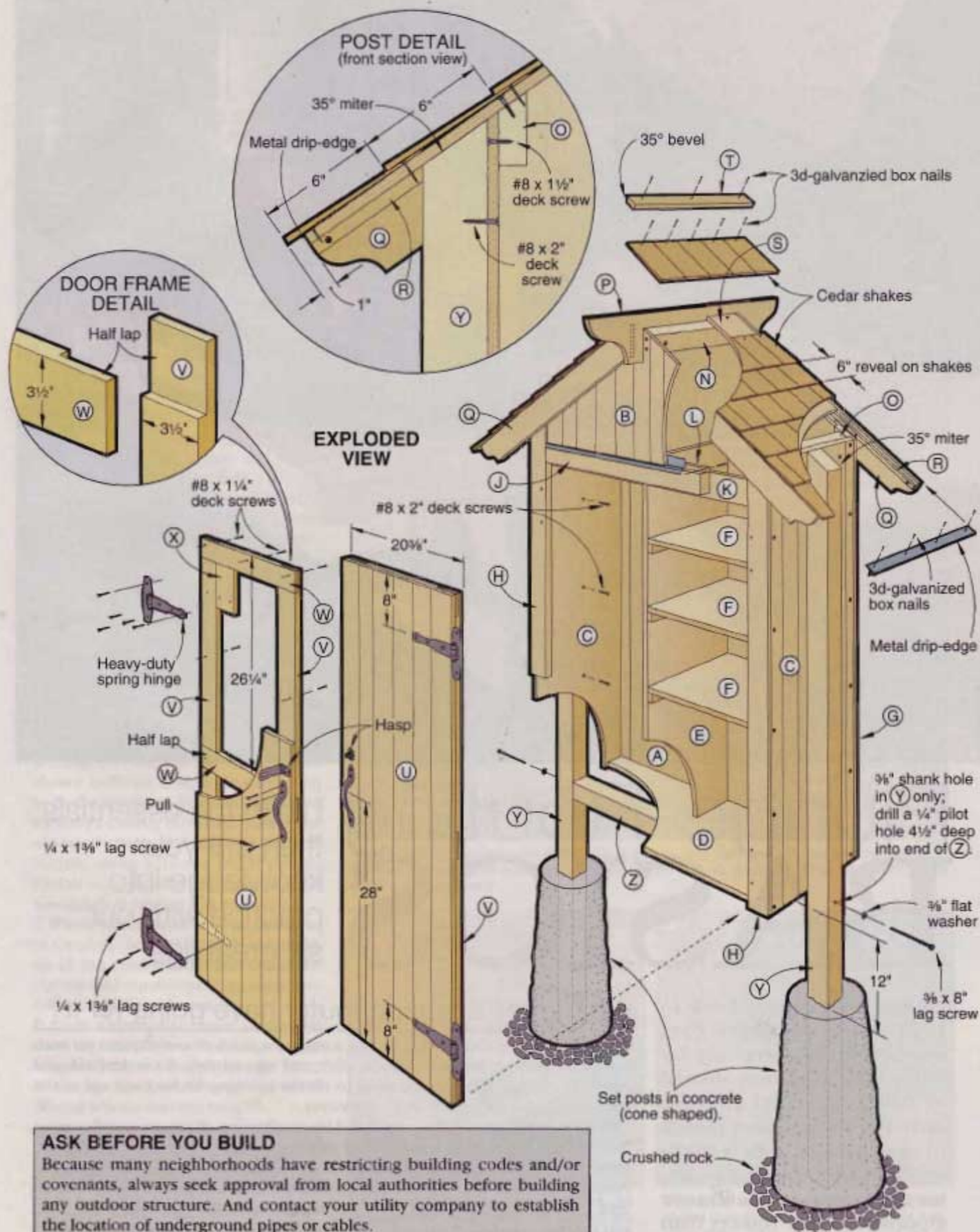

ASK BEFORE YOU BUILD

Because many neighborhoods have restricting building codes and/or covenants, always seek approval from local authorities before building any outdoor structure. And contact your utility company to establish the location of underground pipes or cables.

Project Design: James R. Downing Illustrations: Kim Downing; Lorna Johnson Photographs: Hetherington Photography



Plunge-Routing **BASICS**

Learn the essentials, then put your knowledge into practice with our six great jigs.

Plunge routers date back to 1949, when they were first introduced in Germany by Elu, a company now owned by DeWalt. It wasn't until the early-80s, though, that plunge routers became widely available in North America. Today, manufacturers offer more models of plunge routers than their fixed-base brethren.

What does a plunge router have going for it?

Its forte is making cuts on the interior surface (*or field*) of a workpiece for such tasks as mortising, stopped dados, inlay, and sign-routing. To make field cuts with a fixed-base machine you need to tilt the spinning bit into and out of the cut, a tricky and sometimes dicey maneuver.

With a plunge router, the motor-and-bit mechanism slides up and down on two spring-loaded posts attached to the base. First, you preset the cutting depth, then release a lock that raises the motor and bit to a non-cutting height. Position the router over the cut, switch on the motor, and push it straight down until it contacts a depth-stop. Lock the plunge, make the cut, release the lock, and the motor and bit again spring up. You can even readjust the depth without turning off the router, which is useful for making multiple passes on deep cuts.

Plunge routers have their ups and downs

Plunge routers make short work of some tricky cuts, but don't toss out your fixed-based router just yet. Here's why:

Plunge pros:

- A plunge router is safer than a fixed-base model because its bit protrudes only when cutting.
- Plunge routers typically offer more power—up to 15 amps—and most have variable-speed control, which fixed-base machines generally do not. These are major considerations if you plan to table-mount your router and work with large bits, such as panel-raisers.
- For a table-mounted router, the plunge router's depth-adjustment knobs control bit-height changes more precisely. To take advantage of this feature, you may need to extend your router's height-adjustment knob. Several manufacturers include knob extensions with their plunge routers, or you can buy an extension for \$20 or so.

Plunge cons:

- Plunge routers cost and weigh more than fixed-base routers, and offer no advantage on edge cuts. If you anticipate making mostly edge cuts in your work, you may be better off purchasing a lighter and less expensive fixed-base tool.
- Not all plunge routers work well suspended upside down under a router table. Falling dust can gum up unshielded plunge-posts, which you'll need to clean periodically.
- When mounted in a table, adjusting the bit depth of some models is an awkward, two-handed operation. With others, removing the plunge mechanism springs, which makes it easier to raise a table-mounted router, requires dismantling the machine's motor housing—a procedure we don't recommend.

Continued

Anatomy of a Plunge Router

Although they can perform many of the same duties, plunge routers look distinctly different than fixed-base routers. Beyond the motor, collet, and handles—parts common to both styles—a plunge router also has the following:

Plunge Lock

Tripping a lever, or squeezing or twisting a handle, locks the bit's depth after it has penetrated the workpiece. Releasing the lock lifts the bit at the end of the cut.

Micro-adjust

This feature fine-tunes the cutting depth with micrometer accuracy.

Plunge Rods

A pair of spring-loaded steel rods attached to the subbase guide the motor up and down, perfectly perpendicular to the base.



Turret Stops

For a project that requires progressively deeper cuts, such as deep mortises, you can preset the steps on a turret. Rotating the turret enables you to quickly step from one depth to the next.

Depth Adjustment Rod and Scale

Not all plunge routers offer a depth-of-cut scale, but all have an adjustable rod that helps you halt the plunge at a precise preset depth.

With most plunge routers, you "zero" the tool by locking it at the point where the tip of a straight or spiral bit just touches the work surface. Then you set an adjustable cursor to "0" on the scale. The scale tells you the depth of the dado, mortise, or other cut you'll be making.

Plunge-Routing BASICS

Six great ways to plunge right in

To put a plunge router through its paces, you'll need the correct bit for the job at hand (manufacturers offer hundreds for different shapes and sizes of cuts), and some type of guide (straightedge, template, or jig). In many cases you'll also need guide bushings, which fit into your router's baseplate, to follow the guide.

You can spend good money for accessory jigs, but you can construct your own for next to nothing. So we asked *WOOD*® magazine Senior Design Editor Jim Downing to come up with jigs for six popular plunge routing tasks. (For a more sophisticated plunge-router jig that will handle many of the chores of these individual jigs, see page 62.)

1 Master matching mortises with the help of this adjustable jig



The trick to cutting mortises in table legs is to precisely position the mortise on each leg and to make each mortise exactly the same length. Build the Mortising Jig as shown at right, and you'll be able to cut identical 1/2"-wide mortises time after time.

To set up a cut, mark the length and centerline of the mortise on your workpiece. Clamp the workpiece to the jig's base so the mortise is centered in the slot on the sliding top plate. Lock the plate into place with the wing nuts. The threaded rod acts as a stop, and allows you to adjust the length of the mortise—from 1/2"–2 3/4". Once you've locked in these settings, you can quickly transfer the jig from one workpiece to the next.

Now, fit your router with a 1/4" guide bushing and a 1/2" straight or spiral-flute bit. (For the cleanest cuts, use an up-cut spiral for solid wood; a down-cut spiral with plywood and veneers.) Insert the guide bushing in the jig's slot, turn on the power, plunge, lock, and guide the router from one end of the slot to the other. Deep mortises will require two or more passes—no sweat, thanks to your plunge router's turret stops.

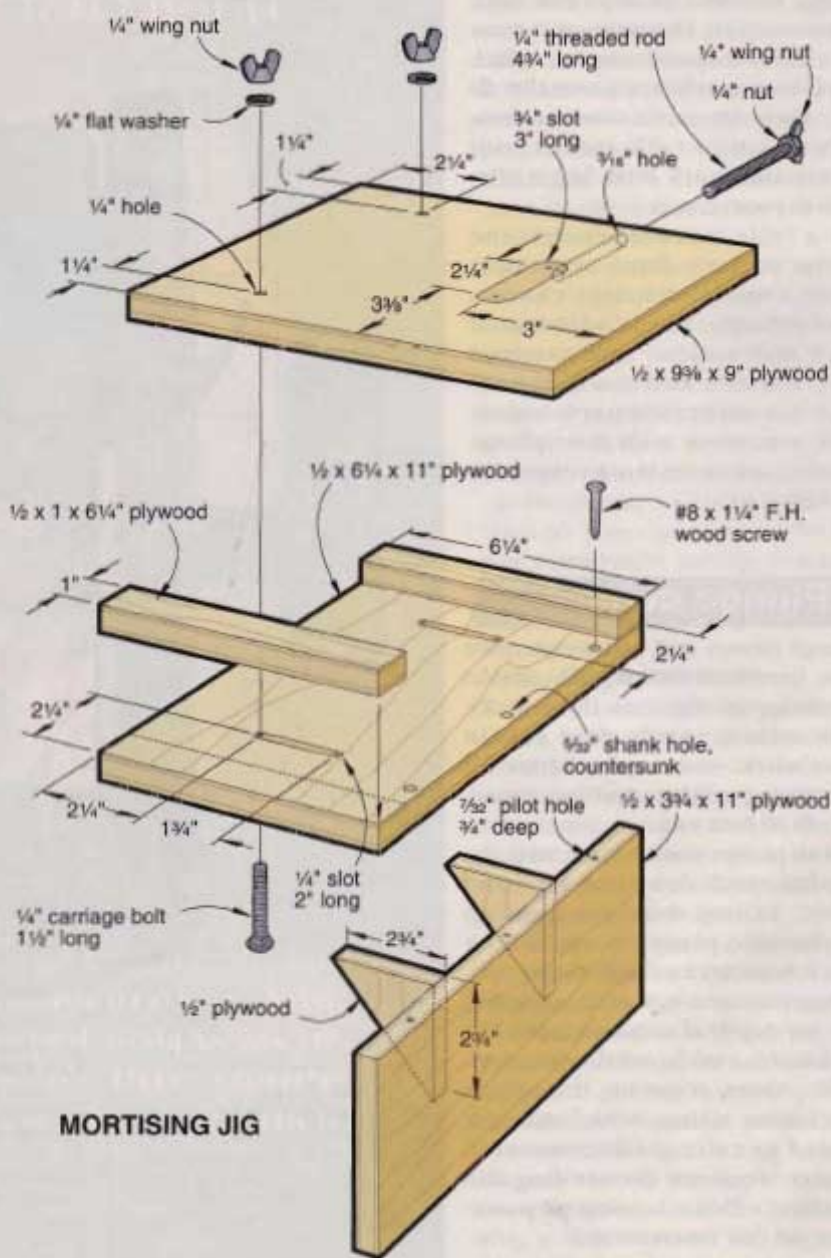

MORTISING JIG

2 For fluting, slots, and dados, just stop, drop, and rout

A plunge router excels at stopped cuts, such as slots, dados, and flutes. For stopped cuts in wide workpieces, such as shelf dados in a bookcase, measure from the edge of your router's baseplate to the cutting edge of the bit. Clamp a straightedge guide that distance from where you want to dado, and a stop at each end of the cut. (Be sure to account for the bit-to-edge measurement on each end of the cut, too. And, don't assume that measurement to be the same all the way around the base plate; your router's collet may not be perfectly centered within the plate.)

For narrow workpieces, such as the one shown in the photo at *right*, use an edge guide that attaches to your router's baseplate. (The circle-cutting trammel we'll show later also makes a good edge guide.) Clamp stopblocks at the ends of the cut as before.



3 Using this jig is the key to well-hung shelves and frames

A sturdy way to hang items such as picture and mirror frames, shelves, and plaques, keyhole slots can spell trouble if they aren't exactly the same distance from the top of the project. You can go nuts offsetting the wall hangers to compensate for the misalignment.

The keyhole-routing jig *below*, devised by *WOOD*® magazine reader Don Thomas and modified by reader Luther Williamson, consists of a frame that fits your router's base. The router rides on the rabbets on each rail.

With the help of a movable stop, you can bore slots $6\frac{1}{2}$ ", $7\frac{1}{4}$ ", or 8"

from the top of the frame. After setting the stop, center and clamp the jig to one of the vertical frame pieces, place the router at the near end of the jig, plunge with a keyhole bit, slide it to the far end, then back out of the cut. Repeat the process on the other vertical frame piece.

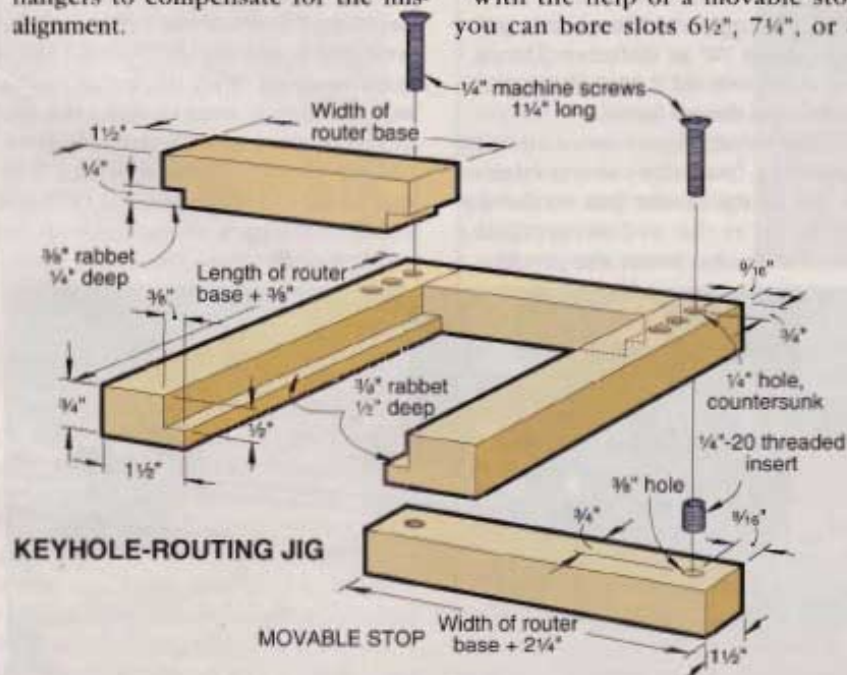

Continued

Plunge-Routing BASICS

4 Routing with templates: Function follows form

With template routing, a shop-made pattern guides your router along cuts for making signs, shallow bowls, or trays. You also can use templates for carving lettering in wooden signs. One big advantage to template routing is that once you make the template, you can use it again and again to create absolutely identical cuts.

First, make a template—usually of $\frac{1}{4}$ " hardboard or $\frac{1}{2}$ " plywood—of the pattern you wish to rout. Because you'll use a guide bushing to steer the router through the cut, you'll need to cut the template pattern slightly larger than the finished pattern. How much larger? Subtract your router bit diameter from that of the guide bushing, and divide the difference by two. Add that measurement to all sides, then cut out the template with your hand-saw or scrollsaw, removing the template pieces you want to remove from the workpiece.

Clamp or affix the template with double-faced tape to the workpiece, rout clockwise around the perimeter of the template, then clean out the center with back and forth passes.

Here's another neat way to use a template and guide bushing with your plunge router. When you need to bore a series of identically spaced holes, such as for shelf pins, make a template like the one shown at *right* and *below*, and you'll do the job more efficiently and chip-free, even in melamine. Size the template holes to accommodate the guide bushing. (We used a $\frac{3}{8}$ " bushing with a $\frac{1}{4}$ " down-spiral bit.) Note: Bore the holes before assembling the cabinet.

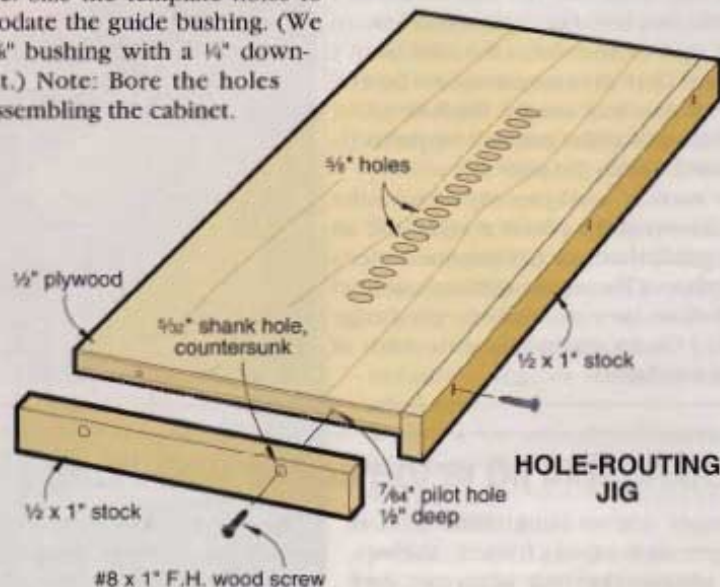

6 Swing a wide arc, or make compact discs

Here we offer two ways to help your plunge router get around. With the Disc-Routing Jig, shown at *far right*, you can use different combinations of bits and bushings to cut any diameter disc from $2\frac{1}{2}$ "-6" in $\frac{1}{8}$ " increments.

Make the template as shown, using a fly-cutter in your drill press. Because the size of the template holes must be exact, make sure to test each cut in scrap first. To avoid chip-out in the finished cuts, cut the holes to about half of their depth, flip over the template, place the center bit into its hole, and complete the cut. You'll find the mini-charts (showing which bit and bushing to use) for each template hole in the *WOOD PATTERNS*® insert in this issue.

For routing larger circles and arcs, build and outfit your router with the Circle-Cutting Trammel, shown at

right and *opposite*, that cuts circles up to about 72" in diameter. The jig's two steel rods slide into the router's subbase, as shown *below*.

Set the radius of your arc or circle by measuring from the cutting edge of the bit to the center pin on the jig, and lock in the radius using the threaded knobs. Insert the pin into a

predrilled hole at the center of the workpiece, and use the trammel like a giant compass. With thicker or harder stock, you may need to make this cut in several progressively deeper passes.

Leery about drilling a center hole that might mar your project? Drill and cut from the back or underside of the workpiece. 📌



5 Raise panels with a plunge

A router removes stock, so how can it *raise* a panel? Actually, plunging with a bearingless bit into the field of a flat panel creates the illusion of frame-and-panel construction. Note that this technique is limited to making raised panels with medium-density fiberboard (MDF), which you plan to paint, rather than clear-finish.

The Panel-Routing Guides, shown at right, amount to a simple frame with splined corners that let you adjust it to a variety of panel sizes. Cleats on the back of the frame capture the panel. And to keep the router from tipping toward the field and ruining the cut, we taped a small disc to one corner of the router's base with double-faced tape.

We made these cuts with a plunge-ogee bit, but you could also use a bearingless ovolo or plunge bead bit. You also can create bevels and coves up to 1½" wide with bigger, 3½" raised-panel cutters, but these are best used in a router table.

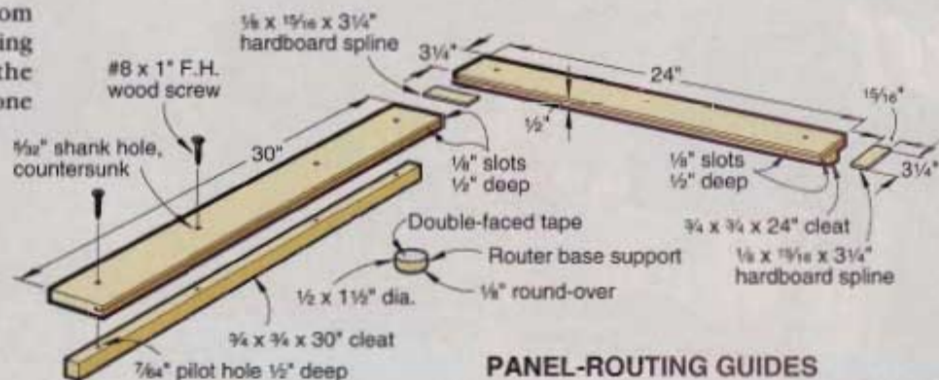
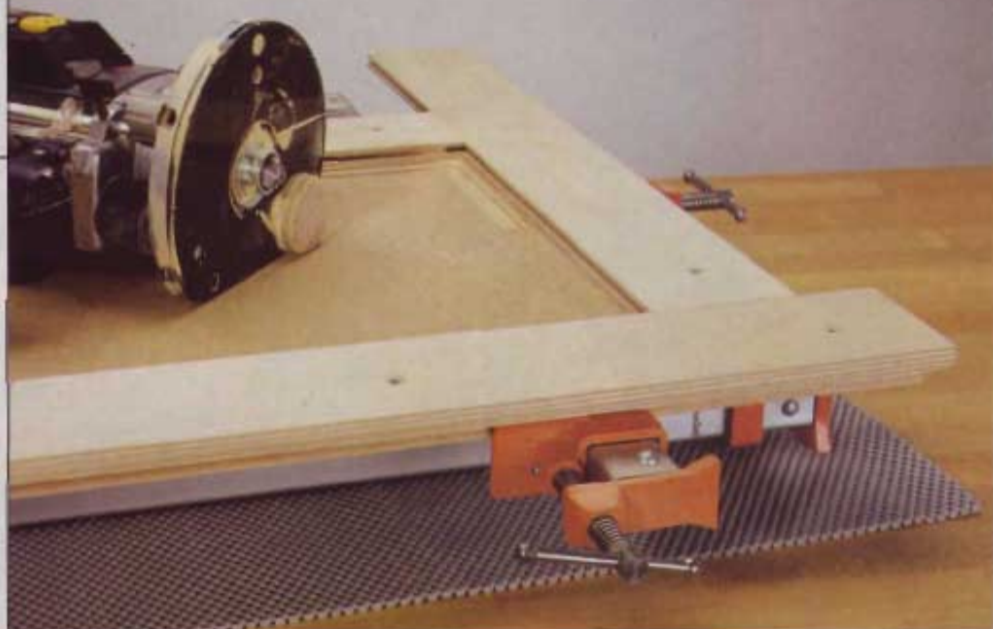

PANEL-ROUTING GUIDES

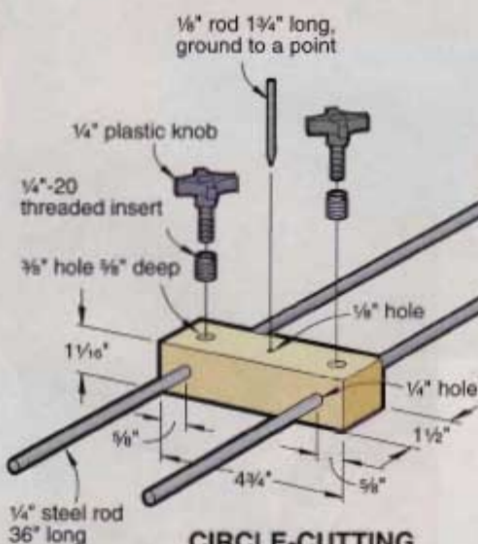

CIRCLE-CUTTING TRAMMEL

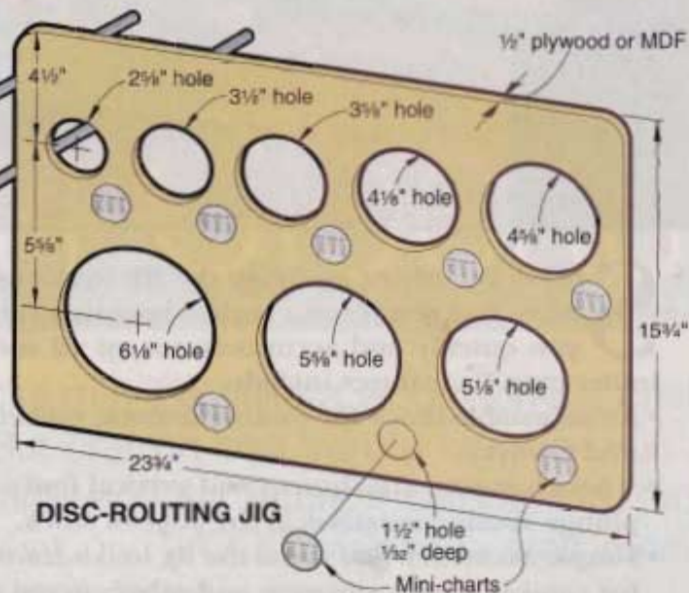

DISC-ROUTING JIG

All-Around Plunge-Router Jig

Now,
make a full range
of special cuts
with impressive
precision

Spend a moment studying the illustrations and photos here, and you'll soon realize how this versatile jig lets you quickly and accurately set up all sorts of plunge router cuts. Its features include:

- An adjustable fence for routing dadoes, rabbets, and grooves.
 - A bench-mount attachment and vertical fence for plunge-routing mortises in the edge of stock.
 - Simple accessory that turns the jig into a trammel for routing circles, ellipses, and other curved cuts.
- Now, let's build this super jig and its components.



OUR PLUNGE-ROUTER JIG AT A GLANCE

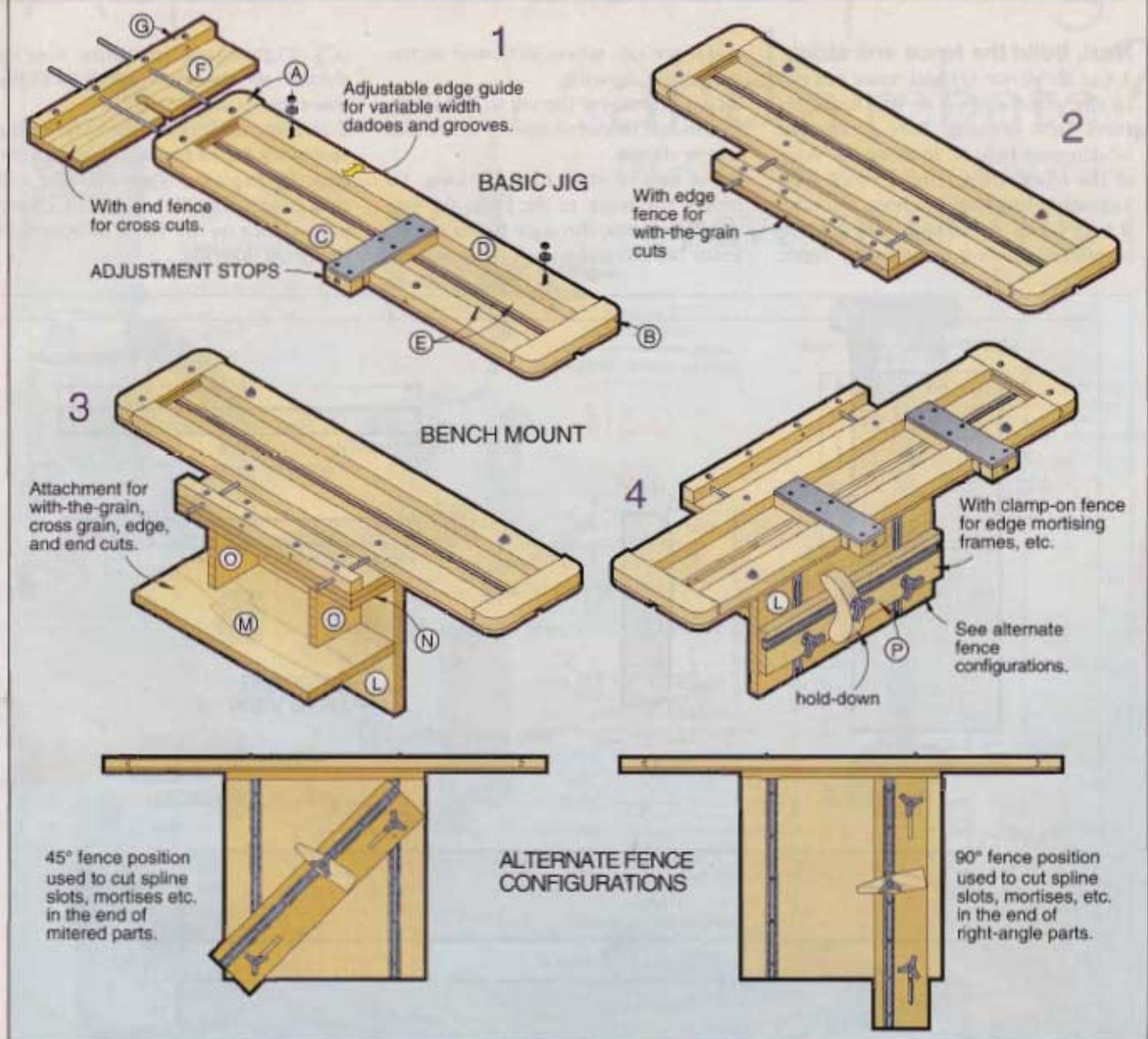

Start with the basic jig

Note: The heart of our plunge router jig is an adjustable frame with clamp-on stops and an end/edge fence. Use this basic jig on its own or in combination with the bench-mount accessory.

1 Cut the ends (A, B) and guide rails (C, D) to the sizes dimensioned in the Bill of Materials and Basic Jig Parts View drawing, *page 64*.

2 Using a $\frac{1}{4}$ " dado blade in your table saw, cut $\frac{1}{4}$ "-deep grooves in the ends (A, B), as shown in the Exploded View drawing on *page 65*. Now rabbet tenons on the ends of the guide rails (C, D) to fit the grooves in ends

(A, B). Bear in mind that rail (D) must slide, so you don't want a tight fit.

3 Cut $\frac{1}{4}$ " dados across the bottoms of end (A) and rail (C), where shown on the Basic Jig Parts View drawing. Later, steel rods that guide the fence will lock into these dados.

4 Cut the radiused corners on ends (A, B) as dimensioned on the Basic Jig Parts View drawing. (We used a band-saw, and sanded to the lines.)

5 Use a drill press with a fence and stopblocks to drill holes in the end (A) and rails (C, D), where located on the Parts View drawing. To make the slots, drill several holes and clear out stock between them with a chisel.

6 Install threaded inserts in the end (A) and rail (C), where shown on the Basic Jig Exploded View drawing.

7 Glue the ends (A, B) to rail (C).

8 Cut the two bottom panels (E) from $\frac{1}{4}$ " hardboard. Drill and countersink holes, where shown on the Parts View drawing. Epoxy $\frac{1}{4} \times 1\frac{1}{2}$ " flathead machine screws to one panel, as shown in the Basic Jig Exploded View drawing. These project through slots in the adjustable guide rail (D).

9 Attach the bottom panels (E) to the glued-up (A/B/C) assembly with glue and wood screws. (Remember that part D is an adjustable part.)

Continued

Plunge-Router Jig

Next, build the fence and stops

1 Cut the fence (F) and fence rail (G) to the sizes shown in the Basic Jig Parts View drawing. Bore a centered $\frac{1}{4}$ "-diameter hole $\frac{1}{4}$ " in along the edge of the fence; then remove stock with a chisel or bandsaw to create a notch.

2 Use a drill press with a fence and stopblocks to drill holes in the fence

and fence rail, where indicated on the Parts View drawing.

3 Glue and screw the rail to the fence, and install threaded inserts in the rail where shown.

4 Cut two $\frac{1}{4}$ " steel rods 12" long. To mount the rods through holes in the fence rail (G) and end (A) or guide rail

(C). Tightening machine screws through the threaded inserts locks the fence into position.

5 To make the stopblocks, refer to the Stopblock Detail that accompanies the Basic Jig Exploded View drawing. Cut two stopblocks (H) and four clamp pads (J, K) to the sizes indicated in the detail drawing.

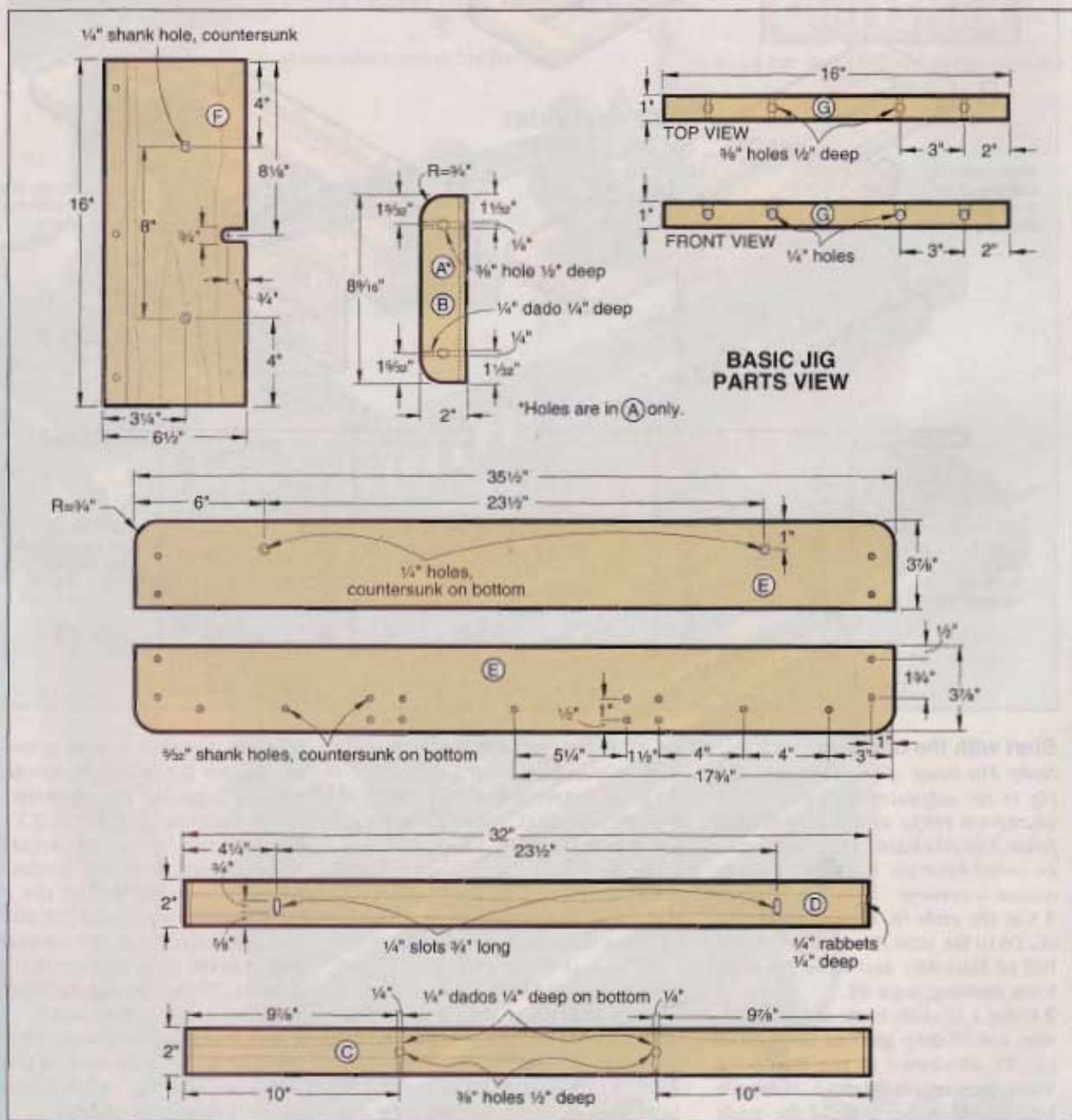

6 Drill a $\frac{3}{8}$ " hole completely through pads (K). Drill $\frac{1}{4}$ " holes $\frac{1}{4}$ " deep in pads (J). Install $\frac{1}{4}$ " threaded inserts in the pads (K).

7 Cut the stopblock tops (D); then drill and countersink holes where shown in the detail. (Note: We initially made the stopblock tops of $\frac{1}{4}$ " hardboard, but found they tended to

buckle when the stops are tightened. For best results, use $\frac{1}{4}$ " aluminum bar stock, available at your local home center.)

8 Assemble the stopblocks with glue and screws, then drive machine screws through the threaded inserts and into the $\frac{1}{4}$ " holes.

Continued

Bill of Materials

Part	Finished Size			Mati.	Qty.
	T	W	L		
BASIC JIG					
A end	$\frac{1}{4}$ "	2"	8 $\frac{1}{2}$ "	M	1
B end	$\frac{3}{4}$ "	2"	8 $\frac{1}{4}$ "	M	1
C guide rail	$\frac{1}{4}$ "	2"	32"	M	1
D guide rail	$\frac{1}{4}$ "	2"	32"	M	1
E guide bottom panels	$\frac{1}{4}$ "	3 $\frac{1}{2}$ "	35 $\frac{1}{2}$ "	H	2
FENCE AND STOPS					
F fence	$\frac{1}{4}$ "	6 $\frac{1}{2}$ "	16"	BP	1
G fence rail	1"	1"	16"	M	1
H stopblock	$\frac{3}{4}$ "	1 $\frac{1}{2}$ "	4 $\frac{1}{2}$ "	M	2
I stopblock top	$\frac{1}{4}$ "	1 $\frac{1}{2}$ "	7 $\frac{1}{2}$ "	AL/H	2
J clamp pad	$\frac{3}{8}$ "	$\frac{1}{2}$ "	1 $\frac{1}{2}$ "	M	2
K clamp pad	$\frac{3}{4}$ "	$\frac{3}{4}$ "	1 $\frac{1}{2}$ "	M	2

Materials Key: M-maple, BP-birch plywood, H-hardboard, AL- $\frac{1}{4}$ " aluminum stock

Continued on page 67

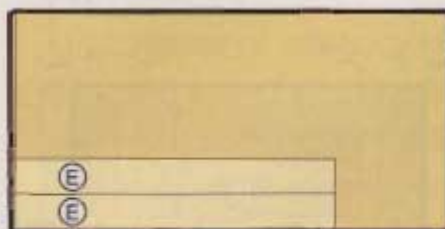

$\frac{1}{4}$ x 24 x 48" Hardboard

CUTTING DIAGRAM

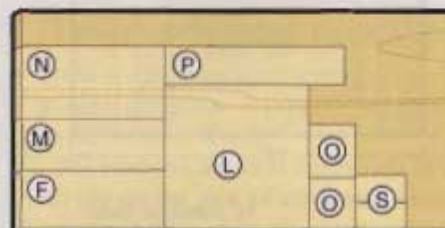
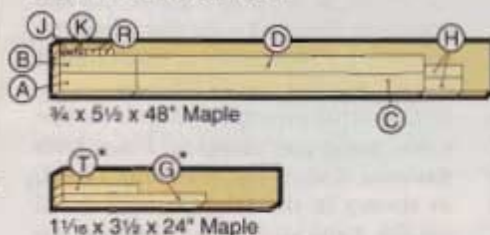

$\frac{3}{4}$ x 24 x 48" Birch plywood

*Plane or resaw to the thickness listed in Bill of Materials

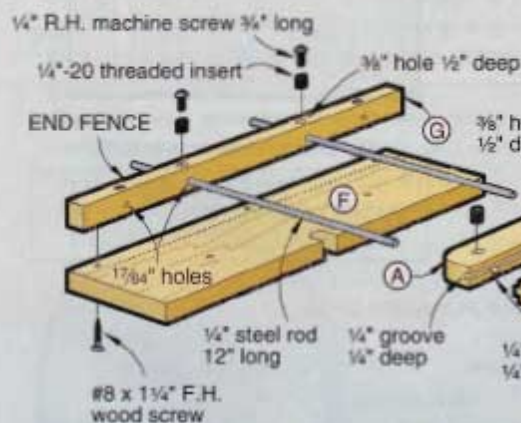
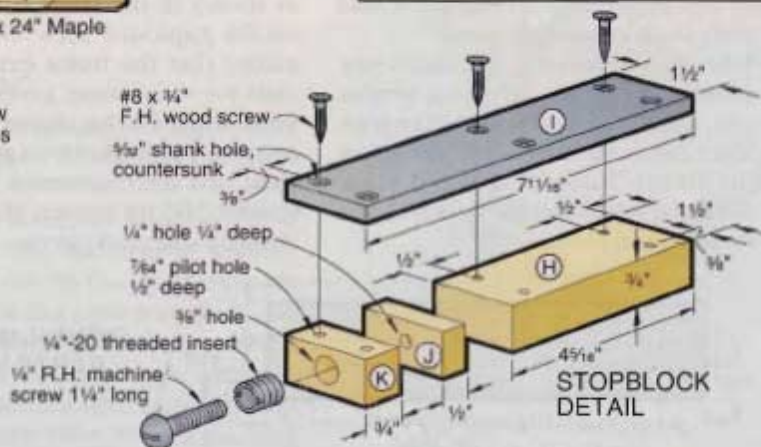

BASIC JIG EXPLODED VIEW

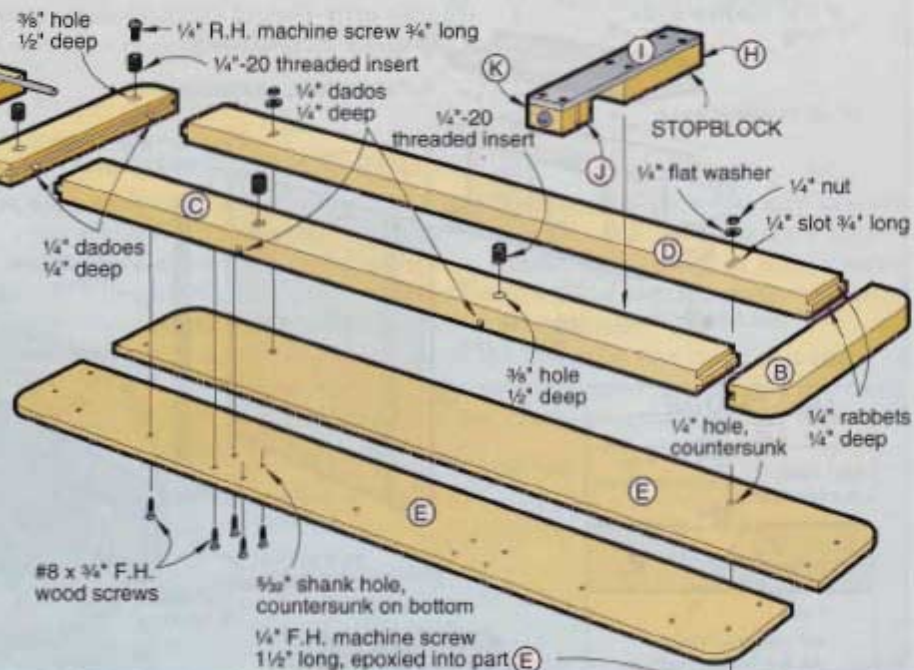



Creating mortises in workpieces goes quickly and precisely with this jig setup.

Bench-mount your jig to make it more hardworking

Note: The bench-mounting system consists of a stool you clamp or bolt to your benchtop, a vertical fence guide that screws to the stool, a clamp-on fence that slides up and down the guide channels and adjusts to any angle, and a hold-down that locks stock against the guide.

1 From $\frac{3}{4}$ " plywood, cut the fence guide (L), stool top (M), stool bottom (N), stool sides (O), and clamp-on fence (P) to the sizes dimensioned on the Bench-Mount Exploded View drawing, below, and the Bench-Mount Parts View drawing.

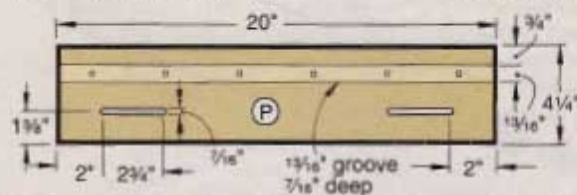

BENCH-MOUNT PARTS VIEW

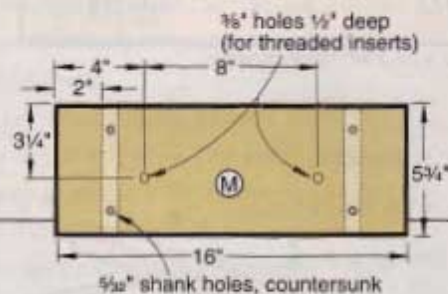
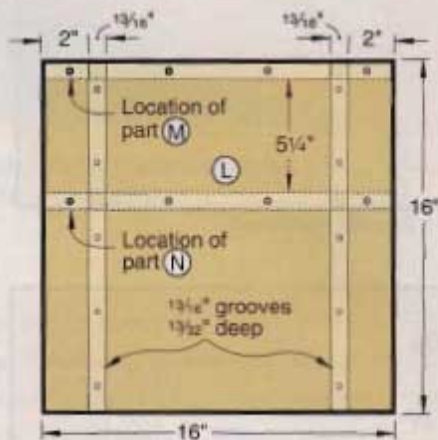

SEE THE WOOD PATTERNS® INSERT FOR FULL-SIZE PATTERN

2 Lay out holes in each part, then drill and countersink where shown. (**Note:** To accurately locate holes for the threaded inserts in the stool top, position the fence (F) you've already made over the stool top, mark and drill the holes, then install the threaded inserts.)

3 Assemble the stool parts (M,N,O) with glue and screws.

4 Mount a dado blade on your table saw's arbor and cut $\frac{1}{16}$ "-wide grooves $\frac{7}{16}$ " deep in the fence guide (L) and clamp-on fence (P). To complete the grooves, cut two pieces of mini-channel to 16" long and one to 20" long.

5 The mini-channels attach to the fence guide and clamp-on fence with flathead machine screws and T-nuts, as shown in the Mini-Channel detail on the Exploded View drawing. To assure that the holes exactly align calls for some more precision drill-press work. Fit the channels into the grooves, and mark which goes where. Next, drill and countersink $\frac{1}{16}$ " holes, spaced $3\frac{1}{2}$ " on center, through the channels and workpieces.

6 When all the holes are drilled, remove the mini-channels and chuck a $\frac{3}{8}$ " bit into your drill press. Turn the workpieces over, center the bit on the $\frac{1}{16}$ " holes, and drill $\frac{1}{32}$ " deep recess holes in parts L and P to accommodate the T-nuts. (The T-nuts we used were a little long, so we shortened them on the grinder.)

7 To install the T-nuts, we trimmed a $\frac{1}{2}$ " dowel to about 6" long and tapped

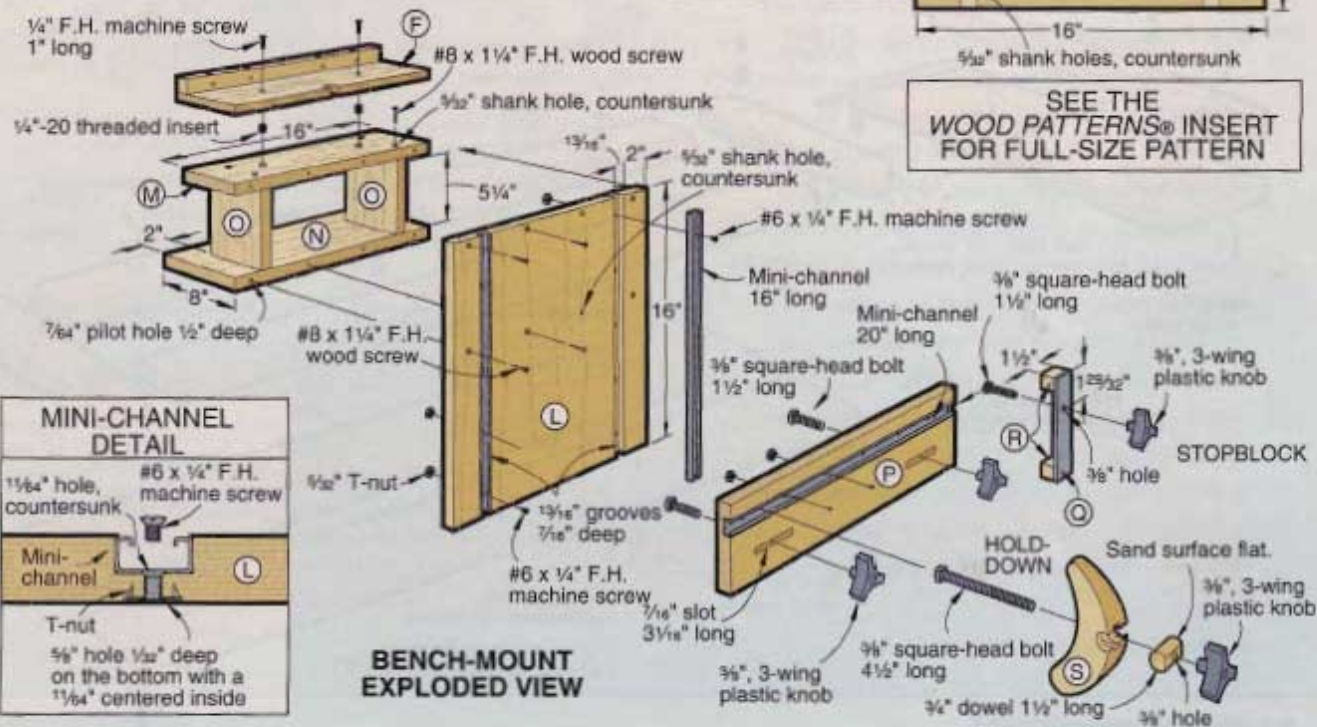

BENCH-MOUNT EXPLODED VIEW

the nuts in place, setting them slightly below the surface. Now reposition the channels, and screw them in.

8 Screw the fence guide (L) to the stool assembly through the pilot holes you drilled in Step 2.

9 To make slots in the clamp-on fence (P), drill several $\frac{3}{16}$ " holes and remove stock between them with a chisel (or use a scrollsaw). Mount the fence to the fence-guide channels with square-head bolts and three-wing plastic knobs, as shown in the Exploded View drawing. The bolt heads slide along the channels.

10 To make a stopblock for this fence, cut $\frac{1}{4}$ " hardboard or aluminum (Q) to $1\frac{1}{2} \times 5\frac{1}{4}$ ", and glue it to two $\frac{3}{4} \times \frac{3}{4} \times 1\frac{1}{2}$ " pieces of maple (R), as shown in the Exploded View drawing.

11 Drill a $\frac{3}{8}$ " hole in the stopblock, as dimensioned on the drawing, slide a

$\frac{3}{8}$ " square-head bolt into the mini-channel, fit the stopblock over the bolt, and screw on a three-wing plastic knob.

12 Cut two pieces of $\frac{3}{4} \times 3 \times 5\frac{3}{4}$ " birch plywood. Install a $\frac{3}{4}$ " dado set in your tablesaw, raise it to $\frac{1}{4}$ ", and cut the centered 1" dado, where shown in the *WOOD PATTERNS*®. Now to create the hold-down (S) laminate the two $\frac{3}{4}$ " plywood pieces together and apply the hold-down pattern. Drill the $\frac{3}{4}$ " hole where shown, and bandsaw the

hold-down to shape. Cut a $\frac{3}{4} \times 1\frac{1}{2}$ " dowel to fit into the hold-down's notch. Sand the dowel flat on one side, and drill a $\frac{3}{8}$ " hole through it. Slide the head of a $\frac{3}{8} \times 4\frac{1}{2}$ " square-head bolt into the fence's mini-channel, and thread on a three-wing plastic knob.

Adapt the jig to cut circles

Note: Just one small accessory turns the jig into a giant compass for routing circles, arcs, and other curves.

1 Cut part (T) to the dimensions shown on the Circle-Cutting Jig Exploded View drawing, below.

2 Lay out and drill holes where indicated on the drawing. To make sure the rod holes will align, place the part up against the end (A) to double-check before you drill. Install threaded inserts and machine screws to lock the jig to the steel rods and a wood screw to serve as a centerpoint.

3 For circles up to $11\frac{1}{2}$ " in diameter, use the basic jig's steel rods. If you want to rout larger circles, cut new rods to the length you need.

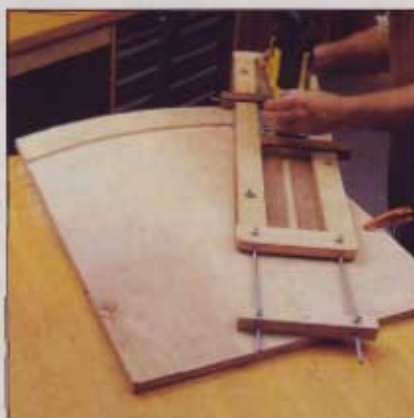

With this special circle-jig attachment, you can rout arcs and circles in large workpieces such as sheet goods.

Written by Jim Hufnagel
Photographs: Hetherington Photography
Illustrations: Roxanne LeMoine

Bill of Materials					
Part	Finished Size			Matl.	Qty.
	T	W	L		
BENCH MOUNT					
L fence guide	$\frac{3}{4}$ "	16"	16"	BP	1
M stool top	$\frac{3}{4}$ "	5 $\frac{1}{4}$ "	16"	BP	1
N stool bottom	$\frac{3}{4}$ "	8"	16"	BP	1
O stool sides	$\frac{3}{4}$ "	5 $\frac{1}{4}$ "	5 $\frac{1}{4}$ "	BP	2
P clamp-on fence	$\frac{3}{4}$ "	4 $\frac{1}{4}$ "	20"	BP	1
Q stopblock	$\frac{1}{4}$ "	1 $\frac{1}{2}$ "	5 $\frac{1}{4}$ "	AL/H	1
R stopblock	$\frac{3}{4}$ "	$\frac{3}{4}$ "	1 $\frac{1}{2}$ "	M	2
S hold-down	1 $\frac{1}{2}$ "	3"	5 $\frac{3}{4}$ "	BP	1
CIRCLE JIG					
T circle jig	1"	1"	8 $\frac{1}{4}$ "	M	1

Materials Key: M—maple, BP—birch plywood, H—hardboard, AL— $\frac{1}{4}$ " aluminum stock

Supplies: $\frac{1}{4}$ "-20 threaded inserts (12); $\frac{1}{8} \times \frac{1}{8}$ " round-head machine screws; $\frac{1}{4} \times 1\frac{1}{2}$ " roundhead machine screws; #8 $\times\frac{3}{4}$ " flathead wood screws; $\frac{1}{4} \times 1\frac{1}{2}$ " flat-head machine screws, flat washers and nuts; #8 $\times 1\frac{1}{2}$ " flathead wood screws; $\frac{1}{4} \times 12$ " steel rods (2); $\frac{1}{4} \times 1$ " flathead machine screws; $\frac{1}{16} \times \frac{1}{16}$ " mini-channel; $\frac{1}{2}$ " T-nuts; #6 $\times\frac{1}{4}$ " flathead machine screws; $\frac{3}{16} \times 1\frac{1}{2}$ " square-head machine bolts (3); $\frac{3}{8} \times 4\frac{1}{2}$ " square-head machine bolt; $\frac{3}{8} \times 1\frac{1}{2}$ " dowel; $\frac{3}{8}$ " 4-wing plastic knobs (3).

Buying Guide
Hardware kit. Includes all hardware described above, plus aluminum, \$46.95 ppd. Ask for kit #PRJ.
Lumber kit. Includes Baltic birch and hardboard plywood, \$26.95 ppd. Kit #LP-2. Schlabach and Sons Woodworking, 720 14th Street, Kalona, IA 52247, or call 800/346-9663.

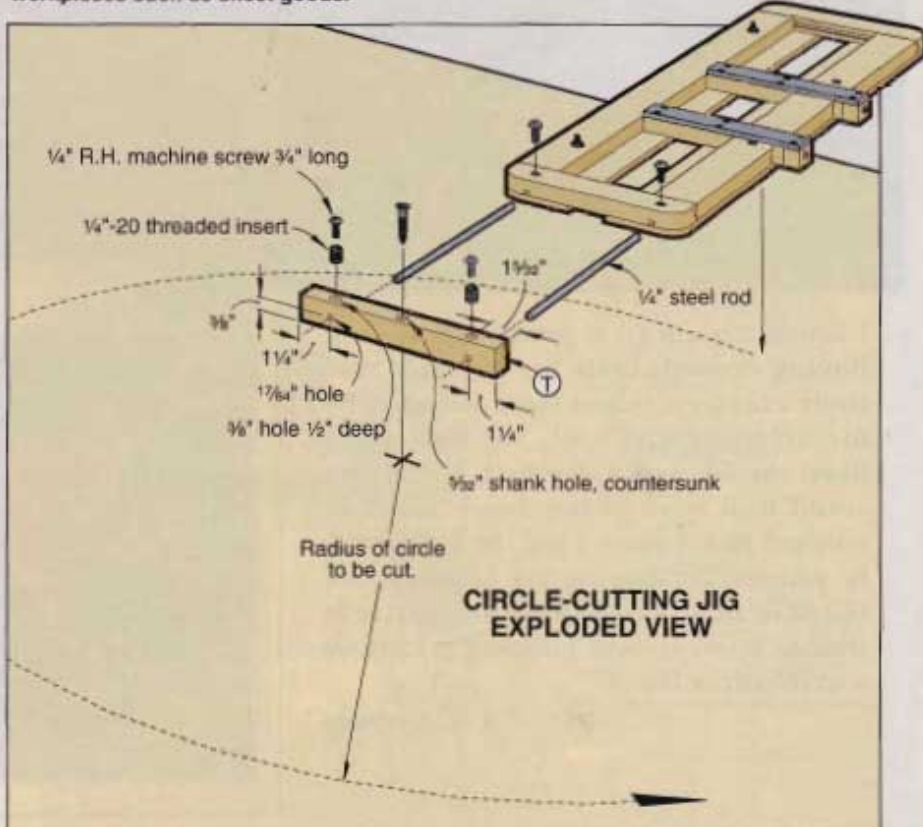

Deluxe Day Bed

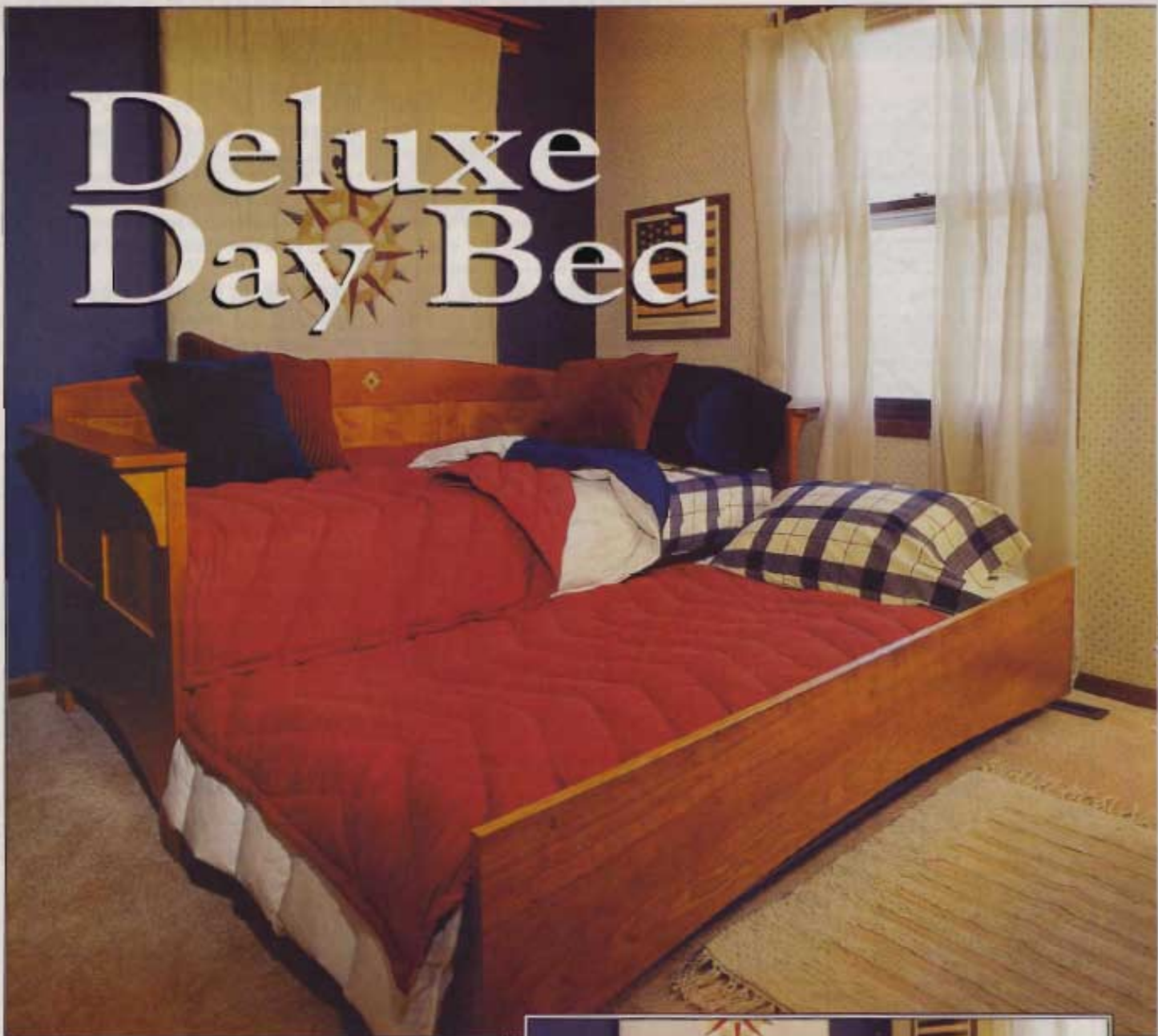

I found myself in a predicament—not having enough beds for my kids and their children when they stopped by for an overnight visit. My wife and I liked the idea of a day bed, but all we could find were either fancy brass or painted metal ones. I got the bed I really wanted by buying an inexpensive trundle bed, salvaging the mattress frames from it, and building a custom surround for them.

James R. Downing

James R. Downing,
Senior Design Editor



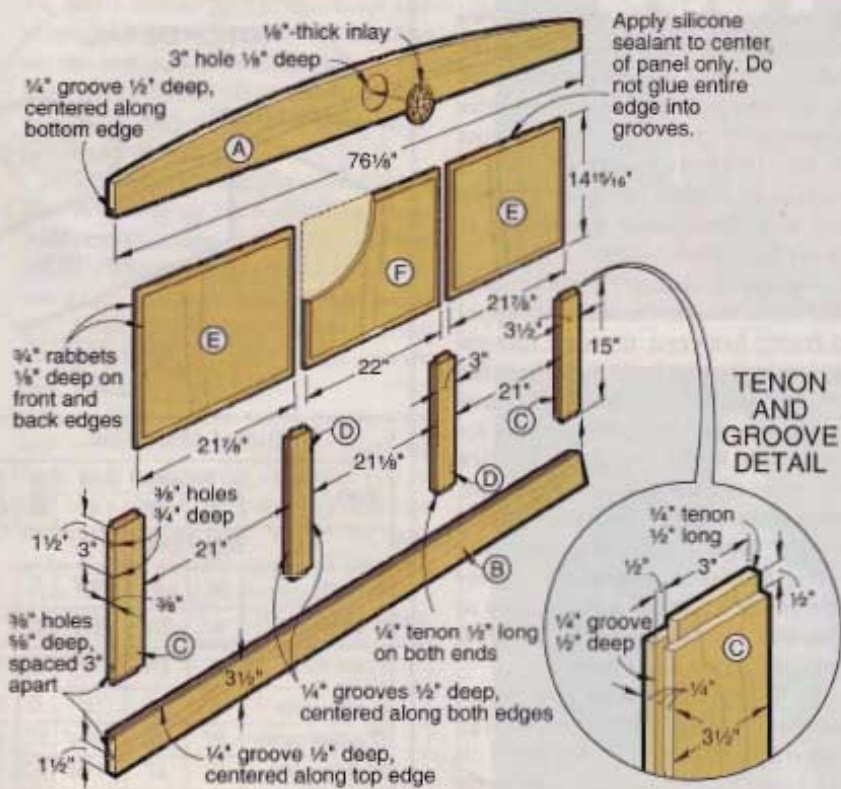

BACK FRAME

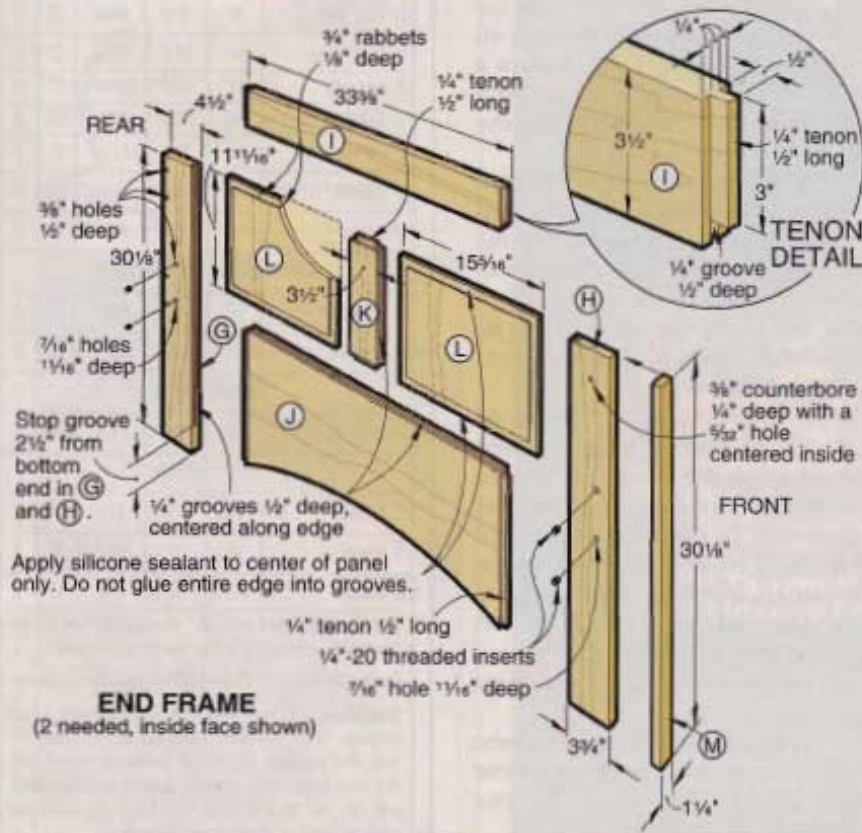

Note: Before starting this project, make sure you have your metal trundle bed frames handy to custom-fit the wooden back and end frames to them. The overall length of the back frame should match the length of the upper bed frame without the legs that came with the bed. Before removing the legs from the purchased trundle bed, measure the height of the upper bed frame. When connecting the upper metal bed frame to the end frames you're about to build, you must allow sufficient clearance for the lower bed frame and mattress to slide in and out easily beneath the upper bed frame.

Begin by cutting and machining the back and end frames

1 From 3/4" stock, cut the back-frame parts (A-F) and end-frame parts (G-M) to the sizes listed in the Bill of materials. (We used cherry, but white oak would work well with this mission-like design. To make panels, E, F, and L we edge-joined 1/2" stock to create oversized panels. After leaving each panel glued-up overnight, we removed the clamps, and sanded both surfaces of each panel smooth. Next, we cut the panels to the sizes listed in the Bill of Materials.)

2 For connecting the back frame to the end frames later, mark the center-points for the four 3/8" holes 1/2" deep on the *inside* face of each rear stile (G), where dimensioned on the Parts View drawing. Use your drill press to drill the holes where marked.

3 Cut or rout 1/4" grooves 1/2" deep centered along the bottom edge of the top rails (A, D), the top edge of the bottom rails (B, J), and the edges of the stiles (C, D, G, H, K), where shown on the Back and End Frame drawings. See the Tenon and Groove detail accompanying the Back Frame drawing for reference. Note that the 1/4" grooves in the end frame stiles (G, H) are stopped 2 1/2" from the bottom end of each. (To ensure flush surfaces when assembling the frames later, we marked what would be the good, or outside, face of each piece and placed the marked faces against the fence when machining the grooves.)

Continued

Deluxe Day Bed

4 Using a dado blade on your table saw, cut tenons on the ends of the stiles (C, D, K) and the rails (I, J) to fit into the $\frac{1}{4}$ " grooves just cut. Cut scrap stock first to verify the fit.

5 Cut $\frac{3}{8}$ " rabbets $\frac{1}{8}$ " deep along the front and back edges of each panel (E, F, L) so the panels will fit easily into the $\frac{1}{4}$ " grooves formed earlier. See the Back and End Frames drawings for reference. With sandpaper wrapped around a square-edged block of wood, sand the rabbeted cuts smooth. Finish-sand each panel now.

6 To ensure that unstained or unfinished areas won't appear between the framework and panels later, stain and finish each panel (E, F, L) now. (We left our panels unstained, but applied two coats of Deft clear lacquer.)

7 Using a fairing stick (we cut a piece of stock to $\frac{1}{4} \times \frac{3}{4} \times 80$ "), lay out and cut the arcs along the top edge of the back top rail (A) and the bottom edge of the lower side rails (J). See the Parts View drawing for reference. Bandsaw the arcs to shape, and sand the arcs smooth using sanding blocks made from the arc-shaped cut-off.

8 As an optional decoration, use a Forstner bit to bore a 3" hole $\frac{1}{8}$ " deep into the back top rail, where shown on the Parts View drawing. You can add our nautical-based design, create your own, or omit this detail. To add our emblem, use $\frac{1}{8}$ " stock and the four-step Adding the Inlay drawing.

Now, assemble the pieces to form the frames

Note: To secure the panels (E, F, L) in the frames in Step 1 below, place a bead of silicone sealant in the center top and bottom portion (about a 2" area is sufficient) of the mating rails. This allows the panels to expand and contract within the grooved openings. Using silicone allows the panels to expand and contract within the frames, yet prevents a "rattling" fit.

1 Dry-fit each frame together to check the fit of all the pieces. Then, glue and clamp each frame together, checking for square. Wipe off any excess glue with a damp cloth.

2 Place $\frac{3}{8}$ " dowel centers in the four $\frac{3}{8}$ " holes in one of the end frame back stiles (G). Clamp the end frame to the

back frame so the top end of C is flush with the top end of G, where shown in the Notch detail accompanying the Exploded View drawing. This will transfer the hole centerpoints from the rear stile (G) to the back frame stile (C) and bottom rail (B). Use a doweling jig to drill $\frac{3}{8}$ " holes $\frac{1}{4}$ " deep in the end frame pieces where indented with the dowel centers.

3 Temporarily clamp the end frames to the back frame. Position the upper bed frame between the end frames. (Use books or blocks to hold it at the correct height.) Using the metal frame as a guide, mark the centerpoints for the threaded inserts on the inside face of the stiles (G, H) on each end frame. Remove the upper bed frame, and drill $\frac{7}{16}$ " holes $\frac{3}{16}$ " deep for the inserts. *Remember that the upper frame needs to be the same height as it was when attached to the leg set it came with when you bought it.*

4 Drive the $\frac{1}{4}$ "-20 threaded inserts into the stiles (G, H). (We used a large screwdriver and took our time to make sure the inserts drove squarely into the wood front and rear stiles.)

5 Cut eight $\frac{3}{8}$ " dowels to $1\frac{1}{4}$ " long (or use dowel pins). Sand a chamfer on the ends of each dowel pin, and cut a glue groove if you cut yours from dowel stock. Glue the dowels into the back frame only.

6 Cut the side panel cover strips (M), armrests (N), and corbels—also called armrest supports—(O) to size. See the Parts View drawing for the shapes of the armrests and corbels.

7 Glue and clamp the cover strips (M) into position, flush with the outside face of each side frame.

8 Locate and drill the $\frac{3}{8}$ " holes $\frac{1}{4}$ " deep with a $\frac{3}{32}$ " shank hole, centered inside through the front stile (H), to house the screws used to secure the corbels (O) in position. Glue and screw the corbels to the sides of the end frames, keeping the top edges flush. After the glue dries, cut $\frac{3}{8}$ " plugs and glue them into place, being careful to align the grain of the plugs with that of the stiles.

9 Notch the armrests (N) to fit around the back frame, where shown in the Notch detail accompanying the Exploded View drawing.

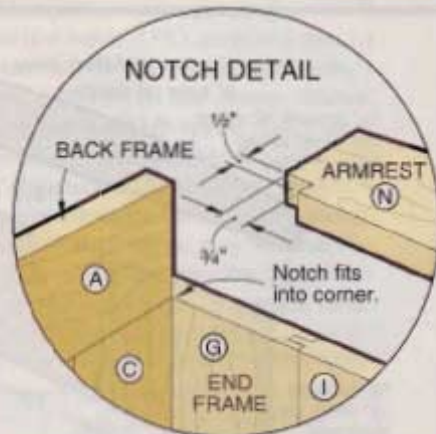

Bill of Materials

Part	Finished Size			Matl.	Qty.
	T	W	L		
BACK FRAME					
A top rail	$\frac{1}{4}$ "	6"	76 $\frac{1}{2}$ "	C	1
B bottom rail	$\frac{1}{4}$ "	3 $\frac{1}{2}$ "	76 $\frac{1}{2}$ "	C	1
C end stiles	$\frac{1}{4}$ "	3 $\frac{1}{2}$ "	15"	C	2
D center stiles	$\frac{1}{4}$ "	3"	15"	C	2
E* outside panels	$\frac{1}{2}$ "	21 $\frac{1}{2}$ "	14 $\frac{1}{8}$ "	EC	2
F* center panel	$\frac{1}{2}$ "	22"	14 $\frac{1}{8}$ "	EC	1
END FRAMES					
G rear stiles	$\frac{1}{4}$ "	4 $\frac{1}{2}$ "	30 $\frac{1}{2}$ "	C	2
H front stiles	$\frac{1}{4}$ "	3 $\frac{1}{4}$ "	30 $\frac{1}{2}$ "	C	2
I top rails	$\frac{1}{4}$ "	3 $\frac{1}{2}$ "	33 $\frac{1}{2}$ "	C	2
J bottom rails	$\frac{1}{4}$ "	13 $\frac{1}{2}$ "	33 $\frac{1}{2}$ "	EC	2
K center stiles	$\frac{1}{4}$ "	3 $\frac{1}{2}$ "	11 $\frac{1}{2}$ "	C	2
L* panels	$\frac{1}{2}$ "	15 $\frac{1}{8}$ "	11 $\frac{1}{8}$ "	EC	4
M strips	$\frac{1}{4}$ "	1 $\frac{1}{4}$ "	30 $\frac{1}{2}$ "	C	2
ARMRESTS AND CORBELS					
N armrests	$\frac{1}{4}$ "	6"	44 $\frac{1}{4}$ "	C	2
O corbels	$\frac{3}{4}$ "	4 $\frac{1}{2}$ "	6"	C	2
FRONT PANEL					
P front panel	$\frac{1}{4}$ "	13 $\frac{1}{2}$ "	74 $\frac{1}{2}$ "	EC	1
SUPPORTS					
Q braces	$\frac{1}{4}$ "	9 $\frac{1}{2}$ "	9 $\frac{1}{2}$ "	EC	2
R cleats	$\frac{1}{4}$ "	1"	8 $\frac{1}{4}$ "	C	2
S cleats	$\frac{1}{4}$ "	$\frac{1}{4}$ "	9 $\frac{1}{4}$ "	C	2

*Cut parts marked with an * oversized. Trim to finished size according to the how-to instructions.

Materials Key: C—Cherry, EC—edge-joined cherry.

Supplies: #8x1 $\frac{1}{4}$ " and #8x1 $\frac{1}{2}$ " flathead wood screws, $\frac{1}{4}$ x2" flathead machine screws with $\frac{1}{4}$ " nuts and washers (4), $\frac{1}{4}$ "-20 threaded inserts with 8- $\frac{1}{4}$ x $\frac{1}{2}$ " roundhead machine screws and flat washers (8), $\frac{3}{8}$ " dowel pins 1 $\frac{1}{4}$ " long (8), silicone sealant, stain (if desired), clear finish.

Continued

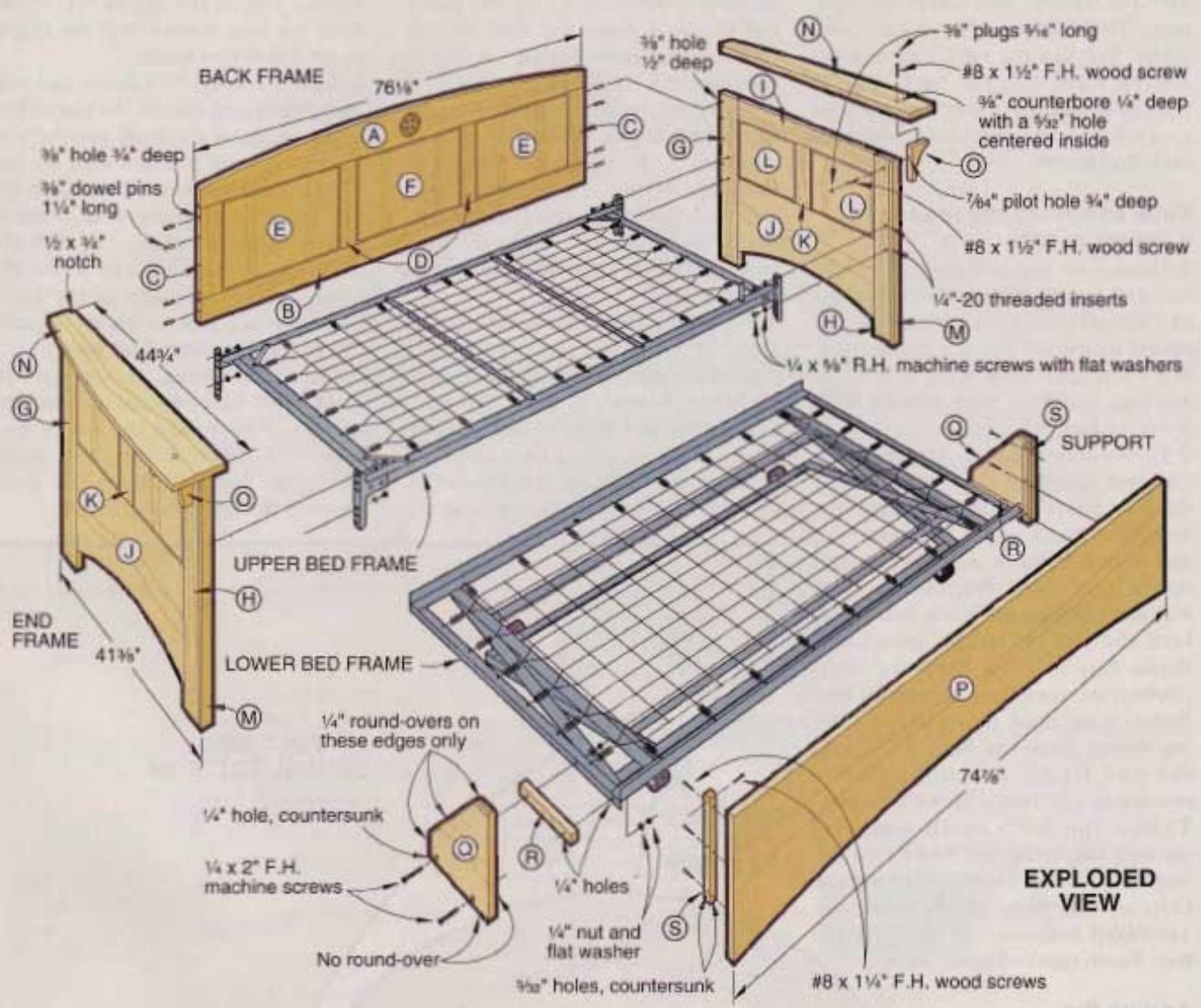

CUTTING DIAGRAM

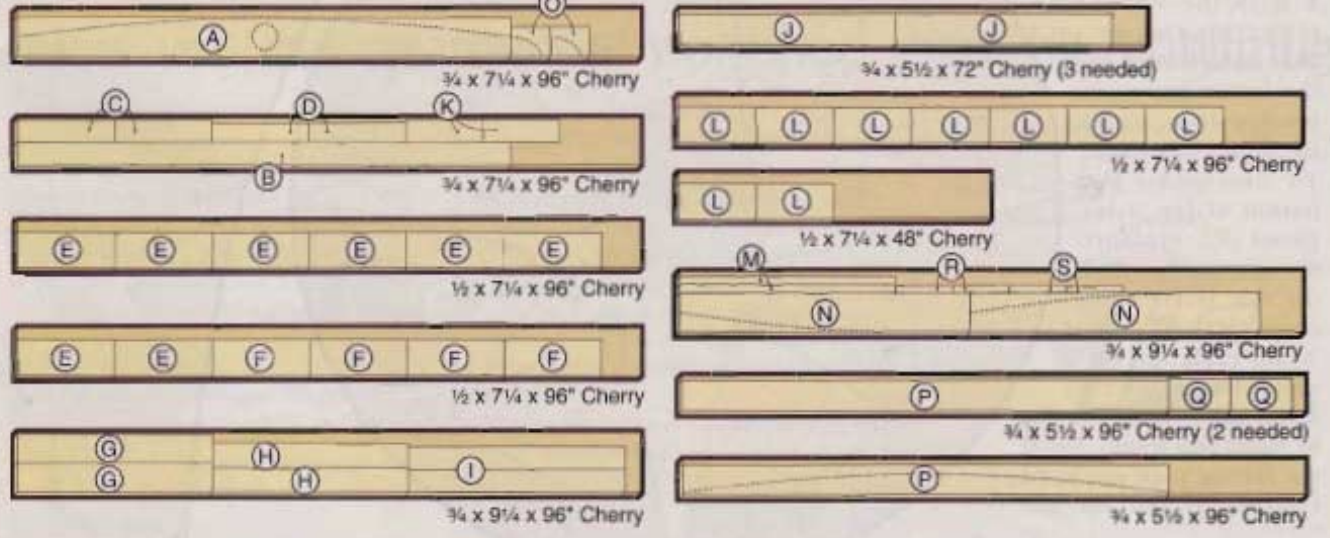

Deluxe Day Bed

10 Glue, clamp, and screw the armrests onto the top edge of each end frame, keeping the back end of each armrest flush with the back edge of the end frame. Make sure the armrests extend $\frac{1}{2}$ " over the inside edge of each end frame.

Final assembly requires a helper or two

1 Finish-sand and seal the back frame and end frames. (We used three coats of Deft clear lacquer, re-coating the raised panels on the last application. We then followed with a coat of Minwax Finishing Wax applied with 0000 steel wool.)

2 To assemble the bed, start by laying one end frame on the floor, making sure to protect it from scratches. Stand the metal upper bed frame on end with a helper's assistance, lining up the bolt holes. Thread bolts with washers through the metal bed frame into the inserts in the wood end frame. Finger-tighten the bolts. Next, position the back frame against the end frame on the floor, fitting the protruding dowels from the back frame into the end frame. Carefully, fit the remaining end frame in place on top. Thread the bolts (with washers) through the metal bed frame into the wood end frame. Finger-tighten these bolts as well. Now, slowly lower the assembled bed onto the floor on its feet. Finish tightening the bolts.

Adding the front panel

1 With the upper and lower mattresses on their metal frames, slide the lower bed frame into position under the upper bed frame. To determine the length of the front panel (P), measure the opening between the side frame cover strips (M) and deduct $\frac{1}{8}$ " on each end or $\frac{1}{4}$ " overall for clearance.

2 Cut the front panel (P) to width and length. Using the fairing stick you used earlier, lay out the arc

along the bottom edge of the panel. Cut the arc to shape and sand smooth. (We used a bandsaw with a helper to support the long piece of stock.)

3 To secure the front panel (P) to the lower bed frame, cut the braces (Q) and cleats (R, S) to size. Glue and screw the vertical cleats (S) flush with the front edge of the front panel braces (Q). Glue and clamp the horizontal cleats (R) flush with the bottom of the braces.

4 Clamp the brace assemblies (Q, R, S) to the lower bed frame. Make sure the braces extend out far enough to clear any hardware along the front edge of the bed frame when the front panel (P) is attached later. Drill $\frac{1}{4}$ " holes through the braces, cleats (R), and metal bed frame. Countersink the

outside face of the braces for $\frac{1}{4}$ " flat-head machine screws. Bolt the braces to the lower bed frame.

5 With the lower bed frame and mattress rolled underneath the upper bed frame, position the front panel (P) so the top edge of P aligns with the top edge of the two bottom rails (J) in the end frames. Clamp the front panel to the vertical brace cleats (S). Slide the lower bed frame out, and screw the cleats to the backside of the front panel. Do not glue so the front panel can be adjusted later if necessary.

6 After final fitting, remove the $\frac{1}{4}$ " front-panel brace-mounting machine screws, finish-sand the parts, and apply the finish to the front panel assembly. Later, reattach the front panel to the lower bed frame. ♣

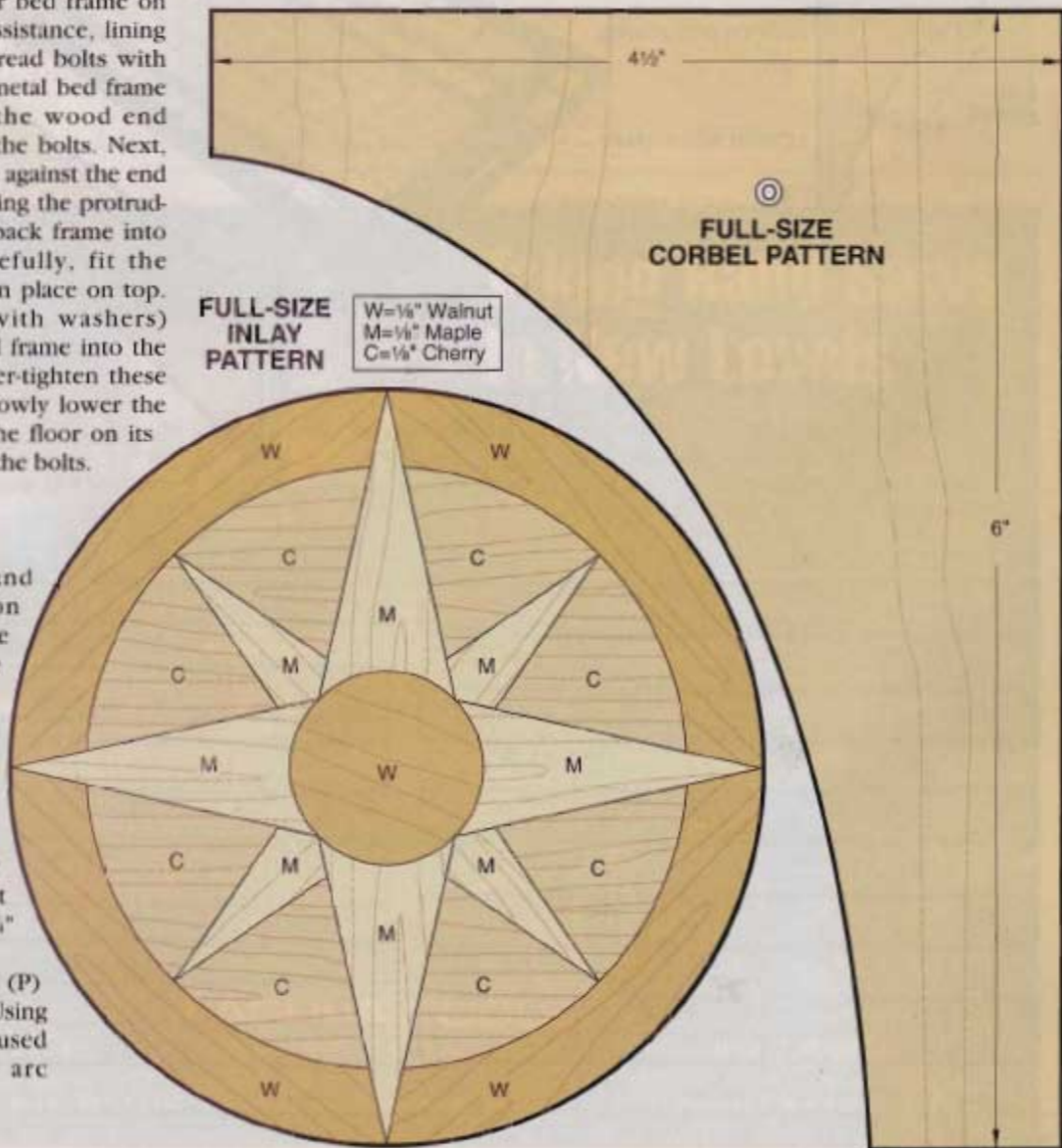

ADDING THE INLAY

STEP 1

Using $\frac{1}{8}$ "-thick stock (and full-size inlay pattern), scrollsaw and assemble the four corner sections.



STEP 2

Dry-fit the four sections into the 3" hole in the trundle bed back frame.



STEP 3

Cut and fit the remaining four maple parts. Glue in place when you are satisfied with the fit.

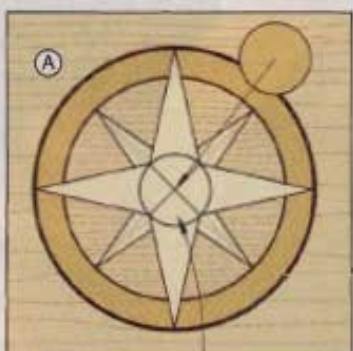

STEP 4

After the glue dries, bore a $\frac{3}{4}$ " hole, $\frac{1}{8}$ " deep centered on the inlay. Cut, fit, and glue a walnut disk into hole. Sand the entire assembly flush.

PARTS VIEW

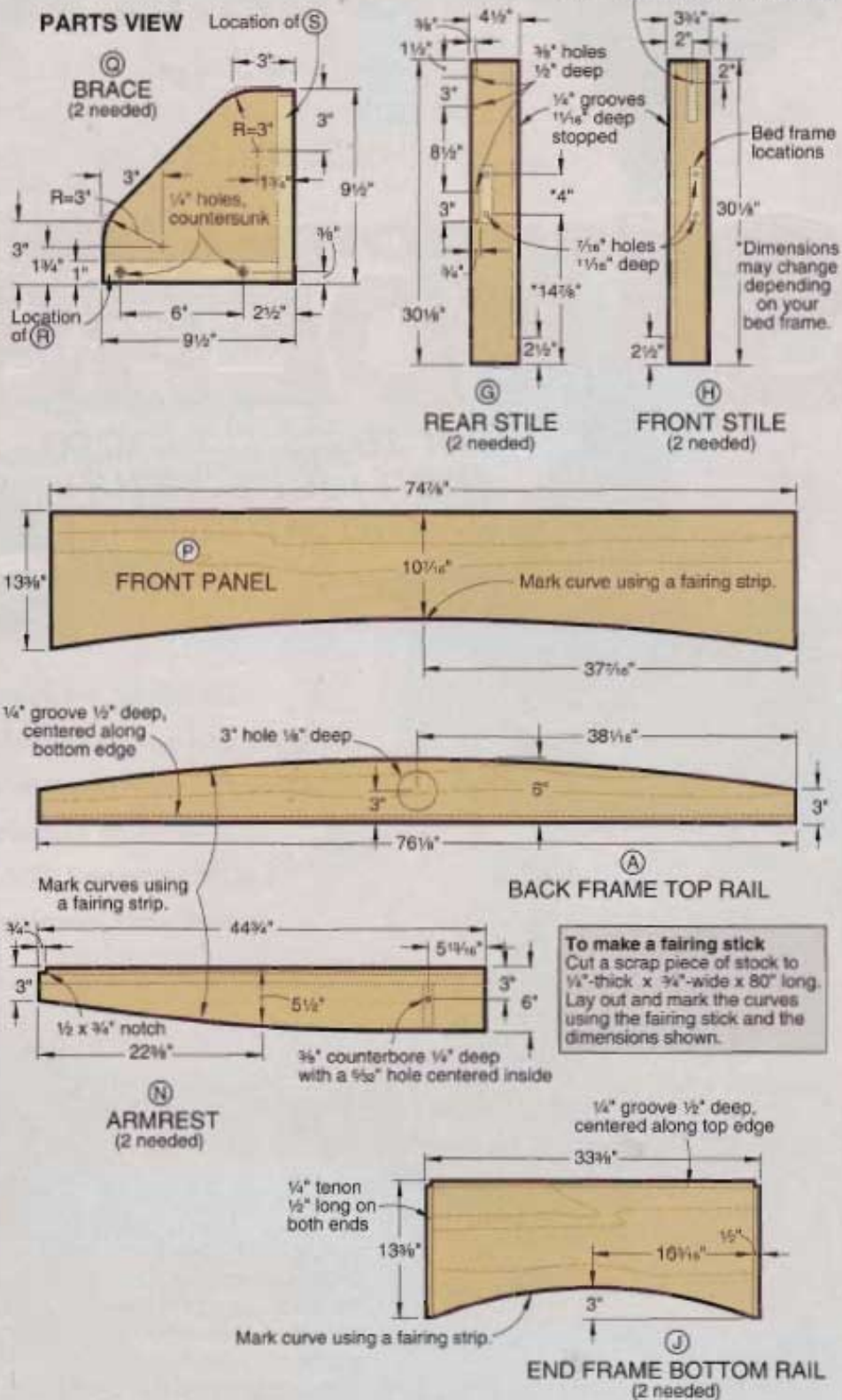

To make a fairing stick
Cut a scrap piece of stock to $\frac{1}{4}$ "-thick x $\frac{7}{8}$ "-wide x 80" long. Lay out and mark the curves using the fairing stick and the dimensions shown.



Random-Orbit **SANDERS**

*Our tests do more
than just scratch
the surface*

Sanding on acrylic
provides an excellent
method of determining
scratch patterns.
See the results
on page 76.

Saying goodbye to old friends can be hard. But that's just what many woodworkers have done by saying so long to their belt sanders and finishing (orbital-only) sanders in favor of a random-orbit sander. And why not? No single tool hogs off wood, and imparts a smooth, scratch-free surface, better than a random-orbit sander.

So which model should you buy? In our tests of 12 machines with 5" pads, we found key performance differences you need to know about before plunking down your hard-earned cash.

Why these machines do the work of two sanders

Like the abrasive pad on a finishing sander, the abrasive disc on a random-orbit sander is mounted off-center on the motor shaft. This offset causes the pad or disc to oscillate in a tiny orbit, which varies from $\frac{5}{64}$ " to $\frac{1}{16}$ " on the machines in this test. This "jitterbug" action removes stock slowly and produces small, circular scratches.

A random-orbit sander, unlike a finishing sander, has a flywheel mechanism that allows the disc to simultaneously spin completely around its 5" diameter while it also oscillates in a tiny orbit. This spinning action serves two purposes. It makes the sander more aggressive, and it helps to blend together the tiny orbits into a less-detectable scratch pattern.

Although the orbiting action of the sander is relatively fixed, the rate at which the disc spins varies depending upon how much sanding pressure you apply to the disc. On many of the first random-orbit sanders introduced years ago, the discs would free-spin at extremely high rates when not in contact with a project surface. This made it all-too-easy to gouge surfaces, so most manufacturers have added brakes that control the rate of spin.

Continued

Fast facts

- Random-orbit sanders work faster and leave less-conspicuous scratches than orbit-only finish sanders (the kind that typically use $\frac{1}{2}$, $\frac{1}{3}$, or $\frac{1}{4}$ sheet of sandpaper).
- Palm-grip random-orbit sanders excel at controllable stock removal on small surfaces, edges, and corners. Side-handle versions make fast work of removing lots of material on flat surfaces.
- High-quality sanders last longer and speed your work because they save you a sanding disc change or two on each job.

You'll find several kinds of random-orbit sanders on today's market, but for this article we focus on these two types.

PALM-GRIP



On a **Palm-grip sander**, the motor housing also functions as a grip. Downward pressure is centered evenly over the pad.

Side-handle sander

You can grip a **Side-handle sander** in your palm, but it also has a side handle and opposing knob for two-handed control. These tend to have a little more power and bite. They typically cost more than palm-grip versions.



SIDE-HANDLE

There are also two other machines you should know about.



Grinder-based sanders

are tops for quickly flattening and shaping material, but we find them too aggressive for most woodshop smoothing tasks.

Air-powered sanders,

also referred to as dual-action (DA) sanders, work aggressively and controllably, but require a compressor with at least a 5-hp motor.



Random-Orbit SANDERS

How the sanders compare in **7 Key Areas**

You can tell a lot about a random-orbit sander just by the way it feels in your hand as you guide it across a surface. And we did plenty of that in the course of our testing. But our hands-

on tests seemed to create more questions than answers. For example, why does one sander remove material with nearly the speed of a hand plane while another seems to

hardly faze the surface? Why does a \$150 sander glide smoothly across a tabletop while the \$40 model shakes, rattles, and all but rolls its way across the same surface? Clearly,

we had to devise a series of tests that answered these, and other, questions. To do that, we came up with objective ways to measure each sander's performance in the following areas.

1. Finish quality:

better machines leave less-detectable scratches

To clearly see the sanding scratches left behind by each of the sanders, we sanded a piece of clear acrylic with each of them. As you can see in the inset photo *below (B)*, the best sanders left scratches that overlapped and blended together in an undetectable pattern. As shown in the large photo *below (A)*, the least-expensive sanders leave noticeable scratches in repeating patterns.

Although the clear acrylic test was insightful, what matters most are the scratch patterns the sanders leave in wood. Here, we found that all of the sanders, regardless of price, left nearly undetectable scratches on natural, unstained wood surfaces, so long as we used 100-grit or finer abrasive.

But, when we applied stain to a sanded surface, the lower-priced machines again revealed their less-than-random patterns. The stained board in the photo *below (C)* was smoothed with sanders costing \$115, \$85, and \$40, from *left to right*. All were equipped with 120-grit abrasive, but only the \$115 Makita BO5021K left a scratch that wasn't readily visible to the naked eye.

We did this test on oak and pine boards with all of the reviewed sanders. (See the chart at *right* for results.) As the chart shows, some sanders save sanding steps by not requiring you to progress as high in abrasive grit to obtain an undetectable scratch pattern.

THE SANDERS SHOW THEIR TRUE GRIT				
Here's how high we had to go in abrasive grit to make sanding scratches undetectable to the eye.				
SANDER	MODEL	PINE*	RED OAK*	
PALM-GRIP	BLACK & DECKER	RO100	240	220
	BOSCH	12950H	180	180
	CRAFTSMAN	11621	220	180
	DEWALT	DW423	220	180
	MAKITA	BO5010	220	180
	MILWAUKEE	6019-B	240	180
	PORTER-CABLE	333VS	100	150
SIDE-HANDLE	RYOBI	RS240	220	180
	BOSCH	3107DVS	100	180
	BOSCH	37250VS	150	150
	MAKITA	BO5021K	150	120

*Tests conducted on a single board of each species. Your results may vary due to differences in hardness and grain structure from board to board.

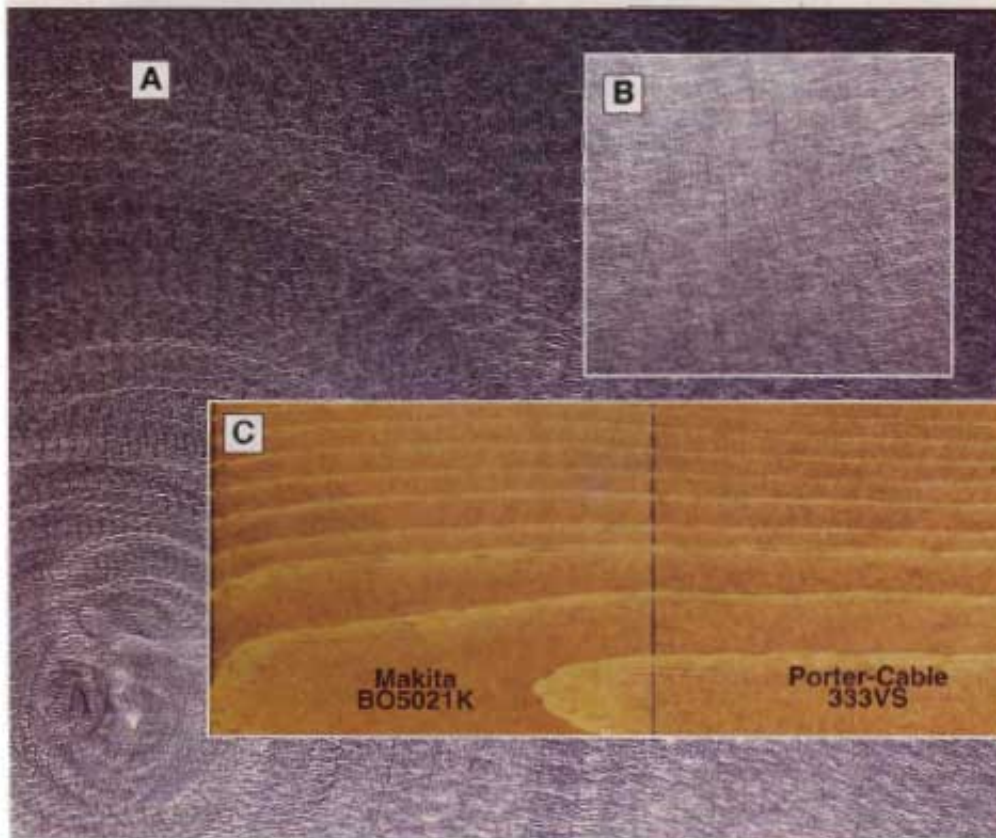

A. Less-expensive sanders leave more-detectable scratches like these left by the Black & Decker RO100 in acrylic.

B. The Bosch 3107DVS left one of the less-detectable scratch patterns of the tested sanders in acrylic.

C. Sanding scratches from 120-grit abrasives varied from nearly undetectable to noticeable in stained pine.

2. Aggressiveness:

a double-edged sword

As you can see in the chart at right, the Bosch sanders remove stock at a rate well above their competitors. That's important to know if you work on large surfaces or need to knock down joints that don't align perfectly.

Of course, trying to control an aggressive sander on delicate materials can be like holding a tiger by the tail. One false move and the abrasive will gouge a surface or cut through delicate veneers. Fortunately, two of the Bosch's (the 3107DVS and 3725DVS) have variable speed that effectively controls the aggressiveness when necessary. Other machines with variable speed include the DeWalt DW423, Porter-Cable 333VS, and Makita BO5021K. The Bosch 1295DH has two speeds.

THE AGGRESSIVENESS TEST

An indicator of how quickly these sanders remove stock.

	SANDER	MODEL	GRAMS OF MAT'L REMOVED*
PALM-GRIP	BLACK & DECKER	RO100	3.96
	BOSCH	1295DH	10.85
	CRAFTSMAN	11621	6.59
	DEWALT	DW423	4.63
	MAKITA	BO5010	6.08
	MILWAUKEE	5019-6	2.62
	PORTER-CABLE	333VS	6.57
SIDE-HANDLE	RYOBI	RS240	6.32
	BOSCH	3107DVS	13.55
	BOSCH	3725DVS	15.07
	CRAFTSMAN	27717	7.62
MAKITA	BO5021K	6.27	

*3/4x2 1/4x4" pine blocks were weighed before and after being sanded for one minute with a new 36-grit disc. Test was conducted three times and the results averaged.

3. Control:

it gives you command of the sanding action

In our tests, we discovered that some random-orbit sanders do a much better job of putting you in the driver's seat than others. Some tended to dart around with no warning. Others obediently responded to the most sensitive command.

On flat panels, only four machines—the Bosch 1295DH, Makita BO5010 and BO5021K, and the Porter-Cable 333VS—behaved flawlessly, regardless of whether we applied direct, downward pressure or off-center pressure. The aggressive Bosch 3107DVS and 3725DVS were difficult to control. Both tools changed direction quickly when we applied pressure to the edge of the pads. Same goes for the Black & Decker, Craftsman, Ryobi, DeWalt, and Milwaukee sanders.

4. Internal quality:

it affects the lifespan of the tool

All the sanders we tested did a good job of sanding, but looking under the hood showed differences in quality between the inexpensive and more-costly tools.

Most of the motors that drive these tools have bearings at the top and bottom of the armature shaft, but the Black & Decker RO100, Craftsman 11621, and Ryobi RS240 use a compressed bushing in place of the top bearing. Bushings wear with continuous use; bearings do not. Bushings hold up well under intermittent duty, but if you'll be sanding hour after hour, we suggest you select a machine with bearings at both the top and bottom.

Electrical contacts that surround each motor armature conduct current that spins the armature. Better motors have more contacts, spreading the current more evenly so the motor develops more power under load. The Black & Decker RO100, Craftsman 11621, and Bosch 1295DH have only 12 contacts. All the other sanders have 24.



BLACK & DECKER RO100

PORTER-CABLE 333VS

Random-Orbit SANDERS

5. Pad brakes: some work quite well

All of the machines have a pad brake with the exception of the Milwaukee 6019-6. So, we expected the majority of pads to spin at a slow speed when we lifted them from a surface. Not necessarily so. We measured the no-load rpm of each with a photo tachometer, and as the chart shows, nearly half of the sanders had pads that spun freely in excess of 2,000 rpm. At those speeds, the tool behaves more like a true disc sander, meaning you have to allow the pad to come to a complete stop before touching it to a surface. We found that we could remove and reposition the sanders on a surface without a risk of gouging only when their pads spun at 400 rpm or less.

SOME SANDERS PUT ON THE BRAKES BETTER THAN OTHERS

An effective pad brake saves you from waiting for a sander to slow down, and helps prevent gouging.

	SANDER	MODEL	FREE-SPINNING PAD RPM'S
PALM-GRIP	BLACK & DECKER	RD100	4,900
	BOSCH	1295DH	3,900
	CRAFTSMAN	11621	246
	DEWALT	DW423	265
	MAKITA	B05010	8,900
	MILWAUKEE	6019-6	8,200
	PORTER-CABLE	333VS	16
SIDE-HANDLE	RYOBI	RS240	254
	BOSCH	3107DVS	350
	BOSCH	3725DVS	2,000
	CRAFTSMAN	27717	190
MAKITA	B05021K	8,600	

7. Dust collection: an important consideration

Few tools will cloud your shop and lungs with dust as quickly as a random-orbit sander. To minimize a sander's airborne dust, a fan on the flywheel pulls dust through the paper and pad and around the paper's outer edge. Most of the sander pads extract dust through eight holes, as shown at *far right*, and use widely available eight-hole paper. The Porter-Cable 333VS's pad, however, has five oblong slots, shown at *near right*, that work best with five-hole paper. (You can use eight-hole paper with this machine, but several of the holes won't collect dust.)

How well do the dust collecting systems work? To find out, we tested each sander with its on-board dust collector alone, and again with each sander hooked up to a shop vacuum. In every case, the shop vacuum improved dust control, but at the expense of convenience. None of the sanders rated excellent at dust collecting because none collected 90 percent or more of the dust—but some machines did better than others. (See chart on the *next page*.)



The Porter-Cable 333VS, left, pulls dust through five holes in the sanding pad and requires special sandpaper to work effectively. Other sanders, like the DeWalt, right, have eight holes.



The Ryobi RS240 was one of two random-orbit sanders that blew clouds of dust through their bags.

6. Sandpaper: two ways to go

Hook-and-loop sandpaper has tiny hooks that interlock with loops on the sanding pad. Pressure-sensitive-adhesive (PSA) abrasive, on the other hand, has a thin coating of adhesive on the back that adheres to the pad.

Though it costs more than PSA, we prefer the hook-and-loop system because you can remove and replace it on the pad multiple times. That doesn't work with PSA discs.

All but the Craftsman and Ryobi sanders come with hook-and-loop pads, and even these can be converted to hook-and-loop paper with an adhesive-backed adaptor. Trouble is, with continuous use, the thin adaptor begins to tear off the pad when you remove the paper.

LET'S GET UNDER THE SURFACE OF RANDOM-ORBIT SANDERS

	MANUFACTURER	MODEL	AMPERAGE	ORBITS PER MINUTE (NO-LOAD)	ORBIT DIAMETER (INCHES)	HEIGHT (INCHES)	LENGTH WITH DUST CONTAINER (INCHES) (1)	DUST CONTAINER TYPE (2)	ABRASIVE DISC (3)	NUMBER OF HOLES IN ABRASIVE DISC	PERFORMANCE RATING (4)										COUNTRY OF ASSEMBLY (5)	WEIGHT (POUNDS)	SELLING PRICE
											AGGRESSIVENESS	CONTROL OVER SANDER MOVEMENT	SANDING PATTERN HANDIENESS	VIBRATION	DUST-COLLECTION EFFECTIVENESS	CONSTRUCTION QUALITY	PAD-BRAKE EFFECTIVENESS	CONTROL OVER RATE OF STOCK REMOVAL	CORD FLEXIBILITY	CORD LENGTH (FEET)			
PALM-GRIP	BLACK & DECKER	RO100	2	12,000	3/16	5 1/4	10 1/2	B	HL	0	P	F	F	G	G	F	P	E	G	0	U	2.66	\$40
	BOSCH	1295DH	2.2-2.4	12,000-14,000	7/16	6	10	PP	HL	0	E	E	E	G	G	E	P	E	E	8	U	3.23	85
	CRAFTSMAN	11621	2.4	12,500	3/16	6	10	B	PSA	0	G	G	G	G	P	F	E	G	G	0	U	2.73	40
	DEWALT	DW423	2	7,900-12,900	3/16	6	10 1/2	B	HL	0	F	G	G	E	G	G	E	E	E	8	U	3.05	80
	MAKITA	B05010	2	12,000	3/16	5 1/2	10	B	HL	0	G	E	G	E	F	E	P	E	E	6 1/2	U	2.67	78
	MILWAUKEE	6019-6	1.8	12,900	3/16	5 1/2	9 1/4	B	HL	0	P	G	F	G	G	F	P	G	E	8	T	2.9	65
	PORTER-CABLE	333VS	2.4	5,000-12,000	3/16	6 1/2	10 1/4	PP	HL	5	G	E	E	E	F	E	E	E	E	8 1/2	U	3.26	85
	RYOBI	RS240	2.4	12,500	3/16	6	10	B	**HL PSA	0	G	G	G	F	P	F	E	G	G	10	U	2.73	40
SIDE-HANDLE	BOSCH	3107DVS	3.3	4,500-13,000	3/16	7 1/4	12 1/2-15 1/2	B	HL	0	E	G	E	G	G	G	E	F	E	6 1/2	S	5.11	115
	BOSCH	3725DVS	3.3	4,500-12,000	3/16	7 1/4	13-14 1/2	B	HL	0	E	G	E	E	G	E	F	F	E	6 1/2	S	4.65	145
	CRAFTSMAN	27717	3	13,000	3/16	6 1/4	8 1/2-9 1/4	SB	PSA	0	G	G	G	G	G	G	E	G	G	10	U	3.2	70
	MAKITA	B05021K	2	4,000-12,000	3/16	5	12 1/2-15	B	HL	0	G	E	E	E	G	E	P	E	E	6 1/2	U	3.1	115

NOTES:

- (*) Bosch 1295DH is a 2-speed model
- 1. Two measurements for side-handle sanders are with the front knob removed and with the knob in place.
- 2. (B) Bag (PP) Porous Plastic (SB) Screen Box
- 3. (HL) Hook-and-Loop (PSA) Pressure Sensitive Adhesive (** Ryobi RS240 comes with pad for PSA abrasives, but has an adaptor for hook-and-loop abrasives.
- 4. **E** Excellent **G** Good
F Fair **P** Poor
- 5. (S) Switzerland (T) Taiwan (U) United States

FOR MORE INFORMATION CALL:

- Black & Decker 800/544-6986 www.blackanddecker.com
- DeWalt 800/433-9258 www.dewalt.com
- Porter Cable 800/487-8665 www.porter-cable.com
- Bosch 877/267-2499 www.boschtools.com
- Makita 800/462-5482 www.makitatools.com
- Ryobi 800/525-2579 www.ryobi.com
- Craftsman 800/377-7414 www.sears.com/craftsman
- Milwaukee 800/243-0870 www.mil-electric-tool.com

For specifications on other types of tools, click on "Tool Comparisons" at www.woodmall.com.



Random recommendations: there's a sander to match most budgets

Our overall favorite among the sanders we tested: the Makita BO5021K. It's compact, has outstanding control, and is a joy to use.

The Bosch 3107DVS and 3725DVS are very aggressive,

well-built machines. Though it's the most expensive of the bunch, the 3725DVS will stand up to lots of heavy use.

Among mid-priced palm sanders, we liked the

Porter-Cable 333VS. It has variable-speed control, handles well, and boasts excellent construction. The similarly-priced Bosch 1295DH rates high in aggressiveness, and handles well.

If you're looking for an inexpensive model, we suggest the Black & Decker RO100. It's the least aggressive tool we tested, but it does come with a hook-and-loop pad.

Written by Bill Krier and Jim Huhnel Product testing: Bob McFarlin Photography: Marty Baldwin

Clever Ways To Recycle Wood Waste

Woodworkers make plenty of sawdust and chips. If you're tired of hauling it to the curb, read on.

Back in 1969, John Harkin, a chemist at the U.S. Forest Service's Forest Products Laboratory in Madison, Wisconsin, wrote a report titled "Uses for sawdust, shavings, and waste chips." His research—at a time when environmental concerns about burning were being raised—turned up nearly three dozen categories of uses and dozens more specific applications within them. His purpose was industrial; he calculated that a sawmill cutting 1,000 board feet of 1"-thick hardwood with a saw having a 1/4" kerf produced 1,085 pounds of sawdust. And lots of sawmills had annual production in millions of board feet!

At home, you don't make as much sawdust and shavings as the big boys do. But you still have to get rid of it. Here are some suggestions:



Till it in

If you mix sawdust (not wood shavings) with garden soil, bacterial action decomposes the wood cellulose in two months to a year, depending on the soil's temperature, moisture, structure, and consistency. The lignin part of the sawdust remains largely decomposed to become a fertile humus that makes the soil more tillable and increases its ability to retain water (especially sandy or clay soils).

However, you should first age the sawdust for several months if you plan to use it in ground that you'll immediately plant. Or, you'll have to add nitrogen-rich fertilizer. That's because if you use fresh sawdust, the bacteria

that decomposes it requires more nitrogen than the wood can provide. So the bacteria will rob it from first the soil, then your plants. Once the wood decomposes, though, the extra nitrogen becomes available to help your garden grow. But if you have acid soil, adding wood waste may prove too much.

Make a mulch

Wood shavings take a lot longer to break down than sawdust. But they make perfect mulch, even when fresh. A 4-6" layer in your flower garden or at the base of orchard trees conserves moisture, keeps the soil from getting too warm, and controls weeds.

Contribute to compost

Because wood compost made from sawdust, shavings, and even bark, mixes more readily with soil than peat moss, for instance, many gardeners and nurserymen prefer it. You can add leaves and other material, too. To speed up decomposition, use a bacterial culture available at garden stores.

Tip toe through the tulips

Have a path through your flower garden? Cover it with your wood waste. It'll eventually break down, but you'll always have more available.

Barbeque it

Outdoor cooks have their favorite wood to put on the coals and add flavor to meats, fish, and poultry. Alder, for instance, enhances salmon and trout. Hickory and mesquite make steaks distinctive. Use sawdust or small shavings, but soak them first in water for 20 minutes. Then, drain and put directly on glimmering coals.



Sweep it up

Got a buddy who's always tinkering with cars? No doubt his garage floor or driveway looks like it. Do him a big favor—bring by a bag of sawdust. It makes a great oil-absorbing sweeping compound.

Put it to bed

Kennel owners, farmers, and even poultry producers could use sawdust and wood shavings for absorbent bedding material. Don't, however, include walnut waste if the recipient has horses. Horses absorb an extractive of the walnut wood through their hooves, which can result in sickness and even death.

Support the arts

Some potters add fine sawdust to their clay or use it and shavings as combustibles when they fire their pots. Check with local potters to see if they could use some.

Let a dealer have it

If you generate a bunch of sawdust and shavings regularly, you might be able to get rid of it with little effort. Look under "Sawdust and shavings" in the Yellow Pages for dealers who usually sell it for livestock bedding. They might even pick it up. ♣

Illustrations: Brian Jensen

Seven Steps To Traditional Chair Caning



The lady of cane

To learn caning basics, we called upon Joanna Schanz of West Amana, Amana Colonies, Iowa. She and her husband, Norman, operate Schanz Furniture in South Amana, a business that specializes in

made-on-the-premises, hand-crafted hardwood furniture and furniture restoration. While Norman, son Michael, and other craftsmen/finishers rank among the most skillful of furnituremakers, Joanna has earned a reputation as an expert caner and basketmaker, which she teaches at the Amana Arts Guild in High Amana.

"I learned caning 35 years ago from a blind man here in the Amana Colonies," Joanna comments as her fingers deftly snake a strand of cane through the pattern. "He was actually a broom maker by trade. But the caning gave me something to do to help the business when I had to be home with the children."

If you ever chance by the Amana Colonies in east central Iowa, and stop at Schanz Furniture, you might catch Joanna at work. If she's gone, you can watch one of the Schanz caners to whom she has taught the skill.

"It's not hard to do, once you understand the directions and make sure one step is correct before weaving the next step. When you've learned the traditional pattern called 'seven-step caning,' you'll have the right mindset to do other patterns," Joanna says with a smile that exudes confidence.

What you don't want to do she laughingly explains with an anecdote:

"One day a man brought in a chair for repair. It had a caned seat that at first looked like an intricate spider-web pattern. But on closer inspection, it was no pattern—just cane going every which direction. When I asked if he wanted it recaned, he said, 'No, this is the first and last time I ever caned, and I want it preserved!' By the time the chair came out of the shop, one of our men had named the man's caning pattern, though. He called it 'jetkyreolf.' Just enough to keep your rear end off the floor."

Patience, practice, and an orderly mindset bring satisfying results



Caned chairs probably originated in China, historians believe, and were brought to Britain, France, and Portugal with the opening of trade in the early 1800s. In the Far East, though, where the rattan palm grows, cane was made (and still is) by stripping its hard outer bark and paring it into strips that were woven not only into chairs, but fish traps and hundreds of other utilitarian items.

Western craftsmen—including Shaker furnituremakers in the United States—mastered the caning technique and gradually improved upon it. During the Industrial Revolution,

machines were developed to weave cane for the production of rattan furniture. Cyrus Wakefield built a factory in Massachusetts in the 1850s especially to manufacture furniture of cane.

Today's revival of interest in craftsmanship has resulted in increased prices for antique furniture and its restoration. And caning is part of that.

What to know before you start

A chair designed for the use of hand-woven cane has holes drilled in the frame to accommodate it. But a chair meant to accept machine-woven cane

Continued

Chair Caning

has a routed groove or channel in the frame to insert the sheet of cane and the spline that holds it in place.

"If you have a chair with holes in the frame, don't rout a channel for machine-woven cane because you'll weaken the chair," cautions Joanna.

"Hole sizes and their spacing may vary from chair to chair," she goes on to explain, "because they're both related to the size of cane used. Medium cane, which is the most common, requires $\frac{3}{4}$ " holes drilled $\frac{3}{4}$ " apart center to center. Fine is the next

most common cane, and needs smaller, $\frac{5}{16}$ " holes that are $\frac{7}{8}$ " apart center to center. On very old chairs, all the holes may not be as regularly spaced, but you should go with the majority. And some large chairs might require two sizes of cane. So you must look at the chair closely to see what size cane to use.

"If you use larger cane than what the holes were sized for, you'll fill them up very fast and make it very difficult, if not impossible, to get all the cane through the holes," Joanna continues.

"If you use cane that's too small, the weaving will be weak."

(Note: *Caners charge for their work by the number of drilled holes in the chair frame. A chair with 72 holes around the seat, at \$1 per hole, would cost \$72 to recane.*)

About the cane itself, Joanna has this to say: "Machine-woven cane has many splices because the machine weaves the cane it's fed. With hand caning, you have quality control. So you might as well use the best cane because the labor will be the same."

7 STEP CHAIR CANING



General materials and tools

Rattan cane, medium or fine (about 250 feet for one chair back or seat)

Binder cane (keep separate from other cane and save for last step)

Scissors

Nut pick, awl, ice pick, or flat-pointed tool

2 dozen wooden pegs (whittled or purchased) or wooden golf tees

Longnose pliers

Nail file or other flat-pointed tool

Large bowl

Warm water

Liquid fabric softener

Spray bottle filled with water

Cloth or towel

Clamp-type clothes pins, 1 dozen

Craft knife or razor blade

For caning materials, look in the Yellow Pages under "craft supplies," or write to: Schanz Furniture, 2773 Hwy 6 Trail, South Amana, IA 52334-8529. 319/622-3529. Fax 319/622-6139. Schanz Furniture also offers the assembled doll-size rocker shown ready to finish and cane for \$100 ppd. You can also order a 5 $\frac{3}{4}$ " square Cane Sampler Trivet for \$15 ppd. Both include cane to complete.



STEP 1



Step 1. Determining alignment

Count the number of holes in the top frame of a back (or the back rail of the seat frame). If there is an odd number, place a peg in the center hole. Then, find the corresponding center hole in the bottom back frame (or front rail of a seat frame) and place a peg in it. The purpose here is to square up the vertical holes to keep the rows of cane straight, which is important if your frame is wider in front than back. You can start in the center hole or the bottom left hole (not the corner hole), as in *Photo 1*.

Now, take out a piece of wet cane, wipe it off, and look at the glossy side to find the "tail." About every 18" or so, you'll find a tiny bump where a leaf was once attached. Each bump has a smooth edge and a rough edge—run your fingernail along the cane to find it. The rough edge can easily catch and break the strand. So you always want to weave with the smooth edge as the leader, and the



STEP 2



rough edge as the tail. And as important, you must keep the cane's shiny side up (facing you) on both sides of the weaving.

Begin *Step 1* by inserting about 4" of the cane into the bottom left hole and pegging it in place. Now run the cane (shiny side up don't forget) up to the corresponding hole at the top of the frame, down the hole, and up the adjacent hole. Pull the cane taut and peg it with a new peg. This peg will become your "traveler" as Joanna calls it.

Now, bring the cane back down to the bottom frame, push it through the next hole, and pull the slack out. (You don't have to keep the cane fiddle-string tight. It'll draw up as the weaving grows and the cane dries.) Pull the traveling peg and put it in the new hole to hold the cane. Repeat the running of the cane up and down (as shown in the *Step 1* drawing) until you've completed all the verticals in this step of the caning. Peg the cane in the last hole you fill.

Cane comes in hanks—1,000 feet of pieces in varying lengths. One hank will do four ordinary chairs with 12×12" seats or four backs. Supply houses also sell cane in half hanks (500 feet) and quarter hanks (250 feet). According to Joanna, No.1 long select cane, called "blue-tied" cane, is the better quality and easier to work with because it has the longest pieces (about 10 feet long).

"In the first steps, longer pieces are better, but when you start weaving, shorter ones are okay," she says. "And

with the cane will come a wider piece called the binder. It's a size larger cane that trims off the weaving."

To do before you start

If you're going to recane a chair, you must prepare it. (For a new chair, move on to the next paragraph.) First, cut away and remove any old cane, being careful to not damage the wood finish. Clean the holes of dirt, finish, or lodged cane to make way for the new cane. Pull nails or tacks. Next, soften the inside edges of the wood

frame to eliminate sharpness that could cut the cane. Finally, refinish areas of the seat frame that need it.

To make cane flexible for weaving, soak coiled individual pieces, each held by a clothespin, in warm water for about 10 minutes. "Some caners put in a few drops of glycerin to help the cane absorb the moisture better," says Joanna. "But I've found that adding fabric softener does the same thing. As the cane dries out—it rattles—you can wipe it with a moist cloth or spray it with water."



STEP 3

Step 2. Side to Side

Now you'll begin to form the squares for the weaving pattern, shown left as Step 2. If the cane you are using is long enough to continue weaving, come up the first side hole, ignoring the corner hole. Run the cane across the top of the previous weaving in the same manner that you did in Step 1. Use the traveling peg to keep the cane tight as you go side to side, as in the photo for Step 2. After you have inserted the cane through the last hole, peg it.

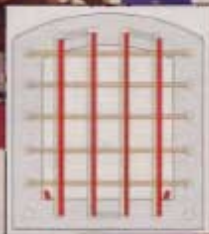

STEP 4

not a corner one), twist or tie the short ends around adjacent cane. If necessary, moisten the cane to keep it from breaking.

Step 4. Real weaving begins

Continue with your piece of cane if long enough. If too short, peg a new piece in the lower left hole next to the corner hole. "Remember, you're completing the little squares, so keep it neat and tidy," Joanna advises. "The first weave here will determine how all the other rows are woven."

Weave Step 4 cane over Step 3 cane and under Step 1 cane, creating little woven squares. (See Step 4 drawing.) Weave across to the matching hole on the opposite side. When pulling cane through, be careful not to lift up or twist the cane, always keeping the shiny side up. When you reach the end of the row, put the cane down through the hole and peg. Now, double check your little squares.

Next, pull the cane up through the next hole and weave back across the

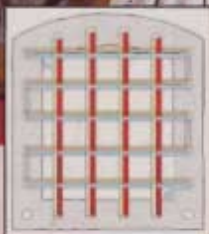

STEP 5

next row under Step 1 cane and over Step 3 cane. Compare the weaving squares in your first two rows. All squares should be exactly alike. If not, check for your mistake.

Continue weaving back and forth. When you've completed Step 4, straighten the squares with your finger, a nutpick, or a peg. Tie off all short ends on the back side of the frame with one of the knots shown on the next page.

Step 5. The first diagonal

Diagonals keep the pattern squares aligned and add strength to the weaving. Begin in the hole next to the corner hole in the lower left of the bottom frame. Insert about 4" of cane down through the hole and peg, making sure the cane isn't twisted and remains shiny side up.

Now, refer to the Step 5 drawing to see how to proceed. (It helps to lay the cane on top of what you've already woven to visualize where

Continued

Chair Caning



STEP 6



you'll go.) You'll want to weave *over* the horizontals (the cane running side to side) and *under* the verticals (the cane running top to bottom). *Note: The weaving in this step isn't difficult; it's finding the correct holes that's hard. Depending on the shape of the frame, some holes may be skipped while others may end up with double strands through them.*

If you do the weave correctly, the cane will pull through easily. If it binds, you're doing something wrong, and you must carefully take out the strand of weaving and start the diagonal again. Each side of the "weaving square" will have a diagonal. The diagonal may not always go in a perfectly straight line to the hole, but may veer or curve toward it. That's okay. But the diagonal should go to the nearest hole *after* passing one side of the weaving square.

Continue weaving the first diagonal using—for the first time—the corner holes. Corner holes usually end up having two diagonals so that a diagonal will be on each side of the weaving square. On curved backs or sides, some holes may also have two diagonals (or have to be skipped and not have a diagonal.) Peg the cane at the end of the weave.

Step 6. The second diagonal

In the weaving of the second diagonal, you'll weave *over* the verticals (cane running top to bottom) and *under* the horizontals (cane running side to side), which is opposite of Step 5. (Diagonals never touch each other except just before they go into a

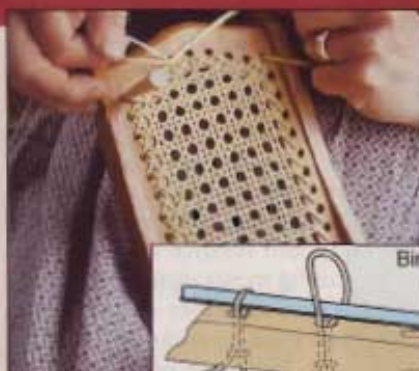

STEP 7

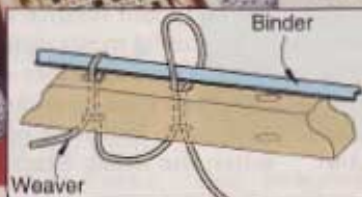

hole.) Begin in the hole next to the corner hole in the lower right of the bottom frame. Insert about 4" of cane down through the hole and peg it, making sure the cane isn't twisted and remains shiny side up. Proceed weaving, referring to the Step 6 drawing.

Now, tie off all loose cane ends on the back side of the frame using one of the two knots diagramed *below*. (You might save any long strands for securing the binder.) After you have fastened the cane, trim the tied cane ends close to the knot.

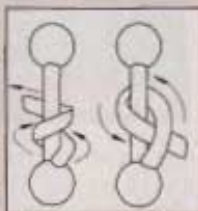

Step 7. Binding the weave

The binder strand that came with your weaving cane is one size larger. You use it to cover the frame holes and give a finished edge to the weave. It should be long enough to go around the whole weaving (but you can splice it if necessary). Corner holes usually are pegged.

Soak the binder and a long length of weaving cane in warm water for about 10 minutes. When it's pliable, start the binder—as always, shiny side up—by pegging it in a corner hole or laying it on top of the hole where the weaver is waiting. The binder goes over the hole and the weaver makes a loop to secure the binder. Then, thread the weaver back down the hole it just came up, as in Step 7 and the photo *above*. With one hand, pull the loop tight from the back side. A dimple will form on the binder when the loop is tight. Continue threading

the weaving cane through adjacent holes and over the binder all around the frame. Keep the binder and the weaver wet and tight. When you come to a corner hole, use a peg to hold the binder and bring the weaver up through the hole next to the corner hole.

You have two choices to end the binder wrap. If your binder/weaver ends up in a corner hole, the binder cane goes down the hole and the weaver comes up the hole. Secure both with a glued wooden peg, *below, top*. The other way is shown in the lower drawing, *below*. Trim the excess ends close to the knot and any fuzzy spots. When you're finished, your caning should look like the woven sample of the traditional Seven Step caning pattern in the photo at the bottom of the page. ♣

Written by Peter J. Stephano
Photographs: Hetherington Photography
Illustrations: Roxanne LeMoine

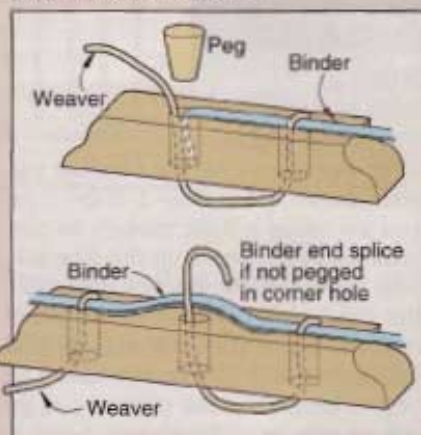

Below: The finished weave of the Seven Step caning pattern should be neat, tight, and trimmed of loose ends.





One-handed clamps deliver crushing force

Squeeze-to-close bar clamps single-handedly changed the way we held things together when they were introduced several years ago. Although they've earned a place in my shop, their clamping force can't begin to approach their twist-handle cousins. But Quick-Jaw Bar Clamps take a major step in that direction.

To test the manufacturer's claim that these models out-clamp the competition, I put the squeeze on my bathroom scale with a leading competitive clamp, and the gripping pressure maxed out at 150 pounds. The Quick-Jaw clamp pegged the reading at 270 pounds before squashing the scale beyond repair.

And the Quick-Jaw outguns the competition in the jaw travel-per-squeeze department. It took me only three pulls of the trigger to move the jaw 1", while I had to squeeze the other clamp five times to travel the same distance.

You can put the same efficiency to work on spreading chores. A couple of spins of a thumbscrew let me slide the fixed jaw off the bar and put it on the opposite end, turning the clamp into an effective spreader.

When I pulled the release lever to take the pinch off my scale, I noticed

another nice innovation of the Quick-Jaw. Instead of simply relieving the pressure, the jaws actually open about $\frac{3}{8}$ ", which makes it easier to remove and reposition the clamp with only one hand. Although handy for making small adjustments, I had to hold the release lever in about halfway to make larger changes in the jaw opening.

One thing does take a little getting used to: The Quick-Jaw's squeeze handle and release mechanism feel like they're inside out, because they're backwards from the more familiar arrangement found on the

competitive product. Though awkward in some situations, I found this configuration worked well when I clamped material to my bench, as it puts the clamp's bar below the benchtop and well out of my way.

—Tested by Bob McFarlin

PRODUCT SCORECARD

Wolfcraft Quick-Jaw Bar Clamp

Performance ★ ★ ★ ★ ☆

Price 12" clamp, \$18

Value ★ ★ ★ ★ ☆

Call Wolfcraft at 630/773-4777, or visit online at www.wolfcraft.com.



When it comes to set up and lay out, tempered steel rules

You can own the finest woodworking tools on the planet, but your work will only be as accurate as the measuring equipment you use. That's why I'd be lost without a set of 6",

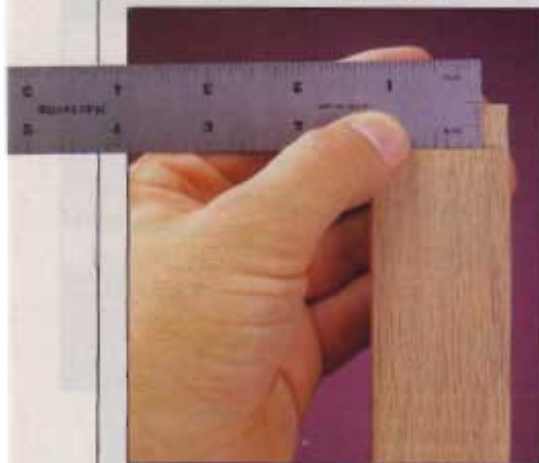

12", and 24" precision steel rules from Hartville Tool and Supply.

Accuracy alone isn't enough, though, if you can't read the numbers and increment marks. The Hartville rules have hair-thin markings etched and painted into a matte surface for outstanding readability. I've used these nearly every day for over a year and the imprinting shows no sign of wear.

The front of each rule has $\frac{1}{16}$ " increments marked along one edge and $\frac{1}{16}$ " spacing on the opposite edge. Additional markings along each end show $\frac{1}{2}$ " increments up to $\frac{1}{2}$ ", a feature I find extremely handy when setting up and measuring rabbets, dadoes, and tenons.

Need to find dead center on a workpiece? One edge of the back mea-

sures out from center to help you do just that. It's marked in millimeters so you don't have to mess with fractions, and also helps when dealing with European-style cabinet hardware. The other edge of the back is graduated in $\frac{1}{2}$ " increments, with every fourth mark numbered—a big help when looking at all those closely spaced lines.

—Tested by Chuck Hedlund

PRODUCT SCORECARD

Precision steel rules #28424

Performance ★ ★ ★ ★ ☆

Price \$60 (set of three)

Value ★ ★ ★ ★ ☆

Call Hartville Tool and Supply at 800/345-2396, or visit online at www.hartvilletool.com

Continued on page 98



Continued from page 86

Size up your blotching stock before staining

I remember how proud I was back in junior high shop class when I built my first project: a small pine jewelry box for mom. I also recall my horror when I finished it—the stain turned my beautiful box blotchy, and the exposed end grain nearly black. I'm over it now, but Wood Size from Titebond could've saved me from years of "blotch-phobia."

This syrupy concentrate, when mixed with water and applied to a workpiece before staining, seals the wood grain to promote consistent stain penetration. I took the ornery

piece of maple shown in the *top* photo and brushed a jagged stripe of Wood Size on the face and ends.

After waiting the recommended 24 hours, I applied stain, and the results, shown in detail in the *bottom* photo, were stunning. As you can see, the sized areas turned out a couple shades lighter than the rest, but the blotchiness virtually disappeared in the sized stripe. And the stained end grain comes close to matching the face grain in color and tone.

As with most water-based products, Wood Size raises the grain slightly after application, but it sanded glass-smooth without clogging the abrasive. The product doesn't settle out from the water after mixing, so I could mix up a batch and store the unused portion for later use.

—Tested by Dave Henderson



PRODUCT SCORECARD

Titebond Wood Size

Performance ★ ★ ★ ★ ★

Price \$12 per quart (makes 3-4 quarts), \$29 per gallon.

Value ★ ★ ★ ★ ★

For more information, call Franklin International at 800/669-4583.

INTERNATIONAL



CORPORATION

"The Power Tool Specialists"

2590 Davie Road, Davie, Florida 33317
Fax (954) 792-3560

- features online ordering for our full line of tools, machinery & accessories
- Hot Monthly Specials for extra low pricing on popular items
- Order our free catalog
- Ask the Tool Guru your tool-related questions
- Read the Tool Guru's Tip of the Month
- Serving your power tool needs for over 30 years
- Best selection & most knowledgeable staff in the industry

1-800-338-3384

LOWEST
Guaranteed
TOOL PRICES

- Free Freight & Same Day Shipping on most UPS orders over \$50 minimum purchase within the contiguous U.S.A.



ALL CHECKS WILL BE HELD 10 BUSINESS DAYS

Call for your FREE catalog!



Circle No. 49

www.internationaltool.com

Protect fingers and teeth when changing blades

Jamming a scrap of wood against a tablesaw blade before loosening the arbor nut is a practice that's probably as old as the saw itself. But that wooden scrap can't protect your fingers or the blade's carbide teeth, should the wrench slip off the nut. Blade-Loc will.

When it's time to change the blade on your saw, crank it to full height and slip the plastic Blade-Loc over it, as shown in the photo below. The blade's teeth engage ribs on the interior circumference of the accessory, and a wide foot on either end stops the blade rotation at the tabletop.

At \$20, Blade-Loc may seem spendy. But, if you've ever nicked a knuckle or chipped the carbide while changing out an expensive blade, you'll appreciate how it virtually eliminates that risk.

—Tested by Dave Henderson

PRODUCT SCORECARD

Blade-Loc

Performance ★ ★ ★ ★ ★

Price \$19.95

Value ★ ★ ★ ☆ ☆

Call BenchDog, Inc. at 800/786-8902 or visit www.benchdog.com.



Continued on page 100

For All Your Woodcarving & Sign Carving Needs

Terrco provides a full line of machine carving and sign carving equipment. Beginning models are the T-110 single spindle bench carver and our CM614 single spindle sign carver.

Intermediate models include the K-Star, a two-spindle heavy duty bench model, and the Northstar, a heavy duty floor model available in one to eight spindles.

Our advanced model is our Master Carver series, which is an extremely heavy duty floor model with from eight to forty spindles.

Website: www.terrco.com
E-mail: info@terrco.com

Terrco, Inc.

222 1st Ave. NW
Watertown, SD 57201
USA
(605) 882-3888
Fax (605) 882-0778



Model T-110 Dupli-Carver



Model CM614 Sign Carver



Multi-Spindle Carving Machine

Circle No. 2175

Refinish Your Future.



Own your own business.

Let your passion for furniture lead you into a new business with a Furniture Medic franchise. We're a complete on-site repair and restoration-refinishing business servicing homes and companies as well as handling moving and insurance claims. We offer extensive training and support with a low initial investment and manageable overhead. Financing is available to qualified candidates and franchises are offered nationwide. Call today to brush up on the details.



FURNITURE MEDIC
"the prescription for beautiful furniture"

www.furnituremedic.com

1-800-WE SERVE

Circle No. 1520



Continued from page 99

Don't get teed off if you cut the wrong size hole in one

If you've ever built a computer desk or entertainment center, you've probably cut holes in your cabinetry to run cords. And you might have been disappointed to find that you had to enlarge those holes because the plugs wouldn't fit through them. But how do you enlarge them without butchering your work? The Oops Pilot Arbor

simplifies the chore by using the erroneous saw as a guide for a larger saw.

For example, I cut a 1½" diameter hole where I wanted a 2½" hole. After threading the 2½" saw onto my hole saw's main arbor and the 1½" saw



onto the Oops arbor, I then replaced the saw's pilot bit with the shaft of the Oops. The smaller saw perfectly piloted the larger saw into the cut (as shown in the inset photo). If you use a hole saw in your shop, you must have one of these dandy helpers. Besides sparing projects from the firewood pile, you also can use the Oops Pilot Arbor to saw wooden rings.

—Tested by Dave Henderson



PRODUCT SCORECARD

Starrett Oops Pilot Arbor G7267

Performance ★ ★ ★ ★ ★

Price \$6 plus shipping

Value ★ ★ ★ ★ ★

Available from Grizzly Industrial. Call 800/523-4777, or visit Grizzly online at www.grizzly.com.



INTRODUCING... KATANA™

The Cutting Edge Of Routing Technology

Safety, performance, and durability. NEW Katana® router bits are manufactured using the highest quality materials on precision multi-axis CNC grinders. They feature: premium micro-grain carbide cutters, high hook and shear angles for clean cutting, anti-kick-back rounded shoulders, an anti-stick coating, a diamond honed 600 grit mirror finish, SAE 4140 solid steel bodies, plus our Safety Gauge Shank™ for easy set up. Katana® brand bits come with a lifetime guarantee, backed by the MLCS reputation for customer service and product support.

FREE CATALOG!
1-800-533-9298



KATANA™ An MLCS Company
2381 Pittman Ave., Huntington Valley, PA 19006



3 PC. ROUND OVER
BEADING BIT SET
\$65 Order Set #12305
WOOD BOX INCLUDED

Circle No. 1360

New!

All Pro™

Professional Series Band Saw Blades

Heavy duty, commercial grade band saw blades.

For use in industrial, woodworking, and furniture manufacturing applications by professional woodworkers and craftsmen.

The most efficient, long lasting blades with induction hardened teeth for cutting wood, plastic, and non-ferrous metal.

Visit Your Olson Dealer and Ask for the New All Pro Blades.

OLSON™

THE OLSON SAW CO.
16 Stony Hill Road, Bethel, CT 06801
Manufacturers of Fine Quality Saw Blades Since 1918

Bandsaw guide throws resawing a gentle curve

A wandering bandsaw blade has cost many a resawing woodworker time and precious stock, but what's a guy to do? Straight fences offer solid stock support, but don't let you pivot the workpiece to account for blade drift. On the other hand, bullnose guides allow too *much* control. The FastTrak Bandsaw Resaw Guide strikes a happy medium between both.

Like a bullnose guide, this anodized aluminum accessory provides a single pivot-point for steering stock through the blade. But, its broad curved face gave me better control than a narrow bullnose. I felt almost as if I could micro-adjust the cut, with a wide swing of the workpiece yielding only a small adjustment in the blade path.

The Resaw Guide's positioning also helped me stay on top of the curve. The manufacturer recommends setting the crown of the guide slightly ahead of the teeth, which struck me as odd. However, with the guide positioned in this manner, I found I could steer the board precisely *into* the cut, rather than *out* of it.

T-slots on the back of the Resaw Guide make mounting it to your bandsaw's rip fence almost as smooth as the wood you'll cut with it. The 7"-tall guide works on virtually any stationary bandsaw, but if you routinely resaw narrow stock, the 4½"-tall version keeps your bandsaw's blade guides closer to your workpiece. ♣

—Tested by Dave Henderson

PRODUCT SCORECARD

FastTrak Resaw Guide

Performance ★ ★ ★ ★ ★

Price \$16, 4½" guide; \$20, 7" guide

Value ★ ★ ★ ★ ★

For more information, call toll-free, 888/327-7725, or visit the FastTrak website at www.dwave.net/~fasttrak.



Wood Workers...

Secure your tools & equipment with the Roll-Top-Cover™



1-800-413-8378 www.pace-edwards.com

Circle No. 1985

The Roll-Top retractable hard tonneau rolls up automatically to allow full access to your truck bed. The PowerBolt™ electric tailgate lock protects your tailgate from theft and secures the bed of your truck like the trunk of your car.

Pace Edwards... products for today's trucks!

Buy Factory Direct and Save Thousands!

Woodworkers Dreamshop



SAVE UP TO
\$5,000.00
ON STEEL BUILDINGS

SAVE THOUSANDS ON SELECT SIZES
25x34 • 30x46 • 40x56 • 50x116

Additional sizes available.
Proudly made in the USA.

- 20 Year Guarantee
- Build it yourself
- Maintenance Free
- 100% Useable Space

CALL TODAY
1-800-463-6062

FREE PRODUCT CATALOG
AND FACTORY PRICE LIST

www.us-buildings.com

U.S. Buildings

Circle No. 2030

BUTTERNUT

The walnut's country cousin

Everyone knows of the black walnut tree. Woodworkers love its wood. Bakers adore its nuts for the flavor given to bread, cookies, and pastries. And who hasn't enjoyed the challenge of picking the meat from a freshly cracked shell?

Did you know, though, that the black walnut has a cousin? It's the butternut (*Juglans cinerea*). And while its tan-colored wood rates just as beautiful in its own right, and its nuts equally satisfying, neither have become as well known.

Widely distributed across the north from New Brunswick to Minnesota and in the south to Arkansas and North Carolina, the butternut tree even looks somewhat like a black walnut. It never attains the walnut's

tall stature nor graceful shape, however. And rarely does it grow to the girth and straightness preferred by lumbermen. Even landscapers shun it because the leaves brown early in the fall. Yet to country people, the butternut has always been appreciated.

In pioneer days, chips of its wood were used to brew a tasty beer. The oil from its nuts went into recipes and ointments. A dark dye extracted from the tree's inner bark turned cloth brownish-yellow. In fact, during the Civil War, Confederate soldiers often wore homespun uniforms colored with butternut dye.

Butternut wood, although lighter and weaker than black walnut, has its special place in woodworking. Because of its lightness, luster, and

During the Civil War, Confederate troops often fought in uniforms dyed with the inner bark of the butternut tree.

satiny texture when sanded, butternut was once favored for paneling in carriages. It's also stable and easily worked, especially by carvers, so the wood was and still is the classic stock for church alters and lecturns. Today not widely available to the woodworking public, butternut becomes venter for the finest architectural installations and the wood of choice for many professional carvers. ♣

Illustration: Jim Stevenson



"All my tools should be this good!"

The **Accu-Miter®** is a professional miter gauge that makes perfect angles easily. Shot-pin action assures dead-on accuracy for common angles — plus a precise protractor scale for everything in between!

Optional accessories:
manual clamp-
pneumatic clamp-
3/8" x 3/4" miter bar-



We do not recommend operating without the saw blade guard, as is shown here.
US Patent #5,038,486

JDS COMPANY

Call or write for our free brochure.

Precision Woodworking Equipment

800 Dutch Square Blvd., Suite 200, Columbia, SC 29210
1-800-382-2637 / SC 803-798-1600
www.thejdscompany.com

\$149

Econ-Abrasives

WE MAKE ABRASIVE BELTS ANY SIZE, ANY GRIT!

Standard Abrasive Sheets

CABINET PAPER

	50/pk	100/pk
60D	\$17.58	\$31.58C
80D	\$16.42	\$29.26C
100 thru 150C	\$15.26	\$26.95C

FINISHING PAPER

80A	\$11.74	\$19.89C
100 thru 280A	\$10.50	\$17.58C

NO LOAD PAPER(white)

100 thru 400A	\$12.90	\$22.40C
---------------	---------	----------

C = 100 SHEETS

Velcro® Vacuum Discs

8 Hole pattern for Bosch sanders

Dia.	Grit	Price
5"	60	\$.48 ea
5"	80	.46
5"	100 thru 320	.45

* Available in 5 hole pattern *

*Wide Belts*Rolls*Flap Wheels
*Pump Sleeves*PSA Discs
*Router & Wood Bits*Wood Glue

ABRASIVE BELTS

Belts are resin bond cloth with a bi-directional splice, specify grits.

1X30	\$.81 ea	3X24	\$.93 ea
1X42	.81 ea	3X27	.96 ea
1X44	.81 ea	4X21 3/4	1.06 ea
2 1/2X16	.85 ea	4X24	1.10 ea
3X18	.86 ea	4X36	1.35 ea
3X21	.90 ea	6X48	3.50 ea
3X23 3/4	.93 ea	6x89	6.24 ea

OTHER SIZES ON REQUEST

HEAVY DUTY SPRING CLAMPS

Clamps come w/PVC tips and grips.

Size	Price
4"	\$1.75 ea
6"	2.25
8"	3.50

JUMBO ROUTER PAD(24" x 36")

It will not allow small blocks of wood to slip out under router or sanding applications.

ROUTER PAD
ONLY \$8.95ea.

JUMBO BELT CLEANING STICK
ONLY \$8.80

*MasterCard, VISA, Discover, Am. Express
*SATISFACTION GUARANTEED!!!

*CALL FOR FREE CATALOG
-TX add appropriate sales tax
-Call for shipping charges

Econ-Abrasives



P. O. Box W1628
Frisco, TX 75034
(972)377-9779

TOLL-FREE ORDERING LINE (800)367-4101

Hawaiian woodworkers show off island woods



RW Butts, Oahu, was awarded top honors in a recent "Woods of Hawaii" show for his 6'-9" five-panel screen. It contains 103 different island-grown woods in their natural colors and hues.

Say "Hawaii" and most mainlanders see images of endless white-sand beaches, roaring surf, ukuleles, and the hula. But the island state has quite a forest industry, too: one that generates annual revenues of nearly \$30 million.

To promote the industry and the sustainable management of the state's forests, the Hawaii Forest Industry Association holds a juried furniture and woodworking exhibition every September in Honolulu. Called "Woods of Hawaii," it's open only to Hawaii residents, and all woods used in entered projects must be from trees that grow there. Rules restrict usage of some woods, such as koa, to 10 percent of a piece and ban the use of rare and endangered woods. About 50 of the



A desk and chair by Tom Calhoun, Maui, features oak, mango, blue gum, eucalyptus, koa, kamani, and camphor woods. The set took Best of Show.

state's top woodworkers annually vie for several thousands of dollars in cash awards and the associated prestige of exhibiting.

For more information on the exhibit or Hawaii's forests, write Hawaii Forest Industry Assoc., P.O. Box 10216, Hilo, HI 96721.

Coming: carving's class act

The world's largest and most prestigious show of wildfowl carving opens in Ocean City, Maryland, on April 28. Besides thousands of carvings of ducks, geese, song birds, shore birds, falcons, and other wildfowl, the 2000 Ward World Championship Wildfowl Carving Competition features classes, demonstrations, free seminars, art auctions, food, music, and more than 100 exhibitors' booths. For the 30th

anniversary of this three-day event, organizers have added a special exhibition. "A Carving Competition Retrospective: 30 Years in the Making" shows the evolution of wildfowl carving.

For more information, contact The Ward Museum of Wildfowl Art, 909 So. Schumaker Dr., Salisbury, MD 21804-8722. Phone 410/742-4988, or e-mail to ward@wardmuseum.org

Photographs: Courtesy Woods of Hawaii and The Ward Museum of Wildfowl Art

"Green" wood grows slowly

You probably don't come in daily contact with certified or "green" wood. And you most likely couldn't tell the difference between it and other wood anyway. Certified wood doesn't look any different. But the forests it comes from are different.

A certified forest managed for sustained yield never looks like it's been logged. It still has big trees, medium-size trees, and little trees growing for the future, rather than lots of large stumps. But the certification process required to label wood and wood products as coming from environmentally friendly forests (managed for a continual supply of trees) happens to be a lengthy and expensive one. So it's not surprising that only about four million acres out of approximately 228 million acres of commercial forest in the United States have so far been certified.

Yet, certified forest acreage (about 40 million acres worldwide) continues to grow because it's coupled with the public's increasing concern for the future of forests. And the demand for products from certified forests grows, too. You'll find certified architectural hardwood veneers, hardwood and softwood plywood, as well as lumber, doors and millwork, flooring, cabinets, home and office furniture, and even musical instruments. "Green" wood eventually will be showing up at your local home center, too, so keep an eye out for it. ♣



"Open Water" by John T. Sharp won the Ward World Championship 1999 Best in World award in Interpretive Wood Sculpture. Sharp carved his work in black walnut.