

Better Homes and Gardens®

WOOD

THE WORLD'S LEADING WOODWORKING MAGAZINE
APRIL 1998 ISSUE 105

9 PRODUCTION SHOP TRICKS

**Speed up your
woodworking with
help from the pros**

Build our

CORNER ENTERTAINMENT CENTER

Plus

- Apple-motif patio chair
- Desktop wind chime
- Computer media box
- Combination square

<http://www.woodmagazine.com>



Display until April 6

Better Homes and Gardens®

WOOD®

THE WORLD'S LEADING WOODWORKING MAGAZINE

CONTENTS



Page 70



Page 42

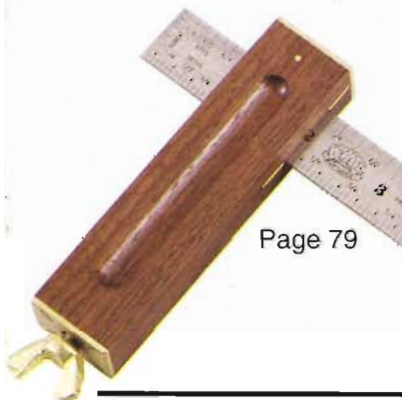

Page 79

33 Wood profile: boxelder

Pink streaks give value to this low-grade wood.

37 The woodworker and the hotel

Meet a craftsman who single-handedly restored a classic Victorian hotel in Durango, Colorado.

48 Nine production-shop tricks

Discover time-saving ways to make multiple project parts from folks who do it for a living.

54 Gel stains

Find out where gel stains perform best, and when not to use them.

56 The WOOD gang makes music

See the results when staffers test-build guitars and a mountain dulcimer from mail-order kits.

70 Midsized fixed-base routers

Check out the latest models in the marketplace and what features make a difference.

Woodworking projects

42 Nice and easy patio chair

Build a handsome, weather-tough chair or two to complement outdoor living areas.

60 Craftsman-style computer center

Fill a corner in your home office with this stylish three-piece set, drawers included.

68 Data central

Store CDs and floppies in an efficient flip-top tower that stands neatly on your desk.

76 Music in the wind

Ring in the balmy days of spring and summer with this perfectly-tuned wind chime.

79 Adjustable square

Craft this precision tool for your measuring and marking needs.



Page 54



Page 68



Page 76

SHORT-SUBJECT FEATURES

2 The Editor's Angle

4 Talking Back

9 Great Ideas For Your Shop

10 Project Showcase

16 Ask WOOD

20 Tips From Your Shop (And Ours)

30 Wood Anecdote

84 Trees For Profit

92 Products That Perform

104 Finishing Touches

Editor **LARRY CLAYTON**
 Managing Editor **JIM HARROLD**
 Art Director **C. L. GATZKE**
 Design Editor **JAMES R. DOWNING**
 Senior Editor/Features **PETER J. STEPHANO**
 Senior Editor/How-To **MARLEN KEMMET**
 Assistant Managing Editor/Products **BILL KRIER**
 Senior Editor/Special-Interest **LARRY JOHNSTON**
 General-Interest Editor **DAVE CAMPBELL**
 Associate Art Director **PERRY A. McFARLIN**
 Assistant Design Editor/Project Builder **JAN HALE SVEC**
 Project Builder **CHARLES I. HEDLUND**
 Senior Graphic Designer **CHERYL A. CIBULA**
 Production/Office Manager **MARGARET CLOSNER**
 Administrative Assistant **SHERYL MUNYON**
 Art Business Office Secretary **BARBARA HELPS**
 Correspondence Writer **ROBBY PEDERSEN**
 Contributing Editors **KIM DOWNING, DAVE HENDERSON,
 LORNA JOHNSON, ROXANNE LeMOINE, BOB McFARLIN**

©Copyright Meredith Corporation 1998
 All rights reserved. Printed in the U.S.A.

Better Homes and Gardens® **WOOD**® magazine (ISSN-0743-894X) is published nine times a year in January, February, March, April, June, August, October, November, and December by Meredith Corporation, 1716 Locust St., Des Moines, IA 50309-3023. Periodicals postage paid at Des Moines, Iowa, and additional mailing offices. Better Homes and Gardens trademark registered in Canada and Australia. Marca Registrada en México. **ONE-YEAR SUBSCRIPTION PRICES:** U.S. and its possessions, \$27; Canada, \$39; other countries, \$47. Canadian GST Reg. #BN 12348 2887 RT. **POSTMASTER:** Send address changes to *Better Homes and Gardens WOOD Magazine*, P.O. Box 55050, Boulder, CO 80328-5050.

CUSTOMER SERVICE INFORMATION: For service on your magazine subscription including change of address, phone toll-free **800/374-9663**. Or, write to *Better Homes and Gardens WOOD Magazine*, P.O. Box 55050, Boulder, CO 80328-5050. Please enclose your address label from a recent issue.

EDITORIAL INFORMATION: Address letters and questions to THE EDITOR, *WOOD Magazine*, 1912 Grand Avenue, Des Moines, IA 50309-3379.

ATTENTION RETAILERS: To carry *WOOD Magazine* in your store, call 800/659-5990, or write: Select Title Program, *WOOD Magazine*, 900 Kingsland, Batavia, IL 60510.



Better Homes and Gardens®

WOOD Online™
 at <http://woodmagazine.com>

Thinking about spring cleaning? During a busy winter of woodworking, chances are you ran across some tools you don't use much anymore. Or maybe you still have some perfectly useful stuff you stashed away when you upgraded. Instead of letting those excess tools take up valuable shop space, turn them into cash. Click over to the Classified Ads on **WOOD ONLINE**, where you can quickly post an ad to sell the things you no longer need. While you're there, you may find a bargain on something you do need, too. ♣

THE EDITOR'S ANGLE

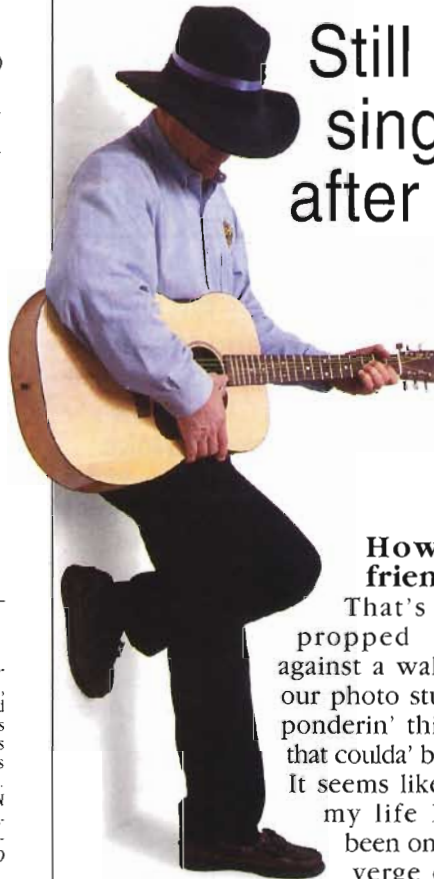

Still a frustrated singer/musician after all these years...
but there's
HOPE!

Howdy friends!

That's me propped up against a wall in our photo studio ponderin' things that coulda' been. It seems like all my life I've been on the verge of a satisfying musical career, and then at just the last

I'm thinkin' 'bout a promisin' musical career that for some reason just never took off.

moment, reality intrudes.

Take, for example, back in grade school, I was getting along just fine in Mrs. Young's piano class, until that first recital when I looked around and I was the only boy there. I quit and took up Whiffle Ball.

Things went better in high school and college during which time I gave it my all in choir and glee club. In a crowd I sounded pretty good, but there were two problems—I couldn't play an instrument and couldn't remember the words to any songs.

So I went back to tickling the ivories and took lessons for about six years. But after all was said and done, I was just fair. "Maybe I should take up another instrument," I thought.

Enter the guitar. It has only six strings, and that encouraged me enough to buy *The Complete Guitar Player* by Russ Shipton. I caught on to the D, E, and A chords pretty well, but then work got in the way and I stopped practicing. Color me unfulfilled.

Then I got what could turn out to be my big break. Not long ago, *WOOD*® magazine's features editor Pete Stephano asked me if I wanted to be one of three staffers to build an instrument for an article in this issue called "The *WOOD* Gang Makes Music From Kits."

Here it was at last; a great opportunity to break into the music business—from the ground up. A couple of weeks later, I received a guitar kit, along with a note from Pete telling me I had to have the instrument built in about three weeks.

Along with *WOOD* magazine's senior graphic designer Cheryl Cibula and assistant design editor/project builder Jan Svec, I plunged in with great enthusiasm. And, believe it or not, we finished with time to spare. You can read about our exploits on *pages 56-59*.

Now that I've got my foot in the music-industry door and have proved to myself that I can build a good-quality instrument, anything can happen, don't you think? But just in case fate steps in again, I think I'm going to keep my day job. ♣

Larry Clayton

For that
"SPECIAL"
project

See Us In
Booth #3654
IWF Atlanta
Aug. 22-25



IN STOCK
NO
MINIMUM
VARIOUS
WOODS



Kits Ready to Assemble &
Finish

FREE
COLOR
CATALOGUE



Adams Wood Products, LTD. LP.
974 Forest Dr., Dept. M 34
Morristown, TN 37814 • Phone (423) 587-2942

Circle No. 1002

Better Homes and Gardens

WOOD Advertising
& Marketing
THE WORLD'S LEADING WOODWORKING MAGAZINE

Publisher **WILLIAM R. REED**
Advertising Director **MARK HAGEN**
Manager, Marketing and New Business Development
CATHERINE BJORK
Asst. Advertising Services Supervisor **PAT HENDERSHOTT**

Display Advertising: 333 N. Michigan Ave., Suite 1101, Chicago, IL
60601 Phone: 312/853-2890 FAX: 312/580-7906
Eastern Advertising Manager **JAMES N. FORD**
Western Advertising Manager **WILL MURPHY**
Administrative Assistant **GERALLIE LEGASPI**

Direct Response Advertising: 1912 Grand Ave., Des Moines, IA
50309-3379 Phone: 515/284-3785 FAX: 515/284-3343
Direct Response Advertising **CINDY ANDERSON**,
PATRICK MADDEN
Administrative Assistant **KRISTI HASEK**
Classified Advertising: Phone: 800/424-3090 FAX: 312/464-0512

Circulation Director **LIZ BREDESON**
Associate Circulation Director **KATHI PRIEN**
Business Manager **JANET DONNELLY**
Senior Product Manager **RICK GROW**
Publishing Director **MAX RUNCIMAN**

MEREDITH PUBLISHING GROUP

CHRISTOPHER M. LITTLE, President
BILL MURPHY, Custom Marketing; **JERRY KAPLAN**, Group Sales;
MAX RUNCIMAN, Controller; **BRUCE HESTON**, Manufacturing;
HAL ORINGER, Circulation; **DEAN PIETERS**, Operations



WILLIAM T. KERR, Chairman and Chief Executive Officer
E. T. MEREDITH III, Chairman of the Executive Committee



TALKING BACK

Check the first keyless chuck

In your issue #100 article "The Evolution of Power Tools" you noted that in 1986 "Sears Craftsman brings out the industry's first electric power drill with a keyless chuck."

About 1948, I purchased a Cummings model 190 1/4" "General Utility" electric drill with a Jacobs Model 4165 keyless chuck. This was my first power tool, and it still works. It came in a metal case with a set of bits, a disc-sanding adapter, sanding discs, a grinding wheel, and a frame that allowed mounting the

drill to a bench top. There is a knurled wheel behind the chuck to hold while tightening or loosening the chuck. Additionally, the manual warned not to use wrenches on the wheel or chuck, but it usually took a pipe wrench to loosen the chuck after it had been run a while.

—Jerry Nicholson, Wichita, Kan.

Pipe wrench or not, maybe Cumming's "keyless" chuck was about 38 years ahead of its time. Every new invention does have to start somewhere.

How to know when you're almost full

I must say that your homemade "Cyclone" (issue #100) certainly encompasses all one's needs in a basement-type dust collector. It's

compact, quiet, inexpensive, and fairly easy to make. Congratulations to Mr. Svec and all who helped to bring his creation to life.

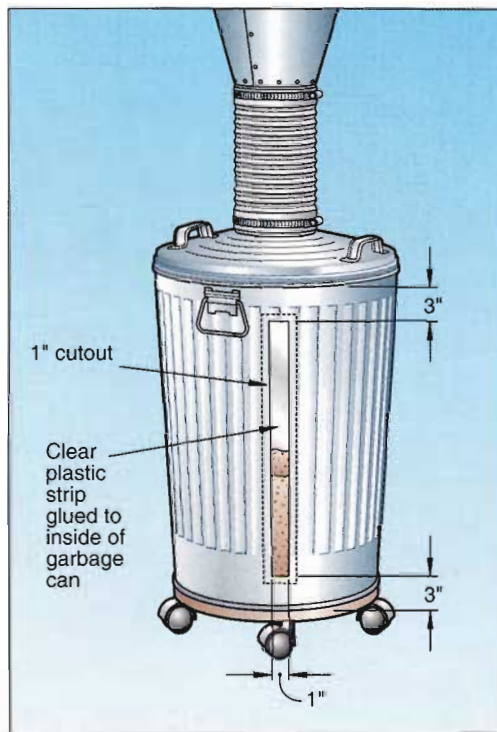

However, I noticed that you use a clear, flexible hose to attach the bottom of the Cyclone to the garbage can that "lets you see when the can is full." Trouble is, the can would then be over-full.

Instead, I suggest cutting out a narrow vertical opening (one inch) in the side of the garbage can, beginning about 3" from the top of the can, and ending about 3" from the bottom. Then, using construction adhesive, attach a strip of clear plastic to the inside of the can, overlapping the cut-out section as shown left. This strip must be sealed air tight. Now you have a window that lets you see how full the can really is.

—Rich Lacey, Willowick, Ohio

Let us know what's on your mind

We welcome your comments, criticisms, suggestions, and yes, even compliments. We'll do our level best to respond to you, perhaps on this page!

Write to us at: Talking Back, WOOD Magazine, 1912 Grand Ave., Des Moines, IA 50309-3379. Send e-mail to: woodmail@woodmagazine.com

Continued on page 6

A jigsaw puzzler

I enjoy your magazine very much and especially liked your piece in the November 1997 issue, "The Amazing Evolution of Power Tools." However, you mentioned that German Albert Kaufmann equipped his wife's sewing machine with a saw blade in 1946 to cut curves and invented the jigsaw. I believe the year indicated is incorrect, as I owned a Sears Craftsman 24" jigsaw manufactured in the late 1930's. I think you had better check the year in which Herr Kaufmann invented his saw.

—Philip Conrad, St. Louis

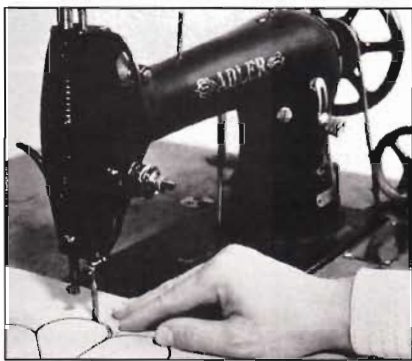

We received several letters like yours, Phil, so we decided to recheck our research. It turns out that in the early years, the term "jigsaw" was used to describe many of the machines that were used to cut curves. But, as tools evolved with the aid of electricity, those machines with the rocking arms that many of you remembered from the 1930's are today called scrollsaws.

It wasn't until Kaufmann's adaptation of the sewing machine, though, that a company would market the first electric hand-held saw that we now refer to as the jigsaw. The so-called Lesto jigsaw was first produced in 1947. The tool proved to be very popular in the 1950's as craftsmen began to realize the advantages of this new technology. Recently, the power tool division of Bosch, which gained a majority share in Kaufmann's company (Scintilla AG) in 1954, celebrated the 50th birthday of the jigsaw.

Sometimes I still prefer my Delta

When you evaluated scrollsaws in the October 1996 issue, you omitted two important criteria. Based on your review, I purchased an Excalibur EX30. I love my EX30, and in many ways it is the king of scrollsaws and deserves the rating you gave it. Yet, when it comes to cutting thick stock and ease of maintenance, my inexpensive Delta 40-560 has the advantage.

First, a scrollsaw should be able to cut evenly in thick wood. I immediately discovered a problem in cutting thick material with the EX30. When I cut stand-up puzzles from 1½" stock, the EX30 does the job less than perfectly, and the wood binds when I attempt to separate the pieces. Yet, when my Delta does the same job, there's no binding.

Also, you should look at ease and frequency of maintenance, such as the need for lubricating the parts. The bushings on my Excalibur need to be oiled after each use, while the bushings on my Delta only need attention after every 20–30 hours of operation.

—Douglas Behm, Worcester, Mass.

With the proper adjustments, Doug, your Excalibur EX30 should cut thick stock as well as your Delta, though not as quickly. In our tests, the Delta 40-560, with its parallel-arm design, did cut more aggressively than the Excalibur EX30, which has a parallel-link arm design. This means that if you feed stock too rapidly when using the EX30, the blade will tend to bow, knocking the cut out of square.

Also, because the Delta has a slightly longer stroke, dust clears the blade better. The cutting action of the EX30 tends to trap dust when cutting thick stock, but it also allows you to cut exceptionally tight curves and helps make it a smooth operator. However, you can adjust the lower arm of the EX30 to cut more aggressively. But, then you can't cut those exceptionally

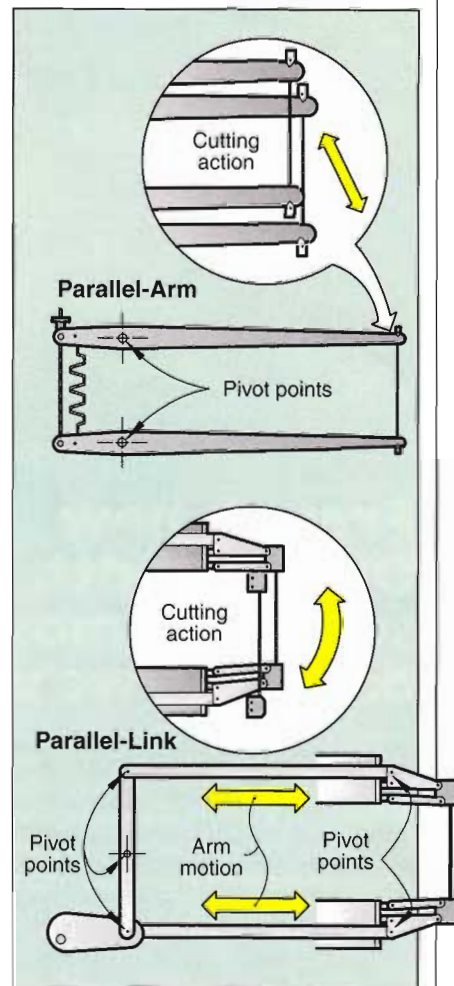

tight curves (a job at which the EX30 excels) as well as with the less aggressive setting.

It's also important to periodically tune even the best machines to make certain you keep getting square cuts. In a scrollsaw, the blade needs to be bidirectionally squared to the table (front to rear and side to side) to ensure square cuts in thick stock.

It's true that the Excalibur requires significantly more maintenance than the Delta. But, the Excalibur is a more complex machine. In our tests, the EX30 offered the smoothest performance with virtually no vibration. Excalibur recommends the frequent lubrication to help maintain the EX30's peak performance. ♣

HANG-IT-HERE Hose/Cord Holder



Shop-vacuum hoses have a way of unwinding on their own, creating a hazard underfoot. To keep yours in check, build our IDEA SHOP™ 3 hose holder.

When you install the mounting screws in the pegboard, just snug them up since overtightening will easily strip out the pegboard.

2" (distance between pegboard holes)
END VIEW
DETAIL

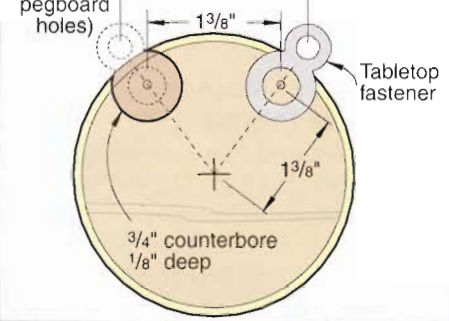

Project Design: Ery Roberts
Photograph: Bill Hopkins
Illustration: Roxanne LeMoine

5/16" hex-head sheet metal screw 1" long
#8 x 1 1/4" F.H. wood screw
3/4" counterbore 1/8" deep with a 7/64" pilot hole centered inside



#8 x 1 1/4" F.H. wood screws

Tabletop fastener

3/4"-thick stock
3" I.D.-PVC pipe 6 1/2" long

5/32" shank holes, countersunk

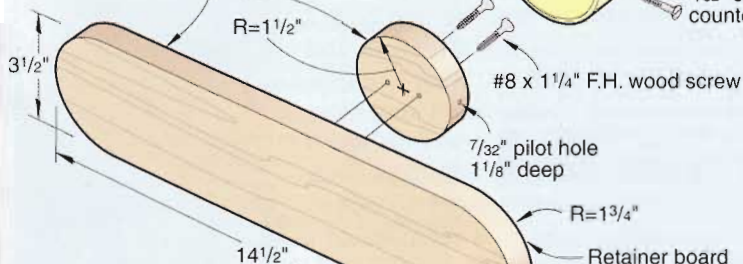

The
Professional's
Choice

for over 60 years

Tech Service
1-800-347-GLUE

Customer Service
1-800-669-4583

©1998 Franklin International

Project Showcase

We feature your best work



Cherry clock case displays authentic design, joinery
Leonard Marschark designed and built this Pennsylvania tall clock, incorporating design elements of the late Chippendale period (circa 1800). The cherry wood came from a tree felled 40 years ago in the Pocono Mountains. Joinery follows tradition, except where modern adhesives and materials improve durability without affecting appearance. Leonard lives in Bedminster, Pennsylvania.



Jewelry box features curved drawer fronts
 A single piece of walnut yielded the curved drawer fronts for this jewelry cabinet designed and built by **Jack Horrocks** of Cincinnati, Ohio. He bandsawed the fronts, then sanded them to final contour with a drum sander and template. A production machinist for General Electric, Jack invested about 75 hours in building the 10 $\frac{3}{4}$ "-tall box. He lined the drawers with antique red velvet, and finished the box with tung oil.



Intarsia from the Mojave reflects desert theme
A.C. Enderle created this intarsia featuring a buffalo skull. Sawn from no. 2 pine and sanded to shape, the individual pieces of the design range from $\frac{1}{8}$ " to $\frac{3}{4}$ " in thickness. Stains provide color accents, with polyurethane for the overall finish on the 16 $\frac{1}{2}$ ×20 $\frac{1}{2}$ " picture. A retired U.S. Marine now living in Barstow, California, A.C. has been making intarsia for about 15 years.

Cherry chest affords superb silverware storage
 When **Will Weatherholtz** started building this Charleston silverware box, he had only a postage stamp-size picture for direction and inspiration. Will, of Moorefield, West Virginia, constructed the classic dining-room accessory from native West Virginia cherry, finished it with tung oil, then waxed it. The box measures 14×9×8". Will, a semiretired toxicologist, pursues woodworking as a member of a West Virginia crafts cooperative.



Continued on page 12

Project Showcase Continued from page 10



Kansas carver fashions saddle for carved horse

Lots of carvers would consider the project done after finishing a 32"-tall, 58-lb. oak horse. But not **Larry Dixon** of Burdett, Kansas. He went on to carve this walnut western saddle for it. Hewn from a 12x12x6" glue-up, the saddle features silver conchas, sail-twine stitching, and wood-burned texture.



Cabin cruiser built from scrapwood and castoffs

William J. Dokupil of Stover, Missouri, builds wooden boats. The retired GM design draftsman built this cabin cruiser mostly from scrap. Oh, maybe we should mention that the craft measures 60" from stem to stern. A junked car's heater blower motor powers the radio-controlled cruiser.



Evenings at school result in walnut jewelry armoire

Working evenings in adult-ed classes, **Nancy Kimber** of Highlands Ranch, Colorado, built this 50"-tall walnut jewelry armoire in 18 months. The hinged sides hide pegs for necklaces, and Nancy cross-stitched the top inlay. A woodworker for three years, the computer programmer says her non-woodworking husband teases her over her "unfeminine" hobby.

First-year woodworker re-creates Scottish classic

Chris Pappas had been woodworking for about a year when he built this oak rendition of a hall table designed in 1904 by Charles Rennie Mackintosh, an innovative Scottish architect, designer, and artist. Chris,



working from photographs, patterned some parts from cardboard first to work out proportions. The table-top measures 25x54". Chris, a retired customs inspector, lives in Richmond, Virginia.

SHOW US YOUR STUFF

Show us your best original work (but, no decks or other home improvements, please). Items built from kits or directly from published plans are ineligible, as are carvings from roughouts. To submit your project for consideration:

- Send sharp color slides or glossy prints of the item. (We can't use Polaroid photos.) Avoid cluttered or busy backgrounds in your shots. Photos cannot be returned.
- Explain what the project is or what it does—we don't want to call your lamp table a plant stand. Describe its features,

wood, finish, and overall dimensions.

- Tell us a little about yourself, too: how old you are, your occupation (or former one, if you're retired), how long you've been a woodworker, and so forth. Include a daytime phone number.
- Send everything to:

WOOD® Magazine
Project Showcase
1912 Grand Ave.
Des Moines, IA
50309-3379

Note: We cannot provide plans, drawings, patterns, measurements, bills of materials, additional photographs, descriptions, or construction details for projects shown here. Nor can we pass out addresses or telephone numbers for Project Showcase exhibitors.

Do batteries catch cold?

I'm planning to buy a cordless drill in the near future, and was wondering if it will hurt the batteries to store them in an unheated garage, or if they should be kept in the house? It can get cold here in Iowa!

—Gary, Iowa, via internet

Gary, we talked with the folks at Eveready, who make nickel cadmium batteries for several tool companies. They said that storing batteries in the cold (down to -40° Fahrenheit) will not harm them. But, they won't perform as well or take as good a charge in a place that is below freezing. They suggest that you charge them in the house.

Blades, blades, and more blades

Well, I finally bought a contractors saw. Now what do I do about blades? As a novice woodworker I'm mainly building projects (cabinets and bookcases) from plywood. Is a combination blade the way to go? Do I need to change to separate ripping and crosscutting blades when working the occasional piece of hardwood?

—Scott Adelman, via internet

With all of the choices in saw blades, Scott, it's easy to be confused about which one to buy. Unfortunately, there isn't one blade that's perfect for all situations. And while most blades will cut through many types of material, they all have their specialty. Here, and in the drawings *right*, is a quick guide to the four basic types of carbide-tipped circular saw blades.

The Flat Top (FT) blade has deep gullets and an aggressive hook angle, which makes it great for fast, heavy-duty ripping. However, the FT isn't great for crosscutting or for use on particleboard, plywood, or any other material that can easily chip or splinter.

Alternate Top Bevel (ATB) blades produce a smooth crosscut in most wood and composite materials. Steep angled tips will cut smoother, but dull more quickly. A 40-tooth blade of this type is a good general crosscutting blade. ATB blades, (as with other blades) with more teeth will cut more smoothly, but at a slower feed rate.

If you could have only one saw blade, we would go with an Alternate Top Bevel

& Raker (ATB&R). You'll find this tooth configuration on most combination blades. They make reasonably smooth rips, miters, and crosscuts in hardwoods, softwoods, plywood, and wood composition materials. These blades are designed with various degrees of angle on the bevel grind. Extremely high angles cut plywood without chipping, but once again, dull more quickly than lower angles.

Triple Chip (TC) blades cut a wide range of alternative materials such as acrylic, plastic laminates, and other hard abrasive materials. Other blades cut wood more smoothly, but TC blades are durable and do not dull as quickly when working with a wide range of materials.

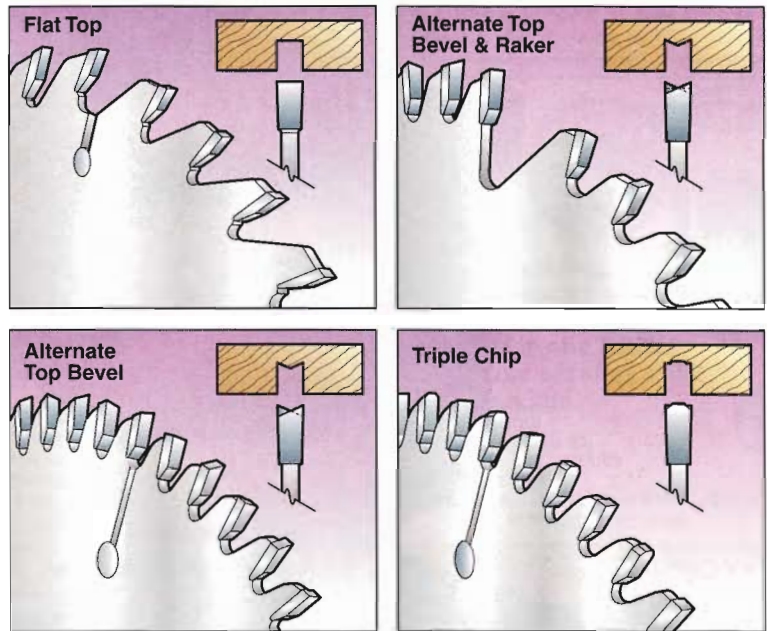

Do you have a question for our woodworking experts?

No matter how simple or perplexing your woodworking problem, we would love to hear from you. We'll do our level best to solve your mystery, and you might even

find your question and our reply on this page.

You can write to us at: Ask WOOD®, 1912 Grand Ave., Des Moines, IA 50309-3379.

Send e-mail to: woodmail@woodmagazine.com

Or, visit our internet page and join one of our discussion groups at: <http://woodmagazine.com>

Continued on page 18

One Stop Wood Shop

- Plywood & Veneer made to order (no min.)
- 30 species
- Custom Cutting
- Competitive Pricing
- We bundle & ship to U.S. & Canada
- Over 65 years of personal service

For catalog & quote: (617) 666-1340

Boulter Plywood Corp.

24-WD Broadway, Somerville, MA 02145

Where the finest cabinetmakers select & blend domestic & exotic hardwood in plywood, veneer & lumber.

WOOD

Circle No. 512



The All New T50PBN STAPLE + NAIL GUN



It Packs A One-Two Punch It Staples! — It Nails!

Meet the 21st Century ARROW T50PBN

- All Steel Construction with long lasting chrome finish.
- Easy Squeeze double leverage mechanism for professional performance with no loss of driving power.
- Cushioned Non-Slip Hi-Viz Handle. Comfortable to use. Easy to locate.
- Visual Refill Window tells you when to reload.

Packs a Double Wallop

- The new T50PBN shoots 6 different size staples: 1/4", 5/16", 3/8", 1/2", 9/16", and 17/32" Ceiltile staples. You can handle any job from upholstering a chair to insulating basements and attics.
- It also drives a 5/8" nail so you can decorate a door panel, build a picture frame, or create doll houses and toys for the kids.
- ARROW T50PBN. Solid. Reliable. Perfect for the handyman, the professional, and the hobbyist. You work hard for your money, spend it wisely.

ARROW tools and supplies are available at home centers, lumberyards and hardware stores.



ARROW FASTENER COMPANY, INC., 271 MAYHILL STREET, SADDLE BROOK, N.J. 07663
ARROW FASTENER (U.K.) LTD., 14 BARCLAY ROAD, CROYDON, SURREY CR0 1JN
JARDEL DISTRIBUTORS, INC., 6505 METROPOLITAN BLVD. EAST, MONTREAL, QUEBEC H1P 1X9
website: www.arrow-fastener.com

© 1998 ARROW FASTENER CO., INC.

ASK WOOD

Continued from page 16

Getting a handle on tooth hook

Could you explain the negative hook and positive hook on saw blades? I recently heard something about using negative hook blades on radial arm saws and positive hook blades on tablesaws. Is it safe to use them in an either/or application? What are the pros and cons? And, how do I recognize a negative or positive hook?

—Frank Zarowny,
Regina, Saskatchewan

Positive and negative hook has to do with the angle of the tooth in relationship to the centerline of the blade. A "positive hook" pitches forward as shown *below*. A tooth that is "in line" with the blade center has "no hook," and a blade that pitches backward has a "negative hook."

Basically, the more positive hook a blade has, the more aggressively it will cut. Also, the more aggressive the cut, the better the chances for problems with kickback. Because radial arms and sliding miter saw blades try to "travel" through the material, the less aggressive cut of negative hook blades make these saws somewhat safer to use by helping you control the speed of the cut. ♣

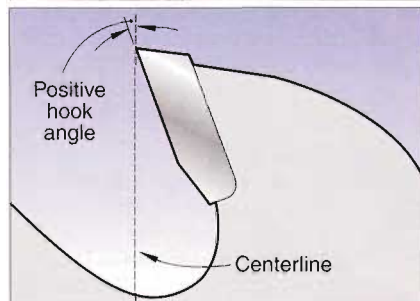
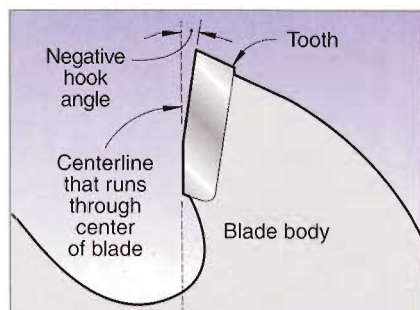



Top-tip-winner Patricia Kaufman built and installed the cabinets in her completely remodeled kitchen.

This issue's top shop tip winner came into woodworking by way of her passion for home remodeling. A true super mom, Patricia Kaufman works at a preschool in the mornings, spends afternoons with her young children, and still finds time to remodel her family's 3,900-square-foot home.

"Although this is our second major remodeling, my husband has little or no interest in it," says Patricia. "I'm doing every room, ceiling to floor, so I've had to make a lot of cabinets, doors, drawers, and trim moldings in the process. If I had come up with the idea (right) about a year earlier, I would have saved a fortune in molding cost."

Your solution to a woodworking problem may be worth \$40. If we select your idea as the Top Shop Tip, you'll win a tool prize valued at \$250 or more, and we'll include your photo in this column. To submit a tip, send a letter, including your daytime phone number, with a photo or drawing of your idea, to:

Tips from Your Shop (And Ours)
 WOOD® Magazine
 1912 Grand Ave.
 Des Moines, IA 50309-3379

Dave Campbell
 GENERAL-INTEREST EDITOR

Holding molding

A long time ago I bought a 2¼" molding bit for my router, but I never had much luck using it on my router table. The bit made irregular cuts in the wood and I just didn't feel safe using it.

Several months ago I decided to build a playhouse. All the doors and windows needed to be trimmed out, and since I didn't want to spend a lot of money on precut moldings, I decided there had to be a better, safer, and more stable way to run this bit.

My solution was to rip my boards down to the 2¼" width that I needed, then clamp each

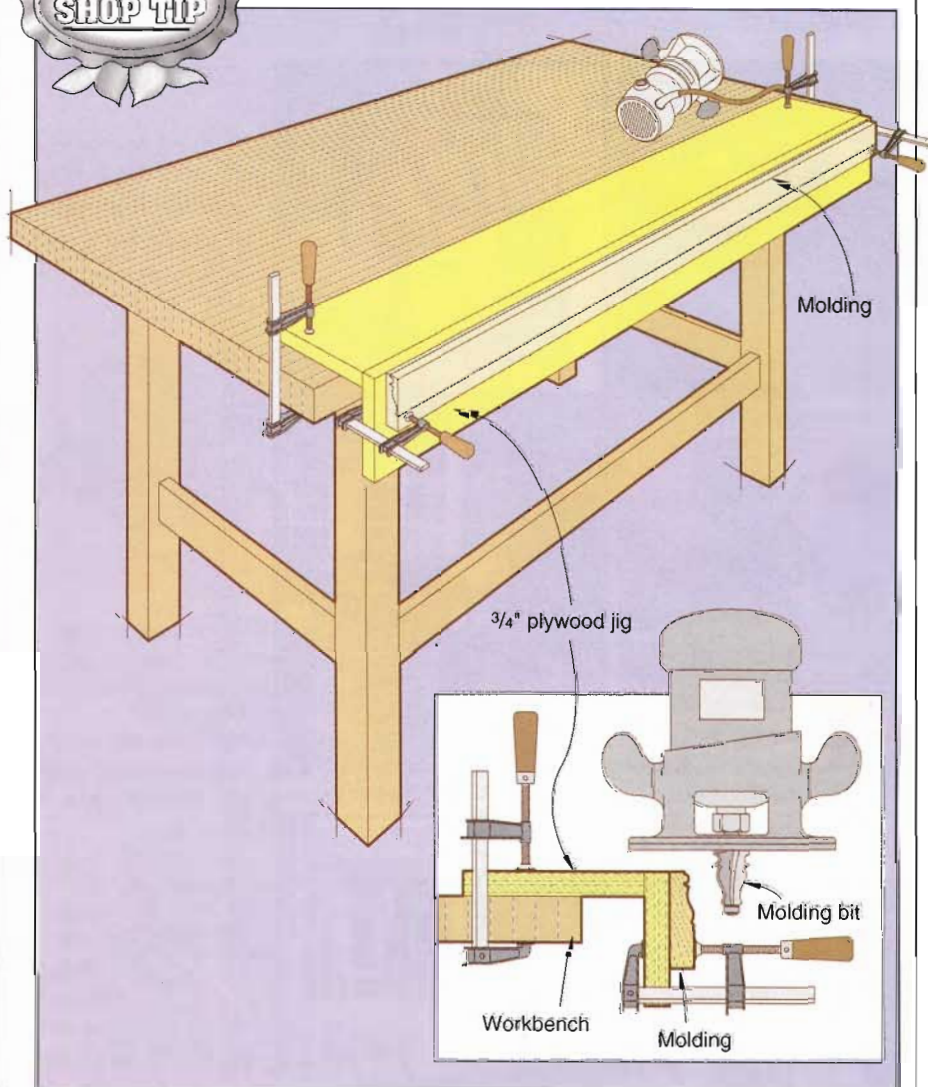

Patricia Kaufman earns The Sommerfeld Cabinetmaking Set with instructional video from CMT USA for submitting this issue's top shop tip.

one to the front edge of a jig clamped to my workbench as shown below. Then, I proceed to run my router down the boards in several passes. This gives me beautiful finished moldings, and I was able to sand them before unclamping them from the jig.

—Patricia Kaufman, Lewiston, Idaho

Continued on page 22

Continued from page 20

How to safely cut the lid from a closed box

One big problem with cutting the lid from a closed box on a table-saw is that the box and lid become more unstable as subsequent cuts are made. The bigger the box, the more potential for binding and gouging, and the more dangerous the operation becomes.

For several years I've been making boxes as small as 4" square and 2" deep for jewelry and other small pieces, and as large as 16"×2'×4' for blankets and toys.

For safe, stable lid cuts, I raise the saw blade to the correct cutting height (slightly greater than the stock thickness) and cut the two long sides first. Next, I apply a small amount of hotmelt glue to each kerf, where shown in the inset illustration *right*. I then make the end cuts and separate the box and lid by cutting the glue with a sharp utility

knife. I also use the knife to peel or shave away the glue before sanding to remove the saw marks.

—John Asb, Lockport, Ill.

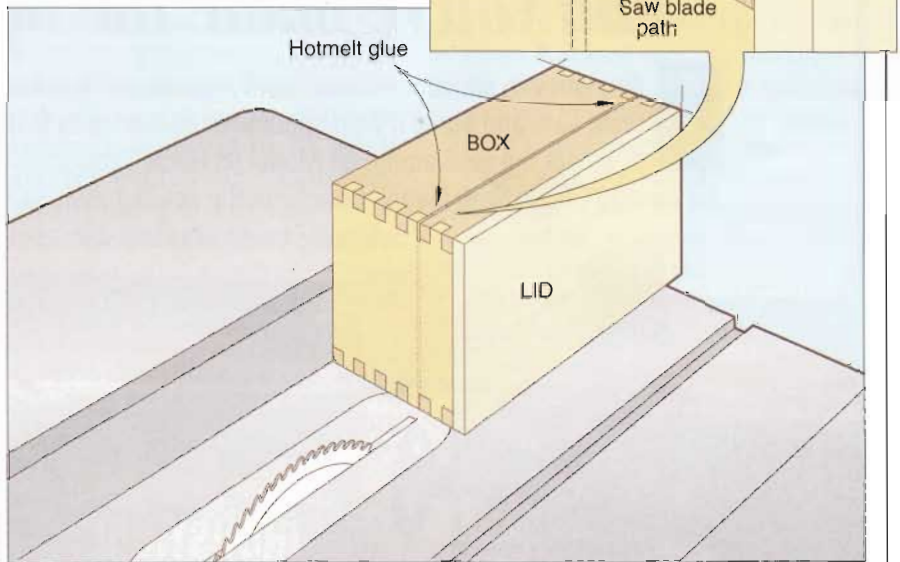

Continued on page 24

**A
breakthrough
in wet/dry vac
filter
performance**

From the makers of
GORE-TEX® Fabric

Traps five times more fine dust than ordinary wet/dry vac filters

Even drywall dust. Tests prove CleanStream® Filters trap 99.7% of all particles at 0.3 microns, compared to less than 20% for conventional filters.

Truly washable for longer life

CleanStream® Filters shed dirt with a simple rinse under running water. By combining moisture-resistant material with exclusive "non-stick" technology, they resist clogging and won't degrade when used to vacuum liquids.

Fits all major brands of wet/dry vacs

Whether you currently use a cloth disc, cartridge or bag filter, there's a CleanStream® Filter to replace it— with no modification to your wet/dry vac. Plus, each filter carries a full one-year limited guarantee.



Buy CleanStream® Filters at your local home center or hardware store, or call **1-800-758-6755**.



CleanStream®
WET/DRY VAC FILTER



Trips to the lumber yard will never be the same with the...



PACE EDWARDS ROLL-TOP-COVER™

This durable hard tonneau cover gives your truck added security with style and retracts in seconds to give you full use of your truck bed whenever additional space is needed.

Roll-Top...We've got you Covered!

www.pace-edwards.com

for more information call toll free 1 888 ROLL-TOP

Circle No. 1985

TIPS FROM YOUR SHOP (AND OURS)

Continued from page 22

Paint rollers make great drill-press buffers

After finishing a number of the Fish Key Rings featured in the January 1997 issue of *WOOD*® magazine, I used my drill press to buff them to a nice shine. First, I cut a 9" paint roller cover to the same length as my sanding drum. (It's important to use a high-quality cover with a phenolic plastic core.) Next, I sand the inside of the roller pieces with a 1" sanding drum until they would fit over a 1½" sanding drum.

I apply my buffing medium with one of the paint roller sections, then buff it off with another roller section. A roller with a ½" nap worked fine for me. You also could use this technique for polishing metal pieces such as jewelry and hardware.

—Steve Prensley, Ronkonkoma, N.Y.

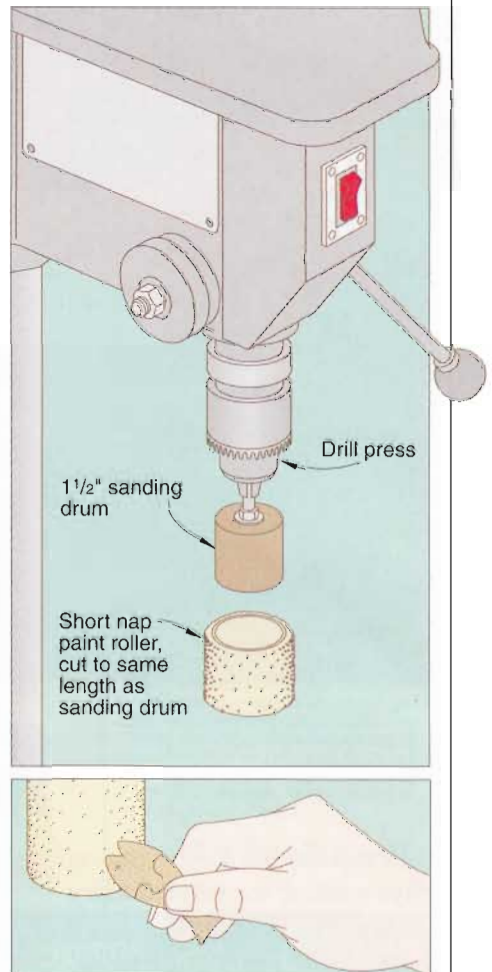

Continued on page 26

CUTTING THE COMPETITION WITH A... "Top-to-Bottom" 5-Year Warranty!*



Copyright 1997 rhindustries. All rights reserved.



RBI presents the Hawk Ultra 226 Scroll Saw with **CHICAGO'S #1 INTARSIA DESIGNER**, Robert J. Hlavacek Sr.

Robert Hlavacek choose the RBI 226 precision scroll saw for all the projects he creates for Chicago's "Brookfield" Zoo. Bob loves RBI's fast & easy blade change system, sand FREE finishes, easy cutting control and our "Top-to-Bottom" 5 year Warranty."

Bob believes the Hawk Ultra's are built "Solid as a Rock!" Bob thinks you should choose the RBI Hawk Ultra family too.

If you're interested in seeing more projects by Robert Hlavacek created on his Hawk Ultra ...read "Creative Woodworks & Crafts magazine."



*COMMERCIAL RATED AT 365 DAYS A YEAR X 5

CALL 1-800-487-2623 FOR YOUR **FREE RBI CATALOG**

rhindustries, inc.

America's Woodworking Machinery Manufacturer

1801 Vine Street • PO Box 369 Harrisonville, MO 64701

Visit the RBI Home page at
www.rbiwoodtools.com

H104

M eeting Your Clamping Challenges...

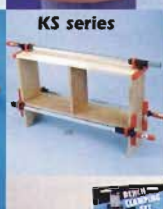

German Tool Quality for the American Craftsman



- Innovative Engineering
- Superior Quality

Gross Stabil Corporation

P.O. Box 368 • Coldwater, MI 49036
toll free: 800-671-0838 • 517-278-6121 • fax: 517-278-5523



Simply the Best...

Performax® owners agree – no other competitor model can compare.

Only Performax offers eleven different models. Only Performax offers patented features and exclusive technology. And only Performax offers the opportunity to see a Performax demonstrated at 200+ dealers worldwide.

We are the sanding specialists. Whether your sanding needs are a few hours on the weekend or all day, everyday, Performax has the model to fit your budget and your needs.

Call us today, let's talk abrasive planing, dimensioning and fine finish sanding in your shop.
1-800-334-4910

16-32" PLUS

Proudly made in the U.S.A.



12257 Nicollet Ave. So. Burnsville, MN 55337 (612) 895-9922

Circle No. 78

TIPS FROM YOUR SHOP (AND OURS)

Continued from page 24

Coffee can can do it

Because shop space is nearly always limited and there are so many different types and sizes of nails and screws, the space-saving hardware organizer shown *right* has been a real advantage in my shop. It lets me see at a glance what's in each can.

My unit uses 26 oz. coffee cans, but the idea can be adapted to other sizes. The frame provides space behind the unit so blown sawdust and dropped hardware end up on the floor where they can be easily picked up. You can leave the can lids on or off, depending on how much sawdust sprays near the organizer and how fast you need to access the cans' contents.

—Larry Flick, Montrose, Colo.

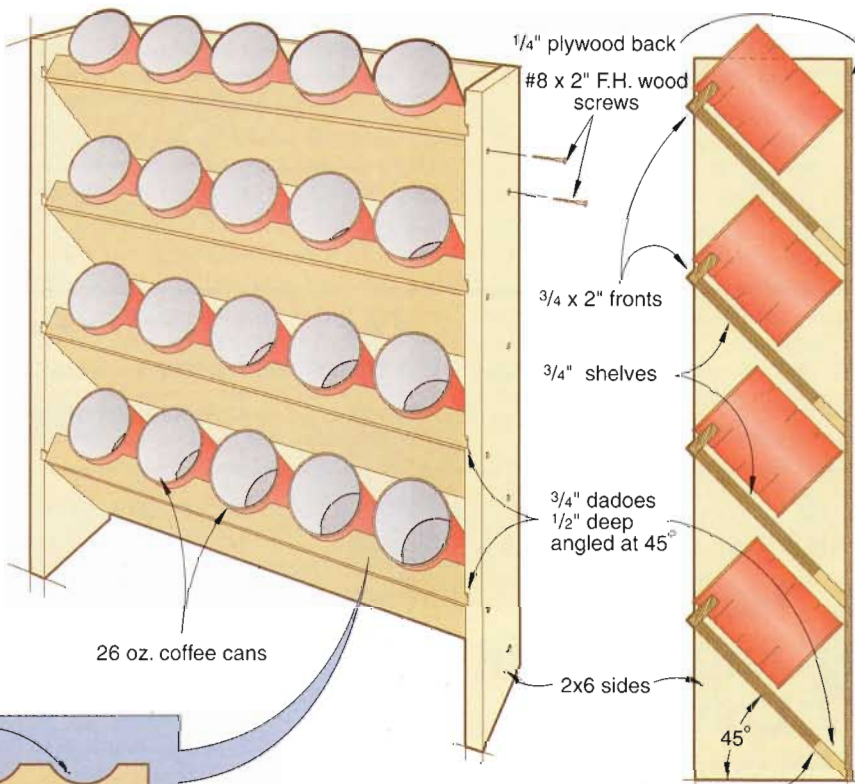
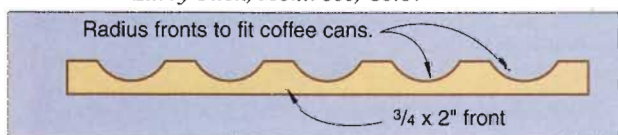

Shelf stops before end of dado so dust and loose hardware can fall out the back.

Continued on page 28

"All my tools should be this good!"

The **Accu-Miter®** is a professional miter gauge that makes perfect angles easily. Shot-pin action assures dead-on accuracy for common angles — plus a precise protractor scale for everything in between!

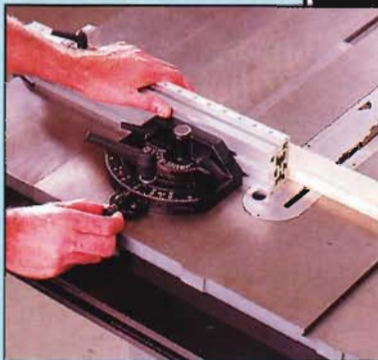

We do not recommend operating without the saw blade guard, as is shown here.
US Patent #5,038,486

Optional accessories:
manual clamp—
pneumatic clamp—
3/8" x 3/4" miter bar—

JDS COMPANY

Precision Woodworking Equipment

Call or write for our free brochure.

800 Dutch Square Blvd., Suite 200, Columbia, SC 29210
1-800-382-2637 / SC 803-798-1600

\$149

Stop getting by. Get real.

The Laguna Tools 16.



- ✓ 9" resaw capacity
- ✓ 1.5 HP motor
- ✓ Cast iron table
- ✓ Cast iron flywheels
- ✓ Dynamically balanced
- ✓ Optional mobility kit
- ✓ Optional miter-gauge
- ✓ Rip fence included
- ✓ Tilting table
- ✓ Made in Italy

LAGUNA TOOLS

(800) 234-1976

(714) 494-7006

<http://www.lagunatools.com>

2265 Laguna Canyon Road
Laguna Beach, CA 92651

Call now for a free video!

Circle No. 615

TIPS FROM YOUR SHOP (AND OURS)

Continued from page 26

New life for worn-out hook-and-loop discs

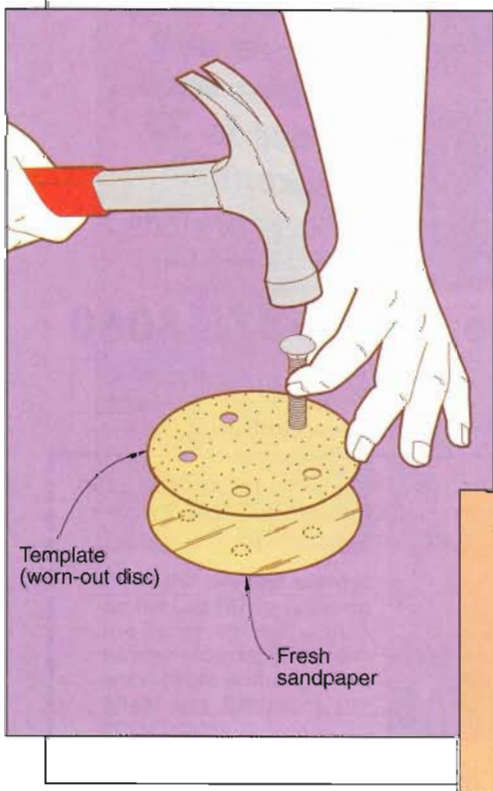

It's late at night. All the stores are closed. You've got a project that needs sanding, and you just wore out your last random-orbit sandpaper disc. You've got plenty of regular sandpaper, but your machine only takes hook-and-loop-backed abrasives. What to do?

Don't give up! Grab a sheet of regular sandpaper, and cut out a disc the same size as the original. Then, find a bolt the same diameter as the dust-collection holes in your disc. Grind the end of the bolt concave so it works as a punch. Put the new disc on a piece of scrap softwood, place the old disc on top of it, and punch out dust-collection holes, using the old disc as a template. Now, glue the back of the new disc to

the face of the old disc with spray adhesive, stick it on the sander, and you're back in business.

—Marilyn Bachelder, Berwick, Maine

A FEW MORE TIPS FROM OUR WOODWORKING PROS

- To make a steel or fiberglass door look as if it's made of wood, try one of the gel stains covered on *pages 54-55*.
- On *pages 37-41* you'll see how a craftsman makes antique beds larger, cuts curved cove moldings on a tablesaw, and lightens dark wood.
- Check out the simple hinge for the lid of a computer-media box on *page 69*. You could adapt it to other boxes.
- See *page 61* for a means of supporting tall pieces when making tablesaw cuts. ♣

ROCK ELM A wood that gives hickory a tough run for the money

Today, if you could find a rock elm (*Ulmus thomasi*) that was somehow passed up by yesterday's lumberjacks, you'd marvel at this species. Before the 1920s, you could readily find stands of trees 100' tall and 3' in diameter from southern Ontario to southern Michigan and Wisconsin.

The rock elm's size, of course, made it attractive to lumbermen. Without a use, though, even the largest of trees won't spark logging activity. But the rock, or cork elm as it is often called, had many.

Back when British shipbuilders scoured the Colonies' vast forests, they discovered rock elm. Its wood was nearly as tough as hickory, yet wouldn't split. And under water, rock elm outlasted any other North American hardwood.

So the virgin stands began to fall, their logs sent overseas. Later, in the dawn of the auto industry, loggers again felled the rock elm to get shock-absorbing stock for wheel hubs, spokes, and frames.

Wooden ice-box manufacturing also prompted rock elm's harvest. The wood stood up well to dampness, and scrubbed clean with little effort. Made into farm implements—and even furniture—it withstood abuse. In fact, lumberjacks preferred rock elm over any other wood for ax handles.

And why is rock elm absent from today's commercial wood list? The species has been relegated to poorer soils, which produce smaller and more widely scattered trees. The large rock elm stands remain history.

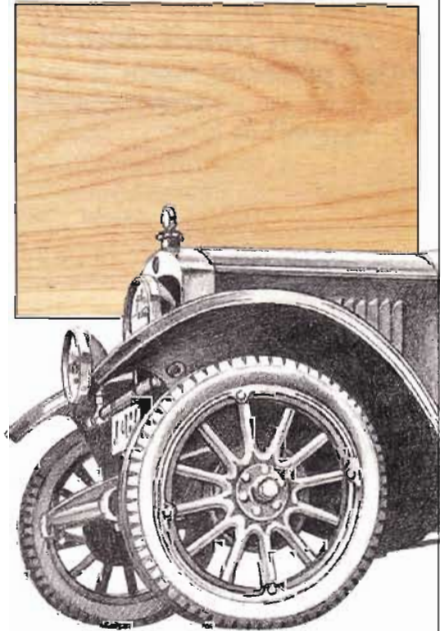

In early auto building, rock elm became hubs and spokes.

Illustration: Jim Stevenson

AWW/W 93 J



TOLL FREE

STAR TOOLS, LLC.
1-888-678-8777

MON - FRI, 7:00 AM - 5:00 PM (Pacific Time)
E-mail address: StarTools@aol.com

**WE HAVE A COMPLETE INVENTORY OF REPLACEMENT PARTS IN STOCK!
CALL FOR NEW STAR TOOLS CATALOG AND WEEKLY SPECIALS**

**2 YEAR WARRANTY
NOW INCLUDED**

ON MOST MACHINES

8" JOINTER

- 2 H.P. 220 V
- JACKSCREW CUTTERHEAD
- DUST PORT

\$3107N

\$785.00



SHOWN WITH OPTIONAL MOBILE BASE



WE NOW CARRY A PREMIUM GRADE OF OLD GROWTH RECLAIMED LUMBER. WE OFFER ANTIQUE PINE, CYPRESS, POPLAR, ANTIQUE GUM AND WIDE BOARD FLOORING. ALL SPECIES ARE 6% MOISTURE OR LESS; AVAILABLE IN ROUGH, S2S & S4S; STARTING AT \$4.00 BF. OTHER SPECIES AVAILABLE.

PRICES & SPECIFICATIONS SUBJECT TO CHANGE WITHOUT NOTICE

25" DUAL DRUM SANDER

- 5 H.P. 220/30 AMPS
- 2 SPEEDS REVERSIBLE
- CAST IRON PLATEN

\$3409

\$1,345.00

18" MODEL AVAILABLE

\$995.00



20" 5 H.P. PLANER

- 5 H.P. /220 VOLT
- 4 KNIFE CUTTERHEAD
- 5" DUSTPORT

\$3725

\$1,400.00



10" 3 H.P. HEAVY DUTY CABINET SAW

- 3 H.P. 220 VOLT 15 AMP
- MOTOR COVER
- 4" DUST PORT
- MICRO ADJUSTER
- FREUD BLADE

\$3202

\$1,075.00

12" 5 H.P. & 10" 5 H.P. ALSO AVAILABLE



SHOWN WITH OPTIONAL MOBILE BASE

OSCILLATING SPINDLE SANDER

- 1 H.P. 110/220 VOLT
- 1725 RPM
- 24" X 24" TABLE TILTS 45°

\$3407

\$485.00



2 H.P. DUST COLLECTOR

- 2 H.P. 220 V
- FREE 10 FT. CLEAR HOSE
- 1182 CFM

\$3820

\$270.00



WEST COAST

MAIN OFFICE SHOW ROOM
9825 PIONEER BLVD.
SANTA FE SPRINGS, CA. 90670
TEL: 562-654-3065
FAX: 562-654-3066
OPEN:
MON - FRI 8:00 a.m. - 5:00 p.m.

ALL MACHINERY SHIPPED F.O.B. SANTA FE SPRINGS CA. OR CLARKSBURG WV.



EAST COAST

SHIPPING WAREHOUSE SHOWROOM
12 ARMORY ROAD,
CLARKSBURG, WV. 26301
TEL: 304-624-6685
(TECH SUPPORT ONLY)
FAX: 304-624-8928

WEST VIRGINIA STORE OPEN:
MON - FRI 8:00 a.m. - 5:00 p.m.
and 1st & 3rd SATURDAY, 9:00 a.m. - 1:00 p.m.

20" BANDSAW

- 3 H.P. 220 VOLT
- 4" DUST PORT
- 12" RESAW CAPACITY

\$3506

\$1,295.00



BOXELDER

The lowliest maple of all

Fast-growing boxelder was widely planted throughout the East and Midwest for street shade and windbreaks until the early 20th century. However, because it lacked the beauty, resistance to storm damage, and long life of its more glamorous cousin, the sugar maple, the practice eventually was discouraged.

In the open reaches of the Great Plains through which flows the Missouri River, though, the boxelder was welcome. Able to endure climate extremes and drought, it grew to greater stature, providing needed shade and shelter from the everpresent winds. Its seeds, like tiny helicopters, swirled with the breezes to find homes for sprouting, and grew where nothing did before.

A true maple, boxelder even today is tapped for its sweet sap, which is made into syrup and sugar. This is especially true in its western range, where the preferred sugar maple fails to grow.

Boxelder's comparatively soft, light wood never attained the woodworking status of the hard and often distinctively grained sugar maple. Yet, where it grows to any great size, it finds its way with other nondescript maples into slack barrels, boxes and crates, woodenware, and inexpensive furniture.

Wood identification

You'll find boxelder (*Acer negundo*) parading under a number of local names—ash-leaf maple, sugar ash, and Manitoba maple to name a few. Throughout most of its range, boxelder inhabits stream and river bottoms, and lake shorelines. In these moist places,

elm, hackberry, black walnut, cottonwood, and willow make up its neighbors.

Except for the occasional specimen in the western part of its range that grows to 75' tall and a diameter of 4', boxelder commonly peaks growth at heights of 40-50' and 2-3' diameters. Rarely does a boxelder reach 100 years of age.

Boxelder's pointed leaves resemble those of white ash, but with more scallops. Double seed pods joined into a v-shape hang on the tree's branches from early summer on. At first glimpse, boxelder's gray-brown bark could also pass for that of white ash—its flattened ridges appear similar—except that the furrows run much shallower.

The wood of boxelder, at 27 pounds per cubic foot dry, weighs nearly the same as white pine and rates as the lightest and weakest of

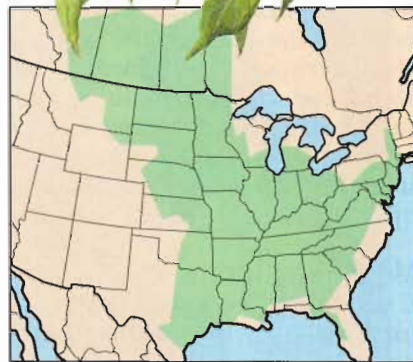
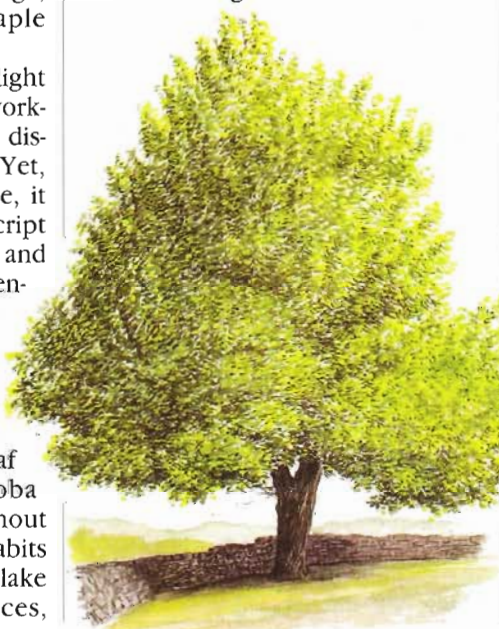

Natural range

the American maples. Close-grained and creamy white in color, boxelder tends to be brittle. Sometimes, a dead or dying boxelder tree contains wood that carries raspberry-colored streaks and flecks, a property that woodturners find especially appealing for bright bowls, slender goblets, and attractive platters.

Uses in woodworking

The light wood lends itself to boxes, carvings, turnings, treenware, toys, and simple furniture or storage projects. Spalted boxelder, with its raspberry streaks, is highly prized for accent work and turnings. The wood isn't suitable for outdoor projects.

Availability

Where boxelder grows to commercial size, it's mixed and marketed with soft maples for retail sale. Small local mills may distinguish boxelder from soft maples, and specialty suppliers of spalted turning blocks and squares certainly do. Lumber should run less than \$2 per board foot for FAS. Veneer or plywood isn't available.

Continued

PERFORMANCE PROFILE

boxelder (*Acer negundo*)



Flatsawn boxelder



Spalted boxelder

Because there's little difference between the color or the working characteristics of boxelder's heartwood and sapwood, you needn't sort through piles looking for one over the other. Once you have your stock, though, keep these working tips in mind.

Machining methods

If you like to work with hand tools (or want to try it), you'll get a kick out of working this soft maple called boxelder. Aside from being low-cost, it's easy on cutting edges, bits, and abrasives. In fact, this is a perfect wood for kids to work.

If, however, you prefer the bite of power tools, keep the standard techniques listed in the box below in mind, and remember the following tips in your shop:

- Although boxelder isn't as hard as most maple you might be used to working, it does have a tendency to burn. Use only sharp cutting edges.

- Hesitating or force-feeding the workpiece while ripping increases the wood's chance of burning. Use a constant feed rate. While routing, keep the wood or the tool moving at a constant rate.

- Boxelder provides the perfect chance to try your hand-planing skills. With a sharp cutter, its close grain will give you a smooth surface. This characteristic also makes it an excellent wood to sand.

- Speed up the rpm rate when drilling boxelder, even though it's a hardwood. With thick wood or large-diameter bits, raise the bit occasionally to clear out chips and reduce the chance of burning. And use a backing board to avoid tearout of this comparatively brittle wood.

- The wood holds nails and screws quite well, but be sure to predrill to avoid splitting.

- Because of its tight grain, boxelder's cousin sugar maple sometimes resists normal gluing, and so

does boxelder. For best results, put down a ribbon of glue on each joining surface, then press them together to spread the glue. Pull the pieces apart, let the glue become tacky, then rejoin and clamp. Make sure to clean up all squeeze-out.

- Like hard maple, boxelder sometimes produces blotchy staining results. On a scrap, try using a conditioning sealer coat before staining. Or, use gel stains.

- All clear finishes, as well as paint, take readily to boxelder.

Carving comments

The straight, close-grained wood of boxelder won't threaten even beginning carvers. Beware, though, that its brittleness can cause runout on long, straight cuts.

Turning tricks

No problems on the lathe with boxelder, except in end grain where its brittleness can cause problems.♣

SHOP-TESTED TECHNIQUES THAT ALWAYS WORK

Any exceptions, and special tips pertaining to this issue's featured wood species, appear elsewhere on this page.

- For stability in projects to be used indoors, always work wood with a maximum moisture content of 8 percent. For outdoor use, wood of 12 percent moisture content is okay.

- Feed straight-grained wood into planer knives at a 90° angle. To avoid tearing, feed figured wood or that with twisted grain at a slight angle of 15°, and take shallow cuts of about 1/32".

- For clean cuts, always rip with a rip-profile blade that has 24-32 teeth. For crosscutting, use a blade with about 40 teeth.

- Avoid drilling with twist drills. They tend to wander in the wood and cause breakout. Always use a backing board under the workpiece to reduce breakout.

- Drill pilot holes for screws.

- Rout with sharp, preferably carbide-tipped, bits and take shallow passes to avoid burning.

- Carving hardwoods generally means shallow gouge bevels—15° to 20°—and shallower cuts.

BOXELDER AT A GLANCE

Cost	\$ \$ \$ \$ \$
Weight	🐘 🐘 🐘 🐘 🐘
Hardness	T T T T T
Stability	▲ ▲ ▲ ▲ ▲
Durability	🕒 🕒 🕒 🕒 🕒
Strength	💪 💪 💪 💪 💪
Toxicity	☠️ ☠️ ☠️ ☠️ ☠️
Workability	🔪 🛠️
Look-alike	white birch

Compiled with woodworker Randy Johnson Illustrations: Steve Schindler

THE WOODWORKER & THE HOTEL

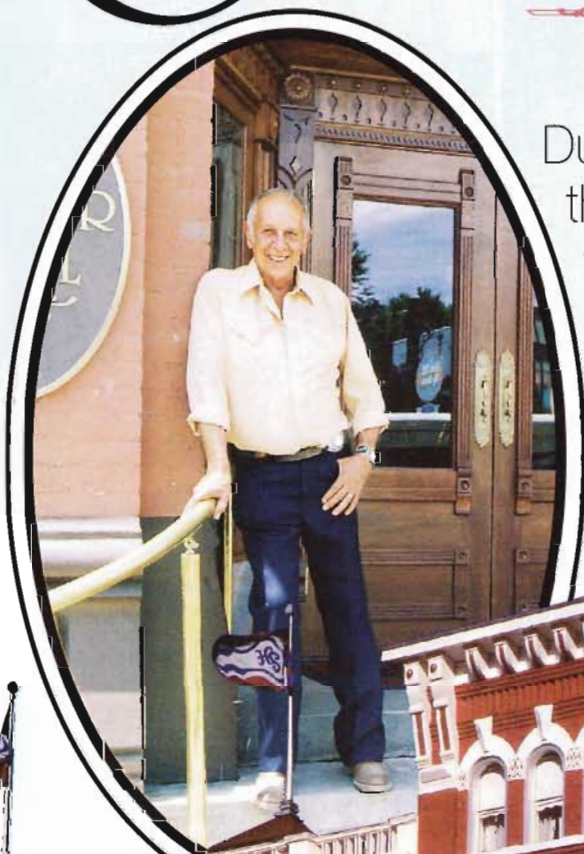

Durango, Colorado's Strater Hotel has the richness of a Victorian cameo, thanks to Charlie Schumacher's 25 years of caring craftsmanship

Continued



THE WOODWORKER & THE HOTEL

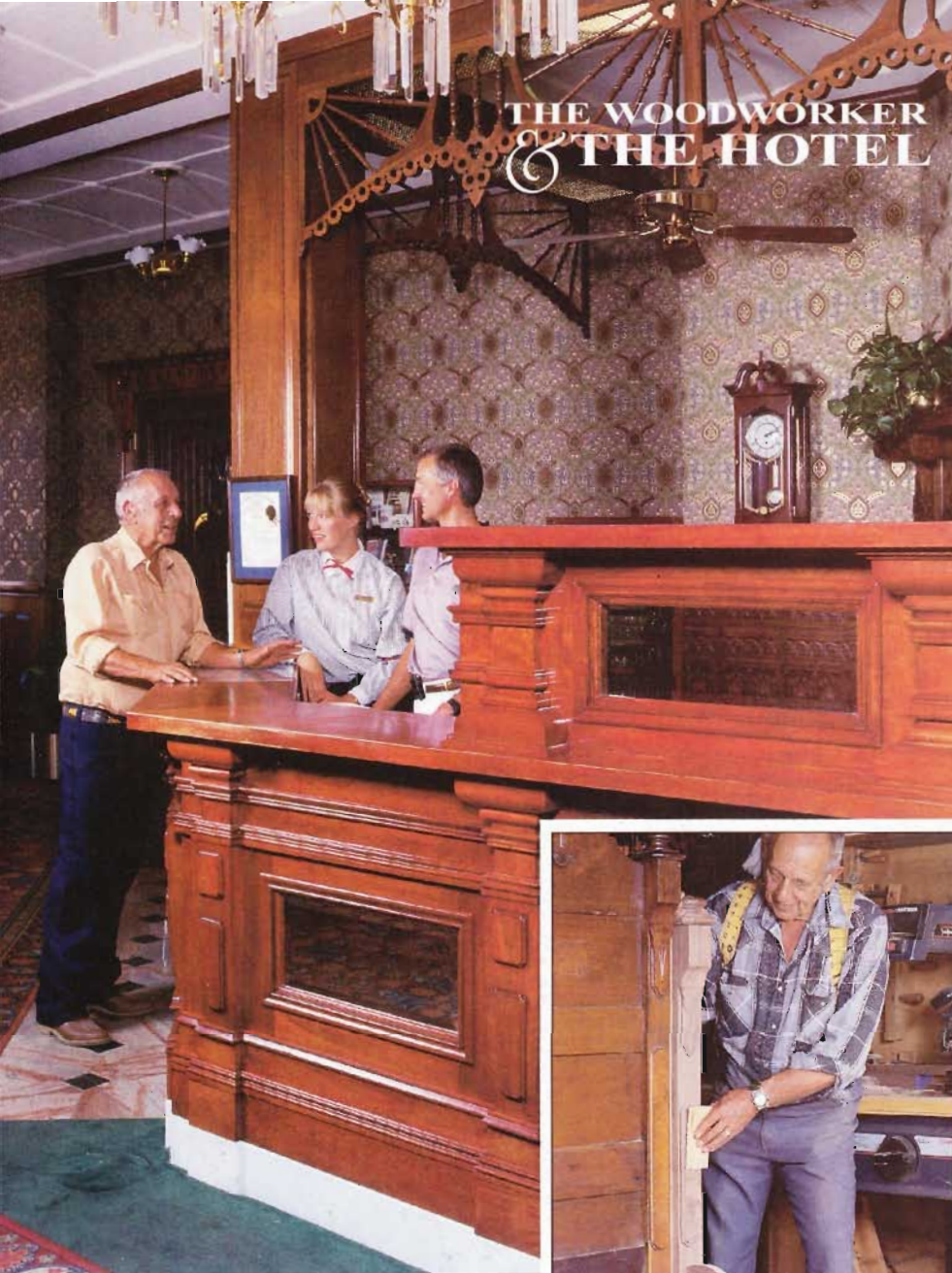

In active retirement, Charlie still drops by the Strater Hotel to chat. At the cherry reception desk he built, he jokes with hotel CEO Rod Barker and receptionist Jennie Polland. Charlie also turned the walnut bric-a-brac above the desk.

From the gleaming mahogany and polished brass of the main entrance, to the cherry front desk and the walnut and oak antiques in its 93 guest rooms, Durango, Colorado's Strater Hotel gives testimony to one man's dedication to craftsmanship. Charlie Schumacher, 70, spent 25 years bringing the 1887 Victorian building into the 20th century while retaining its romance with the past. As



head of maintenance until his retirement a few years ago, he was responsible for mechanical things like heating, cooling, electrical service, and plumbing. But as a skilled woodworker, he and a helper refurbished, restored, and replicated all that was made of wood.

"If it was done here, I did it," Charlie says proudly. Standing at the front desk—a massive structure made of rich-looking, solid cherry—

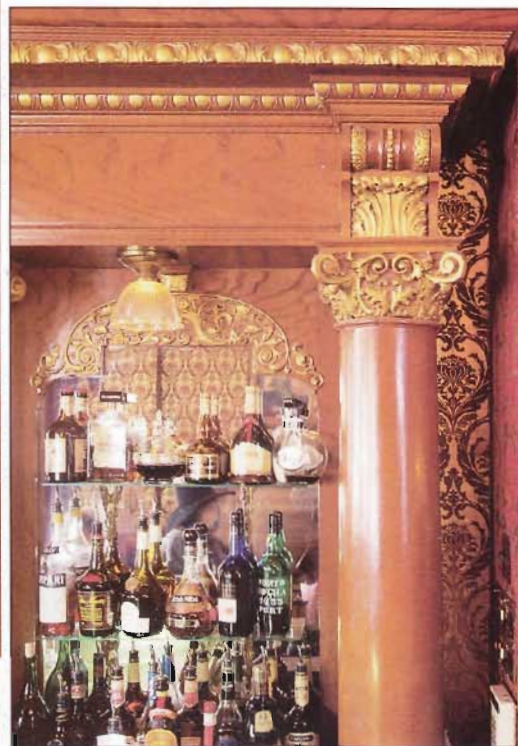

Above: The graining of the back bar in the Diamond Belle Saloon was done 40 years ago with stale beer and pigment when Charlie was a painter. He also claims the gilding on the columns.

Left: In his home workshop, Charlie sands some roughness off one of the new walnut posts he added to increase the vintage Victorian bed's size from double to queen.

he surveys the lush lobby's walnut woodwork as if he had just sunk the last finishing nail. "A lot of this work in the hotel, either Rod Barker [the hotel's chief operating officer], or his dad Earl before him, told me what he wanted it to look like, and I got it there. They never asked me how much it was going to cost, just 'Can you do it?' I like it that way."

Roomfuls of antiques meant to be used

In retirement, Charlie still does work for the Strater Hotel. There's no pressure today, though. He takes as long as he needs to get the job done right.

In his home garage shop just a five-minute drive from the hotel, Charlie

points out a typical assignment: The widening of a Victorian double bed into a queen-size one. He has done it so many times over the years that the process is routine.

"I just add a post at each corner and refit the side rails to them [see photo *opposite page*]. I dowel them on and use good woodworker's glue, not hide glue like they did when it was made." Grabbing a headboard post with two hands, Charlie gives it a strong shake. "Sturdy for an antique, ain't it?"

At the hotel, Charlie had to fix furniture so that it stayed fixed, and he did it well, even if the piece changed character a bit from the original. "The pieces there no longer

squeak like real antiques. Once I even told Rod that I was ruining these antiques that were purchased around the country with modifications just so they'll hold up to use," he recalls. "Rod looked at me and said, 'I'm not in the business of selling antiques. I'm in the hotel business. If they still look like antiques, that's what I want.' So, that's the way it went."

Modifications may alter Victorian furniture's collector value, but to the Strater's guests, the pieces still appear genuine. That's because Charlie took care to disguise alterations by blending them with the origi-



Above: Charlie incorporated Victorian design aspects, such as the scroll top and button rosettes, from other pieces to build this mirrored walnut armoire.



Left: A suite at the Strater features an oak sideboard with a base done by Charlie that features dentil molding, a design feature found on other furniture in the hotel's collection. The bed is one of his enlarged originals.

nal design. "Who's to know that this bed didn't originally have double posts? I'm sure that somewhere they did," he says. And his finishing work faithfully matches the original.

Looking over the new posts he added to the bed, Charlie talks of the steps yet to go through. "I'm going to have to bleach this walnut before I can start staining because it's already too dark. All I use is straight Clorox, brushed on right out of the bottle. It raises the grain a little bit, so I'll have to sand. Then, I'll mix the stain from oil pigments, thin it with turpentine, and test it on scrapwood before I go ahead.

"When I get the color I want, I'll stain, let it dry, then apply polyurethane varnish," he continues. "Sometimes, I use a bit of

Continued

THE WOODWORKER & THE HOTEL



The hotel's downstairs meeting and reception room glows in warm walnut wainscoting and decoratively framed mirrors. Except for chairs and tables, Charlie built it all.



"To build Victorian furniture, you have to learn to carve," advises Charlie as he cuts into a walnut scroll piece intended to replicate original trim on a bed's headboard. "It can also be fun."

orange shellac to color the wood before I stain. It's all pretty much trial and error, with some idea of where you're going."

Charlie's an expert at matching finish color—even enjoys it. This isn't surprising, though; he began his woodworking career as a painter.

Finishing with beer and turkey feathers

Sitting at a table in the hotel's Diamond Belle Saloon, Charlie talks of his early years in Durango, and what could have been a different course. "My granddad was a painter and my dad was a painter. After I came home from the navy in the early 1950s, my brother and I bought out my dad—he was getting tired of painting. I guess painting was all that I thought I could get paid for doing."

Charlie's painting experience preceded the fifties, though. He recalls

his grandfather buying white lead by the 100-pound keg. "We'd break it up and mix linseed oil, turpentine, and pigment with it to get flat paint. For enamel, we'd add varnish to the mix. Then, if you wanted to flatten back the enamel, you'd add a ball of beeswax. Yep, beeswax—a ball about the size of a walnut thinned to liquid with turpentine added to a gallon of paint."

His father and grandfather had been known for their *faux* finishes, paint made to look like another material. Charlie learned from them.

Glancing around the saloon, the grizzled and amiable woodworker gestures to the balusters on the railing that guard the balcony seating. "I marbled those back in the fifties when our painting business was hired. All done with oil paint and a turkey feather. That's how you get that look. Like real marble, ain't it?" he questions, pride still in his

voice. "Then, that back bar there [see photo *page 38*]. Looks like mahogany, doesn't it? It ain't. I did all that graining with stale beer and oil color pigment."

Without hesitation, Charlie goes on to briefly describe his technique. "First, you paint everything a solid color [base coat]. Then you take a bottle of beer, one that's been opened and left out overnight [flat] and mix it with dry pigment color and spread it on. While it's still wet, you stipple it with a brush. Next you take a little brush and draw the grains on. With a badger-hair brush, you blend it. If you don't like it, take a wet sponge and wipe it off and do it again until you get it the way you want. When it's dry, varnish it in, and it's there for 40 years!"

Knowing when you're good enough to make furniture

Woodworking wasn't new to Charlie when he became head of maintenance at the Strater in 1972. After selling the painting business, he worked for a stint as a carpenter, then foreman, for a local building contractor. But his experience with wood actually began as a youngster.

"I started shop in the fourth grade making little wooden gadgets," Charlie remembers. "Then, I took

Cut curved coves on a tablesaw? You bet!

Charlie's not kidding when he says you can make practically anything on a tablesaw. To prove it, he demonstrates (with pine) how he made curved cove moldings of walnut, cherry, and oak for many of the Victorian antiques and woodwork at the Strater Hotel. Of the technique, he advises, "You waste some wood. But then again, what method doesn't?"



Charlie fits his tablesaw with a plywood top, then runs the sawblade through it for zero-clearance. With a trammel fastened to the workpiece and a raised pivot point, he moves the workpiece across the blade.



As you can see, his setup produces a perfect, circular cove cut. Before sawing, he uses the flexible jig over the sawblade to gauge the angle of the cut needed to produce a cove of the desired width.



For the typical trim on a rounded Victorian bed headboard, for instance, Charlie would saw away the waste at the outside edge and along the bottom of the cove. That gives him the perfect half cove he needs.

shop all through high school, including a half-year of mechanical drawing. With my brother's help, I built all the furniture for my folk's house out of solid walnut—all hand done, no machinery. I recall that the lumber came roughsawn at 60 cents a board foot. I'd plane it down by hand and make furniture out of it."

Before Charlie could begin furniture making, though, he had to pass a test imposed by his shop teacher. "He got the point of a lead pencil as sharp as he could, then drew a straight line down a board. 'When you can rip it so half the line is on the board and the other half in the sawdust pile, you're ready to build furniture' was the way he put it."

Charlie had passed that test long before his work at the Strater Hotel began. At the time, he never could have conceived how his skill was to be challenged. Yet, Charlie never was short on confidence.

"Sometimes the owner would describe a project to me or show me a piece that he wanted a replica of, then shake his head, 'But it can't be done.' I'd say, 'Well, somebody did it to start with, and today I've got better tools.'"

One of those instances was an ornate oak sideboard that now sits in luxurious Suite 108 (see photo page 39). The classic Victorian top had been purchased intact, but the lower portion was gone. Charlie built the missing base cabinet to match, complete with hand-carved details. He explains how he arrived at the complementary design.

"Well, this whole place is filled with Victorian antiques—it's a real museum. I'd just wander around and collect ideas from different pieces, then revise them to fit what I was making," he says.

With such woodworking mountains to climb, one would expect that Charlie had a magnificent, fully equipped hotel shop at his disposal, much like the one he now boasts at home. Not quite so.

Treading stairs down into the bowels of the old building, past the laundry and linen storage, Charlie leads the way to the small, home basement-size workshop. "Here's where it was all done, at least most of it. That Craftsman tablesaw there, the 6" jointer, and that bandsaw I bought 25 years ago for \$400—that's what I used. Later, I added a small lathe and a router table, but nothing fancy. Now, an apprentice that I trained carries on the restoration with these same tools."

Charlie stops to survey the small shop that for so long was his second home. He fondly taps the old tablesaw and says, "You know, there's nothing you can't do with this, if you know what you're doin'."

Walking the Strater's halls with Charlie is a literal stroll down Memory Lane. In its public rooms, little woodwork has escaped his touch. And you'd agree with him that there's precious little that was done long ago that can't again be done, given a heap of talent and know-how. Especially if you're named Charlie Schumacher. ♣

Durango's Grand Lady

The dream of young Henry H. Strater to build the grandest hotel in the West became reality in 1887. Constructed of Colorado red brick with hand-carved sandstone sills and cornices, the ornate Strater Hotel cost a then-staggering \$70,000.

Each room boasted a wood-burning stove, comfortable furniture, and a "facility" that combined washstand and commode. Durango townspeople often closed their homes in the winter to stay there.

Through the years, the Strater built a reputation as a social gathering place. The Diamond Belle Saloon continues the tradition. The late western author Louis L'Amour liked the saloon so much that he frequently asked for the room above it. He said the honky-tonk music inspired him.

The renovation of the hotel has been ongoing, beginning with the third owners, Earl and Jentra Barker, and continuing today with their son, Roderick E. Barker. The emphasis is on beauty and Victorian authenticity, with all the modern conveniences. And there's a lot of Old West friendliness, too.

nice and easy **Patio**



Summer will be here before you know it, so now's the perfect time to get busy building two, three, or even four of these oh-so-comfortable patio chairs. When warm weather arrives and you're out there sitting on the deck sipping an ice-cold lemonade, you'll be glad you did.

Chair

Construction begins with the end frames

1 Cut the end frame feet (A), rails (B), uprights (C), and slats (D, E) to the sizes listed in the Bill of Materials (we used cedar).

2 Using the dimensions on the Rail and Foot details accompanying the Base drawing, mark the dado locations on the feet (A) and rails (B). Then, mark the radiused outlines on both feet. Using your tablesaw fitted with a dado blade, cut the $\frac{3}{4}$ "-deep dados on all four parts as shown in the how-to photo below.



Mark the feet and rails, then cut the dados using a tablesaw fitted with a dado blade and stop.

3 Mark the locations, and cut mating half-lap joints across both ends of the uprights (C).

4 Transfer the full-sized apple pattern from the *WOOD PATTERNS*® insert in the center of the magazine to the center slats (E), 3" from the top end of each, where shown on the Base drawing. Drill a blade-start hole, and scroll saw the patterns to shape.

5 Using the full-sized pattern on the insert, mark the outline of the lower crossmember (F), and cut it to shape.

6 Cut a notch centered on the bottom end of the center slats (E) to receive the bottom crossmember (F) later.

7 Use a drum sander to sand the radii on parts A and F.

8 Glue and screw each end frame together in the configuration shown on the Base drawing.

Construct the seat frame, and add the slats next

1 Cut the seat crossmembers (G, H) and supports (I) to size.

2 Mark the locations, and cut rabbets in the crossmembers (G, H) where dimensioned on the Base drawing.

3 Transfer the full-sized patterns from the pattern insert, and cut the bottom edge of the front crossmember (G) and the top edge of the supports (I) to shape. Sand the cut edges smooth.

4 Glue and screw the seat frame together, checking for square and that the bottom edges are flush.

5 Cut the slats (J) and rear cleat (K) to size, bevel-ripping the front edge of K at 15° where shown on the Side Section View drawing.

6 To drill consistently positioned holes in the seat slats, clamp a fence and stop to your drill-press table. Then, drill a countersunk mounting hole, centered from front to back and $\frac{3}{4}$ " from the ends of each seat slat.

7 Rout a $\frac{1}{2}$ " round-over along the front edge of the front slat (J). Rout a $\frac{1}{8}$ " round-over along the back edge of the front slat and along the front and back edges (not ends) of all the remaining slats (J). See the Exploded View drawing and Side Section View for reference. Sand the slats smooth.

Continued

The patio chair at left matches the patio table and benches shown below and featured in the June 1996 issue of *WOOD*® magazine and the glider from the June 1995 issue. If you don't have the plans for these projects, see the box on page 47 for ordering the *WOOD PLANS*® for these projects. Also take a look in the June 1998 issue of *WOOD* magazine for a matching side table and planter.



nice and easy Patio Chair

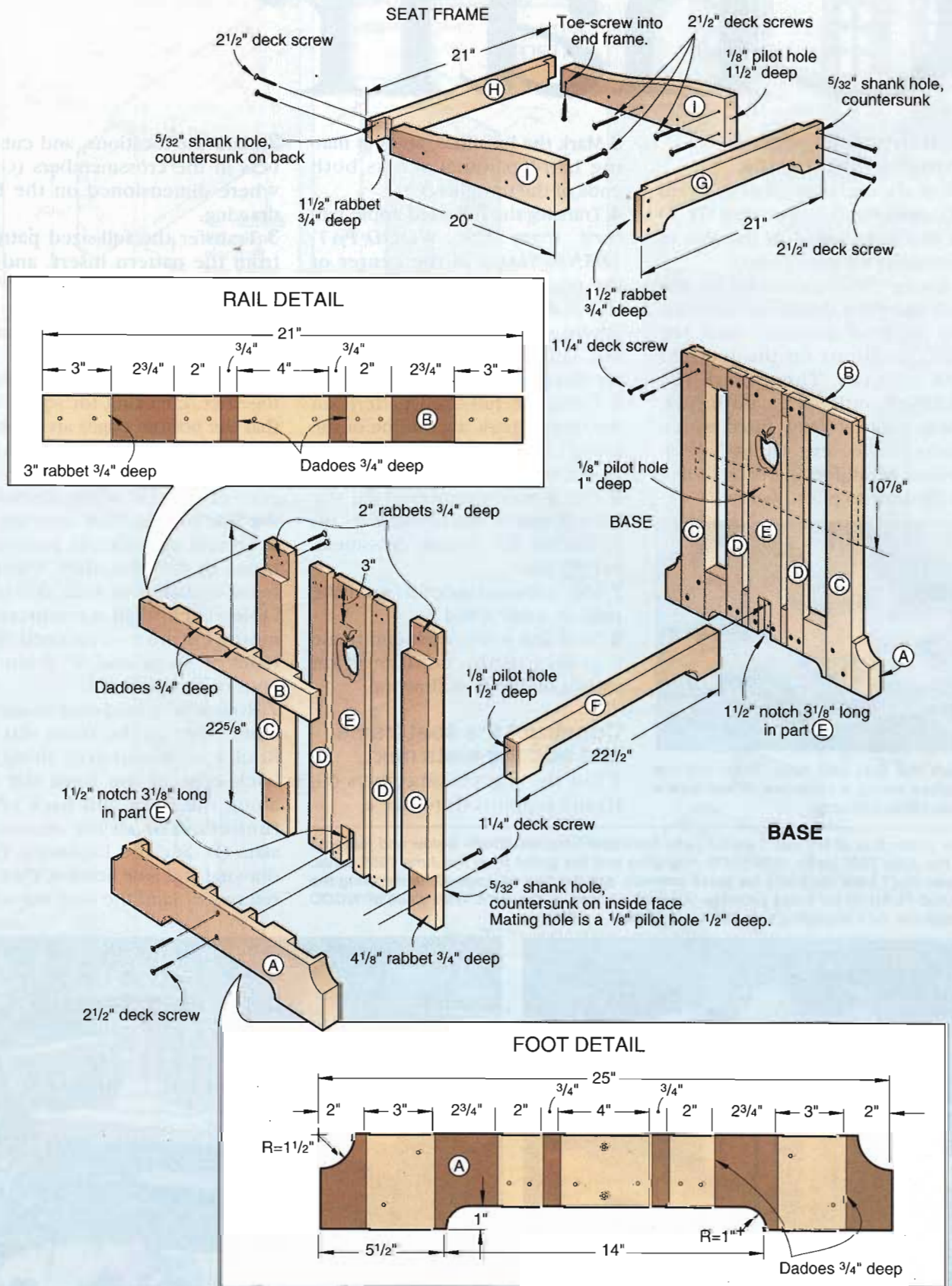

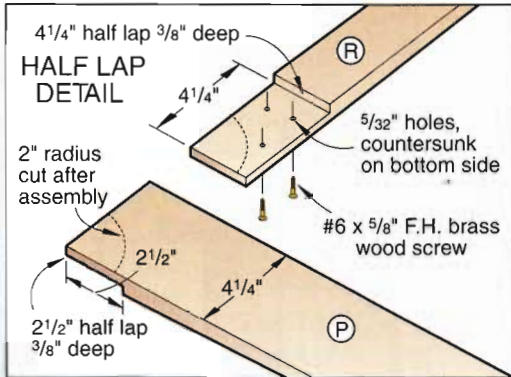

Bill of Materials											
Part	Finished Size			Matl.	Qty.	Part	Finished Size			Matl.	Qty.
	T	W	L				T	W	L		
CARCASE						BACKREST					
A feet	1 1/2"	4 1/8"	25"	C	2	K cleat	3/4"	1 1/2"	21"	C	1
B rails	1 1/2"	2"	21"	C	2	L* splats	3/4"	3 1/2"	19"	C	2
C uprights	1 1/2"	3"	22 5/8"	C	4	M* splats	3/4"	2"	19 3/4"	C	2
D slats	3/4"	2"	21 5/8"	C	4	N* splat	3/4"	7"	21"	C	1
E slats	3/4"	4"	21 5/8"	C	2	O top cleat	3/4"	1"	19"	C	1
F cross-member	1 1/2"	3 3/8"	22 1/2"	C	1	P armrest	3/4"	4 1/4"	24 5/8"	C	2
SEAT						Q supports	3/4"	2"	3"	C	4
G cross-member	1 1/2"	3 1/2"	21"	C	1	R brace	3/4"	2 1/2"	29 1/4"	C	1
H cross-member	1 1/2"	1 3/4"	21"	C	1	S cleat	3/4"	1"	20"	C	1
I supports	1 1/2"	3 1/2"	20"	C	2	Material Key: C-cedar					
J slats	3/4"	1 3/8"	21"	C	12	Supplies: 1/4", 1/2", 2 1/2" deck screws, #6x5/8" brass flathead wood screws, red and green enamel paint, clear exterior finish.					

* Initially cut parts marked with an * oversized. Trim to finished size according to the how-to instructions.

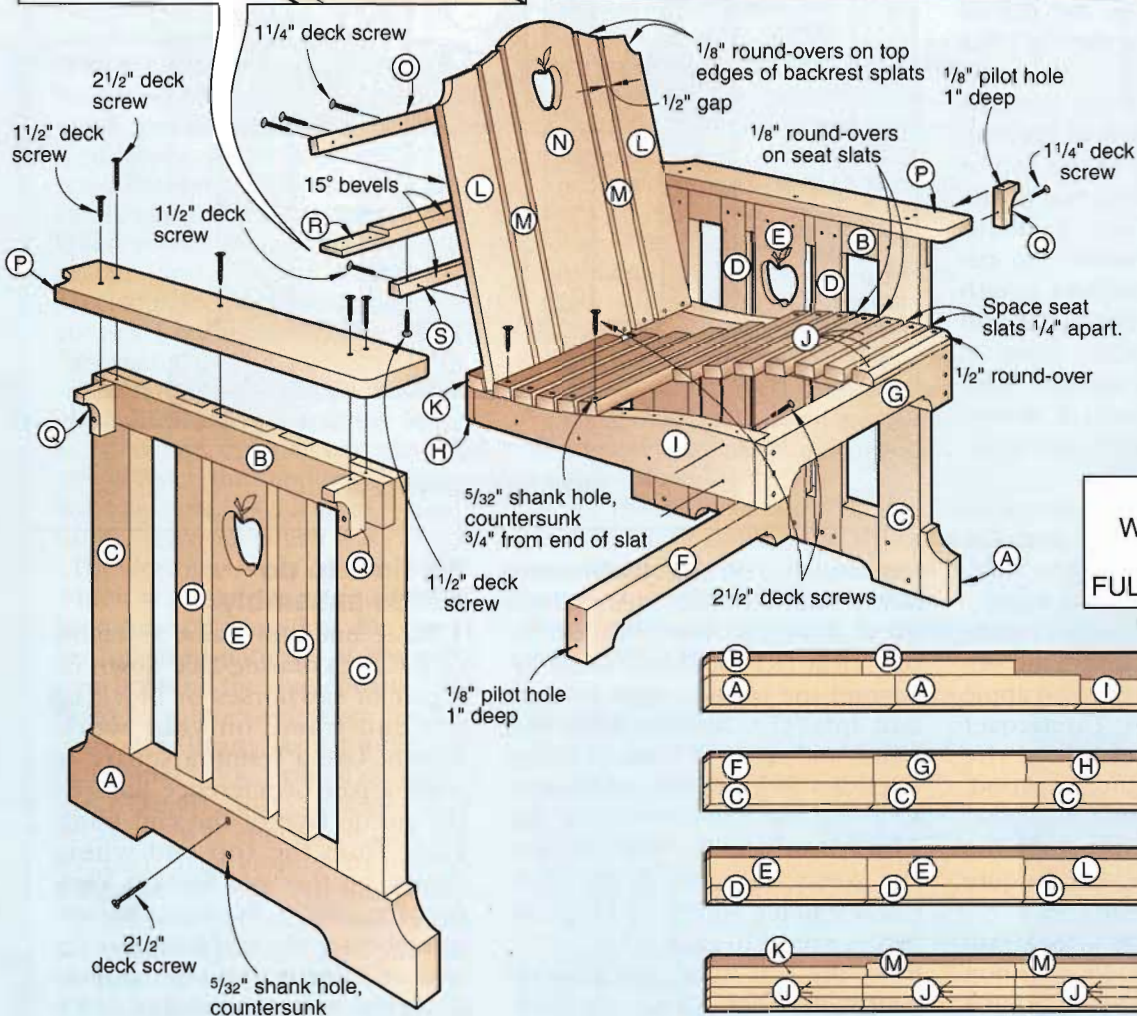

EXPLODED VIEW

SEE THE
WOOD PATTERNS®
INSERT FOR
FULL-SIZED PATTERNS
CUTTING DIAGRAM

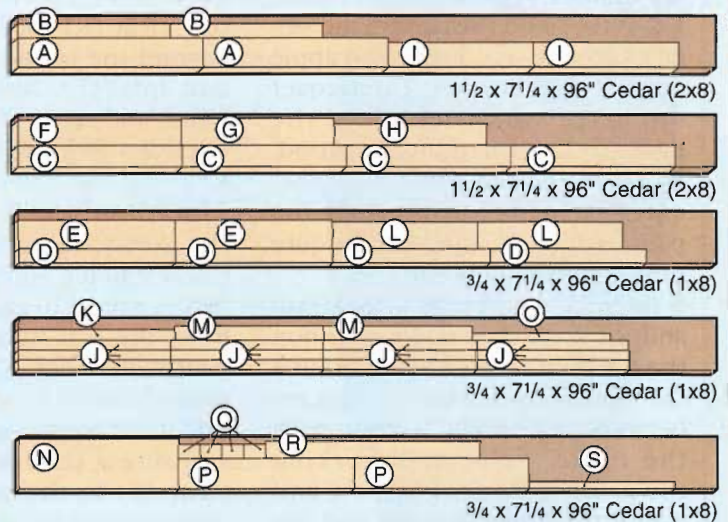

nice and easy Patio Chair

8 Starting at the front and working toward the back, screw the slats, but not the rear cleat (K), in the place where shown on the Support drawing on the pattern insert. (To check the spacing, we used spring clamps to hold the last five slats and cleat in place before attaching. It's important that K attaches to the seat frame where shown on the Side Section View drawing.) Set the rear cleat aside for now; you'll add it later.

Now, build the backrest assembly

1 Cut the backrest slats (L, M, N) to the sizes listed in the Bill of Materials *plus* 1". Cut the top cleat (O) to size.

2 Transfer the full-sized patterns from the pattern insert in the center of the magazine to the top of the slats. Cut the top end of the slats to shape. Then, crosscut the opposite end (bottom) to cut the slats to the finished length stated on the patterns insert and in the Bill of Materials. Rout $\frac{1}{8}$ " round-overs along the top front edge of each slat where shown on the Exploded View drawing. Sand the slats smooth.

3 Transfer the apple pattern to the center slat (N), $1\frac{3}{8}$ " from the slat top. Drill a blade-start hole, and scrollsaw the apple to shape.

4 Paint the apple cutouts in parts E and N. To do this, brush the surfaces around and inside the apple cutouts with lacquer. The lacquer minimizes the wicking of the paint to the surrounding wood. Brush on red and green high-gloss exterior enamel paint. After the paint has dried, sand the lacquer off the surrounding surfaces.

5 Keeping the bottom edges flush and the good face down, position the backrest slats (L, M, N) on a flat work surface. Place $\frac{1}{2}$ " spacers between the slats, starting with the center slat and working toward the ends. Position and clamp the rear cleat (K) and the

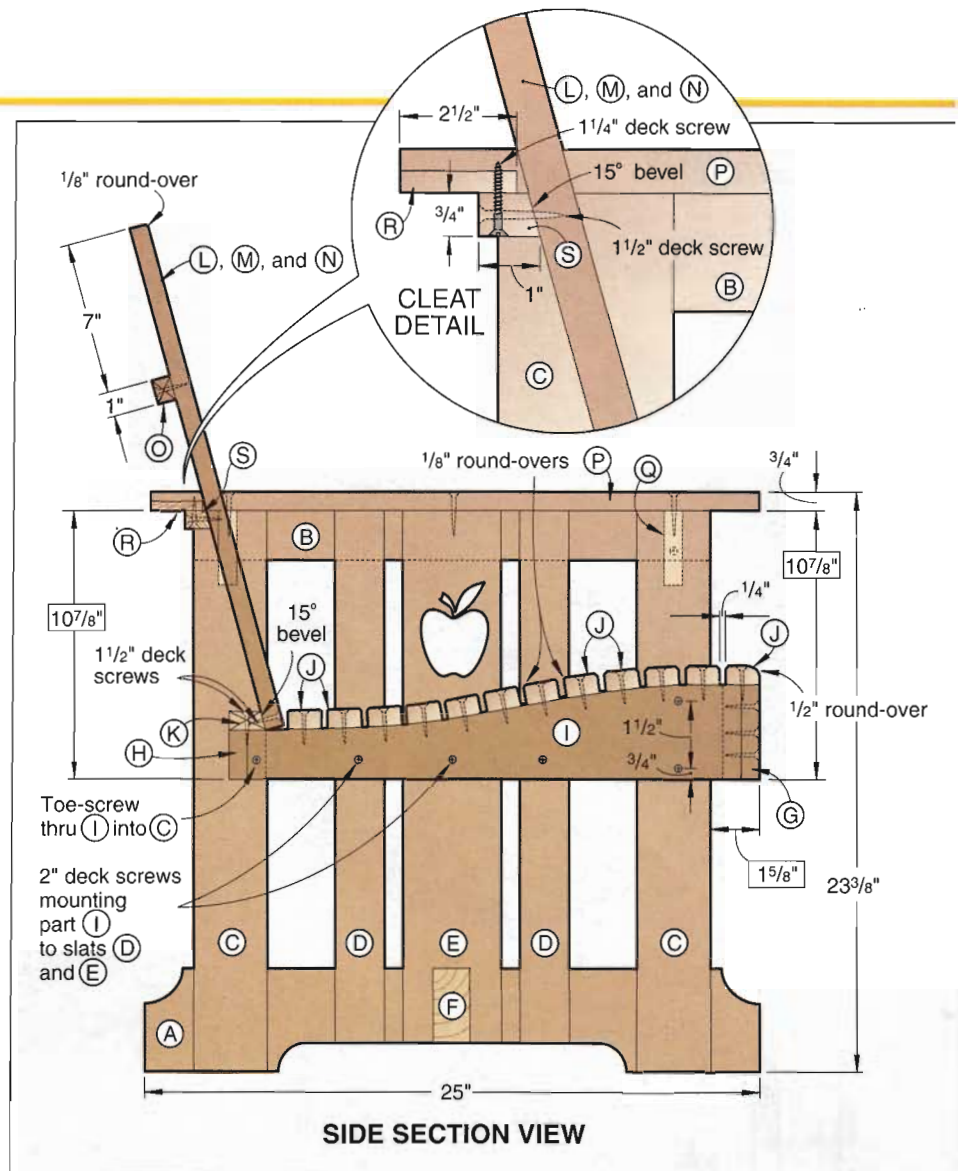

top cleat (O) on the slats where dimensioned on the Side Section View drawing. The ends of the rear cleat (K) should protrude $\frac{1}{2}$ " beyond the outside edge of each end slat (L). Drill countersunk holes, and screw the slats to the O cleat. Flip the assembly over. Keeping the bottom ends of the slats flush with the bottom cleat (K), screw the slats to the cleat. Use a framing square to keep the pieces square to each other.

6 Set the seat frame assembly on your workbench. Clamp the backrest assembly to the seat frame, drill countersunk mounting holes, and screw the backrest bottom cleat (K) to the seat frame rear crossmember (H) at 6" intervals.

It's time to do a little assembly

1 Place one end frame assembly (A, B, C, D, E) outside face down on a pair of sawhorses or block up the end frame on your workbench. Use a framing square to mark a pair of reference lines on the *inside* face of the end frame $10\frac{7}{8}$ " from the top end where shown on the Side Section View drawing *above*. Position the seat assembly on the end frame so the bottom edge of the seat support (I) aligns with the marked reference lines. The front of the seat frame should overhang the front edge of C by $1\frac{3}{8}$ ". Secure the seat support (I) to the two end frame uprights (C) with clamps. Drill

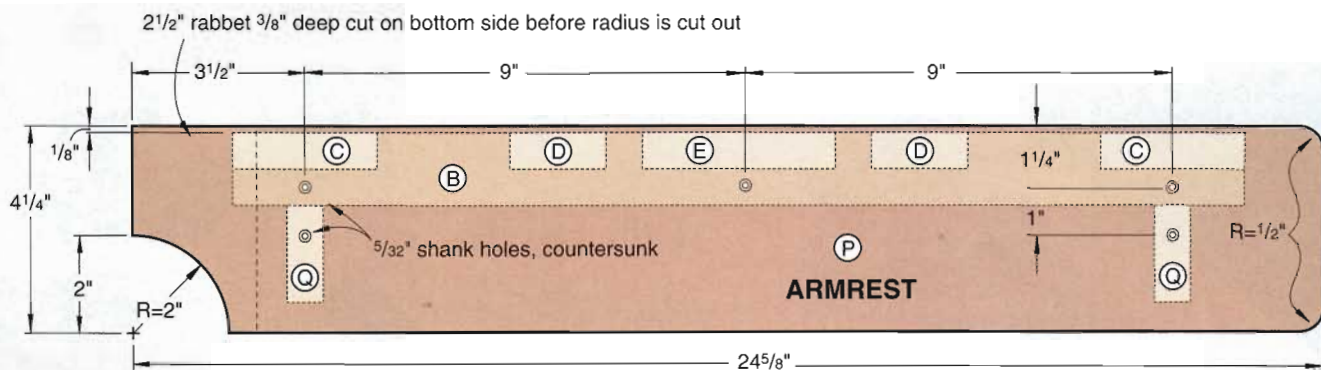

countersunk mounting holes through the seat support (I) into the slats (D, E), and secure the parts with wood screws.

2 Remove the clamps, drill two mounting holes, and screw through the front end of the seat support (I) and into the front upright (C). See the photo *below* for reference. Drill a mounting hole, and toe-screw through the back end of the seat support (I) and into the rear upright (C). Repeat the process described in steps 1 and 2 to attach the opposite end frame.

3 With the chair still on its side, glue and screw the bottom cross-member (F) in place where shown on the Exploded View.

4 Cut the armrests (P), supports (Q), and brace (R) to size. See the pattern insert for the full-sized pattern of the supports (Q). Cut the brace cleat (S) to size, bevel-ripping the front edge at 15°.

5 Cut half-lap joints on the mating ends of the armrests and brace to the size shown on the Half Lap detail accompanying the Exploded View drawing. Glue and screw the armrests to the brace.

6 Transfer the shape from the Armrest drawing, and cut the armrests front corners and outside back corners to shape.

7 Using the pattern on the insert, cut the supports (Q) to shape.

8 Position and clamp the armrest assembly (P, R) on top of the end frames and against the back face of the backrest assembly. Drill the mounting holes, and screw the assembly in place. Position and screw the supports (Q) in place.

9 Finish-sand the entire assembly, and add a quality exterior finish. It's critical to get a good seal on the bottom of the base (those parts that come in direct contact with the ground or patio). Recoat the chair annually. ♣



Drill the mounting holes and drive the screws to secure the front seat support to the front upright.

Interested in some matching outdoor furniture?

Our glider and picnic table with benches were such successes, we've put together a WOOD PLAN® of each. Order the Apple Glider, OFS-1028, \$12.95 ppd., or the Apple Patio Table and Benches, OFS-1038, \$12.95 ppd. from WOOD Magazine Plans, P.O. Box 9255, Des Moines, IA 50306. Or call 1-800-572-9350 to order. These plans are also available through our internet site:

<http://www.woodmagazine.com>

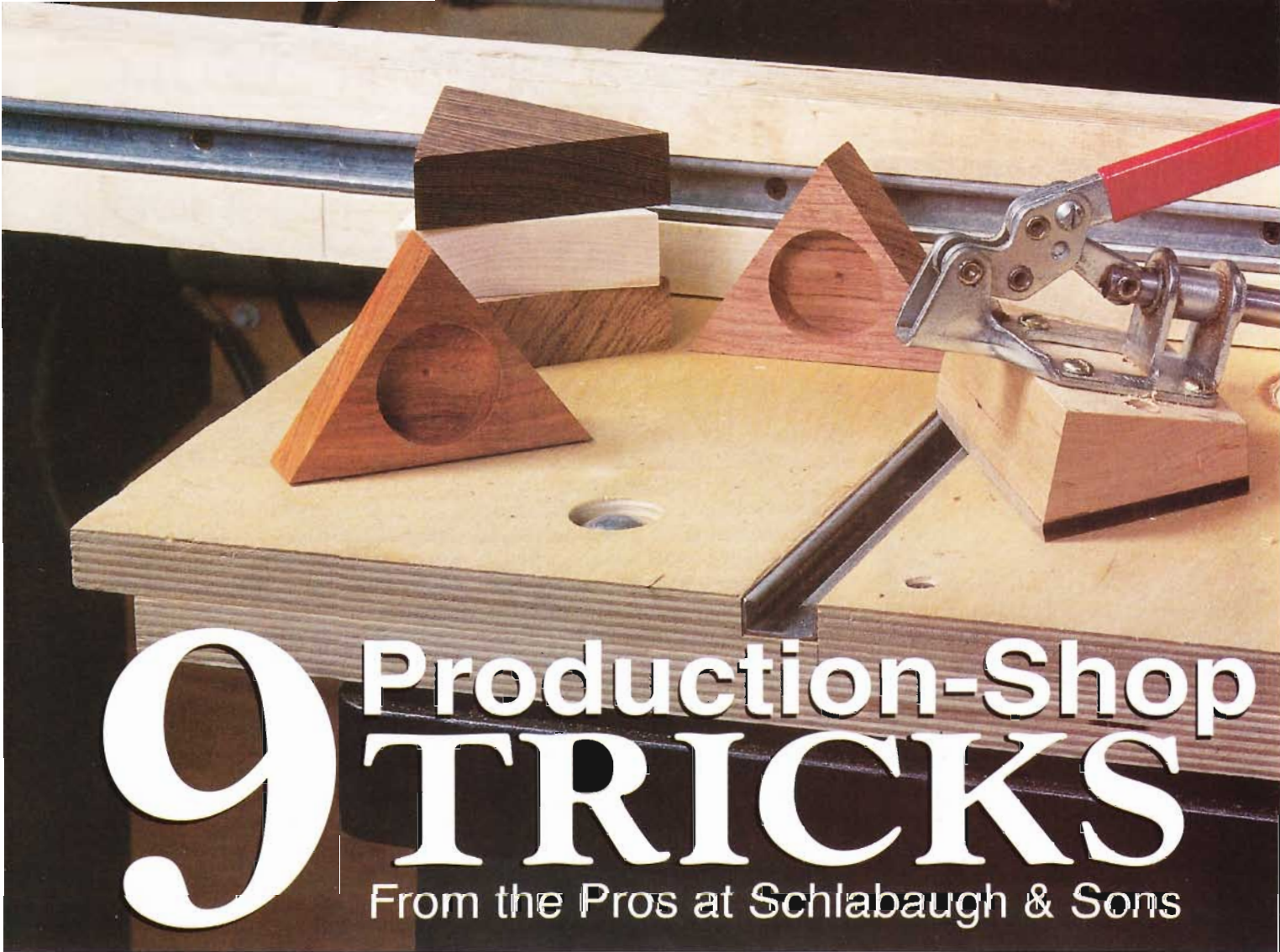

9 Production-Shop TRICKS

From the Pros at Schlabaugh & Sons

When you're woodworking for fun, it's all right to take your sweet time building projects. In fact, stepping back occasionally to admire your handiwork, or carefully working through a new technique, can be among the most enjoyable parts of your hobby. But if you like making multiples of the same project, or if you're in the business of woodworking, speed and efficiency count.

Working smart is one of the things Schlabaugh & Sons prides itself on. These Kalona, Iowa, woodworking pros specialize in building distinctive-looking clocks and other wooden accessories. And fortunately for us, they allowed us to spend a day with them recently to absorb some of their woodworking wisdom firsthand. Here's hoping you can put some of these clever ideas to good use in your shop.

1 Rapid-Fire Hold-down Jig

What's so great about the jig shown *above*? First, it's so simple that you can make it in 15 minutes or less. Second, because it's wedge shaped, it puts forward and

downward pressure on the workpiece. And third, the toggle clamp makes it possible for you to machine parts at an incredibly fast clip. Now, how can you beat that?

2 Shrink-Wrap Your Project Parts

From time to time, you've undoubtedly heard other woodworkers say, "It really wouldn't take me much longer to build six of these than it would just one." To a large extent, that's true. Once you're set up to machine, drill, sand, and finish, for example, doing multiples goes pretty quickly.

But what do you do if you need to store the project parts until you're ready to do the assembly? Schlabaugh bundles like parts together and wraps them with shrink-wrap material.

"What does that do?" you ask. Two things, actually. The material, when wrapped completely around the parts, slows the passage of

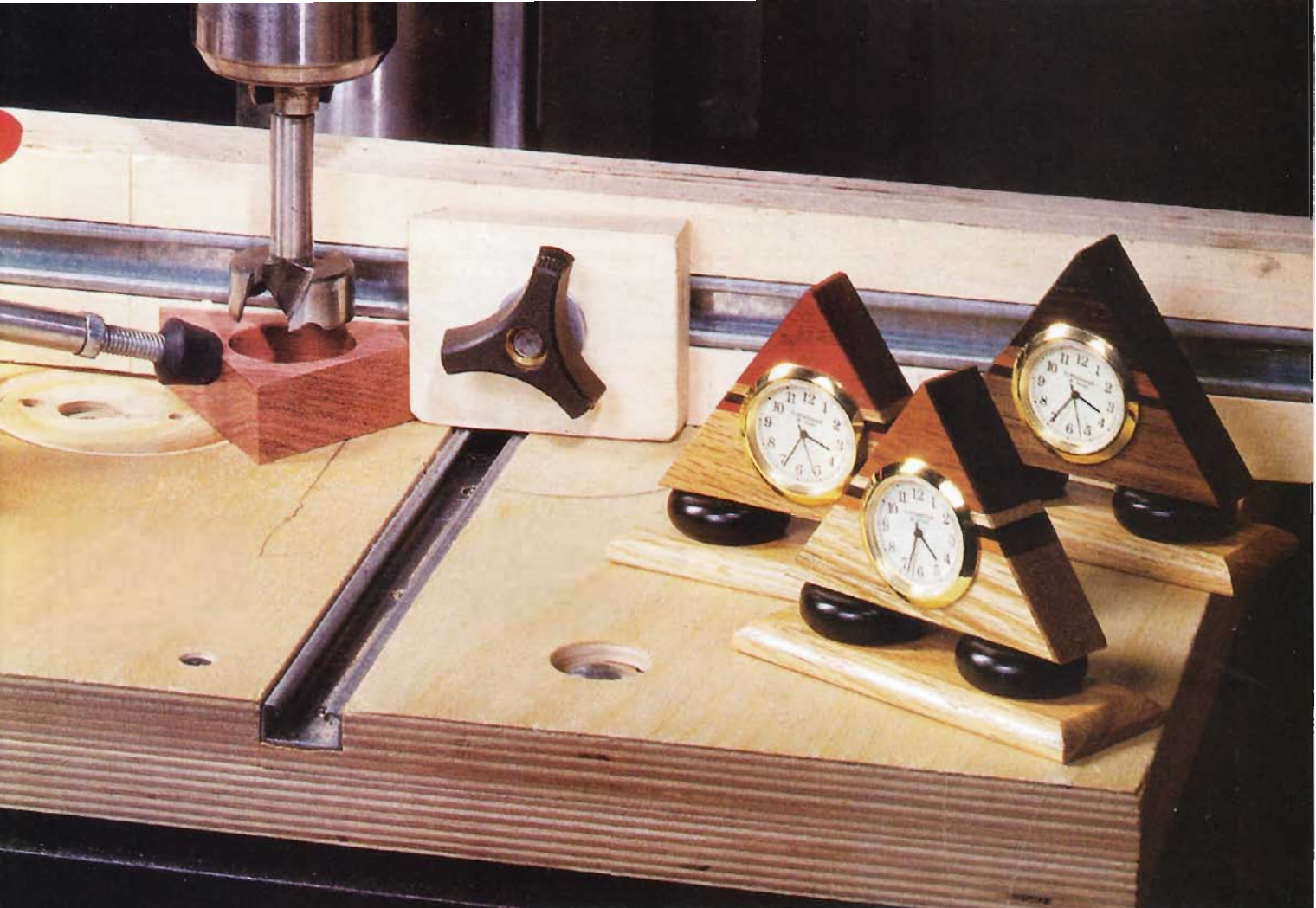

3 In-a-Jiffy Marking Jig

Say you want to make a dozen or more small mantel clocks to sell at a crafts fair, or to give for Christmas gifts. This unbelievably simple marking jig will speed the process considerably.

First, make a template of the clock body, and fasten an edge guide to the template. Now, lay out the centerpoint of the hole you'll drill later to accept the clock movement.

Then, drill a hole in the template to accept a threaded insert, drive in the insert, and thread a screw into the insert. Make sure the screw extends slightly below the template. (You could do the same thing with a brad.)

Next, rip the clock body stock slightly wider than the width of the clock body. And finally, with the edge guide against the ripped

edge of your stock, lay out your clock bodies. Be sure to tap the hole-centering screw (or brad) at each location.



moisture to the wood. And second, this technique binds the parts together tightly, thereby reducing the chances of the material warping or otherwise distorting.

You can get the shrink-wrap material and the dispenser at most home centers. Or, use some Saran Wrap, if you're in a bind.



Continued

4 Machining Multiple Projects From a Single Blank

Many of the items the woodworkers at Schlabaugh's build are relatively small. But, for safety's sake, they always machine the largest pieces of material possible. And they recommend that you do the same.

In the instance of projects like the clocks shown here, machining both ends of a workpiece, then cutting the workpiece in half is a lot safer than working with two smaller pieces. Give this technique a try in your shop, and we think you'll see why we think so much of it.



5 Arch Cutting Made Easy

Chances are good that you have a circle-cutting jig. But did you know that you also can adapt a similar principle to cut arches with a bandsaw?

In the example shown here, an auxiliary table fastens to the bandsaw table by way of metal channel (clamps would work, too). For these clocks, Schlabaugh woodworkers know that the left edge of the jig must be $5\frac{7}{16}$ " from the left edge of the bandsaw table to cut correctly.

A paddle outfitted with a toggle clamp holds the stock to be cut and rotates it through the blade. Here, a sharp $\frac{1}{4}$ " blade is the key to cutting success. See the drawing at *right* for how the jig goes together.





6 A Positive-Stop Sanding Jig

When Schlabaugh has a batch of parts that need to be sanded to the exact same length in a hurry, the guys rely on the clever sanding jig shown here. "Why not just use a power miter saw to do the job?" you may ask. According to Sam Williams, one of the firm's woodworkers, using the jig results in better grain opening, which results in better glue joints. And it's more accurate to boot, for both 90° and miter angles.

Actually, the jig couldn't be simpler. A cam-action clamp holds the workpiece tight against an auxiliary table, which slides back and forth between two channels.

Take a look at the sketch *below*, and you'll see that the sliding table stays snug between the channels and that precise lengths are a breeze to achieve with an adjustable stop. Pretty ingenious, don't you think?

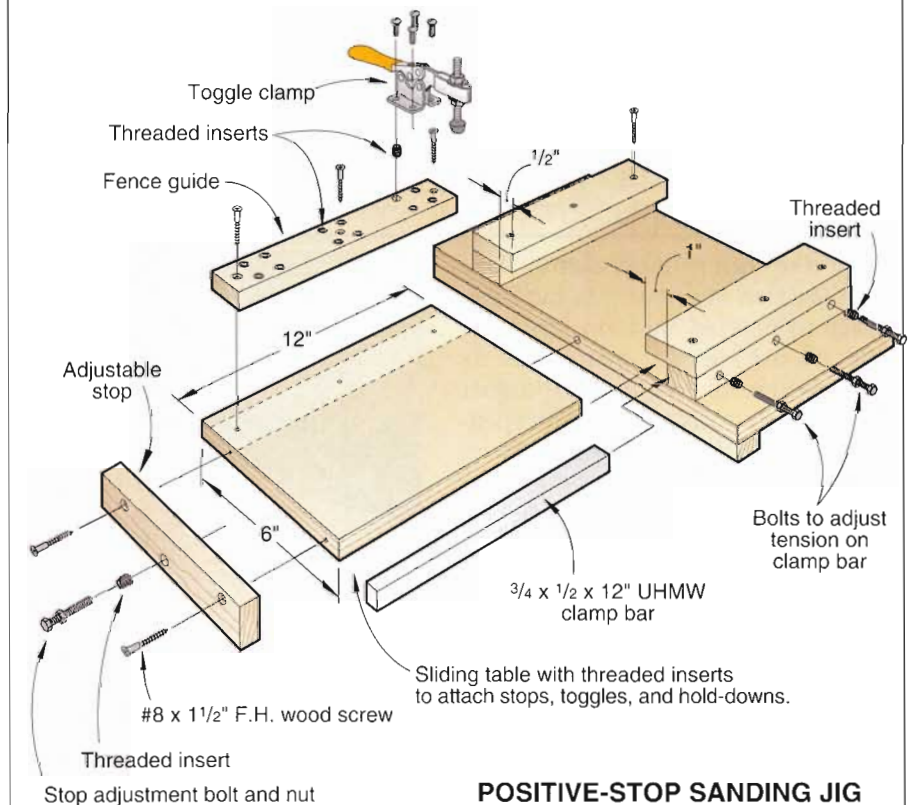
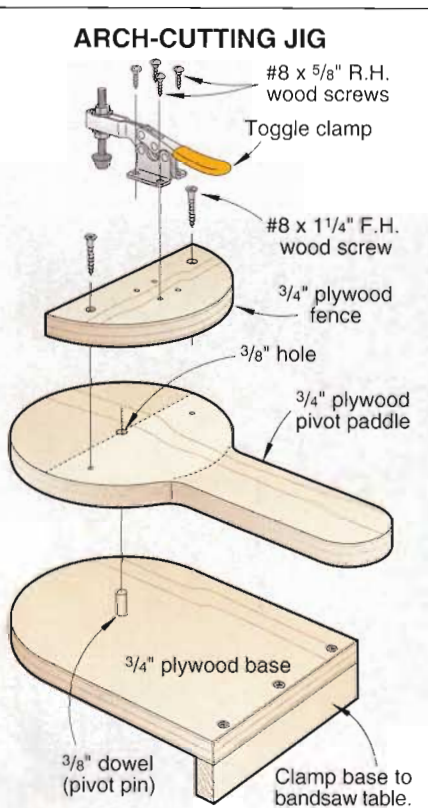

POSITIVE-STOP SANDING JIG

Continued

9 Production-Shop TRICKS

7 Consider Making a Glue-Up Fixture

Waiting for a glue-up to dry overnight usually isn't a big deal for most of us. But production woodworkers have to move faster to use their time wisely and make money.

Take a look at the situation portrayed here. It shows a simple jig that helps Schlabaugh glue up parts for several marking gauge bodies at once. And if that weren't enough, they can then remove the glue-up from the jig, with the clamps still in place, make up some more bodies, and keep on going until they run out of clamps. Whew!

And talk about accurate. The design of the jig, shown in the sketch, allows a worker to position one strip of wood on the three support cleats, short blocks between the polyethylene spacer strips, and the top piece on top of the blocks. Perfect every time!

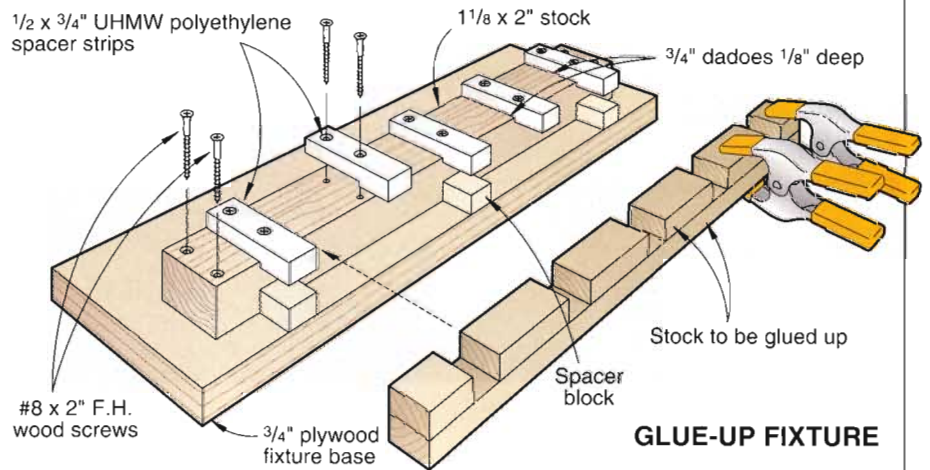

8 A Radial-Arm Saw Auxiliary Table That Prevents Fence Wear and Tear

If you're fortunate enough to have a radial-arm saw that you can dedicate to making right-on 90° cuts, here's an idea for you. Take as much time as you need to adjust your saw so it's perfectly perpendicular to the saw's fence. Now, lock it in place.

Then, if you need to make dados, grooves, or rabbets, simply install your dado set, position the auxiliary table atop the saw table, raise the blade to the appropriate height, and make your cuts.

When you're finished, remove the auxiliary table, change blades, and lower the blade back down for your next cutting operation.

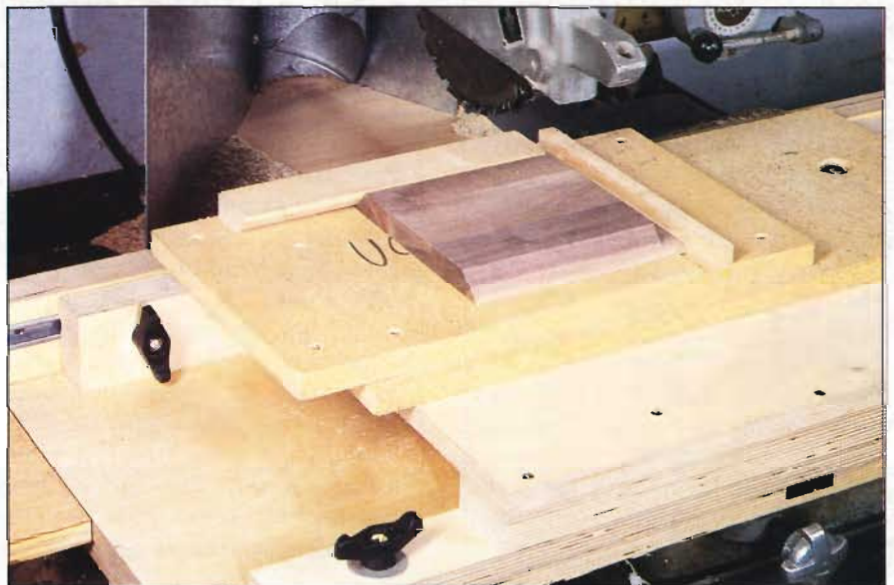

9 Jigging Up For Bevel-Cutting Small Parts

As you probably already know, machining small parts—especially sawing them—can be both tricky and dangerous. Here's a novel way to cut bevels on small parts without getting your hands in harm's way.

The toggle clamp attached to the jig shown here securely captures the small part as the jig slides forward along the rip fence. See the drawing *below* for how the jig goes together. Make one of these for each degree bevel you want to cut.

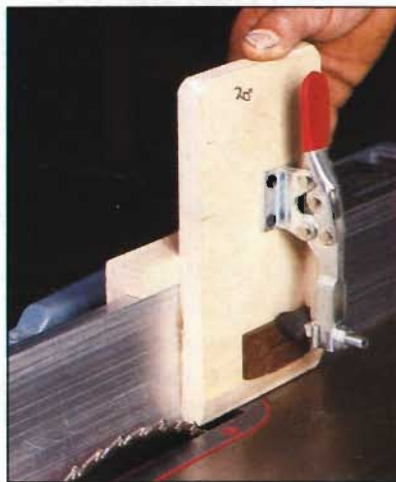

SMALL-PART BEVEL JIG

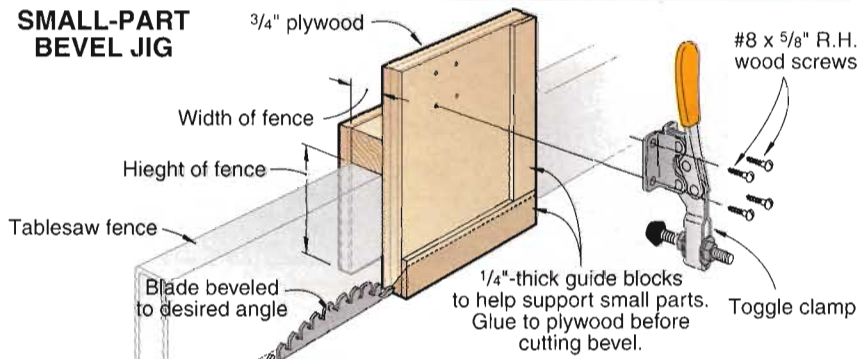

RADIAL-ARM SAW AUXILIARY TABLE

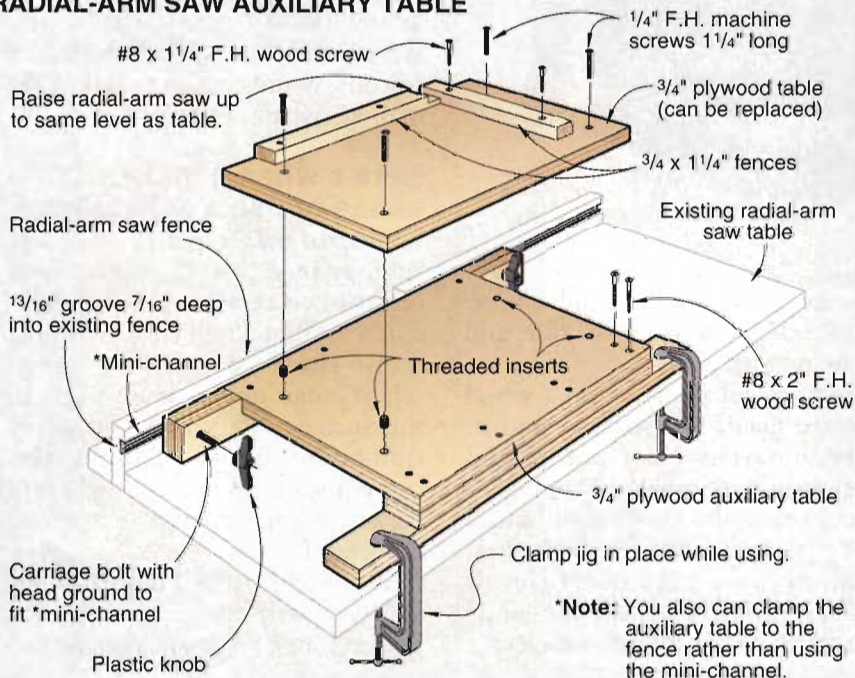

Show Us Some of Your Best Woodworking Tricks

If you have some production-oriented tricks up your sleeve, we'd like you to share them with us so that we can pass them along to other *WOOD*® magazine readers. If we get enough ideas to do another article like this one, we'll publish them in an upcoming issue.

So, what's in it for you? Everyone whose trick we publish will receive their choice of finished Collector's-Edition Hand Tool from the Plans, Jigs, and Kits catalog you received along with the December issue. And the person who sends in the best idea also will get a *WOOD* magazine Easy-to-Assemble Universal Tablesaw Jig Kit.

Send your idea to the address listed *below*, along with a photo or sketch, by May 1, 1998, and we'll get back to you with the results as soon as possible. Good luck! Send your entries to:

My Best Woodworking Tricks
WOOD® magazine
 1912 Grand Avenue
 Des Moines, Iowa 50309-3379

Buying Guide

If you need any of the metal channels, toggle clamps, or knobs used in the jigs shown in this article, contact Schlabaugh & Sons Woodworking, 720 14th Street, Kalona, IA 52247. To order, call 800/346-9663 or e-mail them at schsons@kctc.net. If you want to see some of Schlabaugh's clocks, ask them to send you a catalog.

To take a look at the woodworking jigs we have for sale, refer to our catalog in the December 1997 issue. Or visit our web site at www.woodmagazine.com.

Written by Larry Clayton with John Schlabaugh, Sam Williams, and Eldon Miller
 Photographs: John Hetherington
 Illustrations: Kim Downing; Sam Williams; Lorna Johnson

Gel Stains

Thinking thick may solve your finishing problems

If you've never tried gel stains, you're missing out on what could be an important part of your finishing repertoire. In certain situations (that we'll tell you about) these thickened stains perform better than thin-bodied (liquid) stains. But, they do have limitations. And, as we discovered, subtle differences exist between the three major brands we tested.



Nevertheless, gel stains do have certain drawbacks. We avoid them on projects with lots of tight corners and crevices because the stain collects in these tight spots and is hard to remove. Thin-bodied stains don't have this problem because they wick into tight spots and the areas adjoining them. And, because gel stains don't penetrate as well as thin-bodied stains, they don't bring out the "depth" of the wood grain as well as thin-bodied stains. That's why we prefer thin-bodied stains for porous woods such as oak, ash, mahogany, and walnut.

Here's when it makes sense to use a gel stain

• **Nonporous woods.** Species such as pine, maple, cherry, and birch have relatively nonporous surfaces that don't absorb stains well. These woods have areas where edge or end grain pops to the surface. So, when you apply thin-bodied stains to them, you can get splotchy areas of light and dark staining because of uneven absorption.

As shown in the photo *top left on the next page*, gel stains help you achieve uniform coloration

How gel stains compare to thin-bodied stains

To understand how these two types of stains behave differently, imagine a piece of wood as if it were a slice of bread. Applying a gel stain to wood is like spreading peanut butter onto bread. The peanut butter sticks, but it doesn't penetrate the porous surface of the bread. You can spread the peanut butter, but you can't apply it in a thin or translucent

layer the way you can, say, warmed butter. Like fluid butter, thin-bodied stains go on thin and penetrate the surface.

Because gel stains lie on a wood surface instead of soaking into it, they uniformly color porous and nonporous areas alike. That makes them relatively goof-proof, and a great help to novice finishers. And, because they don't run or splatter, they're especially handy for applying to vertical surfaces.

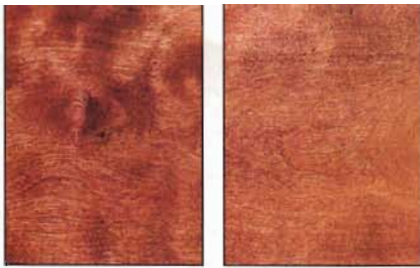

We treated the left side of this birch board with conditioner and a thin-bodied stain. The right side, where we applied a gel stain, shows much more even coloration.

on these woods. Although you can buy “conditioners” specially made for sealing hard-to-stain woods prior to staining with thin-bodied stains, that combination did not give us as good a result as gel stains did.

• **Woods of different species or grain appearance.** Sometimes you can't avoid combining woods of slightly different coloration or mismatching grain patterns in the same project surface. For example, various red oak boards may vary from pale white to pink in tone, and they may have flatsawn or quartersawn grain patterns. If economics dictate that you must use such boards together, you can help give the surface a uniform appearance by using gel stains.

• **Wood graining on man-made surfaces.** Today, you can buy fiberglass and hardboard doors with a wood-grain embossed surface, and steel doors with nonembossed surfaces. Gel stains help you give both types of surfaces a grain-like appearance.

With embossed surfaces you simply apply a gel stain. Because it doesn't spread out, the stain stays on the flat surfaces and collects in heavier amounts in the embossed crevices of the grain.

This same nonspreading quality makes gel stains ideal for applying artificial wood grain to flat surfaces, such as steel doors, with a wood-graining tool. The *top middle* photo shows what happened when we used this tool with thin-bodied and gel stains.

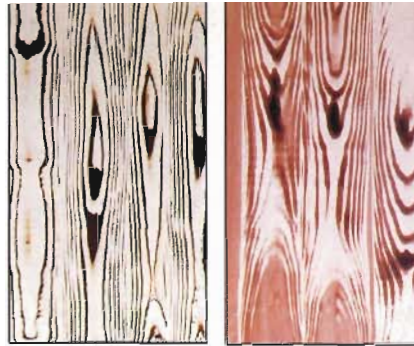

As shown on this plastic-coated surface, gel stains (left) hold a grain pattern better than thin-bodied stains (right), which spread after application.

Note: Zar wood stain, although not a gel stain, is thicker than thin-bodied stains and also works for wood graining. Zar products are made by UGL (800/845-5227).

• **Adding a patina look to country projects.** Because gel stains collect in crevices, they also help you give country projects such as the candle box *below* a faux patina. You simply wipe on the stain, then wipe it off, leaving the stain in crevices and other spots where dirt would accumulate over the years.

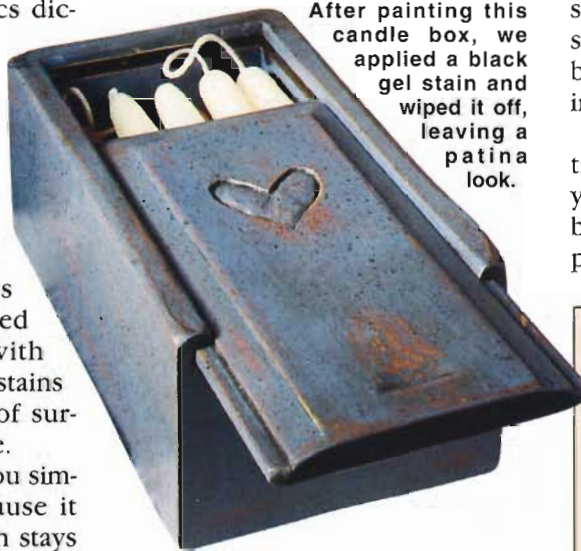

After painting this candle box, we applied a black gel stain and wiped it off, leaving a patina look.

A few words about the three brands we tried

As the photo *top right* reveals, the three gel stains we tried varied considerably in thickness. The Minwax product was just slightly thicker than the Bartley product, and the Wood-Kote stain was considerably thicker than the other two. So, the Wood-Kote product



The three gel stains we tested, from left, Bartley, Minwax, and Wood-Kote, varied in thickness as shown in this run test.

possessed all of the qualities—and drawbacks—of a gel stain to a greater degree than the others.

For example, the Wood-Kote did the best job of masking uneven wood coloration and graining, but it was also the hardest to apply and wipe off. Removing it from crevices was a chore.

If you're a novice and you like the goof-proof nature of gel stains, you can use the Bartley and Minwax products for all of your staining work. Regardless of your skill level, the Wood-Kote seemed best suited to the tasks described in the previous section.

So go ahead and give gel stains a try. Just remember to always test your stain on a sample piece before applying it to your project. ♣

Where to call for more information

Minwax

10 Mountainview Road, Upper Saddle River, NJ 07458-1934
homepage: <http://www.minwax.com>

Bartley Collection

65 Engerman Ave.
Denton Industrial Park
Denton, MD 21629
Call: 800/787-2800

Wood-Kote

P.O. Box 17192
Portland, OR 97217
Call: 800/843-7666
homepage: <http://www.woodkote.com>

THE WOOD® GANG

MAKES MUSIC

FROM KITS

What does it take, besides patience, to build stringed instruments? Find out what we discovered when we tackled three different mail-order kits—two guitars and a mountain dulcimer.



Larry Clayton, in the black hat, can't compete with country singer Garth Brooks, but he does now know how to build a guitar. Jan Svec built the small, but sound-worthy, guitar for his son. And Cheryl Cibula, an accordion player at heart, has vowed to learn dulcimer tunes with the walnut one she built from a kit.

Making a finger pickin'- style guitar

Larry Clayton, editor

I'll call this exercise "What I learned at guitarmaking school." Although it wasn't school, it was a learning process.

The kit arrived with all parts present and accounted for (except a Martin guitar logo decal like the ready-made ones from this famed factory boast), and everything from the wood to the hardware was of good quality and well machined. The body sides were prebent and the neck basically preshaped. So, any problems I had weren't with the kit parts—they began with the badly executed instruction manual, which was woefully lacking in how-to drawings and/or photos. However, I did pick up some new wood-working knowledge and skills along the way (with a little help from C.F. Martin's technical hot line personnel).

The sides of my guitar are cherry. So is the back, and edge-gluing



its two thin, bookmatched panels together required an elaborate clamping setup. Thankfully, everything went well.

Cutting the rabbets to accept the contrasting binding around the top and back of the body proved interesting, too. The rabbet is only about $\frac{1}{16}$ " thick, so cutting it required a simple-to-make jig to guide the laminate trimmer. That was easy compared to fitting the neck to the body. The tolerances were small and the angles had to be precise for this mortise-and-tenon attachment which required lots of sanding to get it right.

As it is on mine, Sitka spruce is the wood of choice on most guitar tops. The vertical-grain wood provided glued and sanded easily. And because of the wood's ability to transfer sound, the manufacturer suggests that only four or five coats of finish be applied to the guitar top to preserve this characteristic. Yet finishing is a major part of the guitarmaking process, I discovered.

I coated mine with Deft Satin and Deft Gloss Clear Finish, both spray lacquers. First, I sanded the neck and body to 320-grit, then I applied 10 coats to the sides and back and

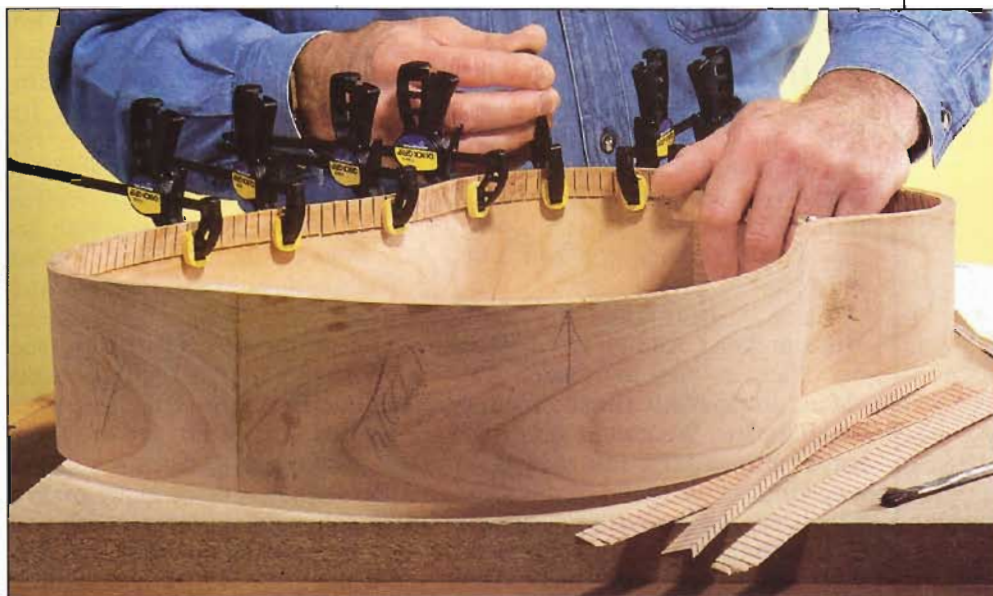

Clamping the ribbing inside the body was just one of the new woodworking techniques Larry learned while building his guitar from a kit.

four coats to the top. After letting the finish set up for two days, I sanded up to 1,500-grit with wet/dry abrasive, and finished with 3M's Finessit-II polishing compound. The Finessit-II really made the finish pop.

Stringing the guitar—a matter of careful measuring and tensioning—

was tedious but not difficult. All in all, I spent at least 40 hours building this OM-style (orchestra model) guitar that has a darn good sound. I'm told country singer Garth Brooks uses one like it. I'm sure, though, that it'll take me more than a week to reach his playing level.



Cherry OM guitar kit

The kit consists of precut and shaped cherry sides, bookmatched cherry back, vertical-grain spruce top, mahogany neck, rosewood bridge and fingerboard, steel strings, mother-of-pearl inlays, instruction book. Maple may be substituted for cherry. Length: 40". Kit no. 18KITZ, \$360 plus \$8 shipping in the U.S., from *The 1833 Shop, Guitarmaker's Connection, a division of the Martin Guitar Company, P.O. Box 329, Nazareth, PA 18064-0329. 800/247-6931.*

Free 27-page catalog.

MUSIC FROM KITS

Building the Guit-A-Long guitar

Jan Hale Svec, assistant design editor

One of my 12-year-old sons (I have twins) had wanted a guitar for the past few years. So, when the opportunity came to build one from a kit, I took it.

The day that the box from Musicmaker's Kits showed up in my office, my first impression was, "Man, look at all these strange-looking parts. What did I get myself into?" But what I found was 11 nicely machined wood parts (six of which needed no further shaping), all the hardware, including a set of steel strings, and the most complete illustrated instruction booklet I have ever read.

One of the first things I encountered in the booklet was a box titled BEFORE YOU BEGIN. It suggested that I read through the entire booklet before beginning. Good advice! Following it familiarized me with building the instrument and helped dispel any misgivings about successfully completing the project.

Because the process of building the guitar is a series of small steps separated by waiting for glue to dry, it's perfectly suited to the weekend/evening woodworker. Many of the operations, such as

gluing the sides and back to their braces, installing and trimming the soundboard, and gluing in the fretboard, take half an hour. But shaping the neck and peghead, fitting the binding, and installing the fret wires and dots took me up to two hours each. In all, I spent about 10 hours unpacking the kit, reading the instructions, and constructing the guitar. That time didn't include the finishing. There, I got a little carried away.

The guitar offered the perfect opportunity to try a highly polished lacquer finish. So after two good coats of gloss Deft, I wet-sanded the guitar with 400-grit sandpaper. Then I applied three more coats of Deft followed by wet-sanding with 600-grit sandpaper. Next, I shifted to a progression of wet-sanding with 1,500-, 2,400-, 3,600-, and 6,000-grit Micro-Mesh. A final polish with Watco Finishing Wax really made it shine. And for a small instrument, it has buoyant sound.

There are a couple of features associated with this kit that I really like. One is the availability of some worthwhile options, such as decorative binding for the body, mother-of-pearl for the fretboard, and a choice of laser-cut rosettes for the soundhole. The other is the opportunity to customize the top profile of the peghead and the bottom end of the fretboard. I did, and now I know that my guitar is one of a kind.



Jan uses the laminate trimmer to trim the sound board on his small guitar.



Guit-A-Long guitar kit

The kit includes mahogany neck and sides, laminated spruce top and back, padauk fretboard, bridge, tail, and steel strings. Length: 36". Kit no. GUIT-80, \$149.95 plus shipping. Mother-of-pearl marking dots, 75 cents each. Cloth strap and buttons, \$14.95, from *Musicmaker's Kits, Inc.*, P. O. Box 2117, Stillwater, MN 55082-3117. 800/432-5487. Free 32-page catalog.

Just hours for an hourglass dulcimer

Cheryl Cibula, senior graphic designer

I ordered the walnut dulcimer kit because the manufacturer recommended it as carefully designed for ease of construction. Plus, it was said to produce a high-quality, traditional instrument with good sound.

Upon opening the box, I found nice-quality wood and fine-quality tuning gears. It also had complete instruction sheets and drawings for assembly and tuning, along with a simple song to play.

For the most part, the pre-machined pieces—the sides, scroll head, and tailstock—fit together well. Some joints, such as at the scroll head, were too snug, so I did a small amount of sanding. I also found several pieces that I couldn't exactly identify in the drawings for precise placement. With educated guesses, I put them where I thought they should go.

Sometimes I was stumped by directions referring to a specific length and drawings showing one quite different. Since the supplier's help hot line only operates 9 a.m. to 5 p.m., I had to figure out which was correct.

The drawings were all hand-done, which was okay for building. But hand-done drawings just don't work for full-sized patterns of the sawn tone holes on the soundboard. I had to go to another reference book to find ones (hearts, as it turned out) that would work. I ended up drilling some small holes below them because I was concerned that they weren't large enough to provide adequate volume. I'm not certain the holes helped sound quality, but they look great and give the dulcimer my personal touch!

When clamping assemblies together—the halves of the soundboard, the soundboard and back to the sides—I used plenty of glue to avoid

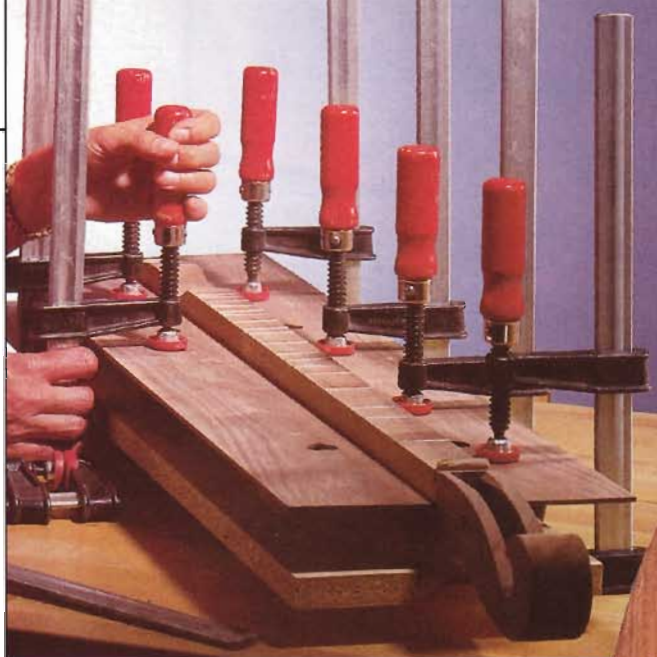

After gluing and clamping the walnut soundboard, Cheryl had to trim it to match the sides of her dulcimer.

starved joints. There definitely was glue squeeze-out as recommended in the instructions—no way will it come apart.

To start the finishing, I sanded down to 120-grit. By this time, though, I had seen Larry's and Jan's instruments, and I couldn't help but follow suit with multiple coats of Deft and fine sanding. Unfortunately, I blew through the finish along the edges and had to recoat those spots. The final 6,000-grit polishing resulted in a luster that made me proud to say, "Hey, I made this!"

I felt the kit was fairly simple (it took about 12 hours), the stringing was straightforward, and the instrument produces a nice sound. But compared to my accordion, its music takes getting used to. ♣

Hourglass dulcimer kit

The kit features shaped solid walnut sides, soundboard, back, and fingerboard. Soundboard and sides are bookmatched, and the fingerboard is fretted. Assembled length: 37½". Kit no. 307, \$132.88 plus shipping, from Stewart MacDonald's Guitar Shop Supply, 21 N. Shafer St., Box 900, Athens, OH 45701. 800/848-2273. Free 104-page catalog.

Photographs: Hetherington Photography



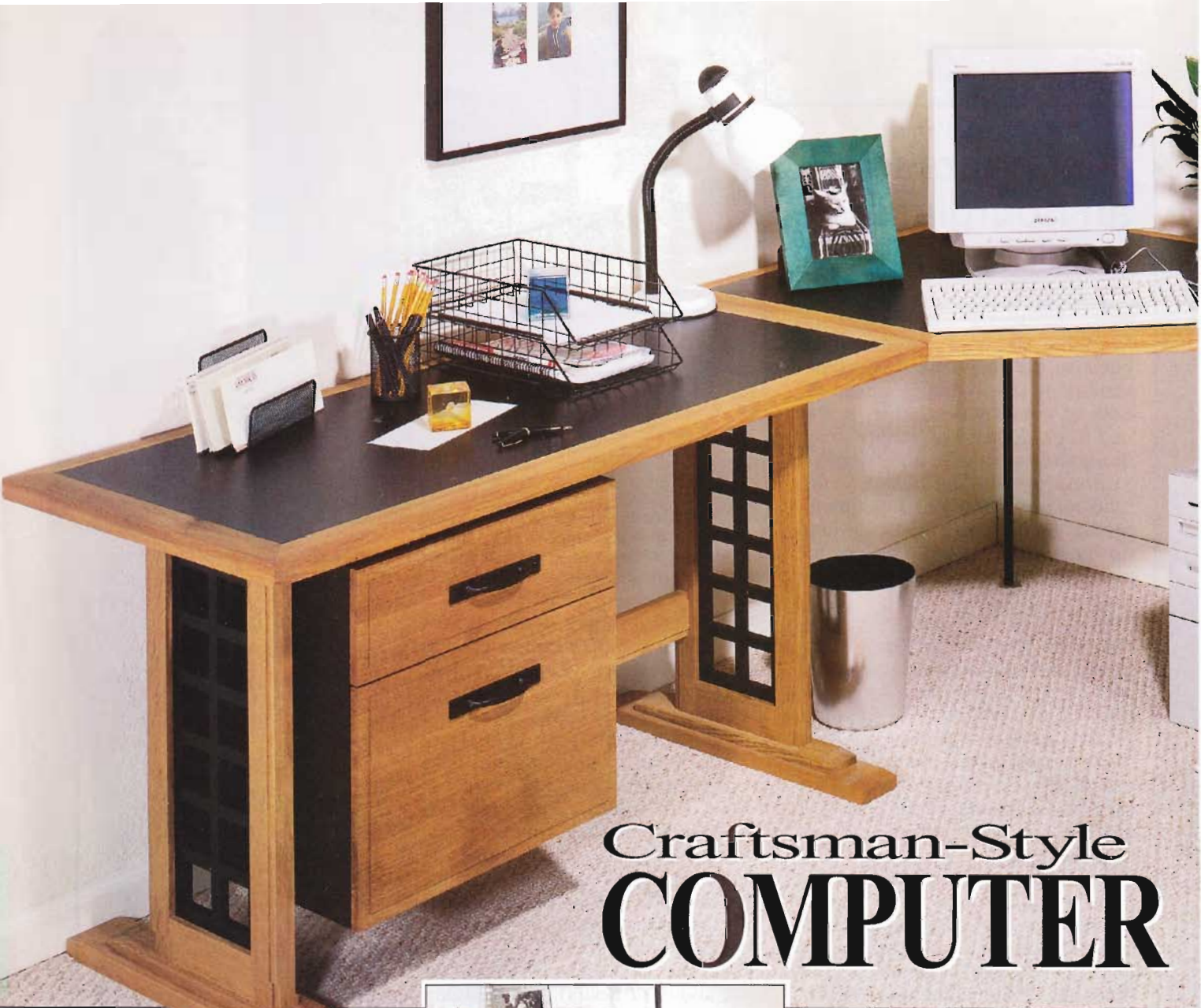

Craftsman-Style COMPUTER

Ask anyone who has a computer, and they'll tell you their old writing desk doesn't cut it in today's home office. And yet, no two office areas are alike. For that reason, we designed this handsome three-piece corner combo. Build all of our modular furniture components if you have the room, or economize and just make the single desk. There are no bad choices.



Add valuable storage with a drawer cabinet and drawers. The cabinet hangs from the top stretcher joining the end supports.

Start by cutting and machining the support pieces

Note: The instructions, Bill of Materials, and Cutting Diagram are for the L-shaped desk with four supports and three tops as shown above. If you decide to build just a single unit (above right) or another combination, adjust the number of pieces accordingly. If room exists, consider lengthening either the right- or left-hand units for more work space.

1 Cut the support frame bases (A), base tops (B), and tops (C) to the sizes listed in the Bill of Materials.

2 Clamp a block of wood (we call this a carriage board) to a base piece



Build just two gridded supports and a banded top for a stylish writing table or work surface for crafts or hobbies.

6 Using the Bottom Rail detail accompanying the Base Exploded View drawing for reference, cut the grooves in the top and bottom rails (D) and uprights (E).

7 Using the Bottom Rail detail for reference, cut the rabbets in each rail (D) to form a tenon that fits snugly into the groove in each upright (E).

8 Mark the mortise locations on the *inside face* of the *back uprights only* where shown on the Mortise detail. Machine the mortises. (We hogged out most of the waste with a Forstner bit, and then chiseled the sides with a mortise chisel.)

Now, let's add the inner grid to each support frame

1 Cut the support grid stiles (F, G) and rails (H, I) to size. (We planed our stock about $\frac{1}{8}$ " less in thickness than the width of the grooves in D and E. If the fit is too tight now, you'll scrape off the paint when fitting the assembled grid in the uprights and rails later.)

2 Using the dimensions on the Support Grid drawing, mark the dadoes and rabbets on the stiles (F, G) and rails (H, I). Using a tablesaw and a miter gauge fitted with an auxiliary fence and stop for consistent cuts from piece to piece, machine each stile and rail.

3 Glue and clamp the grid pieces (F, G, H, I) together, checking for square. Wipe off any excess glue with a damp cloth. (As shown in

Continued

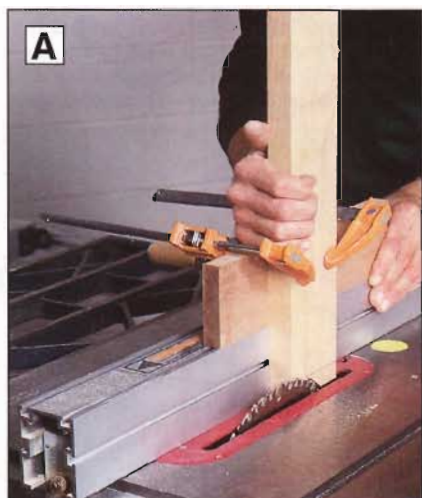

Clamp a base piece to a carriage board, and ride it along the rip fence for support when bevel-cutting the ends.

(A), and use it to ride on the fence as shown in *photo A*. The carriage board supports the pieces when bevel-cutting the ends of A and B at a 10° angle where shown on the Base Exploded View drawing.

3 Rout a $\frac{1}{8}$ " chamfer along the edges of parts A and B where shown on the Base Exploded View and Parts View drawings. The Parts View drawing is on the *WOOD PATTERNS*® insert in the center of the magazine.

4 Cut the support rails (D) and uprights (E) to size.

5 Cut a $\frac{1}{2}$ " rabbet $\frac{1}{8}$ " deep along the outside edge of each upright (E) where shown on the Base Exploded View drawing on the *next* page.

Computer Center

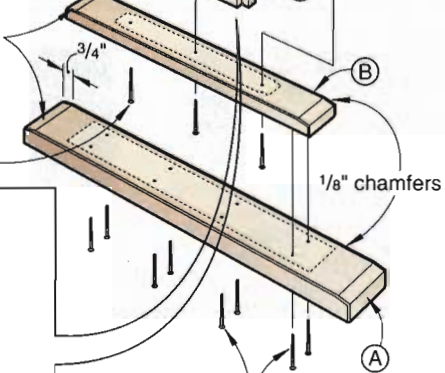
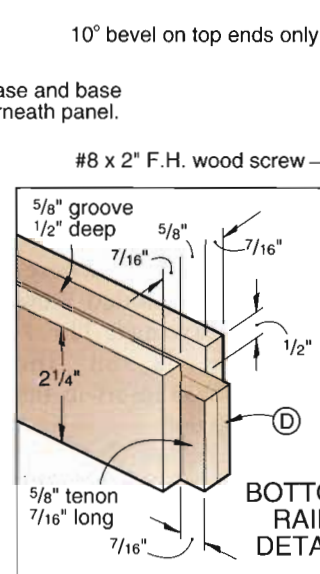
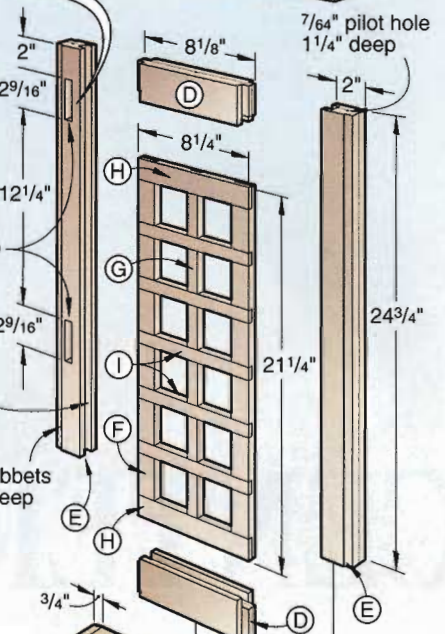
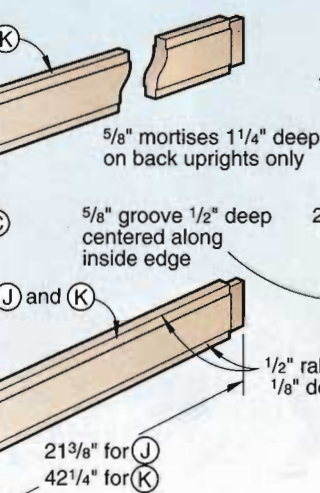
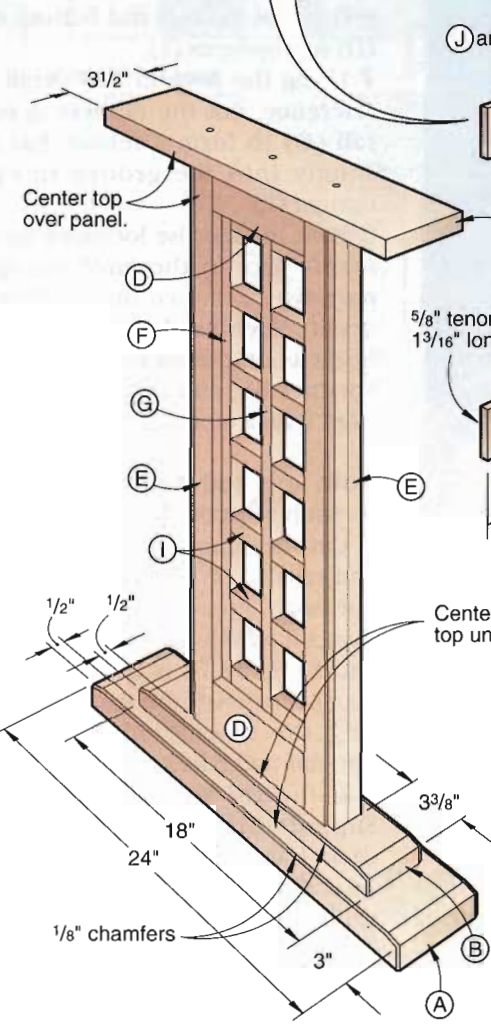
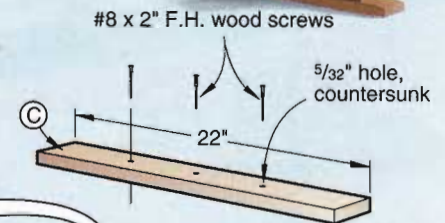
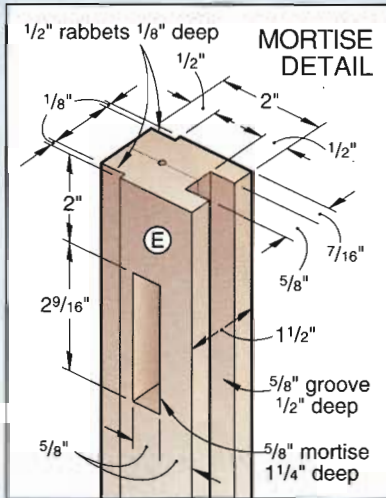
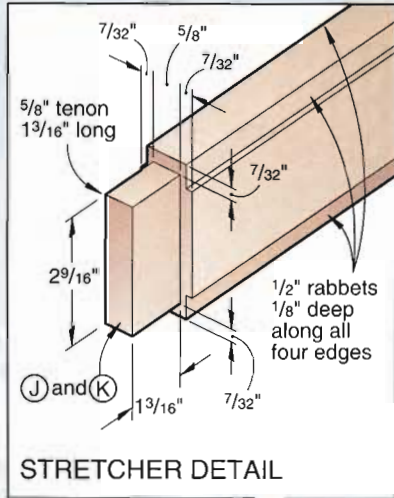

SEE THE
WOOD PATTERNS®
INSERT FOR
FULL-SIZED PATTERNS

Bill of Materials

Part	Finished Size			Mati.	Qty.	Part	Finished Size			Mati.	Qty.	Part	Finished Size			Mati.	Qty.
	T	W	L				T	W	L				T	W	L		
SUPPORT FRAMES						BANDING						DRAWER					
A bases	1 1/16"	3 1/2"	24"	QO	4	O* end tops	3/4"	2"	24"	QO	6	CC sides	1/2"	5"	13 1/2"	QO	2
B base tops	3/4"	2 1/2"	18"	QO	4	P* end btms.	3/4"	1"	24"	QO	6	DD sides	1/2"	10 1/2"	13 1/2"	QO	2
C tops	3/4"	3 1/2"	22"	QO	4	Q* front & back top, short unit	3/4"	2"	32"	QO	2	EE back	1/2"	4 1/2"	15 3/4"	QO	1
D rails	1 1/2"	2 1/4"	8 1/8"	LO	8	R* front & back btm., short unit	3/4"	1"	32"	QO	2	FF back	1/2"	10"	15 3/4"	QO	1
E uprights	1 1/2"	2"	24 3/4"	LO	8	S* front & back top, long unit	3/4"	2"	52"	QO	2	GG front	3/4"	5"	15 3/4"	QO	1
SUPPORT GRIDS						DRAWER CABINET						SUPPORT BLOCK					
F stiles	5/8"	1 1/4"	21 1/4"	B	8	T* front & back btm., long unit	3/4"	1"	52"	QO	2	U* back tops, corner unit	3/4"	2"	38"	QO	2
G stiles	5/8"	3/4"	21 1/4"	B	4	V* back btms., corner unit	3/4"	1"	38"	QO	2	W* front top, corner unit	3/4"	2"	19 13/16"	QO	1
H rails	5/8"	1 1/4"	8 1/4"	B	8	X* front btm., corner unit	3/4"	1"	19 13/16"	QO	1	Y top & btm.	3/4"	14 1/4"	18 1/4"	BP	2
I rails	5/8"	3/4"	8 1/4"	B	20	DRAWER CABINET						Z sides	3/4"	14 1/4"	19"	BP	2
STRETCHERS						AA back	1/4"	18 1/4"	18 1/2"	BP	1	BB spacer	1 1/16"	1"	18 3/4"	QO	1
J short	1 1/16"	3"	21 3/8"	QO	2	TOPS						LL support block	1 1/2"	4"	4"	LO	1
K long	1 1/16"	3"	42 1/4"	QO	2	L short top	3/4"	20"	28"	PW	1	<p>Buying Guide</p> <p>Hardware. 14" over-travel slide, #89731, \$25.79 per pair for the bottom drawer; 14" full-extension drawer slide, #35685, \$19.49 per pair for the top drawer; two mission-style pulls, #10988, \$10.99; and two backplates, #11014, \$11.99; slip-on folder hangers, #63016, \$4.99 for 4"; iron-on birch edge banding, 1 3/16" x 8", #10801, \$2.99. The Woodworkers' Store, 4365 Willow Drive, Medina, MN 55340, or call 800/279-4441 dept. 98049 to order. See their catalog for more hardware to customize your desk.</p>					
M long top	3/4"	20"	48"	PW	1	N corner	3/4"	34"	34"	PW	1						

*Initially cut parts marked with an * oversized. Then, trim to finished size according to the how-to instructions.

Materials Key: QO—quartersawn white oak, LO—laminated quartersawn white oak, B—birch, BP—birch plywood, PW—plywood.

Supplies: #8x1", #8x1 1/4", #8x1 1/2", and #8x2" flathead wood screws; 1/4" hexhead bolts 2 1/2" long with 1/4" flat washers and nuts; plastic laminate (we used Formica Black, #909); contact cement; 1/8x1 1/2" steel bar stock 18 3/4" long with three #8x2 1/2" panhead sheet-metal screws; 3/4" dowel 27 3/16" long; #18x3/4" wire brads; black spray primer and paint; clear finish.

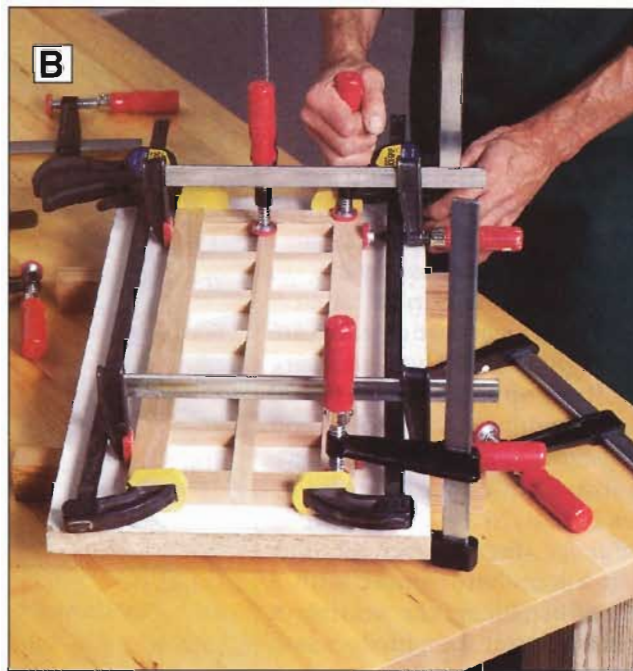
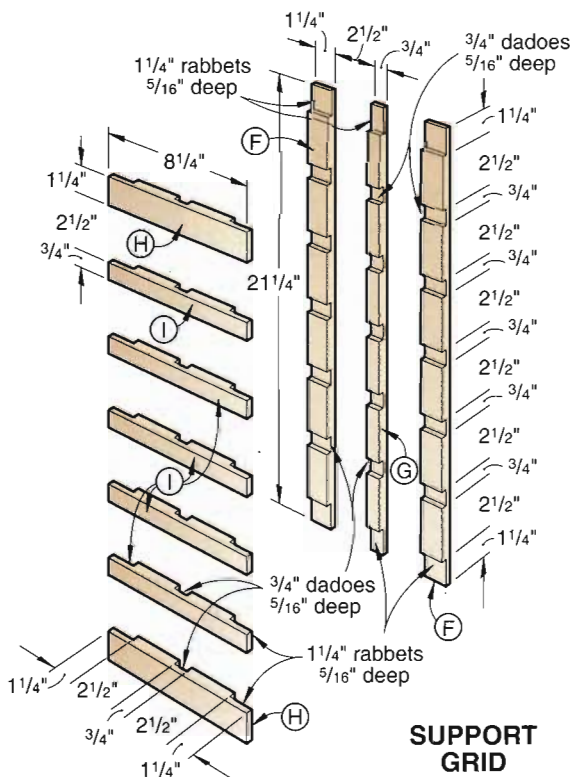

To ensure flat grids, we glued the pieces together, clamped them to flat stock, and left them there until the glue dried.

Continued

Computer Center

photo B, we clamped the pieces together on a piece of flat stock to keep the grid flat.)

4 Sand the grids smooth and paint each grid. (We used Krylon #1316 Charcoal Black all-purpose primer and Krylon #1613 Semi-flat Black spray enamel.)

5 Glue and clamp the grid assemblies between the rails (D) and uprights (E).

6 Drill countersunk mounting holes, and screw B and C to the grid assembly. See the pattern insert for hole locations. Then, drill holes and attach the base (A) to the bottom of each support frame.

Join the supports with a pair of stretchers

1 Cut stretchers J and K to size. (For our units, we used the J's for the shorter desk and the K's for the longer unit. In addition to joining the support frames, the top stretcher supports the drawer cabinet.)

2 Cut a 1/2" rabbet 1/8" deep along each edge of each stretcher (J, K). Cut shoulders across the ends of each stretcher to form a tenon to fit tightly into the previously formed mortises in the back uprights (E).

3 Glue and clamp the stretchers (J, K) between the support frames, checking for square.

Laminate and band the work surfaces

1 Cut the plywood tops (L, M, N) to size. To shape the corner top section (N), mark and cut a 34"-square piece of plywood. Then, measure 21 5/32" from opposite corners and mark a diagonal on the plywood where shown on the pattern insert. Trim just outside the diagonal line with a jigsaw. Next, clamp a wood straightedge directly over the line, and fit a handheld router with a flush-trim bit. Riding the bearing of the bit along the straightedge, rout to the line.

2 Apply the plastic laminate to the three tops using contact cement. (We cut our laminate about 1/2" over-

size in each direction.) Rout the edges of the laminate flush with the edges of the plywood with the same flush-trim bit.

3 Cut the banding (O-X) to the sizes listed in the Bill of Materials plus 2" in length and 1/8" in width.

4 With the outside edges flush, glue and clamp the top banding pieces to the bottom banding pieces where shown on the Banding detail accompanying the Top drawing. Later, joint the outside edge flush. Then, rip the opposite edge (inside edge)

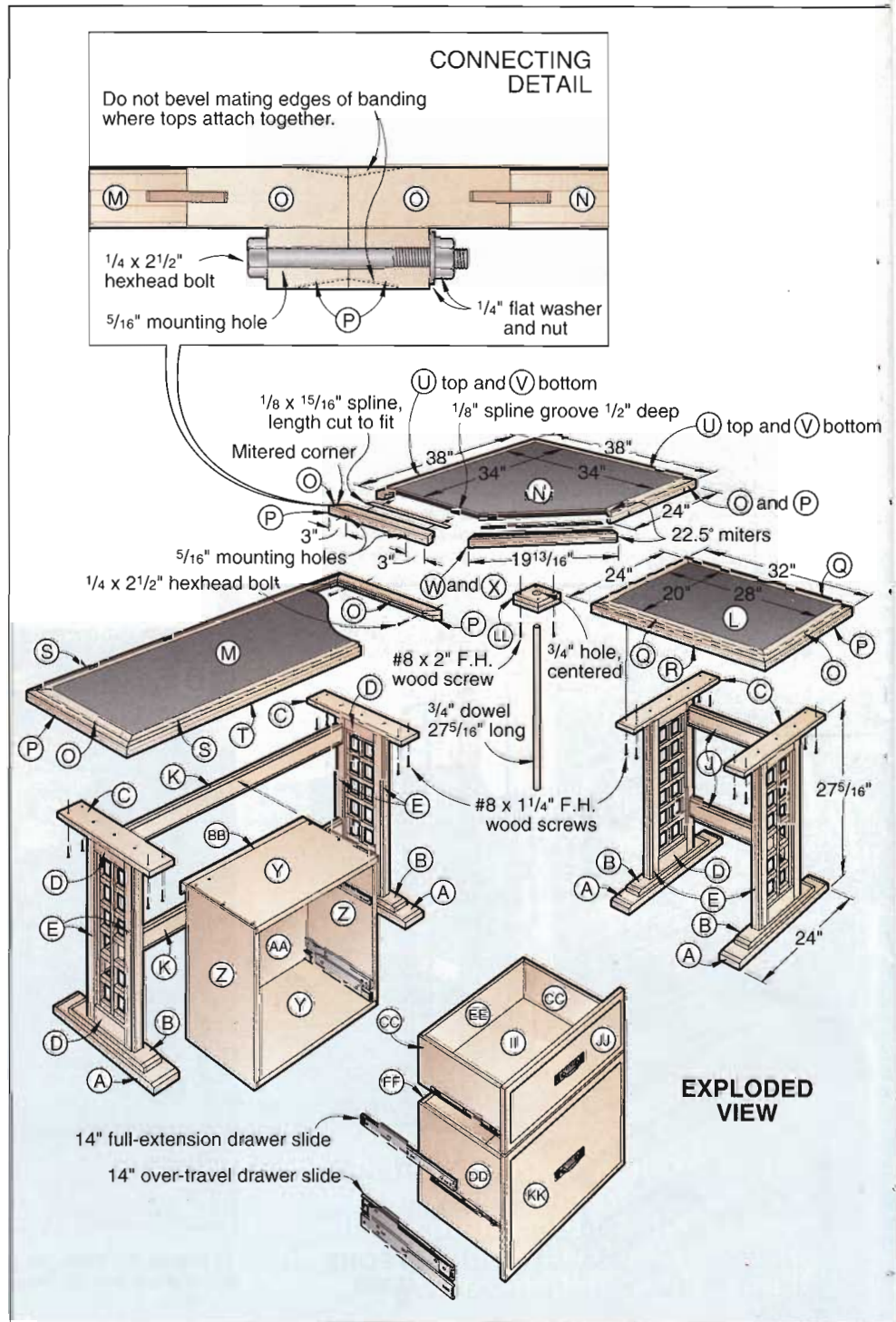

of each banding lamination to the finished width.

5 Cut or rout a $\frac{1}{8}$ " slot $\frac{1}{2}$ " deep along the inside edge of the top banding strip where shown on the Banding detail. Cut the same-sized mating slot in the outside edges of the plywood tops (L, M, N).

Note: If you're building the L-shaped unit, don't bevel the mating edges of the banded top. See the Connecting detail accompanying the Exploded View for reference.

6 Using your tablesaw with a sharp blade, bevel-rip the edges of the banding strips O/P, Q/R, S/T, U/V, and W/X at 10° where shown on the Banding detail.

7 Working around each plywood top, miter-cut the pieces to fit. (As shown in *photo C*, after miter-cutting one end of one piece, we clamped the mating uncut piece in place, and used a straightedge to transfer the start of the miter cut onto the uncut piece.)

8 Cut $\frac{1}{8} \times \frac{15}{16}$ " hardboard splines, and glue and clamp the banding to each plywood top. Keep the mitered joints tight and the top surface of the banding flush with the top surface of the laminate.

9 If you need to sand the top surface of the banding flush with the laminate, place masking tape or heavy packaging tape on the laminate. Then, if the sander wanders off the banding, you'll sand the tape rather than marring the laminate.

Constructing the drawer cabinet comes next

1 Cut the drawer cabinet top and bottom (Y) and sides (Z) to the sizes listed in the Bill of Materials. Cut or rout the rabbets in the sides (Y, Z) where shown on the Drawer Cabinet and Drawers drawing.

2 Dry-clamp the cabinet together. Measure the rabbeted opening, and cut the back (AA) to size. Drill countersunk mounting holes, and glue and screw the cabinet (Y, Z) together. Next, glue and nail the back (AA) in place, using the back to hold the cabinet square. Measure diagonally to check for square, and adjust if necessary.

3 Cut the spacer (BB) and mating steel bar to size. Drill the mounting holes in the steel bar and spacer. (We drilled the holes in the steel

bar on our drill press using a slow speed.) See the Drawer Cabinet and Section View detail on the *next* page for reference. Clean the steel bar thoroughly, and file off any burrs. Mount it and the spacer to the back of the drawer cabinet.

4 Apply the iron-on edge banding to the front of the cabinet (see the Buying Guide for our source).

5 Prime and spray-paint the cabinet black using the same paint you used for the support grids earlier.

Add a pair of drawers to the drawer cabinet

1 Cut the drawer sides (CC, DD), backs (EE, FF), and fronts (GG, HH) to size. Cut the bottoms (II) from $\frac{1}{4}$ " plywood, and false fronts (JJ, KK) from $\frac{3}{4}$ " solid stock.

2 Cut the rabbets and grooves in the drawer pieces where shown on the Drawer Cabinet and Drawers drawing on the *next* page.

3 Glue and screw the drawers together, checking for square. Screw the bottoms (II) in place.

Attaching the drawer slides to the drawer cabinet

Note: The slides come with mounting instructions. We've included additional information in the next two sections to make the process a bit easier to accomplish.

Continued

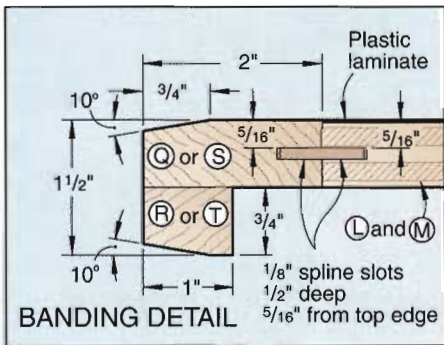

No bevel on this edge when using corner connector. If building a single desk only, cut bevel on all edges.

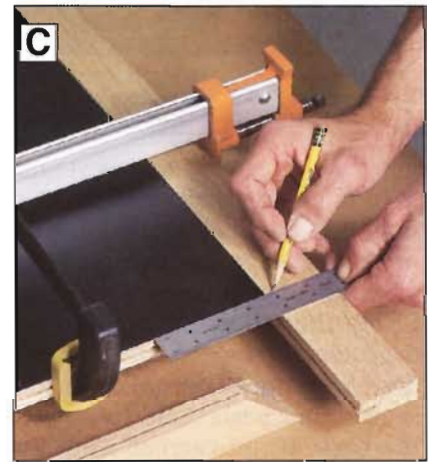
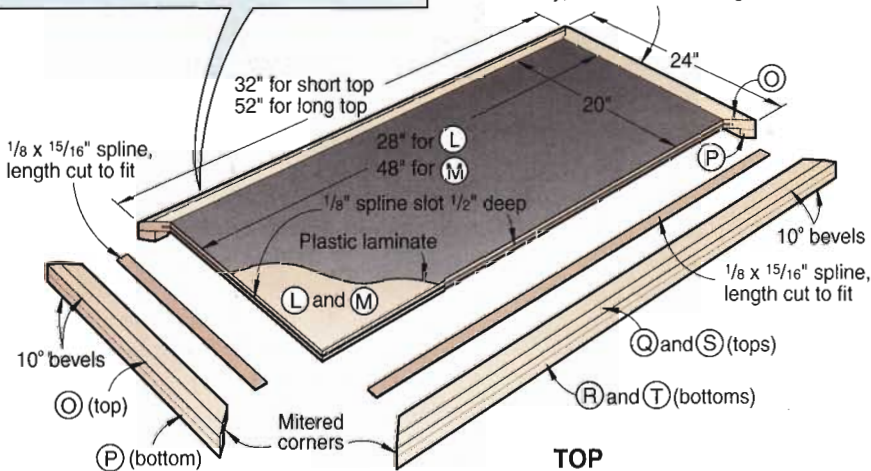

Dry-clamp an uncut piece in place. Then, use a straightedge to mark the miter-cut location on the edge of the banding.

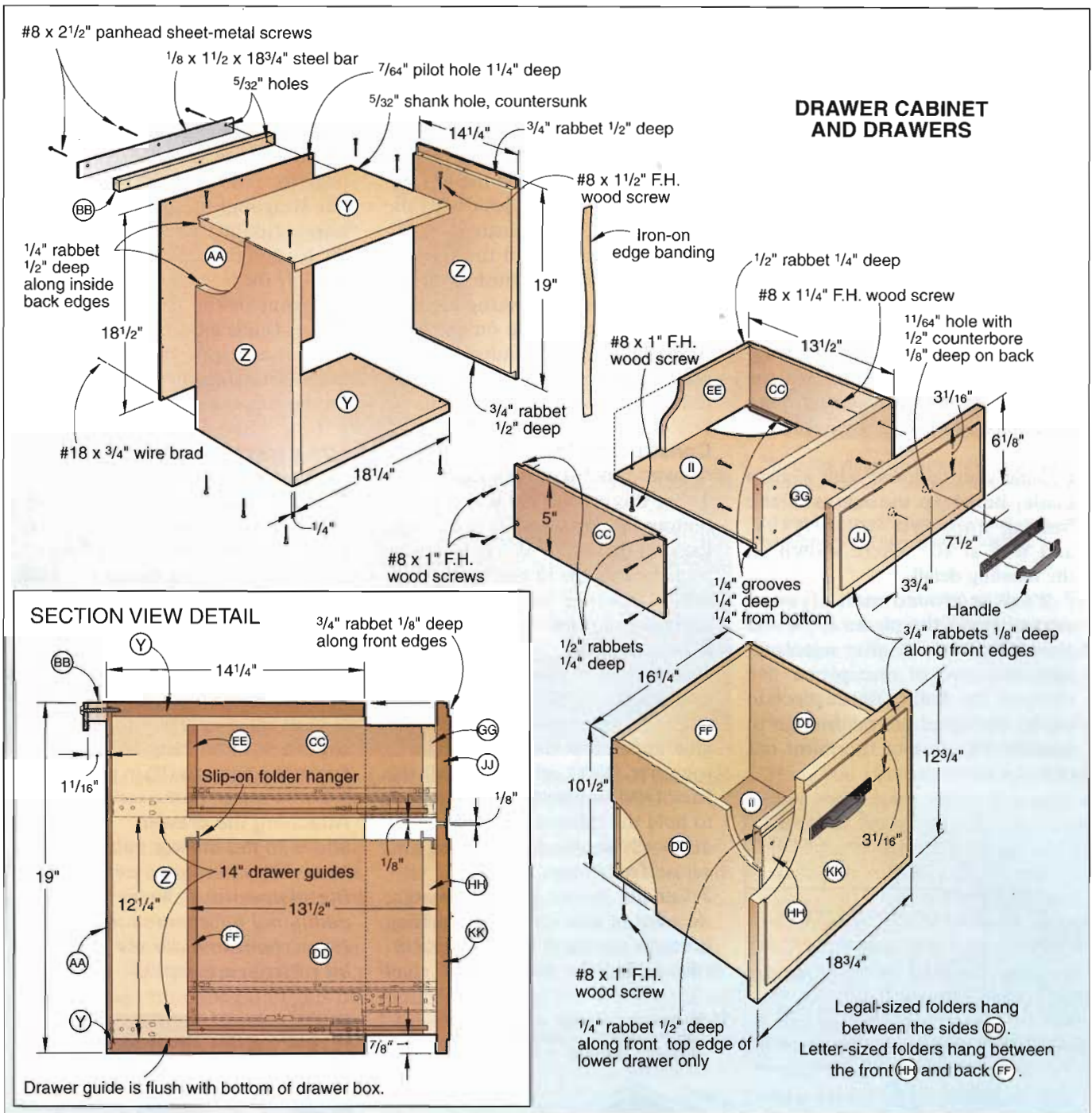

1 To mount the slides exactly 12¼" from the bottom of the drawer cabinet bottom, start by cutting a piece of scrap plywood to 12¼" wide. Clamp the spacer to the inside of the cabinet. Place the cabinet member of the top drawer slide on the spacer, and push it all the way to the back of the cabinet. Drill the pilot holes for the mounting screws as shown in *photo D*. Repeat for the opposite side.

2 Position the cabinet member of the bottom drawer slide in the bottom side corner of the cabinet and push it all the way to the back of the cabinet. Drill the pilot holes for the mounting screws. Repeat for the other side.

Attaching the drawer slides to the drawers

1 Cut a piece of plywood to 3×16" for use as a spacer. Then, cut a ½"

rabbet ⅛" deep along the edge of the plywood. Clamp the plywood to the bottom edge of the bottom drawer so the edge of the rabbet is flush with the side of the drawer where shown in *photo E*.

2 Clip the metal drawer member of the slide to the cabinet member, and position it on the drawer side so the bottom of the slide is against the bottom of the rabbet in the scrap ⅛" below the bottom edge of

Computer Center

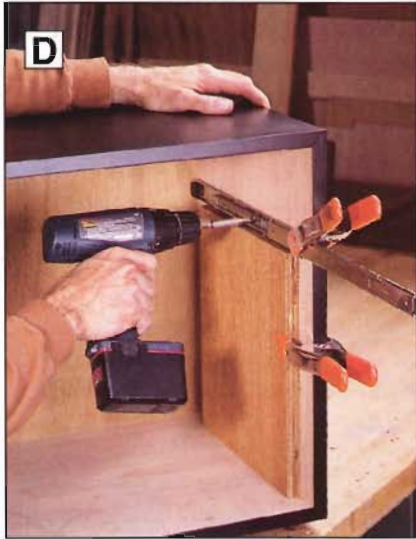

D We used a plywood spacer clamped to the inside of the drawer cabinet to level and position the drawer slides.



E We used a rabbeted piece of plywood to position the bottom edge of the slide $\frac{1}{8}$ " below the bottom edge of the drawer.

the drawer side. With the front of the slide flush with the front of the drawer, drill the pilot holes for the drawer-member mounting screws as shown in *photo E*. Repeat for the other slide.

3 Using the same procedure, drill the pilot holes for the drawer members of the top drawer. This time, the bottom of the drawer slide should be flush with the bottom edge of the drawer side.

4 Fasten the cabinet and drawer members of the slides and install the drawers.

Machining the drawer faces

1 Cut drawer faces (JJ) and (KK) to size. Cut the rabbet around the outside edges of each drawer face.

2 Mark the location of the holes for the pull screws on the back of each drawer face, and drill the countersunk mounting holes.

3 Apply double-faced tape to the fronts of the drawers that are mounted in the drawer cabinet. Position the drawer faces, and press them onto the tape to hold them temporarily in place. The ends of the drawer faces should be flush with the outside surfaces of the drawer cabinet. The top edge of the top drawer face should be flush

with the outside top surface of the cabinet and the bottom edge of the bottom drawer face should be flush with the outside bottom surface of the cabinet. There should be $\frac{1}{8}$ " space between the drawer faces. Once correctly positioned, drill mounting holes through the drawer front and into the drawer faces.

4 Remove the drawer faces (JJ, KK) from the drawers. If you use the same mission-style pulls we used, spray-paint the pulls and backplates satin black. (We painted ours for a better match with the painted grids.) You'll attach the pulls to the drawer faces after the faces have been finished.

Add the corner unit support

1 Laminate two pieces of $\frac{3}{4}$ "-thick stock together, and trim to 4x4" for the corner support (LL). Bore a $\frac{3}{4}$ " hole through the center of the support. Then, drill and countersink four mounting holes through the support. Fasten the support to the underside of the corner top (N) where shown on the pattern insert. If you don't mind drilling into your walls, you can eliminate the corner support, and rest the corner unit top on two cleats screwed to studs in the wall.

2 Cut a piece of $\frac{3}{4}$ " dowel to $27\frac{1}{16}$ " long for the corner section. Spray-paint it semi-flat black.

3 For connecting the top sections, drill $\frac{5}{16}$ " holes through the banding where shown on the Exploded View and Connecting detail. Locate and drill carefully as the holes in the corner section must align with those in the mating section.

Finishing and final assembly

1 Mask off the painted support grids and the plastic laminate tops. Remove the drawer faces and slides from the drawers. Apply a clear finish to the bases, top banding, drawers and drawer faces (we left the wood natural and sealed it with several coats of satin polyurethane).

2 Lay the rectangular tops upside down and position the bases on them. Drill countersunk mounting holes through the support frame tops (C), and screw the bases to the plywood tops.

3 Position the rectangular units adjacent to each other at a room corner. Install the dowel in the support block (LL), and fasten the corner unit to the rectangular units with bolts where shown on the Connecting detail.

4 Determine the best position for the cord grommet(s) on the corner section, and jigsaw the opening(s). To keep your wires tidy, consider installing wire management channels on the bottom sides of the tops.

5 Hang the drawer cabinet on the top stretcher. Fasten the pulls and backplates to the drawer faces. Then, screw the faces to the drawer boxes. Fasten the drawer members of the drawer slides to the drawers and install the drawers in the drawer cabinet.

6 For hanging files in the bottom drawer, cut the file hangers to length, and install them on the top edges of (FF) and (HH). For legal-sized hanging folders, the file hangers attach to the sides (DD). For letter-sized folders, the file hangers sit on the front and back (FF, HH). ♣

DATA CENTRAL

Convenient, good-looking storage for computer stuff



Building this multimedia storage tower is as easy as crashing a program. Good-looking enough to leave on your desktop all the time, it will keep your frequently used floppies, CDs, and other computer media right at hand.

Make the sides first

1 Cut parts A, B, C, and D to the sizes shown in the Bill of Materials.

2 Install a $\frac{1}{2}$ " dado blade on your table-saw. Then, referring to the Side Section View drawing in the *WOOD PATTERNS*® insert in the middle of the magazine, saw 11 dados and one rabbet $\frac{3}{8}$ " deep across each side (A).

3 Form a $\frac{3}{8}$ " rabbet across the top and along each edge of the dadoed side where shown on the drawing.

4 Lay out the 30° angle for the upper back corner of the rabbet on each side, following the dimensions in the Lid and Back detail. Remember to lay out the angle near the right edge of one side and near the left edge of the other to make facing sides.

To cut the angle, saw along the line to the rabbet's depth with a backsaw, then chisel out the small corner piece.

5 Reinstall the standard blade on your tablesaw. Elevate it to cut $\frac{1}{8}$ " deep. Then, set the saw fence $\frac{3}{8}$ " from the blade, and saw the grooves on the outer face of each side where shown on the Exploded View drawing.

6 Drill a $\frac{1}{8}$ " hole $\frac{3}{16}$ " deep in each side (A) where shown.

Complete the carcass

1 On part B, saw or rout a $\frac{5}{16}$ " chamfer on the end that will be the top. (See the Lid and Back detail.) Saw a $\frac{1}{8}$ " rabbet $\frac{1}{8}$ " deep along each edge on the long (back) face. Sand.

2 Rout the lengthwise grooves in part C, using a $\frac{1}{4}$ " roundnose (core-box) bit in a table-mounted router. Adjust the bit to cut $\frac{1}{8}$ " deep.

To space the grooves as shown in the Shelf detail, position a fence $\frac{1}{4}$ " from the bit. Rout the shelf with one edge against the fence, then turn it around and rout along the opposite edge. Next, move the fence $\frac{3}{8}$ " farther from the bit. Rout along both edges in

that position, then move the fence another $\frac{3}{8}$ " from the bit. Continue until all the grooves are routed.

3 Sand all parts. Refer to the Exploded View drawing, and dry-clamp the sides (A), back (B), shelf (C), and bottom (D) together to check their fit. Unclamp, glue, then reclamp.

Build and install the lid

1 Cut parts E and F to size.

2 Form the gluing block (G). To do this, start with a piece of stock that measures $\frac{3}{4} \times 4 \times 6$ ". Tilt your table saw blade to 45° . Then set your saw's fence $\frac{3}{4}$ " from the blade, measuring at table level from the outside of the blade (the side facing away from the fence) to the fence. Rip the piece, and trim to length.

3 Saw a $\frac{1}{8}$ " rabbet $\frac{1}{8}$ " deep across the end of part F that will be the top of the part. Sand all pieces.

4 Refer to the Exploded View drawing, and glue the lid top (E), lid front (F), and gluing block (G) together. Make sure that E and F make a 90° angle, and center the gluing block.

5 After the glue dries, lay the carcass on one side, and place the lid in position. Insert $\frac{1}{8}$ " brass washers between the lid and each side where shown to center the lid between the sides. (We put four washers on each side.)

6 With the lid in place, use a drill press to drill a $\frac{1}{8}$ " hole through each side and $\frac{3}{4}$ " deep into the edge of the lid. Drill in the groove near the back, $\frac{3}{16}$ " from the top. Enlarge the holes through the sides only to $\frac{9}{64}$ ".

7 Cut two pieces of $\frac{1}{8}$ " brass rod 1" long and one piece $4\frac{1}{2}$ " long. Leaving out the spacer washers, push the short brass pieces about halfway into the hinge holes, barely engaging the lid. Check that the lid swings freely. If it binds on the rabbeted corner, sand or otherwise remove material from the rabbet, not the lid.

8 Finish-sand the carcass and lid. Apply a clear finish. (We put on three coats of Deft lacquer, sanding with 320-grit sandpaper between coats.)

9 After the finish dries, install the lid and spacers. Drive the brass hinge pins home with a nail set. Flex the long brass rod slightly, then spring it into the $\frac{1}{8}$ " holes in the sides. 🍌

SEE THE WOOD PATTERNS® INSERT FOR FULL-SIZED PATTERNS

EXPLODED VIEW

Dimensions and materials shown in the exploded view:

- Top lid front (F): $4\frac{3}{4}$ " wide, $47\frac{1}{8}$ " long, $\frac{1}{8}$ " rabbet $\frac{1}{8}$ " deep in part (F), $5\frac{1}{16}$ " high.
- Lid top (E): $7\frac{1}{16}$ " wide, $3\frac{1}{8}$ " stock.
- Gluing block (G): 6 " wide, $\frac{1}{8}$ " hole $\frac{3}{4}$ " deep.
- Side (A): $16\frac{1}{4}$ " high, $1\frac{1}{8}$ " rabbet $\frac{1}{8}$ " deep, $\frac{1}{8}$ " groove $\frac{1}{8}$ " deep $\frac{3}{8}$ " from edge, $1\frac{1}{2}$ " dado $\frac{3}{8}$ " deep, $\frac{1}{2}$ " rabbet $\frac{3}{8}$ " deep, $3\frac{1}{4}$ " stock.
- Back (B): 5 " wide, $1\frac{1}{2}$ " stock.
- Shelf (C): $2\frac{1}{2}$ " high, $1\frac{1}{8}$ " hole $\frac{3}{16}$ " deep, $3\frac{1}{8}$ " stock.
- Bottom (D): $5\frac{5}{8}$ " wide, 5 " high, $\frac{1}{8}$ " hole $\frac{3}{16}$ " deep, $3\frac{1}{8}$ " stock.
- Hardware: $\frac{1}{8}$ " brass rod 1" long, $\frac{1}{8}$ " brass flat washers to center lid, $\frac{1}{8}$ " brass rod $4\frac{1}{2}$ " long, $\frac{9}{64}$ " hole, $7\frac{1}{16}$ " hole, $3\frac{1}{16}$ " hole.

Part	Finished Size			Matl.	Qty.
	T	W	L		
A side	$\frac{3}{4}$ "	6 "	$16\frac{1}{4}$ "	O	2
B back	$\frac{3}{8}$ "	5 "	$15\frac{3}{4}$ "	O	1
C shelf	$\frac{1}{2}$ "	$5\frac{1}{4}$ "	5 "	O	1
D bottom	$\frac{1}{2}$ "	$5\frac{5}{8}$ "	5 "	O	1
E lid top	$\frac{3}{8}$ "	$4\frac{3}{4}$ "	6 "	O	1
F lid front	$\frac{3}{8}$ "	$4\frac{3}{4}$ "	$47\frac{1}{8}$ "	O	1
G* gluing block	$\frac{3}{4}$ "	$\frac{3}{4}$ "	$4\frac{1}{8}$ "	O	1

*Make oversized initially; see how-to instructions.

Materials Key: O—oak
Supplies: $\frac{1}{8}$ " brass rod, $\frac{1}{8}$ " brass flat washers.

SHELF DETAIL

Router table detail showing fence, $\frac{1}{4}$ " roundnose bit, $\frac{1}{8}$ " groove, and $\frac{1}{4}$ " stock.

Project Design: Chuck Hedlund
 Illustrations: Roxanne LeMoine; Lorna Johnson
 Photograph: Marty Baldwin

Midsized FIXED-BASE

Tried and true, they deserve

Today's fixed-base routers have changed little in basic design and function from models available 50 years ago. With good reason. Woodworkers still find this tool's combination of simple operation, compact design, generous power, and fair price tough to beat.



Fast facts

- Fixed-base routers are easy to control and give you more horsepower per dollar than a plunge router. Fixed-base routers aren't appropriate for cutting deep mortises in the field of a workpiece.
- Higher-priced units (\$145 and up) give you more power and greater durability. Unlike low-cost routers, better models accept durable bits with $\frac{1}{2}$ " shanks as well as lighter-duty $\frac{1}{4}$ " bits.
- For ease of handling, look for a model with comfortable handles and an easily accessible switch that doesn't change location as you change the cutting depth of the router bit.

ROUTERS

a place in your shop

In this article we compare popular fixed-base routers that draw from 8 to 12 amps of power. We include “consumer” models that cost as little as \$60, and “professional” routers that cost upwards of \$145.

We tested them primarily in white oak and pine. In both woods we observed their smoothness of operation and ease of handling by using bits ranging from tiny round-over bits to wood-gobbling 3/4"-diameter straight bits set for 1/2"-deep cuts. We judged their power output by pushing them to their limits with deep cuts in the dense white oak. Finally, a mechanical tear-down revealed much about the quality of their components.

Armed with what we learned from these tests, you can make an informed decision about buying one of these units. Here's what you need to know.

How these routers compare with their plunging cousins

Although plunge routers are all the rage these days, there are still plenty of good reasons to choose a fixed-base model. Generally, they're easier to handle than plunge routers because of their lighter weight, compactness, and lower center of gravity. As shown in the photo at left, low-positioned handles help you hold the router steady as you guide it along an edge. Fixed-base routers also give you more power for your buck because of their simple construction.

So, if you don't perform the tasks that plunge routers excel at, such as any cut that starts in the middle of a workpiece (joint mortises, inlay, and sign letters, for example), a

fixed-base router will serve you fine. Although you can make cuts in the middle of a workpiece with a fixed-base router, it's a tricky maneuver at best, and unsafe at worst. That's because you have to *tilt* the running bit into the workpiece to make a plunge cut.

If you plan to mount your router in a table, keep in mind that you can adjust a fixed-base router up and down much more quickly than a plunge router. That said, some woodworkers prefer plunge routers for table use because they can precisely fine-tune the depth of cut by using a threaded height-adjustment knob. (The newest Bosch fixed-base routers—see information on page 74—have threaded micro-adjustment mechanisms not unlike those found on plunge routers.)

Of course, if you simply can't decide, and your pocketbook allows it, many woodworkers own one or more of each type. To us, it makes sense to have a midsized fixed-base router for most edge work, and a 15-amp, variable-speed plunge router for work in the middle of a workpiece, and for table mounting.

Note: If you feel that a plunge router better suits your needs, check out the October 1997 issue of WOOD® magazine. There, we compared 10 popular midsized plunge models.

The ups and downs of height-adjustment controls

Unlike plunge routers, with fixed-base routers you “fix” the cutting depth of the bit before you switch on the tool. The bit stays at its *fixed* depth while the router runs.



A fast and simple twist of the motor housing raises or lowers a Porter-Cable router to the correct cutting depth.

The routers in this article feature four basic mechanisms for adjusting bit depth: twist, ring, rack-and-pinion, and preset indents. With the Porter-Cable models, you simply unlock the motor housing and *twist* it to lower or raise it as shown above. This works fine, but the orientation and height of the switch constantly change in relation to your hands, often making it difficult or impossible to turn the machine on or off while holding onto the router with both hands.

Porter-Cable gets around this problem by making a version of the router with a D-handle that has a built-in trigger switch (see above for an example of a D-handle). With a D-handle, the position of the switch does not change in relation to your hands. If you choose either

Continued

Midsized Fixed-Base Routers

a Porter-Cable or Bosch fixed-base router, we recommend you buy the version with a D-handle.

The other tested routers have mechanisms that keep the switch facing in the same direction regardless of bit depth. And, Ryobi and Sears also keep the switch height constant regardless of depth.

However, despite this advantage, we rank the adjustment mechanism on these routers among our least favorite. That's because the Ryobi and Sears routers, as well as the Milwaukee model shown *below left*, have a *ring* that you rotate to change depth. We found the rings uncomfortable to grip and rotate. The Ryobi system proved especially tiresome because each complete ring revolution only moves the router up or down 1/4" (six full turns to cover its entire range). By comparison, most of the other routers adjust through their full range with 1-1 1/2 rotations of their ring or motor housing. The Milwaukee requires 4 1/2 turns, but has an over-

ride system for instantly sliding the motor completely up or down.

The DeWalt router has a unique *rack-and-pinion* mechanism (see the *opening photo* of this article). Here, you twist a knob that in turn moves a gear fixed to the base. The gear mates with a rack of teeth on the motor housing. To move the router completely up or down requires just 2 1/2 fast and easy turns of the knob. This makes depth changes a breeze compared to the other units. Although the height of the switch changes during up-down adjustments, its orientation remains constant. (See the boxed information on *page 74* if you're considering this router for table mounting.)

Once you adjust most fixed-base routers to the correct cutting depth, you lock in the adjustment by twisting a wing nut that clamps the base tightly against the motor housing. The Ryobi's have a unique cam-action locking lever, shown *below right*, that is more comfortable to use than the wing nuts—something

to consider if your hand strength isn't what it used to be.

The newest Bosch routers, featured on *page 74*, have a flip-out locking lever that's also easy on your fingers. The motor housing slides straight up and down freely until it stops at three *preset indents*. You accurately position the housing between the indents by turning a micro-adjustment knob.

Good ergonomics help you get a grip

In the chart at the end of this article, you'll find a rating for "ergonomics"—a fancy word used to describe features that make a tool comfortable and convenient to use. We assigned an "excellent" rating to the routers that we found easy to hold and control during operation and that offered good bit visibility. The tools that received "good" or "fair" fell short in one or more areas such as having small, uncomfortable handles, hard-to-reach switches, or a high center of gravity.



We found depth-adjustment rings, like the one shown here on a Milwaukee router, difficult and time-consuming to adjust.



The Ryobi routers have innovative and easy-on-the-fingers cam locks for securing the motor housing to the base.

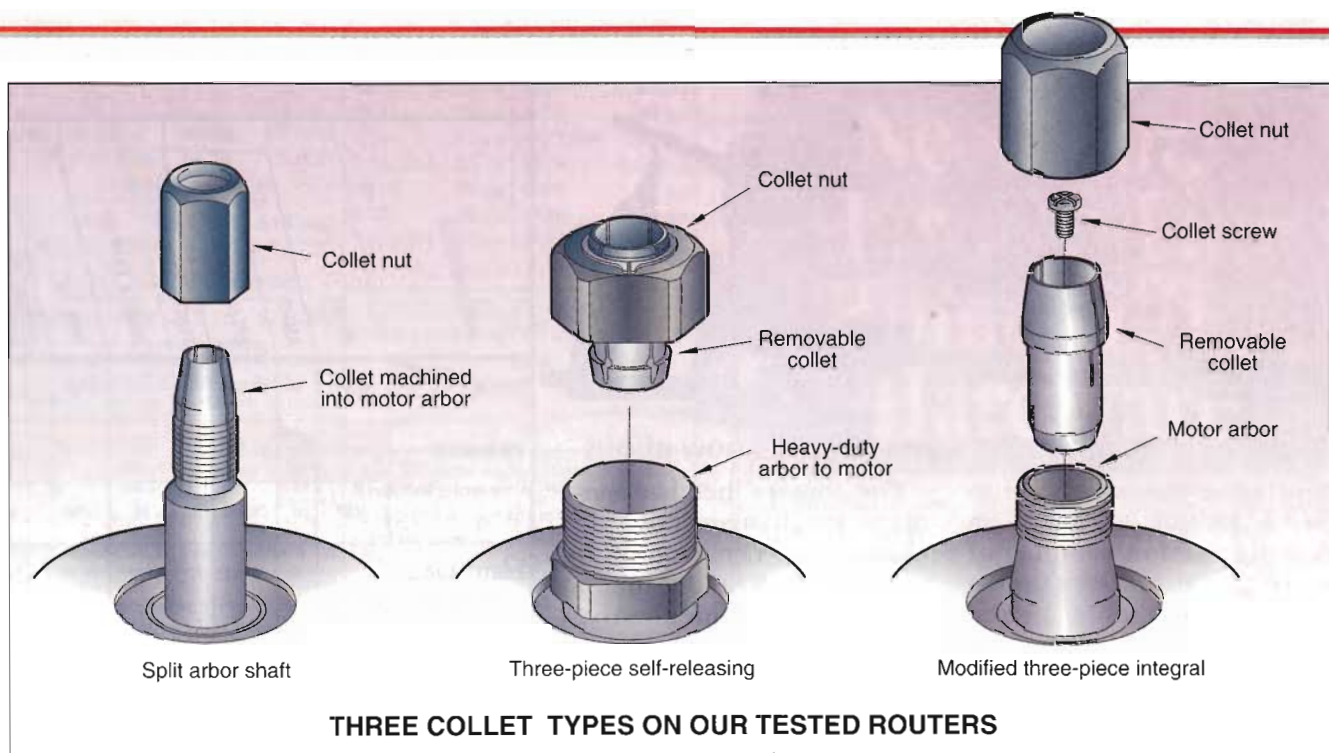

When the going gets tough, these routers get going

One of the things you get when buying a higher-priced router is extra power. The routers costing \$145 and up draw between 9 and 12 amps. All of them earned an "excellent" rating in our hands-on observation of how well they powered a fresh straight bit through deep cuts in white oak. The Ryobi and Sears units, all priced \$130 and under, draw 8-9 amps. They earned "good" ratings in the same test—they made the cut but required more patience on the part of the operator. All of the tested routers have ample power for edging cuts with small- to medium-sized bits.

Here's how we call it on the subject of collets

At the end of the motor arbor on every router is a collet assembly. Although small in size, this assembly has a big impact on your overall satisfaction level. Here are several key areas to carefully consider.

• **Capacity counts.** Most of the tested routers will hold bits with either ¼"- or ½"-diameter shanks,

but three of them hold only ¼" bits. (The chart on the *following pages* tells you which routers hold only ¼" bits.) Unless you rarely use a router, we recommend you purchase a model that accepts both shank diameters. You will be able to select from a wider array of bits, and the ½" shanks will hold up better.

• **Three types to choose from.**

The routers that accept only ¼" bits are also the only machines with split arbor shafts in place of the more-typical three-piece collet assemblies found on the other routers (see the drawings *above*). Most of the tested routers feature a three-piece self-releasing collet, which means that a snap ring pops the collet open after you turn the collet nut. Only the Ryobi R180 has a "modified three-piece integral" collet—a lighter-duty version of the self-releasing variety.

We prefer three-piece collets because you can replace them if the surface that contacts the bit becomes scored. (This can happen if a bit, particularly one that's not tightly secured, stalls during a heavy cut.) With split arbors, the arbor

surface contacts the bit—if you damage the arbor you might as well throw out the router. If you're a light user this likely will never be a problem for you.

• **Collet length is not a big deal.**

Although it makes sense to assume that a longer collet has advantages over a shorter collet, we couldn't find any under actual use. In our tests, the shorter collets, when properly tightened, held the bits securely during tough cuts. We also found that none of the routers—including those with short collets—had excessive bit runout (a bit that doesn't spin a concentric orbit).

• **One wrench or two.**

The Ryobi and Sears units have a spindle lock that enables you to loosen the collet with only one wrench. Although this presents the obvious advantage that you have just one wrench to lose instead of two, we still prefer the two-wrench system. With two wrenches you can lever one wrench against the other while holding both in one hand. In our experience, this time-tested system results in fewer banged knuckles from loosening stubborn bits.

Continued

Mid-sized Fixed-Base Routers



Three new Bosch routers you should know about

Just before this issue went to press, we got our hands on pre-production samples of three Bosch routers (shown above) that should hit the market this Spring. (We originally tested a Bosch 1604A, a router being phased out in favor of these new models.)

Although we tried these routers just briefly, we were quite impressed by the new models 1617, 1617EVS (like the 1617 but with an electronic variable-speed motor), and 1618 (D-handle version of the 1617). All three proved comfortable to handle, plenty powerful, and accurate in our limited test. They accept bits with 1/4" and 1/2" shanks.

The routers' height-adjustment mechanism does not change the orientation of the on/off switch, and a unique micro-adjust mechanism allowed us to precisely raise or lower the bit as little as 1/256". A centering device helps you precisely center the base plate for template work.

We especially liked the EVS and D-handle features, and hope that Bosch might someday decide to combine them in one unit. These routers should sell for a little more than the top routers in our test—perhaps \$160 for the 1617, \$175 (1618), and \$185 (1617EVS)—but they appear to be well worth the money.

MANUFACTURER	MODEL (1)	MOTOR			COLLET		
		AMPS	SPEED RANGE (RPM)	SWITCH TYPE (2)	HANDLE TYPE (3)	TYPE (4)	LENGTH (5) (INCHES)
DEWALT	DW610	9	25,000	TO	MK	3PSR	3/4
MILWAUKEE	5660	10	24,500	SL	RE	3PSR	1 1/8
	5680	12	26,000	SL	RE	3PSR	1 1/8
PORTER-CABLE	690	10	23,000	TO	MK	3PSR	1 1/8
	691	10	23,000	TR	MK/DH	3PSR	1 1/8
RYOBI	R165	8.5	25,000	TR	RE	SA	1/2
	R180	9	25,000	TR	RE	M3PI	1
SEARS	17504	8	25,000	TR	RE	SA	1/2
	17506	9	15,000-25,000	TR	RE	SA	1/2

NOTES:

- (*) Same router available with D-handle as model 1606A.
- (SL) Slide
(TO) Toggle
(TR) Trigger
- (BK) Ball-shaped knob
(DH) D-shaped handle
(MK) Mushroom-shaped knob
(RE) Rabbit-ear shape
- (SA) Split arbor shaft
(3PSR) Three-piece self-releasing
(M3PI) Modified three-piece integral

What to consider if you plan to table-mount the router

In the chart above right we list for each router the diameter of the base opening with the base plate in place (handheld operation), and with it removed (table-mounted operation). If you mount a router in a table, you will appreciate a large opening for gaining access to the collet to loosen and tighten it with wrenches.

In addition to the already-mentioned advantage of two wrenches over one, dual wrenches give you an extra benefit when you table-

mount a router. That's because you don't have to reach under the table to press the spindle lock. Instead, you can stand up and change bits by using both wrenches from above the table.

Although we found the DeWalt's rack-and-pinion height-adjustment system the most convenient in handheld operation, we have concerns about the router when mounted in a table. Of the tested routers, only the DeWalt will fall to the floor if you loosen its base and

fail to support the motor housing with your other hand. Even if you remind yourself to do this, you may be surprised at how easy it becomes to forget. During an extended trial, the router fell out several times when we loosened it and forgot to retighten it before attending to another shop task. The Ryobi routers, which were difficult to adjust up and down in handheld operation as mentioned earlier, proved even more time-consuming when mounted upside down.

CHECK OUT THESE 9 MIDSIZED, FIXED-BASE ROUTERS

BIT SHANK CAPACITY-DIAMETER (INCHES) SPINDLE LOCK (YES, NO)	RANGE (6) (INCHES)	CUTTING DEPTH		DIAMETER OF OPENING IN BASE (INCHES, WITH/ WITHOUT PLATE)	CORD LENGTH (FEET)	MATERIAL OF LOWER HOUSING FOR MOTOR AND BEARING (7)	NOISE (DECIBELS)	EVALUATION (8)						WEIGHT (POUNDS)	COUNTRY OF ASSEMBLY (9)	SELLING PRICE (10)	COMMENTS
		ADJUSTABLE TO ZERO (YES, NO)						EASE OF CHANGING BITS	EASE OF OTHER ADJUSTMENTS	ERGONOMICS	EASE OF USING DEPTH LOCKS	OBSERVED POWER	OVERALL QUALITY				
1/4, 1/2 N	2 3/8	Y	1 1/2, 3 1/2	8	CA	109	G	E	G	G	E	E	6.9	U	155	A basic model that's been one of our favorites for years. Its compact, powerful, built like a tank, and has handy rack-and-pinion depth adjustment.	
1/4, 1/2 N	2	Y	1 1/4, 4	8	CA	100	G	F	F	G	E	G	8.7	U	N/A	A well-made router, but lacking in convenience and ergonomic features. Does not come with a 1/2" collet.	
1/4, 1/2 N	2	Y	1 1/4, 4	8	CA	104	G	F	F	G	E	G	8.8	U	165	A higher-ampage version of the 5660 with standard 1/4" and 1/2" collets.	
1/4, 1/2 N	1 1/4	Y	1 1/8, 3 3/4	7	CA	103	G	G	G	G	E	E	7.8	U	145	A time-tested router that's built to take a lickin'. Its only weak point is its toggle switch. Accepts same motor as P-C 691 and 693.	
1/4, 1/2 N	1 3/4	Y	1 1/8, 3 3/4	10	CA	103	G	G	E	G	E	E	8.4	U	160	Our favorite fixed-base router. Same as the P-C 690 but has a convenient-as-can-be D-handle with built-in trigger switch.	
1/4 Y	1 1/2	Y	2 1/2	10	PL	104	G	F	E	E	G	F	7.6	U	80	A basic router limited by its time-consuming depth-adjustment ring, split arbor shaft in place of a collet, and capacity for only 1/4" bits.	
1/4, 1/2 Y	1 1/2	Y	2 1/2	10	PL	100	G	F	E	E	G	G	8.9	U	130	Big brother to the R165 with capacity for 1/2" bits and slightly more power. It has a better bit-chucking system, but same tedious depth changing.	
1/4 Y	1 1/2	Y	2 3/4, 4 1/4	6	PL	98	F	E	G	E	G	F	7.6	U	60	Like other Sears units, it has lots of plastic components. It adjusts quickly for depth of cut, but has a split arbor shaft in place of a collet. Accepts only 1/4" bits.	
1/4 Y	1 1/2	Y	2 3/4, 4 1/4	10	PL	98	F	E	G	E	G	F	8.7	U	100	Not built for the serious woodworker, but features such as built-in dust collection, variable speed, and trigger switch make it a good value for the occasional woodworker.	

5. For models with split arbor shafts we measured the length of the split.

6. Vertical range of bit measured with the motor housing fully raised and fully lowered.

7. (CA) Cast aluminum
(PL) Plastic

8. **E** Excellent
G Good
F Fair

9. (U) United States

10. Based on lowest available price at time of article's production.

MANUFACTURERS' LISTING:

Bosch 773/286-7330	Milwaukee 800/243-0870	Ryobi 800/525-2579
DeWalt 800/433-9258	Porter-Cable 800/487-8665	Sears Call or visit your local Sears store



When the chips stopped flying, these routers came out tops

Among the so-called "industrial" models priced over \$125, we recommend the Porter-Cable 691 and DeWalt DW610. The DeWalt is more compact than the P-C, and nearly ideal for hand-held use. We found the P-C more versatile because you can buy a plunge router base that accepts its motor. The Bosch routers deserve serious consideration, but we need to do extensive testing with production samples before bestowing our Editors' Choice award.

Among the less-expensive, "consumer" routers, the Sears 17506 gets our nod. Like most routers in its price range, it's not built for heavy use, and it accepts only bits with 1/4" shanks. ⚡

MUSIC IN

A high-style windchime

Start by building the body

1 Plane a $\frac{3}{4} \times 1\frac{3}{8} \times 12$ " piece of mahogany to $\frac{1}{16}$ " thick. Crosscut it in half, and laminate the two pieces with polyurethane glue. Clamp until the glue cures, then crosscut the lamination to $5\frac{3}{8}$ " to form a blank for the body (A).

2 Cut the dadoes for the arms (B) in the body where shown in the Body Front View drawing.

To saw the dadoes on your table-saw, attach an auxiliary fence to your miter gauge, extending about 6" past the dado head. Then saw through it. Place a stopblock $1\frac{1}{8}$ " from the edge of the dado. With the top end of the body blank (A) against the stopblock, saw a dado. Similarly, dado each of the three remaining faces.

Reposition the stopblock to $2\frac{3}{4}$ ". With the same end against the stopblock, saw all four body faces.

3 Saw the decorative kerf on the body where shown, using the standard blade and a stopblock $4\frac{3}{8}$ " from the blade.

4 Then, cut the 15° bevels on the bottom end.

For these cuts, tilt the tablesaw blade to 15° from vertical (75° from the table). Raise it to about $1\frac{3}{8}$ " cutting depth, and saw through the miter-gauge fence.

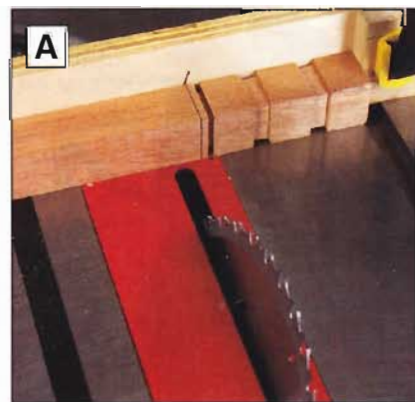

Align the saw kerf through the auxiliary miter-gauge fence with the mark on the body to saw the body bottom bevels.

Mark the body $\frac{3}{16}$ " from the bottom of the kerf on one face. Align the mark with the kerf in the fence, as shown in *photo A*. Position a stopblock at the opposite end of the body, and saw all four bevels.

Add the arms next

1 Cut eight arms (B) to the size shown in the Bill of Materials.

2 Drill a $\frac{1}{16}$ " hole through each arm where shown in the Body Top View drawing.

To drill the holes easily with your drill press, position a fence to center the workpiece under the bit. Then, place a stopblock to locate the hole $\frac{1}{4}$ " from the end.

3 Finish-sand the body (A) and arms (B). (We sanded with 220- and 320-grit sandpaper.)

4 Glue the arms (B) into the dadoes on the body (A). Refer to the Exploded View drawing for positioning, noting that the upper and lower arms on each face extend in opposite directions from the body. Clamp until the glue cures. Afterward, remove squeeze-out with a sharp chisel.

Now, for a wind catcher

1 Cut stock to the size shown for the vane shaft (C) and the eight vanes (D).

2 Saw $1\frac{1}{8}$ " dadoes $\frac{1}{16}$ " deep in the vane shaft where shown in the Vane Shaft Front View drawing.

Cut these as you did the body dadoes. Using a $\frac{3}{4}$ " dado cutter, saw each dado in two overlapping passes to achieve the $1\frac{1}{8}$ " width.

3 Finish-sand the shaft and vanes. Take care not to round the edges.

4 Glue the vanes into the dadoes on the shaft. Notice that here, too, upper and lower vanes on the same side extend out in different directions. Clamp until the glue cures, then remove squeeze-out.

Continued

THE WIND

with a sound to match

Bill of Materials

Part	Finished Size			Mati.	Qty.
	T	W	L		
A* body	1 3/8"	1 3/8"	4 7/8"	M	1
B arm	3/8"	1/2"	2 5/8"	M	8
C vane shaft	3/8"	3/8"	4 1/8"	M	1
D vane	1/8"	1 1/8"	1 3/8"	M	8
E cap	1/2"	5" dia.		M	1
F clapper	1/2"	3 1/4" dia.		M	1

*Cut 5 3/8" long initially, then trim to finished length in accordance with how-to instructions.

Materials Key: M—mahogany

Supplies: chime rods (see Buying Guide), 15-lb. monofilament line, #18 x 1/2" brass escutcheon pins, #214 brass screw eyes, #8 brass ceiling hook, clear exterior finish, polyurethane glue.

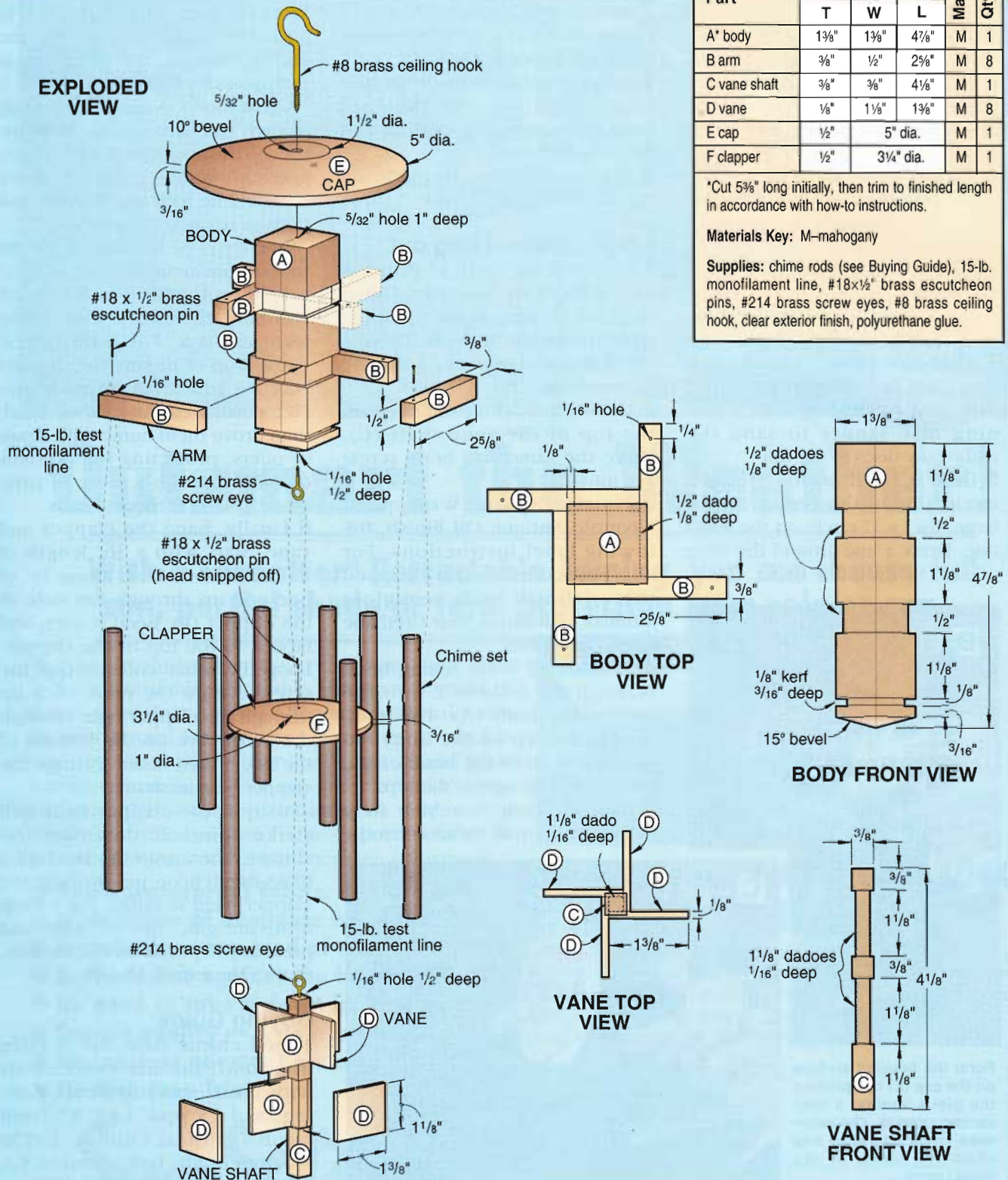

MUSIC IN THE WIND

Make the cap and clapper

1 On ½"-thick stock, lay out two circles, one 5" in diameter for the cap (E) and another 3¼" in diameter for the clapper (F). Lay out two more the same sizes on ¾"-thick scrapwood. Mark the centers on all four.

2 Bandsaw all circles slightly outside the line. At the center of each, drill a ⅛" hole.

3 Enlarge the hole in each scrapwood disc to ¼", and countersink one side. Insert a ¼" flathead machine screw about 3" long as an arbor, and secure with a nut and washer on back.

4 Attach each mahogany disc to its matching scrapwood one with double-faced tape. Chuck each assembly in a portable electric drill, and rotate it against a running disc sander to sand the mahogany discs to the line.

5 Draw a 1½"-diameter reference circle around the center on the large disc, a 1" circle on the small one. Draw a line around the edge of each ⅜" from the back.

6 Bevel the face of each disc from the reference circle on the face to ⅜" thick at the edge.

To do this, spin the workpiece against a disc sander, shown in *photo B*. Check your progress often, as shown in *photo C*.

7 Finish-sand the disc tops and edges. Then, separate the discs from the scrapwood carriers, and sand the bottoms.

8 Enlarge the hole through the cap (E) to ⅝".

Let the chimes ring out

1 Center a ⅝" hole 1" deep on top of the body assembly. Drill a ⅛" hole ½" deep at the tip of the pyramid on the bottom. Drive a #214 brass screw eye into the bottom hole.

2 Center a ⅛" hole ½" deep on the top of the vane shaft (C). Drive the same size brass screw eye into it.

3 Finish all parts. We applied Olympic Antique Oil Finish, following label instructions. For durability outdoors, we topped the oil finish with semigloss Minwax Helmsman Spar Urethane from a spray can.

4 Screw a #8 brass ceiling hook through the hole in E into the hole in the body (A). The hook holds the cap to the body, so screw it in until the bend of the hook snugs up against the top.

5 Hang the body from your shop ceiling, and install the chime rods.

To do so, cut eight 20" lengths of 15-lb. test monofilament. Loop one through each rod as shown in the Exploded View drawing, then bring the ends through the hole in an arm (B). Fold the ends over the end of the arm, and secure them temporarily with tape.

Adjust the loop length so the top of each rod hangs about 4" below the bottom of the body. If the assembly hangs crooked, move some chime rods to different positions to balance the assembly.

When you're satisfied with the rod arrangement, drive a #18×½" brass escutcheon pin into each arm hole to wedge the monofilament in place. For permanence, put a drop of instant glue (cyanoacrylate adhesive) on each pin. (We positioned the pins by hand, then drove them home with a pair of pliers, protecting the bottoms of the arms with a piece of cardboard.) Snip off the line ends.

6 Finally, hang the clapper and vane. Start with a 36" length of monofilament. Push about ½" of one end up through the hole in the clapper (F). Bend it over, and tape it to the top of the clapper. Loop the other end through the screw eye on the vane, back up through the clapper hole, through the screw eye on the bottom of the body, then down through the clapper hole as shown.

Position the clapper so it will strike about 2" down on the chimes. Then, snip the head off a brass escutcheon pin (to help the clapper hang straight), put a drop of instant glue into the hole, and press in the pin to wedge the line. Cut off the excess line. ♣

Buying Guide

Tuned chime rods. Set of eight hand-tuned aluminum chime rods with bronze-color powder coating, \$14.75 ppd. in U.S., from Jacob's Musical Chimes, 10579 Bloomfield St., Los Alamitos, CA 90720, or call 800/627-5840.

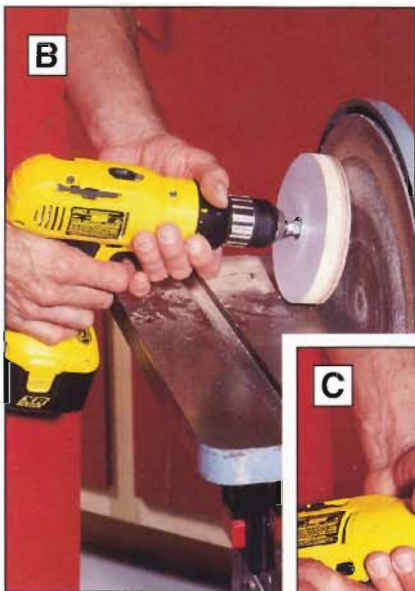

Form the beveled surface on the cap (E) by spinning the piece against a disc sander (*above*). The reference circle and edge line show the limits of the bevel (*right*).



Project Design: Jan Svec Photographs: Hetherington Photography Illustrations: Roxanne LeMoine; Lorna Johnson

Collector's Edition

Adjustable Square

A measuring tool you'll use and treasure forever

Brass and walnut give this beautiful adjustable square the look and feel of a workbench masterpiece. Its handy size and functional design are sure to make it your favorite measuring and marking tool.

Make the handle sides first

1 Cut two pieces of walnut to size for the handle sides (A and B in the Exploded View drawing). Part A measures $1\frac{1}{2} \times 1 \times 4$ "; B, $1\frac{3}{2} \times 1 \times 4$ ".

We started with two pieces of stock $\frac{1}{2} \times 1 \times 12$ " (allowing extra length for safety and convenience). We planed one piece to $1\frac{3}{2}$ " thick and the other to $1\frac{1}{2}$ " thick, then crosscut a 4"-long piece from each.

2 Form the stepped rabbet where shown on the end of part B. To do this easily, make it in three cuts, using a $\frac{3}{8}$ " straight bit in a table-mounted router. Install a zero-clearance insert in the table.

First cut: Measure the thickness of your brass stock, then set the bit's cutting depth to match it. Set a fence on the table $\frac{1}{16}$ " behind the bit. Using a miter gauge fitted with an extension fence to keep the cut square, make one pass with the end of the piece against the table fence. Pull the piece back $\frac{1}{16}$ " from the fence, and make another pass to complete the $\frac{7}{16}$ " rabbet.

Clamp parts A and B together, the rabbeted face to the inside. Check the fit of the brass in the slot—it should fit snugly, but should be loose enough to slide.

Second cut: Leave the cutting depth as for the first cut. Move the table fence to the position shown in the Router Setup (Second Cut) illustration. Using the miter gauge and extension, make one pass with the rabbeted end of the piece against the table fence. Then, pull the end back from the fence $\frac{1}{16}$ " and make another pass to create a $\frac{7}{16}$ " dado.

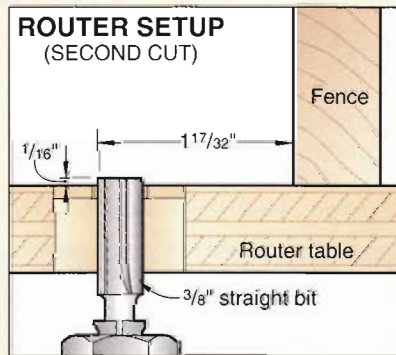

Third cut: Measure the thickness of your steel rule. Adjust the router's cutting depth to that dimension. Now, rout the remaining part of the stepped rabbet, using the miter gauge. Sandwich the handle parts together again, and check the rule's fit. It should slide freely but not sloppily in the narrowest part of the slot.

3 Glue and clamp parts A and B together. Ensure that all edges are flush, and clean glue squeeze-out from the slot.

Drill and rout the handle

1 Drill the holes in the handle for the threaded brass insert and the rod that will clamp the rule in position (shown in the Section View drawing). First, drill for the threaded insert.

To do this, mark the center on the bottom end of the handle (the unslotted end). Chuck a $1\frac{1}{2}$ " bit in your drill press. Position a fence to center the bit on the handle, and clamp the handle to the fence. (We employed an L-shaped piece of scrapwood, as shown below, to help hold the handle securely.) Drill $\frac{1}{2}$ " deep into the handle end.



Continued

Adjustable Square

2 Change to a $\frac{3}{32}$ " bit, and drill a hole centered inside the larger one. Drill to a total depth of $2\frac{3}{8}$ " from the bottom of the handle.

3 Install a $\frac{1}{4}$ " brass threaded insert in the hole. To install it, thread two nuts onto a $\frac{1}{4}$ "-20 hexhead bolt about $1\frac{1}{2}$ " long. Screw the bolt into the insert, run the lower nut down against the insert, and jam it with the other. Clamp the handle in a vise. Then, with a wrench on the bolt head, drive in the insert.

4 Rout stopped covers on the handle sides where shown. A table-mounted router with a $\frac{3}{8}$ " round-nose bit and zero-clearance insert will do the job.

Position a fence to center the bit side-to-side on the handle, and place stopblocks where shown in the photo *below*. Adjust the bit's cutting depth to $\frac{1}{16}$ ". With the end of the handle against the right hand stopblock, lower it onto the bit as shown, and rout to the other stopblock. Repeat on the other side. Raise the bit to $\frac{1}{8}$ ", and repeat.

The clamp bars come next

1 Cut two 1"-long pieces of $\frac{1}{16}$ "-thick \times $\frac{3}{8}$ "-wide brass bar for the upper and lower clamp bars (C and D). Ensure that the edges of the $\frac{3}{8}$ "-wide bar are parallel.

2 Place the upper bar (C) in the handle end slot where shown. On the face of the handle, mark a center $\frac{3}{16}$ " from the slotted end and centered from side to side.

3 Using a drill press, drill a $\frac{1}{16}$ " hole through both parts at the mark.

Remove the brass piece (C), and enlarge the hole through it to $\frac{3}{32}$ ".

4 Replace the upper bar in the slot, and pin it in place. To accomplish this, form a point on one end of a piece of $\frac{1}{16}$ "-diameter brass rod about 6" long. (Chuck the rod in an electric hand drill and spin it against a disc sander.)

Cut the pin to 1" long, measuring from just behind the point. Drive the pin about halfway through the handle, then put a dab of epoxy onto the pin shaft and into the exit hole, using a toothpick. Drive the pin the rest of the way, allowing it to extend about $\frac{1}{8}$ " on each side.

After the epoxy cures, snip the ends off the pin. File the pin flush with the handle on both sides.

5 Adhere the pattern for the lower clamp bar (D) to the other piece of brass. (You'll find the pattern in the *WOOD PATTERNS*® insert in the middle of the magazine.) Cut or file the notch where shown. Then, slide the clamp bar into the handle slot. To bandsaw the notch, first attach the patterned brass to a $\frac{1}{4}\times\frac{3}{4}\times\frac{1}{4}$ " piece of scrapwood with double-faced tape. Saw slightly inside the line with a fine-toothed blade, then file down to it.

6 Cut a piece of $\frac{1}{4}$ "-20 threaded brass rod 3" long. Thread a brass wing nut onto one end, and pin it in place with $\frac{1}{16}$ " brass rod.

To do this, first build a support fixture for drilling the pinhole through the wing nut and rod. For the fixture, saw or rout a $\frac{1}{4}\times\frac{1}{4}$ " groove along the center of a piece

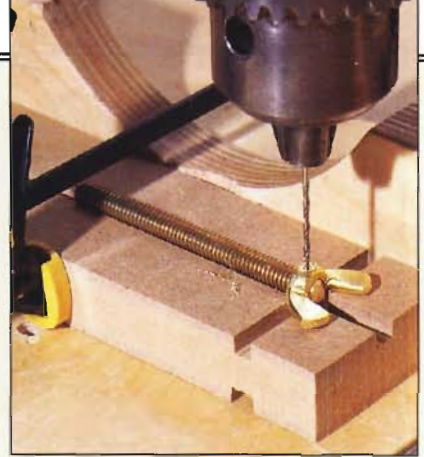

of scrapwood about $\frac{3}{4}\times 2\times 6$ ". Form a same-size dado that intersects the groove about 1" from one end.

Lay the threaded rod and wing nut on the fixture as shown in the photo *above*. To hold the rod approximately level, lay a piece of scrapwood in the groove under the end opposite the nut.

File a small flat spot on the side of the nut, centerpunch it, and drill a $\frac{1}{16}$ " hole through the nut and rod. Drive a $\frac{3}{4}$ " length of $\frac{1}{16}$ " brass rod through the hole. File the ends to leave about $\frac{1}{32}$ " above the surface on each side. Peen over the ends of the pin with a ball-peen hammer, working on a steel backing such as an anvil or another hammer.

Brighten the ends with brass

1 Cut two $\frac{1}{16}\times\frac{3}{4}\times 1$ " pieces of brass for the top and bottom plates (E and F).

2 Drill $\frac{7}{64}$ " holes where shown on the Top and Bottom Plate Full-Size pattern (in the *WOOD PATTERNS* insert). Countersink the holes.

When drilling and countersinking the thin brass, position a fence on the drill-press table to prevent the brass from spinning out of your grip as the bit grabs. You can then hold it down and against the fence with hand pressure.

3 On one part, drill a centered $\frac{3}{32}$ " hole to make the bottom plate (F).

4 Now, attach the top and bottom plates to the handle.

To do so, grip the handle in your vise. Hold the appropriate plate (E or F) in position, and drill a $\frac{1}{16}$ " pilot hole $\frac{7}{16}$ " deep for each screw hole. Put a dab of epoxy in each screw pilot hole, and drive in the screws.

5 Slide the rule into place between the clamp bars, and screw the brass

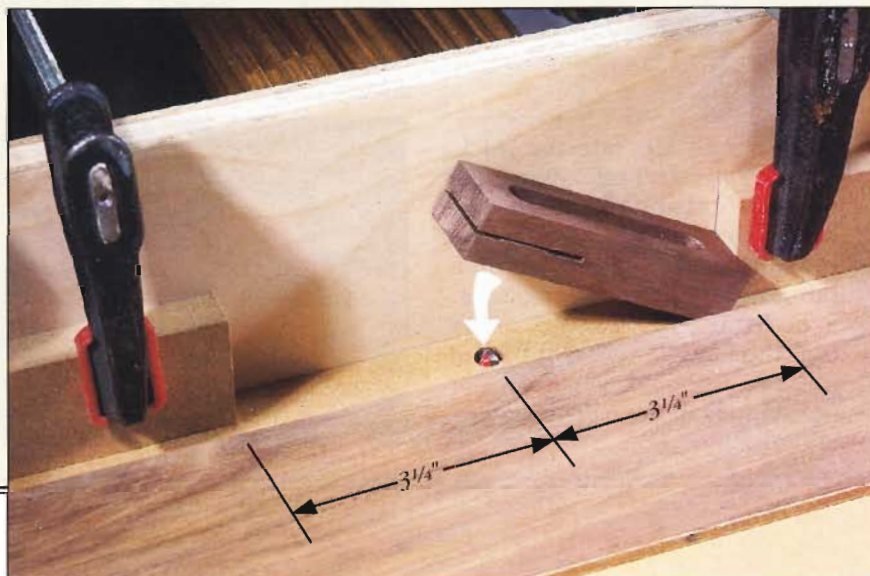

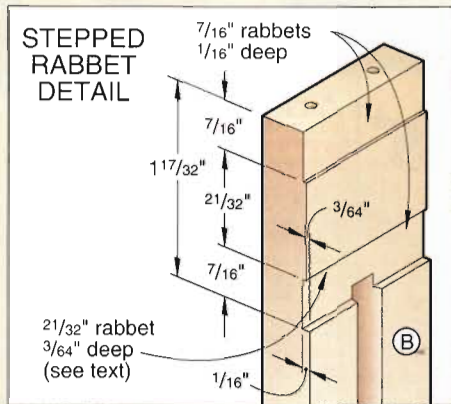

13/32" hole 1/2" deep with a 9/32" hole 2 1/8" deep centered inside (Drill hole centered on bottom end after assembly.)

rod into the insert. With the clamp bars tightened against the rule, there should be 1/16" clearance between the wing nut and the bottom plate. If there's more, file the end of the rod. Remove the rod and rule.

Give the square a fine finish

- 1 File the screw heads flush with the top and bottom plates. (You could also use a disc sander.) Sand out the file marks with 320-, 400-, and 600-grit sandpaper.
- 2 File or sand the brass flush with the wood on the sides and edges. Sand a slight round-over on all corners (brass and wood) for a better feel. Sand inside the coves.
- 3 Apply three coats of clear lacquer, rubbing between coats with a white Scotch-Brite pad. Do not apply lacquer too heavily to the brass parts—it will run.
- 4 After the finish dries, slide the rule into place, and thread in the clamping rod.

Buying Guide

Rule, brass parts. Stainless steel rule with laser-engraved WOOD® magazine logo, brass stock, threaded rod and insert, #4x1/2" flathead wood screws, and wing nut, kit no. AS01, \$18.95 ppd. in U.S. Schlabaugh and Sons, 720 14th St., Kalona, IA 52247. Call 800/346-9663. E-mail: schsons@kctc.net

Project Design: Joseph Fontana
 Illustrations: Kim Downing; Lorna Johnson
 Photography: Hetherington Photography

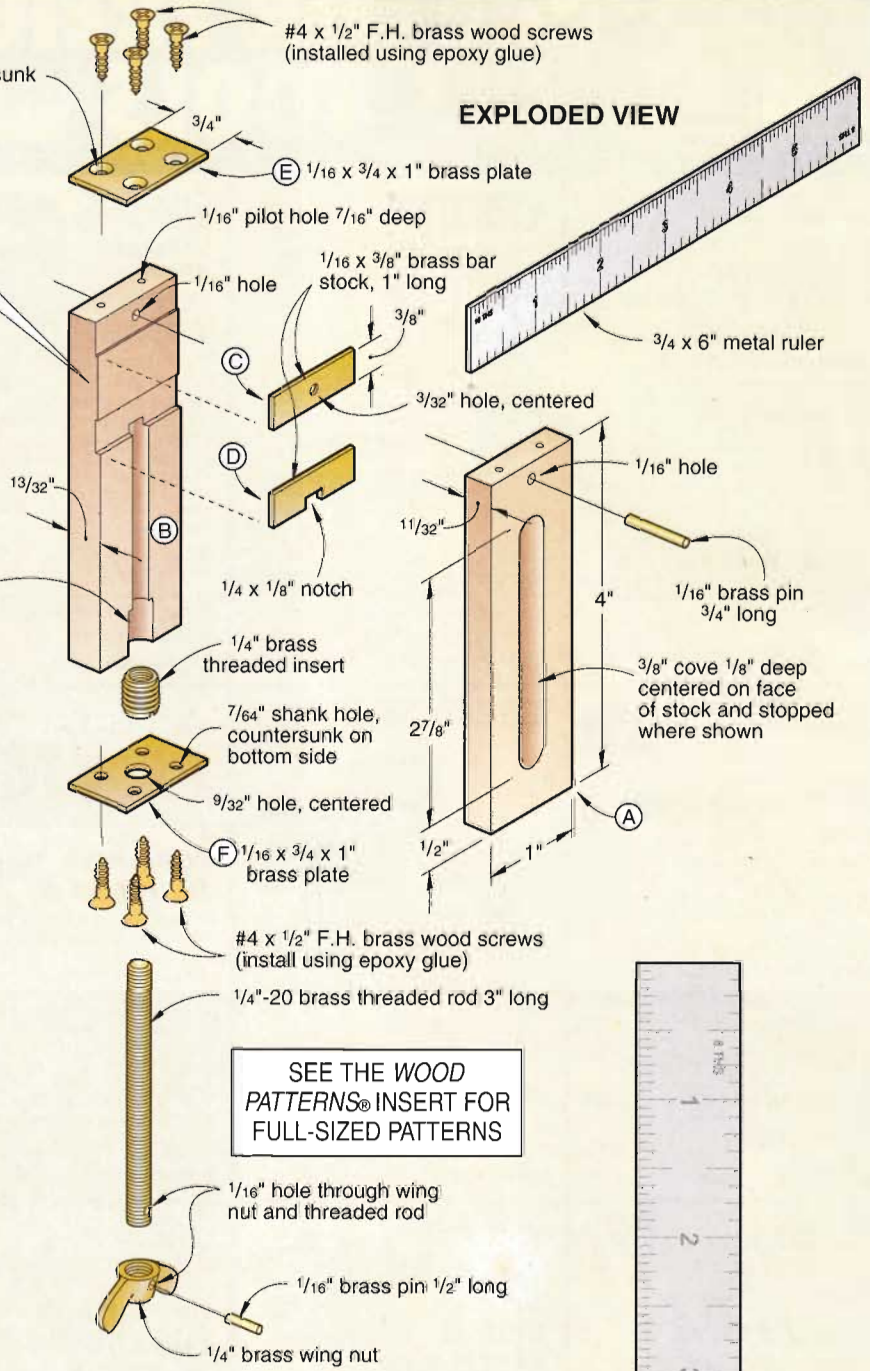

SEE THE WOOD PATTERNS® INSERT FOR FULL-SIZED PATTERNS

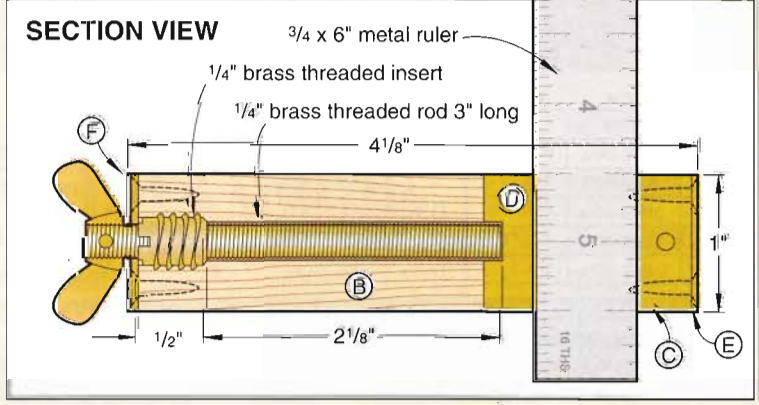



EVEN IF YOU OWN ONLY A SMALL WOODLOT Let Your Trees Grow

According to consulting forester Jim Birkemeier, a properly managed hardwood tree, such as a red oak, growing in southern Wisconsin adds ½" to its adult diameter each year. "Combine that annual growth rate with increasing premiums for larger, quality logs and generally rising stumpage prices, and you get total value growth rates of 20-30 percent a year for managed timber stands," he says. That's why the forestry emphasis at Jim's 300-acre Timbergreen Farm near

Wisconsin forester Jim Birkemeier and his partner Cindy Huppert evaluate a white oak tree. Jim carries a scaling stick that measures tree volume in board feet.

Spring Green, Wisconsin, and other forested land he manages, is on waiting for trees to maximize growth before harvesting them.

"When I started in forestry 20 years ago, we had been taught in college that hardwood trees should be harvested at 14-20" diameter. And that's what we did," Jim comments. "Back then, landowners got about \$16 for a 20"-diameter tree with 320 board feet of lumber in it. But if they had managed their forest and waited until now to harvest, that same tree would be close to 10" larger in diameter and should be worth about \$650 because it's not only larger, but of higher quality [refer to the "added-value" stumpage chart left]. I've found that to get the most profit from your crop [timber] trees, they should grow to at least 24-30" diameter before harvesting."

That doesn't mean, however, that landowners shouldn't harvest some trees on a regular basis. "To give valuable crop trees [e.g., red and white oak, sugar maple, walnut, cherry, ash] room to grow, the woods need to be thinned of smaller and less desirable trees," he advises. "These can be sold for paper pulp, pallet wood, and even low-grade lumber. The object is to grow crop trees of different ages so you can have a continuing [sustained] yield as each age group matures." (See the tree-thinning guidelines right.)

As an example of good forest management, Jim recently worked with a neighboring dairy farmer to do a "crop tree release harvest" on one small hillside. Overmature aspen and red maple were harvested for pallet logs, and 45 crooked and suppressed red oak

STUMPAGE VALUE OF A PROPERLY MANAGED RED OAK TREE											
A TREE THIS SIZE YIELDS →				LUMBER		+	VENEER		=	TOTAL VALUE	
AGE	DIAMETER	BREAST HEIGHT	MERCHANTABLE HEIGHT*	TOTAL VOLUME (BOARD FEET)	VOLUME (BOARD FEET)	VALUE (PER THOUSAND BOARD FEET)	VOLUME (BOARD FEET)	VALUE (PER THOUSAND BOARD FEET)	TOTAL TREE VALUE	PROJECTED VALUE WITH 6% PRICE INCREASE	
52 years	12"	24'	60	60	\$100		None		\$ 6.00	NA	
56 years	14"	24'	90	90	\$200		None		\$ 18.00	NA	
60 years	16"	32'	160	110	\$200		50	\$ 500	\$ 47.00	NA	
64 years	18"	32'	210	140	\$200		70	\$ 750	\$ 80.50	NA	
68 years	20"	40'	320	180	\$200		140	\$ 750	\$141.00	\$ 177.00	
72 years	22"	40'	400	200	\$250		200	\$ 800	\$210.00	\$ 332.00	
76 years	24"	48'	560	300	\$250		260	\$1,000	\$335.00	\$ 666.00	
80 years	26"	48'	680	360	\$300		320	\$1,000	\$428.00	\$1,175.00	
84 years	28"	56'	880	460	\$300		420	\$1,000	\$558.00	\$1,584.00	
88 years	30"	56'	1,025	535	\$300		490	\$1,000	\$650.50	\$1,800.00	

*Merchantable Height = Height of the trunk to 10" top diameter

For Profit

trees were cut for saw logs. The 45 oak trees alone brought \$4,600 from a sawmill. The remaining thinned forest on the hillside now is a magnificent stand of 18-26" diameter red oak crop trees free to grow larger and more valuable.

"Today, if landowners grow trees to their greatest yield potential, they'll benefit from more volume, higher quality, and continually rising prices," says Jim. "And to those who use wood, that also means a continual supply of top-grade lumber in the future." (For information, contact Timbergreen Forestry, S11478 Soeldner Rd., Spring Green, WI 53588.)

Tree-thinning guidelines

Forester Jim Birkemeier follows these guidelines to thin the timber stands he manages:

- Allow 10' spacing for planted hardwood saplings. This gives you approximately 440 trees per acre. Maintain this spacing until the trees reach 8" in diameter, then thin to increase spacing to 20'.

- At 20" diameter, crop trees (either planted or in the woods) should have 35' of space between them, leaving about 36 per acre, plus undergrowth shrubs and saplings.

- When trees reach 30" diameter, increase the distance to 50', leaving 16-20 per acre until harvest.

The trees cut in each thinning can be sold as lower-grade lumber, pulpwood for paper, and pallet stock. Later when larger, they sell as saw or veneer logs.

For All Your Woodcarving & Sign Carving Needs

Terrco provides a full line of machine carving and sign carving equipment. Beginning models are the T-110 single spindle bench carver and our CM614 single spindle sign carver.

Terrco, Inc.

222 1st Ave. NW
Watertown, SD 57201
USA
(605) 882-3888
Fax (605) 882-0778

Intermediate models include the K-Star, a two-spindle heavy duty bench model, and the Northstar, a heavy duty floor model available in one to eight spindles.

Our advanced model is our Master Carver series, which is an extremely heavy duty floor model with from eight to forty spindles.

Write or call for more information.

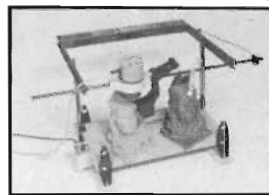

Model T-110 Dupli-Carver



Model CM614 Sign Carver



Multi-Spindle Carving Machine

Circle No. 2175

WoodWorkers Only

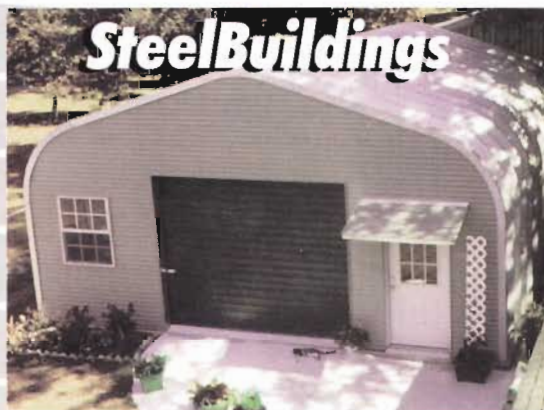

**Save
up to
60%**

**Spring
Inventory
Sale**

SAVE ON SELECT SIZES

25X34 • 30X46

40X56 • 50X116

- America's #1 Arch-Type Manufacturer
- 20 Year Warranty • Easy Financing Available
- Easy Do-It-Yourself Construction
- Free 16 Page Brochure

STEELMASTER®

**Save Thousands
Call Today 1 800 888-4606**



Tool switch's best feature is a gigantic turnoff

Sometimes you have to shut off a machine right now—you don't have time to grope around for the switch, even if you had a hand free to do so. No problem, if the tool is equipped with the ReiTech Easy Off Power Control—you just tap the huge, red stop button with your knee.

I was amazed during testing how little pressure it took to shut off a 10" contractor's saw with the Easy Off control installed. Whether I tapped the 9x12" button at a corner, near an edge, or right in the middle, the switch shut off instantly.

The On switch, a more conventional-looking green button, sits recessed into the switch housing in the top of the outsized Off button, minimizing the danger of accidental actuation. A keylock feature locks out the start button to positively prevent unautho-

ORIZED use of the tool. The tool cord plugs into a receptacle inside the model we tested, and is secured by a clamp (inaccessible from outside the unit).

The switch comes with universal mounting brackets that adapt to most woodworking machines. I found the installation pretty straightforward, although it took some tinkering to mount the large unit on my test saw in a convenient position that wouldn't interfere with the blade elevation crank. After figuring out where to put it, actual installation took only about 30 minutes.

ReiTech offers three versions of the switch. There's the EZO-CR for 110V tools with standard on-off switches (the one I tested); the EZO-PP, which prevents machines not equipped with a magnetic starter switch from restarting automatically after a

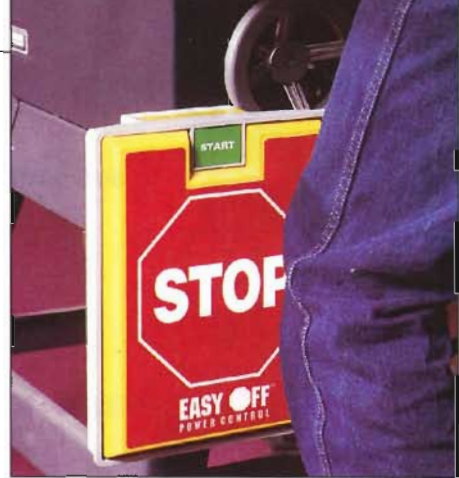

PRODUCT SCORECARD

Easy Off Power Control

Performance	★★★★★
Price	EZO-CR and EZO-MS, \$89.95; EZO-PP, \$169.95
Value	★★★★☆

ReiTech, 11965 12th Ave. S., Suite 200, Burnsville, MN 55337. 800/385-6161.

power outage; and the EZO-MS for machines with magnetic starter switches or those that operate from multiple points. ♣

—Tested by Dave Henderson

Incredible Combination!



The new LX31 and the totally redesigned LT18.

With this combination, you can make almost anything out of wood. The most economical way to set up a dream workshop and at the same time, save space and money!

Call now for a free video!

LAGUNA TOOLS

(800) 234-1976

(714) 494-7006

<http://www.lagunatools.com>

2265 Laguna Canyon Road
Laguna Beach, CA 92651

Circle No. 615

WOODLINE ARIZONA, Inc.
P.O. Box 1530 • Payson, AZ 85547

ALL WOODLINE ARIZONA BITS & CUTTERS FEATURE:
• EUROPEAN CARBIDE • ANTI-KICKBACK DESIGN • SUPER-SLICK FINISH

- All Major Credit Cards Accepted
- Shipping is only \$3.75 per order
- Most items in stock
- Same-day shipping!!
- Order 24 hours-7 days a week **1-800-472-6950**

FREE NEW catalog with over 100 NEW BITS & CUTTERS!

Great Router Bits and Shaper Cutters!

With our 1-PIECE PANEL RAIL & STILE CUTTER, just raise the bit approx. 3/8" to make the matching cut. **5 profiles available:** NEW Double-Roundover and NEW Wedge, Ogee, Roundover, Cove & Bead, Dressed w/ heat-resistant, super slick finish.

- Great fit
- No changing bits.
- No reversing the pieces.
- Just raise, cut—that's all!!

For your Shaper
3/4" Bore **\$89**
1-1/4" Bore **\$99**

DOING JOINING? WE'RE JOINING HEADQUARTERS!
Best Prices, Best Selection, Top quality!

NEW Don't throw those "shorts" away! Now an affordable router bit FINGER JOINER WL-1429 **only \$39.**
For the Shaper WL-1580 **was \$44. Now only \$89.**

NEW "V" FACET & G router bit for up to 1-1/8" material. WL-1488 **only \$30.**

2 PC. SET "V" FACET & G now in 2 sizes for the shaper 3/8" to 5/8" WL-1571 **only \$119.**
3/4" to 1" WL-1572 **only \$139.**

GLUE JOINTS in 2 sizes, for up to 5/8" (also is drawer joint cutter)
1/4" shank WL-1430-1 **only \$24.**
1/2" shank WL-1430-2 **only \$24.**
for up to 1-1/4" material
1/2" shank WL-1430 **only \$35.**

T & G FLOORING CUTTERS
For the Router WL-1488-1 **only \$39.**
For the Shaper WL-1584 **only \$59.**

T&G Router bit For 1/4" to 1/2" material WL-1488-2 **only \$30.**

Router bit CORNER LOCK MITRES in 3 sizes
WL-1420-2 (1/4" shank-up to 5/8" material) **only \$25.**
WL-1420-1 (1/2" shank-1/2" to 3/4" material) **only \$30.**
WL-1420 (for material to 3/4" to 1-1/4") **only \$38.**

NEW Carbide tip ROSETTE CUTTERS
cutting width-2-1/4" \$39. 3-1/4" \$49.

SUPER BUY!!

These great sets are packaged in an attractive wooden box! Available in both 1/4" and 1/2" shank

- 8 pc. Joint Making Set 2 Straight Bits, 6 Dovetails **\$49**
- 6 pc. Roundover Set 1/8" 3/16" 1/4" 5/16" 3/8" 1/2" radius **\$55**
- 5 pc. Cove Set 3/16" 1/4" 5/16" 3/8" 1/2" radius **\$49**

NEW 24 pc. SUPER Set **only \$129.**

SUPER SALE!!

CUTTERS and BEARING SETS (to change depth of cut) Two-Flute Cutters in 1/4" or 1/2" shank. Allen wrench incl.

Priced at only \$15. ea.
\$39. Set of 3

• 5/32" kerf w/3 bearings, cuts slot to fit all biscuit sizes. Sample bag of biscuits incl.
• Rabbeting Bit with 4 bearings for rabbets of 1/4", 3/8" & 1/2" depth
• 1/4" kerf Slot Cutter with 4 bearings for cutting slots of 1/4", 3/8" & 1/2" depth

Circle No. 1395

Lower your cholesterol with the aid of pines

According to a report in the *New England Journal of Medicine*, researchers in Finland have discovered that a plant sterol called sitostanol, common in pine trees, serves to effectively block cholesterol absorption to decrease blood serum cholesterol levels. When made into a fat-soluble stanol ester and used as an ingredient in margarine, it can lower low-density lipoprotein (LDL) cholesterol levels 10-14 percent. The sterol has no effect on triglyceride or high-density lipoprotein (HDL) cholesterol concentrations, though.

At this writing, producers of the margarine, trade-named Benecol in Finland, say that it probably won't be sold in the United States as a diet spread. Instead, it may take the form of a snack bar.

Build-A-Toy® contest ends long run



Nine years is a long time to sponsor a contest. But as do many good things, *WOOD*® magazine's annual Build-A-Toy® contest has come to an end.

Begun in 1989, the then Design-A-Toy™ contest elicited more than 400 entries to vie for the nearly \$17,000 in woodworking tool and supply prizes. That entry level continued for the next few years. Eventually, though, entries began to wane, a signal that reader interest was waning, too. So, the 1997 contest was designated as the last. Watch for the winners' names in the October 1998 issue. Many thanks to the contest's generous prize sponsors and readers who entered over the years.

Photographs: Jim Whetstone
Illustration: Jim Stevenson

Wanted: Youths to intern at historic Mount Vernon

What would it be like to live in the 18th century for 10 weeks, and get paid for it? This year, five youths (graduating high-school seniors and college undergraduate students ages 18-22) will find out.

The lucky ones will serve as interns at Historic Mount Vernon, Virginia, the home of George Washington. Four will demonstrate the agricultural practices of the time (Washington was a progressive leader in early American agriculture). Another, sponsored by the Mid-West Tool Collectors Association, will learn to do period woodworking and building with hand tools.

Each intern receives travel expenses, a weekly stipend of \$200, room and board, period costumes, and educational side trips during the 10-week period (June-August). For information on 1999 intern opportunities and an application, contact John Riley, Assistant to the Director, Mount Vernon Ladies' Association, Mount Vernon, VA 22121. Historic Mount Vernon is an equal opportunity employer.



This woodworker never scraps scrapwood

The old saying, "One man's trash is another man's treasure," has become the motto for one aspect of professional furniture- and cabinet-maker Jim Whetstone's woodworking. Instead of throwing out his multitude of hardwood scraps, Jim creatively recycles them (even ones the size of a quarter) into boxes, banks, and picture frames.

The New Cumberland, Pennsylvania, craftsman says it takes him about 45 minutes a side to glue-up scrapwood to make a bank like the one shown *right*. "Some pieces I apply 'as is' and others I cut and fit to properly mate. There's no rhyme or reason, I just create as I go, mixing colors and shapes." Jim finishes his scrapwood projects with spray coatings of clear, matte lacquer. ♣



Craftsman Jim Whetstone uses scraps of hardwood of all species to make boxes, mirror frames, and banks such as this one that stands 12" high.

Scrap sheetgoods make up the basic box to which scraps are glued. The woodworker cuts and fits pieces, creating as he goes along.



Better Homes and Gardens®

WOOD PATTERNS®

For your woodworking convenience

APRIL 1998

ISSUE 105

Dear Reader: As a service to you, we've included full-sized patterns on this insert for irregular-shaped and intricate project parts. You can machine all other project parts using the Bill of Materials and the drawings accompanying the project you're building.

- Patio Chair
- Computer Desk
- Computer Media Box
- Adjustable Square

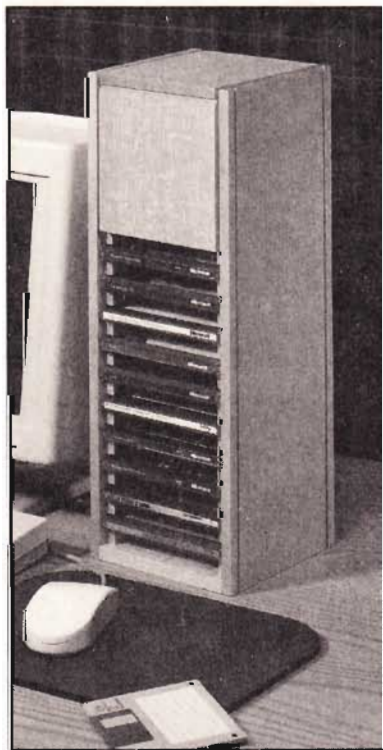
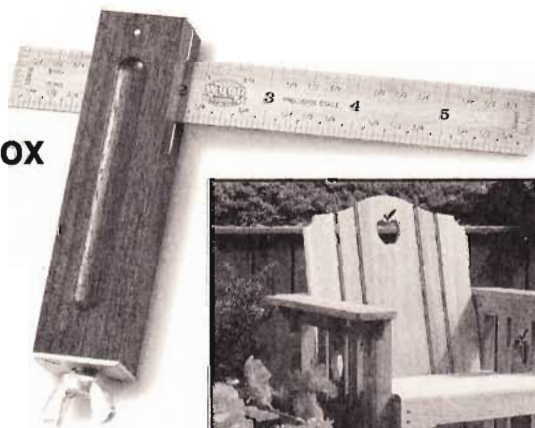

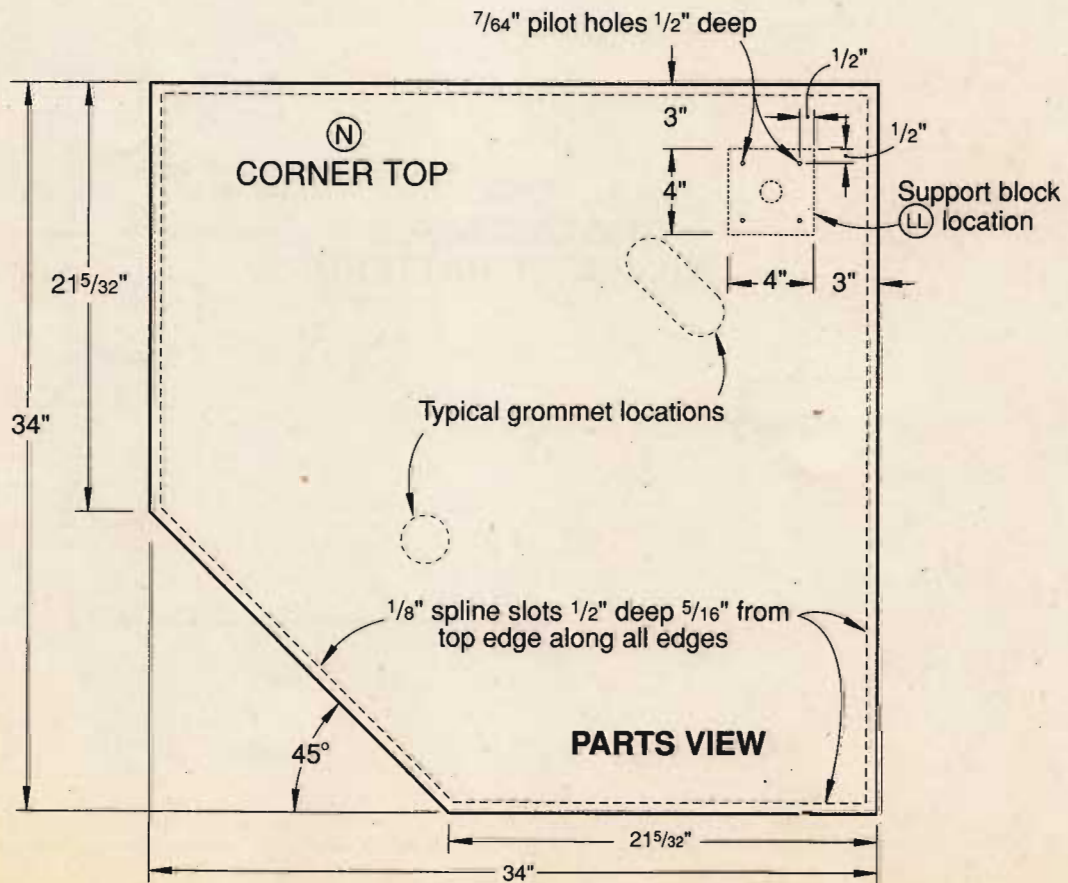
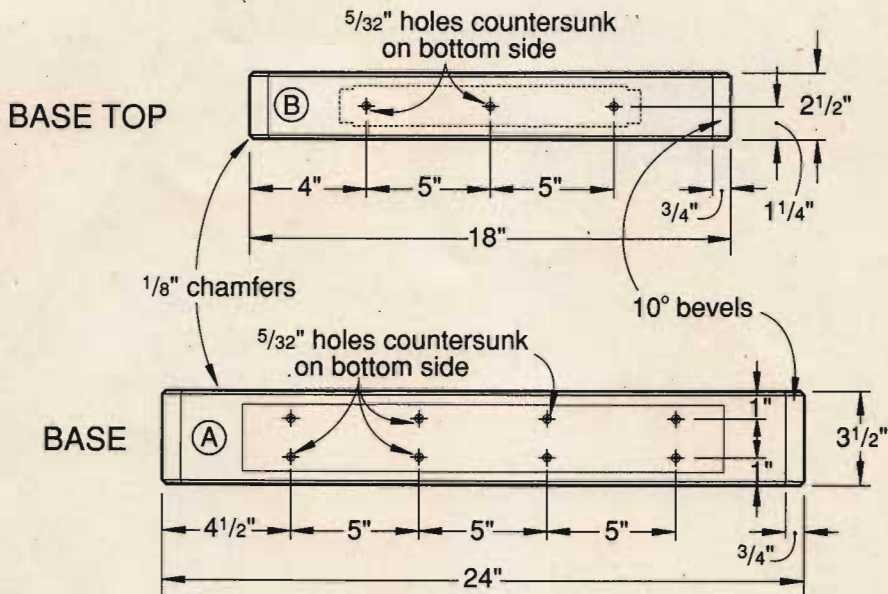

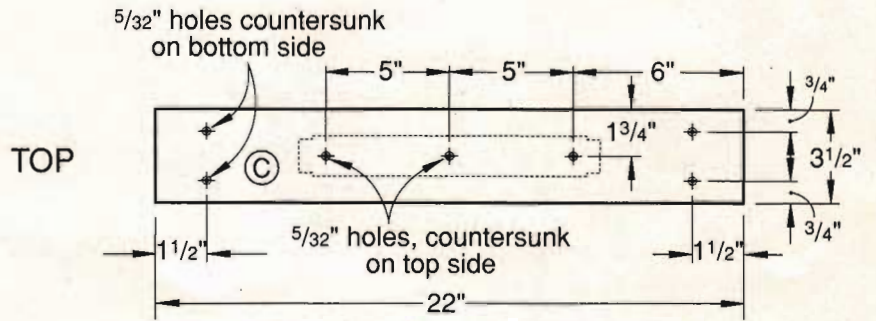

COMPUTER DESK

See page 60

CUTTING DIAGRAM

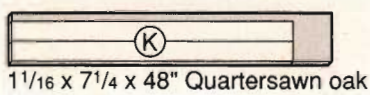
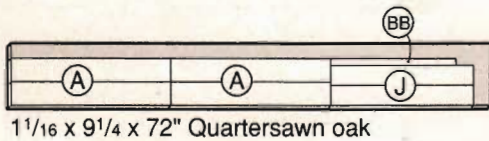

*Plane or resaw to thickness listed in the Bill of Material.

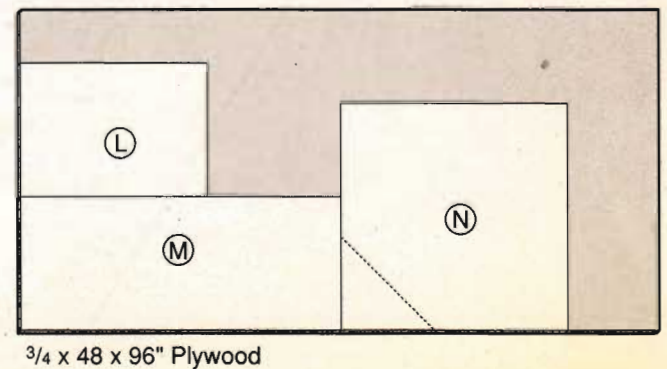
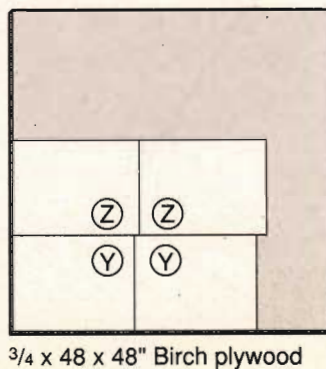
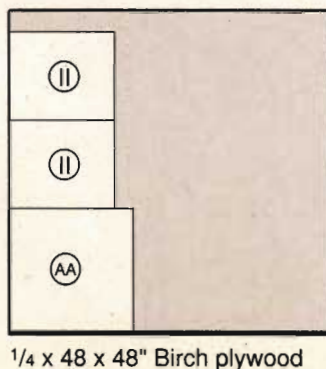
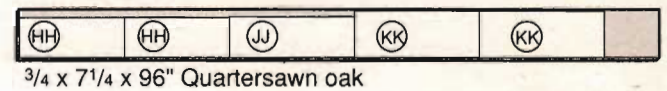
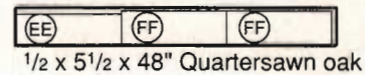
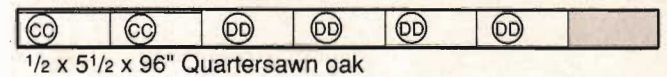
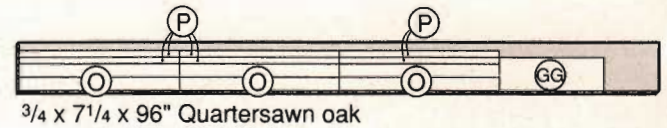
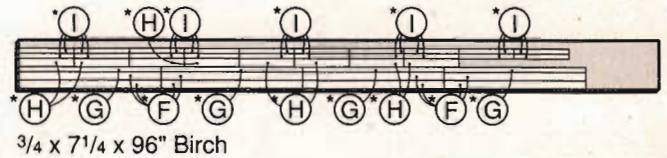
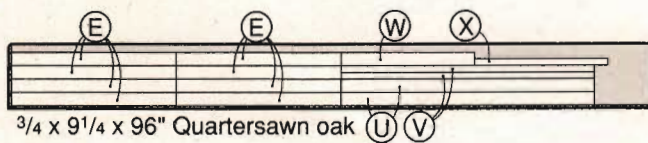
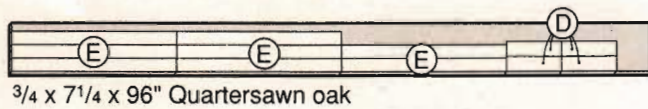
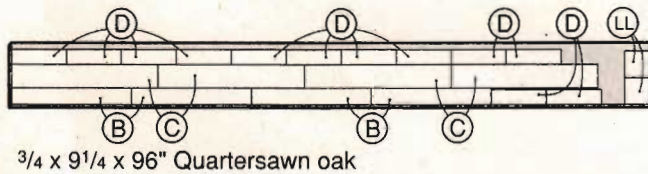

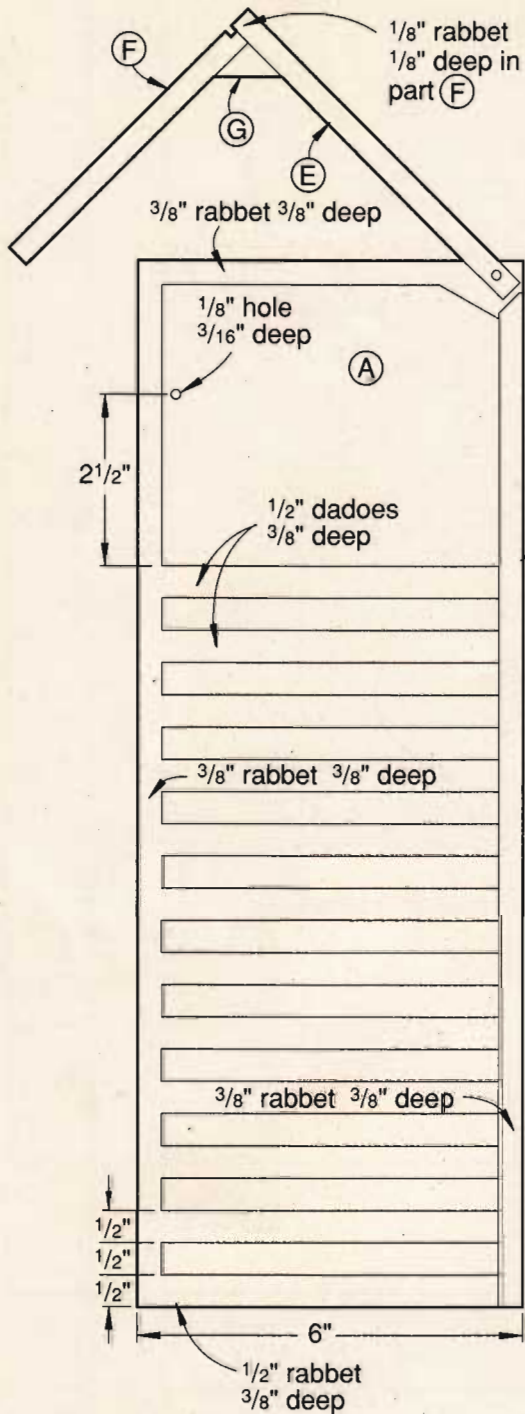

SIDE SECTION VIEW
COMPUTER MEDIA BOX
 See page 68

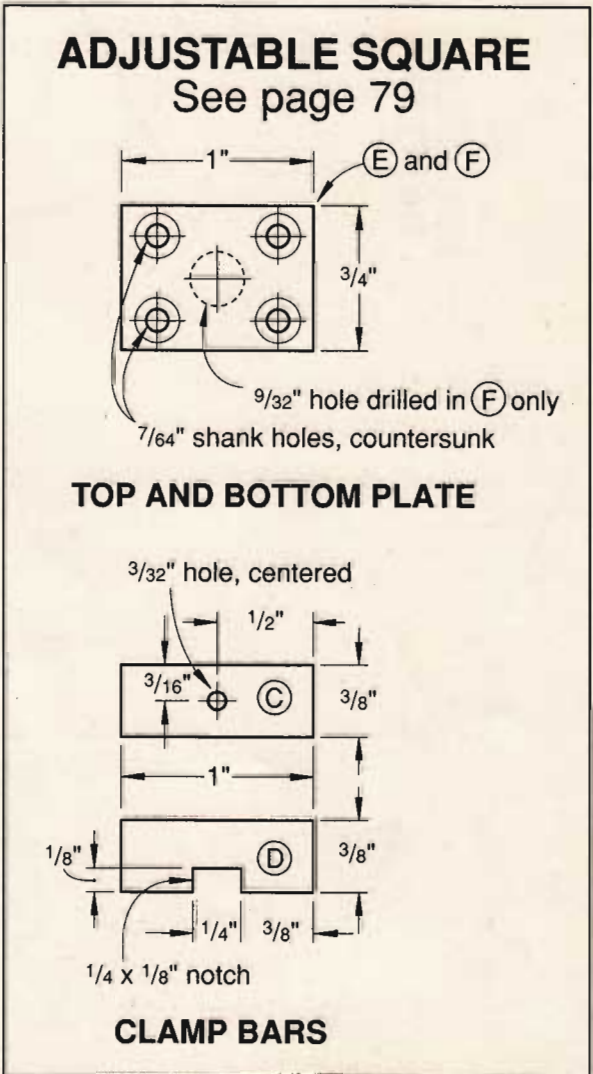
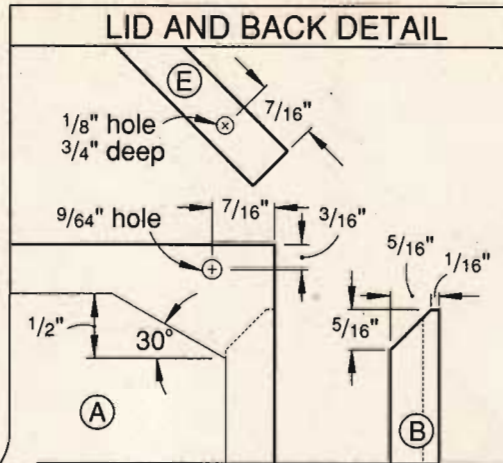

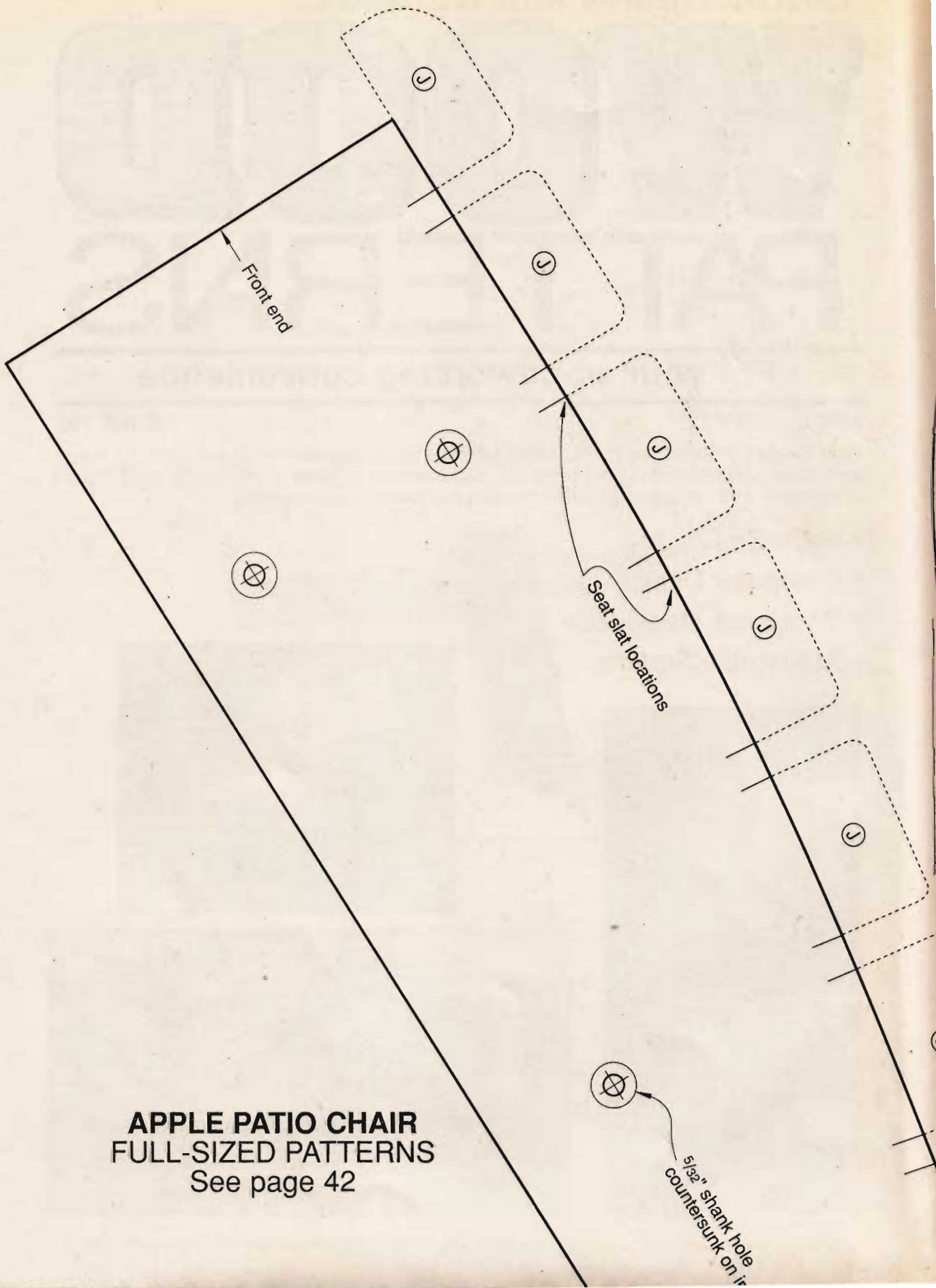

APPLE PATIO CHAIR
FULL-SIZED PATTERNS
See page 42

Ⓝ
FULL-SIZED
PATTERN

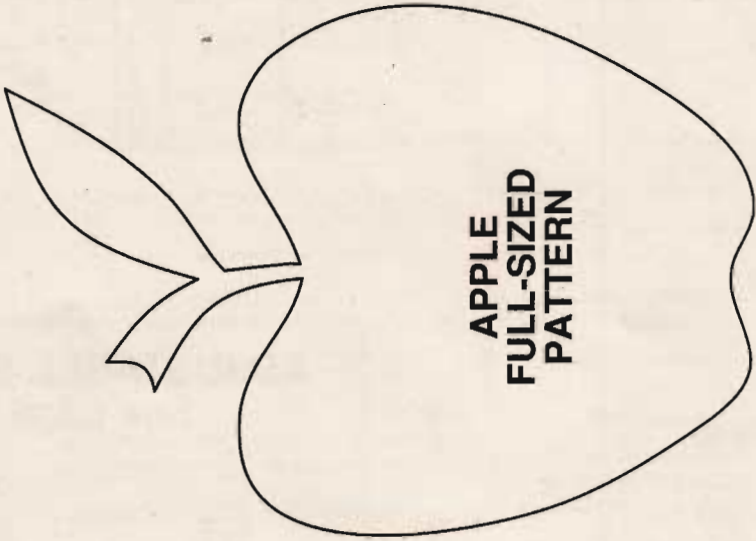

21"

Ⓜ
FULL-SIZED
PATTERN

19³/₄"

Ⓢ

Side face

①
SUPPORT
(2 needed)

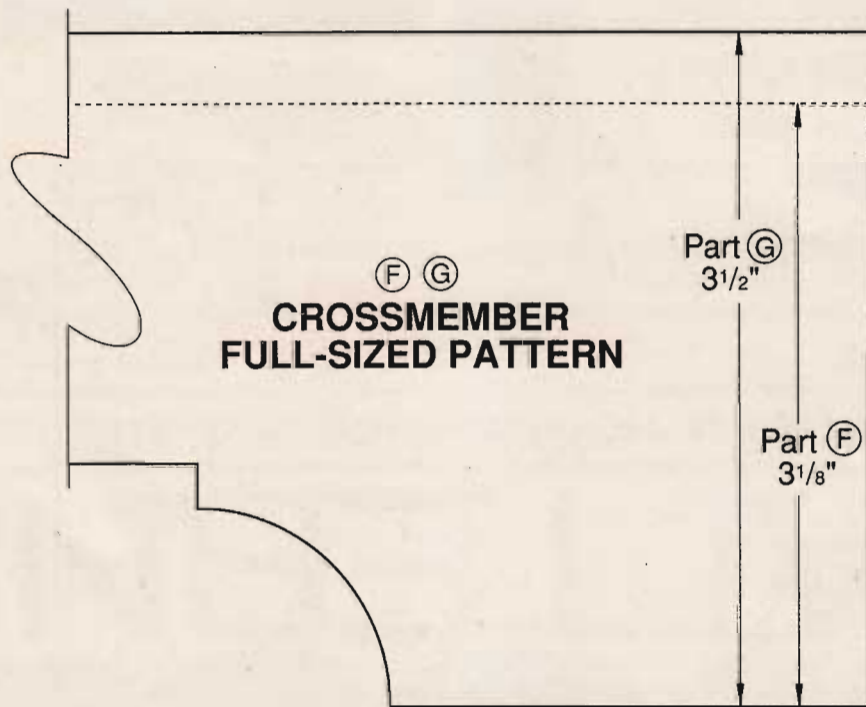
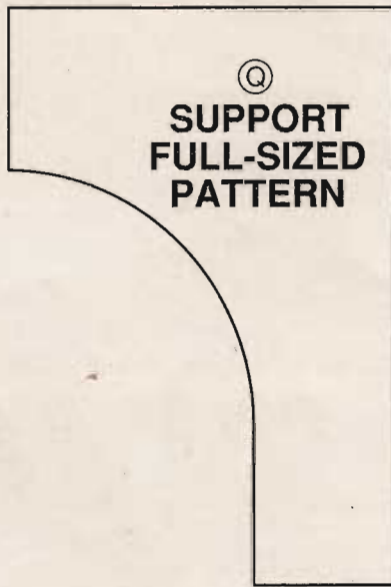

Ⓛ
**FULL-SIZED
PATTERN**

19"

5/32" shank hole
drilled at an angle
through Ⓛ and into ⓐ

15° bevel

