

Better Homes and Gardens®

# WOOD®

THE WORLD'S LEADING WOODWORKING MAGAZINE  
MARCH 1998 ISSUE 104

## MOLDING-BOX MAGIC

Another **WOOD**  
magazine  
exclusive!

Page 72

### GREAT PROJECTS FOR YOUR HOME

- Oak pedestal
- Modular jewelry box
- Corner entertainment center

### FOR YOUR SHOP

- Miter saw stand
- Mobile benchtop-tool cabinet

<http://www.woodmagazine.com>



Display until March 2

Editor **LARRY CLAYTON**  
 Managing Editor **JIM HARROLD**  
 Art Director **C. L. GATZKE**  
 Design Editor **JAMES R. DOWNING**  
 Senior Editor/Features **PETER J. STEPHANO**  
 Senior Editor/How-To **MARLEN KEMMET**  
 Assistant Managing Editor/Products **BILL KRIER**  
 Senior Editor/Special-Interest **LARRY JOHNSTON**  
 Associate Art Director **PERRY A. McFARLIN**  
 Assistant Design Editor/Project Builder **JAN HALE SVEC**  
 Project Builder **CHARLES I. HEDLUND**  
 Senior Graphic Designer **CHERYL A. CIBULA**  
 Production/Office Manager **MARGARET CLOSER**  
 Administrative Assistant **SHERYL MUNYON**  
 Art Business Office Secretary **BARBARA HELPS**  
 Correspondence Writer **ROBBY PEDERSEN**  
 Contributing Editors **KIM DOWNING, DAVE HENDERSON,**  
**LORNA JOHNSON, ROXANNE LeMOINE, BOB McFARLIN,**

©Copyright Meredith Corporation 1998  
 All rights reserved. Printed in the U.S.A.

Better Homes and Gardens® WOOD® magazine (ISSN-0743-894X) is published nine times a year in January, February, March, April, June, August, October, November, and December by Meredith Corporation, 1716 Locust St., Des Moines, IA 50309-3023. Periodicals postage paid at Des Moines, Iowa, and additional mailing offices. Better Homes and Gardens trademark registered in Canada and Australia. Marca Registrada en México. **ONE-YEAR SUBSCRIPTION PRICES:** U.S. and its possessions, \$27; Canada, \$39; other countries, \$47. Canadian GST Reg. #BN 12348 2887 RT. **POSTMASTER:** Send address changes to Better Homes and Gardens WOOD Magazine, P.O. Box 55050, Boulder, CO 80328-5050.

**CUSTOMER SERVICE INFORMATION:** For service on your magazine subscription including change of address, phone toll-free **800/374-9663**. Or, write to Better Homes and Gardens WOOD Magazine, P.O. Box 55050, Boulder, CO 80328-5050. Please enclose your address label from a recent issue.

**EDITORIAL INFORMATION:** Address letters and questions to THE EDITOR, WOOD Magazine, 1912 Grand Avenue, Des Moines, IA 50309-3379.

**ATTENTION RETAILERS:** To carry WOOD magazine in your store, call 800/659-5990, or write: Select Title Program, WOOD Magazine, 900 Kingsland, Batavia, IL 60510.



Better Homes and Gardens®



<http://www.woodmagazine.com>

Wondering if any woodworking events are going on near you this weekend? Want to let people know about an upcoming demonstration? Then the interactive calendar on WOOD ONLINE is for you. From the home page, just click on Calendar, then check particular dates or search by keywords. And, as we said, it's interactive, so you can enter events on the calendar you want others to know about. It's a great place to put your woodworking club's meeting notices, show announcements, and so on. ♣

THE EDITOR'S ANGLE

# Is Necessity the Mother of Invention? Just Ask Matt Allison



Matt impressed his vocational education teacher, Bart Taylor (in background), with his idea for hiding mounting screws behind Shaker peg hooks.

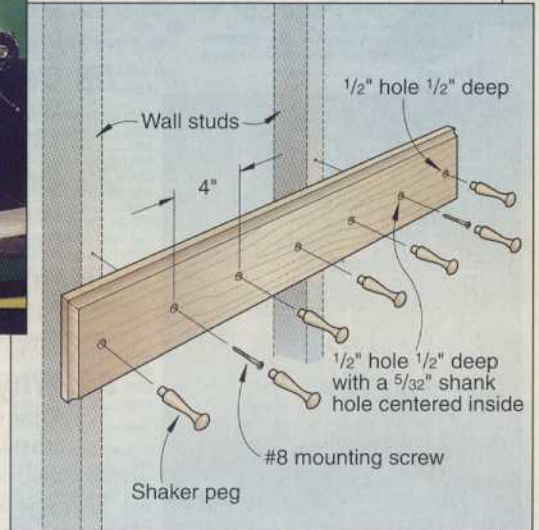

**M**att Allison, a ninth-grader at Soulsbyville School in Tuolumne County, California, likes to skateboard with his friends. And like most kids, he doesn't always put his equipment where it belongs when he's through with it for the day. To help keep all of his gear in one place, Matt, who last year was enrolled in a woodworking course at his school, decided to build a skateboard rack to hold his board, kneepads, gloves, and helmet.

One day, his vocational education teacher, Bart Taylor, happened by the drill press when Matt was working on his project. To his instructor's surprise, Matt was drilling the holes for his pegs about halfway through the rack, then boring a smaller hole centered on each of the larger ones completely through the board.

When asked why, Matt told Bart that he figured if he spaced his pegs at 4" intervals, once he located one stud in the wall to attach the rack to, one of the other holes would match up automatically with another stud. That way, he also could hide the screw holes behind the Shaker pegs. (See the sketch shown above right.)

What Matt's adventure in problem solving shows me is that woodworkers, no matter what their age, are at their best when they're working through the challenges that every woodworking project presents. That's when the breakthroughs occur, the new methods develop, and shop tips, such as this one, raise their beautiful heads.

So what does it feel like having a student who comes up with a novel solution on his or her own? Bart says, "It is truly thrilling when a young person produces something beautiful and useful with their own hands." And in a more philosophical vein, he adds, "In this age of consumerism, entertainment, and ease, let those of us who are able to produce things empower those who haven't yet tasted the satisfaction of producing." ♣

*Larry Clayton*

Better Homes and Gardens®  
**WOOD**

THE WORLD'S LEADING WOODWORKING MAGAZINE

**CONTENTS**



Page 56

**33 Wood profile: mesquite**

This American Southwest species works as well in furniture-making shops as in barbecue grills.

**37 Found-wood furniture**

See how this Washington state craftsman turns logging leftovers into upscale rustic furniture.

**56 Compound mitersaws**

We put 13 models to the test—both 10" and 12" saws—and help you pick the right one.

**72 Crown molding magic**

Learn how to make beautifully shaped boxes from readily available moldings.

**78 How to feather a fowl**

Paint a realistic duck decoy that you'll cherish forever. Buy the blank from our source inside.

**82 Why you pay what you do for wood**

Discover the various stages and costs that impact the retail price of milled woods.



Page 37



Page 72

**Woodworking projects**

**44 Swivel-topped tool cabinet**

Give a pair of benchtop machines a mobile home with this clever shop project.

**50 Brilliant boxes**

Try your hand at box joints while crafting marvelous, stackable, jewelry boxes.

**53 Frame and panel pedestal**

Build an attractive, traditional stand for displaying your favorite works of art.

**62 Made-to-order mitersaw stand**

Customize this hardworking unit to your saw. It includes ample storage and a fence.

**64 Entertainment central**

Add elegance to a room in your home with this tall corner TV/VCR cabinet.

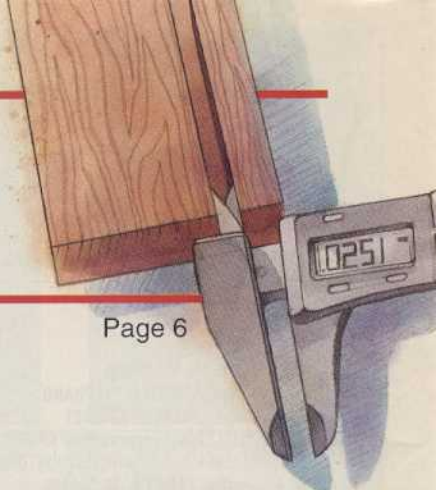

Page 6



Page 64



Page 50

**SHORT-SUBJECT FEATURES**

**1** The Editor's Angle

**4** Talking Back

**6** Great Ideas For Your Shop

**12** Develop Your Shop Skills

**16** Aniline Dyes

**20** Where Safety Begins

**22** Great Ideas For Your Shop

**24** Tips From Your Shop (And Ours)

**100** Ask WOOD

**104** Finishing Touches

For that  
"SPECIAL"  
project



OAK  
TABLE  
BASES

ALAMO

**IN STOCK**  
FREE COLOR CATALOG  
**NO**  
**MINIMUM**



COUNTRY  
FRENCH  
LEGS IN MAPLE



TABLE  
LEGS IN  
MAPLE

**FREE**  
**COLOR**  
**CATALOGUE**

*Adams Wood Products, L.T.D., L.P.*  
974 Forest Dr., Dept. M 39  
Morristown TN 37814

Phone (423) 587-2942 • Fax (423) 586-2188

Circle No. 1002

## TALKING BACK

### More about live oaks

When I read about the live oak in the June 1997 issue, it occurred to me that your readers might like to know about Naval Live Oaks Preserve near Pensacola, Florida. The preserve includes a museum and a nature trail.

In the museum, you will see how various parts of the live oak, which naturally have the shape of a ship's structure, were cut and hewn to fit a particular ship's frame. The nature trail includes not only living samples, but also has photographs posted of particular trees with an outline of the ship's parts overlaying the photo.

You won't find the preserve on most maps, but you can find the entrance by following Highway 98 to a point about one mile east



(south side of highway) of Gulf Breeze, Florida. For anyone interested in early ship building and the use of the live oak, I highly recommend a trip to this site.

—Conrad Bush, Gulf Breeze, Fla.

*Thanks, Conrad. We checked further and learned that Naval Live Oaks is the first and only federal tree farm and was established by John Quincy Adams in 1829. It's part of the Gulf Islands National Preserve. Phone: 904/934-2606.*

### One "cool" improvement

I have now made several of your "One cool catchall" boxes which appeared in the February 1997 issue. I would suggest an alternative to using the bandsaw for the cutouts in the lid and bottom. I found that a 1 1/4" bowl cutting router bit and a router table make a smoother and safer cut than the bandsaw. Also, I've found that I can make several tops and bottoms at once by routing out longer pieces, and then cutting them into appropriate-sized sections. I made three at a time using this procedure.

—James Shawl, Dekalb, Ill.

*Thanks for the great suggestion, Jim. We would*

*like to add that if you use a bowl bit on this inside cut, it will make a more square corner, leaving less room in the corners for the dowel. Simply make the edge 1/8" thicker to keep from crowding that dowel too much.*

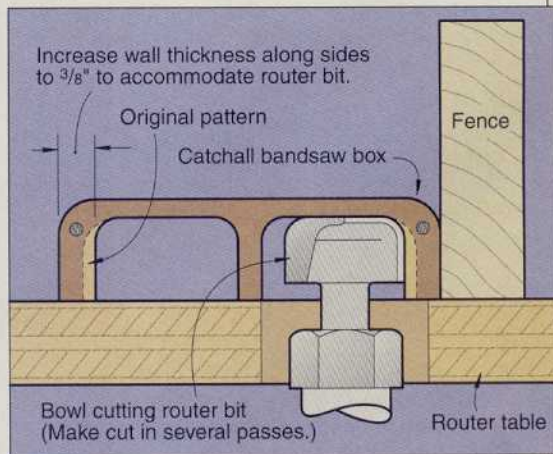

### Let us know what's on your mind

We welcome your comments, criticisms, suggestions, and yes, even compliments. We'll do our level best to respond to you, perhaps on this page!

Write to us at: Talking Back, WOOD Magazine, 1912 Grand Ave., Des Moines, IA 50309-3379. Send e-mail to: woodmail@woodmagazine.com

Better Homes and Gardens®

**WOOD**® & Marketing  
THE WORLD'S LEADING WOODWORKING MAGAZINE

Publisher **WILLIAM R. REED**

Advertising Director **MARK HAGEN**

Manager, Marketing and New Business Development

**CATHERINE BJORK**

Asst. Advertising Services Manager **PAT HENDERSHOTT**

Display Advertising: 333 N. Michigan Ave., Suite 1101, Chicago, IL

60601 Phone: 312/853-2890 FAX: 312/580-7906

Eastern Advertising Manager **JAMES N. FORD**

Western Advertising Manager **WILL MURPHY**

Administrative Assistant **GERALLIE LEGASPI**

Direct Response Advertising: 1912 Grand Ave., Des Moines, IA

50309-3379 Phone: 515/284-3785 FAX: 515/284-3343

Direct Response Advertising Manager **RICH RAINFORTH**

Direct Response Advertising **CINDY ANDERSON,**

**PATRICK MADDEN**

Administrative Assistant **KRISTI HASEK**

Classified Advertising: Phone: 800/424-3090 FAX: 312/464-0512

Circulation Director **LIZ BREDESON**

Associate Circulation Director **KATHI PRIEN**

Business Manager **JANET DONNELLY**

Senior Product Manager **RICK GROW**

Publishing Director **MAX RUNCIMAN**

MEREDITH PUBLISHING GROUP

**CHRISTOPHER M. LITTLE**, President

**BILL MURPHY**, Custom Marketing; **JERRY KAPLAN**, Group Sales;

**MAX RUNCIMAN**, Controller; **BRUCE HESTON**, Manufacturing;

**HAL ORINGER**, Circulation; **DEAN PIETERS**, Operations

**Meredith**  
CORPORATION

**JACK D. REHM**, Chairman of the Board (Retired)

**WILLIAM T. KERR**, Chairman and Chief Executive Officer

**E. T. MEREDITH III**, Chairman of the Executive Committee



# A no-frills, always accurate BOX-JOINT JIG

Basic box-joint jigs like this one have been around for a long time. What's different here is that we tell you the secrets for setting the jig up for perfect results! After you finish building and adjusting the jig, see the article on *page 12* for tips on using it.

**Note:** To use this jig you will need a tablesaw, stackable dado set, and a calipers with dial or digital readout. You can purchase the dial type for \$25-\$40; digital models cost \$60-\$75.

We've found a dial calipers essential because box joints must be cut with exacting accuracy. Why? Any minor error in the width or spacing of the individual "fingers," even .001", multiplies itself with every finger you cut.

For reasons of design and proportion, you typically make the individual "fingers" in box joints as wide as the thickness of the workpieces. In this article, we'll make a jig for cutting 1/4"-wide fingers in 1/4"-thick stock (see the drawing *below* for the precise dimensions of the joints). For thicker or thinner stock you adjust the size of the jig's pin and the width and height of the dado cut accordingly.

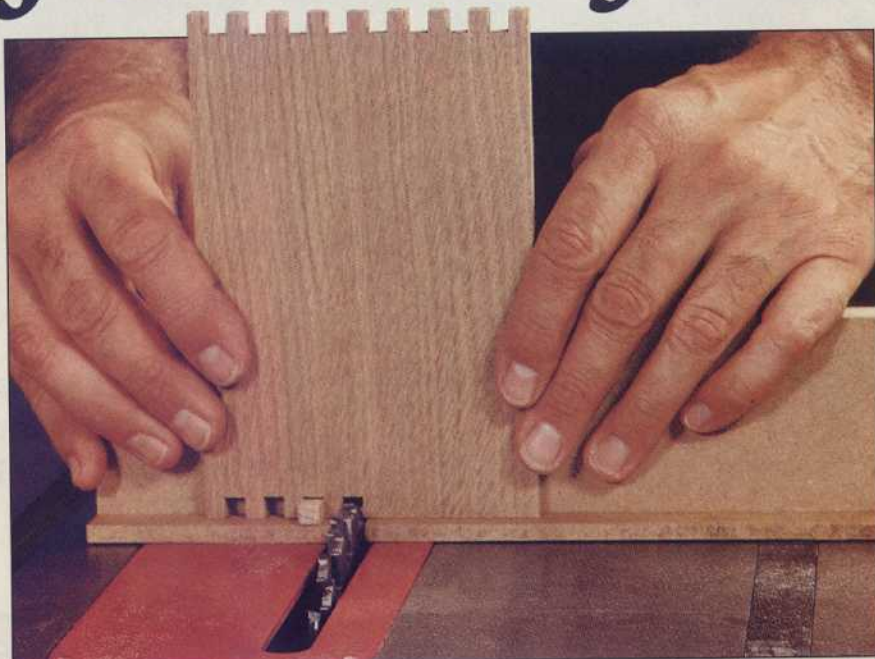

The key to this super-simple box-joint jig is setting it up precisely so the "fingers" of your box joints line up regardless if the workpiece is 3" or 13" wide.

**1** Cut parts A, B, and C to the the sizes shown in the Exploded View drawing *below*. Any flat and straight stock will do.

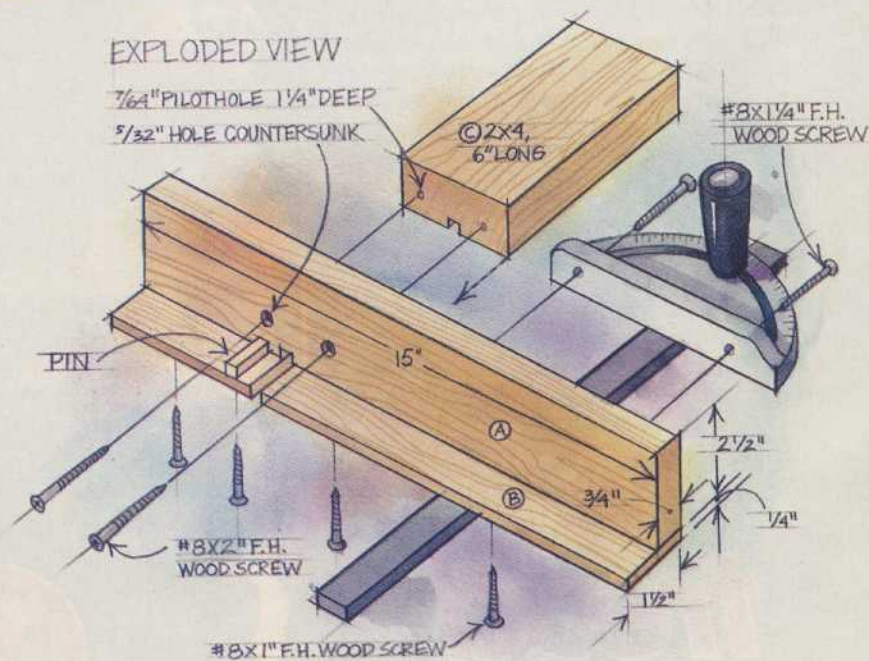
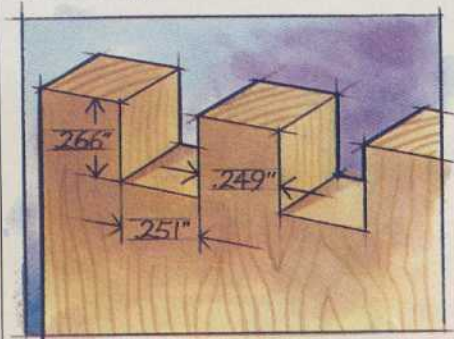

Continued on page 8

## BOX-JOINT JIG

Continued from page 6

**2** Adjust your dado set for a cut that's .001" wider than the joint fingers (.251" in our example). With stackable dado sets you can place commercially made shims between the cutters, or make your own shims from various papers (standard tablet paper measures .002-.005" thick, some tissue and waxed papers measure .001" thick). Check your adjustment by measuring a test cut with your calipers as shown *right*. Raise the dado set  $\frac{1}{2}$ " above the tabletop.

**3** Cut the notch that holds the pin in part A. Do this by holding part A against the miter gauge with part B beneath it as shown *below*. Do not cut into part B.

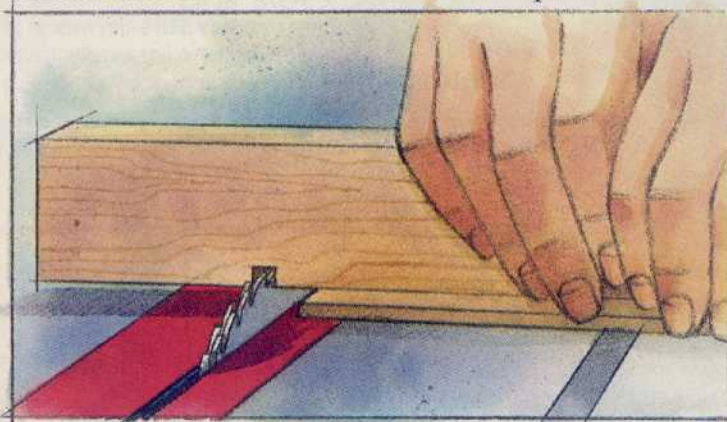

**4** Cut a  $\frac{1}{4} \times \frac{1}{4} \times 6$ " strip of hardwood that fits snugly into the notch you just cut in part A. (The strip should slip into place, yet fit tightly enough so it doesn't fall out.)

Cut a 1½" pin from the strip and glue it into the notch, flush with the back of part A. Save the leftover strip. Screw part B to part A.

**5** Set your miter gauge for a 90° cut. Use the leftover strip to position the jig assembly on the miter gauge. Do this by aligning the jig pin  $\frac{1}{4}$ " from the path of the dado set as shown at *right*. With the pin aligned, temporarily clamp the jig to the miter gauge, then affix the gauge to the jig with screws. Replace the miter gauge into its slot and cut through parts A and B. Attach the blade guard (C) centered behind the notch you just cut.

During this and the following steps, apply pressure to the miter gauge to hold its bar firmly against the right side of the slot. This will keep its distance from the dado set consistent during cuts.

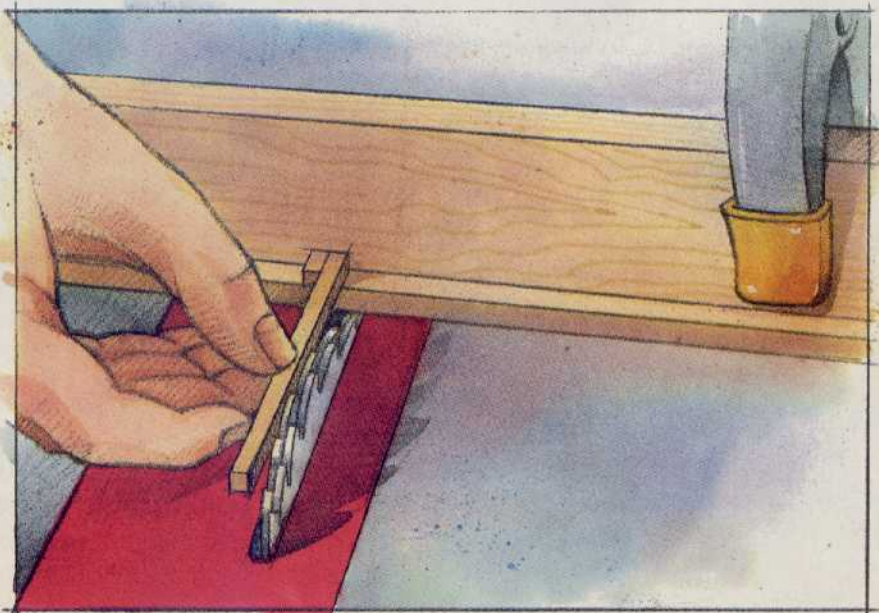

Continued on page 10

## BOX-JOINT JIG

*Continued from page 8*

**6** Position a piece of scrap stock as shown at *right*, and cut a notch into the scrap piece. Position this notch over the pin and make another cut. Position that notch over the pin and repeat the cut.

With your calipers, check the width of the fingers. They should be .001" under your desired finger width. (For our ¼" fingers the calipers should read .249".)

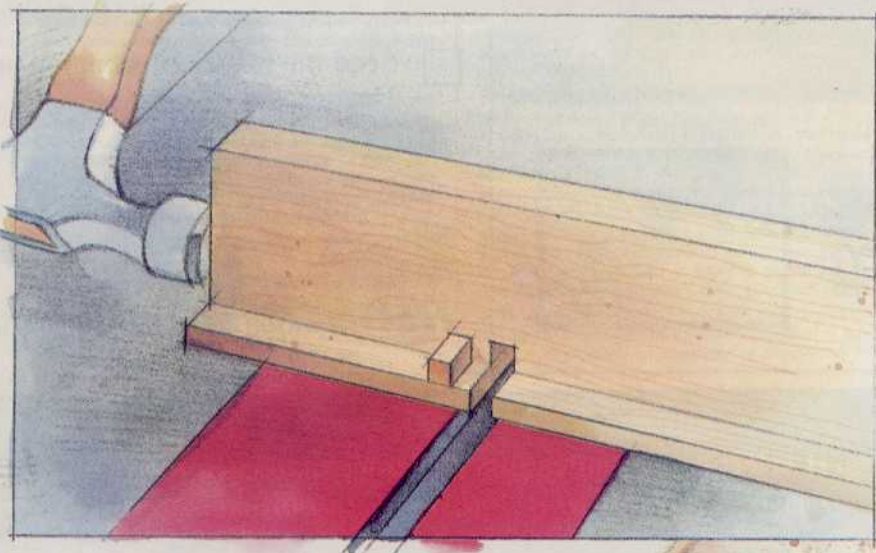
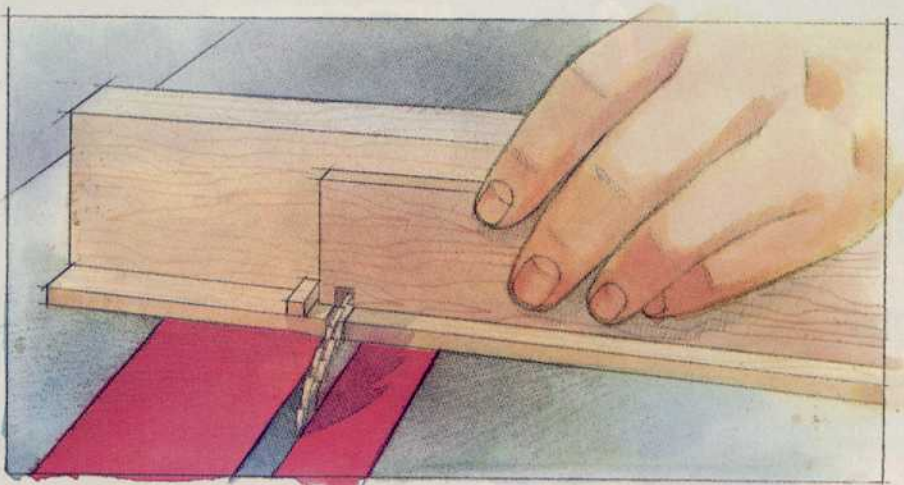

**7** Chances are your jig will need some adjustment to achieve the necessary finger width. If the fingers are too wide, say .255" in our example, tap the end of the jig closest to the blade with a hammer as shown *left*. Make more test cuts and tapping adjustments as necessary. If the fingers are too narrow (.245" in our example), tap the other end of the jig. Even though the jig is screwed in place, the hammer taps will make these fine adjustments.

**8** With your calipers, check the depth of the fingers in your scrap stock. Adjust the height of your blade until the depth reads .016" more than the width of your fingers (.266" in our example). This leaves the fingers long enough so you can sand them flush with the box later. ♣

For complete instructions on using your box-joint jig turn to *page 12*.

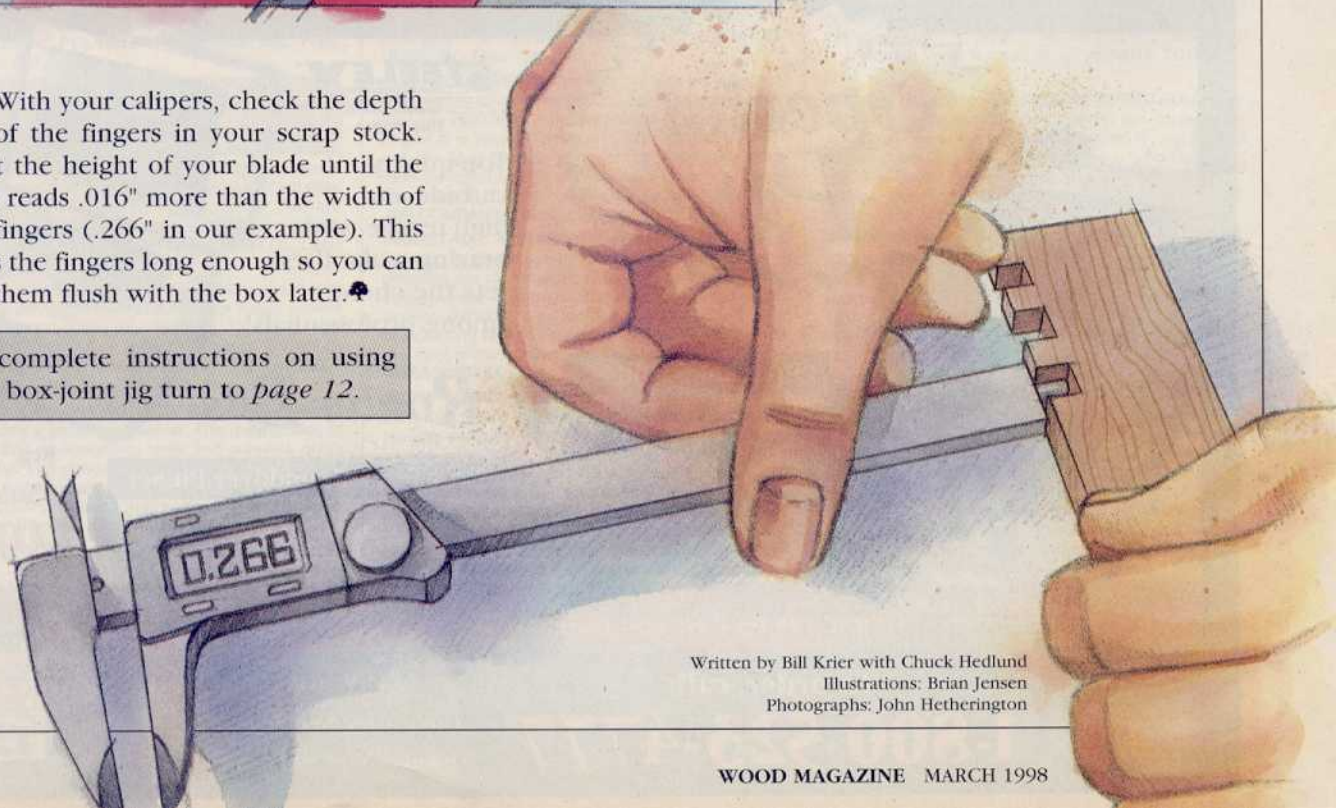

Written by Bill Krier with Chuck Hedlund  
 Illustrations: Brian Jensen  
 Photographs: John Hetherington

How to make snug, good-looking

# BOX JOINTS

Before the advent of cardboard boxes, manufacturers joined the sides of thin wooden boxes with these joints because they were strong and fast to make. Today, box joints have taken on practical *and* decorative roles in projects ranging from jewelry cases to hope chests. After you build the jig featured on *page 6*, follow these steps and see firsthand how easily you can master this joinery method.

**1** Before you cut the actual box joints, keep in mind that the width of your box sides must be an increment of the finger width. Otherwise, you'll wind up with less-than-pleasing partial fingers at

the bottom of your box. So, in the example of  $\frac{1}{4}$ "-thick stock discussed here and in the jig-building article, the width of the workpieces must be an increment of  $\frac{1}{4}$ " (such as 5",  $5\frac{1}{4}$ ",  $5\frac{1}{2}$ ", etc.).

**3** Before you cut the front and back, cut one notch into a scrap piece, just as you cut the first notch into the side piece earlier. Position this notch over the pin as shown *below*, and butt the top edge of the front piece against the scrap before making a cut.

Make the remaining cuts in the front piece by removing the scrap, placing the notch over the pin, and proceeding as described earlier. Cut the back piece just as you cut the front.

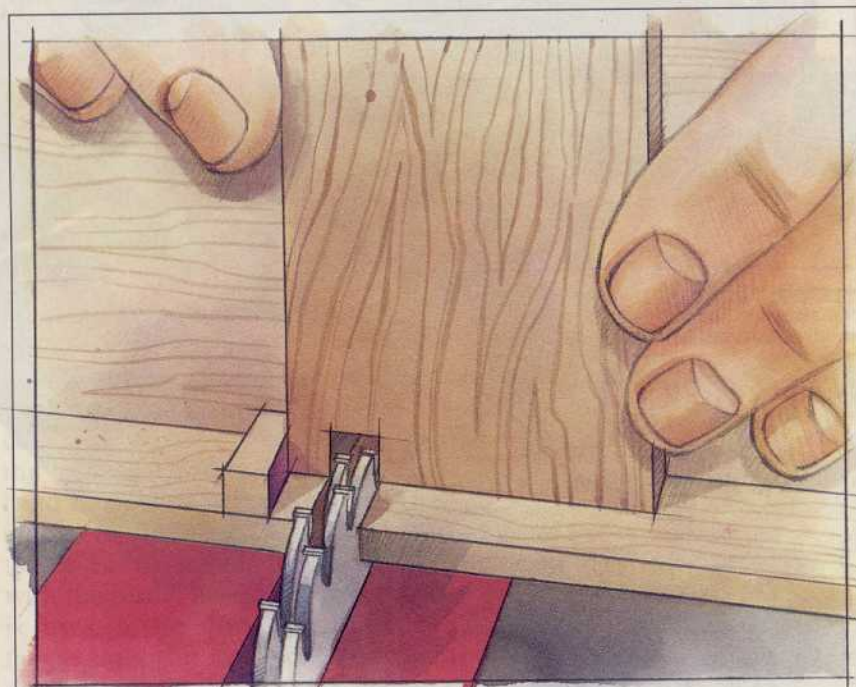

**2** Mark the front, back, and side pieces of your box. Also, mark the top edge on each of these pieces.

For each box you make, you cut the sides consecutively, and the front and back consecutively. It doesn't matter which pair you do first, so we'll start with the sides.

For all of the following cuts, hold the top edge of the work-

piece toward the jig pin for the first cut. Now, put hand pressure on the jig to hold its miter-gauge bar firmly against the right side of the tablesaw channel. Make the first cut as shown *above*. Place the just-cut notch over the jig pin and repeat to cut fingers along the full width of the workpiece. Cut the other side piece in the same fashion.

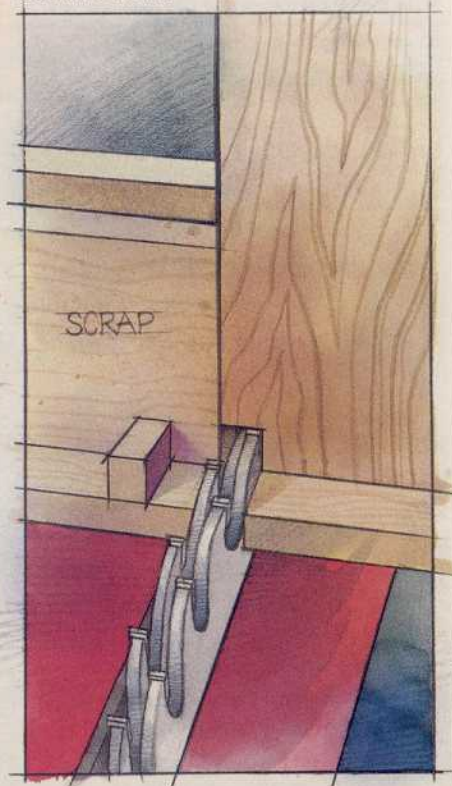

*Continued on page 14*



## DEVELOP YOUR SHOP SKILLS

### BOX-JOINTS *Continued from page 12*

**4** To join your box pieces, apply glue to all of the mating surfaces with a small brush. Tap the joints together with a rubber mallet if necessary. Clamp the box together as shown at *right* (you may need to position a clamp diagonally to square the box).

Note that we used scrap pieces on each side of the corners to evenly distribute the clamping pressure along the joint. Wider boxes may require additional clamps.

After the glue dries, sand the fingers flush with the sides, front, and back. Be careful not to round over the corners. ♣

Written by Bill Krier  
with Chuck Hedlund  
Illustrations: Brian Jensen  
Photograph: John Hetherington

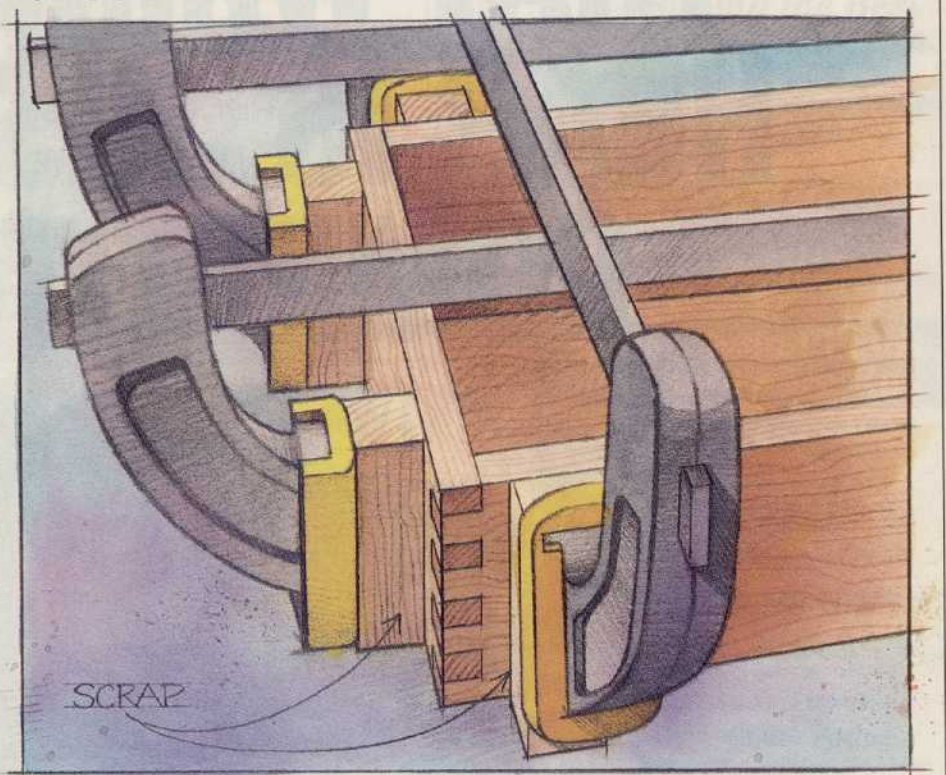

## Give Yourself Some <sup>More</sup> Breathing Room.

The Best Just Got Better!

Introducing The New Model 350

- 55% More Air Flow
- Ultra Quiet
- 95% Ashrae tested main filter
- Lifetime Warranty
- 30 Day Money Back Guaranty.



\*Better Homes and Gardens®  
WOOD® Magazine (Nov. '95)

**JDS AIR-TECH 2000™**

Recent medical studies show that breathing wood dust can be hazardous to your health. The JDS AIR-TECH 2000 will dramatically improve the quality of the air you breathe.

Our model 350 delivers 550 CFM of filtered air. This will clean the air in a 20 x 20 x 8 foot area ten times per hour. For larger areas, our dual speed model 8-12 will deliver 800 or 1,250 CFM of filtered air for only \$495. Our model 10-16 will deliver 1,000 or 1,600 CFM of filtered air for \$695.

The JDS AIR-TECH 2000 systems will remove 99% of particles as small as five microns and 80% of the particles as small as one micron.

Our unique design makes both ceiling installation and filter changing quick and easy.

For the removal of odors, fumes and smoke, our optional charcoal filter is available.

Another quality product from  
Manufactured in the U.S.A.

To place an order or for the dealer nearest you call us toll-free.

And give yourself some breathing room.

**\$259.00**

Model 350

**JDS  
COMPANY**  
1-800-382-2637

# ANILINE DYES

## The brilliant, transparent choice for coloring wood

Aniline dyes offer another approach for your finishing. Whether in wood tones or bright hues, these transparent dyes impart rich color without obscuring the grain.

Changing or enhancing the color of wood while letting its grain show through has been a favorite finishing technique for centuries. Today we often accomplish this with pigmented stains. But before the 1950s, most wood coloring was done with dyes.

Dyeing wood became popular early in the 19th century. The natural dyes available then, extracted from roots, berries, bark, and even insects, yielded beautiful, clear colors. But they weren't lightfast, so the dyed wood faded or changed color over time.

In the 1850s, a British chemist accidentally produced a strong purple dye while working with aniline, a clear, oily, poisonous liquid. Subsequently, scientists synthesized other dye colors. These synthetic dyes delivered the same sparkling colors as the natural ones and were lightfast to boot. They were cheaper, too. Derived mainly from coal tar, synthetic dyes in general came to be known as aniline dyes, and a new chemical dyemaking industry sprang up around them.

Aniline dyes offer an attractive finishing choice today. Pigmented stains, which some characterize as thinned paints, may mask the wood's figure and can lend wood a muddy look. But transparent dye colors, even dark ones, can bring out the grain and add depth. Here's how to dye wood.

### Fixin' to dye

Aniline dye comes as a powder that you dissolve in water, alco-



The dyes are fine powders. When mixed with water, the ones shown become (from left) lemon yellow, brilliant scarlet, bright green, pink, nigrosine black, dark forest green (yes, the brown-looking one), and dark wine cherry.

hol, or petroleum solvents, depending on the formulation. We prefer the water-soluble dyes because they offer maximum clarity and colorfastness and are the easiest to use.

The J.E. Moser water-soluble aniline dyes *above* come in more than six dozen colors from wood tones to bright primary shades and cost around \$4-\$6 per ounce (which makes a quart of liquid dye). We got our dyes from Woodworker's Supply, Inc., 800/645-9292.

For use, stir the dye powder into hot water, shown *above right*. (Don't mix it in boiling water; straight hot tap water works fine.) The standard concentration is 1 oz. of powder to 1 qt. of water. To mix smaller amounts, dissolve about ¼ tsp. of powder into 8 oz. of water; about ⅛ tsp. into 4 oz.

From this starting point, you can adjust the dye color to suit your taste. Just add more water to



Mix the powdered dye into hot water for use. Rubber gloves will keep you from having fancy-colored fingertips.

reduce color intensity or add dye powder to increase it. (To dye the components of the jewelry chest shown on *page 50*, we increased color intensity by stirring ¼ tsp. of powder into 4 oz. of water for both the nigrosine black and dark forest green dyes.)

After mixing, let the dye cool. Then strain the solution through a

*Continued on page 18*

# The Intelligent One-Man Shop.



FIVE PROFESSIONAL QUALITY MACHINES IN ONE.

- ✓ 3 HP 10" table saw with 50" crosscut sliding table and 38" rip capacity.
- ✓ Cast iron mortiser
- ✓ Cast iron tables
- ✓ 3 HP shaper
- ✓ 12" jointer
- ✓ 12" planer
- ✓ 20-second function change

Call now for a free video!

**LAGUNA TOOLS**

(800) 234-1976

(714) 494-7006

<http://www.lagunatools.com>

2265 Laguna Canyon Road  
Laguna Beach, CA 92651

Circle No. 615

## Econ-Abrasives

WE MAKE ABRASIVE BELTS ANY SIZE, ANY GRIT!

### Standard Abrasive Sheets

#### CABINET PAPER

	50/pk	100/pk
60D	\$16.70	\$30.00C
80D	15.60	27.80C
100 thru 150C	14.50	25.60C

#### FINISHING PAPER

80A	\$ 11.15	\$18.90C
100 thru 280A	10.00	16.70C

#### NO LOAD PAPER(white)

100 thru 400A	\$12.25	\$21.25C
---------------	---------	----------

"C" = 100 SHEETS

#### Velcro® Vacuum Discs

8 Hole pattern for Bosch sanders

Dia.	Grit	Price
5"	60	\$.48 ea
5"	80	.46
5"	100 thru 320	.45

\* Available in 5 hole pattern \*

\*Wide Belts\*Rolls\*Flap Wheels  
\*Pump Sleeves\*PSA Discs  
\*Router & Wood Bits\*Wood Glue

\*MasterCard, VISA, C.O.D. or Check  
\*SATISFACTION GUARANTEED!!!  
\*CALL FOR FREE CATALOG  
- TX & NV add appropriate sales tax  
- Continental U. S. shipping add \$5.50

### ABRASIVE BELTS

Belts are resin bond cloth with a bi-directional splice, specify grits.

1X30	\$.81 ea	3X24	\$.93 ea
1X42	.81 ea	3X27	.96 ea
1X44	.81 ea	4X21 3/4	1.06 ea
2 1/2X16	.85 ea	4X24	1.10 ea
3X18	.86 ea	4X36	1.35 ea
3X21	.90 ea	6X48	3.50 ea
3X23 3/4	.93 ea	6x89	6.24 ea

#### OTHER SIZES ON REQUEST

#### HEAVY DUTY SPRING CLAMPS

Clamps come w/PVC tips and grips.



Size	Price
4"	\$1.75 ea
6"	2.25
8"	3.50

#### JUMBO ROUTER PAD(24" x 36")

It will not allow small blocks of wood to slip out under router or sanding applications.

ROUTER PAD  
ONLY \$8.95ea.

JUMBO BELT CLEANING STICK  
ONLY \$8.80

**Econ-Abrasives**

P. O. Box W865021

Plano, TX 75086

(972)377-9779



**TOLL-FREE ORDERING LINE (800)367-4101**

Circle No. 1229

# ANILINE DYES

Continued from page 16

coffee filter or nylon stocking, shown *below*, before applying it to the wood.

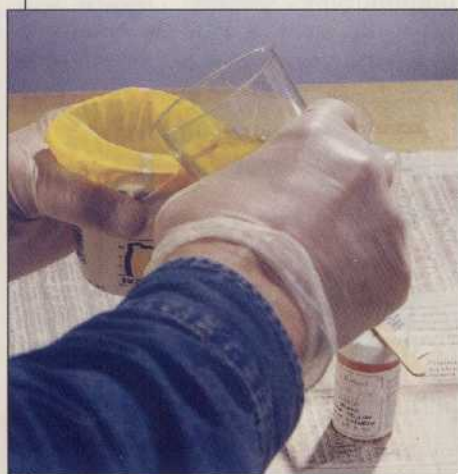

▲ After the dye cools, strain it through a coffee filter into another container. Label the aniline dye containers.

► You don't need top-quality brushes to apply aniline dyes. Foam brushes or inexpensive bristle brushes work fine.

## Tips on dyeing the wood

Sand the project as you would for staining or clear finishing. Do not seal or fill the wood; it must absorb the dye.

Put on the dye by any convenient means—brushing, wiping, spraying, or dipping. We found that



inexpensive foam brushes work just great.

The easiest application method calls for two brushes. Paint on the dye with one brush, keeping the work surface wet, as shown *left*. Wipe away any excess with another brush.

Dye strength controls the color, so you don't need to worry about uneven coats. We found that brush marks and laps posed no problem. If we kept the surface uniformly wet, the color invariably came out smooth and even.

Allow the first application to dry 24 hours. The water-based dye raises the wood grain, so sand away the fuzz with 320-grit abrasive. Clean off the sanding dust, and dye the wood again. Let this application dry, then buff the surface with a white Scotch-Brite pad. You can apply any clear finish to the dyed wood. ♣

Photographs: Hetherington Photography

TABLESAW TABLE TOPICS:

## PLAY IT SAFE WITH ADD-ONS

Safety Man Mike Gililand shows you the proper way to clamp for cutoffs and use a feather board.

Joplin, Missouri, reader Thomas DeSanto wrote to express his thoughts on safety. Here's just one: "Some people might say safety is too expensive and too much trouble; but it isn't as bad as having a glass eye fitted, or getting a hearing aid, or trying to do without a few fingers." I like his line of thinking, although I try to be more positive.

I've also read the safety related concerns generated in the WOOD ONLINE® discussion group at WOOD® magazine's Web site (<http://www.woodmagazine.com>). Several cyber-readers wanted safety opinions on using the tablesaw

fence as a length gauge for repetitive crosscutting. So, for everyone's benefit, here are my thoughts on the subject.



Mike Gililand is a lifelong woodworker and an engineer with 25 year's experience designing and working with woodworking power tools to make them safer. A resident of Missouri, he owns and runs a safety consulting firm.

### Don't get in trouble with your fence as a stopblock

You've seen it done: Someone clamps a stopblock of scrapwood to the tablesaw fence. Then he adjusts the fence to act as a cutoff gauge for repetitive crosscuts.

At *right*, in illustrated form, are two examples of what can go wrong with that setup. In the first example, with the blade guard in place (and no matter what you say, it should always be), the cutoff rotates between the blade and the fence, wedges, then kicks back toward you. In the second example, without the guard, the cutoff rotates, contacts the back of the blade, then kicks back. In both cases, it's the fence that's the culprit because it doesn't allow the cutoff to escape.

The third drawing shows you the safest way to do it. *Remove* the tablesaw fence from the table and clamp a stopblock to the table in its place. Be sure the stopblock is parallel with the blade and yet doesn't intrude on the blade's cutting path. Also be sure that it's securely clamped to the table.

### Bad feather-board placement causes kickback, too

Feather boards—those fingered devices you clamp on to hold the workpiece in place as you rip—are meant to prevent kickback. But that's only if you install them properly. Like any other tool or accessory, there's a right and a wrong way to use them.

On a tablesaw (or radial-arm saw), a correctly positioned feath-

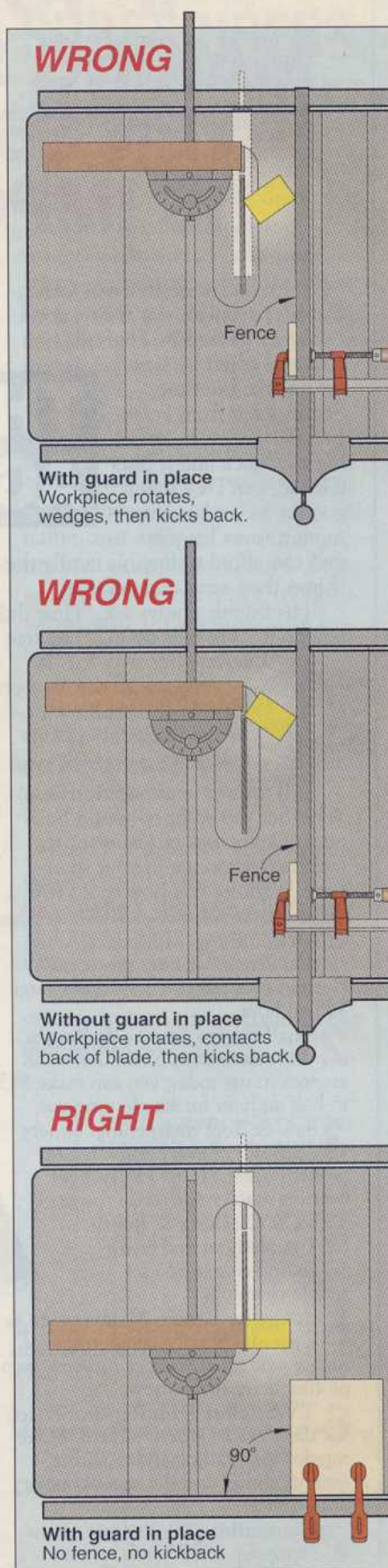

er board holds the workpiece against the fence, as shown in the drawing *near right*. This keeps its alignment true to the blade, assuring a straight, clean cut. Should the saw blade try to kick the wood back, the fingers of the feather board quickly help stop the board's reverse motion.

But, if you clamp the feather board in position so that it pushes against the side of the blade, as shown *far right*, it will actually cause kickback. That's because as the blade cuts the workpiece, the feather board pushes against the offal piece to pinch the blade, resulting in a nasty kickback. 🐿

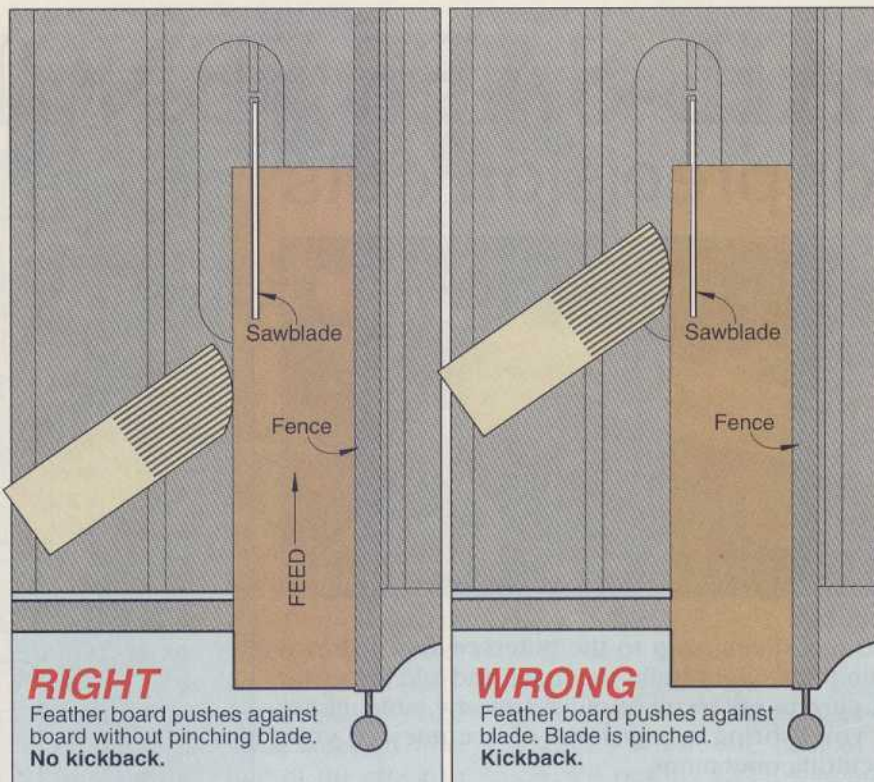

Illustrations: Kim Downing; Lorna Johnson

Send your safety-related questions with a SASE to:

**The Safety Man**  
WOOD Magazine  
1912 Grand Ave.  
Des Moines, IA 50309-3379.

Not all questions will be published, but all will receive a reply.

## Having Fun Making Money...

A Dream Come True for anyone who loves to work with their hands  
Engraving • Airbrushing • Sandblasting



Keith Hohe... a career woodworker now enjoys making money with his Paragraphics Engraving System. Using simple patterns that he just traces and our new ultra-high speed drill (amazing 300,000 r.p.m.) It allows even a non-artist to produce professional results fast and easy.

For your free demonstration video call today!  
(refundable deposit required)

*Paragraphics*  
CORPORATION

1-800-624-7415  
1455 W. Center Orem, Ut 84057  
Financing Available

Circle No. 2160

## "All my tools should be this good!"

The Accu-Miter® is a professional miter gauge that makes perfect angles easily. Shot-pin action assures dead-on accuracy for common angles — plus a precise protractor scale for everything in between!

Optional accessories:  
manual clamp—  
pneumatic clamp—  
3/8" x 3/4" miter bar—

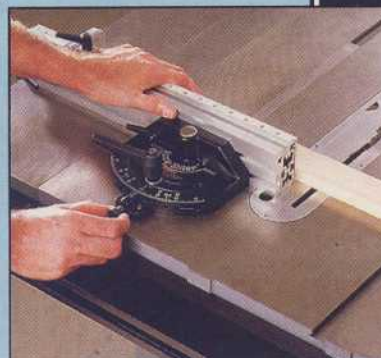

We do not recommend operating without the saw blade guard, as is shown here.  
US Patent #5,038,486

**JDS**  
COMPANY

Precision Woodworking Equipment

Call or write for our free brochure. 800 Dutch Square Blvd., Suite 200, Columbia, SC 29210  
1-800-382-2637 / SC 803-798-1600

\$149

# FAIL-SAFE FENCE STOP

## For precision cuts

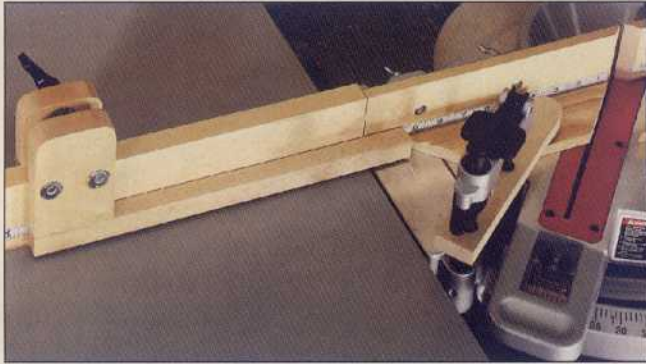

Add this sliding stop to the miter saw fence shown on page 62, or build the fence and add it to your current miter saw or radial-arm saw table. Either way, you'll bring a new level of accuracy to your crosscutting operations.

To use the jig in close to the blade where the stop uprights can get in the way, position the stop on the fence as shown in the photo above. When working further from the blade, position the stop so the extension is on the back of the fence pointing away from the blade and the knob is facing forward where shown on the Exploded View drawing below. 🛠️

Project Design: James R. Downing  
 Illustrations: Kim Downing  
 Photograph: Hetherington Studio

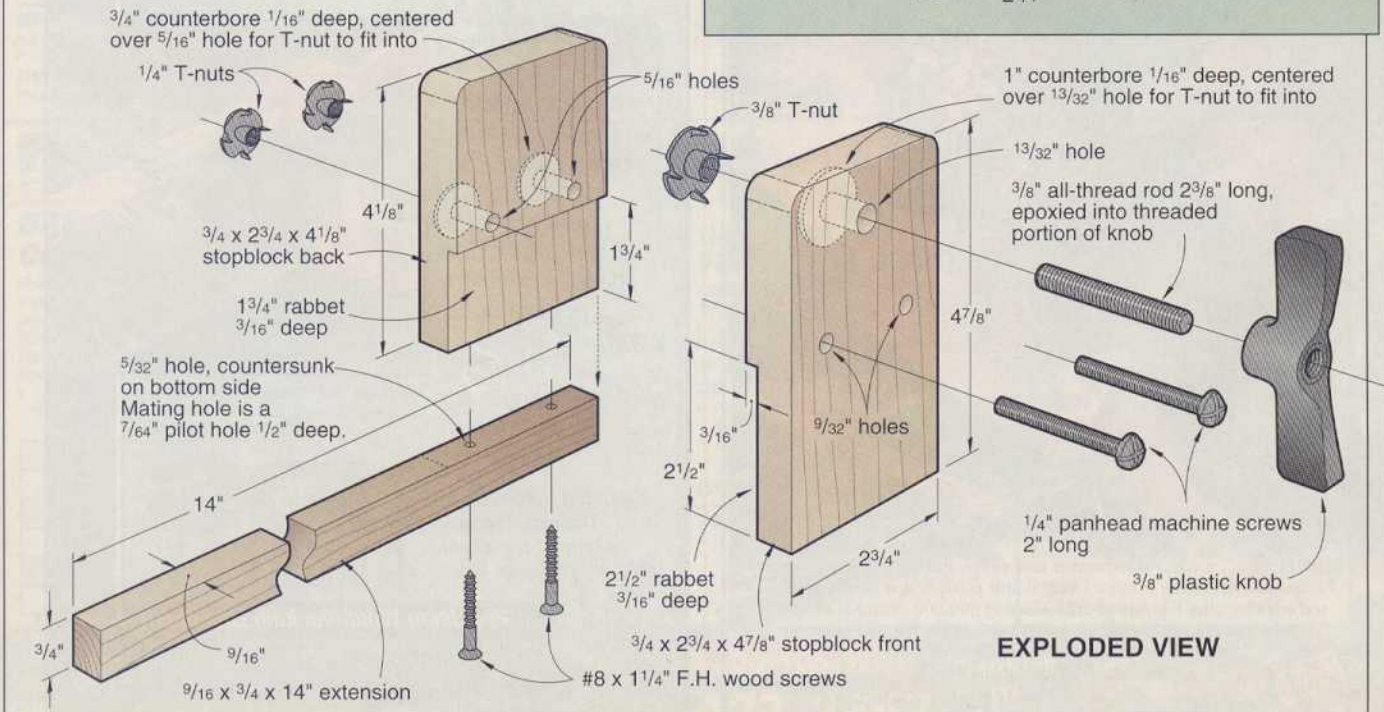
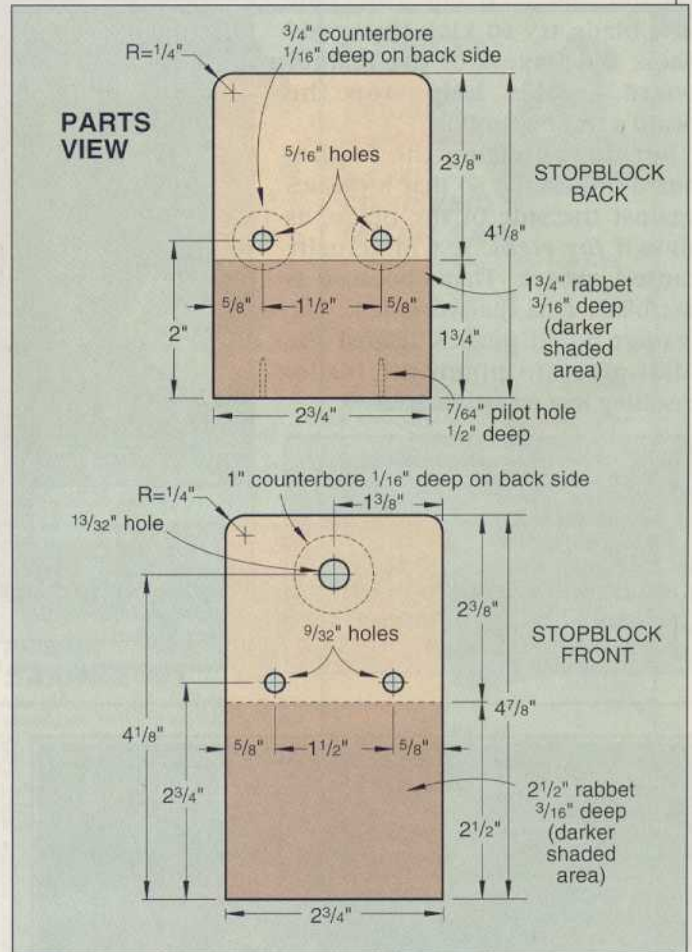



Jay Peterson watches as his students put to use his top shop tip.

Safety comes first, last, and always for Jay C. Peterson, Industrial Arts Instructor at Piute Middle School in Lancaster, California. To promote safety and accuracy for his beginning woodworkers, he came up with a clamping system that works on just about any tool that has a miter slot. And by golly, it won our Top Shop Tip award.

If, like Jay, you've found ways to improve the tools in your shop, or if you've invented any useful jigs or techniques, we want to know about them. We pay \$40 for all tips published. If yours is selected as the Top Shop Tip, you'll win a tool prize valued at \$250 or more and be featured in this column.

To be considered, send a letter, including your daytime phone number, with a photo or drawing of the tip, to:

Tips From Your Shop (and ours)  
WOOD® Magazine  
1912 Grand Avenue  
Des Moines, IA 50309-3379

We try to publish only original shop tips, so please send your idea only to WOOD Magazine. Thanks!

*Bill Krier*

ASSISTANT MANAGING EDITOR

## Teacher's-pet safety clamp

My junior high students have made hundreds of the Sweetheart Keepsake Box that appeared in the January 1991 issue of *Weekend Woodworking Projects*™. Slicing off the box's lid on the bandsaw requires that the guide post be raised about 5" above the table. This exposes a great deal of blade and places the operator's fingers too close to the blade for this woodshop teacher's liking. To help my students make this project safely, I devised the adjustable jaw safety clamp shown below.



For submitting the Top Shop Tip, our intrepid shop teacher wins an 8" Freud Dial-A-Width Dado. Congrats, Jay!

The key to the installation is that the rear jaw of the clamp must be at a right angle to the miter slot. This clamping method also works great for other projects, and on other tools, such as a tablesaw and shaper.

—Jay C. Peterson, Lancaster, Calif.

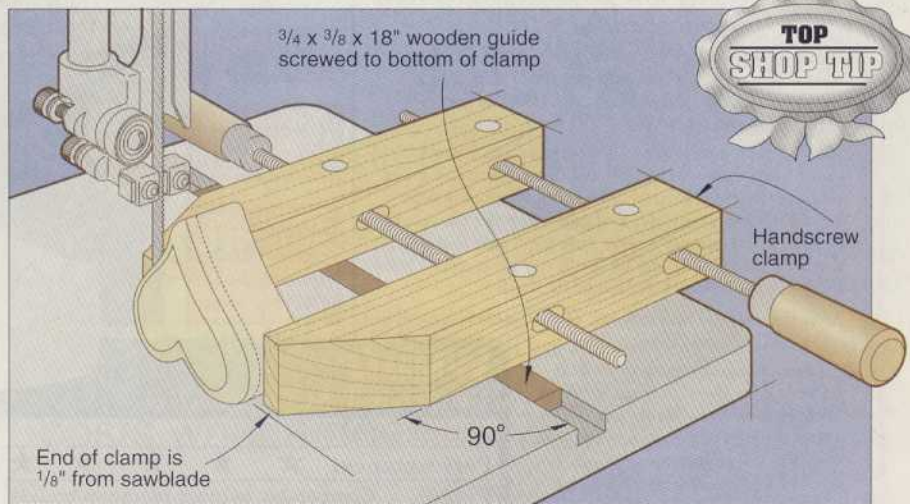

## Resizing dowels ever so slightly

This tip was suggested to me by a retired piano tuner who is without sight but often comes up with *insightful* solutions to my problems. I was concerned about driving dowels into a fragile piece of wood. He suggested that I reduce the size of the dowels with a flat bastard file, as shown right. You place a little pressure on both ends of the file and roll the dowel back and forth. This technique makes it easy to control how much wood you

remove, and the glue grooves remain intact because you're not removing much material.

—Karen J. Myers, Wren, Ohio

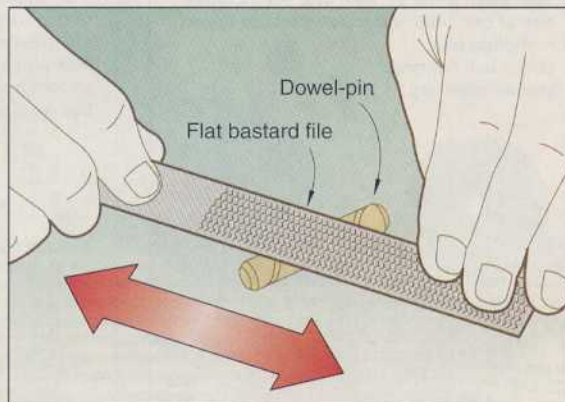

## Fold-down shelf keeps benchtop clutter-free

When I'm working fast, it doesn't take long for my tools to clutter up the workbench. To reposition a project, I often have to remove a tool from the bench and store it somewhere else in the shop—an extra step that eats up time.

For a more efficient use of time, I built a hinged shelf like the one *below* for keeping tools in use at arm's reach. When I'm finished working, the shelf folds flat against the wall.

—Barry Onorato, Danbury, Conn.

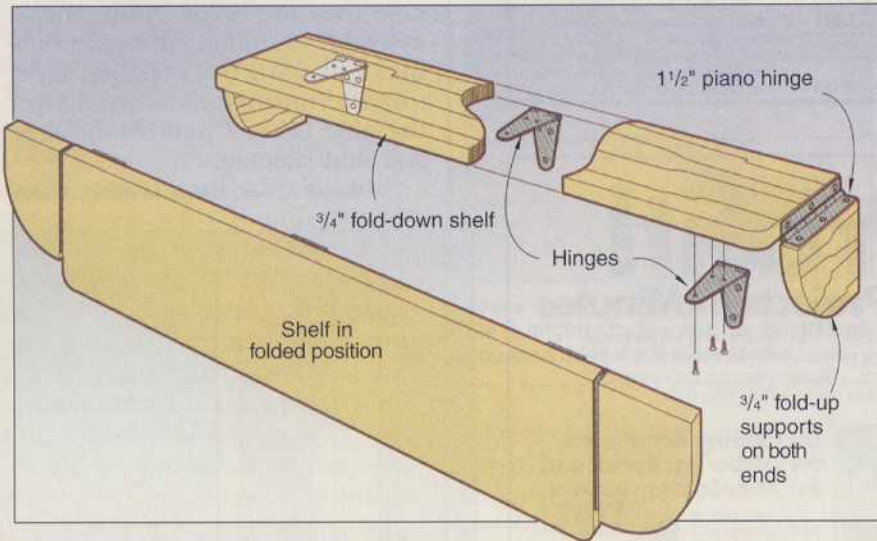

## Improve drill-depth accuracy with plastic tubing

For a depth gauge on a drill bit, masking tape works well on the first few holes. But it doesn't take long for the tape to tear or push up along the length of the bit, thus destroying your accuracy.

For a depth gauge that lasts and lasts, I use a short piece of clear plastic tubing available at the hardware store. The tubing

should have the same or slightly smaller inside diameter as the drill bit's diameter. Chuck the drill bit in a portable drill, and slip a section of the tubing over the bit. Make sure the tubing is pushed up firmly against the jaws of the chuck. Then, cut the tubing to match the hole depth.

—Craig Holden, Ames, Iowa

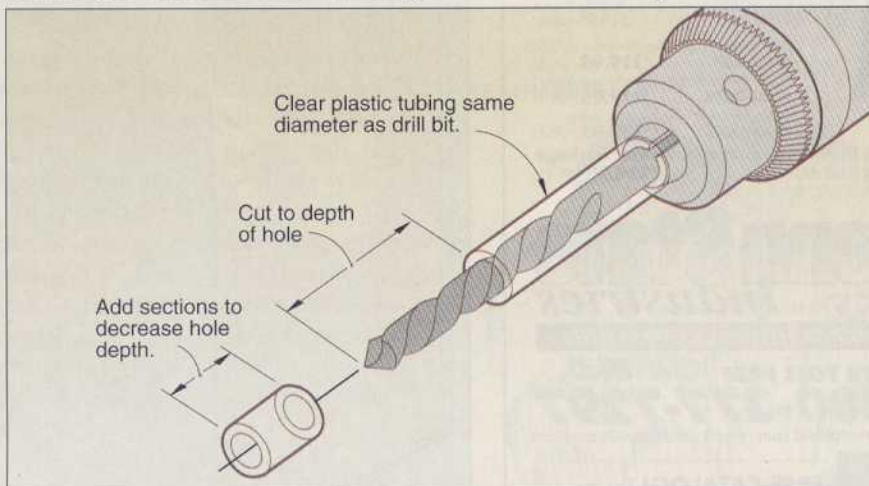

Continued on page 26

The  
Professional's  
Choice

for over 60 years

Titebond  
Original Wood Glue  
1-800-347-GLUE

Customer Service  
1-800-669-4583

©1998 Franklin International



**SENCO**

SFN40K1 1/2-2 1/2" Fin.Nail. .... \$349  
 SLP20 5/8-1-5/8" Brad Nailer Kit \$249  
 SN325+ 6d-12d Frammer ..... \$369

**Makita**

**2708W SALE \$279**  
 8 1/4" Table Saw w/Carbide Blade  
 4303C 6 amp Var Spd Jig Saw ..... \$159  
 9741 Wheel Sander ..... \$169  
 3612C 3hp Pl. Router w/Brake ..... \$258  
 AF501 2" Brad Nailer ..... \$169  
 MAC2000 2hp Twin Stack Comp. .... \$398  
 LS1013 10" Dual Slide Comp. .... \$577  
 LS1211 12" Dual Slide Comp. .... \$759  
 6233DWAE 14.4v Cdls w/2 batt ..... \$189

**BOSTITCH**

**N60FN Kit SALE \$274**  
 Finish Nailer w/ Case & Nails  
 S32SXXIT Stapler ..... \$144  
 BT50KIT Brad Tacker ..... \$185

**BOSCH**

**1587AVSK-50**  
 Ltd. Edition 50th Anniversary Jigsaw w/Non-Mar Base & Case  
**1295DH Swiftsand Dual Range**  
 Sander-Polisher ..... \$88  
 3615K 14.4 V Dbl Battery Drill Kit ..... \$189  
 B2300K 12 V Dbl. Batt. Drill Kit ..... \$129  
 1001VSR 3/8" V/S Drill ..... \$59  
 1613EVS 2 hp V/S Plunge Router ..... \$198  
 B7001 Detail Sander ..... \$89

**1-800-262-5482**SAME DAY SHIPPING  
FREE FREIGHT**HOME LUMBER CO.**Visit our Website at [www.hommelumber.com](http://www.hommelumber.com)

C.O.D.

P.O. Box 370  
Whitewater, WI 53190**DeWALT**

**DW991K2 14.4 V**  
 Double Battery Drill Kit  
**SALE \$199**

**NEW DEWALT BENCH TOPS**

DW788 20" Scroll Saw ..... \$485  
 DW733 12" Anti Skip Planer ..... \$445  
 DW708 12" Dual Slide Comp Saw \$675  
 DW744 10" H.D. Table Saw ..... \$545  
 DW412 2 Amp Palm Sander ..... \$59  
 DW621 2 hp V/S Plunge Router ..... \$218  
 DW321K "Clic" Jig Saw ..... \$159  
 DW705 12" Compound Miter Saw \$349  
 DW935 14.4v Cordless Trim Saw \$149  
 DW991KS-2 14.4v Dnll/Saw Kit ..... \$348  
 DW995K 18v 1/2" Driver Drill Kit ..... \$228  
 DW421 Random Orbit Sander ..... \$73

**IRWIN Paslode**

**IM250CT NEW Compact Trim-**  
 pulse Finish Cdls Kit ..... \$539  
**IM325CT Compact Cdls Frammer** ..... \$398  
 We Have The Largest Assortment  
 of DeWalt & Makita in the USA.

**TIPS FROM YOUR SHOP (AND OURS)**

Continued from page 25

## Minimize glue mess with masking tape

When I'm gluing up assemble-yourself furniture, I use masking tape to keep the glue off parts that are to be stained. I cover each mortise or dowel socket with masking tape, smooth it down with my thumbs, then cut away tape over the holes. Now when I assemble the joint, the glue bubbles out onto the masking tape, not the unfinished wood. After the glue dries, I pull off the tape and start staining.

—David Elmer, Battle Ground, Wash.

# Turn A Profit!

## Make Elegant Pencrafting Projects In Minutes

For less than \$5.00 and in just minutes you can make unique hand turned projects that sell for \$20.00 and up. Our selection of lathe projects includes over eighty 24kt gold plated kits that are easy to turn and make

wonderful gifts. Select from a wide assortment of pencrafting projects. Every kit comes with detailed instructions, a lifetime guarantee and customer support from our knowledgeable staff.

### The Carba-Tec III Variable Speed Mini Lathe

**WINTER SALE \$274<sup>95</sup>**

The perfect lathe for pencrafting and turning small projects. Both beginners and experienced turners will appreciate the quality and convenience of this easy to use, full featured mini-lathe. With the purchase of the Carba-Tec III lathe you'll receive a FREE 35 minute instructional video "Turning Pens and Other Small Projects" - a \$19.95 value!

**Specifications**

- Variable speed 1/4 HP motor
  - Cast iron construction
  - 12-1/2" between centers
  - 3/4" x 16 tpi Spindle w/ #1 MT
  - 6" swing over bed • Weighs 37 pounds
- Includes extras worth \$65:**
- Video tape • 3" toolrest • 4 prong spur center
  - 2" faceplate • 2 belts • Live tailstock center w/ cup & point inserts

**Carba Tec III Mini Lathe SAVE \$151**  
**#CML3** Reg Price - \$289.95 ..... ONLY **\$274<sup>95</sup>** / UPS \$13



### Duplicating Attachment for Carba-Tec, Ryobi® and Jet® Mini-Lathes

**SALE PRICE \$119<sup>95</sup>**

Turn your pencrafting projects more easily, quickly, and accurately. Duplicate from a hand cut pattern, 3-D original, or from PSI pre-cut Profile Templates. Template sets are available for twelve project kits. The Attachment fits all Carba-Tec, Ryobi® and Jet® style mini-lathes. Duplicates up to 10" long with a depth of cut up to 3/4". The cutter is HSS ground on both ends. Includes a FREE instructional video, "Duplicating Attachment Projects and Techniques" - a \$19.95 value!

Duplicator for Carba-Tec mini-lathe w/video  
**#CML-DUP \$119.95 / UPS \$5**  
 Duplicator for Ryobi® mini-lathe w/video  
**#CML-DUPR \$119.95 / UPS \$5**  
 Duplicator for Jet® mini-lathe w/video  
**#CML-DUPJ \$129.95 / UPS \$5**

**Carba-Tec III Mini-Lathe and Duplicator Package**  
**#CML3-PAK SAVE \$251** ..... ONLY **\$384.90** / UPS \$16

Everything you need

**PEN MAKING AND MINI LATHE STARTER SET SAVE \$40**

- Carba-Tec III Mini Lathe
- 7mm Drill Guide
- 1/2" Penmaking Gauge
- 7mm Pen Kit/Pk of 10
- 7mm Pencil Kit/Pk of 10
- "Pen Turning" Instructional Video
- Mandrel w/ bushings & drill bit
- Clear Pen Pouches - Pk of 20

**#CML-SS** ..... ONLY **\$357<sup>90</sup>** UPS \$15

If you already own a lathe

**7MM "SLIMLINE" STARTER SET SAVE \$15**

- 10 Pencil Kits • 10 Pen Kits • Drill Guide
- Long Mandrel • Bushings • Drill Bit

**#PKSS-AL 3/4" x 16 tpi mandrel kit** ..... \$75 SET  
**#PKSS-BL 1" x 8 tpi mandrel kit** ..... \$75 SET  
**#PKSS-CL 5/8" mandrel kit** ..... \$75 SET  
**#PKSS-DL 3/8" drill chuck mandrel kit** ..... \$70 SET

**Penn State Industries**2850 Comly Road,  
Philadelphia, PA 19154**30 DAY MONEY BACK GUARANTEE!****ORDER TOLL FREE 1-800-377-7297**[www.pennstateind.com](http://www.pennstateind.com) / e-mail: [psind@pennstateind.com](mailto:psind@pennstateind.com)

**FREE CATALOG!** For more information about pencrafting equipment, kits, supplies and accessories, order our catalog.

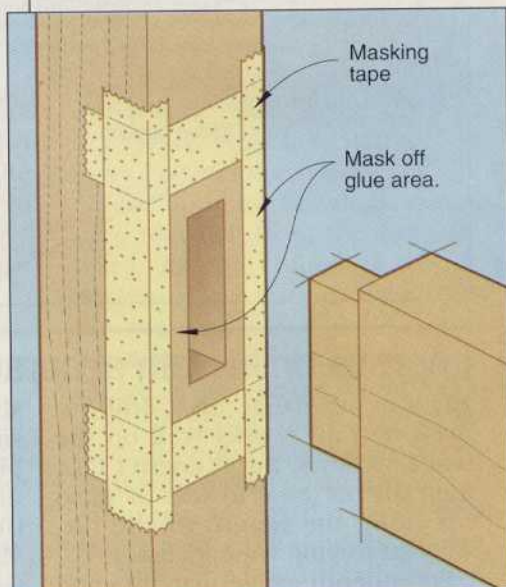

Masking tape

Mask off glue area.

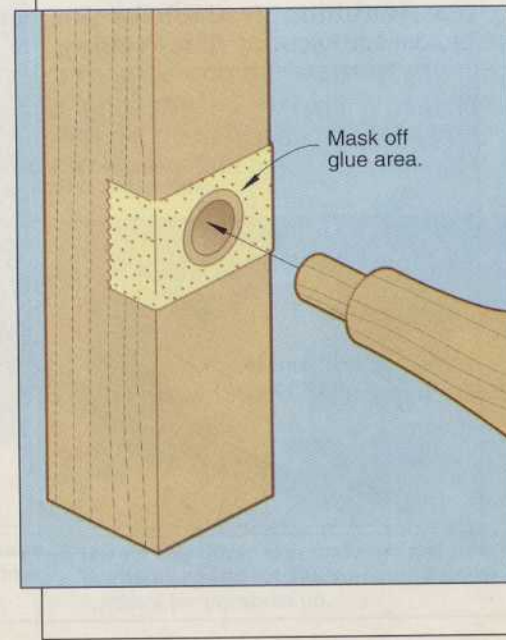

Mask off glue area.

## Clamp block keeps glue blocks in position

Gluing blocks into the corners of butt joints provides good reinforcement. But the technique caused me untold headaches trying to keep things aligned and tight until the glue dried.

Then, I figured out a no-fuss way, shown *below*, to clamp the glue blocks in place. First, I cut two, equally sized scrapwood glue blocks. Next, I cut the right-angle clamp block so the length of the face opposite the 90° angle roughly matches the combined width of the joint and glue blocks. A strip of double-faced tape keeps the clamp block positioned while I install the glue blocks and tighten the clamps.

—Roy Kirkpatrick, Sacramento, Calif

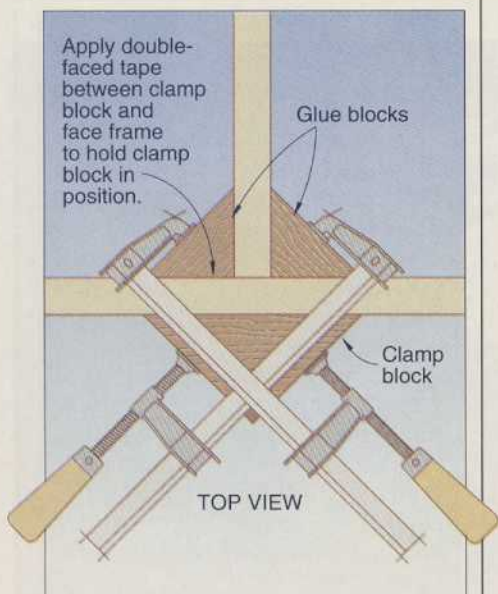
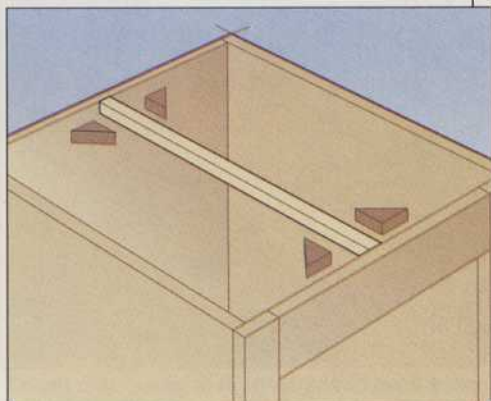

Continued on page 28

## For All Your Woodcarving & Sign Carving Needs

Terrco provides a full line of machine carving and sign carving equipment. Beginning models are the T-110 single spindle bench carver and our CM614 single spindle sign carver.

Intermediate models include the K-Star, a two-spindle heavy duty bench model, and the Northstar, a heavy duty floor model available in one to eight spindles.

Our advanced model is our Master Carver series, which is an extremely heavy duty floor model with from eight to forty spindles.

Write or call for more information.

## Terrco, Inc.

222 1st Ave. NW  
Watertown, SD 57201  
USA

(605) 882-3888  
Fax (605) 882-0778



Model T-110 Dupli-Carver



Model CM614 Sign Carver



Multi-Spindle Carving Machine

Circle No. 2175

# Make Your Workshop PAY OFF BIG!



Craftsmen everywhere are using the low-cost Woodmaster to bring in welcome extra cash and to save on all their lumber needs. You can, too!

With the big 18-inch Woodmaster, the larger 25-inch model or the standard 12-inch planer, you can quickly convert low-cost, rough lumber into valuable finished stock. You can turn out perfect picture frame moldings, crown, bed and base moldings, tongue & groove, door and window trim...all popular patterns...any custom design.

You can do custom work for friends, neighbors, lumberyards, picture framers, home remodelers, hobby shops and businesses.

Because it takes just seconds to convert a \$2 rough board into \$10 worth of finished trim, you can see why so many Woodmaster owners enjoy substantial extra incomes!

## Variable Speed Makes The Difference!

Just a twist of the dial gives you perfect control for planing, sanding or sawing...from 0 to 1,000 cuts per inch. Creates mirror-smooth molding with no sanding required!

Here's what Woodmaster owner L. C. Griffin of Nashville writes: "The shop test article in *Wood Magazine* that said they loved your Variable Feed Rate is what sold me. They were right."

Call or write today for **FREE Facts** on how you can try this **American-Made** tool in your own shop for one full month. Easy terms.



Woodmaster's Quick-Change Molding Head lets you create custom moldings from any stock. Choose from over 250 standard trim and picture frame patterns...or design your own!



Power-fed sanding speeds production and improves the quality of your work. No more waves or cross-grain scratches. Separate sanding head installs in just minutes.



New rip saw attachment lets you gang-rip with power feed in a fraction of the time it takes for multiple hand-fed passes on an ordinary table saw.



**YES!** please rush me your **FREE** Information Kit plus details on your **30-DAY FREE TRIAL!**  
**WOODMASTER TOOLS, INC., DEPT. PW26**  
1431 N. TOPPING, KANSAS CITY, MO 64120

Name \_\_\_\_\_

Address \_\_\_\_\_

City \_\_\_\_\_ State \_\_\_\_\_ Zip \_\_\_\_\_

**CALL TODAY FOR FREE FACTS!**  
**1-800-821-6651**  
**extension PW26**  
**In Canada call**  
**1-800-661-1915**  
www.woodmastertools.com

## One Stop Wood Shop

- Plywood & Veneer made to order (no min.)
- 30 species
- Custom Cutting
- Competitive Pricing
- We bundle & ship to U.S. & Canada
- Over 65 years of personal service

For catalog & quote: (617) 666-1340

### Boulter Plywood Corp.

24-WD Broadway, Somerville, MA 02145

Where the finest cabinetmakers select & blend domestic & exotic hardwood in plywood, veneer & lumber.

# WOOD

Circle No. 512

## CUTTING THE COMPETITION WITH A... "Top-to-Bottom" 5-Year Warranty!\*



Copyright © 1997 rbi industries. All rights reserved.

RBI presents the Hawk Ultra 226 Scroll Saw with **CHICAGO'S #1 INTARSIA DESIGNER**, Robert J. Hlavacek Sr.

Robert Hlavacek choose the RBI 226 precision scroll saw for all the projects he creates for Chicago's "Brookfield" Zoo. Bob loves RBI's fast & easy blade change system, sand FREE finishes, easy cutting control and our "Top-to-Bottom" 5 year Warranty.\*

Bob believes the Hawk Ultra's are built "Solid as a Rock!" Bob thinks you should choose the RBI Hawk Ultra family too.

If you're interested in seeing more projects by Robert Hlavacek created on his Hawk Ultra ...read "Creative Woodworks & Crafts magazine."

\*COMMERCIAL RATED AT 365 DAYS A YEAR X 5

CALL 1-800-487-2623 FOR YOUR FREE RBI CATALOG

rbindustries, inc.

America's Woodworking Machinery Manufacturer

1801 Vine Street • PO Box 369 Harrisonville, MO 64701

Visit the RBI Home page at  
www.rbiwoodtools.com

H102

## TIPS FROM YOUR SHOP (AND OURS)

Continued from page 27

### Use vise as "calipers" for odd-shaped pieces

Occasionally, I need to get the measurements of a piece of odd-shaped hardware. After trying several methods, I found the answer on the front of my workbench.

I place the object I want to measure in my bench vise and snug the vise up so it just holds the object. Then, I measure the distance between the faces of the vise's jaws to get the measurement I need.

—Jim Downing, Design Editor,  
WOOD magazine

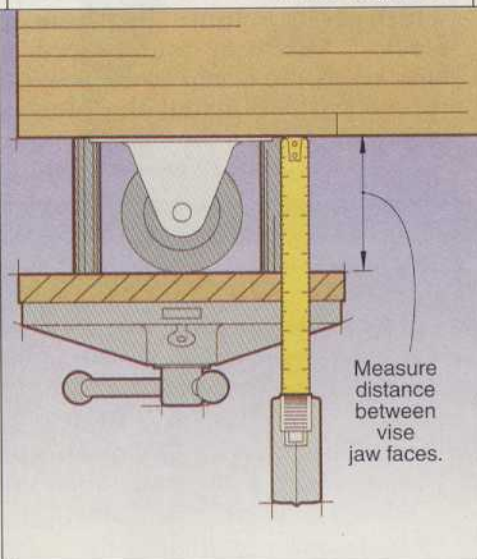

### A FEW MORE TIPS FROM OUR WOODWORKING PROS

- On page 41 you'll find a log-furniture maker's tips for harvesting your own wood.
- Even if you don't build our mitersaw stand on page 62, you can incorporate its fence on your current radial-arm saw or mitersaw stand.
- For a way to make frame-and-panel components with just a tablesaw, see page 54.
- Have you ever considered concealed hinges for your projects? If so, see page 70 for how we installed them in an entertainment center. 🌲



Bob's newest pattern...  
"BAILEY" & DINNER



# MESQUITE

## The thorny jewel of the American Southwest

**I**n the eyes of Native Americans, the mesquite tree of the Southwest represented both shade and sustenance. The tree's sugar-rich bean pods furnished food and drink. Its sap became black dye, gum, and medicine. And sewing needles were made from its sharp thorns. The tribes relied on mesquite wood, too, for fuel, arrows, lodge frames, and even plowshares. Later, pioneer hands worked mesquite into timbers, railroad ties, fence posts, wagon wheels, and sturdy rustic furniture.

In the late 1800s, citizens of San Antonio paved the streets leading to their Texas shrine, the Alamo, with mesquite slabs. In testament to mesquite's durability, remnants of the wood still surface from the activity of street maintenance.

While most 20th-century craftsmen equate mesquite with only the barbecue grill, bands of aficionados promote the wood as furniture-class stock. Their efforts have lifted the wood's reputation out of its native land.

### Wood identification

Seven species of mesquite (*Prosopis glandulosa*, *P. juliflora*, *P. pubescens*, and others) cover some 54 million acres of Texas, and parts of Arizona, California, Colorado, Kansas, Nevada, New Mexico, Oklahoma, Utah, and Mexico. Wherever it grows, it's hardy and persistent.

In the arid part of its range, you'll see mesquite as more of a shrub than a tree. But in

favorable conditions it grows to 50' with a single, but crooked, trunk up to 3' in diameter.

Chocolate-colored, furrowed, and scaly bark make mesquite easy to identify. Its wide, spreading canopy made of twisted branches and long, thin leaves may be the only silhouette on an otherwise featureless landscape.

Spring through fall, yellowish white flowers appear, followed by bean pods up to 8" long. Sharp thorns are everpresent.

The wood of mesquite can vary in color from dark brown with wavy, blackish lines to camel tan. Whatever its color, the grain is straight to wavy, medium to coarse in texture, and tightly interlocked. Weighing 45 pounds per cubic foot dry, it's as heavy as hickory and as strong, but even harder. And the wood rates as stable in use, indoors and out.

### Uses in woodworking

Mesquite can be made into furniture, especially long-wearing tables and chairs. It also becomes carvings, turnings, hardworking flooring, premium gunstocks, and knife handles.



Natural range

### Availability

Mesquite may never reach great commercial importance for woodworking outside its regional range because of a relatively small size and commonly bent and twisted trunk. However, many small companies throughout the Southwest (especially Texas) offer the wood as turning squares, blocks, and in board form. Sawn veneer is sometimes available, too. Expect to pay up to \$10 per board foot for premium stock.

For a free, soft-cover directory of mesquite suppliers (some selling by mail order) and users, send a request to Mesquite Industry Directory, Texas Forest Products Laboratory, P.O. Box 310, Lufkin, TX 75901. Or telephone 409/639-8180. Also use this address to contact the two active promotional groups for this cabinet-class woodworking stock, *Los Amigos del the Mesquite* (Friends of the Mesquite) and the Texas Mesquite Association.

*Continued*

# PERFORMANCE PROFILE

## mesquite (*Prosopis spp.*)

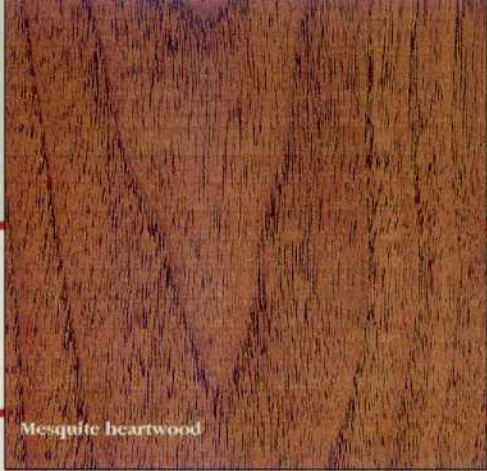

Mesquite heartwood

Mesquite seasons exceptionally well, with little checking, shrinkage, or warp. However, the hard wood has a high extractive content which tends to overheat cutting blades. Use carbide-tipped blades and cutters for your power tools, and follow these tips to work mesquite.

### Machining methods

- Mesquite's hardness and interlocking grain often equate to chipping and tearout when planing. To lessen the problem, feed the wood at a slight angle and take light passes that only remove about 1/32" at a time.
- Feed mesquite slowly against the blade when ripping, giving the gullets plenty of time to clear themselves of sawdust.
- Selecting the correct grain direction when feeding the jointer should pose little problem, but chipping can occur. Start by set-

ting the table height for a 1/16" cut. If there's no tearout, increase the cut to 1/8".

- Use only spurred bits and slower drill-press speeds for mesquite. Clear the bit frequently in thick stock to avoid burnishing the hole sides (glue won't be absorbed).
- Reducing tearout and chipping when routing means shallow passes rather than a heavy one, and a consistent feed rate. Use a backing board to rout end grain.
- Cross-grain sanding on mesquite produces scratches. Where grains meet at right angles, clean up with a cabinet scraper or random-orbit sander. And do not skip grits when sanding this wood.
- When gluing mesquite, use an adhesive with a longer open time. This allows you to lay down a light coat of glue, briefly join the pieces, then pull them apart to allow the adhesive to partially set up before rejoining.

• Always predrill mesquite for nails and screws because of its hardness and density.

• Mesquite poses few problems when staining. Yet, it's best to let the beautiful character of the wood show through a clear finish or penetrating oil. The amount of figure your wood displays should guide your choice.

### Carving comments

• Mesquite, unlike most woods, can be carved green because it checks very little as it dries. You will need power-carving burs, though, starting with less aggressive ones to remove material without tearout.

### Turning tips

• The wood is excellent for turning. Use sharp tools, hone them regularly, and avoid scratches by sanding with the grain while the lathe is off. ♣

### SHOP-TESTED TECHNIQUES THAT ALWAYS WORK

*Any exceptions, and special tips pertaining to machining and working this issue's featured wood species, appear elsewhere on this page.*

- For stability in use indoors, always work wood with a maximum moisture content of 6-7%. Wood for outdoor projects can have 12% moisture.
- Feed straight-grained wood into planer knives at a 90° angle. To avoid tearing, feed figured wood or that with interlocking grain at a slight angle of 15°, and take shallow cuts of about 1/32".

- For clean cuts, rip with a rip-profile blade that has 24-32 teeth. For crosscutting, use a blade with about 40 teeth.
- Avoid drilling with twist drills. They tend to wander from the start hole and cause breakout. Use a backing board under the workpiece when drilling.
- Drill pilot holes for screws.
- Rout with sharp, preferably carbide-tipped, bits and take shallow passes to avoid burning.
- Carving hardwoods generally means shallow gouge bevels—15° to 20°—and shallow cuts.

### MESQUITE AT A GLANCE

Cost	\$\$\$ \$
Weight	ⓂⓂⓂⓂⓂ
Hardness	T T T T T
Stability	▲▲▲▲▲
Durability	⌚⌚⌚⌚⌚
Strength	🦵🦵🦵🦵🦵
Toxicity	☠☠☠☠☠
Workability	🪚 🪚
Look-alike	Teak

Compiled with woodworker Ken Rogers Illustrations: Steve Schindler

# FOUND-WOOD FURNITURE

from a logging legacy

With designs inspired by Washington's Cascade Mountains, Pat Pitsch's furniture relies on logging leftovers and recycled stock

*Continued*

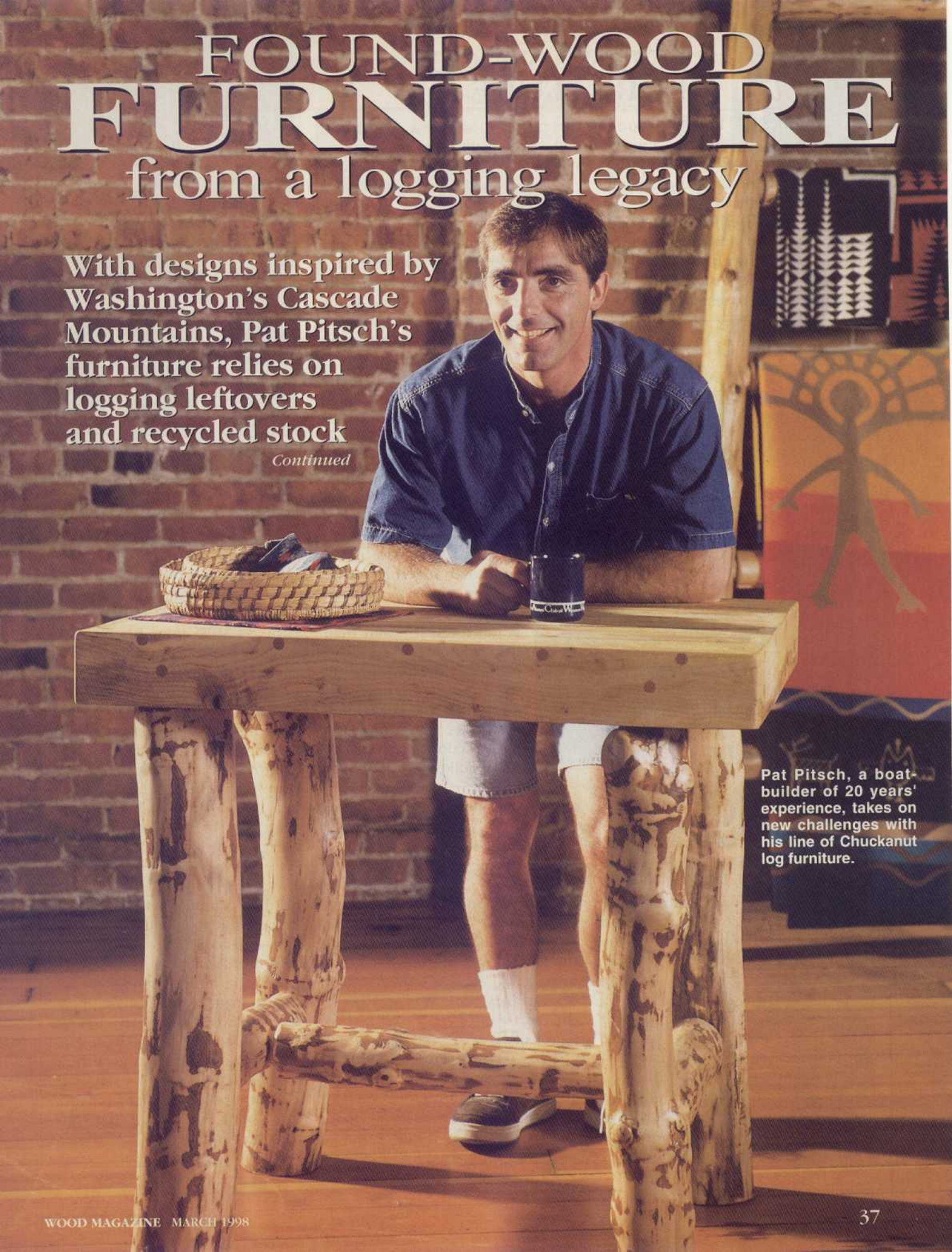
A man with short brown hair, wearing a blue button-down shirt and light-colored shorts, is sitting at a rustic wooden table. The table is made of thick, natural log sections. On the table, there is a woven basket and a dark mug. The background is a brick wall with some decorative items, including a piece of fabric with a stylized figure and a piece with a tree pattern.

Pat Pitsch, a boat-builder of 20 years' experience, takes on new challenges with his line of Chuckanut log furniture.

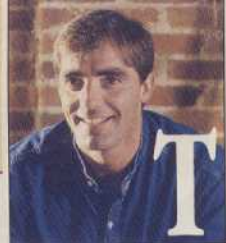

## FOUND-WOOD FURNITURE

**T**here's wood nearly everywhere in the three-level building occupied by Chuckanut Log Design. The building, situated on the fringe of downtown Bellingham, once housed an auto dealership, functioned as a church, and played awhile as a movie theater. Now, the back rooms and basement resemble

the pulp wood piles at a paper mill—except that the wood mostly stands on end against the walls.

"I have a hard time throwing anything out, because it's all usable eventually. I just let the odd pieces of wood sit in a corner until the day when I see what it can become," explains Pat Pitsch, 40, about the abundance of branches and limbs

lining the walls. "Our furniture starts with selecting the wood, piece by piece, to build a design in my head that I believe will look great," continues Pat, enthusiasm behind his words. "You have to visually sort the wood for a balance between what you know the customer wants and what you want to achieve. Then, the piece can come together rather quickly. That's one reason why this type of furniture is more fun to build than the traditional."

Loudly, the dust-sealing door between up-front showroom and back room workplace solidly closes as Mike McDonald enters the shop. Following a two-year

**At a clearing overlooking Chuckanut Bay, Pat Pitsch and Mike McDonald scavenge for odd pieces of wood.**



apprenticeship with a fine-furniture maker, 29-year-old Mike was hired by Pat to help him build log furniture. As Mike joins his boss, they walk and talk, Pat gesturing around the cavernous space (each floor contains 3,300 square feet) as he explains, "We bring the customers back here into the shop to see the rough wood. That's how we get an idea of what they would like. Some people like the natural wood to be very clean—no wormholes, minimal knots. Others prefer chainsaw marks, splits, checks, and every

### Furniture for fish: A tale of the trade

The company called Chuckanut Log Design takes its name from a bay of Puget Sound that laps the shore of Bellingham, Washington. The furniture carrying the name is reminiscent of that first made by the early settlers and loggers in the state. Both the name and the products were born in the mind of Tom Allioti.

In 1990, the then 22-year-old craftsman founded the company to provide quality furniture from eco-

logically friendly sources, such as logging waste. By 1996, Chuckanut log furniture had been installed at the new White Salmon Lodge at nearby Mt. Baker, sold to local restaurants, and was available through *Made in Washington* retail outlets across the state.

Then, Allioti discovered he had a passion besides woodworking: commercial fishing. With a 32' boat built for him by local boat-builder Pat Pitsch, he increasingly

plied the waters for whatever was in season. It soon became decision time—make furniture or fish.

Reenter Pat Pitsch, a woodworker seeking more personal expression to augment his thriving boat-building business. In early 1997, a deal was struck. Tom Allioti gave up furnituremaking to go fishing and Pat Pitsch reset his sights on furniture and new directions for Chuckanut Log Design, the company he purchased.

A queen-size bed of Douglas fir branches such as this sells for \$350 in Chuckanut's Bellingham showroom.



other type of thing. They pick their rustic look."

### Solid stock saved from logging sites and landfills

In the Pacific Northwest, logging has traditionally been done by clearcut. The harvest reduces forest areas to practically pasture until the seeds of new trees spring forth in the now abundant sunlight. Tops, branches, and small trees of no use for lumber are left behind to decompose or become dry enough to burn, thus nourishing the soil of the forest floor.

"We don't get involved in cleaning up logging sites ourselves," comments Pat. "There are people who do that. I just tell them I want everything from 8" in diameter down to 1½". Then, for a price, they'll peel the bark off of everything and deliver it by the flatbed load."

By the time the peeled wood reaches the workshop it's normally air-dry to 15% moisture content, according to Mike. Nevertheless, it gets additional drying time indoors where its moisture content balances with the relative humidity. "In place



Pat introduced this chair of recycled Douglas fir timbers to the Chuckanut line to add a more classic look.

in a home, the wood might check and crack some, but not enough to weaken the furniture. And the defects add to the rustic look."

At Chuckanut, Pat and Mike count on the 8"-diameter pieces of Douglas fir, cedar, and western hemlock as posts for king-size beds and table legs. For regular beds and chairs, 5-6" diameters generally work well. Crosspieces and rails come from 4" stock. Spindles they make from 3-4" branches. And drawer pulls originate as 1½" sticks.

"Mike and I also go out in search of unusual pieces that can become a unique item," Pat notes. "We might drive to the beaches of Chuckanut Bay for driftwood, or up into the Cascades looking for the highly unusual twisted branch or intertwined root. And around here, you've really got to scrounge for hardwood. If I see an alder, maple, tanbark, or some other hardwood tree down or dying, I ask the property owner if I can have it."

Demolition wood has gradually increased its presence in the Chuckanut furniture line, too, as seen in the chair *above*. "The beams can come from all over the country," says Pat. "They're out of old warehouses, military buildings,



A log sofa with hardwood end panels sporting a carved fish sells for \$500. A log chair to match costs about \$300.

and factories. I order them from a timber broker in Duluth who tracks demolitions, then matches up the order. They're trucked to a local sawyer here."

Pat discovered recycled wood when he built his post-and-beam home a few years ago. "Some of the beams were once part of Howard Hughes' aircraft hangar in California. Now, I try to find out where all the planks and timbers I buy for our furniture originate so that each piece then has a story to tell the new owner."

The beams and timbers Pat purchases are normally Douglas fir, those cut from huge, close-grained, old-growth trees right after the turn of the century. Many of them were sawn for vertical grain. Even a dozen years ago, demolition wood such as this would have gone to a landfill or been burned. Now, it resides in neat stacks in the dim, dungeonlike lower levels of Pat's huge leased building.

Pointing to a special niche filled with thick planks, Pat tells about finding a treasure from California in the form of vertical-grain redwood stock retrieved from wine country. "They were part of a mammoth wine vat," he says, grinning. "The

*Continued*





## FOUND-WOOD FURNITURE

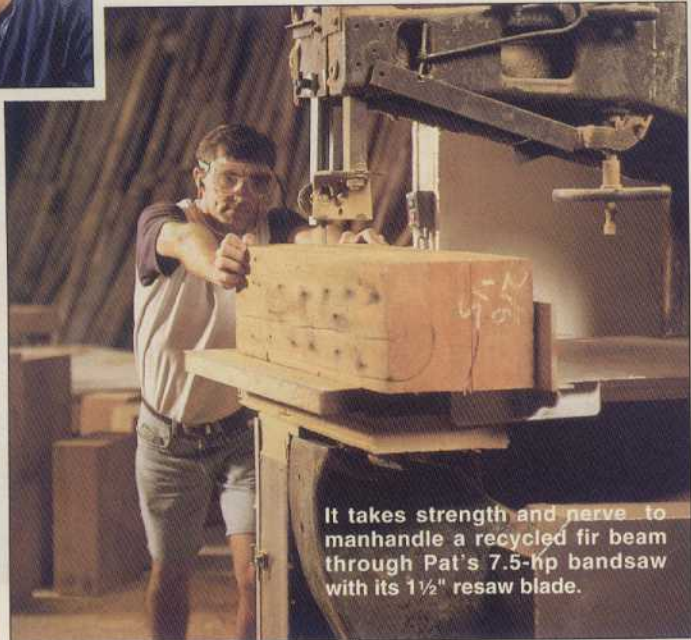

It takes strength and nerve to manhandle a recycled fir beam through Pat's 7.5-hp bandsaw with its 1½" resaw blade.

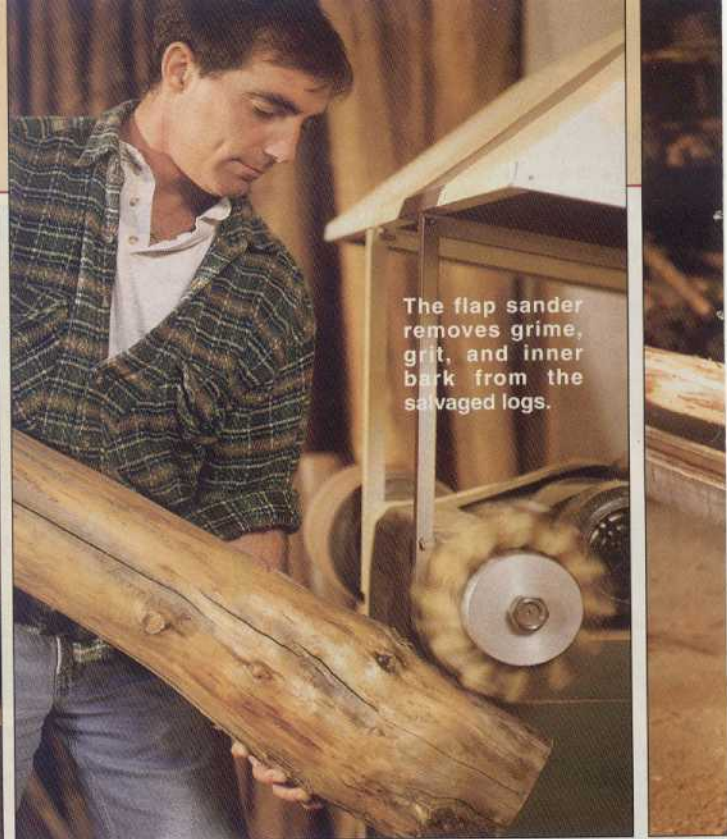

The flap sander removes grime, grit, and inner bark from the salvaged logs.

wood was all weathered gray, but when I ran it through the planer, I couldn't believe what I saw."

### How to get a bang out of joinery

In furnituremaking, it's usually joinery that takes lots of time. In the Chuckanut furniture workshop, it's stock selection.

"Culling the wood that I'll use for a piece is the most time-consuming," Mike notes as he walks the walls of naked branches and limbs. "That's because I select it not only for appropriate size, but also for color. You see, these pieces vary not only by their species, but in their degree of sun bleach, weathering, and roughness."

After the wood has finally been chosen, the assembly process goes comparatively quickly—at least for furniture. The head- and footboard for a log bed, for instance, may only take a few hours.

First, the posts, head- and footboard rails, and spindles are cut to final length at the 16" mitersaw. Then, a flap sander with 80-grit paper removes any surface dirt and roughness, as well as cleans out

depressions (see photo *above*). "You have to know when to stop," says Pat. "We don't want to remove all the wood's character."

Next, the cleaned wood for the rails and spindles receives tenons. And it's an ingenious setup that produces them.

Mike cuts tenons with a power planer hinged to an upright brace that positions the unit over the wood, as shown in the photo *above right opposite page*. As he turns the hand crank, the workpiece revolves in its position between centers on a simple lathe bed. Tenons on rails will be 2" long; on spindles, 1½".

After tenoning, it's time to mortise the posts and rails. For this job, the woodworkers rely on a ½" spade-handle portable electric drill and Forstner bits. Instead of measuring the spacing and boring all the mortises at once, though, Pat and Mike have learned that it's best to do them one at a time.

"If I jump too far ahead in setting up this uneven material, I get in trouble," Mike admits. "It's not like working with boards you've cut to some standard dimension. Because

each stick is slightly different, you've got to fool and fit a bit before drilling."

Most aspects of final assembly—the dry-fitting, the gluing, the clamping—are familiar woodworking steps. One, though, will make any craftsman wince. Mike calls it his "pre-clang slam."

Following a coating of catalyzed, gap-filling glue (National Casein Crosslink Adhesive) in the mortises, Mike seats the tenons of the spindles in the rails with a rubber mallet. Then he repeats the step with the posts.

Now, instead of reaching for pipe clamps, Mike gets a strong hold on the rails, as in the photo *far right opposite page*, lifts the assembly a foot off the floor, then slams it down again. "That really seats them, and keeps me in shape, too," he laughs. "After that, I clamp."

### Shipshape finishing for furniture that lasts

In his boatbuilding, Pat takes pride in finishing the teak and other wood he installs as brightwork. So finishing receives a top priority at Chuckanut Log Design, too.

Mike uses a hinged power hand planer to cut tenons. The hand crank keeps the wood revolving.

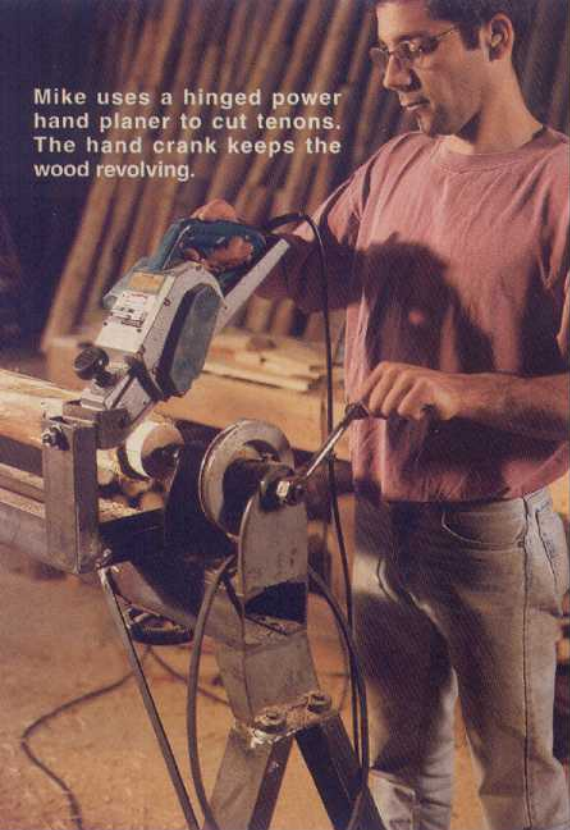

To bore mortises, Mike stands with the log on the shop floor between his feet. The Forstner bit leaves flat-bottomed holes.

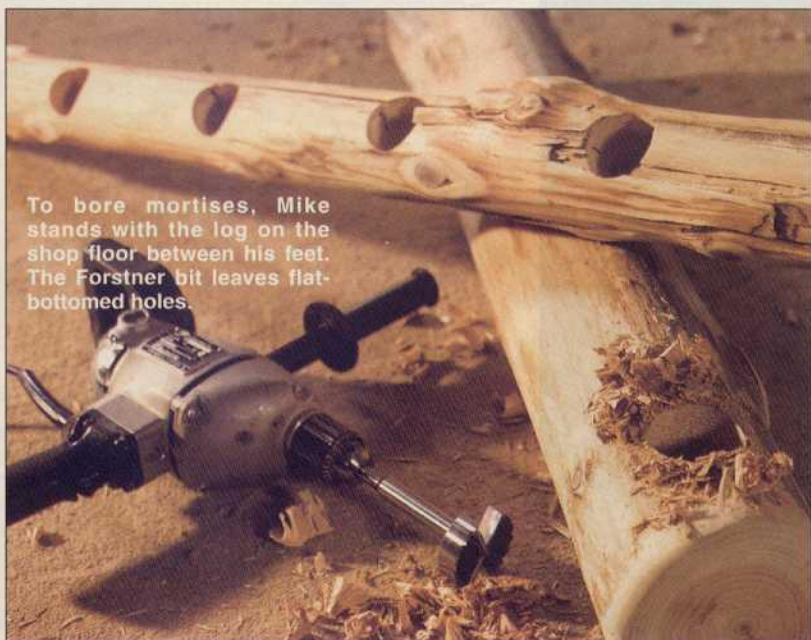

According to Mike, the log furniture gets a final overall sanding with 80-grit. "If we sand it any more than that, the logs lose their rustic look. On cedar, though, I often have to go over it with 120-grit because what's left of the inner bark gets kind of stringy. Of course, maple butcher-block tops and the resawn wood get all the grits through 220."

"We don't stain any of the wood. It has a warm look all its own without it," adds Pat. "Yet, we want the finish to be as durable as the furniture, so for the log pieces we spray on two coats of polyurethane that really has some body to it [Benjamin Moore Stays Clear Acrylic

Polyurethane]. On the chairs and tables that feature resawn vertical-grain wood or maple butcher block, I like to wipe on a few coats of teak oil and sand between, then rub on Briwax and buff it until it glows."

Pat runs his hand across the top rail of a bed headboard. "This furniture looks rough and rustic, but it has to be comfortable to be around. Because it will be for a long time." 🌲

To seat the end tenons in the posts of a foot-board, Mike slams it to the floor. He later clamps the assembly.

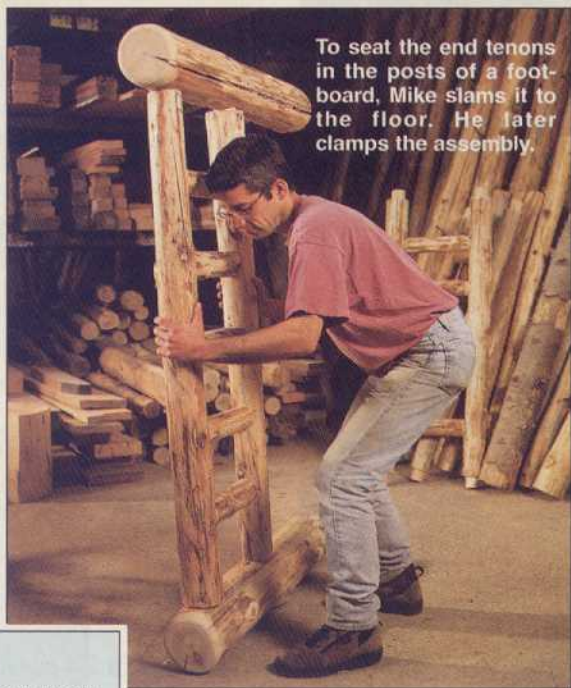

## Found-wood fundamentals

You can find free wood wherever you live. Pat Pitsch salvages the leftovers from logging sites, but you can check with your city forester's office for locations of tree trimmings. Tree service companies, construction sites, power companies, cleared farmland, and landfills also make good sources. And don't forget driftwood along the shores of lakes and rivers.

According to Pat, when you scout found wood, carry a hatchet as well as a saw. Use the hatchet's flat end to rap the wood. A resonant "knock" indicates dry as well as sound wood.

Leave behind any wood with indications of bug infestation. And remove all bark at the site because it may be home to a host of tiny critters you won't want in the shop.

## Want to see more of the Chuckanut line?

For a brochure describing their complete line of rustic furniture, send a self-addressed, stamped, business-size envelope to Chuckanut Log Design, 1421 N. State St., Bellingham, WA 98225.

# Swivel-Topped Tool Cabinet

Now, you  
can store two  
benchtop tools  
in one handy  
mobile unit



Senior Editor/How-To Marlen Kemmet demonstrates flipping the top to switch from the portable planer to the stationary belt/disc sander on our swivel-topped tool cabinet.

Space is a lot like clamps, you just never seem to have enough of either. But, with this storage-conscious cabinet, you can have two tools plus a spacious drawer in the amount of space usually dedicated to one tool. The swivel top rotates 180° and locks in place. This lets you quickly switch tools as needed.

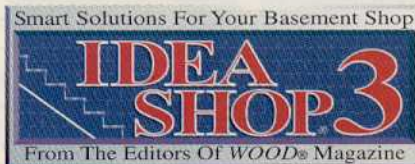

## Let's begin with the carcass assembly

**1** Rip and crosscut the cabinet sides (A), bottom and middle shelves (B), and back (C) to the sizes listed in the Bill of Materials from 3/4" birch plywood.

**2** Mark the locations of the dado and rabbet on the inside face of two of the plywood side panels (A). Cut or rout them to the sizes listed on the Side Section View and Exploded View drawings. (We fitted our tablesaw with a dado blade and wooden auxiliary rip fence. Then, we test-cut scrap pieces of plywood first to verify a snug fit of the mating plywood pieces in their respective rabbets and dados.)

**3** Band the front and back edges of the middle shelf (B) with banding strips (D) where shown on the Exploded View drawing.

**4** To match the reveal formed later between the drawer front (O) and carcass, cut or rout a 1/8" rabbet 1/8" deep along the top and side edges along the outside face of the back (C). See the Exploded View and Side Section drawings for reference.

**5** Glue and clamp the shelves (B) and back (C) between the inside (machined) pieces (A), checking for square. Drill and countersink the mounting holes, and strengthen the assembly with screws.

**6** With the edges and ends perfectly flush, glue the outside (A) panels to the carcass assembly.

**7** From solid stock (we used maple), cut and miter-cut the banding pieces (E, F) to size, and glue and clamp them in place. Later, sand the surfaces flush.

**8** Drill the mounting holes, and

screw the swivel and fixed casters to the bottom corners of the bottom shelf (B).

## Now, construct the swivel top

**1** Cut the center 3/4" plywood panel (G) for the top.

**2** Measure the combined thickness of three pieces of plywood you'll be using for the top (G, J). Cut the width of the top banding (H, I) to the measured thickness. (Since plywood is not exactly 3/4"

thick, you'll need to measure the thickness of the three pieces of plywood to determine the exact width necessary for the banding.) Crosscut the banding to the listed length plus 2".

**3** Cut a dado 3/8" deep, centered along one face of each piece of banding (H, I), for the center top piece (G) to fit snugly into (we test-cut scrap stock first).

**4** Miter-cut the banding pieces (H, I) to wrap around part G.

**5** To ensure matching holes in the

*Continued*

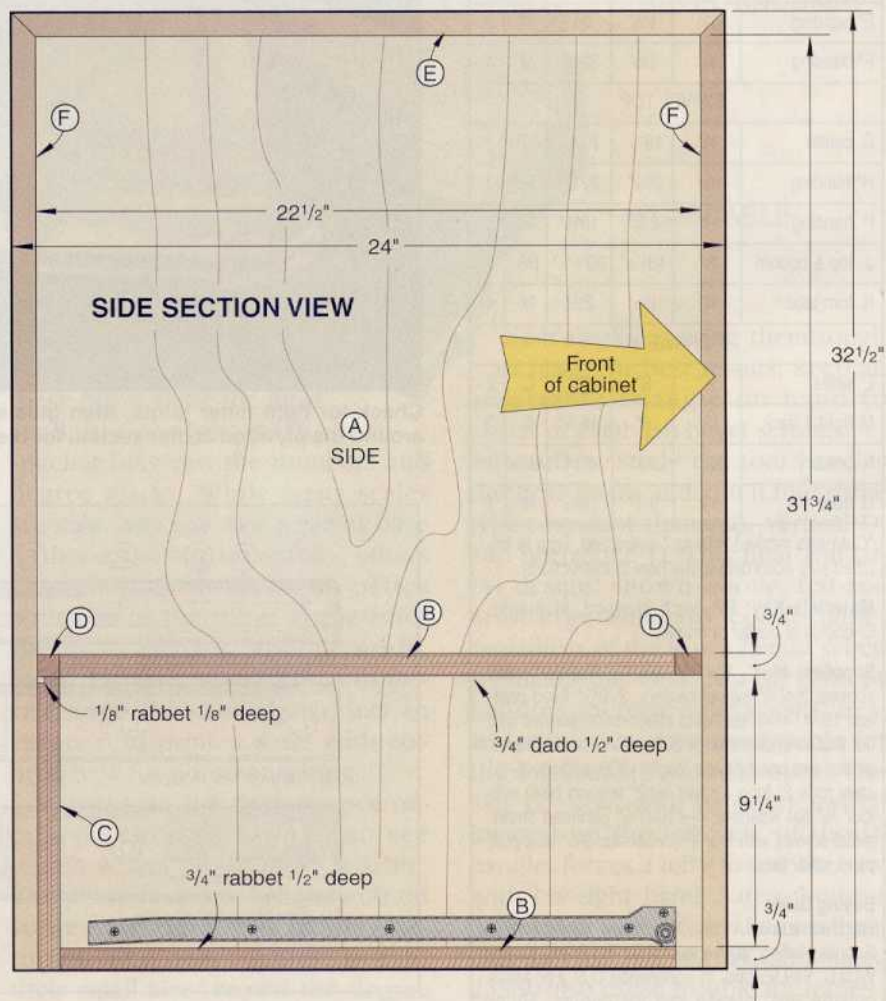

# Swivel-Topped Tool Cabinet

swivel top to those on the inside face of the cabinet, form a hole guide. To do this, cut a piece of  $\frac{3}{4}$ " stock to  $2\frac{1}{4}$ " wide by  $22\frac{1}{2}$ " long. Then, measure from end to end, and find the exact center of the strip, and mark a centerpoint. Use your drill press to drill a  $\frac{3}{8}$ " hole through the strip, and use this as a guide to drill a  $\frac{3}{8}$ " hole through each sidepiece H where shown on the Exploded View

drawing. (Later, as shown in *photo B*, we'll use the template to drill the mating holes in the cabinet sides.)

**6** Glue the banding pieces (H, I) in place around part G as shown in *photo A*. Later, measure the openings, and cut the top and bottom pieces (J) to fit snugly inside the banding. Sand a slight round-over along the mating edges of the banding (H, I) and the top and

bottom pieces (J) where shown on the Pivot detail accompanying the Exploded View drawing.

**7** Drill countersunk mounting holes, and screw the top and bottom pieces (J) in place.

**8** Using the  $\frac{3}{8}$ " holes in both Hs as guides, drill  $\frac{3}{8}$ " holes into each F for a total depth of  $1\frac{1}{8}$ " where shown on the Pivot detail.

**9** Lay the cabinet on its side on your workbench. As shown in

*Continued*

Bill of Materials					
Part	Finished Size			Matl.	Qty.
	T	W	L		
CARCASE					
A sides	$\frac{3}{4}$ "	$22\frac{1}{2}$ "	$31\frac{3}{4}$ "	BP	4
B shelves	$\frac{3}{4}$ "	21"	21"	BP	2
C back	$\frac{3}{4}$ "	20"	10"	BP	1
D banding	$\frac{3}{4}$ "	$\frac{3}{4}$ "	21"	M	2
E* banding	$\frac{3}{4}$ "	$1\frac{1}{2}$ "	24"	M	2
F* banding	$\frac{3}{4}$ "	$1\frac{1}{2}$ "	$32\frac{1}{2}$ "	M	4
SWIVEL TOP					
G center	$\frac{3}{4}$ "	$18\frac{7}{8}$ "	$21\frac{3}{4}$ "	BP	1
H* banding	$\frac{3}{4}$ "	$2\frac{1}{4}$ "	$22\frac{1}{2}$ "	M	2
I* banding	$\frac{3}{4}$ "	$2\frac{1}{4}$ "	$19\frac{5}{8}$ "	M	2
J top & bottom	$\frac{3}{4}$ "	$18\frac{1}{16}$ "	$20\frac{1}{16}$ "	BP	2
K turn tabs	$\frac{1}{2}$ "	$1\frac{1}{2}$ "	$2\frac{1}{2}$ "	M	4
DRAWER					
L sides	$\frac{1}{2}$ "	8"	21"	C	2
M front & back	$\frac{1}{2}$ "	8"	$18\frac{1}{4}$ "	C	2
N bottom	$\frac{1}{4}$ "	19"	21"	BP	1
O front	$\frac{3}{4}$ "	$9\frac{7}{8}$ "	$19\frac{3}{4}$ "	M	1

\*Cut parts marked with an \* oversized. Trim to finished size according to the how-to instructions.

**Materials Key:** BP—birch plywood, M—maple, C—choice of poplar or maple.

**Supplies:** #8x1", #8x1 $\frac{1}{4}$ ", #8x1 $\frac{1}{2}$ " flathead wood screws; 2-2 $\frac{1}{2}$ " swivel casters; 2-2 $\frac{1}{2}$ " fixed casters; 16-#14x $\frac{3}{4}$ " panhead sheet-metal screws with flat washers; one pair of 20" bottom-mount drawer guides (we used Knappe Vogt #1300 guides); 2- $\frac{3}{8}$ " steel rods 2" long (or two  $\frac{3}{8}$ x2" tension pins) with four  $\frac{3}{8}$ " flat washers; 4-#10x1 $\frac{1}{2}$ " panhead sheet-metal screws with four #10 washers; 3 $\frac{3}{4}$ " wire pull; paint, clear finish.

## Buying Guide

**Hardware kit.** All the hardware listed in the Supplies listing above except for the finish. Kit no. WDTC, \$49.95 ppd. in continental U.S. For areas outside this, please call for quotes. Miller Hardware, 1300 M.L. King Pkwy., Des Moines, IA 50314, or call 515/283-1724 to order.



Check for tight miter joints, then glue and clamp the solid maple banding pieces around the plywood center section for the swivel top.

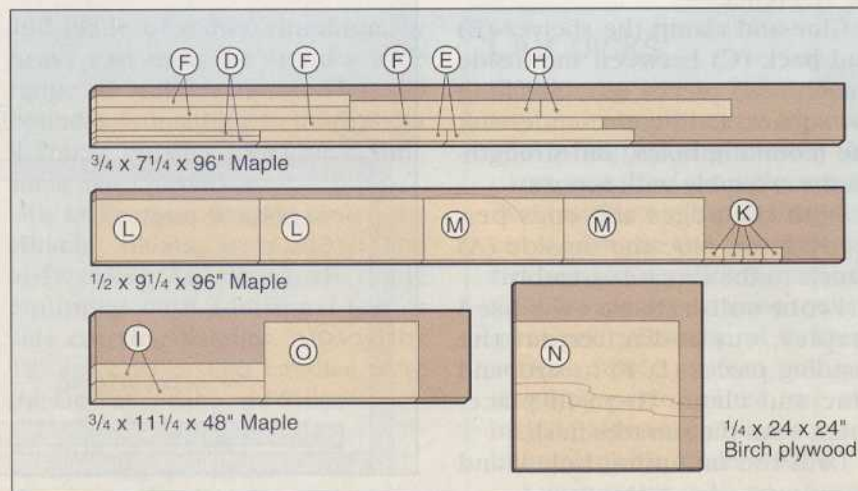

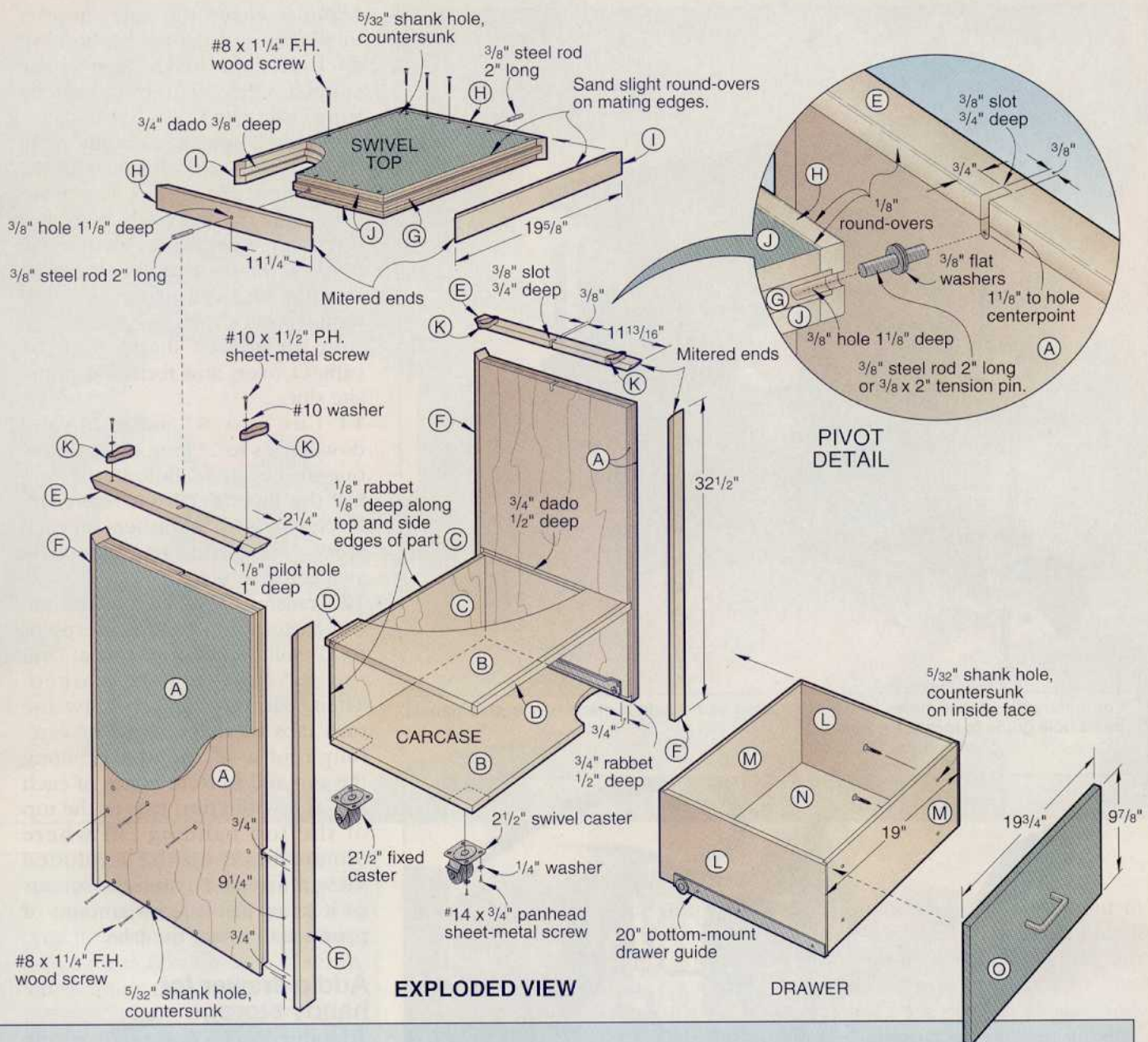

### CUTTING DIAGRAM

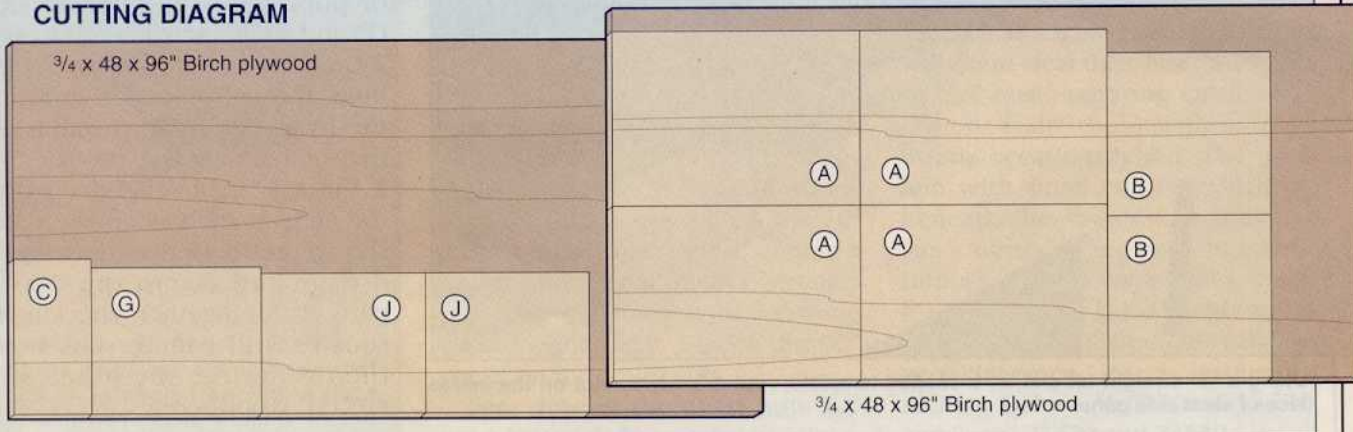

# Swivel-Topped Tool Cabinet

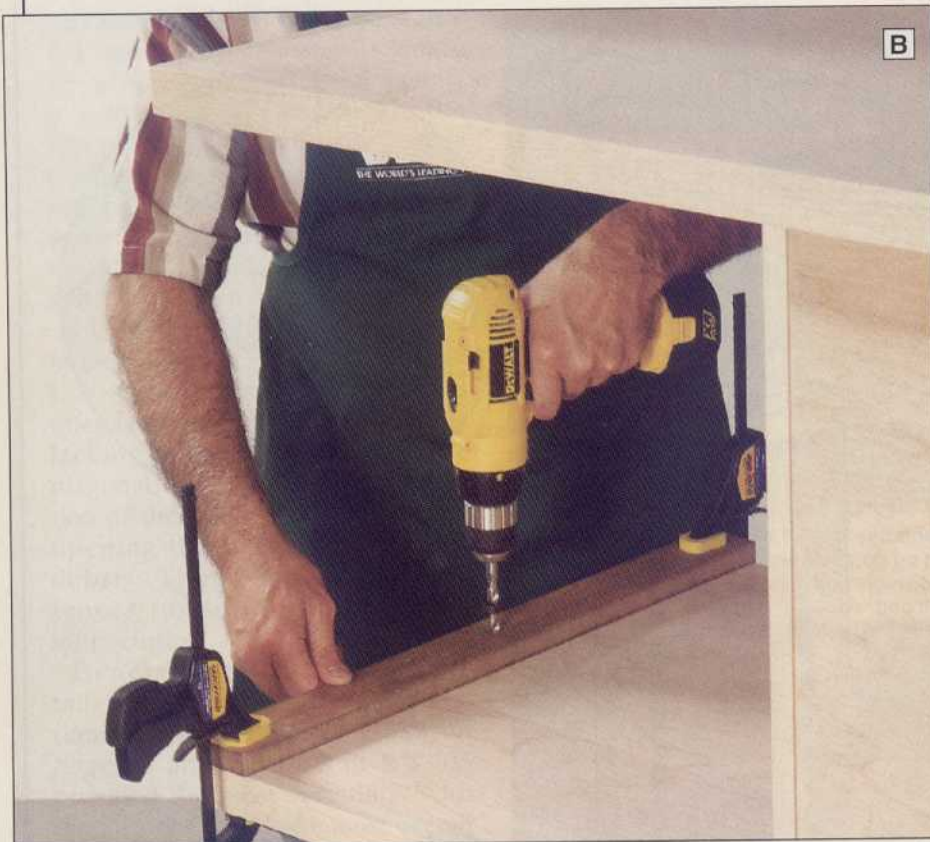

For accurately placed holes in the swivel top and inside surface of the side panels, use a hole guide to locate the holes.

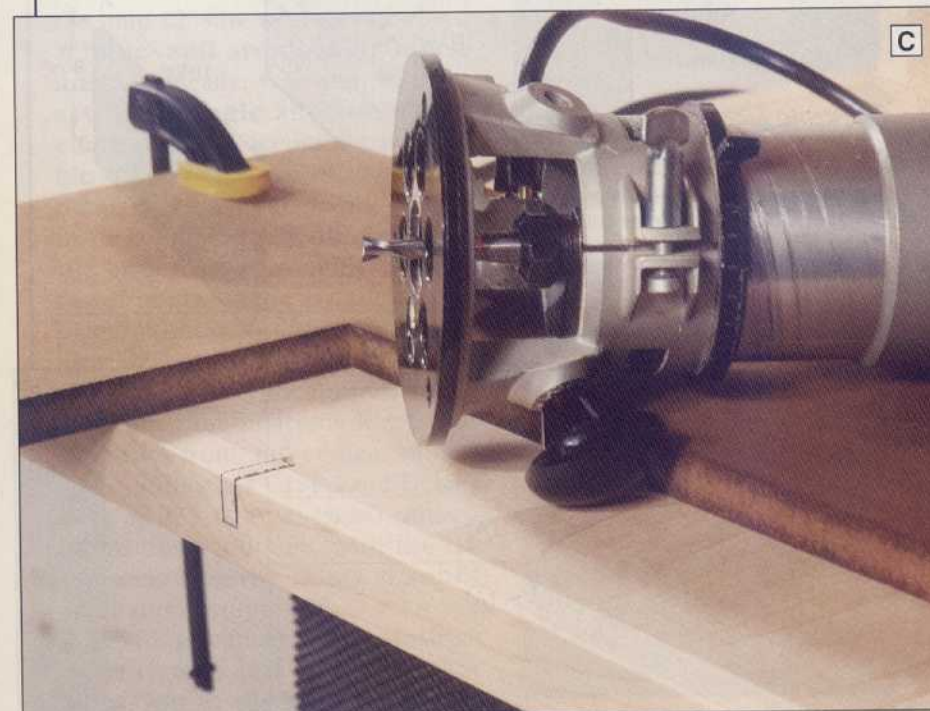

Using a  $\frac{3}{8}$ " straight bit and an L-shaped template, rout a  $\frac{3}{8}$ "-wide slot on the inside face of each side panel.

*photo B*, clamp the hole template in place, and drill a  $\frac{3}{8}$ " hole  $\frac{3}{4}$ " deep into the inside face of the cabinet sides, centered perfectly from end to end.

**10** Using a square, carefully mark the location for the  $\frac{3}{8}$ " slot  $\frac{3}{4}$ " deep centered over the hole drilled in the previous step. For reference, see the layout lines in *photo C*. Fit your router with a  $\frac{3}{8}$ " straight bit, and use an L-shape template as shown in *photo C* to rout the slot to shape. Flip the cabinet over, and form the opposite slot.

**11** Cut two  $\frac{3}{8}$ " smooth steel dowel rods to 2" long each. Epoxy one into each  $\frac{3}{8}$ " hole in the top. See the Pivot detail for reference. Place two  $\frac{3}{8}$ " flat washers on each steel dowel rod, and place the swivel top in place.

**12** Transfer the full-sized turn tab (K) pattern and hole centerpoint to  $\frac{1}{2}$ " solid stock four times. Drill the  $\frac{3}{16}$ " holes where marked. Then, bandsaw or scrollsaw the turn tabs to shape. Sand or carefully rout a  $\frac{1}{8}$ " round-over along the top and bottom edges of each tab. Screw the turn tabs to the top of the top banding (E) where dimensioned on the Exploded View drawing. Tighten the screws so it takes just a small amount of pressure to rotate the tabs.

## Add a drawer for handy storage

**1** From  $\frac{1}{2}$ " stock (we prefer maple or poplar), cut the drawer sides (L) and front and back (M) to size.

**2** Drill four countersunk mounting holes through the back surface of the front piece (M) for attaching the solid drawer face (O) later.

**3** Cut a  $\frac{1}{2}$ " rabbet  $\frac{1}{8}$ " deep along the ends of each sidepiece where shown on the Drawer drawing.

**4** Glue and clamp the drawer parts (L, M) together, checking for square. Drill countersunk holes, then reinforce the joints with #8 $\times$ 1 $\frac{1}{2}$ " wood screws.

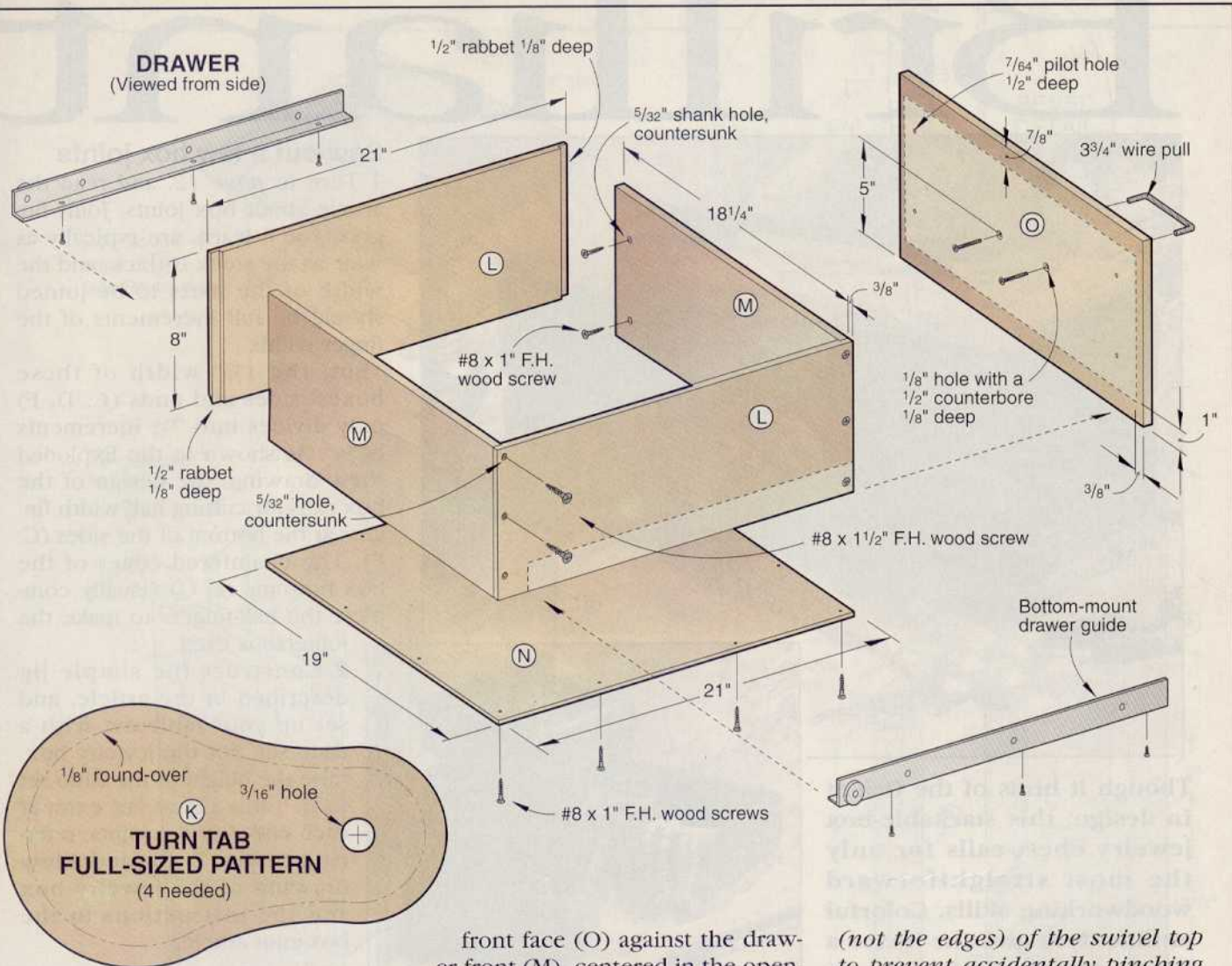

**5** Cut the bottom (N) to size, and glue and screw it in place, again checking for square.

**6** Attach the drawer guides to the drawer as explained in the manufacturer's instructions and where shown on the Exploded View drawing. Then, attach the mating guide pieces to the inside of the drawer opening.

**7** Cut the solid-stock drawer front (O) to size.

**8** Cut two pieces of double-faced tape to an inch long. Place the tape on opposite corners of the drawer front (M). Slide the drawer into the opening in the carcass. Carefully position the drawer

front face (O) against the drawer front (M), centered in the opening. Push O against M to adhere it in place. Remove the drawer from the opening, and screw the face (O) to the front (M).

**9** Locate the centerpoints, and drill the holes for the drawer pull.

### Finish up the cabinet, and add a pair of tools

**1** Remove all the hardware and touch-up sand if necessary. Apply the paint and finish. (We used Hammerite for the painted surfaces and satin polyurethane on the rest where shown on the opening photo.)

**2** Reattach the hardware.

**Note:** When releasing the turn tabs and rotating the top with the mounted tools, grab the ends

(not the edges) of the swivel top to prevent accidentally pinching your fingers between the swivel top and carcass sides. A firm grasp also helps prevent the top from swiveling too quickly.

**3** Mount your tools by centering them so the weight of each tool rests over the pivot pins. Depending on the weight of the tools, you may want to secure them with bolts instead of screws. Also, when mounting the second tool, position it so the weight of the opposing tool is evenly distributed. This will prevent the top with attached tools from whipping around when you release the turn tabs. (We found it useful to have a helper on hand when locating and securing the tools to the swivel top.)



# Brilliant



Though it hints of the Orient in design, this stackable-box jewelry chest calls for only the most straightforward woodworking skills. Colorful aniline dyes give the boxes a bright, fresh look.

*Note:* We show the jewelry chest as a set of two small boxes and one large one. You could build a taller chest by building additional large or small boxes.

## Select some great grain

**1** Select your stock, paying particular attention to grain figure and color match. Much of the box's beauty arises from its prominent wood grain display. (We built our jewelry box from curly maple.) You will need  $\frac{1}{4}$ " and  $\frac{3}{8}$ " stock for the box—we resawed  $\frac{3}{4}$ " boards.

**2** Lay out the parts on stock of appropriate thickness. Position parts A, B, C, D, F, and H for best



appearance—they will be the most visible parts. (For a better look at the grain when laying out the parts, wipe the stock with mineral spirits. It will highlight the figure, then evaporate.)

**3** Cut out parts A, B, C, D, and F, making them  $\frac{1}{16}$ " longer than finished size. (Cut parts A and B to the width shown, but do not make the leg cutouts yet.) The extra length will allow you to cut the box-joint fingers  $\frac{1}{32}$ " longer on each end of each part. After assembly, you can then sand them flush for a perfect fit.

## Saw-cut a few box joints

**1** Turn to *page 12*, and read the article about box joints. Joint fingers, you'll learn, are typically as wide as the stock is thick, and the width of the parts to be joined should be full increments of the finger width.

But, the  $1\frac{7}{8}$ " width of these boxes' sides and ends (C, D, F) only divides into  $7\frac{1}{2}$  increments of  $\frac{1}{4}$ ". As shown in the Exploded View drawing, the design of the box calls for cutting half-width fingers at the bottom of the sides (C, F). The chamfered edges of the box bottoms (E, G) visually complete the half-fingers to make the joints look even.

**2** Construct the simple jig described in the article, and set up your tablesaw with a dado set. For the jewelry box, raise the height of the dado set to  $\frac{3}{32}$ "; this allows  $\frac{1}{32}$ " extra at each end. Cut the joints, referring to the Exploded View drawing of the jewelry box and the instructions in the box-joint article.

## Put the parts together

**1** Referring to the Parts View drawings for parts A and B, lay out the leg cutout on the bottom of each piece. Scrollsaw or bandsaw the cutouts, staying slightly outside the line. Sand to the line.

**2** Fit one part A and one part B together. Notice the mating surfaces of the joint. Then, disassemble the joint, apply glue to all four joints, and reassemble. After gluing parts A and B together, measure the diagonals to ensure that the base is square, and clamp the base with rubber bands.

**3** Similarly, glue together three boxes as shown, using sides C and F and ends D. Square the boxes and clamp.

# Boxes

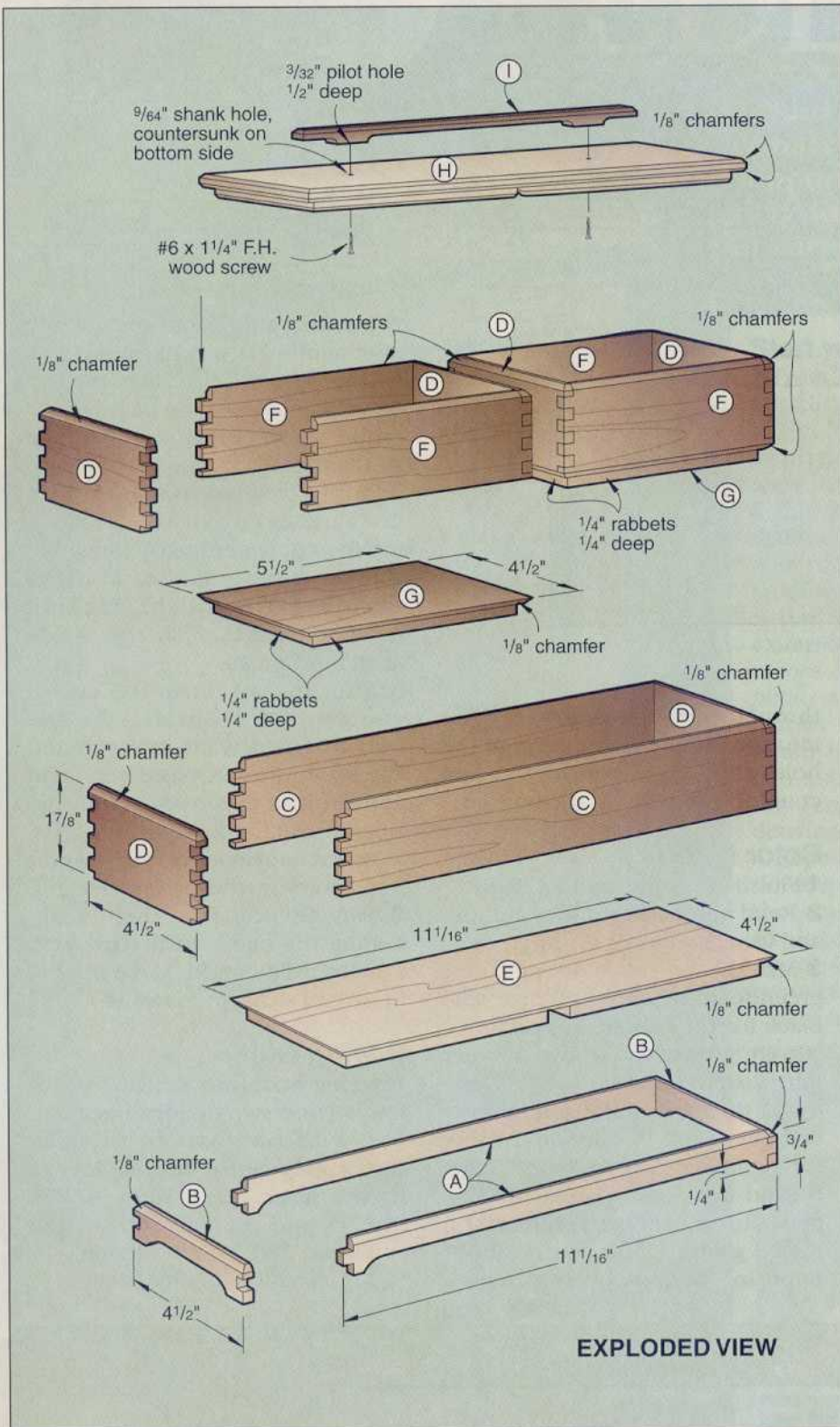

Bill of Materials

Part	Finished Size			Matl.	Qty.
	T	W	L		
A* base side	1/4"	3/4"	11 1/16"	M	2
B* base end	1/4"	3/4"	4 1/2"	M	2
C* long side	1/4"	1 7/8"	11 1/16"	M	2
D* end	1/4"	1 7/8"	4 1/2"	M	6
E long bottom	3/8"	4 1/2"	11 1/16"	M	1
F* short side	1/4"	1 7/8"	5 1/2"	M	4
G short bottom	3/8"	4 1/2"	5 1/2"	M	2
H lid	3/4"	4 1/2"	11 1/16"	M	1
I** handle	3/8"	5/8"	7 1/4"	M	1

\*Initially make longer than shown, then trim to finished size in accordance with how-to instructions.

\*\*Initially make both longer and wider than shown, then cut to finished size in accordance with how-to instructions.

Material Key: M—maple

Supplies: Woodworker's yellow glue; aniline dyes—forest green and nigrosine black; Minwax Antique Oil Finish, jewelry-box liners (see Buying Guide), #6x1 1/4" flathead wood screws.

**4** Allow the glue to dry, then remove the clamps. Sand the sides and ends flush.

## Saw the bottoms and the lid

**1** Cut the bottoms (E and G) and the lid (H) to size.

**2** Glue a bottom to each box, keeping the edges and ends flush with the box sides and ends. Place the half-fingers adjacent to the bottom of each box. Clamp, and clean off the glue squeeze-out.

**3** Saw or rout a 1/4" rabbet 1/4" deep all around the bottom of each box and the bottom side of the lid.

**4** Saw a 3/16"-wide dado 1/4" deep across the middle of the long box's bottom (E) and the bottom side of the lid (H), shown on the Parts View drawing. To cut the dado, install a 3/8" dado blade on the tablesaw. Set the fence 5 1/4" from the blade as a stop. Then, using the miter gauge, saw the dado in two passes, with each end of the lid against the fence.

Continued

# Brilliant Boxes

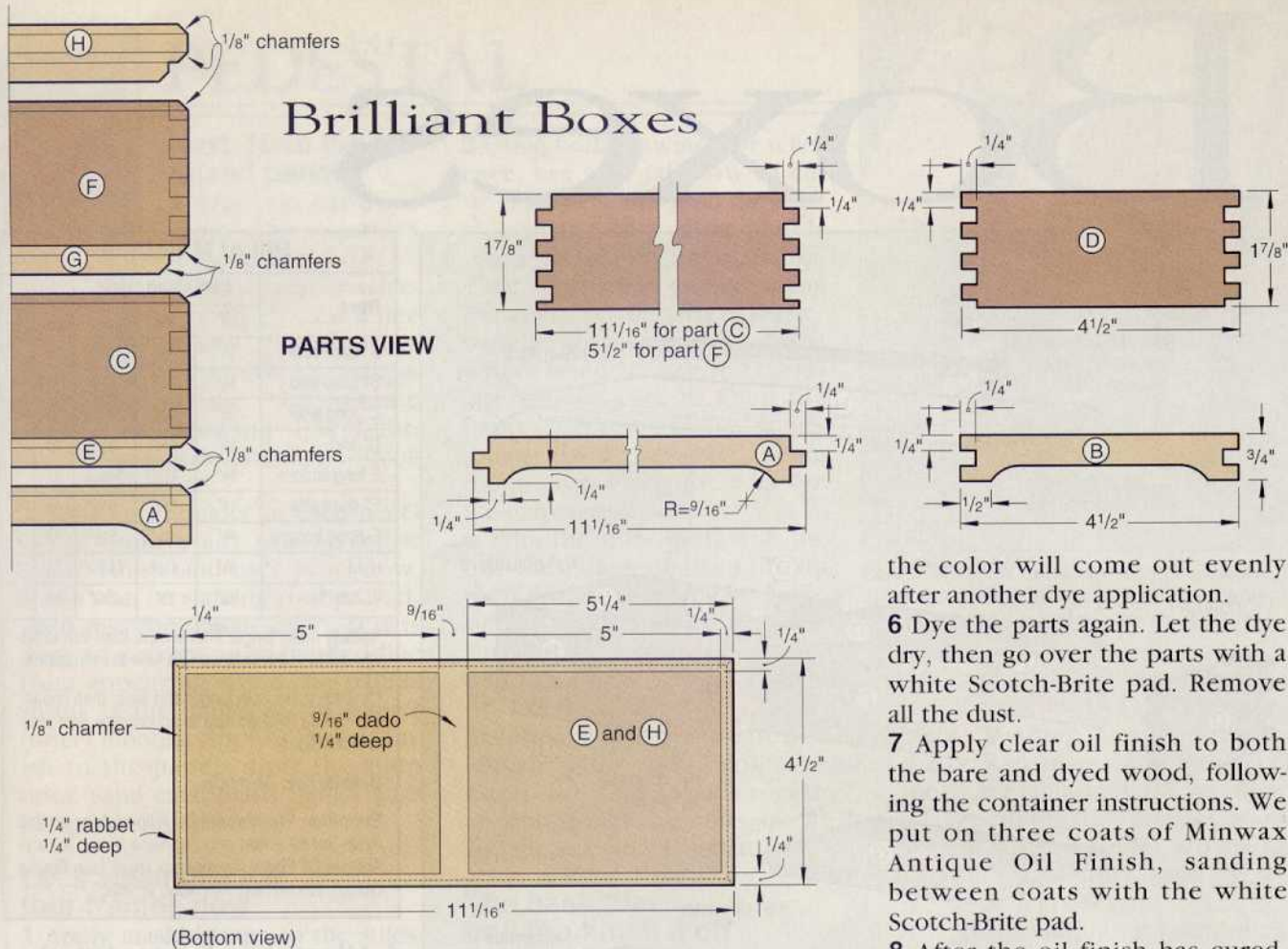

**5** Next, install a chamfer bit in your table-mounted router. Rout  $\frac{1}{8}$ " chamfers around the top and bottom of each box and the lid where indicated.

You can form both chamfers on the bottom with a single setup. Then, lower the bit for the top chamfers. Chamfer the corners inside the  $\frac{9}{16}$ " dados with a hand plane or by sanding.

**6** Sand all surfaces and edges smooth and flush.

**7** Transfer the full-sized pattern for the handle (I) to the stock. Scrollsaw or bandsaw the handle. Sand chamfers on the handle where shown. Sand smooth.

**8** Drill  $\frac{3}{32}$ " pilot holes through the lid where shown. Then hold the handle in position, and drill

through the pilot holes  $\frac{1}{2}$ " deep into the handle posts. Enlarge the holes through the lid to  $\frac{9}{64}$ ", and countersink them on the bottom.

## Color it done

**1** Finish-sand all parts to 320-grit.

**2** Read the article about mixing and using aniline dyes, *page 16*.

**3** Mix the dyes. We mixed forest green for the boxes and nigrosine black for the handle. For each, we stirred  $\frac{1}{4}$  teaspoon of dye powder into 4 oz. of water.

**4** Dye the parts, following the procedures in the dye article. Let dry for 24 hours.

**5** Sand the dyed wood with 320-grit sandpaper to remove the raised grain. Don't worry about exposing bare wood in places—

the color will come out evenly after another dye application.

**6** Dye the parts again. Let the dye dry, then go over the parts with a white Scotch-Brite pad. Remove all the dust.

**7** Apply clear oil finish to both the bare and dyed wood, following the container instructions. We put on three coats of Minwax Antique Oil Finish, sanding between coats with the white Scotch-Brite pad.

**8** After the oil finish has cured, you can rub on paste wax and buff it if you want more sheen. We used Minwax paste wax, and applied it in accordance with the label instructions.

**9** Insert velvet-covered jewelry box liners in the boxes (see the Buying Guide). Trim them to fit, cutting the heavy cardboard with a sharp utility knife. Make the cut in several shallow passes. ♣

## Buying Guide

**Jewelry box liners.** Black velvet liners (one two-divider liner and one with ring bars to fit small boxes and one flat bottom liner to fit the large box), item 300JB, \$12.95 ppd. in U.S. Schlabaugh and Sons, 720 14th St., Kalona, IA 52247, or call 800/346-9663.

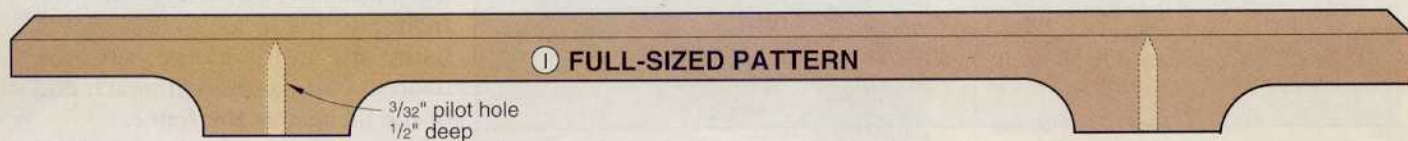

A taxidermy duck sculpture is perched on top of a tall, square wooden pedestal. The pedestal features a classic frame-and-panel design with a wide top rail and a decorative base. The background shows a framed picture of a landscape with birds.

# Frame-and-panel PEDESTAL

Traditionally styled, yet simple to construct, this sensational oak support will serve as a fitting display for even your best sculpture or carving.

## Start with the stiles and rails

**1** From  $\frac{3}{4}$ " stock, cut the stiles (A, B) to the sizes listed in the Bill of Materials plus 1" in length. (For this project, where the artwork displayed should draw the most attention, we selected straight-grained oak.)

**2** Cut the rails (C, D) to size, making sure that they are all the same length.

**3** Fit your tablesaw with a dado blade and an auxiliary wood fence. Attach a wood extension to your miter gauge, and make sure the extension is square to the blade. Cut rabbets across each end of each rail as shown in *photo A*. (We cut scrap stock first to verify that we were making a  $90^\circ$  cut and that a  $\frac{1}{4}$ " tenon  $\frac{3}{8}$ " long would be left after making two cuts across each end of each rail.) See the Tenon detail accompanying the Frame drawing for reference.

**4** Reposition the fence, and cut  $\frac{1}{4}$ " grooves  $\frac{3}{8}$ " deep, centered along the inside edge of the stiles and rails where shown on the Exploded View and Frame drawings. See *photo B* for reference. When cutting the grooves, cut them a hair deeper than the length of the tenons on the rails.

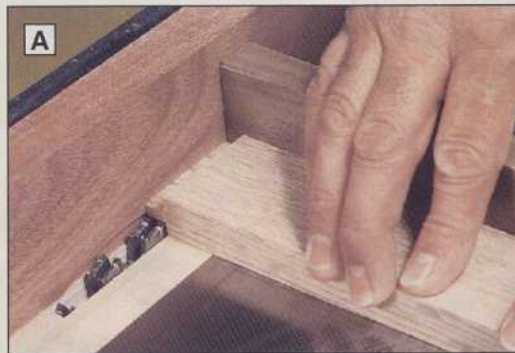

**A** A wood extension secured to our miter gauge minimizes chipout when cutting the rabbets to form the tenons on the ends of the rails.

*Continued*

# PEDESTAL

## Next, form the raised panels

**1** Edge-join narrower stock if necessary to form the panels (E).

**2** Position your table-saw blade and fence where shown in the Bevel detail accompanying the Frame drawing. Bevel-cut-

ting the end grain first, cut a shoulder in each panel.

**3** Sand the shoulder of each panel (E) to remove any saw marks or burns. Finish-sand each panel now. If you plan on staining your project, stain just the panels now. This is done to prevent an unfinished line from appearing when the panels shrink in the frames in the winter (drier) months. Apply a coat of finish to the panels after the stain dries. Sand each panel lightly with 320-grit sandpaper.

## Let's assemble the four frames now

**1** Apply masking tape to the stiles, marking where the rails will be positioned. Remember, the stiles were cut 1" long, so ½" of stile should extend at both ends.

**2** Glue and clamp each of the four frame-and-panel assemblies together as shown in *photo C above right*. Check for square.

For firm support of the workpiece against the table-saw rip fence, we used a pair of feather boards when cutting the grooves in the rails and stiles.

**3** Using both drawings for reference, use your table-saw to cut ¼" grooves ⅜" deep on the back side of the two wide panels where shown on the drawings.

Then, cut mating grooves along the edges of the two narrower panels. For proper alignment when assembling the frames later, make sure to keep the front surface of the frame against the fence when cutting the grooves along the edges of the narrower panels.

**4** Trim the stiles flush with the outside edges of the rails on each end of each frame. Make sure all four frames are the same length when you're done.

**5** Cut four splines to ⅜" wide from ¼" stock (we cut ours from ¼" hardboard). Cut the splines to length. Then, glue, spline, and clamp the four frames together, checking that the ends are flush and the assembly is square.

## The base trim and top finish it off

**1** Cut the base trim pieces (F) to size plus 1" in length. From five-quarter stock (1 ½"), cut the top (G) to size. From ¾"-thick stock, cut the cleats (H) to size.

**2** Fit your router with a classical bit (we used the Freud 99-009). Using the Router detail accompanying

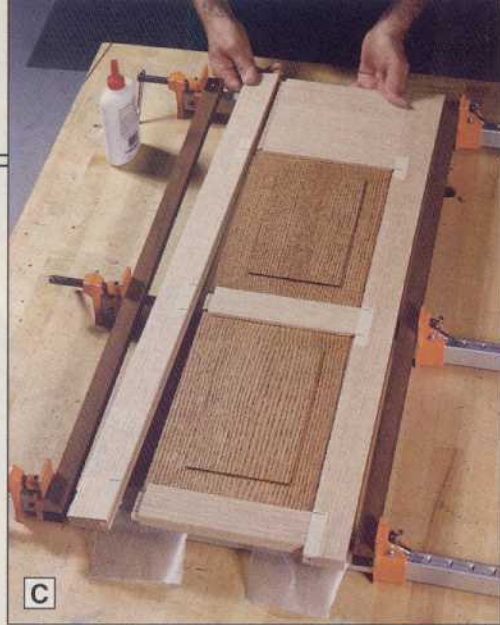

**C** Pencil lines on masking tape allows you to align the pieces when gluing and clamping each frame-and-panel assembly together.

the Exploded View for reference, rout the top edge of each base trim piece (F). Using the same bit, place the bottom side of the top (G) on the router table, and rout its edges.

**3** Miter-cut the base pieces (F) to fit around the pedestal with tight joints at each corner. Glue the trim pieces to the pedestal.

**4** Drill the mounting holes in the cleats (H), and screw them to the bottom of the pedestal top (G) so the pedestal will sit centered on the top of the pedestal.

**5** Finish-sand the pedestal, being careful not to mar the stained and finished panels (we masked them). Apply the stain (we used ZAR Colonial Pine), and apply a finish (we used satin polyurethane).

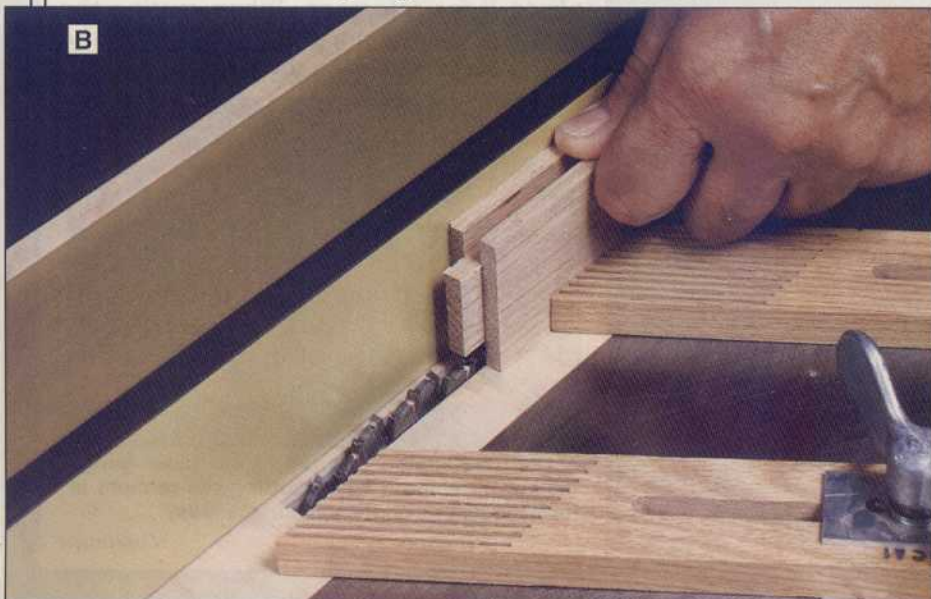

## Bill of Materials

Part	Finished Size			Matl.	Qty.
	T	W	L		
A* stiles	¾"	2"	36"	O	4
B* stiles	¾"	1¼"	36"	O	4
C top & middle rails	¾"	2"	8¾"	O	8
D bottom rails	¾"	7½"	8¾"	O	4
E raised panels	½"	8⅝"	12⅞"	O	8
F* base trim	¾"	4½"	13½"	O	4
G top	1½"	13½"	13½"	O	1
H cleats	¾"	¾"	10½"	O	2

\*Cut parts marked with an \* oversized. Trim to finished size according to the how-to instructions.

Material Key: O—oak

Supplies: #8x1¼" flathead wood screws, stain, clear finish.



# Compound MiterSaws

A no-nonsense look at 13 models

When was the last time you looked—really looked—at compound miterSaws? If you don't already own one, you may find this crosscutting specialist the missing ingredient in your project-building repertoire.

## Fast Facts

- While a 10" compound miterSaw can crosscut 2x6s at 90°, you'll need a 12" saw to handle 2x8s.
- You'll want to replace the saw blade that comes with the saw with a quality crosscut blade for maximum cutting performance.
- Of the three handle types, the horizontal D design proved most comfortable and practical.
- For best portability, choose a miterSaw that has a carrying handle.

## Why own one?

Since power miterSaws and later, compound miterSaws, arrived on the scene in the 1960s, woodworkers and carpenters have relied on these tools to make tricky molding cuts, do trim work, and speed production cutting. Too, a quality compound miterSaw may be your best bet for crafting perfect picture frames. And, in addition to being portable, they offer super-accurate cutting. Couple one with a solid stand such as our new plan on *page 62*, and you'll find cutting long stock a piece of cake.

Yet, in the arena of crosscutting saws, the compound miterSaw faces serious competition. At one end of the spectrum, you have the low-cost and low-tech miter box and backsaw. Though relatively effective at crosscutting and angle-cutting assignments, using one takes time (and energy).

Moving along, you have the basic motorized miterSaw, which—again at a cost lower than a compound miterSaw—can make crosscuts, angle cuts, and bevel cuts (on

pieces standing on edge). But compound cuts? Forget it.

At the other end of the spectrum you have sliding compound miterSaws, which offer greater capacity (capable of cutting 2x12s at 90° [0° on the saw scale] and 2x8s at 45°), and cost on average \$200 more. (See "Sliding Compound MiterSaws" in issue no. 87, April 1996, for more on this saw type.)

It's between the sliders and motorized miterSaws that compound miterSaws fit in. They do an expert job at making compound cuts (in addition to those other miterSaw cuts.) And if their capacity range suits your needs (see "Cutting capacity" on *page 57*), then this workhorse may have a place in your tool stable.

In our sawing tests, we found that most tools cut with acceptable accuracy when minor adjustments are applied. Yet, only the Hitachi and Milwaukee 10" saws and the Delta and Dewalt 12" saws made consistent perfect cuts through the range of tasks.

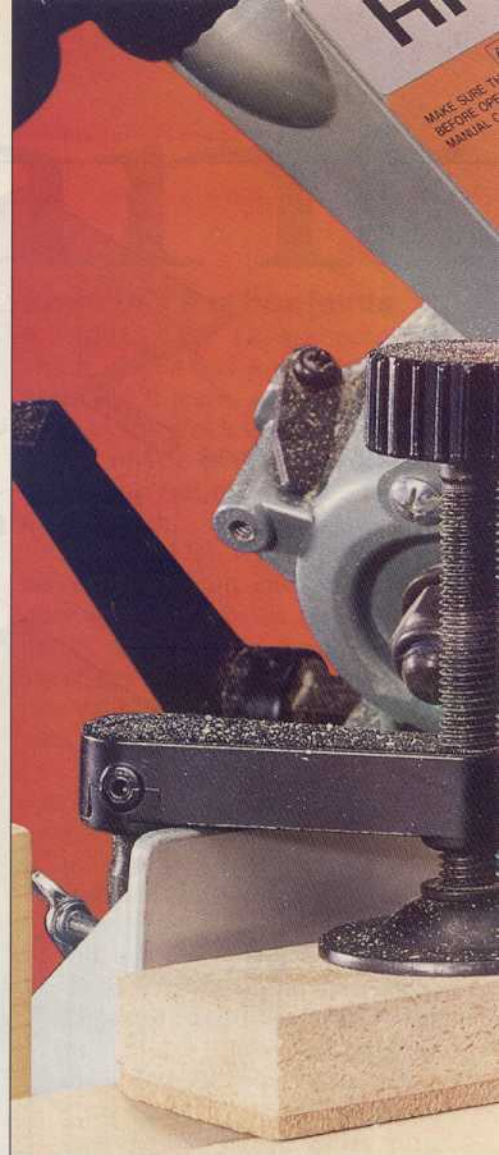

## About our performance test

In all, we tested 13 compound miterSaws: nine 10" models and four 12" models. To ensure fairness, we used 60-tooth general and fine crosscut saw blades from Freud (models TK406 and LU85MO10 for the 10" saws and models TK407 and LU85MO12 for the 12" saws). We also relied on the tools' factory-established detent stops and scales for all saw settings.

Using the same stock, we ran each saw through a variety of cutting tasks, checking the accuracy of each cut. The cuts included a 45° (picture frame) cut, a 45° bevel cut, a straight 90° cut, and a compound crown molding cut. We also cut thick (3½x3½" oak)



and wide stock to measure capacity. See the chart on *page 60*. You'll find here that we also measured for deflection from 0° when crosscutting the thicker stock.

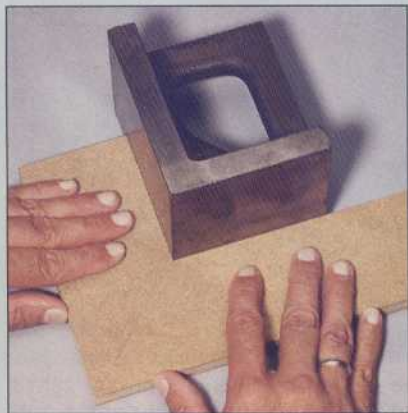

To check each cut, we held the test pieces to an angle iron with a right angle that was precision-machined to .0001 accuracy.

## Features to focus on

When the performance ratings of several tested tools appear equal, look at features and price to make your final decision. Here's a round-up of compound miter saw attributes to help you limit your choices.

- **Cutting capacity.** The maximum height and width of a piece of stock that a compound miter saw can cut—called capacity—decrease significantly as miter and bevel angles increase. We found minor capacity differences among the 10" and 12" saws we tested. If cutting a lot of dimensional lumber, strongly consider a 10" saw with a cutting capacity of at least 3½×5½" for 90° (or 0° on the scale) cuts.

Too, note in the chart how 12" saws have a definite capacity advan-

tage—something to think about if you build decks or work in home construction. These saws can cut 4×8s at 90° and 2×6s at 45°. The bigger saws also offer longer and wider table surfaces, which provide support for larger workpieces.

- **Table inserts.** Put simply, saws with zero-clearance inserts did not collect small annoying cutoffs during our tests; those without such inserts occasionally did. The problem with small cutoffs collecting beneath the saw is that they can jam a turntable and prevent it from turning. And, in some cases, a saw blade can catch loose cut-off pieces and send them flying. Tools lacking zero-clearance inserts in our test include Delta's 36-075 and 36-210, and Sears' 23522 and 23530.

*Continued*



# Compound Miter saws

• **Fences.** A quality fence must provide solid support along its length for workpieces placed flat against it. And the longer and higher the fence, the better. (All the fences examined come with holes, allowing you to mount larger auxiliary wood fences.) At the same time, it must accommodate a tilted blade and motor when cutting bevels.

With the exception of Milwaukee's model 6494-6 at *right* and Makita's LS1040, *middle right*, the 10" saws offer fairly basic fences, with many lacking full support. The inside diagonal end on the left-side portion of these fences leave a gaping opening that can gather cut-off debris. They require auxiliary fences for solid backing when miter-cutting.

Generally, the 12" saws have taller, more elaborate fence systems. Here, the Delta 36-235 on *page 61* and the DeWalt DW705 provided the most versatility, with the former offering the most overall support of the saws tested. The Skil model HD3812 had an extra fence piece, too, leaving the Sears 23514 the lone 12" saw without one.

• **Table- and arm-locking mechanisms.** Ideally, you want to make sawblade angle adjustments as effortlessly and accurately as possible. This boils down to two adjustments: the miter-angle adjustment made by rotating the turntable and the blade/motor assembly, and the bevel angle, made by tilting the blade/motor assembly.

For establishing miter angles, most saws came with locking turn handle/lever combinations located at the saw's front and center. Models such as Hitachi's C10FC and Delta's new 36-235 (shown *right*) offered interesting variations, with the latter receiving the lion's share of admiration by our staff.

All the saws came with positive detent stops left and right that allow you to easily and precisely lock into the most common miter settings. However, while some saws in the 10" class offer only



The fence on Milwaukee's 6494-6 extends to a maximum length of 31", the longest of the 10" saws. The left fence can also be reversed, placing the diagonal end by the tilted saw blade for full support when bevel-cutting.

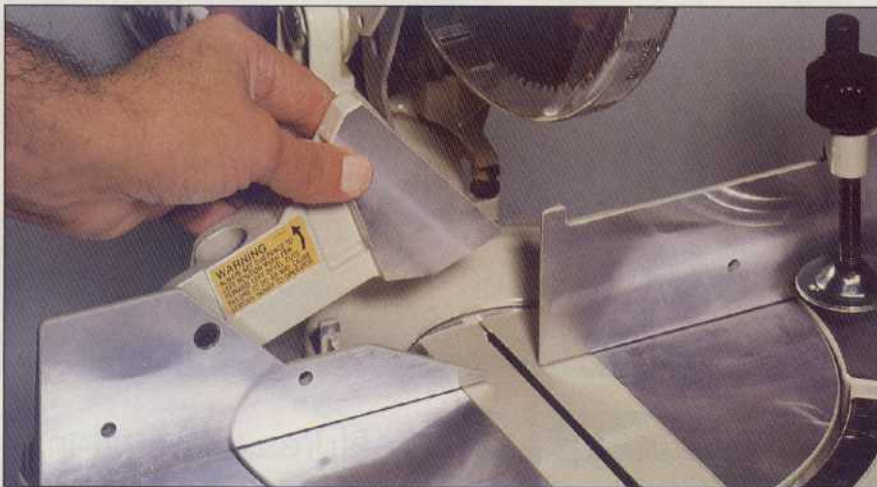

Makita's saw comes with a two-piece flip-up left fence, making it ideally suited for miter and bevel cuts. At 4 1/2", the LS1040's fence ranks as the highest in the 10" class.



To quickly change the miter angle of Delta's 36-235, simply squeeze the lever, pull the arm and turntable to the desired angle, then release.



The scale on the Sears model 23514 shows three color-coded degree settings: standard degrees with detent stop locations for basic miter cuts (white), separate crown molding settings (red), and settings for cutting rafters (yellow).

## ANATOMY OF A COMPOUND MITERSAW

To best operate a compound mitersaw, first adjust the saw's miter and bevel angles to the desired cut, locking these in place; secure your workpiece to the fence and table using a clamp; then, depress the safety switch (if the saw has one) and saw switch, and lower the saw blade/motor assembly, allowing the blade to enter the workpiece.

SAW BLADE/MOTOR ASSEMBLY

FENCE

HOLD-DOWN CLAMP

MITER SCALE

LOCKING SYSTEM

Four saws in our test featured the comfortable horizontal D-handle like this one on DeWalt's model DW705. Delta's 10" saw at left has a vertical D-handle.

CUTTING KNUCKLE

BEVEL SCALE

BEVEL KNUCKLE

TURNTABLE

three detents (at 0°, 22½°, and 45°), others offer as many as five or six. (See the chart.) Three out of four saws in the 12" group (excluding Sears 23514) feature 31.6° detents—the compound mitersaw setting for miter-cutting crown molding while it rests on the table and against the fence. Skil's HD3812 goes one better with a 33.9° detent stop in the bevel scale. (You need both settings to make a compound crown molding cut.)

• **Scales.** Range, readability, and accuracy round out the criteria for judging miter and bevel scales (and the accompanying pointers). Note that Hitachi's C10FC miter scale reaches 60°, while Milwaukee's 6494-6 bevel scale spans from -3° to 50°, the broadest in these two ranges in our tool test.

Because the 12" saws come with larger scales, these prove to be the most readable overall, with more spacing between the numbers and degree marks. While many scales are cast into the saw's metal base (either raised or indented), others amount to printed metal plates attached to the base. These offer the most clarity. For example, Sears' 12" saw, model 23514 (*opposite page, bottom right*), has an easy-to-read printed scale with colored type for different setting.

As you scan the performance ratings on the chart, you can see which scales prove most reliable. The pointers seemed slightly off on some saws and had to be fine-tuned. The bevel scales, due to their small size, crowd the degree

hash marks, making them tough to read. For best results, keep an adjustable triangle on hand to check or establish bevel settings.

• **Handles.** Study the tool handles on these pages and you'll find three types: straight (banana), vertical D, and horizontal D. This final and latest design, shown *above*, felt the most ergonomically comfortable, regardless of the saw's height when we made our cuts. Not all saws or handles include safety switches, and some that do cause trouble for the left-handed woodworker. The Skil 12" saw, with its safety switch located on the left side of the D-handle, forces a lefty to use the saw with his right hand. Safety buttons on the left side of the banana handles on Hitachi's C10FC and Sears' 23530 also cause trouble for lefties.

*Continued*

# Compound MiterSaws

## Other buying points

Use these considerations to firm up your final selection.

**Motor.** Though saw-motor amperage spanned 13 to 15 amps, all of the saws met their assigned tasks with power to spare.

**Blade changing.** Once you install a quality blade on your saw, chances are it will stay there for a good long time. Still, when the time comes to change a blade, you want to do it in an eyewink and with little effort. Innovative here are the Hitachi and Milwaukee 10" saws. Each has an easy-to-remove arbor cover attached to the larger blade-guard system. Since the Hitachi also had a rubber-covered screw that required no tools to remove, it led the pack.

**Dust collection.** When compound mitersaws go to work, they spew out jets of sawdust. Yet the velocity of the output and location of the collecting ports often prevent a tool from catching it all. Honors here go to the Makita 10" saw and the Skilsaw and Delta 12" tools for having the most effective systems.

**Hold-downs.** Many manufacturers put forth their own special design for workpiece hold-downs. While some hold-downs clamp material to the table (see the opening photograph on page 56), others clamp material to the fence (see the Delta tool in the Anatomy photograph on page 59). And several of the hold-downs are sold separately. (We found that only the Hitachi C10FC, the Delta models 36-075, 36-210, and 36-235, and the Skilsaw HD3812 provided hold-downs as standard equipment.) Of the entire universe, we liked the quick-release paddle clamp employed by Delta as compared with those that involve turning a time-consuming threaded rod up and down.

**Portability.** For those who plan to tote their saw from place to place, this can be a serious issue. Because the tested saws were in two sizes

MANUFACTURER/ IMPORTER	MODEL	MOTOR AMPS	BLADE SIZE (INCHES)	BEVEL 0°				BEVEL 45°				MITER RANGE		MITER STOPS LEFT AND RIGHT (DEGREES)	BEVEL RANGE (DEGREES)
				MITER 0°		MITER 45°		MITER 0°		MITER 45°		LEFT (DEGREES)	RIGHT (DEGREES)		
				CUTTING HEIGHT	CUTTING WIDTH (1 1/2"-THICK STOCK)	CUTTING HEIGHT	CUTTING WIDTH (1 1/2"-THICK STOCK)	CUTTING HEIGHT	CUTTING WIDTH	CUTTING HEIGHT	CUTTING WIDTH				
DELTA	36-075	13	10	3 1/2	5 1/2	3 1/2	3 3/4	1 1/2	5 1/2	1 1/2	4	0-48	0-49	0, 22 1/2, 45	-3-48
	36-210	15	10	3 1/2	5 1/2	3 1/2	3 3/4	1 1/2	5 1/2	1 1/2	4	0-49	0-49	0, 22 1/2, 45	-3-48
	36-220	15	10	3 1/2	5 1/2	3 1/2	3 1/2	1 1/2	5 1/2	1 1/2	4 1/4	0-47	0-47	0, 15, 22 1/2, 30, 45	-3-48
HITACHI	C10FC	15	10	3 1/2	5 3/4	3 1/2	3 1/2	1 3/4	5 1/8	1 3/4	3 1/2	0-45	0-60	0, 15, 22 1/2, 30, 45, 60	0-45
MAKITA	LS1040	15	10	3 1/2	5	3	3 1/2	1 1/2	5	1 1/2	3 1/2	0-45	0-52	0, 15, 22 1/2, 30, 45, 52	0-45
MILWAUKEE	6494-6	15	10	3 1/2	5 9/16	3 1/2	3 7/8	2 1/4	5 9/16	1 13/16	4	0-51	0-59	0, 15, 22 1/2, 30, 45	-3-50
PRO-TECH*	7208	15	10	3 1/2	5 3/4	2 5/8	4	1 7/8	5 5/8	1 3/4	4 1/8	0-50	0-50	0, 15, 22 1/2, 30, 45	0-45
SEARS CRAFTSMAN	23522	15	10	3 1/2	5 1/2	3 1/2	3 3/4	1 3/4	5 1/2	1 3/4	4	0-48	0-48	0, 22 1/2, 45	0-45
	23530	15	10	3 1/2	5 1/2	3 1/2	3 3/4	1 3/4	5 1/2	1 3/4	4	0-47	0-47	0, 22 1/2, 45	0-45
DELTA	36-235	15	12	4	7 1/2	4	5 1/2	2	7 1/2	2 1/4	5 1/2	0-47	0-47	0, 15, 22 1/2, 31.6, 45	0-45
DEWALT	DW705	13	12	4	8	4	5 5/8	1 1/2	8	1 1/2	5 3/4	0-47	0-47	0, 15, 22 1/2, 31.6, 45	0-45
SEARS CRAFTSMAN	23514	15	12	4	8	4	5 1/2	1 3/4	8	1 3/4	5 3/4	0-48	0-48	0, 15, 22 1/2, 30, 45	0-45
SKILSAW	HD3812	15	12	4	8	4	5 1/2	2	8	2	5 3/4	0-52	0-52	0, 15, 22 1/2, 31.6, 45	0-45 33.9 STOP

NOTES: \* Note: Pro-Tech also makes a 12" saw, model C7212 (not tested).

- (A) Aluminum (CI) Cast iron
- E** Small, compact, and lightweight.  
**G** Larger and heavier, but has side or top handle for easy carrying.  
**F** Extremely heavy and awkward to transport.
- E** Arbor cover only, guard assembly separate.  
**G** Requires removing bolt or screw to swing guard up and out of way.  
**F** Blade-securing bolt or screw is difficult to replace.  
\*Delta 36075 requires an Allen wrench in end of motor to lock arbor.
- E** High-quality 80-tooth trim blade.  
**G** General-purpose carbide blade.  
**F** Steel trim blade.
- E** Horizontal D-handle—comfortable in left and right hand.  
**G** Vertical D-handle or straight handle set at comfortable angle.  
**F** Angle of handle strains arm during cuts.
- E** Perfect 45° cuts.  
**G** 45° cuts - less than 1/2" off.  
**F** 45° cuts - greater than 1/2" off.  
**P** 45° cuts - greater than 1" off.
- E** Stops accurately at 45°; and cuts accurately.  
**G** Fairly accurate cuts at 45°.  
**P** No stops at 45°.
- E** At 90° cuts through a 5" board.  
**F** At 90° cuts halfway through a 5" board; acceptable for framing.
- Crown moldings cut flat on table with compound angles of 31.6° and 39.9°.  
**E** Miter and bevel marked for crown molding; achieved accurate cuts.  
**G** Mitered joint requires some sanding for perfect fit.  
**F** No markings on scales make settings difficult; joint may require filler.

and made of either aluminum or heavy cast iron, we found a wide range of weights (from 27 to 54 pounds)—something to think about if you're nursing a bad back. Still, some like a heavier saw.

To make transportation easier, the Hitachi, Makita, Sears 23530, and Milwaukee 10" saws all come equipped with additional top or side carrying handles. Among the 12" saws with such handles were the DeWalt, Sears, and Skilsaw.

Written by Jim Harrold  
Product testing: Bob McFarlin  
Photography: Marty Baldwin

## Our picks

Though our test included several impressive performers, when we add in all the user-friendly features, we find ourselves with three terrific tools in the winner's circle. Among the 10" saws, we tip our hat to Hitachi's model C10FC—a super-accurate tool at a great price. Because of its trend-setting fence system and outstanding performance, we also include Milwaukee's more pricey but undeniable model 6494-6.

Among the 12" compound

# 13 COMPOUND MITERSAWS UNDER THE SPOTLIGHT

FENCE HEIGHT LEFT AND RIGHT (DEGREES)	HEIGHT (INCHES)	LENGTH (INCHES)	TURNTABLE	FRAME	BASE MATERIAL (1)	PERFORMANCE EVALUATION															COMMENTS				
						PORTABILITY (2)	BLADE CHANGES (3)	BLADE QUALITY (4)	HANDLE & SWITCH (5)	MITER CUTS 45° (6)	BEVEL CUTS 45° (7)	STRAIGHT CUTS (8)	CROWN MOLDING (9)	DUST COLLECTION (10)	SCALES (11)	MITER LOCK (12)	BEVEL LOCK (13)	BLADE GUARD (14)	DEFLECTION 3/2x31/2" 90° CUT (15)	TABLE INSERT (YES, NO)		WEIGHT (POUNDS)	COUNTRY OF ORIGIN (16)	WARRANTY (YEARS) (17)	SELLING PRICE (18)
2 1/2, 2 1/2	3 9/16	17 3/4	A	A	A	E	F*	F	F	G	E	F	G	P	G	G	E	E	G	N	27	T	2	\$180	A basic saw with a few outdated features. Good price.
2 1/2, 2 3/8	3 7/8	18	A	A	A	E	G	G	F	E	E	F	G	F	G	G	E	E	G	N	32	T	2	230	Okay job-site saw with excellent portability.
2 1/2, 2 3/8	2 3/4	18 39 Ext.	Cl	Cl	Cl	F	G	F	F	E	E	E	E	P	P	G	E	G	F	Y	49	T	2	200	Quality performer, but poor dust collection and hard to read scales.
2 1/2, 2 1/2	3 7/8	20 5/8	A	A	A	E	E	G	F	E	E	E	E	F	G	G	E	E	E	Y	33	T	1	200	Great all-around saw at a good price.
4 1/2, 3	3	18	A	A	A	E	G	F	G	E	E	F	F	G	G	G	E	E	G	Y	27	U	1	350	A decent saw but with some limitations and a stiff price.
3 1/2, 2 1/8	3 5/8	24 1/4	A	A	A	G	E	E	E	E	E	E	E	F	G	G	E	E	E	Y	39	U	L	320	Excellent saw that's loaded with features. High price, but great lifetime warranty.
3 1/2, 3	3 1/8	20 1/2	A	A	A	E	G	G	F	E	E	E	G	P	G	G	E	E	G	Y	38.7	T	1	200	A good performer at a bargain price.
3, 2 1/2	3	19 1/4	A	A	A	E	G	F	F	G	E	E	F	P	P	G	E	F	F	N	31	U	1	220	A basic saw with a hard-to-read scale. Okay price.
3, 2 1/2	2 3/4	18 1/4	Cl	Cl	Cl	F	G	F	F	P	P	E	F	P	P	G	P	F	F	N	54	T	1	220	Inaccurate stops hurt sawing performance. Features need updating.
5, 2 1/2	4 1/8	28	A	A	A	F	F	G	E	E	E	E	E	G	E	E	E	E	E	Y	50	T	2	300	Star performer with great fence and innovative miter lock.
5, 4	4 1/8	22 1/8	A	A	A	G	F	G	E	E	E	E	E	F	E	G	E	E	E	Y	40	U	1	370	Excellent saw in many ways, though expensive.
4, 4	3 1/2	22	A	A	A	G	G	G	F	G	E	E	E	P	E	G	E	F	E	Y	46	T	1	320	Good 12" saw for woodworking and rough carpentry. Affordable.
5, 4	3 3/4	25-28 1/2	A	A	A	G	F	G	E	E	G	E	E	E	E	G	E	F	F	Y	41	T	1	330	Similar to Sears, but with effective dust collection.

10. **E** Dust port and bag contain as much dust as possible.  
**G** 50% of debris contained.  
**F** Less than 50% contained.  
**P** Dust collection ineffective.

11. **E** Scales accurate with easy-to-read veneer miter scale.  
**G** Pointer makes precise settings difficult.  
**P** Pointer too far from scale for precise settings.

12. **E** Table lock lever locks at any angle by simply releasing.  
**G** Requires loosening and tightening table lock handle.

13. **E** Convenient lever locks securely.  
**P** No stops at 0° or 45°.

14. **E** Opens quickly and smoothly.  
**G** Smooth operation, but hits 3 1/2" tall material.  
**F** Jerky operation.

15. While cutting a 3 1/2 x 3 1/2" block  
**E** .001" or less entire 90° cut.  
**G** .001-.010" within square.  
**F** .010-.020" within square.

16. (U) United States (T) Taiwan

17. (L) Lifetime warranty on defects

18. Prices current at time of article's production.

MANUFACTURERS' LISTING:	
Delta 800/438-2486	Milwaukee 414/781-3600
DeWalt 800/433-9258	Pro-Tech 800/888-6603
Hitachi 800/362-7297	Sears 800/377-7414
Makita 800/462-5482	Skil 773/296-7330



Hitachi  
C10FC



Milwaukee  
6494-6



Delta  
36-235

mitersaws, the nod goes to Delta's very affordable and feature-filled 36-235, with DeWalt's DW705 receiving honorable mention for its great performance and portability edge.

One final note: For the reasons of capacity, fence length, and more readable scales, you might consider spending another \$100 for a quality 12" model. Be aware, however, that

a new 80-tooth 12" blade for the larger tool may run \$10 to \$20 more than a comparable 10" blade. Chances are, you won't regret the improved cutting quality you get. ♣



## Made-to-order Miter saw Stand

I built this sturdy miter saw stand 24" deep to accommodate a 12" compound miter saw. If you have a 10" saw, you can make the stand as shallow as 18". Be sure to measure your saw before you start construction. Also, allow space to pivot and bevel the saw blade/motor assembly, room to adjust the bevel angle, and space for dust-collection fittings.

When building your stand, customize it to fit your workshop and miter saw. To do this, keep the top surface of the stand (parts C and E) flush with the top surface of your miter saw table.

For accurate and consistent cuts when trimming pieces to length, consider adding the fence stop shown on page 22.

*Jim Downing*  
Jim Downing  
Design Editor

### Let's begin with the basic cabinet

- 1 Cut the front and back (A), ends (B), top pieces (C, D, E), saw opening ends (F), and supports (G, H) to the sizes listed in the Bill of Materials. From  $\frac{3}{4}$ " maple stock, rip 40' of  $\frac{3}{4}$ "-square strips for the cleats.
- 2 Mark the outline, and cut the front and back (A) to shape.
- 3 Rout a  $\frac{1}{4}$ " round-over along the top front edge of the front H.
- 4 Cut the cleats to the lengths needed. Drill countersunk screw holes through the cleats, using the Cleat detail for reference. Then, assemble the cabinet in the configuration shown on the Exploded View drawing. Drill a  $\frac{1}{4}$ " mounting hole at each corner where shown on the Exploded View, and reinforce the stand with  $\frac{1}{4}$ " carriage bolts.
- 5 Measure the opening and cut the bottom shelf (I) to size. Notch the corners, and install the shelf.

6 Apply plastic laminate to the top surfaces of parts C and E.

7 Rout  $\frac{1}{2}$ " round-overs on the front and back corners of the stand.

### Add the fence pieces next

- 1 Cut the fence pieces J, K, and L to size. (We cut part L as one piece and cut it in two after securing it to the miter saw.)
- 2 Position your miter saw on the stand, and attach the fences (L) to the saw. Mark the location on the stand top for the fences (J, K). Fit your portable router with a straight bit, and use a straightedge to rout a groove to house the fences.
- 3 Mark  $\frac{1}{4}$ " slots  $\frac{1}{2}$ " long in the fence grooves where shown on the Miter saw Setup drawing. The slots allow you to move the fences side-to-side to adjust them once the self-adhesive measuring tape is installed.
- 4 Cut a  $\frac{1}{2}$ " groove  $\frac{1}{16}$ " deep in the fence pieces where shown on the

*Continued on page 94*

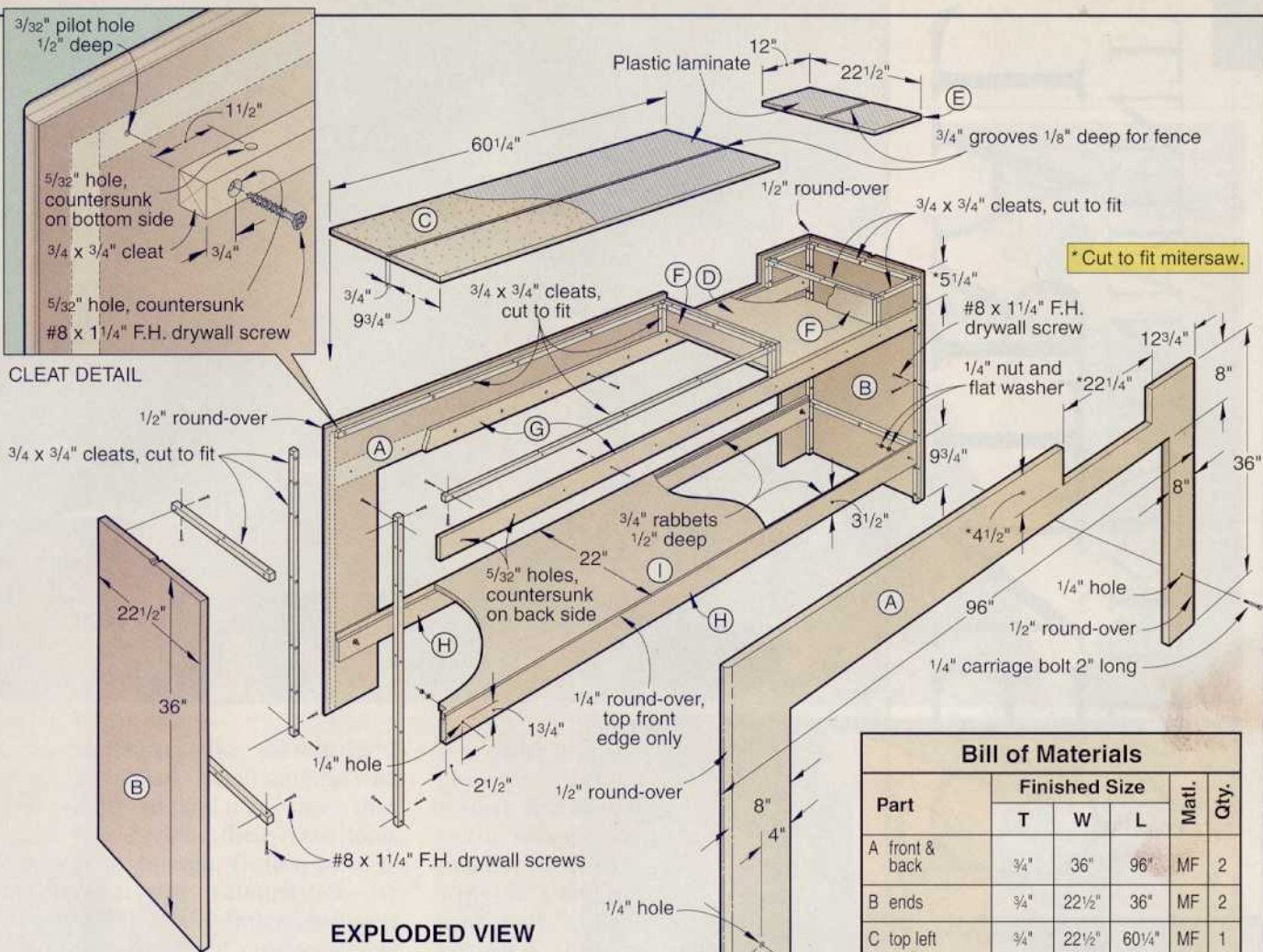

CLEAT DETAIL

EXPLODED VIEW

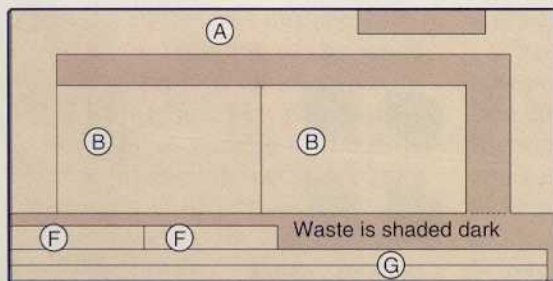

3/4 x 49 x 97" Medium density fiberboard (MDF)

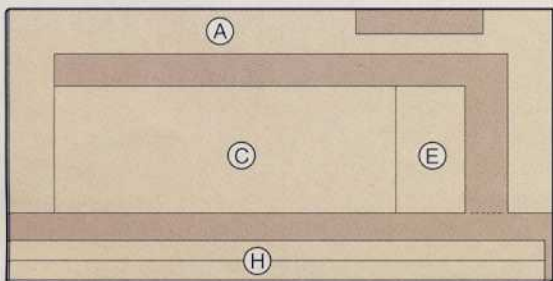

3/4 x 49 x 97" Medium density fiberboard (MDF)

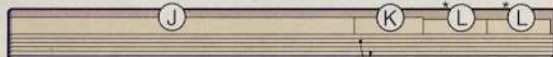

3/4 x 7 1/4 x 96" Maple

\*Plane or resaw to thickness listed in the Bill of Materials.

CUTTING DIAGRAM

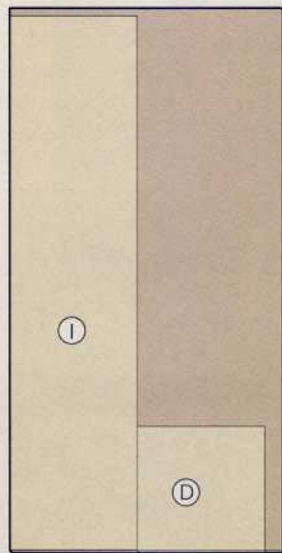

3/4 x 49 x 97" Medium density fiberboard (MDF)

Bill of Materials

Part	Finished Size			Mtl.	Qty.
	T	W	L		
A front & back	3/4"	36"	96"	MF	2
B ends	3/4"	22 1/2"	36"	MF	2
C top left	3/4"	22 1/2"	60 1/4"	MF	1
D top center	3/4"	22 1/2"	23 3/4"	MF	1
E top right	3/4"	12"	22 1/2"	MF	1
F saw opening ends	3/4"	4 1/2"	22 1/2"	MF	2
G long supports	3/4"	2 3/4"	93"	MF	2
H shelf supports	3/4"	3 1/2"	93"	MF	2
I shelf	3/4"	22"	94 1/2"	MF	1
J fence left	3/4"	3"	61"	M	1
K fence right	3/4"	3"	12"	M	1
L fence center	1/2"	2 7/8"	22 1/4"	M	1

**Materials Key:** MF—medium density fiberboard, M—maple.

**Supplies:** #8x1 1/4" drywall screws, #10x1 1/2" pan-head sheet-metal screws with flat washers, 1/4" pan-head machine screws 1 1/4" long with wing nuts, 1/4" carriage bolts 2" long with flat washers and nuts, plastic laminate, paint, clear finish.

**Buying Guide**

**Hardware.** Self-adhesive metal measuring tapes (one L-R tape and one R-L tape), knob and hardware for stop (page 22). Kit no. MS-1, \$22.95 ppd. Schlabaugh and Sons Woodworking, 720 14th Street, Kalona, IA 52247 or call 800/346-9663 to order. E-mail orders to schsons@kctc.net

# ENTERTAINMENT CENTRAL



Store home  
electronics  
gear in style

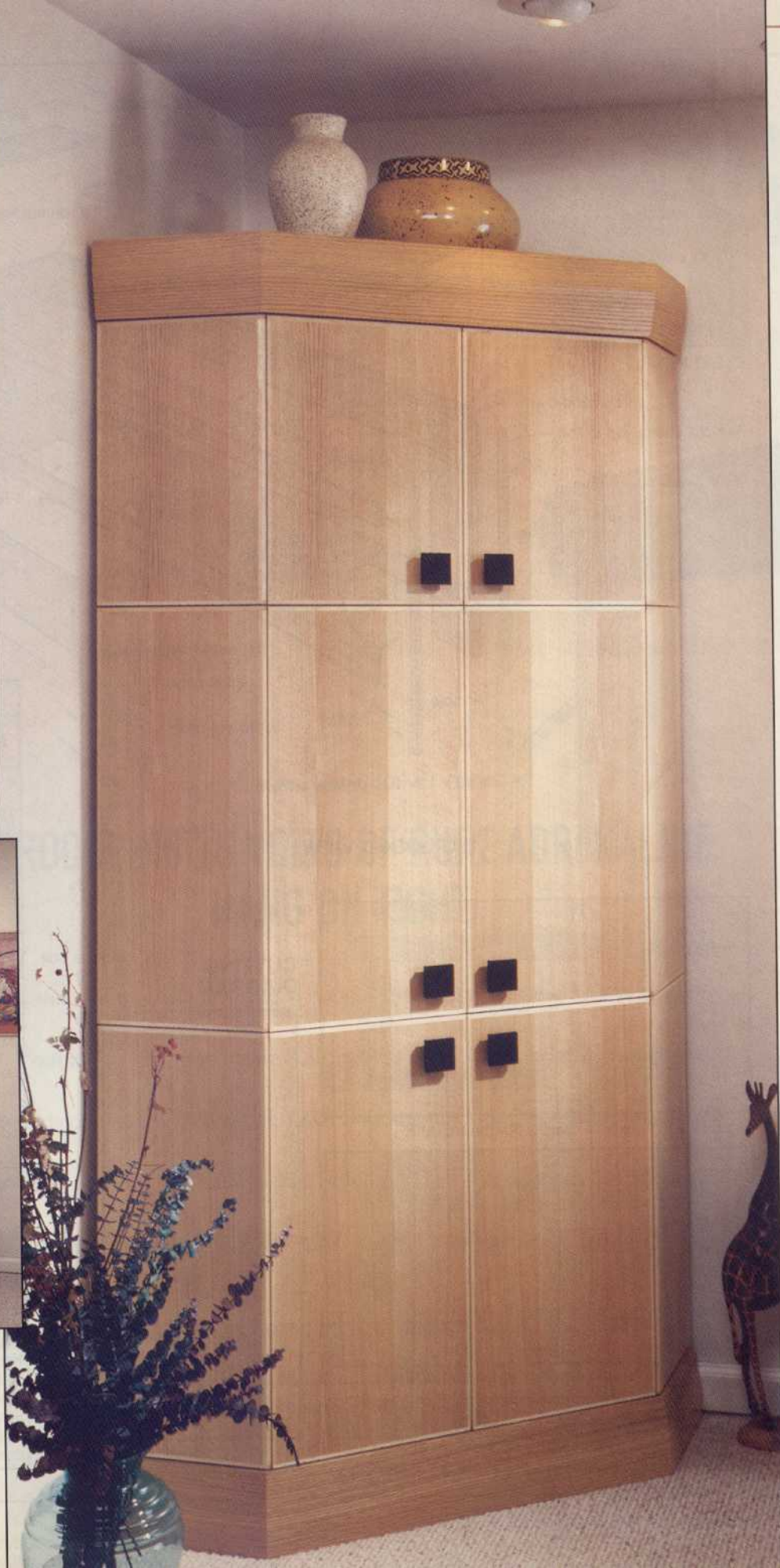

**G**reat-looking corner-cabinet plans are next to impossible to find. That's why we're so proud to present this one to you. Our very own Jim Downing designed it, and should you build it for your home, we know you'll be pleased with the results.

*Note: We designed this cabinet to house most 27" televisions. For some models, though, you'll have to remove the hinges from the cabinet before sliding the TV into place.*

## Let's begin with four identical shelves

**1** Using the Parts View on page 68 for the shelf (A), lay out and cut the four shelves to the same exact shape. See the Cutting Diagram for how we cut four blanks from one piece of 4x8 plywood. (We cut one shelf to exact shape, and then cut the other three slightly oversized. Then, as shown in photo A, we used our handheld router fitted with a piloted straight bit to rout the other three shelves to the exact shape of the first.)

**2** Cut the banding strips (B) from solid stock, and glue and clamp them to the front edge of the shelves (A), making sure the top and bottom surfaces are flush.

## Cut the carcass pieces, and assemble the carcass

**1** Cut the carcass sides (C) to 21½x80". Lay out the dadoes using the dimensions on the Side (A) portion of the Parts View drawing on page 68. Fit your tablesaw with a dado blade and cut the dadoes where marked, taking care to keep the dadoes positioned exactly the same in each.

**2** Using your tablesaw, bevel-rip the back edge of each cabinet side (C) to final width (21¾") at 45°, being careful to rip the bevel on the side opposite the dadoes.

**3** Cut the corner supports (D) to size, bevel-ripping the front edge of

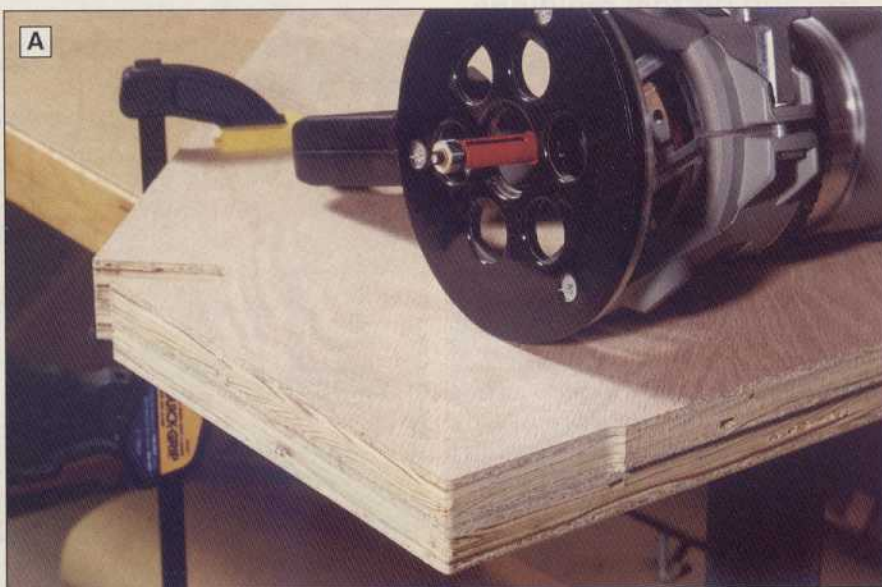

Using your first shelf as a template, rout the final shelves to finished shape with a router fitted with a piloted straight bit.



Secure the notched supports to the previously installed shelves by driving wood screws through the previously drilled cleats.

each at 45°. Mark the notch locations on one, making sure they align with the dadoes in the sides (C). Clamp the two supports face-to-face, and cut the notches in both at the same time.

**4** If you plan on adding the adjustable shelf (Z) later, drill ¼" holes ½" deep for the shelf clips in parts C and D where dimensioned on the Parts View drawing.

**5** From ¼" oak plywood, cut the back (E) to size. When attached later, the top of the back panel is flush with the top of the top shelf, and the bottom of the back panel is flush with the bottom of the bottom shelf.

**6** Cut cleats (F, G, H) to the sizes listed in the Bill of Materials. Drill the mounting holes in the cleats where dimensioned on Drilling the Cleats drawing on page 68.

**7** Glue and screw the cleats (F, G, H) in place.

**8** Connect the sides (C) to the shelves (A, B). Drill countersunk screw holes from the outside of the side pieces, and screw the assembly together, checking for square.

**9** Slide the supports (D) into the shelf notches. Screw through the cleats (F) to secure the supports in place as shown in photo B and in the Assembly detail accompanying the Carcase drawing.

*Continued*



## Here's how to make the top and bottom moldings

**1** Cut the front filler pieces (I, J) and mating banding strips (K, L) to the sizes listed in the Bill of Materials plus 1" in length. Glue and clamp a banding strip to one edge of each filler piece. Later, scrape off the excess glue, and sand the faces smooth.

**2** To get the grain of the molding to wrap around the cabinet, cut two strips of solid stock to 5" wide by 54½" long for molding pieces M and N as laid out on the Cutting Diagram. With the edges flush, glue and clamp the banded filler strips to the back side of the molding pieces. Remove any excess glue with a damp cloth.

**3** Tilt your tablesaw blade 9° from vertical, and bevel-rip one face of each laminated molding strip to achieve a profile on the solid stock like that shown on the Side Section-View detail accompanying the Exploded View drawing. Sand the beveled-cut area smooth.

**4** Cut and miter-cut the laminated molding strips to wrap around the carcass in the configuration shown on the Exploded View drawing and accompanying Top Section-View detail. (We laid out all the pieces before making the first cut to make sure the angled cuts were correctly located and that the grain wrapped around the cabinet.) When cutting these pieces to length, make sure to cut them to fit your cabinet and not necessarily the dimensions we provide.

**5** Drive screws through the cleats to temporarily screw the molding pieces in place with just two screws per section. You may need to adjust the location of the moldings later when aligning them with the side panels and doors, so you'll drive the remaining screws then.

## The banded side panels and doors come next

**1** Using the Cutting Diagram for reference, mark reference marks on your plywood for the side panels (O, P) and doors (Q, R). By marking them now, it's easier to keep them properly oriented for placing on the cabinet so the grain

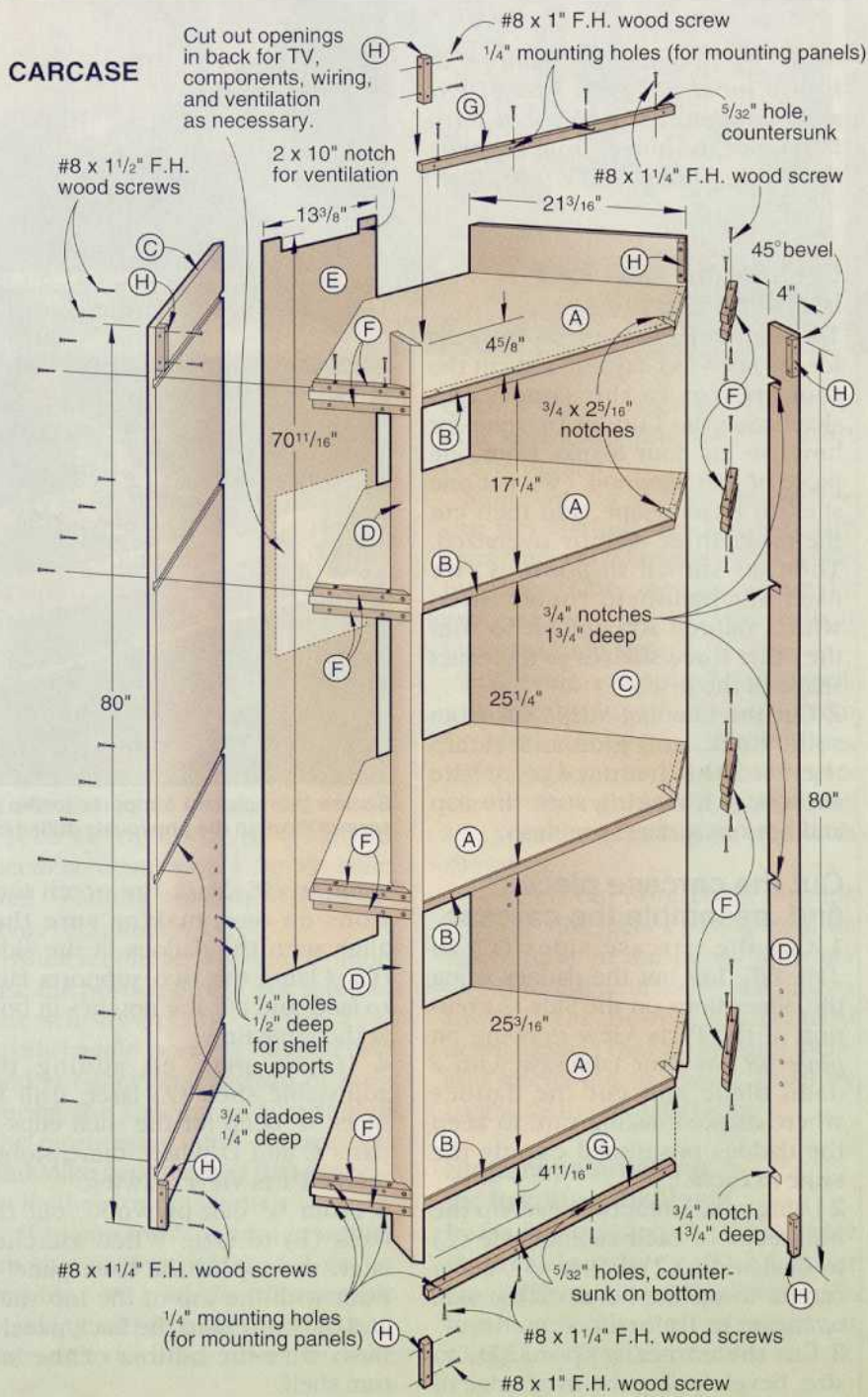
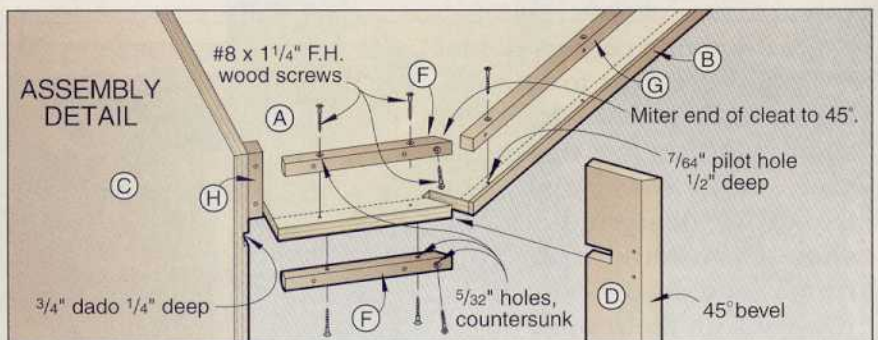

## CUTTING DIAGRAM

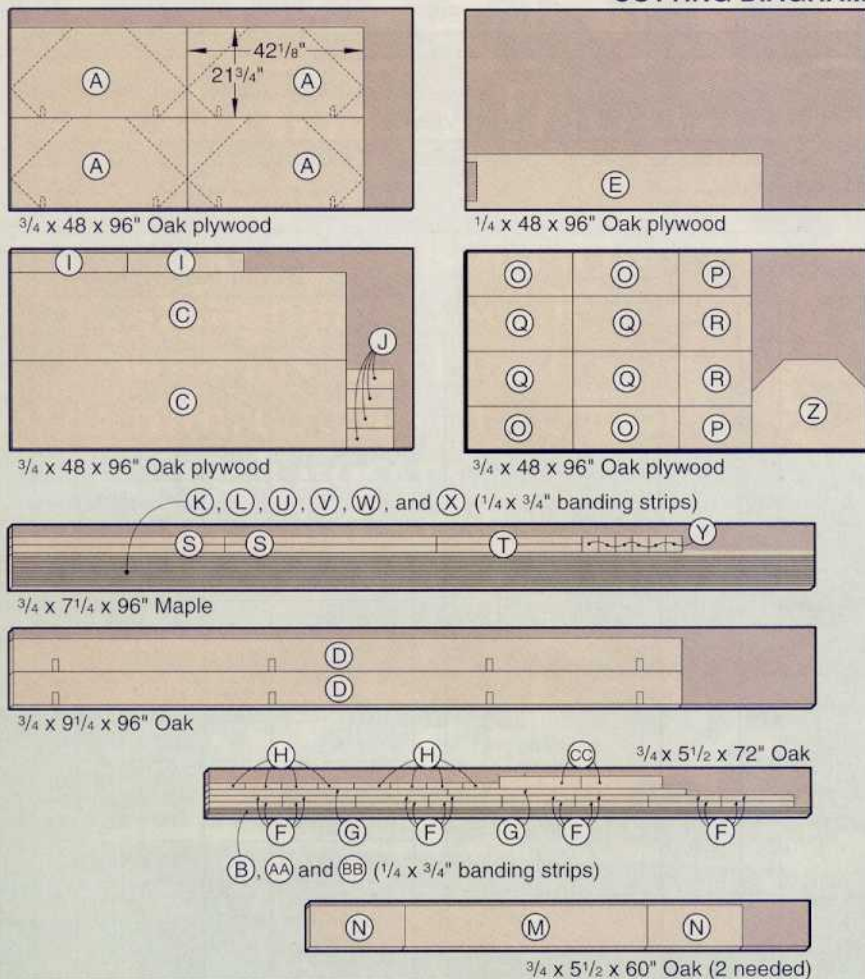

## Bill of Materials for Carcase Assembly

Part	Finished Size			Matl.	Qty.
	T	W	L		
A shelf blanks	3/4"	21 3/4"	42 1/8"	OP	4
B banding	1/4"	3/4"	27 3/4"	O	4
C* sides	3/4"	21 3/16"	80"	OP	2
D supports	3/4"	4"	80"	O	2
E back	1/4"	13 3/8"	70 11/16"	OP	1
F cleats	3/4"	3/4"	8 13/16"	O	16
G cleats	3/4"	3/4"	27 3/4"	O	2
H cleats	3/4"	3/4"	3 7/8"	O	8

\*Cut parts marked with an \* oversized. Trim to finished size according to the how-to instructions.

**Materials Key:** OP—oak plywood, O—oak.

**Carcass Supplies:** #8x1" flathead wood screws, #8x1 1/4" flathead wood screws, #8x1 1/2" flathead wood screws.

runs from the top of the cabinet to the bottom. (For the striking looks of our cabinet, we selected a sheet of straight-grained oak plywood for our panels and doors.) Cut the panels to exact size. (Use a sharp carbide-tipped blade to minimize chip-out when cutting the plywood.)

**2** From solid maple, cut the edge banding (S, T, U, V) to size plus 1" in length.

**3** Cut a 1/2" rabbet 1/2" deep along the back side of the edge that will go next to the doors in the side panels (O, P) where shown on the Side Panel drawing and accompanying detail. It's easy to cut the rabbets in the wrong spot, so we recommend marking them before machining. Then, cut a 1/2" rabbet 1/4" deep along the mating edge of the banding strips (S, T).

**4** Glue and clamp the maple banding (S, T, U, V) to the edges (not ends) of the doors and side panels (O, P, Q, R). Later, trim the banding flush with the ends of the doors, and then glue and clamp the end banding (W, X) in place. Later, trim its ends flush.

**5** Sand the edges of the banding flush with the front and back of each panel and door, being extremely careful not to sand through the veneer.

### MITER DETAIL (TOP VIEW)

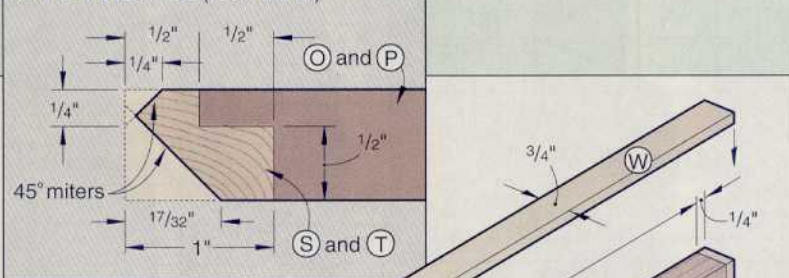

### SIDE PANEL (BACK VIEW)

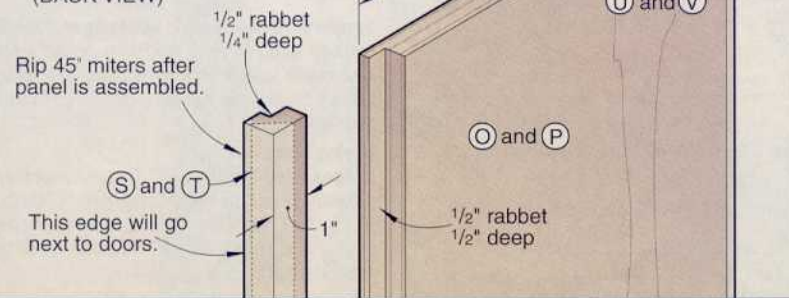

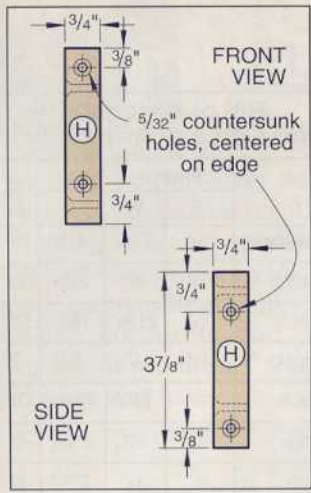

**DRILLING THE CLEATS**

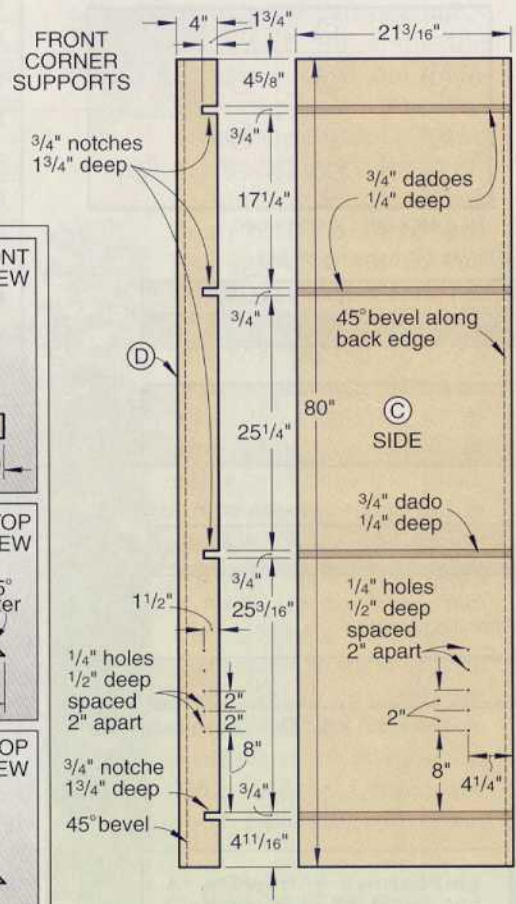
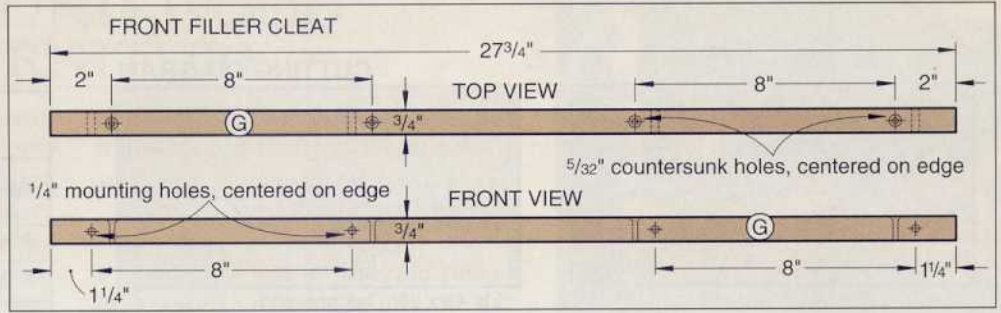
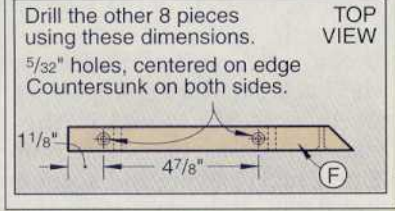
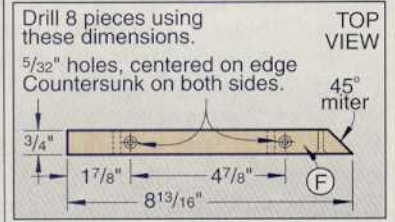
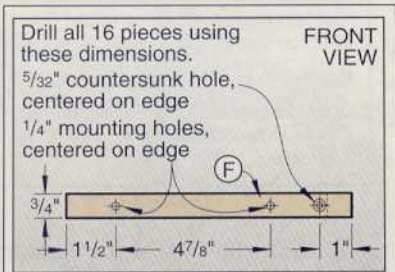

**PARTS VIEW**

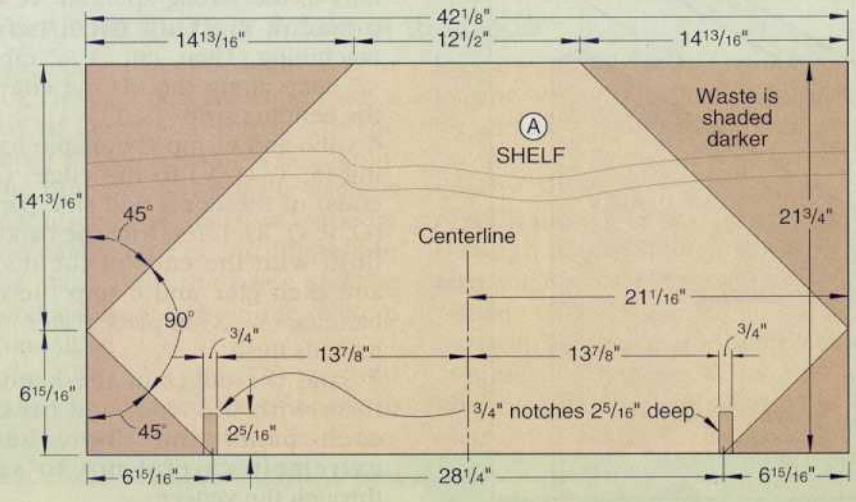

**Bill of Materials**

Part	Finished Size			Mati.	Qty.
	T	W	L		
<b>MOLDINGS</b>					
I* filler strips	3/4"	4 3/4"	28 7/16"	OP	2
J* filler strips	3/4"	4 3/4"	10 7/8"	OP	4
K* banding	1/4"	3/4"	28 7/16"	M	2
L* banding	1/4"	3/4"	10 7/8"	M	4
M* molding	3/4"	5"	29 1/16"	O	2
N* molding	3/4"	5"	11 1/4"	O	4
<b>PANELS AND DOORS</b>					
O panels	3/4"	10 1/2"	25 3/8"	OP	4
P panels	3/4"	10 1/2"	17 3/8"	OP	2
Q doors	3/4"	13 3/4"	25 3/8"	OP	4
R doors	3/4"	13 3/4"	17 3/8"	OP	2
S* banding	3/4"	1"	25 3/8"	M	4
T* banding	3/4"	1"	17 3/8"	M	2
U* banding	1/4"	3/4"	25 3/8"	M	12
V* banding	1/4"	3/4"	17 3/8"	M	6
W* banding	1/4"	3/4"	11 1/4"	M	12
X* banding	1/4"	3/4"	13 3/4"	M	12
Y handles	3/4"	2"	2"	M	6
<b>ADJUSTABLE SHELF</b>					
Z shelf	3/4"	21 3/8"	27 1/8"	OP	1
AA banding	1/4"	3/4"	27 3/8"	O	1
BB banding	1/4"	3/4"	14"	O	2
CC cleats	3/4"	1 1/2"	10"	O	2

\*Cut parts marked with an \* oversized. Trim to finished size according to the how-to instructions.

**Materials Key:** OP-oak plywood, O-oak, M-maple.

**Supplies:** #8x1 1/4" flathead wood screws, #8x1 1/2" flathead wood screws, #8x1 1/4" panhead wood screws with flat washers, hinges (see description below), brass shelf supports, gloss black paint, clear finish.

**Buying Guide**

**Hinges.** Self-closing 165° Grass concealed hinges. Six pair needed. Catalog no. CH1202, \$6.85/pair. Constantine, 2050 Eastchester Road, Bronx, NY 10461, or call 800/223-8087 or 718/792-1600 to order.



**6** Using the Miter detail accompanying the Side Panel drawing on *page 67* for reference, bevel-rip the wide banding on the side panels.

### Now, install the banded side panels and doors

**1** Using the  $\frac{3}{32}$ " spacers as shown in *photo C*, position, clamp, and screw a bottom side panel in place. Repeat to add the center, and then the top side panels. Repeat for the other side of the cabinet. At this point, you may need to adjust the location of the molding (up and down) for equal gaps between all the pieces.

**2** With the location of the molding verified with the doors and panels, glue, clamp, and screw the molding in place, using the spacers for alignment and consistent spacing.

**3** See the Buying Guide for our source of hinges. If you use different hinges, the mounting holes and mounting instructions will probably differ. Using the instructions supplied with the hinges and the dimensions on the Mounting the Doors drawing, mark the hole centerpoints on the back of each door.

**4** Fit your drill press with a  $1\frac{3}{8}$ " Forstner bit stopped to drill  $\frac{1}{2}$ " deep. Then, fit your drill press with a fence to accurately locate the holes  $1\frac{3}{16}$ " from the edge. Test-drill scrap  $\frac{3}{4}$ " plywood first to verify that the point of the bit doesn't go completely through the plywood. (We found that the points on one set of our Forstners had to be filed down.) Bore the hinge holes where marked and as shown in *photo D*. (Notice how we marked stop lines on our drill-press fence to keep the holes exactly  $2\frac{1}{2}$ " from the top and bottom ends of the doors.)

**5** Fit the hinges into the holes just bored in the back face of the doors. Using the screws supplied with the hinges, drill pilot holes, and screw the hinges in place.

**6** Attach the base plate of each hinge to the carcass. See the Mounting the Doors drawing for reference. Following the instructions supplied with the hinges, fit the hinge on the base plate, and secure in place. Make the alignment adjustments as explained in the instructions.

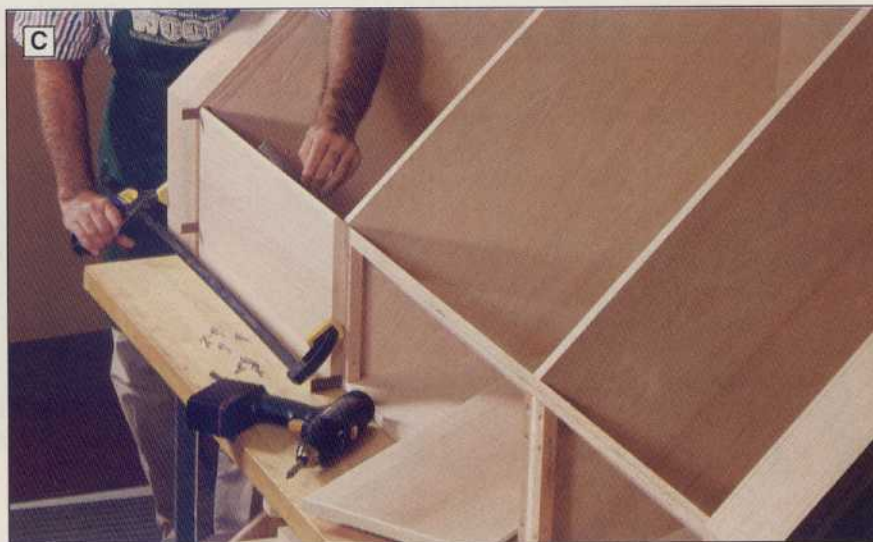

With the cabinet on its back, use spacers to create equal gaps between the molding and banded side panels.

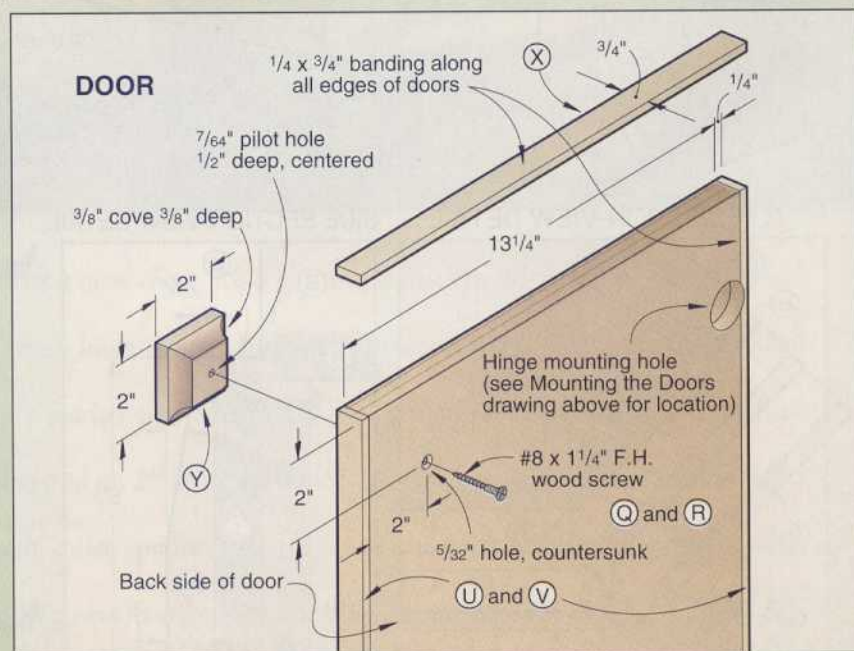
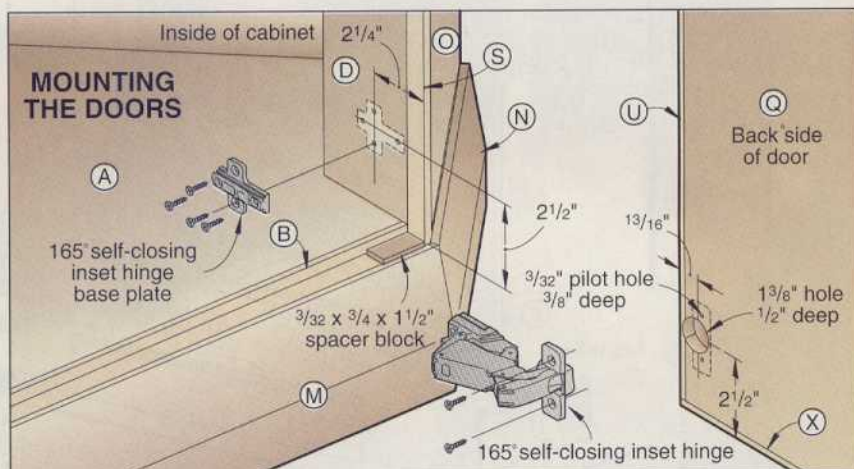



**D** Mark the centerpoints on the doors, and drill a pair of counterbored holes in the back side of each door for attaching the hinges later. A fence keeps the holes aligned.

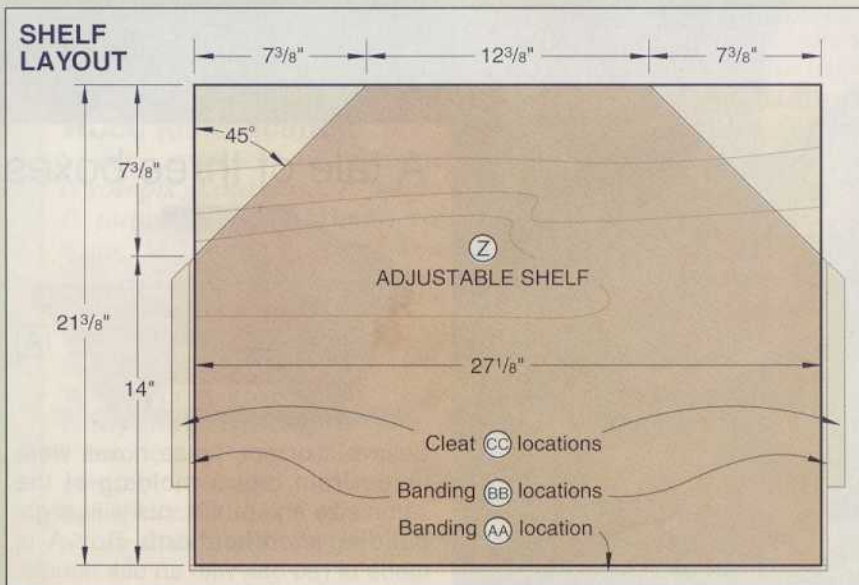
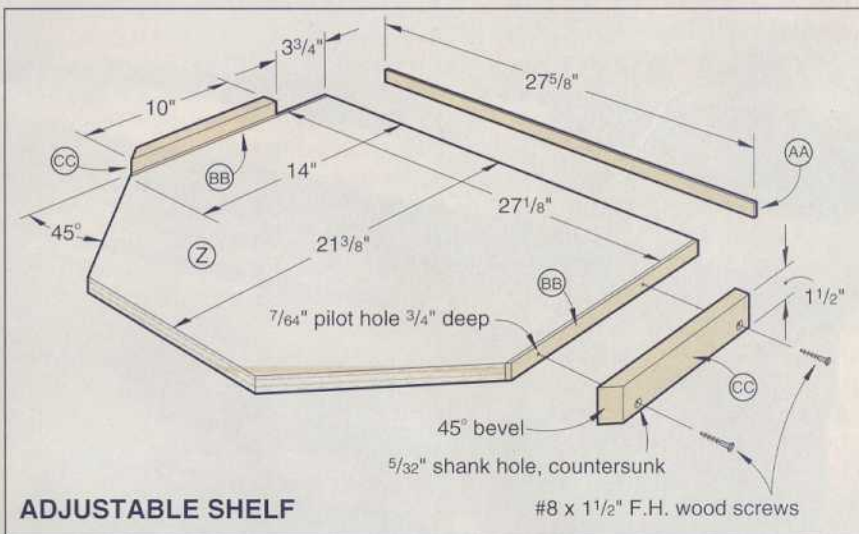

## It's time to machine the door handles

**1** From 3/4" maple, cut seven 2" squares for the handles (Y). Use the extra handle blank to verify your machine settings in the following steps before machining the other handle blanks.

**2** Fit your table-mounted router with a 3/8" cove bit and fence. With the good side up, rout the end grain first on each handle blank to reduce chip out. (To safely hold the 2"-square handles when routing, we used a wood handscrew clamp.) Next, rout the adjoining two edges on each handle blank.

**3** Using your drill press with a fence and stop, drill a 7/64" pilot hole centered in the back side of each handle. See the Door drawing for reference. Sand the handles smooth.

## OK, let's add the shelf and the finish

**1** For additional storage, construct the shelf (Z, AA, BB, CC) in the configuration shown on the Adjustable Shelf drawing. To allow us to get all the panels and shelf (Z) from one piece of plywood, we banded the ends to get the necessary length.

**2** Remove the hinges from the cabinet and doors. To ensure correct placement when reassembling, mark corresponding marks on the hinges and their mating holes.

**3** Remove the knobs and spray-paint them a gloss black.

**4** The back of the cabinet (E) should still be off. If not, remove it; it's easier to finish the cabinet with the back panel not in place. Determine what you'll need for cord holes through the back, and cut the access holes. Depending on your television, you also may need to cut an opening through the back (E) for the rear of your television to extend through. Sand the back smooth.

**5** Apply finish to all the pieces. (We applied three coats of semigloss lacquer, sanding between coats.)

**6** Reattach the hinges and handles. Screw the back panel in place. 🛠️

Written by Marlen Kemmet  
 Project Design: James R. Downing  
 Illustrations: Kim Downing; Lorna Johnson  
 Photographs: Hetherington Studio; Marty Baldwin



## A tale of three boxes



Believe it or not, these boxes were made from crown molding of the same size and profile, but with slight building modifications. Box A is made of red oak with an oak handle. Boxes B and C, made of cherry,

# Crown Molding Boxes

They're shapely, stately, and oh so easy to make

They look like the work of an artist, with their elegant curves and classic proportions. Actually, you can make these delightful boxes with crown molding available at any home center. The trick is in the jigs, and the jigs aren't complicated at all. So, just spend a little time jiggling up, and you'll soon be turning out a variety of impressive boxes. Don't worry—no mathematics or protractors required.



This technique began to hatch in the mind of assistant design editor Jan Svec several years ago. A fellow employee at a millwork shop would take scraps of molding, miter them, and make boxes with vertical sides.

Not bad, thought Jan. Not bad for a beginning.

The next step came when he toured historic homes in Philadelphia, searching for project design ideas for *WOOD*® magazine. "In one house, I saw a tea box with a molding profile inside and out," Jan said. That would be a very complicated project, but

what about a box that's fancy on the outside and plain on the inside? He realized that crown molding would do the trick.

However, part of the beauty of this tea box came from its angled sides, so Jan experimented with ways to cut compound miters without complicated math or fancy equipment. In fairly short order, he came up with the two jigs shown on the *next page*. (For tips on making a similar sliding table jig, see *page 52* of issue 84.)

Why two jigs instead of one? It has to do with the limited height of a tablesaw blade and the need for a high-profile box topped by a low-profile lid. Make them, try them, and you'll see. You'll soon cut these compound miters without ever having to figure an angle in degrees.

You can use the jigs as shown to make boxes of any width and length. They will handle molding up to 4½" wide. As you can see in the sidebar *left*, changing the position of the workpieces in the jigs dramatically changes the appearance of the box. In this article, we'll show you how to build a box like the one in the large photo *left*. Then you can experiment with other styles.

*Continued*



**B**

have cardinal wood and Corian handles, respectively.

We made boxes A and B in the same way, except we positioned the crown moldings upside down in the jigs when cutting the parts



**C**

for box B (relative to how we positioned them when making box A). With box C, we laid the moldings at a flatter angle in the miter-gauge jig. Doing this made the box more upright in stature.



# Crown Molding Boxes

## Ready to try one? First, cut the four sides

Our finished box will measure about 8" wide by 10" long. From a piece of 4 1/4"-wide crown molding, cut two pieces 8 1/2" long and two pieces 10 1/2" long. Cut them in the sequence that they'll follow around the box—side, end, side, end—and number each one near the bottom edge. (This way, the grain will seem to "run" continuously around the box.)

Set your tablesaw blade to 45°, or just a hair over, to make sure that the outside points of the miters will be tight. Slip the miter-gauge jig into the right-hand slot of the table-saw, and load one of the four pieces into it. Lean the molding against the rear fence at the steepest angle that will still allow the blade to cut through it, then measure the distance between the lower edge and the front fence. Cut a spacer to that width, and put it between the workpiece and the fence, as shown *far right*.

The edge that sits higher in the jig will become the top edge of the finished box; the lower edge will be at the bottom. Double-check that before making each cut. Now, with the workpiece wedged firmly between spacer and fence, cut a miter. Do the same at one end of each of the four pieces.

To miter the opposite ends, flip one of the shorter pieces so it's leaning against the front fence, and place the spacer between the workpiece and the rear fence. Line it up with the blade, and clamp a stopblock at the other end. You don't have to measure a thing. Cut that miter, take the piece out, and cut the second short piece exactly the same way, without moving the stopblock.

Remove the stopblock and follow the same procedure for the longer pieces. Tape the four pieces together to check the fit.

### MITER-GAUGE JIG

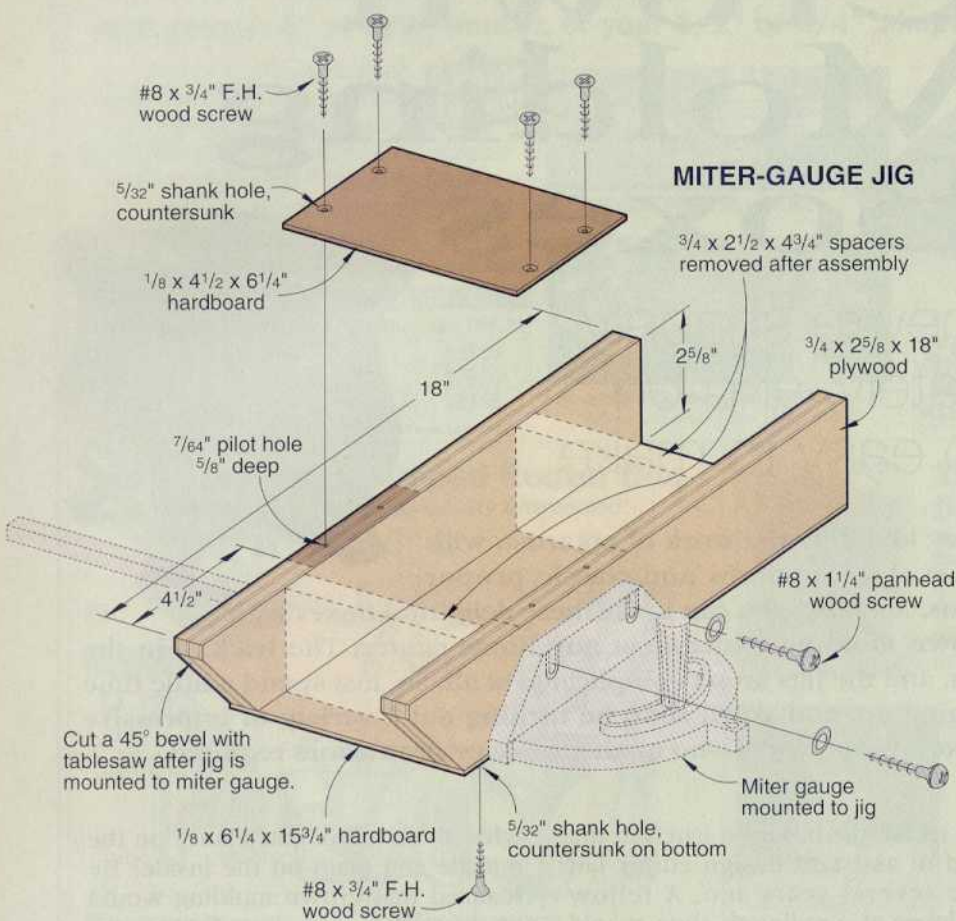

### SLIDING TABLE JIG

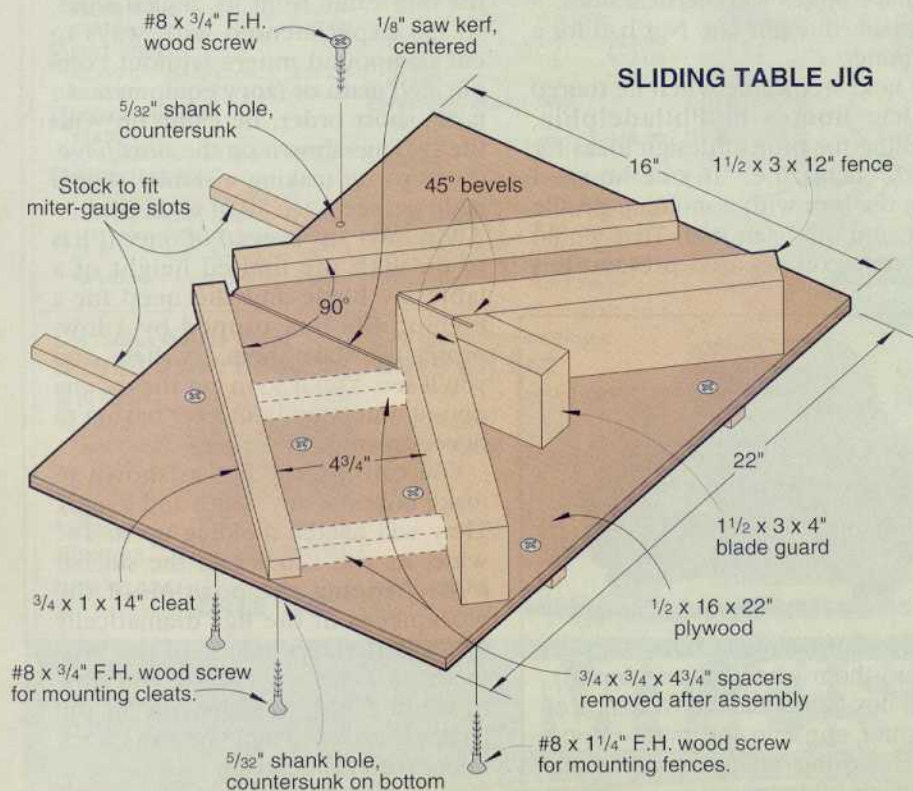

## Adding feet and a bottom won't take you long

Along the bottom edge of each workpiece, measure in 1" from each end and make a mark. Draw a line parallel to the bottom edge and 1" up from that edge. With a compass set to a 1" radius, scribe a curve up to the line.

Use a scrollsaw or bandsaw to cut close to that line. Install a 2" drum in your spindle sander or on your drill press, and sand to the line as shown in the photo below.

As shown in the drawing *bottom*, use a sliding bevel gauge and straightedge to determine the angle for the kerf that holds the box bottom. Again, the number of degrees isn't important. Just set the sliding bevel gauge and use it to set your tablesaw blade.

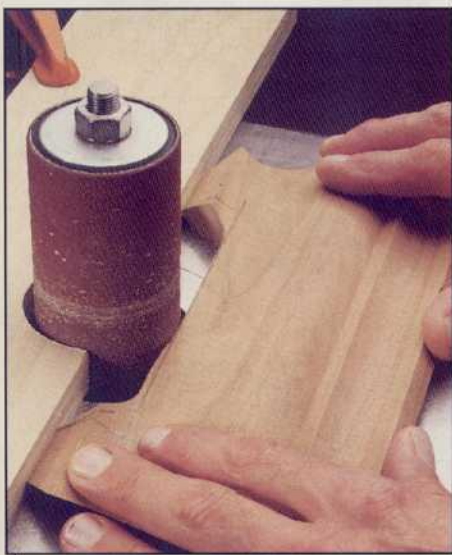

When forming the legs, use a fence with a drum or spindle sander to sand a straight edge and smooth radius.

With the feet of each piece against the rip fence and the molding profile facing up, saw a  $\frac{1}{8}$ "-wide kerf about  $\frac{1}{8}$ " above the leg cutout and  $\frac{3}{16}$ " deep at its shallow side. Do this on all four pieces. Measure the lengths of those kerfs to find the dimensions of the bottom, and cut a piece of  $\frac{1}{8}$ " plywood or solid wood to fit.

After test-fitting, glue together the sides, ends, and bottom of the box. Hold them together with masking tape and a band clamp until the glue dries. Make sure the top edges are lined up at the corners. It's easier to sand away imperfections if they're on the bottom.

## Top off your beautiful box with a matching lid

As you choose molding stock for the lid, keep in mind that the lid pieces cannot meet in the center of the box. That's because there must be a panel at least 1" wide in the center of the lid for mounting a handle. For the box in our example,  $3\frac{1}{2}$ "-wide crown molding will

do the trick. If the box was wider, the  $4\frac{1}{4}$ "-wide stock used for the base might work for the lid as well.

From the  $3\frac{1}{2}$ " crown molding, cut two pieces  $8\frac{1}{2}$ " long and two pieces  $10\frac{1}{2}$ " long. As before, cut in a side-end-side-end sequence and number the pieces.

Also cut a scrap of that molding 1" long and tape it to the box so that its bottom edge fits snugly against the bevel of the box. Lay a straight piece of scrapwood across the box and mark the angle of your scrap molding on it. (See the drawing at *bottom*.) Set the sliding bevel gauge to that angle, and use it to set the tablesaw blade, with the handle of the gauge held against the rip fence as shown on the *next page*.

*Continued*

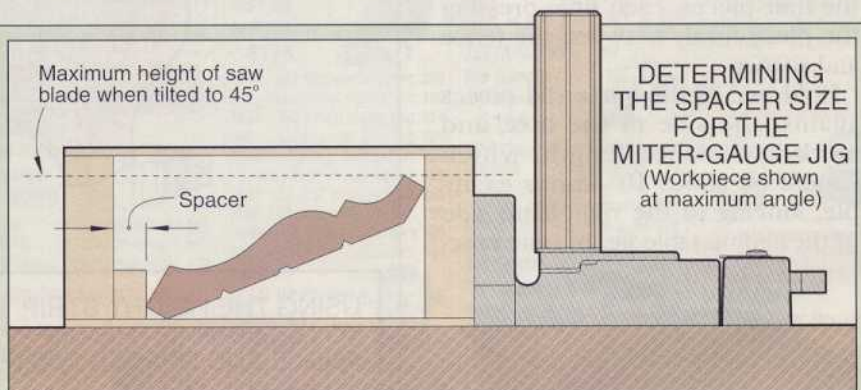

### MEASURING THE ANGLE FOR THE BOTTOM PANEL KERFS

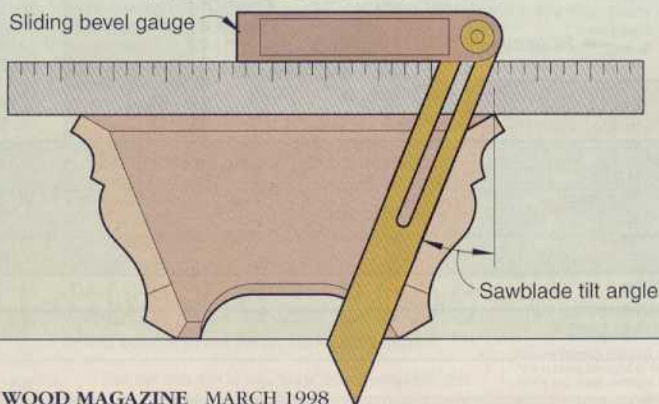

### MEASURING THE ANGLE FOR THE TOP PANEL KERFS

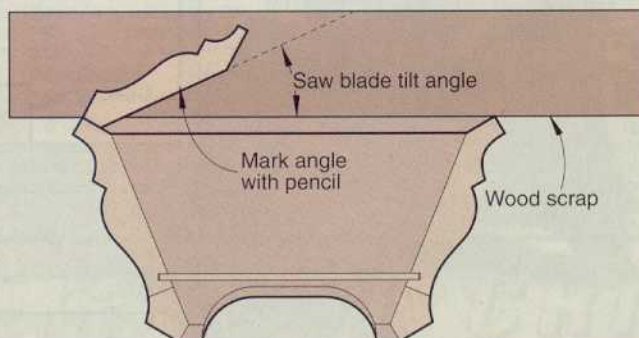

# Crown Molding Boxes

Saw kerfs in each lid piece to receive the top panel. To do so, hold the flat side of the molding against the fence, and cut a slot  $\frac{1}{8}$ " wide and  $\frac{3}{16}$ " deep, at least  $\frac{1}{8}$ " from the edge that will be the highest part of the lid. See the photo *right*.

Place the sliding table jig in the slots of your tablesaw, and set the blade at exactly  $90^\circ$ . To find the correct angle for the miter cut, again use a piece of scrap molding 1" long taped to the box. With a straightedge across the box, measure as shown in the illustration *right middle*. Cut a piece of scrap to a length that equals  $A+B+C$ . Hold this height strip flat against the left fence of the jig, and draw a line along the top edge.

Tilt one of the molding pieces against the fence so that it just covers the line, and measure the gap between the workpiece and the cleat. Cut a spacer to fit that gap. See the drawing at *right bottom*. Cut a miter at one end of each of the four pieces, each time pressing the piece firmly between the fence and spacer.

Hold one of the longer lid pieces against the side of the box, and mark its finished length, which should be about 10" in our example. Moving to the right-hand side of the sliding table jig, put the spac-

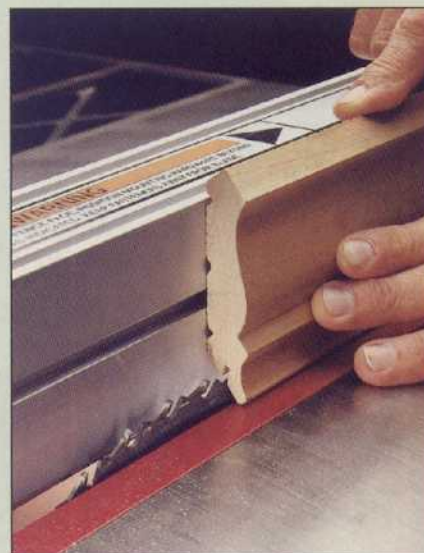
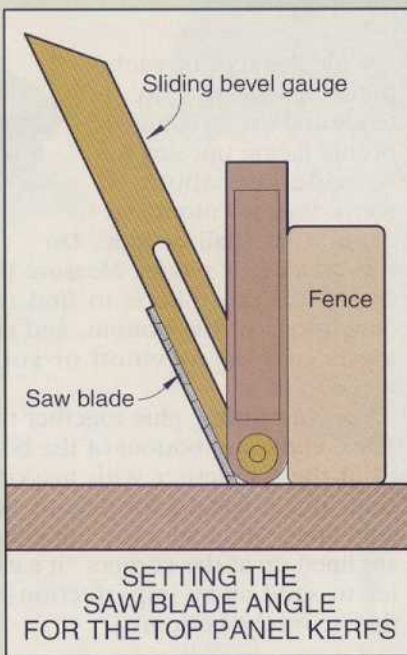

Hold the back side of the molding against your tablesaw's fence to cut the kerf that holds the panel in the center of the lid.

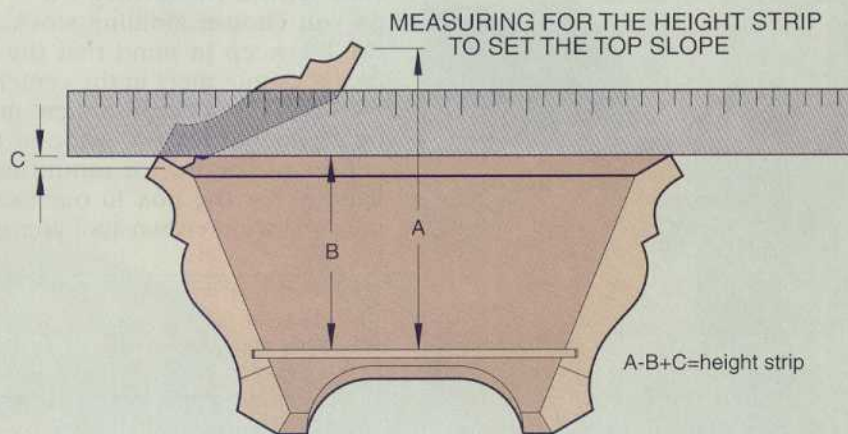

## USING THE HEIGHT STRIP TO DETERMINE THE TOP ANGLE AND SPACER WIDTH

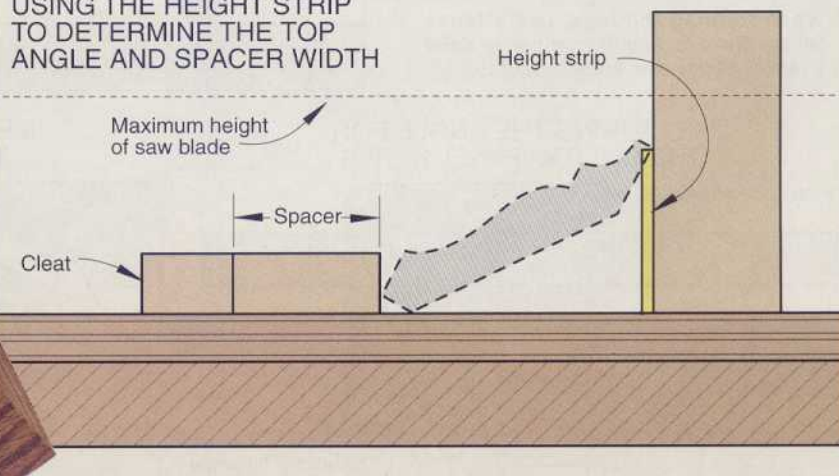

## A few facts about crown molding

You can buy crown molding in many sizes and species. Shown *here* are some of the moldings we worked with during the making of this article. Each one will produce a box with a slightly different look.

Commonly available species include oak, cherry, and poplar, and range in width from 3½" to 7¼". (If you use moldings wider than 4½", you will need to upsize our jigs to accommodate their greater width. Your larger jigs will work just like the ones shown in this article.) We used economically priced poplar for the painted boxes.

When you go shopping, check a couple of sources for selection and price, and inspect the molding's surface carefully. Some mills turn out glass-smooth cuts, and some leave noticeable chatter marks that can be tough to sand out of an elaborate profile.

Also, some mills cut grooves in the back side of the molding and some mills don't. If you prefer a smooth interior, be sure to flip the molding over and check the back before buying.

A wide range of available crown moldings means you can make an infinite variety of boxes.



Attach four cleats at right angles to each other to hold the lid pieces in position on a plywood clamping platform.

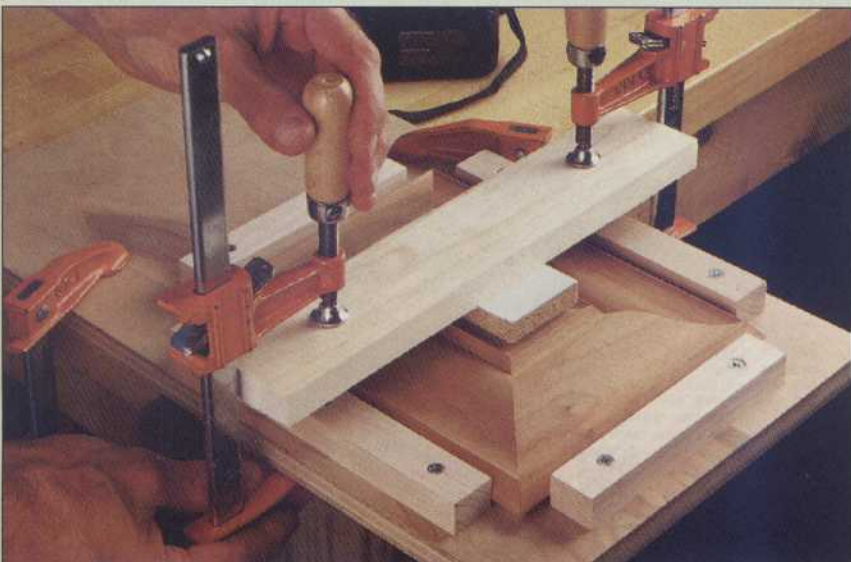

Apply glue to the mitered edges and squeeze them together with the help of some scrap stock and clamps.

er against the cleat and set the workpiece so the blade meets the mark. Clamp a stopblock to the fence and against the point of the mitered end. Cut the miter.

Repeat the procedure for the other long piece, and follow the same steps for the two shorter pieces. Again, the bottom edge of the lid goes at the bottom when cutting. Cut a piece of ½" plywood or solid wood to fit the lid kerfs.

To make a clamping jig for the lid, screw two pieces of scrap to a piece of plywood at right angles, hold the lid together, and set it into that corner. Screw two more scrap pieces into the plywood so that they're tight against the lid as shown in the photo *left middle*.

Take the lid out, glue the miters, and replace the lid assembly into the clamping jig. A board or two on top, held down by clamps, will force the miters snugly together as shown *left bottom*.

For a handle, we suggest a "fin" made of ¼-½" stock, cut to the length of the lid panel and about ½-1" wide. This would be a fine time to use a piece of exotic scrap-wood or Corian. Attach the handle with brass screws from the bottom side of the panel.

Apply the finish of your choice. Paint works well for woods lacking showy grain patterns, or if you want to show off the grain, apply several coats of oil and top it off with paste wax. ♣

Written by Jim Pollock  
and Bill Krier with Jan Svec  
Illustrations: Roxanne LeMoine  
Photographs: Bill Hopkins

# Paint a realistic decoy with simple strokes

# HOW TO

A little gun-shy about painting wildfowl carvings? You won't be after you try this technique from California artist Beebe Hopper. You'll be astonished how easily you can achieve realism.

## Project prep

**Paint.** Acrylic artist's colors: unbleached titanium, titanium white, Mars black, raw umber, and yellow ocher. (Shown left to right in photo top, page 80.)

**Brushes.** #0 liner, #10 blender, #12 cat's tongue, #18 cat's tongue (optional). (Shown left to right in photo top, page 80.)

**Blank.** Canvasback hen decoy.

## Buying Guide

**Brushes, patterns.** Brush set, including sable #0 liner, synthetic #10 blender, and sable #12 cat's tongue; sable #18 cat's tongue brush; painting patterns and instructions for different species; and acrylic artist's colors available. For current prices, write to Beebe Hopper, 731 Beech Ave., Chula Vista, CA 92010-5321.

**Carved decoy.** Canvasback hen, pine or basswood, head on, with glass eyes, item FBL4, \$34.50 plus \$4 shipping in U.S. Dux' Dekes Decoy Co., 1356 North Rd., Greenwich, NY 12834, or call 800/553-4725 to order.

*"You'll leave here today with a finished duck," Beebe Hopper promised a roomful of fledgling decoy painters one morning a few years ago. And, sure enough, by afternoon the room was so full of realistic ducks that it resembled a flyway rest area.*

*The painting proved so enjoyable and the decoy looked so terrific that I asked Beebe to share her technique with WOOD® magazine readers. So, recently, I visited her studio in Chula Vista, California. There, she showed me how to paint a canvasback hen. Here's how to do one yourself.*

—Larry Johnston



## Gather up your supplies

To paint the canvasback hen, you'll need five standard acrylic artist's colors (see Project Prep). You can buy them in tubes from art-supply dealers and many craft-supply stores.

The brushes listed are a key element in Beebe's technique. For the liner and cat's tongue brushes, Beebe prefers red sable bristles (tail hairs from the red tartar marten, a weasel-like animal native to southern

Russia and northern China). "Sable brushes are expensive, but their bristles form a fine point and hold a shape better. You'll see why that's important once we start painting," Beebe says. Her blender has synthetic bristles.

Also round up a couple of water containers (one for clean water to thin the paint, one for rinse water). Foam coffee cups will do the trick. And, you need a palette for your paints. Something like a snap-on coffee-can lid or a plastic plate will do fine.



# FEATHER A FOWL

## Practice the strokes

The basic feather is painted in a single brush stroke. Layering rows of those strokes of various sizes, as shown in the Feathering illustration, creates the realistic effect.

Before dabbing paint on your duck, practice on paper. First, squeeze out a blob of Mars black acrylic onto your palette. Push the end of your cat's tongue brush under the edge of the blob as if you were going to lift it up, and pull out a bit of paint. (The paint surface skins over; by dipping into it along the bottom edge, you get fresh paint rather than paint with chunks of skin in it.)

Thin the paint to an inky consistency with water. Load the brush by pressing it straight down into the paint puddle, fanning the bristles as shown in the photo *above right*. Lift the brush slowly, letting the bristles curve into an arc as shown *above far right*.

Then, hold the brush vertically and slightly above the paper, the open side of the bristle arc toward you. Flick the brush downward and toward you to paint the feather. A light touch is the key to success. Assess the results after painting a few more strokes. The line quality and color should be fairly consistent. Keep the brush relatively dry for the best-looking feathers. Blobs, as shown *far right*, result from too much water.

For narrower feathers, form the bristles into a smaller arc by rolling the sides of the bristle arc on the palette after you pick up the brush. (Beebe made all the strokes in the Feathering illustration with the large #18 brush.)

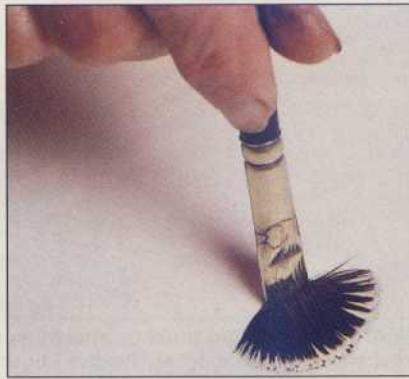

Press the brush straight down and wiggle it slightly to fan out the bristles as you load it for the feather stroke.



As you lift the brush, the bristles will curl into an arc. For a tighter arc, roll the sides on the palette.

"Always curl the cat's tongue brush in the same direction to 'train' it," Beebe says. "An easy way to remember is to keep the writing on the handle facing up."

Outline individual feathers, such as the wings' primaries and the tail feathers, with the liner brush. Paint the quill, then shade in from the edges with the blender to represent the barbs. Shading strokes should slant from the outside edge toward the bottom of the feather, as shown in the illustration on *page 81*.

## Now, you need a duck

Beebe paints precarved decoys. (See our Buying Guide.) You could, of course, paint a bird you carved yourself. And with the right colors, you can paint any species. "These feathers work for everything from chickens to eagles," Beebe says.

Paint the carving first with a coat of white pigmented primer/sealer,

*Continued*

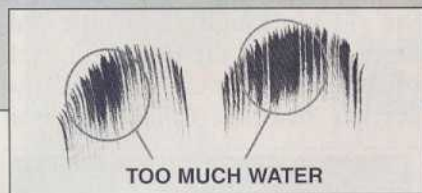

## FEATHERING

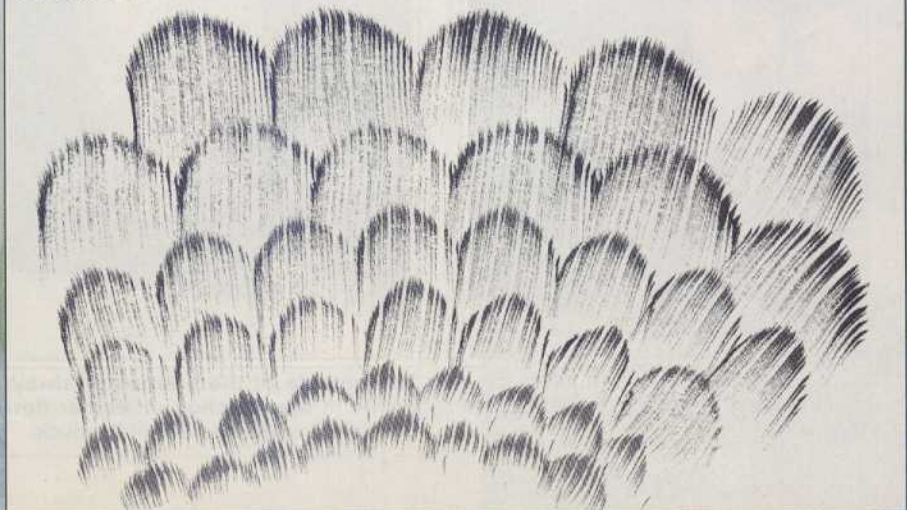

# HOW TO FEATHER A FOWL

such as Kilz (available from paint and hardware stores). If your duck's glass eyes are installed, don't mask them off for painting. "Masking the eyes usually leaves unpainted lines around them, and that really shows. Go ahead and get some paint on them, then clean it off later," Beebe says.

## Give the bird a base coat

Lightly pencil on the guidelines shown in the photo *right*. The lines at the rump follow the carved contours around the wings and sidepockets. Approximate the location of the breast line by referring to the photos.

Paint the head, neck, breast, and rump with raw umber, straight from the tube. "Just slop it on for the base coat," Beebe counsels. "A streaky, uneven coat adds depth. Brush generally in the direction of the feathers [arrows in the photo]," she adds.

To base-coat the back and sidepockets (shown *below*), mix raw umber with unbleached titanium and a touch of yellow ocher. The color must be light enough to contrast with the rest of the bird.

On the bird's back, separate the two colors with a hard line. On the sides, though, blend the colors together at the front and back of the sidepockets. To blend the acrylics, brush across the junction



Don't worry about a neat, even base coat. A streaky one will give the finished bird a softer look.



With the paints and brushes shown, you can change the plain, white carving into a realistic decorative decoy. Arrows show feather flow directions.

with a wet brush to keep the paint from drying right away. Put on a couple of coats, letting the paint dry between coats. (You can hurry it along with a hair dryer.)

## Let the feathers fly

Now, cover the body with feathers. Use thinned unbleached titanium for all feather strokes.

Start at the back of a sidepocket, and paint a row of feather strokes along the lower edge of the body to the front of the sidepocket. Keep the duck's head toward you.



The outside of the bristle arc always points in the direction of feather flow, generally toward the back of the duck.

Otherwise, you'll end up with backward feathers. Paint more rows to cover the sidepocket.

Move up onto the wings, continuing to work from the back forward. As you change the bird's position for painting, always aim the rounded arc of the brush in the direction of the feather flow, shown *below center*. Avoid rigidly uniform feathering patterns; the bird shouldn't look like it's covered with three-tab shingles.

Similarly, feather the duck's head and breast, excluding, of course, the bill. The breast feathers flow down and back. Hold the decoy upside down with the head pointing toward you as you paint feather strokes on the breast. (I painted a breastful of wrong-way plumage in my first attempt.) Then, feather the rump and tail.



Here's the duck with a wash coat over the first round of feathering. Darker feathers barely show up.

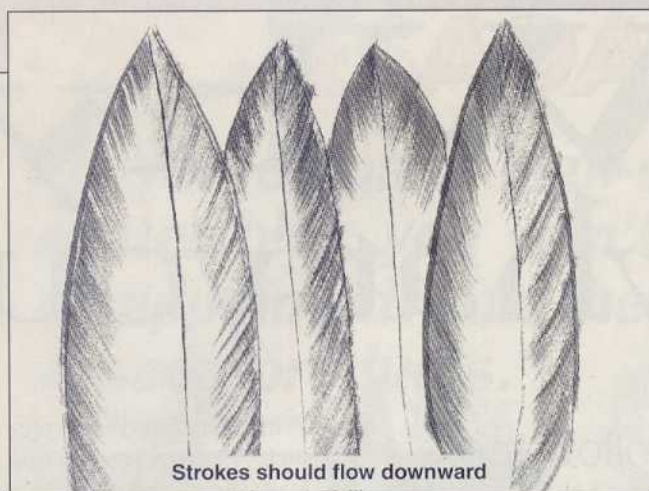

Strokes should flow downward

Paint outlines and quills for the individual feathers with a liner brush. Stroke the blender brush downward from the edge toward the quill to represent the barbs.



Primary groups

Paint the background color areas for the tail feathers and primary groups, then delineate the individual feathers with black painted lines. Shade them with unbleached titanium.

Paint three or four random feather strokes on the back and each sidepocket with raw umber. "Don't paint very many, and don't make them very prominent," Beebe warns.

### Give your work a wash

After the feathering dries, thin a bit of raw umber to a watery consistency. It should look more like dirty water than paint. Brush it lightly over the entire bird, maintaining the contrast between the light area and the darker ones. This wash coat softens the feathering. The decoy should now look approximately like the one in the photo *below left*.

Let the wash dry, then go back over the bird with a second round of feathering. Apply the feather strokes as you did previously, but don't try to match the earlier pattern exactly. This will build the effect of layered feathers.

Let the feathering dry, then apply another overall wash coat of thinned raw umber. After this coat dries, feather the wings and sidepockets again.

The completely feathered duck now has two layers of feathers and two wash coats on the front and rear. The wings and sidepockets have three layers of feathers and two wash coats.

### Add a few more feathers

The primaries (main flight feathers of the wings) lie in a group along the duck's back when the wings are folded. Referring to the photo *above right*, outline the primary group on each side.

Mix a bit of white into raw umber to make a dark tan shade. Paint it on the areas marked out for the primary groups and the duck's tail, both top and bottom.

Sketch lines for three overlapping primaries on each side. Model these and the tail feathers after the illustration *above*. Pencil in the tail feathers as shown, carrying them around to corresponding lines on the bottom of the tail. Then, with thinned black, paint the lines, using the liner brush.

Refer again to the illustration *above*. Shade the primaries and tail feathers with unbleached titanium as illustrated, using the #10 blender brush. Shade the primaries from the outer line toward the center.

The layout for the tail feathers represents feathers fanning from the center. The straight line at the middle is the quill for the center feather, so shade toward that line from the curved lines on each side of it. Paint toward the center from the other curved lines.

After the paint dries, apply a final wash coat of thinned raw umber over the entire bird.

### Some final details

Paint the bill Mars black. Then, wet the top of the head with clean water, and brush a wash of black from the bill along the top of the head and partway down the back of the head. Blend the black in to darken the top of the head—but don't make it look like a distinct stripe.

Add some feather splits—random, short lines ( $\frac{1}{2}$ – $\frac{3}{4}$ " in the direction of feather flow (see the opening photo). Paint them with the liner brush and thinned raw umber. About half a dozen per wing or sidepocket will be plenty. Again, avoid a pattern.

With a pointed stick or the tip of a carving knife, scrape away any paint you got on the eyes. If you use a knife, be careful not to scratch the glass eyes.

Sign your name on the bottom, and date the work. After the paint dries thoroughly—a few days, at least—apply an overall coat of acrylic medium for a clear, matte-finish protective coat. ♣

Project Design: Beebe Hopper  
Photographs: Mike Armbrust, Chula Vista Photo Studio  
Illustrations: Beebe Hopper, Brian Jensen  
Written by Larry Johnston





# Why what you

Follow the  
path of a board  
from forest tree to  
city lumber dealer,  
and you'll know  
why good stock  
costs what it does.

**A** 30"-diameter red oak tree with 55' of clear trunk contains about 1,000 board feet of lumber. A forest products company buys that dandy, forest-grown tree at a stumpage price of \$400 per thousand board feet (MBF), or 40 cents per board foot. But, when you visit your retail hardwood dealer to buy red oak, you might pay almost 10 times that for kiln-dried and surfaced FAS (First and Second grade) stock. "Just where does all that additional cost come from?" you ask.

The hardwood stock you buy from a dealer has been seasoned and kiln-dried down to about 6% moisture content, then ripped, often edged, and surfaced. Getting woodworking stock to that stage, however, nibbles away at the initial board footage—and

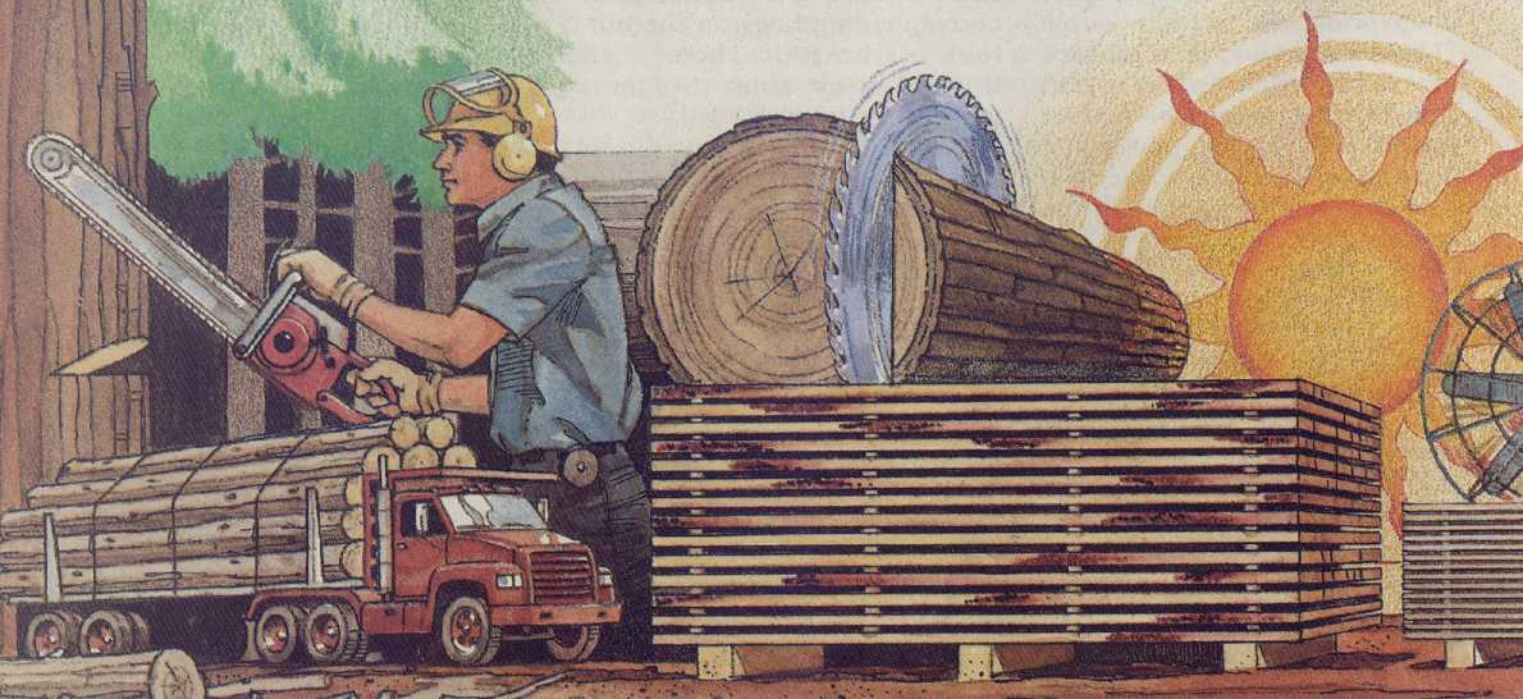

# you pay do for wood

at the same time adds value to it. Follow along to see how all the costs stack up.

## Loggers and lumber loss add to the cost

First, the red oak tree in our example must be felled, bucked, hauled out of the woods, loaded, and trucked to the mill. That costs \$150 per MBF. Sawing the logs from that tree into green boards runs another \$125 per MBF. At this point, the cost to the mill has increased to \$675 (called back-of-mill cost). But, on average, only about 45% (450 of the 1,000 board feet) of the boards in the logs will be clear enough for marketing at retail. The remainder is waste and low-grade lumber sold as pallet stock or for other uses.

Now, the dollar value to the processor of the rough-sawn 450 board feet of high-grade red oak lumber has risen to \$1.23 a board foot. This cost figure includes a 15% markup for sawmill profits and a break from the sale of the low-grade lumber.

## Seasoning takes its toll on the wood

Drying the high-grade lumber to 6% moisture content is usually a two-step process, and it adds another 10% to the cost. And, there's a 7% loss of wood due to splitting and checking (degrade) during air-drying and in the kiln. The drying operation has to make a profit, too, so that tacks on 15%, bringing the value of the stock to \$1.62 a board foot.

## Ripping, crosscutting, and planing reduce the stock

After all this, the original 1,000 board feet of lumber in the red oak tree has shrunk to 418.5 by the time it reaches the rough mill for ripping, crosscutting, and planing. Only 80%, about 335 board feet, of the wood survives the process, which costs \$32 to do. Then, there's another 15% for rough-mill profit tagged on. The cost of a board foot rises all the way to \$2.42.

That's still not a bad price for FAS red oak stock if you could

buy it here. Unfortunately, most of us can't do that, so there's more to come

## Middlemen and dealers make a profit, too

Here, a lumber broker steps in and purchases the wood for resale, increasing the cost by 15% for his profit. This brings the retailer's wholesale cost of the fine red oak to \$2.78 per board foot. What the retailer must add to the board foot price to cover his overhead and profit results in the price you end up paying. Large wood retailers have their own buyers, sparing you the broker fee. That's why lumber sells for less at these businesses. ♣

*Editor's note: Costs and calculations in this article are based on national hardwood industry averages. All forest products companies selling hardwood may not operate similarly or cost out their lumber the same way.*

Written by Peter J. Stephano with Steve Peters  
Illustrations: Jim Stevenson

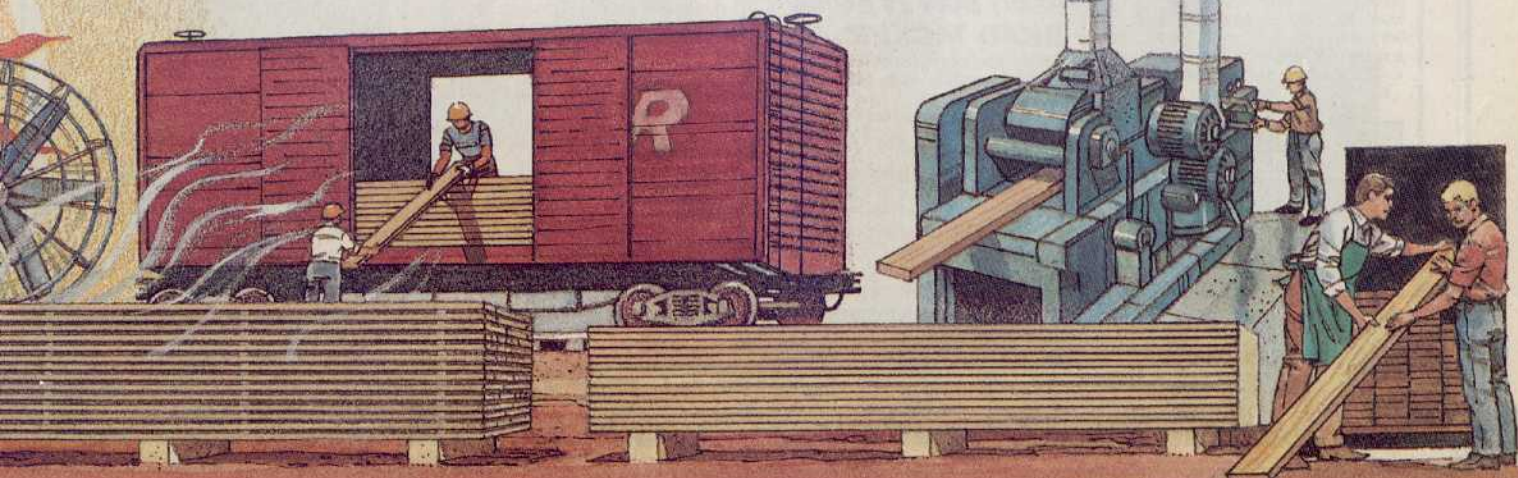

**We're Back....THE SUPER LOW PRICE TOOL STORE!**

**PORTER + CABLE**

693PK  
1-1/2hp  
Router  
with  
1001 base  
& 6931 Plunge base  
& case for only \$198

90900 1.5 hp Router w/Case 158  
310 7/8 hp Router 146  
310 Laminate Trimmer 146  
314 4 1/2" Trim saw 159  
330 Speed bloc Sander 61  
333 RO Sander 5" H&L 63  
334 RO Sander 5" PSA 63  
335 NEW 6" RO Sander 64  
352VS3X21 Sander VS 163  
360 3X24 Sander w/bag 211  
360VSNEW VS Sander 228  
362 4X24 Sander w/bag 228  
362VSNEW VS Sander 228  
548 Wormgear Jigsaw 229  
5116 1/2" Dovetail Jig 276  
556 Buscut Joiner 131  
653 1.5hp Plunge Router 179  
6931 Plunge Base 79  
697 Router Table & Motor 133  
697 Router Table only 133  
7334 4" RO Sander 109  
7518 5 speed 3hp Router 273  
7519 3 hp Router 254  
7537 2 hp D-Handle Rtr 224  
7538 3 hp Plunge Router 269  
7810 Vacuum 257  
9118 Door Planer Kit 234  
9345 Sawboss w/case 136  
9444 Profile Sander 95  
9444VS VS Profile Sander 109  
97310 Trimmer Kit 187  
97325 5" RO Sander 144  
97366 6" RO Sander 148

**NEW NAILGUNS!!!**

BN125  
1 1/4"  
Brad Nailer  
\$86

BN200 2" Brad Nailer 133  
FN250A 2 1/2" 8g Finish 189  
DA250A 2 1/2" angle Finish 245  
NS150 1/4" crown Stapler 156  
FR350 Framing Nailer 299  
CF1540 1-1/2 hp Compressor 293

**NEW CORDLESS!!!**

9662 12V T-style Drill kit 173  
9662F 12V Kit w/flashlight 188  
9663 12V Push handle Kit 184  
9663F Kit w/flashlight 194  
9672 14V Drill Kit 188

**TRUCLIP**

Clamp n Tool Back-to-Back  
Guide Bench Clamp

50C \$ 29.50 BB50 \$ 45.95  
36C 26.50 BB36 37.95  
24C 22.50 BB18 31.95

**Panasonic**

EY6100EQKW  
NEW! PREDATOR  
12 V CORDLESS DRILL  
IRONMAN \$177  
EY6101EQKW 1/2" chuck  
IRONMAN 2 batteries 225

**Milwaukee**

6496-6  
10" Compound  
Slide Miter \$568

6497 Delux 6496 648  
0234-6 1/2" Magnum Drill 128  
0376-6 3/8" Close Qtr Drill 147  
0379-6 1/2" Close Qtr Drill 164  
0415-21 12V Cordless Kit 171  
0479-6 12V R/Angle Cordless 243  
0511-21 14V Cordless 210  
3107-1 2 hp Router 184  
5662 2 hp Router 184  
6020-20 6" RO Sander 153  
6025-20 5" RO Sander 134  
6101-6 NEW Bandfile 193  
6215 Elec. Chainsaw 230  
6266 NEW! Jig Saw 157  
6494-6 10" Compound Miter 314  
6517-20 NEW! Quick Sawzall 154  
6537 VS Super Sawzall 174  
6546-1 Cordless Screwdriver 89  
6767-1 Screwdriver Kit 135

**RYOBI**

AP10 Replacement Blades 24.95  
HT20VSK MULTI TOOL 54  
DBJ50 Mini Biscuit Joiner 68  
05S450 Spindle Sander 158

1/2" Sliding  
Compound  
Miter Saw  
DW708  
\$ 679

**BOSCH**

B4200  
\$129  
VS

Orbital Jigsaw  
1587VSKB Jig Saw Kit 189  
1604AKX 1-3/4 hp Router 159  
1926A D-Handle Router 103  
1609CX TrimKit 233  
1943LED Heat Gun 109  
3283DVS 5" RO Sander 99  
3915 Compound Miter 577  
B1390 1 3/4 hp Router 103  
B1450 2hp VS Plunge Rtr 179  
B1550 3hp Router 199  
B4060 Inline Jig Saw 99  
B7001 VS Detail Sander 78  
B7100 1/3 sheet Sander 99

**DEWALT**

DW682K  
Biscuit Joiner \$198

DW106 3/8" Keyfiss Drill 73  
DW306K RecipSaw 163  
DW321K Jigsaw Kit 163  
DW362K 7 1/4" Crc Saw 129  
DW364 5" PSA R/Sand 74  
DW420 3X21 Ball Sander 187  
DW4431 6" H&L RO Sand 144  
DW444 6" PSA RO Sand 144  
DW610 1 1/2 hp Router 149  
DW615 1 1/4 Plunge Rtr 166  
DW621 2hp Plunge Rtr 217  
DW625 3hp Plunge Rtr 277  
DW670 Trimmer Router 98  
DW673K Trimmer Kit 187  
DW705 12" Comp Miter 354  
DW935 14V Cord's Saw 158  
DW935K Cord's Saw Kit 226  
DW952K 12V Cord'drill 179  
DW951K 14V Cord'drill 198  
DW951K2S 14V Combo Kit 339  
DW955K2S 18V Combo Kit 375

**HITACHI**

C8FB2  
COMPOUND  
SLIDE SAW \$477

C10FA 10" Miter Saw 299  
C10FS 10" Slide Miter 737  
C16FS 15" Miter Saw 658  
NF83A Framing Nailer 388  
EC12 2hp Compressor 286

**SENCO**

SLP20  
Brad nailer \$199

SL520 Light Duty Stapler 249  
SN1+ 2" Finish Gun 289  
SN40 2 1/2" Finish Gun 347  
KSL 1 1/4" Crown Stapler 274  
N65C NEW! Frammer 397  
SCN200R Coil Router 397

**ALPC**

NAIL GUNS  
241SNK  
18 G 3/8-1-1/2" Kit \$96  
0222SP 18G 1-1/4" Kit 69  
E22 shoots pins & staples 137  
249SNK 18 G 3/4-2" Kit 129  
566TP 2-1/2" Finish Gun 202  
626SNK 14" Crown 1" Stapler 98  
350NK 2" 16G Brad Gun 169

**Air-Mite**

AIR COMPRESSORS  
AM78HC4V 1 1/2 hp-2 tank 305

**Rol-Air**

COMPRESSORS  
D1500HP5 1.5 hp  
4.5 gal tank  
\$299

**freud**

94-100 5 pc Router Bit  
Cabinet set \$167

LU85M010 10" SOT Finish 55  
LU84M011 10" SOT Combo 36  
LM72M010 10" 24 Ft 36  
LU85M015 15" 108T Finish 99  
LU82M010 10" SOT Conlan 58  
LU89M010 10" SOT Laminate 67

**Construction Master IV**  
The NEW!!! world's best  
feet-inch-metric-fraction  
calculator. Solves readders  
hips, valleys, stairs

**\$69**

**Pockethole maker \$109**

KPE G JIG  
for pinning  
faceframes,  
butt joints and  
other pocket hole  
applications

**Thakita**

LS1211  
12" Compound  
Miter Saw  
\$757

LS1013 NEW! 10" Slide Compound  
Miter 2-Rail System 577  
3606 1 hp Router 106  
3621A 1 1/4 hp Plunge Router 159  
4200H 4 3/8" Trim Saw 169  
4304 Jig Saw 159  
4305 Jig Saw 156  
6213DVAE 3/8" 12V Cord'drill 176  
6223DVAE 3/8" 14V Cord'drill 198  
6313DVAE 1/2" 12V Cord'drill 196  
9924DB 3X24 Beltsander 188  
AN8300 Framing Nailer 326  
LS1030 10" Miter Saw 199  
LS1040 10" Compound Saw 258

**STABILIA**

LEVELS - Hand holes  
Two vertical vials. Two milled  
faces. Yellow coat.

2464 24" w/hand hole 42  
2469 36" w/hand hole 46  
2467 48" w/hand hole 54  
2468 72" w/hand hole 98  
2859 NEW Laser Level 325  
2556 6 ft -3vial 99  
2700 6 ft 6" -3vial 115  
2701 8 ft -3vial 125

Mention this ad to receive this  
WOOD Magazine plan free

**NEW! DEWALT STATIONARY TOOLS**

10" Table Saw DW744 \$ 539      20" VS Scrollsaw DW788 \$ 449

**USE VISA, MC, DISCOVER**

**FREE SHIPPING** on orders from  
this add over \$50, to the 48 states,  
HI and AK extra. Sales limited to stock  
on hand. Prices subject to change without notice.

**1175 N. EAST, ANAHEIM CA. 92805**  
**OPEN 8-5:30 WEEKDAYS 9-2 SATURDAY**  
Calif. residents add 7.75% state sales tax  
**SERVING YOU FOR OVER 20 YEARS**  
96D

## Mittersaw Stand Continued from page 62

Mittersaw Setup drawing to house the self-adhesive measuring tape.

**5** With the center fence section (L) attached to the mittersaw, miter-cut the center section out of it. Now, adhere the right-to-left tape (R-L) to the left-hand L and fence piece J and the (L-R) tape to the right-hand L and fence section K. For fine-tuning the fences/tapes with the blade, loosen the sheet metal screws in the slots and adjust the fences until the measured increment on the tape is the correct distance from the blade.

**And now, sand and paint your stand**

**1** Fill any imperfections and finish-sand the stand. Prime the assemblies. (We did this in several coats, using a sanding block with 220-grit sandpaper between coats to smooth the primer.) Then, paint the stand as desired. Add a clear finish to the fence pieces. Attach and adjust the fences to the saw.

**MITERSAW SETUP**

\*Measuring tapes are self-adhesive and fit into a 1/2" groove 1/16" deep cut in the fences.

Written by Marlen Kemmet      Project Design: James R. Downing      Illustrations: Kim Downing      Photograph: Hetherington Studio

# STEVE WALL LUMBER CO.

Quality Hardwoods and Woodworking machinery For The Craftsman and Educational Institutions

Ash	4/4	Select	2.15		\$ 73.00
Basswood	4/4	Select	1.90		\$ 59.00
Birch	4/4	Select	2.30		\$ 77.00
Butternut	4/4	1C	2.00		\$ 65.00
Cherry	4/4	Select	3.60		\$ 94.00
Hickory - Pecan	4/4	Select	1.95		\$ 67.00
Mahogany (Genuine)	4/4	Select	3.70		\$ 94.00
Maple (Hard)	4/4	Select	2.80		\$ 81.00
Maple (Soft)	4/4	Select	2.20		\$ 68.00
Poplar	4/4	Select	1.55		\$ 60.00
Red Oak	4/4	Select	2.35		\$ 76.00
Walnut	4/4	Select	3.25		\$ 91.00
White Oak	4/4	Select	2.35		\$ 75.00
Cedar (Aromatic Red)	4/4	1C+Btr.	1.60		\$ 62.00
Cypress	4/4	Select	2.20		\$ 70.00
White Pine	4/4	F.G.	1.10		\$ 51.00
Yellow Pine	4/4	Clear	1.70		\$ 61.00

Above prices are for 100' quantities of kilndried rough lumber sold by the Bd. Ft. FOB Mayodan, NC. Call for quantity discounts. Other sizes and grades available.

Above prices are 20 bd. ft. bundles of clear kilndried lumber 3"-10" wide x 3'-7' long (Random widths & lengths) Surfaced 2 sides or rough. Delivered UPS prepaid in the Continental U.S.

Circle No. 592

## CUSTOM CABINET DOORS

Custom Raised Panel Doors and 1 Piece MDF Now Available.

4/4 Log Run Walnut 100 Bdft. \$145

## STEVE H. WALL LUMBER CO.

BOX 287  
MAYODAN, N.C. 27027  
910-427-0637  
1-800-633-4062  
FAX 910-427-7588

Send \$1.00 For Lumber Catalog  
Prices Subject to Change Without Notice

## ASK WOOD

### Have a question for our woodworking experts?

No matter how simple or perplexing your woodworking problem, we would love to hear from you. We'll do our level best to solve your mystery, and you might even find your question and our reply on this page.

You can write to us at: Ask WOOD®, 1912 Grand Ave., Des Moines, IA 50309-3379.

Send e-mail to:

woodmail@woodmagazine.com

Or, visit our internet page and join one of our discussion groups at: <http://woodmagazine.com>

# Design Breakthrough!

It's the ultimate workbench!

It's a downdraft table!

It's a complete air filtration system!

- 360° Air Collection
- Unique Filter Lock System
- Flourescent Light
- 1100 CFM
- 12' Power Cord
- Filters to 0.5 Micron



Deluxe 30"x69"

- Generous Maple Worktops
- Powerful 930, 1600, or NEW 2850 CFM Motor
- GFI Convenience Outlet
- All Benches Shown with Optional Accessories
- Three Stage Filtering to 0.5 Micron



Ultra Grand 33"x95"

Call now to find out about our Specials on purchases made by May 1st



Overhead Mount

Special Introductory Offer!

\$499 + S&H

Good Until May 1st



Original 30"x54'  
Only \$889 + S&H

## Plane frustrated

After saving a prized piece of curly maple for a special project, I destroyed my gem when I tried to plane it down. The piece had massive chip-out along its entire length. I have a perfectly adjusted, quality planer with recently sharpened knives. This planer continues to plane other stock beautifully. What went wrong, and what can I do to prevent it from happening again?

—Rich Sturim, Seattle

Blame the maple, Rich, not your planer. Wood that has lots of grain angles and reverses, especially figured maples and other exotics, just doesn't take kindly to planing. (We've seen it pop the eyes out of bird's-eye maple!) Try lightly planing your stock to 1/16" over-size, then sand or scrape it to the thickness you want. Attacking the wood at an angle usually gives the best results because the wood fibers tend to shear off more cleanly.



Continued on page 102

# WOODMARK

Visa  
Mastercard  
Amex

P.O. Box 211434 • Bedford, TX 76095

1-800-845-4400 Free Catalog!

Circle No. 1295

**WOOD®**  
**CLASSIFIED MART**  
 For rates: 1-800/424-3090 Fax 312/464-0512

**AUTOMOTIVE**

**SEIZED CARS FROM \$175.** Porsches, Cadillacs, Chevys, BMW's, Corvettes. Also Jeeps, 4WD's. Your Area. Toll Free 1-800/218-9000 Ext. A-14094 for current listings.

**BUSINESS OPPORTUNITIES**

**\$100.00 PER HOUR,** woodworking from your garage, F/T, P/T, no selling. Free info: SATINWOOD CO. 800/365-7305.

**FINANCIAL SERVICES**

**GET OUT OF DEBT!** Free consultation. Debts consolidated. Harassment calls stopped. Payments lowered, interest reduced. Non-profit agency. Prompt professional service. GSCCC 1-800-99-BILLS. Lic./Bonded.

**FINISHING/RESTORATION**

**LINE BOXES EASILY.** Spray-on suede. 31 colors. Free Brochure. DonJer Products, Ilene Court-Bldg. 8W, Bellemead, NJ 08502. 1-800/336-6537.

**HELP WANTED**

**EASY WORK! EXCELLENT PAY!** Assemble Products at Home. Call Toll Free 1-800-467-5566 EXT. 11856.

**INSTRUCTION/EDUCATION**

**LEARN WOODEN BOATBUILDING.** Accredited degree and teacher's programs. Northwest School of Wooden Boatbuilding, 251 Otto Street, Port Townsend, WA 98368. 360/385-4948.

**PLANS/KITS/PATTERNS**

**WOODEN GUMBALL MACHINES!** Excellent gift/craft show idea. Three plans for \$5.00. Patterson Brothers, PO Box 8418, Bossier City, LA 71113.

**TOOLS/EQUIPMENT**

**DRY YOUR OWN LUMBER.** Ebac's user friendly dry kilns 200BF-40,000BF. Mix species in same load. Great 3-year warranty. Over 6000 systems worldwide. Call Today. 1-800/433-9011.

**BAND SAW BLADES:** Low tension Swedish Silicon Steel "TIMBERWOLF" bands. 1/16" thru 1/4". FREE CATALOG 1-800/234-7297. Email: timberwolf2@worldnet.att.net HOME PAGE: timberwolf1.com

**STRAIGHT LINE LUMBER FAST** using your shaper or woodmaster, RBI or table saw. Three different easy build plans. Satisfaction guaranteed. \$9.95: Sun Hardwoods, PO Box 142, Mountain Grove, MO 65711.

**CUSTOM BRANDING IRONS** as low as \$56.25! Great Christmas idea. You're proud of your work; identify it. Any design, logo, signature. VISA/MC. BrandNew 1-800/964-8251.

**FREE!**

**CherryTree**

**Woodcrafting Catalog**



See our **Lighthouse Birdfeeder** & dozens more **NEW** projects!

- Clocks & Parts
- Whirligigs
- Toys
- Wood Parts
- Craft Supplies & more!

Affordable prices, guaranteed quality & fast delivery!

Check out our WebSite at:

[www.cherrytree-online.com](http://www.cherrytree-online.com)

Name: \_\_\_\_\_

Address: \_\_\_\_\_

City: \_\_\_\_\_

State: \_\_\_\_\_ Zip: \_\_\_\_\_

Cherry Tree • Box 369-W038  
 Belmont, OH. 43718-0369  
 or call **TOLL FREE**  
**1-800-848-4363 ext. W038**

Circle No. 1420

**ASK WOOD**

*Continued from page 100*

What's the condition of a "reconditioned" tool?

*I have been shopping around for a circular saw for some time now, and have seen advertisements for "reconditioned" tools with prices lower than new. What does "reconditioned" mean? Ads claim these tools are as good as new. Are they, or do you get what you pay for?*

—Steve Johnston, via internet



We're all tempted by low price tags, Steve. So we checked with the local distributor of DeWalt power tools, and this is what he had to say about DeWalt's reconditioned products.

These tools have either been returned by a customer within a 30-day period after purchase, or were overstocked by a retail store and returned to DeWalt.

If the tools were returned from a retail store, then they've never been used. But it's company policy to call them reconditioned, since someone else put these tools in their warehouse. If they were returned from a customer, it was either because the tool wasn't exactly what they wanted or the tool had a glitch. Since DeWalt will give you a new tool if it malfunctions due to manufacturing reasons within 30 days, the returned tool is then sent back to the factory, inspected thoroughly, and any bad parts are replaced.

These reconditioned tools typically sell for 15-25 percent less than they would otherwise. The manufacturer's lifetime warranty is still in effect, except that if the tool breaks within those first 30 days, they fix that tool instead of giving you another new one. ♣

**Start Your Own Business**  
**CUSTOM ENGRAVING**

*No Experience Necessary • No Artistic Ability Needed*

• 400,000 RPM Engraving Tool

• Unlimited Potential

• Complete Stencils



**Professional Results**



There is no experience necessary because SCM has developed a business opportunity that will have you producing professional engraving in a few short hours – just by tracing lines! **It's That Easy!**

Engrave on... • Glass • Wood • Metal • Stone • Marble • Eggs

To Find Out  
 Just How Easy It Is  
 Call Now For Details...

**1-800-755-0261**

W140 N5946 Lilly Road • Menomonee Falls, WI 53051 (414) 252-3989



Deposit Required

Circle No. 2165

### A comeback for the American elm?

Small-town America's elm-lined streets never quite looked the same after the Dutch elm disease began its devastation in the 1960s. But years of research in developing a disease-resistant strain of American elm (*Ulmus americana*) may finally be paying off.

The New Hampshire-based Elm Research Institute, a nonprofit organization, hopes its new American Liberty elm will make a comeback across the U.S. A purebred elm, not a hybrid, with the graceful, vase-shaped crown that made the American elm so popular, American Liberty has high resistance to Dutch elm disease.

With the help of volunteer troops of the Boy Scouts of America, the Institute is shipping American Liberty elms to cities across the nation. Nonprofit groups may apply to get up to 1,000 free trees for planting by calling 800/FOR ELMS, or by writing the Elm Research Institute, Westmoreland, NH 03467-9985. If you join the organization (\$30 a year) by phone, you'll receive a 2-3'-tall elm at no charge.



Illustration: Steve Schindlar  
Photographs: Hetherington Photography;  
Woodcraft Supply, Inc.

### Forgery, by scrollsaw!

It seems that scrollsawyers stand out among woodworkers as folks who eagerly seek the greatest challenges. At least that's what Bill Thurlow, of Fontana, California, said caused him to forge in wood the signature of *WOOD*® magazine's features editor, Pete Stephano.

The letters and signature in the scroll-sawn plaque, *right*, were cut from ½" sugar maple and specially mounted in a walnut frame. Bill says he simply photocopied a letter he received from Pete regarding a question that he had written, mounted the copy on the wood, and sawed away with his #2 blade.

For script, Bill has had lots of practice. In 1996, the retired law enforcement officer and history buff completed a 4x4' scrollsawn replica of the original handwritten Declaration of Independence—all 1,356 words and 56 signatures cut from solid maple. That project took him eight years, 4,316 inside cuts, and over 700 blades.

"I made a pattern for each line in the document, then cut it out," Bill explains. "By the time it was finished, I was relying on a magnifying glass and regularly visiting my chiropractor." Mounted and framed, Bill's volunteer project now hangs in the county administrative office in San Bernardino. It's been appraised at \$60,000.



Fontana, California, scrollsawyer Bill Thurlow photocopied a signature on a letter for a pattern, then "forged" it out of ½" maple to mount in a shadow-box plaque.

### Own your own Woodcraft store

Woodcraft Supply Corporation of Parkersburg, West Virginia, has announced a franchise development program for its full-line retail woodworking stores. The company is offering a limited number of exclusive territories to supplement its present 23 stores and international mail-order catalog.

"The Woodcraft franchise support system covers many aspects needed to run a successful business," says Bryan Katchur, company president. "Our staff provides consultation on everything from site selection and store design to daily operation. Additionally, we offer name recognition, massive buying power, and lead generation through our Woodcraft catalog."

According to Woodcraft Supply, 18 million U.S. woodworkers spend \$13 billion annually on supplies and equipment. For more information on franchising, call Bill Carroll at 304/422-5412. 🌲

Now available to franchise, each Woodcraft store offers more than 6,000 different products, plus imported and native hardwoods.

