

Better Homes and Gardens®

10th
ANNIVERSARY
ISSUE

WOOD

THE WORLD'S LEADING WOODWORKING MAGAZINE

SEPTEMBER 1994 • ISSUE NO. 72

Please display until November 10

WELCOME TO IDEA SHOP 2™

- *Projects galore*
- *Editor's-choice tools*
- *Shop heating & ventilation*
- *Dust-collection solutions*
- *Tool-storage options*

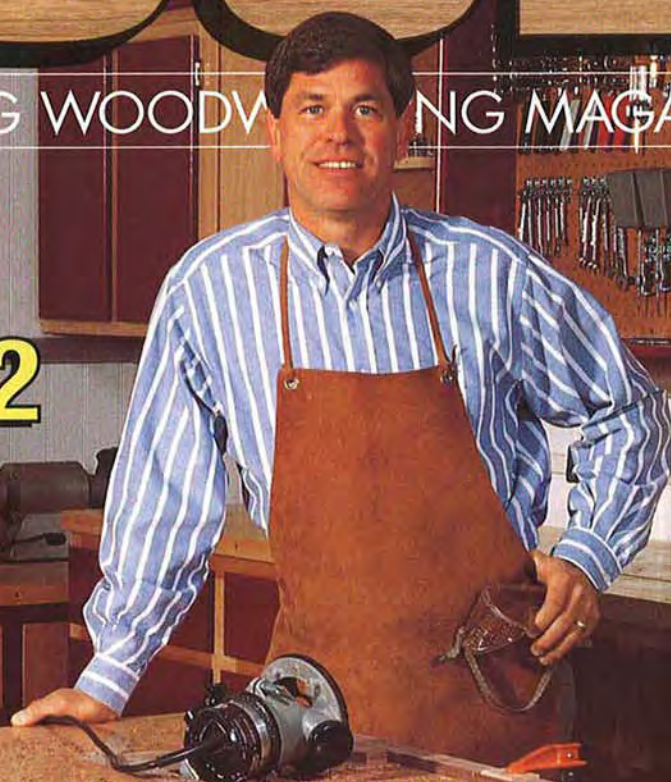

Build this all-purpose
**MOBILE
WORKBENCH**

Complete plans on page 46

\$4.95 U.S.



TOOL TEST:
Oscillating spindle sanders under \$700

KING OF THE SHOP!



IMPORTS, INC.

**FREE
EXTRA SET
OF KNIVES!**

12" PLANER MODEL G1017 ONLY \$395.00

- 2 HP, 110V motor
- Dual-knife cutterhead
- Capacity: 12" wide x 5" thick stock
- Optional dust hood available
- Complete with instruction manual
- Weight: 87 lbs.

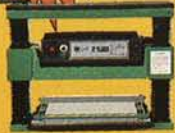

COMBINATION SANDER 6" X 48" BELT — 9" DISC

MODEL G1014 SALE \$189.00

- 3/4 H.P. single phase motor
- Comes complete with miter gauge
- All cast iron body construction
- Machine weighs approx. 114 lbs.



SALE!



15" PLANER PACKAGE DEAL MODEL G1021 SALE \$775.00

- 2 HP, single phase motor
- Magnetic switch protects against overload
- Includes stand
- 3 HSS knives and 2 sided knife setting tool
- Table measures 15" x 20"
- Weighs more than 475 lbs.

SALE!

6" X 17" EDGE SANDER

MODEL G1072 SALE \$215.00

- 3/4 HP motor, single phase, 110/220V
- Belt speed 2300 F.P.M.
- 7" x 13-3/4" cast alum. table
- Appr. shipping weight 88 lbs.
- Bed size 17"



SALE!



20" PLANER MODEL G1033 SALE \$1175.00

- Precision ground cast iron bed
- 3 HP, 220V motor
- 2 speeds: 16' and 20' per. min.
- Capacity: 20" wide x 8" tall
- 4-blade all ball-bearing cutterhead
- Shipping weight: approx. 800 lbs.

SALE!

24" DRUM SANDER

MODEL G1066 SALE \$1075.00

- Single phase, 220V, 5 HP motor
- Separate 1/4 HP belt feed motor
- Dual belt-driven sanding drums
- Heavy-duty magnetic switch
- Built-in dust collection ports
- Shipping weight is 470 lbs.



SALE!



14" BANDSAW

MODEL G1019 SALE \$275.00

- 3/4 H.P., 110V motor
- Table equipped with miter gauge
- Shipping weight 200 lbs.
- Table tilts 45° right and 10° left
- Bandsaw wheels have rubber tires and are fully balanced

SALE!



16" BANDSAW

THE BEST 16" BANDSAW
IN THE WORLD!

MODEL G1073 SALE \$540.00

- 1-1/2 HP, 220V motor
- Heavy-duty rip fence
- One-piece, cast iron body
- Hinged wheel covers
- Micro-adjustable blade guides
- Shipping weight: approx 430 lbs.

SALE!



2 H.P. DUST COLLECTOR

MODEL G1029 SALE \$265.00

WITH FREE 4" X 10' HOSE

- Single phase, 220V, 2 HP motor
- Handles two machines with ease
- Suction capacity: 1182 cfm
- Shipping weight: approx. 124 lbs.
- Complete with instruction manual

SALE!

10" HEAVY-DUTY TABLE SAW

MODEL G1022 SALE \$345.00

- 1-1/2 HP motor, 110/220V
- 2 Cast iron wings
- Precision ground cast-iron table top with T-slots
- Table size with extension wings: 27-1/8" x 40-5/8"
- Shipping weight: approx. 255 lbs.



SALE!

10" TILTING ARBOR SUPER HEAVY-DUTY TABLE SAW

MODEL G1023 SALE \$795.00

- 3 HP motor, 220V
- Precision ground solid cast iron table and wings
- Steel miter gauge
- Shipping weight: 450 lbs.



Table size
with extension
wings is
36.06" x 27.08"

SALE!

1-1/2 H.P. SHAPER

MODEL G1035 SALE \$425.00

- 1-1/2 H.P., 110/220V motor
- 2 interchangeable spindles (1/2" & 3/4")
- Table size 20" x 18" precision-ground, cast iron
- Dual speed, reversing motor
- 2 independently adjustable 2-1/2" x 10" fences
- Shipping weight: approx. 220 lbs.



SALE!

6" x 47" JOINTER HEAVY-DUTY

MODEL G1182 SALE \$355.00

- 1 HP, 110/220V motor
- Cabinet-type stand
- Longest (47") bed of all jointers in its class
- Heavy-duty center-mounted fence
- Shipping weight: approx. 250 lbs.



SALE!

8" SUPER HEAVY-DUTY JOINTER

MODEL G1018 SALE \$635.00

- 1-1/2 HP, 220V motor
- 3-knife cutterhead
- Magnetic switch for safety and overload protection
- 65" x 8" precision ground, cast iron bed
- Shipping weight: 460 lbs.



SALE!



3 H.P. SHAPER

MODEL G1026 SALE \$725.00

- 3 HP, 220V motor with reversing switch
- Heavy-duty all-steel miter gauge with full-length bar
- Cast iron wing
- Solid, polished cast-iron table top
- Table with standard wing attachment measures 28-7/8" x 28"
- Large steel handwheels
- Shipping weight: approx. 365 lbs.

SALE!

WEST OF THE MISSISSIPPI:

P.O. BOX 2069, BELLINGHAM, WA 98227
CUSTOMER SERVICE: (206) 647-0801 FAX: (800) 225-0021

1-800-541-5537



ALL MACHINES
ABOVE ARE F.O.B.
BELLINGHAM, WA OR
WILLIAMSPORT, PA

EAST OF THE MISSISSIPPI:

2406 REACH RD., WILLIAMSPORT, PA 17701
CUSTOMER SERVICE: (717) 326-3806 FAX: (800) 438-5901

1-800-523-4777

Better Homes and Gardens®

WOOD®

THE WORLD'S LEADING
WOODWORKING MAGAZINE

September 1994 • Vol. 11, No. 6 • Issue No. 72

Editorial/Art Staff

Editor **LARRY CLAYTON**
Managing Editor **JIM HARROLD**
Art Director **C. L. GATZKE**
Design Editor **JAMES R. DOWNING**
Senior Editor/Features **PETER J. STEPHANO**
Senior Editor/How-To **MARLEN KEMMET**
Assistant Managing Editor/Products **BILL KRIER**
Special-Interest Editor **LARRY JOHNSTON**
General-Interest Editor **TOM JACKSON**
Associate Art Director **PERRY A. McFARLIN**
Project Builder **CHARLES I. HEDLUND**
Graphic Designer **CHERYL A. CIBULA**
Production/Office Manager **DARLENE REYNOLDS**
Administrative Assistant **MARGARET CLOSNER**
Art Business Office Secretary **NATALIE DeVORE**
Correspondence Writer **DON MOSTROM**

Technical Illustrators **KIM DOWNING, ROXANNE LeMOINE.**
Product Testing **BOB McFARLIN, DAVE HENDERSON,**
GEORGE GRANSETH. Carving **HARLEY REFSAL.**

Publisher **WILLIAM R. REED**

Director, Marketing/Advertising **CHRISTOPHER W. SCHRAFT**
Sales/Marketing Representatives **JON BOOK,**
JAMES N. FORD

Direct Response Marketing **JANA WEDDELL,**
LISA WIEMKEN

Marketing/Advertising Services Manager **SIGRID ANDERSON**
Promotion Supervisor **RICK PALLISTER**
Marketing/Advertising Services Supervisor **PAT HENDERSHOTT**
Administrative Assistant **KATHY GARLAND**
ADVERTISING OFFICE: 1912 Grand Avenue, Des Moines, IA
50309. Phone 515/284-3785

Business Manager **JANET NELSON**
Circulation Manager **ALAN BRUSH**
Senior Product Manager **ROBERT BROWN**

Chairman of the Executive Committee **E. T. MEREDITH III**
Chairman of the Board, Chief Executive Officer **JACK D. REHM**
President, Chief Operating Officer **WILLIAM T. KERR**
Magazine Group President **CHRISTOPHER M. LITTLE**
V.P., Publishing Director **MAX RUNCIMAN**
V.P., Magazine Circulation **HAL ORINGER**

Better Homes and Gardens® WOOD® Magazine (ISSN-0743-894X) is published nine times a year in January, February, April, June, August, September, October, November, and December by Meredith Corporation, 1716 Locust St., Des Moines, IA 50309-3023. Second-class postage paid at Des Moines, Iowa, and additional mailing offices. Better Homes and Gardens trademark registered in Canada and Australia. Marca Registrada en México. **ONE-YEAR SUBSCRIPTION PRICES:** U.S. and its possessions \$22; Canada, \$34; other countries, \$43. **POSTMASTER:** Send address changes to Better Homes and Gardens WOOD Magazine, P.O. Box 55050, Boulder, CO 80322-5050. ©COPYRIGHT MEREDITH CORPORATION 1994. ALL RIGHTS RESERVED. Canadian GST Reg. #R123482887.

WE CARE! **SUBSCRIPTION SERVICE:** For change of address it is best for you to directly contact your local Postmaster who then will notify us. For any other service on your subscription, please write WOOD Customer Service, P.O. Box 55050, Boulder, CO 80322-5050 (enclose a recent label from your magazine for better service). Or you may phone toll-free **800/374-9663**. Editorial Mailing Address: WOOD Magazine, 1912 Grand Avenue, Des Moines, IA 50309-3379.

PRINTED IN U.S.A.

MPA

EDITOR'S ANGLE

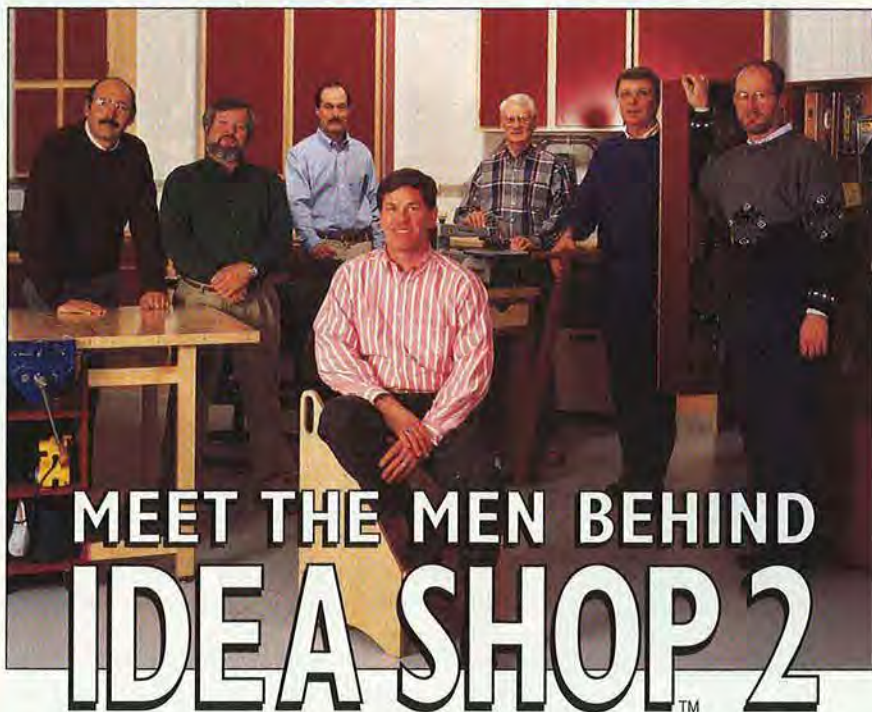

MEET THE MEN BEHIND IDEA SHOP 2™

Taking a breather in the now-completed IDEA SHOP 2 (from left to right): Jim Harrold, Jim Downing, Bill Krier, me, Don Wiperman, Chuck Hedlund, and Jim Boelling.

Readers, I've got to be honest with you. After we completed our first IDEA SHOP in 1992, I wondered how we'd ever manage to match that effort. At the time, it seemed like we had used up every available good idea and included it in that shop. So, even though I didn't share my sentiments with the staff, it was with some trepidation that I asked for volunteers to help create our encore effort, IDEA SHOP 2—THE GARAGE.

As you'll see on page 42 where our shop tour begins, my doubts were unfounded. In many ways, this shop is even better than our first. Why? For one thing, it cost us a lot less to build and equip. For another, this one fits into a space that most of you already have. And believe it or not, IDEA SHOP 2 actually has more ideas in it than the first one did.

I won't spoil your fun by revealing more about the shop here, but I do want to single out some people without whom this project would not have been possible. First, I'd like to thank WOOD® magazine staffers Jim Harrold, Jim

Downing, Jim Boelling, and Bill Krier for helping plan, design, and execute our vision.

My hat also goes off to Don Wiperman and Chuck Hedlund—two of the most experienced and gifted cabinet builders around—for helping us build several of the projects. Guys, you came through when the schedule got tight.

Two of our loyal readers also figured prominently in the success of our effort. Erv Roberts of Des Moines, Iowa, shared with us his design for the drop-leaf workbench featured in the shop. And Arthur Van Den Berg of Two Rivers, Wisconsin, tipped us off to his tool-mover design. Thanks, fellas; we appreciate your valuable input.

And last but not least, let's have three cheers for the manufacturers and suppliers who worked with us in outfitting our shop. They're all listed on page 68.

Photograph: Wm. Hopkins

Larry Clayton

 Print this article

Better Homes and Gardens®
WOOD®
 THE WORLD'S LEADING WOODWORKING MAGAZINE

CONTENTS



37

37 Bud Morrow, gunsmith
 See how an expert checkers gun stocks.

42 Welcome to IDEA SHOP™ 2
 Improve your workshop with the great projects, tools, and ideas in our brand-new garage shop.

46 Drop-leaf mobile workbench
 This sturdy project brims with useful features.

53 Mobile tablesaw base
 Store saw blades and router bits where needed.

58 Accommodating cabinets
 Hang hand tools in these heavy-duty wall units.

62 Storage made simple
 Organize with perforated hardboard and hooks.

64 Hot choices in heaters
 Warm up your shop safely and efficiently.

68 Let's talk tools
 Check out our tool selections for IDEA SHOP 2.

70 Looking up a few old friends
 Meet some of our favorite featured woodworkers.

74 Miss Liberty
 Show your patriotic colors with this carving.

78 Oscillating spindle sanders under \$700
 Read our in-depth report on how they performed.

SHORT-SUBJECT FEATURES

- 1** Editor's Angle
- 4** Talking Back
- 8** Tips From Your Shop (And Ours)
- 20** Ask WOOD
- 28** Products That Perform
- 32** Wood Anecdote
- 34** Great Ideas For Your Shop
- 98** Great Ideas For Your Shop
- 102** Miss Liberty (Continued)



53



58

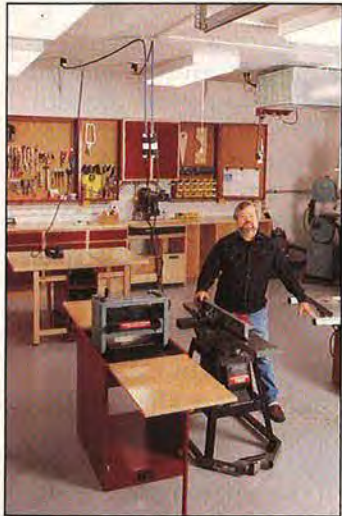

42

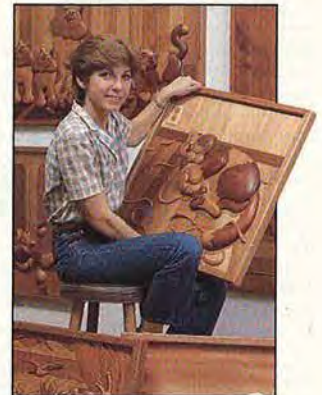

70



46

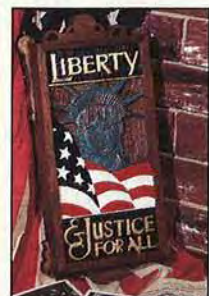

74

This issue's cover wood grain: Butternut

CRAFTSMAN® An American Tradition! Pass it on...



After 65 years as America's premier tool supplier, we've truly become an American tradition. That's why it's no surprise that craftsmen like you pass on their enjoyment of our tools from one generation to the next.

We're rather proud of that tradition, too.

Because it says a lot about the quality and durability of Craftsman tools.

Check out our complete line of radial saws. There's a host of features - like the patented blade guard and the easily accessible carriage bearings. Or take a look at our new wholeshop sawdust collection kit. Attached to your tools, it carries away most of the sawdust that would normally settle around your shop.

You can see the complete line of Craftsman power tools at your local Sears store. Or for convenience, we offer the "Sears Shop At Home" service: 1-800-377-7414.

CRAFTSMAN®

Only at Sears

Wholeshop sawdust collection kit attaches to most stationary and benchtop power tools.

TALKING BACK

Waxed scroll saw table increases control

I found "Rick's Tricks for Scrollsawing Success" from the December 1993 issue informative and helpful. I have an additional tip.

When sawing pine or other resinous woods, the wood will sometimes stick to the table and cause the cut to veer off the cut line. For a solution to this problem, I apply a coat of paste wax to the scroll saw table, and I'm back on line.

—John Garland, Lesterville, Mo.

Voltage is important, too

Your answer to the "Ask WOOD" question about motor horsepower in the January 1994 issue failed to include any mention of voltage of the motors. For the novice comparing motors on amperage draw only, this can be a problem. The comparison must be made on motors of the same voltage (110 or 220 volts) to be valid.

—H. R. McKenzie, Tyler, Texas

Spinning your brush finishes the job

The "Brush Basics" article in the January 1994 issue was an informative one on brush selection and care. Your advice to avoid skimping on brush quality makes good sense, but the article did not mention the use of a "brush spinner" for final cleaning. I use one made by Shur-Line Mfg. of Lancaster, N.Y., to spin the brush and release the final cleaning residue inside a bucket or trash can.

—William B. Graham, Tujunga, Calif.

We contacted Shur-Line Mfg. at 716/683-2500, and found out that this brush spinner also works for cleaning paint rollers.

Safer rust removal

Several years ago, the Early American Industries Association published a rust-removal process similar to the one you printed in the September 1993 issue of WOOD® magazine. The following issue of the association's bulletin immediately pointed out not only the danger of using lye, but also a much safer substitute: sodium carbonate. I have found sodium carbonate in grocery stores in the form of Arm & Hammer Washing Soda, a detergent booster.

The EAIA article recommends using a heaping teaspoon of sodium carbonate per quart of water. A stronger solution can be used, but will not speed up the process very much. You must still use care in handling this product.

—Robert C. Brackett, Hendersonville, N.C.

We welcome comments, criticisms, suggestions, and even compliments. Send your correspondence to: Talking Back, *Better Homes and Gardens*® WOOD® Magazine, 1912 Grand Ave., Des Moines, IA 50309-3379.

That's some stubborn plank!

The "Wood Anecdote" in the February 1994 issue brought back a memory. I was stationed at Milne Bay, New Guinea, during World War II. We found a 2"×12"×16' plank that was left from a ship's dunnage (cargo supports and bracing), and we needed to move it out of our way. It was so heavy it took two men to just budge it.

My platoon officer ordered me to get an axe and chop the plank in half. I took one good lick at the board, and it was hardly dented. We finally ended up dragging the thing into the jungle and leaving it there. It's probably still there for all I know.

For lack of identification, we called that plank "ironwood." I now wonder if it could have been the "turpentine" wood you wrote about in your article. I have worked with several hardwoods, including hard maple, and none of these were as hard as that mystery plank.

—E. H. Vandemark, Dunsmuir, Colo.

New design of an old tool

In the article "He Makes Old Tools Sing Again" in the September 1993 issue, Jim Price mentioned an old tool called a scratch stock that intrigued me. I tried to buy one of these tools, but couldn't find a supplier. After a little research and experimentation, I came up with the design shown below, and used it for making my version of a scratch stock. I grind my scratch-stock blades from dull or broken reciprocating-saw blades.

—Richard A. Murphy, Clifton Park, N.Y.

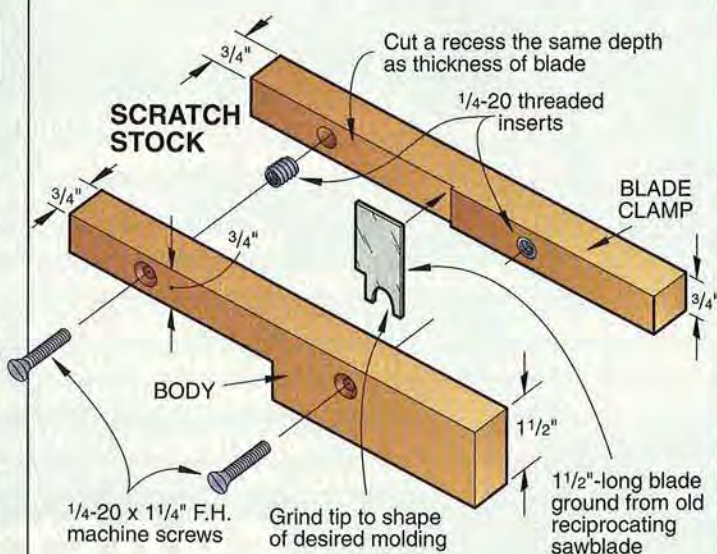

Continued on page 6

Your best projects



Deserve the best cuts

When your work requires absolute precision and quality cuts, there is no substitute for the Freud LU85 -- at any price.

The LU85 produces a flawless cut that requires no sanding. It eliminates chipping and will improve the fit and beauty of your most demanding projects.

Only the award winning LU85 can give you this kind of performance, because no other blade is manufactured with the same care, strict tolerances and fine materials.

The exclusive long-life, titanium-bonded micro-grain carbide tips are ground with special angles, and the laser-cut extra stiff plate is bonded with a thick layer of Teflon® using a special process. This allows the blade to glide through the wood and eliminates pitch build-up.

The LU85 is a precision cut-off saw, ideal for your mitre saw or table saw, for the cutting of natural woods, low pressure laminates and mouldings.

SIZE	TEETH	BORE
8"	64	5/8"
9"	72	58"
10"	80	5/8"
12"	96	1"
14"	108	1"
15"	108	1"

freud®

Precisely what you need.

218 Feld Ave. • High Point, NC 27264

TALKING BACK

Continued from page 4

An angle on cutting tapered workpieces

How can I accurately and safely cut the angles on the ends of the "Seeds & Such Snack Shop" from the September 1993 issue?

—Bill Rettinger, Haddonfield, N.J.

Bill, we cut the long angles on our bird-feeder ends with a bandsaw, and then sanded the edges to the pattern line on a disc sander. However, if you are making several feeders, we suggest you use the tablesaw jig shown in the drawing right. Make this jig from $\frac{1}{4}$ " plywood, fastened to a $\frac{3}{8} \times \frac{3}{4} \times 15$ " (or sized to fit your saw) hardwood guide for the miter-gauge slot. Measure the distance from the miter-gauge slot to the sawblade, and add $\frac{1}{16}$ ". Transfer this measurement to the plywood base, and glue and screw the hardwood guide outside of these marks. Then, cut the jig to size by placing it in the miter-gauge slot and passing it through the blade.

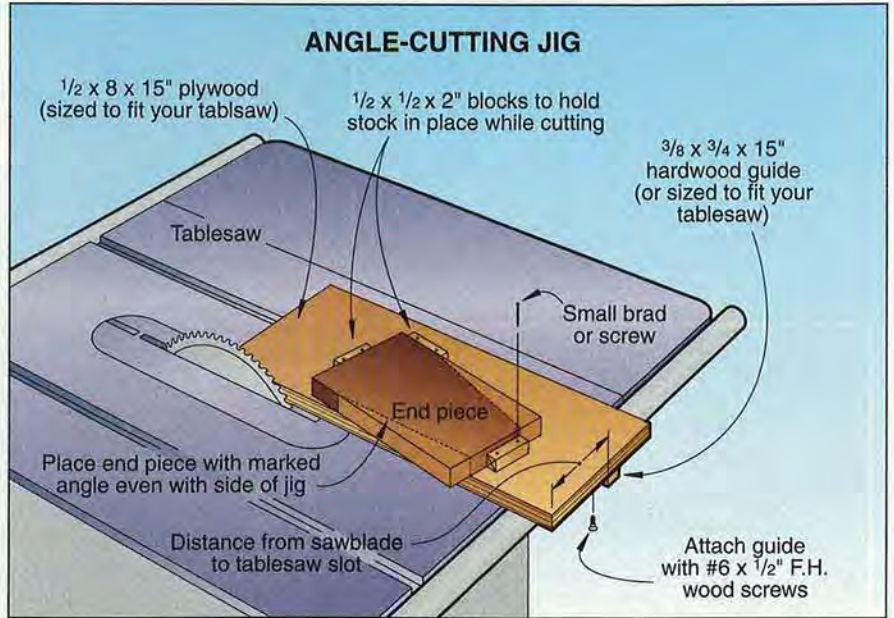

To make the end panels, first cut them to the size listed in the cutting diagram in the bird-feeder article. Draw the long side angles on one end piece, and use this end as a guide for mounting the small placement blocks on the jig. Fasten

these blocks in place with brads or small screws.

Place the end piece in the jig, and cut an angle on one side. Turn the end over, and cut the second angle. You can now produce as many bird-feeder ends as you wish.

POSITION OF BOWL IN LOG	GRAIN SHOWING ON BOWL	GRAIN SHOWING 90° FROM PREVIOUS SKETCH

Where's the bowl in this log?

The Ask WOOD answer "Check those cracks" from the December 1993 issue raised a question: Which is the best side of a bowl blank to fasten to the faceplate?

—Ted Lucas, Alpena, Mich.

We prefer to mount the bowl blank with its face grain glued to a wooden disk or auxiliary faceplate, Ted. We then fasten this auxiliary faceplate to the lathe faceplate with wood screws.

Otherwise, the determining factor of how to mount a bowl blank to the faceplate will be how you want the grain to appear on the finished bowl. There should be no problem with warpage or cracking, provided that your bowl blank is properly cured. See the drawing right to determine how mounting the bowl blank on the faceplate will affect the grain direction of the bowl. 🌲

THE FINEST SAW FROM ANY ANGLE.



**LEFT
BEVEL
CUT**

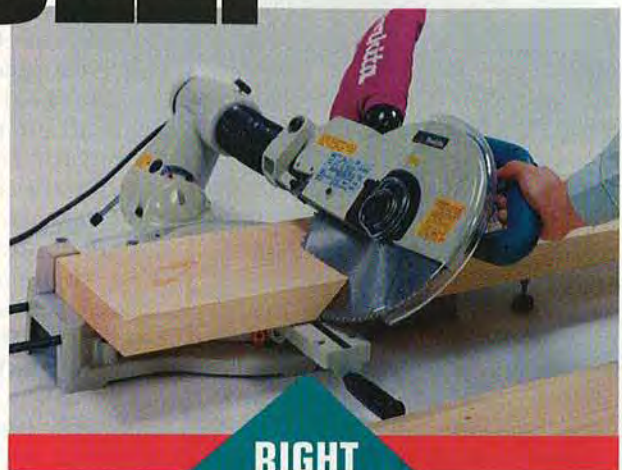

**RIGHT
BEVEL
CUT**

**12" Slide Dual
Compound Saw
Model LS1211**

With an unbeatable combination of breakthrough features and advanced technology Makita's model LS1211 is the most revolutionary compound saw available today.

Its unique design and powerful 15 AMP motor allow miter, bevel and compound cuts to be

made quickly and precisely. And unlike any other saw on the market, the LS1211 can bevel cut up to 45° to the right. What this means is that you can cut virtually any angle with the LS1211.

Makita has also added as standard equipment a 96 tooth carbide tipped blade that produces a super fine cut.

Innovative and versatile from any angle, Makita's Slide Dual Compound Saw is a revolution in power tools.



Model LS1211

Makita[®]
IT'S ALL THE POWER YOU NEED.

Makita U.S.A., Inc., 14930 Northam St., La Mirada, CA 90638-5753

TIPS FROM YOUR SHOP (AND OURS)

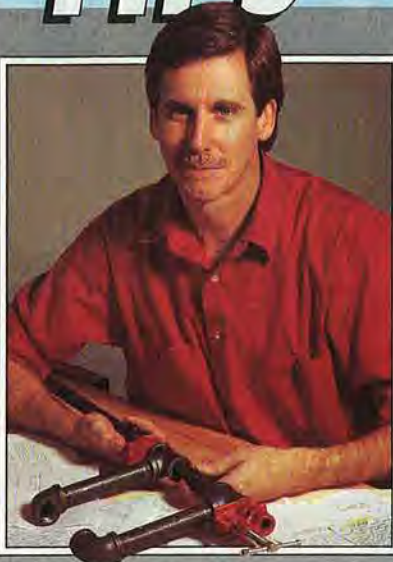

When we first saw E. E. Reynold's shop tip for modified pipe clamps, below right, some of the staff had doubts. As the general interest editor, I investigate these concerns. So I headed for the hardware store, bought the parts, and gave it a test. Sure enough, it works great.

Tips like these—your ideas mostly—help to make this one of the best-read sections of the magazine. And we want to hear about it the next time you discover a new shortcut, technique, or jig. Just send a brief description of the idea and a drawing or photo to:

Shop Tips
WOOD Magazine
 1912 Grand Ave
 Des Moines, IA 50309-3379.

We try to avoid shop tips that have appeared in other magazines, so please send yours to only one. Also note we cannot return your submissions.

If we choose your tip for publication, we'll pay you \$40, plus you'll get a shot at winning a new tool for submitting the top tip. Thanks, and keep those shop tips coming!

Tom Jackson

Magnet bristling with brads ends pounding headache

You're assembling a project with brads, but you may as well be wearing mittens as you try to pick up the tiny brads from the workbench or out of the box.

TIP: Put a bunch of brads on a magnetic pick-up tool. Drill a hole that fits the handle of your tool in a block of scrapwood. Then, instead of pouring out some brads, poke that pickup tool into the box and bring out a cluster of brads. Stand the tool in the block of wood. Now, pick brads off the magnetic tool one at a time for fumble-free nailing. Don't have a magnetic pick-up tool? Tape a craft-store magnet to a scrap of dowel rod.

—Frank H. Day, Anaconda, Mont.

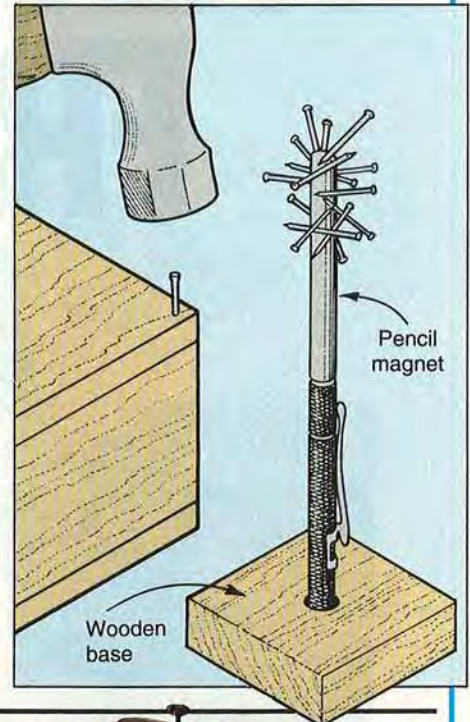

Clamp reaches out with added fittings

Pipe clamps work best on glue-ups that, like some rivers, are wide but not very deep. So, what do you do when you need a clamp with longer reach?

TIP: Thread together 3/4" black-pipe fittings to fabricate a set of sliding extension jaws for a 1/2" pipe clamp. Pick a nipple length that fits the situation, and then thread a tee fitting on one end, and a 90° elbow on the other. Make two such jaws. Remove the sliding jaw of the pipe clamp and slip the tee fittings over the pipe. With the open ends of the elbows face inward. Replace the sliding jaw, and clamp your project, protecting the wood from the rough iron of the elbows.

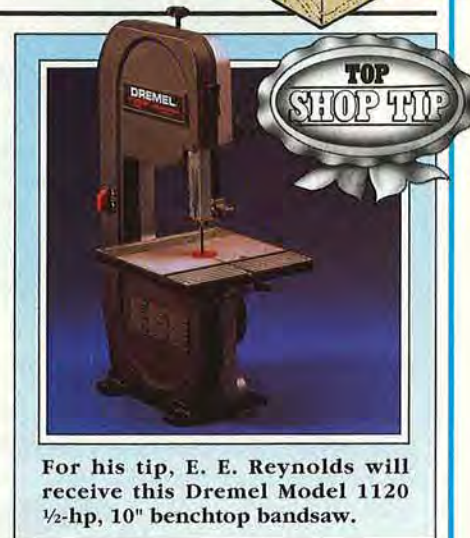

For his tip, E. E. Reynolds will receive this Dremel Model 1120 1/2-hp, 10" benchtop bandsaw.

—E. E. Reynolds, North Charleston, S.C.

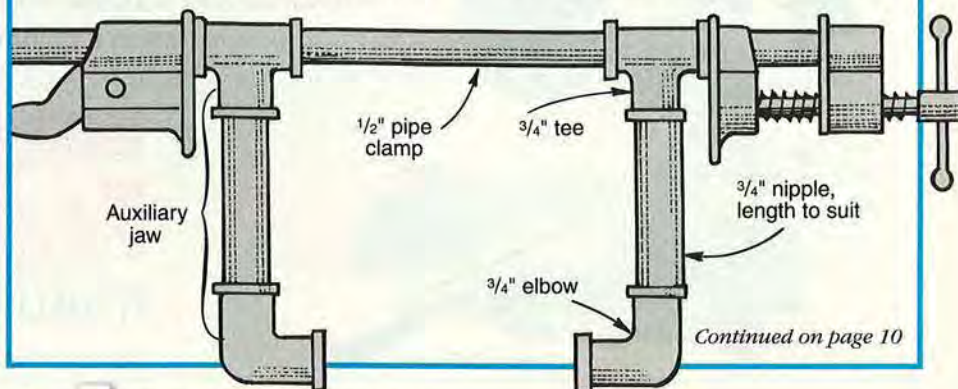

Continued on page 10



In a durability test, the competitor's hammer lasted 60 seconds. If you happen to need one for longer than that, buy a Stanley hammer.

This picture tells the story better than any words can. In our overstrike tests, the Stanley hammer outlasted the competitor's brand by a 4 to 1 ratio.*

You see, after years of research (and a whole lot of sleepless nights) our engineering department concluded that jacketed, solid-core fiberglass is more durable than the compression-

molded variety some of our competitors use to make their hammers.

That's the Stanley philosophy. Don't quit working until your product is perfect. You'll find this kind of dogged determination across the board at Stanley. In everything we make. Like a garage door insulated to reduce noise. Or a closet organizer made

with steel planks instead of wire so it doesn't wrinkle your clothes.

It's innovative thinking like this that's kept us ahead of the competition for more than 150 years. At Stanley we're not happy simply churning out products. We're only happy when our products are better than anyone else's.

STANLEY
helps you do things right.

TIPS FROM YOUR SHOP (AND OURS)

Continued from page 8

Chains take pains from drying parts

When you have a lot of large parts to finish—such as shelves—spreading them out for drying can take up a lot of space. In a small shop, you may not have that space.

TIP: Chains and ceiling hooks can make drying racks that hold a lot of parts in a little space. Screw the hooks into ceiling joists about 12" from the wall (or other distance, as appropriate). Space the hooks as the parts require, and hang a 7-8' length of chain from each. Light-duty chain, such as the twisted-link variety, will suffice for most projects. On each part to be finished, center a screw or nail at each end. Hang the parts horizontally between the chains, placing the screws or nails into the chain links, as shown in the illustration at *near right*.

Using this same idea, you can hang parts vertically, too. Place a screw eye in one end of each part. Then, loop the chain between

two ceiling hooks, and hang the parts from S-hooks on the chain, as shown *below*.

—Richard Trowbridge, Akron, Ohio

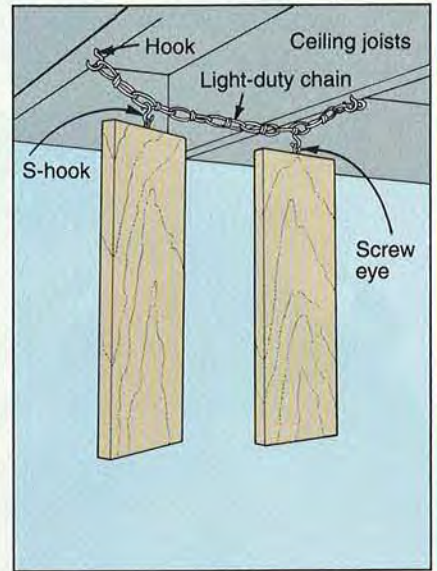
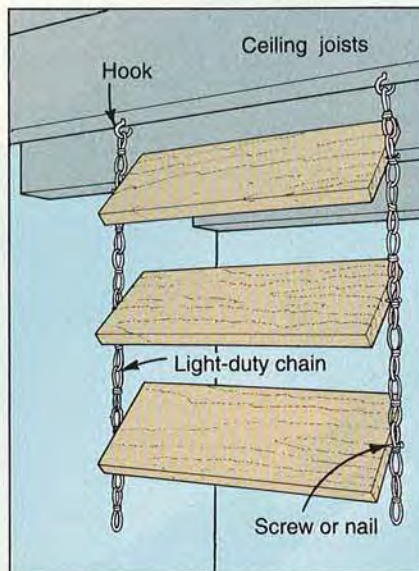

Continued on page 12

Titebond®



Trusted by craftsmen for over 35 years.

Franklin International

2020 Bruck Street
Columbus, Ohio 43207
(614) 443-0241

PROJECT HELP LINE 1-800-347-GLUE
Assistance available 8:00am-5:00pm Monday-Friday EST

■ **Original Titebond Wood Glue**
Superior strength and fast set.

■ **WeatherProof Titebond II Wood Glue**
Passes Type II water resistance.

■ **New!**
Titebond Dark Wood Glue
Original formula now available
for use with darker woods.

MAYBE IT'S TIME YOU SEEK PROFESSIONAL HELP.



Say you've always wanted a good band saw. Or you've about given up trying to make precision cuts with your hand-held circular saw. Or perfect holes with a portable drill.

Tough to know just where to start. Do you go the "big buck" route or try one of those "cheapo no-names"?

This'll help. Delta has been the choice of professional woodworkers for 75 years, now. And the tools you're look-

ing at are built with the same heft and precision we put into our professional tools. Yet they're priced to fit comfortably into any shop.

Whether you're in the market for a bench saw, band saw, scroll saw or drill press, Delta tools are a great place to start.

The scroll saw features our Quickset™ blade changing system. The band saw, our Quickset™ blade tensioning system. So you'll spend more time cutting and less time messing around with blades. And that 12" Portable Planer will have you surfacing your own stock, from 1/8" to 6" thick, up to 12" wide. In your own shop.

They're just part of the broadest line in the industry. Woodworking tools for the master craftsman, the weekend do-it-yourselfer and everyone in between.

Delta. If you think it's time you got some professional help.

Call toll free for the name of the nearest dealer,

home center or hardware store carrying Delta tools. Delta International Machinery Corp., 800-438-2486.

In Canada, 519-836-2840.

Delta is a Pentair Company.

**THE
POWER
OF THE
PROS**



DELTA
WOODWORKING MACHINERY
FOR 75 YEARS



Delta is proud to nationally fund these two PBS programs for woodworkers.

The New Yankee Workshop hosted by Norm Abram.



The American Woodshop with Scott Phillips.

Continued from page 10

Rabbet on tablesaw fence helps you trim panels flush

You've glued some solid-wood edging on a set of plywood panels and now it's time to trim the edging flush. If you don't have a flush-trim router bit, is hand planing the only solution?

TIP: If you own a tablesaw, you're just an auxiliary fence away from a super-quick solution. Make a 1x6" wooden auxiliary fence for your tablesaw, and cut a rabbet in its face exactly as wide as the kerf of your blade. Attach the auxiliary fence to your regular rip fence and position it so that the outside

edge of the blade is flush with the outside face of the auxiliary fence, as shown in the drawings below left. Then, run your workpiece along the fence to trim off the excess edging. We use a 50-tooth, carbide-tipped blade for clean, splinter-free results.

—from the **WOOD®** magazine shop

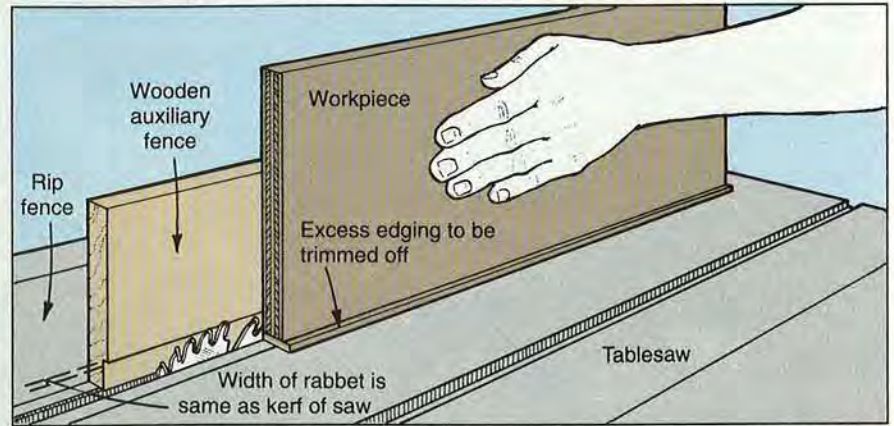
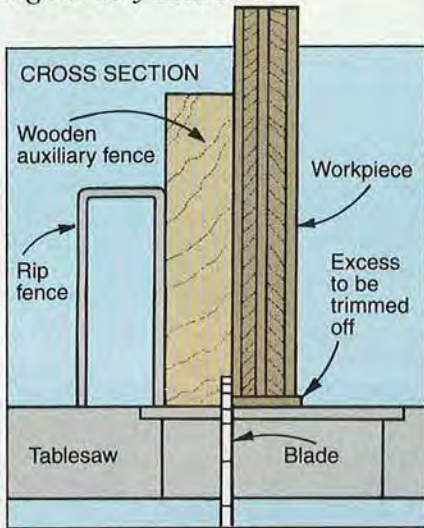

Continued on page 14

Hand tensioned plates insure accurate cuts.

Dyanite® C-4 carbide teeth last 2 to 5 times longer than standard C-4 carbide.

Industry depends on DML...you can too.

Item No. 74032 (shown)

Manufactured in USA for industrial use.

DML Cutting everything but corners.

Superior plate finish for reduced resin and heat build-up.

Plugged expansion slots reduce noise.

Informative packaging helps you select the best blade for your job.

For over 50 years industrial woodworkers have put their trust in DML precision tooling for consistently smooth cuts. Now, you can use the best quality American manufactured cutting tools in your shop.

revolutionary precision-ground Dyanite® C-4 carbide teeth that give you the best quality cuts time after time. Call 1-800-242-7003 for your authorized DML distributor.

DML DML performance and durability—depend on it!

Only award winning DML Golden Eagle® saw blades have

DML Cutting everything but corners.

Tips from **Franklin International**

Makers of **Titebond®** Wood Glue

Chalk Point

All water-based wood glues have a minimum bonding temperature, a property known as a chalk point. Although this critical temperature is different for each product, each glue must be used above this point.

- When a glue dries at or below its chalk point, it dries white and produces a very low-quality bond.
- If the glue you are using dries uncharacteristically white, it has likely dried too cold. In this case, sand off the white film of glue, allow the materials being bonded to warm up, then reglue.
- Remember, the glue in the bond-line will dry at the temperature of the wood, so make sure the wood itself is above the chalk point of the glue.

For more information call 1-800-347-GLUE

Please see our full-color ad on page 10.

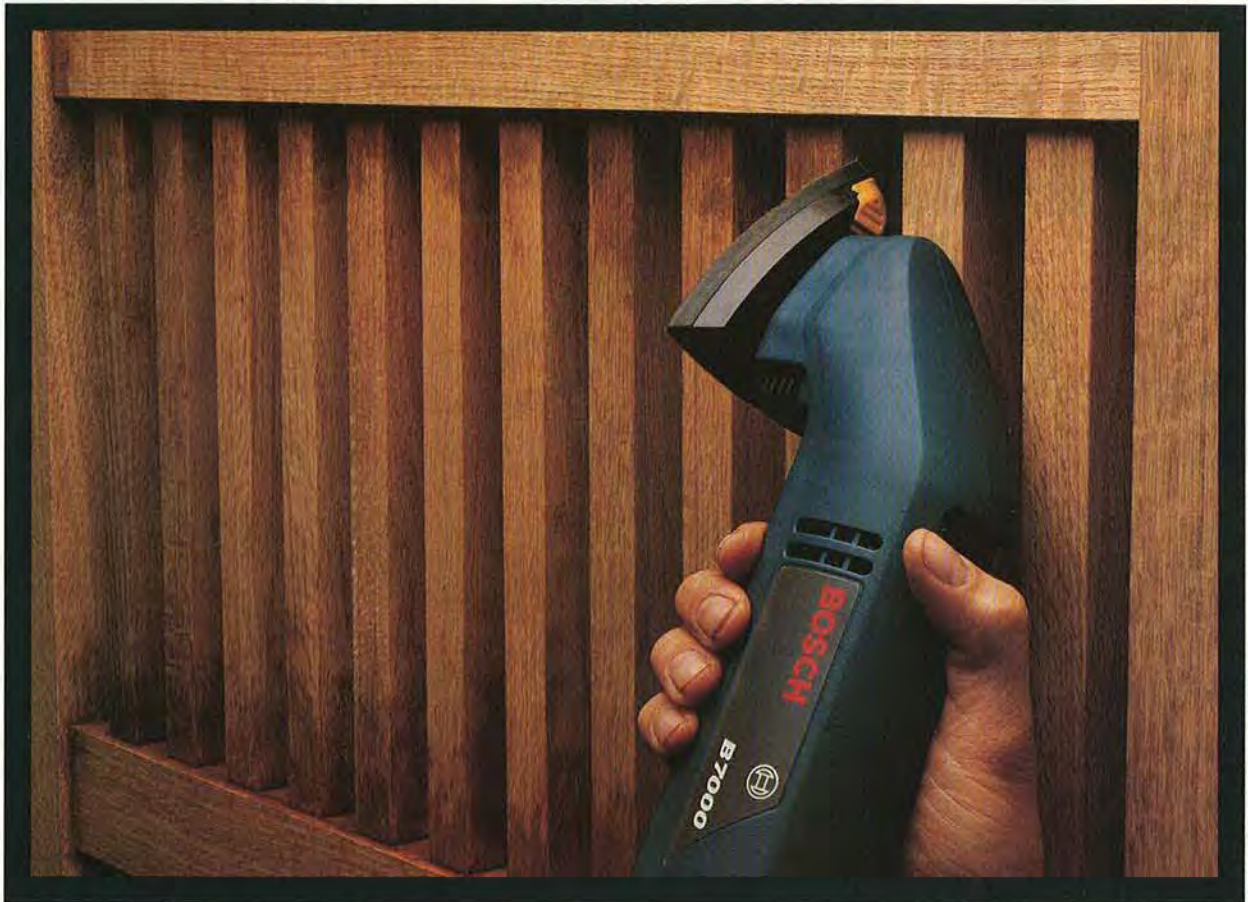

© 1994 S-B Power Tool Company, 4300 W. Peterson Ave., Chicago, IL 60646

Our new sander takes care of details others haven't even thought of.



Most corner sanders just scratch the surface compared to the new Bosch B7000. For example, its motor not only delivers 1.1 amps of true orbital action but also minimizes annoying vibrations.

What's more, to meet the demands of jobs ranging from scraping to polishing there's a wide selection of optional pads. Hook-and-loop backings make them easier to change than messy adhesives. Plus, unlike the competition, pads and head points last longer thanks to the exclusive Clic™ adjustable head.



For added versatility, a pad extender accessory gets the B7000 into places other corner sanders can't touch. And for a cleaner workplace, a dust extraction port is included as standard equipment. Another thing that'll make you breathe easier is its one year warranty, 90 day satisfaction guarantee and one year service protection plan.

Be sure to get the corner sander that's cornered the market on performance, the B7000 from Bosch.



BOSCH
Power Tools

ENGINEERED FOR PERFORMANCE™



**CUT,
GRIND,
SAND,
SHARPEN,
DRILL,
POLISH,
DEBURR,
BUFF,
CARVE,
ROUT,
ETC,
ETC.**



The Dremel Moto-Tool® is the compact, high-speed rotary tool that's extremely versatile. With speeds from 5,000 to 30,000 rpm and more than 150 available bits, it lets you handle almost any job. Use it on wood, metals, ceramic tile, glass, fine

silver, plastics, laminates and more. Look for our book 175 + USES in specially marked Moto-Tool packages where power tools are sold. Or write: Dremel, Dept. W, P.O. Box 1468, Racine, WI 53406-1468 for a free copy.

DREMEL®

Circle No. 33

TIPS FROM YOUR SHOP (AND OURS)

Continued from page 12

Extended jaws improve clothespin clamping

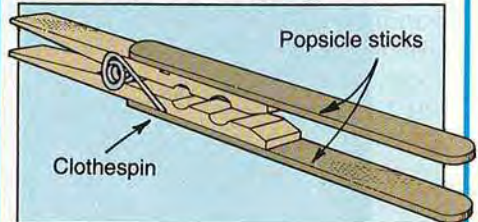

Spring-type clothespins make great clamps for small work. But they'd be even handier sometimes if the jaws opened wider for clamping thicker parts.

TIP: Extend the jaws by gluing scrapwood or Popsicle sticks to the clothespin where shown. Woodworker's (yellow) glue or epoxy will hold the lengthened jaws in place, but be sure to allow the glue to achieve full strength before putting the clothespin clamps into service.

—Joseph Loduca Sr., Fenton, Mo.

Put on lipstick to kiss lock misalignment goodbye

For your drawer lock to work properly, the lock bolt must slide smoothly into the mortise (or hole) you make for it. But, trying to measure and mark that location is driving you crazy.

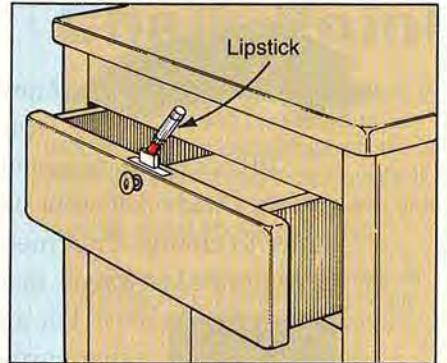

TIP: Extend the lock bolt and put lipstick on the end of it. Retract the bolt, close the drawer, and then extend the bolt. The lipstick will mark the correct position for the bolt hole or mortise. You can mark door locks and cabinet latches this way, too.

—Cynthia Hewitt, Grants Pass, Ore.

Continued on page 16

THE PREDATOR. IT TOOK PANASONIC TO ENGINEER TECHNOLOGY THIS BIG INTO A POWER TOOL THIS COMPACT.

3/8" HEAVY DUTY
KEYLESS CHUCK

PLANETARY GEAR SYSTEM

POWERFUL 12-VOLT MOTOR



PRECISION
22-STAGE CLUTCH

174 IN. LBS. OF
MAXIMUM TORQUE
AT ALL SPEEDS

VARIABLE SPEED
CONTROL WITH
ELECTRIC BRAKE

ERGONOMICALLY
DESIGNED AND
BALANCED

LIGHTWEIGHT
AT ONLY 3.8 LBS

15-MINUTE
"COFFEE BREAK"
CHARGING SYSTEM

"IRONMAN" HIGH-CAPACITY
BATTERY PACK

12V E

PREDATOR See for yourself. There simply is no other cordless power tool that packs so much technology into so compact a tool as the Panasonic Predator EY 6100EQK cordless tool.

Feature for feature, ounce for ounce, The Predator offers the professional more power and better performance than any cordless power tool has a right to. Because it's precision-crafted to offer a power-to-weight ratio that tackles even tough jobs with minimum fatigue. Small enough to work in tight spots. So powerful it devours work.



The "Ironman" high-capacity battery pack, another innovation from Panasonic, delivers more work per charge and uses our 15-minute "Coffee Break" charging system. **15**

And like all Panasonic power tools, The Predator cordless tool comes with our 30-day quality satisfaction guarantee.* Your satisfaction will long outlive the guarantee.

Panasonic®
CORDLESS POWER TOOLS
POWER TO SHAPE THE FUTURE.

*30-DAY QUALITY SATISFACTION GUARANTEE: If you are dissatisfied with any Panasonic Cordless Power Tool for any reason, simply return it to the place of purchase with a dated proof of purchase in the original packaging with all accessories, parts and instructions within 30 days of the date of purchase for a full refund, or call Panasonic at 201-392-6655. Abuse or misapplication of any power tool voids the guarantee.

STEVE WALL LUMBER CO.

Quality Hardwoods and Woodworking machinery For The Craftsman and Educational Institutions

Ash4/4	Select	2.15	\$ 67.00
Basswood4/4	Select	1.70	\$ 57.00
Birch4/4	Select	2.25	\$ 69.00
Butternut4/4	1C	1.85	\$ 59.00
Cherry4/4	Select	3.00	\$ 83.00
Hickory - Pecan4/4	Select	1.80	\$ 61.00
Mahogany (Genuine)4/4	Select	3.15	\$ 86.00
Maple (Hard)4/4	Select	2.35	\$ 71.00
Maple (Soft)4/4	Select	1.80	\$ 59.00
Poplar4/4	Select	1.55	\$ 54.00
Red Oak4/4	Select	2.35	\$ 70.00
Walnut4/4	Select	3.00	\$ 85.00
White Oak4/4	Select	2.30	\$ 69.00
Cedar (Aromatic Red)4/4	1C+Btr.	1.55	\$ 56.00
Cypress4/4	Select	2.10	\$ 64.00
White Pine4/4	F.G.	1.10	\$ 45.00
Yellow Pine4/4	Clear	1.55	\$ 55.00

Above prices are for 100' quantities of kilndried rough lumber sold by the Bd. Ft. FOB Mayodan, NC. Call for quantity discounts. Other sizes and grades available.

Above prices are 20 bd. ft. bundles of clear kilndried lumber 3"-10" wide • 3'-7" long (Random widths & lengths) Surfaced 2 sides or rough. Delivered UPS prepaid in the Continental U.S.

LOG RUN SPECIALS

100 bd. ft. Bundle
 4/4 Cherry \$120
 4/4 Walnut \$140
 Add \$20 for S2S
 Motor Freight Only
 FOB Mayodan

STEVE H. WALL LUMBER CO.

BOX 287
 MAYODAN, N.C. 27027
 910-427-0637
 1-800-633-4062
 FAX 910-427-7588

Send \$1.00 For Lumber Catalog

Circle No. 592

TIPS FROM YOUR SHOP (AND OURS)

Continued from page 14

One-step wheel painting with dowel rod and coat hanger
Painting one side of a small wooden wheel, waiting for it to dry, and then painting the other side takes a lot of time and often leaves you with overlapping paint streaks.

TIP: With this holder you can paint both sides of the wheel at the same time and dry the finished wheels on an old coat hanger. Start by driving a brad through a dowel rod that fits into the axle of the wheel. Bend the point of the brad up parallel with the length of the dowel.

Next cut one end of an old coat hanger and form a loop as shown at below. Paint one side of the wheel, then pick it up by inserting the dowel rod in the axle hole. With the wheel balanced on the brad, paint the other side and transfer the finished wheel to the coat hanger using the dowel rod. When you're done painting, insert the bottom of the coathanger in the loop so the wheels don't fall off. Then hang them up to dry.

—David Burr, Rockville, Md.

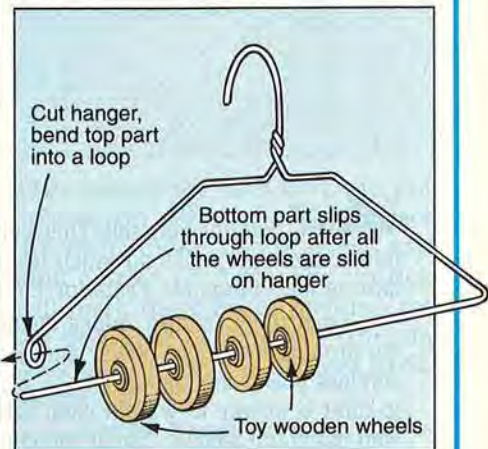
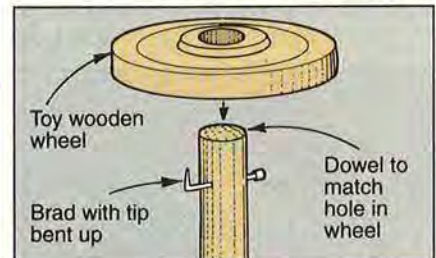

Continued on page 19

- TRIPLE BRIGHT RUGGED CHROME HOUSING
- CONTOURED COMFORTABLE DESIGN
- POSITIVE EASY TO USE THUMB LOCK
- EASY TO READ DUAL MARKINGS FOR LOCATING STUDS
- PRO-TECH™ ANTI-CORROSION FINISHED BLADE



- TEMPERED STEEL BLADE REMAINS RIGID FOR APPROXIMATELY 7 FEET
- TRIPLE REINFORCED NON-SLIP END HOOK
- CALIBRATED FOR TRUE ZERO
- HEAT TREATED HIGH CARBON STEEL RETURN SPRING GIVES LONGER LIFE

RUGGED HEAVY DUTY PROFESSIONAL RULES!

AVAILABLE IN SIZES OF:
 12' 16' 25' 30' 50' 100'

AND A MUST SEE 25' NEON GREEN

Available at Kmart and other leading stores everywhere.



ARROW FASTENER COMPANY, INC. 271 MAYHILL STREET, SADDLE BROOK, NEW JERSEY 07662
 IN UNITED KINGDOM: ARROW FASTENER (U.K.) LTD., 14 BARCLAY ROAD, CROYDON CRO 1 JN UNITED KINGDOM
 IN CANADA: JARDEL DISTRIBUTORS, INC., 6505 METROPOLITAN BLVD. EAST, MONTREAL H1P 1X9 QUEBEC



Hold everything.

Here's the third hand you always wanted: the revolutionary QUICK-GRIP® Bar Clamp.

Its unique pistol-grip handle lets you hold the clamp and adjust jaw pressure with just one hand – an easy solution to even the most demanding clamping problem. For wood, plastic or other

materials, the new QUICK-GRIP Bar Clamp makes any job easier and faster.

The QUICK-GRIP Bar Clamp was named one of *Popular Science's* top 100 new products. You'll know why, the first time you hold one in your hand – it's light, strong, quick to use. It's just what you'd expect from the makers of VISE-GRIP® Tools.

Available from your American Tool distributor.

QUICK-GRIP®
A UNIT OF **AMERICAN TOOL**
COMPANIES, INC.

©1990/1992 American Tool Companies, Inc. **MADE IN USA**

NOW! PLANE, MOLD, SAND and SAW with

Infinitely Variable Power-Feed!

**MAKES YOU MONEY...
SAVES YOU MONEY!**

Put this versatile power-feed tool to work in your shop... see how fast it pays for itself! Quickly converts low-cost rough lumber into valuable finished stock. Turns out perfect picture frame moldings, quarter-round, casing, tongue and groove... all popular patterns... any custom design.

✔ **Just a twist of the dial** puts twice as many cuts-per-inch at your fingertips as any comparable planer – from 70 to over 1,000 CPI! This heavy-duty machine will sail through even the toughest oak at higher speeds, or you can slow it down to handle those “hard-to-work” pieces like curly maple, knotty cedar, burls, knees and much more! A valuable feature for molding work, where profiles make sanding impossible.

✔ **Change to Molding, Sanding or Sawing in just minutes!** Unique “Morse-Taper” Quick Change Cutterhead guarantees fast changeover... bearings remain factory set... precisely aligned at all times.

✔ **Now choose from three powerful models!** Woodmaster introduces the first 18" and 25" Planer/Molders... with all the features that have made the 12" model the most versatile Planer/Molder on the market! Send for Free Facts today!

**FREE
30-DAY
TRIAL!**

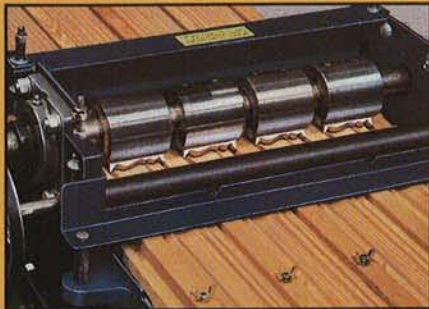

Woodmaster's Quick-Change Molding Head lets you create custom moldings from any stock. Choose from over 250 standard trim and picture frame patterns... or design your own!



Power-fed sanding speeds production and improves the quality of your work. No more waves or cross-grain scratches. Separate sanding head installs in just minutes.



New rip saw attachment lets you gang-rip with power feed in a fraction of the time it takes for multiple hand-fed passes on an ordinary table saw.

**MAIL TODAY OR CALL
1-800-821-6651 Ext PW71**

**FREE
FACTS**

YES! Please rush me your FREE Information Kit plus details on your 30-DAY FREE TRIAL GUARANTEE!

Woodmaster Tools, Dept. PW71, 1431 N. Topping, Kansas City, MO 64120

NAME _____

ADDRESS _____

CITY _____

STATE _____ ZIP _____

PHONE () _____

Here's What Woodmaster Owners Say:

Shop Test Results—"It does an excellent job of planing, on a par with more expensive machines, and even better than some commercial models."

Editor, Workbench Magazine

Best Value—"After checking them all, Woodmaster was obviously the best deal for the money. Also, I would like to acknowledge the polite and prompt service."

E. D. Holtz, North Carolina

TIPS FROM YOUR SHOP (AND OURS)

Continued from page 16

Pour a puddle of glue for easy plugging

Neatly applying woodworker's glue to plugs can be tricky. You just can't dribble a small stream out of the bottle.

TIP: Pour some glue onto a plastic jar lid or other suitable palette. Then, roll the bottom edge of the plug in the puddle of glue to apply an even coating right where you need it. Glue buttons, Shaker pegs, axle pegs, and other similar parts the same way.

—Glyn Roberts, Woodruff, Wis

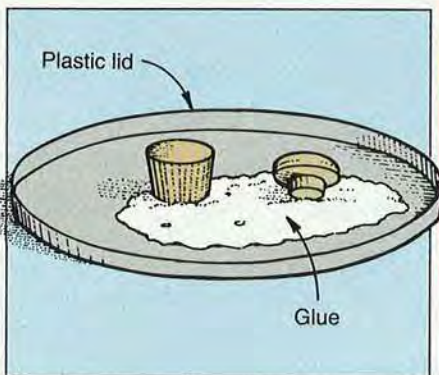

A FEW MORE TIPS FROM OUR WOODWORKING PROS

- Tired of grunting and groaning every time you have to move a big power tool? Take a look at the design for a mobile tablesaw base on page 53. You can apply this "wheelbarrow" design to many stationary power tools.

- Struggling with large, heavy sheets of plywood can strain your back and jeopardize your safety. To get a better handle on your sheet goods try our Roll Around Plywood Cart on page 34 and our Sheet Goods Support Rack on page 98.

- Shop manuals and paperwork often disappear, causing major headaches. An accordion-style file folder will fit neatly on any shop shelf and keep these important papers organized. 📁

One Stop Wood Shop

Domestic and exotic hardwood plywood and lumber, marine plywood, over 30 species in stock—all under one roof.

Custom cutting services to your exact specifications with little or no waste at competitive prices! We specialize in bundling and shipping.

Call (617) 666-1340 today for catalog and quote.

Boulter Plywood Corp.
24-WD Broadway, Somerville, MA 02145

Circle No. 512

We've Added Speed To Every Woodworking Vise...

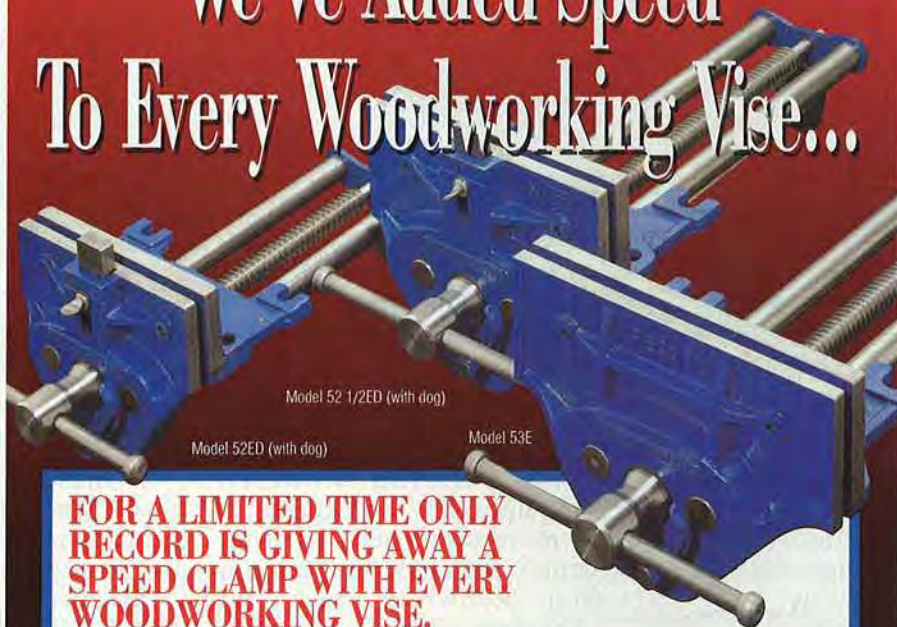

FOR A LIMITED TIME ONLY RECORD IS GIVING AWAY A SPEED CLAMP WITH EVERY WOODWORKING VISE.

We're making this great offer to introduce you to remarkable Record Woodworking Vises... the quality vises that defy comparison!

Remember, before you buy - always compare and you'll insist on Record! You should ensure that the sliding jaw and body are finely cast from grey iron. And, these components should be precision machined on computer controlled equipment for consistent repetitive accuracy so you don't have to worry about 'getting a good one'. Look at the vise side-on. When fully closed the jaws should meet only at the top, leaving a gap at the bottom. That gives you even clamping pressure on the whole depth of the workpiece. And, of course, countersunk holes should be provided so you can fit your own choice of wooden cheeks to protect the work.

The steel main screw should have a buttress thread and quick-release trigger mechanism. This disengages the main screw allowing the jaw to slide freely - saves a lot of time if you're working with different widths of stock. The steel guide rods will be accurately made and fitted, reducing wear and providing a smooth parallel adjustment. And if you intend to install 'stops' along your bench top, you'll find an adjustable 'dog' is a useful extra.

These and other features have made our vises first choice for generations of woodworkers.



Visit your authorized Record Dealer today!

Record Tools Inc.
1920 Clements Road, Pickering, Ontario, Canada L1W 3V6
Canada Tel: (905) 428-1077 Fax: (905) 428-7555
U.S. Tel: (716) 842-1180

BONUS



FREE Record SPEEDCLAMP

Purchase any one of these quick release woodworking vises (52ED*, 52 1/2ED*, 53E with 8", 13", and 15" jaw openings) at your authorized dealer before January 30, 1995 and you'll receive a Record Speedclamp M.S.L. over \$25.00... **ABSOLUTELY FREE!**

LIMITED OFFER! While supplies last

* With adjustable 'dog'.

ASK WOOD

Glue up after staining

I prestain many of the parts I make so that I can store and transport them, and later assemble the parts at crafts fairs. Can you suggest an adhesive for joining these prestained workpieces?

—Doug Grimm, Riverside, Calif.

We don't know of such a glue, Doug. We contacted the glue experts at Franklin International, manufacturers of Titebond-brand adhesives, and they confirmed our suspicions that the stain will interfere with glue penetrating the surface of the wood. This results in a weaker bond at the glue joint.

For a solution to your problem, we suggest that you mask the areas that will be glued. Remove the masking tape as soon as possible after staining the pieces to reduce the amount of tape-adhesive residue. This excess adhesive can be removed with lacquer thinner or acetone. The cleaner the joint surface (no stain, oil, finish, or other contaminant) the stronger the glue joint. Touch up any visible unstained areas after you assemble the project.

Poplar as an outdoor wood

We plan to replace a wrap-around porch on a Victorian home. I can buy readily available and reasonably priced 2"-thick poplar for making the many railing spindles. Is this a good wood to use for turning these spindles?

—Don Seymour, Beverly Hills, Fla.

Yellow poplar machines very nicely and provides an excellent surface for painting. However, this wood does not stand up well when exposed to the weather, and has more often been used for light interior construction, furniture, and interior trim. Redwood, cedar or Eastern white pine have greater decay resistance and a smaller seasonal dimensional change than poplar, and would be better choices for making these spindles.

Whichever wood you use, you can extend the life of these spindles with proper railing design and care. Be sure to prime and paint the spindles to protect them from the elements, paying particular attention to sealing the end grain. Angle the top of the bottom porch rail to prevent water from pooling around the spindle bases, and fill and seal all nail holes.

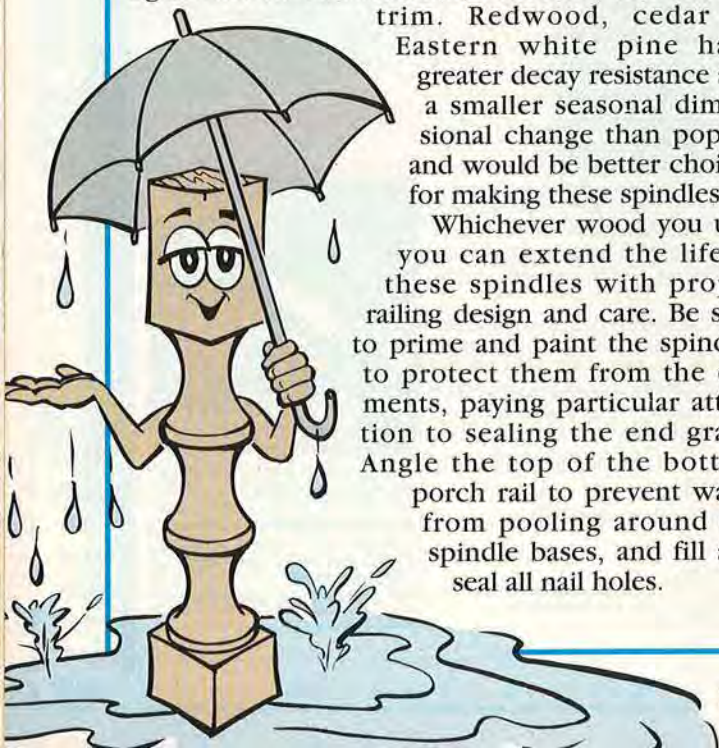

Whether your woodworker's license reads "Beginner," "Intermediate," or "Advanced," you're bound to have a few questions about your favorite hobby. We can help by consulting our staff and outside experts. Send your questions to Ask WOOD®, *Better Homes and Gardens*® WOOD Magazine, 1912 Grand Ave., Des Moines, IA 50309-3379.

More than just a name

Why are some of the saw cuts called by a different name? For example: dado, rabbet, lap, and groove?

—Russ Mobley, Thomson, Ga.

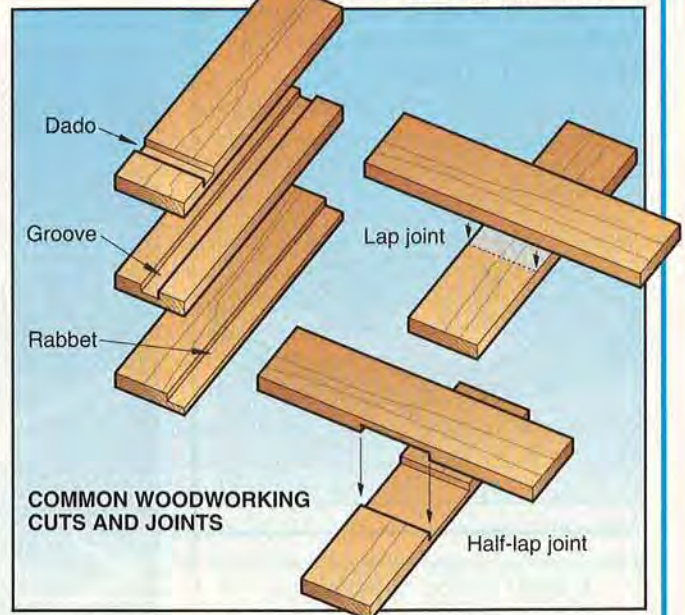

Thanks for asking, Russ. As experienced woodworkers, we tend to take these terms for granted, but some explanation is in order from time to time. These terms describe specific wood cuts, and allow woodworkers to plan or communicate exactly how they will build a project. We define these terms as:

1) A *dado* consists of a flat-bottomed, U-shaped cut that runs across the grain of the wood. Use a dado to mount shelves in cabinets or bookcases.

2) A *groove* is also a flat-bottomed, U-shaped cut, but it runs in the same direction as the wood grain. Use a groove to hold panels in door frames.

2) The term *rabbet* describes a flat-bottomed L-shaped cut that runs along the edge or end of a board. Rabbets can run either across or with the grain. Use a rabbet to inset a back into the sides of a cabinet.

3) Make a *lap joint* by joining two boards so that the face grain of one board crosses the face grain of the other. Cutting a series of parallel dados on both pieces where they intersect makes a *half-lap joint*. Use a lap joint to make X-style picnic table legs. Use a half-lap joint to make an egg-crate style window frame.

Continued on page 22





TRADESMAN[®]

BENCH AND STATIONARY POWER TOOLS

Tools built to last for generations. Tools built to do any project without the brand name expense. These are the features to look for when purchasing your workshop equipment.

TRADESMAN OFFERS THESE QUALITY TOOLS FOR A VARIETY OF OPERATIONS AT AN ECONOMICAL PRICE

TRADESMAN products give you all of this and more. What, you've never heard of us? We've been selling power tools in the U.S. for over 35 years. You may know us under our many private labels or our own brand **TRADESMAN**.

Now is the time to own a **TRADESMAN** Power Tool. If your next power tool purchase is not a **TRADESMAN**, then chances are you paid too much.

TRADESMAN - Tools that are built with **PRIDE**, offer good **PERFORMANCE** all at an economical **PRICE**.



Model # 8035
8" / 10" **DYNASAW**

POWER TOOL SPECIALISTS, INC.
3 Craftsman Road
East Windsor, CT 06088



800-243-5114

Call for a catalog and your nearest dealer

ASK WOOD

Continued from page 20

What can I do with these trees?

My husband and I are buying a farm with harvestable black walnut trees. We are interested in using some of this timber in a home we are building. How can we find commercial sawmills that will turn the logs into sawn lumber and veneers for use in paneling and furniture?

—Pamela Adams, Cincinnati



Contact the Department of Natural Resources of your state, Pam, and request a listing of sawmills. For a list of veneer mills, contact:

Hardwood Plywood Manufacturer's Assn.
1825 Michael Faraday Drive
P.O. Box 2789
Reston, VA 22090-2789
703/435-2900

Veneering wall panels is an advanced and difficult procedure. For a simpler and more-durable product, we recommend you have the paneling made from solid wood.

Looking for a clear finish

I have searched for years for a finish that will not alter the color of the wood in my projects. What can I use that will not darken and obscure the grain of the wood?

—Ivan Walker, Fort Wayne, Ind.

For an answer, Ivan, we contacted Jonathan Kemp of H. Behlen & Bro., a finish manufacturer. His response: "Our water-based finish is water clear because it doesn't have the solvents or resins that give an amber tint to the oil-based finishes.

"Water-based clear finishes dry quickly, with a two-hour recoat time. However, this finish falls between lacquer and polyurethane in the time it takes to reach full hardness or cure. To prevent marring the surface, wait 72 hours after applying the finish before you place anything on it.

"Water-based finishes contain only a fraction of the solvents found in oil-based finishes, and emit far less solvent odor while drying. Because these are water-based products, the initial coat of these finishes will raise the wood grain. Apply light coats and sand between applications to develop a smooth surface."

Continued on page 24

How do the finest woods become your finest work?

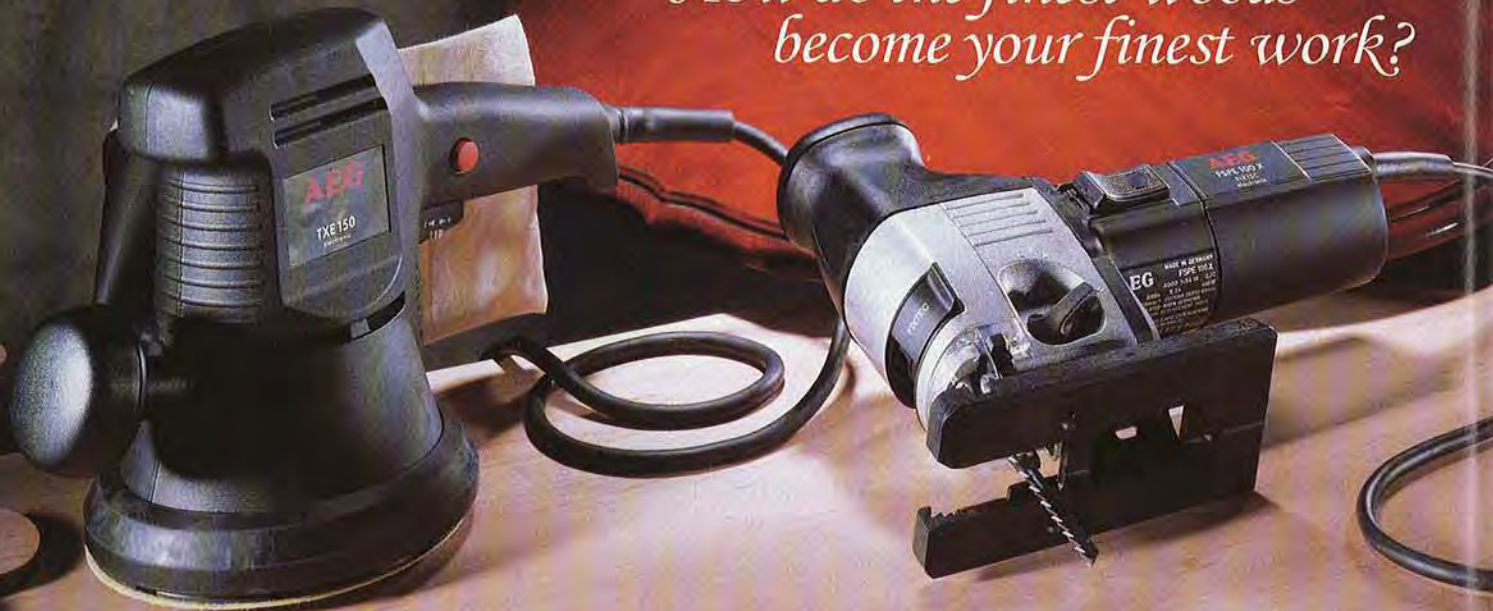

The new AEG TXE 150 Random Orbit Sander: for the smoothest operation and finish.

As *Fine Woodworking* said recently, this 6" dustless, variable speed sander offers a "...precision feel that's hard to quantify; it just feels smooth." Multi-port dust extraction makes perfect finishes easier, even on dark woods. The exclusive Automatic Brake System (ABS) virtually eliminates gouging and burning.

The new AEG Fixtec™ Barrel-Grip and Top-Handle Jigsaws: for precise, intricate cuts.

Experienced woodworkers express amazement at the extraordinary results possible with these breakthrough jigsaws. The roller backup and ceramic guides prevent blade flexing for cleaner, more precise cuts with less finishing work. A patented keyless blade-changing system permits faster, easier blade changes.

For a tool demonstration, see your AEG distributor. Or contact the Electric Tools Division, Chicago Pneumatic Tool Company, 2220 Bleecker St., Utica, NY 13501-1795. Telephone: 1-800-343-0870.



**Chicago
Pneumatic**

HOW I TURNED MY HOBBY INTO A SUCCESSFUL CRAFT BUSINESS.

When I first considered starting my own craft business, I knew I needed to work with the best materials to produce the type of unique crafts customers would pay top-dollar for.



Hawk Scroll Saws are perfect to begin or complement any workshop. It cuts wood, metal, glass, plastic, fabric and more. It will be the most versatile tool you'll ever own.

When time came to purchase a scroll saw, I knew I wanted the best. So I purchased an RBI Hawk Precision Scroll Saw.

With my RBI Hawk Precision Scroll Saw, I now produce the woodworking projects I have always dreamed of creating.



EDGES CUT SO SMOOTH THEY REQUIRE NO SANDING.

Now, I create beautiful crafts and toys, tote painting cut-outs as well as intricate, detailed fretwork and inlays. I really love the fact that my RBI Hawk Precision Scroll Saw cuts edges so smooth it virtually eliminates the need for sanding. With my RBI Hawk, I create projects that my customers will treasure...year after year.



Susan applying the final touches to one of her inspired creations.

HOW I INCREASED MY BUSINESS BY DIMENSIONING WOOD MYSELF.

To produce wood to just the right dimensions for my patterns, my husband and I decided to buy an RBI 812 "3-in-1" Universal wood-planer system. It prepares wood to just the right thickness. Now, I even sell these pre-cut patterns to area craft stores and my own customers.



Using her RBI 812 Woodplaner, Susan easily and quickly dimensions her patterns.

RBI HAS EVERYTHING YOU NEED AT YOUR FINGERTIPS.

When it comes to accessories,

RBI has everything I need. They have the very best selection of accessories including blades, work lights, instructional and pattern books, and much more.

Susan

RBI, THE ARTIST'S CHOICE IN SCROLL SAW TECHNOLOGY.

RBI Hawks are designed and made in the USA for the professional shop and demanding hobbyist. With three sizes to choose from, our 16", 26", and our most popular 20" model, we have the saw that's right for you.

After all, like Susan, you know that the projects you create are only as good as the tools you use.

A FEW REASONS WHY RBI HAWK SCROLL SAWS ARE THE BEST YOU CAN BUY.

PATENTED QUICK CHANGE BLADE

HOLDER—for the fastest and easiest positioning of saw blades there is.



PATENTED REAR CAM-OVER—

quick and easy tension setting. Another RBI exclusive feature.



PATENTED CAM-OVER TENSION AND UPPER BLADE

HOLDER—allows quick blade changes. Also makes inside cuts quick and easy.



CALL TODAY TO ORDER FACTORY DIRECT OR FOR YOUR FREE RBI CATALOG.

30-Day Money Back Guarantee • 3-Year Warranty

1-800-487-2623 Dept. D115

rbi industries

The American Tool Manufacturer

1801 Vine St. • PO Box 369 • Harrisonville, MO 64701

FREE Brochure! Call 1-800-487-2623

or write:

rbindustries, 1801 Vine St., PO Box 369, Harrisonville, MO 64701

Name _____

Street _____

City _____ ST _____ ZIP _____

Phone (____) _____

© 1994 rbindustries. All rights reserved.

D115

WHY ARE WE PRACTICALLY
"GIVING AWAY"



"401

WOODWORKING PATTERNS FOR ONLY 2¢ EACH?"

IF YOU LIKE TO CUT PATTERNS OUT OF WOOD, THIS IS THE SET FOR YOU! YOU'LL FIND A TREASURE HOUSE OF IDEAS INSIDE. 401 BEAUTIFUL WOODWORKING PATTERNS AND DESIGNS.

(By Frank K. Wood)

FC&A, a Peachtree City, Georgia, publisher, announced today that it is practically "giving away" an all-new set of "401 Woodworking Patterns."

- Curvy curios, charming country cats.
- Sturdy shelves, shadow boxes, showy plaques.
- Victorian ladies and stylish gents.
- Rack up your spices, spice up your den.
- Folk art, Shaker art, modern art, too.
- Hanging hearts, huggable bears.
- Welcome signs, house name and number sign, proudly displayed.
- Whizzing whirligigs, models of planes.
- Birthday surprises, decorations for major events.
- Dancing bear, prancing pony, soaring eagle.
- Circus animals and barnyard critters.
- Christmas candy cane mouse and candy cane border for your house
- Comic cartoons.
- Summer garden helpers, lawn deco art.
- Pretty jewelry ideas for girls of all ages.
- Picture-perfect frames, country carousel on a stand.
- Bunnies for Easter, rabbits to hang on the wall.
- Angels of love, Christmas and song.
- And much, much more.



Build all these wooden favorites. Illustrated plans include full-size patterns and complete instructions. To order a set, just return this notice with your name and address and a check for \$7.99 plus \$2.00 shipping and handling, and we will send you "401 Woodworking Patterns." Or, for only \$9.99 plus \$2.00 shipping and handling, you can get both the basic set and an extra 100 large patterns.

Send your check along with your name and address to: FC&A, Dept. OWZ-9, 103 Clover Green, Peachtree City, GA 30269.

You get a no-time-limit guarantee of satisfaction or your money back.

You must cut out and return this notice with your order. Copies will not be accepted!

**IMPORTANT — FREE GIFT OFFER
EXPIRES OCTOBER 15, 1994**

All orders mailed by October 15, 1994, will receive 50 special, seasonal, woodworking patterns as a free gift, guaranteed. Order right away!

©FC&A 1994

ASK WOOD

Continued from page 22

A jig for hinge alignment

I have been unable to find a jig that will align hinges on the door and frame of cabinets and boxes perfectly. Drilling screw holes accurately is also a problem. Can you help?

—Dan Leadbetter, Tacoma, Wash.

A hinge-mortising jig, such as the one shown below, will help you cut aligned hinge mortises, Dan. Place this jig on the cabinet sides or rails, with the appropriate end touching the top or bottom edge of the door. Clamp the jig in place, and use a router equipped with a template guide bushing in its base and a straight bit to cut the mortise. Square the corners with a chisel.

Next, set the door in the cabinet, shimming the door to allow even spacing top and bottom. Mark the top and bottom of the carcass hinge mortises on the door. Remove the door, and use the marks to align the hinge mortising jig. Rout the mortise.

We suggest you consider using a Vix bit to drill the screw holes. These bits are designed with a tapered centering collar that ensures the screw hole will be placed in the center of the counter-sunk screw opening in the hinge. The Vix bit for #5 and #6 screws (part # 434265), and the one for #8 - #10 screws (part # 43273) are priced at \$8.45 each. The Vix bit for #2 - #4 screws (part # 43281) costs \$8.95 (plus \$4.95 handling per order). You can order these bits from: The Woodworker's Store, 21801 Industrial Blvd., Rogers, MN 55374-9514. Or, call 800/279-4441.

Mount the hinges in the mortises with one screw in each leaf, then check that the door operates smoothly before installing the other screws. Lock the hinges in place with the remaining screws after the door is adjusted to move smoothly.

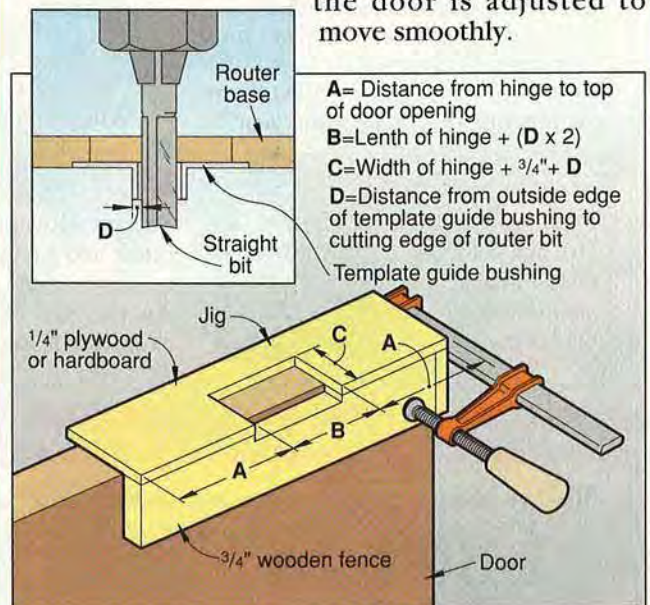

Continued on page 26

For that
"SPECIAL"
project

See Us In
Booth #3654
IWF Atlanta
Aug. 25-28

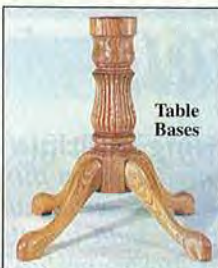

Table
Bases



Table Legs

IN STOCK
NO
MINIMUM
VARIOUS
WOODS



Kits Ready to Assemble &
Finish

FREE
COLOR
CATALOGUE



Adams Wood Products, LTD. LP.
974 Forest Dr., Dept. M 28
Morristown, TN 37814 • Phone (615) 587-2942

Circle No. 1002

**Like Working
With Wood?**
**Assemble and
Finish Your Own
Colonial Times
Grandfather or
Wall Clock**

- Complete Kit and Instructions
- Pre-cut and Pre-Drilled
- Models Available in Solid Oak, Cherry and Black Walnut
- Large Selection of Clock Movements and Accessories

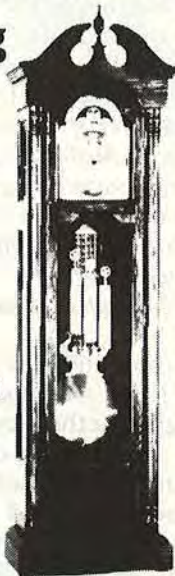

Please send me your free catalog on assembling my own Clock Kit.

Colonial Times Clock Company
550 Parkside Dr., Waterloo, Ont. N2L 5V4
or call toll free 1-800-263-TIME

Name _____

Address _____

City _____

Prov. _____ Postal Code _____

Tel. _____

Veritas® Grinder Tool Rest

Product Development Casebook

The Problem:

To design a versatile grinder tool rest that is stable, square to the wheel, and fully adjustable for accurate grinding with any utility bench grinder.

The Solution:

The Veritas® Grinder Tool Rest can be used with any 6" or 8" bench grinder. The 4" wide table straddles wheels up to 1" wide. It is grooved for sliding jigs and center drilled for rotating jigs. Slotted arms allow a wide range of angular and height adjustments. Spring-loaded gyrotory handles lock it solidly in position and can be rotated out of the way after locking. Accurately machined components.

05M23.01 Grinder Tool Rest **34.95**
(Shipping & handling extra; N.Y. residents add sales tax.)

Another woodworking innovation from *Veritas*®.



To place an order and/or receive a **Free Catalog** of woodworking innovations, call our toll-free number:

1-800-667-2986

Ask for Dept. U405

Distributed by Veritas® Tools Inc.,
12 East River Street,
Ogdensburg, N.Y. 13669
Fax: 1-800-668-1807
Also available from quality tool outlets
and mail-order catalogs.

Circle No. 1002

Like Working With Wood?
Assemble and Finish Your Own Colonial Times Grandfather or Wall Clock

- Complete Kit and Instructions
- Pre-cut and Pre-Drilled
- Models Available in Solid Oak, Cherry and Black Walnut
- Large Selection of Clock Movements and Accessories

Please send me your free catalog on assembling my own Clock Kit.

Colonial Times Clock Company
550 Parkside Dr., Waterloo, Ont. N2L 5V4
or call toll free 1-800-263-TIME

Name _____
Address _____
City _____
Prov. _____ Postal Code _____
Tel. _____

Clamps, Vises and Accessories for both the Professional and the Hobbyist.

Tools for the Woodworker's Trade

Made in America, with pride, by American workers. For a catalog, circle the reader service number.

Warren Tool Group Columbian Hargrave Warren Brink & Cotton

Circle No. 2185

CASCADE TOOLS, INC.

S The Highest Quality Carbide Cutting Tools

Rabbeting Kit*

NEW



Only
\$29.95

PART	CUTTER DIA.	CUTTING LENGTH	OVERALL LENGTH
C1669 1/4" Shank	1 1/4"	1/2"	2 1/8"
C1670 1/2" Shank	1 1/4"	1/2"	2 1/8"

*Kit includes one of each: 3/8" Bearing, 1/2" Bearing, 5/8" Bearing, 3/4" Bearing, Hex Key, Screw

Tongue & Groove Cutter Kit*

NEW



Only
\$48.00

PART	CUTTER DIA.	CUTTING LENGTH	OVERALL LENGTH
C1665 1/2" Shank	1 3/4"	3/4"	3"

*Kit includes: Arbor, two cutters, two bearings and shim set.

One Piece Stile and Rail Sets*

NEW



Only
\$59.95

PART	DESCRIPTION (1/2" Shank)
C1689	Quarter Round
C1690	Bead
C1691	Roman Ogee
C1692	Ogee

*Cut stiles and rails without re-arranging the bit - just flip the workpiece over and re-set the cutting height. Designed for 3/4" material.

Adjustable Finger Joint Bit*

NEW



Only
\$67.00

PART	CUTTER DIA.	CUTTING LENGTH	OVERALL LENGTH
C1682 1/2" Shank	1 9/16"	1 1/4"	3 1/2"

*For 7/16" to 1 3/8" stock.

Under Roundover*

NEW



Only
\$35.00

PART	CUTTER DIA.	CUTTING LENGTH	RADIUS
C1662 1/2" Shank	2 1/8"	3/4"	3/8"

*Used to profile the underside of solid surface countertop edges. Eliminates the need to flip countertops and allows the router base to be well supported.

1/2" Dovetail Pattern*

NEW



Only
\$10.00

PART	CUTTER DIA.	CUTTING LENGTH	OVERALL LENGTH	ANGLE
C1660 1/4" Shank	1/2"	1/2"	2 1/4"	14°

*For use when template is on top of the workpiece.



ORDER 24 HOURS A DAY!

1-800-235-0272

EXT. 46

TOLL FREE FAX: **1-800-392-5077**

\$4.75 SHIPPING CHARGE ON ORDERS LESS THAN \$100.00

Circle No. 1315

ASK WOOD

Continued from page 24

Tip for scrollsawing multiple pieces

I build small boat models from thin (1/32 - 1/8" thick) basswood. When I try to scrollsaw several frames from basswood sheets held together with double-faced tape, the thin pieces break when I separate them. I've tried rubber cement to hold the layers together, but it tends to soak into the wood and causes problems with gluing and staining. Is there a better way to attach these layers of thin wood?

—William H. Smith, Cape Charles, Va.



Bill, we asked Rick Hutcheson, our scrollsaw consultant, for an answer. Rick suggests you fasten the thin basswood together with nails or brads driven into the waste areas of the wood. Cut out

the center sections of the frames first, leaving the material outside the boat frames fastened until the last cut. This way, when you're finished cutting, the frames are free from each other. Rick recommends using #18 or #19 brads to hold the sheets together. Drill pilot holes in solid woods to prevent the wood from splitting while driving these nails. Stack the layers on a steel surface, such as an anvil, and pound the nails completely through the stack, to peen the points of the nails.

Rack up the small pieces

I have a small woodcraft business, and I paint some of my products. Many times, I have to paint small pieces before assembling them. When I lay these pieces down on paper to dry, they often stick to the paper. Do you have an idea that would prevent this from happening?

—Joseph R. Levallee, Carrollton, Texas

Make a drying rack using a few finish nails and scrapwood. Drive three #4 finish nails through the scrap, close enough together so that they will support the painted wooden piece. Repeat this for each item you plan to paint. Set the craft piece on this rack, paint the edges and face, and allow to dry. Now, turn the piece over, paint the remaining face, and place the piece on the rack with the dry-face down. This will give you "paperless" painted pieces for your woodcrafts.



Take the Woodworker's Sourcebook **FREE** and choose a second book **FREE** with a third for just \$8.95!

plus postage and handling



#70230 160 pgs. Retail: \$24.95	#70163 208 pgs. Retail: \$22.95	#70210 128 pgs. Pb. Retail: \$18.95	#70195 176 pgs. Pb. Retail: \$18.95	#70162 128 pgs. Retail: \$16.95	#70229 128 pgs. Pb. Retail: \$18.95
---------------------------------------	---------------------------------------	---	---	---------------------------------------	---



#10323 128 pgs. Pb. Retail: \$16.95	#70164 64 pgs. Retail: \$16.95	#70211 112 pgs. Pb. Retail: \$14.95	#80212 245 pgs. Pb. Retail: \$24.95	#80267 144 pgs. Retail: \$24.95	#80246 384 pgs. Pb. Retail: \$16.95
---	--------------------------------------	---	---	---------------------------------------	---

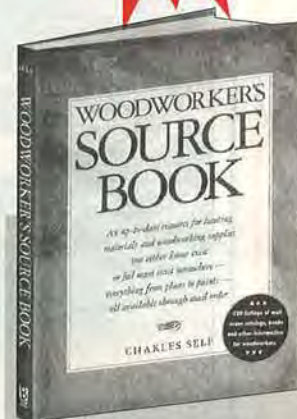

SAVE TIME AND MONEY!

With Woodworker's Sourcebook, you'll find hundreds of suppliers of woodworking tools and materials.

A \$19.95 value, but join today and you'll get it absolutely **FREE**...plus choose a second book **FREE** with a third for just \$8.95.

Join now and receive a special **FREE** gift!

The only plans for a router table that tilts 90° to make your router work easier and safer. A \$7.95 value, you get them **FREE** when you join now.



#80077 254 pgs. Pb. Retail: \$14.95	#80269 224 pgs. Pb. Retail: \$18.95	#80054 486 pgs. Pb. Retail: \$21.95
---	---	---

As a member, you'll enjoy:

- discounts from 15-50%
- your **FREE** Bonus Book program
- **FREE** postage & handling (after this joining offer)
- a Money-back Guarantee on every book you buy!

MAIL THIS CERTIFICATE TODAY FOR YOUR BOOKS AND FREE GIFT!

MEMBERSHIP **SAVINGS** CERTIFICATE

YES! I want to join Woodworker's Book Club. I have read the Membership Plan and understand I have **NO OBLIGATION** to buy any more books. Please send me:

Woodworker's Sourcebook (#70208).....	\$	FREE
and my FREE book selection #.....	\$	FREE
with my third selection book #.....	\$	FREE
plus my FREE Flip-top Router Table Plans #80253.....	\$	FREE
add postage & handling costs.....	\$	4.32
All for just the low price of.....	\$	13.27

(Payment must accompany order. Ohio residents add 49¢ tax. Canadians add 93¢ GST.)

Check enclosed (or) Charge my Visa MasterCard Exp. Date _____

Acct # _____
Signature _____
Name _____
Address _____
City _____ State _____ Zip _____

WOODWORKER'S
BOOK CLUB

P.O. Box 12171
Cincinnati, Ohio 45212-0171

Avoid mail delays and use your Visa or MasterCard to call **TOLL-FREE 1-800-937-0963**

9:00 a.m.—5:00 p.m. Eastern time, weekdays.

Offer good in U.S. and Canada for new members only. Remit in U.S. funds. One membership per household. The club reserves the right to approve all applications and may cancel membership at any time. Please allow 3-4 weeks for delivery.
Circle No. 1175



This glue's no drip; it stains well and stands up to water

Traditional white or yellow woodworker's glue can drip and smear, refuse to take stains, and weaken when exposed to water. To solve all of these problems, Borden came up with a new formula called Weather-Tite Wood Glue.



The gel-like consistency of this glue prevents the inevitable squeeze-out from running down the face of your work. The excess glue beaded up neatly on the glue line, and that allowed me to focus on the work rather than on having to dash around for rags or wet cloths to mop up drips.

This new formula contains wood particles to help the dried glue absorb stains and finishes. On the boards I test-stained, the glue lines all but disappeared.

As to watertightness, I soaked a couple of my glue-ups for a day, and then tried to pry the boards apart. Despite my best efforts, the glue held fast. The water tightness makes this glue ideal for outdoor furniture projects that may get rained on, but I found the other benefits so handy that I plan to use it for all of my work.

—Tested by Bob McFarlin

Elmer's Weather-Tite Wood Glue, about \$3 for an 8-oz bottle. Available at most hardware and home-center stores.

Pushstick performs seven different shop tasks

From the description on its package, this seven-function tool sounded like the Swiss Army knife of pushsticks. You can buy individual tools to perform each of these functions, but no one tool, until the Saw-Aid came along, combines them all.

I found the Saw-Aid most useful as a pushstick. The long front portion let me put pressure on the top of a board, eliminating the chatter you sometimes get with smaller pushsticks. The depth-gauge feature also came in handy. To accurately adjust the cutter height on your tablesaw or router table, simply crank the blade or bit up to the desired setting. The measurements step up in $\frac{1}{8}$ " increments from $\frac{1}{8}$ " to $1\frac{1}{2}$ ".

The sides of this tool serve as angle gauges for 30°, 60°, 45°, and 90° readings. The angles are too short for marking off long cuts, but they work great for checking the tilt of a blade or the fit of a box corner.

The center finder works fairly well too, but only takes stock up

to $2\frac{3}{4}$ " in diameter. My only complaint about this multi-purpose tool is that the thick white marks on the ruler left precise measuring a guess at best.

Despite appearances, the Saw-Aid is no toy. I found the accuracy of the depth gauge and all of the angles dead-on when I checked them against a machinist's square.

All in all, this tool offers enough practical applications to make it useful in any shop. Hang the Saw-Aid by your tablesaw or router table, and you'll use it more than you might think.

—Tested by Bob McFarlin

Saw-Aid, \$14.95 ppd. Stots Corp., 10290 Shelbyville Rd., Louisville, KY 40223. Call 502/244-6047, ext. 10.

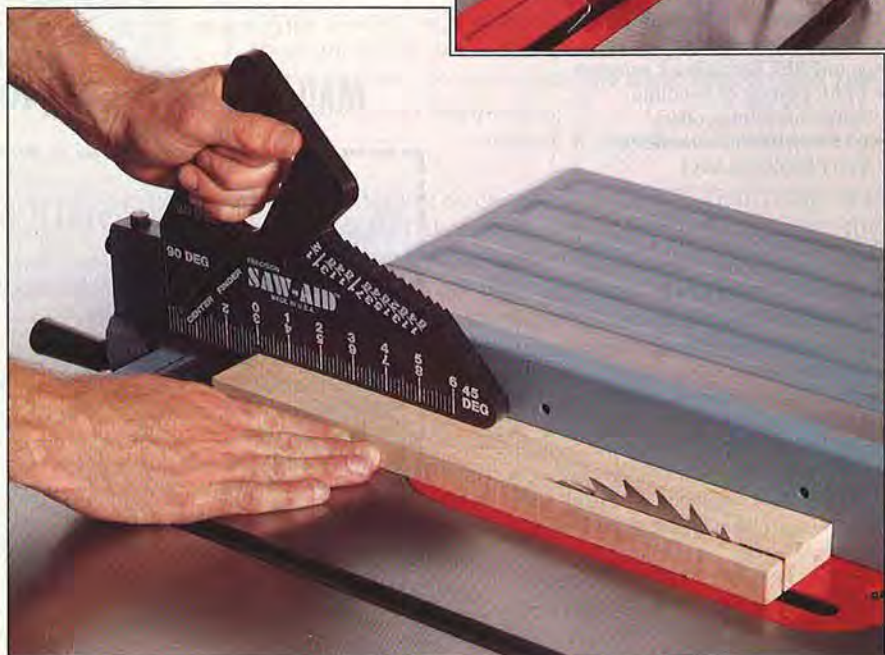
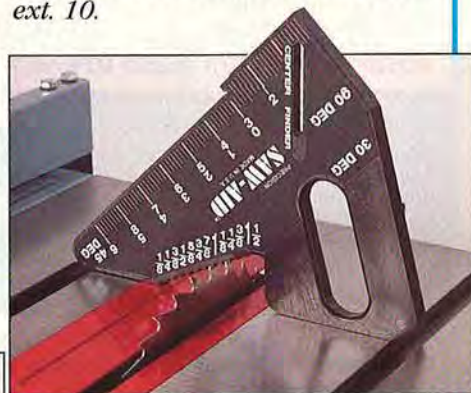

Continued on page 30

Here's What Our Customers Say!

(unsolicited)

Forrest

You are the best!
Your blades are the best!
Your service is the best!
Your sharpening of my (cheap) dado set made it a new set.
It's a pleasure to do business with you -
(I have told this to all of my friends, colleagues and family)

Herbert Needman
Greenlawn, NY

"NO GEN. PURPOSE BLADE PRODUCED BETTER RESULTS than the FORREST 40 tooth Woodworker II." Jim Forrest
Install and leave it for plys & woods to 1 1/2". W. Krier.

Outperformed 36 other PREMIUM blades in WOOD Mag. test P. 45, Sept. 93.

SAVE \$45

Get 9 - \$5 sharpening discount coupons on FORREST or other make carbide blades or dados if ordering before Sept. 30, 1994. Must mention WOOD for coupons & EXTRA BONUS.

WOODWORKER II

TABLE-SLIDE & CHOP

MITERS (gen. prps.) & small PORTABLES (Skill, etc.)

Things you asked us for:

With this ONE ALL PURPOSE blade (40 Teeth) you can SMOOTH RIP & CROSSCUT 1"-2" ROCKHARDS and SOFTWOODS with smooth-as-sanded surface. PLY-VENEERS (oak/birch) crosscut with NO BOTTOM SPLINTER.

- Mostly 1/8" kerf 15", ATB and 20" face hook (easyfeed).
- DOUBLE HARDER and 40% STRONGER CARBIDE.

- Ends blade changing (does rip, combo and crosscut).
- Ends scratchy saw cuts (for the rest of your life).
- Ends second step finishing (jointing or sanding).
- Ends cutting 1/16" oversize to allow for RESURFACING.
- Buy and sharpen ONE blade instead of 3 (24T rip, 50T Combination, 80T Crosscut).
- Strongly recommend our .001 flat large stiffener-dampener against out side of blade for smoothest, QUIETEST CUTS by this and any other blade.
- Use 30T if ripping mostly 2" - 3" hardwoods.
- Side wobble held .001 - others .004/.010 is common! RAISE for THICK woods, LOWER for THIN woods and perfect cut everything! All 5/8" holes, unless otherwise noted.

14" x 40T x 1" BORE	List	SALE	9" x 40T	List	SALE
14" x 40T x 1" *	\$215	\$149	30T	\$146	\$109
12" x 40T x 1" *	195	139	30T	125	99
12" x 40T x 1" *	183	129	8" x 40T 3/32	136	99
12" x 30T x 1" *	162	119	8" x 40T 3/32	136	99
10" x 40T 1/8 & 3/32	156	119	30T 3/32	115	89
30T 1/8 & 3/32	135	99	7-1/4" x 30T 3/32	112	69
			New 6" x 40T 3/32	139	89

5/8" holes std. Boring up to 1-1/4" \$7.50 extra - Shipping \$4.50

QUIET! Also help all your other blades to cut better.

Use our 1/8" DAMPENER STIFFENERS, against one side

4" - \$21
5" - \$24
6" - \$25
Tryable and RETURNABLE. CUTS NOISE to 1/2 or 1/4. Stops vibration, flutter, cutting noise and blade ring. Parallel and flat to .001" *7" and larger available.

5/8" holes std. Boring up to 1-1/4" \$7.50 extra. Others available. Add \$2.50 Shipping.

REDUCE NOISE 50%-75%

WE RECOMMEND OUR FACTORY SHARPENING as some local sharpening creates problems with Micro-chipped edges reducing blade life & cutting quality. 2-4 DAYS ON THESE AND ALL MAKES OF FLAT FACE & CONCAVE CARBIDE TIP SAWS. SHIP VIA UPS. Typical 10" \$45.00, 60T \$17.75. Add return UPS \$4.50 or 2nd Day Air \$8.

SATISFACTION GUARANTEED OR FULL CASH REFUND. 47 years of fine American saw making & sharpening.

Attention: Customer Relations Re: Woodworker I & II Blades
Gentlemen:

I recently ordered and received Woodworker I & II saw blades for my radial and table saws. I used the blades received.

I originally avoided your blades because of the cost in comparison with other models on the market. I saw some chips missing in my old blades, and it was time to toss and replace with new blades. I sighed and ate the additional cost and purchased your blades and stiffeners.

I find your blades of the highest quality. They produce a velvet cut with a polished finish which is not surpassed by any other manufacturer on the market. The wood passes through the saw like a hot knife through butter: smooth and with little effort. I see a similar glide whether it is maple, oak, pine, or whether it is thick or thin. Really fine stuff.

Your production staff can be proud of their work. The production quality is not just good, or to specification, it is exceptional.

In retrospect, the minor difference in cost is well worth the final result. Besides, it is the blade that produces the cut for a piece to outlast the maker.

Glad to make acquaintance with your staff and their work.

Respectfully yours,
David Hares, Esq.
Attorney, St. Louis, MO

(From Another Customer)

In closing I would like to add that the Woodworker II blade is by far the finest saw blade that I have ever used. I also have the Forrest dado set which is without a doubt, the king of all dado sets. I work exclusively with red oak and oak veneer plywood and the dado set performs splinter free cuts as advertised.

It is a pleasure to purchase a product that does what it is advertised to do. Thanks for making such a fine product.

Sincerely,
Dennis R. Schule
Owatonna, MN

WOODWORKER I - For TABLE and RADIAL SAW

this trim and crosscut ALL PURPOSE blade gives scratch free POLISHED cuts on all materials RIP or CROSSCUT up to 2".

- All 60T and 3/32" THIN kerf 30" ATB and 5" face hook on 10" dia and under. 12" and 14" are 20" ATB 1/8" K.
- DOUBLE HARDER and 40% STRONGER carbide.
- THIN KERF:
- Saves 1/3 wood loss on each cut, radial or table. Feeds easy when used for moderate rip and crosscut on table saw. Reduces "JUMP IN" greatly for better "PULL CONTROL". Practically eliminates bottom splinter on RADIAL-CROSS CUT.
- Totally stops ALL bottom and top splinter on ply veneers in push-cut mode on RADIAL.
- Our STIFFENER STRONGLY RECOMMENDED AGAINST outside of blade only for best cuts.

Made and serviced in USA for your benefit.

	List	SALE
14" x 60T x 1" 1/8"	\$224	\$159
12" x 60T x 1" or 5/8" 1/8" K	198	139
10" x 60T x 5/8" 3/32" K	162	129
9" x 60T x 5/8" 3/32" K	156	119
8" x 60T x 5/8" 3/32" K	150	109
New 8-1/4" x 60T x 5/8" 3/32" K	150	109

RYOBI RA200 TS200 SEARS HITACHI PSM8 MAKITA 500B NBA PORTER CABLE 368-1

NEW DADO KING DELUXE DADO SET cuts ALL 1/8" - 29/32 flat bottom grooves WITH or CROSSGRAIN all woods. OAK, BIRCH, VENEER PLYS, and MELAMINE. NO SPINTERING due to unique 4T Neg. Face fillers and 24T outside saws.

OUT PERFORMS 29 + 32 OTHER DADO SETS WOOD Mag., Oct. 91, pg. 62-63 "Best Value" *No tearout on all five woods tested. *Fine Woodworking July/Aug. 1991

Boring up to 1-1/4" SALE! 10% OFF NEW 3/32 Chipper Woodworking \$25 per set \$5.50 Per Set Shipping & Shims Incl. July/Aug. 1991
8 - 5/8" Bore List \$321/SALE \$289 • 10 - 5/8" & 1" Bore List \$389/SALE \$349

Forrest (Superior)	Fried 50008 (Excellent)	V-A 26742 (Good)	U.S. Saw 600-C-FPD (Fair)	V-A 26747 (Poor)
--------------------	-------------------------	------------------	---------------------------	------------------

DURALINE Hi-AT For TABLE & RADIAL SAW

(very good on chop saw too!) STOP SPLINTERING those SPLINTERY OAKS, HARDWOOD VENEERS and thin 2 SIDE LAMINATES ON PARTICLE BOARD. FOR FASTER FEED RATES AND MORE ABSOLUTE SPLINTER CONTROL.

NEW PRICES EFFECTIVE SEPT. 1, 1993

DURALINE Hi-AT

Note: Fine Woodworking Editorial Nov./Dec. 1988 No. 73, pg. 65, S.N. recommends high alternating top bevel (ATB) thin kerfs and large blade stiffeners for smoothest cuts on RADIAL SAW, etc.



Jim Forrest, President and designer microspinning cutting edge.

All 5/8" holes. Boring up to 1-1/4" \$7.50 extra Larger holes - time basis. Shipping \$4.50



	List	SALE
7-1/4" x 60T 3/32"	\$149	\$129
8" x 80T 1/8" & 3/32"	202	\$169
9" x 80T 1/8" & 3/32"	207	\$179
10" x 80T 1/8" & 3/32"	207	\$169

SPECIAL SALE! 10% ONLY \$159

	List	SALE
12" x 80T x 1" 1/8"	212	\$181
12" x 100T x 1" 1/8"	253	\$215
14" x 80T x 1"	232	\$197
14" x 100T x 1"	266	\$226
16" x 100T x 1"	282	\$223
18" x 100T x 1"	294	\$243

CARBIDE IS THE HARDEST OF THE C-4 GRADES AND 40% STRONGER, NOT WEAKER! For 50% to 300% longer life!



CHOPMASTER for SLIDING COMPOUNDS & MITER SAWS
New specs, 5" Neg. Pos. & flat, dist. 001/002 for perfect, light, smooth, splinter free miter joints
NEW AVAILABLE SIZES

	List	SALE
Delta Sidekick 6-1/2"	149	\$ 89
Sears 8-1/4" & Delta	170	99
Hitachi 8-1/2" DeWalt 8-1/2" & Ryobi	179	109
Delta 9" x 80T x 5/8"	204	119
Ryobi-Makita & all	207	129
Hitachi & B&D & DeWalt	229	139
Ryobi-Makita	266	179
Hitachi	277	189

For good gen. prps. cuts use Woodworker I 30T & 40T or Woodworker II 15" x 100T x 1"

Use small stiffener where possible

Quality is why we're different



FORREST MANUFACTURING COMPANY, INC.
461 RIVER ROAD, CLIFTON, NJ 07014
DEALER INQUIRIES WELCOME

BUSINESS OPEN ACCOUNTS AVAILABLE

CA, FL, NJ, NY, Residents Please Add Sales Tax FOR SPECIAL BONUS MENTION WOODS MAGAZINE

We honor Amex, VISA, MasterCard & Discover, Money Orders, Personal Checks, and CODs. Specify Dept. WD when ordering.
PHONE TOLL FREE! 1 (800) 733-7111
(IN NJ; 201-473-5236) FAX: 201-471-3333



Continued from page 28

Turn on your dust collector by remote control

Turning your dust collector on and off requires that you spend a lot of time hiking to and from the machine. That, or you can spend several hours hard-wiring low-voltage switches in your shop.

Now, there's a third way—the DCS-100 wireless dust-collection switching system. To use it, plug the relay module (the beige box) into an outlet, and plug your dust collector into the module. Then, plug the transceiver module (the white box) into any centrally-located electrical outlet in your shop and put the antenna up. Pop an AA battery into the hand-held radio-frequency transmitter, hit the button, and bingo!

For the purpose of my testing, I kept the transmitter in my pocket and pulled it out and clicked the dust collector on and off while working with various power

tools. It worked no matter where I stood or how accurately I aimed it. Eliminating that hike to the dust collector saved a lot of time and ended a distracting hassle.

The only drawback I could think of is that the transmitter might get lost in the clutter on your benchtop—a problem you can easily solve by storing it in a safe, easy-to-find location.

—Tested by
Chuck Hedlund

DCS-100 Starter Kit, (including transceiver module, relay mod-

ule, and hand-held RF transmitter) \$92 ppd. (North Carolina residents add 6% sales tax), from Fernbrook, 83 Pine Rd., Otto, NC 28763. Call 704/524-6125. ♣



LET US GIVE YOU A HAND... "Jorgensen"

E-Z HOLD™

One-Handed Clamps

With E-Z HOLD clamps, there's a whole handful of advantages: the convenience and speed of one-handed operation, affordable quality, strong and durable steel construction, superior engineering and the dependability of the first name in quality clamps—JORGENSEN! You'll be so pleased with the help E-Z HOLD clamps offer your woodworking projects that you'll want to give us "a hand!"

For our catalog send \$1.00 to:
Adjustable Clamp Co.,
410 N. Ashland Ave.
Chicago IL 60622

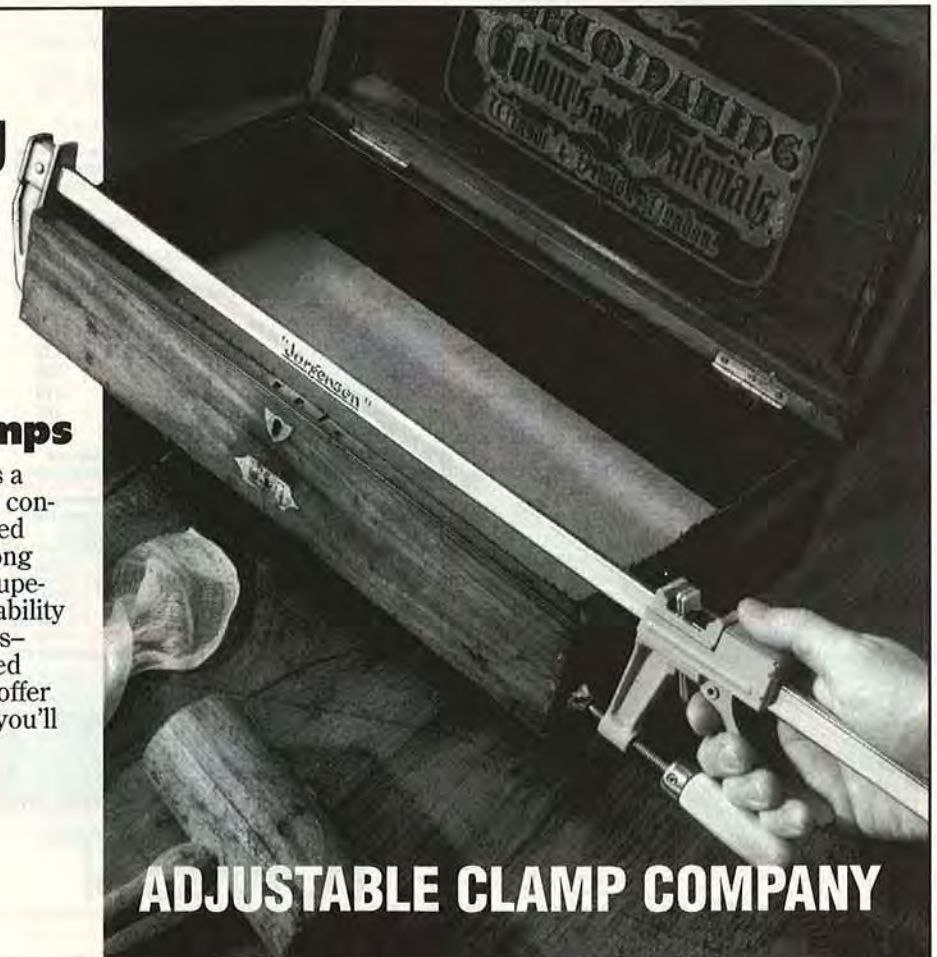

ADJUSTABLE CLAMP COMPANY



Business owners at one of the regular August West training workshops.

Earn \$1,000 a week in your spare time.

Chimney Maintenance: Every Home Needs It!

August West will show you how to clean and maintain chimneys and flues using our state-of-the-art equipment and field proven techniques.

You'll be able to generate sales that range from \$65 to \$140 per call. And easily earn \$1,000 a week in your spare time. More full time.

For less than the cost of a second hand car you can be running "one of the best small businesses in America."

Why Clean Chimneys?

There are nearly one hundred million chimneys, flues and stoves across the continent. Whether they are burning Gas, Oil, Coal or Wood, they *all* need to be cleaned. According to the National Fire Protection Association, they should be cleaned and serviced at least once a year to prevent disastrous fires.

There is an urgent need for this service. And there are very few sweeps.

18 Years of Service

For more than eighteen years, August West has equipped men and women to clean and service chimneys and flues.

We're a national company and 90% of the chimney sweeps in the U.S. and Canada use our system.

Fabulous Earnings

Here's what your part-time weekly income could look like:

2 service calls	=	\$180 Mon
3 service calls	=	\$250 Wed
3 service calls	=	\$230 Fri
5 service calls	=	\$380 Sat
		<u>\$1,040 weekly</u>

August West Backs You Up

We provide you with training and support, workshops, newsletters, technical marketing advice, advertising and promotion manuals and continuing access to the growing chimney sweep community. You have all the advantages of a franchise without any of the drawbacks!

No Strings Attached

You keep all you earn. With August West there are no franchise fees, no commission payments.

For an investment of \$3,995 you get the tools, equipment, and promotional materials you need to start earning money immediately.

Join the many thousands who have found personal freedom, success and the time to do the important things.



Jerry Morelle, owner of Magic Dragon Sweeps, leads an August West workshop. Participants learn how to clean and repair chimneys and flues and market fire protection supplies that generate a lot of additional income.

Write for a Free Information Kit today or...

Better still, pick up the phone and call us at this Toll-Free number:

1-800-225-4016

(In U.S. & Canada)

Ask for Extension **2219**

Copyright © 1994 August West Systems

Send to: August West Systems
38 Austin St., Box 16543, Dept. 4768
Worcester, MA 01601-6543

**Yes, please rush me your
FREE Information Kit.**

Name _____

Address _____

City _____

State _____ Zip _____

Phone () _____



WOOD ANECDOTE

Print this article

CASCARA BUCKTHORN

The holy bark in your medicine cabinet

From missionaries of old to modern soldiers, cascara bark has brought relief to millions.

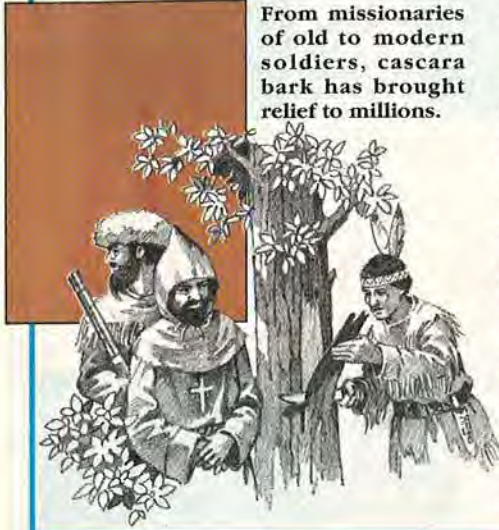

Growing as a small deciduous tree in the big-timber regions of the Pacific Northwest, the cascara buckthorn (*Rhamnus purshiana*) contains a medicinal extract in its bark that's a sure cure for one of mankind's most common maladies. For over 100 years, cascara buckthorn has brought relief to those suffering from constipation.

Although at 10' to 40' tall it's dwarfed by Douglas fir and other commercial species, the cascara buckthorn draws a small army of "cascara barkers" deep into the shady woods every summer. Using nothing more than a sharp knife, itinerant workers from Northern California to British Columbia collect about one million pounds of bark. A typical barker harvests 250 pounds in a day and collects \$50 for the effort. When in doubt about the species, barkers simply taste a small sample of the bark for the bit-

ter flavor and mouth-numbing effect that marks it as cascara.

Local Indians first alerted the area's Spanish missionaries to the beneficial effects of this bitter bark, which was thereafter dubbed cascara *sagrada* or "holy bark." Yet, it wasn't until 1878 that the Parke-Davis company began selling cascara extract to the rest of the country in an over-the-counter formula. By World War II, GIs weary and bloated with C-rations called cascara-based medicine "CC pills."

Cascara wood varies from yellow to orange-brown in color. Although easy to machine and finish, it has little commercial value.

Today, newer formulas have eroded cascara's once-dominant medicinal position. But if you read the labels in the pharmacy, you'll still occasionally see the holy bark—one of nature's safest, most effective laxatives—as an ingredient. ♣

Illustration: Jim Stevenson

BOSCH
1581VS \$144
VS
Orbital Jigsaw
B1650 New! Blacout Joinder \$ 158
B4050 New! Inlino Jig Saw 113
B7000 New! Detail Sander 72

BLACK & DECKER
NEW!
2872K2
12V \$189
2874K
14.4V \$199

1167 3/8" Keyless Drill \$ 72
1180 1/2" Drill \$ 113
1849 Timberwolf Drill 304
1703 10" Miter Saw 189
2037 Drywall Sorewgun 97
2037W Drywall gun w/50ft cord 119
2054 HD Sorewgun 159
2876 1/2" Impact Wrench 149
2721 1 1/2" Router 1/2" colt 148
3105 Reciprocating Saw 145
3379K Blacout Joinder 225
3359 Stp VS Plunge Router 268
4076 7" Wildcat Grinder 165

if you can plug it in...we've got it!
ROCK BOTTOM PRICES ON ALL YOUR FAVORITE TOOLS

PORTER-CABLE
330
Finish Sander
after \$10 rebate \$52

100 7/8 hp Router \$ 99
310 Laminate Trimmer 144
312 Offset Trimmer 159
314 4-3/8" Trim Saw 137
9314 Trim Saw w/ Case 151
315-1 7 1/4" Circular Saw 117
9316-1 Saw w/Case 138
351 3x21 Belt Sander 149
352 3x21 Belt Sander w/bag 152
352VS Variable Speed 352 158
360 3x24 Belt Sander w/bag 189
361 3x24 Belt Sander 182
362 4x24 Belt Sander w/bag 199
363 4x24 Belt Sander 191
410 Underscore Router 148
605 1/2 Sheet Sander 118
606 3/4 Sheet Sander 118
691 1 1/2 Hp Router 133
692 Router with Case 144
691 1 1/2 Hp D-handle Router 148
693 Plunge Base 74
695 Router Table/Motor 218
696 Router Table Only 128
1700 Heat Gun 66
5008 12" Dovetail Jig 77
5116 16" Dovetail Jig 257
7116 24" Dovetail Jig 294
7334 6" R.O. Sander 119
7333S Dust Kit for R.O. Sander 23
9118 3 1/4 hp Plunge Router 233
9118 Door Plane Kit 204
9829 Recipro Saw 147
9381 Hinge Mortise Jig 165
9382 Hinge Mortise Jig 165
9731O Trimmer Kit 193

RYOBI
OSS450
Spindle Sander \$169

AG1200V Heat Gun \$ 39
AP10 10" Planer 369
AP10 Replacement Blades 24.95
BS900 NEW! 9" Band Saw 173
BT3000 Table Saw 529
DS1000 Detail Sander 39
JP155 6" Planer 299
JM100K Blacout Joinder 209
QS1000 Quick Stand 42
RS9K Trimmer 2 base Special 99
R70K Trimmer 2 base Special 99
RA202 8" Radial Arm Saw 388
RE800 Stp Plunge Router 219
RS112 Random Orbit Sander 54
RS115 HD Random Orbit Sander 73
S550 Finish Sander 53
SC160 Scroll Saw 134
TR90U Laminate Trimmer 85
TS251 10" Miter Saw 169
TS254 10" Miter Saw 197
TS250 10" Comp. Miter Saw 238
TS350 15" Miter Saw 355

freud
94-100 5 po Router Bit Cabinet \$158
91-100 13 po 1 1/2" Shank Bit Set 169
92-100 25 po 1 1/2" Shank Bit Set 299
LUB5M010 10" 60T Finish 58
LUB4M011 10" 60T Combo 39
LUB2M010 10" 24T Rip 36
LUB5M015 15" 108T Finish 98
LUB2M010 10" 60T Chipboard 57
LUB3M010 10" 72T Aluminum 57
LUB2M010 10" 60T Corian 45
LUB6M010 10" 80T Laminates 66
LUB7M010 10" 40T ATB 39
LUB7M010 10" 24T Thin Kerf 39
LUB7M010 10" 60T Crosscut 44

Milwaukee
0229-1 3/8" Keyless Drill \$ 106
0407-1 Cordless Drill Kit-Zbit 172
0564-1 Cordless Drain Cleaner 192
3300-1 Rt Angle Drill 189
5192 Dia Grinder 174
6362-1 Hawk Hammer 318
6365-1 1" Hawk Hammer Kit 348
5369-1 3/4" D-handle Falcon Kit 238
5371-1 1/2" Hammer Drill 183
5375-1 1/2" Hammer Drill Kit 178
5392-1 3/8" Hammer Drill 428
6140 4 1/2" Grinder 98
6142 4 1/2" Grinder Kit 123
6175 1 1/4" Chop Saw 278
6369 7 1/4" Circ. Saw Kit 147
8480 10" Circular Saw 258
6490 10" Miter Saw 254
6491 10" Miter Saw w/80 Blade 268
6628 VS Super Sawzall 164
6638-1 Inlino Sorewdriller 74
6646-1 2 spd Inlino Screwdriver 81
6767-1 Sorewdriller Kit 134
8980 Heat Gun Kit 91

SMARTLEVEL
SL224 2" economy Level \$ 54
PR24S 2" Pro Level w/case 88
PR48S 4" Pro Level w/case 105

STABILIA
LEVELS - Hand holes. Two vertical vials. Two milled faces. Yellow coat.
2464 24" \$ 39
2465 36" \$ 42
2467 48" \$ 49
2601 10" POCKET LEVEL 2.5
2699 6 ft - S-vial 99
2700 8 ft 6" - S-vial 115
2701 8 ft - S-vial 125
Economy Style 24" 2434 25
Economy Style 48" 2437 39
Economy Style 72" 2411 59

HITACHI
IT'S BACK!
IT'S NEW!
IT'S MADE
IN THE USA!
C8FB2 COMPOUND
SLIDE SAW \$599
Clamp for C8FB \$ 18.95
Small Piece Fence \$ 12.95
60 Tooth Carbide Blade 39.95
C10FA 10" Miter Saw 269
C12FA 12" Miter Saw 299
NR83A Framing Nailer 379
TR8 Laminate Trimmer 91

DEWALT
DW682K
Biscuit Joinder \$222
DW106 3/8" Keyless Drill 73
DW160 1-1/2 Hp Router 148
DW704 12" Miter Saw 313
DW705 12" Compound 347

TRUPER
Clamp 'n Tool Back-to-Back Bench Clamp
60C \$ 29.60 BB50 \$ 45.85
80C 26.50 BB36 37.95
24C 22.50 BB18 31.95

DELTA
37-070 \$247
6" Table Top Joinder
11-950 6" bench Drill Press \$ 143
14-650 Hollow Mortise Chisler 283
22-540 12" planer 395
29-180 10" band saw 164
31-050 1" belt sander 171
31-080 1" Belt 5" Dia Sander 83
31-340 1" Belt 8" Dia Sander 203
31-480 4" Belt 6" Dia Sander 127
32-100 Plate Joiner 258
36-040 8" Compound Miter 154
36-090 Stalok 10" Miter Saw 213
36-220 10" Compound Miter 228
40-150 16" Scroll Saw 115
40-660 16" Scroll Saw 177
40-640 20" Scroll Saw 294
35-617 10" 60T Carbide Bld 34
35-677 14" 108T Carbide Bld 75

BIESEMEYER
T60 50' Commercial Fence \$ 287
H852 50' Home Shop 237
HS40 40' Home Shop 207
7334 6" R.O. Sander 119
TABLE SAW INSERTS 9.95

REG
EZ1820 Cordless Sorewdriller Kit \$ 79
S175E380 Jig Saw \$ 59
VS280 1/2 sheet sander 39

AIRY
NAIL GUNS
241SK
18 G 3/8"-1/2" Kit \$98
250SK 18 G 3/4"-2" Kit 164
350K 16G 3/4"-2" Kit 198
565T 1"-2-1/2" Finish Gun 204
625SK 1/4" Crown T Sander Kit 104
635SK 1/4" Crown 138 Sander 164
8290 6d-16d Framing Nailer 318

Emglo
AM39HC4V 3/4 HP-2 tank \$ 286
AM78HC2 1 1/2 HP-1 tank 279
AM78HC4V 1 1/2 HP-2 tank 299
New! Oless 116D HP-2 tank 299

Emglo
Pocket hole maker \$109
for joining face frames, butt joints and other pocket hole applications

STIK-ON SANDPAPER
10 yards GOLD C weight paper
Gal. 4 1/2oz glue
BO4510 100 po 19.95 19.95
80 10.95 100 po 18.95 18.95
40 100 9.85 100 po 17.95 12.95
120 9.85 100 po 17.95 12.95
150 9.85 100 po 17.95 12.95
180 9.85 100 po 17.95 12.95
220 9.85 100 po 17.95 12.95

Panasonic
EY6100EQK NEW PREDATOR 12 V CORDLESS DRILL 16 Minute Charge \$199
EY6100CRKW PREDATOR 1 Hour Charge w/2 Batteries 189
EY6718 9.6V Cordless Drill 119

Makita
BO4510 Square Pad Sander 49
BO4530 Round Pad Sander 55
BO5000 Random Orbit Sander 63
LS 1030 10" Miter Saw 189
9.6 V "Black" Battery 24.50
7.2 V "Black" Battery 22.00
9.6 V "Orange" Battery 38.00
9.6 V Flashlight 36.00
3/8" Keyless Chuck 15.00

CONSTRUCTION MASTER III
The world's best feet-inch-metric-fraction calculator. Solve rafters, hips, valleys, stairs
\$ 69

USE VISA, MC, DISCOVER
FREE SHIPPING on orders from this add over \$50. Within continental 48 states, HI and AK extra. Sales limited to stock on hand.

ABBEEY TOOLS

1-800-225-6321

1132 N. MAGNOLIA, ANAHEIM CA. 92801
OPEN 8:30 WEEKDAYS 9:2 SATURDAY
Calif. residents add 7.75% state sales tax
SERVING YOU FOR OVER 18 YEARS
Prices subject to change without notice.

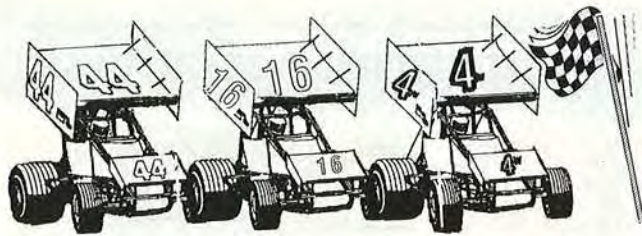

GET TO THE FINISH LINE FASTER

with the **Horsepower** for Abrasive Planing,
the **Speed** for Production Woodworking,
the **Precision** for Flawless Sanding

The power of a Performax Drum Sander will make you feel like a winner every time. Dimension stock or sand to a glass-like finish with the Performax of your choice.

Only Performax offers patented features to sand stock as wide as 44", as short as 2½", as thick as 4" (12" option), and as thin as 1/64". And only Performax offers affordably priced drum sanders starting at \$300.

Don't be left in the dust. Call Toll-Free today for brochures and the dealer nearest you, or write to:



PRO MAX III
MADE IN THE USA

1-800-334-4910
or **(612) 895-9922**

PERFORMAX
PRODUCTS, INC. X

12257 Nicollet Ave. So., WD02, Burnsville, MN 55337

Performax is a proud sponsor of the 4W Sprint Car

Circle No. 78

FREE
3 Piece Turning Tool Set
with Purchase!



The New
Mini Lathe
With
Maximum
Capabilities

The Record Swivel Head Mini Lathe

- 12" capacity between centers. •26" overall length.
- 78 lbs. of cast iron. •Swivel head for bowl turning.

•Order # 08P31 Only: **\$399**

For more information or to request a catalog call:

1-800-542-9115

WOODCRAFT

Dept. 94WI09Q 210 Wood County Industrial Park,
PO Box 1686, Parkersburg, WV 26102-1686



Circle No. 490



The Finest Glue You Will Ever Use.
Guaranteed.

Gorilla Glue is 100% waterproof, solvent-free and incredibly strong. Single side application means twice the economy of other glues. It cures when exposed to moisture in the wood and atmosphere, and it's stainable, self-spreading and leaves no glue line. Bonds exotic and common woods, as well as ceramics, plastics, metals and stone to wood. When hardened, it will not dull tools or clog sandpaper. Cleanup is extremely easy.

If you are not completely satisfied, return the unused portion for a full refund.

36 FL OZ - \$29.95 18 FL OZ - \$19.95
Plus shipping & \$2.00 handling • CA residents add sales tax

To order call: **1-800-966-3458**

The Gorilla Group • PO Box 42532 • Santa Barbara, CA 93140-2532
Visa/MasterCard/Discover

"EVERYONE HAS FURNITURE"

OFFICES, HOTELS, RESTAURANTS, HOMES



Wood furniture is easily damaged during manufacturing, warehousing, transporting or by daily wear and tear. Furniture Medic restoration techniques can save this furniture for a fraction of replacement or refinishing costs. We provide equipment, specialized training and territory.

Your investment starts at **\$11,500***. * See Prospectus for details.

Call Furniture Medic® today for more information.
We accept calls 24 hours a day, 7 days a week.

(800) 877-9933 or **(404) 361-9933** / Fax: **(404) 363-0554**



FURNITURE MEDIC
"the prescription for damaged furniture!"

Master and Unit Licences Available Worldwide.

The Adventures of Dusty Pyles



HEY B.E., HOW'D YOU WIN THE CLEAN SHOP AWARD? I SWEEP BUT I CAN'T SEEM TO KEEP MY SHOP CLEAN.



DUSTY, IT'S EASY WITH THE CLEANAIR SYSTEM. LET ME SHOW YOU...



BY USING A UNIQUE 3-STAGE FILTRATION SYSTEM, THE CLEANAIR EFFECTIVELY CAPTURES 97% OF THE DUST PARTICLES IN THE AIR!... IT'S COMPACT AND VERY QUIET... AFTER 8 MONTHS I'VE NEVER HAD TO CHANGE FILTERS... AND IT MOUNTS ON THE CEILING SO IT'S NEVER IN THE WAY OF MY WORK! JUST LOOK HOW GREAT THIS PLACE LOOKS... AND I'VE BEEN WORKING IN MY SHOP ALL DAY!



BACK IN DUSTY'S SHOP...

I CAN'T WORK LIKE THIS ANYMORE (COUGH)... I WANT MY SHOP TO LOOK LIKE B.E.'S.



HELLO!... TOTAL SHOP, I WANT TO ORDER A CLEANAIR SYSTEM...

TO BE CONTINUED...

And here are just a few more advantages the CleanAir System has over the competition...

- Needs no outside venting
- Effectively cleans the air in an area up to 4000 cubic feet
- Totally quiet operation
- Has no effect on existing room temperature
- Runs on standard house current
- Compact size (25" x 13" x 40") fits almost anywhere
- Heavy gauge steel cabinet with mounting holes
- Contains approximately 18 square feet of filter material
- Easy filter replacement
- Also available in heavy duty model
- 30 day money back guarantee
- One year warranty on all parts
- Built in the USA with a 5 year track record of total customer satisfaction

Why continue fighting the never ending battle with dust? Order **NOW** and receive absolutely **FREE** our Extended Lifetime Warranty (\$29.95 value!)

CleanAir System
260 CFM order # 90175
Suggested List Price \$339
NOW \$269
\$20 shipping

CleanAir System
490 CFM order # 90177
Suggested List Price \$399
NOW \$309
\$20 shipping

Filter Replacement Kit • order # 90176 • \$29.95

NAME _____
 ADDRESS _____
 CITY/STATE _____
 ZIP _____ PHONE _____
 PLEASE SEND MORE INFO
 I WANT TO ORDER # _____
 CK, M/C, VISA, DISCOVER, AMEX
 CARD # _____ EXP. DATE _____

TOLL FREE 1-800-845-9356

TotalShop
 WORLD OF WOODWORKING
 DEPT. #3
 P.O. BOX 25429 • GREENVILLE, SC 29616

MLCS

MAKE BEAUTIFUL RAISED PANEL DOORS WITH YOUR . . . 1/4" or 1/2" ROUTER . . . 1/2" or 3/4" SHAPER

Professional production quality bit makes it quick and easy to produce matching rails and stiles — the panel raising bit with ball bearing guide makes the raised panel perfect every time.

SALE PRICE **\$69⁹⁵** Regular value over \$150.00!
1/4" SHANK SET - ITEM #1301 (includes both bits shown)

SET ALSO AVAILABLE IN 1/2" SHANK - \$79.95 - ITEM #1302

Shaper Cutters set: Item #1303
SAVE! only \$99.95
Set: Rail & Stile & Raised Panel Cutters

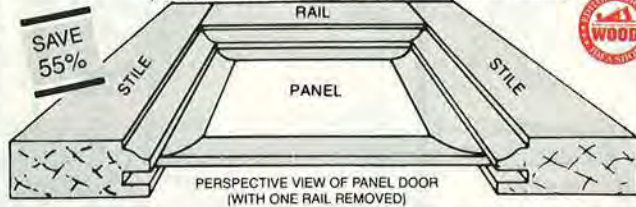

RAISED PANEL BIT
SUPPLIED WITH BALL BEARING
2" Large Diameter
CARBIDE TIPPED
1/4" Shank

REVERSIBLE COMBINATION RAIL and STILE BIT

(For making matching rails and stiles in raised panel doors, etc.) Works with stock from 1 1/16" to 7/8" thick

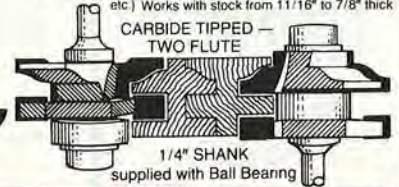

CARBIDE TIPPED ROUTER BITS • PROFESSIONAL PRODUCTION QUALITY GUARANTEED WHEN ORDERING ANY THREE OR MORE DEDUCT \$1.00 EACH • FREE SHIPPING IN CONTINENTAL U.S.

ITEM NUMBER	DESCRIPTION (ALL 2 FLUTE)	SHANK SIZE	PRICE		ITEM NUMBER	DESCRIPTION (ALL 2 FLUTE)	SHANK SIZE	PRICE
#1306	CLASSICAL - 3/16" Radius — 5/8" Cutting Length	1/4"	\$22.50		#1337	FLUSH TRIM - 3/8" Diameter — 1" Cutting Length	1/4"	\$ 7.50
#1307	CLASSICAL - 1/4" Radius — 3/4" Cutting Length	1/4"	\$25.00		#1338	FLUSH TRIM - 1/2" Diameter — 1" Cutting Length	1/4"	\$ 8.00
#1308	CLASSICAL - 3/16" Radius — 5/8" Cutting Length	1/2"	\$22.50		#1339	FLUSH TRIM - 1/2" Diameter — 1-3/16" Cut.Length	1/2"	\$ 8.00
#1309	45° CHAMFER - 3/8" Cutting Length	1/4"	\$13.00		#1340	PATTERN / FLUSH TRIM - 1" Cutting Length	1/4"	\$15.00
#1310	45° CHAMFER - 5/8" Cutting Length NEW!	1/4"	\$15.00		#1341	PATTERN / FLUSH TRIM - 1" Cut. Length NEW!	1/4"	\$17.00
#1311	45° CHAMFER - 5/8" Cutting Length	1/2"	\$17.00		#1342	PATTERN / FLUSH TRIM - 1" Cutting Length	1/2"	\$19.00
#1312	THUMBNAIL - 1- 3/16" Large Diameter	1/4"	\$18.50		#1343	KEYHOLE CUTTER - 3/8" (bit not shown)	1/4"	\$ 8.50
#1313	THUMBNAIL - 2- 5/8" Large Diameter	1/2"	\$35.00		#1344	KEYHOLE CUTTER - 1/2" shown	1/4"	\$ 9.00
#1314	ROUND OVER - 1/8" Radius	1/4"	\$11.00		#1345	DOVETAIL (HSS) - 1/4" Diameter — 7-1/2°	1/4"	\$ 6.50
#1315	ROUND OVER - 3/16" Radius	1/4"	\$11.00		#1346	DOVETAIL - 1/2" Diameter — 14° NEW!	1/4"	\$ 6.00
#1316	ROUND OVER - 5/16" Radius	1/4"	\$14.00		#1347	DOVETAIL - 1/2" Diameter — 14°	1/2"	\$ 6.50
#1317	ROUND OVER - 1/4" Radius NEW!	1/2"	\$12.00		#1348	BEADING - 1/4" Radius	1/4"	\$13.00
#1318	ROUND OVER - 3/8" Radius	1/2"	\$15.50		#1349	BEADING - 3/8" Radius	1/4"	\$15.50
#1319	ROUND OVER - 1/2" Radius	1/2"	\$17.00		#1350	BEADING - 1/2" Radius	1/4"	\$17.00
#1320	ROUND OVER - 3/4" Radius	1/2"	\$21.00		#1351	LOCKMITRE - 7/8" Cutting Length NEW!	1/4"	\$32.00
#1321	MULTIFORM MOULDING - 15/16" Carbide Height	1/4"	\$40.00		#1352	LOCKMITRE - 1-1/8" Cutting Length	1/2"	\$45.00
#1322	MULTIFORM MOULDING - 2" Carbide Height	1/2"	\$40.00		#1353	OGEE RAISED PANEL - 2" Large Diameter	1/4"	\$28.00
#1323	SLOT CUTTER - 3/8" Deep	1/4"	\$14.00		#1354	OGEE RAISED PANEL - 2-3/4" Large Diameter	1/2"	\$32.95
#1324	RABBETING - 1/4" Deep	1/4"	\$15.00		#1355	EDGE BEADING - 3/16" Diameter of Circle	1/4"	\$15.00
#1325	RABBETING - 3/8" Deep NEW!	1/4"	\$13.00		#1356	EDGE BEADING - 5/16" Diameter of Circle	1/4"	\$15.50
#1326	RABBETING - 3/8" Deep	1/2"	\$13.00	#1357	SPIRAL UPCUT - 1/8" Diameter (solid carbide)	1/4"	\$ 9.00	
#1327	CORE BOX - 3/8" Large Diameter	1/4"	\$11.00	#1358	SPIRAL UPCUT - 1/4" Diameter (solid carbide)	1/4"	\$12.00	
#1328	CORE BOX - 1/2" Large Diameter	1/4"	\$13.00	#1359	SPIRAL UPCUT - 1/4" Diameter (solid carbide)	1/2"	\$12.00	
#1329	CORE BOX - 3/4" Large Diameter	1/4"	\$15.00	#1360	SPIRAL UPCUT - 3/8" Diameter (solid carbide)	1/2"	\$24.00	
#1330	BULL NOSE - 1/2" Diameter of Circle	1/4"	\$16.00	#1361	SPIRAL UPCUT - 1/2" Diameter (solid carbide)	1/2"	\$29.00	
#1331	BULL NOSE - 3/4" Diameter of Circle	1/4"	\$21.00	*MOULDING PLANES				
#1332	BULL NOSE - 3/4" Diameter of Circle	1/2"	\$21.00	#1362	1" C.L.	1/4"	\$24.95	
#1333	TONGUE & GROOVE - Straight	1/4"	\$29.00	#1363	1-5/8" C.L.	1/2"	\$29.95	
#1334	TONGUE & GROOVE - Straight	1/2"	\$29.00	#1364	1-5/8" C.L.	1/2"	\$31.95	
#1335	TONGUE & GROOVE - Wedge	1/4"	\$29.00	#1365	1" C.L.	1/4"	\$31.95	
#1336	TONGUE & GROOVE - Wedge	1/2"	\$29.00	#1366	1-11/16" C.L.	1/2"	\$31.95	

FREE — NEW 40 PAGE CATALOG • While in the Philadelphia Area Visit our Fully Stocked Showroom (call for easy directions)

CONTROL THE SPEED OF YOUR ROUTER

ROUT AT THE SPEED THAT GIVES THE BEST RESULTS WITH THE WOOD AND BIT YOU ARE USING!



FEATURES:

- Works With All Routers 3/4 HP or less - 120V 15 Amp.
- Full Horsepower and Torque at All Speeds.
- Gives Your Router a Feature Only Available on Routers Costing Hundreds of Dollars!

~~139.95~~

SALE \$29.95

Order Item #1304
Free Shipping in Continental U.S.

FORSTNER BITS For Perfect Holes

Forstner bits are designed to drill flat bottom or through holes cleanly in end grain, thin stock, veneers and regular stock. Comes with its own attractive wood box and includes the following sizes: 1/4", 3/8", 1/2", 5/8", 3/4", 7/8", 1", 1 1/8", 1 1/4", 1 3/8", 1 1/2", 1 5/8", 1 3/4", 1 7/8", 2", 2 1/8".

Regularly \$99.95

Special Sale \$79.95
16 Piece Set Order Set #1305
Free Shipping in Continental U.S.



To order by Master Charge, Visa, or Discover
Call Toll Free, 7 Day - 24 Hour Order Service

1-800-533-9298

or send check to: **MLCS Ltd.**
P.O. Box 4053 DX, Rydal, PA 19046

BUD MORROW, GUNSMITH

Building one-of-a-kind rifles one at a time

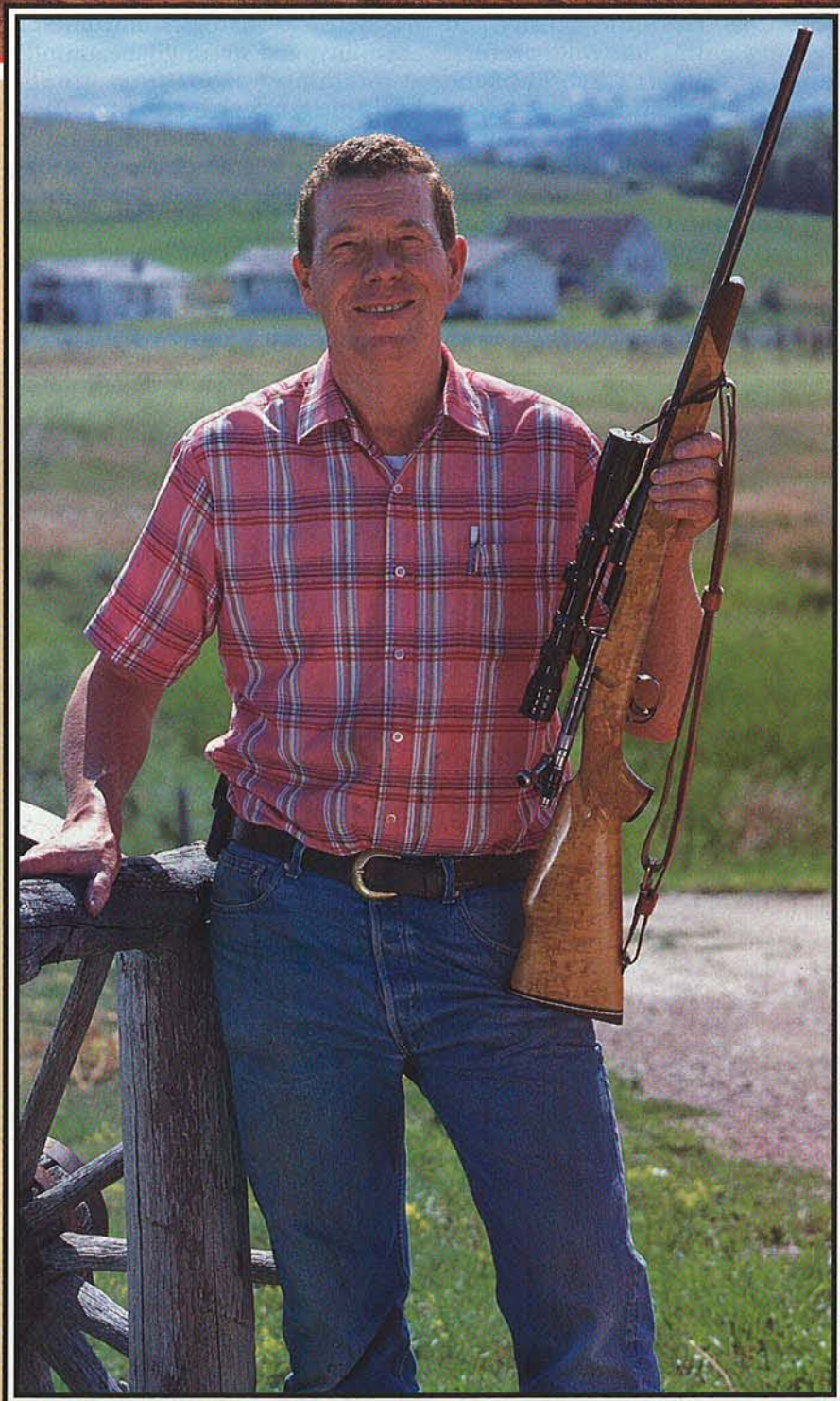

With the Bighorn Mountains in the distance, Bud Morrow shows off the first gun he ever built, a .270 Winchester with a converted Mauser action.



At the foot of the Bighorn Mountains near the town of Sheridan, Wyoming, Bud Morrow builds custom guns for a living. In his crowded shop, the trophy heads of elk, deer, and Bighorn sheep look down on a jumble of files, chisels, bullet boxes, barrels, trigger assemblies, and rifle-stock blanks. Standing at a bench that has been seasoned with decades of iron filings and tung oil, Bud carefully and patiently builds anywhere from 30 to 50 new rifles a year. He also reconditions older rifles like pre-1964 Winchester Model 70s, and old military rifles. As a graduate of the country's oldest gunsmithing school at Trinidad State Junior College in Colorado, and after 35 years of building custom hunting rifles, Bud can rightfully stake his claim as one of the top gunsmiths in the country.

Legacy of the Old West

The Bighorn Mountains own a big chunk of American history. General George Custer met his fate just an hour's drive north from here. An hour to the south you'll find the site of the Hole in the Wall, made famous by Butch Cassidy and the Sundance Kid.

A century after that wild and violent era, the guns are no longer shouldered by soldiers and outlaws, but by big-game hunters. To them the mountains of Wyoming are Mecca. And some of them, those who have the money and the passion for guns and hunting, come to the Sheridan Gun Shop to have Bud Morrow build them a one-of-a-kind rifle.

Continued

 [Print this article](#)

GUNSMITH

If it's too pretty to use, I say "don't buy it."

With a starting price around \$3,000, custom rifles don't come cheap, but Bud would much rather his customers use his rifles than to seal them up for show in a display cabinet.

"I build these guns for people to hunt with," says Bud. "Just because something's pretty doesn't mean it can't serve a purpose. If somebody says it's too pretty to use, I say don't buy it."

So why then would a person pay thousands of dollars for a custom gun and then risk damaging it in the wilderness? "It's a luxury for sure," says Bud, "but it's like the difference between a Cadillac and a Chevrolet. Both will get you down the road, but one feels a whole lot better than the other."

Stalking the perfect stock

The process of fitting the gun to the buyer begins with the selection of wood. Leaning back against his workbench, Bud is talking about trees and the growing conditions that make good gunstocks. "Trees are a lot like people. They want to go through life without too much adversity. But the best wood comes from trees that have to overcome hardships—poor soil, tough climates, and strong winds. These conditions force a tree to grow slower, but that makes the wood better, denser, and more durable."

English walnut (*Juglans regia*), a strong, dense wood with fine pores, takes the top spot on most gunmaker's lists. (It's sometimes called French walnut because

most of it is grown in and exported from France). American black walnut (*Juglans nigra*), much of which lives a pampered life on tree farms, lacks the density and swirling grain that Bud prefers. Bastogne walnut, a hybrid of the English and American trees, offers the strength of English walnut with a beautiful fiddleback grain pattern. On rare occasions, Bud will build a gun from maple, koa, or myrtle, but these are strictly special requests.

Bud's favorite wood, however, is the English walnut harvested in

the rugged, arid regions of Turkey and the Himalayan mountains. The wood from these slow-growing trees is a gunmaker's dream—as dense as marble, unmatched in stability, and strikingly beautiful.

Digging up the roots

Finding good wood has never been easy. "Most of the pretty figure and grain comes into the tree close to the ground," explains Bud. To cut a tree for gunstocks, the tree should be dug up out of the ground to get the roots. "Some cutters know what makes a

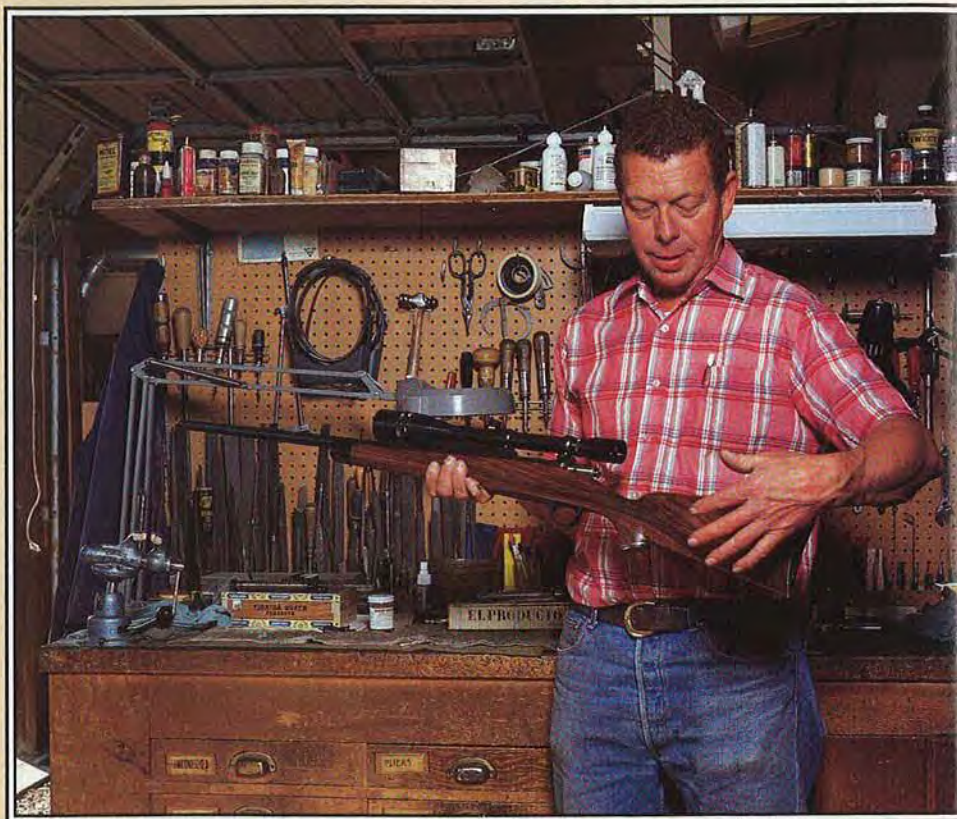

In his shop, Bud explains the ideas behind the clean lines and conservative design of a classically styled, 22-250 rifle he recently built.

Rifle stock blanks

Myrtle

Koa

English walnut

good gunstock. The ones who don't, break my heart," says Bud, referring to the wood he's seen ruined by careless sawing. Out of 100 stock blanks, only two or three usually meet his requirements, and these command a hefty price, anywhere from \$500 to \$1,500. Bud buys most of his stocks from tree cutters, people who drive around the country peddling these premium pieces of wood to gunsmiths.

Once he has a stock blank in hand, Bud sets it aside to air-dry for three to five years. After the

stock has seasoned, he'll take a few measurements to fit the gun to the customer, and discuss style preferences and other details. The basic proportions of most rifles are well established, but Bud may vary the length of the stock up to an inch or so to suit the size and shooting requirements of the customer.

The return of classic style

Gunmaking traditions offer two styles—the classic school and the California school. Bud pitched his tent in the classic camp long ago.

His guns have always cut a clean, conservative profile. The California school, with its embellished curves and diamond inlays ("gingerbread" according to Bud) flowered in the 1960s and '70s at the behest of its guru and champion Roy Weatherby. But like so many other trends, the classic school is back in favor.

Putting it all together

Once he's selected the wood, Bud will square the top of the stock and one side, and then rough out the shape on a band-saw. The recesses for the metal parts are hogged out with a drill press or router and cleaned up with chisels and gouges.

Beyond the rough shape, however, carving a custom gunstock is pure sculpture carried out with rasps, files, chisels, drawknives, and spokeshaves. Plans and patterns don't exist. And Bud has enough of an artist's temperament to know not to force himself to shape a stock on a bad day. "I can't shape or sand if I'm not feeling right about it", says Bud. "I'll go camping or go out in the garden instead. It's a whole lot less expensive to chop down a few bean plants than it is to ruin a thousand-dollar piece of wood."

Where metal meets wood

The biggest woodworking challenge comes when it's time to marry the wood to the metal parts. Any looseness here will eventually destroy the stock as the explosive force of the bullets slam the metal back against the wood. The barrel, bolt action, trigger assembly, and magazine box must fit to tolerances that

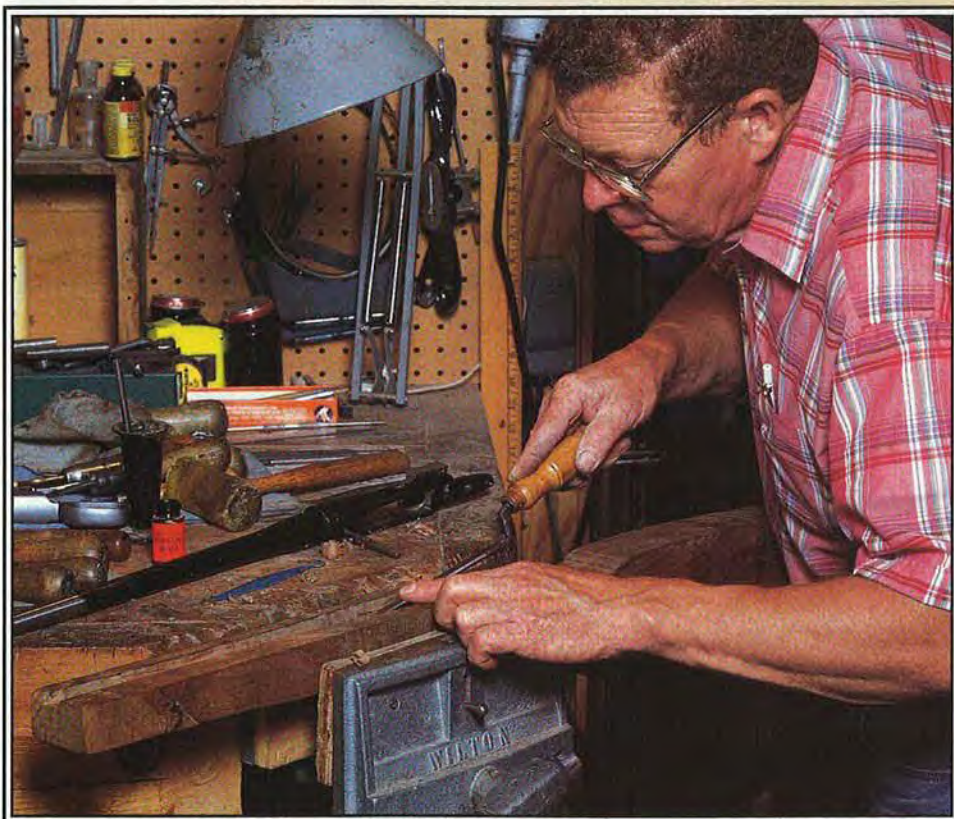

With inletting black covering the barrel on this soon-to-be 25-06, Bud pares a few hundredths of an inch of wood from the side of the barrel groove.

Continued

Maple

English
walnut

Bastogne walnut

GUNSMITH

measure in the thousandths of an inch. For the final fittings, Bud coats each metal part with a carbon-based substance called "inletting black," then drops them down into their recesses. The inletting black marks the high spots on the wood, which Bud pares away with a chisel in paper thin shavings, as shown on in the photo on *page 39*.

Once the metal parts fit, Bud starts sanding with 60-grit sandpaper to bring the top surfaces of the wood and metal perfectly flush, and then continues with finer grits of sandpaper for finishing. When he reaches 220 grit, Bud adds Danish oil or tung oil to the stock and sands that in to help fill the pores, working up to a 600-grit paper. On the last few sandings Bud often switches to Dem-Bart oil, a special low-gloss oil made just for gun stocks. Most oils are too shiny for his tastes, says Bud. "I like to see the wood, not the finish."



Having fit the metal into the wood, Bud brings the two flush with careful sanding.

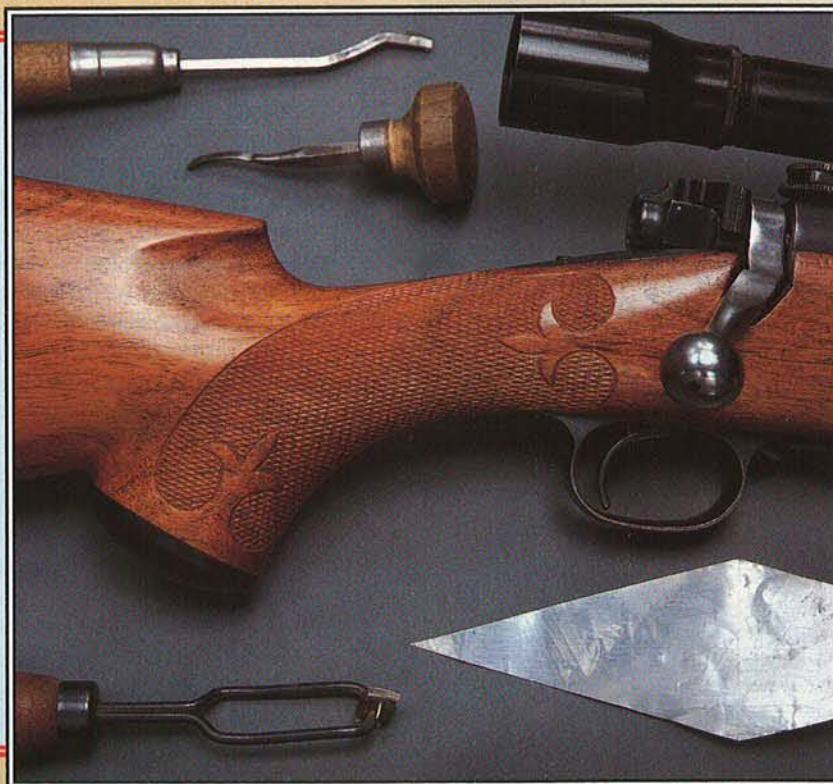

CHECKERING The tell-tale detail

A metal foil pattern shows Bud where to mark the border of his cuts.

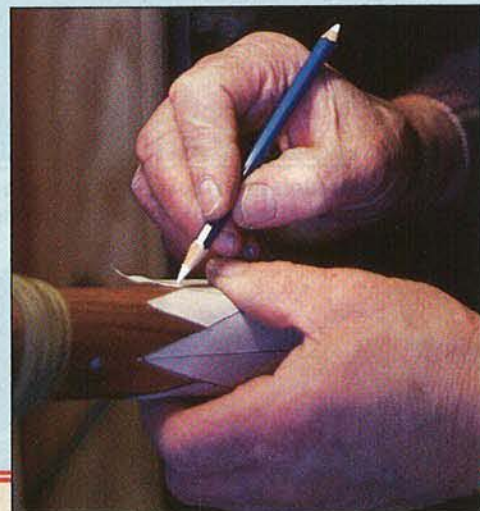

Carving a field of diamonds

Just before the final coat of oil, Bud pulls out his checkering tools and cuts the very fine diamond-shaped patterns around the grip and forearm of the rifle. Checkering provides a slip-resistant surface on the stock, and it's also a good indicator of a high-quality wood and a skilled gunsmith. With their density and tight grain patterns, the better woods support a much smaller checkering pattern, up to 32 lines per inch as opposed to 20 lines per inch for softer woods. And carving these tiny diamonds freehand, using nothing more than a V-tool and a metal-foil pattern as a guide, requires rock-steady hands and unflinching concentration. Even the slightest slip could require days of painstaking repair work.

After he has completed the woodworking, Bud disassembles the metal pieces for bluing, a process that knocks the shine off

the metal and protects it from rust. With the bluing completed, the gun is ready. The whole process, from the first discussions with the buyer to delivery of the finished product, can take eighteen months or more. The customers get awfully anxious to put their hands on the gun, especially near hunting season.

Bud himself gets mighty scarce once hunting season starts. At that point in the year you're not likely to find him in the shop. A better bet would be to look for him out in the mountains, miles from nowhere, crouched with a rifle behind a rock or a tree, looking for a big elk.

His life as a gunsmith

In the last ten years the interest in gunsmithing has grown, according to Bud, but only a handful of people make a living

at building custom rifles. Most of the other gunsmiths around the country also hold down another job, or build rifles on the side as a retirement hobby.

Bud's single-minded devotion to his work won't ever make him rich, but it's still the only way to make a great rifle. And his life-long pursuit of the perfect rifle has its own rewards—peace of mind, pride in work well done, and a shop where he can look out the window to a panoramic view of the mountains. At the top of his profession, Bud has developed the confidence to evaluate his work with an open mind. He's got the experience of nearly four decades with the enthusiasm of a beginner.

"I guess I've never been completely satisfied with any gun I've built," says Bud nonchalantly. That's probably what keeps me at it. "The day I can't learn something new is the day I'll hang up my tools and quit." ♣

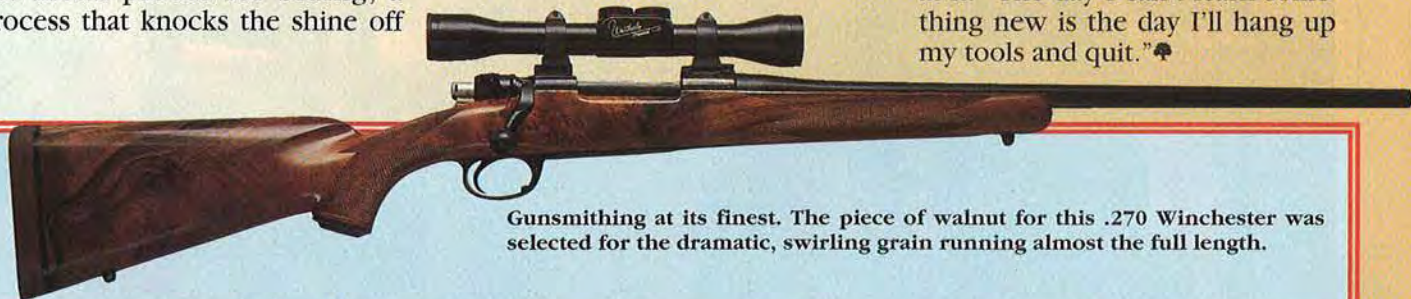

Gunsmithing at its finest. The piece of walnut for this .270 Winchester was selected for the dramatic, swirling grain running almost the full length.

Crosshatching across the rows of parallel lines fills out the pattern.



Over the course of a day or more, Bud continually carves the grooves deeper.



The end result: a perfect field of diamond shaped points.



Written by Tom Jackson Photographs by Tim Murphy Checkering photos: Margery Reitz

WELCOME TO IDEA SHOP 2



Design editor Jim Downing, who headed the shop-concept team, says, "Like a 'now you see it, now you don't' magic trick, a woodworking shop appears in the garage after the vehicles move out. Fluorescent fixtures provide plenty of light, and the white paint on the ceiling and walls enhances it. Epoxy floor paint proves durable and resists grease. Electrical drop cords with twist-lock plugs supply power to machines. For air tools and vehicle care, there's a compressor hose on a ceiling reel."



Do you have the problem of too much woodworking stuff for too little garage space? Or space going to waste because you can't figure out how to organize all those tools and materials? No matter which situation you're in, you'll find help in IDEA SHOP 2™. You'll learn why mobility is a must in garage shops—and how to achieve it. We'll also share some easy ways to solve storage-space problems—and still make room for family vehicles.

Here it is, woodworkers—the sequel to our first IDEA SHOP, which appeared in the September 1992 issue of *WOOD*® magazine. Like its predecessor, our new workshop was more than a year in the making. The creative thought, skill, and energy put into it by the staff was truly impressive. Even some of our readers participated.

In the first IDEA SHOP, we learned what it took to turn a 14×28' space into a serious woodworking shop. And most of the planning evolved from the concept that everything was more or less permanent.

IDEA SHOP 2 offers a different twist. You see, we know that many home woodworkers have their shop in a garage (usually occupied by a vehicle or two). So we took a standard 24×24' double-car garage and designed the space to accommodate a nifty shop—and the family transportation. To accomplish this, our project team had to think mobility, double-duty, comfort, security, and cost. But in the end, one great similarity with our first effort stands out: bunches of terrific, easily adaptable ideas! In this and future issues, we'll share them with you in the form of plans and step-by-step building instructions.

Larry Clayton
Editor

Continued

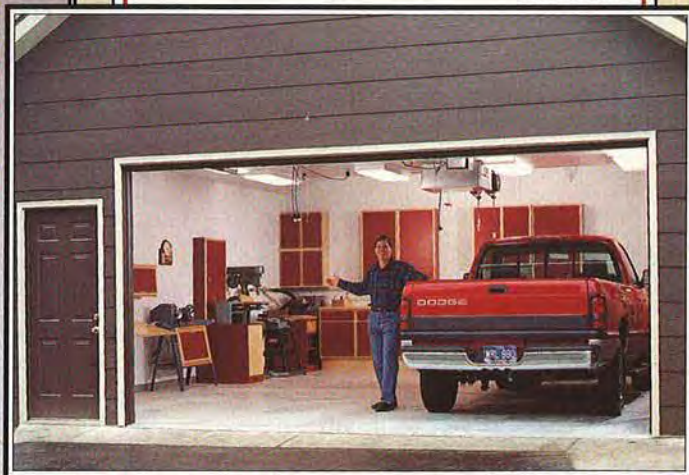

Above: Security can be a problem in an unattached building. Through an open door, it's contents are on view. That's why IDEA SHOP 2 features lockable cabinets that conceal tools and supplies.

All the space you

To make IDEA SHOP 2™ comfortable to work in during cooler weather, we insulated the walls and ceiling. (There's also access to storage space above the ceiling via a pull-down ladder.) We then sheathed the walls with beaded plywood panels; the ceiling with drywall. Both were painted with a reflective white semi-gloss enamel. The floor received a tough coating of epoxy paint. For heating comfort, we installed two small, wall-mounted natural-gas furnaces (20,000 and 30,000 Btu) with sealed combustion chambers. Their positioning on one wall also conserves precious floor space. An open garage door and an exhaust fan supply cooling ventilation in the summer. A ceiling-mounted air-filtration unit cleans recirculated air in the winter.



Above: The sander, jointer, drill press, and planer find homes in the far-left corner of the shop (see floor plan). The lockable cabinet stores drill bits and other accessories. The sander and planer bases were shop built.

Compared to the first IDEA SHOP®, our two-car garage concept offers a much larger space. And here, you adjust the space according to the project you're building, maybe with a vehicle still in the garage. You have a lot of flexibility.

A. R. Downing
Project Designer



Above: The shop vacuum, from its position in the right corner of the shop, collects dust from a run of clear-plastic pipe. With a mobile base, the bandsaw can be positioned anywhere in the shop. Above the heater is the enclosed exhaust fan. The compressor hose connections are for spraying.

The storage challenge

For storage units, we chose reasonably priced yet sturdy and hardworking wall and base cabinets available at home centers. Even though they're at the low end of the manufacturer's product line, the unfinished units feature dovetailed drawer fronts and maple-and-birch-plywood construction. And better still, they save valuable set-up time.

To help create a welcoming work environment, we sprayed the cabinet carcasses and doors of IDEA SHOP 2 with a bright red enamel; we coated the face frames with clear urethane.

Even with a 24'x24' space, there was still the challenge of fitting in all the woodworking equipment and necessary shop furniture. A WOOD® magazine reader shared with us a portable workbench design with fold-down wings that tucks neatly away between base cabinets to the right of the radial-arm saw. Next to it, there's another parking spot just for the table-saw and its mobile base cabinet.

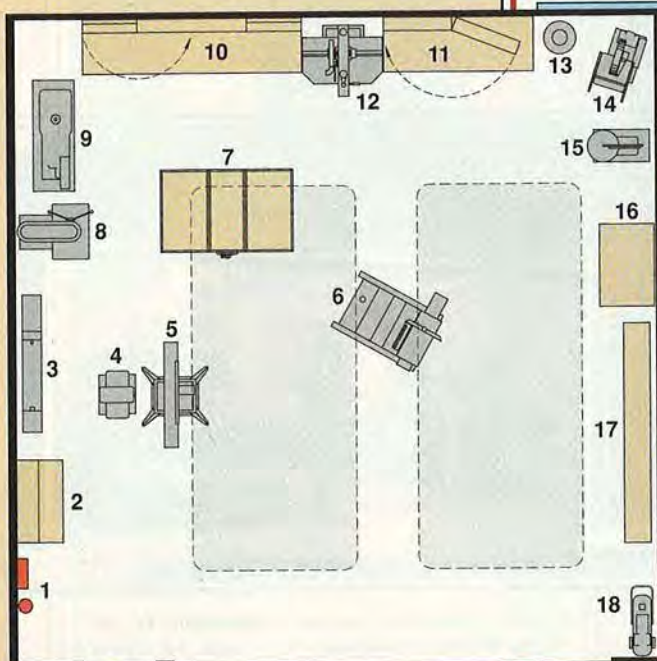

FLOOR PLAN

1. Phone/intercom, first aid.
2. Design and reference center
3. Lathe.
4. Planer.
5. Jointer.
6. Tablesaw.
7. Workbench.
8. Drill press.
9. Sander.
- 10-11. Cabinets.
12. Radial-arm saw.
13. Shop vacuum.
14. Bandsaw.
15. Scroll saw.
16. Mobile tool chest.
17. Lumber storage.
18. Portable air compressor.

Note: Rectangular outlines on the garage floor represent vehicle parking spaces.

need, when you need it



To get flexibility for various projects, yet allow for traditional garage uses, we added commercially made mobile bases to the jointer and the bandsaw. The tablesaw, planer, sander, and scrollsaw have shop-built mobile bases. These all utilize a clever tool-mover system for easy machine parking—again, an idea furnished by yet another *WOOD* magazine reader (watch for it and other ideas in a future issue).

To top things off, we designed and built a special two-sided tool chest on casters. It holds an assortment of clamps on one side and hand and power tools on the other, and parks along one wall. When needed, it can be wheeled alongside the mobile workbench.

How to clear the air

Unlike the first IDEA SHOP, we couldn't install a fixed dust-collection system to serve all possible work areas in this shop where flexibility is foremost. In IDEA SHOP 2, we opted for a shop-vacuum-based system with a fixed duct run between base and wall cabinets along the back wall. It has two countertop connections and directly serves the sander, radial-arm saw, drill press, and bandsaw. For dust collection to other machines, you roll out the vacuum and attach it.

Although IDEA SHOP 2 doesn't have a defined spray-finishing area, we allowed for it. In the far right corner of the shop, above one of the heaters, we mounted a through-the-wall power ventilator (covered when not in use). Right next to the vent is an oil-less connection for compressed air, for the times when you need to spray. (There's an oiled line for air tools on the ceiling-mounted reel in the center of the work area.)

A planning place

Along the wall to the left of the lathe, we created the perfect spot

for design and reference work. As you can see in the photo *right*, its cabinet features storage for books, magazines, plans, and drawing utensils. Below the cabinet, a wall-hung drafting table lifts up to provide a work surface. A step stool that allows access to the upper reaches of the wall cabinets provides a seat for the drafting table.

To the left of the cabinet, we located the telephone—complete with intercom to the house and a flasher to signal incoming calls when the ringer is turned off. The first-aid kit and an ABC-rated fire extinguisher are handily adjacent to the phone. 🌿



Above: Emergency numbers are posted near the telephone. The wall cabinet holds reference materials and plans. A fixture mounted beneath the cabinet sheds light on the countertop below.

A special thanks to Stew Hansen's Dodge City, Des Moines, Iowa, for the 1994 Dodge Ram 1500 pickup truck shown on opening pages.

SHOP COMPONENTS

Air filtration

Model AC460 Air-Cleaning System
Penn State Industries
2850 Comly Rd., Philadelphia, PA
19154 800/377-7297

Cabinets

Great Northern Cabinetry
P.O. Box 207, Rib Lake, WI 54470
715/427-5255

Fire extinguisher

First Alert Model FE10 Garage and
Workshop Fire Extinguisher
Manufactured by BRK Electronics,
780 McClure Rd., Aurora, IL 60504
800/323-9005 or 708/851-7330

First-aid kit

Zee Medical, 22 Corporate Park,
Irving, CA 92714-5105
800/841-8417

Furnaces

Models ASV120RTN-T (20,000
Btu), ASV730RTN-T (30,000 Btu)
Perfection Schwank, P.O. Box 749,
Waynesboro, GA 30830
706/554-2102

Lighting

Four-tube 4' fluorescent fixtures,
no. 11233
Light Concepts Division of Lithonia
Lighting, P.O. Box A, Conyers, GA
30207-0067
404/922-9000

Paint

Sherwin Williams (visit your local
dealer)
Floor: Tile-Clade High Solids
(two-part epoxy), gray
Walls and ceiling: Oil-base Interior
Wall and Wood Primer; Super
Paint Interior Semi-Gloss Latex
Enamel
Cabinets: Ultra One-Stage paint
and Ultra 7000 CC645 Urethane
Clear Coat (automotive finishes)

Wall paneling

Ply-Bead 4x8' beaded plywood
panels
Georgia-Pacific, 133 Peachtree St.
N.E., Atlanta, GA 30303
404/521-4000

Photographs: Wm. Hopkins Illustration: Kim Downing

DROP-LEAF MOBILE WORKBENCH

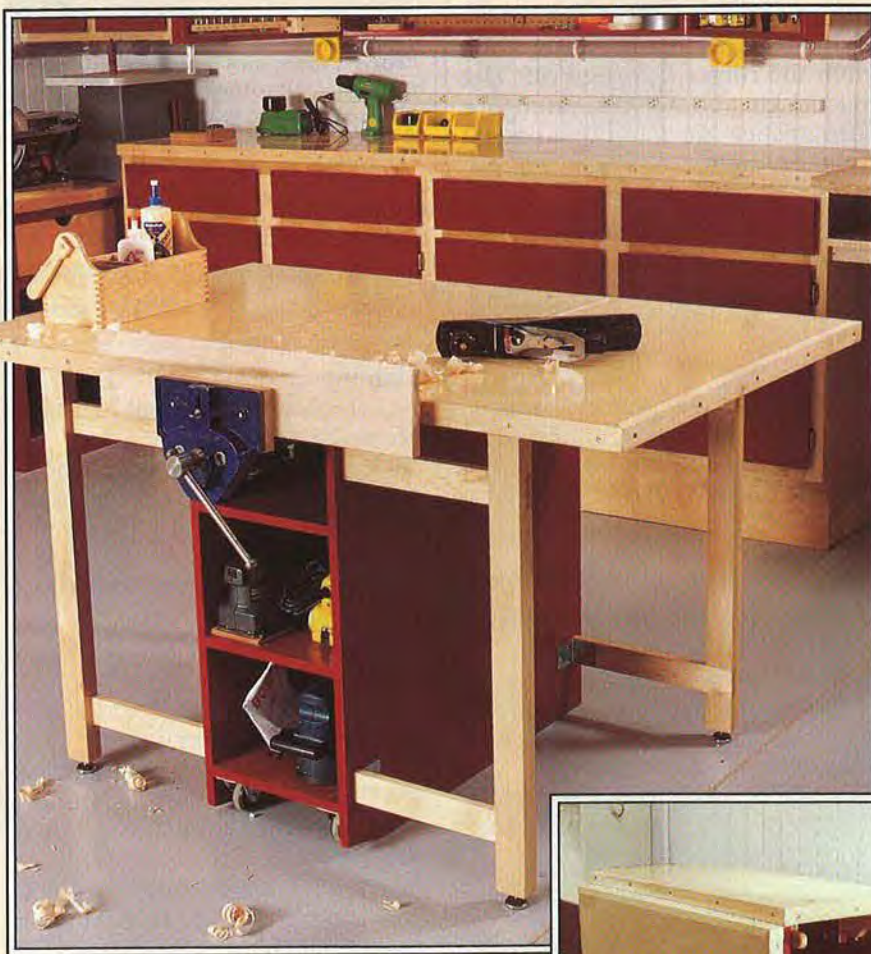

**SUPER-STURDY
AND LOADED
WITH STORAGE**



A rock-solid workbench that's mobile? In the past, this project might have sounded a little far-fetched, but not any more. A while back, *WOOD*® magazine reader Erv Roberts shared with us his garage/shop workbench design. Wanting to keep his cars inside during Iowa's cold, snowy winters, Erv needed a workbench with wheels so he could push it out of the way when the time came to bring his cars inside. He also wanted a workbench with fold-down leaves, giving him the most efficient against-the-wall storage possible. When Erv's hobby calls, his benchtop folds out to a full 36×58".

Start with the base cabinet for a solid foundation

1 Cut the two base side panels (A) to the size listed in the Bill of Materials from $\frac{3}{4}$ " birch plywood.

2 Cut the base banding pieces (B, C) to size from $\frac{3}{4}$ " maple. Glue the banding pieces to the panels where shown on the Base Side Panel drawing on the *opposite page*. See our shop tip on *page 12* for hints on banding edges. Sand the banding flush.

3 Using the same drawing for reference, mark the location of, and cut or rout $\frac{3}{4}$ " dados and grooves $\frac{1}{4}$ " deep into the mating inside surface of each plywood side panel.

4 Mark and cut a $\frac{3}{4}$ ×5" taper on the bottom rear corner of each side panel. When assembling the base later, the tapers must be directly across from each other. The tapers allow the casters to come in contact with the floor without the corners of the side panels rubbing against the floor when moving the workbench.

MOBILE WORKBENCH

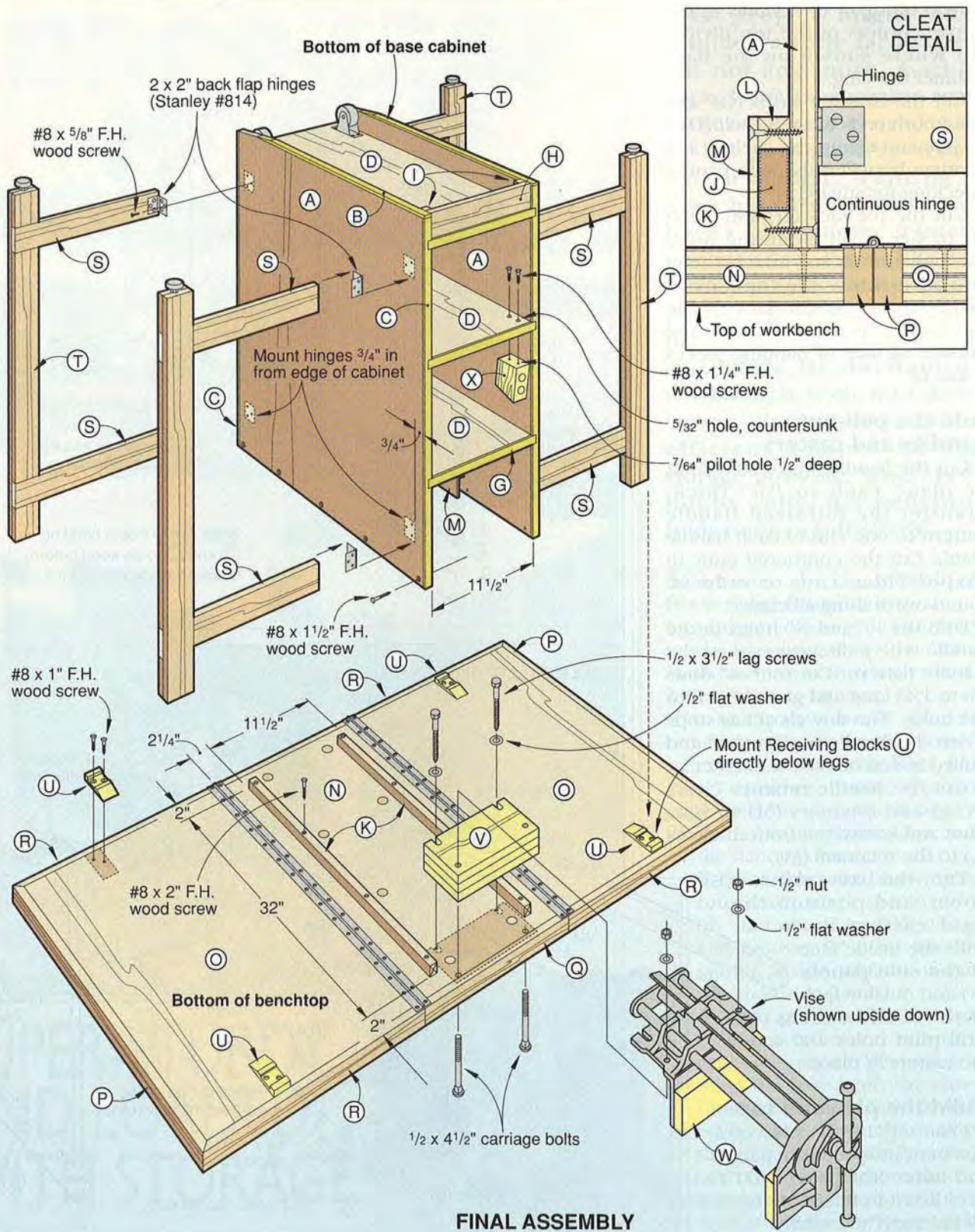

FINAL ASSEMBLY

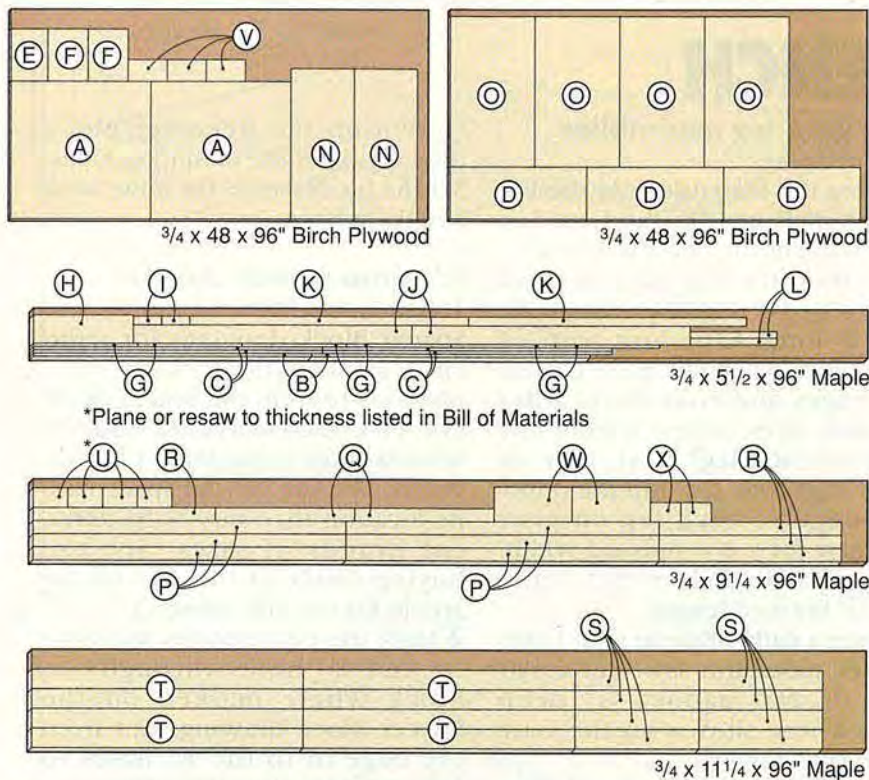

CUTTING DIAGRAM

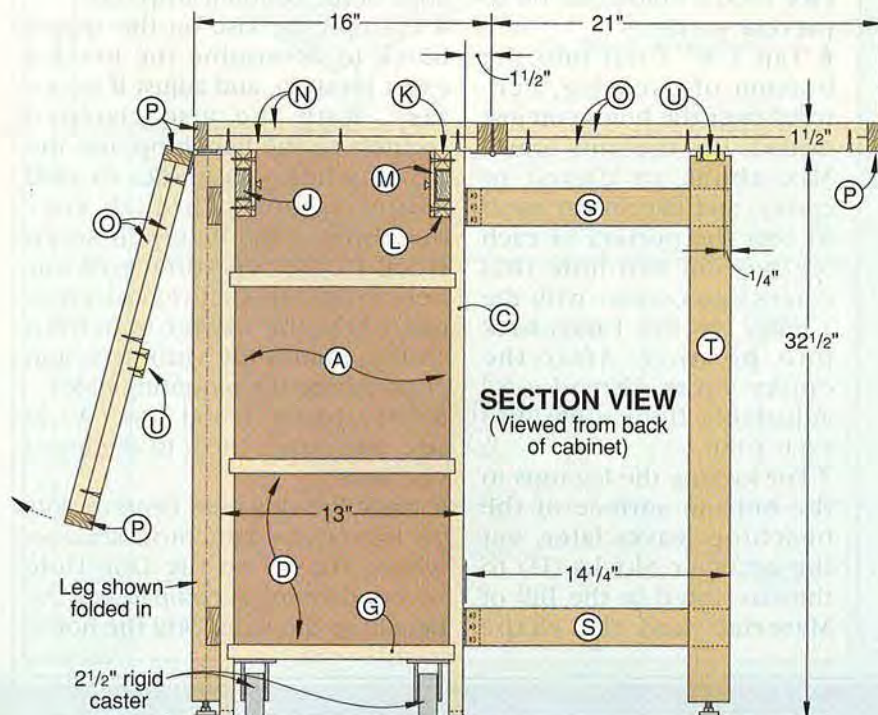
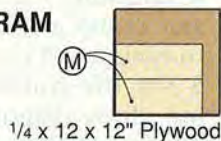

Bill of Materials

Part	Finished Size*			Mtl.	Qty.
	T	W	L		
BASE					
A sides	3/4"	31 1/2"	32 1/4"	BP	2
B btm. bands	1/4"	3/4"	32"	M	2
C side bands	1/4"	3/4"	32 1/4"	M	4
D shelves	3/4"	12"	31 1/2"	BP	3
E divider	3/4"	12"	8 1/2"	BP	1
F dividers	3/4"	12"	9 1/4"	BP	2
G shelf bands	1/4"	3/4"	12"	M	6
H toe kick	3/4"	3 1/4"	11 1/2"	M	1
I cleats	3/4"	1"	3 1/4"	M	2
HANDLE ASSEMBLY					
J handles	1 1/16"	2 1/8"	32"	M	2
K cleats	3/4"	1"	32"	M	2
L cleats	3/4"	3/4"	10"	M	2
M retainers	1/4"	4"	10"	P	2
BENCHTOP					
N* center	3/4"	34 1/2"	14 1/2"	BP	2
O* leaves	3/4"	34 1/2"	19 1/2"	BP	4
P banding	3/4"	1 1/2"	36"	M	6
Q banding	3/4"	1 1/2"	16"	M	2
R banding	3/4"	1 1/2"	21"	M	4
GATE LEGS AND BLOCKS					
S rails	3/4"	2 1/4"	14 1/4"	M	8
T* legs	1 1/2"	2 1/4"	31 1/4"	LM	4
U rec. blocks	1/2"	2 1/4"	3 7/8"	M	4
VISE MOUNT AND JAWS					
V spacer block	2 1/4"	5"	9"	LBP	1
W vise jaws	3/4"	4"	9"	M	2
X dogholder	1 1/2"	2 1/4"	3 1/2"	LM	1

*Initially cut parts marked with an * oversized. Then, trim each to finished size according to the how-to instructions. Note, we measure length with the grain.

Materials Key: BP—birch plywood, M—maple, P—plywood, LM—laminated maple, LBP—laminated birch plywood.

Supplies: #8x3/8", #8x1", #8x1 1/4", #8x1 1/2", and #8x2" flathead wood screws, 8-2x2" heavy duty hinges (Stanley #814 back flap hinge), 2 sections of 1 1/2" continuous hinge 36" long with #6x3/4" flathead wood screws, 3/8" dowel stock, 2-1/2x4 1/2" carriage bolts with flat washers and nuts, 2-1/2x3 1/2" lag screws with 1/2" washers, 2-2 1/2" (3 1/4" overall height) rigid casters with 8-#8x3/4" panhead sheet metal screws, 4-3/8" T-nuts, 4-3/8" nuts, 4 adjustable floor glides, clear finish, paint.

Buying Guide

Vise. Record 52-1/2D, 9" jaw width, 13" jaw opening, with quick-release mechanism. For the current price contact Seven Corners Hardware Inc., 216 W. 7 Street, St. Paul, MN 55102. Or call 800-328-0457 or 612/224-4859 to order.

MOBILE WORKBENCH

2 Glue and clamp the benchtop panels together in pairs with the edges and ends flush. See the Benchtop drawing for reference. (We used sliding-head type clamps around the perimeter. Then, we drilled and countersunk a few screw holes from the bottom side and added a few screws in the middle to pull the panels tightly together.)

3 Trim the laminated benchtop panels to the finished sizes listed in the Bill of Materials.

4 Rip to width and then miter-cut the banding strips (P, Q, R) to size. Drill countersunk mounting holes, and screw (no glue) them to the laminated benchtops.

The gate-leg assemblies come next

1 Using the dimensions in the Bill of Materials and on the Gate Leg drawing, cut the rails (S) to size.

2 To form the legs (T), cut eight pieces of $\frac{3}{4}$ " maple to $2\frac{1}{2}$ " wide by 32" long. Glue four pairs of two pieces each face-to-face, with the edges and ends flush. After the glue dries, scrape it from one edge of each leg. Next, joint or plane that edge flat. Rip the opposite edge of each leg on your tablesaw for a $2\frac{1}{4}$ " finished width. Crosscut both ends of each leg to a $31\frac{1}{4}$ " finished length.

3 Using a dado blade in your table-saw or radial-arm saw, cut a pair of $2\frac{1}{4}$ " dados $\frac{3}{4}$ " deep where shown on the Gate Leg drawing.

4 Checking for square, glue and clamp a pair of rails (S) to each leg (T).

5 On the bottom of each leg, draw diagonals to find center. Drill a $\frac{7}{16}$ " hole 2" deep at each centerpoint. (We used a brad-point bit to prevent wander.)

6 Tap a $\frac{3}{8}$ " T-nut into the bottom of each leg, centered over the holes you just drilled. Pry the nuts loose. Mix about an ounce of epoxy, and use an ear swab to coat the portion of each leg bottom and hole that comes into contact with the T-nuts. Tap the T-nuts back into position. After the epoxy cures, thread a $\frac{3}{8}$ " adjustable floor glide into each T-nut.

7 For locking the leg tops to the bottom surface of the benchtop leaves later, cut the receiver blocks (U) to the size listed in the Bill of Materials and the shape

shown on the Receiver Block drawing. Drill the mounting holes. Set the blocks aside for now; we'll add them later.

It's time to add the vise

1 Using the Final Assembly and Spacer Block drawings for reference, laminate three pieces of $\frac{3}{4}$ " plywood to form the spacer block (V). (We used a Record 52-1/2D woodworker's vise with a 9" jaw width. The size of your spacer and its location may vary with different brands of vises. See the Buying Guide at the end of the article for our vise source.)

2 Mark the centerpoints and bore $\frac{1}{2}$ " and $\frac{5}{8}$ " holes through the block where marked on the Spacer Block drawing. Cut from the edge in to the $\frac{5}{8}$ " holes to form $\frac{5}{8}$ "-wide slots where shown.

3 Clamp the spacer block (V) to the bottom side of the benchtop center section (N) where shown on the Final Assembly drawing. The outside edge of the block should be flush with the outside edge of the banding strip (Q).

4 Position the vise on the spacer block to determine the block's exact location, and adjust if necessary. With the vise clamped securely to the benchtop, use the existing holes as guides to drill mounting holes through your benchtop. (We clamped scrap stock to the top surface of our benchtop top to prevent chip-out.) Flip the center benchtop section (minus the vise) over, and counterbore the mounting holes.

5 Cut a pair of wood jaws (W) to size, and attach them to the metal vise jaws.

6 Mark the dog-hole centerpoints on the center benchtop section—where shown on the Dog Hole Layout drawing accompanying the Benchtop drawing. Drill the holes.

Continued

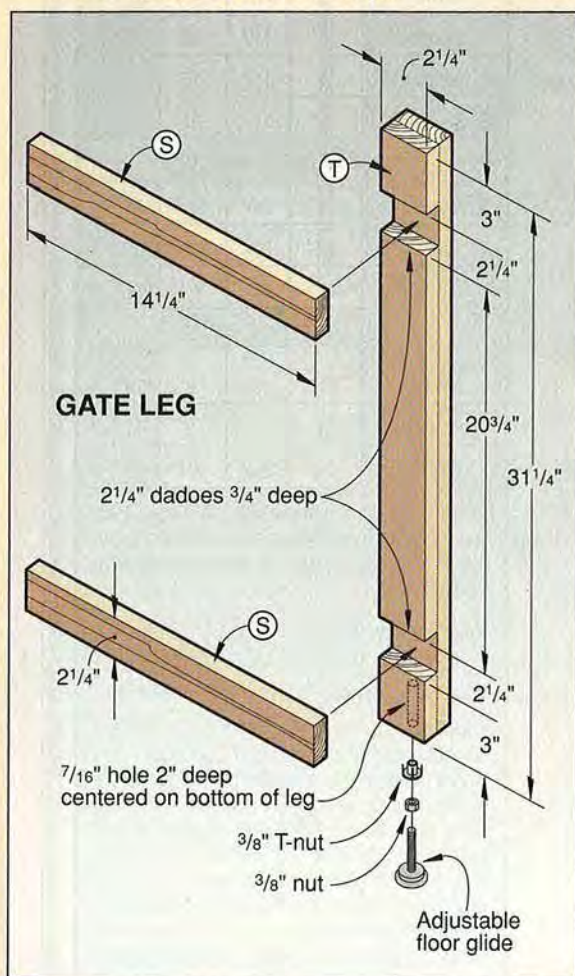

BENCHTOP

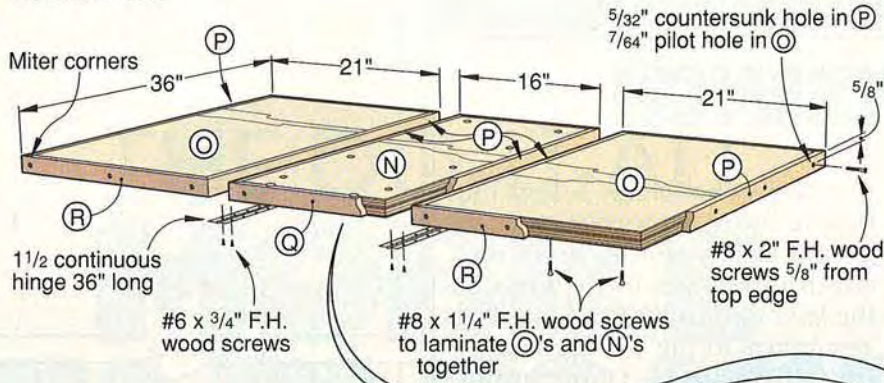

DOG HOLE AND VISE MOUNTING HOLE LAYOUT

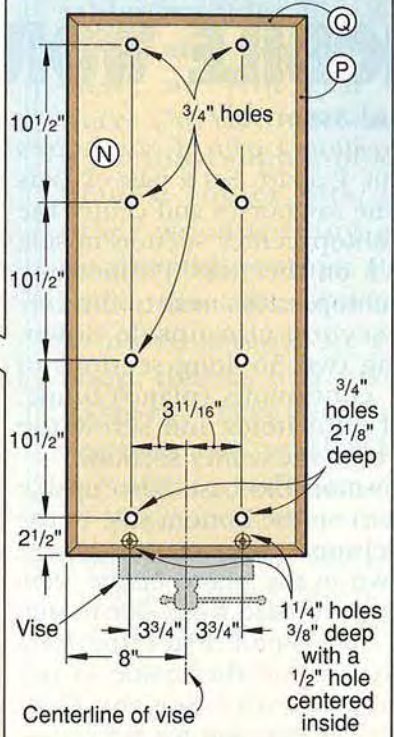

RECEIVER BLOCK

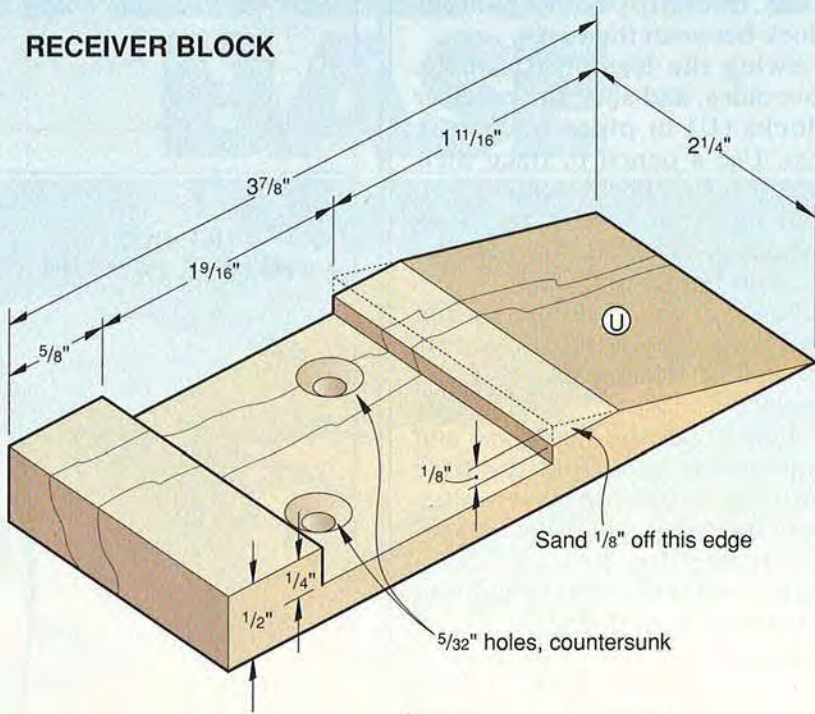

DOG HOLDER

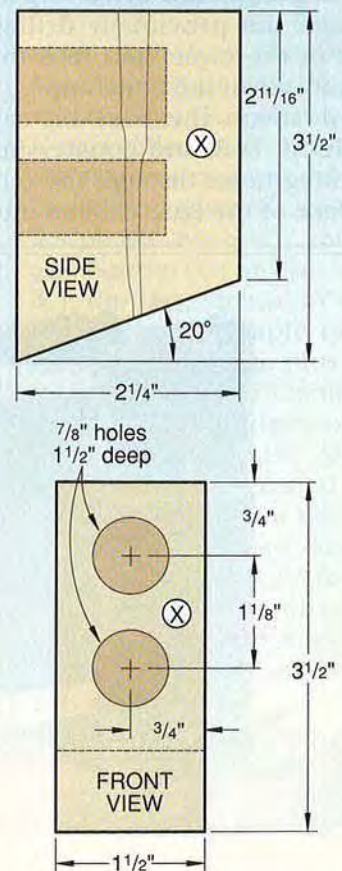

SPACER BLOCK

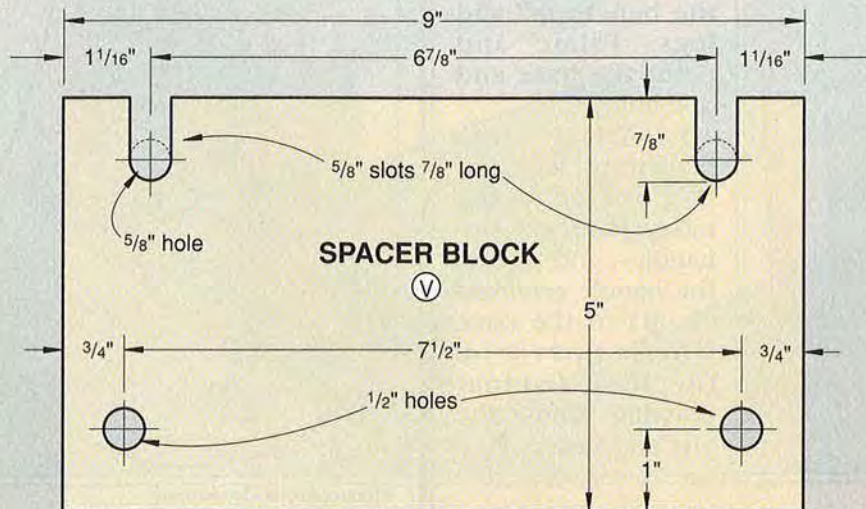

MOBILE WORKBENCH

Final assembly

1 Position a pair of saw horses about 4' apart. Set a pair of 2x4s on the sawhorses and center the benchtop center section upside down on the 2x4s. Position the benchtop leaves next to the center section also upside down. Using two 36"-long sections of 1½" continuous (piano) hinge, drill pilot holes and screw the leaves to the center section.

2 Position the base (also upside down) on the bottom side of the benchtop center section where shown in the photo *below*, centering the base from side-to-side and end-to-end. Place the long cleats (K) on the inside of the side panels (A). See the Final Assembly drawing for reference. Next, clamp the cleats in place to the benchtop. Lift the base off the benchtop, and drive screws through the previously drilled holes in the cleats and into the bottom side of the benchtop.

3 Reposition the base on the benchtop. Drill and countersink mounting holes through the outside face of the base cabinet into

the cleats (K). Next, screw the base to the benchtop cleats.

4 Drill the mounting holes and attach the hinges to the ends of the leg rails. Attach the hinge/leg assemblies to the outside face of the side panels. (For proper spacing between the top ends of the legs and the benchtop bottoms, we slipped a receiver block between the two.)

5 Swing the legs 90° from the base sides, and slide the receiver blocks (U) in place under the legs. Use a pencil to trace their location on the benchtop bottom surface. Swing the legs against the base, and screw the receiver blocks in place.

6 Position the handles (upside down) on the K cleats. Screw the handle retainer pieces (L, M) in place.

7 Remove all the hardware and remove the legs from the base and the benchtop assemblies from the base.

8 Cut the dog holder (X) to shape, and drill a pair of holes in it to house your dogs.

9 Sand all assemblies. Apply a clear finish (we used satin polyurethane) to the benchtops and legs. Prime and paint the base and dog holder.

10 Attach the benchtops, legs, and dog holder to the base. Position the handles, and screw the handle retainers (L, M) to the base where shown on the Base Cabinet drawing. Mount the vise and casters. ♣

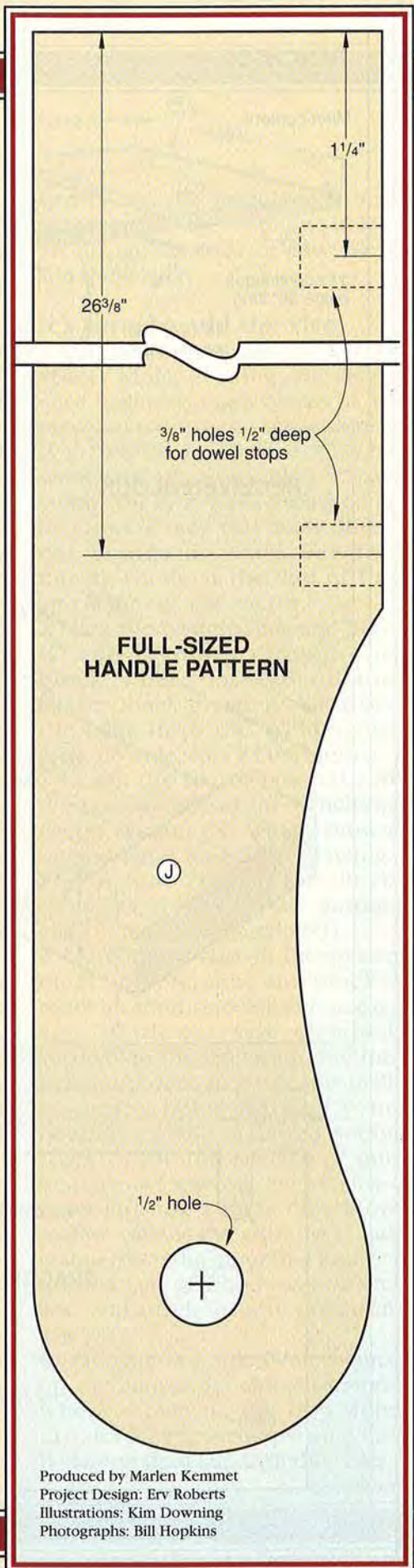
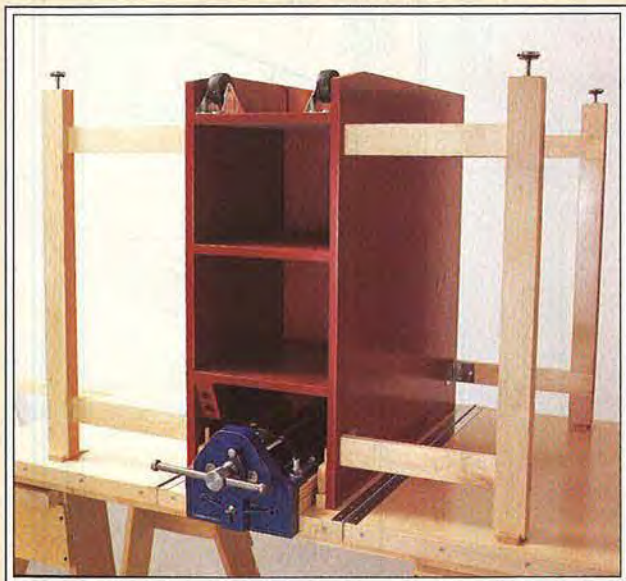

Produced by Marlen Kemmet
Project Design: Erv Roberts
Illustrations: Kim Downing
Photographs: Bill Hopkins

THE DO-IT-ALL MOBILE TABLESAW BASE

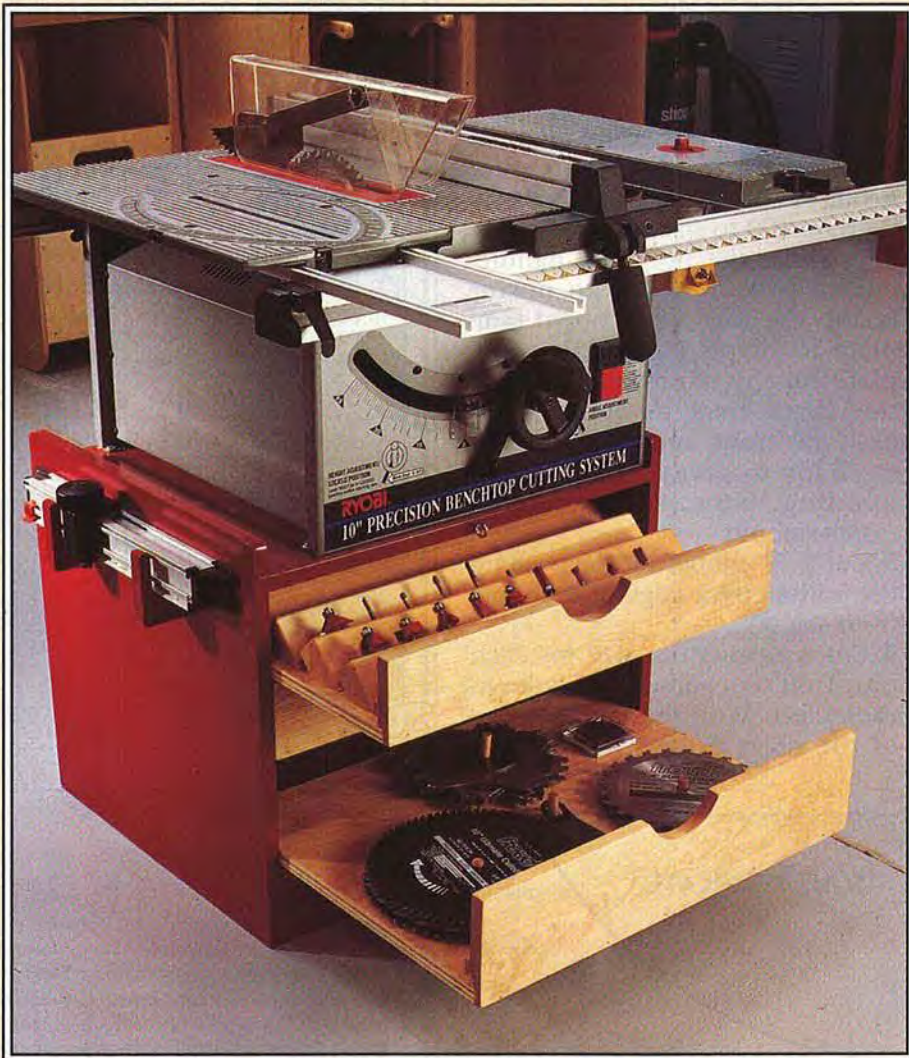

It's sad but true that the space beneath most tablesaws goes to waste. But that needn't be the case, as you can see here. Our cabinet stores a plentiful supply of sawblades, router bits, and other woodworking gear on the sliding trays. Plus, the entire cabinet is easy to move around in your shop, thanks to a pair of casters. Just store it against the wall when the cutting is done.

Note: Our cabinet was made to fit a Ryobi BT3000 benchtop table saw. You might need to change the overall dimensions to fit your particular benchtop saw.

Start with the plywood panels and edging

1 Cut the sides (A, B) to the sizes listed in the Bill of Materials from $\frac{3}{4}$ " birch plywood. Note that side A is $\frac{3}{4}$ " shorter than side B to allow for clearance against the floor later after adding the casters.

2 Cut the back (C) and top and bottom (D) to size.

3 From the edge of $\frac{3}{4}$ "-thick stock, rip the maple edging (E, F, G, H) to size plus 1" in length. Glue and clamp the edging to the edges of the plywood panels where shown on the Exploded View drawing. Later, trim the ends of the edging flush. See the shop tip on *page 12* for our method of trimming the edges of the solid-stock edging flush with the surfaces of the plywood.

4 Mark the locations of the rabbets, grooves, and dadoes in the plywood panels (A, B, C), and cut or rout them to the sizes listed on the

Continued

TABLESAW BASE

Exploded View drawing. (We fit our table saw with a $\frac{3}{4}$ " dado blade and wooden auxiliary rip fence to cut the dados, rabbets, and grooves. Then, we test-cut scrap pieces first to verify a snug fit of the plywood pieces in the dados and grooves.)

Add the tray supports

1 From $\frac{1}{4}$ " hardboard, cut the tray supports (I, J) to size.

2 Position and screw the bottom supports (J) 1" above the bottom dado. Then, using a piece of $\frac{3}{4}$ "-thick stock as a spacer, position the remaining supports (I), drill screw-mounting holes, and screw the supports in place as shown in the photo *above right*. (Note that we placed a long piece of $\frac{3}{4}$ "-thick walnut in the bottom $\frac{3}{4}$ " dados to align the two side panels (A, B) before attaching the supports.)

Let the assembly begin

1 Dry-clamp the plywood panels (A, B, C, D) together to check the fit, and trim if necessary. Then, glue and clamp the pieces, checking for square. (To prevent unsightly glue stains on the plywood, we placed masking tape next to the glue joints before gluing. Later, after the glue dried, we peeled off the tape, taking the glue squeeze-out with it.)

2 Measure the length of the opening, and cut the toekick (K) to shape, tapering the corner where dimensioned on the Wheel detail accompanying the Exploded View drawing. Drill countersunk screw holes, and glue and screw the toekick in place.

3 Turn the assembled table saw base upside down, drill the mounting holes, and screw the $2\frac{1}{2}$ " rigid casters in place.

4 Cut the border strips (L) to size. Drill the countersunk screw holes where shown on the Exploded View drawing. Screw the strips to the top of the cabinet.

Add the three trays for plenty of storage

1 From $\frac{3}{4}$ " maple, rip and crosscut the tray fronts (M, N) to size. From $\frac{3}{4}$ " plywood, cut the tray bottoms (O) to size.

2 Transfer the full-sized handle-cutout pattern *below* to poster board. Cut the poster board template to shape. Center the template on the front face of each tray front. Trace its outline onto each tray front, and cut the radius to shape to create the concave opening. Now, sand the tray fronts smooth.

3 Cut a $\frac{3}{4}$ " rabbet $\frac{3}{8}$ " deep along the bottom back edge of each tray front (M, N).

4 Cut a cleat (P) to size for each tray. Drill six countersunk holes in each cleat. With the bottom edge of the cleat flush with the top

Continued

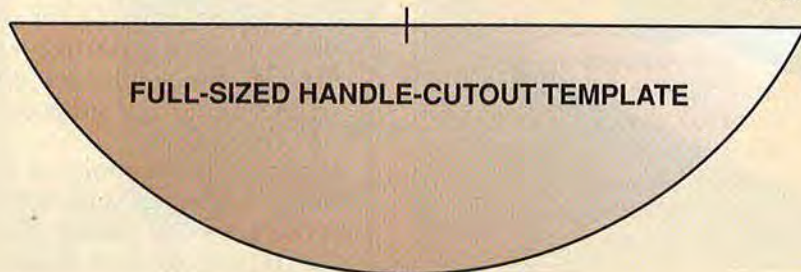

For evenly spaced tray supports, use a piece of $\frac{3}{4}$ "-thick stock to position the pieces before screwing them in place.

Bill of Materials

Part	Finished Size			Mtrl.	Qty.
	T	W	L		
A side	$\frac{3}{4}$ "	$19\frac{1}{2}$ "	$19\frac{1}{4}$ "	BP	1
B side	$\frac{3}{4}$ "	$19\frac{1}{2}$ "	20"	BP	1
C back	$\frac{3}{4}$ "	$23\frac{1}{4}$ "	20"	BP	1
D top & bottom	$\frac{3}{4}$ "	$23\frac{1}{4}$ "	$19\frac{3}{8}$ "	BP	2
E edging	$\frac{1}{4}$ "	$\frac{3}{4}$ "	$19\frac{1}{4}$ "	M	2
F edging	$\frac{1}{4}$ "	$\frac{3}{4}$ "	20"	M	2
G edging	$\frac{1}{4}$ "	$\frac{3}{4}$ "	20"	M	2
H edging	$\frac{1}{4}$ "	$\frac{3}{4}$ "	$23\frac{1}{4}$ "	M	3
I supports	$\frac{1}{4}$ "	$3\frac{3}{4}$ "	$18\frac{1}{2}$ "	HB	4
J supports	$\frac{1}{4}$ "	$5\frac{1}{2}$ "	$18\frac{1}{2}$ "	HB	2
K toekick	$\frac{3}{4}$ "	$3\frac{1}{4}$ "	$22\frac{1}{2}$ "	M	1
L strips	$\frac{3}{4}$ "	$1\frac{1}{2}$ "	20"	M	2
M fronts	$\frac{3}{4}$ "	$4\frac{3}{8}$ "	$22\frac{7}{16}$ "	M	2
N front	$\frac{3}{4}$ "	$6\frac{1}{8}$ "	$22\frac{7}{16}$ "	M	1
O bottoms	$\frac{3}{4}$ "	$18\frac{1}{4}$ "	$22\frac{7}{16}$ "	BP	3
P cleats	$\frac{3}{4}$ "	1"	$21\frac{7}{16}$ "	M	3
Q holders	$1\frac{1}{2}$ "	$2\frac{7}{16}$ "	$21\frac{7}{16}$ "	F	8
R slides	$\frac{1}{4}$ "	1"	$18\frac{1}{2}$ "	HB	2
S holders	$\frac{3}{4}$ "	$2\frac{1}{4}$ "	$3\frac{1}{2}$ "	M	2

Length measured with the grain.

Materials Key: BP—birch plywood, M—maple, HB—hardboard, F—fir.

Supplies: #8x $\frac{3}{4}$ ", #8x $1\frac{1}{4}$ ", #8x $1\frac{1}{2}$ ", #8x $2\frac{1}{4}$ ", #8x $2\frac{3}{4}$ " flathead wood screws, 2- $2\frac{3}{16}$ " (overall length) screw eyes, $\frac{1}{4}$ x 1 x 15 " aluminum bar stock for locking bar, 2- $2\frac{1}{2}$ " rigid casters ($\frac{3}{4}$ " overall height) with 8-#8x $\frac{3}{4}$ " panhead sheet-metal screws, $\frac{3}{8}$ " dowel stock, $\frac{1}{2}$ " dowel stock, primer, red enamel paint, clear finish.

TABLESAW BASE

edge of the rabbet, glue and screw the cleats to the tray fronts. Glue and screw a tray front/cleat assembly to each tray bottom (O), checking that the front is square to the tray bottom.

5 To make the router bit holders (Q), cut four pieces of 2x4 stock to 21⁷/₁₆" long. Mark a centerline along *both edges* (not surfaces) of each piece of 2x4 stock. Starting 1³/₂" from the ends and spacing the centerpoints 2" apart, mark centerpoints on the 2x4".

6 Drill 1/4" and 1/2" router-bit shank holes in the 2x4 stock. The number of 1/4" holes vs. 1/2" holes will be determined by your bit collection. (After drilling into the wood, we wobbled the bit slightly to allow the bit shanks to be removed easily from the holes.)

7 Rout 1/4" round-overs along all edges of each piece of 2x4.

8 Using the Bit Holder detail on the *opposite page* for reference, angle the blade on your tablesaw, and rip each 2x4 section in two. Sand each holder (Q) smooth.

9 Locate and drill countersunk screw holes on the bottom side of each tray (O). Screw the bit holders to the top of each tray.

10 Use the Bottom Tray drawing to assemble the blade, shim, and dado-cutter holders.

11 Cut the drawer slides (R) to size, and glue and clamp them to the cabinet bottom (D), flush against the cabinet sides (A, B).

Consider a few add-ons

1 For hanging the miter-gauge extension on the side of the cabinet, twice transfer the miter-gauge extension holder full-sized pattern to 3/4"-thick stock. Cut the holders (S) to shape, drill a screw hole in each, and screw the holders to the side of the cabinet where shown on the Exploded View drawing.

2 For added security, drill pilot holes and add a pair of 2¹³/₁₆" screw eyes to the cabinet where shown on the Exploded View drawing. Then, crosscut a piece of 1/4x1" aluminum bar stock to 15" long for the locking bar (see the Locking Bar drawing *below right* for reference). Drill a 5/16" hole at each end to align with the screw-eye holes. Later, use padlocks to secure the locking bar to the screw eyes.

Sand it, paint it, and bring on the tablesaw

1 Remove the rigid casters and screw eyes, and finish-sand the entire cabinet.

2 Apply two coats of clear finish to the trays.

3 Apply a coat of primer to the cabinet. Later, apply two coats of red enamel paint to the cabinet. When the paint has dried, reattach the screw eyes and casters.

4 Position the tablesaw on the base, drill mounting holes, and secure with bolts. 🐿

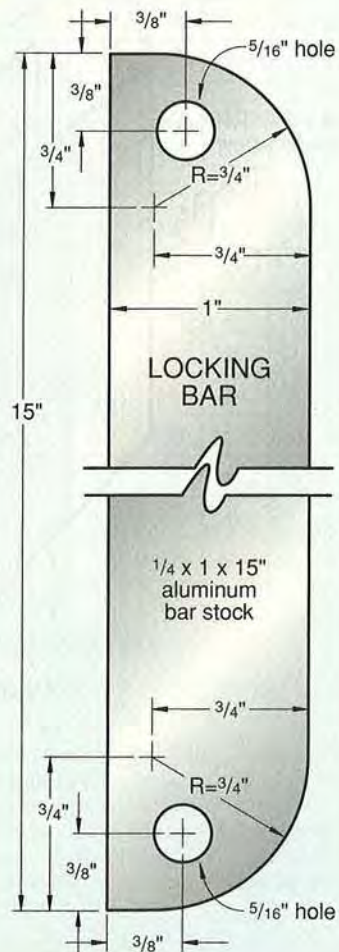
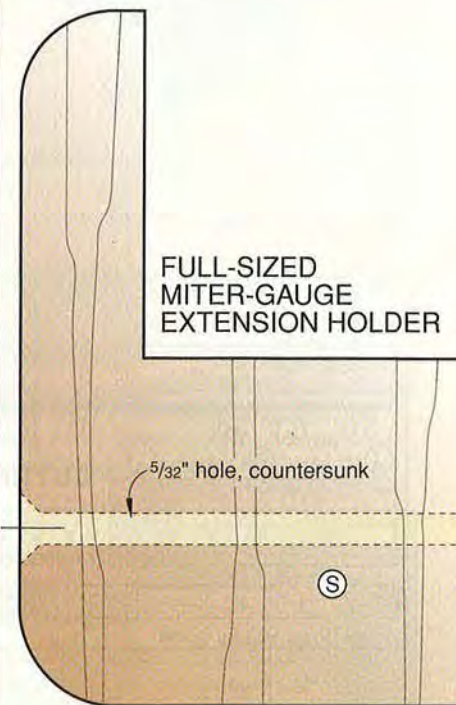
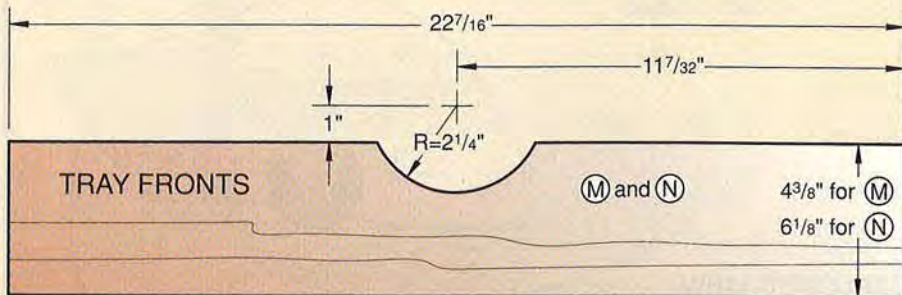

TOP AND MIDDLE TRAYS

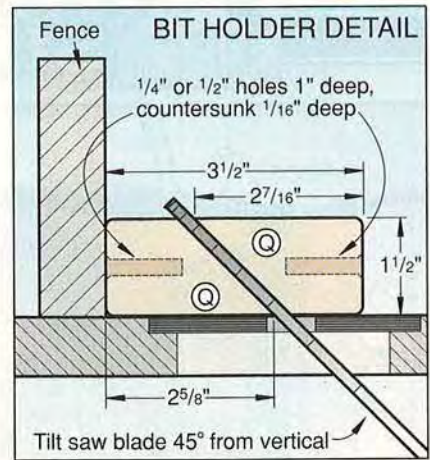
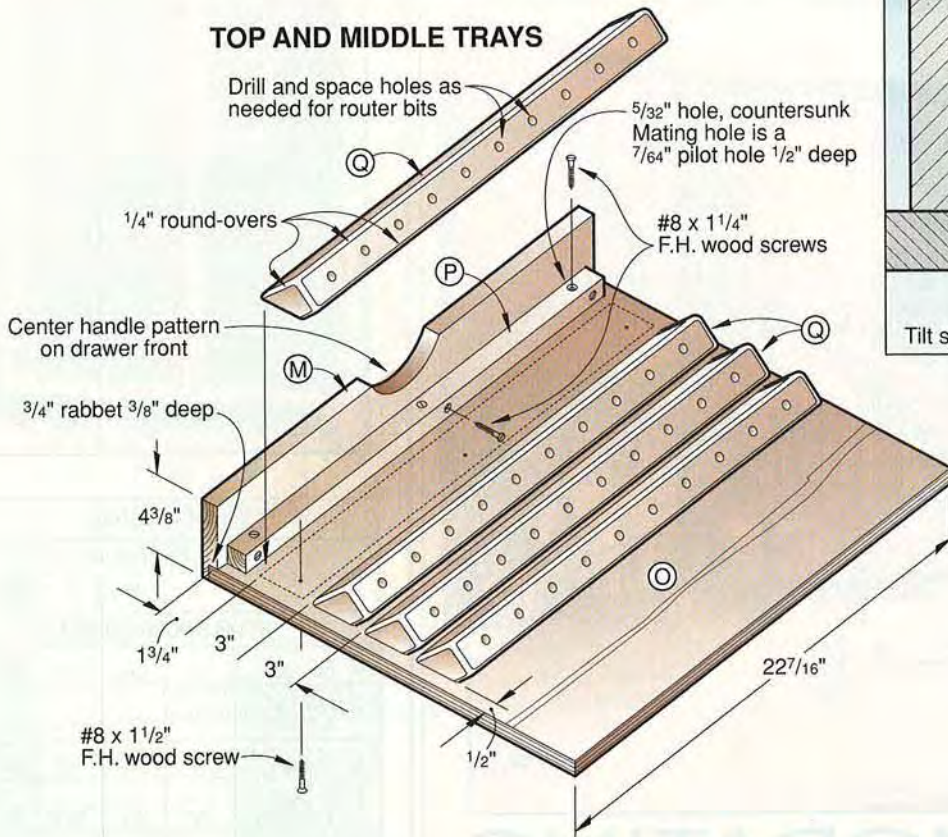

Use 1/4 x 4"-dia. hardboard spacers placed between blades and chippers on 1/2" dowels

Note: Bottom tray is constructed same as top and middle trays

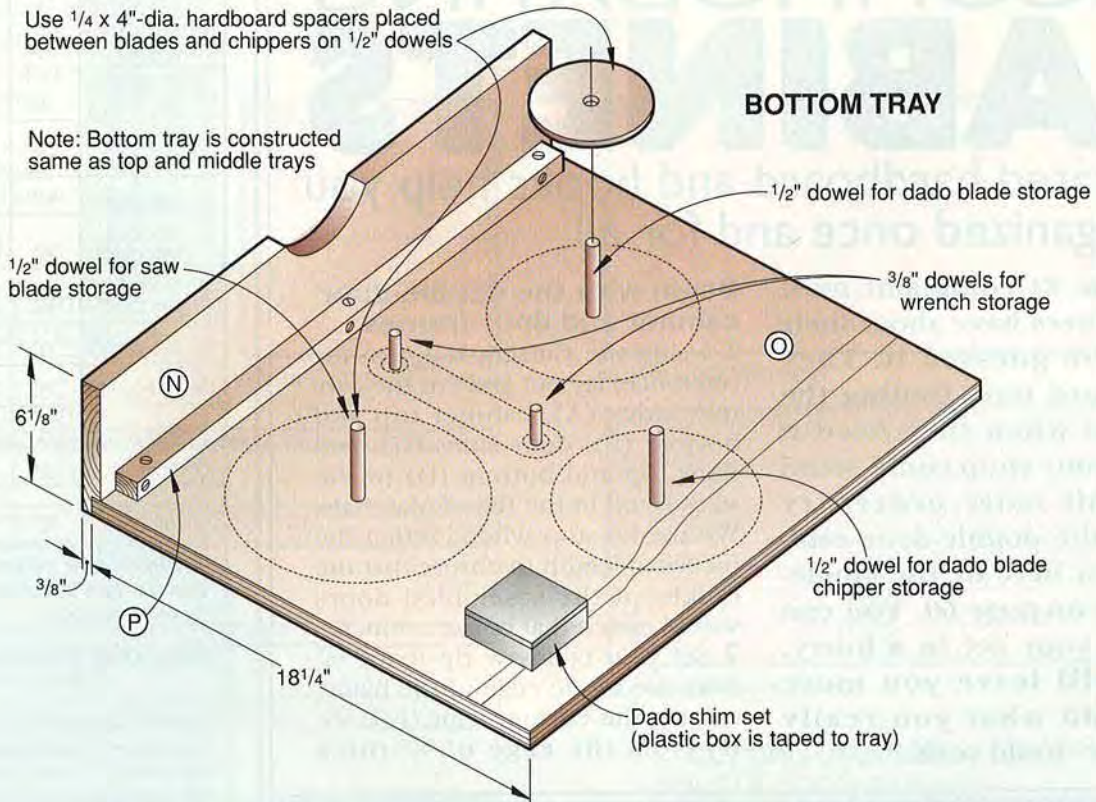

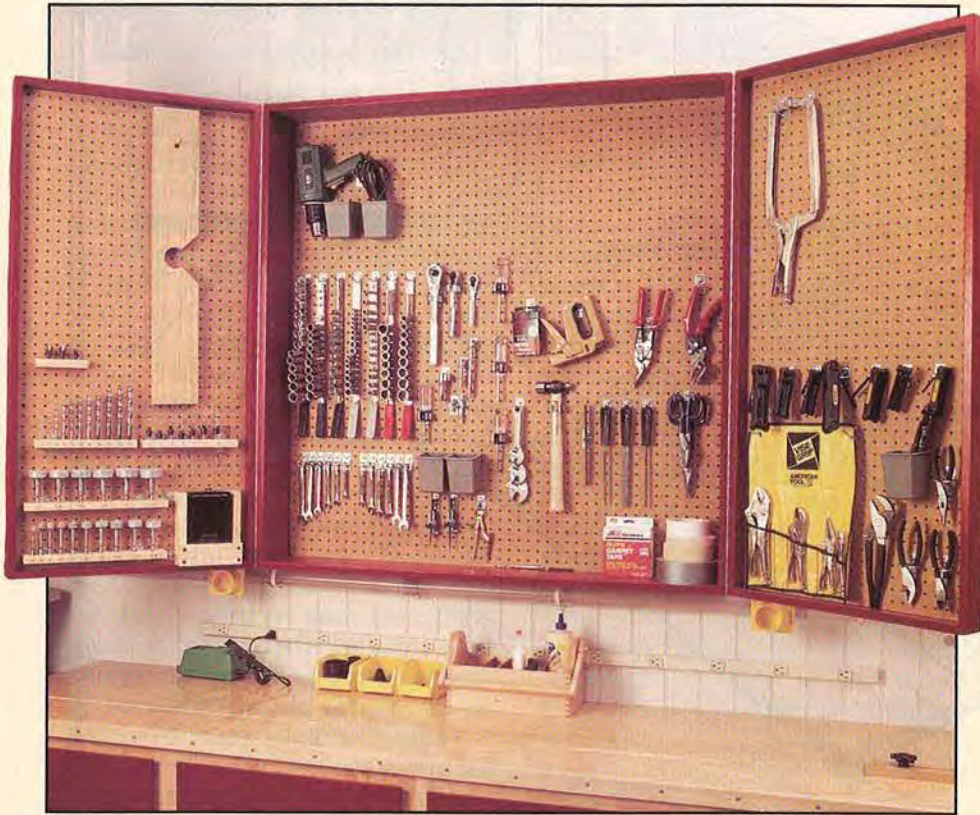

ACCOMMODATING CABINETS

Perforated hardboard and hooks help you get organized once and for all

What's the #1 complaint most woodworkers have about their shop? You guessed it. They have a hard time finding the right tool when they need it most. If your shop could stand a little bit more order, try building the double-door cabinet shown here or the single-door unit on *page 60*. You can clean up your act in a hurry, which will leave you more time to do what you really want to do—build stuff.

Begin with the double-door cabinet and door frames

1 Using the Cutting Diagram for reference, lay out and cut the cabinet sides (A), cabinet top and bottom (B), door sides (C), and door top and bottom (D) to the sizes listed in the Bill of Materials. We used a stop when cutting the pieces to length to ensure that the height of the assembled doors would match that of the cabinet.

2 Set your tablesaw rip fence $\frac{1}{4}$ " from the inside edge of the blade, and rip the edging strips (E, F, G, H) from the edge of $\frac{3}{4}$ "-thick



Bill of Materials

Part	Finished Size			Matl.	Qty.
	T	W	L		
DOUBLE-DOOR CABINET					
A cab. sides	$\frac{3}{4}$ "	6 $\frac{3}{4}$ "	48"	BP	2
B cab. top & bottom	$\frac{3}{4}$ "	6 $\frac{3}{4}$ "	47 $\frac{1}{4}$ "	BP	2
C dr. sides	$\frac{3}{4}$ "	2 $\frac{1}{4}$ "	48"	BP	2
D dr. tops & bottoms	$\frac{3}{4}$ "	2 $\frac{1}{4}$ "	23 $\frac{1}{4}$ "	BP	4
E* cab. top & btm. edging	$\frac{1}{4}$ "	$\frac{3}{4}$ "	47 $\frac{1}{4}$ "	M	2
F* cab. side edging	$\frac{1}{4}$ "	$\frac{3}{4}$ "	48"	M	2
G* dr. top & btm. edging	$\frac{1}{4}$ "	$\frac{3}{4}$ "	23 $\frac{1}{4}$ "	M	4
H* dr. side edging	$\frac{1}{4}$ "	$\frac{3}{4}$ "	48"	M	4
I side cleats	$\frac{3}{4}$ "	1 $\frac{1}{2}$ "	43 $\frac{1}{2}$ "	P	6
J cab. top & btm. cleats	$\frac{3}{4}$ "	1 $\frac{1}{2}$ "	46 $\frac{1}{2}$ "	P	2
K dr. top & btm. cleats	$\frac{3}{4}$ "	1 $\frac{1}{2}$ "	22 $\frac{1}{2}$ "	P	4
L cab. pegbrd.	$\frac{1}{4}$ "	46 $\frac{1}{2}$ "	46 $\frac{1}{2}$ "	PB	1
M dr. pegbrd.	$\frac{1}{4}$ "	22 $\frac{1}{2}$ "	46 $\frac{1}{2}$ "	PB	2
N door panels	$\frac{1}{2}$ "	22"	46"	BP	2
O* sides	$\frac{1}{2}$ "	1"	48"	M	4
P* top & btm. bands	$\frac{1}{2}$ "	1"	24"	M	4

*Initially cut parts marked with an * oversized. Then, trim each to finished size according to the how-to instructions.

Materials Key: BP—birch plywood, M—maple, P—pine, PB—pegboard.

Supplies: 4d finish nails, #12x $\frac{3}{4}$ " panhead sheet metal screws, 3" deck screws, 2-1 $\frac{1}{2}$ "x48" continuous hinge, 2-3" wire pulls, 2 $\frac{1}{2}$ " hasp, 2" barrel bolt, padlock, enamel paint, satin polyurethane.

 **Print this article**

Text continues on page 60

EXPLODED VIEW (DOUBLE-DOOR CABINET)

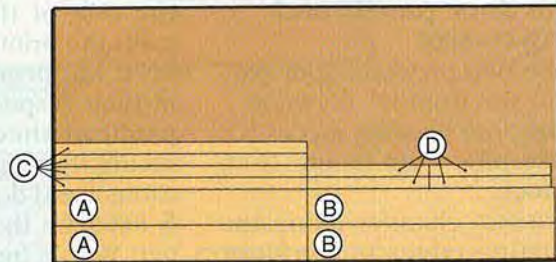
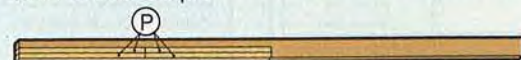
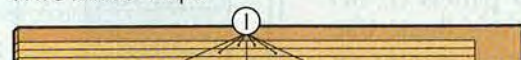
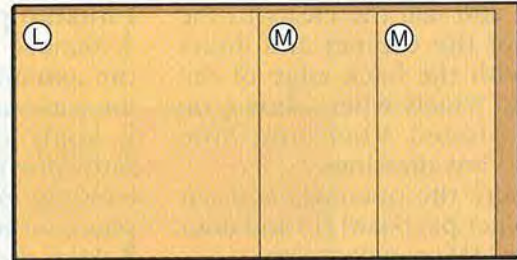
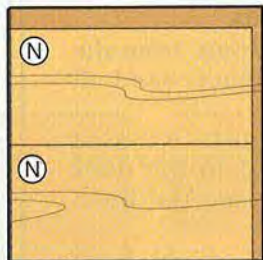
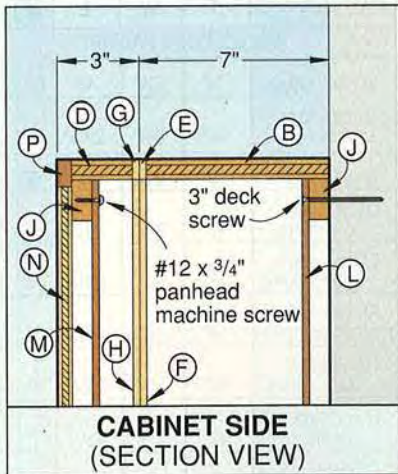
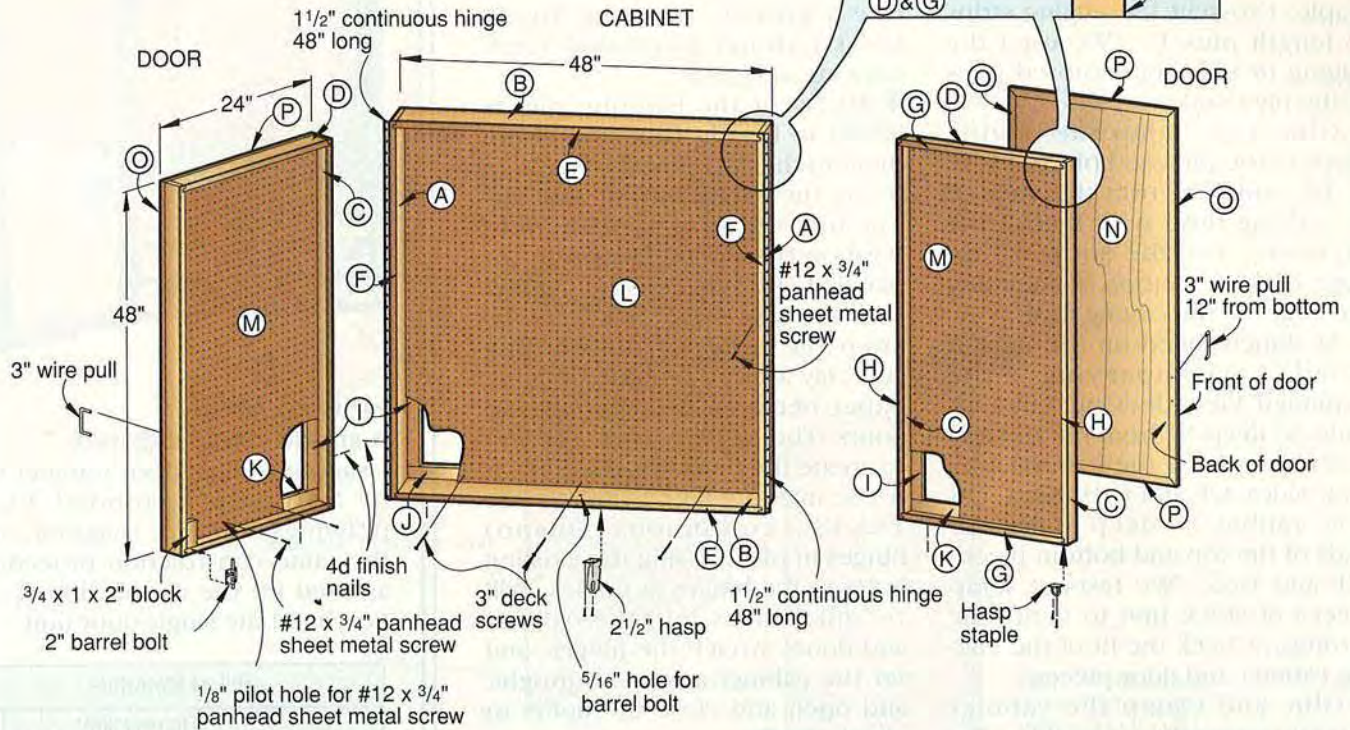

CUTTING DIAGRAM (DOUBLE-DOOR CABINET)

ACCOMMODATING CABINETS

maple. Crosscut the edging strips to length plus 1". (We used the edging to hide the exposed plies of the plywood pieces.)

3 Glue and clamp the edging strips to the plywood pieces (A, B, C, D), and later trim the ends of the edging flush with that of the plywood. See the shop tip on page 12 for a method of trimming the edges of the edging flush.

4 As dimensioned on the Rabbet detail accompanying the Exploded View drawing, cut a $\frac{3}{8}$ " dado $\frac{3}{8}$ " deep $\frac{3}{8}$ " from the top and bottom ends of the cabinet and door sides A/F and C/H. Next, cut a $\frac{3}{8}$ " rabbet $\frac{3}{8}$ " deep along the ends of the top and bottom pieces B/E and D/G. (We test-cut scrap pieces of stock first to verify the settings.) Check the fit of the mating cabinet and door pieces.

5 Glue and clamp the cabinet assembly together, checking for square. Repeat the process to assemble the two doors.

Now, add the cleats and pegboard

1 Cut the cabinet and door cleats (I, J, K) to size from $\frac{3}{4}$ " pine.

2 Glue and nail the cleats to the inside of the cabinet and doors flush with the back edge of the plywood panels where shown on the Exploded View and Side Section View drawings.

3 Measure the openings and cut the cabinet pegboard (L) and door pegboard (M) panels to size.

Cut the door panels and banding to size

1 Cut the two plywood door panels (N) to size from $\frac{1}{2}$ " plywood.

2 Cut the door banding pieces (O, P) to size plus 1" in length from maple stock.

3 Rout a $\frac{1}{16}$ " chamfer along the front mating edges of the door panel (N) and banding (O, P). When joined together in the next step, the chamfers form a decora-

tive V-groove. (See the Single Door Cabinet Exploded View drawing at right.)

4 Miter-cut the banding pieces (O, P) to length. Glue and clamp them to the door panels (N).

5 Lay the cabinet, front side facing up, on your workbench. Position the doors, front side (or paneled side) up, on the cabinet with the edges and ends flush. To keep the hinges from binding later, lay a piece of folded writing paper between the cabinet and doors. The paper acts as a spacer to create the correct gap.

6 Use masking tape to secure the $1\frac{1}{2}\times 48$ " continuous (piano) hinges in place. Using the existing holes in the hinges as guides, drill $\frac{1}{16}$ " pilot holes into the cabinet and doors. Attach the hinges, and set the cabinet assembly upright, and open and close the doors to check the fit.

7 Locate and drill the holes, and attach a 3" wire pull to each door.

8 If locking the cabinet is a consideration, apply the barrel bolt, hasp, and hasp staple to the cabinet and doors.

Finishing touches

1 Remove the hardware from the assembled cabinet. Sand all the parts smooth.

2 Apply a clear finish (we used satin polyurethane) to the door banding O and P; see the intro photo for reference.

3 After the finish dries, mask off the edging, and apply primer to the rest of the surfaces. Later, paint the primed surfaces.

4 Fit the pegboard panels (L, M) in their respective openings. Use panhead sheet metal screws to secure the pegboard panels to the cabinet and doors.

5 Reattach the doors to the cabinet. With a helper, hang the cabinet on the wall, being sure to hit all available studs. Reattach the pulls, barrel bolt, and hasp. 🌲



How to build a single-door cabinet

Using the Single-Door Cabinet Bill of Materials, Exploded View drawings, Cutting Diagram, and the same construction procedure as used on the double-door cabinet, build the single-door unit.

Bill of Materials					
Part	Finished Size*			Mati.	Qty.
	T	W	L		
SINGLE-DOOR CABINET					
A cab. sides	$\frac{3}{4}$ "	$6\frac{3}{4}$ "	48"	BP	2
B cab. top & bottom	$\frac{3}{4}$ "	$6\frac{3}{4}$ "	$29\frac{1}{4}$ "	BP	2
C dr. sides	$\frac{3}{4}$ "	$2\frac{1}{4}$ "	48"	BP	2
D dr. tops & bottoms	$\frac{3}{4}$ "	$2\frac{1}{4}$ "	$29\frac{1}{4}$ "	BP	2
E* cab. top & btm. edging	$\frac{1}{4}$ "	$\frac{3}{4}$ "	$29\frac{1}{4}$ "	M	4
F* cab. side edging	$\frac{1}{4}$ "	$\frac{3}{4}$ "	48"	M	4
G dr. top & btm. cleats	$\frac{3}{4}$ "	$1\frac{1}{2}$ "	$28\frac{1}{2}$ "	P	4
H dr. side cleats	$\frac{3}{4}$ "	$1\frac{1}{2}$ "	$43\frac{1}{2}$ "	P	4
I door panel	$\frac{1}{2}$ "	28"	46"	BP	1
J* side bands	$\frac{1}{2}$ "	1"	48"	M	2
K* top & btm. bands	$\frac{1}{2}$ "	1"	30"	M	2
L dr. & cab. pegboard	$\frac{1}{4}$ "	$28\frac{1}{2}$ "	$46\frac{1}{2}$ "	PB	2

*Initially cut parts marked with an * oversized. Then, trim each to finished size according to the how-to instructions.

Materials Key: BP—birch plywood, P—pine, M—maple, PB—pegboard.

Supplies: 4d finish nails, 3" deck screws, #12 \times $\frac{3}{4}$ " panhead sheet metal screws, $1\frac{1}{2}\times 48$ " continuous (piano) hinge, 3" wire pull, $2\frac{1}{2}$ " hasp, lock, enamel paint, satin polyurethane.

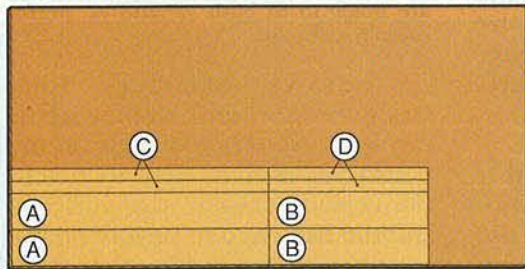
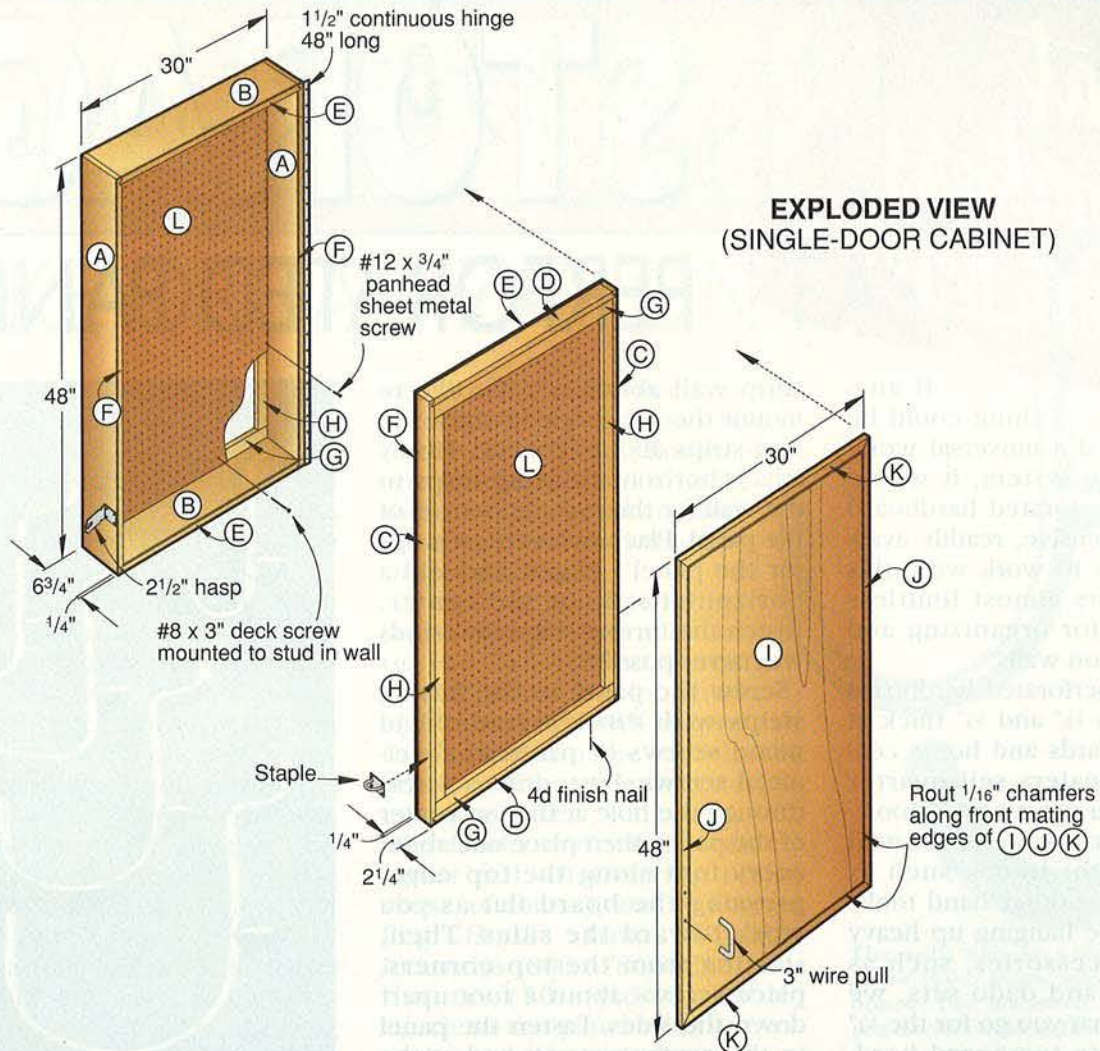

3/4 x 48 x 96" Birch plywood

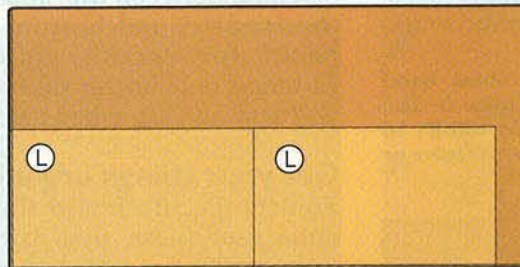

1/4 x 48 x 96" Pegboard



3/4 x 7 1/4 x 96" Pine



3/4 x 3 1/2 x 96" Maple

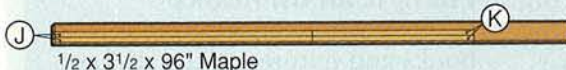

1/2 x 3 1/2 x 96" Maple

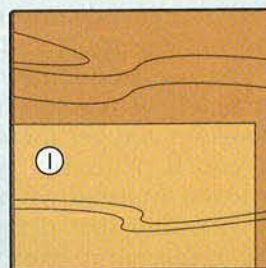

CUTTING DIAGRAM (SINGLE-DOOR CABINET)

What woodworkers need to know

STORAGE

PERFORATED PANELS

If anything could be called a universal workshop storage system, it would have to be perforated hardboard panels. Inexpensive, readily available, and easy to work with, this material offers almost limitless possibilities for organizing and hanging tools on walls.

You'll find perforated hardboard in 4x8' sheets $\frac{1}{8}$ " and $\frac{1}{4}$ " thick at most lumberyards and home centers. Many dealers sell quarter panels or other pre-cut sizes, too.

The $\frac{1}{8}$ "-thick board serves well for lightweight items, such as screwdrivers or other hand tools. But if you'll be hanging up heavy tools and accessories, such as power drills and dado sets, we recommend that you go for the $\frac{1}{4}$ " board. Choose tempered hardboard for toughness.

Put up the panels

When you hang perforated hardboard, space it out from the work-

Some copper wire and a rubber band will secure standard hooks to the board. You also can hold hooks in place with a dab of silicone adhesive or hotmelt glue.

shop wall about $\frac{1}{2}$ ". We like to mount the panels on $\frac{1}{2}$ "-thick furring strips about $\frac{3}{4}$ " wide. Firmly attach horizontal furring strips to the wall for the top and bottom of the panel. Place two vertical strips for the panel's edges, and add a horizontal strip at the center. Fasten the furring strips into studs whenever possible.

Screw the panel to the furring strips with #8x1 $\frac{1}{4}$ " roundhead wood screws or panhead sheet-metal screws. First, drive a screw through the hole at the top center of the panel, then place one about every foot along the top edge, pressing the board flat as you work toward the sides. Then, starting from the top corners, place screws about a foot apart down the sides. Fasten the panel to the center support and at the bottom edge in turn.

You can screw the panel right to open studs, too. If you do, install blocking between the studs at the top, center, and bottom of the panel for secure mounting. Fastened only at the sides, panels will bow and sag when loaded.

Get your things organized

To arrange the board for maximum usefulness, first gather the items you'll hang on it. Lay them out on the floor or on your workbench, organizing them for best space utilization and convenience.

Plan to put the tools and accessories you use frequently within easiest reach. If it's too hard to hang tools up and get them down again, you'll probably just lay them down instead of putting them away. And that defeats the purpose of this entire exercise.

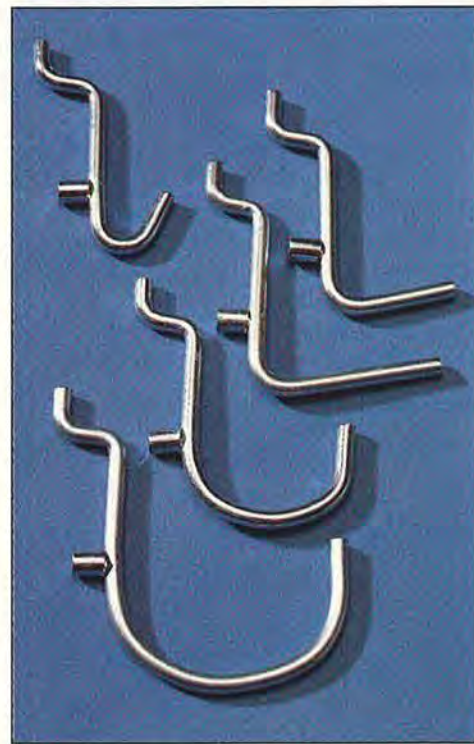

You'll find both straight and curved hooks in several different sizes. Most are made to fit both $\frac{1}{8}$ " and $\frac{1}{4}$ " perforated hardboard.

Handsaws, hammers, long straightedges, and similar items can hang from hooks high on the board yet remain easy to reach. Conversely, chisels, screwdrivers, and the like need to be low on the board so you can lift them from their holders. Just decide generally where you want to put items at this point—you don't need a detailed plan. After all, that's one of the advantages of using perforated hardboard and hooks—you can rearrange things on a whim.

Hang it all on hooks

Now, collect an assortment of hooks and fixtures, and start hang-



Print this article

MADE SIMPLE

MAKE ORGANIZATION EASY

ing things up. You'll find standard pegboard hooks like the ones shown *below and left* at most hardware stores, lumberyards, and homecenters. Plastic bins and jars that hang on pegboard allow you to organize small parts and hardware easily. If you can't find them locally, one mail-order source is Leichtung Workshops (800/321-6840 for catalog).

An annoyance goes along with using perforated board and hooks. Sometimes, when you grab a tool from your neatly organized board, the hook comes off along with it. Hooks with locating tabs are less likely to pop off the board, but will still do so.

You can secure hooks to the board with retainers that clip over the hook and lock into adjoining holes. Look for them at hardware

stores or in mail-order catalogs, such as Leichtung. (You also can bend #12 wire into S-hooks, place one on each side of a hook, then stretch a rubber band between them, shown *opposite page bottom*.)

Power Peg hooks, sold by Sears, offer another solution to the fall-out nuisance. These plastic hooks, shown *right*, feature a ball-shaped tab that snaps into the hole in the board, making them more likely to stay in place.

For hooks that will absolutely never fall off (barring major abuse, of course), look to Forever Peg Hooks from Windsor Peg Hooks from Windsor Industries (800/678-2552). These fixtures (50 styles available) attach to the panel with screws, as shown *below right*.*



The split ball on a Power Peg hook, *above right*, snaps into the hole in the board. The standard hook's straight peg doesn't hold as firmly.

A panhead screw keeps the industrial-strength Forever Peg Hook fixture from popping off the board.

Fixtures like these hold items that won't hang readily from a hook. Install a shelf on your perforated panel using two or more of the long, braced hooks for brackets. Drill holes on the shelf's bottom near the front edge to fit over the hook end.



Photographs: Wm. Hopkins Photography
Illustration: Brian Jensen

HOT CHOICES IN HEATERS

SAY GOODBYE TO WORKSHOP CHILLS

One of the first questions we asked ourselves while planning IDEA SHOP 2™ was "How should we heat it?" After doing plenty of research, we came up with a safe, efficient, and affordable system. Here, we'll tell you about the option we settled on, as well as what we found out about some other heating alternatives.

If you've done any woodworking in the cold, then you know that low temperatures can put a chill on your fun. Of course, you can dress for the cold, but all that extra clothing can be unsafe if it restricts your movement or comes near whirling blades, pulleys, belts, and such.

In this article, we'll explore some of the most practical options for heating a woodworking shop, such as gas furnaces and electric heaters. And although we don't recommend wood-burning stoves, we'll share with you the insights of a woodworker who wouldn't give up his stove for all of the oil in the Persian Gulf.

To get to the bottom of this issue, we consulted with experts in the heating field, sifted through stacks of fire codes, and drew on the experiences of our own staff members. We also spoke with woodworkers who use portable kerosene-, oil-, or propane-fired heaters (including "infrared" heaters) that vent burned gases directly into the shop environment.

However, we advise against using these unvented appliances in an enclosed shop. Why? The exhaust fumes contain carbon monoxide and other combustion byproducts that can build to levels that are hazardous to your health.

Note: Although we have no objection to equipment-intensive or environmentally friendly systems such as heat pumps and solar-heating units, we won't cover them in this article. Instead, we'll concentrate on commonly available and affordable systems that make sense for most any geographical region.

Gas furnaces: The way to go if your budget allows it

A new gas furnace will set you back at least several hundred bucks, but there's no heating source that matches the safety, effectiveness, or convenience of gas systems. However, you may be able save a good deal of money by picking up a used unit. Just be sure to have it inspected by a heating professional.

When selecting a gas-fired appliance, consider how you will keep the air in your shop from entering the furnace's combustion chamber. Why? Workshop air at times contains fine wood dust or volatile fumes from oil-based finishing and refinishing products that could ignite when exposed to a flame. In a garage shop, fumes from a leaking automobile gas tank or gas can also could ignite.

To achieve this separation of shop air and combustion air, you can either keep the furnace in an area sealed off from your shop, or buy a so-called "direct-vent" furnace with a sealed combustion chamber. Direct-vent units draw combustion air from the outdoors via a wall vent. To illustrate how these options compare, we'll take a look at two such systems in WOOD® magazine's original IDEA SHOP™ (described in the September 1992 issue) and IDEA SHOP 2™.

•IDEA SHOP 1: Keeping the furnace out of the shop

IDEA SHOP 1 is housed in a 14x28' insulated room partitioned from an uninsulated storage space under the same roof. In this case,



it made sense to locate a gas furnace in the uninsulated space, away from the dust and fumes of the shop. As you can see in the drawing *bottom*, a 4" pleated filter cleans the returning cold air.

This forced-air system, although relatively expensive, has three key advantages. First, the workshop warms quickly because the two centrally located ceiling vents quickly distribute the heat. Second, the heating system takes up no valuable workshop space. And finally, the system has air-conditioning capacity for comfort during the hottest of months.

• IDEA SHOP 2: The advantages of direct-vent, wall-mounted heaters

If you need to place your heat source within the workshop, as we did with Idea Shop 2, here's

your safest and most convenient option. As shown in the drawing *below*, a direct-vent gas heater mounts on a wall and uses outside air for combustion.

These units install quickly because you need only cut a sin-

gle hole in the wall, place the vent through the hole, and hang the heater on the wall. With our gas-supply lines already in place, it took two of us about three hours to install two Perfection-Schwank

Continued

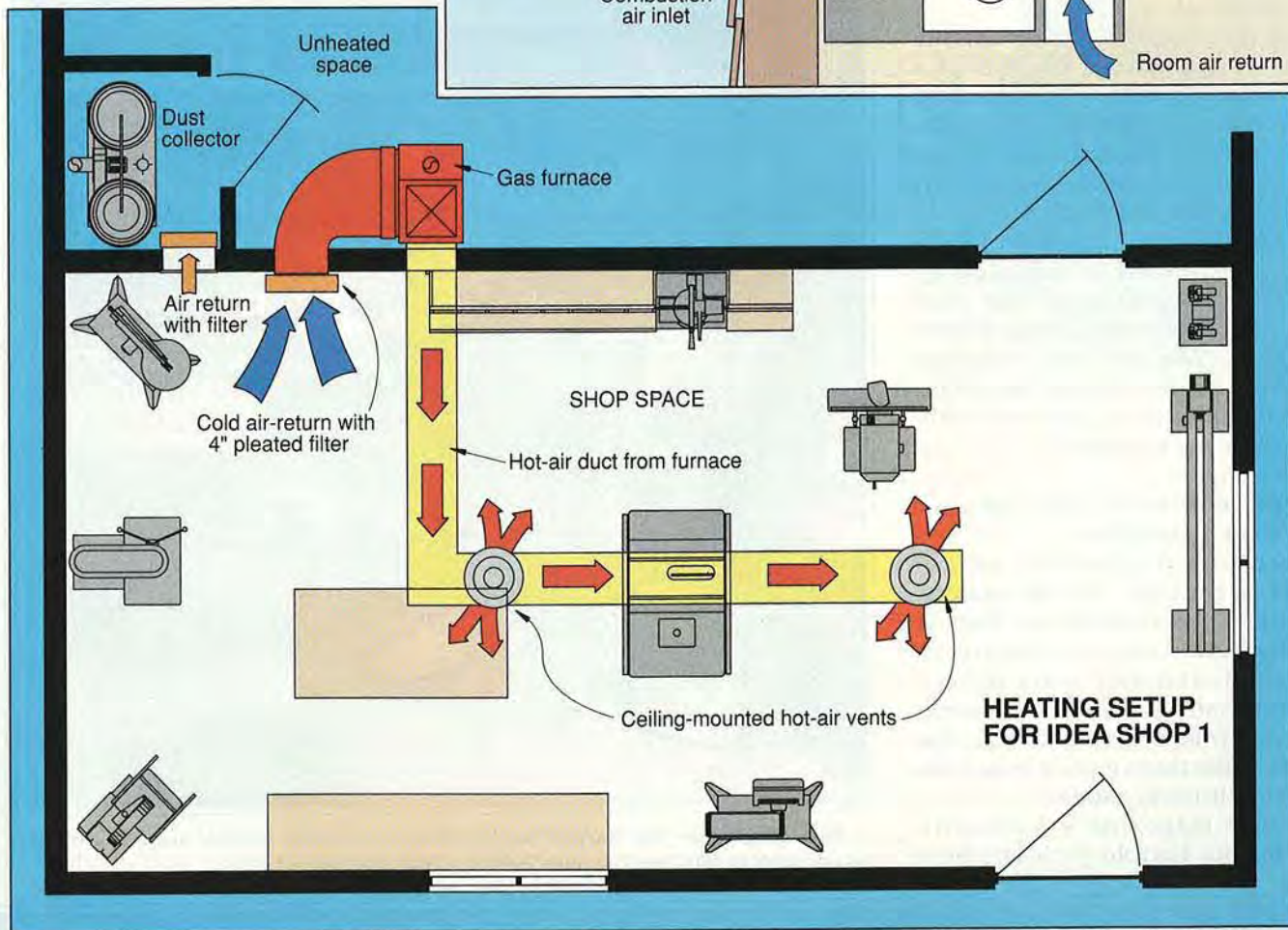
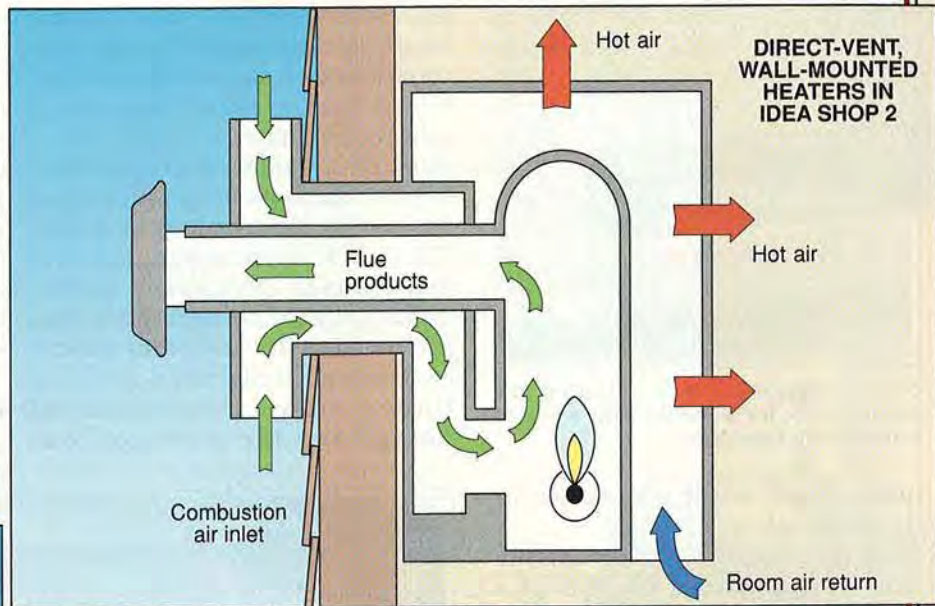

HOT CHOICES IN HEATERS

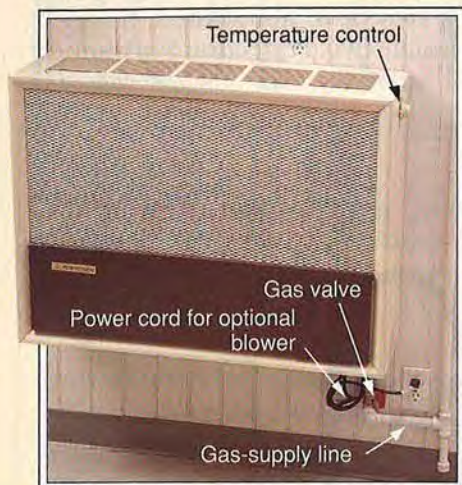

When choosing a wall-mounted gas heater, look for a model with a sealed combustion chamber.

heaters such as the one shown in the photo *above*.

The vent assembly, a key component of this system, consists of a tube inside a tube. The innermost tube channels exhaust air outside, and fresh air enters the combustion chamber through space surrounding the inner tube.

Although these units don't heat a space as quickly as a forced-air furnace, keep in mind that they produce heat even during power outages. (We included optional blowers on our heaters, but found that the units heat quite well without these accessories.)

Electric heaters: OK for certain situations

There's no denying the advantages of portable electric heaters. You can buy them for as little as \$20, there's no installation to speak of, and they don't pollute your shop environment. However, several major disadvantages make them a poor long-term option for most shops.

WOOD magazine's Managing Editor, Jim Harrold (working on a

mantel clock in the photo *below*), has used electric heaters in his garage shop for several years. Now, he's anxious to convert to a gas furnace. As Jim says: "Even a small electric space heater consumes lots of electricity, and I've blown circuits more times than I care to remember."

Jim also has noticed a big jump in his electric bills in months when he has his electric heaters going. That's not surprising since, for most parts of the country, it costs more to generate heat with electricity than with any other source. (According to statistics from the United States Department of Energy and the American Gas

Association, a conventional gas heater, with 78 percent efficiency, costs less than one-third as much to run as an electric heater.)

Nevertheless, portable electric heaters do make sense under certain conditions. If you have a small shop, or live in a warm climate, these appliances provide an economical means of taking the chill out of the air. Just remember to put them on a circuit separate from your tools and lights. As with gas furnaces, you must keep dust from accumulating on the surfaces of an electric heater. For safety's sake, Jim Harrold also unplugs his electric heaters after he's through working in his shop.

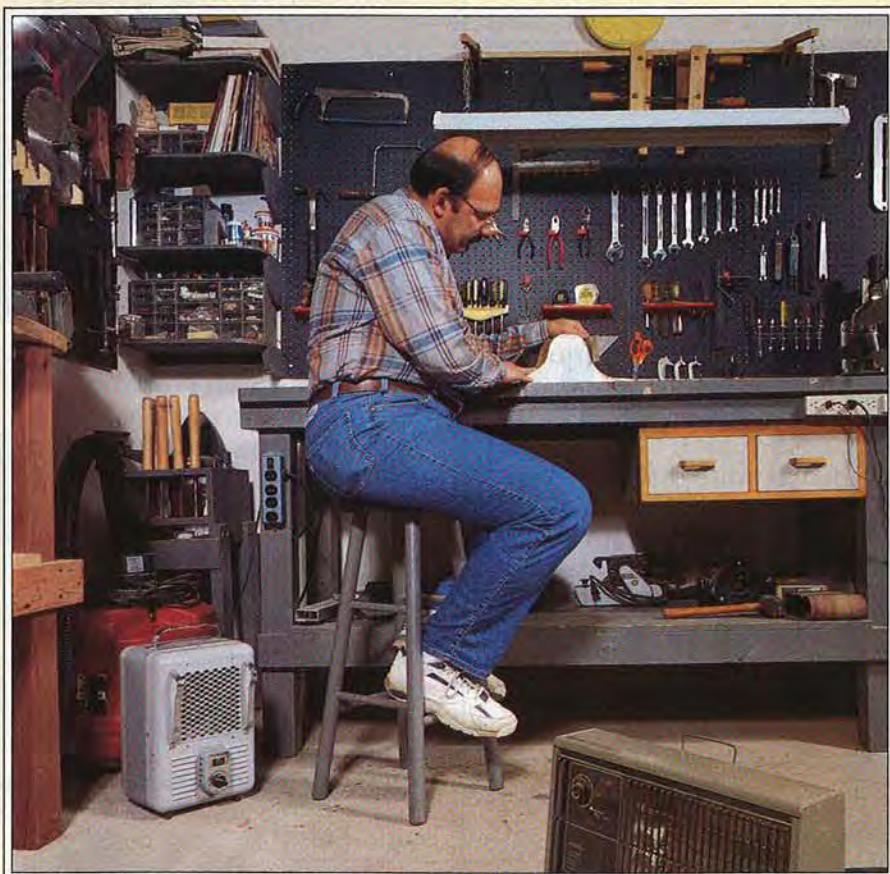

As Managing Editor Jim Harrold has discovered, portable electric heaters, although inexpensive to buy, provide little heat at a high operating cost.

What the fire codes have to say about shop heating

Although the standards put forth by the National Fire Protection Association (NFPA) don't apply to small-scale woodworking shops, we think it makes sense to pay attention to these guidelines when planning a home workshop, too. Here are some key points to consider:

- These standards prohibit the use of heating devices that employ an open flame. So, that rules out most wood-burning stoves, except for air-tight models that draw combustion air from the outside.

- The NFPA also spells out standards for collecting wood dust

from surfaces and the air. Because of the flammability of wood dust, it makes sense to regularly clean it up, paying special attention to surfaces on and surrounding heating appliances. To control airborne dust, you should have an effective means of venting it outside in the summer and filtering it in the winter. You can use compressed air to clean hard-to-reach areas, provided you do it on a regular basis to prevent putting heavy concentrations of suspended dust into the air.

- When purchasing a heating system, keep in mind that the NFPA

standards require that these appliances be listed by the American Gas Association or another recognized testing agency. The heating element or combustion chamber should be permanently guarded to prevent accidental contact by people, material, or equipment.

- In a garage workshop with automobiles, you should protect heating appliances from moving vehicles. That means either situating the heaters where they will not be struck, or placing sturdy steel posts (capable of stopping a rolling car) as protection around them.

What about wood-burning stoves?

Although fire codes discourage the use of most wood-burning stoves in woodworking shops, many woodworkers swear by this time-tested heating source. Since you may already have a woodburning stove, or plan to buy one, we'll share with you the experiences of Don Mostrom, *WOOD* magazine's correspondence writer and an avid log burner.

Like most owners of a wood-burning stove, Don likes the ambience of his stove, and the low cost of operating it (since he harvests his own wood). "I can still recall a frigid winter day a few years ago," Don told us, "I just got the stove cooking good, and the shop was nice and cozy. The only sounds in the air came from the crackling embers and the steady rasping of my hand-saw as I cut some dovetails. It was utterly peaceful, and when I looked up, I saw that snow had started softly falling outside. On days like those, I forget all about the hustle and bustle of living in the 20th century."

Despite their charm, Don admits that woodstoves do have certain drawbacks. "Fueling a

woodstove requires a lot of labor. You have to cut, stack, and chop the wood. Then, you have to put it into the stove and clean out the ashes from time to time. Also, there's no way to keep the fire going while you're out of town, so you have to either have a backup heating system, or remove anything from your shop that may freeze."

Although modern wood-burning stoves with catalytic combustors are much more efficient than older versions, they still dump a fair amount of pollution into the outside air. Remember, too, that new, good-quality woodstoves cost \$500 to \$2,000. And, some pollution-prone areas restrict their use altogether.

If you still have your heart set on a woodstove, Don offers this advice for your consideration:

- "Clean the dust regularly from the woodstove, and maintain at least 3' of clear area around it.

- "Never feed wood dust into the stove—you risk explosion.

- "Be certain your chimney or flue meets local building codes, and clean it regularly.

- "Restrict your finishing tasks to

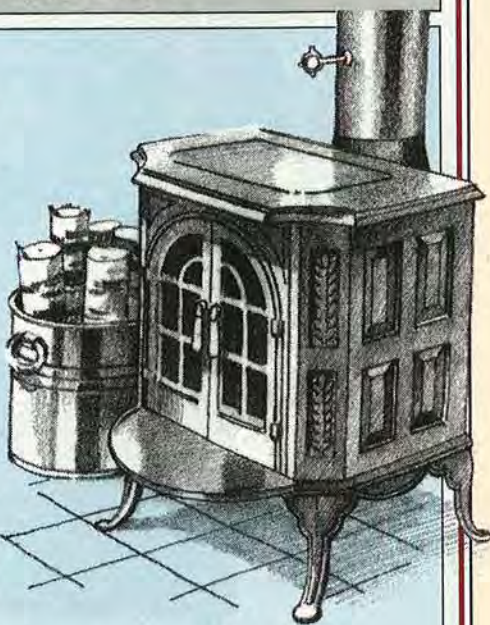

doing no more than a single furniture piece at one time, and do this away from the stove. If I were going to do a lot of lacquer spraying, I would get a spray booth.

- "Before you buy a woodstove, check with the carrier of your homeowner's insurance. A woodstove may affect your coverage or premium. Some insurance companies issue guidelines for safe use of a woodstove." ♣

Written by Bill Krier
Illustrations: Kim Downing
Photographs: William M. Hopkins



LET'S TALK TOOLS

OUR PRODUCT SELECTIONS FOR IDEA SHOP 2™



We relied on Stanley for nearly all of our hand tools, especially items from the company's new Contractor Grade line. Power tools shown here in our mobile tool cart include the Hitachi D 10DF2 cordless drill, Black & Decker Quantum models BD1000 electric drill and BD6200 plunge router, and Bosch model 1290D 1/2-sheet finishing sander.

Besides good organization, a solid workbench, and effective systems for such things as heating and dust collection, a properly outfitted workshop needs quality tools. To help you out, here's a listing of the tools we handpicked for IDEA SHOP 2™.

We thought long and hard before making our selections, and based them on our own hands-on experience. Rather than simply choosing the best or most expensive models available, we picked tools that work well but don't cost an arm and a leg. In short, we would buy these tools for our own workshops.

STATIONARY AND BENCHTOP MACHINERY

Bandsaw, jointer, and thickness planer:
Models 28-245 14" bandsaw, 37-190 6" jointer, and 22-540 12" portable planer
Delta

246 Alpha Drive
Pittsburgh, PA 15238
800/438-2486 or 412/963-2400

Belt/disc sander and bench grinder:
Skil models 3370 4x36" belt and 6" disc sander and 3396 6" bench grinder
S-B Power Tool Co.

4300 West Peterson Ave.
Chicago, IL 60646
312/286-7330

Compressor:
Model VT6196
Campbell Hausfeld

100 Production Drive
Harrison, OH 45030
800/543-8622

Drill press:
Model G1200
Grizzly

P.O. Box 2069
Bellingham, WA 98227
800/523-4777 (east of Mississippi)
800/541-5537 (west of Mississippi)

Lathe:
Model JWL-1236
Jet

P.O. Box 1349
Auburn, WA 98071-1349
800/274-6848
206/351-6000

Oscillating spindle sander and tablesaw:
Models OSS450 and BT3000
Ryobi

5201 Pearman Dairy Road
Anderson, SC 29625
800/525-2579

Radial-arm saw:
Sears Craftsman Model 19632
Call or visit your local Sears store.

Scrollsaw:
Model 1671
Dremel

4915 21st St.
Racine, WI 53406-9989
414/554-1390



PORTABLE POWER TOOLS

Air-powered tools:

Models DH6500 spray gun, MP2847 17-piece accessory kit including blow gun, tire gauge, and tire chuck, TL1016 straight-line sander, PL1501 3/8" air ratchet, NBO03000 brad nailer, SN258KOO finishing stapler, and PA2078 filter/regulator/lubricator
Campbell Hausfeld
 100 Production Drive
 Harrison, OH 45030
 800/543-8622

Belt sander and fixed-base router:

Models DW431 and DW610
DeWalt
 626 Hanover Pike
 P.O. Box 158
 Hampstead, MD 21074
 800/433-9258

Circular saw:

Skil model 5657
S-B Power Tool Co.
 4300 West Peterson Ave.
 Chicago, IL 60646
 312/286-7330

Cordless drill:

Model D 10DF2
Hitachi
 3950 Steve Reynolds Blvd.
 Norcross, GA 30093
 404/925-1774

3/8" electric drill, heat gun, and 1 1/4-hp plunge router:

Quantum models BD1000, BD8300, and BD6200
Black & Decker
 626 Hanover Pike
 Hampstead, MD 21074
 800/762-6672
 410/239-5000

Skil model 5657 portable circular saw by S-B Tool Co.

Sears Craftsman wrench sets



Snips, hex-key sets, and Vise-Grip locking pliers by American Tool Co.

Hitachi model D 10DF2 9.6-volt cordless drill



Square-drive screws from McFeely's



Sears model 11602 1/4-sheet finishing sander

1/4-sheet finishing sander:

Sears Craftsman Model 11602
 Call or visit your local Sears store.

1/2-sheet finishing sander, jigsaw, and random-orbit sander:

Bosch models 1290D, B4200, and 3283 DVS
S-B Power Tool Co.
 4300 West Peterson Ave.
 Chicago, IL 60646
 312/286-7330

Shop vacuum:

Quiet Super Power (QSP) model 900-84 Shop-Vac
 2323 Reach Rd.
 Williamsport, PA 17701-0307
 717/326-0502

POWER-TOOL ACCESSORIES

Abrasive belts, sheets, and hand-sanding blocks:

3M
 Consumer Relations, 3M DIY Division
 3M Center, 515-3N-02
 St. Paul, MN 55144
 (phone number not available)

Bosch model 3283DVS random-orbit sander



Finishing products from Minwax



Sanding blocks and abrasives by 3M

Bostik lubricants



Bench dogs, dado shims, and snug-plug cutters:

Veritas Tools
 12 East River St.
 Ogdensburg, NY 13669
 613/596-0350

Brad-point bits, Forstner bits, tapered countersink bits, router pad, and circle cutter:

Grizzly
 P.O. Box 2069
 Bellingham, WA 98227
 800/523-4777 (east of Mississippi)
 800/541-5537 (west of Mississippi)

Bullet brand twist drill bits:

Black & Decker
 626 Hanover Pike
 Hampstead, MD 21074
 800/762-6672
 410/239-5000

Dado-blade set, router bits, and sawblades:

Freud
 P.O. Box 7187
 High Point, NC 27264
 910/434-8300

Dust-collection system:

Sears whole-shop dust-collection system, no. 29964
 Call or visit your local Sears store.

Mobile bases for jointer and bandsaw:

HTC Products
 P.O. Box 839
 Royal Oak, MI 48068
 800/624-2027
 810/399-6180

Continued on page 93

De Walt model DW431 portable belt sander



Stanley stapler

Various drill bits from Grizzly



Compass and trammel points from McFeely's

In the 10 years since WOOD magazine emerged on the woodworking scene, I've had the pleasure of meeting and writing about some swell woodworking craftsmen and women. Many of them have become good friends, even though I seldom see them. But from time to time I think about all the people I've met. So for this anniversary issue, I thought I'd check in by telephone with some of those people from the past, just to see what they have been up to.

Peter J. Stephano
—Peter J. Stephano, Sr. Editor

WOOD® MAGAZINE'S LOOKING OLD

STEVE BALDWIN, TOYMAKER

Issue 2, Nov./Dec. 1984

"Who's going to pay \$130 for one of these toys until they understand it? That becomes my job. I'm selling them one at a time over 30 years, rather than 3,000 every year. I'm building a following."

Ten years ago, Steve was running his Baldwin Toy Company out of a basement shop in his Omaha home. He would spend hours there when he was free from his high school counseling duties. Then, he'd sell his work at a few art fairs around the Midwest. Today, a lot has changed, but some things remain the same.

"I now have a detached 30x30' shop building on a two-acre lot—my basement shop was 10x15'—and can make all the sawdust that I want to," said Steve from his office at Omaha's Ralston High School. He's been a vocational counselor there for 25 years.

"I remember when a WOOD magazine staff member spent the

weekend photographing my work and interviewing me for that early issue. I can say that I still use that article regularly to showcase my work. And yes, I'm still making the wooden toys, but I have a full-blown catalog now, with prices."

Steve mentioned that he had recently launched a plan business, too, and got over 1,000 responses from his first advertisement. "I was surprised by the demand for the plans of the more complicated, hard-to-build models," Steve noted. "Surprisingly, a lot of them came from Canada."

The veteran toymaker hasn't forgotten where his bread and butter is,

though. "I still produce the Collector's Series of signed and numbered vehicles that I did then. But when that article appeared, I had only made about 100 of the Model A with the rumble seat. Now we're over 900. The series itself has grown to about 30 different models. The General, the train shown in the article (see photo below), well, I've sold 26 of those, starting at \$3,000."

So what else has happened? "My wife and I now do seven to 10 major shows a year," Steve explained. "That's our main form of marketing. Of course, a lot of our business is return sales, because I haven't let up on the quality."

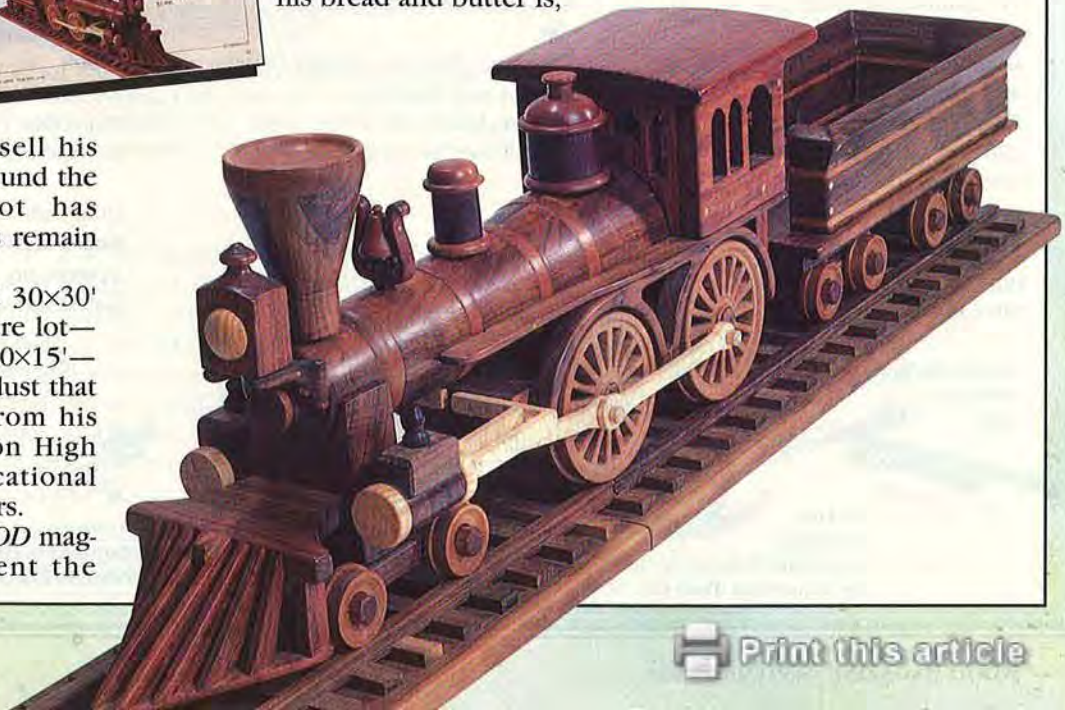

FAMILY REUNION UP A FEW FRIENDS

JUDY GALE ROBERTS, INTARSIA ARTIST

Issue 24, AUGUST 1988

"I choose red cedar for my intarsia because of its varying color and because it doesn't deteriorate. One hundred years from now, a person could sand and refinish one of my pieces and the wood will look as warm and colorful as it does today."

"In 1988 we relied primarily on art fairs, and a few commissions, to sell my intarsia," Judy replied to the question about how life had changed. "But when we



got 5,000 pattern requests from that article in *WOOD*, our little Lufkin, Texas, operation turned *more* into a business. We realized that there really was a market for the patterns that I design. So, we bought a computer to track the names, then started a newsletter. Now, all of my work involves the designing of patterns for intarsia and scrollsawing."

According to Judy and husband Jerry, their pattern customers write to their Texas headquarters from all over the U.S., as well as Australia, Aruba, New Zealand, England, Germany, the Bahamas, Mexico, Hawaii, Japan, and Brazil. Creating 18 new intarsia patterns per year, and three books of

scrollsaw patterns with 35 new ones in each, limits Judy's shop time. "I know when to say 'Uncle' if I run out of ideas," said Judy, "but instead, we keep coming up with new ones. We run out of time more often than ideas—I guess because this business is so exciting.

About the only time I go into the shop now is to do the models for the patterns. Yet, when I do spend time there, it's a lot more enjoyable."

What about the old days? "I do miss the art fairs and the camaraderie between the artists," admitted Judy, "but not the packing and

unpacking. I guess back then I was hoping to become a famous intarsia artist. Now, we're just aiming at the same goal from a different direction. At some point, I'd just like to go back in the shop and create the art—and not worry about selling it. That's every artist's dream."



Continued

ROBERT ST. PIERRE, WOOD SCULPTOR

Issue 5, JUNE 1985

"The exciting part of my work is going from one piece or project to another, learning from each. You develop a feel for the wood, a knowledge of how it behaves. Each reacts differently to laminating, sanding, and the finishing."

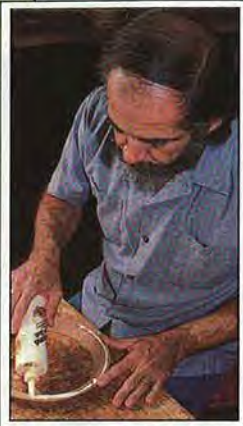

"A lot has happened in those years, but that article in the magazine was probably the

most central thing concerning the success of my work. I have gotten so much feedback from it. It was the exposure, whether the readers were woodworkers or not. And the magazine seems to never die—I still get response," Bob told me from his new home in the Tusquitee Mountains near Hayesville, North Carolina. He and

his wife Mary moved there in July 1993 to get away from the hustle, bustle, and cost of Boston.

"Living here is like being in a bank vault, but instead of gold bars all around, I have trees! And that's new to me," Bob exclaimed. He has always appreciated the varying colors and grain of wood. And he integrates its unique visual qualities into his work that's made up of rings cut with a jigsaw, which he laminates into bowls and other vessels or glues into sculptures. Like a kid in a



candy store, he's now overwhelmed by the stock on the stump that circles him. "We're surrounded by forests. For \$50 I can buy a walnut tree 30" in diameter at the base and tall enough



to get three 8' logs!"

On his acreage, Bob has a new 60x80' shop, with a view. "Through the windows, I see the sun coming over the mountains, and watch wild turkeys and eagles," he said. "I was looking for a place where it was easier to live, because with my work, I can live anywhere. And I found exactly the right place."

And what is Bob's work like these days? "Over the long run, my work has changed dramatically, although the technique remains the same," he explained.

Bob's creations also have spread from New England to around the

Perhaps you'd like to turn your woodworking into a successful career just like our featured professionals did? If so, their stories require some "reading between the lines." Such as:

- Select some good designs, perfect them, and make them the bread-and-butter basis of your work. Steve Baldwin has done that with his Collector's Series.
- Build on success by adding products that tap new markets, just as Robert St. Pierre has done with his expanded line of vessels.
- Take advantage of new opportunities with your talent. Judy Gail Roberts achieved more fame and fortune with designs than actual woodworking.
- Build a solid reputation. Had not Desiree Hajney tested her abilities through carving competitions, she might not be one of the nation's foremost wildlife carvers.

A WOOD® MAGAZINE

Until this issue, Chuck Heiken, an antique furniture restorer, has never appeared on these pages. But his is a great story, nonetheless.

For 23 years, Chuck was in data processing at a large Des Moines-based insurance company. But in 1992 things were changing, and he felt uncomfortable.

"I was getting burned out. My responsibilities were getting further and further removed from

globe, with pieces in 34 countries, including the U.S. embassies in Honduras and South Africa. As Bob sees it, he reached some marketing milestones, too.

"Most of my sales come from three big wholesale shows a year," he noted. "In fact, from the last show a buyer from the chain of Liz Claiborne shops called me to order some display pieces for the stores. Awhile back, I developed a line of wooden cremation urns with screw-on lids that are marketed to funeral directors across the nation. Of course, I still do commission work with my sculptures and vessels—I've had one for an 8'-tall vessel that paid \$12,000. Then, I do a line of floral bowls and vases with glass liners intended to hold fresh-cut flowers."

And what has Bob learned in the last decade? "I've found out that anything is possible. If you believe in something, and want to work hard, success will be there, it will come" he said. "But enjoy what you do, too, and have fun doing it. You can't, though, become successful by only working 8-5. My typical day is 8 a.m. to 10 p.m., seven days a week, and it's been like that since 1984. Still, I love wood, I love form, and I have a great time."

DESIREE HAJNEY, WILDLIFE CARVER

Issue 29, JUNE 1989

"Carving never gets old. One reason is all the things I still want to carve. Another is that I challenge myself. For some reason, a woman gets critiqued more than a man, so I'm more careful with details."



Over forty issues of *WOOD* magazine have been published since we introduced Desiree Hajney. She, husband Bernie, and son Jeff lived in Columbus, Nebraska, then.

Today, they make their home in Wichita, Kansas. But more than her location has changed.

"More doors have opened here, and so many carvers come through town—I've just learned so much," Desiree bubbled. "I just finished a book on carving, we issued a video, and I'm a regular contributor to an English carving magazine! Now, a really big thing has happened: A company called Conversation Concepts has bought six of my designs for reproduction. They make them and then sell them to gift shops around the world! The pieces will be signed and have a little brochure with them about me and my work."

Desiree, who has been carving and regularly accumulating blue

ribbons from national and international carving competitions since 1985, places more career emphasis on teaching now. "I've slowed down around the show circuit," she said. "But I will be teaching at least a dozen seminars across the U.S. this year. And I have bookings for 1995." Not surpris-

ing. Desiree's instructions for carving Roscoe the Raccoon in the issue that interviewed her prompted readers to order over 2,000 carving blanks of the figure so that they could have one, too!

So what is different today? "I'm doing better than I expected. But for a long time I didn't know what to expect—we just went with the flow. These days, Bernie and I are planning two years ahead, and in the near future he'll quit his teaching job to work with me full-time. Our son Jeff has even taken an interest in art. How much better can it get."



READER TAKES THE PLUNGE

the technical, and I needed something different," says Chuck. "I spent about a year looking for something else. Then I read the article about the wood-finishing program at Dakota County Technical College (*"WOOD® Magazine Goes To Finishing School,"* Issue 49, January 1992), and my wife Sharyl and I

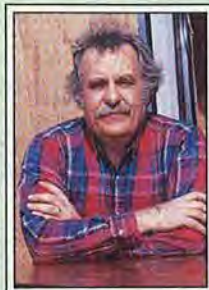

Chuck Heiken, furniture restorer

went there for a visit. I liked what I saw there and decided to attend."

Chuck enrolled in the 10½-month program and graduated. In October 1993, he bought an existing refinishing business with savings. "The school was very realistic when it came to what we could expect in the world.

Because I had done woodworking as a hobby, I had more or less decided on antique restoration before I went there, and placed my emphasis on that. Right now, as Heritage Restorations, I'm located in an antique-oriented business area here in Valley Junction [West Des Moines, Iowa] and keeping myself and my helper, Chad, very busy. And I'm happy again." ♣

Photographs: David Jordan, Jim Elder, Bob Hawks, Hopkins Associates, Peter J. Stephano

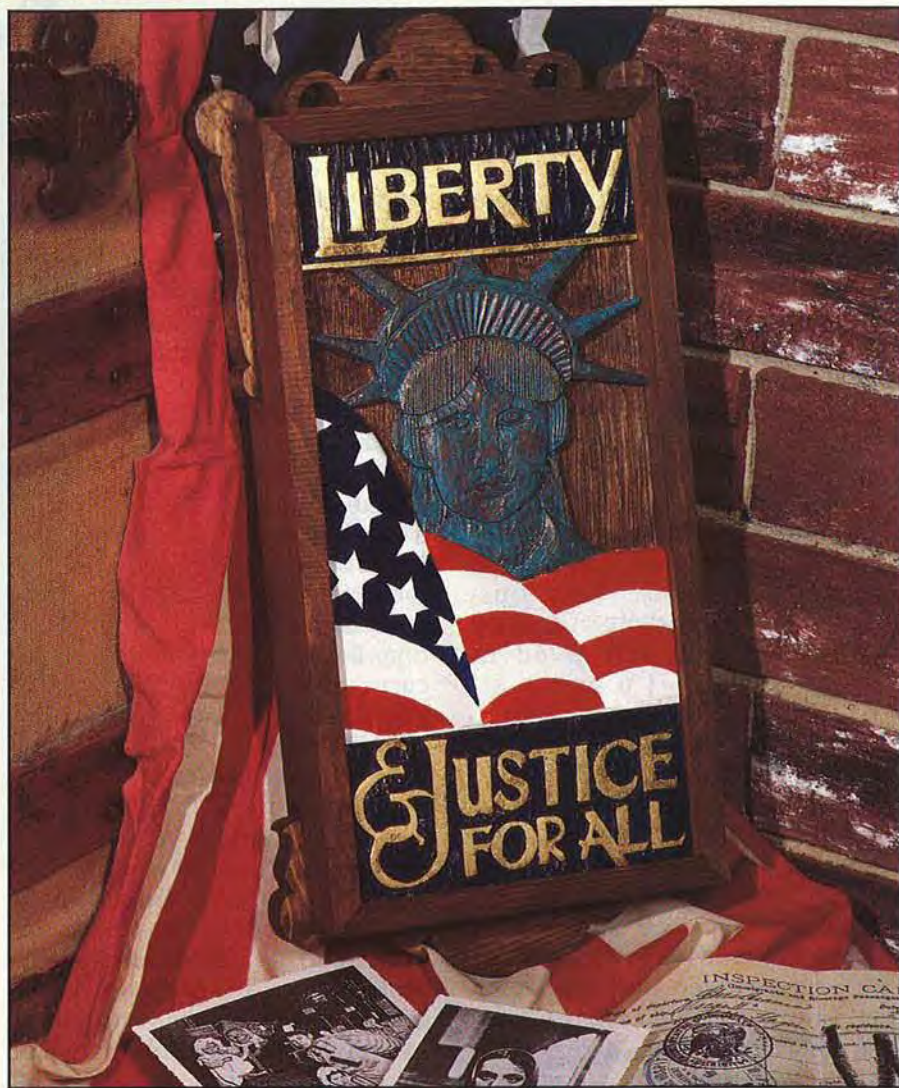

Miss LIBERTY







The Statue of Liberty, our flag, and what they stand for—it's all in this spectacular design from Maryland woodcarver Robert Thomas. And, once you start carving, you'll pledge allegiance to the straightforward techniques used to make this impressive relief plaque.

 [Print this article](#)

We used these tools and supplies

Stock:
1×5¼×12" basswood, ¼"×2×48" pine for frame sides and ends, miscellaneous ¾" pine for frame ornaments.

Gouges:

					
No. 1 Skew 5/16"	No. 5 1/8" 5/16"	No. 7 3/8"	No. 9 1/4"	No. 11 U-veiner 1/16", 3/16"	No. 12 V-tool 1/16", 3/16"

Bench knife

Finishing supplies:

Acrylic artist's colors: Titanium white, cadmium red medium, phthalocyanine blue, permanent green light, Mars black.
Walnut wood stain, gold-leaf kit

Glossary:

Grounding: Removing wood to establish the relief levels before detailing a carving. Start with the deepest relief area in the design when grounding.

Stop cut: An incision along a pattern line. A stop cut enables you to carve toward that line using a knife or gouge without chipping out wood beyond the line. This way, you can establish sharp edges and separations in your carving.

Sweep: The side-to-side curvature of a gouge, designated by a number from 1 to 11. The degree of curvature increases with higher numbers. No. 1 denotes a straight blade; no. 9,

Draw a pencil line across the front surface of a 1×5¼×12" basswood carving block, 2" from the top end. Lay a photocopy of the full-sized Miss Liberty pattern *opposite page* on the wood, placing the top of the pattern on the pencil line. Tape the pattern to the wood at the top, and slide a piece of transfer paper under it. Then, trace the pattern onto the wood.

After removing the paper copy, spray the patterned stock with clear lacquer or artist's fixative. This makes the pattern lines easier to see and harder to rub off as you work.

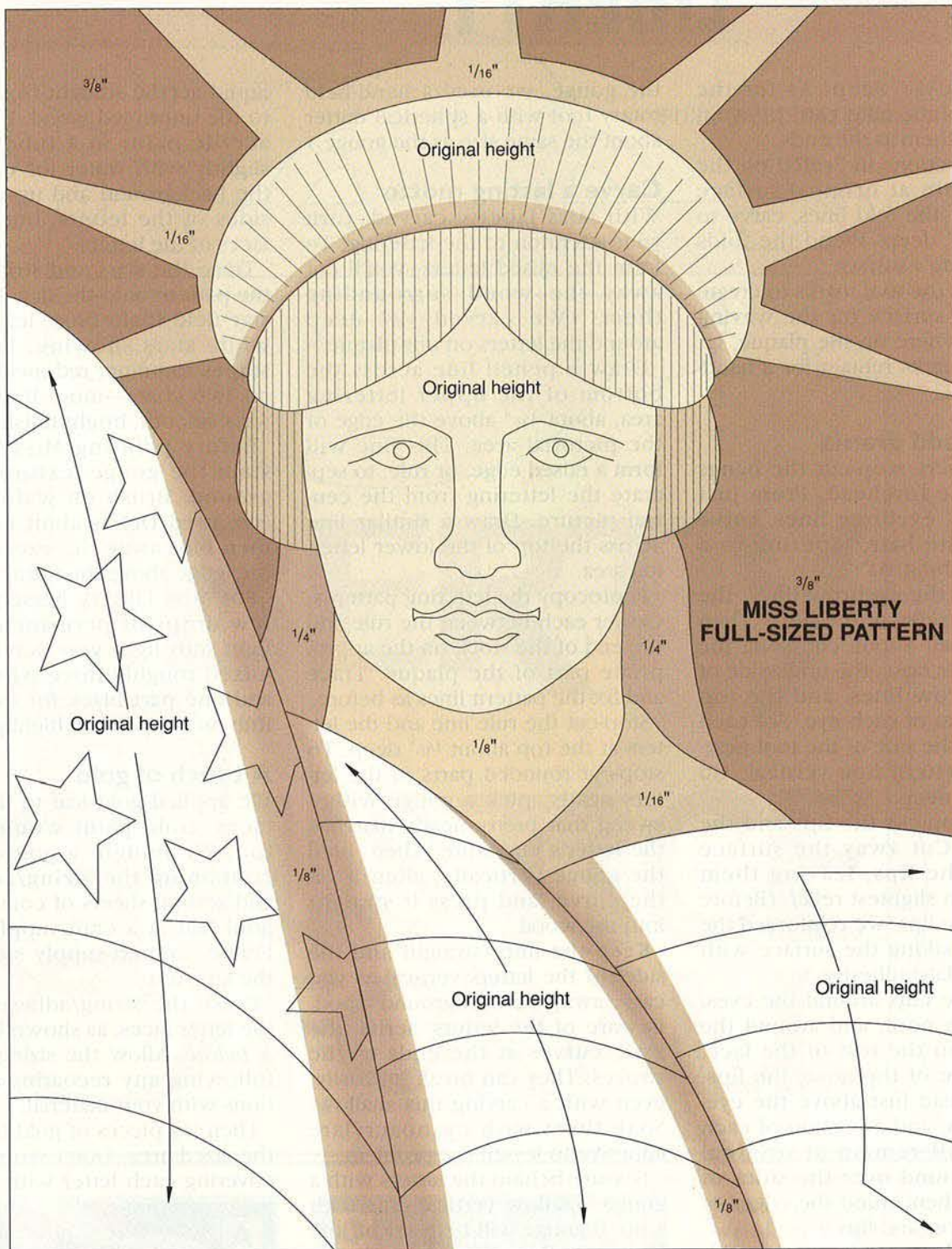

Model Miss Liberty

Stop-cut the pattern lines adjoining the orange-tinted background. This lowest relief level extends to the edge on each side. Start with stop cuts about $\frac{1}{16}$ – $\frac{1}{8}$ " deep.

Begin cutting away the waste with a no. 5 or no. 7 gouge, about $\frac{5}{16}$ " wide. A bent gouge comes in handy for the tight areas between

the crown points at the top and between the head and flag on the side. You also could use power-carving equipment in those spots.

Stop-cut the lines again, and carve deeper. Continue stop-cutting and removing waste wood until you reach a depth of $\frac{3}{8}$ ". Keep the sides of the cuts vertical as you ground the plaque.

Next, stop-cut the pattern lines along the $\frac{1}{4}$ "-deep levels. Alternately stop-cut and remove material with the no. 5 and no. 7 gouges. On the open side, you can use the tip of your knife.

Similarly, ground the remaining levels. Leave the face and bangs at original-surface height. Note that the crown slopes from original

Miss LIBERTY

height to $\frac{1}{16}$ " deep. As for the crown points, take care to avoid chipping them at the ends.

Three sections indicated on the flag remain at original-surface height. At the fold lines, carve to about $\frac{1}{16}$ " deep. Blend the folds into the flag's surface.

Sand out the tool marks to create a smooth surface for the waving flag. Elsewhere on the plaque, let the tool marks remain for a hand-hewn look.

Details add drama

On the face, stop-cut the bangs across the forehead. From just above the eyebrow lines, carve toward the hair, tapering to a depth of about $\frac{1}{32}$ ".

Stop-cut the eyebrow lines, the eyes, and sides of the nose. Then with a small V-tool, cut along the sides of the nose, the underside of the eyebrow lines, and the top and bottom of each eye. For each cut, hold the side of the tool nearest the pattern line vertical. Go about $\frac{1}{16}$ " deep.

Next, stop-cut the lips and the nostrils. Cut away the surface around the lips, leaving them standing in slightest relief. (Before carving the lips, we reinforced the area by soaking the surface with cyanoacrylate adhesive.)

Blend the cuts around the eyes, beside the nose, and around the mouth into the rest of the face. The bridge of the nose, the lips, the forehead just above the eyebrow lines, and a portion of each cheek will remain at original height. Round over the sides of the face, then round the edges of the oval eyes and lips.

Cut the flutes in the crown with a $\frac{1}{8}$ " no. 11 U-veiner. Chamfer the edges of the crown points. Then, with a $\frac{1}{16}$ " V-tool, carve shallow vertical lines on the hair.

Texture the deepest relief layer with gouge cuts. First, groove the areas with a $\frac{1}{4}$ " no. 7 or no. 9 gouge. Then, make random vertical cuts with a $\frac{1}{16}$ " U-veiner. (In the areas we couldn't reach with

the gouge, we used a hand-held rotary tool with a spherical cutter about the same size as the gouge.)

Carve a lasting motto

With Miss Liberty carved, turn your attention to the lettering. To form the raised letters, you'll cut away the wood surrounding them. (We carved $\frac{1}{16}$ " deep around the letters on our plaque.)

Draw a pencil line across the bottom of the upper lettering area, about $\frac{1}{16}$ " above the edge of the pictorial area. This line will form a raised edge, or rule, to separate the lettering from the central picture. Draw a similar line across the top of the lower lettering area.

Photocopy the lettering patterns. Center each between the rule and the end of the stock on the appropriate part of the plaque. Trace and fix the pattern lines as before.

Stop-cut the rule line and the letters at the top about $\frac{1}{16}$ " deep. To stop-cut rounded parts of the letters neatly, pick a gouge with a sweep that pretty nearly matches the letter's curvature. Then, hold the gouge vertically, align it on the curve, and press it straight into the wood.

Keep the lines straight and the sides of the letters vertical as you carve away the background wood. Beware of the letters' serifs, the little curves at the ends of the strokes. They can break off easily, even with a carving this shallow. Soak them with cyanoacrylate adhesive to lessen the problem.

Texture behind the letters with a gouge. Shallow vertical cuts with a no. 9 gouge will help set off the lettering. Block-sand the letter faces and the rules.

Now, show your colors

Paint the plaque with acrylic artist's colors. Start with a primer coat of white for Miss Liberty and the flag.

Paint the textured areas behind the lettering phthalocyanine blue (known as thalo blue). Apply the

liquid acrylic straight from the jar to the unprimed wood. If you use acrylic paint in a tube, thin it slightly with water for use. Paint the background and up onto the sides of the letters, but not the faces of the letters.

Trace the stars and stripes from the pattern onto the flag. Paint the star field thalo blue, leaving the white stars showing. Paint the stripes cadmium red medium. Put on two coats—more if needed—for a smooth, bright finish.

Before painting Miss Liberty, stain the gouge-textured background. Brush on walnut stain (we used Deft walnut no. 400), then blot away the excess. Stain the ledge above the statue's head.

For Miss Liberty herself, mix a few drops of permanent green light into light gray acrylic. (We mixed roughly three parts white and one part black for the gray.) Rub on coppertone highlights.

A touch of gold

We applied gold leaf to the letter faces. Gold paint would work, too. We bought a gold leaf kit containing the sizing/adhesive and several sheets of composition gold leaf at a craft-supply store. Frame and art-supply stores sell the kits, too.

Brush the sizing/adhesive onto the letter faces, as shown in Photo A below. Allow the sizing to dry, following any recoating instructions with your material.

Then lay pieces of gold leaf onto the sized area. Don't worry about covering each letter with a single



FULL-SIZED PATTERNS

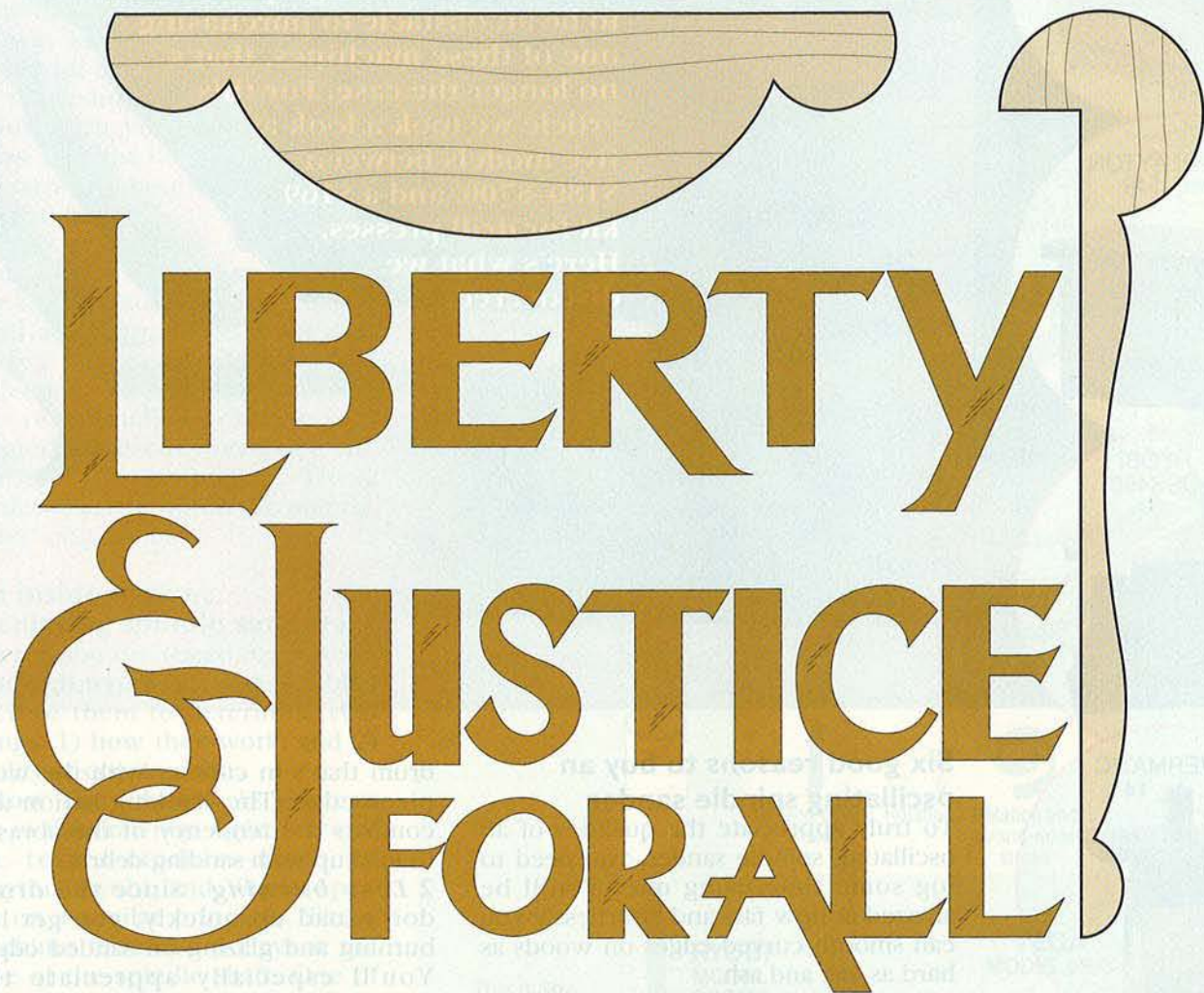

Project Design: © Robert Thomas Photographs: John Hetherington Illustrations: Kim Downing



piece; overlapping edges and wrinkles won't even be visible after you rub the leaf.

Rub the leaf smooth with your finger or a piece of soft cloth, as shown in Photo B. Whisk away the unadhered leaf with a small, stiff brush, as shown in Photo C. You can salvage some of the excess by lifting it with the tip of your carving knife. Apply a protective coating over the letters.

Continued on page 102

OSCILLATING SPINDLE SANDERS

UNDER \$700

We put them to the test

VEGA OS-3



CLAYTON
146



RYOBI
OSS450



POWERMATIC
14



ENLON
EN3407



For quickly and effectively smoothing curved edges, no tool matches the performance of an oscillating spindle sander. And although price used to be an obstacle to purchasing one of these machines, that's no longer the case. For this article we took a look at five models between \$180-\$700, and a \$169 kit for drill presses. Here's what we discovered.

Six good reasons to buy an oscillating spindle sander

To truly appreciate the qualities of an oscillating spindle sander, you need to log some time using one. You'll be amazed at how fast and effortlessly you can smooth curved edges on woods as hard as oak and ash.

Unlike a drill-press sanding drum, the drum of an oscillating spindle sander has two simultaneous motions. As the drum spins at 1720-2000 rpm, it also goes up and down a distance between $1\frac{3}{16}$ - $1\frac{1}{2}$ " every second or two. This stroking motion makes for a huge improvement in performance over a drill-press setup. These advantages became apparent early in our testing:

1 Speed. Oscillating spindle sanders cut much more aggressively than a drum sander that's not moving up and down. That's because the oscillating motion constantly changes the area of the

drum that's in contact with the workpiece edge. The stroking action also combats the tendency of the abrasive to load up with sanding debris.

2 Less burning. Since the drums don't load up quickly, you get less burning and glazing on sanded edges. You'll especially appreciate this attribute if you work with black cherry or maple.

3 Less effort. Because an oscillating sander cuts more aggressively, you don't need to apply as much force against the sanding drum. In turn, you have more control over stock removal. With less force against the drum, you also get an edge that's more square to the face of the workpiece. Why? A sanding drum may flex backward or contort under pressure.

4 No scoring. A sanding drum that doesn't move up and down will leave distinct scoring marks from its abrasive

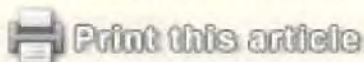

OSCILLATING SPINDLE SANDERS

pinion gear drives two rods up and down. These rods attach to a yoke assembly that forces the spindle shaft up and down.

Although similar in the way their oscillating mechanisms work, the floor-standing Enlon EN3407 and benchtop Powermatic 14 differ substantially in the size and durability of these assemblies. The Enlon has much beefier parts, and an oil bath that keeps its mechanical components running smoothly and with less wear.

•**Quality of construction.** Our inspection and operation of these machines revealed big differences in the quality of construction. Here's how each machine fared.

Not surprisingly, the most expensive machine in this review—the *Clayton 146*—was also the most sturdily constructed. The oscillating assembly has high-quality parts throughout, with the ramp mechanism in a sealed housing filled with oil. This unit will stand up to heavy use.

Typical of a Taiwanese-made machine, the *Powermatic 14* extensively uses cast-iron and

steel throughout its construction. We found the oscillating mechanism sturdy, but some of the parts appeared poorly machined. This didn't create any obvious problems except that the threaded ends of the ¼" and ½" drum shafts did not mate well with the spindle shaft. Because of this, these drums did not center well on the spindle shaft (a problem often referred to as "runout"). This caused the sanding surface to hammer the workpiece. Mark Seymour of Powermatic assured us that the machining of these parts has been improved and shouldn't be a problem with current models.

The *Enlon EN3407* amazed us by not only its sheer mass (about 300 pounds) but also by the quality of its mostly cast-iron components. We expected this machine to just be a larger version of the Powermatic 14, but it shares none of the Powermatic's weak points.

Although it's composed largely of lighter-weight metal and plastic components, the well-designed *Ryobi OSS450* should stand up to the demands of most hobbyist

woodworkers. The weakest point of this machine is its noisy universal motor. Typically, universal motors do not last as long in continuous-duty applications as the induction-type motors found on the other tested machines.

The *Vega OS-3* proved to have the most disappointing construction of the units we tested. Although simple and easy to repair, the machine appears crudely made. Our model arrived with rusty pulleys; the ramp mechanism is encased in a piece of Schedule 40 PVC pipe like the type you would pick up at a corner hardware store. In operation, the entire spindle fell out of the machine when both spindle bearings loosened from their plastic retainers as we pressed a 2" sanding sleeve onto its drum. We tightened the retainers as much as possible, but the same problem persisted.

Four things to consider when comparing tables

To achieve quality results with 99 percent of your work, the table

An oscillating sander kit for your drill press

With a price tag of \$169, the Oscillating Sander Kit from GP Designs costs almost as much as the Ryobi OSS450. So why buy a drill-press kit when you can buy a dedicated sander? After trying the GP Designs unit, we came up with two good reasons for going this route.

First of all, you can have an oscillating spindle sander without devoting any extra shop space to one. Second, unlike dedicated sanders that operate at a fixed speed, you can change the speed of a drill press to suit the diameter of the sanding drum. We found this valuable since small

drums (¾"-diameter and under) sanded slowly on the dedicated units. With these small drums mounted in a drill press, we cranked the speed up to 3000 rpm for aggressive stock removal.

Our tests of the GP Designs kit were largely favorable. It took us about 20 minutes to install the unit on the Grizzly G1200 shown *right*. The stroke was adjustable between ⅛ and ⅝" by moving the clamp attached to the drill-press spoke. The connecting rod attaches and detaches in a second or two for switching between drilling and sanding operations. Included with every kit are well-

designed plans for making a plywood dust-collection box that doubles as a table.

Our only knock against this well-made unit is the location of the on/off switch on the back of the motor housing. You cannot see the switch from an operating position, and reaching around to the back of the drill press proved awkward. The gear motor has its own power cord and plug.

The manufacturer supplies kits for most popular brands of floor-standing and benchtop drill presses. For more information about availability and accessories, call the phone number on *page 82*.

Dust collection: These models cleaned up on the competition

Both the Clayton and Ryobi units have 2½" dust ports for convenient connection to a shop vacuum hose. Hooked up this way, both machines provide for about 95-100 percent collection of the dust. These models work so effectively because both machines have dust-collection ducting that tightly surrounds the spindle just under the surface of the table.

As shown *below*, the Powermatic does a less effective job of dust collection because its ducting does not tightly surround the base of the spindle just under the table. Also, its undersized dust port does

not connect to a common 2½"-diameter vacuum hose.

Like the Powermatic, the Enlon has a tilting table that inhibits the manufacturer from providing tight ducting around the spindle. However, the Enlon compensates for this limitation by having a 4" dust port for connection to a dust collector. Because dust collectors move larger volumes of air than shop vacuums do, a ducting system hooked up to a dust collector can be less than airtight and still work effectively.

The Vega unit provides no means of dust collection.



The Clayton model 146 spewed almost no sanding dust into the air during our tests.



Hooked to a 3-hp shop vacuum the Powermatic 14 collects most, but not all, sanding dust.



With no provision for dust collection, the Vega OS-3 produces a cloud of fine debris.

of an oscillating spindle sander should be solidly supportive, flat, smooth, and fixed at 90° to the spindle. On rare occasions you may need a table that tilts, so we'll also discuss this feature found on three tested machines.

1 Support. The chart on the *following page* shows you the size of each of the tables on our tested models. Keep in mind that the larger tables will provide better support for large workpieces.

2 Flatness. The tables on these machines should be flat to within about .015" across the diagonals of the table. Otherwise, you'll have a hard time sanding square edges. All of the machines passed this standard except for the Powermatic, with a "dished" center that measured .045" lower than all four outside edges. Powermatic's Mark Seymour told us that company officials recognize this problem, and the Taiwanese manufacturer has added a grinding step that will smooth the table considerably (see the *next point*), and make it flat to within a tolerance of .012".

Continued

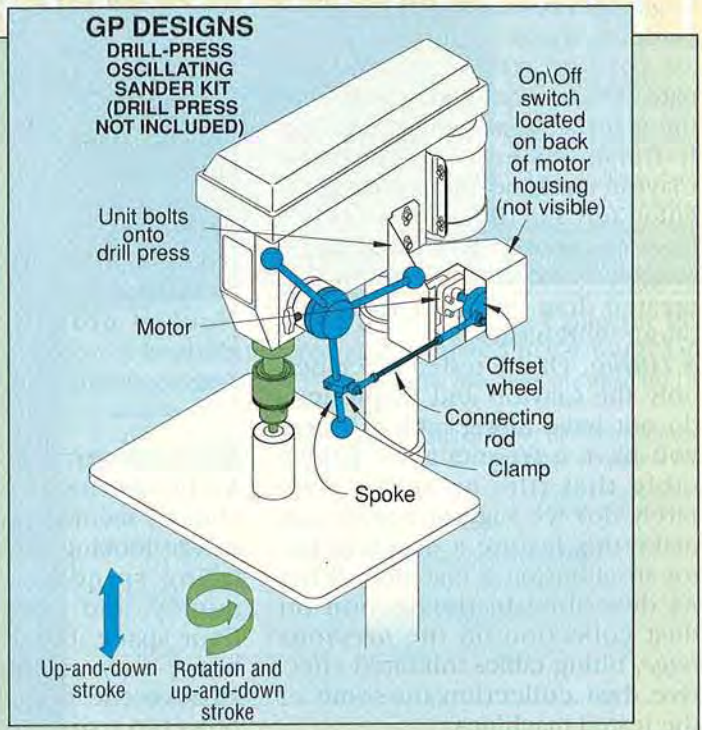

OSCILLATING SPINDLE SANDERS

THE NITTY-GRITTY ON 5 OSCILLATING SPINDLE SANDERS

MANUFACTURER	MODEL (1)	TYPE (2)	MOTOR		SPEED		SPINDLE DIAMETER (INCHES) (5)	SPINDLE STROKE (INCHES)	LENGTH (INCHES)	DRUMS			TABLE SIZE (DEPTH x WIDTH) (INCHES)	PERFORMANCE EVALUATION (9)				OVERALL RATINGS (13)						
			HORSEPOWER (3)	SPINDLE (RPM)	STROKES PER MINUTE (4)	STANDARD SIZES (DIAMETER-INCHES) (6)				OPTIONAL SIZES (DIAMETER-INCHES) (7)	STORAGE (YES, NO)	MATERIAL (8)		DUST-COLLECTION EFFECTIVENESS (10)	TABLE TILT (11)	TABLE FLATNESS	SWITCHES (12)	PERFORMANCE	VALUE	HEIGHT (TO TABLETOP) (INCHES)	WEIGHT (POUNDS)	WARRANTY	COUNTRY OF ORIGIN (14)	SELLING PRICE (1)
CLAYTON	146*	I-ODP	1/2	1750	58	3/4*	13/16	9"	3/4, 1, 2, 3*	-	Y	S	13 1/2 x 21	E	N/A	E	G	10	9	14	80	1 yr.	U	\$675*
ENLON	EN3407	I-TEFC	1	1725	30	19/16	1 1/2	5, 6, 9	**	--	Y	CI	24 1/2 x 24 1/2	G	E	E	G	9	10	36	303	1 yr.	T	595
POWERMATIC	14	I-TEFC	1/2	1720	30	7/8	7/8	5 1/2	1/4, 1/2, 3/4, 1 1/2, 2, 3	--	N	CI	14 1/2 x 14 1/2	F	G	P	E	6	4	19	75	1 yr.	T	300
RYOBI	OSS450	U	*	2000	58	1/2	5/8	4 1/2	1/2, 1	3/4, 1 1/2, 2, 3	Y	MDF-L	14 x 20	E	N/A	E	E	8	10	13 1/2	26	2 yrs.	U	180
VEGA	OS-3	I-ODP	1/4	1750	31-60*	5/8-5/16**	15/16	3	1/2, 1, 2	**	Y	HDP-L	12 x 16	N/A	F	E	P	6	3	13	40	1 yr.	U	360

NOTES:

- (*) Same machine available with a 4 1/2"-high drum shaft as model 140 for \$50 less.
- (I-ODP) Induction, open drip-proof (I-TEFC) Induction, totally enclosed, fan cooled (U) Universal
- Universal motors are typically rated according to amperage draw. Ryobi OSS450 draws 3.5 amps.
- (*) Strokes per minute changed from 31 opm under no load to 60 opm under load.
- (*) Model 140 has a 1/2"-diameter spindle. (**) Main shaft is 5/8" in diameter. Drum shaft is 5/16" in diameter.
- (*) Model 140 comes standard with 1/2", 3/4", 2", and 3" spindles. (**) Enlon comes with drum shafts in various diameters and lengths: 1/4x5", 3/8x6", 1/2x6", 3/8x6", 3/4x9", 1x9", 1 1/2x9", 2x9", 3x9", and 4x9".

- (*) Model 140: 1", 1 1/4", 1 1/2", 2 1/4", 2 1/2" Model 146: 1 1/4", 1 1/2", 2 1/4", 2 1/2", and 3" pneumatic drum. (**) Other sizes available by purchasing sanding drums from other manufacturers.
- (CI) Cast iron (HDP-L) High-density particleboard - laminate covered (MDF-L) Medium-density fiberboard - laminate covered (S) Steel
- E** Excellent
G Good
F Fair
P Poor
N/A - Feature not available

- E** Collects 95-100% of dust
G Collects 85-90% of dust
F Collects 60-85% of dust
- E** Operates easily, locks solidly, with accurate scale.
G Smooth, easy to operate, scale not accurate.
F Smooth, easy to operate, does not lock solidly.
- E** Easily visible and accessible; lockable.
G Accessible, but hard to see; not lockable.
P Cord-mounted, hard to find, and easily damaged.
- 1-10 scale with 10 being the highest possible score.
- (T) Taiwan
(U) United States

3 Smoothness. The Ryobi and Vega units have smooth tabletops made of wood-composite materials covered with a plastic laminate. Workpieces glide easily over these surfaces, as well as the finely finished steel surface of the Clayton machine and the cast-iron Enlon top. On the other hand, the Powermatic unit we tested had a roughly finished cast-iron top that created drag on the bottom side of our workpieces.

4 Tilting. Of the tested machines, only the Clayton and Ryobi units do not have tilting tables. Unless you have a frequent need for a table that tilts up to 45° (we rarely do) we suggest you do not make this feature a deciding factor in choosing a machine. Why? As described in the section on dust collection on the *previous page*, tilting tables inhibited effective dust collection on some of the tested machines.

A scoop from Sears

Just before this issue went to press we visited the engineering and testing facilities for Craftsman stationary tools. While there we got a sneak peek at a new oscillating sander set for sale in October. The \$150 machine appears similar to the Ryobi, but has a direct-drive induction motor. The prototype looked promising, and we'll have a complete test report in an upcoming issue.

Recommendations

At the conclusion of our tests, the choices seemed pretty obvious. If you're looking for the most oscillating spindle sander for the money, and have the available floor space, buy the Enlon. This heavy-duty machine is made to survive the long haul, and has power to spare.

However, many of us don't have much floor space, and among the benchtop models we liked the Clayton and Ryobi units. The Ryobi gives the home hobbyist exceptional value. If you intend to use an oscillating spindle sander heavily, go for the Clayton (buy the model 140 unless you need the 9" drum height of the model 146). If you're really tight on space, try the GP Designs kit. 🐾

MANUFACTURERS' LISTING

Clayton 800/971-5050 810/548-2380	Powermatic 800/248-0144
Enlon 909/468-3688	Ryobi 800/525-2579
GP Designs 203/929-8158	Vega 800/222-8342

Written by Bill Krier
Technical Consultant: Dave Henderson
Illustrations: Kim Downing
Photographs: John Hetherington

Faithful Companion



Individually numbered by hand with 24 karat gold.

Plate shown smaller than actual size of 8" (20.32 cm) in diameter.

Award-winning wildlife artist Randy McGovern creates a magnificent heirloom collector plate.

He's proud, loyal and "Man's Best Friend." A beautiful Black Labrador, portrayed with all the authenticity and emotion for which this celebrated wildlife artist has become renowned across America.

"Man's Best Friend" is the newest collector plate by Randy McGovern, whose works are treasured by knowledgeable collectors of fine wildlife art. In the tradition of the most prized collectibles, this heirloom collector plate is crafted of fine porcelain and lavished with breathtaking color. It is hand-numbered and bordered in 24 karat gold. And each imported plate bears the artist's signature mark on its reverse side.

Priced at just \$29.95, this Limited Edition will be closed forever after just 45 firing days. Available exclusively from The Franklin Mint, Franklin Center, PA 19091-0001.

A Limited Edition Collector Plate. Hand-Numbered and Bordered in 24 Karat Gold.

The Franklin Mint Please mail by September 30, 1994.
Franklin Center, PA 19091-0001

Please enter my order for Man's Best Friend by Randy McGovern. I need SEND NO MONEY NOW. I will be billed \$29.95* when my plate is ready to be sent. *Limit: one plate per collector.*

*Plus my state sales tax and \$2.95 for shipping and handling.

SIGNATURE _____ ALL ORDERS ARE SUBJECT TO ACCEPTANCE

MR/MRS/MISS _____ PLEASE PRINT CLEARLY

ADDRESS _____ APT. # _____

CITY/STATE _____ ZIP _____

TELEPHONE # (_____) _____ 16990-82-001-8LQW

Satisfaction Guaranteed. If you wish to return any Franklin Mint purchase, you may do so within 30 days of your receipt of that purchase for replacement, credit or refund.

Woodworker's Marketplace

WOODWORKER'S CATALOG

Over 4000 products to **BUILD, REPAIR, RESTORE, REFINISH** anything made of wood!

It's the catalog woodworkers rely on—116 pages jam-packed with fine woods, veneers, tools, finishing supplies, and much more—all top quality, all reasonably priced, all with our 60-day no-questions-asked guarantee. For your 2-year subscription send \$1.00 to:

CONSTANTINE
Serving Woodworkers for 181 years

2050 Eastchester Rd., Dpt. 35310, Bronx NY 10461

Circle No. 820

CONVERSION KITS CUT COST!

Band Saw Guide Conversion Kits for Delta 14" and 20", Mini-Max 18", Grizzly 16" & 18" and other saws 14" and larger. Catalog available \$1.00.

Carter PRODUCTS COMPANY, INC.
437 Spring St., NE, Grand Rapids, MI 49503
(616) 451-2928 / FAX: (616) 451-4330

Circle No. 1010

Add that **Distinctive Look** to your woodworking projects. Quality handcrafted, yet reasonably priced panels. Many finishes & designs. Do-it-yourself materials, too! Colorful catalog \$5.00; w/ 12-pc. sample-pack \$19.95 ppd. MasterCard/Visa accepted.

pierced tin
Country Accents®, P O Box 437, Dept. WD/94, Montoursville, PA 17754 • Ph. (717) 478-4127

Circle

Disaster Insurance for Woodworkers

SQUARE DRIVE SCREWS



Made in USA or Canada!

Do-it-Yourself Dozen: Contains 1200 screws, 100 each in 12 popular sizes, with a magnetic bit holder, 3 insert driver bits and a 4-in-1 hand driver. Twelve optional heavy duty storage bins stack, or may be wall mounted with the supplied quick disconnect brackets. **Sizes included:** #6 x 1/2, 5/8, 1-1/4, #8 x 5/8, 1-1/4, 1-1/2, 2, 2-1/2, #10 x 1-1/2, 2, 2-1/2, 3

#1200-FSL-A Without Bins: List \$63.00 **Your Price \$49.95**
#1200-FSL-B With Bins: List \$75.00 **Your Price \$59.95**
Plus Delivery, Virginia Residents add 4-1/2% Sales Tax

Catalog is Free, Samples & Catalog \$3

McFEELY'S
SQUARE DRIVE SCREWS
PO Box 3 • Dept WD994
Lynchburg • VA 24505-0003
1-800-443-7937

Delivery Charges
Order Total \$&H
\$0.01 to \$20.00 \$4.00
\$20.01 to \$50.00 \$5.50
\$50.01 to \$80.00 \$7.00
Over \$80.00 \$8.00

UPS Ground Service Only
Alaska, Hawaii, US Territories and Foreign countries extra.

Circle No. 2450

TOOL SALE

Makita

LS1020 Heavy Duty 10" Miter Saw, Cast Iron Base, Blade & Dust Bag **Super Sale \$299**

6095DWE 9.6V Cordless Driver-Drill Kit w/Free Battery \$139
LS1440 14" Miter Saw \$479
6211DWE 12V Cordless Drill Kit w/FREE Battery \$168
3612BRA 3hp Plunge Router w/Brake \$199
2708W 8 1/4 Table Saw 12A w/GT blade \$299
LS1011 10" Slide Comp. Miter Saw w/blade, clamp, & dust bag \$533
JR3000V Recip Saw w/case \$134
5007NBK 7 1/4 Circ Saw w/Free Case \$129
6404 3/8 Var Sp Rev Drill 0-2100 RPM \$55

DEWALT **NEW**

DW421 Random Orbit Sander **\$84**

DW682K Plate Joiner Kit. \$40 of Free Biscuits \$249
DW625 3 HP Electr. VS Plunge Router \$284
DW364 7 1/4 Circ. Saw w/brake \$145
DW974K-2 NEW 12V Versa Clutch Cds Drill, 2 Batt. \$199
DW945K-2 12V VS Driver Drill Kit w/ 2 Batteries \$168
DW972K-2 12V 3/8 Std. Chuck Cds Drill, 2 Batt. \$199
DW377 7 1/4 NEW Worm Drive Circular Saw \$189

Some stock limited quantities • Prices subject to change

1-800-262-5482

SAME DAY SHIPPING
FREE FREIGHT

HOME LUMBER CO.

MasterCard VISA Discover C.O.D. P.O. Box 370 WHITEWATER, WI 53190

Circle No. 48

Build a SHOP OF YOUR OWN
for prices you could only dream about

LIMITED OFFER



EASY DO-IT-YOURSELF CONSTRUCTION
PACKAGES INCLUDE STEEL, FRAMES, SHEETING AND HARDWARE

30X36 Value \$7,751 NOW \$3,975	36x48 Value \$12,145 NOW \$6,220
40x60 Value \$17,250 NOW \$8,846	46x72 Value \$25,143 NOW \$12,894

Other Sizes Available

MIRACLETRUSS®

1-800-843-8275
FAX 612-544-1835

Made in America **WM**

Woodworker's Marketplace is a section of advertisers offering products by mail. Please contact the advertisers directly or use the number below each ad to request information through the Woodworker's Resource section.

**Full-Size Professional Plan
MISSION STYLE FUTON FRAME**

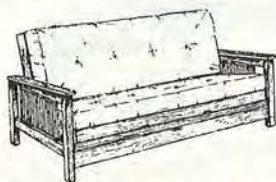

Beautiful and unique! Futon frame converts easily from sofa to queen size bed. Overall size: 41" high, 41" deep and 89" wide.

Plan #720 \$28.00
Catalog of plans (Free with order) . . . \$3.00

Fine Furniture Plans Since 1968
FURNITURE DESIGNS, INC., Dept. BF-94
1827 Elmdale Ave., Glenview, IL 60025 - (708) 657-7526

Circle No. 345

**Classic Heirloom Cradle
Two Cradle Plans
One for Babies
One for Dolls**



You can easily build this classic cradle which will become a cherished family heirloom to pass from generation to generation. Two sizes available... Baby or Doll.

Full Size Plans

Baby size Plan (21 x 35) \$14.95 ppd.
Doll size Plan (10 x 18) \$8.95 ppd.

Spindles available in Oak or Maple. See our catalog which is sent free with your order.

M/C VISA orders call toll-free 1-800-292-8296
ARMOR Box 445 A, East Northport, NY 11731

Circle No. 315

**One-Man Sawmill Turns
Timber Into
Cash!**



30-DAY FREE TRIAL!

Sawmill goes right to the trees...turns out smooth, true-cut lumber - even beginners get excellent results. Just one man (no crew needed) can easily cut enough on weekends to save hundreds of dollars over high lumberyard prices. Factory-Direct selling keeps price low...easy terms...made in USA.

PHONE TOLL FREE 1-800-942-4406 Ext. SW19
TIMBERKING, INC. DEPT. SW19
1431 N. TOPPING, KANSAS CITY, MO 64120

FREE!



The most complete **Woodworking Catalog!** Featuring over **600 NEW** items, **Anniversary Specials** and over 4000 hard-to-find products for your next project. Dept. 43112

Call 1-800-403-9736 Today!

**40 YEAR
ANNIVERSARY**

The Woodworkers' Store

Hardware, Wood, Tools & Know How

Circle No. 965

END WOOD ABUSE!

**Replace "Old-Fashioned
Pin Torture"**



with the **"Wood-Friendly"
Wagner L606
Moisture Meter**

- Deep Penetrating, Pin-Free
- Proven Technology - Used by Agencies to Grade a Large Percentage of US Wood.*

L4.5" x
W2.75" x H1.5"

WAGNER
ELECTRONIC PRODUCTS

1-800-944-7078
IWF booth #36008

Circle No. 1285

Headquarters:
326 Pine Grove Rd.
Rogue River, OR 97537
(503) 582-0541
Fax (503) 582-4138

*REQUEST INFORMATION.
© 1993 WAGNER ELECTRONIC PRODUCTS, INC.

***FREE PLANS
for Woodworkers**



- *FREE Plans for:**
- Sliding Glass Door Lock
 - Yard Whirlygig
 - Trapeze Tumbler
 - Two Table Saw Cars
 - Dalmatian Decoration

*Send \$2.00 for our catalog and we will include a FREE project plan featuring full sized patterns for six different projects (\$7.99 value). Our catalog offers over 400 woodworking plans for furniture, country projects, toys, lamps, whirlygigs, and many other indoor and outdoor projects. We are the #1 plan source for the woodworking hobbyist.

I am enclosing \$2.00. Please send catalog and plans for six projects.

Name _____

Address _____

City _____

State _____

Zip _____

Meisel Hardware Specialties
P.O. Box 70 W9
Mound, MN 55364-0070

Circle No. 401

Van Dyke's

Presents a Catalog

with supplies for upholstery, antique restoration, wood working, caning, brass hardware, carvings and many related trades!

40 Years in Creative Arts & Trades

Many Hard-To-Find Items!

SEND \$1.00 FOR CATALOG TO:

VAN DYKE'S RESTORERS

Dept. D99, P.O. Box 278, Woonsocket, SD 57385

Circle No. 2077



Anderson™ BEDROOM ORGANIZER

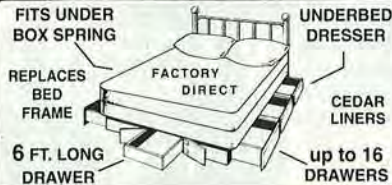

PUT A DRESSER UNDER ANY BED

Increase drawer storage with this beautiful, top quality, solid wood, dust proof, underbed dresser. Replaces bed frame. Fits under any size box spring. Shipped UPS. FREE TRIAL

FREE CATALOG 1-800-782-4825

Circle No. 1795

MAXIMUM RV PROTECTION

STEEL BLDGS

SAVE UP TO 45%

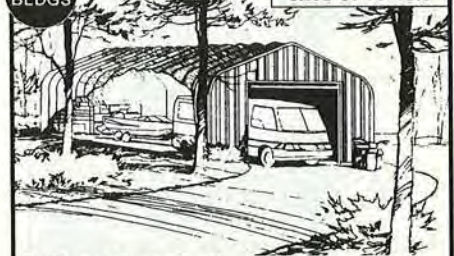

Buy Factory Direct. 20 x 32 • 25 x 48
Build it yourself! 35 x 56 • 50 x 124

800-888-4606 STEELMASTER

Circle No. 2030

Garrett Wade Free...



We carry over 5,000 high quality woodworking supplies and tools that are nearly impossible to find anymore.

For your FREE catalog Call Toll-Free or write to:

Garrett Wade Co., Inc.
161 6th Avenue, Dept. 956
New York, NY 10013
800-221-2942

Circle No. 855

Free Workshops • Prizes • Hundreds of Products • Seminars by Mastercraftsmen

See the Widest
Variety of
Woodworking
Products All
Under One Roof!!



★THE
WOODWORKING
SHOWS★
machinery • tools • supplies



1994/1995 SHOWS

- Atlanta
- Columbus
- Hartford
- Milwaukee
- Seattle
- Baltimore
- Dallas/Ft. Worth
- Houston
- No. California
- St. Louis
- Buffalo
- Delaware Valley
- Indianapolis
- North Jersey
- Tampa
- Charlotte
- Denver
- Kansas City
- Pittsburgh
- Washington, D.C.
- Chicago
- Detroit
- Long Beach
- Portland
- plus others!
- Cincinnati
- Harrisburg
- Massachusetts
- San Mateo

Call for free brochure Monday - Friday 8:30 am - 5 pm Pacific Time
1-800-826-8257 or 310-477-8521

Circle No. 2095

MAKE NEW WOODEN YARD SWINGERS

FROM OUR FULL SIZE PATTERNS, & EASY TO FOLLOW INSTRUCTIONS!

CUT FROM STANDARD LUMBER!

HANG 'EM FROM YOUR TREES OR FRONT PORCH!

\$5.50 EA. COUPLE--ALL 3 ONLY \$14.50

The Winfield Collection, Dept. C84
112 E. Ellen St, Fenton, MI 48430

Order from this ad or send for our FREE catalog of over 1800 unique woodcraft projects!

A SMALL BREEZE SETS THEM SWINGING!

Quality
MECHANISMS
For Making
WOODEN BARREL

- ↳ Pens
- ↳ Pencils
- ↳ Roller Balls
- ↳ Fountain Pens

plus other related items.

Wholesale/Retail

Call or Write:

BereahardWoods.co

6367 Eastland Rd. Brookpark, Ohio 44142
216-234-7949 Master Card/Visa

Circle No. 510, 1900

FREE WOODWORKING CATALOG

Rated #1 in USA

100%
Made
in USA

- Hawk Precision Scroll Saws
- "4-in-1" & "3-in-1" Woodplaners
- The BEST accessories, blades, books & much more

FREE CATALOG • CALL 800-487-2623

rbindustries
The American Tool Manufacturer
1801 Vine St. • Harrisonville MO 64701 D95

Circle No. 84

Wood Moisture Meter

Professionals and hobbyists can choose from 8 different Mini-Ligno moisture meters:

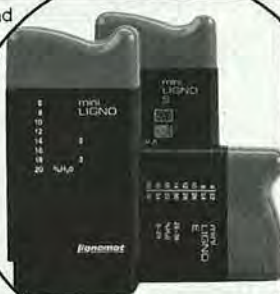

Versatile
Affordable
Sturdy!
Over 100,000 units sold.

Also introducing
New Mini-Ligno XL

For brochure contact:

Lignomat USA, Ltd. PO Box 30145
503/257-8957 800/227-2105 Portland, OR 97230

Circle No. 1250

Revolutionary "2-in-1" TRIMMER/ MOWER

Takes the place of both your hand-held trimmer and steel-bladed mower!

The DR® TRIMMER/MOWER rolls "light as a feather" on two BIG WHEELS! TRIMS far easier, better, more precisely than hand-held trimmers. Plus MOWS everything from whole lawns (even wet!) to tough, waist-high growth with ease! Rocks, roots, stumps, etc., do it no harm because the "DR®" has no steel blade to bend or dull. Perfect for ALL mowing and trimming around smaller properties, vacation homes, etc., or for finish-up mowing and trimming after riding mowers on larger parcels. A delight for anyone to use!

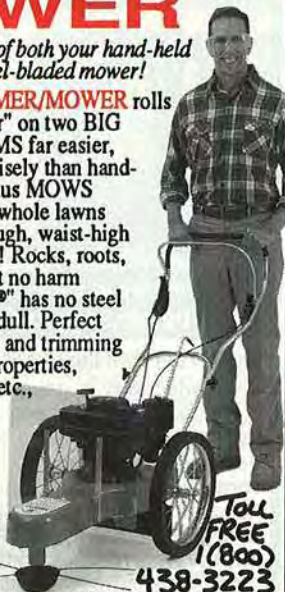

Toll
FREE
(800)
438-3223

Please mail this coupon today for FREE DETAILS about the Revolutionary DR® TRIMMER/MOWER, including prices of Manual, Electric Starting and ALL-ELECTRIC Models; "Off-Season" Savings now in effect, and 30-Day Risk-Free Trial. There is no obligation.

Name _____

Address _____

City _____ State _____ ZIP _____

To: COUNTRY HOME PRODUCTS®, Dept. 11468
Box 89, Ferry Road, Charlotte, VT 05445

© 1994 CFP, Inc.

Exclusive CMT's new 8-piece Rabbit-Master Kit

Here's a super price on the most versatile Rabbeting Kit on the market. You'll get an 1-3/8"-diameter Rabbeting Bit, 6 top-quality bearings and an allen key to cut 6 of the most useful rabbets.

800-622 1/4" Shank

List: \$39.90
SALE: \$32.90

800-623 1/2" Shank

List: \$46.90
SALE: \$35.90

- Baked-on Teflon®.
- Antikickback design.
- Micrograin carbide edges.
- Fatigue-Proof® steel shanks and bodies.
- Shear angles that slice, not chop.



Cut 6 depths with one bit,
simply by changing bearings!
1/2" 7/16" 3/8" 5/16" 1/4" 1/8"

Shipping and Handling \$4.00

CMT TOOLS
5425 Beaumont Center Blvd.,
Tampa, FL 33634

Call toll-free 24-hours a day:

1-800-531-5559

813-886-1819 FAX: 813-888-6614

Dealer & export inquiries welcome

In Canada call 1-800-387-7005

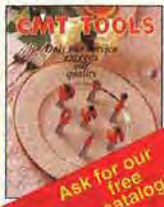

Ask for our
free
catalog!

Circle No. 1310

FREE
Clockmaking
Catalog



100%
Satisfaction
Guaranteed!

WELCOME TO CLOCKMAKING!

It's a natural for people who love working with their hands. It's easy as 1-2-3 and clocks make sensational gifts!

Klockit's new FREE catalog has:
Clock Kits & Plans, American-made Quartz Movements, Mechanicals, Dials, Hands and Numerals. Plus, Quartz Clock Inserts, Wood Turned Parts, Hardware, Posters, Watches and More!

Name _____

Address _____

City _____

State, Zip _____

KLOCKIT Dept. WD94
P.O. Box 636
Lake Geneva,
WI 53147-9961
Call 1-800-KLOCKIT
(556-2548)

Circle No. 2335

RIP AW

The Portable Sawmill.

The "affordable portable" one man band sawmill. Weighs only 45 lbs. Cuts 20" diameter logs into lumber. Minimum 1/8" to maximum 9" thickness. 14"W x 9"H throat capacity. Write or call for free brochure. Videos also available.



Better Built CORPORATION

(508) 657-5636

845 Woburn St., Suite 3, Dept. W09, Wilmington, MA 01887

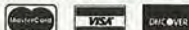

Circle No. 10

Woodworker's HARDWARE

Manufacturer's Hardware For The Home Craftsman

FREE CATALOG

Huge line of **SPECIALIZED** Cabinet and Furniture Hardware.

- Knobs
- Pulls
- Hinges
- Locks
- Connectors
- Lighting
- Abrasives
- Drawer Slides
- Cabinet Accessories
- Much, Much More!



Send or call for a **FREE CATALOG**
PO Box 784
St. Cloud, MN 56302

1-800-383-0130

Circle No. 960

5" Random Orbit Sander With Dust Pickup
\$79.95

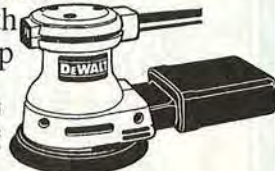

DEWALT
High Performance Industrial Tools

DW421

DW705

DW625

DW972K-2

DW991K

DW364

DW682K

- 12" compound mitre saw \$359.
- 3 hp vs plunge router 269.
- NEW!** 12v drill kit with 2 batteries 189.
- NEW!** 14.4 volt driver drill kit 199.
- 7-1/4" saw with brake 149.
- Heavy duty plate jointer with case 225.

TOOL CRIB

P.O. Box 13720
Grand Forks ND 58208-3720

OF THE NORTH

Sept. Wood **1-800-358-3096**

Circle No. 6

THE WOODTURNERS CATALOG



Craft Supplies USA offers woodturners the finest selection of woodturning tools and accessories anywhere.

CHOOSE FROM:

- HENRY TAYLOR TOOLS
- RICHARD RAFFAN TOOLS
- DALE NISH WORKSHOPS
- WOODFAST WOOD LATHES
- COMPLETE LINE OF PEN, PENCIL, FOUNTAIN AND ROLLERBALL KITS

We offer the best quality, prices and service, guaranteed!
Send \$2.00 for our 52 page color catalog.

Craft Supplies USA
PO Box 50300
Provo UT 84605-0030
Phone (801) 373-0919

Circle No. 830

It's As Easy As 1-2-3-4-5

Introducing the new EZ-1 from AIRY



Model EZ-1

Meet the world's first five function nailer. Use both brad nails and staples from the same tool. AIRY's patented design allows you to choose different fasteners without changing tools or making adjustments. This could be the handiest tool you'll ever own. Ideal for moldings, furniture, cabinets, upholstery, picture frames, insulation and much more.

The EZ-1 comes ready to use with its own carrying case and an assortment of 5 different fasteners.

National Hardware Show/Chicago Booth #9092
IWF / Atlanta Booth #3E26

AIRY
AIRY SALES CORPORATION

14535 Valley View Ave., #N
Santa Fe Springs, CA 90670
310-926-6192 • (FAX) 310-404-1400

STAINED GLASS VIDEO & CATALOG



Improve the Looks and value of your home with:

- Entry doors & sidelights
- Kitchen cabinet inserts
- Tiffany lampshades

Save money and make it yourself - Delphi shows you how!

Make Your Own Custom Stained Glass...

The perfect way to get started in stained glass. Our 25-minute video covers all the basics: Scoring, breaking, foiling, and soldering. Filled with clear and simple instructions, hints, close-ups, and examples to help you craft your own stained glass windows, lamps, and more. VHS only.
#6149VW...\$10.95 + \$3.00 shipping/hand.

A \$10.95 rebate is applied to your next order. If you don't wish to purchase, just return the video for a prompt refund, but keep the 80-page color catalog.

To Order - Call Toll Free: 1-800-248-2048



2116 E. Michigan Ave.
Lansing, MI 48912

Circle No. 1920

The Japan Woodworker's Catalog is . . .

loaded with the best tools you can get your hands on. In our catalog you will find a high selection of Japanese saws, waterstones, chisels, planes, carving tools, cutlery and books. Send \$1.50 for our catalog and supplements during the next two years.

THE JAPAN WOODWORKER
1731 Clement E-31, Alameda, CA 94501
Phone 1-800-537-7820

Circle No. 190

**HEGNER...
F-A-S-T
BLADE CHANGES!**

Now you can enjoy the fastest, easiest and most reliable blade changing system available! Find out about HEGNER Scroll Saws and their many advantages. Call or write for FREE information today!

1-800-220-4264
In Canada 800-220-6545

Advanced Machinery
P.O. Box 312, Dept. 633
New Castle, DE 19720

Circle No. 3

Oscillating Spindle Sanders
for discriminating woodworkers
who demand the best

FREE Color Catalog
1-800-971-5050



CLAYTON™
MADE IN USA

Circle No. 18

Introducing The Most Versatile, Affordable Planer You'll Ever Buy.



Comes Pre-Wired with a 3 HP (TEFC) Motor

Here's What The RBI 812 Can Do.

- No other planer gives you this much versatility at such an affordable price.
- The 812 is a heavy-duty, 3-in-1 precision wood-working-system complete in just one compact tool.
- The Model 812 will plane, mold, or sand at 11 feet per minute all day long.
- Create cabinets and furniture
- Customize home woodworking
- Finish and dimension stock
- Turn rough lumber into beautiful molding in minutes
- Produce uniform surfaces
- Plane to 12" wide in seconds
- Create hundreds of ornamental moldings or picture frames on hard or soft woods with standard or customized knives
- Eliminate distortions caused by tedious hand sanding

Call 800-487-2623 To Order or FREE Catalog.

Our Guarantee To You
30-Day Money Back Guarantee
3-Year Warranty

rb industries
The American Tool Manufacturer
1801 Vine Street • PO Box 369
Harrisonville, MO 64701

Circle No. 84

GREAT IDEA!

"This has to be the most attractive and practical way yet to cover a pickup bed."

A key locked roll-up hard cover that's weathertight.



for free brochure on the **ROLL-TOP-COVER™**

call or write: Pace-Edwards Co.
100 Commercial Street
Centralia, WA 98531

1-800-338-3697

Circle No. 1985

VIDEO CATALOG OF HISTORIC SHIP MODEL KITS



Discover the world's oldest and most rewarding hobby... model ship building! Watch our 25-minute VHS video and learn the secrets of building museum quality wooden ship models. You'll see the finest selection of authentic ship models- superb replicas you build yourself- close up and in incredible detail. Even if you've never built a model before, you can create a magnificent keepsake to be treasured for many generations. Send \$5.00 for your video today! (Refundable with your first order.) **Free with your video!** 92 page color catalog of ship model kits and accessories.

MODEL EXPO, INC. Dept. WD94
P.O. Box 1000, Mt. Pocono Industrial Park,
Tobyhanna, PA 18466-1000

Enclosed is \$5.00, to be refunded with my first order.

Name: _____
Address: _____
City: _____ State: _____ Zip: _____

Item No. SST900C
© Model Expo, Inc. 1993

Circle No. 1075

SAVE MONEY! KILN DRY LUMBER

MAKE MONEY!

Kiln Dry for others.

As the nation's largest manufacturer of dehumidification Dry Kilns, we can supply you with the same type equipment used by many of the major firms.



1-800-777-NYLE 207-989-4335
Nyle Standard Dryers, Inc.
P.O. Box 1107, Bangor, Maine 04402
FAX # 207-989-1101

Circle No. 1260



OWN A FURNITURE RESTORATION BUSINESS

Perfect 2nd Career

Make \$200-\$2,000 a day! Unlimited market; turn-key business. Free workshops. Set-Up Shop for \$2,999-\$9,999! Part-time or full-time. Great for men, women, families.

**Make Molds*Veneer*Resilver
Strip*Repair*Refinish**

Business Preview Video \$8.95 - Catalog \$2.00

MINUTEMAN, INC., Ste. 17

Box 8, Waterloo, WI 53594

1-800-733-1776



Circle No. 1661

Wood-Mizer®

Models from \$6995!*

World's Largest
Manufacturer
of Portable
Sawmills

**Own a
Sawmill!**



1-800-553-0219

32-Page Full-Color Catalog \$2.00
Business Profitability Booklet \$2.00
66-Minute Demonstration Video \$10.00
Mastercard or Visa Accepted
*Shown with optional trailer

Wood-Mizer Products, Inc.
8180 West 10th Street, Dept. GQ88
Indianapolis, IN 46214-2400

Circle No. 94

WOODCARVING



IS FUN AND PROFITABLE

Want to carve decoys, statues or gun stocks?

It's easy when you use the Dupli-Carver Series wood carving machines. A patented five axis carving action allows these machines to complete difficult undercuts and contours as no other machine can. Complete machines available starting as low as \$395.00.

SEND \$1.00 FOR OUR FULL LINE BROCHURE AND PRICE LIST AND START PLANNING YOUR FULL OR PART-TIME BUSINESS.



MARLIN DIVISION

terco incorporated

222 1st Ave. N.W. W46 • Watertown, SD 57201
(605) 882-3888 • Fax (605) 882-0778

Circle No. 2150

Wanted!

SERIOUS WOODWORKERS

As a serious woodworker, you know the difference between cheap cutting tools and

Top Quality American
Made cutting tools.



... Eagle America
knows the difference too.

For FREE
catalog call:

1-800-872-2511

Circle No. 1320

Buckboard Bench

(real springs)



Kit includes:
authentically
designed steel
springs that give
a little, metal arms
& backrails, com-
plete hardware &
detailed
instructions.

42"L x 13"W, 18"H to seat, 30"H to back.

\$49.00 Also
available, pre-cut and drilled oak for the bench.
\$60 addl.

The Roudebush Co.

Box 348A, Star City, Indiana 46985

800-847-4947

(Visa, MC Accepted) Price includes shipping UPS. IN res. incl. 5% sales tax.

Circle No. 1085

MAKE IT MOBILE

WITH HTC MOBILE MACHINE BASES

For a FREE
Full-Color Catalog
of HTC's Complete
Product Line Call:
1-800-624-2027



Circle No. 1245

WATER WELL DRILL KIT



Thousands of happy gardeners and homeowners have discovered the Hydra-Drill secret. They drilled their own wells and their gardens prove it! You can, too.

Call or write us today and we'll send you a big, free package of information about drilling your own well with the Hydra-Drill.

Video Available!

DeepRock

7620 Anderson Road
Opelika, AL 36802

Call Toll Free

1-800-333-7762

(Ask for Operator 7620)

Circle No. 1915

PLANS AND PATTERNS FOR THE HOME CRAFTSMAN

NEW 1994 FALL CATALOG
FEATURES



- PLANS & PATTERNS FROM 25 COMPANIES
- WOODWORKING BOOKS
- DREMEL TOOLS & ACCESSORIES
- EXPANDED CHRISTMAS SELECTION
- PROJECTS FOR THE ENTIRE FAMILY
- MONEY BACK GUARANTEE

SEND \$3.00 OR VISA/MC CALL 1-800-576-9174

CREATIVECRAFT PLANS: SUITE 20
9654 CEDAR COVE LANE / INDIANAPOLIS, IN 46250

WOOD TOY

- ★ Patterns
- ★ Parts
- ★ Wheels
- ★ Many New Patterns to Choose from.
- ★ Executive toys



SEND \$1.00 FOR NEW CATALOG

toys and joys

Box 628w Lynden, Wash. 98264

Circle No. 465

SPIRAL STAIRS

Coast to Coast Delivery

FREE ENCLOSED TREAD ENDS \$220.00 VALUE

Save 30% to 50% Stock & Custom Stairs Strong Steel Frame Oak or Brass options 3'6" to 7' Diameter Easy To Install

FREE BROCHURE Call or Write -

SALTER INDUSTRIES

PO BOX 183 EAGLEVILLE PA 19408 610-631-1360 FAX 610-631-9384



Circle No. 1995

Heavy Glass Table Tops

FACTORY DIRECT DISCOUNT PRICING



- Table Tops
- Shelves
- Doors
- Display Cases
- Entertainment Centers
- Tempered Glass

TABLE TOPS BY PHONE

SATISFACTION GUARANTEED!

WGB GLASS ■ SHAPES ■ THICKNESSES ■ EDGE DESIGNS

FOR FREE IDEA CATALOG AND PRICE LIST SEND POST CARD TO:

WGB GLASS 19785 W. 12 MILE RD., STE. 357 SOUTHFIELD, MI 48076

TO PLACE ORDERS: CALL 1-800-288-6854

HARDWOODS

EXOTIC & DOMESTIC OVER 75 SPECIES

LUMBER • VENEER • TURNING STOCK

COLLECTORS SAMPLE KIT

30 GORGEOUS WOODS \$39.00
Exotic & Domestic from Around the World 1/2" X 3" X 6" Sanded Finish *ppd in Cont US

Together with Book of Fine Hardwoods \$51.00 *ppd in Cont US

Over 70 woods shown in full color. Charts compare physical properties. 60 pgs



1-800-423-2450
WOODWORKERS Source

5402 S. 40th Street • Phoenix, AZ 85040
SATISFACTION GUARANTEED

Circle No. 598, 2090

TRUNKS are BEAUTIFUL!

but not if they're battered and missing parts. We'll show you how to make your trunk beautiful again.



TRUNK REPAIR VIDEO

Shows step-by-step how to paint and line your trunk. 30 minutes. VHS. \$19.95 + \$2.90 shpg. The only how-to guide on trunk repair & decoration. 28 pages, color photos. 5 volumes, \$35.

TRUNK REPAIR SUPPLIES CATALOGUE
Authentic hardware and leather replacement parts to restore any trunk. \$2.50. FREE with video order.

TRUNK I.D. GUIDE \$4.50.
TX res. + 7 1/2%, FL res. + 6% tax.

To order call **1-800-553-2649**

CHAROLETTE FORD TRUNKS

P.O. Box 536 • Dept. W • Spearman • TX • 79081

Supplement Your Income From Your Home With A Computer!



Begin part-time and still retain the security of your present position. We offer 20 services you can perform for your community from your home. No experience necessary—easy to learn. We provide training and computer. For FREE explanation cassette and literature call:

1-800-343-8014, ext. 184
Computer Business Services, Inc.

BRANDING IRON

For hard and soft wood

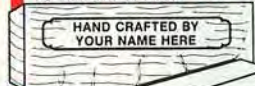

\$2900

Plus \$3.00 for shipping and handling
Nebr. residents add correct sales tax

- Shipped in one week
- Solid brass head — raised letters
- 1st Line: HAND CRAFTED BY — as above
- 2nd Line: Your choice — 20 characters/spaces max.
- Electric iron available for \$49.00 + \$3.00

ORDER TOLL FREE...

1-800-826-7606

Order by mail from: **NOVA TOOL CO.**

P.O. Box 2791
Dublin, CA 94568



Circle No. 160

Imagine Little Red Riding Hood without a forest.

Only You Can Prevent Forest Fires.



USDA Forest Service and your State Forester.

Supergrit® SANDPAPER



- DISCS- H&L, PSA, VAC
 - DRUM SANDER ROLLS- H&L
 - BELTS- AO, SC, ZIR
 - ROLLS- Jwt, Xwt, Cloth & Ewt
 - SHEETS- AO, SC, GARNET
- For Wood, Autobody and Metal

FREE 20 PAGE CATALOGUE

& Incredible close-out sheets. Best prices and shipment

RED HILL CORP.

P.O. BOX 4234
GETTYSBURG, PA 17325

800-822-4003

Circle No. 1267

PORTER+CABLE

100	7 8 HP ROUTER	\$102
310	PRODUCTION LAMINATE TRIMMER	145
312	PRODUCTION OFFSET LAMINT TRIMMR	158
314	4 1/2" TRIM SAW	135
315-1	7 1/4" BUILDERS SAW	117
330	SPEED BLOCK FINISHING SANDER	60
332	QUIKSAND 5" RNDM ORB W/STIKIT PAD	66
332K	332 W/CASE & 100 SHEETS PAPER	92
333	QUIKSAND W/HOOK & LOOP, DUSTLS	74
333K	333 W/CASE & 50 SHEETS PAPER	99
334	QUIKSAND W/STIKIT, DUSTLESS	74
334K	334 W/CASE & 100 SHEETS PAPER	99
345	SAW BOSS 6" CIRCULAR SAW	104
347	7 1/4" FRAMERS SAW 15 AMP, 10.25 LBS	128
351	3" X 21" BELT SANDER	148
352	3" X 21" BELT SANDER W/DUST BAG	152
9352VS	3" X 21" VS DSTLS BELT SANDR W/CSE	165
360	3" X 24" BELT SANDER W/DUST BAG	192
361	3" X 24" BELT SANDER	184
362	4" X 24" BELT SANDER W/DUST BAG	197
363	4" X 24" BELT SANDER	192
410	UNDERSCRIBE LAMINATE TRIMMER	148
411	MITER FOLD LAMINATE TRIMMER	165
447	7 1/4" FRAMERS SAW W/BRAKE 15 AMP	138
505	1 2 SHT FIN SANDER	124
550	NEW POCKET CUTTER	178
556	BISC JOINER W/CASE & TILT FENCE	172
556K	SAME AS ABOVE W/100 BISCUITS	195
690	1 1/2 HP ROUTER W/1 1/4" & 1 1/2" COLLETS	149
690K	690 W/CS, EDGE GUIDE, & TEMP GD KIT	179
9690	1 1/2 HP ROUTER W/CASE	144
691	1 1/2 HP "D" HANDLE ROUTER	149
693	PLUNGE BASE ROUTER, 1 1/2 HP	169
695	SHAPER TABLE W/ 1 1/2 HP ROUTER	217
696	SHAPER TABLE	129
2820	3 8" VSR DRILL, 0-1200 RPM W/CHK	89
5008	DOVETAIL TEMPLATE	79
5009	MORTISE & TENON JIG	47
5116	OMNI JIG	253
6931	PLUNGE ROUTER BASE	74
7116	NEW 24" OMNIJIG	293
7310	LAMINATE TRIMMER, 5.6 AMP	88
7312	OFFSET TRIMMER	127
7319	TILT BASE TRIMMER	99
7335	5" RANDOM ORBIT SANDER, VS W/CSE	132
7335K	7335 W/CS, DUST EX SYS, 100 SHTS PPR	165
7336	6" RANDOM ORBIT SANDER, VS W/CSE	137
7336K	7336 W/CS, DUST EX SYS, 100 SHTS PPR	169
7333	RANDOM ORBIT DUST EXTRACTION	24
7518	3 1/4 HP FIXED BASE ROUTER-5 SPEED	269
7519	3 1/4 HP FIXED BASE ROUTER-1 SP	235
7536	2 1/2 HP FIXED BASE ROUTER	202
7537	2 1/2 HP FIXED BASE "D" HNDL RTR	208
7538	3 1/4 HP PLUNGE ROUTER-1 SPEED	235
7539	3 1/4 HP PLUNGE ROUTER-5 SPEED	269
7549	TOP HANDLE BAYONET SAW	134
7649	BARREL GRIP BAYONET SAW	147
7700	NEW 10" LASERLOC MITER SAW	338
9118	PORTA PLANE KIT W/CASE, CRBD BLD	209
9314	1 1/2" TRIM SAW KIT	152
9315	7 1/4" BUILDERS SAW KIT	139
9345	SAW BOSS 6" CIRCULAR SAW KIT	123
9347	7 1/4" FRAMERS SAW W/STEEL CASE	138
9637	TIGER SAW VAR SPD RECIP SAW KIT	144
9647	TIGER CUB RECIP SAW KIT	119
9840	CRDLS DRILL KIT W/2 BAT, CS KYLS CK	148
9853S	12V CROLS KIT W/2 BAT, CASE	169
97310	LAMINT TRIMMR KIT W/4 BASES & CS	194

Panasonic

EY610CRKW	NEW PREDATOR 9.6V CORDLESS KIT VSR W/KYLS CHUCK, 22 STAGE CLUTCH W/2 BAT, CASE & CHRGR	158
EY6100CRKW	NEW PREDATOR 12V CORDLESS KIT VSR W/KYLS CHUCK, 22 STAGE CLUTCH W/2 BAT, CASE, & CHARGER	189

RYOBI

BT3000S	10" TABLE SAW WITH STAND	549
AP12	12" PORTABLE PLANER	398
TSS220	8 1/2" SLIDE COMPOUND MITR SAW	438
OSS450	OSCILLATING SPINDLE SANDR	174
D36VSR	3 8" VSR DRILL, 4.0 AMP, 0-2500 RPM	59

SUPER SPECIAL!  **\$184**

636 OSCILLATING TRIANGULAR SANDER INCLUDES CASE & PAPER ASSORTMENT

ALL CHECKS WILL BE HELD 10 BUSINESS DAYS



DELTA

14-650	HOLLOW CHISEL MORTISER	284
22-160	12" BENCH TOP PLANER	396
28-280	BENCH TOP BAND SAW	164
31-080	1" BELT 5" DISC SANDER	83
31-460	4" BELT 6" DISC SANDER	128
33-060	NEW SIDEKICK 6 1/2" FRAME & TRIM SAW	379
34-182	TENONING JIG	84
37-070	NEW 6" VS BENCH JOINTER	269
40-560	16" SCROLL SAW, 2 SPEED	179
50-075	DUST COLLECTOR SWEEPER, 3/4 HP	254
50-175	NEW KICKSTAND PRtbl WORK STAND	179

Milwaukee

0406-1	9.6V KYLS CDLS DRILL KIT W/2BAT, CS	169
0407-1	SAME AS ABOVE BUT 12 VOLT	173
6010	1/2 SHEET FINISHING SANDER	123
6017	1/4 SHEET FINISHING SANDER W/BAG	56
6125	5" RANDOM ORBIT SANDER	113
6256	6" RANDOM ORBIT SANDER	118
6266	TOP HANDLE JIG SAW	144
6491	10" MITER SAW W/BAG & 80T BLADE	288
6492	10" MITER SAW KIT COMPLETE	334
6507	VAR SPEED SAWZALL W/BLADES & CSE	145
6508	SAME AS 6507 BUT W/PERMANENT CRD	145
6527	SUPER SAWZALL W/BLADES & CASE	174
6528	SAME AS 6527 BUT W/PERMANENT CRD	174

SENCO

SLP20	BRAD NAILER W/CASE 5 8" 1 5 8" CAP	268
SPN40	FINISH NAILER W/CASE 1 1/4" 1 1/2" CAP	378

HITACHI
MODEL C8FB2
8 1/2" Slide
Compound Miter
Saw



Includes 24T carbide blade, vise, dust bag & 50' extension cord
\$579.00

AIRY
MODEL 0241SK
Brad Finish
Nailer Kit



Shoots 18 gauge brad from 13/32" - 1 9/16" and includes case & 5000 assorted brads
\$98.00

Jorgensen

ITEM	JAW LENGTH	OPEN CAP	OUR PRICE EACH	BOX OF 6	
ADJUSTABLE HANDSCREWS					
#0	8"	4 1/2"	11.70	57.95	
#1	10"	6"	12.50	67.95	
#2	12"	8 1/2"	14.50	77.95	
STYLE 37 2 1/2" THROAT 1 1/4" X 3/4"					
3706	6"	6"	6.00	32.50	
3712	12"	12"	6.50	35.00	
3718	18"	18"	6.95	37.75	
3724	24"	24"	7.50	42.50	
3730	30"	30"	8.80	47.75	
3736	36"	36"	9.95	53.95	
PONY CLAMP FIXTURES					
#50	3 1/4" BLACK PIPE CLAMPS		7.90		
#52	1 1/2" BLACK PIPE CLAMPS		6.75		
PONY SPRING CLAMPS - 3201HT 1" - 1 1/2"					
3202HT 2"			1.79	3203HT 3"	3.99

AIRY

USES SENCO NAILS & STAPLES!

0241SK	18 GAUGE BRAD NAILER 3 8" 1 9/16" WITH CASE & 5000 NAILS (SAME AS SLP20)	98
0250SK	18 GAUGE BRAD NAILER 3 4" 2" W/CASE & 5000 NAILS	165
0565T	ANGLE FINISH NAILER 1" 2 1/2" (SAME AS SFN1 & SFN2)	204
0626SK	NARROW CROWN 1 1/4" STAPLER 1 1/2" 1 1/4"	104
0645S	NARROW CROWN 1 1/4" STAPLER 3 4" 1 3 4" CAPACITY	189
8290	STICK FRAMING NAILER - 6 TO 16 PENNY CAPACITY, COMPATIBLE W/SENCO OR HITACHI NAILS	319
EZ-1	SHOOTS 1 1/4", 3 8", 1 1/2" CRN STAPLES & BRADS, 5 8" CAP, W/CASE & 5000 ASSORTED FASTENERS	99

DEWALT

DW100	3 8" DRILL, 0-2500 RPM, 4 AMP	67
DW318K	4.5 AMP HVY DTY JIG SAW KIT W/CS	147
DW360	7 1/4" SAW W/BRAKE	149
DW430	3" X 21" DUSTLESS BELT SANDER	164
DW431	3" X 21" DSTLS BELT SANDER VAR SP	180
DW610	1 1/2 HP ROUTER, 9 AMP	147
DW614	1 1/4 HP PLUNGE ROUTER	143
DW615	1 1/4 HP PLUNGE ROUTER, VAR SP	158
DW624	3 HP HVY DTY PLUNGE ROUTER	245
DW625	3 HP HVY DTY PLUNGE RTR, VAR SP	289
DW682K	BISCUIT JOINER KIT	224
DW9090	SUPER BATTERY CHARGER	119
DW9442K	9.6V CORDLESS KIT W/2 BATTERIES	148
DW9452K	12V CORDLESS KIT W/2 BATTERIES	166

HITACHI

D10DFKBE	9.6V. CRDLS DRILL KIT W/2BAT & CS-KYLS	149
D10GVKABE	12V CORDLESS DRILL KIT W/2 BAT	189
D10VC	3 8" DRILL VAR SP, REV, 3.2 AMPS	59
SV12SA	4 3 8" PALM GRIP SANDER	54
C8FB2	8 1/2" SLIDE COMPOUND MITER	279
C10FC	10" COMPOUND MITER SAW	590
C16SV2	TOP HANDLE JIG SAW W/CASE	158
P20SB	3 1/4" PLANER, 3.4 AMP	88
TR6	LAMINATE TRIMMER	92
M8V	VAR SPEED PLUNGE ROUTER, 1 1/4"	149
TR12	3 HP PLUNGE ROUTER	184
M12V	3 HP VAR SPEED PLUNGE ROUTER	232

BOSCH
MODEL 1587VS
Orbital Action
Jig Saw



INCLUDES FREE CARRYING CASE! Adjustable footplate, 1" stroke length
\$162.00

PORTER+CABLE
MODEL 9853S
3/8" Cordless
Driver/Drill Kit



Includes 2 batteries, charger & steel case. 12V, 1 hour charge. Var. speed, reversible.
\$169.00

BOSCH
MODEL 1613EVS
2 Hp Plunge
Router



INCLUDES EDGE GUIDE! Electronic variable speed with Microfine Depth Adjustment.
\$199.00

BOSCH

1003VSR	3 8" VSR DRILL W/KEYLESS CHUCK	92
1194VSR	1 1/2" VSR, 2 STAGE HAMMER DRILL	139
1272D	3" X 24" DUSTLESS BELT SANDER	206
1273D	4" X 24" DUSTLESS BELT SANDER	200
1273DVS	4" X 24" VS DUSTLSS BELT SANDER	219
1370DEV6	6" VS DSTLS RNDM ORB SNDR	234
1584VS	CLIC BARREL HANDLE JIG SAW, VS INCLUDES FREE CASE	157
1587VS	TOP HANDLE JIG SAW, VS W/CASE	162
1604	1 3 4 HP ROUTER	142
1608	LAMINATE TRIMMER	95
1609KX	DELUXE INSTALLERS KIT W/4 BASES	229
1613EVS	2 HP VAR SP PLUNGE ROUTER INCLUDES FREE EDGE GUIDE	199
1614EVS	1 1/4 HP VAR SP PLUNGE ROUTER	159
1615EVS	3 1/4 HP VAR SP PLUNGE ROUTER INCLUDES FREE EDGE GUIDE	289
3054VSR	12V CORDLESS KIT W/2 BAT, CASE	188
3282DVS	5" VS DUSTLESS RANDOM ORBIT	95
87000	TRIANGULAR CORNER SANDER	75

Emqlo

AM78HC4V	1 1/2 HP COMPRESSOR	\$299.00
----------	---------------------	----------

SKIL

77	7 1/4" WORM DRIVE CIRCULAR SAW	145
1605-02	BISCUIT JOINER WITH CASE & FREE GLUE SYSTEM	129
2736-04	12V VSR CORDLESS DRILL KIT WITH 15 PIECE BIT SET	135
3400	10" TABLE SAW W/FREE CARB BLADE	179
5657	7 1/4" CIRCLE SAW W/6 CARBIDE BLOS	119
5860	8 1/4" WORM DRIVE SAW	172
9410	4 1/2" DISC GRINDER	59

MIRKA Abrasives, Inc.

5" SOLID PSA PAPER - 100 PER ROLL	80 - 320 GRIT	\$12.95
5" HOLED PSA PAPER - 100 PER ROLL FOR PORTER CABLE 5" HOLED PADS - 80 - 320 GRIT		12.95
6" SOLID PSA PAPER - 100 PER ROLL	80 - 400 GRIT	15.95
6" HOLED PSA PAPER - 100 PER ROLL FOR PORTER CABLE 6" HOLED PAD		17.95
80 GRIT	100 - 320 GRIT	16.95
5" HOOK & LOOP PAPER FOR PORTER CABLE	5" HOOK & LOOP PADS - 50 PER BOX	10.95
80 - 320 GRIT		10.95
5" HOOK & LOOP PAPER FOR BOSCH 3283DVS 50 PER BOX	80 - 320 GRIT	10.95
6" HOOK & LOOP PAPER FOR BOSCH 1370DEV5 50 PER BOX	80 - 320 GRIT	12.95

freud

JS100	BISCUIT JOINER	164
JS102	BISC JOINER W/TILT FENCE & DUSTBG	189
FT2000E	3", hp PLUNGE ROUTER VS	205
EB100	EDGE BANDING SYSTEM	208
EDS132	13.2V CRDLS DRILL KIT W/2 BAT	215
FC107	7 PC CARBIDE FORSTNER BIT SET	84
F410	10" X 80T QUIET BLADE	48
F810	10" X 80T QUIET BLADE	73
LM72M10	10" X 24T FLAT TOP RIP BLADE	36
LU82M10	10" X 60T CROSSCUT RIP BLADE	48
LU84M10	10" X 50T ATB COMBO BLADE	40
LU85M10	10" X 80T ATB FOR MIRROR FINISH	58
LU87M10	10" X 24T RIP BLADE THIN KERF	39
LU88M10	10" X 60T CROSSCUT THIN KERF	45
SD3003	8" SAFETY DADO WITH CASE	116
SD503	NEW 8" SUPER DADO SET	168
TK206	10" X 24T THIN KERF RIPPING	25
TK306	10" X 40T THIN KERF COMBINATION	25
TK606	10" X 60T ATB COMPOUND MITR BLD	39
TK806	10" X 80T ATB ULTIMATE CROSSCUT	44
TK906	10" X 50T THIN KERF CROSSCUT	29
TK406	10" X 60T THIN KERF FINISHING	34
90-100	15 PC ADVANCED ROUTER BIT SET	159
91-100	13 PC ROUTER BIT SET	179
94-100	CABINET DOOR SET, 1 1/2" SHANK	158
95-100	5 PC CABINET & MOULDING BIT SET	199

INTERNATIONAL TOOL CORPORATION

1-800-338-3384 • 1939 TYLER STREET, HOLLYWOOD, FLORIDA 33020 • FREE FREIGHT & SAME DAY SHIPPING ON MOST UPS ORDERS OVER \$50.00 MINIMUM PURCHASE WITHIN THE CONTINENTAL U.S.A.

QUANTITIES LIMITED - NOT RESPONSIBLE FOR TYPOGRAPHICAL ERRORS - PRICES SUBJECT TO CHANGE WITHOUT NOTICE • FAX US YOUR ORDER AT 1-305-927-0291

LET'S TALK TOOLS

Continued from page 69

Router speed controller:

MLCS
P.O. Box 4053
Rydal, PA 19046
800/533-9298
215/938-5060

Scrollsaw magnifying lamp and footswitch:

Penn State Industries
2850 Comly Rd.
Philadelphia, PA 19154
800/377-7297

Socket-wrench set, adjustable-jaw wrenches, and flush-rivet pliers:

Sears
Call or visit your local Sears store.

Square-drive screws and driving bits, adjustable trammel and pencil compass:

McFeely's
P.O. Box 3
Lynchburg, VA 24505-9937
800/443-7937

HAND TOOLS

Most hand tools including planes, saws, rules, hammers, chisels, squares, screwdrivers, levels, and knives:

Stanley
600 Myrtle St.
New Britain, CT 06050
203/225-5111

Sorta-Neat system for organizing fasteners by Plano



Pipe clamps, E-Z Hold Bar Clamps, and handscrew clamps:

Jorgenson and Pony brands Adjustable Clamp Co.
417 N. Ashland Ave.
Chicago, IL 60622
312/666-0640

Quick-Grip Bar Clamps, Quick-Grip spring clamps, tin snips, aviation snips, Vise-Grip Locking Pliers, and Chesco fold-up hex-key sets:

American Tool Companies
301 S. 13th St., Suite 600
Lincoln, NE 68508
402/435-3300

MISCELLANEOUS SUPPLIES

Fastener organization and storage:

Sorta-Neat Sort-N-Store System Plano Molding Co.
431 E. South St.
Plano, IL 60545-1061
800/874-6905

Finishes:

Minwax
15 Mercedes Drive
Montvale, NJ 07645

Lubricant sprays:

Bostik
Boston St.
Middleton, MA 01949
800/726-7845 (U.S.)
800/461-0418 (Canada)

Quick-Grip Bar Clamps by American Tool Co.



Freud saw blades, dado set, and router bits



Jorgensen and Pony clamps from Adjustable Clamp Co.

Foot switch for scrollsaws from Penn State Industries

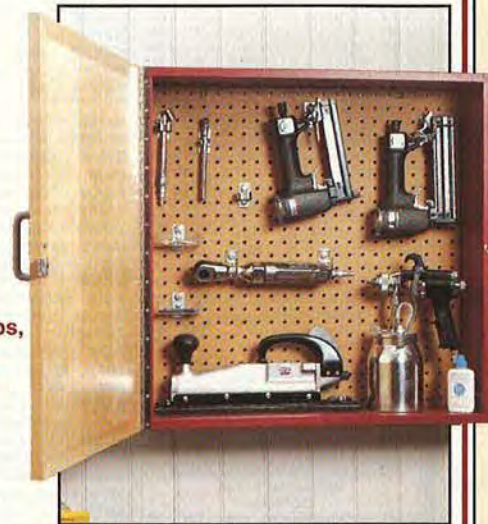

Our air-tool cabinet features pneumatic tools from Campbell Hausfeld (see story listing for model numbers). We also included Bostik pneumatic lubricant.

Pegboard-hook system for storage and display of tools and fasteners:

Windsor Industries
86 Elinor Ave.
Akron, OH 44305
800/678-2552
216/733-2266

Reels for compressed air hose and electric cords:

Reelcraft Industries
2842 E. Business 30
P.O. Box 248
Columbia City, IN 46725-9987
800/444-3134

Vise:

Model 52½ED Record Tools
1920 Clements Road
Pickering, Ont. L1W 3V6
905/428-1077

Wall standards and brackets for lumber storage:

Woodworker's Supply
1108 N. Glenn Rd.
Casper, WY 82601
800/645-9292
307/237-5528

Delta	Description	List	Sale
23-700	Wet/Dry Grinder	234	178
23-680	6" Bench Grinder 1/4 HP	86	75
11-950	8" Drill Press	199	138
31-050	1" Belt sander 2.0 amp	104	78
31-460	4" Belt/Disc Sander	198	129
31-340	1" Belt/Disc Sander	268	204
40-560	1/2" 2 speed Scroll Saw	266	178
11-990	12" Bench Drill Press	276	205
11-090	32" Radial Bench Drill Press	399	305
43-355	3/4" Shaper 1-1/2 HP	864	749
43-505	1/2" Bench Router/Shaper	399	285
22-540	12" Bench Top Planer	398	338
36-220	10" Compound Miter Saw	350	229
28-180	Bench Band Saw	232	165
28-190	NEW 12" Band Saw	465	385
40-640	20" Bench Scroll Saw	465	295
37-070	NEW 6" wisp Bench Joiner	337	249
14-100	Howell Chisel Mortiser	668	249
46-700	10" Wood Lathe	548	445
33-990	10" Radial Arm Saw	488	339
37-280	6" Motorized Jointer	488	395
50-179	3/4" HP 2 stage Dust Collector	483	345
33-055	8-1/4" Sawbuck comp w/legs	865	615
32-100	8-1/4" Table Saw 13 amp	343	245
32-100	Stationary Planer	645	255
36-400	8-1/4" Compound Miter Saw	224	155
34-915	30" Unifence	385	239
34-897	50" Delta Unifence	525	285
36-755	10" Tilt Arbor Saw	1264	965
34-444	Contractors Table Saw	812	619
17-900	16-1/2" Floor Drill Press	462	399
33-060	"Sideluck" Miter Saw	510	375
14-070	14" Floor Drill Press	450	349
37-190	NEW 6" Deluxe Joiner	554	465
36-275	NEW 8-1/4" Builders Jointer	444	265
36-210	NEW 10" Compound Miter Saw	348	259
36-070	NEW 10" Miter Saw	284	169

Model	Description	List	Sale
60720W	3/8" wisp Reverse Drill 7.2V	128	84
61720W	3/8" wisp Drill Kit w/ 2 batt.	220	109
50900W	3-3/8" Saw Kit 9.6 volt	270	145
ML900	Incandescent Flashlight 9.6V	347	37
DA3910W	3/8" angle Drill Kit 9.6 volt	312	169
6012HDWE	2 speed Drill Kit w/2 batt.	243	129
6093DWE	6093DWE Drill Kit w/2 batteries	270	139
6095DWE	6095DWE Drill Kit w/2 batteries	139	139
6201DWE	NEW 9.6V Drill Kit w/2 batt.	298	165
6211DWE	12V Drill Kit w/2 batteries	330	175
632007-4	9.6 volt Battery	47	30
632002-4	7.2 volt Battery	39	28
5007NBA	7-1/4" Saw w/electric brake	263	129
5008NBA	8-1/4" Saw w/electric brake	346	195
B04510	1/4 sheet Pad Sander	106	59
9900B	3" x 21" Belt Sander w/bag	344	169
99240B	3" x 24" Belt Sander w/bag	329	178
43011B	Orb. var. spd Jig Saw 3.5A	292	149
JR3000V	var. speed Recip Saw w/case	252	135
LS1020	10" Miter Saw 3.5 amp	630	355
9820-2	Blade Sharpener	394	199
N1900B	3-1/4" Planer with case	244	129
9514B	4" Disc Grinder 4.6 amp	111	59
B04550	1/4 sheet Pad Sander w/bag	98	54
DA3000R	3/8" Angle Drill	314	179
2708W	8-1/4" Table Saw	585	295
2711	10" Table Saw with brake	1067	595
6404	3/8" Drill Rev. 0-2100 rpm	112	58
6510LVR	3/8" Drill Rev. 0-1050 rpm	168	93
6820V	0-4000 rpm Drywall Gun	171	92
6013BR	1/2" Drill Rev. 6 amp	280	139
9401	4" x 24" Belt Sander w/bag	378	215
4302C	var. speed Orbital Jig Saw	351	199
5077B	7-1/4" Hypoid Saw	281	155
5007NB	7-1/4" Circular Saw 13 amp	232	124
5007NBK	5007NB Saw w/ plastic case	129	129
2012	12" Portable Planer	959	339
LS1011	10" Slide Compound Saw	946	539
3612BRA	3 HP Plunge Router w/ brake	524	175

1994 TOOL CATALOG AVAILABLE
 Call Toll-Free 1-800-328-0457 In Minn. Call (612)224-4859
 FAX: (612)224-8268
 CHECK • MONEY ORDER • VISA • MASTERCARD • DISCOVER
SEVEN CORNERS ACE HDW. INC.
 216 West 7th St. • St. Paul, MN 55102 • Est. 1933

Model	Description	List	Sale
DW3647-1/4"	Circ. Saw w/brake 13 A...	285	154
DW945K-2	3/8" 12V cds Drill Kit w/2 batt	309	169
DW944K-2	3/8" 9.6V cds Drill Kit w/2 batt	283	149
DW6101-1/2"	HP 2 handle Router	274	154
DW411	1/4 sheet Palm Sander, 1.7 amp	57	58
DW1003/8"	Drill, 4 amp, 0-2500 rpm, rev.	118	68
DW682KNEW	Biscuit Joiner with case	429	238
DW705	12" Compound Miter Saw	706	379
DW615NEW	1-1/4 HP Elec. Pipe Router	290	158
DW625NEW	3 HP var. spd Plunge Router	274	154
DW675KNEW	3-1/8" Planer with case	289	164
DW431	NEW 3 x 21 wisp Belt Sander	331	184

Model	Description	List	Sale
DW952K3/8"	wisp incl. one 9.6V batt.	280	165
DW952K3/8"	wisp incl. one 12V batt.	306	179
DW962K-2	3/8" wisp incl. two 9.6V XRBatt	324	189
DW972K-2	3/8" wisp incl. two 12V XRBatt	352	199
DW991K	3/8" wisp incl. one 14.4V XRBatt	370	219

Model	Description	List	Sale
501	Porta Nailer complete	265	205
501	Face Nailer complete	265	205

Model	Description	List	Sale
6204	4' Fiberglass	179	65
6205	5' Fiberglass	199	75
6206	6' Fiberglass	225	82

Model	Description	List	Sale
F1000A12"	Planer/6" Joiner	2970	1559
P12R	12-9/32" Planer	1470	779
P12RA	Planer/Joiner	1940	979
C8FB	8-1/2" Slide Compound Saw	1400	599
G12SA	4-1/2" Grinder 6.9 amp	160	89
ND100VAK	NEW 12V Cordless Drill Kit	393	199
NR83A	Fram Nailer 2 - 3-1/2 Full Head	700	385
NR83AA	Framing Nailer 2 - 3-1/2	750	414
NT65A	16 ga. Brad Nailer 1 - 2-1/2	610	328
NV83AB	Coil Roofing Nailer 7/8 - 1-3/4	750	409
NV83A	Coil Nailer 2 - 3-1/4	750	415

Model	Description	List	Sale
B-50	50" Commer. Saw Fence	345	298
T-SQUARE	52 5/2" Homeshop Fence	279	238
T-SQUARE	40 40" Homeshop Fence	259	208
T-SQUARE	28 28" Homeshop Fence	249	198

Item#	Length	Width	Open	Cap	List	Sale	Box
#1	8"	4-1/2"	19.76	11.75	58.00		
#2	12"	6-1/2"	22.63	12.50	66.00		
#3	14"	8-1/2"	25.95	14.50	78.00		
#4	16"	12"	32.88	18.00	99.00		
#4	16"	12"	42.76	23.95	139.00		

Item#	Jaw Length	List	Sale	Box of 6
3724	24"	14.25	7.99	42.50
3730	30"	15.88	8.85	47.95
3736	36"	17.36	9.99	53.75

Model	List	Sale	Lots	
50 3/4"	Black Pipe Clamps	14.87	7.90	89.95
52 1/2"	Black Pipe Clamps	12.40	6.80	72.95

Model	Description	List	Sale
1587VS	NEW Top Hand "CLIC" Jig Saw	292	149
1587VS	NEW Barrell "CLIC" Jig Saw	285	149
Bosch Metal	Case for above Jig Saws	34	32
Bosch	3/4" blade assortment for Jig Saws	27.99	99
1942	Heat Gun 600° - 900°	125	78
1272D	3" x 24" Belt Sander with bag	375	204
1273D	4" x 24" Belt Sander with bag	380	208
11-212VSR	Bulldog 3/4" SDS Riny Drill	390	209
1347AK	4-1/2" Grinder w/cs & access	185	103
1348AE	5" Grinder 8.5 amp	225	129
1194VSR12"	var. speed Hammer Drill	282	149
1194VSRK	above Hammer Drill w/case	313	169
1608	5.6 amp Laminate Trimmer	168	95
1609K	Lam Installers Kit with 1609	343	184
1609XK	Deluxe Installers Kit	405	228
1604A	1-3/4 HP 2 Handle Router	250	139
1604AK	same as above w/case & acc.	318	185
1606A	1-3/4 HP D-handle Router	295	165
3258	3-1/4" Planer w/blade guard	247	155
3258K	3258 Planer with steel case	273	169
3270DV3	3 2 1/2 wisp belt sander w/ bag	270	165
1273DV5	Svar. spd 4" x 24" Belt Sander	415	219
1614	NEW 1HP Plunge Router	245	149
1614EV5NEW	NEW 1-1/4HP v/spd Pige Rtr	283	155
1613	NEW 1-3/4 HP Plunge Router	316	169
1613EV5NEW	NEW 2HP v/spd Plunge Router	383	219
1615	NEW 3 HP, Plunge Router	430	259
1615EV5NEW	NEW 3HP v/spd Pige Router	505	278
1632VSRK	Recip Saw 8.4A orb-wisp	225	154
3050VSRK	9.6V cds v/sp Drill Kit comp	298	149
3051VSRK	3050VSRK w/keyless chuck	299	145
13710DV5D	6" Random Orbital Sander	427	224
3283DV5	5" Random Orbital Sander	169	98
3283DV5K	3283DV5 Kit complete	199	118
B1650K	NEW Biscuit Joiner	289	165
B7000	NEW Corner Detail Sander	122	79
84500	NEW In Line Jig Saw	199	119

Model	Description	List	Sale
3338	2-1/4 HP v/spd Plunge Router	501	159
3375	3-1/8" Unlv. planer 7.2 amp	329	159
3380	Biscuit joiner with case	569	185
3339	NEW 3HP v/sp Plunge Router	511	269

Model	Description	List	Sale
1166	3/8" Drill 0-2500 rpm 4 amp	111	65
79-034	Workmate 400	181	109
2694	7-1/4" Super Sawcat w/case	285	152
2695	8-1/4" Super Sawcat w/case	328	162

Model	Description	List	Sale
LP6-20	Sight Level w/package - 20x	310	195
LP6-20XL	LP6-20 w/9056 Tripod & 7620 Rod	259	259
L6-20	Meridian Level - 20x	290	188
LT8-300	Level Transit - 26x	695	445
LT8-300P	above Level w/optical plumb	821	518
LT6-900	Level Transit - 20x	389	249
ALT6-900	Automatic Level - Transit - 18x	638	409
ALTP6-900	above Level w/ripod & rod	708	469
ALP6-180	above Level w/ripod & rod	570	375
ML100I	NEW Laser Level	1099	945
ML100	NEW Laser Level w/detector	1249	1075

Model	Description	List	Sale
TS-254	10" Miter Saw	440	209
RE600	3 HP Plunge Router	500	235
BE321	3" x 21" var. spd Belt Sander	310	135
TFD22VRK	12V cordless Drill	365	155
FF1000	Flashlight uses 7.2, 9.6, 12V battery	19.95	
JM100K	Biscuit joiner w/case	475	218
BT3000	10" Table Saw with stand	1125	529
TSS220	8-1/2" Scomp. Comp. Saw	966	445
DS1000	NEW Detail Sander	90	44
AP12	NEW 12" Bench Planer	884	399
RA202	NEW 8-1/4" Bench Radial Saw	800	389
BS900	NEW 9" Bench Band Saw	340	174
OSS450	NEW Oscillating Spindle Sander	340	174

Model	Description	List	Sale
MSx636	FEIN Triangle Sander Kit	499	185
LPN672	PONY Air Palm Nailer w/glove	949	99

Model	Description	List	Sale
2200	Pump Jack	79	58
2201	Pump Jack Brace	30	20
2203	Pump Jack guard rail holder	31	21
2204	Workbench & rail holder combo	53	39

Model	Description	List	Sale
2601	Wall Jack	167	108

Model	Description	List	Sale
890	1-1/2 HP Router 8 amp	260	138
691	1-1/2 HP Router D-handle	285	155
695	1-1/2 HP Router/Shaper	400	223
696	HD Shaper Table	230	129
351	3" x 21" Belt Sander w/bag	280	154
352	3" x 21" Belt Sander with bag	290	159
360	3" x 24" Belt Sander with bag	365	194
361	3" x 24" Belt Sander with bag	345	189
362	4" x 24" Belt Sander with bag	380	205
363	4" x 24" Belt Sander with bag	360	195

Model	Description	List	Sale
315-1	7-1/4" Top Hdle Circular Saw	225	118
9315-1	315-1 comp w/cs & carb bid.	255	139
97751	1/2" wisp Hammer Drill w/cse	270	155
9118	Table Plane Kit 7 amp	390	215
505	1/2 sheet Pad Sander	230	128
6611	3/8" var. speed Drill 5.2 amp	220	125
6614	1/2" var. speed Drill 0-750 rpm	230	128
6615	7514 with keyless chuck	230	128
7549	Top handle Jig Saw 4.8 amp	270	135
330	Speed Biscuit Sander 1/4 sheet	110	60
555	Plate Biscuit Joiner with case	320	159
556	555 jointer w/5556 tilt fence	184	104
345	6" Saw Boss 9 amp	190	104
9345	345 comp. w/cse & carb bid.	220	124
9647			

Woodworkers Resource



You can get useful ideas and product information by mail. Use the coupon in this section to order your choice of literature listed below. Each company mails the catalogs or information directly to you.

POWER TOOLS

SCROLL SAW, CRAFT & WOODWORKING CATALOG—Specialty products from the exclusive distributors of HEGNER, the precision saws with SCROLLVERGNUEGEN. Complete information on scroll accessories, including blades and lettering guides. Also JET Clamps, HEGNER Lathes, PLANO Vertical Glue Press, and more. Toll-free customer service hotline included! **AMI, LTD.** \$2.00. *Circle No. 3.*

TOOL CRIB CATALOG—Since 1948, woodworkers, homebuilders, industry and schools across the country have looked to the Tool Crib as their source for power tools and equipment. Our prices are low; our sales people are knowledgeable; and our service is first-rate! We stock over 10,000 tools with top name brands like Black & Decker, Delta, Ryobi, Makita, Powermatic, Jet, Freud, Bosch, Porter Cable, Milwaukee and many more. We offer competitive prices with quality service and same day shipping. Send for your NEW 1993 catalog. It's worth it! **TOOL CRIB.** \$3.00. *Circle No. 6.*

TRANSPOWER, CP TOOLS INC.—A fine line of quality woodworking machinery, saws, shapers, planers and more. Send for free catalog. **CP TOOLS INC.** Free. *Circle No. 15.*

CLAYTON MACHINE—Sand curved pieces with ease. New American-made oscillating spindle sander features many unique details. Quality built, for a lifetime of enjoyable and dependable service. Dust collector hook-up, ground steel top, dynamically balanced spindle with sealed oil-bath cam and quick change drums are all standard. Several models to choose from. Catalog. **CLAYTON MACHINE.** Free. *Circle No. 18.*

TOOLS AND ACCESSORIES—120 page color catalog features Record lathes, Porter-Cable routers, sanders, saws, drill-drivers, pocket hole cutters, grinders, biscuit joiners, Vega lathe duplicators and saw fences, Vacu-Presses and more. Best quality, fairly priced, every tool backed by our 182 years' experience and 60-day money-back guarantee. 2 year subscription. **CONSTANTINE'S.** \$1.00. *Circle No. 20.*

ENLON IMPORT CORP.—With our exclusive manufacturer, we offer the best deals for your woodworking needs. A large selection of Fine Woodworking Machinery, Tools and accessories for your home and business workshop. Check out our seasonal sales for your life time savings. Catalog. **ENLON IMPORT CORP.** Free. *Circle No. 35.*

NEW POWER TOOL ELIMINATES HAND SANDING—No more bloody knuckle, sore finger sanding. Unique sander, sands along edges and into corners, without bouncing off or running away. The secret is the distinct triangular sanding pad, combined with a high speed oscillation. German made. Brochure shows sander in action. **FEIN POWER TOOLS, INC.** \$1.00. *Circle No. 37.*

INCA MACHINERY INFORMATION—Com-plete information on the famous line of Inca woodworking machines. Designed for precision work by the small to medium sized cabinet shop. Used by thousands of hobbyists and professionals. Table saws, bandsaws, joiner/planers, dust collector, radial arm saw. **GARRETT WADE CO.** Free. *Circle No. 44.*

HOME LUMBER—For the largest selection of Makita at the right price. We also provide great pricing on Amana Carbides, DeWalt power tools, Bostitch Air Nailers & David White Instruments. Same day shipping, free freight. We accept Visa, Mastercard, Discover, COD. Send for information. **HOME LUMBER.** \$1.00. *Circle No. 48.*

INTERNATIONAL TOOL CORPORATION CATALOG—features the best tools & accessories at the absolute lowest prices anywhere! Whether you are a home woodworker or an industrial user, you will find an incredible selection featuring Porter Cable, Bosch, Skil, Freud, Delta, Milwaukee, Hitachi, and many,

many more. We offer same day shipping, the most knowledgeable sales staff and free shipping on most UPS orders in the continental U.S. **INTERNATIONAL TOOL CORP.** Free. *Circle No. 49.*

LOBO POWER TOOLS—Fine crafted woodworking power tool, top quality, affordable prices. A commitment of customer satisfaction, with a full 1 year warranty. We sell a complete line with many options for our band saws, table saws, planers, jointers, double drum sanders, edge sanders, wide belt sanders, power feeders and many, many more. Send today for a free brochure. **LOBO POWER TOOLS.** Free. *Circle No. 57.*

WOODWORKING MACHINE CATALOG—New 24-page color catalog introduces many new do-it-yourself woodworking machines. Includes planers, dust collectors, drill presses, sanders, lathes, and specializes in scroll saws and accessories. **PENN STATE INDUSTRIES.** Free. *Circle No. 75.*

DUST COLLECTOR SYSTEMS—Keep your shop clean and safe from saw dust with one of our large capacity Commercial Style Dust Collection Systems. Catalog features our new DC-3 1-1/2 H.P. Portable System. Free hose and adapters are supplied with any purchase. Full line of Dust Collection accessories is available from Penn State Industries. Catalog. **PENN STATE INDUSTRIES.** Free. *Circle No. 76.*

SURFACE PLANER—Information package available from Penn State Industries describing the specifications and applications of its super 12" inch surface planer. Special discount pricing available on current promotion. **PENN STATE INDUSTRIES.** Free. *Circle No. 77.*

GET TO THE FINISH LINE FASTER—with a Performax drum sander. Don't spend hours with a hand-held belt sander. Sand ultra-wide stock ultra-smooth in just minutes. Models start at \$300 to \$3495. Select the model that fits your budget and your needs. New metal abrasive fasteners keep sandpaper tight without re-wrapping. **PERFORMAX PRODUCTS.** \$1.00. *Circle No. 78.*

WOODWORKING TOOLS & ACCESSORIES—While the history of RBlndustries goes back 60 years, this is the first time we've brought together all our precision-made tools and accessories in one catalog. The Hawk Precision Scroll Saw, 4-in-1 Woodplaner, Panel Master Door Machine, Router System, and much more. Quality equipment built here in the heart of America. When you buy from us, you deal directly with the manufacturer. Our prices, quality, and 3 year Warranty reflect our commitment. Send today for FREE information. **RB INDUSTRIES, INC.** Free. *Circle No. 84.*

MINI POWER TOOL CATALOG—Designed for easy reference, Ryobi's "shirt pocket" Power Tool Catalog includes our complete line of power tools, categorized by type: bench top, cordless, hand-held and stationary models. It features individual tool photographs with specifications and clear descriptions that offer specific uses and benefits. Accessories are also listed. Send for catalog. **RYOBI.** Free. *Circle No. 86.*

TOOLS ON SALE™—A division of Seven Corners Ace Hardware, Inc. offers a catalog of over 400 pages of the most popular brands of power tools available anywhere, all at discounted prices. Included are saws, planers, sanders, routers, drills and more from manufacturers such as Milwaukee, Makita, Porter Cable, Black & Decker, Dewalt, Freud, Bosch, Delta, and many more. Now introducing a full range of Werner brand ladders. Tools on Sale™ division of **SEVEN CORNERS ACE HARDWARE, INC.** \$1.00. *Circle No. 92.*

PORTABLE SAWMILLS—Convert logs into valuable lumber—Wood-Mizer® Products manufactures a line of portable bandsaw mills that allows the novice as well as the experienced sawyer to safely convert standing logs into lumber. Then, with the use of our SolaryDry™ Kiln or Vacu-Kiln™ to dry your lumber, you could increase the value of every board you produce. We manufacture some of the most progressive woodworking equipment on the market today. Product videos available. Send for our 31-page catalog. **WOOD-MIZER PRODUCTS.** \$2.00. *Circle No. 94.*

HAND TOOLS

TOOLS THAT MAKE IT EASY!—Turning tools, carving tools, planes, scrapers, clamps, bits, squares, saws, stones, mallets, jigs—every tool you can think of and then some, in Constantine's 120-page full color catalog. \$1 brings you every regular issue for the next 2 years. **CONSTANTINE'S.** \$1.00. *Circle No. 110.*

PERSONAL BRANDING IRONS—Brochure describes branding irons that enable you to put your name on your work quickly and easily. Made especially for branding wood, they are available with 1, 2, 3 or 4 lines of copy. Changeable date also available. **NOVA TOOL CO.** \$1.00. *Circle No. 160.*

IMPROVE YOUR WOODWORKING SKILLS!—Craftsmen around the world have discovered the secret of better quality work. The 72 page Japan Woodworker Catalog is loaded with a huge selection of Japanese saws, waterstones, chisels, gouges, carving tools, planes, cutlery and garden tools. Send for 1992 catalog and all supplements for two years. **THE JAPAN WOODWORKER.** \$1.50. *Circle No. 190.*

STAINS / FINISHES

SOLVENT AND WATER BASE FINISHES—Check Constantine's big 120-page catalog for the latest in finishing technology—stains, lacquers, polyurethanes, penetrating finishes, plus gloss and satin varnishes, milk paint, even hard-to-find specialty products like padding lacquer, shellac powder, and gold leaf. \$1 brings you every regular issue for the next 2 years. **CONSTANTINE'S.** \$1.00. *Circle No. 210.*

PLANS

WOODWORKERS' PLANS AND SUPPLIES—Wood projects are simplified with the high quality plans, specialty hardware and other supplies offered by Armor Products. Over 100 plans are available for making toys, desks, clocks, pool tables, lamps, chests, and other furniture. Movements, dials, moldings, ornaments, doll-house kits, door harp supplies and tuning pins are also available. **ARMOR PRODUCTS.** \$1.00. *Circle No. 315.*

FULL-SIZE FURNITURE PLANS CATALOG—Illustrates and describes over 200 plans for making furniture of quality found in museums and fine furniture stores. Plans include rollout desk, cradles, dining tables, chairs, buffets, chests, gun cabinets, poker table, children's furniture, rocking horse, spinning wheels, and more. Bill of materials exploded drawings assist the woodworker. **FURNITURE DESIGNS, INC.** \$3.00. *Circle No. 345.*

430 AFFORDABLE HOME PLANS—This top seller has plans to satisfy modest and medium building budgets. Each of four sections—one, 1½, two-story, and multi-level—includes styles such as Tudor, Early American, Spanish & Western, and Contemporary. Floor plans include houses for narrow and sloping sites. Economical rectangular shapes as well as expandable 1½ story houses are included. A handy check list is provided to help you plan a more affordable home. Blueprints available. **HOME PLANNERS, INC.** \$9.95 ppd. *Circle No. 373.*

DECK PLANNER—Not just another collection of deck ideas or photos. Practical plans and details are provided for 25 different decks, including single-, double-, and multi-level designs, and wrap-around decks. These beautiful wood decks are designed for a variety of house styles and feature storage compartments, serving counters, overhead trellises, and seating areas. How-to data and project starters for the build-it-yourselfer as well as information necessary to effectively oversee deck construction are also included. Blueprints and material lists available. **HOME PLANNERS, INC.** \$8.95. *Circle No. 374.*

ENCYCLOPEDIA OF HOME DESIGNS—A total of 500 different designs offers the richest and most varied selection of plans now available in any single home plan book. Exterior styles include Early American, Colonial, Federal, Tudor, French, Spanish, and Contemporary. Over 1,368 illustrations make this volume the perfect reference and idea-book. Blueprints available. **HOME PLANNERS, INC.** \$12.50. *Circle No. 375.*

200 BUDGET-SMART HOME PLANS—200 intriguing plans by seven Blue Ribbon Designers have been selected to meet the needs of those with restricted building budgets. This rich collection of homes, ranging from 902 to 2,540 square feet, has strong styling coupled with low-cost livability. Blueprints available. **HOME PLANNER, INC.** \$8.50. *Circle No. 376.*

PROJECT PLANS—Full-size patterns for over 500 easy-to-build woodworking projects. Nation's leading source for scroll saw patterns, cow projects, toy plans, yard ornaments, wood furniture, etc. Over 3000 hard-to-find specialty items. Send for your big new 80-page catalog. **MEISEL HARDWARE SPECIALTIES.** \$2.00. *Circle No. 401.*

WOODWORKERS—Send for our color catalog with many exciting new plans available. Six styles of bed plans such as 2 Car Beds, Gingerbread Bed, Futon Sofa, Lounge and Bunk/Sofa Combo. New designs in lawn furniture are Adirondack Tete-A-Tete, Patio Rocking Glider, Small Garden Wishing Well, Bird Feeders and Bird Houses. We have added a Doll Cradle, Baby Cradle, Toddler Caster Horse and a variety of craft items. Full size templates, material list, instructions and cutting diagram. **SPECIALTY FURNITURE DESIGNS**. \$2.00. *Circle No. 445.*

WOOD TOY PATTERNS—Patterns for all ages including children's patterns and executive toys. New catalog has many new patterns to choose from including parts and wheels. Send for new catalog today. **TOYS AND JOYS**. \$1.00. *Circle No. 465.*

LUMBER

QUALITY EXOTIC LUMBER/TURNING WOODS—We offer a comprehensive selection of fine quality exotic woods. Also available are mechanisms for making wooden barrel pens/pencils/roller balls/fountain pens. Ebony, Kingwood, Tulipwood, Snakewood, African Blackwood, Cocobolo, Bloodwood, Figured Maple, Spalted Maple, Padauk, etc. Unique and unusual turning woods and burls are also available. Send for catalog. **BEREA HARDWOODS**. \$1.00. *Circle No. 510.*

ONE STOP WOOD SHOP—Domestic and exotic hardwood plywood and lumber, marine plywood, over 30 species in stock—all under one roof. Custom cutting services to your exact specifications with little or no waste at competitive prices! We specialize in bundling and shipping. Send for catalog. **BOULTER PLYWOOD CORP.** Free. *Circle No. 512.*

LUMBER & VENEERS—The finest selection in the USA! Constantine's 120-page catalog features imported and domestic hardwoods, turning squares, carving blocks, magnificent veneers in more than 80 different species. Everything from Ash to Zebrawood—walnut, rosewood, Gaboon ebony, cocobolo, padauk, maple, holly, purpleheart, bubinga, oak, cherry, poplar, mahogany and more. **CONSTANTINE'S**. \$1.00. *Circle No. 515.*

STEVE H. WALL LUMBER CO—Quality hardwoods and woodworking machinery for the craftsman and educational institutions. 16-page catalog lists 17 species of popular hardwoods at wholesale prices. Also dealers for MiniMax, Freud and ProCut woodworking machines. **STEVE H. WALL LUMBER CO**. \$1.00. *Circle No. 592.*

EXOTIC IMPORTED AND DOMESTIC HARDWOODS—Over 75 species of lumber, bowl blanks, turning squares and veneer. Samples ($\frac{1}{2}$ " x 3" x 6") ideal for craftsmen, furniture and cabinet makers, architects, and designers available. Catalog provides common and botanical name, source, and description of each wood. Send for catalog. **WOODWORKERS SOURCE**. \$1.00. *Circle No. 598.*

VIDEOS

LAGUNA TOOLS VIDEO—Learn why most European workshops are using a central machine center rather than separate machines. 90 min. video presentation of "The Intelligent One Man Shop, The Robland X 31". Send for video. **LAGUNA TOOLS**. \$6.00. *Circle No. 615.*

GENERAL WOODWORKING CATALOGS

WOODWORKER'S CATALOG—Constantine really knows lumber and tools—they've been in the business since before you were born! 120-page catalog of imported and domestic woods, veneers, carvings, moldings, tools, jigs, finishes, hardware and more—all backed by a 60-day money-back guarantee and 182 years' experience! 2 year subscription. **CONSTANTINE'S**. \$1.00. *Circle No. 820.*

THE WOODTURNERS CATALOG—48 color pages of the finest woodturning tools, machinery and supplies available. Featuring Henry Taylor, Sorby, Richard Raffan and Dale Nish workshops. Catalog price refunded with order. **CRAFT SUPPLIES USA**. \$2.00. *Circle No. 830.*

MASTER TOOLS CATALOG—1994-95 236-page master woodworking tools catalog. Full line of the best hand tools, power tools & accessories, machinery, glues, finishing supplies, workbenches, and much more. Hundreds of books included. All four-color. Lots of technical information. **GARRETT WADE CO**. \$4.00. *Circle No. 855.*

GRIZZLY IMPORTS, INC.—1994 is our 11th year of providing woodworkers with an incredible selection of machines, tools and accessories at prices you can afford. Send for your free 1994 catalog today and celebrate with tremendous savings on all your woodworking needs. **GRIZZLY IMPORTS INC.** Free. *Circle No. 860.*

MINI POWER TOOL CATALOG—Designed for easy reference, Ryobi's "shirt pocket" Power Tool Catalog includes our complete line of power tools, categorized by type: bench top, cordless, hand-held and stationary models. It features individual tool photographs with specifications and clear descriptions that offer specific uses and benefits. Accessories are also listed. Send for catalog. **RYOBI**. Free. *Circle No. 925.*

WOODWORKING CATALOG—48-page full-color catalog of top quality woodworking machines and supplies. See the American made tools! Total Shop is bringing production home. Many tools now made in the U.S.A. Dust collectors, table saws, lathes, drills, you name it we have it. Catalog free! **TOTAL SHOP**. Free. *Circle No. 940.*

COMPLIMENTARY TOOL CATALOG—Woodcraft offers over 4,000 of the finest quality woodworking tools, books, supplies, and cabinet hardware in our complete full color catalog. Craftsmen, cabinetmakers, carvers, woodturners, and hobbyists have depended on Woodcraft since 1928. Backed by Woodcraft's unconditional guarantee. Free technical assistance. **WOODCRAFT SUPPLY CORP.** Free. *Circle No. 955.*

WOODWORKER'S HARDWARE—offers a free 192 plus page catalog of cabinet and furniture hardware. Products stocked include knobs, pulls, hinges, drawer slides, lighting, entertainment center hardware, kitchen cabinet accessories, abrasives, adhesives, and more. All orders shipped the next business day after they are received. **WOODWORKER'S HARDWARE**. Free. *Circle No. 960.*

THE WOODWORKERS' STORE CATALOG—New! The Woodworkers' Store 1994/95 catalog with hundreds of new items features 112 full color pages of domestic and exotic hardwoods, veneers, wood parts, specialty hardware, kitchen accessories, finishing supplies, tools, books, and plans... Many exclusive items and hard to find specialties. Orders shipped in 24 to 48 hours. Toll free ordering. Over 40 years in business! Satisfaction guaranteed. Catalog. **THE WOODWORKERS' STORE**. Free. *Circle No. 965.*

KITS

OUR QUEEN ANNE FURNITURE KITS—are ready to assemble and finish. They include dining room table, chairs, hutch, sideboard, a variety of occasional tables, and a personal desk. All are made in solid cherry, oak, walnut, and mahogany. We also stock individual Queen Anne legs for every project. Complete information in our brochure packet. **ADAMS WOOD PRODUCTS**. Free. *Circle No. 1002.*

BANDSAW GUIDES AND GUIDE CONVERSION KITS—Brochure and Technical Bulletin describe bandsaw guide models featuring all-ball-bearings or support blocks. Three sizes of each model fit most saws 14" and larger. Also offered are conversion kits for popular saws and a complete line of mounting brackets and studs. **CARTER PRODUCTS CO., Inc.** \$1.00. *Circle No. 1010.*

COLONIAL TIMES CLOCK COMPANY CATALOG—Create your own family heirloom from one of our 15 styles of pre-cut machine-sanded grandfather clock or wall clock kits complete with all the necessary hardware. We also carry a complete selection of weight-driven and keywound movements, dials and accessories. **COLONIAL TIMES CLOCK COMPANY**. Free. *Circle No. 1015.*

SHIP MODELING CATALOG—Historic Ship Models—Museum quality replicas you build yourself. Pre-cut wooden parts, metal and brass fittings, cloth sails, plans and instructions. Send for 80 page color catalog. **MODEL EXPO, INC.** \$1.00. *Circle No. 1075.*

BUCKBOARD BENCH KIT—Kit includes, steel springs that give a little, metal arms and back rails, hardware, and complete instructions. Also available kit with oak parts cut to size. Send for information. **THE ROUEBUSH CO.** 50¢. *Circle No. 1085.*

PUBLICATIONS

WOODWORKER'S LIBRARY—Check Constantine's catalog for the best selection of how-to books, plans and videos, plus tools, woods, hardware and finishes—all backed by a 60-day money-back guarantee and Constantine's 182 years of experience! 2 year subscription. **CONSTANTINE'S**. \$1.00. *Circle No. 1115.*

FREE WOODWORKING BOOKS!!—Get a FREE woodworking book with the money-saving joining offer from Woodworker's Book Club. After you join, you have NO OBLIGATION to buy any more books. As a member, you'll get reviews of more than 100 of the newest and best woodworking books each month—every one discounted from 15 - 50%! Plus your satisfaction is guaranteed 100% on every book you buy. See our full page ad in this issue or send for FREE information. **WOODWORKER'S BOOK CLUB**. Free. *Circle No. 1175.*

SHOP ACCESSORIES

ECON-ABRASIVES—manufactures abrasive belts up to 52" wide in any grit. We carry hundreds of woodworking related accessories including: Velcro® backed discs, bar clamps, wood glue, drawer slides, chisels, hinges and hundreds of sanding accessories. Send for our 1992 catalog. **ECON-ABRASIVES**. Free. *Circle No. 1229.*

EASY DOES IT—with HTC'S power tool accessories. Discover many unique items, designed only with you, the dedicated woodworker, in mind. Make your machinery safer, increase the working area of your shop and accomplish nearly impossible tasks easily, quickly, accurately. Full-line catalog and price list. **HTC PRODUCTS, INC.** Free. *Circle No. 1245.*

WOOD MOISTURE METER—Avoid moisture defects such as cracking, warping, splitting, delamination. The pin-type moisture meter "Mini-Ligno" can read surface or core moisture in any thickness of lumber, from veneer through heavy timbers. A flat surface is not necessarily required, thus the Mini works on rough sawn lumber and curved or round pieces. A most versatile instrument. Many hobbyists and professionals use the Mini-Ligno C or E/C with attachments to monitor lumber during air or kiln drying or use external electrode for depth readings. Catalogue describes complete line of moisture meters. **LIGNOMAT USA, LTD.** Free. *Circle No. 1250.*

ROUTER SPEED CONTROL—Reduces speed electronically without reducing torque. Route at the speed that gives best results with the wood and bit you are using. Speed adjustable from full speed to 0 RPM. Less tear out—stops burning—less wear on bits—easy to use. Send today for information. **MLCS LTD.** Free. *Circle No. 1251.*

LUMBER DRYING—Dry your own lumber using our equipment and your insulated chamber. Dehumidification systems from 300 BF to 45,000 BF. Easy to operate equipment offers high quality kiln-dried lumber for pennies per foot. These long-lasting made-in-the-USA units can pay for themselves in one month! Send for free catalog. **NYLE STANDARD DRYERS, INC.** Free. *Circle No. 1260.*

SUPERGRIT® SANDING/REFINISHING CATALOG & CLOSE-OUT SHEET—Belts (aluminum oxide, silicone carbide zirconia), discs (plain, PSA, Hook & loop vacuum), sheets (cabinet, crocus, emery, non-loading, waterproof), rolls (cloth, hol, drum sander, PSA), bowl turning & lathe supplies, dust masks, scuff pads, tack cloths, tape. **RED HILL CORP.** Free. *Circle No. 1267.*

"WOOD-FRIENDLY"™ L606 MOISTURE METER—uses advanced electromagnetic wave technology to accurately measure wood moisture content from 6% to 30% to a depth of $\frac{3}{4}$ ". No pins to "abuse" wood and leave ugly holes. Check out boards from top to bottom in just seconds before you buy and avoid the headaches of splitting, warpage, delaminating and failed glue joints. The Wagner L606's convenient pocket size, easy-to-read analog meter, and low price make it a must for anyone working with wood. Literature. **WAGNER ELECTRONIC PRODUCTS, INC.** Free. *Circle No. 1285.*

BITS, BLADES, CUTTING TOOLS

ASK FOR CMT'S CATALOG AND WE'LL GIVE YOU \$5!—CMT Tools will send you our free, full-color router bit catalog and we'll give you a \$5.00 discount on your first order! CMT bits feature anti-kickback design, Teflon coatings and micrograin carbide cutting edges. Our catalog is packed with accessories, project ideas and safety tips—it's one catalog you'll want to keep! **CMT TOOLS, INC.** Free. *Circle No. 1310.*

CASCADE TOOLS—The 1993 Cascade Tools catalog is the finest ever. It's jammed with great buys on SY brand industrial-grade router bits, shaper cutters and an excellent assortment of hard-to-find accessories. You'll have to see it to believe it. **CASCADE TOOLS, INC.** Free. *Circle No. 1315.*

ENLON IMPORT CORP.—Check out n' Save. We offer a wide selection with over 100 varieties of professional quality carbide tipped router bits & shaper cutters with irresistible prices. find out yourself. Catalog. **ENLON IMPORT CORPORATION**. Free. Circle No. 1318.

1995 EAGLE AMERICA WOODWORKING CATALOG—Top Quality American Made cutting tools featuring over 850 router bits. Plus the largest selection of American Made saw blades, shaper cutters, forstners, rosettes, brad points and more. Over 2,000 unique and hard to find tools and accessories. **EAGLE AMERICA CORP.** Free. Circle No. 1320.

FREUD—Premier line of carbide-tipped sawblades, router bits, shaper cutters and other woodworking tools. Freud offers a full-line on anti-kickback carbide-tipped router bits. Send for a free new router bit catalog. **FREUD**. Free. Circle No. 1321.

SUPER-SMOOTH, EXTRA-DURABLE, CARBIDE-TIPPED CIRCULAR SAW BLADES—Get a smooth-sanded surface with our all-purpose 40-tooth Woodworker Blade. You will be able to rip and cross-cut 1 - 2 in. rock hards and soft woods with an unbelievably smooth finish. You will also be able to cross-cut oak and birch ply-veneers with no bottom splinters. Send today for our information pack. **FORREST MFG. CO., INC.** \$1.00. Circle No. 1322.

PRODUCTION QUALITY CARBIDE TIPPED ROUTER BITS—Large discounts. New expanded catalog featuring a huge selection of Carbide Tipped Router Bits, Raised Panel Door Sets, Shaper Cutters, Solid Carbide Bits, The Router Speed Control, plus our unique line of clamps, tools and supplies. Save 50% to 70%. Value, quality, and prompt service guaranteed! **MLCS LTD.** Free. Circle No. 1350.

HARDWARE/ WOOD PARTS

HARDWARE CATALOG—A unique 48-page catalog of the very finest in classic, traditional solid brass cabinet hardware. All of British or No. American manufacture. Double & single post handles, knobs, escutcheons, standard & specialty hinges, box hardware, brass screws, castors, latches, catches, locks, and more. **GARRETT WADE CO.** \$3.00. Circle No. 1427.

INCOME OPPORTUNITIES

MAKE MONEY IN FURNITURE RESTORATION THE MINUTEMAN WAY—Earn \$200-\$1000 per day stripping, repairing, refinishing, mirror resilvering, and/or veneering, at home or in shop, spare time or full time. We provide complete training; no experience necessary. Free workshop teaches you latest in furniture restoration. You have to see it to believe it! Business preview video \$19.95. Send for catalog. **MINUTEMAN**. \$2.00. Circle No. 1661.

MISCELLANEOUS

PUT A DRESSER UNDER ANY BED!—Up to 16 large drawers. Fits all beds, solid wood construction, dust proof, cedar partitions, ball bearing drawer slides, long center storage. Beautiful, economical, space saving storage. Shipped UPS. 32-page catalog. **ANDERSON MFG. CO.** \$1.00. Circle No. 1795.

MECHANISMS FOR MAKING WOODEN BARREL PENS—Pencils/Roller Ball Pens/Fountain Pens. High quality. Low prices. Whole-sale/Retail. Plus other related items. **BEREA HARDWOODS CO.** \$1.00. Circle No. 1900.

LOOKING FOR PIERCED TIN? COME TO THE SOURCE!—70+ page color highlighted catalog introduces you to a treasury of pierced metal panels affordably priced and ready to install in your woodworking projects. Available in a wide variety of sizes, 16 different types of metal (copper & brass, tool) & over 300 designs. Custom size & design a specialty. OR all the materials and tools needed to create it yourself. Catalog includes furniture plans you can order, lantern kits, specialized metal piercing tools and MORE. **COUNTRY ACCENTS**. \$5.00. Circle No. 1910.

HOW TO DRILL YOUR OWN WATER WELL—Free! Big information package, including "How to Drill Your Own Water Well" booklet. There's no limit to the wonderful things you can do when you have your own private water system and no water bills. Learn how over 100,000 home water wells have been drilled this easy, low-cost way since 1962. Video also available. **DeepRock MFG. CO.** Free. Circle No. 1915.

DELPHI STAINED GLASS—80-page color catalog of stained glass and related supplies. Beveled glass,

hard-to-find tools, hundreds of unique patterns, kits, books, videos, and lots more. For 18 years, we've supplied both hobbyists and professionals with quality products, friendly advice, and fast 24-hour shipping. All products guaranteed 100%. **DELPHI STAINED GLASS**. \$4.50. Circle No. 1920.

ROLL-TOP COVER—QUICK & EASY! The Roll-Top Cover instantly rolls out to keep contents dry and secure. When not required it rolls into its small 9 1/2" storage canister for carrying tall loads. The full length handle can be easily operated with one hand from either side of the truck. Send for brochure. **PACE-EDWARDS CO.** \$1.00. Circle No. 1985.

SALTER INDUSTRIES—Salter Industries manufacture high quality spiral stairs to meet the design needs of today. Oak and brass options are available to combine with a sturdy steel main frame. Stock or custom stairs range in diameter from 3'6" to 7'. Brochure. **SALTER INDUSTRIES**. \$1.00. Circle No. 1995.

STEELMASTER BUILDINGS—are available in almost any size for almost any use. From 10' to 100' wide and any length imaginable. Whether you need a back yard shop... an industrial shop... equipment storage building... whatever your requirements, you'll find a Steelmaster that's just the right size for the job. Our buildings are so easy to construct, most owners opt to construct their buildings themselves which adds up to even bigger savings. Send for information. **STEELMASTER**. \$1.00. Circle No. 2030.

IF YOU ARE INTERESTED IN RESTORING ANTIQUES—this 272-page catalog packed with unusual, hard-to-find items is just for you. Included are hundreds of essential items for antique restoration including top quality brass reproduction hardware, oil lamps and accessories, numerous wood component repair parts and kits, caning and basketry supplies, everything needed for wood refinishing, related tools, books, and a complete line of upholstery equipment and supplies. All at wholesale prices. Send for this informative catalog. **VAN DYKE'S RESTORERS**. \$1.00. Circle No. 2077.

LEGAL IVORY—Virtually identical to animal ivory. Tagua is the nut from a tropical palm tree. Ideal for jewelry, knobs, small turnings, inlay, or scrimshaw. Available in 3 sizes. Send for information. **WOODWORKERS SOURCE**. Free. Circle No. 2090.

***THE WOODWORKING SHOWS* MACHINERY, TOOLS AND SUPPLIES**—Hundreds of products for the woodworker demonstrated and sold at discount prices at every "Woodworking Show". In-depth seminars and free workshops on a variety of woodworking topics. Shows are scheduled in 27 cities. Send for

free brochure. **"THE WOODWORKING SHOWS"**. Free. Circle No. 2095.

CARVING SUPPLIES

WOOD CARVING MACHINES AND ACCESSORIES—make all types of wood carving easy, fun and profitable. The machines do the work. Whether for sign carving, flat 3-D, decoys, panels, gun stocks or furniture, we have the proper machine for the job. Professional woodcarving for the hobbyist and superior quality for the professional. Begin your hobby or full or part-time business by ordering our catalog and price list. **MARLIN INDUSTRIES**. \$1.00. Circle No. 2150.

CLAMPS

CLAMPS AND VISES—New 6-page, full-color catalog features clamps, vises and accessories for both the professional and the hobbyist. All products made in U.S.A. Send for catalog. **WARREN TOOL GROUP**. \$2.50. Circle No. 2185.

MERLE ADJUSTABLE CORNER CLAMP—Quick & easy to use. It forces your work into square. Fully adjustable from 2 1/2" x 2 1/2" to 69" x 69" in. Perfect for clamping picture frames, cabinets, or anything that requires 90° corner clamping. The Merle Clamp is cast aluminum & steel construction, a true industrial quality tool. Send today for information. **MLCS LTD.** Free. Circle No. 2250.

CLOCKS

KLOCKIT'S FREE 64-PAGE COLOR CATALOG—is packed with the largest selection of beautiful wood clock kits for all skill levels, a huge selection of quartz and mechanical clock movements, dials and accessories, turned wood parts, music movements, tools and much more for the craftsman! **KLOCKIT**. Free. Circle No. 2335.

FASTENING PRODUCTS

SQUARE DRIVE SCREWS—Thousands agree—once you try them you will never want to use anything else! The square drive recess virtually eliminates work-damaging driver bit "cam-out," the deep threads result in exceptional holding power, and they are heat treated for strength. Sizes from #4 x 3/8" to #12 x 4", with stainless steel, solid brass, brass plated, and zinc plated available. Quantity discounts. Send for literature. **McFEELY HARDWOODS**. \$1.00. Circle No. 2450.

WOODWORKER'S RESOURCE

TO ENSURE PROMPT HANDLING OF YOUR ORDER FOLLOW THESE INSTRUCTIONS:

- Circle your choice
- Enclose check or money order for cost of booklets plus \$2.00 service charge (no stamps accepted)
- NO FOREIGN ORDERS ACCEPTED
- Send coupon and remittance to address above
- ALLOW 4-6 WEEKS FOR DELIVERY
- Coupon expires October 11, 1995

WOOD SUBSCRIPTION

A 1 year WOOD subscription (9 issues) for \$25.00 (U.S. price)—a \$19.55 savings off newsstand rate (Circle No. 4000). Allow 6-8 weeks for first issue. Be sure to include payment with total below. NO FOREIGN ORDERS ACCEPTED ON THIS COUPON; please contact Subscription Dept. directly.

Circle numbers below corresponding to items in this issue. Please include \$2.00 for handling charge.

3.....\$2.00	77.....Free	374.....\$8.95	830.....\$2.00	1115.....\$1.00	1321.....Free	2077.....\$1.00
6.....\$3.00	78.....\$1.00	375.....\$12.50	855.....\$4.00	1175.....Free	1322.....\$1.00	2090.....Free
15.....Free	84.....Free	376.....\$8.50	860.....Free	1229.....Free	1350.....Free	2095.....Free
18.....Free	86.....Free	401.....\$2.00	925.....Free	1245.....Free	1427.....\$3.00	2150.....\$1.00
20.....\$1.00	92.....\$1.00	445.....\$2.00	940.....Free	1250.....Free	1661.....\$2.00	2185.....\$2.50
35.....Free	94.....\$2.00	465.....\$1.00	955.....Free	1251.....Free	1795.....\$1.00	2250.....Free
37.....\$1.00	110.....\$1.00	510.....\$1.00	960.....Free	1260.....Free	1900.....\$1.00	2335.....Free
44.....Free	160.....\$1.00	512.....Free	965.....Free	1267.....Free	1910.....\$5.00	2450.....\$1.00
48.....\$1.00	190.....\$1.50	515.....\$1.00	1002.....Free	1285.....Free	1915.....Free	4000.....\$25.00
49.....Free	210.....\$1.00	592.....\$1.00	1010.....\$1.00	1310.....Free	1920.....\$4.50	
57.....Free	315.....\$1.00	598.....\$1.00	1015.....Free	1315.....Free	1985.....\$1.00	
75.....Free	345.....\$3.00	615.....\$6.00	1075.....\$1.00	1318.....Free	1995.....\$1.00	
76.....Free	373.....\$9.95	820.....\$1.00	1085.....50c	1320.....Free	2030.....\$1.00	

Name (please print) _____
 Address _____
 City _____
 State _____ Zip Code _____
 Phone (Optional): _____

I AM ENCLOSING:
 \$ _____ for priced items
 \$ 2.00 for handling
 \$ _____ total remittance

GREAT IDEAS FOR YOUR SHOP

Cut large panels safely with our SHEET GOODS SUPPORT RACK

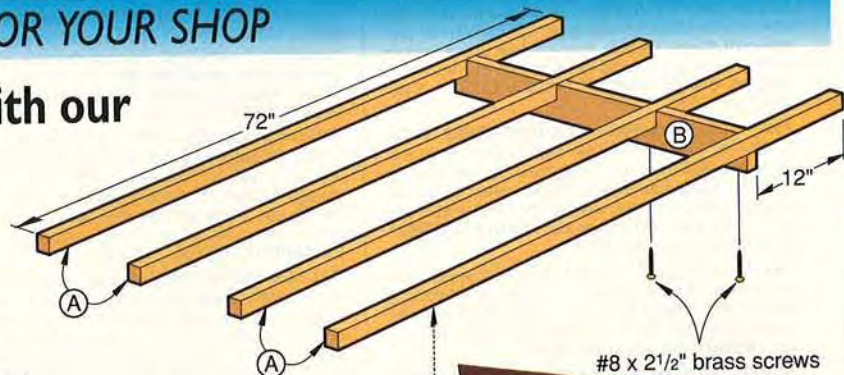

Build and use this handy helper and you'll never again

worry about plywood off-cuts crashing to the ground. Just put your workpiece on the rack, set your circular-saw blade about $\frac{1}{8}$ " deeper than the thickness of the sheet goods, and cut. Fasten all the pieces with brass screws—should you nick one, the soft brass won't damage your sawblade as steel screws would. When you're done, the rack stores easily on a wall. ♣

Project Design: Jim Downing
Photograph: Bill Hopkins, Jr.
Illustration: Roxanne LeMoine

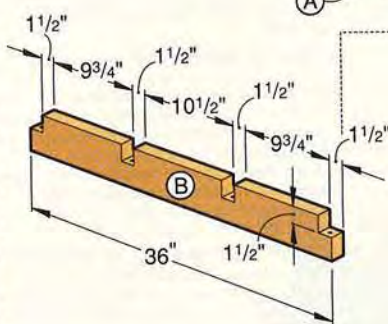

#8 x 2 1/2" brass screws



BILL OF MATERIALS

A—1 1/2 x 1 1/2 x 72" (4 pieces)

B—1 1/2 x 3 1/2 x 36" (2 pieces)

Print this article



SAVE BIG!

Manufactured exclusively for us, you can rest assured that you're buying the best value—**NO ONE CAN TOUCH US!**



SALE!
\$725.00
Reg. \$795.00

3 H.P. Shaper (G1026)

- 3 interchangeable spindles: 1/2", 3/4" and 1"
- Heavy-duty all-steel miter gauge with full-length bar
- Cast iron wing
- Solid, polished cast iron table top
- Table with standard wing attachment measures 28 7/8" x 28"
- Large steel handwheels for easy adjustment
- Magnetic safety switch
- Shipping weight: approx. 400 lbs.

1-800-541-5537

P.O. BOX 2069, BELLINGHAM, WA 98227
Customer Service (206) 647-0801 FAX (800) 225-0021
WEST OF THE MISSISSIPPI



SALE!
\$795.00
Reg. \$850.00

10" Tilting Arbor Super Heavy Duty Table Saw (G1023)

- 3HP Motor, 220V
- Precision ground solid cast iron table and wings
- Steel miter gauge
- Heavy-duty lever lock rip fence
- T-slots for miter gauge attachment
- Extra-large steel handwheels
- Magnetic safety switch
- Shipping weight: approx. 450 lbs.

ALL MACHINES ARE F.O.B.
BELLINGHAM, WA OR WILLIAMSPORT, PA



SALE!
\$425.00
Reg. \$495.00

1 1/2 H.P. Shaper (G1035)

- 2 interchangeable spindles: 1/2" & 3/4"
- Table size 20" x 18"
- Precision-ground, cast iron table
- Dual speed, reversing motor
- 2 independently adjustable 2 1/2" x 10" fences
- Shipping weight: approx. 300 lbs.

1-800-523-4777

2406 REACH ROAD, WILLIAMSPORT, PA 17701
Customer Service (717) 326-3806 FAX (800) 438-5901
EAST OF THE MISSISSIPPI



Eliminate Hand Sanding, Sawing, Scraping, & Polishing



With the Fein "Triangle" Sander, time consuming, sore finger, bloody knuckle sanding, sawing, scraping & polishing are a thing of the past.

Imagine using a power tool to sand all those areas where before, you had to fold up a piece of paper and "finger sand." With the Fein "Triangle" Sander, you can sand right up to, into and along edges & corners without dulling the edge or altering the profile. Plus, the Fein Sander won't run away from or bounce off of the edge line.

But It Will Do More Than Just Sand

You can remove the triangle pad and replace it with a special circular saw blade. The saw blade is only 1/32" thick, and perfect for detail work.

NEW Scraper Blade

Great for scraping off old paint, removing glue from tiles & rugs. It even cuts through old hardened caulk. You won't have to tape your knuckles to scrape with the Fein Scraper Blade.

NEW Polishing Pad

Put a mirror polish on chrome, buff along edges and into corners . . . you name it and the Fein Polishing Pad will put a shine on it.

It's easy to get more information, simply call:
(800)441-9878



FEIN Power Tools Inc.
3019 W. Carson St
Pittsburgh, PA 15204
(412)331-2325

©Fein Power Tools, Inc. 1994

Circle No. 37



Build this Adirondack furniture with our easy to follow instructions, material list, cutting diagram and FULL SIZE TEMPLATES
New Adirondack Tete-A-Tete \$12.95
Adirondack Chair 10.95
Adirondack Footstool 4.95

Specialty Furniture Designs

797 W. Remus Road, Dept. 25
Mt. Pleasant, MI 48858 • 1-800-892-4026
Color Catalog \$3.00, free with order. Visa/MC/Disc MI add 6%

Circle No. 445

YOU DESERVE QUALITY HARDWOODS

Order an advantage pack today!

25 Board ft., 30"-60" long, 4"-10" wide, surfaced 2 sides to 13/16", clear one face

Cherry	\$79	Poplar	\$55
Red Oak	\$76	Hard Maple	\$72

Thin Stock Packs Also Available

We pay UPS shipping to most destinations in the Eastern time zone, other areas slightly higher. Discover, Visa/MC Accepted. Free catalog w/ order.

Bristol Valley Hardwoods

4300 Rt 64, Canandaigua, NY 14424
1 (800) 724-0132 (ext. 11)

Circle No. 513

Wake Up Energized!

Enjoy the ultimate in sleeping comfort. Select Comfort supports your entire body on a cushion of air that gives you the firmness you want at the touch of a button.



Select Comfort's patented air design conforms to your body shape for relaxing sleep and perfect spinal support.



With Select Comfort, you each get exactly the firmness you need.

Studies prove our exclusive air design supports your spine more evenly than metal coil mattresses or waterbeds. And because Select Comfort has no springs to wear out and sag, we can offer you one of the longest warranties in the bedding industry - 20 years.

Why Not Feel For Yourself?

With our 90 Night No-Risk Trial, you

can sleep on it for three months before you decide. For more information, call toll-free or return the coupon below.

Variable Firmness: A Comfort Breakthrough.

Dual air chambers inside the mattress can each be made firmer or softer, so you each get the exact support you need.



The Only Mattress with Push Button Firmness Control.



Call For Store Nearest You

1-800-831-1211

Please send me a FREE Video, Brochure and Price List.

Name _____
Address _____
City _____ State _____
Zip _____ Phone _____

Mail to: Select Comfort Corporation
6105 Trenton Lane N., Minneapolis, MN 55442
Dept 2991

12" PLANER/MOLDER



CASTERS OPTIONAL

Using the Belsaw 12" Planer/Molder by Powermatic, you can turn rough lumber into valuable moldings. You can even earn extra money selling these profiles to contractors or cabinet shops. Also, substantial savings can be realized by milling the trim for your home. Call today for more information and the authorized Belsaw by Powermatic distributor nearest you!

POWERMATIC®

McMinnville, TN 1-800-248-0144

Here's the one thing Belgians don't waffle on.



90 Minute Demo Video Available

Ask Us About Financing

The Robland X31 is as welcomed in European workshops as a home run in the World Series. We put together a 12" jointer, 12" planer, 10" table saw, 50" sliding table, and a shaper with a mortiser. No cheating. No compromises. Some 1100 lbs. of cast iron stability, with three separate 3HP motors. It stays put. It stays true. And it stays neatly in a little corner of your shop.

That's why Belgians call the Robland X31 The Intelligent One Man Shop. About the only thing you can't make on it is breakfast.

LAGUNA TOOLS

(800) 234-1976 (714) 494-7006

2265 Laguna Canyon Road, Laguna Beach, CA 92651

Circle No. 615

Breathe Cleaner Air In Your Shop

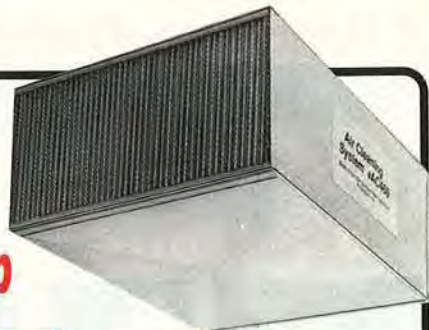

**Model #AC460
Air Cleaning System
Only \$279.00 (UPS \$12)**

Features of the AC460 Include:

- A washable pre-filter that captures most of the dust.
- A high efficiency 12"x 24"x 15" internal bag filter that captures 98% of particles 3 microns or larger and captures particles as small as .3 microns.
- Quality Construction: Durable galvanized steel housing. The filters easily clip in and out of the filter housing.

Woodworker's Journal: Jan. 1994

- Product Review "The Penn State Air Cleaning System will help keep your shop environment pleasant and healthy."

Popular Woodworking: Jan. 1994

- Readers Choice Award Winner "Innovative Safety"

Wood Magazine: Sept. 1994

- Selected for "Idea Shop 2"

Combat the hazards of airborne sawdust in your work and living environment with the new high-efficiency AC460 Air Cleaning System.

This powerful 460 CFM system will completely filter and recirculate the air in a typical 20'x 20'x 8' shop over 8 times every hour.

At only 40 lbs., the AC460 can be easily mounted, placed strategically in your shop, or transported to the job-site.

PENN STATE INDUSTRIES

800-377-7297

(Department W)

2850 Comly Rd. • Phila., PA 19154

VISA, Master & Discover Cards Accepted
Call or Write for 32 pg. Color Catalog

Circle No. 75, 76, 77

For Our New Catalog Please Call 1-800-786-5626

TRUE VALUE & TRUE QUALITY



OVER 150 DIFFERENT WOODWORKING MACHINES AVAILABLE



LOBO POWER TOOLS



Orders Only:

(800) 786-5626

Chicago:

(219) 794-9255

Atlanta:

(404) 416-6006

Main Office:

9031 E. Slauson Ave.

Pico Rivera, Ca. 90660

(310) 949-3747



Circle No. 57



HOME PLANNERS LIBRARY

1-800-322-6797



SAVE OVER 40%

BOOKS & BLUEPRINTS FOR YOUR NEW HOME

COUNTRY



1 200 country designs from classic to contemporary by 7 winning designers. 224 pages \$7.95

BUDGET-SMART



2 200 efficient plans from 7 top designers, that you can really afford to build! 224 pages \$7.95

MOVE-UP



3 200 stylish designs for today's growing families from 7 hot designers. 224 pages \$7.95

NARROW-LOT

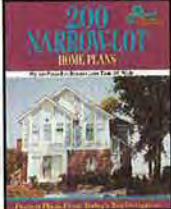

4 200 unique homes less than 60' wide from 7 designers. Up to 3,000 square feet. 224 pages \$7.95

ENCYCLOPEDIA



5 500 exceptional plans for all styles and budgets—the best book of its kind! 352 pages \$9.95

DECKS



6 25 outstanding single and multi-level deck plans you can build or contract yourself. 112 pages \$7.95

LANDSCAPES



7 40 fabulous front yards. 208 pages \$12.95
8 40 beautiful back yards. 160 pages \$12.95

MOST POPULAR



9 400 of our customers' favorite, proven plans in a variety of styles. 272 pages \$9.95

AFFORDABLE

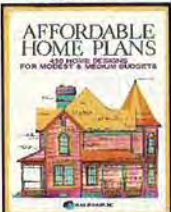

10 403 cost-saving plans specially selected for modest to medium building budgets. 320 pages \$8.95

LUXURY



11 154 fine luxury plans—loaded with luscious amenities! 192 pages \$14.95

ONE-STORY



12 470 designs for all lifestyles. 860 to 5,400 square feet. 384 pages \$8.95

TWO-STORY



13 478 designs for one-and-a-half and two stories. 1,200 to 7,200 square feet. 416 pages \$8.95

VACATION



14 258 designs for recreation, retirement and leisure. 256 pages \$5.95

MULTI-LEVEL



15 312 designs for split-levels, bi-levels, multi-levels and walkouts. 320 pages \$6.95

CONTEMPORARY

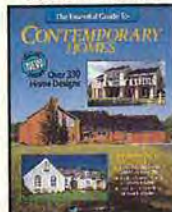

16 Revised! 341 sleek, modern designs featuring open floor planning. 304 pages \$9.95

TRADITIONAL



17 Revised! 403 elegant, beautiful homes in classic styles with today's amenities. 304 pages \$9.95

NEW ENGLAND

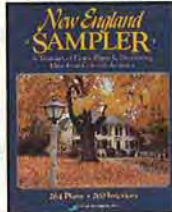

18 260 home plans and 200 decorating ideas from Colonial America. 384 pages \$14.95

VICTORIAN



19 160 striking Victorian and Farm-house designs from three leading designers. 192 pages \$12.95

WESTERN



20 215 designs that capture the spirit and diversity of the Western lifestyle. 208 pages \$8.95

EMPTY-NESTER



21 200 exciting plans for empty-nesters, retirees and childless couples. 224 pages \$6.95

STARTER



22 200 easy-to-build plans for starter and low-budget houses. 224 pages \$6.95

Yes!

PLEASE SEND ME THE DESIGN BOOKS I'VE CIRCLED:

1	2	3	4	5	6	7	
8	9	10	11	12	13	14	
15	16	17	18	19	20	21	22

NOTE!

For maximum savings, order several books at once!

Order any 3 books—DEDUCT \$3
Order any 4 books—DEDUCT \$5
Order any 5 books—DEDUCT \$10
Order 6 or more books—DEDUCT \$15
Order all 22 books pay—JUST \$125

Total Amount.....	\$
Postage & Handling.....	\$ 3.00
New Design Portfolio.....	\$ FREE
Sales Tax (AZ 5% MI 6%).....	\$
Total Enclosed.....	\$

Please remit in U.S. funds

FREE!



Limited Offer!
With any purchase, receive our latest New Design Portfolio absolutely free!

WMM49

AVAILABLE AT LOCAL BOOKSTORES OR ORDER BY CREDIT CARD

CALL TOLL-FREE 1-800-322-6797



MAIL TO:
HOME PLANNERS, INC.
DEPT. BK., 3275 WEST INA ROAD, SUITE 110, TUCSON, AZ. 85741

Miss LIBERTY



A framework for Liberty

Miter-cut four pieces of 1/4"-thick pine 2" wide, to frame the carving. Fit these frame pieces, but do not attach them yet. Transfer the patterns for the top, bottom, and corner ornaments to 3/4" stock. (We used pine.) Scrollsaw them. Cut two of each corner piece, and flip one of each over for the opposite corner.

Sand all of the frame pieces and ornaments to 320 grit, rounding over the corners (except on mating surfaces). Stain the inside faces of the frame to match the textured area on the carving.

Attach the frame to the carving with brads and glue. Let the front edge of the frame stand out about 1/4" from the carving. To do this easily, lay the carving facedown on a couple of 1/4"-thick strips about 11" long as you install the frame pieces.

Set the brads and fill the holes on the outside of the frame. Sand the frame. Then, glue the top, bottom, and corner ornaments to the frame where shown. Clamp with rubber bands. Let dry, then stain the outside of the frame. Apply a clear finish.

Drive two #214 screw eyes into the carving's back, about 3" from the top near each edge. Tie the picture wire between them to hang your masterpiece. ♣

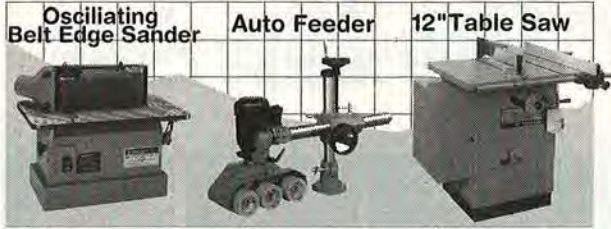
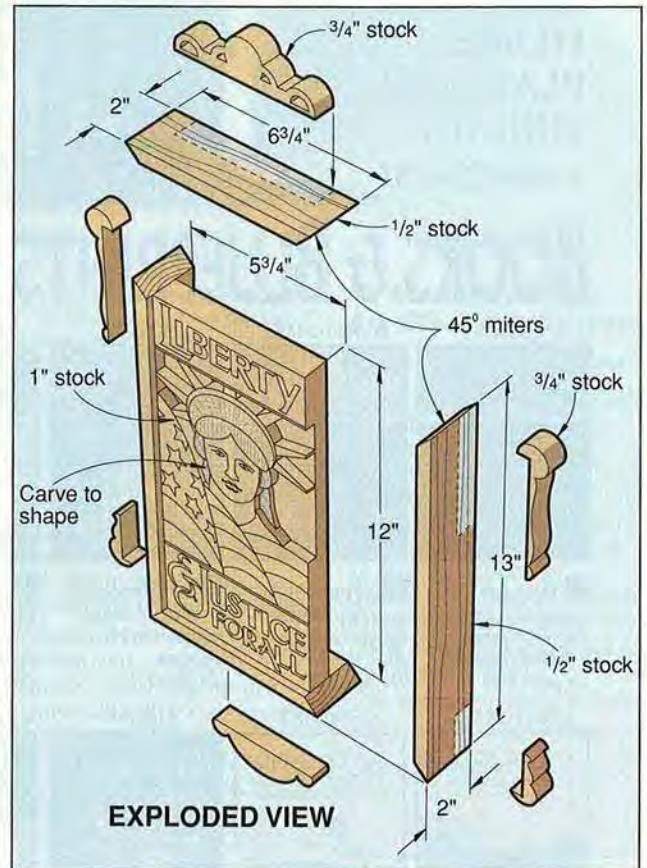

▲ \$165 ▲ \$395 ▲ \$740



▲ \$470 ▲ \$615 ▲ \$285



▲ \$760 ▲ \$1290 ▲ \$1190

TRANSPOWER FOR EXPRESS NEW CATALOG CALL **1-800-654-7702 818 333-7701**

C.P.Tools, Inc 14257 E.DonJulian Rd., Industry, CA. 91746

Econ-Abrasives

WE MAKE ABRASIVE BELTS ANY SIZE, ANY GRIT!

Standard Abrasive Sheets

CABINET PAPER		
	50/pk	100/pk
60D	\$15.00	\$27.00C
80D	14.00	25.00C
100 thru 150C	13.00	23.00C
FINISHING PAPER		
80A	\$ 10.00	\$17.00C
100 thru 280A	9.00	15.00C

NO LOAD PAPER(white)
100 thru 400A \$11.00 \$19.00C
"C" = 100 SHEETS

Velcro® Vacuum Discs
8 Hole pattern for Bosch sanders

Dia.	Grit	Price
5"	60	\$.48ea
5"	80	.46
5"	100 thru 320	.45

* OTHER PRODUCTS *

- *Wide Belts*Rolls*Flap Wheels
- *Pump Sleeves*PSA Discs
- *Router & Wood Bits*Wood Glue

ABRASIVE BELTS

PLEASE SPECIFY GRITS

1X30	\$.73 ea	3X24	\$.84 ea
1X42	.73 ea	3X27	.87 ea
1X44	.73 ea	4X21 3/4	.96 ea
2 1/2X16	.77 ea	4X24	.99 ea
3X18	.78 ea	4X36	1.20 ea
3X21	.81 ea	6X48	3.14 ea
3X23 3/4	.84 ea	2 1/4X80	2.94 ea

OTHER SIZES ON REQUEST

HEAVY DUTY SPRING CLAMPS

Clamps come w/PVC tips and grips.

Size	Price
4"	\$1.75 ea
6"	2.25
8"	3.50

JUMBO ROUTER PAD(24" x 36")

It will not allow small blocks of wood to slip out under router or sanding applications. ROUTER PAD ONLY \$8.95ea.

JUMBO BELT CLEANING STICK
ONLY \$8.80

- *MasterCard, VISA, C.O.D. or Check
- *SATISFACTION GUARANTEED!!!
- *CALL FOR FREE CATALOG
- TX & NV add appropriate sales tax
- Continental U. S. shipping add \$5.50

Econ-Abrasives
P. O. Box B865021
Plano, TX 75086
(214)377-9779

TOLL-FREE ORDERING LINE (800) 367-4101

Be a Home Inspector Earnings of up to \$900 per day possible!

Train at home in your spare time...no previous experience needed!

Home inspection is one of the hottest career fields of this decade. Over 60% of all homes sold today are inspected for structural and mechanical defects...banks, mortgage companies and potential home owners want to know about a house before they invest their money. According to ASHI **Home Inspectors throughout the country are charging up to \$300 per job, and many are performing three or more inspections per day.** And there's plenty of opportunity for you to earn this kind of money, because the demand for Home Inspectors exceeds the supply. Once you've gained some experience and established your reputation as a top-notch Home Inspector, it's possible for you to start earning up to \$900 a day!

Only ICS gives you training this practical, this complete. Our unique "Quick-Learn" method enables you to start making money while still training!

You get real-world instruction in all the important areas of home inspection. When you finish your training you'll be a skilled professional, confident in your abilities to deliver thorough "top to bottom" inspections. Step-by-step lessons show you how to inspect basements...crawl spaces...heating and cooling systems...electrical systems...plumbing...interior structure...attics...doors and windows...garages...exterior structure...grounds...appliances and much more. You're also taught about checking for pests, radon gas and other health hazards.

We give you special tools and test instruments to use during your training and later on the job.

These include wire gauges, circuit analyzer, pocket caliper, punch/awl, screwdriver set, high-powered professional flashlight, inspection mirror, binoculars and more. Unlike many home inspection courses, we go beyond the mere technical aspects and teach you how to prepare special forms and reports that document your inspections. You'll be able to provide your customers with clear, detailed reports on your conclusions and recommendations about the property. You'll be amazed at how quickly the word spreads that you are an expert inspector who can be relied upon to deliver top-quality home inspections. Your business will grow by the day as more and more people request your services.

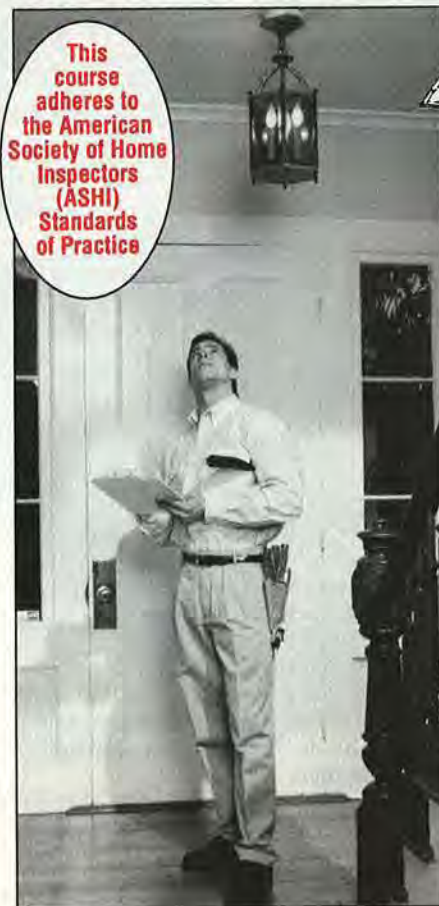

Whether you want a full- or part-time job or want to start your own Home Inspection business, ICS training is the fastest way to get started in this high-paying field.

With ICS you train at home, during the hours you choose. Keep your present job while you train for a better one. Everything is explained in plain English. And our tuition is the lowest of any Home Inspection correspondence course!

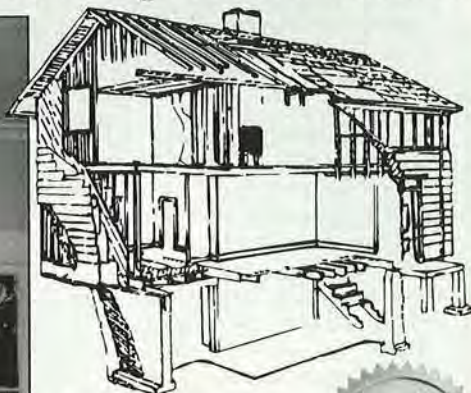

ICS training is nationally accredited.

ICS is a member of the National Home Study Council in Washington, D.C. whose accrediting commission is listed by the U.S. Department of Education as a nationally recognized accrediting agency.



Call Now or Send for FREE information!

We'll send you full information and color literature **ABSOLUTELY FREE.** Everything you'll need to know about our revolutionary Home Inspection Course is explained in complete detail...including all the facts on the opportunities waiting for you in this high-paying career field.

Send Free



MAIL THIS COUPON TODAY FOR FREE FACTS! OR CALL TOLL FREE!
1-800-595-5505 Ext. 5258
Call Anytime—24 hours a day, 7 days a week.



School of Property Management, Dept. A8DS84S
925 Oak Street, Scranton, PA 18515

YES! I want to know how ICS training will help me make more money, start a new career, even get into a business of my own. No obligation and no salesman will visit you.

Name _____ Age _____
Address _____ Apt. # _____
City _____ State _____ Zip _____
Phone (_____) _____

Accredited Member, National Home Study Council

Celebrating 10 Years

of successful partnerships with our readers and advertisers

Dear Reader,

It's hard for me to believe, but this issue marks the 10th anniversary of **WOOD**® magazine, and our dedication to publishing the finest woodworking magazine anywhere. On this occasion, I'd like to personally thank you and the other 2.9 million readers for your loyal support during our first decade. And on behalf of all of us here on the **WOOD** team, I pledge to you our continued efforts in the years ahead.

WOOD magazine has evolved both graphically and editorially over the years, but our dedication to excellence has been a hallmark since the very first issue in September 1984. Our editorial mission has remained the same, too. "Our goal is to create an editorial product that serves the home woodworker better and more broadly than any competing woodworking publication and in more depth and singleness of purpose than the mechanics and how-to magazines. Specifically, it's designed to reach out to woodworkers and supply them with the kinds of ideas, information, and instruction that will help them improve their level of craftsmanship and, in the process, feel good about themselves and their hobby."

It is with this mission in mind that we conceive of, plan, research, write, and present every article that goes into the magazine. And, of course, it's why we shop-test all of the woodworking projects and techniques, and go out of our way to ensure that the information we present is fresh and up-to-date and of practical benefit to you as a home hobbyist woodworker.

Once again, thanks for your past support, and here's to a long, lasting relationship between us.

Best regards,

Larry Clayton
Larry Clayton
Editor

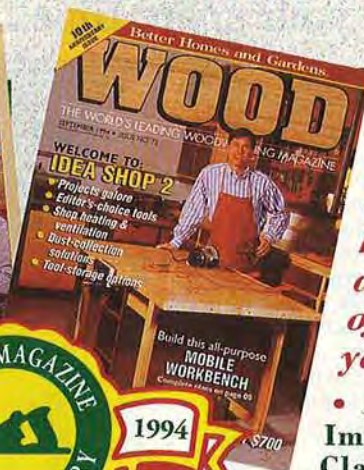
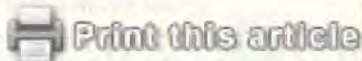

*A special "thank you" to these companies who have advertised in at least one issue of **WOOD**® each year since 1984:*

• Advanced Machinery Imports • Adjustable Clamp Co. • Armor Products • Constantine's • Freud USA • Furniture Designs • Garrett-Wade • HTC Products, Inc. • Wood-Mizer Products, Inc. • Lignomat USA Ltd. • Marlin Div. terreo inc. • Meisel Hardware Specialties • Nova Tool Co. • Delta International Machinery Corp. • RB Industries • Toys & Joys • Williams & Hussey Machine Co., Inc. • Woodcraft Supply Corp. • The Japan Woodworker • Woodmaster Tools • Woodworkers Store

*Thank you to these advertisers for making **WOOD** the world's leading woodworking magazine:*

• Abbey Tools • Acme Electric Tool Crib • Adams Wood Products • Arrow Fasteners • Berea Hardwoods Co. • Better Built Corp. • Bosch Power Tool Corp. • Boulder Plywood Corp. • Cascade • CP Tools • Clayton Machinery Corp. • Country Accents • Craft Supplies USA • Delmhorst Instrument Co. • Delphi Stained Glass • DML/Primark • Econ Abrasives • Emerson Electric Corp. • Enlon Import Corp. • Fein Power Tools • Forrest Mfg. Co. • Franklin International • Furniture Medic • Grizzly Imports • Home Lumber • Industrial Abrasives • International Tool Corp. • Jet Equipment and Tools • Klockit • Laguna Tools • Lobo Power Tools, Inc. • MLCS LTD • Makita USA, Inc. • McFeely Hardwoods and Lumber • Miracle Steel Structure • Minuteman Inc. • Model Expo • Nyle Standard Dryers, Inc. • Pace-Edwards Co. • Performax Products • Record Tool Corp. • Rodale Press, Inc. • The Roudebush Co. • Ryobi America • Seven Corners Hardware • Skil • Stanley Tools • Steelmaster Buildings, Inc. • Specialty Furniture Designs of Michigan • The Winfield Collection • The Woodworking Shows • Total Shop • Van Dyke Supply Co. • Steve Wall Lumber Co. • Woodcarvers Supply, Inc. • Woodworkers Source



Better Homes and Gardens®

WOOD®

Man has always been attracted to curves. But until now, no one quite knew how to sand them.



It takes a tool that caresses curves other sanders can't reach, and smooths them with a motion others can't match. It takes a tool that didn't exist until now.

The Oscillator™ by Ryobi. The Oscillator adapts to sweeping curves or tight switchbacks with the optional 1/2" to 3"  spindles stored right at your fingertips. Its compound rotary and  up-and-down motion sands both with and against the grain to give you smoother finishes faster. In a swift pass or two, The Oscillator reduces blade, bit, and burn marks  to dust which your vac neatly pulls through the built-in dust port. All of which makes The Oscillator a perfect companion for your scroll, jig, or band saw. And a shortcut to the silky, shapely curves you've always dreamed about. If curves attract you now, just wait 'til you Oscillate them.

All Ryobi products are warranted for two full years. For more information, call 1-800-525-2579.

Made in U.S.A.

RYOBI

Making Innovative Concepts A Reality™

©Ryobi America Corp. 1994, 5201 Pearman Dairy Road, Suite 1, Anderson, S.C. 29625-8950



Real Summer Savings are here, with **Enlon's Exclusive Manufacturer.** You'll get the finest machines and our lowest prices ever. **Save 10% on all accessories during this Summer Sale.** Summer Sale starts July 5th, ends Sept. 17th, 1994.

ENLON WILL EXTEND THE LIMITED WARRANTY TO (1) FULL YEAR ON ALL SALES AFTER JUNE 1ST, 1994

ORDERS
1-800-888-9697
Mon.-Fri. 7:00am-5:00pm (Pacific Time)
Sat. 9:00 am- 1:00 pm (Pacific Time)

Prices & Specifications are subject to change without notice.
*F.O.B. City of Industry, CA or Clarksburg, WV

6" JOINTER ▶

- 1 H.P., 110/220V
- 3-KNIFE CUTTERHEAD
- 47" BED LENGTH

*EN3101
REG.:\$370.00
SALE:
\$330.00



8" HEAVY DUTY JOINTER ◀

- 1 1/2 H.P., 220V
- 3-KNIFE CUTTERHEAD
- 65" BED LENGTH

*EN3102
REG.:\$645.00
SALE:
\$615.00



2 H.P. DUST COLLECTOR ▶

- 220V, 15 AMPS
- 1,059 C.F.M.
- 2 INTAKES @ 4"

*EN-DC20
REG.:\$275.00
SALE:
\$270.00



FREE 4" x 10" P.V.C. HOSE with purchase of any Dust Collector.

6" JOINTER ▶

- 1 H.P., 110/220V SINGLE PHASE MOTOR

- CENTER MOUNT CAST IRON FENCE W/TABLE SLIDE PROTECTOR
- QUICK ADJUSTMENT HAND CRANK FOR OUTFEED TABLE
- STURDY BASE CABINET W/DUST COLLECTOR CHUTE

*EN3104
REG.:\$380.00
SALE:
\$360.00



8" HEAVY DUTY JOINTER ▶

- 1 1/2 H.P., 220V, SINGLE PHASE MOTOR
- CENTER MOUNT CAST IRON FENCE W/TABLE SLIDE PROTECTOR
- QUICK ADJUSTMENT HAND CRANK FOR OUTFEED TABLE
- MAGNETIC SAFETY SWITCH, 65" LONG CAST IRON BED

*EN3105
REG.:\$660.00
SALE:
\$650.00



10" H.D. TABLE SAW ▶

- 1 1/2 H.P., 110/220V, SINGLE PHASE MOTOR

- 41" X 27" TABLE SIZE W/CAST IRON EXTENSIONS
- BUILT-IN DUST COLLECTOR CHUTE
- PRECISION SINGLE LEVEL RIP FENCE W/MICRO-ADJUSTMENT

*EN3201
REG.:\$375.00
SALE:
\$345.00



12" PLANER ◀

- 2 H.P., 110V, 14 AMPS
- 16,000 C.P.M.
- 2-KNIFE CUTTERHEAD

EN-PN12
REG.:\$375.00
SALE:
\$365.00

FREE SHIPPING IN CONTINENTAL U.S.



15" PLANER ▶

- 3 H.P., 110/220V, 30/15 AMPS
- 2 SPEEDS: 16 & 20 F.P.M.
- 3-KNIFE CUTTERHEAD

*EN-PN15
REG.:\$860.00
SALE:
\$825.00



10" SUPER H.D. TILTING ARBOR TABLE SAW ◀

- 3 H.P., 220V, 15 AMPS
- PRECISION GROUND CAST IRON TABLE
- PRECISION LEVER LOCK FENCE SYSTEM
- STEEL BASE CABINET

*EN3202
REG.:\$840.00
SALE:
\$750.00



1 1/2 H.P. WOOD SHAPER ◀

- 110/220V, 7,000/10,000 R.P.M.
- 1/2" & 3/4" SPINDLES
- CAST IRON TABLE

*EN3302
REG.:\$490.00
SALE:
\$420.00



3 H.P. HEAVY DUTY WOOD SHAPER ◀

- 220V, 7,000/10,000 R.P.M.
- 1/2", 3/4" & 1" SPINDLES
- CAST IRON TABLE

*EN3303
REG.:\$785.00
SALE:
\$715.00



3 H.P. SLIDING TABLE WOOD SHAPER ▶

- 220V, 7,000/10,000 R.P.M.
- 24" X 9" SLIDING TABLE
- 1/2", 3/4" & 1" SPINDLES

*EN3304
REG.:\$990.00
SALE:
\$940.00



6" X 48" BELT/9" DISC SANDER ▶

- 3/4 H.P., 110/220V
- MITER GAUGE
- ADJUSTABLE TABLE 0-45°

*EN-SN69
REG.:\$190.00
SALE:
\$180.00



6" X 30" EDGE SANDER ▶

- 1 1/2 H.P., 110/220V
- 6" X 80" BELT
- QUICK RELEASE LEVER
- CAST IRON TABLE
- (MAGNETIC SWITCH IS OPTIONAL)

*EN3405
REG.:\$420.00
SALE:
\$360.00



OSCILLATING SPINDLE SANDER ▶

- 1 H.P., 110V/220V, SINGLE PHASE MOTOR
- SPINDLE SPEED 1,725 R.P.M.
- 75 OSCILLATIONS PER MINUTE
- 10 SPINDLES FROM 1/4" TO 4" DIA. INCLUDED

*EN3407
REG.:\$595.00
SALE:
\$565.00



Call for FREE Catalog or Router Bits and Shaper Cutters Catalog.



GIFT CERTIFICATES AVAILABLE

SHOWROOM/MAIN OFFICE: 19400 E. SAN JOSE AVE., CITY OF INDUSTRY, CA 91748
CUSTOMER SERVICE: TEL: (909)468-3688 FAX: (909)468-3689
HOURS: MON-FRI 8:00AM-5:00PM, SAT 9:00AM - 1:00PM P.T.

SHOWROOM/SHIPPING WAREHOUSE:
12 ARMORY ROAD, CLARKSBURG, WV 26301
HOURS: MON-FRI 8:00AM - 5:00PM, SAT 9:00 AM - 1:00 PM E.S.T.