

Better Homes and Gardens®

WOOD

SPECIAL!
How to make
bandsaw dovetails

THE #1 MAGAZINE FOR HOME WOODWORKERS

APRIL 1992 • ISSUE NO. 51
Please display until April 13

SMART SHOPPING

- **BANDSAW ROUNDUP**
- **3 SUPERSHARP PORTABLE PLANERS**
- **LUMBER-BUYING TIPS**

RAIN FOREST UPDATE

PROJECT LINEUP

- Kid's clothes tree
- Turned oil lamps
- Corner plate rack
- Carver's trade sign
- Knitter's carryall
- Tilting dovetail jig
- Pizza paddle

BUILD THIS HEIRLOOM HIGH CHAIR Page 56

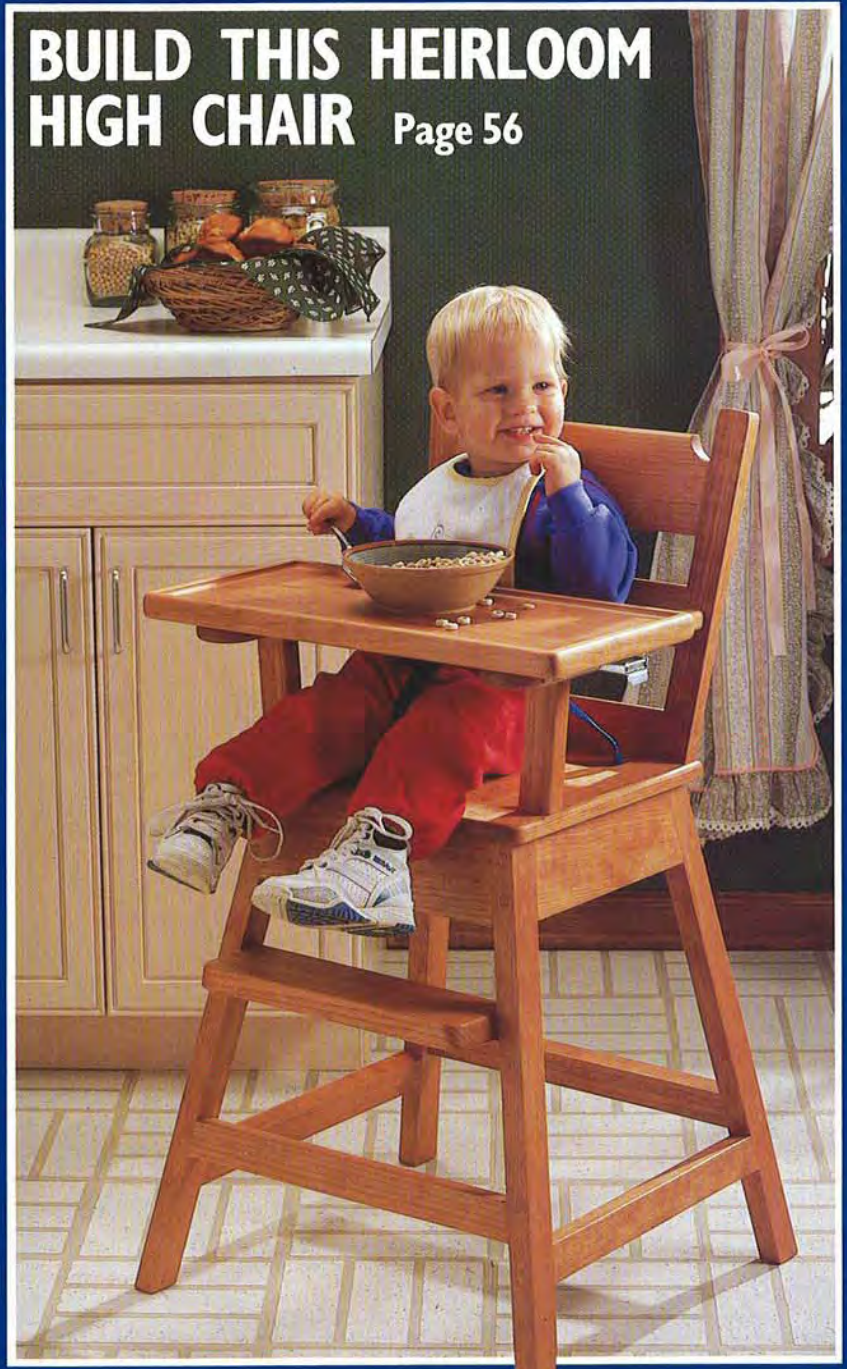



IMPORTS, INC.

"IMPORTERS OF FINE MACHINERY"

**LOOK
PRICES HELD
FOR 1992!**



**10" HEAVY DUTY
TABLE SAW
MODEL G1022**

Reg. \$365. **SALE \$355⁰⁰**
F.O.B. BELLINGHAM, WA or WILLIAMSPORT, PA



**SUPER HEAVY DUTY
TABLE SAW
MODEL G1023**

ONLY \$895⁰⁰
F.O.B. BELLINGHAM, WA or WILLIAMSPORT, PA



**16" BAND SAW
MODEL G1538**

ONLY \$525⁰⁰
F.O.B. BELLINGHAM, WA or WILLIAMSPORT, PA



**2 H.P. DUST
COLLECTOR
MODEL G1029**

ONLY \$295⁰⁰
F.O.B. BELLINGHAM, WA or WILLIAMSPORT, PA



**1 1/2 H.P. SHAPER
MODEL G1035**

ONLY \$495⁰⁰
F.O.B. BELLINGHAM, WA or WILLIAMSPORT, PA



**3 H.P.
SHAPER
MODEL G1026**

ONLY \$850⁰⁰
F.O.B. BELLINGHAM, WA or WILLIAMSPORT, PA



**6" x 47" HEAVY DUTY
JOINTER
MODEL G1182**

Reg. \$375. **SALE \$345⁰⁰**
F.O.B. BELLINGHAM, WA or WILLIAMSPORT, PA



**8" x 65" SUPER
HEAVY DUTY JOINTER
MODEL G1018**

Reg. \$695. **SALE \$650⁰⁰**
F.O.B. BELLINGHAM, WA or WILLIAMSPORT, PA



**12" PLANER
MODEL G1017**

Reg. \$385. **SALE \$375⁰⁰**
F.O.B. BELLINGHAM, WA or WILLIAMSPORT, PA



(Stand
Optional)

**15" PLANER
MODEL G1021**

ONLY \$735⁰⁰
F.O.B. BELLINGHAM, WA or WILLIAMSPORT, PA



**20" PLANER
MODEL G1033**

ONLY \$1,295⁰⁰
F.O.B. BELLINGHAM, WA or WILLIAMSPORT, PA



**6" x 48" COMB.
SANDER
MODEL G1014**

ONLY \$195⁰⁰
F.O.B. BELLINGHAM, WA or WILLIAMSPORT, PA



If you live **WEST** of the Mississippi:

1-800-541-5537 ORDERS
(206) 647-0801 CUSTOMER SERVICE
P.O. BOX 2069
BELLINGHAM, WA 98227



**CALL FOR YOUR
FREE CATALOG!**

92-103R

If you live **EAST** of the Mississippi:

1-800-523-4777 ORDERS
(717) 326-3806 CUSTOMER SERVICE
2406 REACH RD.
WILLIAMSPORT, PA 17701



KENN POTTORFF

A WOODWORKER WHO'S DEFINITELY THINKING AHEAD

"I would like to be remembered well into the 21st century"



Kenn Pottorff and a few of the toys he's making for his great-grandchildren, who have yet to be born.

Not long ago, a letter came across my desk that made me sit back and say, "Gee, what a great idea!" Kenn Pottorff, an 80-year-old *WOOD*® magazine reader, wrote to tell me that he's busy building toys for his great grandchildren. What's so unusual about that, you ask? Nothing, except that he doesn't have any great-grandchildren yet.

Kenn said, "I have this weird notion that I would like to be remembered well into the 21st century, long after I'm gone, so I'm boxing up some toys for my great grandchildren. The boxes will be marked 1st, 2nd, 3rd, 4th, and so on to eliminate any confusion over which child should get which toy."

Kenn, a woodworker who loves spending lots of time in his shop, reports that he has six grandchil-

dren at this time. "Since none of them are married yet, though, it will be some time before the gift-giving begins," he says.

Kenn's letter reminds me once again of how special it is to be a woodworker, and of how much people appreciate it when we share with them something that we have made with our hands. Most of us probably don't think about our work living on long after we are gone, but chances are good that at least some of it will. I know that I'll approach each project I build from now on in a different light as a result of having read Kenn's letter.

Thanks for taking the time to write, Kenn. And thanks, too, for including some projects from *WOOD* magazine as part of your gift-giving gesture. We're proud to be included in your plans. ♣

Larry Clayton

EDITORIAL MAILING ADDRESS: *WOOD* magazine, P.O. Box 11454, Des Moines, IA 50336-1454. **WE CARE!**
 SUBSCRIPTION SERVICE (including change of address): *WOOD* Customer Service, P.O. Box 10628, Des Moines, IA 50336-0628. Please enclose your address label from a current issue. If you wish, call toll-free 800/374-9663.
 CUSTOMER-SERVICE TEAM: Marjene Cline, Velma Williams, Tom Ackert, Andrea Gilbert.

The Dependable Source Since 1976

Woodworkers SALE

EXPIRES 4-15-92

	SALE
3-1/2" Shaker Peg	\$12.50/100
2-7/16" Medium Peg	\$12.00/100
1-3/4" Mini Peg	\$ 6.00/100
1-3/8" Candle Cup	\$14.00/100
1" Toy Wheel	\$ 4.00/100
1-1/4" Toy Wheel	\$ 6.50/100
1-1/2" Toy Wheel	\$ 8.00/100
Axle Peg for Above	\$ 3.00/100
3/4" Round Ball	\$ 7.00/100
1" Round Ball	\$10.00/100
1-1/2" Round Ball	\$ 3.00/10
3/8" or 1/2" Birch Button	\$ 1.50/100
5/8" Picture Hanger	\$ 1.50/100
1-5/8" Sawtooth Hanger	\$ 3.00/100

1-800-722-0311

To receive sale prices use Sale #B22

Catalog \$1.00 (FREE With Order)
 We accept M/C, VISA, Check, or M.O.
 All orders add \$4.00 handling.
 TX add 7% tax. (Canada add 30% - Money Order Only) Alaska, Hawaii add 15% for freight.



Woodworks

P.O. Box 14507 Ft. Worth, TX 76117

ENERGY-SAVING SUN-PORCH™ CONVERTIBLE SUNSPACE

More value for less money!

INSULATED
 WINTER SUN SPACE CONVERTS
 TO A SUMMER SCREEN ROOM!



MOUNTS READILY ON DECKS, PATIOS, OR LANDSCAPE TIES

Choice of stunning Opal White or Bronze-Tint glazings on white or bronze framework QWIK™ window/screen change system Do-it-yourself assembly America's #1 value.

Send \$2 for Color Catalogues, Prices, SENT FIRST CLASS MAIL.

Dealer Inquiries Welcome



VEGETABLE FACTORY, INC.
 P.O. Box 1353, Dept. WOO
 Stamford, CT 06904-1353

VIDEO & CATALOG

FREE with Rebate*



Improve the Looks and value of your home with:

- Entry doors & sidelights
- Kitchen cabinet inserts
- Tiffany lampshades

Save money and make it yourself - Delphi shows you how!

Make Your Own Custom Stained Glass...

The perfect way to get started in stained glass. Our 25-minute video covers all the basics: Scoring, breaking, foiling, and soldering. Filled with clear and simple instructions, hints, close-ups, and examples to help you craft your own stained glass windows, lamps, and more. VHS only.

#G149VW...\$10.95 + \$3.00 shipping/hand.

* A \$10.95 rebate is applied to your next order. If you don't wish to purchase, just return the video for a prompt refund, but keep the 80-page color catalog.

To Order - Call Toll Free: 1-800-248-2048



2116 E. Michigan Ave.
Lansing, MI 48912

NEW! DRUM SANDER

with Infinitely Variable Power Feed!



At last! A complete power-feed Drum Sander at an affordable price! Choose from 26" and 38" models.

Now you can save hours of tedious hand scraping and sanding. In a matter of seconds, you can turn out satin-smooth panels, doors, shelves and other glued-up pieces. No more dips and waves. No more gouging. Infinitely variable power feed gives you total control. Turns out perfectly flat, glass-smooth panels that look better and take stain more evenly than any you could do by hand.

Send for complete facts. See how the Woodmaster can finish cabinet pieces, resawn stock, paneling, tabletops, knees, burls and much more! Made in U.S.A. Easy terms.

Call Toll-Free 1 (800) 821-6651 Ext. RW45
 YES! Please rush my FREE INFORMATION KIT and details on your 30-Day Free Trial Guarantee.

Woodmaster Tools Dept. RW45
2908 Oak, Kansas City, MO 64108

NAME _____
ADDRESS _____
CITY _____
STATE _____ ZIP _____
PHONE () _____

Better Homes and Gardens®

WOOD

THE #1 MAGAZINE FOR HOME WOODWORKERS

This issue's cover wood grain: hickory

Cover photo: Wm. Hopkins

APRIL 1992

ISSUE NO. 51

WOOD PROFILE

Hickory: Tougher than nails, and versatile, too 33

When America's pioneers needed handles for their tools, or spokes for their wagon wheels, they turned to hickory.



CRAFTSMAN CLOSE-UP

The chairs of Whispering Pines 35

Discover how (and why) Pennsylvania Amish woodworker David Swarey relies on simple, home-generated energy and pneumatic stationary power tools to make beautiful, enduring, hardwood chairs.

CARVING

Carver's-pride trade sign 40

Isn't it time you advertise your favorite form of woodworking? Check out our exclusive trade-sign design inside.



SHOP-TESTED TECHNIQUES

Bandsawed through-dovetail joints 44

Create novel through-dovetail joint designs, and then cut the dovetails out using our step-by-step directions and hardworking bandsaw jig.

Tilting-table dovetail jig 49

Easy to make, and still easier to use, this handy shop aid lets you cut clean, precise through dovetails for drawers, chests, and small decorative boxes.

NOW YOU CAN BUILD IT Knitter's companion 52

After making the jig and taking our short course in bandsawed-through dovetails, prove your cutting prowess by crafting this handsome carrier. It works just as well for old magazines as it does for yarn.

TOOL BUYER'S UPDATE **54**
Portable planers

Since our April 1990 story on portable planers, three more impressive models have entered the market. Find out how they held up during our performance trials.



Happy-days high chair **56**

Don't wait until after the baby is born to make this family heirloom—you may not have the time. Our sturdy design features a safety strap and a convenient lift-up table for fast cleanup.

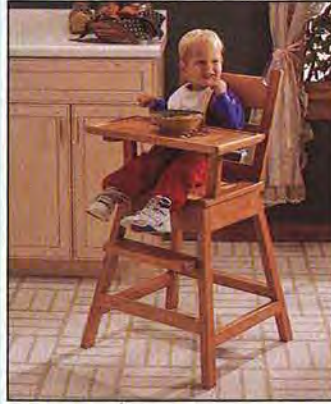

TURNING **64**
Decorator oil lamps

Shaped like tulips, these pleasing turnings hold all the needed parts to fill an evening with a warm old-fashioned glow.

TOOL BUYMANSHIP **66**
Bandsaw roundup

Before you drop big bucks on a bandsaw, see how the big wheels have fared in our test of 12 popular models. You'll be glad you did.



Board buying basics **72**

Cut through the confusing lumberyard jargon, and learn just what you need to know when choosing wood from your local dealer.

CRAFT SHOP **74**
Prizewinning plate rack

Showcase your favorite plate on this stunning corner plate holder.

No-problem pizza paddle **76**

Now, at last, you can handle your homemade pizza like a pro.

Aquatic-playmates clothes tree **78**

Playful whales and dolphins make this the perfect kid's room project.

SHORT-SUBJECT FEATURES

Editor's Angle	1	Wood Anecdote	31
Talking Back	6	Rain Forest Update	80
Great Ideas For Your Shop	12	Yesterday's Tools	82
Tips From Your Shop	16	Tool Industry Insider	83
Products That Perform	26	Finishing Touches	88

Mobile Machine Bases

to put your entire shop on wheels

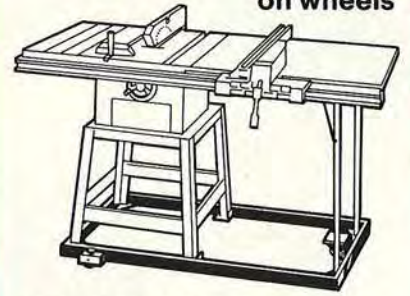

EXPANDS YOUR WORKING AREA
 MAKES CLEAN-UP A SNAP

- Over 1000 models to choose from
- Designed for correct machine fit
- Constant 3-wheel suspension insures tool stability
- Dual wheel locks for positive positioning
- No lifting needed to move or dropping to use
- Protects machine settings and components
- All steel and precision welded
- Lifetime warranty

Work Supports

to do your best safely and accurately



DESIGNED TO HELP YOU SUPPORT AND SAFELY MOVE WORK PIECES THRU YOUR MACHINES

- No tools needed for simple, positive height adjustments
- Top quality, galvanized, ball-bearing rollers
- 4 heavy duty threaded rubber-tipped levelling feet.
- Heavy gauge steel components
- Lifetime warranty

Available at better tool stores



FREE CATALOG



HTC Products, Inc.
 120 E. Hudson • P.O. Box 839
 Royal Oak, Michigan 48068-0839

1-800-624-2027

The
American
Toolmaker

rbi industries, Inc.

Woodworking Tools & Accessories

To Order
1-800-487-2623
Or Fax: 816-884-2463
Call Toll-Free

Do the job right and with the right tool.

Whether you are a new or experienced woodworker . . . a hobbyist or pro . . . the precision tools from rbi industries make it fast, easy and fun for the entire family to produce hundreds of projects.

All rbi products are made here in America to meet world-class standards. That's why we have a 30 Day Trial Offer and an incredible 3 YEAR Warranty!

Turn your hobby and spare time into extra cash.

The HAWK Precision Scroll Saw and The 4-in-1 Woodplaner have been the beginning of many craft related businesses.



Think of all you'll make with these versatile tools.

gingerbread cutouts
shelf bracket & trim
puzzles
picture frames
jewelry boxes
decorative custom
molding
wooden nameplates
curios
decorative folk art
shadow boxes
dimensioned wood
yard ornaments
items for tole painting
Christmas ornaments
inlays
marquetry
wood joints
templates
stack cutting
tongue in groove flooring
patterns
toys
handcrafted gifts
plaques
cabinet doors
stained glass gifts
plus much more...

MEET THE **rbi** FAMILY OF TOOLS & ACCESSORIES

- THE PANELMASTER
- THE 4-IN-1 WOODPLANER
- THE ROUTER MATES
- ROLLER STANDS
- THE HAWK PRECISION SCROLL SAW

and much, much, more . . .



rbi industries, *The American Toolmaker*

1801 Vine Street • P.O. Box 369
Harrisonville, MO 64701

QUALITY
SINCE
1929

Better Homes and Gardens® **WOOD**

THE #1 MAGAZINE FOR HOME WOODWORKERS

April 1992 • Vol. 9, No. 3 • Issue No. 51

Editorial/Art Staff

Editor **LARRY CLAYTON**
Managing Editor **JIM HARROLD**
Art Director **C. L. GATZKE**
Assistant Art Director **PERRY A. MCFARLIN**
Graphic Designer **CHERYL A. CIBULA**
Design Editor **JAMES R. DOWNING**
Senior Editor **PETER J. STEPHANO**
How-To Editor **MARLEN KEMMET**
Products/Techniques Editor **BILL KRIER**
Special-Interest Editor **LARRY JOHNSTON**
Project Builder **JAMES E. BOELLING**
Administrative Assistant **DARLENE REYNOLDS**
Business Office Clerk **MARGARET CLOSNER**
Secretary **ROSEMARIE BURCH**

Technical Consultants: Product Testing **GEORGE GRANSETH**,
BOB MCFARLIN; Products That Perform **STEVE OSWALT**;
Wood Science **PAUL MCCLURE**; Collectible Tools
PHILIP WHITBY; Carving **HARLEY REFSAL**

Publisher **WILLIAM R. REED**
Advertising Director **CHRIS W. SCHRAFT**
Advertising Representatives **CRAIG KAPLAN**,
BRENDEAN DELANEY, **ANDREA CHERNUS**
Promotion/Research Director **EILEEN SULLIVAN**
Advertising/Marketing Services Manager **SIGRID FOLKERS**
Publisher's Assistant **NANCY LOPEZ**
Advertising Assistant **KIMBERLY DAVIS**
ADVERTISING OFFICES: 750 Third Ave., New York,
NY 10017. Phone 212/551-6903.

Circulation Manager **ALAN BRUSH**
Newsstand Circulation Director **MICHAEL SENIOR**
Business Manager **TERRY UNSWORTH**
Production Director **ROBERT C. FURSTENAU**
Public Relations **SONDY DAGGETT**

Magazine Group Officers

Group President **WILLIAM T. KERR**
SVP, Publishing Director **ADOLPH AUERBACHER**
SVP, Editorial Director **DORIS EBY**
SVP, Operations **DEAN PIETERS**
Group VPs: Publishing Directors **MYRNA BLYTH**,
BURTON H. BOERSMA, **CHRISTOPHER M. LEHMAN**
Group VP, Circulation Director **CLEM SEVDE**
Controller **MAX RUNCIMAN**

Corporate Officers

Chairman of Executive Committee **E.T. MEREDITH III**
Chairman of the Board **ROBERT A. BURNETT**
President and Chief Executive Officer **JACK D. REHM**
Group Presidents: Broadcasting **PHILIP A. JONES**;
Magazine **WILLIAM T. KERR**; Real Estate **ALLEN SABBAG**;
Books **JOSEPH J. WARD**

Better Homes and Gardens® **WOOD**® (ISSN-0743-894X) is published nine times a year in January, February, April, June, August, September, October, November, and December by Meredith Corporation, 1716 Locust St., Des Moines, IA 50309-3023. Second-class postage paid at Des Moines, Iowa, and at additional mailing offices. Better Homes and Gardens trademark registered in Canada and Australia. Marca Registrada en México. **ONE-YEAR SUBSCRIPTION PRICES:** U.S. and its possessions, \$24.97; Canada, \$34; other countries, \$38. **POSTMASTER:** Send address changes to *Better Homes and Gardens WOOD*, Box 10628, Des Moines, IA 50336-0628. ©COPYRIGHT MEREDITH CORPORATION 1992. ALL RIGHTS RESERVED. PRINTED IN U.S.A. Canadian GST Reg. #R123482887.

MPA

New books from the experts at WOOD.

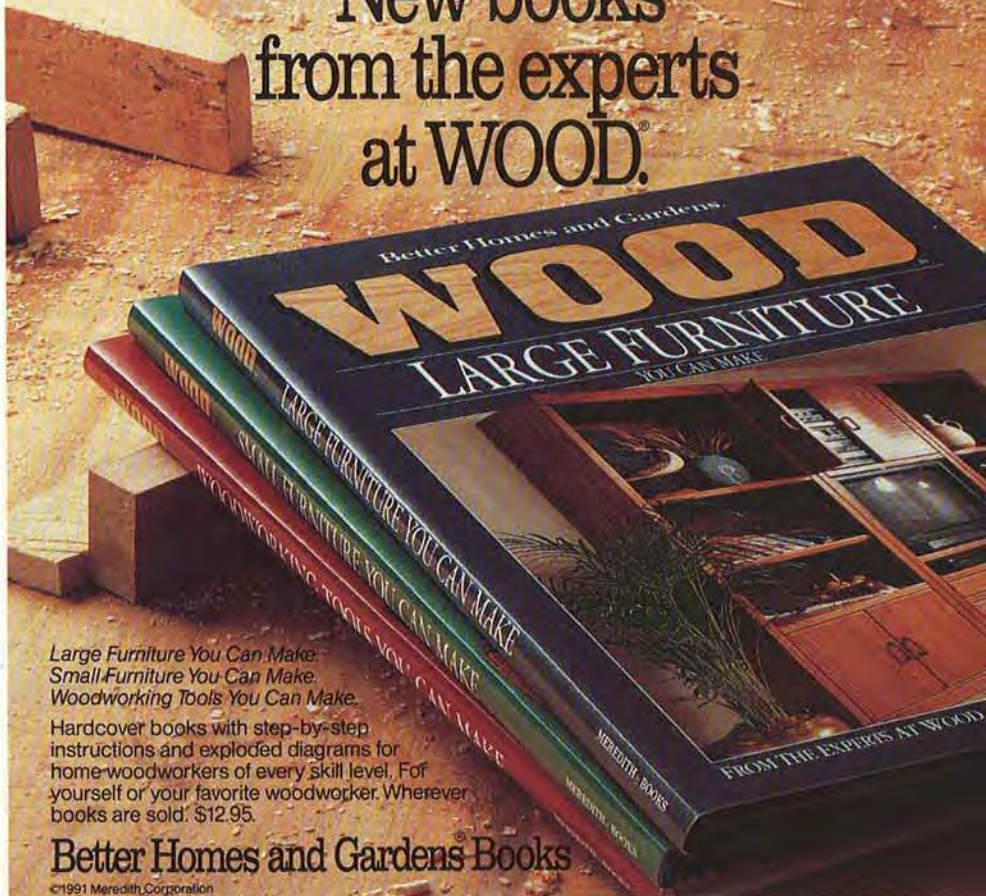

Large Furniture You Can Make.
Small Furniture You Can Make.
Woodworking Tools You Can Make.

Hardcover books with step-by-step instructions and exploded diagrams for home woodworkers of every skill level. For yourself or your favorite woodworker. Wherever books are sold. \$12.95.

Better Homes and Gardens® Books

©1991 Meredith Corporation

April is Minwax® National Woodworking Month™



\$300 to replace. \$10 to repair.

Use High Performance Wood Filler by Minwax® for the big jobs, indoors and out. Won't shrink, crack or fall out. Hardens and can be worked on in 15 minutes.

If wood is soft or rotted, use High Performance Wood Hardener first to form a rock solid base.

Free booklet: *Tips on Wood Finishing*
Minwax Company, Inc., Dept. WO 032
P.O. Box 426, Little Falls, NJ 07424



High Performance Wood Filler **MINWAX**

© 1990 Minwax Co., Inc.



Fine Craftsmanship Deserves the Very Best.

Craftsmanship begins with the idea. The final result depends on the tool and the craftsman. Atrax tools are made from premium fine-grade carbide, the best on the market today. Atrax offers over 600 styles and sizes to bring the craftsman's ideas to quality results.

ATRAX Tooling Provides Results.

For a catalog or information call:
1-800-237-3521



ATRAX

Distributor inquiries invited.



TALKING BACK

We welcome comments, criticisms, suggestions, and even compliments. Send your correspondence to: Talking Back, Better Homes and Gardens® WOOD® magazine, P.O. Box 11454, Des Moines, IA 50336-1454.

Snowshoe how-to from Maine



I enjoyed reading your snowshoe article in the December 1991 issue because I have always been interested in seeing these ancient crafts perpetuated. Perhaps, some of your readers might want more detailed instruction in snowshoe making. My book, to the best of my knowledge, is the only one of its kind. Thanks for your time and good magazine.

—Gil Gilpatrick,
Skowhegan, Maine

Thanks, Gil, for bringing your book to our attention. Your spiral-bound publication offers lots of illustrations and diagrams, along with plenty of how-to instruction in its 100 pages. To order Gil's book, send \$13.95 ppd. to: Building Snowshoes, Gil Gilpatrick, P.O. Box 461, Skowhegan, ME 04976. (Maine residents, add 6 percent sales tax; Canadians, add \$2 for air shipment, U.S. currency only.)

"Steamed up" over removing dents

I'm writing in reference to the article "Doing away with dents," in the December 1991 issue. As a former professional furniture refinisher, I have dealt with many dents. I'm afraid that the process suggested is a "band-aid" approach. The dents are actually still there and only covered up.

To truly remove the dents, it is necessary to first strip the piece. Have this professionally done. Once you have the piece back home, dampen the surface and cover it with a damp cloth or paper towels. Then, cover this with waxed paper. Place a piece of Masonite or plywood on top of these layers, and then, after 24 hours, remove the layers, allowing the surface to dry. The dents will be gone.

Why does this work? When moistened, the fibers rearrange themselves to their original conformation. That's because a dent is nothing more than crushed wood cells. When you apply moisture, these cells expand into their original shape. After the piece dries, continue sanding and finishing.

—W.J. "Joe" Kopp, Oak Ridge, Tenn.

Continued on page 8.

BUILDING OUR NAME...

BUILDING YOUR DREAMS...

ONE YEAR WARRANTY



WIDE BELT SANDER

CT-2575 24"..... \$4290
CT-3775 36"..... \$5390



SHAPER

SP-3400 1.5 HP..\$469
SK-30SPA 3 HP.. \$849
SP-34T TILTING..\$1695



TABLE SAW

HTS0012 12"..... \$789
TS-1010 10"..... \$1295
TS-1414 14"..... \$2690

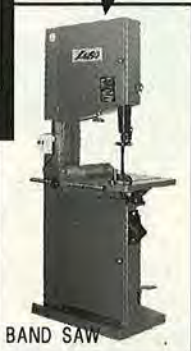

BAND SAW

BS-1316 16"..... \$299
BS-0163 16"..... \$499
BS-0183 18"..... \$649
BS-0202 20"..... \$1290



JOINTER

JT-1007 7"..... \$309
JT-1008 8"..... \$639
JT-0012 12"..... \$1895

WE SPECIALIZE IN CUSTOMER SATISFACTION



9034 Bermudez Street,
Pico Rivera CA 90660
MAIN OFFICE:(213)949-3747
ATLANTA:(404) 416-6006
(800)786-5626 (order only)

LOBO POWER TOOLS

CLAMPS CLAMPS CLAMPS

QUAKER STATE is the Home for CLAMPS, all under one roof.

QUICK-GRIP BAR CLAMP



Light. Strong. Fast.
The Bar Clamp that's
so easy, you can use it
with one hand!

Cat. #	Jaw Opening	Price
#2100	6"	\$12.95
#2101	12"	14.95
#2102	18"	15.95
#2103	24"	17.95
#2104	36"	19.95
#2105	4 Piece Corner Kit	5.95
#2106	6" Clamp & Corner Kit	17.50

6" MINI BAR CLAMP

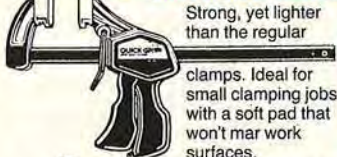

Strong, yet lighter
than the regular

clamps. Ideal for
small clamping jobs
with a soft pad that
won't mar work
surfaces.
#2108 - 6" Mini Clamp...\$10.95



"BENCH" HOLD-DOWN CLAMP

Strong, quick hold-down
for mounting on your
workbench. A full 5" opening
allows for extra thick
clamping 3/4" hole accepts
mounting hardware under-
neath workbench.

#2109 - Hold-Down Clamp...\$19.95

BACK-TO-BACK BENCH CLAMP

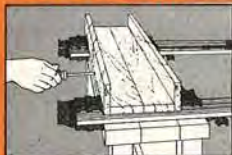

18" GRIP 36" GRIP
\$31.95 \$39.95

TRU-GRIP

CLAMP 'N TOOL GUIDE

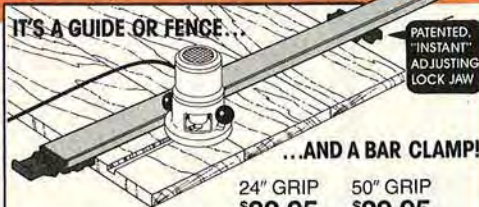

IT'S A GUIDE OR FENCE...

PATENTED
"INSTANT"
ADJUSTING
LOCK JAW

...AND A BAR CLAMP!
24" GRIP 50" GRIP
\$22.95 \$29.95

ALL OUR PRODUCTS ARE GUARANTEED!

SINGLE SLEEVELESS Drum Sanders. Build this BENCHTOP SPINDLE SANDER



with our plans
and instructions
for only \$11.99

Plans describe the sliding motor
mount that adjusts drum height
for full range sanding application.

Strong "F" Weight Sandpaper

3" x 10' rolls that outlast regular
sandpaper 3X. Assortment pack of
1 each...80, 120, 220...\$12.99



Sleeveless DRUM SANDERS



3/4" x 3" Long	\$15.95
1" x 3" Long	14.95
2" x 3" Long	18.99
3" x 3" Long	19.99
Kit of all 4	64.99
Drum Sander Plans	11.99
3" x 10' Pre-cut Sandpaper	
Roll Assortment	12.99

BONUS Kit of all 4 Drums,
receive FREE Plans & 1
FREE 3" x 10' Sanding
Roll...80, 120 or 220 grit.

PORTER+CABLE Random Orbit Riot!

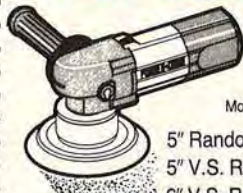

Sanders shipped
freight FREE!

Models #7334, 7335, 7336

5" Random Orbit	\$119.99
5" V.S. Random Orbit	129.99
6" V.S. Random Orbit	134.99

New! DUST COLLECTION

for P-C Random Orbit Sanders. The
RIGHT WAY to DUST COLLECT...hood
connects your sander to your Shop-Vac.
6' Flex Hose included ... \$24.99
(Fits both 5" and 6" Sanders)



5" Replacement Pad	\$14.99
6" Replacement Pad	17.99
5" Contour Pad	14.99
6" Contour Pad	17.99

COME SAND WITH US!



FREQUENT "SANDERS" CLUB™

EVERY 5th ABRASIVE ORDER IS ON THE HOUSE!
All Items Listed Below Qualify!

To compensate users of large and small amounts of sanding
supplies, we have made it fair to both customers. Simply, take
the abrasive total of your first 4 orders, (belts, discs, sheets,
rolls, non-wovens, belt cleaners only) and divide by 4 to get your
average order. That is your total dollar amount of FREE abra-
sives. Please keep track of your purchases with form provided.
To place your FREE order, please mail, we cannot accept phone
orders. Only Available Through Mail Order. (Max. free \$100.00).

SUNGOLD Sanding Belts

You've Tried the Rest...
Now Buy the Best!

BUY 12 BELTS...
GET A BAKER'S DOZEN FREE!
(A Total of 25 Belts)



BELT SIZE	PRICE 25 BELTS	BELT SIZE	PRICE 25 BELTS
1 x 30	\$16.99	3 x 24	\$19.99
1 x 42	17.99	4 x 21	24.99
2 1/2 x 16	17.99	4 x 21 3/4	24.99
3 x 18	18.49	4 x 24	25.99
3 x 21	18.99		

(Avail. in 40, 60, 80, 100, 120, 150, & 220)

BELT SIZE	PRICE FOR 13 BELTS
4 x 36	\$24.99
6 x 48	35.99

Buy 6 Get 7 FREE

BUY 3...GET 1 FREE!

SILICON CARBIDE 9" x 11" SANDING SHEETS



Buy 3 Packs of Sheets
Get 1 Pack FREE!
(MIX and MATCH GRITS O.K.I.)

"WHITE" Silicon Carbide
Non-loading. Available in 80,
100, 120, 150, 220 & 320 grits.
#1305-50 Sheet Pkg. \$12.99

BUY 3...GET 1 FREE!

STICKY ROLLS

Buy 3 Sticky Rolls...Get 1 FREE!
(MIX and MATCH GRITS O.K.I.)

4 1/2" x 10 yds. for finishing sanders. Silicon
Carbide, "WHITE" non-loading available in
80, 100, 120, 150, 220 & 320 grits.

#1120 - 1 Roll for ... \$11.99



BUY 3...GET 1 FREE!

SUPER STRONG "F" Weight ROLLS

Rolls for your 1/4 and 1/2 Sheet Vibrating Sander
Buy 3 Orange "F" Weight Rolls, Get 1 Roll FREE!
(MIX and MATCH GRITS O.K.I.)

4 1/2" x 25' ROLLS, ORANGE, ALUMINUM OXIDE.
Will outlast regular "C" weight Cabinet Paper 5x or
more. Available in 80, 100, 120, 150, 220 & 320 grits.
#1012 - 1 Roll for ... \$12.99



BUY 3...GET 1 FREE!

PORTER+CABLE RANDOM ORBIT DISCS

Buy 3 Boxes of Sticky Discs (100/Box)
Get 1 Box FREE! (MIX and MATCH GRITS O.K.I.)

Silicon carbide non-loading "B" weight sticky
discs available in rolls of 50 per grit size.

BUY 50...GET 50 FREE!

#1150 - 5" Sticky Discs	\$15.99
#1160 - 6" Sticky Discs	19.99

(Comes in 80, 100, 120, 150, 220, 320 grits)

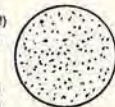

BOSCH RANDOM ORBIT DISCS

Buy 3 Boxes of Velcro Discs (100/Box)
Get 1 Box FREE! (MIX and MATCH GRITS O.K.I.)

Aluminum oxide non-loading "B" weight
Velcro backing with 8 hole pattern.

BUY 50...GET 50 FREE!

#1201 - 5" BOSCH Discs	\$24.99
#1221 - 6" BOSCH Discs	29.99

(Order in multiples of 50 per grit size. Avail. in 80, 100, 120, 150, 220, 320 grits.)



BUY 3...GET 1 FREE!

BULLDOG GOLD RANDOM ORBIT DISCS

Buy 3 Boxes of Bulldog Gold (100/Box)
Get 1 Box FREE! (MIX and MATCH GRITS O.K.I.)

EXTRA Heavy Duty "D" weight Sticky Discs.

BUY 50...GET 50 FREE!

#1170 - 5" Bulldog Discs	\$20.99
#1180 - 6" Bulldog Discs	25.99

(Order in multiples of 50 per grit size. Avail. in 80, 100, 120, 150, 220, 320 grits.)



QUAKER STATE
WOODWORKING SUPPLY

4434 KUTZTOWN ROAD
READING, PA 19560

1-800-776-5467

FOR FAST DELIVERY!

Check Money Order Discover

MasterCard Visa C.O.D. (Add \$4.75)

S & H: Under \$25 - add \$3.75. PA residents add 6% sales tax.



FREE SHIPPING

on orders over

\$25.00

CONTINENTAL U.S. ONLY!

Rabbeting

This indispensable cutter is used for many shaping operations from plowing to rabbeting.

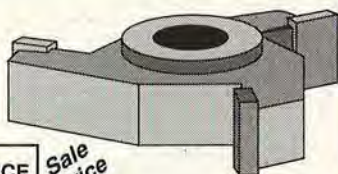

3/4" BORE

PART	CUTTER DIA. A	CUTTING LENGTH B	PRICE	Sale Price
C2030	2-5/8"	1/4"	\$24 ⁹⁵	\$22 ⁴⁵
C2031	2-5/8"	3/8"	\$26 ⁹⁵	\$24 ²⁵
C2032	2-5/8"	1/2"	\$28 ⁹⁵	\$26 ⁰⁵
C2033	2-5/8"	3/4"	\$32 ⁹⁵	\$29 ⁶⁵
C2034	2-5/8"	1"	\$35 ⁹⁵	\$32 ³⁵
C2035	2-5/8"	1-1/2"	\$36 ⁹⁵	\$33 ²⁵
C2036	2-5/8"	2"	\$59 ⁹⁵	\$53 ⁹⁵



Corner Round

We offer a wide selection of corner round cutters to handle your every need. These cutters are also used to produce perfect quarter round mouldings.

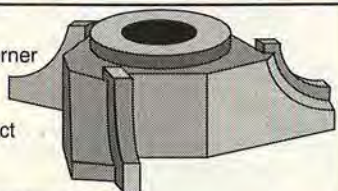

3/4" BORE

PART	CUTTER DIA. A	CUTTING LENGTH B	CUTTING RADIUS r	PRICE	Sale Price
C2059	2-5/8"	7/16"	1/4"	\$24 ⁹⁵	\$22 ⁴⁵
C2060	2-5/8"	9/16"	3/8"	\$26 ⁹⁵	\$24 ²⁵
C2061	2-7/8"	5/8"	1/2"	\$28 ⁹⁵	\$26 ⁰⁵
C2062	3-3/8"	7/8"	3/4"	\$35 ⁹⁵	\$32 ³⁵
C2063	3-7/8"	1-1/4"	1"	\$49 ⁹⁵	\$44 ⁹⁵
C2064	4-1/2"	1-1/2"	1-1/4"	\$49 ⁹⁵	\$44 ⁹⁵



Bead

Used to produce single or multiple face beadings. Ideal for duplicating mouldings and trim.

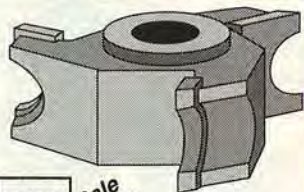

3/4" BORE

PART	CUTTER DIA. A	CUTTING LENGTH B	CUTTING DIA. d	PRICE	Sale Price
C2052	2-5/8"	1/2"	1/4"	\$24 ⁹⁵	\$22 ⁴⁵
C2053	2-5/8"	5/8"	3/8"	\$26 ⁹⁵	\$24 ²⁵
C2054	2-5/8"	3/4"	1/2"	\$28 ⁹⁵	\$26 ⁰⁵
C2055	2-5/8"	1-1/16"	3/4"	\$32 ⁹⁵	\$29 ⁶⁵
C2056	2-5/8"	1-1/4"	1"	\$35 ⁹⁵	\$32 ³⁵



Flute

These cutters work great for reproducing period architecture.

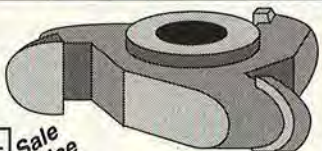

3/4" BORE

PART	CUTTER DIA. A	CUTTING LENGTH B	PRICE	Sale Price
C2046	2-5/8"	1/4"	\$24 ⁹⁵	\$22 ⁴⁵
C2047	2-5/8"	3/8"	\$26 ⁹⁵	\$24 ²⁵
C2048	2-5/8"	1/2"	\$28 ⁹⁵	\$26 ⁰⁵
C2049	2-5/8"	3/4"	\$32 ⁹⁵	\$29 ⁶⁵
C2050	2-5/8"	1"	\$35 ⁹⁵	\$32 ³⁵



1-800-235-0272

CALL 24 HRS. A DAY & ASK FOR A FREE CATALOG!

EXCLUSIVE DISTRIBUTORS OF INDUSTRIAL CARBIDE TOOLING

MasterCard VISA

FREE SHIPPING ON ORDERS TOTALING \$100⁰⁰ OR MORE!

TALKING BACK

Continued from page 6

Turning tiny trinkets: Need lathe

Due to my interest in wood jewelry, I would like to purchase a lathe for small turnings. Where do I purchase a lathe of less than 12 inches in length?

—Emilia L. Munch, Franklinton, La.



In our January 1992 issue (No. 49, pages 25-29), we ran a story on Bonnie Klein, a talented lady who turns miniature objects on a small lathe that she designed and sells. To buy one, write: Klein Designs, 6415 115th Place S.E., Renton, WA 98056.

Milk paint needs more punch

I tried the milk paint recipe that you ran in your August 1991 issue (No. 44). I was surprised that it worked. It felt like a latex paint after it dried, except for one problem. It seems to come off with a wet cloth. Perhaps I cooked it too long or did something wrong. Can you suggest a cure?

—Gerald Spalla, Cannonsburg, Penn.

Gerry, the milk paint recipe we published does not include lime, a key ingredient in old-time milk paint. We asked Bess Naylor, owner of the Olde Mill Cabinet Shoppe in York, Pennsylvania, and an expert on milk paint, to give us a better understanding of this product. Here's her response:

"Artisans and craftsmen relied on milk paint or casein-based paints from the time they picked up their first paintbrush. Not only are the paints inexpensive and easily available, but they have a longevity unsurpassed by other finishes. Here's why:

"Casein is curd, a precipitate formed from soured skim milk. Casein gives milk paint its bonding strength. The curd is separated from the whey (the liquid part) and dried. The addition of an alkali, such as lime, makes the material water-soluble and the paint more durable. After lime is added, you can add various pigments to make different colors. Here is a time-honored recipe:

- 4 lbs. skimmed milk, 4 ozs. linseed oil, 6 ozs. lime (freshly slaked), and 3 lbs. whiting (or other pigments). Place lime in a container and pour the milk over it. Add oil slowly while stirring. Add whiting or pigments by distributing evenly on surface while mixing. The recipe makes 1/2 gallon.

"This recipe is from *The Painters and Varnishers Guide*, by P.F. Tingry, Sherwood, Neely & Jones, Paternost Row, London, England.

"We carry an excellent commercial formulation of milk paint in our store. For a free copy of our catalog, write to me at the following address: Bess J. Naylor, Olde Mill Cabinet Shoppe, 1660 Camp Betty Washington Rd., York, PA 17402."

Continued on page 10

Turn empty space into EXTRA STORAGE!

Build Professional-Quality Furniture
Even If You've Never Worked Wood Before!

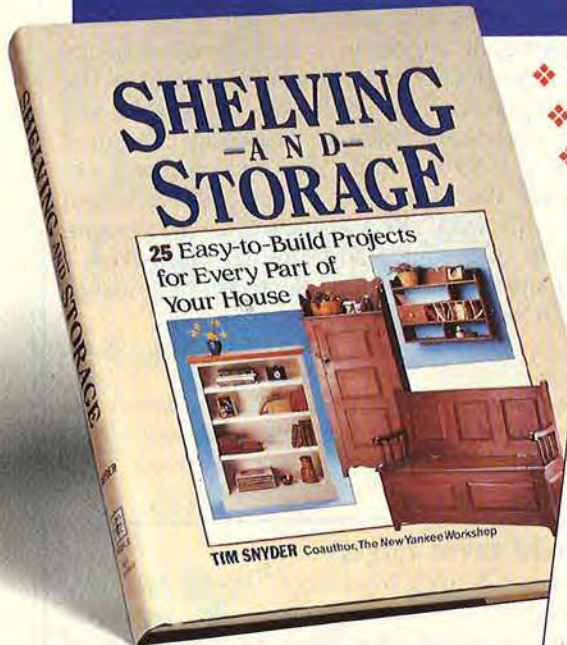

- ❖ 25 easy-to-build projects
- ❖ Detailed step-by-step instructions
- ❖ Over 375 photos, drawings, diagrams and exploded views
- ❖ Professional "secrets" that guarantee success
- ❖ Sources for tools, hardware and accessories
- ❖ And more!

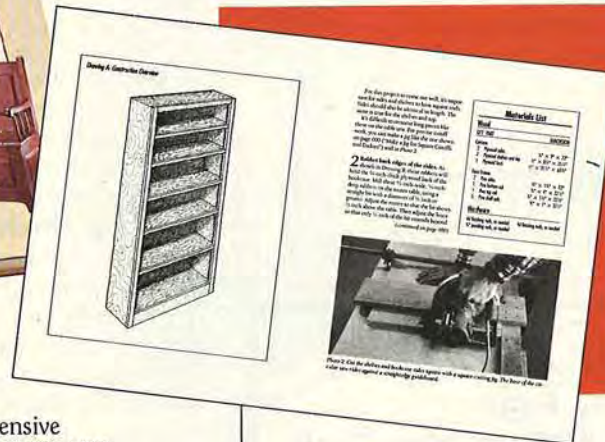

FREE
21-DAY
SHOP TEST

Let master carpenter Tim Snyder show you how to build beautiful, customized storage *quickly, easily, and inexpensively*. All you need are a few basic power tools, some inexpensive materials and Tim Snyder's **SHELVING AND STORAGE**.

This all-new volume gives you everything you need to build . . . assemble . . . finish . . . and install 25 space-saving projects for every room!

Build a colonial storage bench . . . a set of spacious utility shelves . . . a chest of drawers . . . a toybox . . . even a complete wall closet—without breaking your budget.

What's more, you'll learn the kind of wood-working savvy it takes years to accumulate, including how to:

- ❖ Make traditional mortise-and-tenon joints on your table saw.
- ❖ Compensate for irregular surfaces and out-of-plumb walls.
- ❖ Raise panels without warping or cracking them.
- ❖ Build a table-saw duplicating jig.
- ❖ And much more.



In just a weekend!
Make this formal bookcase for your living room — for only \$50!

Simply clip and mail this coupon and we'll rush you a copy of **SHELVING AND STORAGE** to examine free without risk or obligation to buy. Plus we'll also send you a copy of *Building Outdoor Structures*—yours free just for looking.

FREE 21-DAY SHOP TEST!

YES! Send me my free copy of *Building Outdoor Structures* and a copy of **SHELVING AND STORAGE** to shop-test free for 21 days. If I decide to keep **SHELVING AND STORAGE**, I'll pay for it in three easy installments of \$8.99 (\$10.65 CDN funds plus GST) each, plus postage and handling. (There is no interest or finance charge.) Otherwise, I'll return the book with the invoice within 21 days and owe nothing. *Building Outdoor Structures* is mine to keep no matter what I decide.

42630

Name _____

Address _____ Apt# _____

City _____ State _____ Zip _____



Send no money now. Just clip and mail this coupon today to:
RODALE BOOKS, Emmaus, PA 18098

ROBLAND X 31

THE INTELLIGENT ONE-MAN SHOP



- 1100 lbs. • 3 separate 3HP motors • 12" jointer • 12" planer • 10" table saw
- 3HP shaper • mortiser • tremendous space saver

The Robland X 31 is designed to make maximum use of minimum space, ideal for the small professional shop and the demanding hobbyist. Change from one tool to another in 20 seconds or less! Solid, sturdy, reliable.

2081 LAGUNA CANYON RD., LAGUNA BEACH, CA 92651

LAGUNA TOOLS

1-800-234-1976 or 714-494-7006



WOODCRAFT

*The Leading Edge
in Woodworking Tools*

FREE Tool Catalog

Our complete woodworking tool catalog features over 4,000 of the finest quality woodworking tools, books, and supplies available today.

See the difference
yourself
FREE!



Order yours today!
Call 1-800-542-9115

Or write: Woodcraft, Dept. 92WI04Q
210 Wood County Industrial Park
P. O. Box 1686
Parkersburg, WV 26101-1686

TALKING BACK

Continued from page 8

New, improved code for Marlow Woodcuts

If you are writing to Marlow Woodcuts, makers of fine scrollsaw ornaments (September 1991, issue No. 45), you'll want to use this updated address: Marlow Woodcuts, Box 297, 706 Locust St., Americas, KS 66835.

Old cabinet goes high tech

I just completed a television cabinet project of my own when I noticed Larry Clayton's article in the October 1991 issue. I really had fun doing this, and the project just didn't seem to last long enough. I started with a 1959 Admiral floor console made entirely of solid oak. I replaced the 23" black and white unit with a 25" RCA color-track remote unit. With the help of a router and Dremel Moto-Tool, I managed to shoehorn the new electronics right into the cabinet. It works great!

—Jim Ross, *Linthicum, Md.*

Jim, thanks for sharing your experience with us. Be sure to see our article on retrofitting an old television cabinet on pages 82-83 in the February 1992 issue (No. 50).

Safety shield saves fingers

Your "Quick-as-a-Wink Chisel Rack" in the February 1991 issue (No. 41) is a splendid idea. However, each time I see racks like these on the walls of my friends' shops, I get cold chills. Chisels hanging from wall racks pose a safety threat. We all know they are sharp as knives and can slice a finger quite easily. My suggestion is to surround the chisels with acrylic plastic, a transparent material that any woodworker can cut easily in his or her shop. I hope this "clears up" a possible hazard.

—Ralph Castberg, *Diamond Springs, Calif.*

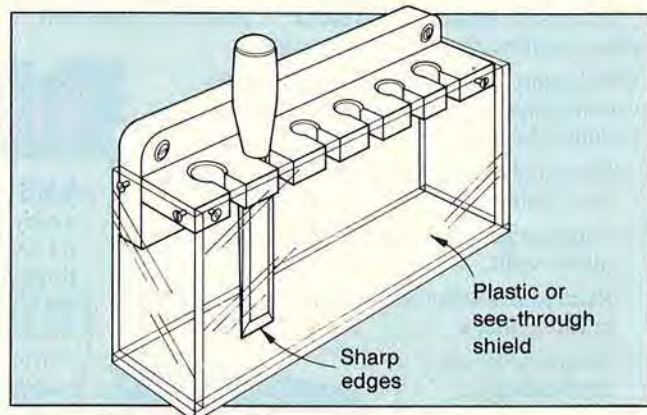

Good safety idea, Ralph. We'll pass it on to the readers through the drawing above. (It's based on your drawing.) You can purchase acrylic plastic at most hardware stores, homecenters, or at stores specializing in plastic sheet goods. ♣

Another "buy 1 tool get our 228 page tool free" offer.

Just a few of the unique woodworking tools of the 3,500 others available from our most versatile tool, the 1992 Garrett Wade Catalog. The 228 page catalog is Free with any order from this ad. Or if you would just like the catalog, send us \$4.00 with your name and address.

A / 2 Band Saw Books by Mark Duginske

Learn what makes your bandsaw tick. Tune-up and maintenance; blade selection, tracking and tensioning; plus cutting methods for various woods and other materials. Hundreds of tips and shortcuts. Unlock your saw's potential.

- 02L09.03 Band Saw Basics \$ 9.95
16L04.02 Band Saw Handbook \$16.95

B / The Saw Setting Gauge That Can Be Read From Any Position

Most gauges have at least one or two main weaknesses. They either rest partially on the insert plate which is usually not the same height as the main table, or are so thin that it is difficult to ensure that teeth are being gauged at the top of the arc. This gauge is made from machined 3/4" thick Aluminum and is 9" long. With 1/4" graduations on one end and 1/8" on the other, it will indicate any height from 1/8" to 2". Most useful for table saws but also handy for routers. The markings are vertical on one face and horizontal on the other, so you can read them easily and accurately.

- 71K26.02 Saw Setting Gauge \$17.95

D / Our 202GF Gap Filling Glue Fills Gaps

It has a very high solids content so that small gaps in our joinery are actually filled - with strength. And the "squeeze-out" beads right up and chips off when dry. No soaking in to ruin finishes. Dries to a light tan. Water clean-up.

- 62J01.01 1 pt. 202GF \$ 7.25
62J01.03 1 qt. 202GF \$13.10

C / 1/16" Super Narrow Blades

You may have never seen a blade like this. A 24tpi raker style, it produces smooth cuts while making incredibly tight turns. We recommend using our Cool Blocks with these delicate blades, because they can be set closer to the blade without danger of overheating.

Cabinetmaker's Special Bandsaw Blades

A Garrett Wade exclusive. They look like "skip tooth" blades. But each tooth is actually formed as a hook, with every 5th tooth an unset raker. The result is a very smooth cutting blade that feeds easily. 1/4" blade is for general work, and 1/2" for resawing and heavy straight sawing.

- 93 1/2" Blades (Delta 14" and copies)
33K11.01 1/16" Scroll \$15.95
33K11.02 1/4" (4 tpi) Cabinet \$11.95
33K11.03 1/2" (3 tpi) Cabinet \$12.95



- 80" Blades (Sears 12")
33K12.01 1/16" Scroll \$14.95
33K12.02 1/4" Cabinet \$10.95
33K12.03 1/2" Cabinet \$11.95
72" Blades (Shopsmith)
33K13.01 1/16" Scroll \$13.40
33K13.02 1/4" Cabinet \$10.25
33K13.03 1/2" Cabinet \$10.95

E / The "Blind Nailer" Used To Be A Staple In Every Finish Carpenter's Tool Box

This unique tool allows you to set nails or brads invisibly. Slip the special chisel, with its finger nail shaped cutting edge, into the positioning jig and tighten the clamping screw. Place the flat sole on the wood and strike the end of the chisel with a firm tap with the palm of your hand. The Blind Nailer will lift a perfect small chip from the surface. Hammer your nail or brad in and then glue the chip back in place.

- 44K01.04 Blind Nailer \$19.95

F / Special Bandsaw "Cool Blocks" Prolong Blade Life & Increase Accuracy

Made of a special graphite impregnated Phenolic laminate, this set of 4 replaces your upper and lower side blade guides. Cool Blocks run cooler and are more slippery than conventional steel guides. Since they can be set actually touching the blade, they give you better control of the cut.

- Model
33K09.01 "A" Delta 14" \$11.95
33K09.02 "B" Sears 12" \$11.95
33K09.04 "D" Shopsmith \$12.95
33K09.05 "E" Old Sears (1/4" Rd.) \$11.95
33K09.06 "F" Jet 14" (fits Delta copies) \$11.95
33K09.20 "K" New Tilt-Head Sears \$16.95



Garrett Wade Co., Inc.

161 Avenue of the Americas
New York, NY 10013 Dept. 146

Call Toll Free 800-221-2942
(NY 212-807-1757 No Collect Calls Please)

Please send me these Garrett Wade tools and include a FREE 1992 Catalog with my order. (Prices good until September 14, 1992)

Name: _____

Address: _____

City: _____ State: _____ Zip: _____

Check or Money Order Discover

Visa MasterCard

American Express

Expiration Date: _____



STOCK#	QTY.	DESCRIPTION	PRICE	TOTAL
GW	1	1992 Catalog (free with order from this ad)	\$4 00	

New York Residents add applicable Sales Tax
Shipping & Handling: \$3.25 for order total up to \$10
\$4.55 for \$10.01 to \$20
\$5.45 for \$20.01 to \$50
\$6.90 for over \$50.

Sub Total
Sales Tax
Shipping
Grand Total

You Can't Top



8" DRILL PRESS



8 1/4" COMPOUND MITER SAW



CONTRACTOR SERIES
10" COMPOUND MITER SAW



8" BENCH TOP TABLE SAW



10" DRILL PRESS



10" COMPOUND MITER SAW



CONTRACTOR SERIES
8 1/4" SLIDE COMPOUND MITER SAW



10" BENCH TOP TABLE SAW

Because Craftsman has the most complete line of quality bench top power tools in the industry... backed up by the Craftsman guarantee of satisfaction and Sears legendary service.

You can't top that promise of reliability because we life-test every new Craftsman bench-top tool we design. In fact, it takes ten separate steps just to jam-test our radial arm saw. And that's only one of 40 separate tests we run on this saw. To motor-test our 8 1/4" slide compound miter saw, we put it through 20,000 cycles in less than three working days.

Our Bench Tops...



4"x6" BELT/DISC SANDER



8 1/4" COMPACT RADIAL SAW



13" SCROLL SAW



16" SINGLE SPEED SCROLL SAW



10" BENCH TOP BAND SAW



12" WOOD LATHE



16" VARIABLE SPEED SCROLL SAW



CONTRACTOR SERIES
20" SCROLL SAW
(INCLUDES LEG SET)

Our 20" variable speed scroll saw was tested at its maximum speed of 2,000 rpm for 500 hours. Of course, then we ran it some more at 150% of its maximum, to insure it will pass every test our customers can give it.

To see all of these great looking bench-top tools for yourself, just zip on down to your Sears store. Or order direct from our Sears catalog, 1-800-366-3000, toll-free, 24 hours a day, 7 days a week.

CRAFTSMAN®

Only at Sears



EARN CASH, PRIZES FOR YOUR TOP SHOP TIP

Do you have a great shop tip (or two) you'd like to share with other WOOD® magazine readers? For each published submission, you will get at least \$25 from WOOD magazine (as much as \$200 if we devote a page or more of space elsewhere in the magazine to your idea). You also may earn a woodworking tool for submitting the Top Shop Tip for the issue.

We try not to use shop tips that have appeared in other magazines, so please send yours to only one. We do not return shop tips. Mail your tip(s), address, and daytime phone number to:

Top Shop Tip
WOOD magazine
P.O. Box 11454
Des Moines, IA 50336-1454

Organize quickly with moldings and hardboard

Few things can become as cluttered as a workbench drawer. Your valuable shop time ticks away while you rummage through your tool drawer, trying to uncover the router wrenches or some other tool you need.

TIP: Establish a separate compartment for each tool and its accessories with custom drawer dividers. Assemble them quickly with quarter-round molding, hardboard, and hotmelt glue as shown below.

—Edward Kreusser, M.D., San Diego, Calif.

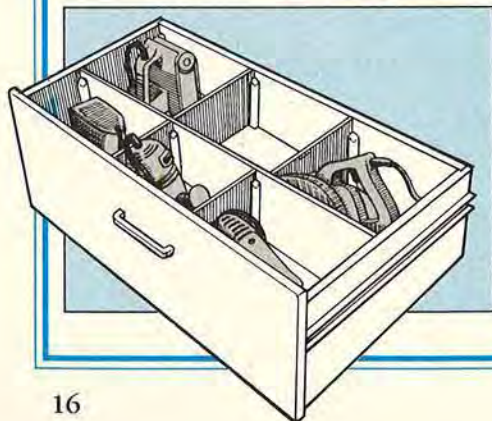

Router shaves edge for gap-free joint

You're troubled by gaps along the mating line between the top and bottom parts of a small box you've just completed. Is there some way to true up the mating edges without resorting to a lot of sanding or planing?

TIP: This is a job for your table-mounted router fitted with a straight bit. For each part, cut spacer blocks about 1/8" taller than the inside depth. Fasten them inside the part with double-faced tape. Then, place the part upside

For his winning tip, George will receive a Ryobi RS115 random orbit sander, right.



down on the router table as shown below. Adjust the router to take a light cut—about 1/32"—off the edge all around. Do the same for the other part. You'll end up with flat, true mating surfaces for a lid that fits the way you want it to.

—George E. Casey, Tacoma, Wash.

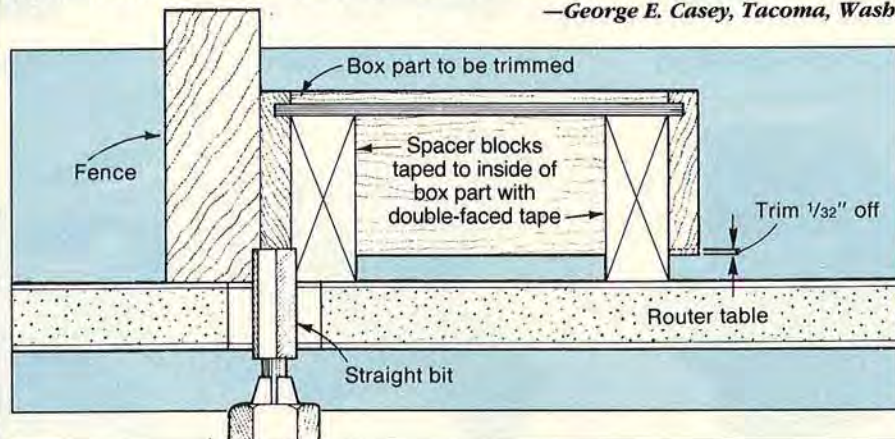

Plumbing part grips clamps for easy gluing

Clamping a large glue-up with pipe clamps can turn into a wrestling match. The task becomes much easier if you secure the clamps to a clamping table, but finding a way to attach the clamps to the table can become a battle, too.

TIP: Plastic holders for 3/4" plastic plumbing pipe, such as the Genova #52107 illustrated, provide an inexpensive, effective solution.

Steel 3/4" pipe snaps right in, and the holder has enough grip to keep the clamp from tipping over while you lay your glued-up stock in place. Mount the holders on two 3/4x1" strips, spaced to meet your needs, and then attach the strips to a piece of plywood to make a portable clamping table. Available from hardware stores, homecenters, or plumbing shops, the pipe holders ordinarily cost about 15¢ apiece.

—H. Dick Reynolds, Jr., Mediapolis, Iowa

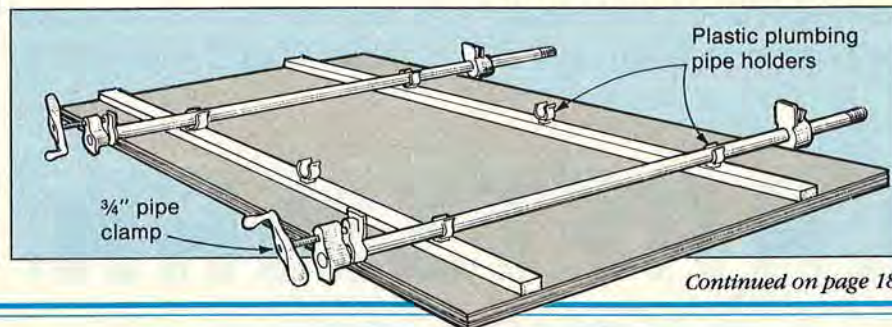

Continued on page 18

WHOLESALE

Discount Prices

GUARANTEED LOWEST POWER TOOL MAIL-ORDER PRICES ANYWHERE!

RYOBI 10" SLIDING TABLE SAW WITH FREE STAND



MODEL BT3000S
21-01 **\$529**

RYOBI 10" PLANER
MODEL AP10

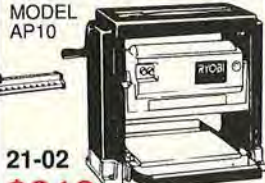

21-02 **\$319**

RYOBI 10" MITER SAW
MODEL TS254



21-03 **\$169**

RYOBI PLANER/JOINTER
MODEL JP155

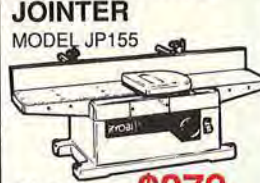

21-04 **\$279**

RYOBI 16" SCROLL SAW
MODEL SC160



21-05 **\$129**

RYOBI RANDOM ORBIT SANDER
MODEL RS115



21-06 **\$67**

RYOBI 3 HP ROUTER
MODEL R600

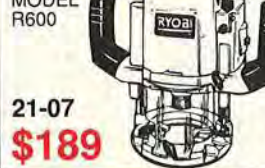

21-07 **\$189**

RYOBI 4" GRINDER & WOODCARVER
MODELS G1155C AND WC101

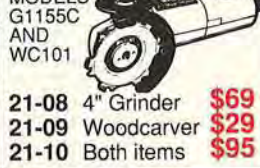

21-08 4" Grinder **\$69**
21-09 Woodcarver **\$29**
21-10 Both items **\$95**

RYOBI BISCUIT JOINTER
MODEL JM100K



21-11 **\$197**

RYOBI DRYWALL DRIVER
MODEL E3800



21-12 **\$65**

RYOBI PALM SANDER
MODEL S500A



21-00 **\$34**

RYOBI DRYWALL CUT-OUT
MODEL DCU65



21-13 **\$67**

RYOBI 8 1/4" RADIAL ARM SAW
MODEL RA200



21-14 **\$229**

RYOBI LAMINATE TRIMMER
MODEL TR30U

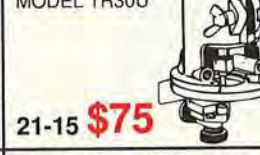

21-15 **\$75**

RYOBI BELT SANDERS
MODELS BE321 BE424



21-16 3" X 21" **\$125**
21-17 4" X 24" **\$163**

RELIANT 1 HP 14" BAND SAW CLOSED BASE
MODEL DD90



21-18 **\$259**

RELIANT DUST COLLECTORS
MODELS NN720, NN820, NN830



21-19 1 HP **\$199**
21-20 2 HP **\$299**
21-21 3 HP **\$429**

RELIANT 15" PLANER WITH STAND
MODEL DD37



21-22 **\$795**

RELIANT 6" BELT, 9" DISC SANDER WITH STAND
MODEL DD69



21-23 **\$199**

RELIANT 6" WITH JOINTER WITH STAND
MODEL DD38



21-24 **\$259**

RELIANT 18" SCROLL SAW
MODEL AL18



21-25 **\$219**

BOSCH 5" RANDOM ORBIT SANDER
MODEL 3263DVS



21-26 **\$107**

PORTER CABLE 6" SAW BOSS
MODEL 345



21-27 **\$99**

MAKITA BLADE SHARPENER
MODEL 98202



21-28 **\$197**

SKIL 12V CORDLESS DRILL/DRIVER W/2 BATTERIES
MODEL 273504



21-29 **\$125**

MORE RYOBI

- 21-30 TS220 8" Sliding Compound Miter **\$419**
- 21-31 1323ALSK Long Shoe Planer **127**
- 21-32 331 2 HP Router **149**
- 21-33 W660 7 1/4" Circular Saw **79**
- 21-34 S45 1/3 Sheet Sander **59**

MORE SKIL

- 21-35 1605 Biscuit Joiner **\$129**
- 21-36 77 7 1/4" Worm Drive Saw **149**
- 21-37 7484 Random Orbit Sander **99**

MORE MAKITA

- 21-38 6200DW Extra Torque Driver/Drill **\$143**
- 21-39 6170DW 7.2V Driver/Drill **67**
- 21-40 DA390DW 9.6V Cordless Angle Drill **149**
- 21-41 6402 3/8" VSR Drill 5.2 amp **97**
- 21-42 4200N 4 3/8" Circular Saw **129**
- 21-43 LS1011 10" Slide Compound Miter **439**
- 21-44 3612BR 3 HP Router **165**
- 21-45 1900BW 3 1/4" Planer **112**
- 21-46 9401 4" x 24" Belt Sander **173**
- 21-47 9924DB 3" x 24" Belt Sander **153**

MORE BOSCH

- 21-49 1581VS Top Handle Jig Saw **\$137**
- 21-50 1582VS Barrel Jig Saw **137**
- 21-51 1604 1 3/4 HP Router **135**
- 21-52 3272 3 1/4" Planer **99**

MORE RELIANT

- 21-54 DD55 17" Floor Drill Press **\$279**
- 21-55 EE30 3 HP Shaper **795**
- 21-56 NN100 40" Lathe W/Stand **199**
- 21-57 DD12 12" Table Saw **469**

WHOLESALE DIVISION
DEPT. WWD42
PO BOX 189
MALDEN, MA 02148

SPECIAL SHIPPING & HANDLING
\$500/Each Order TRUCK SHIPMENTS **\$3000**
TO 48 States Additional for each truck item only.

ORDER TOLL FREE 800-736-6586

MAJOR CREDIT CARDS ACCEPTED
VISA M.C. DISCOVER

GUARANTEE
If not fully satisfied, return unused in original package within 30 days for full refund or exchange.

OFFER EXPIRES 4/30/92 Misprints subject to correction. MA, ME, RI RESIDENTS ADD SALES TAX

Exclusively Performax Precision Drum Sanders

5
YEAR
ANNIVERSARY

Our Customers Say: "You know you really oughta tell people that the Performax really does what you say it'll do."

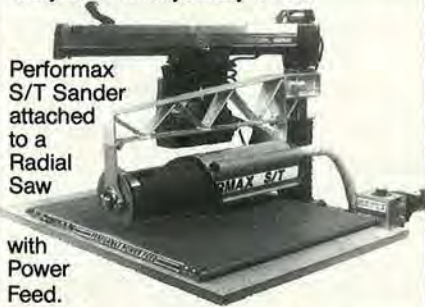

Performax S/T Sander attached to a Radial Saw

with Power Feed.

So After 5 Years of Ads, Here Goes: It really is rigid. It really does sand 44" wide in two passes. It really is precise. It really is affordable. It really does have new and really improved abrasive fasteners. It really is the best drum sander money can buy. It really will exceed your expectations.

A REALLY BIG THANK YOU TO ALL WHO MADE THIS ANNIVERSARY POSSIBLE.

For a Free Brochure and the Dealer Nearest You Call
1-800-334-4910

or (612) 895-9922

or write: PERFORMAX PRODUCTS, W1
12211 Woodlake Drive, Burnsville, MN 55337

BUILD THIS CLASSIC "Roll Top" OAK DESK from pre-cut first quality kit



Here's the turn-of-the-century "Roll-Top" you've always wanted. A full size oak desk, yours now at extraordinary savings . . . because you build it yourself from pre-cut kit parts. No special tools needed. When finished, you'll possess a magnificent showpiece for your home or office — worth at least twice what you pay for the kit! Send for details without obligation.

FREE Full color catalog gives you all the facts

Please send my free Craftsman's Corner color catalog featuring the Classic Roll Top Desk and many other top quality hardwood kits. I understand I have no obligation.

Print Name _____

Address _____

City _____

State _____ Zip _____

CRAFTSMAN'S CORNER
Dept. WD • 4012 N.E. 14th St. • Box AP
Des Moines, IA 50302

TIPS FROM YOUR SHOP (AND OURS)

Continued from page 16

For a satin finish, apply gloss first

Satin or semigloss varnishes contain dulling agents that can cloud your finish after the necessary multiple applications.

finish doesn't cloud up as much, and its reflective surface reveals flaws better. And, you can easily tell which areas have received less sanding than others. Finally, add a satin top coat.

TIP: When you want a satin finish, apply the same brand of gloss varnish for the undercoats. The gloss

—Kenneth R. Thornley,
West Hartford, Conn.

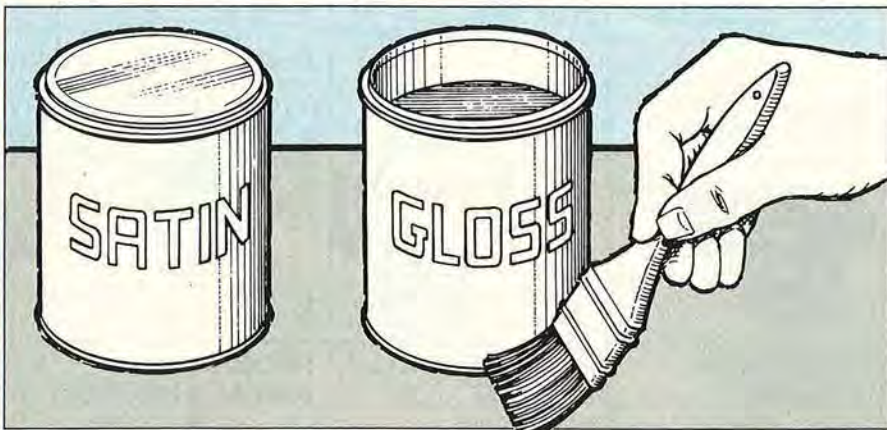

Radial-arm saw gets into swing with thinner table board

You need to readjust the miter angle on your radial-arm saw. Unfortunately, that means you must again raise the arm so the blade will clear the table, make your adjustment, and then lower it again. What a lot of bother!

of 1 1/16"-thick particleboard, for instance, just cut a piece of 1/2"-thick particleboard to fit in place of the thicker piece. (Save the piece you take out for possible future use.) With the thinner piece in place, your blade will clear the table easily without raising the arm, and you can adjust your miter angle in short order.

TIP: Replace the section of the saw table behind the fence with thinner material. For a table made

—David Ryan, Columbus, Ohio

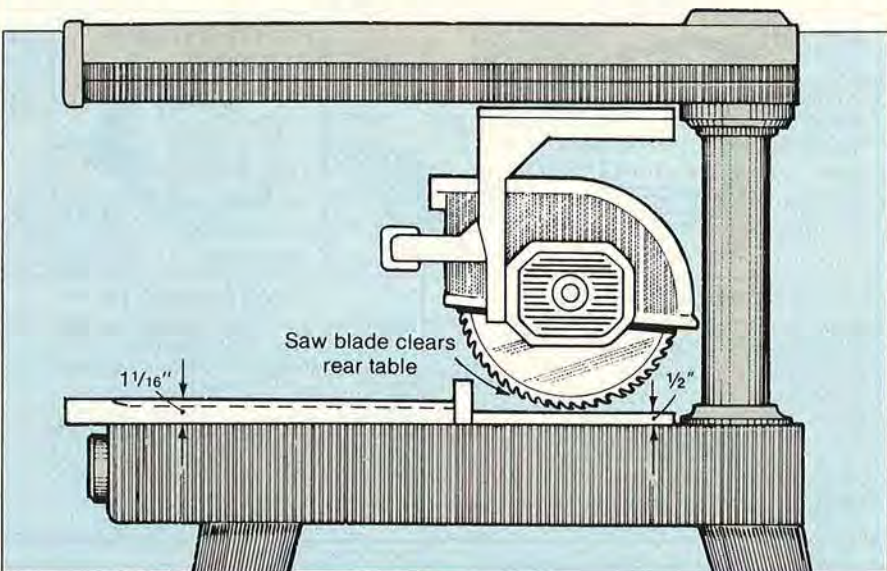

Hinge swings into action when holes require spacing

Drilling a series of accurately spaced holes can be a grueling task. Even a small misalignment becomes a glaring error in a row of evenly spaced holes.

TIP: Line up those holes smartly with a simple spacing jig for your drill press. Attach a fence (thicker than the material you'll be drilling) to the wooden auxiliary table of your drill press. Drill out the end hinge hole on the long arm of a T-hinge to accept a machine screw the diameter of the hole you'll be drilling.

Now, secure the hinge to the fence top so that the distance from the fence to the screw equals the distance from the edge of the board to the hole location. Clamp the jig to the drill-press table so that the distance from the drill bit to the screw is the same as

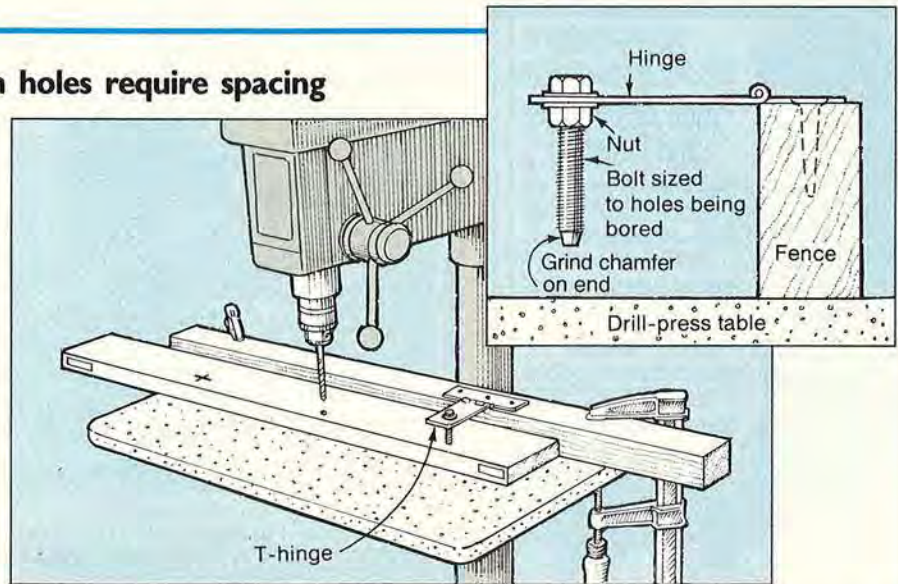

the space between the holes, and the distance from the drill bit to the fence equals the distance from the edge of the board to the hole.

With the jig in place, measure, mark, and drill the first hole. Now, slide the workpiece along

the fence. The screw on the hinge will fall into the drilled hole to stop the board in the correct position for drilling the next hole. Repeat the process to drill the rest of the holes with accurate spacing.

—Ed Abrams, Greenville, N.Y.

Continued on page 20

Be your own boss in one of today's fastest-growing fields. Be a home inspector!

Let NRI at-home training be your first step toward a business of your own where you can earn as much as \$1,000 a day!

Home inspection is fast becoming one of today's hottest career fields. Already one out of every four homes sold is inspected ... and experts say demand is growing 30% to 50% a year. Plus, while the average job takes only a few hours to do, inspectors can make from \$100 to over \$300 per home! Now with NRI, you can, too.

Get the tools you need to set up shop fast — including a computer and home inspection software you keep

From foundations, floors, and roofs to insulation, plumbing, ventilation, and radon testing, NRI training covers every important phase of the home inspection process. NRI even gives you hands-on experience with the tools you need to get into the home inspection business fast. Architect's scale, feet-and-inches calculator, folding rule, Polaroid camera, radon test kit: They're all yours to train with, keep, and use on the job. Plus you get the one piece of equipment no successful home inspector should be without ...

Only NRI gives you a powerful computer system, complete with exclusive home inspection software! Under the guidance of



your NRI instructor, you learn how to use your computer and software to create the kind of comprehensive inspection reports clients pay top dollar for.

Your FREE NRI catalog tells more

Learn how to earn extra cash in your spare time or run your own full-time inspection business! If the coupon is missing, write to NRI Schools, McGraw-Hill Continuing Education Center, 4401 Connecticut Avenue, NW, Washington, DC 20008.

SEND TODAY FOR FREE CATALOG!

NRI Schools
McGraw-Hill Continuing Education Center
4401 Connecticut Avenue, NW, Washington, DC 20008



For career courses approved under G.I. Bill,
 check for details

Check one FREE catalog only:

- | | | |
|--|---|--|
| <input type="checkbox"/> HOME INSPECTION | <input type="checkbox"/> Automotive Servicing | <input type="checkbox"/> Microcomputer Servicing |
| <input type="checkbox"/> Electrician | <input type="checkbox"/> Small Engine Servicing | <input type="checkbox"/> Computer Programming |
| <input type="checkbox"/> Building Construction | <input type="checkbox"/> Locksmithing | <input type="checkbox"/> Appliance Servicing |
| <input type="checkbox"/> Air Conditioning, Heating & Refrigeration | | <input type="checkbox"/> Gunsmithing |

Name _____ Age _____

Address _____

City _____ State _____ Zip _____

Accredited member, National Home Study Council

1348-032

Do-It-Yourself Kits



**Factory Direct
Clocks and Furniture**
**Also Assembled
and Finished**

- Grandfather Clocks, Mantel and Wall Clocks
- Curios, Tables, Chairs, Desks, Cradle...and more!
- Solid 3/4" Black Walnut, Cherry, or Oak
- Heirloom Quality
- Solid Brass West German Movements and Dials
- Money Back Guarantee



I am interested in
 Do-It-Yourself Kits
 Finished Clocks
 Finished Furniture

SEND \$1 FOR COLOR CATALOG

Name _____
 Street _____
 City _____
 State _____ Zip _____
 (Please Print)



**EMPEROR
CLOCK COMPANY**
 World's Largest Manufacturer of Grandfather Clock Kits
 Dept. 4219 Emperor Industrial Park
 Fairhope, Alabama 36532 • Phone 1-205-928-2316

WEINER DOG

This loveable Dachsund will capture your heart. Wind-up music box plays "How Much Is That Doggie In The Window" while his tail wags. Parts Kit includes all necessary parts - no lumber.



#01576 Plans 4.00
 #04576Z Plans & Parts 11.50
 #04576 Parts Only: 8.00Ea, 21.90/3, 65.90/10

TURNINGS
 #16001 3-1/2" Shaker Peg SPECIAL - 12.50/100
 #16021 2-1/2" Shaker Peg 7.50/50, 13.75/100
 #16041 1-3/4" Shaker Peg 7.50/100, 15.00/250
 #16081 1" Shaker Peg 5.50/100, 23.75/500
 #18031 Large Candle Cup 9.50/50, 17.00/100
 #18091 Brass Inserts 5.50/50, 9.00/100
 #13106 3/4" dia. Wood Ball 5.20/50, 7.90/100
 #13108 1" dia. Wood Ball 6.70/50, 10.90/100
 #13112 1-1/2" dia. Wood Ball 15.25/50, 29.00/100
 #13116 2" dia. Wood Ball 8.90/10, 42.00/50

WHEELS
 #10648 1" x 3/8" Wheel 5.50/100
 #10710 1-1/4" x 7/16" Wheel 7.50/100
 #10812 1-1/2" x 1/2" Wheel 6.00/50, 10.50/100
 #10914 1-3/4" x 9/16" Wheel 8.50/50, 15.00/100
 #11016 2" x 5/8" Wheel 9.50/50, 17.00/100
 #12001 7/32" Axle Peg ... 2.00/50, 3.10/100, 14.00/500

MISC. PARTS
 #62501 Door Harp Tuning Pegs ... 10.00/50, 17.00/100
 #13156 3/4" Drilled Clapper Balls 5.00/50, 8.00/100
 #62515 1/4-lb. #4 Door Harp Wire (540-ft.) 9.95
 #33018 1-1/4"x1/8" Hrdwd. Heart . 5.50/100, 12.50/250
 #50321 1/2"x1-7/8" Pic. Hanger ... 4.00/100, 17.50/500
 #50021 Self-Fastening Sawtooth .. 4.00/100, 17.00/500

CRAFTER'S MART

Box 2342-W • Greeley, CO 80632
 64-Page CATALOG: \$2 with credit towards first order, Free with any order. Check, MasterCard or VISA (include daytime phone, card no., exp. date & signature).
 PROCESSING CHARGE: Continental U.S. \$4;
 AK, HI, APO & FPO \$10; Canada \$16; Foreign 20% plus \$10 (U.S. Funds). CO Res. add 3% tax. No C.O.D.s.
 PHONE ORDERS: 8am-5pm Mon-Fri, Mountain Time.
 Information: (303) 351-0676

1 - 800 - 999-3445

TIPS FROM YOUR SHOP (AND OURS)

Continued from page 19

Scrapwood eases pressure caused by clamp shortage

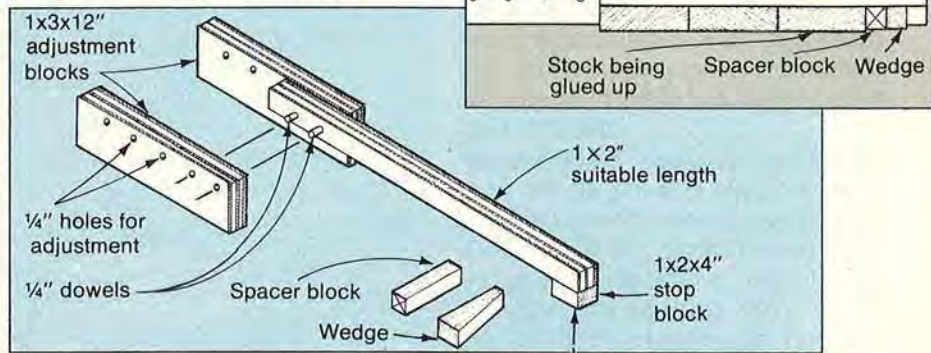

After you gather all of your clamps together, you're one short of the number you'd like to have for an edge-gluing job.

TIP: Take a few minutes to build a clamp from scrapwood. Select a piece of 1x2 stock about 18" longer than the width of your assembled stock. Attach a 1x2x4" stop block at one end, and then drill two dowel holes 2" apart in the other end as shown above. Insert dowels so that they extend 1" from each side of the clamp

board. Then, drill dowel holes on 2" centers through two 1x3x12" pieces for the adjustment blocks.

To use the shop-built clamp, place the clamp board over the work to be glued. Slip an adjustment block over the dowels on each side, placing them to allow about an inch of extra width between the work and the clamp slot. Then, place a spacer block and a wooden wedge at the fixed end of the clamp slot and drive the wedge in to clamp the work.

—Dan Craney, Oak Ridge, N.J.

Pipe clamps provide basis of a hefty end vise

You want to add an end vise to your workbench sooner or later. You'd prefer to do it sooner, but there just isn't room in your tool budget for it right now.

TIP: Fashion your own end vise from some lumber and a pair of 3/4" pipe clamps. Bore holes through the bench end for the clamps, following the example

shown below. Install blocking as needed to transfer clamping forces to the sliding clamp jaw instead of the workbench supports. Add a 1x4 for the fixed jaw at the end of the bench, and then construct the laminated movable jaw shown. The butterfly openings allow the jaw to swivel to accommodate objects having non-parallel sides.

—Floyd Jines
Baton Rouge, La.

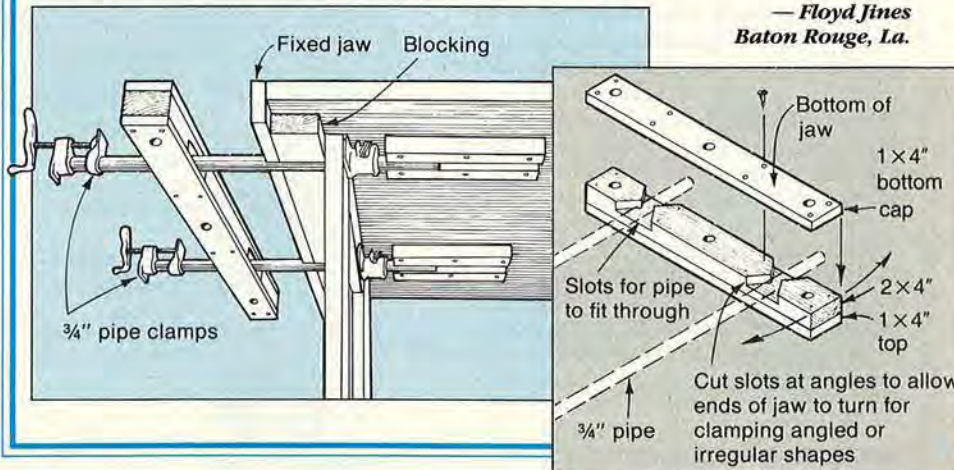

Bend a strip to hold work flat

To make a good cut with a table-mounted router, you must hold the work down firmly. Doing that without getting your fingers into the danger zone can be a challenge, particularly with an irregular workpiece.

TIP: Build a springy hold-down like the one shown below. Rip a 1/8" strip off the edge of a 24" length of 2x4. Cut a 10° angle at each end of the 2x4 where shown, and then glue on the strip to form an arch. The curved strip will press your workpiece down firmly while you rout it.

—Bruce Graham, Bennington, Kan.

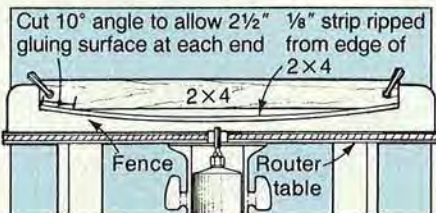

To bandsaw a true edge, set up an extra-long fence

You need to cut a true edge on a board. The only problem is, you don't have a tablesaw or radial-arm saw, only a bandsaw.

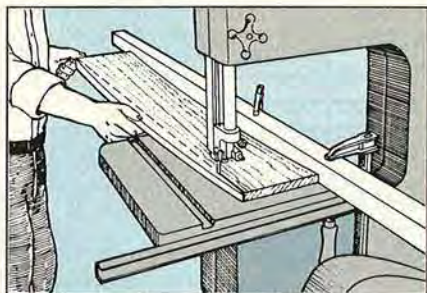

TIP: Add a long fence to your bandsaw to true that board. Make one a few inches longer than twice the length of the board you want to true. Clamp it to the saw table, extending a little more than a board length on each side of the blade, and then saw with your widest blade. Cut the second edge against the standard fence.

—Cheryl Diggs, Virginia Beach, Va.

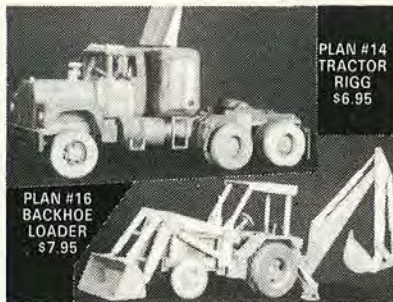

PLAN #14
TRACTOR
RIGG
\$6.95

PLAN #16
BACKHOE
LOADER
\$7.95

STICKLER FOR DETAIL? At last, an exciting new line of REALISTIC Wood Block Models that you can build with your own scrap wood & dowels, and my easy to follow instructions.

TRACTOR RIGG - This 19" long, 10 1/2" Tractor is equipped with a detailed engine, drive-train, & rear axle assembly. Plan details include a pivoting hood, front steering, detailed leafsprings, mirrors, ladders, step tank, flaps/guards, air cleaner, air tanks, and much more.

BACKHOE/LOADER - 25" plus. Challenging fun featuring over 35 easy to make pivoting joints, working hydraulic cylinders, detailed steering, removable roll cage, & lots of instrument gage, levers & lights.

Send U.S. check or U.S. money order in the above amount to:
Gatto Plan Supply, Box 1568, R.D. #1, Hamburg, PA 19526

DOMESTIC & FOREIGN HARDWOODS

Quality stock for Cabinet Work
Most all sizes from 1" to 4" in thickness

HARDWOODS

ASH—BASSWOOD—BIRCH
BUTTERNUT—CHERRY
CHESTNUT—EBONY—MAPLE
OAK—POPLAR—ROSEWOOD
TEAK—WALNUT
Also hardwood plywoods

SOFTWOODS

SUGAR PINE—CYPRESS—CEDAR
SPRUCE—DOUGLAS FIR etc.
MAURICE L. CONDON CO., INC.
242 Ferris Ave., White Plains, NY 10603
914-946-4111

Monday through Friday 8 AM to 4:30 PM

WOODWORKER'S CATALOG

Over 4000 products to
**BUILD, REPAIR,
RESTORE,
REFINISH**
anything made of wood!

It's the catalog woodworkers rely on — 116 pages jam-packed with fine woods, veneers, tools, finishing supplies, and much more—all top quality, all reasonably priced, all with our 60-day no-questions-asked guarantee. For your 2-year subscription send \$1.00 to:



CONSTANTINE
Serving Woodworkers for 180 years

2050 Eastchester Rd., Dpt. 35203, Bronx, NY 10461

NEED
EXTRA
INCOME?

SIGNCARVING



IS FUN & PROFITABLE

And it's easy, if you use the Marlin Woodcarvers and accessories. You can carve signs quickly at home or at swap meets. No special training is required. The machines do the work, the operator has the fun and the profits. These machines will also 3-D carve panels and plaques. Our templates work well with other machines.

SEND \$1.00 FOR OUR FULL LINE BROCHURE AND PRICE LIST AND START PLANNING YOUR FULL OR PART-TIME BUSINESS.



MARLIN INDUSTRIES, INC.

Rt. 70, Box 191, Dept D23
Cashiers, NC 28717
(704) 743-5551

SCROLLVERGNÜGEN*

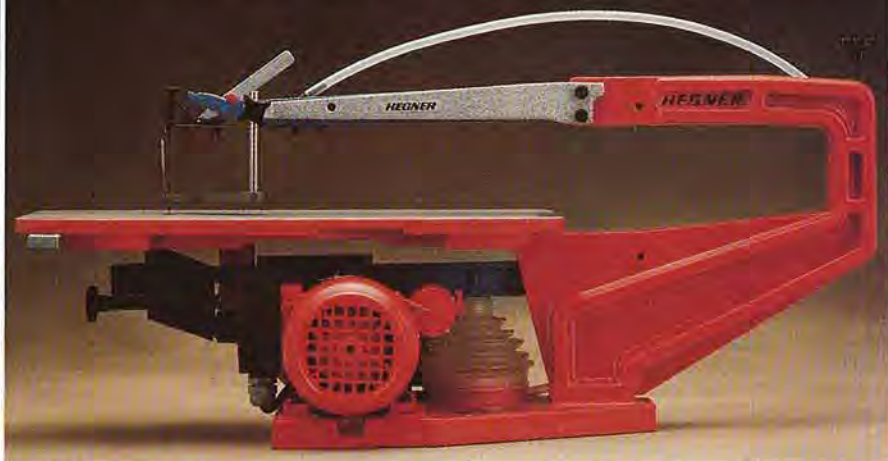

What the experts say about HEGNER Scroll Saws:

"best overall..." — Wood
"highly favored..." — Fine Woodworking
"ultimate in tools..." — Workbench

*VERGNÜGEN: A German noun meaning delight of pleasure.

1-800-648-4264
(in Delaware call 322-2226)

ADVANCED
MACHINERY
IMPORTS

P.O. Box 312, Dept. 484
New Castle, DE 19720
FAX 302•322•3479

Please send FREE INFORMATION on HEGNER Scroll Saws. 484

Name _____

Address _____

City, State _____

Phone _____ Zip _____

335 GREAT SHOP TIPS

THE BEST IDEAS COLLECTED FROM OUR POPULAR COLUMN
"TIPS FROM YOUR SHOP (AND OURS)"

IN WOOD, MAGAZINE



333 GREAT SHOP TIPS contains valuable information from the editors and readers of WOOD magazine - shared knowledge that makes working in your shop better, faster, safer, and easier. We've organized the tips into 24 convenient categories with an index for easy accessibility to any subject.

HOW TO ORDER

To order "335 Great Shop Tips," send your name, daytime phone number and address, city, state and zip, plus \$10.95 (U.S.) (Canadian readers add \$1.00), which includes postage and handling to:

335 GREAT SHOP TIPS
P.O. Box 9255
Des Moines, IA 50306

Allow 6-8 weeks for shipping and handling.

To order by phone, call 1-800-374-9663 (9 a.m. to 5 p.m. CST)

STEVE WALL LUMBER CO.

Quality Hardwoods and Woodworking Machinery For
The Craftsmen and Educational Institutions

Species	Grade	Price	UPS Special	Price
Ash	4/4 Select	1.90		\$59.00
Basswood	4/4 Select	1.30		\$47.00
Birch	4/4 Select	1.60		\$53.00
Butternut	4/4 Log Run	1.40		\$55.00
Cherry	4/4 Select	2.45		\$68.00
Cypress	4/4 Select	1.60		\$49.00
Hickory	4/4 Select	1.50		\$47.00
Mahogany (Genuine)	4/4 Select	2.70		\$73.00
Maple (Hard)	4/4 Select	1.55		\$52.00
Maple (Soft)	4/4 Select	1.30		\$48.00
Pecan	4/4 Select	1.50		\$47.00
Poplar	4/4 Select	1.20		\$45.00
White OR Red Oak	4/4 Select	1.80		\$57.00
Walnut	4/4 Select	2.50		\$71.00
Cedar (Aromatic Red)	4/4 1C+Br.	1.35		\$46.00
White Pine	4/4 FG.	.85		\$37.00
Yellow Pine	4/4 Clear	1.20		\$45.00

Above prices are for 100' quantities of kilndried rough lumber sold by the Bd. Ft. FOB Mayodan, NC. Call for quantity discounts. Other sizes and grades available.

Above prices are 20 bd. ft. bundles of clear kilndried lumber 3" x 10" wide x 3' 7" long (Random widths & lengths) Surfaced 2 sides or rough. Delivered UPS prepaid in the Continental U.S.

LUMBER SPECIALS

CHERRY 100 Bd. Ft. Bundle Log Run 2S 13/16 \$ 90*
WALNUT 100 Bd. Ft. Bundle #1 Common 4/4 \$ 110*
*FOB Mayodan - Motor Freight Only

Call For Best Prices On *MiniMax*

STEVE H. WALL LUMBER CO.
BOX 287 • MAYODAN, N.C. 27027

919-427-0637 • 1-800-633-4062 • FAX 919-427-7588

Send \$1.00 For Lumber and Machinery Catalog

As Featured in Wood Products Guide!

MLCS, Ltd.

1/4" or 1/2" Shank Carbide-Tipped Router Bit Molding Plane Profiles



\$24.95/\$29.95

\$27.95

\$29.95

\$27.95

SPECIAL OFFER:
Set of all four bits
only \$99.95

Set of four quickly produces classic traditional mouldings. 2 flute carbide tipped

Order by
VISA • MasterCard • Discover
7 Day/24 Hour Service,
Call 1-800-533-9298
or send check to: **MLCS, Ltd.,**
P.O. Box 4053 DT
Rydal, PA 19046

Econ-Abrasives

WE MAKE ABRASIVE BELTS ANY SIZE, ANY GRIT!

Standard Abrasive Sheets

CABINET PAPER

	50/pk	100/pk
60D	\$15.00	\$27.00C
80D	14.00	25.00C
100 thru 150C	13.00	23.00C

FINISHING PAPER

80A	\$ 10.00	\$17.00C
100 thru 280A	9.00	15.00C

WET/DRY PAPER

220 thru 600	\$14.00	\$24.00C
NO LOAD PAPER(white)		
100 thru 400A	\$11.00	\$19.00C

"C" = 100 SHEETS

ABRASIVE BELTS

PLEASE SPECIFY GRITS

1X30	\$.73 ea	3X24	\$.84 ea
1X42	.73 ea	3X27	.87 ea
1X44	.73 ea	4X21 3/4	.96 ea
2 1/2X16	.77 ea	4X24	.99 ea
3X18	.78 ea	4X36	1.20 ea
3X21	.81 ea	6X48	3.14 ea
3X23 3/4	.84 ea	2 1/4X80	2.94 ea

OTHER SIZES ON REQUEST

JUMBO CLEANING STICK

ONLY \$8.80

2X2X12

Velcro® Vacuum Discs

8 Hole pattern for Bosch Sanders

Dia.	Grit	Price
5"	60	\$.48 ea
5"	80	.46
5" 100 thru 320	.45	



* OTHER PRODUCTS*

*Wide Belts*Rolls*Flap Wheels
*Pump Sleeves*PSA Discs
*Router Bits*Wood Glue
*Wood Bits*Velcro® Discs
*Wood Clamps*Sanding Blocks
*Drawer Slides*Hinges*TV Swivels

*MINIMUM ORDER \$25.00

*MasterCard, VISA, C.O.D. or Check

*SATISFACTION GUARANTEED!!!

*CALL FOR FREE 1991 CATALOG

- TX & NV add appropriate sales tax

- Continental U. S. shipping

charges add \$5.50

Econ-Abrasives

P. O. Box B865021

Plano, TX 75086

(214)377-9779



NATIONAL ORDERING LINE (800)367-4101

TIPS FROM YOUR SHOP (AND OURS)

Continued from page 21

Keep cord in suspense for fewer surprises

While belt-sanding a project piece on top of your workbench, you lurch to a stop when the sander cord snags on the bench edge. That problem fixed, you start again, but almost run over the cord with the sander.

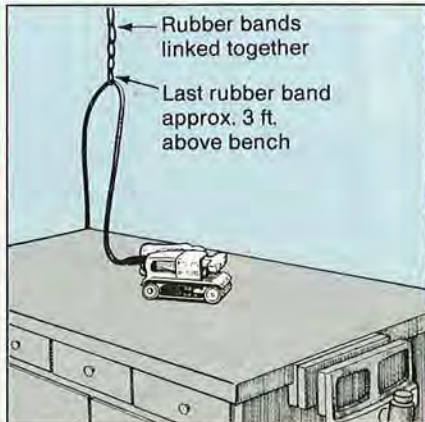

Rubber bands linked together
Last rubber band approx. 3 ft. above bench

TIP: Get that cord out of the way with a few stout rubber bands. Loop them together to form a chain about three feet shorter than the distance from your shop ceiling to the benchtop. Screw a hook into the ceiling above the center of your workbench, and hang your rubber-band chain from it. Now, when you plug in a tool, pass the cord through the bottom rubber band first. Position the cord so it stays off the bench.

—Dan Walters, Merritt Island, Fla.

MORE TIPS FROM OUR WOODWORKING PROS

- Do you have trouble seeing your pencil marks on dark woods such as walnut? If so, give your eyes a break by employing the marking technique described on page 52.
- Making smooth openings like the one on our knitting carrier can be rough. Try our method of drilling holes and then cutting between them for smooth results. It's on page 52.
- Don't need a high chair? Check out the article on page 63, anyway, for a neat way to make trays.

SAME DAY SHIPPING!
FREE FREIGHT!

It Just Doesn't Get Any Better Than This!

Panasonic

EY6005BC
12 V, 1 Hour,
Keyless Drill Kit
w/2 Batteries
\$179

EY6205BC 12v,VSR dr w/cs 179
EY571BC 9.6v dr w/cs2 bat 149

Emqlo

AM78-HC4V
1-1/2 HP Vertical
Twin Tank
\$319

AM99-HC4V New 2hp twr tkn 389
AM99-HC4 2hp twin tank 379
AM78-HC41-1/2hp twin tank 309
AM39-HC4V3/4hp v twin tank299
0453/8" x 50' Goodyear hose 20

JET

JJ-6CS
6" Long
Bed Jointer
\$439

JBS-14CS 14" wd bandsaw 439
DC-610 1 HP dust collector 229
DC-1182 dust collector cfm 439
JCS-10A 10" cab. saw w/fnc 899
JWP-15H 15" planer 3 hp 1149

PORTER-CABLE

9853 NEW!
12 V, 3/8" VSR,
2 Speed Drill Kit
w/Keyless Chuck
\$149

9852 12v, 3/8", 2sp kit 149
9854 12v, 1/2" drill kit 159
7334 random orbital sander 119
7335 5" VS random sander 129
7336 6" VS rdm sander 134
97310 laminate trimmer kit 188
352 3x21 sander with bag 138
360 3x24 sander with bag 184
362 4x24 sander with bag 189

555
Plate Jointer
With Case & 500'
Assorted Biscuits
\$179

555 plate jointer w/case 165
7537 2-1/2 D hndl router 209
9345 6" s. boss kit w/5 blds 124
7549 top handle VS jig saw 144
7539 NEW 3-1/4hp pl. router 265
690 1-1/2 HP router 132
691 1-1/2 hp D hdl router 144
7518 3-1/4 hp 5sp router 259
7538 3-1/4 hp pl. router 224
9637 elec. vs tiger saw kit 139
693 1-1/2 hp plunge router 164
6931 plunge router base 78

Makita

LS1011
10" Compound
Mitre Saw
\$439

3612BR 3 hp plunge router 165
9820-2 blade sharpener 195
6095DW 3/8" w/kssc chuck 139
5007NBA 7-1/4" saw w/b. br 129
2708W 8-1/4" table s. w/bl. 264
2012 12" planer w/dust cht 459

W WEDGE

SL224 NEW!
24" Rail
w/Module
\$54

SMPR2 2" pro rail w/module 98
TR-2 2" level w/module 108
TR-4 4" level w/module 128
PR4 4" Pro Rail w/module 118
PR78 78" Pro Rail w/module 148

The Accu-Miter

Precision
Mitre Gauge
\$149

Complete Line In Stock!

HITACHI

C8FB
8-1/2" Compound
Mitre Saw
\$439

P12RA 12" planer/6" jointer 829
P12R NEW 12" port. planer 649
D10DFK VSR dr kitw/2 bat 159
C12FA 12" mitre saw 375
C10FA 10" mitre saw 289
C7BD 7-1/4" saw w/case 129
M12V 3-1/4 hp VS pl. router 224
TR12 3 hp plunge router 169
CB75F resaw bandsaw 1599
F1000A 12" planer/6" jointer 1499

freud

JS100
Jointing System
W/Case & 500'
Assorted Biscuits
\$174

JS100 jointing sys. w/case 159
FRT-2000 wdn router table 169
FT-2000 3.25 plunge router 179
EB-100 edge banding sys. 229

Milwaukee

0402-1
12 Volt VSR
Cordless Kit
W/Keyless Chuck
\$168

0399-1 12v VSR cdlr dr kit 159
0234-1 1/2" VSR magnum 119
1676-1 2 sp. hole hawg kit 249
6368 7-1/4" saw w/bl.cs.fnc 135
6256 VS top handle jig saw 139
6527 NEW vs super sawzall 165
6125 5" r. orbital sander 129
5371-1 1/2" hammer dr. kit 185
5397-1 3/8" hammer dr. kit 139

Porta-Nails

401P
Hardwood
Floor Nailer
\$189

501 floor face nailer 189

DEWALT

1707
8-1/2" Compound
Mitre Saw
\$399

1765 bel/disc sander 449
7770-10 3.5 hp 10" rad. saw 869
7790 3.5 hp 12" radial saw 1149

PERFORMAX S/T

Per-ST100
Radial Saw
Surface Sander
\$289

Pro stand 349
Powerfeed attachment 319
Pro Max II stationary sander 1489
Super Max stat. sander 2269
Super Max-25 drum sander 2695

DELTA

22-540
12", Portable
Planer w/Dust
Collector Chute
\$409

40-640 20" VS scroll saw 329
43-505 router/shaper 275
11-090 radial drill press 289
46-700 12" vs wood lathe 429
28-180 bench bandsaw 169
23-700 wet/dry grinder 159
11-950 8" bench drill press 145
40-560 16" 2 sp. scroll saw 184

PONY AIR

LPN672
Air Palm Nailer
With Glove
\$94

Drives 6d-50d nails!

POWERMATIC

1791000
63 Artisan Saw
W/Vega Fence
\$699

1660760 66 saww/50' Beis 1749
1791050 6" jointer w/stand 499
1791060 14" bandsaw w/std 599
1791070 1-1/2hp dust col. 399

DELTA

34-782
3 HP Unisaw
w/Unifence
& Motor Cover
\$1699

34-763 3hp Jet-Lock unif 1529
34-761 1.5hp Jet-Lock unif 1349
34-445 10" c. saw w/fnc,ems 849
34-444 10" contractors' saw 619
34-330 8-1/4" bench tbl saw 229
33-990 10" radial arm saw 599
28-283 14" band saw w/base 735
33-055 8-1/4" Sawbuck w/lgs 589
37-280 6" motorized jointer 399
34-080 10" mitre saw 199
43-375 3 hp 2sp hd shaper 1609
22-662 13" planer w/std/EMS 1179
31-730 6" belt/12" disc sndr 1099
37-350 8" jointer w/std 1499
40-601 18" V.S. scroll saw 719

SKIL

2736-04
12 V, 3/8" VSR
Keyless Drill Kit
W/2 Batteries
\$129

7484 5" random orb. sander 109
1605 NEW plate jointer w/cs 119
77 7-1/4" worm drive saw 145
5660 8-1/4" 60° pro bevel s 139
58608-1/4" 60° rafter master 169

BLACK & DECKER

2694
7-1/4" Super
Sawcat W/Brake
\$138

2684 7-1/4" sawcat w/br. 128
2685 8-1/4" sawcat w/br. 138
2695 8-1/4" sawcat w/br. 148

Elu

3338
2-1/4 HP
Electronic VS
Plunge Router
\$245

1186 3/8" VSR 5 amp drill 99
1316 3/8" VSR 5 amp drill 109
3380 jointer/spliner w/case 245

BOSCH

1581VS
Top Handle
Jig Saw w/Case
& 30 Blades
\$184

1582VS barrel grip jig saw 139
1582VS barrel grip Clic jig s 139
1632VSK VS recip saw kit 145
3050VSRK 3/8 kit w/2 batt 129
3258 3-1/4" power plane 128
1654 7-1/4" saw w/ct blade 118
1611EVS 3-1/4 vs pl router 229
1611 3 hp plunge router 199
1604 1-3/4 hp router 129
1370DEVSK 6" r. sander kit 299

RYOBI

BT3000 NEW!
10" Sliding
Table Saw
\$549

AP10 10" portable planer 358
BE321 3x21 VS belt sander 128
JM100K NEW plate jointer 205
TFD220VRK 12vcldis kit/2bat 165
RE-600 3hp vs pl. router 204
JP-155 6-1/8" jointer/planer 299
RA-200 8-1/4" rad. arm saw 248
TS254 10" m. saw w/ct. bl 209
WC101 wood carver blade 40

David White

ALTP6-900
18 Auto Level-
Transit Package
\$439

LP6-20 20x sight level pkg 199
AL8-22 22 x auto level 425
L76-900 20 x level transit 249
L78-300 26 x transit 449
LT8300P 26 x opt. transit 529
ALT6-900 18x a. level transit 389

WOOD Mar./April 92

1-800-358-3096 FAX US YOUR ORDER! 1-701-746-2857

Box 1716 • Grand Forks, ND • 58206
Send \$3.00 For 208 Page Catalog

TOOL CRIB
OF THE NORTH
DIVISION OF **W.C.M.C.**

FREE FREIGHT IN 48 CONTIGUOUS USA • SAME DAY SHIPPING • ERRORS AND PRICES SUBJECT TO CHANGE

MODERN-DAY CRACKLING

AN OLD-TIME FINISH FROM A SPRAY CAN

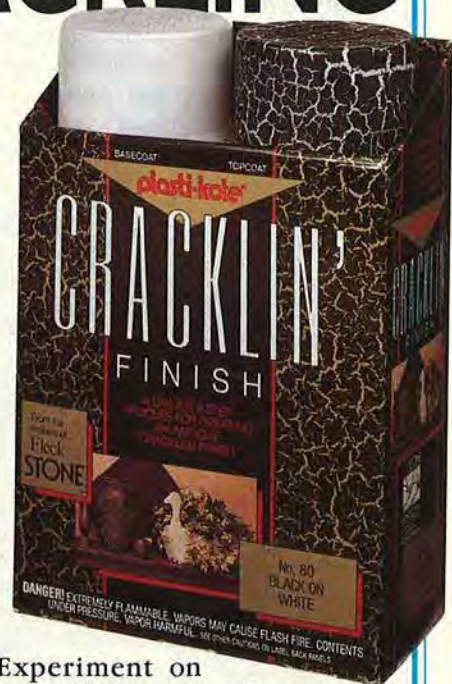

Decades ago, the accidental mixing of the wrong paint and varnish ingredients produced startling results better suited to alligators than fine furniture. Even so, the cracked effect had a charm of its own, creating a striking finish of contrasting colors.

Today, you can achieve a crackled finish on wood (and on other materials as well) from a two spray-can kit made by Plasti-Kote. When testing the kit, we had to practice before we felt comfortable using the two components. But once mastered, the kit gave us impressive crackled surfaces that promised lots of possibilities.

Take a pop at crackling—it's a snap

To try your hand at crackling, first prepare a clean, smooth, sanded surface. Then, seal the bare wood with a lacquer-based primer.

Next, spray on the colored base coat, applying the material evenly as you hold the spray nozzle about 8" away from the surface. Since this is a spray lacquer, it will dry quickly. Build up a uniform base coat by spraying on three or four layers. Allow 30 minutes to dry.

After finishing the last base layer, allow the surface to dry. (We waited an hour or so.) Then, apply the top coat, which comes in a contrasting color. For a small crackling pattern, we completely covered the base coat with one layer of the top coat. For a medium pattern, we made two passes over the surface. And for large crackles, we found that four consecutive passes did the trick, creating a heavy top layer. Thick layers of both base and top coats assure coarse crackling.

Within a few minutes after applying the top coat, you'll be amazed as you watch the finish begin to crack and shrink, exposing the base layer. You'll probably produce a finish that isn't uniformly crackled all over, but that's part of the fun and intrigue.

Five helpful hints

- For the best results, apply Cracklin' Finish when room, paint, and project temperatures are between 60 and 85 degrees. And be sure you're in a well-ventilated area, away from open flames or other fire hazards for a safe, worry-free application.

- Experiment on scrap with this unusual product before applying it to your project.
- You cannot switch colors by applying the top coat first and covering it with a layer of base coat. That's because the base coat contains the chemicals that make the top coat crackle.
- This finish appears textured, but don't be fooled. It's plenty smooth enough for most uses.
- Indoor accent pieces like those pictured *above* are perfect for this finish, but the manufacturer says it's durable enough for outdoor projects, too.

Your color options

Cracklin' Finish comes in black on white, white on black, black on red, black on gold, gray on black, and white on gold antique. The 12-oz. cans of base coat and top coat will cover 18 to 25 square feet. And though we only tried the product on wood, the manufacturer says it also works on metal, glass, and plastic.

Plasti-Kote, Cracklin' Finish kit, suggested price \$12.95. For more information, call 800/431-5928. ♣

Written by George Brandsberg Photographs: Plasti-Kote, Inc.

MUST LIQUIDATE!

AT FAR BELOW DEALER COST!

**Ryobi Over-Engineers
Making Too Costly To
Produce. C.O.M.B Now
Authorized to Liquidate.**

ALL 3 FOR ONLY \$447
You save \$1,249.00!
Plus FREE S/H
when you buy all three.
Give Item # C3782-7685 For the set.

Less Than 29¢ on the Dollar!

New, in Factory Sealed Cartons!

NO CORDS, NO HOSES, NO HASSLES!



1/2 HP Gas-Powered Tools!

1/2" IMPACT DRILL
Ryobi List: \$518.00

At C.O.M.B. **\$149**
Item # C3617-7685
S/H \$7 Each

**PNEUMATIC ROTARY
HAMMER DRILL**
Ryobi List: \$660.00

At C.O.M.B. **\$149**
Item # C3616-7685
S/H \$7 Each

RECIPROCATING SAW
Ryobi List: \$518.00

At C.O.M.B. **\$149**
Item # C3615-7685
S/H \$7 Each

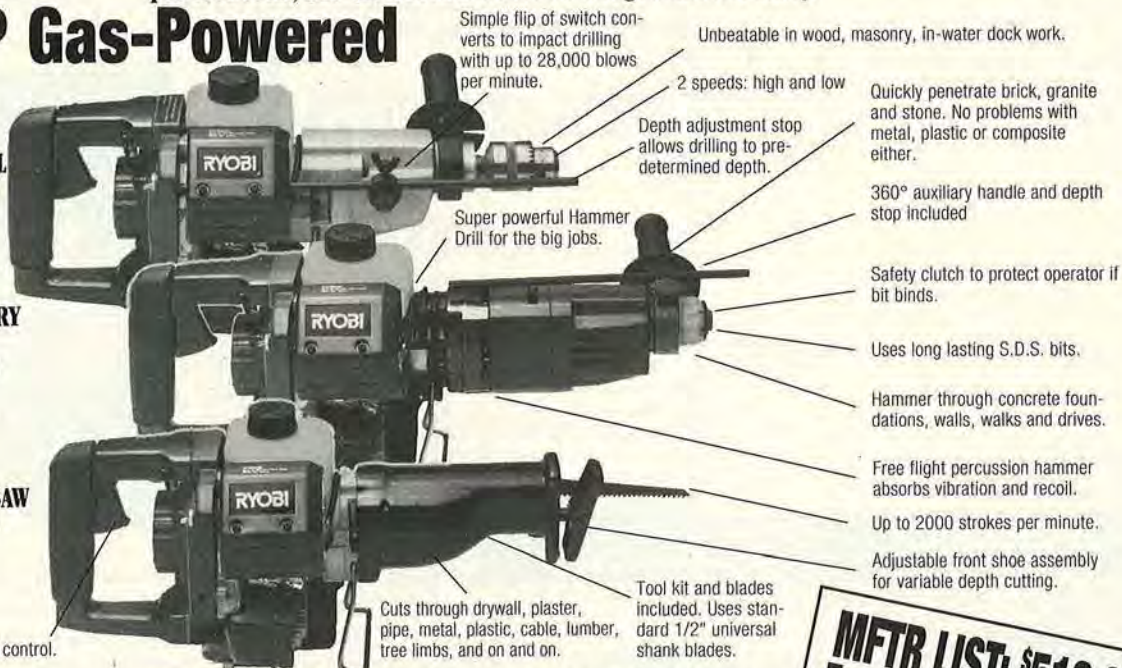

RYOBI OVER-ENGINEERS, MAKING TOO COSTLY TO PRODUCE

The Japanese have a thing for quality and Ryobi Japan went overboard, even by their own standards. Petro-powered, fully portable, silky smooth and legendarily durable Reciprocating Saws, Hammer Drills and Rotary Hammers so over-built that their costs soared to three times what the American market would bear! The solution? Typically bold. Send the accountants home, ignore the ledgers, and sell the lot without regard to cost.

BRUTE-FORCE POWERFUL IN ANY WEATHER

If you ever use power tools outdoors, or in the weather, or around water, or under the pressure of a deadline, or over an extended period of time, you'll know the value of totally portable no-holds-barred quality, and the feel of it, too. No need for cords or pick-up mounted generators; the power is in your palm! These are brute-force powerful, commercial-grade tools, built to operate all day long on concrete, masonry, cable, pipe, timbers — the tough jobs.

BUY BELOW COST!

If you don't think this is a fantastic deal, check the Grainger's catalog for prices! Even at \$518 to \$660 each, these tools are worth their asking price. But when you can **BUY BELOW COST** at 29 cents on the dollar, only \$447 gets you all three tools! There are over 100 Service Centers nationwide (list in box) and each unit is backed by C.O.M.B.'s 30 day satisfaction guarantee. Not surprisingly, supplies are limited so call now!

LOOK AT THESE STANDARD FEATURES!

- Weighs only 12 pounds
- 15.9 cc, 2-cycle engine
- Solid state electronic ignition for fast, easy starts
- Recoil starter
- All position diaphragm carburetor functions at any angle
- Hardened Steel gears for long life
- Variable speed throttle
- Die cast aluminum cylinder head for increased heat dispersion and reduced weight
- Durable ball bearing construction
- "D"-style handle designed to isolate vibrations
- Lightweight large capacity fuel tank won't rust and is gas and heat-resistant
- Convenient built-in tool rests
- Air cleaner with polyurethane foam filter

**MFTR LIST: \$518.00
to \$660.00
OUT THEY GO
4 Monthly Payments of
\$39***

or \$149 Each
Shipping/Handling \$7 Each.
*Payment Plan includes S/H. MN residents add 6.5% sales tax. Monthly Payment Plan available for Visa, MC, Discover & C.O.M.B. Card purchases only.



**AUTHORIZED LIQUIDATORS
of Bankruptcy Merchandise and
Manufacturers' Overproduction**

1-800-522-3035

Segment # 2680155

C.O.M.B. Corp., Authorized Liquidator

720 Anderson Avenue, St. Cloud, MN 56395

Send _____ Ryobi Gas-Powered Tool(s), Item # _____, at \$ _____ each, plus \$7 S/H (only MN residents add 6 1/2% sales tax). Sorry, no COD orders. Please state segment number 2680155.

My check or money order is enclosed (no delays in processing orders paid by check).

PLEASE CHECK: C.O.M.B. CARD VISA MASTERCARD DISCOVER

Account No. _____ Exp. ____/____/____
Name _____ Apt.# _____
Address _____
City _____ State _____ ZIP _____
Phone (____) _____
Sign Here _____

WOOD PARTS FROM MIDWEST DOWEL WORKS

Compare Our Low Prices!

Qty.	Cost
3-1/2" Poplar Shaker Peg	\$15/100
1-3/4" Mini Shaker Peg	\$7/100
3-1/2" Country Wall / Mug Peg	\$15/100
2-1/2" Country Shorty Peg	\$12/100
Large Bean Pot Candle Cup	\$17/100
Brass Inserts	\$9/100
1/2" Mini Candle Cup	\$10/100
1-1/2" Toy Wheel	\$10/100
2" Toy Wheel	\$17/100
Axel Pegs	\$4/100

SMOOTH SANDED HEARTS

3/4" x 1/8" Hearts	\$2.75/100
3/4" x 1/2" Hearts	\$4.50/100
1" x 3/16" Hearts	\$4.00/c
1" x 3/8" Hearts	\$6.50/c
1-3/8" x 1/8" Hearts	\$5.50/c
1-3/8" x 1/4" Hearts	\$7.50/c
1-3/8" x 1/2" Hearts	\$10/100
2" x 1/2" Hearts	\$18/100

FREE 16-PAGE CATALOGUE

Circle this section for FREE Dowels — mixed pack, Maple, Oak, Walnut Cherry, from 1/4" up to 1" Approximately 10 LFT. 14" long. \$5.00 value with any order.

Great Buys!

Qty.	Cost
3/8" x 36" Standard Dowels	\$21/100
3/4" x 36" Oak Dowels	\$15/10
3/8" Maple Buttons	\$2.15/100
1/2" Maple Buttons	\$2.25/100
1-1/2" Maple Spindles	\$9/100
2-1/8" Maple Spindles	\$18/100

ORDER NOW

MC/Visa Check Enclosed

Total Cost _____

Handling **\$3.00**

Ohio residents add 5% sales tax _____

Final Cost _____

MC/Visa Number _____
 Expires _____ Phone _____
 Name _____
 Address _____
 City/State/Zip _____

MIDWEST DOWEL WORKS

4631 Hutchinson Road
 Cincinnati, Ohio 45248
 (513) 574-8488

Same Day Service | Order before Noon
 Factory Direct | Satisfaction Guaranteed

PRODUCTS THAT PERFORM

A reasonably priced HVLV spraying system



Because of environmental awareness and stiffer legislation, many woodworking professionals are switching to high-volume low-pressure (HVLV) spraying systems for applying finish to their work. Why? Because these systems operate at pressures as low as 4 psi, which means that they do not atomize finishes the way compressor-driven sprayers do. With less overspray, these tools efficiently deliver a high percentage of the finish directly to the project, and not into the air.

Until now, these turbine-driven HVLV systems have cost upwards of \$700, pretty steep for the hobbyist. Enter Wagner's FineCoat Low-Overspray Finishing System, a HVLV system that most home woodworkers can live with. The self-contained unit offers handy storage for its paint cup and



light, well-constructed hose. A single knob adjusts the spray pattern from 1/4" to 12" wide.

I tried several water-based and oil-based clear finishes with the FineCoat system. Until I got used to it, I had a problem with the finish flooding onto the surface. But after some practice, I could produce a finish that was close in quality to the ones I apply with my conventional compressed-air system. Although I wouldn't use the FineCoat on something that demands a mirror-like finish, such as a car, the end-result was more than adequate for woodworking projects. And, the almost-total lack of overspray was a true blessing.

As the FineCoat's directions point out, the tool does not work with heavy-bodied latex paints. I had good results with oil-based lacquers, polyurethanes, and enamels, but I did have to slightly thin a water-based clear finish so it would draw through the gun.

The gun is lightweight and comfortable to hold, but while cleaning up, I couldn't get my hand in through the mouth of the paint cup. For the asking price, I can't think of a better spraying system.

—Tested by Bob McFarlin

Wagner FineCoat Low-Overspray Finishing System, \$179 to \$209 at hardware stores and homecenters nationwide. For the location of the dealer nearest you, call 800/328-8251.

TRANSPOWER

SINCE 1953

FOR EXPRESS NEW CATALOGUE CALL

1-800-654-7702

SUPER HEAVY DUTY WOODWORKING EQUIPMENT



250 H.D. Table Saw 1 1/2 HP \$350
 200A H.D. Table Saw 3HP \$795
 200A W BIESEMEYER Fence \$995



650 H.D. 6" Jointer 1 HP \$295
 860 H.D. 8" Jointer 1 1/2 HP \$670
 1200 H.D. 12" Jointer 3HP \$1695



150 Shaper Router 1 1/2 HP \$398
 500 Shaper Router 3HP \$698
 860 Tilt Spindle Shaper \$1250
 150 Auto Planer 12" \$328
 650 Auto Planer 15" \$695
 200A Auto Planer 20" \$1195
 Dust Collector 1HP \$169
 Dust Collector 2HP \$285
 Dust Collector 3HP \$385

We also carry complete line of top quality BAND SAWS, AIR DRUM SANDER, DISC SANDER, BELT SANDERS, AUTO FEEDERS and DRILL PRESS.

TCM Industries, Inc. 322 Paseo Sonrisa, Walnut, CA 91789
 In California (714) 594-0780

New router bits prevent kickback

If you've ever witnessed router-bit kickback, you know how nerve-racking and potentially dangerous it can be. Because I have experienced it firsthand, I was eager to try Freud's new line of bits designed for safer routing.

The hefty new bits are painted red and have extra steel behind each carbide cutting edge. These "chip limiters" reduce the likelihood of kickback by minimizing the amount of material that each cutting edge can remove as it rotates past the workpiece.

Using a table-mounted router, I tried several of these bits ranging from 1/2" to 1 1/2" in diameter. There was no hint of kickback, even when I jammed the end of a long workpiece into the 1 1/2" wide bit shown below. The additional weight of these bits did not seem to slow my router or contribute to vibration. My cuts were smooth as silk, and the chip limiters didn't restrict my feed rate.

Jim Brewer of Freud says that his company's entire line of router bits—with the exception of some small bits such as solid-carbide trim bits—will be converted to this new design. And, he said the new design should not result in higher prices.

—Tested by Bill Krier

Freud's chip-limiting router bits, available at Freud dealers nationwide. For more information, call Freud at 919/434-3171.



Continued on page 28

IN STOCK —
NO MINIMUM

FOR THAT SPECIAL PROJECT

FREE
BROCHURE



QUEEN ANNE LEGS



TABLE BASES W/CARVED FEET
(Slides available)



COUNTRY KITCHEN LEGS



Adam's Wood Products, Inc.

974 Forest Drive - Dept. M14 Morristown, TN 37814

TELEPHONE 615-587-2942

FAX 615-586-2188

Quality

EXOTIC LUMBER

Figured Domestic
Turning Wood
Exceptional Quality
Personal Friendly Service

Whether you are a
Beginner or Professional,
We welcome your inquiries

Call or Write.

BereaHardWoods.co.

125 JACQUELINE DRIVE • BEREA, OHIO 44017
216-243-4452

Supergrit
Random Orbital Sander Discs
5" White PSA 180 Grit \$15.00/100

PREMIUM QUALITY BELTS: BEST RESIN OVER RESIN, "X" WEIGHT 10/Box

1 x 42	\$.70 ea.	4 x 24	\$1.00 ea.
3 x 18	.75	4 x 36	1.25
3 x 21	.80	5 x 48	2.80
3 x 24	.85	5 x 60	5.25

ADHESIVE CLOTH DISCS: BEST RESIN OVER RESIN, "X" WEIGHT

5" Diameter	\$.80 ea.	9"	\$1.65 ea.
6"	.90	10"	1.85
8"	1.30	12"	2.25

Prices quoted 80 grit, other grits available.

GARNET PAPER — ORANGE
A/O CABINET PAPER — BROWN

40 Grit	50 PK	\$15.00	
60 Grit	50 PK	14.00	
80 Grit	50 PK	13.00	
100, 120, 150	100 PK	22.00	
180, 220	100 PK	19.00	

WATERPROOF PAPER — BLACK
180 thru 1200 100 PK \$23.00

NO LOAD PAPER — WHITE
180 through 400 100 PK \$20.00
Also Shop Rolls • Cloth Sheets • Drums

CLEANING STICKS \$3.50 Small \$6.50 Large

RED HILL CORP., P.O. BOX 4234, GETTYSBURG, PA 17325
(800) 822-4003
Free Freight to most areas
Free catalogue

RIP AW

The Portable Sawmill.

The "affordable portable" one man band sawmill. Weighs only 45 lbs. Cuts 20" diameter logs into lumber. Minimum 1/8" to maximum 9" thickness.

Write or call for free brochure.

Better Built CORPORATION

(508) 657-5636

845 Woburn Street, Dept. W, Wilmington, MA 01887



STOP PERFBORD HOOK FALLOUT!

M-CLIPS™ are THE guaranteed perfect solution to this annoying problem! Fit both 1/8" and 1/4" perfbord. Send SASE for free sample or \$6.99 + \$2.00 p&h for pkg. of 50 to: AETECH, P.O. Box 6298, Dept. W15 10 Shadowstone Lane Lawrenceville, NJ 08648

MAKE NEW WOODEN YARD SWINGERS
FROM OUR FULL SIZE PATTERNS, & EASY TO FOLLOW INSTRUCTIONS!

CUT FROM STANDARD LUMBER!

YD62 YD61 YD36

HANG 'EM FROM YOUR TREES OR FRONT PORCH!

\$5.50 EA. COUPLE----ALL 3 ONLY \$14.00

The Winfield Collection, Dept W32
1450 Torrey Rd, Fenton, MI 48430
Catalog of 1000 patterns \$1.00 (free w/ order)

A SMALL BREEZE SETS THEM SWINGING!

HARDWOODS

EXOTIC & DOMESTIC OVER 75 SPECIES

LUMBER • PLYWOOD • VENEERS
TURNING SQUARES & BLANKS

COLLECTORS SAMPLE KIT

30 EXOTIC & DOMESTIC WOODS
1/2" x 3" x 6" SANDED FINISH

\$29.00 PLUS \$5.00 S&H

Ideal for: Collectors • Schools • Craftsmen • Cabinet
& Furniture Makers • Architects • Designers



1-800-423-2450

WOODWORKERS Source

5402 S. 40th St. • Phoenix, AZ 85040
(602) 437-4415

WOOD TOY

- ★ Patterns
- ★ Parts
- ★ Wheels
- ★ Many New Patterns to Choose from.
- ★ Executive toys



SEND \$1.00 FOR
NEW CATALOG &
RECEIVE COUPON
FOR FREE
WHEELS & AXLE
PEGS.

toys and joys

Box 628W Lynden, Wash. 98264

DELMHORST MODEL J-88 WOOD MOISTURE METER

INSURE THE QUALITY OF EVERY PROJECT
VALUE PRICED AT \$110



Easy to read LED Display indicates 10 ranges of Moisture Content between 6% and 20%.
• 3yr. warranty • Complete with carrying case, batteries, and pins.
• Delmhorst offers over 45 years of experience and service second to none!
CALL TOLL-FREE: (800) 222-0638
NEW JERSEY: (201) 334-2557

DELMHORST
INSTRUMENT CO.

51 Indian Lane East, Dept. 931, Towaco, NJ 07082

Quickest Way to Round Edges

Actual size is
7" x 2" x 1"



At last, a simple hand tool that quickly and precisely rounds over sharp edges! Choice of bodies in Rockmaple or Blackwalnut. Radi-Plane Professional Edge finishing tools. Call 800-326-5415 for dealer nearest you. Made in the U.S.A.

L.A. Mathers Co.
Stockton, CA

RADI-PLANE

FREE CATALOG

Send today for your **FREE** copy of our 68 page full-color catalog. You'll find the best prices for over 3,000 brand-name products. Included are power tools and accessories, hand tools, screws, hardware, wood components, plans, how-to books, and much more.

Trend-lines®

Discount
Woodworking Tools
and Supplies

To order your **FREE** catalog, just fill out the coupon below and mail it to:

Trend-lines
Dept. WD32
375 Beacham St.
Chelsea, MA 02150



Name _____

Address _____

City _____

State _____ Zip _____

DEPT. WD32

Build Power Tools You Can Be Proud Of... And SAVE!!!

Remember when "quality craftsmanship" meant something? With GIL-BILT tools it still does.

- Construct your own:
- 12-in BAND SAW
 - 18-in BAND SAW
 - 10-in. TILT/ARBOR SAW
 - LATHE/DRILL PRESS COMB.
 - 9-in TILT TABLE SAW
 - 6-in BELT SANDER
 - SPINDLE SHAPER
 - CIRCULAR SAW TABLE

GIL-BILT kits include step-by-step plans, full scale patterns and all necessary metal parts and components except wood and motor. Made in America with pride by Gilliom Manufacturing, Inc. since 1946.

Send \$7.50 per plan or \$25.00 for plans for all eight tools listed above or send \$2 for descriptive brochure only. Satisfaction Guaranteed.

GILLIOM MANUFACTURING, INC.,

Dept. WD32
P. O. Box 1018
St. Charles, MO 63302
Phone (314) 724-1812



Featured here: 18-in. Band Saw

Specs: Throat capacity 18 in.

Thickness capacity 12 in.

Table size 26 in. x 28 in.

Table tilt 0° to 45°

Blade furnished 124 in. x 1/4 in. x 6T

Table height 39 1/2 in.

Overall dimensions 33 1/2 in. wide

29 in. deep

71 1/2 in. high

Speed (w/1,725 rpm motor)

425 rpm 2000 bfpm

Order No. 451-K only \$219.50 (less

cost of plan, if previously

purchased) plus shipping

Speed reduction kit available for cutting steel.

PRODUCTS THAT PERFORM

Continued from page 27

Easy-does-it fasteners for hollow walls

Hanging shelf supports or cabinets between studs with fasteners can be a hassle. Now, manufacturer ITW Buildex, with its E-Z Anchor, and its new E-Z Toggle, has simplified the process. The anchor portion of each fastener has broad screw threads and serves as its own drill bit. This means you can use the same No. 2 Phillips bit in your portable drill to screw the anchor into the wall, and then to drive the screw into the anchor.

In 1/2" drywall, I seated the anchors in seconds, making shelf-bracket hanging a snap. The company's tests on a factory-fresh 1/2" drywall wall showed that the anchor supports 155 pounds before the surrounding wall gave in. From a drywall ceiling, that figure was 50 pounds.

The E-Z Toggle—a self-drilling toggle bolt—is stronger yet. (In the same test, the wall failed at 230 pounds, the ceiling at 90 pounds.) While you don't want to approach those limits, the figures show real holding power.

The E-Z Toggle is the better choice for hanging cabinets. However, don't use it if attaching cabinets to a double thickness of drywall, or to drywall backed by foam insulation. Either will interfere with opening of the toggle.

—Tested by Bob McFarlin



ITW Buildex E-Z Anchor, suggested retail \$1.79 for four, or 35¢ each; ITW buildex E-Z Toggle, suggested retail \$1.99 for 2 or 75¢ each. At hardware stores and homecenters.

Pull-stroke saws cut cleanly, quickly, and effortlessly

Any woodworkers concerned about fine craftsmanship will pull for these Japanese imports. That's because they're an impressive pull-stroke handsaw line engineered to make smooth precision cuts every time. Made by the folks at Takagi Tools, the Shark Saw Series handsaws feature comfortable pistol-like plastic handles and fine-toothed replaceable blades that lock securely in place. To change blades, you need only press the convenient blade-release button built into the handle.

Takagi Tools' Shark Saw Series handsaws have plenty of extremely sharp teeth and thin-bodied blades, resulting in lots of cutting action per stroke and less effort for you. I tested two saws, a 10 $\frac{1}{2}$ " blade with 17 teeth per inch (model No. 10-2410), and a 15" saw with 10 teeth per inch (model

No. 10-2315). Both rate as the sharpest and quickest-cutting handsaws I've ever used.

If you're not familiar with pull-stroke saws, remember these tips when using one. First, hold the blade at a lower angle—about 10° to the workpiece surface to keep from lifting the workpiece on the pull stroke. Second, practice making long, smooth strokes in scrap before tackling a real project. I loaned one of the saws to my brother-in-law. While cross-cutting a piece of stock, he cut his pants—but not his leg—when the saw came toward him more easily than he expected.

The smaller of these saws, despite a rigid plastic spline along much of its back, is sufficiently flexible to cut dowels nearly flush to your work.

—Tested by Steve Oswalt



Takagi Tools' Shark Saw Series of handsaws, \$22.99 for the model 10-2410 (\$16.99 for a replacement blade), and \$24.99 for the 10-2315 (\$18.99 for a replacement blade). Include \$3.25 for postage for one item, \$4 for two items, and \$4.50 for three items. To order, or for more information, write: C.R.S. Inc., P.O. Box 4567, Spokane, WA 99202-0567. Call 509/926-1724.

Continued on page 30

Quality Woodworking Machines at Affordable prices from Penn State Industries

Dept. B, 2850 Comly Road • Phila, Pa. 19154 • Info: 215-676-7609
 Order Toll Free 1-800-288-7297 • Visa, Master, & Discover Cards accepted
 When ordering - Add UPS Shipping Charges as noted • Pa residents add 7% Sales Tax
 Call or Write for our New 24 Page Color Catalog



Two Way Sanders

Features of both models:

- Dust collector on belt
- Tables tilt to 45°
- Sealed ball bearings
- Easy belt tracking

6x9 Sander:

- Includes stand
- 9" Disc • 6"x48" Belt
- 3/4 HP, 1720 RPM
- Free Belts & Discs worth \$21.00

#S69 ... \$219.95 (UPS \$30)

4x8 Sander:

- 8" Disc • 4"x36" Belt
- 1/3 HP, 1720 RPM
- Free Belts & Discs worth \$14.00

#S48 ... \$109.95 (UPS \$8)

ON SALE



Super 125 Planer only \$359.95

This machine will pay for itself time and again by planing your own wood. Finishes wood like machines many times its price.

- Portable at 65 lbs
- 26.2 fpm power feed
- HSS Knives 12-1/2" wide
- Motor: 16Amp, 8000RPM 2HP, 115V
- 1/8" Max depth of cut

#PLA ... \$359.95 (UPS \$15)

Extra Knives ..\$25/pair

Dust Chute ... \$15/ea (UPS \$3)

Stand \$39/ea. (UPS \$6)

ON SALE



Variable Speed Scroll Saw only \$169.95

Cuts intricate patterns in many different materials. Electronically controlled motor gives full power at all speeds 400-1800cpm.

FREE ACCESSORIES:

- Dust blower • 1 dz blades
- EZ Set permanent top arm blade holders • EZ jig to attach standard holders • 4 blade holders • Neptune 1-1/2" lettering guides w/6 patterns

Specifications:

- Motor: 1.3 Amp, 110V
- Throat: 15" deep • Stroke-3/4"
- Tilt 0-45° left • Cut Depth: 2"
- Blades: uses pin & plain end

#SVS \$169.95 (UPS \$10)

NEW



Dust Collectors 750 CFM Portable Dust Collector:

This 1-1/2HP model is lightweight and portable at less than 50 lbs.

- 1-1/2HP, 110/220V • 1 outlet @ 4" • 1 Bag @ 20 gal • Wt: 46 lbs • 750CFM • Free: 8' of hose, 1 ea 4" to 3", 1 ea 4" to 2" adaptor.. \$15Value

#DC3 \$209.95 (UPS \$10)



900 CFM Dust Collector:

This 1-1/2HP model allows for use in 2 or more machines & gives improved service for long runs of hose.

- 1-1/2HP, 110/220V • 2 outlets @ 4" • 2 Bags @ 30 gal • Wt: 120lbs • 900CFM • Free: 50' of hose, 1 ea 4" to 3", 2 ea 4" to 2" adaptors.. \$40Value

#DC2 \$299.95 (UPS \$30)



610 CFM Dust Collector:

This collector is perfect for hook-ups to almost any single machine.

- 1HP, 110/220V • 1 outlet @ 4" • 2 Bags @ 20 gal • Wt: 75lbs • 610 CFM • Free: 8' of hose, 1 ea 4" to 3" & 4" to 2" adaptors.. \$15 Value

#DC1 \$199.95 (UPS \$20)

CURVED or STRAIGHT MOLDINGS

Both are yours with a W&H Molder/Planer

Thousands of professionals and serious woodworkers use our American-made cast iron molder/planers to produce smooth moldings, raised panels, crowns and curved molding.

In the shop or at the job site, W&H meets your needs every day with quick knife changeover and ultimate versatility with all kinds of wood.

Over 40 years of experience supports our products with a 5 year warranty! Call or write today for our FREE information kit!

800-258-1380 (USA) 603-654-6828
FAX 603-654-5446

Williams & Hussey
Machine Co., Inc.
Dept. 232CM



P.O. Box 1149 Wilton, NH 03086



JEWELRY CHEST PLAN

Imagine having enough room to organize all your jewelry! Two side closets are 16" high so long necklaces can hang tangle-free. Eight drawers provide storage for smaller pieces. Hinged top reveals a vanity mirror. Patterns drawn FULL SIZE. Order hdw. parts below.

#W141 Jewelry Chest Plan..... \$3.99/EA

Hardware Parts

This 104-piece package contains all the hardware needed to build the jewelry chest above. Plan and wood not included.

#1523 Jewelry Chest Hdw. \$16.95/PKG

HOW TO ORDER: List quantity, part number, item, price & total of order. Include \$4.95 shipping & handling per order. MN residents add 6.5% sales tax. Mail check or money order. Credit card customers call TOLL FREE 1-800-441-9870.

MEISEL HARDWARE SPECIALTIES
P.O. BOX 70W-4 MOUND, MN 55364

PRODUCTS THAT PERFORM

Continued from page 29

Charger energizes most any battery pack in 13 minutes

Wouldn't it be great if all of your cordless power-tool batteries fit the same charger? Black & Decker says its new Univolt Universal Express Charging System will recharge most nickel-cadmium batteries in 13 minutes.

B&D says this charger extends battery life by two to three times by switching over to a low maintenance charge once the battery recharges. Most chargers switch only when a thermostat senses a heat rise in the battery to about 40 degrees Celsius. That's an important distinction because heat buildup is a rechargeable battery's biggest enemy.

To test B&D's claim that the new charging system accepts nearly any tool's ni-cad battery pack, ranging from 2.4 to 13.2 volts, I tried an assortment of battery packs from Black & Decker, Bosch, Makita, Panasonic, Porter-Cable, Ryobi, and Sears cordless drills. All of these packs take an hour to charge with their original chargers. The claim that the unit will charge all packs in 13 minutes or less proved true with all but two test packs (which took 18- and 21-minute charges).

The Univolt makes charging nearly foolproof. Lights warn you if a pack's inserted back-

ward, defective, or if the charger or pack is severely overheated. Another light warns you that the battery has a resistance to charging (probably because it hasn't been used for some time) and will require a 16-hour trickle charge.

So far, Black & Decker has discovered only a handful of packs the charger won't take: AEG's 12-volt pack and most Skil and Metabo packs. If you have a question about the compatibility of your battery packs, call the toll-free number listed below.

I was impressed with the Univolt's performance. However, it takes up about twice as much space as a normal charger, and it costs more than most cordless drills (battery, charger, and all).

If you use several cordless tools from various manufacturers, this charger will pay dividends in faster charges and longer battery life. And, you won't have to keep track of several chargers.

—Tested by Bill Krier

Black & Decker Univolt Universal Express Charging System, \$175-\$199 at industrial/construction distributors nationwide. Call 800/762-6672 for product information or the location of your nearest dealer.



QUASSIA NATURE'S CURE-ALL CUP

People in the West Indies carved cups of the medicinal quassia wood.



Throughout the Caribbean islands grows a gorgeous tree similar in shape and size to North American white ash—oval-crowned and about 80' tall—but with bright red blooms set off by dark green foliage. Bees naturally flock to the beautiful flowers for nectar. The honey the bees produce, though, proves bitter and inedible.

That's because the quassia tree (*Picrasma excelsa*) brims with a resin containing quassin, an effective natural insecticide. In fact, except for bees and ladybugs, quassin zaps everything from aphids to sawflies and slugs. In milder doses, however, it directly benefits humans.

When European colonists settled in Jamaica, for instance, they learned from the natives to carve

cups from the cream-colored quassia wood. These they filled with water to stand undisturbed for up to two days. When they drank the resin-saturated potion, it relieved upset stomach and fought fever. An even stronger solution, made by soaking quassia chips in water, rid their bodies of lice when applied externally. Much milder extractions were used to flavor liqueurs, marmalades, and puddings.

Organic gardeners today know quassin as a safe, biodegradable insecticide that spares beneficial insects. It also can be sprayed on fruit trees to keep birds from nibbling produce. However, quassin must still be extracted by soaking wood chips (available through garden centers) in water. 🌱

Illustration: Jim Stevenson

INTRODUCING...

The WoodE™

FROM LABORSABER®
RETRACTABLE SAW
BRINGS IT ALL HOME!

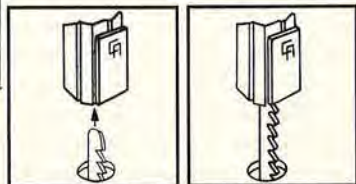

WORKS FROM THE BOTTOM UP...AND INSIDE OUT!

The Saw That Changed An Industry
Now available in an economy priced Professional model for your WOODWORKING SHOP!

Intricate scrolling, fine woodworking, complex shaping and cutting without making an access cut - this is what the LABORSABER® RETRACTABLE SAW has been doing for industry for over 20 years! Now, a scaled version of this industry leader is available for your home woodworking shop at a price that makes owning this quality saw even more valuable.

LABORSABER®
RETRACTABLE
WoodE-SERIES™
PROFESSIONAL
& AFFORDABLE
FOR THE HOME
WOODWORKING
CRAFTSMAN!

**MADE
IN THE
U.S.A.**

VIDEO AVAILABLE!

CALL OUR TOLL-FREE NUMBER FOR MORE INFORMATION **1-800-331-6480**

DIANSUPLY / LABORSABER COMPANY

4505 GREEN PARK ROAD • ST. LOUIS, MISSOURI 63123 • 314-892-8597 • FAX: 314-892-6814
LABORSABER, E-SERIES, The WoodE and "The Saw That Changed An Industry" Are Registered Trademarks/Slogans of Diansupply/Laborsaber inc.

Buy Direct From The Manufacturer And **SAVE!**

Buy 12 "EVER-LAST" Belts... Get 12 Belts FREE!



Need ROLLS, WIDE BELTS, DISCS,
SLEEVES, STROKE BELTS, etc.
Write for catalog.

- Belts available in 36, 50, 60, 80, 100, 120, 150, 180, 220, 320 grit sizes. Please specify grit sizes when ordering, otherwise an assortment will be supplied.
- 1" x 30" ... \$16.50/Doz. + 12 FREE
 - 1" x 42" ... \$16.95/Doz. + 12 FREE
 - 2" x 48" ... \$25.25/Doz. + 12 FREE
 - 2 1/2" x 16" ... \$17.95/Doz. + 12 FREE
 - 3" x 18" ... \$18.25/Doz. + 12 FREE
 - 3" x 21" ... \$19.25/Doz. + 12 FREE
 - 3" x 24" ... \$19.75/Doz. + 12 FREE
 - 4" x 21" ... \$23.50/Doz. + 12 FREE
 - 4" x 21 3/4" ... \$23.75/Doz. + 12 FREE
 - 4" x 24" ... \$24.00/Doz. + 12 FREE
 - 4" x 36" ... \$28.75/Doz. + 12 FREE
 - 6" x 48" ... \$37.50/1/2 Doz. + 6 FREE
- Other size belts on request.**
- Belt Cleaning Stick \$4.95 each

9" x 11" PAPER SHEETS

A/O or Garnet Cabinet Paper

	50 PACK	100 PACK
40-D ...	<input type="checkbox"/> \$17.00	<input type="checkbox"/> \$32.00
50-D ...	<input type="checkbox"/> \$16.00	<input type="checkbox"/> \$29.00
60-D ...	<input type="checkbox"/> \$15.00	<input type="checkbox"/> \$27.00
80-D ...	<input type="checkbox"/> \$14.00	<input type="checkbox"/> \$25.00
100-C ...	<input type="checkbox"/> \$13.00	<input type="checkbox"/> \$23.00
120-C ...	<input type="checkbox"/> \$13.00	<input type="checkbox"/> \$23.00
150-C ...	<input type="checkbox"/> \$13.00	<input type="checkbox"/> \$23.00
No Load Finishing Paper (White)		
120-C ...	<input type="checkbox"/> \$14.00	<input type="checkbox"/> \$24.00
150-C ...	<input type="checkbox"/> \$14.00	<input type="checkbox"/> \$24.00
180-A ...	<input type="checkbox"/> \$11.00	<input type="checkbox"/> \$19.00
220-A ...	<input type="checkbox"/> \$11.00	<input type="checkbox"/> \$19.00
280-A ...	<input type="checkbox"/> \$11.00	<input type="checkbox"/> \$19.00
320-A ...	<input type="checkbox"/> \$11.00	<input type="checkbox"/> \$19.00
400-A ...	<input type="checkbox"/> \$11.00	<input type="checkbox"/> \$19.00

For Fast Delivery Call Toll Free
1-800-428-2222 (U.S.A.)
1-800-222-2292 (PA only)

SHIPPING CHARGES: \$4.75 Continental U.S.
Minimum Order \$25.00
PA Residents Add 6% Sales Tax.

INDUSTRIAL
BRASIVES CO.
643 N. 8th ST. • READING, PA 19612

MONEY ORDER CHECK
 MASTER CARD VISA

MAKE BEAUTIFUL RAISED PANEL DOORS WITH YOUR ... 1/4" or 1/2" ROUTER ... 1/2" or 3/4" SHAPER

Professional production quality bit makes it quick and easy to produce matching rails and stiles — the panel raising bit with ball bearing guide makes the raised panel perfect every time.

SALE PRICE
FOR COMPLETE SET **\$69.95** Regular value over \$150.00!
1/4" Shank set item #554 (includes all bits shown below)

SET ALSO AVAILABLE IN 1/2" SHANK - \$79.95 - Item #852

Shaper Cutters set:
Item #1059
SAVE! only \$99.95
Set: Rail & Stile & Raised Panel Cutters

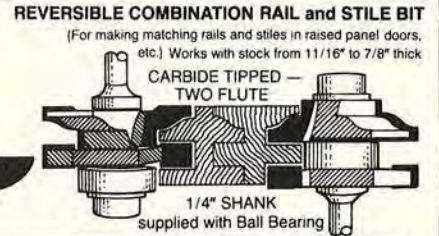
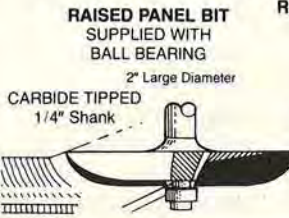
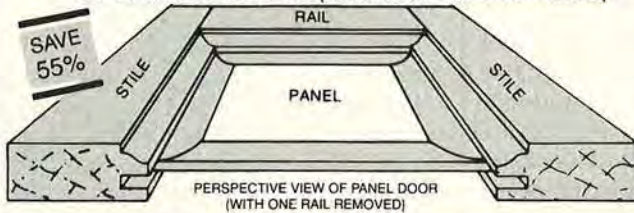

CARBIDE TIPPED ROUTER BITS • PROFESSIONAL PRODUCTION QUALITY GUARANTEED WHEN ORDERING ANY THREE OR MORE DEDUCT \$1.00 EACH. • FREE SHIPPING IN CONTINENTAL U.S.

ITEM NO.	BEST CUT BEST PRICE	DESCRIPTION	ANGLE/DEPTH/RADIUS CIRCLE DIAMETER	LARGE DIA.	CUTTING LENGTH	SHANK SIZE	PRICE
#601	Solid Carbide	1/8" Spiral Cutter		1/8"	1/2"	1/4"	\$ 9.00
#603		1/4" Spiral Cutter		1/4"	3/4"	1/4"	\$12.00
#903		1/4" Spiral Cutter		1/4"	3/4"	1/2"	\$12.00
#904		3/8" Spiral Cutter		3/8"	1"	1/2"	\$24.00
#905		1/2" Spiral Cutter		1/2"	1 1/2"	1/2"	\$29.00
#530		3/16" Edge Beading	3/16" Dia. of Circle		1/2"	1/4"	\$15.00
#531		5/16" Edge Beading	5/16" Dia. of Circle		1/2"	1/4"	\$15.50
#350		1/8" Round Over	1/8" R	3/4"	3/8"	1/4"	\$11.00
#351		3/16" Round Over	3/16" R	7/8"	1/2"	1/4"	\$11.00
#230		1/4" Round Over	1/4" R	1"	1/2"	1/4"	\$12.00
#353		5/16" Round Over	5/16" R	1 1/8"	1/2"	1/4"	\$14.00
#209		3/8" Round Over	3/8" R	1 1/4"	5/8"	1/4"	\$15.00
#355		1/2" Round Over	1/2" R	1 1/2"	3/4"	1/4"	\$17.00
#655		1/2" Round Over	1/2" R	1 1/2"	3/4"	1/2"	\$17.00
#656		3/4" Round Over	3/4" R	2"	7/8"	1/2"	\$21.00
#199		Multiform Moulding	Unlimited Patterns	2 1/4"	2"	1/2"	\$40.00
#205		1/4" Cove	1/4" R	1"	1/2"	1/4"	\$12.00
#206		3/8" Cove	3/8" R	1 1/4"	9/16"	1/4"	\$13.00
#207		1/2" Cove	1/2" R	1 1/2"	5/8"	1/4"	\$14.00
#643		1/2" Cove	1/2" R	1 1/2"	5/8"	1/2"	\$15.00
#208		3/4" Cove	3/4" R	1 7/8"	3/4"	1/2"	\$26.00
#231		5/32" Roman Ogee	5/32" R	1 1/4"	1 5/32"	1/4"	\$16.00
#232		1/4" Roman Ogee	1/4" R	1 1/2"	3/4"	1/4"	\$17.00
#506		1/2" Pattern	Flush Trim	1/2"	1"	1/4"	\$15.00
#508		3/4" Pattern	Flush Trim	3/4"	1"	1/4"	\$17.00
#366		1/8" Slot Cutter	3/8" Deep	1 1/4"	1/8"	1/4"	\$14.00
#368		1/4" Slot Cutter	3/8" Deep	1 1/4"	1/4"	1/4"	\$14.00
#204		3/8" Rabbeting	3/8" Deep	1 1/4"	1/2"	1/4"	\$13.00
#670		3/8" Rabbeting	3/8" Deep	1 1/4"	1/2"	1/2"	\$14.00

ITEM NO.	BEST CUT BEST PRICE	DESCRIPTION	ANGLE/DEPTH/RADIUS CIRCLE DIAMETER	LARGE DIA.	CUTTING LENGTH	SHANK SIZE	PRICE
#211		3/8" Core Box	round nose	3/8"	3/8"	1/4"	\$10.00
#212		1/2" Core Box	round nose	1/2"	1 1/32"	1/4"	\$13.00
#418		3/4" Core Box	round nose	3/4"	5/8"	1/4"	\$15.00
#213		1" Core Box	round nose	1"	3/4"	1/2"	\$17.00
#548		Lockmitre		2"	7/8"	1/4"	\$32.00
#214		1/4" Straight	plunge cutting	1/4"	3/4"	1/4"	\$ 6.50
#216		3/8" Straight	plunge cutting	3/8"	1"	1/4"	\$ 6.50
#474		1/2" Straight	plunge cutting	1/2"	1"	1/4"	\$ 7.00
#219		3/4" Straight	plunge cutting	3/4"	1"	1/4"	\$ 9.50
#779		3/4" Straight	plunge cutting	3/4"	1 1/2"	1/2"	\$10.00
#462		1/2" Bull Nose	1/2" Dia. of Circle		3/4"	1/4"	\$16.00
#464		3/4" Bull Nose	3/4" Dia. of Circle		1"	1/4"	\$21.00
#764		3/4" Bull Nose	3/4" Dia. of Circle		1"	1/2"	\$21.00
#545		Tongue & Groove	Straight	1 5/8"	1"	1/4"	\$29.00
#845		Tongue & Groove	Straight	1 5/8"	1"	1/2"	\$29.00
#546		Tongue & Groove	Wedge	1 3/16"	1"	1/4"	\$29.00
#846		Tongue & Groove	Wedge	1 5/8"	1"	1/2"	\$29.00
#450		1/8" Beading	1/8" R	3/4"	3/8"	1/4"	\$11.00
#233		1/4" Beading	1/4" R	1"	1/2"	1/4"	\$13.00
#454		3/8" Beading	3/8" R	1 1/4"	5/8"	1/4"	\$15.50
#455		1/2" Beading	1/2" R	1 1/2"	3/4"	1/4"	\$17.00
#500		3/8" Flush	Trimming	3/8"	1/2"	1/4"	\$ 7.00
#501		3/8" Flush	Trimming	3/8"	1"	1/4"	\$ 7.50
#503		1/2" Flush	Trimming	1/2"	1"	1/4"	\$ 8.50
#221		1/2" Flush	Trimming	1/2"	1 3/16"	1/2"	\$ 8.00
#558		Thumbnail		1 3/16"	3/8"	1/4"	\$18.50
#858		Thumbnail		2 1/2"	3/4"	1/2"	\$35.00
#579		Molding Plane		1 1/8"	1 3/4"	1/4"	\$31.95
#879		Molding Plane		1 1/8"	1 3/4"	1/2"	\$31.95

New 32-page catalogue featuring 100's of high-quality router bits, plus other professional woodworking products.

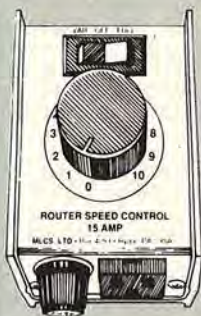

CONTROL THE SPEED OF YOUR ROUTER

ROUT AT THE SPEED THAT GIVES THE BEST RESULTS WITH THE WOOD AND BIT YOU ARE USING!

FEATURES:

- Speed Adjustable from Full Speed to 0 RPM
- Full Horsepower and Torque at All Speeds
- Go Back and Forth from Any Pre-Set Speed to Full Speed at the Flip of a Switch
- Works with All Routers 3/4 HP or Less
- 120V 15 Amp
- Gives Your Router a Feature Only Available on Routers Costing Hundreds of Dollars!

NOW ONLY
\$39.95
Order Item #200

EASY TO USE - Simply plug in Speed Control and plug your router into the Speed Control - turn dial for best results. (Speed Control has a clip that can be worn on your belt or hung on wall or left loose.)

• Reduces speed electronically without reducing torque; electronic feed-back maintains speed by increasing voltage to motor as load increases.

Visit Our Fully Stocked Showroom
(Call for easy directions - 8:30-5:00 M-F)

While in the Phila. Area

To order by Master Charge, Visa, or Discover Call Toll Free, 7 Day - 24 Hour Order Service,
1-800-533-9298 or send check to: **MLCS Ltd., P.O. Box 4053D P, Rydal, PA 19046**

HICKORY

Tougher than nails, and versatile, too

Because he fought tenaciously at the Battle of New Orleans in 1815, General Andrew Jackson's soldiers nicknamed him Old Hickory. His Tennesseans knew the wood well enough to make that comparison, since it grew abundantly in their state. If something had to be tough and strong, they made it of hickory—from ax, hammer, pick, and shovel handles to wagon spokes, hitch trees, and rims. Worked green, it became chairs.

The Choctaws and other Indians of the lower Mississippi River Valley had long used hickory for bows and baskets, but they also drew on its sap for sweet syrup and sugar and its nuts for cakes and meal. The pioneers who followed Davy Crockett valued hickory as firewood, too (it produces 24 million Btus per cord, about the same output as 200 gallons of No. 2 fuel oil). They also smoked ham and bacon with hickory.

Wood identification

North America claims 16 species of hickory, of which the most abundant and commercially important is the shagbark (*Carya ovata*). Other species native to the eastern half of the U.S. and Canada include the shellbark, bitternut, mockernut, pignut, water, swamp, and pecan. The hardwood lumber industry, though, doesn't distinguish between them.

Although hickory grows best in bottomland soils, you'll find it on loamy hillsides as well as



rocky slopes. In the forest, hickory will grow to 140' tall and a diameter of 30", frequently with no branches for 50–60'.

Shagbark and shellbark hickory have long, loose plates of gray bark that appear to be peeling off the trunk. The bark of other hickories varies from furrowed to ridged, but always has a gray color. Hickories generally have from five to seven oblong, pointed leaflets per leaf stem, including a grouping of three at the tip. The fruit develops during the summer into woody four-lobed husks up to 2" long that contain the nut.

Generally straight-grained and coarse-textured, air-dried hickory weighs about 50 pounds per cubic foot. Hickory heartwood varies from tan to brownish-red. The sapwood is nearly white. Although some woods equal hickory in a single property, such as



Natural range

hardness or stiffness, not one commercially available wood can match it in the combination of hardness, bending strength, stiffness, and shock resistance.

Uses in woodworking

Traditionally, hickory has been used for objects that require strength and must take abuse—tool and implement handles, ladder rungs, and wagon wheels. In sports, hickory became hockey sticks, tennis rackets, bows, skis, and even fishing rods. Man-made materials have replaced hickory in many of these products today, but the wood still lends itself to chairs, rockers, stools, and tables—and any project requiring bent wood.

Availability

Hickory is plentiful throughout the eastern U.S., and its cost is low—about \$1.50 per board foot. You'll find hickory plywood available, too, but if it's specifically pecan, it commands a premium price. Veneer costs 50 cents a square foot.

Continued

hickory (*Carya spp.*)

Hickory

Remember that hardwood retailers may mix pecan boards in with other hickories and sell them all as hickory. Since pecan tends to have a more pinkish tone, it could alter staining and finishing results if mixed with tan-colored hickories in the same project. So for best results, sort if it's possible.

Machining methods

Because hickory's hardness even tops sugar maple, you'll definitely need carbide-tipped blades and cutters for your power tools. With that caution in mind, follow these additional tips:

- To avoid surface chipping when planing hickory, feed the wood at a slight angle.
- Feed hickory slowly when ripping, allowing the blade plenty of time to clear itself of sawdust. Crosscutting with a carbide blade poses no problems.
- Jointing straight-grained stock should be effortless, but occasional wavy-figured wood may chip, so take lighter cuts.
- In steam-bending hickory, use

only the straightest-grained stock, then make arcs slightly tighter than needed. Pull the arch wider for an exact fit.

- Use only spurred bits and slower drill-press speeds when drilling hickory, and clear the bit often on thick stock to avoid burnishing.
- To avoid tearout, take light routing passes with a consistent feed rate.
- Avoid cross-grain sanding on hickory because it scratches. Where grains meet at right angles, do your cleanup with a cabinet scraper or random-orbit sander.
- For best results when gluing, use an adhesive with longer open time, such as white glue. Lay down a light coat, briefly join the pieces, then pull apart to allow glue to partially setup before reassembling them.
- Always drill pilot holes for fasteners in hickory, otherwise the wood may split.
- Although hickory responds to all stains and finishes equally well, you may want to fill the grain for ultimate smoothness.

Carving comments

Although hickory seldom finds its way into carvers' hands because of its extreme hardness, should you wish to tackle some of this tough wood, try these tactics:

- In addition to a shallow gouge bevel of 15°–20°, grind a bevel of 10° on the backside of the gouge tip, an always helpful trick for difficult hardwoods.
- Begin with medium cutting burrs if you plan to power carve. The heavy bite of coarse cutters will chip the wood.

Turning tips

- Like most very hard woods, hickory poses no problems in between-centers turning, such as for chair parts, if you use sharp shearing tools (and resharpen them as they become dull).
- If you have to sand before applying a finish, avoid scratches by sanding with the lathe shut off, and only with the grain. ♣

SHOP-TESTED TECHNIQUES THAT ALWAYS WORK

Any exceptions—and special tips pertaining to this issue's featured wood species—appear under headings elsewhere on this page.

- For stability in use, always work wood with a maximum moisture content of 8 percent.
- Feed straight-grained wood into planer knives at a 90° angle. To avoid tearing, feed wood with figured or twisted grain at a slight angle (about 15°), and take shallow cuts of about 1/32".
- For clean cuts, rip with a rip-

profile blade with 24–32 teeth. Smooth cross-cutting requires at least a 40-tooth blade.

- Avoid drilling with twist drills. They tend to wander and cause breakout. Use a backing board under the workpiece.
- Drill pilot holes for screws.
- Rout with sharp, preferably carbide-tipped, bits and take shallow passes to avoid burning.
- Carving hardwoods generally means shallow gouge bevels—15° to 20°—and shallow cuts.

HICKORY AT A GLANCE

Cost	\$ \$ \$ \$ \$
Weight	⚖️ ⚖️ ⚖️ ⚖️ ⚖️
Hardness	T T T T T
Stability	▲ ▲ ▲ ▲ ▲
Durability	🕒 🕒 🕒 🕒 🕒
Strength	🔪 🔪 🔪 🔪 🔪
Toxicity	☠️ ☠️ ☠️ ☠️ ☠️
Workability	🔪 🪚
Look-alike	Elm, Locust

THE CHAIRS OF WHISPERING PINES

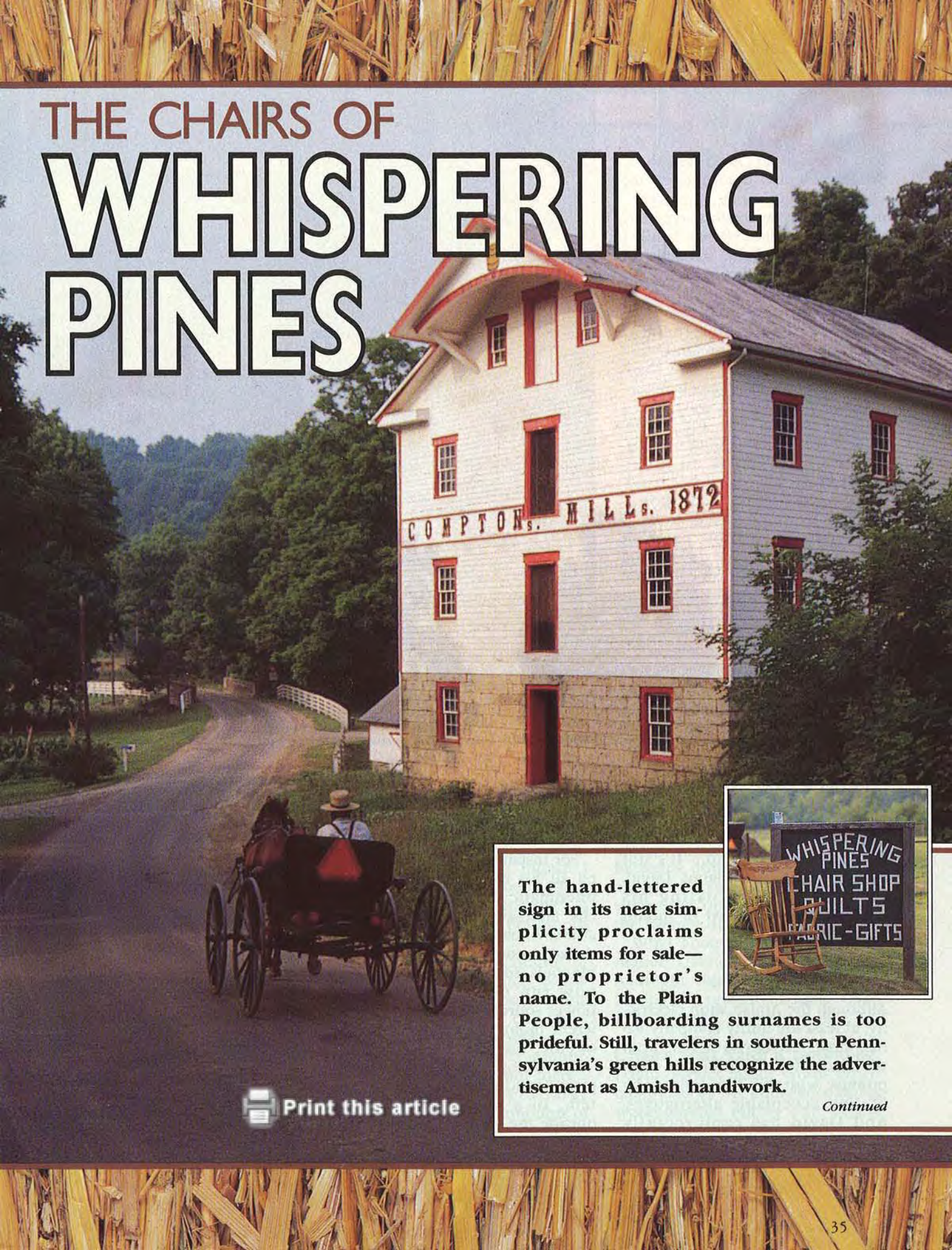

COMPTON'S MILLS 1872

The hand-lettered sign in its neat simplicity proclaims only items for sale—no proprietor's name. To the Plain People, billboarding surnames is too prideful. Still, travelers in southern Pennsylvania's green hills recognize the advertisement as Amish handiwork.



 Print this article

Continued

WHISPERING PINES

The sign draws a few cars from the highway each day during the tourist season to David and Rosie Swarey's house that nudges the village of Pocahontas, Pennsylvania. And those visitors typically park next to the Swarey family's horse-drawn wagon, carriage, or buggy. It's forbidden for Amish to own or drive automobiles.

In warmer months, the overhead workshop door remains open for light and fresh air. David, with a hat of woven straw shading his bearded face, greets potential customers with a wave and a smile. Rosie, in cap and apron, walks over from weeding her vegetable garden—after all, there might be an interest in her handmade quilts. The boys, traditionally clad in suspended trousers and plain shirts, bolt barefoot from the house to see the visiting "English," as the Amish call those outside the fold.

Sometimes, visitors just browse through the line of oak or cherry side chairs, captain's chairs, rockers, bar stools, and tables, and of course, the bright, geometric quilts. Mostly, though, drop-ins mean business, for Amish quality craftsmanship is renowned throughout Pennsylvania.

David, a relative newcomer to the settlement after only two years, wasn't unnerved by founding a woodworking business in a rural, unfamiliar land. "It's not hard to establish," claims David, an elfish grin wrinkling his cheeks. "It's just word of mouth how I got started."

Hooking up to "Amish electricity"

Although the Amish shun electricity, at least the utility company variety that arrives via a line from the road, they often forge a compromise with the 20th century by finding acceptable alternatives. And David has resourcefully

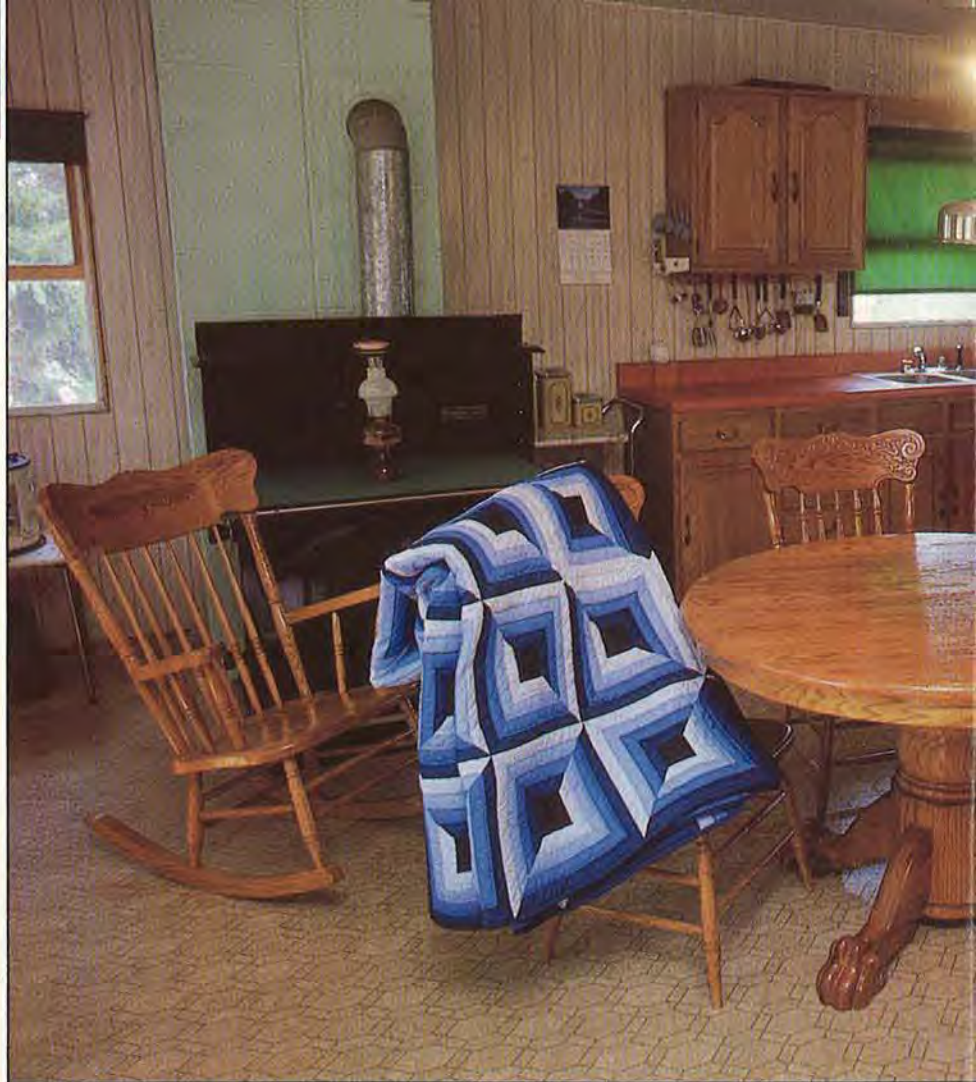

▲ The basic simplicity of the Swarey's large family kitchen highlights David's chairs and table, and one of Rosie's beautiful geometric quilts. The chairs sell for \$90 to \$130 and the round table for \$450. Note the white gas lantern—no electricity is allowed in an Amish home. Curtains and framed pictures aren't allowed, either.

adapted modern woodworking tools to conform to the Plain People's code. Observers know the alternatives as "Amish electricity."

For instance, David has converted all his electric tools to either pneumatic or hydraulic power. His tablesaw, drill press, radial-arm saw, bandsaw, lathe, 72"-long stroke sander, shaper, and portable tools, such as his circular saw, now run on these alternative power sources. "I just buy the different motors to change from the electric," he says.

An 18 hp diesel engine energizes David's 90–100 psi air system. In a small, narrow shed outside the shop, he's connected



▲ David's old bandsaw long ago shed its electric motor. It now runs on economical pneumatic power, as do most of his machines. Others run on hydraulics.



When formal education ends after eighth grade in America's Amish schools, the boys usually turn to farm work, while the girls help out in the home and care for young ones. Yet, there are other choices.

▲ John follows his dad's example by pounding chair parts together as young David intently watches. The boys like woodworking, too.

At 14, David Swarey began his hands-on woodworking education by making pallets in a shop on the family farm in Juniata County, Pennsylvania. His 13 brothers and sisters worked the farm or neighboring ones, practiced a variety of manual trades, or pursued domestic work, but as is the custom, they never strayed far from home.

Over the years, David's knowledge of wood and woodworking grew as he moved with his family to other Amish communities in eastern Ontario, New York, and then back to Pennsylvania. Today, David, 35, his wife Rosie, daughter Mary Ann, and sons John, David, and Mahlon, make up one of the 25 families of the Pocahontas settlement in Somerset County, Pennsylvania.

Unlike the predominate "Old-Order" Amish of Lancaster County, who congregate in members' homes for Sunday service, they are "Meeting-House Amish"—that is, they built a church in which to gather. And, they sometimes adhere to other traditional ways less strictly, such as allowing photographs for instructional purposes.



►At day's end, David rounds up a horse while son David calls the jersey cow in for milking—its rich milk provides the family with butter.

the diesel to a hydraulic pump and twin compressors. "Pneumatic is handy," says David. "You can move the machines where you want—just hook up to the line and join with the hoses."

David's dust collection system also relies on air power. The air rotates a 12×28" squirrel-cage blower that exhausts sawdust and debris through PVC pipe to an outside storage tank. But David's not one to waste anything. "The shavings and sawdust are for garden mulch and livestock bedding—I got two horses and one cow to take care of," he comments. There are other economical benefits.

"I got an air pump hooked up in the well for water," he adds, "and we do all the laundry with hydraulic [two converted, ringer-type washers]. Once a month I get fuel—they come by with a truck and deliver. All together, it costs about \$35 to \$50 per month to run everything."

The Amish permit gasoline or diesel-fueled engines such as David's to perform necessary work. Gasoline-engine-driven combines and other farm equipment are even okay within some communities, as long as horses pull them!

Small generators—not large enough to create great amounts of the prohibited 110-volt alternat-

ing current—generally meet approval, too. An Amish farmer or household may use generators to charge batteries, as long as the batteries don't power "worldly" appliances, such as radios, televisions, or computers. But not in the Swarey household.

What about lights for working nights? David literally burns the midnight oil—a refined version. He says, "For light, I hang Coleman lanterns. They work fine."

Chairs that take a pounding

David doesn't mince words when talking about the endurance of his woodworking efforts. "My chairs should last for 90 years," he says.

Continued



WHISPERING PINES

Does that infer a lifetime guarantee? "Pretty well so, but it depends how people use them—throw them around or whatever. They could break then."

But if ever chairs were built to take a pounding, David's qualify. After all, that's what it takes to put them together.

With his high-crowned hat settled firmly over sweat-dampened hair, David illustrates an important aspect of chair construction. "People say that it's the glue that don't hold up when a chair comes apart. But it's not the glue, it's how you put it together," he says, picking up a spindle. "Lots of people make a chair and drill holes that are a little bit too big. Then the legs and spindles get loose over the years because the glue can't hold a gap. It's gotta be tight enough to pound together. You gotta pound."

The question of a starved joint snaps his head up from his work. "No, no, never. You gotta rub glue around in the hole first, then it penetrates," he points out. "The only thing that can happen bad is if you drill everything tight, then put the wrong post in the hole. It's next to impossible to get it out. And I done that already." Amused at the recall, he chuckles.

Parts from Plain People

When David and his family joined the other Amish in Poca-hontas, his future was uncertain, but he did have an immediate plan. "I just started the chair business," he says. "Nobody around here was doing that. But even if I made hickory rockers [a common Amish product] and there was another fella, that wouldn't bother me. There's enough of a market."

Enough of a market for sure. In fact, David started out crafting all the parts for his products. Now, though, to keep up with demand, he's turned to subcontractors.



▲ In the morning sunlight streaming through the wide-open door, David traces the pattern for a chair arm on rough-sawed red oak.

▼ "Most people drill the holes a little too large, then the glue can't fill the gap," says David. "To assemble a chair, you gotta pound."

"I was turning all the posts and spindles myself, but I got so busy that I either had to hire help or get somebody to do it," says David. "So, I took my patterns [profiles] to a Mennonite guy, and he does all my woodturning now."

David farms the chair backs out, too. He explains, "I have them made in Lancaster. But they're just bowed and pressed with a design. I do all the edge tapering at the bandsaw myself."

Seats, however, David does himself. He wouldn't think of delegating that responsibility.

A short-cut to seats and other laborsavers

"I came up with that pattern for the seats. It's something no one else has, a different shape," he says, hefting a thick, glued-up slab





► David built a jig for the seat blank to follow in back-and-forth travel as the solid dado head in his tablesaw contours the glued-up blank of wood.

of red oak. "They're better built than you can buy in the stores."

David edge-joins as many as eight pieces of wood for a chair seat, believing that "the more you cut it up the better it is, really. I'd never make a solid seat out of one board," he says. "It would split. A glue joint is stronger than just the wood." And David's chair seats won't warp, either, because he carefully alternates the grain direction of each piece.

An ingenious, practical craftsman, David brought the contouring of the seat blank into the 20th century with the development of a jig. Before the jig, he had shaped seats by hand with a rounded draw knife, creating contours that "grabbed your bottom." Now, with a solid dado head mounted on the tablesaw arbor,



Want to know more about Amish life? Read: *The Amish, the Enduring Spirit*, by Leslie Ann Hauslin, with color photos by Jerry Irwin, Crescent Books, N. Y., \$9.95, plus \$3 postage in U.S.
From: Splendor of Pennsylvania
P.O. Box 399
Paradise, PA 17562

For more information on David's handcrafted products
Write: David Swarey
Whispering pines
Chair Shop
Meyersdale Rd. 3,
Pocahontas, Pa 15552



and a guide clamped to the table, David can move the seat blank back and forth across the cutter until the contours have been cut—a matter of minutes, see the photo *above*.

Other laborsaving setups David uses include a router-type, straight-cutter bit chucked into the drill press to bore mortises for the back in a chair's rear posts. David also encased a cutter in a tube to shape the tenons on spindles and legs. A shop-built touch sander puts the near-finish smoothness on chair parts. But it's a simple technique involving nonremoval of stock that catches a your attention in David's shop.

"Ya, I just leave the little cone of wood on the end of the post where it was attached to the lathe," notes David. "That gives

me something to pound on when I'm assembling. Then, I saw it off and clean up the end grain with a palm sander. Otherwise, the parts are all finish-sanded and ready for the spray lacquer before I put them together."

A horn sounds outside. David seats his hat, brushes dust from his ample chest, and politely excuses himself. "Some people just drive by that never were here before," he says excitedly as he exits the shop. "We get a lot of out-of-state cars because we're so close to Maryland, you see. And here's another one that found us." His voice trails off as he moves off toward the newly arrived vehicle. "And, ya never know, they might buy somethin'." ♣

Written by Peter J. Stephano
Photographs: Jerry Irwin



CARVER'S-PRIDE

TRADE



Whether you're a veteran carver or a newcomer, here's a powerful statement you can make in wood. A dynamic portrayal of a woodcarver, low-relief lettering, and your name all work together to instantly identify you as one who cares about carving.

For centuries, craftsmen and tradesmen have announced their shops with distinctive pictorial signs. Years ago, many people couldn't read, but they could quickly recognize a barber pole or giant pair of glasses.

Today, graphic signs stand out on a crowded street and are easy to recognize. Attractive, finely crafted signs proclaim: "I am proud of what I do, and I do it well." Knowing that you carvers feel that way, we asked Robert Thomas Jr., a woodcarver and graphic artist, to design this one especially for you.

Personalize your pattern

First, photocopy the half-sized pattern on the *opposite page* at 100 percent. Then, place your name in the space provided at the bottom. Carefully hand-letter your name in block letters to match the sign style. Or, you can buy rub-on letters from a stationery or art supply store for a professional look. In the Letratype rub-on line of 36-point (½"-tall) type, (see the Buying Guide on *page 43* for our source), try Clarendon Medium for names 12–15 letters long, Times Bold for longer names, or Clarendon Bold for shorter ones.

WE USED THESE TOOLS AND SUPPLIES

- Wood 1½×12×15" basswood or other carving wood
Bandsawed blank in northern basswood available for \$23.50 ppd. in U.S., Ozark Mountain Crafts, Box R, Branson, MO 65616, or call 417/561-8275.
- Gouges
 - 10mm #7
 - 8mm #1
 - 8mm #1 bent
 - 8mm #5
 - 6mm #7
 - 5mm #9
 - 3mm #11 U-veiner
 - 1mm #11 U-veiner
- V-tools
 - 3mm #12
 - 3mm #12 bent
- Skew
 - 8mm #2
- Knife
 - Bench knife

SIGN

Remember, you also can adjust the size of the space for the name, if necessary. After all, this will be *your* sign.

Next, lay the pattern down

Now, enlarge your personalized, half-sized pattern on a photocopying machine set at 200 percent. The enlarged pattern barely fits one 11×17" sheet of paper, so enlarge it in two halves and tape them together. If the copier doesn't go up to 200 percent, enlarge the pattern

at 141 percent and then enlarge the resulting copy at 141 percent. (Or, use 121 percent, 129 percent, and 129 percent.)

Place the enlargement, with transfer paper underneath, on the sapwood side of your workpiece (the tops of the end-grain arcs

point to the sapwood side). Tape the pattern in place, and then trace all the lines except for the slanted, parallel lines in the background. (A french curve and ruler will add to your accuracy.)

Remove the paper pattern and spray artist's fixative or clear lacquer onto the carving blank so you won't smear the lines as you carve. Then, bandsaw around the sign perimeter. Saw slightly outside the pattern line, and sand down to it.

Continued

HALF-SIZED PATTERN

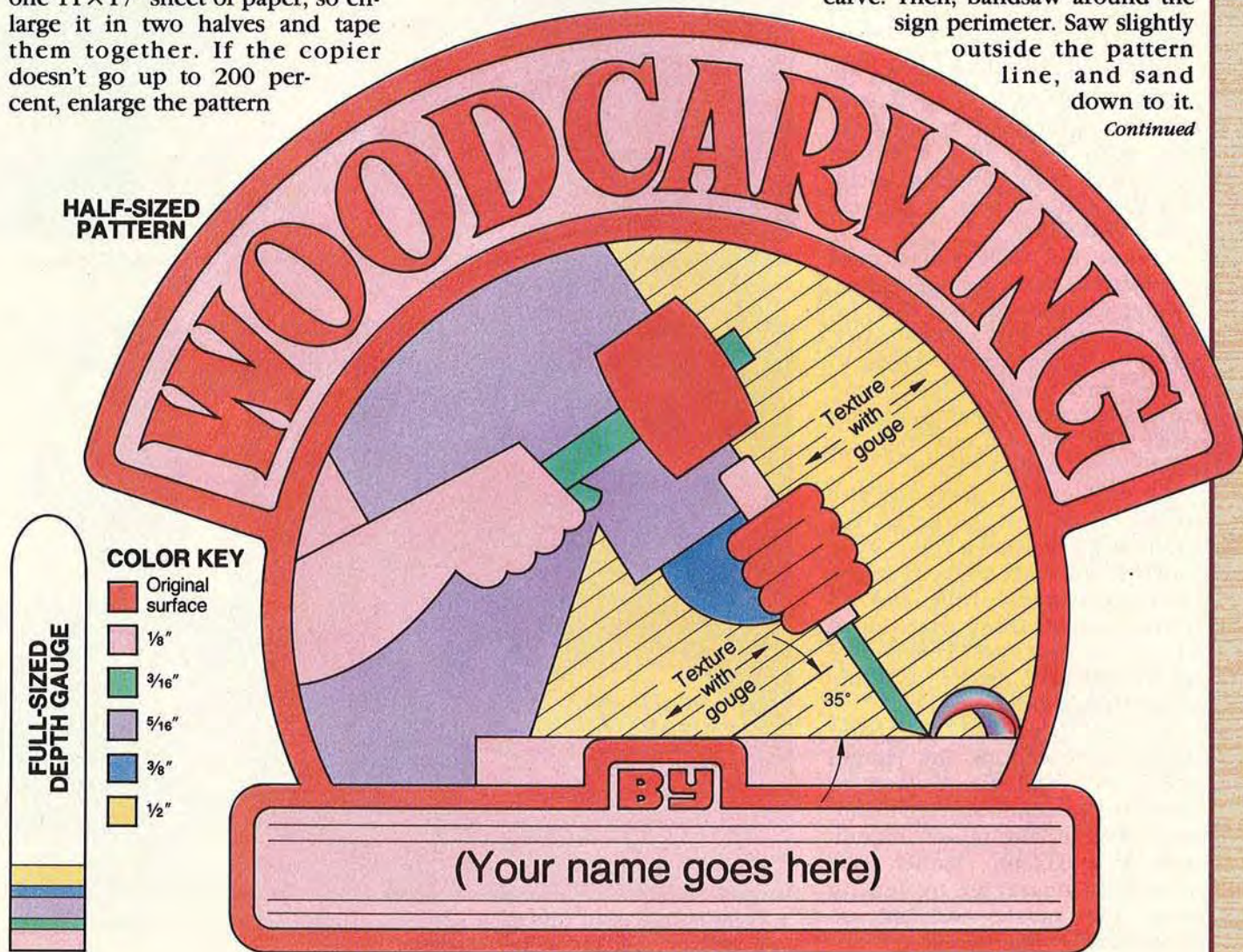

TRADE SIGN

Now, make some chips

Start carving the central design. Hold your carving in place with a bench hook or, for more convenience, a urethane mat.

With your bench knife, make vertical cuts along the pattern lines, as shown *right*. These *stop-cuts* enable you to cut toward a line without removing wood beyond it—they stop your cut. You can stop-cut with your V-tool, too, by cutting along the pattern line with one edge of the tool held vertically. Whichever tool you use, take care not to undercut the line. Straight, vertical sides will make your sign look sharp.

Transfer the depth gauge on the *previous page* to a $\frac{1}{2} \times 2\frac{1}{2}$ " strip cut from a file card or old business card. Then, start removing wood with your gouges to establish the relief levels, a process called *grounding*.

Choose the tools you're most comfortable with for grounding. (We prefer palm-handled tools for ease of control.) At various times, you'll use gouges, skew chisels, V-tools, and your knife. Some carvers like spoon-bent gouges for relief work, but you can complete this carving without them.

As you carve, measure the depth with the gauge and a straightedge as shown *right*. Work down to the final levels in stages, alternately stop-cutting and removing wood. Don't try to do it in one cut, and don't concentrate on a single area. Rather, carve the entire design as one piece.

As you approach the final depths indicated by the pattern color tints and gauge, start to smooth the relief surfaces. But, don't aim for the glassy smoothness of a tabletop. Rather, give your sign character by letting some tool marks and texture show that it's handwork.



▲ Create straight sides for your relief areas by stop-cutting along pattern lines. Be careful not to slope or undercut the sides.



▲ Check carving levels with the depth gauge, which is keyed to the color-coded pattern. Measure each level at several points.

Take care of a few details

With the grounding completed, draw lines $\frac{1}{4}$ " apart at a 35° angle where shown on the pattern. With each line as a center, dig the flutes about $\frac{1}{16}$ " deep with a 5mm No. 9 gouge as shown *below*. Then, carve a narrow groove in the bottom of each with a 1mm U-veiner. Round the top corners with the skew.

Separate the fingers on the hand holding the chisel with the 1mm U-veiner. Then, with your bench knife, contour the chip at the

chisel tip as shown on the pattern and in the photo, *bottom*. Round the chisel handle with a skew, and then chamfer each corner of the blade and each finger slightly.

Separate the carver's mallet arm from the sleeve with a shallow V-tool or veiner groove. Then, with your knife, pare the thumb down so it's a little lower than the mallet handle. Chamfer the arm and hand, sleeves, and body with the skew. Sand the corners of the mallet and the carver's workpiece just enough to smooth them.

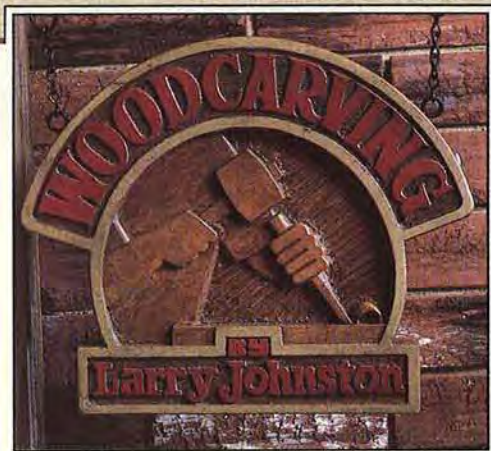

Put it in writing

Stop-cut the lettering, being particularly careful to maintain straight, vertical lines and smooth curves (a V-tool works well for this). For curves, try stop-cutting with a gouge of appropriate curvature (*sweep*) held vertically.

Carve only a shallow relief around the letters ($\frac{1}{8}$ " on your depth gauge). Because of the shallow relief, you won't make many cuts before reaching final depth, reducing the number of opportunities to correct wavy lines. So, start slightly outside the carving line with your first cut and work deliberately toward it.

A worthy finish

Apply a dark stain to your sign (we used Minwax Early American). For a rich look, stain it once, let that coat dry, and then stain it again. After the stain has dried, paint the letters with country red acrylic artist's paint. Accent the border with antique beige. When the paint has dried, apply two coats of satin polyurethane varnish.

Buying Guide

● **Rub-on letters.** Letratype capitals and lower-case, 36 point, in Clarendon Medium (46249CLN), Times Bold (48129CLN), or Clarendon Bold (96916CLN), \$7.95 each ppd. in U.S., The Art Store, 600 Harding Road, Des Moines, IA 50312. Or call 800/652-2225. ♣

Written by Larry Johnston
Project Design: Robert Thomas Jr.
Photographs: John Hetherington; Wm. Hopkins
Illustrations: Mike Henry



▲ Begin texturing the background with a deep gouge, carving along the pattern line. Then, groove the bottom of each cut with a U-veiner. The pattern shows the 35° angle to use for laying out the lines.

◀ Contour the chip to form a smooth curl. For the best effect, match the slope angle on the inside right end with that on the outside left end.

OUR INNOVATIVE JIG MAKES 'EM EASY TO DO BANDSAWED

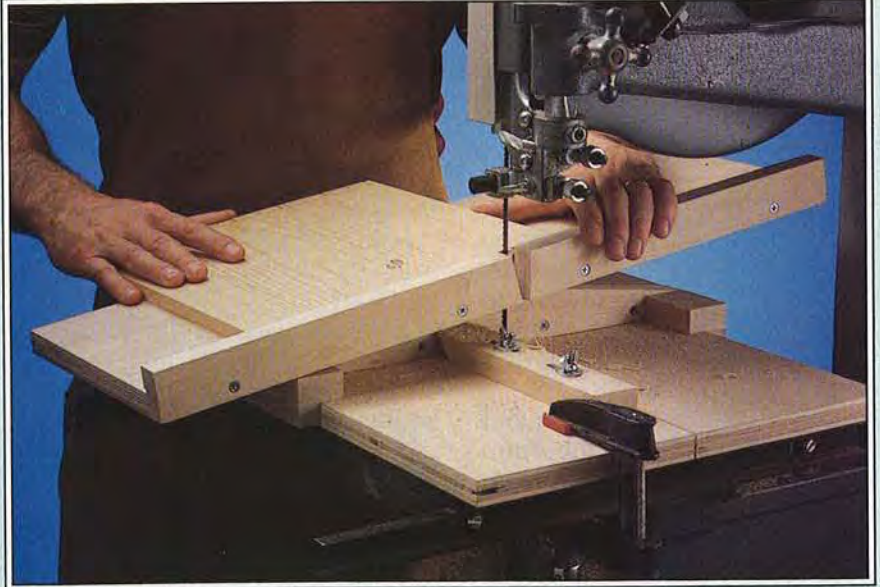

From time to time I drop by Design Editor Jim Downing's office and find him hard at work—leaned back in a chair, his feet propped up, his mind deep in thought. At times like these, you can bet he's cooking up a new or better way to perform some woodworking task. On one such occasion recently, Jim seemed especially entranced, so I asked him what he was thinking.

"A jig," he replied in a soft monotone, his eyes still fixed on a distant point.

"One for making through dovetails quick and easy with a bandsaw," he added.

Before the day was out, Jim shared a sketch of his jig idea with me. And within a week, we found ourselves standing shoulder to shoulder in the shop bandsawing clean, accurate, and downright great-looking through dovetails with a working model of the jig. (See the photo above.) Needless to say, I could hardly wait to show you how to use this ingenious device.



Print this article

Bill Krier

Products and Techniques Editor

What's a through-dovetail joint?

As you can see in the drawing right, the tails of through-dovetail joints extend completely through the thickness of the pins on the adjoining workpiece. In the days before power tools and modern

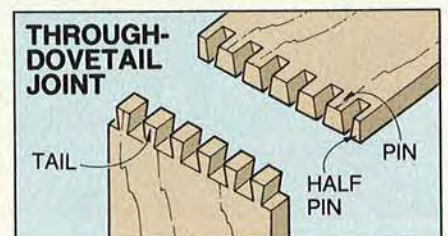

THROUGH-DOVETAIL JOINTS

adhesives, skilled craftsmen painstakingly scribed, handsawed, and chiseled these joints in the making of furniture, trunks, and all sorts of boxes. The resulting joints proved mechanically strong and aesthetically pleasing.

Today, through-dovetail joints serve primarily as a design element. Several router jigs on today's market will make through-dovetail joints, but these cost upwards of \$200. In this article, we'll show you how to cut through-dovetail joints with a jig costing just a few dollars.

Up-front planning pointers

Before you get knee-deep into the actual cutting of the workpieces, keep the following in mind:

- Knowing the difference between tails and pins is one of the most important tasks in planning and making through-dovetail joints. Things will work out fine, though, if you just remember this: the face grain of tails looks like a dove's tail (trapezoid), and the face grain of pins is rectangular.

- When working out a dovetail project design, take note that you

can change the size and spacing of the tails and pins for a pleasing, custom-made look. On the following pages, we've provided four examples of attractively designed dovetail joinery as a guide. During layout, don't forget to plan for two equally sized half-pins at either end of the joint.

- You'll also have to decide which sides of your project have tails and which sides have pins. If you're building a box such as the Yarn Carrier on page 52, the front and back pieces should have tails for appearance's sake. But, if you're building drawers, the sides should have tails for the strength to survive opening and closing.

Start by making our handy-dandy jig

To construct the dovetail jig, turn to page 49. After you assemble the jig, we'll see you back here!

Note: This jig helps you make dovetail joints in stock as wide as your bandsaw's throat depth. For example, with a 14" bandsaw, you can make dovetailed boxes or drawers with sides up to 14" wide.

Ladies and gentlemen, mark your workpieces

To help keep everything straight, gather the four sides of your project and mark each of the *inside* and *outside* surfaces and number each corner as shown below.

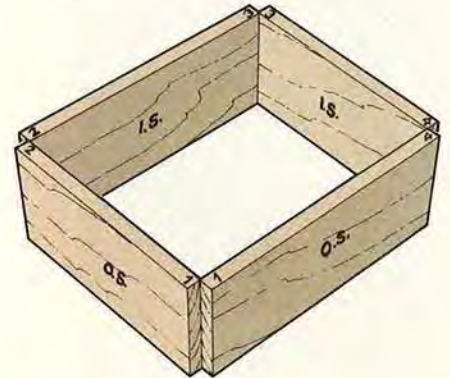

Now, lay out the pins and half-pins

For each dovetail joint, follow the 5-step marking process for equally spaced dovetails below. Note that to mark the pins you also need to lay out the tails on the end of the stock. This will give you a good idea of what the assembled joint will look like.

Continued

LAYING OUT EQUALLY SPACED DOVETAILS

Step 1

Mark the length of the tails and pins (thickness of adjoining stock plus 1/32") on ends of stock. Number the corresponding joints (1 and 1, 2 and 2, etc.) so you can match up the joints later.

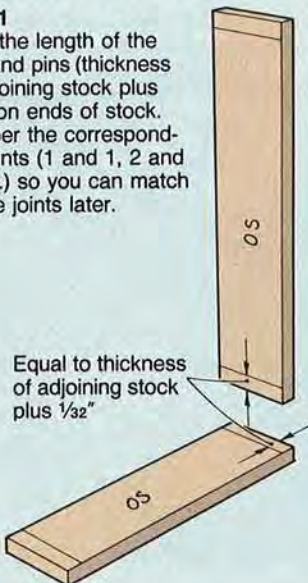

Step 2

Determine the number of tails desired. This drawing shows the difference in appearance between two and six equally spaced tails on 3/4 x 4" stock. More than six tails on this width of stock would make the base of each tail less than 1/4", and result in a fragile joint. With 4" stock, we prefer three tails to avoid a machine-cut appearance.

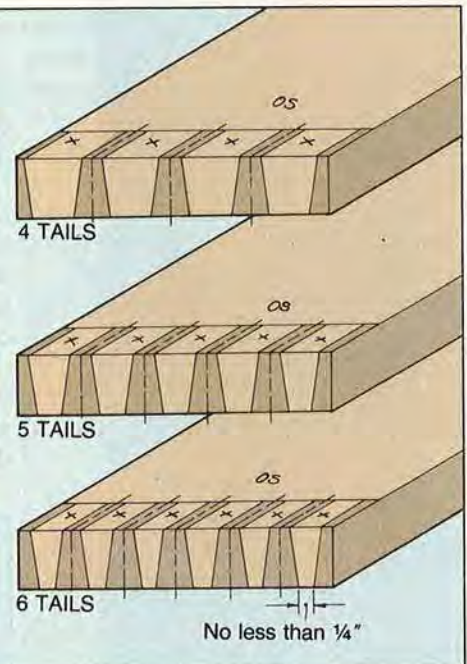
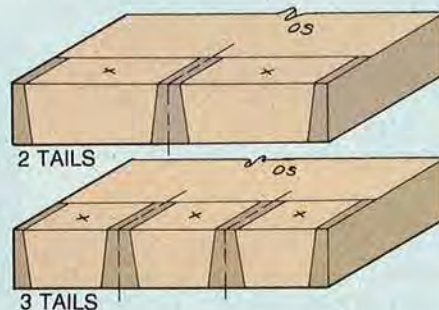

Step 3 continues on the next page.

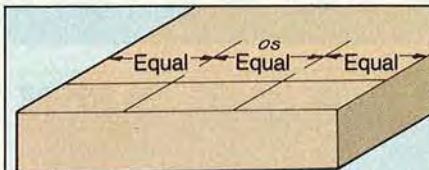

Step 3
Divide stock into equal parts. Your marks are centerpoints for the tails.

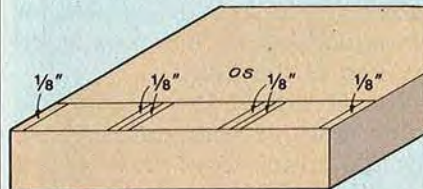

Step 4
Lay out cutting guidelines for the pins $\frac{1}{8}$ " to either side of the tail centerlines. Lay out half-pin cutting guidelines $\frac{1}{8}$ " in from the edges of the stock.

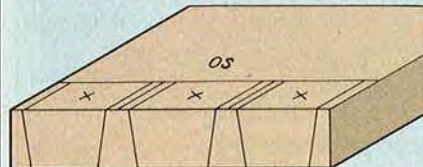

Step 5
Starting with the half-pins, transfer 8° tail lines from all pin guidelines as shown. Mark an X on the waste area between the pin guidelines.

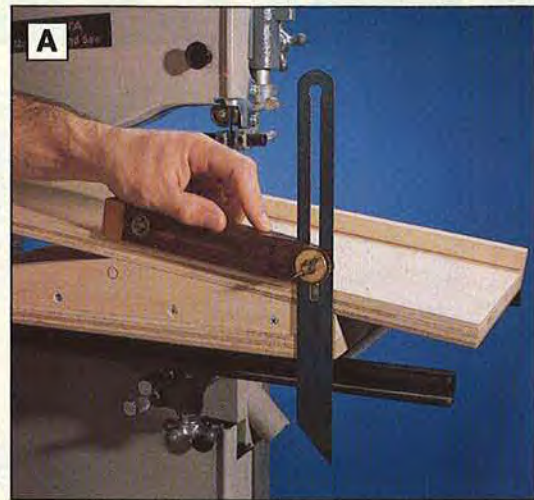

A
Align the blade of your sliding T-bevel with the side of the jig to set it for the dovetail angle.

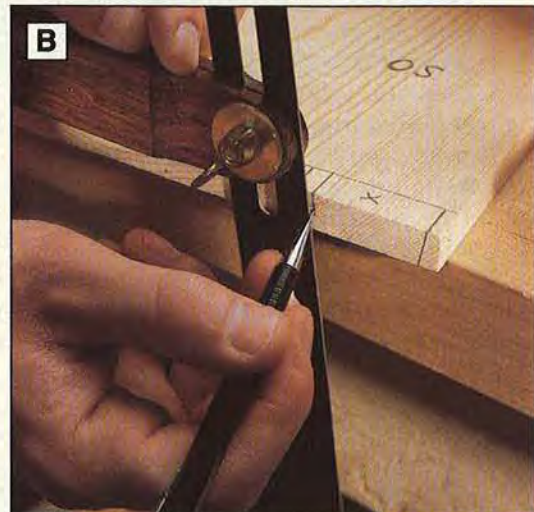

B
Transfer the dovetail angle to your workpiece with the sliding T-bevel.

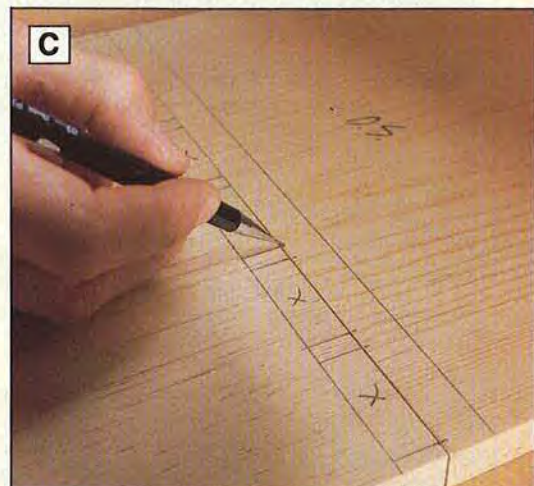

C
For consistent pins, transfer the pin marks from one workpiece to another.

To mark the 8° dovetail angles, rest the body of your sliding T-bevel on the pivoting table of the through-dovetail jig and align its blade with the jig's side as shown in Photo A. This way, you can transfer the exact dovetail angle as determined by the "pitch" of the jig's table (see Photo B).

As shown in Photo C, you can save time and ensure consistent joints by transferring the pin marks to the other workpiece (and in turn, to the opposite end of the originally marked board).

If you're feeling especially adventurous, you can try your hand at laying out unequally spaced dovetails and dovetails of varying

TIP: For thin, consistent marks that will help you cut better-fitting joints, use a 0.5 mm mechanical pencil.

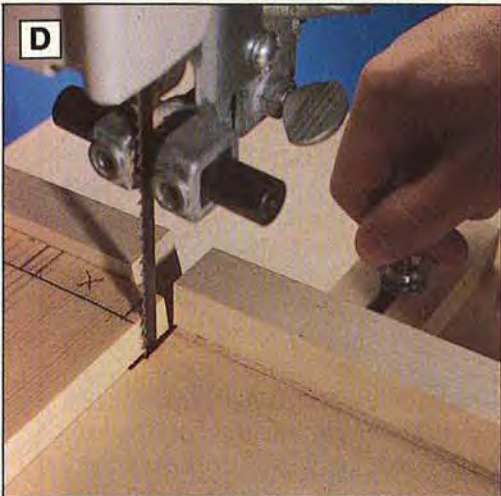
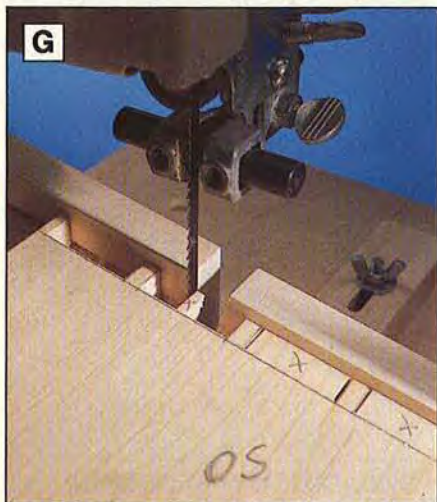
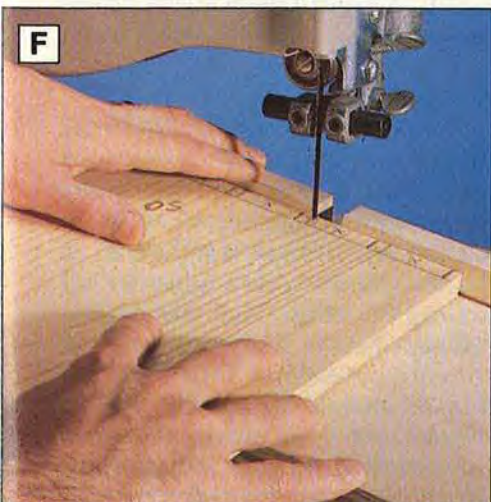
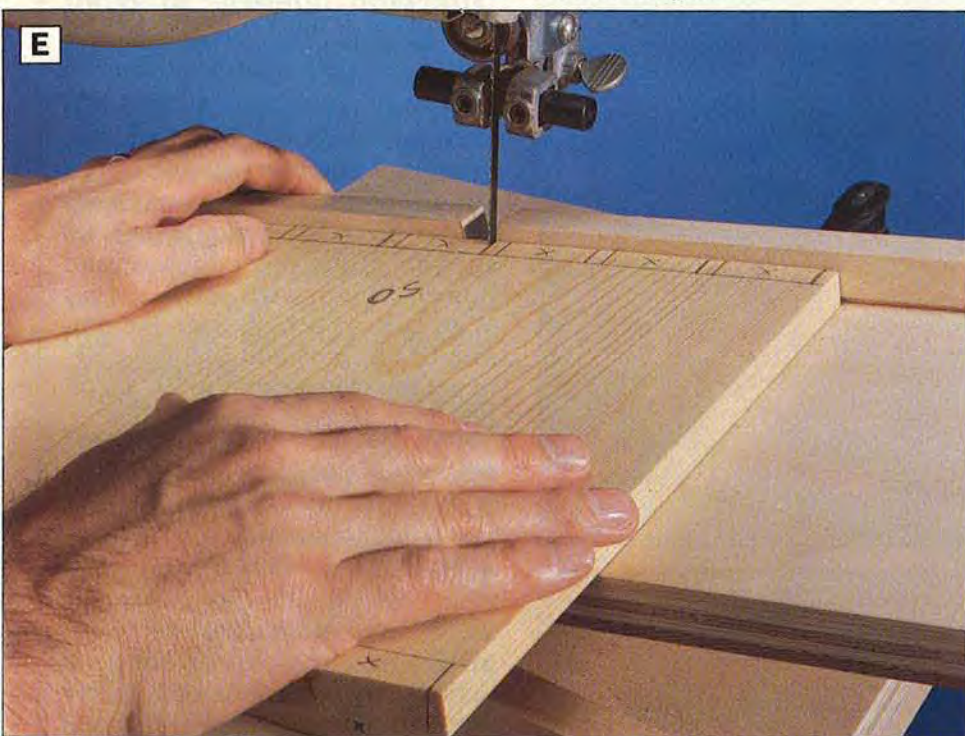

Photo D: Slide the jig and workpiece to within $\frac{1}{16}$ " of the pin length, and tighten the stop's wing nuts.

Photo E: With the jig tilted to the left, cut inside the lines on the right side of the waste areas.

Photo F: Tilt the jig to the right, then cut inside the lines on the left side of the waste areas.

Photo G: Remove the waste material by making multiple cuts. Be careful not to cut into the pins.



widths. (See the examples on pages 46 and 48.) Just remember to keep your design symmetrical for the most pleasing result.

Here's how to cut the pins and half-pins

For the following steps, use a $\frac{1}{4}$ " bandsaw blade. And, make sure your bandsaw's guides are adjusted so the blade doesn't wander during cuts.

Adjust the bandsaw table for a 90° cut, and clamp the base of the through-dovetail jig onto the bandsaw table. Set the jig's stop so the blade cuts to within $\frac{1}{16}$ " of the full length of the pins as shown in Photo D. Tilt the jig's table to your left, and cut inside the lines on the right side of each waste ("X") area as shown in Photo E. Remember to hold the workpiece firmly against the fence during all cuts.

Tilt the jig's table to the right, and cut the other side of the pins as shown in Photo F. Next, remove all the waste between the two bandsaw kerfs by making multiple cuts as shown in Photo G. Tilt the jig's table as necessary so you remove *only* the waste material. Do not cut into the pins.

Now, adjust the jig's stop so the bandsaw blade cuts up to the marked line. Remove the remaining material by slowly sliding the stock across the bandsaw-blade teeth as shown *below*. Remember to tilt the jig's table while nearing the end of each cut.

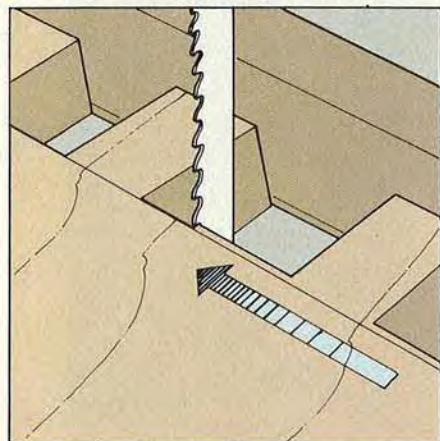

Continued

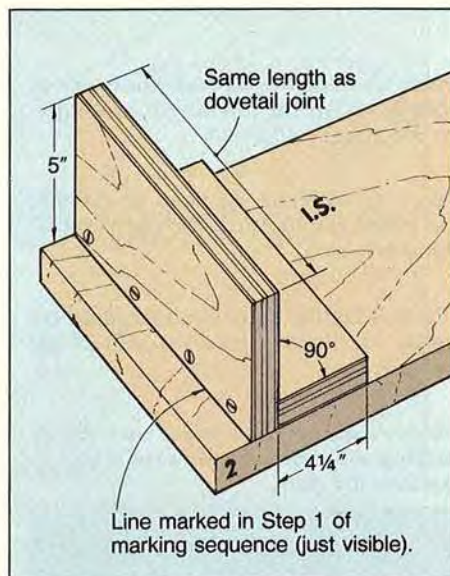

Next, mark the tails

After cutting all the pins and half-pins, reassemble your workpieces so the numbered corners match up. It's important to keep these pieces organized because you will custom-cut the tails to fit each set of pins and half-pins.

For a cutting guide, you need to trace the outline of the pins and half-pins onto the adjoining piece of stock. First, place the workpiece that you'll cut tails into on the bench, inside surface up. Position an L-shaped bracket made from 3/4" plywood on this workpiece as shown at *left*. Clamp the workpiece and bracket onto your bench.



Now, place the already-cut workpiece against the bracket, with the outside surface facing away from the bracket, and clamp it into place as shown at *left*. Be sure to align the edges of the boards flush with each other. With a sharp pencil, trace the outline of the pins and half-pins. Remove the clamps, and mark X's on the material between the tails.

Clamp the workpieces to the bracket for accurate tail marking.

It's time to cut the tails

To remove the material between the tails, follow the four-step sequence shown at *left*. (You don't need the jig because these cuts are 90° to the surface of the workpiece.) Be careful to cut along the pencil marks without completely removing them. Removing too much material will result in a sloppy fit.

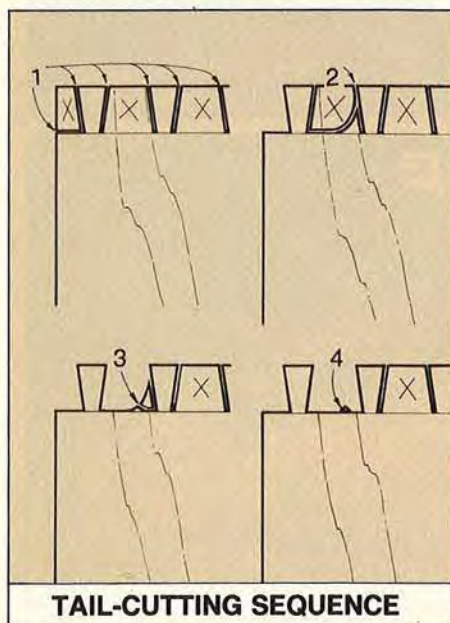

Assemble the joints

Before gluing, test-fit all four joints and bandsaw away any high spots that prevent the joints from coming together. Then, with a small brush, apply a light coat of white woodworker's glue to all mating surfaces. The white glue sets up slower than yellow glue, so you have time to check the box or drawer for square.

After the glue dries, belt-sand the protruding tails flush with surrounding surfaces. ♣

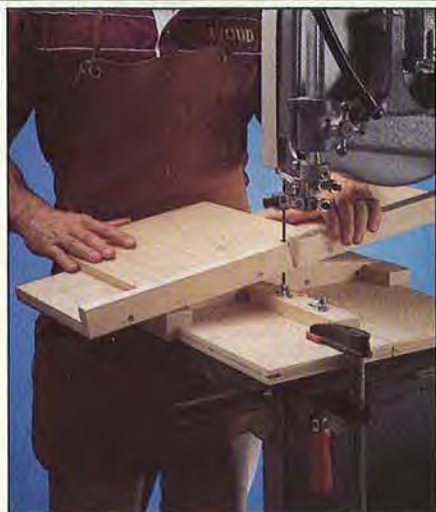

TILTING-TABLE DOVETAILED JIG

Cutting dovetails just got a whole lot simpler

I've often admired the good looks of through dovetails. But the hassle of setting up, adjusting, and using most jigs has kept me at bay. So, when Jim Downing, our design editor, came up with this jig, my first thought was, "not another complicated jig."

Boy, was I in for a surprise. My very first joints cut on this jig fit tight and looked professional.

Take a look at the knitting carrier on page 52 for proof of how easy it is to do quality work with this jig,

Marlen Kemmet
Marlen Kemmet, How-To Editor

Note: We built our dovetail jig to fit a Delta 14" bandsaw. If the throat depth on your bandsaw is less than 14", you'll have to shorten the overall length of the table/fence assembly.

Start with the pivoting-table assembly

1 Cut the table (A), fence (B), and support block (C) to the sizes listed in the Bill of Materials.

2 Mark the location, and cut a $\frac{3}{16}$ " dust-relief groove $\frac{3}{16}$ " deep along one face of the fence (B) where shown on the Exploded View drawing at right.

3 Glue and screw the fence to the table with the bottom edges flush.

4 Mark diagonals on both ends of the support block. Next, drill a $\frac{3}{8}$ "

Continued

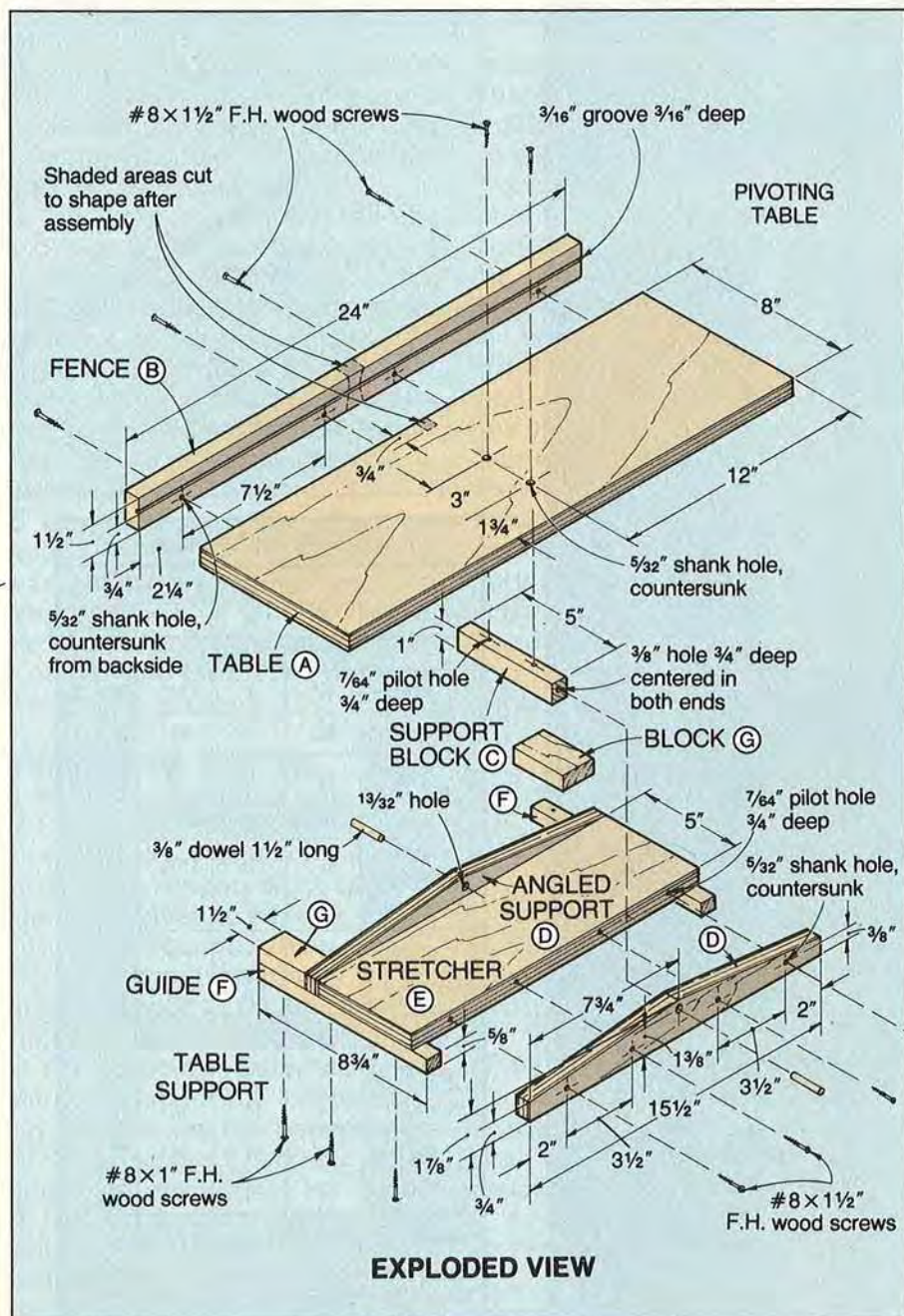

DOVETAIL JIG

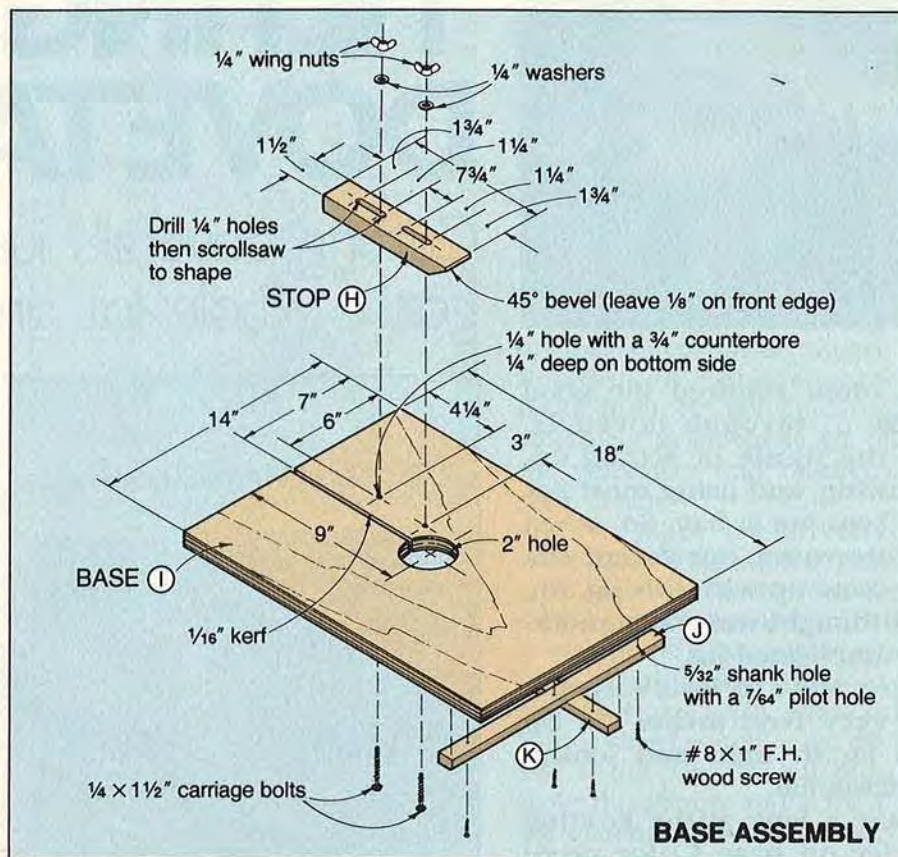

Bill of Materials						
Part	Finished Size			Mati.	Qty.	
	T	W	L			
PIVOTING TABLE						
A	table	3/4"	8"	24"	BP	1
B	fence	3/4"	1 1/2"	24"	B	1
C	support block	3/4"	1"	5"	B	1
TABLE SUPPORT						
D	angled supports	3/4"	1 7/8"	15 1/2"	B	2
E	stretcher	3/4"	5"	15 1/2"	BP	1
F	guides	5/8"	3/4"	8 3/4"	B	2
G	blocks	3/4"	1 1/2"	2 1/4"	B	2
BASE						
H	stop	3/4"	1 1/2"	7 3/4"	B	1
I	base	3/4"	14"	18"	BP	1
J	guide	3/8"	3/4"	14"	B	1
K	guide	3/8"	3/4"	17 1/4"	B	1
Material Key: BP—birch plywood, B—birch						
Supplies: #8 x 1" flathead wood screws, #8 x 1 1/2" flathead wood screws, double-faced tape, 3/8" dowel stock, 2-1/4 x 1 1/2" carriage bolts, 1/4" wing nuts, 1/4" flat washers, paraffin, clear finish.						

hole 3/4" deep centered in each end of the block. (To ensure straight holes, we clamped the support in a handscrew clamp, squared it with the drill-press table, and then drilled the holes.)

5 Mark a pair of centerpoints on the top of the table (A) where shown on the Exploded View drawing. Drill and countersink a pair of 5/32" holes where marked.

6 Glue and clamp the support block (C) to the bottom of the table, centered from side to side and 3/4" from the back edge of the table. Then, using the previously drilled holes in the table as guides, drill a pair of 7/64" pilot holes in the support block. Secure the support block to the table with a pair of wood screws.

And now for the table support

1 Cut the angled supports (D) to the size listed in the Bill of Materi-

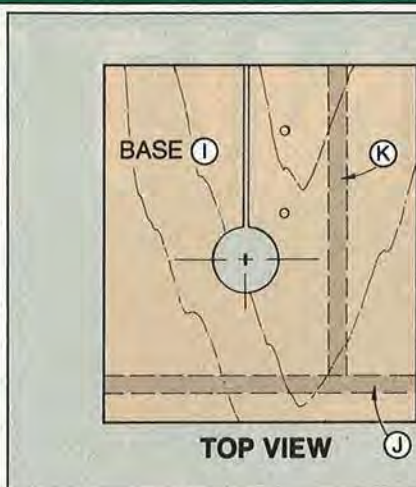
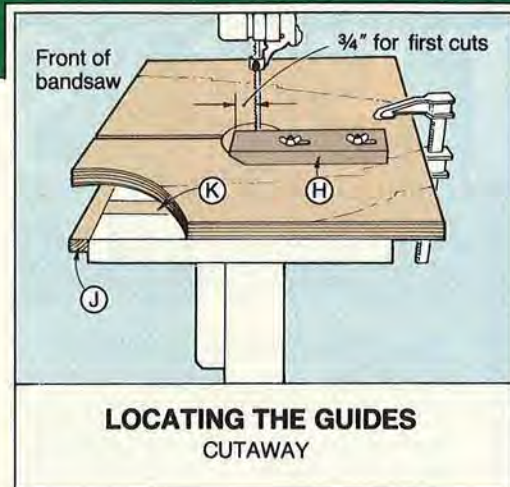

STEP 1 Install a $\frac{1}{4}$ " blade in your bandsaw. Adjust the blade guides, and square the bandsaw table to blade.

STEP 2 Align the front edge of your bandsaw blade with the center of the 2" hole.

STEP 3 Glue the guides (J, K) to the bottom side of base. After the glue dries, drill mounting holes, and install screws to further secure the guides to the jig's base.

als. Using double-face tape, stick the pieces together face-to-face, with the edges and ends flush. Mark the layout lines and hole centerpoints where dimensioned on the Exploded View drawing.

2 Cut the angled supports to shape (we used a bandsaw). Sand the angled top edges smooth. Drill a $1\frac{3}{32}$ " hole through both pieces. Drill and countersink four $\frac{5}{32}$ " holes through the taped together pieces where marked. Separate the pieces, and remove the tape.

3 Cut the table-support stretcher (E), guides (F), and blocks (G) to size. With the ends and bottom edges flush, glue and clamp the angled supports (D) to the stretcher (E). Using the previously drilled holes in the angled supports (D) as guides, drill $\frac{7}{64}$ " pilot holes into the stretcher, and drive #8x1 $\frac{1}{2}$ " wood screws to further strengthen the joints.

4 Glue and screw the blocks (G) to the guides (F). Glue and screw the guide/block assemblies to the stretcher assembly, flush with the ends of the stretcher and parallel to each other.

Construct the base assembly

1 Cut the stop (H), base (I), and alignment guides (J, K) to size. The base must fit between the guides (F) with no free play. Angle-cut one end of the stop where shown on the Base Assembly drawing at *opposite page, top*.

2 To form the $\frac{1}{4}$ "-wide slots in the stop (H), mark the hole cen-

terpoints, drill the holes, and then cut between the holes with a scrollsaw. You also could drill overlapping holes, and clean the waste with a sharp chisel.

3 Mark the centerpoints on the top face of the base for a pair of carriage bolts. Drill the $\frac{1}{4}$ " holes, and then drill a $\frac{3}{4}$ " counterbore $\frac{1}{4}$ " deep on the bottom side.

4 Mark the kerf and 2" hole centerpoint on the base (I). Bandsaw the kerf. (We cut the hole in our base the same size as the hole in our bandsaw table.)

5 Glue and screw the alignment guides to the bottom side of the base as described on the Top View portion of the drawing titled Locating the Guides. (See the Cutaway and Back View drawings for further reference.)

Finishing up your jig

1 Sand the assemblies smooth.

2 Cut two $\frac{3}{8}$ " dowels to 1 $\frac{1}{2}$ " long. Put a drop of glue in each $\frac{3}{8}$ " hole in the support block (C). Position the pivoting table on the table support, and drive the $\frac{3}{8}$ " dowels through the holes in the angled supports (D) and into the holes in the support block.

3 For a smooth sliding action of the table support on the base, apply paraffin on the bottom sides of the stretcher (E) and the inside edges of the guides (F).

4 If desired, add a coat of clear finish to all but the waxed areas. Although a finish helps keep the jig clean, it is not necessary.

5 Insert the carriage bolts through the base. Using the guides as guides, clamp the base assembly to the bandsaw table. Position the front edge of the stop (H) $\frac{3}{4}$ " ahead of the front edge of the bandsaw blade where shown on the Cutaway drawing. Tighten the stop to the base.

6 As shown on the Back View drawing, tilt the table to one side and cut into the table ($\frac{3}{4}$ ") until the table support comes in contact with the stop. Tilt the table in the opposite direction and make a second cut. Now, using successive cuts and tilting the table back and forth, remove all of the waste material from between the first two bandsaw cuts.

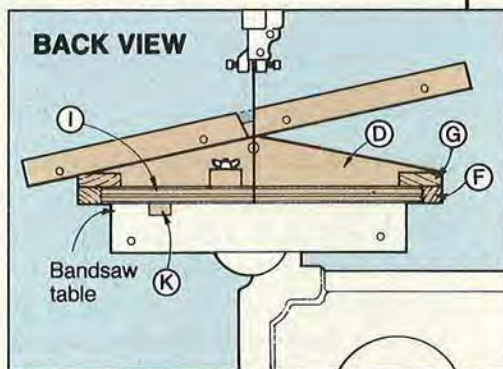

7 Refer to the preceding techniques article for instructions on using the jig, and then proceed to the following article to build a beautiful knitting carrier. ♣

Produced by Marlen Kemmet.
Project Design: James R. Downing.
Photographs: Hopkins Associates.
Illustrations: Jamie Downing; Bill Zaun

KNITTER'S

FEATURING

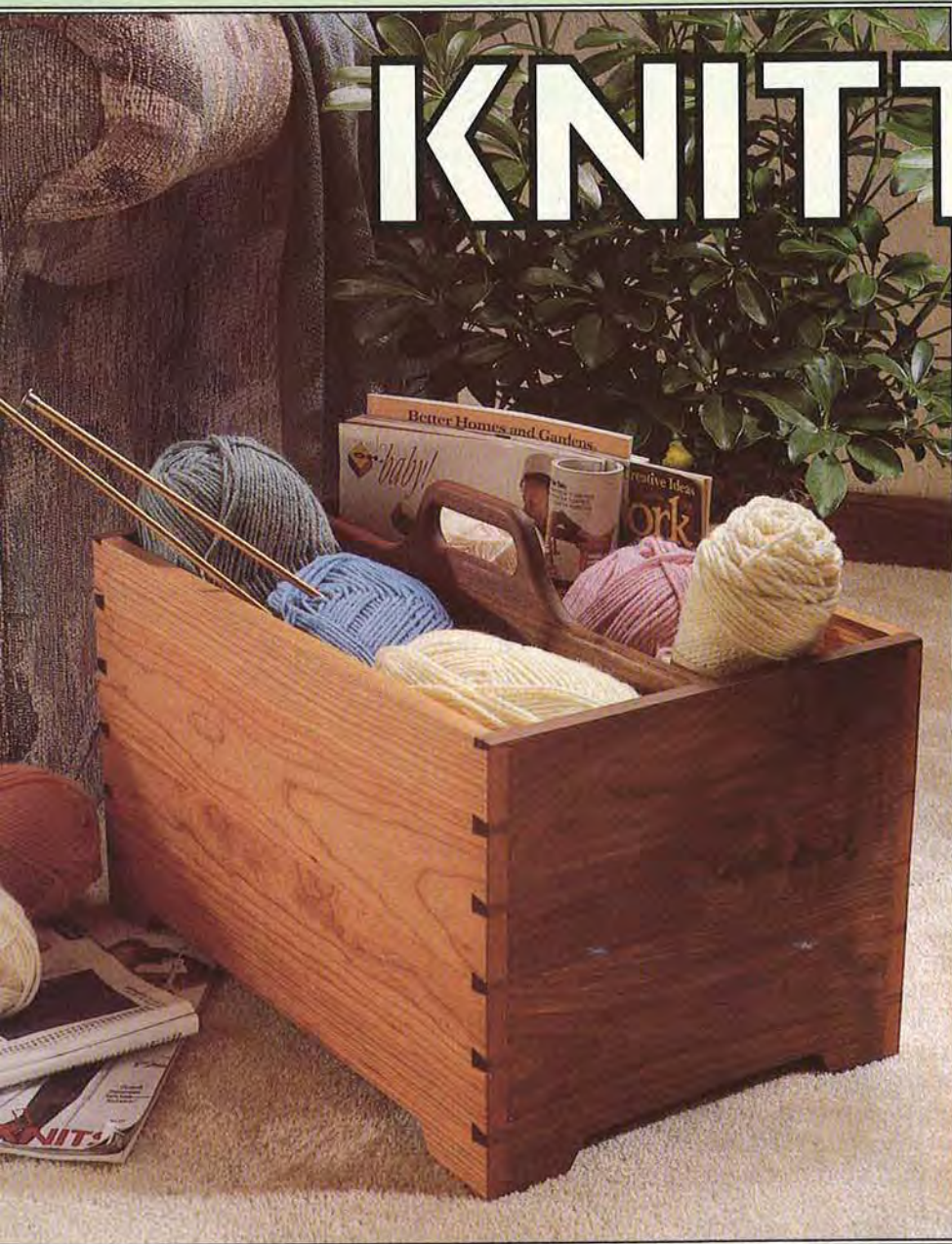

Don't let the dovetails we used for this fancy walnut and cherry knitting carrier scare you off. Armed with our dovetail jig (page 49) and after reading the techniques article on how to use it with a bandsaw (page 44), you can complete this project successfully in an evening or two, no problem. And who knows, maybe someone will knit you a new scarf or sweater for your efforts.

Note: To keep the project lightweight, we used ½" stock. You can either resaw or plane thicker stock, and then edge-join the ½"-thick boards. The drawing titled How To Resaw shows the method we used to resaw thicker stock.

Produced by Marlen Kemmet
Photograph: Hopkins Associates

Project Design: James R. Downing
Illustrations: Kim Downing; Bill Zaun

Edge-join narrow stock to form the wide pieces

1 Cut enough ½"-thick walnut and cherry strips to form panels for the sides (A), ends (B), and divider (C). (We edge-joined two boards for each A and B panel, and three boards for the C panel.) Cut the pieces so the edge-joined panels measure about ¼" wider and 1" longer than the finished size listed in the Bill of Materials.

2 Glue and clamp the pieces for each panel edge to edge, with the surfaces flush. Later, remove the clamps and sand smooth.

3 Rip and crosscut the panels (A, B, C) to the sizes listed in the Bill of Materials.

Cut the dovetails, and assemble the parts

1 To make the dovetail markings easier to see, apply masking tape on the surfaces to be marked. (Pencil lines on walnut are hard to see.) Mark the dovetails as described in the techniques article.

2 Cut matching dovetails in the ends of the side and end panels.

3 Cut or rout a ½" dado ¼" deep centered on the inside face of the end panels (B).

4 Assemble, but don't glue, the pieces (A, B, C) to check the fit.

5 Transfer the full-sized Half Handle pattern, including the hole centerpoints to the top of the divider (C) where located on the Exploded View drawing. Drill a pair of 1" holes inside the marked handle opening. Then, use a scrollsaw or coping saw to cut the opening and handle to shape.

6 Rout ¼" round-overs in the handle opening and along the top edge of the divider where shown on the Exploded View drawing.

COMPANION

FINE DOVETAIL JOINERY

7 Mark the cutout along the bottom edge of each side and end panel where dimensioned on the drawing. Cut to shape.

8 Cut the shelves (D) and cleats (E) to size. Sand all the pieces.

9 Mark the locations on the inside of the end panels, drill mounting holes, and fasten the cleats.

10 Then, glue and clamp the pieces together, checking for square. Using a damp cloth, wipe off any excess glue immediately.

11 Finish-sand, glue the shelves in place, and apply the finish. 🌲

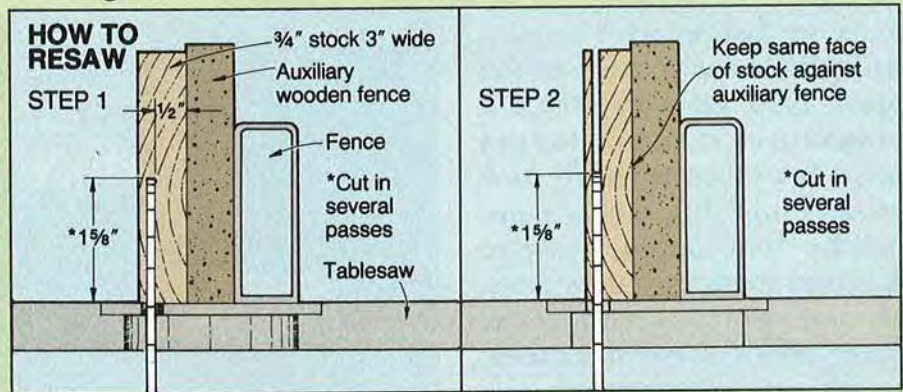

Bill of Materials					
Part	Finished Size			Mater.	Qty.
	T	W	L		
A* sides	1/2"	10 1/2"	18"	EJC	2
B* ends	1/2"	10 1/2"	12"	EJW	2
C* divider	1/2"	11 7/8"	17 1/2"	EJW	1
D shelves	1/2"	5 1/8"	17"	EJC	2
E cleats	1/2"	3/4"	5 1/8"	W	4

*Initially cut parts marked with an * oversized. Then, trim each to finished size according to the how-to instructions.

Material Key: EJC—edge-joined cherry, EJW—edge-joined walnut

Supplies: masking tape, #8 x 3/4" flathead wood screws, clear finish.

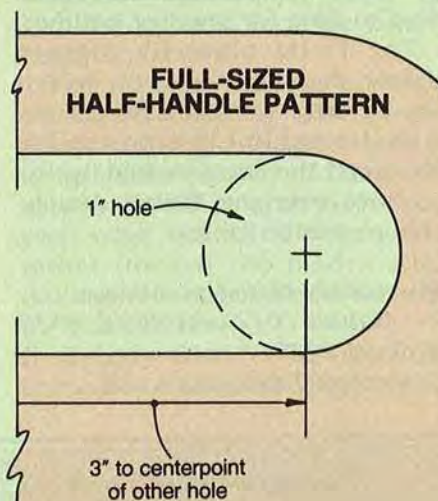
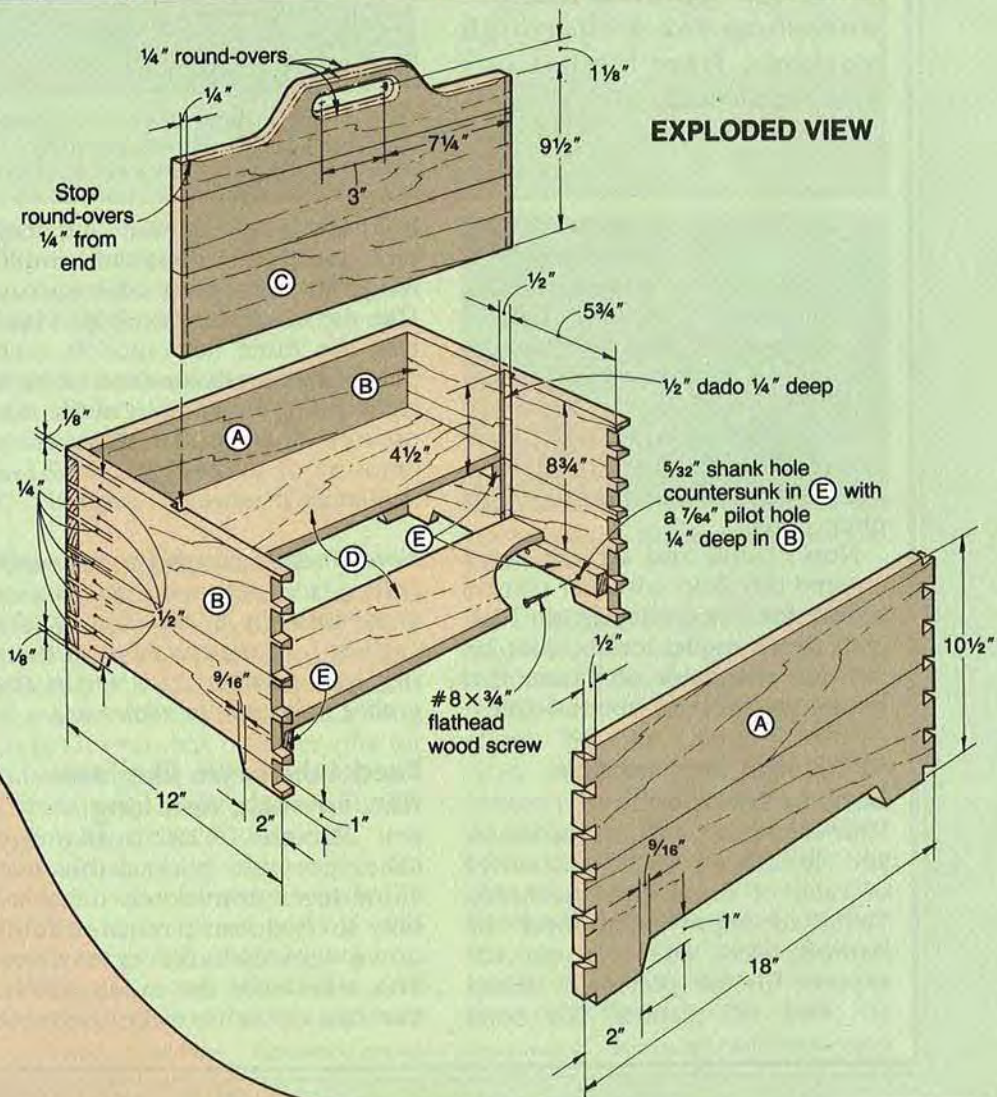

A TALENTED NEW TRIO OF... PORTABLE

Since we last reported on portable thickness planers in the April 1990 issue of *WOOD*® magazine, manufacturers have introduced three new models into this highly competitive tool category. We've received loads of letters from readers who want to know more about these machines, so we ordered them into our workshop for a thorough workout. Here's what our tests uncovered.



We tested these three new entries in the portable-planer market (from left): Delta 22-540, Hitachi P12R (shown as model P12RA with attachable 6" jointer), and Grizzly G1017. All three machines plane 12"-wide boards.

In our last test, we looked at the Ryobi AP-10, various Taiwanese machines of similar construction, and the Sears 23381, all selling in the \$350-\$400 range. We also included the higher-priced Makita 2012 (\$460-\$500). Of these machines, the Makita was clearly superior, with the Ryobi having a slight edge on the planers in its price range.

Now, Delta and Grizzly have entered this field with 12" planers selling for just under \$400. Hitachi offers a model for about \$620, with an attachable 6" jointer that boosts the price to about \$820.

What the new models have in common

Four steel posts support the motor and cutterhead (head assembly) of each of these new machines. That's an improvement over the stamped steel sides that provide support for the previously tested 10" and 12" planers. The posts

hold the head assembly and feed table rigidly in alignment, simplifying any necessary adjustments. Like the machines in our previous test, the three new models each planed a smooth, uniform surface right out of the box. All of the machines draw about the same amount of amperage and have similar feed rates.

Note: To help you judge these machines, we assigned each one a grade between A (excellent) and F (failure). At the end of the following two sections, we recap the grades from our previous test.

Feed tables: we like 'em flat, smooth, and long

A+ Hitachi P12R. Unlike any other portable planer, this machine has a continuous metal table, so it doesn't require fold-down or attachable extensions. This eliminates the misalignment that can occur between the table

and extensions. The heavily ribbed aluminum table has a 3/32"-thick steel slip plate that's screwed down, so sawdust cannot accumulate under it.

B+ Delta 22-540 and Grizzly G1017. These Taiwanese-made machines have similar basic construction, with a few notable differences. Both models have stainless-steel slip plates, similar to the Makita and Ryobi machines. These work well, but you do have to check underneath them from time to time for sawdust buildup.

The Delta plate fit slightly tighter than the Grizzly's, which should help prevent sawdust accumulation. But, for portability we prefer the Grizzly's fold-up extensions over the Delta's detachable extension tables.

Previously tested machines:

- A- Makita 2012 and Ryobi AP-10
- B Sears 23381
- C Various Taiwanese units

PLANERS

SPECS FOR THREE NEW PORTABLE PLANERS

MANUFACTURER/ IMPORTER	MODEL	CAPACITY			FEED RATE (FEET PER MIN.)	CUTS PER INCH	ACCESSORIES		CUTTERHEAD MATERIAL	WEIGHT (LBS.)	COUNTRY OF ORIGIN	SELLING PRICE
		WIDTH (INCHES)	THICKNESS (INCHES)	AMPS			STANDARD	OPTIONAL				
DELTA	22-540	12	6	15	26	51	BLADE-ADJUSTMENT GAUGE, BLADE WRENCHES	DUST-COLLECTION HOOD	STEEL	68	TAIWAN	390
GRIZZLY	G1017	12	5½	16	26	55	BLADE-ADJUSTMENT GAUGE, BLADE WRENCHES		STEEL	80	TAIWAN	385
HITACHI	P12R	12	6¾	15	26	72	BLADE-ADJUSTMENT GAUGE, BLADE WRENCHES, OILER	DUST-COLLECTION HOOD, JOINTER, BLADE-SHARPENING STONE	STEEL	62	JAPAN	620

Blade changing: convenience counts

A Hitachi P12R. Thanks to magnetic alignment guides, blade changing is slightly easier than on the other units. A locking mechanism prevents the cutterhead from rotating during changes.

B+ Delta 22-540. Springs in this machine's cutterhead lift up the blade to the height of a special jig. You lock the blade in place by tightening pinch gibs. This proves simple enough, but it would be nice if you could lock the cutterhead in place.

This machine has double-edged blades, so you'll be able to cut your visits to the sharpening shop in half. (Steve Holley of Delta tells us you should be able to sharpen each edge twice.) If you would rather discard the blades after dulling both edges, a new set sells for \$22.40 list.

B Grizzly G1017. This machine compares about equally to the

Delta in blade changing (the cutterhead has jack screws instead of springs for raising the blade). It has a single-edged knife.

Previously tested machines:

A+ Makita 2012

A Ryobi AP-10

B- Sears 23381

C- Various Taiwanese units

Our recommendations

Among portable planers, the Hitachi P12R is in a class by itself both in terms of performance *and* price. If you can afford it, buy this machine. It's built to last a long time (it even has oil reservoirs for lubricating the support rods and comes with a half-pint of oil).

For an extra \$200 or so, you can add the ruggedly constructed jointer, which weighs only 22 pounds and slips on and off with ease (see photo *above right*).

We rate both the Delta and Grizzly models as better machines



The lightweight Hitachi jointer attaches with ease.

than the planers we earlier tested in their price range. These two machines rate so closely that we really have to nitpick for differences. We like Grizzly's instruction manuals—see the Tool-Industry Insider report on *page 83*—and this machine's attached table extensions. If you like the idea of a nearby dealer, then the Delta will probably serve you better. And, the Delta has an optional dust-collection hood—Grizzly does not offer this option. ♣

Written by Bill Krier Technical consultant: George Granseth Photographs: John Hetherington



HAPPY-DAYS

HIGH CHAIR

It's supersafe and easy to clean



Now, I could tell you all sorts of neat things about this hardwood high chair, but I'll let my son Slade, shown at *left*, do the talking, or should I say babbling. If I understand him correctly, he's gaga over the sturdy wobble-free construction, and removable and adjustable rimmed tray (for catching those inevitable spills). But he's not cooing over the safety strap that—once buckled—keeps him from slipping out to pull the dog's tail.

Marlen Kemmet
Marlen Kemmet, How-To Editor

 Print this article

Note: As shown at left and at right, we designed and built two contrasting high chairs—one traditional and one featuring a colorful balloon backrest. If you wish to make the latter, we'll supply you with a full-sized pattern of the balloon and a backrest assembly drawing. Just send \$2 (this will cover our production costs) and a 7½ × 10½" self-addressed envelope with two 29¢ stamps to:

*Balloon High Chair
WOOD® magazine
P.O. Box 11454
Des Moines, IA 50336-1454.
(Foreign readers: Please include an international reply coupon.)*



Start with the splayed base

1 From 1½" thick stock (we used cherry), cut the legs (A) to the sizes listed in the Bill of Materials. From the same stock, cut the upper side rails (B), and lower side rails (C) to size plus 1" in length.
2 Set your sliding T-bevel at 10°, and mark the angles on the ends of the legs and rails where shown on the Leg Assembly drawing.
3 Miter-cut the rails to length.
4 Mark the four mounting-hole centerpoints on the outside edge of each leg where located on the Leg Assembly drawing. (Don't

Continued

HIGH CHAIR

mark the two footrest mounting holes, you'll drill them later.)

5 Clamp one of the upper side rails (B) to your workbench, and then glue and position one of the legs next to it where shown in Photo A. Drill the counterbored mounting holes through the leg and into the rail where marked and shown in Photo A. Drive the screws. Add the lower rail in the same manner. Next, glue and fasten the other leg to the two rails. Repeat the process to form the other leg assembly (A, B, C).

6 To obtain the proper angle along the top edges of the two leg assemblies, tilt the blade on your tablesaw 10° from vertical. Add an auxiliary wooden fence to your miter gauge, and angle the miter gauge 10° left of center. Hold one leg assembly—outside face down—firmly against the miter gauge, and *check that the top rail is parallel to the miter gauge slot.* (This ensures a straight cut along the top edge of the top rail.) Adjust the miter gauge slightly if necessary.

7 As shown in Photo B, bevel-rip the top edge of each leg assembly. Trim just enough to angle the top edge without shortening the assembly. See the Side View portion of the Leg Assembly drawing on the *opposite page* for reference.

8 Reposition the miter gauge 10° right of center. With the outside face down and as shown in Photo C, miter-cut the bottom edges of the feet. Check that the leg assemblies are the same length.

Join the leg assemblies with the stretchers and footrest

1 Cut the upper stretchers (D) and lower stretchers (E) to size plus 1" in length.

2 As shown in Step 1 of the two-step drawing on top of the *opposite page*, tilt the tablesaw blade 1° right of vertical. With the outside face down, cut an 11° miter across one end of each stretcher. (For tight-fitting joints the 1° angle is necessary.) Miter-cut the opposite end as shown in Step 2.

Continued

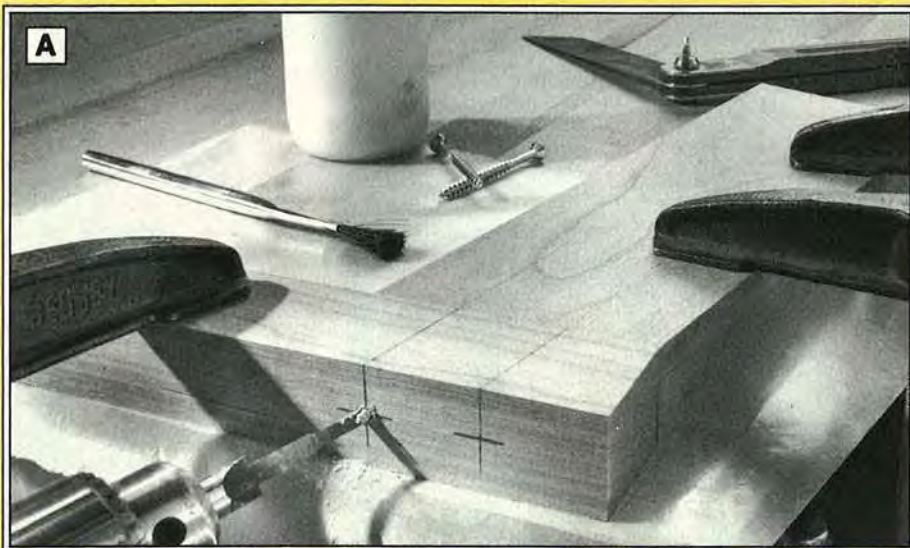

Drill counterbored mounting holes through the leg into the end of the top rail, and drive screws to join the pieces.

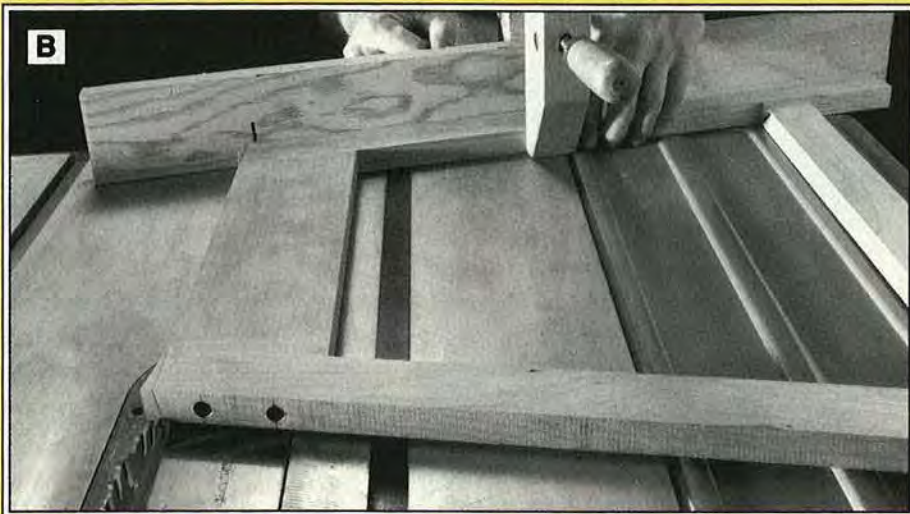

Using a miter gauge with a wooden auxiliary fence for support, bevel-rip the top edge of the leg assembly.



Adjust the miter gauge 10° right of center, and bevel-rip the bottom edge of the leg assembly parallel to the top edge.

HIGH CHAIR

3 Using masking tape, tape the stretchers between the leg assemblies to check the fit. Trim the stretchers if necessary.

4 Drill mounting holes, and glue and screw the stretchers between the leg assemblies.

5 Sand $\frac{1}{8}$ " round-overs along the edges of the base parts where shown on the Base drawing.

6 Cut the footrest (F) to size, bevel-cutting the ends at 10° and then radiusing the front corners. Rout $\frac{1}{4}$ " round-overs on the footrest, stopping where shown on the Base drawing.

7 Position the footrest so it's parallel to the floor and snug between the front legs. Then, drill

the mounting holes, and glue and screw it in place.

8 Plane a piece of cherry to $\frac{1}{2}$ " thick. Using a $\frac{3}{8}$ " plug cutter, cut seventy $\frac{3}{8}$ " plugs from the $\frac{1}{2}$ " stock. Plug the holes, matching the grain direction of the plug with the piece being plugged. Save the remaining plugs.

Make the platform seat

1 Edge-join pieces of $\frac{3}{4}$ "-thick stock to form a 14"-square blank for the seat. Crosscut the ends of the blank for a $13\frac{1}{4}$ " length.

2 Mark the location and drill the holes for all of the mounting-hole centerpoints where dimensioned on the Seat drawing. Note that the

three holes used for attaching the backrest to the seat are drilled at 10° . See the Backrest detail accompanying the Seat Assembly drawing on page 62 for reference.

3 Mark the centerpoints and drill a pair of $\frac{1}{4}$ " holes for each of the three strap slots. With a scrollsaw or coping saw, cut between the $\frac{1}{4}$ " holes to form the slots.

4 Rout $\frac{1}{4}$ " round-overs where shown on the Seat drawing.

5 Clamp the seat to the base, centered from side to side and front to back. Use the previously drilled mounting holes in the seat as guides to drill pilot holes into the base. Do not screw the seat to the base just yet.

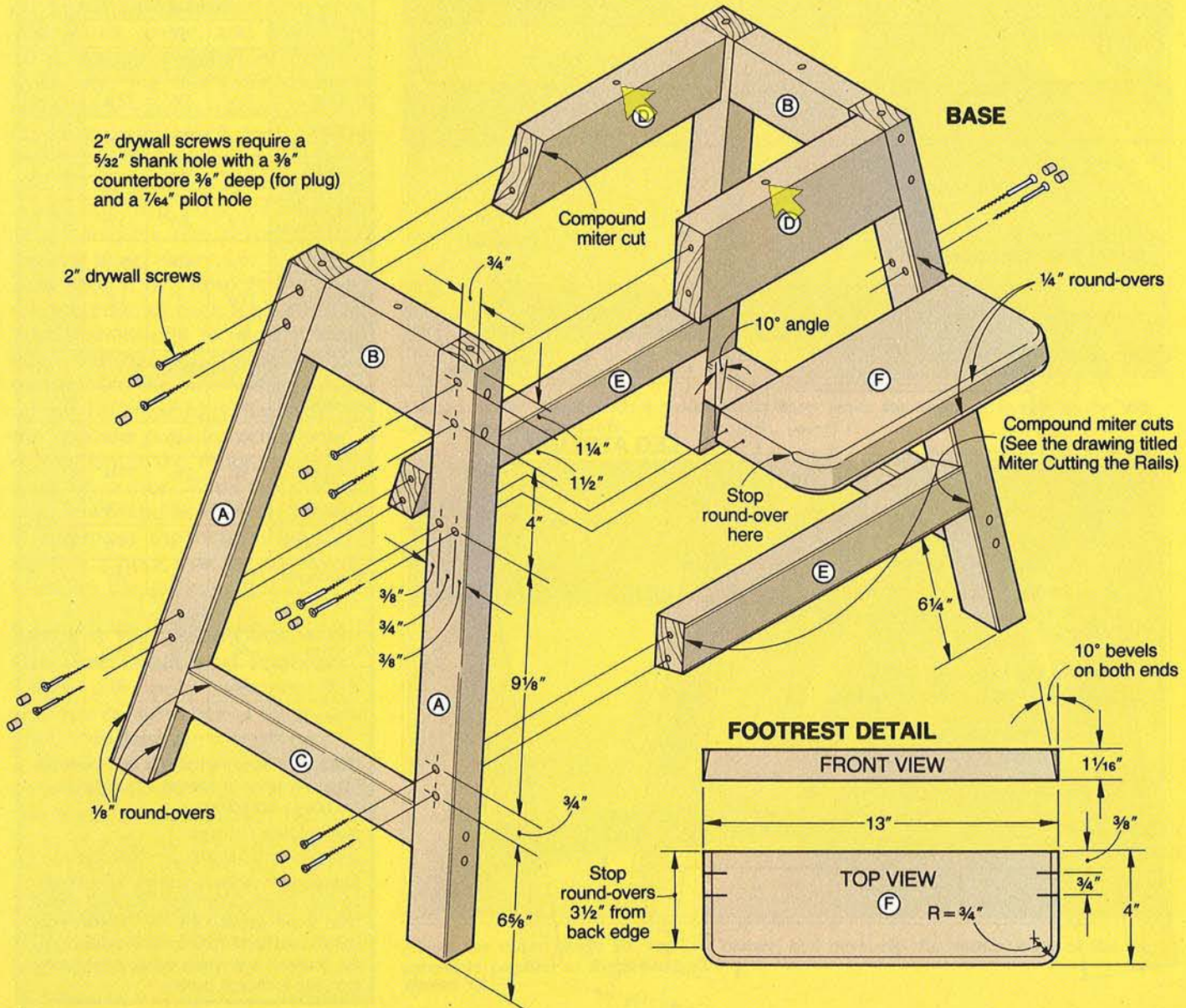

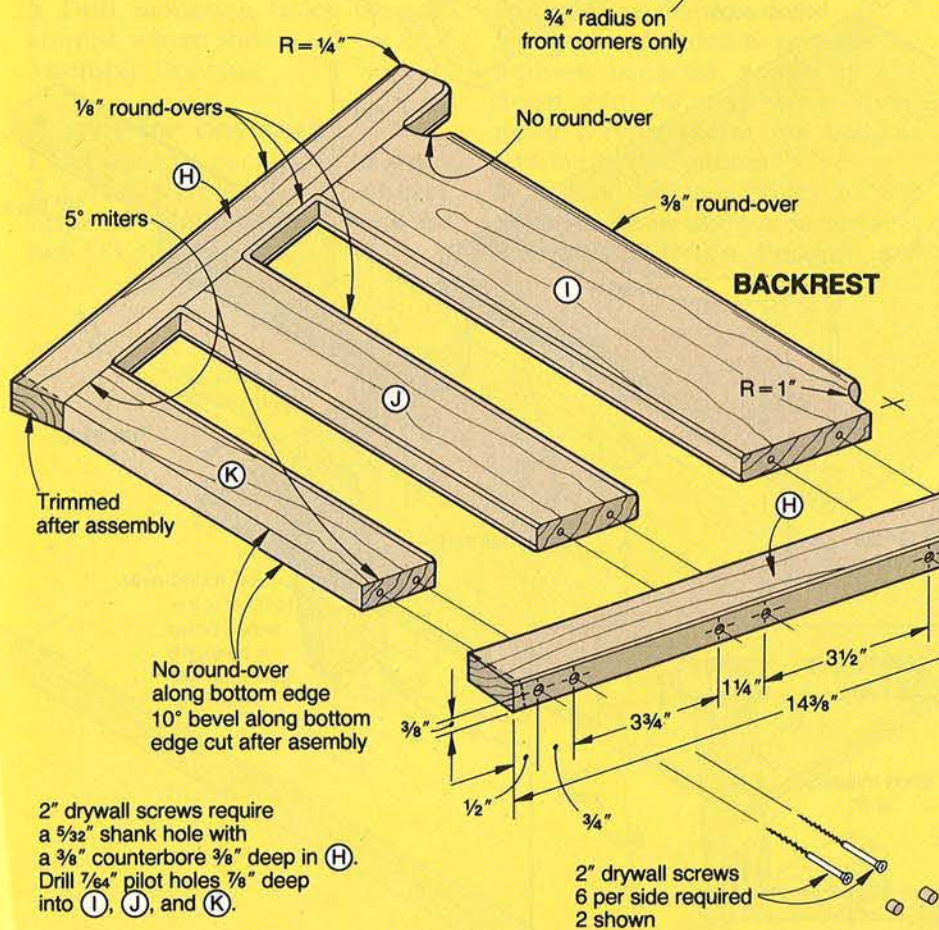
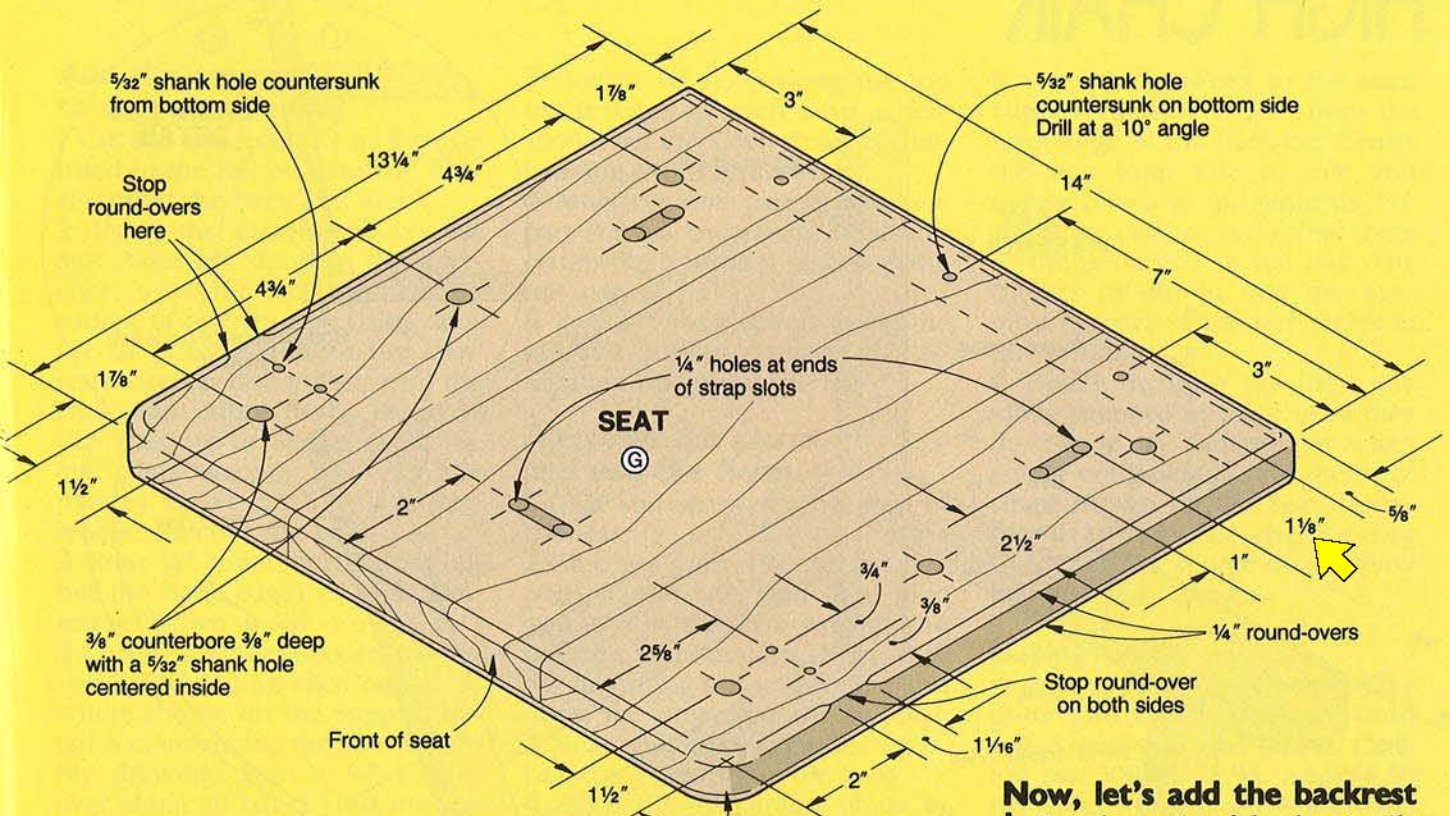

Now, let's add the backrest

1 Cut the pair of backrest stiles (H) to size. Now, cut the backrest rails (I, J, K) to size, miter-cutting the ends at 5°.

2 Mark and cut a 1" radius at each top corner of the backrest top (I) where shown on the Backrest drawing at left.

3 Mark the hole centerpoints, drill the holes, and screw the backrest assembly (H, I, J, K) together. (Do not plug the holes.)

4 Rout 3/8" round-overs along the top edge of the backrest top (I) where shown on the Seat Assembly drawing. Do not rout the 1" radiused corners.

Switch bits, and rout (or sand) 1/8" round-overs along the edges of the backrest assembly, but not its bottom edge where noted on the Backrest drawing.

5 Tilt your tablesaw blade 10° from vertical, and set your miter gauge 10° from center. Check that the bottom backrest rail (K) is parallel to the miter-gauge slot. Cut the bottom edge of the backrest assembly at 10° where shown on the Backrest detail accompanying the Seat Assembly drawing.

Continued

HIGH CHAIR

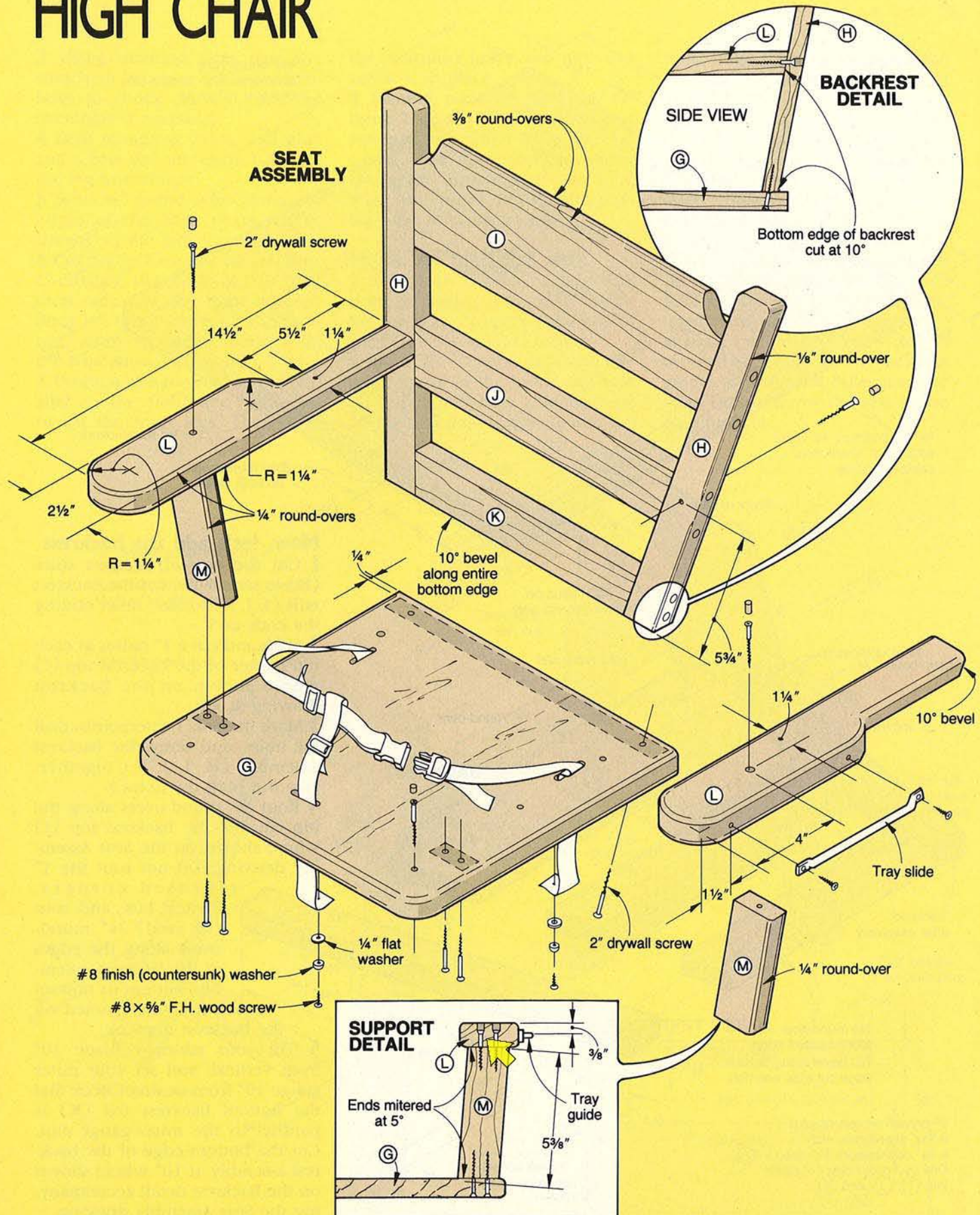

Add the armrests to support the tray

1 Cut the armrests (L) to the size listed in the Bill of Materials, bevel-cutting the back end at 10°.

2 Using the dimensions on the Seat Assembly drawing for reference, mark the radii on the top surface of one armrest. Using double-faced tape, adhere the armrests together face-to-face with the ends and edges flush. Bandsaw the armrests to shape, sand the cut edges smooth, and pry the pieces apart with a wooden wedge. Remove the tape.

3 Rout a 1/4" round-overs along all but the *back* edges of each armrest as shown at left.

4 Cut the armrest supports (M) to size, miter-cutting each end at 5° where shown on the Support detail accompanying the Seat Assembly drawing. Rout a 1/4" round-over along all edges (but not the ends) of both supports.

5 Drill mounting holes in each armrest where shown on the Seat Assembly Drawing.

A tray for tiny tots

1 Cut the tray panel (N) to size.

2 Cut a pair of 3/4 x 1" cherry strips 32" long (enough stock for two O's and two P's).

3 Rout a 1/4" cove along the top inside edge of each strip where shown on the Cove detail accompanying the Tray drawing.

4 Miter-cut one part O and one part P from each strip. Glue and clamp the four trim pieces to the tray panel.

5 Rout 1/4" round-overs along the top and bottom edges of the assembled tray. Sand the tray.

Assemble the pieces, and add the finish

1 Glue and screw the backrest to the seat.

2 Glue and screw the armrest supports to the seat, and then glue and screw the armrests to the backrest and supports. Now, drill the mounting holes, and glue and screw the armrests to the backrest.

3 Next, glue and screw the seat/backrest assembly to the base.

4 Glue the remaining plugs in place. Finish-sand the entire chair, and add the finish.

5 If you've decided to go with the balloon backrest, rough-up the finish with 00 steel wool. Then, using acrylics, paint the balloon and landscape pattern.

6 Attach the tray glides to the armrests where shown on the Seat Assembly drawing. Position the

tray on the armrests so the back edge of the tray is 5 1/2" from the front edge of the backrest. Center the tray from side to side and lightly clamp to the armrests. Position the catches and screw them to the underside of the tray. The catches should fit into the rear-most notches in the tray glides in this position.

7 Finally, to keep the little one safely strapped in place (and they do love to try and get out when you're not looking), add the three straps shown on the Seat Assembly drawing. See the Buying Guide for our source of strapping material and fasteners.

Buying Guide

• **Tray-support hardware.** Tray glide and catch, made of cold rolled steel and zinc plated. Catalog no. 30866, \$5.95. Add \$4.50 per order for postage. Woodworkers' Store, 21801 Industrial Blvd., Rogers, MN 55374-9514.

• **Strap and buckles.** 6' of 1"-wide blue nylon webbing and plastic buckles, \$5.95 ppd. Miller Hardware, 1300 Harding Road, Des Moines, IA 50314. ♣

Produced by Marlen Kemmet
Project Design: Bruce Pierce
Photographs: Hopkins Associates
Illustrations: Kim Downing; Mike Henry

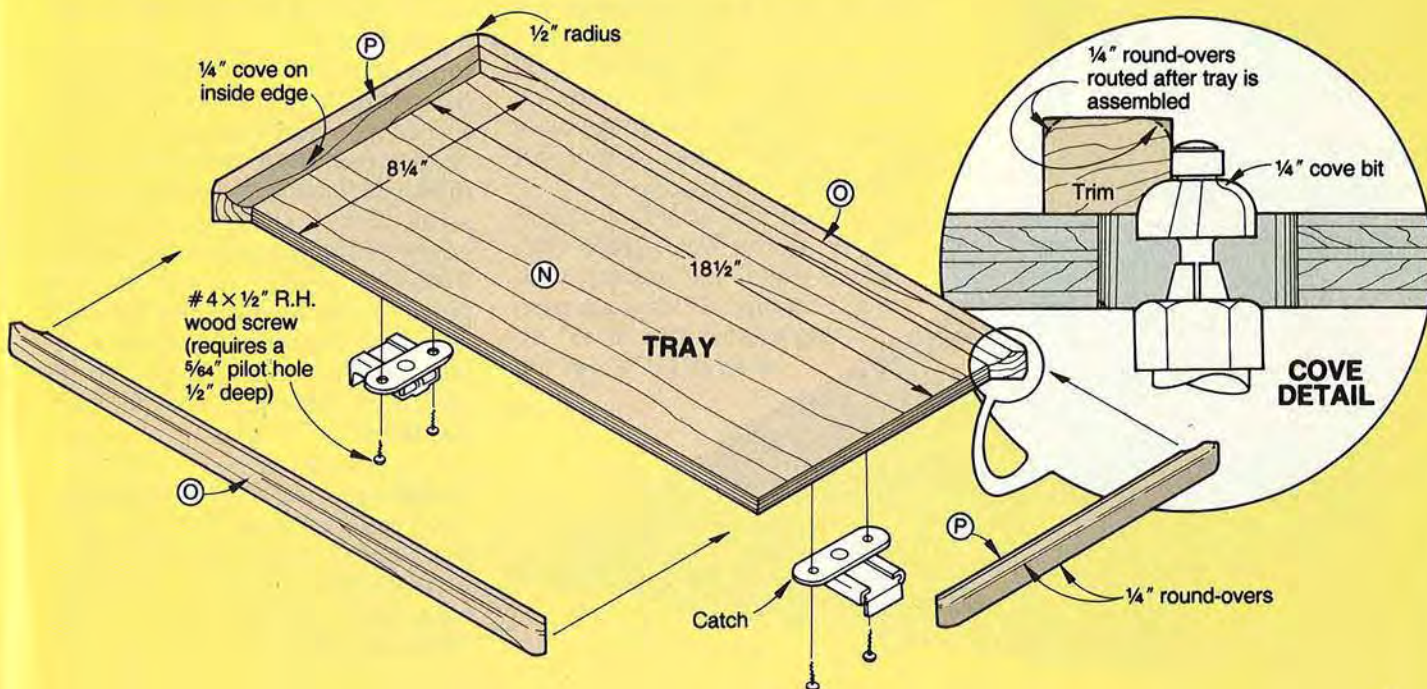

Bright-idea woodturnings

DECORATOR

These turned, tulip-like lamps add a cheerful touch to any setting, any time. But they really shine when you light them. Then, their warm glow lends a delightful air to any occasion.

Tools and supplies

Screw center; spur center; cone tail center; 3" faceplate.

1/2" spindle gouge; 1/2" skew; 1/8" parting tool.

Hardwood stock 2 1/2 x 2 1/2 x 7 1/2", 1 x 1 x 8", 7/8 x 3 1/2 x 3 1/2".

You can turn the three parts that make up the lamp from the same wood, or choose contrasting woods for the striking effect shown in the photo. (We used maple and walnut.)

Turn the lamp holder from a 2 1/2 x 2 1/2 x 7 1/2" square. Draw diagonals to locate the center on each end. With a brad-point bit and a drill press, drill a centered 1/8" hole 2" deep at one end.

Mount the square with a screw center at the headstock and a cone center at the tailstock (the drilled end goes at the tailstock). Transfer the templates, *opposite page*, to light cardboard and cut them out.

Leaving about 1/2" of square stock at the headstock end, round down the turning with a 1/2" gouge. With your parting tool, cut in to 1/2" diameter 1 5/8" from the

headstock and 3/8" diameter 1 5/8" from the tailstock. Form the supporting cones, and then turn the lamp holder to the template dimensions. Sand with progressively finer grits from 150 to 400 before parting off the waste at the tailstock end where shown on the Forming the Lamp Holder drawing, Step 1. Remove the turning from the screw center.

Drilling for the oil lamp

Grip the square bottom with a handscrew clamp, and drill an 1 1/16" hole for the Pyrex lamp insert, centering it on the 1/8" hole. Next, turn the workpiece end for end, placing the flat top on the drill-press table. Wrap a shop rag around the turning. Then, grip it with a handscrew clamp, and drill a 3/8" hole 2 1/8" deep (1/16" into the holder bottom) where shown on the Forming the Lamp Holder drawing, Step 2. Saw the waste off and sand the bottom.

A spindle for a stem

Working your way down the lamp, locate and mark the center on each end of a 1 x 1" square 8" long. Remove the screw center from your lathe and install a spur center to turn the stem.

After rounding down the stock, mark the turning sections from your template. Then, cut the coves with your spindle gouge. Roll the center beads with a gouge or skew, checking the contour with the template. Form a 3/8" tenon 1/2" long on each end. Sand, and then remove the stem from the lathe.

Finish up with the faceplate

Turn the base from 7/8"-thick stock 3 1/2" square. Cover your 3" faceplate surface with double-faced tape, stick the wood to it, and clamp for about 20 minutes.

OIL LAMPS

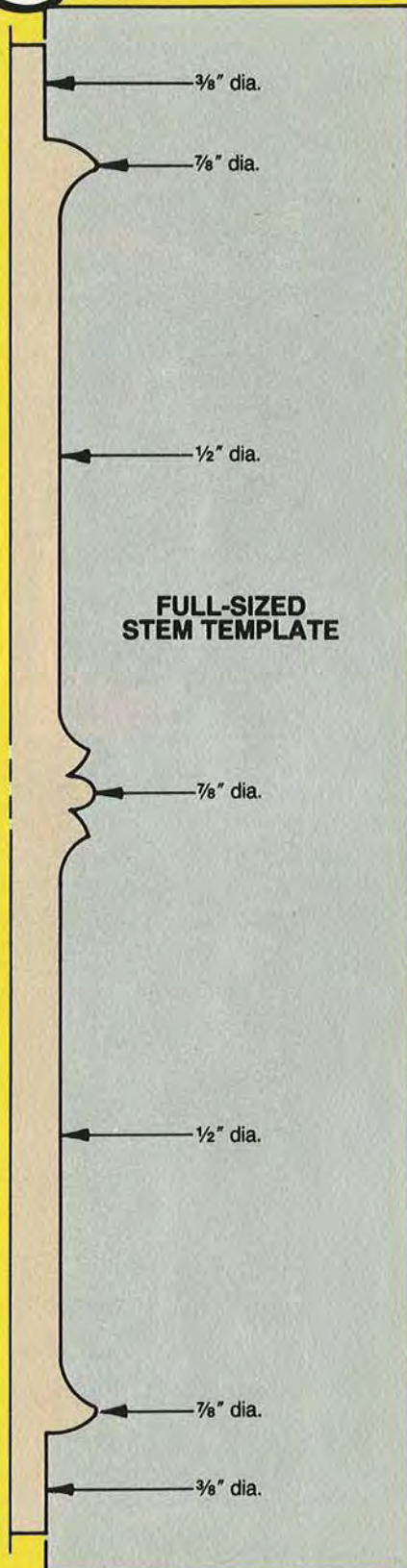
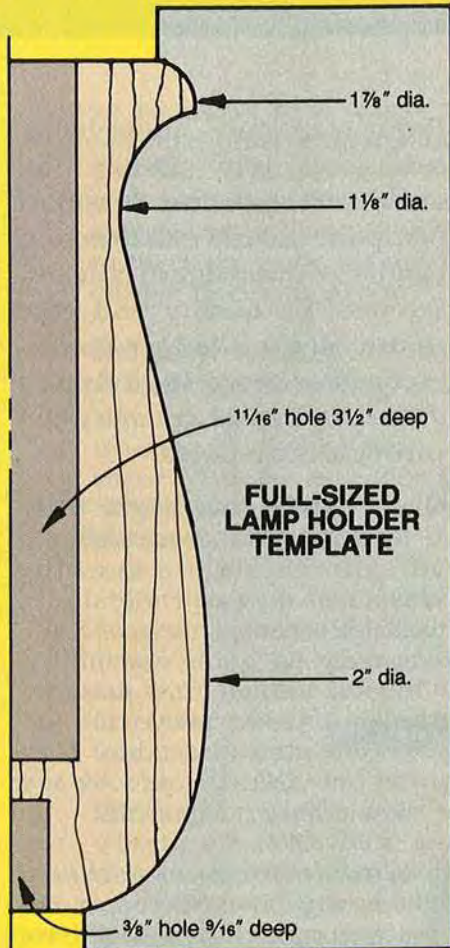
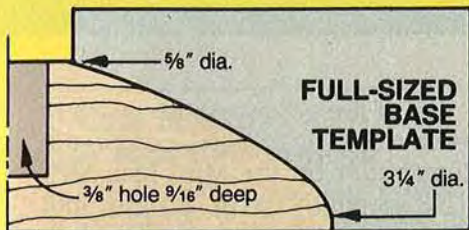

With the base template as a guide, shape and sand the base, and mark the center for the stem hole. Hold the faceplate with a handscrew clamp as you bore the $\frac{3}{8}$ " hole $\frac{9}{16}$ " deep with a brad-point bit in a drill press. Now, remove the base turning from the faceplate—dribble lacquer thinner along the joint to break the bond.

Assemble the lamps with wood-working glue. After applying a clear finish, install the lamp inserts, pour in some lamp oil, and light them up to cast a warm glow over the scene.

Buying Guide

• **Lamp inserts.** Two Pyrex glass inserts with wicks, \$12 ppd. in U.S. Warren Vienneau, 146 Ridge Ave., Pittsfield, MA 01201. 🌲

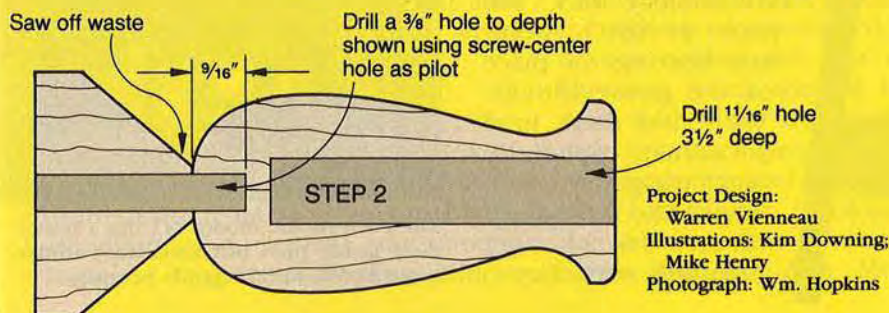
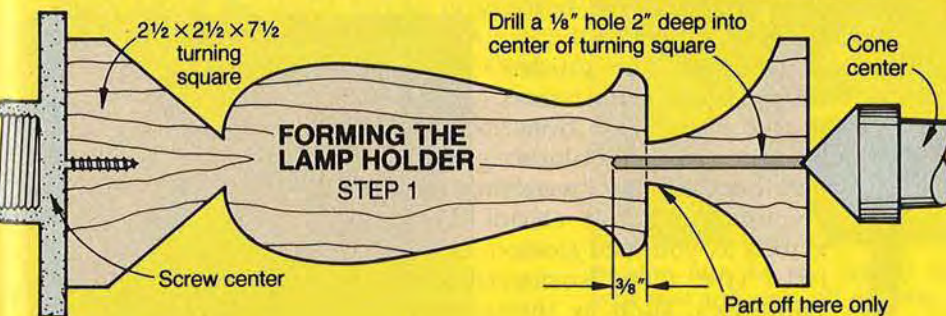

Project Design:
Warren Vienneau
Illustrations: Kim Downing,
Mike Henry
Photograph: Wm. Hopkins

The Great

BANDSAW

A smart shoppers' guide to

 Print this article

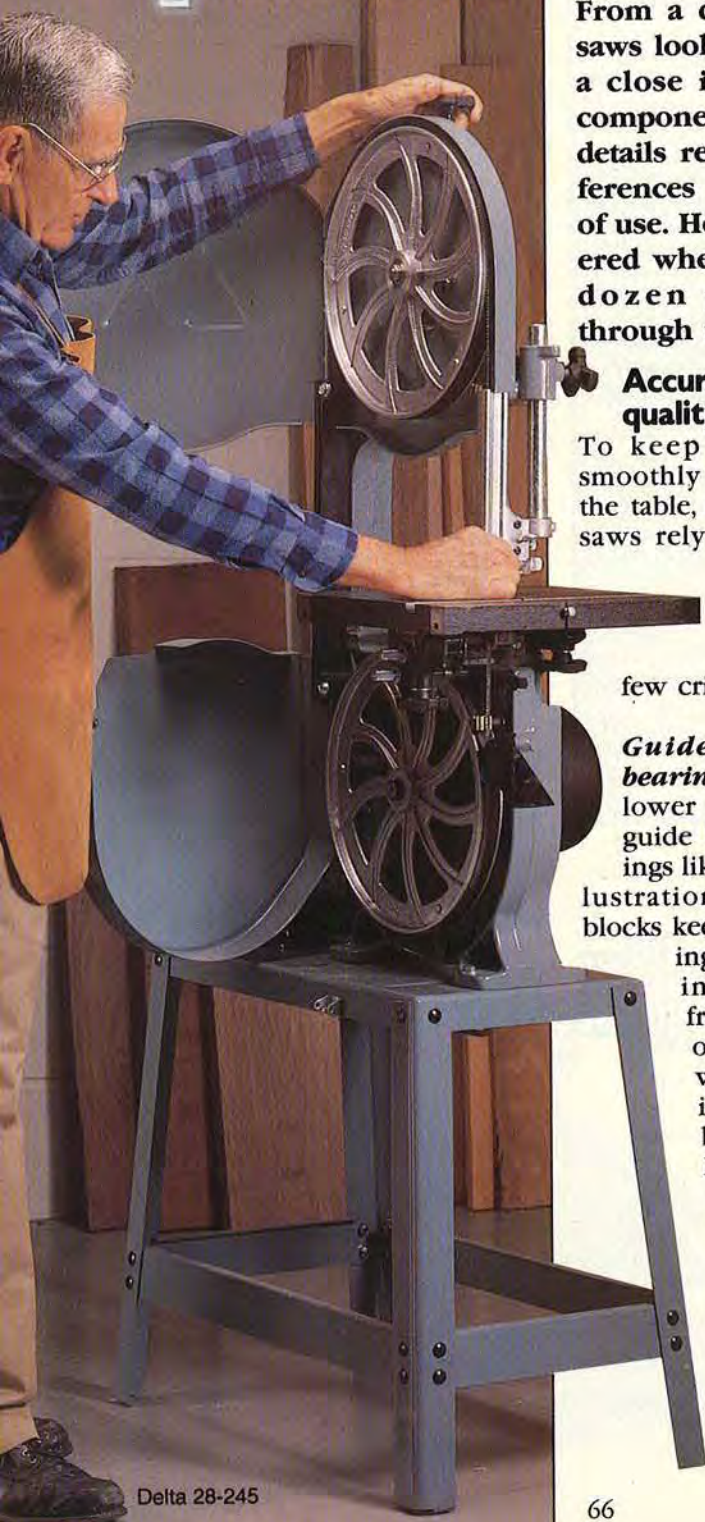

From a distance, most bandsaws look pretty similar. But, a close inspection of small components and construction details reveals significant differences in quality and ease of use. Here's what we discovered when we recently put a dozen popular models through their paces.

Accurate cuts begin with quality guide assemblies

To keep the blade running smoothly and perpendicular to the table, manufacturers of bandsaws rely on guide assemblies.

You'll find these located above and below the table. Let's take a close look at a few critical components:

Guide blocks and thrust bearings. Both the upper and lower guide assemblies have guide blocks and thrust bearings like those shown in the illustration at right. The guide blocks keep the blade from twisting, and the thrust bearings prevent the blade from bending backward or working off the wheels as you feed stock into the saw. Some bandsaws, such as the Powermatic 043 (see photo at right), substitute bearings in place of the guide blocks. We found these hard to adjust, especially since the guide assembly has no fine-adjustment knobs and requires wrenches.

All of the guide assemblies were reasonably accessible except the lower unit on the Mini Max S45. This assembly is in a tight spot that makes adjustments difficult at best. Andy Shook of SCMI, which sells the Mini Max line, told us his

UPPER-GUIDE ASSEMBLY ON THE DELTA 28-245

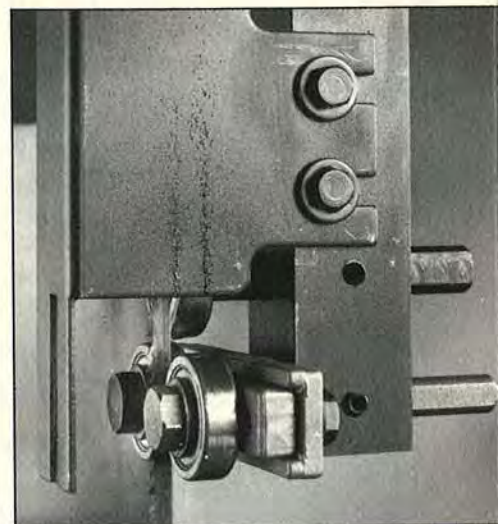
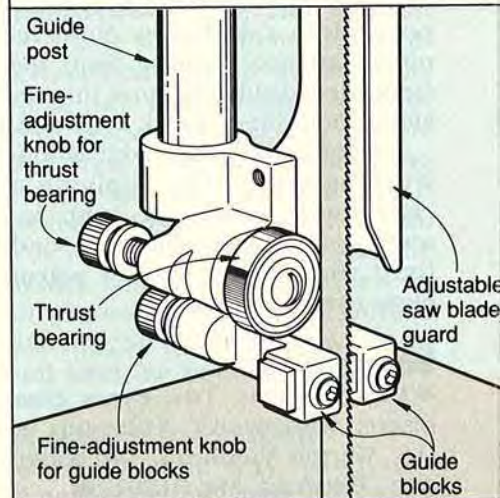

The Powermatic model 043 has a heavy-duty guide post but lacks fine-adjustment knobs for the guide bearings.

ROUNDUP

12 popular models

Cool blocks: A smart investment

For \$12-\$17 you can outfit your bandsaw with accessory guide blocks sure to outperform the steel guide blocks that come standard on most bandsaws. We tried Cool Blocks in both the Delta and Inca saws and found that they improved our cuts, kept the blade cooler, and reduced the machine's noise level. Because these blocks are made of a self-lubricating phenolic laminate that's much softer than steel, you can adjust them to just touch the blade. Upper and lower replacement blocks are available for Delta bandsaws from many Delta dealers and for most other bandsaws from Garrett Wade at the address or phone numbers on *page 70*.

company is looking into having the Carter Guide Company supply new upper and lower guides for the machine.

Fine-adjustment knobs. For your bandsaw to work well, you must precisely adjust the guide blocks or guide bearings and thrust bearings each time you change a blade. We rate the Delta as one of the top machines in this area because you can quickly and precisely position these parts by twisting the readily accessible fine-adjustment knobs with your fingers. With these parts adjusted, you lock them into position with two easy-to-use thumbscrews (not visible in the drawing *opposite*). The General 490-1 and Inca 340 also earned impressive marks in this area, but both cost more than the Delta.

Guide post. This steel shaft supports the upper-guide assembly and slides up and down for various cutting depths. It should remain parallel to the blade throughout its movement, and should not twist. To prevent twisting, almost

all bandsaws have square, hexagonal, or round posts with a groove. Because the Grizzly models have round posts without grooves, they can twist when adjusted up or down. This requires you to check the guide alignment after each change in cutting depth.

Bandsaw wheels: A delicate balancing act

Like the wheels on your car, bandsaw wheels will vibrate unless properly balanced. With the exception of the Sears machine, all of the wheels on our test machines were balanced by drilling a series of holes in the tire rims. The Sears bandsaw has small balancing weights clipped to the rim.

As a group, wheels made of cast iron ran with the least amount of vibration. Only three of the higher-priced saws featured cast-iron wheels: General 490-1, Mini Max S45, and Powermatic 141. Of the machines with aluminum wheels, the Delta, Inca, and Kity also earned "excellent" ratings for quality of machining and lack of vibration.



Brushes like the one on the Inca 340 help keep dust and resin off the tire.

To keep the blade tracking properly, the wheels are crowned slightly and have a rubber tire that aids traction. However, when the tire becomes covered with dust and resin, the blade may not track properly. So, we were surprised that only a handful of the saws had built-in brushes for cleaning the tires, as shown on the Inca 340 *above*. The Kity 613, Mini Max S45,

Continued



General 490-1



Kity 613



Mini Max S45



Powermatic 141

BANDSAW ROUNDUP



Inca 340



Grizzly G1012



Grizzly G1538



Powermatic 043

and Powermatic 043 also feature brushes. These don't eliminate dirt buildup, but they sure help.

Blade changing: Convenience does count

Since few of us relish the chore of changing bandsaw blades, we timed ourselves as we changed the blade on each of the tested machines. (You'll find the results in the chart on *page 71*.) Here are some factors that affect blade changes:

Covers. Removing the covers for the upper and lower wheel compartments can really slow you down. That's why we prefer these saws with hinged covers and a retaining clip for quick opening and closing: Delta 28-245, General 490-1, Powermatic 141, and Sears 24844. With the Grizzly and Inca machines, you must remove the covers entirely, and the retaining knobs on the Grizzly, Jet, and Powermatic 043 bandsaws come completely off. After changing blades, we often found ourselves searching for these knobs.

Table slot. As you can see in the chart on *page 71*, five of the tested saws have a blade-removal table slot that exits at the front of the table (see drawings *below*). With front-exiting table slots, you

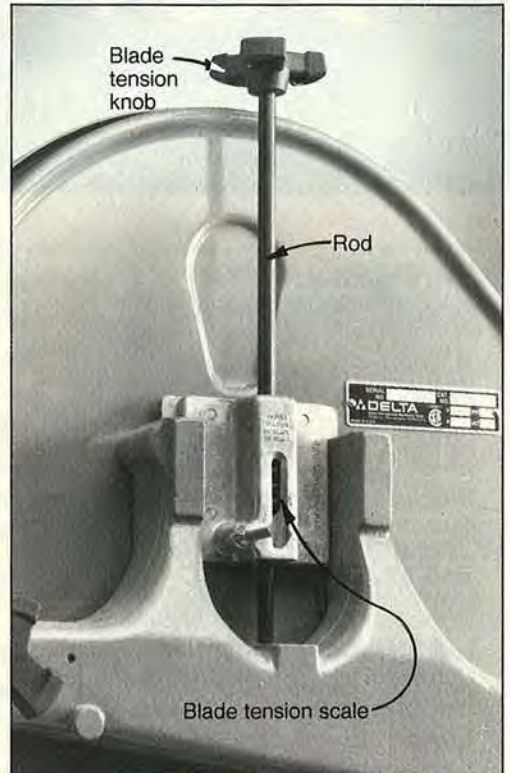
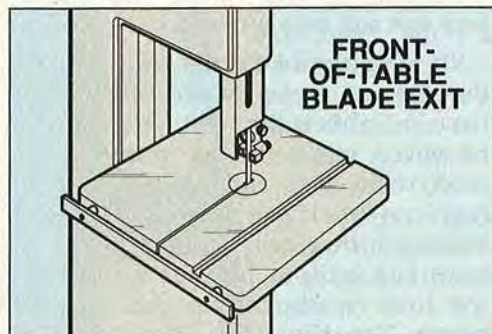
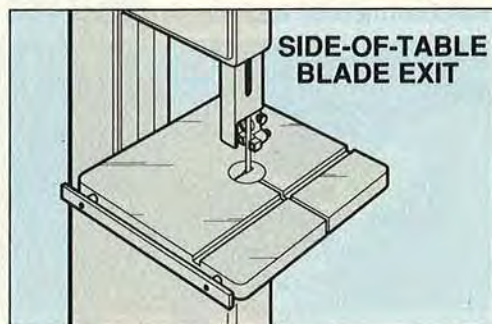

A long rod on the Delta puts the tension knob above the upper wheel compartment.

must remove the fence assembly before removing the blade. We prefer saws with slots that exit the side of the table for hassle-free blade changes.

Tensioning. To quickly and comfortably release or tighten the tension knob, it should be located above the upper wheel-compartment cover as shown *above* on the Delta. The tension knobs on the Grizzly and AMT saws have shorter rods that leave the knobs uncomfortably close to the cover.

All of the saws except the Kity and the Grizzly machines have tension scales. We don't consider these to be essential items, but they help you quickly get the approximate tension (something that beginning woodworkers especially appreciate).

Still more buying points for you to keep in mind

Before purchasing any bandsaw, examine the following items:

Trunnions. These mechanisms control the table tilt and come in the two types shown *above right*. We prefer the

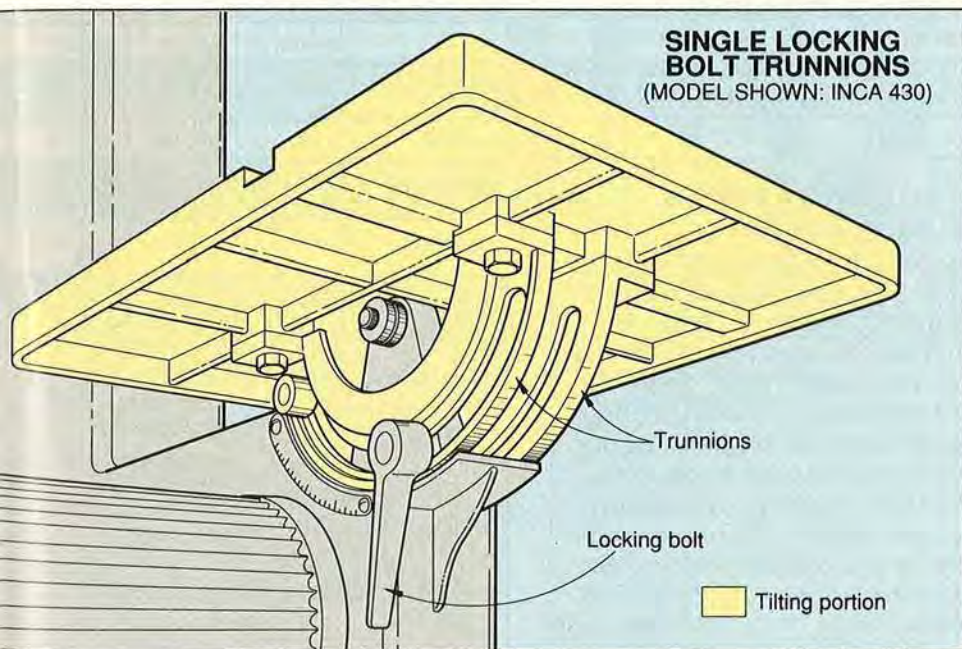
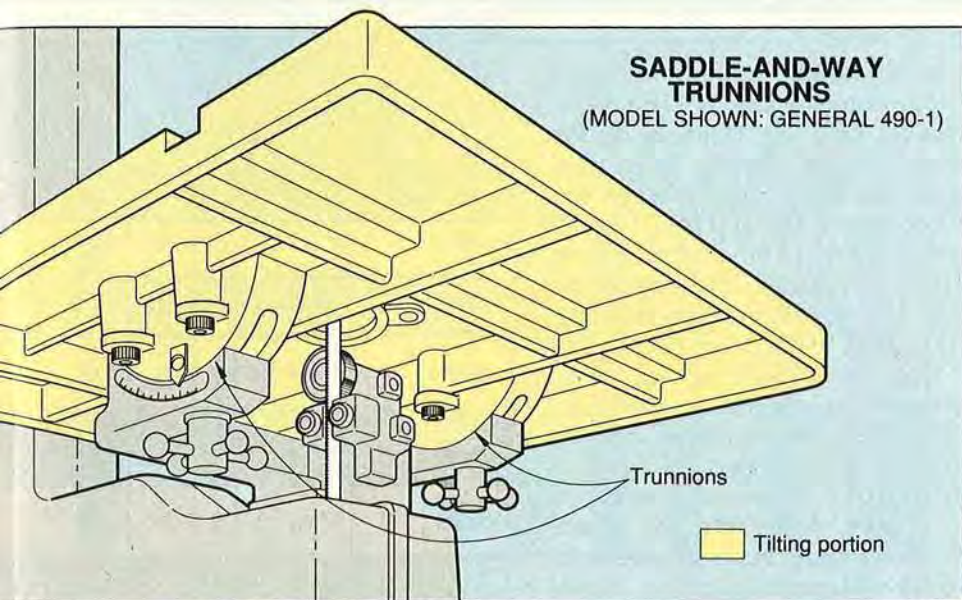

smoother action of the saddle-and-way trunnions, provided they are well machined and tight fitting. The trunnions of the General, Delta, and Powermatic 141 were the most precisely machined of the models in our test. The Inca and Mini Max bandsaws had the best of the single-locking-bolt trunnion mechanisms.

Power. All of the saws in our test have plenty of power for making curved cuts in stock up to 2" thick. If you plan to use your

bandsaw for cutting stock thicker than 2", it should have at least a ¾-hp motor.

Accessories. If you plan to use a fence or miter gauge with your bandsaw, note on the chart on page 71 that only a few models have these items as standard accessories. When purchased separately, such accessories can add \$100 or more to your costs.

As you also can see in the chart, a few of the bandsaws have two-piece frames. For three of these

machines—the AMT, Delta, and Jet—you can purchase a riser-block accessory. This 6"-or-so long piece of iron bolts between the two halves of the frame to give you about 12" of total cutting depth when resawing.

Dust collection. Bandsaws make mounds of fine sawdust. But, only the Delta, Inca, Mini Max, Powermatic, and Sears bandsaws feature dust-collection ports.

Recommendations:

Under \$500: For all-around best value, we found the Sears tilting-head bandsaw tops in this class. We tested the deluxe model 24844 that has a digital readout of blade speed, tension, and tilt (about \$450). The readout came in handy at times, but we would just as soon spend \$350 for the same saw without this feature. (A single-speed, nondigital version with ⅛ less hp and a smaller table is also offered for \$300.) The tilting head flexes a bit compared to other bandsaws, but this shouldn't affect your results unless you're resawing or trying to make precise cuts in hardwood stock more than 1" thick.

If you want to resaw, take a look at the Jet JBS14CS (about \$435). It has enough power for this task, and accepts a riser block for really deep cuts. In our tests, it quickly became apparent that more attention to detail was paid in the design and construction of this machine than the other Taiwanese models.

Over \$500: The hands-down winner in this group is the Delta 28-245 (about \$580). Its guide assemblies and trunnions were as good or better than several saws costing hundreds of dollars more. Versions of this bandsaw have been around for years, and Delta engineers have managed to maintain the quality of this machine while not allowing its price to skyrocket. You can buy this band-

Continued

BANDSAW ROUNDUP



AMT 4113



Jet JBS14CS



Sears 24844

saw as the model 28-283 with an enclosed base and ¾-hp motor for about \$160 more.

Although we found the Delta to be the best all-around value, several other machines in this class deserve mention. If you have \$1,050 or so, the General 490-1 bandsaw is a super-solid machine that runs even smoother than the Delta. However, we would like to see the manufacturer add a dust-collection port and wheel brush. The Mini Max was the smoothest and most powerful machine in our test, but we'll reserve recommending this machine until we see its new guide assemblies.

The Grizzly G1012 has some drawbacks, but for the money, you can't find a machine with more pure resawing muscle. And, if you have limited space, or if you simply enjoy finely engineered and versatile machines, consider the Inca 340. It weighs only 55 pounds, but it can resaw hardwoods or deftly cut tight curves with a ½" blade.

How to make your current bandsaw work better

Bandsaws can be notoriously finicky, especially if you can't afford a top-of-the-line model or have to settle for a used machine. Fortunately, there's a book that can help. We've read the *Bandsaw Handbook* by Mark Duginske and use it to work the bugs out of our own saws. The 320-page book covers blade selection, machine adjustments, maintenance, safety, cutting techniques, and a few simple projects. Get your copy by sending \$18.95 ppd. to: Garrett Wade, Dept. WD, 161 Avenue of the Americas, New York, NY 10013-1299. Or, call 800/221-2942 or 212/807-1155 to order by phone. 🌲

Written by Bill Krier
 Technical consultant: Bob McFarlin
 Photography: Hopkins Associates
 Illustrations: Kim Downing

MANUFACTURER/ IMPORTER	MODEL NO.	TYPE ¹	THROAT	CAPACITIES (IN.)	
				CUTTING HEIGHT	BLADE WIDTHS
AMT	4113	S	13¾	6	½-¾
DELTA	28-283	S	13¾	6	½-¾
	28-245				
GENERAL	490-1	S	15	6¾	½-¾
GRIZZLY	G1538	S	15½	10½	¼-1
GRIZZLY	G1012	S	18	9½	½-1½
INCA	340	S/B	10½	6¼	½-1½
JET	JBS14CS	S	13¾	6	½-¾
KITY	613	S	12	8	½-1
MINI MAX	S45	F	17	10	¼-1
POWERMATIC	043 Artisan	S	13¾	5½	½-¾
	141	S	14	6½	½-¾
SEARS	24844	S	12	6	½-1½

- (B) Bench (F) Floor (S) Stand
- (CA) Cast aluminum
(CI) Cast iron
- Evaluated on lack of vibration and quality of machining.
- (B) Ball (R) Roller
- (AA) Anodized aluminum
(CA) Cast aluminum
(CI) Cast iron
- (F) Front-of-table exit for blade removal.
(S) Side-of-table exit for blade removal.
- Feet per minute
- (B) Belt (D) Direct

MANUFACTURERS' LISTING:

AMT
215/948-0400

Delta
800/438-2486
412/963-2400

General
819/472-1161

Grizzly Imports
East of Mississippi River:
717/326-3806
West of Mississippi River:
206/647-0801

THE LOWDOWN ON A DOZEN BANDSAWS

		WHEELS		TABLE			POWER TRAIN				GUIDES						ACCESSORIES ¹⁸											
		MATERIAL ²	EVALUATION ³	BEARINGS ⁴	SIZE (INCHES)	MATERIAL ⁵	BLADE REMOVAL ⁶	HORSEPOWER	VOLTS	BLADE SPEED ⁷	DRIVE ⁸	POST EVALUATION ⁹	UPPER TYPE ¹⁰	EVALUATION ¹¹	LOWER TYPE ¹⁰	EVALUATION ¹¹	TRUNNIONS ¹²	EVALUATION ¹³	COVER ¹⁴	EVALUATION ¹⁵	BLADE CHANGE TIME ¹⁶	FRAME ¹⁷	STANDARD	OPTIONAL	WEIGHT (POUNDS)	COUNTRY OF ORIGIN ¹⁹	LIST PRICE	SELLING PRICE ²⁰
CA	F	B	14x14	CI	S	¾	110	3,000	B	F	S	F	S	F	CI, SW	G	H, 2	F	E	CI, 2	ST	F, MG, RB, TE	163	T	-	\$376*		
CA	G	B	14x14	CI	S	¾	110 or 220	3,000	B	E	S	E	S	E	CI, SW	E	H, 2	E	E	CI, 2	ST	F, L, MG, RB, SA	224	U	965	740		
						½	110																					
CI	E	B	15x15	CI	S	1	110	3,000	B	E	S	E	S	G	CI, SW	E	H, 2	E	E	CI, 1	ST	F, L, MG	295	C	989 without motor	1050 with motor		
CA	F	B	16x16	CI	S	1½	110	1,130 1,699 2,859	B	P	S	F	S	F	CI, SW	F	R, 2	P	F	CI, 2	F, MG, ST	-	200	T	-	525*		
CA	F	B	18x18	CI	S	2	220	1,036 1,310 1,660	B	P	S	F	S	F	CI, SW	F	R, 2	P	F	CI, 2	F, MG, ST	-	280	T	-	625*		
CA	E	R	12½x12½	AA	F	¾	110	3,281	D	E	C	E	C	E	CA, SL	G	R, 1	F	E	CA, 1	F	CC, FM, MG, SA, ST, TE	55	S	795	795*		
CA	F	B	14x14	CI	S	1	110	2,350	B	F	S	F	S	F	CI, SW	G	H, 2	F	E	CI, 2	MG, ST	F, RB	180	T	585	435		
CA	E	B	20x20	CA	F	1	110	4,320	B	E	W	F	W*	P	CA, SS, SL	F	H, 1	G	F	S, 1	F, ST	MG, TE	143	F	995	995*		
CI	E	B	19½x19½	CI	F	1.8	220	3,000	B	E	B	E	B	P	CI, SL	F	H, 2	G	F	S, 1	F	MG	330	I	1495	1400		
CA	F	B	15x15	CI	F	¾	110	3,000	B	E	B	P	B	P	CI, SL	P	H, 2	F	G	S, 1	ST	F, L, MG	154	T	792	599		
CI	E	B	15x15	CI	S	1	110	3,000	B	E	B	P	S	P	CI, SW	E	H, 2	E	E	CI, 1	L, ST	CC, F, MG	225	U	1557	1400		
CA	F	B	23x27	CA	F	¾	110	1,500 3,000	B	G	S	G	S	F	TH	F	H, 1	G	G	CA, 2	L, SA, ST	CC, F, MG	131	U	-	300-450#		

- 9. Evaluated on post's ability to remain square with blade throughout travel.
 - 10. (B) Ball bearings
(C) Cool blocks
(S) Steel blocks
(W) Wooden blocks
(* No lower thrust bearing)
 - 11. Evaluated on ease of adjustment.
 - 12. (CA) Cast aluminum
(CI) Cast iron
(SL) Single locking bolt
(SS) Stamped steel
(SW) Saddle and way
(TH) Tilting head
 - 13. Evaluated on quality of machining, fit of parts, and smoothness of table tilt.
 - 14. (H) Hinged
(R) Removable
(1) One-piece
(2) Two-piece
 - 15. Evaluated on ease of opening and closing.
 - 16. **E** 1 to 2 minutes
G 2 to 3 minutes
F 3 to 4 minutes
 - 17. (CA) Cast aluminum
(CI) Cast iron
(S) Steel
(1) One-piece
(2) Two-piece
 - 18. (CC) Circle-cutting kit
(F) Fence
(FM) Fence micro-adjuster
(L) Lamp
(MG) Miter gauge
(RB) Riser block
(SA) Sanding attachment
(ST) Stand
(TE) Table extensions
 - 19. (C) Canada
(F) France
(I) Italy
(S) Switzerland
(T) Taiwan
(U) United States
 - 20. Selling prices based on advertisements, catalogs, and dealer inquiries at time of article's writing.
- GUIDE TO EVALUATION GRADES:
E Excellent **G** Good **F** Fair **P** Poor
- (*) Plus shipping (#) Three models available

<p>Inca (Available from Garrett Wade) 800/221-2942 212/807-1155</p>	<p>Kity (Available from Farris Machinery) 800/872-5489 816/229-3055</p>	<p>Mini Max (Available from SCMI) 404/448-1120</p>	<p>Powermatic 800/248-0144 615/473-5551</p>	<p>Sears (Contact your local store or telecatalog center)</p>
--	--	---	--	--

BUYING BOARDS

Although Jim uses the terms FAS, Select, and No. 1 Common, he admits that exactly understanding their meaning isn't mandatory for a hobbyist, unless you shop by mail or otherwise sight unseen (see the box, *right*, for grades). "Instead, focus on what you expect the wood to be, and then look for it," Jim says.

"You have to ask for what you want in plain English," Jim continues. "To use cherry as an example, if you want the unfinished wood to be all orange-brown, without any lighter sapwood showing, say so. Then, you'll be pointed in the right direction. Will you accept sapwood or knots on the back of the boards, where they won't show in the project? To the dealer, that means a less

"You have to ask for what you want in plain English."

costly grade than if you said, 'I only want all-clear wood.'

Jim agrees with the Denver woodworker about the possible dangers of buying unsurfaced lumber—advice that might have served Ken Palmer well. "Let's say you're looking at unsurfaced lumber that you're told is Select grade," he says. "That means that only one side has to be FAS—the other side can be No. 1 Common. What are you going to do when you get those boards home and plane them down to $1\frac{3}{16}$ " or whatever, and the wood you take off the FAS face reveals the defects of the poorer side?"

"And finally," says Dave Boykin, "you can't forget about moisture content after you get your wood home. All wood should acclimate to the relative humidity where it

Understanding hardwood measure

Hardwood lumber thickness is expressed in quarters of an inch instead of inches and fractions. Four-quarter ($\frac{4}{4}$) equals 1"-thick stock, $\frac{6}{4}$ adds up to $1\frac{1}{2}$ " material, and so on. This applies to surfaced stock—surfaced four sides (S4S) and surfaced two sides (S2S). Rough-sawed (unplaned) stock measures about $\frac{1}{8}$ " thicker than planed stock. Hardwood boards also come in random widths and lengths rather than standard thicknesses and widths (1×6 , 2×4 , etc.), because mills saw for clearest yield with the least amount of waste.

Too, you buy hardwood by the board foot, a unit that equals 144 cubic inches of wood, instead of the running foot. Think of a board foot as a piece of stock 1" thick and 12" square.

Dealers figure board footage in quarters of an inch thickness, starting at 1" (even if you order less). So, a $\frac{5}{4}$ board 6" wide and 72" long represents 3.75 board feet. Here's the calculation: 1.25 (thickness) \times 6 (width) \times 72 (length) equals 540 cubic inches. Divide 540 by 144 to determine the number of board feet in the stock (3.75).

What you get from a grade

Generally, the hardwood boards you'll buy fall into the three top grades as established by the Na-

tional Hardwood Lumber Association, and as explained and illustrated below.

First and Seconds (FAS)

This grade yields the most clear wood from the widest and longest boards.

Selects

This provides the same amount of clear wood as FAS, but it comes from only one side of narrower and shorter boards. The back side has defects as found in the next lower grade.

No. 1 Common

An economical grade for uses requiring short and narrow clear cuts. This grade has about one-third waste.

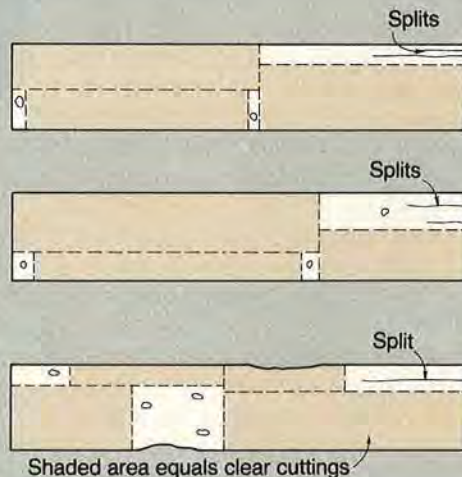

will be used once made into a project. So, sticker your wood for a week or so in your house—or the shop, if it's the same humidity level as your home. You can also

stand it straight up on end. With thick pieces, saw the boards into the approximate cutting sizes you need. That helps it acclimate to your home faster." 🌲

Photograph: Bob Calmer Illustration: Mike Henry

Make a dull corner dishy with this **PRIZEWINNING**



 [Print this article](#)



Here's a winner. The editors of *Plate World*, a magazine for decorative-plate collectors, headquartered in Niles, Illinois, pinned the blue ribbon for the magazine's "Do-It-Yourself Display" contest on this corner plate holder. Timothy Burke of Ramsey, Minnesota, designed and built the original as a four-plate display; we've scaled it down to show off one 8½" plate. But who's to stop you from building a batch of them?

Enlarge the half-pattern, *opposite page*, on gridded paper or by photocopying at the percentages indicated. Select two boards ¾×9×14" (glue up narrower stock, if necessary) and one ¾×4½×12" for each single-plate holder. (We used red oak.)

Joint one edge of each wide piece, and then stack both together with double-faced tape. Make sure to align the jointed edges. Crosscut the boards to 13¾", and then attach the pattern to the top piece with spray adhesive.

With a Forstner bit or spade bit chucked into a drill press, bore 1¼" holes where shown on the

PLATE RACK

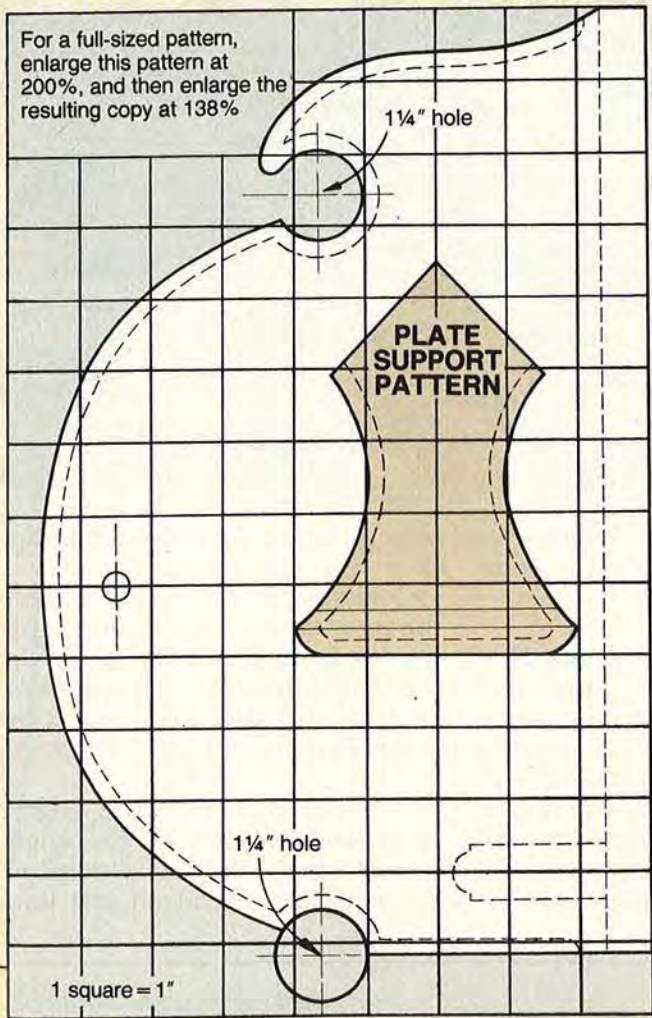
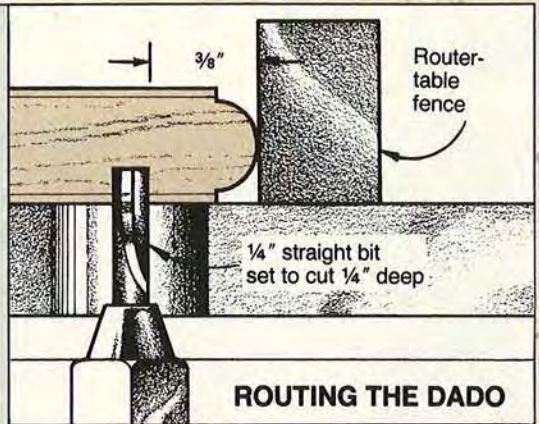
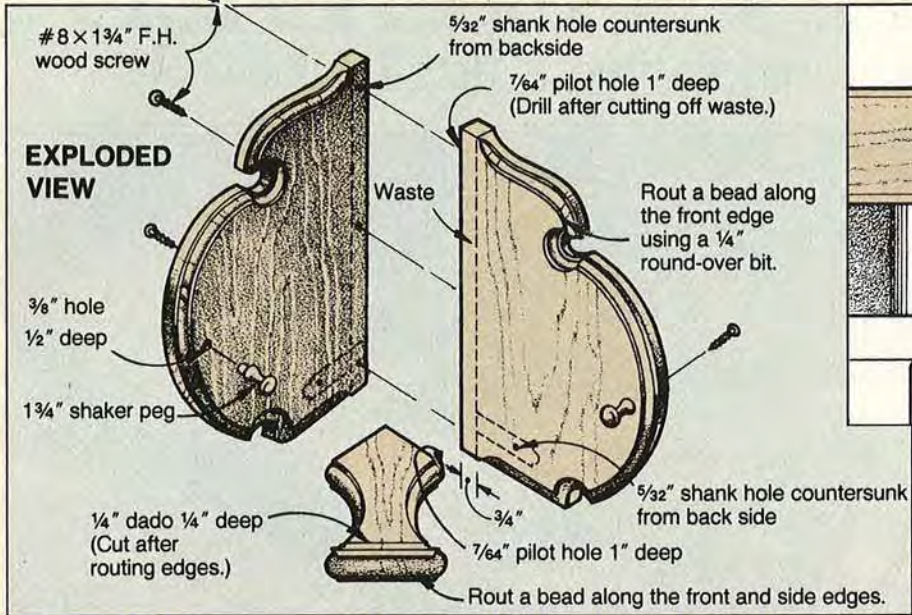

pattern. Bandsaw around the pattern line. Now, mark the center on one end of the $\frac{3}{4} \times 4\frac{1}{2} \times 12$ " board. With your table saw miter gauge set at 45° , saw one corner off the board, starting from the center mark. Then, flip the board over and repeat the cut. Affix the enlarged Plate Support pattern to the piece, aligning the right angle with the one on the workpiece. Bandsaw the plate support.

Drill the holes for the shaker pegs where shown. Then, chuck a sanding drum in your drill press, and sand all edges. Install a $\frac{1}{4}$ " beading bit in your table-mounted router, and then rout along the front edge of each side piece where shown on the Exploded View drawing. *Stop the cut $\frac{7}{8}$ " from the back edge of each board at both top and bottom.* With a hanging-slot bit, rout a slot centered near the top on back of each piece

Change to a $\frac{1}{4}$ " beading bit. Adjust the router depth to cut a bead $\frac{1}{16}$ " deep. Then, rout the plate support along both edges where shown. Refer to the Routing the Dado drawing to rout the plate groove with a $\frac{1}{4}$ " straight bit.

Cut $\frac{3}{4}$ " off the back edge of the right side piece. When setting your saw fence for this cut, be sure to measure to the edge of the blade away from the fence. Position the blade as low as possible, and use your pushstick when making this cut.

Drill screw holes where shown on the Exploded View drawing. Sand all parts before you assemble the two sides and plate support with screws and glue. Glue the shaker pegs into place, and then apply your favorite finish. 🍷

Project Design: Timothy Burke Photograph: Wm. Hopkins Illustrations: Jamie Downing, Jim Stevenson



NO-PROBLEM PIZZA PADDLE

Makes snack time a pizza cake



You'll be a snack-time hero after you make this great pizza handler. No more sizzled fingertips from hauling the pizza out of the oven! No more scars on the cookware from the pizza cutter! No more pieces hanging over the edge of a too-small serving plate! From oven to table, this server makes pizza fun.

Note: We used ½"-thick maple for this project. You can plane or resaw thicker stock.

Rip and crosscut three boards to ½ × 4½ × 24". You'll edge-glue them together, so here's a procedure that helps control cupping by alternating the grain. It also ensures a flat glue-up by compensating for minor deviations from 90° in your tablesaw setup.

● Rip all three boards with the

arcs in the end grain pointing up. Saw both edges on one board.

● Flip this piece over, and place it between the two remaining pieces, as shown in the Gluing Up the Stock drawing, *opposite page*.

● Apply woodworker's glue (we used Titebond II), and clamp.

Now, draw a centerline lengthwise on the back of the edge-joined stock. Mark a centerpoint 7" in from one end on that line,

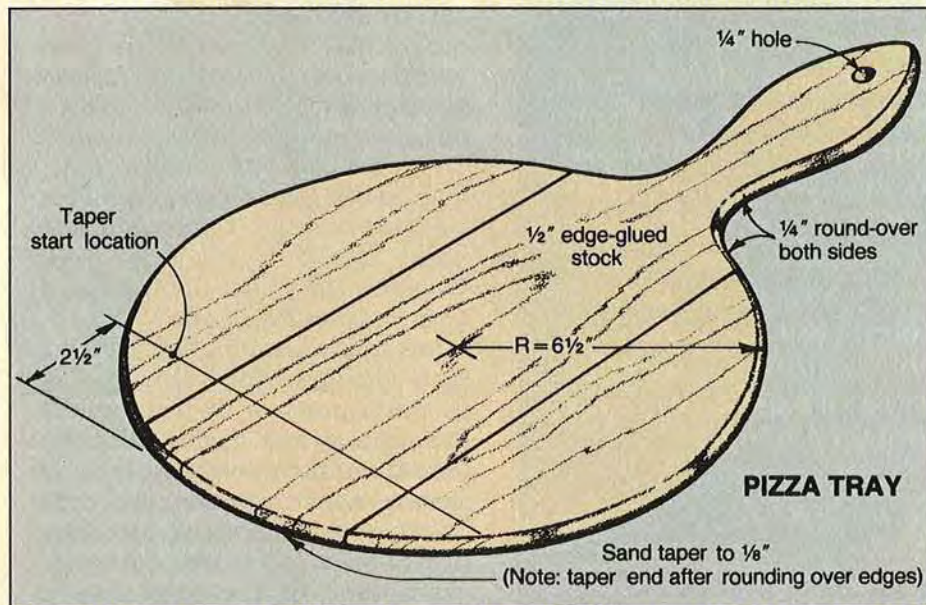
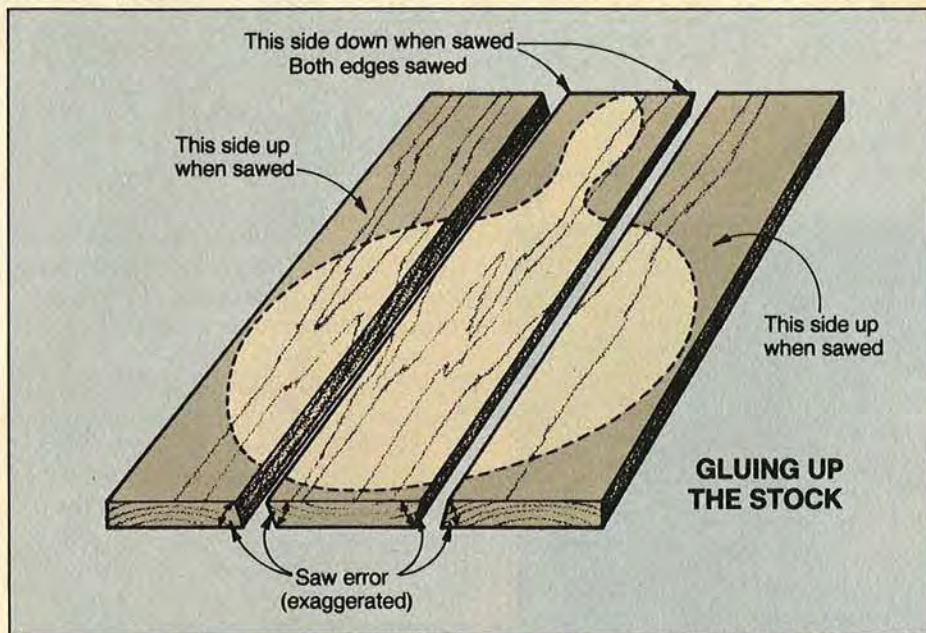

and draw a 13"-diameter circle (using a 6½" radius). Then, trace the full-sized handle pattern below onto the board, aligning it along the centerline and joining the circle to create a giant paddle. Cut out the paddle with your scrollsaw or bandsaw, staying slightly outside the pattern line.

Sand to the line, and rout a ¼" round-over around the paddle's perimeter on both sides. Drill a ¼" hole where shown. Draw a line across the paddle that's perpendicular to the centerline, 2½" from the rounded end.

Now, clamp the paddle to your workbench, with the pencil line facing up and the rounded end jutting past the edge. With your portable belt sander, start from the line and taper-sand the server to ⅛" thick at the front edge. (We made fast work of this operation with 24- and 36-grit belts.)

Sand out the grit marks from the coarse belts with progressively finer belts to 120-grit. Turn to your finishing sander for final smoothing. Finally, apply a food-safe coating such as Behlen's Salad Bowl Finish while you figure out the guest list for your pizza party.

Buying guide

Behlen's Salad Bowl Finish. One pint, \$9.50 ppd. in U.S. (Canadian orders: \$12.50 U.S. funds), catalog No. 85006, Armor Products, Box 445, East Northport, NY 11731. 📍

Illustrations: Jamie Downing; Jim Stevenson
Photograph: John Hetherington

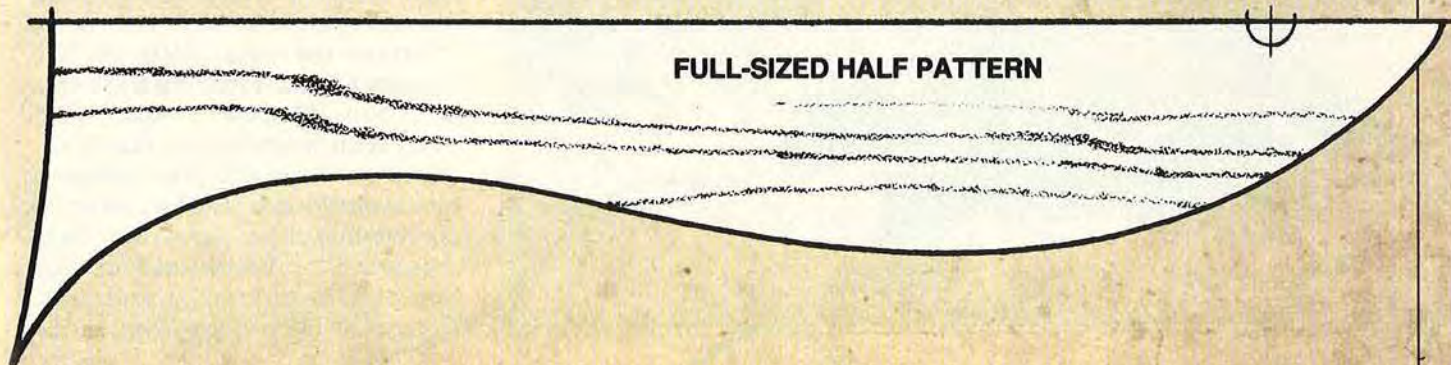



A clothes tree for youngsters

 Print this article

AQUATIC PLAYMATES

You'll need a piece of 1/8"-thick stock 3x36" for the flippers on our aquatic mammals. Plane or resaw thicker stock to size.

Cut eight 3/4x6x9" hardwood boards, and then crosscut a length of 1 1/2x1 1/2" stock to 42". (We chose birch.) Fasten the 6x9" boards together into stacks of four with double-faced tape, aligning the edges. With spray adhesive, attach a photocopy of the dolphin pattern, *opposite page*, to the top of one stack and the whale pattern to the other.

Cut out the dolphins and whales with a bandsaw. (*Scrollsaws: Since scrollsaws won't handle a three-inch stack, make an extra copy of each pattern, tape your boards together in pairs, and cut out the whales and dolphins two at a time.*) Cut eight whale flippers and eight dolphin flippers from 1/8" stock.

Without separating the cutouts, sand all edges with a drum sander in a drill press, or by hand where the drum won't reach. Mark the location of the dowel holes where shown on the patterns, and then separate the cut pieces. Mark the dowel-hole locations along the centerline of the post where shown, transferring the spacing from the cutouts.

Center the edge holes on the cutouts with a doweling jig. Then, drill the 3/8" dowel holes 1 1/16" deep with a brad-point bit.

For the upright post, place a fence on your drill-press table to center the bit on the work. Then, using a stop-block and clamp, bore the lower hole on each face. Continue by moving the block

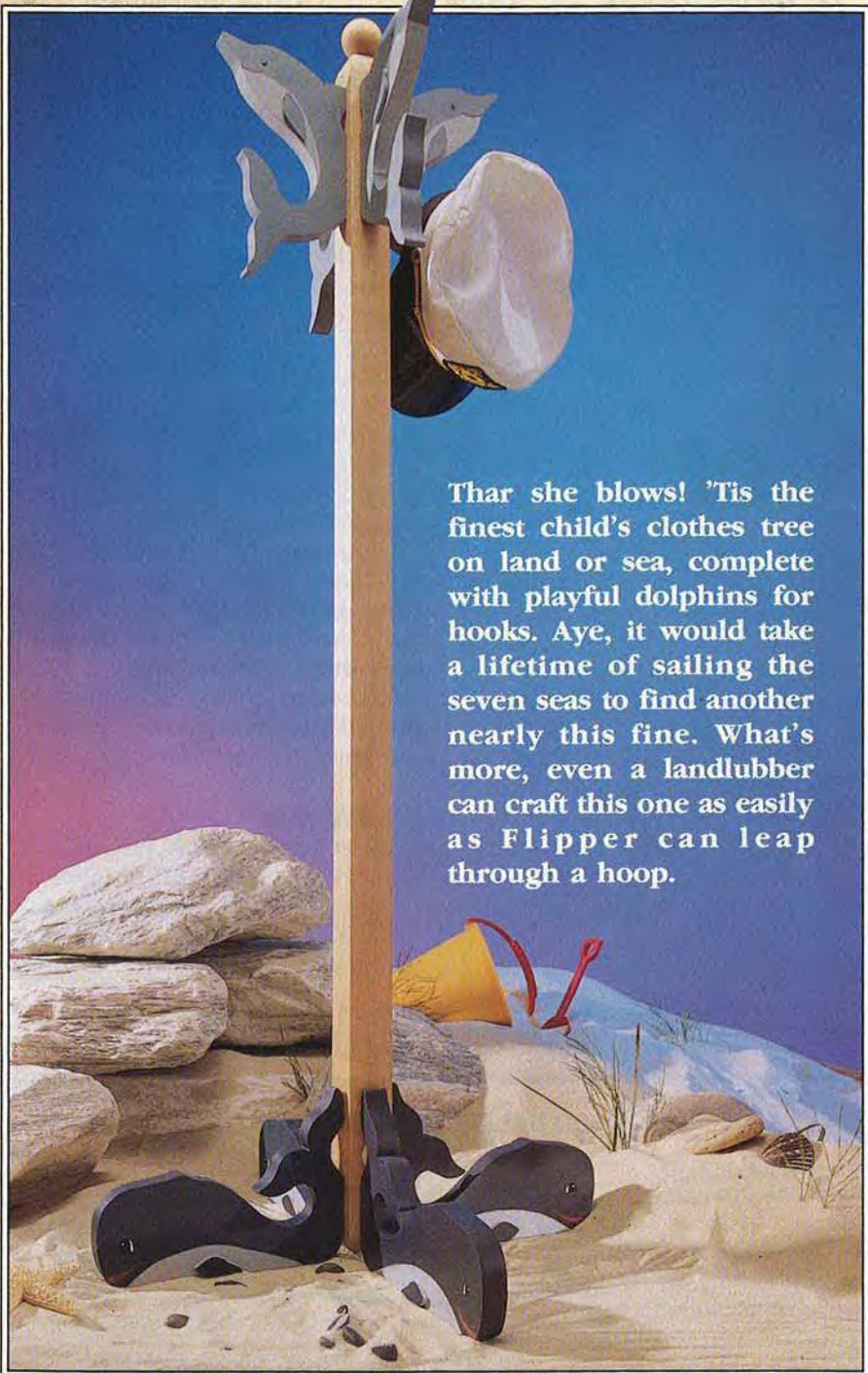

Thar she blows! 'Tis the finest child's clothes tree on land or sea, complete with playful dolphins for hooks. Aye, it would take a lifetime of sailing the seven seas to find another nearly this fine. What's more, even a landlubber can craft this one as easily as Flipper can leap through a hoop.

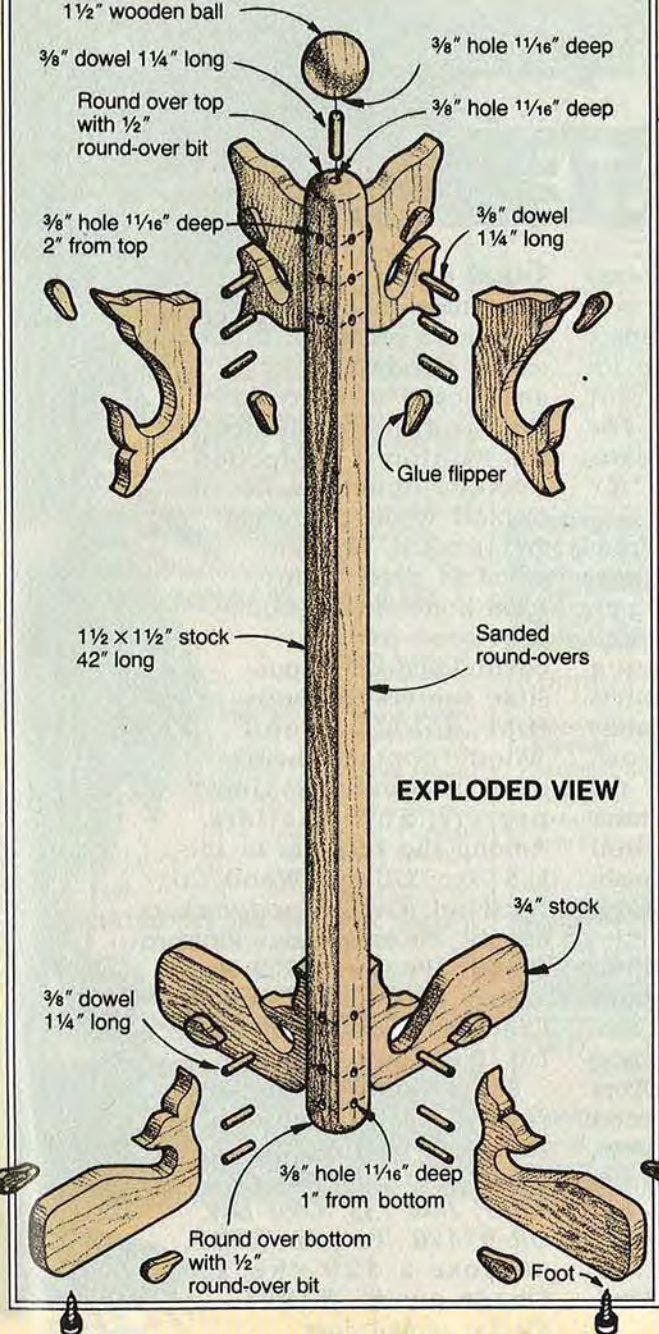

and drilling each face at each of the remaining five positions. Rout 1/2" round-overs along the top and bottom of the post with a table-mounted router.

Then, grip a 1 1/2"-diameter wooden ball with a handscrew clamp, and drill a 3/8" dowel hole 1 1/16" deep in it with the drill press. Center a like-sized dowel hole on top of the post.

Sand all pieces. Glue the flippers on, and then paint the dolphins and whales. (We used Ceramcoat colors indicated on the patterns.) Assemble with dowels and glue. Apply a clear finish, and add rubber feet. 🐬

Project Design: Harlequin Crafts
 Illustrations: Jamie Downing; Jim Stevenson
 Photograph: Wm. Hopkins

To paint eyes, paint eye shape white. Let dry, and then paint front portion black, leaving a white highlight dot.

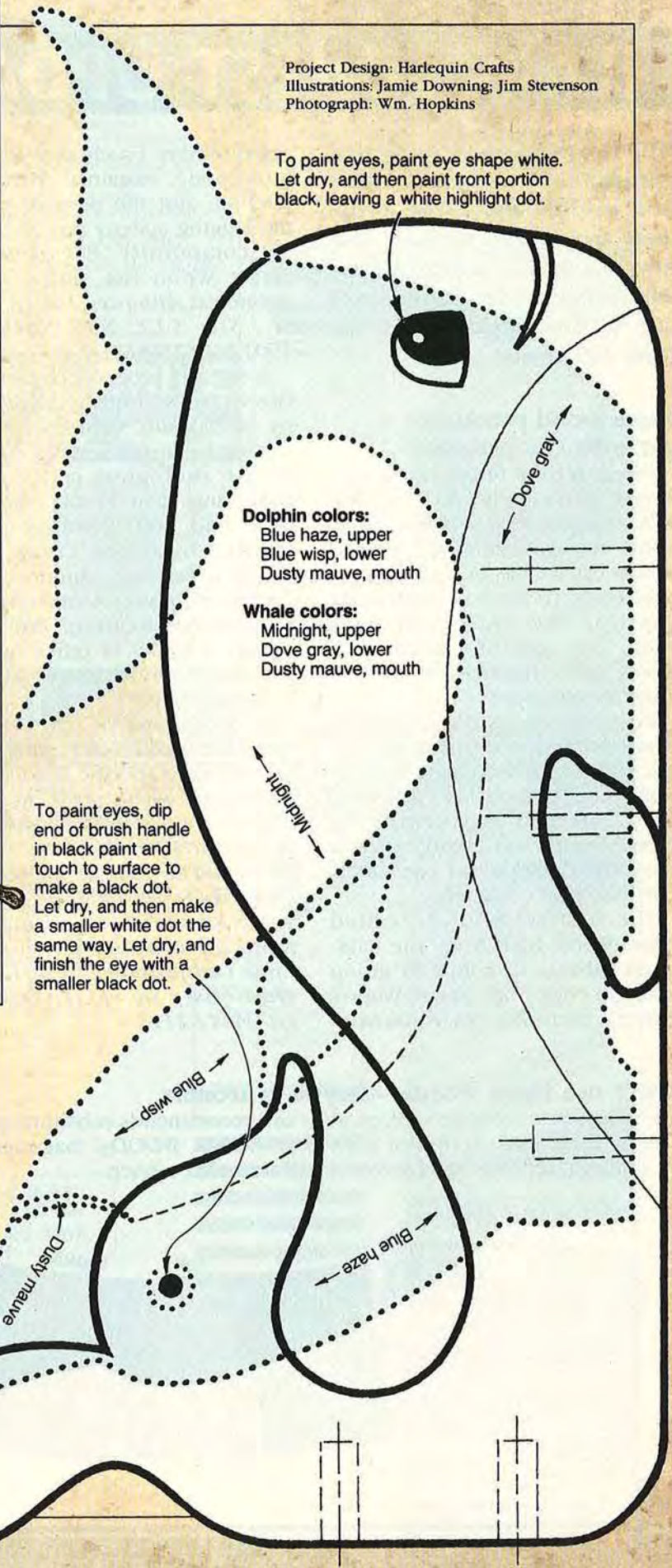

RAIN FOREST UPDATE

Woodworkers, environmental groups, and businesses aren't just talking about the problems facing the world's rain forests—they're acting. Here's what's been happening since our update appeared in the June 1991 issue.

Some wood producers get with the program

Concern for the future of the rain forests, particularly those in Brazil's Amazon region, leads many home woodworkers and professionals (as well as buyers of hand-crafted articles) to suddenly question the sources of their stock. They ask, "If I use tropical wood, am I responsible for rain forest destruction?"

Fortunately, some tropical wood producers do treat the forest, and the environment, responsibly. And at long last, programs have emerged for identifying these sources and certifying their products so that wood consumers can buy with conscience.

The first such effort, called Smart Wood, hails from The Rainforest Alliance, a nonprofit group based in New York. Smart Wood's criteria includes environmental

responsibility (such as watershed protection), sustained yield production, and the positive impact the logging activity has on the local community. For a current Smart Wood list, contact: *The Rainforest Alliance, 270 Lafayette St., Ste. 512, New York, NY 10012. 212/941-1900.*

A second program comes from Green Cross Certification Company of Oakland, California, which already has made a name for itself in the ecological certification field. More than 60 manufacturers have had their product claims verified by Green Cross. Now, Green Cross has announced the first wood-product manufacturer to seek certification, the Knoll Group, a leader in office furnishing and a division of Westinghouse Electric.

To attain Green Cross certification, the Knoll Group first must identify their specific tropical timber sources as well as their sources for cherry and oak from temperate forest areas. Green Cross will investigate the sources, grade them ecologically, and develop standards for rating. For more information, write: *Green Cross Certification Co., 1611 Telegraph Ave., Ste. 1111, Oakland, CA 94612-2113.*

Good wood

Oregonian John Shipstad, a professional woodworker and board member of the Woodworkers Alliance for Rainforest Protection (WARP) updates a list of tropical wood producers and retailers of their wood in order to inform concerned woodworkers of environmentally responsible sources. At press time, John's "Good Wood" contact sheet cited 16 producers, importers, and retailers. Among the retailers in the U.S. are: Gilmer Wood Co., Portland, Ore.; Woodworkers Supply, Phoenix, Ariz.; Pittsford Lumber, Pittsford, N.Y.; Hand-loggers Hardwood, Larkspur, Calif.; and Edensaw Woods, Ltd., Port Townsend, Wash.

For a Good Wood list, send a self-addressed, stamped, business-sized envelope to: *John Shipstad, WARP, Box 133, Coos Bay, OR 97420.* To join WARP, enclose a \$20 check (made out to WARP) for the annual dues.

Don't use these woods—they're in trouble

The Rainforest Alliance's Tropical Timber Project has compiled a list of endangered woods (*below*),

and recommends substituting other woods. *WOOD®* magazine endorses that advice.



Photograph: John Hetherington Illustration: Jim Stevenson

WOODWORKERS

Save on Wood - Tools - Supplies!

OVER
4000
ITEMS

Send for
New 1992
132 Page
Money Saving
CATALOG

OUR
62nd Year

Dept. WM392, 1735 W. Cortland Ct., Addison, IL 60101
Please enclose \$1.00 to help pay postage and handling.

Finest Dimensioned
HARDWOODS and
Quality VENEERS

42 VARIETIES

1/64" to 4" Thickness

Fast service on choice kiln dried
Wood and Veneers, Moldings, Trim,
Hand and Power Tools, Lamp Parts,
Upholstery Supplies, Clock Move-
ments and Kits, Hard-to-Find Hard-
ware, Finishing Materials, Books
... over 4000 items in stock! Crafts-
man—Woodworker's best friend.

CRAFTSMAN WOOD
SERVICE

Full-Size Professional Plan ADIRONDACK CHAIR



Make this classic American
design. Our special
version may be
folded for storage
by using ordinary
hardware available
at your local
store. Be ready
for Summer and
get your plan now!

Plan #700 \$14.00
(catalog free with order)



CATALOG 200 full-size
professional furniture
plans — \$3.00

FURNITURE DESIGNS, INC., Dept. BA-42
1827 Elmdale Ave., Glenview, IL 60025
(708) 657-7526

SPECIAL WOODCARVING GIFT WG92

\$24.95 PLUS POSTAGE #1FS S/rop has coarse leather one side.
Finished leather opposite side.

ADD POSTAGE

U.S.A. \$3.50
CANADA \$6.50
FOREIGN
\$8.50



SPECIAL OFFER INCLUDES:

- 1— Custom made oak & leather folding strop.
- 1— Custom made walnut handled knife with solid brass inter-changeable chuck.
- 1— Heavy duty whittling blade, honed razor sharp, ready for carving.

Free 6-Page instruction booklet.

Complete catalog free with purchase, or send \$1.00 for catalog only.

WARREN TOOL CO. INC.

2209-1 Rt. 9G, Rhinebeck, N.Y. 12572
TEL. (914) 876-7817

N.Y. RES. ADD SALES TAX / USA - Check or money order.
Canada & Foreign money order (only).
USA — COD UPS available at extra cost.

SQUARE DRIVE SCREWS

Simply the Best!

- Square Drive Beats Driver Slippage
- Hardened Steel for Extra Strength
- Deep Thread for Super Grip
- Also Brass & Stainless



Send \$3 for Samples and Catalog

McFEELY
HARDWOODS

P.O. Box 3 • 712 12th St.
Lynchburg • Va • 24505
Toll Free 1-800-443-7937
or FAX (804) 847-7136

NEW "FINGER RELEASE" BLADE CLAMPS FOR SCROLL SAWS

Designed to fit most constant tension
scroll saws (except far east imports).



CATALOG \$1.00
with details and
information on--
BLADES - BOOKS
PATTERNS

**EXCALIBUR
SCROLL SAWS**

SEYCO "The Scroll Saw Specialist"

1414 Cranford Dr • Box 472749
Garland, TX 75047 - 2749
1 800 462-3353

Van Dyke's

Presents a
Catalog

with supplies for
upholstery, antique
restoration, wood
working, caning,
brass hardware,
carvings and many
related trades!

36 Years in Creative Arts & Trades

Many Hard-To-Find Items!

SEND \$1.00 FOR CATALOG TO:
Van Dyke's Restorers
Dept. D55 • Woonsocket, SD 57385



WOODCRAFT

FULL SIZE PATTERNS

SIMPLE TO MAKE * FUN * PROFITABLE

Check the Packets of Interest to YOU!

- 100 yard ornaments animals, birds, signs, more!
- 200 pattern packet for scroll, band & jigsaws!
- Show stoppers - 22 craft show top-sellers!
- 25 fun, profitable "wind-action" whirligigs.
- Attractive Dutch Windmill - 5 feet tall.
- Country Critters-100 patterns, decorative projects!
- 125 pattern "Fun Packet" assortment.
- Yard Characters - Dutch, Amish, bending lady, more.
- Yard Critters-sheep, pig, geese, chickens, more!
- Over 30 Christmas decorations & centerpieces.
- 3 foot tall Santa, snowman, soldier & candle.
- Over 20 quick and easy bird houses.

Send \$8.00 per packet. Pick 3 for only \$16.00
Fast Service • Satisfaction Guaranteed

ACCENTS, Dept. MA42, Box 7387, Gonic, NH 03839

WOODCRAFT CATALOG - \$2.00 (Free with order)

Cradle Plans

You can easily
build this
classic cradle
which is sure
to become a
family heir-
loom. Avail-
able in two
sizes: Baby &
Doll size.

Two Cradle Plans
One for Babies
One for Dolls



72 pg. catalog
free with order

Baby size Plan (21 x 35) \$11.50
Spindle Kit with Pivots \$30.25
Doll size Plan (10 x 18) \$5.25
Spindle Kit with Pivots \$12.95

M/C Visa orders call toll-free 1-800-292-8296

Frt. 48 States \$3.50, AK, HI add 25% of order. NY add tax.
Canada add 50%. Use Visa/MC or M.O. in U.S. funds. Min.
order is \$15.00. Catalog \$1.00 or sent FREE with order.

ARMOR, Box 445-E, East Northport, NY 11731

16 SHOWS THIS SPRING!

★The
Woodworking Shows★
machinery
tools • supplies



- Atlanta
- Charlotte
- Chicago
- Ft. Lauderdale
- Indianapolis
- Kansas City
- Milwaukee
- North Jersey
- No. California
- Philadelphia
- Sacramento
- San Bernardino
- So. California
- St. Louis
- Tampa
- Ventura

Call for free brochure

Monday - Friday 8 am - 5 pm Pacific Time
1-800/826-8257 or 310/477-8521

Wood Moisture Meter

pocket-size
MINI-LIGNO
Range: 6-20%
in 1% steps
Size: 1"x2 1/4"x5 1/2"

\$110
only

Including
Case, Battery, Pins for
3/16" or 7/16"
measuring depth.

Also available as
Mini E, 6-36%



Lignomat USA Ltd.
503-257-8957 800-227-2105

P.O. Box 30145
Portland, OR 97230

The Japan Woodworker's Catalog is...

loaded with the best tools you can get your hands on.
In our catalog you will find a huge selection of
Japanese saws, waterstones, chisels, planes,
carving tools, cutlery and books. Send
\$1.50 for our catalog and supplements
during the next two years.

THE JAPAN WOODWORKER
1731 Clement E-17, Alameda, CA 94501
Phone 1-800-537-7820

SPECIAL OFFER

BRANDING IRON

For hard and soft wood

HAND CRAFTED BY
YOUR NAME HERE

\$2600

Plus \$3.00 for
shipping and handling

Nebr. residents add
correct sales tax

SATISFACTION GUARANTEED
or your money back

- Shipped in one week
- Solid brass head — raised letters
- 1st Line: HAND CRAFTED BY — as above
- 2nd Line: Your choice — 20 characters/spaces max.
- Complete with wood handle
- As above but with 3rd line — \$37.00 + \$3.00

ORDER TOLL FREE 1-800-826-7606

For free brochure, write or call (402) 464-0511

Order by mail from: **NOVA TOOL CO.**

12500 Finigan Rd., Dept. BH
P.O. Box 29341, Lincoln, NE 68529



SUBSCRIBERS

PLEASE NOTE

Wood® subscribers often express interest in products and services which are supplied by our company, Meredith Corporation, and by other reputable firms.

Accordingly, we sometimes send our subscribers offers for books, other magazines or home related products and services of potential interest.

We also make subscriber names and addresses available to other firms who are able to supply appropriate products and services. We screen all such offers and take great care to see that information about these products and services is sent only to subscribers who, according to our records, are most likely to be interested.

While we believe the distribution of this information is of benefit to our subscribers, we firmly respect the wishes of any subscriber who does not want to receive it. Should you wish to restrict this, simply send your request to:

P.O. Box 10263
Des Moines, IA 50336-0263

Please enclose a current address mailing label. Please be specific as to whether it is still all right to receive Meredith Corporation offers or whether you want to stop all offers from any company including Meredith. We will gladly honor your request.

YESTERDAY'S TOOLS

PLOW & COMBINATION PLANES

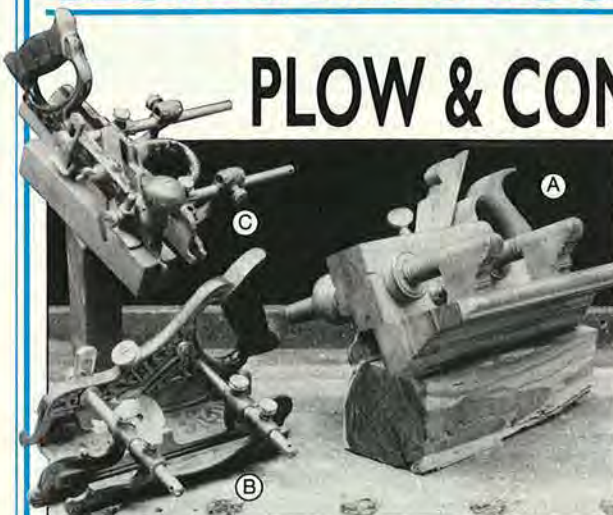

Tucker & Appleton of Boston solid boxwood plow plane (A), circa 1870, worth about \$250; Miller's Patent No. 41, combination plane (B), circa 1875, in iron with fillister bed, about \$500; Traut's Patent No. 45 (Stanley) (C) introduced 1884, worth \$150.

LEGENDS IN THEIR OWN TIME

Throughout most of the 1800s, carpenters and cabinetmakers relied on dozens of highly specialized wooden molding planes and a plow plane to cut molding profiles, grooves, and rabbets to desired shapes and sizes. As you would expect, their toolboxes filled in a hurry.

But changes were in the wind. They began with the screw-arm plow plane around 1820. This tool featured threaded wooden arms that supported a guide fence. The addition of the guide fence, which you set to a needed width and made parallel to the plow-plane cutter, allowed craftsmen to make straight, accurate plows in board faces and edges. (See the Tucker & Appleton screw-arm plow plane, *above*.)

Then, in 1870, another important plow-plane development took place. That's when Charles Miller, then of Brattleboro, Vermont, patented a plane that cut fillisters (rabbets), plows, and tongues for the making of tongue-and-groove lumber. Known as the Miller's Patent No. 41 (B in the photo), the plane was all metal, except the handle. Interestingly, this tool signaled the decline of wood plow and molding planes.

The No.41 proved simple to use and take apart for compact storage, and it did everything a wood-

en plow plane did—and more. Craftsmen also appreciated the fact that they could buy the plane in either iron or showy brass. Both versions came with ornately decorated surface.

For 14 years, the Miller's patented plane was king of the Stanley tool line. Then, another quantum leap occurred when Justus A. Traut developed the No. 45 combination plane for Stanley (C in the photo). It included a sliding middle section capable of holding cutters of many sizes and profiles, and a clamp that firmly secured the blades in place during use. In all, the new Stanley No. 45 came with 21 cutters ranging from a 1/8" plow to the 1 1/2" sash cutter. Later, Stanley added more convenient depth stops and cutters for beading, grooving, and rounding, along with adjustable spurs or slitting knives that run ahead of the plane to score wood fiber at each cutter edge. These made cuts much cleaner and easier.

By all standards, the No. 45 was the most advanced plane of its day, and it quickly became the most popular. Manufactured until 1962, it continues to work hard for those lucky craftsmen who own one. For a new comparable plane, check out the Record's Paragon Multiplane, sold through Garret Wade. Call 800/221-2942. ♣



HATS OFF TO GRIZZLY FOR NEW, EASY-TO-FOLLOW INSTRUCTION MANUALS

Grizzly's new manuals offer loads of clearly worded advice.



As anybody who has bought a Taiwanese woodworking machine knows, most of the instruction manuals leave a lot to your imagination. They typically have terrible translations, few good illustrations, and now and then, some bad advice. (We once read a manual for a Taiwanese jointer that advised standing on the fence if it wasn't straight!)

So, we were delighted to hear that Grizzly Imports has taken the initiative to publish its own manuals. And, after reading a few samples, we have to rate these among the best manuals offered by any manufacturer or importer.

The booklet provided with the model G1017 planer (see portable planer review on pages 54 and 55) is typical: It has 28 pages

covering safety, unpacking, electrical requirements, assembly, adjustments, operating procedures, troubleshooting, maintenance, and parts lists and diagrams. Everything is clear and well illustrated. At the time of this article's production, Grizzly had revised manuals for 30 of its most popular machines, with more on the way.

[Print this article](#)

Wood-Mizer®

World's Largest Manufacturer of Portable Sawmills

Own a Sawmill!

Start a Profitable Business!
Save money cutting your own lumber, make money cutting for others.

1-800-553-0219

32 Page Full Color Catalog - \$2.00
66-minute demonstration video-\$10.00
MasterCard or Visa accepted

8180 West 10th Street • Dept. QQ59
Indianapolis, Indiana 46214-2400

DRY YOUR OWN LUMBER...

...With an EBAC Wood Drying System

Whether you're a serious home woodworker, small cabinet shop or a large wood retailer, EBAC has a wood drying system that's affordable for you.

EBAC Wood Dryers:

- save you money
- are easy to operate
- are energy efficient
- give you higher quality wood
- give you complete control over your wood's moisture content

CALL OR WRITE TODAY!
EBAC LUMBER DRYERS
106 John Jefferson Rd., Suite 102
Williamsburg, VA 23185

1-800-433-9011 • FAX (804) 229-3321
in Canada: 416-985-2123 • FAX (416) 985-3708

RESTORE FURNITURE for SECURE INCOME

Perfect 2nd Career

Make \$200-\$2,000 a day! Unlimited market; turn-key business. Free workshops. Set-Up Shop for \$2,999-\$9,999! Part-time or full-time. Great for men, women, families.

Make Molds*Veneer*Resilver Strip*Repair*Refinish

Business Preview Video \$19.95 - Catalog \$2.00

MINUTEMAN, INC., Ste. 17
Box 8, Waterloo, WI 53594
1-800-733-1776

FOR INFORMATION ABOUT PLACING AN ADVERTISEMENT IN

Better Homes and Gardens. WOOD®

PLEASE WRITE:
CHRIS SCHRAFT
WOOD MAGAZINE
750 THIRD AVENUE
NEW YORK, NY 10017

OR CALL COLLECT: 212-551-6904

Backyard Dream Come True.

A SteelMaster steel building is the perfect place for a home business, from car repair to woodworking to crafts. SteelMaster buildings are economical, maintenance free, corrosion resistant, and easy to assemble. Plus, our **FACTORY DIRECT PRICES** will save you thousands.

Call 1-800-527-4044
In Canada Call:
1-800-387-2343

STEELMASTER
© 1989 SteelMaster

Trakita FREE FREIGHT • Same Day Service
Low Prices On Largest Assortment.

 2012 12" SURFACE PLANER \$459⁰⁰	 9035N 1/3 SHEET SANDER Super Buy! Straight Line or Orbital Reg. \$72 While They Last \$44⁸⁸
 6095DWE CORDLESS DRILL, 9.6V. Kit Incl: Keyless Chuck, Charger, Case, & 2 Batteries \$138⁸⁸	 \$266⁰⁰ 2708 - 8 1/4" TABLE SAW w/ Carbide Blade

CALL 1-800-262-5482

HOME LUMBER CO.
449 WHITWATER ST., WHITWATER, WI 53190 C.O.D.

Worth writing for...



You can get useful ideas and product information by mail. Use the coupon in this section to order your choice of literature listed below. Each company mails the catalogs or information directly to you.

POWER TOOLS

SCROLL SAW, CRAFT & WOODWORKING CATALOG—Specialty products from the exclusive distributors of HEGNER, the precision saws with SCROLLVERGUEGEN. Complete information on scroll accessories, including blades and lettering guides. Also JET Clamps, HEGNER Lathes, PLANO Vertical Glue Press, and more. Toll-free customer service hotline included! AMI, LTD. \$2.00. *Circle No. 3.*

PROFESSIONALS ONLY—Information on the new line of FELDER BF6 woodworking machines, including table saw, shaper, jointer/planer and combination machines, starting as low as \$4,899. Also ULMIA Table Saws. Deal directly with the importer. Get complete information on the best professional machine value! AMI LTD. \$1.00. *Circle No. 4.*

1991-92 TOOL CRIB CATALOG—offers a wide selection of merchandise for home woodworkers to industrial builders and features top manufacturers such as Black & Decker, Delta, Makita, Porter Cable, Bosch, Milwaukee, Ryobi, Freud and many more. We offer competitive prices with quality service and same day shipping. 208 page 1991-92 catalog. It's worth it! TOOL CRIB. \$3.00. *Circle No. 6.*

PORTABLE SAW MILL—a one man saw mill weighing 45 lbs. Gas and electric models will cut dimensional lumber from logs up to 20 in. diameter. Send for brochure. BETTER BUILT CORP. Free. *Circle No. 10.*

175-PLUS USES GUIDE—for Dremel Moto-Tool. Written from the do-it-yourselfer's view, this book shows how to plan and do a variety of everyday projects using the versatile Moto-Tool and cordless Freewheeler. 96-page book with over 275 photos includes tips on using Moto-Tool with flex-shaft, drill press, router attachment, chainsaw sharpening attachment, shaper/router table. DREMEL. Free. *Circle No. 33.*

INCA MACHINERY INFORMATION—Complete information on the famous line of Inca woodworking machines. Designed for precision work by the small to medium sized cabinet shop. Used by thousands of hobbyists and professionals. Table saws, bandsaws, jointer/planers, dust collector, radial arm saw. GARRETT WADE CO. Free. *Circle No. 44.*

HOME LUMBER—For the largest selection of Makita at the right price. We also provide great pricing on Amana Carbides, Bostitch Air Nailers & David White Instruments. Same day shipping, free freight. We accept Visa, Mastercard, Discover, COD. Send for information. HOME LUMBER. Free. *Circle No. 48.*

THE SAW THAT CHANGED AN INDUSTRY!—Now available in an economy priced Professional Model for

your woodworking shop! Imagine! Incredibly intricate scrolling, complex shaping and cutting without making an access cut—this is what the LABORSABER® RETRACTABLE SAW has been doing for industry for over 20 years! Now, a scaled down version of this industry leader is available for your woodworking needs—and at a price that makes owning this quality saw even more attractive. Send for free information. DIANSUPPLY/LABORSABER COMPANY. Free. *Circle No. 50.*

LOBO POWER TOOLS—Fine crafted woodworking power tool, top quality, affordable prices. A commitment of customer satisfaction, with a full 1 year warranty. We sell a complete line with many options for our band saws, table saws, planers, jointers, double drum sanders, edge sanders, wide belt sanders, power feeders and many, many more. Send today for a free brochure. LOBO POWER TOOLS. Free. *Circle No. 57.*

WOODWORKING MACHINE CATALOG—New 24-page color catalog introduces many new do-it-yourself woodworking machines. Includes planers, dust collectors, drill presses, sanders, lathes, and specializes in scroll saws and accessories. PENN STATE INDUSTRIES. Free. *Circle No. 75.*

DUST COLLECTOR SYSTEMS—Keep your shop clean and safe from saw dust with one of our large capacity Commercial Style Dust Collection Systems. Catalog features our new DC-3 1-1/2 H.P. Portable System. Free hose and adapters are supplied with any purchase. Full line of Dust Collection accessories is available from Penn State Industries. Catalog. PENN STATE INDUSTRIES. Free. *Circle No. 76.*

SURFACE PLANER—Information package available from Penn State Industries describing the specifications and applications of its super 12 1/2 inch surface planer. Special discount pricing available on current promotion. PENN STATE INDUSTRIES. Free. *Circle No. 77.*

GET TO THE FINISH LINE FASTER—with a Performax drum sander. Don't spend hours with a hand-held belt sander. Sand ultra-wide stock ultra-smooth in just minutes. Models start at \$300 to \$2595. Select the model that fits your budget and your needs. New metal abrasive fasteners keep sandpaper tight without re-wrapping. PERFORMAX PRODUCTS. \$1.00. *Circle No. 78.*

THE PRECISION SCROLL SAW FOR THE ENTIRE FAMILY!—The Hawk was designed for beginners and built for expert woodworkers. Learn how to produce creative leisure time projects for fun or to make money...we'll show you how! Make cuts so intricate and smooth they don't require sanding. Four models to choose from. Send today for all the facts. RB INDUSTRIES, INC. Free. *Circle No. 84.*

THE VERSATILE RBI WOODPLANNER/MOLDER/SANDER!—It's indispensable! It's 4-in-1. It's RBI's Woodplaner/Molder/Sander/Gang Saw. Find out how the Woodplaner saves you money turning rough stock into beautiful professional quality projects. With 3 models to choose from there's one that fits your needs. It does it all, so you can do it all! Send today. RB INDUSTRIES, INC. Free. *Circle No. 85.*

SCROLL SAWS, ACCESSORIES, PATTERNS, BOOKS—A complete brochure on all kinds of scroll saw accessories. Featuring Excalibur scroll saws and lettering layout guides from Seyco, "The Scroll Saw Specialists." Free pamphlet, "Selecting Your Scroll Saw" included. Send for brochure. SEYCO SALES CO. \$1.00. *Circle No. 89.*

MOLDER-PLANERS FROM WILLIAMS & HUSSEY—Mold, plane, and edge, convert from moulder to planer in less than 2 minutes. The W-7 series is available in 3 models for manual, power in feed, or power in feed/out feed. The units plane to a satin, almost sanded finish, produce doll house to crown sized mouldings, raised panels, and curved molding. Custom knives available up to 7" wide and 3/4" depth of profile. Rugged, well-made, dependable, and transportable. Complete with sturdy movable stand. Send for catalog. WILLIAMS & HUSSEY. \$1.00. *Circle No. 93.*

PORTABLE SAWMILLS—Convert logs into valuable lumber—Wood-Mizer® Products manufactures a line of portable bandsaw mills that allows the novice as well as the experienced sawyer to safely convert standing logs into lumber. Then, with the use of our SolaryDry™ Kiln or Vacu-Kiln™ to dry your lumber, you could increase the value of every board you produce. We manufacture some of the most progressive woodworking equipment on the market today. Product videos available. Send for our 31-page catalog. WOOD-MIZER PRODUCTS. \$2.00. *Circle No. 94.*

HAND TOOLS

RADI-PLANE—Professional edge finishing tools. The RADI-PLANE lets you quickly round-over an edge without the time or trouble of routing and sanding. Duel, micro-adjustable cutters provide for a quick, precise rounded edge in just one pass. Send for more information. L. A. MATHERS CO. Free. *Circle No. 142.*

PERSONAL BRANDING IRONS—Brochure describes branding irons that enable you to put your name on your work quickly and easily. Made especially for branding wood, they are available with 1, 2, 3 or 4 lines of copy. Changeable date also available. NOVA TOOL CO. \$1.00. *Circle No. 160.*

IMPROVE YOUR WOODWORKING SKILLS!—Craftsmen around the world have discovered the secret of better quality work. The 72 page Japan Woodworker Catalog is loaded with a huge selection of Japanese saws, waterstones, chisels, gouges, carving tools, planes, cutlery and garden tools. Send for 1992 catalog and all supplements for two years. THE JAPAN WOODWORKER. \$1.50. *Circle No. 190.*

PLANS

OVER 1000 WOODCRAFT PATTERNS!—Enjoy making gifts, toys, lawn ornaments, holiday designs, whirligigs, folk art, bird houses and feeders, household and yard accessories plus much more! Simple enough for the beginner, fun and profitable for the pro. Send for catalog plus sample pattern. ACCENTS IN PINE. \$2.00. *Circle No. 310.*

WOODWORKERS' PLANS AND SUPPLIES—Wood projects are simplified with the high quality plans, specially hardware and other supplies offered by Armor Products. Over 100 plans are available for making toys, desks, clocks, pool tables, lamps, chests, and other furniture. Movements, dials, moldings, ornaments, dollhouse kits, door harp supplies and tuning pins are also available. ARMOR PRODUCTS. \$1.00. *Circle No. 315.*

SALES TESTED DESIGNS—available as plans only, parts kits, or plans and parts kits. Complete stock of parts, tools and supplies. Door Harps to Digital Electronic/Wood Projects. Full size plans! Catalog \$2.00 refundable on first order. CRAFTERS MART. \$2.00. *Circle No. 328.*

FULL-SIZE FURNITURE PLANS CATALOG—Illustrates and describes over 200 plans for making furniture of quality found in museums and fine furniture stores. Plans include rolltop desk, cradles, dining tables, chairs, buffets, chests, gun cabinets, poker table, children's furniture, rocking horse, spinning wheels, and more. Bill of materials exploded drawings assist the woodworker. FURNITURE DESIGNS, INC. \$3.00. *Circle No. 345.*

STICKLER FOR DETAIL?—At last an exciting new line of realistic wood block models that you can build with your own scrap wood and dowels and my easy-to-follow instructions. Highly detailed plans for a 20x8 1/4-in. dump truck. GATTO PLAN SUPPLY. \$8.00. *Circle No. 355.*

PROJECT PLANS—Full-size patterns for over 500 easy-to-build woodworking projects. Nation's leading source for scroll saw patterns, cow projects, toy plans, yard ornaments, wood furniture, etc. Over 3000 hard-to-find specialty items. Send for your big new 72-page catalog. MEISEL HARDWARE SPECIALTIES. \$1.00. *Circle No. 401.*

THE COMPLIMENTS NEVER END!—when you show off your completed projects made from our full size patterns. Over 1000 unique, easy to make designs include popular folkart, wind action whirligigs, old world Santas, country furniture, shelves and shadow boxes, action toys, 3D layered animals, country critters, yard ornaments, Christmas yard decorations and more! No enlarging required—just trace our patterns onto wood and cut out. Fast service, satisfaction guaranteed. Send for our latest catalog. THE WINFIELD COLLECTION. \$1.00. *Circle No. 480.*

LUMBER

QUALITY EXOTIC LUMBER/TURNING WOODS—We offer a comprehensive selection of fine quality exotic woods: Ebony, Kingwood, Tulipwood, Snake-wood, African Blackwood, Cocobolo, Bloodwood, Figured Maple, Spaulled Maple, Padauk, etc. Unique and unusual turning woods and burls are also available. Send for catalog. BEREHA HARDWOODS. \$1.00. *Circle No. 510.*

WOODWORKERS! HELP CELEBRATE OUR 62ND YEAR OF SERVICE—Send for our new 132-page Craftsman 1991-92 Catalog #58. 42 varieties of choice hardwoods 1/4 in. to 4-in. thickness. Fine hardwood veneers, tools, moldings, trim, marquetry inlays, upholstery and lamp supplies, finishes, clock kits, and hard-to-find hardware. 4,000-plus items for your projects. CRAFTSMAN WOOD SERVICE CO. \$1.00. *Circle No. 520.*

STEVE H. WALL LUMBER CO—Quality hardwoods and woodworking machinery for the craftsman and educational institutions. 22-page catalog lists 15 species of popular hardwoods at wholesale prices. Also dealers for MiniMax, Freud and ProCut woodworking machines. STEVE H. WALL LUMBER CO. \$1.00. *Circle No. 592.*

EXOTIC IMPORTED AND DOMESTIC HARDWOODS—Over 75 species of lumber, bowl planks, turning squares and veneer. Samples 1/8" x 3" x 6"

ideal for craftsmen, furniture and cabinet makers, architects, and designers available. Catalog provides common and botanical name, source, and description of each wood. Send for catalog. WOODWORKERS SOURCE. \$1.00. *Circle No. 598.*

VIDEOS

LOBO POWER TOOLS—Complete one stop location for all affordable woodworking power tools. Excellent quality at the most affordable prices. Customer satisfaction is job #1. We inventory and sell a full line of band saws, table saw, planers, jointers, sanders (all sizes) and much, much more. All equipment has a 1 year warranty. Send for video; price refundable with \$500 purchase. LOBO POWER TOOLS. \$10.00. *Circle No. 645.*

GENERAL WOODWORKING CATALOGS

CONSTANTINE'S WOODWORKERS' CATALOG—116 pages—over 4,000 woods, veneers, inlays, carvings, moldings, legs, pegs—everything for people who like to build with, turn, carve, refinish wood! Includes 33 pages of hand and power tools, 24 pages of hard-to-find hardware, 12 pages of finishing supplies... books, kits, plans and more... all backed by Constantine's 180 years of woodworking experience and 60-day no-questions-asked guarantee. 2 year subscription. ALBERT CONSTANTINE AND SON, INC. \$1.00. *Circle No. 820.*

MASTER TOOLS CATALOG—1991-92 220-page master woodworking tools catalog. Full line of the best hand tools, power tools & accessories, machinery, glues, finishing supplies, workbenches, and much more. Hundreds of books included. 220 pages. All four-color. Lots of technical information. GARRETT WADE CO. \$4.00. *Circle No. 855.*

GRIZZLY IMPORTS, INC.—Our new 1992 catalog is bigger and better than ever! We have added many new items to our already large selection of affordably priced woodworking machines, tools and accessories. Send for your free woodworking source catalog. GRIZZLY IMPORTS INC. Free. *Circle No. 860.*

TOOLS ON SALE—A division of Seven Corners Ace Hardware Inc. offers a comprehensive catalog featuring over 820 pages of the most competitive prices in the industry. If you're looking for savings and fast delivery on over 6500 items, request our catalog. This catalog offers one of the most complete selections of power tools available anywhere from the most respected manufacturers in the industry: Milwaukee, Makita, Porter-Cable, Black & Decker, Freud, Bosch, Delta, and many more. SEVEN CORNERS ACE HARDWARE. \$1.00. *Circle No. 920.*

DISCOUNT WOODWORKING TOOLS AND SUPPLIES—Get your FREE copy of Trendline's new 68 page full-color catalog. You'll find the best prices for over 3,000 brand name products including: power tools and accessories, hand tools, screws, hardware, wood components, plans, books, and much more. TRENDLINES. Free. *Circle No. 950.*

COMPLEMENTARY TOOL CATALOG—Woodcraft offers over 4,000 of the finest quality woodworking tools, books, supplies, and cabinetry hardware in our complete full color catalog. Craftsmen, cabinetmakers, carvers, woodturners, and hobbyists have depended on Woodcraft since 1928. Backed by Woodcraft's unconditional guarantee. Free technical assistance. WOODCRAFT SUPPLY CORP. Free. *Circle No. 955.*

KITS

OUR QUEEN ANNE FURNITURE KITS—are ready to assemble and finish. They include dining room

table, chairs, hutch, sideboard, a variety of occasional tables, and a personal desk. All are made in solid cherry, oak, walnut, and mahogany. We also stock individual Queen Anne legs for every project. Complete information in our brochure packet. ADAMS WOOD PRODUCTS. Free. *Circle No. 1002.*

OAK FURNITURE AND ACCESSORY KIT CATALOG—features a full range of top quality oak furniture kits and accessory items plus unfinished assembled furniture. Featured items include roll top desks in several styles, stacking barrister's bookshelves, tables, chairs, file cabinets, bedroom furniture, Mariner's globe, plus many more. Send for catalog and enjoy true woodcrafting pleasure. CRAFTSMANS CORNER. Free. *Circle No. 1017.*

DO-IT-YOURSELF KITS—Choose from a large selection of grandfather, wall and mantel clocks, as well as elegantly styled accent furniture pieces. Kits are made of solid 3/4" hardwoods, primarily cherry, oak, and black walnut. Buy direct from the factory and save. Send for 36 page color catalog. EMPEROR CLOCK CO. \$1.00. *Circle No. 1030.*

SHOP ACCESSORIES

WOOD MOISTURE METER—Insure the quality of every project by using a wood moisture meter. Delmhorst Model J-88 is ideal for a woodworking shop or the serious craftsman. Easy to read LED display indicates 10 ranges of moisture content between 6% & 20%. Send for catalog on our complete line of wood moisture meters. DELMHORST INSTRUMENT CO. Free. *Circle No. 1217.*

LUMBER DRYING SYSTEMS—Ebac Lumber Dryers offers a wide variety of sizes from 50 B.F. to over 10,000 B.F. You get the highest quality lumber dried down to 6%-8% moisture content. Our controllers make them easy to operate and energy efficient. Kiln construction guide included to build your chamber. EBAC LUMBER DRYERS. Free. *Circle No. 1228.*

EASY DOES IT—with HTC'S power tool accessories. Discover many unique items, designed only with you, the dedicated woodworker, in mind. Make your machinery safer, increase the working area of your shop and accomplish nearly impossible tasks easily, quickly, accurately. Full-line catalog and price list. HTC PRODUCTS, INC. Free. *Circle No. 1245.*

WOOD MOISTURE METER—Avoid moisture problems such as cracking, warping, splitting, delamination etc. by using a moisture meter, as described in the latest brochure. Moisture Meter Mini-Ligno is designed for serious hobbyists and woodworkers. Attachments for depth measurements and remote reading during air and kiln drying are available. Available Moisture Range 6-20%, 6-36% or 4-30%, 4-60%. Catalog describes complete line of moisture meters. LIGNOMAT USA, LTD. Free. *Circle No. 1250.*

ROUTER SPEED CONTROL—Reduces speed electronically without reducing torque. Route at the speed that gives best results with the wood and bit you are using. Speed adjustable from full speed to 0 RPM. Less tear out—stops burning—less wear on bits—easy to use. Send today for information. MLCS LTD. Free. *Circle No. 1251.*

WHOLESALE SANDPAPER, BELTS, SHEETS, CLOTH & PAPER DISCS—for orbital sanders. Shop rolls, flap wheels, hot melt glue sticks, dust masks, scuff pads, tack cloths, tape, wipers, etc. Supergrit offers quality abrasive and refinishing products at wholesale prices directly to the consumer. \$25.00 minimum order. Prompt, free UPS shipment to most areas. 20 page catalog. RED HILL CORP. 50¢. *Circle No. 1267.*

BITS, BLADES, CUTTING TOOLS

AmMax TOOL CO.—offers "Professional Quality" tungsten carbide tipped router bits, shaper cutters, saw blades, and 16" scroll saw machine, at lower "wholesale prices." 16" scroll saw featuring light load, cutting without blade breakage. UL and CSA approved. Nicholson carbide tipped saw blades from \$6.90; woodworking files from \$6.95. AmMAX TOOL CO. 50¢. *Circle No. 1304.*

ATRAx—Fine craftsmanship deserves the very best. Craftsmanship begins with the idea. The final result depends on the tool and the craftsman. Atrax cutting tools are made from premium fine-grade carbide, the best on the market today. Atrax offers over 600 styles and sizes of cutting tools to bring ideas to quality results. Send for catalog. ATRAX. Free. *Circle No. 1305.*

CASCADE TOOLS—New 1992 catalog is packed full of affordably priced, industrial grade s/y brand router bits and shaper cutters as well as hard to find accessories. Also included are many new items added just this year. CASCADE TOOLS, INC. Free. *Circle No. 1315.*

PRODUCTION QUALITY CARBIDE TIPPED ROUTER BITS—MLCS Ltd. has a new 32-page catalog featuring hundreds of high quality carbide tipped router bits, shaper cutters, the Router Speed Control, the "Merle Adjustable Corner Clamp," plus other Professional Woodworking Products. Prices 50% to 70% lower than elsewhere. Value, quality and prompt service guaranteed! MLCS LTD. Free. *Circle No. 1350.*

HARDWARE/WOOD PARTS

HARDWARE CATALOG—A unique 48-page catalog of the very finest in classic, traditional solid brass cabinet hardware. All of British or No. American manufacture. Double & single post handles, knobs, escutcheons, standard & specialty hinges, box

hardware, brass screws, castors, latches, catches, locks, and more. GARRETT WADE CO. \$3.00. *Circle No. 1427.*

SQUARE DRIVE SCREWS—Thousands agree—once you try them you will never want to use anything else! The square drive recess virtually eliminates work-damaging driver bit "cam-out," the deep threads result in exceptional holding power, and they are heat treated for strength. Sizes from #4 x 3/8" to #12 x 4", with stainless steel, solid brass, brass plated, and zinc plated available. Quantity discounts. Send for literature. McFEELY HARDWOODS. \$1.00. *Circle No. 1450.*

WOOD TOY PATTERNS—Patterns for all ages including children's patterns and executive toys. New catalog has many new patterns to choose from including parts and wheels. Send for new catalog and receive a coupon for free wheels and axle pegs. TOYS AND JOYS. \$1.00. *Circle No. 1480.*

QUALITY AMERICAN-MADE WOOD TURNINGS—such as shaker pegs, spindles, toy wheels, toy parts, craft items, and dowel rods in birch, oak, walnut, and cherry. Send for complete 32-page catalog. WOODWORKS. \$1.00. *Circle No. 1490.*

INCOME OPPORTUNITIES

MAKE MONEY IN FURNITURE RESTORATION THE MINUTEMAN WAY—Earn \$200-\$1000 per day stripping, repairing, refinishing, mirror resilvering, and/or veneering, at home or in shop, spare time or full time. We provide complete training; no experience necessary. Free workshop teaches you latest in furniture restoration. You have to see it to believe it! Business preview video \$19.95. Send for catalog. MINUTEMAN. \$2.00. *Circle No. 1661.*

MISCELLANEOUS

DELPHI STAINED GLASS—80-page color catalog of stained glass and related supplies. Beveled glass,

hard-to-find tools, hundreds of unique patterns, kits, books, videos, and lots more. For 18 years, we've supplied both hobbyists and professionals with quality products, friendly advice, and fast 24-hour shipping. All products guaranteed 100%. DELPHI STAINED GLASS. \$4.50. *Circle No. 1920.*

IF YOU ARE INTERESTED IN RESTORING ANTIQUES—this 240-page catalog packed with unusual, hard-to-find items is just for you. Included are hundreds of essential items for antique restoration including top quality brass reproduction hardware, oil lamps and accessories, numerous wood component repair parts and kits, caning and basketry supplies, everything needed for wood refinishing, related tools, books, and a complete line of upholstery equipment and supplies. All at wholesale prices. Send for this informative catalog. VAN DYKE'S RESTORERS. \$1.00. *Circle No. 2077.*

UNIQUE GREENHOUSE/SCREENHOUSE IDEA—A gardener's paradise during the winter months, a bug-free screen room during the summer months. That's the concept behind the versatile new Sun-Porch. This two-in-one sunspace features sturdy aluminum framing, 1" shatter-resistant glazing, do-it-yourself assembly, and mounts readily on decks, patios, landscape ties. Color catalog includes models, prices; sent first class mail. VEGETABLE FACTORY, INC. \$2.00. *Circle No. 2078.*

LEGAL IVORY—Virtually identical to animal ivory. Tagua is the nut from a tropical palm tree. Ideal for jewelry, knobs, small turnings, inlay, or scrimshaw. Box of 10 REGULAR size (up to 1 1/2" diameter) or Box of 5 JUMBO. Send for information. WOODWORKERS SOURCE. Free. *Circle No. 2090.*

***THE WOODWORKING SHOWS* MACHINERY, TOOLS AND SUPPLIES**—Hundreds of products for the woodworker demonstrated and sold at discount prices at every "Woodworking Show". In-depth seminars and free workshops on a variety of woodworking topics. Shows are scheduled in 28 cities. Send for free brochure. *THE WOODWORKING SHOWS*. Free. *Circle No. 2095.*

CARVING SUPPLIES

WOOD CARVING MACHINES AND ACCESSORIES—make all types of wood carving easy, fun and profitable. The machines do the work. Whether for sign carving, flat 3-D, decoys, panels, gun stocks or furniture, we have the proper machine for the job. Professional woodcarving for the hobbyist and superior quality for the professional. Begin your hobby or full or part-time business by ordering our catalog and price list. MARLIN INDUSTRIES. \$1.00. *Circle No. 2150.*

WOODCARVING TOOLS—Whittlers and carvers—Warren Tool Co. offers a complete catalog of whittling and carving, hand/power tools, sharpening stones, wood cut-outs and related wood carving supplies. WARREN TOOL CO., INC. \$1.00. *Circle No. 2185.*

CLAMPS

MERLE ADJUSTABLE CORNER CLAMP—Quick & easy to use. Fully adjustable from 2 1/2" to 69x69 in. Perfect for clamping picture frames, cabinets, or anything that requires 90° corner clamping. The Merle Clamp is cast aluminum & steel construction, a true industrial quality tool. Send today for information. MLCS LTD. Free. *Circle No. 2250.*

QUAKER STATE WOODWORKING SUPPLY INC.—one of the largest "Quick-Grip" and "Jorgensen" dealers on the EAST COAST. Great prices along with expert service and advice will make QUAKER STATE your supplier of woodworking clamps and acc. Information and price list. QUAKER STATE. Free. *Circle No. 2260.*

Worth writing for...



Better Homes and Gardens®
WOOD Magazine, April 1992
Dept. APWO92
P.O. Box 2713
Boulder, Colorado 80329-2713

TO ENSURE PROMPT HANDLING OF YOUR ORDER FOLLOW THESE INSTRUCTIONS:

- Circle your choice
- Enclose check or money order for cost of booklets plus \$2.00 service charge (no stamps accepted)
- **NO FOREIGN ORDERS ACCEPTED**
- Send coupon and remittance to address above
- **ALLOW 4-6 WEEKS FOR DELIVERY**
- Coupon expires April 11, 1993

WOOD SUBSCRIPTION

1. A 1 year WOOD subscription (9 issues) for \$24.97 (U.S. price)—a \$10.58 savings off newsstand rate. Allow 6-8 weeks for first issue. Canadian price \$34.00. Be sure to include payment with total below. **NO FOREIGN ORDERS ACCEPTED ON THIS COUPON;** please contact Subscription Dept. directly.

Circle numbers below corresponding to items in this issue. Please include \$2.00 for handling charge.

3\$2.00	76Free	190\$1.50	592\$1.00	1017Free	1315Free	2090Free
4\$1.00	77Free	310\$2.00	598\$1.00	1030\$1.00	1350Free	2095Free
6\$3.00	78\$1.00	315\$1.00	645\$10.00	1217Free	1427\$3.00	2150\$1.00
10Free	84Free	328\$2.00	820\$1.00	1228Free	1450\$1.00	2185\$1.00
33Free	85Free	345\$3.00	855\$4.00	1245Free	1480\$1.00	2250Free
44Free	89\$1.00	355\$8.00	860Free	1250Free	1490\$1.00	2260Free
48Free	93\$1.00	401\$1.00	920\$1.00	1251Free	1661\$2.00	
50Free	94\$2.00	480\$1.00	950Free	126750¢	1920\$4.50	
57Free	142Free	510\$1.00	955Free	130450¢	2077\$1.00	
75Free	160\$1.00	520\$1.00	1002Free	1305Free	2078\$2.00	

Name (please print) _____
Address _____
City _____
State _____ Zip Code _____

I AM ENCLOSING:

\$ _____ for priced items
\$ 2.00 for handling
\$ _____ total remittance

DELTA BENCH TOP TOOLS	
Model	List Sale
23-700 Wet/Dry Grinder.....	234 159
23-680 6" Bench Grinder 1/4 HP.....	86 75
23-880 6" Bench Grinder 1/2 HP.....	151 115
11-850 6" Drill Press.....	199 145
28-160 10" Hobly Band Saw.....	210 145
31-050 1" Belt Sander 2.0 amp.....	104 78
31-450 4" Belt Sander.....	198 145
31-340 NEW 1" Belt's Disc Sander.....	269 188
31-080 NEW 1" Belt's Disc Sander.....	134 94

NEW TOOLS BY DELTA	
40-660 16" 2 speed Scroll Saw.....	266 184
23-580 5" Bench Grinder 1/5 HP.....	62 54
11-990 12" Bench Drill Press.....	276 209
11-090 3/4" HP 2 stage Dust Collector.....	389 309
43-355 3/4" Shaper 1 1/2 HP.....	964 685
43-505 1/2" Bench Router/Shaper.....	399 279
22-540 12" Bench Top Planer.....	595 398
36-220 10" Compound Miter Saw.....	350 245
28-180 Bench Band Saw.....	232 169
40-640 NEW 20" Bench Scroll Saw.....	466 335
23-675 NEW 6" Grndr/3x24Belt Sndr.....	141 105
14-600 Hollow Chisel Mortiser.....	668 465

DELTA STATIONARY	
34-761 10" Unisaw 1-1/2 HP.....	1715 1295
33-990 10" Radial Arm Saw.....	818 585
37-280 6" Motorized Jointer.....	488 389
50-179 3/4 HP 2 stage Dust Collector.....	483 399
50-181 2 HP Dust Collector.....	865 610
70-200 NEW 20" Floor Drill Press.....	1049 775
37-154 DJ15 6" Jointer w/3/4 HP motor.....	1079 775
33-055 8-1/4" Sawbuck comp.w/ice.....	865 589
34-330 NEW 8-1/4" Table Saw 13A.....	343 229
34-985 1/6 HP Stock Feeder.....	688 485
34-670 10" Motorized Table Saw.....	511 395
32-100 Station Planer Jointer.....	645 285
36-040 8-1/4" Compound Miter Saw.....	224 165
34-915 30" Unifence.....	385 239
34-897 50" Delta Unifence.....	525 295
36-755 NEW 10" Tilt Arbor Saw.....	1264 865
34-445 34-444 Saw with 30" unifence.....	200 809

MILWAUKEE TOOLS	
6527 NEW Sawzall with case.....	299 164
6528 new Sawzall w/ired cord.....	299 164
6125 NEW 5" Random Orbit Sander.....	200 119
6126 NEW 6" Random Orbit Sander.....	205 125
0399-1 12V odless Drill Kit complete.....	299 165
0402-1 new Drill w/keyless chuck.....	304 169
0395-1 9.6V cordless Drill w/case.....	279 158
0224-1 3/8" Drill 4.5 amp magnum.....	199 115
0234-1 1/2" Drill 4.5 amp 0-850 rpm.....	219 122
0244-1 1/2" Drill 4.5 amp 0-600 rpm.....	219 122
0222-1 3/8" Drill 3.5 amp 0-1000 rpm.....	185 105
0235-1 3/8" Drill 3.5 amp 0-1000 rpm.....	175 102
0379-1 1/2" close quarter Drill.....	249 147
6539-1 cdis Screwdriver 180 rpm.....	125 75
6546-1 cdis Screwdr 200 & 400 rpm.....	135 79
3102-1 Plumbers right angle Drill Kit.....	350 195
5399 1/2" D-hole Hammer Drill Kit.....	318 184
1676-1 HD Hole Hawk with case.....	449 244
6511 2 speed Sawzall with case.....	234 134
6750-1 Drywall Gun 0-4000 5 amp.....	159 93
6507 Original Sawzall with case.....	249 132
6170 1/4" Chop Saw 15 amp.....	479 279
6014 Orbital Sander 1/2 sheet.....	209 116
8977 variable temp. Heat Gun.....	114 75
5397-1 3.8" var. spd Hammer Drill Kit.....	239 139
5371-1 1/2" var. spd Hammer Drill Kit.....	335 188
3107-1 1/2" var. spd rt angle Drill Kit.....	360 199
6754-1 Drywall Gun 0-4000 5.4 amp.....	189 114
3300-1 1/2" var. speed rt angle Drill.....	319 179
5680 Router 2 HP - 12 amp.....	355 205
6215 16" Chain Saw.....	299 174
0235-1 1/2" Drill w/keyless chuck mag.....	219 125
6145 4-1/2" Grinder 10,000 rpm.....	159 95
6142 6145 with case & acces.....	197 129
6749-1 Drywall Gun 0-2500 5.4 amp.....	209 117
5353 Eagle 1-1/2" Rot. Hammer w/case.....	895 499
6365 7-1/4" Circular Saw 13 amp.....	209 120
6367 above Saw - double insulated.....	225 122
6366 6365 w/ence & carbide blade.....	219 125
6368 6365 w/ence,carb. blade & cse.....	239 134
6377 7-1/4" Worm Drive Saw.....	319 175

Buy any 7-1/4" saw(6365,6366,6367,6368,6377)& receive an Extra Milw. Carbide Tip Saw Blade an \$11.00 value - FREE

FREEM CARBIDE TIPPED SAW BLADES		
Item	Description Teeth List Sale	
LUB2M010	Gen Pur. A.T.B. 10" 40 67	
LUB2M011	Cut-off 10" 60 90	
LUB4M011	Cut-off 6" 60 76	
LUB5M010	Super Cut-off 10" 60 112	
LUB2M010	Flang 10" 24 66	
LUB3M010	Cut-off 10" 60 82	
LUB7M010	Thin Kerf 10" 24 70	
LUB8M010	Thin Kerf 10" 60 86	
LUB9M010	Ultimate 10" 80 125	
TK206	10" Framing 24 38	
TK303	7-1/4" Finishing 40 27	
TK306	10" Finishing 40 27	
TK906	10" Combo 50 52	
SD306	6" Dado - Carbide.....	215 109
SD308	6" Dado - Carbide.....	229 119
F0	1-3/4" x 5/8" Biscuit 1000 Qty.....	32 27
F10	2-1/8" x 3/4" Biscuit 1000 Qty.....	32 27
F20	3-1/4" x 1" Biscuit 1000 Qty.....	34 29
FA	Assorted Biscuits 1000 Qty.....	34 29
FB100	16 piece Forstner Bit Set.....	331 165
94-100	5 pc. Router Bit Door System.....	319 159
J510	Biscuit Joiner with case.....	159 105
FT2000	3-1/4 HP Plunge Router.....	179 105
FT2000E	3-1/4 HP w/spd Plunge Router.....	410 209

MAKITA TOOLS		
Model	List Sale	
6070DW	3/8" v/spd Reverse Drill 7.2V.....	130 74
6071DW	above Drill w/removable batt.....	199 105
5090DW	3-3/8" Saw Kit 9.6 volt.....	256 137
6010DWK	3/8" cordless Drill Kit 7.2V.....	170 97
6010SDW	3/8" cordless Drill Kit 7.2V.....	99 59
343000DW	3/8" Angle Drill 7.2 volt.....	251 134
43900DW	9.6 cordless Recip Saw Kit.....	230 127

6012HDW	2 spd Drill w/clutch-comp.....	236 125
6092DW	var. spd Drill Kit complete.....	125 127
6093DW	w/spd Drill w/clutch-comp.....	261 135
6093DWL	6093DW Drill Kit w/Flash.....	299 165
6095DWE	6095DW Drill Kit w/2 batteries.....	270 139
632007-4	9.6 volt Battery.....	40 30
632002-4	7.2 volt Battery.....	40 28

5007NBA	7-1/4" Saw w/electric brake.....	238 127
5008NBA	8-1/4" Saw w/electric brake.....	295 158
B04510	1/4 sheet Pad Sander.....	93 54
9000B	3" x 21" Belt Sander w/bag.....	276 144
99240B	3" x 24" Belt Sander w/bag.....	293 159
9045N	1/2 sheet Fin. Sander w/bag.....	241 129
JR018B	Orb. var. speed Jig Saw 3.5A.....	289 139
39300V	var. speed Recip Saw w/cse.....	235 129
LI2102	10" Miter Saw 3.5 amp.....	560 295
9820-2	Blade Sharpener.....	387 195
19008W	3-3/4" Planer with case.....	217 114
11119	4-3/8" Planer 7.5 amp.....	255 139
1100	3-1/4" Planer with case.....	226 125
90275PC	7" Sander/Polisher.....	288 154
3601B	1-3/8 HP Router.....	256 139
B04550	1/4 sheet Pad Sander w/bag.....	89 57
DA3000T	3/8" Angle Drill.....	280 148
FD210M	3/4" var. spd Hmr Drill w/cse.....	300 165
2708W	8-1/4" Table Saw.....	509 265
2711	10" Table Saw with brake.....	651 289
1805B	6-1/8" Planer Kit with case.....	717 365
5005BA	5-1/2" Circular Saw.....	234 135
6404	3/8" Drill Rev. 0-2100 rpm.....	210 98
6151LVR	3/8" Drill Rev. 0-1050 rpm.....	149 83
6820V	0-4000 rpm Drywall Gun 5.2 A.....	169 90
6013BR	1/2" Drill Rev. 6 amp.....	256 139
5402A	16" Circular Saw 12 amp.....	662 345
3612BR	3 HP Plunge Router.....	377 165
9401	4" x 24" Belt Sander w/bag.....	337 175
4302C	var. speed Orbital Jig Saw.....	302 159
5077B	7-1/4" Hypoid Saw.....	255 138
LS1440	14" Miter Saw.....	744 435
LI1030	NEW 10" Miter Saw.....	420 225
5007NB	7-1/4" Circular Saw 13 amp.....	210 114
3612B	3 HP Plunge Router w/base.....	377 165
2012	12" Portable Planer.....	895 445
LI1011	10" Slide Compound Saw.....	842 455

DELTA TOOLS		
34-444	Table Saw Complete w/1-1/2 HP motor & stand	615.00
34-445-34-444	Table Saw complete w/30" Unifence and 32-010 EMS system	829.00

28-283 14"	Band Saw w/encloused stand and 50-274 mobile base	739.00
------------	---	--------

22-662 13"	Planer with 2 HP motor, stand, and 32-011 EMS system	1185.00
------------	--	---------

17-900 16-1/2"	Floor Drill Press	385.00
----------------	-------------------	--------

40-601 18"	Scroll Saw w/stand and blades	709.00
------------	-------------------------------	--------

BOSTITCH AIR NAILERS		
N80S-1	Stick Nailer Super Sale.....	389
N80C-1	Utility Coil Nailer.....	645 400
T36-50	Sheath & Decking Stapler.....	595 305
N12B-1	Coil Roofing Nailer.....	645 445
N60F-2	Finishing Nailer.....	625 355
C11	Brad Nailer.....	270 164
WC300	1 HP Pancake Compressor.....	445 295

SKIL SIZZLERS		
3810	10" Miter Saw.....	263 209
3810K	3810 w/60 tooth Carbide Blade.....	229 229
77	7-1/4" Worm Drive Saw.....	230 144
5825	6-1/2" Worm Drive Saw.....	255 159
2735-04	12 volt cordless Drill Kit.....	210 137
2735-04X	2735-04 w/keyless chuck.....	235 137
1605-02	NEW Biscuit Jointer w/cse.....	200 119
7584	NEW 5" Rndm Orbit Sander.....	160 104

PANASONIC CORDLESS		
EY6205BC	NEW variable speed 12 volt Drill w/15 minute charger & case.....	390 179
EY6200B	NEW 2 speed 12 volt Drill D-handle with 15 minute charger.....	350 178
EY6281BC	NEW variable speed 9.6 volt Drill w/15 minute charger.....	350 165
EY571B	var. speed 9.6 volt Drill Kit.....	239 128
EY571BC	EY571B with case.....	275 139
EY6270BCNEW	12 volt 1/2" Drill w/keyless chuck var. spd w/15 min. charger & case.....	421 215

LEIGH DOVETAIL JIGS	
D1258R-12	List 329.00-Sale 269.00
D1258R-24	List 399.00-Sale 325.00

LEIGH INSTRUCTIONAL VIDEO SALE		
MMTA 24	Mort. & Tenon attachment.....	299 175

HITACHI TOOLS		
C75B	7-1/4" Circular Saw.....	214 109
C7BD	7-1/4" Circular Saw with brake.....	230 129
M12V	NEW 3 HP var. speed Router.....	447 225
TR12	Plunge Router 3 HP.....	354 169
F1000A-12	Planer/6" Jointer.....	2835 1519
C12FA	10" Deluxe Miter Saw.....	538 269
C10FA	NEW 12" Miter Saw.....	632 295
C8FB	8-1/2" Slide Compound Saw.....	899 445
C12FD	NEW 12" Carb bld 4".....	68 43
C15FB	15" Miter Saw.....	745 375
FTUR	LUB5M015 15" c/bld 108 tooth.....	180 105

1992 TOOL CATALOG AVAILABLE
 Call Toll-Free 1-800-328-0457 In Minnesota Call (612)224-4859
 FAX: (612)224-8268
CHECK - MONEY ORDER - VISA - MASTERCARD - DISCOVER
SEVEN CORNERS ACE HDW. INC.
 216 West 7th St. • St. Paul, MN 55102 • Est. 1933

DELTA TOOLS		
34-444	Table Saw Complete w/1-1/2 HP motor & stand	615.00
34-445-34-444	Table Saw complete w/30" Unifence and 32-010 EMS system	829.00

28-283 14"	Band Saw w/encloused stand and 50-274 mobile base	739.00
------------	---	--------

22-662 13"	Planer with 2 HP motor, stand, and 32-011 EMS system	1185.00
------------	--	---------

17-900 16-1/2"	Floor Drill Press	385.00
----------------	-------------------	--------

40-601 18"	Scroll Saw w/stand and blades	709.00
------------	-------------------------------	--------

DELTA		
#34-080	10" Miter Saw	429.00
XTRA SPECIAL		198.00

TOOLS ON SALE™
 AMERICA'S LOWEST PRICED TOOLS
 FREE FREIGHT TO THE 48 CONTINENTAL STATES ON EVERY ITEM
 PRICES SUBJECT TO CHANGE WITHOUT NOTICE

PIRANHA By B & D CARBIDE TOOTH BLADE				
Model #	Dia.	Teeth	List	Sale
73-716	5-1/2	18	13.70	7.35
73-717	7-1/4	18	13.90	7.99
73-737	7-1/4	24	17.20	9.29
73-757	7-1/4	40	31.30	16.79
73-759	8-1/4	40	44.65	24.99
73-719	8-1/4	22	19.65	11.95
73-715	5-1/2	16	13.70	7.99
73-740	10	32	32.98	15.95
73-770	10	60	67.02	29.95
73-711	10	50	55.08	29.95

PORTA NAILER		
401	Porta Nailer complete.....	265 189
501	Face Nailer complete.....	265 189

We stock genuine Porta nails!

BAUER LADDERS		
30404	4 Fiberglass 300 lb rating.....	155 60
30405	5 Fiberglass 300 lb rating.....	174 70
30406	6 Fiberglass 300 lb rating.....	190 80

FINISHING TOUCHES

FRONT & CENTER
WOODWORKERS WHO MAKE A DIFFERENCE

Name:
Santa Cruz
Toymakers

Age:
60-70 years

Home:
Santa Cruz, California

Occupation:
Retired all

WOOD® connection:
Subscribers over the years

"Our loosely structured group of men and women meets for lunch once a month to bring in the toys we've made," explains Albert. "We then give all the items to one member to distribute to an agency of his or her choice."

According to Albert, the toy recipients are non-profit operations such as Headstart, county child abuse prevention centers, the Red Cross, and others. "We donate at least 200 toys a year," says Albert.

In recognition of the toymakers' efforts, the Aptos and Santa Cruz libraries display samples of the club's projects twice a year. "In the four years that we've been doing this, we've had the satisfaction of knowing that our work has delighted children all over our area," says Albert.



Santa Cruz Toymakers pose with their toys for needy kids. From left, Roy and Fran Hubbard, Jahn Jansen, Al Raboff, Warren Lawson, Stan Wolfberg, Bernadine and Jim Miller, and Bob Gilbert.

Once a month, Tiny's Family Restaurant in Santa Cruz, California, becomes a dispersing point for a dozen or two handcrafted toys. The toys represent the monthly production of the nine-member-strong Santa Cruz Toymakers, an informal woodworking group founded by Albert Raboff, a retired salesman.

You can contact the Santa Cruz Toymakers by dropping a line to: Albert Raboff, 275 Up Yonder Rd., Santa Cruz, CA 90756.

Do you know a subscriber who makes a difference? Send details to: Front and Center, WOOD magazine, P.O. Box 11454, Des Moines, IA 50336-1454.

FINISHING AT THE SANDBOX

Before sandpaper was developed in 1860, wood was often smoothed by fine sand under a piece of damp, soft leather.

CROWN TREES SET SAIL

In the century before American independence, England relied heavily on New World forests to outfit the Royal Navy. Their own forests nearly depleted, English shipbuilders and joiners looked to the colonies for hardwoods such as oak and hickory for ribs and planking, and softwoods, especially white pine, for masts.

In fact, Royal Tree viewers tramped the New England countryside, marking as royal property pines more than 2' in diameter. These were reserved for masts. And special ships resembling barges, each holding as many as 50 logs of 100' length, would carry them to England.

RIVER-BOTTOM TEAK RECOVERED

Rather than look to the forest for teak, Bob Steber explored a river. And this Lake Hiawatha, New Jersey, businessman found enough teak—and rosewood—to fill 200 semitrailer trucks.

Bob, president of Quality Woods Ltd. and an experienced Southeast Asia traveler, noted that teak and other logs rafted down Burma's Rangoon River often sank out of sight when tethers broke. He approached the Burmese (now called Myan-

mar) government in 1989 with a recovery plan.

Utilizing sonar equipment and native divers, Steber's team salvaged 2,000 teak logs and 500 rosewood logs—many of which had been submerged for 50 years—from the Rangoon. Bob has turned the wood into lumber and flooring, which he markets from his stateside headquarters (Quality Woods Ltd., P.O. Box 205, Lake Hiawatha, New Jersey 07034). ♣

▶ With sonar equipment, search teams looked for logs on the river bottom. Then, native divers went down and secured them.

▼ Workers survey rescued logs on the banks of the Rangoon River in Burma. The total haul: 2,000 teak logs and 500 rosewood logs.



Illustration: Jim Stevenson

THROUGH THICK AND THIN.

Mill your own rough-sawn boards to the thickness *you* desire. Be free to really design your work, instead of being at the mercy of pre-dimensioned lumber.

We've taken what we've learned about thickness planing in professional shops over the years and scaled it to the home-shop. Hefty enough to handle large stock. Yet compact enough to tuck away when you're not using it.

Like all of our tools, it's built to become a loyal member of your "shop staff" through thick and thin.

You'll find Delta quality shop tools at your local Delta machinery dealer or at leading home center and hardware stores.

Call toll free and we'll give you the name of the store nearest you. Delta International Machinery Corp., 800-438-2486. In Canada, call: 519-836-2840.

The new Delta 12" Portable Planer. Features a stationary, stainless steel table for smooth feeding, and extension tables for ample work support. A top-mounted control handle raises and lowers cutterhead for easy, precision adjustment.



Two-knife cutterhead makes 16,000 cuts/minute to assure a perfectly smooth finish. Surfaces stock from 1/8" to 6" thick, up to 12" wide, with absolute accuracy.

Cutterhead and feed assembly effortlessly ride up and down on four precision-ground steel columns. This adds stability and eliminates motor vibration. Feed rate automatically adjusts itself. Stationary table means infeed and outfeed levels stay put.



Move it to wherever you're working. Or move it into storage when it's not in use. Features built-in handles and removable table extensions.



**Building
On Tradition**
DELTA
A Pentair Company

NOW! PLANE, MOLD, SAND and SAW with



Infinitely Variable Power-Feed!

MAKES YOU MONEY... SAVES YOU MONEY!

Put this versatile power-feed tool to work in your shop... see how fast it pays for itself! Quickly converts low-cost rough lumber into valuable finished stock. Turns out perfect picture frame moldings, quarter-round, casing, tongue and groove... all popular patterns... any custom design.

✓ **Just a twist of the dial** puts twice as many cuts-per-inch at your fingertips as any comparable planer — from 70 to over 1,000 CPI! This heavy-duty machine will sail through even the toughest oak at higher speeds, or you can slow it down to handle those “hard-to-work” pieces like curly maple, knotty cedar, burls, knees and much more! A valuable feature for molding work, where profiles make sanding impossible.

✓ **Change to Molding, Sanding or Sawing in just minutes!** Unique “Morse-Taper” Quick Change Cutterhead guarantees fast changeover... bearings remain factory set... precisely aligned at all times.

✓ **Now choose from three powerful models!** Woodmaster introduces the first 18" and 25" Planer/Molders... with all the features that have made the 12" model the most versatile Planer/Molder on the market! Send for Free Facts today!

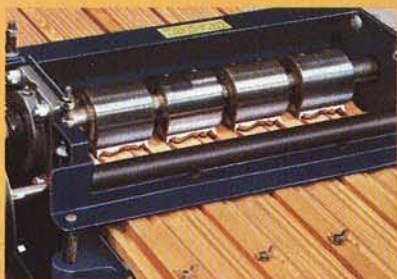

Woodmaster's Quick-Change Molding Head lets you create custom moldings from any stock. Choose from over 250 standard trim and picture frame patterns... or design your own!



Power-fed sanding speeds production and improves the quality of your work. No more waves or cross-grain scratches. Separate sanding head installs in just minutes.



New rip saw attachment lets you gang-rip with power feed in a fraction of the time it takes for multiple hand-fed passes on an ordinary table saw.

**MAIL TODAY OR CALL
1-800-821-6651 Ext PW52**



YES! Please rush my **FREE** Information Kit
Woodmaster Tools, Dept. PW52, 2908 Oak, Kansas City, MO 64108

NAME _____

ADDRESS _____

CITY _____

STATE _____ ZIP _____

PHONE () _____

Here's What Woodmaster Owners Say:

Shop Test Results—“It does an excellent job of planing, on a par with more expensive machines, and even better than some commercial models!”

Editor, Workbench Magazine

Best Value—“After checking them all, Woodmaster was obviously the best deal for the money. Also, I would like to acknowledge the polite and prompt service!”

E. D. Holtz, North Carolina