

Better Homes and Gardens®

WOOD®

THE #1 MAGAZINE FOR HOME WOODWORKERS

FEBRUARY 1992 • ISSUE NO. 50
Please display until February 11

**WOOD TESTS 20
POWER MITERSAWS**

CARVING

**LEARN CHIP CARVING
FROM A PRO**

**MORE GREAT
PROJECTS!**

Toy wrecker

Bandsawed whale

Old-West birdhouse

**Chip-carved
weather station**

Valentine cutout

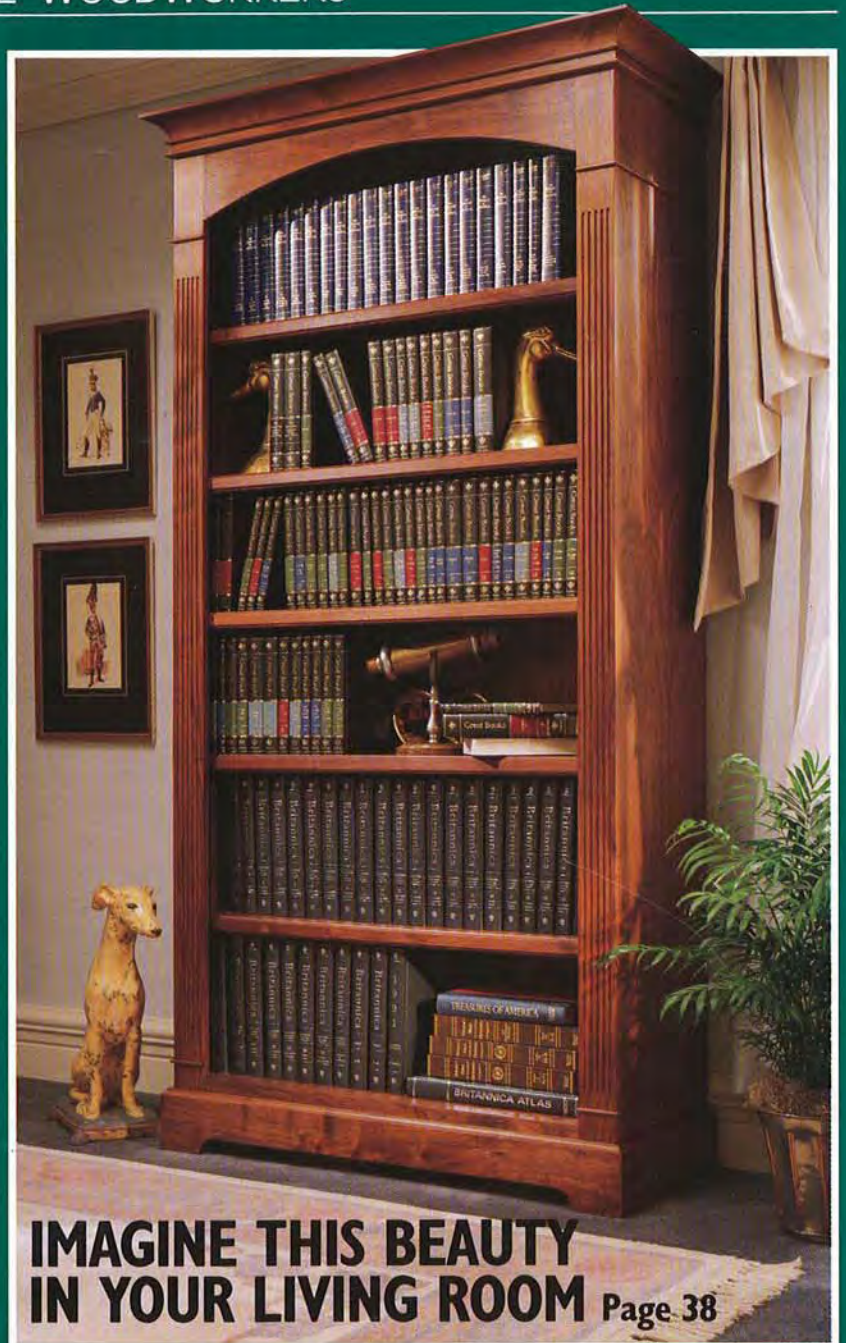

**IMAGINE THIS BEAUTY
IN YOUR LIVING ROOM** Page 38





IMPORTS, INC.

"IMPORTERS OF FINE MACHINERY"

**LOOK
PRICES HELD
FOR 1992!**



**10" HEAVY DUTY
TABLE SAW
MODEL G1022**

Reg. \$365. **SALE \$355⁰⁰**
F.O.B. BELLINGHAM, WA or WILLIAMSPORT, PA



**SUPER HEAVY DUTY
TABLE SAW
MODEL G1023**

ONLY \$895⁰⁰
F.O.B. BELLINGHAM, WA or WILLIAMSPORT, PA



**16" BAND SAW
MODEL G1538**

ONLY \$525⁰⁰
F.O.B. BELLINGHAM, WA or WILLIAMSPORT, PA



**2 H.P. DUST
COLLECTOR
MODEL G1029**

ONLY \$295⁰⁰
F.O.B. BELLINGHAM, WA or WILLIAMSPORT, PA



**1 1/2 H.P. SHAPER
MODEL G1035**

ONLY \$495⁰⁰
F.O.B. BELLINGHAM, WA or WILLIAMSPORT, PA



**3 H.P.
SHAPER
MODEL G1026**

ONLY \$850⁰⁰
F.O.B. BELLINGHAM, WA or WILLIAMSPORT, PA



**6" x 47" HEAVY DUTY
JOINTER
MODEL G1182**

Reg. \$375. **SALE \$345⁰⁰**
F.O.B. BELLINGHAM, WA or WILLIAMSPORT, PA



**8" x 65" SUPER
HEAVY DUTY JOINTER
MODEL G1018**

Reg. \$695. **SALE \$650⁰⁰**
F.O.B. BELLINGHAM, WA or WILLIAMSPORT, PA



**12" PLANER
MODEL G1017**

ONLY \$385⁰⁰
F.O.B. BELLINGHAM, WA or WILLIAMSPORT, PA



(Stand
Optional)

**15" PLANER
MODEL G1021**

ONLY \$735⁰⁰
F.O.B. BELLINGHAM, WA or WILLIAMSPORT, PA



**20" PLANER
MODEL G1033**

ONLY \$1,295⁰⁰
F.O.B. BELLINGHAM, WA or WILLIAMSPORT, PA



**6" x 48" COMB.
SANDER
MODEL G1014**

ONLY \$195⁰⁰
F.O.B. BELLINGHAM, WA or WILLIAMSPORT, PA



If you live **WEST** of the Mississippi:

1-800-541-5537 ORDERS
(206) 647-0801 CUSTOMER SERVICE
P.O. BOX 2069
BELLINGHAM, WA 98227



**CALL FOR YOUR
FREE CATALOG!**

92-103

If you live **EAST** of the Mississippi:

1-800-523-4777 ORDERS
(717) 326-3806 CUSTOMER SERVICE
2406 REACH RD.
WILLIAMSPORT, PA 17701



THE EDITOR'S ANGLE

OUR ART DIRECTOR, YES... AND ONE HECK OF A WOODWORKER, TOO!

I often have used this space to write about the woodworking exploits of various *WOOD* magazine staffers. But you haven't read much about Lee Gatzke, our art director. Lots of readers have told us how well they like the look of our magazine, and Lee can take

much of the credit for that. He and Assistant Art Director Perry McFarlin have done wonders making *WOOD* magazine as exciting graphically as it is editorially.

Lee also is one heck of a woodworker. He does have a bit of an advantage on most of us, though. Trained as a commercial artist, he can visualize a project and get it down on paper in a hurry. And being a designer, the projects he cooks up look great, too.

Lee seems to especially enjoy designing and making turning projects. (Keep your eye out for his music box and potpourri bowl in upcoming issues.) But he builds lots of other pieces as well for use around his house. The oak entertainment center shown here is a good example of his special talents. Beautiful, don't you think?

Like many of us, Lee always has a project of some kind going. In the case of the entertainment center, he long had been wanting to buy a modular stereo system to enjoy with his wife, Nancy. But since the only place available in his family room to store the gear was a corner, coming up with the right design proved tricky. "Everything worked out just like I wanted it to, though," Lee reports. "And best of all, Nancy loves it."

Now, there's a woodworker who knows how to keep the peace at home. Nice going, Lee! ♣

Larry Clayton

Photograph: Lee Gatzke

EDITORIAL MAILING ADDRESS: *WOOD* magazine, P.O. Box 11454, Des Moines, IA 50336-1454. **WE CARE!**
SUBSCRIPTION SERVICE (including change of address): *WOOD* Customer Service, P.O. Box 10628, Des Moines, IA 50336-0628. Please enclose your address label from a current issue. If you wish, call toll-free 800/374-9663.
CUSTOMER-SERVICE TEAM: Marjane Cline, Velma Williams, Tom Ackert, Andrea Gilbert.

FREE CATALOG

Send today for your **FREE** copy of our 72 page full-color catalog. You'll find the best prices for over 3,000 brand-name products. Included are power tools and accessories, hand tools, screws, hardware, wood components, plans, how-to books, and much more.

Trend-lines®

Discount Woodworking Tools and Supplies

To order your **FREE** catalog, just fill out the coupon below and mail it to:

Trend-lines
Dept. WD22
375 Beacham St.
Chelsea, MA 02150



Name _____
Address _____
City _____
State _____ Zip _____
DEPT. WD22



QUILT RACK PLAN

Display your favorite quilt in style and keep it wrinkle-free with this country-style quilt rack. It's easy to make from 3/4" pine. Plans drawn **FULL SIZE** for easy transfer to wood. Measures approximately 32" long x 31" high x 14" deep. Order hardware parts below.
#W738 Country Quilt Rack Plan..... **\$6.99/EA**

Hardware Parts

This package contains 14 white birch spindles and 20 birch screw-hole buttons. Project plan, wood and paint are not included.
#9862 Country Quilt Rack Hardware Parts
..... **\$18.99/PKG**

HOW TO ORDER: List quantity, part number, item, price & total of order. Include \$4.95 shipping & handling per order. MN residents add 6.5% sales tax. Mail check or money order. Credit card customers call TOLL FREE 1-800-441-9870.

MEISEL HARDWARE SPECIALTIES
P.O. BOX 70 W 2 MOUND, MN 55364

ENERGY-SAVING
SUN-PORCH™

CONVERTIBLE SUNSPACE

More value for less money!

**INSULATED
WINTER SUN SPACE CONVERTS
TO A SUMMER SCREEN ROOM!**



**MOUNTS
READILY ON
DECKS, PATIOS,
OR LANDSCAPE
TIES**

- Choice of stunning Opal White or Bronze-Tint glazings on white or bronze framework
- QWIK™ window/screen change system
- Do-it-yourself assembly
- America's #1 value.

**Send \$2 for Color Catalogues, Prices,
SENT FIRST CLASS MAIL.**

Dealer Inquiries Welcome



VEGETABLE FACTORY, INC.
P.O. Box 1353, Dept. WOO
Stamford, CT 06904-1353

GREAT ENCOURAGEMENT FOR SHIPWRIGHTS!

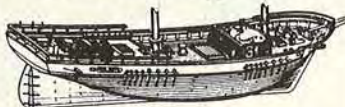

All gentlemen shipwrights and able-bodied modelists who have a mind to provide for themselves amusement and satisfaction through the traditional craft of ship modeling, an opportunity now offers to acquire, through the minimal cost of one Colonial Dollar (\$1.00), a catalogue of fine and unique ship model kits, plans, books and fittings from the renowned company of Model Shipways located in Mt. Pocono, in the state of Pennsylvania.

MAIL THIS COUPON TODAY!

Send \$1.00 for a catalog to:

MODEL EXPO, INC., Dept. WD22
PO Box 1000, Mt. Pocono, PA 18344

Name _____

Address _____

City _____

State _____

Zip _____

Better Homes and Gardens.

WOOD®

THE #1 MAGAZINE FOR HOME WOODWORKERS

This issue's cover wood grain: cottonwood

Cover photo: Wm. Hopkins

FEBRUARY 1992

ISSUE NO. 50

CRAFTSMAN CLOSE-UP

Meet the master illusionist of relief carving 33

Just imagine being able to make a 1¼"-thick carving look three-dimensional! One-of-a-kind carver Rick Harney knows how to, and he's ready to tell all.



Shelving showcase 38

Give your old classics or prized book sets pleasing display with this stately walnut bookcase. It features a traditional fluted face frame, a richly molded top, and six roomy shelves.



CARVING

Decorative carving, Swiss-style 44

Learn the basics of chip-carving from expert Wayne Barton, and then, using only two knives, try your hand making his beautifully ornate weather-station design.

TOOL BUYMANSHIP Power mitersaws 48

These mighty crosscutters offer accuracy and portability, and chances are good that you can find one that suits your wallet. Here's the lowdown on over two dozen models.



Custom mitersaw cabinet 56

Outfit your power mitersaw with this long-armed work station. It features a mobile scrap bin, trusty table extensions, and a stopblock.

Logging along the mighty Mississippi 62

Travel to the banks of the Big Muddy with us for a visit with the ecology-minded Anderson-Tully Company, a major producer of quality North American hardwoods.



SANDBOX SERIES

Rough 'n' ready wrecker 68

With this tough, on-call, little tow truck, your youngster can pull a disabled toy vehicle quickly and easily to the nearest service station. See the plans inside.



TURNING

Green-wood turning 72

If you think of woodturning as a showdown against a hard, dry, unyielding chunk of wood, dip your gouge into some tree-fresh stock.



THE CRAFT SHOP

Short-Branch Saloon 76

This spring, welcome back the neighborhood wrens by building our decorator frontier-style birdhouse. They'll whoop it up when they see it.

Be mine, valentine 78

On February 14, rekindle romance in your life by surprising your sweetheart with this charming scrollsawed memento.

Save a whale 80

You don't need a shore home to display this nostalgic nautical decoration. But you will have a whale of a good time making and painting it.

SHORT-SUBJECT FEATURES

Editor's Angle	1	Products That Perform	27
Talking Back	5	Yesterday's Tools	31
Great Ideas For Your Shop	9	TV Retrofit	82
Kids On Parade	10	Ask WOOD®	90
Tips From Your Shop	14	Finishing Touches	96

Mobile Machine Bases

to put your entire shop on wheels

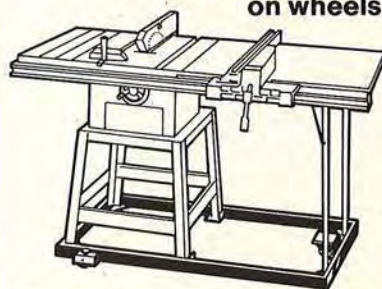

EXPANDS YOUR WORKING AREA
MAKES CLEAN-UP A SNAP

- Over 1000 models to choose from
- Designed for correct machine fit
- Constant 3-wheel suspension insures tool stability
- Dual wheel locks for positive positioning
- No lifting needed to move or dropping to use
- Protects machine settings and components
- All steel and precision welded
- Lifetime warranty

Work Supports

to do your best safely and accurately

Model HRT-18



UNIQUE TAPERED WEDGE ELIMINATES SLIP DOWN. TESTED TO 1000 lbs.

44"-26½" height range

Adjustable levelling feet

HEAVY DUTY

DESIGNED TO HELP YOU SUPPORT AND SAFELY MOVE WORK PIECES THRU YOUR MACHINES

- No tools needed for simple, positive height adjustments
- Top quality, galvanized, ball-bearing rollers
- 4 heavy duty threaded rubber-tipped levelling feet.
- Heavy gauge steel components
- Lifetime warranty

Available at better tool stores



FREE CATALOG



HTC Products, Inc.
120 E. Hudson • P.O. Box 839
Royal Oak, Michigan 48068-0839

1-800-624-2027

AMAZING PRICE BREAKTHROUGHS!

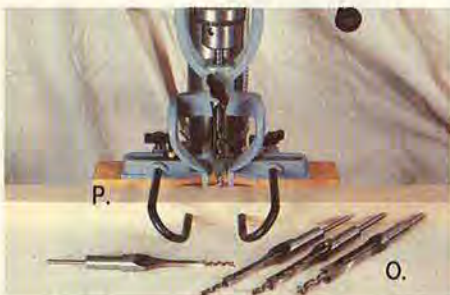
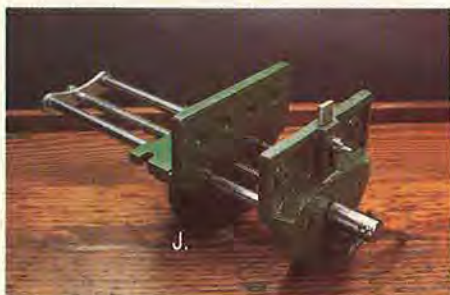
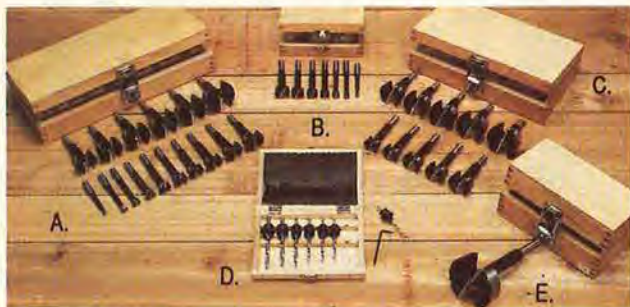

A. 16 pc. Forstner Bit Set #77581 \$87.95

All bits 3 1/2" overall, precision ground, HRC 50-52. Sizes 1/4" through 2 1/8" in wooden case. All 3/8" shanks. Sizes over 1 1/2" supplied with saw teeth to eliminate overheating.

B. 7 pc. Forstner Bit Set #77571 \$27.95

All bits 3 1/2" overall, precision ground, HRC 50-52. Sizes 1/4" through 1" in wooden case.

C. 10 pc. Forstner Bit Set #53982 \$74.95

All bits 3 1/2" overall, precision ground, HRC 50-52. Sizes 1", 1 1/8", 1 1/4", 1 3/8", 1 1/2", 1 5/8", 1 3/4", 1 7/8", 2", 2 1/8" in handsome wooden case. All bits with saw teeth for faster heat-free drilling!

D. 22 pc. HSS Tapered Drill, Countersink/Bore, Stop Collar Set #12232 \$26.95

For screw sizes #s 5, 6, 7, 8, 9, 10, 12. Wood case included.

E. Jumbo Forstner Bits #18302 \$139.95

8 pc. Set includes E-2/4 - 3/4 all with saw teeth.
 2 1/4" Bit #18232 \$21.95 2 3/4" Bit #18272 \$27.95
 2 3/8" Bit #18242 \$22.95 2 7/8" Bit #18282 \$31.95
 2 1/2" Bit #18252 \$24.50 3" Bit #77591 \$33.99
 2 5/8" Bit #18262 \$25.50 3 1/8" Bit #18292 \$35.95

F. Classic Bench Hold-down #54012 \$6.95

Tap on top secures your work, tap at the back releases it. Great for any workbench top.

G. Special Anti-Kickback Device #50179 \$31.95

Tablesaw Anti-Kickback #50179 \$31.95
 Radial Anti-Kickback #74131 \$31.95
 Shaper Anti-Kickback #74141 \$31.95
 Optional 2 pc. Aluminum Track #74201 \$10.95

H. Anti-Kickback Featherboard & Hold Down #29402 \$11.95

Featherboard fits into miter gauge slot of your tablesaw and locks into position. Also prevents material from raising off the blade.

I. Safety Push Block #54032 \$3.95

Sure grip 3" x 5" pad. Helps keep hands away from planer, jointer or tablesaw blades.

J. Quick Release, Large Capacity Bench Vise #54002 \$37.95

Heavy cast iron construction with built-in steel bench dog. Jaws are 7" wide and predrilled for adding wooden faces. Opens to 11" and mounts to a 2 5/8" or thinner section of your bench.

K. 5 pc. Jumbo Bradpoint Drill Set #54992 \$18.95

Comes in sizes 9/16", 5/8", 7/8" & 1". All with 3/8" shanks.

L. 7 pc. Carbide Tipped Bradpoint Drill Set #53992 \$31.95

Creates clean entry holes with no overheating. Sizes 1/8", 3/16", 1/4", 5/16", 7/16", & 1/2". Wooden case included.

M. 25 pc. Bradpoint Drill Set #77611 \$17.95

Fits any 3/8" or larger chuck. Free metal index.

N. 7 pc. Stop Collar Set #93361 \$4.95

O. 4 pc. Mortise & Chisel Set #54022 \$39.95

Comes with sizes 1/4", 5/16", 3/8" & 1/2". Standard 5/8" shank fits most brand's mortise attachment.

P. Mortise Attachment #64202 \$24.95

Fits all major brands and imports including Jet, Grizzly and Delta. For 5/8" shank, chisels and bits.

Better Homes and Gardens® WOOD®

THE #1 MAGAZINE FOR HOME WOODWORKERS

February 1992 • Vol. 9, No. 2 • Issue No. 50

Editorial/Art Staff

Editor **LARRY CLAYTON**
 Managing Editor **JIM HARROLD**
 Art Director **C. L. GATZKE**
 Assistant Art Director **PERRY A. McFARLIN**
 Graphic Designer **CHERYL A. CIBULA**
 Design Editor **JAMES R. DOWNING**
 Senior Editor **PETER J. STEPHANO**
 How-To Editor **MARLEN KEMMET**
 Products/Techniques Editor **BILL KRIER**
 Special-Interest Editor **LARRY JOHNSTON**
 Copy/Production Editor **JOHN D. HOFHEIMER**
 Project Builder **JAMES E. BOELLING**
 Administrative Assistant **DARLENE REYNOLDS**
 Business Office Clerk **MARGARET CLOSNOR**
 Secretary **ROSEMARIE BURCH**

Technical Consultants: Product Testing **GEORGE GRANSETH, BOB McFARLIN**; Products That Perform **STEVE OSWALT**; Wood Science **PAUL McCLURE**; Carving **HARLEY REFSAL**

Publisher **WILLIAM R. REED**
 Advertising Director **CHRIS W. SCHRAFT**
 Advertising Representatives **CRAIG KAPLAN, BRENDEN DELANEY, ANDREA CHERNUK**
 Promotion/Research Director **EILEEN SULLIVAN**
 Advertising/Marketing Services Manager **SIGRID FOLKERS**
 Publisher's Assistant **NANCY LOPEZ**
 Advertising Assistant **KIMBERLY DAVIS**
ADVERTISING OFFICES: 750 Third Ave., New York, NY 10017. Phone 212/551-6903.

Circulation Manager **ALAN BRUSH**
 Newsstand Circulation Director **MICHAEL SENIOR**
 Business Manager **TERRY UNSWORTH**
 Production Director **ROBERT C. FURSTENAU**
 Public Relations **SONDY DAGGETT**

Magazine Group Officers

Group President **WILLIAM T. KERR**
 SVP, Publishing Director **ADOLPH AUERBACHER**
 SVP, Editorial Director **DORIS EBY**
 SVP, Operations **DEAN PIETERS**
 Group VPs: Publishing Directors **MYRNA BLYTH, BURTON H. BOERSMA, CHRISTOPHER M. LEHMAN**
 Group VP, Circulation Director **CLEM SEVDE**
 Controller **MAX RUNCIMAN**

Corporate Officers

Chairman of Executive Committee **E.T. MEREDITH III**
 Chairman of the Board **ROBERT A. BURNETT**
 President and Chief Executive Officer **JACK D. REHM**
 Executive Vice President **WILLIAM T. KERR**
 Group Presidents: Broadcasting **PHILIP A. JONES**;
 Magazine **WILLIAM T. KERR**; Real Estate **ALLEN SABBAG**

Better Homes and Gardens® WOOD® (ISSN-0743-894X) is published nine times a year in January, February, April, June, August, September, October, November, and December by Meredith Corporation, 1716 Locust St., Des Moines, IA 50309-3023. Second-class postage paid at Des Moines, Iowa, and at additional mailing offices. Better Homes and Gardens trademark registered in Canada and Australia. Marca Registrada en México. ONE-YEAR SUBSCRIPTION PRICES: U.S. and its possessions, \$24.97; Canada, \$34; other countries, \$38. POSTMASTER: Send address changes to Better Homes and Gardens WOOD, Box 10628, Des Moines, IA 50336-0628. ©COPYRIGHT MEREDITH CORPORATION 1992. ALL RIGHTS RESERVED. PRINTED IN U.S.A. Canadian GST Reg. #R123482887.

NPA

In Ohio, please add 6% Sales Tax. Minimum order \$18.95. All orders add \$4.00 shipping/handling charge.

1-800-345-2396

940 W. Maple St., Hartville, Ohio 44632
 Offer available in 48 continental states only.



TALKING BACK

We welcome comments, criticisms, suggestions, and even compliments. Send your correspondence to: Talking Back, Better Homes and Gardens® WOOD® magazine, P.O. Box 11454, Des Moines, IA 50336-1454.

Reader modifies calendar/clock plan

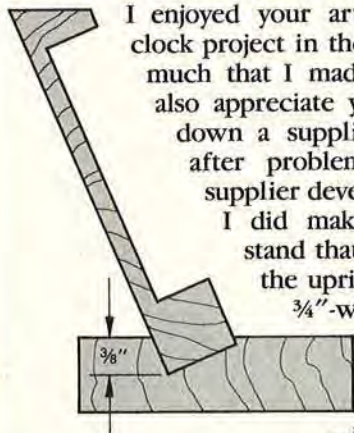

I enjoyed your article on the calendar/clock project in the August 1991 issue so much that I made three of the units. I also appreciate your effort in tracking down a supplier for the mechanism after problems with the original supplier developed.

I did make one change in the stand that made it easier to glue the upright to the base. I cut a $\frac{3}{8}$ "-wide dado in the base at a 65° angle, and left the bottom of the upright square.

—Bill Alven, Philadelphia, Pa.

For any of you who missed the substitute source for the electronic calendar/clock mechanism, you can order one for \$19.95 ppd. from New Products, 15 West Street, Spring Valley, NY 10977. Identify it as the calendar/clock for the WOOD magazine project. Sorry, no telephone orders.

Garrett Wade also carries Eakes' book

I just wanted to respond to a couple of things in your October 1991 issue. Jon Eakes' book *Fine Tuning Your Radial-Arm Saw* is available from our catalog (ask for item No. 96L05.02) for \$14.50 ppd. Also, concerning your article on slow-set epoxy, when I want a slow-set waterproof structural adhesive, I prefer phenol-resorcinol, a time-tested product with a working time of up to 3 hours.

—Henry Lanz for Garrett Wade Company, Inc.

Fine Tuning Your Radial-Arm Saw, by Jon Eakes, Catalog No. 96L05.02, \$14.50 ppd. from Garrett Wade, 161 Avenue of the Americas, New York, NY 10013-1299; phone 800/221-2942.

Put your music in a box, but not for a song

In response to Nancy Learn Peckham's request in the Ask WOOD column in the September 1991 issue for information on custom-made music box movements: I can provide this service, for tunes as long as 35 seconds. I need the sheet music and a cassette recording of the piece on piano. The cost is roughly \$1,500, and takes about one month. Write me, Frank Borges Clock Repair, 35 Forest St., Waterford, CT 06385, or call 203/440-3000.

—Frank Borges, Waterford, Conn.

Continued on page 6

STEVE WALL LUMBER CO.

Quality Hardwoods and Woodworking Machinery For The Craftsmen and Educational Institutions

Ash	4/4	Select	1.90	UPS	\$59.00
Basswood	4/4	Select	1.30	Special	\$47.00
Birch	4/4	Select	1.60		\$53.00
Butternut	4/4	Log Run	1.40		\$68.00
Cherry	4/4	Select	2.45		\$49.00
Cypress	4/4	Select	1.60		\$47.00
Hickory	4/4	Select	1.50		\$73.00
Mahogany (Genuine)	4/4	Select	2.70		\$52.00
Maple (Hard)	4/4	Select	1.55		\$46.00
Maple (Soft)	4/4	Select	1.30		\$47.00
Pecan	4/4	Select	1.50		\$45.00
Poplar	4/4	Select	1.20		\$57.00
White OR Red Oak	4/4	Select	1.80		\$71.00
Walnut	4/4	Select	2.50		\$48.00
Cedar (Aromatic Red)	4/4	1C+Btr.	1.35		\$37.00
White Pine	4/4	FG.	.85		\$45.00
Yellow Pine	4/4	Clear	1.20		

Above prices are for 100' quantities of kilndried rough lumber sold by the Bd. Ft. FOB Mayodan, NC. Call for quantity discounts. Other sizes and grades available.

Above prices are 20 bd. ft. bundles of clear kilndried lumber 3"-10" wide - 3'-7" long (Random widths & lengths) Surfaced 2 sides or rough. Delivered UPS prepaid in the Continental U.S.

LUMBER SPECIALS

CHERRY 100 Bd. Ft. Bundle Log Run S2S 13/16 \$ 90*
WALNUT 100 Bd. Ft. Bundle #1 Common 4/4 \$ 110*
 *FOB Mayodan - Motor Freight Only

Call For Best Prices On *MiniMax*

STEVE H. WALL LUMBER CO.

BOX 287 · MAYODAN, N.C. 27027

919-427-0637 · 1-800-633-4062 · FAX 919-427-7588

Send \$1.00 For Lumber and Machinery Catalog

BUILDING OUR NAME...

BUILDING YOUR DREAMS...



WIDE BELT SANDER

CT-2575 24" \$4290
 CT-3775 36" \$5390

SHAPER

SP-3400 15 HP. \$469
 SK-30SPA 3 HP. \$849
 SP-34T TILTING. \$1695

TABLE SAW

HTS0012 12" \$789
 TS-1010 10" \$1295
 TS-1414 14" \$2690

BAND SAW

BS-1316 16" \$299
 BS-0163 16" \$499
 BS-0183 18" \$649
 BS-0202 20" \$1290

JOINTER

JT-1007 7" \$309
 JT-1008 8" \$639
 JT-0012 12" \$1895

WE SPECIALIZE IN CUSTOMER SATISFACTION



9034 Bermudez Street,
 Pico Rivera CA 90660
 MAIN OFFICE:(213)949-3747
 ATLANTA:(404) 416-6006
 (800)786-5626 (order only)

LEBO POWER TOOLS

FREE
Clockmaking
Catalog



It's 60 exciting new pages of clockmaking and wood projects.

- Clock Kits • Wood Models, Whirligigs
- American-made Quartz Movements • Mechanicals • Wood Plans, Parts
- Dials, Hands, Numerals •

At great low prices! Send for your **FREE** catalog today.

Name _____

Address _____

City, State, Zip _____

Or call Toll-Free 1-800-556-2548
and mention Dept. WD22.

KLOCKIT™

P.O. Box 542, Dept. WD22
Lake Geneva, WI 53147

The Ultimate Woodworking Tool.



The Woodworkers' Store
New! 1991-92 Catalog
Over 150 new, hard-to-find items!

Yes! Send me the next four issues of The Woodworkers' Store catalog for only \$2/year.

Name _____

Address _____

City _____

State _____

Zip _____

The Woodworkers' Store

Dept. 13117
21801 Industrial Blvd.
Rogers, MN 55374
Credit card orders
(612) 428-2199

TALKING BACK

Continued from page 5

Wiring diagram correction corrected

In the June 1991 issue, we published an incorrect wiring diagram for a remote dust-collector switch. In September 1991, we printed in this column a "correction" based on a schematic drawn for us by a certified electrician. Again, we weren't entirely correct. So now we have had the remote switch reengineered by electrical consultant Ron Tesdell and verified by the service department of Puckett Electric Tool, Inc.

The drawing is for conduit installation instead of flexible cable. That's because we don't know whether the installation you have in mind will be surface mounted or in a wall. We have included Ron's materials list for both 120-volt and 240-volt service. The list calls for parts by brand name, but you can ask your supplier for equivalent parts. The parts and diagrams also are suitable for 110-volt and 220-volt installations.

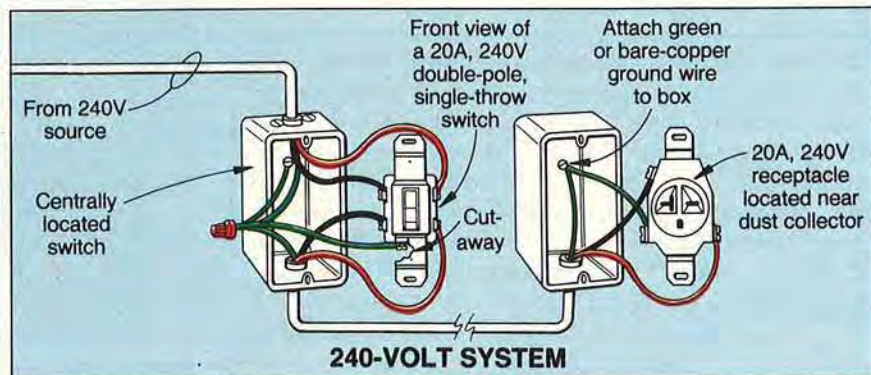
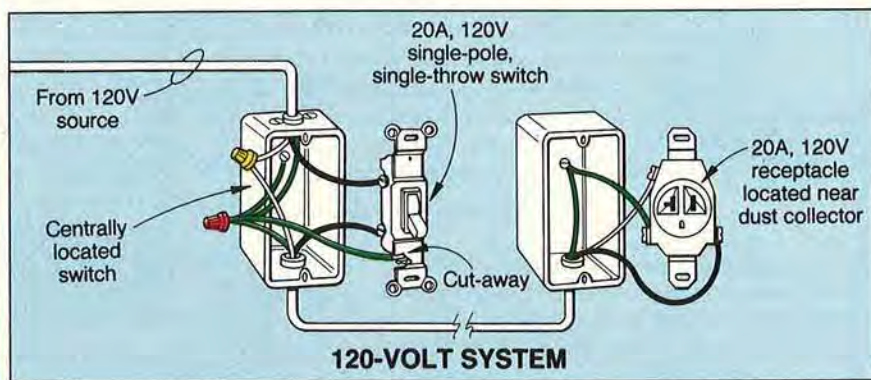

120-volt system switch materials list

- P&S 20-amp SPST switch 20AC1
- P&S 5351 20-amp 120V receptacle, NEMA 5-20R
- RACO 660 Handy Box
- RACO 865 Handy Box Switch Cover
- RACO 863 Handy Box Receptacle Cover
- #12 THHN Black Solid Wire
- #12 THHN White Solid Wire
- #12 THHN Green Solid Wire
- Conduit, 1/2" EMT, with appropriate fittings
- IDEAL wire connectors, yellow and red
- RACO 973 Ground Screws

240-volt system switch materials list

- P&S 20-amp DPST switch 20AC2-hp
- P&S 5851 20-amp 250V receptacle, NEMA 620R
- RACO 660 Handy Box
- RACO 865 Switch Cover
- RACO 863 Handy Box Receptacle Cover
- #12 THHN Red Solid Wire
- #12 THHN Black Solid Wire
- #12 THHN Green Solid Wire
- Conduit, 1/2" EMT, with appropriate fittings
- IDEAL wire connectors, red
- RACO 973 Ground Screws

rbi industries, Inc.

Woodworking Tools & Accessories

The
American
Toolmaker

To Order
1-800-487-2623
Or Fax: 816-884-2463
Call Toll-Free

Do the job right and with the right tool.

Whether you are a new or experienced woodworker . . . a hobbyist or pro . . . the precision tools from rbi industries make it fast, easy and fun for the entire family to produce hundreds of projects.

All rbi products are made here in America to meet world-class standards. That's why we have a 30 Day Trial Offer and an incredible 3 YEAR Warranty!

Turn your hobby and spare time into extra cash.

The HAWK Precision Scroll Saw and The 4-in-1 Woodplaner have been the beginning of many craft related businesses.



Think of all you'll make with these versatile tools.

- gingerbread cutouts
- shelf bracket & trim
- puzzles
- picture frames
- jewelry boxes
- decorative custom molding
- wooden nameplates
- curios
- decorative folk art
- shadow boxes
- dimensioned wood
- yard ornaments
- items for tole painting
- Christmas ornaments
- inlays
- marquetry
- wood joints
- templates
- stack cutting
- tongue in groove flooring
- patterns
- toys
- handcrafted gifts
- plaques
- cabinet doors
- stained glass gifts
- plus much more...

MEET THE **rbi** FAMILY OF TOOLS & ACCESSORIES

- THE PANELMASTER
- THE 4-IN-1 WOODPLANER
- THE ROUTER MATES
- ROLLER STANDS
- THE HAWK PRECISION SCROLL SAW

and much, much, more . . .



rbi industries, *The American Toolmaker*

1801 Vine Street • P.O. Box 369
Harrisonville, MO 64701

**QUALITY
SINCE
1929**

As Featured in Wood Products Guide!

MLCS, Ltd.

1/4" or 1/2" Shank Carbide-Tipped Router Bit Molding Plane Profiles



SPECIAL OFFER:
Set of all four bits
only \$99.95

Set of four
quickly produces classic
traditional mouldings
2 flute carbide tips

Order by
VISA • MasterCard • Discover
7 Day / 24 Hour Service,
Call 1-800-533-9298
or send check to: MLCS, Ltd.,
P.O. Box 4053 DT
Rydal, PA 19046

WOOD PARTS FROM MIDWEST DOWEL WORKS

Compare Our Low Prices!

	Qty.	Cost
3-1/2" Poplar Shaker Peg	\$15/100	—
1-3/4" Mini Shaker Peg	\$7/100	—
3-1/2" Country Wall / Mug Peg	\$15/100	—
2-1/2" Country Shorty Peg	\$12/100	—
Large Bean Pot Candle Cup	\$17/100	—
Brass Inserts	\$9/100	—
1/2" Mini Candle Cup	\$10/100	—
1-1/2" Toy Wheel	\$10/100	—
2" Toy Wheel	\$17/100	—
Axel Pegs	\$4/100	—

SMOOTH SANDED HEARTS

3/4" x 1/8" Hearts	\$2.75/100	—
3/4" x 1/2" Hearts	\$4.50/100	—
1" x 3/16" Hearts	\$4.00/c	—
1" x 3/8" Hearts	\$6.50/c	—
1-3/8" x 1/8" Hearts	\$5.50/c	—
1-3/8" x 1/4" Hearts	\$7.50/c	—
1-3/8" x 1/2" Hearts	\$10/100	—
2" x 1/2" Hearts	\$18/100	—

Great Buys!

	Qty.	Cost
3/8" x 36" Standard Dowels	\$21/100	—
3/4" x 36" Oak Dowels	\$15/10	—
3/8" Maple Buttons	\$2.15/100	—
1/2" Maple Buttons	\$2.25/100	—
1-1/2" Maple Spindles	\$9/100	—
2-1/8" Maple Spindles	\$18/100	—

ORDER NOW

MC/Visa Check Enclosed

Total Cost _____

Handling **\$3.00**

Ohio residents
add 5 1/2% sales tax _____

Final Cost _____

MC/Visa Number _____

Expires _____ Phone _____

Name _____

Address _____

City/State/Zip _____

FREE 16-PAGE CATALOGUE

Circle this section for FREE Dowels
— mixed pack, Maple, Oak, Walnut
Cherry, from 1/4" up to 1"
Approximately 10 LFT. 14" long.
\$5.00 value with any order.

MIDWEST DOWEL WORKS

4631 Hutchinson Road
Cincinnati, Ohio 45248
(513) 574-8488

Same Day Service / Order before Noon
Factory Direct / Satisfaction Guaranteed

TALKING BACK

Continued from page 6

In-Line product review is right on target

In-Line Industries' Special Performance Package, reviewed in the September 1991 Products that Perform section, lives up to all the claims made about it. After installing the new turned pulleys and belt on my 1977 Sears 10" tablesaw, it is better than new. It has more power, yet it vibrates so little that I can stand a nickel on edge on the table and cut wood without knocking the coin over. Please keep up the good work by testing products and telling your readers about them!

—William E. Brader, Warren, Pa.



Two solutions to the bleeding oil-based finishes

Here's an easier way to keep red oak that's been finished with Danish oil from bleeding (Ask WOOD, October 1991). Add 6-10 tablespoons of Japan Drier to a quart of oil stain. This will cause the stain in the open-grained wood to dry very quickly. This also works with mahogany, which also bleeds sometimes. If your paint dealer doesn't stock this drier, he should be able to order it. Be sure to try this on scrap before trying it on your project.

—Robert Mikkelsen, Salinas, Calif.

Behlen's Japan Drier, 1 pt. Catalog No. B700-1805, \$12.01 ppd. from Wood Finishing Supply Co., 100 Throop Street, Palmyra, NY 14522-3743; phone 315/597-3743, and ask for the free finishing booklet.

About bleeding from oil-based stains: Applying stains in a room warmer than 65 degrees could contribute to the problem. Keep your workpiece away from heat sources such as forced-air heat, sunlight, or a fireplace. Also, set the piece being dried on narrow scrapwood sticks to promote air circulation all around it.

—Mrs. Don Lundquist, Hackensack, Minn.

Product Guide disappoints this subscriber

Your November 1991 issue of WOOD® magazine is a big rip-off. To call this a special edition is an insult to your subscribers. This issue is simply a collection of advertisements. If you repeat this type of issue in the future, you can expect my subscription cancellation the next day. I subscribe to five woodworking magazines. Keep yours the best. 🍀

—Charles Ley, Lynbrook, N.Y.



 Print this article

PLAIN-HANDY PLANE HOLDER

Like all precision tools in the shop, your planes need and deserve safe, sturdy storage. Consider this adaptable wall-hung organizer the answer, regardless of which size planes you may own. Using the design shown and the notes below, you can build these holders from scrapwood. Then, secure them to your shop wall. We included a dado in the base (A) to protect the plane blade from damage.

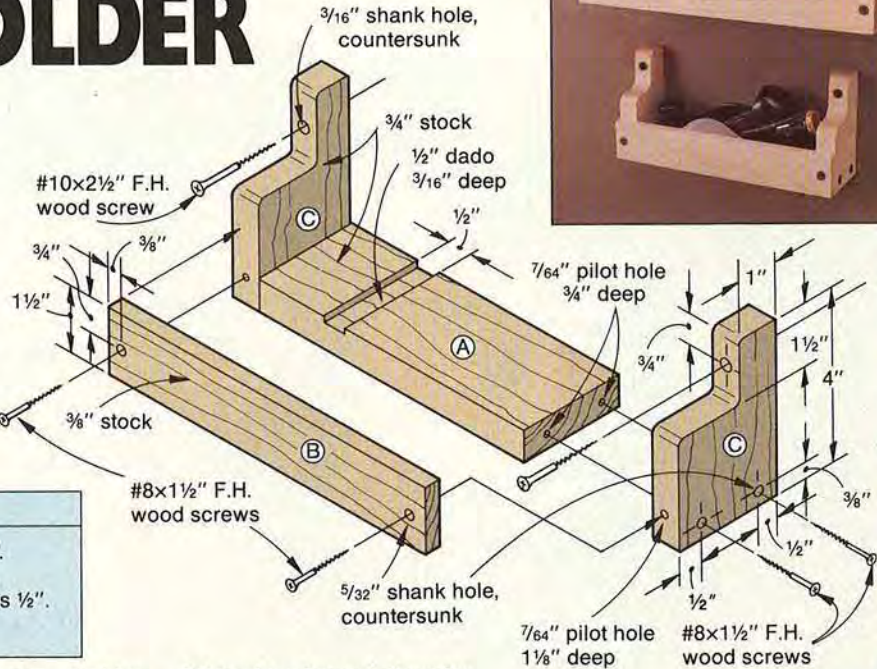

Construction Notes

Length of A equals length of plane plus 1/2".
 Length of B equals length of A plus 1 1/2".
 Width of A and C equals width of plane plus 1/2".
 Center the dado in A under plane blade.

Project Design: Kevin Heilman Photograph: Wm. Hopkins Illustrations: James A. Downing

WAGNER

SPRAY
 Fine Finishes
 with the New
WAGNER
 Fine Coat
 Low Overspray
 Finishing System



only **\$179⁹⁹**

HVLP High Volume Low Pressure. The Ideal "Fine Finishing Tool." Great for applying Varnishes, Stains, Lacquers and water based finishes!

Guarantee! If not completely satisfied after 60 days, return it for a full refund. A NO RISK TRIAL!

PHONE

1-800-776-5467
 ...they are out the next day!

- Check MasterCard
 - Discover
 - Visa (Please include exp. date)
- PA residents add 6% sales tax.
 S & H: Under \$25 - add \$3.75.

Our Gift To You...

FREE SHIPPING

on orders over \$25.00
 (Continental U.S. only)

OFFER GOOD 'TIL
 APRIL 1, 1992

PHONE

1-800-776-5467
 ...they are out the next day!

QUAKER STATE WOODWORKING SUPPLY
 4434 Kutztown Rd.
 Reading, PA 19560

PORTER-CABLE

RANDOM ORBIT SANDERS



P-C MODEL
 #7334, 7335,
 7336

- 5" Random Orbit..... \$119.99
 - 5" V.S. Random Orbit... \$129.99
 - 6" V.S. Random Orbit... \$134.99
- (Sanders shipped freight FREE!)

New! DUST COLLECTION for P-C Random Orbit Sanders. The RIGHT WAY to DUST COLLECT... hood connects your sander to your Shop-Vac. 6" Flex. Hose Included..... \$24.99
 (Fits both 5" and 6" Sanders)



BULLDOG GOLD



New! **RANDOM ORBIT DISCS**
 EXTRA Heavy Duty "D" weight.
Buy 50, Get 50 FREE!!!
 5" Bulldog Discs... \$20.99
 6" Bulldog Discs... \$25.99
 (Available in 80, 100, 120, 150, 180, 220, & 320 grits.)

SUNGOLD

SANDING BELTS
 Buy 12 Belts
 Get 13 FREE!



You've Tried the Rest NOW BUY THE BEST!

65% polyester, 35% cotton, belts don't stretch, sand cooler, and stay sharper longer.

BELT SIZE	PRICE/25 or 13* Belts
1x30	\$16.99
1x42	17.99
2 1/2 x 16	17.99
3x18	17.99
3x21	18.99
3x24	19.99
4x21	24.99
4x21 3/4	24.99
4x24	25.99
4x36*	24.99
6x48*	35.99

Available in 40, 60, 80, 100, 120, 150 and 220 grit. Please order in multiples of 5 per grit size.
 Belt Cleaning STICKS... \$4.99
 3 for \$9.99 6 for \$15.99

QUICK-GRIP

BAR CLAMPS



The ONE-HANDED Clamp That's Sweeping The Country!

JAW OPEN	PRICE EA	SPECIAL OFFER!
6"	\$12.75	FREE Shipping with orders over \$25.00.
12"	\$14.95	
18"	\$15.95	
24"	\$17.75	
36"	\$19.75	

"SINGLEY"

Sleeveless DRUM SANDERS

3/4" x 3" Long	\$15.95
1" x 3" Long	14.95
2" x 3" Long	18.99
3" x 3" Long	19.99
Kit of all 4	64.99
Drum Sander Plans	11.99
3" x 10" Pre-Cut Sandpaper Roll Assortment	12.99

Strong "F" Weight SANDPAPER

3" x 10" rolls that outlast regular sandpaper 3X. Assortment pack of 1 each... 80, 120, 220... \$12.99

TRU-GRIP

CLAMP 'N TOOL GUIDE Bar Clamping Straight Edge

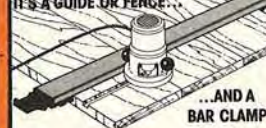

Power Tool Guide, Instant Fence, Assembly Clamping, Corner Clamping, No Cranks, No Screws.

24" Grip... \$22.95
 50" Grip... 29.95



Back-To-Back BENCH CLAMP

Instantly turns Bench-Top into a "Super Capacity" Workholding System.
 18" Grip... \$31.95
 36" Grip... 39.95



KIDS ON PARADE

Music makers in silhouette

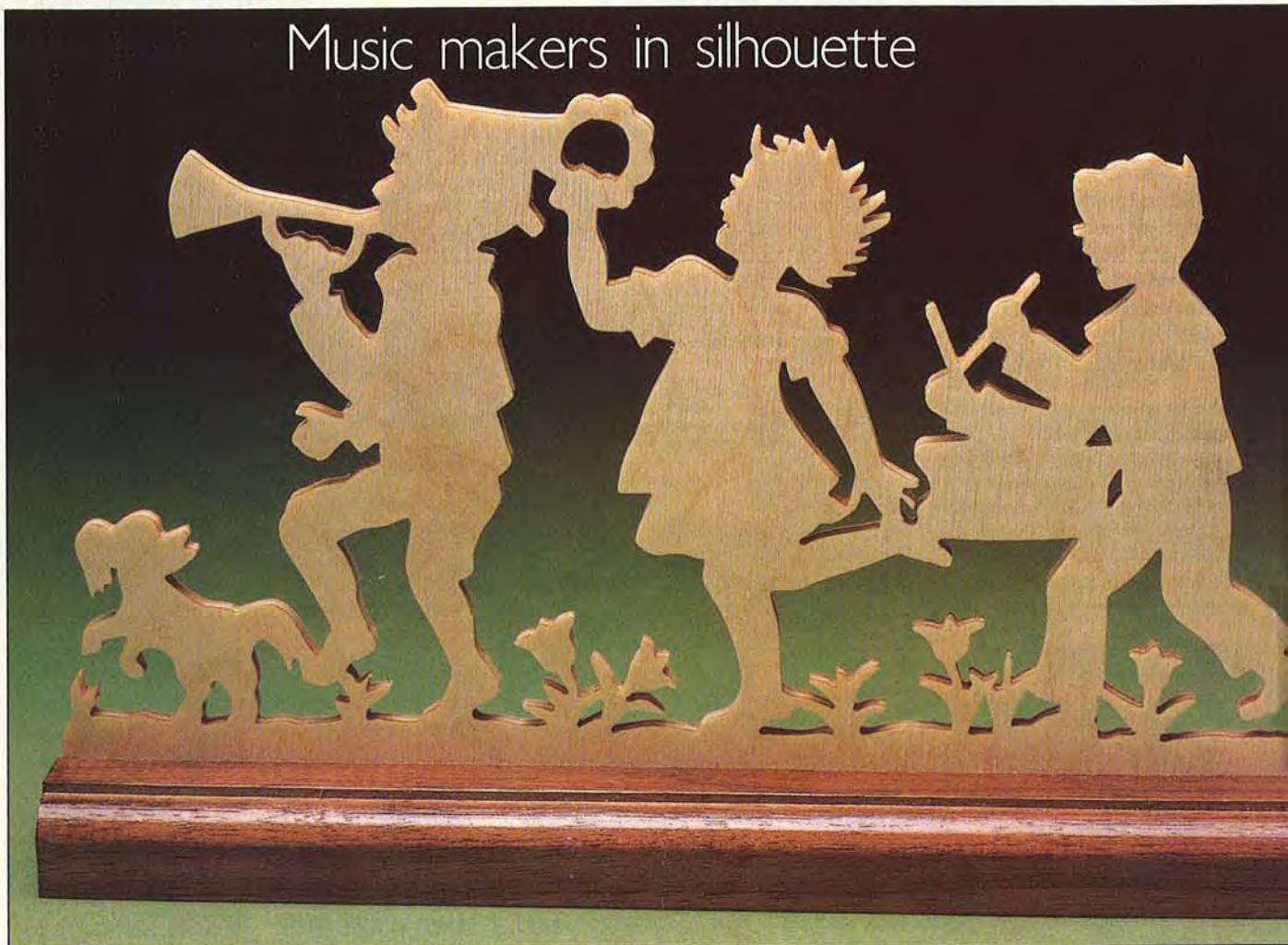

Don't let the parade pass you by. Tighten your scrollsaw blade to just the right note, and then pitch in to cut out this energetic marching band in silhouette. Go ahead and whistle while you work—these kids would understand.



Print this article

You'll need $\frac{1}{8} \times 5 \times 9\frac{1}{2}$ " hardwood stock or plywood (we used Baltic birch plywood) for the cut-out and $\frac{3}{4} \times 1\frac{1}{2} \times 8\frac{3}{4}$ " hardwood stock for the base. The small inside cuts on this pattern call for a scrollsaw that accepts plain-end blades. (We used a #5 blade, $.035 \times .015$ " with 15 teeth per inch.) If yours doesn't, ask your tool dealer if blade holders are available to adapt your saw to take plain-end blades.

Photocopy the full-sized pattern on the *opposite page*. Attach it to your stock with spray adhesive.

Thin stock lends itself to stack-cutting, so you could cut several bands at once. In fact, you can saw up to five pieces at a time. Hold them together with tape or brads driven into waste areas.

Not only will you have extras for friends, but you'll also find the cutting more controllable. You'll be less likely to cut off the fine details when you work with a thick stack of material.

Drill $\frac{1}{16}$ " blade start holes where indicated on the pattern. Then, begin cutting out the smallest inside details, such as the spaces between the drum and the



FULL-SIZED PATTERN

● Red dots indicate locations to drill 1/16" blade start holes for interior cuts.

drummer or between the youngsters' feet and flowers. Progress to larger details, and cut the outside line last.

To make a base for your silhouette, cut a piece of hardwood (we chose walnut) $\frac{3}{4} \times 1\frac{1}{2} \times 8\frac{3}{4}$ ". Saw a $\frac{1}{8}$ " blade kerf $\frac{1}{4}$ " deep along the middle of the topside with a tablesaw. Round the base's top edges with a $\frac{1}{4}$ " round-over bit in a table-mounted router.

Mount the silhouette in the slot and finish. We sprayed on clear lacquer for a natural finish, spraying from several angles to cover all the inside edges. ♣

Design: Elaine Hutcheson, Paper Cut Art, Virginia Beach, Va.
Illustration: Mike Henry Photograph: Hopkins Associates

How to build a sound

Some people buy stocks, bonds, mutual funds.

Then there are those of us who invest in tools, machines, wood.

One thing's for sure, whether you're in "the market" or in the shop, it pays to buy the very best. To make the smartest investments you can.

That's why at Delta, we build our machines with a long-term payoff in mind. We look at how well they'll be producing for you 20 years from now. Just try to talk an old-timer into parting with his old Delta machine.

We're also constantly working to develop new products and accessories. And looking for ways to improve on our old standbys.

The idea is to help you round out your shop. Solidify your investment.

We're staking our future on it.

**Building
On Tradition**
DELTA
A Pentair Company

For information on these and other new products, call toll free for the name of your nearest Delta distributor. Delta International Machinery Corp., Pittsburgh, PA., 800-438-2486. In Canada, call: 519-836-2840.

NEW

The new Delta 16" 2-Speed Scroll Saw cuts an inside curve like a sports car at speeds of 850 and 1725 CS/M, with a 2" depth of cut. Cast-iron table and frame. Just one of our full line of scroll saws ranging from 15" to 24" capacities.



NEW

Here's a real luxury. A machine devoted entirely to mortising. Faster and more accurate than a drill press. And don't be fooled by its small size. It'll handle work up to a full 4" under holddown and accommodate mortising chisels up to 1/2" x 1/2".

NEW

The Delta Blues. Our complete line of heavy weight, carbide-tipped, perfectly balanced Shaper Cutters, that is making our competition green with envy. Computer aided design and machining means precise profiles. We'll even make a custom profile for you.



investment portfolio.

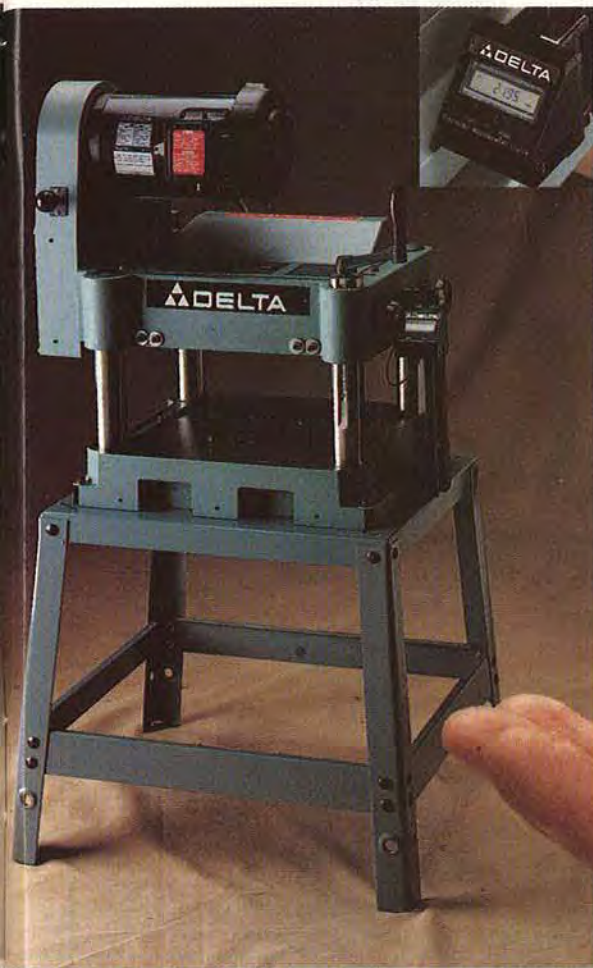

NEW

This Stationary Plate Joiner goes way beyond a portable joiner. A foot pedal controls blade movement so both hands are free to control your work. Handles all types of joints in all three biscuit sizes.

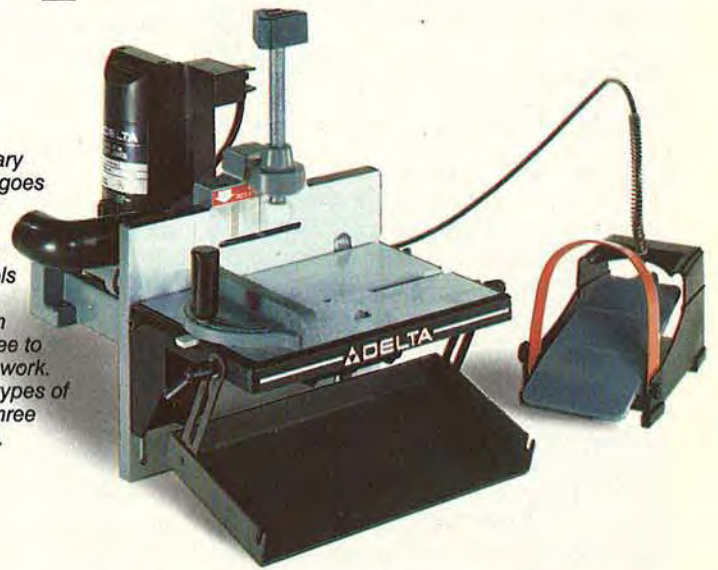

A handful of prevention is worth a shopful of cure. If you agree it's time to stop eating, breathing and sweeping all that dust, we've got the right dust collector to meet your needs. A whole range of two-stage, industrial quality, portable dust collectors, ranging from $\frac{3}{4}$ to 3 HP, will let you breathe easier.



FREE EMS AND STAND Handle 13" wide and 5.9" thick stock with the Delta 13" Planer. Lets you precision plane down to $\frac{1}{8}$ " thickness. Rugged cast-iron throughout.

Buy now and we'll throw in our heavy-gauge steel stand for free.* And just for good measure, we'll add on a free Electronic Measuring System to eliminate the guesswork.*



Standards of the Industry. We set them and we won't compromise them for any reason. But how about a rebate or two. Or four. Choose one or all four of these "Standards": Our Combination 6" Belt/12" Disc Sander, 8" Precision Jointer, Heavy Duty Wood Shaper and any model Unisaw® 10" Tilting Arbor Saw. Each comes with a hundred dollar rebate check from Delta.*

*Offer good only from participating distributors in the continental U.S., Alaska, Hawaii and Canada, from September 1, 1991 thru March 31, 1992. To qualify, machines must be purchased with motors.



EARN CASH, PRIZES FOR YOUR TOP SHOP TIP

Do you have a great shop tip (or two) you'd like to share with other WOOD® magazine readers? For each published submission, you will get at least \$25 from WOOD magazine (as much as \$200 if we devote a page or more of space elsewhere in the magazine to your idea). You also may earn a woodworking tool for submitting the Top Shop Tip for the issue.

We try not to use shop tips that have appeared in other magazines, so please send yours to only one. We do not return shop tips. Mail your tip(s), address, and daytime phone number to:

Top Shop Tip
WOOD magazine
P.O. Box 11454
Des Moines, IA 50336-1454

Old glove finger protects carver's thumb

As careful as you are, it's all too easy to gash your thumb while carving. Wearing a glove is just too clumsy, though.

TIP: Don't wear the entire glove, just a part of it. Cut the fingers from an old leather glove before you throw it away. Then, just slip one onto your thumb whenever you carve. Always endeavor, of course, to keep your thumb and fingers out of harm's way.

—Maurice Anderson, Denver, Colo.



Bigger knobs enable easier adjustments

Sometimes, you just can't grip a small adjustment knob firmly enough to turn it. Pliers will batter it up in no time, particularly a knob you adjust frequently, such as the scrollsaw blade tensioner shown right.

TIP: Cut a disc from 3/4" scrapwood with your holesaw (a 2"-diameter one works well). Round over the edges for comfort and safety. Bore (or scrollsaw if the knob isn't round) a hole in the center to fit tightly over the troublesome knob, and then glue the big gripper in place with epoxy.

For even heftier knobs, use thicker stock. Or, add style by starting with laminated discs.

—Bob Thompson, Harrisburg, Pa.

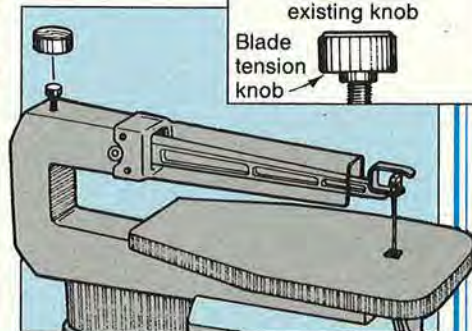
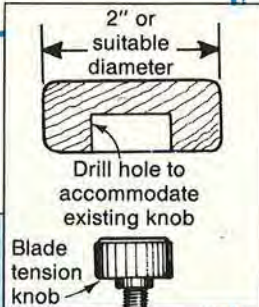

For his winning tip, Bob will receive a Skil Professional plate joiner kit, model 1605-02.



Panels won't defeat you if you deck them first

Wrestling sheet goods around in a small shop wears you out fast. And trying to place sawhorses so you can cut a panel without assistance adds another dimension to your irritation.

TIP: If you have an outdoor deck and it's a nice day, don't even mess with those sheets or sawhorses inside your shop. Lay the

material flat on the deck, placing the cutting line over a space between decking planks. Adjust your portable circular saw to cut a little deeper than the material thickness. Now, you can cut the sheet safely and easily. As a bonus, you'll have less sawdust to sweep up in your shop, too.

—Janet A. Collins, East Bridgewater, Mass.

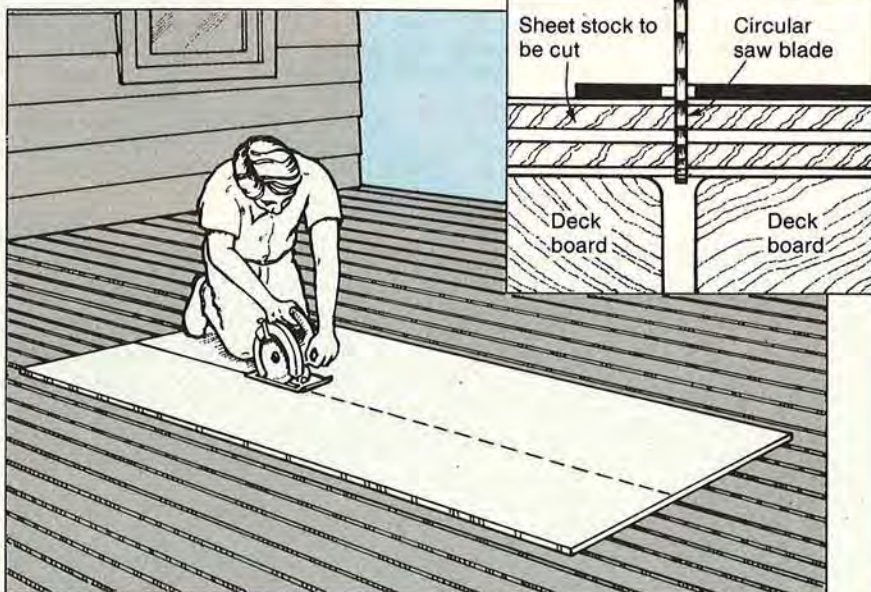

Continued on page 16



Round and round it goes. Where it stops nobody knows.

The Dremel Moto-Tool is a compact, high-speed rotary tool that really gets around. With variable speeds, ranging from 5,000 to 30,000 RPMs, and over 150 specially designed bits and accessories, it allows you to complete all kinds of tasks, on all kinds of materials.

With the right bit and the right speed you can sand, carve, shape and rout wood. Change the bit, adjust the speed and use the Moto-Tool to grind, cut and deburr metal. You can even use it to shape and cut plastic or polish silver.

If we were to list all the ways you could use the Dremel

Moto-Tool, this ad would go on forever. However, you can get a 95 page, detailed guide that explains bits, speeds and 175+ uses, in specially marked Moto-Tool boxes at Hardware, Home Center and Hobby Stores. Or write to Dremel, Marketing Dept., P.O. Box 1468, Racine, WI 53406-1468, for a free copy.

DREMEL® MOTO-TOOL®
High-Speed Rotary Tool

NEW!
MagicMat

A MUST FOR ANY
WOODWORKERS' SHOP!



The ideal Mat for Routing, Belt Sanding, Scraping, Hand Sanding, etc. This Mat is NOT foam, NOT carpet padding, and NOT underlayment material! IT IS 1/2" dense rubber that will NOT slide on wood, laminate, corian, plywood, etc.

Cat. #6340... \$10.99 or 2 for... \$20.00



MAT SIZE:
36" x 24"

Money Back
Guarantee!

FREE! With any MagicMat purchase, you will receive a Plan to make your own Push BLOCKS for Table Saws, Jointers, Radial Arms, etc. It uses a small piece of MagicMat which we supply.

1-800-776-5467

Orders over \$25.00 shipped FREE! Under \$25 - \$3.75
(CONTINENTAL U.S. ONLY!)

Check MasterCard Visa (include exp. date)
 Discover PA Residents add 6% Sales Tax.

**QUAKER STATE
WOODWORKING SUPPLY**
4434 Kutztown Road • Reading, PA 19560

FREE
Woodworking
Catalog



It's 36 exciting new pages of woodworking plans, projects and more.

Birdhouses, Whirligigs • Toys
Books, Videos • Tools • Wood Parts
• Furniture • Outdoor Decoratives •

At great low prices! Send for your FREE catalog today.

Name _____

Address _____

City, State, Zip _____

Or call Toll-Free 1-800-556-2548
and mention Dept. WDA22.



A Division of Klockit
P.O. Box 542, Dept. WDA22
Lake Geneva, WI 53147

**TIPS FROM YOUR SHOP
(AND OURS)**

Continued from page 14

Crank it up, not down, when setting your saw

After cutting a series of dados with your tablesaw, you find some of them too shallow.

TIP: Your tablesaw arbor moved down as you sawed, due to vibration and pressure on the blade. Guard against blade creep by following this procedure when you

adjust blade depth: Lower the blade below your intended setting, and then raise it to the desired height. Don't lower the blade to the cutting height. If your saw has a locking knob on the height-adjustment crank, be sure it's tight before you start to saw.

—from the WOOD magazine shop

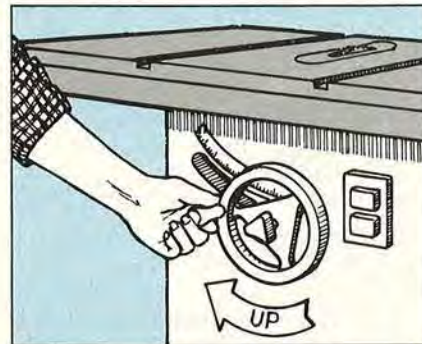
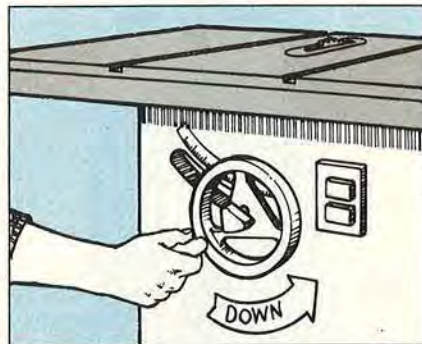

Paint filter keeps router innards clean

Your table-mounted router sucks in a lot of sawdust under the table. You'd like to help it breathe a little cleaner air.

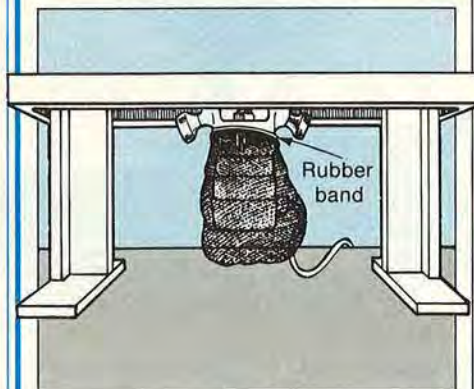

TIP: Affix a bag-type painter's strainer to the top of the router motor housing. Cut a hole for the cord, and secure the bag to the router with a wide rubber band. It helps to drop a small piece of scrapwood into the nylon-mesh bag to keep it extended. Shake the dust off the bag occasionally so it won't clog and cut off air flow.

—Bruce Buckingham,
Mt. Pleasant, Iowa

Temporary feet lift project above harm's way

Before a project reaches completion, it can suffer a lot of dents and dings in the shop. Cabinets or bookcases built of plywood often end up with chipped face veneer at the bottom from being shoved around on the shop floor.

TIP: Attach scrapwood blocks to the bottom corners of your project with finishing nails or screws. Leave the temporary feet on until you've finished the project and moved it to its final location.

—from the WOOD magazine shop

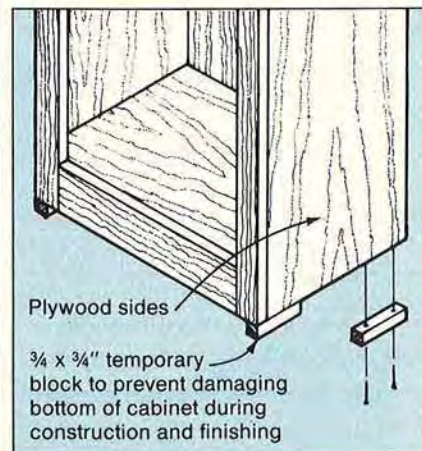

Continued on page 18

Van Dyke's

Presents a Catalog

with supplies for upholstery, antique restoration, wood working, caning, brass hardware, carvings and many related trades!



36 Years in Creative Arts & Trades

Many Hard-To-Find Items!

SEND \$1.00 FOR CATALOG TO:
Van Dyke's Restorers
Dept. D55 - Woonsocket, SD 57385

SCROLL-VERGNÜGEN

Enjoy scroll sawing as it is meant to be! Get FREE information about HEGNER Precision Scroll Saws, your #1 choice for over fifteen years. Call or write today!

1-800-648-4264

ADVANCED MACHINERY IMPORTS, LTD. (in Delaware 322-2226)
P.O. Box 312, Dept. 486
New Castle, DE 19720



Diamond Whetstone™

- Save Time — Avoid send out grinding.
- Save Carbide — Do your own professional sharpening.
- Save Money — Pay for your stone in a few sharpenings.
6" x 2" Diamond Whetstone \$46.00
8" x 2 1/2" Diamond Whetstone \$75.00

Specify:
Fine, Coarse
or X-coarse

Add \$2.50
shipping &
handling

Major
Credit
Cards

DIAMOND MACHINING TECHNOLOGY, INC.
Dept. WD22
85 Hayes Memorial Dr.
Marlborough, MA 01752

Ask for it at your favorite Sporting Goods Dealer



WOODWORKERS

Save on Wood - Tools - Supplies!

OVER
4000
ITEMS

Finest Dimensioned
HARDWOODS and
Quality VENEERS

42 VARIETIES
1/64" to 4" Thickness

Send for
New 1992
132 Page
Money Saving
CATALOG

OUR
62nd Year

Fast service on choice kiln dried
Wood and Veneers, Mouldings, Trim,
Hand and Power Tools, Lamp Parts,
Upholstery Supplies, Clock Move-
ments and Kits, Hard-to-Find Hard-
ware, Finishing Materials, Books
... over 4000 items in stock! Crafts-
man—Woodworker's best friend.

CRAFTSMAN WOOD SERVICE

Dept. WM292, 1735 W. Cortland Ct., Addison, IL 60101
Please enclose \$1.00 to help pay postage and handling.



WOODCRAFT PATTERNS

FOR FUN & PROFIT!

SHOP-TESTED FULL SIZE PATTERNS

- 125 Pattern Fun Packet assortment!
- 25 fun, profitable "wind-action" whirligigs.
- Country Critters-100 patterns, decorative projects!
- Attractive Dutch Windmill - 5 feet tall.
- 100 yard ornaments animals, birds, signs, more!
- 200 pattern packet for scroll, band & jigsaws!
- Show stoppers - 22 craft show top-sellers!
- Over 20 easy to make bird houses.

Send \$8.00 per packet. Pick 3 for only \$16.00
Fast Service • Satisfaction Guaranteed

ACCENTS, Dept. MA22, Box 7387, Gonic, NH 03839
WOODCRAFT CATALOG - \$2.00 (Free with order)

GET STARTED ON HOME IMPROVEMENT PROJECTS WITH HOMETIME VIDEOS.

SPECIAL OFFER:
Any Three Videos Just \$29.00!



Dean Johnson and JoAnne Liebler of PBS's "Hometime."

HOMETIME videos bring out the do-it-yourselfer in you. They give you confidence to tackle bigger projects that will enhance, protect and add value to your home.

Each tape is 40 to 90 minutes - an expanded version of a project aired on the popular PBS-TV series, "HOMETIME." You learn how to get ready with the right plans, tools and materials. Then go step-by-step, right to the finish, for expert results quickly and easily. Includes a printed Project Guide with checklists and detailed instructions.

We'll send you any three of the titles listed above for just \$29.00 (plus shipping/handling). Satisfaction guaranteed or return in 10 days for your money back. For rush service - or to have tapes sent directly to others - call 24 hours, toll-free:

1-800-257-0700



HOMETIME

Circle your selections below. Three titles for \$29.00.
Two titles for \$22.00. Or \$13.00 per single title.

- | | |
|----------------------------|-------------------------------|
| #19 Basic Landscaping | #05 Framing |
| 11 Bathrooms | 17 Furniture Refinishing |
| 16 Cabinets | 12 Interior Paint & Wallpaper |
| 15 Ceramic Tile | 13 Kitchens |
| 25 Common Home Repairs | 44 Log Cabin |
| 31 Contracting a Home (I) | 20 Patios & Walkways |
| 32 Contracting a Home (II) | 07 Plumbing |
| 14 Decks | 02 Roofing |
| 09 Drywall | 33 Storage |
| 08 Electrical | 37 Three Season Porch |
| 04 Fences & Gates | 28 Vinyl Flooring |
| 10 Finish Carpentry | 06 Windows & Doors |
| 38 Finishing a Basement | 26 Wood Flooring |

___ 3-Pack @ \$29.00 \$ _____

___ Tapes in addition to above @ \$9 ea. \$ _____

___ 2-Pack @ \$22.00 \$ _____

___ Single tape only @ \$13.00 \$ _____

Subtotal \$ _____

(In MN, add 6 1/2% sales tax) \$ _____

Shipping/Handling \$ 3.00

Total amount \$ _____

Check/Money order enclosed MasterCard Visa
Card # _____ Expires _____

Please make check or money order payable to HOMETIME. No COD's. Allow 4 weeks for delivery. Mail to: Hometime, 4275 Norex Drive, Chaska, MN 55318. Or call 1-800-257-0700.

Name (Please print) _____

Address _____

City/State/ZIP _____

Phone (_____) _____ WM 2/92

TIPS FROM YOUR SHOP (AND OURS)

Continued from page 16

Piping for your shop vacuum makes cleaning up a cinch

A shop vacuum sure expedites cleanup, but moving the machine around in a crowded shop soon becomes bothersome.

TIP: Place the vacuum in an out-of-the-way spot, such as a corner, and then fabricate remote vacuum-hose hookups with PVC plastic pipe as shown *right*. Select a pipe diameter that matches the hose connection on your machine—1½" works for many. Install T-fittings to provide hose-connection ports, covering unused ones with slip-on pipe caps. Use sheet-metal screws rather than glue at the joints so you can open up the system in case you need to clear a clog.

Connect the unit to the system with a flexible coupling, and provide a way to disconnect it in

order to remove it for emptying. Be sure you can reach the switch to turn the machine on and off, or else provide a remote power

switch. When it's all set up, just slip the hose on the nearest fitting and clean up with no fuss.

—Dean Jenkins, Woodburn, Ind.

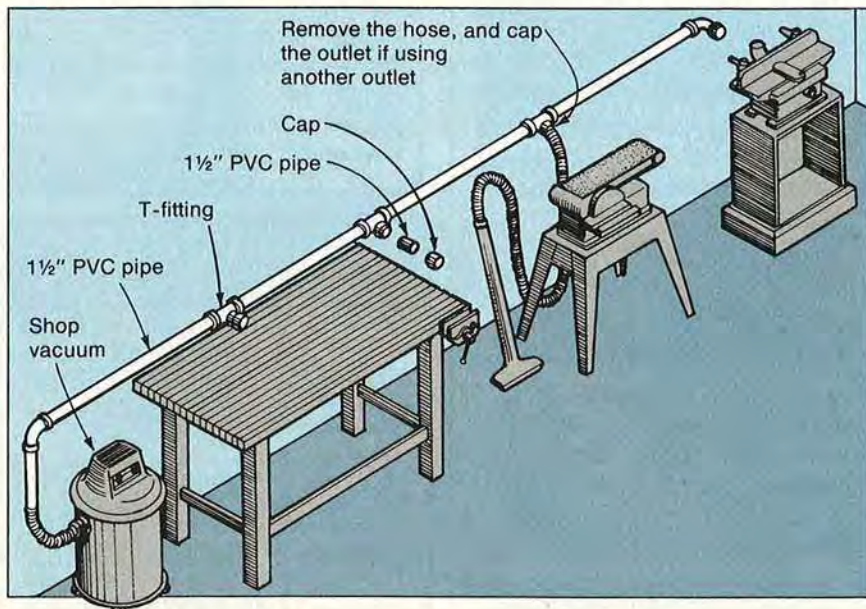

Buy 1 Tool And Get Our 228 Page Tool Free.



A / Giant 17" x 11" Aluminum Shop Dustpan Makes Short Work Of Clean Up
Shops generate huge amounts of debris. The extra capacity of this dustpan makes clean-up faster. It's like using a shovel instead of a trowel.
24K03.01 Giant Dustpan \$13.40

B / Band Saw Blade Tuning Stone Helps Produce Tighter, Smoother Curves
This 3" x 1/2" x 1/4" Silicon Carbide stone is strongly recommended in the best-seller *Band Saw Handbook*. Comes with complete instructions on how to gently round the backs of your blades. The difference in performance is remarkable.
38M01.01 Blade Tuning Stone \$8.95

C / Versatile & Strong Shop Cloths Repay Their Extra Cost Quickly
Soft as cotton rags but much thicker, and a lot stronger than paper toweling. Very absorbent, lint free and can be rinsed and reused many times. Great for picking up glue squeeze-out and staining as well as machinery clean-up. Each is 10 1/4" x 16 3/8".
23K02.01 100 Shop Cloths \$12.95

Do-It-Yourself Kits



*Factory Direct
Clocks and Furniture*
**Also Assembled
and Finished**

- Grandfather Clocks, Mantel and Wall Clocks
- Curios, Tables, Chairs, Desks, Cradle...and more!
- Solid 3/4" Black Walnut, Cherry, or Oak
- Heirloom Quality
- Solid Brass West German Movements and Dials
- Money Back Guarantee



SEND \$1 FOR
COLOR CATALOG

- I am interested in
- Do-It-Yourself Kits
 - Finished Clocks
 - Finished Furniture

Name _____
Street _____
City _____
State _____ Zip _____
(Please Print)



EMPEROR
CLOCK COMPANY

World's Largest Manufacturer of Grandfather Clock Kits
Dept. 4218 Emperor Industrial Park
Fairhope, Alabama 36532 • Phone 1-205-928-2316

Quality

EXOTIC LUMBER

**Figured Domestic
Turning Wood**
*Exceptional Quality
Personal Friendly Service*

Whether you are a
Beginner or Professional,
We welcome your inquiries
Call or Write.

BereaHardWoods..

125 JACQUELINE DRIVE • BEREA, OHIO 44017
216-243-4452

SPECIAL OFFER

BRANDING IRON

For hard and soft wood



HAND CRAFTED BY
YOUR NAME HERE

\$2600

Plus \$3.00 for
shipping and handling

Nebr. residents add
correct sales tax

SATISFACTION GUARANTEED
or your money back

- Shipped in one week
- Solid brass head — raised letters
- 1st Line: HAND CRAFTED BY — as above
- 2nd Line: Your choice — 20 characters/spaces max.
- Complete with wood handle
- As above but with 3rd line — \$37.00 + \$3.00

ORDER TOLL FREE **1-800-826-7606**

For free brochure, write or call (402) 464-0511

Order by mail from: **NOVA TOOL CO.**

12500 Finigan Rd., Dept. BH
P.O. Box 29341, Lincoln, NE 68529



TIPS FROM YOUR SHOP (AND OURS)

Continued from page 19

Tape bristles together for a substitute stencil brush

When you have a small amount of stenciling to do, it's tempting to avoid the expense of buying a stencil brush by daubing the paint on with a standard brush. Trouble is, an ordinary brush isn't stiff enough for stenciling. Then, too, you could end up ruining a good brush that way.

TIP: Before you try to stencil with your standard paintbrush, wrap masking tape around the bristles. The tightly bundled bristles will be stiff enough for stenciling. The tape will also keep the bristles from splaying out and breaking off. After the job, remove the tape. Your brush will be unharmed.

—Barbara Maxwell,
Cuyaboga Falls, Ohio

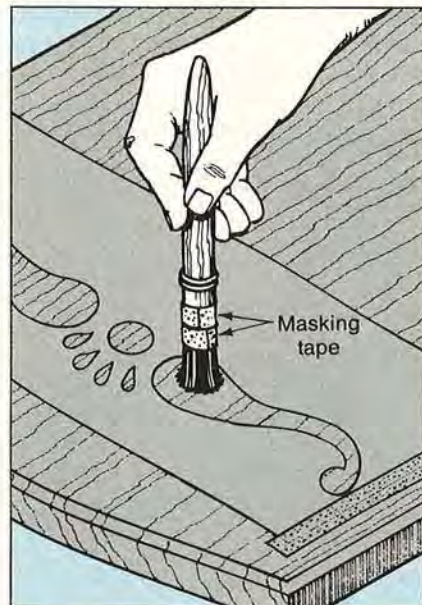

Benchtop stays clean if you paper it over

You really do try to keep your benchtop clean. But gluing, painting, staining, varnishing, and other tasks invariably end up leaving puddles or stains behind, marring that spotless surface.

TIP: A roll of masking paper from the paint store will keep that benchtop tidy. Hang the roll with

a simple holder at one end of your bench. Tear strips off and lay them on the bench before you start a messy job. Paint and glue and other goo won't soak through, so when you're done, cleanup is as easy as throwing out the paper. Masking paper comes in several sizes—we found 12" × 60 yd. to be convenient.

—from the WOOD® magazine shop

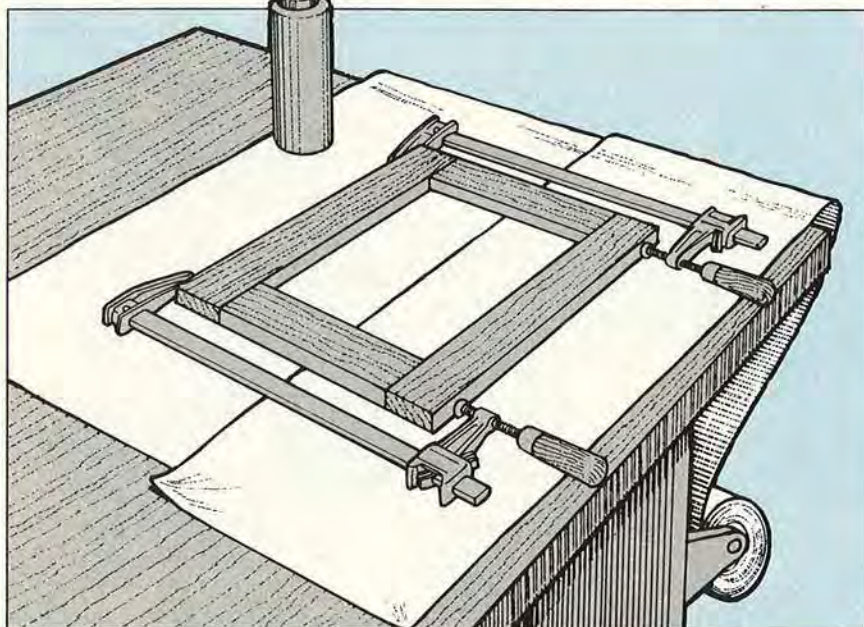

Marked handles aid in turning-tool selection

It's convenient to lay turning tools under the lathe bed while working. If the handles all look the same, though, it's difficult to pick up the right tool when you can't see the cutting tips.

TIP: Color-code each handle with a paint stripe. Mark gouges, for instance, with red, and skewers with blue. Mark the size on each one (or draw a profile of the tip) with a black marker. Now, when you reach for a tool, you'll be sure to get the right one.

—William White, Williston, Vt.

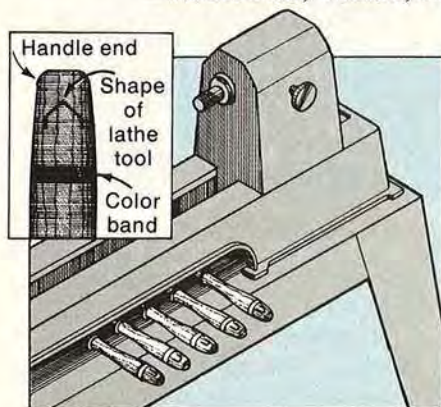

MORE TIPS FROM OUR WOODWORKING PROS

- Cove molding will dress up almost any furniture project, or a room. Fluting adds another classic decorative touch. See how to make your own cove molding and do your own fluting, starting on *page 39*.
- With a little ingenuity, you can adapt our mitersaw-cabinet fence and stop block to fit your radial-arm saw. See how we used the system on *page 59*.
- Don't have a mitersaw? Go ahead anyway and build the mobile bin on *page 57* to roll around your shop to catch cut-offs from your tablesaw, bandsaw, and other equipment.
- Make scraps into toy wheels using our method described on *page 71*.

VIDEO LATHE.

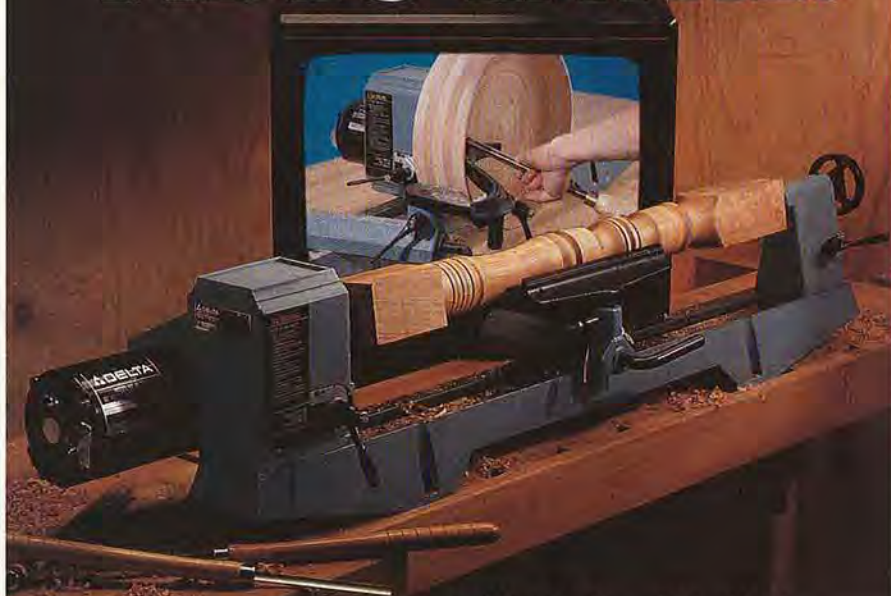

Actually, it's the new Delta 12" Variable Speed Wood Lathe. Packaged with a free instructional video and plans for making a Colonial Foot Stool.* Priced for a homeshop budget.

Now's your chance to move beyond straight cuts, flat surfaces and shaped edges. Your chance to think *round*. Even if you've never laid your hands on a lathe.

Dial the speed you want, from 500 to 2000 rpm, for everything from initial roughing to final finishing. Work up to 36" between centers, 12" over the bed. Or use the unique pivoting head for outboard turning of stock up to 16" diameter.

If you're ready to round out your repertoire, call toll free for the name of your Delta Dealer:

Delta International Machinery Corp., 800/438-2486.
In Canada, call: 519-836-2840

Building
On Tradition
DELTA
A Pentair Company

*While supplies last.

WOODWORKER'S CATALOG

More than 4,000 hard-to-find products to

**BUILD, REPAIR,
RESTORE, REFINISH**
anything made of wood!

It's the catalog woodworkers rely on for fine woods, veneers, finishing supplies, tools, hardware, moldings, adhesives and more...all top quality, reasonably priced, and covered by our 60-day no-questions-asked guarantee. Just \$1.00 brings you the 116 page color catalog plus all supplements for two full years.



CONSTANTINE
2054F Eastchester Road, Bronx NY 10461

Name _____
Address _____
City _____
State/Zip _____

Serving woodworkers for 180 years

*Collector's Edition

ANGLE BEVEL

 Print this article

Note: You'll need $\frac{3}{16}$ " walnut for this project. You can either resaw or plane thicker stock to size.

Collector's-Edition Tool Plans

We've presented plans for the following homemade tools in previous issues of *WOOD*® magazine: 1) marking gauge, 2) depth gauge, 3) finish scraper, 4) try square, 5) sanding block, 6) strip sander, 7) hand-screw clamps, and 8) center finder. To order the instructions, send \$2 per plan and a self-addressed #10 business envelope with one first-class stamp *per plan* or \$11.95 ppd. for all eight plans to Collector's-Edition Tools, *WOOD* magazine, P.O. Box 11454, Des Moines, IA 50336-1454.

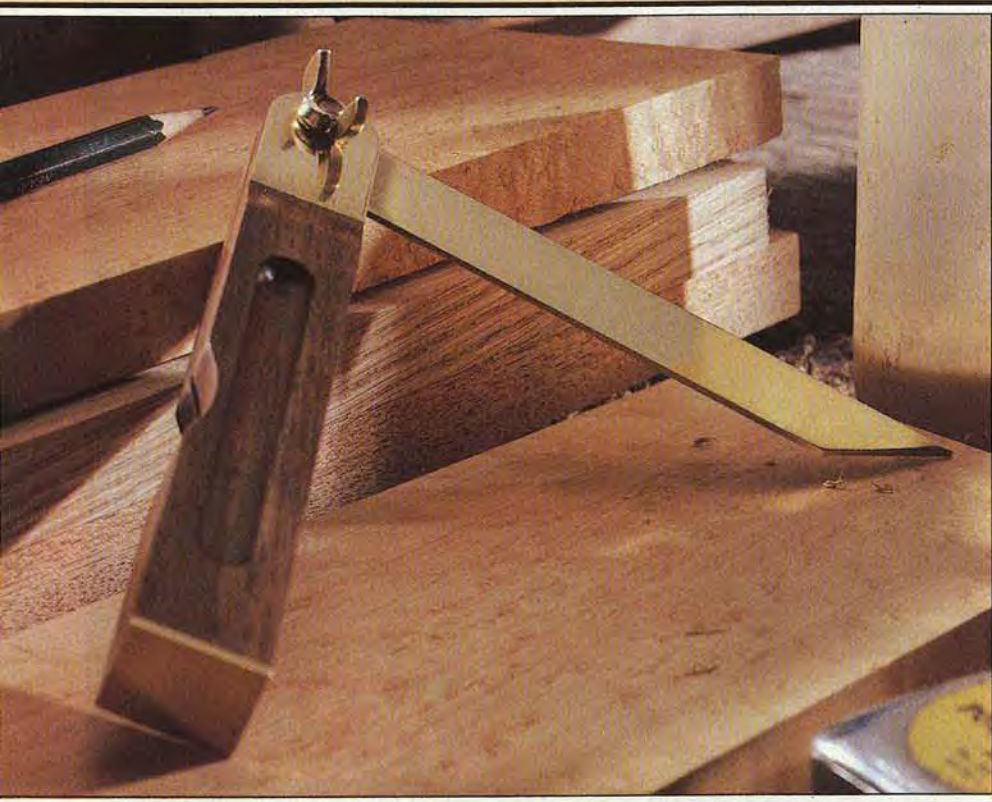

For more than 30 years now, going back to the time when I cut my first board, I've loved the heft, feel, accuracy, and rich look of fine hand tools. If you, too, share the same passion, then let me talk you into making my brass and walnut angle bevel. Whether you're a novice or an advanced woodworker, you'll find that this tool serves its purposes well and makes an attractive addition to your tool assortment.



Jim Boelling
Project Builder

Machine the handle blank

- 1 Cut a piece of walnut to $\frac{3}{16} \times 1 \times 18$ " (we planed $\frac{3}{4}$ " stock to $\frac{3}{16}$ " thick).
- 2 Cut a $1\frac{5}{8}$ " rabbet $\frac{3}{16}$ " deep across both ends of the stock where shown on the Handle Blank drawing.
- 3 Fit your table-mounted router with a $\frac{3}{8}$ " core box bit and raise it $\frac{1}{8}$ " above the surface of the table. Clamp a fence to your router table, and clamp a start- and stop-block to the fence where shown on the drawing on *page 24*.
- 4 With the rabbeted ends facing down, position one end of the handle blank against the start-block, and lower the blank onto the spinning cove bit. Holding the blank firmly against the fence, push the stock until the opposite end of the blank reaches the stopblock. Keeping the same surface down, turn the blank end for end and repeat the process to form the second cove on the other end where shown on the Handle Blank drawing.
- 5 Crosscut two $7\frac{1}{4}$ "-long pieces from the 18" blank where shown on the Handle Blank drawing.

Continued

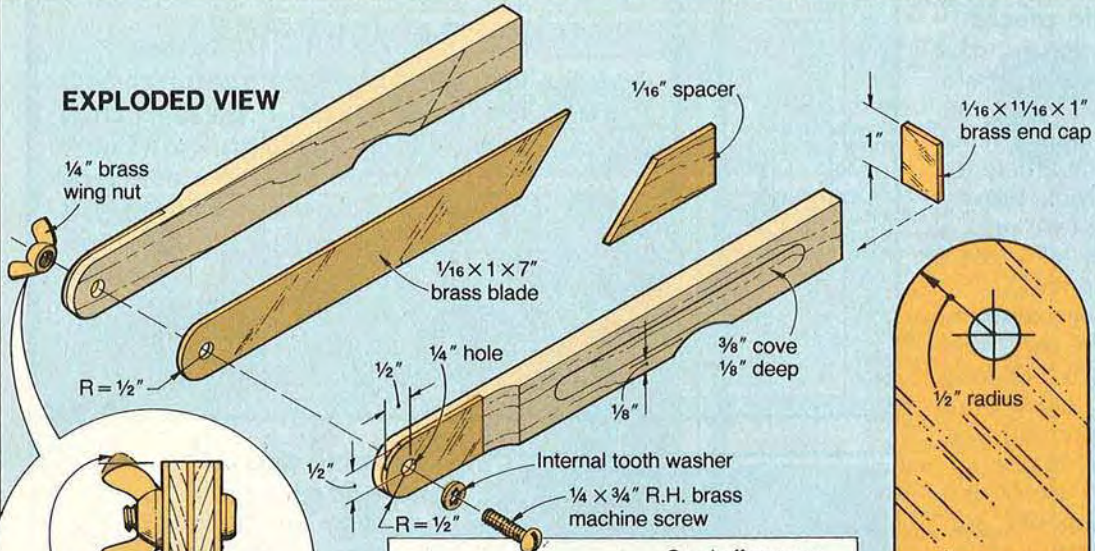
EXPLODED VIEW



Sand or grind corners so wing nut will clear edges of bevel

WING NUT DETAIL

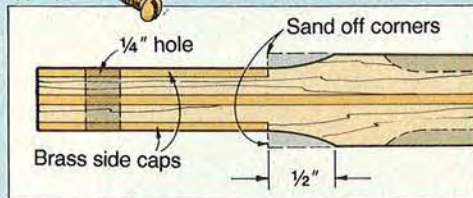

TOP VIEW DETAIL

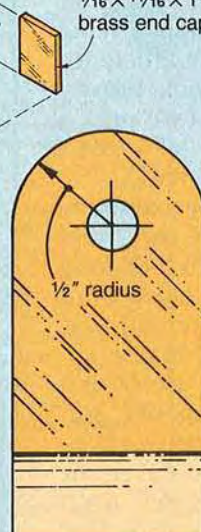

HANDLE



BLADE

HANDLE BLANK

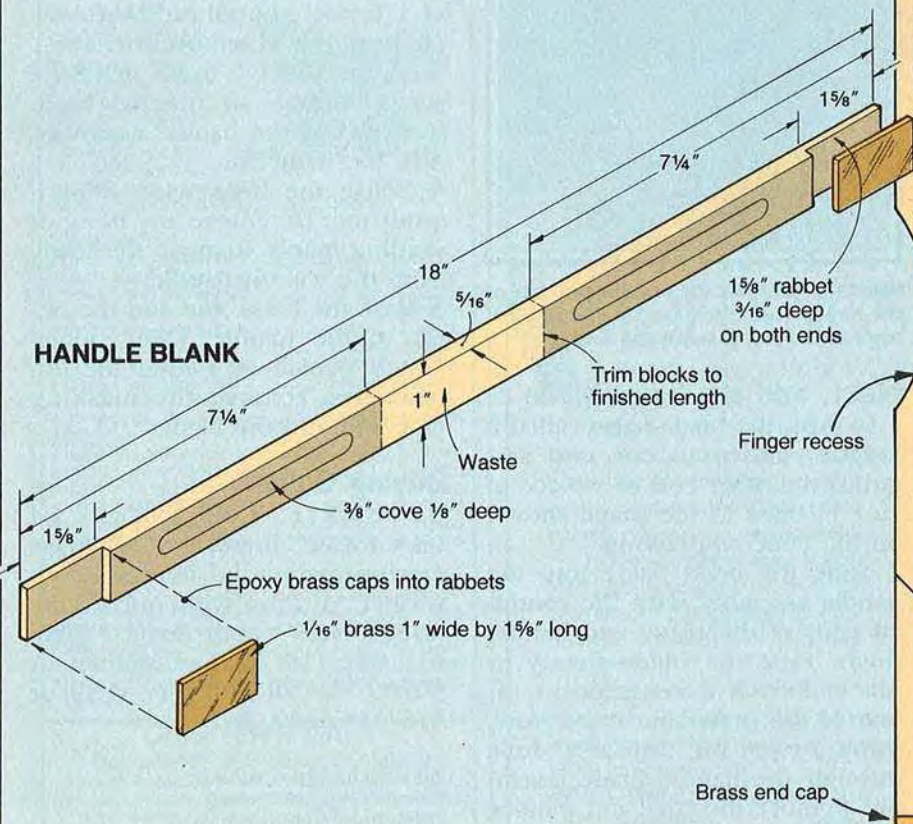

FULL-SIZED PATTERNS

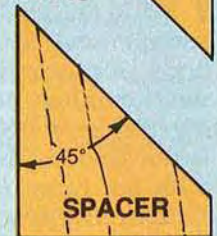

ANGLE BEVEL

Add the brass and laminate the handle pieces

1 To form the brass side caps, start by scribing a $\frac{1}{2}$ " radius on both ends of one of the 12" lengths of $\frac{1}{16}$ "-thick brass. (See the Buying Guide at the end of the article for our source of $\frac{1}{16}$ "-thick brass.) Cut the radii to shape (we used a bandsaw fitted with a $\frac{1}{4}$ " blade). File the cut edges smooth.

2 Using a hacksaw or bandsaw, crosscut each end of the brass strips to obtain the two $1\frac{5}{8}$ "-long brass side caps. Next, cut a third piece to $1\frac{1}{16} \times 1$ " for the end cap.

3 For better adhesion to the epoxy in the next step, use 60-grit sandpaper to rough up one surface of each piece of brass.

4 Spread an even coat of epoxy on the sanded surfaces, and *lightly* clamp the brass side caps into the rabbets in the handle pieces where shown on the Handle Blank drawing on the previous page. (Note: Excessive clamping pressure will cause all or most of the epoxy to squeeze out, resulting in a weak bond between the walnut and brass.) After the epoxy has cured, cut and sand the walnut flush with the brass.

5 Cut a $\frac{1}{16}$ "-thick piece of brass to the shape shown on the Pattern drawing for the spacer.

6 With the ends and edges flush, glue and clamp the spacer between the handle pieces, see the Exploded View drawing for reference. Later, trim the end of the handle square.

7 Epoxy the remaining piece of brass to the trimmed end of the laminated handle.

8 Mark the finger recess on the handle where shown on the Patterns drawing. Using a drum sander, sand the recess to shape.

9 Mark the slight radius on the walnut next to the ends of the brass side caps where shown on the Top View detail accompanying the Exploded View drawing. Drum-sand to the line and even with the brass, *being careful not to sand the brass*, as shown in the photo *middle right*.

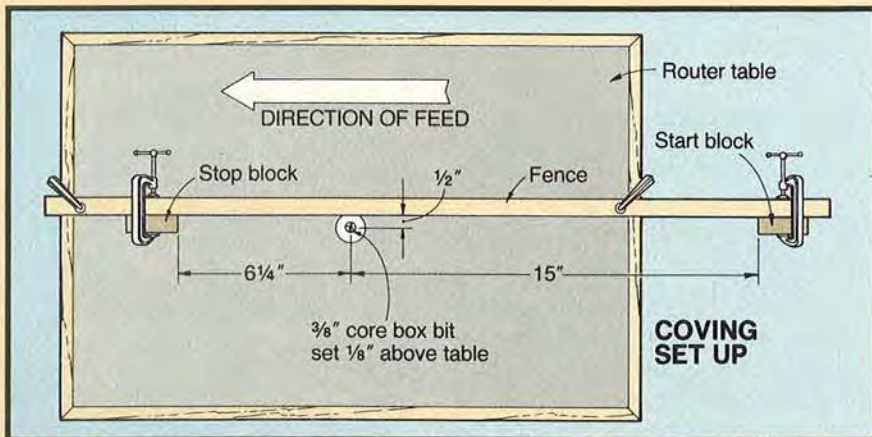

Mark the radii on the walnut portion of the handle, and then sand to the line being careful not to sand the brass.

Next, add the brass blade

1 To form the blade (also called a tongue), miter-cut one end and radius the other end of a piece of $\frac{1}{16} \times 1$ " brass to the shape shown on the Patterns drawing.

2 Slide the brass blade into the handle assembly with the rounded ends of the blade and handle flush. Tape the blade firmly in place. Punch a centerpoint on one of the brass side caps. Now, using a twist bit, drill a $\frac{1}{4}$ " hole through the handle/blade assembly. Remove the tape, and remove the blade from the handle.

Assemble the parts, and add the finish

1 Sand or file the wings of a $\frac{1}{4}$ " brass wing nut to the shape shown on the Wing Nut detail accompanying the Exploded View drawing. For accurate measuring later, the wings on the nut must not protrude beyond the edges of the handle assembly where shown on the detail.

2 For a better finished appearance, sand or file the slotted head of a $\frac{1}{4} \times \frac{3}{4}$ " roundhead brass machine screw to remove the slot.

3 Insert the $\frac{1}{4}$ " brass machine screw though an internal tooth washer and the handle assembly. Add the wing nut.

4 Polish the brass with 400-grit sandpaper to remove any filing or sanding marks. Remove the blade from the walnut handle.

5 Mask the brass, and add the finish to the handle. (We applied Watco Danish oil.) After the finish dries, remove the masking tape and add the blade.

Buying Guide

Bevel kit. Two pieces of $\frac{1}{16} \times 1 \times 12$ " brass, $\frac{1}{4} \times \frac{3}{4}$ " brass machine screw, $\frac{1}{4}$ " internal tooth washer, $\frac{1}{4}$ " brass wing nut, kit no. AB895, \$8.95 ppd. Puckett Electric, 841 11th St., Des Moines, IA 50309 or call 800/544-4189 or 515/244-4189. 📍

Produced by Marlen Kemmet
Project Design: Jim Boelling
Photographs: John Hetherington
Illustrations: Kim Downing; Mike Henry



WOODCRAFT

The Leading Edge
in Woodworking Tools

FREE Tool Catalog

Our complete woodworking tool catalog features over 4,000 of the finest quality woodworking tools, books, and supplies available today. See the difference yourself **FREE!**



Order yours today!
Call 1-800-542-9115

Or write: Woodcraft, Dept. 92W102Q
210 Wood County Industrial Park
P. O. Box 1686
Parkersburg, WV 26101-1686

Buy Direct From The Manufacturer And **SAVE!**

Buy 12 "EVER-LAST" Belts... Get 12 Belts FREE!



Need ROLLS, WIDE BELTS, DISCS,
SLEEVES, STROKE BELTS, etc.
Write for catalog.

Belts available in 36, 50, 60, 80, 100, 120, 150, 180, 220, 320 grit sizes. Please specify grit sizes when ordering, otherwise an assortment will be supplied.

- 1" x 30" ... \$16.50/Doz. + 12 FREE
- 1" x 42" ... \$16.95/Doz. + 12 FREE
- 2" x 48" ... \$25.25/Doz. + 12 FREE
- 2 1/2" x 16" ... \$17.95/Doz. + 12 FREE
- 3" x 18" ... \$18.25/Doz. + 12 FREE
- 3" x 21" ... \$19.25/Doz. + 12 FREE
- 3" x 24" ... \$19.75/Doz. + 12 FREE
- 4" x 21" ... \$23.50/Doz. + 12 FREE
- 4" x 21 3/4" ... \$23.75/Doz. + 12 FREE
- 4" x 24" ... \$24.00/Doz. + 12 FREE
- 4" x 36" ... \$28.75/Doz. + 12 FREE
- 6" x 48" ... \$37.50/1/2 Doz. + 6 FREE

Other size belts on request.
 Belt Cleaning Stick \$4.95 each

For Fast Delivery Call Toll Free
1-800-428-2222 (U.S.A.)
1-800-222-2292 (PA only)

9" x 11" PAPER SHEETS A/O or Garnet Cabinet Paper

	50 PACK	100 PACK
40-D ...	<input type="checkbox"/> \$17.00	<input type="checkbox"/> \$32.00
50-D ...	<input type="checkbox"/> \$16.00	<input type="checkbox"/> \$29.00
60-D ...	<input type="checkbox"/> \$15.00	<input type="checkbox"/> \$27.00
80-D ...	<input type="checkbox"/> \$14.00	<input type="checkbox"/> \$25.00
100-C ...	<input type="checkbox"/> \$13.00	<input type="checkbox"/> \$23.00
120-C ...	<input type="checkbox"/> \$13.00	<input type="checkbox"/> \$23.00
150-C ...	<input type="checkbox"/> \$13.00	<input type="checkbox"/> \$23.00

No Lead Finishing Paper (White)

120-C ...	<input type="checkbox"/> \$14.00	<input type="checkbox"/> \$24.00
150-C ...	<input type="checkbox"/> \$14.00	<input type="checkbox"/> \$24.00
180-A ...	<input type="checkbox"/> \$11.00	<input type="checkbox"/> \$19.00
220-A ...	<input type="checkbox"/> \$11.00	<input type="checkbox"/> \$19.00
280-A ...	<input type="checkbox"/> \$11.00	<input type="checkbox"/> \$19.00
320-A ...	<input type="checkbox"/> \$11.00	<input type="checkbox"/> \$19.00
400-A ...	<input type="checkbox"/> \$11.00	<input type="checkbox"/> \$19.00

SHIPPING CHARGES: \$4.75 Continental U.S.
Minimum Order \$25.00
PA Residents Add 6% Sales Tax.

MONEY ORDER CHECK
 MASTER CARD VISA

**INDUSTRIAL
BRASIVES CO.**
643 N. 8th ST. • READING, PA 19612

MADAME BUTTERFLY

A novel door harp with a popular theme. Parts Kit includes basic door harp kit plus plywood. You provide 3/4" stock.
#01312 Plans 3.50
#04312Z Plans & Parts 8.75
#04312 Parts Only: 5.75/Ea, 15.30/3, 44.50/10



TURNINGS

#16001 3-1/2" Shaker Peg	8.00/50, 14.00/100
#16021 2-1/2" Shaker Peg	7.50/50, 13.75/100
#16041 1-3/4" Shaker Peg	7.50/100, 15.00/250
#16081 1" Shaker Peg	5.50/100, 23.75/500
#18031 Large Candle Cup	9.50/50, 17.00/100
#18091 Brass Inserts	5.50/50, 9.00/100
#13106 3/4" dia. Wood Ball	5.20/50, 7.90/100
#13108 1" dia. Wood Ball	6.70/50, 10.90/100
#13112 1-1/2" dia. Wood Ball	15.25/50, 29.00/100
#13116 2" dia. Wood Ball	8.90/10, 42.00/50

WHEELS

#10648 1" x 3/8" Wheel	5.50/100
#10710 1-1/4" x 7/16" Wheel	7.50/100
#10812 1-1/2" x 1/2" Wheel	6.00/50, 10.50/100
#10914 1-3/4" x 9/16" Wheel	8.50/50, 15.00/100
#11016 2" x 5/8" Wheel	9.50/50, 17.00/100
#12001 7/32" Axle Peg	2.00/50, 3.10/100, 14.00/500

MISC. PARTS

#62501 Door Harp Tuning Pens	10.00/50, 17.00/100
#13156 3/4" Drilled Clapper Balls	5.00/50, 8.00/100
#62515 1/4-lb. #4 Door Harp Wire (540-ft.)	9.95
#33018 1-1/4"x1/8" Hrdwd. Heart	5.50/100, 12.50/250
#50321 1/2"x1-7/8" Pic. Hanger	4.00/100, 17.50/500
#50021 Self-Fastening Sawtooth	4.00/100, 17.00/500
#11601 2-1/2"x3/4" Flip-Flop Wheel	3.50/10, 15.00/50

(Made from White Birch)

CRAFTER'S MART

Box 2342-W • Greeley, CO 80632
64-Page CATALOG: \$2 with credit towards first order, free with any order. Check, MasterCard or VISA (include daytime phone, card no., exp. date & signature).
PROCESSING CHARGE: Continental U.S. \$4;
AK, HI, APO & FPO \$10; Canada \$16; Foreign 20% plus \$10 (U.S. Funds). CO Res. add 3% tax. No C.O.D.s.
PHONE ORDERS: 8am-5pm Mon-Fri, Mountain Time.
Information: (303) 351-0876

1-800-999-3445

Anytime Anywhere Anywood

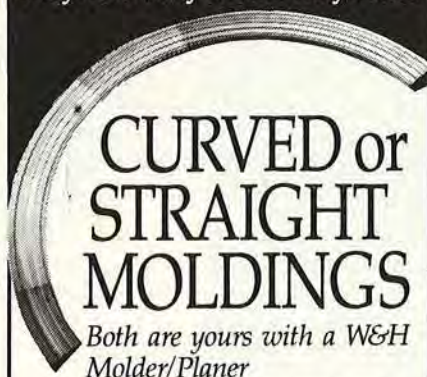

CURVED or STRAIGHT MOLDINGS

Both are yours with a W&H Molder/Planer

Thousands of professionals and serious woodworkers use our American-made cast iron molder/planers to produce smooth moldings, raised panels, crowns and curved molding.

In the shop or at the job site, W&H meets your needs every day with quick knife changeover and ultimate versatility with all kinds of wood.

Over 40 years of experience supports our products with a 5 year warranty! Call or write today for our FREE information kit!

800-258-1380 (USA) 603-654-6828
FAX 603-654-5446

Williams & Hussey
Machine Co., Inc.



Dept. 232BM
P.O. Box 1149 Wilton, NH 03086

BUILD THIS Heirloom Cradle

FROM A PRE-CUT
SOLID OAK KIT



Quality Woods

FREE Full color catalog gives you all the facts

Austin's Cradle welcomes a new grandchild into your family, then serves as a loving tie to new generations for many years to come. Easy to assemble from pre-cut oak wood parts. No special tools needed.

Please send my free Craftsman's Corner Catalog featuring Austin's Cradle and many other top quality oak kits. I understand I have no obligation.

Print Name: _____

Address: _____

City: _____

State: _____ Zip: _____

CRAFTSMAN'S CORNER
Dept. WC • 4012 N.E. 14th St. • Box AP
Des Moines, IA 50302

Turn on to Record Power!

A name synonymous with Quality and Performance for over 100 years, Record Tools now present their new line of Woodturning Lathes.



SHOWN WITH OPTIONAL BOWL TURNING ATTACHMENT

CORONET CL-3...The Latest Woodturning Lathe for the Professional or Craftsman

Heavy duty cast iron head & tail stocks combined with the solid 1-1/2" twin bed bars reduce vibration to a minimum. The main bearing is easily adjustable to eliminate all traces of float and it's silent running unlike roller bearings. It has a massive contact area with the shaft it supports, so it never needs replacing if kept properly lubricated and adjusted. The rotating head stock allows bowl turning up to 30" diameter (with the bowl turning attachment). Features 5 speed Poly-V Drive system. The CL3/36 comes with 10" single tool rest, and the CL3/48 a 17" double tool rest and extra tool rest base. See chart for specifications.

SPECIAL INTRODUCTORY OFFER!



Buy a CL1 or CL3 Record Lathe and receive this High Speed Steel Spindle and Bowl Turning Tool Set.

M.S.L. \$265⁷⁵

ABSOLUTELY FREE!

Cat. No. RP CHS8 Set of 8 Record HSS Turning Tools

OFFER IN EFFECT FROM JANUARY 1, 1992 TO MARCH 31, 1992. FOR A LIMITED TIME ONLY WHILE QUANTITIES LAST.

Record



Record Tools Inc.
1915 Clements Road, #1, Pickering, Ontario, Canada L1W 3V1

U.S.A. Toll Free: 1-800-267-8367

Don't miss your turn...

Hurry into your Record Dealer now to see these great Woodturning Lathes!

Coronet Woodturning Lathes are loaded with features:

- Heavy duty cast construction.
- 4 prong positive contact system.
- Choice of 36" or 48" turning between centres.
- Complete range of accessories.

Specifications	CL1 (not shown)	CL3
Distance between centres	36" or 48"	36" or 48"
Swing over bed bars	12"	12"
Swing over bench (with gap kit)	22"	—
Swing with bowl attachment	—	30"
Over all length	63" or 75"	64" or 76"
Spindle/tailstock bore	No. 1 M.T.	No. 1 M.T.
Spindle thread size	3/4" - 16"	3/4" - 16"
Spindle speeds	545, 1150, 2400	510, 750, 1120, 1650, 2400
Tailstock travel	1 1/4"	1 1/4"
Tailstock bore diameter	5/16"	5/16"

Motor Specifications:

Horse Power	1/2 TEFC	3/4 TEFC
Frame	Nema 56	—
Shaft	5/8" x 1 7/8"	5/8" x 4"
Weight (with motor)	158-176 lbs	190-200 lbs



Hurry in to your Record Dealer now to see these great Woodturning Lathes!

USA

ALBERT CONSTANTINE AND SON, INC. 2050 Eastchester Road, Bronx, New York, 10461 (212) 792-1600

ALBERT CONSTANTINE AND SON, INC. 1040 E. Oakland Park Blvd., Ft. Lauderdale, FL, 33334 (305) 561-1716

DURFEE HARDWARE 65 Rolfe Street, Crawston, R.I. (401) 461-0800

MASTER INDUSTRIAL SUPPLY, INC. 606 Main Street, Middletown, CT, 06457 (203) 346-7771

NORTHLAND WOODWORKING SUPPLY 65 Wurz Avenue, Utica, NY, 13502 (315) 724-1299

SHOPSMITH WOODWORKING CENTER 121 W. Nyack Rd., Unit 5, Nanuet, NY, 10954 (914) 624-0104

SHOPSMITH WOODWORKING CENTER 11000 Roosevelt Blvd., Philadelphia, PA, 19116 (215) 673-9227

STONE MOUNTAIN POWER TOOL CORPORATION 6290 Jimmy Carter Boulevard, Norcross, GA., 30071 (404) 446-8390

THE SOURCE 8815 Telegraph Road, Lorton, VA., 22079 1-800-452-9999

THE SOURCE 9205 Venture Court, Manassas, VA., 22111 1-800-562-7972

WHOLE EARTH ACCESS 2990 7th Street, Berkeley, CA., 94710 (415) 428-1600

WOODSMITH STORE 2625 Beaver Avenue, Des Moines, IA., 50310 (515) 255-8979

WOODWORKERS STORE AT SOUTH NORWALK 85 Water Street, South Norwalk, CT., 06854 1-800-422-2783

THE WOODCRAFTMAN'S STORE 2116 West Coliseum Blvd., Fort Wayne, IN., 46808 (219) 482-4822

WOODWORKING UNLIMITED 6038 E. 82nd Street, Indianapolis, IN., 46250 1-800-829-6419

WOODWORKING UNLIMITED OXFORD SQUARE SHOPPING CENTER 246 E. Semoran Blvd., Casselberry, FL., 32707 1-800-729-5045

WOODWORKING UNLIMITED UNION POINT SHOPPING CENTER 767 East Fort Union Blvd., Midvale, UT., 84074 1-800-788-5761

CANADA

ACKLANDS LTD. 12410 142nd St., Edmonton, Alberta T5L 4K2 (403) 453-3071

ACKLANDS LTD. 8651 Eastlake Drive, Burnaby, B.C. V5A 3X4 (604) 421-2311

ACKLANDS LTD. P.O. Box 950, 1402 Quebec Ave. Saskatoon, Saskatchewan S7K 3M4 (306) 244-6171

BARGAIN EQUIPMENT SUPPLY & TOOL LTD. 20460 Langley Bypass, Langley, B.C. V3A 5E7 (604) 534-4853

HOUSE OF TOOLS 100 Mayfield Common, Edmonton, Alberta T5P 4K9 (403) 486-0123

HOUSE OF TOOLS 136-8228 MacLead Trail SE, Calgary, Alberta T2H 2B8 (403) 258-0005

WOOD'N WORKS 460 2nd Ave., North, Saskatoon, Saskatchewan S7K 2C3 (306) 244-9663

PRODUCTS THAT PERFORM

Sensing metal in wood

While preparing to mount a vise on a laminated maple benchtop recently, I needed to locate—and avoid—the 1/2" all-thread rod I knew lurked unseen inside. An ordinary stud finder, which measures density, wasn't up to this job, but I found a tool that was.

The Zircon Voltage-Metal Sensor's red LED light and shrill tone alerted me to the rod immediately, even though it was under 1 1/8" of solid maple. I received the same results scanning for small screws under 1" of cherry.

There is a wide range of uses for this tool, including finding live electrical wires, metal pipes, and studs in the wall. For the home woodworker, it may prove most useful for checking recycled or



otherwise unusual boards for nails, brads, or other bits of wire before running the stock through the tablesaw, jointer, or planer.

It's also a good safeguard for checking turning blanks culled from your firewood pile. It's not only a good buy in terms of saving your tools, but also with regard to safety.

—Tested by Jim Boelling

Zircon Voltage-Metal Sensor, suggested retail \$21, available at ACE Hardware stores.



When the light's on, you're plugged in

You set a sheet of plywood on sawhorses and lay out your project's cutting lines. Then you plug your portable circular saw into the extension cord, slip on safety glasses, and pull the saw's trigger. Nothing happens, because your extension cord's not plugged in.

If this occasionally happens to you, you'll appreciate the LED Cord from Woods Wire Products. A warm orange glow from the LED indicator lamp in the clear rubberized receptacle end of the cord shows you have power. When changing a bit or blade, this light can warn you that the power tool you're working on is

plugged in and live. Incidentally, Woods says the LED lamp should last about 30,000 hours.

Even without the lamp, there's a lot to like about this cord. I tested the #14x50' version for several weeks in my basement workshop. Coiling some cords is like wrestling a giant boa constrictor. This one throws out flat and straight and rolls up without kinking or binding. The receptacle end also grips plugs tightly.

One final advantage I discovered applies to folks living in colder climates where you have to plug your car in to keep the engine from freezing on winter nights. With the extension cord running to the car, you only need to look out the window and check the glow to know there's juice to the engine warmer.

—Tested by Bob McFarlin

LED Cords, by Woods Wire Products, are available in homecenters and cooperatives. The suggested retail price for 50' cords: #14, \$18.56; #12, \$27.75. For 100' cords: #14, \$32.75; #12, \$47.58. For the location of a retailer near you, call 800/447-4364.

Continued on page 28

New Year, New Tools, New Beginning!



BOSCH

1581VS
Top Handle
Jig Saw W/Case
& 30 Blades
\$184



1581VS top handle jig saw 132
1582VS barrel grip jig saw 132
3050VSRK 3/8" vsr kit-2 batt 128
1370DEVSK 6" ran sndr kil299*
*above item Free Fed-Ex to 48 states!
3283DVS dusts rdm. sander 99
1273DVS 4x24 vs belt sndr 188
1604 1-3/4 hp router 129
1611EVS 3-1/4 hp vs pl. rtr 229

Makita

6095DWE
3/8", VSR,
W/Keyless
Chuck & Extra Battery
\$144



LS1030 10" miter saw 229
3612BR 3 hp plunge router 165
2012 12" planer w/dust ch 469
LS1011 10" comp mitre saw 439

PORTER-CABLE

7334
Random Orbital
Sander W/Case
& 2 Rolls Paper
\$149

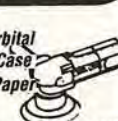

7334 5' random orbit sndr 118
7335 5' VS rand orbit sndr 129
7336 6' VS rand orbit sndr 134
555 plate jointr w/cs-500 bisc179
555 plate jointer w/cse 165
9853 12V VSR drill-keys chk 149
9345 6" Saw Boss kt 124
9637 VS Tiger Saw kit 139
7538 3-1/4hp plunge router 224
7539 3-1/4 hp 5 sp ping routr 265



RYOBI

BT3000 NEW!
10" Sliding
Table Saw
\$549



TSS220 8-1/2" comp. saw 439
AP10 10" portable planer 358
RE600 3 hp, vs pl. router 199
TS254 10" mit saw w/c.t. bl. 209
RS115 4-1/2" rand orb sander 75
R331 2 hp D-Handle router 129
JM100K NEW plate jointer 205
TFD220VRK 12v cdls kt/2 bat165



SKIL

2736-04
12V, Drill
W/2 Batt.
\$135



7484 5' rand orbital sander 109
1605 NEW plate jointer kit 119
77 7-1/4" worm drive saw 145

Elu

3338
2-1/4 HP
Electric VS
Plunge Router
\$245



3380 joiner/spliner w/case 245
1703-1 10" miter saw 188
1707 8-1/2" comp saw 399

HITACHI

C8FB
8-1/2" Compound
Mitre Saw
\$439



P12RA 12" planer/6" jointer 799
C10FA 10" miter saw 269
M12V 3-1/4 hp vs pl. router 224

Milwaukee

6527 NEW!
Super Sawzall
\$165



0402-1 12V vsr kt w/keyls ch 165
6125 5' random orbital sander 129
6368 7-1/4" saw w/ct bl.cs, fnc135

POWERMATIC

1660760
66 Saw 3 HP
W/50" Biesemeyer
\$1699



1791000 63 saw w/Vega fnc 699

freud

JS-100
Jointing System
W/Case
\$159



FT2000 3-1/4 hp pl. router 175
1703-1 10" miter saw 188
EB100 edge banding system 229

WOOD / Feb. '92

1-800-358-3096

FAX US YOUR ORDER!
1-701-746-2857

TOOL CRIB

OF THE NORTH
DIVISION OF

Box 1716 • Grand Forks, ND • 58206
Send \$3.00 For 208 Page Catalog

FREE FREIGHT IN 48 CONTIGUOUS USA • SAME DAY SHIPPING • ERRORS AND PRICES SUBJECT TO CHANGE

PRODUCTS THAT PERFORM

Continued from page 27

Gun handle takes the cramp out of using spray cans

With improved paints and wider spray patterns, today's canned spray paints go beyond just small jobs or touch-up work. They now take on bigger roles in the finishing of large furniture pieces and metal work. With these assignments, not only do you have to maintain the proper distance, speed, and overlap while spraying, but eventually, your finger cramps from pushing the small button on top of the can.

To the rescue comes the Tru-Test Can-Gun, a comfortable plastic handle that locks securely into the spray-can top, providing you with a trigger mechanism that holds down the spray nozzle. You regulate the spray by pulling the trigger fully or partially.

I use the gun handles in my auto-body shop to apply messy undercoatings and strippers. They let me spray on material evenly, and, better yet, I found I can re-use the durable gun handles through hundreds of cans.

For a meager two bucks, moderate spray-can users can benefit from this product and feel good about their investment. For those of you who do a lot of spraying, or who regularly apply messy or caustic materials, this may be one of the smartest buys you'll make this year.

—Tested by Bob McFarlin

Tru-Test Can-Gun, by SafeWorld Int'l, Inc., about \$2 at True Value Hardware stores.



Wood-Mizer

World's Largest Manufacturer of Portable Sawmills

Own a Sawmill!

Start a Profitable Business!

Save money cutting your own lumber, make money cutting for others.

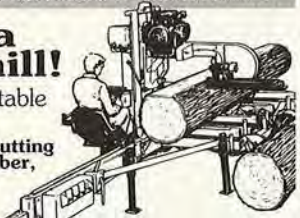

1-800-553-0219

32 Page Full Color Catalog - \$2.00
66-minute demonstration video - \$10.00
MasterCard or Visa accepted

8180 West 10th Street • Dept. QQ58
Indianapolis, Indiana 46214-2400

Wood Moisture Meter

pocket-size
MINI-LIGNO
Range: 6-20%
in 1% steps
Size: 1"x2 1/4"x5 1/4"

\$110
only

Including
Case, Battery, Pins for
3/16" or 7/16"
measuring depth.

Also available as
Mini E, 6-36%

Lignomat USA Ltd.
503-257-8957 800-227-2105

P.O. Box 30145
Portland, OR 97230



BUILD YOUR OWN QUEEN ANN FURNITURE

JUST ASSEMBLE OUR KITS



SOLID CHERRY, OAK
MAHOGANY, WALNUT
FREE BROCHURE
No Minimum Required

DESIGN YOUR OWN!

with our wide variety of stock legs



Adams Wood Products, Inc.
974 Forest Drive, DEPT. M10
Morristown, TN 37814 • Phone 615-587-2942



3-in-1 Shop Helper: lots of tool for the money

Leichtung says the Helper performs the functions of a centerline finder, a stopblock, and a doweling jig—all for the price of one tool. The opposing thread pattern on the lead screw—the heart of this tool—automatically centers it in any of the three modes.

During my tests, the tool fastened securely as a stopblock—and as a hold-down—on fences ranging from 1/4" to 2 1/2" thick. A movable, locking rod made fine adjustment here a snap.

By replacing the rod with a pencil, I could draw a centerline bisecting stock as thick as 2 1/2". That makes the Helper a handy tool for lining up mortise drill holes or spline slots.

Set up as a doweling jig, the Shop Helper let me drill centered holes on board edges, and on



ends cut at any angle. It even adjusts for boring at a compound angle, if that's what you need. Quick-change hardened steel bushings for 1/4", 5/16", and 3/8" drill bits come with the Helper.

—Tested by Bob McFarlin

3-in-1 Shop Helper, catalog no. 96347, \$34.98 ppd., from Leichtung Workshops, 800/321-6840. For the Shop Helper with an extra set of bushings, order catalog no. 96347 and catalog no. 99572, for \$38.97 ppd.

Continued on page 30

INTRODUCING...

The Wood'E™

FROM LABORSABER®

RETRACTABLE SAW
BRINGS IT ALL
HOME!

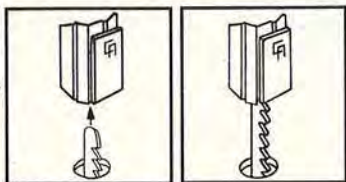

WORKS FROM THE BOTTOM UP...AND INSIDE OUT!

The Saw That Changed An Industry
Now available in an economy priced Professional
model for your WOODWORKING SHOP!

Intricate scrolling, fine woodworking, complex shaping and cutting without making an access cut - this is what the LABORSABER® RETRACTABLE SAW has been doing for industry for over 20 years! Now, a scaled version of this industry leader is available for your home woodworking shop at a price that makes owning this quality saw even more valuable.

VIDEO AVAILABLE!

CALL OUR TOLL-FREE NUMBER **1-800-331-6480**
FOR MORE INFORMATION

DIANSUPPLY / LABORSABER COMPANY

4505 GREEN PARK ROAD • ST. LOUIS, MISSOURI 63123 • 314-892-8597 • FAX: 314-892-6814
LABORSABER, E-SERIES, The Wood'E and "The Saw That Changed An Industry" Are Registered Trademarks/Slogans of Diansupply/Laborsaber inc.



Fine Craftsmanship Deserves the Very Best.

Craftsmanship begins with the idea. The final result depends on the tool and the craftsman. Atrax tools are made from premium fine-grade carbide, the best on the market today. Atrax offers over 600 styles and sizes to bring the craftsman's ideas to quality results.

**ATRAX Tooling
Provides Results.**

For a catalog or
Information call:
1-800-237-3521



ATRAX

Distributor inquiries invited.

Continued from page 29

A new angle on miter-cutting molding

Miter-cutting moldings on a table-saw represents a special challenge. Either you carefully set and reset your tablesaw gauge to get perfect cuts, or rely on more costly miter accessories. But with every resetting, you run the risk of altering your angles ever so slightly.

Now, Leichtung Workshops says its Perfect Miter Square lets *anyone* cut perfect 90° angles on moldings and frames with one easy setup. It resembles two standard gauges joined at the corner to form an exact, rigid right angle.

In my tests, I found that the Miter Square fit snugly in my Craftsman tablesaw miter gauge channel. When using it, I set the accessory just once. Then, I placed a molding piece against one gauge face for the first cut; I cut the mating molding using the other gauge face. To check my

work, I fit the two pieces in the corner of a square. The joint was always flawless.

In all, the tool proves quite forgiving. Your second cut will always compensate for any deviation from a 45° setting to give you that 90° corner.

I needed a wooden auxiliary fence on my gauge to keep the moldings from slipping as I cut. The Miter Square comes with plans for a wooden, jig that should help secure your workpiece against the gauge and cut opposing frame parts to the same length.

For the person who makes a lot of picture frames or square mitered corners, this tool could be a real asset. But for making hexagonal or octagonal frames, the accessory loses its advantage over the standard gauge. As for longer room moldings and door frames, most



folks prefer to cut these with a radial-arm saw or a miter saw.

—Tested by Bob McFarlin

Leichtung Workshop's Perfect Miter Square No. 26625 (for Sears models), or No. 29363 for DeWalt, Rockwell, and Delta saws, \$55.98 ppd. Call 800/321-6840. 📞

Quality Woodworking Machines at Affordable prices from Penn State Industries

Dept. B, 2850 Comly Road • Phila, Pa. 19154 • Info: 215-676-7609
 Order Toll Free 1-800-288-7297 • Visa, Master, & Discover Cards accepted
 When ordering - Add UPS Shipping Charges as noted • Pa residents add 7% Sales Tax
 Call or Write for our New 24 Page Color Catalog



Two Way Sanders

Features of both models:
 • Dust collector on belt
 • Tables tilt to 45°
 • Sealed ball bearings
 • Easy belt tracking

6x9 Sander:

• Includes stand
 • 9" Disc • 6"x48" Belt
 • 3/4 HP, 1720 RPM
 • Free Belts & Discs worth \$21.00
 #S69 ... \$219.95 (UPS \$30)

4x8 Sander:

• 8" Disc • 4"x36" Belt
 • 1/3 HP, 1720 RPM
 • Free Belts & Discs worth \$14.00
 #S48 ... \$109.95 (UPS \$8)

ON SALE



Super 125 Planer only \$359.95

This machine will pay for itself time and again by planing your own wood. Finishes wood like machines many times its price.

• Portable at 65 lbs
 • 26.2 fpm power feed
 • HSS Knives 12-1/2" wide
 • Motor: 16Amp, 8000RPM 2HP, 115V
 • 1/8" Max depth of cut

#PLA \$359.95 (UPS \$15)
 Extra Knives ..\$25/pair
 Dust Chute ... \$15/ea (UPS \$3)
 Stand \$39/ea. (UPS \$6)

ON SALE



Variable Speed Scroll Saw only \$169.95

Cuts intricate patterns in many different materials. Electronically controlled motor gives full power at all speeds 400-1800cpm. **FREE ACCESSORIES:**

Dust blower • 1 dz blades
 • EZ Set permanent top arm blade holders • EZ jig to attach standard holders • 4 blade holders • Neptune 1-1/2" lettering guides w/6 patterns

Specifications:

• Motor: 1.3 Amp, 110V
 • Throat: 15" deep • Stroke-3/4"
 • Tilt 0-45° left • Cut Depth: 2"
 • Blades: uses pin & plain end

#SVS \$169.95 (UPS \$10)

NEW



Dust Collectors 750 CFM Portable Dust Collector:

This 1-1/2HP model is lightweight and portable at less than 50 lbs.

• 1-1/2HP, 110/220V • 1 outlet @ 4" • 1 Bag @ 20 gal • Wt: 46 lbs • 750CFM • Free: 8' of hose, 1 ea 4" to 3", 1 ea 4" to 2" adaptor.. \$15Value

#DC3 \$209.95 (UPS \$10)



900 CFM Dust Collector:

This 1-1/2HP model allows for use in 2 or more machines & gives improved service for long runs of hose.

• 1-1/2HP, 110/220V • 2 outlets @ 4" • 2 Bags @ 30 gal
 • Wt: 120lbs • 900CFM • Free: 50' of hose, 1 ea 4" to 3", 2 ea 4" to 2" adaptors.. \$40Value

#DC2 \$299.95 (UPS \$30)



610 CFM Dust Collector:

This collector is perfect for hook-ups to almost any single machine.

• 1HP, 110/220V • 1 outlet @ 4" • 2 Bags @ 20 gal
 • Wt: 75lbs • 610 CFM • Free: 8' of hose, 1 ea 4" to 3" & 4" to 2" adaptors.. \$15 Value

#DC1 \$199.95 (UPS \$20)

YESTERDAY'S TOOLS

THE MARVELOUS MITER TRIMMER

You can *really* cut corners with this old-timer

 Print this article



Few results please a woodworker more than tight-fitting miter joints. That's why, over the decades, toolmakers have designed many devices for cutting them. But nothing else can rescue a sloppy miter more handily than the cast-iron miter trimmers, manufactured since the Civil War. Craftsmen still use them to clean up miters, bevels, and square cuts in stock as wide as 6".

Miter trimmers feature a pair of removable knives in a V configuration, with adjustable gauges that stop at 90° and 45°. You can set the gauges to trim frame pieces for hexagons or other polygons.

Evolved from planes

Miter trimmers evolved from planes used with wooden or iron guides called chute boards, or shooting boards. Early trimmers used a knife or large plane iron on a long handle that pivoted below a worktable.

The trimmer shapes perfect angles by shaving thin slices of wood from ends of already miter-cut stock. Those post-Civil War machines, like the Oliver trimmer *above*, and those that followed, can slice about one degree or 1/16" per pass to correct an angle or length. The resulting true and super-smooth surface leaves no obstruction to a perfect joint.

By the turn of the century, the Pootatuck Machine Works' Lion trimmer was most popular among

carpenters and in small shops. Fay & Egan, Fox, and Oliver made similar machines.

Buying an antique trimmer

When searching for a good used trimmer, avoid any with broken or missing parts. And ask if there's an extra set of knives (one to sharpen, one to use). Expect to pay \$75 to \$150 for an antique trimmer in good condition, more for an Oliver or special ornate model. (New ones cost twice as much.) If you can't get your blade sharpened locally, or want it done by a miter-trimmer specialist, check with Pootatuck Corporation's Suzanne Nothnagle at 802/674-5984. Plan on cleaning, adjusting, and lubricating your trimmer for smooth operation.

Six tips for good trimming

Many craftsmen like the old trimmers better than the new ones, but either way, your miters are sure to improve when you use one in the following manner.

- Keep the knives sharp.
- Don't force the tool.
- When necessary, take several thin cuts to get down to your line.
- Set the gauges using scrap first.
- Check the angle with either a square or a bevel.
- Cut the largest or longest pieces first, and then the shortest, trimming to length and adjusting the gauges slightly as necessary. ♣

Photograph: Tim Murphy

MAKE POPULAR COUNTRY SHADOW BOXES



Display your small treasures in style!

EASY FULL SIZE PATTERNS FOR 16 ORIGINAL DESIGNS #SBX-\$11.50
Catalog of 1000 Original Designs-\$1.00 (FREE w/order)

The Winfield Collection, Dept W22
1450 Torrey Road, Fenton, MI 48430

WOOD PATTERNS

3-D PLAQUES-MOBILES-YARD ORNAMENTS
Each Pattern Given in 3 Sizes

- * FISHES
- * CAROUSEL HORSE
- * EAGLE
- * BUTTERFLY
- * CASTLES
- * ANGEL
- * SEA HORSE
- * DOLPHINS

\$4.50 each or 3 for \$12.00 ppd.
\$1.00 for pattern list only
ca. res. add 6%

HOUSE OF STARR

P.O. BOX 783 ANGELS CAMP, CA. 95222

WOOD TOY

- * Patterns
- * Parts
- * Wheels
- * Many New Patterns to Choose from.
- * Executive toys



SEND \$1.00 FOR NEW CATALOG & RECEIVE COUPON FOR FREE WHEELS & AXLE PEGS.

toys and joys

Box 628W Lynden, Wash. 98264

Simple to Build!
Great Gift Idea!
\$9.95 + S&H

THE ONIT



Impresses everyone!
Easy to make multi-purpose Furniture. Just flip it over and it turns into a Chair, Step Ladder or Ironing Board.

ONIT PLANS, \$9.95, plus \$1.50 (S&H)
Hardware Kit, \$9.50, plus \$3.50 (S&H)

MONEY BACK GUARANTEED

GOLD COUNTRY WOODWORKS Dept. WF2
1615 Wimbledon Dr., Auburn, CA 95603

MAKE BEAUTIFUL RAISED PANEL DOORS WITH YOUR . . . 1/4" or 1/2" ROUTER . . . 1/2" or 3/4" SHAPER

Professional production quality bit makes it quick and easy to produce matching rails and stiles — the panel raising bit with ball bearing guide makes the raised panel perfect every time.

SALE PRICE
FOR COMPLETE SET \$69⁹⁵ Regular value over \$150.00!

1/4" Shank set item #554 (includes all bits shown below)

SET ALSO AVAILABLE IN 1/2" SHANK - \$79.95 - Item #852

Shaper Cutters set:
Item #1059
SAVE! only \$99.95
Set: Rail & Stile & Raised Panel Cutters

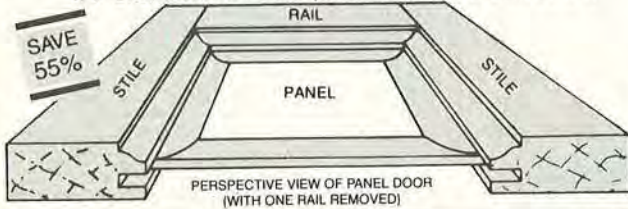

RAISED PANEL BIT
SUPPLIED WITH BALL BEARING



REVERSIBLE COMBINATION RAIL and STILE BIT

(For making matching rails and stiles in raised panel doors, etc.) Works with stock from 11/16" to 7/8" thick



CARBIDE TIPPED ROUTER BITS • PROFESSIONAL PRODUCTION QUALITY GUARANTEED WHEN ORDERING ANY THREE OR MORE DEDUCT \$1.00 EACH. • FREE SHIPPING IN CONTINENTAL U.S.

ITEM NO.	BEST CUT BEST PRICE	DESCRIPTION	ANGLE/DEPTH/RADIUS CIRCLE DIAMETER	LARGE DIA.	CUTTING LENGTH	SHANK SIZE	PRICE	ITEM NO.	BEST CUT BEST PRICE	DESCRIPTION	ANGLE/DEPTH/RADIUS CIRCLE DIAMETER	LARGE DIA.	CUTTING LENGTH	SHANK SIZE	PRICE
#601	Solid Carbide	1/8" Spiral Cutter		1/8"	1/2"	1/4"	\$ 9.00	#211	3/8" Core Box	round nose		3/8"	3/8"	1/4"	\$10.00
#603		1/4" Spiral Cutter		1/4"	3/4"	1/4"	\$12.00	#212	1/2" Core Box	round nose		1/2"	1 1/32"	1/4"	\$13.00
#903		1/4" Spiral Cutter		1/4"	3/4"	1/2"	\$12.00	#418	3/4" Core Box	round nose		3/4"	5/8"	1/4"	\$15.00
#904		3/8" Spiral Cutter		3/8"	1"	1/2"	\$24.00	#213	1" Core Box	round nose		1"	3/4"	1/2"	\$17.00
#905		1/2" Spiral Cutter		1/2"	1 1/2"	1/2"	\$29.00	#548	Lockmitre			2"	7/8"	1/4"	\$32.00
#530		3/16" Edge Beading	3/16" Dia. of Circle		1/2"	1/4"	\$15.00	#214	1/4" Straight	plunge cutting		1/4"	3/4"	1/4"	\$ 6.50
#531		5/16" Edge Beading	5/16" Dia. of Circle		1/2"	1/4"	\$15.50	#216	3/8" Straight	plunge cutting		3/8"	1"	1/4"	\$ 6.50
#350		1/8" Round Over	1/8" R	3/4"	3/8"	1/4"	\$11.00	#474	1/2" Straight	plunge cutting		1/2"	1"	1/4"	\$ 7.00
#351		3/16" Round Over	3/16" R	7/8"	1/2"	1/4"	\$11.00	#219	3/4" Straight	plunge cutting		3/4"	1"	1/4"	\$ 9.50
#230		1/4" Round Over	1/4" R	1"	1/2"	1/4"	\$12.00	#779	3/4" Straight	plunge cutting		3/4"	1 1/2"	1/4"	\$10.00
#353		5/16" Round Over	5/16" R	1 1/8"	1/2"	1/4"	\$14.00	#462	1/2" Bull Nose	1/2" Dia. of Circle		3/4"	1/4"	\$16.00	
#209		3/8" Round Over	3/8" R	1 1/4"	5/8"	1/4"	\$15.00	#464	3/4" Bull Nose	3/4" Dia. of Circle		1"	1/4"	\$21.00	
#355		1/2" Round Over	1/2" R	1 1/2"	3/4"	1/4"	\$17.00	#764	3/4" Bull Nose	3/4" Dia. of Circle		1"	1/2"	\$21.00	
#655		1/2" Round Over	1/2" R	1 1/2"	3/4"	1/2"	\$17.00	#545	Tongue & Groove	Straight		1 5/8"	1"	1/4"	\$29.00
#656	3/4" Round Over	3/4" R	2"	7/8"	1/2"	\$21.00	#845	Tongue & Groove	Straight		1 5/8"	1"	1/2"	\$29.00	
#199		Multiform Moulding	Unlimited Patterns	2 1/4"	2"	1/2"	\$40.00	#546	Tongue & Groove	Wedge		1 3/16"	1"	1/4"	\$29.00
#205		1/4" Cove	1/4" R	1"	1/2"	1/4"	\$12.00	#846	Tongue & Groove	Wedge		1 5/8"	1"	1/2"	\$29.00
#206		3/8" Cove	3/8" R	1 1/4"	9/16"	1/4"	\$13.00	#450	1/8" Beading	1/8" R		3/4"	3/8"	1/4"	\$11.00
#207		1/2" Cove	1/2" R	1 1/2"	5/8"	1/4"	\$14.00	#233	1/4" Beading	1/4" R		1"	1/2"	1/4"	\$13.00
#643		1/2" Cove	1/2" R	1 1/2"	5/8"	1/2"	\$15.00	#454	3/8" Beading	3/8" R		1 1/4"	5/8"	1/4"	\$15.50
#208		3/4" Cove	3/4" R	1 7/8"	3/4"	1/2"	\$26.00	#455	1/2" Beading	1/2" R		1 1/2"	3/4"	1/4"	\$17.00
#231		5/32" Roman Ogee	5/32" R	1 1/4"	15/32"	1/4"	\$16.00	#500	3/8" Flush	Trimming		3/8"	1/2"	1/4"	\$ 7.00
#232		1/4" Roman Ogee	1/4" R	1 1/2"	3/4"	1/4"	\$17.00	#501	3/8" Flush	Trimming		3/8"	1"	1/4"	\$ 7.50
#506		1/2" Pattern	Flush Trim	1/2"	1"	1/4"	\$15.00	#503	1/2" Flush	Trimming		1/2"	1"	1/4"	\$ 8.50
#508		3/4" Pattern	Flush Trim	3/4"	1"	1/4"	\$17.00	#221	1/2" Flush	Trimming		1/2"	1 3/16"	1/2"	\$ 8.00
#366		1/8" Slot Cutter	3/8" Deep	1 1/4"	1/8"	1/4"	\$14.00	#558	Thumbnail			1 3/16"	3/8"	1/4"	\$18.50
#368		1/4" Slot Cutter	3/8" Deep	1 1/4"	3/4"	1/4"	\$14.00	#858	Thumbnail			2 1/2"	3/4"	1/2"	\$35.00
#204		3/8" Rabbeting	3/8" Deep	1 1/4"	1/2"	1/4"	\$13.00	#579	Molding Plane			1 1/8"	1 3/4"	1/4"	\$31.95
#670		3/8" Rabbeting	3/8" Deep	1 1/4"	1/2"	1/2"	\$14.00	#879	Molding Plane			1 1/8"	1 3/4"	1/2"	\$31.95

New 32-page catalogue featuring 100's of high-quality router bits, plus other professional woodworking products.

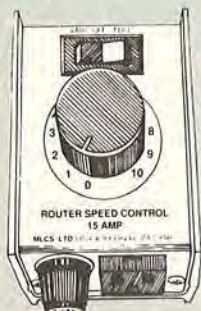

CONTROL THE SPEED OF YOUR ROUTER

ROUT AT THE SPEED THAT GIVES THE BEST RESULTS WITH THE WOOD AND BIT YOU ARE USING!

FEATURES:

- Speed Adjustable from Full Speed to 0 RPM
- Full Horsepower and Torque at All Speeds
- Go Back and Forth from Any Pre-Set Speed to Full Speed at the Flip of a Switch
- Works with All Routers 3/4 HP or Less
- 120V 15 Amp
- Gives Your Router a Feature Only Available on Routers Costing Hundreds of Dollars!

EASY TO USE - Simply plug in Speed Control and plug your router into the Speed Control - turn dial for best results. (Speed Control has a clip that can be worn on your belt or hung on wall or left loose.)

• Reduces speed electronically without reducing torque; electronic feed-back maintains speed by increasing voltage to motor as load increases.

NOW ONLY \$39.95
Order Item #200

Visit Our Fully Stocked Showroom
(Call for easy directions - 8:30-5:00, M-F)

While in the Phila. Area

To order by Master Charge, Visa, or Discover Call Toll Free, 7 Day - 24 Hour Order Service,
1-800-533-9298 or send check to: **MLCS Ltd., P.O. Box 4053D P, Rydal, PA 19046**

Rick Harney's depth-defying
tricks of perspective make him
**THE MASTER
ILLUSIONIST
OF RELIEF CARVING**

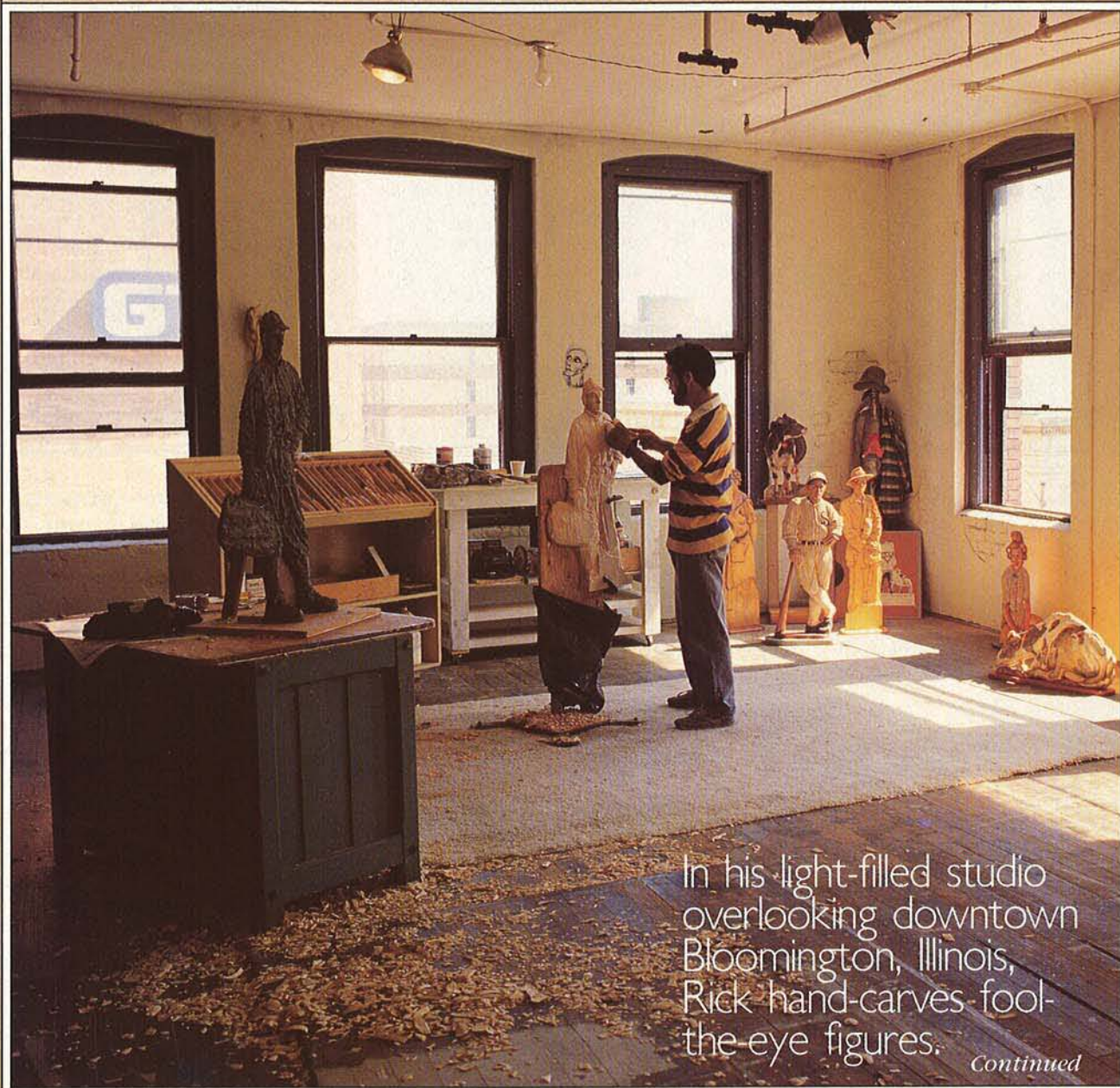

In his light-filled studio overlooking downtown Bloomington, Illinois, Rick hand-carves fool-the-eye figures.

Continued

Shoeless
Joe



Rick Harney sculpts like Norman Rockwell drew. Affectionately, realistically, and with great attention to detail, the woodcarver renders his whimsical three-dimensional portraits from small-town America.

In one corner of Rick's studio, *Shoeless Joe*, leans on his bat, as if he had just stepped out of the movie *Field of Dreams*. His uniform, its folds bathed in early-morning sunlight, links him to the 1919 Chicago White Sox. The lines in his face, though, express some uncertainty.

"Shoeless Joe Jackson was a tragic story," says Rick, who carved the figure in relief from a 1¼"-thick jelutong board. "He couldn't read or write, and he wore no shoes when he tried out for the team. Yet, he batted .375 in the fateful series."

Joe's glory days ended on the front pages of the nation's newspapers. According to Rick, he was tossed out of baseball for taking a \$5,000 bribe to throw the World Series against the Red Sox.

Shoeless Joe—or Rick's carving of him—can still be bought for around the same amount. Rick asks \$3,000 to \$5,000 apiece for his carvings.

Behind each of Rick's carvings lies a story. The woman in rollers, titled *Slumber Party*, represents his wife Betsy's best friend in college. But like most of his work, there's something familiar enough

Slumber
Party



When Rick Harney travels around the twin cities of Bloomington and Normal, Illinois, it's mostly by bicycle. Sure, he likes the fitness aspect, but he's also practical.

Rick, 37, rents a third-floor studio downtown, where, he says, "It's darn hard to find a long-term parking spot." Because of that, he hauls his bicycle up two flights of stairs and down a couple of winding hallways to park it. But Rick figures that's just part of an artist's toil, a road he chose to follow.

"I started out in college as a business major, because I had always been good with arithmetic and other calculations," he recalls. "But a few courses in art helped me to change my mind."

As a result, Rick dropped out for awhile and went to work with a church renovation firm in nearby Peoria, where his talent guided him to painting murals and sculpting statues in fiberglass. When he did complete his degree

from Illinois State University in 1986, it was in art.

Rick took to wood right away, but it wasn't until 1990 that his pieces received recognition from other woodcarvers. That year, his carving *Rough Draft*, see photo, left, took first place in relief at Davenport, Iowa's International Woodcarvers Congress. Then a few months later, he received another first place at a woodcarvers' competition in Branson, Missouri.

Rick, who works part-time in a paint store to pay for wood, art supplies, and loft rent (his wife Betsy works, too), looked forward to the \$1,150 prize money he had won. "But on the way back from Branson, my car blew its engine. And that cost \$1,900! It's all part of the struggle," he says.

about the person that you wouldn't have to know the story.

Everyone, for instance, has an aunt or neighbor lady who could have posed for *Frances*. And although *J. Clement Stone* is a portrait of the Chicago financier of the '50s, whose book on positive thinking impressed Rick, the face could be that of an insurance salesman or used car dealer. And it was the face that lured him.

"It was a real challenge to do a portrait in that scale, 24" tall and 18" wide," says Rick. "But Stone was just fascinating enough that I could stand to look at him for the two months it took to carve."

Rick's subjects usually come from old photographs of common everyday folks. He believes that's why people relate to them. Opening a photo album and pointing to a brown-tinted print, he says, "You just know that this person is someone's aunt, because she reminds you of yours."

Turning up the volume

Viewed head on from only a few feet away, Rick's work looks fully round. Yet, in the 6 years since his first carving, made from a 3/4"-thick board, none has exceeded 1 3/4" thick. "Come on, it *can't* be that thin!" most people insist.

How does he do it? "I add volume to the wood," the carver says matter-of-factly.

Of course, Rick's talking about visual volume—an optical illusion where something looks lifelike in depth, but really isn't. Look at the nose and the cap visor on *Shoeless Joe*, for instance, or the horse in *Rough Draft* with a view from muzzle to hindquarter. It's a fool-the-eye technique that begins before a gouge ever touches wood.

"First I make a quick sketch of the figure to give me an idea of the rough form or pose," explains Rick. "But, it's in the clay model that volume begins." Although few carvers make clay models, it makes good sense to Rick.

Continued



Frances ▶

▼ *J. Clement Stone*

▼ *Udder Contentment*

MASTER ILLUSIONIST



Left: Rick gets ideas for his carvings from old photographs. The photo he holds was the basis for *Fiber Test* resting on the floor in the background.

Top right: Rick's unorthodox, self-taught carving technique places his left hand against the wood.

Bottom right: Painted shading helps create the illusion of depth in Rick's carvings.

Below: A companion piece for *Shoeless Joe* will be Boston Red Sox catcher Bill Carrigan. Rick works on the original clay model for the figure.

Reality through exaggeration

"The deep lines I use are really a drawing technique," the carver explains. "I have to exaggerate the lines that define depths, and that's real critical. In the clay, I can get all the deep lines right, so that in the wood I don't make deep cuts in the wrong places."

Rick will spend about three days perfecting a clay model. The actual carving, though, may take as long as 3 months to complete, because, as Rick describes the technique, "It's a very slow, take-away process." Once though, Rick's pieces took even longer. That was before he won a 12-piece set of Henry Taylor gouges at the Davenport carvers' competition.

"When I started carving, I had only three ordinary carpenter's chisels from the hardware store," Rick remembers, amused. "I didn't know any carvers to give me advice."

Carving aches and pains

Rick knew little about wood, either. But all that has changed now, and his pieces emerge from pine, basswood, or jelutong that a local hardwood outlet planes and joints for him.



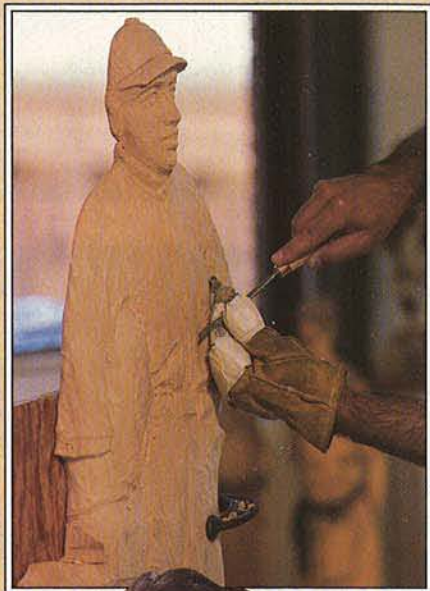

"My first pieces warped because they were made from one board," Rick admits. "Now, I glue up two or three boards to width. And, I'll glue in dowels where an area might need extra support—like on *Shoeless Joe's* bat. I also learned that I'll never carve poplar again." The thought makes him chuckle. "After carving *J. Clement Stone*, I had to take a few months off because I got tennis elbow so bad I couldn't carve a chip."

In addition to his fine set of carving tools, Rick uses a sabersaw, a die grinder, and a radial-arm saw. "I crosscut my wood on the radial-arm," he says, "then, I'll saw my pieces to rough, outline shape with the sabersaw. I use the

grinder to remove large areas of wood down to the critical stage."

Rick does, though, need his indispensable leather glove. "I never carve without it," he says, inspecting its battered surface. "You see, the work's real flat, and I'm right on top of it. I get in so tight with the chisels that it pushes my hand against the wood. Besides, I did catch the tip of a finger once."

Adding the glow of color

Rick's first carvings carried little more than a clear varnish, letting the lines and tool marks create the image. Then, he started accenting depth lines with stain. "Some of the carvers I had met around town said 'Oh, you got to stick with a clear finish so people can see the wood.' But I found out that on display, my pieces often almost vanished," he says.

Now, Rick's carvings carry solid coats of paint in some areas. "By highlighting and shading, I add to the depth," he explains. "Paint enhances the illusion."

The painting takes time, too. That's because Rick gradually builds the color up with thin coats. Rick uses a slow-drying blend of artists' oil colors thinned with varnish to wash consistency. "And if I don't like what I've done, I can take it off," he says.

Sometimes nothing beats the look of natural wood, which he used for the bodies of the sheep in *Fiber Test* and the figure's arms and face in *Rough Draft*. "There, I only added some tiny dabs of color," he says. "I keep experimenting, trying to get it right." And when it's right, it's a masterful illusion, like *Shoeless Joe* standing in the morning light. ♣

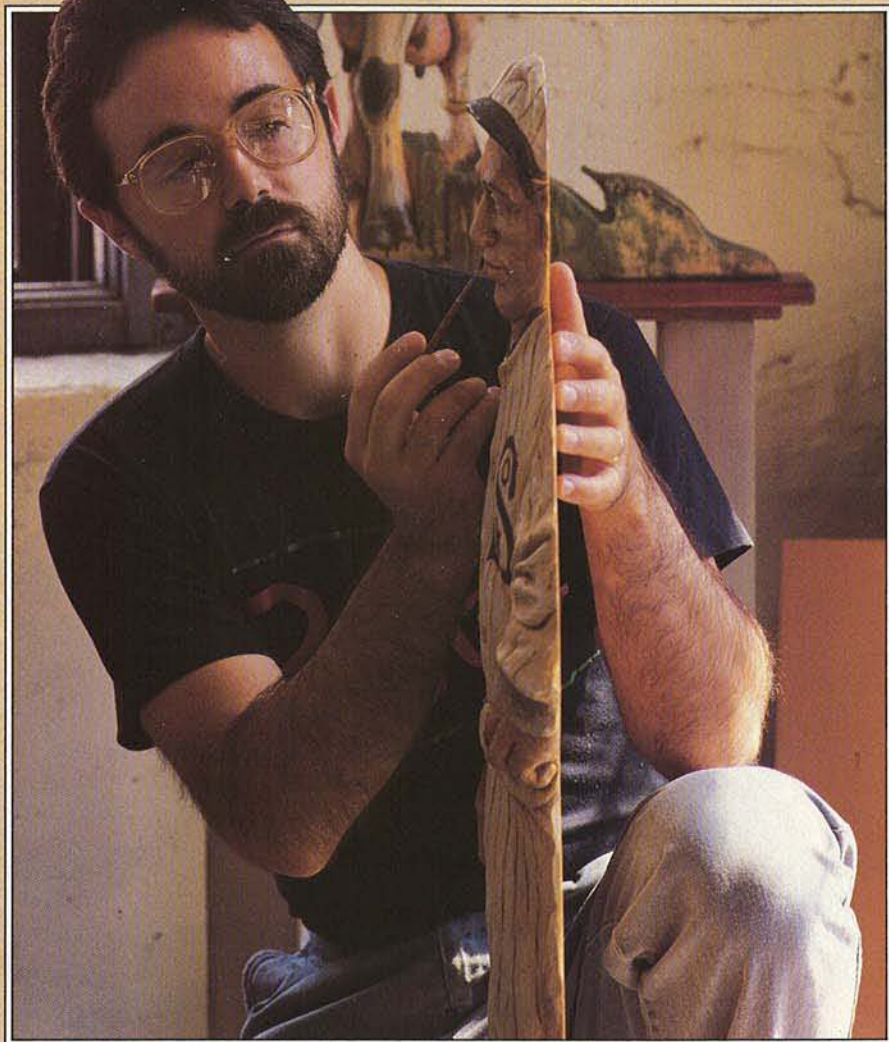

Want to contact Rick?

Write: Rick Harney
19 Payne Pl.
Normal, IL 61761

Written by Peter J. Stephano
Photographs: Todd V. Phillips

SHELVING

A NATURAL FOR

Fluted face-frame stiles and a richly molded top set the style for this full-length bookcase. On the practical side, its capacity may amaze you. As shown here, six shelves (five of which adjust on standards and brackets) measure $13 \times 38\frac{3}{8}$ " each, leaving more than enough room for three sets of encyclopedias. Once you build the bookcase, you'll find it the perfect accent for a home study, family room, or any other haunt where you enjoy reading.

Start with the basic cabinet

1 From $\frac{3}{4}$ " plywood (we used walnut), cut the sides (A) and top and bottom (B) to the sizes listed in the Bill of Materials. (To support the thin veneer fibers and minimize splintering when cross-cutting the plywood, we lightly marked the cutlines with a pencil. Next, we placed masking tape next to the cutlines, made the cuts, and then removed the remaining tape.)

2 Referring to the Basic Cabinet drawing, mark the rabbet and dado locations across the top inside edge and $5\frac{1}{4}$ " from the bottom edge of the sides (A). Cut or rout the rabbets and dados. (We used a router fitted with a straight bit and an edge guide.)

3 Cut a $\frac{1}{4}$ " rabbet $\frac{1}{2}$ " deep along the back inside edge of each side piece (A). See the Back Panel detail for reference. Now, cut a pair of $\frac{5}{8}$ " grooves $\frac{3}{16}$ " deep on the inside face of each side piece for the shelf standards. (We test-cut the groove in a piece of scrap stock



SHELVING SHOWCASE

Attach the face frame, and rout the molding groove

1 Glue and clamp the face frame to the cabinet. (Before clamping the face frame to the cabinet, we placed masking tape on the walnut plywood next to the joints being glued, so any glue squeeze-out dried on the tape. Later, after the glue dried, we peeled off the tape and excess glue. We've found this process easier than trying to remove the squeeze-out with a damp cloth or trying to scrape it off after it's dried.)

2 Mount a flush-trimming laminate bit into your router. Rout the $\frac{1}{16}$ " protruding outside edge of the stile flush with the outside face of the cabinet sides (A). (We found this more effective than trying to plane the edges flush.)

Continued

Cutting Diagram

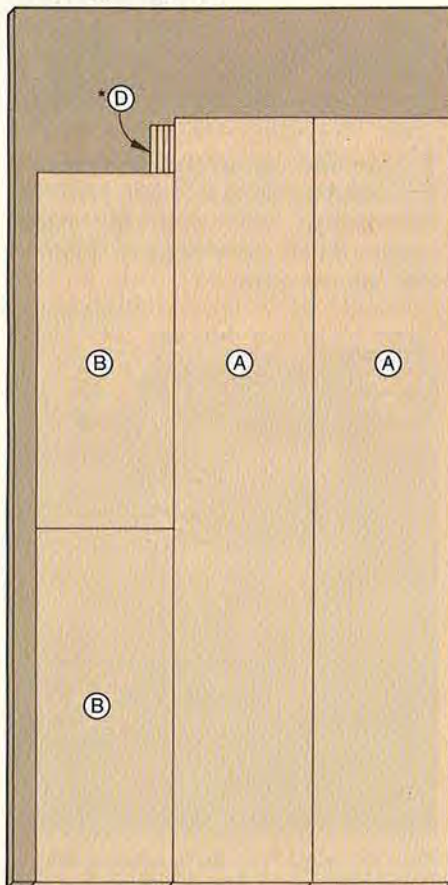

$\frac{3}{4} \times 48 \times 96$ " Walnut Plywood

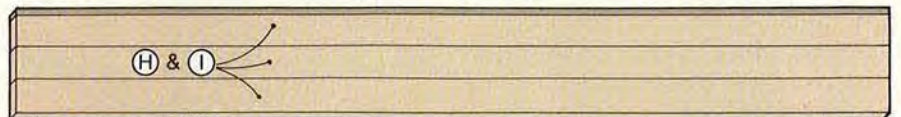
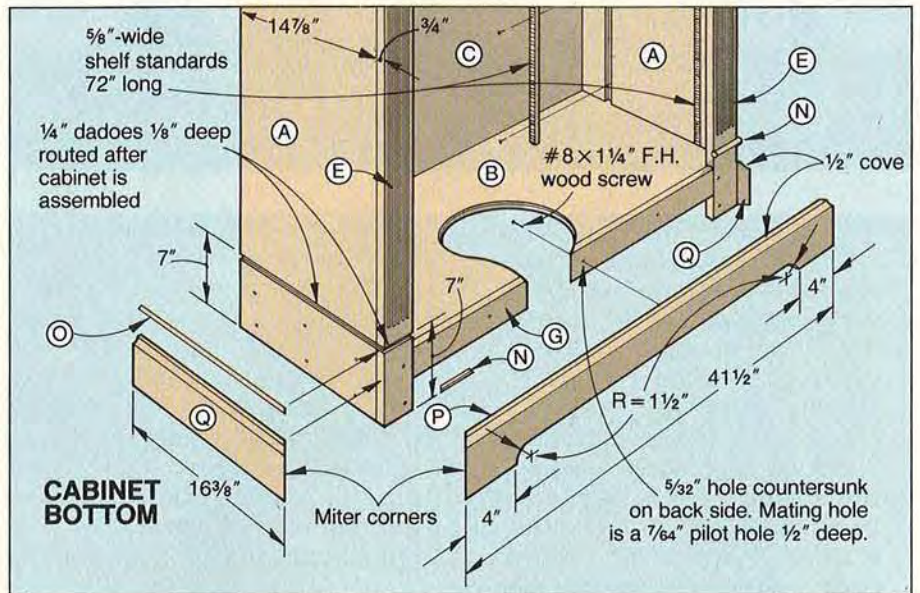

$\frac{3}{4} \times 11 \frac{1}{4} \times 96$ " Walnut

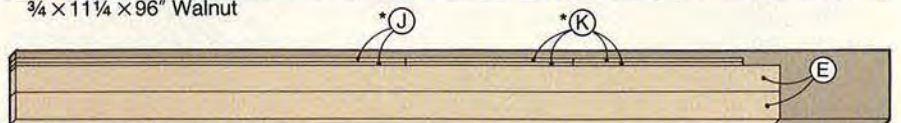

$\frac{3}{4} \times 7 \frac{1}{4} \times 96$ " Walnut

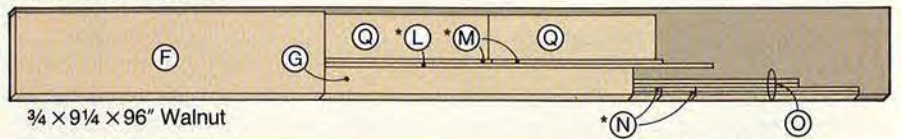

$\frac{3}{4} \times 9 \frac{1}{4} \times 96$ " Walnut

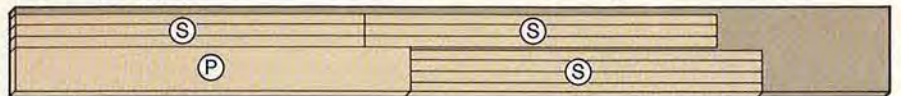

$\frac{3}{4} \times 9 \frac{1}{4} \times 96$ " Walnut

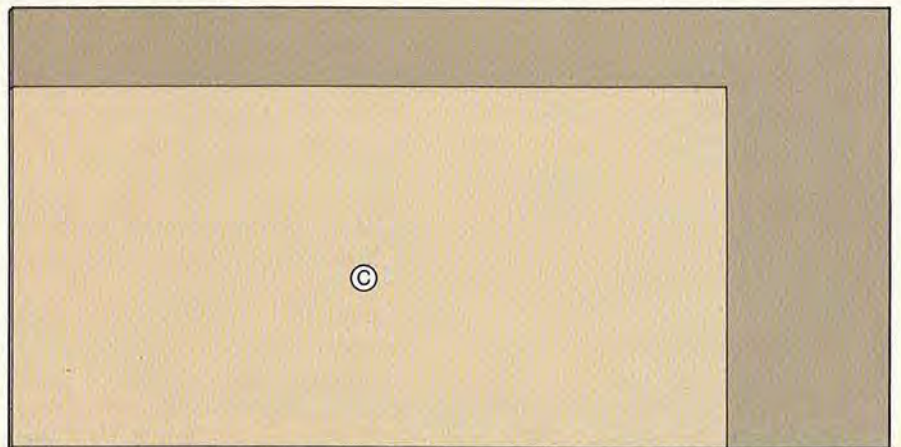

$\frac{1}{4} \times 48 \times 96$ " Walnut Plywood

*Plane or resaw to the size listed in Bill of Materials.

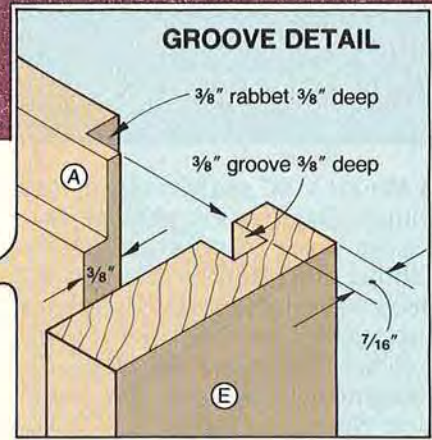
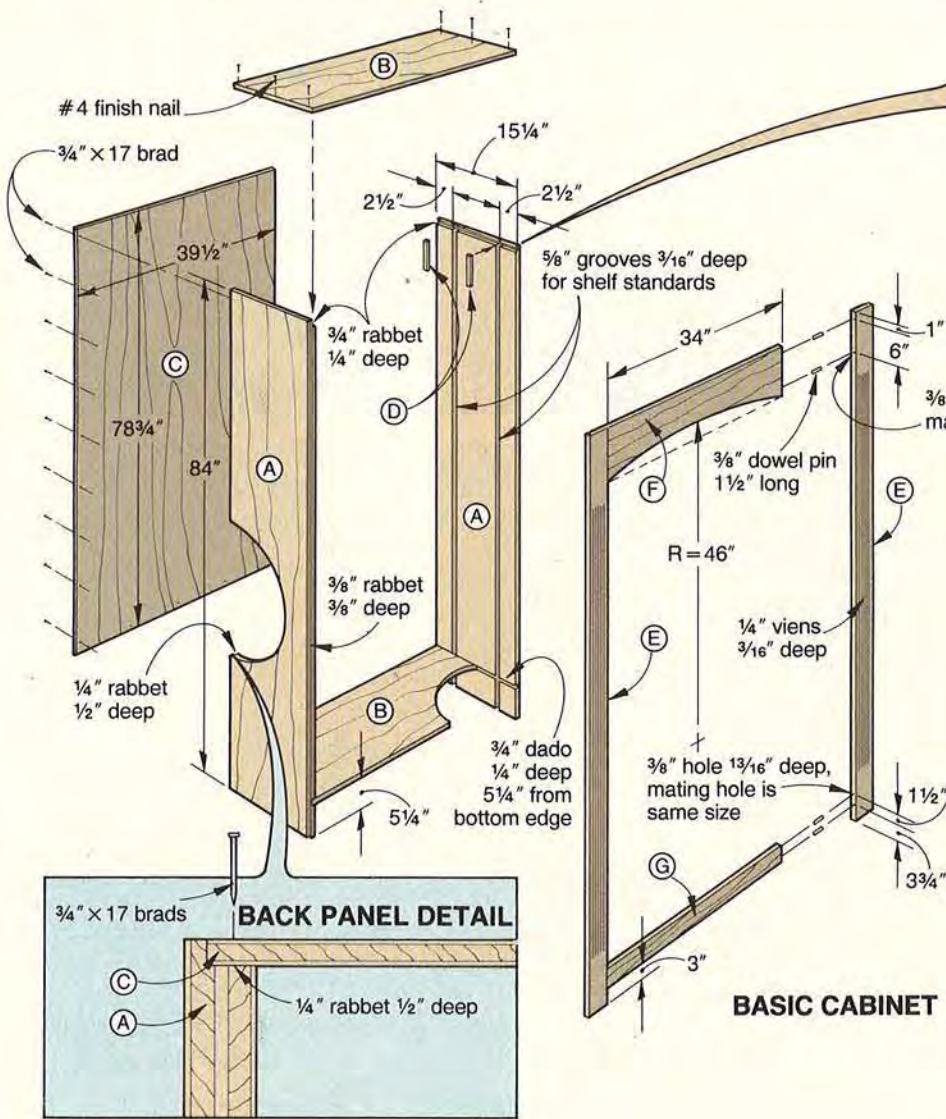

Bill of Materials

Part	Finished Size			Material	Qty.
	T	W	L		
BASIC CABINET					
A	3/4"	15 1/4"	84"	WP	2
B	3/4"	14 5/8"	39"	WP	2
C	1/4"	39 1/2"	78 3/4"	WP	1
D	3/16"	5/8"	5 1/8"	WP	4
E*	3/4"	31 1/8"	84"	W	2
F	3/4"	9"	34"	W	1
G	3/4"	3"	34"	W	1
MOLDING					
H*	1 13/16"	3"	44 1/4"	LW	1
I*	1 13/16"	3"	17 3/4"	LW	2
J*	1/4"	1/2"	41"	W	2
K*	1/4"	1/2"	16 1/8"	W	4
L*	3/4"	3/8"	40 3/4"	W	1
M*	3/4"	3/8"	16"	W	2
N*	3/8"	1/4"	3 1/4"	W	4
O*	3/8"	1/4"	15 7/8"	W	4
P*	3/4"	5"	41 1/2"	W	1
Q*	3/4"	5"	16 3/8"	W	2
SHELVES					
R*	3/4"	13"	38 3/8"	WP	5
S*	3/4"	1 1/4"	38 3/8"	W	10

*Initially cut parts marked with an * oversized. Then, trim each to finished size according to the how-to instructions.

Material Key: WP—walnut plywood, W—walnut, LW—laminated walnut

Supplies: 3/8" dowel pins 1 1/2" long, #8 x 1 1/4" flathead wood screws, #8 x 1 1/2" flathead wood screws, #4 finish nails, 3/4" x 17 brads, 5/8" x 72" flush-mounted shelf standards (walnut finish) with mounting brads and supports, finish.

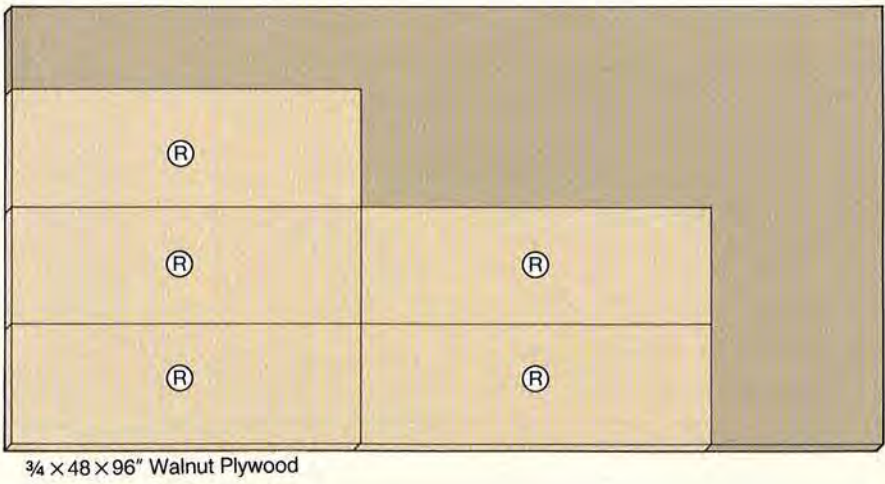

SHELVING SHOWCASE

3 Mount a $\frac{1}{4}$ " straight bit in your router. Clamp a straightedge (we used a piece of plywood) to the cabinet side. Clamp a straightedge (we used a piece of plywood) to the cabinet side. Rout a $\frac{1}{4}$ " dado $\frac{1}{8}$ " deep 10" from the top edge of the cabinet top where shown on the Cabinet Top drawing. Move the straightedge and rout the other side. Now, rout the front face. Using the Cabinet Bottom drawing for reference, rout the dado across the bottom of the cabinet.

Next, shape some cove molding for the cabinet top

1 To form the thick top cove molding, cut three pieces of $\frac{3}{4}$ "-thick stock to $3\frac{1}{2}$ " wide by 8' long. (This will give you enough stock for parts H and I.)

2 Glue and clamp the three pieces of stock face-to-face with the edges and ends flush.

3 Scrape the excess glue from one edge, and then joint it flat. Now, rip the opposite edge on your tablesaw for a 3" finished width.

4 Resaw or plane the lamination to $1\frac{1}{16}$ " thick.

5 Clamp a piece of straight stock to the top of your 10" tablesaw where shown on the drawing *bottom right*. Raise the blade $\frac{1}{8}$ " above the saw table surface, and pass the workpiece over the blade. Continue to raise the blade and take light cuts (no more than $\frac{1}{8}$ " per pass) until you achieve the full $\frac{1}{2}$ " depth of the cove. (We found that an 80-tooth, carbide-tipped blade produced the smoothest cuts.)

6 Follow the four-cut sequence on the *opposite page* to trim the edges of the molding to shape.

7 Miter-cut the front cove molding piece (H) and the two side pieces (I) to fit the front and sides of the cabinet.

8 Drill mounting holes through the cabinet for attaching the cove molding pieces (H, I). Glue and screw the pieces in place, flush with the top of the cabinet. (See the Cove Molding detail accompanying the Cabinet Top drawing.)

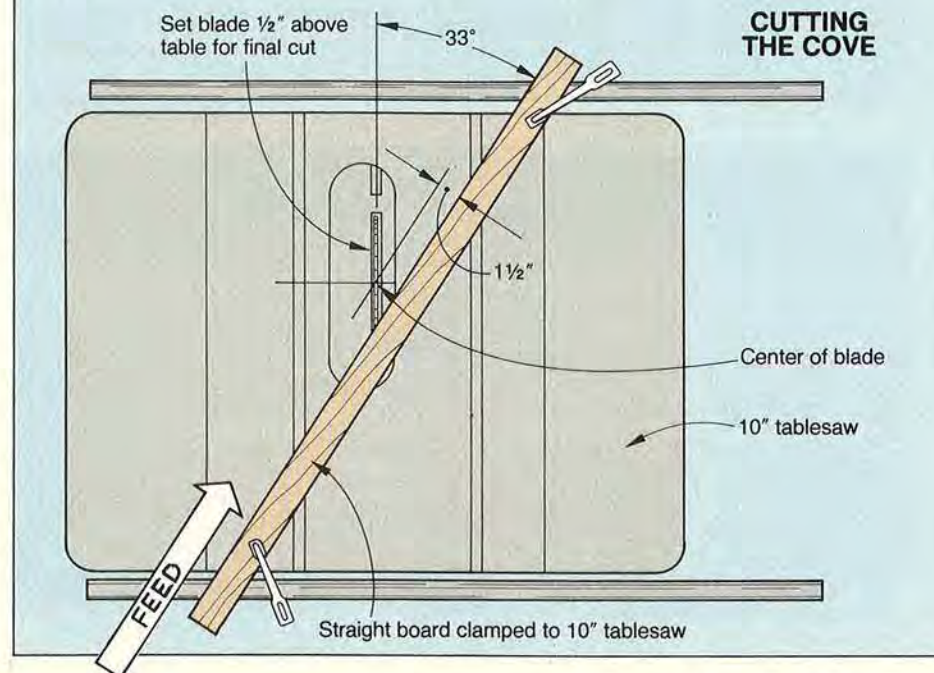
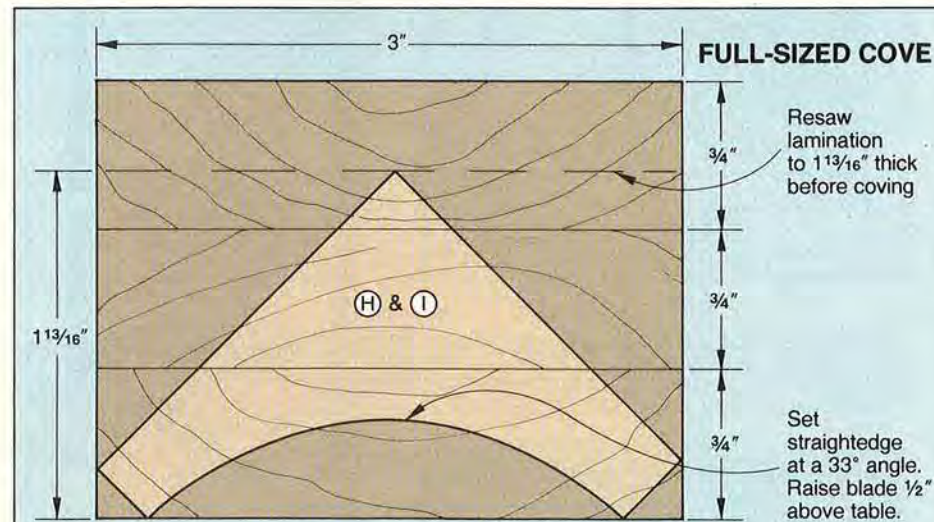
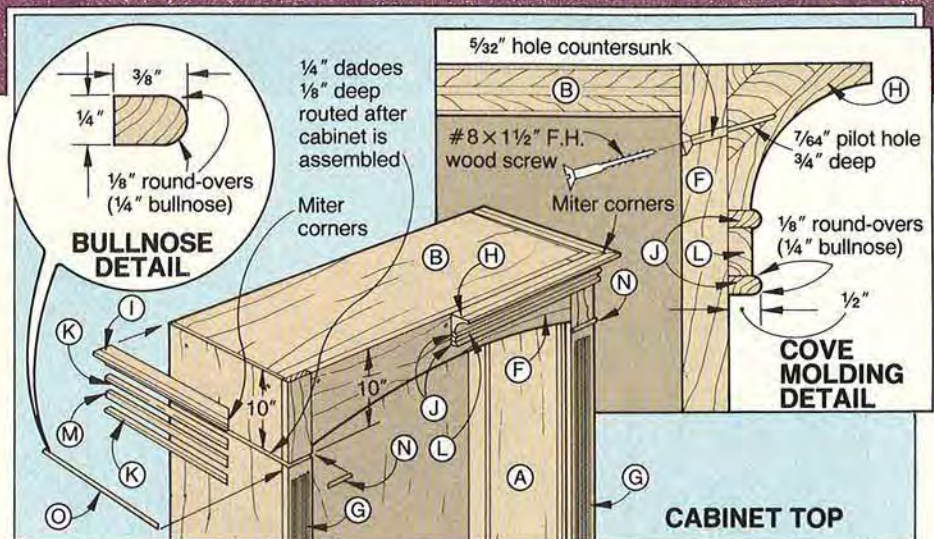

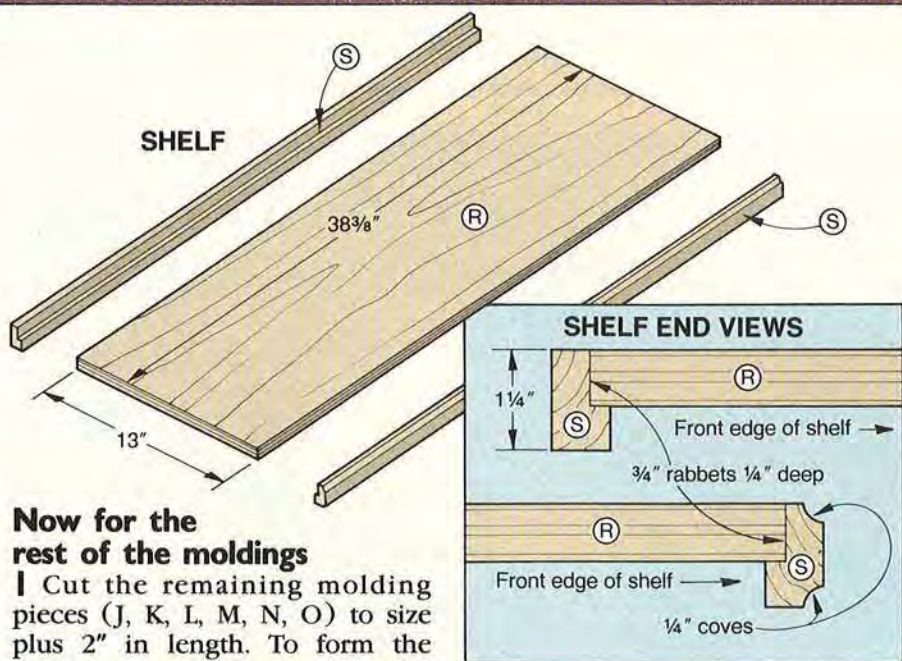
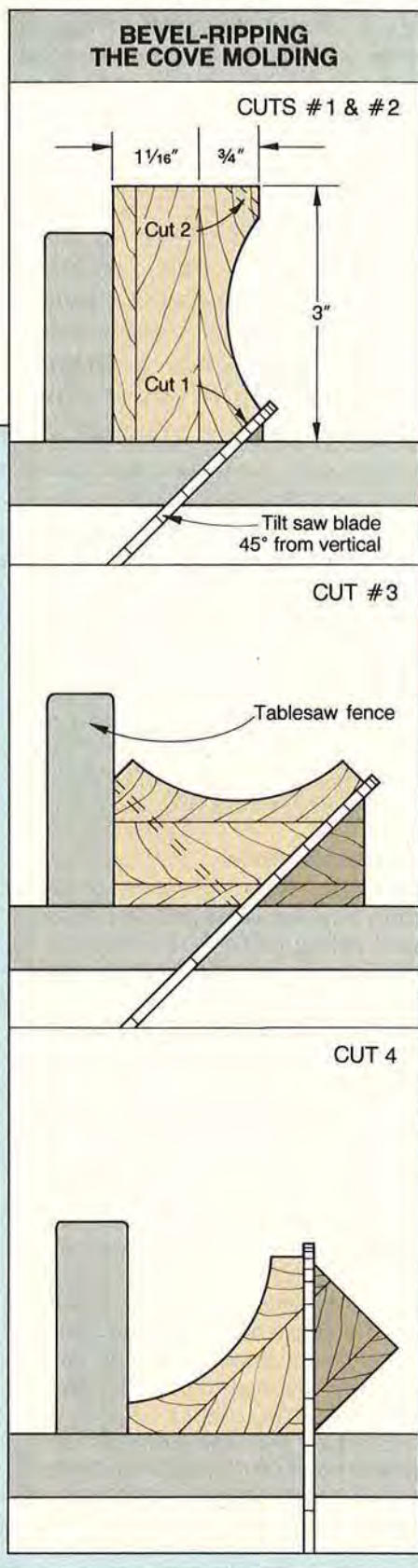

Now for the rest of the moldings

1 Cut the remaining molding pieces (J, K, L, M, N, O) to size plus 2" in length. To form the bullnose on the front edge of J and K, rout a pair of $\frac{1}{8}$ " roundovers along the front edge. See the Bullnose detail accompanying the Cabinet Top drawing.

2 With the back edges flush, glue part L between parts J. Repeat with the side pieces K and M. Miter-cut the ends, and then glue and clamp the trim strips J/L and K/M to the cabinet.

3 Miter-cut the bull-nosed strips N and O to length for both the cabinet top and bottom. Glue them into the previously cut dados in the cabinet.

4 Cut the base molding pieces (P, Q) to size plus 2" in length. Rout a $\frac{1}{2}$ " cove along the top outside edge of each.

5 Using the Cabinet Bottom drawing for reference, miter-cut the pieces to length, mark the radii on the front piece, and cut it to shape. Drill mounting holes through the cabinet and into the back side of the base molding pieces. Glue and screw the pieces to the cabinet bottom.

Cut and edge the shelves, then finish your cabinet

1 Cut the walnut plywood shelves (R) and front and back strips (S) to size plus 1" in length.

2 Cut or rout $\frac{3}{4}$ " rabbets $\frac{1}{4}$ " deep in each strip where shown on the Shelf drawing. Next, rout $\frac{1}{4}$ " coves along the front edge where shown on the End View drawing.

3 Glue the strips to the front and back of the shelf. Later, crosscut both ends to trim the shelves to finished length. Sand smooth (we wrapped sandpaper around a $\frac{1}{2}$ " piece of dowel to sand the coves.)

4 Finish the cabinet. (We applied one coat of Watco Dark Walnut Oil Finish, followed by five coats of Watco Natural Oil Finish.)

5 Nail the shelf standards in the grooves, checking that the numbers on the standards are right-side up.

Buying Guide

• **Shelf standards.** 72" flush-mounted walnut-finished standard, catalog No. 34058 (four needed), \$3.75 each. Supports for standard, catalog No. 33852, \$3.95 for a pack of 20. Add \$4.50 per order for P&H. Woodworkers' Store, 21801 Industrial Blvd., Rogers, MN 55374-9514. ♣

Produced by Marlen Kemmet
Project Design: Jim Downing
Photographs: Hopkins Associates
Illustrations: Kim Downing; Mike Henry
Photo Stylist: Nancy Briggs

DECORATIVE CARVING, SWISS

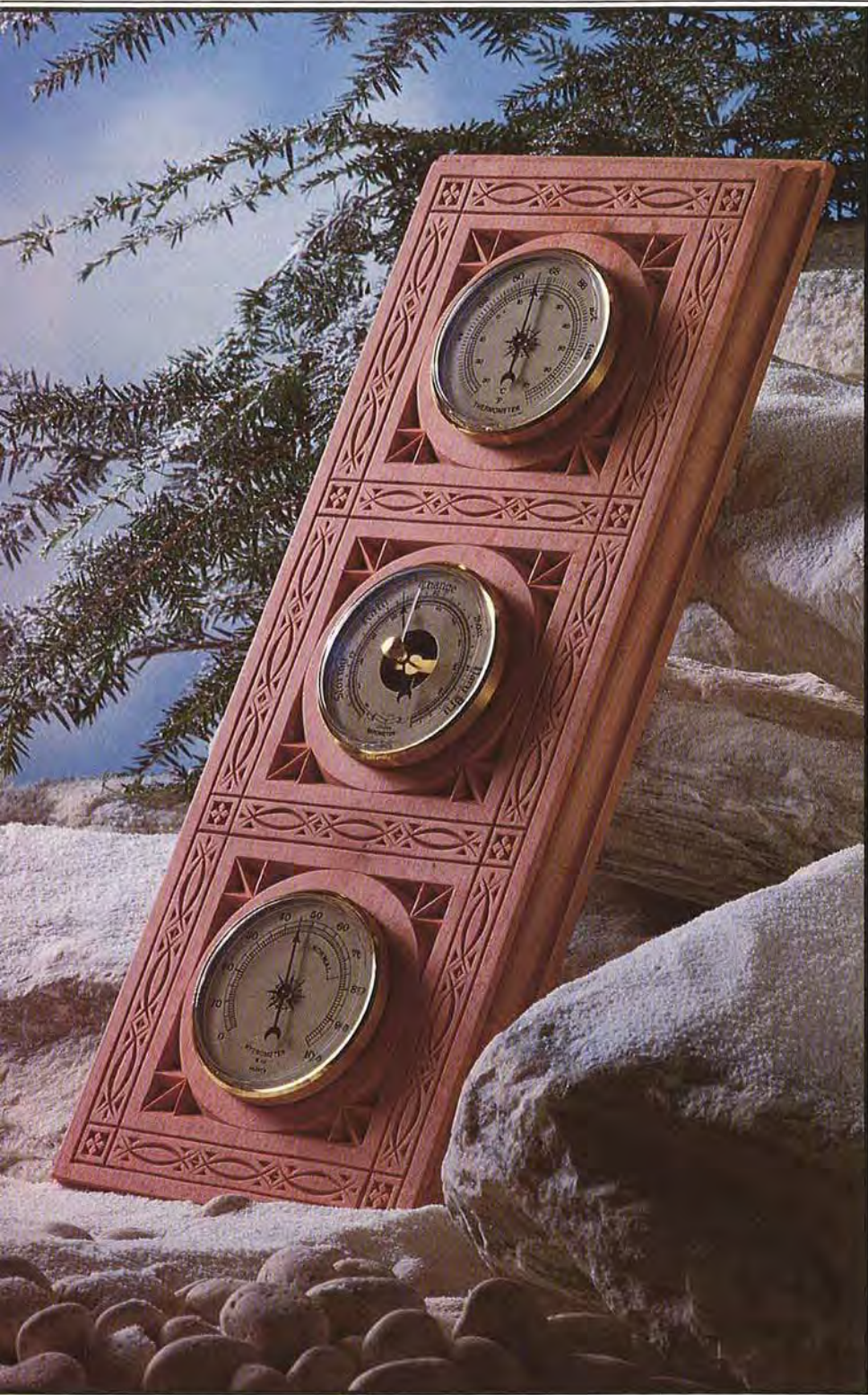

Wayne Barton was traveling light when he came to chip carve with the *WOOD*® magazine staff not long ago. That's because chip carving in the Swiss tradition calls for just two knives. They're the only tools he used to carve this beautiful weather station. Read on—we'll show you how to carve one yourself.

Tools and Supplies

We used these tools and supplies:

Basswood $\frac{3}{4} \times 6\frac{1}{2} \times 15\frac{1}{2}$ "

Swiss chip-carving knives

- cutting knife
- stab knife

Layout tools

- compass
- metric ruler

Ceramic sharpening stones

- medium
- ultra-fine

Spray-on polyurethane finish

Sharp knives—the only way to carve

Chip carving with dull knives is like riding a bicycle with flat tires—you can do it, but it isn't very satisfying, and you have a hard time keeping control. "There is just no substitute for a sharp blade in carving," according to master carver Wayne Barton. So, before you try carving, put keen edges on those knives.

Sharpen both the cutting knife and stab knife on a medium ceramic stone and hone them on an ultra-fine one. For the cutting knife, lay the side of the blade on the stone and raise the back edge of the blade until you can just slip a dime under it. That's about 10°, the proper angle.

Sharpen the stab knife at the factory-set 30° angle. As you carve, touch up the edges occasionally on the ultra-fine stone.

STYLE

Learn the basics, then carve this masterpiece

Chip carving—cutting precise chips from wood to leave an engraved design—dates back to earliest civilizations. Swiss-style chip carving as practiced today has its roots in the Middle Ages.

Back then, peasants turned to *kerbschnitzen* (notch or groove carving) to embellish wooden furniture, utensils, and other household goods. Often, they decorated the home itself with carved doors and woodwork. Many designs reflected the intricate stone carving of the cathedrals.

Get a grip before you start

Professional chip-carver Wayne Barton uses the two Swiss-style knives illustrated *far right*, the *cutting* knife to remove wood and the *stab* knife to make decorative impressions. You'll do most of your work with the cutting knife, and you'll always hold it in one of two positions.

For the first position, hold the knife in your right hand (or left, if you're left-handed), placing the first joint of the thumb at the blade end of the handle. Then close your fingers around the handle. With the workpiece in your lap, turn the inside of your wrist toward your body, resting your thumb and index-finger knuckle on the wood as you cut.

For the second position, move your thumb to the spine of the blade, tilt the blade away from you, and rest your index-finger knuckle on the wood. Compare the first and second positions in the illustrations, *above right*.

Maintain a 65° angle between the blade side and the workpiece in both positions. Keep your elbow close to your body when making straight or three-cornered chips, and make sure your knife hand rests on the work to help control your cuts.

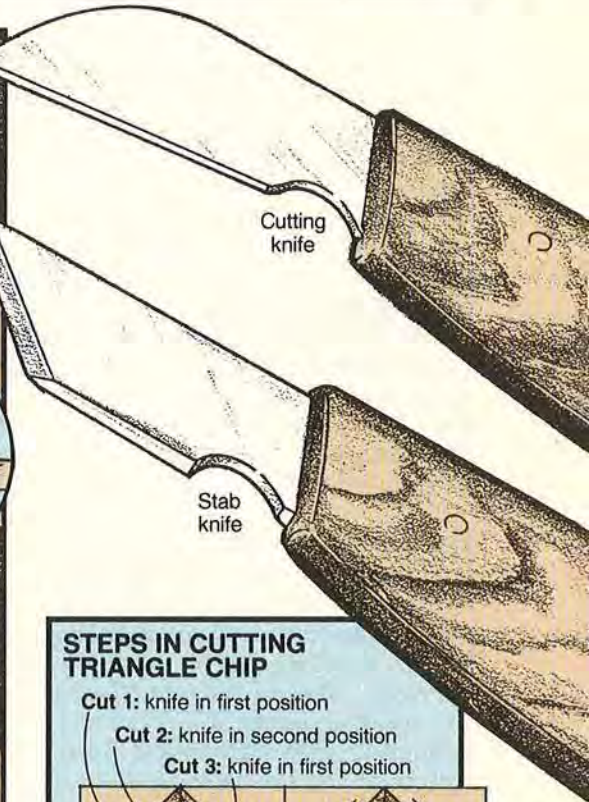
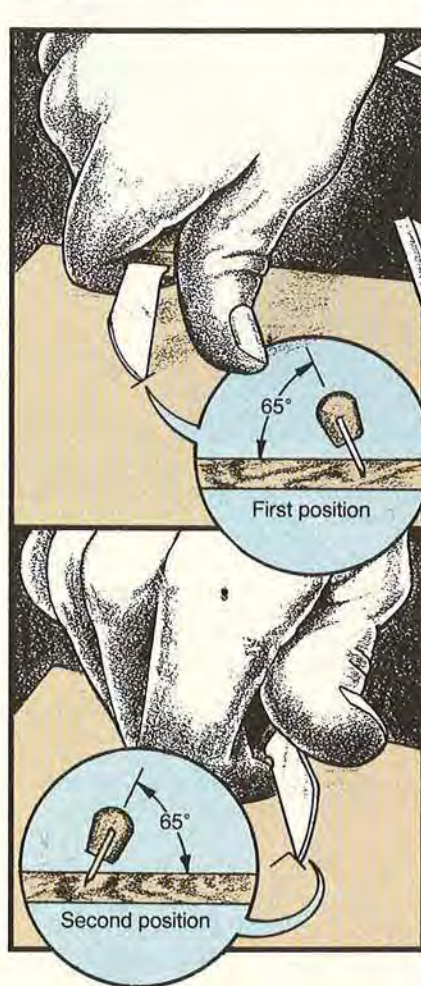

STEPS IN CUTTING TRIANGLE CHIP

Cut 1: knife in first position

Cut 2: knife in second position

Cut 3: knife in first position

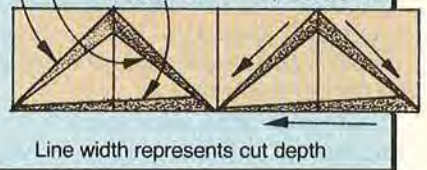

Try out the basic cuts

You'll rely on three basic cuts for all of your chip carving—the straight chip (or straight line), the curved chip (or curved line), and the triangular chip. To begin cutting the straight chip, hold the knife in the first position, and cut along the pattern line in one direction. Then, turn the wood around and cut the other direction, releasing the chip. To vary chip size, change the cutting depth and the distance between your cuts, but don't change the angle of the blade to the work.

Cut the curved chip the same way, but raise the knife handle to reduce the length of the blade in the wood. For tighter-radius

curves, raise the handle higher.

Carve the triangular chip in three steps (shown in the illustration *above*). Hold your knife in the first position for the first cut. Rotate the wood about 90°, and change to the second grip position for the next cut. Without turning the board, go back to the first grip for the third cut.

The stab knife isn't a cutting knife, it makes decorative impressions. Grip it as you would an ice pick, keeping the sharp edge toward you as shown on *page 46, Photo A*. With the knife perpendicular to the workpiece, force the tip into the wood to make an indentation. Rock the knife toward you to extend the line.

Continued

SWISS STYLE

Rout a carving board

Rout a decorative edge along both edges and ends of a $\frac{3}{4}$ "-thick basswood board, leaving a $5\frac{5}{16} \times 14\frac{5}{8}$ " carving face on top. To determine the initial board size, rout an edge on scrapwood and measure the width of the cut. Then, add twice that measurement to the length and width of the pattern. (Our $\frac{5}{32}$ " roman-ogee bit formed a profile $\frac{3}{8}$ " wide, so we added $\frac{3}{4}$ " to each pattern dimension, and cut our carving board to $6\frac{5}{16} \times 15\frac{3}{8}$ ".)

Transfer the carving design to your board, following the instructions with the pattern, *opposite page*. Locate the center of the middle instrument hole at the center of your workpiece.

Let the chips fly!

Divide the carving into quarters, and then work from the outside in on each quarter. "Start with the largest chips in the area you're carving," Wayne advises. Carve the weather station's lace border beginning with the curved chips, followed by the diamonds and the small triangles. Then, carve the straight chips. Make the stab-knife impressions last.

"I like to start with cuts across the grain," Wayne says. As you progress, turn your work so you don't make the first cut along a new line toward work you've already done. If the wood splits out, apply a dab of glue with the knife tip to stick the flake back in.

Cut the curved lace border uniformly. Carve the chips shallow and narrow at each end and about $\frac{1}{16}$ - $\frac{3}{32}$ " wide at the middle (*Photo B*). Carve the straight border chips a little less than $\frac{1}{16}$ " wide. The constant knife angle maintains proper depth for both.

At each corner, carve four triangular chips to form a diamond inside a square. Then, cut a notch at the center of each side of the diamond to create the flower. Extend the large chips surrounding the instrument locations almost to the centerline on each side as shown



A. The stab knife leaves a triangular impression when forced straight into the wood.



B. Your hand can't always rest fully on the board, but you can maintain control with your thumb on the surface, as here in cutting curved chips for the border near the edge of the board.

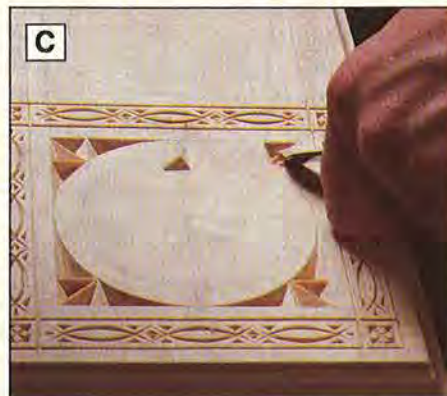

C. The cutting knife remains at a constant 65° side angle to the work. As a result, large, wide chips, such as those around instrument holes, will be deeper than the small ones in the border.

in *Photo C*. Hold the standard knife angle as you cut the large chips. They'll be about $\frac{1}{4}$ " deep.

Aim for uniformity among similar elements, but don't be dismayed if they don't match precisely. That's expected. "So what, if it's a little off," Wayne comments. "It's hand work."

Now, the weather report

Bore a $\frac{1}{4}$ " pilot hole at the center of each instrument location with a brad-point bit in a drill press. Then, guide on the pilot hole to bore each instrument hole with a holesaw. The Klockit instruments we used (see Buying Guide at *right*) mount in $2\frac{5}{16}$ " holes.

Now, erase any leftover layout marks and sand the carving lightly, but don't sand away any of the sharp edges. Apply dull or matte-finish polyurethane with light spray applications from several

angles. After the finish dries, mount the instruments and hang the board for all to see.

Buying Guide

- **Complete chip-carving kit.** Swiss-made cutting knife and stab knife; medium and ultra-fine ceramic sharpening stones; book, *Chip Carving Techniques and Patterns* by Wayne Barton; metric ruler; compass for layout; and two basswood practice boards; \$73 ppd. in U.S., Alpine School of Woodcarving Ltd., 225 Vine Ave., Park Ridge, IL 60068.
- **Cutting knife and stab knife.** Knives only, \$28 ppd. in U.S., address above.
- **Set of weather instruments.** Thermometer, hygrometer, and barometer, \$18 per set ppd. in U.S., product No. 71103, Klockit, Box 636, Lake Geneva, WI 53147, or call 800/556-2548. ♣

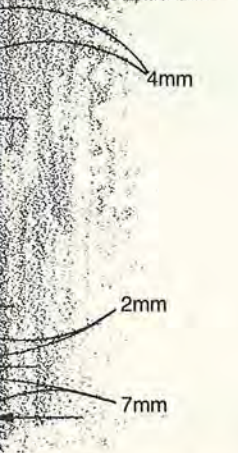
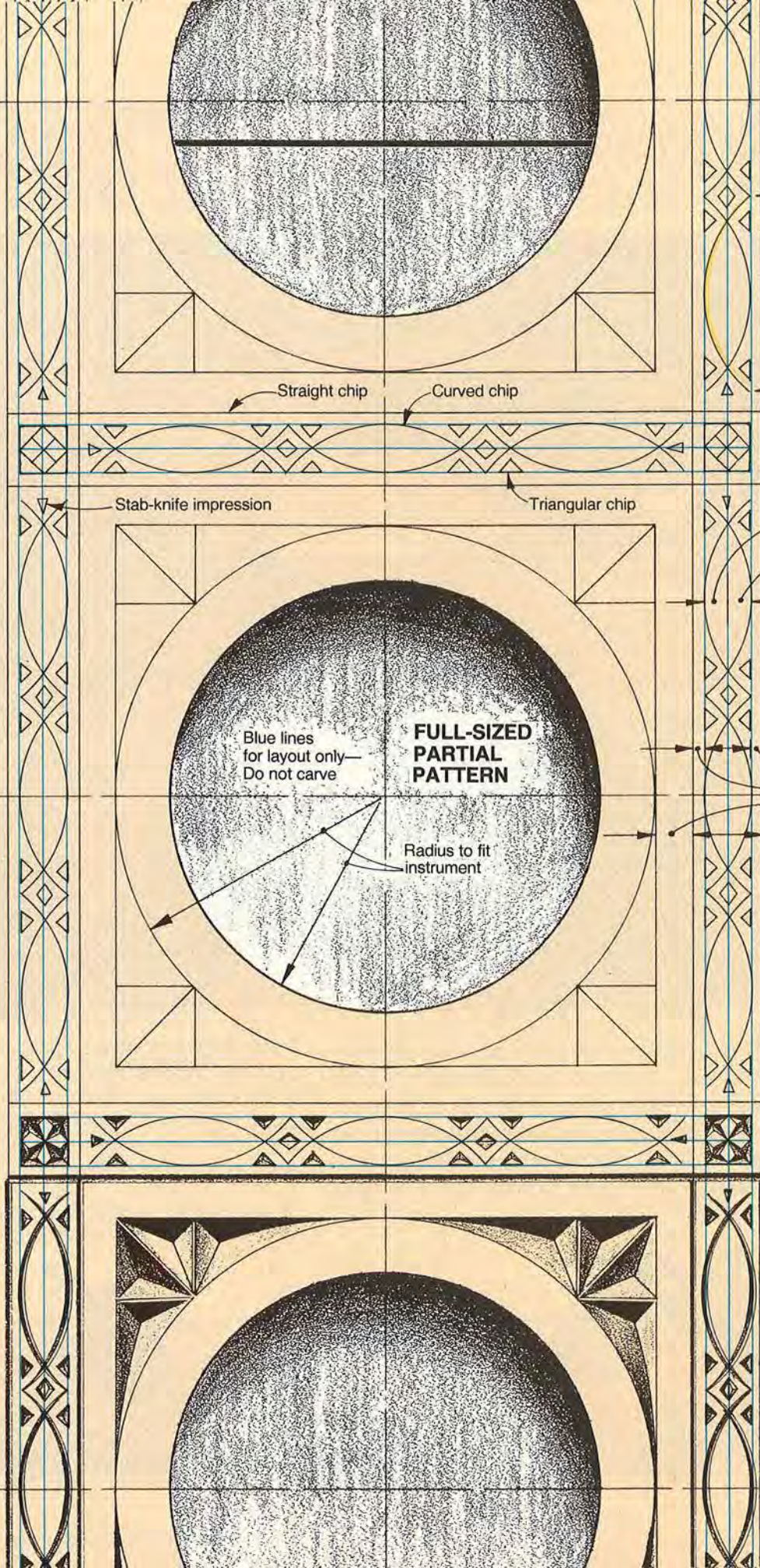

For a full-sized pattern, photocopy the section left twice. Designate one copy the center. Cut the other copy in half at the middle instrument's horizontal centerline. Align the top edge of the top piece with the top instrument centerline on the uncut copy. Join the bottom half to the uncut copy at the lower instrument's centerline. Tape them together, and cut off the top and bottom outside the border.

Trace the pattern onto your board with graphite paper. Or, lay out the lines shown on the pattern and draw the design with a soft pencil. Transfer the template to stiff cardboard to aid in tracing or drawing the curved border.

Written by Larry Johnston
with Wayne Barton
Photographs: Wm. Hopkins;
John Hetherington
Illustrations: Mike Henry

A smart alternative
to radial-arm saws

POWER



Ever since Rockwell introduced the first power miter saw in 1967, these tools have become increasingly popular with contractors and home woodworkers alike. They're accurate, easy to adjust, portable, and safer and less expensive than radial-arm saws. But that's not all. Some new models let you make compound cuts (combined angle and bevel cuts) and crosscut stock up to 12" wide.

Four types of saws for you to choose from

Whatever your woodworking needs or budget, a saw in one of the following categories should meet your requirements.

• **Angle-only miter saws** (Retail price range: \$190-\$310 for 10")

10" MITER SAWS

Hitachi C10FA



Makita LS1030

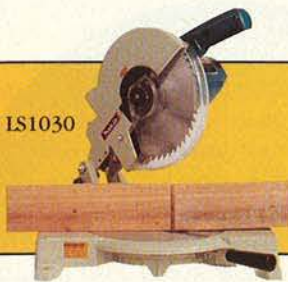

Ryobi TS254

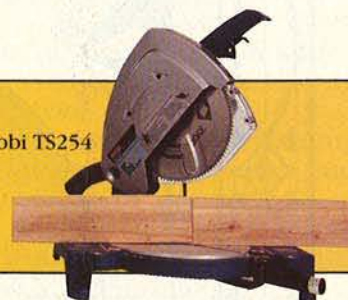

MITERSAWS

saws; models with blades as large as 15" cost up to \$470.)

Similar to the original Rockwell miter saw, machines such as the one illustrated *below*, have a turntable that rotates 45° (or more) left and right. The motor/blade assembly, mounted to the back of the turntable, moves with it.

Simply constructed, these machines adjust easily and cut accurately. To cut a bevel you must stand the workpiece on edge. For all practical purposes, you cannot make compound cuts with these.

• **Compound miter saws** (Retail price range: \$150–\$170 for 8¼" models; \$215–\$250 for 10" saws.)

As shown in the illustration *bottom left*, the motor/blade assembly of these machines rotates just like an angle-only miter saw does, and it also tilts up to 45° to the operator's left for bevel cuts.

These qualities make it easier to bevel-cut many moldings and perform compound cuts such as those required for crown moldings. However, we found that these saws make rougher cuts than most of the angle-only miter saws. The reason: compound miter saws have a relatively complex "knuckle" that secures the motor/blade assembly to the turntable. Because these knuckles have more parts, which are made of

thinner materials than found in the knuckles on many angle-only miter saws, they also have more give in them.

We consider these machines adequate for most carpentry tasks, but not accurate enough for fine furniture and cabinetry work.

• **Sliding-compound miter saws** (Retail price range: \$400–\$500.)

These machines give you the advantages of a compound miter saw, and they have a sturdy knuckle mechanism that helps yield smooth cuts. And, because the motor-blade assembly slides forward, crosscutting capacity in-

Continued

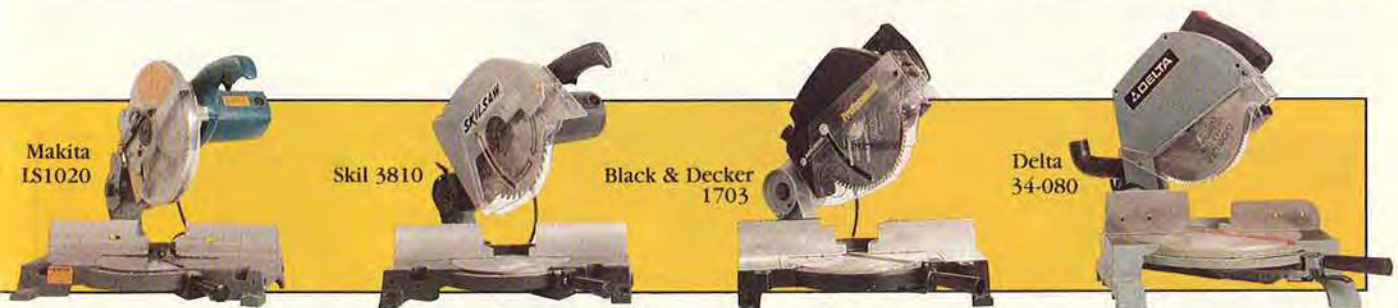
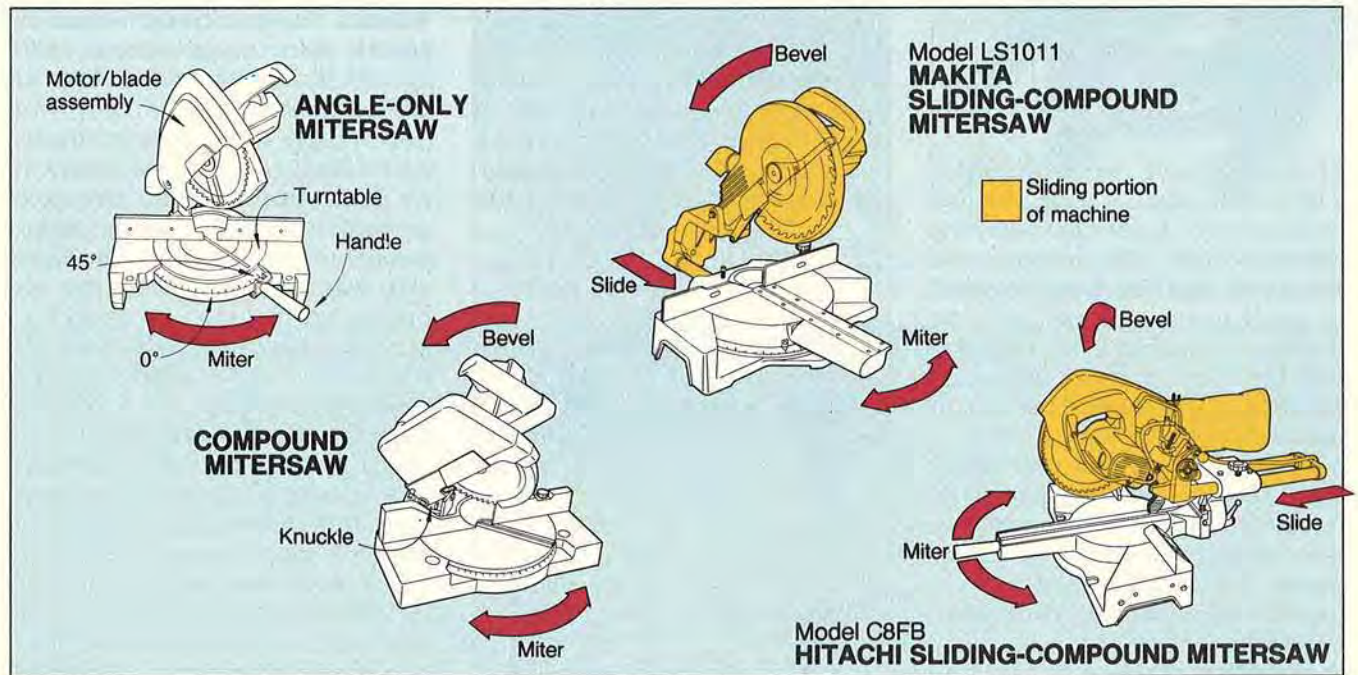

POWER MITERSAWS

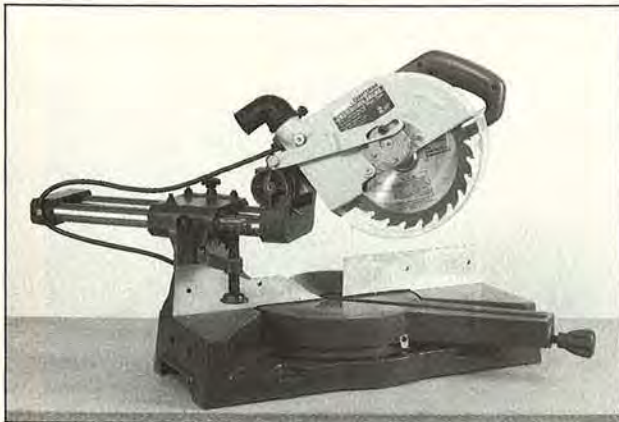

The AEG SKS 300 *left*, Sears 23488 *above left*, and Ryobi TSS220 *above right*.

base. Both systems work well.

AEG, Ryobi, and Sears plan to introduce sliding-compound saws that should be available by publication. (See photos *above and left*.) Although we couldn't obtain test samples of these machines, we were able to inspect prototypes of all three saws at various trade shows. Like the Hitachi, these machines have dual sliding rods. Unlike any other sliding compound saw on today's market, the AEG has a rugged induction

motor and innovative dual dust-collection ports that draw dust from behind *and* below the blade (through the turntable). You'll find specifications for these three models on *page 54*.

• **Delta Sawbuck and Sidekick** (Retail price range: about \$570 for the Sawbuck and \$400-plus for the Sidekick.)

Although these two products technically aren't miter-saws, we've included them because they come closer to being miter-saws than anything else. The Sidekick was not available for testing, but we've included its specifications on *page 54*. Delta officials tell us it will be similar to the Sawbuck in features, but downsized for affordability.

The Sawbuck cuts as well as any of the sliding-compound saws, but with the advantages of a 16" crosscut capacity and additional work support provided by its 52"-long table. Although the Sawbuck weighs more than any miter-saw, it has wheels for portability. You can purchase the Saw-

creases to 12". To operate these saws, you pull the blade forward in its elevated position, turn on the motor, push the blade down into the front edge of the work-piece, and then push the saw to complete the cut.

As you can see by the illustrations on the *previous page*, the two tested models in this category have different sliding mechanisms. The Hitachi C8FB has exposed, dual sliding rods. The Makita LS1011 works in a similar fashion, but with one rod that slides in and out of the tool's

Delta Sawbuck (with accessory legs).



MITERSAWS OVER 10"



Hitachi C15FB



Ryobi TS380



Hitachi C12FA

buck with optional fold-up legs as shown on the *opposite page*, or simply place the machine on sawhorses. Because of this machine's design, you need to slide work onto the Sawbuck from either side of the table, a task which requires more side clearance than the other mitersaws in this article.

The Sawbuck accepts dado sets, and it stays in alignment through months of use because its twin rods are sturdily supported on both ends. If you have the money and space, we consider the Sawbuck a good investment.

Buying points to consider

• **Cutting capacity.** In the chart on *page 54*, you'll find the maximum cutting capacities supplied to us by manufacturers for their mitersaws. In our own tests, we discovered that among 10" angle-only mitersaws, only the Makita LS1030 and the Ryobi TS254 allow you to bevel-cut a 2x4 on edge. Other models came close, but did not quite complete the cut. (The other 10" saws required a spacer block between the fence and workpiece in order to make the cut.) In this same class, only

the Ryobi TS254 and Delta 34-080 were capable of crosscutting a 2x6 at 90°.

• **Blades and blade changing.** Most mitersaws come with steel blades capable of only rough cuts. Our advice: discard this blade and buy a good-quality carbide-tipped crosscut blade. One company's representative told us that manufacturers include an inexpensive blade just so they can claim their saw comes with a blade. He admitted that the saws need carbide-tipped blades to perform optimally, but said that including good blades would push many saws past the "price points" set for those products.



The Freud LU91MO10, *foreground*, has teeth with a 5° negative hook.

If you buy a sliding-compound saw, we suggest that you invest in a carbide-tipped blade with a 5° negative hook, such as the Freud LU91MO10 shown in the foreground *below left*. As you can see, the teeth of such a blade lean 5° backward rather than forward. This subtle difference results in a less aggressive cut that pushes the board down and back against the fence. In our tests, positive-hooked blades tended to grab the wood and lift it when used in a sliding-compound saw.

Since you'll need to change blades occasionally, we also rated the machines according to the ease of this operation (see "blade changing" in the chart on *page 55*). Machines that rated high in this area had spindle locks and easy-to-reach arbor nuts for quick changes. Most of the machines with low marks featured hard-to-remove guards that obstructed the arbor nut.

• **Handle types.** Even though D-handles, such as those found on a sliding-compound saw or Sawbuck, work well with any saw that you push through stock, we

Why we have a power mitersaw in the WOOD® magazine shop

A radial-arm saw may be the most versatile woodworking machine ever invented, but in our shop we've replaced the radial-arm saw with a sliding-compound saw. Here's why:

• **Safety.** Manufacturers have told us that more liability lawsuits result from accidents involving the radial-arm saw than any other woodworking machine. Because of the rotation of its blade, the motor/blade assembly of a radial-arm saw has a tendency to jump at the operator. This hazard is compounded during ripping because kickbacks are

common. *In the WOOD magazine shop, we have never ripped a board with a radial-arm saw.*

• **Accuracy and adjustments.** Once properly adjusted, a radial-arm saw will cut accurately, but making these adjustments can be tricky. And, radial-arm saws can slip out of adjustment from vibration or jarring.

• **Cost.** Radial-arm saws for the home shop range from \$300 to \$600. You can buy an accurate angle-only mitersaw for under \$200, and a top-of-the-line sliding-compound mitersaw for under \$500.

Continued



POWER MITERSAWS

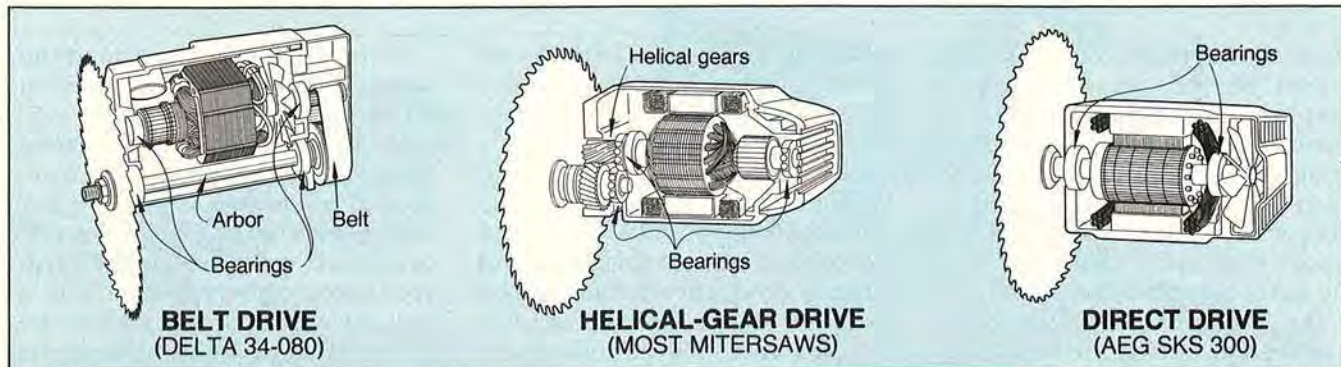

prefer a chop-style handle on miter saws with motor/blade assemblies that move downward in the cutting stroke. (See the photo below for examples of both styles.)



We prefer chop-style handles (*foreground*) over D-handles (*background*).

The chop-style handles feel more comfortable and don't seem to stress your hand and wrist as much as D-handles do.

• **Drive system.** Of all the miter saws on today's market, only the Delta 34-080 has belt drive. All others have helical-gear drive, except for the AEG SKS 300 with direct drive via a 3,360 rpm induction motor. (See cutaway illustrations above.) The belt-drive

feature gives the Delta machine unmatched "excellent" ratings in the "blade deflection" and "noise" columns of the chart on page 55. The reason? The Delta saw has a long arbor—like that found on a table saw—supported on both ends by ball bearings. This arbor reduces blade deflection, resulting in smoother cuts.

Although all universal-motor miter saws make plenty of noise, the belt-driven Delta is the quietest of the batch.

• **Blade guards.** To do its job effectively, a guard has to do these things: 1) Protect you from the blade throughout the cutting motion. 2) Allow you to view the blade at the point it enters your workpiece. 3) Swing out of the way as you make the cut without becoming stuck. 4) Be sturdy enough to last for the life of the saw. We combined these criteria and gave the machines a grade under the heading "guard" in the chart on page 55. Overall, the Hitachi saws had the best guards.

• **Machine weight.** If you plan to move your miter saw from place to place, pay close attention to its weight (similar-looking models can vary tremendously in weight). The reason: one model

has a cast-iron base and turntable while another has lighter aluminum components.

Which model should you buy?

As with most power tools, the old adage "You get what you pay for" applies to miter saws. Nevertheless, we feel that the models listed on the next page have an edge over similarly priced competitors.



The Hitachi C10FA angle-only miter saw, *right*, has a heavier knuckle assembly than the Ryobi TS254, *left*.



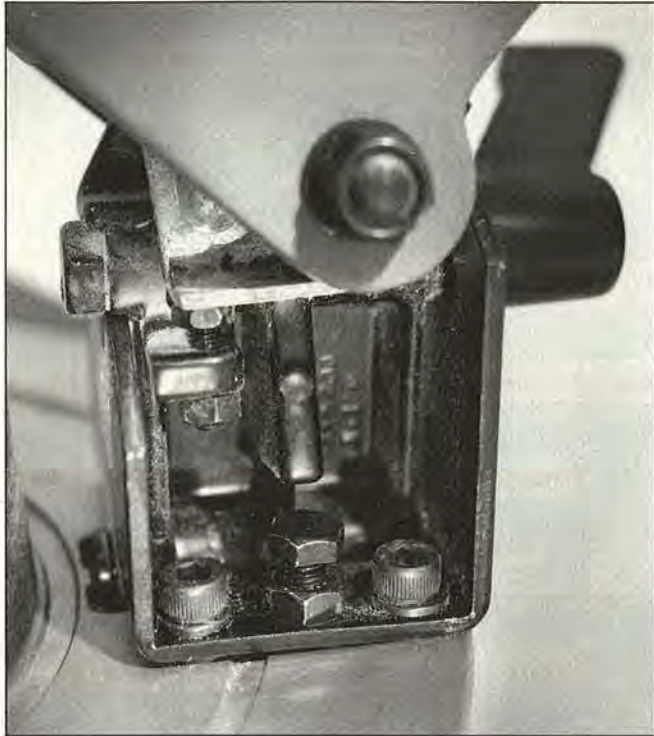

The Ryobi TS200 has adjustable stops for 0° and 45° bevel cuts—a timesaving feature when making these cuts.



An easy-to-adjust depth stop is just one of several well-designed controls on the Hitachi C8FB.

● **Angle-only miter saws**

If you want to buy the best saw in this category, buy one of the Hitachis. As shown on the *opposite page*, all of the Hitachis have heavy-duty construction, especially in the critical knuckle area.

If you want to spend a little less, the Delta 34-080 is a good machine if you're not going to move it around too much or change blades a great deal. It's quieter than most miter saws and solidly built.

For take-anywhere convenience and good cutting capacity at a down-to-earth price, we couldn't find a machine that matches the value of the Ryobi TS254.

● **Compound miter saws**

Among the 8¼" compound miter saws, we give our highest marks to the Sears 23468 and Ryobi TS200. The Sears machine almost got our nod because it is the only saw in this class that will crosscut a 2×6. Unfortunately, it doesn't have stops for 0° and 45° bevels, so you have to set these each time

you change them. Although the Ryobi won't crosscut a 2×6, it has positive 0° and 45° bevel-stops (see photo *above left*), and its light weight aids portability. We found its modified D-handle a little awkward.

The three 10" models in this category—supplied by Delta, Sears, and Tradesman—left us unimpressed. Except for some minor modifications, all appear to be essentially the same machine. They suffer from poor dust collection (almost no sawdust winds up in the dust bag) and poorly engineered guards that leave the back of the blade exposed.

● **Sliding-compound miter saws**

Because of its 10" blade, the Makita LS1011 has slightly more cutting capacity than the Hitachi C8FB. However, we found the Hitachi easier to adjust with better locking mechanisms and stops. For example, note the simple but effective depth-stop mechanism in the photo *above right*.

Because the Hitachi has a split



Hitachi C8FB

fence with a large gap between the two halves, the machine requires an auxiliary wooden face for cutting small workpieces (the Makita does not require such a face). All in all, choosing between these two models is a toss-up.

You may also want to take a serious look at the AEG SKS 300. Although we weren't able to test one, this saw has some impressive features. In addition to its rugged induction motor and dual dust-collection points, the AEG comes standard with a quick-action work clamp and a negative-hook, carbide-tipped blade. ♣

Written by Bill Krier
Product testing: George Granseth
Photographs: Wm. Hopkins
Illustrations: Kim Downing

POWER MITERSAWS

COMPARISON OF 3

MANUFACTURER/ IMPORTER	MODEL	SIZE (INCHES)	BLADE		CAPACITY ²				MOTOR				
			TYPE ¹	CROSSCUT	45° MITER	45° BEVEL	COMPOUND 45° MITER 45° BEVEL	AMPS	NO-LOAD SPEED (RPM)	BRAKE ⁷	SPINDLE LOCK (YES/NO)	DRIVE ⁴	
SLIDING-COMPOUND MITERSAWS	AEG	SKS 300	10	C	2 1/16 x 11 25/32	2 1/8 x 8 5/16	2 1/8 x 11 25/32	2 1/8 x 8 5/16	N/A	3,360	E	Y	D
	DELTA	Sawbuck 33-050	8	S	2 3/4 x 16	1 3/4 x 12	1 3/4 x 16	1 3/4 x 12	15	5,500	E	Y	G
	DELTA	Sidekick 33-060	6 1/2	C	1 1/2 x 11 1/4	1 1/2 x 9 1/4	1 5/8 x 11 1/4	1 5/8 x 9 1/4	12	5,500	E	Y	G
	HITACHI	C8FB	8 1/2	C	2 5/16 x 12	2 5/16 x 8 5/8	1 25/32 x 12	1 25/32 x 8 21/32	9.5	4,900	E	Y	G
	MAKITA	LS1011	10	S	2 15/16 x 12	2 15/16 x 8 15/32	1 9/16 x 12	1 9/16 x 8 15/32	12	4,600	E	Y	G
	RYOBI	TSS220	8 1/2	C	2 5/16 x 12	2 5/16 x 8 5/8	1 25/32 x 12	1 25/32 x 8 5/8	10	4,500	E	Y	G
	SEARS	23488	8 1/4	C	2 1/2 x 12	2 1/2 x 8 5/8	1 3/4 x 12	1 3/4 x 8 5/8	10	5,000	E	Y	G
COMPOUND MITERSAWS	BLACK & DECKER	9425	8 1/4	S	2 1/4 x 5 1/4	2 1/4 x 3 3/4	1 3/4 x 5 1/4	1 3/4 x 3 3/4	8	3,600	E	N	G
	DELTA	36-040	8 1/4	S	2 1/8 x 5 1/8	2 1/8 x 3 1/2	1 1/2 x 5 1/8	1 1/2 x 3 1/2	9	5,200	E	Y	G
	DELTA	36-220	10	S	2 5/8 x 5 3/4	2 5/8 x 4 1/4	1 7/8 x 5 3/4	1 7/8 x 4 1/4	15	4,900	E	Y	G
	RYOBI	TS200	8 1/4	S	2 3/16 x 5	2 3/16 x 3 5/8	1 9/16 x 5	1 9/16 x 3	8	5,000	E	Y	G
	RYOBI	TS260	10	S	3 1/16 x 5 3/4	3 1/16 x 4 3/4	2 1/16 x 4 3/4	2 1/16 x 4 1/8	12.5	4,800	E	Y	G
	SEARS	23468	8 1/4	S	2 1/16 x 5 1/2	2 1/16 x 3 3/4	1 1/2 x 5 1/2	1 1/2 x 3 3/4	9	5,000	E	N	G
	SEARS	23460	10	S	2 5/8 x 5 3/4	2 5/8 x 4 1/4	1 7/8 x 5 3/4	1 7/8 x 4 1/4	15	4,900	E	Y	G
	TRADESMAN	8330A	10	S	2 5/8 x 5 3/4	2 5/8 x 4 1/4	1 7/8 x 5 3/4	1 7/8 x 4 1/4	15	4,900	E	Y	G
ANGLE-ONLY MITERSAWS	BLACK & DECKER	1703	10	C	3 1/8 x 4 3/4	3 1/8 x 3 3/8	-	-	12	5,500	M	N	G
	DELTA	34-080	10	S	2 1/2 x 5 3/4	2 3/8 x 4	-	-	13	4,500	ME	N	B
	HITACHI	C10FA	10	S	3 1/8 x 4 7/16	3 1/8 x 3 1/8	-	-	15	4,500	E	Y	G
	HITACHI	C12FA	12	S	3 3/4 x 5 5/8	3 3/4 x 3 9/16	-	-	15	4,000	E	Y	G
	HITACHI	C15FB	15	S	4 3/4 x 7 9/32	4 3/4 x 5 15/32	-	-	15	3,400	E	Y	G
	MAKITA	LS1020	10	S	3 1/2 x 4 3/4	3 1/2 x 3 1/2	-	-	12	4,100	E	Y	G
	MAKITA	LS1030	10	S	3 1/2 x 4 15/16	3 1/2 x 3 1/2	-	-	12	4,600	E	Y	G
	RYOBI	TS254	10	S	3 9/16 x 5 9/16	3 9/16 x 3 7/8	-	-	12.5	5,000	E	Y	G
	RYOBI	TS380	15	S	4 13/16 x 7 1/4	4 13/16 x 5 7/16	-	-	15	3,400	E	Y	G
	SKIL	3810	10	S	3 1/2 x 4 1/4	3 1/2 x 3 1/2	-	-	15	5,200	E	Y	G

1. (C) Carbide-tipped, (S) Steel
 2. Height x width (inches)
 3. (E) Electric, (M) Manual,
 (ME) Manual electric (electric brake
 engages when you press button on
 handle)

4. (B) Belt
 (D) Direct
 (G) Gear
 (P) Plastic
 5. (A) Aluminum
 (C) Cast iron

6. (DB) Dust bag, (DH) Dust hose, (FL) Folding legs, (LG) Long
 extension guides, (QC) Quick-action clamps, (SC) Screw
 clamps, (SG) Short extension guides, (WT) Worktable
 7. (C) Chop-style, (D) D-handle
 (*) See photo on page 52

8. **E** Excellent
F Fair

G Good
P Poor

9. (G) Germany, (J) Japan, (T) Taiwan, (U) United States
 10. Selling prices based on ads, catalogs, and dealer inquiries at time of
 article's production.

TYPES OF MITERSAWS

STOPS		BASE MATERIALS ⁵		ACCESSORIES ⁶			PERFORMANCE EVALUATION ⁸				WEIGHT (POUNDS)	COUNTRY OF ASSEMBLY ⁹	LIST PRICE	SELLING PRICE ¹⁰
MITER	BEVEL	FRAME	TURNTABLE	STANDARD	OPTIONAL	HANDLE TYPE ⁷	GUARD	BLADE CHANGING	NOISE	BLADE DEFLECTION				
0, 15, 22.5, 30, 45	0, 45	A	A		DH, LG, QC, WT	*	NOT AVAILABLE AT TIME OF TESTING				46.3	G	\$999	\$599
0, 22.5, 31.6, 45	0, 45	P	P		FL	D	G	F	G	G	78	U	781	570
0, 22.5, 31.6, 45	0, 45	A	A		SC, LG	D	NOT AVAILABLE AT TIME OF TESTING				48	T	500-plus	400-plus
0, 15, 22.5, 31.6, 35.3, 45	0, 30, 33.9, 45	A	A	DB	LG, SC, SG	D	G	E	F	G	37.4	J	859	450
0, 15, 22.5, 30, 45	0, 45	A	A	DB, SC		D	G	F	F	G	34.8	J	818	450
0, 15, 22.5, 31.5, 45	0, 45	A	A	DB		D	NOT AVAILABLE AT TIME OF TESTING				44	J	N/A	N/A
0, 15, 22, 30, 45	0, 45	CI	CI	SC	DB	D	NOT AVAILABLE AT TIME OF TESTING				70	T	-	400
0, 22.5, 45		P	P			C	G	F	G	F	17	G	245	160
0, 15, 22.5, 30, 45	0, 45	A	A	DB		D	G	F	G	F	15.75	T	224	170
0, 15, 22.5, 30, 45	0, 45	CI	A			D	F	G	G	F	60	T	350	240
0, 22.5, 45	0, 45	P	A		DB	D	F	E	G	F	14	U	306	170
0, 15, 22.5, 31.5, 45	0, 34, 45	CI	CI		DB	C	NOT AVAILABLE AT TIME OF TESTING				52	T	N/A	N/A
0, 22.5, 45	-	CI	CI		DB, SC	C	G	F	G	F	37.5	T	-	150
0, 22.5, 45	0, 45	CI	CI	DB	SC, SG	C	F	G	G	F	60	T	-	250
0, 15, 22.5, 30, 45	0, 45	CI	CI	DB, SC, SG		C	F	G	G	F	60	T	330	215
0, 22.5, 45	-	A	A	DB		D	P	P	F	G	28	U	350	190
0, 22.5, 45	-	CI	A		DB	D	P	P	E	E	55	T	308	220
0, 22.5, 30, 45	-	A	A	DB, SC, SG	LG	C	E	G	G	G	44	J	538	300
0, 15, 22.5, 30, 45	-	A	A	DB, SC, SG	LG	C	E	G	G	G	40	J	632	340
0, 15, 22.5, 30, 45	-	A	A	DB, SC, SG	LG	C	E	G	G	G	55	J	745	400
0, 15, 22.5, 30, 45	-	CI	CI	DB, SC, SG		C	G	F	F	G	40	J	539	310
0, 15, 30, 45	-	A	A	DB, SC, SG		C	G	F	G	G	23.3	J	414	260
0, 22.5, 45	-	A	A		DB, LG, SC, SG	C	F	G	F	G	33.5	U	397	200
0, 22.5, 30, 45	-	A	A	DB	LG, SC, SG	C	P	G	G	G	50.6	J	793	470
0, 15, 22.5, 30, 45	-	CI	CI	DB	SC, SG	C	P	P	P	G	51	T	350	240

MANUFACTURERS' LISTING:

AEG
800/243-0870 or 203/447-4600

Black & Decker
800/762-6672 or 301/239-5300

Delta
800/438-2486 or 412/963-2400

Hitachi
404/925-1774

Makita
714/522-8088

Ryobi
800/525-2579
803/226-6511

Sears
Visit your nearest store
or telecatalog center

Skil
312/286-7330

Tradesman
(Power Tool Specialists)
800/243-5114
203/654-1761

Custom MITERSAW CABINET



A cut above the rest



If you're sold on the safety and accuracy of a miter saw, or want to replace your old radial-arm saw, have we got the project for you! Our unit comes complete with a stand and a roll-out bin for chips and cut-offs. Add to that an extended fence and its hairline-accurate stop, and you've put your miter- and cross-cutting problems to an end.

Note: We designed this cabinet to support a DeWalt 8½" miter saw measuring 18" wide by 20" deep. You may need to change some dimensions to fit your miter saw.

Let's start with the stand

1 Cut the stand sides (A), back (B), and shelf (C) to the sizes listed in the Bill of Materials from ¾" plywood (we used birch).

2 Cut a ¾" rabbet ⅜" deep along the back inside edge of each cabinet side (A) where shown on the Stand and Mobile Bin drawing on the *opposite page*.

3 Using the dimensions on the drawing, mark the angled layout on the top end of the side pieces, and cut the ends to shape.

4 Cut the shelf banding strip (D) to size, and then cut or rout a ¾" rabbet ⅜" deep along the top inside edge. Glue and clamp the strip to the front edge of the shelf (C) with the ends and top surfaces flush.

5 Cut the two shelf supports (E) and rear dust-deflector strip (F) to size.

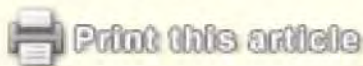

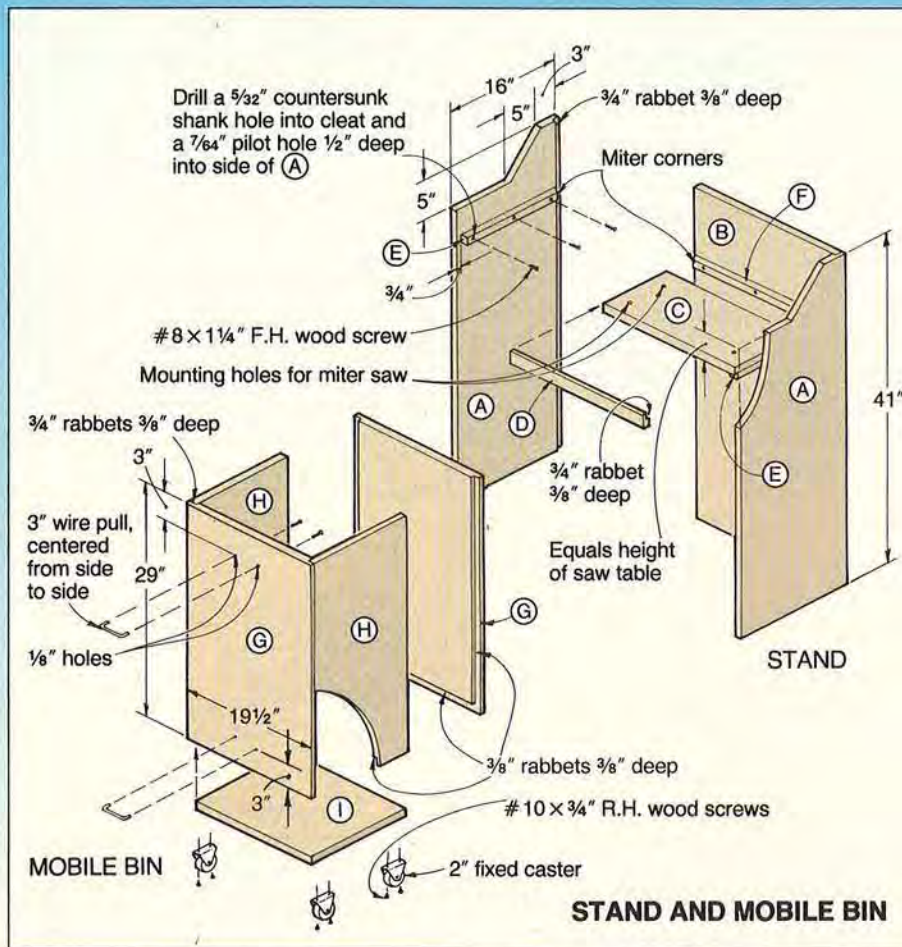

Bill of Materials					
Part	Finished Size			Mater.	Qty.
	T	W	L		
STAND					
A sides	3/4"	16"	41"	BP	2
B back	3/4"	20 3/4"	41"	BP	1
C shelf	3/4"	8 3/4"	20"	BP	1
D band	3/4"	1 1/2"	20"	B	1
E shelf supports	3/4"	1"	14 1/2"	B	2
F dust strip	3/4"	1"	20"	B	1
MOBILE BIN					
G front & back	3/4"	19 1/2"	29"	BP	2
H sides	3/4"	14 1/4"	29"	BP	2
I bottom	3/4"	14 1/4"	18 3/4"	BP	1
TABLES AND FENCES					
J table	3/4"	4 5/8"	75"	BP	1
K table	3/4"	5 3/8"	18"	BP	1
L band	3/4"	1 1/2"	75"	B	1
M band	3/4"	1 1/2"	18"	B	1
N spacers	3/4"	3/4"	1"	B	10
O fence	1 1/16"	2 3/4"	75"	B	1
P fence	1 1/16"	2 3/4"	18"	B	1
Q fence	1/2"	3"	21"	B	1
R support	3/4"	4 1/4"	35 1/4"	BP	1
S braces	3/4"	10"	10"	BP	2
SUPPORT BRACKET					
T support arm	3/4"	2"	13 3/8"	B	1
U cleat	3/4"	1"	2"	B	1
Material Key: BP—birch plywood, B—birch Supplies: #8 x 1 1/4" flathead wood screws, #8 x 1 1/2" flathead wood screws, #8 x 2" flathead wood screws, #8 x 3" flathead wood screws, #10 x 2 1/2" flathead wood screws, 4—2" fixed casters with #10 x 3/4" roundhead wood screws for mounting, 2—1/4" threaded inserts, 2—1/4" nuts, 2—adjustable nylon floor glides, 2—3" metal wire pulls, adhesive-backed tape measure, enamel paint.					

Note: Position the fixed shelf (C) so the table of your miter saw is flush with the top surface of the extension tables (J, K). Depending on your particular miter saw, your shelf height may be different from ours.

6 Measure and mark the locations for the shelf supports and dust strip where shown on the Stand and Mobile Bin drawing above. Then, drill and countersink mounting holes through the stand assembly, and screw the shelf supports and dust strip to the stand.

7 Glue and clamp the stand together, checking for square.

It's time to roll out the mobile bin

1 Cut the bin front and back (G), sides (H), and bottom (I) to size (we used birch plywood).

2 Cut rabbets along the front,

back, and side pieces to the sizes given on the Stand and Mobile Bin drawing.

3 Glue and clamp the bin together, checking for square. Later, remove the clamps, drill mounting holes, and mount four 2" fixed casters to the bottom of the bin. Drill the holes for a pair of 3" wire pulls in the bin front. The bottom pull makes for ease in lifting when discarding the contents.

Let's make the extension table and fence assemblies

1 Cut the left-hand tabletop extension (J), right-hand tabletop extension (K), banding strips (L, M), and spacers (N) to size. The spacers allow chips and sawdust to fall through the extension tables, avoiding buildup against the fence and stop.

2 Cut the fences (O, P, Q) to size.

For smooth sliding of the stop on part O later, ensure that part O is uniform in thickness and width.

3 Cut a 1 7/32" groove 1/16" deep along the front face of part O to house the tape measure.

Continued

MITERSAW CABINET

4 Using the Top View detail accompanying the Exploded View drawing for reference, cut a $\frac{1}{4}$ " slot $\frac{1}{2}$ " deep across one end of parts O and P. Then, cut a $\frac{1}{2}$ " rabbet $\frac{1}{4}$ " deep across both ends of the middle replaceable fence (Q) to form a tongue that will mate in the outside-fence slots.

5 Cut a pair of $\frac{5}{16}$ " grooves $\frac{1}{4}$ " deep along the front and back of the left-hand fence (O) where shown on the End View detail.

6 Glue and screw the spacers (N) between the left-hand fence (O) and table (J) with the top surface of the table flush with those of the spacers. Glue and clamp the banding strips (L, M) to the front of their respective tables.

7 Cut the left-hand fence-assembly support (R) and braces

(S) to size. Drill the mounting holes and screw a pair of $\frac{1}{4}$ " T-nuts into the mounting holes in the bottom of the support (R) to the sizes shown on the Foot detail accompanying the Exploded View drawing below.

8 Glue and screw the right-hand fence (P) and brace (S) to the table (K). Then, as shown in the photo on the opposite page, screw the table (K) and brace (S) to the right-hand stand side (A). (We

used a square-cut corner support to hold the table assembly square when attaching it to the stand.)

9 Drill the mounting holes, and glue and screw the support (R) and brace (S) to the left-hand table assembly.

Anchor the long extension table to the wall

| Position the stand with its back edge flush with a wall in your workshop. Position your miter-

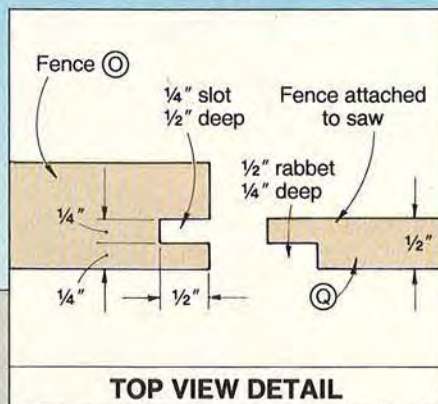
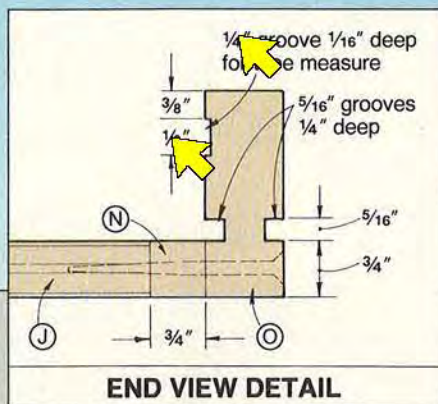

EXPLODED VIEW

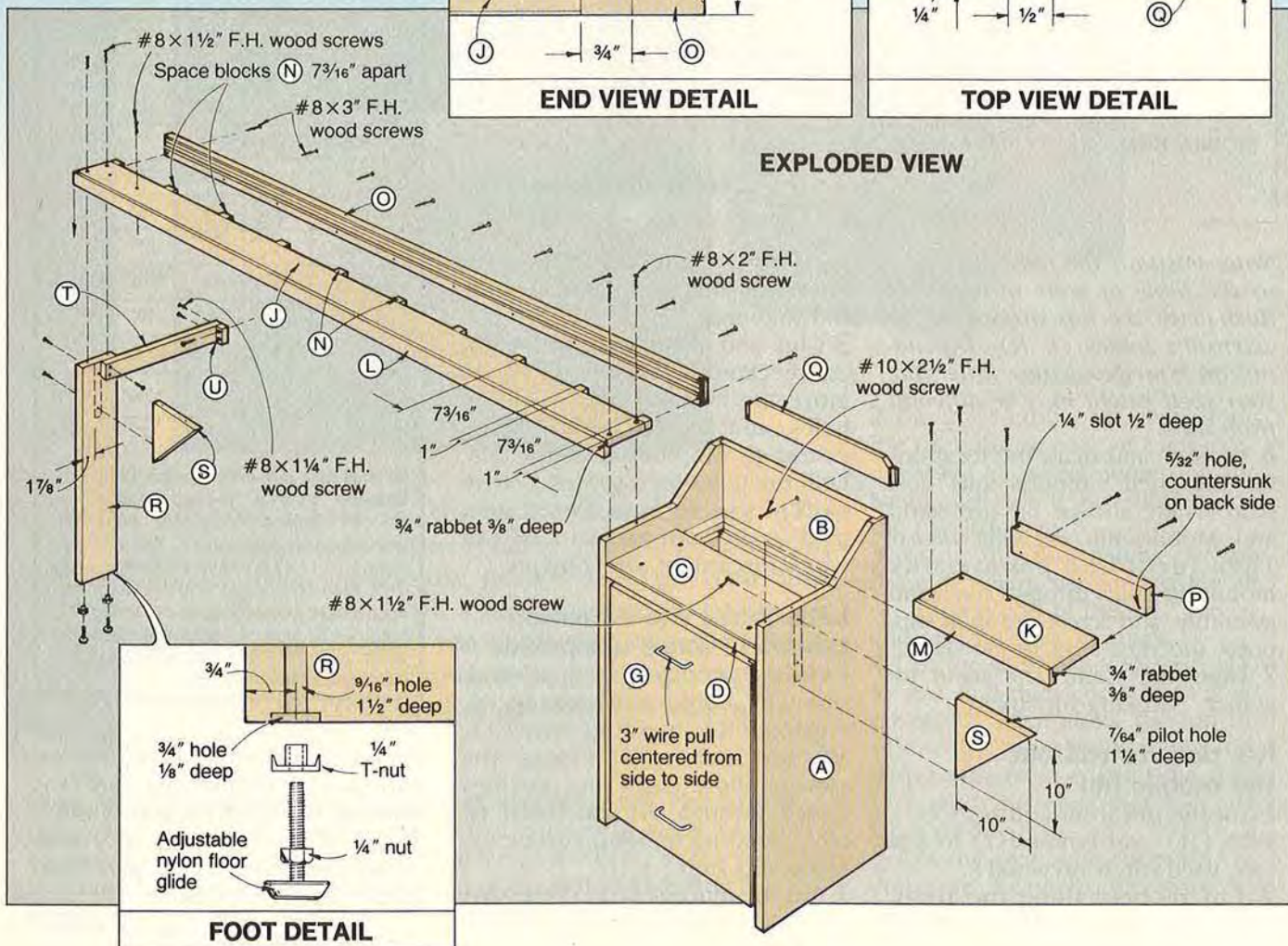

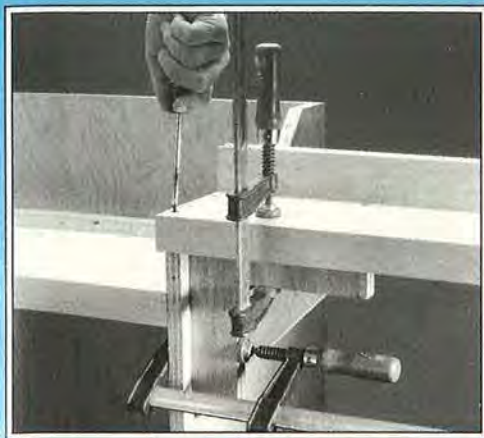

Fasten the table and brace to the bin side, using a square-cut corner support for stability.

saw on the stand. Verify that the top surface of the saw table is flush with the right- and left-hand extension tables. Adjust the shelf height if necessary.

2 Fasten the left-hand fence to the stand, and adjust the floor glides in the end support (R). Use a straightedge or long straight board to check that the left-hand tabletop (J) aligns with right-hand tabletop (K).

3 Cut the support arm (T) and cleat (U) to size.

4 Sand, prime, and paint the stand, bin, and table support (see the opening photo for specifics). We used red aerosol enamel.

5 Attach the support arm and cleat to the end support (R). Screw cleat to your shop wall to brace the end of the left-hand extension table against the wall.

6 Drill a mounting hole in the stand back (B) where shown on the Exploded View drawing, allowing you to anchor the stand firmly to the wall.

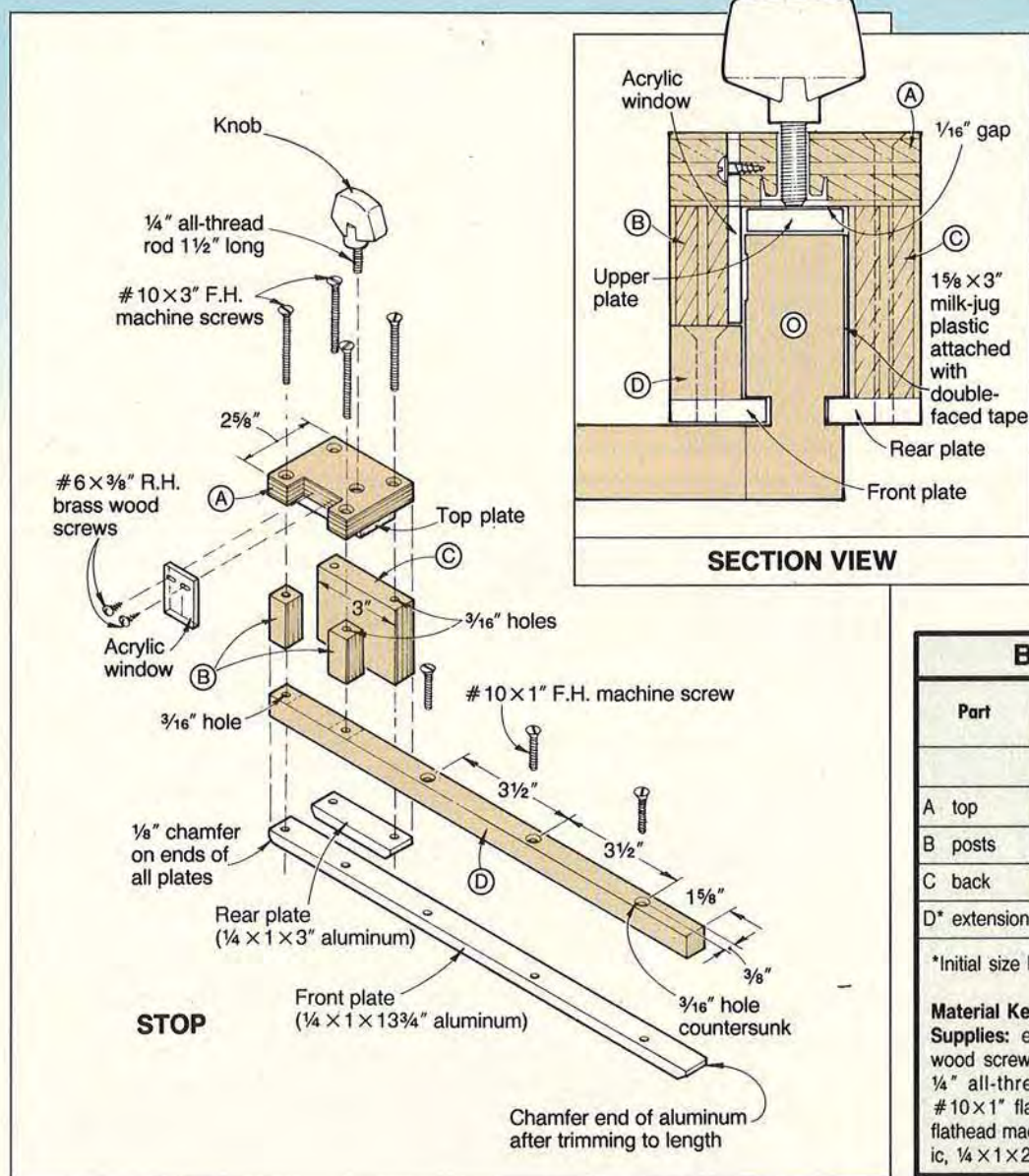

For consistent lengths, add the stop block

1 Cut the stop top (A), posts (B), back (C), and extension (D) to sizes listed in the Bill of Materials.

2 Using the Stop and Parts View drawings for locations, epoxy the parts together where shown. After the epoxy has cured, drill and countersink all holes through the assembly where dimensioned on the

Continued

Bill of Materials					
Part	Finished Size			Mtrl.	Qty.
	T	W	L		
STOP BLOCK					
A top	3/4"	2 5/8"	3"	BP	1
B posts	3/4"	3/4"	1 1/4"	BP	2
C back	3/4"	2"	3"	BP	1
D* extension	3/4"	3/4"	13 3/4"	B	1

*Initial size before cutting to length.

Material Key: BP—birch plywood, B—birch
Supplies: epoxy, #6 x 3/8" roundhead brass wood screws, #6 x 5/8" flathead wood screw, 1/4" all-thread rod 1 1/2" long, 1/4" T-nuts, #10 x 1" flathead machine screws, #10 x 3" flathead machine screws, 1/8 x 1 1/4 x 1 7/8" acrylic, 1/4 x 1 x 20" aluminum bar stock.

MITERSAW CABINET

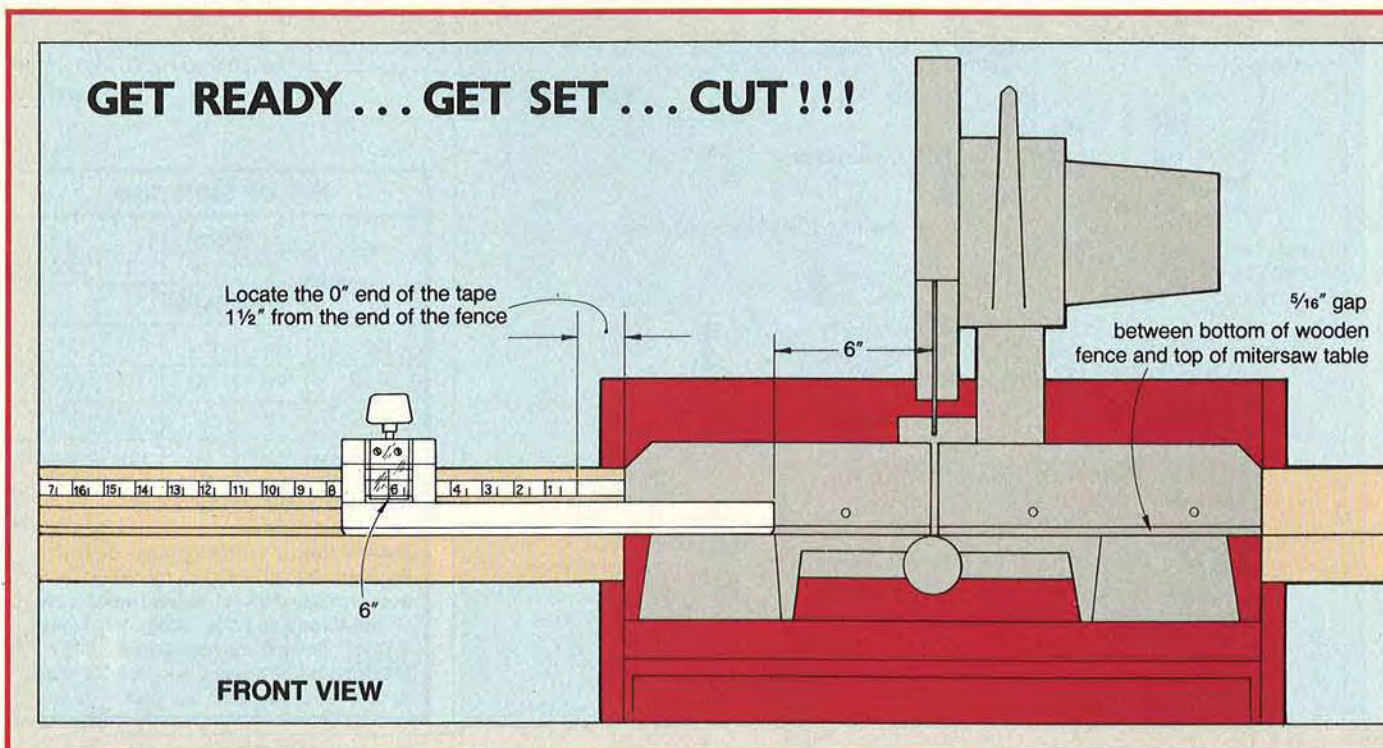
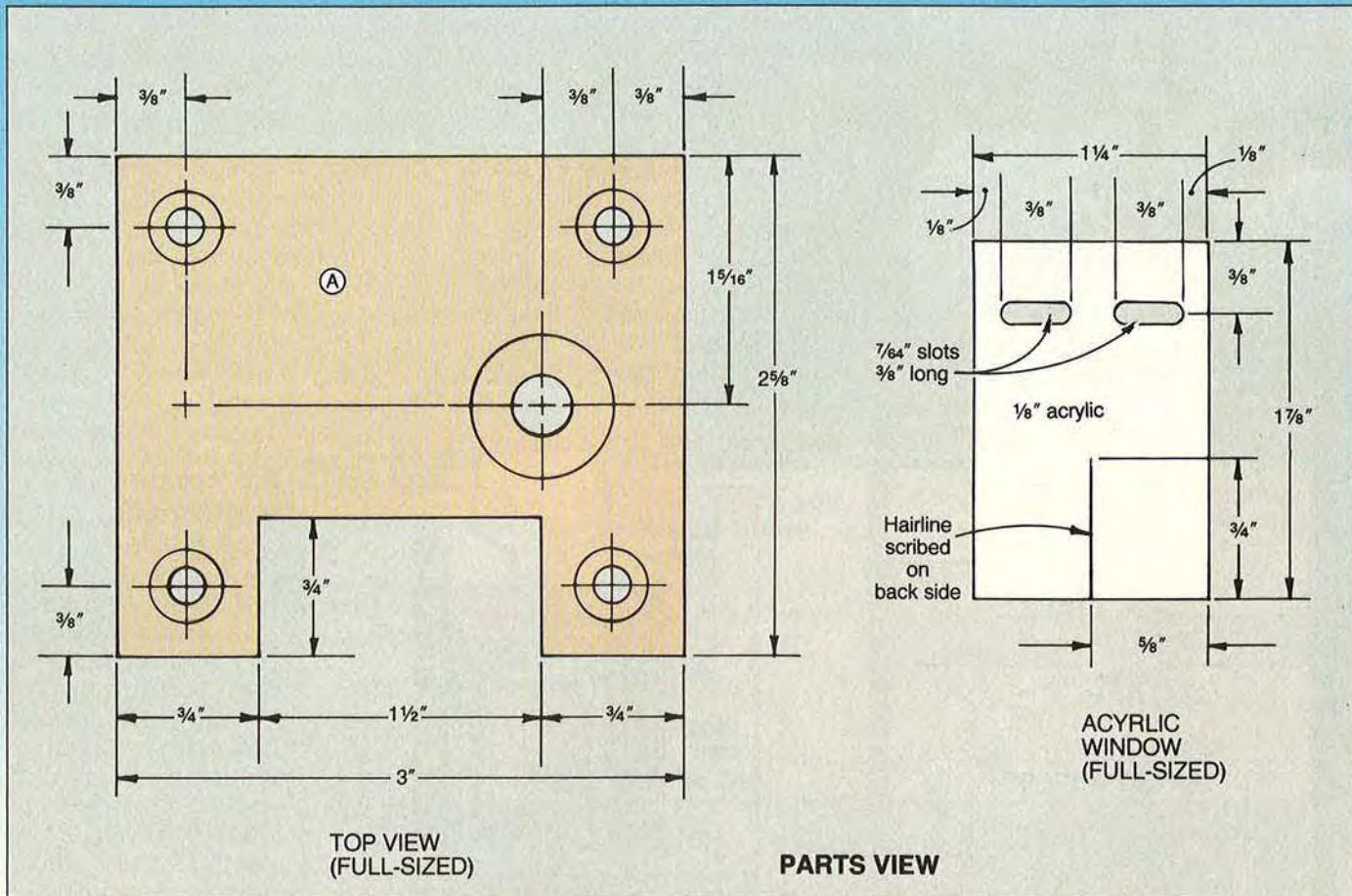

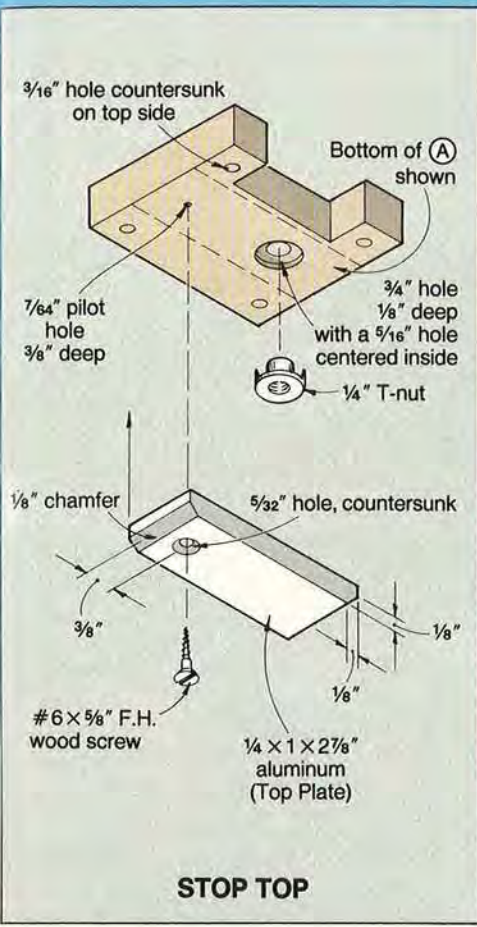

drawing. Don't forget to drill the counterbored hole on the bottom side of the top (A); see the Stop Top drawing at *left* for reference.

3 From $\frac{1}{4} \times 1$ " aluminum, cut the top, front, and rear plates to length (we used a hacksaw).

4 Clamp or tape the aluminum strips to the stop assembly where shown on the Section View detail accompanying the Stop drawing. Using the existing holes in the stop as guides, drill $\frac{5}{32}$ " holes through the aluminum. Using a 10-24 tap, thread the holes in the front and rear plate to mate with #10 machine screws.

5 Drill and countersink a $\frac{5}{32}$ " hole in the aluminum Top Plate where shown on the Stop Top drawing.

6 Epoxy a $\frac{1}{4}$ " T-nut into the counterbored hole on the bottom side of part A. Be careful not to get epoxy in the threaded opening of the T-nut.

7 From $\frac{1}{8}$ " acrylic, cut the window to the size shown on the Parts View drawing. Drill holes side by side to form a pair of adjustment slots. Scribe a line down the center of the window. High-

light the line with a black marker.
8 Sand a chamfer on each end of the aluminum top plate where shown on the Stop Top drawing.

Assemble the stop pieces

1 Screw the three aluminum plates to the stop assembly.

2 Cut a piece of $\frac{1}{4}$ " all-thread rod to $1\frac{1}{2}$ " long. Epoxy and thread one end into the knob. Sand or grind a slight chamfer onto the bottom end of the threaded rod.

3 Fasten the top plate to the stop top where shown on the Stop Top drawing. Back the screw out slightly to create a $\frac{1}{16}$ " gap between the end of the plate and the stop top (A) where shown on the Section View drawing accompanying the Stop drawing.

4 Mask the aluminum, and paint the stop. Fasten the acrylic window to the stop so the screws are centered in the adjustment slots.

5 Cut a piece of milk-jug plastic to $1\frac{1}{2} \times 3$ ". Using double-faced cloth-backed tape, adhere the plastic to part C where shown in the Section View detail. The plastic helps the stop slide smoothly.

Set your miter saw on the shelf (C) and check that the top surface of the saw table is flush with the top surfaces of the extension tables (K, L). Slide the middle fence (Q) in position, leaving a $\frac{5}{16}$ " gap between the bottom edge of the fence and the top edge of the miter saw table. See the Front View drawing for reference.

Position the miter saw so the miter saw fence is directly behind the middle fence (Q). Trace the location of the mounting holes in the miter saw fence onto the middle fence (C). Drill mounting holes, and then fasten the middle fence to the miter saw fence.

Drill mounting holes, and bolt the saw to the shelf. Attach the adhesive-backed tape measure to the left-hand fence where shown on the drawing at *left*. For easier

sliding, rub paraffin on the mating parts of the stop and fence.

Slide the stop assembly onto the fence so the aluminum front and rear plates slide freely in the grooves in the left-hand extension fence. Position the stop so the marked hairline on the acrylic window centers over the beginning (0") on the tape. Tighten the knob to lock the stop on the fence. Using a fine-toothed carbide-tipped blade, cut the end of the stop extension to length.

Now, by moving the stop exactly 6" away from the blade, the hairline marked on the acrylic window will automatically align over the 6" marking on the tape. Should you ever need to adjust the window, loosen the #6 screws slightly, adjust as necessary, and tighten the screws. Remove the

stop, and sand or file a slight chamfer on the cut end of the front aluminum plate.

Buying Guide

• **Hardware kit.** 72" adhesive-backed tape measure, knob, $\frac{1}{4}$ " threaded rod $1\frac{1}{2}$ " long, $\frac{1}{4} \times 1 \times 24$ " aluminum (holes are not drilled or tapped), $\frac{1}{8} \times 1\frac{1}{4} \times 1\frac{7}{8}$ " acrylic, 4-#10 \times 3" F.H. machine screws, 3-#10 \times 1" F.H. machine screws, 2-#6 \times $\frac{3}{8}$ " roundhead brass wood screws, #6 \times $\frac{5}{8}$ " F.H. wood screw, 3- $\frac{1}{4}$ " T-nuts, 2-adjustable nylon floor glides. Kit No. MS2273, \$17.75 (US) plus \$5 postage. Call for postage outside U.S. Add \$3.25 for a 10-24 tap. Puckett Elec., 841 11th St., Des Moines, IA 50309, or call 800/544-4189 or 515/244-4189 to order. 🌲

LOGG

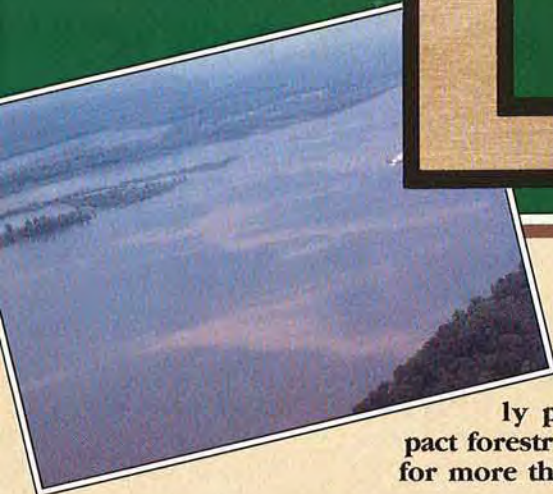

A true tale about how one gentle, lumber-industry giant has quietly practiced low-impact forestry with hardwoods for more than half a century.

WOOD ON THE ROAD



Editor Pete Stephano listens as Tony Parks, Anderson-Tully's vice president of land management, explains how trees left to grow large will straighten out any early bows in the trunk.

The Anderson-Tully Company, a more than century-old lumber producer, has a big reputation among industry insiders. For years, I'd heard that the company's vast hardwood holdings, which stretch along the Mississippi River from Illinois to Louisiana, yield some of the widest, thickest, and clearest hardwood boards found anywhere. And, Anderson-Tully's responsible forestry practices are near legendary.

To find out if this was all true, I contacted Anderson-Tully officials and secured an invitation to their Memphis headquarters. Then, for four days I saw how Anderson-Tully accomplishes everything I'd heard. Now I understand why they have earned a place at the leading edge of ecology-minded timber production.

Peter J. Stephano

Peter J. Stephano
Senior editor

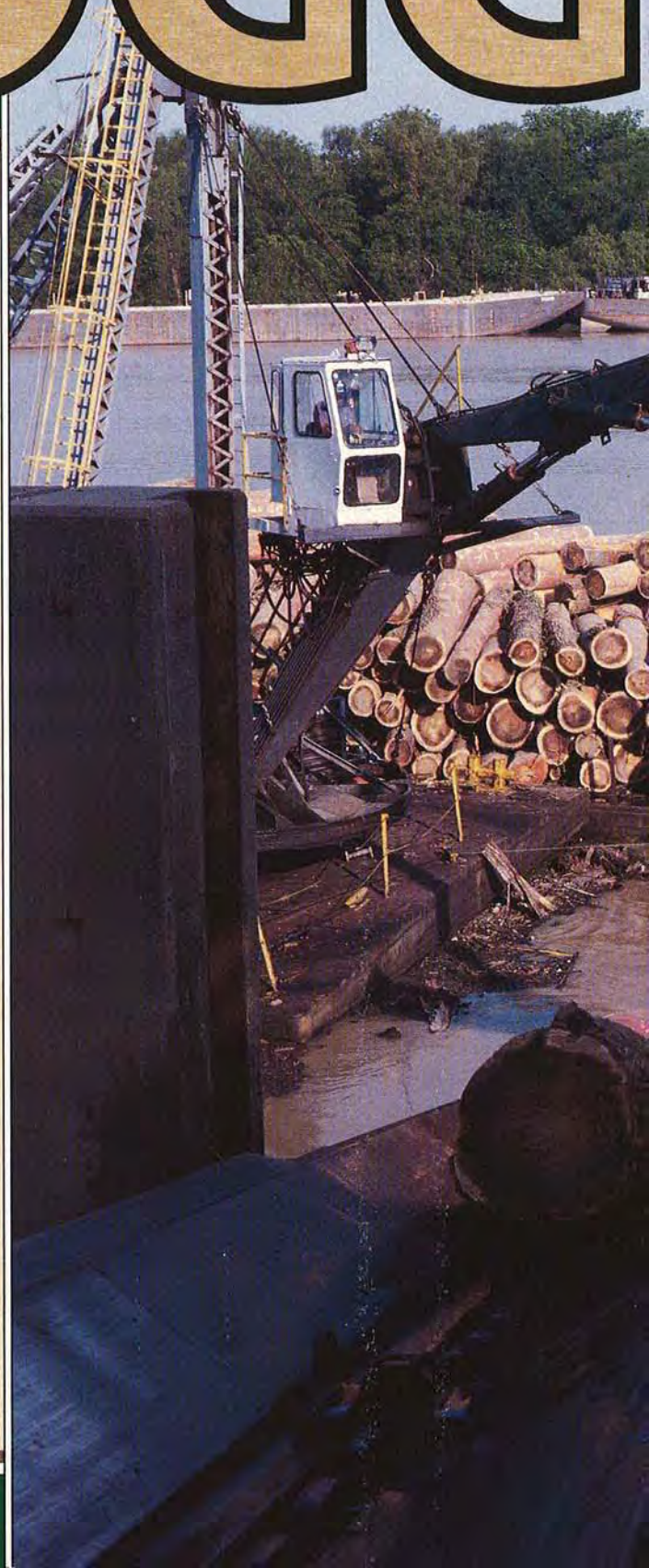

ING ALONG THE MIGHTY MISSISSIPPI

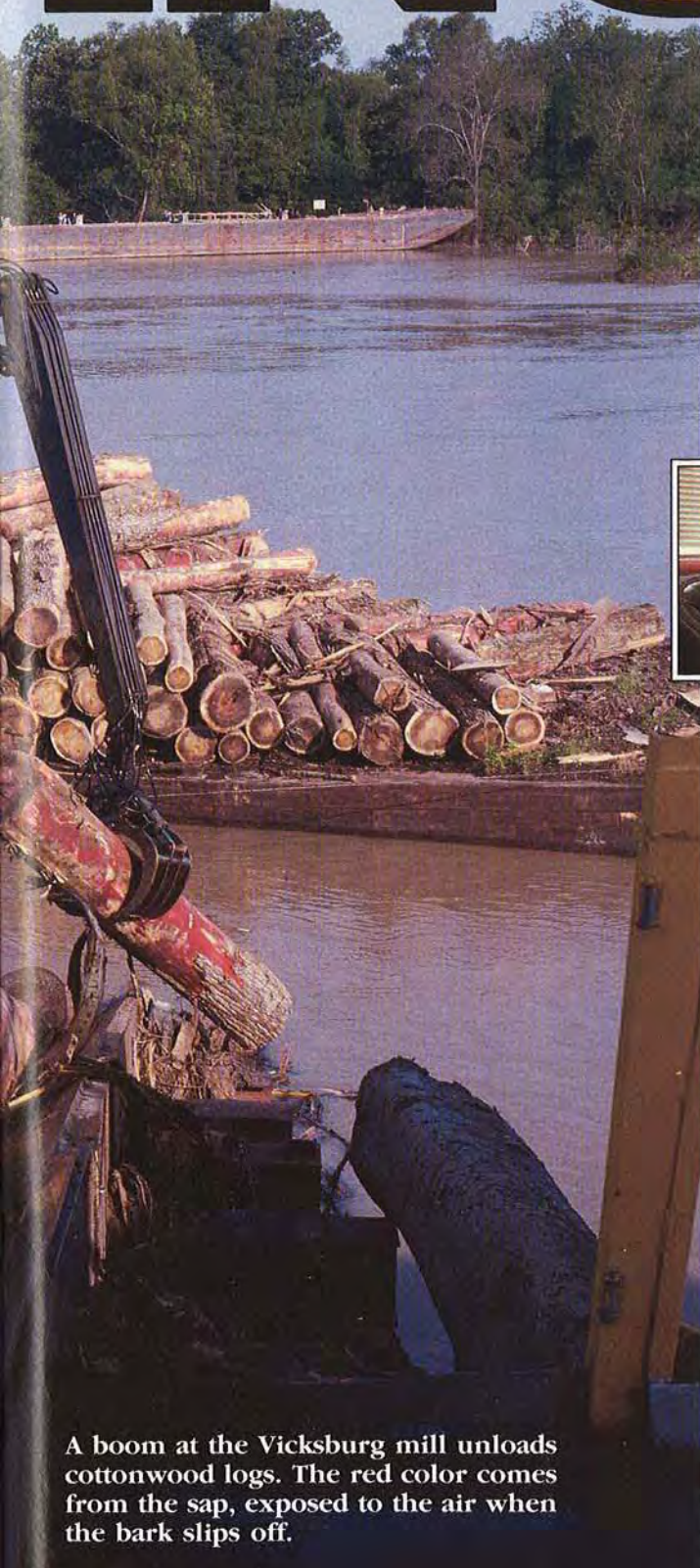

A boom at the Vicksburg mill unloads cottonwood logs. The red color comes from the sap, exposed to the air when the bark slips off.

In our business, we want the quality that comes from great big trees, not scrawny, skimpy ones," says John M. Tully. He's the 65-year-old president of the Memphis-based Anderson-Tully Company, one of the nation's largest hardwood producers. Raising his hands to emphasize the point, he adds, "But to get great big, quality trees, you gotta get tiny seedlings first."

John Tully's big trees do begin as little bitty ones, but they grow up in a leafy, green neighborhood filled with trees of all ages. In the science of silviculture (tree-growing), that's called uneven-age management, and it calls for an intensive knowledge of the land as well as all the trees that nature puts there.



John Tully began the data-reliant management that guides the company's intensive, uneven-age, forestry practices.

Nature still selects the trees

If you were to fly from St. Louis to New Orleans, at any one particular moment you'd likely see Anderson-Tully-owned timber below. Forester Tony Parks, the company's vice president for land management, tells when and how this vast ownership began.

"Back in 1889, when the company was first established in Memphis, the founders saw a value in the land that others didn't. Most companies would either buy the timber, cut it, then get out; or they would buy the land, cut the timber, then let the land go for back taxes," he says. "Rather than cut out and get out, Anderson-Tully added land all the way down to Vicksburg and maintained the land in its natural condition by buying available timber from outside sources and saving its own." Those century-old decisions, combined with a long-term land and timber management plan (rooted in 1937 and formalized in 1968), have meant a sustainable hardwood supply for the company's mills.

Most Anderson-Tully forest is bottomland, made up of rich soil deposits left by the overflowing Mississippi River. Yet, there are huge upland stands, too. The mix naturally generates 120 tree species.

Continued

LOGGING

“We allow nature to make the species selections, and then we manage what she puts on those sites,” explains Tony of the company’s nearly hands-off forestry technique. From the mix that nature gives them, Anderson-Tully receives 65 species with commercial value. Of these, 28 go to U.S. and foreign markets in the form of processed lumber, while the remaining supply paper pulp, veneer, and other specialty needs.

Around-the-globe marketing

In a typical year, the company cuts from its lands and mills more cottonwood by far than any other species. After that come the oaks, hackberry, sweetgum, sycamore, and ash. The remainder represents a broad spectrum—sweet pecan, locust, Kentucky coffee tree, magnolia, persimmon, elm, sassafras, willow, tulip-tree (yellow poplar), and so on.

However, under Anderson-Tully’s complete forest management plan, the species mix to be cut annually isn’t dictated by marketing needs, but by foresters in the field. “What we cut,” says Tony, “is based on what we determine we can harvest in each species without exceeding its annual growth.”

Marketing the 70 million board feet of such a mix of wood flowing from the forest each year challenges the sales department. “With all the species we have, you can see how important it is to develop markets,” says Richard Wilkerson, one of the company’s sales representatives. “What makes my job difficult is that those species are coming to the sawmill whether they’re selling or not, because we’re going to do what’s best for the resource.”

As a result, sales representatives inventory what’s available, and then seek out probable customers. That’s why a good portion of Anderson-Tully’s cottonwood ends up in Japan, where it’s made into door jams, trim, and furniture. The persimmon also goes to Japan, but it’s manufactured into golf-club heads. Texas manufacturers make cottonwood into louvered shutters. Sycamore finds its way into chair manufacturing, and sweetgum gets utilized for paint-grade moldings and other millwork.

Much of the quality ash from the bottomlands is used for furniture and cabinets in the United King-

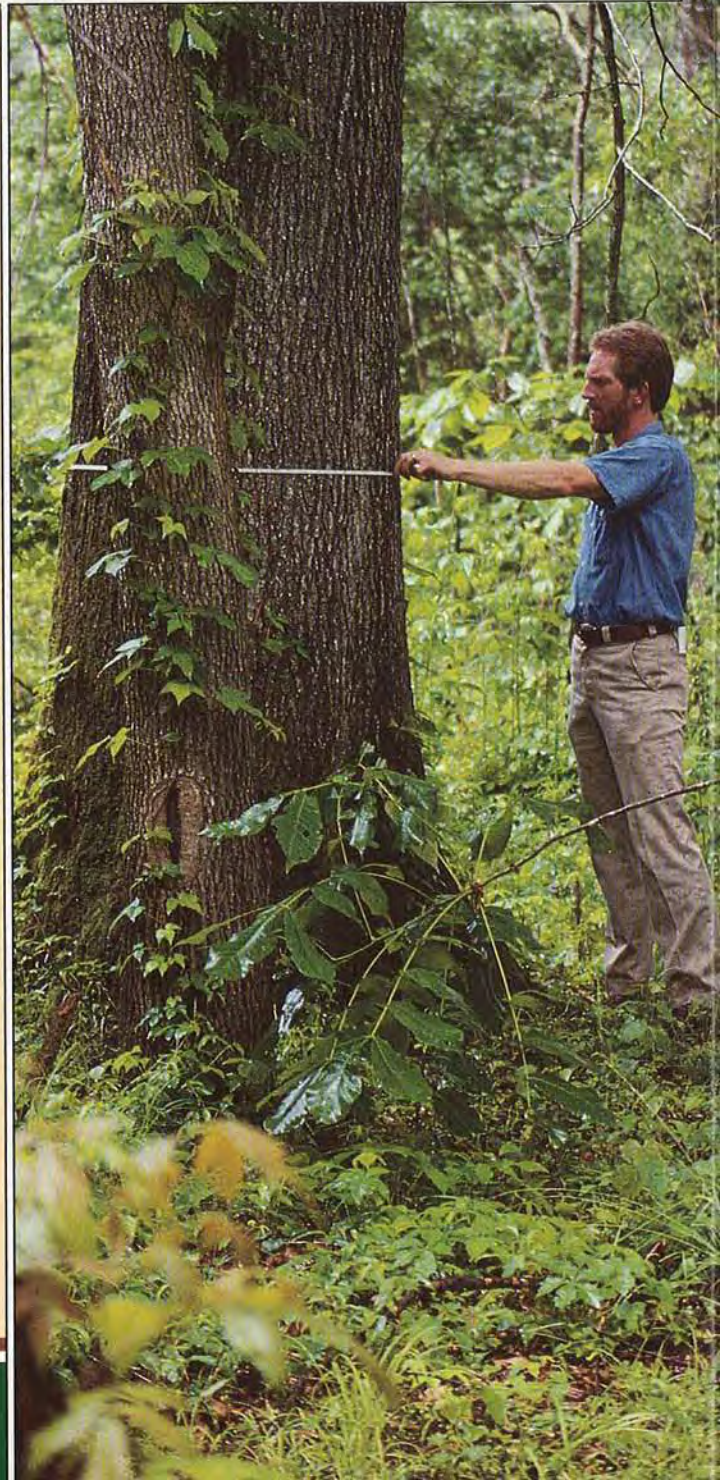

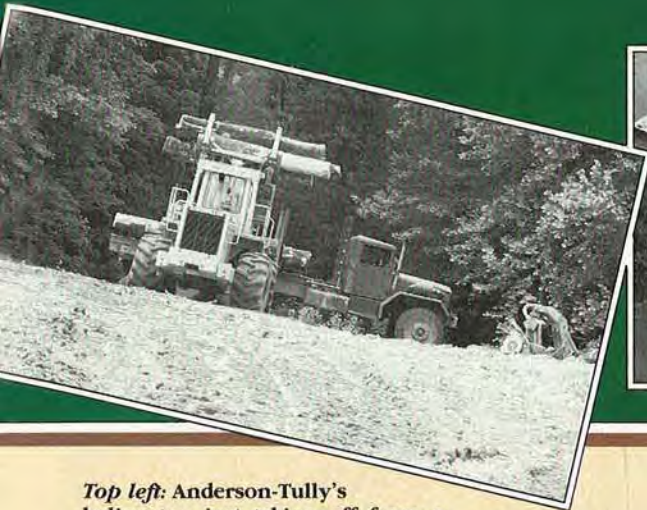

Top left: Anderson-Tully's helicopter, just taking off from a log barge, comes in handy for the foresters who manage the company's thousands of acres of timber.

Top center: Six-wheel-drive, military-surplus trucks team up with log stackers to haul logs from the bottomland forest to the river landing for loading.

Top right: Much of the timber harvested from company lands moves by barge to the mill. A barge such as the one tied up at the derrick boat at Mile Three on the Arkansas River can carry logs totaling 300,000 board feet.

Left: In a bottomland stand north of Memphis, forester Jack O'Connell measures the diameter of a cherry-bark red oak. "Most companies would cut this one," he says. "We'll let it add quality along with the quantity."

dom. Then, of course, there are the shipments of oak, ash, and other cabinet-class woods to U.S. furniture companies such as Bernhardt, Drexel, Henredon, and Thomasville. And about 18–20 million board feet go to homecenters and retail hardwood dealers, eventually ending up in the hands of home woodworkers.

Managing a forest tree by tree

Unlike softwood trees such as Douglas fir or yellow pine that can be mass-planted as seedlings, hardwood trees usually regenerate naturally. When the right conditions exist, a red oak, for instance, emerges from an acorn planted by a squirrel or sprouts from the stump of a felled or fallen tree.

Left alone to mature, the resulting bottomland forest would include shade-tolerant species like beech and boxelder, along with light-loving ones such as green ash, sweetgum, and red and white oak. The individual trees in each species may or may not develop into quality specimens. But, by promoting the best growth over decades through selection-cutting (rather than "selective" cutting, which typically means cutting

the best and removing the rest), a forester can manipulate the amount of sunlight that reaches the trees. This encourages the growth of preferred species into high-grade sawlogs.

Tramping through a bottomland stand along the Mississippi River, about 60 miles north of Memphis, Anderson-Tully forester Jack O'Connell explains how the concept works. "On any site, we like to have areas that were harvested, trees that are to be harvested, and small trees that will take the place of the large trees. That way, you'll never miss the forest."

Jack manages an extensive piece of the company's timberlands that extends from Cairo, Illinois, to Helena, Arkansas. He speaks with pride as he points to

trees in the stand. "That cherry-bark oak there has 1,200–1,300 board feet in it, and it'll yield about 80 percent No. 1 common and better lumber," Jack comments. "Red oak usually brings \$225 to \$300 per thousand board feet on the stump, but there aren't any quotes for quality like this. It's an example of our management objective." The tree we're looking at would make many a woodworker drool. It's limb-free for 48' and has a 42" diameter at breast height.

"Anybody can grow timber like this on sites like these, if they wait long enough," Jack adds, smiling. "We just try to do it a little quicker."

Ensuring big, quality trees for the future takes planning. And to make that a more manageable task, Anderson-Tully long ago divided its land into four huge blocks, each with a forester in charge. Then, each block is further divided into thousands of 160-acre management units the company calls compartments.

"A 160-acre compartment is the largest unit we feel that we can manage under this system, because it's a real hands-on approach," says Jack. Tony Parks chimes in, "What Jack means is that we manage our forests tree by tree."



"Over a 14 year period, we've cut a million board feet from here and we still have 3,000 board feet per acre in condition to grow," says forester Fred Newcomb, standing in the same area shown in the aerial view at top. A century ago, it was cotton fields.

Continued

LOGGING

Tree-by-tree management as practiced by Jack and other company foresters actually involves marking every tree to come out of the forest, whether it's for pulpwood or sawlogs. "It's labor intensive, but it's the only way to make sure we are getting what we want in the forest," adds Jack.

"By cutting in any given compartment every 10 years or so," he continues, "we can keep monitoring the open-canopy areas. It's necessary to understand relationships between species and sizes. Here in this stand, for instance, at age 25 years the sweetgum trees would be dominant because they grow faster in the sunlight, but 10 years later, the red oak will start to break through the canopy, eventually passing the sweetgum. What we end up with is red oak with a clearer bole [trunk] because it had to compete."

"Our logs consistently run between 41 and 43 percent U. S. Forest Service No. 1 grade," says Tony Parks. "The average for the whole southeastern hardwood forest is only about 6 percent."

Logging on the river

In the old days, transporting logs from the Mississippi River Delta bottomlands involved chaining them together into large rafts, then floating the rafts downstream to the sawmill. Today, logs still come to Anderson-Tully's Vicksburg mill from upstream, but in towboat-escorted convoys of huge barges, each carrying 150,000 to 300,000 board feet per barge.

"About 60 percent of the harvest on company lands comes out to river landings," says Paul Henry, an Anderson-Tully logging superintendent. "But in my block, [Helena, Arkansas, to Greenville, Mississippi], about 98 percent is river logging. And with river transportation, we can deal in volume. We try to take in nine barges per trip because we're often several hundred river miles above the mill."

Paul stands on the derrick boat, a massive, flat-decked, floating platform equipped with a loading boom and combination bunkhouse/kitchen/mess hall for the crew. It's anchored at the log landing on Big Island, a vast forest surrounded by three rivers—the White, the Mississippi, and the Arkansas.

"This island has maybe a hundred 160-acre compartments or more," says Paul, "and 3,000–4,000

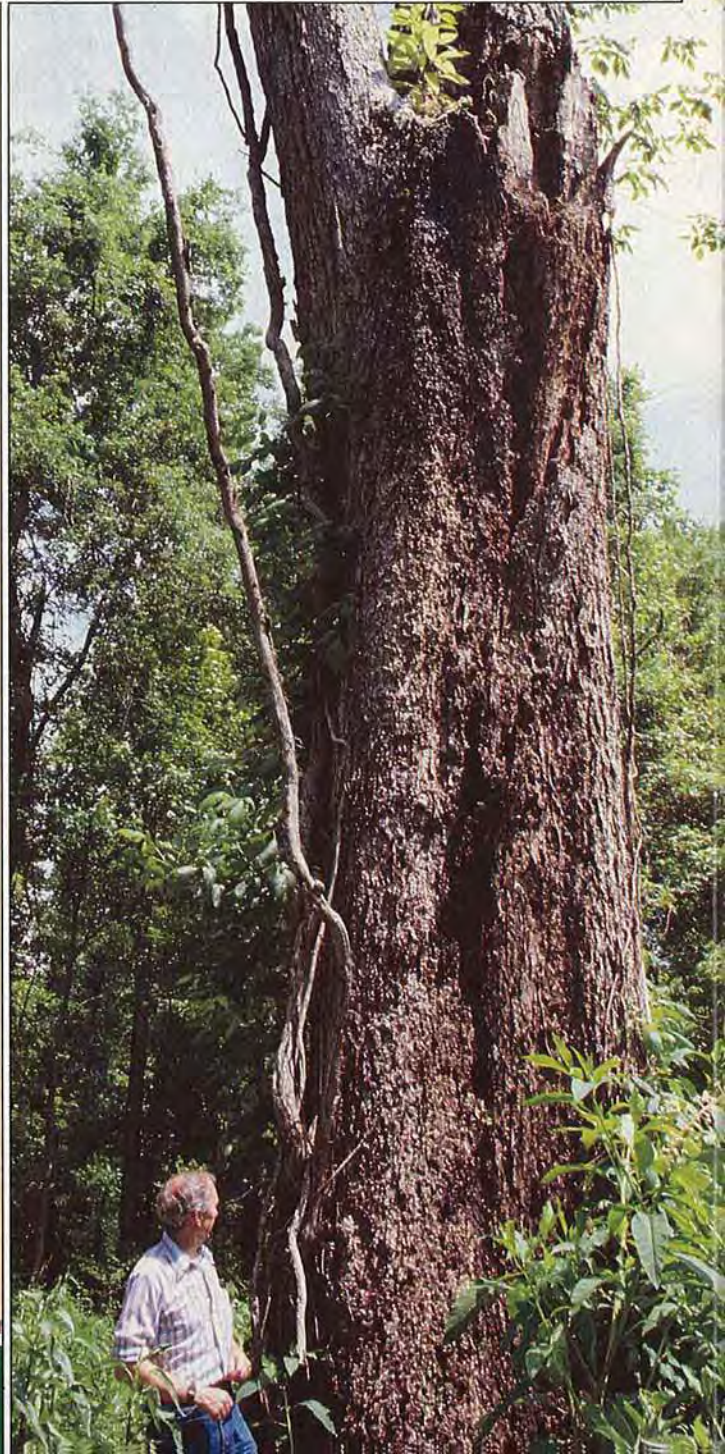

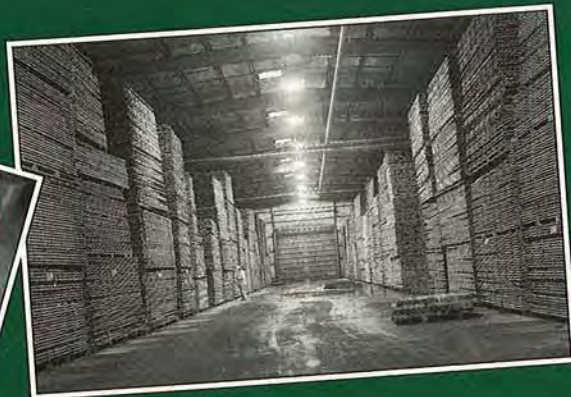
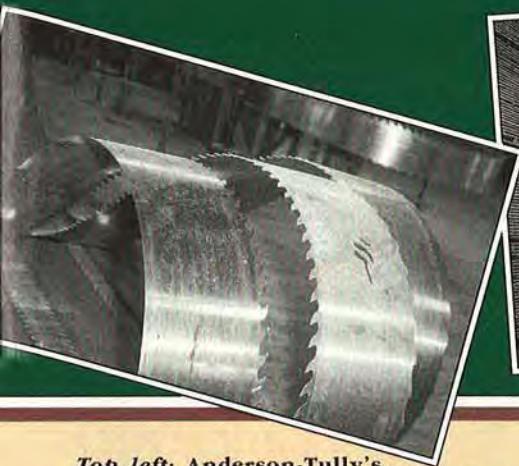

Top left: Anderson-Tully's

Vicksburg sawmill operations cover 150 acres, including three sawmills, acres of predrying area, and a large kiln capacity. In the U. S. hardwood industry, it's the largest lumber processing complex of its kind.

Top center: Sawing large logs requires bandsaw blades from 12" to 14" wide and 46½' long. Such blades cost as much as \$1,200, and are mended and resharpened right in the mill.

Top right: One-and-a-third million board feet of sawed hardwood fills the predryer from floor to ceiling three stacks deep per side. Fans keep the air slowly moving through the stickered wood until it's dry enough for the kiln.

Left: Uneven-age silviculture manages for wildlife as well as trees. Forester Johnny Lack has several trees per acre like the old pecan he stands by. These snag trees—he calls them pet trees—become nesting areas for birds and dens for mammals, including raccoons and even bears.

acres that need to be cut this year. We've already cut six barges in the two weeks since we started, and because of wet weather, we got started late."

John D. Ballinger, a logger from Pine Bluff, Arkansas, contracts with Anderson-Tully to harvest timber. He's been logging since 1946, and observes how it is to drop and haul huge Big Island logs of cottonwood, hackberry, and ash.

"The bigger the timber, the less trouble there is with it," John says with the hint of an Arkansas drawl. "It's a lot easier to log and you make more volume. It's not unusual to cut 90,000 board feet a day, hauling logs from three or four miles in the woods. That is, if the weather holds and equipment don't break down."

"In this selection cutting, there's always plenty of timber left," he points out, adjusting the visor of his cap and gazing back over his shoulder at the dense trees. "It don't do a lot of damage, either."

Nodding, Tony Parks says, "We feel that in the future there will continue to be a great demand for wood, but unless you can produce it in an ecologically sensitive manner, you're not going to have a market." Adds Johnny Lack, forester for the block, "We had an ecology professor visit here once. He saw one of our bottomland stands and said, 'This is a virgin forest.' I told him, 'Well, it may be virgin, but seven years ago we cut 11,000 board feet per acre out of here.'" And to John Tully and his successors, that will always be the way of a Delta harvest.

HUNTING CLUBS

Where birds, bear, bucks, and bobcats roam

According to Jimmy Bullock, one of Anderson-Tully's two wildlife biologists, providing for wildlife is company policy.

"In 1984 the company adopted a resource management guide that integrates wildlife, forestry, and logging," notes Jimmy, "and one part says that the deer herd is a resource just like timber, and that it should be monitored and managed to ensure that it's maintained in quality condition, the same as trees."

"One way that's done is with the cooperation of hunting clubs that lease Anderson-Tully timberland. We have 242 clubs, and most are involved in deer management and data collection on herd condition."

Within state laws and the biologists' guidelines, clubs set their own goals for deer, such as more 2½-year-old bucks, then regulate members' hunting accordingly. The result has been a healthy deer herd in balance with the land.



Club members pose with trophy mounts from last deer season.

Mike Staten, the company's other wildlife biologist, has a deep interest in songbirds. Their feeding and nesting grounds in wooded areas across North America have shrunk.

"Because of uneven-age management, our forests always have a mixture of tree-top levels, hollow trees to provide nesting areas, and wildlife food, too, such as pokeweed and dewberries. Nontimber trees like mulberry and dogwood contribute to the diversity," he says.

That's why on Anderson-Tully timberlands you'll find all the furry and feathery members of a forest community. "We look at them as supplying a richness to our forest stands," says Mike. 🌲

Written by Peter J. Stephano Graphic design: Perry A. McFarlin
Photographs: Mark J. Istvanko; Jimmy Bullock/Anderson-Tully



WRECKER

Every now and then, even the sturdiest toy vehicle “breaks down” somewhere and needs to go to the “shop” for repairs. When that happens at your house, we’ve got the truck your child needs to get the hauling job done. For heavy loads, simply have him lock the boom’s lift bar in the up position—just like the real McCoy—and off he’ll go.

Note: You’ll need some thin stock for this project. You can either plane or resaw thicker stock to the sizes in the Bill of Materials.

Laminate the cab

1 Cut a piece of $\frac{3}{4}$ " pine to 2" wide by 12" long for the cab (A).

2 Measuring 1" from each end of the pine stock, mark the location for a $1\frac{3}{8}$ " dado. Cut the marked dados $\frac{1}{2}$ " deep where shown on the top of page 70.

3 Crosscut the pine into two equal lengths. Mark the windshield location on one piece where shown on the Windshield detail accompanying the Tractor drawing. Align the top of the windshield flush with the top

Continued

Bill of Materials					
Part	Finished Size			Mati.	Qty.
	T	W	L		
A* cab	1½"	2"	3"	LP	1
B hood	¾"	2"	1½"	P	1
C chassis	¾"	2"	6¾"	P	1
D bed	¾"	¾"	4 1/8"	P	1
E boom	¾"	1¾"	5 1/8"	P	1
F lift bar	¼"	½"	3 5/8"	B	1
G hook	¼"	1"	1 1/8"	B	1
H* inner wheels	¾"	2" dia.		P	4
I* outer wheels	¾"	2" dia.		P	6

*Initially cut parts marked with an * oversized. Then, trim each to finished size according to the how-to instructions.

Material Key: LP—laminated pine, P—pine, B—birch

Supplies: #8 finish nails, 10– $\frac{3}{8}$ " flat washers, mason's line or $\frac{1}{16}$ "-diam. cord, $\frac{3}{8}$ " dowel stock, $\frac{1}{2}$ " dowel stock, 7– $\frac{1}{2}$ " wood buttons, $\frac{3}{8}$ " all-thread rod 5½" long with nuts and washers for sanding arbor, clear finish.



EXPLODED VIEW

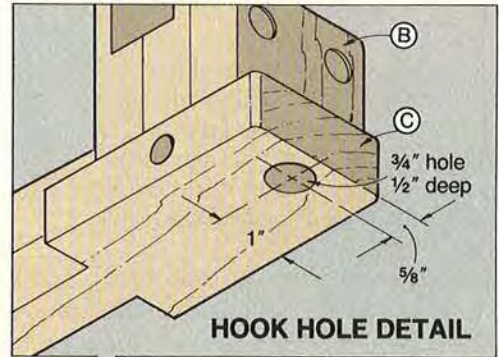
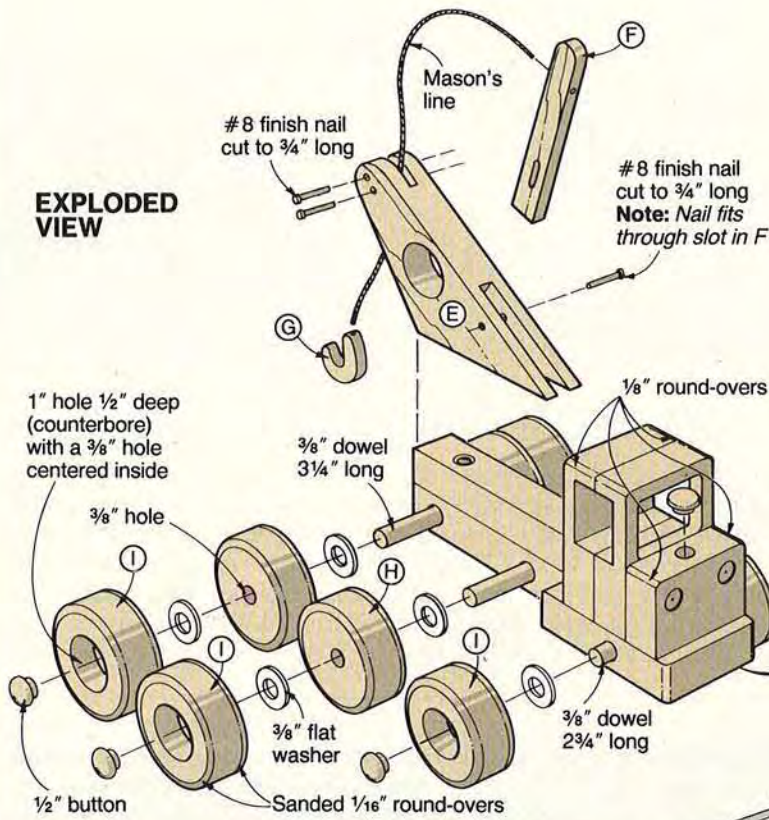

WHEEL SECTION DETAIL

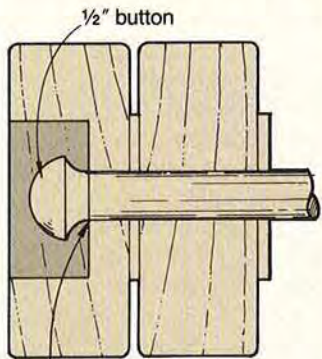

WINDSHIELD DETAIL

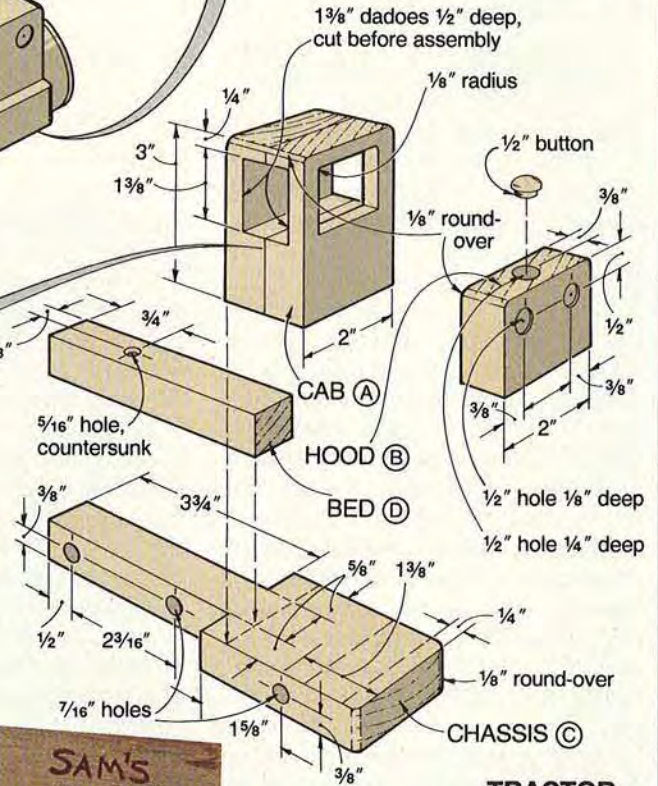
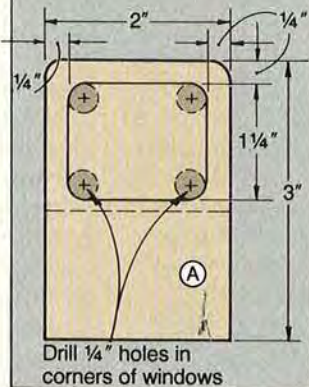

TRACTOR

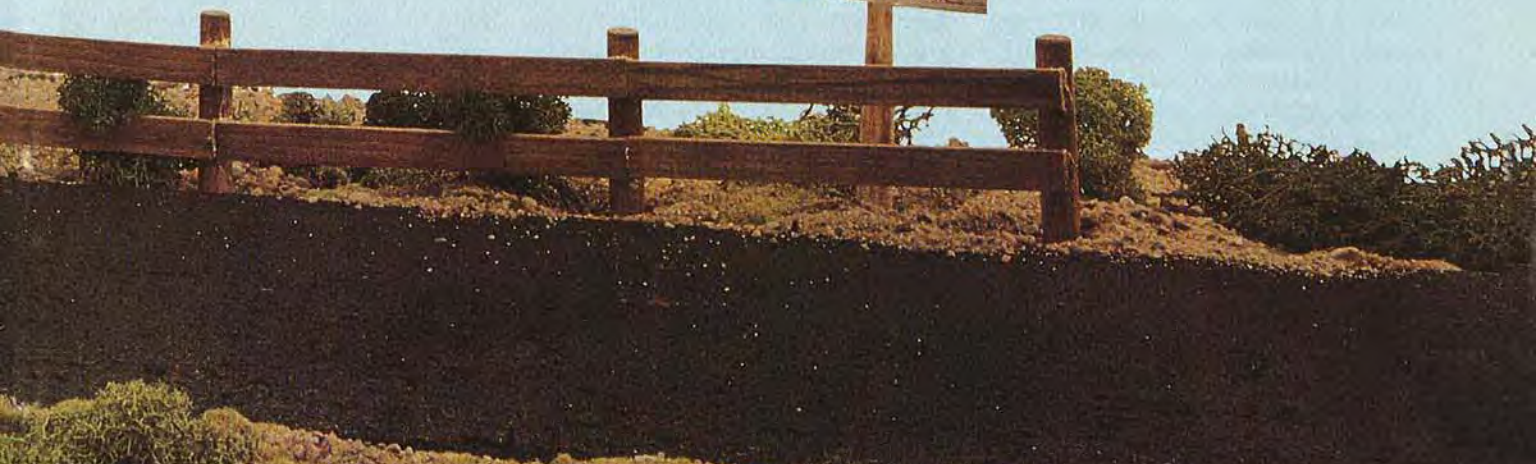

ROUGH 'N' READY WRECKER

of the dado. Now, drill four $\frac{1}{4}$ " holes inside the marked square. Cut the opening to shape with a scrollsaw or coping saw. Sand or file the edges of the opening.

4 Apply glue to the mating surfaces of cab parts (A), align the dados, and clamp. Remove excess glue before it dries.

5 Trim the top and bottom of the cab lamination to length where shown on the Windshield detail.

Now, cut the body parts

1 Cut the hood (B), chassis (C), and bed (D), to the sizes listed in the Bill of Materials. Cut the chassis to the shape shown on the Tractor drawing.

2 Sand $\frac{1}{8}$ " round-overs on the hood, cab, and chassis where shown on the Tractor drawing.

3 Mark all the hole centerpoints on the hood, chassis, and bed. One at a time, support each piece

with a handscrew clamp, and drill the holes (we used a drill press) to the sizes listed on the Tractor drawing. Don't forget to drill a $\frac{3}{4}$ " hole $\frac{1}{2}$ " deep on the bottom front of your other toys where shown in the Hook Hole detail accompanying the Exploded View drawing. The hole allows the wrecker hook (G) to fit into it for towing.

4 With the bottom and edges of the cab and hood flush, glue and clamp them together. Recessing the hood $\frac{1}{4}$ " from the front end of the chassis to form the bumper, glue and clamp the cab assembly to the chassis. Later, glue and clamp the bed on top of the chassis and against the back of the cab. Sand smooth, and glue a $\frac{1}{2}$ " button into the radiator cap hole.

Add the boom and lift bar

1 From $\frac{3}{4}$ " pine, cut a block $1\frac{3}{4} \times 5\frac{1}{8}$ " long for the boom (E).

2 Using carbon paper, transfer the boom outline, hole centerpoints, and $\frac{1}{8}$ " and $\frac{1}{4}$ " slot locations to the boom blank.

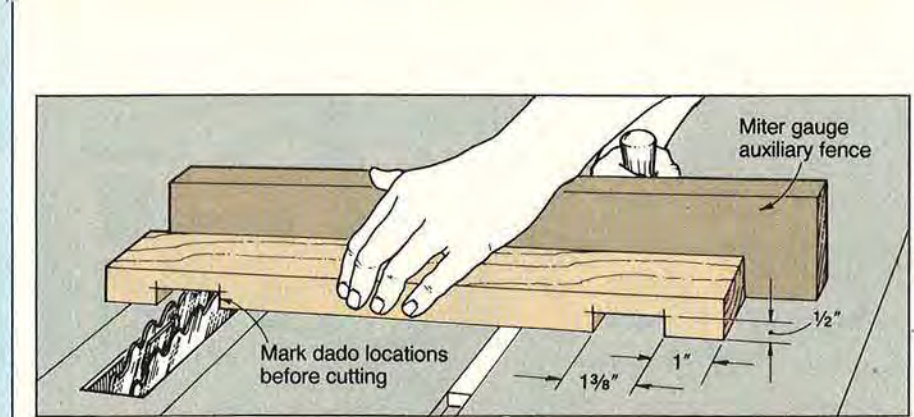

GET YOUR ROUGH N'READY TOY PLANS HERE

To date, we've presented plans for the following matching set of toys: (1) semi-trucks and trailers, (2) excavator, (3) bulldozer, (4) dump truck and lowboy, (5) front-end loader, and (6) road grader. If you are interested, send \$2 and a #10 business envelope with 55¢ postage for each plan you want, or for all six plans, send \$8.95 plus a 7×10" envelope with \$1.20 postage to WOOD® magazine Toy Plans, P.O. Box 11454, Des Moines, IA 50336-1454.

3 Drill the holes to the sizes stated on the Boom drawing.

4 With a bandsaw, cut the slots to size. (You also could use a push block, and cut the slots on the tablesaw.) Cut the boom to shape.

5 Glue the boom to the bed where shown on the Section View drawing.

6 Using carbon paper and the full-sized patterns, transfer the lift bar (F) and the hook (G) outlines, as well as the hole and slot locations for each to $\frac{1}{4}$ " birch stock. Cut the two parts to shape.

7 Form the slot in the lift bar where marked. Using a handscrew clamp to hold the parts steady, drill a $\frac{1}{16}$ " hole through the hook and lift bar where marked. Then, drill the $\frac{1}{8}$ " counterbores. These holes will hide the boom-line knots later.

8 Snip three #8 finish nails to $\frac{3}{4}$ " long. Position the lift bar in the boom slot. Press the top two nails into the $\frac{3}{32}$ " holes in the boom. (We used a drop of instant glue in each hole to secure the nails.) Align the slot in the lift bar with the lower $\frac{3}{32}$ " hole in the boom, and press the bottom nail into position, trapping the lift bar in the boom slot.

9 Cut a piece of cord (we used mason's line) to about 7" long. Tie a knot on one end and thread the other end through the hole in

the lift bar, pulling the knot into the counterbore. Pass the line between the nails in the boom, and thread it through the hole in the hook. Now, tie a knot on this end and tug the line to draw the knot into the hook's $\frac{1}{8}$ " hole.

Next up, the wheels

1 To make 10 wheels (H, I), cut a piece of $\frac{3}{4}$ "-thick pine to 4×36 ". Starting 3" from one end, mark 10 centerpoints 3" apart.

2 With a compass, mark a 2"-diameter circle (1" radius) at each marked centerpoint.

3 Chuck a 1" Forstner bit into your drill press. Attach a scrap work surface to your drill-press table. As shown in the photo below, center the bit over a marked centerpoint, and bore a $\frac{1}{2}$ "-deep hole in six of the marked circles. (We used the stop on our drill press to ensure a uniform depth.)

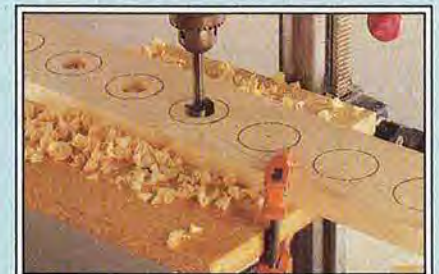

Mark the wheel centerpoints and radii, and use a 1" Forstner bit to drill holes $\frac{1}{2}$ " deep for each wheel.

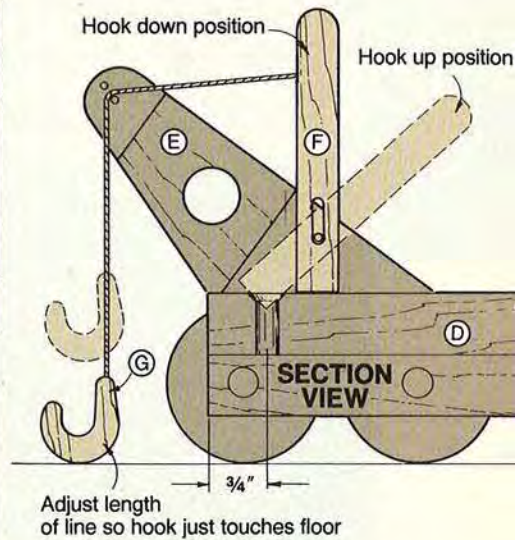
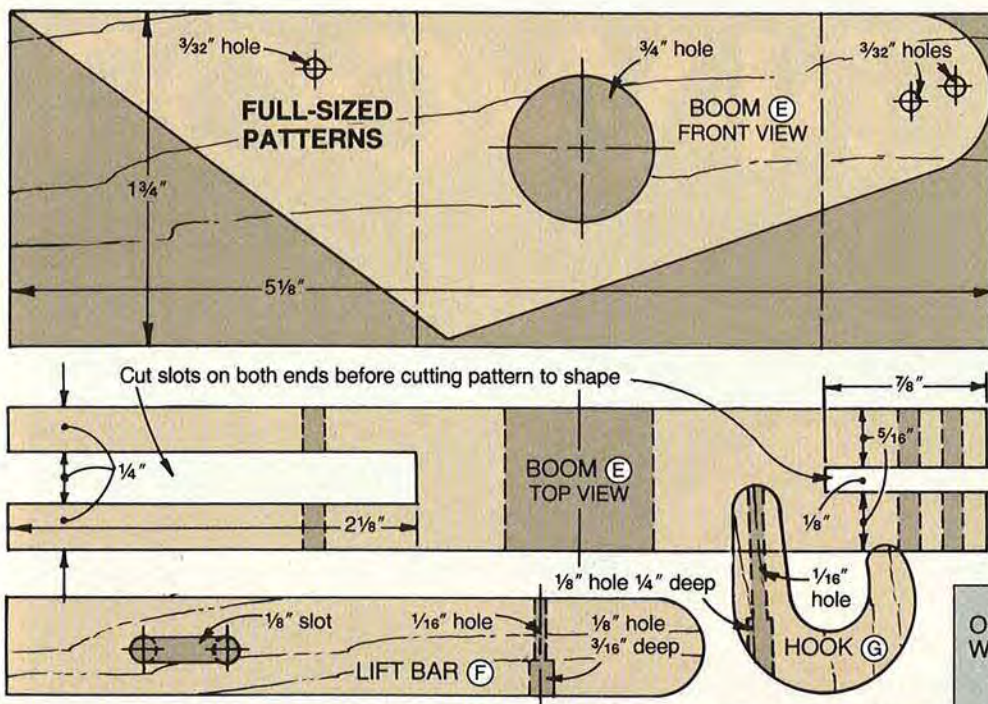

4 Chuck a circle cutter into your drill press. Using the drawing *below* for reference, turn the cutter blade so the pointed end is on the inside to cut a perfect wheel. Adjust the circle-cutter arm to cut the correct diameter.

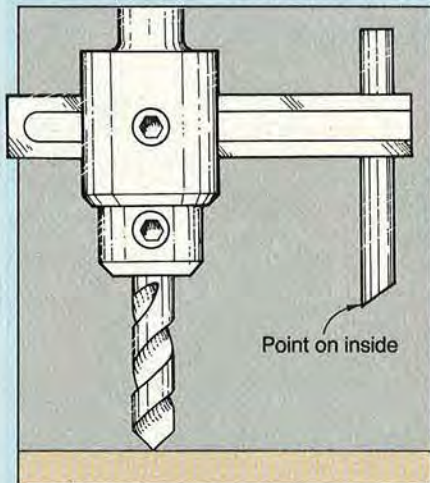

Center the circle-cutter pilot bit over the Forstner-bit depression, and cut the outside of the wheels to shape.

large the 1/4" pilot hole to 3/8". Repeat for each wheel.

7 Cut a piece of 3/8" all-thread rod to 5 1/2" long, and chuck it into your drill press. Then, using nuts and washers, attach a pair of wheels to the work arbor where shown in the drawing *above right*. With the drill press running at about 750 rpm, hand-sand a 1/8" round-over on the wheels where shown on the drawing. (We found sanding the round-overs safer and easier than trying to rout them on a router table.)

Mount the wheels

1 Cut two 3/8" axles to 3 1/4" long and one to 2 3/4" long.

2 Glue one wheel onto each dowel axle so the end of the dowel is flush with the inside of the counterbore where shown on the

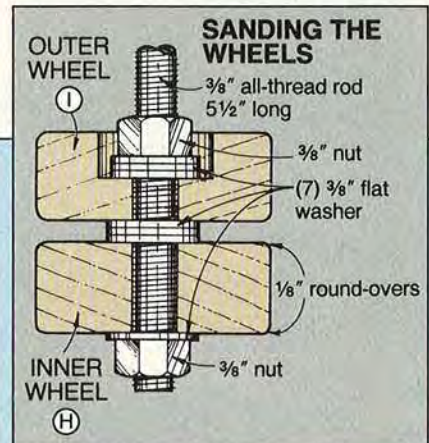

Wheel Section detail. After the glue dries, place 3/8" flat washers on the axles next to the glued wheels. Slide the front axle through the front-axle hole, and add a washer onto the protruding axle end. Glue on the remaining wheel, leaving enough free play so the wheels turn easily. Repeat the process with the back axles, adding an inside wheel and washer on each side of the chassis.

3 To add the hub caps, set the wrecker on its side. Place a drop of glue on the ends of the axle dowels, and glue a 1/2" button on the end of the dowel. After the glue dries, flip over the assembly and repeat for the other hub caps.

4 Apply a clear finish to all the parts (for a durable finish, we used polyurethane). ♣



Produced by Marlen Kemmet
Project Design: James R. Downing
Photographs: Wm. Hopkins
Illustrations: Kim Downing, Bill Zaun

GREEN-WOOD

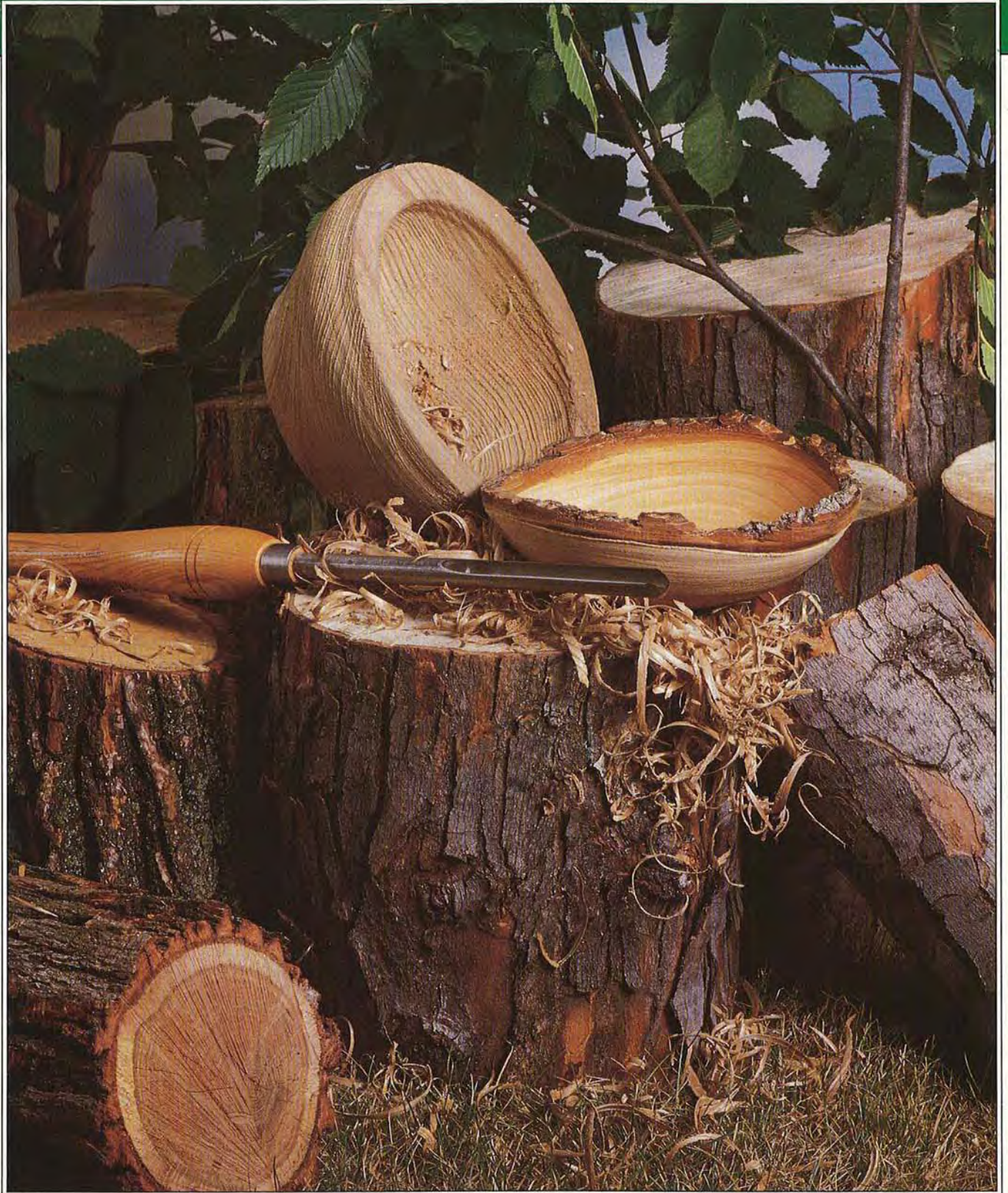

TURNING

A hands-on guide to a fresh experience

Woodworkers usually avoid working with green wood. When it comes to turning, though, lots of people actually prefer it. You may join that crowd after you find out how easy and satisfying green-wood turning can be. We've gathered some pointers to help you get started. Once you start, the absolute pleasure of it will keep you going.

If you think of woodturning as a grit-your-teeth showdown against a hard, unyielding chunk of wood, it's time to turn green. Green wood, that is.

When *WOOD*® magazine Senior Editor Pete Stephano had to have a large catalpa tree in his yard cut down a while back, we had a chance to practice with a couple of the logs. We marveled at the almost magical power our lathe and turning tools seemed to have in the freshly cut wood. Give it a try, yourself. You'll find such sheer pleasure in turning green wood that you may figure that's the only reason to do it.

You'll soon discover it's not. For instance, you'll find green wood readily available, maybe as close as your backyard. When you buy it, green wood often sells for less than seasoned or kiln-dried wood. Sometimes it's free.

You can't beat it for workability, either. Tools practically glide through green wood. And, they hold their edges longer, too. You'll spend more time turning and less time sharpening after you join the Green Revolution.

Actually, green-wood turning shouldn't be called a revolution; it goes back to the very roots of

turning. Before motor-driven lathes and high-quality steel tools, woodworkers turned green wood out of necessity. They simply did not have the power or the tools to turn hard, dried wood.

Gather some green wood

Tree surgeons and landscaping firms, firewood dealers, contractors clearing land, broken branches in your backyard—all are potential sources of green logs or limbs. (See "How to Transform Found Wood into Usable Stock," *WOOD* magazine, September 1990, for information on harvesting your own wood.) Many specialty wood dealers sell green-wood blanks for turning, also.

But, won't it warp?

You probably have one main concern about turning green wood. You're afraid that you'll invest time and effort in turning a terrific bowl that will just end up warping, aren't you? In fact, that's exactly what's going to happen.

The secret to success lies in expecting warpage and having a

plan for dealing with it. You have two choices. First, you can rough-turn a thick-walled bowl, let it season (and warp), and then finish-turn it months later to end up with a round bowl. Or, you can turn a finished form with thinner walls. As it seasons, warpage will become another element of the bowl's design.

Seven tips to start with

No matter which approach you want to try, here are some tips to get you started.

- Use a small faceplate, one about 3" in diameter. Attach it to the bowl-bottom side of the blank so that you can turn the inside and outside in one mounting.

- Screw the lathe faceplate to the bandsawed blank. Although many turners mount dried blanks with adhesives, *don't count on glue or tape for mounting green wood*. Joint failure could injure you or others in your shop.

- Make sure you align two of the screws along the grain. Those two will serve as index marks for a bowl you'll remount to finish.

Continued

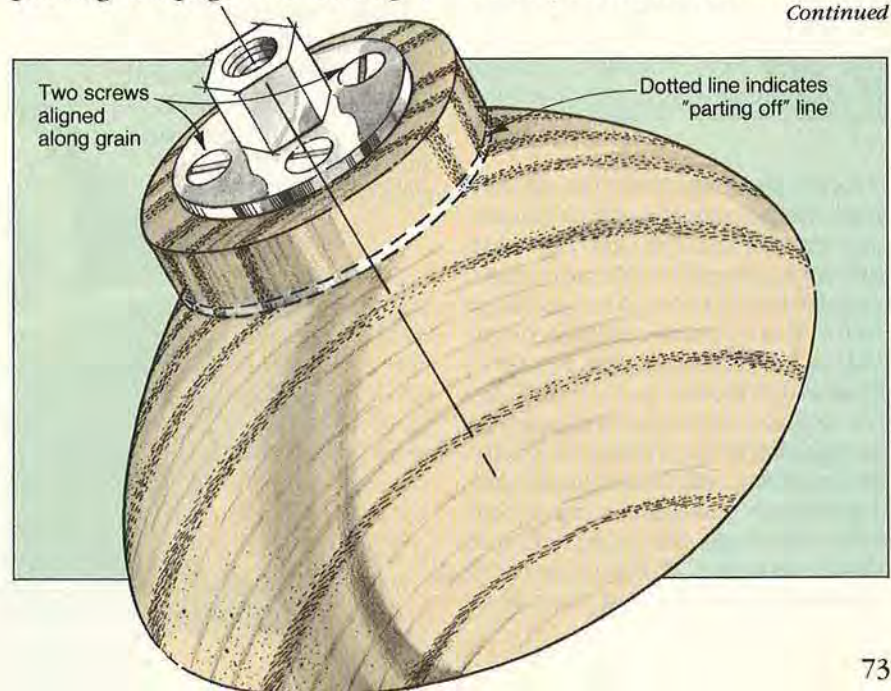

GREEN-WOOD TURNING

• Stand outside the firing zone when you start the lathe. That's always a good safety rule, but with green wood, it may keep you drier, too. Your spinning blank can sling off a surprising quantity of moisture (and maybe a few insects). The amount of slung sap depends on the kind of wood you're turning and its freshness.



• Keep your tools sharp. Don't think that because green wood cuts easily you can get by with dull tools. They'll bend the resilient fibers rather than cutting them. Your bowl-turning gouge will suffice for the green bowl.

• Turn the inside and outside in one session. If you're roughing out a bowl to be finish-turned after seasoning, establish the general shape at this stage. Leave the wall thickness about $\frac{1}{10}$ of the bowl's diameter. If you're turning a finished bowl, turn to your usu-

al wall thickness, but leave a little extra material on the base or foot.

• Strive for uniform wall thickness to promote even moisture loss during seasoning. This minimizes cracking.

Some tips for seasoning your bowl

If you rough-turned your bowl to finish later, here are some seasoning tips. Skip down to the bottom tip if you turned a finished form.

• Unscrew the turning from the faceplate. Apply a sealer such as paste wax to moderate moisture loss and prevent checking and cracking. Store the bowl away from air movements and extreme temperature variations until it's ready to re-turn.

• Check the bowl daily for the first week or so. Cracking or checking indicates that the wood is drying too quickly; apply more wax or sealer. If you live in a dry climate, put the bowl inside a plastic bag, too. Your bowl will be ready for finish-turning in about three months.

• Monitor the seasoning more accurately with a scale indicating grams or fractions of an ounce, if you want to be precise. Record the date and bowl weight when seasoning starts. Then, weigh it periodically and

note the readings. When the weight remains stable for several days, complete the bowl.

• Rejoin the bowl and faceplate after seasoning. Drive screws into the existing holes along the grain and redrill the others. Now, with your gouge and scrapers, bring the turning into round again. Complete the shape, sand, and finish as you would any bowl.

• If you turned a finished bowl in the first session, sand it with progressively finer sandpaper while still on the lathe. Since you won't be re-turning it, this will be your last chance to put a fine surface on it. Many woods polish up nicely when green. Remove the bowl from the faceplate and set it aside in a draft-free spot to season.

Watch for checking and cracking as above, though the thinner, more flexible wall section of the finished form won't be so likely to crack. After it seasons about three months, sand the bottom flat, and then finish your one-of-a-kind bowl as you prefer.



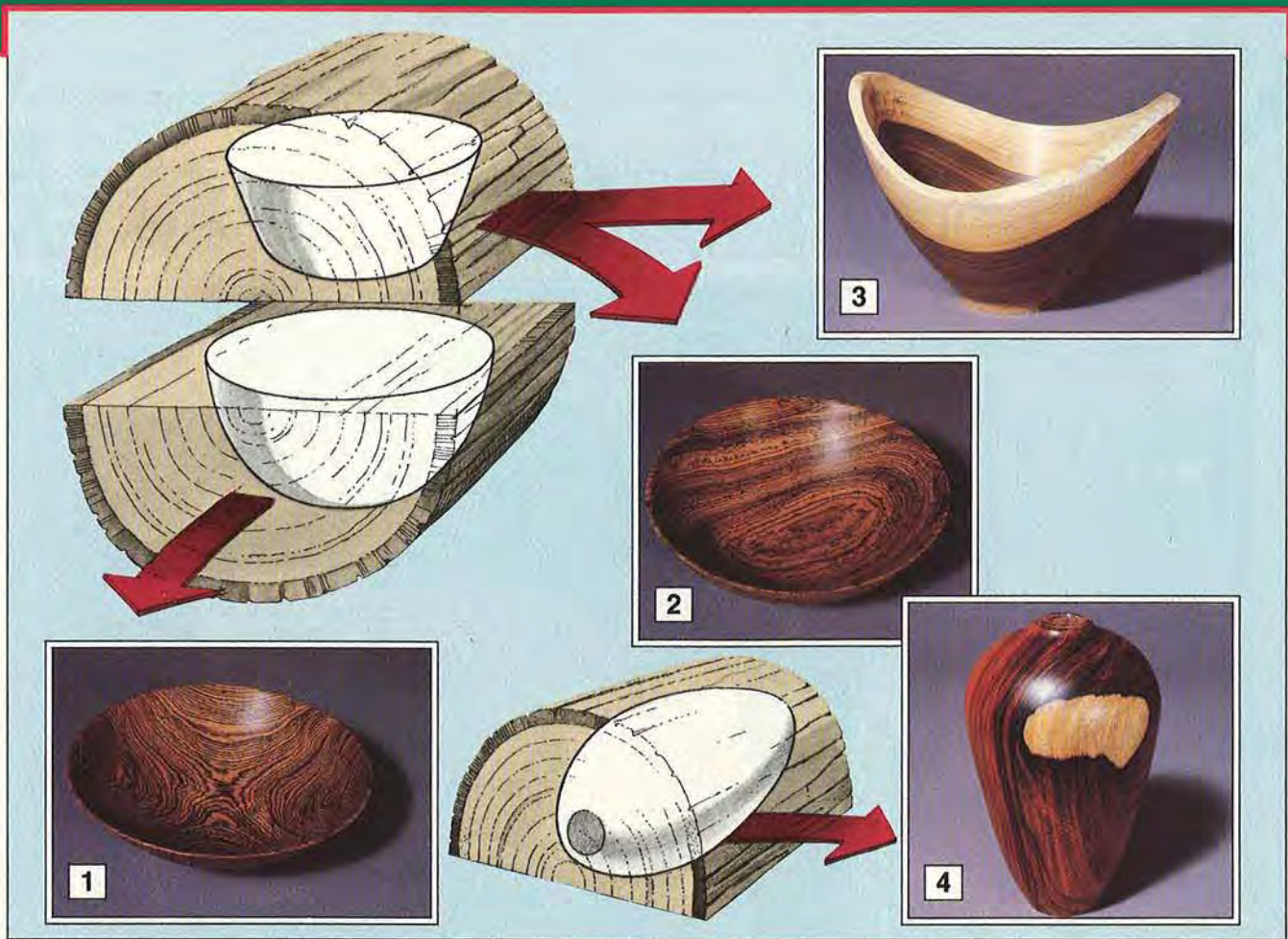

Lots of choices for displaying grain

While green wood is a natural for turning bark-edged bowls, that's not your only choice. Depending on the wood, just flipping the blank over could result in a much more dramatic turning; it's all in knowing how the turning's position in your chunk of wood affects grain display.

In any position, color variations between heartwood and sapwood provide one design aspect. Consider cracks, isolated discolorations, or figure in the wood, also. Do you want to minimize their impact or highlight them as effective design elements?

The accompanying illustration, adapted from Arizona turner Todd Hoyer's study "Wood and its relationship to the turned object," shows turned vessels placed in the log different ways. The corresponding photos show the resulting grain pattern for each turning.

Heartwood for the rim

An open bowl with the rim at the heartwood side of a halved log brings out the familiar saddle-shaped grain pattern in *Photo 1*. This placement yields the largest possible bowl from a given log.

Changing the bowl shape changes the grain display with this positioning. Instead of flaring the bowl rim outward, turn it inward; you'll see two bull's-eyes opposite each other with saddles between them.

Heartwood for the base

To bring out the parallel-ring pattern shown in *Photo 2*, orient your bowl with the base at the heartwood side of your blank. You'll turn natural-edge bowls as in *Photo 3* or those with bark edges with this placement, too.

Log size influences the shape of the rings that you'll end up with.

They'll fall into an oval pattern when you turn a small-diameter log. But, you'll develop a round pattern (or more nearly so, anyway) in a bowl from a larger one.

Try varying the relationship between log diameter and bowl size for different effects. Bowl shape, however, doesn't alter grain display when you locate the base in the heartwood.

Yearn to turn an urn?

An urn or vase will display continuous parallel rings around the outside whether the top is at the heart side or bark side. Shape won't alter it, either.

Want a light sapwood highlight on one side at the widest diameter, as shown in *Photo 4*? Just locate your vase or bowl along the log's axis (end grain at top and bottom), but offset it toward the outside of the log. ♣

Written by Larry Johnston with Gary Zeff and Todd Hoyer Illustrations: Todd Hoyer; Jim Stevenson Photographs: Gary Zeff; John Hetherington

Short Branch



With the birds' winter trip south nearly over, it won't be long before they're back in town looking for lodging. To get ready for them, mosey down to your workshop right now to build this frontier-style saloon.

 [Print this article](#)

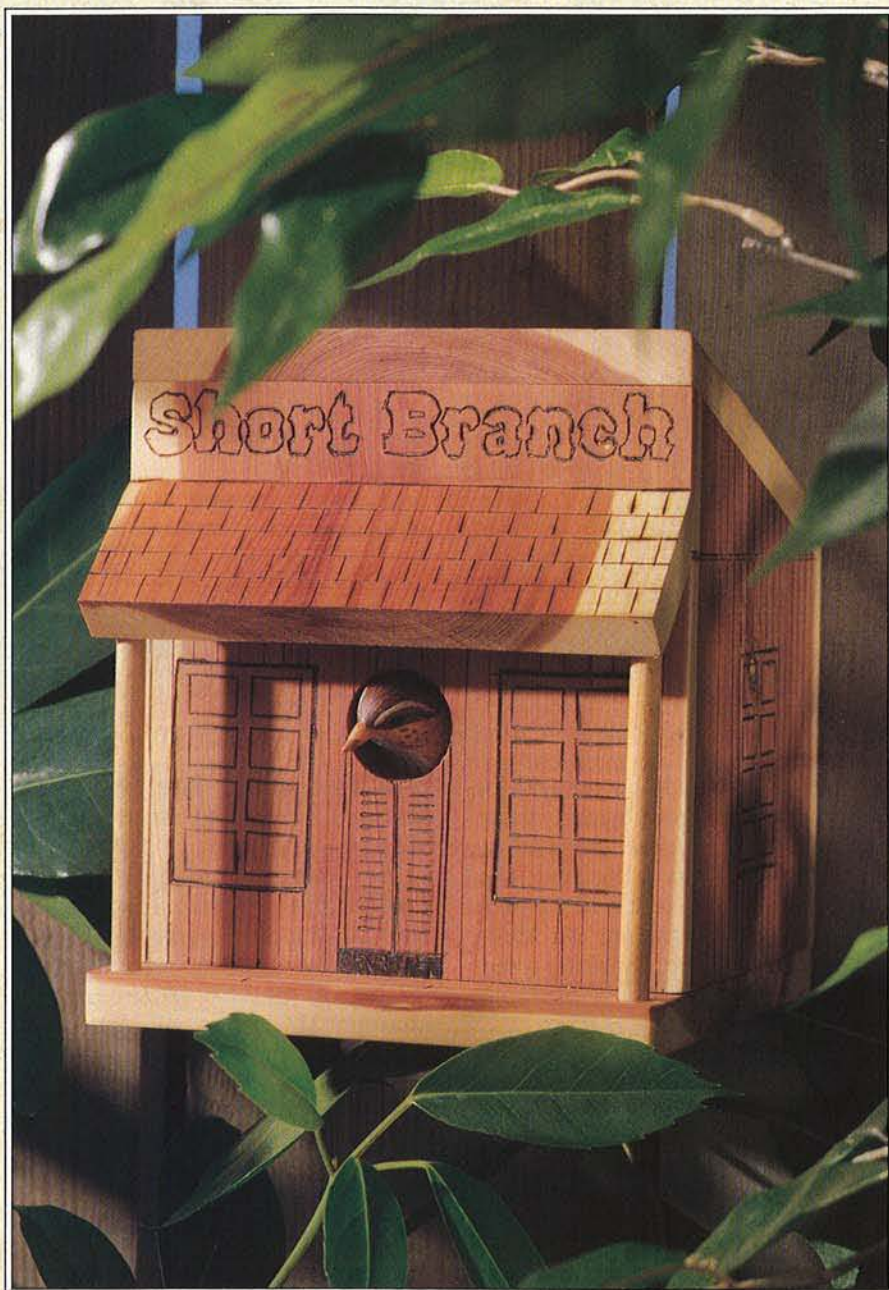

Note: Sized for wrens, this decorator birdhouse includes ventilation and drain holes, and a bottom that comes off for cleaning. Hang or mount it 6-10' above the ground. If you mount it with the back against a solid surface, drill

two $\frac{3}{8}$ " vent holes near the top of each side wall.

Plane or resaw a 6×39" piece of cedar to $\frac{1}{2}$ " thick. You'll need a $\frac{1}{4}$ " dowel 9" long, too. Cut the pieces for the Short Branch with

Saloon

It's for the birds

your tablesaw, following the Cutting diagram, *below right*.

Rout a $\frac{1}{2}$ " rabbet $\frac{1}{4}$ " deep on each inside edge of the front and back walls where shown on the Exploded View drawing. Temporarily assemble the front, back, and sides. With the bottoms even, mark each side wall at the front and back wall top corners. Disassemble, draw a line between the points on each side wall, and cut the angled tops. Drill the $1\frac{1}{8}$ " hole in the front wall.

Now, draw the swinging door (see photograph) for woodburning. Draw the two lines at each side of the door about $\frac{1}{16}$ " apart. Space the horizontal louvers $\frac{1}{8}$ " apart. Draw $1\frac{1}{2} \times 2\frac{1}{4}$ " rectangles for the windows, dividing them into eight panes with $\frac{1}{8}$ " spacing. Place them $\frac{3}{4}$ " from the bottom, $\frac{1}{2}$ " in from each edge on front and centered on each side.

Using our headline for your full-sized pattern, woodburn the sign. Then, add parallel vertical lines about $\frac{1}{4}$ " apart on the front, back, and sides (except around the lettering). Woodburn floorboards on the porch and shingles on the porch roof.

Drill $\frac{1}{4}$ " dowel holes and drain holes through the base and $\frac{3}{4}$ " vent holes through the back wall where shown. Cut two $\frac{1}{4}$ " dowels $4\frac{1}{4}$ " long and sand a 45° angle on one end of each.

Now, glue the four walls, roof, and porch roof together. Attach the bottom with screws, but no glue. Insert the dowels from the bottom, pushing them up to meet the porch roof. Glue them to the base, but not to the porch roof, and then cut them off flush with the bottom of the base.

Apply a clear, outdoor finish (we used Thompson's Water Seal) before opening the Short Branch for business. 🍄

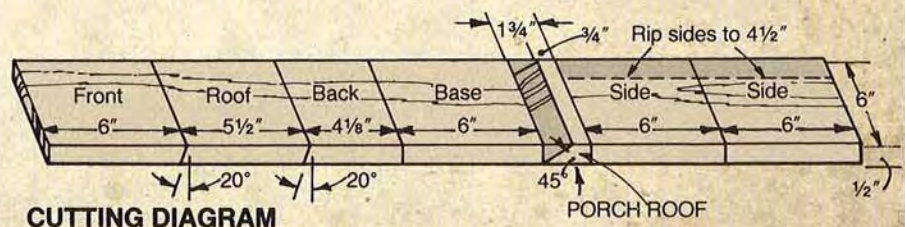
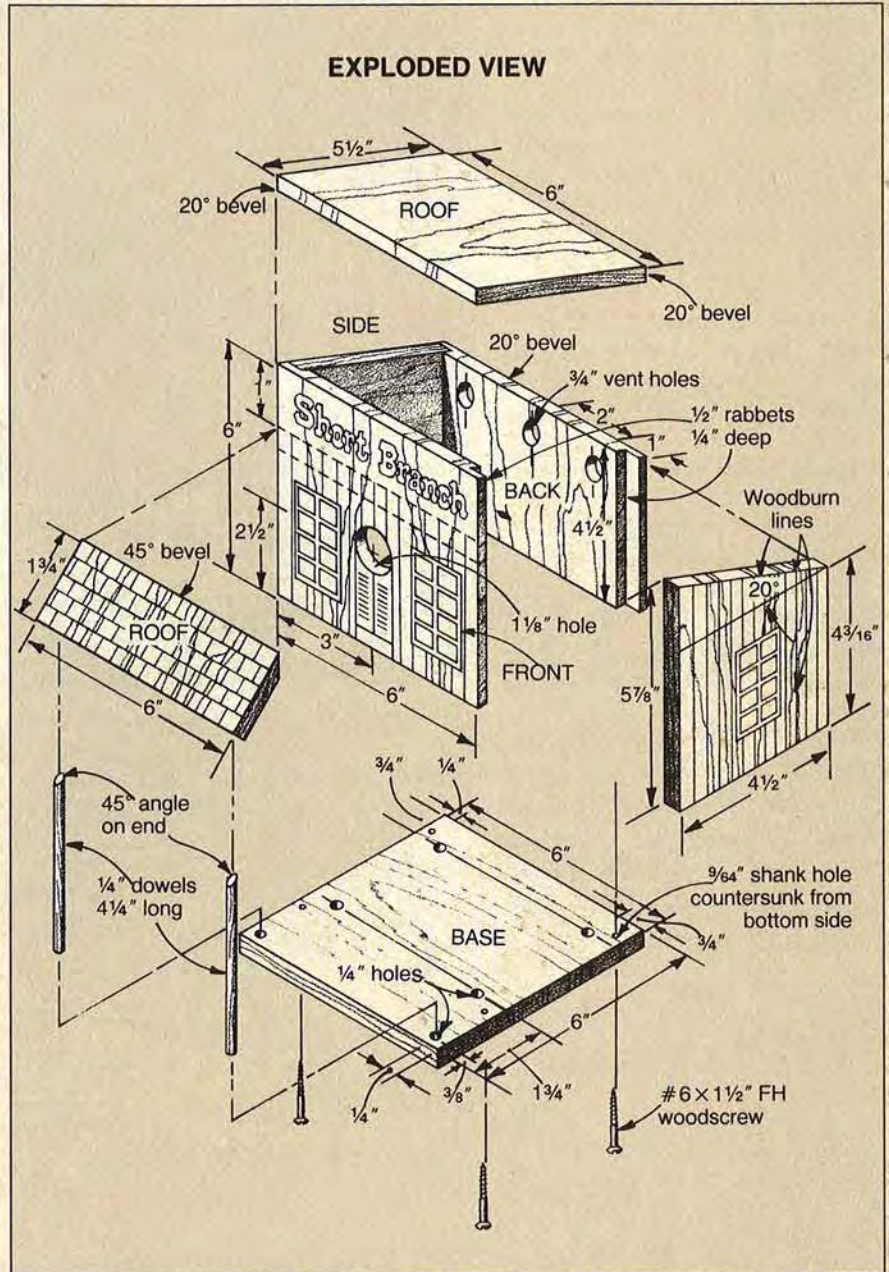

Project Design: James R. Downing Photograph: Hopkins Associates Illustrations: Jamie Downing; Jim Stevenson



A scrollsaw
pattern
with heart

BE MINE, VALENTINE

Many of you have told us that the scrollsaw is your first love in woodworking. Here's a heartfelt offering for Valentine's Day combining your first love with a scene of another one.

 [Print this article](#)

FULL-SIZED PATTERNS

Red dots indicate
locations for drilling
 $\frac{1}{16}$ " blade start holes

Base

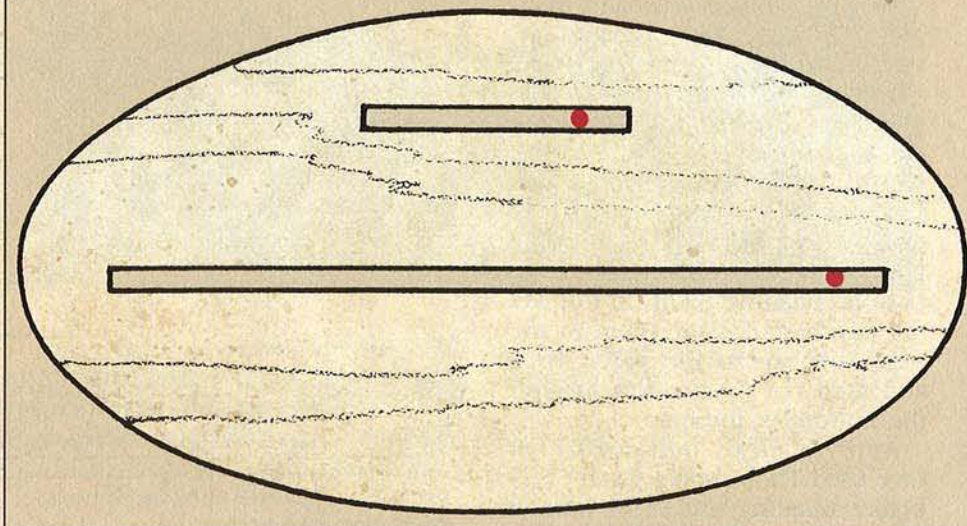

Note: You'll need $\frac{1}{8}$ "-thick hardwood or plywood for the heart and silhouette and $\frac{3}{4}$ " hardwood for the base. Also, since the silhouette has some tight corners and small cuts, select a fine, plain-end blade for your scrollsaw. (We used a #5 blade, $.037 \times .015$ ", with 14 teeth per inch.)

Cut two $4\frac{1}{2}$ "-square pieces of $\frac{1}{8}$ " solid stock or plywood. (We used Baltic birch plywood and solid purpleheart.) Also cut a 3×5 " piece of $\frac{3}{4}$ "-thick hardwood for the base. (We selected oak.)

Photocopy the full-sized patterns below for the silhouette, heart, and base. Separate them and affix them to the appropriate stock with spray adhesive or rubber cement. (We applied the silhouette pattern to the

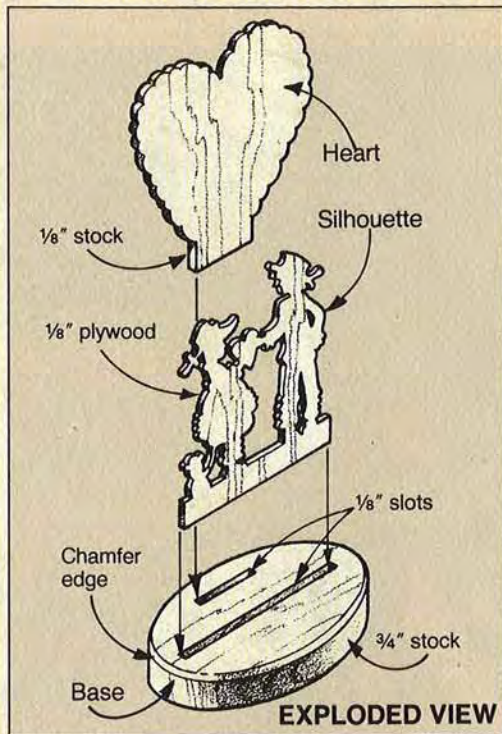

plywood and the heart to the purpleheart stock.)

Drill $\frac{1}{16}$ " blade start holes where indicated on the silhouette pattern. Then, begin scrollsawing with the inside cuts. Complete the silhouette by cutting around the outside line, taking care with small details such as the children's noses or the girl's pigtail. Next, cut out the heart.

Drill $\frac{1}{16}$ " blade start holes for the two slots in the base where shown on the pattern. Cut out the slots with your scrollsaw, and then saw around the oval outline and sand. For an extra touch, rout a chamfer around the base top.

Apply a clear finish to the base, silhouette, and heart. Place the cutouts into the base slots where shown, and then deliver to your sweetheart. ♣

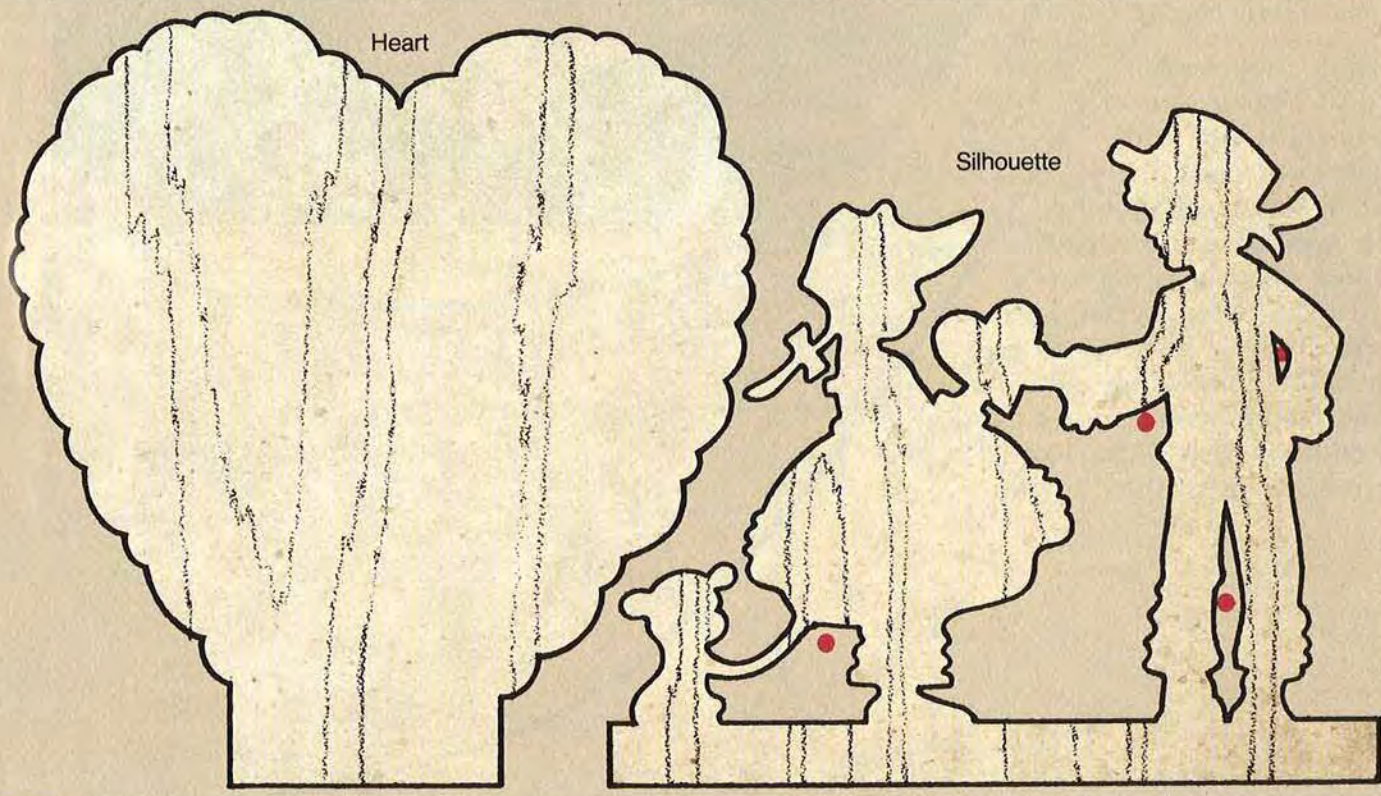



SAVE A WHALE

In wood

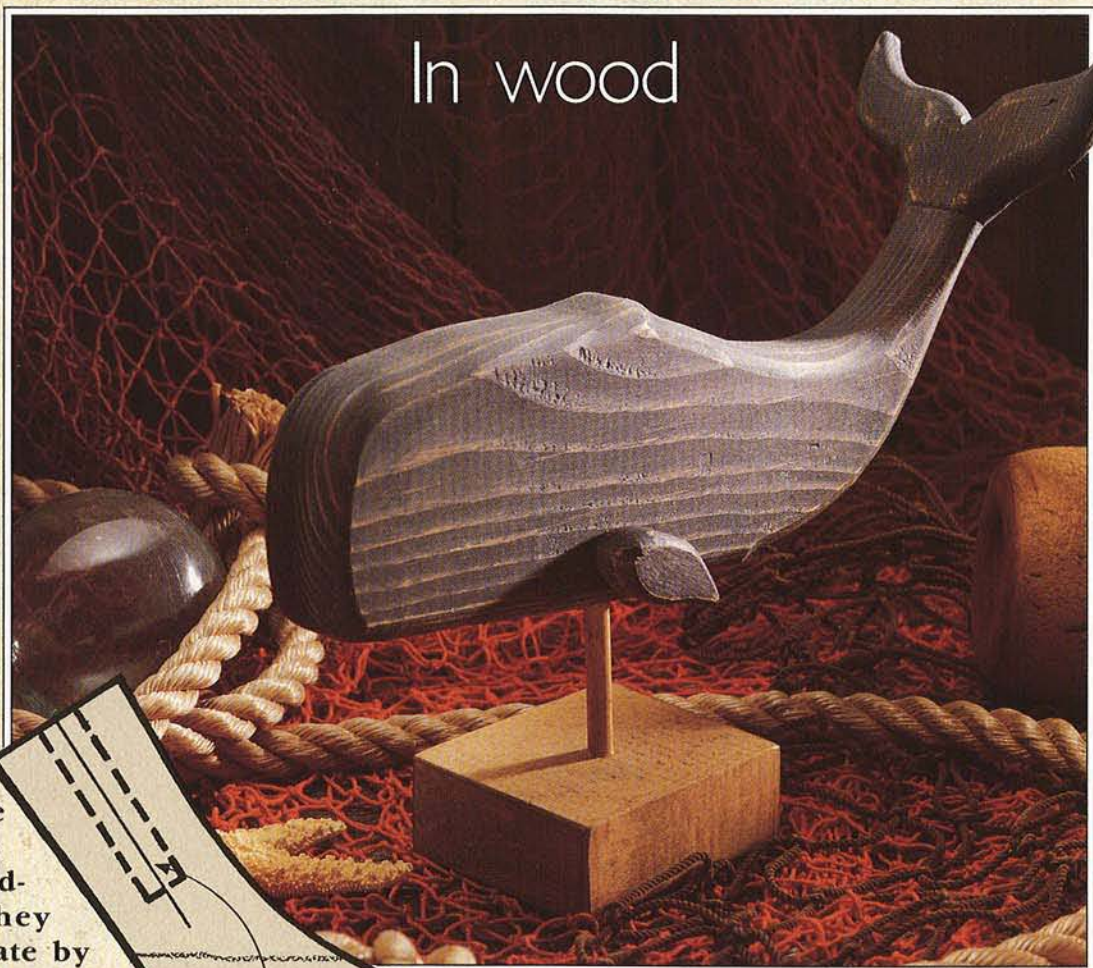

When they spoke of burning the midnight oil, old-timers meant they were working late by the light of an oil lamp, a lamp that might have burned whale oil. But, you won't have to burn much oil to make this whale. And, after you're done, you'll have a nautical decoration that looks like it came from the age of the oil lamp.

1/4" hole
1" deep
centered

FULL-SIZED PATTERNS

 [Print this article](#)

Fashion your whale

You'll need pine, fir, or cedar to make your whale—one piece $1\frac{1}{2} \times 4\frac{1}{2} \times 13\frac{1}{2}$ " (a piece of 2×6 works well) for the body, one $\frac{3}{4} \times 5 \times 6$ " for the tail and flippers, and one $1\frac{1}{2} \times 3 \times 4$ " for the base.

Photocopy the full-sized patterns below, and transfer them to your stock. Because you need two flippers, it's easiest to stack-cut these pieces using just one pattern. Now, cut out the body, tail, and flippers with your scrollsaw or bandsaw.

Drill the $\frac{3}{8}$ " hole $1\frac{1}{2}$ " deep where shown on the body pattern. To do this, place a doweling jig on the body loosely, and then insert a short dowel in place of the drill bit. Align the dowel with the 6° angle reference line on the pattern, and then tighten the jig. Bore the hole with a brad-point bit. (We held the workpiece on the bench with a wooden hand-

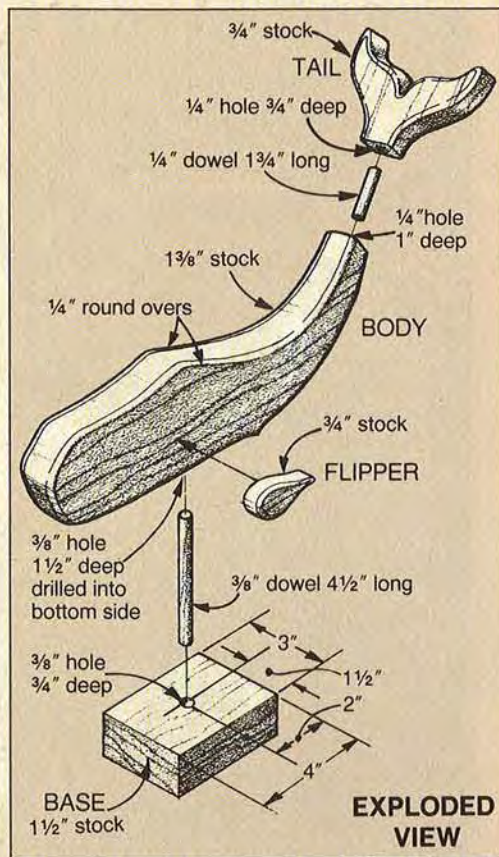

screw clamp while drilling.)

Refer to the Exploded View drawing, and then drill the $\frac{3}{8}$ " hole $\frac{3}{4}$ " deep in the base using a drill press or drill guide to keep the hole vertical. Next, drill the $\frac{1}{4}$ " dowel holes where shown on the body and tail.

Rout edges where shown with a piloted $\frac{1}{4}$ " round-over bit in a table-mounted router. Temporarily attach the flippers to scrapwood with double-stick tape or hotmelt glue to keep your fingers farther away from the bit when routing.

Join the tail to the body with a dowel and glue. Sand all parts. Then, glue the flippers to the body where shown. Glue a $\frac{3}{8}$ " dowel $4\frac{1}{2}$ " long into the hole in the base.

Finish the base and dowel with maple stain. Paint the whale dark gray, and scuff with 150-grit sandpaper when dry to expose some of the wood grain. Finally, glue the whale to the base dowel. 🐋

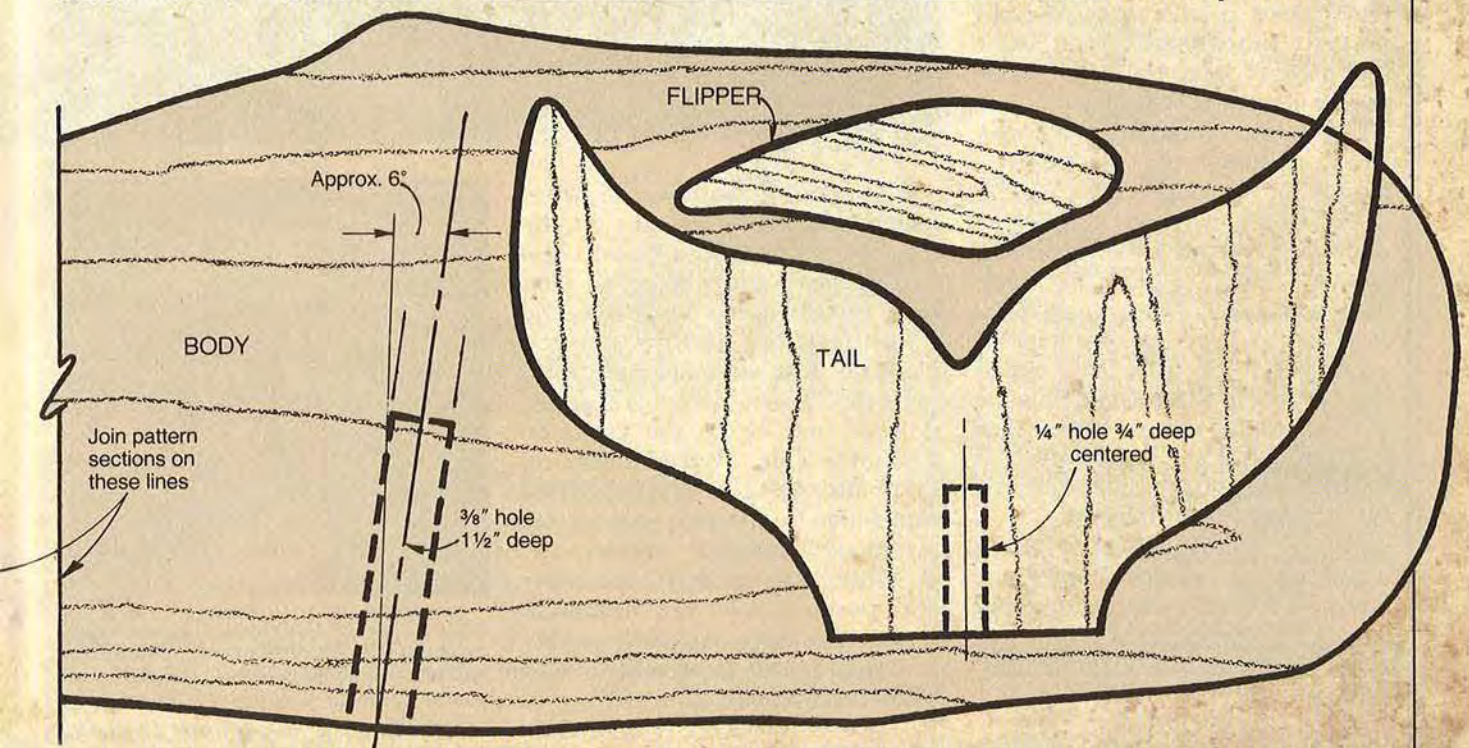

GET READY..GET (T.V.) SET..

Here's the scenario. You've got an old television console or entertainment center sitting in your family room. And even though the original television has long since gone on the blink, the unit simply looks too good to throw out. If you're like me, you've probably put a portable TV on top of it, and possibly a VCR on that.

There is a better way, folks. Read on and I'll share with you what we did with my now-recycled pecan console, the one posing with me *right*.

Larry Clayton

Larry Clayton, Editor

Here's how to prepare the console cavity

1 Start by unplugging your set, removing the back panel from the console, and making a visual survey of what's got to come out. Once that's done, call in a qualified service person to remove the picture tube. Why? Even units that haven't been used for some time can pose a severe shock hazard, so don't take any chances. Next, unscrew the plastic trim around the opening.

2 Measure and record the height, width, and depth of the opening you've created. With this information in hand, select a television that fits the opening. Be sure to get a stereo TV with front speakers, as you will be depending on the set's sound system rather than the console's.

Now, build a platform

1 Study the drawings shown here, and determine how many inches you need to elevate your new TV to make it fit the opening. Make sure you don't cover up your controls.



Then, cut a solid-wood front trim piece that conforms to the shape of the TV's base. Next, cut a pair of cleats and a plywood platform to the same length as the front trim piece. The width of the platform depends on the depth of the TV.

2 Glue and clamp the cleats to the underside of the platform. Later, after the glue dries, glue and clamp the front trim piece to the plywood platform.

3 Slide the platform assembly into position from the back side of the console, and test-fit the TV to ensure that everything's OK. Slide the TV back out.

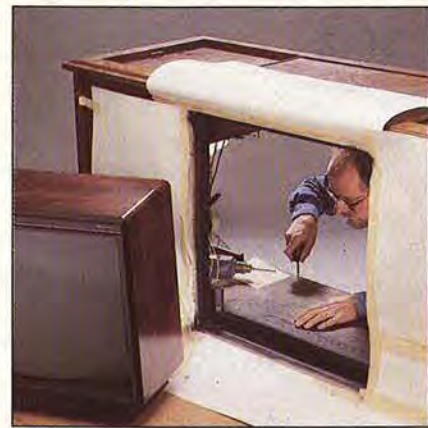

After masking off and painting the front trim and surrounding wood (or staining and finishing), install the new platform you've just built.

RETROFIT

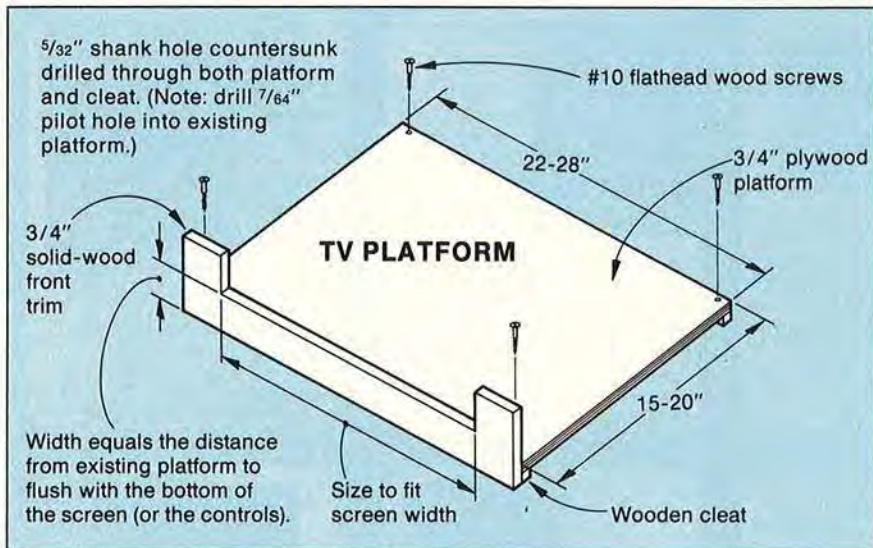
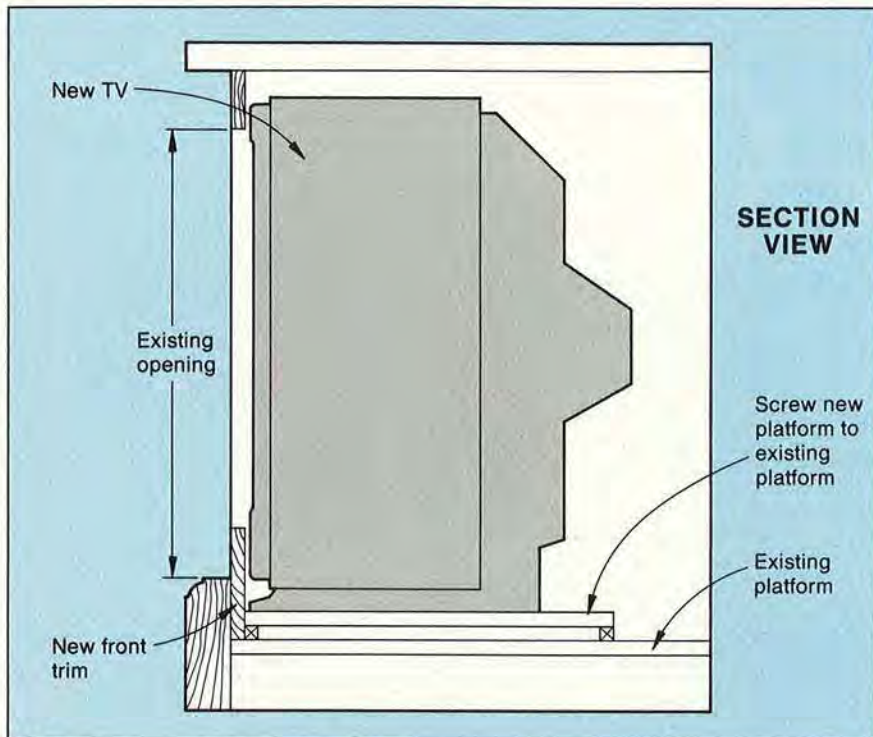

Finishing up

1 Mask off the area surrounding the opening, and apply finish to the new trim piece. (We used matte-black spray enamel to paint the front trim and the adjacent wood. However, you may want to stain and finish the trim to match the color of the console.)

Photographs: Wm. Hopkins, John Hetherington

2 While you're waiting for the paint to dry, secure the platform to the console with four flathead wood screws, one in each corner, as shown.

3 Now, slide in your new TV, replace the back panel, and plug in your set. You're in business! 🍄

Illustrations: Kim Downing

NEED EXTRA INCOME?

WOODCARVING



IS FUN AND PROFITABLE

Want to carve decoys, statues or gun stocks?

It's easy when you use the Dupli-Carver Series wood carving machines. A patented five axis carving action allows these machines to complete difficult undercuts and contours as no other machine can. Complete machines available starting as low as \$359.00.

SEND \$1.00 FOR OUR FULL LINE BROCHURE AND PRICE LIST AND START PLANNING YOUR FULL OR PART-TIME BUSINESS.



MARLIN INDUSTRIES, INC.

Rt. 70, Box 191, Dept D22
Cashiers, NC 28717
(704) 743-5551



RESTORE FURNITURE for SECURE INCOME

Perfect 2nd Career

Make \$200-\$2,000 a day! Unlimited market; turn-key business. Free workshops. Set-Up Shop for \$2,999-\$9,999! Part-time or full-time. Great for men, women, families.

Make Molds*Veneer*Resilver Strip*Repair*Refinish

Business Preview Video \$19.95 - Catalog \$2.00

MINUTEMAN, INC., Ste. 17
Box 8, Waterloo, WI 53594

1-800-733-1776



Full-Size Professional Plan ADIRONDACK CHAIR



Make this classic American design. Our special version may be folded for storage by using ordinary hardware available at your local store. Be ready for Summer and get your plan now!

Plan #700 \$14.00
(catalog free with order)

CATALOG 200 full-size professional furniture plans — \$3.00

FURNITURE DESIGNS, INC., Dept. BA-22

1827 Elmdale Ave., Glenview, IL 60025
(708) 657-7526

DOMESTIC & FOREIGN HARDWOODS

Quality stock for Cabinet Work
Most all sizes from 1" to 4" in thickness

HARDWOODS

ASH—BASSWOOD—BIRCH
BUTTERNUT—CHERRY
CHESTNUT—EBONY—MAPLE
OAK—POPLAR—ROSEWOOD
TEAK—WALNUT
Also hardwood plywoods

SOFTWOODS

SUGAR PINE—CYPRESS—CEDAR
SPRUCE—DOUGLAS FIR etc.
MAURICE L. CONDON CO., INC.
242 Ferris Ave., White Plains, NY 10603
914-946-4111
Monday through Friday 8 AM to 4:30 PM

CATALOGS FOR CRAFTSMEN

*Select the catalogs you want
from over 50 listings!
Use coupon on page 88 to order.*



NEW! Craft & Woodworking Catalog. Top-quality tools & accessories for your shop. This new catalog includes complete information & prices on HEGNER

Precision Scroll Saws, blades, & accessories for other scroll saws. Also includes HEGNER Lathes & Duplicators, HEGNER Accura Precision combination machine, PLANO Vertical Glue Press, FELDER Woodworking Sytems, bar clamps & lots more. Free. Circle #1.

ADVANCED MACHINERY IMPORTS



Furniture Designs, Inc.

Catalog of 200 full-size professional plans for building fine, museum-quality furniture, including cradles, roll-top desks, tables, chairs, buffets, beds, chests, gun cabinet, rocking horse, children's furniture and more. Catalog \$3.00. Circle #2.

FURNITURE DESIGNS, INC.



Buy your sanding belts direct from the manufacturer—Industrial Abrasives is the company that

gives you 12 free belts with every dozen ordered. But sanding belts are not the only product we have to offer. In our catalog you will find many specialty items not readily available in your hardware store. Price of catalog refunded with first order. \$1.00. Circle #3. **INDUSTRIAL ABRASIVES CO.**



Ready to assemble Queen Anne furniture for dining and living room. Queen Anne table

and chair legs, country kitchen table legs, various table bases, turning squares. All items available for quick shipment from stock. Available in walnut, cherry, mahogany, and oak. Free catalogue. Circle #4.

ADAMS WOOD PRODUCTS, INC.



Moisture-related problems such as shrinking, warping and cracking can ruin the most beautiful wooden pieces built. Avoid wood moisture problems by checking the wood with a moisture meter! The pocket-size Mini Ligno moisture meter is for the serious hobbyist and professional woodworker. Free catalog. Circle #5. **LIGNOMAT**



Your Personal Brand

One-page brochure from NOVA TOOL CO. describes branding irons that enable you to put your name on your woodwork quickly and easily. Made especially for branding wood, they can be made with 1, 2, 3 or 4 lines of copy. Both torch heated and electric models

available. \$1.00. Circle #6.

NOVA TOOL CO.



Router owners — Large Discounts. New 32-page catalog featuring hundreds of high quality carbide tipped router bits and shaper cutters, solid carbide bits, the "Router Speed Control" and "Merle Adjustable Corner Clamp" plus other Professional Woodworking Products. Prices 50% to 70% lower than elsewhere. **VALUE, QUALITY and PROMPT SERVICE GUARANTEED.** Send for information. Circle #7. **MLCS, LTD.**



Over 500 easy-to-build woodworking project plans. Over 100 new projects every year! Nation's leading source for scroll saw patterns, cow projects, toy plans, yard ornaments, furniture, etc. Over 3000 hard-to-find specialty items. Send for your NEW 72-page catalog. Catalog \$1.00. Circle #8. **MEISEL HARDWARE SPECIALTIES**



Specializing in Abrasives and Refinishing Products for Wood Working. With RED HILL CORP., you're guaranteed quality, reasonable prices, prompt shipment and free freight. Small orders welcome! Send for information. Circle #9.

RED HILL CORPORATION



The Woodworkers' Store catalog with over 150 new items. 100 full color pages of domestic and exotic hardwoods, veneers, wood parts, specialty hardware, kitchen accessories, finishing supplies, tools, books, and plans . . . exclusive items and hard-to-find specialties. Orders shipped in 24 to 48 hours. Satisfaction guaranteed. Catalog: \$1.00. Circle #10.

THE WOODWORKERS' STORE



The RBI Hawk Scroll Saw, 4-in-1 Woodplaner, Router Mates, and more. All these plus much more can be found in our new full color "All Products" catalog. See the entire line of products and accessories from RBindustries, The American Toolmaker. Catalog FREE. Circle #11. **RBI INDUSTRIES**



Turn your clock making ideas into reality. Create beautiful clocks from our large selection of exclusive clock kits, dials, quartz & mechanical clock movements. We also offer music movements & kits to create beautiful musical jewelry boxes. Request our current 60-page catalog so you too can produce beautiful keepsakes. Circle #12. **KLOCKIT**

1991-1992 Tool Crib Catalog offers a wide selection of merchandise for home woodworkers to industrial builders and features top manufacturers such as Black & Decker, Delta, Makita, Porter Cable, Milwaukee, Ryobi, Freud and many more. We offer competitive prices with quality service and same day shipping. 208-page 1991-92 catalog. It's worth it! \$3.00. Circle #13. **TOOL CRIB**



Unique Catalog Available. Imported Natural Weaving Supplies materials for seat weaving, basketry, wicker, cabinets, wreaths and much more. Webbing, rush, cordages, reeds, grasses, raffia, wood parts, brass hardware, tools, handles, beads, dyes, books, rattans, kits, wheels and more. Send for free catalog. Circle #14. **FRANK'S CANE & RUSH SUPPLY**



Make popular country folk art wind action whirligigs and mobiles, country shelves and shadowboxes, eye-catching yard figures, Christmas decorations, simple furniture, toys, games and much more. Simply trace our full size patterns onto wood and cut out . . . no enlarging is ever necessary! Don't miss our latest catalog featuring over 1,000 unique projects—\$1.00. Circle #15. **WINFIELD COLLECTION**



Stop pegboard hook fall-out forever! M-CLIPS are the guaranteed perfect solution to the annoying problems of pegboard hooks that come loose when a tool is removed. Fits both 1/2" and 1/8" perfbboard, locks into adjacent holes and holds hooks tightly in place. Send for information and free sample. Circle #16. **AETECH CORP.**



One man saw mill, weighing only 45 lbs. Ripsaw cuts 20" diameter logs any length into dimensional lumber. The narrow kerf band saw blade cuts quickly and accurately with minimum waste. Maximum cutting width of 14" with a thickness adjustment from 1/8" to 9". High performance model for only \$1599. Less expensive models available. Free information. Circle #17. **BETTER BUILT CORPORATION**

Loveable Seal Complete Kit

NEW #1-LSK



Beautiful Oak Custom Knife, Whittling Brad (Hone Sharp), Basswood (Seal) cut-out (5 1/2" long). 6-page Carving instruction booklet. Send for catalog, \$1.00. Circle #18. **WARREN TOOL CO.**



Executive Wood Toys! Now you can create this 1929 Ford van and many others like it from our detailed and easy-to-read patterns. We offer you a complete line of patterns, parts, and wheels. Create lasting memories with our Executive Wood Toys. Send \$1.00 for catalog. Circle #29. **TOYS AND JOYS**

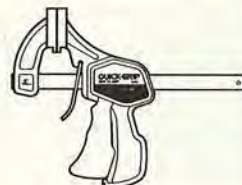

CLAMPS, CLAMPS, CLAMPS . . . Quaker State Woodworking Supply is your source for Quick-Grip, Jorgensen, and Tru-Grip clamps. Low Cost, Free Shipping on orders over \$25, Toll-Free Number and FAST delivery! Send for FREE catalog. Circle #20. **QUAKER STATE WOODWORKING SUPPLY**



SEYCO "The Scroll Saw Specialists" new catalog features items of interest to scroll sawers and

craftworkers. EXCALIBUR Scroll Saws, lettering layout guides, top quality blades, patterns, "Finger Release" blade clamps, books and other scroll sawer's supplies. Catalog \$1.00 Circle #21. **SEYCO**



Quality hardwoods and woodworking machinery for the craftsman and educational institutions. 20-page catalog lists 17 species of popular woods at wholesale prices. Also deals for MiniMax, Freud and Pro Cut woodworking machines. Catalog \$1.00. Circle #22. **STEVE H. WALL LUMBER COMPANY**



ECON-ABRASIVES' new catalog is here! Our industrial grade sandpapers are known nationwide. You will find our expanded line of wood-working accessories to include: Velcro® backed discs, sanding drums, backup pads, chisels, router pads, machinery, and hundreds of other woodworking related items. Send for free catalog. Circle #23. **ECON-ABRASIVES**



FREE Discount Woodworking Tools and Supplies catalog. 68 pages in full-color offering the best prices for over 3,000 brand name products. Included are power tools and accessories, hand tools, screws, hardware, wood components, plans, books and much more. Catalog FREE. Circle #24. **TREND-LINES**



Lawn Furniture Plans Color Catalog—Plans available are picnic tables, adirondack designs, swings (both children & adult), lawn chairs, rockers, planters & a wishing well with running water. All items have been built & tested several times before drawn into plan form. Curved and hard to make pieces have full-size templates. \$2.00. Circle #25. **SPECIALTY FURNITURE DESIGNS OF MI**



Now available: the Super Max 37" single or dual drum. In one pass sand cabinet doors, face frames, table tops and counter tops to a flawless finish in minutes. Select the Performax drum sander to fit your budget and your needs, \$300 - \$3500. Free Brochure. Circle #26. **PERFORMAX PRODUCTS, INC.**



This is the one catalog you cannot afford to be without. Our 1992 tools catalog is over 220 pages thick, all color, and filled with tips and techniques. This, plus the widest variety of fine woodworking hand tools, hand power tools, books, project supplies and finishing supplies separates this from all others. A great many items are exclusive to Garrett Wade. An invaluable reference and source book—famous all over the world. \$4.00. Circle #27. **GARRETT WADE COMPANY**



Do-it-Yourself Kits. Grandfather, wall and mantel clocks as well as elegantly styled accent furniture pieces available in do-it-yourself kits or completely assembled and finished. Kits are made of solid 3/4" cherry, oak, and walnut. \$1.00 for 36-page color catalog. Circle #28. **EMPEROR CLOCK COMPANY**



Woodworking Catalogue. Get your copy of our new full-color catalogue. You'll find the best prices and selection on thousands of different items for the craftsmen, cabinet makers and hobbyists. Tools, books, and supplies are some of the many items we carry. Packed with gobs of goodies you can't resist. FREE. Circle #29. **HARTVILLE TRUE VALUE HARDWARE**



Classical Designs and Modern Electronic Music Box Plans. FULL SIZE PATTERNS with Parts Kits available, for Beginner to Intermediate Woodworker. Largest selection/lowest prices for Electronic Music Boxes. Wood turnings, parts, and supplies. Bulk prices available. \$2, refundable. Circle #30. **CRAFTER'S MART**

#BereaHardWoods..

High quality exotic woods and unusual/figured domestic woods. Turning blocks and squares in burl, spalted and unusual figures. Selected woodworking tools and accessories for the craftsman. We pride ourselves in offering quality woods and tools with courteous and knowledgeable service. Catalog \$1.00. Circle #31. **THE BEREA HARDWOODS CO.**



116 pages—over 4000 woods, veneers, inlays, carvings, moldings, legs, pegs—everything for people who like to build with, turn, carve, refinish wood! Includes 33 pages of hand and power tools, 24 pages of hard-to-find hardware, 12 pages of finishing supplies . . . books, kits, plans and more . . . all backed by Constantine's 180 years of woodworking experience and 60-day no-questions-asked guarantee. 2 year subscription, \$1.00. Circle #32. **CONSTANTINE'S**



FREE Gold Country Woodworks catalog. Our catalog features full-size plans for building projects for the whole family plus hard to find tools and products. See details in our catalog about a FREE Rolling Ruler. 2 year subscription . . . FREE. Circle #33. **GOLD COUNTRY WOODWORKS**

VAN DYKE'S RESTORERS—your source for hard-to-find items in woodworking, upholstery, antique restoration and trades. This new 240-page catalog features a large selection of solid brass hardware, chair/table/roll-top desk components, carved China cabinet glass, relief carved wood appliques and more! Catalog \$1.00. Circle #34. **VAN DYKE'S RESTORERS**



If you enjoy wood carving or wood working, a versatile Marlin wood carving machine may be just what you need. Sign carving, three-dimensional carving of decoys, sculptures, plaques, panels and moldings as well as gun stocks and furniture pieces are easily carved on one of the three models of machines Marlin offers. FREE BROCHURE. Circle #35. **MARLIN INDUSTRIES, INC.**

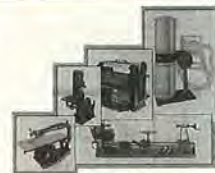

BUY DIRECT AND SAVE! Here's your source for those hard to find wood-working products. Our woodworking machines are manufactured by the SAME FACTORIES that make SEARS, DELTA and other popular brands. Catalog features Scroll Saws, Planers, Lathes, Dust Collectors, Sanders and many "one of a kind" products and accessories. FREE CATALOG. Circle #36. **PENN STATE INDUSTRIES**



Tools on Sale™, a division of Seven Corners Ace Hardware, has a wide variety of tools for the professional or do-it-yourselfer. Our catalog, perfect for anyone using hand or power tools, is packed with the most respected names in the industry: Makita, Milwaukee, Skil, B&D, Ryobi, Delta, Bosch, Porter Cable and many more. We are noted for fast friendly service. Catalog \$2.00. Circle #37. **TOOLS ON SALE™**



At last, an exciting new line of realistic wood block models that you can build with your own scrap wood and dowels and my easy-to-follow instructions. Highly detailed plans from 50 parts to 250 separate parts. Brochure 75¢. Circle #38. **GATTO PLAN SUPPLY**



DePEE'S SPLIT RING CHUCK. A wood turner's dream! DePee's Ltd. split ring holder surpasses all holders on the market in its ability to turn large projects, remove & replace project in holder quickly, & still hold concentricity. Especially desirable for craftsmen who are into vase & bowl turning where it is necessary to do inside & outside turning. Brochure \$1.00. Circle #39. **DePEE'S LTD.**



Exotic Imported and Domestic Hardwoods—Over 75 species of lumber, bowl blanks, turning squares and veneer. Collectors Sample Kit. 30 exotic and domestic woods. 1/2" x 3" x 6" sanded finish. Ideal for collectors, cabinet and furniture makers, designers and architects. Send for more information, \$1.00. Circle #40. **WOODWORKERS SOURCE**



Williams & Hussey. Thousands of professionals use our American-made molder/planers to produce curved or straight

moldings. Over 40 years of experience with a 5-year warranty. In the shop or at the job site, W&H meets your needs every day with quick knife changeovers and ultimate versatility with all kinds of wood. Free brochure. Circle #41. **WILLIAMS & HUSSEY**

We have added 20 new quality oak furniture kits to our already popular selections. Your choice of office, dining room, and bedroom heirloom quality furniture is better than ever before. New selections also include items for the hobbyist and game room. Using only simple hand tools you will have the satisfaction and pride of saying, "I built it myself." Catalog \$1.00. Circle #42. **CRAFTSMAN'S CORNER**



End "Cam-Out" with over 300 varieties of Square Drive Screws featured in McFeely's new full color catalog. Included are hardened

steel cabinet screws, face frame screws, trim head screws, and solid brass, silicon bronze, stainless steel and plated styles. McFeely's also features carbide tipped router bits and saw blades, clamps, woodworking books, and more. Send for catalog, \$1.00. Circle #43. **MCFEELY'S**

World Leader in Furniture Restoration **MINUTEMAN** offers the latest in systems and equipment—best by performance. Earn \$200-\$1,000 per day stripping, repairing, refinishing, mirror resilvering and/or veneering. No experience necessary; complete training provided. FREE Professional Furniture Restoration Workshop. Business Preview video \$19.95. Circle #44. Catalog \$2.00. Circle #45. **MINUTEMAN**



Dremel 1695 Variable Speed Scroll Saw. From 200 to 2,000 blade strokes per minute and anywhere inbetween lets you cut materials at the proper speeds. Get clean, accurate cuts while preventing saw blade wear and tear. Saw has the kind of features you want on a digital, top-of-the-line variable speed scroll saw. Send for free catalog. Circle #46. **DREMEL**



If you are making toys and other items for craft shows, don't overlook our great selection of patterns for rocking horses, toys, cars, clocks and furniture. Specialty supplies, hardware, tools and gift items also available. Catalog \$1.00. Circle #47. **ARMOR PRODUCTS**



EBAC LUMBER DRYERS

Ebac Lumber Dryers offers a wide variety of sizes from 50 B.F. up to over 10,000 B.F. You get the highest quality dried lumber down to 6-8% moisture content. Our controllers make them easy to operate and energy efficient. Kiln Construction Guide included to build your own chamber. Circle #48. **EBAC SYSTEMS, INC.**



Buy 50 Random Orbit Discs get 50 Free! Quaker State Woodworking Supply is your source for Porter-Cable and Bosch Random Orbit Sanders and the only supplier that offers 50 free sanding discs with every 50 purchased! Low Cost, Free Shipping on orders over \$25, Toll-Free Number and FAST delivery! Send for FREE catalog. Circle #49. **QUAKER STATE**



Fine craftsmanship deserves the very best. Craftsmanship begins with the idea. The final result depends on the tool and the craftsman. Atrax tools are made from premium fine-grade carbide, the best on the market today. Atrax offers over 600 styles and sizes to bring ideas to quality results. Send for FREE catalog. Circle #50. **ATRAX**



Variable feed rate planers, drum sanders and stroke sanders from Woodmaster Tools. Free information on 12", 18" and 25" planers. . . 26" and 38" drum sanders. Facts on 30-day free trial. Free. Circle #51. **WOODMASTER TOOLS**



OVER 1000 WOODCRAFT PATTERNS! Create gifts, toys, whirligigs, lawn ornaments, holiday designs, country projects, bird houses, feeders, children's items, household accessories PLUS much more! Simple enough for beginners, fun and profitable for the pro. Catalog plus sample pattern only \$2.00. Circle #52. **ACCENTS IN PINE**



The saw that changed the industry! Now available in an economy priced professional model for your woodworking shop. Imagine! Incredibly intricate scrolling, complex shaping and cutting without making an access cut—this is what the **LABORSABER® RETRACTABLE SAW** has been doing for industry for over 20 years! Now, a scaled down version is available for your woodworking needs. Send for FREE information. Circle #53. **DIANSUPLY/LABORSABER COMPANY**



Condon's selection is unsurpassed. You'll find 43 different species of lumber in stock. 27 more available on special request. Interior, marine, and aircraft plywood are stocked in a variety of species, along with over 40 stock moldings. Custom profiles on request. 30-page color catalog \$2.00. Circle #54. **M.L. CONDON COMPANY INC.**



FREE WOODWORKING TOOL CATALOG! Woodcraft Supply offers over 4,500 of the finest woodworking tools, books, supplies, and cabinetry hardware in our complete full-color catalog. Cabinetmakers, craftsmen, carvers, woodturners, and woodworking hobbyists have depended on Woodcraft since 1928. Toll free ordering and free assistance, too. Send for information. Circle #55. **WOODCRAFT SUPPLY**



Power tools you can build and save—build sturdy woodworking tools from kits (sold for over 40 years)—warranty on parts. Simple step-by-step plans with full-size patterns for wood base. Plans and patterns can be purchased separately. Catalog \$1.00 Circle #56. **GILLIOM MANUFACTURING**



ROUTER BIT AND SHAPER CUTTER CATALOG— We have one of the largest selections of fine cutting tools in stock and ready for same day shipment. All of our router bits and shaper cutters are industrial quality and affordably priced. Also includes is an expanded line of woodworking tools and accessories. Send for free catalog. Circle #57. **CASCADE TOOLS, INC.**

Free Catalog



Natural Weaving Supplies for the Craftsman

Learn seat weaving for fun or profit. Large selection of stand canes, cane webbing, flat reeds and fibres, chair kits, wood parts, books and more.

Frank's Cane and Rush Supply
7252 Heil Avenue, Dept. W1
Huntington Beach, Ca. 92647
(714) 847-0707

SPECIAL WOODCARVING GIFT WG92

\$24.95 PLUS POSTAGE #1FS Strop has coarse leather one side. Finished leather opposite side.

ADD POSTAGE

U.S.A. \$3.50
CANADA \$6.50
FOREIGN \$8.50



SPECIAL OFFER INCLUDES:

- 1— Custom made oak & leather folding strop.
- 1— Custom made walnut handled knife with solid brass inter-changeable chuck.
- 1— Heavy duty whittling blade, honed razor sharp, ready for carving.

Free 6-Page instruction booklet.

Complete catalog free with purchase, or send \$1.00 for catalog only.

WARREN TOOL CO. INC.

2209-1 Rt. 9G, Rhinebeck, N.Y. 12572
TEL. (914) 876-7817

N.Y. RES. ADD SALES TAX / USA - Check or money order.
Canada & Foreign money order (only).
USA — COD UPS available at extra cost.



The Portable Sawmill.

The "affordable portable" one man band sawmill. Weighs only 45 lbs. Cuts 20" diameter logs into lumber. Minimum 1/8" to maximum 9" thickness.



Write or call for free brochure.

Better Built CORPORATION

(508) 657-5636

845 Woburn Street, Dept. W, Wilmington, MA 01887

DRY YOUR OWN LUMBER...



...With an EBAC Wood Drying System

Whether you're a serious home woodworker, small cabinet shop or a large wood retailer, EBAC has a wood drying system that's affordable for you.

EBAC Wood Dryers:

- save you money
- are easy to operate
- are energy efficient
- give you higher quality wood
- give you complete control over your wood's moisture content

CALL OR WRITE TODAY!

EBAC LUMBER DRYERS

106 John Jefferson Rd., Suite 102
Williamsburg, VA 23185

1-800-433-9011 • FAX (804) 229-3321

in Canada: 416-985-2123 • FAX (416) 985-3708

16 SHOWS THIS SPRING!

★The Woodworking Shows★
machinery tools • supplies

- Atlanta
- Charlotte
- Chicago
- Ft. Lauderdale
- Indianapolis
- Kansas City
- Milwaukee
- North Jersey
- No. California
- Philadelphia
- Sacramento
- San Bernardino
- So. California
- St. Louis
- Tampa
- Ventura

Call for free brochure
Monday - Friday 8 am - 5 pm Pacific Time
1-800/826-8257 or 310/477-8521

SQUARE DRIVE SCREWS



Simply the Best!

- Square Drive Beats Driver Slippage
- Hardened Steel for Extra Strength
- Deep Thread for Super Grip
- Also Brass & Stainless

Send \$3 for Samples and Catalog

McFEELY HARDWOODS

P.O. Box 3 • 712 12th St.
Lynchburg • Va • 24505
Toll Free 1-800-443-7937
or FAX (804) 947-7136

ADVERTISEMENT



1992 CATALOG

FREE WOODWORKING CATALOG— We offer a tremendous selection of fine Woodworking machinery, power tools and Accessories at unbelievably low prices. Choose from a wide variety of stationary machines, Makita tools and hundreds of useful accessories including router bits, shaper cutters and more. Order your FREE catalog and take advantage of the selection and savings. Circle #58. GRIZZLY IMPORTS, INC.



Creative, unique plans for all skill levels. Including beautiful furniture additions for your home, wooden toy plans, whirling kits, wood turned parts, hardware and supplies. Other items include how-to books, do-it-yourself videos and more. Available free for the asking. Circle #59.

THE GENEVA COMPANY

Catalog for Craftsmen ORDER FORM

Circle the catalogs you want. Fill out the coupon and include your check made out to Better Homes and Gardens®, WOOD for the cost of the catalogs you ordered plus the \$2 handling fee. **No stamps accepted. No foreign orders. Please allow 4-6 weeks for delivery.**

Send to: **Better Homes and Gardens® WOOD**
Dept. FECS92
P.O. Box 2713
Boulder, CO 80329-2713

- | | | | | | |
|------------|------------|------------|------------|-------------|------------|
| 1. FREE | 11. FREE | 21. \$1.00 | 31. \$1.00 | 41. FREE | 51. FREE |
| 2. \$3.00 | 12. FREE | 22. \$1.00 | 32. \$1.00 | 42. \$1.00 | 52. \$2.00 |
| 3. \$1.00 | 13. \$3.00 | 23. FREE | 33. FREE | 43. \$1.00 | 53. FREE |
| 4. FREE | 14. FREE | 24. FREE | 34. \$1.00 | 44. \$19.95 | 54. \$2.00 |
| 5. FREE | 15. \$1.00 | 25. \$2.00 | 35. FREE | 45. \$2.00 | 55. FREE |
| 6. \$1.00 | 16. FREE | 26. FREE | 36. FREE | 46. FREE | 56. \$1.00 |
| 7. FREE | 17. FREE | 27. \$4.00 | 37. \$2.00 | 47. \$1.00 | 57. FREE |
| 8. \$1.00 | 18. \$1.00 | 28. \$1.00 | 38. 75¢ | 48. FREE | 58. FREE |
| 9. FREE | 19. \$1.00 | 29. FREE | 39. \$1.00 | 49. FREE | 59. FREE |
| 10. \$1.00 | 20. FREE | 30. \$2.00 | 40. \$1.00 | 50. FREE | |

I am enclosing:

\$ _____ for priced items
\$ 2.00 for handling
\$ _____ total remittance

Name _____
Address _____
City _____
State _____ ZIP _____

Coupon expires March 14, 1993



STOP PERFBORARD HOOK FALLOUT!

M-CLIPS™ are THE guaranteed perfect solution to this annoying problem! Fit both 1/8" and 1/4" perfborard. Send SASE for free sample or \$6.99 + \$2.00 p&h for pkg. of 50 to: AETECH, P.O. Box 6298, Dept. W14
10 Shadowstone Lane
Lawrenceville, NJ 08648

Cradle Plans

You can easily build this classic cradle which is sure to become a family heirloom. Available in two sizes: Baby & Doll size.

Two Cradle Plans One for Babies One for Dolls



72 pg. catalog
free with order

Baby size Plan (21 x 35) \$11.50
Spindle Kit with Pivots \$30.25
Doll size Plan (10 x 18) \$5.25
Spindle Kit with Pivots \$12.95

M/C Visa orders call toll-free 1-800-292-8296

Frt. 48 States \$3.50. AK, HI add 25% of order. NY add tax. Canada add 50%. Use Visa/MC or M.O. in U.S. funds. Min. order is \$15.00. Catalog \$1.00 or sent FREE with order.

ARMOR, Box 445-E, East Northport, NY 11731

FOLDING CHAIR PLANS 12.95 FULL-SIZED TEMPLATES



A unique ancient style that we redesigned with wider contour seat and back, plus arms that fold. May use inside or outside and folds flat for storing or travel. Is a snap to build with very few tools.

Catalog \$2.00 free with order, M/C or Visa
SPECIALTY FURNITURE DESIGNS
797 West Remus Rd. Dept. W-13
Mt. Pleasant, MI 48858
(517) 772-6292 MI Res. 4%



MIRRORA®

THE
HAND
MIRROR
COMPLIMENT

PERFECTLY
BEVELED
MIRROR

FLORAL Glass & Mirror, Inc.

895 Motor Parkway, Hauppauge, NY 11788
516/234-2200 • 800-647-7672



PLAN #14
TRACTOR
RIGG
\$6.95

PLAN #16
BACKHOE
LOADER
\$7.95

STICKLER FOR DETAIL? At last, an exciting new line of REALISTIC Wood Block Models that you can build with your own scrap wood & dowels, and my easy to follow instructions
TRACTOR RIGG - This 19" long, 10 1/2" tractor is equipped with a detailed engine, drive-train, & rear axle assembly. Plan details include a pivoting hood, front steering, detailed leafsprings, mirrors, ladders, step tank, flaps/guards, air cleaner, air tanks, and much more
BACKHOE/LOADER - 25" plus. Challenging fun featuring over 35 easy to make pivoting joints, working hydraulic cylinders, detailed steering, removable roll cage, & lots of instrument gage, levers & lights
Send U.S. check or U.S. money order in the above amount to:
Gatto Plan Supply, Box 1568, R.D. #1, Hamburg, PA 19526

NEW "FINGER RELEASE" BLADE CLAMPS FOR SCROLL SAWS

Designed to fit most constant tension scroll saws (except far east imports).



CATALOG \$1.00
with details and
information on--
BLADES - BOOKS
PATTERNS

EXCALIBUR SCROLL SAWS

SEYCO "The Scroll Saw Specialist"
1414 Cranford Dr • Box 472749
Garland, TX 75047 - 2749
1 800 462-3353

HARDWOODS

EXOTIC & DOMESTIC OVER 75 SPECIES

LUMBER • PLYWOOD • VENEERS
TURNING SQUARES & BLANKS

COLLECTORS SAMPLE KIT 30 EXOTIC & DOMESTIC WOODS 1/2" x 3" x 6" SANDED FINISH

\$29.00 PLUS \$5.00 S&H

Ideal for: Collectors • Schools • Craftsmen • Cabinet
& Furniture Makers • Architects • Designers



1-800-423-2450

WOODWORKERS Source

5402 S. 40th St. • Phoenix, AZ 85040
(602) 437-4415

Backyard Dream Come True.



A SteelMaster steel building is the perfect place for a home business, from car repair to woodworking to crafts. SteelMaster buildings are economical, maintenance free, corrosion resistant, and easy to assemble. Plus, our **FACTORY DIRECT PRICES** will save you thousands.

Call 1-800-527-4044

In Canada Call:
1-800-387-2343



© 1989 SteelMaster

5"
or
6"



Supergrit

Random Orbital Sander Discs
5" White PSA 180 Grit \$15.00/100

PREMIUM QUALITY BELTS: BEST RESIN OVER RESIN, "X" WEIGHT 10/Box

1 x 42	\$7.00 ea.	4 x 24	\$1.00 ea.
3 x 18	.75	4 x 36	1.25
3 x 21	.80	6 x 48	2.80
3 x 24	.85	6 x 60	5.25

ADHESIVE CLOTH DISCS: BEST RESIN OVER RESIN, "X" WEIGHT

5" Diameter	\$.80 ea.	9"	\$1.55 ea.
6"	.90	10"	1.85
8"	1.30	12"	2.25

Prices quoted 80 grit, other grits available.

GARNET PAPER — ORANGE **WATERPROOF PAPER — BLACK**

A/O CABINET PAPER — BROWN 180 thru 1200 100 PK \$23.00

40 Grit 50 PK \$16.00

60 Grit 50 PK 14.00

80 Grit 50 PK 13.00

100, 120, 150 100 PK 22.00

180, 220 100 PK 19.00

NO LOAD PAPER — WHITE

180 through 400 100 PK \$20.00

Also Shop Rolls • Cloth Sheets • Drums

CLEANING STICKS \$3.50 Small \$6.50 Large

RED HILL CORP., P.O. BOX 4234, GETTYSBURG, PA 17325

(800) 822-4003 Free Freight to most areas

Free catalogue

The Japan Woodworker's Catalog is . . .

loaded with the best tools you can get your hands on. In our catalog you will find a high selection of Japanese saws, waterstones, chisels, planes, carving tools, cutlery and books. Send \$1.50 for our catalog and supplements during the next two years.

THE JAPAN WOODWORKER
1731 Clement E-16, Alameda, CA 94501
Phone 1-800-537-7820

FOR INFORMATION ABOUT PLACING AN ADVERTISEMENT IN

Better Homes and Gardens® WOOD®

PLEASE WRITE:

CHRIS SCHRAFT
WOOD MAGAZINE
750 THIRD AVENUE
NEW YORK, NY 10017

OR CALL COLLECT:
212-551-6904

91C-110

EXCLUSIVE DISTRIBUTORS OF



SALE!

OUR BIGGEST EVER!

We would like to convince you of the high quality of our bits, so, for a limited time only, we are offering our bits at prices only seen with cheaper imports. Our bits have thicker carbide and are ground with up to 600gr diamond wheels.

We guarantee you'll be satisfied!

Roundover Bits with Bearing Guide

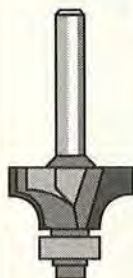

1/4" SHANK					
PART	CUTTER DIA. A	CUTTING LENGTH B	OVERALL LENGTH C	RADIUS r	SALE!
C1175	7/8"	3/8"	2"	1/8"	\$10 ⁰⁰
C1177	1"	1/2"	2"	1/4"	\$11 ⁰⁰
C1179	1-1/4"	5/8"	2-1/4"	3/8"	\$14 ⁰⁰

1/2" SHANK					
PART	CUTTER DIA. A	CUTTING LENGTH B	OVERALL LENGTH C	RADIUS r	SALE!
C1184	1"	1/2"	2-1/4"	1/4"	\$11 ⁰⁰
C1185	1-1/8"	1/2"	2-3/8"	5/16"	\$12 ⁰⁰
C1186	1-1/4"	5/8"	2-1/2"	3/8"	\$14 ⁰⁰

Double Fluted Straight Bits

1/4" SHANK				
PART	CUTTER DIA. A	CUTTING LENGTH B	OVERALL LENGTH C	SALE!
C1001	1/4"	3/4"	2"	\$6 ⁰⁰
C1002	5/16"	11/16"	2"	\$6 ⁰⁰
C1003	3/8"	3/4"	2"	\$6 ⁰⁰
C1004	1/2"	3/4"	2"	\$8 ⁰⁰

1/2" SHANK				
PART	CUTTER DIA. A	CUTTING LENGTH B	OVERALL LENGTH C	SALE!
C1008	1/4"	3/4"	2-1/2"	\$6 ⁰⁰
C1009	5/16"	3/4"	2-1/2"	\$6 ⁰⁰
C1010	3/8"	3/4"	2-1/2"	\$6 ⁰⁰
C1011	1/2"	1-3/16"	2-1/2"	\$8 ⁰⁰



Dovetail Bits 2 Flutes



1/4" SHANK					
PART	CUTTER DIA. A	CUTTING LENGTH B	OVERALL LENGTH C	ANGLE a	SALE!
C1068	3/8"	3/8"	1-3/4"	8°	\$5 ⁰⁰
C1069	1/2"	1/2"	1-3/4"	14°	\$5 ⁰⁰
C1071	3/4"	11/16"	2-1/8"	14°	\$7 ⁰⁰

1/2" SHANK					
PART	CUTTER DIA. A	CUTTING LENGTH B	OVERALL LENGTH C	ANGLE a	SALE!
C1074	1/2"	1/2"	2-1/4"	14°	\$5 ⁰⁰
C1076	3/4"	7/8"	2-1/2"	14°	\$8 ⁰⁰

Chamfer Bits 2 Flutes

1/4" SHANK				
PART	CUTTER DIA. A	CUTTING LENGTH B	OVERALL LENGTH C	SALE!
C1129	1"	7/16"	2"	\$12 ⁰⁰
C1130	1-3/8"	5/8"	2-1/4"	\$16 ⁰⁰

1/2" SHANK				
PART	CUTTER DIA. A	CUTTING LENGTH B	OVERALL LENGTH C	SALE!
C1131	1-1/8"	1/2"	2-1/4"	\$14 ⁰⁰
C1132	1-3/8"	5/8"	2-3/8"	\$16 ⁰⁰

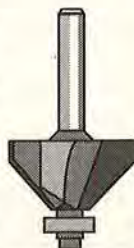

ORDER 24 HOURS A DAY!



1-800-235-0272



FREE SHIPPING ON ORDERS TOTALING \$100⁰⁰ OR MORE!

Whether your woodworker's license reads "Beginner," "Intermediate," or "Advanced," you're bound to have a few questions about your favorite hobby. We can help by consulting our staff and outside experts. Send questions to:

Ask WOOD

Better Homes and Gardens®

WOOD® Magazine

P.O. Box 11454

Des Moines, IA 50336-1454

Angle bevels don't lie

As a novice woodworker, I have one problem that continually perplexes me. How do you get the exact angle of something? Is there an instrument other than a protractor that gives precise degrees?

—Mike Shamp, Philadelphia, Pa.

Mike, don't give up on your protractor just yet. By itself, it often falls short in determining an exact angle if you simply place it on the cut edge of a length of wood and make a reading. However, the tool that may solve your problem is the angle bevel. Team it up with your protractor and your accuracy will improve instantly, whether you're measuring inside or outside corners.

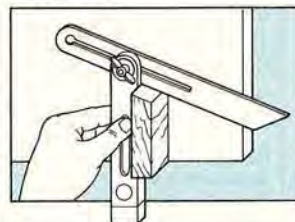

First, loosen the swinging blade of the angle bevel and hold it against the angle as shown in Drawing A, above. Now, tighten the locking nut to fix the blade.

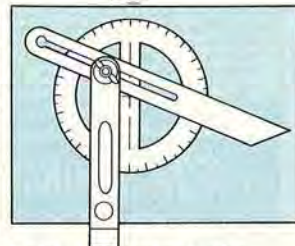

Next, place the handle of the angle bevel along the straight edge of your protractor as in Drawing B, letting the blade intersect the centerpoint of the protractor's circle. Take your angle-degree reading where the blade intersects the circle's outer edge.

Restoring the bite on your brad-point bits

I've used my brad-point bits quite a lot lately. Consequently, they're getting dull, and if I'm not careful, they overheat. I have looked at various publications covering the sharpening of small tools, but none seem to cover brad-point bits. Do you have any information on sharpening these bits?

—Fred Nuss, Allentown, Pa.

Fred, WOOD Product/Techniques Editor Bill Krier and Project Builder Jim Boelling agree that letting a local sharpening service restore the cutting edge to your brad-point bits works better than anything else. It costs about \$2 a bit for a like-new cutting edge, but for quality bits, it's money well spent.

What they don't tell you about water-based finishes

In all the information I've read about water-based finishes, one item always gets overlooked. The can the finish comes in rusts! Obviously, the can is coated to prevent this from happening, but the coating scratches when I pry the lid off. After a while, rust particles fall into the finish every time I open the can, rendering my chances at a fine finish impossible. Out of one gallon of water-based polyurethane, which cost me \$39.99, I have only been able to use about one quart. Can you help?



—Kevin Patch, Pittsburgh, Pa.

Kevin, as long as we have air to breathe, water and iron will combine to make rust. To work around the problem, mix the one gallon of water-based finish thoroughly after you first bring it home, and then pour it through several layers of cheesecloth and into four one-quart mason jars. Now, screw on the accompanying lids containing rubber or neoprene seals. This will allow you to use and reuse your finish (one quart at a time) and eliminate rust buildup. After each use, wipe the jar's threads and lid dry before resealing the contents.

As for the contaminated finish you still have in your shop, try straining it, too, through cheesecloth while pouring it into the one-quart jars. This should remove the detracting rust particles.

Miffed by mildew

Could you please help me with a problem in our bathroom? I used Valspar Danish Oil Finish on the oak moldings and cupboard doors, but the high humidity in this space causes mildew. What can I do to correct the problem?

—Jim Stewart, Gold River, B.C.

Jim, to rid your woodwork of mildew, try cleaning it with the following solution: 1/3 cup of household detergent and 1 quart of household bleach in a bucket containing 3 quarts of warm water. Make sure that the detergent you use does not contain ammonia. Stir the solution, and then apply it with a scrub brush to remove the mildew. Wipe the moisture from the wood with a rag.

If the wood dries rough, lightly sand it with 400-grit sandpaper. Then, finish with a water-repellent preservative such as a clear polyurethane. If painting, go with a paint containing a mildewicide. To ensure a mildew-free space in the future, consider buying and installing a bathroom ventilator to remove moist air.



Dee Pee's Split Ring Chuck

A unique concept in clamping wood for turning. This one tool with its split ring design allows projects to be securely mounted by the total circumference of the split ring. It can be removed and replaced easily and all surfaces remain concentric. Extremely valuable for craftsmen, hobbyists, and especially Vo-tech wood students. Allows projects from min. diameter of 3/4" to max. size for lathe. Order by lathe thread size, 7/8"-14, 1"-8, 1 1/8"-7 or 8, 1 1/4"-8 or 1 1/2"-8 or 12.

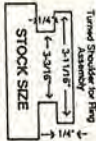

Wood Turning Quick & Easy!

Complete your projects with ease—no wasted time with the face plate and wood screws. The split ring is designed to continually tighten itself whereas the face plate and screws are constantly working loose.



DEE PEE-S™
SPLIT RING CHUCK

\$150. plus \$4.50 ship/handling
MD residents add 5% sales tax
1-800-253-2569
VISA—MASTERCARD

Send for brochure for more information

PATENT APPLIED FOR

Econ-Abrasives

WE MAKE ABRASIVE BELTS ANY SIZE, ANY GRIT!

Standard Abrasive Sheets

CABINET PAPER		
	50/pk	100/pk
60D	\$15.00	\$27.00C
80D	14.00	25.00C
100 thru 150C	13.00	23.00C
FINISHING PAPER		
80A	\$ 10.00	\$17.00C
100 thru 280A	9.00	15.00C
WET/DRY PAPER		
220 thru 600	\$14.00	\$24.00C
NO LOAD PAPER(white)		
100 thru 400A	\$11.00	\$19.00C
"C" = 100 SHEETS		

Velcro® Vacuum Discs		
8 Hole pattern for Bosch sanders		
Dia.	Grit	Price
5"	60	\$.48ea
5"	80	.46
5"	100 thru 320	.45

*MINIMUM ORDER \$25.00
*MasterCard, VISA, C.O.D. or Check
*SATISFACTION GUARANTEED!!!
*CALL FOR FREE 1991 CATALOG
- TX & NV add appropriate sales tax
- Continental U. S. shipping charges add \$5.50

ABRASIVE BELTS

PLEASE SPECIFY GRITS

1X30	\$.73 ea	3X24	\$.84 ea
1X42	.73 ea	3X27	.87 ea
1X44	.73 ea	4X21 3/4	.96 ea
2 1/2X16	.77 ea	4X24	.99 ea
3X18	.78 ea	4X36	1.20 ea
3X21	.81 ea	6X48	3.14 ea
3X23 3/4	.84 ea	2 1/4X80	2.94 ea

OTHER SIZES ON REQUEST

JUMBO CLEANING STICK

ONLY \$8.80

2X2X12

* OTHER PRODUCTS*

*Wide Belts*Rolls*Flap Wheels
*Pump Sleeves*PSA Discs
*Router Bits*Wood Glue
*Wood Bits*Velcro® Discs
*Wood Clamps*Sanding Blocks
*Drawer Slides*Hinges*TV Swivels

Econ-Abrasives

P. O. Box B865021

Plano, TX 75086

(214)377-9779



Worth writing for...



You can get useful ideas and product information by mail. Use the coupon in this section to order your choice of literature listed below. Each company mails the catalogs or information directly to you.

POWER TOOLS

SCROLL SAW, CRAFT & WOODWORKING CATALOG—Specialty products from the exclusive distributors of HEGNER, the precision saws with SCROLLVERGNEGEN. Complete information on scroll accessories, including blades and lettering guides. Also JET Clamps, HEGNER Lathes, PLANO Vertical Glue Press, and more. Toll-free customer service hotline included! AMI, LTD. \$2.00. *Circle No. 3.*

PROFESSIONALS ONLY—Information on the new line of FELDER BF6 woodworking machines, including table saw, shaper, jointer/planer and combination machines, starting as low as \$4,899. Also ULMIA Table Saws. Deal directly with the importer. Get complete information on the best professional machine value! AMI LTD. \$1.00. *Circle No. 4.*

1991-92 TOOL CRIB CATALOG—offers a wide selection of merchandise for home woodworkers to industrial builders and features top manufacturers such as Black & Decker, Delta, Makita, Porter Cable, Bosch, Milwaukee, Ryobi, Freud and many more. We offer competitive prices with quality service and same day shipping. 208 page 1991-92 catalog. It's worth it! TOOL CRIB. \$3.00. *Circle No. 6.*

PORTABLE SAW MILL—a one man saw mill weighing 45 lbs. Gas and electric models will cut dimensional lumber from logs up to 20 in. diameter. Send for brochure. BETTER BUILT CORP. Free. *Circle No. 10.*

175-PLUS USES GUIDE—for Dremel Moto-Tool. Written from the do-it-yourselfer's view, this book shows how to plan and do a variety of everyday projects using the versatile Moto-Tool and cordless Freewheeler. 96-page book with over 275 photos includes tips on using Moto-Tool with flex-shaft, drill press, router attachment, chainsaw sharpening attachment, shaper/router table. DREMEL. Free. *Circle No. 33.*

INCA MACHINERY INFORMATION—Complete information on the famous line of Inca woodworking machines. Designed for precision work by the small to medium sized cabinet shop. Used by thousands of hobbyists and professionals. Table saws, bandsaws, jointer/planers, dust collector, radial arm saw. GARRETT WADE CO. Free. *Circle No. 44.*

THE SAW THAT CHANGED AN INDUSTRY!—Now available in an economy priced Professional Model for your woodworking shop! Imagine! Incredibly intricate scrolling, complex shaping and cutting without making an access cut—this is what the LABORSABER® RETRACTABLE SAW has been doing for industry for over 20 years! Now, a scaled down version of this industry leader is available for your woodworking needs—and at a price that makes owning this quality saw even more attractive. Send for free information. DIANSUPPLY/LABORSABER COMPANY. Free. *Circle No. 50.*

LOBO POWER TOOLS—Fine crafted woodworking power tool, top quality, affordable prices. A commitment of customer satisfaction, with a full 1 year warranty. We sell a complete line with many options for our band saws, table saws, planers, jointers, double drum sanders, edge sanders, wide belt sanders, power feeders and many, many more. Send today for a free brochure. LOBO POWER TOOLS. Free. *Circle No. 57.*

WOODWORKING MACHINE CATALOG—New 24-page color catalog introduces many new do-it-yourself woodworking machines. Includes planers, dust collectors, drill presses, sanders, lathes, and specializes in scroll saws and accessories. PENN STATE INDUSTRIES. Free. *Circle No. 75.*

DUST COLLECTOR SYSTEMS—Keep your shop clean and safe from saw dust with one of our large capacity Commercial Style Dust Collection Systems. Catalog features our new DC-3 1-1/2 H.P. Portable System. Free hose and adapters are supplied with any purchase. Full line of Dust Collection accessories is available from Penn State Industries. Catalog. PENN STATE INDUSTRIES. Free. *Circle No. 76.*

SURFACE PLANER—Information package available from Penn State Industries describing the specifications and applications of its super 12½ inch surface planer. Special discount pricing available on current promotion. PENN STATE INDUSTRIES. Free. *Circle No. 77.*

GET TO THE FINISH LINE FASTER—with a Performax drum sander. Don't spend hours with a hand-held belt sander. Sand ultra-wide stock ultra-smooth in just minutes. Models start at \$300 to \$2595. Select the model that fits your budget and your needs. New metal abrasive fasteners keep sandpaper tight without re-wrapping. PERFORMAX PRODUCTS. \$1.00. *Circle No. 78.*

THE PRECISION SCROLL SAW FOR THE ENTIRE FAMILY!—The Hawk was designed for beginners and built for expert woodworkers. Learn how to produce creative leisure time projects for fun or to make money...we'll show you how! Make cuts so intricate and smooth they don't require sanding. Four models to choose from. Send today for all the facts. RB INDUSTRIES, INC. Free. *Circle No. 84.*

THE VERSATILE RBI WOODPLANER/MOLDER/SANDER—It's indispensable! It's 4-in-1. It's RBI's Woodplaner/Molder/Sander/Gang Saw. Find out how the Woodplaner saves you money turning rough stock into beautiful professional quality projects. With 3 models to choose from there's one that fits your needs. It does it all, so you can do it all! Send today. RB INDUSTRIES, INC. Free. *Circle No. 85.*

SCROLL SAWS, ACCESSORIES, PATTERNS, BOOKS—A complete brochure on all kinds of scroll saw accessories. Featuring Excalibur scroll saws and lettering layout guides from Seyco, "The Scroll Saw Specialists." Free pamphlet, "Selecting Your Scroll Saw" included. Send for brochure. SEYCO SALES CO. \$1.00. *Circle No. 89.*

MOLDER-PLANERS FROM WILLIAMS & HUSSEY—Mold, plane, and edge, convert from moulder to planer in less than 2 minutes. The W-7 series is available in 3 models for manual, power in feed, or power in feed/out feed. The units plane to a satin, almost sanded finish, produce doll house to crown sized mouldings, raised panels, and curved molding. Custom knives available up to 7" wide and ¾" depth of profile. Rugged, well-

made, dependable, and transportable. Complete with sturdy movable stand. Send for catalog. WILLIAMS & HUSSEY. \$1.00. *Circle No. 93.*

PORTABLE SAWMILLS—Convert logs into valuable lumber—Wood-Mizer® Products manufactures a line of portable bandsaw mills that allows the novice as well as the experienced sawyer to safely convert standing logs into lumber. Then, with the use of our SolaryDry™ Kiln or Vacu-Kiln™ to dry your lumber, you could increase the value of every board you produce. We manufacture some of the most progressive woodworking equipment on the market today. Product videos available. Send for our 31-page catalog. WOOD-MIZER PRODUCTS. \$2.00. *Circle No. 94.*

HAND TOOLS

PERSONAL BRANDING IRONS—Brochure describes branding irons that enable you to put your name on your work quickly and easily. Made especially for branding wood, they are available with 1, 2, 3 or 4 lines of copy. Changeable date also available. NOVA TOOL CO. \$1.00. *Circle No. 160.*

IMPROVE YOUR WOODWORKING SKILLS!—Craftsmen around the world have discovered the secret of better quality work. The 72 page Japan Woodworker Catalog is loaded with a huge selection of Japanese saws, waterstones, chisels, gouges, carving tools, planes, cutlery and garden tools. Send for 1992 catalog and all supplements for two years. THE JAPAN WOODWORKER. \$1.50. *Circle No. 190.*

PLANS

OVER 1000 WOODCRAFT PATTERNS!—Enjoy making gifts, toys, lawn ornaments, holiday designs, whirligigs, folk art, bird houses and feeders, household and yard accessories plus much more! Simple enough for the beginner, fun and profitable for the pro. Send for catalog plus sample pattern. ACCENTS IN PINE. \$2.00. *Circle No. 310.*

WOODWORKERS' PLANS AND SUPPLIES—Wood projects are simplified with the high quality plans, specialty hardware and other supplies offered by Armor Products. Over 100 plans are available for making toys, desks, clocks, pool tables, lamps, chests, and other furniture. Movements, dials, moldings, ornaments, dollhouse kits, door harp supplies and tuning pins are also available. ARMOR PRODUCTS. \$1.00. *Circle No. 315.*

SALES TESTED DESIGNS—available as plans only, parts kits, or plans and parts kits. Complete stock of parts, tools and supplies. Door Harps to Digital Electronic/Wood Projects. Full size plans! Catalog \$2.00 refundable on first order. CRAFTER'S MART. \$2.00. *Circle No. 328.*

FULL-SIZE FURNITURE PLANS CATALOG—Illustrates and describes over 200 plans for making furniture of quality found in museums and fine furniture stores. Plans include rolltop desk, cradles, dining tables, chairs, buffets, chests, gun cabinets, poker table, children's furniture, rocking horse, spinning wheels, and more. Bill of materials exploded drawings assist the woodworker. FURNITURE DESIGNS, INC. \$3.00. *Circle No. 345.*

STICKLER FOR DETAIL?—At last an exciting new line of realistic wood block models that you can build with your own scrap wood and dowels and my easy-to-follow instructions. Highly detailed plans for a 20x8 1/2-in. dump truck. GATTO PLAN SUPPLY. \$8.00. *Circle No. 355.*

UNIQUE WOOD PATTERNS—Let your imagination run wild. Each pattern given in 3 sizes. No enlarging or reducing is necessary. Simply trace, cut and create. A list of suggestions and helpful hints included with each pattern. List of patterns only \$1.00. HOUSE OF STARR. \$1.00. *Circle No. 375.*

PROJECT PLANS—Full-size patterns for over 500 easy-to-build woodworking projects. Nation's leading source for scroll saw patterns, cow projects, toy plans, yard ornaments, wood furniture, etc. Over 3000 hard-to-find specialty items. Send for your big new 72-page catalog. MEISEL HARDWARE SPECIALTIES. \$1.00. *Circle No. 401.*

LAWN FURNITURE PLANS COLOR CATALOG—Plans available are picnic tables, adirondack designs, swings (both children & adult), lawn chairs, rockers, planters and a wishing well with running water. All items have been built and tested several times before drawn into plan form. Curved and hard to make pieces have full-size templates. SPECIALTY FURNITURE DESIGNS OF MI. \$2.00. *Circle No. 445.*

THE COMPLIMENTS NEVER END!—when you show off your completed projects made from our full size patterns. Over 1000 unique, easy to make designs include popular folk art, wind action whirligigs, old world Santas, country furniture, shelves and shadow boxes, action toys, 3D layered animals, country critters, yard ornaments, Christmas yard decorations and more! No enlarging required—just trace our patterns onto wood and cut out. Fast service, satisfaction guaranteed. Send for our latest catalog. THE WINFIELD COLLECTION. \$1.00. *Circle No. 480.*

LUMBER

QUALITY EXOTIC LUMBER/TURNING WOODS—We offer a comprehensive selection of fine quality exotic woods: Ebony, Kingwood, Tulipwood, Snake-wood, African Blackwood, Cocobolo, Bloodwood, Figured Maple, Spalted Maple, Padauk, etc. Unique and unusual turning woods and burls are also available. Send for catalog. BEREA HARDWOODS. \$1.00. *Circle No. 510.*

WOODWORKERS! HELP CELEBRATE OUR 62ND YEAR OF SERVICE—Send for our new 132-page Craftsman 1991-92 Catalog #58. 42 varieties of choice hardwoods 1/4 in. to 4-in. thickness. Fine hardwood veneers, tools, moldings, trim, marquetry inlays, upholstery and lamp supplies, finishes, clock kits, and hard-to-find hardware. 4,000-plus items for your projects. CRAFTSMAN WOOD SERVICE CO. \$1.00. *Circle No. 520.*

STEVE H. WALL LUMBER CO—Quality hardwoods and woodworking machinery for the craftsman and educational institutions. 22-page catalog lists 15 species of popular hardwoods at wholesale prices. Also dealers for MiniMax, Freud and ProCut woodworking machines. STEVE H. WALL LUMBER CO. \$1.00. *Circle No. 592.*

EXOTIC IMPORTED AND DOMESTIC HARDWOODS—Over 75 species of lumber, bowl planks, turning squares and veneer. Samples 1/2" x 3" x 6" ideal for craftsmen, furniture and cabinet makers, architects, and designers available. Catalog provides common and botanical name, source, and description of each wood. Send for catalog. WOODWORKERS SOURCE. \$1.00. *Circle No. 598.*

VIDEOS

LOBO POWER TOOLS—Complete one stop location for all affordable woodworking power tools. Excellent quality at the most affordable prices. Customer satisfaction is job #1. We inventory and sell a full line of band saws, table saw, planers, jointers, sanders (all

sizes) and much, much more. All equipment has a 1 year warranty. Send for video; price refundable with \$500 purchase. LOBO POWER TOOLS. \$10.00. *Circle No. 645.*

GENERAL WOODWORKING CATALOGS

CONSTANTINE'S WOODWORKERS' CATALOG—116 pages—over 4,000 woods, veneers, inlays, carvings, moldings, legs, pegs—everything for people who like to build with, turn, carve, refinish wood! Includes 33 pages of hand and power tools, 24 pages of hard-to-find hardware, 12 pages of finishing supplies... books, kits, plans and more... all backed by Constantine's 180 years of woodworking experience and 60-day no-questions-asked guarantee. 2 year subscription. ALBERT CONSTANTINE AND SON, INC. \$1.00. *Circle No. 820.*

MASTER TOOLS CATALOG—1991-92 220-page master woodworking tools catalog. Full line of the best hand tools, power tools & accessories, machinery, glues, finishing supplies, workbenches, and much more. Hundreds of books included. 220 pages. All four-color. Lots of technical information. GARRETT WADE CO. \$4.00. *Circle No. 855.*

GRIZZLY IMPORTS, INC.—Our new 1992 catalog is bigger and better than ever! We have added many new items to our already large selection of affordably priced woodworking machines, tools and accessories. Send for your free woodworking source catalog. GRIZZLY IMPORTS INC. Free. *Circle No. 860.*

WOODWORKING CATALOGUE—Get your copy of our new full-color catalogue. You'll find the best prices and selection on thousands of different items for the craftsman, cabinetmaker, and hobbyist. Tools, books, and supplies are some of the many items we carry. Packed with gobs of goodies you can't resist. HARTVILLE TRUE VALUE HARDWARE. Free. *Circle No. 865.*

TOOLS ON SALE—A division of Seven Corners Ace Hardware Inc. offers a comprehensive catalog featuring over 820 pages of the most competitive prices in the industry. If you're looking for savings and fast delivery on over 6500 items, request our catalog. This catalog offers one of the most complete selections of power tools available anywhere from the most respected manufacturers in the industry: Milwaukee, Makita, Porter-Cable, Black & Decker, Freud, Bosch, Delta, and many more. SEVEN CORNERS ACE HARDWARE. \$1.00. *Circle No. 920.*

DISCOUNT WOODWORKING TOOLS AND SUPPLIES—Get your FREE copy of Trendline's new 68 page full-color catalog. You'll find the best prices for over 3,000 brand name products including: power tools and accessories, hand tools, screws, hardware, wood components, plans, books, and much more. TRENDLINES. Free. *Circle No. 950.*

COMPLEMENTARY TOOL CATALOG—Woodcraft offers over 4,000 of the finest quality woodworking tools, books, supplies, and cabinetry hardware in our complete full color catalog. Craftsmen, cabinetmakers, carvers, woodturners, and hobbyists have depended on Woodcraft since 1928. Backed by Woodcraft's unconditional guarantee. Free technical assistance. WOODCRAFT SUPPLY CORP. Free. *Circle No. 955.*

THE WOODWORKERS' STORE CATALOG—New! The Woodworkers' Store 1991-92 catalog with over 150 new items features 100 color pages of domestic and exotic hardwoods, veneers, wood parts, specialty hardware, kitchen accessories, finishing supplies, tools, books, and plans. Many exclusive items and hard to find specialties. Orders shipped in 24 to 48 hours. \$1.00 credited toward first purchase. Satisfaction guaranteed. WOODWORKERS' STORE. \$1.00. *Circle No. 965.*

KITS

OUR QUEEN ANNE FURNITURE KITS—are ready to assemble and finish. They include dining room

table, chairs, hutch, sideboard, a variety of occasional tables, and a personal desk. All are made in solid cherry, oak, walnut, and mahogany. We also stock individual Queen Anne legs for every project. Complete information in our brochure packet. ADAMS WOOD PRODUCTS. Free. *Circle No. 1002.*

OAK FURNITURE AND ACCESSORY KIT CATALOG—features a full range of top quality oak furniture kits and accessory items plus unfinished assembled furniture. Featured items include roll top desks in several styles, stacking barrister's bookshelves, tables, chairs, file cabinets, bedroom furniture, Mariner's globe, plus many more. Send for catalog and enjoy true woodworking pleasure. CRAFTSMANS CORNER. Free. *Circle No. 1017.*

DO-IT-YOURSELF KITS—Choose from a large selection of grandfather, wall and mantel clocks, as well as elegantly styled accent furniture pieces. Kits are made of solid 3/4" hardwoods, primarily cherry, oak, and black walnut. Buy direct from the factory and save. Send for 36 page color catalog. EMPEROR CLOCK CO. \$1.00. *Circle No. 1030.*

QUALITY CLOCK KITS AND PLANS—Handmade and semi-assembled of carefully selected 3/4 in. cherry, oak, or walnut with beveled glass. Or build from "scratch" using our detailed plans and trim pieces. Choice of quality movements. Established in 1916. KUPEL CHIME CLOCK WORKS. Free. *Circle No. 1050.*

SHOP ACCESSORIES

WOOD TURNER'S DREAM!—De Pee's Ltd. Split Ring Holder surpasses all holders on the market in its ability to turn large projects in holder quickly, and still hold concentrically. Especially desirable for craftsmen who are into vase and bowl turning where it is necessary to do inside and outside turning. Send for information. DE PEE-S. \$1.00. *Circle No. 1220.*

LUMBER DRYING SYSTEMS—Ebac Lumber Dryers offers a wide variety of sizes from 50 B.F. to over 10,000 B.F. You get the highest quality lumber dried down to 6%—8% moisture content. Our controllers make them easy to operate and energy efficient. Kiln construction guide included to build your chamber. EBAC LUMBER DRYERS. Free. *Circle No. 1228.*

EASY DOES IT—with HTC'S power tool accessories. Discover many unique items, designed only with you, the dedicated woodworker, in mind. Make your machinery safer, increase the working area of your shop and accomplish nearly impossible tasks easily, quickly, accurately. Full-line catalog and price list. HTC PRODUCTS, INC. Free. *Circle No. 1245.*

WOOD MOISTURE METER—Avoid moisture problems such as cracking, warping, splitting, delamination etc. by using a moisture meter, as described in the latest brochure. Moisture Meter Mini-Ligno is designed for serious hobbyists and woodworkers. Attachments for depth measurements and remote reading during air and kiln drying are available. Available Moisture Range 6-20%, 6-36% or 4-30%, 4-60%. Catalog describes complete line of moisture meters. LIGNOMAT USA, LTD. Free. *Circle No. 1250.*

ROUTER SPEED CONTROL—Reduces speed electronically without reducing torque. Route at the speed that gives best results with the wood and bit you are using. Speed adjustable from full speed to 0 RPM. Less tear out—stops burning—less wear on bits—easy to use. Send today for information. MLCS LTD. Free. *Circle No. 1251.*

WHOLESALE SANDPAPER, BELTS, SHEETS, CLOTH & PAPER DISCS—for orbital sanders. Shop rolls, flap wheels, hot melt glue sticks, dust masks, scuff pads, tack cloths, tape, wipers, etc. Supergrit offers quality abrasive and refinishing products at wholesale prices directly to the consumer. \$25.00 minimum order. Prompt, free UPS shipment to most areas. 20 page catalog. RED HILL CORP. 50c. *Circle No. 1267.*

BITS, BLADES, CUTTING TOOLS

ATRAX—Fine craftsmanship deserves the very best. Craftsmanship begins with the idea. The final result depends on the tool and the craftsman. Atrax cutting tools are made from premium fine-grade carbide, the best on the market today. Atrax offers over 600 styles and sizes of cutting tools to bring ideas to quality results. Send for catalog. ATRAX. Free. *Circle No. 1305.*

CASCADE TOOLS—New 1992 catalog is packed full of affordably priced, industrial grade s/y brand router bits and shaper cutters as well as hard to find accessories. Also included are many new items added just this year. CASCADE TOOLS, INC. Free. *Circle No. 1315.*

PRODUCTION QUALITY CARBIDE TIPPED ROUTER BITS—MLCS Ltd. has a new 32-page catalog featuring hundreds of high quality carbide tipped router bits, shaper cutters, the Router Speed Control, the "Merle Adjustable Corner Clamp," plus other Professional Woodworking Products. Prices 50% to 70% lower than elsewhere. Value, quality and prompt service guaranteed! MLCS LTD. Free. *Circle No. 1350.*

HARDWARE/WOOD PARTS

HARDWARE CATALOG—A unique 48-page catalog of the very finest in classic, traditional solid brass cabinet hardware. All of British or No. American manufacture. Double & single post handles, knobs, escutcheons, standard & specialty hinges, box hardware, brass screws, castors, latches, catches, locks, and more. GARRETT WADE CO. \$3.00. *Circle No. 1427.*

SQUARE DRIVE SCREWS—Thousands agree—once you try them you will never want to use anything else! The square drive recess virtually eliminates work-

damaging driver bit "cam-out," the deep threads result in exceptional holding power, and they are heat treated for strength. Sizes from #4 x 3/8" to #12 x 4", with stainless steel, solid brass, brass plated, and zinc plated available. Quantity discounts. Send for literature. McFEELY HARDWOODS. \$1.00. *Circle No. 1450.*

WOOD TOY PATTERNS—Patterns for all ages including children's patterns and executive toys. New catalog has many new patterns to choose from including parts and wheels. Send for new catalog and receive a coupon for free wheels and axle pegs. TOYS AND JOYS. \$1.00. *Circle No. 1480.*

INCOME OPPORTUNITIES

MAKE MONEY IN FURNITURE RESTORATION THE MINUTEMAN WAY—Earn \$200-\$1000 per day stripping, repairing, refinishing, mirror resilvering, and/or veneering, at home or in shop, spare time or full time. We provide complete training; no experience necessary. Free workshop teaches you latest in furniture restoration. You have to see it to believe it! Business preview video \$19.95. Send for catalog. MINUTEMAN. \$2.00. *Circle No. 1661.*

MISCELLANEOUS

SEAT WEAVING SUPPLY CATALOG—A full line of supplies for chair caning, seat weaving, wicker repair, furniture repair, and other exotic materials like rattan and bamboo poles, sennet, manila fibre and more. FRANK'S CANE AND RUSH SUPPLY. Free. *Circle No. 1940.*

IF YOU ARE INTERESTED IN RESTORING ANTIQUES—this 240-page catalog packed with unusual, hard-to-find items is just for you. Included are hundreds of essential items for antique restoration including top quality brass reproduction hardware, oil

lamps and accessories, numerous wood component repair parts and kits, caning and basketry supplies, everything needed for wood refinishing, related tools, books, and a complete line of upholstery equipment and supplies. All at wholesale prices. Send for this informative catalog. VAN DYKE'S RESTORERS. \$1.00. *Circle No. 2077.*

UNIQUE GREENHOUSE/SCREENHOUSE IDEA—A gardener's paradise during the winter months, a bug-free screen room during the summer months. That's the concept behind the versatile new Sun-Porch. This two-in-one sunspace features sturdy aluminum framing, 1" shatter-resistant glazing, do-it-yourself assembly, and mounts readily on decks, patios, landscape ties. Color catalog includes models, prices; sent first class mail. VEGETABLE FACTORY, INC. \$2.00. *Circle No. 2078.*

LEGAL IVORY—Virtually identical to animal ivory. Tagua is the nut from a tropical palm tree. Ideal for jewelry, knobs, small turnings, inlay, or scrimshaw. Box of 10 REGULAR size (up to 1 1/2" diameter) or Box of 5 JUMBO. Send for information. WOODWORKERS SOURCE. Free. *Circle No. 2090.*

***THE WOODWORKING SHOWS* MACHINERY, TOOLS AND SUPPLIES**—Hundreds of products for the woodworker demonstrated and sold at discount prices at every "Woodworking Show". In-depth seminars and free workshops on a variety of woodworking topics. Shows are scheduled in 28 cities. Send for free brochure. *THE WOODWORKING SHOWS*. Free. *Circle No. 2095.*

CARVING SUPPLIES

WOOD CARVING MACHINES AND ACCESSORIES—make all types of wood carving easy, fun and profitable. The machines do the work. Whether for sign carving, flat 3-D, decoys, panels, gun stocks or furniture, we have the proper machine for the job. Professional woodcarving for the hobbyist and superior quality for the professional. Begin your hobby or full or part-time business by ordering our catalog and price list. MARLIN INDUSTRIES. \$1.00. *Circle No. 2150.*

WOODCARVING TOOLS—Whittlers and carvers—Warren Tool Co. offers a complete catalog of whittling and carving, hand/power tools, sharpening stones, wood cut-outs and related wood carving supplies. WARREN TOOL CO., INC. \$1.00. *Circle No. 2185.*

CLAMPS

MERLE ADJUSTABLE CORNER CLAMP—Quick & easy to use. Fully adjustable from 2 1/2" to 69x69 in. Perfect for clamping picture frames, cabinets, or anything that requires 90° corner clamping. The Merle Clamp is cast aluminum & steel construction, a true industrial quality tool. Send today for information. MLCS LTD. Free. *Circle No. 2250.*

QUAKER STATE WOODWORKING SUPPLY INC.—one of the largest "Quick-Grip" and "Jorgensen" dealers on the EAST COAST. Great prices along with expert service and advice will make QUAKER STATE your supplier of woodworking clamps and acc. Information and price list. QUAKER STATE. Free. *Circle No. 2260.*

CLOCKS

KLOCKIT'S FREE 64-PAGE COLOR CATALOG—is packed with the largest selection of beautiful wood clock kits for all skill levels, a huge selection of quartz and mechanical clock movements, dials and accessories, turned wood parts, music movements, tools and much more for the craftsman! KLOCKIT. Free. *Circle No. 2335.*

Worth writing for...



Better Homes and Gardens®
WOOD Magazine, February 1992
Dept. FEWO92
P.O. Box 2713
Boulder, Colorado 80329-2713

TO ENSURE PROMPT HANDLING OF YOUR ORDER FOLLOW THESE INSTRUCTIONS:

- Circle your choice
- Enclose check or money order for cost of booklets plus \$2.00 service charge (no stamps accepted)
- NO FOREIGN ORDERS ACCEPTED
- Send coupon and remittance to address above
- ALLOW 4-6 WEEKS FOR DELIVERY
- Coupon expires March 14, 1993

WOOD SUBSCRIPTION

1. A 1 year WOOD subscription (9 issues) for \$24.97 (U.S. price)—a \$10.58 savings off newsstand rate. Allow 6-8 weeks for first issue. Canadian price \$34.00. Be sure to include payment with total below. NO FOREIGN ORDERS ACCEPTED ON THIS COUPON; please contact Subscription Dept. directly.

Circle numbers below corresponding to items in this issue. Please include \$2.00 for handling charge.

3\$2.00	77Free	315\$1.00	592\$1.00	965\$1.00	126750¢	2078\$2.00
4\$1.00	78\$1.00	328\$2.00	598\$1.00	1002Free	1305Free	2090Free
6\$3.00	84Free	345\$3.00	645\$10.00	1017Free	1315Free	2095Free
10Free	85Free	355\$8.00	820\$1.00	1030\$1.00	1350Free	2150\$1.00
33Free	89\$1.00	375\$1.00	855\$4.00	1050Free	1427\$3.00	2185\$1.00
44Free	93\$1.00	401\$1.00	860Free	1220\$1.00	1450\$1.00	2250Free
50Free	94\$2.00	445\$2.00	865Free	1228Free	1480\$1.00	2260Free
57Free	160\$1.00	480\$1.00	920\$1.00	1245Free	1661\$2.00	2335Free
75Free	190\$1.50	510\$1.00	950Free	1250Free	1940Free	
76Free	310\$2.00	520\$1.00	955Free	1251Free	2077\$1.00	

Name (please print) _____
Address _____
City _____
State _____ Zip Code _____

I AM ENCLOSING:

\$ _____ for priced items
\$ 2.00 for handling
\$ _____ total remittance

DELTA BENCH TOP TOOLS		
Model	List	Sale
23-700	Wet/Dry Grinder	234
23-880	6" Bench Grinder 1/4 HP	86
23-880	8" Bench Grinder 1/2 HP	151
11-950	8" Drill Press	199
21-180	10" Hobby Band Saw	210
31-050	1" Belt sander 2.0 amp	104
31-460	4" Belt/Disc Sander	196
31-340	NEW 1" Belt/Disc Sander	268
31-080	NEW 1" Belt/Disc Sander	134

NEW TOOLS BY DELTA		
Model	List	Sale
40-560	16" 2 speed Scroll Saw	266
23-580	5" Bench Grinder 1/5 HP	62
11-990	12" Bench Drill Press	276
11-490	32" Radial Bench Drill Press	399
43-355	3/4" Shaper 1 1/2 HP	684
43-505	1/2" Bench Router/Shaper	399
22-540	12" Bench Top Planer	598
36-220	10" Compound Miter Saw	350
28-180	Bench Band Saw	232
40-640	NEW 20" Bench Scroll Saw	466
23-675	NEW 6" Grndr/3x24Belt Sndr	141

DELTA STATIONARY		
Model	List	Sale
34-761	10" Unisaw 1-1/2 HP	1715
33-990	10" Radial Arm Saw	8185
37-280	6" Motorized Jointer	488
30-170	3/4 HP 2 stage Dust Collector	483
50-181	2 HP Dust Collector	885
70-200	NEW 20" Floor Drill Press	1049
37-154	DJ15 6" Jointer w/3/4 HP Motor	1420
33-055	8-1/4" Sawbuck w/Planes	865
34-330	NEW 8-1/4" Table Saw 13A	343
34-985	1/6 HP Stock Feeder	698
34-670	10" Motorized Table Saw	511
32-100	NEW Station Plate Jointer	645
36-400	NEW 8-1/4" Cmpd Mitr Saw	224
34-915	30" Unifence	385
34-997	50" Delta Unifence	525
36-755	NEW 10" Tilt Arbor Saw	1264
34-445	34-444 Saw with 30" unifence	1200

MILWAUKEE TOOLS		
Model	List	Sale
6527	NEW Sawzall 8 amp variable speed with case	299
0399-9	12V cdss Drill Kit complete	299
0402-1	Hand Drill w/keyless chuck	304
0395-1	9.6V cordless Drill w/case	279
0224-1	3/8" Drill 4.5 amp magnum	199
0234-1	1/2" Drill 4.5A mag 0-850 rpm	219
0244-1	1/2" Drill 4.5A mag 0-600 rpm	219
0222-3	3/8" Drill 3.5 amp 0-1000 rpm	185
0228-1	3/8" Drill 3.5 amp 0-1000 rpm	179
0375-1	3/8" close quarter Drill	219
0379-1	1/2" close quarter Drill	249
6539-1	cds Screwdriver 190 rpm	125
6540-1	6539-1 Driver w/bits & case	159
6541-1	cds Screwdr 200 & 400 rpm	135
6102-1	Plumbers right angle Drill Kit	350
5399	1/2" H-die Hammer Drill Kit	319
1676-1	HD Hole Hawg with case	449
6511	2 speed SawZall with case	234
6750-1	Drywall Gun 0-4000 5 amp	159
6507	TSC SawZall with case	249
6014	1/4" Chop Saw 15 amp	479
6014	Orbital Sander 1/2 sheet	119
6977	variable temp. Heat Gun	114
5397-1	3.8" var. spd Hammer Drill Kit	239
5371-1	1/2" var. spd Hammer Drill Kit	335
3107-1	1/2" var. spd rt angle Drill Kit	360
6754-1	Drywall Gun 0-4000 5.4 amp	189
3300-1	1/2" var. speed rt angle Drill	319
5660	1-1/2 HP Router - 10 amp	325
5680	Router 2 HP - 12 amp	355
6215	16" Chain Saw	299
0235-1	1/2" Drill w/keys chuck mag	219
6145	4-1/2" Grinder 10,000 rpm	159
6142	6145 with case & access	197
6749-1	Drywall Gun 0-2500 5.4 amp	209
5353	Eagle 1-1/2" Rot. Hammer w/cases	499
6365	7-1/4" Circular Saw 13 amp	209
6367	above Saw - double insulated	205
6366	6365 w/ence & carbide blade 219	125
6368	6365 w/ence,carb. blade & case	239
6377	7-1/4" Worm Drive Saw	319

TOOLS ON SALE! X-TRA SPECIAL		
Buy any 7-1/4" saw (6365, 6366, 6367, 6368, 6377) & receive an Extra Milw. Carbide Tip Saw Blade an \$11.00 value - FREE		
FREUD CARBIDE TIPPED SAW BLADES		
5/8" Bore - Industrial Grade		
Item	Description	Teeth
LJ72M010	Gen Pur. A.T.B. 10" 40	67
LJ82M010	Cut-off 10"	60
LJ84M011	Comb 10"	50
LJ85M010	Super Cut-off 10"	60
LM72M010	Ripping 10"	24
LJ73M010	Cut off 10"	60
LJ87M010	Thin Kerf 10"	24
LJ88M010	Thin Kerf 10"	60
LJ98M010	Ultimate 10"	60
TK206	10" Framing	24
TK303	7-1/4" Finishing	40
TK306	10" Finishing	40
TK906	10" Combo	50
SD306	6" Dado - Carbide	215
SD308	8" Dado - Carbide	229
F0	1-3/4" x 5/8" Biscuit 1000 Qty.	32
F10	2-1/8" x 3/4" Biscuit 1000 Qty.	32
F20	2-3/4" x 1" Biscuit 1000 Qty.	34
FA	Assorted Biscuits 1000 Qty.	34
FB100	16 pieces Forstner Bit Set	331
94-100	5 pc. Router Bit Door System	319
FT2000	3-1/4 HP Plunge Router	179
EB100	Edge Banding Machine	229

MAKITA TOOLS		
Model	List	Sale
6070DW	3/8" w/spd Reverse Drill 7.2V	130
6071DWK	above Drill w/removable batt.	109
5090DW	3-3/8" Saw Kit 9.6 volt	256
6101DWK	3/8" cordless Drill Kit 7.2V	170
6105DWK	3/8" cordless Drill Kit 7.2V	99
DA3000DW	3/8" Angle Drill 7.2 volt	251
4390DW	9.6 cordless Recip Saw Kit	230

6012HDW	2 spd Drill w/clutch-comp	236
6092DW	vspd Drill Kit complete	252
6093DW	vspd Drill w/clutch-complete	261
6093DWL	6093DW Drill Kit w/Flash Lt.	299
6095DW	6093DW Drill Kit w/keys chuck268	135
6095DWE	6095DW Drill Kit w/2 batteries270	139
632007-4	9.6 volt Battery	48
632002-4	7.2 volt Battery	40

5007NBA	7-1/4" Saw w/electric brake	238
5008NBA	8-1/4" Saw w/electric brake	295
804510	1/4 sheet Pad Sander	93
9900B	3" x 21" Belt Sander w/bag	278
9924DB	3" x 24" Belt Sander w/bag	293
9045N	1/2 sheet Fin. Sander w/bag	241
9041BV	Orb. var. spd Jig Saw 3.5A	289
9041BV	var. speed Recip Saw w/case	235
9820-2	10" Mitr Saw 3.5 amp	560
9820-2	Blade Sharpener	387
1900BW	3-3/4" Planer with case	217
1911B	4-3/8" Planer 7.5 amp	255
9100	3-1/4" Planer with case	426
9205PSC	7" Sander/Polisher	288
3601B	1-3/8 HP Router	256
804550	1/4 sheet Pad Sander w/bag	99
DA3000R	3/8" Angle Drill	280
HEP210N	3/4" var. spd Hmr Drill w/case	300
2708W	8-1/4" Table Saw	509
2711	10" Table Saw with brake	851
1805B	6-1/2" Circular Saw with case	317
5005BA	5-1/8" Circular Saw	234
6404	3/8" Drill Rev. 0-2100 rpm	2A
6510LVR	3/8" Drill Rev. 0-1050 rpm	149
6403BR	1/2" Drill Rev. 6 amp	258
5012A	16" Circular Saw 12 amp	662
3612BR	3 HP Plunge Router	377
9401	4" x 24" Belt Sander w/bag	337
4302C	var. speed Orbital Jig Saw	302
5077B	7-1/4" Hypoid Saw	255
LS1440	14" Mitr Saw	744
LS1030	NEW 10" Mitr Saw	420
5007NB	7-1/4" Circular Saw 13 amp	210
3612B	3 HP Plunge Router sq/base	377
2012	12" Portable Planer	895
LS1011	10" Slide Compound Saw	842

SENCO AIR NAILERS		
Model	List	Sale
SFN1	Finishing Nailer 1" - 2"	377
SFN2	Finish. Nailer 1-1/2" - 2-1/2"	571
SN525	Nailer 1-7/8" - 3-1/4"	665
SN4	General purpose 2" - 3-1/2"	695
S42	Planner 5/8" - 1"	351
SS5	Slipster 5/8" - 1-1/2"	351
LKS	Planner 1" - 1-1/2"	399

BOSTITCH AIR NAILERS		
Model	List	Sale
N80S-1	Stick Nailer Super Sale	389
N80C-1	Utility Coil Nailer	845
N126-1	Sheath & Decking Stapler	595
N135-1	Coil Roofing Nailer	845
N80FN-2	Finishing Nailer	625
T31	Brad Nailer	270
CWC100	1 HP Pancake Compressor	445

SKIL SIZZLERS		
Model	List	Sale
3810	10" Mitr Saw	263
3810K	3810 w/60 tooth Carbide Blade	239
77	7-1/4" Worm Drive Saw	230
77-04	77 saw w/case,carb. blade,inc. lube292	135
2735-0A	12 volt cordless Drill Kit	210
2735-0A	2735-0A w/keyless chuck	235
1605-2	NEW Biscuit Jointer w/case	200
7584	NEW 5" Rndm Orbit Sander	160

PANASONIC CORDLESS		
Model	List	Sale
EY8205BC	NEW variable speed 12 volt Drill w/15 minute charger & case	390
EY6005B	12V cdss Drill w/1 hr charger	315
EY6209B	NEW 2 speed 12 volt Drill D-handle with 15 minute charger	350
EY6281BC	NEW variable speed 9.6 volt Drill w/15 minute charger w/case	350
EY571B	var. speed 9.6 volt Drill Kit	239
EY6207BCNEW	12 volt 1/2" Drill w/keyless chuck var. spd w/15 min. charger & case	421

LEIGH DOVETAIL JIGS		
Model	List	Sale
D1258R-12	List 329.00-Sale 269.00	
D1258R-24	List 399.00-Sale 325.00	

LEIGH INSTRUCTIONAL VIDEO SALE 29.00		
Model	List	Sale
MMTA 24"	Mort. & Tenon attachment	299

HITACHI TOOLS		
Model	List	Sale
CT5B	7-1/4" Circular Saw	214
CT8D	7-1/4" Circular Saw with brake	230
M12V	NEW 3 HP var. speed Router	447
TR12	Plunge Router 3 HP	354
F1000A-12	Planner/6" Jointer	2835
CI0FA	10" Deluxe Mitr Saw	538
CI2FA	NEW 12" Mitr Saw	632
C8FB	8-1/2" Slide Compound Saw	899
FRUJL	NEW 100088-1/2" Carb bid 48 1" bid	48
CI5FB	15" Mitr Saw	745
FRUJL	NEW 15" 15" carb bid 108 tooth	180

1992 TOOL CATALOG AVAILABLE
 Call Toll-Free 1-800-328-0457 In Minnesota Call (612)224-4859
 FAX: (612)224-8263
 CHECK - MONEY ORDER - VISA - MASTERCARD - DISCOVER
SEVEN CORNERS ACE HDW. INC.
 216 West 7th St. - St. Paul, MN 55102 - Est. 1933

DELTA TOOLS		
Model	List	Sale
34-444	Table Saw Complete w/1-1/2 H.P. motor & stand	615.00
34-445-444	Table Saw Complete w/30" Unifence and 32-010 EMS system	829.00
28-283 14"	Band Saw w/encloused stand and 50-274 mobile base	739.00
22-662 13"	Planner with 2 HP motor, stand, and 32-011 EMS system	1185.00
17-900 16-1/2"	Floor Drill Press	385.00
40-601 18"	Scroll Saw w/stand and blades	709.00

DELTA 10" MITRE BOX XTRA SPECIAL 199.00		
Model	List	Sale
28-283 14"	Band Saw w/encloused stand and 50-274 mobile base	739.00

DELTA 10" MITRE BOX XTRA SPECIAL 199.00		
Model	List	Sale
28-283 14"	Band Saw w/encloused stand and 50-274 mobile base	739.00

DELTA 10" MITRE BOX XTRA SPECIAL 199.00		
Model	List	Sale
28-283 14"	Band Saw w/encloused stand and 50-274 mobile base	739.00

DELTA 10" MITRE BOX XTRA SPECIAL 199.00		
Model	List	Sale
28-283 14"	Band Saw w/encloused stand and 50-274 mobile base	739.00

DELTA 10" MITRE BOX XTRA SPECIAL 199.00		
Model	List	Sale
28-283 14"	Band Saw w/encloused stand and 50-274 mobile base	739.00

DELTA 10" MITRE BOX XTRA SPECIAL 199.00		
Model	List	Sale
28-283 14"	Band Saw w/encloused stand and 50-274 mobile base	739.00

DELTA 10" MITRE BOX XTRA SPECIAL 199.00		
Model	List	Sale
28-283 14"	Band Saw w/encloused stand and 50-274 mobile base	739.00

DELTA 10" MITRE BOX XTRA SPECIAL 199.00		
Model	List	Sale
28-283 14"	Band Saw w/encloused stand and 50-274 mobile base	739.00

DELTA 10" MITRE BOX XTRA SPECIAL 199.00		
Model	List	Sale
28-283 14"	Band Saw w/encloused stand and 50-274 mobile base	739.00

DELTA 10" MITRE BOX XTRA SPECIAL 199.00		
Model	List	Sale
28-283 14"	Band Saw w/encloused stand and 50-274 mobile base	739.00

FINISHING TOUCHES

ARE WE KEEPING TREES AWAKE?

Trees need their sleep, according to James R. Fazio in the newsletter *Arbor Day*. Birches and dogwoods are especially sensitive to intense artificial light, such as that produced by high-pressure sodium streetlights. The extra light causes the trees to grow too early in the season or continue growing too late into the year. Then, their tender shoots become frost victims. But, adds Fazio, "...the problem is not common enough to lose sleep over."

ADDING CLASS TO A DASH

When it comes to being classy, many Americans want it up front, where it can be seen. At least that's what Richard Fussell

CRITTER CARVING

Racine Festival Hall in Racine, Wisconsin, will for the fourth year be the scene of the Dremel/Ducks Unlimited Masters Carving Competition May 16-17. In 1991, 215 carvers entered 530 carvings in hopes of snaring a share of the \$22,000 in contest prizes.

This year's spring date, rather than the February timing of past years' competitions, will bring exhibitor and supplier booths outdoors. For information on entering and show hours, contact Dremel at 4915 21st St., Racine, WI 53406, or call 414/554-1390.



Ted Dobson, of Park Ridge, Illinois, won *WOOD* magazine's People's Choice Award at the 1991 Dremel/Ducks Unlimited competition with this carving of a dog with a wood duck.

of Plainfield, New Jersey, found out concerning auto dashboards.

Fussell owns a company called Comet Dashboards by Hailey, which outfits such costly conveyances as Infinity Q45s and BMW 525s with luxurious wooden dashboards priced at about \$2,000.

Brookside Veneers, of Metuchen, New Jersey, supplies Fussell with veneers of madrone and walnut burl, and bird's-eye maple. Including the polyurethane finish, the custom dashes measure less than 1/16" thick. The company produces 150 dashboards per week.

FRONT AND CENTER: WOOD READERS WHO MAKE A DIFFERENCE

Name: Frank Paxton, Jr.
Age: 72
Home: Kansas City, Mo.
Occupation: Retired lumber company executive
WOOD® connection: Subscriber since 1985

In 1990, Frank retired from the helm of the Kansas City-based Frank Paxton Lumber Company, a major hardwood supplier to industry, cabinet shops, millwork houses, and school shop programs from the Rockies to the Ohio River. While heading the company, he had always advocated manual arts in the schools, fearing that shop curriculums would be abandoned. "Youngsters should learn to use their hands as well as their minds," he told readers in *WOOD* magazine, February 1986.

Frank hasn't changed. As a member of the board of his city's Guadalupe Center, he's helping to develop education programs for the Hispanic population. At fundraisers, he rolls up his sleeves.

"Before, all I'd ever done with nonprofit, volunteer programs was donate money. But with the Guadalupe Center, I'm a worker. At fiestas I pour beer and do all kinds of stuff. Helping people trying to help others—I enjoy that."

On the serious side, Frank wants to curb the school dropout rate among Kansas City's Hispanic children. Hispanic students number about 15 percent of the city's school-age population.

"What we've got in mind is a kind of training school, an alternative to what the public schools offer. Even some major corpora-

Frank Paxton, once at home with hardwoods, now helps Kansas City's Hispanic minority.

tions, such as IBM, have offered matching funds. Right now, we've got some programs in the arts, but no woodworking. I want to bring woodworking in, somehow."

For more information regarding Kansas City's Hispanic programs, write: Guadalupe Center, Inc., 1015 W. 23rd St., Kansas City, MO 64108.

Do you know a subscriber who makes a difference? Please send details to: Front and Center, WOOD® magazine, P.O. Box 11454, Des Moines, IA 50336-1454. ♣



NOW! PLANE, MOLD, SAND and SAW with



**FREE
30-DAY
TRIAL!**

Infinitely Variable Power-Feed!

MAKES YOU MONEY... SAVES YOU MONEY!

Put this versatile power-feed tool to work in your shop... see how fast it pays for itself! Quickly converts low-cost rough lumber into valuable finished stock. Turns out perfect picture frame moldings, quarter-round, casing, tongue and groove... all popular patterns... any custom design.

✓ **Just a twist of the dial** puts twice as many cuts-per-inch at your fingertips as any comparable planer — from 70 to over 1,000 CPI! This heavy-duty machine will sail through even the toughest oak at higher speeds, or you can slow it down to handle those “hard-to-work” pieces like curly maple, knotty cedar, burls, knees and much more! A valuable feature for molding work, where profiles make sanding impossible.

✓ **Change to Molding, Sanding or Sawing in just minutes!** Unique “Morse-Taper” Quick Change Cutterhead guarantees fast changeover... bearings remain factory set... precisely aligned at all times.

✓ **Now choose from three powerful models!** Woodmaster introduces the first 18" and 25" Planer/Molders... with all the features that have made the 12" model the most versatile Planer/Molder on the market! Send for Free Facts today!

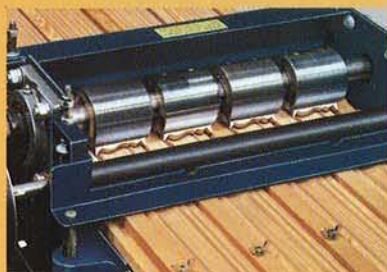

Woodmaster's Quick-Change Molding Head lets you create custom moldings from any stock. Choose from over 250 standard trim and picture frame patterns... or design your own!



Power-fed sanding speeds production and improves the quality of your work. No more waves or cross-grain scratches. Separate sanding head installs in just minutes.



New ripsaw attachment lets you gang-rip with power feed in a fraction of the time it takes for multiple hand-fed passes on an ordinary table saw.

**MAIL TODAY OR CALL
1-800-821-6651 Ext PW51**



YES! Please rush my FREE Information Kit
Woodmaster Tools, Dept. PW51, 2908 Oak, Kansas City, MO 64108

NAME _____

ADDRESS _____

CITY _____

STATE _____ ZIP _____

PHONE () _____

Here's What Woodmaster Owners Say:

Shop Test Results—“It does an excellent job of planing, on a par with more expensive machines, and even better than some commercial models.”

Editor, Workbench Magazine

Best Value—“After checking them all, Woodmaster was obviously the best deal for the money. Also, I would like to acknowledge the polite and prompt service.”

E. D. Holtz, North Carolina

Engineering A Great Table Saw Wasn't Easy.

Selecting The Name Was. Craftsman!

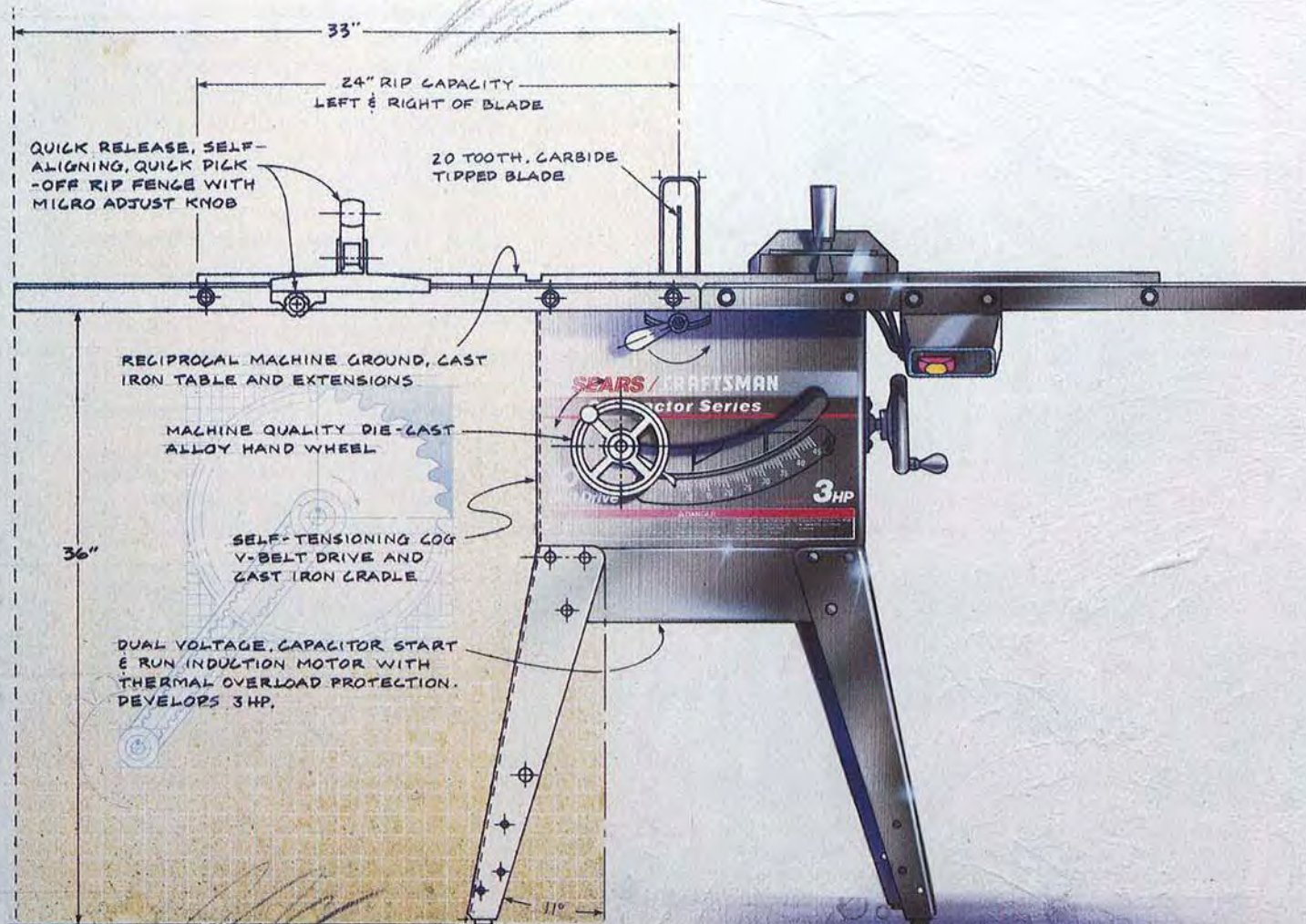

The precision engineering of the Contractor Series table saw was designed specifically for the serious woodworker. From the power of the motor to the accuracy of our patented Exact-I-Cut alignment system, we've spared no effort to ensure all the power and accuracy you'll ever need.

And you don't have to call for the name of your "nearest" distributor to see the many features. Just zip on down to your Sears store to see for yourself.

CRAFTSMAN®

Only at Sears

Horsepower shown on tools is maximum developed.