

Better Homes and Gardens®

WOOD

WIN BIG!
THE GREAT
SHOP-ORGANIZER HUNT
See page 6

THE #1 MAGAZINE FOR HOME WOODWORKERS

FEBRUARY 1991 • ISSUE NO.41
Display until February 14

**LEARN NORWEGIAN
FLAT-PLANE
CARVING**

**10 TIPS TO
SCROLLWORK SUCCESS**

**SMART-SHOPPER'S
GUIDE TO
WOODWORKING
CLAMPS**

LOTS TO MAKE!
Fat Cat™ end loader
Power tool caddy
Turned flowers
Balloon wall plaque
Cherry wall cabinet
Dandy door harp
Country napkin
holder

EXECUTIVE'S BRIEFCASE
with a luxurious leather lining
See page 44



U.S. \$3.95

Fine Instruments For The Serious Woodworker

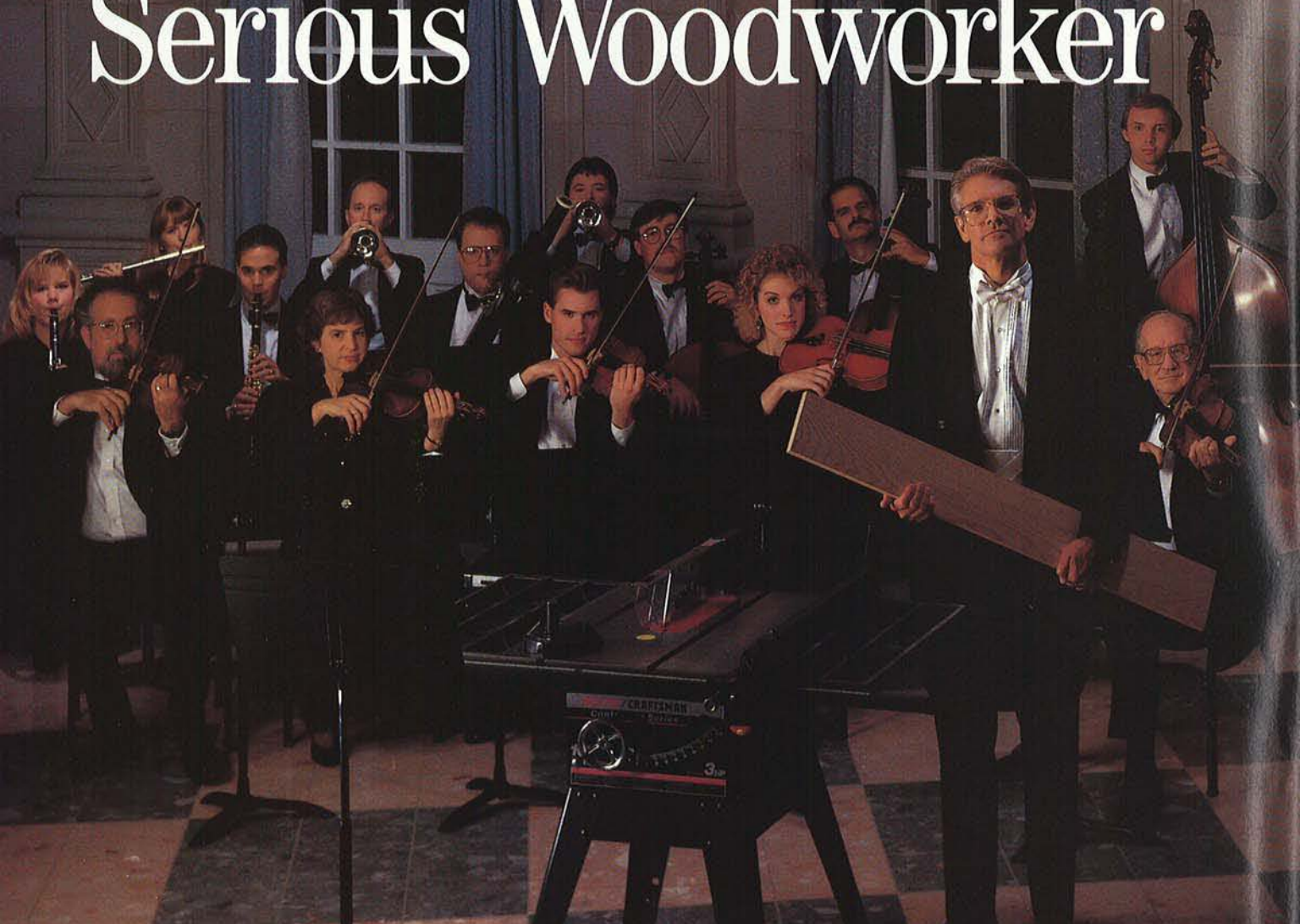

The sound of a Craftsman Contractor Series power tool may not be symphonic, but it sure will be music to your ears.

The table saw featured here reflects our attention to details... from our patented Exact-I-Cut alignment system to the dual voltage induction motor that develops a full three horsepower.

After years in business, we know what it takes to satisfy the serious woodworker. Every stationary tool in the Contractor Series was engineered to give you all the power and accuracy you'll ever need for the most demanding project.

We invite you to see the many Craftsman features for yourself at your nearby Sears store.

CRAFTSMAN®

Only at Sears

CONTROL THE SPEED OF YOUR ROUTER - ROUT AT THE SPEED THAT GIVES THE BEST RESULTS WITH THE WOOD AND BIT YOU ARE USING!



FEATURES:

- Speed Adjustable from Full Speed to 0 RPM
- Full Horsepower and Torque at All Speeds
- Go Back and Forth from Any Pre-Set Speed to Full Speed at the Flip of a Switch
- Works with All Routers 3/4 HP or Less
- 120V 15 Amp
- Gives Your Router a Feature Only Available on Routers Costing Hundreds of Dollars!

NOW ONLY \$39.95 Order Item #200

- Less Tear Out
- Feed at Comfortable Rate
- Better, Safer Results with Large Diameter Bits
- Less Wear on Bits
- Less Noise and Softer Starts at Lower Speeds
- Stops Burning

EASY TO USE - Simply plug in Speed Control and plug your router into the Speed Control - turn dial for best results. (Speed Control has a clip that can be worn on your belt or hung on wall or left loose.)

• Reduces speed electronically without reducing torque; electronic feed-back maintains speed by increasing voltage to motor as load increases.

CARBIDE TIPPED ROUTER BITS PROFESSIONAL PRODUCTION QUALITY GUARANTEED WHEN ORDERING ANY THREE OR MORE DEDUCT \$1.00 EACH. ALL PRICES ARE POSTAGE PAID

ITEM NO.	BEST CUT BEST PRICE	DESCRIPTION	ANGLE/DEPTH/RADIUS CIRCLE DIAMETER	LARGE DIA.	CUTTING LENGTH	SHANK SIZE	PRICE
#601		1/8" Spiral Cutter		1/8"	1/2"	1/4"	\$ 9.00
#602		3/16" Spiral Cutter		3/16"	5/8"	1/4"	\$12.00
#603	Solid Carbide	1/4" Spiral Cutter		1/4"	3/4"	1/4"	\$12.00
#903		1/4" Spiral Cutter		1/4"	3/4"	1/2"	\$12.00
#904		3/8" Spiral Cutter		3/8"	1"	1/2"	\$24.00
#905		1/2" Spiral Cutter	1/2"	1 1/2"	1/2"	\$29.00	
			*Proper Adaptor Will Be Supplied				
#350		1/8" Round Over	1/8" R	3/4"	3/8"	1/4"	\$11.00
#351		3/16" Round Over	3/16" R	7/8"	1/2"	1/4"	\$11.00
#230		1/4" Round Over	1/4" R	1"	1/2"	1/4"	\$12.00
#353		5/16" Round Over	5/16" R	1 1/8"	1/2"	1/4"	\$14.00
#209		3/8" Round Over	3/8" R	1 1/4"	5/8"	1/4"	\$15.00
#355		1/2" Round Over	1/2" R	1 1/2"	3/4"	1/4"	\$17.00
#656		3/4" Round Over	3/4" R	2"	7/8"	1/2"	\$21.00
#199		Multiform Mounding	Unlimited Patterns	2 1/4"	2"	1/2"	\$40.00
#340		1/8" Cove	1/8" R	5/8"	3/8"	1/4"	\$12.00
#205		1/4" Cove	1/4" R	1"	1/2"	1/4"	\$12.00
#206		3/8" Cove	3/8" R	1 1/4"	5/8"	1/4"	\$13.00
#207		1/2" Cove	1/2" R	1 1/2"	3/4"	1/4"	\$14.00
#208		3/4" Cove	3/4" R	1 7/8"	3/4"	1/2"	\$28.00
#460		1/4" Bull Nose	1/4" Dia. of Circle		3/8"	1/4"	\$14.00
#461		3/8" Bull Nose	3/8" Dia. of Circle		3/4"	1/4"	\$15.00
#462		1/2" Bull Nose	1/2" Dia. of Circle		7/8"	1/4"	\$16.00
#464		3/4" Bull Nose	3/4" Dia. of Circle		1 1/8"	1/4"	\$19.00
#506		1/2" Pattern	Flush Trim	1/2"	1"	1/4"	\$15.00
#507		5/8" Pattern	Flush Trim	5/8"	1"	1/4"	\$16.00
#508		3/4" Pattern	Flush Trim	3/4"	1"	1/4"	\$17.00
#366		1/8" Slot Cutter	3/8" Deep	1 1/4"	1/8"	1/4"	\$14.00
#368		1/4" Slot Cutter	3/8" Deep	1 1/4"	1/4"	1/4"	\$14.00
#204		3/8" Rabbeting	3/8" Deep	1 1/4"	1/2"	1/4"	\$13.00

ITEM NO.	BEST CUT BEST PRICE	DESCRIPTION	ANGLE/DEPTH/RADIUS CIRCLE DIAMETER	LARGE DIA.	CUTTING LENGTH	SHANK SIZE	PRICE
#210		1/4" Core Box	round nose	1/4"	1/4"	1/4"	\$ 9.00
#211		3/8" Core Box	round nose	3/8"	3/8"	1/4"	\$10.00
#212		1/2" Core Box	round nose	1/2"	1 1/2"	1/4"	\$13.00
#418		3/4" Core Box	round nose	3/4"	5/8"	1/4"	\$15.00
#213		1" Core Box	round nose	1"	3/4"	1/2"	\$17.00
#214		1/4" Straight	plunge cutting	1/4"	3/4"	1/4"	\$ 6.50
#215		5/16" Straight	plunge cutting	5/16"	1"	1/4"	\$ 6.50
#216		3/8" Straight	plunge cutting	3/8"	1"	1/4"	\$ 6.50
#217		7/16" Straight	plunge cutting	7/16"	1"	1/4"	\$ 6.50
#474		1/2" Straight	plunge cutting	1/2"	1"	1/4"	\$ 7.00
#775		1/2" Straight	plunge cutting	1/2"	2"	1/2"	\$14.00
#218		5/8" Straight	plunge cutting	5/8"	1"	1/4"	\$ 7.00
#219		3/4" Straight	plunge cutting	3/4"	1"	1/4"	\$ 9.50
#220		1" Straight	plunge cutting	1"	1 1/2"	1/2"	\$11.00
#500		3/8" Flush	Trimming	3/8"	1/2"	1/4"	\$ 7.00
#502		1/2" Flush	Trimming	1/2"	1/2"	1/4"	\$ 7.50
#503		1/2" Flush	Trimming	1/2"	1"	1/4"	\$ 8.50
#221		1/2" Flush	Trimming	1/2"	1 3/16"	1/2"	\$ 8.00
#545		Tongue & Groove	Straight	1 5/8"	1"	1/4"	\$29.00
#845		Tongue & Groove	Straight	1 5/8"	1"	1/2"	\$29.00
#546		Tongue & Groove	Wedge	1 3/16"	1"	1/4"	\$29.00
#846		Tongue & Groove	Wedge	1 5/8"	1"	1/2"	\$29.00
#450		1/8" Beading	1/8" R	3/4"	3/8"	1/4"	\$11.00
#451		3/16" Beading	3/16" R	7/8"	1/2"	1/4"	\$11.00
#233		1/4" Beading	1/4" R	1"	1/2"	1/4"	\$13.00
#453		5/16" Beading	5/16" R	1 1/8"	1/2"	1/4"	\$14.00
#454		3/8" Beading	3/8" R	1 1/4"	5/8"	1/4"	\$15.50
#455		1/2" Beading	1/2" R	1 1/2"	3/4"	1/4"	\$17.00
#530		3/16" Edge Beading	3/16" Dia. of Circle		1/2"	1/4"	\$15.00
#531		5/16" Edge Beading	5/16" Dia. of Circle		1/2"	1/4"	\$15.50

New 24-page catalogue now available, featuring hundreds of bits.

MAKE BEAUTIFUL RAISED PANEL DOORS . . . WITH YOUR 1/4" ROUTER!

Professional production quality bit makes it quick and easy to produce matching rails and stiles — the panel raising bit with ball bearing guide makes the raised panel perfect every time.

Regular value Over \$150.00
SALE PRICE \$69.95 FOR COMPLETE SET

ORDER ITEM # 554 for
 1/4" Shank Bit
 (Includes all bits shown below)

REVERSIBLE COMBINATION RAIL and STILE BIT

(For making matching rails and stiles in raised panel doors, etc.) Works with stock from 1 1/16" to 7/8" thick

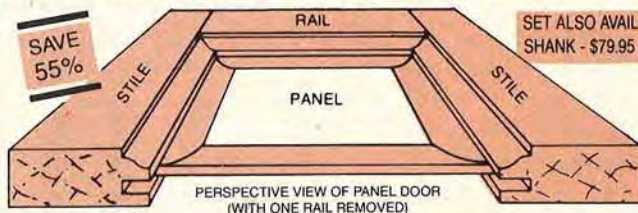

SET ALSO AVAILABLE IN 1/2" SHANK - \$79.95 - Item #852

RAISED PANEL BIT SUPPLIED WITH BALL BEARING

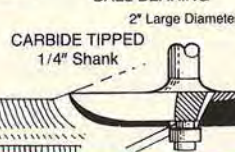

To order by Master Charge or Visa Call Toll Free, 7 Day - 24 Hour Order Service,
 1-800-533-9298 or send check to: **MLCS Ltd., P.O. Box 4053DA, Rydal, PA 19046**

Better Homes and Gardens®
WOOD

THE #1 MAGAZINE FOR HOME WOODWORKERS

February 1991 • Vol. 8, No. 2 • Issue No. 41

Editorial/Art Staff

Editor **LARRY CLAYTON**
 Managing Editor **JIM HARROLD**
 Art Director **C. L. GATZKE**
 Assistant Art Director **PERRY A. McFARLIN**
 Design Editor **JAMES R. DOWNING**
 Senior Editor **PETER J. STEPHANO**
 How-To Editor **MARLEN KEMMET**
 Products/Techniques Editor **BILL KRIER**
 Special-Interest Editor **LARRY JOHNSTON**
 Copy/Production Editor **JOHN D. HOFHEIMER**
 Project Builder **JAMES E. BOELLING**
 Administrative Assistant **DARLENE REYNOLDS**
 Business Office Clerk **MARGARET CLOSNER**
 Secretary **ROSEMARIE BURCH**

Technical Consultants: Product Testing **GEORGE GRANSETH**;
 Products That Perform **STEVE OSWALT**; Wood Technology
PAUL L. McCLURE; Collectible Tools **PHILIP WHITBY**
 Carving **HARLEY J. REFSAL**

Publisher **WILLIAM R. REED**
 Advertising Representatives **PAUL DaCRUZ, MARK S. JOSEPHSON, CHRIS W. SCHRAFT**
 Promotion/Research Director **EILEEN SULLIVAN**
 Marketing Services Manager **NANCY DALY**
 Publisher's Assistant **LORIANNE DeCICOPPO**
 Sales Secretary **ALICIA SANTANA**
 Circulation Director **CLEM SEVDE**; Circulation Manager **ALAN BRUSH**; Newsstand Circulation Director **MICHAEL SENIOR**
 Business Manager **TERRY UNSWORTH**
 Production Director **ROBERT C. FURSTENAU**
 Editorial Research Director **C. RAY DEATON**
 Public Relations **SONDY DAGGETT**

Magazine Group Officers

Group President **JAMES A. AUTRY**
 Senior Vice President, Publishing Director **ADOLPH AUERBACHER**
 Group Vice Presidents: Publishing Directors **MYRNA BLYTH, BURTON H. BOERSMA, CHRISTOPHER M. LEHMAN**;
 Controller **MAX RUNCIMAN**; Editorial Director **DORIS EBY**;
 Operations **DEAN PIETERS**

WE CARE!

EDITORIAL MAILING ADDRESS: WOOD Magazine, P.O. Box 11454, Des Moines, IA 50336-1454.
SUBSCRIPTION SERVICE (including change of address): WOOD Customer Service, P.O. Box 10628, Des Moines, IA 50336-0628.
 Please enclose your address label from a recent issue. If you wish to phone, call toll-free 800-678-2666.
ADVERTISING: WOOD Magazine Advertising, 750 Third Ave., New York, NY 10017. Phone 212/551-6903.

Better Homes and Gardens® WOOD® — the #1 magazine for home woodworkers (ISSN-0743-894X) is published eight times a year in January, February, April, June, August, September, October, and December by Meredith Corporation, 1716 Locust St., Des Moines, IA 50336. Second-class postage paid at Des Moines, Iowa. Better Homes and Gardens trademark registered in Canada and Australia. Marca Registrada en Mexico. **ONE-YEAR SUBSCRIPTION PRICES:** United States and its possessions, \$19.97; Canada, \$29; other countries, \$38. **POSTMASTER:** Send address changes to WOOD, 1716 Locust St., Des Moines, IA 50336.
 ©COPYRIGHT MEREDITH CORPORATION 1990. ALL RIGHTS RESERVED. PRINTED IN U.S.A.

MPA

**GENEVA SPECIALTIES
FREE CATALOG...**

Your New Friend In Woodworking!



We're a division of Klockit—a company serving clockmakers and woodworking hobbyists for over 20 years! And here's what we offer in our new FREE catalog:

- Quality Woodworking Products and Crafting Supplies at Low Prices
- Volume Discounts
- Incredible Selection
- Innovative Ideas, Tools and Supplies

We've hand-picked every item for the Geneva Specialties catalog to make your hobby more enjoyable, rewarding and profitable. Call for your FREE catalog!



Toll-Free
1-800-556-2548

Or write: Geneva Specialties, P.O. Box 542,
Dept. WDA21 Lake Geneva, WI 53147

"In Accuracy, Finish and Quality of Craftsmanship, the General Led the Army of Tablesaws We Tested."

SOURCE: BH&G WOOD DEC. '89



VEGA FENCE WITH 50" RIP CAPACITY INCLUDED

MOTOR COVER
MAGNETIC STARTER
3HP, 1PH or 5HP, 3PH
U.S. MOTOR.

Recruit "the GENERAL" for Your Shop

only \$1595.00 f.o.b., York, PA
Telephone (717) 764-5000

WILKE MACHINERY COMPANY
3230 Susquehanna Trail
York, PA 17402



One of America's Most Respected Names In Woodworking Machinery

Send \$1.00 for New, 52-Page **BRIDGEWOOD MACHINERY CATALOG**. Featuring over 60 outstanding woodworking machinery values.

©1990 Dremel, Racine, WI



The perfect tool for a little gardening.

Introducing the new MiniMite from Dremel®. The smallest cordless power tool with a removable, rechargeable battery pack. It has 2 speeds for precision detailing. And takes the thorns out of intricate refinishing jobs.

MINIMITE™
Cordless Rotary Tool from Dremel

Mobile Machine Bases

to put your entire shop
on wheels

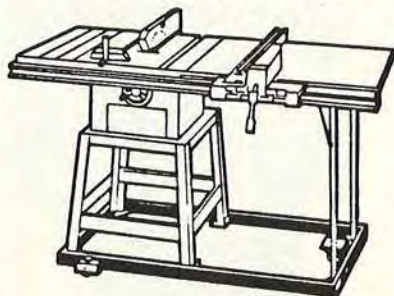

EXPAND WORKING AREA
MAKE CLEAN-UPS A SNAP

- * Hundreds of Models available
- * 3 - 2½" Ø Wheels for Stability
- * Dual wheel locks for Positive Positioning
- * Raises machine *only* ¾"
- * All Steel & Precision Welded
- * Lifetime Warranty

Work Supports

to do your best
safely & accurately

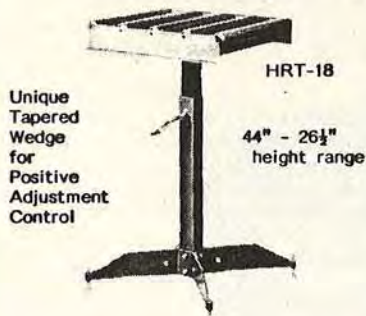

DESIGNED TO HELP YOU SUPPORT
AND SAFELY MOVE WORK PIECES
THRU YOUR MACHINES

- * No tools needed for simple, positive height adjustments
- * Top quality, galvanized, ball-bearing Rollers
- * Non-marring Leveling Pads
- * Heavy Gauge Steel Components
- * Lifetime Warranty

All Products - Made in America &
Available at Better Tool Stores

Free Catalog



HTC Products, Inc.
120 E. Hudson • P.O. Box 839
Royal Oak, Michigan 48068-0839

(313) 399-6185 • (800) 624-2027

Better Homes and Gardens®

WOOD®

THE #1 MAGAZINE FOR HOME WOODWORKERS

This issue's cover wood grain: Aspen

Cover photo: Hopkins Associates

FEBRUARY 1991

ISSUE NO. 41



CRAFTSMAN CLOSE-UP

Down-home dough bowls 25

Typically, you turn bowls, but John Sadler of Tennessee's Cumberland Mountains begs to be different. He shapes his rustic creations with a chainsaw and hewing hatchet.

CARVING PROJECT

The Norwegian bachelor farmer 30

Learn Scandinavian flat-plane carving while shaping our amiable, rough-hewn caricature. Send for the basswood blank for a head start.

Fat Cat™ front-end loader 34

Our rugged construction toy lets youngsters dig in when the going gets tough and scoop up soil, sand, and gravel—just like the real thing.

DEVELOP YOUR SHOP SKILLS

10 tips for improving your scrollwork 38

No need to scroll in the dark with this short course. It shows you how to sink your tool's teeth into any number of projects with great success.



Hardwood briefcase 40

Get down to business with the plans for this executive's companion. The end result will impress your associates—we guarantee it. Use our source for the hardware and liner.

A handcrafted legacy lives on 47

Meet a company that makes guitars for the stars the old-fashioned way—Martin Guitars of Nazareth, Pennsylvania, established in 1839.

IN SEARCH OF THE PERFECT FINISH

Lacquer that's music to your ears 52

When applied to musical instruments, a finish must sound as good as it looks. Discover Martin Guitars' formula for an exquisite, lasting finish.

Super-simple tool transport 54

Allow your benchtop tools to roam by building our roll-around home for three. Casters and convenient handles make for easy mobility.

TOOL BUYMANSHIP

The smart shopper's guide to clamps 56

A new generation of specialists joins forces with the likes of the handscrew, bar and C-clamp to give woodworkers the widest-ever range of holding-power options.

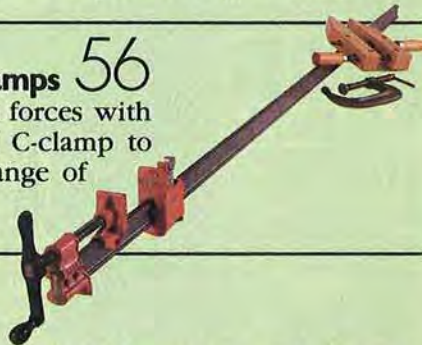

TURNING PROJECT

Fanciful flowers 61

Don't wait till spring to surprise your favorite person with flowers when you can turn a beautiful bouquet from found wood in no time.

Arizona turning showcase 62

Selected vases and bowls prove the talents of this state's woodturners.

THE CRAFT SHOP

Ride the wind 64

You'll fly high after seeing our balloon wall plaque, and that's no hot air!

Graceful geese napkin holder 66

Country's come home to roost with this charming, one-evening scrollsawed project.

Cheery, cherry door harp 68

Dowels, not strings, support the wood balls that make this melodious project sing.



Washed-up wood 70

Business is picking up for a father and son who collect driftwood.

SURVIVAL GUIDE

Buying Forstner bits 72

Discover the quality difference between high- and low-priced bits

Cabinet, cabinet on the wall 74

Balanced in design from top to bottom, this cherry accent piece lets you perk up an otherwise plain-Jane wall.

Test your woodworking IQ 78

Sharpen your pencils and try your smarts on 18 challenging questions.

SHORT-SUBJECT FEATURES

Editor's Angle	6	Shop Sense	20
Talking Back	8	Wood Anecdote	22
Tips from Your Shop	12	Ask WOOD	84
Great Ideas	19	Delta Scrollsaw	88

Exclusively Performax Precision Drum Sanders

**Revolutionary Component Concept!
It's Versatile....It's Expandable....
and best of all....It's Affordable!**

You select the components to fit your budget and your needs. The Performax S/T Sander attaches to a radial saw or to a Pro Stand.

Patented Drum Design

dissipates heat for hours of steady use, offers greater strength and durability, dimension stock to within .01 of an inch.

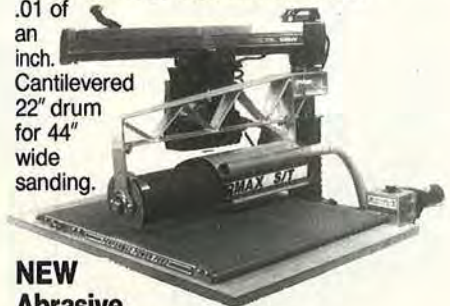

Cantilevered 22" drum for 44" wide sanding.

NEW Abrasive Take-Up Mechanism

keeps abrasive tight, accepts any grit of abrasive.



No-Give Power Feed

offers infinitely variable feed rate of 0-10' or 0-20'/minute. Feed multiple pieces as short as 2 1/4" and the thinnest veneer.

NEW Dual Drum Super Max

The only dual drum sander that lets you easily change grits for any abrasive combination.

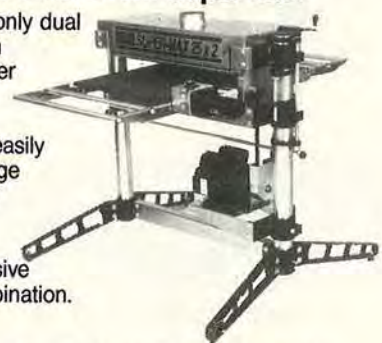

For Maximum Performance and Maximum Value Buy a Performax. It WILL exceed your expectations.

For a Free Brochure and the Dealer Nearest You Call
1-800-334-4910

or (612) 895-9922
or write: PERFORMAX PRODUCTS, W3
12211 Woodlake Drive, Burnsville, MN 55337

Create A Family Treasure with Kuempel Chime Red-i-Kut Kits



- Each case carefully handcrafted by grandfathers
- 3/4" solid walnut, cherry or oak
- Precision movements—chime rods or tubular bells
- Handcrafted pendulums
- Individually hand-painted moonwheels
- Plans, kits, and finished clocks

Write or Call for Catalog \$2.00
1-800-328-6445

Between 8 a.m. and 4 p.m. CST

Our 75th Year!

Kuempel Chime

Dept. 025, 21195 Minnetonka Blvd.
Excelsior, MN 55331

THE EDITOR'S ANGLE

THE GREAT SHOP-ORGANIZER HUNT IS ON...



Above: Just a few of the organizers in the WOOD magazine shop.



Left: You'll receive free a WOOD Cumulative Index just for entering, and you also may win one of these two impressive wood-working tools.

...AND WE WANT TO HEAR FROM YOU

FREE MONEY From Scrap Wood



Hawk 20 "	\$949
72 Blades	15
Pattern Pack	39
Foot Switch	33
Reg.	\$1036
Save	\$237
Only	\$799

Turn your hobby and creativity into savings and income.

DON'T WAIT - ORDER TODAY

30 DAY RISK FREE GUARANTEE

TO ORDER CALL

1-800-535-8665

OR MAIL TO

RBIndustries

Box 369

Harrisonville, MO 64701

Send TODAY for

FREE Fact Kit!

Name _____
Address _____
City _____ State _____ Zip _____
Phone (____) _____

SW291

Be honest, now. Wouldn't you like it a lot if your shop was just a bit more organized, a bit tidier? I sure would. And I think I've come up with an idea that can help all of us get our shops shaped up in a hurry.

Here's the plan. I'd like you to send in a snapshot of one or more of the best original ideas you've ever come up with to organize your shop—and the tools and supplies in it. (Be sure that you put your name, home address, and daytime telephone number on each photo.) Big solutions, small solutions—I'd like to see them all.

Just for taking the time to share your idea(s) with us, I'll send you a complimentary copy of the ever-so-handy WOOD magazine Cumulative Index (a \$4.95 retail value). You say you want more of an incentive? Then, how's this? If yours is one of the dozen ideas we select for publication in an upcoming issue of the magazine, you can choose

between a Delta 34-080 10" motorized miter box or a Ryobi RE 600 3-hp router (both shown in the photo *above* and valued at over \$250). Or, if you prefer, I'll write you a check for \$150 in payment for your idea. Not bad, huh?

OK, ladies and gentlemen, start your shop-organizer-idea engines. I'm counting on you for some really terrific input. Quebec residents not eligible. Send your entries (by April 1, 1991) to:

THE GREAT SHOP-ORGANIZER HUNT

c/o WOOD MAGAZINE

P.O. Box 11454

Des Moines, IA 50336-1454

P.S. I'll make sure you have your free Cumulative Index in hand, as well as notification about whether or not we have selected your idea for publication, by June 1, 1991. ♣

Larry Clayton



New!

Variable Speed Super V-15" Scroll Saw

• Dial any speed from 400 to 1800 cuts/min!

• Saws with similar features sell for over \$700

• Special introductory price...

only **\$189.95**

(item #SVS, UPS \$10)

Cut intricate patterns in many different types of materials with this versatile machine. Purchase includes many FREE extras.

This new model features a powerful, high quality electronically controlled universal motor that gives full power and torque at all speeds. Similar in design to our Super-15" model, the cutting action has been re-engineered to give smoother cutting and performance equal to saws many times the price.

Dial any speed from 400 - 1800 cuts/min to set the speed specifically for the job at hand. Use slower speeds for cutting plastics, metals and hardwoods.



FREE ACCESSORIES:

- Dust blower • 1 dz blades • EZ-Set permanent top-arm blade holder • 4 Standard blade holders • EZ Jig for attaching standard blade holders • Neptune 1-1/2" lettering guides w/6 patterns

Specifications:

- Motor: Universal motor w/electronic speed control. 110V, 1.3Amp, sealed ball bearings
- Speeds: 400 -1800 cuts/min
- Throat : 15" deep • Stroke - 3/4"
- Tilt : 0 - 45° left • Cut Depth: 2"
- Blades: accepts pin and plainend
- Construction - cast iron

Scroll Saw Products

Super 15" Scroll Saw

Our most popular model. Same specs as Super V-15 model with single speed 1650 cpm motor, dust blower optional. Same free accessories as listed above.

#SAW ... Only **\$119.95** (UPS \$10)

Dust Blower (option for Super 15" saw)
#BKT **\$15.00/kit** (+)

Variable Speed Motor Upgrade

Convert your saw to variable speed! This quality motor will fit our Super 15" model and other saws of similar design. Also fits Sears™ 16", and "C" arm "Superscroll" styles - 18", 22", and 26" sizes. Limited 90 day warranty on non-Penn State saws.

#SVM Only **\$99.00** (UPS \$4)

Magnifier Lamp

Great for magnifying scroll work or closeup work of any kind.



#SML (reg 29.95) On Sale ... **\$22.95** (UPS \$3)

Scroll Saw Stand (On Sale)

34" High - the perfect height.
#STD .. (reg \$39), On Sale **\$26** (UPS \$4)

Foot Switch

For hands free operation. Installs in line w/power cord. Easy hook-up. 7 amp, 6 ft
#FSW **\$20.00** (+)



Wood Lathe XL-40

Reg \$299.95, **On Sale \$249.95**

Includes **FREE** 8 piece Wood Chisel Set ... **\$34 Value**

Our new XL-40 Wood Lathe surpasses every lathe in its price range with quality & features you would expect from machines many times its price. FEATURES

Heavy Duty cast iron construction provides smooth turning action • 40" Centers • 16" Swing for turning larger bowls • Smooth toolrest movement on 1" solid steel rails • "Live" center on tailstock • Motor mounted for easy positioning and belt changes • Sturdy 52" steel base mounts on table top or optional stand.

PURCHASE INCLUDES:

- Lathe with Motor & Base • Toolrest
- 6" Faceplate • 8 pc wood turning chisel set

SPECIFICATIONS:

- MOTOR: 1720 RPM, 1/2HP, 8AMP, 110V
 - 3 Speeds: 660, 1500, 2850 RPM
 - Headstock thread - 3/4" x 10 tpi
 - Overall length: 60" - Weight : 100lbs
- Item # L40 **On Sale \$249.95** (UPS \$20)

Lathe Stand

Heavy duty, Wt. 25Lbs
Size: 28"H X 56"L X 21" W
Item #LST **\$44/ea** (UPS \$6)

Super 125 Planer On Sale \$359.95



This machine will pay for itself time and again by planing your own wood. Finishes wood like machines many times its price.

- Portable at 65 lbs • Power feed
 - 12 1/2" wide High Speed Steel Knives
- Shipped assembled and ready to run.

SPECIFICATIONS:

Motor: 16Amp, 115V, 8000RPM, 2HP • 26.2 fpm auto feed rate • 16,000 Cuts/min • Thickness of stock: 3/16" - 6" • 1/8" Max depth of cut • 2 HSS knives
Item #PLA **\$359.95** (UPS \$15)

Two Way Sanders

FREE DISCS & BELTS with Purchase Save up to \$21
• Dust Collection on both models
• Stand included with 6 x 9 Model

6" x 9" Sander

Model #S69 ... Only **\$219.95** (UPS \$30)
Has versatile 9" disc & 6" x 48" belt. Heavy duty design includes stand. **FREE With Purchase** : 3 belts, 4 discs (various grits) worth \$21. Motor: 3/4 HP, 1720 RPM, 110/220V. Wt: 100 #

4" x 8" Sander

Model #S48 ... Only **\$114.95** (UPS \$8)
A unique design with an 8" disc & 4" x 36" belt. Portable at only 38 #, includes quick release lever for belt changes. **FREE With Purchase** - 3 belts, 4 discs (various grits) worth \$14. Motor: 1/3 HP, 1720 RPM, 120V. Wt: 38 #

Features of Both Models:

- Dust collection outlets included.
- Tables: tilt to 45°, includes mitre gauge, moves to vertical belt position.
- Easy belt tracking adjustment.
- Belt table tilts/locks to horiz & vert positions
- Sealed ball bearings

Planer Accessories



Free plans for roller stand with purchase of rollers

Extra Set of 2 Knives

High Speed steel, 12-1/2" long.
Item #PKN **\$25.00/set** (+)

Dust Chute

For vacuum takeoff of wood chips.
#PDS .. (reg \$24), On Sale... **\$15** (UPS \$3)

Planer Stand (Heavy duty)

Drilled for Super 125 Planer. 27-1/4" High.
#PST ... (Reg \$44), On Sale... **\$39/ea** (UPS \$6)

Roller Stand

HTC brand support stand w/heavy duty ball bearing roller. Height adjusts from 25" - 44".
#PRS ... (reg \$40), On Sale ... **\$35** (UPS \$4)

Ball Bearing Rollers

(Minimum purchase 2 rollers). Build a roller stand, infeed/outfeed table etc. with these 13" X 2" Heavy Duty rollers. Includes **FREE** plans for roller stand shown above.
Item #BBR **\$6.50/ea** (\$3 UPS /order)

Dust Collectors

FREE HOSE & FITTINGS with PURCHASE Save up to **\$40.00!!**



Model #DC1

Model #DC-1 - Only **\$199.95** (UPS \$20)
610 CFM flow makes this collector perfect for hookups to almost any single machine.

FREE With Purchase (\$15 Value)
8' of hose • 1 ea. 4" to 3" & 4" to 2" adaptor

Model #DC-2 - Only **\$299.95** (UPS \$30)
900 CFM flow allows for use on 2 or more machines & gives improved service for long runs of hose or ducting. Suitable for larger planers, drum & belt sanders
FREE With Purchase (\$40 Value)
30' of hose • (1) 4" to 3" & (2) 4" to 2" adaptors

Specifications:	DC-1	DC-2
Motor	1 HP, 110/220V	1-1/2 HP, 110/220V
Outlets	1 @ 4"	2 @ 4" or 1 @ 6"
Flow	610 CFM	900 CFM
Bags	2 @ 20 Gal.	2 @ 30 Gal.
Weight	75 pounds	120 pounds

Penn State's Commitment

We unconditionally guarantee your satisfaction with our fine machines. All of our machines carry a Thirty day Money Back Guarantee and One year Warranty.

Quality Woodworking Machines At Affordable Prices from

PENN STATE INDUSTRIES - W

2850 Comly Road • Phila, Pa 19154

Order Toll Free 1-800-288-7297 (Ext 90) Information 1-215-676-7609 (ext 15)

Visa, Master, & Discover Card accepted Pa residents add 6% Sales Tax

When ordering - Add UPS Shipping Charges as noted

(+) No freight charge for accessories ordered with a machine, add \$3 if ordered separately. UPS charges are for Continental U.S. only (Call for shipping charges to other locations)

Call or Write for our **NEW 16 Page Color Catalog**

TRIMTRAMP™ SAW TABLE

The most labor efficient, cost effective portable tool for quality cuts available in the market today.

MONEY BACK GUARANTEE.



- ◆ Converts your portable circular saw into a precision miter and crosscut sawtable instantly.
- ◆ Cutting action is backward, providing unsplinted cuts of cabinet-maker quality.
- ◆ Provides: perfect 90° picture-frame quality miter joints everytime, perfect compound miters, variable angles, and crosscuts boards up to 16" wide.

The TRIMTRAMP is convenient! It can be used, clamped in a B & D "WORKMATE," on a bench, on the floor, or you can disengage your saw for use as a handtool.

To obtain a FREE brochure or order your TRIMTRAMP, call 1-800-267-8776. (Mon.- Fri. 9 am - 5 pm EST)

To place your order by mail just return this coupon to: TRIMTRAMP LTD. P.O. Box 740, Buffalo, N.Y. 14213.

Please send me your FREE brochure.

TRIMTRAMP Purchase Price of \$99.95 enclosed, together with a \$10.00 delivery charge.

Check Visa MasterCard Expiration Date _____

Card Signature _____ Card #: _____

Customer Name (print) _____

Customer Address: _____

State _____ Zip _____ Phone _____

*TRIMTRAMP™ is the registered trademark of TRIMTRAMP LTD, product protected under U.S. pat. 4,909,111.

WOODWORKER'S CATALOG

Over 4000 products to

BUILD, REPAIR, RESTORE, REFINISH

anything made of wood!

116 pages, jam-packed with fine woods, veneers, inlay borders, finishing supplies, hardware, glue plus hand and power tools, how-to books, plans and much, much more. All first quality, all easy to order by phone or mail, and all covered by our 60-day no-questions-asked guarantee.



YES! Rush my 116 page, full color Woodworker's Catalog. I enclose \$1.00 shipping and handling.

Name _____

Address _____

City/State/Zip _____

Mail to:

CONSTANTINE'S, 2054F Eastchester Rd., Bronx, NY 10461



TALKING BACK

We welcome comments, criticisms, suggestions, and even compliments. Send your correspondence to: Talking Back, Better Homes and Gardens® WOOD® Magazine, P.O. Box 11454, Des Moines, IA 50336-1454.



Japanese reader has yen for WOOD®

Your magazine greatly interests me and I would like to subscribe. Would you accept a credit card? Otherwise, I have to exchange Japanese yen for the U.S. dollar.

Woodworking has been my favorite hobby since I was a teenager. It started, of course, with Japanese-style hand tools. Power tools were introduced into my workshop in 1957, while I was living in Portland, Oregon. I have been strongly interested in wood turning, mostly bowls, because the turned products are clearly dependent on my skill. I look forward to retiring from my position as president of the University of Tsukuba in March 1993 when I turn 68.

—F.K. Anan, M.D., Tokyo

Thanks, Doc. Our circulation staff would be overrun if readers used charge cards for subscriptions and renewals, according to our circulation manager, Alan Brush. In the case of overseas readers, when currency exchange poses a problem, we can make an exception. Send a letter with information including your charge-account name and number, your name, mailing address, and signature to WOOD Customer Service, P.O. Box 10667, Des Moines, IA 50336-0667. We are pleased that our WOOD family extends beyond North America. See page 10 for further evidence.

Reader gets his bearings in Buffalo—and so can you

I have made many adjustable roller stands for my workshop and for my friends' shops. Instead of using wooden ends for the bearing in the end of the plastic pipe, I used 1½" pipe with a plastic bearing I bought through Buffalo Bearing (2205 Kenmore Ave., Buffalo, NY 14207).

Order item number 12P40D. The cost is \$1.60 plus tax. They also carry other types of rollers already made up for conveyer systems.

—Thomas Klass, Hamburg, N.Y.

Tom, thanks for your letter. We spoke to company president Greg Winkelman, who reminded us that the bearings should be ordered in pairs since two would be needed for each roller. The cost is \$3.20 per pair, plus shipping and handling and, for New York residents, an 8 percent tax. Buffalo Bearing, although not a woodworker's store, also sells router-bit bearings, shaper guides, and similar hardware. For information or for ordering, call 800-669-8019.

WOOD® readers are safe at home

A pair of sharp-eyed readers called our bluff regarding the September 1990 woodshop safety quiz, one with a letter concerning router setup, the other writing about circular-saw safety.

In reading your September issue, I noticed one potentially harmful situation in the article "How Safe are your Woodworking Habits?" Picture No. 1 displays the router bit being changed while the tool is still plugged in [as cited in the quiz answer], but notice also the position of the user's right hand. If it were to slip off the wrench, the protruding router bit could make an ugly cut on the bottom of his hand.

Solution: Some routers allow the base assembly to be lowered, safely covering the bit while still allowing access to the collet-locking nut. Or, secure the router, base assembly up, in a padded vice.

—William Young, Hopkinsville, Ky.

Bill, yours sounds like the voice of experience, and, as it turns out, you weren't the only reader to notice safety violations we overlooked. Read on.

When operating a circular saw, I always try to place the wide part of the saw shoe on the supported stock. Figures No. 5 and 6 on page 71 both show the wide part of the shoe on the piece that will fall away. With the wide part of the shoe on the supported piece, the saw will remain much more stable when the cut is completed, thus producing a cleaner cut and reducing the possibility of injury. Both pictures show a right-handed person using a left-handed saw.

Also, in shopping for a circular saw, I found that most of the cheaper saws are rated in horsepower, while the more expensive saws are rated in amps. This makes it difficult to compare the power output. Your October issue listed manufacturer's ratings for several power tools, but I am afraid that they may be using different methods to obtain the rating. The issue did a fine job of highlighting the features most useful in a power tool.

—Lester Bartel, Madison, Ala.

Looking good, Lester. The wide part of the saw shoe should, whenever possible, be on the supported stock. Of course, if a right-handed saw had been used for the photos, the setup shown would have been proper. As for horsepower ratings, our tool-buyership specialist, Bill Krier, already is planning such an article in response to yours and other letters.

Continued on page 10



CASCADE TOOLS, INC.

P.O. Box 3110, Bellingham, WA 98227

ACCESSORIES



BRAD DRIVER

Hold and set brads with this simple but effective tool. Just squeeze and you're done!

PART NO. C3078

ONLY \$795

PUSH BRADS IN THE EASY WAY!

BEARING LUBRICANT

Made by Dri-Cote, this lubricant protects and lubricates bearings and bearing mechanisms. Especially effective on router bit bearings and rub collars.

- Effective to 550°F!
- Repels dirt and moisture.

PART NO. C3074 ONLY \$345

(1.7 oz. Dropper-tip Bottle)



FENCE FOR INCRA JIGS™

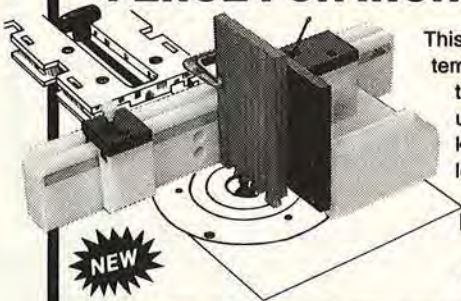

This unique fence system attaches directly to your jig and is used in making all kinds of joints. You'll love it!

PART NO. C3009

ONLY \$5495

RIGHT ARM CLAMP

This clamp is a real gem. Its secret is its pivoting arm which squares the work for perfect gluing, joining and fastening.

- Opens up to 1 1/2"
- Clamp is approximately 6" long.

PART NO. C3029

ONLY \$1000 or 6 for ONLY \$5500



SUPER BRAD NAILER



This light weight pneumatic nailer drives 18 gauge brads from 5/8" to 1-9/16" into almost any kind of wood. Excellent choice!

PART NO. C3082

ONLY \$12995

BISCUITS FOR JOINING WITH ROUTER

Why buy a biscuit-cutting machine when a small router will do?
3 sizes in bags of 100...

PART NO. C3021 \$495

(Size "0" - use C1042 bit - \$12)

PART NO. C3022 \$495

(Size "10" - use C1098 bit - \$22)

PART NO. C3023 \$495

(Size "20" - use C1098 bit - \$22)



TO ORDER, CALL TOLL FREE

1-800-235-0272



90C-111

Buy Direct From The Manufacturer And **SAVE!**

Buy 12 "EVER-LAST" Belts... Get 12 Belts FREE!



Need ROLLS, WIDE BELTS, DISCS,
SLEEVES, STROKE BELTS, etc.
Write for catalog.

Belts available in 36, 50, 60, 80, 100, 120, 150, 180, 220, 320 grit sizes. Please specify grit sizes when ordering, otherwise an assortment will be supplied.

<input type="checkbox"/> 1" x 30" ... \$15.50/Doz. + 12 FREE
<input type="checkbox"/> 1" x 42" ... \$15.70/Doz. + 12 FREE
<input type="checkbox"/> 2" x 48" ... \$21.50/Doz. + 12 FREE
<input type="checkbox"/> 2 1/2" x 16" ... \$17.50/Doz. + 12 FREE
<input type="checkbox"/> 3" x 18" ... \$17.75/Doz. + 12 FREE
<input type="checkbox"/> 3" x 21" ... \$18.75/Doz. + 12 FREE
<input type="checkbox"/> 3" x 24" ... \$19.00/Doz. + 12 FREE
<input type="checkbox"/> 4" x 21" ... \$23.50/Doz. + 12 FREE
<input type="checkbox"/> 4" x 21 1/4" ... \$23.75/Doz. + 12 FREE
<input type="checkbox"/> 4" x 24" ... \$24.00/Doz. + 12 FREE
<input type="checkbox"/> 4" x 36" ... \$26.95/Doz. + 12 FREE
<input type="checkbox"/> 6" x 48" ... \$35.95/1/2 Doz. + 6 FREE

Other size belts on request.
 Belt Cleaning Stick \$4.95 each

For Fast Delivery Call Toll Free
1-800-428-2222 (U.S.A.)
1-800-222-2292 (PA only)

9" x 11" PAPER SHEETS
A/O or Garnet Cabinet Paper

50 PACK	100 PACK
40-D <input type="checkbox"/> \$17.00	<input type="checkbox"/> \$31.00
50-D <input type="checkbox"/> \$16.00	<input type="checkbox"/> \$28.00
60-D <input type="checkbox"/> \$15.00	<input type="checkbox"/> \$26.00
80-D <input type="checkbox"/> \$14.00	<input type="checkbox"/> \$24.00
100-C <input type="checkbox"/> \$13.00	<input type="checkbox"/> \$22.00
120-C <input type="checkbox"/> \$13.00	<input type="checkbox"/> \$22.00
150-C <input type="checkbox"/> \$13.00	<input type="checkbox"/> \$22.00

No Load Finishing Paper (White)

120-C <input type="checkbox"/> \$14.00	<input type="checkbox"/> \$24.00
150-C <input type="checkbox"/> \$14.00	<input type="checkbox"/> \$24.00
180-A <input type="checkbox"/> \$11.00	<input type="checkbox"/> \$19.00
220-A <input type="checkbox"/> \$11.00	<input type="checkbox"/> \$19.00
280-A <input type="checkbox"/> \$11.00	<input type="checkbox"/> \$19.00
320-A <input type="checkbox"/> \$11.00	<input type="checkbox"/> \$19.00
400-A <input type="checkbox"/> \$11.00	<input type="checkbox"/> \$19.00

SHIPPING CHARGES: \$4.50 Continental U.S.

MONEY ORDER CHECK
 MASTER CARD VISA

**INDUSTRIAL
BRASIVES CO.**
643 N. 8th ST. • READING, PA 19612

TALKING BACK

Recycle jigs by fastening with screws instead of nails

Thank you for the article "How to Transform Found Wood into Usable Stock," in Issue No. 37 (September 1990). For many years I have been looking for a way to true-up warped, bent, and twisted pieces of wood from my scrapbox. You have an elegant solution.

Why do you use nails to assemble the jig? I use drywall screws for almost every job, especially for jigs, which are sometimes used for only a short time. With screws I can more easily salvage the wood. Perhaps I am overlooking something.

As a senior on pension, I buy magazines from the newsstand, and only after checking each issue against several competing magazines. You will be pleased to know that my increasing stack of WOOD magazines strongly suggests that WOOD is indeed number one. Do not change anything.

—Colin Adams, Woodbridge, Ontario.

Colin, thanks for the kind words. Your point about using screws for jigs is a good one, especially if you might want to reuse the jig wood later.

Magazine makes its mark in Germany

During a stay in the U.S., I read some issues of your magazine. I'm so interested in it that I don't want to miss it in Germany. Two features particularly interest me. One is the wood profile, and the other is the Collector's-Edition tools. I already have made the try square and the clamps.

Can I get copies of magazines with any other Collector's-Edition tools? I would like to suggest for inclusion a German version of a carpenter's mallet.

—Egan Weeks, Nordenham, Germany

Egan, thanks for your vote of confidence in WOOD. And yes, we can provide you with the information you missed out on.

The series began with a sanding block (December 1986), followed by a depth gauge (December 1988), a hand scraper (April 1989), and a strip sander (August 1989). The handscrew clamp (June 1990) came next, and then we presented the try square (September 1990.) We detailed the center finder in the January 1991 issue. Yet another one in our line is on the drawing board even as we write. You can buy plans for any of these projects for \$2 each, or the back issue of WOOD containing the plan for \$4.95 each, postage paid, by writing to: Back Issues, WOOD Magazine, P.O. Box 11454, Des Moines, IA 15336-1454. We accept VISA, MasterCard, check, or money order.



WOOD PARTS FROM MIDWEST DOWEL WORKS

Compare Our Low Prices!

	Qty. Cost
3-1/2" Poplar Shaker Peg	\$15/100
1-3/4" Mini Shaker Peg	\$7/100
3-1/2" Country Wall/Mug Peg	\$15/100
2-1/2" Country Shorty Peg	\$12/100
Large Bean Pot Candle Cup	\$17/100
Brass Inserts	\$9/100
1/2" Mini Candle Cup	\$10/100
1-1/2" Toy Wheel	\$10/100
2" Toy Wheel	\$17/100
Axel Pegs	\$4/100

SMOOTH SANDED HEARTS

3/4" x 1/8" Hearts	\$2.75/100
3/4" x 1/2" Hearts	\$4.50/100
1" x 3/16" Hearts	\$4.00/c
1" x 3/8" Hearts	\$6.50/c
1-3/8" x 1/8" Hearts	\$5.50/c
1-3/8" x 1/4" Hearts	\$7.50/c
1-3/8" x 1/2" Hearts	\$10/100
2" x 1/2" Hearts	\$18/100

Great Buys!

	Qty. Cost
3/8" x 36" Standard Dowels	\$21/100
3/4" x 36" Oak Dowels	\$15/100
3/8" Maple Buttons	\$2.15/100
1/2" Maple Buttons	\$2.25/100
1-1/2" Maple Spindles	\$9/100
2-1/8" Maple Spindles	\$18/100

ORDER NOW

MC/Visa Check Enclosed

Total Cost _____

Handling **\$3.00**

Ohio residents add 5% sales tax _____

Final Cost _____

MC/Visa Number _____

Expires _____ Phone _____

Name _____

Address _____

City/State/Zip _____

FREE 16-PAGE CATALOGUE

Circle this section for FREE Dowels — mixed pack, Maple, Oak, Walnut Cherry, from 1/4" up to 1" Approximately 10 LFT. 14" long. \$5.00 value with any order.

MIDWEST DOWEL WORKS

4631 Hutchinson Road
Cincinnati, Ohio 45248
(513) 574-8488

Same Day Service/Order before Noon
Factory Direct/Satisfaction Guaranteed

Carvers take shine to elusive polish

Thank you for the article on Santa by Ron Ransom in the December 1990 issue. I have sent for the full-



sized pattern. My question is, "where do you purchase Griffin Shoe Polish?" I have been unable to find it, and some stores have told me

they are out of business. Could you find out where Mr. Ransom purchased this product, or maybe he can recommend a substitute. I would appreciate any information you can forward to me.

—Mary Post, Lake Orion, Mich.

Mary, you are not alone in your search for the Bark-Brown Griffin Shoe Polish recommended by

carver Ron Ransom as an anti-queing finish.

David Draves, senior merchandise manager at Woodcraft Supply Corp. in Boston, reports that his company could have sold more than 300 cans of the polish since September—if they had stocked it.

Some shoe repair professionals we talked to never had heard of it, while others thought Griffin had gone out of business long ago. Not so, says Draves, who located the company in Central Islip, New York, and arranged to sell that elusive product as a mail-order item.

A 1⁵/₁₆ oz. can of Bark Brown, catalog No. 50I08, or Neutral Paste Wax, catalog No. 50I09, costs \$2.50, plus a \$4 shipping and handling charge. To order, call 800-225-1153 or write to Woodcraft Supply Corp., P.O. Box 1686, Parkersburg, WV 26102.

Smaller vacuum hoses need taming, too

On page 26 of the September 1990 issue, you recommended a Sears hose lock for use on shop vacs. I tried to buy a



hose lock in a smaller size at Sears, but they only make them in the large (2½") size. A lot of us hobbyists use the small shop vac with the 1½" hose, so I resorted to another idea. I simply used self-adhesive Velcro™. By coiling the hose into its stored position, I was able to determine where on the hose end to stick one piece of Velcro™—put it where it won't interfere with any attachments—and where on the vacuum to stick the matching piece. It works beautifully. 🌲

—William McCollum Oakdale, Minn.

Now, Add Instant Earning Power To Your Shop!



30-Day Free Trial!



Woodmaster's Quick-Change Molding Head lets you create custom moldings from any stock. Choose from over 250 standard trim and picture frame patterns...or design your own!



Power-fed sanding speeds production and improves the quality of your work. No more waves or cross-grain scratches. Separate sanding head installs in just minutes.



New rip saw attachment lets you gang-rip with power feed in a fraction of the time it takes for multiple hand-fed passes on an ordinary table saw.

Craftsmen everywhere are using the low-cost Woodmaster to bring in welcome extra cash and to save on all their lumber needs. You can, too!

With the new 18-in. Woodmaster or the standard 12-in. model, you can quickly convert low-cost rough lumber into valuable finished stock. You can turn out perfect picture frame moldings, crown, bed and base moldings, tongue & groove, door and window trim...all popular patterns...any custom design.

You can do custom work for friends, neighbors, lumberyards, picture framers, home remodelers, hobby shops and businesses.

Because it takes just seconds to convert a \$2 rough board into \$10 worth of finished trim, you can see why so many Woodmaster owners enjoy substantial extra incomes!

Variable Speed Makes The Difference!

Just a twist of the dial gives you perfect control for planing, sanding or sawing...from 0 to 1,000 cuts per inch. Creates mirror-smooth molding with no sanding required!

Here's what Woodmaster owner L.C. Griffin of Los Angeles writes: "The shop test article in *Wood Magazine* that said they loved your Variable Feed Rate is what sold me. They were right."

Call or write today for free facts on how you can try this American-made tool in your own shop for one full month. Easy terms.

CALL TOLL-FREE

800-821-6651 EXT. PW43



YES! Please rush me your **FREE** Information Kit plus details on your **30-DAY FREE TRIAL GUARANTEE!**

WOODMASTER TOOLS, INC., DEPT PW43
2908 OAK STREET • KANSAS CITY, MO 64108

Name _____
Address _____
City _____ State _____ Zip _____
Telephone (_____) _____

EARN CASH, PRIZES FOR YOUR TOP SHOP TIP

Do you have a great shop tip (or two) you'd like to share with other WOOD® magazine readers? For each published submission, you will get at least \$25 from WOOD magazine (up to \$200 if we devote a page or more of space elsewhere in the magazine to your idea). You also may earn a woodworking tool for submitting the top shop tip for the issue.

We try not to use shop tips that have appeared in other magazines, so please send your tip to only one publication. We cannot return shop tips. Mail your tips, address, and daytime phone number to:

Top Shop Tip
WOOD Magazine
P.O. Box 11454
Des Moines, IA 50336-1454

An answer for loose scrollsaw-blade pins

Many woodworkers prefer pin-type scrollsaw blades because they mount so quickly and easily. Unfortunately, the pins occasionally work themselves loose from the blades.

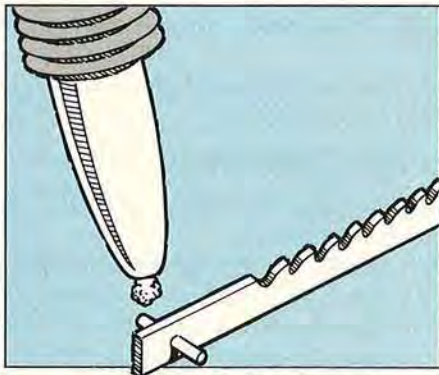

TIP: Add a drop of Loctite or cyanoacrylate (instant) glue to each side of the pin and allow to dry overnight. That's it—no more loose pins to worry about.

—R. I. Smith,
Halifax, Nova Scotia

Put a grinding halt to motor costs

A motor adds mightily to the cost of benchtop power tools such as grinders, buffers, and strip sanders. Since you can't use more than one of these machines at once, it's a shame to tie up a lot of money in a motor for each machine.

For his tip, Dennis receives a Porter-Cable model 693 router.



TIP: You can mount these benchtop tools alongside each other and run them with one motor that slides from tool to tool as shown below. Fasten a ½-1 hp motor to a length of ¾" pipe with eye- or U-bolts and a plywood base. Add a step-down pulley to the motor and a switch along the front of the bench. Cut holes into the bench top for the belts to run through.

—Dennis Baer, Fayetteville, Ga.

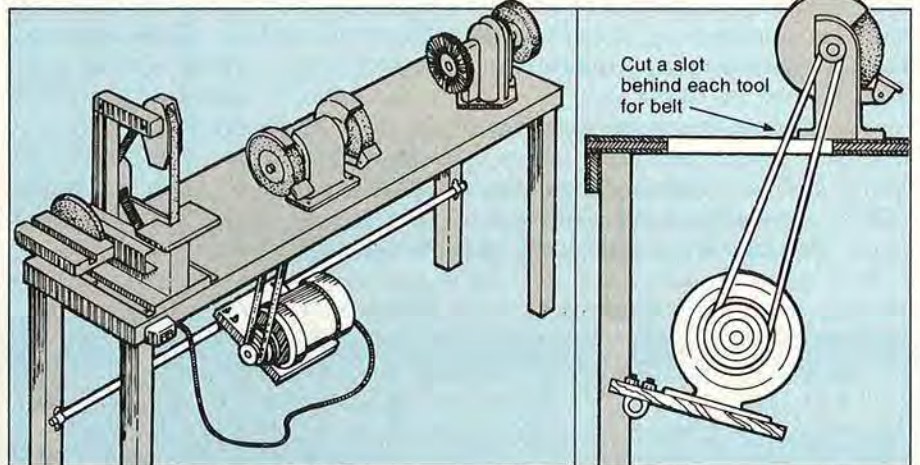

Another solution for small-part finishing

Painting, staining, and finishing small pieces frustrates most woodworkers because the objects refuse to stay put as you brush or spray them. Using your fingers to hold the pieces can be messy, and the finish may adhere the objects to your work surface.

movement of 8"-long sharpened rods. With the box assembled, you can coat small pieces of most any shape without fear of fingerprints and smudges.

—W.P. Locke, Huntington Beach, Calif.

TIP: Build a finishing box such as the one shown at right. From ¾" stock, cut the sides, top, and bottom of a 4×10×20" box (or larger if necessary). Clamp the top and bottom pieces together and drill ¼" through holes simultaneously to ensure alignment. Unclamp the assembly, and epoxy 3" lengths of ¼" steel rod with sharpened points into the bottom holes. Enlarge the top holes just slightly to permit free, but not sloppy, up-and-down

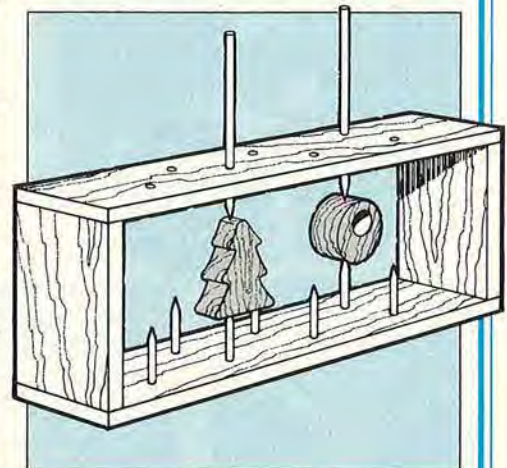

Continued on page 14

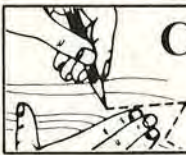

Compare this offer with any other book club for Price • Quality • Benefits • Selection!



An absolutely no-risk guarantee.



1122P \$14.95



2979P \$14.95



3079P \$14.95



3500 \$25.95
Counts as 2



3344 \$21.95



3021P \$14.95



3189 \$25.95
Counts as 2



3324 \$26.95
Counts as 2



2789P \$16.95



3177P \$24.95



60274P \$17.95



3014P \$12.95



3349 \$21.95



1971P \$12.95

Select 5 Books for only \$4.95

(values to \$128.70)
and get a **FREE Gift!**



3174P \$13.95



3053P \$12.95



3404 \$26.95
Counts as 2



3264 \$24.95



2704 \$24.95



3144 \$25.95
Counts as 2



2909P \$12.95



3334 \$18.95



3255 \$26.95
Counts as 2



3326 \$26.95
Counts as 2



3097 \$23.95



3164 \$26.95
Counts as 2

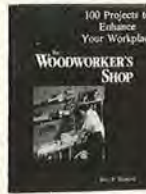

3134 \$22.95



2774P \$18.95

Membership Benefits • Big Savings. In addition to this introductory offer, you keep saving substantially with members' prices of up to 50% off the publishers' prices. • **Bonus Books.** Starting immediately, you will be eligible for our Bonus Book Plan, with savings of up to 80% off publishers' prices. • **Club News Bulletins.** 15 times per year you will receive the Book Club News, describing all the current selections—mains, alternates, extras—plus bonus offers and special sales, with scores of titles to choose from. • **Automatic Order.** If you want the Main Selection, do nothing and it will be sent to you automatically. If you prefer another selection, or no book at all, simply indicate your choice on the reply form provided. You will have at least 10 days to decide. As a member, you agree to purchase at least 3 books within the next 2 years and may resign at any time thereafter. • **Ironclad No-Risk Guarantee.** If not satisfied with your books, return them within 10 days without obligation! • **Exceptional Quality.** All books are quality publishers' editions especially selected by our Editorial Board.

FREE when you join!

15 Practical Woodworking Projects From Percy Blandford

Fascinating projects from master craftsman Percy Blandford include toys, furniture, a go-cart, and more!



HOW-TO BOOK CLUB

Blue Ridge Summit, PA 17294-0800

Please accept my membership in the How-To Book Club and send the 5 volumes listed below, plus my FREE copy of 15 Practical Woodworking Projects From Percy Blandford (3124P), billing me \$4.95. If not satisfied, I may return the books within ten days without obligation and have my membership cancelled. I agree to purchase at least 3 books at regular Club prices during the next 2 years, and may resign any time thereafter. A shipping/handling charge and sales tax will be added to all orders.

--	--	--	--	--

Name _____

Address _____

City _____

State _____ Zip _____ Phone _____

Signature _____

Valid for new members only. Foreign applicants will receive special ordering instructions. Canada must remit in U.S. currency. This order subject to acceptance by the How-To Book Club. WD291

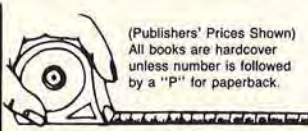

(Publishers' Prices Shown)
All books are hardcover unless number is followed by a "P" for paperback.

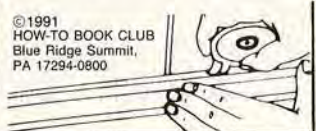

©1991
HOW-TO BOOK CLUB
Blue Ridge Summit,
PA 17294-0800

Total Shop



FREE

30 pg.
FULL
COLOR

Woodworkers
Catalog

Full of
top quality
woodworking machines
tools and accessories.

P.O. Box 25429, Greenville, SC 29616
Dept. #3

1-800-845-9356

CALL TODAY!



Tungsten Carbide Router Bits

- INDUSTRIAL GRADE, THICK CARBIDE
- SEALED BALL BEARINGS
- 40 - 60 % BELOW WHOLESALE

COVE BITS



Radius	Price
1/4	\$ 14
3/8	\$ 15
1/2	\$ 17

ROUNDROVER OR BEADING



Radius	Price
3/16	\$ 12
1/4	\$ 13
5/16	\$ 14
3/8	\$ 14
1/2	\$ 15

ROUNDNOSE BITS



Diameter	Price
1/8	\$ 8
1/4	\$ 9
3/8	\$ 11

AMER. EXP. - TOLL FREE - C.O.D.

1-800-767-4747

Or Mail Check to:

SKYCROFT TOOLS, INC.

P.O. Box 418W5
Myersville, MD 21773-0418

TIPS FROM YOUR SHOP (AND OURS)

Continued from page 12

Making the most of masking tape

If you only use masking tape for painting tasks, you've just scratched the surface of potential applications.

TIP: As shown in the three examples below, you can use masking

tape for many marking and alignment tasks. Here, we lay out the position of a hinge, mark the cutting lines for a slot after drilling the two end holes, and align letters on a wood surface. Unlike pencil marks, the masking tape lifts off easily.

—From the WOOD magazine shop

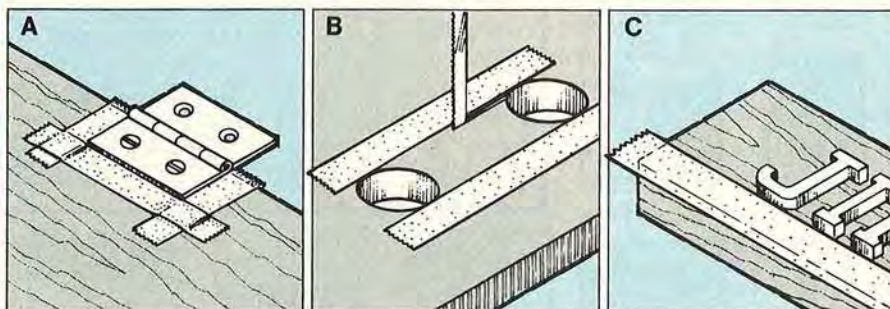

Struttin' your stuff for smoother planing

Many planers have infeed and outfeed tables that provide little support for long stock. Extension tables help, but you need to level them with the planer tables.

TIP: You can minimize chances of snipe at the end of your boards by building hinged extension tables such as the one shown below. These work well with planers that have stationary tables.

A hydraulic press works nicely for flattening the pipe ends, but you also can do the job with a hammer. Once assembled, adjust the pitch of the extension table by turning the 1/4" nuts. With a level or long straightedge, check to make sure the planer table and extension table form a single plane. These homemade struts also work well to support extensions for radial-arm saws and tablesaws.

—John Patton, St. Louis

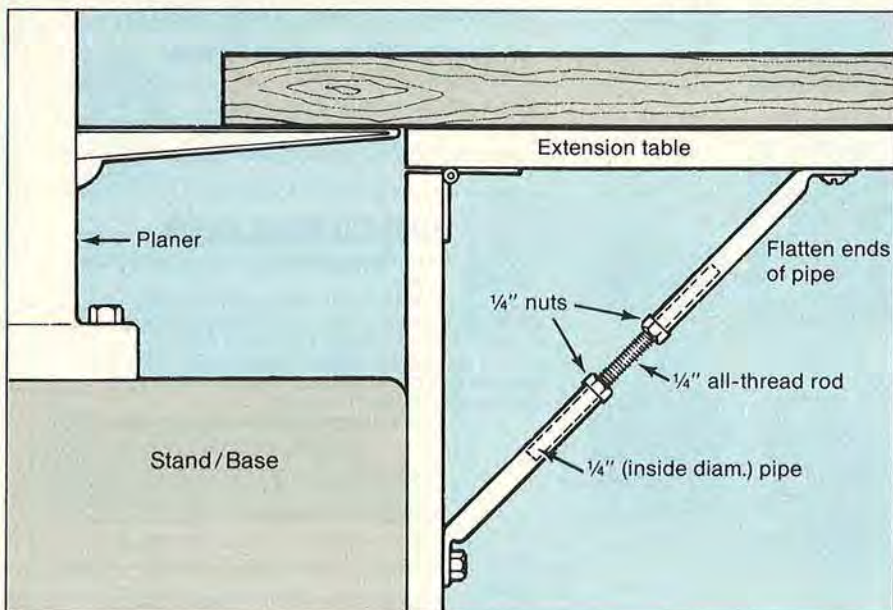

Foldaway tabletop extender for bandsaws

Most bandsaws come with small tabletops that don't adequately support large workpieces. You could bolt on an extension table, but what if you work in tight quarters and can't afford the space?

TIP: With 3/4" plywood and drop-leaf hardware, you can fashion an extension table. When not needed, the table drops to the side of the bandsaw.

—Ray W. DeVore, Caledonia, N.Y.

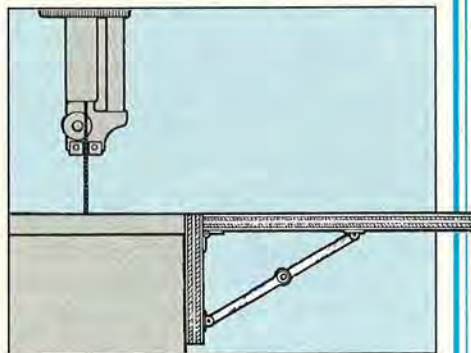

A steamy solution for wood indentations

Small dents often crop up on the surfaces of workpieces before you complete a project. You could fill the indentations with putty, but these repairs rarely blend in naturally. Applying a wet cloth to the dent and heating it with an iron sometimes raises the wood fibers, but not always.

TIP: With a hand-held clothing steamer or iron, shoot some steam onto the affected area. The steam will raise the wood fibers of shallow indentations, allowing you to re-level the area with a little sanding.

—Kerry Kumlien, Milton, Wis.

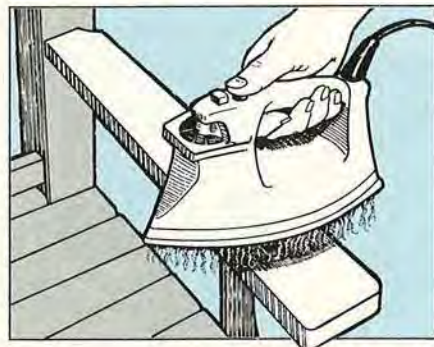

Continued on page 16

STEVE WALL LUMBER CO.

Quality Hardwoods and Woodworking Machinery For
The Craftsmen and Educational Institutions

Call For
Best Price On

MiniMax

Ash	4/4	Select	1.90	UPS	\$64.00
Basswood	4/4	Select	1.30	Special	\$46.00
Birch	4/4	Select	1.60		\$52.00
Butternut	4/4	Select	1.70		\$54.00
Cherry	4/4	Select	2.25		\$65.00
Hickory	4/4	Select	1.30		\$46.00
Mahogany (Genuine)	4/4	Select	2.60		\$72.00
Maple (Hard)	4/4	Select	1.55		\$51.00
Maple (Soft)	4/4	Select	1.25		\$45.00
Pecan	4/4	Select	1.30		\$46.00
Poplar	4/4	Select	1.20		\$44.00
White & Red Oak	4/4	Select	1.80		\$56.00
Walnut	4/4	Select	2.50		\$70.00
Cedar (Aromatic Red)	4/4	1C+Br.	1.25		\$45.00
White Pine	4/4	F.G.	.85		\$36.00
Yellow Pine	4/4	Clear	1.20		\$44.00

Above prices are for 100 quantities of kilndried rough lumber sold by the Bd. Ft. FOB Mayodan, NC. Call for quantity discounts. Other sizes and grades available.

Above prices are 20 bd. ft. bundles of clear kilndried lumber 3'-10" wide x 3'-7" long (Random widths & lengths) surfaced 2 sides or rough. Delivered UPS prepaid in the Continental U.S.

**STEVE H. WALL
LUMBER CO.**
BOX 287 • MAYODAN, N.C.
27027
919-427-0637
1-800-633-4062
FAX 919-427-7588

Send \$1.00 For Lumber
and Machinery Catalog

Cradle Plans

You can easily build this classic cradle which is sure to become a family heirloom. Available in two sizes: Baby & Doll size.

72 pg. catalog
free with order

Baby size Plan (21 x 35) \$11.50
Spindle Kit/Rosettes \$26.25
Doll size Plan (10 x 18) \$5.25
Spindle Kit/Rosettes \$12.95

M/C Visa orders call toll-free 1-800-292-8296

Frt. 48 States \$3.50. AK, HI add 25% of order. NY add tax. Canada add 50%. Use Visa/MC or M.O. in U.S. funds. Min. order is \$15.00. Catalog \$1.00 or sent FREE with order.

ARMOR, Box 445-E, East Northport, NY 11731

Two Cradle Plans One for Babies One for Dolls



RESTORE FURNITURE for SECURE INCOME Perfect 2nd Career

Make \$200-\$2,000 a day! Unlimited market; turn-key business. Free workshops. Set-Up Shop for \$2,999-\$9,999! Part-time or full-time. Great for men, women, families.

Make Molds*Veneer*Resilver
Strip*Repair*Refinish

Intro Video \$12.95 - Catalog \$2.00

MINUTEMAN, INC., Ste. 17

Box 8, Waterloo, WI 53594

1-800-733-1776

FOLEY BELSAW 4 POWER-FED TOOLS IN 1

Plane • Mold • Saw • Sand



Now you can use this ONE power-feed shop to turn rough lumber into moldings, trim, flooring, furniture - All popular patterns, Rip-Plane-Mold & Sand ... separately or in combination with a single motor. Low Cost ... You can own this power tool for only \$50 DOWN!

30 DAY FREE TRIAL!
RUSH COUPON TODAY!



Foley-Belsaw Co.
6301 Equitable Rd.
Kansas City, Mo. 64120

YES, Please send me complete facts about your PLANER - MOLDER-SAW-SANDER and details about 30-Day Trial offer and that I will receive your quarterly Woodworking Catalog. Dept. 91615.

NO, I'm not interested in a Foley-Belsaw PLANER-MOLDER-SAW-SANDER but please send me your Free Woodworking Catalog. Dept. 44148.

Name _____
Address _____
City _____ State _____ Zip _____

BUILD YOUR OWN QUEEN ANN FURNITURE

with our wide variety of stock legs



-OR-
JUST ASSEMBLE
OUR COMPLETE KITS



Matching dining and occasional tables available in

FREE BROCHURE
(no minimum required)

Adams Wood Products, Inc.
974 Forest Drive • Dept. D10102
Morristown, TN 37814 • Phone (615) 587-2942



ACCU-JOINT Put Your Router Back to Work



Make Your Router Work For You - Thousands of And Hobbyists These Are Two Tools Made

YOUR \$299 CHOICE

Table Saw Find Out Why Professionals Alike Say Of The Finest Today

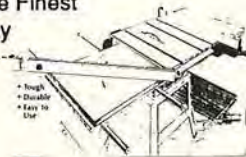

The **MULE** Sliding Table

Made To Fit All Saws

CALL 1-800-535-8665
REG OR MAIL TO
\$399 **RBIndustries**
Box 369
Harrisonville, MO 64701

MW291

TIPS FROM YOUR SHOP (AND OURS)

Continued from page 15

This straightedge helps you rout and rip accurately

A straightedge aids ripping a large sheet of plywood with a portable circular saw, or routing dados into a panel, but it takes time to adjust the straightedge so the blade or bit cuts exactly on your layout line.

TIP: Make a smarter straightedge by gluing a 2"-wide strip of 1/2"-thick stock to an equally long piece of 1/4" plywood or tempered hardboard. Both pieces should be a few inches longer than your longest cuts, and the 1/4" piece should be wider than the distance from your saw's blade (or router's straight bit) to the edge of the tool's base. When the glue dries, rip or rout the 1/4" stock as shown below. Now, you can align this just-cut edge with your layout mark and know where the cut will start.

—Roger Boulet, Winnipeg, Manitoba

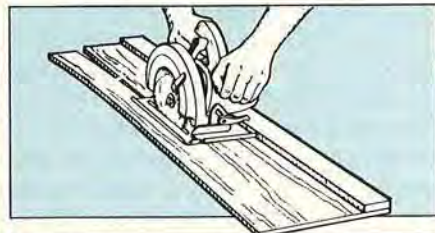

A handy storage spot for your tools

Tools that get occasional use don't deserve premium bench or shelf space in a tight-quarters workshop. Where do you put them?

TIP: Make better use of available space by storing tools on carts that roll under your bench as shown below. Assemble the cart from 3/4" stock for the sides, 1/2" plywood for the bottom, and four casters.

—Janeil Johnson, Whitehorse, Yukon

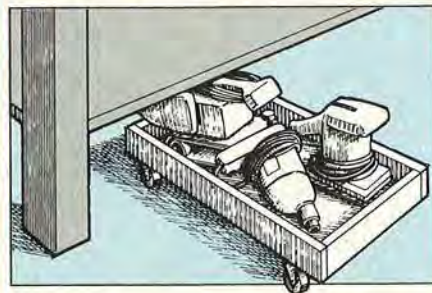

DOMESTIC & FOREIGN HARDWOODS

Quality stock for Cabinet Work Most all sizes from 1" to 4" in thickness

HARDWOODS

ASH—BASSWOOD—BIRCH
BUTTERNUT—CHERRY
CHESTNUT—EBONY—MAPLE
OAK—POPLAR—ROSEWOOD
TEAK—WALNUT
Also hardwood plywoods

SOFTWOODS

SUGAR PINE—CYPRESS—CEDAR
SPRUCE—DOUGLAS FIR etc.
MAURICE L. CONDON CO., INC.
242 Ferris Ave., White Plains, NY 10603
914-946-4111
Monday through Friday 8 AM to 4:30 PM

5" or 6" Supergrit
Random Orbital Sander Discs
5" White PSA 180 Grit \$15.00/100

PREMIUM QUALITY BELTS: BEST RESIN OVER RESIN, "X" WEIGHT 10/Box			
1 x 42	\$.70 ea.	4 x 24	\$1.00 ea.
3 x 18	.75	4 x 36	1.25
3 x 21	.80	6 x 48	2.80
3 x 24	.85	6 x 89	5.25

ADHESIVE CLOTH DISCS: BEST RESIN OVER RESIN, "X" WEIGHT

5" Diameter	\$.80 ea.	9"	\$1.65 ea.
6"	.90	10"	1.85
8"	1.30	12"	2.25

Prices quoted 80 grit, other grits available.

GARNET PAPER — ORANGE	WATERPROOF PAPER — BLACK
A/O CABINET PAPER — BROWN	180 thru 1200 100 PK \$23.00
40 Grit 50 PK \$16.00	NO LOAD PAPER — WHITE
60 Grit 50 PK 14.00	180 through 400 100 PK \$20.00
80 Grit 50 PK 13.00	Also Shop Rolls • Cloth Sheets • Drums
100, 120, 150 100 PK 22.00	
180, 220 100 PK 19.00	

CLEANING STICKS \$3.50 Small \$6.50 Large

RED HILL CORP., P.O. BOX 4234, GETTYSBURG, PA 17325
(800) 822-4003 Free Freight to most areas
Free catalogue

SAVE MONEY!

KILN DRY LUMBER



MAKE MONEY!

Kiln Dry for others. As the nation's largest manufacturer of dehumidification Dry Kilns, we can supply you with the same type equipment used by many of the major firms.

Call or write today for free facts that will help you make and save money.

nyle DRY KILN SYSTEMS

207-989-4335 **1-800-777-NYLE**
Nyle Corporation
P. O. Box 1107, Bangor, Maine 04401



Unique and Traditional Clock Kits

Clockmaking Components

Create masterpieces or simple timekeepers from Klockit's line of exclusive kits. Choose from stately Grandfathers, handsome Mantles, charming Country Shelf Clocks and Weather Stations. If you prefer something already assembled, we have those too, including fascinating Cuckoo Clocks.

Klockit is your source for quartz and mechanical movements and accessories, unique hardware, music movements and jewelry box kits, model kits, craft items and more.

And we guarantee your satisfaction!

Call Toll-Free today!
1-800-556-2548
for a FREE 64-page catalog.

KLOCKIT

P.O. Box 542
Dept. WD21
Lake Geneva, WI 53147



One giant try square

How many times have you worked on a large project and wished you had a try square as big as a carpenter's framing square?

TIP: By adding blocks of wood as shown below, you can convert a framing square into an oversized try square for those big jobs. First, cut the blocks to size from 1/4" - 3/4" stock and clamp them in position on the

square. Then, drill 1/8" holes completely through the blocks and square blade. Remove the clamps, scuff the blade with 80-grit sandpaper, apply epoxy glue to the mating surfaces, and reassemble. Insert 1/8" brass or steel pins of the appropriate length. Hold the assembly together with masking tape until the glue sets, then sand the pins flush with the surfaces of the blocks.

—Leslie Douette, Prince Edward Island, Canada

Quick reference for hole diameters

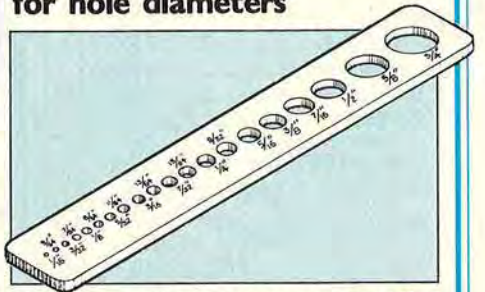

How many times have you stared at a drill bit, dowel, bolt, or one of a million other workshop tidbits and tried to guess its diameter?

TIP: Drill holes of graduating sizes as shown above into a piece of scrap plywood (1/4x1 1/2x18" works fine.) Now, you can quickly determine the diameter of all those odds and ends. Don't forget to carry this handy aid to the store to help you make the correct purchase.

—Jackie Ramirez, Long Branch, N.J.

Continued on page 18

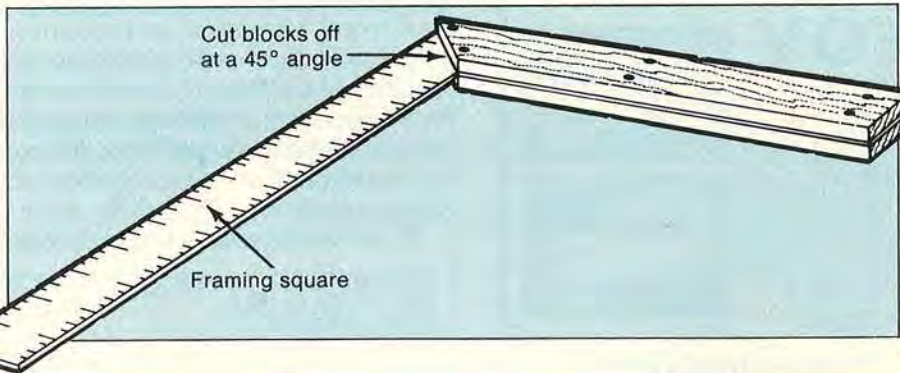

"NEW YEAR...OLD PRICES!"

"IMPORTERS OF FINE TOOLS"

IMPORTS, INC.

UNIQUE RIGHT ARM CLAMP

The secret in this clamp is its pivoting arm which squares the work for gluing, joining and fastening. Dozens of uses. Very popular!

Model G1952 ONLY \$9⁹⁵

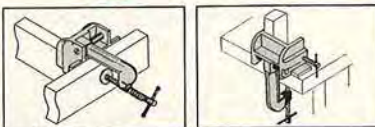

NEW!

MADE IN U.S.A.

The incredible "BOARD BUDDIES", anti-kickback device. OPTIONAL TRACK AVAILABLE!

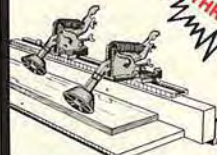

TABLE SAW "BOARD BUDDIES" ONLY \$39⁹⁵
Model G2370
RADIAL "BOARD BUDDIES" ONLY \$39⁹⁵
Model G2371
SHAPER "BOARD BUDDIES" ONLY \$39⁹⁵
Model G2372

ASK FOR OUR FREE CATALOG TODAY!

West of the Mississippi orders

1-800-541-5537

Service (206) 647-0801

East of the Mississippi orders

1-800-523-4777

Service (717) 326-3806

STAPLER



A well balanced unit with safety nose. Takes 1/2" to 7/8" staples.

Weights only 2.5 lbs!

Model G1847 ONLY \$89⁹⁵

BRAD NAILER



Great for casing and finish work with safety nose. Weights only 2.62 lbs!

Model G1852 ONLY \$99⁹⁵

SUPER BRAD NAILER



The best all-around finishing gun with safety nose.

Weights only 3.3 lbs! Takes 5/8" to 1-9/16" nails.

Model G1861 ONLY \$129⁹⁵



VICE CLAMP

For Drill-Presses

Grips and releases instantly!

6" VICE CLAMP Model G1872 ONLY \$7⁹⁵

9" VICE CLAMP Model G1873 ONLY \$9⁹⁵



25-PC. SANDING DRUM SET

• 1/2", 3/4", 1", 1 1/2", & 2" rubber drums

Model G1280 ONLY \$14⁹⁵

WOOD PARTS
QUALITY - PRICE - SERVICE

1 3/4" Mini Shaker Peg	6.00/100
3 1/2" Reg. Shaker Peg	15.00/100
Reg. Candle Cup	16.00/100
1" Wheel	4.00/100
1/4" Axel Pegs	3.50/100
1 5/8" Sawtooth Hanger	3.00/100
1 1/2" Birch Spindle	8.25/100
1 1/2" Oak Spindle	11.50/100

Orders under \$25.00 add \$2.50 shipping.
Over \$25.00 shipped FREE. Serving Continental U.S.A. Only.

American Woodcrafters Supply
PO Box G 24 Page Catalog
Riceville, IA 50466 75c or
515-985-4032 FREE with Order

The Japan Woodworker's Catalog is . . .

loaded with the best tools you can get your hands on. In our catalog you will find a huge selection of Japanese saws, waterstones, chisels, planes, carving tools, cutlery and books. Send \$1.50 for our catalog and supplements during the next two years.

THE JAPAN WOODWORKER
1731 Clement EB, Alameda, CA 94501
Phone 1-800-537-7820

TIPS FROM YOUR SHOP (AND OURS)

Continued from page 17

Scrollsawing small letters
Stencils and templates work fine as guides for scrollsawing 1" or larger letters, but not so well for smaller letters—if you can even find small sizes. Accurately marking smaller letters with a pencil and following those layout lines with your scrollsaw can prove taxing.

TIP: Purchase vinyl press-on letters from office-supply or art stores. The letters come in many different sizes, styles, and colors. Once applied to the wood, you can follow the outline of these letters easier than you can split a pencil line. To remove the vinyl, gently lift the letters with an X-acto knife, or sand the surface of the letters after mounting them to a workpiece.

—Dick Foxworthy, Widefield, Colo.



HARDWOODS
EXOTIC & DOMESTIC OVER 75 SPECIES
LUMBER • PLYWOOD • VENEERS
TURNING SQUARES & BLANKS

COLLECTORS SAMPLE KIT
30 EXOTIC & DOMESTIC WOODS
1/2" x 3" x 6" SANDED FINISH
\$29.00 PLUS \$5.00 S&H

Ideal for: Collectors • Schools • Craftsmen • Cabinet & Furniture Makers • Architects • Designers

1-800-423-2450
WOODWORKERS Supply
5402 S. 40th St. • Phoenix, AZ 85040
(602) 437-4415

WOOD TOY

- ★ Patterns
- ★ Parts
- ★ Wheels
- ★ Many New Patterns to Choose from.
- ★ Executive toys

SEND \$1.00 FOR NEW CATALOG & RECEIVE COUPON FOR FREE WHEELS & AXLE PEGS.

toys and joys
Box 628W Lynden, Wash. 98264

FOR INFORMATION ABOUT PLACING AN ADVERTISEMENT IN

Better Homes and Gardens®
WOOD®

PLEASE WRITE:
BILL REED
WOOD MAGAZINE
750 THIRD AVENUE
NEW YORK, NY 10017

OR CALL COLLECT:
212-551-6904

Build Power Tools You Can Be Proud Of... And SAVE!!!

Remember when "quality craftsmanship" meant something? With GIL-BILT tools it still does.

- Construct your own:
- 12-in BAND SAW
- 18-in BAND SAW
- 10-in. TILT/ARBOR SAW
- LATHE/DRILL PRESS COMB.
- 9-in TILT TABLE SAW
- 6-in BELT SANDER
- SPINDLE SHAPER
- CIRCULAR SAW TABLE

GIL-BILT kits include step-by-step plans, full scale patterns and all necessary metal parts and components except wood and motor. Made in America with pride by Gilliom Manufacturing, Inc. since 1946.

Send \$7.50 per plan or \$25 for plans for all eight tools listed above or send \$2 for descriptive brochure only. Satisfaction Guaranteed.

GILLIOM MANUFACTURING, INC.,
Dept. WD21
P. O. Box 1018
St. Charles, MO 63302
Phone (314) 724-1812

Featured here: 18-in. Band Saw

Specs: Throat capacity 18 in.
Thickness capacity 12 in.
Table size 26 in. x 28 in.
Table tilt 0° to 45°
Blade furnished 124 in. x 1/4 in. x 6T
Table height 39 1/2 in.
Overall dimensions 33 1/2 in. wide
29 in. deep
71 1/2 in. high
Speed (w/1,725 rpm motor)
425 rpm 2000 b/rim
Order No. 451-K only \$219.50 (less cost of plan, if previously purchased) plus shipping
Speed reduction kit available for cutting steel.

More tips from our woodworking pros

You'll find more useful shop tips scattered throughout this issue of WOOD magazine:

- For a simple, shop-proven box-joint jig, see page 42.
- You say you've got only one rabbit bit and it's the wrong size for your project? Try the method shown on page 42 for placing spacers between the workpiece and the rabbit bit.
- Attention toy builders: See page 36 for a simple way of producing wheels.
- To keep faceplate screws away from your turning project, attach a wooden auxiliary faceplate as shown on page 61.
- For a simple technique to make a project looked aged, see the finishing method on page 66. 🌲



NEW GROUND MARKETING
QUALITY & INNOVATION

LOCKWOOD POWER™ Oscillating Spindle Sander

Leaves no sanding lines!
A professional edge on
Contour Sanding.
Spindles, 6 inches long,
1/4 inch to 3 inch dia's.

- Worm and Gear Drive
- 5/8 hp Motor
- 1 1/2 inch stroke
- 57 Strokes per minute
- 6 inch spindle length
- 8 spindles available



MADE IN USA

Write or call for free information!



NEW GROUND MARKETING
P.O. Box 718
Lansdowne PA 19050

(215) 622-2445

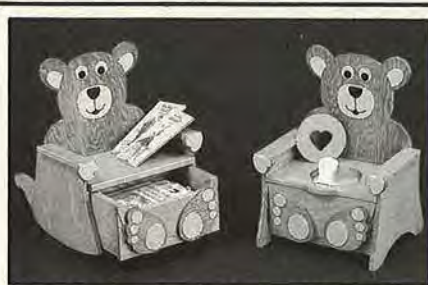

GREAT FOR GRANDKIDS

Get plans for both projects ---the rocking chair and the potty chair. Rocking chair features safety stops on back of rockers, plus a convenient storage drawer. The potty chair features plastic chamber pot plus squirt deflector. Both chairs measure approximately 21" high. Plans drawn **FULL SIZE** on huge blueprint sheets. You get plans for building both projects plus a chamber pot and squirt deflector. (Wood not included.) Order #9632 Teddy Rocking Chair/Potty Chair Plan and Potty Chair Parts for \$18.99/SET postage paid. MN residents add \$.84 sales tax/set.

TO ORDER: Visa or MasterCard customers call toll free. Mail order customers send check or money order.

Phone TOLL FREE 1-800-441-9870
(Credit Card Orders Only)



MORE PLANS

See hundreds of additional plans. Order our 72-page catalog for only \$1 or receive catalog FREE with order.

MEISEL HARDWARE SPECIALTIES

P.O. BOX 70 W 2 A MOUND, MN 55364

SHOP SENSE

Print this article

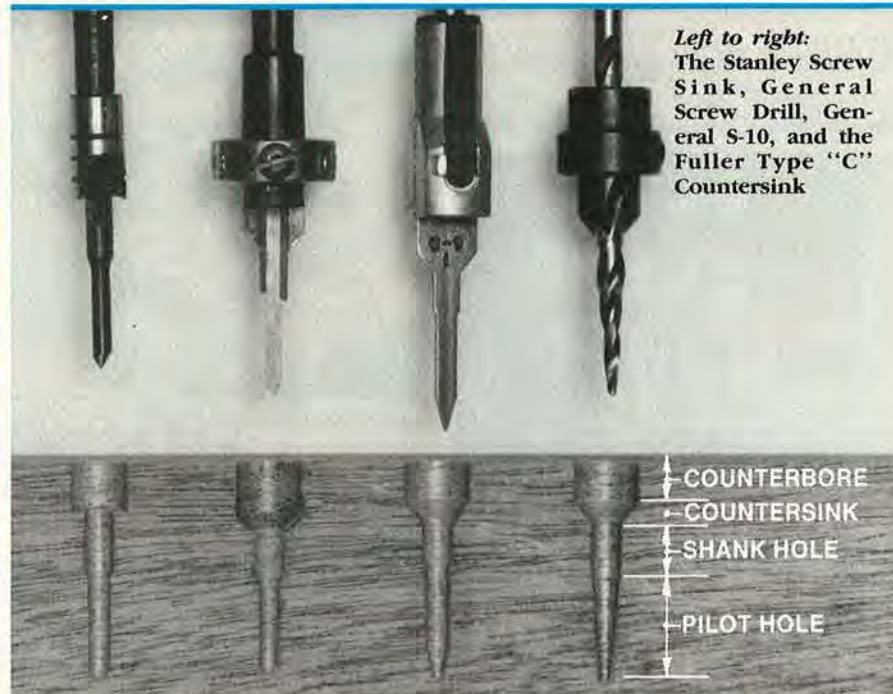

Left to right:
The Stanley Screw Sink, General Screw Drill, General S-10, and the Fuller Type "C" Countersink

SCREW DRILLS

Tired of drilling four separate holes—one for the pilot, another for the screw shank, a third for the countersink, and yet another for the plug—to keep wood screws from cracking your project? With one of the screw-hole bits on the market, you can drill all four holes in one easy step.

Sizing up screws

Regardless of size, screws have the same basic components: the head, shank, and threads. A screw-hole bit accommodates all three. As shown *above*, the screw head fits into the countersink. Drill deeper to counterbore if you wish to plug the hole. The shank hole houses the nonthreaded portion of the screw. At the bottom, the pilot hole is the same size as the root diameter—the diameter of the screw between the threads—of the screw. Here the threaded portion of the screw takes hold and bites into the wood.

The all-in-one answer to perfectly prepared screw holes

The choice: A one- or multiple-piece bit

The screw-hole bits on the market today fall into one of two categories: one-piece bits and multipiece bits. The differences are worth learning about.

You'll find *one-piece bits* (see the bit on the far left *above*), usually made from tool steel, in sizes ranging from #4 to #12. One-piece bits are limited to drilling a specific screw size and length. Optional stop collars control the depth of the countersink and counterbore. To fit several screw sizes and lengths, you'll need a handful of one-piece bits.

Multipiece bits have a blade or a high-speed twist-steel bit to drill the pilot hole. Note that the General Screw Drill and the General S-10 shown *above* both have pilot blades; compare each with the taper drill pilot of the Fuller Type "C" Countersink. An adjustable, locking collar fits over the pilot bit to cut the hole for the screw shank and countersink.

Stop collars control the depth of the countersink/counterbore.

Multipiece bits (\$8 to \$12 each) cost about two times more than one-piece bits (\$4 to \$6 apiece). However, they have several advantages over one-piece bits in that each multipiece bit adjusts for several screw lengths by moving the locking collar on the pilot bit. They also tend to cut cleaner with less burning.

Rhode Island manufacturer W.L. Fuller, Inc., offers a tapered twist drill bit, shown on the far right in the photo at left. According to company president Warren Fuller, the tapered bits drill a hole proportioned to the shape of the screw. The screw drives easily, yet provides holding power the entire length of the thread.

You can use both types of bits in either a portable drill or drill press. We suggest drilling at slow speeds (250-500 rpm). Gradually feed the bit into the wood and clear the bit often to prevent heat build-up. Forcing the bit causes it to overheat and burn the wood. In repeated heavy use, the pilot tips of one-piece bits can get hot, lose their temper, and snap off in the workpiece.

What bit's right for you

If you occasionally drill just a few holes for standard-size screws, a one-piece set of four bits, at about \$10, will do.

If you drill lots of holes, use many different screw lengths and sizes in your projects, or work primarily in hardwoods, you'd be much better off investing in a multipiece set. Four-bit sets (for #6, #8, #10, and #12 screws) with straight-shanked pilot drills cost about \$13. A set of four tapered bits with countersink collars costs about \$35. For about \$60, you can get a tapered-bit set that includes plug cutters to drill the right-sized plug for filling the counterbored screw hole. 🌿

SAVE BIG Money

ONLY \$699⁰⁰
Less Power

Save Like The Pro's With Our 5 in 1 Planer/Sander/
Molder/Rip/Joiner
Turn Cheap Unfinished Lumber Into Beautiful
Finished Woods, Molding, Picture Frames and
More

OUR
LOWEST
PRICE
EVER

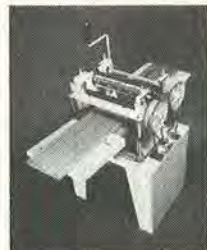

- SAVE BIG - EARN BIG -
BIG 12" CUT

\$699⁰⁰ Less Power
MODEL 812

3 H.P. Motor Switch
\$999 MODEL 812

Order TODAY
CALL 1-800-535-8665

Or Mail To
RBI Industries
Box 369

Harrisonville, MO 64701

The "ORIGINAL"
Model 812

PW291

MUSICAL INSTRUMENT PLANS, KITS & SUPPLIES



Harps, Lyres,
Banjos, Guitars,
Violins, Mandolins,
Hammer Dulcimers,
Mountain Dulcimers,
Psalteries & more!

CATALOG: \$1.00

MUSICMAKERS KITS, INC.

423 S. Main St. Dept. B8
Stillwater, MN 55082

612-439-9120

CRAFTSMAN EQUIP YOUR SHOP AT GREAT SAVINGS

Catalog of over 300 plans to
build your own tools,
\$1.00, refundable



A wide variety of plans from complete machines & attachments to handtools for home, school & commercial shops. Featured also are accessories for wood and metal cutting lathes, drills, saws, sanders etc., plus things to make of wood and metal.

WOOD-MET SERVICES

3314 WEST SHOFF CIR. DEPT. WOOD
PEORIA, ILLINOIS 61604

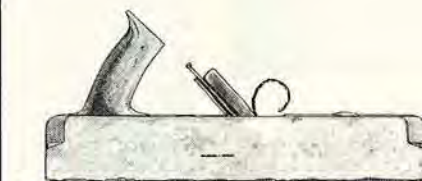

APPALACHIAN HARDWOODS

Beautiful grain and textures. Exceptionally workable. Our Appalachian hardwoods are locally grown, personally selected and kiln-dried... a guarantee of our measure of quality. ■ We handle 21 species of domestic hardwoods, softwoods and hard-to-find imports. ■ Send \$2.00 for our catalogue today (refunded with order). All purchases at delivered prices. **EDLCO**

P.O. Box 5373-A, Asheville, N.C. 28813
For fast service, call 1-704-255-8765

Do-It-Yourself Kits



Factory Direct
Clocks and Furniture
Also Assembled
and Finished

- Grandfather Clocks, Mantel and Wall Clocks
- Curios, Tables, Chairs, Desks, Cradle...and more!
- Solid 3/4" Black Walnut, Cherry, or Oak
- Heirloom Quality
- Solid Brass West German Movements and Dials
- Money Back Guarantee



I am interested in
 Do-It-Yourself Kits
 Finished Clocks
 Finished Furniture

SEND \$1 FOR
COLOR CATALOG

Name _____
Street _____
City _____
State _____ Zip _____



(Please Print)
**EMPEROR
CLOCK COMPANY**

World's Largest Manufacturer of Grandfather Clock Kits
Dept. 3817, Emperor Industrial Park
Fairhope, Alabama 36532 • Phone 1-205-928-2316

THE WOOD OF THE BIBLE

Cedar's ease of working, finishing, and durability made it the favorite of Egyptian woodworkers and shipbuilders.

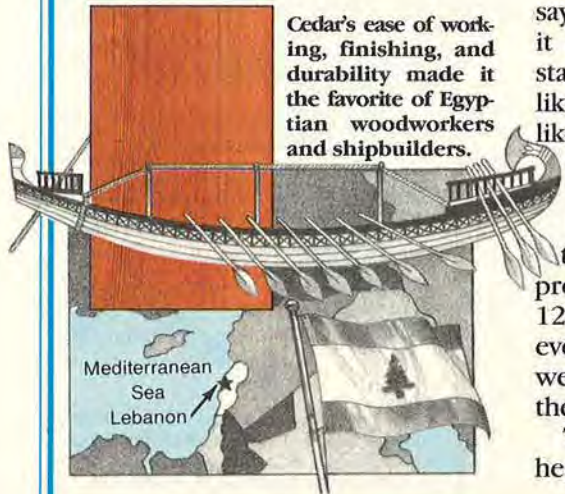

Of the many building materials used in the ancient world, one stands out—the cedar of Lebanon (*Cedrus libani*). Wood historian Albert J. Constantine, Jr., in his book *Know Your Woods* (Charles Scribner's Sons, New York, 1975), says the Old Testament alone cites it nearly 50 times. Psalms 92:12 states, "The righteous shall flourish like the palm tree: he shall grow like a cedar in Lebanon."

In Lebanon and Syria during those early times, vast cedar forests grew. And there's no doubt that this Lebanese cedar was impressive. A mature tree could stand 120' tall and 8' in diameter. However, neighboring countries that were not similarly blessed coveted the towering timbers.

The Egyptians, for instance, drew heavily on the Lebanese cedars.

During the reign of Pharaoh Snefru alone (2,000 B.C.), it is recorded that a fleet of 40 ships carried Lebanese logs to Egypt.

There, laborers hewed the cedar into timbers for royal river barges and seagoing vessels. An entire ship discovered by archaeologists inside a pyramid in 1954 contained cedar planks 75' long and 5" thick! Egyptian cabinetmakers and carpenters favored cedar of Lebanon, too, because of its workability and aroma. In fact, ancient tombs containing expertly crafted cedar furniture, shrines, and coffins bear this out.

Today, remnants of the once-vast cedar forest remain protected in the Cedars of Lebanon National Park, located about 90 miles north of Beirut. And the Lebanese still revere the tree—it appears on their flag as a national symbol. 🌲

Illustration: Jim Stevenson

PARAGAUGE™

THE PERFECT SHOP ACCESSORY FOR ANYONE WHO OWNS A TABLE OR RADIAL ARM SAW

Designed for both the home and professional shop, Paragauge will accurately set any table or radial arm saw so precise that anyone can now cut wood accurate to within 10/1000"—virtually eliminating binding, burning and dangerous kickback.

Easy-to-follow directions show how to use **Paragauge** for setting a perfectly parallel rip fence (up to 18 inches wide), setting inside bevels and setting blade height. Radial arm saw owners can use **Paragauge** as a square for crosscutting, setting the width for ripping, setting blade depth and even check for table levelness and heel in horizontal position. **Paragauge** is so versatile and accurate everyone can now cut wood with professional quality results.

Paragauge also saves the cost of upgrading to a new saw or adding an expensive parallel-locking fence to your current equipment!

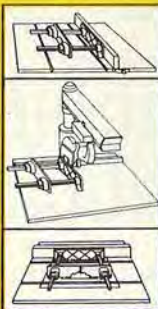

A Proven Performer

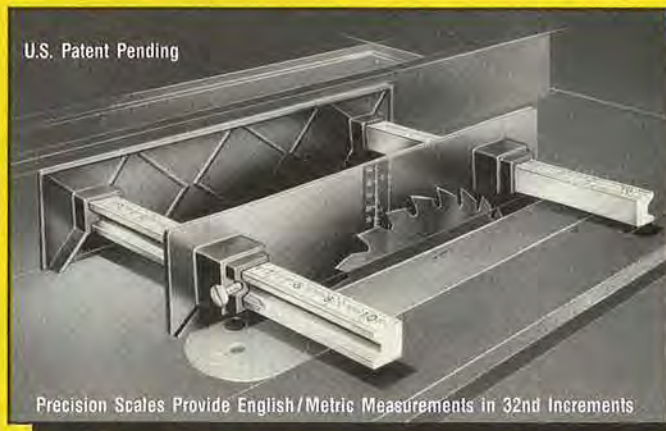

NOTE: We suggest that Model PG-18 only be used on table tops measuring at least 36" wide. For smaller saws or when using the gauge on a radial arm saw, Model PG-12 is recommended.

NOW AVAILABLE IN TWO SIZES

MODEL

Only!

PG-12 (12 inch) **\$34.95** +\$3.50 S&H

PG-18 (18 inch) **\$39.95** +\$5.00 S&H

MI Residents Please Add 4% Sales Tax

"MADE IN THE U.S.A." For Quality You Can Depend On!



To Order Call Toll Free



1-800-343-6129

(7 Day - 24 hour service)

- OR -

To order by check or for a FREE BROCHURE write: Accuset Tool Co., Inc., P.O. Box 1088 Dept. D, Troy, MI 48099
30 Day Money Back Satisfaction Guarantee • SORRY, NO C.O.D.'s



6391 \$23.95 6364 \$14.95 Softcover 6028 \$24.95 0116 \$24.95 6286 \$19.95 6279 \$9.95 Softcover 6047 \$12.95 *0109 \$15.00 4631 \$19.95



6221 \$21.95 6123 \$17.95 6276 \$16.95 5882 \$19.95 6275 \$29.95 6215 \$35.00 *4569 \$24.95 6231 \$24.95 6341 \$18.95 Softcover



5841 \$27.95 6220 \$32.95 6270 \$14.95 Softcover 6209 \$13.95 *0160 \$25.95 *4633 \$24.95 *0113 \$15.95 *0097 \$19.95 6304 \$21.95

NAIL DOWN A GREAT DEAL!



4627 \$19.95 6016 \$24.95 6104 \$12.75 Softcover

HOW MEMBERSHIP WORKS To take advantage of this offer, just select any 3 books shown here. Send no money now. Just return the coupon and we'll send you your choice of any three books worth up to \$102.90 for a no-risk examination.

If you aren't completely satisfied with these books, return them to us within 10 days. You will be under no obligation, and you will owe nothing. Otherwise, we will bill you just \$4.95 for all 3 books (plus postage and handling) and begin your membership.

As a member, you'll receive our regular mailing 15 times a year (about every three and a half weeks). Each mailing describes the Main Selection (our featured item of the month) and many other selections.

To get the Main Selection, do nothing—it will be sent automatically. To order something else, or nothing at all, tell us on your Reply Card and mail by the given date.

You always have at least 10 days to make your choice. If your Bulletin ever arrives late, and you receive a selection without having had at least 10 days to decide, simply return it for full credit at our expense.

All you agree to buy is two additional selections over the next year. (A shipping and handling charge plus applicable sales tax is added to all shipments.) You may cancel your Membership at any time thereafter.

Don't delay! Complete this coupon today and mail to: Popular Science Book Club, 1716 Locust Street, Des Moines, IA 50336.



*0153 \$27.95 *0089 \$19.95

*Original Custom-written POPULAR SCIENCE Books



6124 \$17.95 6375 \$11.95 Softcover 6002 \$14.95 6255 \$24.95



6328 \$19.95 Softcover 6201 \$19.95 6171 \$19.95 *4618 \$34.95



50-603

Popular Science BOOK CLUB®

THE #1 DO-IT-YOURSELF BOOK CLUB

YES! Please enroll me as a Member of Popular Science Book Club® and send me the 3 books indicated by the numbers I have filled in below. (Total value of up to \$102.90!) Bill me only \$4.95 total plus shipping and handling (and sales tax where applicable). I understand the Membership Plan described in this ad and I agree to buy two additional books at Club prices plus shipping, handling and any applicable sales tax, during the next year. Thereafter, my Membership may be canceled either by me or Popular Science Book Club® at any time. All orders are subject to routine credit approval.

Signature _____

New Member Bonus: If you wish, you may select a 4th book now at 50% off the publisher's price (plus shipping and handling and applicable sales tax).

001-50R32

Name _____ (please print)

Address _____

City _____ State _____ Zip _____

This offer valid in U.S.A. only. Your Membership is subject to acceptance by Popular Science Book Club. This offer expires September 30, 1991. POPULAR SCIENCE BOOK CLUB, 1716 LOCUST STREET, DES MOINES, IA 50336. W/S '91

NEW!

MAJOR ADVANCE IN FORSTNER BIT DESIGN

10-pc. FORSTNER BIT SET

All with Saw-Teeth

\$84⁹⁹
plus \$5.00 s/h

#10-1336



All bits 3 1/2" overall with 3/8" shanks. Precision Ground. HRC50-52. Sizes: 1", 1 1/8", 1 1/4", 1 3/8", 1 1/2", 1 5/8", 1 3/4", 1 7/8", 2", 2 1/8" in handsome wood case.

SAW TEETH

ELIMINATE OVERHEATING,
ELIMINATE BURNING
AND CUT FASTER
WITHOUT LOSS
OF ANY
FORSTNER
BIT FUNCTION

SAW-TOOTH JUMBO FORSTNER BITS

Complete Set of 8

SAVE
OVER
\$105.00

\$139⁹⁹
plus \$10.00 s/h

#10-1350



16-pc. FORSTNER BIT SET

\$89⁹⁹
plus \$7.00 s/h

#10-1330



Sizes over 1 1/2" with Saw-Teeth

All bits 3 1/2" overall with 3/8" shanks. Precision Ground. HRC50-52. Sizes: 1/4" through 2 1/8" in wood case.

7-pc. CONVENTIONAL FORSTNER BIT SET

\$29⁹⁹
plus \$4.00 s/h

#10-1325



All bits 3 1/2" overall with 3/8" shanks. Precision Ground. HRC50-52. Sizes: 1/4" through 1" in wood case.

1/2" Shanks;
6" O/A



2 1/4"	10-1316	\$22.99
2 3/8"	10-1317	24.99
2 1/2"	10-1318	26.99
2 5/8"	10-1319	28.99
2 3/4"	10-1320	30.99
2 7/8"	10-1321	32.99
3"	10-1322	34.99
3 1/8"	10-1323	36.99

plus s/h: 1 Bit \$4.00; ea. add'l bit \$2.00

22-pc. HSS TAPERED DRILL, COUNTERSINK/BORE, STOP COLLAR SET

\$29⁹⁹
plus \$4.00 s/h

#05-0007

NEW!



For Screw Sizes #5, 6, 7, 8, 9, 10, 12. Wood case included.

NEW!

SUPPLE
SUEDE
LEATHER
WORKSHOP
APRON

\$19⁹⁹
plus \$4.00 s/h

#03-0003

21"x33". 4 pockets.



5-pc. JUMBO BRAD POINT DRILL SET

Specialy Priced

\$19⁹⁹
plus \$3.00 s/h



9/16", 5/8", 3/4", 7/8", 1" with 3/8" shanks.

"NO HASSLE 30-DAY MONEY BACK GUARANTEE"

VISA/MC TOLL FREE 1-800-666-7227 Dept. WM021 (Incl. Canada)

DOLLAR TRADING CORP., Dept. WM021, P.O. Box 68666, Indianapolis, IN 46268

(IN and CT Buyers Please Add Sales Tax)

IN TENNESSEE'S CUMBERLAND MOUNTAINS,
JOHN SADLER CONTINUES A PIONEER TRADITION

DOWN-HOME DOUGH BOWLS

 [Print this article](#)

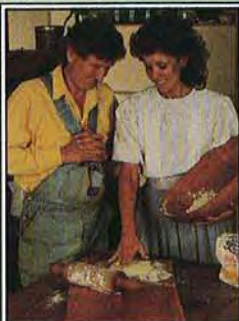

John Sadler helps his wife, Linda, roll out biscuit dough in their 1800s-vintage cabin down in Billy Hill Hollar.

Paul Warner, a reader from Perry, Georgia, sent us quite a letter awhile back. Paul, a woodturner, had met a fellow craftsman who impressed him—so much so that he suggested an article. Taking his advice, we traveled to central Tennessee to visit bowl maker John Sadler and Linda, his wife.

There, in the ridged country around Bradyville, we found a 20th-century man sharing time with the past. At

day's end, John, a plumber by trade, walks into the last century to practice a craft mastered by his great-grandfather and grandfather before him.

Deep in a wooded hollow behind the family ranch house, John, 47, cleaves wood and works it into the large bowls that generations have used to mix the daily dough. For him, the work has become a link to simpler times. To others, his bowls represent examples of old-time craftsmanship.

Continued

Rugged people settled the Tennessee hill country. They scraped a living off the land, planting crops of corn and cotton in clearings hewed from the forest. Luxuries were rare, and skills became commodities to trade for necessities.

"Nearly every community back then had a blacksmith," says John Sadler, his drawl softening the spaces between words. "There was somebody who built barns, and one who made bowls, and like that. And it's my understanding that they generally swapped out rather than bein' paid."

John pauses to refresh his pinch of snuff, then continues. "Boy Lemons was a right handy old bowl maker in these parts—he taught my kin. He lived up at the top of the hill there, in what we called Old Boy House. That house was so open. Why, my Daddy said you could throw a cat through the roof and count chickens through the floor. Hard to believe

people was raised like that, but they made do."

Today, only crumbling supports mark the site of Boy Lemons' house. And, according to John, the dough bowls Boy made from buckeye or yellow poplar have vanished, too—no doubt worn thin, then through, from twice-a-day biscuit making over the years. But, just as stories from yesterday have passed down, so has the bowl-making tradition—from grandfather directly into the hands of John Sadler.

Whistling up dead man's wood

Out of every 100 dough bowls John makes annually, about 30 will be of buckeye—a white, easily worked wood—and the rest come from cherry, butternut, black walnut, and some persimmon. In the old days, bowl makers didn't offer such variety.

"My granddaddy, when he made bowls, used buckeye," John

says. "It's native to this part of the country, it's soft wood, and light. The womenfolk, you know, didn't want a really heavy bowl to tote. Buckeye's a hill tree—you won't find it in the flat country very often. At one time, it went for making caskets. That's why some of the old-timers around here still call it 'dead man's wood.'"

In the hill country, "whistlin' up" means to fetch, gather, or get, and it covers how John obtains much of his bowl wood. Yet, it doesn't always come for free.

"I always keep my eye out for a good tree, even when I drive to work," John explains. "Folks around here know that I make these bowls, and volunteer where there might be a good tree. I do run across a deal once in awhile. Why, matter of fact, I've traded two, three bushels of apples for a walnut tree. They's my wife Linda's apples, of course," he adds, the family humor in the tale evident on his face.

John's dough bowls come in round, oval, and the traditional oblong shapes, and in buckeye, butternut, cherry, and walnut. He also makes breadboards and rolling pins to match.



John ambles over to a BIG log, and kicks away the protective sawdust piled against one cut end to expose dark orange wood. "I was looking for some white walnut [butternut] on an old boy's place down in the barns [barrens, flat country] when I spotted this big old cherry," he says. "I've made a deal with the wife to make her some bowls in exchange for the tree. That's how this wood come about—one of the biggest cherries I've worked—it'll turn out 25–30 bowls."

What does a good bowl tree look like? Quite different from one destined for furniture stock. Says John, "The main thing is size, 'cause you can't get a big bowl out of a little tree. And, you'd think that a real straight log would make the prettiest bowls, but many times that's not the case. Some of the best lookin' cherry bowls I've made came from an old rough log that my brother-in-law give me. Before I was makin' bowls, I wouldn't have carried it home for firewood—lots of knots. But, when I opened that log up, I found I could ease a bowl right up to a knot or a defect, and pick up a lot of curly grain."

Down in Billy Hill Hollar

As a stone rolls, it's about 200 yards from John and Linda's home atop the ridge to the cabin in the hollow. By foot down the switch-backed road, it's twice that.

The cabin rests in the shade of tall tulip poplars. A brook tinkles by. Ferns flourish. A split-rail fence defines the yard-turned-work-area. And although the building is less than 10 years old, it looks as if it has always been there. A high-pitched, tin-covered roof, wide-open pillared porch, and stone steps mark it as down-home. John seeks seclusion there to hew his bowls, and keep touch with his roots.

"There was an old feller by the name of Billy Hill—in fact that's



John likes to rough-shape his bowls at his cabin in the hollow. There's no telephone to interrupt him as he works the inside of the bowl with a hand adz.

what we call this place now—Billy Hill Hollar. Yup, he got out a corn crop and raised a family down here. When I built my cabin, I thought of him," John says, introducing his hideaway. "There's no electricity, just kerosene lamps and a wood stove. I don't have to listen to phones a-ringin', or worry about someone's leaky faucets. I built the cabin to look like it just grewed here."

John stops, letting nature's sounds briefly take over—a whippoorwill's call, wind in the poplars, water over rocks in the brook. "You step back in time when you come down over the hill. It makes me feel a little bit closer to my raisin'."

And, for working wood to make his bowls, John doesn't need electricity in the hollow. Boy Lemons would approve.

Continued

Shaping up a dough bowl

"As Boy taught him, Grandad would have cut the log off with a crosscut saw, then split it open with a maul and a large wedge called a glut," John says, describing the hand-me-down methodology. "Probably, he would have used a broad ax to work his bowl down into a chunk. Next, he'd have stepped up to a hewing hatchet—sharp on one side—to shape the outside of the bowl, then maybe a hand plane. On the inside, he'd work with a hand adz and a scorp. To smooth it up, he'd have sanded with a piece of glass or pottery. Old bowls won't be slick," he adds, "just smooth enough to keep from gettin' a splinter in your hand."

For roughing out his bowls at the cabin, John substitutes a chainsaw for much of the ax, hewing hatchet, and adz work. But, the process begins almost as it did 100 years ago.

"I used to take my logs to a local sawmill to open up, but it got so that those old boys would see me comin' and just shake their head," says John. "So, I've been doing it myself, sawing off two-foot chunks and splitting them with a chainsaw part way, then taking a glut and a maul to rive them open. I can read the grain better, anyhow," he says, bending over to run his hand across the clean, cut end of a walnut log. "Trees are just like human beings, you know, they're not perfect by no means. Often the heartwood will be at different places from one end of the log to another."

John's dough bowls run big—a standard oblong one measures 23" long, 15" wide, and about 6" deep, with $\frac{5}{8}$ "-thick walls. It takes a good-sized tree for raw material because he won't use the pith ("I step back from the heart at least two inches.").

With the split chunk of wood before him, John begins rough-shaping. "Just like buildin' a house, with bowl carvin' you got

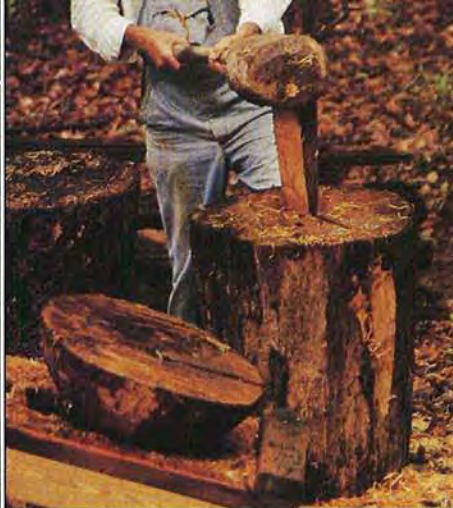

With a glut and a one-piece maul made from hickory, the bowl maker opens up a butternut log.

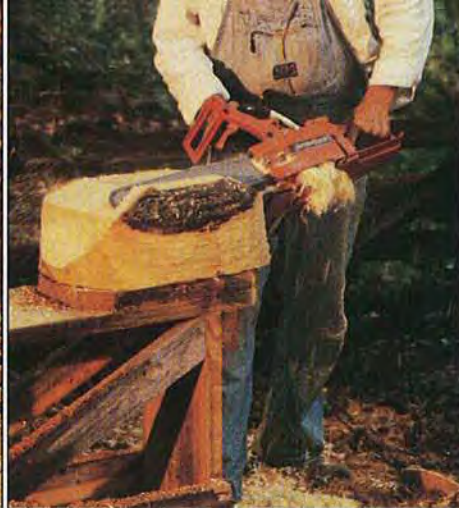

After drawing the bowl's rim outline on the wood, John shapes the outside by shaving with his chainsaw.



With a technique similar to cutting a mortise, the craftsman saws deep incisions, then clears them away. The bowl won't shift in the form-fitting saddle.

Sitting on the steps of his cabin, John cleans up uneven surfaces on the outside of his bowl with a hewing hatchet.





Situated near the house, John's outdoor shop with its different workstations resembles a merry-go-round.



Grinding, then sanding, removes all the saw and adz marks from the bowl, as well as fine-tunes the shaping.



After belt-sanding, John hand-sands with 320-grit paper for super-smoothness, all the while taking off tiny high spots that his hands notice.

"It makes sense to put tree oil on a tree," says John about his walnut-oil finish. Pioneers left the bowls unfinished, or rubbed in lard.



to start with a good foundation. And my foundation is the rim."

A template gives him the bowl outline, which he draws on the wood. Then, with $\frac{3}{4}$ " deep plunge cuts of the chainsaw, he follows the pattern. From there, he takes the bowl over to the shaving horse where he clamps it in place and makes angled cuts to trim the ends and sides, as shown in the photo, *opposite page, top right*.

John's practiced eyes know exactly how much wood to take off to keep the bowl in proportion. Once he has worked the outside to form, he turns over the bowl-to-be, sets it in a form-fitting, custom-made saddle to hold it steady, and commences to cut out the inside, as shown *opposite page, center*. He trims with the hand adz.

Finally, the bowl—its walls whittled to $\frac{3}{4}$ " thick and the bottom to about $1\frac{1}{2}$ "—is ready for the curing shed, a storm cellar next to the house. "Open-grain woods like buckeye," John notes, "cure out in $2\frac{1}{2}$ to 3 months. Cherry and walnut take twice as long. And, no wood moves enough while dryin' to hurt the appearance. When I go to finishing, I can shape it up. Course," he adds, "I leave the rim uneven so it won't look machined."

A tree-to-tree finish

At his electrified workstation atop the hill, John smooths up his cured bowls. He removes saw and adz marks from the inner and outer surfaces with power tools, and finally hand-sanding, see photos *left*, with grits from 60 to 320. "All the time I continue to shape that bowl," John says.

John believes most bowls were left unfinished. That won't do for his, however, since those who pay \$150 to \$250 for them want a display piece. "I've used olive oil and mineral oil, but walnut oil accents the grain the best," he says. "And, it seems natural to put a tree oil on a tree." 🌲

Written by Peter J. Stephano
Photographs: Jim Hale

THE NORWEGIAN BACHELOR FARMER

A ROUGH-HEWN CARICATURE THAT TEACHES YOU SCANDINAVIAN, FLAT-PLANE CARVING

Flat-plane carving had its origins in the rustic and rugged peasant carvings done in Scandinavia 150–200 years ago, according to Harley J. Refsal, carver and instructor in Scandinavian folk art at Luther College, Decorah, Iowa. “The style takes its name from the flat planes created with the knife cuts, a technique that at first glance seems rough and unsophisticated. But, the knife marks that shape the piece become a part of it—when you take away wood with the blade or gouge, you create an element,” he explains. “A cut to remove wood from the leg becomes a heavy crease in the pants. In flat-plane carving you don’t shape the figure, then go around putting knife cuts in to smooth it.”

Harley learned flat-plane carving in Norway in 1965, and has practiced the style ever since. In fact, in 1989 and 1990, he returned to the land of its origin to teach the technique to Norwegians—all the folk-art carvers had passed away.

The figures Harley carves represent the kinds of people he grew up with in rural Hoffman, Minnesota. And the flat-plane style suits them. “It’s a rough-hewn way of depicting rough-hewn people,” Harley says, “like this Norwegian bachelor farmer, made famous by Garrison Keillor’s book,



Harley Refsal

Lake Wobegon Days. But remember, a caricature isn’t supposed to be realistic, so features that stick out, such as ears, feet, cap, etc., must be larger than life.”



 [Print this article](#)

You'll need these tools and supplies

The farmer requires a $2\frac{1}{4} \times 2\frac{1}{4} \times 6\frac{1}{2}$ " block of basswood on which to transfer the pattern shown on page 83. Or, start with the prime northern basswood blank sawn from two directions, shown *below*. It has lines drawn on to get you going. Send \$9.95

(U.S.) ppd. (two for \$17.50) to: *Harley Refsal Woodcarving, 619 North St., Decorah, IA 52101. Allow 4-6 weeks for delivery.* For a booklet containing 20 patterns of Harley's favorite figures, add just \$9.95 and request "Patterns."



Pre-sawn blank

You'll need the carving tools illustrated *below*:



Knives

- bench-type carving knife



Gouges

- $\frac{1}{2}$ " No. 6 or 7 palm gouge
- $\frac{1}{4}$ "- $\frac{3}{8}$ " No. 4 or 5 gouge
- $\frac{1}{8}$ "- $\frac{3}{16}$ " No. 9 gouge
- $\frac{1}{8}$ " 45° V-tool



Finish Materials

- Water-soluble, acrylic artist's paints in white, red, blue, green, brown, and yellow (or any other colors you care to substitute)
- No. 7 or No. 8 brush
- No. 000 brush
- Boiled linseed oil
- Burnt-umber artist's oil color (or brown oil stain)

After assembling all the tools and supplies you'll need for this project (see list, *left*), study the front- and back-view photographs of the completed farmer. And, turn to the closeup photograph of the figure's face on page 33. In the full-figure photos, note the sharp, prominent cuts that produce creases and folds, elbows and knees. Study the facial close-up to see how each angular cut of the knife defines a feature—nose, cheeks, ear. Now, you're ready to start carving.

Carve from the bottom up

With your knife, shape the figure's legs, as in photo *below*. Be sure that you don't round the legs so they resemble perfect cylinders—the goal is to leave as many large, flat planes as possible. Take advantage of the cuts to make folds and creases. Imagine that if you sawed off one of the figure's legs midway between knee and ankle, and looked at the cross-section, the shape would be octagonal rather than round.



Bold knife strokes shape the leg. Remember, the cut you create stays there.

For the crotch of the farmer's pants, make two strongly defined cuts in an upside-down "V" shape. And, don't cut the crotch in too high. Locate it no more than $\frac{1}{2}$ " from the spot where his legs join the trunk of his body.

Now, turn the figure over and shape the seat of the farmer's overalls with your knife blade. In the photo *below* you can see the bold V-cuts required to form a crease—one cut down and in, the next up and in to meet it.



One cut down and in, another up and in make a fold in the cloth.

Now that you have carved his seat, turn your attention and your blade to the feet. Note how large the shoes appear in the photos. There's a double reason for this. First, you must leave them large to provide a solid base for the figure to stand on. Second, their size is part of the caricature.

Carve the shoes without attention to detail, avoiding the natural tendency to round them. Let a minimum number of flat cuts define their shapes. For the soles, for instance, you need only to trim the wood with flat, thin, vertical cuts around the edge of the shoe. Any attempt to accent the sole by making it a protrusion can result in a break-off of the cross grain (something to remember when you get to the cap visor, too). Let the farmer's pant legs fall all the

Continued

NORWEGIAN FARMER

way to the ground in back (see rear-view photo), but make cuts to represent folds where his pants break on top of his shoes (see front-view photo).

Put his hands in his pockets

Before carving the farmer's arms, plan your cuts so his hands will disappear into his overall pockets. And, as with the legs, avoid carving perfect cylinders. Instead, try to make large, flat cuts that meet sharply at the edge of the wood, as if his shirt had been starched and ironed.

Separate the arms from the body at the chest with cuts to form a wide-legged "V" on the inside of the elbow (for detail, see photo on the next page, *top right*).

These cuts also narrow and define the width of his chest.

The widest part of the figure is the area where the hands enter the pockets. And, the hands in those pockets tend to push out the overalls, so leave more wood at those points.

When you're satisfied with the look and shape of his arms, turn the farmer over to work on the back.

With a $\frac{1}{2}$ " No. 6 or No. 7 gouge, cut across the grain (horizontally) with scooping motions to remove wood between the arms. This creates the small of his back. (Here, the gouge makes it difficult to leave flat planes, but try to keep gouge marks to a minimum.) Leave each arm $\frac{1}{2}$ " wide at the outer elbow. Then, clean up the elbows with the same type of cuts you used on the inner elbows—sharp edges on the elbows are okay (see elbow, *left and top right*). After the elbows, you will have shaped your farmer from the neck down.



A gouge removes wood to form the small of the back.

Character for a caricature

Before starting to carve the head, draw on large ears and sideburns as shown on the pattern and the photo *above right*. Don't be afraid to exaggerate. Place the ear at least two-thirds of the way back on the side of the head. Then, with your knife, remove wood from in front of, on top of, and behind the ear so that it protrudes about $\frac{1}{4}$ " at the thickest point (just below and behind the top).

Next draw on the line for his seed cap. (Note that the cap goes all the way down to his collar behind the ears). Then, narrow the wood of the cap over the face so the visor ends up sticking out about $\frac{1}{32}$ " from the side of the farmer's head, as shown in the photo *far right*.

By now, you have probably trimmed off the sideburn outlines, so draw them in again. *Note: While working on the ears and sideburns, constantly check both sides of the head to see that the ears are level with each other and the same approximate size.* Then, recess the area below and in front of the ears about $\frac{1}{32}$ ", as in the photo of the finished face, *right*.



Pencil lines define the exaggerated ears and sideburns.

Taper the front part of the ears so that they disappear under the sideburns. To detail the inside of the ear, make a stabbing cut with the point of a $\frac{1}{8}$ "– $\frac{3}{16}$ " No. 9 gouge, as in photo *below*. Then, with the same tool, make a few shallow sweeps from the surrounding wood and into the cut.



Detail ears with a simple stab cut from a small gouge.

Next, shape the underside of the cap visor with a shallow $\frac{1}{4}$ "– $\frac{3}{8}$ " No. 4 or 5 gouge. Run the tool carefully from front to back and toward the forehead. With your knife, remove wood from the top side of the visor to follow the curvature you carved on the underside. *Use caution at this stage.* You're carving across grain, and if you make the visor thinner than $\frac{3}{16}$ ", or exert too much pressure with a tool, it can break off. Make a stop cut on the forehead under the visor to help shape the face.

Thinned acrylic paints allow the wood grain to show. Add a patina by slightly darkening linseed oil with stain.

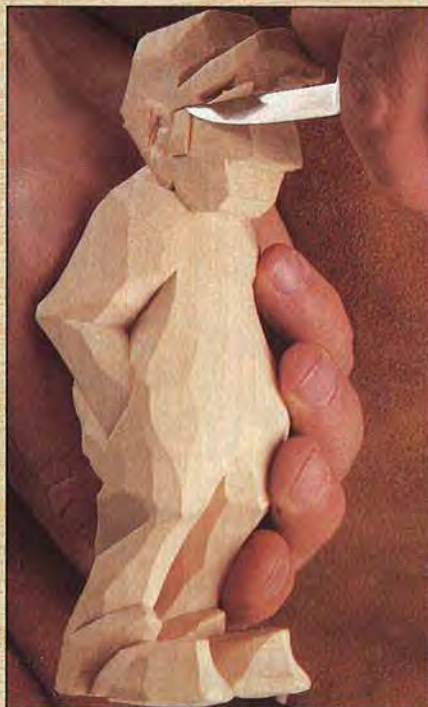

Note the thick cap visor. If you carve it too thin, though, or use excess pressure, the cross-grained wood could break.

Now, you're ready to tackle the face—often thought of as the most difficult step in carving. So, proceed slowly and refer to the photo of the finished face, *below*.

Begin by drawing a vertical centerline down the front of the face. Then, remove wood with your knife at an outwardly slop-

ing angle toward the back of the head. (If you look at someone's face, it isn't flat, but tapers toward the tip of the nose.)

To form the smile lines on both sides of the nose, make V-cuts with your knife. Note that they begin at the bulb or fattest part of the nose, then run down and outward like the legs of the letter A.

With a shallow V-cut, make the mouth, noting that it's located on the face slightly closer to the nose than to the tip of the chin. Accent the lower lip by cutting a shallower and shorter V-cut below and parallel to the mouth.

Using the same V-cuts as above, shape the eye sockets, at the same time thinning and forming the nose. With your small No. 9 gouge, scoop out the final sockets. You'll paint in the eyes later.

Now, it's time to add a few details. For the overall suspenders, first draw on lines, then vein (lightly cut) them with your V-tool. Vein the eyebrows, sideburns, and shirt collar as well. To make the brass buttons on his overalls, use the same stab technique you did to detail the inner ear. And, before you put away your tools, take the V-tool and add your name and the date to the bottom of one of the carved figure's shoes.

Paint that shows the grain

Referring to the photos here and on page 31, paint your farmer. Remember to thin the paints with water so the grain will show through (except the colors you use for the eyes, which should be opaque). Experiment first.

After the paint on your carving has thoroughly dried, liberally apply boiled linseed oil to which you've added just a hint of brown oil-stain or burnt umber artist's oil color. This gives your figure a protective patina. 🍷

Written by Peter J. Stephano
with Harley J. Refsal
Project design: Harley J. Refsal
Photographs: Bob Calmer
Graphic design: Perry A. McFarlin

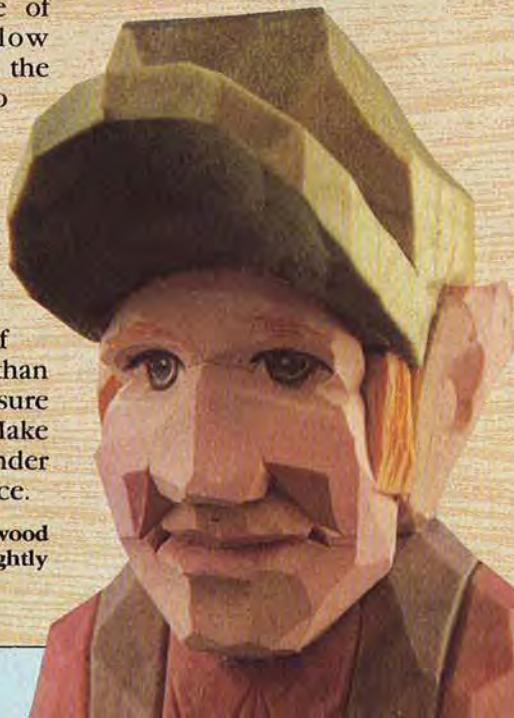

 Print this article

FOR LOADS OF FUN
THE FAT CAT[®]

FRONT-END LOADER

Our latest piece of heavy equipment may be pint-sized, but this tough-as-nails toy will be **BIG** with the sandbox set. Its pivoting-bucket assembly, in the skillful hands of an imagina-

tive child, will move “mountains” of material. For information on how to obtain plans for the other Fat-Cat toys we’ve published, please see the box on page 37.



Note: You'll need thin stock for this project. You can either plane or resaw thicker stock to size.

First, the cab and chassis

1 Cut a piece of $\frac{3}{4}$ " pine to $2\frac{1}{8}$ " wide by 12" long for the cab (A).

2 Measuring 1" from each end of the pine, mark the locations for a pair of $1\frac{3}{8}$ "-wide dadoes. Using your tablesaw and a miter gauge, cut the dadoes $\frac{1}{2}$ " deep where shown in the drawing at right.

3 Crosscut the pine into two equal lengths. Mark the windshield location on one piece (see the Window detail below for reference). Mark the top of the windshield flush with the top of the dado.

Continued

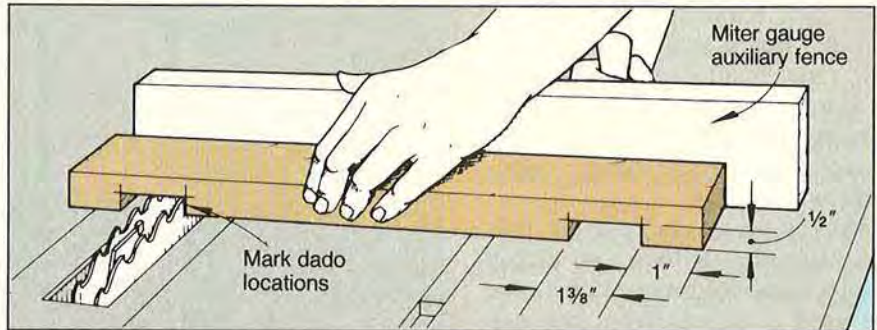

Bill of Materials

Parts	Finished Size*			Mati.	Qty.	Parts	Finished Size*			Mati.	Qty.
	T	W	L				T	W	L		
A* cab	1 1/2"	2 1/8"	3"	LP	1	BUCKET ASSEMBLY					
B chassis	3/4"	2 1/8"	4 1/4"	P	1	F bottom	1/4"	2"	3"	P	1
C hood	1 1/2"	1 1/2"	1 1/2"	LP	1	G back	1/4"	2 1/4"	3"	P	1
D support	1"	1 1/8"	1 5/8"	LP	1	H ends	1/4"	2 1/4"	2 1/4"	P	2
E* wheels	3/4"	2" dia.		P	4	I arms	1/2"	1"	2 5/8"	P	2

*Initially cut parts marked with an * oversized. Then, trim each to finished size according to the how-to instructions.

Material Key: LP-laminated pine, P-pine

Supplies: $\frac{3}{8}$ " dowel stock, $\frac{1}{2}$ " dowel stock, $\frac{3}{8}$ " wood button, $\frac{1}{2}$ " wood buttons, $\frac{3}{8}$ " all-thread rod $5\frac{1}{2}$ " long with nuts and washers for sanding arbor, $\frac{1}{4} \times 1\frac{1}{2}$ " U-bolt, #4 $\times \frac{1}{2}$ " flat-head wood screws, $\frac{5}{8}$ " \times 16 brads, clear finish.

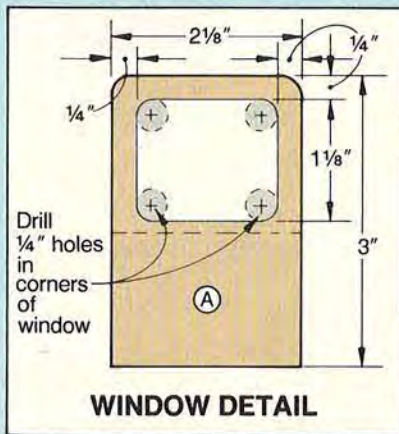

WINDOW DETAIL

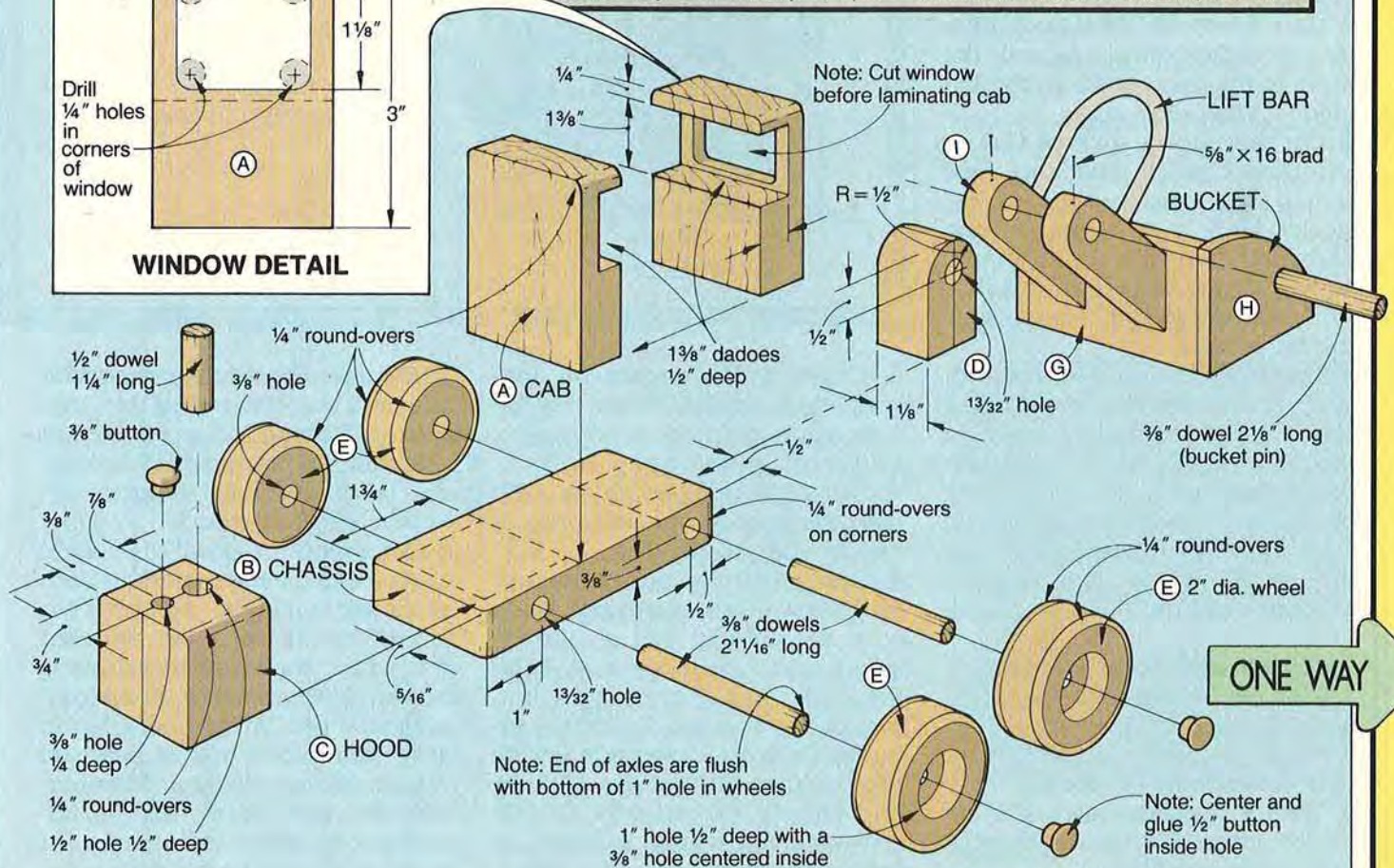

FRONT-END LOADER

Now, drill four $\frac{1}{4}$ " holes at each corner on the inside of the marked windshield. Cut the opening to shape with a scrollsaw or coping saw. Sand or file the cut edges of the windshield.

4 Apply glue to the mating surfaces, align the dadoes, and clamp the cab parts. Remove excess glue (we used a chisel) from the cab interior before it dries.

5 Trim the top and bottom of the cab lamination to length where dimensioned on the Window detail on the previous page. Sand $\frac{1}{4}$ " round-overs along the cab top where shown on the drawing.

6 Cut the chassis (B) to size.

Add the hood and bucket support

1 Glue and clamp two pieces of $\frac{3}{4}$ "-thick pine for the hood (C). Sand $\frac{1}{4}$ " round-overs on the top edges where shown on the Exploded View drawing.

2 Mark the smokestack and radiator-cap centerpoints, and drill the holes to the sizes stated on the Exploded View drawing.

3 Cut the bucket support (D) to size from 1"-thick pine stock (we laminated two pieces of $\frac{1}{2}$ " stock). Mark a $\frac{1}{2}$ " radius on one end, and bandsaw it to shape. Mark the centerpoint, and drill a $1\frac{3}{32}$ " hole through the support for the bucket pin.

4 Sand the chassis, hood, and support. Spread glue on the mating surfaces, and clamp the support to the front of the chassis, positioning it flush with one end of the chassis and centered from side to side. Next, glue and clamp the cab to the chassis and support, and then add the hood.

Time to add some wheels

1 To make four wheels (E), cut a piece of $\frac{3}{4}$ "-thick pine to 4×14 ". Starting 3" from one end, mark four centerpoints 3" apart.

2 With a compass, mark a 2"-diameter circle (1" radius) at each marked centerpoint.



Mark the wheel centerpoint locations 3" apart on the pine, and drill holes $\frac{1}{2}$ " deep for each wheel.



Center the circle-cutter pilot bit over the Forstner-bit depression, and cut the wheels to shape.

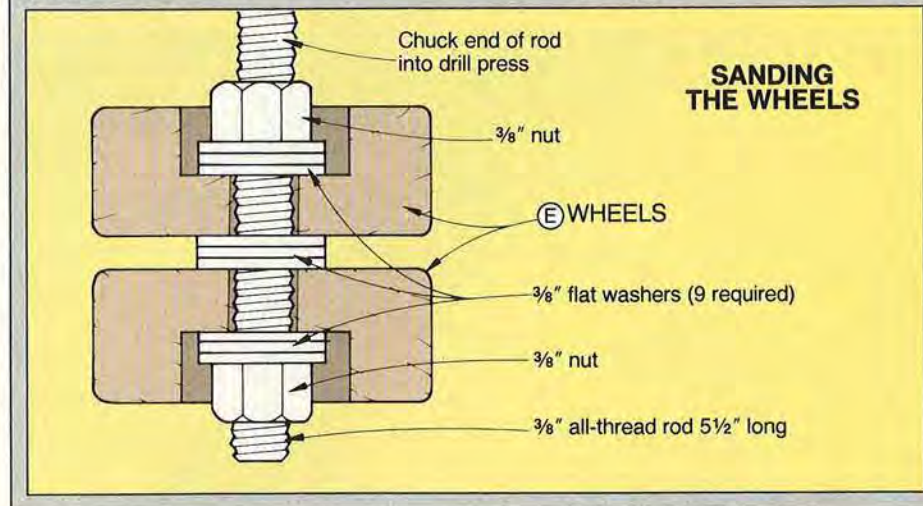

SANDING THE WHEELS

3 Chuck a 1" Forstner bit into your drill press. Center the bit over each marked centerpoint, and bore a $\frac{1}{2}$ "-deep hole as shown in the photo *above*. (We used the stop on our drill press to ensure uniform depth.)

4 Chuck a circle cutter into your drill press. Turn the cutter blade with the pointed end on the inside to cut a perfect wheel. Raise the blade $\frac{5}{8}$ " higher than the bottom of the pilot bit. Center the pilot bit over the depression left by the Forstner bit in each 1" hole, and slowly—about 250 to 500 rpm—cut the wheels to shape as shown in the photo *above right*.

5 Remove the circle cutter, and chuck a $\frac{3}{8}$ " twist drill bit into your drill press. Secure a wheel in a handscrew clamp, and enlarge the $\frac{1}{4}$ " pilot (axle) hole to $\frac{3}{8}$ ". Repeat for each wheel.

6 Cut a piece of $\frac{3}{8}$ " all-thread rod to $5\frac{1}{2}$ " long, and chuck it into your drill press. Attach two wheels at a time to the threaded rod where shown in the drawing *above*. With the drill press running at about 750 rpm, hand-sand a $\frac{1}{4}$ " round-over on each wheel where shown in the drawing. (We found sanding the round-overs safer than trying to rout them on a router table.)

BUCKET ASSEMBLY

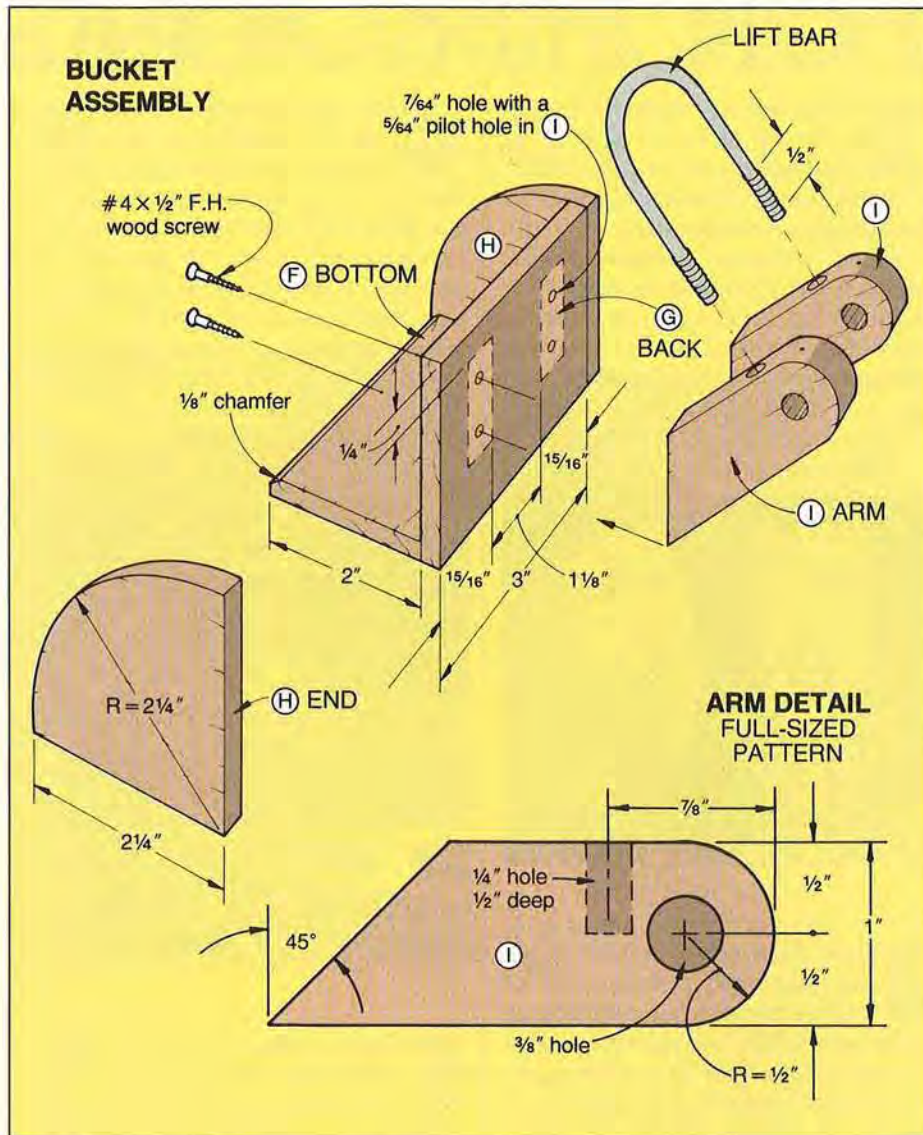

Next, assemble the bucket

1 Cut the bucket bottom (F), back (G), and ends (H) to size and shape from $\frac{1}{4}$ " stock. Sand a $\frac{1}{8}$ " chamfer along the top front edge of the bucket bottom.

2 From $\frac{1}{2}$ " stock, cut the arms (I) to size, mitering the front ends at 45° . See the drawings *above* for reference and the Bill of Materials for sizes.

3 Mark the centerpoints, and drill a $\frac{1}{4}$ " hole $\frac{1}{2}$ " deep in each arm for the lift-bar U-bolt and a $\frac{3}{8}$ " hole through each bucket arm.

4 Sand the pieces. Then, with the edges and ends flush, glue and clamp the bucket parts (F, G, H).

5 Using a hacksaw, trim the ends of a $1\frac{1}{2}$ " U-bolt so only $\frac{1}{2}$ " of threaded portion remains on each end (see the Bucket Assembly drawing for specifics).

6 Set the arms on a flat surface, and epoxy the threaded ends of the U-bolt into the $\frac{1}{4}$ " holes in the arms, checking that the arms are parallel to each other and that the mitered front ends remain flush. (You want the bucket support to fit easily between the arms.)

7 Hold the arm assembly against the back of the bucket assembly, and trace the arms outlines onto the bucket back. Drill four $\frac{7}{64}$ " holes through the back and $\frac{5}{64}$ "

pilot holes into the arms. Screw the arms to the bucket back.

8 Cut a $\frac{3}{8}$ " dowel to $2\frac{1}{8}$ " long for the bucket pin. Position the arms on both sides of the bucket support, and slide the dowel pin in place. Snip off the head of a $\frac{5}{8}$ " \times 16 brad and chuck it into your portable drill. Drill a pilot hole through each arm and into the dowel pin. Drive a $\frac{5}{8}$ " \times 16 brad through each pilot hole to secure the arms to the bucket pin.

Mount the wheels, and move some gravel

1 Cut the axles to length from $\frac{3}{8}$ " dowel stock as dimensioned on the Exploded View drawing.

2 Glue one wheel onto each dowel axle so that the end of the dowel is flush with the inside of the counterbore. After the glue dries, slide the axle through the axle hole and glue another wheel to the end of the axle dowel, leaving enough free play so the wheels turn easily.

3 To add the hubcaps, set the loader on its side. Place a drop of glue on the ends of the axle dowels, and glue a $\frac{1}{2}$ " wood button to the end of the dowel. After the glue dries, flip over the assembly and repeat for the other hubcaps.

4 Add the radiator cap and smokestack. Mask the U-bolt and apply the finish. 🐱

Fat-Cat-Toy Plans

We've presented plans for the following Fat-Cat toys: 1) semi-trucks and trailers, 2) excavator, 3) bulldozer, 4) dump truck and lowboy. To order the instructions, send \$2 per plan (four plans available) and a self-addressed envelope with one first-class stamp *per* plan to Fat Cat Toys, WOOD Magazine, P.O. Box 11454, Des Moines, IA 50336-1454.

Produced by Marlen Kemmet
Project Design: Steven Bruni
Photographs: Bob Calmer
Illustrations: Kim Downing; Mike Henry

10 TIPS FOR IMPROVING

Next time you attend a wood-working show, check out the scrollsaw booths. You'll meet demonstrators who can scroll rings around most woodworkers. What do they know that you may not? Just a few tricks, such as the tips on these pages.

1 Because of the rapid up-down strokes of its arms, a scrollsaw vibrates excessively when not securely fastened to a stand. If your machine doesn't have such a perch, bolt the scrollsaw to a sturdy surface. If you need to store your scrollsaw between uses, clamp it down.

If you can't clamp or bolt down the machine, try placing a thin foam pad, such as a carpet pad, underneath the machine as shown below.

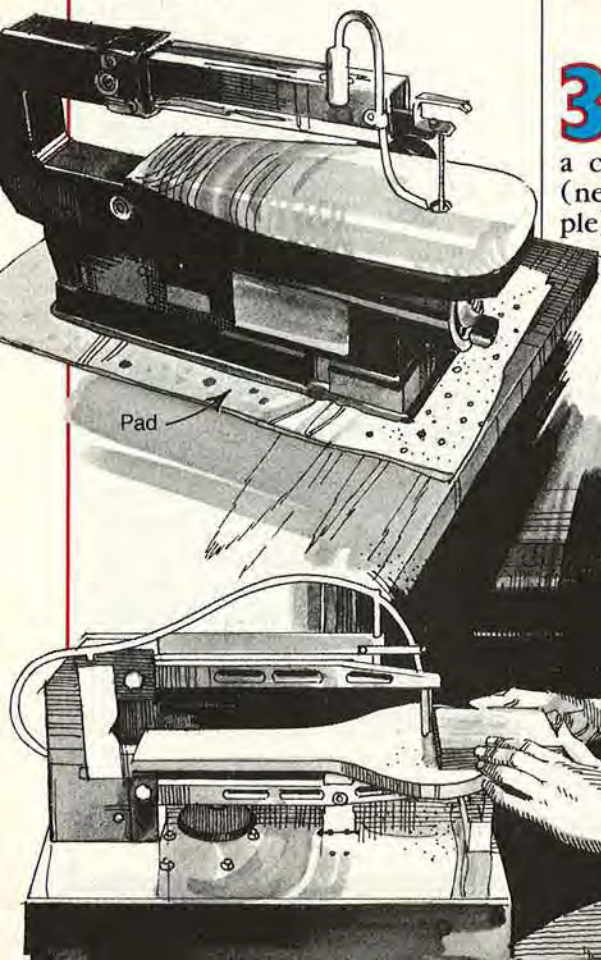

2 Scrollsaws come with a variety of blade clamps, but whatever the style, make sure the blade sits straight in the clamps as shown below.

With that accomplished, set the blade for the correct tension. Remember that you can tension a wide blade more than a narrow blade and that overtightening will lead to excessive blade breakage. On the other hand, a loose blade will flex sideways and backwards.

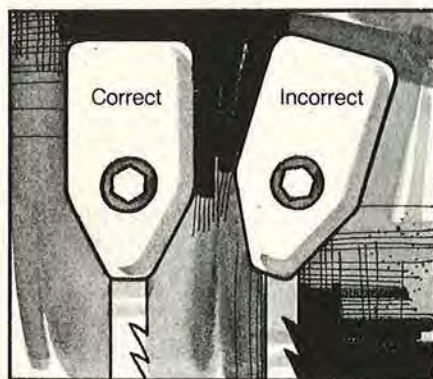

3 Time flies when you're having fun with a scrollsaw, so adjust the machine's table to a comfortable working height (near elbow level for most people). You'll also find it helpful to sit on a chair or stool.



4 As shown below, scrollsaw blades will flex under even slight feed pressure, so you need to occasionally slow down the feed rate and allow the blade to straighten itself. If you don't, you may cut a kerf that's not perpendicular to the table or bowed slightly. While cutting thick or dense stock, you may need to pause every 1/2" or so.

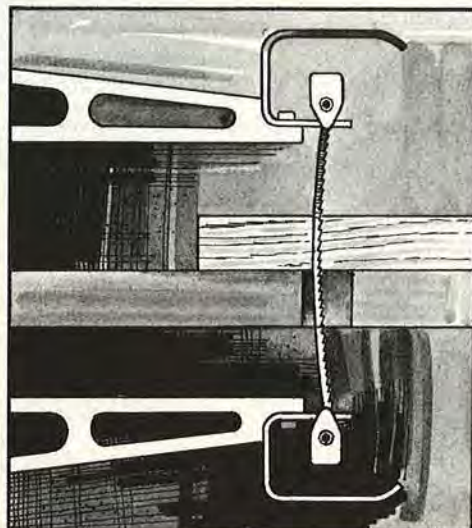

5 We've found that paper patterns are easier to see than patterns transferred directly to the wood surface by carbon paper or other means. Adhere the paper to the workpiece with adhesive spray or double-faced tape.



YOUR SCROLLWORK

6 A dustblower helps you see exactly where you're cutting, but for it to be effective, you must reposition it for each stock thickness. Most blowers put out a small volume of air, so place the hose tip no more than 1/2" from the cutting action.

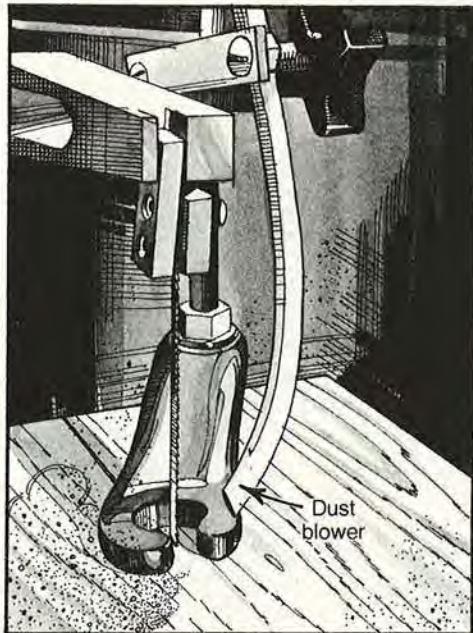

7 As you move the workpiece into the blade, start and exit the cut at a sharp point on the pattern rather than along a smooth line as shown *below*. Otherwise, your lines will have small "humps" where you enter and exit the cut.

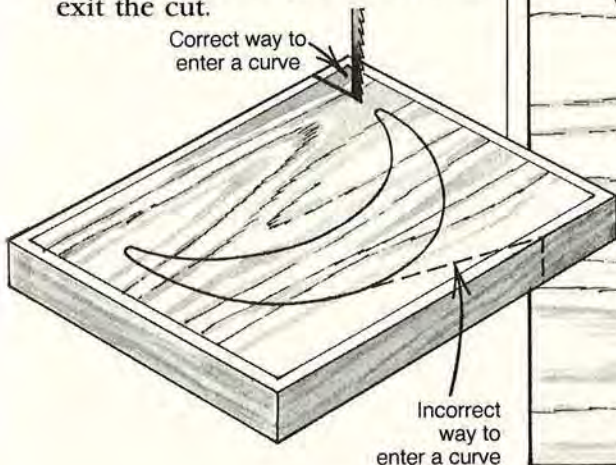

8 Because many of us have become accustomed to following layout lines on a bandsaw—a machine that doesn't allow cutting extremely tight curves—we're not used to rotating a workpiece as shown *below*. Experienced scrollers often spin their workpieces in full circles to

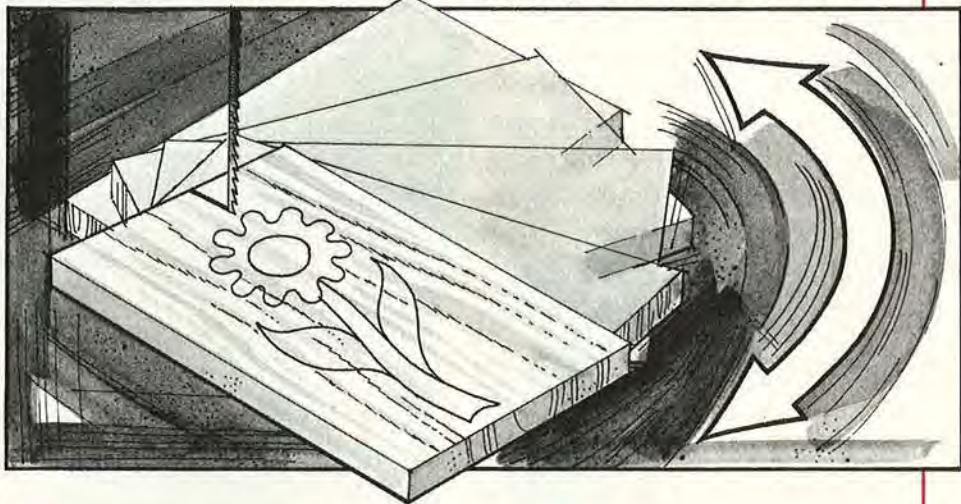

precisely follow tight twists and turns. When carefully executed, this maneuver may look tricky, but it just requires some practice.

To train yourself, draw some squiggly lines on a scrap piece and see how closely you can follow your markings. Soon you'll be spinning with the best of 'em.

9 Sometimes, you can't spin your way through extremely tight spots such as the narrow corner shown *below*. To smoothly execute this maneuver, first cut all the way into the corner, then back up the blade for Cut 2. Now you have enough room to turn the blade around and make the exit cut.

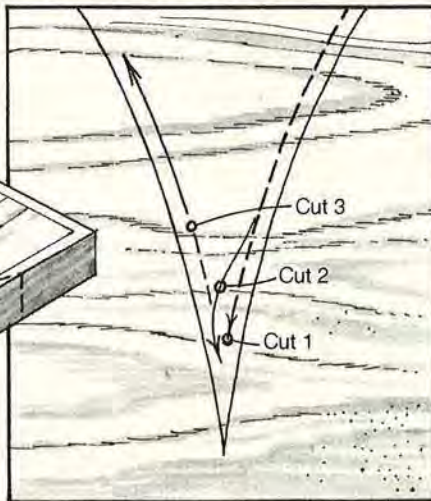

10 We hear from a lot of readers who have problems cutting thick, hard stock with a scrollsaw. If that sounds like you, try a wider, skip-tooth blade. (For more about blades, see the April 1990 issue.) Go slow and clear away cutting debris by backing the blade out of the cut often. ♣

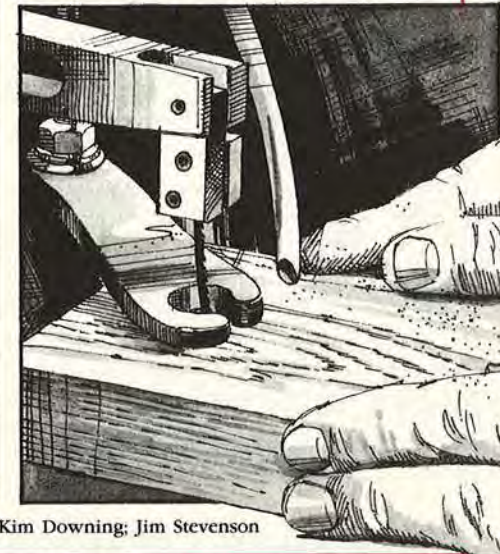

Illustrations: Kim Downing; Jim Stevenson

HARDWOOD

Off and on for about five years, we've fiddled with various briefcase designs. But until now, we just weren't satisfied with the results.

Designing a sturdy handle proved to be the biggest hurdle: leather wouldn't do, plywood was out of the question, and solid stock split too easily. We hope you'll like how we licked that problem, and put together an affordable Buying Guide for the top-notch brass hardware and leather liner. Now, it's time to get down to business!



Note: You'll need some 1/4"-thick oak for the case frame. You can resaw or plane thicker stock to size, or see the Buying Guide at the end of the article for our source of solid stock and plywood. If you resaw or plane your own stock, let the milled wood acclimate a couple of days before proceeding. The stock you build with must remain flat.



Print this article

Start with the case frame

1 From 1/4" stock (we used quarter-sawed red oak), cut the briefcase sides (A) and front and back (B) to the sizes listed in the Bill of Materials.

2 Fit your tablesaw with a zero-clearance insert (our Delta requires a 1/2"-thick insert; we used plywood). Attach a 1/4" dado blade to your tablesaw. Raise the blade through the insert 1/4" above the surface of the saw table.

3 Construct the jig and stop block shown on the Box Joint Jig drawing on page 42. Carefully locate and cut the two 1/4" kerfs in the jig. For snug-fitting box joints, the distance between the guide pin and kerf must be exactly 1/4".

Note: To check the accuracy of your jig, test-cut box joints in scrap stock the same thickness and width as parts A and B; adjust if necessary.

4 Machine the frame sides and then the front and back as shown in the two-step drawings titled Box-Jointing the Side and Box-Jointing the Front and Back.

5 Cover the mating surfaces of the box joints with glue (we used woodworker's glue and a small brush). Glue and clamp the pieces (A, B) and check for square. Caution: overclamping can cause the pieces to bow. Immediately wipe off excess glue with a damp cloth.

Continued

BRIEFCASE

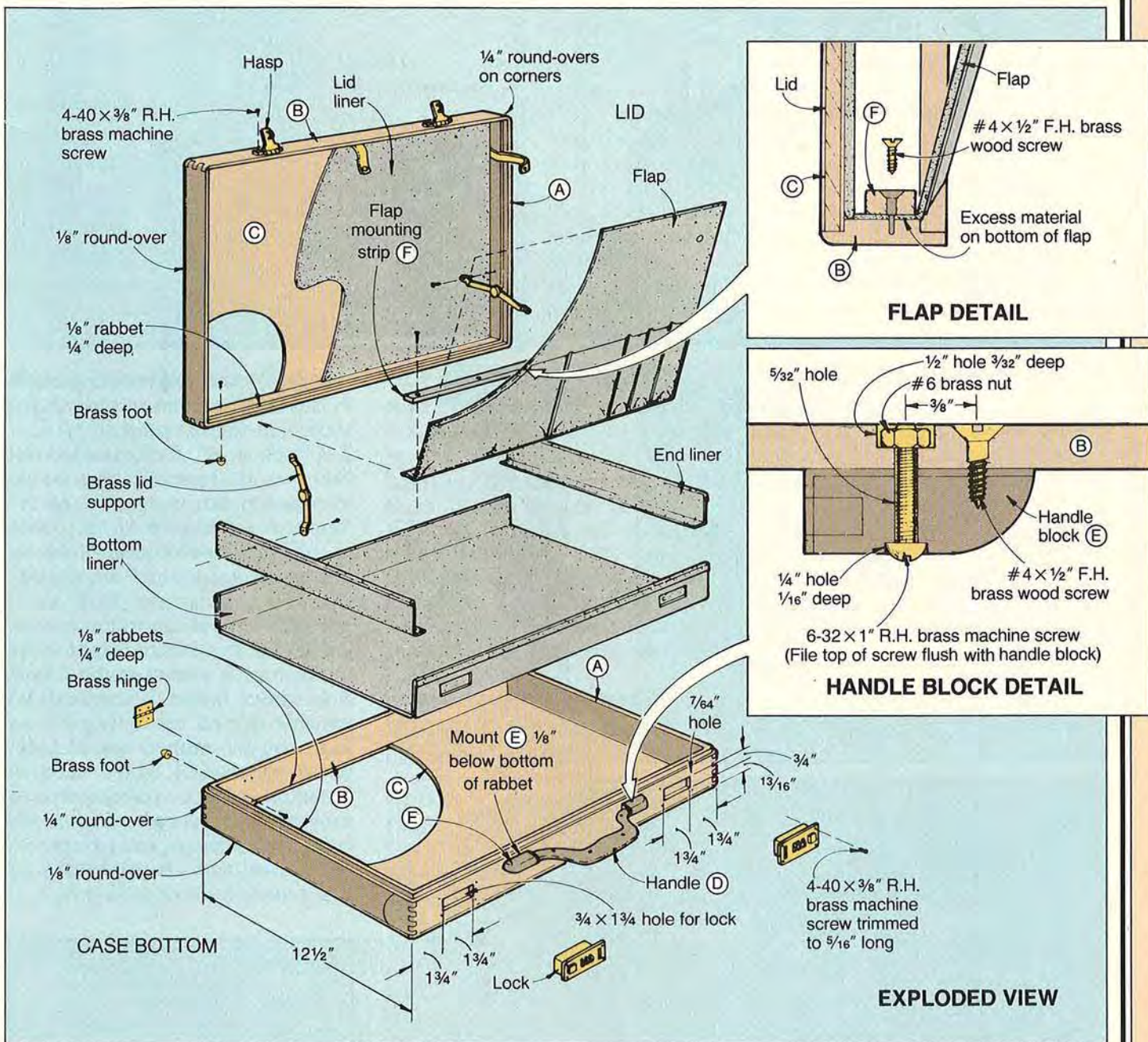

Bill of Materials											
Parts	Initial Size			Mati.	Qty.	Parts	Initial Size			Mati.	Qty.
	T	W	L				T	W	L		
A sides	1/4"	3 3/4"	12 1/2"	O	2	D handle blanks	3/8"	2 3/8"	6 3/8"	W	2
B front & back	1/4"	3 3/4"	18"	O	2	E handle blocks	1/2"	5 3/8"	1 1/2"	W	2
C panels	1/4"	12 1/4"	17 3/4"	OP	2	F flap strip	1/4"	1/2"	16 1/2"	O	1

Material Key: O-oak, OP-oak plywood, W-walnut

Supplies: 4-40 × 3/8" roundhead brass machine screws, 6-32 × 1" roundhead brass machine screws, 6-32 × 1/4" brass machine screws, 6-32 brass nuts, #4 × 1/2" flat-head brass wood screws, #4 × 3/8" roundhead brass wood screws, #4 × 1/4" roundhead brass wood screws, .032" brass 2 3/8 × 6 3/8" for handle, .032" brass 1/2 × 8" for handle blocks, 1/8"-diam. brass rod 6" long, epoxy, finish.

HARDWOOD BRIEFCASE

BOX-JOINT JIG

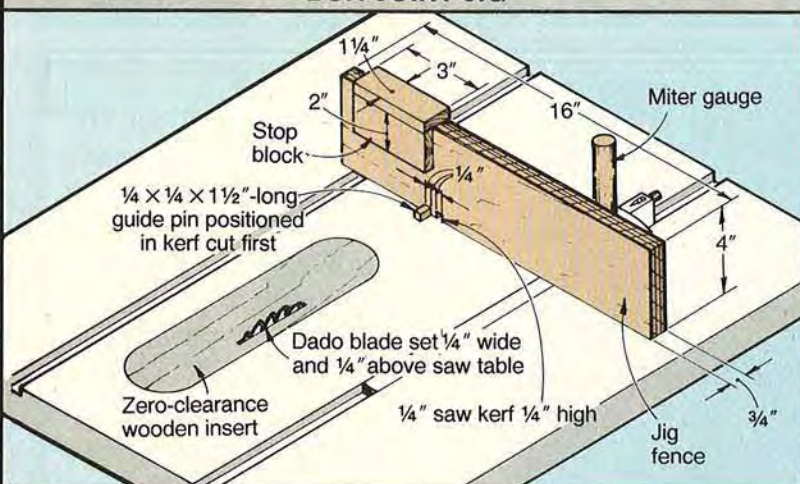

BOX-JOINTING THE SIDES

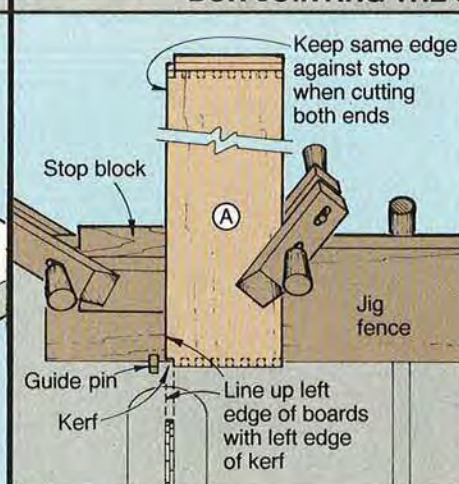

STEP 1.
Cut $\frac{1}{4} \times \frac{1}{4}$ notch in corner.

STEP 2.
Slide corner of notch firmly against guide pin and cut second notch in both boards.

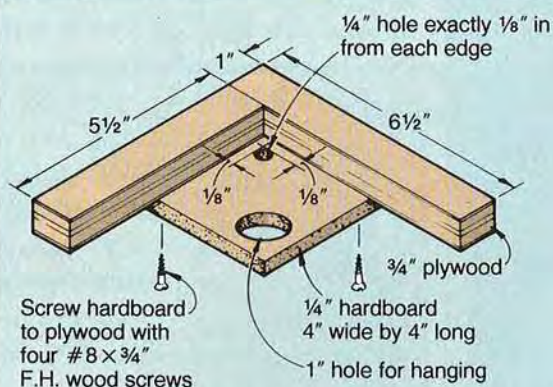

CORNER RADIUS JIG
View from bottom side

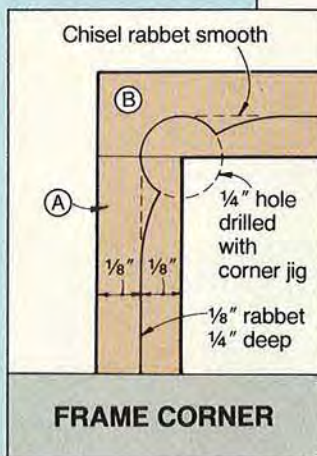

FRAME CORNER

Now, fit the plywood panels

1 Build the corner-radius jig shown in the drawing at left.

2 Chuck a $\frac{1}{4}$ " flat-bottomed bit into your drill press. Clamp the jig in position on one corner of the frame where shown in the photo at left. The inside corner of the jig must be snug against the outside corner of the frame. Drill a $\frac{1}{4}$ " hole $\frac{1}{4}$ " deep in the frame corner. Repeat the procedure (eight times total) at each corner of the frame.

3 In order to use a standard $\frac{3}{8}$ " carbide-tipped rabbeting bit to form the $\frac{1}{8}$ " rabbets for the plywood panels (C), you'll need to insert $\frac{1}{4}$ "-thick spacers where shown on the drawing below. To form these spacers, cut two pieces of $\frac{1}{4}$ " hardboard to $3\frac{3}{4} \times 12$ " and two pieces to $3\frac{3}{4} \times 17$ ".

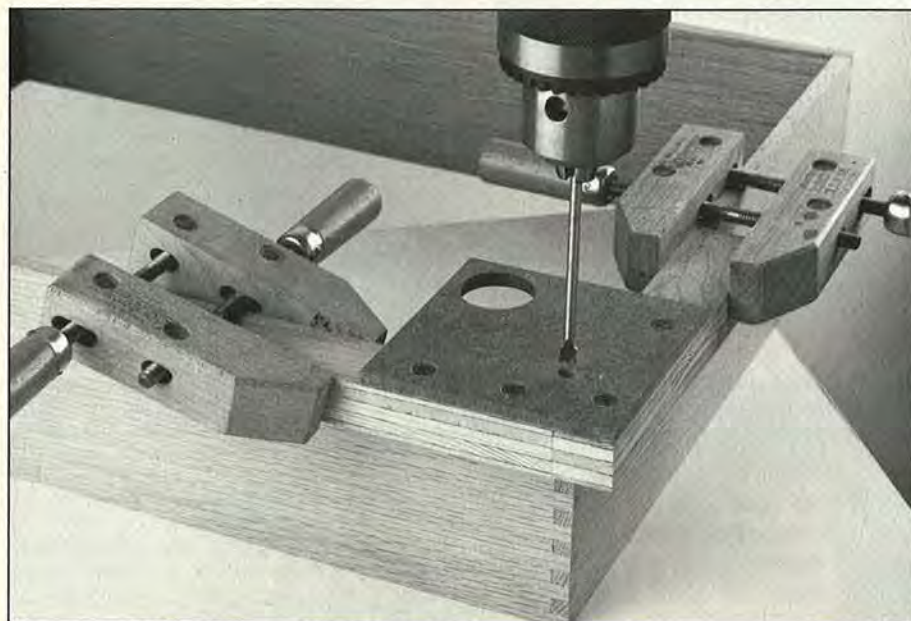

Clamp the radius jig to the corners of the case frame, and use a $\frac{1}{4}$ " flat-bottomed bit to form the round inside corners for the rabbets.

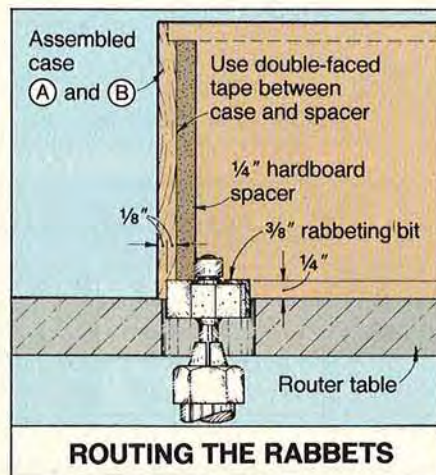

ROUTING THE RABBETS

BOX-JOINTING THE FRONT AND BACK

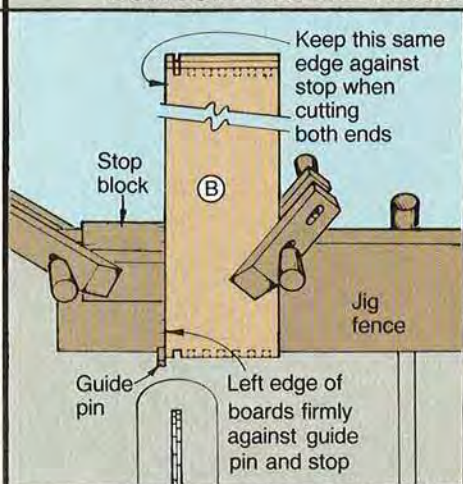

STEP 1.
Cut first notch.

STEP 2.
Place notch over guide pin and cut second notch.

4 Secure the spacers against the inside surfaces of the case pieces with double-faced tape. Fit your router with a $\frac{3}{8}$ " carbide-tipped rabbeting bit, and raise it $\frac{1}{4}$ " above the router table. Then, rout a $\frac{1}{8}$ " rabbet around the top and bottom inside edges of the case assembly where shown *below left*. Remove the spacers and set them aside; you'll use them to rout the rabbet on the inside of the lid.

5 Chisel the waste between the rabbets and $\frac{1}{4}$ " holes in each corner where shown on the drawing titled *Frame Corner at left*.

6 From $\frac{1}{4}$ " oak plywood, cut the two panels (C) to fit the rabbeted openings in the oak case. Using a circle template, mark a $\frac{1}{8}$ " radius on each panel corner. Sand to the line until each panel fits the open-

Cut the case apart and form a lip

1 Make four cuts where shown in Step 1 of the three-step drawing *below*. (After making each cut, we taped two $\frac{1}{8}$ " spacers in each kerf to keep the case from binding when making the final cut.)

2 Reposition the fence where shown in Step 2 of the drawing *below*, and trim the top edge of the case bottom even with the outside finger.

3 To create the lip on the case bottom, fit your tablesaw with a $\frac{3}{8}$ " dado blade and an auxiliary wooden fence, and cut the $\frac{1}{4}$ " rabbets $\frac{1}{8}$ " deep where shown in Step 3 of the drawing *below*.

4 Rip the hardboard spacers you used earlier to 1" wide and tape them in place in the lid. Now, us-

ing. Now, glue the panels into the openings.

7 Fit your router table with a $\frac{1}{4}$ " round-over bit and fence, and rout the four corners (not edges) of the case (see the Exploded View drawing for reference).

8 Rout a $\frac{1}{8}$ " round-over along the case edges.

ing the corner radius jig and the drawing titled *Routing the Rabbets for reference*, drill the corners, and rout a $\frac{1}{8}$ " rabbet $\frac{1}{4}$ " deep along the bottom *inside* edge of the lid. File or sand the four corners of the lip in the case bottom to fit into the radiused corners of the lid.

5 Mark the lock-hole locations on the case bottom (see the Exploded View drawing). Drill blade-start holes and cut the lock holes to shape. (We used a portable jig-saw—some call it a sabersaw—and a smooth-cutting blade.)

One classy custom handle coming up

Note: Our prototype wood handles eventually split along the grain. Epoxying brass between solid stock solved that problem. When drilling and sanding the handle, use slow speeds to prevent overheating. Excessive heat will soften the epoxy, causing the brass to delaminate from the walnut.

1 Cut two pieces of $\frac{3}{8}$ " walnut and one piece of .032" brass to $2\frac{3}{8} \times 6\frac{3}{8}$ " (we used a bandsaw to cut the brass). For better adhesion to the epoxy and walnut, rough up both sides of the brass with 80-grit sandpaper.

2 Follow the 4-step drawing on the following page to form the brass-and-walnut handle.

Continued

CUTTING THE CASE IN TWO

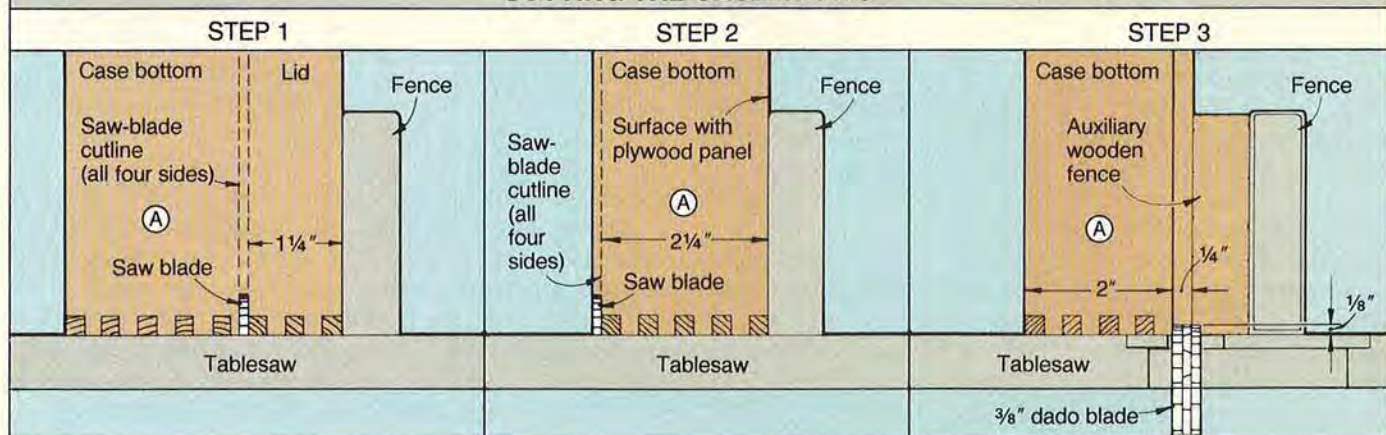

HARDWOOD BRIEFCASE

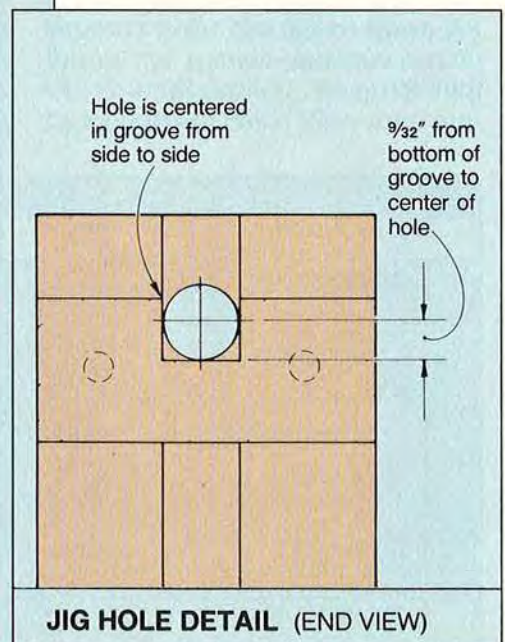
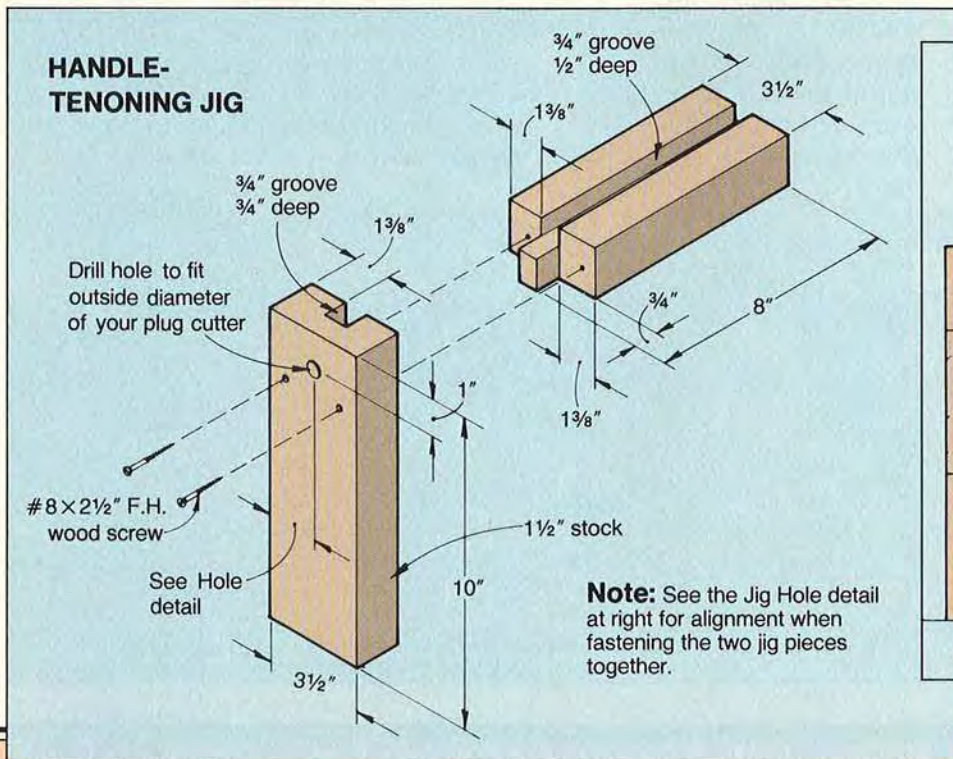
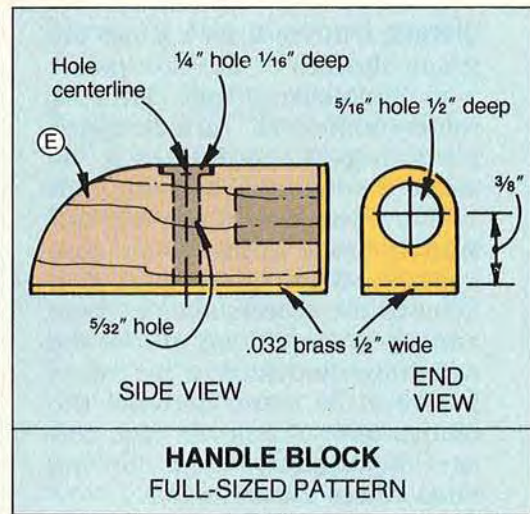
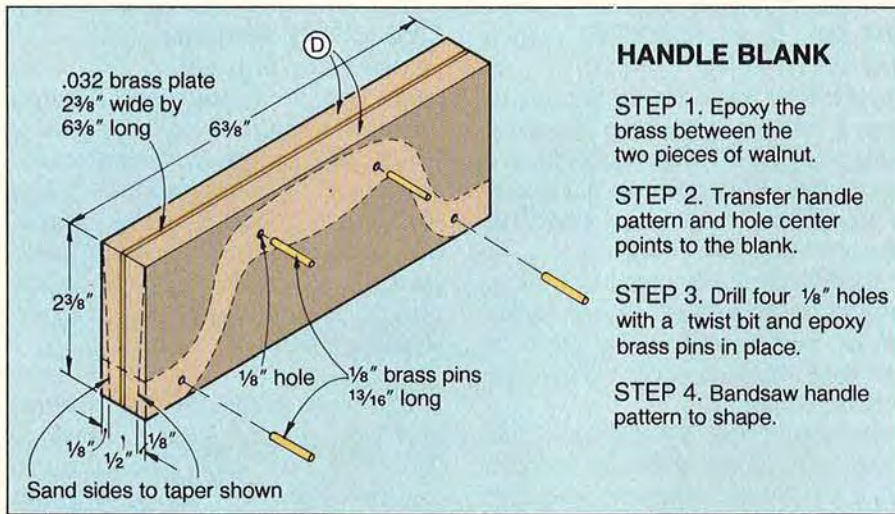
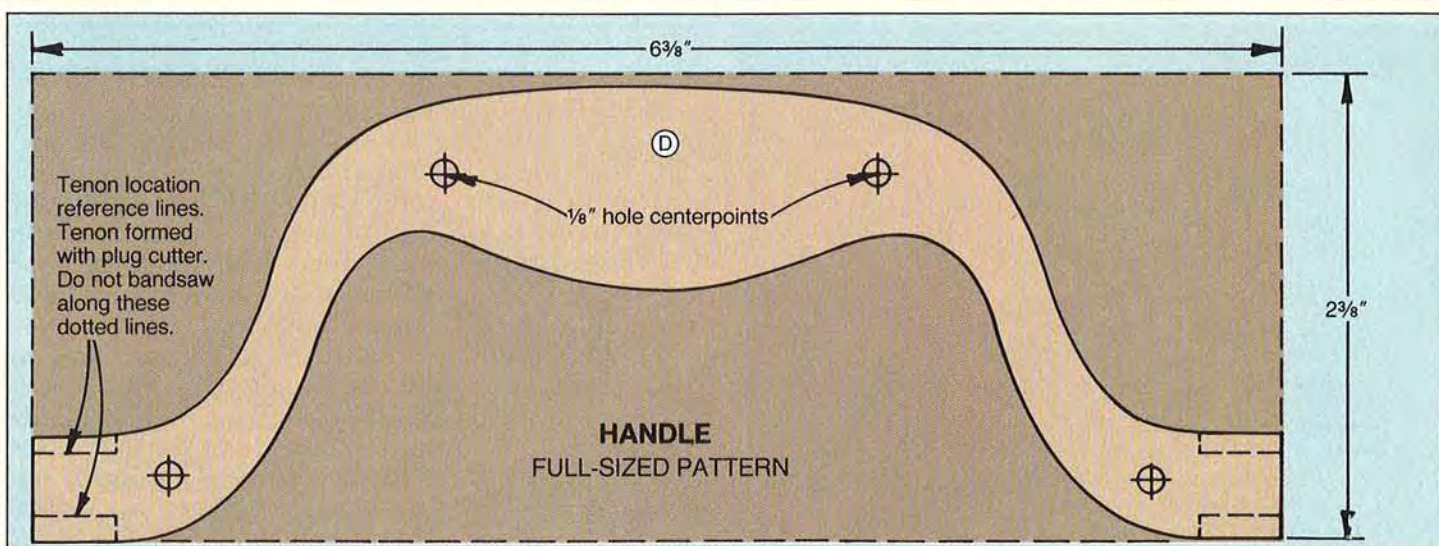

3 Build the handle-tenoning jig shown on the drawing *far left, bottom*. (We constructed ours from an 18"-long piece of 2×4.)

4 Sand both walnut surfaces until the handle fits snugly into the $\frac{3}{4}$ " groove in the handle-tenoning jig.

5 Fit your portable drill with a $\frac{5}{16}$ " plug cutter. Slide the handle into the jig and clamp it in place. Now, use the plug cutter to cut a $\frac{5}{16}$ " tenon $\frac{7}{16}$ " long on both ends of the handle as shown in the photo at *right*.

6 Sand the handle to the tapered shape shown on the Handle Blank drawing. Then, rout or sand $\frac{3}{16}$ " round-overs on all edges of the handle except at the tenons.

7 Cut two pieces of walnut to $\frac{1}{2} \times \frac{5}{8} \times 1\frac{1}{2}$ " for the handle blocks (E). Then, cut two pieces of .032" brass to $\frac{1}{2}$ " wide by 4" long. Form a 90° bend in the middle of the brass. Sand both surfaces of the brass for better adhesion, and then epoxy a handle block (E) to each brass piece.

8 After the epoxy has cured, hold the block/brass assembly in a handscrew clamp, and drill a $\frac{5}{16}$ " hole $\frac{1}{2}$ " deep through the brass and into the walnut where shown at *left*.

9 Trim the brass flush with the ends of the walnut. File and sand a $\frac{1}{4}$ " round-over on each handle block. See the Handle Block drawing at *left* for reference. Now, drill the $\frac{5}{32}$ " and $\frac{1}{4}$ " holes in each block where shown.

It's time to attach the handle

1 Position the handle blocks on the handle tenons. Sand the handle tenons slightly if necessary for a good fit into the block holes. Center the assembly from side to side on the case and $\frac{1}{8}$ " below the routed rabbet where shown on the Exploded View drawing. Tape the assembly in position.

2 Using the previously drilled $\frac{5}{32}$ " holes in the blocks as guides, drill the same-sized holes through the

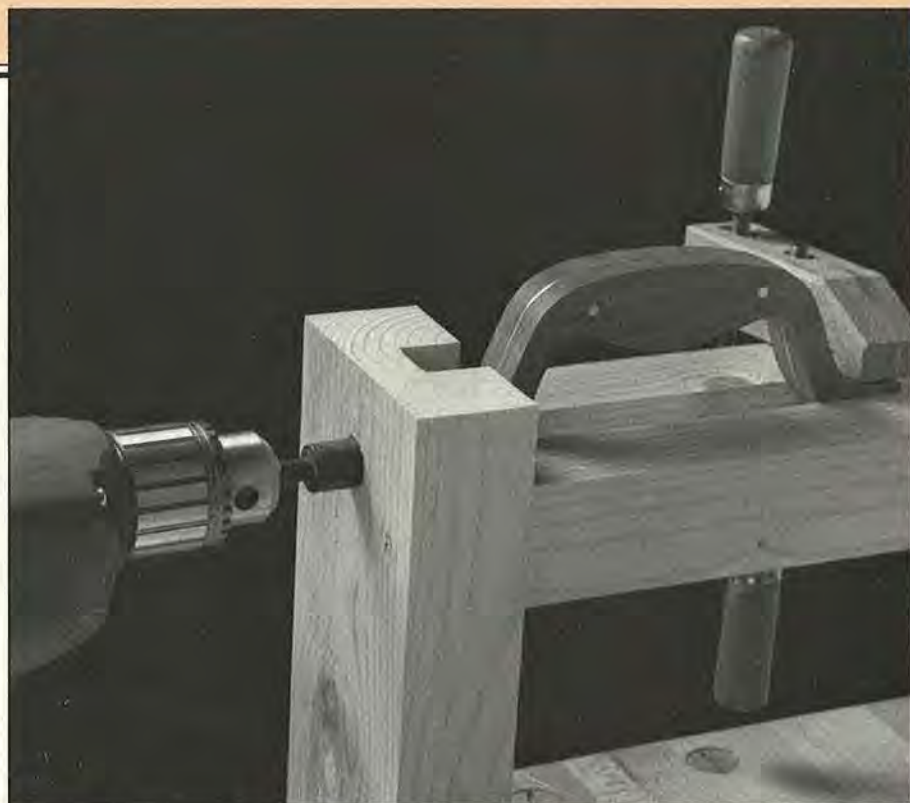

Use a $\frac{5}{16}$ " plug cutter and the tenoning jig to form the round tenons on the ends of the laminated brass-and-walnut handle.

case. Counterbore the hole on the inside of the case with a $\frac{1}{2}$ " Forstner bit.

3 Referring to the Handle Block drawing for reference, epoxy the machine screw and nut to secure the blocks and handle to the case. Then, mark the centerpoints and drill $\frac{5}{64}$ " holes through the case and $\frac{1}{4}$ " into each block. Counter-sink the holes. Epoxy and drive a #4 × $\frac{1}{2}$ " brass flathead wood screw into each to further secure the blocks to the case.

4 Remove the machine-screw slot by filing and sanding.

Apply the finish, and install the hinges and locks

1 Finish-sand the case and apply the finish to the interior and exterior. (We left the wood natural and applied three coats of polyurethane.)

2 Chuck the threaded end of one of the hinge screws into a portable drill. Turn on the drill and hold the rotating head against a belt sander to sand the slotted head flat. Then, polish the head with 320-grit wet/dry sandpaper.

Remove the screw from the drill chuck and repeat with the seven remaining screws.

3 Spray the polished screw heads with clear lacquer. Let dry.

4 Referring to the drawing titled Mounting the Hinge for reference, tape the hinges in position and drill $\frac{3}{32}$ " pilot holes into the case.

5 With a toothpick, fill the hinge-mounting holes with epoxy. Then, use the toothpick to apply epoxy to the threads of each screw. Thread the screws through the holes and into the mounting holes. Let the epoxy cure.

6 Tape a lock in position in one of the rectangular holes previously cut in the case. Using the lock holes as a guide, drill $\frac{7}{64}$ " holes through the case. Refer to steps 2, 3, and 5 above to fasten the locks to the case.

7 Push the hasps into the locks. Using the holes in the hasps as guides, mark the hasp-hole locations on the case. Drill a $\frac{7}{64}$ " hole at each mark. Refer to the method previously described to remove the screw slots and then epoxy the hasps to the case.

Continued

HARDWOOD BRIEFCASE

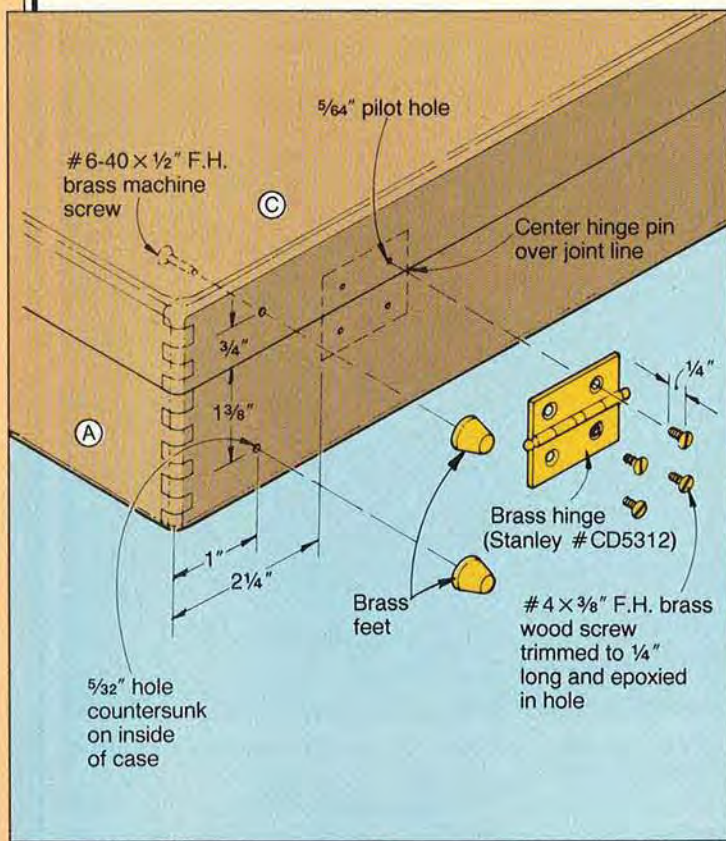

MOUNTING THE HINGE

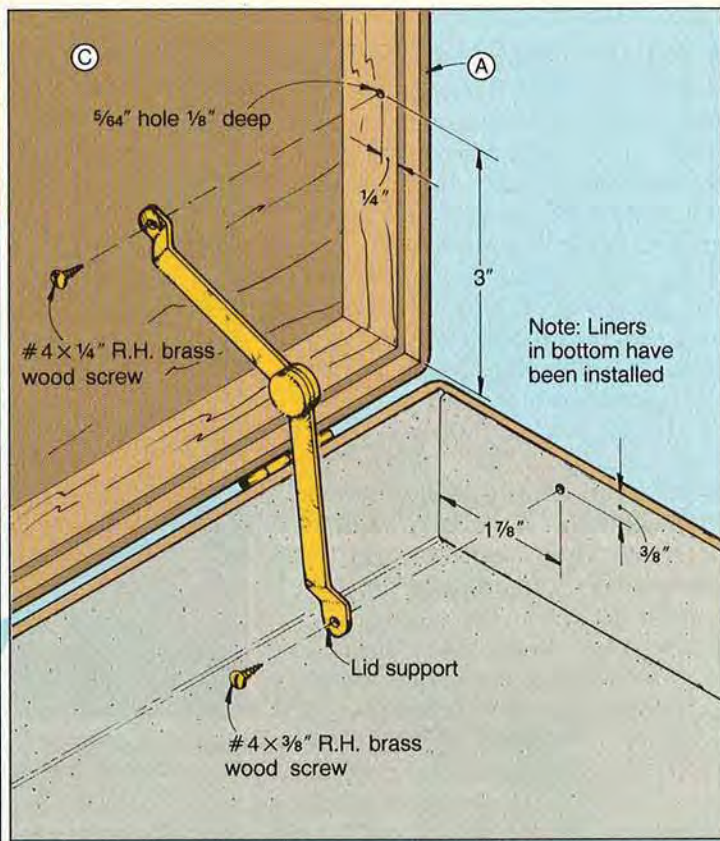

MOUNTING THE LID SUPPORT

Add the feet and liner and head for the office

1 Using the drawing titled Mounting the Hinge, drill the mounting holes and fasten the feet to the case. (To secure the feet, we placed a drop of epoxy into each foot before threading the mounting screw in place.)

2 Cut the flap-mounting strip (F) to size. Drill and countersink four 7/64 inch holes through the strip.

3 To get the liner to stick to the case, lightly rough up the mating interior surfaces with 80-grit sandpaper. Sand all but the side edges of the lid—they don't get covered with the leather lining.

4 With woodworker's glue or epoxy, glue the end-liner pieces first. (As shown below, we used two pieces of stock to hold the end-liner pieces firmly against the case until the glue dried.) Be careful not to get any adhesive on the good face of the liner pieces. Now, install the bottom liner, us-

ing a stack of books or other heavy objects to hold the liner flat until the glue dries.

5 Attach the lid supports where shown above.

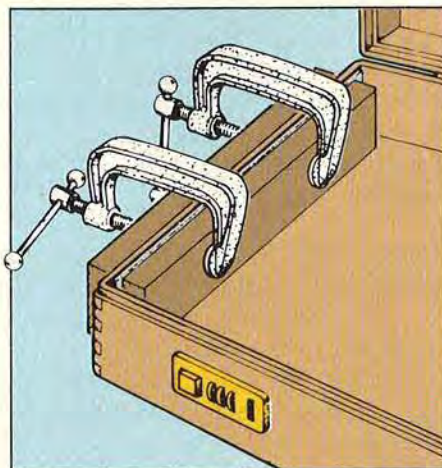

6 Adhere the liner to the lid interior. Then, using the Flap detail accompanying the Exploded View drawing and the flap mounting strip (F), attach the bottom edge of the flap to the lid.

Buying Guide

• **Briefcase hardware.** Pair of brass combination locks with hasps, pair of lid supports, four feet, pair of hinges, .032 x 4 x 10" brass, 6" of 1/8" diameter brass rod. \$39.40 (U.S.) ppd. For the pigskin liner, add \$78 (U.S.). Broman's Luggage, 209 Central Avenue, Osseo, MN 55369.

• **Hardwood kit.** Two pieces of 1/4 x 4 x 12 1/2" oak, two pieces of 1/4 x 4 x 18" oak, and two pieces of 1/4 x 12 3/4 x 18" oak plywood. Kits also available in genuine mahogany and walnut. Red oak kit \$24.95 ppd., genuine mahogany kit \$27.95 ppd., or walnut kit \$34.95 ppd. (All funds U.S.) Woodworkers' Dream, 510 Sycamore Street, Nazareth, PA 18064. Call 800-247-6931 or 215/759-2837 to order. ♣

Produced by Marlen Kemmet
Project Design: James R. Downing; Jim Boelling
Photographs: Hopkins Associates
Illustrations: Kim Downing; Bill Zaun



AT THE C. F. MARTIN COMPANY

A HANDCRAFTED LEGACY LIVES ON

Name some music stars—Paul McCartney, Bonnie Raitt, Arlo Guthrie—and you can bet they own Martin guitars. So do country music's Ricky Skaggs and Johnny Cash. In fact, the roster of Martin guitar owners reads like a musical Who's Who. Some, in fact, have been responsible for the adoption of popular Martin models—the mother-of-pearl inlaid D-45 shown on this page, for instance, was first created for Gene Autry.

Continued

The C. F. Martin Company has made guitars since 1833, and basically, hasn't changed its tune in the hand-building process responsible for the acclaim of its instruments.

That's because the words written by Frank Henry Martin in the company's 1904 catalog strike a familiar chord with employees even today: *"How to build a guitar to give this tone is not a secret. It takes care and patience. Care, in selecting the material, laying out the proportions, and attending to the details which add to a player's comfort. Patience, in giving the necessary time to finish every part. A good guitar cannot be made for the price of a poor one, but who that has used a good one regrets the extra cost?"*

Sound from six generations

In the early 1800s, Markneukirchen, a village in northern Germany, was known for its violin makers. But there were other talented wood craftsmen living there, too. Among them, a skilled carpenter and cabinetmaker named Georg Martin.

One day Georg happened upon a traveler carrying a stringed instrument he had never before seen. It was a guitar. Fascinated by its sound, he decided to build one.

Over the years, Georg Martin became an accomplished guitar maker. When his son, Christian Frederick, became old enough to work wood, he too, built guitars.

The Martin's reputation for quality instruments grew, much to the dismay of the violin makers guild, which the Martins refused to join. The friction built until 1833, when Christian Frederick Martin, finally fed up with the bickering, packed his tools and sailed for the United States to set up shop in New York City.

A growing instrument repair and guitar-making business, plus a desire for the country,



Details make the Martin D-45 worth \$5,300. A rosewood headplate and an ebony fingerboard feature abalone-pearl inlay and gold-plated tuning machines for the strings.

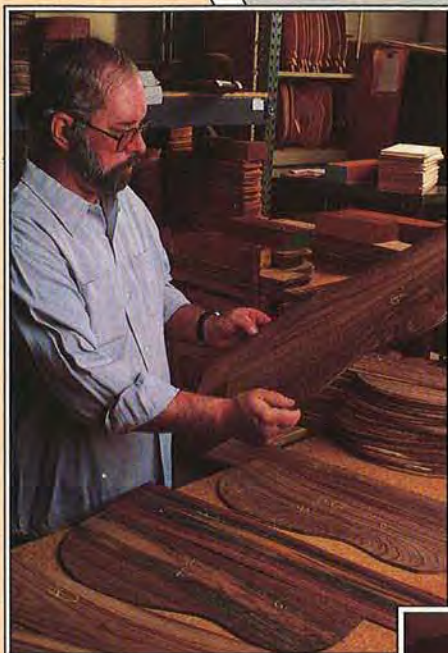

◀ “I match the Brazilian rosewood backs and sides by color and grain pattern,” says George Savercool. That’s a demanding job since the thin-sawed stock rarely comes from flitches of the same log. Although the Martin company prefers quarter-sawed stock to avoid wild grain, it’s not always available.

▶ “Only two Martin guitar models have sides bent in a heated press,” notes Larry Fehnel. “All others must be bent to shape by hand on a stationary, electric bending iron heated to about 375–400 degrees.”

▼ Bracing a guitar top strengthens it against the pull of the strings, but over-bracing can jeopardize the tone. “To increase treble response and volume, I use a chisel to feather the spruce braces where strength isn’t as critical,” notes Ralph Miller.



eventually led C. F. Martin to the green, rolling hills around Nazareth, Pennsylvania, in 1839. There, in a setting much like that he loved in his native Germany, he built guitars and sent them to New York to sell in the United States, and in time, in shops around the world.

During the 1850s, C. F. Martin’s son, Christian Frederick, Jr., entered the business. In 1867, he succeeded his father as company president, as would other Martins after him. Today, in the sixth generation, Christian Frederick Martin IV heads the company. And, out in the shop, among the 100 employees who produce 9,300 guitars a year, he’s called “Chris” as he makes the rounds.

Guitar players prove plenty picky

“Anything you do to or with a guitar has an effect. You even change the sound when you wrap your arm around it,” notes Mike Longworth, musician, craftsman, guitar historian, and Martin’s customer-relations manager.



That’s why the choice of wood plays such an important part in the making of an acoustic guitar—different woods have different tones. And appearance, too.

“Martin guitar owners tend to be extremely picky, not only in the sound of an instrument, but in how it looks,” notes Dick Boak, a guitarist as well as the company’s advertising manager. “If they see any character or figure in the wood whatsoever, they think it must be a defect! And, I guess that’s our fault because we like to think our quality control has been the most stringent of the industry.” That’s why only certain woods have become part of the company tradition.

▼ David Anthony glues a ribbon inside a rosewood guitar body. “It’s made from ¼”-thick Spanish cedar, kerfed at regular intervals so it bends easily,” he says. The ribbons—one at the top edge and another at the back—act as stiffeners as well as a gluing surface for the top and back. Ordinary clothespins clamp the ribbons in place.

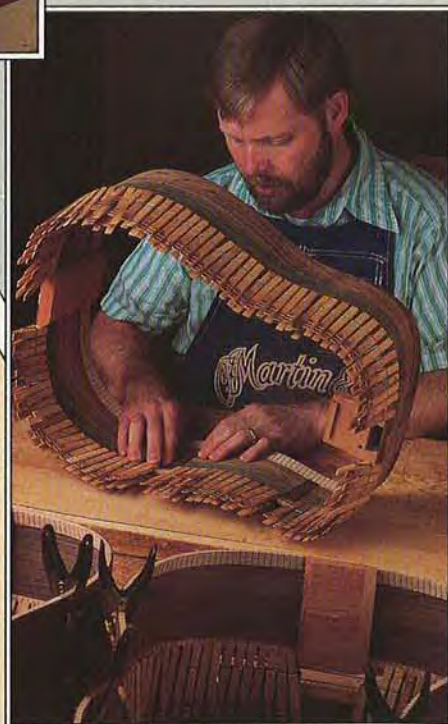

Continued

►With a drawknife and 15 minutes of time, Willard Silvius will bring the semi-shaped, mahogany neck to within $\frac{1}{16}$ " of final dimension, then it will be finish-sanded. "We hand-shape all guitar necks from a bandsawed and partially machined roughout," he says from his carefully arranged work space.

▼ Tim Teel eyes the crucial alignment of the neck to the body. "To get the two compound angles at the base of the neck, I make a few deft cuts with a chisel. Then, it fits perfectly into the body's dovetail," he notes. After fitting the neck, the parts go separate ways for finishing before final joining.

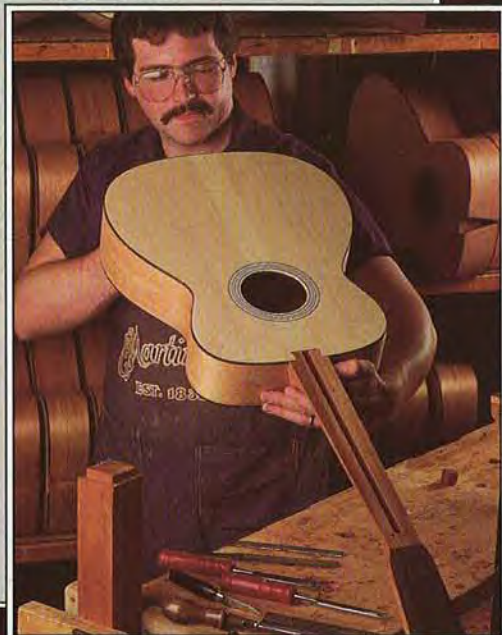

▼ "I play guitar at home for my own enjoyment, as I have for about 20 years," says Al Realo, "but it's part of my quality control job here." The D-45 model he's checking could be rejected for a speck in the finish or slight fretting inaccuracy. "Sometimes, nothing shows up until the strings start pulling on the body," Al adds, as he strums a popular tune.

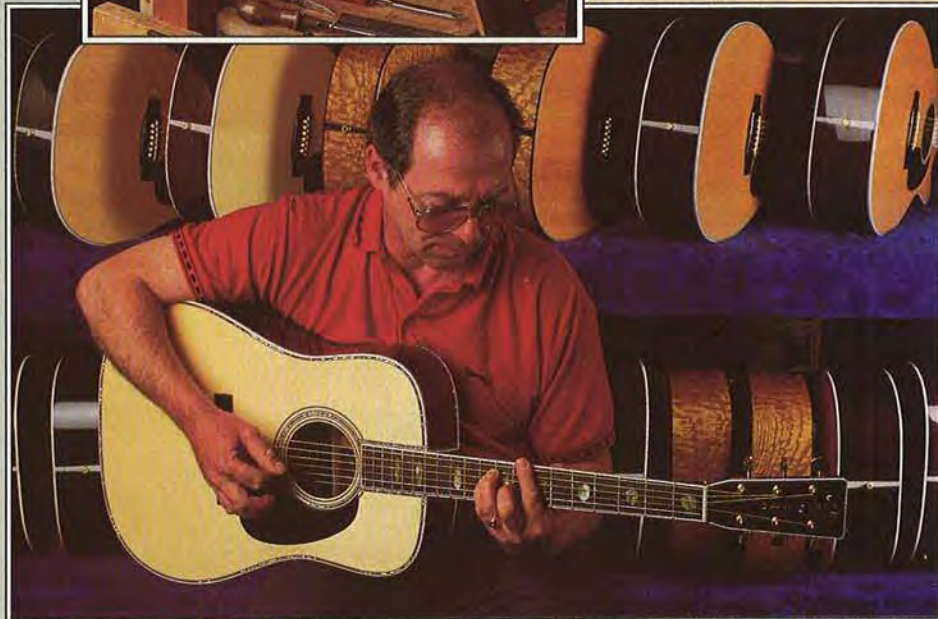

Tops—finished to a thickness of less than $\frac{1}{8}$ "—must be strong enough to withstand the 190 pounds of pull applied by the steel strings. Yet, tops must have the flexibility to vibrate. "We've used spruce from all over the world," says Boak, "but quarter-sawed, vertical-grain Sitka spruce from Alaska and the Canadian Northwest makes an ideal top on steel-string guitars.

"The sides [$\frac{5}{64}$ " thick] and backs [$\frac{1}{8}$ " thick] of guitars are designed to absorb sound as well as reflect it," he continues. "Generally, hardwoods flavor the sound by doing both."

For sides and backs, Martin craftsmen prefer Brazilian rosewood, when they can get it. That hasn't been easy, though, since a 1969 export embargo made the wood practically unobtainable in quantity. Why does this species work so well? Besides being extremely strong and stable when quarter-sawed, the wood produces a deep, warm, and resonant bass, according to Boak. Other popular woods include East Indian rosewood (with tonal qualities similar to its Brazilian cousin), tropical American mahogany, Hawaiian koa, and European fiddleback maple.

Martin's traditional woods may eventually be supplemented by other species, though. "Given the dwindling supply of material resources," says Boak, "Martin is making a concerted effort to educate our guitar customers regarding the differences between the natural character markings of wood versus actual defects."

Old-fashioned hand craftsmanship lingers on

Inside the modern one-story, powder-blue Martin guitar plant on Sycamore Street, all pre-conceived assembly line impressions vanish. Instead of factory-like conveyor belts moving partially completed guitars from place to place, men and women ply their special

skills at individual work benches. The atmosphere belongs to the last century.

"What we do is teach someone to do one job, and they stay with that job until they are adept at it," explains Martin historian Mike Longworth. "Martin's philosophy creates master craftsmen and an unequaled product."

Highlighted by this individual craftsmanship, guitar making at Martin takes on the aura of a custom operation. Unlike the lonely luthier crafting single instruments, at Martin, stock models are built in batches of 6, 12, and 25.

Each neck begins as raw stock, and then is bandsawed and machine-shaped before the crucial fitting of one to the other (shown *opposite center*). At this step, Tim Teel must shave the wood from the compound-angled base of the neck so that it slips into the dovetail and aligns perfectly. That done, the neck is handcarved to its final shape with a drawknife, *opposite top*. Then, the neck and body part company, not to join again until they've been finished (see pages xx), detailed, and polished to perfection. When the two meet again, they'll make music.

Ralph Miller, Martin's bracing specialist, sums up the company approach to guitar making, "Martin has a special way they want it, and that hasn't changed much in the 43 years I've been here."

Want to tour the Martin Guitar Factory?

Tours of the Martin plant at 510 Sycamore St. in Nazareth, begin at 1:15 p.m., Mon.-Fri. There's also a small museum and The 1833 Shop, a retail outlet, offering souvenirs, used instruments, and accessories. The Woodworkers Dream, at 10 W. North St., sells native and exotic hardwoods, guitar parts, and kits. For a catalog, write C. F. Martin Co., P.O. Box 329, Dept. W, Nazareth, PA 18064 (call 215-759-2064). ♣

Written by Peter J. Stephano
Photographs: Steve Uzzell

The hands of Dennis Kromer skillfully insert the thin metal frets into an ebony fingerboard. "This one has a custom abalone-pearl inlay of our 'tree of life' design," he notes.



LACQUER THAT'S



A vacuum clamp holds the guitar in position so walnut-colored filler can be rubbed into the back and sides with a soft cotton bun.

At the C. F. Martin Company, a guitar not only has to look super and take abuse, it must sound great, too. But, you don't have to be a guitar maker to appreciate the finish they've refined over the last 60 years. Their tried and true lacquer sure performs!



IN SEARCH OF
THE
PERFECT
FINISH

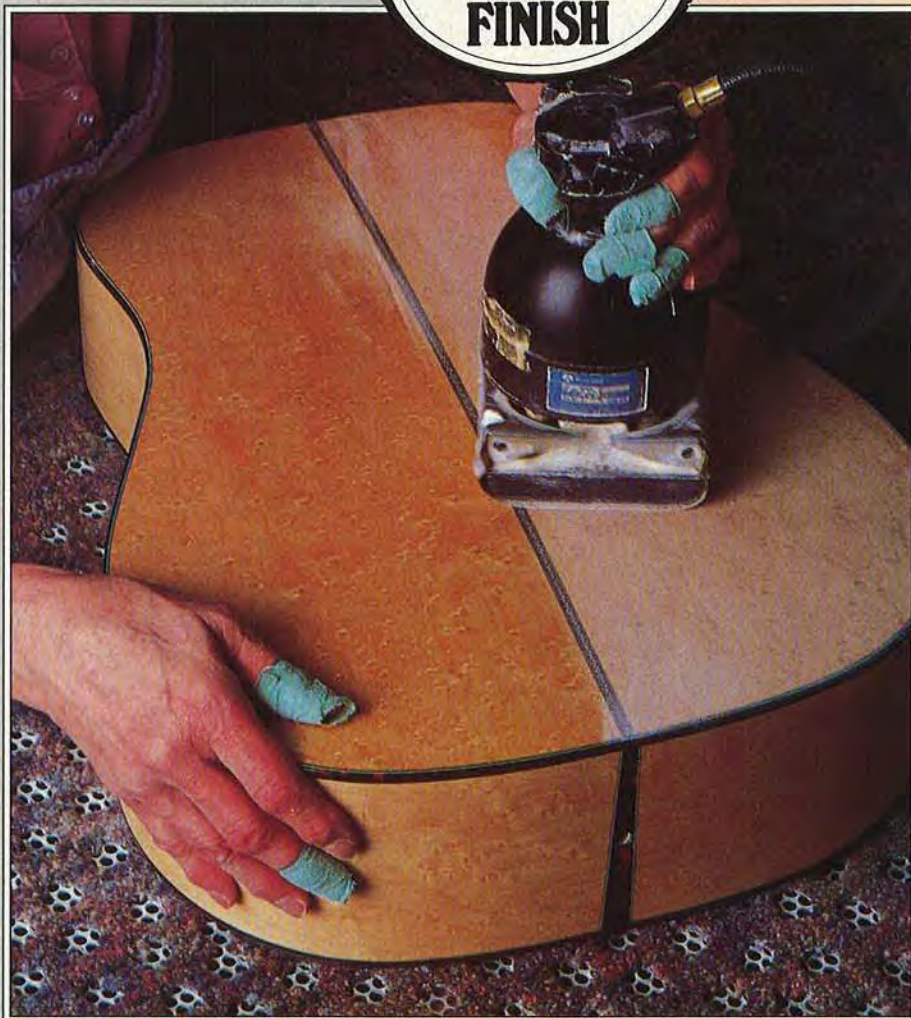

Jeanette Smith sands a maple guitar body with 220-grit paper between lacquer coats. The bench top has dust evacuation.

There's no way around it: Attaining the perfect finish on a guitar takes time. That's because a finish on a musical instrument has to do several things. Says Dick Boak of the Martin company, "It has to be thin so as not to disturb the tone, beautiful to enhance the wood, durable enough to stand up to the instrument's often-rigorous handling, and stay flexible over time."

The rosewood Martin uses in their guitars made finding the perfect finish a double challenge. That's because rosewood has a high resin content that can contribute to adhesion problems, pigment bleeding, fisheyes, and sinking pores. And, the resin can impede the drying of some finishes, such as polyurethane.

So, Martin finishing centers on spray application of successive thin coats of nitrocellulose lacquer, with some twists. And, although you won't be able to exactly duplicate their factory process, there are some products that enable you to come close (see Buying Guide at end of article). Even if you don't make guitars, you'll find that this type of finish works great on anything that must look super, yet take use.

Wood awash in vinyl

"The final finish will only look as good as the wood underneath," Boak comments. At Martin, finish-sanding starts with 60-grit paper and ends with 180-grit, because too fine a grit would make the surface so smooth the finish wouldn't adhere. (A sponge and plastic cup in the sound hole keeps the guitar's inside free of sanding dust and finish.)

Martin does not stain the rich-grained rosewood on their guitars. But, an alcohol-based aniline dye on mahogany parts helps them match the rosewood. Oil-based stains, which react with lacquer, are avoided.

MUSIC TO YOUR EARS

To ensure that rosewood's natural resins don't bleed through the lacquer finish, a worker sprays on a wash-coat of specially-formulated vinyl sealer immediately after the guitar has been sanded. "As well as holding in the rosewood resin, the sealer keeps our walnut-colored pore filler—which goes on next—from staining the wood," says Boak. "And, it actually helps the lacquer adhere."

Following a light scuffing or sanding with 400-grit paper, the guitar body receives the filler coat, used on all porous woods to provide a uniform base for the lacquer finish. "We brush the walnut-colored filler onto the back and sides [closed-grain woods like maple and spruce don't require filling]," Boak explains. After five minutes or so, when the filler develops a leathery texture, it's forced into the pores by hand with a bun made of T-shirt material filled with cotton wadding [photo, top left opposite]."

Guitar tops at this point get a fine sanding with 180-grit paper. After sanding, a finisher wets the top slightly with water to raise the grain, lets it dry, then sprays it again with sealer. When dry, the sealer coat undergoes another light sanding with 400-grit paper.

After that sanding, the entire guitar body gets a final sealer coat. This covers the colored filler on the back and sides, and adds protection to the top. Then two hours later, the guitar receives a spray-coat of lacquer sealer. "This cancels out the slight dissimilarity between the vinyl and the lacquer coats yet to come," notes Boak.

Warm lacquer and elbow grease

Within an hour after spraying on the lacquer sealer, another employee adds a coat of clear gloss lacquer. If dried overnight, the bodies would have to be resanded for the next coat to adhere.

Polishing the body with buffing compound and a lamb's-wool bonnet is Ed Morper's specialty. He's been creating mirrorlike finishes on Martin guitars for 18 years. Here, he works on rosewood.



The Martin company uses a nitrocellulose lacquer with a high solids content that is specially formulated to be sprayed warm, a technique that reduces viscosity for better flow. (Immersing a can of spray lacquer in 110–120 degree tap water does the same thing. *Never* heat it on the stove.)

"Depending on the coarseness of grain, we'll give the instrument two to three coats of gloss, allowing it to dry 45 minutes between," he says. "It's important to get a good buildup before sanding. Otherwise, you might break through to the vinyl layers, which shows up in the finish. So, after the lacquer cures for 48 hours, it's sanded with 220- to 280-grit paper [photo bottom left opposite]."

The back and sides of each guitar then go through the sequence of lacquering and sanding two more times, for a total of six coats. Tops, because their non-porous wood requires less finishing, receive four coats. According to Boak, "A thin finish aids the tone and won't check as easily."

Finally, to achieve the mirrorlike, high-gloss finish Martin guitar buyers expect, the instruments are polished first at low speed

Finishing Buying Guide

● **Sealer.** Behlen's Qualalacq clear sanding sealer, qt., no. 854, \$7.95.

● **Filler.** Behlen's Pore-O-Pac tintable paste wood filler, qt., no. 748 med. brown or no. 776 natural, \$10.90.

● **Lacquer.** Behlen's Qualalacq nitrocellulose, clear spraying lacquer, qt., no. 853, \$8.95. (Also Behlen's Jet-Spray 13-oz. aerosol cans, no. 739, \$5.95.)

● **Polish.** Mirro-Glaze Professional Cleaner No.4, 16-oz. bottle, no. 540 and Professional Cleaner No.7, same size, no. 541, \$8.50 each.

From Stewart-McDonald's Guitar Shop Supply. For catalog, write 21 N. Shafer St., Box 900, Athens, OH 45701. 800-848-2273 (614/592-3021).

● **Lemon oil, linseed oil (raw).** To protect and preserve exotic wood fingerboards. About \$3 pint at hardware stores and paint centers.

Photographs: Steve Uzzell

with a lamb's-wool buffing bonnet and a medium-grit, liquid, polishing compound, see above. After a final buff of the body at higher speed with a fine-grit compound, the guitar's neck is joined, the bridge located and glued, then it is strung, finely tuned, inspected, and shipped on its way.

Note: Guitar necks are finished the same as bodies, except that the ebony or rosewood fingerboards receive a special, non-hardening oil rather than lacquer. ♣

SUPER-SIMPLE TOOL

Most woodworkers we know have the same problem: not enough shop space. Well, we can't expand your shop, but we've come up with a tool cart guaranteed to make the most of the space you do have. Just mount three benchtop tools to the interchangeable shelves, put the tool you need on top, and store the others below deck until you need them.



Sensible
storage
on wheels
for your
benchtop
machines

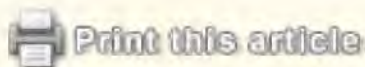

Start with the basic cabinet

1 Cut the cabinet sides (A) and fixed shelves (B) to the sizes listed in the Bill of Materials.

2 Using the Exploded View drawing for reference, mark the dowel-hole centerpoints on each of the three shelves, and drill $1\frac{3}{16}$ " holes $\frac{1}{2}$ " deep where marked. From $\frac{3}{4}$ " dowel stock, cut four dowels 2" long each. Sand a slight chamfer on each end of each dowel. Set the dowels aside.

3 Cut or rout $\frac{3}{4}$ " dadoes and rabbets in the sides where dimensioned on the Exploded View drawing. Then, cut a $\frac{1}{4}$ " rabbet $\frac{1}{4}$ " deep along the back inside edge of each side piece to house the back panel (C).

4 Dry-clamp the parts (A, B) together, and check for square. Also, make sure that the front edges of the sides and fixed shelves are flush. Measure the opening, and cut the back panel (C) to size from $\frac{1}{4}$ " plywood or hardboard. Glue and clamp the shelves between the sides, and then glue and nail the back panel in place, checking for square.

Now, for the handles, foot, and casters

1 Rip and crosscut two pieces of $\frac{3}{4}$ "-thick solid stock (we used birch) to $1\frac{1}{2}$ " wide by $31\frac{1}{2}$ " long for the handles (D).

2 Transfer the Handle pattern to one end of each handle blank. Cut and sand the handle ends to shape. Drill the mounting holes, and glue and screw the handles to the cabinet where shown on the Exploded View drawing.

3 Now, cut the foot (E) to shape (we cut this from a piece of 2×4 stock). Drill the mounting holes and screw the foot to the cart. Then, drill the mounting holes and fasten a pair of casters to the opposite end. (We used regular casters; you might want to consider using locking-type casters.)

Add the shelves; you're nearly finished

1 Cut the interchangeable shelves (F) to size. Bore a pair of $\frac{7}{8}$ " holes through each shelf where shown on the Exploded View drawing. The holes need to be centered over the $1\frac{3}{16}$ " holes in the fixed shelves.

2 For a glass-smooth finish, fill the voids and edges of the particleboard. (We applied Durham's Rock Hard Putty and let it dry for a couple hours. Then, we sanded the filled areas and added more putty where necessary.) Sand and paint the cart and shelves. (We applied several coats of sanding sealer, sanding between coats with 220-grit paper. We sprayed on a coat of semi-gloss enamel paint, allowed it to dry, and then sprayed on a second coat.)

3 To reduce vibration, cut a piece of carpet to the same size as an interchangeable shelf ($13\frac{1}{2}\times 24$ "). Mark the locations and cut a pair of $\frac{7}{8}$ " holes in the carpet, and stick the carpet to the top shelf with double-faced tape.

4 Position your machines on the shelves, mark the locations on the shelves for the mounting holes, and drill the holes. Fasten the machines to the shelves. 🌲

TRANSPORT

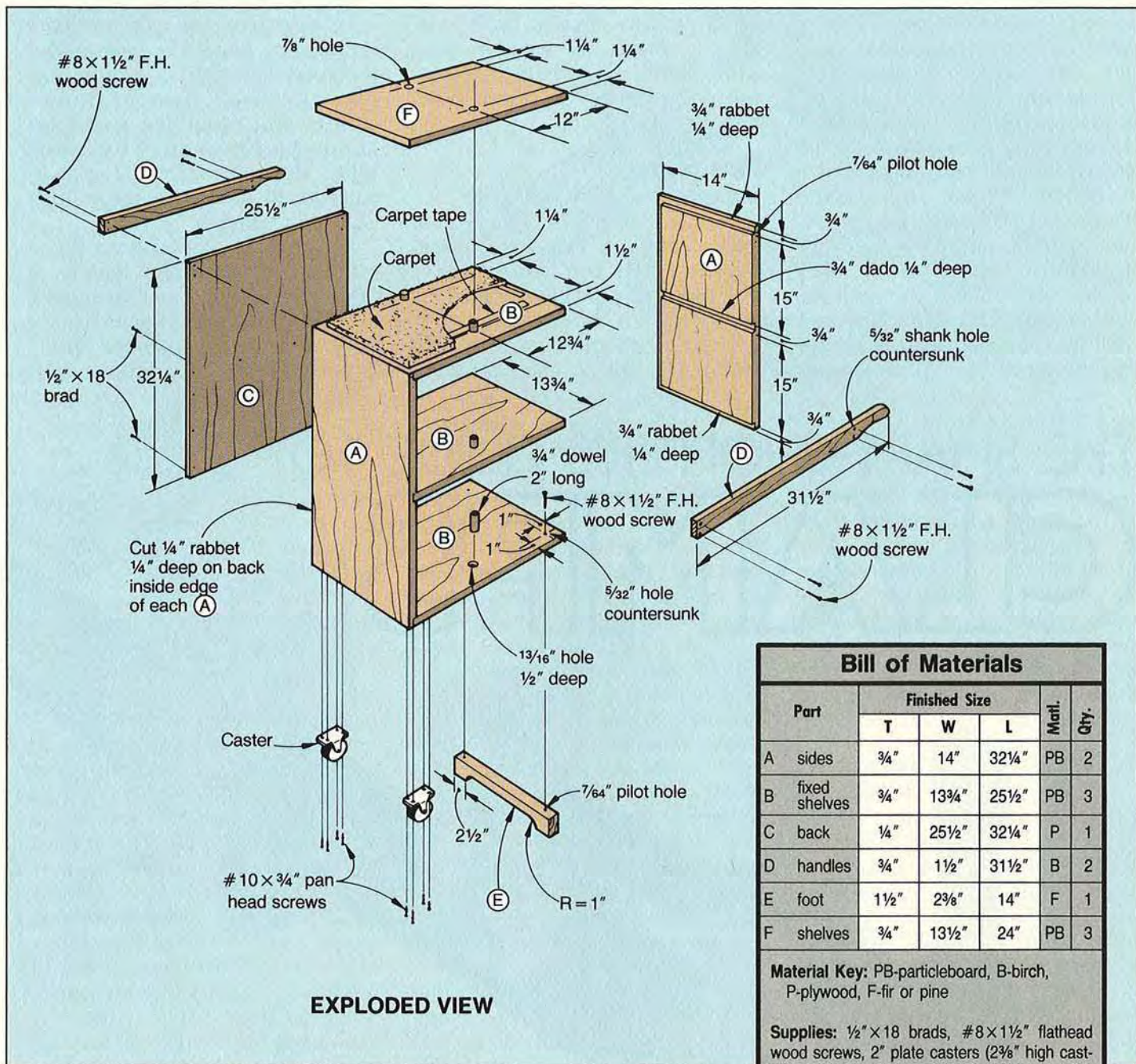

Part		Finished Size			Mater.	Qty.
		T	W	L		
A	sides	3/4"	14"	32 1/4"	PB	2
B	fixed shelves	3/4"	13 3/4"	25 1/2"	PB	3
C	back	1/4"	25 1/2"	32 1/4"	P	1
D	handles	3/4"	1 1/2"	31 1/2"	B	2
E	foot	1 1/2"	2 3/8"	14"	F	1
F	shelves	3/4"	13 1/2"	24"	PB	3

Material Key: PB-particleboard, B-birch, P-plywood, F-fir or pine

Supplies: 1/2" x 18 brads, #8 x 1 1/2" flathead wood screws, 2" plate casters (2 3/8" high casters mounted with #10 x 3/4" pan-head screws), 3/4" dowel stock, carpet, double-faced tape (carpet tape), paint.

Project Design: James R. Downing Photograph: Bob Calmer Illustrations: Kim Downing

HANDLE (D)
FULL-SIZED PATTERN
OF END

At one time or another, you've probably heard a fellow woodworker advise, "You can never have too many clamps." How true! It's a rare woodworking project that doesn't demand the use of one or more of these invaluable shop aids. And, some projects require oodles and oodles of clamps. What's a woodworker to do? Though each person's needs differ, we thought you might find it helpful to know about each clamp that has earned a permanent spot in the *WOOD*® magazine shop. And, because "Buy another clamp" isn't the right answer to many clamping dilemmas, we'll also share some tips for getting the most from your clamps.

THE OLD RELIABLES

Some clamps, such as those shown on the first three pages of this article, have helped woodworkers for decades. And with good reason—they're indispensable in most any woodworking shop. Here's some help in building an inventory of these time-tested shop helpers.

Pipe clamps: inexpensive and versatile

If you can afford only one type of clamp over two feet long, we recommend that you buy a set of **standard 3/4" pipe clamps** such as those shown *below*. These all-around performers, which cost about \$12 apiece (not counting

the pipe), consist of a tail-stop that quickly adjusts along any length of 3/4" pipe and a stationary head with tightening screw.

In addition to the fixtures themselves, you'll also need some threaded black pipe, which you can purchase at most home-centers and plumbing stores for about \$1 per foot. Why black pipe? This variety costs less than galvanized and holds the adjustable stop better.

For most woodworkers, a set of 10 pipe clamps in pipe lengths of 30" (four pipes), 42" (four pipes), and 62" (two pipes) will handle most jobs. To save storage space, it makes sense to postpone pur-

THE SMART-SHOPPER'S GUIDE TO CLAMPS

 Print this article

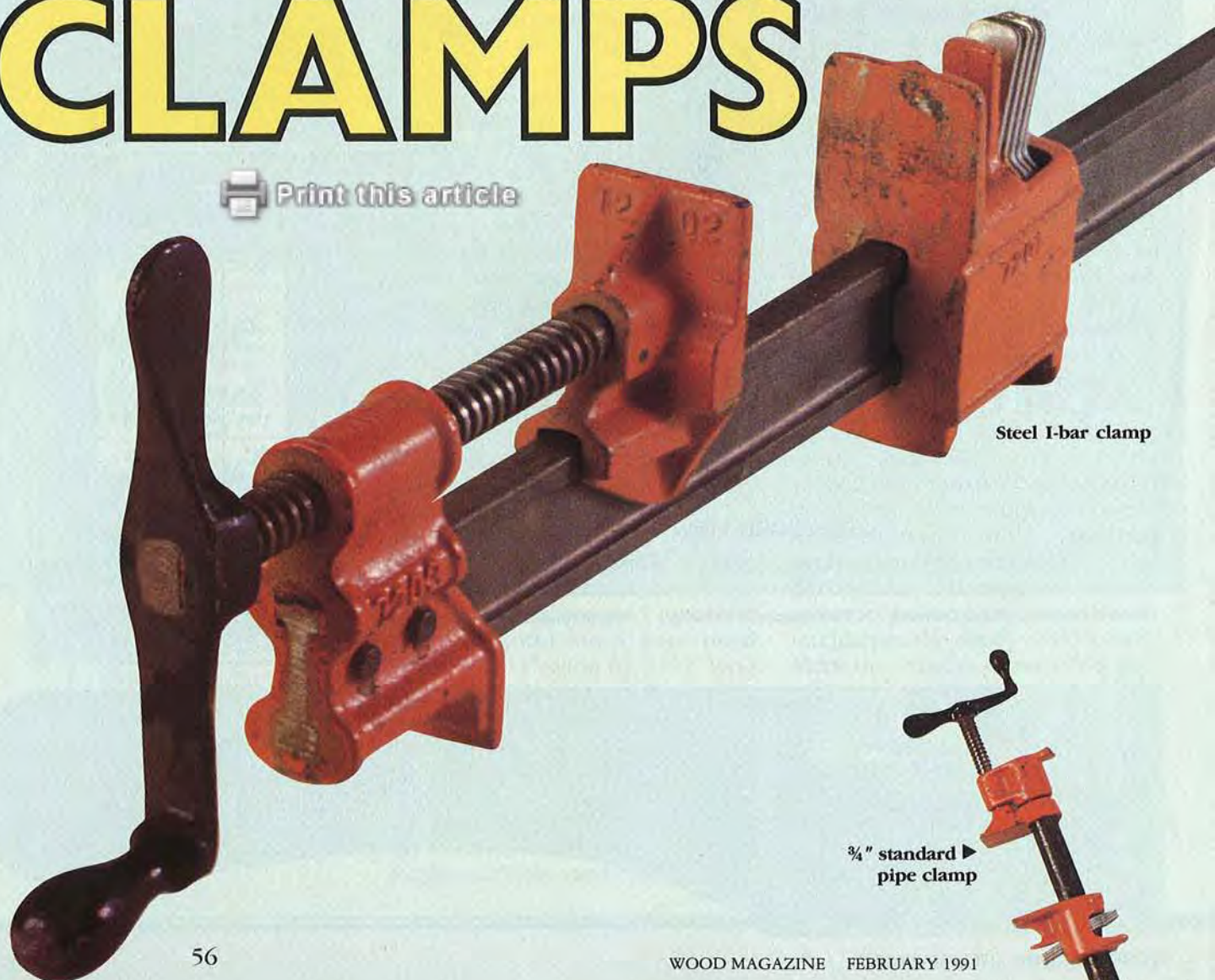

Steel I-bar clamp

3/4" standard pipe clamp

chasing the clamp fixtures and pipes until a job demands them.

For a few dollars more, you can purchase fixtures for a **reversible pipe clamp** such as the one shown *below*. With this variation, the sliding end has a screw, so you can turn around the two heads and spread apart workpieces for quick disassembly.

Bar clamps: plenty of choices

For maximum rigidity over long spans, nothing tops a **steel I-bar clamp** such as the one *below*. We have four 5-footers in the

WOOD magazine shop for clamping edge-joined tabletops.

Although superior to pipe clamps, I-bar clamps weigh more and cost about \$30 apiece for 5' models.

Wooden bar clamps allow you to clamp broad expanses, too, but at considerably less cost than the steel I-bar type. You can buy one set of the fixtures shown *below* from the Hartford Clamp Co. for about \$15 (you have to supply a 1¼ × 2½" wooden bar). We suggest you mill the bars from birch and then wax or oil their surfaces to prevent glue buildup.

Because of their speed and convenience, no clamp gets more use for smaller jobs than **light-duty steel bar clamps**. You can pur-

chase these in lengths from 6" to 36", but we find the 6" and 12" models most useful.

Two of the largest suppliers of these clamps, the Adjustable Clamp Co. (makers of Jorgensen and Pony-brand clamps) and Bessey, offer different versions as shown by the models *below*. Both types have advantages. The Jorgensen clamp has a disc clutch that prevents the adjustable end from slipping. In our experience, these clutches normally work fine, but occasionally stick.

With the Bessey, the movable end grips tiny serrations along the bar, requiring you to apply forward pressure on the screw while you turn it. Though more expensive, the Besseys have larger pads with nonmarring plastic caps.

You'll pay \$9-\$10 for a 12" Jorgensen light-duty steel bar clamp and \$3-\$4 more for a similar Bessey clamp. Remember that you'll eventually need at least 12 of

these, and you can often save money by buying six at once.

C-clamps: affordable, with pressure to spare

You can buy C-clamps with capacities from 1" to 6" and throat depths up to 6¼". Because of their rigidity, these clamps apply tremendous amounts of pressure to your workpiece—a feature that comes in handy for thick laminations and stubborn workpieces.

Handscrews: the classic lives on

These timeless woodworking clamps, such as the one *above*, have wide, wooden jaws that operate independently, allowing you to clamp nonparallel surfaces. You can adjust the nonmarring jaws to spread pressure over the entire surface or concentrate the force on a small spot. They're fairly expensive at about \$18 for an 8"-jaw model.

Continued



Handscrew

C-clamp



◀ ¾" reversible pipe clamp

Bessey ▶ light-duty steel bar clamp

Jorgensen ▶ light-duty steel bar clamp

Wooden ▶ bar clamp



Strap clamp

Handscrew made from plans offered on opposite page.

Spring clamps: instant positioning

These clamps give you an extra "hand" when you need to hold a workpiece in position before securing it with handscrews or other clamps. We keep a variety of spring clamps such as the one shown *below* in our shop, but we make the greatest use of 6"-long models with 2" maximum openings (\$3-\$4 each).

Cam-action clamps: lightweight and quick

For those delicate clamping tasks where the workpiece won't support a lot of weight, and you don't need a great deal of pressure, a cam-action clamp works nicely. As shown *below*, you can buy cam-action clamps with either wooden jaws or plastic jaws that resist glue better. Either type costs \$10-\$15 in lengths ranging from 8" to 24".

Strap clamps: buy the ratcheting type

These clamps, such as the one shown *above*, prove indispensable for jobs that require wrap-around pressure. Chairs, bowls, and other multisided projects benefit from this handy helper. With most strap clamps, you must tighten the strap with a screwdriver or wrench, but some have a rapid-action ratcheting mechanism that greatly simplifies this task. You just grab a built-in lever, flip it back and forth a few times, and there you have it. No fuss. You'll pay about \$10 for a 15'-long clamp.

SOME NICE LUXURIES

Sure, you can get along without the following clamps in your workshop, but we find them real time-savers or just plain handy.

Quick-Grip clamps: for times when you need three hands

True to its name, the Quick-Grip clamp from American Tool Companies works fast, thanks to its triggerlike action. And, you can one-hand these lightweight clamps, freeing your other hand to position the workpiece. We rely on four of the 12" Quick-Grips in the *WOOD* magazine shop, and love using them. However, they're not cheap at \$18-\$25 for the 12-36" models.

Locking clamps: We like the deep-jaw types

As shown *below*, both American Tool Companies (makers of Vise Grips) and Bessey have designed clamps with the locking-pliers mechanism. These cost \$10-\$30, depending on capacity, but work well for repetitive tasks. We often utilize the deep-jawed version because it extends up to 15" over the edge of a work surface.



Bessey locking bar clamp

American Tool Companies deep-jaw locking clamp



Spring clamp ▼

◀ Wooden-jaw cam-action clamp (left). Plastic-jaw (right) ▶

Tru-grips: As versatile as a clamp can get

Griset Industries now makes two variations in its Tru-grip line of clamps: the original **Clamp 'N Tool Guide** shown in top and bottom views *below*, and the newer **Back-To-Back Bench Clamp** to its *right*. Both versions have a cam-action device that exerts light to medium pressure. The 50"-long Clamp 'N Tool guide makes a fantastic straightedge for routers or portable circular saws because of its low height (about 1/2"). The Back-To-Back Bench Clamp has jaws on both its top and bottom, so a pair will hold your workpieces securely in place atop a bench. Expect to pay \$30-\$50 per clamp.



Toggle clamps: instant holding force for all your jigs

If you're into repetitive cutting or shaping that requires jigs, here's a must-have clamp. You can buy many varieties for \$10-\$15 each. With one of the most common types (shown *below* on a mortising jig), you push the handle forward to exert downward pressure on the workpiece. Similar versions have a low-silhouette handle for tight areas. Other models exert pressure horizontally for those times when you want to hold workpieces tight against a fence.

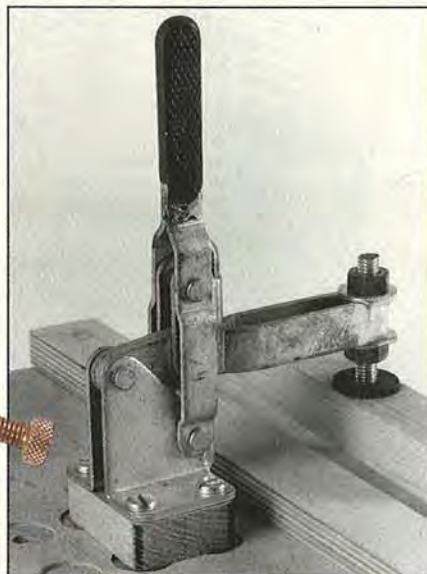

Toggle clamps place secure holding force wherever you need it.

Case clamps: handy for cabinetry projects

Case clamps, such as the model shown *below* from Hafele, work much like pipe clamps except they have long jaws that help you square up a cabinet as you clamp it. Two of these will cost you more than \$100, so we suggest them only if you build cabinets on a regular basis.

Handscrew kit and plans

Plans, article reprint, and hardware kit for an 8" handscrew, \$9.99 from Leichtung Workshops. Call 800/237-5907.

Manufacturers listing:

Adjustable Clamp Company
312/666-0640

American Clamping Corporation
(importer of Bessey clamps)
800-828-1004
In Canada: 800-265-8678

American Tool Companies
402/683-2315

Hafele America
919/889-2322

The Hartford Clamp Company
203/528-1708

Written by Bill Krier
Technical consultant: George Granseth
Photographs: John Hetherington

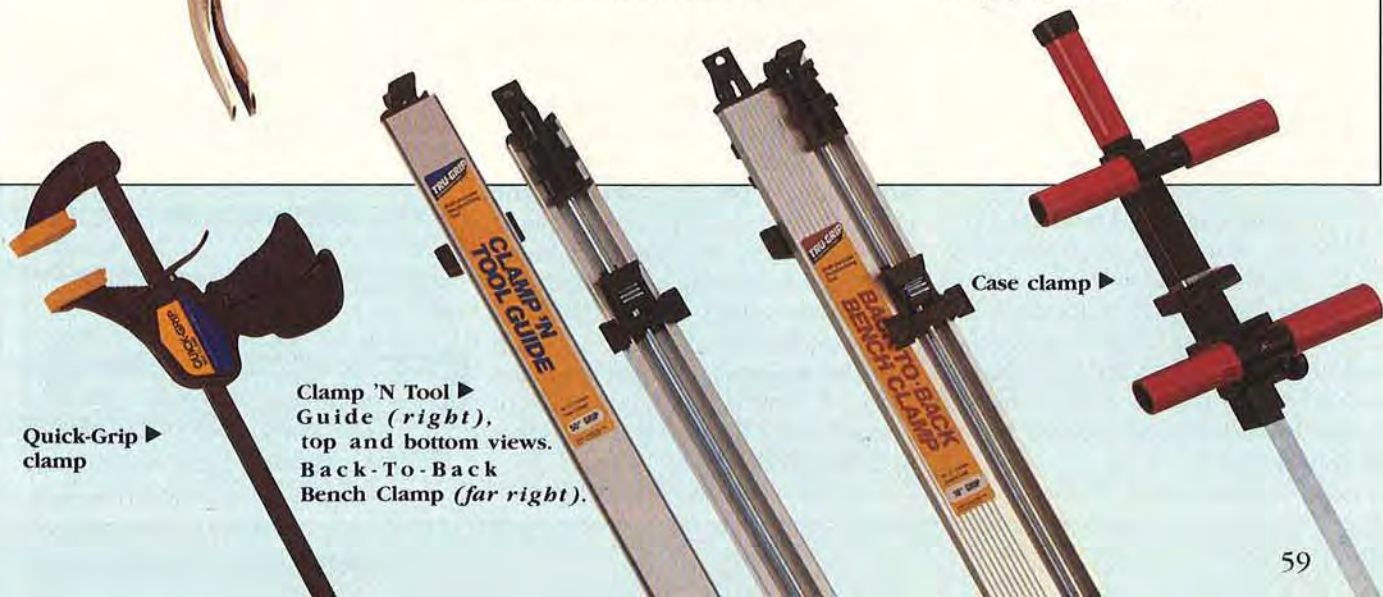

Quick-Grip clamp

Clamp 'N Tool Guide (right), top and bottom views. Back-To-Back Bench Clamp (far right).

Case clamp

TIPS FOR GETTING THE MOST FROM YOUR CLAMPS

 Print this article

Before you go out and buy a new set of clamps, keep in mind that you might save some money by getting better performance from your current clamps. To give you a hand, we've rounded up some of the best pearls of clamping wisdom from the *WOOD*® magazine shop.

Note: For eight great pipe-clamp tips, see pages 66 and 67 of the August 1989 issue of WOOD magazine. Many of these tips work equally well with bar clamps, too.



BOE'S FIVE COMMANDMENTS FOR PROPER CLAMPING

Boe knows clamps (Jim Boelling, *WOOD* magazine's project builder, that is), so we asked him to come down from his workshop with five of his best clamping commandments. As always, Boe came through with some dandy tips.

I Thou shalt commit to dry clamping. Before you put a drop of glue to any surface, dry-assemble and clamp your workpiece. This way, you'll know if the pieces fit and whether you have enough clamps to get the job done properly.

III Thou shalt not overclamp. No amount of clamping pressure has ever turned a bad joint into a good joint. So, re-machine ill-fitting parts rather than force them into alignment with clamps. Sooner or later, badly fitted joints will come back to haunt you.

II Thou shalt spread the pressure evenly. Some clamps, such as most bar and C-clamps, exert pressure in small areas. So, place auxiliary blocks of wood between the clamps and workpiece to spread out the pressure evenly.

IV Thou shalt protect the workpiece. If you're not careful, clamps will dent or stain your project's surface. To be on the safe side, place wooden pads over the jaws of the clamp. To prevent glue from reacting with the metal clamp and staining the wood, lay a protective sheet of waxed paper between the metal bars of a clamp and the workpiece. Make sure the jaws of your clamps are free of grease, dirt, clumps of dried glue, or other debris.

V Thou shalt properly position the line of pull. Whenever you clamp edge-joined boards, make sure the clamp screw and opposing jaw line up with the center of the joined boards. If you position the clamp a little high or low as shown *below*, bowing likely will result. 

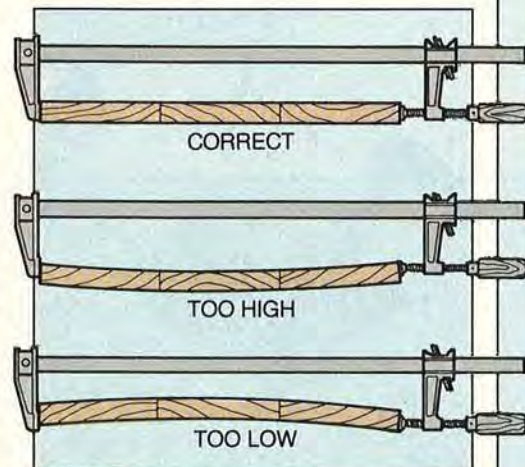

Illustrations: Kim Downing; Jim Stevenson

FANCIFUL FLOWERS

FROM FOUND WOOD

Don Hart of Pasadena, Texas, enjoys transforming wood that most people consider useless into beautiful turned objects. For this project, he salvaged a downed limb from a

 [Print this article](#)

Attach a wooden auxiliary faceplate to a 3" metal faceplate (see the drawing *below right* for reference). After you find a 4"- to 6"-diameter limb, bandsaw it down the center through the pith. Next, cut a 2"- to 2½"-diameter plug from the limb section where shown. Using cyanoacrylate adhesive (epoxy also works), center and adhere the plug to the auxiliary faceplate.

With your lathe running at 1,500 rpm and using a ¼" spindle gouge, start at the rim and rough-shape the outside of the flower. (See the Full Sized Section View drawing.) Try to leave the bark on the rim of the turning.

Don suggests that you begin hollowing the flower interior with a ¼" bowl gouge. Alternate back and forth, hollowing the inside and then refining the shape of the outside until the wall thickness of the turning measures about ⅛". He also advises putting a fine bead of cyanoacrylate on the rim to keep the bark from separating from the wood.

Slow your lathe to 800 rpm, and sand the flower. Make the final shaping cuts on the base with a ¼" spindle gouge, and then sand that area. With the lathe running, apply a light coat of paste wax to the turning with a cloth, being careful not to let the cloth catch on the rough bark edge.

Part the flower from the faceplate and drill a ⅛" hole ¼" deep into the base bottom. To form the stem, soak a piece of ⅛" dowel stock in hot water for about 10 minutes. This will enable you to bend the dowel and form a more realistic-looking stem. 🌱

Photographs: Gaye Hart; Bob Calmer
Illustrations: Kim Downing; Bill Zaun

neighbor's pear tree to create a stylish bouquet of flowers.

Another in a collection of designs from the nation's top woodturners



Don Hart

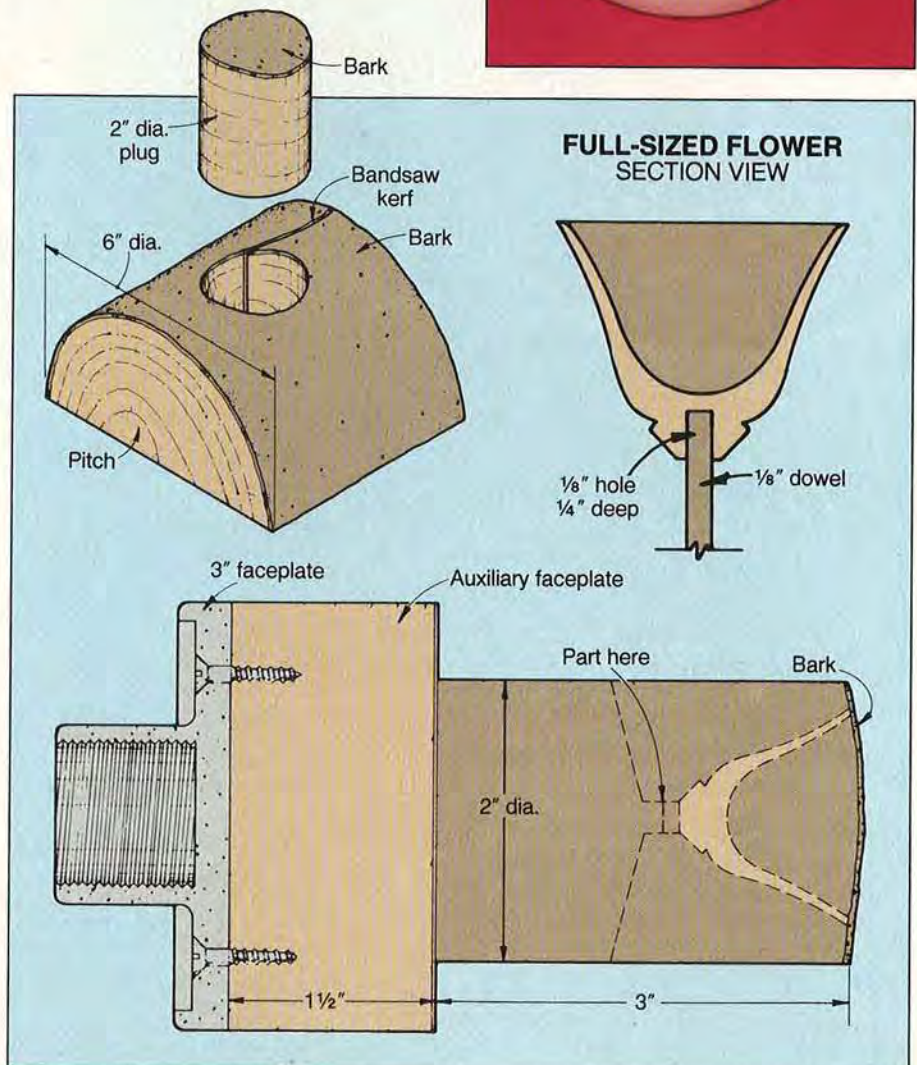

ARIZONA TURN

HOT SHAPES FROM THE SOUTHWEST



Recently, the Arizona Woodturners Association organized a monthlong members' exhibit at Arizona State University in Tempe. Shown here are selected pieces from that show. The Phoenix-based club, a chapter of the American Woodturners Association, consists of 42 beginning, intermediate, and professional woodturners.

 [Print this article](#)

Greg Campbell, Tempe
7½" diameter, 5¼" high, *above left*.

Greg found New Zealand walnut beautiful to turn and sand when he created this masterpiece. He shaped the inside and outside of the base and formed the ⅜"-thick walls with a roundnosed scraper. Greg used Watco Natural Oil for the finish.

Jim Stephenson, Tempe
5½" diameter, 7" high, *above right*.

Jim used ash veneer and ebony for the base, maple and walnut burl for the midsection, and walnut and ash for the top. Jim's eye for detail carries over from his business—Palo Verde Machine—a manufacturer of precision parts for aircraft and armorments.

Ray Allen, Yuma
15" diameter, 13" high, *above center*.

Ray's polychromatic turning consists of 1,241 pieces of mesquite, pernambuco, rosewood, holly, bubinga, and ebony. The feather pattern near the bowl's top reflects a pottery design found at New Mexico's Santa Clara Pueblo. Ray adapted the shape from a photo of a bowl dated 100 B.C. to 200 A.D., and unearthed at the Mica grave at the Hope-Well-Mound site in California.

ING SHOWCASE

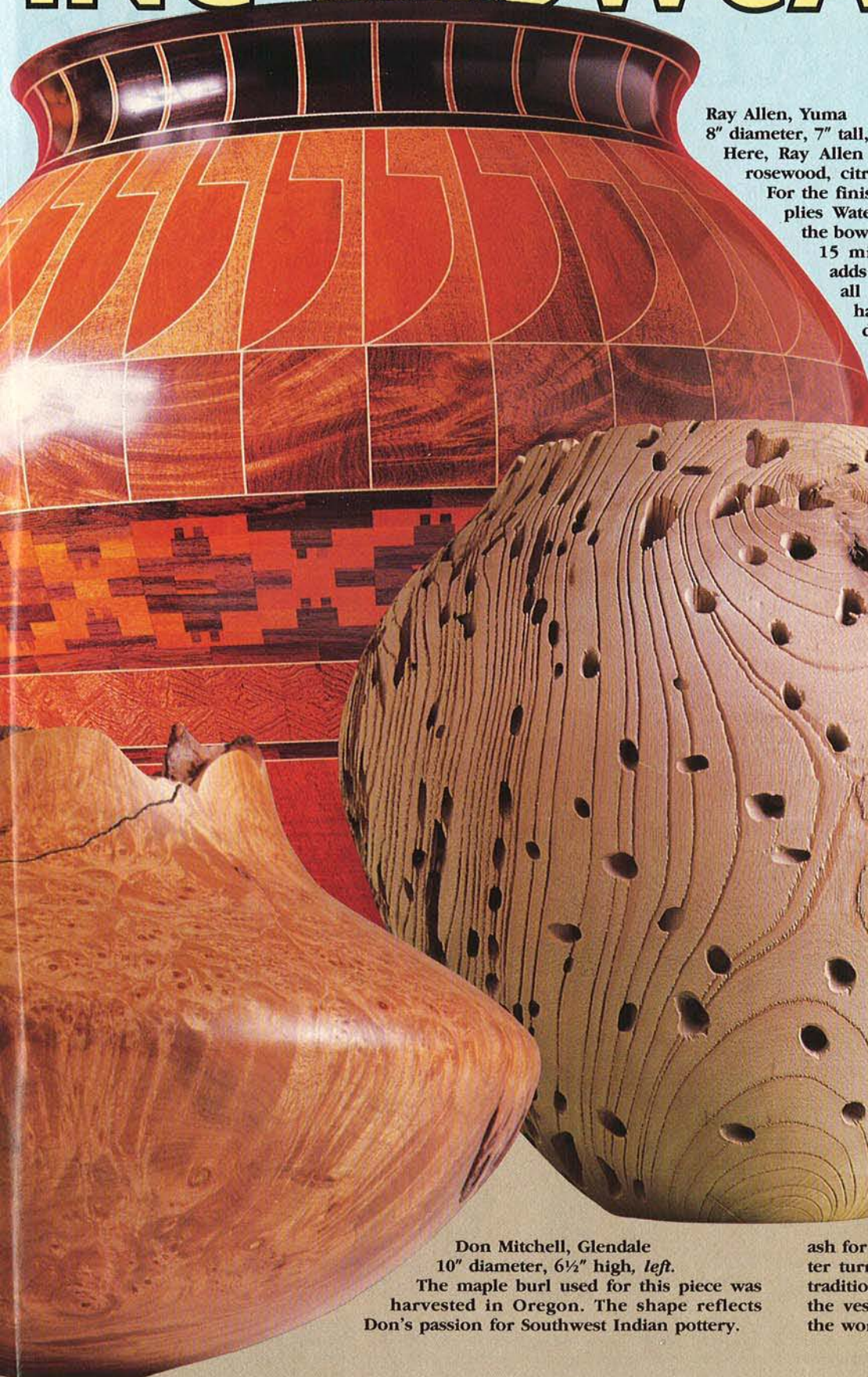

Ray Allen, Yuma
8" diameter, 7" tall, *left*.

Here, Ray Allen combined black walnut, maple, rosewood, citrus, eucalyptus, and purpleheart. For the finish, Ray sands to 600-grit, and applies Waterlox, a tung-oil based finish, to the bowl. Next, he lets the bowl set about 15 minutes (until sticky), and then adds a bit more Waterlox to remove all the finish except for that which has soaked into the wood. The next day, he repeats the process. Finally, Ray applies paste wax with 0000 steel wool, and removes the piece from the lathe.

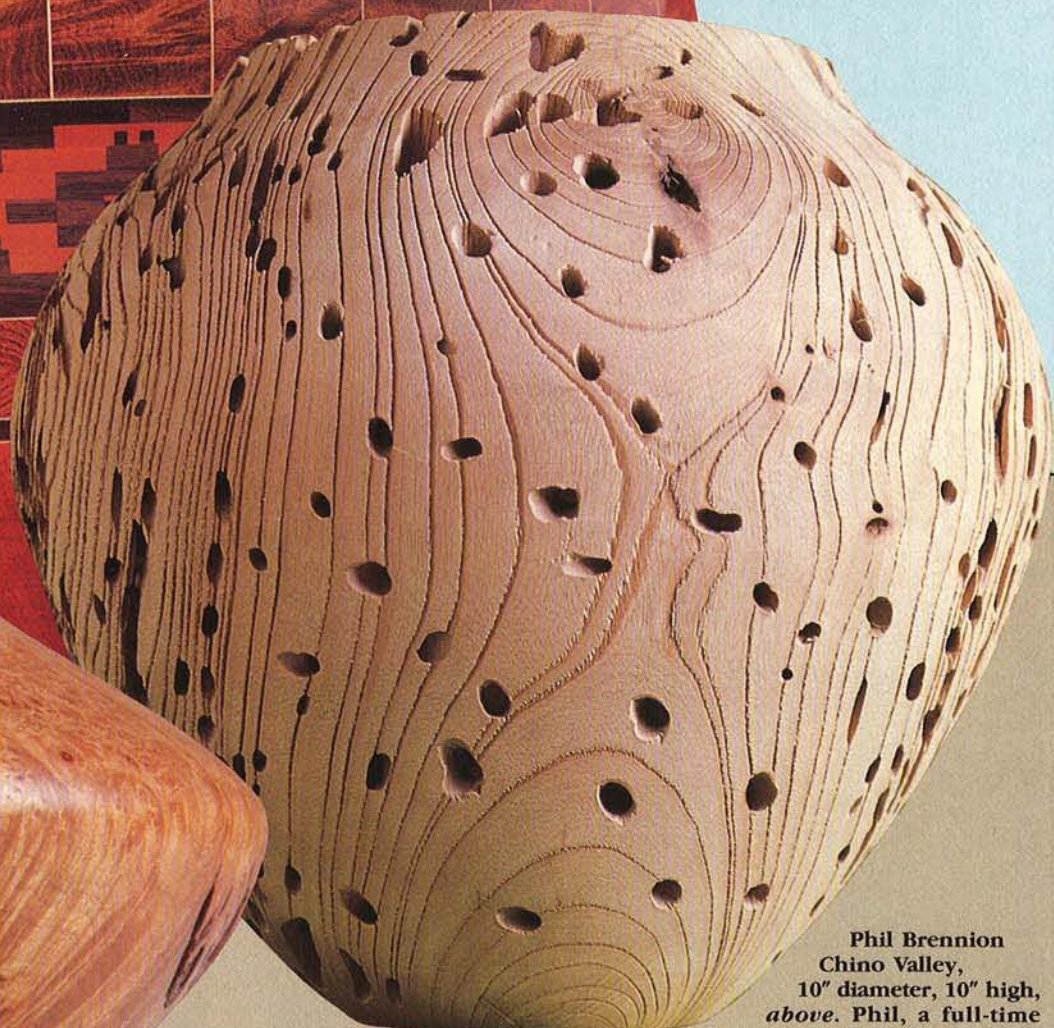

Phil Brennon
Chino Valley,
10" diameter, 10" high,
above. Phil, a full-time
turner, collected the wormy

ash for this piece in central Arizona. After turning it to a shape inspired by a traditional Hopi design, Phil sandblasted the vessel to remove the residue from the worm holes and texture the wood.

Don Mitchell, Glendale
10" diameter, 6½" high, *left*.

The maple burl used for this piece was harvested in Oregon. The shape reflects Don's passion for Southwest Indian pottery.

RIDE THE WIND

An intarsia wall hanging that's a breeze to build

 [Print this article](#)



To make the balloon, plane or re-saw two pieces of stock (we used oak and walnut) to $\frac{3}{8}$ " thick. Cut a piece from each that measures $3\frac{1}{4}$ " wide by $3\frac{3}{4}$ " long. With double-faced tape, join the two pieces face to face. Using carbon paper, transfer the balloon pattern to the top piece. Cut the balloon outline to shape with a bandsaw fitted with a $\frac{1}{8}$ " blade or a scrollsaw.

Trace the balloon's outline onto a piece of $\frac{3}{4}$ " plywood. Cut the plywood to shape, and bore a $\frac{3}{4}$ " hole about halfway through it. Glue a 6"-long $\frac{3}{4}$ " dowel into the hole in the plywood.

Cut the balloon pieces to shape. Mix the parts (you'll have enough for two balloons). With hot-melt adhesive, spot-glue the parts together and then to the plywood. Drum- or belt-sand the surface of the balloon to shape (see the Side View for reference).

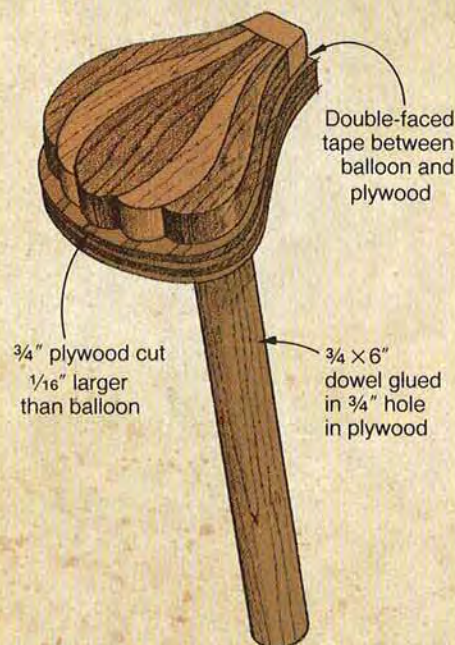

Remove the balloon pieces from the holder, scrape off the hot-melt adhesive, and sand a slight round-over on the interior edges of each balloon piece.

As shown on the sketch below, transfer the shapes of the people and basket to the end of a piece of $\frac{3}{8}$ " maple and oak respectively. (It's easier to cut and sand the tiny pieces when they're part of a longer piece of stock.)

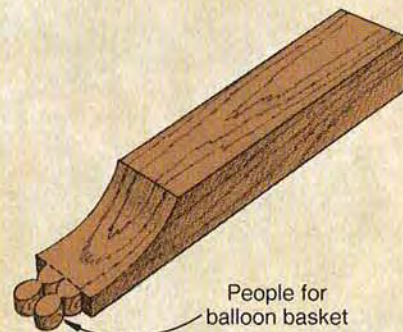

Cut and sand the basket and people to shape, and crosscut them from the end of the strips.

Transfer the sky pattern to a $\frac{1}{2}$ x8x8" piece of cherry. Bandsaw slightly outside the pattern's perimeter. Cut the individual sky pieces to shape. Sand a slight round-over along all edges of each sky piece. Cut a $6\frac{1}{2}$ "-diameter disk from $\frac{1}{4}$ " plywood.

Finish-sand all the parts. Glue the sky pieces to the plywood disk. Now, starting with the center piece, glue the balloon to the sky using the photo as a positioning guide. Then, glue the basket and people to the sky where shown. Add the finish. Drill a $\frac{1}{8}$ " hole $\frac{3}{8}$ " deep where shown on the Side View drawing. ♣

FULL-SIZED PATTERN

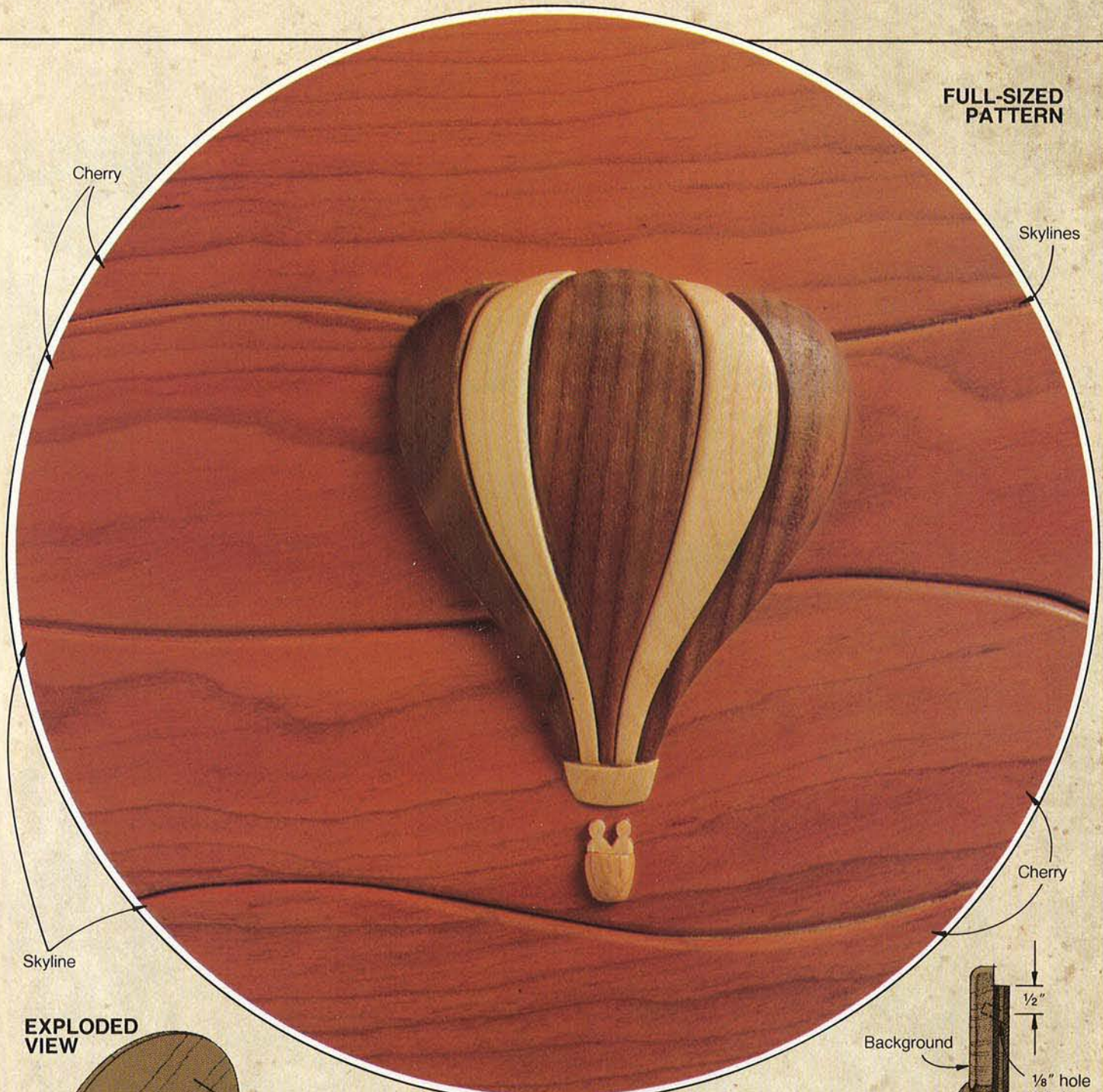

EXPLODED VIEW

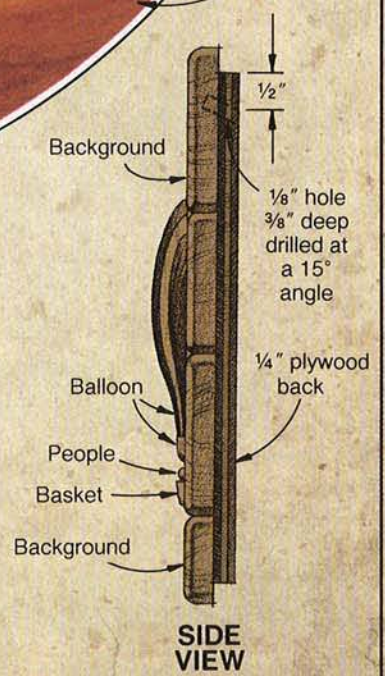
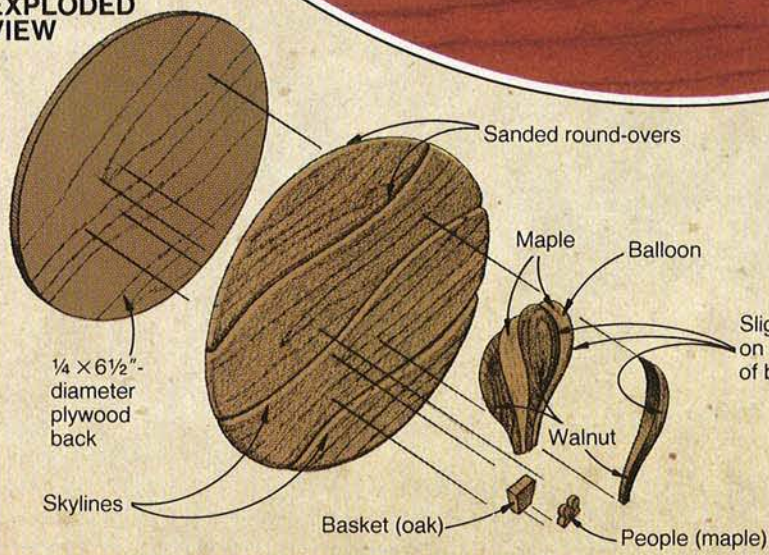

SIDE VIEW



A napkin holder
with lots of
country charm

GRACEFUL GOOSE

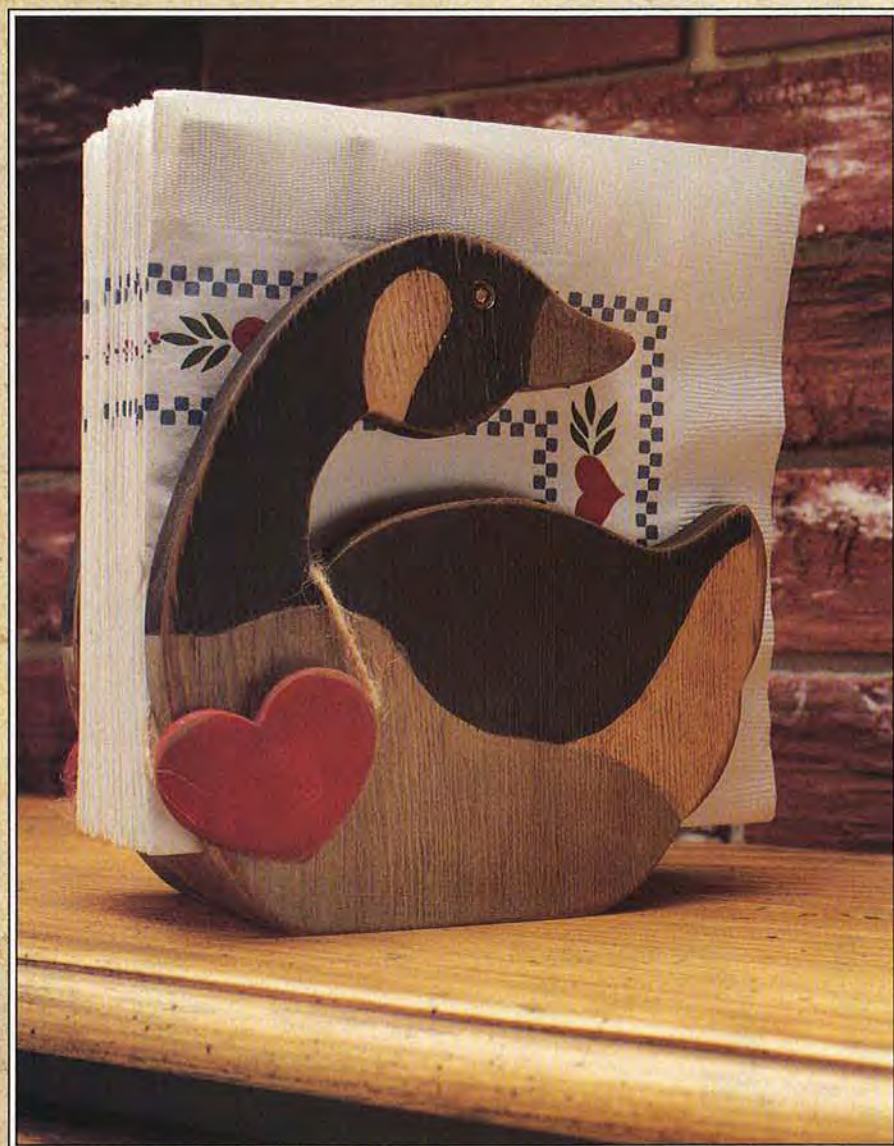

Project Design: Woodworks Unlimited, Ghent, N.Y.

Photograph: Hopkins Associates

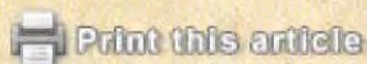

Take a gander at this accommodating accent for your kitchen table. It combines two well-loved country symbols—a goose and a heart—into a practical accessory.

Transfer the full-sized goose pattern on the opposite page onto $\frac{1}{2}$ "-thick stock and the heart pattern onto $\frac{1}{4}$ " stock (we used clear white pine). To keep the neck portion strong, follow the grain direction on the Exploded View drawing when laying out the pieces. With a bandsaw fitted with a $\frac{1}{8}$ " blade or a scrollsaw with a #9 skip-tooth blade, cut out the geese and heart shapes. (Double-faced tape allowed us to stack and cut out the geese and hearts in pairs.) From $\frac{3}{4}$ " stock, cut the bottom of the holder to $2 \times 4\frac{3}{4}$ ". Cut or sand the ends of the divider to the same shape as the goose outline. Then, drill a pair of $\frac{1}{8}$ " holes $\frac{1}{2}$ " deep in each heart where located on the full-sized pattern. Sand the parts.

For the best results, paint the geese before assembly, but mask the areas that will contact the base. (To paint the pieces, we used water-based acrylics and a no. 6 sable brush.) Apply the gray (a mixture of black and white), the black, and finally the white. Paint the hearts red.

To achieve the aged look, lightly sand the edges of each goose and heart after the paint has dried. To further age the project, rub on a brown-colored stain (we used a water-based acrylic) and immediately wipe off most of it. Using a $\frac{1}{4}$ " brad-point bit, form a slight depression for each eye.

Glue the divider between the goose pieces. Cut two pieces of thin jute cord to $6\frac{1}{2}$ " long. Glue the ends of each cord into the holes in the heart. Hang the hearts around each goose neck, and fill the holder with napkins. ♣

Illustrations: Jamie Downing; Jim Stevenson

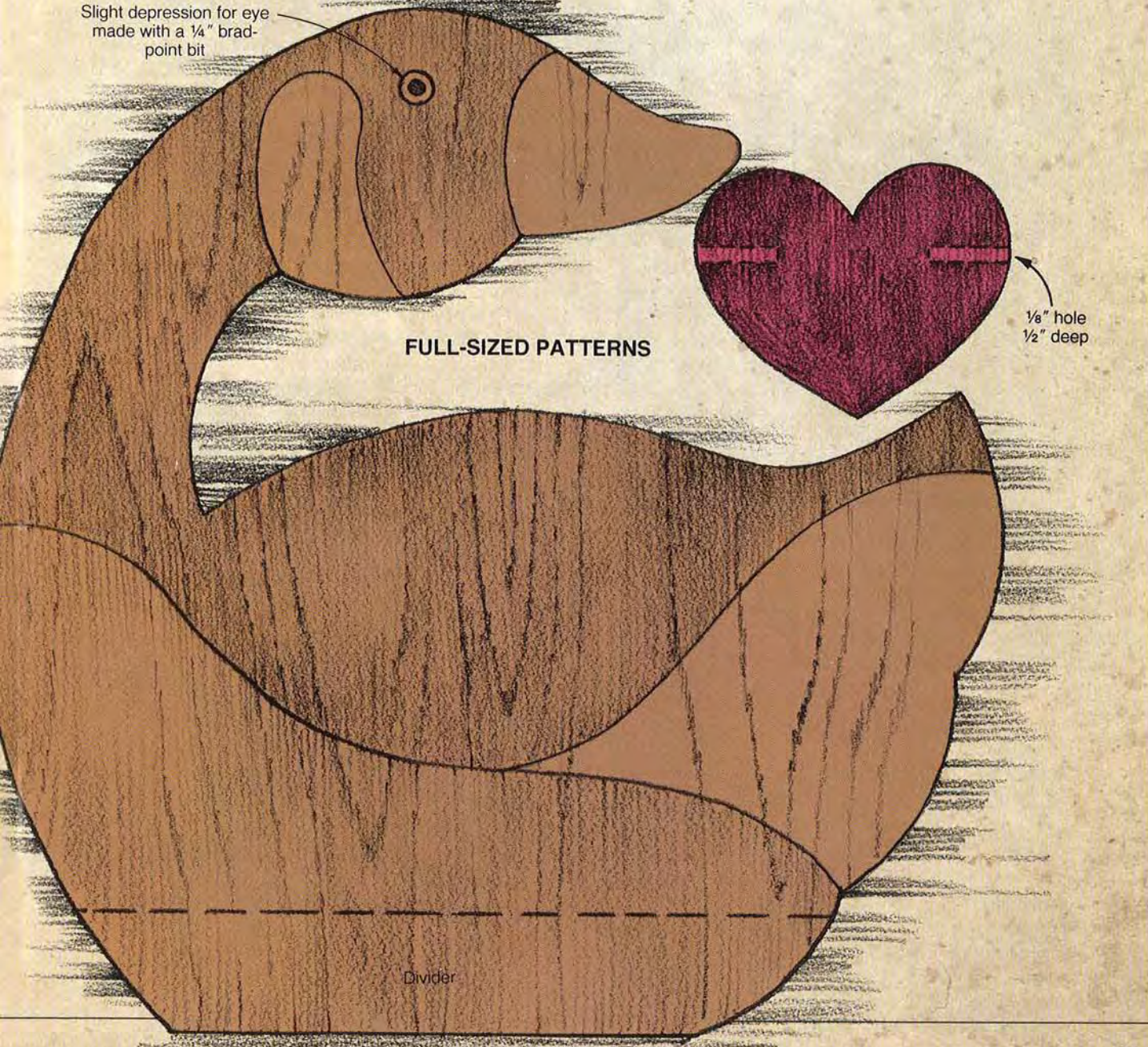
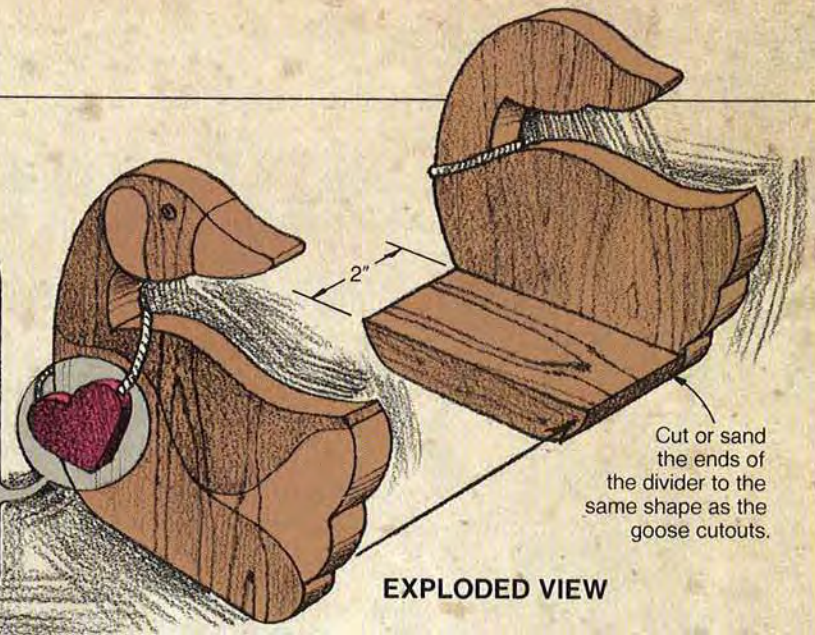
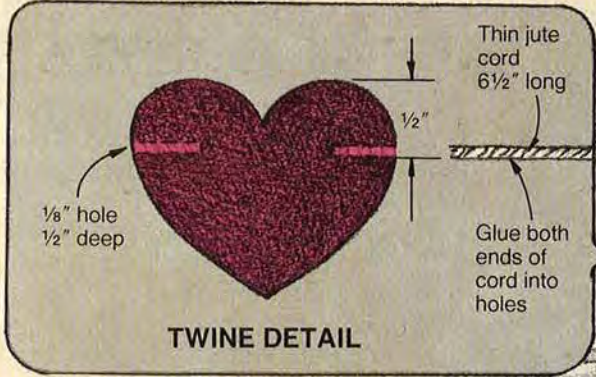



CHEERY, CHERRY DOOR

A "Welcome" Addition to Your Home's Entry

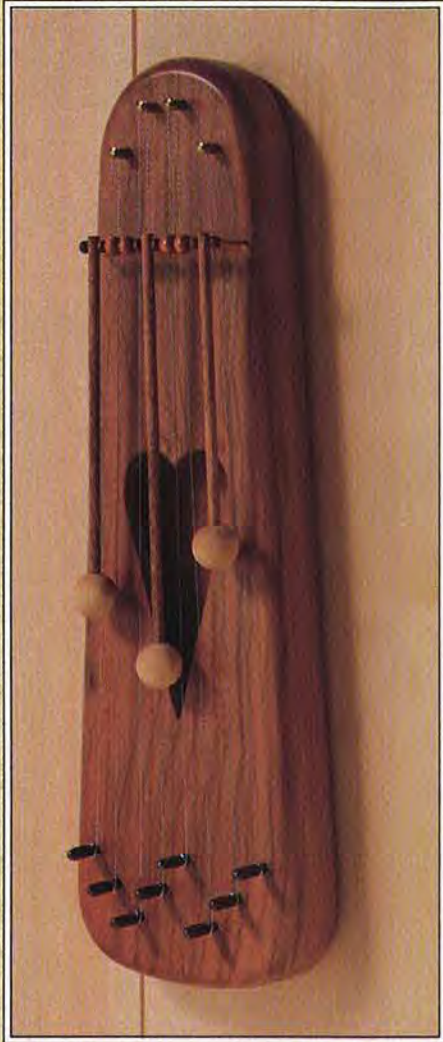

We've heard a symphony of door harps over the years, but Robert Kiser's design sounds better than any we've listened to. What's Bob's secret? He hangs the wooden balls on dowels instead of wires or string. See the Buying Guide for our source of pins, music wire, and a clapper assembly.

Plane or resaw cherry to obtain two pieces measuring $\frac{1}{4} \times 5 \times 16''$ for the front and back pieces (A). Using double-faced tape, stick the front and back together face-to-face with the edges and ends flush. Draw a centerline where shown on the Exploded View drawing. With carbon paper, transfer the curved end patterns to the top piece. The finished length of the harp equals $15\frac{3}{8}''$.

Draw a pair of lines between the two end patterns to complete the outline. Refer to the dimensions on the Exploded View drawing and mark the two center-points for the heart opening as well as the point at the bottom of the heart. With a bandsaw, cut the taped-together pieces to

shape, cutting just *outside* the marked line. Separate the pieces and remove the tape. Using a Forstner or a spade bit, bore two 1" holes for the heart-shaped opening. Draw lines from the outside edges of each hole to the heart's point, and finish cutting the heart to shape with a scroll-saw. Sand both pieces smooth.

Rip and crosscut the sides (B) to $\frac{1}{2} \times \frac{3}{4} \times 16''$. Using the full-sized patterns as guides, mark and cut the wedge-shaped ends (C, D) to size. With the surfaces flush and a $10\frac{1}{2}''$ -long spacer between the end pieces, glue and clamp the frame pieces (B, C, D) in the configuration shown *below*.

Using the front piece (A) as a template, center it on the frame parts and trace its outline on the frame. Bandsaw the frame to shape, cutting just outside the marked line.

Glue and clamp the front and back pieces to the frame. Later, sand to the marked line for flush edges. Mark the location, and drill the holes for the tuning pins, bridge pins, clapper assembly, and hanging hole.

Rout a $\frac{3}{8}''$ round-over along the top and bottom. Sand and add the finish (we used aerosol lacquer).

 Print this article

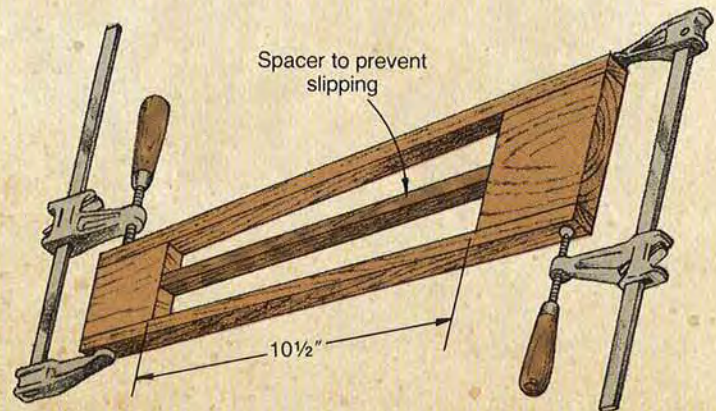

HARP

With a mallet, tap the bridge pins into the holes. Tap the tuning pins about $\frac{1}{8}$ " into their mating holes. Use the tuning-pin wrench to thread the pins into the holes. String the wire where shown in the Exploded View drawing. Put two drops of instant glue in each $\frac{5}{64}$ " hole, and adhere the clapper assembly to the harp. Hang the harp on the inside of your door.

Buying Guide

• **Hardware kit.** 15' of #6 music wire, tuning wrench, 4 brass bridge pins, 8 steel tuning pins, 1 clapper assembly, and detailed wiring instructions. \$9.50 ppd. Violet Crown Harpery, 1502 Cullen Ave., Austin, TX 78757

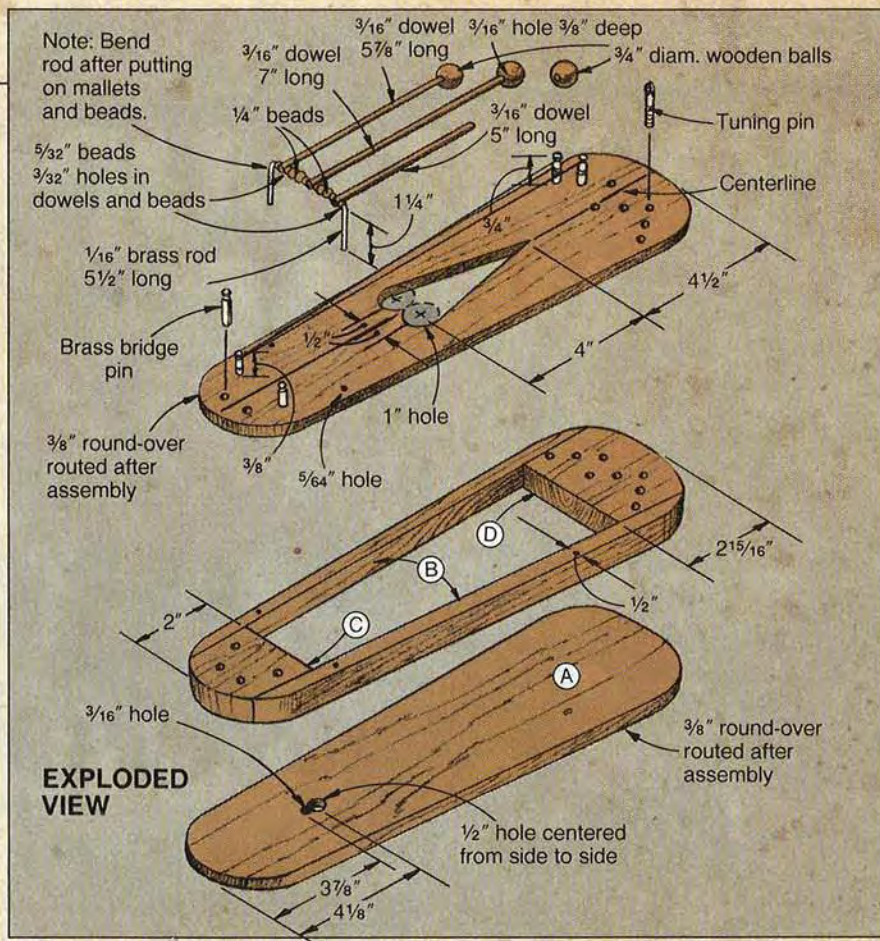

FULL-SIZED END PATTERNS

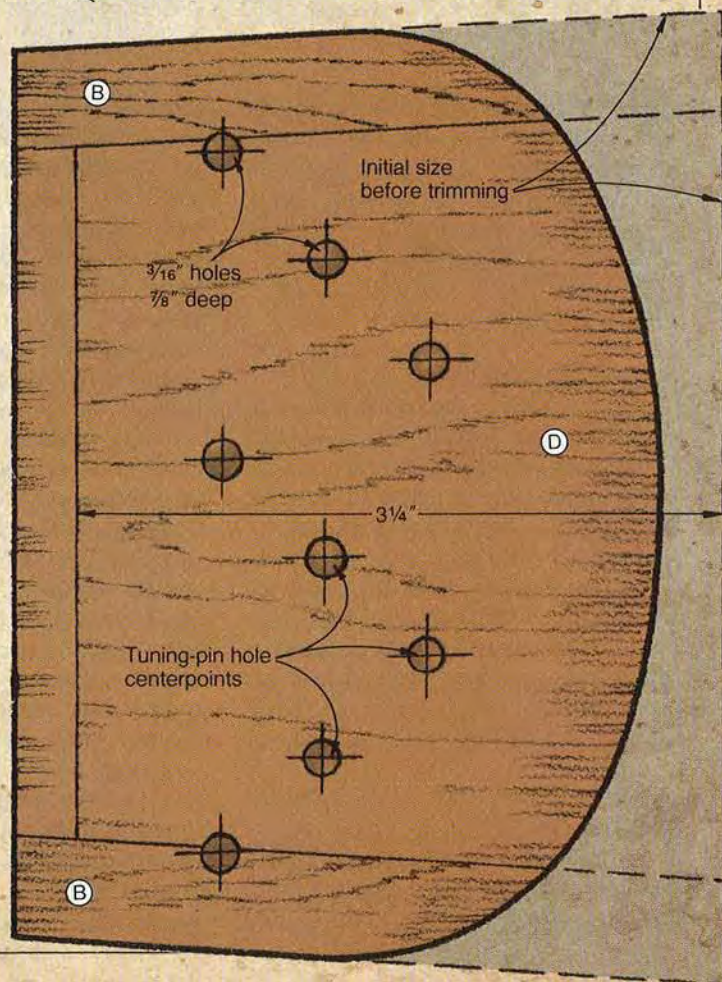
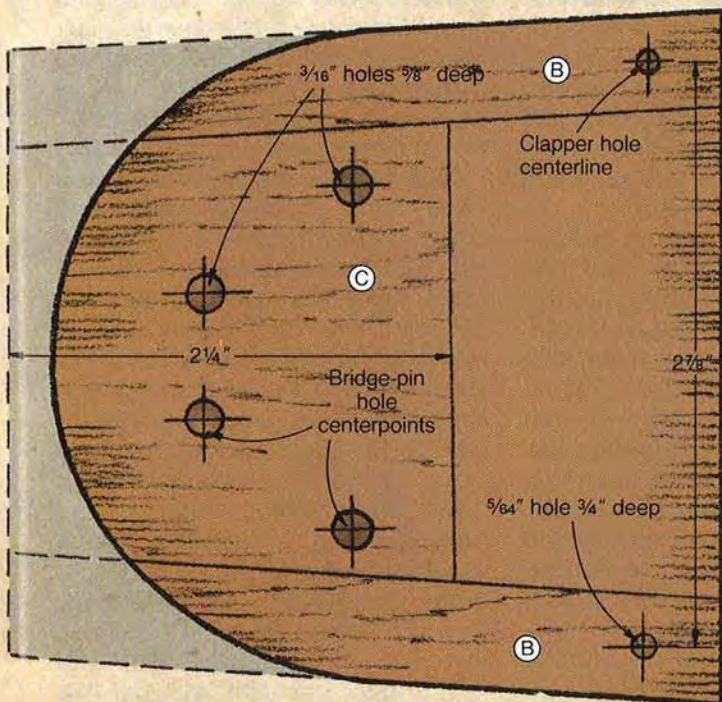

Project Design: Robert Kiser, Violet Crown Harpery, Austin, Texas.
Photo: Hopkins Associates. Illustrations: Jamie Downing; Jim Stevenson

WASHED-UP WOOD

ALONG THE OREGON COAST, CRAFTSMEN LOOK TO THE OCEAN FOR STOCK

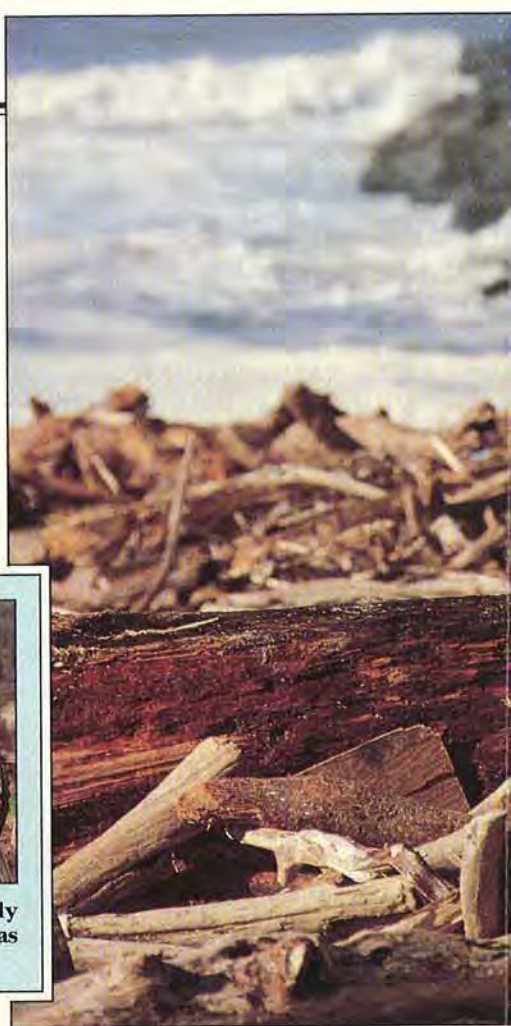

Sam sinks into a cozy, clam-shaped easy chair hued from the trunk of a huge cedar tree. He found the wood on the beach.



A giant myrtle tree furnished the bizarrely bleached and burlled roots that stand out as one of Phil's prized finds.

When most of us need wood, we march down to our hardwood dealer or lumberyard. Enterprising Oregon woodworkers Phil Clausen and son Sam, though, head for the beach instead.

Winter storms roil the Pacific waters off the Oregon coast, building waves that pound more than 300 miles of beach. Inland, torrential rains of the season swell rivers to their banks. Like waters from wide-open faucets, the floods surge to the ocean, sweeping obstacles before them. The inevitable clash with the incoming tide creates a driftwood delicatessen—one that offers specials every day.

EIGHTEEN YEARS BUILDING, NEVER A PENNY FOR STOCK
To Oregon's beachcombing woodworkers, Phil and Sam Clausen, the lull of a storm signals harvesttime.

The father-and-son team knows that Mother Nature's forces have littered the coastline near their shop with wooden casualties—root balls, branches, planks, entire trees. Free for the taking (it's perfectly legal on Oregon public beaches), the washed-up wood will find new life in their workshop.

"Back in 1964, we had a memorable flood that literally lined the beaches with wood," says Phil. "I've been woodworking full-time 18 years since then, and we're still drawing off that reservoir."

Phil, 62, and Sam, 38, own and operate Clausen Studio in tiny Riverton, on the Coquille River, a short drive from the oceanside towns of Bandon and Coos Bay. Together, they craft rustic and unusual free-form tables, chairs, lamps, and other wood accessories.

In addition to drawing from their beach bequeathal, the Clausens commandeer wood wherever they happen to find it. "Besides working the beach, a little wood comes

down the Coquille River every winter, from the interior, that doesn't make it to the ocean," explains Phil. "We also haul from logging areas on public lands, such as the national forests and Bureau of Land Management parcels.

"From the beach, we get logs and even whole trees: redwood, Douglas fir, white fir, pine, cedar, and cypress," Phil continues. "Sometimes, there'll be maple, myrtle, alder, oak, and yew—every kind of tree that you'd find in the forest. In '64, even big redwoods from Northern California washed up—and I mean trees with 20,000 board feet of wood!"

Occasionally, they pluck a real prize. "A few years ago, Sam found a mahogany log on the beach," says Phil. "I suspect it fell off a ship. Anyway, it had been in tropical water for some time, because it was full of holes bored by shellfish. He had it sawed at the mill. Some of it went to a local woodworker for an interesting-looking hutch."



Where Oregon's Coquille River empties into the ocean at Bandon, cedar, fir, pine, and other woods pile up on the beaches.

WOOD IS WHERE YOU FIND IT

No ocean beaches for driftwood near you? Take heart. Rivers, river-fed lakes, and reservoirs all offer some free-for-the-picking stock. And, one of these natural wood depositories shouldn't be far from wherever you happen to live. Best times of year? Look for wood just after the spring snow melt and runoff. In reservoirs, try during late summer when the water level drops.

What will you find? Remnants of trees native to your area that probably died on the stump and were blown into the river or lake bed. If you live near a major waterway, the washed-up wood you'll find might have originated hundreds of miles away.

Sometimes, a surprise comes only after they work the wood in the shop—like the time the woodworkers found a 3"-diameter, solid piece of vine perfect for a lamp base. Then, they discovered that their treasure was poison oak! "We got a good case of it," Sam recalls, chuckling at the thought.

Hardwood trees, stumps, and burls also find their way into the Clausens' shop via tips from friends. In fact, they acquire some extraordinary wood that way. "A dredging crew was digging out the river bottom for a boat ramp when they brought up a sunken tree. We went over to see the log and discovered that it was myrtle, but somehow the wood had acquired a blue cast during its submergence. I slabbed it up to sell as tabletops."

OCEANSIDE LOGGING ISN'T A PICNIC

The tools and equipment Phil and Sam need to reap their harvest of free wood rivals that of a small log-

ging operation. Four-wheel drive pickups sporting oversized tires overcome traction problems on beach sand and provide pulling power. "We mount a winch above the bed," notes Phil, "and raise the log lengths right into the truck."

To handle 7'- and 8'-diameter trees, such as redwood, Phil wields a chainsaw fitted with a super-sized 60" bar. "The only way to get through those big ones!" he says.

But, even with tools matched to the job, the beachfront loggers tackle a tedious task when they harvest driftwood. That's because sand permeates every piece, and it takes a toll. "Trees from the river bottom will have some sand and pebbles in them," Phil says, "but driftwood is the worst. When there's no bark, the wind blows sand right into the grain. You can't wash it all out or blow it out with a compressor. Even when a log has bark, there'll be sand in the end grain. So, when we cut at the beach we constantly sharpen the chain.

And," he adds, "in the shop, the sand dulls saw blades and bits that we have to replace or resharpen."

Phil and Sam consider the inconvenience of sharpening, plus wear and tear to cutting edges, a small price to pay for the wood they bring home. Because, in all ways, it proves exceptional.

"Except for that one blue-colored myrtle tree dragged from the river, neither salt nor fresh water have much effect on a wood's color," Phil notes. "But, and it seems kind of strange, wood that has been immersed in any kind of water seems to dry faster than green wood, and has greater stability."

There's no difference between sanding, staining, or finishing found wood than wood from the lumberyard, say the woodworkers. "All in all, it's satisfying stock," Phil sums up. "And what beats all is that you just never know what you're going to find." 🌲

Written by Peter J. Stephano
Photographs: Mary Schamehorn



The woodworker's survival FORSTNER

FIVE DIFFERENT TYPES OF FLAT-BOTTOM-HOLE BITS TO CHOOSE FROM

Not long ago, Larry Clayton, *WOOD*® magazine's editor, stopped by my office and asked me if I had seen a recent advertisement for low-priced Forstner bits. "Can you believe that price—\$89.99 for 16 bits?" Larry asked. "I wonder if they're any good?"

His questions convinced me that the time was right to shed some light on the subject. So, I made a few calls to the major manufacturers and distributors of Forstner bits, all of whom agreed to send me samples. With more than 100 bits in five styles from no fewer than 11 suppliers in hand, I turned the testing over to Jim Boelling, *WOOD* magazine's project builder. After two weeks of tryouts, Jim let me know, in no uncertain terms, how the various samples performed.

Bill Kier

Products/Techniques Editor

 Print this article

Early on in my research, I realized that even though many manufacturers label their products as Forstner bits, few of these tools resemble the bit Benjamin Forstner invented in 1886 for cutting smooth-walled, flat-bottomed holes. The Salem, Oregon, blacksmith would be amazed that manufacturers from around the world still are fiddling with his design more than 100 years later. I uncovered these five variations:



CONVALCO.

These bits, made exclusively by Connecticut Valley Manufacturing (CONVALCO) in New Britain, Connecticut,

closely resemble Forstner's original bit. Some similarities include an almost-nonexistent centerpoint, two continuous rims without spurs, and hand-sharpened lifting cutters.

Tony Garro of CONVALCO told me that only his company machines Forstner bits from solid bar stock. "We don't forge our bits like the imports do," Tony said. He also explained that his bits have more mass near the rim. Like saw blades or any other cutting tool, extra mass near the scoring edge absorbs and dissipates heat.

You can buy these premium-priced bits through the mail from either Woodcraft Supply or directly from the manufacturer. Only CONVALCO supplies Forstner bits in 1/16" increments.



Imported Forstner.

European and Southeast-Asian manufacturers produce this bit at a relatively low cost

because the notch behind each lifting cutter allows them to machine-grind the cutters. These bits, as well as the following three types, have centerpoints ranging from 1/8" to 1/4" in length, depending on the diameter of the bit.



Multi-spur.

Like the teeth on a sawblade, side-by-side cutting edges along the rim of multi-spur bits aggressively score the walls of the hole. Multiple spurs help keep the rim cool, but also add to the manufacturing cost.

Multiple spurs help keep the rim cool, but also add to the manufacturing cost.



Carbide-tipped.

Because they have cutters, centerpoints, and two scoring spurs made of carbide,

these bits last and last, but cost more than any other type.



Single lifter.

Made by Vermont American and sold under its name as well as under the Sears brand, these

bits have just one rim and lifter. Interestingly, the 1/2"-and-smaller sizes were the only bits in our tests with flutes along their shanks for improved chip evacuation.

guide to buying... BITS

WHAT OUR TESTS REVEALED

Style and looks are one thing, but like you, I wanted to know how the various bits performed. So, Jim Boelling and I decided to judge the bits according to the three criteria listed below. You'll find the complete results in the chart at right.

1. Sharpness from the factory

Right out of the package, the bits varied greatly in the sharpness of their lifting cutters and rims. The carbide-tipped and CONVALCO bits had the finest edges, and the Chinese-made bits had visibly rough lifting cutters. These rough edges cut fairly well, but left minute scratches in hole bottoms.

2. Resistance to burning

As the rim and centerpoint of Forstner bits heat up, two things can happen. First, the rim can turn blue (a sign that it has lost temper). Without temper, the softened cutting edge quickly dulls. Also, as shown in the photo below right, an overheated rim will burn the walls of the hole.

To test for resistance to burning, we started with sharp, cool bits, and cut 1/2"-deep holes in hard maple with 1 1/2" bits running at the recommended speed of 250 rpm. Only the CONVALCO, multi-spur, and carbide-tipped bits allowed us to make multiple holes without waiting for the bit to cool considerably between holes.

3. Smoothness of cuts

If you intend to use your Forstner bits to make holes with exposed

Continued on page 89

PERFORMANCE RATINGS OF SOME WIDELY AVAILABLE FORSTNER BITS

SUPPLIER	TYPE ¹	SHARPNESS ²		RESISTANCE TO BURNING ²		SMOOTHNESS OF CUT ²		COUNTRY OF ORIGIN ³	PRICE OF SINGLE BIT ^{4,5}	SET PRICES ⁵
		LIFTING CUTTERS	RIM	CENTERPOINT	RIM	HOLE WALL	HOLE BOTTOM			
Amana	IF	E	E	G	G	E	F	I	N/A	\$59 A
Constantine's	IF	E	E	E	G	E	E	A	\$12.95	75.25 B
Delta	IF	G	G	G	G	G	F	WG	13	N/A
Dollar Trading Corp.	IF*	F	G	G	G	G	F	C	6.99	97.50 #C, 33 #B
Freud	IF	E	E	G	G	E	E	A	9	160 C
	CT	E	E	E	E***	E	E	I	45 B	N/A
Garrett Wade	IF	E	E	G	G	E	E	A	11.85	99.90
	MS	E	E	E	E	E	E	A	16.20	N/A
Irwin	IF	E	E	E	E	E	E	A	16.89	77.95 G
	MS	E	E	E	E	E	E	A	16.89	77.95 G
Leichtung	IF	G	E	F	G	E	F	T	8.99	99.99 B
	MS	E	E	E	E	E	E	T	29.99 A	199.99 D
Vermont-American	SL	G	E	G	F	G	E	US	17	54 G
Woodcraft	CO	E	E	E	E	E	E	US	21.90 #	54.95 #E
	IF	F	F	F	F	F	F	WG	13.35 #	69.95 #B
	MS	E	E	E	E	E	E	A	18.50 #B 33.25 #A	N/A
Woodworker's Supply of New Mexico	IF**	E	E	G	G	E	E	T	9.75	59.95 B, 199 C
	MS**	E	E	E	E	E	E	T	29.75 A	299 D
	CT	E	E	E	E***	G	G	A	26	435.50 F

N/A Not available.

*Similar bits available from AMT.

Dollar Trading Corp. provides

multi-spur bits in sizes 1 1/2"-2 1/8".

**Similar bits available from

Grizzly. ***In place of rim, these

bits have two scoring spurs.

1. (CT) Carbide tipped; (CO)

CONVALCO; (MS) Multi-spur; (SL)

Single lifter; (IF) Imported

Forstner.

2. (E) Excellent; (G) Good;

(F) Fair.

3. (A) Austria; (C) China; (I) Italy;

(T) Taiwan; (US) United States;

(WG) West Germany.

4. Price for 3/4" bit unless noted

otherwise. (A) 2 1/8" bit; (B) 1" bit.

5. # Postage-paid price

6. (A) 6 sizes from 3/8" to 1"; (B) 7

sizes from 1/4" to 1"; (C) 16 sizes

from 1/4" to 2 1/8"; (D) 8 sizes from

2 1/8" to 3"; (E) 3 sizes (1/4", 3/8",

1/2"); (F) 13 sizes from 3/4" to 3 1/8";

(G) 4 sizes from 5/8" to 1".



We came across the good, the bad, and the ugly of burned walls in our tests. Holes resulted from left: CONVALCO, Chinese-made, and West German-made Forstner bits.

CABINET, CABINET

Clean and simple with a Shaker air about it, our cherry wall cabinet makes a nice addition to most any wall in need of dressing up. You can build it in two evenings and enjoy it for a lifetime.

Note: You'll need some thin stock for this project. You can either resaw or plane thicker stock to size.

Start with the basic case

1 From $\frac{3}{4}$ "-thick cherry, cut the sides (A), fixed shelf (B), and top and bottom (C) to the sizes listed in the Bill of Materials.

2 Mark the locations and cut a $\frac{3}{4}$ " dado $\frac{1}{4}$ " deep on the inside face of each cabinet side. Then, cut or rout a $\frac{3}{8}$ " rabbet $\frac{1}{4}$ " deep along the back inside edge of each cabinet side.

3 Mark the shelf-hole centerpoints and drill $\frac{1}{4}$ " holes $\frac{1}{2}$ " deep on the inside face of the side pieces (40 holes total).

4 After viewing the Chamfer detail for reference, rout a chamfer along the front and side edges of the top and bottom pieces (C).

5 Sand the cabinet pieces. Now, dry-clamp the cabinet with the back edges flush; check for square. Mark the dowel-hole centerpoints on the top and bottom pieces, and drill $\frac{3}{8}$ " holes through the top and bottom and 1" into the ends of the side pieces. Remove the clamps.

6 Cut eight $\frac{3}{8}$ "-diameter dowels $1\frac{3}{4}$ " long (we used cherry dowel stock; see the Buying Guide for our source). Next, glue, dowel, and clamp the cabinet assembly (A, B, C), checking for square. Wipe off excess glue with a damp cloth. Trim and sand the protruding end of each dowel flush with the cabinet surface.

7 Mark the location and fasten the hinges to the cabinet side. (See the Buying Guide for our source of hardware.)

Continued



 Print this article

CABINET

It's time to add the back

1 Cut three pieces of $\frac{1}{4}$ "-thick cherry to $4\frac{1}{16}$ " wide by $22\frac{3}{4}$ " long for the back panel (D). Sand a slight round-over on the front edges of each piece. (The drawing at *right* shows the method we use to resaw thicker stock to size.)

2 Rout a $\frac{3}{8}$ " rabbet $\frac{1}{4}$ " deep along the inside edge of the top and bottom pieces (C) to match the rabbet previously cut in the side pieces. Use a sharp chisel to square the corners where the rabbets meet.

3 Lay the cabinet facedown. Position the three back pieces (D) in the rabbeted opening. Drill and countersink holes in the back-panel pieces to the sizes shown on the Exploded View drawing.

The door comes next

1 Cut the door stiles (E) and rails (F) to size. Then, cut two pieces of cherry to $4\frac{1}{2} \times 15$ ". Plane or resaw the pieces to $\frac{1}{4}$ " thick for the door panel (G). Glue and clamp the pieces edge to edge with surfaces and ends flush.

2 Cut or rout a $\frac{1}{4}$ " groove $\frac{1}{2}$ " deep along one edge of each rail and stile where shown on the Spline detail on the previous page. From $\frac{1}{4}$ " cherry, cut four splines to size.

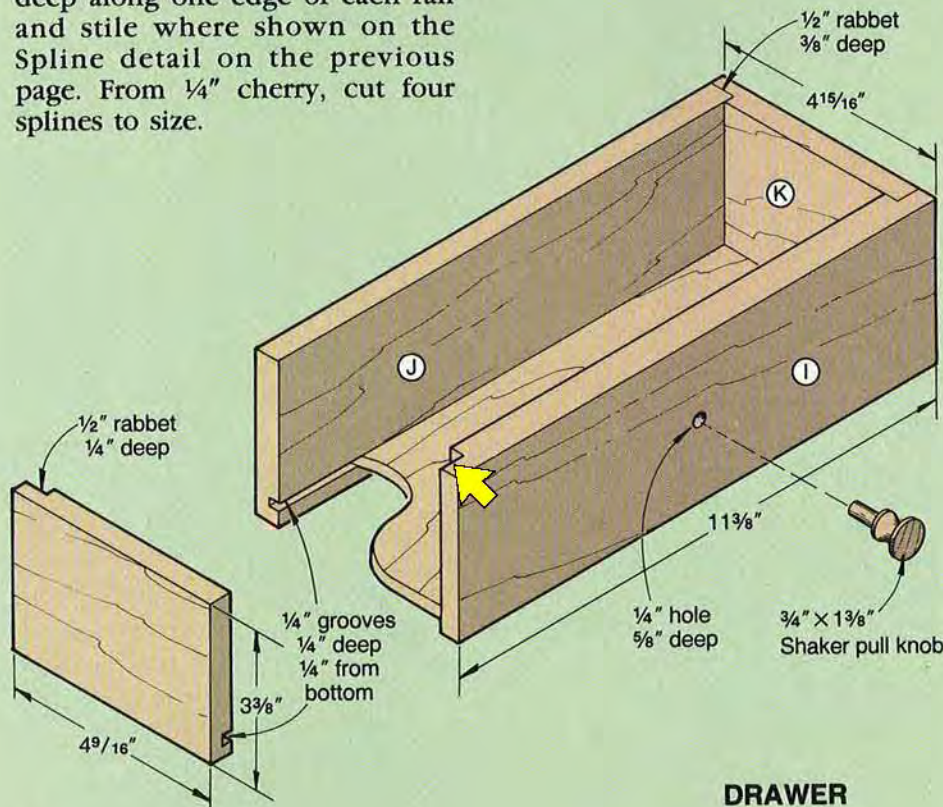

DRAWER

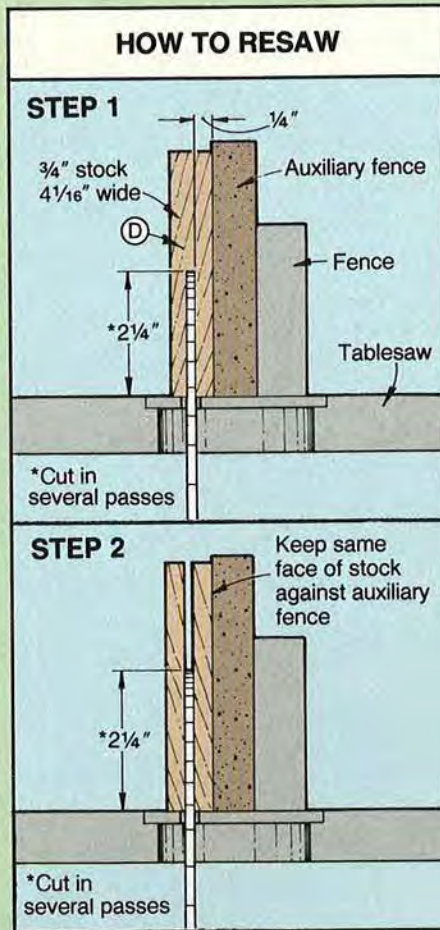

3 Test-fit the door pieces; the panel should be slightly undersized about $\frac{1}{16}$ " in each direction to allow it to expand without splitting the assembled door. Then, glue and clamp the door. Allow the panel to float inside the frame *without glue*.

4 Mark the centerpoint, and drill a hole for the Shaker pull knob.

5 Cut the adjustable shelves (H) to size.

Add the drawer and then the finish

1 Cut the drawer front (I), back (J), sides (K), and bottom (L) to sizes listed in the Bill of Materials.

2 Cut a $\frac{1}{4}$ " groove $\frac{1}{4}$ " deep $\frac{1}{4}$ " from the bottom edge of the front, back, and side pieces where shown in the drawing at *left*.

3 Cut $\frac{1}{2}$ " rabbets on both ends of the front piece and the back end of each side piece (see the Drawer drawing for particulars).

4 Draw diagonal lines from corner to corner to find the center of the drawer front, then drill the mounting hole for the Shaker knob in the drawer front.

5 Dry-clamp the pieces and check the fit of the drawer in the opening. Then, glue and clamp the drawer parts.

6 Drill a pair of mounting holes through the cabinet back.

7 Sand the cabinet, back, door, and drawer. Apply the finish to the cabinet and knobs (we left the cherry natural and brushed on several coats of polyurethane). Add the knobs. Finally, add the magnetic catch and strike plate.

Buying Guide

• **Hardware.** One $\frac{3}{4}$ "-diam. and one 1"-diam. Shaker pull knob, one pair of $1\frac{1}{2}$ "-long no-mortise hinges, magnetic catch, two 8" pieces of $\frac{3}{8}$ " cherry dowel. Cabinet kit no. 101WD, \$9.95 (U.S.) ppd. Cherry Tree Toys, P.O. Box 369, Belmont, OH 43718. 🌲

Produced by Marlen Kemmet

Project Design: Dean Young,

Des Moines, Iowa

Photographs: Hopkins Associates

Illustrations: Jamie Downing; Bill Zaun

WOOD® Magazine announces:

1991 BUILD-A-TOY™

**Our Third Annual Juried Contest
to benefit deserving kids through Toys-for-Tots**



ENTRY DEADLINE: FEBRUARY 1, 1991

Great prizes for every skill level! New Judging Categories!

Prizes for Original Designs and Built from Plans!

Holiday exhibition at the Museum of American Folk Art!

Enter by November 1, 1990 to be eligible for Museum exhibit.

We're proud to invite woodworkers of every age and skill level to participate in the Third Annual WOOD Magazine BUILD-A-TOY Juried Contest.

This year, we've expanded the competition into new areas. Special citations will be awarded to woodworkers who build toys from plans as well as original design entries. There are also several new judging categories.

We've added more valuable prizes contributed by leading WOOD advertisers. Some winning toys will be chosen for editorial features in future issues of WOOD.

There's even an exhibition of winners scheduled for the 1990 holiday season at the Museum of American Folk Art in New York City. (Toys received by November 1, 1990 will be eligible for display in the Museum's Christmas Tree exhibition.)

BUILD-A-TOY is the best way we know of for woodworkers to get the

COMPETITION PRIZES AND CATEGORIES			
	STUDENT (K-12):	HOME HOBBYIST:	PROFESSIONAL:
DESIGN: These 15 categories are open to original design entries only.			
Grand Prize	KITY: K-5 Machine (\$2,000 value)	Delta: \$2,500 in merchandise	Freud: \$2,000 in merchandise
First Prize	Black & Decker: \$1,500 in merchandise	Shopsmith: Mark V (\$1,600 value)	AEG: \$1,000 in merchandise
Second Prize	Jet: 14" Band Saw (\$579 value)	Grizzly: \$500 in merchandise	Skil: \$500 in merchandise
Third Prize	American Tool Cos.: \$500 in merchandise	Lobo: \$500 in merchandise	Wilke: BW1-P Planer (\$400 value)
Fourth Prize	Industrial Abrasives: \$250 in merchandise	Leichtung: \$250 in merchandise	Milwaukee Electric: 4" Belt Sander with Bag (\$348 value)
SPECIAL CITATIONS: These 39 categories are open to both original and existing designs.			
Best use of Router	AmMax: Scroll saw	Porter Cable: \$1,000 in merchandise	Ryobi: \$1,000 in merchandise
Best use of Wood	Adams Wood Products: Turning Squares Constantine's: \$100 in merchandise	RBI: 14" Scroll Saw	Makita: \$500 in merchandise
Best Carved Toy	Dremel: \$500 in merchandise	Dremel: \$500 in merchandise	Dremel: \$500 in merchandise
Best Finish	Deft: \$1,000 in merchandise	Minwax/Watco: \$1,000 in merchandise	Performax: ST Sander
Best Truck	How-To Book Club: \$100 Membership Toys and Joys: Antique Car Plans	Meisel: \$500 in merchandise Dollar Trading: Carving Set	Craftsman Wood Service: Turning Squares Brandmark: Branding Iron
Best Car	Constantine's: \$100 in merchandise	Berea: Assortment of Hardwoods	Furniture Designs: Plans
Best Pull Toy	DML: 10" Carbide-Tipped Blade	Formby's: Gift Set	Timbers Woodworking: Gift Certificate
Best Train	Rodale: Woodworking Books	Seven Corners: \$250 in Power Tools	How-To Book Club: \$100 Membership
Best Bank	Formby's: Gift Set	Fisher Hill: Rip Straight	DML: 10" Carbide-Tipped Blade
Best Airplane	Nova Tool: Branding Iron	Accents in Pine: Set/Blueprints	Constantine's: \$100 in merchandise
Most Number of Toy Entries	Accuset Tool: ParaGauge Econ Abrasives: \$100/Sandpaper	Woodcraft Supply Corp.: \$100 Gift Certificate	Diamond Machining Technology: 8" Fine Whetstone
Best Boat	Tarheel Filing: Router Insert	Fisher Hill: Rip Straight	Penn State: Variable Speed Scroll Saw
Best Puzzle	St. Croix Kits: Thumb Piano	MLCS: Master Set	Hardwoods of Illinois: 20 sq. feet of Walnut

WOOD® Magazine's 1991 BUILD-A-TOY Contest

There is no limit to the number of entries. Please provide the following information for each toy submitted.

My entry is: Original Design* Built from plans

My skill level is: Student Home Hobbyist Professional

Name _____

Address _____

City _____ State _____ ZIP _____

Daytime Phone (_____) _____

*For Original Design entries: I certify that I have designed and built this toy myself. Should my entry win, I agree to cooperate with WOOD Magazine to supply builder's notes and a bill of materials for publication.

Signature _____ Date _____

Send toys to: 1991 BUILD-A-TOY, WOOD Magazine,
1912 Grand Avenue, Des Moines IA 50309

recognition they deserve for great craftsmanship. We'd like as many entries as we can get.

That's because WOOD Magazine's BUILD-A-TOY Competition is also the contest with the biggest heart. The toys you submit will be contributed to the TOYS-FOR-TOTS program of the U.S. Marine Corps Reserve.

Help make some deserving kids happy this Christmas.

**1991 BUILD-A-TOY
ENTRY DEADLINE:
FEBRUARY 1, 1991.**

TEST YOUR WOODWORKING

I.Q.



Taking tests back in high-school shop class sure wasn't much fun. Now, though, only your enjoyment is at stake. Challenge your know-how, and then check your answers against those at the bottom of the page.

 [Print this article](#)

HOW DID YOU DO?

16-18 Shop wizard

11-15 A cut above

7-10 Run of the mill

less than 7 Hill of sawdust

FROM TREE TO BOARD

1. What size is a board foot?
A. 1×6×18" B. 1×12×12"
C. 2×6×12" D. 12×12×12"
2. What's the greatest difference between red and white oak?
A. Red oak is a different color
B. White oak makes a durable outdoor project
C. White oak costs less
3. If you followed the old adage about how long it takes to air-dry green wood, how long would it take to dry a piece 3½" thick?
A. 4 years B. 6 months
C. 2½ years
4. After seasoning, will a board be narrower or shorter than when it was green?
A. Shorter B. Neither
C. Both D. Narrower

WORK THAT WOOD

5. Which of the following can be done on a bandsaw?
A. Ripping B. Cutting circles
C. Resawing D. Mitering
6. When ripping on the table-saw, how much blade should extend above the wood?
A. 1½" B. The teeth C. ¾"
D. Double wood thickness
7. What is the shortest board you can safely run through a jointer?
A. One half the bed width
B. 24" C. 10" D. 12"
8. Hardwood should be drilled at a faster speed than softwood.
A. True B. False

PUTTING PROJECTS TOGETHER

9. What is the strongest woodworking joint?
A. Butt B. Shouldered butt
C. Tongue-and-groove
D. Mortise-and-tenon
10. Veneering became popular in the Machine Age of the 1800s.
A. True B. False
11. When is a dado a groove?
A. When it runs with the grain
B. Only across grain
C. At the end of a board
D. On the edge of a board
12. When someone mentions aliphatic-resin glue, what are they talking about?
A. Glue warmed in a pot
B. Yellow glue
C. Contact cement
13. What can slow-cure epoxy do that 5-minute epoxy can't?
A. Be sanded B. Resist water
C. Fall out D. Accept paint

THE FINAL TOUCH

14. What hand tool did the finish sander replace?
A. Sanding block B. Plane
C. Cabinet scraper
15. Which of the following finishing materials comes from a tree?
A. Linseed oil B. Tung oil
C. Aniline dye D. Lacquer
16. For outdoor use, a clear finish should contain what?
A. Tint color B. Varnish
C. Pigment D. UV inhibitors
17. What is "fish eye"?
A. Smelly varnish B. A blemish
C. Wood figure D. Router bit
18. When sanding, how do you know when to switch to the next finer grit?
A. It no longer removes wood
B. You run out
C. When it feels smooth
D. After five minutes

10. (B) Veneering was popular in ancient Egypt to conserve precious wood.
11. (A) A dado goes across the grain, grooves with it.
12. (B) The old reliable—creamy yellow woodworker's glue.
13. (B) It holds up better to moisture than any other glue.
14. (C) Cabinet scrapers were used to finely smooth wood.
15. (B) Seeds of the tung tree, from China, yield oil.
16. (D) Ultraviolet light (UV) penetrates the wood and discolors it.
17. (B) Craters occur in lacquer when there are traces of silicone on the wood.
18. (A) No kidding!

1. (A,B,C) Usually 1×12×12", but other combinations work.
2. (B) Try putting red oak outside for a few years.
3. (C) Dry green wood two years for the first 1" of thickness, then one year for each added 1".
4. (D) Wood shrinks only in width and thickness.
5. (A,B,C,D) A versatile tool.
6. (B) To remove sawdust, the teeth need only to clear the wood.
7. (D) For safety's sake, regard 12" as minimum.
8. (B) Slower speeds avoid burning.
9. (D) Mainly because of the amount of gluing surface.

Answers

Illustration: Jim Stevenson

Refinishing School

Bonus Guide
when you
order now

Introducing
REFINISHING FURNITURE,
the instructive
new how-to
video from
Better
Homes
and
Gardens.®

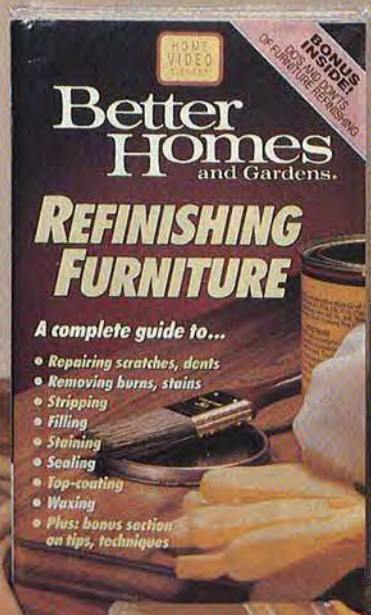

Nothing could be a better reflection on you — than your ability to refinish furniture you thought was all but finished.

Now you'll polish these skills to a fine luster with **REFINISHING FURNITURE**, the inspiring new home video from Better Homes and Gardens® magazine.

Refinishing, from the beginning

Even if you've had no experience restoring or repairing furniture, **REFINISHING FURNITURE** will soon have you rescuing potential heirlooms from the junk pile.

You'll see close up how to revitalize finishes when they are still usable, and repair scratches, water spots, dents — even burns and gouges!

Because it's on video tape, you can replay any section



as often as you need to. And you can actually see a technique demonstrated with your own eyes, to pick up on important subtleties that words sometimes don't convey.

Stripping made easy

In **REFINISHING FURNITURE**, you'll see, in easy-to-follow close-ups, how to strip old finishes. You'll discover how the pros handle bleaching, restaining, filling, and sealing.

You'll find out how to choose and apply the all important finish coat. And you'll learn how to do professional-calibre oil-and-abrasive polishing.

So if you'd like to master the art of refinishing, the place to start is **REFINISHING FURNITURE**. Order your copy now!



Credit Card Users



Call TOLL FREE
1-800-678-2699

MAIL TODAY TO:

Better Homes and Gardens®
P.O. Box 11430
Des Moines, Iowa 50336-1430

*TAX NOTE: We are required to collect and pay STATE taxes in AZ, CO, CT, FL, IL, KS, MA, MD, MI, MN, MO, NM, PA, and WI. We are required to collect and pay STATE/LOCAL taxes in CA, GA, IA, NY, OH, TN, TX, VA, and WA.

Better Homes and Gardens® REFINISHING FURNITURE ORDER FORM



YES, please send me the Better Homes and Gardens® Home Video, **REFINISHING FURNITURE**. I understand the video—and the **BONUS Guide**—are mine for just \$19.95 plus \$3.00 shipping and handling, plus applicable state and local taxes.

CHECK METHOD OF PAYMENT:

Check or Money Order Enclosed, Payable to Better Homes and Gardens®.

I prefer to bill my: American Express VISA MasterCard

Account Number: _____ Expiration Date: ____/____/____

Signature: _____

NAME _____
(Please Print)

ADDRESS _____ Apt. # _____

CITY _____ STATE _____ ZIP _____

KEY #280164

FREE CATALOG

Trend-lines® Discount Woodworking Tools and Supplies

Send today for your **FREE** copy of our 72 page full-color catalog. You'll find the best prices for over 3,000 brand-name products. Included are power tools & accessories, hand tools, screws, hardware, wood components, plans, how-to books, and much more.



To order your **FREE** catalog call Toll-Free,

1-800-366-6966

Or Write: Dept. WD21 • 375 Beacham St.
Box 6447 • Chelsea, MA 02150

Wood Moisture Meter

- Avoid Moisture Problems
- Protect your Masterpiece

MINI LIGNO

Incl. Case, Batteries and Pins for 3/8" and 7/16" Measuring Depth,

only **\$110**

also from Lignomat:
MINI-LIGNO E
Range: 6%

Easy-to-use, sturdy instruments for the professional woodworker or serious hobbyist. Great for lumber, veneer, fiberboards. Ask for free catalog on the complete line of moisture meters and accessories for kiln drying.

Lignomat USA Ltd.
503-257-8957, 800-227-2105

P.O. Box 30145bh
Portland, OR 97230



DRY YOUR OWN LUMBER...

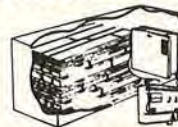

...With an EBAC Wood Drying System

Whether you're a serious home woodworker, small cabinet shop or a large wood retailer, EBAC has a wood drying system that's affordable for you.

EBAC Wood Dryers:

- save you money
- are easy to operate
- are energy efficient
- give you higher quality wood
- give you complete control over your wood's moisture content



CALL OR WRITE TODAY!

EBAC LUMBER DRYERS

106 John Jefferson Rd., Suite 102
Williamsburg, VA 23185

1-800-433-9011 • FAX (804) 229-3321

NEW "FINGER RELEASE" BLADE CLAMPS FOR SCROLL SAWS

Designed to fit most constant tension scroll saws (except far east imports).



CATALOG \$1.00 with details and information on--
BLADES - BOOKS
PATTERNS

EXCALIBUR SCROLL SAWS

SEYCO "The Scroll Saw Specialist"

1414 Cranford Dr • Box 472749

Garland, TX 75047 - 2749

1 800 462-3353

TOULAN 2500 CORNERS CAMCLAMP



The Corner Clamp is an all British invention which has won National acclaim and prizes for its unique design.

How to use your Corner Clamp

- Place cam in hole.



- Clamp by rotating cam.



SUGGESTED RETAIL \$12.95

SPECIAL INTRODUCTORY OFFER

4 Corner Camclamps \$ 45.00

10 Corner Camclamps 100.00

20 Corner Camclamps 180.00

CHECK WITH ORDER OR C.O.D.
Freight pre-paid.

Toulan USA

Exclusive Importer

235 Canterbury
P.O. Box 12389
Beaumont, Texas 77726

Div. Tech Rep & Associates

BUILD THIS FRENCH-CANADIAN SETTLE BENCH



14"d x 21-1/2'h x 65-1/2"

The original is on display at the Ethan Allen Homestead, in Burlington, VT; you can make an accurate copy using our plans with how-to instructions from craftsman Harry Wicks. Send check or money order for \$9. Allow 4-5 weeks for delivery (Canadian residents remit postal money order in U.S. funds to):

HAMMERMARK ASSOCIATES
P.O. Box 201-ABW2, Floral Park, NY 10002-0201

In a rush? Call 516.352.5198
and use your Visa or MasterCard.

Catalog available for \$1 (refundable)

BAND SAW BLADES

WELDED TO YOUR EXACT LENGTH

Complete Band Saw Blade Line
Including Saw Mill Blades

We also carry:

- Scroll Saw Blades
- Hand Saws
- Circular Saw Blades
- Hole Saws
- Hack Saws
- Sanding Belts
- Sanding Disks
- Router Bits
- Files
- Rasps
- Scrapers

SEND \$1.00 FOR CATALOG or
TO ORDER PHONE OR WRITE TO:

BUCKEYE SAW COMPANY

P.O. BOX 46857
CINCINNATI, OHIO 45246
1-800-543-8664 • 1-513-860-0572
FAX 1-513-860-0578

Van Dyke's

Presents a Catalog

with supplies for upholstery, antique restoration, wood working, caning, brass hardware, carvings and many related trades!

36 Years in Creative Arts & Trades

Many Hard-To-Find Items!

SEND \$1.00 FOR CATALOG TO:
Van Dyke's Restorers
Dept. D55 • Woonsocket, SD 57385



NEED
EXTRA
INCOME?

SIGNCARVING



IS FUN & PROFITABLE

And it's easy, if you use the Marlin Woodcarvers and accessories. You can carve signs quickly at home or at swap meets. No special training is required. The machines do the work, the operator has the fun and the profits. These machines will also 3-D carve panels and plaques. Our templates work well with other machines.

SEND \$1.00 FOR OUR FULL LINE BROCHURE AND PRICE LIST AND START PLANNING YOUR FULL OR PART-TIME BUSINESS.



MARLIN INDUSTRIES, INC.

Rt. 70, Box 191, Dept D012
Cashiers, NC 28717
(704) 743-5551

16 SHOWS THIS SPRING!

★ The Woodworking Shows ★

machinery
tools • supplies



- Atlanta
- Boston
- Charlotte
- Chicago
- Cincinnati
- Dallas
- Delaware Valley
- Denver
- Indianapolis
- Kansas City
- Milwaukee
- No. California
- Sacramento
- So. California
- St. Louis
- Tampa

Call for free brochure
Monday - Friday 8 am - 5 pm Pacific Time
1-800/826-8257 or 213/477-8521

Wood-Mizer®

World's Largest Manufacturer Of Portable Sawmills



OWN YOUR OWN SAWMILL
Four Models To Choose From
BUY DIRECT

1(800)553-0219

In Indiana call: (317) 271-1542
44-page catalog or use your MasterCard or VISA to order our 50-minute demonstration video—\$10.00
Wood-Mizer Products, Inc. • Dept. Q052
8180 W. 10th St., Indianapolis, IN 46214-2430



YOU CAN BUILD YOUR OWN ACOUSTIC GUITAR

GUITAR KITS from WOODWORKER'S DREAM
the exotic wood division of: **THE MARTIN GUITAR COMPANY**
10 West North St. • Nazareth, PA 18064 • 1-800-247-6931

New HEGNER for under \$400



(offer expires Mar. 1, 1991)

1-800-648-4264

(in Delaware 322-2226)

ADVANCED MACHINERY IMPORTS, LTD

P.O. Box 312, Dept. 439
New Castle, DE 19720



HAVE FUN WITH WOODCRAFT

FUN, PROFITABLE-FULL SIZE PATTERNS

- 125 pattern Fun Packet assortment!
- 8 enjoyable wind-action whirlygigs.
- Over 50 Country Cut patterns - 100's of projects.
- Show Stoppers - 22 craft show top-sellers!
- Funville - 27 toy cars, trucks, train, ferry, more.
- Attractive Dutch Windmill - 5 feet tall.
- 100 yard ornaments, animals, birds, signs, more!
- 10 easy to make bird feeders.

Send \$8.00 per packet. Pick 3 FOR ONLY \$16.00
Fast Service • Satisfaction Guaranteed!

ACCENTS, Dept. MA21, Box 7387, Gonic, NH 03839

WOODCRAFT CATALOG - \$2.00 (Free with order)

B

UILD an Old Order Amish Buggy • Concord Stage Coach • Covered Wagon • 1890 Peddlers Wagon in 1' scale or an 1893 gas driven car reputed to be the first successful gas engine car. Plans are \$16.95 ea. + \$3 hdg/ins. Special offer: Buy any 2 plans and get a free \$5 plan for making spoked wheels. Plans are drawn as full size cutting patterns for easy construction. Photos, exploded assembly views and construction hints are also included. Credit cards \$20 min. Visa/Mastercard accepted. Brochure \$1/free with order. N.J. res. add 7% tax. Tel: 201-835-9339.

CRISS-CROSS CREATIONS
BOX 324 • WAYNE, N.J. 07470

Superior Quality Carbide Tipped Router Bits & Cutters

Check our quantity discount price and monthly sales item. Same day shipping. S&H is included. Catalog & distributor price is available.

Tool No.	Diagram	Radius/Angle	Cutting		Shank		Price	Tool No.	Diagram	Radius/Angle	Cutting		Shank		Price
			Dia.	Len.	Dia.	Len.					Dia.	Len.			
T100B	Corner Rounding	1/8	3/4	5/16	1/4	1-1/4	10.00	T301B	Roman Ogee	5/32	1-1/8	15/32	1/4	1-1/4	15.00
T101B		3/16	7/8	3/8	1/4	1-1/4	10.00	T302B		1/4	1-1/2	21/32	1/4	1-1/4	16.00
T102B	Beading	1/4	1	7/16	1/4	1-1/4	11.00	T303B	Slot Cutter	5/32	1-1/8	15/32	1/2	1-1/2	15.00
T103B		5/16	1-1/8	1/2	1/4	1-1/4	12.00	T304B		1/4	1-1/2	21/32	1/2	1-1/2	16.00
T104B	Cove	3/8	1-1/4	5/8	1/4	1-1/4	14.00	T1501B	Core Box	1-1/4	1/8	1/4	1-1/2	9.00	
T105B		1/2	1-1/2	3/4	1/4	1-1/4	16.00	T1503B		1-1/4	1/4	1/4	1-1/2	10.00	
T110B	Chamfer	1/2	1-1/2	3/4	1/2	1-1/2	16.00	T1506B	Carbide Tipped Dovetail	1-1/4	1/2	1/4	1-1/2	11.00	
T111B		5/8	1-3/4	7/8	1/2	1-1/2	19.00	T1512B		1-1/4	1/2	1/2	1-1/2	11.00	
T112B	Straight Bit w/ Beaving	3/4	2	1	1/2	1-1/2	20.00	T601	V Groove	1/4	1/4	1/4	1	9.00	
T113B		1	2-1/2	1-1/4	1/2	1-1/2	32.00	T602		3/8	3/8	1/4	1	10.00	
T200B	Mortising	1/8	3/4	5/16	1/4	1-1/4	10.00	T603	Classical	1/2	3/8	1/4	1	12.00	
T201B		3/16	7/8	3/8	1/4	1-1/4	10.00	T604		5/8	5/8	1/4	1-1/8	13.00	
T202B	Mortising	1/4	1	7/16	1/4	1-1/4	11.00	T605	Classical	3/4	5/8	1/2	1-1/2	14.00	
T203B		5/16	1-1/8	1/2	1/4	1-1/4	12.00	T1602		1/2	1/2	1/4	1-1/4	5.00	
T204B	Mortising	3/8	1-1/4	5/8	1/4	1-1/4	14.00	T1604	1/4" Straight Bit Single Double flute	3/4	3/4	1/2	1-1/2	6.50	
T205B		1/2	1-1/2	3/4	1/4	1-1/4	16.00	T1606		1	7/8	1/2	1-1/2	7.50	
T210B	Mortising	1/2	1-1/2	3/4	1/2	1-1/2	16.00	T1607	1/4" Straight Bit Single Double flute	1/2	1/2	1/2	1-1/2	5.00	
T212B		3/4	2	1	1/2	1-1/2	20.00	T2201s		1/8	1/2	1/4	1-3/16	5.00	
T901B	Mortising	1/4	1	3/8	1/4	1-1/4	11.00	T2202s	1/4" Straight Bit Single Double flute	3/16	1/2	1/4	1-3/16	5.00	
T902B		3/8	1-1/4	1/2	1/4	1-1/4	12.00	T2205d		1/4	3/4	1/4	1-3/16	5.50	
T903B	Mortising	1/2	1-1/2	5/8	1/4	1-1/4	13.00	T2207d	1/4" Straight Bit Single Double flute	3/8	1	1/4	1-3/16	5.50	
T904B		1/4	1	3/8	1/2	1-1/2	11.00	T2209d		1/2	1	1/4	1-3/16	5.50	
T905B	Mortising	3/8	1-1/4	1/2	1/2	1-1/2	12.00	T2211d	1/4" Straight Bit Single Double flute	5/8	3/4	1/4	1-3/16	6.50	
T906B		1/2	1-1/2	5/8	1/2	1-1/2	13.00	T2212d		3/4	3/4	1/4	1-3/16	7.50	

Visa/MasterCard • 214-234-5824 • 800-966-6543 • Mon. ~ Fri., 8AM ~ 7PM CT
Check/M.O. • C&L Int'l, Inc./Dar Chyi U.S.A. • 1729 Analog, Richardson, TX 75081

Tool No.	Diagram	Radius/Angle	Cutting		Shank		Price
			Dia.	Len.	Dia.	Len.	
T1203	Hinge Boring	1/8	3/4	3/8	1-1/2	17.00	
T1204			1-1/4	3/4	3/8	1-3/4	18.00
T1205	Half Round	1-3/8	3/4	3/8	1-3/4	20.00	
T1206			1-1/2	3/4	3/8	1-3/4	22.00
T801	Cove Beading	15/16	1/4	1/4	1-1/4	13.00	
T802			1-1/16	3/8	1/4	1-1/4	14.00
T803	Chamfer	1-3/16	1/2	1/4	1-1/4	15.00	
T805			1-7/16	3/4	1/4	1-1/4	17.00
T805L	Straight Bit w/ Beaving	1-7/16	3/4	1/2	1-3/4	19.00	
T807			1-11/16	1	1/2	1-3/4	21.00
T2501B	Mortising	3/16	1	1/2	1-1/4	12.00	
T2502B			1/4	1-1/8	9/16	1/4	1-1/4
T2503B	Mortising	5/16	1-1/4	5/8	1-1/4	14.00	
T401B			Chamfer	45°	1	3/8	1/4
T403B	Mortising	45°			1-3/8	5/8	1/4
T403B			Mortising	45°	1-3/8	5/8	1/2
T2004B	Straight Bit w/ Beaving	1/2			1	1/4	1-1/4
T2008B			V Groove	1/2	1	1/2	1-1/4
T701	Mortising	3/8			1/2	1/4	1
T702			Mortising	1/2	1/2	1/4	1
T2101	Mortising	1/2			13/32	1/4	1
T2102			Mortising	5/8	9/16	1/4	1-1/4
TC-12B	Classical	3/16			1-3/8	11/16	1/4
TC-12B 1/2			Classical	3/16	1-3/8	11/16	1/2
TC-16B	Classical	1/4			1-5/8	13/16	1/4
TC-16B 1/2			Classical	1/4	1-5/8	13/16	1/2
T2601	Carbide Tipped Keyhole	3/8			3/16	1/4	1

We need people who can see the forest for the trees.

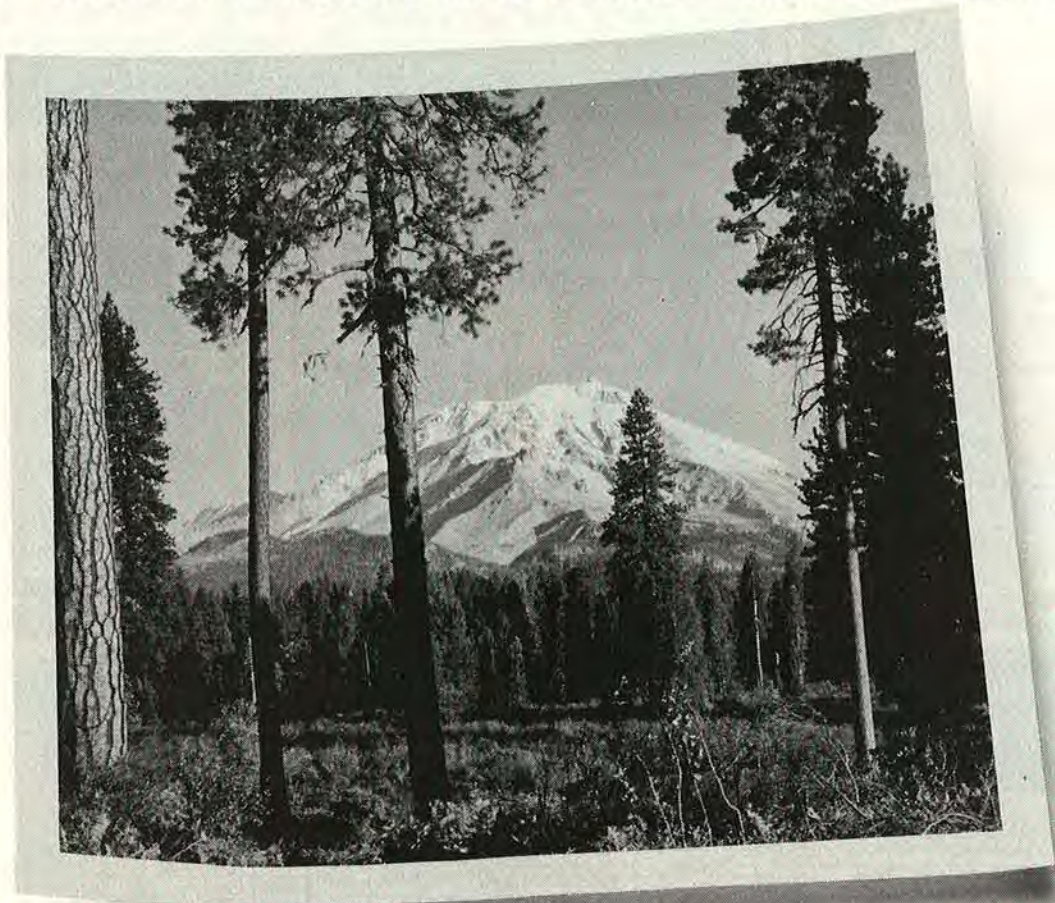

Air pollution. Acid rain. Gypsy moth infestation. Global warming. The stress and damage experienced by America's forests represents a serious part of our growing environmental crisis. And these problems affect everyone—from people who make their living in forest-related industries to people who use wood products and enjoy outdoor recreation.

What can you do to help? Plenty! Join other Americans

across the country in protecting our existing forests and planting new acreage. It's all part of Global ReLeaf, our national campaign to help reverse the trends of our worldwide environmental crisis. And, we need people who really do understand the value of these essential and threatened resources.

Can Global ReLeaf make a difference? Yes. But not without

your support. For more information on how you can help, write Global ReLeaf, American Forestry Association, P.O. Box 2000, Dept. GR3, Washington, DC 20013.



You can make a world of difference.

NORWEGIAN FARMER

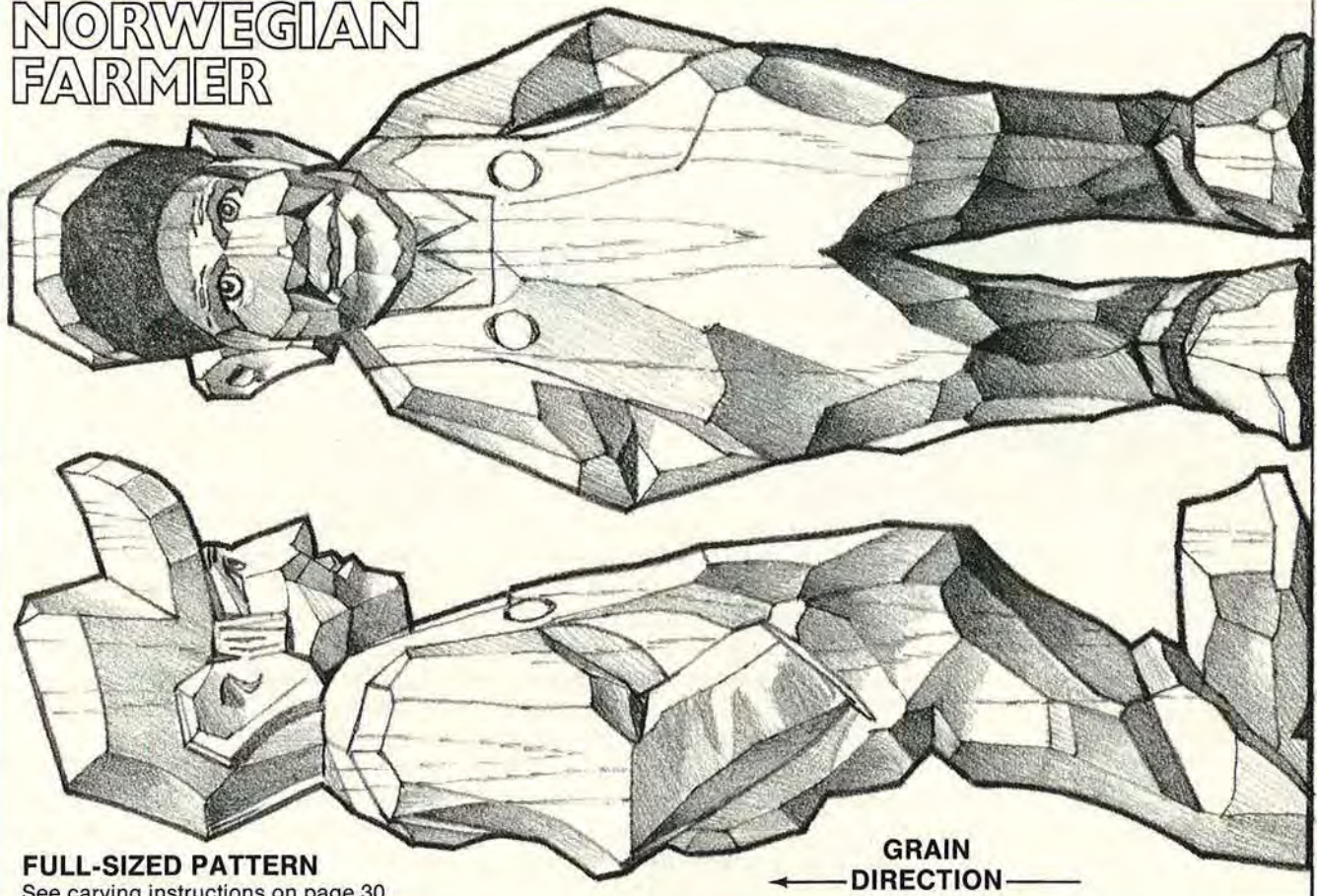

FRONT VIEW

SIDE VIEW

GRAIN DIRECTION ←

FULL-SIZED PATTERN

See carving instructions on page 30

TRANSPOWER HEAVY DUTY, HIGH QUALITY & FULL WARRANTY
 Don't have to cost a fortune!

For express catalogue call
800-654-7702



SHAPER / ROUTER MACHINE
 Extra Large Table
Only \$698

WIDE BELT SANDER

AUTO PLANER

BAND SAW

TABLE SAW

AUTO FEEDER



3600HD 24" x 7"
 10 HP Motor \$6150
 4800HD 36" x 7"
 15 HP Motor \$8995

EDGE SANDER

AP150 12", 2 HP \$339
 AP650 15", 2 HP \$695
 AP200A 20, 3 HP \$1245
 AP400 24", 7½ HP \$2590

JOINTER

SB500 14", ¾ HP \$285
 SB600 16", 1½ HP \$495
 SB800 18", 2 HP \$625
 SB800 20", 3 HP \$1340

DUST COLLECTOR

TS200A 10", 2 HP \$795
 TS200HD 10", 3 HP \$895
 TS300HD 12", 3 HP \$1495
 MS250 10", 1½ HP \$365

AIR DRUM SANDER
 Sale \$285

RF150 ¼ HP, 3 rollers,
 10" travel \$385
 RF250 1 HP, 3 rollers,
 20" travel \$595

WOOD LATHE
 Sale \$595



1", ¾" & ½" spindles, ¼" & ½" router bit
 chucks, 3 HP motor, 25" x 22" milled table,
 T-slot miter gauge, 8000 / 11000 reversible
 2 speeds, 3" spindle travel, independent
 precision fence, 6" insert opening, side &
 top spring hold-downs.

SP860 Tilting spindle sharpener \$1150
 HP600 3HP sharpener \$825
 DH150 1½ HP sharpener \$398

SD800 6" x 90" belt,
 2 HP w/stand \$435
 SD1200 6" x 132" belt,
 2 HP w/stand \$990

JT650 6", 1HP \$325
 JT860 8", 1½ HP \$685
 JT980 8", 2 HP \$745
 JT1200 12", 3HP \$1695

747 1 HP, 2 bags \$165
 2000 2 HP, 2 bags \$295
 3000 3 HP, 2 bags \$375
 4000 3 HP, 4 bags \$475

1 HP motor, 1725 RPM
 4" x 9" sanding brush,
 4" x 9" air drum, 1" shaft.

17" swing, 36" travel, ¾ HP
 motor, 6 speeds, cabinet
 stand, sanding attachment.

TRANSPOWER TCM Industries, Inc. 322 Paseo Sonrisa, Walnut, CA 91789 In California call (714) 594-0780
 For express catalogue, call 1-800-654-7702

ASK WOOD

Whether your woodworker's license reads "Beginner," "Intermediate," or "Advanced," you're bound to have a few questions about your favorite hobby. We can help by consulting our staff and outside experts. Send questions to:

Ask WOOD
Better Homes and Gardens®
WOOD® Magazine
P.O. Box 11454
Des Moines, IA 50336-1454



What's a woodworker to do?

Although I want to make many of the toys and other items you publish in your interesting magazine, I am dissuaded from doing so because my shop tools are limited.

I have a handsaw, circular saw, and sabersaw. I have a hand plane, a belt sander, and an orbital sander. I have a 3/8" electric drill and a cordless screwdriver. But I don't own a lathe, drill press, bandsaw or scrollsaw, so the making of toy wheels and such is left to my sabersaw and ingenuity.

Is there any way you could show more projects that don't require such expensive shop equipment?

—Phil Gabler, Deerfield Beach, Fla.

Phil, every woodworker in our reading audience either has walked in your shoes or is walking in them right now. And for this very reason, in this issue of

WOOD, we have introduced the new, six-page Craftshop section (see pages 64-69). Now, woodworkers with little time and/or a limited number tools can come away with three great, easy-to-do projects.

We work to include buying guides in many of our project write-ups that tell readers where to buy thin stock, toy wheels, and other items that require special machining. Just look through past issues for some of our sources, and then write to these mail-order houses for their catalogs. You'll be amazed at how much machining you can avoid by going this route.

Finally, as you continue to grow in your hobby, you'll want to invest in a few more tools to expand your woodworking horizons. Surveys tell us most of our readers own routers, and/or tablesaws.

Emqlo

AM78-HC4V
1-1/2 HP Vertical
Twin Tank
\$299

AM99-HC4 NEW 2hp twin tank 359
AM78-HC4 1-1/2 hp twin tank 289
AM39-HC4V 3/4 vert. twin tank 279
K15A8P 1.5 HP wheelbarrow 599

DELTA

34-762
3 HP Unisaw
W/Unifence
\$1579*

34-761F 1.5 hp unisaw w/fence 1379*
34-763 3 hp Jet Lock unisaw 1399*
34-761 1.5 hp Jet Lock unisaw 1199*
34-445 10" cont saw w/30"uni 689*
34-670 10" motorized table saw 389
34-330 8-1/4 bench table saw 199
28-283 14" bandsaw w/stand 589*
33-055 8-1/4" sawbuck w/legs 569
37-280 6" motorized jointer 379

22-540 12"
Portable Planer
\$418

43-505 router shaper 298
40-560 16" bench scroll saw 185
36-040 8-1/4" compound miter 158
34-080 10" miter saw 199
31-460 4x36 belV6" disc sander 138
43-375 3 hp 2 speed shaper 1479*
22-667 13" planer w/deluxe stand 1149
40-601 18" VS scroll saw w/stand 589*
50-179 3/4 hp dust collector 338
32-100 plate jointer 288
34-985 1 phase stock feeder 469
43-355 NEW! 1.5 hp wd shaper 699

NEW TOOLS FOR THE NEW YEAR!

POWERMATIC

166760 66 Saw
3 HP W/50" Bies.
\$1679

1791000 #63 Artisan saw w/Vega 699
1791050 #53 6" jointer w/stand 479
1791060 #43 14" bandsaw w/std 599

BOSCH

1581VS
Top Handle
Jig Saw
\$132

1582VS barrel grip Clic jig saw 132
1632VSK VS reciprocating saw kit 135
3050VSRK 3/8" VSR kit w/2 batt 128
3283DVS
Dustless Random
Orbital Sander
\$98

1273DVS 4x24 VS belt sander 188
1611EVS 3-1/4 hp VS pl. router 233
1604 1-3/4 hp router 122
1609K 3 in one trimmer kit 168

BIESEMEYER

50L12
50" Commercial
W/12" Left
\$299

Elu

3338
2-1/4 HP VS
Plunge Router
\$249

3304 1 hp VS plunge router 179
3380 jointer/spliner with case 249
3375 3-1/8" universal planer 159
4024 3x21 VS sander with frame 189

HITACHI

C8FB
8-1/2" Compound
Miter Saw
\$459

C15FB 15" miter saw 389
C12FA 12" miter saw 329

RYOBI

AP10
10" Portable
Planer
\$348

JP-155 6-1/8 jointer/planer 308
RA-200 8-1/4 radial arm saw 248
TS25IU 10" miter saw 178
RE600 3 hp VS plunge router 208
R500 2-1/4 hp plunge router 148
BE321 3x21 VS belt sander 128
JM100K NEW! plate jointer 219

Makita

6093DWX 3/8" VSR
W/Keyless Chuck
\$138

3612BR 3 hp rd. base pl. router 168
5007NBA 7-1/4" saw w/electric br 128
2708W 8-1/4" table saw w/c.t. bl. 259
2012 12" portable planer 468
LS1030 10" miter saw 229
LS1011 10" comp. miter saw 488
1900BW 3-1/4" planer with case 118

freud

FT94PK
3 Piece
Set
\$399

3-1/4 hp pl. router (FT-2000) 5 pc. door set (94-100)w/perfecta cutter (99-PK-1)
JS-100 jointing system with case 159
FRT-2000 wooden router table 169

LEI

D1258R-24
24" Dovetail Jig
\$279

D1258R-12 12" dovetail jig 239
MMTA-24 24" mortise attach. 159
MMTA-12 12" mortise attach. 149
LJV instructional video 29

SKIL
POWER TOOLS

2735-04
12 Volt 3/8"
VSR Drill Kit
W/2 Batteries
\$129

77 7-1/4" worm drive saw 145
5550 NEW! 7-1/4" circular saw 99
1605 plate jointer kit 124

PORTER-CABLE

7334
Random
Orbital Sander
\$118

7335 NEW! VS random sander 129
7336 NEW! 6" VS random sander 134
330 speed block finish sander 59
352 3x21 sander with bag 133
97310 laminate trimmer kit 185
9505 Commemorative
Finish Sander
W/Oak Case
\$137

9850 3/8" cldss 12v driver/dr. kit 134
555 plate jointer with case 165
9345 6" saw boss kit 124
690 1-1/2 hp router 128
691 1-1/2 HP D handle router 138
7538 NEW! 3-1/4 hp pl. router 238

Milwaukee

0402-1
3/8", 12v Keyless
Drill Kit
\$169

6507 VS Sawzall with case 134
6527 NEW! VS super sawzall 169
5397-1 3/8" hammer drill kit 139
0395-1 3/8" VSR clds drill kit 149
0234-1 1/2" VSR 0-850 magnum 114

CALL FOR MIKE, TOM OR STEVE!
1-800-358-3096

Box 1716 • Grand Forks, ND • 58206
Send \$2.00 For 170 Page Catalog

FAX US YOUR ORDER!

WOOD Feb. 1991 1-701-772-8725

TOOL CRIB

OF THE NORTH
DIVISION OF B C & E Electric

Rebates Expire 2-28-91

* Price Includes Rebate!

Free Freight in Continental USA
Same Day Shipping
Factory Authorized Service
Full Line Distributor

Do all tablesaws have tilting arbors?

We've had a running joke among a group of amateur woodworkers at work. We've all seen advertisements for tilting-arbor tablesaws. What we want to know is aren't most saws tilting arbor, but only some advertised that way? We've looked through industrial-product manuals and dictionaries, but can't find a good definition of what constitutes "tilting arbor."

—Michael Miller, West Allis, Wis.

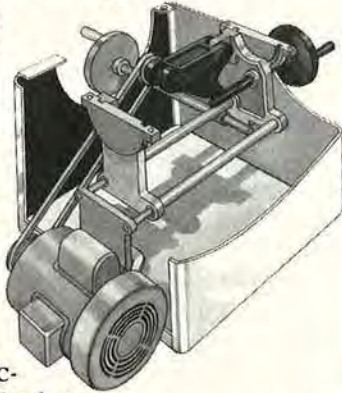

It's a rare tablesaw sold today for the home woodworker's market that doesn't have a tilting arbor, Mike. In practice, the motor—and therefore the sawblade arbor—tilts when you turn the crank. This has become so common that many tablesaw ads no longer mention this feature.

A truckful of American ebony



I live in the north Georgia mountains where the white pine trees have become infested with pine beetles. To curb this situation, the Forest Service is cutting roads into the wilderness to allow timber men to cut the infested trees. A persimmon tree stood in the way of one of these roads and had to be cut down. Because of its size, the Forest Service estimated it to be 450 years old. I acquired about 120 board feet of lumber from this tree, with some pieces 10" wide. What might I use it for?

—Tom Jervis
Blue Ridge, Ga.

You now own some mighty nice hardwood, Tom. As we told WOOD readers in an August 1986 "Wood Anecdote," persimmon is North America's only ebony. Because it's dense, hard, and shock resistant, most persimmon becomes the heads of golf clubs. But, you can work the wood into anything that must take abuse—tabletops come to mind.

Continued on page 86

New! Conveyor Drive DRUM SANDER with Infinitely Variable Power Feed!



30-Day Free Trial!

At last! A complete power-feed Drum Sander at an affordable price! Choose from 26" and 38" models. **SAVES TIME... IMPROVES RESULTS.** Use this high-tolerance machine for light dimensioning as well as the finest finish work. Now you can add new beauty to each woodworking project...save hours of tedious hand sanding! In a matter of seconds you can produce a satin-smooth finish impossible to duplicate with hand methods or hand-held power sanders...no more low spots, waves or cross-grain marks!

FREE FACTS! Send for complete facts on how you can try this low-cost tool in your own shop for one full month without risk. See how the sander can dimension and finish-sand cabinet pieces, resawn stock, paneling, toys, tabletops, knees, burls, crotches and much, much more! Made in U.S.A. Easy Terms.

Call Toll Free 1(800)821-6651, Ext. RW43

- ✓ **NEW INFINITELY VARIABLE CONVEYOR FEED** gives you total control...eliminates oversanding at first and last few inches of a board!
- ✓ **NEW FELT-BACKED ABRASIVE** mounts in just seconds to Velcro covered drum! The harder you sand, the tighter it stays! Eliminates stretching...allows fast removal and re-use!

FREE FACTS **YES!** Please rush my **FREE INFORMATION KIT** and details on your 30-Day Free Trial Guarantee.

Woodmaster Tools, Dept. RW43
2908 Oak, Kansas City, MO 64108

NAME _____
ADDRESS _____
CITY _____
STATE _____ ZIP _____

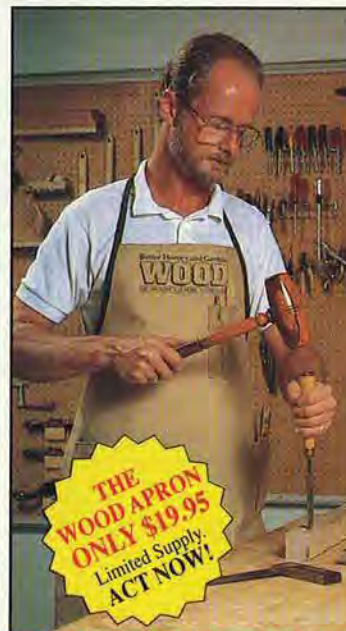

THE WOOD APRON ONLY \$19.95
Limited Supply. ACT NOW!

A GREAT GIFT IDEA

FOR WOOD® MAGAZINE READERS!
Just Look At These Features:

- ★ **Tough, durable nylon** material resists glue and abrasion
- ★ **3 pockets** designed to hold a tape, folding rule, metal rule, and pencil
- ★ **Attractive beige color** with a brown border and the WOOD® logo
- ★ **One size fits all**
- ★ **Lightweight, comfortable**

YES! Please send me The WOOD® Apron. Here is my check or money order for \$19.95 U.S. Includes shipping and handling. Send to: WOOD® Apron, P.O. Box 11454, Des Moines, IA 50336-1454, or, call 800-678-2666.

My Name _____
Address _____ Apt. # _____
City _____
State _____ Zip _____
 MasterCard VISA Expiration Date _____
Card No. _____
Signature _____

ASK WOOD

Continued from page 85

Original sin

I'm confused. I've been browsing through magazines other than the best two—WOOD® and Weekend Woodworking Projects®—and have seen projects that are dead ringers for some of yours, save for a few modifications....I understand that two different people might have the same idea at the same time, but I thought that whoever was first owned the idea. Could you explain the legal aspects of this?

—Sam Johnson, Barnwell, SC

Sam, in addition to the project designs we develop from scratch at WOOD, you'll find many designs in the magazine attributed to outside designers. When working with these folks, we have them sign a non-exclusive, unlimited copyright license (your basic legal agreement) that cites them as licensor of the project design. They

give us permission "to print, publish, display, perform, reproduce, and use in all forms, works and derivative works" the purchased project design.

Our agreement says that the licensor "warrants [that the project design] is original" and "previously unpublished."

We also verbally ask project designers if they indeed originated the design. When they tell us "yes," then, unless we have conflicting information, we take them at their word. That's not to say that we haven't been duped a time or two.

If, on the other hand, a design leaves us suspicious, then we immediately drop the project. And even when we buy an original design, we often improve on the construction, safety, and design of the project — in effect, adding our own personal thumbprint.

Working thin

I would like to see drawings for inlays in marquetry, parquetry, and veneering in future issues of WOOD magazine. Could you consider designs for seashells, horns of plenty, and geometric shapes?

—Earl Glass, Cabool, MO.

Earl, though we do not specialize in the subjects you mention, we have covered the Marquetry Society of America (MSA)

in issue 7, page 34, and featured a handsome marquetry project in issue 17, pages 74-77.

Incidentally, to contact the MSA, write: Marquetry Society of America, Inc., Dept. W, P.O. Box 224, Lindenvurst, NY 11757.

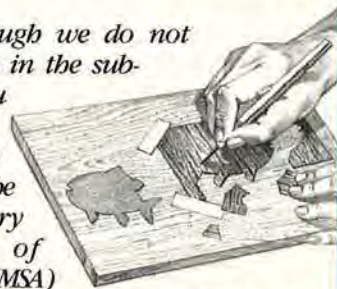

DELTA		HTC AVAILABLE
34-782	10" 3 HP UNISAW W/ UNIFENCE	
34-783	10" 5 HP 3 PH W/ UNIFENCE	
43-075	3 HP 1 PH HD Shaper	
37-350	8" DJ-20 Joiner W/STAND	
31-730	6" Bell 12" Disc	
33-890	12" RADIAL ARM SAW	
40-601	18" VS SCROLL SAW	
33-990	10" RADIAL ARM SAW	
22-951	DJ-33 13" PLANNER	
50-179	3/4" DUST COLLECTOR	
50-180	1 HP DUST COLLECTOR	
50-181	2 HP DUST COLLECTOR	
34-985	1 PH STOCK FEEDER 110V	
34-994	1 PH STOCK FEEDER 230V	
34-995	3 PH STOCK FEEDER 230V	
33-150	8-1/4" SAW BUCK	
34-444	10" CONTR. SAW COMPLETE	
31-380	4" X 132" EDGE SANDER	
34-670	10" MOTORIZED SAW	
40-150	15" SCROLL SAW	
31-050	1" X 30" SANDER	
23-700	WET DRY GRINDER	
31-460	4" BELT 6" DISC	
17-200	16-1/2" DRILL PRESS	
34-897	DELTA UNIFENCE	

RYOBI		
RE600	3HP VAR. SPD. ROUTER	\$209
API10	10" SURFACE PLANNER	357
TS25IU	10" MITER SAW	169

BOSCH		
1611	3 HP PLUNGE ROUTER	\$199
1611EVF	3HP V.SPD PLUNGE ROUTER	234
1604	1-3/4 HP ROUTER	122
1604K	1-3/4 HP ROUTER KIT	166
1606	1-3/4 HP D-HANDLE ROUTER	144
1608	5.6 AMP. LAM. TRIMMER	88
1609K	3 IN 1 TRIMMER KIT	167
3270D	3 X 21 SANDER W/BAG	134
1272	3 X 24 SANDER	163
1272D	3 X 24 SANDER W/BAG	168
1273DVS	4 X 24 VARIABLE SPEED SANDER W/BAG	188
3050VSRK	9.6V CORDLESS W/CLUTCH	133
91066	1/2" MIGHTY MIDGET VSR	89
1347	4-1/2" MINI-GRINDER	108
1582VS	BARREL GRIP JIG SAW	132
1581VS	TOP HANDLE JIG SAW	132
1632VSK	VS RECIP. SAW W/CASE	135

HITACHI		
C-8FB	8-1/2" COMPOUND MITER SAW	\$447
C-15FB	15" MITER SAW	399
TR-12	3HP PLUNGE ROUTER W/ACCES. VALUE AT \$60	175

FREUD		
JS-100	PLATE JOINER W/CASE	\$164
EC-900	DOOR SYSTEM SHAPER SET	278
9A-100	DOOR SYSTEM ROUTER SET	159
FB-107	7 PC. FORSTNER BIT SET	48
FB-100	16 PC. FORSTNER BIT SET	154
FT-2000	ROUTER	185

SAW BLADES		
5/8" BORE, INDUSTRIAL GRADE, CARBIDE TIPPED		
LJ72M010	Gen. Purp. A.T.B.	10" 40 58 39
LJ81M010	Gen. Purp.	10" 40 45 43
LJ82M010	Cut-off	10" 50 77 45
LJ84M011	Combination	10" 50 55 42
LJ85M010	Super Cut-off	10" 80 95 57
LJ72M010	Ripping	10" 24 57 38
LJ73M010	Cut off	10" 60 70 44
LJ87M010	Thin kerf	10" 24 68 39
LJ88M010	Thin kerf	10" 60 74 44
LJ89M010	Ultimate	10" 80 107 79
LJ89M010	Non-ferrous metal	10" 72 87 59
PS203	Plywood	7-1/4" 40 36 25
PS303	Gen'l Purp.	7-1/4" 24 25 19
DS306	6" Dado - Carbide	184 109
DS308	8" Dado - Carbide	196 119

SENCO		
SFN1 265.00	LS2 249.00	
SFN2 386.00	LS5 279.00	
EMGL0 1/2 HP HC4V 299.00		

PORTER-CABLE		
330	SPEED BLOC SANDER	\$55
351	3 X 21 SANDER	125
352	3 X 21 SANDER W/BAG	128
360	3 X 24 SANDER W/BAG	175
361	3 X 24 SANDER	169
362	4 X 24 SANDER W/BAG	185
363	4 X 24 SANDER	181
617	7-1/4" SAW 15 AMP	114
315	7-1/4" SAW 13 AMP	114
314	4-1/2" TRIM SAW	128
690	1-1/2 HP ROUTER	128
9118	PORTA PLANE KIT	185
555	PLATE JOINER W/CASE	164
505	1/2 SHEET PAD SANDER	109
7334	RANDOM ORBIT SANDER	118

POWERMATIC *TM*

Model 66 Table Saw

50" Biesemeyer Rip Fence, 3HP 1PH or 5HP, 3 PH motor

F.O.B. Our Warehouse

Model 180 18" Planer

7 1/2 HP, 3 PH OR 5 HP, 1 PH motor

Knife Grinder, Sectional Roll and Chipbreaker.

Call For Our Low Prices!

We carry the entire Powermatic line at very attractive prices. Please call for our prices on the Model 66 and other Powermatic machines. You'll be glad you did!

TARHEEL FILING CO., INC.		
FO	1-3/4" X 1/8" Biscuits 1000 Qty	32 27
F10	2-1/8" X 3/8" Biscuits 1000 Qty	32 27
F20	2-3/8" X 1/2" Biscuits 1000 Qty	34 29
FA	Assorted Biscuits 1000 Qty	34 27
WC104	4 pc. chisel set w/cse. 1/4"-1"	54 39
WC106	6 pc. chisel set w/cse. 1/4"-1"	73 52
WC110	10 pc. chisel set w/cse. 1/4"-1-1/2"	119 79
FB100	16 pc. forstner bit set 1/4"-2-1/4"	284 154
94-100	5 pc. router bit door system	230 159
JS100	Biscuit Joiner w/cse & 1000 ASST BISCUITS	300 186

TARHEEL FILING CO., INC.
CALL TOLL FREE 1-800-322-6641
LOCAL 919-231-3323
FAX 919-231-9980

MAIL CHECK OR MONEY ORDER TO TARHEEL FILING
 3400 LAKE WOODARD DR., RALEIGH, NC 27604
 NO COD'S PLEASE. ERRORS SUBJECT TO

PLEASE MENTION THIS AD WHEN YOU CALL!

ORDERS PLACED BY VISA, MASTERCARD, CASHIER CHECKS OR MONEY ORDERS WILL BE SHIPPED THE SAME DAY. ALLOW 2-3 WEEKS FOR PERSONAL OR COMPANY CHECKS.

FREE FREIGHT ON PORTABLES (CONT. U.S.A. ONLY). MIN. ORDER \$50.00

NO COD'S PLEASE. PRICES SUBJECT TO CHANGE WITHOUT NOTICE.

BACK-ISSUE SALE



While supplies last, you can order the issues listed below. We will process orders on a first-come, first-serve basis, and when the magazines are gone, that's it.

WOOD® MAGAZINE

#7 Surface sander, coffee table, hall shelf, magazine rack, doll furniture, classic radio, carving tools, resawing jig, palm sanders.

#8 Coat-tree, snack tray, jeep, desk set, charm bears, necklace, wall hanging, sled, mallets, scrollsaws, bending wood, router bits.

#9 Dining table, clocks, jewelry box, multi-machine, Japanese handtools, furniture stripping, PEG, seating standards.

#10 Parsons table, dining chair, lantern, ceiling fixture, wren house, airplane, air compressors, plastic laminates, waterstones.

#12 Scrollsaw, breakfast tray, tie rack, tow truck, sandpaper storage, parrot magnets, bookends, power miter saws, old tools.

#13 Cedar chest, kid's table and chairs, mug rack, kitchen cabinet standards, jewelry case, drum-sanding, thickness planers.

#14 Rocking horse, candy caddy, earrings, folk toys, magazine rack, sanding block, faceplate turning, turning tools, tung oil.

#17 Outdoor settee, dining table, carving board, plane rack, template and pin routing, radial-arm saws, dust control.

#19 Cradle, bird feeder, kid's mirror, turned clock and vase, notepad holder, tool chest, power carvers, router dovetail jigs.

#20 Mantel clock, wine rack, candle holder, money clip and key chain, doll stroller, hand mirror, bulldozer, buckles, scrollsaw tips.

#21 Barrister's bookcase, file cabinet, picture frame, letter opener, bandsawed boxes, turned spice jars, plunge routers.

#22 Tall clock, onlay vase and table, blade-height gauge, teddy-bear clock, swan necklace, clothes rack, combination machines.

#23 Patio set, 2 stove-bowls, pantograph board, turned earrings, playhouse, plate joiners, chair caning, diamond stones.

#24 Outdoor planters, kid's trucks, 3 cutting boards, homemade sawhorse, drill-press ratings and techniques, wood mosaics.

#25 Curio cabinet, glue caddy, kid's wheelbarrow, zoo carousel, rolling pin, safe/key keeper, oval marker, layout tools, framing.

#26 Ornaments, yo-yo, wall clock, baja buggy, whale notepad holder, depth gauge, cribbage board, inlay tray, shop vacuums.

#27 Country bench and cabinet, floor lamp, box-joint jig, recipe-card box, trucks, perfume decanter, relief carving, circular saws.

#28 Trestle table, finish scraper, birdhouse, plant stand, stack-laminated bowls, stationary belt sanders, cowboy boot carving.

#29 Entertainment center, low-voltage lighting, train whistle, bud vase, napkin holder, parrot mobile, tops, replacement rip fences.

#30 Shaker chair, doll cradle, rod rack, strip sander, carved whale, portable belt sander, cabinet clean-up, treated wood.

#31 Woody car, rip fence, waddling duck, woven basket, candle holder, tabletop frame, jointers, working small, world's woods.

#32 Tambour desk, oak mirror, bookends, tabletop easel, recipe-card holder, biplane, carved angel, table-saws, toxic woods.

#33 Router table, dry sink, desert landscape, FAT CAT trucks, turned bracelets, router tests and tricks, microwaved bowls.

#34 Psaltery, dollhouse, tablesaw base, framed hummingbird, carved bluegill, sandblasting, planers, thin-kerf blades.

#35 Oak settee, monster truck, spoon rack, hand screw clamps, toy wheels, tabletop finish, Shopsmith vs. Total Shop.

WEEKEND WOODWORKING PROJECTS™

#1 Helicopter toy, cutting board, decorative sleigh, spice rack, scone, pocket-watch clock.

#2 Rose jewelry box, arched-top clock, napkin rings, penguins, message center, jelly-bean machine.

#3 Sportsman's coatrack, tractor, nameplate, decorative rocking horse, teddy bear bookshelf.

#4 Salt-and-pepper set, bird feeder, honeybee, dresser mirror, crayon caddy, towel ring, house sign.

#5 Adirondack chair, footstool, bandsawed basket, plant stand, oak casserole server, acorn box.

#6 Scandinavian candle holder, door harp, snack tray, Ferris wheel, bandsawed box, music box.

#7 Bookcase, carved fruits, country basket, dresser-top kid's lamp, quilt hanger, handsaw bookends.

#8 Armored-car bank, coaster set, whale stamp box, turned biscuit cutter, serving tray, table lamp.

#9 Redwood bench, marble game, toy dining set, barn birdhouse, carousel, night-light clown.

#10 Child's rocker, hourglass, antique clothes rack, wall plaque, planter basket, butter churn.

#11 Country wood quilt, plate rack, dragster, pineapple bookends, heron wall clock, eggs and bowl.

#12 Holiday blocks, turned teleidoscope, tree candle holder, shadow box, clown toy, wood jewelry.

#13 Mortar and pestle, wall mirror, fish cutting board, grasshopper toy, dovetail shelving, lamp.

#14 Two-part patio chair, tone box, carved spoon, rocking cow, whirligig, turned baseball bat.

#15 Corner cabinet and shelf, clothes tree, folding table, keepsake box, candle lantern, U.S. puzzle.

#16 Porch swing, stately planter, wood castle, country cabinet, alpine-ride toy, crumb-box cutting board.

HERE'S HOW TO PLACE YOUR ORDER

1) Fill out the form at right, indicating which issues you want to purchase.

2) Send the order form to:

WOOD Back-Issue Sale

P.O. Box 11454

Des Moines, IA 50336-1454

NOTE: Due to our limited supplies of these magazines, we'd prefer that you purchase your magazines by credit card (MasterCard, VISA). This allows us to charge you only for those magazines we have in stock at the time we receive your order. We also will accept checks, payable to WOOD Back Issue Sale, but this may increase the processing time on our end. Allow 4-6 weeks for delivery. Phone credit-card orders: 800-678-2666.

Name _____
 Address _____
 City _____ State _____
 Zip _____ Daytime Phone _____
 VISA MasterCard Exp. Date _____
 Credit Card # _____
 Signature _____

Single issues @ \$4.95 ppd. For foreign orders, please add \$1 per issue.

WOOD	7	8	9	10	12	13	14	17	19	20	21	22				
	23	24	25	26	27	28	29	30	31	32	33	34	35			
WEEKEND	1	2	3	4	5	6	7	8	9	10	11	12	13	14	15	16

★ SANDPAPER ★

NO GIMMICKS — GREAT PRICES

BELTS: GRITS ASSORTED

SHEETS: (9 x 11) PRICE

UNLESS OTHERWISE SPECIFIED

CABINET PAPER

1 x 30	\$.69 ea	3 x 24	\$.80 ea	50 /pk	100 /pk
1 x 42	.69 ea	3 x 27	.83 ea	40-D	\$16 /pk \$30 /pk
1 x 44	.69 ea	4 x 21¼	.91 ea	50-D	15 /pk 27 /pk
2½ x 16	.73 ea	4 x 24	.94 ea	60-D	14 /pk 25 /pk
3 x 18	.74 ea	4 x 36	1.14 ea	80-D	13 /pk 23 /pk
3 x 21	.77 ea	6 x 48	2.98 ea	100 thru 150C	12 /pk 21 /pk
3 x 23¼	.80 ea	2¼ x 80	2.47 ea		

OTHER SIZES ON REQUEST

FINISHING PAPER

NO LOAD PAPER

	50 /pk	100 /pk
180-A thru 400-A	\$10 /pk	\$18 /pk

	50 /pk	100 /pk
80-A	\$ 9 /pk	\$16 /pk
100 thru 280A	8 /pk	14 /pk

WET / DRY PAPER

	50 /pk	100 /pk
220 thru 600A	\$13 /pk	\$23 /pk

PRESSURE SENSITIVE

ADHESIVE DISCS!

6"	\$1.06 ea	★ OTHER ITEMS ★
8"	1.99 ea	★ WIDE BELTS
9"	2.46 ea	★ ROLLS
10"	3.05 ea	★ FLAP WHEELS
12"	4.45 ea	★ PUMP SLEEVES
15"	6.95 ea	

★ JUMBO CLEANING STICK \$8.80 ★

ECON-ABRASIVES
P. O. BOX B865021
PLANO, TX 75086

IN TEXAS 214-377-9779
 OUTSIDE TEXAS 1-800-367-4101

TEXAS AND NEVADA RESIDENTS ADD STATE TAX
 CONTINENTAL U.S. SHIPPING CHARGES ADD \$4.25

- ★ MINIMUM ORDER \$25.00
- ★ MASTERCARD, VISA OR CHECK
- ★ SATISFACTION GUARANTEED!!
- ★ CALL FOR NEW 1991 CATALOG



WOODCRAFT®

The Leading Edge

in Woodworking Tools

Complimentary Tool Catalog

Our new complete woodworking tool catalog features over 4,500 of the finest quality woodworking tools, books, supplies, and cabinetry hardware available today.

Give us a toll-free call to receive your own catalog FREE!



Order yours today!
Call 1-800-542-9115

Or write: Woodcraft Supply, Dept. 91WIO2Q
 #210 Wood County Industrial Park, P. O. Box 1686
 Parkersburg, WV 26101



Blade-changing features set apart this inexpensive scrollsaw during tests in the **WOOD®** magazine shop.

DELTA'S NEW SUB-\$200 MODEL 40-560

We've always liked the hassle-free blade changes on Delta's best 18" scrollsaw—the electronic variable speed model 40-601. So, when we heard that Delta had built the same blade-changing system into a scrollsaw selling for under \$200, we just had to try it out. As you'll see, we weren't disappointed.

What sets this scrollsaw apart

At first glance, Delta's new model 40-560 scrollsaw looks a lot like other inexpensive scrollsaws also made in Taiwan. The 16"-capacity machine has constant-tension parallel arms, a heavy cast-iron base and 11¾"-diameter table, and a two-speed, ½-hp motor that runs at 850 or 1,790 cutting strokes per minute. However, a closer look reveals several exclusive features.

The 40-560 doesn't require you to remove the blade clamps when changing blades. With Delta's Quickset blade-changing system, you simply flip forward a tension-release lever located near the front of the top arm and insert a special wrench into the clamp assembly as shown at right. With one turn of the wrench, you release the blade from either the top

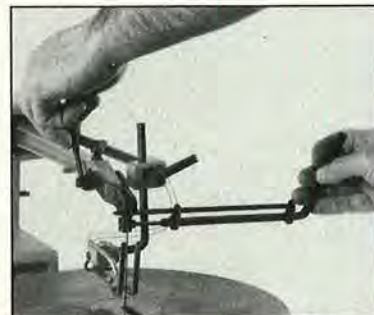

or bottom clamps. To replace the blade, just slip it into the top or bottom clamp and secure it with the wrench. To reset the blade tension, you only have to flip backward the tension lever.

This scrollsaw also has a smartly designed blade guard/hold-down. The sturdy assembly pivots and adjusts up, down, and sideways.

What we discovered in our tests

The Quickset blade-changing system made the 40-560 scrollsaw a joy to use. Blade tensioning was a snap, and the blower cleared debris well. The level of vibration was acceptable with the machine securely mounted to a work surface. ♣

Photographs: John Hetherington

FORSTNER BITS

Continued from page 73

walls and bottoms, then only the bits with *excellent* ratings in this area will do. With the others, you'll wind up doing a lot of difficult sanding.

The CONVALCO bits cut the smoothest and flattest bottoms of any of the Forstner bits largely because of their finely ground cutters and miniscule centerpoints. However, without a centerpoint to serve as a pilot, the CONVALCO bits had a tendency to wander across the surface of any workpiece not securely clamped in place on a drill-press table.

Ready to buy?

With the testing completed, I asked Jim to select his favorite bits in three price ranges. The following picks include a few of Jim's comments:

Low price: "For the money, the Chinese-made Forstners performed well, and I recommend them for the woodworker who has only occasional need for a Forstner bit. If you use Forstner bits all the time, however, it will be worth your money to invest in a higher-quality set. For smaller holes, especially pocket holes, Vermont American's 1/2"-and-smaller bits really impressed me."

Medium price: "The Austrian-made Forstners seemed to be of consistent quality from importer to importer. As long as I didn't push them too hard, their rims resisted burning fairly well. Of the various brands, the Irwin bits performed best. I just wish they were available in more than four sizes."

High price: "If you make heavy use of a Forstner bit, buy the multi-spurs. If you need flat-as-can-be holes, put your money into CONVALCO bits." 🌲

Photographs: Hopkins Associates

ANTIQUE reproduction furniture HARDWARE



HORTON BRASSES
Nooks Hill Rd. PO Box 120J
Cromwell, Ct 06416 203-635-4400
send \$3.00 for a catalog



STOP PERFBORD HOOK FALLOUT!

M-CLIPS™ are THE guaranteed perfect solution to this annoying problem! Fit both 1/8" and 1/4" perfbord. Send SASE for free sample or \$5.99 + \$1 p&h for pkg. of 50 to: AETECH, P.O.Box 6298, Dept. W8 10 Shadowstone Lane Lawrenceville, NJ 08648

WARREN TOOL CO. INC. (10) Piece set of woodcarving tools



ORDER #COMBI-M "WARREN TOOLS GIVE YOU THE EDGE!"
Send \$31.95 Ppd. (USA) Check or Money Order, C.O.D. U.S. —Honed Ready To Use TEL (914) 876-7817

N.Y. res. ADD State Tax \$3.00 SHIPPING Foreign orders ADD \$6.00 SHIPPING.
Warren Tool Co. Inc. 2209-1, RL 9G, Rhinebeck, N.Y. 12572

Full-Size Professional Plan ADIRONDACK CHAIR



Make this classic American design. Our special version may be folded for storage by using ordinary hardware available at your local store. Be ready for Summer and get your plan now!

CATALOG 200 full-size professional furniture plans — \$3.00 Plan #700 \$12.95 (Catalog free with order)

FURNITURE DESIGNS, INC. Dept. BA-21
1827 Elmdale Ave., Glenview, IL 60025
(708) 657-7526

PENNSYLVANIA HARDWOODS

SATISFACTION GUARANTEED

SIZE	SPECIES	PRICE PER BOARD FT.
15/16	WALNUT	\$1.60
3/4 & 4/4	RED OAK	\$1.60/1.75
3/4 & 4/4	CHERRY	\$1.60/1.98
3 to 10/4	POPLAR	\$1.05
4 to 8/4	ELM	\$.90
4/4	HARD MAPLE	\$1.30

NO MINIMUM ORDER. ALL HARDWOODS KILN DRIED. For a NEW 20 page catalog featuring over 20 domestic hardwoods, quantity discounts, package deals at delivered prices & much more, send \$1.00 to cover postage & handling to:

TO ORDER CALL:
(716) 945-1510



Northeastern Hardwoods, P.O. Box 365-C, Salamanca, NY 14779
The Finest Quality At The Right Price!

RIP AW

The Portable Sawmill.

The "affordable portable" one man band sawmill. Weighs only 45 lbs. Cuts 20" diameter logs into lumber. Minimum 1/8" to maximum 9" thickness.

Write or call for free brochure.

Better Built CORPORATION

(508) 657-5636
845 Woburn Street, Dept. W, Wilmington, MA 01887



NEW GIVE YOUR WOOD PRODUCTS A FRESH LOOK WITH

Our Pattern Book for bandsaw, scrollsaw or jigsaw. Contains 50 unique full page patterns. Some are easy — some are more challenging — but all are fun to make. Send only \$10.75 (includes postage and handling) to:

CUT IT OUT ENTERPRISES

PO Box #404, Dept. W1
Clearfield, PA 16830

(Please allow 4 to 6 weeks for delivery.)

SPECIAL OFFER

BRANDING IRON

For hard and soft wood

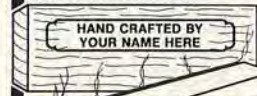

\$2400

Plus \$2.00 for shipping and handling

Nebr. residents add correct sales tax
SATISFACTION GUARANTEED or your money back

- Shipped in one week
- Solid brass head — raised letters
- 1st Line: HAND CRAFTED BY — as above
- 2nd Line: Your choice — 20 characters/spaces max.
- Complete with wood handle
- As above but with 3rd line — \$37.00 + \$2.00

ORDER TOLL FREE 1-800-826-7606

For free brochure, write or call (402) 464-0511

Order by mail from: **NOVA TOOL CO.**
12500 Finigan Rd., Dept. BH
P.O. Box 29341, Lincoln, NE 68529



When It Comes To Home Projects, If You've Got The Will

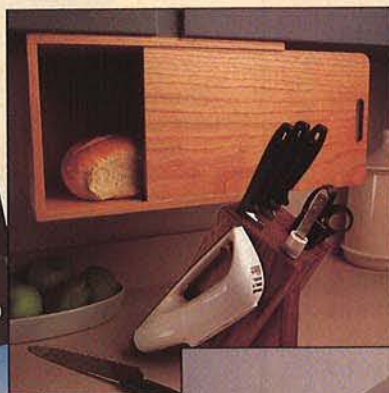
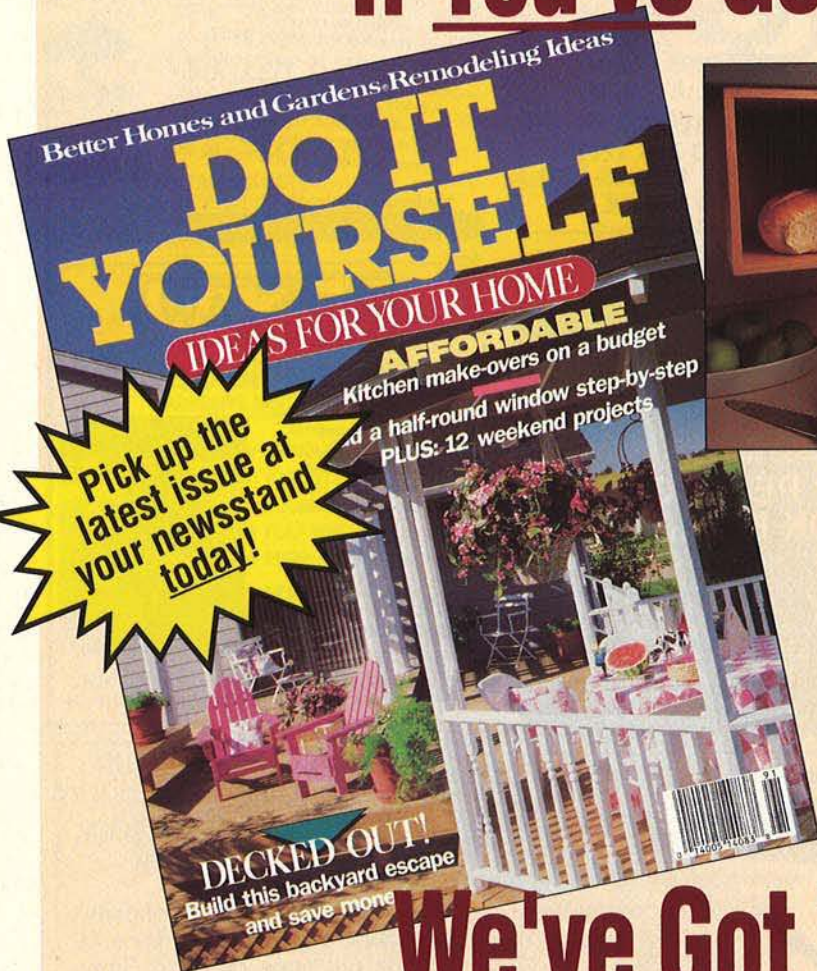

We've Got The Way.

BEAUTIFY YOUR HOME, INSIDE AND OUT

Have you dreamed of transforming your basic backyard into a restful retreat complete with deck and gazebo? How about revamping the kitchen?

Would you like to create a hobby room in the attic? Remodel the basement, add new lighting along your walks or make your closets clutter-free?

If you find satisfaction in projects like these, then take a look at DO IT YOURSELF Magazine.

We'll help you fix it up. Build it on. Organize. Refinish. DO IT YOURSELF gives you loads of ideas for simply improving your living space with affordable, fun projects.

STEP-BY-STEP HELP

It's easy to tackle big projects like building that dream kitchen ... country bath ... or stylish portico. You get everything you need for successful

completion, from clear-cut directions to advice on materials and finishes! And if you prefer to work from plans, we'll tell you how to order.

QUICK AND EASY PROJECTS

Try your hand at building a flip table or playhouse furniture. From recaning a chair to stenciling a floorcloth -- you'll learn lots of techniques to add your personal touch to every nook and cranny of your home.

BUYER'S MARKET

Plus our Buyer's Market section will introduce you to new products. We'll tell you where to find everything from kit furniture to tools to innovative flooring!

So no matter if you're a beginner or pro -- if you've got the ambition, DO IT YOURSELF can help you with your next undertaking!

Worth writing for...



Print this article

You can get useful ideas and product information by mail. Use the coupon in this section to order your choice of literature listed below. Each company mails the catalogs or information directly to you.

POWER TOOLS

SCROLL SAW AND LATHE INFORMATION—More than 20 pages of information, including full-color photos, on HEGNER precision scroll saws, HEGNER lathes, and HEGNER duplicators. Find out why these machines are considered state of the art, and what to look for when shopping for scroll saws or lathes. AMI, LTD. \$1.00. *Circle No. 3.*

WOODWORKING PROFESSIONALS ONLY—Now save 50% on machinery, 70% on operating costs! How? By using the world's finest production quality universal machine. Commercial durability, utmost precision, set-up in seconds. No other tool combines usable capabilities like FELDER. Thousands sold all over the world. Now available in America through AMI. Send for brochure. AMI LTD. \$1.00. *Circle No. 4.*

TOOL CRIB OF THE NORTH IS ANNOUNCING OUR NEW CATALOG—It features a wide selection of merchandise for your home woodworker to your industrial builder. Top manufacturers such as Black & Decker, Delta, Makita, Porter Cable, Bosch, Milwaukee, Ryobi, Freud and many more. We offer competitive prices with quality service and same day shipping. Send today for your new Acme Electric catalog. It's worth it. ACME ELECTRIC. \$2.00. *Circle No. 5.*

PORTABLE SAW MILL—a one man saw mill weighing 45 lbs. Gas and electric models will cut dimensional lumber from logs up to 20 in. diameter. Send for brochure. BETTER BUILT CORP. Free. *Circle No. 10.*

175-PLUS USES GUIDE—for Dremel Moto-Tool. Written from the do-it-yourselfer's view, this book shows how to plan and do a variety of everyday projects using the versatile Moto-Tool and cordless Freewheeler. 96-page book with over 275 photos includes tips on using Moto-Tool with flex-shaft, drill press, router attachment, chainsaw sharpening attachment, shaper/router table. DREMEL. \$4.00. *Circle No. 33.*

FREE WOODWORKING POWER TOOL CATALOG—Buy planners, jointers, shapers, table saws, scroll saws, bandsaws, drill presses, wood lathes, sanders, dust collection systems, and more...direct from the factory and save. Foley-Belsaw sells direct to you...so you save on every purchase. You'll find quality power tools, plus hand tools and accessories to meet all of your woodworking requirements. Complete money-back guarantee. Send for details. FOLEY-BELSAW. Free. *Circle No. 41.*

MANUFACTURED SINCE 1926—the Foley-Belsaw Circular Sawmill lets you go right to the trees to turn out smooth, true-cut lumber. Available with heavy-duty steel base or with plans and track provided for owner built wood base. Will accurately saw logs up to 14 ft. in length and up to 24 in. in diameter. Complete money-back guarantee. Send for details. FOLEY-BELSAW CO. Free. *Circle No. 42.*

INCA MACHINERY INFORMATION—Complete information on the famous line of Inca woodworking machines. Designed for precision work by the small to medium sized cabinet shop. Used by thousands of hobbyists and professionals. Table saws, bandsaws, joiner/planners, dust collector, radial arm saw. GARRETT WADE CO. Free. *Circle No. 44.*

MAKITA U.S.A. INC.—offers all new 152-page mini-catalog on its professional line of electric power tools, with special emphasis on the entire cordless line. Catalog provides

complete information along with available accessories and practical applications. MAKITA U.S.A. INC. Free. *Circle No. 61.*

WOODWORKING MACHINE CATALOG—New 16-page color catalog introduces many new do-it-yourself woodworking machines. Includes planers, dust collectors, drill presses, sanders, lathes, and specializes in scroll saws and accessories. PENN STATE INDUSTRIES. Free. *Circle No. 75.*

SCROLL SAW—Information package available from Penn State Industries describing the specifications and applications of its super VS-15" variable speed scroll saw. Special discount pricing available on current promotion. PENN STATE INDUSTRIES. Free. *Circle No. 76.*

SURFACE PLANER—Information package available from Penn State Industries describing the specifications and applications of its super 12 1/2-inch surface planer. Special discount pricing available on current promotion. PENN STATE INDUSTRIES. Free. *Circle No. 77.*

PERFORMAX DRUM SANDERS—Exclusive features at an affordable price for precise wide surface sanding. The complete line includes the retrofitting Performax Component Sander, the Pro Max and the Super Max 25, Super Max 25X2, and super brush sander. New accessories for production-mode sanding of pieces as small as 2 1/4" long. Send for brochure. PERFORMAX PRODUCTS. \$1.00. *Circle No. 78.*

THE PRECISION SCROLL SAW FOR THE ENTIRE FAMILY!—The Hawk was designed for beginners and built for expert woodworkers. Learn how to produce creative leisure time projects for fun or to make money...we'll show you how! Make cuts so intricate and smooth they don't require sanding. Over six models to choose from. Send today for all the facts. Send for the facts. RB INDUSTRIES, INC. Free. *Circle No. 84.*

THE VERSATILE RBI WOODPLANNER/MOLDER/SANDER!—It's indispensable! It's 4-in-1. It's RBI's Woodplanner/Molder/Sander/Gang Rip Saw. Find out how the Woodplanner saves you money turning rough stock into beautiful professional quality projects. With 3 models to choose from there's one that fits your needs. It does it all, so you can do it all! Send today. RB INDUSTRIES, INC. Free. *Circle No. 85.*

SKIL CORPORATION—Full color, complete line, power tool catalog. Features cordless screwdrivers, drills and the cordless Skilwrench™. Corded products include circular saws, drills, drywall drivers, sanders, hammer drills, jigsaws, planes, roto hammers, sander/grinders, shears, routers, xtra tools, bench top tools and reciprocating saw. All product accessories are also shown. SKIL CORPORATION. \$1.00. *Circle No. 88.*

SCROLL SAWS, ACCESSORIES, PATTERNS, BOOKS—A complete brochure on all kinds of scroll saw accessories. Featuring Excalibur scroll saws and lettering layout guides from Seyco, "The Scroll Saw Specialists." Free pamphlet, "Selecting Your Scroll Saw" included. Send for brochure. SEYCO SALES CO. \$1.00. *Circle No. 89.*

MOLDER-PLANERS FROM WILLIAMS & HUSSEY—Mold, plane, and edge, convert from moulder to planer in less than 2 minutes. The W-7 series is available in 3 models for manual, power in feed, or power in feed/out feed. The units plane to a satin, almost sanded finish, produce doll house to crown sized mouldings, raised panels, and curved molding. Custom knives available up to 7" wide and 3/4" depth of profile. Rugged, well-made, dependable, and transportable. Complete with sturdy movable stand. Send for catalog. WILLIAMS & HUSSEY. \$1.00. *Circle No. 93.*

PORTABLE SAWMILLS—Convert logs into valuable lumber—Wood-Mizer® Products manufactures a line of portable bandsaw mills that allows the novice as well as the experienced sawyer to safely convert standing logs into lumber. Then, with the use of our SolaryDry™ Kiln or Vacu-Kiln™ to dry your lumber, you could increase the value of every board you produce. We manufacture some of the most progressive woodworking equipment on the market today. Product videos

available. Send for our 40-page catalog. WOOD-MIZER PRODUCTS. \$1.00. *Circle No. 94.*

BRIDGEWOOD WOODWORKING MACHINERY—a new 52-page catalog of fine BRIDGEWOOD wood and metalworking machinery is available from Wilke Machinery Company. The BRIDGEWOOD line includes a wide range of products for use in the serious home workshops up through the industrial applications. WILKE MACHINERY CO. \$1.00. *Circle No. 96.*

HAND TOOLS

DIAMOND WHETSTONES BY DMT—Rescue your routers, lap carbide edges; discover the ease and speed of sharpening on Diamond Whetstones. Five sizes from 3" to 12" in the fine, course, and extra course. Finest monocrystalline industrial diamonds permanently bonded in nickel. Lubricated with water. Stays flat, unbreakable, long life. Fifteen years of serving sharpening needs. Satisfaction guaranteed. Send for full color catalog. DIAMOND MACHINING TECHNOLOGY, INC. \$2.00. *Circle No. 112.*

RADI-PLANE—Profession edge finishing tools. The RADI-PLANE lets you quickly round-over an edge without the time or trouble of routing and sanding. Duel, micro-adjustable cutter provides for a quick, precise rounded edge in just one pass. Send for more information. L. A. MATHERS CO. Free. *Circle No. 142.*

PERSONAL BRANDING IRONS—Brochure describes branding irons that enable you to put your name on your work quickly and easily. Made especially for branding wood, they are available with 1, 2, or 3 lines of copy or with your logo. Changeable date also available. NOVA TOOL CO. \$1.00. *Circle No. 160.*

THE JAPAN WOODWORKER'S 72-PAGE CATALOG—is loaded with the a huge selection of Japanese saws, waterstones, chisels, planes, carving knives, cutlery and garden tools. See our Tools As Art section for the most expensive hand tools available. Send for 1991 catalog and all supplements for two years. WOODLINE TOOL & SUPPLY. \$1.50. *Circle No. 190.*

STAINS/FINISHES

DEFT SOUTHWEST COLLECTION PAMPHLET—Bring the colors of a desert sunrise into your home with Deft's new Desert Oak White Wood Stain and tint base. Pamphlet shows a wide variety of pastel colors available. DEFT, INC. Free. *Circle No. 215.*

DEFT ACT NOW PAMPHLET—Be environmentally aware during and after your wood finishing projects. Let Deft show you how. DEFT, INC. Free. *Circle No. 216.*

FREE WOOD REFINISHING PRODUCTS—Make wood refinishing easy with products from 3M. Do-it-yourselfers can restore and protect wood like the experts. Send today for free sample. 3M. Free. *Circle No. 268.*

PLANS

OVER 1000 WOODCRAFT PATTERNS!—Enjoy making gifts, toys, lawn ornaments, holiday designs, whirligigs, folk art, bird houses and feeders, household and yard accessories plus much more! Simple enough for the beginner, fun and profitable for the pro. Send for catalog plus sample pattern. ACCENTS IN PINE. \$2.00. *Circle No. 310.*

WOODWORKERS' PLANS AND SUPPLIES—Wood projects are simplified with the high quality plans, specialty hardware

and other supplies offered by Armor Products. Over 100 plans are available for making toys, desks, clocks, pool tables, lamps, chests, and other furniture. Movements, dials, moldings, ornaments, dollhouse kits, door harp supplies and tuning pins are also available. ARMOR PRODUCTS. \$1.00. *Circle No. 315.*

SALES TESTED DESIGNS—available as plans only, parts kits, or plans and parts kits. Complete stock of parts, tools and supplies. Door harps to digital electronic/wood projects. Full size plans! Bulk prices on turnings, dowels and music movements. Catalog price refundable on first order. CRAFTER'S MART. \$2.00. *Circle No. 328.*

BUILD MINIATURE HORSE-DRAWN VEHICLES—The Concord Stagecoach symbol of the Old West, the Conestoga Covered Wagon, and the Prairie Schooner are some of the vehicles you can build using our plans in 1/12 and 1/8 scale. Concord Coach and Conestoga are available in full size 1" scale cutting patterns. Also English vehicles, some in 1/20 scale cutting patterns excellent for beginners. Ready-made plastic wheels available for 1/20 scale vehicles. Also books featuring from England, "Making Horse-Drawn Vehicles" by John Thompson, who has done extensive work in this area. CRISS-CROSS CREATIONS. \$1.00. *Circle No. 332.*

INSPIRATIONS IN WOOD—Many new, unique designs of projects never before seen are offered in clear, concise plans. These plans are easy enough for the beginner to follow yet satisfying enough for the expert. Create working toys, furniture and home improvement projects that will amaze your family and friends. Great for gifts. Send for catalog. D&D INSPIRATIONS. \$2.00. *Circle No. 335.*

SEND FOR CATALOG OF FULL SIZE FURNITURE PLANS—all the most popular designs. Early America, Spanish, modern, Queen Anne styles. 270 plans (bill of materials, perspective and exploded view drawings). DALCRAFT, INC. \$1.00. *Circle No. 339.*

PATTERNS BY DESIGN GROUP—Hundreds of interesting, useful and fun items to create for personal use or profitable sale. Our newest catalog contains plans for toys, games, plaques, puzzles, birdhouses, planters, furniture, and much more! All Design Group patterns are professional, "same size" blueprints. No enlarging or reducing is necessary. Simply trace outline of item onto wood and create! Started in 1977, Design Group has sold thousands of patterns to thousands of satisfied customers. Prices start at \$1.00, all patterns come with a full money-back guarantee. Wholesale and bulk prices are available on request. Fully illustrated catalog. DESIGN GROUP. \$1.00. *Circle No. 340.*

FULL-SIZE FURNITURE PLANS CATALOG—Illustrates and describes over 200 plans for making furniture of quality found in museums and fine furniture stores. Plans include rollout desk, cradles, dining tables, chairs, buffets, chests, gun cabinets, poker table, children's furniture, rocking horse, spinning wheels, and more. Bill of materials exploded drawings assist the woodworker. FURNITURE DESIGNS, INC. \$3.00. *Circle No. 345.*

STICKLER FOR DETAIL?—At last an exciting new line of realistic wood block models that you can build with your own scrap wood and dowels and my easy-to-follow instructions. Highly detailed plans for a 20x8 3/4-in. dump truck. GATTO PLAN SUPPLY. \$8.00. *Circle No. 355.*

COUNTRY FURNITURE PLANS—Our catalog features more than 37 designs—from a washstand to a roll top desk. Our new book on finishing and refinishing will show you how to finish projects like the pros. Also included are various products for the home workshop. Send for our latest catalog (price of catalog deductible from first order). HAMMERMARK ASSOCIATES. \$1.00. *Circle No. 370.*

MOOSERACK—Full size pattern with easy step by step instructions. A unique design for a one of a kind coatrack. Hangs from a wall or any standard size door. An easy weekend project. Great gift for children. JOBUCK™. \$6.95. *Circle No. 380.*

PROJECT PLANS—Over 400 easy-to-build woodworking project plans. Nation's leading source for door harp plans and parts, holstein cow projects, toy plans, country furniture, etc. Over 3000 hard-to-find specialty items. Send for your big new 72-page catalog. MEISEL HARDWARE SPECIALTIES. \$1.00. *Circle No. 401.*

THE YEAR'S BEST PROJECT PLANS—From the editors of Popular Science® Magazine, 32 easy-to-build and fun-to-do indoor and outdoor woodworking projects you'll be proud to complete. 186-page volume includes materials lists, and complete step-by-step instructions fully illustrated with photos and diagrams. Hundreds of hours of enjoyment for all skill levels...plus FREE gift for saying "yes" to preview. Send for

details. Woodworking Projects Yearbook. POPULAR SCIENCE®. Free. *Circle No. 418.*

NEW QUALITY SCROLLSAW PLANS—Professional quality, from children's toys and country gifts to lawn ornaments and furniture. Cost refundable with first order. RNR SPECIALTIES. \$1.00. *Circle No. 430.*

BACKYARD STRUCTURES—Contains designs for 21 really different storage sheds, 5 cabanas, 13 animal shelters, 3 barns, 13 garbage enclosures, 3 studios, and more, plus 8 plans in book. 66 designs in all, for which plans can be ordered. Full color. SUN DESIGNS. \$10.45. *Circle No. 454.*

MAKING TIMELESS TOYS IN WOOD—contains 40 heirloom-quality designs, with 20 mini-plans in book. Full color, 96 pages. SUN DESIGNS. \$11.45. *Circle No. 455.*

MAKE TOP SELLING COUNTRY WOODCRAFTS—from full size patterns. Turn your scrapwood into decorative, highly profitable projects. Easy to make from our full size patterns and instructions—no enlarging necessary! Over 1000 unique designs include popular folk art, old fashioned St. Nicks, nostalgic country furniture, country shelves and shadowboxes, action toys, shelf sitters, country critters, life size yard animals, Christmas yard decorations and more! Next day shipment, satisfaction guaranteed. Send for our latest catalog. THE WINFIELD COLLECTION. \$1.00. *Circle No. 480.*

WOOD-MET SERVICES CATALOG LISTS SOME 700 PLANS—to build a wide variety of tools and accessories to equip your workshop. They vary from complete machines to hand tools, photo accessories to shop methods. Included are some 80 attachments for your lathes, drill presses & routers, over 60 hand tools, plus sander, welder, shaper, table saw accessories, etc. Others include a portable band sander, metal spinning tools, air compressor, 3/4" spindle wood shaper, metal lathe & chisels & a 12-in. thickness planer. Send for catalog, order plans, build the equipment for your shop and save. WOOD-MET. \$1.00. *Circle No. 496.*

LUMBER

QUALITY EXOTIC LUMBER/TURNING WOODS—We offer a comprehensive selection of fine quality exotic woods: Ebony, Kingwood, Tulipwood, Snakewood, African Blackwood, Cocobolo, Bloodwood, Figured Maple, Spalted Maple, Padauk, etc. Unique and unusual turning woods and burls are also available. Send for catalog. BEREA HARDWOODS. \$1.00. *Circle No. 510.*

WOODWORKERS! HELP CELEBRATE OUR 60TH YEAR OF SERVICE—Send for our new 148-page Craftsman 1990-91 Catalog #57. 42 varieties of choice hardwoods 1/64 in. to 4-in. thickness. Fine hardwood veneers, tools, moldings, trim, marquetry inlays, upholstery and lamp supplies, finishes, clock kits, and hard-to-find hardware. 4,000-plus items for your projects. CRAFTSMAN WOOD SERVICE CO. \$1.00. *Circle No. 520.*

EdLco — WE KNOW OUR LUMBER—Educational Lumber Company is pleased to offer you our new catalog, stacked with excellent buys at delivered prices. Available to you are over 21 species of imported as well as domestic hardwoods, softwoods, turnings, shorts, veneers. All our lumber is kiln dried. As school shop suppliers for 35 years, we know our lumber. It is top-grade. Send today and receive your BONUS GIFT: 4 new furniture designs. EDUCATIONAL LUMBER CO., Inc. \$2.00. *Circle No. 530.*

THIN LUMBER—Approximately 20 species—1/8" to 3/4" thickness. Thinner material sanded, all KD & surfaced—UPS delivery in continental US included in price. Packages of micro-lumber 1/8" - 1/2" thick. HARDWOODS OF ILLINOIS. 50c. *Circle No. 545.*

NORTHEASTERN HARDWOODS—We offer over 20 species of the highest quality kiln dried domestic hardwoods. Sold on board footage or cut to order basis. Compare our quality and prices. Unconditional satisfaction guaranteed. Great monthly specials. Super package deal at delivered prices. Attractive quantity discounts. Quick delivery. Send for new catalog. NORTHEASTERN HARDWOODS. \$1.00. *Circle No. 563.*

RARE IMPORTED EXOTIC AND DOMESTIC HARDWOODS—The world renowned Martin Guitar Co. sells exotic woods (4/4, 6/4, 8/4) and sawn veneers (1/8", 1/4", & 1/2" Sanded Stock), plus guitar parts, kits, accessories and second quality guitars. No minimum order. Send for catalog. WOODWORKER'S DREAM. \$2.00. *Circle No. 578.*

STEVE H. WALL LUMBER CO—Quality hardwoods and woodworking machinery for the craftsman and educational

institutions. 22-page catalog lists 15 species of popular hardwoods at wholesale prices. Also dealers for MiniMax, Freud and ProCut woodworking machines. STEVE H. WALL LUMBER CO. \$1.00. *Circle No. 592.*

EPOXIES/GLUES

ARE YOU CURIOUS ABOUT EPOXIES?—Our application notes and product literature will tell you how adhesives work, how coating systems are designed, and how to make paint, varnish and fillers stick better and last longer. We are chemists. We make all our own products and write all our own literature. We can answer your questions. SMITH & CO. Free. *Circle No. 760.*

GENERAL WOODWORKING CATALOGS

ADVANCED WOODWORKING—Specialty products catalog from the exclusive distributors of Hegner & Felder woodworking machinery. Includes complete selection of scroll saw blades, accessories, and improvements for almost any scroll saw. Also the Hegner precision scroll saws, lathes & duplicators, Jet clamps, workbenches, Felder systems & more. AMI, LTD. \$2.00. *Circle No. 801.*

CONSTANTINES' CATALOG FOR WOODWORKERS—116 pages packed with over 4,000 products for fine woodworking. Included are 250 kinds and sizes of domestic and imported hardwoods; 150 varieties of exotic veneers, top quality woodworking tools, hard-to-find specialty hardware and accessories; wood finishes, books, plans, and more. 60-day money back guarantee if not fully satisfied. Serving the woodworker since 1812. ALBERT CONSTANTINE AND SON, INC. \$1.00. *Circle No. 820.*

MASTER TOOLS CATALOG—1990-91 220-page master woodworking tools catalog. Full line of the best hand tools, power tools & accessories, machinery, glues, finishing supplies, and much more. Hundreds of books included. 220 pages. All four-color. Lots of technical information. GARRETT WADE CO. \$4.00. *Circle No. 855.*

THE BEST THING THAT EVER HAPPENED TO THE AMERICAN WORKSHOP—You will simply be amazed at the number of new items we have brought on line this year. Our incredible catalog features a huge selection of wood and metal working machinery and accessories. Loaded with tons of goodies you can't resist. GRIZZLY IMPORTS INC. Free. *Circle No. 860.*

SEND FOR JET EQUIPMENT & TOOLS FREE CATALOG—to get details on bandsaws, tablesaws, jointers, shapers, drill presses, lathes, sanders, dust collectors and training videos. All Jet machinery comes with a 1-year limited warranty, replacement parts and repair service availability. JET EQUIPMENT & TOOLS. Free. *Circle No. 876.*

TOOL CATALOG—"Innovation" sets Leichtung apart from the rest! You'll find tools and accessories for the serious woodworker, do-it-yourselfer and hobbyist, many of exclusive design. 78 page full color catalog, 400-plus items. LEICHTUNG WORKSHOPS. Free. *Circle No. 878.*

TOOLS ON SALE—A division of Seven Corners Ace Hardware Inc. offers a comprehensive catalog featuring over 820 pages of the most competitive prices in the industry. If you're looking for savings and fast delivery on over 6500 items, request our catalog. This catalog offers one of the most complete selections of power tools available anywhere from the most respected manufacturers in the industry: Milwaukee, Makita, Porter-Cable, Black & Decker, Freud, Bosch, Delta, and many more. SEVEN CORNERS ACE HARDWARE. \$1.00. *Circle No. 920.*

DISCOUNT WOODWORKING TOOLS AND SUPPLIES—Get your FREE copy of Trendline's new 72 page full-color catalog. You'll find the best prices for over 3,000 brand name products including: power tools and accessories, hand tools, screws, hardware, wood components, plans, books, and much more. TRENDLINES. Free. *Circle No. 950.*

COMPLEMENTARY TOOL CATALOG—Woodcraft offers over 4,000 of the finest quality woodworking tools, books, supplies, and cabinetry hardware in our complete full color catalog. Craftsmen, cabinetmakers, carvers, woodturners, and hobbyists have depended on Woodcraft since 1928. Backed by Woodcraft's unconditional guarantee. Free technical assistance. WOODCRAFT SUPPLY CORP. Free. *Circle No. 955.*

WOODWORKERS STORE CATALOG—New! The Woodworkers' Store 1990-91 catalog with over 250 new items features 100 color pages of domestic and exotic hardwoods, veneers, wood parts, specialty hardware, kitchen accessories, finishing supplies, tools, books, and plans. Many exclusive items and hard to find specialties. Orders shipped in 24-48 hours. \$1.00 credited toward first purchase. Satisfaction guaranteed. WOODWORKERS STORE. \$1.00. *Circle No. 965.*

WOODWORKERS SUPPLY—offers high quality tools and supplies for skilled, amateur, and professional woodworkers. Our complete catalog includes machinery, hand tools, plans, router bits, shaper cutters, wood specialties, and more. For your two year subscription send to WOODWORKERS SUPPLY. \$2.00. *Circle No. 975.*

KITS

OUR QUEEN ANNE FURNITURE KITS—are ready to assemble and finish. They include dining room table, chairs, hutch, sideboard, a variety of occasional tables, and a personal desk. All are made in solid cherry, oak, walnut, and mahogany. We also stock individual Queen Anne legs for every project. Complete information in our brochure packet. ADAMS WOOD PRODUCTS. Free. *Circle No. 1002.*

FREE STANDING BACKYARD GYMS—Countryside Woodworking Inc. (CWI) offers 6 models and 11 options for a wide variety of family fun gyms. The only Backyard Gym you'll ever buy. 4x6 and 4x4 construction, playground rated hardware. Complete kits include all lumber. Hardware only kits also available. Send for complete color catalog. CWI. \$1.00. *Circle No. 1005.*

POOL TABLE KITS AND COMPONENTS—Save hundreds of dollars in dealer's mark-up and manufacturer's costs by completing a kit or building from scratch. The "Continental Kit" contains all the components and instructions you'll need to build a tournament quality slate pool table at home in a couple of week-ends. The completeness of this kit makes it a practical and enjoyable project for the first time or experienced kit builder. If you are more ambitious, build a pool table from scratch. We supply only the finest Italian slates, leather pockets, billiard cloth, rail cushions and other components. Send for complete information. CONTINENTAL BILLIARDS. \$1.00. *Circle No. 1016.*

OAK FURNITURE AND ACCESSORY KIT CATALOG—features a full range of top quality oak furniture kits and accessory items plus unfinished assembled furniture. Featured items include roll top desks in several styles, stacking barrister's bookshelves, tables, chairs, trunks, file cabinets, bedroom furniture, Mariner's globe, plus many more. Send for full color catalog and enjoy true woodcrafting pleasure. CRAFTSMANS CORNER. Free. *Circle No. 1017.*

DO-IT-YOURSELF KITS—Choose from a large selection of grandfather, wall and mantel clocks, as well as elegantly styled accent furniture pieces. Kits are made of solid 3/4" hardwoods, primarily cherry, oak, and black walnut. Buy direct from the factory and save. Send for 36 page color catalog. EMPEROR CLOCK CO. \$1.00. *Circle No. 1030.*

QUALITY CLOCK KITS AND PLANS—Handmade and semi-assembled of carefully selected 3/4 in. cherry, oak, or walnut with beveled glass. Or build from "scratch" using our detailed plans and trim pieces. Choice of quality movements. Established in 1916. KUEMPEL CHIME CLOCK WORKS. \$2.00. *Circle No. 1050.*

MUSIC MAKER'S KEEP BOOK—a 32-page resource catalog for building and learning to play handmade musical instruments. This source book contains plans, blueprints, kits, books, hardware, strings and accessories for building such instruments as guitars, banjos, dulcimers, harps, violins, pipes, and more. MUSICMAKER'S KITS. \$1.00. *Circle No. 1080.*

LOG CABIN DOLLHOUSE—Plans, kits, completed houses. Standard scale 1 in. equals 1 ft. House is 23"x34"x17" high. Stone chimney and fireplace, wood shingle roof. Plans adaptable to any style log house. Send for informational brochure with photos. WOODWORKING UNLIMITED. \$2.00. *Circle No. 1095.*

SHOP ACCESSORIES

PARAGAUGE—NOW ANYONE CAN CUT WOOD ACCURATE TO WITHIN 10/1000 INCH—ParaGauge was developed to provide the woodworker a perfectly parallel measurement quickly and accurately to help alleviate the tedious and sometimes inaccurate task of setting a rip fence. ParaGauge accurately measures distances up to 18 in. in

length between the saw blade and rip fence and up to 2.5 in. in depth without resetting or relocating the gauge. Para Gauge is completely portable and can be used on just about any tool requiring a parallel measurement. ACCUSET TOOL CO. INC. 25c. *Circle No. 1205.*

WOOD MOISTURE METER—End wood warping nightmares with a high quality precision instrument from Electrophysics. Avoid damage and deformation; eliminate stains, decay, mold, and failed joints. Eight models to choose from in the MT Series of wood moisture meters designed and made in Canada. For moisture contents from 3% to 60%. Accessory probes and custom services available. A wood moisture meter is an essential tool for the home hobbyist, serious enthusiast, professional woodworker, commercial kiln or sawmill operator, wood carver, and everyone who works with wood. Free catalog gives complete information. ELECTROPHYSICS. Free. *Circle No. 1230.*

RIPSTRATE SAVES FINGERS—for table saw and radial arm saw users. Brochure describes the RIPSTRATE and shows how it gives straighter cuts, speeds the work, prevents kickbacks, and keeps hands away from the blade. FISHER HILL PRODUCTS. 25c. *Circle No. 1235.*

EASY DOES IT—with HTC'S power tool accessories. Discover many unique items, designed only with you, the dedicated woodworker, in mind. Make your machinery safer, increase the working area of your shop and accomplish nearly impossible tasks easily, quickly, accurately. Full-line catalog and price list. HTC PRODUCTS, INC. Free. *Circle No. 1245.*

BUY YOUR SANDING BELTS DIRECT FROM THE MANUFACTURER—Industrial Abrasives is the company that gives you 12 free belts with every dozen ordered. But, sanding belts are not the only product we have to offer. In our catalog you will find many specialty items not readily available in your hardware store. Price of catalog refunded with first order. INDUSTRIAL ABRASIVES CO. \$1.00. *Circle No. 1248.*

WOOD MOISTURE METER—Avoid moisture problems such as cracking, warping, splitting, delamination etc. by using a moisture meter, as described in the latest brochure. Moisture Meter Mini-Ligno is designed for serious hobbyists and woodworkers. Attachments for depth measurements and remote reading during air and kiln drying are available. Available Moisture Range 6-20%, 6-36% or 4-30%, 4-60%. Catalog describes complete line of moisture meters. LIGNOMAT USA, LTD. Free. *Circle No. 1250.*

ROUTER SPEED CONTROL—Reduces speed electronically without reducing torque. Route at the speed that gives best results with the wood and bit you are using. Speed adjustable from full speed to 0 RPM. Less tear out—stops burning—less wear on bits—easy to use. Send today for information. MLCS LTD. Free. *Circle No. 1251.*

WHOLESALE SANDPAPER, BELTS, SHEETS, CLOTH AND PAPER DISCS—for orbital sanders, flexible sanding cloths, pads, tack cloths, pressure sensitive adhesive, wipers, dust mask—Super Grit offers its quality abrasive and refinishing products at wholesale prices directly to the consumer. Try our extra strength hot melt glue sticks for wood. \$25 minimum order, prompt free UPS shipment to most areas. Catalog/Price List. RED HILL CORP. 50c. *Circle No. 1267.*

LABOR-EFFICIENT, COST EFFECTIVE TRIMTRAMP—Instantly converts your hand held circular saw into a precision miter and cross-cut saw table that provides unsplintered cuts of cabinet maker quality by allowing you to pull the saw backwards through the work. Fixed fences provide perfect 90° picture frame quality miter joints and compound miters, everytime. Also cuts variable angles and cross-cuts up to 15° wide. Send for free brochure. TRIMTRAMP LTD. Free. *Circle No. 1280.*

WEDGE INNOVATIONS' SmartLevel®—Digital electronic carpenters level measures all angles with up to 1/10 degree accuracy. Automatically calculates percent of slope and pitch (inches of rise per foot of run), and can be recalibrated into perfect balance with the push of a button. Helps you achieve exact measurements and professional quality with the minimum effort. WEDGE INNOVATIONS. Free. *Circle No. 1293.*

BITS, BLADES, CUTTING TOOLS

BANDSAW BLADES FOR ALMOST ANY TYPE BANDSAW—both wood and metal cutting. Also circular saw blades, router bits, sanding belts and discs. Send for catalog. BUCKEYE SAW CO. \$1.00. *Circle No. 1307.*

BYROM INTERNATIONAL "THE WORLD'S ROUTER BIT SOURCE"—manufactures and offers you over 1,000 industrial

quality router bits. Choose from high speed steel, solid carbide, carbide tipped, and the newest innovation in router bits today, "Byrom Gold Titanium Nitride coated high speed steel." All Byrom router bits are available in English and metric sizes. Send for your new Byrom router bit catalog. Get \$3 back off your first purchase from your dealer. BYROM INTERNATIONAL. \$3.00. *Circle No. 1308.*

CARBIDE-TIPPED ROUTER BIT AND SHAPER CUTTER CATALOG—We have hundreds of styles and thousands in stock ready to be shipped. We specialize in quantity discounts and same day shipping. These are top quality industrial router bits and shaper cutters at super low prices. Send now to receive new giant catalog. CASCADE TOOLS, INC. Free. *Circle No. 1315.*

TIRED OF THE IMPORTS?—All new 1991 router bit catalog featuring over 1100 items. This factory direct mail order 56-page catalog offers the industry's largest selection of the finest quality American made router bits, shaper cutters, and accessories. EAGLE AMERICA CORP. Free. *Circle No. 1320.*

WOODWORKING TOOLS—Freud provides the finest in hand tools, carbide cutting tools, and hand held power tools. From drills and sanders to carbide saw blades and router bits. Send for catalog. FREUD. \$2.00. *Circle No. 1321.*

SUPER-SMOOTH, EXTRA-DURABLE, CARBIDE-TIPPED CIRCULAR SAW BLADES—Get a smooth-as-sanded surface with our all-purpose 40-tooth Woodworker Blade. You will be able to rip and cross-cut 1 - 2 in. rock hards and soft woods with an unbelievably smooth finish. You will also be able to cross-cut oak and birch ply-veneers with no bottom splinters. Send today for our information pack. FORREST MFG. CO., INC. \$1.00. *Circle No. 1322.*

PRODUCTION QUALITY CARBIDE TIPPED ROUTER BITS—MLCS Ltd. offers a full line of professional production quality carbide tipped router bits at 50-70% lower than retail prices. We sell through the mail and only direct to craftsmen. Send today for catalog. MLCS LTD. Free. *Circle No. 1350.*

SAW BLADE VALUES—Olson Saw's unique "furniture band" is specifically designed to provide fast, smooth cuts in all types of wood. Included in Olson's free literature package are a huge list of resin on resin abrasives and carbide tipped circular saw blades in addition to a growing selection of band scroll (incl. pinned), jewelers and spiral saw blades. OLSON CATALOG SALES. Free. *Circle No. 1365.*

ROUTER BITS, SHAPER CUTTERS, FORSTNER BITS—Boring bits, saw blades. All heavy duty industrial grade tungsten carbide. You name it, if it rotates and cuts, we have it. Quality, price, selection, save 50% or more over "wholesale" prices. Catalog comes with a \$3.00 discount coupon. SKYCROFT TOOLS INC. \$1.00. *Circle No. 1372.*

HARDWARE/WOOD PARTS

TURNED WOOD PARTS—Quality shaker pegs, candle cups, spindles, wheels, balls, dowels, screwhole buttons, cargo and much more. High quality. Reasonable prices. Fast service. American made. Free shipping on orders over \$25. 28-page catalog. AMERICAN WOODCRAFTERS SUPPLY. 75c. *Circle No. 1405.*

HARDWARE CATALOG—A unique 48-page catalog of the very finest in classic, traditional solid brass cabinet hardware. All of British or No. American manufacture. Double & single post handles, knobs, escutcheons, standard & specialty hinges, box hardware, brass screws, castors, latches, catches, locks, and more. GARRETT WADE CO. \$3.00. *Circle No. 1427.*

SQUARE DRIVE SCREWS—Thousands agree—once you try them you will never want to use anything else! The square drive recess virtually eliminates work-damaging driver bit "cam-out," the deep threads result in exceptional holding power, and they are heat treated for strength. Sizes from #4 x 3/8" to #12 x 4", with stainless steel, solid brass, brass plated, and zinc plated available. Quantity discounts. Send for literature. McFEELY HARDWOODS. \$1.00. *Circle No. 1450.*

WOOD TOY PATTERNS—Patterns for all ages including children's patterns and executive toys. New catalog has many new patterns to choose from including parts and wheels. Send for new catalog and receive a coupon for free wheels and axle pegs. TOYS AND JOYS. \$1.00. *Circle No. 1480.*

TRADITIONAL TURNINGS FOR THE HOME CRAFTSMAN—Unique selection of bedposts, table legs (dining, sofa, coffee, and end), hutch, gourmet, and kitchen. American, European, and Contemporary designs, available in Ponderosa Pine. Sanded and ready for assembly and finish.

Send for catalog. TRADITIONAL TURNINGS. \$2.00. Circle No. 1485.

DESIGN & DECORATE WITH WOOD MOULDINGS—Contains full-color photos of various household rooms showing extensive use of wood mouldings. Profile drawings of all wood mouldings used to create these finished designs are also shown, plus suggested alternative profiles. A simple way to transform an ordinary room into a showplace on a minimum budget. WOOD MOULDING & MILLWORK PRODUCERS ASSN. \$1.00. Circle No. 1487.

QUALITY AMERICAN-MADE WOOD TURNINGS—such as shaker pegs, spindles, toy wheels, toy parts, craft items, and dowel rods in birch, oak, walnut, and cherry. Send for complete 32-page catalog. WOODWORKS. \$1.00. Circle No. 1490.

INCOME OPPORTUNITIES

AMITY, NATION'S #1 QUALITY FURNITURE RESTORATION CO. SINCE 1971—New product catalog featuring: Complete restoration systems. Amity non-flammable water based stains and finishes, Permafuse repair products, stripping solvents, chemicals and supplies. Amity 1-2-3 wipe-on finishes and much more. Regional workshops in your area. AMITY. \$1.00. Circle No. 1605.

MAKE MONEY IN FURNITURE RESTORATION THE MINUTEMAN WAY—Earn \$200-\$1000 per day stripping, repairing, refinishing, mirror resilvering, and/or veneering, at home or in shop, spare time or full time. We provide complete free training; no experience necessary. Free workshop teaches you latest in furniture restoration. You have to see it to believe it! Intro video \$12.95, Send for catalog. MINUTEMAN. \$2.00. Circle No. 1661.

MISCELLANEOUS

FOLEY-BELSAW INSTITUTES' NEW WOODWORKING CORRESPONDENCE COURSE—for people with the desire to learn how to work with wood and the proper use of tools. Create over 20 projects using professional plans and tools like a table saw, router with stand, and more...all included with the

course. Complete money-back guarantee. Send for details. FOLEY-BELSAW INSTITUTE. Free. Circle No. 1930.

LEARN ALL THE SKILLS—of professional upholstery and refinishing techniques in the comfort of your own home. The Foley-Belsaw Institute system of "hands on" training provides clear, step-by-step instructions in the use of tools and materials on actual furniture "kits"...all included with the course. Complete money-back guarantee. Send for details. FOLEY-BELSAW INSTITUTE. Free. Circle No. 1931.

THE CUSHION CONTOUR SANDER—is a new concept in pneumatic drum sanding. Sanding sleeves are slid over an air bag (inflated with a hand tire pump) on an arbor to mount it between centers on a wood lathe. Drum effectively takes on profiles, curves, and bevels practically eliminating flat spots and chatter marks. INDUSTRIAL ABRASIVES CO. \$1.00 (refunded with first order). Circle No. 1976.

IF YOU ARE INTERESTED IN RESTORING ANTIQUES—this 216-page catalog packed with unusual, hard-to-find items is just for you. Included are hundreds of essential items for antique restoration including top quality brass reproduction hardware, oil lamps and accessories, numerous wood component repair parts and kits, caning and basketry supplies, everything needed for wood refinishing, related tools, books, and a complete line of upholstery equipment and supplies. All at wholesale prices. Send for this informative catalog. VAN DYKE'S RESTORERS. \$1.00. Circle No. 2077.

UNIQUE GREENHOUSE/SCREENHOUSE IDEA—A gardener's paradise during the winter months, a bug-free screen room during the summer months. That's the concept behind the versatile new Sun-Porch. This two-in-one sunspace features sturdy aluminum framing, 1" shatter-resistant glazing, do-it-yourself assembly, and mounts readily on decks, patios, landscape ties. Color catalog includes models, prices; sent first class mail. VEGETABLE FACTORY, INC. \$2.00. Circle No. 2078.

NEED PARTS!?!—If you are having trouble locating parts for your radial arm saw because of recent changes in their availability, Wolfe Machinery could be your answer. We have a full line of parts, including obsolete ones for 10-20" DeWalt radial arm saws. Send today for free information. WOLFE MACHINERY CO. Free. Circle No. 2080.

HOW TO MAKE PICTURE FRAMES—Instructions for the do-

it-yourself on how to make picture frames using standard mouldings. Tells what tools to use and how to build and finish picture frames. WOOD MOULDING & MILLWORK PRODUCERS ASSN. 75c. Circle No. 2085.

COMPUTER SOFTWARE—Woodworking Magazine Index for Wood, Fine Woodworking, Woodwork, Woodsmith, Today's Woodworker, and 1987-1990 issue of Woodworker's Journal and Workbench. Now you can find the article you remembered, and know the magazine, issue and page without searching through many printed indexes. Yearly updates can be added to the original index. Send for brochure; price refundable with order of Woodfind. WOODFIND. \$1.00. Circle No. 2089.

WOODWORKING ASSOCIATION OF NORTH AMERICA—First international association for woodworkers. Benefits include our monthly bonus packets, Project-Of-The-Month, Group Purchase Opportunity, free woodworking problem solving through full time consultant, 50% discount on regional show admission and more. Send for sample magazine and application. WOODWORKING ASSOC. OF NORTH AMERICA. \$3.00. Circle No. 2092.

CARVING SUPPLIES

WOODCARVING CATALOG—64-page catalog packed with over 2500 items specializing in woodcarving and decoy carving. Included are carving woods, large selection of hand carving chisels, gouges, knives. Power carving tools and the largest selection of bits, cutters, burrs and abrasives, woodburners, extensive painting supplies and brushes, books and videos. CRAFTWOODS. Free. Circle No. 2110.

DECOY AND WOOD CARVERS WISHBOOK—48-page catalog features wide selection of tools and supplies for decoy carvers, wood carvers, wood turners. Chisels, gouges, sharpening stones, precision grinding tools, Foredom tools, Fire Brush patterns, pneumatic sanders, glass eyes, pewter feet, patterns, paints, reference books. P. C. ENGLISH, INC. \$1.00. Circle No. 2115.

WOOD CARVING MACHINES AND ACCESSORIES—make all types of wood carving easy, fun and profitable. The machines do the work. Whether for sign carving, flat 3-D, decoys, panels, gun stocks or furniture, we have the proper machine for the job. Professional woodcarving for the hobbyist and superior quality for the professional. Begin your hobby or full or part-time business by ordering our catalog and price list. MARLIN INDUSTRIES. \$1.00. Circle No. 2150.

WOODCARVING TOOLS—Whittlers and carvers—Warren Tool Co. offers a complete catalog of whittling and carving, hand/power tools, sharpening stones, wood cut-outs and related wood carving supplies. WARREN TOOL CO., INC. \$1.00. Circle No. 2185.

WOOD CARVERS SUPPLY INC.—OUR 35TH YEAR—Complete 64-page color catalog including over 2,000 carving tools, books & supplies, such as carousel animal kits, gun checkering tools, ship model kits, plus much more. We offer great service, quality products and a 30-day money back guarantee. Send for 2-year subscription. WOOD CARVERS SUPPLY INC. \$2.00. Circle No. 2190.

CLAMPS

MERLE ADJUSTABLE CORNER CLAMP—Quick & easy to use. Fully adjustable from 2 5/8" to 69x69 in. Perfect for clamping picture frames, cabinets, or anything that requires 90° corner clamping. The Merle Clamp is cast aluminum & steel construction, a true industrial quality tool. Send today for information. MLCS LTD. Free. Circle No. 2250.

CLAMPING MADE EASY—THE NEW TOULAN 2005 CORNER CAMCLAMP FROM ENGLAND—Introduced at IWF-90, this little award winning clamp was an overwhelming success. Awarded the Britain Engineering award of Excellence and selected to the design Centre of London, the clamp makes clamping easy, fast, efficient. TECH REP & ASSOCIATES. Free. Circle No. 2270.

CLOCKS

KLOCKIT'S FREE 64-PAGE COLOR CATALOG—is packed with the largest selection of beautiful wood clock kits for all skill levels, a huge selection of quartz and mechanical clock movements, dials and accessories, turned wood parts, music movements, tools and much more for the craftsman! KLOCKIT. Free. Circle No. 2335.

Worth writing for...



Better Homes and Gardens®
WOOD Magazine, February 1991
Dept. FEWO91
P.O. Box 5103
Pittsfield, MA 01203-5103

TO ENSURE PROMPT HANDLING OF YOUR ORDER FOLLOW THESE INSTRUCTIONS:

- Circle your choice
- Enclose check or money order for cost of booklets plus \$2.00 service charge (no stamps/foreign)
- Send coupon and remittance to address above
- ALLOW 4-6 WEEKS FOR DELIVERY
- Coupon expires March 15, 1992

WOOD SUBSCRIPTION

1. A 1 year WOOD subscription (8 issues) for \$19.97 (U.S. price)—an \$11.63 savings off newsstand rate. Allow 6-8 weeks for first issue. Canadian price \$29.00. Be sure to include payment with total below. NO FOREIGN ORDERS ACCEPTED ON THIS COUPON; please contact Subscription Dept. directly.

Circle numbers below corresponding to items in this issue. Please include \$2.00 for handling charge.

3\$1.00	93\$1.00	345\$3.00	592\$1.00	1030\$1.00	1320Free	1976\$1.00
4\$1.00	94\$1.00	355\$8.00	760Free	1050\$2.00	1321\$2.00	2077\$1.00
6\$2.00	96\$1.00	370\$1.00	801\$2.00	1080\$1.00	1322\$1.00	2078\$2.00
10Free	112\$2.00	380\$6.95	820\$1.00	1095\$2.00	1350Free	2080Free
33\$4.00	142Free	401\$1.00	855\$4.00	120525c	1365Free	208575c
41Free	160\$1.00	418Free	860Free	1230Free	1372\$1.00	2089\$1.00
42Free	190\$1.50	430\$1.00	876Free	123525c	140575c	2092\$3.00
44Free	215Free	454\$10.45	878Free	1245Free	1427\$3.00	2110Free
61Free	216Free	455\$11.45	920\$1.00	1248\$1.00	1450\$1.00	2115\$1.00
75Free	268Free	480\$1.00	950Free	1250Free	1480\$1.00	2150\$1.00
76Free	310\$2.00	496\$1.00	955Free	1251Free	1485\$2.00	2185\$1.00
77Free	315\$1.00	510\$1.00	965\$1.00	126750c	1487\$1.00	2190\$2.00
78\$1.00	328\$2.00	520\$1.00	975\$2.00	1280Free	1490\$1.00	2250Free
84Free	332\$1.00	530\$2.00	1002Free	1293Free	1605\$1.00	2270Free
85Free	335\$2.00	54550c	1005\$1.00	1307\$1.00	1661\$2.00	2335Free
88\$1.00	339\$1.00	563\$1.00	1016\$1.00	1308\$3.00	1930Free	
89\$1.00	340\$1.00	578\$2.00	1017Free	1315Free	1931Free	

Name (please print) _____

Address _____

City _____

State _____

Zip Code _____

I AM ENCLOSING:

\$ _____ for priced items

\$ \$2.00 for handling

\$ _____ total remittance

DELTA BENCH TOP TOOLS			
Model	List	Sale	
23-700 Wet/dry grinder	201	159	
23-680 6" bench grinder 1/4 HP	81	75	
23-680 8" bench grinder 1/2 HP	136	115	
11-950 8" drill press	164	139	
14-040 14" drill press	313	309	
40-150 15" hobby scroll saw	178	139	
28-160 10" hobby band saw	189	144	
31-050 1" belt sander 2.0 amp	93	78	
31-460 4" belt/disc sander	178	139	
31-340 NEW 1" belt/disc sander	226	175	

NEW TOOLS BY DELTA			
40-560 1/2" speed scroll saw	266	195	
23-580 5" Bench grinder 1/5 HP	60	54	
11-990 12" Bench Drill Press	266	195	
11-090 32" Radial bench drill press	399	279	
22-540 12" Portable planer	595	399	
22-450 1/2" Bench router/shaper	399	279	

DELTA STATIONARY			
34-761 10" universal 1-1/2 HP	1715	1399	
33-980 10" radial arm saw	727	565	
33-280 6" motorized jointer	440	375	
50-178 3/4 HP 2 stg. dust coll.	435	339	
50-180 1 HP dust collector	535	415	
50-182 2 HP dust collector	760	599	
22-667 13" planer w/2 HP motor			
newland & ext. wings	1750	1099	
33-050 NEW 8-1/4" Sawbuck	742	545	
33-055 Above saw comp w/legs	865	655	
34-330 NEW 8-1/4" Tbl Saw 13A	321	195	
34-985 1/6 HP stock leader	698	459	
32-100 NEW station plate jointer	645	289	
36-040 NEW 8-1/4" compd mitre saw	216	159	
34-897 50" Delta uniface	500	338	
36-755 NEW 10" Tbl Arbor Saw	1203	875	

MILWAUKEE TOOLS			
6527 NEW SawZall vispd 8 amp			
w/ice & Quick Loc Cord	299	165	
0399-1 NEW 1/2" cdss var/spd drill			
w/batt. charger & case	290	155	
0395-1 9.6V cdss. drill w/ice	270	148	
0219-1 9.6V cdss. drill w/ice	295	165	
0224-1 3/8" drill 4.5A magnum	189	112	
0234-1 1/2" drill 4.5A magnum	209	112	
0244-1 1/2" drill 4.5A magnum	209	112	
0222-1 3/8" drill 3.5A-1000 rpm	179	102	
0228-1 3/8" drill 3.5A-1000 rpm	169	99	
0375-1 3/8" close quarter drill	208	125	
0379-1 1/2" close quarter drill	243	154	
6539-1 Cdss. scrvn. 190 rpm	119	69	
6540-1 Cdss. scrvn. w/bits & cse	159	108	
6546-1 Cdss. scrvn. 200 & 400 rpm	126	75	
3102-1 Pimbrs rt angle drill kit	330	185	
3002-1 Electricians rt angle drill	330	182	
5399 1/2" D-hole ham drill kit	312	179	
1676-1 H.D. Hole Ham w/ice	429	229	
6511 2 sp SawZall w/ice	224	129	
6750-1 Drywall gun 4-0000 4.5A	154	89	
6507 TSC SawZall w/ice	239	129	
6170 1/4" chop saw	430	259	
6014 Orbital sander 1/2 sheet	209	118	
8977 Var. temp heat gun	114	75	
5397-1 3.8" visp ham. drill kit	232	137	
5371-1 1/2" visp ham. drill kit	335	185	
3107-1 1/2" visp rt angle drill	340	189	
6754-1 Drywall gun 4-0000 4.5A	179	119	
3300-1 1/2" visp mag rt angle drill	309	179	
5660 Router 1-1/2 HP - 10amp	325	195	
5660 Router 2 HP - 12 Amp	355	219	
5455 7/8" polisher 1750 rpm	219	127	
6215 1/8" chain saw	280	169	
6365 7-1/4" circular saw	204	119	
6366 7-1/4" circ. saw w/ice & bid.	214	125	
6368 7-1/4" circ. saw w/ice			
blade & case	239	135	
0235-1 1/2" drill kylls. chuck mag	215	125	
6016 1/4 sheet pad sander	84	49	
6145 4.5" grinder 10,000 rpm	159	95	
6142 6145 w/ice & access	197	125	
6749-1 Drywall gun 0-2500 4.5A	189	125	
6377 7-1/4" worm drive saw	295	169	

FREUD SAW BLADES			
5/8" Bore - Industrial Grade			
CARBIDE TIPPED SAW BLADES			
Item	Description	Teeth	List Sale
L072M010	Gen Pur. - A.T.B. 10' 40"	58	38
L082M010	Cut-off 10"	60	77
L04M011	Comb 10"	50	65
L085M010	Super Cut-off 10"	80	96
LM72M10	Ripping 10"	24	57
L073M010	Cut-off 10"	60	70
L087M010	Thin kerf 10"	24	60
L088M010	Thin kerf 10"	60	74
L098M010	Ultimate 10"	80	107
SD306	8" Dado - Carbide	184	105
SD309	8" Dado - Carbide	186	109
F0	1-3/4" x 5/8" Bisc. 1000 Qty.	32	27
F10	2-1/8" x 3/4" Bisc. 1000 Qty.	32	27
F20	2-3/4" x 1" Bisc. 1000 Qty.	34	29
FA	Assor. Biscuits 1000 Qty.	34	29
WC106	6 pc. chisel set w/ice 1/4"-1"	73	52
FB100	16 piece forstner bit set	294	158
94-100	5 pc. router bit dossier	288	155
JS100	Biscuit Jointer w/ice	300	159
CE82	Planer w/ice & carb blds	216	135
FT2000	3-1/4 HP plunge router	299	179

THE NEW "TK" BLADE SERIES

Item	Description	Teeth	List Sale
TK203	1-1/4" Framing	24	29
TK206	10" Framing	24	33
TK303	1-1/4" Finishing	40	36
TK306	10" Finishing	40	39
TK903	1-1/4" Combo	30	31
TK906	10" Combo	45	26

MAKITA CORDLESS			
Model	List	Sale	
60700W 3/8" vispd rev. drill, 7.2v	130	78	
60710DW 3/8" vispd rev. drill	199	115	
w/removable batt., 7.2v	199	115	
50900W 3-3/8" saw kit, 9.6v	256	139	
60100DW 3/8" cds drill kit, 7.2v	164	95	
60105DW 3/8" cds. drill kit, 7.2v	251	149	
DA30000W 3/8" angle drill, 7.2v	251	149	
84000W Hammer drill kit, 9.6v	272	149	
43900W 9.6 cds recip saw kit	230	128	
6012HDW 2 speed, driver drill			
w/ulutch & case 9.6	236	122	
60920W V/isp drill, kit complete	250	125	
60930W V/isp drill w/clutch-complete	261	127	
632007-4 9.6 volt battery	48	30	
632002-4 7.2 volt battery	40	28	
5007NBA 7-1/4" saw w/elec. brake	233	124	
5008NBA 8-1/4" saw w/elec. brake	284	158	
BD4510 1/4 sheet pad sander	85	54	
9900B 3" x 21" belt sander w/bag	288	144	
9045DB 3x 24" belt sander w/bag	282	145	
4200N 1/2" slit fin. sand. w/bag	231	129	
4301VB Orb. visp jig saw 3.5A	289	155	
JR3000V Vs. recip saw w/ice	227	124	
LS1020 10" mitre saw 3.5A	463	289	
9820-2 Blade sharpener	373	195	
1900BW 3-3/4" planer w/ice	209	114	
1911B 4-3/8" circ. saw 7.5A	240	139	
1100 3-1/4" planer w/ice	401	205	
9027SPC 7" sander/polisher	276	149	
3601B 1-3/8 HP router	255	139	
9045Z 4" grinder, 3.5 amp	126	69	
90180 6" round sander	101	64	
BD4050 1/4 sht pad sander w/bag	86	58	
DA3000W 3/8" angle drill	270	148	
HP2010N 3/4" visp hmr. drill w/ice	300	165	
2708W 8-1/4" table saw	504	249	
2711 10" table saw w/brake	841	479	
2030N 12" planer/jointer	3120	1665	
2040 15-5/8" planer	2595	1459	
1895B 6-1/8" planer kit w/ice	679	359	
5095BA 5-1/2" circular saw	223	135	
6494 3/8" drill rev. 0-2100 rpm 2A, 10A	140	65	
6510LV 3/8" drill rev. 0-1050 rpm	145	79	
6013BL 1/2" drill rev. 6 Amp	241	135	
5402A 16" circular saw 12 amp	636	325	
3612BR 3 HP plunge router	377	189	
9401 4" x 24" belt sander w/bag	318	165	
4302C V spd. orb. jig saw	302	159	
5077B 14" Hydrolid saw	252	138	
LS1440 14" Mitre saw	721	435	
LS1030 NEW 10" Mitre saw	414	225	
5007NB 7-1/4" circ saw 13A	209	112	
3612B 3 HP plunge router sq/base	377	189	

DELTA TOOLS			
34-444 Table Saw Complete			
w/1-1/2 H.P. motor & stand	605.00		
34-445-34-444 Table Saw			
complete w/3" Uniface	789.00		
37-154 DJ15 6" Jointer			
w/3/4 H.P. motor	999.00		
28-283 14" Band Saw			
w/closed stand			
3/4 H.P. motor	675.00		
70-200 NEW 20" Drill Press			
729.00			
17-900 16-1/2" Floor Drill Press			
385.00			
40-601 18" Scroll Saw			
w/stand and blades	689.00		
DELTA #3A-080 10" MITRE BOX XTRA SPECIAL			
195.00			
List 299.00			

SENCO AIR NAILERS			
Model	List	Sale	
SFN1 Finishing nailer 1" - 2"	377	285	
SFN2 Fin. nailer 1.5" - 2.5"	571	405	
SN325 Nailer 1-7/8" - 3-1/4"	685	445	
SN4 Gen'l purpose 2" - 3-1/2"	685	479	
LS2 Pinner 5/8" - 1"	351	255	
SKS Stapler 5/8" - 1-1/2"	351	255	
LS5 Pinner 1" - 1-1/2"	399	295	

BOSTICH AIR NAILERS			
Model	List	Sale	
N80C-1 Utility coil nailer	795	399	
N80S-1 Stick nailer	795	399	
T36-50 Sheath & decking stapler	595	334	
N112B-1 Coil roofing nailer	795	399	
N60FM-2 Finishing nailer	625	335	
T31 1/2" Brad nailer	245	149	
CWC100 1 HP Pancake Compressor	445	299	

SKIL SIZLERS			
6590-02 NEW 12" EMH hammer			
drill w/ice 4 amp	255	129	
3810 10" Mitre saw	263	209	
3810S 3810 w/60 tooth carb blade	235		
77 7-1/4" worm drive saw	230	144	
2735-04 12v vispd cordless drill			
complete w/ice, & 2 batt.	210	125	
1605 NEW Biscuit Jointer w/ice	200	118	

LEIGH DOVETAIL JIGS

Model	List	Sale
D1258R-12 List 329.00 Sale 235.00		
D1258R-24 List 399.00 Sale 279.00		

LEIGH INSTRUCTIONAL VIDEO SALE 29.00

Model	List	Sale
MMT 12" multiple mort. & tenon attachment for D1258-12	269	219
MMT 24" multiple mort. & tenon attachment for D1258-24	299	135

1991 TOOL CATALOG AVAILABLE
 Call Toll-Free 1-800-328-0457 in Minnesota Call (612)224-8658
 FAX: (612)224-8263
 CHECK - MONEY ORDER - VISA - MASTERCARD - DISCOVER
SEVEN CORNERS ACE HDW. Inc.
 216 West 7th St. - St. Paul, MN 55102 - Est. 1933

DELTA TOOLS			
34-444 Table Saw Complete			
w/1-1/2 H.P. motor & stand	605.00		
34-445-34-444 Table Saw			
complete w/3" Uniface	789.00		
37-154 DJ15 6" Jointer			
w/3/4 H.P. motor	999.00		
28-283 14" Band Saw			
w/closed stand			
3/4 H.P. motor	675.00		
70-200 NEW 20" Drill Press			
729.00			
17-900 16-1/2" Floor Drill Press			
385.00			
40-601 18" Scroll Saw			
w/stand and blades	689.00		
DELTA #3A-080 10" MITRE BOX XTRA SPECIAL			
195.00			
List 299.00			

TOOLS ON SALE™
 AMERICA'S LOWEST PRICED TOOLS
 FREE FREIGHT TO THE
 48 CONTINENTAL STATES ON EVERY ITEM.
 PRICES SUBJECT TO CHANGE WITHOUT NOTICE.

PIRANHA By Black & Decker				
Model #	Dia.	Teeth		

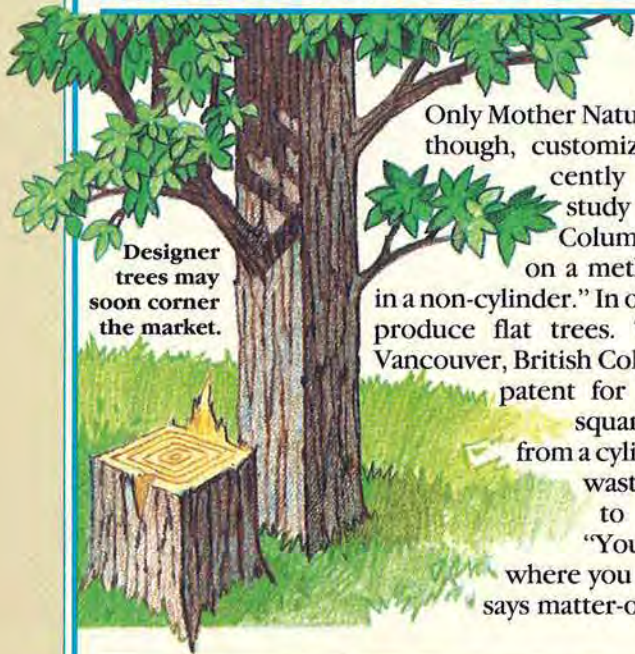

Designer trees may soon corner the market.

DESIGNER TREES

Only Mother Nature makes trees. Robert Falls, though, customizes them. Robert, who recently completed his doctorate study at the University of British Columbia, holds a Canadian patent on a method of "culturing cambium in a non-cylinder." In other words, he thinks he can produce flat trees. The 38-year-old native of Vancouver, British Columbia, has also applied for a patent for his technique of growing square trees. Flat boards sawed from a cylindrical trunk result in lots of waste, so Falls researched ways to change the trunk's shape. "You accelerate wood formation where you want the corners to be," he says matter-of-factly.

FIRST SAW WAS A SERPENT



Greek legend has it that Talus invented the first saw in 1,200 B.C., according to author Ronald S. Barlow. In his book, *The Antique Tool Collector's Guide to Value* (\$12.95, Windmill Publishing Co., El Cajon, Calif., 1985), Barlow says the ancient Greek discovered the principle of set saw teeth while severing a tree limb with the jawbone of a large serpent. He later reproduced the snake's teeth on a sheet of hammered iron. And the rest, as they say, is history.

PARTS FOR YESTERDAY'S TOOLS

When readers write to ask where they can buy parts for obsolete woodworking machines, we often can't provide much help. But we just met a guy who can, especially if you own an old DeWalt saw.

Chuck Wolfe owns and operates Wolfe Machinery in Johnston, Iowa, a business that sells new and used machinery. He carries a host of brand-name machines for both metal- and woodworking, but specializes in DeWalt radial-arm saws. "I've got parts for many old-model

DeWalts, and if I don't have a part, I can probably make it," Chuck says. For inquiries, write: *Wolfe Machinery, 6107 Merle Hay Rd., Johnston, IA 50131*. Call 800-345-6659 or 515/270-2766.

Other possible sources for old machines and parts are members of the Antique Woodworking Power Tool Association (AWPTA). To receive the bimonthly journal covering companies and equipment, send \$14 (U.S.) to AWPTA, P.O. Box 1027, *Connellsville, PA 15425*.

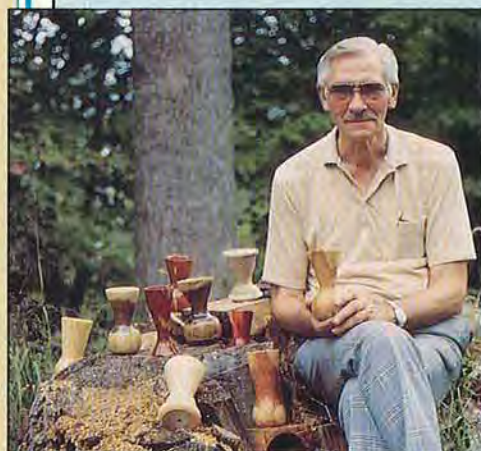

From his seat atop the stump of a storm-felled yellow poplar, Flay Terres points out some of the vessels he's turned from Hurricane Hugo's leftovers.

READER REAPS HUGO'S HARVEST

Flay Terres, of Gastonia, North Carolina, has only been working wood since his retirement in 1987 (he was a machinist for 40 years). Nevertheless, he earned a special citation in *WOOD* magazine's 1989 Design-A-Toy contest with his train engine. Now, he writes, he's taken up turning, and thanks to Hurricane Hugo, has a tremendous supply of wood.

"Because of your article on drying green bowls in the microwave [February 1990 issue, p. 46], I am now able to fulfill a lifetime dream. I can go into the woods, cut a chunk of green wood, and

turn it into a finished piece within a few days," Flay says in his letter. Since September 1989, when Hugo unleashed its devastation on the Carolinas, the late-blooming woodworker has tried to make a dent in the downed trees. We found out during a telephone call that he has over 40 vases turned from green wood. "I've turned poplar, apple, dogwood, sassafras, cedar, and even sumac," he notes. "People call me to pick up trees." Last September, on the first anniversary of the storm, Gastonia's public library displayed Flay's collection. 🌲

RYOBI PRESENTS "THE WORKAHOLICS™" OF NEW CORDLESS DRILLS.



ENGINEERED TO SET A NEW PERFORMANCE STANDARD FOR CORDLESS DRIVER/DRILLS. THE RYOBI 7.2V, 9.6V AND 12V TORQUE FORCE SERIES FEATURES BREAKTHROUGH MOTOR TECHNOLOGY TO DELIVER MORE POWER LONGER. A KEYLESS CHUCK, ELECTRIC BRAKE AND BUILT-IN BIT STORAGE ARE STANDARD. NEW ERGONOMIC DESIGN AND PRECISION ENGINEERING MEAN BALANCE, HANDLING EASE AND POWER SECOND TO NONE. SEE THE RYOBI RETAILER NEAR YOU.

RYOBI®

W O R K A H O L I C S

RYOBI AMERICA CORPORATION, 1424 PEARMAN DAIRY RD., ANDERSON, SC 29625

The Delta Stationary Plate Joiner makes you more productive.

What more can we say?



How about \$299?*

This is one impressive machine. At *any* price.

Even if you already own a portable, your shop isn't really complete without our stationary plate joiner. It's a workhorse that allows you to handle more work, quicker and more accurately.

It bolts right to your bench. And thanks to a spring-action foot pedal that controls blade movement, your hands are free to control your work and speed up the whole operation.

A die cast aluminum table supports your work. It raises, it lowers, it does whatever is necessary to handle the stock thickness. And it's slotted to handle an adjustable stock stop for repetitive operations.



You can handle any type cut you can imagine. With all three biscuit sizes. And all for a little less than you'd pay for a top brand portable.

For the name of your nearest Delta Distributor call toll free: 800/438-2486. *Or if you'd like a demonstration video, send a check or money order for \$5 to Delta International Machinery Corp., 246 Alpha Drive, Pittsburgh, PA 15238.*

*Offer good only from participating distributors in the continental U.S., Alaska and Hawaii from October 1, 1990 to April 30, 1991.

**Building
On Tradition**
DELTA
A Pentair Company