

Better Homes and Gardens®

# WOOD

THE #1 MAGAZINE FOR HOME WOODWORKERS

JANUARY 1991 • ISSUE NO.40  
Display until January 15

Make your own  
**LARGE-SCALE  
MOLDINGS**

**RESPIRATORS**  
What to look for

**WOOD TESTS 18**  
**SPRAY PAINTS**

**UNBEATABLE  
PROJECTS**

Carved duck plaque  
Wall-hung gun cabinet  
Shaker-style basket  
Center finder tool  
Country shadow box  
Split-turned vase  
Scrollsaw ornament  
Seascape puzzle

It's New!  
**THE  
CRAFT  
SHOP**

See page 66

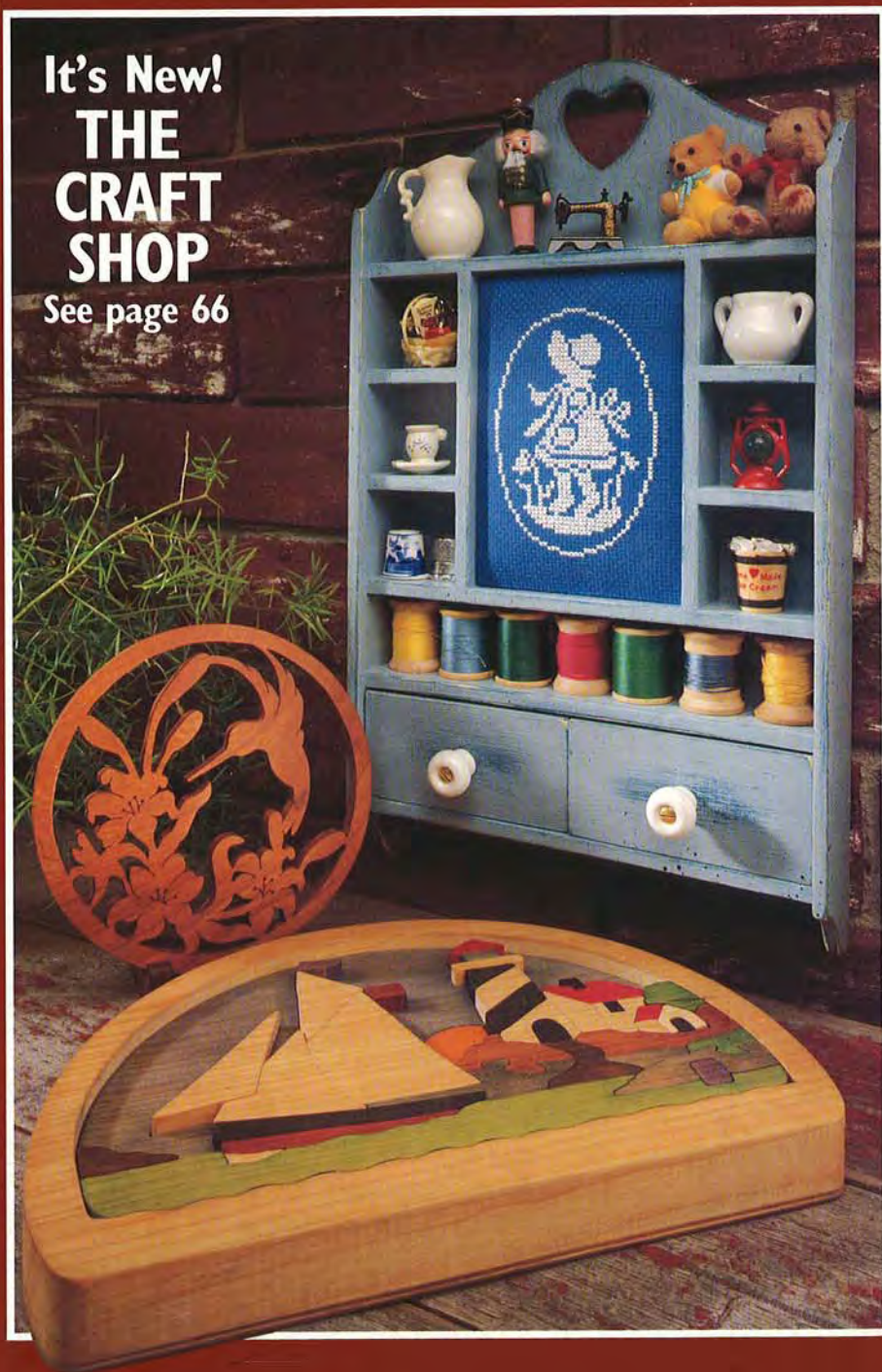

# Trend-Lines™

**FREE!**  
Pocket Hole  
Drill Guide  
With Every Order!

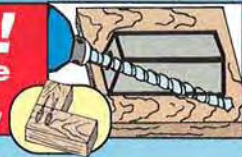

**A**  
**\$9.95**  
Value!

# SUPER SALE!

**1100 Dowels,  
Plugs & Buttons**

## 115 Pc Drill Bit Set

Now you can make exact size holes & save over \$300. You get 60 wire gauge bits size 1 to 60, 26 letter size bits A-Z, & 29 fractional standard size bits 1/16" to 1/2" in 64ths. High speed steel.

NN15 \$129.00



Now  
**\$59.95**

Packed with fluted dowels, hardwood plugs, & hardwood buttons. 1/4" dowels are 1 1/4" long, 5/16", 3/8", & 1/2" are 1 1/2" long. 1/2" dowels are 1 1/2" long. Buttons are 3/8" & 1/2" diameter. Round & flat head plugs are 1/4", 5/16", 3/8" & 1/2" dia.

YY1120 **SPECIAL VALUE**



Now  
**\$27.95**

## Router/Jig Saw Table

Get stationary tool accuracy, speed & control from our portable work table. Includes, safety guard, miter gauge, trammel point, and 1 & 2 piece fences. 18 5/8" x 12 3/8" high. Heavy duty Steel.

VA396 \$37.95



Now  
**\$29.95**

## Work Support

This 16 lb., cast iron base work support stays put. Raises up to 40" for accurate sawing, drilling or planing. Big 2 1/4" dia. ball-bearing smooth steel roller.

NNFM87 \$59.95



Now  
**\$49.95**

## Table Saw Fixture

Lets you make complicated cuts with complete safety. Machined to exact 90° angle with control knob. Mounts firmly in a standard 3/8" D, 3/4" W groove. Make raised panels, slots for splines and more!

BY12

**FREE \$12**  
Toggle clamp

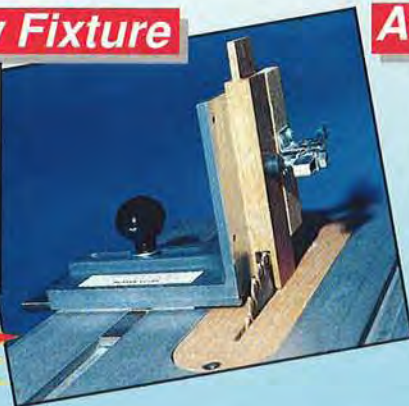

Now  
**\$69.95**

## Adjustable Dado

Carbide tipped adjustable dado makes clean 1/4" to 13/16" grooves. 6 1/2" diameter with a 5/8" arbor. 5000 RPM maximum.

AC300 **SUPER PRICE**



Now  
**\$39.95**

**MONEY BACK GUARANTEE: Examine any item Risk-Free for 30 days**



**Order Toll Free!**  
**800-767-9999**

**Or Send Your Order To:**

Trend-Lines Inc.,  
DEPT. WD11, 375 Beacham St.,  
Box 6447, Chelsea, MA 02150

DEPT. WD11  
Offer Expires 2/15/91



Add just \$4.00 shipping & Handling regardless of how many items you order!

**FREE**  
**CATALOG**  
**OFFER!**

Write today or call 1-800-366-6966 for your free Discount Woodworking Tools & Supplies Catalog

You'll find the best prices for over 3,000 brand name products. Included are power tools & accessories, hand tools, screws, hardware, wood components, plans, books, & much more.

**New!**

## Variable Speed Super V-15" Scroll Saw

• Dial any speed from 400 to 1800 cuts/min!

• Saws with similar features sell for over \$700  
• Special introductory price...

only **\$189.95**

(item #SVS, UPS \$10)

Cut intricate patterns in many different types of materials with this versatile machine. Purchase includes many FREE extras.

This new model features a powerful, high quality electronically controlled universal motor that gives full power and torque at all speeds. Similar in design to our Super-15" model, the cutting action has been re-engineered to give smoother cutting and performance equal to saws many times the price.

Dial any speed from 400 - 1800 cuts/min to set the speed specifically for the job at hand. Use slower speeds for cutting plastics, metals and hardwoods.



### FREE ACCESSORIES:

• Dust blower • 1 dz blades • EZ-Set permanent top-arm blade holder • 4 Standard blade holders • EZ Jig for attaching standard blade holders • Neptune 1-1/2" lettering guides w/6 patterns

### Specifications:

• Motor: Universal motor w/electronic speed control. 110V, 1.3Amp, sealed ball bearings  
• Speeds: 400 - 1800 cuts/min  
• Throat : 15" deep • Stroke - 3/4"  
• Tilt : 0 - 45° left • Cut Depth: 2"  
• Blades: accepts pin and plainend  
• Construction - cast iron

## Super 125 Planer On Sale .... \$359.95



This machine will pay for itself time and again by planing your own wood. Finishes wood like machines many times its price.

• Portable at 65 lbs • Power feed  
• 12 1/2" wide High Speed Steel Knives  
Shipped assembled and ready to run.

### SPECIFICATIONS:

Motor: 16Amp, 115V, 8000RPM, 2HP-26.2 fpm auto feed rate • 16,000 Cuts/min • Thickness of stock: 3/16" - 6" • 1/8" Max depth of cut • 2 HSS knives  
Item #PLA ..... \$359.95 (UPS \$15)

## Planer Accessories



Free plans for roller stand with purchase of rollers

### Extra Set of 2 Knives

High Speed steel, 12-1/2" long.  
Item #PKN .....\$25.00/set (+)

### Dust Chute

For vacuum takeoff of wood chips.  
#PDS ..(reg \$24), On Sale....\$15 (UPS \$3)

### Planer Stand (Heavy duty)

Drilled for Super 125 Planer. 27-1/4" High.  
#PST ...(Reg \$44), On Sale...\$39/ea (UPS \$6)

### Roller Stand

HTC brand support stand w/heavy duty ball bearing roller. Height adjusts from 25" - 44"  
#PRS ...(reg \$40), On Sale ...\$35 (UPS \$4)

### Ball Bearing Rollers

(Minimum purchase 2 rollers). Build a roller stand, infeed/outfeed table etc. with these 13" X 2" Heavy Duty rollers. Includes FREE plans for roller stand shown above.  
Item #BBR ..... \$6.50/ea (\$3 UPS /order)

## Scroll Saw Products

### Super 15" Scroll Saw

Our most popular model. Same specs as Super V-15 model with single speed 1650 cpm motor, dust blower optional. Same free accessories as listed above.

#SAW ... Only **\$119.95** (UPS \$10)

Dust Blower (option for Super 15" saw)  
#BKT ..... \$15.00/kit (+)

### Variable Speed Motor Upgrade

Convert your saw to variable speed! This quality motor will fit our Super 15" model and other saws of similar design. Also fits Sears<sup>(tm)</sup>16", and "C" arm "Superscroll" styles - 18", 22", and 26" sizes. Limited 90 day warranty on non-Penn State saws.  
#SVM .....Only **\$99.00** (UPS \$4)

### Magnifier Lamp

Great for magnifying scroll work or closeup work of any kind.

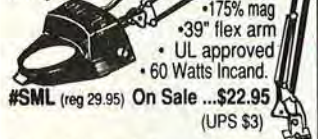

•175% mag  
•39" flex arm  
• UL approved  
• 60 Watts Incand.  
#SML (reg 29.95) On Sale ...**\$22.95** (UPS \$3)

### Scroll Saw Stand (On Sale)

34" High - the perfect height.  
#STD .. (reg \$39), On Sale **\$26** (UPS \$4)

### Foot Switch

For hands free operation. Installs in line w/power cord. Easy hook-up. 7 amp, 6 ft  
#FSW ..... **\$20.00** (+)

## Two Way Sanders



FREE DISCS & BELTS with Purchase  
Save up to \$21

• Dust Collection on both models  
• Stand included with 6 x 9 Model

### 6" x 9" Sander

Model #S69 ... Only **\$219.95** (UPS \$30)

Has versatile 9" disc & 6" x 48" belt. Heavy duty design includes stand.  
FREE With Purchase : 3 belts, 4 discs (various grits) worth \$21. Motor: 3/4 HP, 1720 RPM, 110/220V. Wt: 100 #

### 4" x 8" Sander

Model #S48 ... Only **\$114.95** (UPS \$8)

A unique design with an 8" disc & 4" x 36" belt. Portable at only 38 #, includes quick release lever for belt changes.  
FREE With Purchase - 3 belts, 4 discs (various grits) worth \$14. Motor: 1/3 HP, 1720 RPM, 120V. Wt: 38 #

### Features of Both Models:

• Dust collection outlets included.  
• Tables: tilt to 45°, includes mitre gauge, moves to vertical belt position.  
• Easy belt tracking adjustment.  
• Belt table tilts/locks to horiz & vert positions  
• Sealed ball bearings

## Dust Collectors

FREE HOSE & FITTINGS with PURCHASE  
Save up to **\$40.00!!**



Model #DC1

Model #DC-1 - Only **\$199.95** (UPS \$20)

610 CFM flow makes this collector perfect for hookups to almost any single machine.

FREE With Purchase (\$15 Value)  
8' of hose • 1 ea. 4" to 3" & 4" to 2" adaptor

Model #DC-2 - Only **\$299.95** (UPS \$30)

900 CFM flow allows for use on 2 or more machines & gives improved service for long runs of hose or ducting. Suitable for larger planers, drum & belt sanders  
FREE With Purchase (\$40 Value)  
30' of hose • (1) 4" to 3" & (2) 4" to 2" adaptors

Specifications:	DC-1	DC-2
Motor	1 HP, 110/220V	1-1/2 HP, 110/220V
Outlets	1 @ 4"	2 @ 4" or 1 @ 6"
Flow	610 CFM	900 CFM
Bags	2 @ 20 Gal.	2 @ 30 Gal.
Weight	75 pounds	120 pounds

## Penn State's Commitment

We unconditionally guarantee your satisfaction with our fine machines. All of our machines carry a Thirty day Money Back Guarantee and One year Warranty.

## Quality Woodworking Machines At Affordable Prices from

# PENN STATE INDUSTRIES - W

2850 Comly Road • Phila, Pa 19154

Order Toll Free 1-800-288-7297 (Ext 90) Information 1-215-676-7609 (ext 15)

Visa, Master, & Discover Card accepted Pa residents add 6% Sales Tax

When ordering - Add UPS Shipping Charges as noted

(+) No freight charge for accessories ordered with a machine, add \$3 if ordered separately. UPS charges are for Continental U.S. only (Call for shipping charges to other locations)

Call or Write for our NEW 16 Page Color Catalog



## Wood Lathe XL- 40

Reg \$299.95, On Sale **\$249.95**

Includes FREE 8 piece Wood Chisel Set ... \$34 Value

Our new XL-40 Wood Lathe surpasses every lathe in its price range with quality & features you would expect from machines many times its price. FEATURES .....

Heavy Duty cast iron construction provides smooth turning action • 40" Centers • 16" Swing for turning larger bowls • Smooth toolrest movement on 1" solid steel rails • "Live" center on tailstock • Motor mounted for easy positioning and belt changes • Sturdy 52" steel base mounts on table top or optional stand.

### PURCHASE INCLUDES:

• Lathe with Motor & Base • Toolrest  
• 6" Faceplate • 8 pc wood turning chisel set

### SPECIFICATIONS:

• MOTOR: 1720 RPM, 1/2HP, 8AMP, 110V  
• 3 Speeds: 660, 1500, 2850 RPM  
• Headstock thread - 3/4" X 10 tpi  
• Overall length: 60" - Weight : 100lbs  
Item # L40 ..... On Sale **\$249.95** (UPS \$20)

### Lathe Stand

Heavy duty. Wt. 25Lbs  
Size: 28"H X 56"L X 21" W  
Item #LST .... **\$44/ea** (UPS \$6)



# The Basics of Woodworking In a Compact Combination

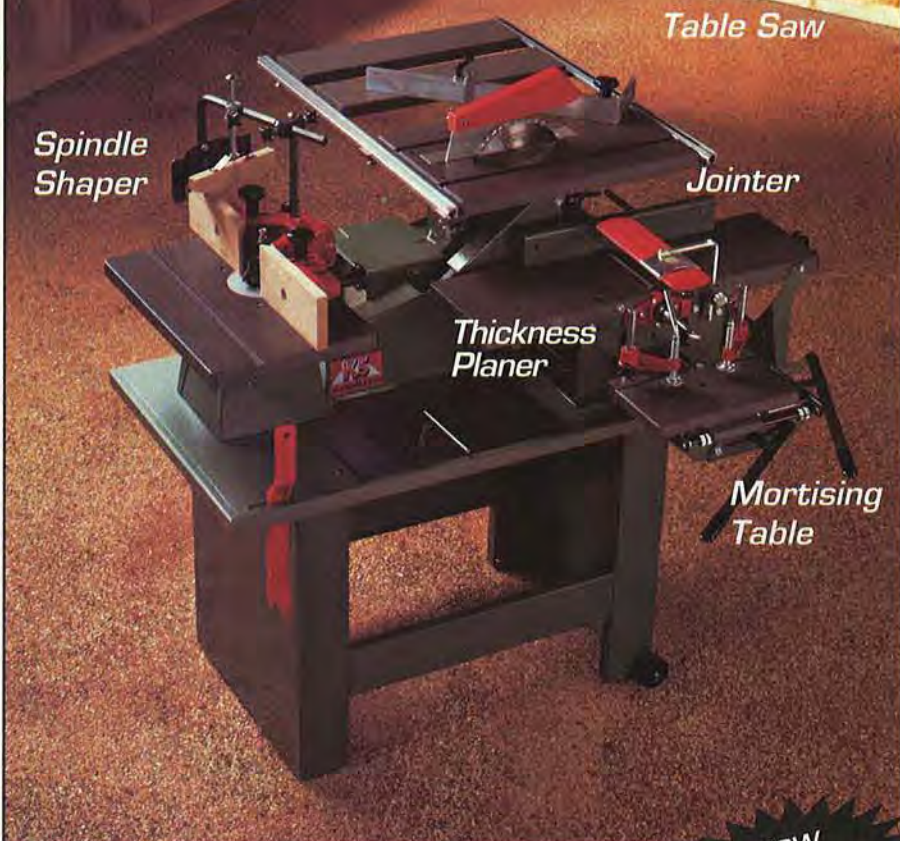

Table Saw

Spindle  
Shaper

Jointer

Thickness  
Planer

Mortising  
Table

## The Ideal Woodworking System For the Craftsmen of the '90's

**NOW  
Video Demo  
Only \$6<sup>95</sup>**

The "Craftsmen of the '90's" (according to the experts) will fall into one of three categories; Executives looking for a hobby that will relieve the stress associated with long hours at a desk, Artist/Entrepreneurs who will seek to prove that quality furniture and home accessories don't necessarily come from an assembly line (and that you really can be your own boss), and Retirees who want to stay active while creating things of beauty for family and friends (either for extra income or just for the fun of it).

The K-5 offers every woodworker (even the ones the experts forgot) a perfect blend of precision, capacity, space economy and reasonable price. Our engineers have avoided gimmicks like electronic readouts and bulky attachments in favor of dynamically balanced cutterheads and a simple, straightforward drive system. Whether you're just starting out, or making a change in your shop, call now to find out why the K-5 is the fastest growing system on the market today.

**New Video Demo Price! Just 6.95!**  
Call or Write for Video or Free Info.

**1-800-USA-KITY**

Farris Machinery  
320 N. 11th St. Dpt A191  
Blue Springs, MO 64015

Video Demonstration  
Includes \$25 Gift Certificate  
(6.95 Enclosed)

FREE Information Kit

Name \_\_\_\_\_

Address \_\_\_\_\_

City \_\_\_\_\_

State \_\_\_\_\_ ZIP \_\_\_\_\_ Phone (\_\_\_\_) \_\_\_\_\_



WOODWORKING MACHINES

# Better Homes and Gardens® WOOD®

THE #1 MAGAZINE FOR HOME WOODWORKERS

January 1991 • Vol. 8, No. 1 • Issue No. 40

### Editorial/Art Staff

Editor **LARRY CLAYTON**  
Managing Editor **JIM HARROLD**  
Art Director **C. L. GATZKE**  
Assistant Art Director **PERRY A. MCFARLIN**  
Design Editor **JAMES R. DOWNING**  
Senior Editor **PETER J. STEPHANO**  
How-To Editor **MARLEN KEMMET**  
Products/Techniques Editor **BILL KRIER**  
Special-Interest Editor **LARRY JOHNSTON**  
Copy/Production Editor **JOHN D. HOFHEIMER**  
Project Builder **JAMES E. BOELLING**  
Administrative Assistant **DARLENE REYNOLDS**  
Business Office Clerk **MARGARET CLOSNER**  
Secretary **ROSEMARIE BURCH**

Technical Consultants: Product Testing **GEORGE GRANSETH**;  
Products That Perform **STEVE OSWALT**; Wood Technology  
**PAUL L. McCLURE**; Collectible Tools **PHILIP WHITBY**  
Carving **HARLEY J. REFSAL**

Publisher **WILLIAM R. REED**  
Advertising Representatives **PAUL DaCRUZ, MARK S. JOSEPHSON, CHRIS W. SCHRIFT**  
Promotion/Research Director **EILEEN SULLIVAN**  
Marketing Services Manager **NANCY DALY**  
Marketing Services Assistant **CORINNE OLESON**  
Publisher's Assistant **LORIANN DeCICOPPO**  
Sales Secretary **ALICIA SANTANA**  
Circulation Director **CLEM SEVDE**; Circulation Manager **ALAN BRUSH**; Newsstand Circulation Director **MICHAEL SENIOR**  
Business Manager **TERRY UNSWORTH**  
Production Director **ROBERT C. FURSTENAU**  
Editorial Research Director **C. RAY DEATON**  
Public Relations **SONDY DAGGETT**

### Magazine Group Officers

Group President **JAMES A. AUTRY**  
Senior Vice President, Publishing Director **ADOLPH AUERBACHER**  
Group Vice Presidents: Publishing Directors **MYRNA BLYTH, BURTON H. BOERSMA, CHRISTOPHER M. LEHMAN**;  
Controller **MAX RUNCIMAN**; Editorial Director **DORIS EBY**;  
Operations **DEAN PIETERS**

### WE CARE!

**EDITORIAL MAILING ADDRESS:** WOOD Magazine, P.O. Box 11454, Des Moines, IA 50336-1454.

**SUBSCRIPTION SERVICE (including change of address):** WOOD Customer Service, P.O. Box 10628, Des Moines, IA 50336-0628.

Please enclose your address label from a recent issue. If you wish to phone, call toll-free 800-678-2666.

**ADVERTISING:** WOOD Magazine Advertising, 750 Third Ave., New York, NY 10017. Phone 212/557-6600, extension 6095.

Better Homes and Gardens® WOOD® — the #1 magazine for home woodworkers (ISSN-0743-894X) is published eight times a year in January, February, April, June, August, September, October, and December by Meredith Corporation, 1716 Locust St., Des Moines, IA 50336. Second-class postage paid at Des Moines, Iowa. Better Homes and Gardens trademark registered in Canada and Australia. Marca Registrada en Mexico. **ONE-YEAR SUBSCRIPTION PRICES:** United States and its possessions, \$19.97; Canada, \$29; other countries, \$38. **POSTMASTER:** Send address changes to WOOD, 1716 Locust St., Des Moines, IA 50336.

©COPYRIGHT MEREDITH CORPORATION 1990. ALL RIGHTS RESERVED. PRINTED IN U.S.A.



## CONTROL THE SPEED OF YOUR ROUTER - ROUT AT THE SPEED THAT GIVES THE BEST RESULTS WITH THE WOOD AND BIT YOU ARE USING!

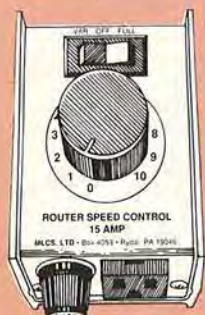

### FEATURES:

- Speed Adjustable from Full Speed to 0 RPM
- Full Horsepower and Torque at All Speeds
- Go Back and Forth from Any Pre-Set Speed to Full Speed at the Flip of a Switch
- Works with All Routers 3/4 HP or Less
- 120V 15 Amp
- Gives Your Router a Feature Only Available on Routers Costing Hundreds of Dollars!

NOW ONLY \$39.95 Order Item #200

- Less Tear Out
- Feed at Comfortable Rate
- Better, Safer Results with Large Diameter Bits
- Less Wear on Bits
- Less Noise and Softer Starts at Lower Speeds
- Stops Burning

**EASY TO USE** - Simply plug in Speed Control and plug your router into the Speed Control - turn dial for best results. (Speed Control has a clip that can be worn on your belt or hung on wall or left loose.)

• Reduces speed electronically without reducing torque; electronic feed-back maintains speed by increasing voltage to motor as load increases.

## CARBIDE TIPPED ROUTER BITS PROFESSIONAL PRODUCTION QUALITY GUARANTEED WHEN ORDERING ANY THREE OR MORE DEDUCT \$1.00 EACH. ALL PRICES ARE POSTAGE PAID

ITEM NO.	BEST CUT BEST PRICE	DESCRIPTION	ANGLE/DEPTH/RADIUS CIRCLE DIAMETER	LARGE DIA.	CUTTING LENGTH	SHANK SIZE	PRICE
#601		1/8" Spiral Cutter		1/8"	1/2"	1/4"	\$ 9.00
#602		3/16" Spiral Cutter		3/16"	5/8"	1/4"	\$12.00
#603	<b>Solid Carbide</b>	1/4" Spiral Cutter		1/4"	3/4"	1/4"	\$12.00
#903		1/4" Spiral Cutter		1/4"	3/4"	1/2"	\$12.00
#904		3/8" Spiral Cutter		3/8"	1"	1/2"	\$24.00
#905		1/2" Spiral Cutter	1/2"	1 1/2"	1/2"	\$29.00	
			*Proper Adaptor Will Be Supplied				
#350		1/8" Round Over	1/8" R	3/4"	3/8"	1/4"	\$11.00
#351		3/16" Round Over	3/16" R	7/8"	1/2"	1/4"	\$11.00
#230		1/4" Round Over	1/4" R	1"	1/2"	1/4"	\$12.00
#353		5/16" Round Over	5/16" R	1 1/8"	1/2"	1/4"	\$14.00
#209		3/8" Round Over	3/8" R	1 1/4"	5/8"	1/4"	\$15.00
#355		1/2" Round Over	1/2" R	1 1/2"	3/4"	1/4"	\$17.00
#656		3/4" Round Over	3/4" R	2"	7/8"	1/2"	\$21.00
#199		<b>Multiform Moulding</b>	Unlimited Patterns	2 1/4"	2"	1/2"	\$40.00
#340		1/8" Cove	1/8" R	5/8"	3/8"	1/4"	\$12.00
#205		1/4" Cove	1/4" R	1"	1/2"	1/4"	\$12.00
#206		3/8" Cove	3/8" R	1 1/4"	5/8"	1/4"	\$13.00
#207		1/2" Cove	1/2" R	1 1/2"	3/4"	1/4"	\$14.00
#208		3/4" Cove	3/4" R	1 7/8"	3/4"	1/2"	\$26.00
#460		1/4" Bull Nose	1/4" Dia. of Circle		3/8"	1/4"	\$14.00
#461		3/8" Bull Nose	3/8" Dia. of Circle		3/4"	1/4"	\$15.00
#462		1/2" Bull Nose	1/2" Dia. of Circle		7/8"	1/4"	\$16.00
#464		3/4" Bull Nose	3/4" Dia. of Circle		1 1/8"	1/4"	\$19.00
#506		1/2" Pattern	Flush Trim	1/2"	1"	1/4"	\$15.00
#507		5/8" Pattern	Flush Trim	3/8"	1"	1/4"	\$16.00
#508		3/4" Pattern	Flush Trim	3/4"	1"	1/4"	\$17.00
#366		1/8" Slot Cutter	3/8" Deep	1 1/4"	1/8"	1/4"	\$14.00
#368		1/4" Slot Cutter	3/8" Deep	1 1/4"	1/4"	1/4"	\$14.00
#204		3/8" Rabbeting	3/8" Deep	1 1/4"	1/2"	1/4"	\$13.00

ITEM NO.	BEST CUT BEST PRICE	DESCRIPTION	ANGLE/DEPTH/RADIUS CIRCLE DIAMETER	LARGE DIA.	CUTTING LENGTH	SHANK SIZE	PRICE
#210		1/4" Core Box	round nose	1/4"	1/4"	1/4"	\$ 9.00
#211		3/8" Core Box	round nose	3/8"	3/8"	1/4"	\$10.00
#212		1/2" Core Box	round nose	1/2"	1 1/2"	1/4"	\$13.00
#418		3/4" Core Box	round nose	3/4"	5/8"	1/4"	\$15.00
#213		1" Core Box	round nose	1"	3/4"	1/2"	\$17.00
#214		1/4" Straight	plunge cutting	1/4"	3/4"	1/4"	\$ 6.50
#215		5/16" Straight	plunge cutting	5/16"	1"	1/4"	\$ 6.50
#216		3/8" Straight	plunge cutting	3/8"	1"	1/4"	\$ 6.50
#217		7/16" Straight	plunge cutting	7/16"	1"	1/4"	\$ 6.50
#474		1/2" Straight	plunge cutting	1/2"	1"	1/4"	\$ 7.00
#775		1/2" Straight	plunge cutting	1/2"	2"	1/2"	\$14.00
#218		5/8" Straight	plunge cutting	5/8"	1"	1/4"	\$ 7.00
#219		3/4" Straight	plunge cutting	3/4"	1"	1/4"	\$ 9.50
#220		1" Straight	plunge cutting	1"	1 1/2"	1/2"	\$11.00
#500		3/8" Flush	Trimming	3/8"	1/2"	1/4"	\$ 7.00
#502		1/2" Flush	Trimming	1/2"	1/2"	1/4"	\$ 7.50
#503		1/2" Flush	Trimming	1/2"	1"	1/4"	\$ 8.50
#221		1/2" Flush	Trimming	1/2"	1 3/16"	1/2"	\$ 8.00
#545		Tongue & Groove	Straight	1 5/8"	1"	1/4"	\$29.00
#845		Tongue & Groove	Straight	1 5/8"	1"	1/2"	\$29.00
#546		Tongue & Groove	Wedge	1 9/16"	1"	1/4"	\$29.00
#846		Tongue & Groove	Wedge	1 5/8"	1"	1/2"	\$29.00
#450		1/8" Beading	1/8" R	3/4"	3/8"	1/4"	\$11.00
#451		3/16" Beading	3/16" R	7/8"	1/2"	1/4"	\$11.00
#233		1/4" Beading	1/4" R	1"	1/2"	1/4"	\$13.00
#453		5/16" Beading	5/16" R	1 1/8"	1/2"	1/4"	\$14.00
#454		3/8" Beading	3/8" R	1 1/4"	5/8"	1/4"	\$15.50
#455		1/2" Beading	1/2" R	1 1/2"	3/4"	1/4"	\$17.00
#530		3/16" Edge Beading	3/16" Dia. of Circle		1/2"	1/4"	\$15.00
#531		5/16" Edge Beading	5/16" Dia. of Circle		1/2"	1/4"	\$15.50

New 24-page catalogue now available, featuring hundreds of bits.

### MAKE BEAUTIFUL RAISED PANEL DOORS . . . WITH YOUR 1/4" ROUTER!

Professional production quality bit makes it quick and easy to produce matching rails and stiles — the panel raising bit with ball bearing guide makes the raised panel perfect every time.

Regular value Over \$150.00  
**SALE PRICE \$69.95 FOR COMPLETE SET**

ORDER ITEM # 554 for 1/4" Shank Set (Includes all bits shown below)

**RAIL & STILE SHAPER CUTTER**  
 Item #150 - \$49.95

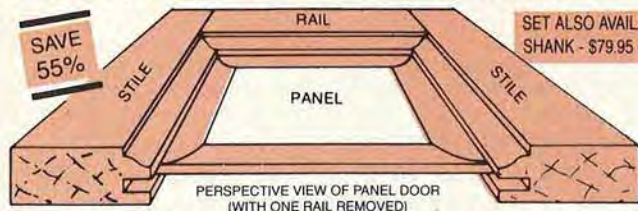

PERSPECTIVE VIEW OF PANEL DOOR (WITH ONE RAIL REMOVED)

SET ALSO AVAILABLE IN 1/2" SHANK - \$79.95 - Item #852

**RAISED PANEL BIT** SUPPLIED WITH BALL BEARING

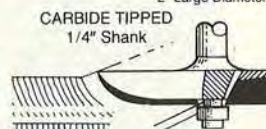

### REVERSIBLE COMBINATION RAIL and STILE BIT

(For making matching rails and stiles in raised panel doors, etc.) Works with stock from 1 1/16" to 7/8" thick



To order by Master Charge or Visa Call Toll Free, 7 Day - 24 Hour Order Service,

1-800-533-9298 or send check to: **MLCS Ltd., P.O. Box 4053DA, Rydal, PA 19046**

## Mobile Machine Bases

to put your entire shop  
on wheels

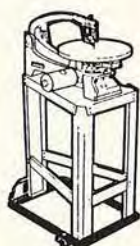
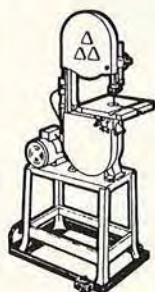
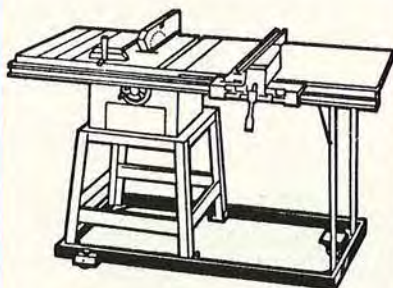

### EXPAND WORKING AREA MAKE CLEAN-UPS A SNAP

- Models available for every type, make & size of machine
- 3 - 2 1/2" ø Wheels for Stability
- Dual wheel locks for Positive Positioning
- Raises machine only 3/4"
- All Steel & Precision Welded
- Lifetime Warranty

All Products - Made in America &  
Available at Better Tool Stores

Free Catalog



**HTC Products, Inc.**  
120 E. Hudson • P.O. Box 839  
Royal Oak, Michigan 48068-0839

(313) 399-6185 • (800) 624-2027

Better Homes and Gardens®

# WOOD®

THE #1 MAGAZINE FOR HOME WOODWORKERS

This issue's cover wood grain: *Satinwood*

Cover photo: *Hopkins Associates*

JANUARY 1991

ISSUE NO. 40

WOOD PROFILE

## Black cherry: The poor man's mahogany 25

Today, cherry reigns as a princely hardwood. But years ago, furniture-makers regarded it as merely a substitute for Honduras mahogany.



## CRAFTSMAN CLOSE-UP 27 Boomer's people

Californian Bob Boomer carves a national reputation of excellence from gnarled manzanita limbs he scouts in the Sierra National Forest.

## SURVIVAL GUIDE 32 Respirators

Though shaping, sanding, and finishing add foreign particles to your workshop's air, you can breathe easier with the good news found here.



## Carve a canvasback 34

Our new carving department takes to the air with a sensational waterfowl relief.

## SHOP-TESTED TECHNIQUES 38 Large-scale moldings

Building large moldings doesn't require a lot of fancy jigs and tools. In fact, you can cut most profiles with a table saw.



## NOW YOU CAN BUILD IT Sharpshooter's showcase 44

Outdoor enthusiasts, here's a project you'll definitely want in your sights—our multi-featured oak gun cabinet.

## Waiting for the woodworking bus 52

In San Diego, young kids wait eagerly for a one-of-a-kind bus that brings Sheila Dawson's woodshop-on-wheels to their school.

## The Shaker oval carrier 54

Construct a bit of history in your shop when you successfully build a classic Shaker design from cherry.



## FINISH BUYMANSHIP Enamel spray paint 58

For those projects better suited for paint, you'll want to pore over this article to find out more about aerosol products.

## HOMEMADE TOOL Center finder 60

Welcome another member to our Collector's Edition of fine brass-and-walnut tools. This one will earn a place in your apron.



## Woodworking clubs 62

Some of the country's best woodworking groups offer advice on how to keep your club going and growing.

## TURNINGS Split-turned vase 64

Beginning this month, you'll find a turning article in every WOOD magazine. Here, try your gouge on a reader's novel design.

## CRAFT SHOP Nature in the round 66

Our new section of fun-to-make projects opens with a scrollsawed hummingbird.

## Country shadowbox 68

Here's the perfect eye-catcher for a display of thimbles and other small items.

## Relief puzzle 70

Set sail for a good time by scrollsawing a relief puzzle with the lure of the sea.



## Forest update 72

Booby-trapping trees, a spiteful sabotage practiced by so-called radical environmentalists in the Northwest, headlines our timber update.

### SHORT-SUBJECT FEATURES

Editor's Angle . . . . .	6	Great Ideas . . . . .	22
Talking Back . . . . .	8	Wood Anecdote . . . . .	23
Tips from Your Shop (And Ours) . . . . .	14	Old Hand Ways . . . . .	74

# Over 400 WOOD PARTS

Something for Everyone  
*Toy Builders!*



2-3/4" Spoke Wheel	\$ 1.00 / EA	\$10.00 / 12
1" x 5/16" Wheel	\$ 4.00 / 100	\$35.00 / 1000
1" x 3/8" Wheel	\$ 5.00 / 100	\$45.00 / 1000
1-1/2" Wheel	\$ 4.00 / 30	\$ 9.50 / 100
2" Wheel	\$ 3.10 / 12	\$16.00 / 100
Axle Pegs for above	\$ 3.50 / 100	\$30.00 / 1000
2-3/8" Little Man	\$ 1.40 / 7	\$12.00 / 100
1" Truck Tire	\$ 1.60 / 8	\$10.00 / 100
1-1/2" Truck Tire	\$ 2.40 / 8	\$14.00 / 100
1-5/8" Pickel Barrel	\$ 3.00 / 12	\$18.00 / 100

## Crafters!



1-5/8" Sawtooth Hanger	\$ 3.00 / 100	\$25.00 / 1000
2-3/4" Sawtooth Hanger	\$ 4.50 / 100	\$28.00 / 1000
5/8" Picture Hanger	\$ 2.00 / 100	\$15.00 / 1000
1-7/8" Picture Hanger	\$ 4.50 / 100	\$35.00 / 1000
3/8" Round Bead	\$ 3.25 / 100	\$22.50 / 1000
1/2" Round Bead	\$ 3.50 / 100	\$25.00 / 1000
1/2" x 5/8" Spool	\$ 5.00 / 100	\$20.00 / 500
5/8" x 3/4" Spool	\$ 6.50 / 100	\$27.50 / 500
2" Puffed Heart	\$ .60 / EA	\$12.00 / 25
2-1/2" Puffed Heart	\$ .75 / EA	\$15.00 / 25
2-1/2" Hen Egg	\$12.50 / 25	\$45.00 / 100
4-1/4" Goose Egg	\$ 3.00 / EA	\$30.00 / 12

## Woodworkers!



	BIRCH	OAK
1-3/8" Candle Cup	\$15.00 / 100	\$28.00 / 100
1/4" x 36" Dowel	\$18.00 / 100	\$25.00 / 100
1-3/4" Shaker Peg	\$ 5.00 / 100	\$10.00 / 100
3/8" Button	\$ 1.50 / 100	\$ 2.00 / 100
1/2" Button	\$ 1.50 / 100	\$ 2.00 / 100
1-1/2" Spindle	\$ 8.00 / 100	\$11.00 / 100
2" Spindle	\$14.00 / 100	\$18.00 / 100
5-3/4" Spindle	\$ .50 / EA	\$ .65 / EA
3-1/2" Shaker Peg	\$14.00 / 100	\$24.00 / 100
1" Round Knob	\$ 4.50 / 25	\$ 6.00 / 25

To receive sale prices use Sale #B11 ALL NEW WOOD PARTS CATALOG \$1.00

**FREE With Order**  
We accept M/C, VISA, Check, or M.O. All orders add \$4.00 Handling.  
TX add 7% tax. Canada add 30%, Alaska, Hawaii add 15% for freight.



P.O. Box 14507 Ft. Worth, TX 76117  
(817) 281-4447

# Exclusively Performax

## Precision Drum Sanders

Revolutionary Component Concept!  
It's Versatile....It's Expandable....  
and best of all....It's Affordable!

You select the components to fit your budget and your needs. The Performax S/T Sander attaches to a radial saw or to a Pro Stand.

### Patented Drum Design

dissipates heat for hours of steady use, offers greater strength and durability, dimension stock to within .01 of an inch.

Cantilevered 22" drum for 44" wide sanding.



### NEW Abrasive Take-Up Mechanism

keeps abrasive tight, accepts any grit of abrasive.

### No-Give Power Feed

offers infinitely variable feed rate of 0-10' or 0-20' /minute. Feed multiple pieces as short as 2 1/4" and the thinnest veneer.



### NEW Dual Drum Super Max

The only dual drum sander that lets you easily change grits for any abrasive combination.

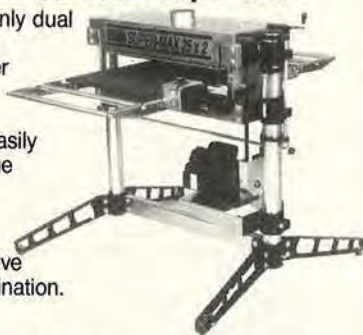

**For Maximum Performance  
and Maximum Value  
Buy a Performax.**

**It WILL exceed your expectations.**

For a Free Brochure and the Dealer Nearest You Call  
**1-800-334-4910**

or (612) 895-9922

or write: PERFORMAX PRODUCTS, W3  
12211 Woodlake Drive, Burnsville, MN 55337

## THE EDITOR'S ANGLE

# WELCOME TO THE

# NEW

# IMPROVED

# WOOD MAGAZINE

For the past several months, the staff and I have been working feverishly on our plan to increase the frequency of *WOOD* magazine to eight issues a year. It's been an exhilarating experience for all of us. After all, it's not often that a staff has the opportunity to increase a magazine's editorial coverage by a whopping 120 pages a year. Fortunately, your unyielding support of the product we produce has made this growth possible.

Here's what we've done. For all of you who have been asking us to publish more easy-to-build projects, we're unveiling a new six-page section called The Craft Shop. It's full of delightful items that you'll have fun making and then using yourself or giving as gifts. Over a year's time, that'll be about two dozen more projects for you to choose from. Take a look on pages

66-71 and see what you think of our premier effort.

But there's more! Our readers who love carving or woodturning will be pleased to learn that we're increasing our coverage in both of these areas, too. We'll have at least four pages devoted to carving and two pages of turning material in each issue. To make certain that we bring you the best possible information, we will be tapping into our network of carving and turning experts for help.

Well, there you have it—the "New, Improved" *WOOD* magazine. It's everything you have come to expect from us over the past six years plus some exciting innovations. Here's hoping you like the changes. If you have time, I'd like to hear what you think of them. Just drop me a note here at *WOOD* Magazine, P.O. Box 11454, Des Moines, IA 50336-1454. ♣

*Larry Clayton*



# Another "buy 1 tool get our 220 page tool free" offer.

Just a few of the unique woodworking tools of the 3,500 others available from our most versatile tool, the 1991 Garrett Wade Catalog.

The 220 page catalog is Free with any order from this ad. Or if you would just like the catalog, send us \$4.00 with your name and address.

## A / 2 Band Saw Books by Mark Duginske

Learn what makes your bandsaw tick. Tune-up and maintenance; blade selection, tracking and tensioning; plus cutting methods for various woods and other materials. Hundreds of tips and shortcuts. Unlock your saw's potential.

- 02L09.03 Band Saw Basics \$ 9.95  
16L04.02 Band Saw Handbook \$16.95

## B / The Saw Setting Gauge That Can Be Read From Any Position

Most gauges have at least one or two main weaknesses. They either rest partially on the insert plate which is usually not the same height as the main table, or are so thin that it is difficult to ensure that teeth are being gauged at the top of the arc. This gauge is made from machined 3/4" thick Aluminum and is 9" long. With 1/4" graduations on one end and 1/8" on the other, it will indicate any height from 1/8" to 2". Most useful for table saws but also handy for routers. The markings are vertical on one face and horizontal on the other, so you can read them easily and accurately.

- 71K26.02 Saw Setting Gauge \$16.95

## D / Our 202GF Gap Filling Glue Fills Gaps

It has a very high solids content so that small gaps in our joinery are actually filled - with strength. And the "squeeze-out" beads right up and chips off when dry. No soaking in to ruin finishes. Dries to a light tan. Water clean-up.

- 62J01.01 1 pt. 202GF \$ 6.95  
62J01.03 1 qt. 202GF \$12.50

## C / 1/16" Super Narrow Blades

You may have never seen a blade like this. A 24tpi raker style, it produces smooth cuts while making incredibly tight turns. We recommend using our Cool Blocks with these delicate blades, because they can be set closer to the blade without danger of overheating.

## Cabinetmaker's Special Bandsaw Blades

A Garrett Wade exclusive. They look like "skip tooth" blades. But each tooth is actually formed as a hook, with every 5th tooth an unset raker. The result is a very smooth cutting blade that feeds easily. 1/4" blade is for general work, and 1/2" for resawing and heavy straight sawing.

- 93 1/2" Blades (Delta 14" and copies)  
33K11.01 1/16" Scroll \$15.95  
33K11.02 1/4" (4 tpi) Cabiner \$11.95  
33K11.03 1/2" (3 tpi) Cabiner \$12.95

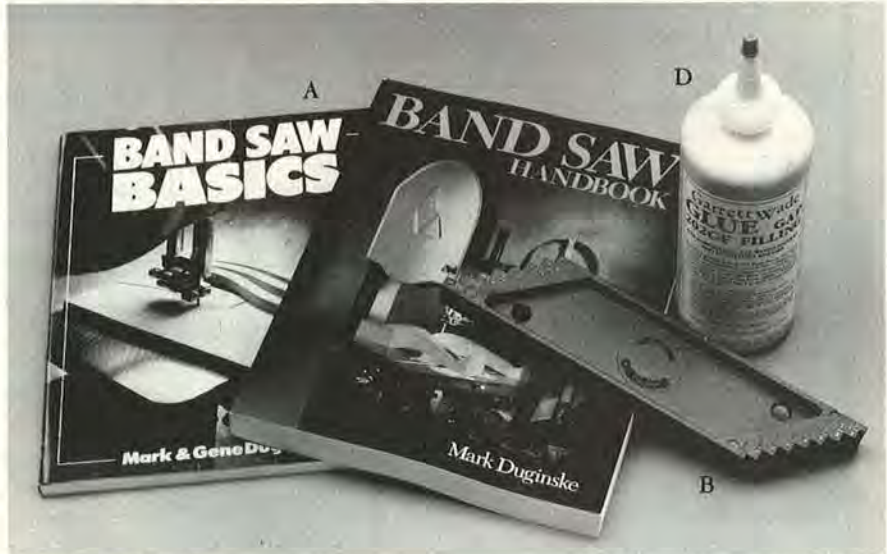

- 80" Blades (Sears 12")  
33K12.01 1/16" Scroll \$14.95  
33K12.02 1/4" Cabiner \$10.95  
33K12.03 1/2" Cabiner \$11.95  
72" Blades (Shopsmith)  
33K13.01 1/16" Scroll \$13.40  
33K13.02 1/4" Cabiner \$10.25  
33K13.03 1/2" Cabiner \$10.95

## E / The "Blind Nailer" Used To Be A Staple In Every Finish Carpenter's Tool Box

This unique tool allows you to set nails or brads invisibly. Slip the special chisel, with its finger nail shaped cutting edge, into the positioning jig and tighten the clamping screw. Place the flat sole on the wood and strike the end of the chisel with a firm tap with the palm of your hand. The Blind Nailer will lift a perfect small chip from the surface. Hammer your nail or brad in and then glue the chip back in place.

- 44K01.03 Blind Nailer \$15.95

## F / Special Bandsaw "Cool Blocks" Prolong Blade Life & Increase Accuracy

Made of a special graphite impregnated Phenolic laminate, this set of 4 replaces your upper and lower side blade guides. Cool Blocks run cooler and are more slippery than conventional steel guides. Since they can be set actually touching the blade, they give you better control of the cut.

- Model  
33K09.01 "A" Delta 14" \$11.95  
33K09.02 "B" Sears 12" \$11.95  
33K09.04 "D" Shopsmith \$12.95  
33K09.05 "E" Old Sears (1/4" Rd.) \$11.95  
33K09.06 "F" Jet 14" (fits Delta copies) \$11.95  
33K09.20 "K" New Tilt-Head Sears \$16.95

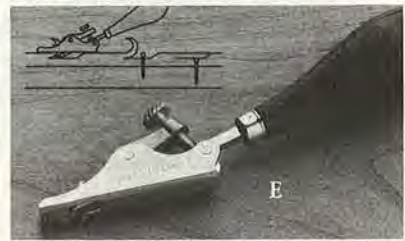
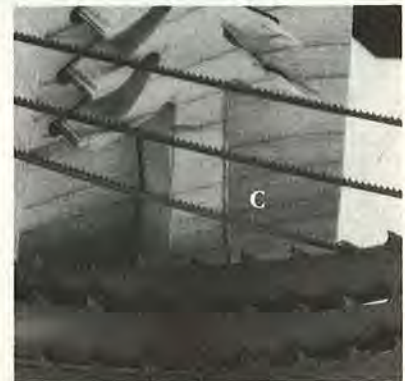

## Garrett Wade Co., Inc.

161 Avenue of the Americas  
New York, NY 10013 Dept. 123  
Call Toll Free 800-221-2942  
(NY 212-807-1757 No Collect Calls Please)



Please send me these Garrett Wade tools and include a FREE 1991 Catalog with my order. (Prices good until September 14, 1991)

Name: \_\_\_\_\_

Address: \_\_\_\_\_

City: \_\_\_\_\_ State: \_\_\_\_\_ Zip: \_\_\_\_\_

Check or Money Order Card Number

Visa  MasterCard

American Express

Expiration Date \_\_\_\_\_

STOCK #	QTY.	DESCRIPTION	PRICE	TOTAL
GW	1	1991 Catalog (free with order from this ad)	\$4 00	

New York Residents add applicable Sales Tax  
Shipping & Handling: \$2.90 for order total up to \$10  
\$4.10 for \$10.01 to \$20  
\$4.95 for \$20.01 to \$50  
\$6.25 for over \$50

Sub Total  
Sales Tax  
Shipping  
Grand Total

# CASCADE TOOLS, INC.

P.O. Box 3110, Bellingham, WA 98227

## ACCESSORIES



### BRAD DRIVER

Hold and set brads with this simple but effective tool. Just squeeze and you're done!

PART NO. C3078

ONLY \$7<sup>95</sup>

PUSH BRADS IN  
THE EASY WAY!

### BEARING LUBRICANT

Made by Dri-Cote, this lubricant protects and lubricates bearings and bearing mechanisms. Especially effective on router bit bearings and rub collars.

- Effective to 550°F!
- Repels dirt and moisture.

PART NO. C3074 ONLY \$3<sup>45</sup> (1.7 oz. Dropper-tip Bottle)



### FENCE FOR INCRA JIGS™

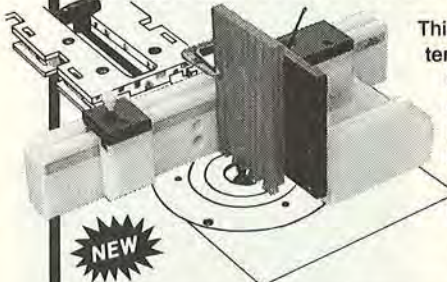

This unique fence system attaches directly to your jig and is used in making all kinds of joints. You'll love it!

PART NO. C3009

ONLY \$54<sup>95</sup>



### RIGHT ARM CLAMP

This clamp is a real gem. Its secret is its pivoting arm which squares the work for perfect gluing, joining and fastening.

- Opens up to 1 1/2".
- Clamp is approximately 6" long.

PART NO. C3029

ONLY \$10<sup>00</sup> or 6 for ONLY \$55<sup>00</sup>



### SUPER BRAD NAILER



This light weight pneumatic nailer drives 18 gauge brads from 5/8" to 1-9/16" into almost any kind of wood. Excellent choice!

PART NO. C3082

ONLY \$129<sup>95</sup>

### BISCUITS FOR JOINING WITH ROUTER

Why buy a biscuit-cutting machine when a small router will do?  
3 sizes in bags of 100...

PART NO. C3021 \$4<sup>95</sup>

(Size "0" - use C1042 bit - \$12)

PART NO. C3022 \$4<sup>95</sup>

(Size "10" - use C1098 bit - \$22)

PART NO. C3023 \$4<sup>95</sup>

(Size "20" - use C1098 bit - \$22)



TO ORDER, CALL TOLL FREE

1-800-235-0272



90C-111

## TALKING BACK

We welcome comments, criticisms, suggestions, and even compliments. Send your correspondence to: Letters Editor, Better Homes and Gardens® WOOD® Magazine, P.O. Box 11454, Des Moines, IA 50336-1454.

### Mystery lines revealed

While reading pages 22 and 23 in your October issue [issue 38], I came across a line that left me in the dark. At the bottom of the Tips column, you say, "Now, cover the replacement parts with dirty..." and then continue to the next page. Something's missing. I enjoy the magazine and find the tips very helpful.

—John Cooper, Owosso, Mich.

Well, John, the truth is we have mischievous gremlins lurking around in the wee hours eating bits and pieces of our copy. Just kidding, of course, but to help you and other readers fill in the missing copy, insert the following sentences into your issue 38. "...stripping agent and that will speed the aging process of your new parts. About the third time you do this, you won't be able to distinguish the new part from the old ones."

Sorry for the inconvenience. We'll work to do better the next time around.

### Second take on Penn State tools

In your October issue on power tools, you failed to identify some significant additions and improvements to our product line. Our Super-15" scrollsaw (model Super-V15") where speeds from 400-1800 cuts per minute may be dialed from the motor. This model is priced at \$189.95 and offers a dust blower as a standard feature. Significant additions to our single speed Super-15" model (also found with the Super-V15 model) include improved cutting action (with less vibration), a permanent top arm blade holder system to simplify making internal cuts, a new jig to assist mounting blades in standard blade holders, plus free lettering guides and blades. The Super-15 model sells for \$119.95 without the dust blower. Our Super 125 planer was reviewed in your April 1990 issue but was omitted from your summary of thickness planers. It has two 12 1/2" knives, makes 1600 cuts per minute, and features an auto-feed of 26 feet per minute. The unit sells for \$359.95. Also excluded from the power tool issue was our XL-40 wood lathe. It has 40" centers and a 16" swing. The motor is 1/2 horsepower with three speeds, and the tailstock includes a live center. A free 6" faceplate and an 8-piece wood chisel set is included with the purchase. The price is \$249.95, plus \$44.00 for the optional stand.

—Ed Levy, Penn State Industries, Phila., Pa.

Continued on page 11

# DISCOVER THE SECRETS OF THE TURN-OF-THE-CENTURY CABINETMAKERS!

**Build more than 50 American Country Furniture classics—as skillfully as the old masters—with tools you already own!**

Now it's easier than ever to create classic American country furniture—with the simple, step-by-step plans and procedures in this giant 420-page volume!

With AMERICAN COUNTRY FURNITURE at your workbench, you can now build more than 50 pieces of classic furniture as skillfully as the old masters—with tools you already have in your workshop!

**Here's everything you need—step-by-step plans and exclusive woodworking secrets!**

Let renowned cabinetmaker David T. Smith and the woodworkers at Rodale Press show you how to make these beautiful pieces:

- A stunning Porringer table with country cabriole legs.
- A handsome Shaker chest of drawers.
- A rare Pie Safe Cupboard.
- A Shaker candlestand
- And many more—a Pencil Post Bed . . . Queen Anne Side Chair . . . Corner Table . . . Herb Cupboard . . . Book Shelf . . . and still more—50 great-looking pieces!



**OVER 50 PROJECTS, many never before published!**

**MORE THAN 200 PHOTOS of finished projects from every angle!**

**STEP-BY-STEP DIRECTIONS take the mystery out of fine woodworking!**

**EXPLODED ILLUSTRATIONS to show you exactly what to do and when!**

**HUNDREDS of woodworking hints, tips and techniques!**

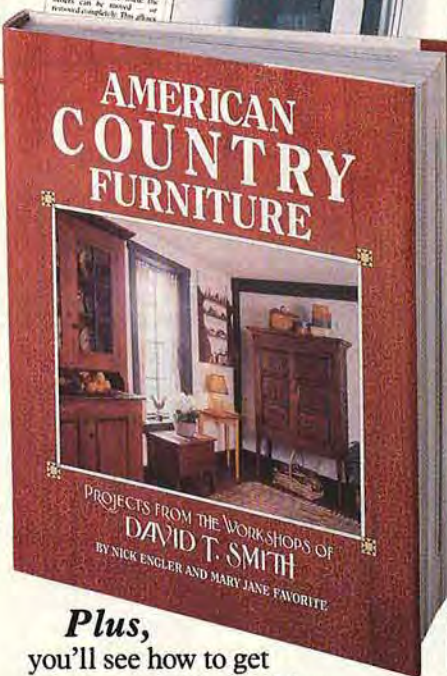

**Plus,** you'll see how to get museum quality finishes . . . simple steps for handcutting dovetails . . . the easy way to join a tabletop and leaves . . . and more!

Try AMERICAN COUNTRY FURNITURE—without risk—and get FREE plans for the 12 best woodworking jigs we know! Order your copy today!

## EXCLUSIVE FREE GIFT OFFER!

**YES!** Please rush my free copy of 12 Easy-to-Make Jigs for Precision Woodworking and send AMERICAN COUNTRY FURNITURE for a 21-day FREE examination. If I decide to keep the book, I'll pay three interest-free installments of \$9.98 (\$11.98 CDN funds) each, plus postage and handling. Otherwise, I'll return the book with the invoice within 21 days and owe nothing. Either way, the free jigs book is mine to keep.

**SAVE CASH!** Send \$29.95 (\$35.95 CDN funds) payment now and we'll pay postage and handling charges. Same return privileges as above. 42396

**FREE!**

## The 12 most useful JIGS ever invented!

Now your mortising can be more precise . . . your miter cuts faster . . . your tapers more uniform . . . and much more!

It's all possible with the build-it-yourself jigs outlined in 12 Easy-to-Make Jigs for Precision Woodworking. You'll receive this book free, as our "thank you" gift for trying AMERICAN COUNTRY FURNITURE. Order your copy today!



NAME \_\_\_\_\_

ADDRESS \_\_\_\_\_ APT. # \_\_\_\_\_

CITY \_\_\_\_\_

STATE \_\_\_\_\_ ZIP \_\_\_\_\_

(NOTE: PA, NY, CA and IL residents please add sales tax.)

Clip and mail to:  
**RODALE BOOKS, Emmaus, PA 18098**

# Forstner Bit **SPECTACULAR**

Quality, imported Forstner Bits make glass smooth, flat bottom, clean holes, even through veneer, knots, and end grain, in any direction. Indispensable for furniture making. Will bore any arc of a circle, make pocket and blind holes and even make overlapping holes for mortising.



**ONLY \$28<sup>99</sup>**  
**7-Pc. Set #77571**  
 1/4" to 1" In Wooden Case

- Precision ground, quality bits
- Machined from high-carbon steel
- Hardened to HRC 50-52
- Reusable moulded covers protect rims



**ONLY \$33<sup>99</sup>**

**3" Forstner Bit**  
**1/2" Shank**  
 #77591

**22-Pc. Taper Drill Set**  
**Sturdy Wooden Case #12232 \$27<sup>50</sup>**  
 • 7 Tapered bits • 7 Adjustable stop collars  
 • 7 Countersinks/ • Single-twist design  
 Counterbores • Sizes #5, 6, 7, 8, 9, 10, & 12



**25-Pc. Brad Point Drill Set**  
 Fits any 3/8" or larger chuck. Includes FREE metal index.  
 #77611 **\$28<sup>00</sup>**  
 2 or more sets **\$25<sup>00</sup> ea.**

**Complete 16-Pc. Set**  
**\$88<sup>99</sup>**



#77581

**Call Toll Free:**  
**800-345-2396**

Order Mon. through Sat. 8:30 to 5:00  
 Ask for Tool Order Dept.

**Or Mail to:**

940 West Maple St., Hartville, Ohio 44632  
 \$3.00 Ship/Handling Charge on All Orders  
 In state, please add 5% sales tax

**HARTVILLE TRUE VALUE**

**Tool and Supply Inc.**



IMPORTS, INC.



### STAPLER

An excellent, lightweight unit that is very well balanced. Weighs only 2.5 lbs! Comes complete with safety (not shown). Takes 1/2" to 7/8" staples.

**MODEL G1847**  
**ONLY \$89<sup>95</sup>**



### DRAFTING BOARD

Fits easily on desk, table, counter-top or lap and allows you to quickly lay out your plans! Comes complete with vinyl carrying case.

**MODEL G1303**  
**ONLY \$39<sup>95</sup>**

**G1304 Drafting Head ONLY \$19<sup>95</sup>**



### BRAD NAILER

A favorite for casing and finish carpentry work. Nicely balanced and weighs only 2.62 lbs. Comes with safety. Takes 3/8" to 1-3/16" nails.

**MODEL G1852**  
**ONLY \$99<sup>95</sup>**



### FEATHERBOARD

Locks everything safely and securely into place. Works as an anti-kickback device — prevents material from raising up off the blade.

**MODEL G1312**  
**ONLY \$18<sup>95</sup>**



### SUPER BRAD NAILER

The best all-around finishing gun with safety. Well-balanced, lightweight — weighs only 3.3 lbs. Takes 5/8" to 1-9/16" nails.

**MODEL G1861**  
**ONLY \$129<sup>95</sup>**



### EZE-ANGLE GUIDE

Cut 160 different angles with no saw adjustment! Use on your radial arm saw!

**MODEL G1256**  
**ONLY \$19<sup>95</sup>**

**CALL FOR YOUR FREE CATALOG!**

**1-800-541-5537**

(West of the Mississippi)

**1-800-523-4777**

(East of the Mississippi)

90-108

# TALKING BACK

Continued from page 8

## Enough tools already

I was disappointed in your October issue [issue 38] of WOOD magazine. I subscribed for the purpose of receiving issues full of regular and interesting wood-working articles, not power tool evaluations. Is this going to be the format for the future? If so, then let me off the wagon.

—Dan Rutledge, Converse, TX

Dan, we've had a few other responses like yours, which means that an explanation is in order. The special tool issue of WOOD was a free bonus issue as described in *The Editor's Angle* on page 7. We are not planning to do a tool guide of this sort in WOOD's new eight-issues-per-year format. We did think, however, that while we were making the switch readers might enjoy a change of pace, especially if they were in the process of making a major tool purchase.

## The answer is not blowing in the wind

On page 24 of your issue 38, reader Mike Atkins of Shell Beach, California suggested turning your compressor outlet pressure down to 20 psi to "dust yourself off." He also stated that the "air can get into cuts and lift up the skin. Ouch!"

At the paper mill where I'm employed, safety is a "big" item. Safety meetings, safety contests, safety bulletins, safety training, and a safety supervisor are all part of my environment. And again and again, it's been stressed to us to never use compressed air to dust yourself off. An air bubble may enter the bloodstream at a cut, and "ouch" in this case could mean death, or at the least a company penalty of time off without pay.

Instead, when at home I use a soft bristled brush to dust myself off, and then head to my basement to wash. Thanks for listening.

—Don I. Rathke, Friendship, Wis.

Don, on behalf of all of our readers, thanks for the strong warning and advice. About a day or two after you wrote, we received a second letter on this subject from Joe Snyder of Safford, Arizona. He also claims that a company he worked for docked employees for dusting off with an air hose. Instead, he recommends cleaning up with a shop vacuum. Dusting off is a dangerous practice well worth avoiding.

Continued on page 13



# ★ SANDPAPER ★

NO GIMMICKS — GREAT PRICES

BELTS: GRITS ASSORTED		SHEETS: (9 x 11) PRICE	
UNLESS OTHERWISE SPECIFIED			
1 x 30	\$ .69 ea	3 x 24	\$ .80 ea
1 x 42	.69 ea	3 x 27	.83 ea
1 x 44	.69 ea	4 x 21 1/4	.91 ea
2 1/2 x 16	.73 ea	4 x 24	.94 ea
3 x 18	.74 ea	4 x 36	1.14 ea
3 x 21	.77 ea	6 x 48	2.98 ea
3 x 23 1/4	.80 ea	2 1/4 x 80	2.47 ea
OTHER SIZES ON REQUEST			
NO LOAD PAPER		FINISHING PAPER	
	50/pk	100/pk	50/pk 100/pk
180-A thru 400-A	\$10/pk	\$18/pk	80-A \$ 9/pk \$16/pk
			100 thru 280A 8/pk 14/pk
PRESSURE SENSITIVE		WET/DRY PAPER	
ADHESIVE DISCS!		50/pk 100/pk	
			220 thru 600A \$13/pk \$23/pk
6"	\$1.06 ea	★ OTHER ITEMS ★	★ JUMBO CLEANING STICK \$8.80 ★
8"	1.99 ea	★ WIDE BELTS	
9"	2.46 ea	★ ROLLS	
10"	3.05 ea	★ FLAP WHEELS	
12"	4.45 ea	★ PUMP SLEEVES	
15"	6.95 ea		

**ECON-ABRASIVES**  
**P.O. BOX B865021**  
**PLANO, TX 75086**  
 IN TEXAS 214-377-9779  
 OUTSIDE TEXAS 1-800-367-4101  
 TEXAS AND NEVADA RESIDENTS ADD STATE TAX  
 CONTINENTAL U.S. SHIPPING CHARGES ADD \$425

## New! Conveyor Drive DRUM SANDER with Infinitely Variable Power Feed!



At last! A complete power-feed Drum Sander at an affordable price! Choose from 26" and 38" models. SAVES TIME... IMPROVES RESULTS.

Use this high-tolerance machine for light dimensioning as well as the finest finish work. Now you can add new beauty to each woodworking project...save hours of tedious hand sanding! In a matter of seconds you can produce a satin-smooth finish impossible to duplicate with hand methods or hand-held power sanders...no more low spots, waves or cross-grain marks!

**FREE FACTS!** Send for complete facts on how you can try this low-cost tool in your own shop for one full month without risk. See how the sander can dimension and finish-sand cabinet pieces, resawn stock, paneling, toys, tabletops, knees, burls, crotches and much, much more! Made in U.S.A. Easy Terms.

Call Toll Free 1(800)821-6651, Ext. RW42

- ✓ **NEW INFINITELY VARIABLE CONVEYOR FEED** gives you total control...eliminates oversanding at first and last few inches of a board!
- ✓ **NEW FELT-BACKED ABRASIVE** mounts in just seconds to Velcro covered drum! The harder you sand, the tighter it stays! Eliminates stretching...allows fast removal and re-use!

**FREE FACTS**  **YES!** Please rush my **FREE INFORMATION KIT** and details on your 30-Day Free Trial Guarantee.

Woodmaster Tools, Dept. RW42  
 2908 Oak, Kansas City, MO 64108

NAME \_\_\_\_\_  
 ADDRESS \_\_\_\_\_  
 CITY \_\_\_\_\_  
 STATE \_\_\_\_\_ ZIP \_\_\_\_\_

# Test Our Bits & Cutters

At no obligation with our no-risk 30 day trial

Order the tool you want to try out. If it is not exactly to your satisfaction, send it back and we will replace it or immediately refund your money. You pay only a small non-refundable shipping charge on items returned.



**FREE** \* Complete catalog sent upon your request  
\* Plastic caliper for any order (\$4.00 value)

**Toll Free**  
**1-800-782-6629**

**PRECISION TOOLS FOR SKILLFUL WOODWORKERS.**  
**INDUSTRIAL QUALITY CARBIDE TIPPED ROUTER BITS**  
**AND SHAPER CUTTERS.**

CUTTER	ORDER #	CUT DIA	CUT L	SNK D.	PRICE
Straight	ST206	1/4	3/4	1/4	5.50
	ST210	3/8	1	1/4	5.50
	ST213	1/2	1	1/4	5.50
	ST413E	1/2	2	1/2	14.00
	ST216	5/8	1	1/4	5.90
Flush Trim	ST219	3/4	1	1/4	8.50
	ST425	1	1 3/16	1/2	8.80
	FT210	3/8	1	1/4	6.50
	FT213	1/2	1	1/4	6.50
Dovetail	FT413	1/2	1 3/16	1/2	6.50
	DV210	3/8	3/8	1/4	4.60
	DV213	1/2	1/2	1/4	4.60
	DV413	1/2	1/2	1/2	4.60
Core Box	DV419	3/4	7/8	1/2	6.50
	DV425	1	7/8	1/2	7.50
	CB206	1/4	1/4	1/4	8.00
	CB210	3/8	5/16	1/4	9.00
45° Chamfer	CB213	1/2	3/8	1/4	11.00
	CB219	3/4	1/2	1/4	14.00
	CB425	1	5/8	1/2	16.00
	CH213	1 3/16	1/2	1/4	12.00
Rabbet	CH216	1 3/8	5/8	1/4	13.00
	CH422	1 7/8	7/8	1/2	18.00
Rounding Over	RB232	1 1/4	1/2	1/4	12.00
	RB432	1 1/4	1/2	1/2	12.00
	<b>RADIUS</b>				
	CR203	1/8	3/8	1/4	10.00
	CR205	3/16	7/16	1/4	10.00
	CR206	1/4	1/2	1/4	11.50
	CR210	3/8	5/8	1/4	14.00
Roman Ogee	CR213	1/2	3/4	1/4	16.00
	CR419	3/4	1	1/2	20.00
	CR425	1	1 1/4	1/2	32.00
	RO204	5/32	15/32	1/4	15.00
Cove	RO206	1/4	3/4	1/4	16.00
	RO406	1/4	3/4	1/2	16.00
	CV203	1/8	3/8	1/4	11.00
	CV206	1/4	1/2	1/4	11.00
Classical	CV210	3/8	9/16	1/4	12.00
	CV213	1/2	5/8	1/4	13.00
	CV419	3/4	3/4	1/2	25.00
	CS206	1/4	5/8	1/4	19.00
	CS406	1/4	5/8	1/2	19.00

**LOCK MITRE**  
ML470 \$34  
1/2" shank

**STILE & RAIL**  
**Reversible**  
RS248  
1/4" shank \$37  
RS448  
1/2" shank \$37

**OGEE FILET**  
OF466  
1/2" shank  
O.D. 2 1/2"  
\$24

**KEY HOLE**  
KH210  
1/4" shank  
\$6.50

**DRAW PULL**  
DP435  
1/2" shank \$29

**SLOT CUTTERS**  
SL204  
1/4" shank \$16  
SL404  
1/2" shank \$16  
6 others  
in our free catalog

**FINGER JOINTER**  
FJ463  
1/2" shank \$53

**TONGUE & GROOVE**  
TG230  
1/4" shank \$29  
TG444  
1/2" shank \$29

**MULTI-MOULDING**  
MM454  
1/2" shank \$39

**SAVE \$10.00**  
**5PC WOODWORKING KIT**  
1. AUTO CENTER PUNCH  
2. SCRIBER W/MAGNETIC PICK UP  
3. STEEL RAFTER & CARPENTER SQUARE  
4. PLASTIC STEEL CALIPERS  
5. 6" 3 WAY HAND SAW  
**\$14.99**

**PANEL RAISER**  
**\$49**  
EACH

**HORIZONTAL PANEL RAISING**  
5" O.D. 3/4" Bore  
3mm Carbide

We stock more than 50 types of 3-wing shaper cutters

**Top of the line** **Made in U.S.A.**

**Nicholson**  
10" 60T \$39.99  
10" 36T \$18.10  
10" 40T \$26.89  
Retail values up to \$60

**Carbide Tipped**

**NEW PRODUCTS**  
2-piece Stile & Rail -- \$69 a set

**15 PC Router Bits Set**  
**\$109.99**  
WOOD CASE INCLUDED / \$12.00 Value

**SAVE 30%**

**All 2 Flute Carbide Tipped.**

1/4" Shank Only

Most popular bits are selected in this set  
*Ideal Gift for woodmakers*

**SHAPER CUTTERS — Your Choice** **\$29.00 each**

1/4" & 1/2" OR. RD. **C905** FEMALE SASH **C975** OGEE & BEAD **C993**

1/8" & 3/8" OR. RD. & 1/4" BEAD **C952** MALE SASH **C976** OGEE **C906**

**SHAPER CUTTERS / CABINET SETS**  
**SAVE \$10.00** **3/4" BORE BUSHED TO 1/2"**

**FOR TWO SIDES.** Decorative design work thickness 1 1/8" — 1 3/4" **\$150**

**FOR ONE SIDE** Decorative design work thickness 1 1/8" — 3/4" **\$140**

**C921** CABINET MOULDING SET **\$160**

**C922** COVE & BEAD SET

**C940** CONCAVE STILE & RAIL SET **\$140**

**C994** OGEE STILE & RAIL SET **\$140**

**C945** CONVEX STILE & RAIL SET

**SAME DAY SHIPPING** Count on us!

Shipping is FREE for orders over \$60 and is only \$2 for smaller orders.

Call us toll free

1-800-782-6629 or 1-(619) 535-8940 in CA

HOURS: MON thru FRI 7 AM to 6 PM

NEW: SAT 8 AM — 2 PM

Send your check to: 12655 Danielson Court, Suite 310  
P.O. Box 520, Poway, CA 92064  
Member of the Better Business Bureau

# TALKING BACK

Continued from page 11

## The silicone solution

My wife was delighted with the "Autumn Delight Necklace" featured in the September issue [issue 37], and asked that I make several. I made a couple necklaces using different types of woods (walnut, purple heart, and mahogany), and Watco natural oil before spraying with Deft gloss clear wood finish. She thought using the different woods made the necklaces unique. But there was a problem.

It seems that the wooden beads shifted around causing the clasp to move from the back of the neck when worn. I solved this by putting a small amount of silicone in each of the end beads. The result: no more shifting beads.

—Larry L. Maly, Tempe Ariz.

## Reduced speed = greater torque

I am sure that by now you have received many letters about the lathe article in your October issue of WOOD [issue 38, pages 70-73]. This was a fine article and I enjoyed reading it, but you must know that horsepower is never increased by any mechanical speed change. When you mechanically reduce speed, torque at the spindle increases. This must be what you meant to say.

I read and enjoy every issue of your fine magazine. Thanks for the good work.

—Thomas St. John, Orlando Fla.

Tom, we appreciate the clarification.

## Fast fixes for your tablesaw chart

After reviewing our October tool guide, issue 38, we ran across a few errors on the tablesaw chart on page 40 that you'll need to correct. First, switch the labels "AMPS" and "HORSEPOWER" along the top of the chart. Next, change the Bridgewood data under "CUTTING DEPTH" from 4 1/4" to 3 1/4". Now, follow the Inca line across to "COUNTRY OF ORIGIN" and change the "S" to "F". Finally, please note that the Powermatic Artisan's Saw model 63 shown on the cover is not included in the chart. 🌲

MANUFACTURER/ IMPORTER	MODEL NUMBER	BLADE SIZE	MOTOR BLADE SPEED (RPM)	BENCH TOP OR STATIONARY	TABLE TYPE	TABLE SIZE (WxD)	WEIGHT	HP CAPACITY	ACCEPTS DADO BLADES	CUTTING DEPTH	FENCE RAIL	DRIVE MECHANISM (DIRECT/IDLE)	STYLET TYPE	MOTOR		COUNTRY OF ORIGIN*	SUGGESTED PRICE			
														AMPS	HORSEPOWER					
Airt	4571	10	3450	S	D	40 1/2 x 27 1/2	211	25	Y	3 1/4	T	B	H	O	1 1/2	1 1/2	110/220	T	415	
Black & Decker	5419	8 1/2" x 10"	3000	B	FS	26 1/2 x 15 1/2	35	3/8 HP (1/2")	Y	1 1/4	T	D	B	I	1	1	115	115	U	257
Bridgewood	TSC 108	10	4000	S	D	27 x 40	295	40	Y	4 1/4	N	B	H	O	N/A	N/A	110/220	U	639	
	388 (250V)	12	4500	S	D	36 x 27	415	50	Y	3	T	B	N/A	N/A	N/A	N/A	220	115	U	1091
Delta	3444	10	4000	S	D	40 x 27 1/2	225 w/90W	25	Y	2 3/4	T	B	H	O	1 1/4	1 1/4	110/220	U	495	
	34140	10	3400	S	D	35 1/2 x 23 1/2	152	25	Y	2 1/4	T	D	B	I	1	1	110	110	U	317
	24270	10	3300	S	D	27 1/2 x 36 1/2	130	24	Y	3 1/4	R	B	H	O	N/A	25	115	U	521	
	10-104 (100V)	10	4000	S	D	27 1/2 x 36	464	25	Y	3 1/4	T	B	H	O	1 1/2	1 1/2	110/220	U	2043	
	24330	8 1/2	4500	B	P	36 x 20	40	12	Y	2 3/4	B	D	B	S	N/A	13	115	U	343	
Felco-Orion	000009	10	3450	S	D	40 x 27 1/2	365	25	Y	3 1/4	B	B	H	O	1 1/4	1 1/4	200/110	U	1091	
General	2501	10	4000	S	D	36 x 28	415	25	Y	3 1/4	B	B	B	O	3	3	110/220	C	1330	
Grady	G1027	10	4000	S	D	41 x 27 1/2	255	25	Y	3 1/4	T	B	B	O	1 1/4	1 1/4	110/220	T	345	
	G1023 2HP	10	4140	S	D	36 x 27 1/2	500	26 1/2	Y	3 1/4	N	J	B	O	3	3	110	220	T	816
Inca	250	12, 12 1/2" x 10"	3450	B	CM	20 x 33 1/4	66	22 1/2	Y	2 1/2	A	B	H	O	1 1/4	1 1/4	110/220	S	991*	

# GRAPHIC WIZARD

FAST... ACCURATE... PRACTICAL

- IT'S A COMPASS
- IT'S A PROTRACTOR
- IT'S A T-SQUARE
- CIRCLES UP TO 24" DIA
- ANGLES
- PARALLEL VERTICAL LINES
- CUBES
- 3-D DRAWINGS
- GRAPHS

An everyday time saving instrument for the home, shop, office, desk, drawing board, or even on the job. The "WIZARD" is a must. Functions as six precision hand tools in one.

As Seen On T.U.  
THE ULTIMATE  
ROLLING RULER

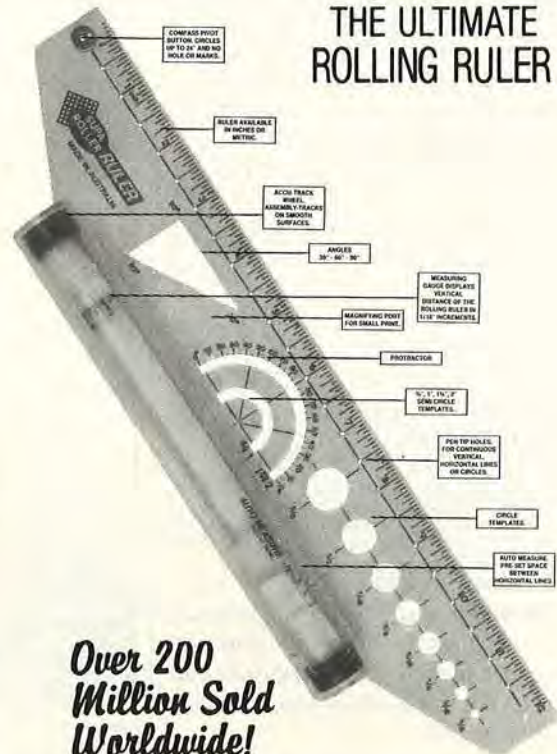

Over 200  
Million Sold  
Worldwide!

**GREAT FOR LAYOUTS**  
TRACKS ON GLASS, METAL, WOOD,  
SHEETROCK, PAPER ALMOST ANYTHING

**ORDER NOW...**

**ONLY \$19.95 EACH**

**OR SAVE AND ORDER...**

**TWO... 25% SAVINGS... \$14.95 EACH**

**PLUS SHIPPING AND HANDLING INSURANCE**

**ONE \$3.50 TWO \$4.50**

**30 DAY MONEY BACK GUARANTEE. LIFETIME WARRANTY.**

**ORDER TOLL FREE: 1-800-426-3555**

OR MAIL TODAY TO:



**THE WIZARD**



883 CAPE HAZE LANE, NAPLES, FLORIDA 33942

**Perfect for your shop!**

Please allow 4 to 6 weeks for delivery.

Graphic Wizard Enterprises Inc.



## EARN CASH, PRIZES FOR YOUR TOP SHOP TIP

Do you have a great shop tip (or two) you'd like to share with other WOOD® magazine readers? For each published submission, you will get at least \$25 from WOOD® magazine (up to \$200 if we devote a page or more of space elsewhere in the magazine to your idea). You also may earn a woodworking tool for submitting the top shop tip for the issue.

We try not to use shop tips that have appeared in other magazines, so please send your tip to only one publication. We cannot return shop tips. Mail your tips, address, and daytime phone number to:

**Top Shop Tip**  
WOOD Magazine  
P.O. Box 11454  
Des Moines, IA 50336-1454

### An economical buffer

A drill-mounted buffing wheel can perform all sorts of workshop polishing chores. But, at about \$10 apiece, the cost of several wheels really adds up.

**TIP:** Cut a paint-roller tube into lengths to fit over a 1½" sanding drum (thick naps work best). Slip these fuzzy tubes onto the drum and polish away.

—Mark D. Hoover, Poway, Calif.

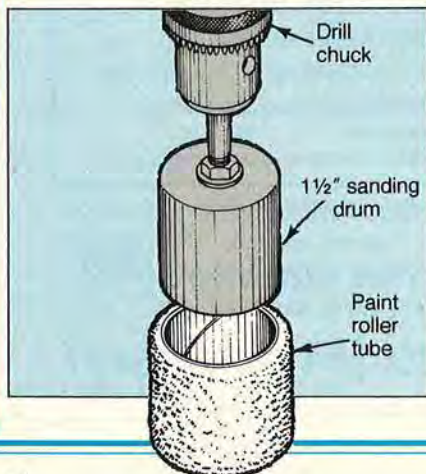

### Turn your Workmate into a framing clamp

Black & Decker Workmates are just about the handiest shop accessory to come along since the sawhorse, but they do have their limitations. For example, the mechanism exerts clamping pressure in only two directions, so you still need pipe or bar clamps when clamping four-sided projects.

**TIP:** By fashioning four of the add-on blocks shown below, you can clamp frames and some odd-shaped workpieces with your Workmate. Size the dowel to fit the dog holes in your Workmate, and cut the threaded rod to a length that suits your needs (6-8" should do it). Note that you must flatten the end of the rod before adding the clamp block so the block doesn't fall off.

—Lyle Kruger, Effingham, Ill.

For his tip,  
Lyle receives a  
Skil model 5550  
circular saw.

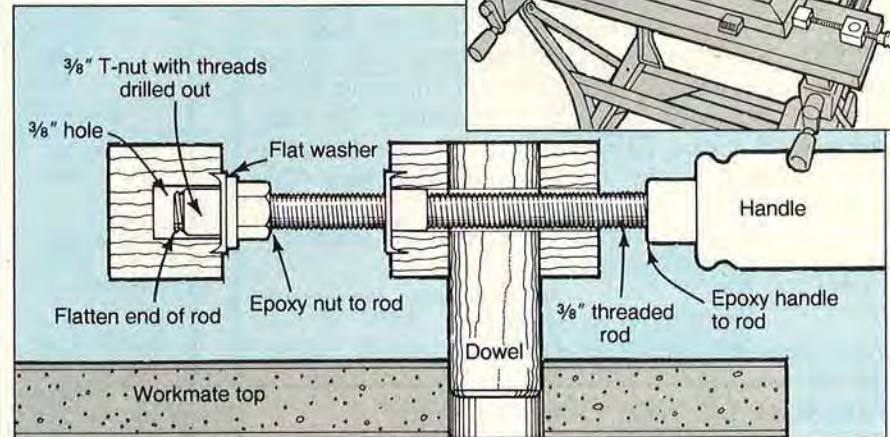
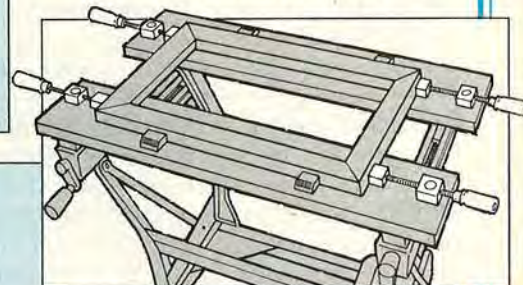

### A better auxiliary drill-press table

Auxiliary drill-press tables enlarge your working area and eliminate the hassle of finding a scrap block to back up the workpiece. But, their centers quickly become chewed up. And, removing the auxiliary table takes time if you have to loosen several nuts.

**TIP:** Build an auxiliary table like the one at right. While you're at it, cut several of the 4×4" inserts so you always have a spare on hand. When one becomes full of drill holes, just slap in a replacement. Add dowels that tightly fit the press standard table, but still allow you to easily lift off the auxiliary table when necessary.

—Marvin Clore, Cut Bank, Mont.

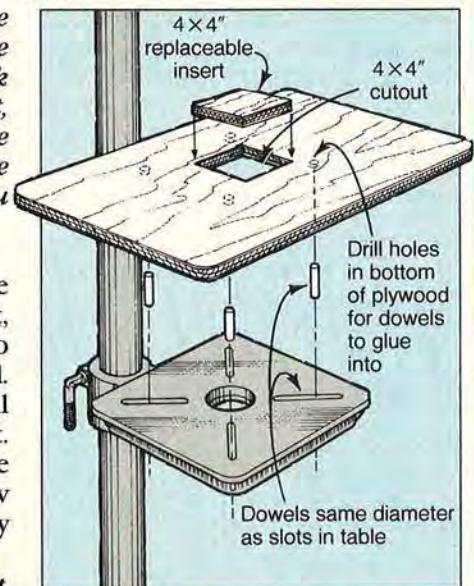

Continued on page 16





Chimney sweeps at one of the regular August West training workshops.

# What You Should Know About Making \$1,000 a Week in Your Spare Time.

**Be your own boss,  
Choose your own hours.**

We'll show you how to be a Professional Chimney Sweep! You can join thousands of men and women in this fast growing service business. And you can do it in your spare time!

With August West's state-of-the-art equipment and proven techniques, you'll quickly learn how to clean a chimney in less than an hour and walk away with an average of \$65 every time.

You could be earning as much as \$1,000 a week working part-time. Many August West sweeps earn twice that each week when they work full-time.

## Why Clean Chimneys?

There are nearly one hundred million chimneys, flues and stoves across the continent. Whether they are burning gas, oil, coal or wood, they all need to be cleaned. According to the National Fire Protection Association, they should be cleaned at least once a year to prevent disastrous fires.

So there is an urgent need for this service. And there are very few sweeps. The potential is enormous. Get your share!

Copyright © 1990 August West Systems, Inc.

## Fabulous Earnings

Here's what your part-time weekly income could look like:

3 chimneys x \$65	=	\$195 Mon
3 chimneys x \$65	=	\$195 Tues
3 chimneys x \$65	=	\$195 Wed
2 chimneys x \$65	=	\$130 Thurs
5 chimneys x \$65	=	\$325 Sat
		<u>\$1,040 weekly</u>

## 14 Years of Service

August West has been outfitting men and women for chimney sweeping for more than fourteen years. We're a national company and 90% of the chimney sweeps in the U.S. and Canada use our system.

## No Strings Attached

You keep all you earn. With August West there are no franchise fees, no commission payments.

For an investment of under \$3,000 you get the tools and equipment you need to start earning money immediately.

That includes the famous, high-powered SOOTSWEeper®, the dust collector Mother Earth News calls "The Height of Technology".

Most important of all: August West backs you up, provides you with training and support, workshops, newsletters, technical and marketing advice, advertising and promotion manuals and continuing access to the growing chimney sweep community. You have all the advantages of a franchise without any of the drawbacks!

## Free Information Kit

Join the many thousands who have found personal freedom, success and the time to do the important things.

Learn more about this extraordinary business. Write for our Free Information Kit today.

Better still, pick up the phone and call us at this Toll-Free number:

**1-800-225-4016**

Ask for Extension 883

(In MA: 508-753-5544)

Send to: August West Systems, 38 Austin St., Box 658, Dept. 4558, Worcester, MA 01601

**Yes, please rush me your FREE Information Kit.**

Name \_\_\_\_\_

Address \_\_\_\_\_

City \_\_\_\_\_ State \_\_\_\_\_

Zip \_\_\_\_\_ Phone (\_\_\_\_) \_\_\_\_\_

**August West**



**Systems**

# Turn your drill press into a Biscuit Joiner. Only \$159.



Shopsmith has developed a revolutionary new biscuit joiner that attaches to most drill presses\*

This stationary Biscuit Joiner is easier and more accurate than portable units because you move the wood into the cutter, instead of moving the biscuit joiner into the wood. Shopsmith's new **Universal Biscuit Joiner** features a dust-collection chute that allows

you to create precision joints virtually dust-free! Satisfaction assured with Shopsmith's 30-day Money-Back Guarantee and one full year warranty!  
**555485 Universal Biscuit Joiner .....\$159.00**

**Call TOLL FREE 1-800-543-7586 (ask for ext. 100)**  
 to order direct, or find the location of your nearest Shopsmith store.



**Shopsmith Inc.**

Woodworking Centers  
 3931 Image Drive  
 Dayton, OH 45414-2591

\*For use with any 2000-4100 RPM drill press.

© 1990 Shopsmith, Inc.

## TIPS FROM YOUR SHOP (AND OURS)

Continued from page 14

### Elevated pipe clamps

Pipe clamps work great for edge-gluing cutting boards, tabletops, and the like, but it can be a chore to keep them from rolling on their sides as you work. And, elevating the clamps off the bench makes the job easier.

**TIP:** Assemble two pair of pipe-clamp holders from 3/4" pipe and fittings such as the pair shown below. First, mount 6" nipples to 3/4x6x6" plywood bases with flanges. For each pair, cut one T-joint in half, and drill and tap the other for a 1/4" thumb screw. It helps to cover the pipe clamps with masking tape for protection from glue drips. Once the assembly dries, you can remove it from the holders and replace it with two more pipe clamps for your next assembly.

—Burl Rice, Topeka, Kan.

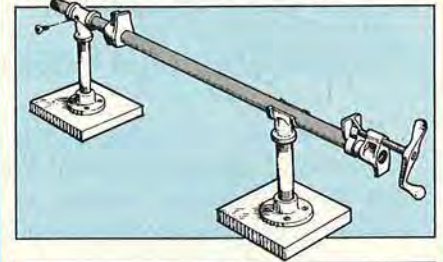

### Surefire plug alignment

To hide wooden plugs, it helps to align the grain of the plugs with the grain of the workpiece. However, sometimes—particularly on small plugs—you can't tell which way the grain runs.

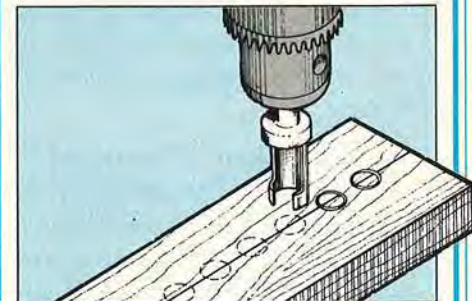

**TIP:** Before cutting the plugs, draw a pencil mark parallel to the grain as shown above. The mark guides you when gluing the plugs in place, and disappears when you sand the plugs flush.

—Richard Rentfrow, Raleigh, N.C.

Continued on page 18

### Build Power Tools You Can Be Proud Of... And SAVE!!!

Remember when "quality craftsmanship" meant something? With GIL-BILT tools it still does.

Construct your own:

- 12-in BAND SAW
- 18-in BAND SAW
- 10-in. TILT/ARBOR SAW
- LATHE/DRILL PRESS COMB.
- 9-in TILT TABLE SAW
- 6-in BELT SANDER
- SPINDLE SHAPER
- CIRCULAR SAW TABLE

GIL-BILT kits include step-by-step plans, full scale patterns and all necessary metal parts and components except wood and motor. Made in America with pride by Gilliom Manufacturing, Inc. since 1946.

Send \$7.50 per plan or \$25 for plans for all eight tools listed above or send \$2 for descriptive brochure only. Satisfaction Guaranteed.

**GILLIOM MANUFACTURING, INC.,**

Dept. WD11  
 P. O. Box 1018  
 St. Charles, MO 63302  
 Phone (314) 724-1812



Featured here: 18-in. Band Saw  
**Specs:** Throat capacity 18 in.  
 Thickness capacity 12 in.  
 Table size 26 in. x 28 in.  
 Table tilt 0° to 45°  
 Blade furnished 124 in. x 1/4 in. x 6T  
 Table height 39 1/2 in.  
 Overall dimensions 33 1/2 in. wide  
 29 in. deep  
 71 1/2 in. high  
 Speed (w/1,725 rpm motor)  
 425 rpm 2000 bfpm  
 Order No. 451-K only \$219.50 (less cost of plan, if previously purchased) plus shipping  
 Speed reduction kit available for cutting steel.

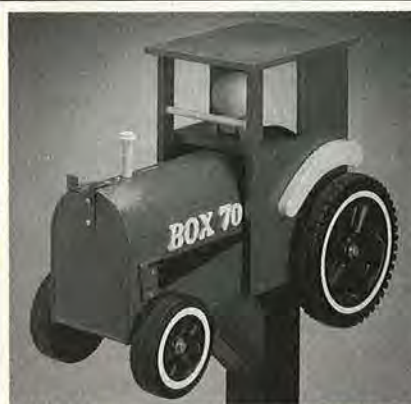

### FIRST CLASS MAILBOXES

It's hard to believe how easy it is to make this great looking project. You'll find it easy to build because you'll be getting big blueprint sheets that show each piece drawn FULL SIZE. You can make it from 1/2" plywood. Besides the plans you'll be getting the wheels, axles, axle caps, smokestack, wooden farmer's head, and hat. (Note: the mailbox and plywood are not included in kit.) Order #9631 Tractor Mailbox Plan & Hdw. Kit for \$26.99/KIT postage paid.

MN residents add \$1.32 sales tax/kit.

TO ORDER: Visa or MasterCard customers call toll free. Mail order customers send check or money order.

Phone TOLL FREE 1-800-441-9870  
 (Credit Card Orders Only)



#### MORE PLANS

See hundreds of additional plans. Order our 72-page catalog for only \$1 or receive catalog FREE with order.

**MEISEL HARDWARE SPECIALTIES**

P.O. BOX 70 W 2 MOUND, MN 55364

# Your workshop can PAY OFF ...BIG!

SAVE ... convert low cost rough lumber for use in your home projects  
**OR**  
EARN EXTRA INCOME by supplying custom Planed Lumber, trim, and molding to lumberyards ... contractors ... cabinetmakers ... home hobbyists and others ...



**FREE**  
WOODWORKING  
CATALOG...  
SEE COUPON FOR  
DETAILS...

## FOUR BIG ADVANTAGES ...



PLANE



MOLD



SAW



SAND

### You can plane, mold, saw & sand All with Automatic Power Feed!

From the Day It Arrives ... the Planer will make and save you money. With shortages and inflation driving lumber prices sky-high, this versatile power feed tool quickly pays for itself by easily converting low cost rough lumber into high value finished stock. In just one pass turn out your own quarter round, door and window stop, casing, tongue-and-groove ... all popular patterns. Other operators are making cases for grandfather clocks, furniture, picture frames, bee hives, bed slats, surveying stakes ... all kinds of millwork.

**Built For Pros ... Priced For Home Craftsmen ...** it is engineered and built to industrial standards, but factory-direct selling keeps the price low. Handles tough oak and walnut as easily as pine, and so simple to operate even beginners with no experience can use it.

**Start Your Own Business ...** with just this one low cost power feed machine in a corner of your garage or basement, you're set up to supply lumberyards, cabinetmakers, carpenters, remodelers, contractors and hobbyists in your area with custom-planed lumber, trim, molding ... All of their millwork requirements. You can supply picture frame moldings to art shops, hardware and department stores, or sell direct to framing shops. All standard patterns are available from stock, or we'll custom grind a knife to your own special design or sample.



**FREE**  
BOOKLET!

Get **FREE**  
BOOK with  
facts and  
full details

... RUSH COUPON TODAY!

**SAVE!! FACTORY PRICES DIRECT TO YOU!**

**PLUS Receive a FREE Woodworking Tool and Accessory Catalog**

Just Mail Coupon ...  
**30-DAY FREE TRIAL OFFER!!!**  
ACT NOW!  
Coupon  
Brings  
Full Details!



**FOLEY-BELSAW CO.**  
6301 EQUITABLE RD  
KANSAS CITY, MO 64120  
Established in 1926

- YES, please send me the FREE Booklet that gives me complete facts about your Planer-Molder-Sander-Saw and full details on how I can qualify for a 30-Day FREE Trial right in my own shop. I understand there is No Obligation and that No Salesman will call and that I will receive your quarterly Woodworking Catalog. Dept. 91595.
- NO, I'm not interested in a Foley-Belsaw-Planer-Molder-Sander-Saw, but please send me your free Woodworking Catalog. Dept. 44140.

NAME \_\_\_\_\_  
ADDRESS \_\_\_\_\_  
CITY \_\_\_\_\_ STATE \_\_\_\_\_ ZIP \_\_\_\_\_

# ANYTIME ANYWHERE ANYWOOD

mold plane and edge

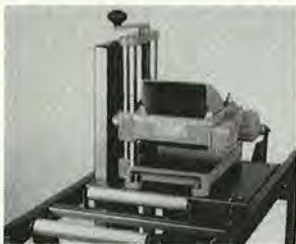

Professionals and hobbyists alike know the strengths of the W&H molder-planer. Superior US-made construction and quick two-minute cutter changes make it a snap to cut moldings and plane hardwoods. It's fast, easy, and super-smooth.

Our five-year warranty and free 30-day trial are your assurance that W&H goes the distance.

Mail this ad or call us toll-free today.  
1-800-258-1380 In NH 603-654-6828

Williams & Hussey Dept. 231AM  
Riverview Mill, P.O. Box 1149  
Wilton, NH 03086



YES! Send your free information kit today.

Name \_\_\_\_\_  
Address \_\_\_\_\_  
City \_\_\_\_\_ State \_\_\_\_\_ Zip \_\_\_\_\_

# APPALACHIAN HARDWOODS

Beautiful grain and textures. Exceptionally workable. Our Appalachian hardwoods are locally grown, personally selected and kiln-dried... a guarantee of our measure of quality. ■ We handle 21 species of domestic hardwoods, softwoods and hard-to-find imports. ■ Send \$2.00 for our catalogue today (refunded with order). All purchases at delivered prices. **EDLCO**

P.O. Box 5373-A, Asheville, N.C. 28813  
For fast service, call 1-704-255-8765

## TIPS FROM YOUR SHOP (AND OURS)

Continued from page 16

### A quick check when sharpening spade bits

You can resharpen spade bits relatively easily, but checking your accuracy can pose problems.

**TIP:** To make sure that you sharpened both sides of the bit to the same length, just lay the bit

into the groove of your combination square's blade. The distances marked by "X" in the drawing below should be equal (1" in this example), with the cutting edges parallel to each other.

—Ted Wonderly, Mertztown, Pa.

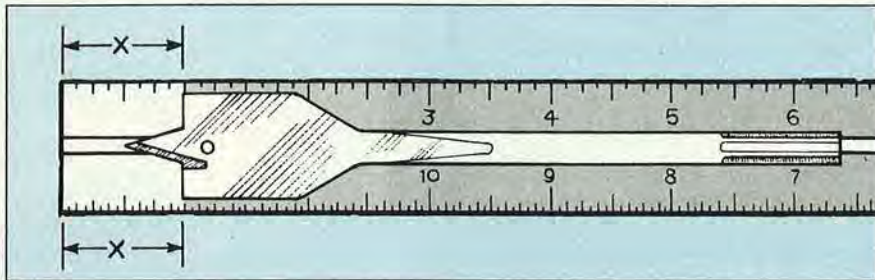

### Assemble a cheap-to-make flexible sanding pad

When sanding contoured surfaces such as dowels or chair legs, a flexible sanding pad helps you reach nooks and crannies, and doesn't wear out as fast as plain sandpaper. But, the commercially available models cost a buck or two.

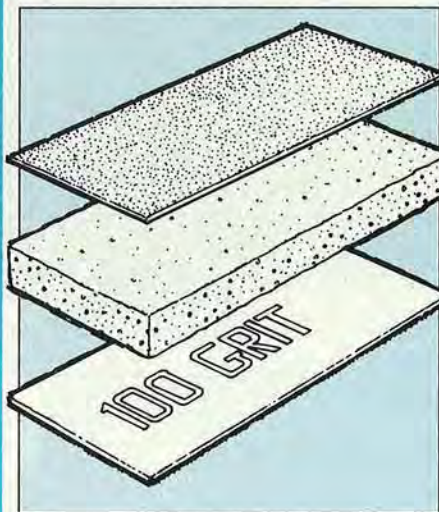

**TIP:** You can save some of your hard-earned money by attaching 2½×4½" sheets of sandpaper to similar-sized pieces of carpet-underlay foam as shown above. I put sheets of differing grits on each side of the pad, and secure them with spray adhesive.

—Ray Sweeney, Elizaville, N.Y.

### Double-duty sanding/push block

Safety-conscious woodworkers really appreciate push blocks, especially when surfacing stock on a jointer. A slight modification to this accessory helps it serve other shop tasks.

**TIP:** Cut a sheet of sandpaper to fit your push block and secure the abrasive with a strip of hardwood and self-tapping screws as shown below. I use a Shopsmith push block (part No. 513711, about \$5.50), two ¼×½×3" hardwood strips, and ¾" screws. A half sheet of paper (3½×9") fits perfectly.

Now, you can sand large surfaces comfortably. Leave the paper attached for a better grip when using the tool as a push block.

—Robert Maurice, Hartford, Wis.

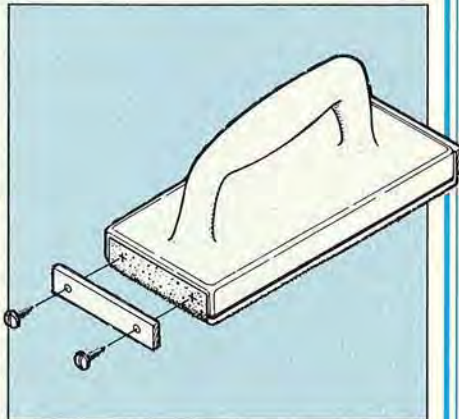

Continued on page 20

# PARAGAUGE™

**THE PERFECT SHOP ACCESSORY  
FOR ANYONE WHO OWNS A  
TABLE OR RADIAL ARM SAW**

*Designed for both the home and professional shop, Paragauge will accurately set any table or radial arm saw so precise that anyone can now cut wood accurate to within 10/1000" — virtually eliminating binding, burning and dangerous kickback.*

Easy-to-follow directions show how to use **Paragauge** for setting a perfectly parallel rip fence (up to 18 inches wide), setting inside bevels and setting blade height. Radial arm saw owners can use **Paragauge** as a square for crosscutting, setting the width for ripping, setting blade depth and even check for table levelness and heel in horizontal position. **Paragauge** is so versatile and accurate everyone can now cut wood with professional quality results.

**Paragauge** also saves the cost of upgrading to a new saw or adding an expensive parallel-locking fence to your current equipment!

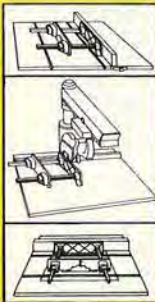

# A Proven Performer

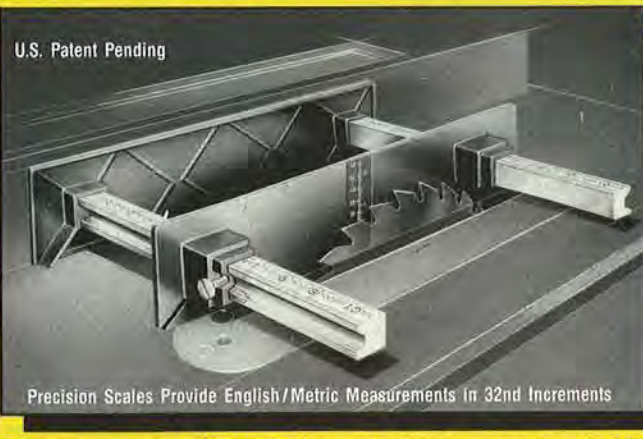

NOTE: We suggest that Model PG-18 only be used on table tops measuring at least 36" wide. For smaller saws or when using the gauge on a radial arm saw, Model PG-12 is recommended.

**NOW AVAILABLE  
IN TWO SIZES**

**MODEL**  
*Only!*  
PG-12 (12 inch) **\$34.95** +\$3.50 S&H  
PG-18 (18 inch) **\$39.95** +\$5.00 S&H  
MI Residents Please Add 4% Sales Tax

**"MADE IN THE U.S.A."  
For Quality You Can Depend On!**



To Order  
Call Toll Free



**1-800-343-6129**

(7 Day - 24 hour service)

- OR -

To order by check or for a **FREE BROCHURE** write:  
Accuset Tool Co., Inc., P.O. Box 1088 Dept. D, Troy, MI 48099  
30 Day Money Back Satisfaction Guarantee • SORRY, NO C.O.D.s



## Superior Quality Carbide Tipped Router Bits & Cutters

Check our quantity discount price and monthly sales item. Same day shipping. S&H is included. Catalog & distributor price is available.

Tool No.	Diagram	Radius/Angle		Cutting		Shank		Price	Tool No.	Diagram	Radius/Angle		Cutting		Shank		Price	
		Dia.	Len.	Dia.	Len.	Dia.	Len.				Dia.	Len.	Dia.	Len.				
T100B	Corner Rounding	1/8	3/4	5/16	1/4	1-1/4	10.00	T301B	Roman Ogee	5/32	1-1/8	15/32	1/4	1-1/4	15.00			
T101B		3/16	7/8	3/8	1/4	1-1/4	10.00	T302B		1/4	1-1/2	21/32	1/4	1-1/4	16.00			
T102B		1/4	1	7/16	1/4	1-1/4	11.00	T303B		5/32	1-1/8	15/32	1/2	1-1/2	15.00			
T103B		5/16	1-1/8	1/2	1/4	1-1/4	12.00	T304B		1/4	1-1/2	21/32	1/2	1-1/2	16.00			
T104B		3/8	1-1/4	5/8	1/4	1-1/4	14.00	T1501B	Slot Cutter	1-1/4	1/8	1/4	1-1/2	9.00				
T105B		1/2	1-1/2	3/4	1/4	1-1/4	16.00	T1503B		1-1/4	1/4	1/4	1-1/2	10.00				
T110B		1/2	1-1/2	3/4	1/2	1-1/2	16.00	T1506B		1-1/4	1/2	1/4	1-1/2	11.00				
T111B		5/8	1-3/4	7/8	1/2	1-1/2	19.00	T1512B	1-1/4	1/2	1/2	1-1/2	11.00					
T112B		3/4	2	1	1/2	1-1/2	20.00	T601	Core Box	1/4	1/4	1/4	1	9.00				
T113B	1	2-1/2	1-1/4	1/2	1-1/2	32.00	T602	3/8		3/8	1/4	1	10.00					
T200B	Beading	1/8	3/4	5/16	1/4	1-1/4	10.00	T603		1/2	3/8	1/4	1	12.00				
T201B		3/16	7/8	3/8	1/4	1-1/4	10.00	T604		5/8	5/8	1/4	1-1/8	13.00				
T202B		1/4	1	7/16	1/4	1-1/4	11.00	T605	3/4	5/8	1/2	1-1/2	14.00					
T203B		5/16	1-1/8	1/2	1/4	1-1/4	12.00	T1602	Carbide Tipped Dovetail	1/2	1/2	1/4	1-1/4	5.00				
T204B		3/8	1-1/4	5/8	1/4	1-1/4	14.00	T1604		3/4	3/4	1/2	1-1/2	6.50				
T205B		1/2	1-1/2	3/4	1/4	1-1/4	16.00	T1606		1	7/8	1/2	1-1/2	7.50				
T210B	1/2	1-1/2	3/4	1/2	1-1/2	16.00	T1607	1/2		1/2	1/2	1-1/2	5.00					
T212B	3/4	2	1	1/2	1-1/2	20.00	T2201s	1/4" Straight Bit Single flute Double flute		1/8	1/2	1/4	1-3/16	5.00				
T901B	Cove	1/4	1	3/8	1/4	1-1/4	11.00			T2202s	3/16	1/2	1/4	1-3/16	5.00			
T902B		3/8	1-1/4	1/2	1/4	1-1/4	12.00	T2205d	1/4	3/4	1/4	1-3/16	5.50					
T903B		1/2	1-1/2	5/8	1/4	1-1/4	13.00	T2207d	3/8	1	1/4	1-3/16	5.50					
T904B		1/4	1	3/8	1/2	1-1/2	11.00	T2209d	1/2	1	1/4	1-3/16	5.50					
T905B		3/8	1-1/4	1/2	1/2	1-1/2	12.00	T2211d	5/8	3/4	1/4	1-3/16	6.50					
T906B		1/2	1-1/2	5/8	1/2	1-1/2	13.00	T2212d	3/4	3/4	1/4	1-3/16	7.50					
T1203	Hinge Boring	1		3/4	3/8	1-1/2	17.00											
T1204		1-1/4		3/4	3/8	1-3/4	18.00											
T1205	Half Round	1-3/8		3/4	3/8	1-3/4	20.00											
T1206		1-1/2		3/4	3/8	1-3/4	22.00											
T801		15/16		1/4	1/4	1-1/4	13.00											
T802		1-1/16		3/8	1/4	1-1/4	14.00											
T803		1-3/16		1/2	1/4	1-1/4	15.00											
T805	1-7/16		3/4	1/4	1-1/4	17.00												
T805L	Cove Beading	1-7/16		3/4	1/2	1-3/4	19.00											
T807		1-11/16		1	1/2	1-3/4	21.00											
T2501B		3/16		1	1/2	1/4	1-1/4	12.00										
T2502B	1/4		1-1/8	9/16	1/4	1-1/4	13.00											
T2503B	5/16		1-1/4	5/8	1/4	1-1/4	14.00											
T401B	Chamfer	45°		1	3/8	1/4	1-1/4	11.00										
T403B		45°		1-3/8	5/8	1/4	1-1/4	12.00										
T403B		45°		1-3/8	5/8	1/2	1-1/4	12.00										
T2004B	Straight Bit w/ Bearing	1/2		1	1/4	1-1/4	7.00											
T2008B		1/2		1	1/2	1-1/4	7.00											
T701	V Groove	3/8		1/2	1/4	1	8.50											
T702		1/2		1/2	1/4	1	9.50											
T2101	Mortising	1/2		13/32	1/4	1	6.00											
T2102		5/8		9/16	1/4	1-1/4	7.00											
TC-12B	Classical	3/16		1-3/8	11/16	1/4	1-1/4	18.00										
TC-12B 1/2		3/16		1-3/8	11/16	1/2	1-1/2	18.00										
TC-16B		1/4		1-5/8	13/16	1/4	1-1/4	19.00										
TC-16B 1/2		1/4		1-5/8	13/16	1/2	1-1/2	19.00										
T2601	Carbide Tipped Keyhole	3/8		3/16	1/4	1	7.50											

Visa/MasterCard • 214-234-5824 • 800-966-6543 • Mon. ~ Fri., 8AM ~ 7PM CT  
Check/M.O. • C&L Int'l, Inc./Dar Chyl U.S.A. • 1729 Analog, Richardson, TX 75081

# WOODWORKER'S CATALOG

There are over 4,000 money saving reasons why woodworkers rely on Constantine.

4,000 woodwork items—to help you Build-Restore-Repair-Refinish! Over 200 different woods ... 150 veneers ... 500 plans ... cabinet hardware ... 96 How-To Books ... 118 carving tools and chisels ... 76 inlay designs ... and lots more for One-Stop, Right-Price Shopping without leaving home!  
**All in our 116 page, full color catalog — and all yours for only \$1.00!**



YES, rush, my 1991

Constantine's Woodworker's Catalog. My \$1.00 is enclosed.

Name \_\_\_\_\_

Address \_\_\_\_\_

**CONSTANTINE** Est. 1812  
 2054Y Eastchester Road  
 Bronx, NY 10461

City \_\_\_\_\_

State \_\_\_\_\_

Zip \_\_\_\_\_

## NEW HEGNER precision scroll saws

Are you ready for a scroll saw that gives you everything you want? Rated #1 for over a decade, the 1991 HEGNER models are priced as low as **\$399**, and now are even more

- Convenient
- Precise
- Vibration-free
- Affordable



For **FREE** information call **(302) 322-2226** or send in the coupon!

Please send me free information on HEGNER Precision Scroll Saws.

Name \_\_\_\_\_

Address \_\_\_\_\_

City, State, Zip \_\_\_\_\_

Phone \_\_\_\_\_

**ADVANCED MACHINERY IMPORTS, LTD.**  
 P.O. Box 312, Dept. 438  
 New Castle, DE 19720

## TIPS FROM YOUR SHOP (AND OURS)

Continued from page 18

### A one-minute fix for a creepy radial-arm saw

Radial-arm saws rate as one of the most dangerous machines in your shop, and they can be especially threatening if the blade carriage tends to creep forward on its own.

**TIP:** Tilt the machine backwards slightly by elevating the front legs as shown below. If the base doesn't have pads that elevate by turning them, add shims.

—David M. Johnson,  
 New Springfield, Ohio

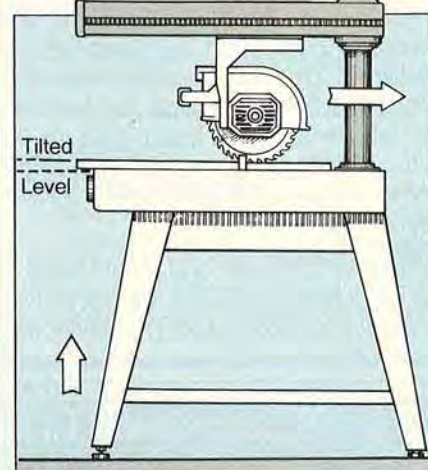

### MORE TIPS FROM OUR WOODWORKING PROS

- To learn how to disguise wood imperfections such as worm holes and cracks, see page 30.
- Our bench hook on page 34 will help you relief-carve safely and comfortably.
- See the note on page 36 for a simple and inexpensive way to stain wood with a child's watercolor set.
- Bend thin wood using the hot-water-and-form technique described on pages 54 and 55.
- Make your own lightweight anvil from scrap 2x4 and a pipe. See page 56.
- On page 64 you'll see how we laminated square turning blanks from four smaller pieces of wood. 🌲



WOOD® Magazine announces:

# 1991 BUILD-A-TOY™

**Our Third Annual Juried Contest  
to benefit deserving kids through Toys-for-Tots**



**ENTRY DEADLINE: FEBRUARY 1, 1991**

*Great prizes for every skill level! New Judging Categories!*

*Prizes for Original Designs and Built from Plans!*

*Holiday exhibition at the Museum of American Folk Art!*

*Enter by November 1, 1990 to be eligible for Museum exhibit.*

**W**e're proud to invite woodworkers of every age and skill level to participate in the Third Annual WOOD Magazine BUILD-A-TOY Juried Contest.

This year, we've expanded the competition into new areas. Special citations will be awarded to woodworkers who build toys from plans as well as original design entries. There are also several new judging categories.

We've added more valuable prizes contributed by leading WOOD advertisers. Some winning toys will be chosen for editorial features in future issues of WOOD.

**There's even an exhibition of winners scheduled for the 1990 holiday season at the Museum of American Folk Art in New York City. (Toys received by November 1, 1990 will be eligible for display in the Museum's Christmas Tree exhibition.)**

BUILD-A-TOY is the best way we know of for woodworkers to get the

## COMPETITION PRIZES AND CATEGORIES

	STUDENT (K-12):	HOME HOBBYIST:	PROFESSIONAL:
<b>DESIGN:</b> These 15 categories are open to original design entries only.			
<b>Grand Prize</b>	KITY: K-5 Machine (\$2,000 value)	Delta: \$2,500 in merchandise	Freud: \$2,000 in merchandise
<b>First Prize</b>	Black & Decker: \$1,500 in merchandise	Shopsmith: Mark V (\$1,600 value)	AEG: \$1,000 in merchandise
<b>Second Prize</b>	Jet: 14" Band Saw (\$579 value)	Grizzly: \$500 in merchandise	Skil: \$500 in merchandise
<b>Third Prize</b>	American Tool Cos.: \$500 in merchandise	Lobo: \$500 in merchandise	Wilke: BW1-P Planer (\$400 value)
<b>Fourth Prize</b>	Industrial Abrasives: \$250 in merchandise	Leichtung: \$250 in merchandise	Milwaukee Electric: 4" Belt Sander with Bag (\$348 value)
<b>SPECIAL CITATIONS:</b> These 39 categories are open to both original and existing designs.			
<b>Best use of Router</b>	AmMax: Scroll saw	Porter Cable: \$1,000 in merchandise	Ryobi: \$1,000 in merchandise
<b>Best use of Wood</b>	Adams Wood Products: Turning Squares Constantine's: \$100 in merchandise	RBI: 14" Scroll Saw	Makita: \$500 in merchandise
<b>Best Carved Toy</b>	Dremel: \$500 in merchandise	Dremel: \$500 in merchandise	Dremel: \$500 in merchandise
<b>Best Finish</b>	Deft: \$1,000 in merchandise	Minwax/Watco: \$1,000 in merchandise	Performax: ST Sander
<b>Best Truck</b>	How-To Book Club: \$100 Membership Toys and Joys: Antique Car Plans	Meisel: \$500 in merchandise Dollar Trading: Carving Set	Craftsman Wood Service: Turning Squares Brandmark: Branding Iron
<b>Best Car</b>	Constantine's: \$100 in merchandise	Berea: Assortment of Hardwoods	Furniture Designs: Plans
<b>Best Pull Toy</b>	DML: 10" Carbide-Tipped Blade	Formby's: Gift Set	Timbers Woodworking: Gift Certificate
<b>Best Train</b>	Rodale: Woodworking Books	Seven Corners: \$250 in Power Tools	How-To Book Club: \$100 Membership
<b>Best Bank</b>	Formby's: Gift Set	Fisher Hill: Rip Straight	DML: 10" Carbide-Tipped Blade
<b>Best Airplane</b>	Nova Tool: Branding Iron	Accents in Pine: Set/Blueprints	Constantine's: \$100 in merchandise
<b>Most Number of Toy Entries</b>	Accuset Tool: ParaGauge Econ Abrasives: \$100/Sandpaper	Woodcraft Supply Corp: \$100 Gift Certificate	Diamond Machining Technology: 8" Fine Whetstone
<b>Best Boat</b>	Tarheel Filing: Router Insert	Fisher Hill: Rip Straight	Penn State: Variable Speed Scroll Saw
<b>Best Puzzle</b>	St. Croix Kits: Thumb Piano	MLCS: Master Set	Hardwoods of Illinois: 20 sq. feet of Walnut

### WOOD® Magazine's 1991 BUILD-A-TOY Contest

There is no limit to the number of entries. Please provide the following information for each toy submitted.

My entry is:  Original Design\*  Built from plans

My skill level is:  Student  Home Hobbyist  Professional

Name \_\_\_\_\_

Address \_\_\_\_\_

City \_\_\_\_\_ State \_\_\_\_\_ ZIP \_\_\_\_\_

Daytime Phone (\_\_\_\_\_) \_\_\_\_\_

\*For Original Design entries: I certify that I have designed and built this toy myself. Should my entry win, I agree to cooperate with WOOD Magazine to supply builder's notes and a bill of materials for publication.

Signature \_\_\_\_\_ Date \_\_\_\_\_

Send toys to: 1991 BUILD-A-TOY, WOOD Magazine,  
1912 Grand Avenue, Des Moines IA 50309

recognition they deserve for great craftsmanship. We'd like as many entries as we can get.

That's because WOOD Magazine's BUILD-A-TOY Competition is also the contest with the biggest heart. The toys you submit will be contributed to the TOYS-FOR-TOTS program of the U.S. Marine Corps Reserve.

Help make some deserving kids happy this Christmas.

**1991 BUILD-A-TOY  
ENTRY DEADLINE:  
FEBRUARY 1, 1991.**



RYOBI CREATED A REVOLUTION IN BENCHTOP POWER TOOLS WITH INNOVATIVE PRODUCTS LIKE THE AP10 COMPACT SURFACE PLANER AND RA200 PORTABLE RADIAL ARM SAW. THE TRADITION CONTINUES WITH OUR NEW 16" SCROLL SAW FEATURING THE ACCUCLEAR™

# RYOBI WORK

RYOBI AMERICA CORPORATION,

## GREAT IDEAS FROM OUR SHOP

 Print this article

### HOLD-DOWN KNOBS

Turn to the lathe for savings

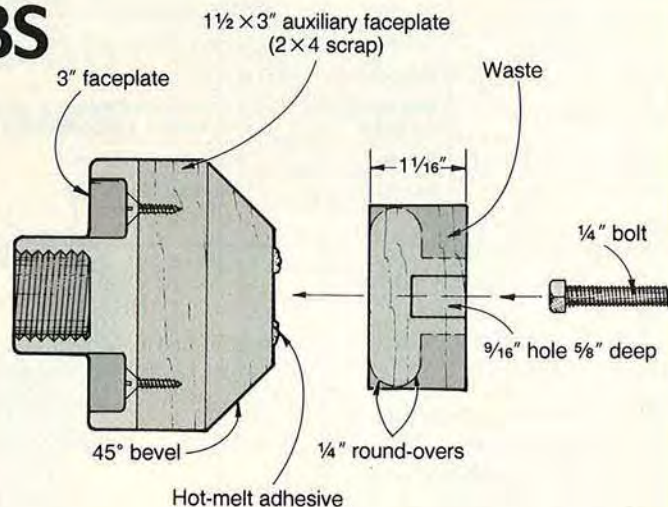

You can sink a lot of money in knobs with threaded studs such as those used on the router-table fence shown above. "Why not make them?" we asked ourselves the other day when we needed four knobs for a project.

Project Design: Marlen Kemmet

To make your own knobs, start by mounting a piece of oak to an auxiliary faceplate as shown above. Then, using a skew or small gouge, turn the knob to shape and sand smooth. Next, drill a 9/16" hole with a Forstner bit, and epoxy a 1/4"

Photograph: Bob Calmer

hex-head bolt into the hole. Before epoxying, check that the bolt fits the mating T-nut and that the exposed thread will be long enough to go through the stock and into the T-nut. Our knobs measured 2" in diameter. 🌲

Illustration: Jamie Downing



DUST REMOVAL SYSTEM, AND A NEW 10" MITER SAW THAT'S BEEN REDESIGNED TO PRODUCE THE LARGEST CUTTING CAPACITY IN ITS CLASS — EVEN HANDLING 2"x 6" STOCK AT 90°. THE RYOBI "WORKAHOLICS" — PRECISION-CRAFTED TO DELIVER STATE-OF-THE-ART PERFORMANCE.

# A H O L I C S™

ANDERSON, SC 29625

## WOOD ANECDOTE

 Print this article

### LIGNUM VITAE

The stock that does everything but swim



At home in water, lignum vitae helped submarines run quietly.

*An explosion rocked the humid night. Thrown to the deck, the young Confederate crewman escaped the projectiles flying everywhere. But not all hands were as lucky. Glancing into the boiler room, he found the first mate lying still. Was it a mortar shell that had felled him? It couldn't be; they were alone on the ocean.*

The blow that struck the Confederate cruiser *Georgia* on that fateful evening in 1864 came from no enemy gunner. Instead, the awesome burst and devastating shrapnel was from shattering wood.

During the early days of oceangoing steamships, shipyards made many engine cogs and shafts of lignum vitae, an iron-tough wood so heavy it sinks in water. Unfortunately, crews found out that the wood also comes apart under extreme pressure when combined

with more than 150° heat—as was created in the engine room when the *Georgia* mate stoked the fire through the open boiler door.

Incidences such as this caused shipbuilders to abandon lignum vitae in machinery aboard surface vessels. However, because sea water naturally lubricates the wood, lignum vitae was adopted as the material for silent-running propeller shaft bearings in submarines and has only recently been displaced by space-age substances.

Above sea level, lignum vitae's remarkable hardness made it perfect for chopping blocks, block-and-tackle assemblies, and casters. Early woodworking tool manufacturers relied on the wood for mallets, plane soles, and bandsaw guide blocks. And, should you happen on a bowling ball from the 1800s, expect that it, too, will be rollable, rockhard lignum vitae. ♣

Illustration: Jim Stevenson

# Compare this offer with any other book club for Price • Quality • Benefits • Selection!

An absolutely no-risk guarantee.



3167P \$14.95



3244 \$26.95  
Counts as 2



3177P \$24.95  
Counts as 2



3255 \$26.95  
Counts as 2



1122P \$14.95



3334 \$18.95

## Select 5 Books for only \$4.95

(values to \$133.70)  
and get a **FREE Gift!**



2704 \$24.95

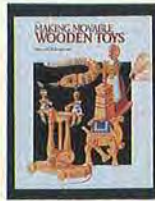

3079P \$14.95



1648P \$14.95



3021P \$14.95



3014P \$12.95



3051 \$24.95



3189 \$25.95



3264 \$24.95



9289 \$40.00  
Counts as 3

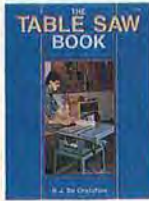

2789P \$16.95



3347 \$26.95  
Counts as 2



3326 \$26.95  
Counts as 2

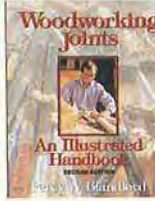

3324 \$26.95  
Counts as 2



3344 \$21.95



3174P \$13.95



3349 \$21.95



1971P \$12.95



3500 \$25.95  
Counts as 2



## HOW-TO BOOK CLUB

**FREE when you join!**

### 15 Practical Woodworking Projects From Percy Blandford

Fascinating projects from master craftsman Percy Blandford include toys, furniture, a go-cart and more!



A \$6.95 Value!

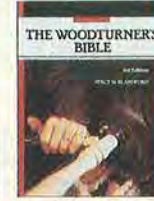

3404 \$26.95  
Counts as 2



3269 \$27.95  
Counts as 2



3064 \$21.95



3134 \$22.95



3144 \$25.95



3058P \$15.95

**Membership Benefits • Big Savings.** In addition to this introductory offer, you keep saving substantially with members' prices of up to 50% off the publishers' prices. • **Bonus Books.** Starting immediately, you will be eligible for our Bonus Book Plan, with savings of up to 80% off publishers' prices. • **Club News Bulletins.** 15 times per year you will receive the Book Club News, describing all the current selections—mains, alternates, extras—plus bonus offers and special sales, with scores of titles to choose from. • **Automatic Order.** If you want the Main Selection, do nothing and it will be sent to you automatically. If you prefer another selection, or no book at all, simply indicate your choice on the reply form provided. You will have at least 10 days to decide. As a member, you agree to purchase at least 3 books within the next 2 years and may resign at any time thereafter. • **Ironclad No-Risk Guarantee.** If not satisfied with your books, return them within 10 days without obligation! • **Exceptional Quality.** All books are quality publishers' editions especially selected by our Editorial Board.

WD191



3053P \$12.95

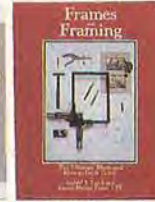

2909P \$12.95



2774P \$18.95



2979P \$14.95



2629 \$24.95

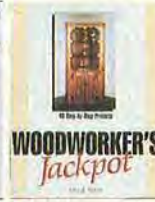

3154P \$16.95



(Publishers' Prices Shown)  
All books are hardcover unless number is followed by a "P" for paperback.

If card is missing, use the address to join:  
HOW-TO BOOK CLUB, Blue Ridge Summit, PA 17294-0800

A shipping/handling charge and sales tax will be added to all orders.

©1991  
HOW-TO BOOK CLUB  
Blue Ridge Summit,  
PA 17294-0800





# Black CHERRY

## The poor man's mahogany

Although today we think of black cherry as one of the classic furniture woods, it wasn't always that way. Settlers in the Appalachian Mountains, for example, valued the tree's fruit more than its wood. They dubbed the tree "rum cherry" because from its dark purple cherries they brewed a potent liquor. Also, black cherry's inner bark contributed to tonics and cough medicines. Elsewhere, though, the wood was more appreciated.

Early New England furniture-makers often found the price of fashionable Honduras mahogany beyond reach and turned instead to native black cherry. Because black cherry wood eventually darkens to a deep reddish brown, these frugal craftsmen mixed

what they called "New England mahogany" in with the real thing.

Today, cherry still appears in classic reproductions of colonial-style furniture. It has also climbed in popularity as a new look in kitchen cabinets.

### Wood identification

Black cherry (*Prunus serotina*) ranges from the Missouri River east to the Atlantic Ocean, but the species develops best in the Allegheny and Appalachian Mountains of the East. There, in forest conditions, trees grow to 100' heights and 4' diameters.

Young black cherry has satiny, dark, red-brown bark that develops into gray flaky scales as the tree matures. Oval-shaped, pointed leaves appear in the spring. Then, before the new, reddish leaves turn dark green, flowing clusters of white flowers bloom. By late summer, purple, pea-sized cherries appear. Birds eat them and distribute the seeds.

The heartwood of black cherry has a light pinkish-brown color when freshly cut. Sunlight deepens it to a dark orange-red. The cream-colored sapwood, however, never darkens to match.

Black cherry's straight, close, and finely textured grain generally features a gently waving figure. Sometimes, trees yield boards with rippled or quilted patterns. Dark spots—actually gum pockets—often appear in



Natural range

black cherry heartwood. Avoid selecting these boards, or at least keep pockets to a minimum.

At 35 pounds per cubic foot, black cherry weighs less than maple. And, it is two-thirds as hard but just as strong and stable.

### Uses in woodworking

Rated as a fine cabinet and furniture stock by centuries of craftsmen, black cherry has few limits. It takes abuse as tables, desks, and chairs. Black cherry also becomes musical instruments and architectural paneling, as well as millwork. It's only moderately durable outdoors.

### Availability

At about \$3 per board foot, black cherry costs approximately the same as red oak. Outlets farther from the source will, of course, charge more. You also can buy black cherry plywood—usually almost twice the price of a sheet of red oak. Plain-sliced veneer costs about 50 cents per square foot; figured veneer runs slightly more. Turning squares, buttons, and plugs also are available.

*Continued*



# PERFORMANCE PROFILE

## black cherry (*Prunus serotina*)

Black cherry with sapwood

Black cherry with gum pockets

### Machining methods

Select boards with a minimum of sapwood and gum pockets. *Then, remember these tips:*

- Black cherry planes extremely well due to its fine, close grain, but take light cuts in jointing. Dull blades burnish it.
- We've found that for some reason steel blades burn black cherry less than carbide-tipped blades. Avoid burning by feeding the stock without hesitation. In crosscutting, carbide blades outperform steel.
- Except for the common twist drill, any type of bit does well. However, use slower drill press speeds (about 250 rpm). A pause will burn the wood.
- In routing, black cherry doesn't chip or tear like maple, but it will burn during a split-second hesitation. Take light passes without stopping.
- All types of woodworking adhesives work well, as long as you carefully control squeeze-out. It mars a clear finish more jarringly than on other woods. To

check, wipe joints with thinner.

- Because black cherry is nearly as hard as maple, it scratches easily in cross-grain sanding, so never overlap strokes where joints bring the grain together at right angles, such as the corner of a face frame. For best results, use a cabinet scraper to remove scratches between grit changes.
- You probably won't want to stain cherry, except to blend sapwood with darker heartwood. For control, we recommend aniline dye. To hasten cherry's natural tendency to darken, mix a solution of 1 or 2 ounces of sodium hydroxide (lye, poisonous) to a gallon of water, brush it on the wood, then neutralize with water. Experiment for shades.
- Although oil finishes and clear lacquers or varnishes work equally well on cherry, you'll get a smoother finish on this fine-grained wood if you thin the first coat to act as a sealer. Then, sand with 400-grit or 0000 steel wool after it's dry and recoat.

### Carving comments

Although hard, black cherry takes detail and finishes beautifully. *For an eye-catching, natural-finish carving, follow these suggestions:*

- Flat-sawed wood has the most grain pattern; quarter-sawed boards (growth rings perpendicular to the width of the board), the least.
- Power-carving tools fit black cherry. Use carbide burrs.
- To remove small scratches on the finished carving, first sand with a coarse sanding drum followed by a fine sanding drum. Then, go over the piece with a coarse sanding disc, using a rocking motion. Hand-sand with 150-grit, then 320-grit.

### Turning tricks

Cherry turns nearly effortlessly, as long as you use sharp tools to shear the wood. To sand, shut off the lathe and start with 150-grit, working only with the grain. ♣

### SHOP-TESTED TECHNIQUES THAT ALWAYS WORK

*Any exceptions, and special tips pertaining to this issue's featured wood species, appear under headings elsewhere on this page.*

- For stability in use, always work wood with a maximum moisture content of 8 percent.
- Feed straight-grained wood into planer knives at a 90° angle. To avoid tearing, feed wood with figured or twisted grain at a slight angle (about 15°), and take shallow cuts of about 1/32".
- For clean cuts, rip with a rip-

profile blade with 24–32 teeth. Smooth crosscutting requires at least a 40-tooth blade.

- Avoid drilling with twist drills. They tend to wander and cause breakout. Use a backing board under the workpiece.
- Drill pilot holes for screws.
- Rout with sharp, preferably carbide-tipped, bits and take shallow passes to avoid burning.
- Carving hardwoods generally means shallow gouge bevels—15° to 20°—and shallow cuts.

### BLACK CHERRY AT A GLANCE

Cost	\$ \$ \$ \$ \$
Weight	Ⓜ Ⓜ Ⓜ Ⓜ Ⓜ
Hardness	T T T T T
Stability	▲ ▲ ▲ ▲ ▲
Durability	⌚ ⌚ ⌚ ⌚ ⌚
Strength	🦵 🦵 🦵 🦵 🦵
Toxicity	☠ ☠ ☠ ☠ ☠
Workability	🔪 🔪
Look-Alike	
Beech, Honduras mahogany	

# BOOMER'S PEOPLE

A California carver mingles memories with mountain manzanita

A carving seen while teaching high-school industrial arts in Hawaii changed Bob Boomer's life. "It rekindled a childhood interest," says Bob.

Now, the Ahwahnee, California, carver gets top dollar for his work, and doesn't regret giving up a teaching career. "I've never looked back," he says.

*Continued*



"Waiting" depicts the Indians of Southern California's Mojave Desert.

# BOOMER'S PEOPLE

 Print this article

**T**wo miles up the mountain road from his Ahwahnee, California, home, Bob Boomer lets up on his truck's accelerator, swings into a small clearing, and stops. Getting out, the lanky carver strides toward a large stone surface in the ground. Five, maybe six, feet across, it resembles a tabletop set in the earth.

"Here's where the Indians camped, and this is where they ground their acorns," Bob

*Right:* For this Hawaiian dancer, Bob chose a manzanita chunk with the perfect shape to represent movement.

*Far right:* "Wind Mother," from red cedar root, with a wing forming a blanket, has the natural movement Bob likes in his raw material.

says. Nodding toward the rock, he points out a dozen or more cylindrical holes about the diameter of a coffee mug and twice as deep. "They pounded the acorns with stones in those holes—like working a mortar and pestle," he explains. "Then, they poured water through the ground meal to remove the tannic acid. When the bitterness was gone, the meal was ready to cook into mush. I still imagine the Indians kneeling here, pounding acorns." A smile dances across his boyish face as he adds, "I've been told it tasted a little bit like dirt."

Bob, in fact, does more than conjure up images of Native Americans for his mind's eye, he regularly depicts them in his carvings. "I'm not an expert on Indians by any means, but they've always fascinated me," says the 47-year-old craftsman. "I've done Hopi, Navajo—Southwest Indians—and even Hawaiians, because they were colorful and people seemed to recognize them better. But when I do a seated piece, such as an Indian grinding acorns or with a basket, they'll be Indians from California tribes. They're the ones that visited places like this."



## The San Joaquin shapes a carver

Bob grew up on a small farm along the Brenda Slough in the agriculturally rich San Joaquin Valley, near Chowchilla. "The town was named after a tribe of Indians from the Sierra Nevada Mountains. My father would take us camping and trout fishing up there. In some places," he recalls, "we would find lots of obsidian chips, left behind from the Indians' arrowhead making—and, if we were lucky, an arrowhead."

The carver has a vivid memory of those teenage times and Indian sign, but no less so the opportunities he had to work wood. "As kids, we helped on the farm and at my uncle's ranch. I drove the tractor, plowed, irrigated, and picked cotton," he says.

"We didn't have television until I was 13 or 14, so for entertainment," Bob continues, "we'd make something in my Dad's basement shop. Or, my grandfather's—he was a cabinetmaker on the side. I remember walking into his woodshop and smelling walnut, maple, and oak."

The young California farm boy learned to whittle, carving patterns he found in *Boy's Life* magazine. But, during senior high school and college Bob abandoned carving, only rekindling an interest in 1968, the year he and Carol, his wife, finished their degrees and taught in Hawaii.

After returning from the islands, Bob took a teaching position in Madera, California. There, his pursuit of carving, and his production, grew. "By my eighth year, I made the equivalent of half my teaching salary from carving, and decided to try it full-time."

Now, as a successful carver, Bob portrays more and more subjects that he's familiar with, such as his California Indians, field workers picking grapes or cotton, a woman behind a pioneer plow. "I really give my uncle credit for instilling in me the love of manual labor," Bob says, in reference to the past. "Now, that all ties in with the figures I do of people working. It's a simple existence, there's beauty in it, and I'm drawn to those subjects. And, it's a perfect match for the wood."

## People of the soil from mountain stock

Bob's hands create the carvings. Only nature, however, could perfect the wonderfully multicolored and irregularly shaped manzanita that he retrieves from the nearby Sierra National Forest. Growing at elevations from 3,000' to 8,000', manzanita (*Arctostaphylos pungens*) primarily appears as a 4'- to 6'-tall shrub, capable of offering only its root burl to woodworkers. Yet, in areas on the west side of the Sierra Nevada, just below the grandness of Yosemite National Park, manzanita grows to tree-like proportions. And, it's these twisted limbs—sometimes as big around as a man's thigh—that Bob seeks.

"Under the Forest Service's firewood permit," he notes, "I can only cut dead and down wood—up to two cords a year. So I drive around looking for big manzanita that's completely dead, with a minimum of real wide cracks. And, the wood I cut has to have a natural flow or curve, not standard straight-grained stuff."

*Continued*



# BOOMER'S PEOPLE

Bob doesn't worry about sealing the wood for seasoning. The natural cracks that developed when it dried on the mountainside become visual elements in his statuesque carvings.

"Some holes, such as from bugs," he says, "just have to be filled, though. I do that by sanding at the belt sander to get some fine dust, then I mix it with epoxy, and press it deep into the hole. If there's a wide crack, but the piece is still pretty enough to carve, I drill a hole across the crack, and plug it with a manzanita dowel, then sand it flush. That keeps it from opening up any further. The plug ends up looking like a small knot."

Sometimes, though, despite his hole-filling and crack-plugging, the wood surprises Bob. "Like on this piece," he says, sliding the edge of a carving chisel into a deep cut in a half-finished figure. "I started cutting here, and ants poured out! When that happens, I'll just throw it out, if it's not an exceptional piece of wood. A good one, I'll fumigate."

Since there's always a chance that dead, downed wood corrals tiny livestock, Bob has all of his carvings professionally fumigated with methol bromide (a pesticide used on California-grown fruit exported to Japan) in a pressure chamber at the U.S. Department of Agriculture facility in Fresno. "I have six or

*Left:* "Homeward," a 22"-tall, Southwest-themed double-carving, may bring \$3,000 to \$4,000 or more in a gallery.

*Below:* Bob adds fine detail to his carvings in hard manzanita with a dental burr in a pneumatic handpiece.

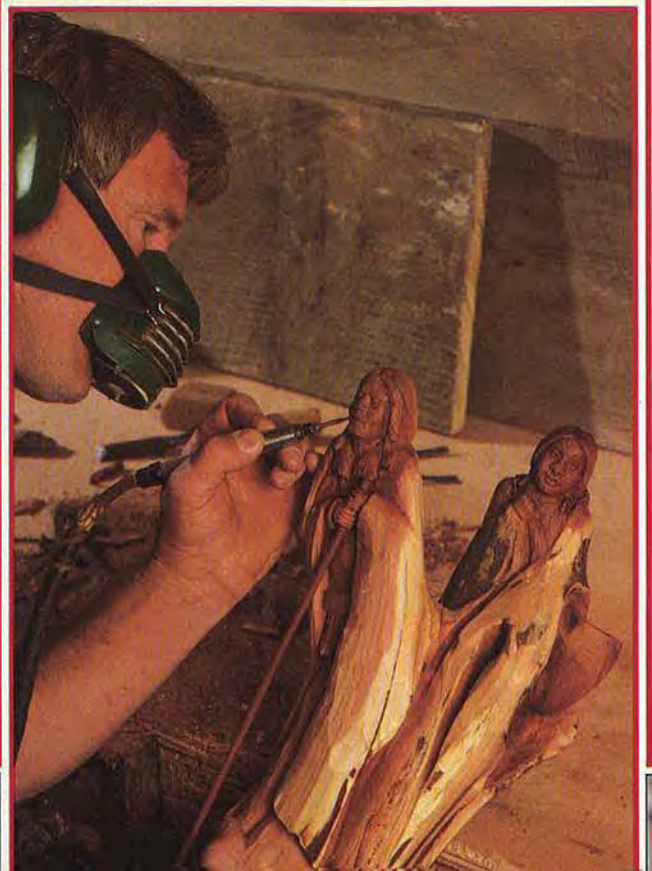



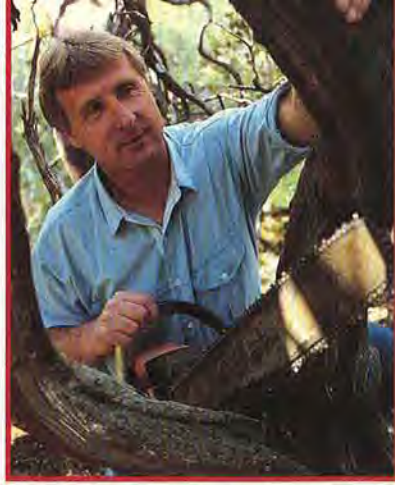

**Above:** A mountain manzanita tree like this grows only at or above 3,500' altitude. Short at 10' tall, its branches may spread out 20' in diameter.

eight carvings fumigated at a time," he says. "After they're treated, I apply the finish."

### **Wood that moves for carvings that catch the eye**

To most woodworkers, wood that moves implies instability. Movement, though, is exactly what this accomplished carver strives for. "I want my carvings to *look* as if they're about to do something, to have some movement," he comments. "It catches people's eyes."

Untrained in art, and limited in drawing skills except for rough sketching, Bob relies on video technology to capture the movement he wants in a carving. "I take my video camera down into the valley, and shoot workers picking grapes, for instance. Then, when I replay it through the VCR, I stop-frame the scene and do a quick sketch of the movement," he explains.

Sometimes, Bob has the subject for a carving all sketched, then tries to find a piece of wood that will work. "At other times, it's just the opposite—I find a piece of wood that's great and rack my brain trying to see what that form could be doing," he says. "With my seated Indian woman [see page 29], for instance, I found a cedar root that swept out like that, so the flowing wood became her blanket fluttering in the wind. You see, a bust, a head, is not a challenge if all I have to do is carve the wood away. There's a

big difference between working a face somewhere into the wood, instead of transforming all the wood into a face."

The carvings standing around Bob's rustic workshop—none more than 24" tall—reflect the combination of natural wood and what he decided to add to it. At one end of his bench stands an unfinished pair of Indian women, the figures hewed from a double-trunk projection of manzanita. Near the wood-burning stove, next to a pile of stock yet to be touched, is a semi-completed figure of a Hawaiian dancer, the head and naked torso shaped from dark heartwood and contrasting with untouched sapwood.

"I try to make the natural wood and my carving on it go together," Bob points out. "They have to balance. Sometimes, I just want to preserve as much of the beautiful color and form of the wood as possible, but I always have to ask, 'Just exactly where on the wood will I do my carving?'"

### **Manzanita meets the mallet**

Bob began carving with a mallet and chisels, and stuck with them when he turned professional. After a year, though, he realized that he had to increase his production just to make ends meet. His answer—a Bosch die grinder to rough out the hard manzanita. "I was doing OK, improving my work with the tools I had. Then, I had a visitor," Bob recalls.

His visitor, a middle-aged German man, apprenticed as a child to a master carver. "He knew which tools to use and how to use them," he says. "He was outspoken, critical, and a bit arrogant. When he asked to see my shop, I couldn't say 'No.' Then, he dissected me pretty severely, but in a good way," Bob comments, making a playful grimace. "He looked at my tools and said 'No good' about everything except the grinder. Yet, he noted that I didn't have the right cutters."

As Bob remembers it, the drop-in carver then fetched a tool catalog from his car. "He pointed out the carbide, spiral cutters that are safer, and the right shapes. From then on, my work was better."

That he turns to grinders and other power tools to carve doesn't phase Bob a bit. "I'm no purist," he admits. "With the 30,000-rpm die grinder and a spiral cutter, I can remove wood quickly. I still use a mallet and 1" framing chisel once in a while—and can take off wood nearly as fast."

For detailing, Bob bought a Dotco pneumatic handpiece (usually used for industrial deburring) and a variety of bits, including dental burs for extremely fine work on faces. He powers it with a compressor that, because of its noise, sits about 30 yards away from the shop. The air arrives via galvanized pipe.

Sanding consumes about 75 percent of the time Bob spends on each of his works, even though his carvings feature some natural, untouched surfaces. To remove tool marks, he starts with 100 grit. Then, he moves on to 180 grit, 220 grit, and before finishing, 0000 steel wool. To get into detailed areas, such as on a face, Bob tapes sandpaper around a piece of vacuum hose slipped over a section of ¼" steel rod inserted in the chuck of a portable drill. "And, because I was going through so many drills," he notes, "I switched to an industrial-grade one that turns at 4,000 rpm." Bob also saves money by cutting his own sanding disks. He attaches them with rubber cement to the face of the drill insert.

"I've tried all types of clear finishes for the manzanita," Bob remarks concerning his final step. "Watco oil seems to work best. I put on one heavy coat, wipe it off after 30 minutes, then put a second coat on several days later. I don't want too much shine. It would take away from the wood—and my people." 🌲

Written by Peter J. Stephano    Photographs: Dan Sullivan



Like many of you, I make every attempt to collect sawdust at its source. And, when I'm finishing or refinishing a project, I always ventilate a room. But no matter how hard I try, some sawdust and vapors always wind up in the air. Since I don't like to gamble with my health, I decided to get the lowdown on respirators. Now, I know what products will protect my lungs, and I'm breathing a whole lot easier.

*Bill Kier*  
Products/Techniques Editor

# The woodworker's survival RESPIR

## WHEN DO YOU NEED ONE?

For a long time, I've known that many of the chemicals found in oil-based finishing and refinishing products can harm my health. Lately, the effects of wood dust have received a lot of attention, too. To get the official word on wood dust, I called my local OSHA (Occupational Safety and Health Administration) office. The industrial hygienist there told me that OSHA considers all wood dust hazardous to health, and has recently lowered the permissible exposure levels

for wood dust in the workplace.

How do you know if the air in your home shop has too much wood dust? You don't, but as Dick Flynn of North Safety Equipment told me: "The bottom line is that if you're working with wood and creating dust—regardless of your collection procedures—you should always wear a respirator."

*Note: For more information on how to properly use a respirator, see the article on page 84.*

## BUY A NIOSH/MSHA-APPROVED MODEL

All of the manufacturers I spoke with said a woodworker should settle for nothing less than a respirator jointly approved by the National Institute for Occupational Safety and Health

(NIOSH) and the Mine Safety and Health Administration (MSHA). These organizations approve respirators for specific hazardous substances. For example, you need to wear a dusts/mists-approved respirator when sanding. For applying finishes, strippers, or other oil-based products, look for a gas/vapor-approved unit. Gas/vapor respirators typically have dust/mists-approved prefilters.

With this information in mind, the large number of non-approved dust masks on the shelves of my local hardware and discount stores startled me. For instance, the most widely sold masks—commonly labeled "nuisance masks" or "nontoxic dust masks," such as the one shown on the left in the photo at left—have no approval rating. Manufacturers told me they recommend these masks only for nontoxic dusts.



A typical nuisance mask such as the one at left has one strap and a thinner filter material than its NIOSH/MSHA-approved counterpart at right.

 Print this article

# guide to buying... **RESPIRATORS**

## CARTRIDGE-TYPE REUSABLE RESPIRATORS: THE VERSATILE CHOICE

Unlike disposables, reusable respirators hold interchangeable cartridges for absorbing a wide variety of pollutants. A separate prefilter as shown at *right* fits on top of the cartridge for catching large particulates.

These respirators cost \$20-\$25 just for the facepiece (without cartridges or prefilters), but offer a cost advantage over disposables if you frequently need a respirator. For example, one change of gas/vapor pre-filters and cartridges costs \$8-\$14, compared to about \$11-\$15 for equivalent disposables. Dust/mist cartridges and prefilters will cost about \$4 to \$5 per change.

After wearing reusable and disposable respirators from several manufacturers, I noticed that the reusables formed a slightly tighter seal against my face. Don Reycroft of North Safety Equipment agreed with my findings:



Reusable respirators have screw-in cartridges, prefilters, and plastic caps for holding the prefilters atop the cartridges.

"The soft silicone facepiece of reusables conforms better to facial features."

On the other hand, disposables weigh less and don't interfere with your line of sight as much as cartridge types. Since you just throw them away, you don't have to bother with cleaning disposables or changing exhalation and inhalation valves.

## THE BEST OF BOTH WORLDS?



3M's disposable Easi-Care respirator looks like a reusable mask, but costs just a few dollars more than other gas/vapor-approved disposables.

Recently, a friend in the auto-body business tipped me off to a disposable mask that costs \$14 to \$17, but looks and works like a cartridge-type mask. Naturally, I just had to check out his claims. Sure enough, the 3M Easi-Care paint-spray respirator shown at *left* has a supple facepiece that fits as tightly as any cartridge-type respirator. Although you can't change the cartridges, you can replace the prefilters several times before the cartridges wear out. My distributor charges about \$8 for a pack of 10 prefilters.

## DISPOSABLES: THE CONVENIENT CHOICE

If you have only occasional need for a respirator, a disposable unit might be your best buy. In the past several years, throwaway respirators have become increasingly popular. When choosing a disposable, keep in mind that some models (such as the one I'm wearing on page 32) have exhalation valves. These one-way valves add to the cost, but help reduce heat and condensation inside the mask.

### For more information

- **Moldex/Metric.** Call 800-421-0668 or 213/870-9121.
- **North Safety Equipment.** Call 401/943-4400.
- **3M.** Call 800-328-1667 or 612/733-8029 for retail sources; for respirator advice, call 800-243-4630 or 612/733-6234. ♣

Photographs: Bob Calmer

# CARVE A CANVASBACK

## Drake and hen wall plaque

When Jim Barnett, a local carver, showed me his duck wall plaque, I was impressed, but skeptical. I have a hard time carving the Thanksgiving turkey, much less this eye-catcher. "Not to worry," Jim assured me. "All you need are just a few carving tools, one piece of  $\frac{3}{4}$ " stock, a child's watercolor set, and some step-by-step instructions." Sure enough, within two hours, I had my project all carved and ready for finishing. I was so pleased with the results, I decided to present the carving to my father, an avid hunter.

*Markus Kemmet*  
How-to Editor

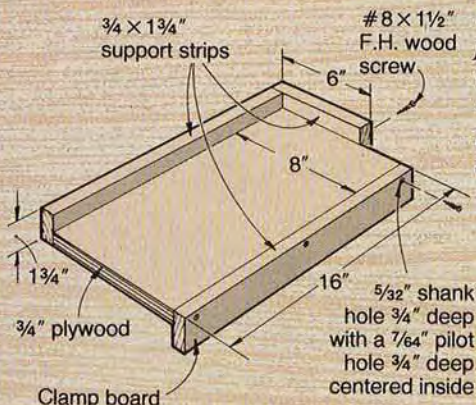

### Cut the stock and transfer the pattern

**1** Cut a piece of  $\frac{3}{4}$ "-thick stock to 5" wide by  $14\frac{1}{2}$ " long. (We used butternut; see the Buying Guide for our source. You also could select walnut, sugar pine, basswood, chestnut, white pine, jelutong, or Ponderosa pine.)

**2** Mark a reference line 1" from the bottom edge of the blank. With carbon paper, transfer the full-sized Duck pattern on page 36 to the carving blank, aligning the bottom of each duck's body with the marked reference line.

**3** Rout or cut a 45° chamfer along the face edges of the blank.

**4** Using the full-sized pattern for reference, mark an oval reference line around the duck-body outlines. You'll need the oval for cut locations when removing the background material later.

### Let the carving begin

*Note: Relief carvers employ a variety of setups to secure their workpieces. We prefer a bench hook like the one shown at left. By placing your carving blank on the base, you can comfortably carve in several directions before turning the blank around. Secure the clamp board in the jaws of your vise to hold it steady. Always carve toward one of the support strips—never toward your body.*

**1** With a  $\frac{3}{16}$ " or  $\frac{1}{4}$ " V-parting tool, cut on the outside of the marked line to carve the outline of both ducks as shown in the photo at right. See the Buying Guide at the end of the article

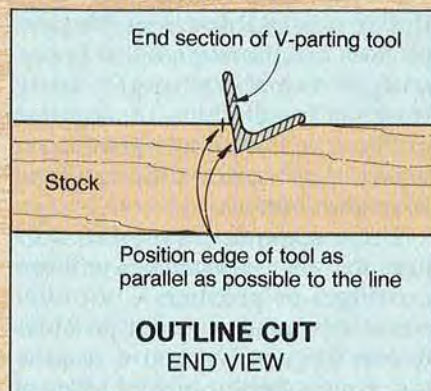

for our source of tools. See the drawing above for reference when angling your tool to make the line. Do not carve away the line. If you're right-handed, drive the tool with your right hand and guide the tool with your left. Jim Barnett, the carver shown in the



Cutting just outside the marked outline, use a V-parting tool to outline both the drake and hen bodies.



### GROUNDING THE BACKGROUND

After grounding, clean this area with the V-parting tool.

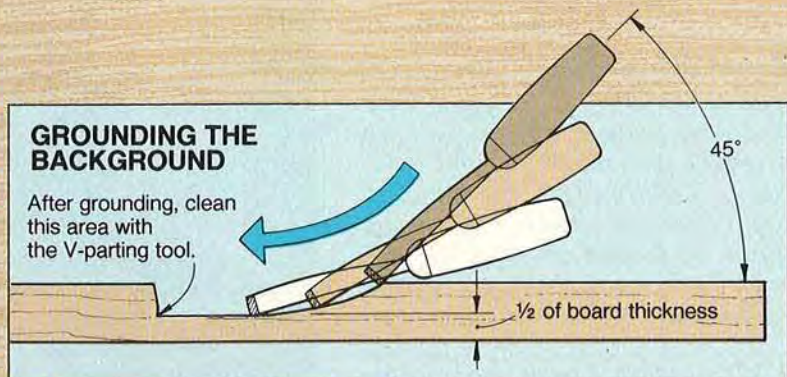

photos throughout this article, happens to be left-handed. (We made our first outlining cuts about  $\frac{1}{8}$ " deep. Then, we carved a second and third set of cuts, deepening the groove to about  $\frac{3}{8}$ ".) The normal cutting depth for a low-relief carving is half the thickness of the wood.

**2** With a  $\frac{3}{8}$ " or  $\frac{1}{2}$ " no. 7 gouge, remove the stock (a process called grounding) between the oval reference line and V-groove outline as shown in the photo *below*. To make these cuts, start just on the *inside* of the marked oval reference line, and with the scooping motion shown in the drawing titled Grounding the Background Cuts, push the gouge into the wood at about a  $45^\circ$  an-

gle. Lay the tool nearly flat as you take out the long slices. Do not make the bottom of the grounding cut deeper than the V-grooved outline cuts.

**3** Utilize the V-parting tool to remove splinters at the end of the gouge grounding cuts and next to the V-cuts where shown on the drawing *above*.

**4** With a  $\frac{3}{8}$ " no. 3, 4, or 5 gouge, make shallow cuts to round over the edges of both duck bodies as shown in the photo *below*.

**5** Using a V-parting tool, make a shallow V-cut for the lower mandible (a duck's lower bill) on each duck. See the full-sized Duck pattern on the following page for reference. Utilizing the same tool, make a shallow cut for the nostril

on each bill. Then, make an even shallower cut where the bill meets the head (this cut separates the head and bill, and simplifies painting the ducks later).

**6** With a  $\frac{3}{8}$ " no. 6 gouge, make a single pass to form the eye channel and cheek. Next, use the gouge to form the neck recess as shown in the photo *below* and located on the full-sized pattern.

**7** With the V-parting tool, make three cuts to form the wing feathers on the back of each duck body. Repeat the process to form the tail feathers.

**8** Utilizing the  $\frac{3}{8}$ " no. 5 gouge, smooth out the tool marks on each duck. Make very shallow cuts to remove the high spots.

*Continued*



With a  $\frac{3}{8}$ " or  $\frac{1}{2}$ " gouge, start just inside the marked oval to remove the background next to the duck.



Make shallow cuts with the gouge to round over the outside edges of both duck bodies.



Use the  $\frac{3}{8}$ " no. 6 gouge to form the neck recess. Start at the neck center and work to the outside.

## CARVE A CANVASBACK

### Color brings the ducks to life

*Note: We painted our ducks with a child's watercolor set and a 1/4" brush. Lightly apply the paint to the wood to avoid hiding the grain. To darken an area, use several light coats instead of one heavy coat.*

**1** With a 1/4" brush, paint the drake's breast and tail section black. Carefully paint the areas just next to the background to avoid having the paint bleed onto the background. If it does bleed, make a shallow cut with a gouge to remove the colored portion of the background.

**2** Mix black and just a dab of yellow ochre to paint the bills. Mixing the yellow with the black



Paint the drake's eye red with a fine-tipped brush.

### FULL-SIZED PATTERN

1 × 5 × 14 1/2" butternut

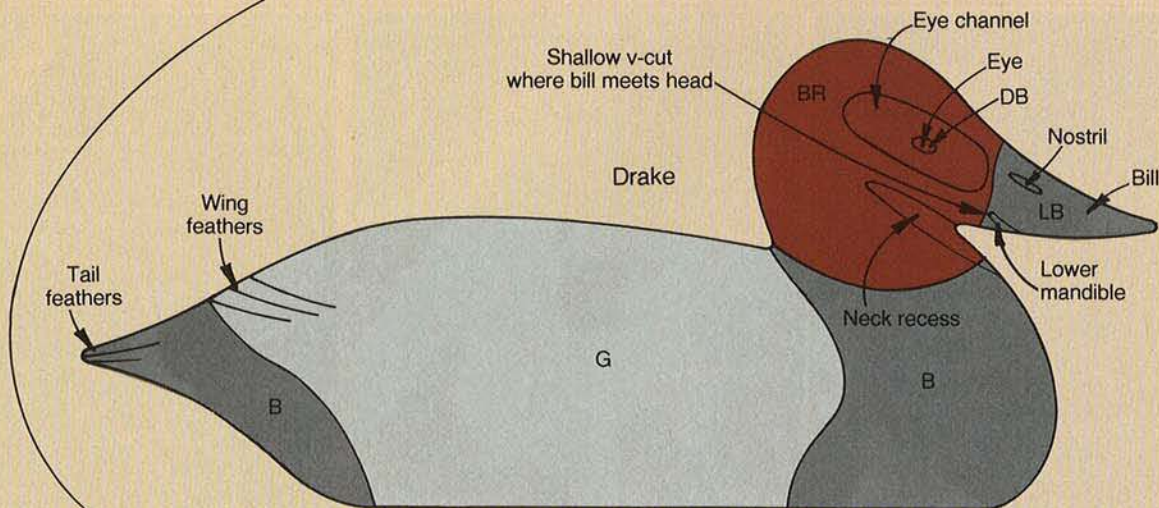

results in a lighter, more natural-colored bills. Apply light coats. If the color is too transparent after it fully dries, add another coat.

**3** Mix a light gray for the body portion of both ducks by blending white and just a touch of black. Brush on the paint.

**4** Using burnt umber (medium brown), paint the head, breast, and tail area of the hen.

**5** Mix red and burnt umber to form a brick-red color, and paint the drake's head.

**6** Using a fine-tipped brush, paint the drake's eye red and the hen's eye dark brown. To avoid smudging or running, let the paint dry completely before painting the pupils in the next step.

**7** With a black fine-tipped felt marker or the tip of a fine brush, add the black pupil to each duck's eye. To prevent smudging, let the paint dry for an hour or two before applying the sealer (if necessary, you can speed up the process with a hair dryer).

**8** Lightly wipe on a finish. (We left the butternut natural and sealed the wood with Watco Danish Oil.) The oil slightly darkens the butternut, making the use of a stain unnecessary.

**Supplies:**  $\frac{3}{4} \times 5 \times 14\frac{1}{2}$ " carving blank, water colors, clear satin finish (oils work well).

## Buying Guide

• **Carving tools.**  $\frac{1}{4}$ " V-parting tool, catalog no. 18A52, \$7.90.  $\frac{3}{8}$ " no. 6 gouge, catalog no. 18C11, \$7.90.  $\frac{3}{8}$ " no. 5 gouge, catalog no. 18A41, \$7.90. Complete kit of three tools for \$19.95 ppd., catalog no. 18A61 (for the set), from Woodcraft, 210 Wood County Industrial Park, P.O. Box 1686, Parkersburg, WV 26102. To order, call 800-225-1153.

• **Butternut.**  $\frac{3}{4} \times 5 \times 14\frac{1}{2}$ ", \$3.95 ppd. for one, or two for \$6.95 ppd. Canadian readers add \$2 per order for additional postage. The Woodcraft Shop, 2724 State Street, Bettendorf, IA 52722. Call 800-397-2278 or 319/359-9684. ♣

Produced by Marlen Kemmet  
Project Design: James R. Barnett  
Photographs: Bob Calmer; Hopkins Associates  
Illustrations: Kim Downing; Bill Zaun

### COLOR KEY

B - black  
LB - light black  
G - gray  
BU - burnt umber  
BR - brick red  
DB - dark brown

Oval reference line

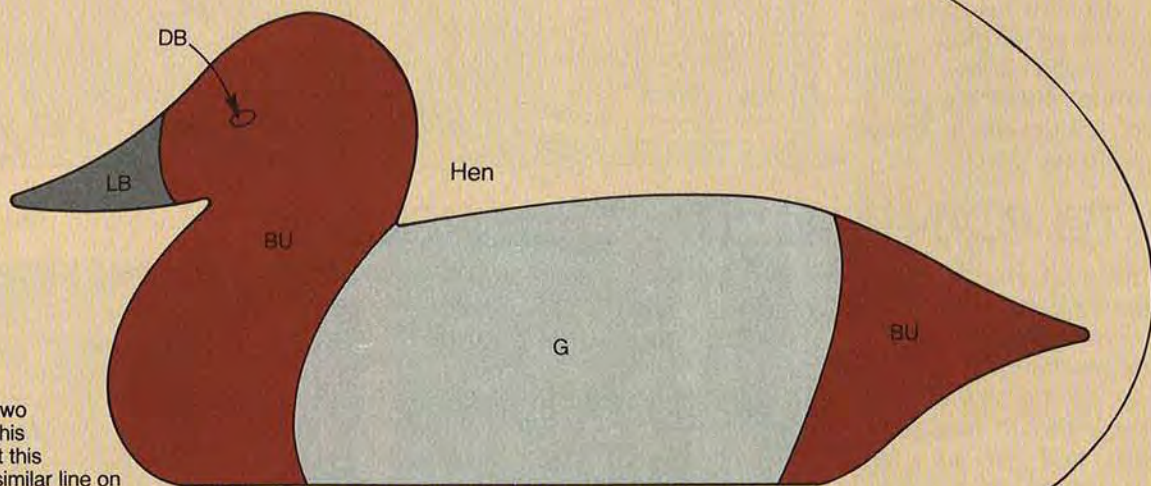

Join the two sides of this pattern at this line and similar line on other half of pattern.

Chamfered edges



ADD THE CROWNING TOUCH TO YOUR PROJECTS

# LARGE-SCALE MOLDINGS

Like the gingerbread trimmings on a Victorian home, large-scale moldings such as those at *right* lend stately elegance to projects from curio cabinets to clocks. And surprisingly, you don't need a lot of fancy jigs or tools to make them. Come along and we'll show you how it's done.

Although large-scale moldings appear complex, they're actually made up of several easy-to-make smaller moldings. It's not until you stack moldings together that they take on a look of "How did you ever do that?" To help you through the process, we'll show you how to plan the molding and how to shape its large components—coves, round-overs, bullnoses, and dentils—on your tablesaw. Then, you can combine these big pieces with smaller, router-made moldings for a stunning effect.

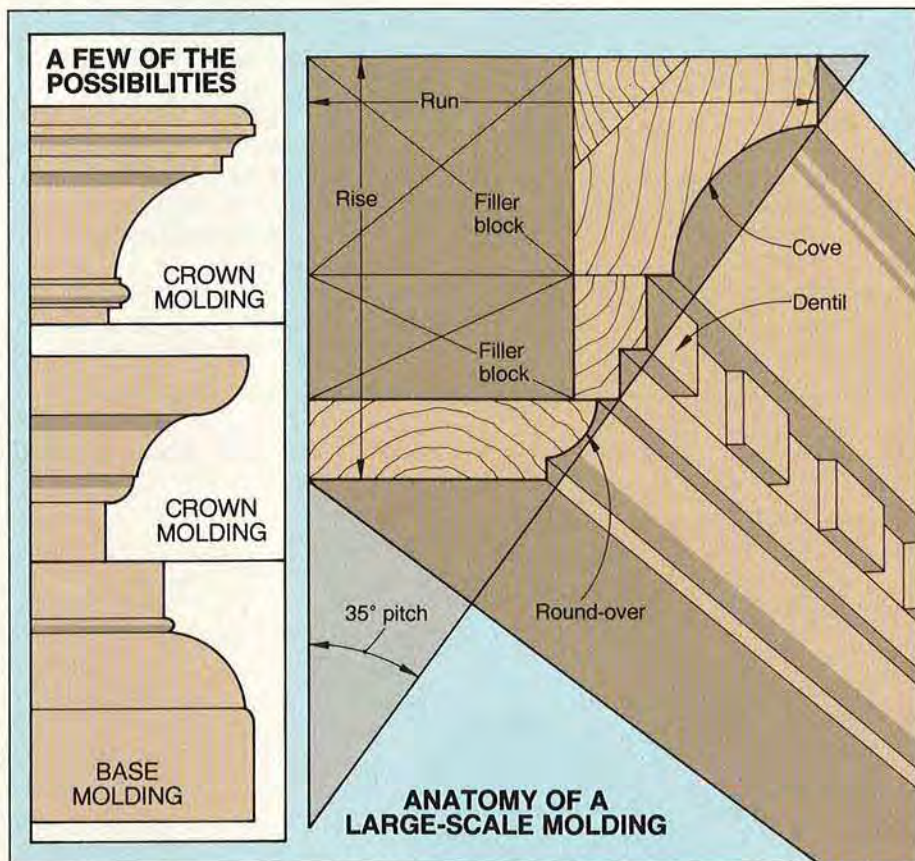

## HOW TO PLAN A LARGE-SCALE MOLDING

With the help of the cutaway drawing *above right*, you can design your own moldings by following these guidelines:

- Depending on the size of your workpiece, you should first determine the **rise** and **run** of a descending or ascending molding. You want the molding to be in proportion with the overall dimensions of the workpiece, neither overpowering its design nor too small to make an impact. This can be a tricky task, so you might

try browsing through your local furniture store for an idea of molding dimensions for pieces similar in size to your project.

- After determining rise and run, connect these perpendicular lines with an angled **pitch** line between 15° and 40°.

- Now, draw the profile of the molding, roughly following the pitch line for a smooth, flowing look. In this article, we'll show you how to produce these elements often found in large-scale

moldings: **coves** (concave curves), **round-overs** (convex curves), **bullnoses**, and **dentils**.

- You can mix and match these elements until you come up with a pleasing effect. But, before you cut and assemble the molding, make a full-sized cardboard profile. Hold this pattern in place on your project as a final check of its size and proportion.

- To help you get started, we've drawn three more variations as shown *above*.



# HOW TO CUT COVES WITH YOUR TABLESAW

Many large-scale moldings have fairly large coves plus several smaller moldings to enhance this prominent feature. Armed with the step-by-step instructions *below*, you can cut any of six different-sized coves shown on the next page.

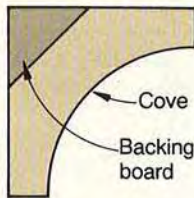

**1** Before you get to the fun part, though, you need to build the simple cove-cutting jig shown at *right*. This will enable you to guide the workpiece at an angle over the blade. After completing the jig, attach it to your rip fence. **2** After choosing a cove radius, check the chart on the following page for the depth of the cove. Raise your tablesaw's blade for the prescribed depth of cut, and mark a centerline onto the table-top directly over the saw arbor as shown *below*. Replace the saw's insert, lower the blade below the table, and extend the mark across the width of the insert.



With your blade set for the height of the final coving cut, mark the arbor's center on your table saw top.

*Continued*

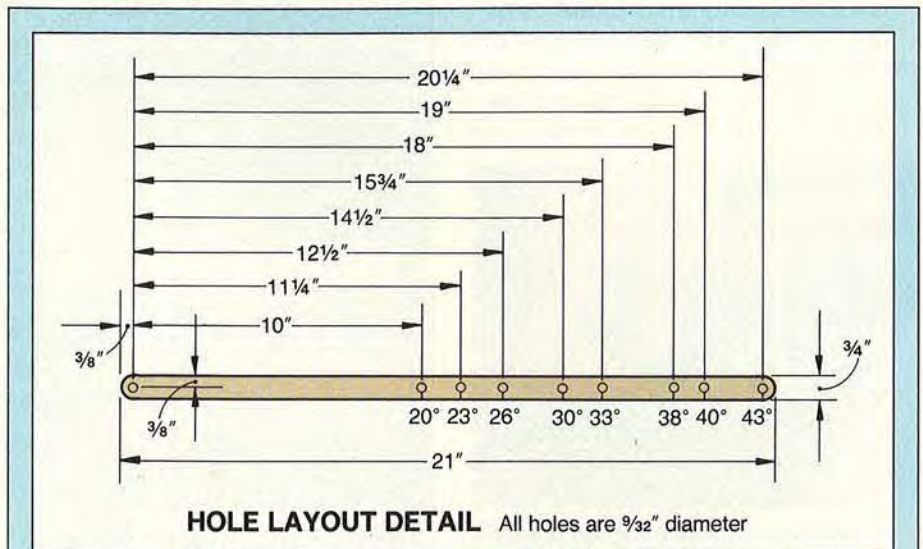

## HOW TO BUILD A COVE-CUTTING JIG

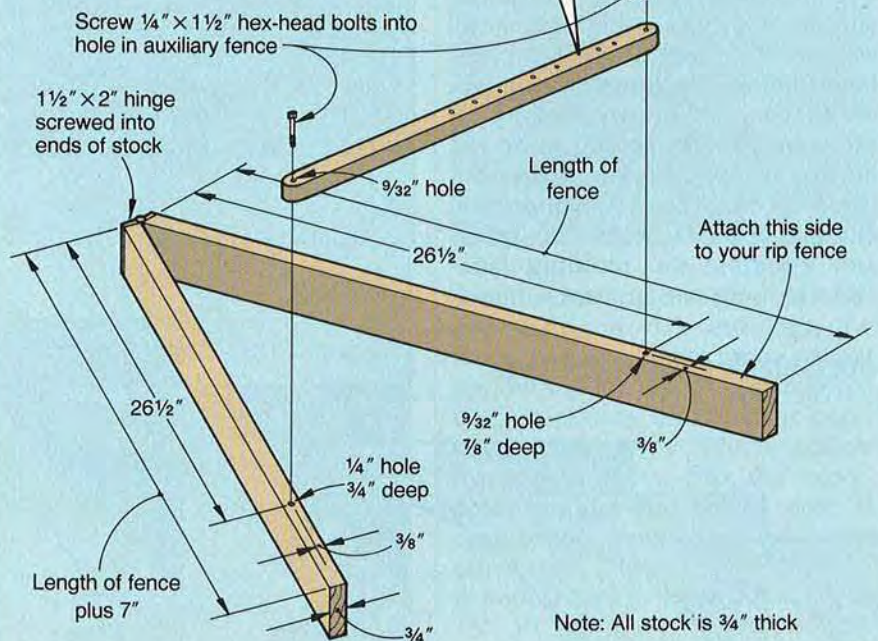



**3** Check the chart for the necessary fence angle and fence-to-blade offset. After adjusting the jig to the proper angle (see the drawing *below right* for how to do this), slide it toward the blade until you reach the desired fence-to-blade offset as shown *below*.



Set the auxiliary fence for the fence-to-blade offset by measuring perpendicularly from the fence.

**4** Now, refer again to the chart, and cut your stock to size. Be sure to cut the stock several inches long to allow for miter-cutting later. As you can see by looking at the cove profiles *below*, some require a backing board. This backing must be glued on before you cut the cove. It helps you miter and assemble the molding later and can be most any stock.

HANDY GUIDE TO CUTTING COVES WITH A TABLESAW (USING A 10" BLADE)						
Cove radius	Width of cut	Depth	Fence-to-blade offset	Fence angle	Cove stock thickness x width (inches)	Backing board thickness x width (inches)
3/4"	1 1/16"	7/32"	3/4"	20°	3/4 x 1 5/8	Not Needed
1"	1 13/32"	5/16"	1"	23°	1 1/16 (5/4 stock) x 1 3/4	Not Needed
1 1/4"	1 3/4"	3/8"	1 1/16"	26°	3/4 x 2 1/8	1/2 x 2 1/8
1 1/2"	2 3/32"	7/16"	1 1/4"	30°	3/4 x 2 1/2	3/4 x 2 1/2
1 3/4"	2 15/32"	1/2"	1 1/2"	33°	3/4 x 3	1 x 3
2"	2 27/32"	9/16"	1 5/8"	38°	3/4 x 3 1/4	1 1/8 x 3 1/4

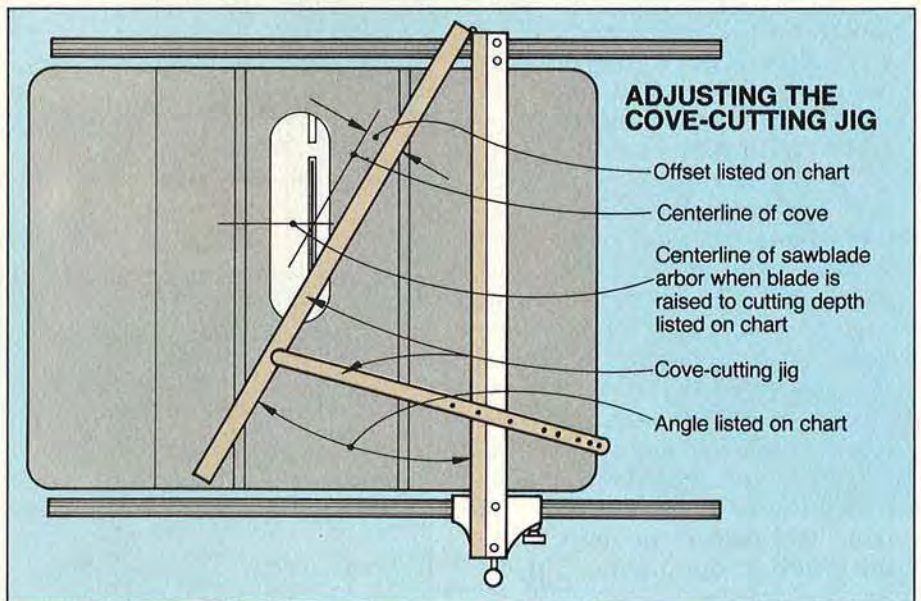

### FULL-SIZED COVE PROFILES

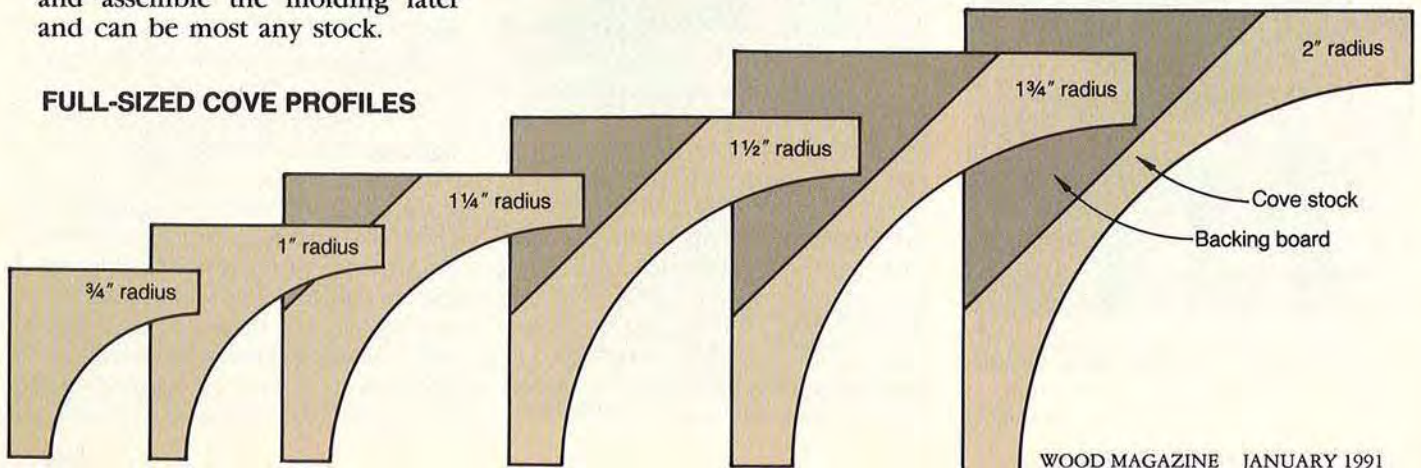

**Editor's note:** Before taking the next step, make some cuts in scrap stock to test your results.

**5** Raise the blade  $\frac{1}{8}$ " above the saw table, and pass the workpiece over the blade as shown below. Continue to raise the blade and take light cuts until you achieve the full depth of the cove. You can use any 10" blade, but we made our smoothest cuts with an 80-tooth, carbide-tipped blade, taking no more than  $\frac{1}{8}$ " of stock with each pass.



Masking tape, foreground, covers the unused opening in the table saw insert to reduce the flying sawdust.

**6** To sand the blade marks from the workpiece, make a custom sanding block by cutting off a slice of the cove profile, and transferring the cove shape to a block as shown in the inset photo below. Then, bandsaw the block to shape. As a sanding guide, draw pencil lines across the cove and sand the profile with 60-grit abrasive until the pencil lines disappear as we're doing below.

**7** Now, cut the workpiece to its final shape by making 45° rips in the sequence shown below.



As you sand the cove molding, be careful to remove only the saw marks. Smooth with 100- and 150-grit papers.

## 5 EASY STEPS TO A ROUND-OVER

Equipped with the right bit, you can safely rout round-overs up to a  $\frac{3}{4}$ " radius. But, if you don't have such a bit, or want to cut larger round-overs, then try this procedure:

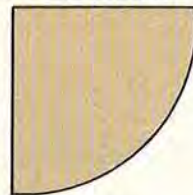

**1** First, attach an auxiliary fence of  $\frac{3}{4}$ "-or-thicker stock to your rip fence. Now, mark the desired radius on the end of the stock.

**2** Set your blade for a 45°-bevel cut and elevate the blade to the necessary height for removing the stock up to the marked radius as shown below. Set the workpiece aside, turn on the saw, and carefully slide your fence over until the blade cuts about  $\frac{1}{8}$ " into the auxiliary fence. Turn off the saw and align the fence and workpiece so the blade cuts just outside the marked radius. When you're satisfied that the cut will fall exactly on the outside of the line, make your cut.

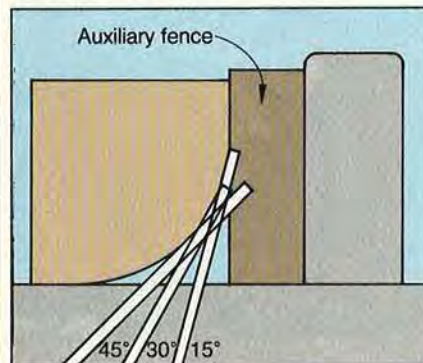

**3** Slide the fence to the side, set your blade at 40°, and align the fence and workpiece for a cut that removes stock up to the marked line. As shown on the next page, make a cut with Side A against the fence. Then, flip the workpiece end-for-end, place Side B against the fence, and make another cut.

**4** Repeat Step 3 with the blade at 35°, 30°, 25°, 20°, 15°, 10°, and 5°.

*Continued*

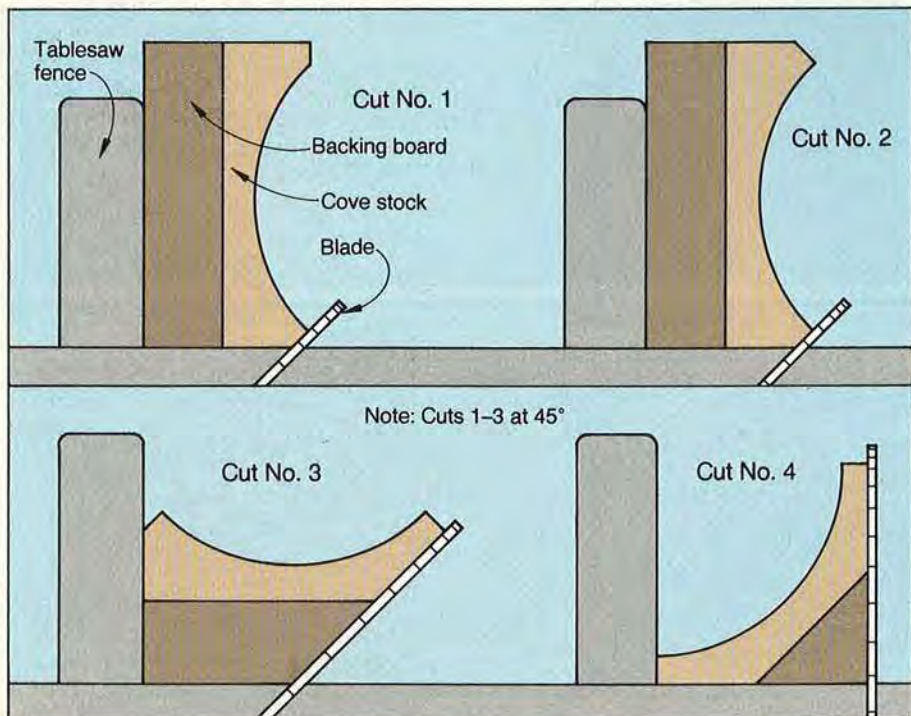

## 6 QUICK STEPS TO A BULLNOSE

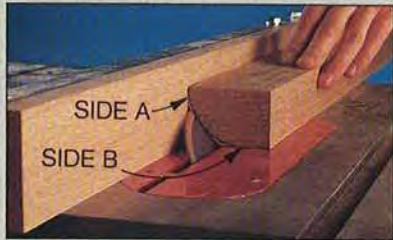
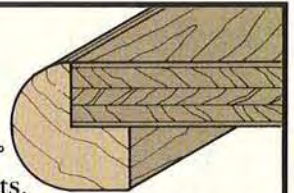

After completing a 45° bevel cut, make your first 40° cut with Side A against the fence.

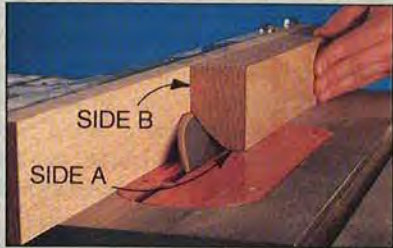

For the second 40° cut, flip the workpiece end for end and place Side B against the fence.

By taking the round-over procedure a few steps further, you can make a bullnose profile such as the one shown *above*. These large bullnoses also make an attractive edge on counters and tabletops.

Just mark the radius on the end of a workpiece and follow the 6-step procedure *below*. After mak-

ing the 45° and 40° cuts, repeat Steps 3–6 with the blade at 35°, 30°, 25°, 20°, 15°, 10°, and 5°. Then, transfer the radius to a sanding block and bandsaw it to shape as described in Step 5 at *left*. Smooth the facets with 60-, 100-, and 150-grit abrasives.

**5** Now, make a sanding block for smoothing out the facets. Start by marking the same radius on a 6"-long block of wood as shown *below*. After bandsawing along the marked line, apply 60-grit adhesive-backed sandpaper to the block and sand the facets.



Transfer the radius of your round-over to a sanding block, then bandsaw the block to shape.

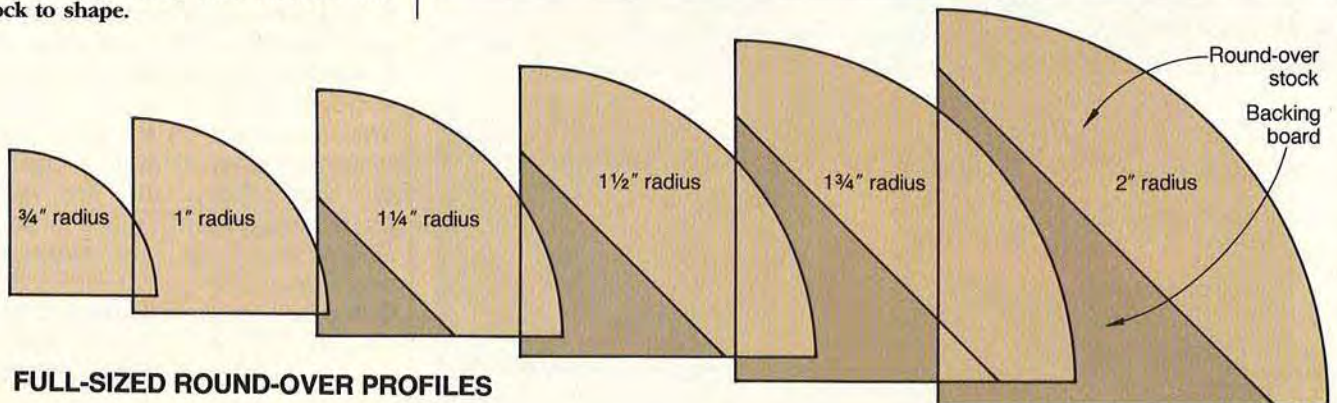
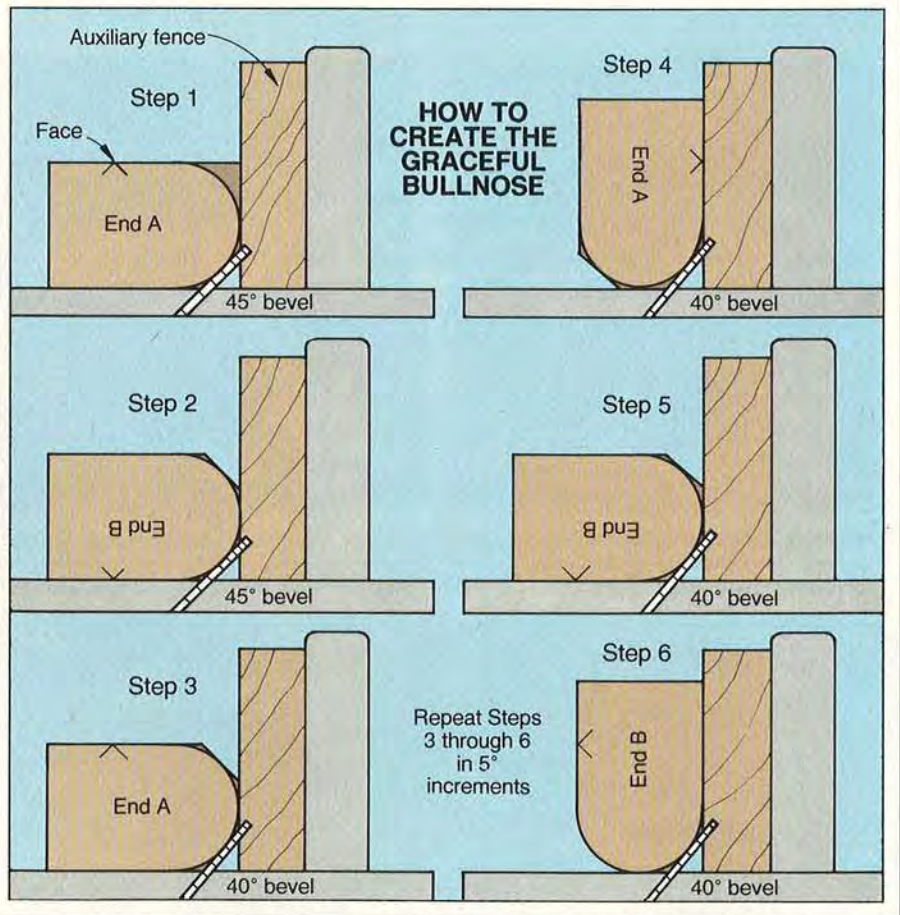

FULL-SIZED ROUND-OVER PROFILES

# ADD STATELY ELEGANCE WITH THE DENTIL PROFILE

As you can see by looking at the molding on pages 38 and 39, these projections help create a stately, architectural quality. Dentils work best when combined with a large cove molding.

Typically, a dentil has square teeth separated by a distance equal to the width of each tooth as shown by dimension X in the drawings at *right* and *below*. For furniture, X normally equals  $\frac{3}{8}$ " to  $\frac{3}{4}$ ", Y is equal to or less than X, and dimension Z should be about one-third of X. Here's an easy way to make a dentil:

**1** First, you'll need to construct a basic indexing jig similar to the one shown *below*. After attaching an auxiliary fence of  $\frac{3}{4}$ " plywood to your miter gauge, mount a dado blade in your tablesaw that's set to equal the width of one tooth (X). You'll get the best results with a sharp, stackable dado set that cuts a flat notch.

For this example, let's say X equals  $\frac{3}{8}$ ". In this case, you should cut a  $\frac{3}{8}$ " notch (marked Notch A in the drawing *below*),  $\frac{3}{8}$ " high through the miter-gauge auxiliary fence. Now, remove the fence and cut Notch B with exactly  $\frac{3}{8}$ " between the two notches. Then, machine a piece of stock that's  $\frac{3}{8} \times \frac{3}{8} \times 1\frac{1}{2}$ " and glue this indexing pin into Notch A so it protrudes  $\frac{3}{4}$ " out from the face of the fence.

**2** To cut the dentils, butt one squared end of your workpiece against the left side of the index-

ing pin and cut a notch into the workpiece. Place this notch over the indexing pin and make another cut. Repeat this process along the length of the workpiece as shown *below*.



Firmly hold your workpiece against the auxiliary miter-gauge fence as you cut the dentil notches.

**3** Next, cut a rabbet into the workpiece as shown by the shaded area on the drawing *below*. Then, cut the dentil to its finished width as shown by the saw kerf.

**4** Before you miter your dentil stock, plan each cut so you have a nearly complete notch or tooth at each corner. When the dentil stock meets at a mitered corner, notches should meet notches or teeth should meet teeth.

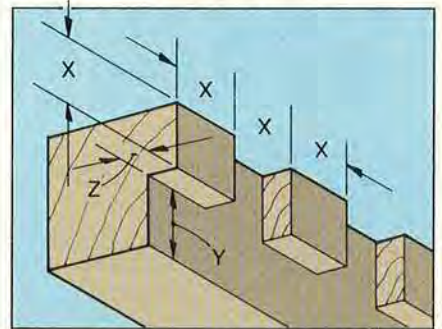
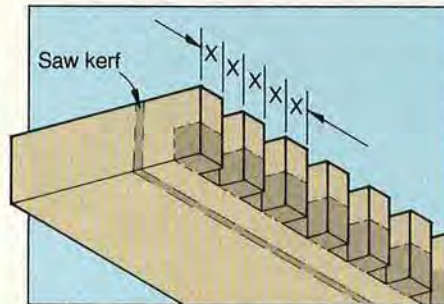

## Some tips for completing your large-scale molding

- Miter the individual moldings as you attach one layer at a time to your project. This way, you have better control over your miter cuts and can minimize any gaps between the pieces. Don't try to assemble the entire molding, then miter it and attach it to the project.

As you attach the layers, work from the bottom or top of the molding—the size of the molding and the project will dictate the most convenient procedure. For the gun case on page 44, we turned the cabinet upside down and started with the large cove moldings.

- As you glue together each layer, minimize nailing by clamping the pieces in place. (Don't forget to first dry-clamp the pieces in place to check for fit.) If you must use brads to adequately secure the piece, don't forget to predrill pilot holes. For a drill bit that's just the right size, just chuck one of the brads into your drill.

- Take your time to make sure the miters match closely. And, clean up any mismatched miters as you go rather than waiting until you completely assemble the molding to do any sanding or putty work. 🐿

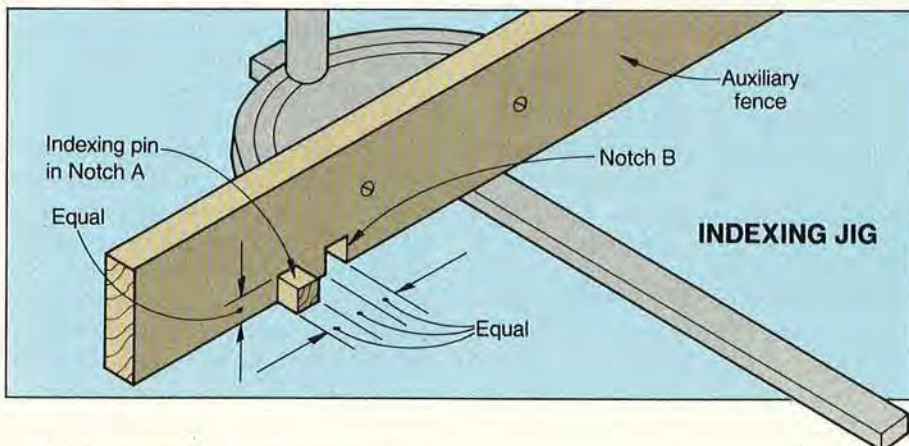

Written by Bill Krier with  
Jim Boelling and Jim Downing  
Illustrations: Kim Downing;  
Mike Henry  
Photographs: Bob Calmer

A High-Caliber Gun Cabinet

# SHARPSHOOTER'S

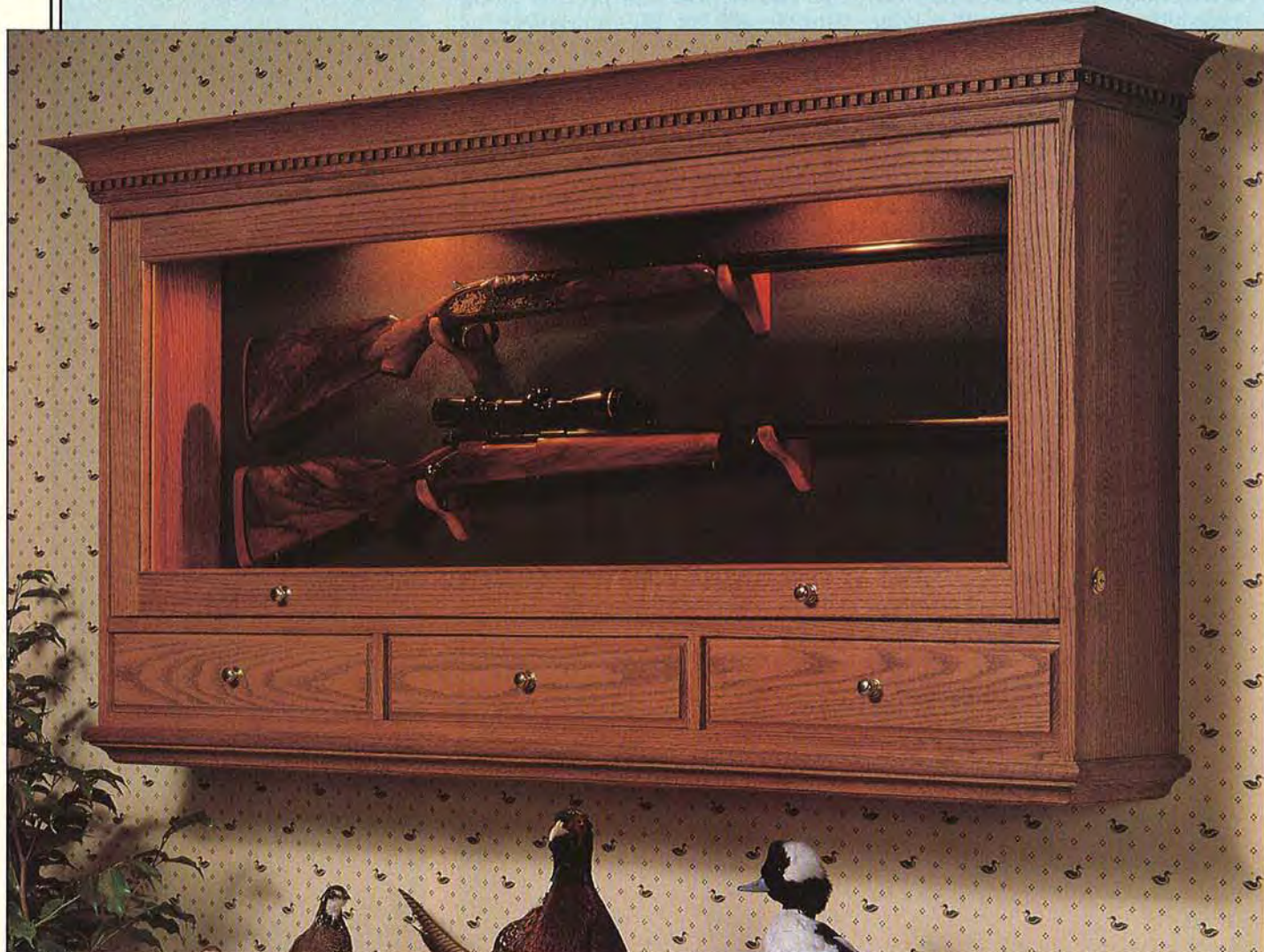

Every couple of weeks, we hear from a reader who's on the hunt for a gun cabinet. Not long ago, we decided to design one for all of you outdoor enthusiasts.

This handsome wall-hung unit features a lighted, lockable gun compartment with a  $\frac{1}{4}$ " safety-glass door. We've included locking pins that secure the three drawers, which can store gun-cleaning supplies and game calls.

For those of you who don't hunt or shoot, but like the looks of this unit, think about installing a shelf or two in the compartment and displaying other valued collectibles in this case.

*Note: For details on building the decorative moldings gracing the top and bottom of our wall-hung gun cabinet, refer to the techniques article starting on page 38.*

## Start with the basic cabinet

From  $\frac{3}{4}$ " oak plywood, cut the cabinet end panels (A), shelves (B), and dividers (C) to the sizes listed in the Bill of Materials on page 47. Note the grain direction shown on the Cutting Diagram before cutting the pieces.



Print this article

# SHOWCASE

**2** Cut or rout the  $\frac{3}{4}$ " dados and  $\frac{3}{4}$ " rabbets in the end panels and the bottom two shelves where shown on the Basic Cabinet drawing. (After marking the dado and rabbet locations, we placed masking tape along the marked cut lines. The tape supports the thin veneer and greatly reduces splintering when cutting.)

**3** Cut a  $\frac{3}{8}$ " dado  $\frac{3}{8}$ " deep in each end panel where shown on the Dado detail.

**4** For the door locks, bore a  $\frac{3}{4}$ " hole through each end panel, drilling from the outside in and backing the stock with scrap to prevent chipout. Now, mark the centerpoints on the middle shelf (B) and drill  $\frac{3}{8}$ " holes for the drawer lock pins.

**5** If you wish to add the can lights (see the Buying Guide for our source), mark the centerpoints and draw a pair of  $3\frac{1}{4}$ "-diameter circles on the top shelf where shown on the drawing. Drill a blade start hole, and cut the holes to size with a jigsaw.

**6** Dry-clamp the pieces (A, B, C), with the front and back edges flush. Check for square and tight-fitting joints. Trim if necessary. Now, glue and clamp the assembly. (We placed masking tape next to the joints to catch any glue squeeze-out.)

**7** Measure the opening, and cut the cabinet back (D) to size from  $\frac{3}{4}$ " plywood. (To highlight the guns, we covered our fir-plywood cabinet back with velour fabric—we used Robe Velour II. If you want the wood grain to show, use oak plywood.) Mark the centerpoints and drill and countersink the holes for mounting the back to the cabinet.

**8** Cut the end panel front trim pieces (E) to size. With the edges

and ends flush, glue and clamp them to the front of the end panels (A). To continue the  $\frac{3}{8}$ " dado into the trim pieces (see the Dado detail accompanying the Basic Cabinet drawing for location), mark and drill a  $\frac{3}{8}$ " hole  $\frac{3}{8}$ " deep where shown. Chisel to the hole to form the stopped dado.

**9** Cut the top rail (F) and bottom trim pieces (G, H) to size. Glue and clamp them to the cabinet.

## Add the lower trim assembly

**1** For trim pieces I and J, cut a piece  $2 \times 78$ ". Rout the front edge of the long piece to the shape shown on the Section View detail accompanying the Lower Trim Assembly drawing. Miter-cut trim pieces I and J to length.

**2** Cut the back strip (K) to size. Glue and nail part J to the bottom of the cabinet where shown on the drawing and detail. Be sure to center it from side to side. Then, add parts I and K.

**3** Cut the filler strips (L) and bottom piece (M) to size. Glue the filler strips to the bottom piece flush with the front and back edges. Then, glue and nail the L-M assembly to the bottom of the molding frame (I, J, K). Make sure that the back edge of M is flush with the back edge of the cabinet pieces A and K, and centered from side to side.

**4** For trim pieces N and O, cut a piece of  $\frac{3}{4}$ " oak to  $1\frac{1}{4} \times 78$ ". Using the process described on page 39, form the cove along the front edge with your tablesaw. Miter-cut trim pieces N and O to length. Glue and clamp the front trim piece (N) to the assembly. Next, add the end trim pieces (O).

**5** Cut trim pieces P and Q to size plus 2" in length. Using a router table fitted with a fence, rout a  $\frac{1}{4}$ "

round-over along one edge of each piece. Miter-cut the pieces to length. Glue and clamp P and Q to the assembly. Sand the trim.

## The upper trim assembly comes next

**1** Cut the filler strips (R, S) to size. Glue and clamp them to the cabinet top where shown on the Upper Trim Assembly drawing and accompanying detail.

**2** Cut one piece of  $\frac{3}{4}$ "-thick oak to  $2 \times 90$ ". Now, cut a  $\frac{3}{4}$ "-thick piece of stock (it doesn't show, so pine will do) to the same length and width for the backing board. You'll use both pieces to form the cove molding (T, U).

**3** Glue and clamp the pieces face to face where shown in drawing on page 48. Using the technique on page 40, form the cove along one surface of the oak. Bevel-rip the edges of the lamination.

**4** Miter-cut the top cove molding pieces (T, U) to length. Glue and clamp them to the filler strips (R, S) where shown on the drawing.

**5** Cut a piece of  $\frac{1}{4}$ " stock (we planed thicker stock to  $\frac{1}{4}$ " thick) to  $\frac{7}{8} \times 80$ " for trim parts V and W. Using a table-mounted router fitted with a fence and a  $\frac{1}{8}$ " round-over bit, rout  $\frac{1}{8}$ " round-overs along both front edges of the entire length. Miter-cut the pieces to length and glue them in place.

**6** Cut a piece of  $\frac{3}{4}$ "-thick oak to  $\frac{3}{4} \times 80$ " for parts X and Y. Viewing the Dentil Mold detail for reference and the process on page 47 for details, form the dentil mold on the long strip. Carefully measure the front piece to ensure the dentil patterns at each mitered end will be identical. Miter-cut the dentil mold pieces (X, Y) to length. Glue the dentil mold pieces to the cabinet.

*Continued*

# SHARPSHOOTER'S SHOWCASE

## Storing Your Guns and Ammo

Michael McIntosh, shotgun editor of *Gun Dog* magazine offers the following advice: Store ammunition in another locked cabinet elsewhere in your house. Don't keep the ammo for the firearms in the same cabinet as the weapons. And, prevent accidental discharge of the weapon by using trigger locks, as well as chamber locks for high-powered rifles.

Educate everyone in your home about safe gun handling. "Remember," advises Michael, "children don't understand the potential danger of a firearm. Keep the key that opens the cabinet away from the gun cabinet and out of the reach of children."

### DADO DETAIL

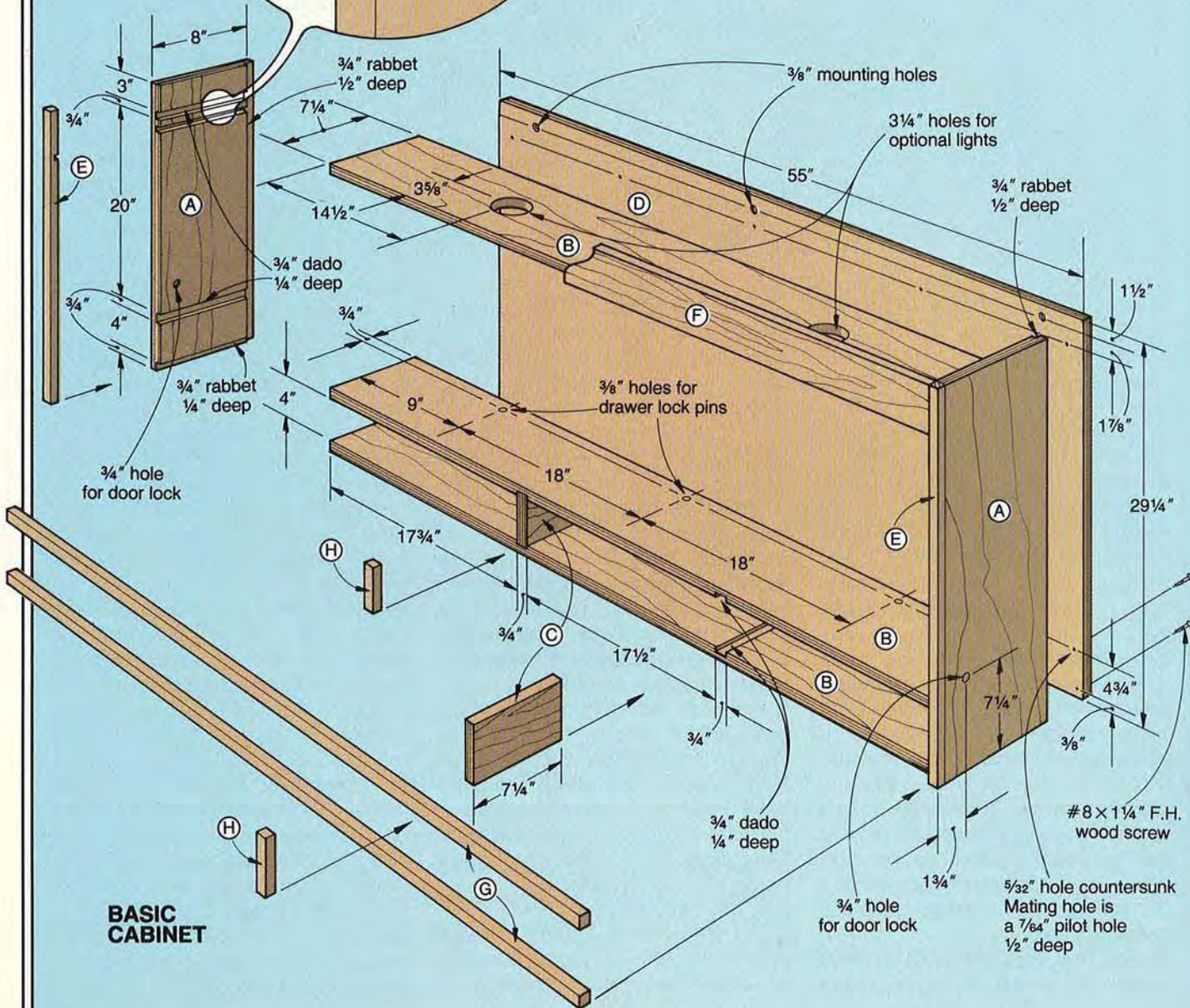
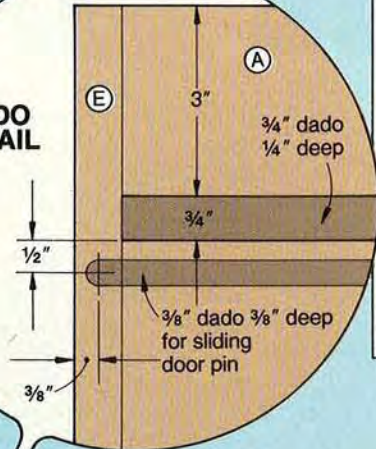

### BASIC CABINET



## Cutting Diagram

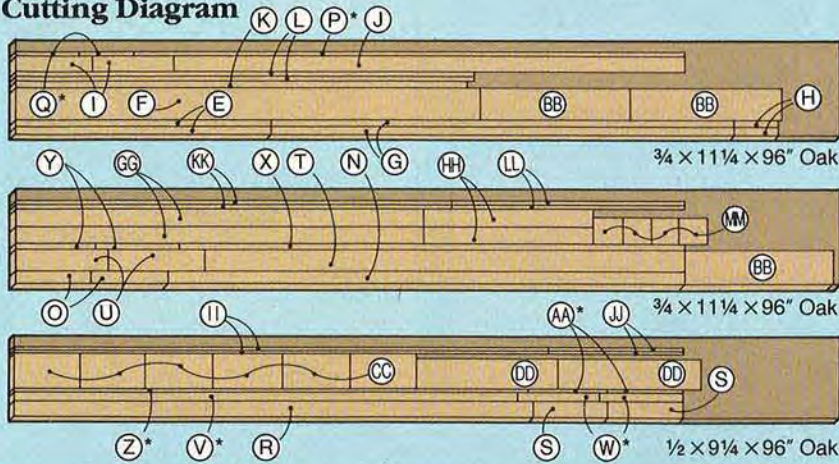

1/2 x 5 1/2 x 48" Oak

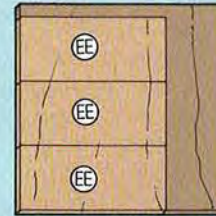

\*Plane or resaw parts marked with an \* to the thickness stated in the Bill of Materials

1/4 x 24 x 24" Oak Plywood

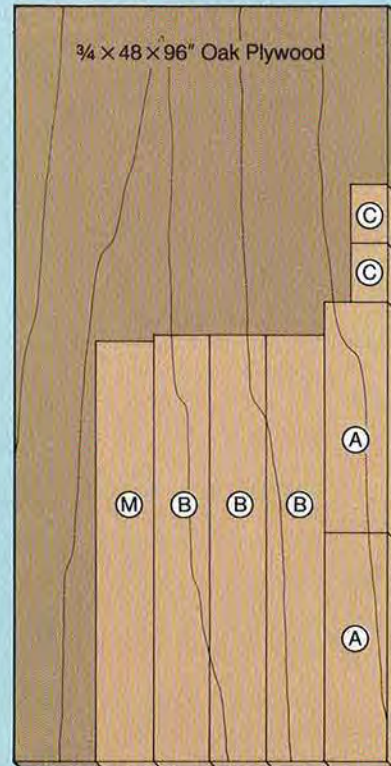

3/4 x 48 x 96" Fir Plywood

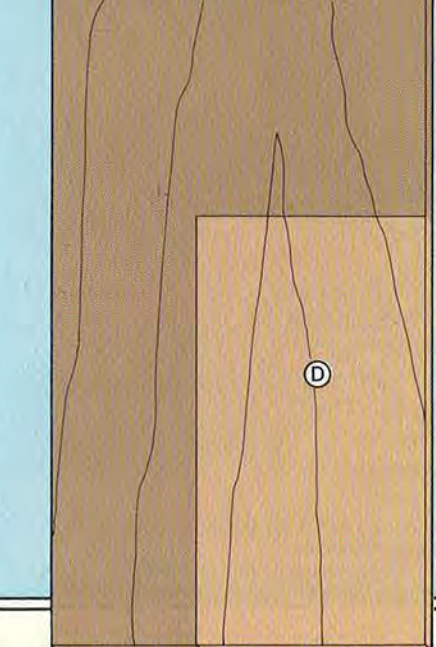

## Bill of Materials

Parts	Finished Size*			Mater.	Qty.	Parts	Finished Size*			Mater.	Qty.
	T	W	L				T	W	L		
<b>BASIC CABINET</b>						<b>UPPER TRIM ASSEMBLY</b>					
A ends	3/4"	8"	29 1/4"	OP	2	U* cove mold	1 1/2"	2 1/2"	11"	LO	2
B shelves	3/4"	7 1/4"	54 1/2"	OP	3	V* trim	1/4"	7/8"	57 1/4"	O	1
C dividers	3/4"	4 1/2"	7 1/4"	OP	2	W* trim	1/4"	7/8"	9 5/8"	O	2
D back	3/4"	29 1/4"	55"	P	1	X* dentil mold	3/4"	3/4"	57"	O	1
E trim	3/4"	3/4"	29 1/4"	O	2	Y* dentil mold	3/4"	3/4"	9 1/2"	O	2
F rail	3/4"	3 3/4"	54"	O	1	Z* trim	1/4"	1/4"	56"	O	1
G trim	3/4"	3/4"	54"	O	2	AA* trim	1/4"	1/4"	9"	O	2
H trim	3/4"	3/4"	4"	O	2	<b>DRAWERS</b>					
<b>LOWER TRIM ASSEMBLY</b>						BB fronts	3/4"	3 15/16"	17 7/16"	O	3
I* trim	3/4"	2"	9 1/4"	O	2	CC sides	1/2"	3 15/16"	7 5/8"	O	6
J* trim	3/4"	2"	56 1/2"	O	1	DD backs	1/2"	3 7/16"	16 15/16"	O	3
K strip	3/4"	3/4"	52 1/2"	O	1	EE bottoms	1/4"	7 5/8"	16 15/16"	OP	3
L filler strips	3/8"	3/4"	53 1/2"	O	2	<b>DOOR</b>					
M bottom	3/4"	7 3/4"	53 1/2"	OP	1	FF stops	1/4"	3/8"	19"	O	2
N* cove mold	3/4"	1 1/4"	56"	O	1	GG rails	3/4"	2"	49 7/8"	O	2
O* cove mold	3/4"	1 1/4"	9"	O	2	HH stiles	3/4"	2"	19 3/4"	O	2
P* trim	3/8"	3/8"	54 1/4"	O	1	II* trim	1/4"	1/2"	49 7/8"	O	2
Q* trim	3/8"	3/8"	8 1/8"	O	2	JJ* trim	1/4"	1/2"	15 3/4"	O	2
<b>UPPER TRIM ASSEMBLY</b>						KK* stops	5/16"	3/4"	50 7/8"	O	2
R filler strip	1/2"	1 3/4"	56 1/2"	O	1	LL* stops	5/16"	3/4"	16 3/4"	O	2
S filler strips	1/2"	1 3/4"	8 3/4"	O	2	<b>GUN SUPPORTS</b>					
T* cove mold	1 1/2"	2 1/2"	60"	LO	1	MM supports	3/4"	3"	3 1/4"	O	4

\*Initially cut parts marked with an \* oversized. Then, trim each to finished size according to the how-to instructions.

**Material Key:** OP-oak plywood, P-plywood, O-oak, LO-laminated oak

**Supplies:** masking tape, #8 x 1 1/4" flathead wood screws, 1 1/4" x 17 brad, 1/2" x 18 brads, #8 x 3/4" flathead brass wood screws, 3/8" dowel pins 1 1/2" long, 3/8" dowel stock for drawer locks, #6 x 1 1/4" flathead brass wood screws, 1/4" safety glass for door, 3/8" x 2 1/2" lag screws, 3/8" washers, #8 brass finish washers, carpet tape, 29 1/4 x 55" velour fabric, carpet tape, stain, finish.

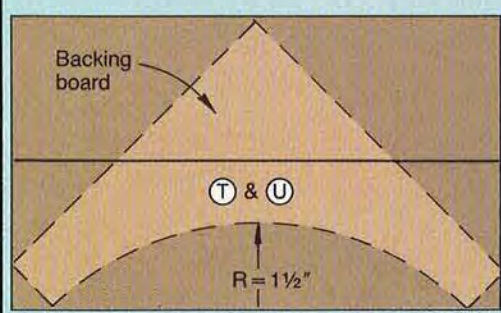
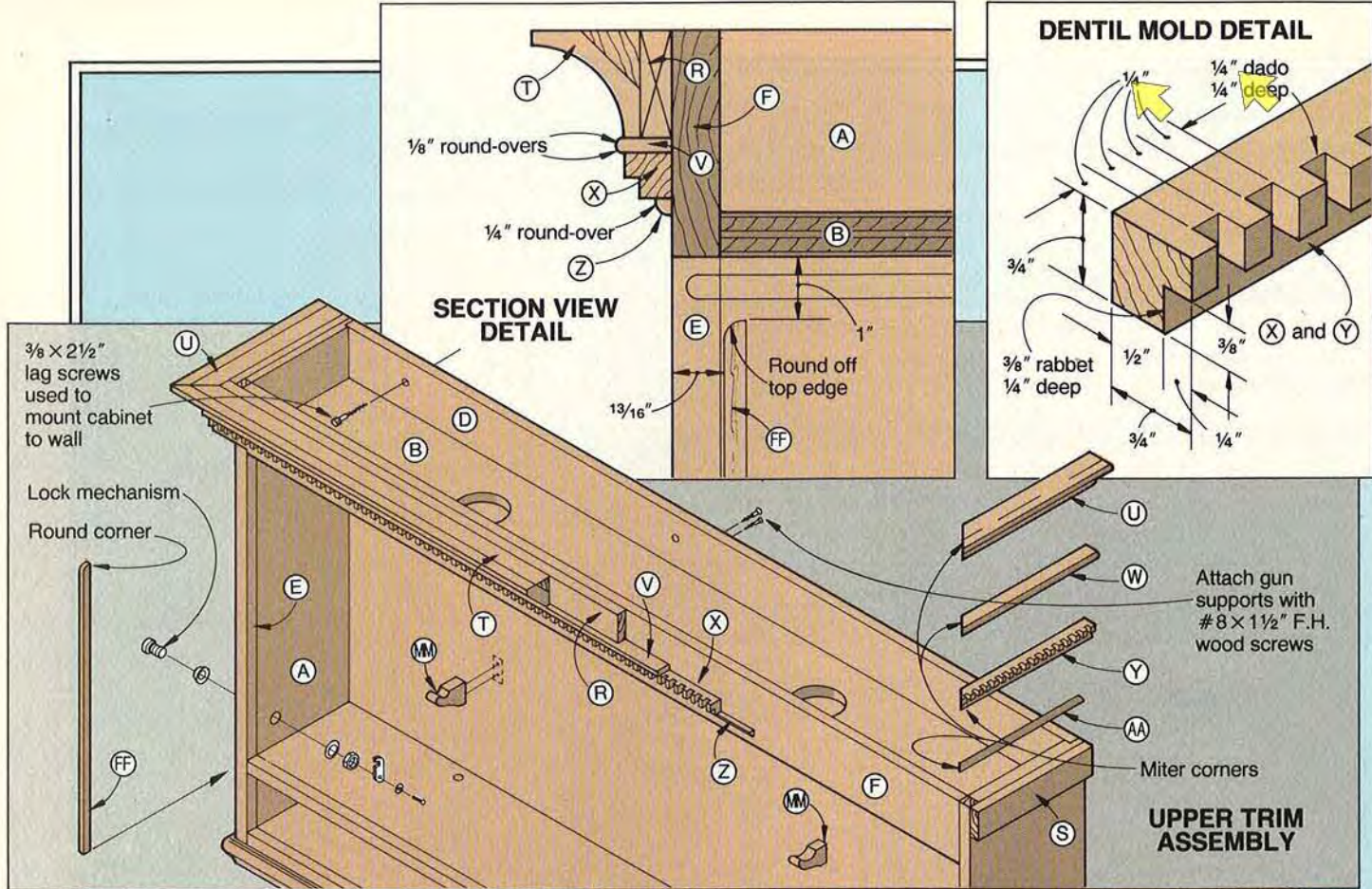

**COVE MOLD LAMINATION**  
FULL-SIZED PATTERN

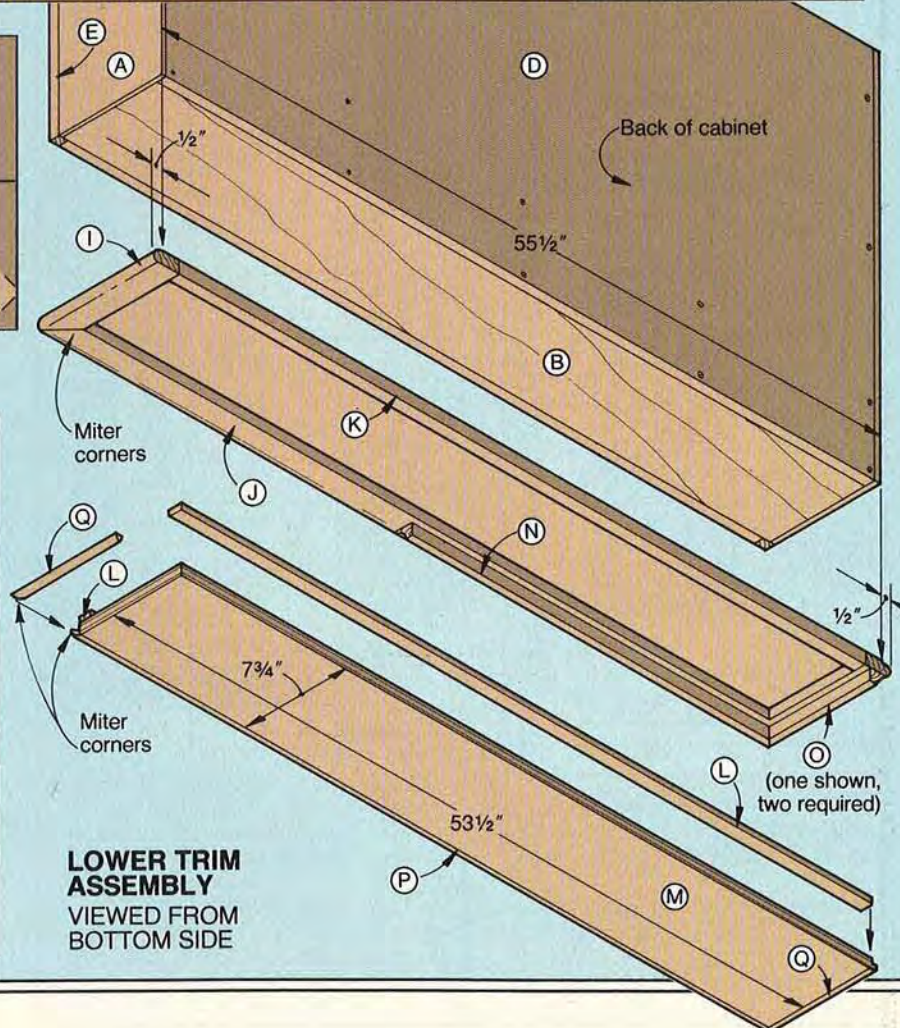
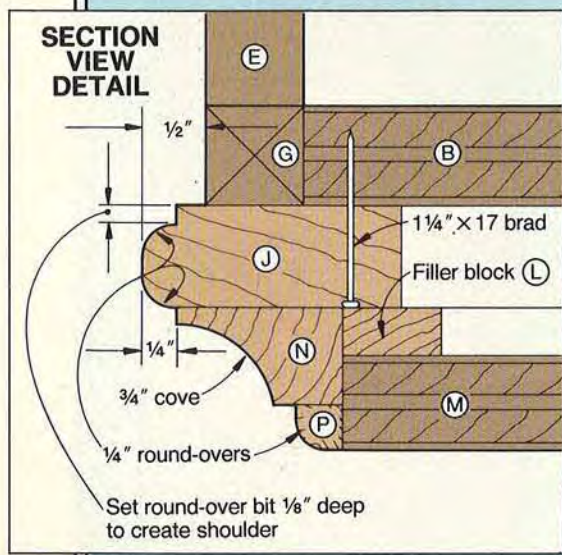

# SHARPSHOOTER'S SHOWCASE

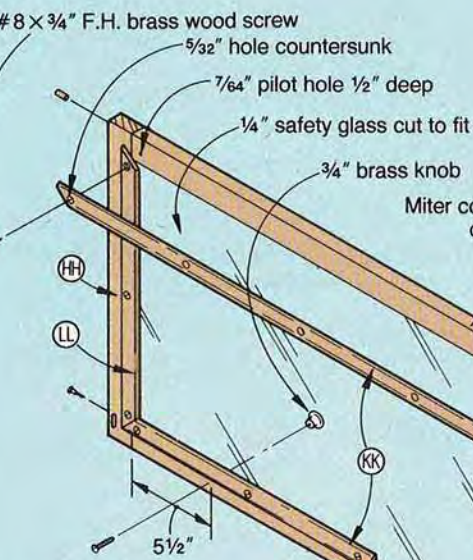
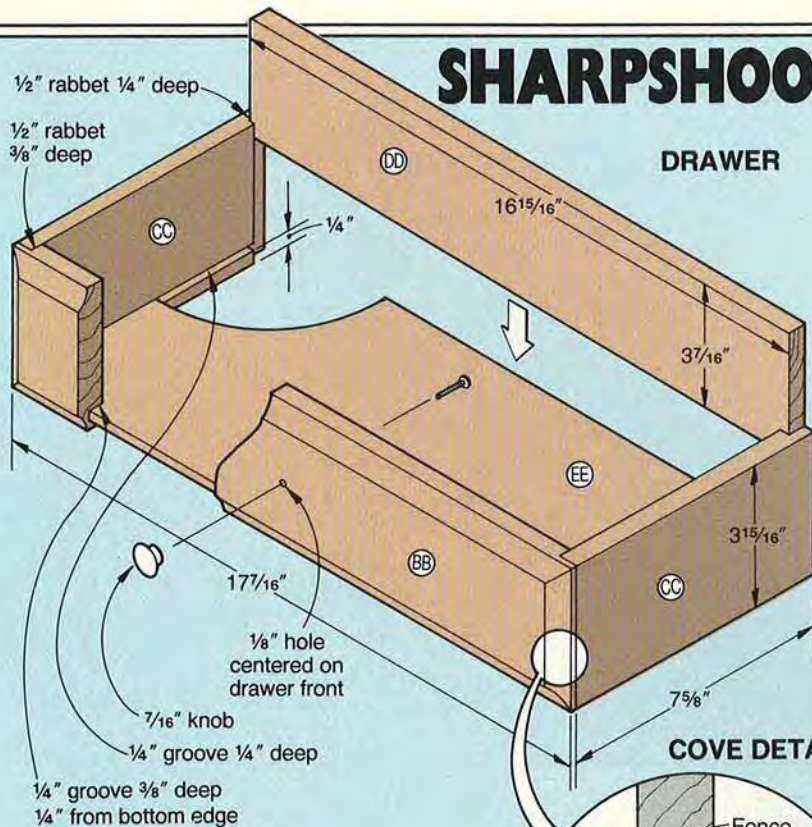

**DOOR SECTION DETAIL**

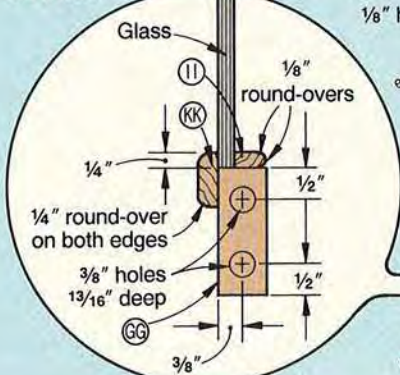

**DOOR VIEW FROM BACK SIDE**

**DRAWER**

**COVE DETAIL**

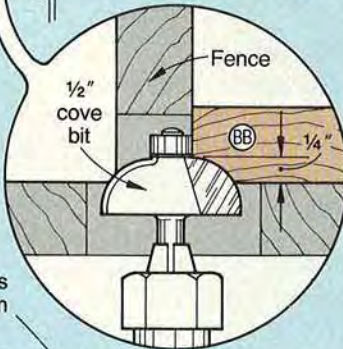

**7** Cut a piece of  $\frac{3}{4}$ " oak to  $1\frac{1}{2} \times 78$ ". Rout a  $\frac{1}{4}$ " round-over along one edge of the strip. Now, make two ripping cuts to trim the quarter-round molding parts Z and AA from the oak board. Miter-cut the pieces to length and glue and clamp them to the cabinet. Sand the trim smooth.

## Here's how to build the three drawers

**1** Cut the drawer fronts (BB), sides (CC), backs (DD), and bottoms (EE) to the sizes listed in the Bill of Materials.

**2** Cut the rabbets and grooves in the drawer sides and front where shown on the Drawer drawing.

**3** Mark diagonals on the front face of each drawer front to find center. Drill a  $\frac{1}{8}$ " hole in each drawer front for the knob screw.

**4** Dry-clamp each drawer to check the fit of the joints and the fit of the drawers in the openings. Trim if necessary. Next, rout a cove around the front edge of each drawer front where shown on the Cove detail accompanying the Drawer drawing.

**5** Glue and clamp the drawer parts, checking for square.

## Now, add the door

**1** Cut the door stops (FF) to size. Cut or sand a  $\frac{3}{8}$ " radius on the top front corner of each (see the Upper Trim Assembly drawing for reference). Glue and clamp the stops to the cabinet sides where shown on the Section View detail of the drawing.

**2** Cut the door rails (GG) and stiles (HH) to size. So that the glass will fit well, use your straightest stock for these parts.

**3** Mark the dowel-hole center-points on the ends of the rails where shown on the Door Section detail accompanying the Door drawing. Drill  $\frac{3}{8}$ " holes  $1\frac{3}{16}$ " deep where marked (we used a doweling jig). Position dowel centers in the holes, and transfer the hole locations to the stiles, and then drill  $\frac{3}{8}$ " holes  $1\frac{3}{16}$ " deep.

*Continued*

# SHARPSHOOTER'S SHOWCASE

**4** Glue, dowel, and clamp the door, checking for square.

**5** Mark the two guide-pin hole centerpoints on the stiles where shown on the drawing. Drill a  $\frac{3}{8}$ " hole  $\frac{1}{2}$ " deep at each mark. Cut two  $\frac{7}{8}$ "-long pieces of  $\frac{3}{8}$ " dowel, and glue one piece—to function as a guide pin—in each hole.

**6** Cut the front trim pieces (II, JJ) to size plus 2" in length. Rout  $\frac{1}{8}$ " round-overs along the front top and bottom edges of each. Miter-cut the pieces to length and sand. Glue and clamp the trim pieces to the front of the door where shown on the Door Section detail.

**7** Cut the glass stops (KK, LL) to size plus 2" in length. Rout  $\frac{1}{4}$ " round-overs along the edges of each where shown on the Door Section detail. Drill and countersink  $\frac{5}{32}$ " holes through the stops where shown on the Door drawing. Sand the stops. Set the glass stops aside; you'll fasten them to the door after you install the glass.

**8** To form the  $\frac{1}{4}$ " slots in the door stiles for the lock bar (see the drawing at *right* for reference), mark a centerline and drill a series of  $\frac{1}{4}$ " holes  $\frac{1}{2}$ " deep for each slot. With a chisel, trim the waste between the holes to finish forming the slots. Now, drill and countersink a  $\frac{9}{16}$ " hole  $\frac{1}{4}$ " deep where shown on the drawing. Then, drive a #6 wood screw into the hole. (The screw serves as latch for the lock.)

**9** Cut or file a notch in the lock bar to the shape shown on the Lock drawing. The notch should fit over the screw installed in the previous step.

## You're almost done—keep up the good work

**1** Cut three pieces of  $\frac{3}{8}$ " dowel stock to  $1\frac{1}{8}$ " long. Drill a  $\frac{1}{16}$ " hole  $\frac{5}{16}$ " deep centered in the top of each, and sand a  $\frac{1}{8}$ " chamfer on the bottom end where shown on the Drawer Pin drawing.

**2** Fasten a  $\frac{7}{16}$ " brass knob and a #8 brass finish washer to each drawer pin.

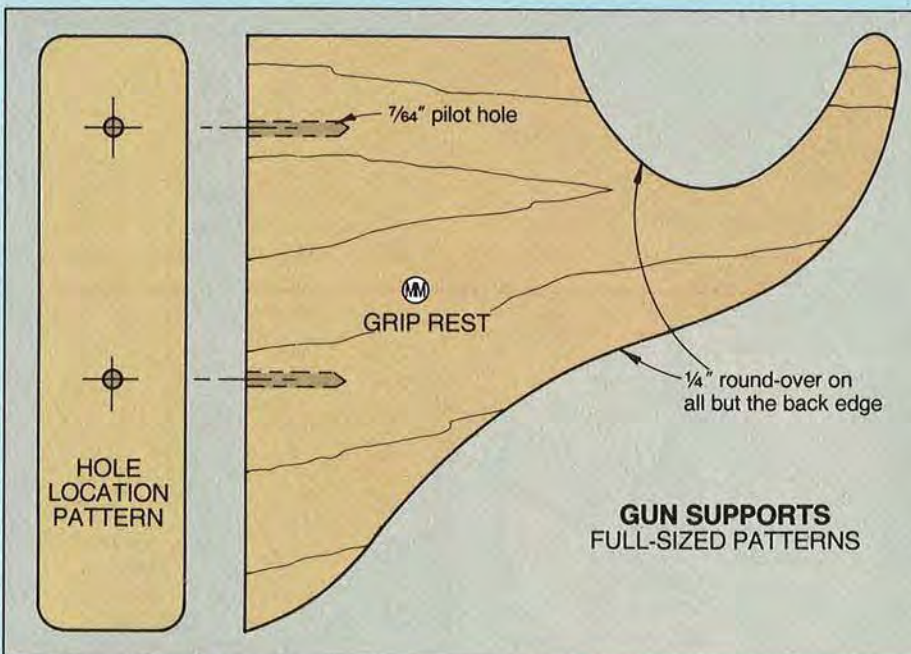
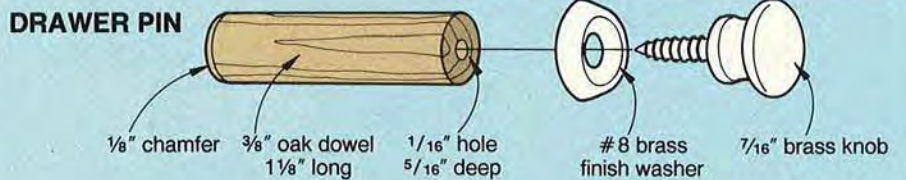
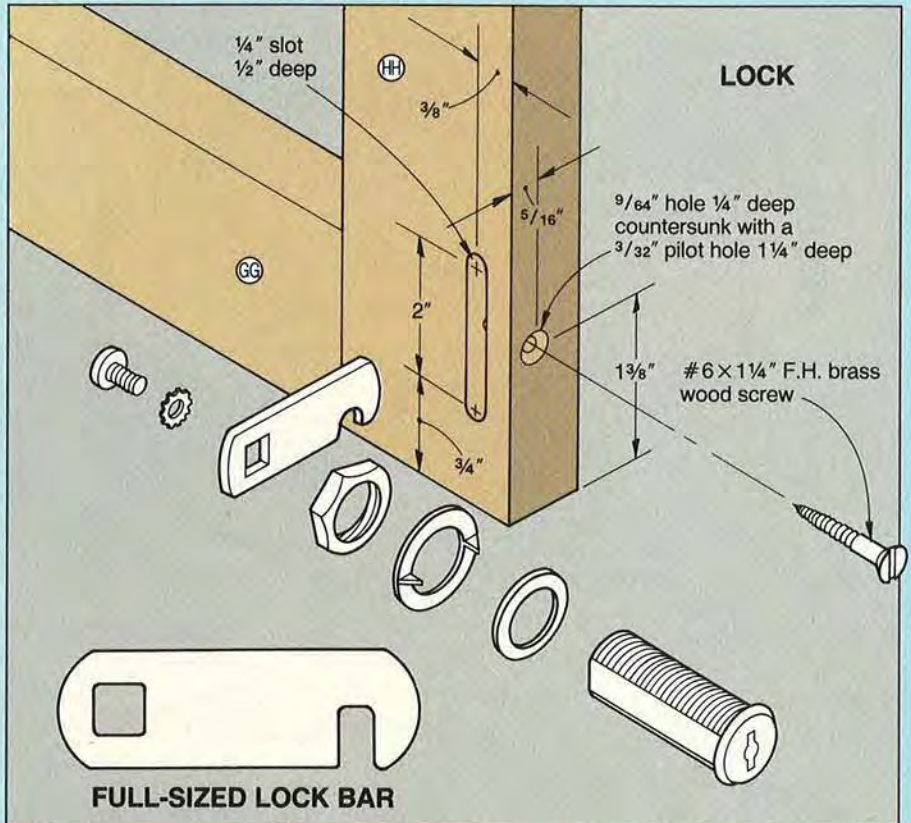

**3** With the drawers fully closed, insert a pin in each  $\frac{3}{8}$ " hole in the middle shelf (B). With the door locked and the pins in place, the drawers cannot be pulled open. This prevents someone without a key from gaining access to the drawers' contents.

**4** Transfer the gun support patterns (MM) below to posterboard and cut them to shape. Check the fit of the supports against your guns and adjust if necessary. Transfer the shape to  $\frac{3}{4}$ " oak. Cut and sand them to shape. Rout  $\frac{1}{4}$ " round-overs on all but the back edges of each support.

**5** To attach the velour fabric to the plywood back (D), adhere strips of carpet tape near each edge on the front face of the fir plywood. Stretch the cloth over the plywood back, and trim off the excess. Temporarily fasten the back to the cabinet with one screw at each corner. Set the cabinet on its back, and determine the location of the gun supports for each firearm. Lightly trace the location on the cloth and remove the back from the cabinet.

**6** Sand and stain the cabinet, door, drawers, gun supports, and glass stops. Apply the finish.

**7** To embellish your gun-cabinet glass, sandblast the full-sized pattern at *right* to opposite corners of the cabinet and the detail lines along each edge of the glass. Cover the glass with a vinyl resist, and transfer the acorn and line patterns shown at *right* to the resist. Cut the resist with an X-acto knife. Peel off the resist from the areas to be blasted, sandblast the glass, and peel off the remaining resist. The photo at *right* shows what the sandblasted pattern on our glass looked like. (For more information on sandblasting, see pages 34-39 of the April 1990 issue of *WOOD* magazine, or send \$2 and a self-addressed business envelope to Sandblasting Techniques, *WOOD* Magazine, P.O. Box 11454, Des Moines, IA 50336-1454.)

**8** Install the glass and glass stops (KK, LL). Rub a little paraffin into the door guide-pin slot. Working from the back of the cabinet, slide the door into position (the guide pins protruding from the stiles fit into the  $\frac{3}{8}$ " dadoes).

**9** Screw the supports to the cabinet back. With the door in place, replace the cabinet back, and add the knobs, locks, and lights.



FULL-SIZED  
SANDBLAST PATTERN



Closeup of sandblasted pattern.

**10** For mounting the completed gun cabinet to the wall, mark mounting-hole centerpoints  $1\frac{1}{2}$ " from the top edge of the plywood back (D). Position the centerpoints so they'll center over wall studs. Drill the holes and hang the cabinet. (We used three  $\frac{3}{8}$ " x  $2\frac{1}{2}$ " lag screws to securely fasten our gun cabinet to the wall.)

## Buying Guide

• **Hardware.** Three  $\frac{7}{16}$ " brass knobs, two brass-plated cam locks, five  $\frac{3}{4}$ "-diameter solid brass knobs. Gun cabinet hardware kit, product no. WD191, \$31.50 ppd. Constantine, 2050 Eastchester Road, Bronx, NY 10461. Or, call 800-223-8087 to order.

• **Can lights.**  $3\frac{1}{8}$ " body diameter by  $2\frac{3}{4}$ " high with a 9' electrical cord. Requires a 40-watt bulb (not included). Catalog no. E3900, \$31.40 ppd. per pair. The Woodworkers' Store, 21801 Industrial Blvd., Rogers, MN 55374-9514, or call 612-428-2199. ♣

Produced by Marlen Kemmet  
Project Design: James R. Downing; Jim Boelling  
Photographs: Hopkins Associates  
Illustrations: Kim Downing; Mike Henry

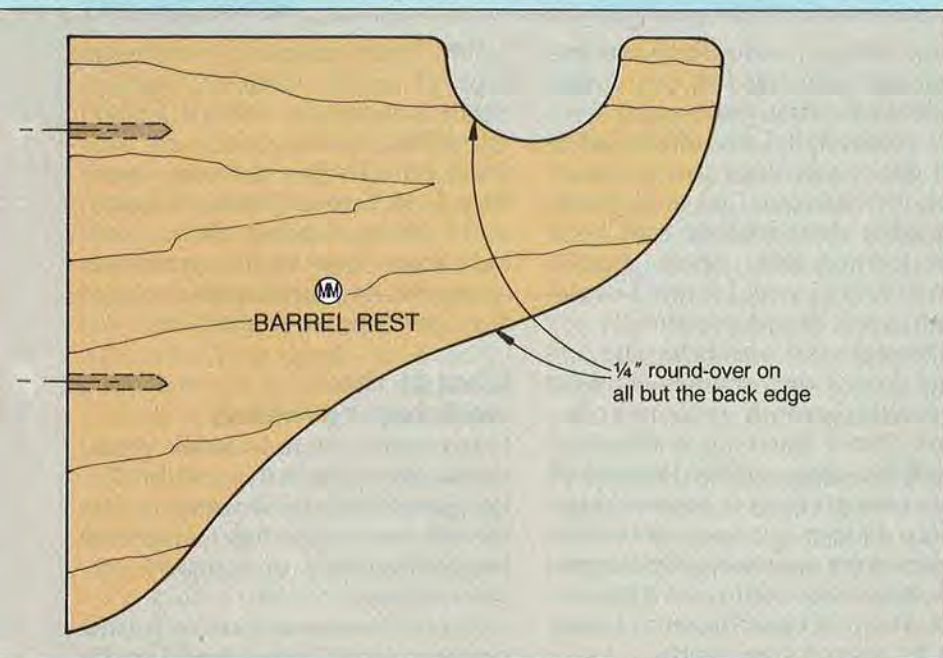



# IN SAN DIEGO, SOME CHILDREN ACTUALLY WAITING FOR THE

**Woodworker-on-the-road** Sheila Dawson helps create a sense of pride and self-confidence in children through a mobile program called "I Can Build It Myself." Here, she shares some of her workshop-proven techniques.

**I**n the early 70s, Sheila Dawson was a secretary. Her husband, Ray, enjoyed a woodworking hobby, and they spent evenings together in the shop. "Ray had taught me how to use all the tools," Sheila recalls, "and I was getting that feeling of accomplishment that even my job couldn't give me."

Sheila's first woodworking projects were toys for their son, Glenn, a toddler. "Because Glenn was there in the shop with us, for safety I had to teach him what not to touch," Sheila says. "So, I marked 'off-limits' tools and areas, and set up a special work place."

Under Sheila's guidance, Glenn could start and drive nails at 1½ years old. And when he learned how to use one tool, his mother taught him another. That, essentially, was how Sheila got the idea for kid's woodworking classes.

## The woodshop hits the road

In 1974, after two years of woodworking and watching her son's progress, it occurred to Sheila that woodworking just might be the medium by which she could flourish as a teacher—a longtime dream. At the same time, children would build self-confidence. To test her idea, she approached Glenn's teacher at his Montessori school and asked for outside space during the summer



Outside an elementary school in Mission Hills, youngsters await their private lessons in the woodworking bus. *Left to right, Peter Kornberg, Michelle Morrison and daughter Arielle (also at right), Terence Kamberg and his mother, Hilary Smith, and teacher Sheila Dawson.*



for a children's woodshop. An enthusiastic response led to a dozen students the first time out.

"I rescheduled my office hours and spent mornings that summer with the children. I let them teach me what they wanted and how they learned best," Sheila recalls. "By summer's end, I knew I could teach a safe wood program."

Through the observers she invited from other schools, as well as word-of-mouth recommendations, Sheila lined up a schedule of classes that would keep her busy enough to quit her secretarial job. As they continue to be, her classes were sponsored by Parent-Teachers Associations (PTA) to provide the enrichment classes cut by loss of state funds.

"At first I hauled everything around in my station wagon," Sheila remembers. "When I started visiting more schools, my husband retrofitted a delivery truck, then a '58 Crown Coach, and now a '74 Twin Coach." Since then, kids from four to ten years old count the days until Sheila's arrival in the big, tan school bus.

## Class in the workshop on wheels

Fitted with 10 individual workstations, each adjustable for height, Sheila's workshop on wheels sets the mood for serious project-building, in a highly creative setting.

The children select only one project to build from the 15 to 20



# LIKE STAYING AFTER SCHOOL WOODWORKING BUS

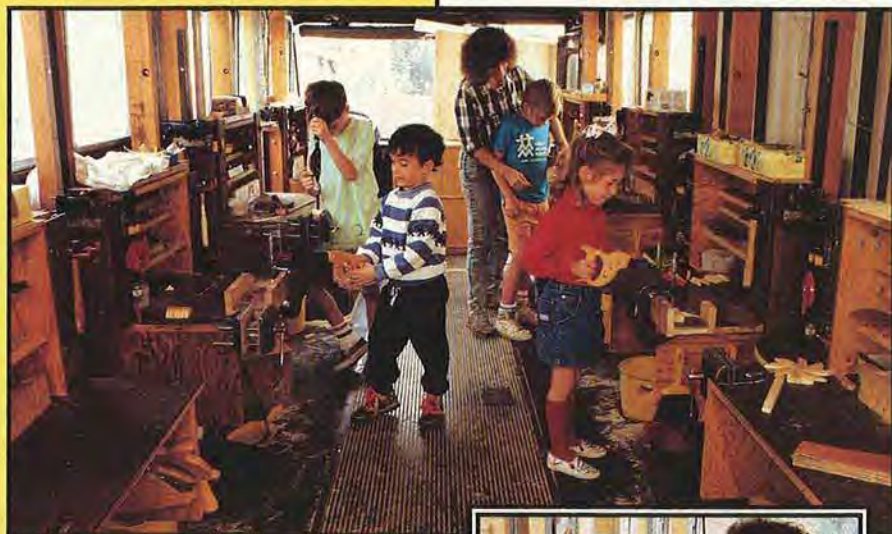

Working at benches adjustable for height, the children concentrate on building with the skills they've just learned. Sheila walks the aisle, checking on progress.

Peter Kornberg receives some confidence-building praise from his teacher. Sheila's motto, posted in the bus, reads, "Every project that leaves this woodshop is absolutely perfect."



offered in five categories: rolling things, floating things, flying things, communication things, and functional things. Although the projects fall into classifications of easy, medium, and hard, 90 percent can be built in the hour of allotted class time with the hand tools provided: a 7-ounce hammer with shortened handle, rubber sanding blocks, a 16" saw, a miter box, a C-clamp, tri-square, a hand drill, a screwdriver, and a bench vise.

Why not just teach them some safety, give them the basics of technique, and turn them loose? "Because," says Sheila, "if you give kids a pile of scrapwood without any instruction, the things they build get very free-

form, with lots of nails, split wood, and pieces falling off. Children learn best when they want to build something specific.

"Every child has gifts," says the woodworking teacher. "Sometimes they're locked in [mentally], and sometimes they surface more in the classroom. But here, I've had 3½-year-olds outperform eight-year-olds, through their ability to catch on to the logical process, and to trust in themselves."

## Projects build a circle of love

Sheila doesn't measure her reward from woodworking classes in dollars. Without what she has come to call "the circle of love," 16 years of teaching might have worn her down.

## Sheila's tips on working with kids

- **No fooling around.** "Kids must first accept this."
- **Kids must be volunteers.** "When they want to be there, they obey the rules."
- **Children must be in control of their bodies.** "No unruly children at workbenches."
- **Two hands on the tool.** "Do not hold wood you are sawing or a nail after it stands alone."
- **The wood never moves.** "If it moves, they must see why. Most tasks involve clamping."
- **The younger the child, the more important instant gratification.** "They must take a project home from one lesson."
- **Don't require measurements in fractions of an inch.** "Use 2-4-6-8-10 inches. They lay the ruler on the wood."
- **Help children transfer information.** "First, show all the steps, then work with individuals to apply them."
- **The younger the child, the fewer saw cuts.** "In the beginning, two crosscuts for kids under three, four cuts up to age five; at age eight, six."

To order a copy of Sheila's 300-page book, *I Can Build It Myself, that fully describes her teaching techniques, send \$19.50 ppd. (Calif. residents add 7.25 percent sales tax) to: Children's Woodshop Publications, P.O. Box 178451, San Diego, CA 92117.*

"That one-hour class is very intense—the children work so very hard," Sheila comments. "There's a real joy of achievement at the end, when they go home. That's what the parents get to see. I don't see that, I only see them making their project. But, it only takes one parent a week to share that true joy to keep me going. That's the circle of love." 🌱

Written by Peter J. Stephano  
Photographs: Gary Zeff



# AN EIGHTEENTH-CENTURY CLASSIC THE SHAKER

**O**n a recent vacation, Jim Downing, our design editor, visited the Hancock Shaker Village near Pittsfield, Massachusetts. At the woodshop, craftsman Cliff Myers invited Jim to join him in making a traditional Shaker carrier. After trying the techniques in our own shop, we're inviting you to construct a bit of history for yourself.

*Note: You'll need some thin stock for the carrier and handle. You can plane or resaw thicker stock to size, or see our source listed in the Buying Guide at the end of this article.*

## Construct the band form, pipe support, and two shapers

**1** Cut four pieces of  $\frac{3}{4}$ "-thick stock to  $6 \times 9$ " (two pieces of  $2 \times 8$  also would work). Glue and clamp the pieces with the ends and edges flush.

**2** Transfer the full-sized band-form pattern from the opposite page to the top piece of stock. Bandsaw the form to shape. Sand the form edges.

**3** Mark the start-point reference line on the top surface of the form where shown on the full-sized patterns drawing.

**4** Refer to the Pipe Support drawing at *right* to build the support. You'll use this and a pipe clamp later to clinch the tacks that hold the carrier together.

**5** Transfer the shaper outline from the full-sized pattern drawing to two pieces of  $\frac{3}{4}$ " stock that measure  $6 \times 9$ ". Tilt your bandsaw table  $10^\circ$  from horizontal. Bandsaw the two shapers to shape, cutting just *outside* the marked line (the



entire line should still be visible when you're done cutting). Drill two 1" holes in each shaper where shown on the drawing titled *Shaping the Carrier Band*.

## The carrier band comes next

**1** Cut a piece of  $\frac{5}{64}$ " (.075") thick cherry to  $3 \times 27$ ". See the Buying Guide for our source of thin cherry or plane your own to size. (The Shakers also used maple and ash.)

**2** Transfer the full-sized finger pattern and hole locations to one end of the band (see the full-sized pattern on page 57 for reference). Drill twelve  $\frac{1}{16}$ " holes through the band where marked.

**3** On the end opposite the fingers, sand a  $1\frac{1}{2}$ "-long taper. See the drawing on page 56 for reference.

**4** Bandsaw the fingers to shape. Using a utility or hobby knife and the full-sized band pattern for reference, bevel-cut the edges and ends of each finger. (We followed the Shaker style of beveling the insides of the fingers at about  $20^\circ$  and reducing the bevel to  $10^\circ$  near the end of the fingers.) Now, come back and finish forming the beveled V where the  $20^\circ$  cuts meet. Next, bevel-cut the ends of the fingers.

**5** Soak the band in hot water for 25 minutes (we did this in a plas-



# OVAL CARRIER



tic wallpaper water tray; a bathtub also would work). Drain the water and immediately pour boiling water over the band and soak it for one minute. Working quickly now, remove the band from the water and wrap it snugly around the form. Position the band so that the tapered end sits directly under the start-point reference line on the form and the beveled edges on the fingers face out. To avoid splitting the band between the fingers, hold all three fingers until the tacks are secured in the following steps.

*Continued*

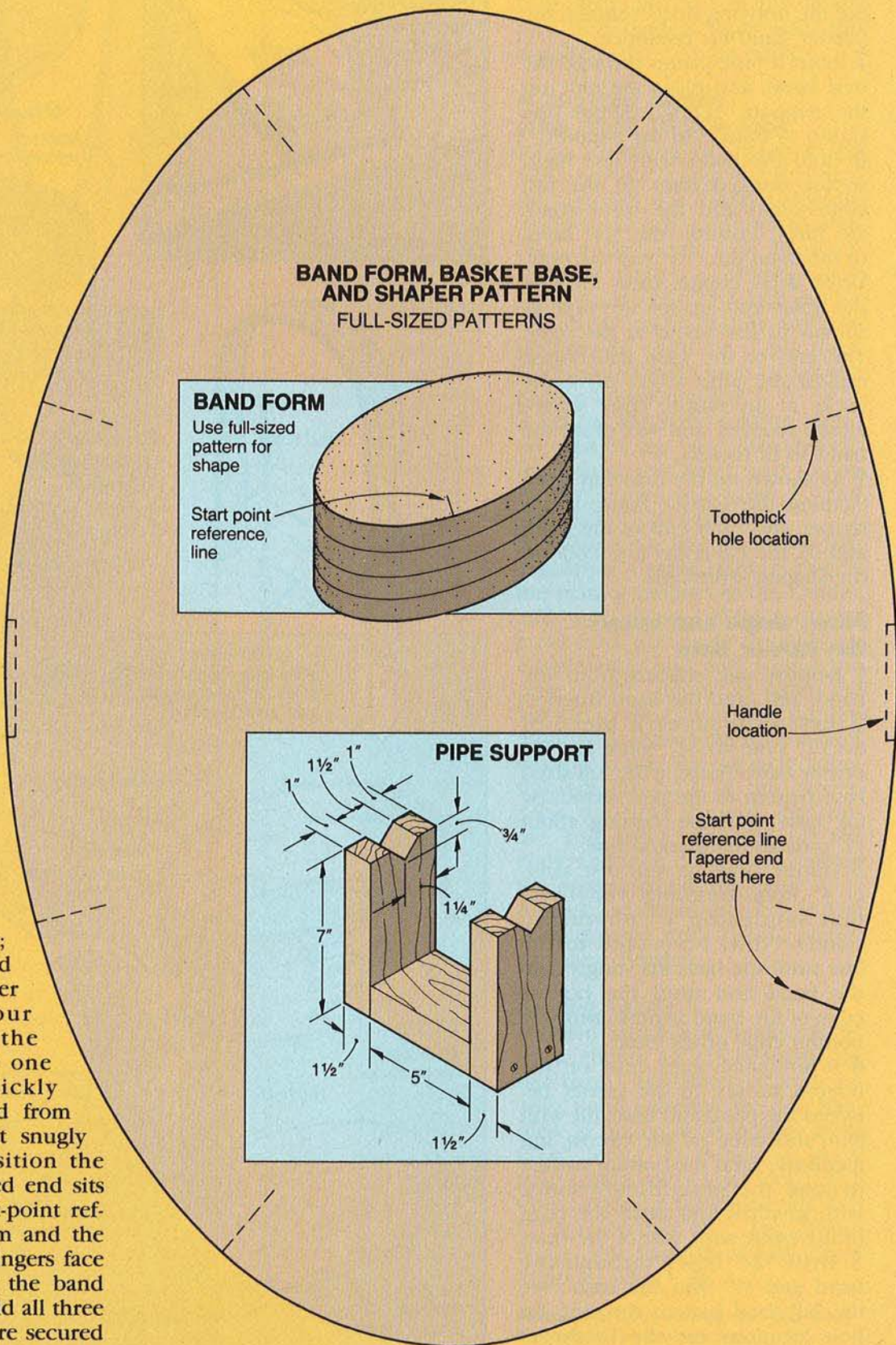

# OVAL CARRIER

**6** Lightly mark a reference line on the top-lapped edges of the band. See the drawing titled Shaping the Carrier Band for reference.

**7** Insert a pipe clamp through the oval band, and place the pipe on the support. Lightly tighten the clamp to hold it to the support.

**8** Hold the band with one hand so the marked lines on the top edges align and the band edges are flush. Position the  $\frac{1}{16}$ " holes in the band directly over the pipe. Drive #1½ copper tacks through the holes and against the pipe as shown in the photo at *far right*. The end of the tack will clinch against the pipe. Don't drive the tacks at an angle; they won't clinch properly and will cause the band to fit loosely.

**9** As shown on the drawing titled Shaping the Carrier Band, slip a shaper into each end of the band and let the band dry and cool on the shapers overnight.

## Now, shape and install the carrier base

**1** Remove the shapers from the band, and sand the band interior.

**2** Resaw or plane a piece of 6×12" pine to  $\frac{1}{4}$ " thick for the carrier base. Transfer the full-sized base pattern to the pine. Bandsaw the base to shape, cutting about  $\frac{1}{8}$ " outside the marked line.

**3** Tilt the table on your disc sander 4° from horizontal (or, use a belt sander on a conversion stand). Now, bevel-sand to the line until the base fits snugly into the band and until the bottom edge of the band is flush with the bottom edge of the base.

**4** If any small gaps exist on the bottom surface of the carrier between the band and base, fill with glue and wipe off the excess. Immediately sand the bottom surface to load the glue-filled crevice with sawdust and flush the edge of the band with that of the base.

**5** Drill  $\frac{5}{64}$ " holes through the band and  $\frac{1}{2}$ " into the base (see the full-sized pattern drawing for hole locations and the Toothpick Hole detail at *right* for reference).

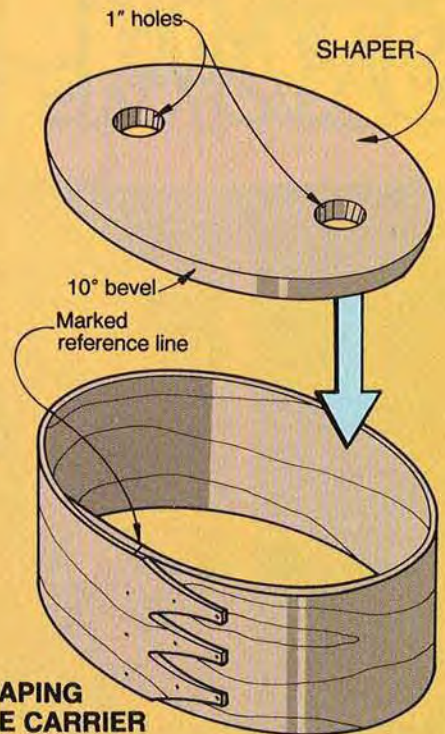
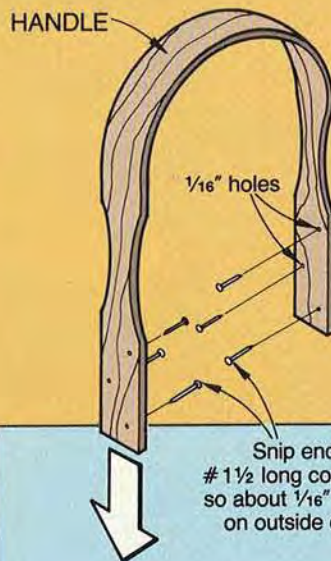
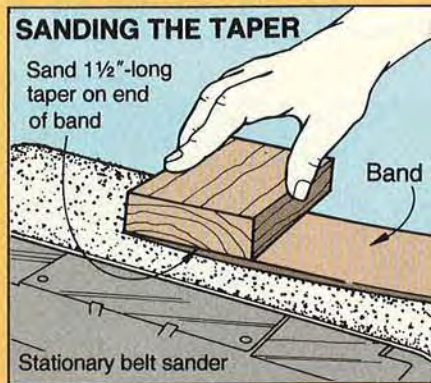

## SHAPING THE CARRIER HANDLE

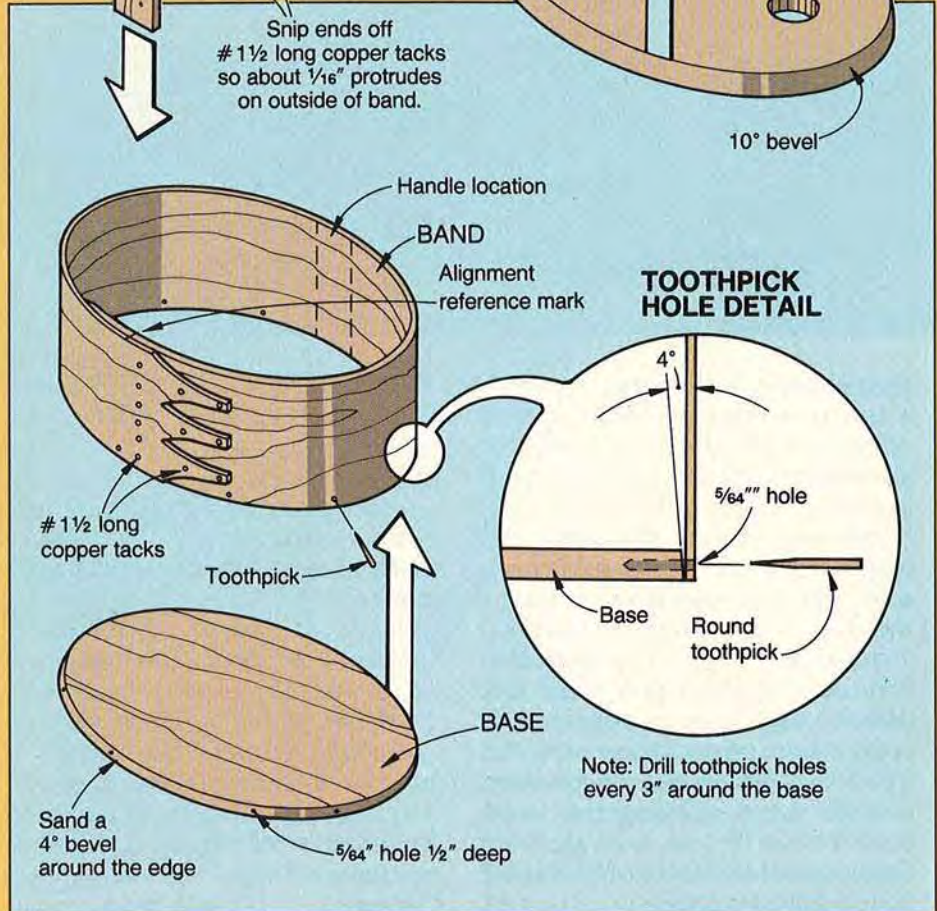
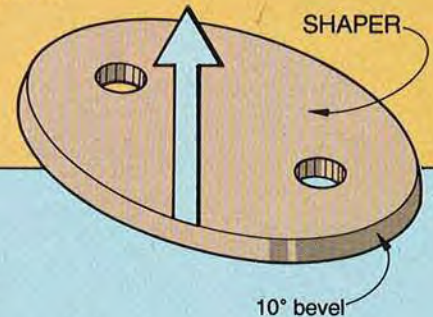

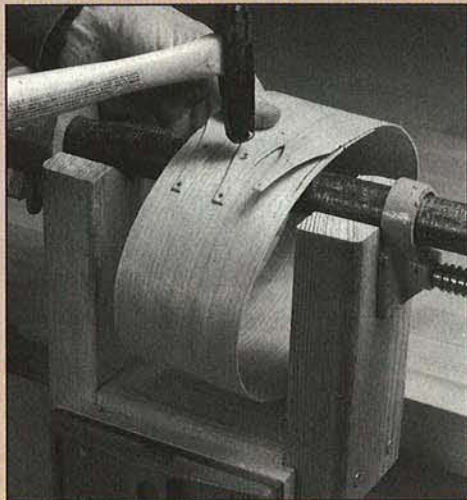
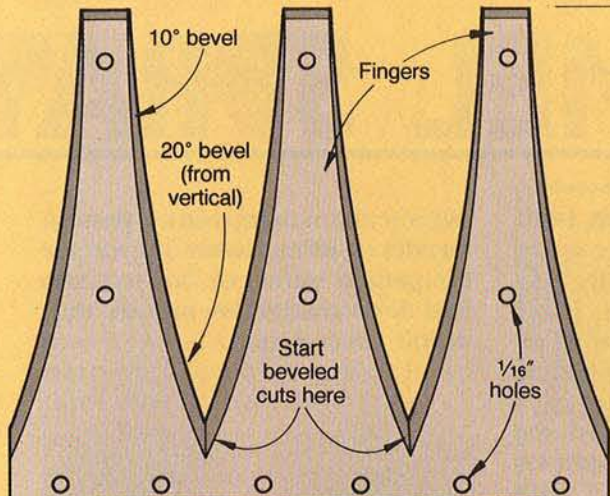

Tack the band together using the anvil support and a pipe clamp.

**BAND**  
FULL-SIZED  
PATTERN

Overall length of the band equals 27"

1 1/2"-long  
taper

**HANDLE**  
FULL-SIZED  
HALF  
PATTERN

1/16" holes

Tap a round toothpick through the hole in the band and into the base. Trim the end of the toothpick and sand it flush with the outside surface of the band.

### A tapered handle adds 'that Shaker look'

**1** Cut a piece of 1/8" cherry to 3/4" wide by 18 1/2" long for the handle. Transfer the full-sized handle pattern and hole locations to both ends of the handle strip. Bandsaw the four curves to shape. Using the rounded end of a belt sander or a drum sander, lightly sand the bandsawed contours. Drill three 1/16" holes through each end of the handle where marked.

**2** Follow the same soaking method used for the band. Remove the band from the water, and immediately center and wrap it over one end of the band form.

**3** Position the handle in the basket. Apply a small bead of glue to the mating surfaces of the handle, and then drive 7/16"-long copper tacks from the inside through the handle and band and against the pipe on the support to fasten the handle to the carrier. See the Exploded View drawing for the sizes of tacks to use. For the tacks going through the back of the carrier, drive the tacks through the handle and band, snip 1/8" off the ends, and then drive them against the pipe to clinch the ends.

**4** Sand and finish the carrier. The Shakers used milk paints, stains, and clear finishes.

### Buying Guide

• **Band stock and tacks.** .075" thick cherry 3x27" (enough for one band). 1/8" cherry 3/4" wide by 18 1/2" long (enough for one handle). 1/2 ounce #1 1/2 copper tacks (7/32" long), 1/2 ounce of #1 1/2 long copper tacks (7/16" long). \$11 (U.S.) ppd. for #4 carrier kit, \$18 (U.S.) for two kits. The Home Shop, 500 East Broadway, Charlotte, MI 48813. ♣

Produced by Marlen Kemmet with John Wilson  
Photographs: Hopkins Associates  
Illustrations: Jamie Downing; Bill Zaun

# ENAMEL SPRAY

## How we conducted the test

To be as fair as possible, we tested all the paints on identically prepared pieces of  $\frac{3}{4}$ " birch. For a smooth finish, first we brushed on one coat of Pratt & Lambert Clear Lacquer Sanding Sealer to each  $5 \times 10$ " test piece. We stood the test pieces vertically and sprayed them from a distance of 12" with three coats of red paint.

To test for coverage (opacity) we also applied three coats of each paint to half-black, half-white cards.

## What we looked for in the spray paints

As you can see by looking at the chart *opposite*, we judged the paints by five characteristics and assigned excellent (red dot), good (orange), fair (green), and poor (blue) ratings. Here's how we defined each standard:

**Spray pattern.** As depicted in the drawing *above*, aerosol paints have nozzles that spray in one of two ways: round or fan. Because of its wider pattern, a fan-type nozzle distributes paint more

evenly than most round-pattern nozzles. Unfortunately, all of the fan-pattern paints in our test also had low solid contents, so they didn't cover well.

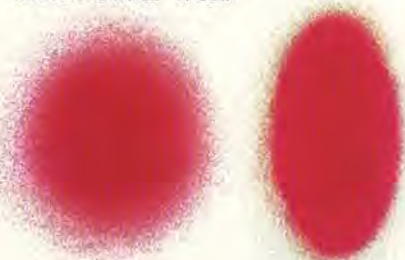

ROUND PATTERN

FAN PATTERN

**Runniness.** Paint sags and runs can really slow you down, and, fortunately, most of the paints earned at least a "good" rating in this area. Even those paints with blue and green dots in runniness will perform satisfactorily on a horizontal surface.

**Drying time.** For the paints to earn their ratings here, they had to pass our "hand-slick" test—a measurement of the amount of time that elapses before you can run your finger across the paint without marring it.

## Meet the man who led the testing effort

For expert help with this article, we enlisted Bob McFarlin, a home woodworker and full-time auto-body man who has logged thousands of hours in a spray-painting booth. Right up front, Bob told us that aerosol spray enamels can't deliver the same performance as automotive enamels and other finishes compatible with a compressor-fed spray gun. Why? Aerosol cans are designed primarily for convenience—not performance—so they contain fewer pigments

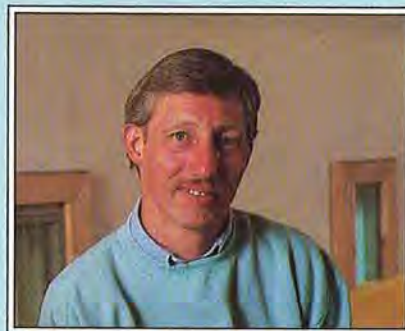

than nonaerosol paints. Nevertheless, after tabulating his test results, Bob remarked that several of the spray-can paints did impress him.



Most of the projects featured in *WOOD* magazine sport a clear finish that allows the beauty of the wood grain to show through. Occasionally, though, we opt for a painted finish for one reason or another. And like many of you, we usually buy a fast-dry spray enamel in hopes of getting the job done quickly.

But several of us on the staff have had mixed results with these paints. Although some brands deliver the desired effect, others don't seem to cover well and/or take forever to dry.

This got us curious. So, we went shopping one afternoon and rounded up all the brands we could find at local stores and brought them in for a closer look. And after some extensive testing, we think we've found out what separates the winners from the also-rans.

 Print this article

# PAINT WOOD® PUTS 18 PRODUCTS TO THE TEST

**Opacity.** This quality refers to the number of coats it takes to cover a surface and depends largely on the amount of pigments in the paint. As shown *below*, some paints covered completely in three coats; others did not.



Rust-Oleum's Wood Saver (*right*) completely covered a black-and-white card in three coats; Red Devil's Polyurethane Gloss Enamel didn't.

**Glossiness.** The level of reflectiveness in a paint or clear finish depends on your own taste, and we left it up to Bob to judge this criteria by eye.

## After all the paint dried: our conclusions

Tabulating the results was a red-letter event for paints from hardware chains. Ace's Premium Enamel and True Value's Tru-Test Hi-Q Enamel earned excellent and good ratings exclusively.

Although some paints didn't fare as well, some qualities make them good for specific tasks. For example, Rust-Oleum's Stop Rust Protective Coating took more than 30 minutes to dry, but it earned excellent ratings in all other areas—something to consider if you don't mind slower drying. And, even though Rust-Oleum's Wood Saver scored low in some areas, it's the only product with Teflon—a moisture-resistant barrier for outdoor applications. 🍀

## AT-A-GLANCE RATINGS FOR 18 ENAMEL SPRAY PAINTS

BRAND	SIZE (ounces)	SPRAY PATTERN	RUNNINESS	DRYING TIME <sup>2</sup>	OPACITY <sup>4</sup>	GLOSSINESS <sup>5</sup>	PRICE <sup>6</sup>
Ace Premium Enamel	11.5	● R	●	●	●	●	\$2.59
Dupli-Color Epoxy Enamel	11	● F	●	●	●	●	2.49
Dutch Boy Fast-Drying Spray Enamel	11	● F	●	●	●	●	1.37
Krylon Interior/Exterior Enamel	12	● R	●	●	●	●	2.99
Krylon Rust Magic	12	● R	●	●	●	●	2.99
Plasti-Kote Rust Not Enamel	12	● R	●	●	●	●	2.98
Plasti-Kote Ultra Super Enamel	12	● R	●	●	●	●	2.98
Red Devil Polyurethane Gloss Enamel	12	● F	●	●	●	●	3.60
Rust-Oleum Metal Saver Epoxy Coating	12	● F	●	●	●	●	3.49
Rust-Oleum Stops Rust Protective Coating	12	● R	●	●	●	●	3.76
Rust-Oleum Wood Saver	12	● R	●	●	●	●	3.89
Sears Best Anti-Rust Enamel	12	● R	●	●	●	●	2.51
Sears Best High Gloss Enamel	12	● R	●	●	●	●	2.51
Sherwin-Williams Super Acrylic Controls Rust Spray Enamel	12	● F	●	●	●	●	3.99
Target Best Spray Enamel	12	● R	●	●	●	●	1.99
Tru-Test Hi-Q Enamel	11.9	● R	●	●	●	●	3.25
Tru-Test Industrial X-O Rust	11.5	● R	●	●	●	●	4.39
Tru-Test X-O Rust	11.9	● R	●	●	●	●	4.29

1. (F) FAN (R) ROUND

● WIDE, UNIFORM PATTERN

● WIDE, UNIFORM PATTERN WITH SOME SPITTING

● SMALL PATTERN WITH SOME SPITTING

● SMALL PATTERN, PAINT DOESN'T FLOW TOGETHER WELL

2. ● NO RUNS IN 3 COATS

● RUNS IN FIRST COAT ONLY

● RUNS IN FIRST AND SECOND COATS

● RUNS IN ALL 3 COATS

3. ● 5-10 MINUTES

● 10-20 MINUTES

● 20-30 MINUTES

● MORE THAN 30 MINUTES

4. ● COVERS IN 3 COATS

● ALMOST COVERED IN 3 COATS

● NOT COVERED IN 3 COATS; 4 COATS WOULD COVER

● NOT CLOSE TO COVERING IN 3 COATS

5. ● HIGH REFLECTION, GOOD FLOW, DID NOT PULL WOOD FIBERS

● GLOSS WITH SOME HAZE

● HAZY, LITTLE GLOSS

● NO REFLECTION, NO GLOSS

6. Prices are what we paid at local hardware and department stores. Prices will vary from region to region and store to store.

Another fine homemade tool from the *WOOD*® magazine shop

\*Collector's Edition

# CENTER FINDER

Jim Boelling, *WOOD* magazine's project builder, loves the challenge of building usable yet impressive-looking hand tools for our shop. For this walnut-and-brass center finder, the latest in our Collector's Edition series, Jim wanted the tool to look distinctive, feel comfortable in his hand, and be small enough to fit in his shop apron. This tool meets Jim's criteria, and it's terrific for locating the center of dowels and other round stock, too.

 Print this article

## Let's shape the handle first

**1** From  $\frac{3}{4}$ "-thick walnut stock, rip and crosscut a piece  $1\frac{3}{8}$ " wide by 12" long. (We cut this piece extra long for safety in machining.)

**2** Where shown in Step 1 of the Handle Blank drawing, miter-cut both ends of the stock at  $45^\circ$ .

**3** Cut a  $\frac{1}{2}$ " rabbet  $\frac{1}{16}$ " deep on the right end of the walnut where shown on Step 2 of the drawing.

**4** Crosscut the walnut  $4\frac{1}{2}$ " from each end where shown in Step 3 on the drawing.

**5** Follow Step 1 of the two-step drawing far *right* to epoxy the handle pieces; check that the surfaces are flush. (We used quick-set epoxy.) Later, remove the handle from the 4"-square block.

**6** Transfer the handle pattern to one side of the handle blank and then to the other side. Using your bandsaw fitted with a  $\frac{1}{4}$ " blade, cut just outside the line to shape the handle. Then, sand to the line.

**7** Rout a  $\frac{1}{4}$ " round-over on the handle where shown on the Exploded View drawing.

## Trim the handle with brass

**1** From  $\frac{1}{2} \times \frac{3}{4} \times 12$ " brass, use a hacksaw or a bandsaw fitted with a  $\frac{1}{4}$ " or  $\frac{3}{8}$ " blade to crosscut two pieces  $2\frac{7}{8}$ " long. See the Buying Guide for our source of brass. (We took one section off each end of the 12" piece of brass to keep one square factory-cut end on each piece of brass.)

**2** For better adhesion to the epoxy, rough up one face of each piece of brass with 80-grit sandpaper. With the square factory-cut edges of the brass pieces butting each other, epoxy them to the inside face of the handle blank.

**3** As shown in the photo at *right*, use a bastard file to notch the brass flush with the groove in the walnut. Be careful not to increase the depth or width of the groove.

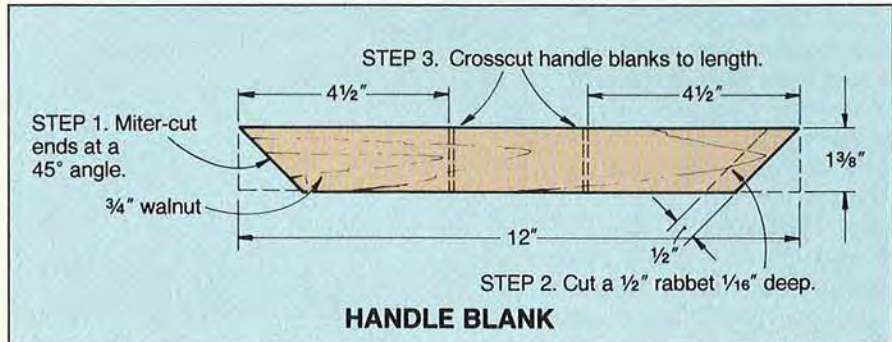
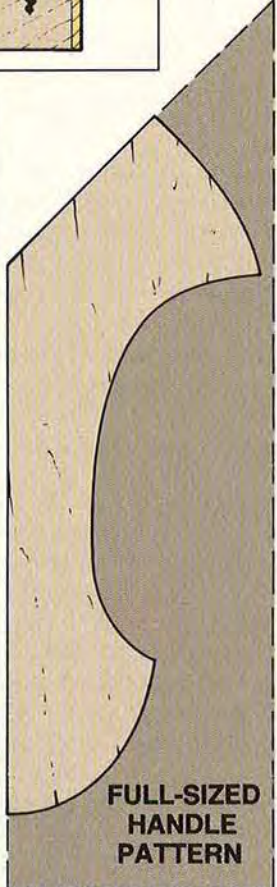
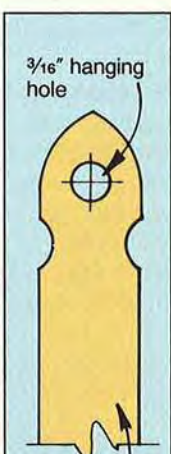
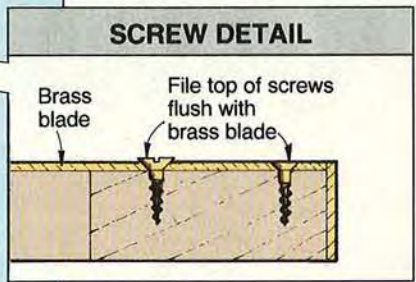
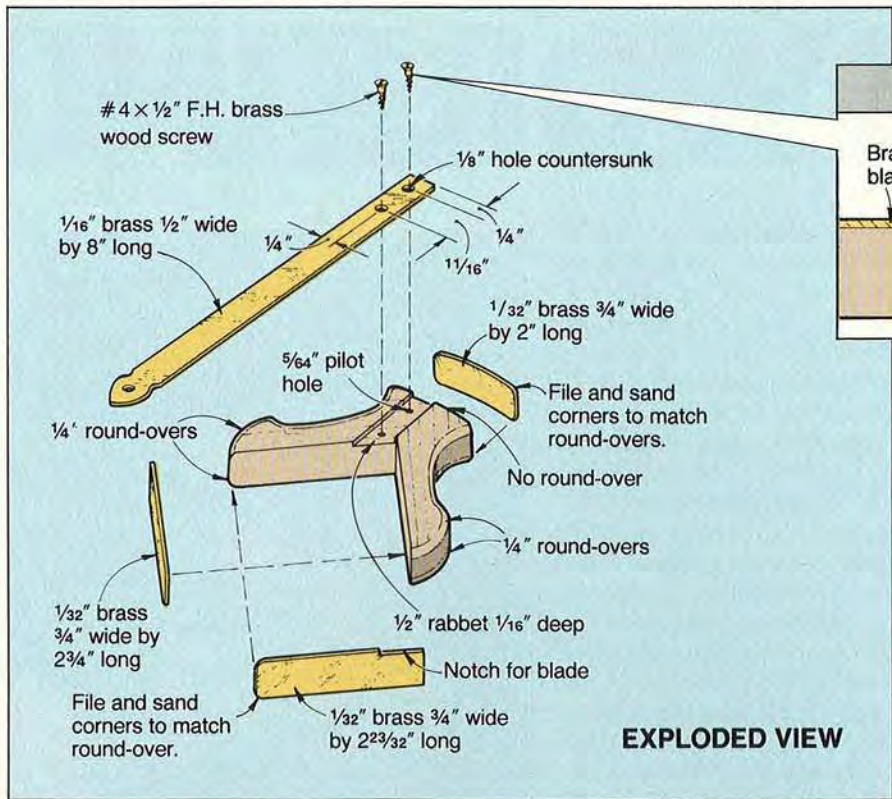

Use a bastard file to form a notch in the brass to match the groove cut in the walnut handle.

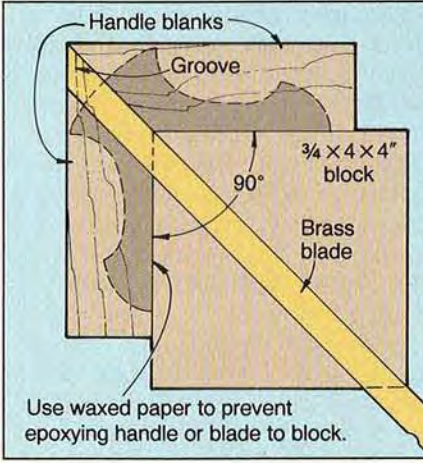

**JOINING THE HANDLE**

STEP 1. Cut a 3/4"-thick piece of scrap exactly 4 x 4". Epoxy the handle blank pieces, using the block to maintain a square inside corner.

STEP 2. Clamp blade to block with one edge of the blade carefully aligned with opposite corners of block. Without moving the blade, position the handle so the blade fits into the groove. File the rabbet slightly if necessary for a good fit. Epoxy the blade into the rabbet.

**Epoxy the brass blade to the handle**  
 | Crosscut a piece of 1/16 x 1/2 x 12" brass to 8" long. Transfer the

hanging-hole centerpoint and blade-end shape to the brass (see the full-sized pattern above right). Drill a 3/16" hanging hole where

marked. Shape the tapered end of the brass blade with a bastard file and the concave contours with a rattail file.

Continued on page 80

# WOODWORKING

**Starting a woodworking club may not be as hard as keeping one going and growing. Here's advice from veterans of thriving organizations.**

In many cases, woodworking clubs spring from an announcement posted on a lumberyard bulletin board. People show up at the first meeting, and the club is off and running. But when that first rush of enthusiasm wanes, it takes some special techniques to hold members' interest month after month.

## **Make the most of meeting moxie**

Scheduling meetings seems pretty basic. Club veterans, though, have differing strategies.

"One thing we found that holds the club together is to always set the meeting for the same night, at the same time, and in the same place," advises Arnold Geiger, treasurer, Alaska Creative Woodworkers Association, of Anchorage. Even then, there are sometimes problems.

"Of course, some people will still forget," he adds, "and that's why we get our newsletter out about a week before the meeting as a reminder. We hold separate board meetings where we handle most of the business. The general membership gets bored with business, so we just give a brief report, then it's on with the evening's planned demonstration."

During the summer, the Anchorage group—it has grown to 280 members in five years—doesn't bother with meetings. "After a long Alaskan winter, people are fishing or visiting and we couldn't get anyone to come anyway," Arnold says.

Jeff Heyen, of the 300-member 3M Woodworking Club, in Minneapolis-St. Paul, says his club

meets regularly once a month, but the site changes. "We may meet at the 3M Center, somebody's shop, or a retailer's store, depending on what's going on."

In Fort Walton Beach, Florida, the 70-member Florida Woodworkers Association likes to supplement their monthly meetings with a get-together called "The Sawdust Huddle," held on different nights. Board member Brian Collins enjoys those special evenings.

"We meet at a member's shop, get the tour, then sit around and talk woodworking," he explains. "At meetings, it's business, show-and-tell, and demonstration."

Russ Filbeck, president emeritus of the San Diego Fine Woodworkers Association, a group of 725, touts a different meeting philosophy. "Frankly, monthly meetings get old. Bimonthly meetings [six annually] are far enough apart that people don't seem to want to miss

one," he says. "We hold our meetings at a church social hall, and we spark attendance with a raffle, in addition to a speaker. Retailers donate small items, such as a sharpening stone or a chisel. The raffle also raises \$40-50 every meeting to pay for refreshments."

## **One for all and all for one**

"Woodworking clubs aren't selfish organizations. It's one for all and all for one," says Geiger of the Anchorage club. "The basis of the club is the education of its members. The experienced teach the inexperienced, and we bring in experts so we avoid internal burn-out over time."

Phoenix-area woodworker Andy Trotti, past president and one of the organizers of the Arizo-

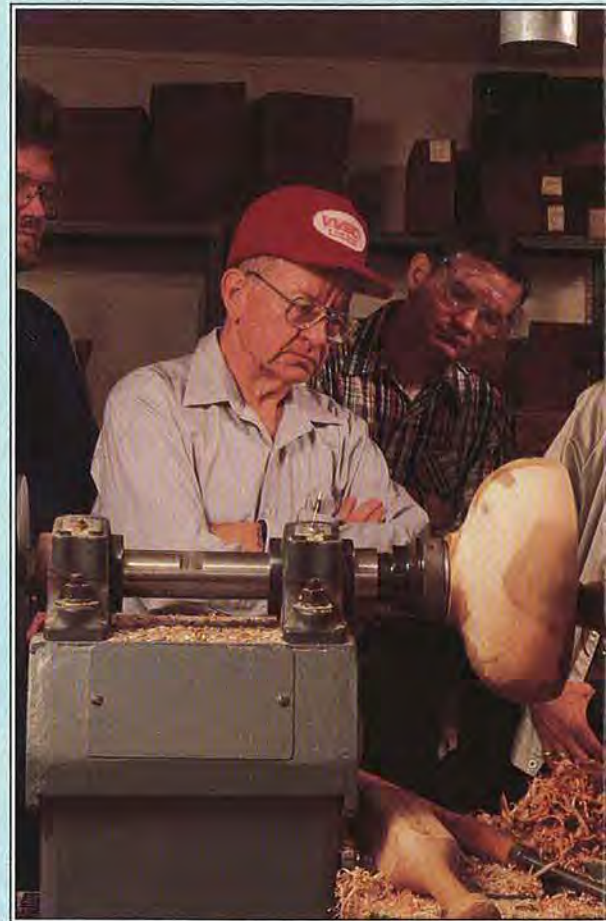

na Association of Fine Woodworkers, cautions founding fathers. "Now, we have about 170 members, but when we began in 1981, something almost killed us off right away. Some members wanted a guild system, where novices couldn't be officers until they had passed certain requirements regarding degree of skill."

As Andy remembers it, professional woodworkers in the newly formed group would have liked to have judged each nonprofessional's work and shop, then voted on their status. "That system would have excluded a lot of good people and discouraged people who would otherwise participate," he explains.

Assuring mutual benefit and maintaining member equality was



# CLUBS TIPS FOR SUCCESS FROM THOSE IN THE KNOW



◀ During a Saturday get-together at a member's shop, Tulsa woodworkers learn some new turning techniques.

wood, and get some pretty good prices from a local supplier," says Heyen. "Our club also arranges with dealers in town for other group buys, such as tools."

Woodworkers in Fort Walton Beach rack up savings when they come to meetings. Collins comments, "Because we live in a small community, we rely heavily on mail-order suppliers. But no one can afford to buy and store, say, 1,000 wood screws. So, the club makes bulk purchases, and we sell smaller parcels during meetings at our own 'woodworker's' store.' We discount screws, wheels, dowels, sanding belts, and blades, and make some money."

## Club strategies that won't work

Fledgling clubs oftentimes think about having a mutual shop. "Forget it," says Trotti.

"Liability insurance will kill you. Because we meet in the woodshop of the State School for the Deaf, in Phoenix, we're required to carry \$1 million in liability. For 12 meetings, that costs almost \$500. And, only the demonstrator uses the equipment."

Trotti has some advice regarding commercialism, too. "Keep it

out of meetings," he says. "Members don't want to listen to a sales pitch as part of a tool demo."

New clubs can also over-organize, according to Collins. "We tried doing member surveys regarding interests," he says. "Less than 30 percent filled them out." And, asking people to step forward at election time doesn't work in Fort Walton Beach, either. "For new officers, don't ask for volunteers. Instead, pick some likely candidates, phone them, and put on the pressure."

## Club corporations? You bet!

Many woodworking clubs incorporate, for these primary reasons:

- Large clubs save newsletter mailing expense with a nonprofit bulk-rate mailing permit.

- A corporation doesn't have to be tax-exempt. Small clubs may only see limited savings in exchange for extra legal work and additional annual reports.

- In some states, nonprofit corporations become eligible for state fine arts grants to defray expenses for visiting speakers.

- Incorporating can protect officers and board members from legal suits over possible member injuries in a seminar or demonstration. The corporation's assets would limit damage awards.

- Always check with legal counsel for incorporation advice. ♣

important to Anchorage and Phoenix founders. In San Diego, the woodworking club added simple economics to shore up the common interest.

"We started contacting retailers in the area early on, and got them to support the club through discounts to members," says Filbeck. "That way, members can recoup their membership fee [presently \$20 per year] very quickly. Our members get anywhere from 10- to 40-percent discounts from about 20 retailers in San Diego County. We advertise and publicize the firms and they're there for our people."

Billfold incentives keep the 3M Woodworking Club active and happy, too. "Usually twice a year we have a group buy of hard-

For a newsletter from the clubs mentioned, send a self-addressed, stamped, business-sized envelope to:

*Alaska Creative Woodworkers Assoc.*  
P.O. Box 20176  
Anchorage, AK 99520-1796

*Arizona Assoc. of Fine Woodworkers*  
P.O. Box 44264  
Phoenix, AZ 85064

*Note: The 3-M Woodworking Club does not publish a newsletter.*

*Florida Woodworkers Association*  
P.O. Box 1023  
Fort Walton Beach, FL 32549

*San Diego Fine Woodworkers Assoc.*  
P.O. Box 99656  
San Diego, CA 92109

Photograph: Bob Hawks

# SPLIT-TURNED



Bob Taylor developed an early appetite for turning. At age 5, he was ready to start turning but unable to reach the lathe. To solve the problem, his father, an industrial arts teacher, built him a box to stand on. Bob, now a professor at Auburn University, still enjoys lathe work in his spare time. In fact, this split-vase design is one of his better sellers at craft fairs.

*Note: You'll need two 2×2×24" turning squares to make this project. If you don't have stock this size, laminate thinner stock or see the Buying Guide at the end of the article for our source.*

## Preparing the stock for turning

- 1 Cut four pieces of 2×2" stock (we used oak) to 11¾" long.
- 2 Joint two adjacent edges of each piece; check that the jointed edges are square to each other.
- 3 Now, rip the other two edges of

each piece so each piece measures 1⅞" square.

4 Cut two pieces of heavy paper (we used a grocery sack) to 2" wide by 10¾" long.

5 Glue and clamp two of the turning squares with the paper in place where shown in Step 1 of the drawing below. Please note the end-grain configuration. Check that the edges and ends are flush. Later, use an X-acto knife to trim the excess paper. The paper allows the lamination to be split after turning. Repeat with the other two squares.

6 Cut one piece of the paper to 3¾" wide by 10¾" long. Glue and clamp the two laminations.

7 To support the corners—they have a tendency to chip when turning—wrap 1" strapping tape around the lamination where shown on Step 2 of the drawing.

8 Transfer the full-sized template patterns on page 88 to posterboard, and cut them to shape.

## GOUGE DETAIL

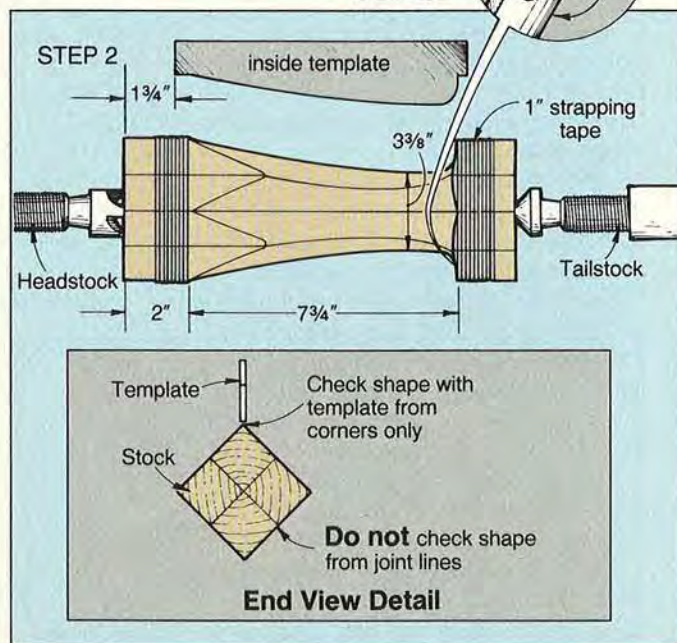
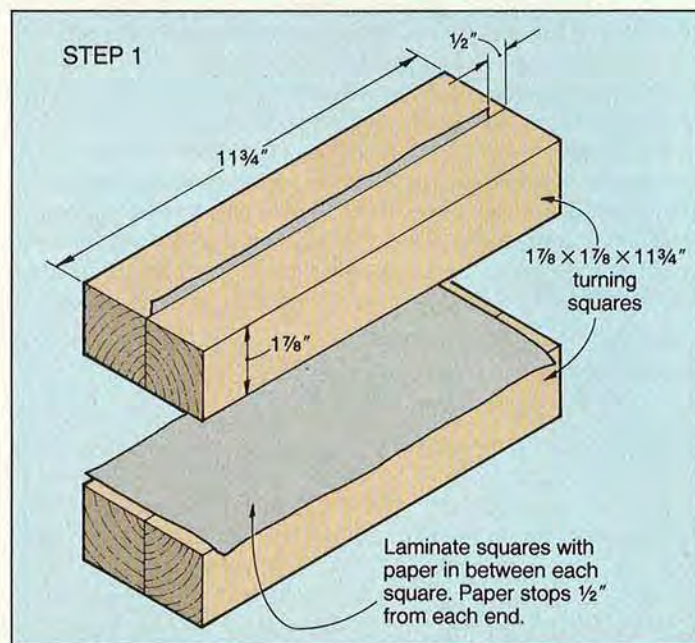
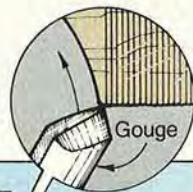

# VASE

A design with a "hole" lot of appeal

## It's time to shape the inside

**1** Using Step 2 of the drawing for reference, and the *inside template* on page 64, turn the lamination to shape. (We recommend a lathe speed of 750 rpm. To minimize chipping, we used a sharp  $\frac{1}{2}$ " gouge.) Avoid using a scraper; it tends to leave a rough surface. Also, to reduce chipping at the radiused end, see the Gouge detail for tool-positioning reference when making the cut. Stop frequently and check the shape of the curve against that of the inside template where shown on the End View detail accompanying Step 2 of the drawing. *Don't make the curve too deep. The deeper the curve, the larger the openings in the completed vase.*

**2** Sand the curved area smooth. Remove the strapping tape and split the lamination as shown in the photo at *right*.

## Turn the outside to shape

**1** Glue and clamp (no paper this time) the four turning squares in the positions shown on Step 3 of the drawing. Make sure that the curves stay aligned with each other

when clamping. Let the glue dry overnight.

**2** Using the *outside template* and a gouge, turn the vase lamination to the shape shown in Step 4 of the drawing. (We used a speed of about 1,200 to 1,500 rpm to minimize tool chatter caused by the openings.) Leave a  $\frac{3}{4}$ "-diameter waste tenon on the top and on the bottom of the turning.

**3** Remove the tool rest and sand the vase. (We wrapped sandpaper

around a felt pad to do this.) Holding your hand under the turning—like you'd throw a slow-pitch softball—sand the turning. *Don't* wrap your thumb around to the top of the turning. Holding the paper underneath the turning and using a speed of about 1,200 rpm helps prevent the sandpaper from catching in the openings.

**4** Alternating between the top and base, make parting cuts at each tenon where shown on Step 4 of the drawing. Angle the tool where shown so the vase bottom is slightly concave and will sit flat. Do the same with the top to create the angled opening.

**5** Remove the turning from the lathe and use a  $\frac{5}{8}$ " Forstner bit to bore a hole through the top of the turning and into the hollow middle. Sand the top of the bored opening smooth. Apply finish.



Using a mallet and 1" chisel, split the lamination at the four paper joints.

## BUYING GUIDE

• **Turning squares.** 2 pieces of 2 x 2 x 24" red oak, catalog no. WD291, \$13.35 ppd. Constantine's, 2050 Eastchester Rd., Bronx, NY 10461. Or, call 800-223-8087 to order. 🌲

STEP 3

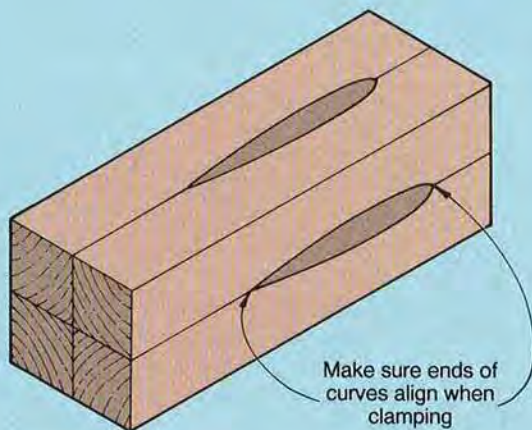

STEP 4

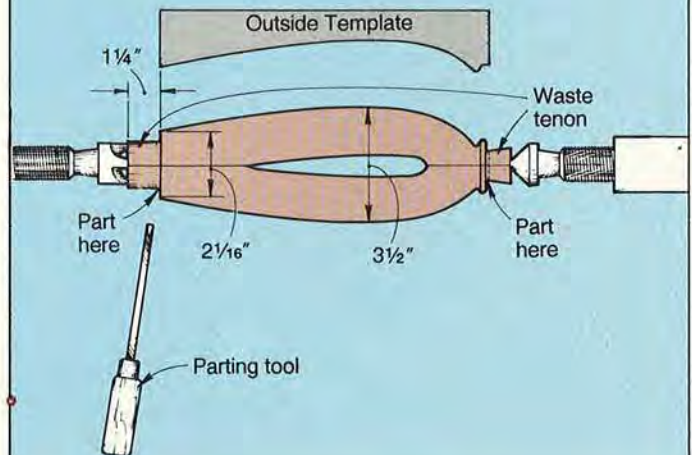



**W**elcome to The Craft Shop, a new section of the magazine devoted to quick-and-easy projects that require a minimum of tools and materials.

If you like scroll-sawed projects, hand-painted designs, cutouts, and small decorative items, I know you'll really enjoy this section.

Enough talk; the time has come to snip the ribbon and open the doors. Have fun and don't forget to make a few extra.

*Larry Clayton*

For the *WOOD* magazine staff

## SCROLLSAW DECORATION NATURE-IN-THE



Capture the beauty of spring with this delightful scroll-saw project. Make the stand to display it or simply hang it in front of a window.

 [Print this article](#)

To make your decoration, start with a 6×12" piece of fine-grained hardwood such as cherry or walnut, and plane or resaw it to 3/8" thick. Cut a 6"-square workpiece from this. (Use the remaining 6" square for a second decoration.)

With carbon paper or a photocopy and spray-on adhesive, transfer the full-sized pattern to the workpiece. Chuck a 3/32" bit into your drill, and drill blade-start holes where shown on the pattern.

Thread a scrollsaw blade through one of the holes and begin cutting the openings. (We used a blade with 18 teeth per inch.) When cutting the

bird's narrow beak, begin your cut at the head—both at the top and bottom of the beak—and cut toward the end of the beak to avoid breaking it. Continue reinserting the blade in the holes and cutting until all the openings are complete, including the stamen lines in the flower centers.

Finally, form the outside perimeter of the decoration by cutting just outside the marked line, and then sanding to the line. (We used a disk sander.) Remove the paper pattern from the decoration with lacquer thinner. To do this, dampen a cloth with lacquer thinner and press against the paper pattern. Peel off the paper and use the cloth to wipe off any sticky residue on the wood.

To make the stand, follow the three-step cutting process shown *far right*. Finish-sand both pieces and apply a finish. (We applied two coats of tung oil.) You might want to hang this project in front of a window. ♣

# ROUND

Drill  $\frac{3}{32}$ " holes through the workpiece wherever there is a red dot on the pattern at right. This will allow you to insert your scrollsaw blade at these points for cutting each opening to shape.

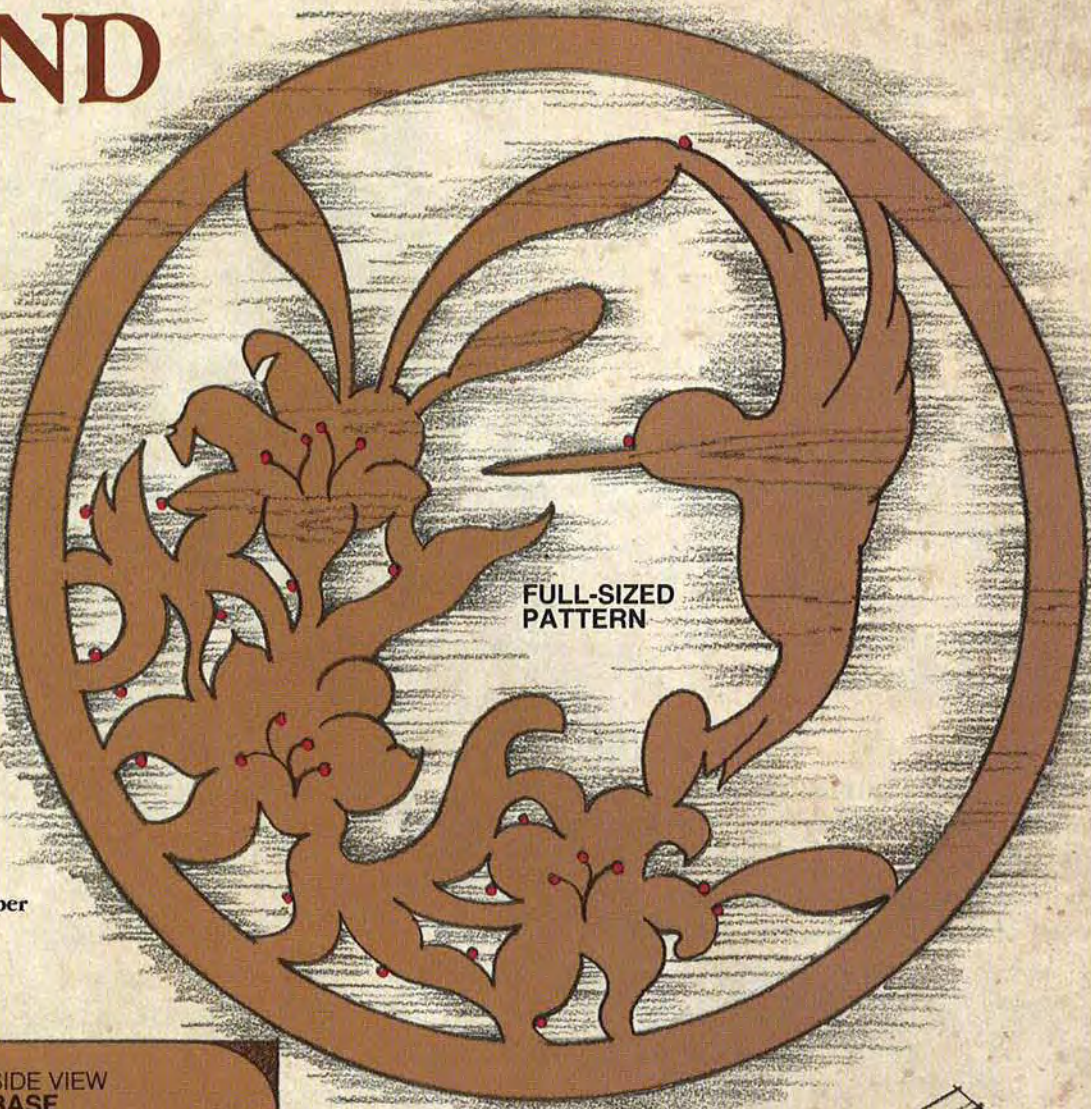

After scrollsawing the pattern, you can easily accomplish touch-up sanding by using an emery nail file or sandpaper wrapped around a stick.

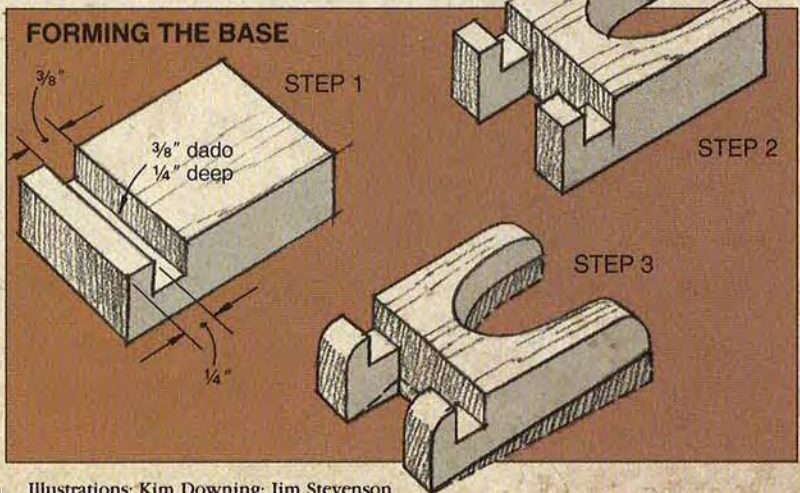
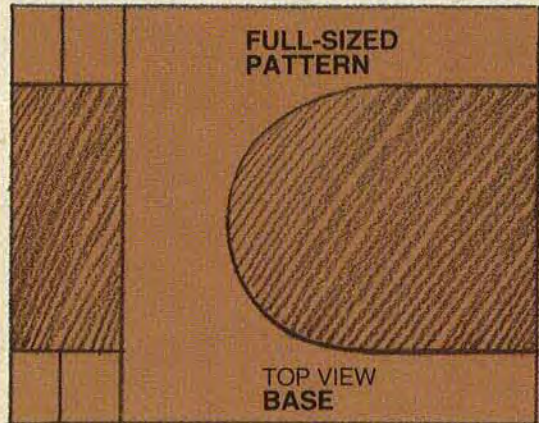
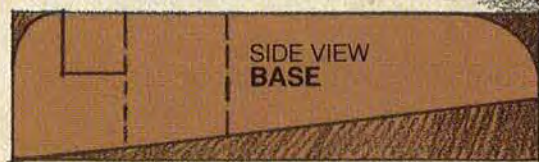

Project Design: Nancy Clavier Photograph: John Hetherington Illustrations: Kim Downing; Jim Stevenson



 Print this article

# ODDS 'N' ENDS COUNTRY SHADOW BOX

Fanciers of small collectibles, at last you have the perfect project for showcasing thimbles and other small items. Then, add our counted cross-stitch design for a center highlight.

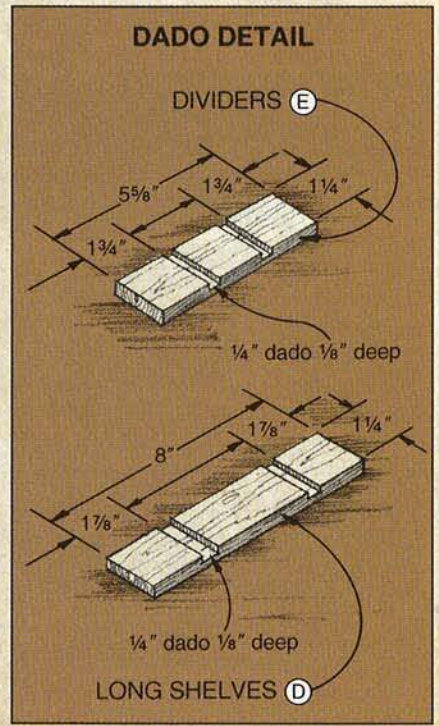
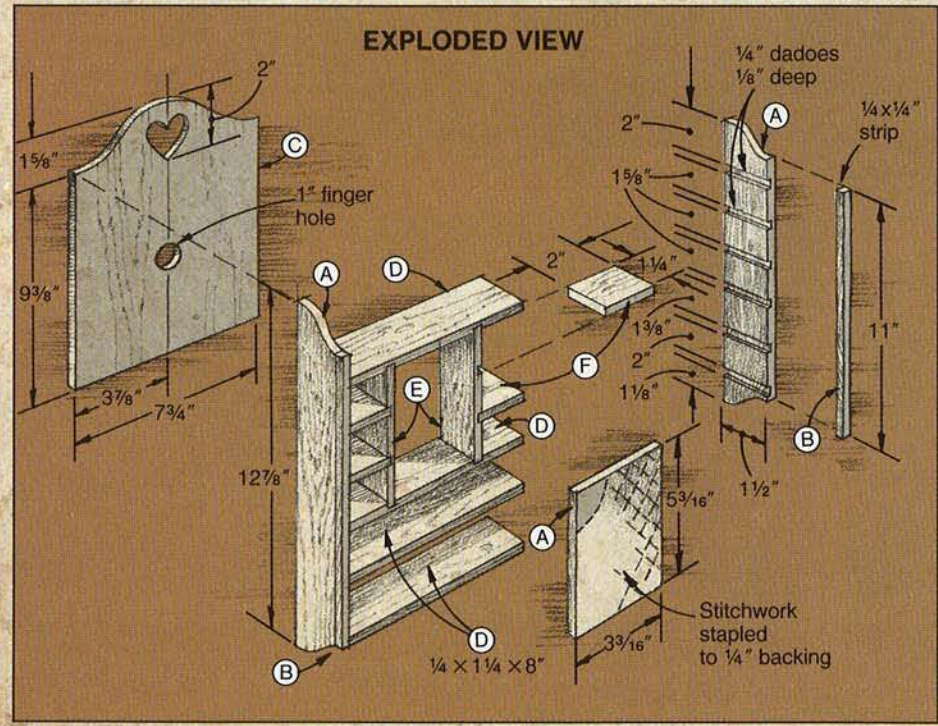
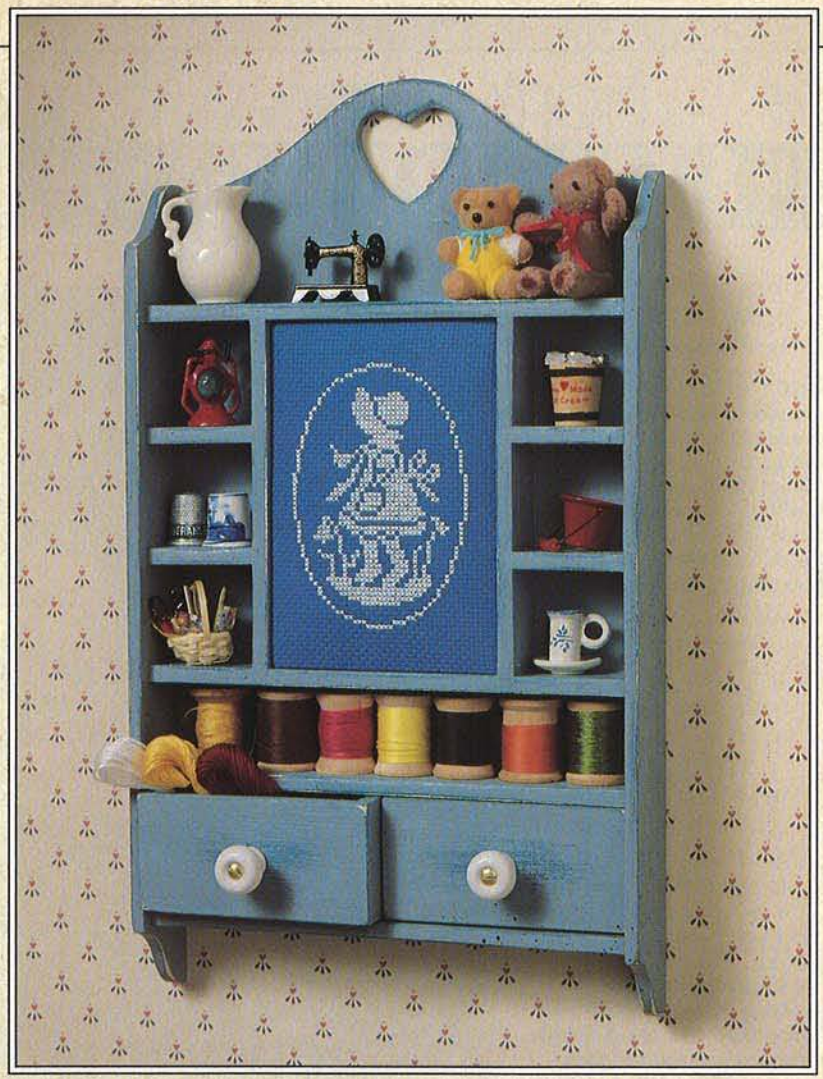

**Note:** See page 86 for the stitchwork pattern we used and the Exploded View drawing for the dimensions of the 1/4"-thick piece used to back the stitchwork.

To make the side pieces (A), cut a piece 12 7/8" long by 3 5/8" wide from 1/4" stock (plane or resaw thicker stock). Using a try square and the dimensions on the Exploded View drawing, mark the location of the 1/4" dadoes on the stock. Now, cut or rout 1/4" dadoes 1/8" deep across the piece where marked. Rip two 1 1/2"-wide side pieces (A) from the 3 5/8"-wide dadoed piece.

Cut two pieces of 1/4" stock to 1/4" wide by 12 7/8" long for the facing strips (B). With the surfaces

and ends flush, glue and clamp a strip to the front of each side (A).

Transfer the full-sized top and bottom pattern shown below to the cabinet sides (A, B). Using a scrollsaw or bandsaw, cut the top and bottom of each cabinet side to shape.

From 1/4" stock, cut the two back pieces to 3 7/8" wide by 11" long for the backboard (C). Transfer the heart outline to each of the 3 7/8"-wide pieces. Then, cut the pieces to shape, and glue and clamp them edge to edge.

Transfer the Backboard Top pattern to the backboard, and cut to shape. Drill a 1" finger hole through the backboard. The hole allows you to easily remove the stitchwork without prying.

Cut the four long shelves (D) and the two dividers (E) to the sizes shown in the Dado detail. Mark the dado locations on two of the shelves and both dividers where dimensioned on the detail. Cut or rout the dadoes. Cut the four short shelves (F) to size. Dry-clamp the assembly to check the fit of all the pieces. Trim if necessary. Then, glue and clamp the assembly, checking for square. Measure the opening, and cut the stitchwork backing (G) to size minus 1/16" in length and width.

Using the Drawer drawing for reference, cut pieces H, I, J to size. Cut 1/4" rabbets 1/8" deep where shown. Glue and clamp each drawer. Drill a 1/8" hole in the center of each drawer front.

Brush on the desired color of paint. (For our country antique look, we applied a medium blue paint, followed by a light blue. Next, we sanded the edges to make the project appear worn. Finally, we speckled the project with dark navy blue.)

Attach the knobs. With the quilt batting in place, stretch the stitchwork around the backing piece and staple it in place. Slide the stitchwork/backing in place, and hang the project where it's sure to be noticed. 🍷

Project Design: James R. Downing  
 Cross-Stitch Design: Dixie Falls  
 Photograph: Hopkins Associates  
 Illustrations: Jamie Downing, Jim Stevenson

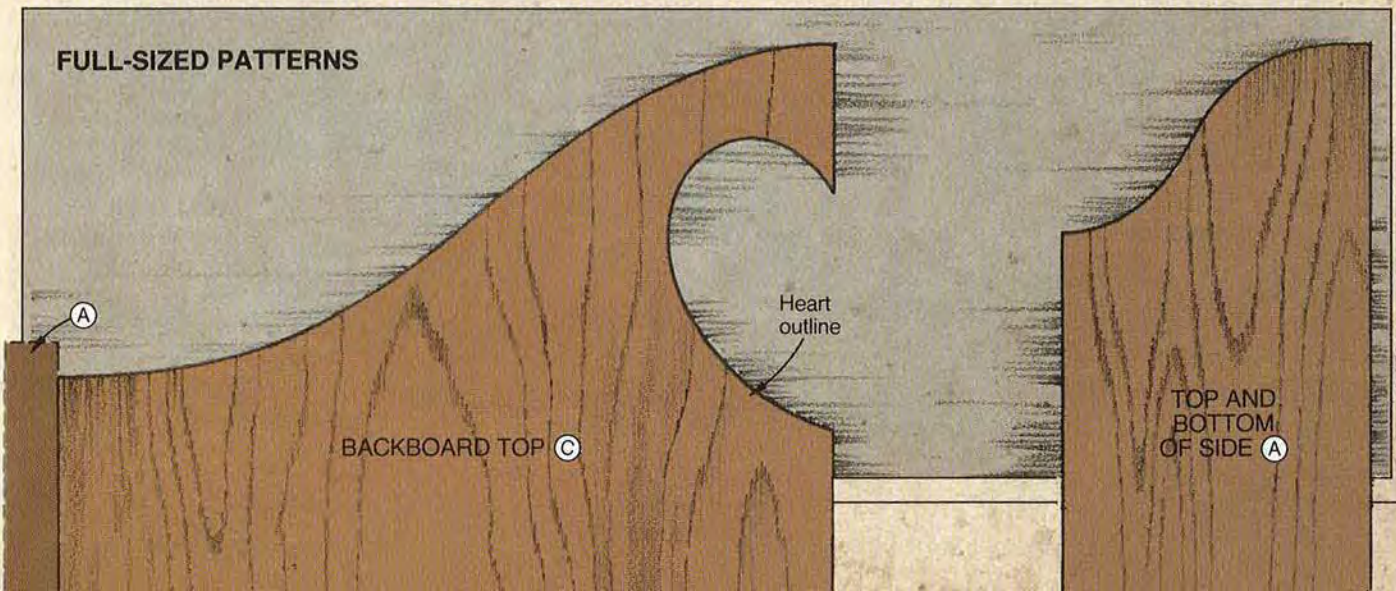
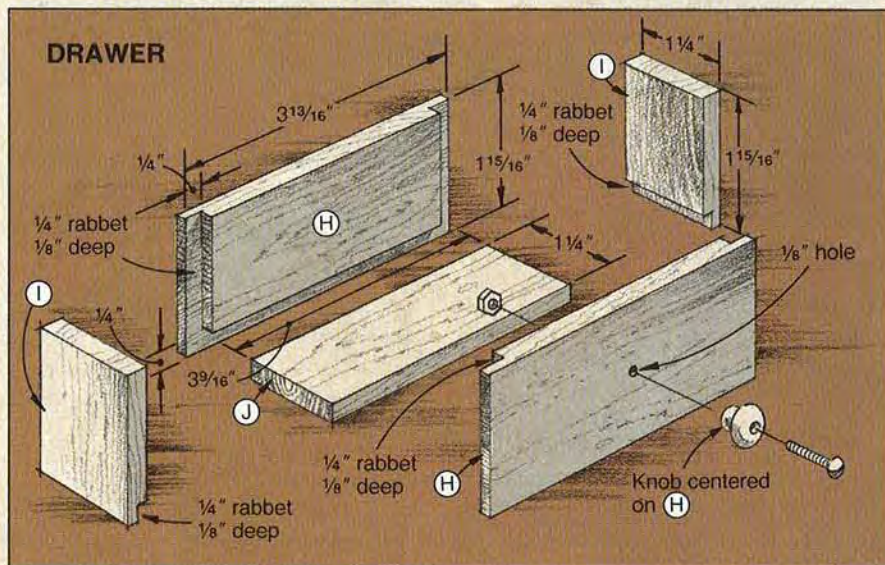



## LURE OF THE SEA

# RELIEF PUZZLE

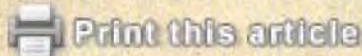

When you scrollsaw and paint the parts for this colorful coastal scene, you're setting sail for a good time. Place the puzzle in a child's longing hands or on a shelf for its pure visual beauty.

Cut a  $\frac{3}{4}$ " clear pine board to 7×11". Sand the front and back of the board. Transfer the full-sized pattern to the stock, aligning the bottom of the pattern with the bottom of the board. (We made a photocopy of the pattern and mounted it to the stock with spray-on adhesive.)

Scrollsaw around the outside of the frame. (Using a #9 blade, we sawed just outside the outline.) Drill a  $\frac{3}{32}$ " blade start hole through the board where marked on the pattern and thread the scrollsaw blade through the hole. Cut the interior edge of the frame. Switch to a #6 blade and cut the individual pieces to shape. Remove the paper pattern pieces. (We used lacquer thinner to dissolve the adhesive.)

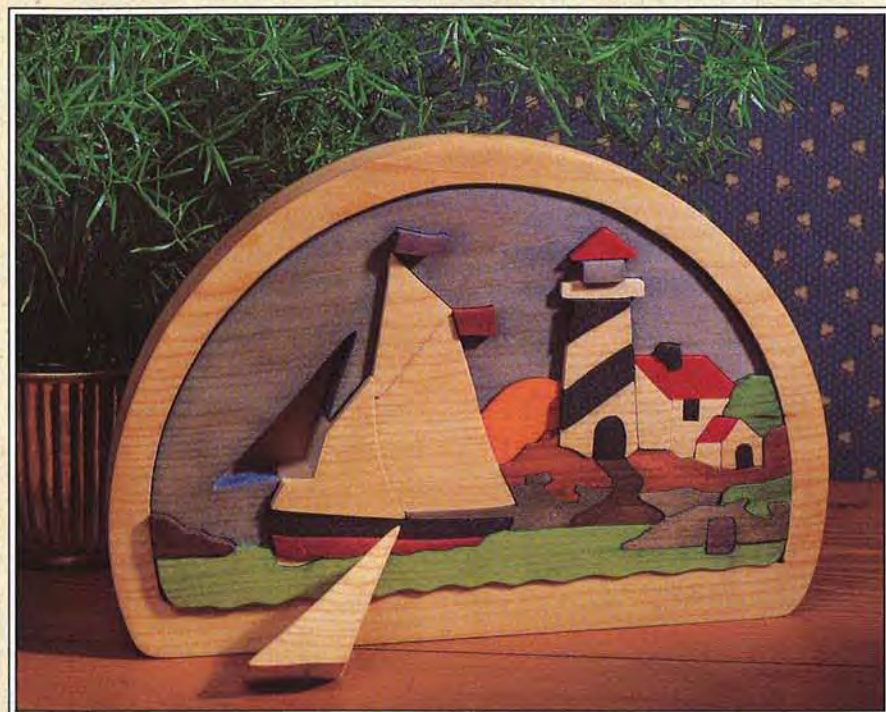

Lay the pine frame on a piece of  $\frac{1}{8}$ "-thick plywood or hardboard, and trace the frame's outline on it. Cut the backing to shape. With the edges flush, glue the backing to the frame. Sand flush the edges of the frame and backing.

To create the three-dimensional effect, sand the sky and sun pieces to reduce the thickness to  $\frac{1}{2}$ ". (We used a stationary sander; a belt sander also would work.) Finish-sand all the pieces.

Finally, following the lead of the photo *above* or your own imagination, paint or dye the puzzle pieces. For an easier-to-assemble puzzle, paint just the front and side surfaces. To make assembling the puzzle more challenging, paint all surfaces of the pieces. (We used wood dyes for the colored pieces—watered-down acrylic paints also work well. We left the sail pieces, frame, and parts of the lighthouse natural. Later, we applied several coats of mineral oil to all the pieces to seal them.)

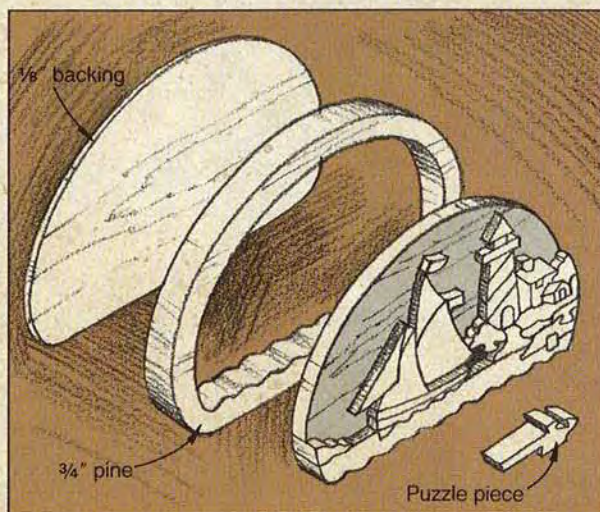



For a three-dimensional effect, sand the sun and sky pieces to 1/2" thick (light-gray area).

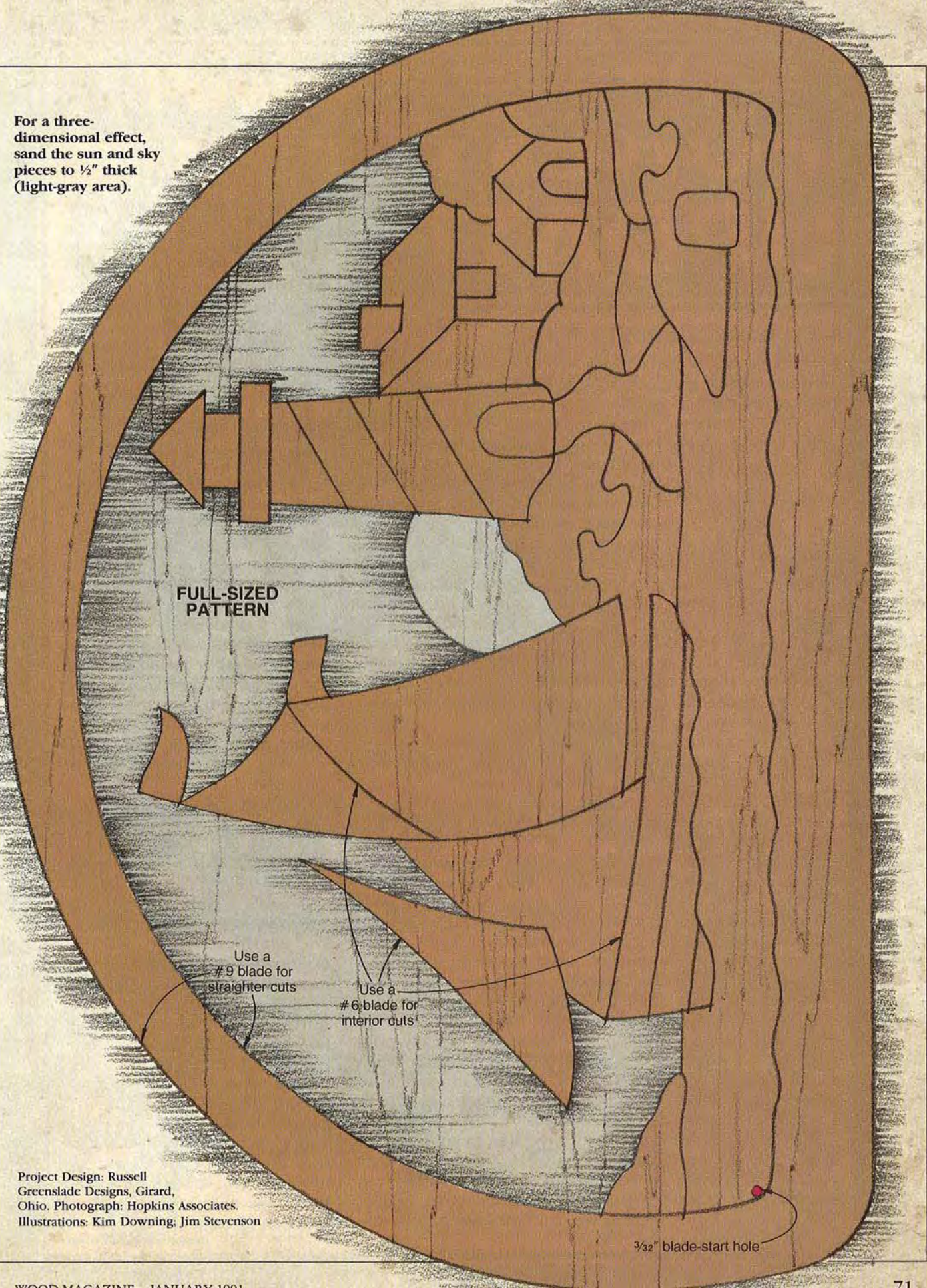

**FULL-SIZED  
PATTERN**

Use a  
#9 blade for  
straighter cuts

Use a  
#6 blade for  
interior cuts

3/32" blade-start hole

Project Design: Russell  
Greenslade Designs, Girard,  
Ohio. Photograph: Hopkins Associates.  
Illustrations: Kim Downing; Jim Stevenson

# FOREST UPDATE

## BOOBY-TRAPPED TREES

The Hardwood Manufacturers Association (HMA) calls it "environmental terrorism." But spiking trees and sabotaging logging equipment to stop the harvest of trees borders on outright lunacy. When a spike the size of a 20-penny nail buried in a log hits a huge, high-speed saw blade at the mill, someone's likely to be maimed—or killed. That's because the blade can explode, sending metal flying. And, as far as monkey-wrenching equipment, loggers already suffer a high on-the-job injury rate. Failing machines won't help.

But, according to Robert Slocum, executive vice president of the North Carolina Forestry Association, that's what has occurred in his state. He cites instances of tree-spiking and sabotage at logging sites in the Pisgah National Forest during the last logging season. Fortunately, no one has been killed. And, just in case these tactics are news to you, they've been taking place for years in California, Oregon, and Washington. There, though, the vandals have the good sense to mark spiked trees.

## WOODWORKERS vs. RAIN FORESTS?

From what we've read and heard in the last several months, there are mixed reactions from woodworkers on the use of exotic woods, especially those from South America's rain forests. Cardinal wood, mahogany, rosewood, tulipwood, and others fall into this category.

A woodworkers' boycott of South American species has been mentioned. If that happens, others say, those hardwoods will drop in value, and rain-forest dwellers will just slash-and-burn all the more to make room for cash crops. Then, too, much of the imported mahogany actually originates on plantations in Central and South America, where it was planted generations ago and managed much like our commercially grown fir and pine. So, what's the answer regarding what wood to use?

If there is one, we don't have it yet. But, in an upcoming issue we'll publish the results of a survey. We've sent questionnaires to timber buyers, importers—anyone with an insight regarding South American wood and other exotics. When we read their replies, we can formulate an opinion.

 Print this article

## THE DOLLAR SIDE OF PROTECTING OLD GROWTH

Setting aside millions of acres of old-growth Douglas fir in the Pacific Northwest to save the northern spotted owl isn't without costs. Besides idle mills and lost jobs, the price of wood and things built of wood—such as new homes—will rise, says Random Lengths, Inc., a Eugene, Oregon, publisher of market analyses in the Northwest's forest-products industry.

According to their calculations, the average-sized new home measures about 2,000 square feet and costs a median price of around \$120,000. (The National Home Builders Association cites \$94,800.) If the price of softwood lumber goes up \$100 per thousand board feet (mbf), a wood-frame home will cost an additional \$2,320. If you use fir in your woodworking, the cost breaks down to 10 cents per board foot. And, you'll use smaller dimension lumber, because most 2x10s and 2x12s come from old-growth.



### The spotted owl may be just the beginning

The Northwest Forest Resource Council warns its forest-products industry members in a fact sheet circulated last June that the northern spotted owl may be just the first domino in a long list of excuses environmentalists will come up with to shut down public timber to logging. According to the association, if you apply the domino theory, the next dominoes could be the Columbia River murrelet (a small bird), the wild salmon, and the Mexican spotted owl. 🌲

Illustration: Jim Stevenson

# Now, Add Instant Earning Power to Your Shop!



**30-Day Free Trial!**

## Here's What Woodmaster Owners Say:

"The shop test article in *Wood Magazine* that said they loved your Variable Feed Rate is what sold me. They were right."

L.C. Griffin, Los Angeles, CA

"I cleared over \$400 for a Saturday's work with my Woodmaster. It has paid for itself many times. It gives me extra money doing something I really like."

B.L. Watts, Cleveland, OH

Craftsmen everywhere are using the low-cost Woodmaster to **bring in welcome extra cash** and to save on all their lumber needs. You can, too!

With the new 18-in. Woodmaster or the standard 12-in. model, you can quickly convert low-cost rough lumber into valuable finished stock. You can turn out perfect picture frame moldings, crown, bed and base moldings, tongue & groove, door and window trim...all popular patterns...any custom design.

You can do custom work for friends, neighbors, lumberyards, picture framers, home remodelers, hobby shops and businesses.

Because it takes just seconds to convert a \$2 rough board into \$10 worth of finished trim, you can see why so many Woodmaster owners enjoy substantial extra incomes!

## Variable Speed Makes The Difference!

Just a twist of the dial gives you perfect control for planing, sanding or sawing...from 0 to 1,000 cuts per inch. Creates mirror-smooth molding with no sanding required!

You **save** because the Woodmaster does the job of separate tools costing hundreds of dollars more. And you **keep on saving** year after year on all of your lumber needs!

Call or write today for free facts on how you can try this American-made tool in your own shop for one full month. Easy terms.



Woodmaster's Quick-Change Molding Head lets you create custom moldings from any stock. Choose from over 250 standard trim and picture frame patterns...or design your own!



Power-fed sanding speeds production and improves the quality of your work. No more waves or cross-grain scratches. Separate sanding head installs in just minutes.



New rip saw attachment lets you gang-rip with power feed in a fraction of the time it takes for multiple hand-fed passes on an ordinary table saw.

## 30-Day Free Trial!

Send for complete facts on how you can try this low-cost, 4-in-1 power tool in your own shop for 30 days completely without risk! We'll also send you complete details on how you are fully protected by Woodmaster's One Full Year Limited Warranty.

## Call Toll-Free 1-800-821-6651



Yes! Please rush me your **FREE** Information Kit plus details on your **30-DAY FREE TRIAL GUARANTEE!**

WOODMASTER TOOLS, INC., DEPT PW42  
2908 OAK STREET • KANSAS CITY, MO 64108

Name \_\_\_\_\_

Address \_\_\_\_\_

City \_\_\_\_\_

State \_\_\_\_\_

Zip \_\_\_\_\_

Phone ( \_\_\_\_\_ ) \_\_\_\_\_

## Tungsten Carbide Router Bits

- INDUSTRIAL GRADE, THICK CARBIDE
- SEALED BALL BEARINGS
- 40 - 60 % BELOW WHOLESALE

### COVE BITS



Radius	Price
1/4	\$ 14
3/8	\$ 15
1/2	\$ 17

### ROUND-OVER OR BEADING



Radius	Price
3/16	\$ 12
1/4	\$ 13
5/16	\$ 14
3/8	\$ 14
1/2	\$ 15

### ROUNDNOSE BITS



Diameter	Price
1/8	\$ 8
1/4	\$ 9
3/8	\$ 11

AMER. EXP. - TOLL FREE - C.O.D.

**1-800-767-4747**

Or Mail Check to:

**SKYCROFT TOOLS, INC.**  
P.O. Box 418W5  
Myersville, MD 21773-0418



NEW GROUND MARKETING  
QUALITY & INNOVATION

## LOCKWOOD POWER™ Oscillating Spindle Sander

Leaves no sanding lines!

A professional edge on  
Contour Sanding.  
Spindles, 6 inches long,  
1/4 inch to 3 inch dia's.

- Worm and Gear Drive
- 5/8 hp Motor
- 1 1/2 inch stroke
- 57 Strokes per minute
- 6 inch spindle length
- 8 spindles available



MADE IN USA

Write or call for free information!



NEW GROUND MARKETING  
P.O. Box 718  
Lansdowne PA 19050

(215) 622-2445

## OLD HAND WAYS

# HIDE MY TOOLS, HERE COMES THOREAU!

“Near the end of March, 1845, I borrowed an axe and went down to the woods by Walden Pond...”

Henry David Thoreau, 1851



Even if you know nothing else about Henry David Thoreau, you probably recall that at the age of 28 years, he took to the woods near Concord, Massachusetts, built a one-room cabin, and advised us to “simplify, simplify.” Yet, in spite of Thoreau’s philosophical gifts, he was a terror. In fact, Thoreau was the dread of all working men. He, as it turned out, was a tool-borrower. And, as he admits, he began by borrowing the most personal and elemental—another man’s axe!

“The owner of the axe, as he released his hold on it, said that it was the apple of his eye; but I returned it sharper...”

Well, thanks Henry, but why did you ruin the handle? As it were, Henry had just begun felling pines when the axe-head worked loose. He cut a new hickory wedge, drove it in with a stone, and then made a fatal move. He “placed the whole to soak in a pond-hole in order to swell the wood.”

Don’t do it, Henry! Soaking the handle to tightly swell the wood in the eye of the axe seems like a good idea. In truth, it backfires.

The hickory handle swells with the water and locks tight in the iron head, but the swelling crushes the wood cells. When the wood dries, the damaged cells shrink con-



siderably smaller than before, and the handle ends up looser than ever. Leave your axe out in the rain a few times and see. Nevertheless, Henry kept right on, diligently working to prepare the green timbers for his new cabin.

“I hewed the main timbers six inches square, most of the studs on two sides only, and the rafters and floor timbers on one side, leaving the rest of the bark on, so that they were just as straight and much stronger than sawed ones.”

Thoreau knew the value and strength of simplicity. The round timbers were stronger, if heavier, than rectangular pieces. And, by hewing one side, he not only created a flat surface to nail to, he also ensured that his work would last more than just a few years. His reasoning was this: Bark is waterproof (if it were not, trees would dry out and die). Flattening one side of the poles allowed the moisture to slowly escape and the green wood to season so that it wouldn’t rot and attract insects.

With knowledge such as this, Thoreau managed a sturdy, yet comfortable cabin that measured 10×15’. Although we think of it as entirely of logs, the cabin had lath-and-plaster walls. He had developed his skills as a carpenter the

year before, when he helped his father build the family house, and learned where to borrow tools.

**“Each stick was carefully mortised or tenoned by its stump, for I had borrowed other tools by this time.”**

So, someone's auger, mallet, rule square, and chisel weren't there when the cow shed suffered for repair. No wonder “the mass of men lead lives of quiet desperation.” Writers have borrowed their tools!

With little concern over acquiring tools, Henry reveled in his work. “Shall we forever resign the pleasure of construction to the carpenter?” he happily wrote.

By that August, Henry returned the borrowed axe. To replace it, he found “an old axe which nobody claimed.” With this orphan blade, he chopped the stumps out of his bean field for firewood. Striking through dirt and rock quickly ruined the tool, of course. Small wonder that this work inspired his most well-known maxim. Splitting the stumps, Henry tells us, “warmed me twice—once while I was splitting them, and again when they were on the fire.”

If no one claimed the axe before, those few weeks of stump-grubbing sealed its fate. The grit wore out the bit and the impact spread the eye of the axe. Henry persisted, though, and “putting a hickory helve from the woods into it, made it do.”

Henry did return the axe he borrowed sharper than he received it. And, he did learn to make a good handle for the one he found. As a true do-it-yourselfer, Henry learned as he worked, and as the greatest of all American philosophers, he had a few things to teach us as well. 🌲

**By Roy Underhill**

Master housewright at Colonial Williamsburg and host of the popular PBS series *The Woodwright's Shop*, Underhill is also an author and lecturer.

Illustration: Jim Stevenson

**PENNSYLVANIA HARDWOODS**  
**SATISFACTION GUARANTEED**

SIZE	SPECIES	PRICE PER BOARD FT.
15/16	WALNUT	\$1.60
3/4 & 4/4	RED OAK	\$1.60/1.75
3/4 & 4/4	CHERRY	\$1.60/1.98
3 to 10/4	POPLAR	\$1.05
4 to 8/4	ELM	\$ .90
4/4	HARD MAPLE	\$1.30

TO ORDER CALL:  
 (716) 945-1510



Northeastern Hardwoods, P.O. Box 365-C, Salamanca, NY 14779  
*The Finest Quality At The Right Price!*



**STOP PERFBORARD HOOK FALLOUT!**

**M-CLIPS™** are THE guaranteed perfect solution to this annoying problem! Fit both 1/8" and 1/4" perfborard. Send SASE for free sample or \$5.99 + \$1 p&h for pkg of 50 to: AETECH, P.O. Box 6298, Dept. W7 10 Shadowstone Lane Lawrenceville, NJ 08648

**Total Shop**

**FREE**

**30 pg. FULL COLOR**

**Woodworkers Catalog**

Full of top quality woodworking machines tools and accessories.

P.O. Box 25429, Greenville, SC 29616 Dept. #3

**1-800-845-9356**

**CALL TODAY!**

**HEAVY DUTY ROUTER TABLE AND FENCE SYSTEM**

Featuring LEXAN® INSERT PLATES

(A) TABLE TOP - Features an extra large 1" x 24" x 32" double laminated 'MDF' with standard mitre gauge slot. Includes large shatterproof 8" x 11 3/4" Lexan® insert to accommodate any new generation portable router. #400-0117 \$99.95

(B) DELUXE FENCE - Now 37" long. Split system, self clamping with vacuum attachment. #400-0211 \$68.95

(C) LEG ASSEMBLY - Sturdy Hardwood Maple with dovetail joint design and leg level adjusters. #400-0300 \$89.95



Retail Value \$258.85

CALL FOR FREE COPY OF OUR NEW 56 PAGE ROUTER/SHAPER/ACCESSORY CATALOG.

INTRODUCTORY OFFER Pkg. Price **\$232.88**



1-800-872-2511

**The Woodworkers' Store**

**New! 1990-91 Catalog**

- No Price Increases!
- Over 250 New Items!
- Hard-to-Find Products!
- Many Exclusives!
- Selection Includes: Hardwoods, Wood Parts, Craftplans, Specialty Hardware, Finishing Supplies, Kitchen Accessories, and much much more!
- 24 to 48 Hour Shipment!
- Satisfaction Guaranteed!

Send Now! \$1.00 (3rd class)  
 \$2.00 (1st class)  
**\$1.00 Refundable on first order!**

Name \_\_\_\_\_  
 Address \_\_\_\_\_  
 City \_\_\_\_\_ State \_\_\_\_\_ Zip \_\_\_\_\_

**The Woodworkers' Store**  
 21801 Industrial Blvd. Dept. 1624  
 Rogers, MN 55374

# CATALOGS FOR CRAFTSMEN



1. Now anyone can set a table and radial arm saw accurate to within  $10/1000$ "! Designed for both the home handyman & professional, PARAGAUGE provides a parallel measurement up to 18" for setting rip fences & up to  $2\frac{1}{2}$ " in blade depth. Completely portable, PARAGAUGE can also be used to set band saws, drill presses & router tables. Send for information.

ACCUSET TOOL CO., INC.



## Furniture Designs, Inc.

2. Catalog of 200 full-size professional plans for building fine, museum-quality furniture, including cradles, roll-top desks, tables, chairs, buffets, beds, chests, garden cabinets, rocking horse, children's furniture and more. Catalog \$3.00.

FURNITURE DESIGNS, INC.



3. 1990 Tool Crib Catalog features a wide selection of merchandise for everyone, from home woodworkers to industrial builders. We offer competitive price with quality service and same day shipping. Send \$2.00 today for your 1990 Tool Crib Catalog. It's worth it!

ACME ELECTRIC.



4. You're not alone when you do it yourself. CONSTANTINE'S Woodworkers Catalog is right alongside with whatever you need to build, restore, repair and refinish. Over 4,000 items including hardwoods, brass cabinet hardware, 150 kinds of veneers, inlays, moldings, specialty woodworking tools, wood finishes, plans and books. Catalog \$1.00.

CONSTANTINE'S

## KLOCKIT™

5. Turn your clockmaking ideas into reality. Create beautiful clocks from our large selection of exclusive clock kits, dials, quartz and mechanical clock movements. We also offer music movements and kits to create beautiful musical jewelry boxes. Request our current 64 page catalog so you too can produce beautiful keepsakes.

KLOCKIT.



6. Over 400 easy-to-build woodworking project plans. Nation's leading source for door harp plans and parts, holstein cow projects, toy plans, country furniture, etc. Over 3000 hard-to-find specialty items. Send for your NEW 72 page catalog. Catalog \$1.00.

MEISEL HARDWARE SPECIALTIES.



7. Executive Wood Toys! Now you can create this 1929 Ford van and many others like it from our detailed and easy-to-read patterns. We offer you a complete line of patterns, parts, and wheels. Create lasting memories with our Executive Wood Toys. Send \$1.00 for catalog.

TOYS AND JOYS.



8. FREE WOODWORKING TOOL CATALOG! Woodcraft Supply offers over 4,500 of the finest quality woodworking tools, books, supplies, and cabinetry hardware in our complete full-color catalog. Cabinetmakers, craftsmen, carvers, woodturners, and woodworking hobbyists have depended on Woodcraft since 1928. Toll free ordering and free technical assistance, too. Send for information.

WOODCRAFT SUPPLY.

**Armor Products**

Since 1967

- Clock Movements
- Toy Plans & Parts
- Furniture Plans
- Wood Goods
- Assorted Hinges
- Door Harp Parts

**9.** If you are making toys and other items for craft shows, don't overlook our great selection of patterns for rocking horses, toys, cars, clocks and furniture. Specialty supplies, hardware, tools and gift items also available. Catalog \$1.00.

ARMOR PRODUCTS.



**10.** Stop pegboard hook fall-out forever! M-CLIPS are the guaranteed perfect solution to the annoying problems of pegboard hooks that come loose when a tool is removed. Fit both 1/4" and 1/8" perfbboard, lock into adjacent holes and hold hooks tightly in place.

AETECH CORP.

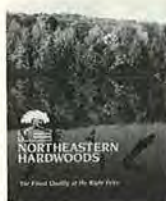

**11.** We offer over 20 species of the highest quality kiln dried domestic hardwoods. Sold on board footage or cut to order basis. Compare our quality and prices. UNCONDITIONAL SATISFACTION GUARANTEED. Very attractive package deals at delivered prices. Quantity discounts available. Send \$1.00 for NEW catalog.

NORTHEASTERN HARDWOODS.

# OVER 1000 FULL SIZE PATTERNS

**12.** Make popular country folkart, wind action whirligigs and mobils, country shelves and shadowboxes, eyecatching yard figures, Christmas decorations, simple furniture, toys, games and much more. Simply trace our full size patterns onto wood and cut out...no enlarging is ever necessary! All of our unique projects are available in our latest Winfield Collection Catalog \$2.00.

WINFIELD COLLECTION.



**13.** One-page brochure from NOVA TOOL COMPANY describes branding irons that enable you to put your name on your woodwork quickly and easily. Made especially for branding wood, they are available with 1, 2 or 3 lines of copy or with your logo. \$1.00.

NOVA TOOL COMPANY.



**14.** Ready to Assemble and Finish Kits, include Desks, Chairs, Dining Tables, Hutches, Sideboards, and Living Room Occasional Tables. Beautiful Queen Anne style available in Cherry-Oak-Mahogany-and Walnut. Catalog also includes various legs, and table bases for the serious woodworker.

ADAMS WOOD PRODUCTS, INC.



**15.** HERE'S YOUR HELP - HTC's line of Mobile Bases, Outfeed Rollers, Rollertables, Stock Stands, Pedestal Rollers and Saw Guards will help you - in your shop - to do your best alone. Free catalog.

HTC PRODUCTS, INC.



**16.** Lumber drying. Nyle Corp., the largest manufacturer in the United States of dehumidification Dry Kiln Systems, offers "Introduction to Dehumidification Lumber Drying." Free catalog.

NYLE CORP.



**17.** NEW! Craft & Woodworking Catalog. Top-quality tools and accessories for your shop. This new catalog includes complete information and prices on HEGNER Precision Scroll Saws, blades, and accessories for other scroll Saws. Also includes HEGNER Lathes & Duplicators, HEGNER Accura Precision combination machine, PLANO Vertical Glue Press, FELDER Woodworking Systems, bar clamps and lots more.

ADVANCED MACHINERY IMPORTS.



**18.** Tools on Sale, a division of Seven Corners Ace Hardware, has a wide variety of tools for the professional or do-it-yourselfer. Our catalog, perfect for anyone using hand or power tools, is packed with the most respected names in the industry: Makita, Milwaukee, Skil, B&D, Ryobi, Delta, Bosch, Porter Cable & many more. We are noted for fast, friendly service. Free Catalog.

TOOLS ON SALE.



**20.** McFeely's 48-page catalog features the incredible square drive screw in steel, solid brass and stainless steel, router bits, veneers and veneer tape, and other woodworking specialties. Catalog \$ .75.

MCFEELY'S.

**ADVERTISERS**

Please Note  
For information  
regarding  
this special  
advertising  
section,  
please call:

Wood Magazine  
Lori Del Cioppo  
212-551-6903



**21.** FREE Discount Woodworking Tools and Supplies catalog. 72 pages in full-color offering the best prices for over 3,000 brand name products. Included are power tools and accessories, hand tools, screws, hardware, wood components, plans, books, and much more. Catalog FREE.

TREND-LINES



**22.** OVER 1000 WOODCRAFT PATTERNS! Create gifts, toys, whirligigs, lawn ornaments, holiday designs, country projects, bird houses, feeders, children's items, household accessories PLUS much more! Simple enough for beginners, fun and profitable for the pro. Catalog plus sample pattern only \$2.00.

ACCENTS IN PINE.



**23.** VAN DYKE'S RESTORERS – your source for hard-to-find items in Woodworking, Upholstery, antique restoration and trades. This new 216 page catalog features a large selection of solid brass hardware, chair/table/roll-top desk components, carved China cabinet glass, relief carved wood appliques and more! Catalog \$1.00.

VAN DYKE'S RESTORERS.



**24.** TRIMTRAMP™ sawtable allows your portable circular saw to make unsplintered picture-frame quality miter cuts, and crosscuts, and combination cuts with greater accuracy, efficiency, portability and safety than a radial arm saw, at a fraction of the cost.

TRIMTRAMP LTD.



**25.** Classical Designs and Modern Electronic Music Box Plans. FULL SIZE PATTERNS, with Parts Kits available, for Beginner to Intermediate Woodworker. Largest selection/lowest prices for Electronic Music Boxes. Wood turnings, parts, and supplies. Bulk Prices available. \$2.00 refundable.

CRAFTER'S MART.



**26.** CRAFTSMAN WOOD SERVICE CO. – your one stop source for all your wood hobbyist needs. Sanded lumber is our specialty. Our 61st year – over 4000 items. World's largest selection of choice dimensioned hardwoods, 42 varieties Amaranth to Zebra, 1/8" to 4" thickness.

148- page Catalog \$1.00.

CRAFTSMAN WOOD SERVICE CO.



**27.** NEW! CARBIDE-TIPPED BRAD POINT DRILLS. Outperform High Speed 40 to 1. Can run at high speeds without overheating. Accurate, clean entry holes. 7-pc. set. SPECIALLY PRICED: No hassle 30-day Money Back Guarantee. Write for information.

DOLLAR TRADING CORPORATION.



**28.** SEARS POWER AND HAND TOOLS CATALOG – FEATURING CRAFTSMAN TOOLS...QUALITY YOU CAN TRUST. The 148 page catalog is packed with values for the professional and the do-it-yourselfer. It contains a full line of stationary, portable and bench top power tools, tool accessories, hand tools, and much more. FREE AT SEARS RETAIL OR CATALOG STORES.



**29.** GARRETT WADE'S 1991 catalog is the one you cannot afford to be without. 220 pages in 4-color of the very best in hand tools, books, finishing supplies and much more for the craftsman. Also filled with hundreds of tips and a wealth of other information. \$4.00.

GARRETT WADE CO., INC.



**30.** World Leader in Furniture Restoration MINUTEMAN offers the latest in systems and equipment – best by performance. Earn \$200 to \$1,000 per day stripping, repairing, refinishing, mirror resilvering and/or veneering. No experience necessary; complete training provided. FREE Professional Furniture Restoration Workshop. Catalog \$2.00.

MINUTEMAN, INC.



**31.** Router owners – Large Discounts. New 32-page catalog featuring hundreds of high quality carbide tipped router bits and shaper cutters, solid carbide bits, the "Router Speed Control" and the "Merle Adjustable Corner Clamp" plus other Professional Woodworking Products. Prices 50% to 70% lower than elsewhere. VALUE, QUALITY, and PROMPT SERVICE GUARANTEED. Send for information.

MLCS, LTD.



**32.** Build your own musical instruments! We have the finest designs available for making harps, dulcimers, violins, guitars, banjos, mandolins, and much more. Complete kits, or blueprints and musical hardware, all listed in the MUSICMAKER'S KEEP BOOK Catalog \$1.00.

MUSICMAKER'S KITS, INC.





**33.** The RBI Woodplaner is a combination woodplaner, sander, molder and gang rip saw all in one precision machine. Patented quick-change cutterheads convert functions in a matter of minutes. Learn about all the woodplaners outstanding features with RBI's free color Catalog.

RB INDUSTRIES, INC.



**34.** THE WOODWORKER'S STORE CATALOG - New! The Woodworkers' Store 1990-91 catalog with over 250 new items features 100 color pages of domestic and exotic hardwoods, veneers, wood parts, specialty hardware, kitchen accessories, finishing supplies, tools, books, and plans...Many exclusive items and hard to find specialties. Orders shipped in 24 to 48 hours. \$1.00 credited towards first purchase. Satisfaction guaranteed. THE WOODWORKER'S STORE.



**35.** 24-page catalog from one of America's larger woodworking tool suppliers - quite different than the first flyer Total Shop sent out back in 1977. This catalog is the best ever and will inform you on the finest woodworking tools available. Free catalog.

TOTAL SHOP.



**WOODS OF THE WORLD**

**36.** EXOTIC IMPORTED AND DOMESTIC HARDWOODS - over 75 species of lumber, bowl blanks, turning squares, and veneer. Collectors Sample Kit - 36 exotic and domestic woods. Catalog provides common and botanical name, source, and description of each wood. \$1.00.

WOODWORKER'S SUPPLY.



**37.** Specializing in Abrasives & Refinishing Products for Wood Working. With RED HILL CORP., you're guaranteed quality, reasonable prices, prompt shipment and free freight. Small orders welcome! Send for information.

RED HILL CORPORATION.



**38.** Quality hardwoods and woodworking machinery for the craftsman and educational institutions. 16-page catalog lists 19 species of popular woods at wholesale prices. Also dealers for MiniMax, Freud and Pro Cut woodworking machines. Catalog \$1.00.

STEVE H. WALL LUMBER CO.



**39.** Door Harp parts, wheels, spindles, hearts, shaker pegs and dowels are just some of the many turnings you will find in our new "Sketches" catalog. Plus "how to use" ideas. Low prices & fast service! Catalog \$1.00.

WOODWORKS.



**40.** Tungsten carbide router bits and cutters. Large selection of the most wanted profiles. Nationally known for money saving discounts, quality tools, and fast service. Call or write now.

SKYCROFT TOOLS, INC.

**Catalogs for Craftsmen  
ORDER FORM**

Circle the catalogs you want. Fill out the coupon and include your check made out to Better Homes and Gardens® WOOD for the cost of the catalogs you ordered plus the \$2 handling fee. Please allow 4-6 weeks for delivery. Coupon expires February 18, 1992.

- |           |           |           |           |           |
|-----------|-----------|-----------|-----------|-----------|
| 1. Free   | 9. \$1.00 | 17. Free  | 25.\$2.00 | 33. Free  |
| 2. \$3.00 | 10. Free  | 18. Free  | 26.\$1.00 | 34.\$1.00 |
| 3. \$2.00 | 11.\$1.00 | 20. \$.75 | 27. Free  | 35. Free  |
| 4. \$1.00 | 12.\$2.00 | 21. Free  | 28. Free  | 36.\$1.00 |
| 5. Free   | 13.\$1.00 | 22.\$2.00 | 29.\$4.00 | 37. Free  |
| 6. \$1.00 | 14. Free  | 23.\$1.00 | 30.\$2.00 | 38.\$1.00 |
| 7. \$1.00 | 15. Free  | 24. Free  | 31. Free  | 39.\$1.00 |
| 8. Free   | 16. Free  |           | 32.\$1.00 | 40. Free  |

Send to: **Better Homes and Gardens® WOOD**  
Dept. JNCC 91,  
P.O. Box 5103  
Pittsfield, MA 01203-5103

I am enclosing: \$\_\_\_\_\_ for priced items  
\$ 2.00 for handling  
\$\_\_\_\_\_ total remittance

Name \_\_\_\_\_  
Address \_\_\_\_\_  
City \_\_\_\_\_  
State \_\_\_\_\_  
Zip \_\_\_\_\_

# BUILD YOUR OWN QUEEN ANN FURNITURE

With Our Kits

SOLID  
CHERRY, WALNUT  
OAK, MAHOGANY



OVAL  
COFFEE



COFFEE



END

FREE BROCHURE DESCRIBES

LIVING ROOM / DINING ROOM PIECES



Adam's Wood Products, Inc.

DEPT. M11, 974 FOREST DRIVE, MORRISTOWN, TN 37814

TELEPHONE 615-587-2942

FAX 615-586-2188

## WOOD PARTS

QUALITY - PRICE - SERVICE



1 3/4" Mini Shaker Peg .....	6.00/100
3 1/2" Reg. Shaker Peg .....	15.00/100
Reg. Candle Cup .....	16.00/100
1" Wheel .....	4.00/100
1/4" Axel Pegs .....	3.50/100
1 5/8" Sawtooth Hanger .....	3.00/100
1 1/2" Birch Spindle .....	8.25/100
1 1/2" Oak Spindle .....	11.50/100

Orders under \$25.00 add \$2.50 shipping.

Over \$25.00 shipped FREE. Serving Continental U.S.A. Only.

**American Woodcrafters Supply**

PO Box G  
Riceville, IA 50466  
515-985-4032

24 Page Catalog  
75c or  
FREE with Order

## DeWalt Radial Arm Saws

### Need Parts?

- Preventative Maintenance Service • On-Site Breakdown Repair • In-Shop Complete Reconditioning
- Obsolete Part Fabrication • Radial Arm Remachining
  - Motor Rewinding • Motor Rotor Repair
- Motor Starters & Controls • Blade Sharpening
- Service on Paint Shaking and Tinting Equipment

- Ambitech Motor Brakes • Delta • DML Blades
- DeWalt Radial Arm Saws
- Murphy Rogers Dust Collectors

- Powermatic • Safety Speed Cut Panel Saws



Phone: 515-270-2766  
Fax: 515-270-0628

Wolfe

machinery  
6107 Merle Hay Road  
P.O. Box 497  
Johnston, IA 50131

800-345-6659

## NEW COMPUTER INDEX

Computer index of woodworking magazines through 1990. Every issue of Wood, Fine Woodworking, Woodsmith, Woodwork, Today's Woodworker, and 1987 - 1990 issues of Woodworker's Journal and Workbench.

Locates in seconds article titles  
by any word in title

Yearly updates - All magazines  
Indexed in one place

You need - IBM compatible, HD, 512K, DOS 2.0+

WOODFIND \$49.95 + \$4.50 S&H or send \$1.00  
for brochure (refundable with order).

Check or money order to: WOODFIND,  
P.O. Box 2703, Dept. D, Lynnwood, WA 98036

## BUILD IT YOURSELF

TOYS • PUZZLES • PLAQUES • PLANTERS  
FURNITURE • LAWN ITEMS • BIRD HOUSES  
ROCKING & RIDING HORSES • PLAY SETS



## PATTERNS

SAME SIZE • NO ENLARGING  
HUNDREDS OF FUN ITEMS  
1,000 CRAFT & HOW-TO BOOKS \$1.00

Design Group, Box 514-Z, Miller Place, N.Y. 11764

## RESTORE FURNITURE

for  
SECURE INCOME  
Perfect 2nd Career

Make \$200-\$2,000 a day! Unlimited  
market; turn-key business. Free  
workshops. Set-Up Shop for \$2,999-  
\$9,999! Part-time or full-time. Great  
for men, women, families.

Make Molds\*Veneer\*Resilver  
Strip\*Repair\*Refinish

Intro Video \$12.95 - Catalog \$2.00  
MINUTEMAN, INC., Ste. 17  
Box 8, Waterloo, WI 53594  
1-800-733-1776



# CENTER FINDER

Continued from page 61

**2** Sand the portion of the brass that will fit into the groove in the handle. Follow Step 2 of the two-step drawing to epoxy the blade to the handle. After the epoxy has cured, remove the center finder from the 4"-square block, and file the end of the blade flush with the outside edge of the handle.

**3** Mark the location of the two holes on the blade where dimensioned on the Exploded View drawing. Use a center punch to slightly indent each marked hole to prevent the drill bit from skidding. Drill a 5/64" pilot hole 1/2" deep where indented.

**4** Now, switch bits, and use a twist-drill bit to drill a pair of 1/8" shank holes just through the brass. Countersink the holes slightly so the bottom of the slot in the #4 x 1/2" brass screws line up just a hair above the surface of the brass blade. See the Screw detail for reference.

**5** Drive the screws. Then, file off the head of each one until it is flush with the surface of the brass.

## Finding center is close at hand

**1** Bend a piece of 1/32 x 3/4 x 2 1/4" brass to conform to the end of the handle. Sand the mating surface of the brass, and epoxy and tape it to the handle. Remove the tape after the epoxy has cured and sand any rough edges.

**2** Sand and file the brass flush with the walnut surfaces.

**3** Finish-sand and hang the center finder on a wire. Spray on several coats of clear finish.

## Buying Guide

• **Brass.** 1/32 x 3/4 x 12" brass, 1/16 x 1/2 x 12" brass, and 3 #4 x 1/2" brass wood screws, \$4.99 ppd. If you need an 8" mill bastard and an 8" second-cut (rattail), file add \$8. Puckett Electric., 841 11th St., Des Moines, IA 50309. 🍀

Project Design: Jim Boelling  
Photographs: Hopkins Associates  
Illustrations: Kim Downing; Bill Zaun

## SPECIAL OFFER

# BRANDING IRON

For hard and soft wood



\$24.00

Plus \$2.00 for  
shipping and handling

Nebr. residents add  
correct sales tax

SATISFACTION GUARANTEED  
or your money back

- Shipped in one week
- Solid brass head — raised letters
- 1st Line: HAND CRAFTED BY — as above
- 2nd Line: Your choice — 20 characters/spaces max.
- Complete with wood handle
- As above but with 3rd line — \$37.00 + \$2.00

ORDER TOLL FREE 1-800-826-7606

For free brochure, write or call (402) 464-0511

**NOVA TOOL CO.**

Order by mail from:  
12500 Finigan Rd., Dept. BH  
P.O. Box 29341, Lincoln, NE 68529



**Now you can have Lifetime Security in a CASH business where you can easily make up to \$200.00 per day and more**

**Find out how ...**

**... send NOW for your**

**FREE Lifetime Security Fact Kit**



Your FREE Lifetime Security Fact Kit tells you how to make \$18.00 to \$30.00 an hour in your own Foley-Belsaw Full-Service Saw and Tool Sharpening Business. Your FREE Fact Kit explains how you can:

- be your own BOSS!
- work full time or part time, right at home.
- do work you enjoy and take pride in.
- operate a CASH business where 90¢ of every dollar you take in is clear cash profit.

And it is *so easy* to learn. Foley-Belsaw gives you all the facts and instructions. No previous experience or special training is necessary. All you need is the desire and ambition to be your own boss. Foley-Belsaw tells you everything you need to know to be successful.

There's plenty of business where you live to keep you busy. It doesn't matter whether you live in a big city, small town or a small farm community.

You'll quickly be able to develop the skills necessary to earn a steady income. You'll be able to sharpen all types of saws, garden and shop tools for home, farm and industry.

Profits from your Foley-Belsaw Full-Service Sharpening Business can provide...

- ... CASH for future security or supplemental income
- ... CASH for travel, vacations, fishing trips
- ... CASH for the things you've always wanted!

And you'll be able to set your own hours and not

have to worry about layoffs and strikes. There are no franchise fees. Best of all—age or physical condition is no barrier—any age person can succeed.

You can be like Steve Taylor of Brookville, Ohio, who told us:

*"... the first year I grossed \$21,000.00."*

Or James B. Jones, of Albuquerque, NM who reported:

*"This past summer my sales and service amounted to almost \$6,000.00 a month."*

But you've got to get the FACTS before you can get started. So WRITE NOW for your FREE Lifetime Security Fact Kit. It's yours to keep with NO OBLIGATION. **The Foley-Belsaw Company**  
6301 Equitable Rd., Dept. 20940  
Kansas City, MO. 64120



**FREE LIFETIME SECURITY FACT KIT**



Foley-Belsaw Co.  
6301 Equitable Rd., Dept. 20940  
Kansas City, Mo. 64120

**YES**, I want to know more! Please rush my FREE Lifetime Security Fact Kit. No obligation

Name \_\_\_\_\_

Address \_\_\_\_\_

City \_\_\_\_\_ State \_\_\_\_\_ Zip \_\_\_\_\_

( \_\_\_\_\_ ) Phone \_\_\_\_\_



**FINALLY**, a Bulldozer Model with WORKING tracks. This large model is 16" x 29" x 15" with plenty of detail. Plans are \$7.00.

**D & M Woodcraft**

Dept. WD, 12301 Palmbeach, Houston, Texas 77034



**PORTER-CABLE**

#555  
**Plate Joiner**  
**\$139.95\***

\*w/package offer only!

<b>Package #1</b>	
1-#555 Plate Joiner w/case	\$139.95
2-1000 Pc Box of Biscuits (each)	34.95
<b>TOTAL</b>	<b>\$209.85</b>
*Free UPS!	
<b>Package #2</b>	
1-#555 Plate Joiner w/case	\$139.95
1-1000 Pc Box of Biscuits	34.95
1-New Tilt Fence	49.95
<b>TOTAL</b>	<b>\$224.85</b>
*Free UPS!	



1530 N. Old Rand Road Wauconda, IL 60084  
708/526-1411 800/243-TOOL (FOR ORDERS).  
Call or write to receive our sale flyers!

Statement of Ownership, Management and Circulation (Required by 39 U.S.C. 3685) I.A. Title of Publication: Better Homes and Gardens Wood. 1.B. Publication No. 724890. 2. Date of Filing: September 28, 1990. 3. Frequency of Issue: Eight times a year in January, February, April, June, August, September, October and December. 3A. No. of Issues Published Annually: 8. 3B. Annual Subscription Price: \$19.97. 4. Complete Mailing Address of Known Office of Publication: 1716 Locust Street, Des Moines, Polk County, IA 50336. 5. Complete Mailing Address of the Headquarters of General Business Offices of the Publisher: 1716 Locust Street, Des Moines, Polk County, IA 50336. 6. Full Names and Complete Mailing Addresses of Publisher, Editor, and Managing Editor: Publisher: William R. Reed, 750 Third Avenue, New York, NY 10017; 1716 Locust Street, Des Moines, IA 50336; Editor: Larry Clayton, 1912 Grand Avenue, Des Moines, IA 50312; Managing Editor: James V. Harrold, 1912 Grand Avenue, Des Moines, IA 50312. 7. Owner: Meredith Corporation, 1716 Locust Street, Des Moines, IA 50336. The Names and Addresses of Stockholders Owning or Holding 1 Percent or More of the Total Amount of Stock: The Bank of New York, 90 Washington Street, New York, NY 10015; Bankers Trust, 16 Wall Street, Proxy Dept., Level D, New York NY 10005; Boston Safe Deposit & Trust Co., Securities Operation Dept., One Boston Pl., Boston, MA 02108; Brown Brothers Harriman & Co., 63 Wall Street, New York, NY 10005; The Chase Manhattan Bank, Proxy Dept., 20 Pine Street, New York, NY 10081; Citibank & Co., Proxy Dept., 111 Wall Street, New York, NY 10043; INVESCO Capital Management, Inc. 1315 Peachtree St., N.E., Suite 300, Atlanta, GA 30309, Manufacturers Hanover Trust Co., P.O. Box 1765, Church Street Station, New York, NY 10008; Mellon Bank, 3 Mellon Bank Center, Pittsburgh, PA 15259; Norwest Corporation, Norwest Center, 6th & Marquette, Minneapolis, MN 55479; Northern Trust, 50 S. LaSalle Street, Chicago, IL 60675; Reich & Tang, 100 Park Ave., New York, NY 10017; State Street Bank & Trust Co., P.O. Box 2136, Boston, MA 02106; U.S. Trust Co. of New York, 770 Broadway, 9th Floor, New York, NY 10003. The E. T. Meredith and Bohan families and family foundations own directly or beneficially, through some of the nominees listed above, approximately 33.0 percent of the issued and outstanding stock of the corporation. Each nominee holds stock for one or more stockholders. 8. Known Bondholders, Mortgagees, and Other Security Holders Owning or Holding 1 Percent or More of Total Amount of Bonds, Mortgages, or Other Securities: None. 9. Item 9 of PS Form 3526 not applicable. 10. Extent and Nature of Circulation—A. Total No. Copies (Net press run): Average No. Copies Each Issue During Preceding 12 Months, 710,340; Actual No. Copies of Single Issue Published Nearest to Filing Date, 742,922. B. Paid and/or Requested Circulation: 1. Sales Through Dealers and Carriers, Street Vendors, and Counter Sales: Average No. Copies Each Issue During Preceding 12 Months, 94,000; Actual No. Copies of Single Issue Published Nearest to Filing Date, 75,000. 2. Mail Subscriptions (Paid and/or requested): Average No. Copies Each Issue During Preceding 12 Months, 452,714; Actual No. Copies of Single Issue Published Nearest to Filing Date, 475,000. C. Total Paid and/or Requested Circulation (Sum of 10B1 and 10B2): Average No. Copies Each Issue During Preceding 12 Months, 546,714; Actual No. Copies of Single Issue Published Nearest to Filing Date, 550,000. D. Free Distribution by Mail, Carrier, or Other Means; Samples, Complimentary, and Other Free Copies: Average No. Copies Each Issue During Preceding 12 Months, 14,012; Actual No. Copies of Single Issue Published Nearest to Filing Date, 17,250. E. Total Distribution (Sum of C and D): Average No. Copies Each Issue During Preceding 12 Months, 560,726 Actual No. Copies of Single Issue Published Nearest to Filing Date, 567,250. F. Copies Not Distributed: 1. Office Use, Left Over, Unaccounted, Spoiled After Printing: Average No. Copies Each Issue During Preceding 12 Months, 757; Actual No. Copies of Single Issue Published Nearest to Filing Date, 672. 2. Return from News Agents: Average No. Copies Each Issue During Preceding 12 Months, 148,857; Actual No. Copies of Single Issue Published Nearest to Filing Date, 175,000. G. Total (Sum of E, F1, and 2)—should equal net press run shown in A: Average No. Copies Each Issue During Preceding 12 Months, 710,340; Actual No. Copies of Single Issue Published Nearest to Filing Date, 742,922. 11. I certify that the statements made by me above are correct and complete. (Signed) James V. Harrold, Managing Editor

**Wood Moisture Meter**

- Avoid Moisture Problems
- Protect your Masterpiece

**MINI LIGNO**

Incl. Case, Batteries and Pins for 3/8" and 1/2" Measuring Depth.

only **\$110**

also from Lignomat:  
**MINI-LIGNO E**  
Range: 6%

Easy-to-use, sturdy instruments for the professional woodworker or serious hobbyist. Great for lumber, veneer, fiberboards. Ask for free catalog on the complete line of moisture meters and accessories for kiln drying.



**Lignomat USA Ltd.** PO Box 30145bh  
503-257-8957 800-227-2105 Portland, OR 97230

**BAND SAW BLADES**

WELDED TO YOUR EXACT LENGTH

Complete Band Saw Blade Line Including Saw Mill Blades

We also carry:

- Scroll Saw Blades • Hand Saws
- Circular Saw Blades • Hole Saws
- Hack Saws • Sanding Belts
- Sanding Disks • Router Bits
- Files • Rasps • Scrapers

SEND \$1.00 FOR CATALOG or TO ORDER PHONE OR WRITE TO:

**BUCKEYE SAW COMPANY**  
P.O. BOX 14794  
CINCINNATI, OHIO 45250-0794  
1-800-543-8664 (Except Ohio)  
1-513-621-2159 (In Ohio)

WARREN TOOL CO. INC. (10) Piece set of woodcarving tools



ORDER #COMBI-M "WARREN TOOLS GIVE YOU THE EDGE!"  
Send \$31.95 PpA (USA) Check or Money Order. C.O.D. UPS. —Honed Ready To Use TEL (914) 876-7817

OFFER EXPIRES 3/1/91  
N.Y. res. ADD State Tax Foreign orders ADD \$6.00 SHIPPING.  
Warren Tool Co. Inc. 2209-1, Rt. 9G, Rhinebeck, N.Y. 12572

**Supergrit**  
Random Orbital Sander Discs  
5" White PSA 180 Grit \$15.00/100

**PREMIUM QUALITY BELTS: BEST RESIN OVER RESIN, "X" WEIGHT 10/Box**

1 x 42	\$ .70 ea.	4 x 24	\$1.00 ea.
3 x 18	.75	4 x 36	1.25
3 x 21	.80	5 x 48	2.80
3 x 24	.85	6 x 66	5.25

**ADHESIVE CLOTH DISCS: BEST RESIN OVER RESIN, "X" WEIGHT**

5" Diameter	\$ .80 ea.	9"	\$1.65 ea.
6"	.90	10"	1.85
8"	1.30	12"	2.25

Prices quoted 90 grit, other grits available.

**GARNET PAPER — ORANGE** WATERPROOF PAPER — BLACK  
A/O CABINET PAPER — BROWN 180 thru 1200 100 PK \$23.00

40 Grit	50 PK	\$16.00
80 Grit	50 PK	14.00
80 Grit	50 PK	13.00
100, 120, 150	100 PK	22.00
180, 220	100 PK	13.00

**NO LOAD PAPER — WHITE**  
180 through 400 100 PK \$20.00  
Also Shop Rolls • Cloth Sheets • Drums

**CLEANING STICKS** \$3.50 Small \$6.50 Large

**RED HILL CORP., P.O. BOX 4234, GETTYSBURG, PA 17325**  
**(800) 822-4003** Free Freight to most areas  
Free catalogue

**Wood-Mizer**  
World's Largest Manufacturer Of Portable Sawmills

**OWN YOUR OWN SAWMILL**  
Four Models To Choose From  
BUY DIRECT  
**1(800)553-0219**

In Indiana call: (317) 271-1542  
**FREE** 44-page catalog or use your MasterCard or VISA to order our 50-minute demonstration video—\$10.00  
Wood-Mizer Products, Inc. • Dept. QQ51  
8180 W. 10th St., Indianapolis, IN 46214-2430

**BRANDING IRON**  
Your Satisfaction Guaranteed

- Convenient torch heating
- Solid Brass—lasts years
- Special wording available
- Electric Models Start at \$44.95
- 2nd line—20 letters/spaces max.
- 1/4" letters
- Distinctive Border
- Add \$2.50 shipping and handling
- OH res. add 6% sales tax

**\$23.95**

Order by mail from: **BrandMark**  
462 Carthage Dr. Dept. W-1  
Beavercreek, OH 45385  
513-426-6843

TO ORDER CALL TOLL FREE  
**1-800-323-2570**  
(ORDERS ONLY)  
8:00-5:00 EASTERN TIME

**Van Dyke's**  
Presents a Catalog  
with supplies for upholstery, antique restoration, wood working, caning, brass hardware, carvings and many related trades!

36 Years in Creative Arts & Trades  
Many Hard-To-Find Items!

SEND \$1.00 FOR CATALOG TO:  
**Van Dyke's Restorers**  
Dept. D55 • Woonsocket, SD 57385

**NEW**

GIVE YOUR WOOD PRODUCTS A FRESH LOOK WITH

Our Pattern Book for bandsaw, scrollsaw or jigsaw. Contains 50 unique full page patterns. Some are easy — some are more challenging — but all are fun to make. Send only \$10.75 (includes postage and handling) to:

**CUT IT OUT ENTERPRISES**

PO Box #404, Dept. W1  
Clearfield, PA 16830

(Please allow 4 to 6 weeks for delivery.)

**MUSICAL INSTRUMENT PLANS, KITS & SUPPLIES**



Harp, Lyres, Banjos, Guitars, Violins, Mandolins, Hammer Dulcimers, Mountain Dulcimers, Psalteries & more!

CATALOG: \$1.00

**MUSICMAKERS KITS, INC.**

423 S. Main St. Dept. B8  
Stillwater, MN 55082

612-439-9120

**The Japan Woodworker's Catalog is . . .**

loaded with the best tools you can get your hands on. In our catalog you will find a huge selection of Japanese saws, waterstones, chisels, planes, carving tools, cutlery and books. Send \$1.50 for our catalog and supplements during the next two years.

**THE JAPAN WOODWORKER**  
1731 Clement E7, Alameda, CA 94501  
Phone 1-800-537-7820

**DRY YOUR OWN LUMBER...**



**...With an EBAC Wood Drying System**

Whether you're a serious home woodworker, small cabinet shop or a large wood retailer, EBAC has a wood drying system that's affordable for you.

**EBAC Wood Dryers:**

- save you money
- are easy to operate
- are energy efficient
- give you higher quality wood
- give you complete control over your wood's moisture content

**CALL OR WRITE TODAY!**

**EBAC LUMBER DRYERS**

106 John Jefferson Rd., Suite 102  
Williamsburg, VA 23185

1-800-433-9011 • FAX (804) 229-3321

**SQUEALS OF DELIGHT**

for the discriminating woodworker.

24" x 54" with pink wash and white saddle, will catch all eyes. Children love it. Makes an excellent decorator piece.

Complete full sized plans with instructions \$12.50  
Shipping & handling included.

Send check or money order for Rocking Pig Pattern To:

**Rocking Critters Wood & Things**

P.O. Box 654  
Crowley, TX 76036

**Rocking Pig**

PATTERN



**MAKE THESE!**



**WAGNER SAFE-T-PLANER**

Fits Drill Press or Radial Arm Saw  
**ABSOLUTELY SAFE!**

Impossible to Grab or Kick Back

PICTURE FRAMES, RAISED PANELS, ROSETTES, PLANES, RABBETS, TENONS, MOULDINGS

KIT INCLUDES: 3 lifetime hi-speed steel cutters, grinding wheel, arbor, wrench, 8 pg. photo instructions.

**GUARANTEED! SUGGESTED RETAIL PRICE**

DRILL PRESS KIT \$45.00

\$3.00 S&H OK ADD TX.

Available From Dealers  
Catalogs or Write to:

**G & W Tool Inc.**

P.O. Box 691464  
Tulsa, OK 74169  
(918)-486-2761

RADIAL SAW KIT \$50.00

(State Make, Model, Shaft Dia)



"DEALERS INQUIRIES WELCOME"

**Breathe Easier!**



Powered Air Respirators for Wood Dust

**\$279** Model AGH

Excellent for all woodworking jobs which create "DUST." Also offers eye protection. Can be worn with beard and glasses. Systems also available for paint and lacquer fumes.

**AIRSTREAM DUST HELMETS**

16 Division St. W. Elbow Lake, MN 56531  
Toll Free 1-800-328-1792 or 218-685-4457

**ANTIQUE reproduction furniture HARDWARE**



**HORTON BRASSES**  
Nooks Hill Rd. PO Box 120J  
Cromwell, Ct 06416 203-635-4400  
send \$3.00 for a catalog

**BUILD THIS FRENCH-CANADIAN SETTLE BENCH**



14"d x 21-1/2'h x 65-1/2"

The original is on display at the Ethan Allen Homestead, in Burlington, VT; you can make an accurate copy using our plans with how-to instructions from craftsman Harry Wicks. Send check or money order for \$9. Allow 4-5 weeks for delivery (Canadian residents remit postal money order in U.S. funds to):

**HAMMERMARK ASSOCIATES**  
P.O. Box 201-ABW1, Floral Park, NY 10002-0201

**In a rush? Call 516.352.5198 and use your Visa or MasterCard.**

Catalog available for \$1 (refundable)

**WOODWORKERS**

Save on Wood - Tools - Supplies!

OVER 4000 ITEMS

Send for New 1991 148 Page Money Saving CATALOG



Finest Dimensioned HARDWOODS and Quality VENEERS

42 VARIETIES

1/64" to 4" Thickness

Fast service on choice kiln dried Wood and Veneers, Moldings, Trim, Hand and Power Tools, Lamp Parts, Upholstery Supplies, Clock Movements and Kits, Hard-to-Find Hardware, Finishing Materials, Books . . . over 4000 items in stock! Craftsman — Woodworker's best friend.

**CRAFTSMAN WOOD SERVICE**

Dept. WM-191, 1735 W. Cortland Ct., Addison, IL 60101  
Please enclose \$1.00 to help pay postage and handling.

**Traditional Turnings**

Traditional Turnings for the home craftsman.

Unique selection of bedposts, table legs, (dining, sofa, coffee, end), hutch, gourmet kitchen. Available in Ponderosa Pine.

Send \$2.00 for catalog. Special Price(s) with this ad



\$49. Set  
Dining Table

1-800-476-7411



P.O. Box 1056 • Conley, GA 30027



\$85. Set  
Cannonball Bed

SAVE MONEY!

# KILN DRY LUMBER



## MAKE MONEY!

Kiln Dry for others. As the nation's largest manufacturer of dehumidification Dry Kilns, we can supply you with the same type equipment used by many of the major firms.

Call or write today for free facts that will help you make and save money.

**nyle**  
**DRY KILN**  
SYSTEMS

207-989-4335  
P. O. Box 1107, Bangor, Maine 04401

1-800-777-NYLE  
Nyle Corporation

## Do-It-Yourself Kits



*Factory Direct*  
*Clocks and Furniture*  
**Also Assembled and Finished**

- Grandfather Clocks, Mantel and Wall Clocks
- Curios, Tables, Chairs, Desks, Cradle...and more!
- Solid 3/4" Black Walnut, Cherry, or Oak
- Heirloom Quality
- Solid Brass West German Movements and Dials
- Money Back Guarantee



- I am interested in
- Do-It-Yourself Kits
  - Finished Clocks
  - Finished Furniture

SEND \$1 FOR COLOR CATALOG

Name \_\_\_\_\_  
 Street \_\_\_\_\_  
 City \_\_\_\_\_  
 State \_\_\_\_\_ Zip \_\_\_\_\_



**EMPEROR**  
CLOCK COMPANY

World's Largest Manufacturer of Grandfather Clock Kits  
Dept. 3816, Emperor Industrial Park  
Fairhope, Alabama 36532 • Phone 1-205-928-2316

## SHOP SENSE

Print this article

# RESPIRATOR TIPS

### How to get the most from your mask

While compiling the *Survival Guide* information about respirators (see page 32), we heard over and over from our industry sources that a respirator must be properly worn and maintained. These pointers will extend the life of your respirator and keep your lungs clear, too:

- If you have respiratory problems, such as emphysema or asthma, check with your doctor before using a respirator. Because the air-filtering components of respirators add resistance to the flow of air, your lungs have to work harder while you wear a respirator.
- Remember that cartridge-type respirators come in several sizes. Buy a mask that fits you, and return any respirator that doesn't form a tight fit around your nose and mouth.
- Even when wearing a respirator, you should properly ventilate your work area. This will reduce the chances of exposure to hazardous materials and increase the life of your respirator.



Even with your equipment hooked up to a dust collector, it still makes sense to wear a respirator.

- Between uses, store a gas/vapor-approved respirator in an airtight plastic bag as shown at left. Doing so will extend the life of the charcoal filters and keep the face-piece free of sawdust and other debris.
- A gas/vapor respirator has lost its effectiveness when you smell odors through it. Change cartridges in reusable masks and pitch disposables as soon as they clog or wear out.
- Even small doses of wood dust over long periods of time can cause chronic lung ailments. So, it makes sense to wear a respirator even if you're in your shop for just a short time. It doesn't pay to take chances with your health.
- Since no dust collector captures 100 percent of air-borne wood-dust particles, you should wear a respirator even when your dust collector is running.

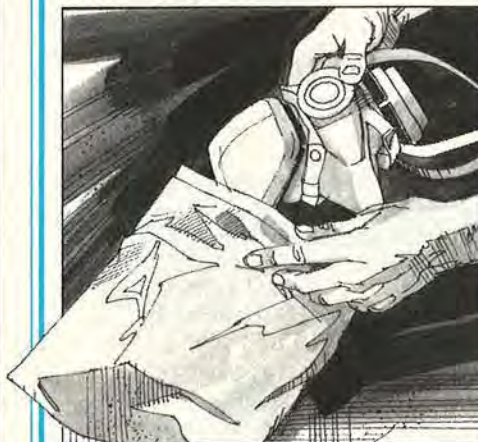

To extend the life of gas/vapor respirators, store them in an airtight resealable plastic bag.

Illustrations: Jim Stevenson



**WOODCRAFT®**  
The Leading Edge  
in Woodworking Tools

**Complimentary Tool Catalog**

Our new complete woodworking tool catalog features over 4,500 of the finest quality woodworking tools, books, supplies, and cabinetry hardware available today.

Give us a toll-free call to receive your own catalog **FREE!**

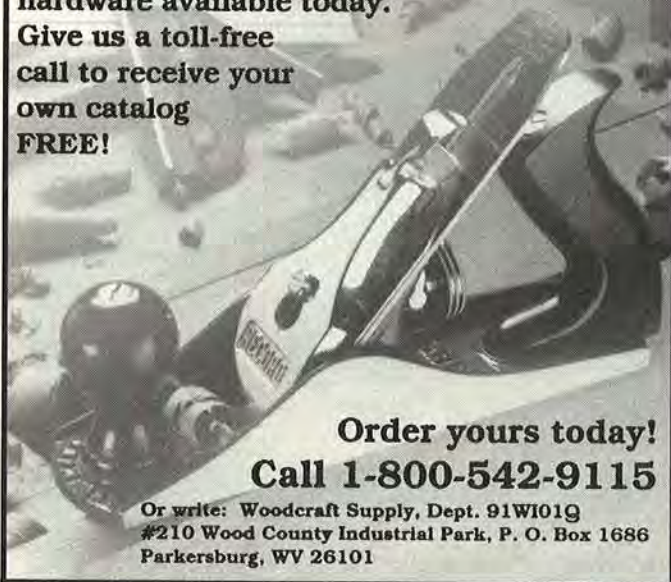

**Order yours today!**  
**Call 1-800-542-9115**

Or write: Woodcraft Supply, Dept. 91WI01Q  
#210 Wood County Industrial Park, P. O. Box 1686  
Parkersburg, WV 26101

**MADAME BUTTERFLY**

Here's a different door harp! Parts Kit includes all needed parts except 3/4" stock. We have several other totally unique door harp designs.

- #01312 Plans ..... 3.50
- #04312Z Plans and Parts Kit ..... 8.75



**WINTER SALE**

Prices good through 2-28-91

**TURNINGS**

- #16001 3-1/2" Shaker Pegs ..... 12.00/100
- #16008 3-1/2" Oak Shaker ..... 25.00/100
- #16021 2-1/2" Shaker Pegs ..... 11.50/100
- #16041 1-3/4" Shaker Pegs ..... 5.00/100
- #18031 Lg. Candle Cup ..... 14.00/100
- #18036 Lg. Oak Candle Cup ... 27.50/100
- #18091 Brass Inserts ..... 8.00/100
- #13106 3/4" Ball ..... 6.00/100
- #13108 1" Ball ..... 8.00/100
- #13112 1-1/2" Ball ..... 2.00/10
- #13116 2" Ball ..... 5.00/10
- #14013 3/8" Button ... 1.50/100, 7.00/500
- #14014 1/2" Button ... 1.50/100, 7.00/500
- #15601 1-1/8" S1 Spindle ..... 8.00/100
- #15711 S11 Spindle ... 9.00/10, 40.00/50

**DOOR HARP PARTS**

- #13158 3/4" Clapper Balls ..... 7.00/100
  - #62501 Tuning Pins ..... 14.00/100
  - #62515 Music Wire, 1/4# ..... 9.95/Roll
  - #25561 9.5"x12" 1/8" Plywood ..... 8.00/10
  - #04310 Standard Door Harp Kit ..... 4.95/Ea, 13.50/3, 39.50/10
- Includes: 8 tuning pins, 4 clappers balls, nylon cord, 2 pc. 9-1/2" x 12" plywood, music wire and sawtooth hanger.

**INDUSTRIAL SCREWS**

- #S6260 #6x1" ..... 1.10/100, 10.25/1000
- #S6261 #6x1-1/4" ..... 1.20/100, 11.50/1000
- #S6262 #6x1-5/8" ..... 1.60/100, 15.00/1000
- #S6263 #6x2" ..... 2.00/100, 19.75/1000

**HARDWARE**

- #50001 1-5/8" Sawtooth ..... 4.25/144
- #50703 3" Lazy Susan ... 0.85/Ea, 3.00/4
- #50704 4" Lazy Susan ... 1.15/Ea, 3.00/3
- #50706 6" Lazy Susan ... 2.00/Ea, 5.00/3

**DOWELS - 3-FOOT**

- #15002 1/8" ..... 2.50/25, 8.50/100
- #15004 1/4" ..... 4.75/25, 16.00/100
- #15006 3/8" ..... 7.50/25, 25.50/100
- #15008 1/2" ..... 2.55/5, 11.50/25

BULK PRICES AVAILABLE

**WHEELS & AXLE PEGS**

- #10648 1", 1/4" hole ..... 4.10/100
- #10710 1-1/4", 1/4" hole ..... 6.00/100
- #10812 1-1/2", 1/4" hole ..... 7.50/100
- #10814 1-3/4", 1/4" hole ..... 11.50/100
- #11016 2", 1/4" hole ..... 8.00/50
- #11018 2-1/4", 3/8" hole ..... 4.50/20
- #11020 2-1/2", 3/8" hole ..... 6.50/20
- #11022 2-3/4", 3/8" hole ..... 7.50/20
- #12001 7/32" AP1 ..... 3.10/100
- #12004 11/32" AP4 ..... 1.50/20

**CRAFTER'S MART**

P.O. BOX 2342-W • GREELEY, CO 80632

64-Page CATALOG: \$2 with credit towards first order, Free with any order. Check, MasterCard or VISA (include daytime phone, card no., exp. date & signature). CO Res. add 3% tax. No C.O.D.s. PROCESSING CHARGE: Continental U.S. \$4; AK, HI, APO & FPO \$10; Canada \$16; Foreign 20% plus \$10 (U.S. Funds). PHONE ORDERS: 8am-5pm Mon-Fri - Mtn. Time. Info: (303) 351-0676

**1 - 800 - 999-3445**

**LIFE IS WHAT YOU MAKE IT...**



**rbi MAKES IT BETTER!**

There's nothing more satisfying than stepping back and looking at the project you've just completed. It's exactly the way you had dreamed it would be... the wood, the finish, the detail. Everything is right.

Some folks might say that it takes a master craftsman to complete a project like that, but you know it's just a matter of having the right tool. But more than a power tool, The Hawk is an investment in yourself and your family.

Because of the safety and precision built right into every Hawk, the entire family can be a part of your hobby. From creating simple projects like puzzles and country crafts to finely detailed marquetry inlays, The Hawk is the tool to build your workshop around.

Don't wait another day to find out how to make it better for you and your family with the Hawk Precision Scroll Saw.

There's a full range of styles and sizes... one to fit your family and workshop. Call today and we'll rush you a free Fact Kit with all the details about The Hawk.

**1-800-535-8665.**

**rbi industries, inc.**

1801 Vine Street • Harrisonville, MO 64701 • 1-800-535-8665

**YES!** Please rush me all the facts about Hawk Precision Scroll Saws and other RBI woodworking tools for my shop!

NAME: \_\_\_\_\_

ADDRESS: \_\_\_\_\_

CITY: \_\_\_\_\_ STATE: \_\_\_\_\_ ZIP: \_\_\_\_\_

PHONE: \_\_\_\_\_ SW191

# COUNTRY SHADOW BOX Continued from page 69

Cut a piece of 14-count marine blue aida to  $5\frac{1}{4} \times 7\frac{3}{8}$ ". This allows an inch overhang on all edges. Center and stitch the full-sized pattern shown at right to the fabric. We used white embroidery floss.

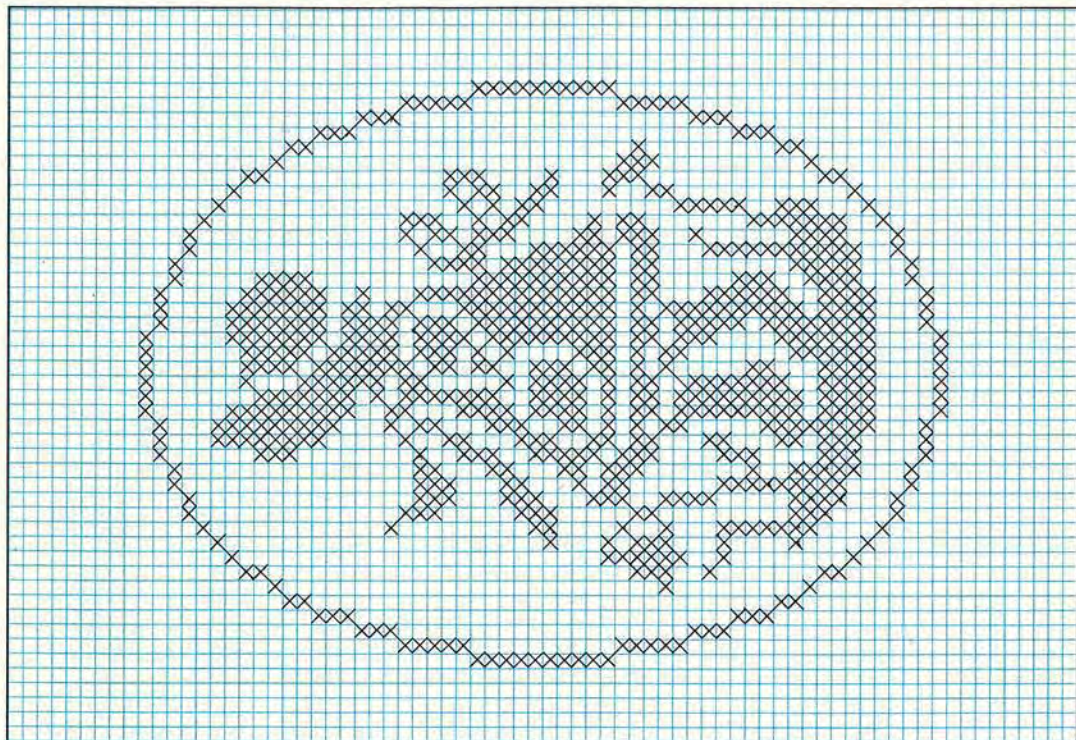

# "Jorgensen"®

AND

# "Pony"®

## CLAMPS

Dependable extra hands for all types of clamping and work-holding jobs:  
Woodworking Projects, Home Maintenance, and Furniture Repair.

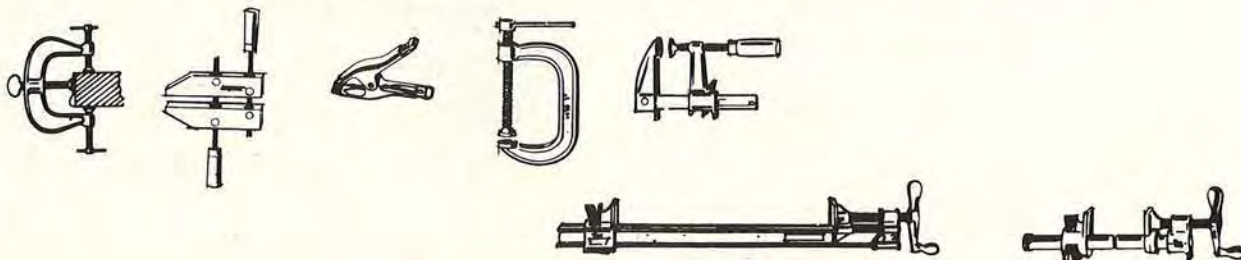

Write for **FREE LITERATURE.**

For big 32-page "how-to-clamp-it" catalog, send \$1.00.

**ASK YOUR DEALER**

**ADJUSTABLE CLAMP COMPANY**

*THE CLAMP FOLKS*

410 N. Ashland Avenue • Chicago, IL 60622



**TRANSPOWER**

SINCE 1953

FOR EXPRESS NEW CATALOGUE CALL

**1-800-654-7702****SUPER HEAVY DUTY WOODWORKING EQUIPMENT**

250 H.D. Table Saw 1 1/2 HP ..... \$350  
 200A H.D. Table Saw 3HP ..... \$795  
 200A W BIESEMEYER Fence ..... \$995

650 H.D. 6" Jointer 1 HP ..... \$295  
 860 H.D. 8" Jointer 1 1/2 HP ..... \$670  
 1200 H.D. 12" Jointer 3HP ..... \$1695



150 Shaper Router 1 1/2 HPS298 ..... \$328  
 500 Shaper Router 3HP ..... \$698  
 860 Tilt Spindle Shaper ..... \$1150  
 150 Auto Planer 12" ..... \$328  
 650 Auto Planer 15" ..... \$648  
 200A Auto Planer 20" ..... \$1195  
 Dust Collector 1HP ..... \$169  
 Dust Collector 2HP ..... \$285  
 Dust Collector 3HP ..... \$385

We also carry complete line of top quality **BAND SAWS, AIR DRUM SANDER, DISC SANDER, BELT SANDERS, AUTO FEEDERS and DRILL PRESS.**

**TCM Industries, Inc.** 322 Paseo Sonrisa, Walnut, CA 91789  
 In California (714) 594-0780

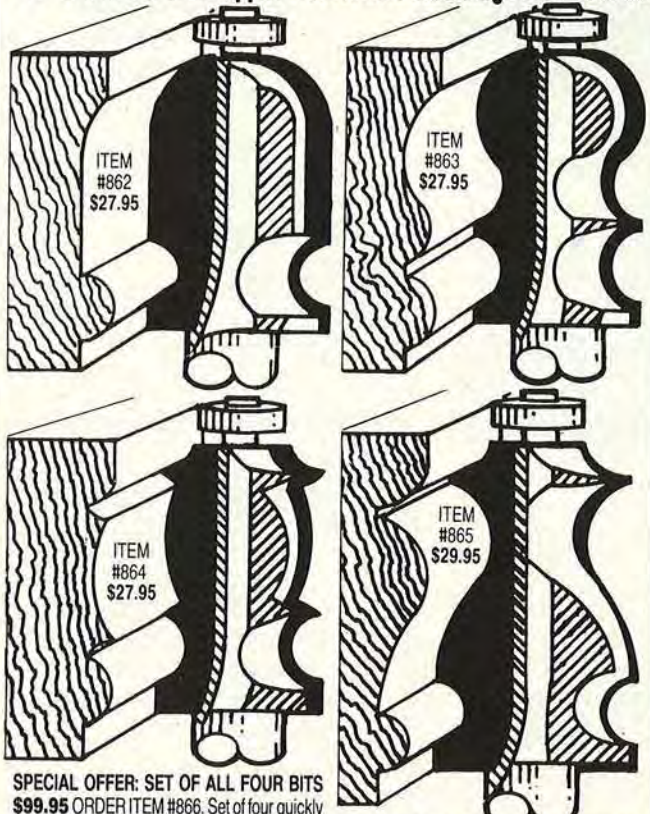
**1/2" Shank Carbide-Tipped Router Bits Moulding Plane Profiles**

**SPECIAL OFFER: SET OF ALL FOUR BITS \$99.95 ORDER ITEM #866.** Set of four quickly produce classic traditional mouldings. Bits are shown Full Size - 2 Flute Carbide Tipped.

Order by VISA / MasterCard, 7 Day / 24 Hour Service, Call 1-800-533-9298

© 1990 or send check to: **MLCS Ltd., P.O. Box 4053DD, Rydal, PA 19046**

Buy Direct From The Manufacturer And **SAVE!**

## Buy 12 "EVER-LAST" Belts... Get 12 Belts FREE!



Need ROLLS, WIDE BELTS, DISCS,  
SLEEVES, STROKE BELTS, etc.  
Write for catalog.

Belts available in 36, 50, 60, 80, 100,  
120, 150, 180, 220, 320 grit sizes.  
Please specify grit sizes when ordering,  
otherwise an assortment will be supplied.

- 1" x 30" ... \$15.50/Doz. + 12 FREE
- 1" x 42" ... \$15.70/Doz. + 12 FREE
- 2" x 48" ... \$21.50/Doz. + 12 FREE
- 2 1/2" x 16" ... \$17.50/Doz. + 12 FREE
- 3" x 18" ... \$17.75/Doz. + 12 FREE
- 3" x 21" ... \$18.75/Doz. + 12 FREE
- 3" x 24" ... \$18.00/Doz. + 12 FREE
- 4" x 21" ... \$23.50/Doz. + 12 FREE
- 4" x 21 1/4" ... \$23.75/Doz. + 12 FREE
- 4" x 24" ... \$24.00/Doz. + 12 FREE
- 4" x 36" ... \$28.95/Doz. + 12 FREE
- 6" x 48" ... \$35.95/1/2 Doz. + 6 FREE

Other size belts on request.

- Belt Cleaning Stick ..... \$6.95 each

For Fast Delivery Call Toll Free  
1-800-428-2222 (U.S.A.)  
1-800-222-2292 (PA only)

**9" x 11" PAPER SHEETS**

A/O or Garnet Cabinet Paper

	50 PACK	100 PACK
40-D	\$17.00	\$31.00
50-D	\$16.00	\$28.00
60-D	\$15.00	\$26.00
80-D	\$14.00	\$24.00
100-C	\$13.00	\$22.00
120-C	\$13.00	\$22.00
150-C	\$13.00	\$22.00
No Load Finishing Paper (White)		
120-C	\$14.00	\$24.00
150-C	\$14.00	\$24.00
180-A	\$11.00	\$19.00
220-A	\$11.00	\$19.00
280-A	\$11.00	\$19.00
320-A	\$11.00	\$19.00
400-A	\$11.00	\$19.00

SHIPPING CHARGES: \$4.50 Continental U.S.

- MONEY ORDER  CHECK
- MASTER CARD  VISA

**INDUSTRIAL  
BRASIVES CO.**  
643 N. 8th ST. • READING, PA 19612

**A GREAT GIFT IDEA**

FOR WOOD®  
MAGAZINE  
READERS!

Just Look At  
These Features:

- ★ **Tough, durable nylon** material resists glue and abrasion
- ★ **3 pockets** designed to hold a tape, folding rule, metal rule, and pencil
- ★ **Attractive beige color** with a brown border and the WOOD® logo
- ★ **One size fits all**
- ★ **Lightweight, comfortable**

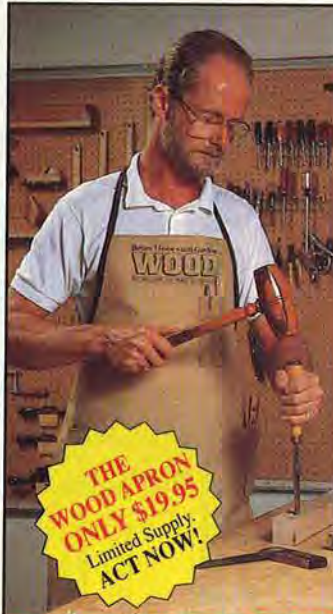

**THE  
WOOD APRON  
ONLY \$19.95**  
Limited Supply.  
ACT NOW!

**YES!** Please send me The WOOD® Apron. Here is my check or money order for \$19.95 U.S. Includes shipping and handling. Send to: WOOD® Apron, P.O. Box 11454, Des Moines, IA 50336-1454, or, call 800-678-2666.

My Name \_\_\_\_\_

Address \_\_\_\_\_ Apt. # \_\_\_\_\_

City \_\_\_\_\_

State \_\_\_\_\_ Zip \_\_\_\_\_

MasterCard  VISA \_\_\_\_\_ Expiration Date \_\_\_\_\_

Card No. \_\_\_\_\_

Signature \_\_\_\_\_

## VISIT THE SHOW NEAR YOU!

- Free Workshops • Prizes •
- Hundreds of Products •
- Seminars by Mastercraftsmen •

★ *The*  
**Woodworking Shows** ★  
 machinery  
 tools • supplies

See the Widest Variety of  
**Woodworking Products**  
 All Under One Roof!!

HUNDREDS OF ITEMS! NEW PRODUCTS!!  
 Machinery • Power & Hand Tools • Supplies

### COMING IN 1990 - 1991

- |                   |                  |
|-------------------|------------------|
| • Atlanta         | • Louisville     |
| • Baltimore       | • Milwaukee      |
| • Boston          | • No. California |
| • Charlotte       | • Oregon         |
| • Chicago         | • Pittsburgh     |
| • Cincinnati      | • Rochester      |
| • Columbus        | • Sacramento     |
| • Dallas          | • Seattle        |
| • Delaware Valley | • So. California |
| • Denver          | • St. Louis      |
| • Detroit         | • Tampa          |
| • Indianapolis    | • Twin Cities    |
| • Kansas City     |                  |

1-800-826-8257 or 213-477-8521

Call NOW to be placed on mailing list for  
 FREE Brochure & Discount Coupons  
 Phone Hours 8-5 Pacific Time Weekdays

## NOVA 4 JAW SELF CENTERING CHUCK



The NOVA Chuck combines all the advantages of 3 and 4 jaw chucks as well as combination chucks while solving the disadvantages of them all.



**Advantages:**

- Wide Jaw Movement
- Same Jaw used for Expansion or Contraction
- Quick 2-way Lever Action
- Holds Square Stock
- All Machined Steel
- Safe-Easy to Use
- Optional Jaws Available



**Sizes Available:**

- Sears 3/4-16
- General 260 1 1/4-8
- Delta/Rockwell 1"-8
- Shopsmith 5/8" plain
- Powermatic 90 1 1/2-8

**PRICE \$159.95**  
 plus \$3.75 shipping

### THE WOODTURNERS CATALOG

Send \$2.00 for our 48 page color catalog  
 \$2.00 refunded with order/free with purchase

## CRAFT SUPPLIES U.S.A.

1287 E. 1120 S.  
 PROVO, UT 84606



(801)373-0917 Fax (801)374-2879

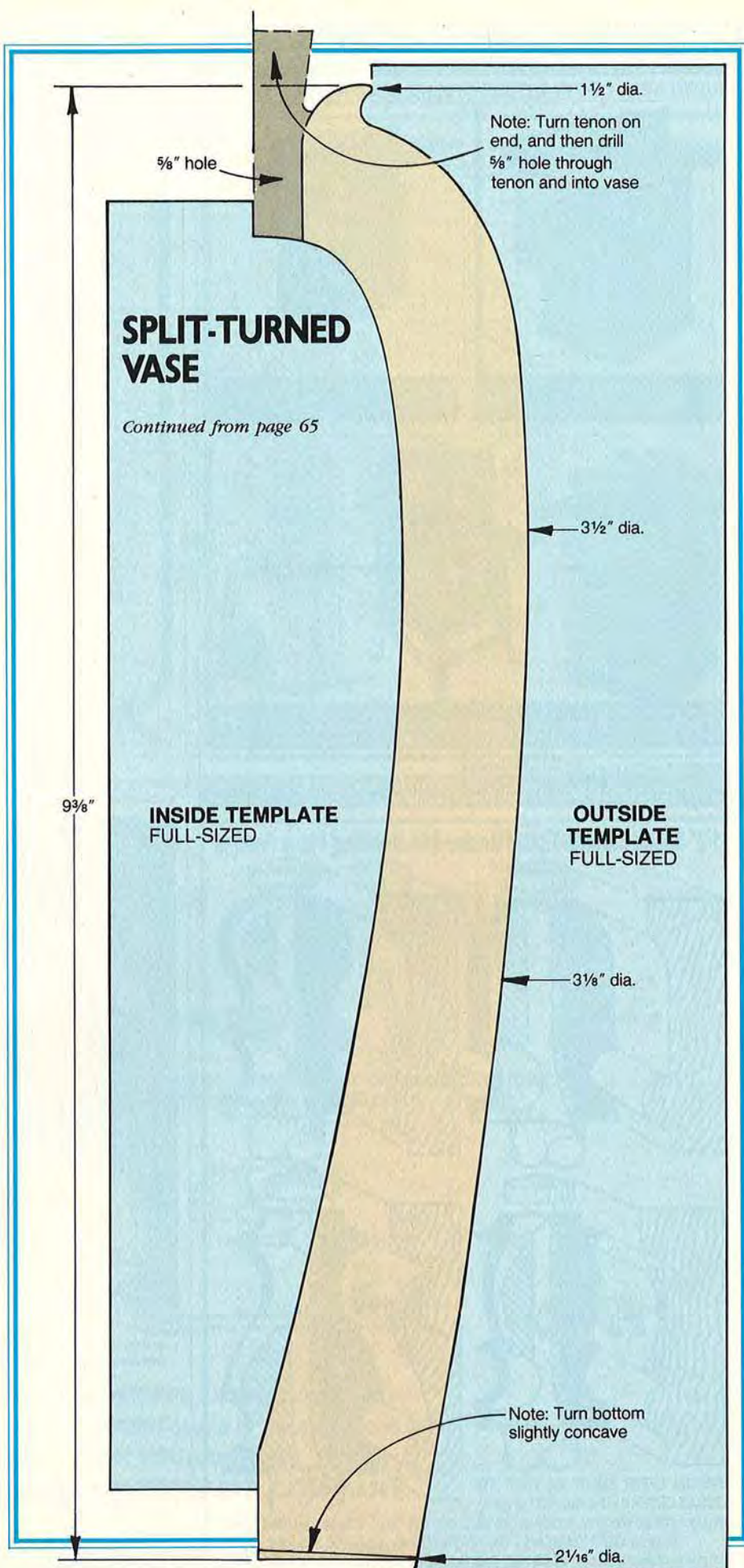

**RYOBI**  
POWER TOOLS

Free Freight!

Limited Offer

AP10 **\$348.** RE-600 **\$208.**

10" Portable Planer 3 HP VS Plunge Router  
 JP-155 6-1/8" jointer 308 R-500 2-1/4 hp pl. router 148  
 RA-200 8-1/4" r. arm saw 248 TR30U laminate trimmer 88  
 TS251U 10" miter saw 178 BE321 3x21 belt sander 128  
 SC160 NEW! scroll saw 148 TFD220VSRK 12v cdls drill 158  
 BT250010" bench table saw 298 JM100K NEW! plate jointer 218

Same Day Shipping!

**TOOL CRIB**  
OF THE NORTH  
DIVISION OF **Acme Electric**

P.O. Box 1716  
Grand Forks, ND 58206 **1-800-358-3096**

**Unique Childrens Furniture™**  
With More Than One Use

6 Different Patterns With Materials List  
And Easy To Follow Instructions



- Table/Bench
- Toy Box/Bookshelves
- Bench Toy Box/Desk
- Easel Board/Paper Tray
- Book/Toy Shelves
- Rocking Chair/Desk

**6 Patterns Included**  
With Bonus, Full-Size Pattern  
(Rocking Chair/Desk pictured above.)

Simple Details©  
1317 Industrial Way  
Palmer, AK 99645

**\$8.95** — Postage and Handling Inc.

**HARDWOODS**

**EXOTIC & DOMESTIC**  
OVER 75 SPECIES

LUMBER • PLYWOOD • VENEERS  
TURNING SQUARES & BLANKS

**COLLECTORS SAMPLE KIT**  
36 EXOTIC & DOMESTIC WOODS  
1/2" x 3" x 6" SANDED FINISH  
**\$29.00 + \$5.00 S&H**

Ideal for collectors, cabinet and furniture makers, designers and architects.

FOR OUT-OF-TOWN ORDERS  
**1-800-423-2450**

**WOODWORKERS Supply**

5402 S. 40th St. • Phoenix, AZ 85040  
(602) 437-4415

NEED EXTRA INCOME?

**WOODCARVING**



**IS FUN AND PROFITABLE**  
Want to carve decoys, statues or gun stocks?

It's easy when you use the Dupli-Carver Series wood carving machines. A patented five axis carving action allows these machines to complete difficult undercuts and contours as no other machine can. Complete machines available starting as low as \$359.00.

SEND \$1.00 FOR OUR FULL LINE BROCHURE AND PRICE LIST AND START PLANNING YOUR FULL OR PART-TIME BUSINESS.

**MARLIN INDUSTRIES, INC.**  
Rt. 70, Box 191, Dept D11  
Cashiers, NC 28717  
(704) 743-5551

**NEW "FINGER RELEASE" BLADE CLAMPS FOR SCROLL SAWS**

Designed to fit most constant tension scroll saws (except far east imports).



FREE CATALOG with details and information on--  
**BLADES - BOOKS PATTERNS**

**EXCALIBUR SCROLL SAWS**

**SEYCO "The Scroll Saw Specialist"**  
1414 Cranford Dr • Box 472749  
Garland, TX 75047 - 2749  
**1 800 462-3353**

**TOULAN 2500 CORNER CAMCLAMP**

New From England



The Corner Clamp is an all British invention which has won National acclaim and prizes for its unique design.

**How to use your Corner Clamp**

- Place cam in hole.
- Clamp by rotating cam.

SUGGESTED RETAIL \$12.95  
SPECIAL INTRODUCTORY OFFER

4 Corner Camclamps \$ 45.00  
10 Corner Camclamps 100.00  
20 Corner Camclamps 180.00

CHECK WITH ORDER OR C.O.D. Freight pre-paid.

**Toulan USA**  
Exclusive Importer  
235 Canterbury  
P.O. Box 12389  
Beaumont, Texas 77726

Div. Tech Rep & Associates

**RIP SAW**

**The Portable Sawmill.**

The "affordable portable" one man band sawmill. Weighs only 45 lbs. Cuts 20" diameter logs into lumber. Minimum 1/8" to maximum 9" thickness.



Write or call for free brochure.

**Better Built CORPORATION**  
(508) 657-5636  
845 Woburn Street, Dept. W, Wilmington, MA 01887

**SQUARE DRIVE SCREWS**

Simply the Best!

- Square Drive Beats Driver Slippage
- Hardened Steel for Extra Strength
- Deep Thread for Super Grip
- Also Brass & Stainless



Send \$3 for Samples and Catalog

**McFEELY HARDWOODS**  
P.O. Box 3 • 712 12th St.  
Lynchburg • Va • 24505  
Toll Free 1-800-443-7937  
or FAX (804) 847-7136

Full-Size Professional Plan  
**ADIRONDACK CHAIR**



Make this classic American design. Our special version may be folded for storage by using ordinary hardware available at your local store. Be ready for Summer and get your plan now!

CATALOG 200 full-size professional furniture plans — \$3.00

Plan #700 . . . . . \$12.95  
(Catalog free with order)

**FURNITURE DESIGNS, INC., Dept. BA-11**  
1827 Elmdole Ave., Glenview, IL 60025  
(708) 657-7526

Quality

**EXOTIC LUMBER**

Figured Domestic Turning Wood  
Exceptional Quality  
Personal Friendly Service

Whether you are a Beginner or Professional, We welcome your inquiries  
Call or Write.

**Berea Hardwoods Co.**  
125 JACQUELINE DRIVE • BEREA, OHIO 44017  
216-243-4452

**TROPICAL HARDWOOD EPOXY**  
glues any wood we ever heard of

**EPOXY FAIRING GEL**  
fills holes - sands like wood

**CLEAR PENETRATING EPOXY SEALER**  
consolidates softer woods  
primes for paint or varnish

**SMITH & CO.**

Industrial and Marine  
Synthetic Resins and Specialties

5100 Channel Avenue  
Richmond, CA 94804  
(415) 237-6842

NEW TOLL FREE LINE  
800-234-0330

**Wood Moisture Meter**

END WOOD WARPING NIGHTMARES



ONE YEAR UNCONDITIONAL GUARANTEE

HAND HELD - EASY TO USE - LARGE DIAL - RUGGED - RELIABLE - SOLID-STATE

MT 100 TESTER \$83  
BOTH 4% - 16%  
MT 250 METER \$95

**EIGHT MODELS IN THE PRECISION MT SERIES FOR MOISTURE CONTENTS FROM 3% TO 60%**  
IDEAL FOR HOME OR INDUSTRIAL DRYING OF ALL KINDS OF WOOD  
HIGH QUALITY INSTRUMENTS DESIGNED AND MADE IN CANADA

Complete detailed information, instructions, and batteries included. Detachable wood probes, accessories, and custom services available. Monitor drying with remote sensing humidity and temperature meters. Above prices in U.S. Dollars to U.S. Customers. Add \$5 shipping. Canadian Residents call or write for Canadian prices. For free catalogue or to order, call or write now to:

**Electrophysics**  
(416) 470-9522

132 Helen Avenue  
Markham, Ontario  
Canada L3R 1J5

# STEVE WALL LUMBER CO.

Quality Hardwoods and Woodworking Machinery For  
The Craftsmen and Educational Institutions

Ash	4/4	Select	1.90	UPS	\$64.00
Basswood	4/4	Select	1.30		\$46.00
Birch	4/4	Select	1.60		\$52.00
Butternut	4/4	Select	1.70		\$54.00
Cherry	4/4	Select	2.25		\$65.00
Hickory	4/4	Select	1.30		\$46.00
Mahogany (Genuine)	4/4	Select	2.60		\$72.00
Maple (Hard)	4/4	Select	1.55		\$51.00
Maple (Soft)	4/4	Select	1.25		\$45.00
Pecan	4/4	Select	1.30		\$46.00
Poplar	4/4	Select	1.20		\$44.00
White & Red Oak	4/4	Select	1.80		\$56.00
Walnut	4/4	Select	2.50		\$70.00
Cedar (Aromatic Red)	4/4	1C+Bt.	1.25		\$45.00
White Pine	4/4	F.G.	.85		\$36.00
Yellow Pine	4/4	Clear	1.20		\$44.00

Above prices are for 100' quantities of kilndried rough lumber sold by the Bd. Ft. FOB Mayodan, NC. Call for quantity discounts. Other sizes and grades available.

Above prices are 20 bd. ft. bundles of clear kilndried lumber 3"-10" wide x 3'-7" long (Random widths & lengths) Surfaced 2 sides or rough. Delivered UPS prepaid in the Continental U.S.

Call For  
Best Price On

*MiniMax*

STEVE H. WALL  
LUMBER CO.  
BOX 287 • MAYODAN, N.C.  
27027

919-427-0637  
1-800-633-4062

FAX 919-427-7588

Send \$1.00 For Lumber  
and Machinery Catalog

## WOODCRAFT PATTERNS



FOR FUN & PROFIT!

### SHOP-TESTED FULL SIZE PATTERNS

- 6 enjoyable wind-action whirligigs.
- 200 pattern packet for scroll, band & jigsaws!
- Yard Critters - bear, fawn, raccoon, skunks, more.
- Yard Characters - Dutch, Amish, bending lady, more.
- Country Classics - enjoyable top-selling projects!
- Adirondack chair & matching garden bench.
- "Sturdy Steed" rocking horse - create an heirloom!
- Show Stoppers - 25 "Child Pleaser" best sellers!

Send \$8.00 per packet. Pick 3 FOR ONLY \$16.00

Fast Service • Satisfaction Guaranteed!

ACCENTS, Dept. MA11, Box 7387, Gonic, NH 03839

WOODCRAFT CATALOG - \$2.00 (Free with order)

## WOOD TOY

- ★ Patterns
- ★ Parts
- ★ Wheels
- ★ Many New Patterns to Choose from.
- ★ Executive toys

SEND \$1.00 FOR  
NEW CATALOG &  
RECEIVE COUPON  
FOR FREE  
WHEELS & AXLE  
PEGS.

*toys and joys*

Box 628W Lynden, Wash. 98264



## SUBSCRIBERS

### PLEASE NOTE

Wood® subscribers often express interest in products and services which are supplied by our company, Meredith Corporation, and by other reputable firms.

Accordingly, we sometimes send our subscribers offers for books, other magazines or home related products and services of potential interest.

We also make subscriber names and addresses available to other firms who are able to supply appropriate products and services. We screen all such offers and take great care to see that information about these products and services is sent only to subscribers who, according to our records, are most likely to be interested.

While we believe the distribution of this information is of benefit to our subscribers, we firmly respect the wishes of any subscriber who does not want to receive it. Should you wish to restrict this, simply send your request to:

Wood®  
P.O. Box 10263  
Des Moines, IA 50336

Please enclose a current address mailing label. Please be specific as to whether it is still all right to receive Meredith Corporation offers or whether you want to stop all offers from any company including Meredith. We will gladly honor your request.

## FIND IT FAST

with the All-New WOOD® INDEX



### You Get:

- ★ Six Easy-Access Mini Indexes
  - Finishing and Refinishing
  - Projects
  - Tools
  - Turning
  - Carving
  - Wood — From Tree to Board
- ★ An Extensive General Index—Issues 1 through 30
- ★ A 3-Page Quick-Reference Wood-Species Guide

**YES!** Please send me the WOOD® Cumulative Index. Here is my check or money order for \$4.95 (Foreign orders \$5.95). Send to: WOOD® Cumulative Index, P.O. Box 11454, Des Moines, IA 50336-1454, or, call 800-678-2666.

My Name \_\_\_\_\_

Address \_\_\_\_\_ Apt. # \_\_\_\_\_

City \_\_\_\_\_

State \_\_\_\_\_ Zip \_\_\_\_\_

MasterCard  VISA Expiration Date \_\_\_\_\_

Card No. \_\_\_\_\_

Signature \_\_\_\_\_

# ASK WOOD

Whether your woodworker's license reads "Beginner," "Intermediate," or "Advanced," you're bound to have a few questions about your favorite hobby. We can help by consulting our staff and outside experts. Send questions to:

Ask WOOD

WOOD® Magazine

P.O. Box 11454

Des Moines, IA 50336-1454

We'll answer all questions, but due to the volume of mail, we can't publish every letter. We may edit letters selected for publication.

## Prayer of the Woods

Several years ago while vacationing in Florida, I went to Wekiwa Springs Park and saw a plaque inscribed with a "Prayer of the Woods." Since then, I've thought of the prayer many times. It describes the uses of wood from the cradle to the grave. I would like to have a copy of the prayer, but I haven't been able to locate it in any book. I hope someone can find it.

—George Dreves, Hillsdale, N.Y.

The Wekiwa Springs Park near Orlando no longer displays the poem, but some helpful Florida Department of Natural Resources employees located the poem at another state park. George, we now understand why this verse stuck in your memory:

I am the heat of your hearth  
on the cold winter nights;  
the friendly shade screening you from the  
summer sun;  
and my fruit are refreshing draughts  
quenching your thirst as you journey on.  
I am the beam that holds your house;  
the board of your table;  
the bed on which you lie,  
the timber that builds your boat.  
I am the handle of your hoe;  
the door to your homestead;  
the wood of your cradle,  
the wood of your coffin.  
I am the bread of your kindness,  
and the flower of beauty.  
Ye who pass by listen to my prayer:  
Harm me not.

According to a park employee, the author's name has been lost.

## TRIMTRAMP™

INSTANTLY CONVERTS YOUR PORTABLE CIRCULAR SAW INTO A PRECISION MITER AND CROSSCUT SAWTABLE



- Constrains your saw to cut backwards and downwards like a radial arm saw, for unsplintered cuts of cabinet-maker quality.
- Fixed left and right 45° fences provide perfect 90° picture-frame-quality miter joints every time. Right hand miter fence adjustable through 135°.
- Crosscuts boards up to 15" wide. No set-up change required between crosscuts and miter cuts, because crosscut fence instantly flips down out of the way, also clearing sawdust from the crosscut fence.
- Can be used on a bench, clamped in a B&D "WORKMATE", or on the floor.
- 24" x 32" x 5"; carries under one arm; do your cutting outside.
- Disengage your saw for use as a handtool, or re-engage it, in 5 seconds.

TRIMTRAMP® with a good saw is an excellent sawtable for fine carpentry at an affordable cost. When a variety of different cuts has to be made in sequence, such as trimming around a door, it is the most labor-efficient sawing device available. TRIMTRAMP is the first precision power sawing device a craftsman should acquire. If you try TRIMTRAMP first you will never buy a radial-arm saw. If you already own a good table saw, you will appreciate TRIMTRAMP for its portability and efficiency.

TRIMTRAMP accepts the following saws and many others:  
Skil #s 5150, 5350, 5656, B&D #s 5728, 5738, 5748, 3027, 3028, 3030, Makita 7-1/4" saw;  
Sears #s 600, 650, 850, 900

### MONEY BACK GUARANTEE

If you are not satisfied, return your TRIMTRAMP within six weeks for a full immediate refund of the purchase price. TRIMTRAMP LTD., P.O. Box 740, Buffalo, N.Y. 14213 Telephone 416-795-1115. No collect calls please.

Purchase price of \$99.95 enclosed, together with \$10.00 delivery charges.

Check  Visa  MasterCard Expiry Date: \_\_\_\_\_

Card Signature: \_\_\_\_\_ Card #: \_\_\_\_\_

Customer name (print): \_\_\_\_\_

Customer address: \_\_\_\_\_

State \_\_\_\_\_ Zip \_\_\_\_\_ Phone \_\_\_\_\_

\*TRIMTRAMP is the registered trademark of TRIMTRAMP LTD., product protected under U.S. pat. 4,909,111

## WOOD PARTS FROM MIDWEST DOWEL WORKS

### Compare Our Low Prices!

	Qty.	Cost
3-1/2" Poplar Shaker Peg	\$15/100	___
1-3/4" Mini Shaker Peg	\$7/100	___
3-1/2" Country Wall / Mug Peg	\$15/100	___
2-1/2" Country Shorty Peg	\$12/100	___
Large Bean Pot Candle Cup	\$17/100	___
Brass Inserts	\$9/100	___
1/2" Mini Candle Cup	\$10/100	___
1-1/2" Toy Wheel	\$10/100	___
2" Toy Wheel	\$17/100	___
Axel Pegs	\$4/100	___

### SMOOTH SANDED HEARTS

3/4" x 1/8" Hearts	\$2.75/100	___
3/4" x 1/2" Hearts	\$4.50/100	___
1" x 3/16" Hearts	\$4.00/c	___
1" x 3/8" Hearts	\$6.50/c	___
1-3/8" x 1/8" Hearts	\$5.50/c	___
1-3/8" x 1/4" Hearts	\$7.50/c	___
1-3/8" x 1/2" Hearts	\$10/100	___
2" x 1/2" Hearts	\$18/100	___

### Great Buys!

	Qty.	Cost
3/8" x 36" Standard Dowels	\$21/100	___
3/4" x 36" Oak Dowels	\$15/10	___
3/8" Maple Buttons	\$2.15/100	___
1/2" Maple Buttons	\$2.25/100	___
1-1/2" Maple Spindles	\$9/100	___
2-1/8" Maple Spindles	\$18/100	___

### ORDER NOW

MC/Visa  Check Enclosed

Total Cost \_\_\_\_\_

Handling \$3.00

Ohio residents add 5% sales tax \_\_\_\_\_

Final Cost \_\_\_\_\_

MC/Visa Number \_\_\_\_\_

Expires \_\_\_\_\_ Phone \_\_\_\_\_

Name \_\_\_\_\_

Address \_\_\_\_\_

City/State/Zip \_\_\_\_\_

### FREE 16-PAGE CATALOGUE

Circle this section for FREE Dowels  
— mixed pack, Maple, Oak, Walnut  
Cherry, from 1/4" up to 1"  
Approximately 10 LFT. 14" long.  
\$5.00 value with any order.

## MIDWEST DOWEL WORKS

4631 Hutchinson Road  
Cincinnati, Ohio 45248  
(513) 574-8488

Same Day Service/Order before Noon  
Factory Direct/Satisfaction Guaranteed

# Worth writing for ...

You can get useful ideas and product information by mail. Use the coupon in this section to order your choice of literature listed below. Each company mails the catalogs or information directly to you.

## POWER TOOLS

**SCROLL SAW AND LATHE INFORMATION**—More than 20 pages of information, including full-color photos, on HEGNER precision scroll saws, HEGNER lathes, and HEGNER duplicators. Find out why these machines are considered state of the art, and what to look for when shopping for scroll saws or lathes. AMI, LTD. \$1.00. *Circle No. 3.*

**WOODWORKING PROFESSIONALS ONLY**—Now save 50% on machinery, 70% on operating costs! How? By using the world's finest production quality universal machine. Commercial durability, utmost precision, set-up in seconds. No other tool combines usable capabilities like FELDER. Thousands sold all over the world. Now available in America through AMI. Send for brochure. AMI LTD. \$1.00. *Circle No. 4.*

**TOOL CRIB OF THE NORTH IS ANNOUNCING OUR NEW 1990 CATALOG**—It features a wide selection of merchandise for your home woodworker to your industrial builder. Top manufacturers such as Black & Decker, Delta, Makita, Porter Cable, Bosch, Milwaukee, Ryobi, Freud and many more. We offer competitive prices with quality service and same day shipping. Send today for your new 1990 Acme Electric catalog. It's worth it. ACME ELECTRIC. \$2.00. *Circle No. 6.*

**PORTABLE SAW MILL**—A one man saw mill weighing 45 lbs. Gas and electric models will cut dimensional lumber from logs up to 20 in. diameter. Send for brochure. BETTER BUILT CORP. Free. *Circle No. 10.*

**175-PLUS USES GUIDE**—for Dremel Moto-Tool. Written from the do-it-yourselfer's view, this book shows how to plan and do a variety of everyday projects using the versatile Moto-Tool and cordless Freewheelers. 96-page book with over 275 photos includes tips on using Moto-Tool with flex-shaft, drill press, router attachment, chainsaw sharpening attachment, shaper/router table. DREMEL. \$4.00. *Circle No. 33.*

**FREE WOODWORKING POWER TOOL CATALOG**—Buy planers, jointers, shapers, table saws, scroll saws, bandsaws, drill presses, wood lathes, sanders, dust collection systems, and more...direct from the factory and save. Foley-Belsaw sells direct to you...so you save on every purchase. You'll find quality power tools, plus hand tools and accessories to meet all of your woodworking requirements. Complete money-back guarantee. Send for details. FOLEY-BELSAW. Free. *Circle No. 41.*

**MANUFACTURED SINCE 1926**—the Foley-Belsaw Circular Sawmill lets you go right to the trees to turn out smooth, true-cut lumber. Available with heavy-duty steel base or with plans and track provided for owner built wood base. Will accurately saw logs up to 14 ft. in length and up to 24 in. in diameter. Complete money-back guarantee. Send for details. FOLEY-BELSAW CO. Free. *Circle No. 42.*

**INCA MACHINERY INFORMATION**—Complete information on the famous line of Inca woodworking machines. Designed for precision work by the small to medium sized cabinet shop. Used by thousands of hobbyists and professionals. Table saws, bandsaws, joiner/planers, dust collector, radial arm saw. GARRETT WADE CO. Free. *Circle No. 44.*

**POWER TOOLS YOU CAN BUILD AND SAVE**—Build sturdy woodworking tools from kits and save—sold for over 40 years—warranty on parts. Simple step-by-step plans with full size patterns for wood base. Plans and patterns can be purchased separately. Send for descriptive brochure. GILLIOM MFG. INC. \$1.00. *Circle No. 47.*

**MAKITA U.S.A. INC.**—offers all new 152-page mini-catalog on its professional line of electric power tools, with special emphasis on the entire cordless line. Catalog provides complete information along with available accessories and practical applications. MAKITA U.S.A. INC. Free. *Circle No. 61.*

**WOODWORKING MACHINE CATALOG**—New 16-page color catalog introduces many new do-it-yourself woodworking machines. Includes planers, dust collectors, drill presses, sanders, lathes, and specializes in scroll saws and accessories. PENN STATE INDUSTRIES. Free. *Circle No. 75.*

**SCROLL SAW**—Information package available from Penn State Industries describing the specifications and applica-

tions of its super VS-15" variable speed scroll saw. Special discount pricing available on current promotion. PENN STATE INDUSTRIES. Free. *Circle No. 76.*

**SURFACE PLANER**—Information package available from Penn State Industries describing the specifications and applications of its super 12½-inch surface planer. Special discount pricing available on current promotion. PENN STATE INDUSTRIES. Free. *Circle No. 77.*

**PERFORMAX DRUM SANDERS**—Exclusive features at an affordable price for precise wide surface sanding. The complete line includes the retrofitting Performax Component Sander, the Pro Max and the Super Max 25, Super Max 25X2, and super brush sander. New accessories for production-mode sanding of pieces as small as 2¼" long. Send for brochure. PERFORMAX PRODUCTS. \$1.00. *Circle No. 78.*

**THE PRECISION SCROLL SAW FOR THE ENTIRE FAMILY**—The Hawk was designed for beginners and built for expert woodworkers. Learn how to produce creative leisure time projects for fun or to make money...we'll show you how! Make cuts so intricate and smooth they don't require sanding. Over six models to choose from. Send today for all the facts. Send for the facts. RB INDUSTRIES, INC. Free. *Circle No. 84.*

**THE VERSATILE RBI WOODPLANER/MOLDER-SANDER**—It's indispensable! It's 4-in-1. It's RBI's Woodplaner/Molder/Sander/Gang Rip Saw. Find out how the Woodplaner saves you money turning rough stock into beautiful professional quality projects. With 3 models to choose from there's one that fits your needs. It does it all, so you can do it all! Send today. RB INDUSTRIES, INC. Free. *Circle No. 85.*

**SKIL CORPORATION**—Full color, complete line, power tool catalog. Features cordless screwdrivers, drills and the cordless Skilwrench™. Corded products include circular saws, drills, drywall drivers, sanders, hammer drills, jig-saws, planes, roto hammers, sander/grinders, shears, routers, xtra tools, bench top tools and reciprocating saw. All product accessories are also shown. SKIL CORPORATION. \$1.00. *Circle No. 88.*

**SCROLL SAWS, ACCESSORIES, PATTERNS, BOOKS**—A complete brochure on all kinds of scroll saw accessories. Featuring Excalibur scroll saws and lettering layout guides from Seyco, "The Scroll Saw Specialists." Free pamphlet, "Selecting Your Scroll Saw" included. Send for brochure. SEYCO SALES CO. \$1.00. *Circle No. 89.*

**MOLDER-PLANERS FROM WILLIAMS & HUSSEY**—Mold, plane, and edge, convert from moulder to planer in less than 2 minutes. The W-7 series is available in 3 models for manual, power in feed, or power in feed/out feed. The units plane to a satin, almost sanded finish, produce dull house to crown sized moldings, raised panels, and curved molding. Custom knives available up to 7" wide and ¾" depth of profile. Rugged, well-made, dependable, and transportable. Complete with sturdy movable stand. Send for catalog. WILLIAMS & HUSSEY. \$1.00. *Circle No. 93.*

**PORTABLE SAWMILLS**—Convert logs into valuable lumber—Wood-Mizer™ Products manufactures a line of portable band saw mills that allows the novice as well as the experienced sawyer to safely convert standing logs into lumber. Then, with the use of our SolaryDry™ Kiln or Vacu-Kiln™ to dry your lumber, you could increase the value of every board you produce. We manufacture some of the most progressive woodworking equipment on the market today. Product videos available. Send for our 40-page catalog. WOOD-MIZER PRODUCTS. \$1.00. *Circle No. 94.*

**BRIDGEWOOD WOODWORKING MACHINERY**—a new 52-page catalog of fine BRIDGEWOOD wood and metal-working machinery is available from Wilke Machinery Company. The BRIDGEWOOD line includes a wide range of products for use in the serious home workshops up through the industrial applications. WILKE MACHINERY CO. \$1.00. *Circle No. 96.*

**QUICK-GRIP™ BAR CLAMPS**—Revolutionary new tool for one-handed operation. Positive locking action; strong, yet lightweight; large pads won't mar work. Sizes 6"–36" AMERICAN TOOL CO., INC. 25¢. *Circle No. 105.*

**DIAMOND WHETSTONES BY DMT**—Rescue your routers, lap carbide edges; discover the ease and speed of sharpening on Diamond Whetstones. Five sizes from 3" to 12" in the fine, coarse, and extra coarse. Finest monocrySTALLINE industrial diamonds permanently bonded in nickel. Lubricated with water. Stays flat, unbreakable, long life. Fifteen years of serving sharpening needs. Satisfaction guaranteed. Send for full color catalog. DIAMOND MACHINING TECHNOLOGY, INC. \$2.00. *Circle No. 112.*

**PERSONAL BRANDING IRONS**—Brochure describes branding irons that enable you to put your name on your work quickly and easily. Made especially for branding wood, they are available with 1, 2, or 3 lines of copy or with your logo. Changeable date also available. NOVA TOOL CO. \$1.00. *Circle No. 160.*

**THE JAPAN WOODWORKER'S 72-PAGE CATALOG**—is loaded with the huge selection of Japanese saws, waterstones, chisels, planes, carving knives, cutlery and garden tools. See our Tools As Art section for the most expensive hand tools available. Send for 1990 catalog and all supplements for two years. WOODLINE TOOL & SUPPLY. \$1.50. *Circle No. 190.*

## STAINS/FINISHES

**DEFT SOUTHWEST COLLECTION PAMPHLET**—Bring the colors of a desert sunrise into your home with Deft's new Desert Oak White Wood Stain and tint base. Pamphlet shows a wide variety of pastel colors available. DEFT, INC. Free. *Circle No. 215.*

**RUST-OLEUM**—Protect your home from costly damage caused by moisture and harsh sunlight. The top name in metal protection, Rust-Oleum is known for sealing out moisture and keeping its rich color. Now, Rust-Oleum Wood Saver Paint is made with a unique patented formula that protects wood trim, doors, fences, railings and outdoor furniture. 8-page Homeowner's Guide, Brochure and coupon. RUST-OLEUM. Free. *Circle No. 265.*

**FREE WOOD REFINISHING PRODUCTS**—Make wood refinishing easy with products from 3M. Do-it-yourselfers can restore and protect wood like the experts. Send today for free sample. 3M. Free. *Circle No. 268.*

## PLANS

**140 WOOD PROJECTS**—Easy-to-follow construction plans for desks, chairs, coffee and end tables, book cases, magazine racks, sewing cabinets, kitchen accessories, lamps, figurine shelf, fishing tackle rack, even a toboggan for winter fun! A great variety of projects, complete. A.T.H. CO. \$10.95. *Circle No. 302.*

**OVER 1000 WOODCRAFT PATTERNS!**—Enjoy making gifts, toys, lawn ornaments, holiday designs, whirligigs, folk art, bird houses and feeders, household and yard accessories plus much more! Simple enough for the beginner, fun and profitable for the pro. Send for catalog plus sample pattern. ACCENTS IN PINE. \$2.00. *Circle No. 310.*

**WOODWORKERS' PLANS AND SUPPLIES**—Wood projects are simplified with the high quality plans, specialty hardware and other supplies offered by Armor Products. Over 100 plans are available for making toys, desks, clocks, pool tables, lamps, chests, and other furniture. Movements, dials, moldings, ornaments, dollhouse kits, door harp supplies and tuning pins are also available. ARMOR PRODUCTS. \$1.00. *Circle No. 315.*

**SALES TESTED DESIGNS**—available as plans only, parts kits, or plans and parts kits. Complete stock of parts, tools and supplies. Door harps to digital electronic/wood projects. Full size plans! Bulk prices on turnings, dowels and music movements. Catalog price refundable on first order. CRAFTER'S MART. \$2.00. *Circle No. 328.*

**PATTERNS BY DESIGN GROUP**—Hundreds of interesting, useful and fun items to create for personal use or profitable sale. Our newest catalog contains plans for toys, games, plaques, puzzles, birdhouses, planters, furniture, and much more! All Design Group patterns are professional, "same size" blueprints. No enlarging or reducing is necessary. Simply trace outline of item onto wood and create! Started in 1977, Design Group has sold thousands of patterns to thousands of satisfied customers. Prices start at \$1.00, all patterns come with a full money-back guarantee. Wholesale and bulk prices are available on request. Fully illustrated catalog. DESIGN GROUP. \$1.00. *Circle No. 340.*

**FULL-SIZE FURNITURE PLANS CATALOG**—Illustrates and describes over 200 plans for making furniture of quality found in museums and fine furniture stores. Plans include rollout desk, cradles, dining tables, chairs, buffets, chests, gun cabinets, poker table, children's furniture, rocking horse, spinning wheels, and more. Bill of materials exploded drawings assist the woodworker. FURNITURE DESIGNS, INC. \$3.00. *Circle No. 345.*

**STICKLER FOR DETAIL?**—At last an exciting new line of realistic wood block models that you can build with your own scrap wood and dowels and my easy-to-follow instructions. Highly detailed plans for a 20x83¼-in. dump truck. GATTO PLAN SUPPLY. \$8.00. *Circle No. 355.*

**COUNTRY FURNITURE PLANS**—Our catalog features more than 37 designs—from a washtand to a roll top desk. Our new book on finishing and refinishing will show you how to finish projects like the pros. Also included are various products for the home workshopper. Send for our latest

catalog (price of catalog deductible from first order), HAM-MERMARK ASSOCIATES. \$1.00. Circle No. 370.

**PROJECT PLANS**—Over 400 easy-to-build woodworking project plans. Nation's leading source for door harp plans and parts, holstein cow projects, toy plans, country furniture, etc. Over 3000 hard-to-find specialty items. Send for your big new 72-page catalog. MEISEL HARDWARE SPECIALTIES. \$1.00. Circle No. 401.

**THE YEAR'S BEST PROJECT PLANS**—From the editors of Popular Science Magazine, 32 easy-to-build and fun-to-do indoor and outdoor woodworking projects you'll be proud to complete. 186-page volume includes materials lists, and complete step-by-step instructions fully illustrated with photos and diagrams. Hundreds of hours of enjoyment for all skill levels...plus FREE gift for saying "yes" to preview. Send for details. Woodworking Projects Yearbook. POPULAR SCIENCE. Free. Circle No. 418.

**BACKYARD STRUCTURES** — Contains designs for 21 really different storage sheds, 5 cabanas, 13 animal shelters, 3 barns, 13 garbage enclosures, 3 studios, and more, plus 8 plans in book. 66 designs in all, for which plans can be ordered. Full color. SUN DESIGNS. \$10.45. Circle No. 454.

**STATIONARY ROCKER PLANS**—Build a fine and comfortable rocker with our easy to follow plans & patterns and hardware kit. 3 models available. Also sharpening machines, 12" knife sharpener, profile grinder, sander-grinder. Send for our color brochure. VIEL TOOLS INC. \$1.00. Circle No. 475.

**WOOD—MET SERVICES CATALOG LISTS SOME 700 PLANS**—to build a wide variety of tools and accessories to equip your workshop. They vary from complete machines to hand tools, photo accessories to shop methods. Included are some 80 attachments for your lathes, drill presses & routers, over 60 hand tools, plus sander, welder, shaper, table saw accessories, etc. Others include a portable band sander, metal spinning tools, air compressor,  $\frac{3}{4}$ " spindle wood shaper, wood lathe & chisels & a 12-in. thickness planer. Send for catalog, order plans, build the equipment for your shop and save. WOOD-MET. \$1.00. Circle No. 496.

## LUMBER

**QUALITY EXOTIC LUMBER/TURNING WOODS**—We offer a comprehensive selection of fine quality exotic woods: Ebony, Kingwood, Tulipwood, Snakewood, African Blackwood, Cocobolo, Bloodwood, Figured Maple, Spaulded Maple, Padauk, etc. Unique and unusual turning woods and burls are also available. Send for catalog. BEREA HARDWOODS. \$1.00. Circle No. 510.

**WOODWORKERS! HELP CELEBRATE OUR 60TH YEAR OF SERVICE** — Send for our new 148-page Craftsman 1990-91 Catalog #57. 42 varieties of choice hardwoods 1/84 in. to 4-in. thickness. Fine hardwood veneers, tools, moldings, trim, marquetry inlays, upholstery and lamp supplies, finishes, clock kits, and hard-to-find hardware. 4,000-plus items for your projects. CRAFTSMAN WOOD SERVICE CO. \$1.00. Circle No. 520.

**EdLco — WE KNOW OUR LUMBER** — Educational Lumber Company is pleased to offer you our new catalog, stacked with excellent buys at delivered prices. Available to you are over 21 species of imported as well as domestic hardwoods, softwoods, turnings, shorts, veneers. All our lumber is kiln dried. As school shop suppliers for 35 years, we know our lumber. It is top-grade. Send today and receive your BONUS GIFT: 4 new furniture designs. EDUCATIONAL LUMBER CO., Inc. \$2.00. Circle No. 530.

**NORTHEASTERN HARDWOODS**—We offer over 20 species of the highest quality kiln dried domestic hardwoods. Sold on board footage or cut to order basis. Compare our quality and prices. Unconditional satisfaction guaranteed. Great monthly specials. Super package deal at delivered prices. Attractive quantity discounts. Quick delivery. Send for new catalog. NORTHEASTERN HARDWOODS. \$1.00. Circle No. 563.

**LUMBER DRYING** — Nyle Corp., the largest U.S. manufacturer or dehumidification dry kiln systems, offers literature on its complete line of small kiln packages from 300-50,000 BF. NYLE CORP. Free. Circle No. 565.

**RARE IMPORTED EXOTIC AND DOMESTIC HARDWOODS**—The world renowned Martin Guitar Co. sells exotic woods (4/4, 6/4, 8/4) and sawn veneers ( $\frac{1}{8}$ ",  $\frac{1}{4}$ ", &  $\frac{1}{2}$ " Sanded Stock), plus guitar parts, kits, accessories and second quality guitars. No minimum order. Send for catalog. WOODWORKER'S DREAM. \$2.00. Circle No. 578.

**STEVE H. WALL LUMBER CO.**—Quality hardwoods and woodworking machinery for the craftsman and educational institutions. 22-page catalog lists 15 species of popular hardwoods at wholesale prices. Also dealers for MiniMax, Freud and ProCul woodworking machines. STEVE H. WALL LUMBER CO. \$1.00. Circle No. 592.

**EXOTIC IMPORTED AND DOMESTIC HARDWOODS**—Over 75 species of lumber, bowl planks, turning squares and veneer. Samples ( $\frac{1}{2}$ " x 3" x 6") ideal for craftsmen, furniture and cabinet makers, architects, and designers available. Catalog provides common and botanical name, source, and description of each wood. Send for catalog. WOODWORKERS SUPPLY. \$1.00. Circle No. 598.

## EPOXIES/GLUES

**ARE YOU CURIOUS ABOUT EPOXIES?**—Our application notes and product literature will tell you how adhesives work, how coating systems are designed, and how to make paint, varnish and fillers stick better and last longer. We are chemists. We make all our own products and write all our own literature. We can answer your questions. SMITH & CO. Free. Circle No. 760.

## GENERAL WOODWORKING CATALOGS

**ADVANCED WOODWORKING**—Specialty products catalog from the exclusive distributors of Hegner & Felder woodworking machinery. Includes complete selection of scroll saw blades, accessories, and improvements for almost any scroll saw. Also the Hegner precision scroll saws, lathes & duplicators. Jet clamps, workbenches, Felder systems & more. AMI, LTD. \$2.00. Circle No. 801.

**CONSTANTINES' CATALOG FOR WOODWORKERS**—116 pages packed with over 4,000 products for fine woodworking. Included are 250 kinds and sizes of domestic and imported hardwoods; 150 varieties of exotic veneers, top quality woodworking tools, hard-to-find specialty hardware and accessories; wood finishes, books, plans, and more. 60-day money back guarantee if not fully satisfied. Serving the woodworker since 1812. ALBERT CONSTANTINE AND SON, INC. \$1.00. Circle No. 820.

**MASTER TOOLS CATALOG**—1990-91 220-page master woodworking tools catalog. Full line of the best hand tools, power tools & accessories, machinery, glues, finishing supplies, and much more. Hundreds of books included. 220 pages. All four-color. Lots of technical information. GARRETT WADE CO. \$4.00. Circle No. 855.

**THE BEST THING THAT EVER HAPPENED TO THE AMERICAN WORKSHOP**—You will simply be amazed at the number of new items we have brought on line this year. Our incredible catalog features a huge selection of wood and metal working machinery and accessories. Loaded with tons of goodies you can't resist. GRIZZLY IMPORTS INC. Free. Circle No. 860.

**SEND FOR JET EQUIPMENT & TOOLS FREE CATALOG**—to get details on bandsaws, tablesaws, joiners, shapers, drill presses, lathes, sanders, dust collectors and training videos. All Jet machinery comes with a 1-year limited warranty, replacement parts and repair service availability. JET EQUIPMENT & TOOLS. Free. Circle No. 876.

**TOOLS ON SALE**—A division of Seven Corners Ace Hardware Inc. offers a comprehensive catalog featuring over 820 pages of the most competitive prices in the industry. If you're looking for savings and fast delivery on over 6500 items, request our catalog. This catalog offers one of the most complete selections of power tools available anywhere from the most respected manufacturers in the industry: Milwaukee, Makita, Porter-Cable, Black & Decker, Freud, Bosch, Delta, and many more. SEVEN CORNERS ACE HARDWARE. \$1.00. Circle No. 920.

**COMPLEMENTARY TOOL CATALOG**—Woodcraft offers over 4,000 of the finest quality woodworking tools, books, supplies, and cabinetry hardware in our complete full color catalog. Craftsman, cabinetmakers, carvers, woodturners, and hobbyists have depended on Woodcraft since 1928. Backed by Woodcraft's unconditional guarantee. Free technical assistance. WOODCRAFT SUPPLY CORP. Free. Circle No. 955.

**THE WOODWORKERS STORE CATALOG**—New! The Woodworkers' Store 1990-91 catalog with over 250 new items features 100 color pages of domestic and exotic hardwoods, veneers, wood parts, specialty hardware, kitchen accessories, finishing supplies, tools, books, and plans. Many exclusive items and hard to find specialties. Orders shipped in 24-48 hours. \$1.00 credited toward first purchase. Satisfaction guaranteed. WOODWORKERS STORE. \$1.00. Circle No. 965.

## KITS

**OUR QUEEN ANNE FURNITURE KITS**—are ready to assemble and finish. They include dining room table, chairs, hutch, sideboard, a variety of occasional tables, and a personal desk. All are made in solid cherry, oak, walnut, and mahogany. We also stock individual Queen Anne legs for every project. Complete information in our brochure packet. ADAMS WOOD PRODUCTS. Free. Circle No. 1002.

**DO-IT-YOURSELF KITS**—Choose from a large selection of grandfather, wall and mantel clocks, as well as elegantly styled accent furniture pieces. Kits are made of solid  $\frac{3}{4}$ " hardwoods, primarily cherry, oak, and black walnut. Buy direct from the factory and save. Send for 36 page color catalog. EMPEROR CLOCK CO. \$1.00. Circle No. 1030.

**MUSIC MAKER'S KEEP BOOK**—a 32-page resource catalog for building and learning to play handmade musical instruments. This source book contains plans, blueprints, kits, books, hardware, strings and accessories for building such instruments as guitars, banjos, dulcimers, harps, violins, pipes, and more. MUSICMAKER'S KITS. \$1.00. Circle No. 1080.

## SHOP ACCESSORIES

**PARAGAUZE—NOW ANYONE CAN CUT WOOD ACCURATE TO WITHIN 10/1000 INCH**—ParaGauge was developed to provide the woodworker a perfectly parallel measurement quickly and accurately to help alleviate the tedious and sometimes inaccurate task of setting a rip fence. ParaGauge accurately measures distances up to 18 in. in length between the saw blade and rip fence and up to 2.5 in. in depth without resetting or relocating the gauge. Para Gauge is completely portable and can be used on just about any tool requiring a parallel measurement. ACCUSET TOOL CO. INC. 25¢. Circle No. 1205.

**WOOD MOISTURE METER**—End wood warping nightmares with a high quality precision instrument from Electro-Physics. Avoid damage and deformation; eliminate stains, decay, mold, and failed joints. Eight models to choose from in the MT Series of wood moisture meters designed and made in Canada. For moisture contents from 3% to 60%. Accessory probes and custom services available. A wood moisture meter is an essential tool for the home hobbyist, serious enthusiast, professional woodworker, commercial kiln or sawmill operator, wood carver, and everyone who works with wood. Free catalog gives complete information. ELECTROPHYSICS. Free. Circle No. 1230.

**EASY DOES IT**—with HTC'S power tool accessories. Discover many unique items, designed only with you, the dedicated woodworker, in mind. Make your machinery safer, increase the working area of your shop and accomplish nearly impossible tasks easily, quickly, accurately. Full-line catalog and price list. HTC PRODUCTS, INC. Free. Circle No. 1245.

**BUY YOUR SANDING BELTS DIRECT FROM THE MANUFACTURER**—Industrial Abrasives is the company that gives you 12 free belts with every dozen ordered. But, sanding belts are not the only product we have to offer. In our catalog you will find many specialty items not readily available in your hardware store. Price of catalog refunded with first order. INDUSTRIAL ABRASIVES CO. \$1.00. Circle No. 1248.

**WOOD MOISTURE METER** — Avoid moisture problems such as cracking, warping, splitting, delamination etc. by using a moisture meter, as described in the latest brochure. Moisture Meter Mini-Ligno is designed for serious hobbyists and woodworkers. Attachments for depth measurements and remote reading during air and kiln drying are available. Available Moisture Range 6-20%, 6-36% or 4-30%, 4-60%. Catalog describes complete line of moisture meters. LIGNOMAT USA, LTD. Free. Circle No. 1250.

**ROUTER SPEED CONTROL**—Reduces speed electronically without reducing torque. Route at the speed that gives best results with the wood and bit you are using. Speed adjustable from full speed to 0 RPM. Less tear out—stops burning—less wear on bits—easy to use. Send today for information. MLCS LTD. Free. Circle No. 1251.

**WHOLESALE SANDPAPER, BELTS, SHEETS, CLOTH AND PAPER DISCS**—for orbital sanders, flexible sanding cloths, pads, lack cloths, pressure sensitive adhesive, wipers, dust mops—Super Grit offers its quality abrasive and refinishing products at wholesale prices directly to the consumer. Try our extra strength hot melt glue sticks for wood. \$25 minimum order, prompt free UPS shipment to most areas. Catalog/Price List. RED HILL CORP. 50¢. Circle No. 1267.

## BITS, BLADES CUTTING TOOLS

**AmMax TOOL CO.**—offers "Professional Quality" tungsten carbide tipped router bits, shaper cutters, saw blades, and 16" scroll saw machine, at lower "wholesale prices." 16" scroll saw featuring light load, cutting without blade breakage. UL and CSA approved. Nicholson carbide tipped saw blades from \$6.90; woodworking files from \$6.95. AM-MAX TOOL CO. Free. Circle No. 1304.

**BANDSAW BLADES FOR ALMOST ANY TYPE BANDSAW**—both wood and metal cutting. Also circular saw blades, router bits, sanding belts and discs. Send for catalog. BUCKEYE SAW CO. \$1.00. Circle No. 1307.

**CARBIDE-TIPPED ROUTER BIT AND SHAPER CUTTER CATALOG**—We have hundreds of styles and thousands in stock ready to be shipped. We specialize in quantity discounts and same day shipping. These are top quality industrial router bits and shaper cutters at super low prices. Send now to receive new giant catalog. CASCADE TOOLS, INC. Free. Circle No. 1315.

**TIED OF THE IMPORTS?**—All new 1991 router bit catalog featuring over 1100 items. This factory direct mail order 56-page catalog offers the industry's largest selection of the finest quality American made router bits, shaper cutters, and accessories. EAGLE AMERICA CORP. Free. Circle No. 1320.

**WOODWORKING TOOLS** — Freud provides the finest in hand tools, carbide cutting tools, and hand held power tools. From drills and sanders to carbide saw blades and router bits. Send for catalog. FREUD. \$2.00. Circle No. 1321.

**SUPER-SMOOTH, EXTRA-DURABLE, CARBIDE-TIPPED CIRCULAR SAW BLADES**—Get a smooth-as-sanded surface with our all-purpose 40-tooth Woodworker Blade. You will be able to rip and cross-cut 1-2 in. rock hards and soft woods with an unbelievably smooth finish. You will also be able to cross-cut oak and birch ply-veneers with no bottom splinters. Send today for our information pack. FORREST MFG. CO., INC. \$1.00. Circle No. 1322.

**PRODUCTION QUALITY CARBIDE TIPPED ROUTER BITS** — MLCS Ltd. offers a full line of professional production quality carbide tipped router bits at 50-70% lower than retail prices. We sell through the mail and only direct to craftsmen. Send today for catalog. MLCS LTD. Free. *Circle No. 1350.*

**ROUTER BITS, SHAPER CUTTERS, FORSTNER BITS.** — Boring bits, saw blades. All heavy duty industrial grade tungsten carbide. You name it, if it rotates and cuts, we have it. Quality, price, selection, save 50% or more over "wholesale" prices. Catalog comes with a \$3.00 discount coupon. SKYCROFT TOOLS INC. \$1.00. *Circle No. 1372.*

## HARDWARE/WOOD PARTS

**TURNED WOOD PARTS**—Quality shaker pegs, candle cups, spindles, wheels, balls, dowels, screwhole buttons, cargo and much more. High quality. Reasonable prices. Fast service. American made. Free shipping on orders over \$25. 28-page catalog. AMERICAN WOODCRAFTERS SUPPLY. 75c. *Circle No. 1405.*

**HARDWARE CATALOG**—A unique 48-page catalog of the very finest in classic, traditional solid brass cabinet hardware. All of British or No. American manufacture. Double & single post handles, knobs, escutcheons, standard & specialty hinges, box hardware, brass screws, castors, latches, catches, locks, and more. GARRETT WADE CO. \$3.00. *Circle No. 1427.*

**SQUARE DRIVE SCREWS**—Thousands agree—once you try them you will never want to use anything else! The square drive recess virtually eliminates work-damaging driver bit "cam-out," the deep threads result in exceptional holding power, and they are heat treated for strength. Sizes from #4 x 3/8" to #12 x 4", with stainless steel, solid brass, brass plated, and zinc plated available. Quantity discounts. Send for literature. McFEELY HARDWOODS. \$1.00. *Circle No. 1450.*

**WOOD TOY PATTERNS** — Patterns for all ages including children's patterns and executive toys. New catalog has many new patterns to choose from including parts and

wheels. Send for new catalog and receive a coupon for free wheels and axle pegs. TOYS AND JOYS. \$1.00. *Circle No. 1480.*

**TRADITIONAL TURNINGS FOR THE HOME CRAFTSMAN**—Unique selection of bedposts, table legs (dining, sofa, coffee, and end), hutch, gourmet, and kitchen. American, European, and Contemporary designs, available in Ponderosa Pine. Sanded and ready for assembly and finish. Send for catalog. TRADITIONAL TURNINGS. \$2.00. *Circle No. 1485.*

**QUALITY AMERICAN-MADE WOOD TURNINGS** — such as shaker pegs, spindles, toy wheels, toy parts, craft items, and dowel rods in birch, oak, walnut, and cherry. Send for complete 32-page catalog. WOODWORKS. \$1.00. *Circle No. 1490.*

## INCOME OPPORTUNITIES

**MAKE MONEY IN FURNITURE RESTORATION THE MINUTEMAN WAY**—Earn \$200-\$1000 per day stripping, repairing, refinishing, mirror resilvering, and/or veneering, at home or in shop, spare time or full time. We provide complete free training: no experience necessary. Free workshop teaches you latest in furniture restoration. You have to see it to believe it! Intro video \$12.95. Send for catalog. MINUTEMAN. \$2.00. *Circle No. 1661.*

## MISCELLANEOUS

**FOLEY-BELSAW INSTITUTES' NEW WOODWORKING CORRESPONDENCE COURSE**—for people with the desire to learn how to work with wood and the proper use of tools. Create over 20 projects using professional plans and tools like a table saw, router with stand, and more...all included with the course. Complete money-back guarantee. Send for details. FOLEY-BELSAW INSTITUTE. Free. *Circle No. 1930.*

**LEARN ALL THE SKILLS**—of professional upholstery and refinishing techniques in the comfort of your own home. The Foley-Belsaw Institute system of "hands on" training provides clear, step-by-step instructions in the use of tools and materials on actual furniture "kits"...all included with the course. Complete money-back guarantee. Send for details. FOLEY-BELSAW INSTITUTE. Free. *Circle No. 1931.*

**THE CUSHION CONTOUR SANDER** — is a new concept in pneumatic drum sanding. Sanding sleeves are slid over an air bag (inflated with a hand tire pump) on an arbor to mount it between centers on a wood lathe. Drum effectively takes on profiles, curves, and bevels practically eliminating flat spots and chatter marks. INDUSTRIAL ABRASIVES CO. \$1.00 (refunded with first order). *Circle No. 1976.*

**IF YOU ARE INTERESTED IN RESTORING ANTIQUES**—this 216-page catalog packed with unusual, hard-to-find items is just for you. Included are hundreds of essential items for antique restoration including top quality brass reproduction hardware, oil lamps and accessories, numerous wood component repair parts and kits, caring and basketry supplies, everything needed for wood refinishing, related tools and books, and a complete line of upholstery equipment and supplies. All at wholesale prices. Send for this informative catalog. VAN DYKE'S RESTORERS. \$1.00. *Circle No. 2077.*

**NEED PARTS?!**—If you are having trouble locating parts for your radial arm saw because of recent changes in their availability, Wolfe Machinery could be your answer. We have a full line of parts, including obsolete ones for 10-20" DeWalt radial arm saws. Send today for free information. WOLFE MACHINERY CO. Free. *Circle No. 2080.*

**COMPUTER SOFTWARE**—Woodworking Magazine Index for Wood, Fine Woodworking, Woodwork, Woodsmith, Today's Woodworker, and 1987-1990 issue of Woodworker's Journal and Workbench. Now you can find the article you remembered, and know the magazine, issue and page without searching through many printed indexes. Yearly updates can be added to the original index. Send for brochure; price refundable with order of Woodfind. WOODFIND. \$1.00. *Circle No. 2089.*

## CARVING SUPPLIES

**DECOY AND WOOD CARVERS WISHBOOK**—48-page catalog features wide selection of tools and supplies for decoy carvers, wood carvers, wood turners, Chisels, gouges, sharpening stones, precision grinding tools, Fore-dom tools, Fire Brush burners, pneumatic sanders, glass eyes, pewter feet, patterns, paints, reference books. P. C. ENGLISH, INC. \$1.00. *Circle No. 2115.*

**WOOD CARVING MACHINES AND ACCESSORIES**—make all types of wood carving easy, fun and profitable. The machines do the work. Whether for sign carving, flat 3-D, decoys, panels, gun stocks or furniture, we have the proper machine for the job. Professional woodcarving for the hobbyist and superior quality for the professional. Begin your hobby or full or part-time business by ordering our catalog and price list. MARLIN INDUSTRIES. \$1.00. *Circle No. 2150.*

**WOODCARVING TOOLS** — Whittlers and carvers — Warren Tool Co. offers a complete catalog of whittling and carving, hand/power tools, sharpening stones, wood cut-outs and related wood carving supplies. WARREN TOOL CO., INC. \$1.00. *Circle No. 2185.*

**WOOD CARVERS SUPPLY INC.—OUR 35TH YEAR**—Complete 64-page color catalog including over 2,000 carving tools, books & supplies, such as carousel animal kits, gun checking tools, ship model kits, plus much more. We offer great service, quality products and a 30-day money back guarantee. Send for 2-year subscription. WOOD CARVERS SUPPLY INC. \$2.00. *Circle No. 2190.*

## CLAMPS

**MERLE ADJUSTABLE CORNER CLAMP** — Quick & easy to use. Fully adjustable from 2 1/2" to 69x69 in. Perfect for clamping picture frames, cabinets, or anything that requires 90° corner clamping. The Merle Clamp is cast aluminum & steel construction, a true industrial quality tool. Send today for information. MLCS LTD. Free. *Circle No. 2250.*

## CLOCKS

**BUILD HEIRLOOM CLOCKS** — Now create beautiful heirloom quality clocks right in your own home. Choose from magnificent chiming grandfather clocks to charming wall clocks. 32-page catalog also offers a selection of music boxes, music movements, traditional barometers, and a huge variety of quartz movements and dials for custom clock building. Satisfaction guaranteed. THE AMERICAN CLOCKMAKER. \$1.00. *Circle No. 2320.*

**KLOCKIT'S FREE 64-PAGE COLOR CATALOG**—is packed with the largest selection of beautiful wood clock kits for all skill levels, a huge selection of quartz and mechanical clock movements, dials and accessories, turned wood parts, music movements, tools and much more for the craftsman KLOCKIT. Free. *Circle No. 2335.*



Better Homes and Gardens®  
WOOD MAGAZINE, January 1991  
Dept. JNWO91  
P.O. BOX 5103  
Pittsfield, MA 01203-5103

### TO ENSURE PROMPT HANDLING OF YOUR ORDER FOLLOW THESE INSTRUCTIONS:

- Circle your choice
- Enclose check or money order for cost of booklets plus \$2.00 service charge (no stamps/foreign)
- Send coupon and remittance to address above
- ALLOW 4-6 WEEKS FOR DELIVERY
- Coupon expires February 19, 1992

### WOOD SUBSCRIPTION

1. A 1 year WOOD subscription (8 issues) for \$19.97 (U.S. price) — an \$11.63 savings off newsstand rate. Allow 6-8 weeks for first issue. Canadian price \$27.97. Be sure to include payment with total below. NO FOREIGN ORDERS ACCEPTED ON THIS COUPON; please contact Subscription Dept. directly.

### FREE LITERATURE

Circle numbers below corresponding to items in this issue. Please include \$2.00 for handling charge

10.	75.	215.	760.	1230.	1315.	2080.
41.	76.	265.	860.	1245.	1320.	2250.
42.	77.	268.	876.	1250.	1350.	2335.
44.	84.	418.	955.	1251.	1930.	
61.	85.	585.	1002.	1304.	1931.	

### PRICED LITERATURE

Numbers below refer to items on which there is a charge. Please include proper remittance.

3....\$1.00	94....\$1.00	328....\$2.00	510....\$1.00	855....\$4.00	1321....\$2.00	1661....\$2.00
4....\$1.00	96....\$1.00	340....\$1.00	520....\$1.00	920....\$1.00	1322....\$1.00	1976....\$1.00
6....\$2.00	105....25c	345....\$3.00	530....\$2.00	965....\$1.00	1372....\$1.00	2077....\$1.00
33....\$4.00	112....\$2.00	355....\$8.00	563....\$1.00	1030....\$1.00	1405....75c	2089....\$1.00
47....\$1.00	160....\$1.00	370....\$1.00	578....\$2.00	1080....\$1.00	1427....\$3.00	2115....\$1.00
78....\$1.00	190....\$1.50	401....\$1.00	592....\$1.00	1205....25c	1450....\$1.00	2150....\$1.00
88....\$1.00	302....\$1.95	454....\$10.45	598....\$1.00	1248....\$1.00	1480....\$1.00	2185....\$1.00
89....\$1.00	310....\$2.00	475....\$1.00	801....\$2.00	1267....50c	1485....\$2.00	2190....\$2.00
93....\$1.00	315....\$1.00	496....\$1.00	820....\$1.00	1307....\$1.00	1490....\$1.00	2320....\$1.00

Name (please print) \_\_\_\_\_

Address \_\_\_\_\_

City \_\_\_\_\_

State \_\_\_\_\_ Zip Code \_\_\_\_\_

### I AM ENCLOSING:

\$ \_\_\_\_\_ for priced items

\$ 2.00 for handling

\$ \_\_\_\_\_ total remittance





## FINISHING TOUCHES

### THE TREE THAT WOULDN'T QUIT

During a Hawaiian stay in 1866, author Mark Twain planted a seedling of the monkeypod tree on the island of Kauai. By 1956, the tree—designated as a state historical landmark—had grown so large that when a windstorm blew it over, more than 5,000 board feet of lumber were salvaged! That's roughly half the

amount of structural lumber used in the building of a 2,000 square foot home. This wood, though, was made into a mountain of bowls and other commemorative items. However, the stump soon shot sprouts. Today, the landmark tree is still growing into a good-sized, second-generation monkeypod nearly 60' tall.

### MOUNTAIN MONOPOLY

The Appalachian Mountains—that stretch from southern Quebec to northern Alabama—contain more species of trees than you'll find in all of Europe, according to the Appalachian Hardwood Manufacturers Association. Jim Gundy, the association's executive officer, says the range contains 1,500 to

1,800 native hardwood species.

"No one knows what the exact count is, but every hardwood native to the U.S. either grows here now or grew here at one time. Before the Ice Age, the Appalachians were like a giant aboretum of American hardwoods." He notes, though, that not all those species are commercially available.



### NO WONDER IT RAINS IN A RAIN FOREST

Trees, by gathering carbon dioxide in their leaves and turning the carbon into sugars and starches, release oxygen into the atmosphere. Did you know, though, that they give off lots of moisture, too?

According to the Georgia-Pacific Corporation, a large tree, such as found in the Amazon rain forest, can release 178 gallons or more of water per day.

The yield, of course, depends on the climate. Leaves release this moisture in order to maintain the proper balance between solid cells and water for growth. In wet climates, trees take in, and thus have to give off, more water.

### DELTA DUSTS OFF DOUBT

The federal Occupational Safety and Health Administration's (OSHA) new and tighter standards for commercial workplace environments goes into effect December 31, 1992. And, it has many full-time woodworkers scratching their heads over what to do about OSHA's stringent wood-dust control requirements.

To help reduce the confusion, Delta International Machinery

Corporation has published a brochure that explains the OSHA standards and suggests solutions. To get a copy of "Wood Dust Control and Collection Systems," send \$3 to cover postage and handling to: Delta International Machinery Corp., 246 Alpha Dr., Pittsburgh, PA 15238. For additional information about the brochure, call 800-438-2486, or 412/963-2425. ♣

Illustrations: Jim Stevenson Photo courtesy of The Colonial Williamsburg Foundation

## Tools of the trade



*In colonial times, logs were ripped with a long, double-handled pit saw.*

For Colonial Williamsburg craftsmen, 17th- and 18th-century tools have become extensions of their hands, but most of us know little about the adzes, blades, and saws that built America. Soon, though, you can change that.

Early next year, you'll be able to view an exhibit of approximately 2,000 tools at Colonial Williamsburg's DeWitt Wallace Decorative Arts Gallery. The Virginia historical attraction received a \$52,000 grant from the National Endowment for the Humanities to plan this first major museum exhibition of Early American hand tools. According to project director Jay Gaynor, the exhibit will include documents, demonstrations, and lectures. While the emphasis will be on woodworking tools, other trades also will be represented. For more information, call 804/229-1000.



**NEW!**

# MAJOR ADVANCE IN FORSTNER BIT DESIGN

## 10-pc. FORSTNER BIT SET

All with Saw-Teeth

**\$84<sup>99</sup>**

plus \$5.00 s/h

#10-1336



All bits 3 1/2" overall with 3/8" shanks. Precision Ground. HRC50-52. Sizes: 1", 1 1/8", 1 1/4", 1 3/8", 1 1/2", 1 5/8", 1 3/4", 1 7/8", 2", 2 1/8" in handsome wood case.

**SAW TEETH  
ELIMINATE OVERHEATING,  
ELIMINATE BURNING  
AND CUT FASTER  
WITHOUT LOSS  
OF ANY  
FORSTNER  
BIT FUNCTION**

## SAW-TOOTH JUMBO FORSTNER BITS

Complete Set of 8

**SAVE  
OVER  
\$105.00**

**\$139<sup>99</sup>**

plus \$10.00 s/h

#10-1350



## 16-pc. FORSTNER BIT SET

**\$89<sup>99</sup>**

plus \$7.00 s/h

#10-1330



Sizes over 1 1/2" with Saw-Teeth

All bits 3 1/2" overall with 3/8" shanks. Precision Ground. HRC50-52. Sizes: 1/4" through 2 1/8" in wood case.

## 7-pc. CONVENTIONAL FORSTNER BIT SET

**\$29<sup>99</sup>**

plus \$4.00 s/h

#10-1325



All bits 3 1/2" overall with 3/8" shanks. Precision Ground. HRC50-52. Sizes: 1/4" through 1" in wood case.

1/2" Shanks:  
6" O/A



2 1/4"	10-1316	\$22.99
2 3/8"	10-1317	24.99
2 1/2"	10-1318	26.99
2 5/8"	10-1319	28.99
2 3/4"	10-1320	30.99
2 7/8"	10-1321	32.99
3"	10-1322	34.99
3 1/8"	10-1323	36.99

plus s/h: 1 Bit \$4.00; ea. add'l bit \$2.00

## 22-pc. HSS TAPERED DRILL, COUNTERSINK/BORE, STOP COLLAR SET

**\$29<sup>99</sup>**

plus \$4.00 s/h

#05-0007

**NEW!**



For Screw Sizes #5, 6, 7, 8, 9, 10, 12. Wood case included.

**NEW!**

**SUPPLE  
SUEDE  
LEATHER  
WORKSHOP  
APRON**

**\$19<sup>99</sup>**

plus \$4.00 s/h

#03-0003

21"x33". 4 pockets.



## 5-pc. JUMBO BRAD POINT DRILL SET

Specialty Priced

**\$19<sup>99</sup>**

plus \$3.00 s/h



#04-0115

9/16", 5/8", 3/4", 7/8", 1" with 3/8" shanks.

**"NO HASSLE 30-DAY MONEY BACK GUARANTEE"**

VISA/MC **TOLL FREE 1-800-666-7227** Dept. WM011 (Incl. Canada)

DOLLAR TRADING CORP., Dept. WM011, P.O. Box 68666, Indianapolis, IN 46268

(IN and CT Buyers Please Add Sales Tax)

# Fine Instruments For The Serious Woodworker

A symphony orchestra of diverse musicians in formal attire is performing in a grand, ornate hall. In the foreground, a Craftsman table saw is prominently displayed on a checkered floor. The saw is a black, three-legged model with a silver blade guard and a control panel featuring a '3HP' label. The musicians are playing various instruments including violins, violas, cellos, double basses, trumpets, and flutes. The background features large windows with blue curtains and classical architectural details.

The sound of a Craftsman Contractor Series power tool may not be symphonic, but it sure will be music to your ears.

The table saw featured here reflects our attention to details... from our patented Exact-I-Cut alignment system to the dual voltage induction motor that develops a full three horsepower.

After years in business, we know what it takes to satisfy the serious woodworker. Every stationary tool in the Contractor Series was engineered to give you all the power and accuracy you'll ever need for the most demanding project.

We invite you to see the many Craftsman features for yourself at your nearby Sears store.

**CRAFTSMAN®**

Only at Sears