

Woodsmith®

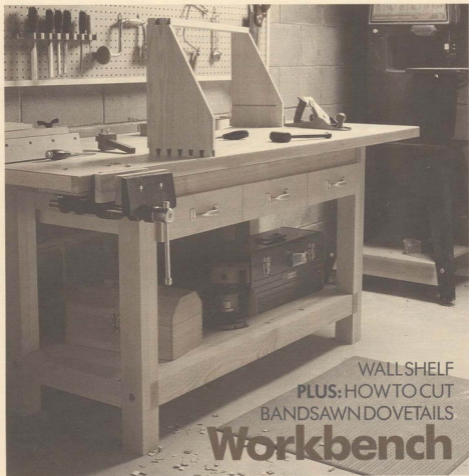

WALLSHELF
PLUS: HOW TO CUT
BANDSAWN DOVETAILS

Workbench

Woodsmith



Editor	Donald B. Peschke
Design Director	Ted Kralicsek
Managing Editor	Douglas L. Hicks
Assistant Editors	Douglas M. Lidster Kent A. Buckton Terry J. Strohmman
Project Designer	Ken Munkel
Technical Illustrators	David Kreyling Cary Christensen Rod Stoakes Chris Glowacki
Customer Service	Linda Morrow, Mgr. Lisa Thompson
Project Supplies	Leslie Ann Gearhart
Controller	Paul E. Gray
Computer Operations	Ken Miner
Administrative Ass'ts.	Cheryl Scott Sandy Baum
Sourcebook	Jean Carey
Woodworking Shows	Steve Curtis
Building Maintenance	Archie Krause

WOODSMITH STORES

General Manager	Steve Krohmer
Marketing Manager	Steve Dozier
Store Managers:	
St. Louis, MO	Jon Behrle
Berkeley, CA	Michael DeHaven
Des Moines, IA	Kent Welsh

WOODSMITH (ISSN 0164-4114) is published bimonthly (February, April, June, August, October, December) by Woodsmith Publishing Co., 2200 Grand Ave., Des Moines, IA 50312.

Woodsmith is a registered trademark of Woodsmith Publishing Co.

©Copyright 1989 by Woodsmith Publishing Co. All Rights Reserved.

Subscriptions: One year (6 issues) \$15.95, Two Years (12 issues) \$27.95. Canada and Foreign: add \$2 per year, U.S. funds only. Single copy price, \$3.95.

Second Class Postage Paid at Des Moines, Iowa and at additional offices.

Postmaster: Send change of address to Woodsmith, Box 491, Mt. Morris, IL 61054.

SUBSCRIPTION QUESTIONS? Call 800-435-0715 (IL residents: 800-892-0753). 7:30 AM to 8:30 PM, CST, weekdays.

SAMPLE COPY: We will send a free sample copy of Woodsmith to anyone. Just send us his/her name and address.

Sawdust

One of the most popular projects we've ever shown in *Woodsmith* is the European-style workbench featured about three years ago (in *Woodsmith* No. 50). It's quite a bench. And probably exactly what most woodworkers have in mind as the center of their shop.

But that bench is quite an undertaking to build. Don't get me wrong, I think it's well worth the effort. But it's certainly not a weekend project.

We wanted to come up with another bench. One that was easy to build, sturdy, and would serve you well over the years—even if it isn't a classic European-style bench.

Every time we sat down to design this simple bench, we ran into the problem of design overload. It's a problem common to many projects. Once you get started, you want to add a feature, and add a feature, and add a feature. Soon the simple bench is complicated. We finally decided to limit the design by setting three basic criteria.

First, the base (legs) had to be built out of easy-to-obtain construction lumber. (We built the base out of fir 2x4's).

Second, the joinery used for the base had to be basic, not something like wedged mortise and tenons. (We used very simple versions of lap joints and butt joints.)

And third, the top had to be easy to construct and not too expensive. (We chose a solid-core door, but you could use two layers of plywood.)

What we wound up with is a good solid bench that can be built in a weekend and will probably last a lifetime. But if you have a little time left over, you can add a few features.

First on our list was a set of drawers. You can add the three simple drawers shown in this issue. Or, you can build a more elaborate storage unit like the one on the European-style bench. In fact, the base was sized for this storage unit if you want to add it later. (Refer to *Woodsmith* No. 50.)

As for vises, we've listed a group of vises that could be used on this bench, see Sources on page 24. These are basic woodworking vises that mount to the front of the bench. You could get a little more function out of the bench by adding a dog row and a tail vise at the end of the bench.

DOVETAILS. Just as a good workbench is the cornerstone of a shop, there are certain joints that are hallmarks of woodworking. The one that comes to mind first is the dovetail joint.

This classic joint is great for all sorts of cabinetwork, and particularly for making

drawers. But it's also a joint that many woodworkers tend to shy away from. Too complicated. Requires too much precision.

Okay, let's face it, if a joint requires using hand tools (like a back saw and a set of sharp chisels), more than likely we'll find a different joint... or a different way to make it.

If you don't want to use hand tools to make dovetails, your options are limited. There are several dovetail jigs on the market that cut through dovetails with a router. But they tend to be expensive.

Another way is to use a band saw. That's the basis for the technique shown in this issue. Actually, it all started with a friend of mine, Mark Duginski. For many years Mark has been a representative of INCA machinery. He works at many of the wood-working shows across the country and gives seminars on working with a band saw.

Periodically Mark stops by our shop to talk about a new technique he's developed for the band saw. The one I found most intriguing was his method for cutting dovetails.

The basic technique involves using two jigs, one to cut the tails and one to cut the pins (the two interlocking parts of a dovetail joint). In general, it's easy to get my attention with almost any jig, but Mark's technique and jigs are particularly interesting.

When cutting dovetails, jigs make it easy to make repeated, accurate cuts at the angle needed for both parts of the dovetail joint.

However, that's not what got my attention about Mark's technique. The jig he devised not only sets the angle, but also sets the spacing of each cut. By spacing, I mean aligning the cut to a precise point. And in the case of dovetails, spacing is equally as critical as the angle.

The spacing is usually determined by making a pencil line. But pencil lines are not very precise. So, how does Mark solve the problem of precise alignment? With spacer blocks. Nothing new, but in combination with the angle jigs, they produce accurate cuts over and over again, with no guesswork.

What about all the other techniques Mark told us about? Well, he decided to write a book, *The Band Saw Handbook*. It just came out and Mark is pretty excited about it—a three-month project that took two years to complete. (I know how he feels.) It's filled with his experience of many years of working with band saws.

NEXT ISSUE. The next issue of *Woodsmith* (No. 67) will be mailed during the week of February 12, 1990.

Tips & Techniques

SIMPLER RESAWING

In *Woodsmith* No. 63 you showed two techniques for resawing thick boards into thin lumber: one for the table saw and the other for the band saw. I use a hybrid method that combines both of these techniques.

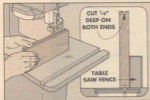

This technique works well with boards of almost any width, but really it's useful when resawing boards that are too wide to cut all the way through on the table saw.

To use this method, I first set up the table saw to score the two

edges of the board with cuts about $\frac{1}{4}$ " deep, see inset drawing. Then, to finish resawing the board all the way through, I switch to the band saw, see drawing. The scored cut lines on each edge of the board act as guides for the band saw blade.

Try to cut down the side of the scored line as closely as possible. Since the kerf left by the table saw blade is wider than the band saw blade, this gives you a "guide" to make the final cut.

With this method, a resawing guide on the band saw is not needed since the scored lines help control blade drift. This results in boards of uniform thickness which means there will be less final planing needed.

*Ed Shaffer
Rochester, Minnesota*

ROUTER TABLE/WORKBENCH

I've found yet another use for my *Woodsmith* router table: I use it as a workbench to temporarily hold benchtools like grinders and scroll saws. (My shop is small, and I don't have the space to permanently mount these tools on a bench.)

First, mount each tool onto its own plywood base. I made the bases for all the tools one uniform size. To make each base, I cut $\frac{3}{4}$ "-thick plywood to the same width as the top of the router table. (On my table, this is 30".) Then I drilled two $\frac{1}{4}$ " holes in the plywood, $1\frac{1}{2}$ " in from each edge. (These holes must align with the carriage bolts that hold the router table fence.) Each benchtop tool is then bolted to its plywood base.

To mount the tool to the router table "workbench," remove the fence and fasten the plywood base

to the table using the same carriage bolts, washers, and wing nuts that hold the fence, see drawing.

*John Inman
Virginia Beach, Virginia*

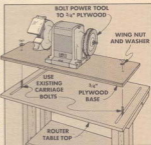

Editor's Note: If your router table is not the Woodsmith design, you can attach benchtop tools by installing a pair of T-nuts from the underside of the table or threaded inserts from the top. Then bolt the plywood base in place.

SANDING STRAP

When I'm sanding rounded objects or working on the lathe, I use a special sanding strap with dowel handles.

To make the sanding strap, start by laying down a 24" length of duct tape — sticky side up. Now put a couple of dowel handles on top of the tape about 3" from each end. Then fold the ends of the tape over the dowels and stick the tape down onto itself to hold the

handles in place, see drawing.

After securing the handles, set a strip of sandpaper on top of the sticky surface of the tape. Trim the edge of the sandpaper to the width of the duct tape.

To use the sanding strap, simply grasp the dowel handles and work the strap back and forth over the object.

*John Bittel
Staten Island, New York*

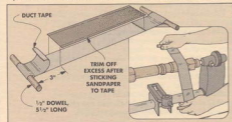

GLUE BRUSH

Here's a solution to the problem of applying glue to small surfaces such as grooves, rabbets and dadoes — without getting glue on surfaces that are to be stained and finished.

I've found that a pencil-style typewriter eraser (the kind with the bristles on one end) makes a perfect glue brush. The bristles carry an ample amount of glue yet are stiff enough to spread the glue evenly into tight spaces. And since the bristles are synthetic, they are easily washed clean after use.

Also the eraser easily removes unwanted pencil marks left on surfaces to be finished. It's more abrasive than a regular eraser so it removes lines quickly and it's easier than sanding.

*Russell Abbott
Port Townsend, Washington*

SHOP BRUSH

I keep a brush in my shop commonly used by a draftsman. The bristles on this brush are longer and softer than most shop brushes so it cleans up sawdust around equipment and down in cracks and corners easily.

Drafting brushes are available at art supply stores for about \$5.

*Steve French
Rochester, New York*

SEND IN YOUR TIPS

If you'd like to share a tip with others, send in your idea to *Woodsmith*, Tips & Techniques, 2200 Grand Ave., Des Moines, Iowa 50312.

We pay \$15 for accepted tips. Please send an explanation and a sketch if needed (we'll draw a new one).

Workbench

Construction lumber and a weekend's work can produce the most used tool in the shop... a workbench. This one features a base made of 2x4's and a solid-core door for a top.



All I wanted was a simple workbench. A bench that was sturdy, had a large work surface, and didn't cost a lot. And I wanted to build it in a weekend.

So Saturday morning I went to the local lumberyard and by Sunday night my basic bench was complete. The base of the bench is made out of fir 2x4's. The top is a solid-core door. Lumberyards and building centers often have slightly damaged doors at a discount. Or, you could make the top out of two pieces of $\frac{3}{4}$ " plywood.

The basic bench worked great, but by the next weekend I began thinking some drawers sure would be handy. So I added three drawers that are joined together with router-cut dovetails. I also added a sliding tray in one drawer to keep things organized.

Since I couldn't fit everything into the drawers, I added a shelf underneath. Then a woodworking vise was the final touch. The point is this project can be simple or involved. The basic bench can be put together in a weekend. Or you can add storage and a vise

for a more versatile bench.

JOINERY. The end frames of the bench are assembled with lap joints. But, instead of cutting lap joints in the traditional way, I built them up by laminating 2x4's together. The uprights are stacked (laminated) in a way to create "notches" for the crosspieces (braces), refer to the Exploded View.

This brought up the question of the best way to laminate the 2x4's together. If you have enough clamps, you can glue and clamp them together. Or, you can glue, and then nail them together. (Here I'd use finish nails.) Or, glue and screw them together.

There was another question about how to join the rails (horizontal pieces) to the legs. I chose a draw-bolt system that allows you to knock down the bench if you ever need to move it in the future.

FINISH. To protect the bench and keep glue from sticking to it, I finished the bench with two coats of General Finishes Two-Step oil/urethane finish.

EXPLODED VIEW

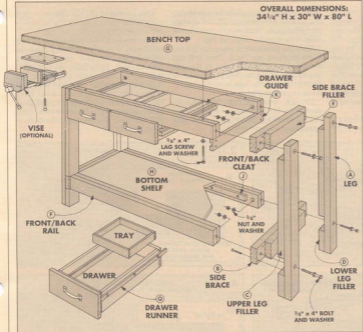

OVERALL DIMENSIONS:
34 1/4" H x 30" W x 80" L

SUPPLIES

BASIC BENCH

- (2) 2x4's, 96"-long
- (1) 1 1/2" x 30" x 80" solid-core door (or laminate 2 sheets of 3/4" plywood together to get a 1 1/2"-thick top)
- (1) piece 3/4" plywood, 24" x 48" (16 1/8" x 48" for shelf, use scrap for cleats)
- (8) 3/8" x 4" hex bolts
- (20) 3/8" washers
- (8) 3/8" nuts
- (4) 3/8" x 4" lag bolts
- (16) #8 x 1 1/2" flathead woodscrews
- (100) #8 x 2 1/2" woodscrews or 8d finish nails

DRAWERS

- (4) 1x6's, 96"-long
- (1) 3/4" x 5 1/2" x 96" (hardwood for drawer guide system)
- (1) piece 1/2" plywood, 48 x 48" (for drawer and tray bottoms)
- (18) #8 x 1" flathead woodscrews
- (20) #8 x 1 1/2" flathead woodscrews
- (8) #8 x 4" flathead woodscrews
- (3) drawer pulls w/ screws

OPTIONAL

- (1) woodworking vise (see Sources on page 24 for more information on this)

MATERIALS

BASIC BENCH

A Legs (4)	1 1/2 x 3 1/2 - 32 1/2
B Side Braces (4)	1 1/2 x 3 1/2 - 23
C Upper Leg Fillers (4)	1 1/2 x 3 1/2 - 21
D Lower Leg Fillers (4)	1 1/2 x 3 1/2 - 4 1/2
E Side Brace Fillers (4)	1 1/2 x 3 1/2 - 16
F Fmt. / Back Rails (8)	1 1/2 x 3 1/2 - 48 3/8
G Bench Top (1)	1 1/2 x 30 - 80
H Bottom Shelf (1)	3/4 Ply. - 16 1/8 x 48
I Side Cleats (2)	3/4 Ply. - 1 1/2 x 16
J Fmt. / Back Cleats (2)	3/4 Ply. - 1 1/2 x 42

DRAWERS*

K Drawer Guides (6)	3/4 x 2 1/8 - 22 1/2
L Drawer Stops (3)	3/4 x 1 - 14 1/2
M Drawer Fnt./Backs (6)	3/4 x 4 3/8 - 14 1/2
N Drawer Sides (6)	3/4 x 4 3/8 - 20 1/4
O Drawer Bottoms (3)	1/2 Ply. - 13 1/2 x 20 1/8
P False Fronts (3)	3/4 x 4 3/8 - 16
Q Drawer Runners (6)	1/2 x 3/4 - 22 1/2
R Tray Splines (2)	1/4 x 1/2 - 19 1/2
S Tray Sides (2)	1/2 x 1 3/8 - 9 1/4
T Tray Fmt. / Backs (2)	1/2 x 1 3/8 - 12 1/8
U Tray Bottom (1)	1/4 Ply. - 9 1/8 x 12 1/8

*Material for three drawers and one tray

CUTTING DIAGRAM

BASIC BENCH

2 x 4 - 96" (ONE BOARD)



2 x 4 - 96" (FOUR BOARDS)



2 x 4 - 96" (FOUR BOARDS)



DRAWERS

1 x 6 - 72" (TWO BOARDS)



1 x 6 - 96" (ONE BOARD)



1 x 6 - 96" (ONE BOARD)



3/4" (ACTUAL) x 5 1/2 - 96" (3.7 BD. FT.) HARDWOOD FOR GUIDES AND RUNNERS



ALSO REQUIRES: ONE PIECE OF 3/4" PLY., 24" x 48". ONE PIECE OF 1/4" PLY., 48" x 48"
ONE SOLID-CORE DOOR OR TWO SHEETS OF 3/4" PLYWOOD FOR TOP

END FRAMES



The first step in building the bench is to build the two end frames. To make each frame, begin by cutting two legs (A) to a length of 32½". (Note: This gives you an overall

bench height of about 34¼" when the top is on.) The length of the legs can be varied to fit your height.

BUILDING THE FRAMES. With the legs cut to length, cut the two side braces (B) 23"

long, see Fig. 1. Lay two legs (A) side-by-side and position one side brace (B) 4½" up from the bottom ends. Then place the other brace flush to the top of the legs, see Fig. 1.

Once the pieces are in place, lay out the screw locations, see Fig. 2. Then, drill and countersink ⅜" shank holes in the side braces (B), see Fig. 2a. Now glue and screw the side braces to the legs using No. 8 x 2½" wood screws, see Fig. 2a.

ATTACH THE FILLER PIECES. To strengthen the end frames I added upper (C) and lower leg fillers (D), and two side brace fillers (E), see Fig. 3.

After I trimmed the filler pieces to fit, I clamped the pieces in position while I glued and screwed them in place, see Fig. 3.

BOLT HOLES. All that's left to complete the end frames is to drill and countersink the holes for the bolts that connect the rails, refer to Fig. 7. These holes are 1¾" down from the top edge of the side braces, and centered on the width of the legs, see Fig. 4.

Once the hole locations have been marked, counterbore 1"-dia. holes, ⅜" deep on the outside face of the end frames. Then drill ⅜"-dia. holes centered in the counterbores, see Fig. 4a.

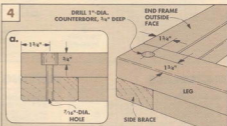
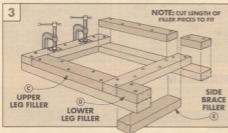
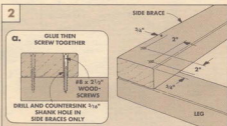
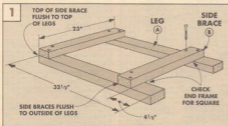

RAILS



After the end frames are built, I made the four rails (F) that run across the front and back of the bench. Each rail is made from two 2x4's laminated together.

BUILD THE RAILS.

To make each rail, start by cutting two 2x4's to a rough length of 50". After the rail pieces are cut to rough length, glue them together to form a 3" x 3½" rail blank, see Fig. 5.

Shop Note: Rather than using clamps, and then waiting for the glue to dry, I screwed the rails together with 2½"-long screws. Be sure to drill shank holes and countersink the

holes before screwing the pieces together, see Fig. 5.

TRIM TO LENGTH. After gluing together all four rails, I trimmed them to a finished

length of 48¾", see Fig. 5. (Note: The only reason for this particular length is so the Tool Cabinet shown in *Woodsmith* No. 50 would fit between the end frames.)

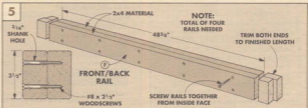

RAIL CONNECTORS

The rails are connected to the end frames with a draw-bolt system. This system not only allows the joint to be tightened if it becomes loose, it's also easy to make and goes together quickly.

POCKET HOLES. The first step is to mark the location of the pocket holes on the rails. The holes are centered on the face of the rails and located $1\frac{3}{4}$ " in from each end, see Fig. 6a. Now, drill a 1"-dia. hole, 2" deep at the marked location. Then, to provide a flat surface for the washer and nut to draw against, square up the edge of the hole nearest the end of the rail, see Fig. 6.

END HOLES. Once the pocket holes have been squared up, I drilled $\frac{7}{16}$ "-dia. holes centered on the ends of the rails, see Fig. 6a. These holes are positioned in the center of

the flat side of the pocket hole.

BOLT TOGETHER. Now the rails can be bolted to the end frames. Just insert a $\frac{3}{8}$ " x 4" hex head machine bolt with a washer. Push the bolt through the countersunk hole in the end frame and into the hole in the end of the rail, see Fig. 7.

Then slip a washer and nut in the pocket hole and tighten the bolt holding the nut with an open end wrench. (See the tip at right for a trick I used to start the nuts.) If the rails won't draw up tight against the end frames, you may want to use the undercutting technique shown in Shop Notes on page 11.

Design Note: To keep the pocket holes from showing, I positioned the rails so these holes faced in toward the center of the bench, see Exploded View on page 5.

SHOP TIP

To help start the nut (in the pocket hole) on the end of the machine bolt, I attached the nut to a small scrap of wood with a piece of double-sided carpet tape.

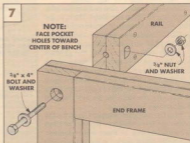
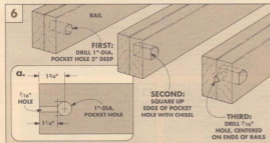
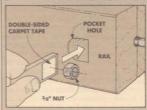

TOP AND SHELF



After the base has been bolted together, all that's left is to attach the top (G) and bottom shelf (H). I used a $1\frac{3}{4}$ "-thick solid-core door as a top. But you could laminate

two pieces of $\frac{3}{4}$ " plywood together instead. **ATTACH THE TOP.** To attach the top (G), turn the top and the base upside down and center the base on the top. Then mark and drill the mounting holes on the bottom side of the top rails, see Fig. 8. Now attach the top with $\frac{3}{8}$ " x 4" lag screws and washers.

INSTALL SHELF. Finally, cut a $\frac{3}{4}$ " plywood shelf (H) to width to fit between the rails. (I used a 48"-long piece to fit between the end frames which are 48 $\frac{1}{2}$ " apart.) Use some left over plywood to make $1\frac{1}{2}$ "-wide shelf cleats (J). Then attach the shelf cleats $\frac{3}{4}$ " down from the top inside edge of the bottom rails and side braces, see Fig. 9a. Note: Don't cover the pocket holes when attaching the cleats so you can get to the draw bolts.

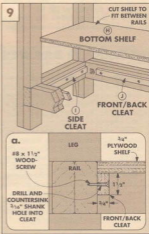
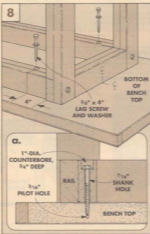

DRAWER GUIDES

After the basic bench was built, I added a set of drawers. The first step here is to build and install the **drawer guides (K)**. For durability, I used hard maple to make the guides, but you could make them out of pine (same as the drawers).

CUT GUIDES TO SIZE. There are a total of six drawer guides made from $3/4$ "-thick stock. However, the two center guides are laminated together, see Fig. 10. To make things easier, I glued up the two center guides to a rough width of $23/4$ ". Then I trimmed the center guides along with the two side guides to a finished width of $221/2$ " and cut them $221/2$ "-long, see Fig. 10.

CUT THE GROOVES. Once the guides are cut to size, grooves are cut to accept the drawer runners, see Fig. 10. I cut these $1/2$ "-deep grooves with a $3/4$ " dado blade.

To cut the grooves, first position the table saw fence $7/8$ " from the blade. Then, to get the $13/16$ "-wide groove centered on the guides, I made two passes, turning the pieces end-for-end after each pass.

MOUNT THE GUIDES. After the grooves have been cut, drill and countersink shank holes at the locations shown in Fig. 10. Then position the side guides so they're flush against the top front rail (F) and screw them to the legs (A) with No. 8 x $11/4$ " flathead woodscrews, see Fig. 11.

With the side guides in place, position the center guides so the three drawer openings are equal, see Fig. 11. Once they're in place, screw the center guides to the top rails with No. 8 x 4" woodscrews, see Fig. 12.

DRAWER STOPS. Finally, I cut **drawer stops (L)** to stop the back of the drawer, see Fig. 13. After building the drawers, screw the stops in position so the back of the drawers hit the stops before the drawer's false front hits the end of the drawer guides.

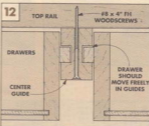
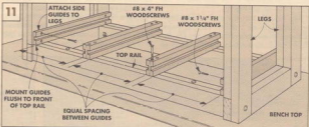
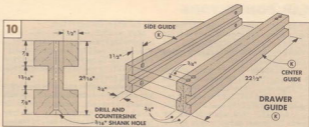

ALTERNATE DRAWER JOINT

As an alternative to using a dovetail joint for the drawers (shown on opposite page), you could use a dado/rabbit corner joint. If you do, the drawer fronts/back (M) are cut 1" shorter ($131/2$ " long), and the sides (N) are cut 1" longer ($211/4$ " long).

This joint is made by cutting a $1/4$ " x $1/4$ " dado on the drawer sides (N), located $3/4$ " in from each end, see Fig. 2. Then, cut the mating $1/4$ " x $1/4$ " tongue on both ends of the drawer fronts and backs, see Fig. 2.

After cutting the joints, cut the grooves for the drawer bottoms. Also cut grooves in two drawer sides for the tray splines.

Complete the drawers by cutting the bottoms (O) to fit. Then glue up the drawers, tacking the corners together, see Fig. 1.

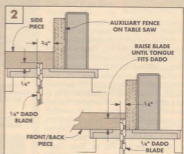
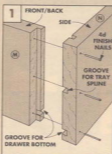

DRAWERS



When the drawer guides are in place, the drawers can be built to fit between the guides. Since these drawers will be subjected to a lot of weight, I built them with dovetail

joints, using a router and the dovetail jig shown in *Woodsmith* No. 58. (For an alternate joint, see the box on the opposite page.)

To build the drawers, start by cutting the fronts/back (M) to length, $\frac{1}{8}$ " less than the distance between the drawer guides and to a width of $4\frac{1}{8}$ ", see Fig. 14. Then cut the sides (N) to the same width and $20\frac{1}{4}$ " long. After the pieces have been cut to size, rout the dovetail joints on the ends of the pieces.

BOTTOM GROOVE. Before assembling the drawer, cut a $\frac{1}{4}$ "-deep groove for the plywood bottom (O), see Fig. 15. The width of the groove is determined by the thickness of the plywood. (In our case this was $\frac{1}{4}$ ".)

TRAY GROOVE. To provide additional storage, I added a tray to one of the drawers, refer to Fig. 17. To make a ledge for the tray to slide on, cut a groove $2\frac{1}{2}$ " down from the top edge of the drawer sides, see Fig. 15.

After the tray groove is cut, assemble the drawers. Then cut the $\frac{1}{4}$ " x $\frac{1}{2}$ " tray splines (R) to fit in the grooves and glue them in place, see Fig. 14.

FALSE FRONTS. The next step is to cut and attach the false fronts (P). Once the fronts are cut, drill and countersink four mounting holes, see Fig. 15. Then position the fronts flush to the bottom of the drawer and centered on the width, and screw them to the drawers, see Fig. 16.

RUNNERS. All that's left to complete the drawers is to cut the $22\frac{1}{2}$ "-long hardwood drawer runners (Q) and mount them so they slide in the drawer guides, see Fig. 16.

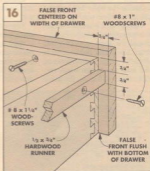
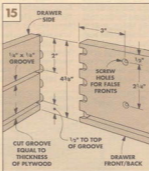
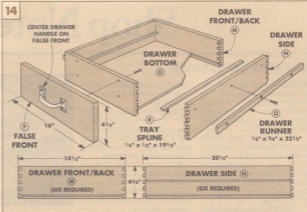

TRAY

It's always aggravating when small tools get lost in the bottom of a large drawer. To keep this from happening, I built a shallow sliding tray for one of the drawers.

THE SIDES. The first step in building the tray is to cut the $\frac{1}{2}$ "-thick, $1\frac{3}{4}$ "-wide tray sides (S) to length, see Fig. 17. Then cut the front and back (T) pieces $\frac{1}{8}$ " smaller than the inside of the drawer. On our tray this was $12\frac{7}{8}$ ", see Fig. 17.

Once the tray pieces are cut to length, the ends can be dovetailed together. (If you use the alternate joint shown on the opposite page, the length of the pieces will be different.) Also cut grooves for the plywood bottom (see Fig. 17a.) and assemble the tray.

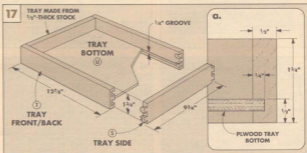

Shop Notes

JIG FOR DOVETAILS

■ When it came time to make the dovetails for the Wall Shelf (shown on page 18), I built a jig to hold the stock so I could accurately align my chisel to chop out the waste sections.

BUILD THE JIG. The jig consists of a base with a guide fence bolted on top, see Fig. 2. I started by cutting the base and the guide fence the same size, see Fig. 1. (Tip: I used double-sided carpet tape to hold the pieces together while cutting.)

While the pieces are still taped together, drill counterbored holes for the bolts that hold the pieces together, see Fig. 1.

FENCE. When using this jig, the workpiece is sandwiched between the base and the guide fence, see photo. But in order to align the chisel to chop down on the base line of the waste sections (refer to Fig. 3), the guide

fence has to be trimmed back so the front edge is exactly in line with the base line.

FRONT STOP. After the guide fence is trimmed back, add a stop to the front of the base, see Fig. 2. I extended this front stop below the base so I'd have a lip to clamp in a vise, see photo.

BOLT IT TOGETHER. All that's left is to attach two $\frac{5}{16}$ " carriage bolts, nuts, washers, and a couple of wing nuts, see Fig. 2. (I used large plastic wing nuts, see Sources, page 24.)

USING THE JIG. After completing the jig, I got down to the fun part: chopping out the dovetails.

To use the jig, slide your workpiece under the fence and push it tight against the front stop. Make sure the front edge of the guide fence is directly above the scribed base line, then tighten down the fence, see Fig. 3.



To chop out the waste sections, place the chisel flat against the fence and chop straight down, see Fig. 3. Next, hold the bevel side of the chisel up on the front edge of the workpiece. Now gently tap out a layer of the waste section, see Fig. 4.

UNDERCUT. To make the next cut, hold the chisel against the

guide fence again, but tilt the handle of the chisel toward you to undercut the shoulder slightly, see Fig. 5. (Undercutting helps the joint pull together.)

When you've undercut half-way through the stock, turn the piece over and start chopping from the other side to finish.

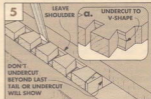
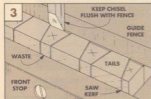
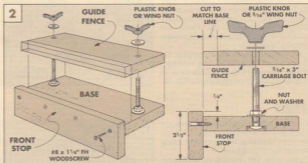
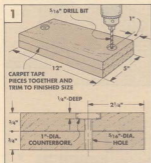



UNDERCUTTING

■ Sometimes it's difficult to get a tight joint line when you butt one piece into another. (Like attaching the rails to the legs on the Workbench shown on page 4.) The problem is both surfaces need to be *perfectly* flat for the joint to pull completely together.

UNDERCUTTING. To avoid problems, I use a technique called *undercutting*. This is simply cutting out a recess on the end of the rails until a small shoulder remains around the perimeter. Since only the shoulder touches the adjoining piece, it's much easier to pull the joint tight, see Fig. 1.

UNDERCUTTING THE ENDS. To undercut the rails on the Workbench, I laid out a $\frac{1}{4}$ "-wide border around the perimeter of

the ends of the rails, see Fig. 2. Then I chopped straight down on this border line with a chisel to score the line $\frac{1}{2}$ "-deep.

CHOP OUT WASTE. Once the border line is defined, the waste can be chiseled away. To do this,

hold the chisel with the bevel facing against the end of the rail. This keeps the chisel from digging in too deeply, see Fig. 2.

To keep the shoulder from breaking off, start the chisel at the border line, paring away the

end grain as you work toward the center of the recess, see Fig. 2a. After the end of the rail has been undercut, attach the rail to the leg. As you tighten the draw-bolt, the joint should pull together without gaps.

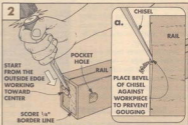
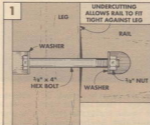

SAWDUST RELIEF

■ Jigs and fences are great for aligning and guiding workpieces. For example, on a table saw if I need to cut several pieces to the same length, I attach a simple fence to the miter gauge, see Fig. 1. Then I clamp a stop block to the fence.

Okay, it's an easy procedure that's almost fool-proof. Almost. There's one little problem that can really mess things up—sawdust or woodchips.

As you're working, sawdust is bound to accumulate along the edge of the fence or at the end of the stop block. Unless you carefully clean it out, it will gradually build up to the point that it will throw off your cut.

RELIEF CHAMFER. There's an easy way to prevent this. I make it a practice to cut a chamfer on the bottom edge of fences and stops. The chamfer gives the sawdust somewhere to go

without having to brush it out of the way all the time.

On the end of a stop block, for example, I cut off the bottom corner. You can cut off as much as $\frac{1}{4}$ "—as long as it's less than the thickness of the workpiece that will be pushed up against it.

I also chamfer off the bottom front edge of the fence about $\frac{1}{8}$ " high to leave space for sawdust to accumulate.

On other equipment that

creates chips of wood in addition to sawdust (like a router table or drill press), I make the chamfer even larger, see Fig. 2.

DOVETAIL SPACERS. Relief chamfers are useful on other jigs as well. When I cut the dovetails on the band saw (see pages 12 to 17), it was important to keep the spacer blocks tight against each other. So I cut chamfers on the bottom edges of the blocks to keep sawdust from building up.

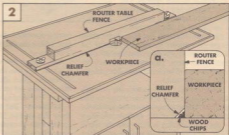
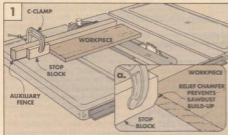

Bandsawn Dovetails

About a year ago, Mark Duginske, a woodworker from Wausau, Wisconsin, dropped by our shop one fall afternoon. He wanted to share with us one of his methods for cutting dovetail joints.

When I first saw Mark's sample dovetail joint, I thought it was cut by hand — or maybe with an expensive router jig such as the Leigh jig. The joint was cut so both the pins and tails were exposed (called a *through* dovetail joint) — and it fit together perfectly.

Mark's system uses a band saw and two jigs — one to hold the board to cut the tails and one to cut the pins. (These are the two interconnecting parts of a dovetail, see drawing below.)

SPACER BLOCK SYSTEM

The basis of the system is a series of spacer blocks. When cutting on the band saw, the blocks space the tail and pin cuts so the two pieces will interlock perfectly. To vary the width of the pins or tails, all you have to do is vary the width of the blocks. Using this system you can create an infinite variety of tail and pin patterns.

CLEAN INITIAL CUTS. The system solves what I consider to be the most difficult part of cutting through dovetails with hand tools — the initial cuts. They have to be straight, square, and to a consistent depth. (For more on dovetail theory and how to cut a dovetail joint by hand, see *Woodsmith* No. 19.)

LAYOUT TIME. There's another advantage to this system. You don't have to spend a lot of time accurately laying out each joint. I usually lay out the first joint so I don't get confused. But then all the other joints (in a drawer for example) can be cut using the same procedure and they will all be exactly the same. This means the parts for the drawers will be interchangeable (side for side, front for back).

WIDTH LIMITATION. As with any dovetailing system, there are limitations to this method. The most obvious has to do with the maximum width of the workpieces. Since some of the cutting is done with the workpiece between the blade and the arm of the



band saw, the pieces can't be too wide. On my 12" band saw, I found that the workpieces couldn't be much wider than 11½".

PREPARATION TIME. Another disadvantage is the time it takes to build the necessary jigs. If you only want to cut dovetail joints for one project, this system may not be worth it. You will have to spend a couple of hours building jigs before you can get started cutting joints. But if you expect to be

the hard part — cutting to a line — and allows me to concentrate on the final fit of the joint.

Note: Before going on, I should explain that what we're presenting here is Mark's basic system. We modified the system and some of the jigs slightly. To read Mark's original approach, pick up a copy of his new book, "Band Saw Handbook" published by Sterling Publishing.

TAILS AND PINS

A through dovetail joint consists of two halves: the tails and the pins. At first it can be a little confusing what is what.

The *tails* look like a dove's tail (hence the name of the joint) when viewed from the side of a drawer (or the side of the Wall Shelf shown on page 18). The *pins* look like rectangles (sort of like a box joint) when viewed from the front or back of the drawer.

To add to the confusion, when viewed from the ends of the boards, the tails look like pins (usually tall ones), and the pins look like little tails. This all may sound confusing now, but it will clear up once you've cut a few dovetail joints.

DIRECTION OF STRENGTH. Okay, which board gets the tails, and which board gets the pins? And does it make any difference? A dovetail joint is *mechanically* strong in only one direction.

If the joint is cut on a drawer, the pins should be cut on the drawer front, see the drawing. Then the mechanical strength of the joint holds the drawer together as it's pulled open. On the Wall Shelf, the pins are cut on the top to hold up the weight of the whole cabinet, and the bottom to help support the drawers.

LAYOUT

Laying out a dovetail joint — the size and placement of the tails and pins — is worth some time and thought. If the layout isn't on the plan, it's best to draw the tails and pins on paper. Then, once you get a layout you like, it can be transferred to the workpieces.

WIDTH OF PIN VS. TAIL. It's a matter of individual preference, but I prefer the pins to

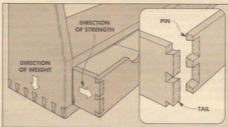

cutting dovetails on other projects in the future, I think the time it takes to build the jigs is well spent.

And, though this system is accurate and flexible, it's not the fastest way to cut dovetails. Even after building the jigs, there's some set-up time and handwork involved. The band saw doesn't do it all.

HANDWORK. But that's what I like most about this system. I find the handwork that comes with chopping out a dovetail joint especially satisfying. This system eliminates

be narrower than the tails. Generally, I like the widest part of the tails to be about four times as wide as the narrowest part of the pins. (This can vary for appearance though.)

ANGLES. The angles of the dovetails is also a matter of personal (visual) preference within limits. The general rule is that the angle should be somewhere between 1:5 (78½°) and 1:8 (83°).

When setting up to cut dovetails on the

band saw, I found it easiest to build the jigs at an 80° angle (or 10° off 90°). This works out to a ratio of about 1:5¼. It's strong enough for most applications and looks nice.

SYMMETRICAL LAYOUT. There's one more thing to consider when laying out dovetails that will be cut using this band saw technique. The layout has to be symmetrical. That is, one half of the layout has to be a mirrored image of the other half. As long as

the layout is symmetrical, you can still vary the width of the individual tails by varying the width of the spacer blocks.

READY TO CUT. After you've decided on the layout, you can transfer it to one end of the board that will have the tails (see the next page). Then you're ready to start cutting your first dovetail joint. (Well, almost. You still have to make the jigs. The first one is explained below.)

AUXILIARY BAND SAW TABLE

You can cut dovetails on your band saw with only two jigs — the tail jig (shown on page 14) and the pin jig (shown on page 16). But I found it difficult to balance these jigs and a long workpiece on my Sears band saw. It only has a 12½" x 14" table.

To solve this problem, I built a 24" x 24" auxiliary table from a piece of ¾" plywood, see Fig. 1. It sits directly on top of the band saw table, refer to Fig. 4. (I found this bigger table useful for other projects as well.)

ADD RUNNER. To hold the auxiliary table in position on the band saw, I glued a ¼"-thick hardwood runner to the bottom of the plywood, see Fig. 1. Cut the runner to width to match the miter gauge slot on your band saw. Then position it so the edge of the auxiliary table will clear the arm on the band saw.

NEWSLOTS. After the runner was attached, I cut a slot in the auxiliary table directly over the runner, see Fig. 1a. This slot (dado) is used to guide a runner that's on the bottom of the tail jig. Since I wanted to use my miter gauge in this slot for other jobs, I cut it the

same size as the slot in my band saw table.

Next, to hold and guide the pin jig, I cut a second slot (groove) the same size and at right angles to the first slot, see Fig. 1.

BLADE SLOT. With the slots cut, set the auxiliary table on the band saw and push it into the blade until an 11"-long slot is cut in the plywood, see Fig. 1.

Both jigs require a stop block. To mount this block, I widened the blade slot to ¼" wide. (Since the runner was already attached, I had to turn the plywood upside down to cut the wider slot on the table saw.)

STOP BLOCK. The stop block stops jigs and workpieces that ride on the auxiliary table.

To make the stop, glue a 2½" x 3" block of 1½" stock to the top of a piece of plywood, see Figs. 1 and 2. Glue the block at one end of the plywood, and then cut the ends of the block and plywood off flush. (I also chamfered the bottom edge as a sawdust relief. For more on this, see page 11.)

To keep the sliding stop block square on the table, cut a ¼"-wide groove in the bottom

of the plywood and glue in a ¼" Masonite runner, see Fig. 2. The runner slides in the blade slot on the auxiliary table.

TURNBUCKLES. The auxiliary table is held down to the band saw table with a couple of turnbuckles. To make the turnbuckles, first resaw spacer blocks just a hair thinner than the thickness of the band saw table, see Fig. 3. (These spacer blocks will be positioned so they just clear the outside edges of the band saw table, see Fig. 4.)

After resawing, drill a counterbored hole in the spacer block to accept a ½" carriage bolt. Now insert the bolt into the hole, and then screw the spacer block to the bottom of the plywood table, see Fig. 3. The carriage bolt head should be captured in the counterbore between the block and the plywood.

The turnbuckles are rectangular pieces of ¾" plywood with a ½" hole drilled off-center, see Fig. 1. To tighten the turnbuckles, you can use a ½" wing nut or a plastic knob. (We're offering the knobs through Woodsmith Project Supplies, see page 24.)

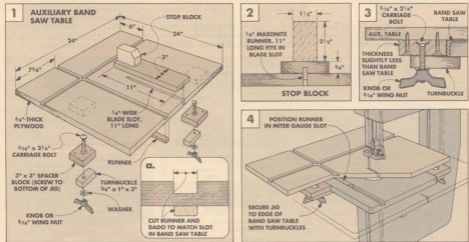

Dovetails: The Tails

Before you begin bandsawing dovetails, there are a few things to do. The workpieces have to be prepared, the band saw tuned up, and a tail jig built.

STOCK PREPARATION

To begin, it's important that any stock to be joined is flat and planed to a uniform thickness.

SQUARE UP ENDS. After you're sure the boards are flat, next square up the ends of the workpieces and cut them to finished size. Then mark the base lines to correspond to the thickness of the matching board, see Step 1 on the opposite page.

BAND SAW TUNE UP

After the stock is prepared, you should spend a few minutes checking that your band saw is tuned up so the cuts will be straight and true. (For information on tuning up a band saw, see *Woodsmith* No. 51.)

BLADE. To cut dovetails, I use a $\frac{1}{4}$ " blade with six teeth per inch. Be sure the blade is sharp and tensioned correctly.

BLADE GUIDES. The most important thing to check is the location of the blade (side) guides — both above and below the table. These hold the blade in line for a straight cut and should be a hair away from the blade. (For more information, see page 23.)

TAIL JIG

Once the saw is tuned up, you can begin building the tail jig. This jig holds the workpiece at the correct position while cutting.



BASE. Start by cutting a $\frac{3}{4}$ " plywood base 15° wide and 24° long, see Fig. 1.

RUNNER. Next, cut a runner to fit in the miter gauge slot in the plywood auxiliary table, see Fig. 1a. Position the runner in a dado on the bottom of the base so the base clears the band saw arm when the runner is in the miter gauge slot.

FRONT FENCE. After the runner is glued in, I screwed a fence on top of the base to hold the miter gauge slot in the plywood auxiliary table, see Fig. 1a. Position the fence, I used my table saw's miter gauge, see Fig. 2.

STOP FENCE. The last part to make is a stop fence. It's a piece of $\frac{3}{4}$ " stock with a squared-off hole cut in it for a C-clamp, see Fig. 3.

CUTTING PROCEDURE

The procedure for cutting the tails is shown in the drawings on the opposite page. Before you cut dovetails on a project, I'd recommend working through the whole process — tails and pins — on some scrap.

LAYOUT. I start by laying out all the tails, see Step 2. (This isn't really necessary since the spacer blocks position the cuts. But

there's security in seeing the cuts being made where they're supposed to be.)

SPACER BLOCKS. Next, cut spacer blocks from $\frac{3}{4}$ " stock that match the distances from the corner of one tail to the same corner on the next tail, see Step 3. This means there will always be one more tail than the number of spacer blocks.

STOP FENCE AND BLOCK. Then position the workpiece on the tail jig and clamp down the stop fence, see Steps 4 and 5. Next, push the jig into the blade until the blade touches the scribed base line and clamp down the stop fence, see Step 6.

Safety Note: On Step 4 we're showing the band saw's guide post high above the workpiece. That's okay when the saw is turned off, but always lower the guard right over the workpiece before turning on the power.

CUTTING. Now it's a matter of adding the spacer blocks one at a time (in alphabetical order) and making cuts, see Cutting Sequence at far right. Then flip the board over and make the second sequence of cuts.

Shop Note: Usually you will be joining both ends of a board with dovetails. To simplify the explanation of the cutting sequence, we're showing only one end. Once you're familiar with the sequence, you can flip the board end-for-end and edge-for-edge before adding each spacer block.

CLEAN OUT WASTE. After both sides of the tails are cut, chip out the waste areas between the tails, see Steps 7 and 8.

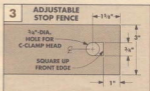
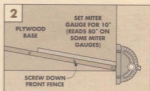
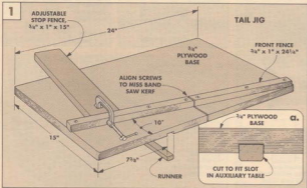

STEP BY STEP



1 Make sure board for tails is true and ends are square. Then set the marking gauge to thickness of board for the pins. Mark the base line on both faces and edges.

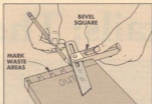

2 For reference when cutting, mark the size and spacing of tails on the end of the board with a pencil and bevel gauge. Then mark waste sections with an "X."

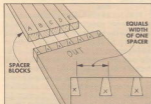

3 To determine the width of each spacer block, measure from upper left corner of one tail to upper left corner of the next tail. Then cut block to size.

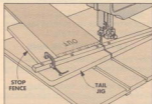

4 Now mount the tail jig on the band saw. Next, set workpiece on the jig and align the first tail with the blade (see Step 5). Then clamp down the stop fence.

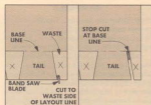

5 For the first cut, align blade with line on the first tail, left drawing. Then push the jig (and workpiece) into blade and stop at scribed base line, right drawing.

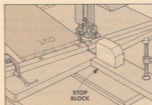

6 Next, clamp the stop block down to the auxiliary table with a C-clamp. Then follow the cutting sequence in box at right. Between cuts, add the spacer blocks.

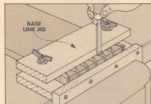

7 To chop out waste between the tails, I use the base line jig shown on page 10. Work from both sides of the board and undercut toward the center (see page 10).

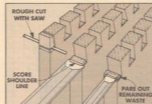

8 Finally, rough cut area outside the last tail $\frac{1}{8}$ " oversize. Then score the shoulder with a wide chisel (left) and pare out the waste with a narrow chisel (right).

CUTTING SEQUENCE

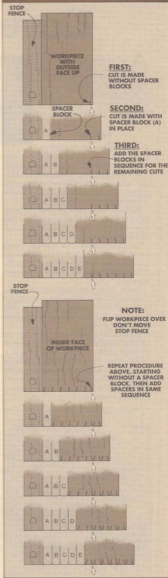

Dovetails: The Pins

After you've finished chipping out the waste areas between the tails, the next step is to cut the pins on the other board to fit in those areas. The challenge is getting all of the pins to fit perfectly — not too tight or too loose.

PIN JIG

To cut the pins, there's one last jig to make — the pin jig. It holds the workpiece at an angle that matches the tail angle.

CUT TWO SQUARES. The jig is made from two squares of $\frac{3}{4}$ " plywood with angled wedges between them, see Fig. 1. I started by cutting the two squares $12" \times 12"$.

RUNNER. Next, cut a $20"$ -long runner to attach to the bottom of the jig, see Fig. 1. This runner fits in the groove cut across the auxiliary table (perpendicular to the blade).

To hold the runner, cut a $\frac{1}{4}$ "-deep dado centered on the bottom of one of the plywood squares. Now glue the runner into the dado so an $8"$ -long tongue sticks out one end, see Fig. 1.

FENCE. After the runner is glued on, the next step is to glue a fence along one edge of the top plywood square, see Fig. 1a. This fence keeps the workpiece and all the spacer blocks in position.

WEDGES. The last pieces to cut are the $12"$ -long wedges, see Fig. 1. I cut these off the ends of a piece of plywood, see Fig. 2.

Shop Note: To cut a tight-fitting dovetail joint, the pin angles must be the same as the tail angles. The easiest way to make sure they're the same is to set the miter gauge off the tail jig, refer back to Fig. 2 on page 14.

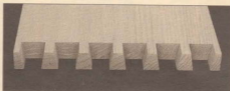

ASSEMBLY. Once the wedges are cut, glue them between the two plywood squares to create the angled jig, see Fig. 1.

LAYING OUT THE PINS

After the pin jig is built, you're finally ready to start the last step — laying out and cutting the pins.

Start by setting the marking gauge to the thickness of the board for the tails and mark base lines on both faces.

MARK CUT LINES. Next, use the tails in the first board to mark the cut lines for the pins on the second board, see Step 1 on the opposite page. (Shop Tip: Clamping a small backer board along the base line helps hold the pieces in position.)

Then, to keep everything straight, I mark the waste areas (the areas where the tails will fit into) with an "X".

CUTTING THE PINS

After the layout is complete, you can mount the pin jig on the band saw, see Step 2. Then align the jig so the blade cuts in the waste area, right next to the line marking that area, see Step 3.

SET STOP BLOCK. Next, set the stop block

to keep the cut from going too deep, see Step 4. (Note: The pin jig doesn't move towards the blade like the tail jig. The workpiece slides forward on the jig.)

MAKE THE CUTS. Now it's just a matter of making all of the angled cuts using the same spacer blocks as when cutting the tails, see Cutting Sequence Box.

TURN JIG AROUND. After all of the cuts are made in one direction, turn the jig around and align the blade clearly in the waste area, see Step 5. Then repeat the process of adding spacer blocks and making cuts. After the cuts are complete, chop out the waste between the pins as you did with the tails.

TRIM TO FIT. The most important step is the next one. Check how the pins and tails fit together, see Step 6. Then, if necessary, tap the pin jig over to trim a little more off the sides of all the pins, see Step 7. (Note: It's easy to take too big of a cut, so just barely move the jig.) Continue sneaking up and cutting until the fit is perfect.

ASSEMBLY

Now comes the fun part. Tap the joint together and check the final fit, see Step 8. When the joint fits properly, it can be glued up to finish the project you're working on.

CLEANING UP. Once the joint is together, the end grain of the pins and tails may stick above the face of the boards, or be recessed. If the end grain sticks above the surface, file the pins or tails flush. If it's recessed, use a plane to shave the face of the boards down to the end grain of the pins and tails.

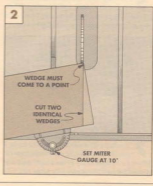
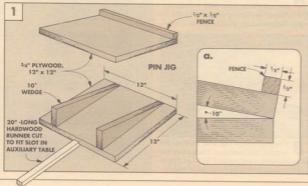

STEP BY STEP

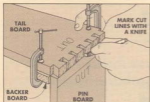

1 To lay out pins, first mark base lines on both faces. Then hold tail board on the end of pin board and mark cut lines with a knife. Mark waste areas with "X's".

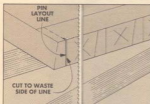

3 Note the position of the blade in relation to the layout line. The blade should cut in the waste area so the layout line is just barely "saved."

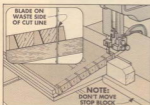

5 Next, turn the pin jig around so angle faces opposite direction. Then align blade alongside the layout line, but clearly in the waste area. Clamp down jig.



7 To trim off just a hair more, keep the pin jig clamped to the auxiliary table and tap the jig with a mallet. You should be able to move it a little without unclamping.

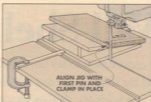

2 Mount pin jig and workpiece (outside up) on band saw. Align jig so blade will cut in waste next to first pin (see Step 3). Then clamp down tongue of jig.



4 Now push workpiece into blade and stop at the base line. Then clamp down the stop block and make cuts shown in cutting sequence at top of box on right.

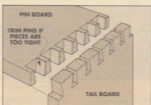

6 After completing cutting sequence, chop out waste area, then check how pins and tails fit. If they're too tight you can trim a hair more off the pins, see Step 7.

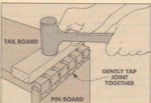

8 After the pins fit into the areas between the tails, the joint can be tapped together. Use a backing board for even pressure and to prevent splitting.

CUTTING SEQUENCE

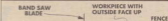

FIRST: MAKE FIRST CUT WITHOUT SPACER

SECOND: ADD SPACER (A) AND MAKE CUT

THIRD: CONTINUE TO ADD SPACERS UNTIL ALL CUTS FACING ONE DIRECTION ARE COMPLETED

WORKPIECE WITH OUTSIDE FACE STILL UP

TURN JIG SO ANGLE FACES OPPOSITE DIRECTION

FIRST: MAKE CUT WITHOUT SPACER BLOCKS

SECOND: ADD SPACER BLOCKS AND MAKE CUTS IN THE SAME SEQUENCE AS ABOVE

THIRD: ADD SPACER BLOCKS AND MAKE CUTS IN THE SAME SEQUENCE AS ABOVE

FOURTH: ADD SPACER BLOCKS AND MAKE CUTS IN THE SAME SEQUENCE AS ABOVE

FIFTH: ADD SPACER BLOCKS AND MAKE CUTS IN THE SAME SEQUENCE AS ABOVE

Wall Shelf

This is the perfect opportunity to try out handsawn dovetails. Even if you don't build the shelf, check out the unique hidden hanging system that holds the shelf on any wall.



This wall shelf is a great way to try out the technique of cutting dovetails on a band saw (see page 12). The four sides of the shelf, as well as the drawers, are all joined with dovetails.

A word about dovetails. Dovetails are an age-old joinery technique. Yet, they seem right at home on contemporary furniture, especially those pieces with very simple lines that allow the dovetails to be accented. The wall shelf is an ideal candidate for dovetails. The joinery provides a nice touch of decoration — and it's a subtle way to show off your craftsmanship.

THE DRAWERS. I also used dovetails to make the three drawers that fit in this wall shelf. However, with the drawers closed, what you see on the front of the drawer doesn't look like a dovetail — it looks more like a box joint (see the photo above). You have to open the drawer to see the characteristic dovetail shape on the drawer's sides.

HANGING SYSTEM. Besides dovetails, this shelf offers another interesting challenge — hanging it on the wall once it's done. Of course, if you use screws or any type of anchor devices, you'll want to drive them into wall studs. Not an easy task. Even if you can locate the studs, there's only a slim chance they'll be in the right location for hanging the shelf.

Instead, I mounted the shelf by hanging it on a long cleat that is in turn mounted to the wall. The nice part is that the screws can be located anywhere along the length of the cleat. Then the whole system is hidden from view so you don't see any screw heads or even the cleat. (For more on the hanging system, see page 21.)

WOOD AND FINISH. The shelf shown here is made from red oak and finished with two coats of McCloskey's Heirloom Eggshell Varnish. The combination of oak and a matte finish enhances the contemporary look of the shelf design.

EXPLODED VIEW

OVERALL DIMENSIONS :
16" H x 36" L x 81 1/2" D

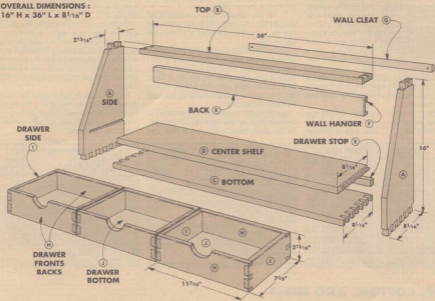

SIDE LAYOUT

DRAWER LAYOUT

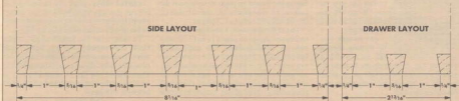

MATERIALS AND SUPPLIES

WOOD PARTS

SHELF

A Sides (2)	3/4 x 8 1/2 - 16
B Top (1)	3/4 x 2 1/2 - 36
C Bottom (1)	3/4 x 8 1/2 - 36
D Center Shelf (1)	3/4 x 8 1/2 - 36
E Back (1)	3/4 x 2 1/4 - 34 1/2

HANGER SYSTEM

F Wall Hanger (1)	1/2 x 3/4 - 34 1/2
G Wall Cleat (1)	1/2 x 1 1/8 - 34 1/2

DRAWERS

H Dr. Frts/Backs (6)	1/2 x 2 1/2 - 11 1/2
I Dr. Sides (6)	1/2 x 2 1/2 - 7 1/2
J Dr. Bottoms (3)	1/8 ply. x 7 1/2 - 11 1/2
K Drawer Stop (1)	3/4 x 9/16 - 34 1/2

SUPPLIES

- 8.2 Board ft. 3/4"-thick oak
- 4.1 Board ft. 1/2"-thick oak
- 12" x 24" piece 1/4" plywood
- McCloskey's Eggshell Varnish

CUTTING DIAGRAM

3/4" x 8 1/2" - 72 (4.1 Bd. Ft.)

A A C

3/4" x 8 1/2" - 72 (4.1 Bd. Ft.)

D

1/2" x 8 1/2" - 72 (4.1 Bd. Ft.)

F H H H H H H H H H

I I I I I I I I I I I I I I I I

K

*DRAWERS REQUIRE 12" x 24" PIECE OF 1/4" PLYWOOD

SIDES



I started building the wall shelf by making the two sides (A). Cut these pieces $8\frac{1}{16}$ " wide (to accommodate the dovetail layout) and to a length of 16". (The angled front edge of these side pieces will be cut off later.) If you don't have flat, wide boards, build up the width by edge-gluing some narrower pieces.

STOPPED DADO. Before cutting the dovetail joints, I routed a stopped dado for the center shelf (D). This dado is stopped

about 1" from the front edge of both side pieces so it doesn't show.

To cut the stopped dadoes, mount a $\frac{1}{4}$ " straight bit in the router table and set it to cut $\frac{3}{16}$ "-deep. Position the fence $\frac{3}{8}$ " from the bit, see Fig. 2.

Since this is a blind cut (the bit is under the workpiece and you can't see where it is), I put a reference mark on the router table fence at the center of the bit, see Fig. 2. Then I put another mark on the workpiece 1" from the front edge to indicate the stopping point for the dado, see Fig. 2.

ROUTING THE DADOES. To rout the dado in the side piece for the right side of the shelf, lay the piece down on the router table and

push it through the straight bit, stopping when the two reference marks are aligned, see Fig. 2.

However, for the piece on the left side, you have to make a plunge cut. Turn on the router and slowly lower the workpiece onto the turning bit. You have to lower it so the reference marks align when the piece is flat on the table. Then push the workpiece across the router table moving from right to left, see Fig. 3.

Shop Note: Although you can accomplish the same thing by routing from left to right, I wouldn't recommend doing it that way. The rotation of the bit can pull the workpiece away from the fence.

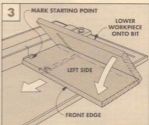
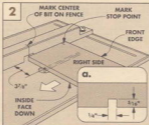
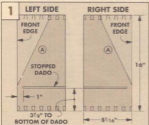

TOP, BOTTOM, AND SHELF



After the dadoes are routed in the side pieces (A), you can cut the top (B) and bottom pieces (C) to finished size.

CUT TO SIZE. Start by ripping the top (B) to a width of

$2\frac{3}{16}$ ", see Fig. 4. Then rip the bottom (C) to match the width of the side pieces ($8\frac{1}{16}$ " wide). As for length, cut both pieces to a uniform length of 36".

DOVETAILS. With the pieces cut to size, you can lay out the dovetail joints. I followed the layout shown on page 19 laying out the tails on the side pieces (A) and the pins on the top (B) and bottom (C) pieces.

To cut the dovetails, I used the band saw technique shown on pages 12 to 17. There's only one small problem. The angle hasn't been cut off the front edge of the side-pieces yet, refer to Fig. 1. But I found it easiest to lay out and cut the tails all the way across the side pieces to prevent confusion. (You don't have to chop them all out. Just chop out the

three waste areas on the side pieces for the pins on the top piece.)

CENTER SHELF. After the dado joints are cut, you can begin work on the center shelf (D). Start by cutting the shelf the same width ($8\frac{1}{16}$ " as the sides (A), see Fig. 4.

To determine the length of the center shelf, dry-assemble the top, bottom and sides. Then measure the inside distance between the sides. (In my case, this was $34\frac{1}{2}$ ".) Then add $\frac{1}{2}$ " for the $\frac{1}{4}$ "-long tongues on each end of the center shelf and cut the shelf to length ($35\frac{1}{2}$ " long).

CUT TONGUES. To make the tongues at the ends of the center shelf, I cut rabbets on the top and bottom faces of the shelf with a dado blade, see Fig. 5. Sneak up on the height of the blade until the tongue fits snugly into the dado in the side pieces (A).

TRIM TONGUE. Since the dadoes on the side pieces are stopped, you have to trim the tongues back, see Fig. 6. To do this, score the front edge with a chisel, and then pare back the tongue just like you did when cutting the dovetails (refer to Step 8 on page 15).

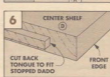
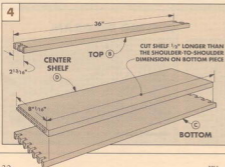

ASSEMBLY

At this point all the joinery is complete. All that remains is to mark and cut the angles off the front edge of the side pieces (A).

MARK ENDS. To mark the angles, first dry-assemble all of the pieces. Then mark a point X where the bottom edge of the top piece (B) meets the side pieces (A), see Fig. 7. Mark a point Y where the top edge of the center shelf

(D) meets the side pieces. Now, disassemble the pieces and draw a line between the marks.

CUT OFF ANGLE. Once the angles are marked, cut just shy of the line with the band saw, see Fig. 8. Then plane to the line with a hand plane.

ASSEMBLY. Now the wall shelf can be

glued and clamped, see Fig. 9. (Don't over-tighten or the top piece might bow.)

CLEAN-UP JOINTS. After the glue dries, remove the clamps and check the joints. If the pins and tails stick above the surface of the boards, plane or sand them off flush. If they're slightly recessed, use a plane to shave the boards down to the pins and tails.

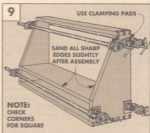
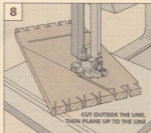
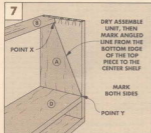

INVISIBLE HANGER

To mount the shelf to the wall, I used a hidden hanging system. It consists of two beveled strips that interlock and permits the mounting screws to be located anywhere (so they can screw into the wall studs).

BACK. Start by cutting a shelf back (E) to a rough width of 3" and to length to fit between the shelf sides (A), see Fig. 1.

To accommodate the hidden strips, first cut a 2½"-wide groove in the back face of the shelf back (E). I cut the groove by making repeat passes over a dado blade, see Fig. 2.

Then cut this piece 2¼" wide to produce an L-shaped piece, see Fig. 3.

HANGER. The shelf actually hangs on two ½"-thick inter-

locking strips — a hanger and a wall cleat. To make the hanger (F), cut a piece about 2" wide and the same length as the back (34½"). Then bevel-rip off a ¾"-wide strip, see Fig. 4.

CLEAT. Now follow the same procedure to make the 1½"-wide wall cleat (G), see Fig. 5.

ASSEMBLY. Next, glue the hanger (F) to the top back face

of the back piece (E). Face the bevel toward the back piece, see Fig. 1a.

Once the glue dries, glue this unit under the top (B) of the wall shelf, see Fig. 1.

WALL MOUNTING. Next, screw the cleat (G) to the wall studs. Then set the shelf over the cleat so the beveled strips interlock, see Fig. 1a.

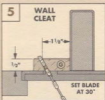
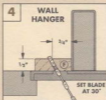
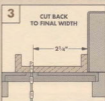
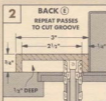
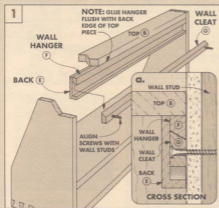

DRAWERS



After building the basic wall shelf, I built three drawers to fit the opening between the center shelf and the bottom. The three drawers are simply open boxes with through dovetail corner joints.

CUT THE PIECES. Start building the drawers by cutting the $\frac{1}{2}$ "-thick drawer fronts/back (H) and drawer sides (I) to a width $\frac{1}{16}$ " less than the height of the opening. In my case, I cut these pieces $2\frac{3}{16}$ " wide, see Fig. 10.

As for length, cut the sides (I) $7\frac{3}{8}$ " long. To determine the length of the fronts/back (H), measure the inside opening on the shelf ($34\frac{1}{2}$ ") and subtract $3\frac{1}{2}$ " (to allow space between the drawers). Then, to determine the length of one front/back piece, divide by three ($11\frac{1}{3}$ ").

DOVETAILS. After cutting the drawer pieces to size, I cut the dovetails following the Drawer Layout shown on page 19. To use the band saw method described on pages 12 through 17, you only need one $1\frac{1}{2}$ "-wide spacer block. (Note: The $\frac{1}{2}$ " thickness of the drawer parts doesn't effect the basic procedure for cutting the dovetails, just the location of the base lines.)

FINGER HOLE. After cutting the dovetail joints, lay out and bandsaw an off-set $1\frac{1}{4}$ " radius finger hole on the top edge of each

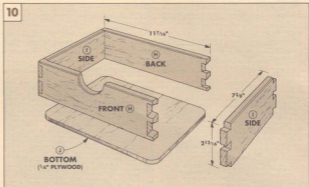

drawer front, see Fig. 11. Then, to make it smooth for fingers, file down the *inside* edge of the hole, see Fig. 11a.

Now glue and assemble the drawers, and check for square.

DRAWER BOTTOM. The drawer bottom (J) fits in a rabbet routed in the bottom edges of the drawer, see Fig. 12a. To do this, mount a $\frac{3}{8}$ " rabbet bit on the router table and move the assembled drawer around the bit in a clockwise direction, see Fig. 12. (Note: The depth of the rabbet should be slightly deeper than the thickness of the plywood bottom.)

Now cut the drawer bottoms from $\frac{1}{4}$ " plywood (it's usually a little less than $\frac{1}{4}$ " thick), and round the corners to fit in the rabbets, see Fig. 13. Then glue the bottoms in place.

CHAMFER. With the drawer bottoms in place, I softened all the edges of the drawers with a $\frac{1}{16}$ " chamfer, see Fig. 14.

DRAWER STOP. The last step is to add the drawer stop (K), see Fig. 15. It's simply a $\frac{3}{4}$ " x $\frac{3}{8}$ " strip glued to the shelf bottom (C) at the back of the opening. Position the strip so the drawers stop about $\frac{1}{8}$ " back from the front edge of the shelf, see Fig. 15a.

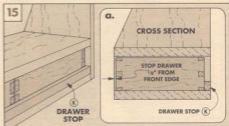
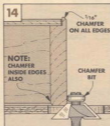
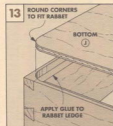
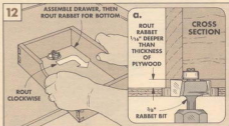
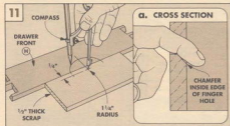

Talking Shop

PLYWOOD FOR JIGS

■ One question that comes up frequently is what material to use to make jigs. Most of the jigs in our shop are made out of plywood. Plywood is flat, consistent in thickness, and dimensionally stable — ideal for jigs.

SOFTWOOD PLYWOOD. Almost everyone has some softwood (fir or pine) plywood left over from a building project. It's so readily available and inexpensive, that it's tempting to use it for jigs.

But softwood plywood has so many voids in the inner plies (layers) that the edges aren't very smooth. On a jig you want smooth edges for workpieces to run against or to act as stops.

A second problem is that the face veneers are often covered with knots, defects, and raised grain. It's difficult to push a workpiece over such a surface.

HARDWOOD PLYWOOD. The alternative is to use plywood with a harder face veneer. Most of the jigs I've built are made from 3/4" birch or maple plywood. Both of these are clean and relatively void-free. But they can be expensive. Unless you have some scrap left over from a project, it's expensive to buy it just for jigs.

Currently, a local home center sells 3/4" birch plywood for \$34.99 a sheet as opposed to \$18.99 for softwood plywood.

BALTIC BIRCH. You might have noticed that the jigs shown in this issue are made from a special kind of hardwood ply-

wood — Baltic Birch from the Soviet Union. This is what I consider a "Cadillac" material for building jigs. (Before going on, let me say that these jigs do not have to be built from Baltic Birch. Any plywood will work.)

Baltic Birch plywood is built up of many thin (about 1/16" thick), consistent layers of veneer. The 18mm-thick (about 3/4") Baltic Birch is made up of thirteen layers versus seven layers for 3/4"-thick American plywood, see photo. This makes the edges clean enough to use as a finished edge on some projects.

The white birch face veneers are slightly less than 1/16" thick, but considerably thicker than on American hardwood plywood. This allows for some additional sanding on the surface.

"Baltic Birch is a unique product consisting of one piece face and inner plies," explains Mark Aquino, of Allied International, the sole importer of Baltic Birch since 1967. "It's virtually void-free. You won't hit a seam or knot, and the multi-ply edge gives it a decorative appeal."

APPLEPLY. About four years ago States Industries of Eugene, Oregon started manufacturing an American version of Baltic Birch called ApplePly.

Bill Powell, Market Development Manager explains that since they were competing with Baltic Birch they would sell their product to be "as American as

ApplePly" (hence the name).

ApplePly consists of 1/16"-thick core veneers of western red alder (not apple). For the face veneers, States Industries offers just about any domestic hardwood (most commonly maple and birch) in typical 1/32" (or less) thickness.

DIMENSIONS. Since Baltic Birch is imported, its dimensions are metric. Thicknesses range from 3mm (about 1/8") to 18mm (about 3/4"). And the sheet size is unusual to Americans — 5 feet by 5 feet. ApplePly's dimensions are familiar — 1/4", 3/8", 1/2", 5/8", and 3/4" thicknesses and 4 x 8 foot sheets.

PROS AND CONS. The advantage of both products is the large number of thin laminations of solid clear veneers. This makes the edges clean and the panels strong and stiff (especially after dadoes are cut in them). They also hold screws better than standard plywood.

The large number of layers also creates a few disadvantages. When you get that many layers in a panel, you might get some movement (warp) in the panel. I've had problems with both of these products warping, especially in thinner thicknesses. (But not much more than is typical of any thin standard hardwood plywood.)

In the manufacturing process it takes a long time to lay up all those layers, so the price is

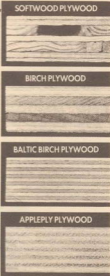

higher. Locally, a 3/4"-thick sheet (5 ft. x 5 ft.) of Baltic Birch sells for \$57.60 (\$2.30 a sq. ft.). A sheet (4 ft. x 8 ft.) of ApplePly sells for \$68.00 (\$2.12 a sq. ft.). This compares to \$1.09 a sq. ft. for standard birch plywood.

AVAILABILITY. Baltic Birch and ApplePly aren't available at every lumber yard. But both are distributed nationwide and can be found at some retail outlets.

For more on obtaining Baltic Birch or ApplePly, see page 24.

BAND SAW SIDE GUIDES

■ When setting up the band saw to cut dovetails (pages 12 to 17), the most important step is getting the side guides adjusted just a hair away from the blade.

COOL BLOCKS. Mark Duginske recommends replacing the standard side guides with "Cool Blocks." These are made from a

phenolic plastic laminate material. To cut down on friction, the blocks are impregnated with dry graphite lubricants.

The advantage of using Cool Blocks is that you can adjust them so they lightly touch the blade. Then, when you turn on the saw, the blade opens up a

very slight canal through the blocks, and the blade can't move very far out of line. (The canal is cut since the blade is thicker at the weld, and the band saw's wheels might be out of round.)

ADJUSTMENT. One problem we've noticed with the Cool Blocks is they tend to wear

quickly. So you need to readjust them periodically. (You can resurface them with a file or sandpaper.) To get the accuracy I wanted for the dovetails, I adjusted the guides about every 15 minutes of cutting time.

For information on ordering Cool Blocks, see page 24.

Sources

WORKBENCH VISE

When we finished the Workbench (shown on page 4), we started looking for a good cast iron woodworking vise to mount to the front of the bench.

One of the best-known names in vises is Record. These vises are made in England and have a sound reputation for quality.

In addition to Record vises, two other manufacturers have entered the market in the U.S. One is Cambridge Tool Company of Canada which also offers a full line of vises (similar to those made by Record). And recently Jorgensen (famous for its line of clamps) has introduced a woodworking vise.

We looked at the vises available from these three companies, as well as some "generic" vises (probably from Taiwan or China) that are offered by some catalog companies.

We narrowed our choices down to vises that fall into a mid-size and price range.

We would suggest a vise like the Record #52D which has heavy-duty cast jaws and steel guide rods. The Jorgensen vise also falls in this category as well

as two Cambridge vises. (See box below for catalog sources of these and other vises.)

Basically you want a vise that has fairly large jaws (7" wide or larger) to hold lumber either vertically or horizontally.

Some models come with a quick-release feature that adds only a small amount to the cost but sure makes working with the vise a lot easier.

Although there are a number of vises that are well suited for the Workbench, we chose two vises to make available from **Woodsmith Project Supplies**. Both vises are made by Cambridge Tool of Canada.



A good basic vise for the Workbench is the one shown at right in photo above. It has cast iron jaws that are 7" wide by 3" high and open to 3 1/4" (between the two hard maple jaw faces included with the vise).

Basic Vise

•766-103 Basic Vise ... \$64.95

If you're looking for more than just a basic vise, I'd choose one that has a quick-release mechanism, like the one shown on the left in the photo. To loosen the front jaw, just give the handle a half-turn counter-clockwise and you can slide the front jaw all the way in or out.

The jaws on this vise are 7" x 3" and open to 7 3/4" (between the hard maple jaw faces included). It also has a solid brass pop-up dog in the top of the front jaw.

Instructions for mounting are provided by Cambridge. Mounting hardware is not included. (All you need is four bolts.)

Quick-Release Vise

•766-101 Large Vise with Quick-Release \$79.95

BALTIC BIRCH AND APPLEPLY

In Talking Shop, page 23, we talked about two unique plywood products, Baltic Birch and ApplePly.

To find a local distributor or dealer for Baltic Birch, you can call Allied International toll free at (800)343-9074.

To find a local distributor or dealer for ApplePly, you can call States Industries toll free at (800)537-0419.

COOL BLOCKS

In Talking Shop, page 23, we talked about replacing the guide blocks on your band saw with Cool Blocks.

These graphite impregnated, phenolic laminated blocks are available to fit a number of different band saws. They are sold in sets of four: two for the upper and two for the lower guides.

Cool Blocks are available from the Garrett Wade catalog, see the address below.

WING NUTS

Wing nuts are great for making any sort of jig that has a moveable section or fence you have to adjust and re-tighten.

We found some large plastic wing nuts with brass threads. These nuts are almost 3" in diameter, which makes working with them a joy. (They're shown on the base line holding jig on page 10.)

Wing Nuts

You can order large wing nuts from **Woodsmith Project Supplies**. The brass threaded insert in each nut is sized for a 5/8" dia. bolt. Packaged in a set of four.

•766-210 Large Wing Nuts, Package of Four \$5.95

ORDER INFORMATION

BY MAIL

To order by mail, use the form on the protective cover of a current issue or write your order on a piece of paper, and send it with your check or money order. (Please include \$1.50 shipping charge with each order.) IA residents add 4% sales tax. Send order to:

Woodsmith Project Supplies
P.O. Box 10350
Des Moines, IA 50306

BY PHONE

For faster service use our Toll Free order line. Phone orders can be placed Monday through Friday, 8:00 AM to 5:00 PM Central Standard Time.

Before calling, have your VISA or Master Card ready.

1-800-444-7002

*Allow 4 to 6 weeks for delivery.
Note: Prices subject to change after September, 1990.*

ALTERNATE CATALOG SOURCES

Similar hardware and supplies may be found in the following catalogs. However styles and sizes may vary. Please refer to each catalog for ordering information.

Garrett Wade Tools
161 Ave. of the Americas
New York, NY 10013
Vises, Cool Blocks

Grizzly Imports, Inc.
P.O. Box 2069
Bellingham, WA 98227
Vises

Shopsmith
3931 Image Drive
Dayton, OH 45414
Vises

Woodworker's Supply
5694 Alameda Place N.E.
Albuquerque, NM 87113
Vises

Woodcraft Supply
P.O. Box 1686
Parkersburg, WV 26102
Vises

Woodworkers' Store
21801 Industrial Boulevard
Rogers, MN 55374
Vises, ApplePly