

TABLE SAW  
TECHNIQUES

**TOUGH CUTS MADE EASY**  
SMALL PIECES—NO PROBLEM

# ShopNotes

Vol. 15 Issue 90

www.ShopNotes.com

## HOW TO GET THE MOST OUT OF A **PLUNGE ROUTER**

**20 COOL TOOLS**  
UNDER \$50

**PUT AIR POWER**  
TO WORK IN YOUR SHOP

**5 EASY STEPS**  
FOR PANIC-FREE GLUE-UPS

**PLUS!**

**3 ALL-NEW  
SHOP PROJECTS**

**SHOP-BUILT  
LAYOUT TOOL** pg. 34

**3-IN-1 PORTABLE  
MULTI-TOOL** pg. 28

**ROLL-AROUND  
WORK CART** pg. 18

▲ Build this no-fuss  
mortising jig pg. 11



A Publication of August Home Publishing

# Contents

## Features

### storage solutions

#### Roll-Around Work Cart 18

A "shop-in-a-box" perfectly describes this roll-around work cart. With eight drawers and open shelves with easy access, everything is right where you need it. Plus, the large work surface comes in handy for all kinds of shop tasks.

### weekend workshop

#### 3-in-1 Multi-Tool 28

This router table packs a lot of big-time features into a compact package. Using an ordinary palm router, you can accurately rout, mortise, and joint both small and large workpieces.

### fine tools

#### All-Purpose Layout Tool \_\_\_\_\_ 34

Featuring a set of replaceable keys, this layout tool serves a wide range of uses — whether you're laying out dovetails or mortises, or checking the thickness of freshly planed stock.

### in the shop

#### Putting Air Power to Use in the Shop \_\_\_\_\_ 38

Tired of tangled and in-the-way air hoses? Make using your compressor more efficient by piping your shop for air. Here's what you need to know to set up a compressed air system.

## Departments

#### Readers' Tips \_\_\_\_\_ 4

### router workshop

#### Using a Plunge Router 8

A plunge router is a versatile tool. Learn what you need to know to get the most out of it.

### materials & hardware

#### Tool Steel \_\_\_\_\_ 12

Does the type of steel in your chisels or plane irons really make a difference? Here's the answer.

### jigs & accessories

#### "Ultimate" Drilling Guide \_\_\_\_\_ 14

Accurately installed hardware or perfectly spaced shelf pin holes — it's a snap with this precision drilling guide.



Using a Plunge Router page 8



3-in-1 Multi-Tool page 28



All-Purpose Layout Tool page 34

# Cutoffs



Roll-Around Work Cart

page 18

## Shop Short Cuts 16

*Shop-tested tips and techniques to solve your woodworking problems.*

**hands-on technique**

## Gluing Up a Panel 26

*Take the hassle and worry out of gluing up a flat panel with our simple, five-step process.*

**setting up shop**

## 5 Space-Saving Worksurfaces 42

*Need an extra worksurface? We feature five ideas that will work in any size shop.*

**mastering the table saw**

## Tough Cuts Made Easy 44

*Cutting small parts on the table saw can be quite a challenge. These tips and techniques provide solutions for doing it easily and safely.*

**great gear**

## 20 Cool Tools for Under \$50 48

*You're sure to find the perfect gift in this collection of stocking-stuffers.*

## Sources 51

**W**hen I bought my first router, it was a very basic tool. Not much more than a small motor with a couple handles attached. So, I was always looking for ways to make that router do more and work harder.

Now it seems like an endless array of routers are available, from heavy-duty plunge models to tiny powerhouses you can hold in the palm of your hand. Even though routers have improved, I still look for ways to make them work harder.

In this issue, we're featuring a couple articles that do just that. Beginning on page 8, we'll show you tips on choosing and using a plunge router. And we've included a simple jig to help you get more out of this versatile tool.

If small routers are more your style, be sure to check out the article on page 28. We'll show you how to turn a palm router into a 3-in-1 multi-tool.

*Tom*



This symbol lets you know there's more information available online at [www.ShopNotes.com](http://www.ShopNotes.com)

STATEMENT OF OWNERSHIP, MANAGEMENT, AND CIRCULATION (Required by 39 U.S.C. 3685)																																																						
	Average no. copies each issue during preceding 12 months	Average no. copies of single issue published nearest to filing date																																																				
1. Publication Title: ShopNotes 2. Publication No.: 1062-9416 3. Filing Date: August 17, 2004 4. Issue Frequency: Bi-monthly 5. No. of issues published annually: 2 6. Annual subscription price: \$12.00 7. Complete mailing address of business office of publisher: 2200 Grand Avenue, Des Moines, IA 50312 8. Complete mailing address of the headquarters or general business office of the publisher: 2200 Grand Avenue, Des Moines, IA 50312 9. Full names and complete mailing addresses of publisher, editor, and managing editor: Publisher: Donald S. Pfaendtner, 2200 Grand Avenue, Des Moines, Iowa 50312 Editor: Terry Davidson, 2200 Grand Avenue, Des Moines, Iowa 50312 10. Owner: ShopNotes Publishing Company, 2200 Grand Avenue, Des Moines, Iowa 50312 11. Known bondholders, mortgagees, and other security holders owning 1 percent or more of total amount of bonds, mortgages, or other securities: None 12. Does not apply 13. Publication Title: ShopNotes 14. Issue Date for Circulation Data Below: July/August 2004 (ISSN: 1535-1225) 15. Extent and nature of circulation: <table border="1" style="width: 100%; border-collapse: collapse;"> <tr> <td>A. Total number of copies (net press run)</td> <td style="text-align: right;">218,517</td> <td style="text-align: right;">218,143</td> </tr> <tr> <td>B. Paid and/or requested circulation:             <table border="1" style="width: 100%; border-collapse: collapse;"> <tr> <td>1. Paid (including individual paid subscriptions stated on Form 3541)</td> <td style="text-align: right;">148,854</td> <td style="text-align: right;">148,827</td> </tr> <tr> <td>2. Paid directly subscription</td> <td style="text-align: right;">0</td> <td style="text-align: right;">0</td> </tr> <tr> <td>3. Sales through dealers and carter, street vendors, counter sales, and other non-ISP paid distribution</td> <td style="text-align: right;">0</td> <td style="text-align: right;">0</td> </tr> <tr> <td>4. Other classes mailed through the USPS</td> <td style="text-align: right;">0</td> <td style="text-align: right;">0</td> </tr> </table> </td> <td style="text-align: right;">148,854</td> <td style="text-align: right;">148,827</td> </tr> <tr> <td>C. Total paid and/or requested circulation</td> <td style="text-align: right;">148,854</td> <td style="text-align: right;">148,827</td> </tr> <tr> <td>D. Free distribution outside the mail (carriers, complimentary, and other free copies):             <table border="1" style="width: 100%; border-collapse: collapse;"> <tr> <td>1. Carriers (including or stated on Form 3541)</td> <td style="text-align: right;">0</td> <td style="text-align: right;">0</td> </tr> <tr> <td>2. Locality or other non-ISP</td> <td style="text-align: right;">0</td> <td style="text-align: right;">0</td> </tr> <tr> <td>3. Other classes mailed through the USPS</td> <td style="text-align: right;">0</td> <td style="text-align: right;">0</td> </tr> </table> </td> <td style="text-align: right;">0</td> <td style="text-align: right;">0</td> </tr> <tr> <td>E. Free distribution outside the mail (carriers or other means):             <table border="1" style="width: 100%; border-collapse: collapse;"> <tr> <td>1. Total free distribution</td> <td style="text-align: right;">0</td> <td style="text-align: right;">0</td> </tr> <tr> <td>2. Total free distribution</td> <td style="text-align: right;">0</td> <td style="text-align: right;">0</td> </tr> <tr> <td>3. Copies not distributed</td> <td style="text-align: right;">70,663</td> <td style="text-align: right;">70,316</td> </tr> <tr> <td>4. Copies not distributed</td> <td style="text-align: right;">0</td> <td style="text-align: right;">0</td> </tr> <tr> <td>5. Total</td> <td style="text-align: right;">70,663</td> <td style="text-align: right;">70,316</td> </tr> <tr> <td>6. Percentage Paid and/or requested circulation</td> <td style="text-align: right;">84.9%</td> <td style="text-align: right;">84.9%</td> </tr> </table> </td> <td style="text-align: right;">70,663</td> <td style="text-align: right;">70,316</td> </tr> </table>	A. Total number of copies (net press run)	218,517	218,143	B. Paid and/or requested circulation: <table border="1" style="width: 100%; border-collapse: collapse;"> <tr> <td>1. Paid (including individual paid subscriptions stated on Form 3541)</td> <td style="text-align: right;">148,854</td> <td style="text-align: right;">148,827</td> </tr> <tr> <td>2. Paid directly subscription</td> <td style="text-align: right;">0</td> <td style="text-align: right;">0</td> </tr> <tr> <td>3. Sales through dealers and carter, street vendors, counter sales, and other non-ISP paid distribution</td> <td style="text-align: right;">0</td> <td style="text-align: right;">0</td> </tr> <tr> <td>4. Other classes mailed through the USPS</td> <td style="text-align: right;">0</td> <td style="text-align: right;">0</td> </tr> </table>	1. Paid (including individual paid subscriptions stated on Form 3541)	148,854	148,827	2. Paid directly subscription	0	0	3. Sales through dealers and carter, street vendors, counter sales, and other non-ISP paid distribution	0	0	4. Other classes mailed through the USPS	0	0	148,854	148,827	C. Total paid and/or requested circulation	148,854	148,827	D. Free distribution outside the mail (carriers, complimentary, and other free copies): <table border="1" style="width: 100%; border-collapse: collapse;"> <tr> <td>1. Carriers (including or stated on Form 3541)</td> <td style="text-align: right;">0</td> <td style="text-align: right;">0</td> </tr> <tr> <td>2. Locality or other non-ISP</td> <td style="text-align: right;">0</td> <td style="text-align: right;">0</td> </tr> <tr> <td>3. Other classes mailed through the USPS</td> <td style="text-align: right;">0</td> <td style="text-align: right;">0</td> </tr> </table>	1. Carriers (including or stated on Form 3541)	0	0	2. Locality or other non-ISP	0	0	3. Other classes mailed through the USPS	0	0	0	0	E. Free distribution outside the mail (carriers or other means): <table border="1" style="width: 100%; border-collapse: collapse;"> <tr> <td>1. Total free distribution</td> <td style="text-align: right;">0</td> <td style="text-align: right;">0</td> </tr> <tr> <td>2. Total free distribution</td> <td style="text-align: right;">0</td> <td style="text-align: right;">0</td> </tr> <tr> <td>3. Copies not distributed</td> <td style="text-align: right;">70,663</td> <td style="text-align: right;">70,316</td> </tr> <tr> <td>4. Copies not distributed</td> <td style="text-align: right;">0</td> <td style="text-align: right;">0</td> </tr> <tr> <td>5. Total</td> <td style="text-align: right;">70,663</td> <td style="text-align: right;">70,316</td> </tr> <tr> <td>6. Percentage Paid and/or requested circulation</td> <td style="text-align: right;">84.9%</td> <td style="text-align: right;">84.9%</td> </tr> </table>	1. Total free distribution	0	0	2. Total free distribution	0	0	3. Copies not distributed	70,663	70,316	4. Copies not distributed	0	0	5. Total	70,663	70,316	6. Percentage Paid and/or requested circulation	84.9%	84.9%	70,663	70,316
A. Total number of copies (net press run)	218,517	218,143																																																				
B. Paid and/or requested circulation: <table border="1" style="width: 100%; border-collapse: collapse;"> <tr> <td>1. Paid (including individual paid subscriptions stated on Form 3541)</td> <td style="text-align: right;">148,854</td> <td style="text-align: right;">148,827</td> </tr> <tr> <td>2. Paid directly subscription</td> <td style="text-align: right;">0</td> <td style="text-align: right;">0</td> </tr> <tr> <td>3. Sales through dealers and carter, street vendors, counter sales, and other non-ISP paid distribution</td> <td style="text-align: right;">0</td> <td style="text-align: right;">0</td> </tr> <tr> <td>4. Other classes mailed through the USPS</td> <td style="text-align: right;">0</td> <td style="text-align: right;">0</td> </tr> </table>	1. Paid (including individual paid subscriptions stated on Form 3541)	148,854	148,827	2. Paid directly subscription	0	0	3. Sales through dealers and carter, street vendors, counter sales, and other non-ISP paid distribution	0	0	4. Other classes mailed through the USPS	0	0	148,854	148,827																																								
1. Paid (including individual paid subscriptions stated on Form 3541)	148,854	148,827																																																				
2. Paid directly subscription	0	0																																																				
3. Sales through dealers and carter, street vendors, counter sales, and other non-ISP paid distribution	0	0																																																				
4. Other classes mailed through the USPS	0	0																																																				
C. Total paid and/or requested circulation	148,854	148,827																																																				
D. Free distribution outside the mail (carriers, complimentary, and other free copies): <table border="1" style="width: 100%; border-collapse: collapse;"> <tr> <td>1. Carriers (including or stated on Form 3541)</td> <td style="text-align: right;">0</td> <td style="text-align: right;">0</td> </tr> <tr> <td>2. Locality or other non-ISP</td> <td style="text-align: right;">0</td> <td style="text-align: right;">0</td> </tr> <tr> <td>3. Other classes mailed through the USPS</td> <td style="text-align: right;">0</td> <td style="text-align: right;">0</td> </tr> </table>	1. Carriers (including or stated on Form 3541)	0	0	2. Locality or other non-ISP	0	0	3. Other classes mailed through the USPS	0	0	0	0																																											
1. Carriers (including or stated on Form 3541)	0	0																																																				
2. Locality or other non-ISP	0	0																																																				
3. Other classes mailed through the USPS	0	0																																																				
E. Free distribution outside the mail (carriers or other means): <table border="1" style="width: 100%; border-collapse: collapse;"> <tr> <td>1. Total free distribution</td> <td style="text-align: right;">0</td> <td style="text-align: right;">0</td> </tr> <tr> <td>2. Total free distribution</td> <td style="text-align: right;">0</td> <td style="text-align: right;">0</td> </tr> <tr> <td>3. Copies not distributed</td> <td style="text-align: right;">70,663</td> <td style="text-align: right;">70,316</td> </tr> <tr> <td>4. Copies not distributed</td> <td style="text-align: right;">0</td> <td style="text-align: right;">0</td> </tr> <tr> <td>5. Total</td> <td style="text-align: right;">70,663</td> <td style="text-align: right;">70,316</td> </tr> <tr> <td>6. Percentage Paid and/or requested circulation</td> <td style="text-align: right;">84.9%</td> <td style="text-align: right;">84.9%</td> </tr> </table>	1. Total free distribution	0	0	2. Total free distribution	0	0	3. Copies not distributed	70,663	70,316	4. Copies not distributed	0	0	5. Total	70,663	70,316	6. Percentage Paid and/or requested circulation	84.9%	84.9%	70,663	70,316																																		
1. Total free distribution	0	0																																																				
2. Total free distribution	0	0																																																				
3. Copies not distributed	70,663	70,316																																																				
4. Copies not distributed	0	0																																																				
5. Total	70,663	70,316																																																				
6. Percentage Paid and/or requested circulation	84.9%	84.9%																																																				

# Tips for Your Shop

## Small Parts Carousel

I like to keep extra screws, bolts, and other hardware on hand to save me trips to the hardware store. The problem is all these parts can

be difficult to store and organize. To solve this problem, I built the small parts storage carousel you see in the drawing below.

The carousel consists of a single base unit and a set of storage units sized to hold plastic bins. The storage units rotate so you can find the part you need quickly and easily. And, as shown in the drawing above, you can build and stack as many units as needed for additional storage.

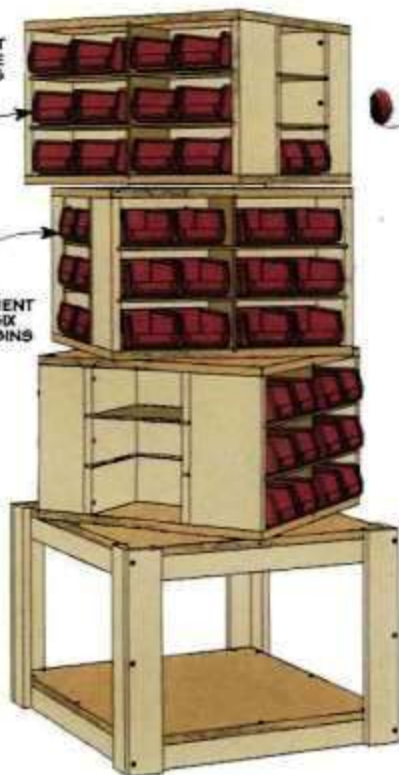

**Base.** To make it easy to access the storage bins, I built a simple base (drawing at left). First, cut the top and bottom shelves to size. And then connect them to the L-shaped legs and frame. Finally, add a lazy Susan to allow the unit to rotate.

**Storage Unit.** Each storage unit is built from  $\frac{3}{4}$ " plywood and  $\frac{1}{4}$ " hardboard. Start by cutting the base and top to size. Then make four separate storage compartments to hold two different sizes of 4"-wide bins (one deep and one shallow).

The two larger compartments are made by joining two sides and a divider to a back. Dadoes in the sides and back hold the  $\frac{1}{4}$ " hardboard shelves and divider (main drawing and inset). The small center compartments are formed by connecting the backs of the large compartments by two spacers and a set of small shelves. Here again, dadoes hold the shelves in position.

To use the carousel, just slide in the bins and fill them with small parts. Then a spin is all it takes to find the part you need.

*John Dutcher  
Salt Lake City, Utah*

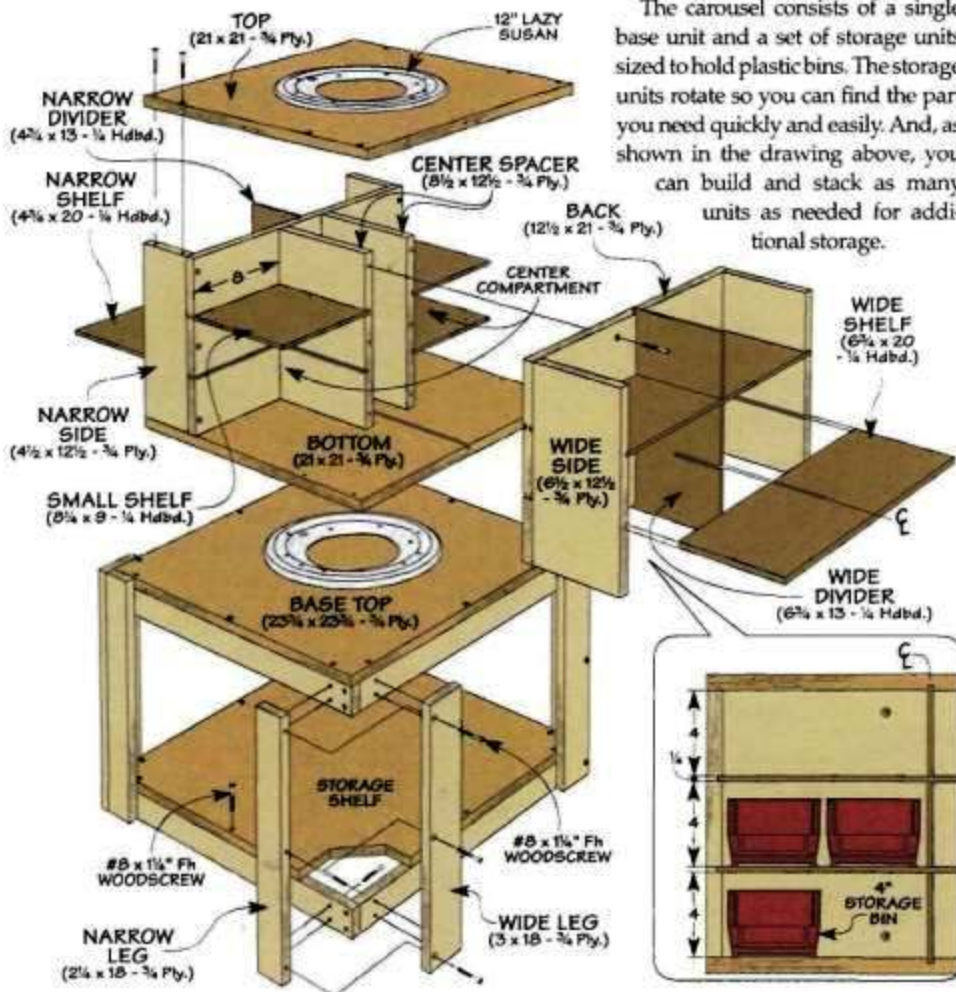

## Scrap Wood Organizer

Storing pieces of scrap wood in my shop is always a challenge. It takes a lot of time (not to mention space) to sort through the piles tucked here and there throughout my shop. So I built the simple and inexpensive scrap wood organizer you see in the drawing below.

The organizer is made by stacking concrete forming tubes together. They come in a variety of sizes so you can adapt the compartments to fit your needs.

Once you decide on the configuration of the tubes, you can then size and build a simple frame to contain them. The frame I built is made to sit securely on the floor in my shop.

Finally, I sort the scraps by size and species of wood so I can quickly find just the piece I need. Now my shop is organized, clean, and free from clutter.

*Leslie Harrison  
Bremerton, Washington*

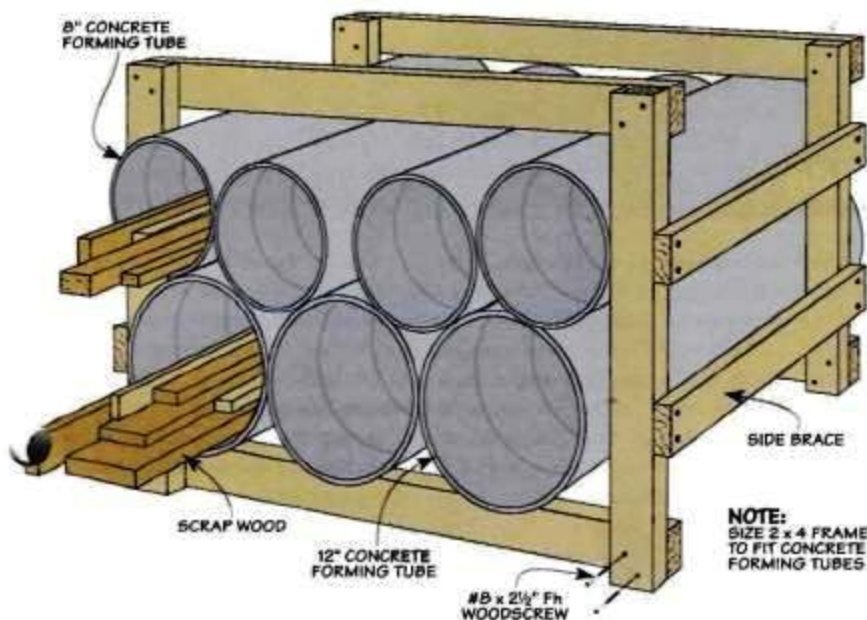

## Submit Your Tips

If you have an original shop tip, we would like to hear from you and consider publishing your tip in one or more of our publications. Just write down your tip and mail it to: *ShopNotes*, Tips for Your Shop, 2200 Grand Avenue, Des Moines, Iowa 50312. Please include your name, address, and daytime phone number (in case we have any questions). If you would like, you can FAX it to us at 515-282-6741 or simply send us an email message at: [shopnotes@shopnotes.com](mailto:shopnotes@shopnotes.com). We will pay up to \$200 if we publish your tip.

## The Winner!

Congratulations to Paul McKibben of Norcross, Georgia. His tip on making a panel saw guide for cutting sheet goods was selected as winner of the *Porter-Cable* router just like the one shown at the right. The panel saw guide is inexpensive to build and simple to use.

To find out how you could win a *Porter-Cable* router, check out the information above. Your tip just might be a winner.



PUBLISHER Donald B. Peschke

EDITOR Terry J. Strohman  
MANAGING EDITOR Bryan Nelson  
CONTRIBUTING EDITOR Vincent Ancona  
ASSOCIATE EDITORS Phil Huber, Ted Raife  
ASSISTANT EDITORS Ron Johnson, Mitch Holmes,  
Randall A. Masey, Dennis Perkins

EXECUTIVE ART DIRECTOR Todd Lambirth  
ART DIRECTOR Cary Christensen  
SENIOR GRAPHIC DESIGNER Jamie Downing  
SENIOR ILLUSTRATOR Roger Reiland  
ILLUSTRATORS David Ka. Jernyn, Peter J. Larson

CREATIVE DIRECTOR Ted Kralicek  
SENIOR PROJECT DESIGNERS Ken Munkie,  
Kent Welsh, Chris Fitch  
PROJECT DESIGNERS/BUILDERS Mike Donovan,  
John Doyle  
SHOP CRAFTSMEN Steve Curtis, Steve Johnson

SR. PHOTOGRAPHERS Crayola England, Dennis Kennedy  
ASSOCIATE STYLE DIRECTOR Rebecca Cunningham  
ELECTRONIC IMAGE SPECIALIST Allan Ruhnke

VIDEOGRAPHERS Craig Ruegsegger, Mark Hayes

*ShopNotes* (ISSN 1092-8696) is published bimonthly (Jan., March, May/July, Sept., Nov.) by August Home Publishing, 2200 Grand Ave., Des Moines, IA 50312. *ShopNotes* is a registered trademark of August Home Publishing. ©Copyright 2006 by August Home Publishing. All rights reserved. Subscriptions: Single copy: \$4.95. One year subscription (6 issues): \$27.95. Canada/International add \$10 per year, U.S. funds. Canadian Subscriptions: Canada Post Agreement Number 40088201. Send change of address information and blocks of undeliverable copies to: P.O. Box 881, Station Main, Markham, ON L3P 6M6. Canada BN 84397 5478 RT. Periodicals Postage Paid at Des Moines, IA and at additional mailing offices. Postmaster: Send change of address to *ShopNotes*, P.O. Box 27108, Boone, IA 50007-2108.

[www.ShopNotes.com](http://www.ShopNotes.com)

## ONLINE SUBSCRIBER SERVICES

- **ACCESS** your account
- **CHECK** on a subscription payment
- **TELL US** if you've missed an issue
- **CHANGE** your mailing or e-mail address
- **RENEW** your subscription
- **PAY** your bill

Click on "Subscriber Services" in the list on the left side of our home page. Menus and forms will take you through any of the account-maintenance services you need.

## HOW TO REACH US:

FOR SUBSCRIPTIONS, ADDRESS CHANGES  
OR QUESTIONS, WRITE OR CALL:  
Customer Service  
2200 Grand Ave., Des Moines, IA 50312  
800-333-5854 8 a.m. to 5 p.m. CT

OR SEND AN E-MAIL TO:  
[orders@shopnotes.com](mailto:orders@shopnotes.com)

AUGUST HOME  
PUBLISHING COMPANY

Printed in U.S.A.



## Panel Saw Guide

I work with a lot of sheet goods in my shop. And it's always difficult to break the large sheets down to size. To help me with this task, I built the panel saw guide shown in the photo above. It's inexpensive to build and easy to use.

To build the cutting guide, you can begin with a base of  $\frac{3}{4}$ "-thick Baltic birch plywood. Then add cleats along each edge. The cleats

add strength to the base and raise the saw guides to provide a pocket for the panel being cut.

Next, you'll build the saw guide. It's made by attaching a couple of lengths of  $\frac{1}{2}$ " aluminum channel to the edge of two pieces of  $\frac{3}{4}$ " hardwood stock, as shown in the drawing and detail below.

You'll want to space the guides so they fit the base of your circular saw. To do this, first square up one guide and mount it with screws to the end cleats. Then mount the other guide in position.

To use the panel guide, slide a sheet beneath the saw guides. Then slip your circular saw between the channel guides, line things up, and push the saw along the guide.

*Paul McKibben  
Norcross, Georgia*

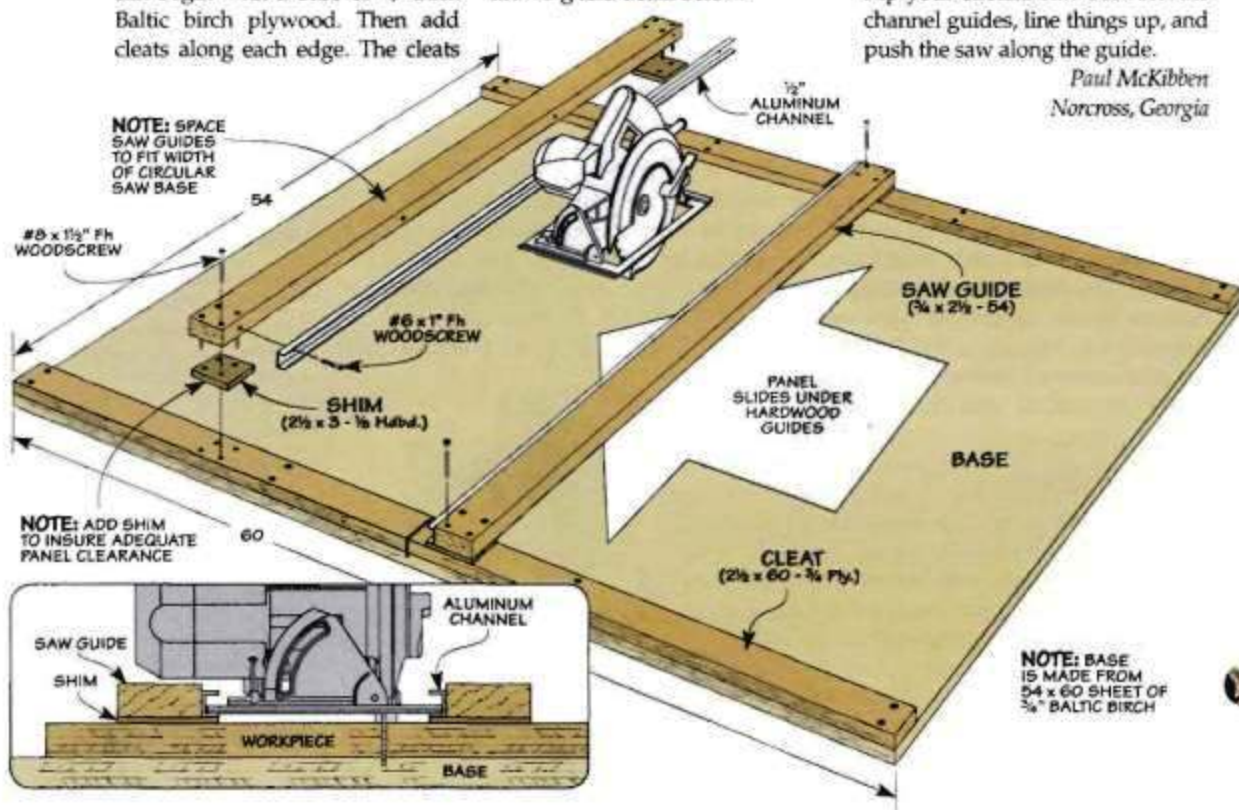

## Clamp Storage Rack

After years of storing my long bar and pipe clamps all over the shop, I built the clamp storage rack you see in the photo at right. The rack stores all my clamps in one place. And by storing each size of clamp in line one behind the other, I always have easy access to the exact size I need.

The rack is simply three different-sized shelves. Each shelf sits at a slight angle and has notches at the edge to hold the clamps securely in place (Side View). The shelves are connected with screws to side and

back pieces (drawing below). This provides solid support and makes it easy to mount the rack to the wall.

To build the storage rack, cut each shelf to size. Next, you can use a  $1\frac{1}{8}$ "-dia. Forstner bit to drill spaced holes along one edge of each shelf (Top View). Then trim away the waste with a jig saw. Finally, attach the sides and backs, mount the rack, and hang up your pipe clamps.

Larry Fellows  
Taylor, Michigan

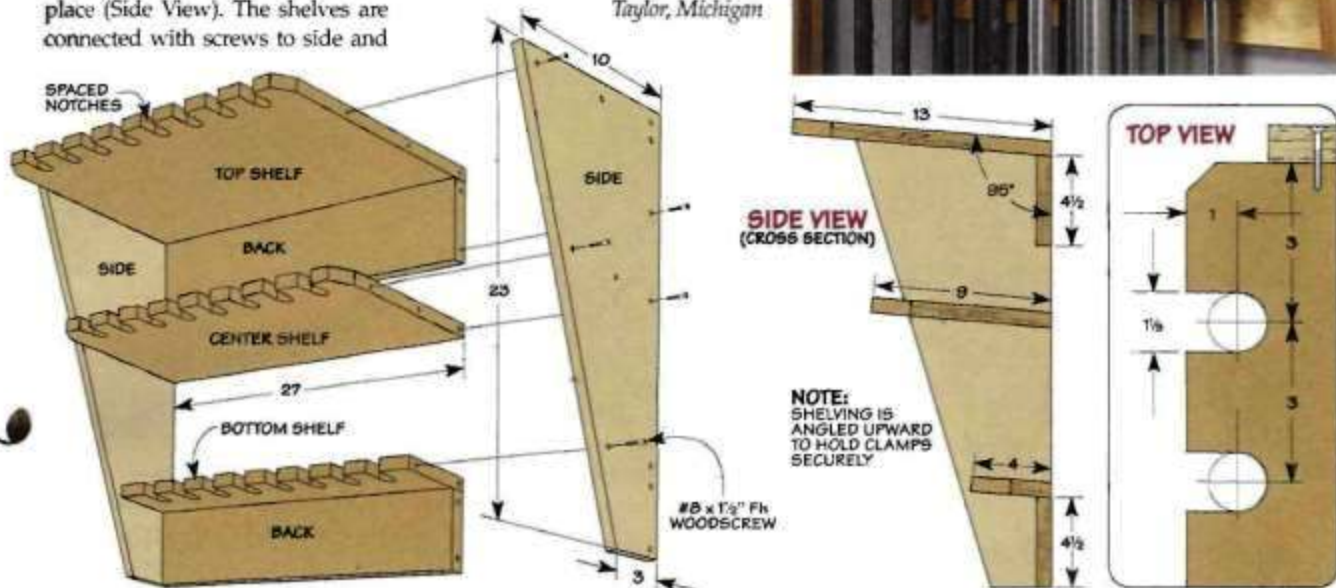

## Quick Tips



▲ To keep the cords of his power tools under control, **Serge Duclos** of Delson, Quebec, Canada, simply loops a rubber band over a small dowel, wraps the rubber band over the cord, and then secures it over the dowel again.



▲ **Mike Ruffalo** of Columbia, MO, adds a right angle plug to the cord of his portable power tools. This prevents the plug from pulling away from the extension cord whenever tension is placed on the cord.

www.ShopNotes.com

## FREE TIPS BY EMAIL

Now, you can have the best, time-saving secrets, solutions, and techniques sent directly to your computer. Just go to [www.ShopNotes.com](http://www.ShopNotes.com) and click on "FREE Tips by Email" to sign up. You'll receive a new tip by email each week.



get the most from your  
**Plunge Router**



Learn how to turn this handy tool into a shop workhorse.

Plunge routers are nothing new. But if you've never owned or used one, a lot about them can seem quite a bit different from the fixed-base router you may be used to. So to get the most benefit from a plunge router, you first need to understand the "mechanics" that make it work. Then the simple techniques for using a plunge router will come easy.

**The Plunge.** The trick that a plunge router can do is really pretty simple but extremely useful. With a plunge router you can turn on the motor and then lower the spinning bit straight down into the workpiece (or plunge) with complete control. This means that, unlike a fixed-base router, you're not limited to starting and stopping a cut at the edge of a workpiece. Stopped grooves, dados, mortises, pockets for inlay, and fluting are all fair game for a plunge router.

**The Key Features.** But before you can go to work with a plunge router, it's best to familiarize yourself with the unique features that set it apart. The photos at left and on the opposite page point these out.



## Plunge Router Basics: The Key Features

**Spring Action.** On a plunge router, the motor and base are a single unit. A pair of posts attached to the base mate with spring-loaded sockets in the motor casing. They allow the motor to travel up and down on the base. You push against the force of the springs to lower the motor and bit, then at the end of the cut the springs take over to lift the motor and bit back up.

**Plunge Lock.** When you lower the bit into a cut, you don't want to have to concern yourself with keeping it at a constant depth. So a plunge router has a lock that fixes the motor at any position along the posts (photos, top row). The most common type is an easy-to-reach, spring-action lever that you trip with a finger or thumb. You pull it down to release the lock and simply let it spring back when you want to re-engage it.

**Depth Rod and Stop.** So you release the plunge lock and push the motor and bit into the cut. But what stops the bit at the correct depth? This job is handled by an adjustable depth rod and stop.

Together, the depth rod and stop form a simple system. As you see in the photos on the opposite page, the depth rod is housed in the motor casing. It can be easily adjusted up or down and then locked securely in place. The rod sits over a depth stop on the base. When the motor is plunged, the rod contacts the stop at the correct depth.

Most newer plunge routers have "stepped" depth stops, as shown at right. This arrangement allows you to make progressively deeper cuts without having to readjust the rod after each cut. You first adjust for a full-depth cut at the lowest step. Then you rotate the stop to a higher step and work your way down cut by cut. It's a really handy feature.

**Micro-Adjust.** A quick adjustment of the depth rod will get you close to your target. But for dead-on precision you'll find a micro-adjust feature built in to most routers. Fine-tuning the depth is literally as easy as turning a knob.



▲ **Grip Plunge Lock.** Turning the handgrip on this plunge router locks and unlocks the plunge action.



▲ **Lever Lock.** The most common type of plunge lock is a spring-action lever. You pull it back to release the lock.



▲ **Stepped Depth Stop.** The steps of this rotating "turret" stop let you quickly make a cut in several passes.



▲ **Micro-Adjust.** A micro-adjust dial provides an easy and accurate way to fine-tune the depth of cut.



▲ **Spindle Lock.** Depressing the button locks the spindle so the collet can be tightened or loosened with one wrench.



▲ **A Handy Switch.** You won't have any trouble finding the trigger switch on the handgrip of this plunge router.

**Changing Bits.** Since you can't separate the motor from the base, access to the collet for bit changes is often tight. Most plunge routers get around this problem by including a spindle lock that makes "one-wrench" bit changes possible.

**Turning It On.** There's just one more item I want to mention. Controlling a plunge router during a cut is definitely a "two-handed" job. This means the critical controls

need to be right at hand and easy to operate — including the on/off switch. For this reason you'll find the switch on a plunge router very near or right on one of the handgrips. The toggle switch on the router on the opposite page can easily be reached with a finger while still maintaining a firm grip. An even handier option is a trigger switch located on the handgrip (photo above). This is my favorite.

## plunge routing **Basics**

A plunge router can handle a lot of challenging tasks. Routing accurate stopped grooves and dados is a good example. And this job is a good way to get acquainted with the basics of using a plunge router.

**First, Set the Depth.** Once the bit is installed, the first step is to adjust the depth of cut. The procedure is going to vary on different brands of plunge routers, but in general it follows the same basic steps. The photos in the box below take you through the process. Remember to set the final depth using the lowest step on the depth stop.

**Guiding the Cut.** Before starting the cut, you need a way to guide the router. For basic operations like a stopped groove or dado, I like to use a straightedge clamped to the workpiece. With the flat side of the base against the guide, you have very steady control of the router (upper right photo).

**Ready to Go.** With the guide in place, set the router over the left end point of the cut. (You'll move the router left to right.) When you plunge into the workpiece, you don't want to guess where the bit



**▲ Position the Router.** Lower the bit to the surface to position the router for the plunge.

will enter. So with the router turned off, I release the plunge lock and drop the bit to the surface. Then I position the router over the layout, as shown in the inset photo above.

**The Cut.** With the router in position, raise the bit above the surface and you're ready to start the cut. First, you flip the switch, then you disengage the plunge lock and hold it. As you plunge, you want to be sure to hold the router very firmly with both hands — especially as the bit contacts the workpiece.

You want to push down until the depth rod hits the stop. Once

at full depth, I like to re-engage the plunge lever to keep the motor and bit from rising up on me. Now simply move the router slowly and steadily along the straightedge. Near the end of the cut, I slow down slightly so I can stop right on my layout line.

When you reach the end line, disengage the plunge lock and the springs will take over and raise the bit out of the cut. Once the router hits the top of the posts, turn it off.

**Control.** I've found that one of the keys to smooth, accurate plunge routing is maintaining firm control before, during, and after the cut. So the trick here is to get a good feel for the location and operation of the on/off switch and plunge lock. This will come easily with a little practice. 

## Setting The Depth: One, Two, Three



**▲ Zero the Bit.** After installing the bit, set the router flat on your benchtop. Release the plunge lock, lower the bit to the surface, and re-engage the lock.



**▲ Zero Depth Rod and Dial.** Next, unlock the depth rod and lower it to contact the bottom step of the depth stop. Adjust the scale to read zero at this point.



**▲ Set Depth Rod.** Now, raise the depth rod until the scale on the dial matches the desired depth of cut. Finally, lock the depth rod in place.

## Using a Simple: Mortising Jig

If all you ever did with your plunge router was rout mortises, I think you'd still consider it a great investment. It's fast, easy, and most importantly, you get cleanly cut and dead-on accurate mortises.

**First, a Jig.** To rout a mortise efficiently, you'll need an easy and accurate way to guide the plunge router. My answer is the jig you see at right. It consists of a pair of adjustable guides attached to a hardboard baseplate that replaces the router's baseplate (lower right photo). The guides snug up to either side of the workpiece to position and stabilize the cut. (To find complete plans for the jig, see the margin.)

**The Setup.** To get started, you'll need the jig in place and the bit installed in the router. (I prefer a spiral upcut bit for mortising.) With the mortise laid out, I clamp the workpiece down so that the jig will slide along it without obstruction (lower left photo).

**Adjust the Jig.** The next step is to use the layout lines on the workpiece to set up the jig. So set the router and jig on the workpiece with the bit roughly over the layout and slide the guides loosely up against it. To center the bit on the

layout, lower it to the surface and lock it in place. Now, you can "tweak" the position of the jig on the workpiece until the bit falls between the layout (right photo below). At this point, snug the guides up to the workpiece and tighten them down (left photo below). The jig should slide easily along the workpiece but without any slop or wobble.

**The Cut.** Routing the mortise is really no different from the basic procedure described earlier. I always use multiple passes to "step" the mortise down at about  $\frac{1}{4}$ " per cut. Plus, I like to start the cut by plunging just to the inside of the end line. Then I rout back to the layout line before routing forward. This is easier than trying to plunge several times at the exact same spot. To end the cut right on the mark, you can clamp a stop block to the workpiece, as shown in the upper right photo.

Since the workpiece is trapped firmly between the two guides, all you need to concentrate on are the "plunge mechanics." And when

**▲ Making the Cut.** Once the jig is adjusted, routing the mortises is a simple operation. A stop block takes any guesswork out of ending the cut.



**▲ A Simple Jig.** The two adjustable guides sandwich the workpiece, giving you very easy and steady control of the router during the cuts.

you lift the jig off the workpiece, I think you'll be surprised that a technique this easy can give such top-notch results.



**▲ Centering the Bit.** Lower the bit to the surface and then reposition the jig to center it on the layout.

**◀ Tighten the Guides.** With the jig positioned on the workpiece, snug up the guides and tighten the wing nuts.

**ShopNotes**  
Go ONLINE  
EXTRAS

Go to our website [ShopNotes.com](http://ShopNotes.com) to find complete plans for the plunge router mortising jig.

## taking a look at **Tool Steel**

Does the type of steel in your tools make a difference in their performance? Here's what I found out.

■ If you've shopped around for chisels or plane irons recently, it's easy to get confused. The different types of steel used to make them — like O1, A2, and D2 — reads like alphabet soup. And the descriptions in some catalogs lead you to believe that certain types of steel (like A2 and D2) are the answer to all woodworkers' problems.

**The Differences.** One of the things you might read is that A2 steel is harder to sharpen than O1 steel. Or you can't get as sharp an edge with A2. On the other hand, some folks claim that A2 holds its edge longer than O1.

Now you can find a lot of technical information about steel, but without a degree in metallurgy it won't make much sense. What it really comes down to is the carbide content. Basically, A2 and D2 steel are tougher than O1 because of their higher carbide content. You already know how tough carbide is from using a carbide-tipped saw blade or router bit. But are there any real differences when it comes to using them in the shop?

**Shop Use.** To set up a practical test for the steel, I decided to use block planes. I ordered some O1

and A2 plane irons to put them to work in a "real-world" scenario in my workshop.

The irons for my *Veritas* low angle block plane came from *Lee Valley*. And *Hock Tools* supplied the irons for my old Stanley 60½ low angle block plane. (Refer to Sources on page 51 for more information.)

**Honing.** The first thing to do was use a guide (photo at left) to hone all of the irons the same way. I used wet-dry sandpaper, progressing from 800- to 2000-grit. Then I flattened the back and honed a microbevel on each one.

As for the claim that A2 steel is tougher to hone because of its hardness, I honestly couldn't tell much difference. The reason could be that these are high-quality blades and were already ground and lapped flat. They didn't need a lot of honing to get a sharp edge. I even changed the bevel angle from 25° to 30° but still didn't notice much of a difference in sharpening.

◀ **A Sharp Edge.** A honing guide ensures a consistent cutting angle and square edge.





▲ **A Tough Test.** Shaving the end grain of a workpiece requires a keen cutting edge. As the edge dulls, the plane "chatters" and can't make a clean shaving.

**Slicing End Grain.** Once the irons were sharpened, it was time to put them to the test. A good way to do this is to plane end grain. I made hundreds of passes with each iron on the end of  $\frac{3}{4}$ "-thick white oak stock. I tried to keep the shavings the same thickness (0.010" to 0.015") for all the irons. What I was looking for was how much effort it took to get a continuous shaving.

Another thing I looked at was the quality of the shaving. With a freshly honed iron, you should get a crisp, clean shaving across the width and thickness of the board.

**A Dull Edge.** As the edges dulled, I began to see some dust mixed in with the shavings. And it was harder to push the plane to get a good shaving. The plane would skip, or chatter, across the workpiece. Plus, the shavings were noticeably smaller (photo above).

**Planing is Believing.** Now you might be thinking that this wasn't really a scientific test. And that's true. But what I learned was interesting. The O1 iron started out sharper than the A2 iron. It didn't take as much effort as with the A2 iron to get a clean shaving.

But there was a trade-off. The A2 irons were able to keep taking shavings long after the O1 irons gave up. I was able to get shavings with the O1 irons up to about 350 passes. The A2 irons were still able to cut shavings at 500 passes, but it did take quite a bit more effort.

**Options.** So were my results something that everyone would expect? To get a little more insight, I talked to a few tool suppliers. Ron Hock of *Hock Tools* and Robin Lee of *Lee Valley* both stated that a lot of woodworkers request A2 steel. They agree that there's a perception that A2 makes a better tool for woodworking. Some suppliers, like *Lie-Nielsen*, only offer A2 steel for their chisels and plane irons.

But the sales of chisels or plane irons using O1 steel are strong. Hock feels that O1 steel initially gives you a sharper cutting edge than A2. And Lee believes that most users can get a sharper edge with O1 because most woodworkers believe it's easier to sharpen.

Joel Moskowitz at *Tools for Working Wood* agrees that it's easier to get a sharp edge with O1 steel, so it's an excellent steel for chisels. But he didn't necessarily agree that you couldn't get as sharp an edge with A2 steel. And for mortising chisels that really take a beating, he prefers the harder D2 steel because it's even tougher than A2 steel.

**Making a Choice.** Still confused about which steel to look for on your next tool purchase? If you want the sharpest edge possible, I'd go with O1. But if you don't like sharpening as often, then choose the tougher A2 or D2 steel.

For my shop, there's definitely room for both types. Rough work, like chopping mortises or hand

planing stock to thickness, makes A2 or D2 steel a better choice. For fine finish work where I want the best surface possible using the sharpest tool, I'll go for my O1 steel chisel or hand plane. 🛠️

► **Fluffy Shavings.**

A freshly sharpened plane iron slices cleanly through tough end grain for a smooth cut.



◀ **Short Shavings.**

When a plane iron dulls, it starts to make "toothpick" shavings and dust.

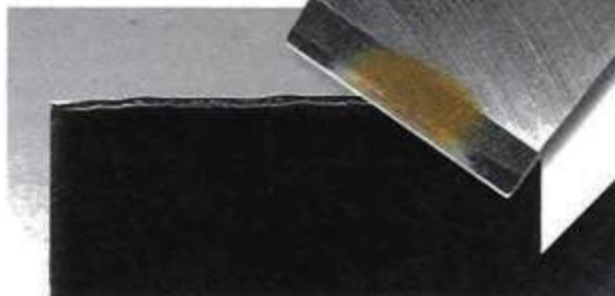

▲ **O1 Steel.** While you can get a sharper edge with O1 steel, it can become dull sooner than A2. The result is a cutting edge that rounds over, requiring more effort to make a shaving across the end grain.

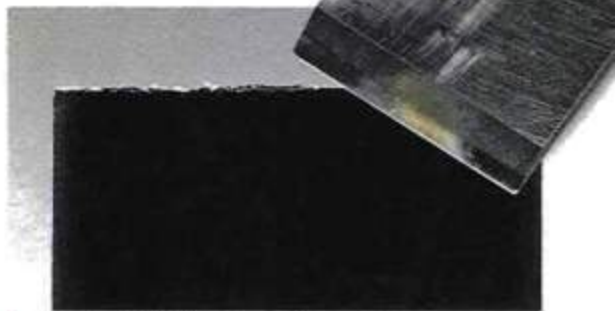

▲ **A2 Steel.** While A2 steel is harder than O1, the cutting edge is more fragile. It can break down, leaving a rough edge, but still be sharp enough to make a cut on end grain.

# ultimate Drilling Guide

Save time and improve the accuracy of installing hardware.



■ Installing hardware can be a real hassle. It always seems to take more time than it should. Until now, the best way to speed up the process was to make a simple drilling jig.

There are couple problems doing this, however. First, I usually have to make separate jigs for drilling shelf pin holes, installing drawer and door pulls, or adding hinges. Besides that, these jigs generally only work for one project.

**All-in-One Jig.** So when I came across the *True Position Drilling Guide*, I was a little curious. It claims to be a universal jig to precisely locate everything from shelf pins and hinges to knobs and pulls, and even drawer slides in a pinch.

The description sounded almost too good to be true. So I picked one

up to try it out. In the photo above, you'll find everything that comes in the basic set (bit not included). For sources, turn to page 51.

## A CLOSER LOOK

**At the heart of the guide** are two aluminum scales that are joined to form a T-shape. Each leg is graduated in both standard and metric scales. The scales "zero" out at the center of the 'T'.

**Sliding Guides.** To give the guide its versatility, it comes with two adjustable guides. Each one has a hardened steel bushing that is aligned with the fixed bushing in the main body of the guide. These sliding guides easily adjust to match the spacing of the hardware.

◀ **Easy to Use.** Drilling for knobs and pulls is as simple as setting the guides to match the hardware.

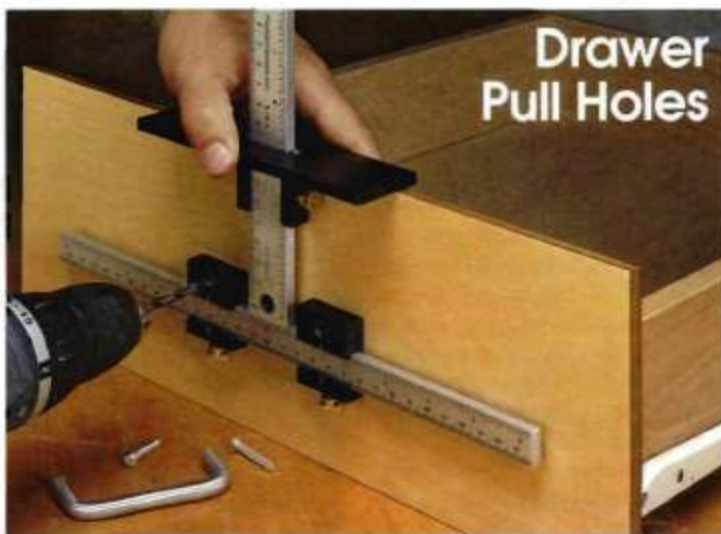

**Top Stop.** The final piece of the guide is the large top stop. It slides on the wide center arm and sets the position of the holes in relation to the edge of the workpiece.

## TWO MAIN TASKS

There are two main jobs the drill guide excels at — locating holes for pulls and knobs in drawers or doors and setting up for drilling adjustable shelf support holes.

**Drawer Hardware.** You can see how the guide works on a drawer in the photo on the facing page. After marking the center of the drawer, you can use the top stop and sliding guides to accurately position the holes for drilling.

**Door Pulls and Knobs.** The process for drilling doors is pretty much the same. The only difference is you can use the end stop to register the guide on the top or bottom of the door as well as the edge.

**Shelf Support Holes.** Another place where the guide saves time is drilling a series of shelf support holes. Although you can use it to drill holes before assembly, I found it works just as well for adding them once a case has been assembled.

To drill a set of three holes at one time, mark the position of the center hole. Then you can line up the "zero" line of the guide with the mark and drill the holes. To drill more holes, you can use a pin to reference the guide, as you can see in the photo above.

## Shelf Pin Holes



▲ **Extra Guides.** Getting an additional pair of drill guides (top) makes it easier to drill a longer series of holes (left).

A project with a face frame requires a slightly different setup. Here, you'll need to remove the top stop and flip the guide around so the knurled knobs butt against the face frame. (You can drill the rear holes the same as before.)

**More Holes.** For smaller cabinets, drilling three holes at a time will work just fine. But on taller cabinets, I suggest getting an additional pair of sliding guides, (margin at right). If you need to drill long runs of holes, you may want to consider the line drilling extensions shown in the box below.

## FINAL DETAILS

Besides knobs, pulls, and shelf pins, the manufacturer says the guide can also locate holes for drawer slides and European-style hinges. I'm a little skeptical about these two

applications, though. And that's because the guide is designed to drill 5mm holes only. So before you start drilling, make sure this will work with your hardware.

**One Complaint.** This is really my only complaint with the *True Position Drilling Guide*. There's quite a bit of hardware out there that uses different hole sizes, so making bushings in several other sizes would be a big help.

**The Bottom Line.** Now you may be wondering just how much an "ultimate" drilling guide costs. For the system shown on the opposite page (the body, two sliding guides, and an end stop), the cost is about \$140. Any other accessories that you'd like to add will cost more. That's a lot, I know, but it'll quickly pay for itself in improved accuracy and time saved.

## Big Project Add-on: Drilling Extensions

Although the basic drilling guide will work on any size project, it can be tedious drilling holes in batches of only three at a time. To save set-up time, you may want to consider the line drilling extensions shown in the photo at right.

The heavy-duty aluminum bars are basically super-sized versions of the sliding guides. They attach with brass knobs and one end is

threaded to accept the end stop from the basic guide. Altogether, you can drill up to 25 holes before you'll need to reposition the guide. Convenience has its price, however. The extensions cost \$120 for the set.

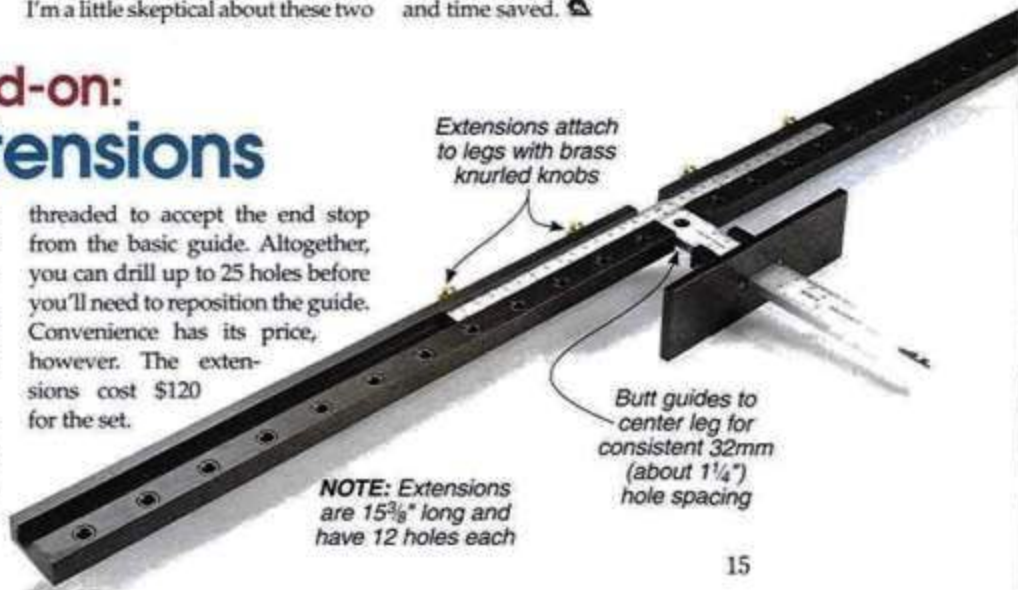

# Shop Short Cuts

## Attaching Slides

Installing drawer slides level and at the right height can be a challenge. For the roll-around work cart on page 18, I used a simple technique to make the job easier — and all it takes is a scrap piece of MDF or plywood.

Starting at the top, cut the spacer to match the height needed for installing the top drawer slide. With the spacer against the side of the cart, set the slide in position on



▲ **Bottom Slide.** A piece of  $\frac{1}{4}$ " hardboard positions the slide up off the bottom of the cabinet.

top and then screw it in place. Next, move the spacer to the other side and repeat the process.

To install the remaining slides, just trim the height (width) of the spacer to match the position for each slide and repeat the process (photo at right and drawing at left below). For the bottom slides, I simply used a  $\frac{1}{4}$ " hardboard spacer, like you see in the photo above.

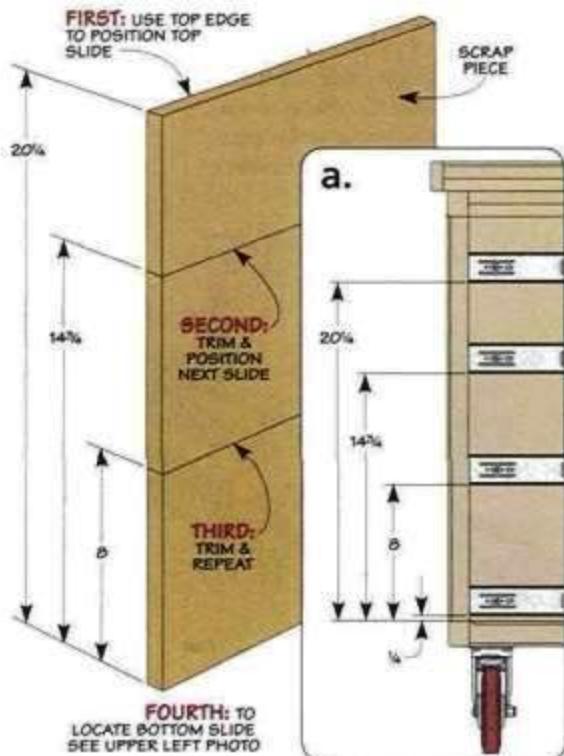

## Wing Cutter: Handle Mount Hole

I wanted to create a pocket in the end of the corner posts of the workcenter to trap the pipe for the handle. Unfortunately, none of my hole saws or drill bits were the exact diameter needed to get

a perfect fit. That's where a wing-cutter came to the rescue.

Just set the wing cutter to the size of the outside diameter of the pipe and use your drill press to cut the  $\frac{1}{2}$ "-deep circular groove.

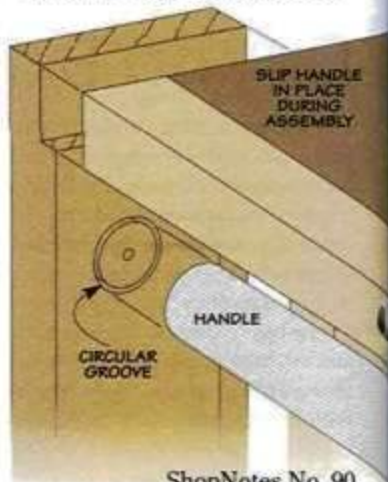
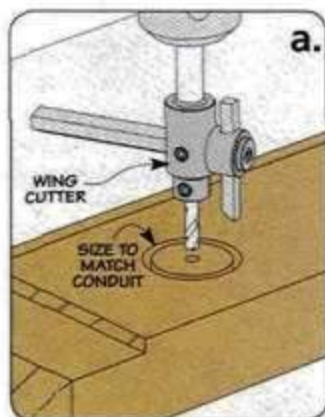



## Working with Brass

The brass I picked up for the keys of the layout tool on page 34 needed a little work before it could be used. The edges were rounded, so it wasn't quite flat, and it needed a bit of polishing. The nice thing is it only took a few simple steps to clean it up.

To flatten the key so it would slide smoothly in the groove of the index block, I used a piece of 120-grit sandpaper attached to the top of a workbench. Simply slide the brass back and forth until it's flat, as shown in photo A.

After shaping each key, rub the brass lightly with a fine abrasive pad to get rid of any scratches (photo B). A piece of steel wool (0000) provides a soft luster, as shown in photo C. Finally, to seal and protect the look of the key, spray on a couple coats of lacquer (photo D).

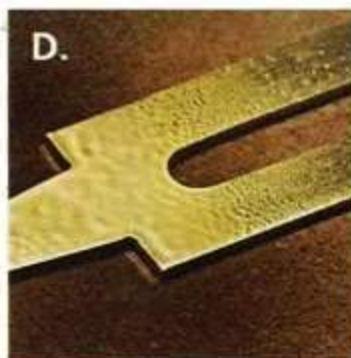
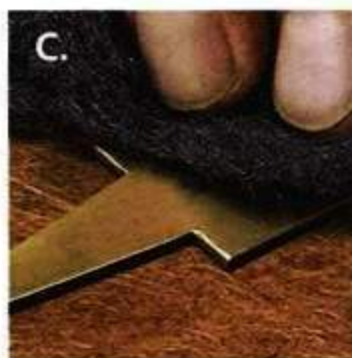
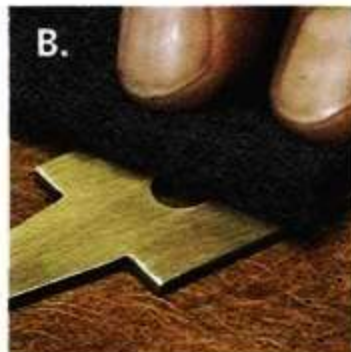
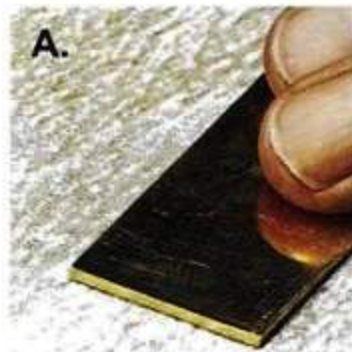

## Cutting Extra-Wide Grooves

A good way to cut the wide grooves needed for the router table inserts on page 28 is to start with an extra-long workpiece. This way you can make the cuts for both pieces at the same time so they're sized identically (Figure 1). To do this, you'll need to make multiple passes with the dado blade. Just set your dado blade to make a wide cut and set the depth of cut to match the thickness of the inserts as shown in Figure 1a.

To center the groove perfectly, you'll want to set the fence on your table saw so it's slightly off the center of the workpiece and make the first pass. Then turn the workpiece around and make a second pass. To widen the groove, adjust the fence and continue turning the workpiece end-for-end to keep the groove centered until you reach the final size of the groove.

After completing the wide groove, you can trim the top and back pieces to size so they're ready to be assembled (Figure 2).

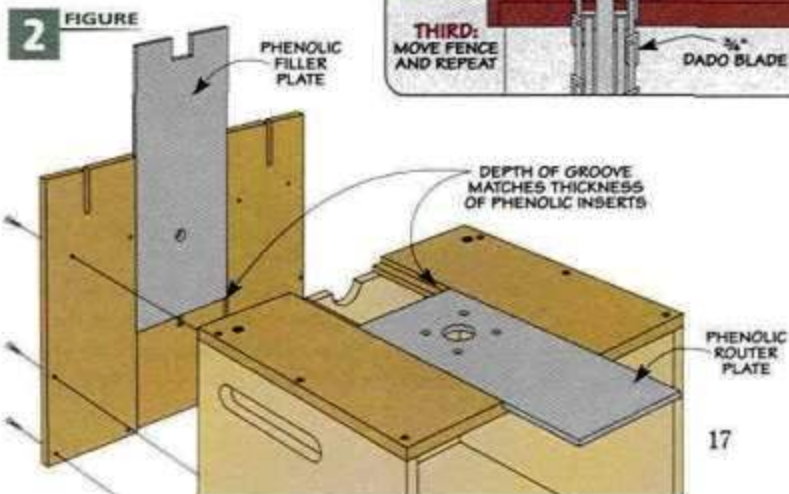
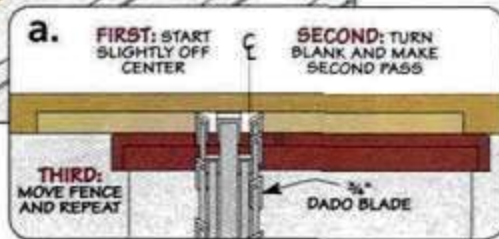
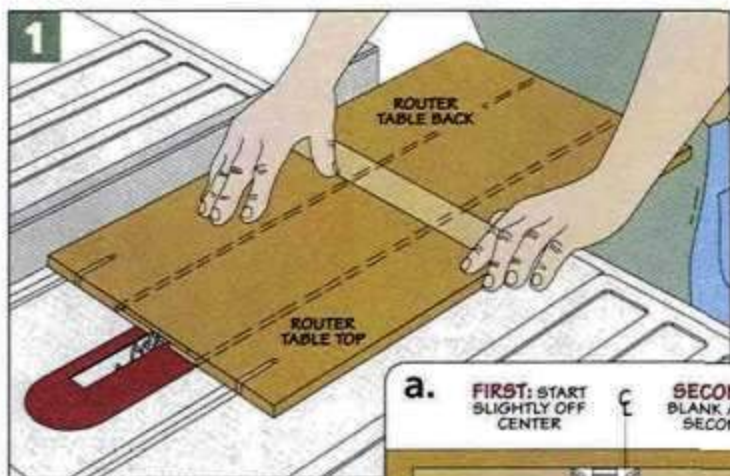

This handy cart is loaded with storage options and provides a rock-solid worksurface no matter what the task.

## roll-around Work Cart

■ If your shop is anything like mine, there are two things you can't get enough of — storage and work surface. That's why this roll-around work cart is a welcome addition.

With eight, heavy-duty drawers on full-extension slides and six easy-access shelves, you'll have

the tools and supplies you need for any project close at hand. And the beefy top means room to work isn't a problem either.

The case is made from  $\frac{3}{4}$ " Baltic birch plywood, while the top is a double layer of MDF with a hardboard cover. It won't have

any trouble standing up to the demands of your shop. I also added hardwood trim to protect the MDF and plywood edges.

But the most eye-catching part of the project is the drawer handles. They give the cart a really "high-end," professional look.

# Exploded View Details

OVERALL DIMENSIONS:  
24"D x 50"W x 35"H

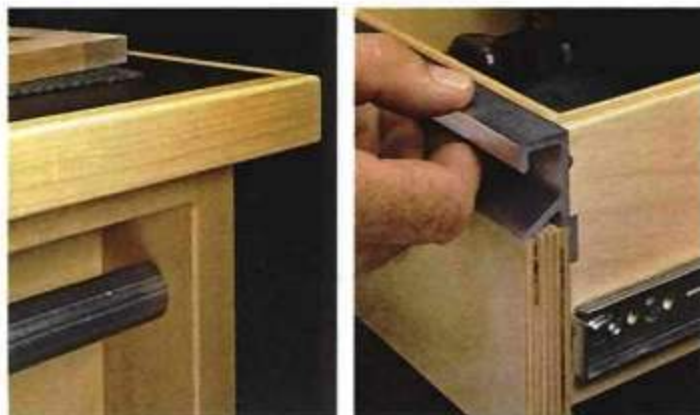
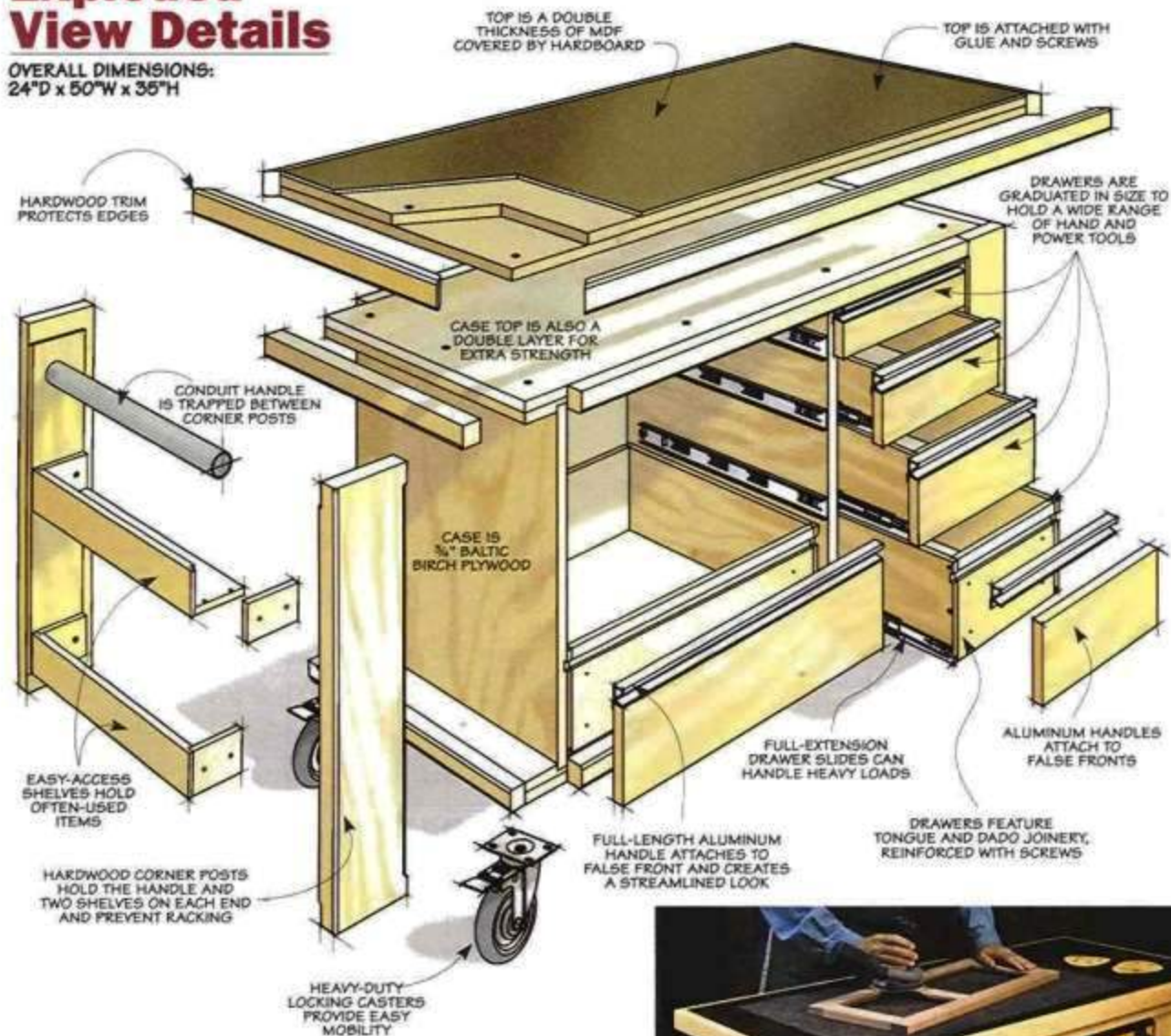

▲ **Two Handles.** Inexpensive conduit makes a great handle for the work cart. But the extruded aluminum drawer pulls turn it into a great-looking project. Best of all, they're easy to install.

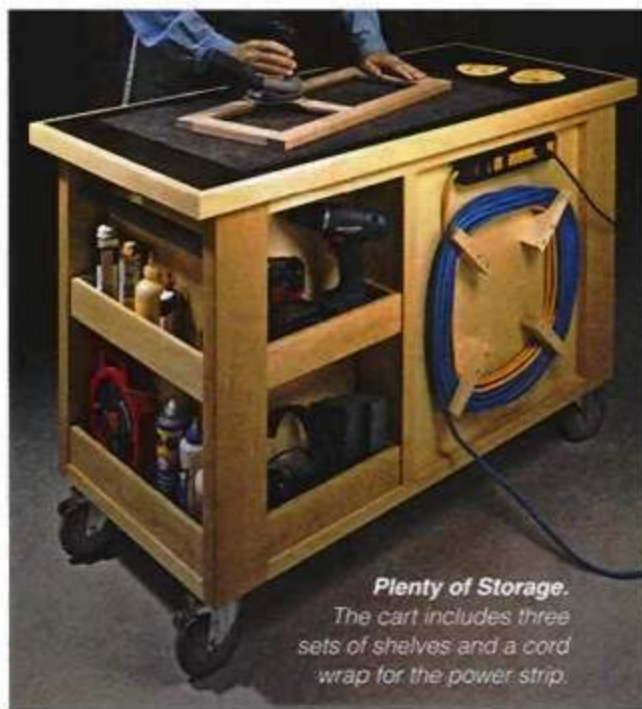

**Plenty of Storage.**  
The cart includes three sets of shelves and a cord wrap for the power strip.

# building the Case

The foundation for this cart is a strong and sturdy case. So that's where I started. As you can see in the drawing at right, the case is built from  $\frac{3}{4}$ " plywood, using dado joints throughout. To make the cart really solid, I used two layers for the top and bottom.

**Top and Bottom.** I began by cutting the four top and bottom panels to size. You can set two of the panels aside since they'll be attached later. Then, with a dado blade on the table saw set to match the thickness of your plywood, you're ready to cut the dados that hold the case sides and divider. You can start with the dados on each end, since they're all cut with the same fence setting (Figure 1a). Then, simply reset the fence and cut the dados for the divider.

**Sides and Divider.** Now you can turn your attention to the case sides and divider. They're identical in size, but they each require different joinery. The right side and divider have grooves that hold the narrow back, creating a recess for the shelves that are added later (see Figure 1c). The left side and divider are rabbeted to hold the wide back, as in Figures 1b and 1c.

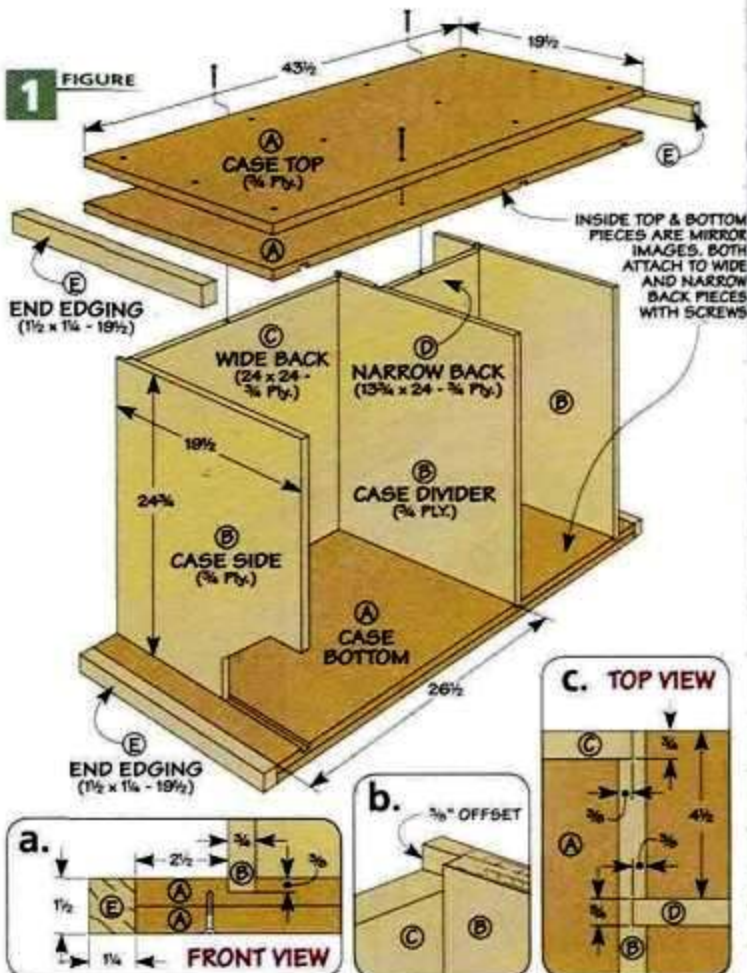

**Assembly.** This is a good time to predrill and countersink holes from the top and bottom to fasten the two back pieces. Then you're ready to assemble the case. Beginning with the inside top panel, attach the

sides and divider with glue, then add screws to hold the back panels. Now you can flip the assembly over and do the same to attach the inside bottom piece.

The next step is to attach the two pieces you set aside earlier that complete the case top and bottom. The thing to keep in mind here is making sure the edges of the pieces stay flush all around.

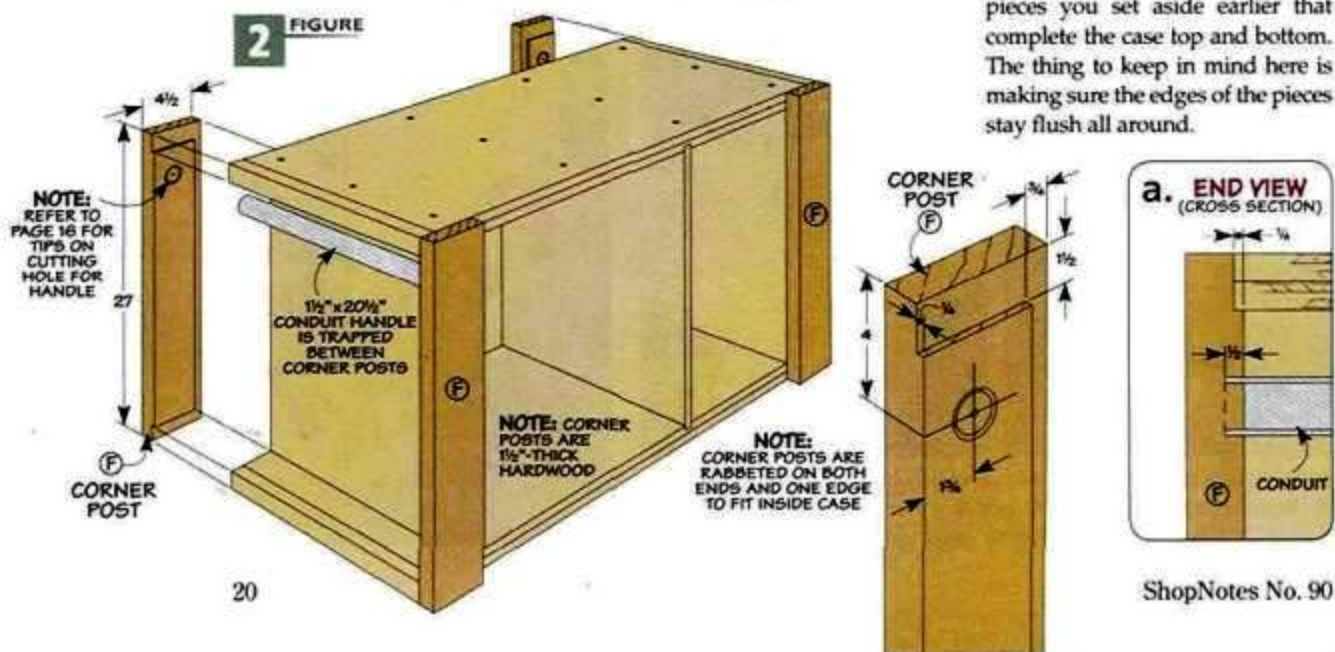

**Edging.** With the plywood case complete, you're ready to add some of the hardwood edging. The edging not only makes the cart look a lot nicer, but it also prevents wear and tear on the plywood corners.

I started with the end pieces on the top and bottom because they need to be in place before the other pieces are added (Figure 1). They're simply cut to width and length, and then glued in place.

**Corner Posts.** The next step is the attaching the corner posts. They add stability and hold the handles. To fit in the case, they're rabbeted along one edge and on both ends (Figure 2). Shop Short Cuts on page 16 shows how I cut the holes to fit the handles perfectly. Once that's complete, just slip the handle in each hole and glue the posts in place.

Adding the rest of the trim is pretty straightforward. You can start by attaching the top and bottom side pieces. Then just add the single vertical piece on the back of the cart. Once everything is in place, pull out your router and rout a  $\frac{1}{4}$ " chamfer on the inside edges.

**3** FIGURE

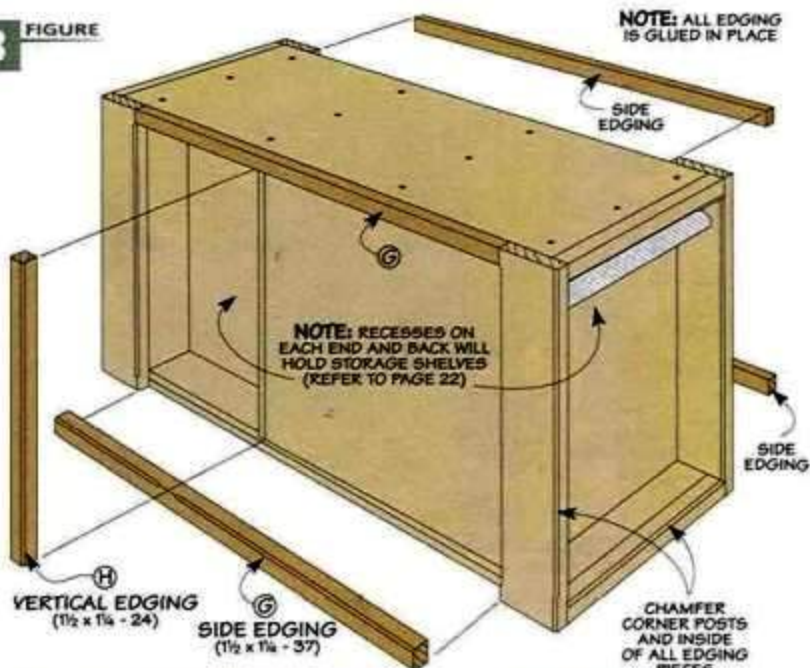

## Materials & Hardware

### CASE

A Case Top/Bottom (4)	19 1/2 x 43 1/2 - 3/4 Ply.
B Case Sides/Divider (3)	19 1/2 x 24 3/4 - 3/4 Ply.
C Wide Back (1)	24 x 24 - 3/4 Ply.
D Narrow Back (1)	24 x 13 3/4 - 3/4 Ply.
E End Edging (4)	1 1/2 x 1 1/4 - 19 1/2
F Corner Posts (4)	1 1/2 x 4 1/2 - 27
G Side Edging (4)	1 1/2 x 1 1/4 - 37
H Vertical Edging (1)	1 1/2 x 1 1/4 - 24

### SHELVES

I End Shelf (2)	1/2 x 3 1/4 - 19
J End Shelf Sides (4)	1/2 x 2 1/2 - 3 1/4
K Upper End Shelf Face (2)	1/2 x 3 - 19
L Lower End Shelf Sides (4)	1/2 x 3 - 3 1/4
M Lower End Shelf Face (2)	1/2 x 3 - 19
N Back Shelf (1)	1/2 x 5 1/4 - 13
O Upper Back Shelf Sides (2)	1/2 x 5 1/4 - 2 1/2
P Upper Back Shelf Face (1)	1/2 x 3 - 13
Q Lower Back Shelf Sides (2)	1/2 x 5 1/4 - 3
R Lower Back Shelf Face (1)	1/2 x 3 - 13
S Cord Cleats (4)	1 x 2 - 6

### TOP

T Top Support (2)	22 1/2 x 48 1/2 - 3/4 MDF
U Top (1)	22 1/2 x 48 1/2 - 1/4 Hdbd.
V Top Side Edging (2)	3/4 x 1 3/4 - 50
W Top End Edging (2)	3/4 x 1 3/4 - 24

### DRAWERS

X Drawer 1 Front/Back (2)	3 3/4 x 21 1/2 - 1/2 Ply.
Y Drawer 1 Sides (2)	3 3/4 x 18 - 1/2 Ply.
Z Drawer 2 Front/Back (2)	3 3/4 x 11 1/4 - 1/2 Ply.
AA Drawer 2 Sides (2)	3 3/4 x 14 - 1/2 Ply.
BB Drawer 3 Front/Back (2)	5 x 21 1/2 - 1/2 Ply.
CC Drawer 3 Sides (2)	5 x 18 - 1/2 Ply.
DD Drawer 4 Front/Back (2)	5 x 11 1/4 - 1/2 Ply.
EE Drawer 4 Sides (2)	5 x 14 - 1/2 Ply.
FF Drawer 5 Front/Back (2)	6 1/4 x 21 1/2 - 1/2 Ply.
GG Drawer 5 Sides (2)	6 1/4 x 18 - 1/2 Ply.
HH Drawer 6 Front/Back (2)	6 1/4 x 11 1/4 - 1/2 Ply.
II Drawer 6 Sides (2)	6 1/4 x 14 - 1/2 Ply.
JJ Drawer 7 Front/Back (2)	7 3/8 x 21 1/2 - 1/2 Ply.
KK Drawer 7 Sides (2)	7 3/8 x 18 - 1/2 Ply.
LL Drawer 8 Front/Back (2)	7 3/8 x 11 1/4 - 1/2 Ply.
MMDrawer 8 Sides (2)	7 3/8 x 14 - 1/2 Ply.
NN Lrg. Drawer Bottoms (4)	17 1/2 x 21 3/4 - 1/4 Ply.
OO Sm. Drawer Bottoms (4)	13 1/2 x 11 1/2 - 1/4 Ply.
PP Drawer 1 False Front (1)	2 3/4 x 23 7/8 - 3/4 Ply.
QQ Drawer 2 False Front (1)	2 3/4 x 13 3/8 - 3/4 Ply.
RR Drawer 3 False Front (1)	4 x 23 7/8 - 3/4 Ply.
SS Drawer 4 False Front (1)	4 x 13 3/8 - 3/4 Ply.
TT Drawer 5 False Front (1)	5 1/4 x 23 7/8 - 3/4 Ply.
UU Drawer 6 False Front (1)	5 1/4 x 13 3/8 - 3/4 Ply.
VV Drawer 7 False Front (1)	6 3/8 x 23 7/8 - 3/4 Ply.
WW Drawer 8 False Front (1)	6 3/8 x 13 3/8 - 3/4 Ply.

- (16) #14 x 1" Sheet Metal Screws
- (16) 1/4" Washers
- (20) #8 x 2 1/2" Fh Woodscrews
- (44) #8 x 1 1/4" Fh Woodscrews
- (72) #6 x 1 1/4" Fh Woodscrews
- (72) #6 x 1" Fh Woodscrews
- (40) #6 x 3/8" Rh Woodscrews
- (2) 1 1/2" x 20 1/2" EMT Conduits
- (4) 5" x 1 1/4" Swivel Casters w/Brake
- (4) 23 7/8" Extruded Aluminum Drawer Pulls
- (4) 13 3/8" Extruded Aluminum Drawer Pulls
- (4) 14" Full-Extension Drawer Slides
- (4) 18" Full-Extension Drawer Slides



To download a free cutting diagram for the Work Cart, go to: [www.ShopNotes.com](http://www.ShopNotes.com)

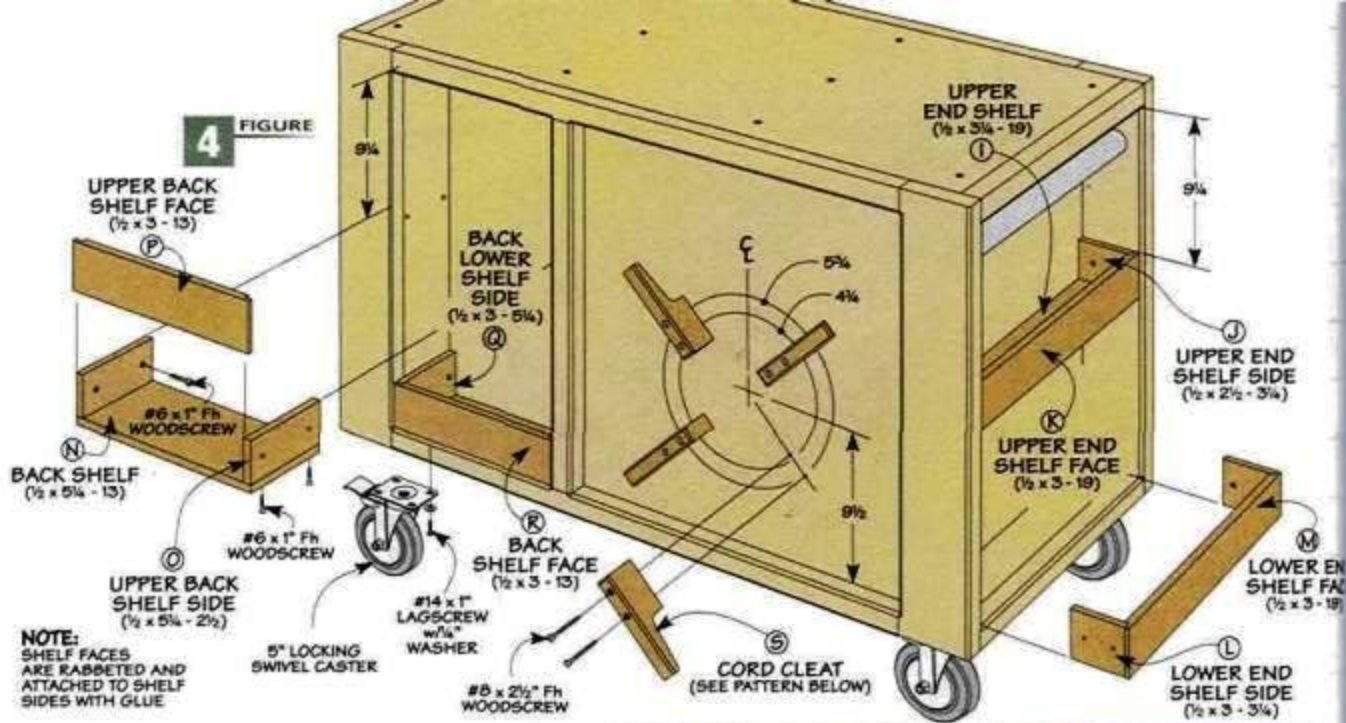

## adding the Shelves & Top

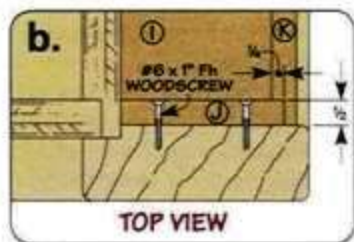
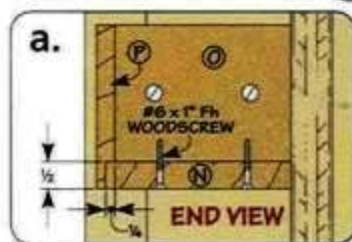

▼ **Power strip.** Adding a power strip guarantees you'll always have an outlet within easy reach.

With the case assembled, the cart is beginning to take shape. The next step is to add some organization. I started by adding shelves in the recesses on the ends and back.

**Shelves.** I wanted the shelves to be big enough to hold a cordless drill and a few of my other more

commonly used tools. And to build them I decided to use hardwood that matched the edging.

The construction is pretty simple. Each shelf is attached to two sides with screws from the bottom. The face is rabbeted along the bottom and both ends to fit over the shelf and then assembled with just glue. Figures 1a and 1b, above, show how this works. I sized each of the shelf assemblies to fit the recesses and then attached them to the sides of the case with screws.

You'll also notice that the lower shelves are formed by the bottom of the case. So the face is only rabbeted on the ends. Then just add the shelf sides to complete them.

**Cord Cleats.** I expected to do a lot of power tool work with the cart, so next I added a power strip and an extension cord. This way, you'll always have an outlet handy when you need to plug in a sander or any other corded tool to work on your projects. I didn't want the long extension cord to be in the



### Cleat Pattern

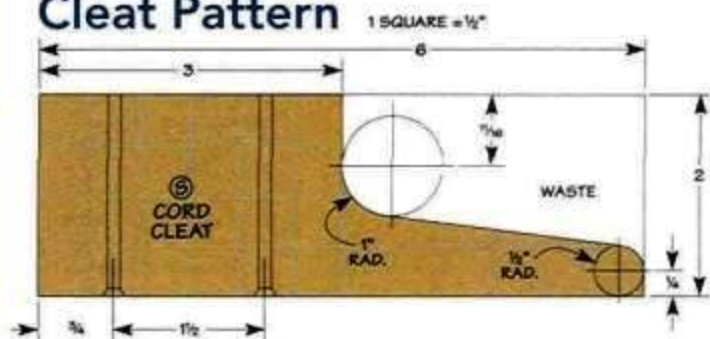

way, though, so I also added a set of four cleats on the back to neatly wrap it around when not in use.

The cleats are just hardwood blocks that I cut to the shape shown on the opposite page and attached with screws. The easiest way to shape them is to drill the hole establishing the radius and remove the waste at the band saw.

**Add the Casters.** The cart weighs quite a bit on its own, but it will be really heavy once the drawers are loaded with tools. So when it came time to choose casters, I made sure to use something that could handle the load. For the casters I used, refer to Sources on page 51.

To mount the casters, you first need to flip the cabinet on its top. Then you can predrill holes for the large lag screws needed to hold them in place. The photo at lower right gives you an idea of how this works. The thing to keep in mind here is to make sure you're mounting them in the plywood bottom and not the edging. Then just screw the casters in place.

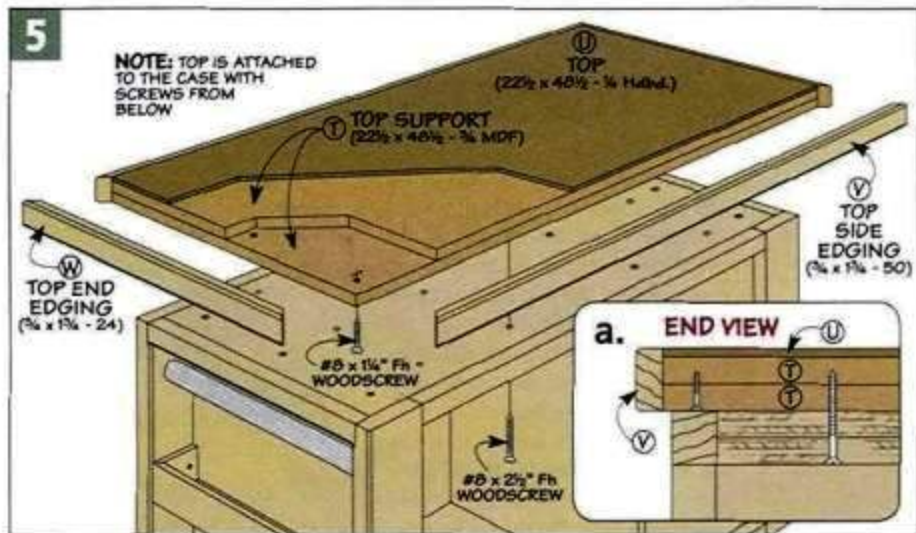

**The Top.** Now you can turn your attention to the top. It's just two pieces of MDF glued and screwed together with a hardboard top. I cut both pieces of MDF and the hardboard at the table saw without changing the fence setting to make sure they were all identical. Then, I lined up the MDF panels, clamped them together, and drilled holes for

the screws. Finally, I added glue and fastened the pieces together.

You can glue the hardboard top on now, or you can just secure it with carpet tape and make it easier to replace if it gets damaged. The box below shows a simple option for making it replaceable.

**Mitered Edging.** I added hardwood edging to match the case, mitering it to fit around the top. The edging protects the MDF from damage that can occur in the shop.

Finally, I attached the top to the case with screws from the inside. I predrilled the holes and used long screws through the double layers of plywood into the MDF to make sure the top stayed secure.

## Replaceable Top Option

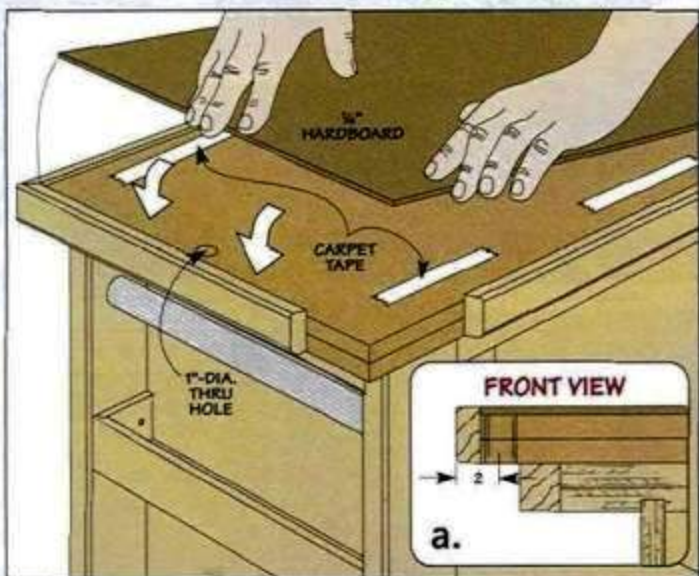

**▲ Replaceable Top.** Since the top will see a lot of wear, you may want to replace the hardboard. A simple way to make this easier is to drill a hole through the MDF layers so you can pop out the old piece when it's time for a change. Just attach the top with carpet tape.

### Casters.

Adding heavy-duty, locking casters makes the cart mobile but still steady.

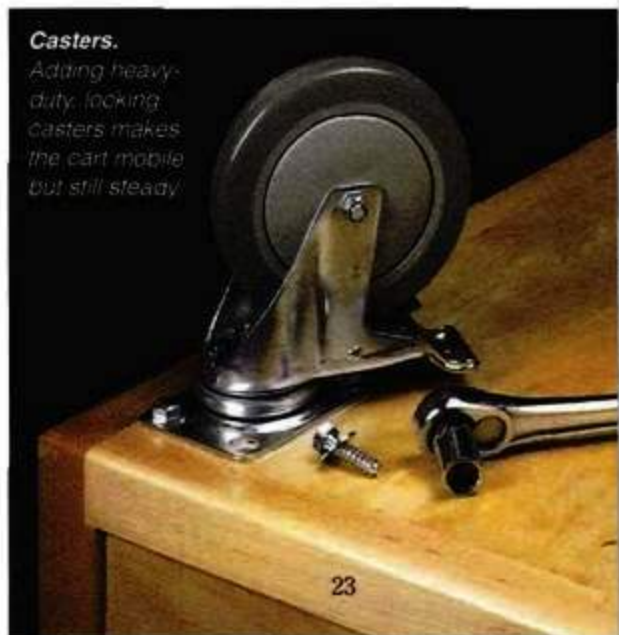

# simple, sturdy Drawers

You can already see how useful the cart is going to be now that the top and wheels are attached. But the addition of the drawers is what really makes the cart a must-have item for your shop. And building the drawers isn't tough. They're different sizes, but they're all built using the same technique.

**Cutting the Pieces.** As you can see in Figures 6 and 8, the heights are the same for each side-by-side pair of drawers. That is, the two top drawers are both  $3\frac{3}{4}$ ", the second pair are 5", and so on as you work downward. So the easiest way to cut

6 FIGURE

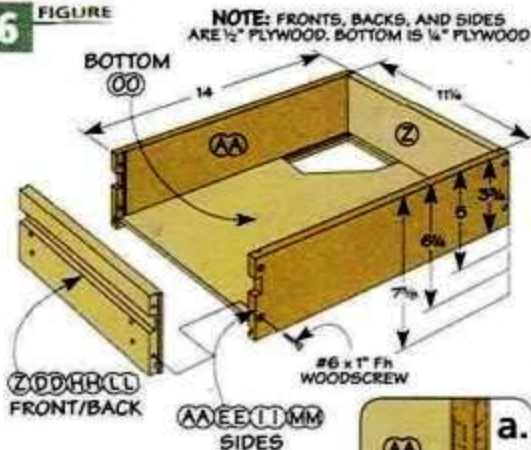

## NARROW DRAWERS

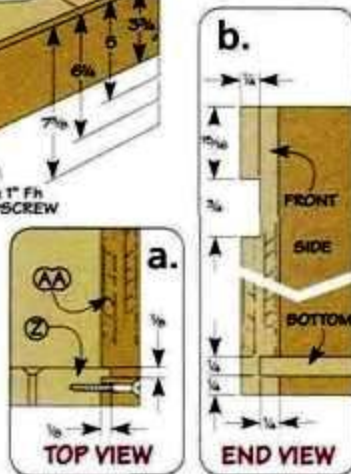

out the parts for the drawers is to work on one pair at a time. This way, you can use the same table saw fence setting to make sure you get consistent results. To keep the parts from getting mixed up, I labeled each piece.

**Joinery.** The next step is to cut the tongue and dado joint on each of the drawer pieces. Since the drawers will be holding a lot of weight, I decided to countersink screws in the sides to reinforce the joint. The joinery is mostly to help with alignment during assembly. You'll only need a  $\frac{1}{8}$ "-square tongue and matching dado, so you can cut them with a standard blade on the

table saw. The technique for cutting this joint is shown in the box on the bottom of the opposite page.

Once you've completed the tongue and dado joinery, you can put a dado blade in the saw and cut the groove that will hold the  $\frac{1}{4}$ " plywood drawer bottom. Then you can cut the bottoms to size.

**Assembly.** Now that you've finished cutting all the pieces, you can begin assembling the drawers.

7 FIGURE

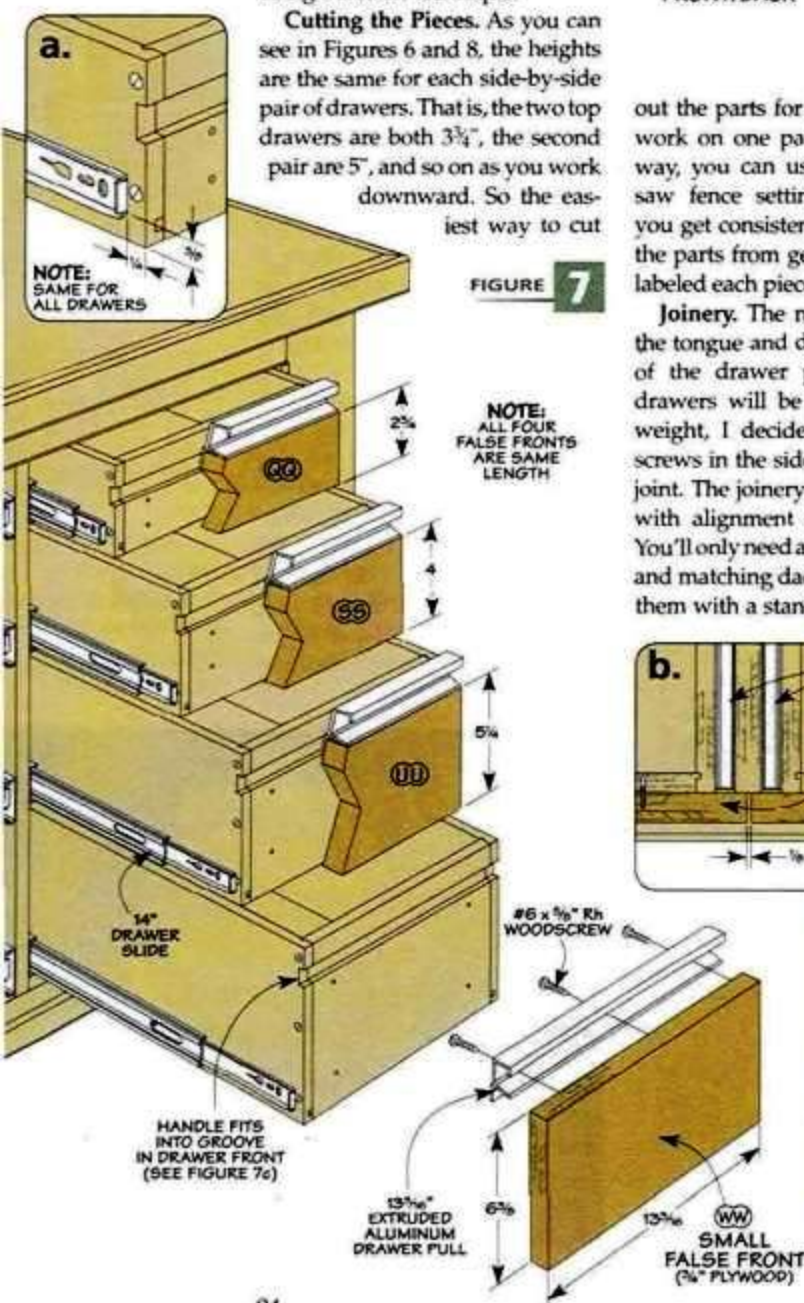



One thing to keep in mind here is to make sure the screws won't be in the way of the groove you'll cut to hold the handle. This groove will make room for the false front and handle assembly. And the groove goes through both the sides and the front, so the drawers need to be assembled before making this cut.

A little glue and the screws are all it takes to complete the drawers. When they're all assembled, you can move back to the table saw and use a dado blade to cut the  $\frac{3}{4}$ " groove in the front of each drawer.

**False Fronts and Drawer Pulls.** I chose an extruded aluminum drawer pull to give the drawers the look of a mechanic's tool chest. Since the aluminum comes in 8' lengths, you'll need to cut each piece to fit the drawer. You can cut the aluminum with a carbide-tipped blade on the table saw. With the handles attached, the false fronts are sized to keep an even,  $\frac{1}{8}$ " gap around each drawer. The false front and handle assembly fits into the grooves you cut in the drawers earlier, and attaches with screws.

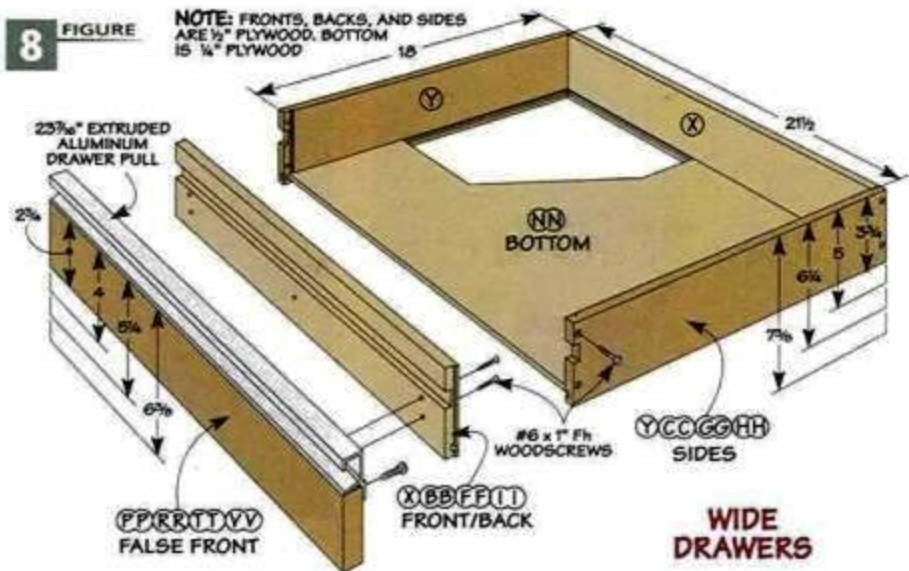

The thing to keep in mind here, is that the false fronts are not centered on the drawers, but overlap the divider, as shown in Figure 7b.

Now, all you need to do is apply a finish and then mount the drawer slides. For an easy technique, refer to Shop Shortcuts on page 16. Then you're ready to load up the cart and put it to work in your shop.

## Drawer Joinery

To beef up the strength of each drawer and make sure they could handle the weight of my heavier power tools, I assembled them with screws. A tongue and dado joint helps keep the drawer pieces aligned during assembly.

The nice thing about this joint is you can cut both parts at the table saw with a standard blade. Using the miter gauge, cut the shallow dados in the side pieces, as shown in detail 'a' at right. To form the tongue on the front and back, you'll need to add an auxiliary fence and slide it next to the blade. Use the miter gauge again to make the cuts on both ends of each piece (detail 'b'). Then just drill and countersink holes for the screws, add a little glue and assemble them.

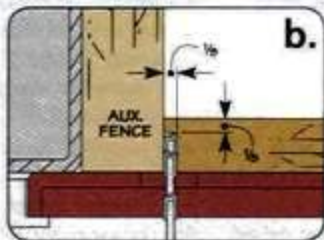
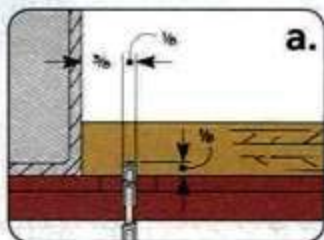

▲ **Large Drawers.** With full-extension slides and a variety of sizes, these drawers will hold anything you need.

# 5 steps to panic-free Panel Glueups

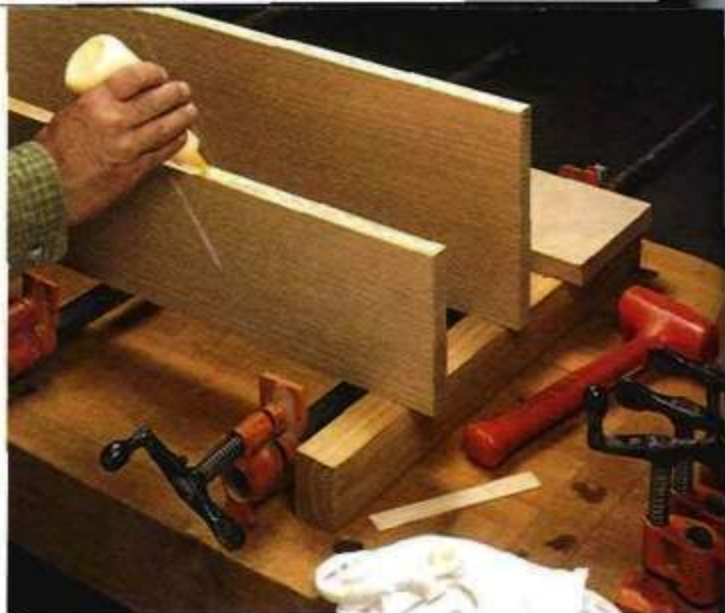

■ A lot goes into making a great-looking, solid-wood panel. First, you need to select and size the stock. Next comes jointing the edges. These are both jobs that you can work on at a pretty deliberate and easy pace. But then the final step — gluing up the panel — is where things can get tense. It's often what makes or breaks the end result, and you only have one shot at it.

The challenge is that glueups are always fast and furious. Once the glue goes on, you don't have much time to think about what to do next and how to handle glitches that might (and usually do) come up. Well, I've found that there's an easy way to avoid all the stress and guarantee success. All you have to do is approach a panel glueup with a simple step-by-step routine.

## 1 Be Prepared

Step one is to get everything in place and ready to go. So after the boards are jointed and the order of the joints is clearly marked, the first thing I do is clear off my benchtop.

Now, I've found that no matter what type of clamps I use, they always bow under pressure. And you won't get a flat panel if it's resting on a bowed clamp. So next I cut a spacer to support each end of the panel above the pipe or bar

clamps on the benchtop. A second plus to this arrangement is that it's much easier to reposition a clamp if the panel isn't resting on it.

After waxing the top edge of the spacers, I position them on the bench and then start laying out clamps — one near each end and then about every 12" in between. Next, I begin to lay the boards over the clamps, spreading



the jaws to "loosely" fit the width of the panel. When all the boards are laid out, another set of clamps is sized and set aside to fill in along the top of the panel.



## 2 Next, the Glue

Now, you're ready for the glue. I only apply glue to one half of each paired joint. Since a three-board panel will have two joints, I'll stand two of the boards on edge and apply glue to each of these.

First, I lay a continuous and liberal bead of glue on each edge, starting with the far board (main photo). Once I set the glue bottle

down, I go to work spreading the glue evenly over the edges (left photo). A strong joint depends on a continuous layer of glue so this is important. Don't rely on contact and pressure to spread the glue.

A thin strip of wood makes a good spreader. In a pinch, a finger will do, but it's messy and you'll spend time cleaning up afterward.

### 3 Apply the Clamps

With a full, even coating of glue on each edge, you can now lay the boards flat and apply the clamps. You want to leave enough space between the jaws so that you can lay the boards down without having to force the jointed edges past one another. This makes it easier to align the boards, and you'll avoid scraping off the glue you just applied. Once the boards are laid out, slide them together and carefully align the joints.

There are just a couple of things you need to keep in mind when applying and tightening the clamps. The first is to balance the clamping pressure on both sides of the panel.

Applying all your clamps on one side can cause the panel to bow. So use the extra clamps you set aside on top to alternate with the bottom clamps. And as you can see in the photo at right, the upper clamps don't rest directly on the panel.

I start by snugging up the lower clamps with light pressure. Then the upper clamps go on, tightening them just enough to keep them in place. With all the clamps in place I gradually step up the pressure going from clamp to clamp. This helps keep the boards aligned and the panel flat. When the clamps are tight, you should see an even bead of squeezeout at the joints.



### 4 Now, Check and Adjust

At this point, you can't assume that the panel is flat and all the joints are perfectly flush. So the fourth step is a quick check, followed by any necessary adjustments.

First, before the glue tacks up, take a look at each joint to make sure the boards are flush or at least pretty close. Your eyes and your fingers are your best tools here.

I have two cures for a misaligned joint. Near the ends of the panel, a clamp tightened over the joint will level it out. Through the center of the panel where a clamp won't

reach, I use a dead-blow mallet to force the "high" side of the joint down. If you need to, loosen a clamp or two to make this easier.

Next, I pick up a straightedge to check for flatness across the width of the panel, as shown at left. I check across both ends and the middle to look for gaps that give away a bow. If you see a dip or crown in the panel, check to see if the heads of the clamps are positioned correctly (inset photo). Moving a clamp (or clamps) up or down slightly can help flatten a bowed panel.

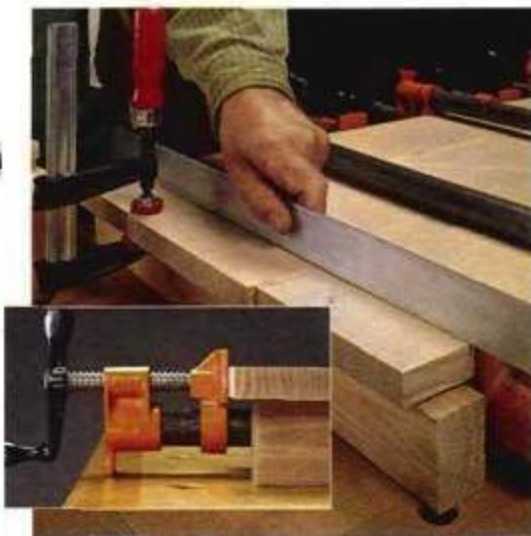

### 5 Finally, Clean Up

By now things should be well under control, but you can't relax completely just yet. Here, I like to give the glue squeezeout about ten minutes to "skin over" and then clean off as much as I can.

This early cleanup has a couple of advantages. Dried glue takes a lot of careful effort to remove without doing damage to the panel. But the still-gummy glue scrapes off easily

(photo at right). And with the glue out of the way, I can better see if the clamps are exerting enough pressure and the joints are tight.

After scraping the top, flip the panel over and do the same to the bottom. Finally, hoist the panel off the bench and stand it (with the joints horizontal) out of the way. And when the clamps come off, you'll surely like what you see. 🐶



# 3-in-1, shop-built Multi-Tool

Router table, mortiser, edge jointer — this compact, easy-to-build project does it all.

■ A palm router packs a big punch into a compact size. This makes it easy to use and gives you more control and great visibility.

But sometimes it's easier, and safer, to bring the workpiece to the router. So I gave my palm router an upgrade and built the multi-tool you see in the photo above.

It allows me to work with narrow moldings or small pieces. And the fence and a unique router adjustment system makes it easy to quickly set up for a series of cuts, like dados or grooves.

**Handy Features.** To give it all this versatility, the tool has a few handy, built-in features. First, a

couple of workpiece supports provide greater control when working with long stock. In addition, you can attach a simple edge-jointing fence to quickly put a square edge on small parts. Finally, the router plate can be inserted vertically to easily rout mortises, as shown in the photo on the opposite page.

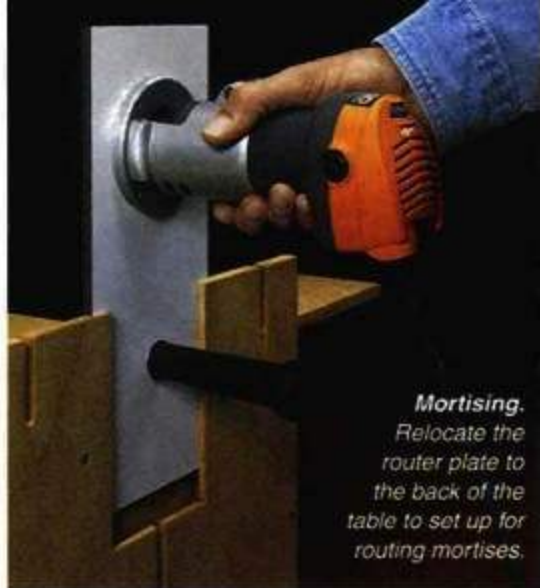

**Mortising.**  
Relocate the router plate to the back of the table to set up for routing mortises.

## Exploded View Details

**OVERALL DIMENSIONS:**  
13½"D x 15"W x 14"H  
(37"W WITH WORKPIECE SUPPORTS ATTACHED)

**NOTE:** MULTI-TOOL BUILT FROM ½" BALTIC BIRCH PLYWOOD

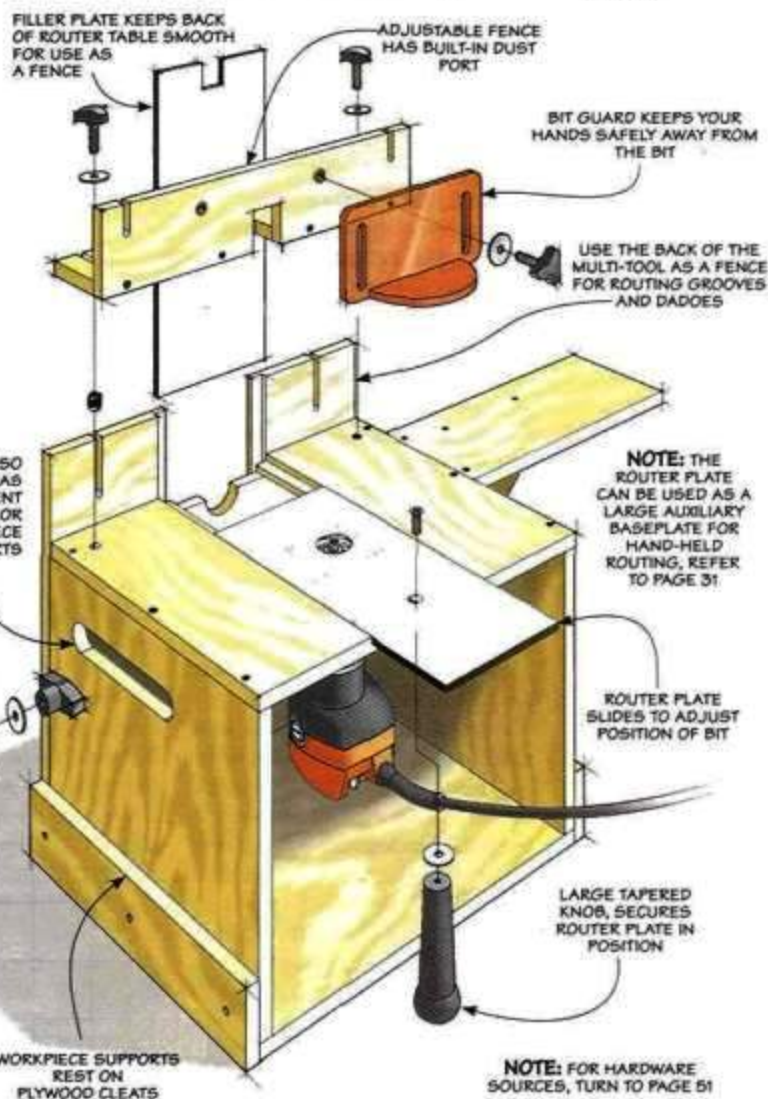

## Materials & Hardware

### CASE

A Base (1)	14 x 12 - ½ Ply.
B Sides (2)	10 x 12 - ½ Ply.
C Case Back (1)	10 x 13 - ½ Ply.
D Top (1)	14 x 12 - ½ Ply.
E Back (1)	14 x 14 - ½ Ply.
F Router Plate (1)	5 x 12 - ¼ Phenolic
G Filler Plate (1)	5 x 12 - ¼ Phenolic

### WORKPIECE SUPPORTS

H Cleats (2)	2½ x 12½ - ½ Ply.
I Tops (2)	5 x 11 - ½ Ply.
J Sides (2)	5 x 8 - ½ Ply.
K Supports (2)	7 x 7 - ½ Ply.
L Pinch Blocks (2)	¾ x 2 - ½ Ply.

### FENCE

M Face (1)	3 x 14 - ½ Ply.
N Base (1)	2½ x 14 - ½ Ply.
O Braces (4)	2 x 2 - ½ Ply.
P Dust Port (1)	3⅝ x 3 - ½ Ply.

### JOINTER FENCE

Q Fence (1)	3 x 25 - ½ Ply.
-------------	-----------------

### HOLD-DOWN

R Hold-Down Face (1)	2 x 12 - ½ Ply.
S Plate (1)	1 x 12 - ¼ Phenolic

- (1) ¼" - 20 x 4½" Tapered Knob
- (3) ¼" - 20 T-knobs
- (6) ¼" - 20 x 1" Studded 3-Point Knobs

- (10) ¼" Washers
- (6) ¼" - 20 Threaded Inserts
- (2) ¼" - 20 x 2" Carriage Bolts
- (2) ¼" - 20 x ¾" Fh Machine Screws
- (1) .064" x 1" - 12" Brass Strip
- (1) .032" x 1" - 12" Brass Strip
- (54) #8 x 1" Fh Woodscrews
- (1) Bit Guard

**ShopNotes** To download a free cutting diagram for the Router Table, go to: [www.ShopNotes.com](http://www.ShopNotes.com)

**GO ONLINE EXTRAS**

# a simple, plywood Case

The whole point of the multi-tool is to help get other projects done. So you don't want to spend a lot of time building it. As you see in Figure 1, I kept this table simple by using screw-together construction.

**From the Bottom Up.** I began construction of the table by making the case. When you get right down to it, it's just a plywood box that's open at the front. You'll find all the dimensions for cutting the case pieces to size in Figure 1. But before you assemble the parts, there are some details I want to point out.

**Handles.** The first is a slot that's cut in each side. These slots serve two purposes. First, they act as handles to make carrying the table easy. Second, they'll be used to mount and adjust the workpiece supports you'll build later.

Another detail to mention is the notch in the case back. This notch provides clearance for a bit when the table is set up for routing mortises (refer to page 33).

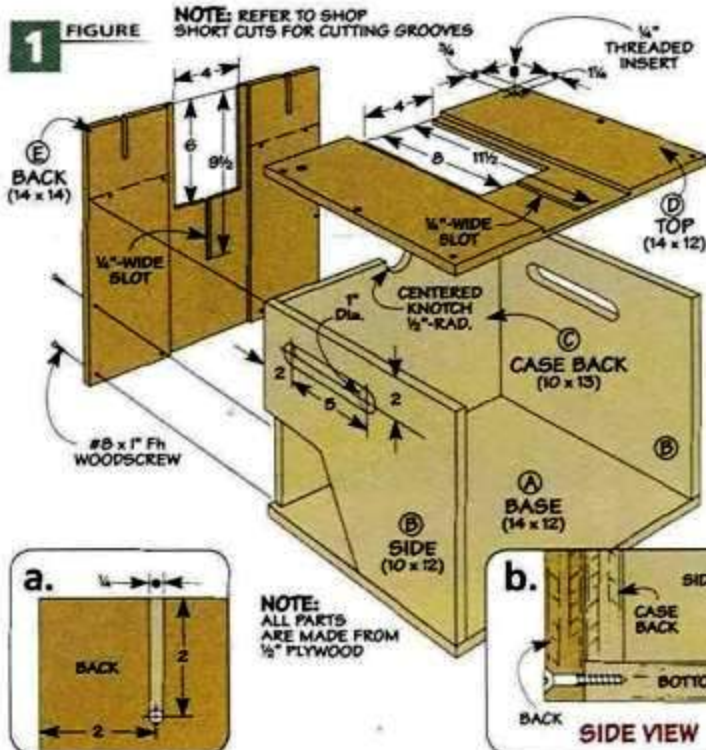

**Top and Back.** The other key details are in the top and back of the table. Here, you'll see that each piece has a large, square notch cut into it. These are made to fit

a pair of phenolic plates. You'll attach the router to one plate. The other is used as an insert to provide a smooth, continuous surface.

The depth of the grooves matches the thickness of the phenolic (mine was 1/4"). So you want to have this material on hand before cutting the groove. (Turn to page 51 for sources.) If you take a look at page 17, you can learn how the grooves are cut at the table saw.

Finally, along the top edge of the back, I cut two small slots, as in Figure 1a. These will be used to attach a mortising hold-down. Once you have all these things complete, you can assemble the case with glue and screws.

**Phenolic Plates.** The phenolic plates I mentioned earlier are the next pieces to make. In Figure 2, you can see that the router plate and filler plate are identical in size. But there are a couple of differences that I want to highlight.

To provide an opening for the largest router bit I might use, I drilled a 1 1/2"-dia. hole. You'll also need to drill a few mounting holes to match your router base.

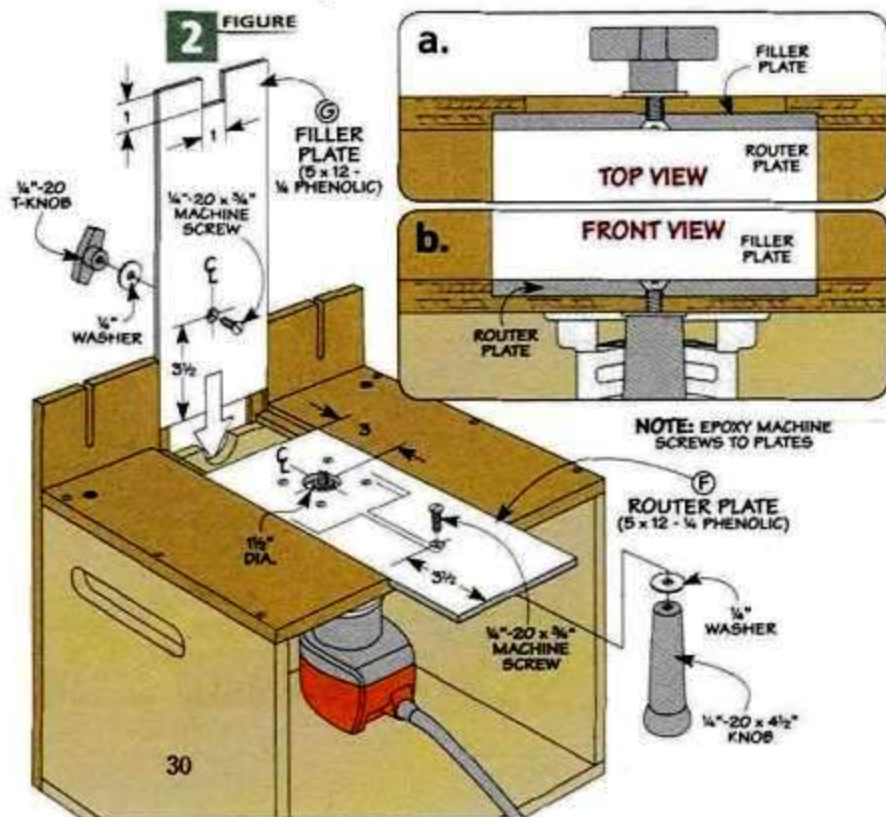

All that remains to complete the router plate is to drill a countersunk hole for a screw that attaches to a tapered knob and washer (Figures 2 and 2b). You'll use the knob to lock the router in place after adjusting the position of the bit.

As a side benefit of this setup, I found that once the palm router was attached to the plate, it made a stable baseplate for hand-held routing, as you can see in the photo below. This gives you great control and support when routing profiles.

**Filler.** There are only a couple of things to do on the filler plate, as shown in Figure 2a. At the other end of the plate, I cut a clearance notch. Like the notch in the case back, it allows the bit to be recessed flush with the table top when the router is mounted on the back.

### WORKPIECE SUPPORTS

At this point, the case is pretty much complete. And, along with the fence (shown on the next page), you could start using it. But I'd encourage you to build the supports you see in Figure 3.

What I really like about them is that you can adjust their

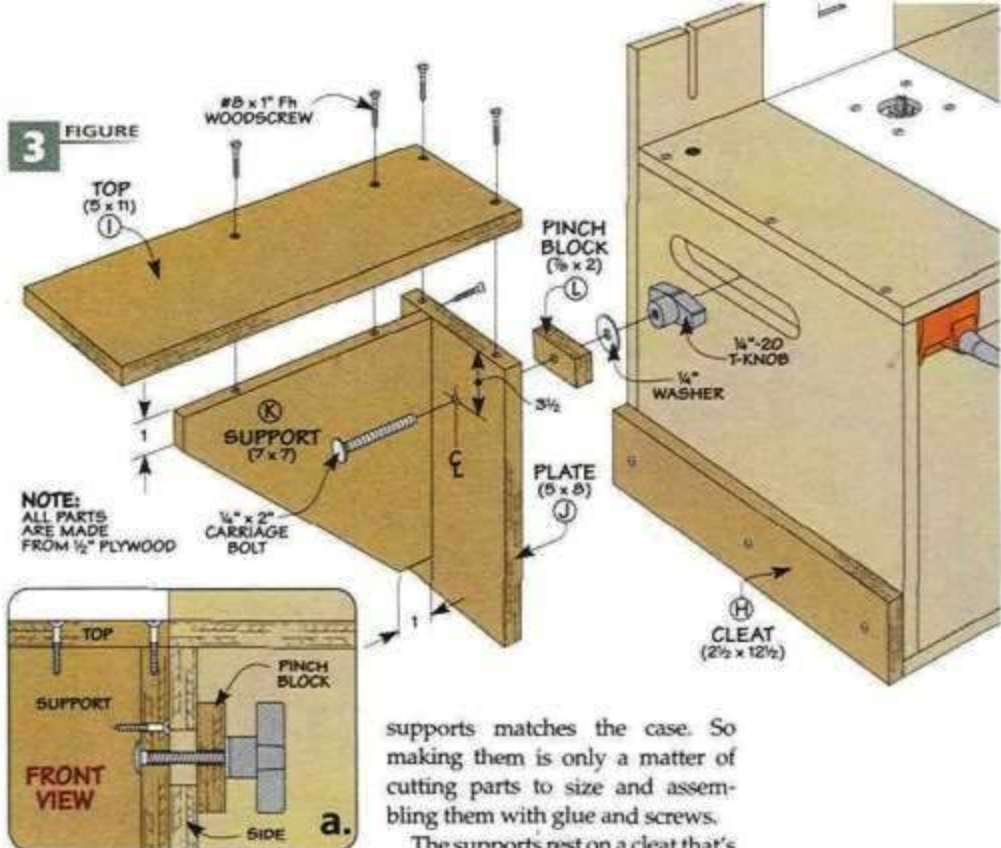

position so they provide support in just the right place, as in the lower right photo below. And as the inset photo shows, they tuck neatly in the case for storage.

**Simple Construction.** As you see above, the construction of the

supports matches the case. So making them is only a matter of cutting parts to size and assembling them with glue and screws.

The supports rest on a cleat that's sized to keep the top of the support flush with the tabletop. And to fix the supports in place, I used a plywood pinch block, carriage bolt, washer, and knob (Figure 3a).

Now, the table is complete. But as I mentioned before, you still need to make the fence.

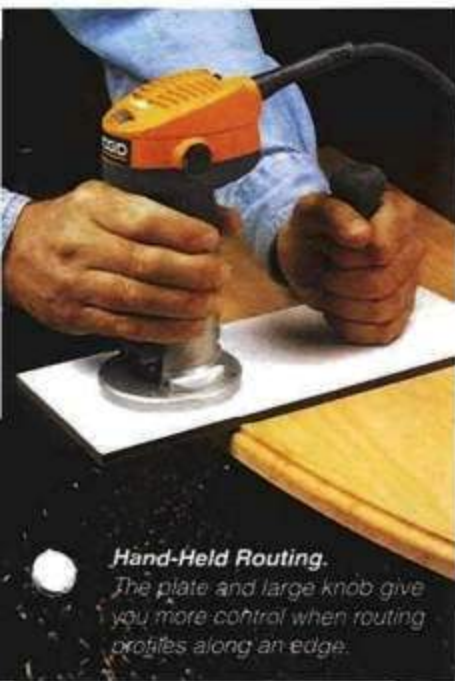

**Hand-Held Routing.**  
The plate and large knob give you more control when routing profiles along an edge.

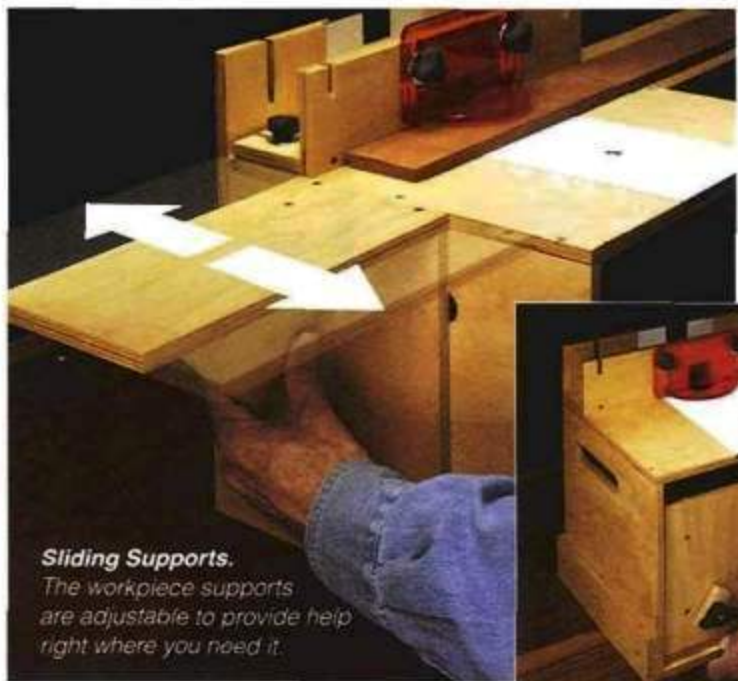

**Sliding Supports.**  
The workpiece supports are adjustable to provide help right where you need it.

**Compact Design.** The supports tuck inside the case for easy carrying and storage.

## an adjustable Fence

The last piece of the router table to make is the fence. You can see how it goes together in Figure 4. It's an L-shaped assembly consisting of a face and base. Four braces on the back square it up and provide an attachment point for a dust port.

**Fence Details.** Before you glue everything together, there are few things to take care of. The first is a pair of centered notches to allow for the router bit.

Second, near each end of both the base and face is a slot (Figures 4a and 4b). The slots in the base allow you to adjust the position of the fence. And those in the face allow you to attach an auxiliary fence that you can use for jointing (box below). Finally, a pair of threaded inserts in the face allow you to attach a bit guard.

**Using the Fence.** Now you're ready to put the multi-tool to use.

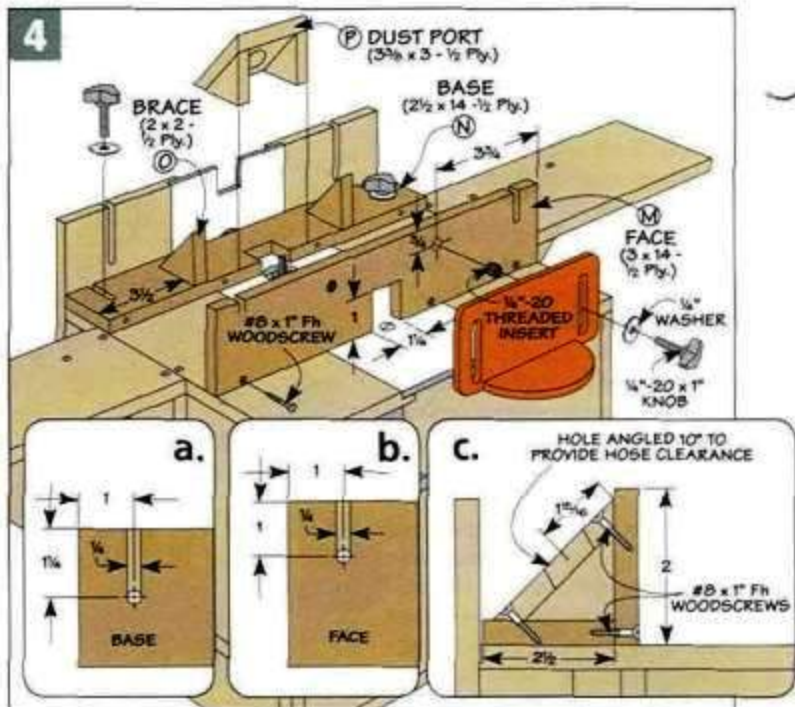

To handle the widest range of tasks, you have several options for positioning the bit. The fence works great for routing with profile bits. For cuts away from the edge of a

workpiece, you can slide the router plate out to position the bit. And finally, for routing even farther from the edge, remove the fence and use the back of the table instead.

## Jointing Fence

Normally, I use a jointer to put a clean edge on a workpiece. But that just isn't safe to do with small parts. However, you can use the multi-tool (photo at right).

The key is the long jointing fence you see below. It attaches to the main fence with studded knobs and washers. Brass strips in two different thicknesses provide a smooth surface for the workpiece and allow you to take thin cuts to get a perfectly square edge.

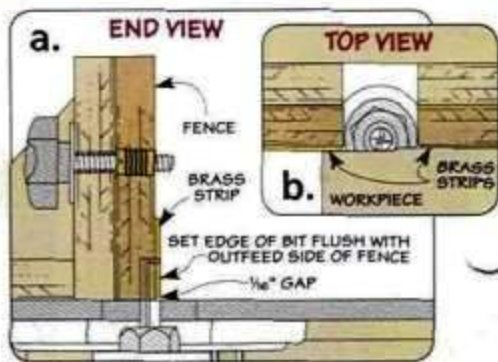
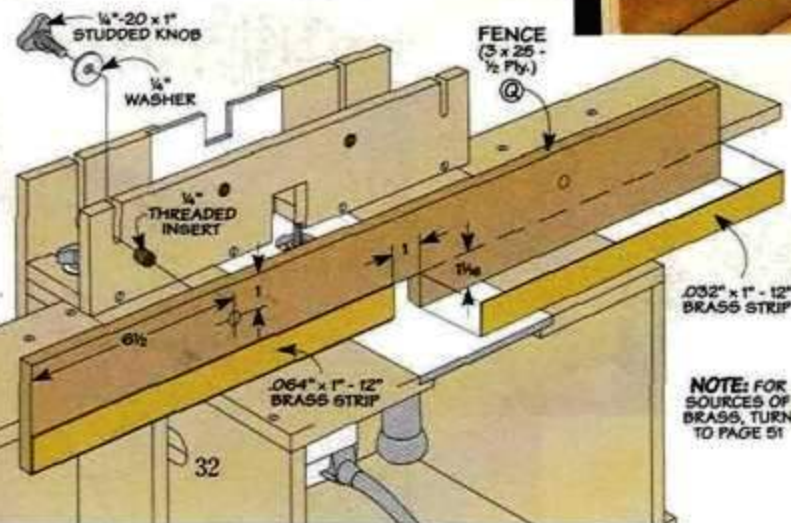
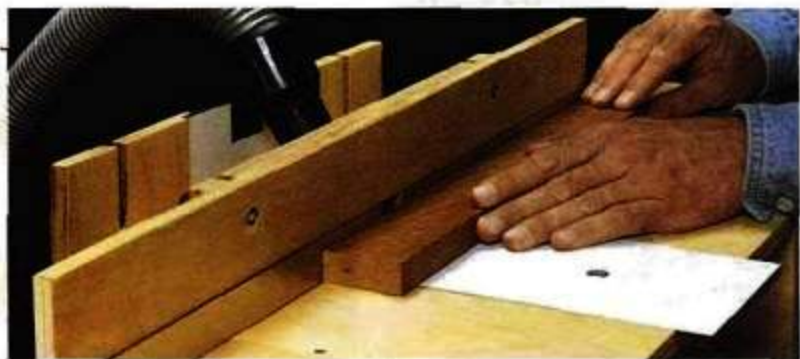

NOTE: FOR SOURCES OF BRASS, TURN TO PAGE 51



# How To Rout Mortises

Besides your everyday routing tasks, there's one other job where this table shines — routing mortises. It turns a simple router table into a mortising machine.

The key to mortising accurately lies in inserting the palm router horizontally on the back of the table, as shown in the photo at right and the drawings below. All it takes to do this is to switch the positions of the router plate and filler plate.

**Make the Hold-down.** Before getting into the steps to mortising, it's a good idea to make the hold-down shown below as well. Not only does this keep the workpiece firmly against the table, it also acts as a guide to rout the mortises.

**The Setup.** The drawings below show you the simple, three-step

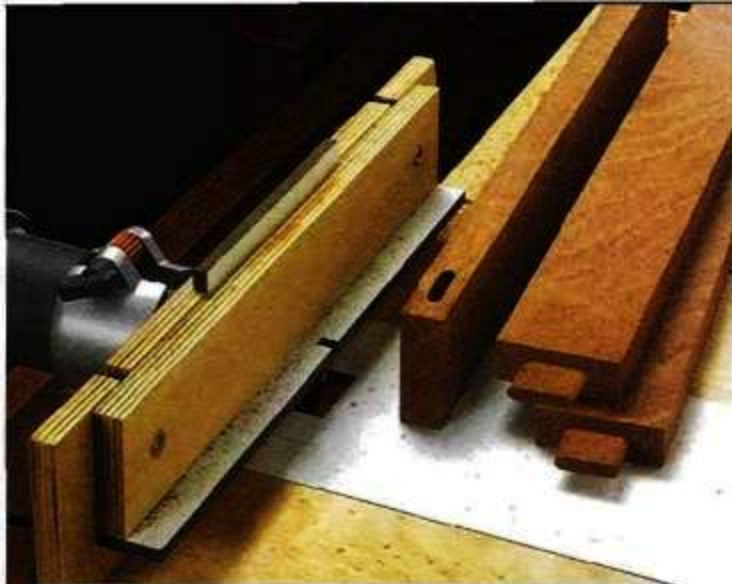

◀ **Perfect Mortises.** An ordinary straight bit and a simple hold-down is all it takes to rout mortises using the multi-tool.

process for making each mortise. But there are some additional things I want to highlight. First, when routing, you'll move the workpiece from left to right. (This is the reverse of how you would typically use the router table.)

And second, it's best to rout the mortises in multiple passes. This does several things: it allows the chips to clear easier so you get a cleaner cut, you'll prevent burning, and it prolongs the life of both the palm router and the bit.

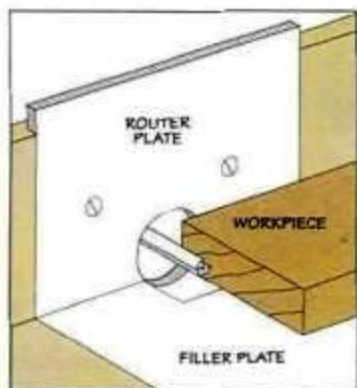

▲ **Setting up the Bit.** Use a workpiece as a set-up gauge to locate the router bit to cut in the center of the workpiece.

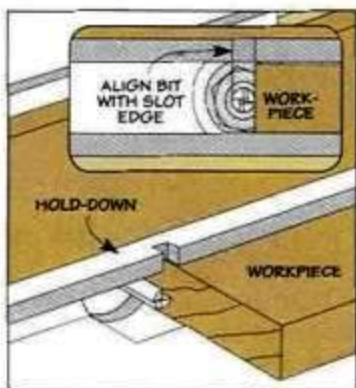

▲ **Position Hold-Down.** Set the hold-down on the workpiece and align the notch with the edge of the bit. Then lock the hold-down in place.

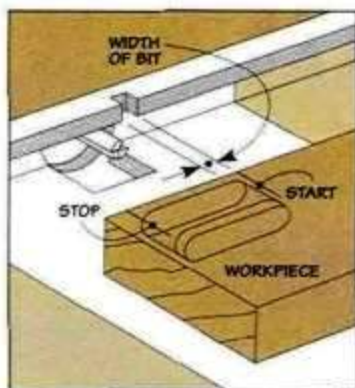

▲ **Rout Mortise.** Use layout lines and the guide notch on the hold-down to rout the mortise. Take shallow cuts for best results.

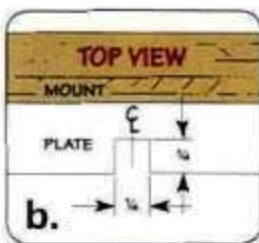
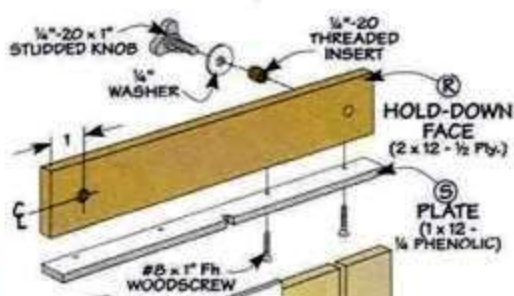
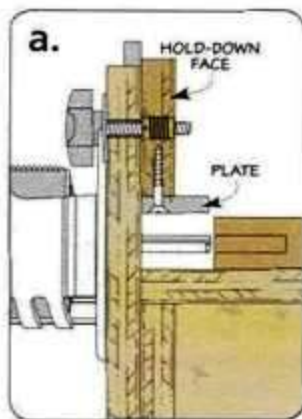

fine tools

# all-purpose Layout Tool

Build this handy tool in an afternoon and you'll use it for a wide range of tasks around the shop.

■ When you first look at the photos, you might think this is a basic dovetail layout tool. But looks can be deceiving. There's a lot more to it than that. You'll find other uses around the shop for this handy tool, like laying out mortises.

The nice thing about building this tool is that you can put it together in an afternoon or weekend. If you look at the drawings on the next page, you'll see what I mean. The wood pieces are small, so it's a good opportunity to use some exotic or

special wood without worrying about breaking the bank.

**An Easy Build.** The construction of this layout tool is pretty simple. There's a slotted wood base with a guide strip that runs along its length. This allows a pair of index blocks and brass "keys" to slide back and forth. The guide strip keeps the blocks (and keys) square to the base as you adjust them to suit the job at hand. And the long edge of the base makes a solid reference face against the workpiece.

If you look closely, you'll see that the brass keys fit in a groove in the index blocks. The keys are slotted so they can be adjusted in and out.

As for the hardware, you can see I kept that pretty simple, too. A couple of brass flange bolts and rubber washers from the hardware store tie everything together.

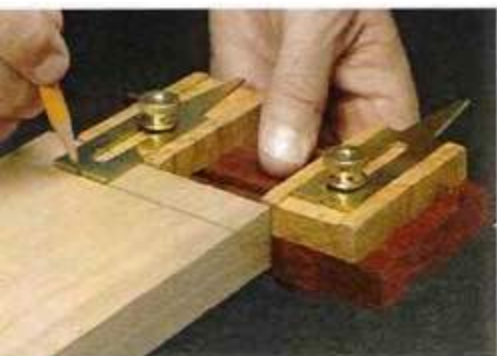

▲ **Scribing Lines.** A small notch in the end of each key holds your pencil tip for marking lines parallel to the edge of a workpiece.



▲ **Dovetail Layout.** The angled dovetail keys make quick work of spacing and marking the pins of hand-cut dovetail joints.

Knurled brass nuts give it a more refined "fine tool" look and make it easy to reposition the index blocks (see Sources, page 51).

**Base.** Building this layout tool starts from the ground up, so the first thing you need to do is make the base. I started by sizing the base to final width and length.

The next step is to drill the start and stop holes for the slot, like you see in Figure 1. Then use a  $\frac{1}{4}$ "-dia. straight bit to rout the slot. And while you have the router fence locked in position, you can flip the workpiece over and switch to a  $\frac{1}{2}$ "-dia. straight bit to rout the groove on the bottom. This way, you can guarantee the centerlines of the slot and groove are aligned.

After that's done, you can step back to the table saw to cut the groove for the guide strip. The last thing to do for the base is to rip the guide strip to size and glue it in place. Then you can start to work on the index blocks.

**Index Blocks.** Because the index blocks are small, it's safer to make them from one long piece of stock. After you rip the stock to width, drill the holes for the bolts and cut the saw kerf on each end (Figure 2). I used a straight bit in the router table to make the centered groove for the brass keys. The goal is to make sure the width of the brass stock you'll be using for the keys

## Exploded View Details

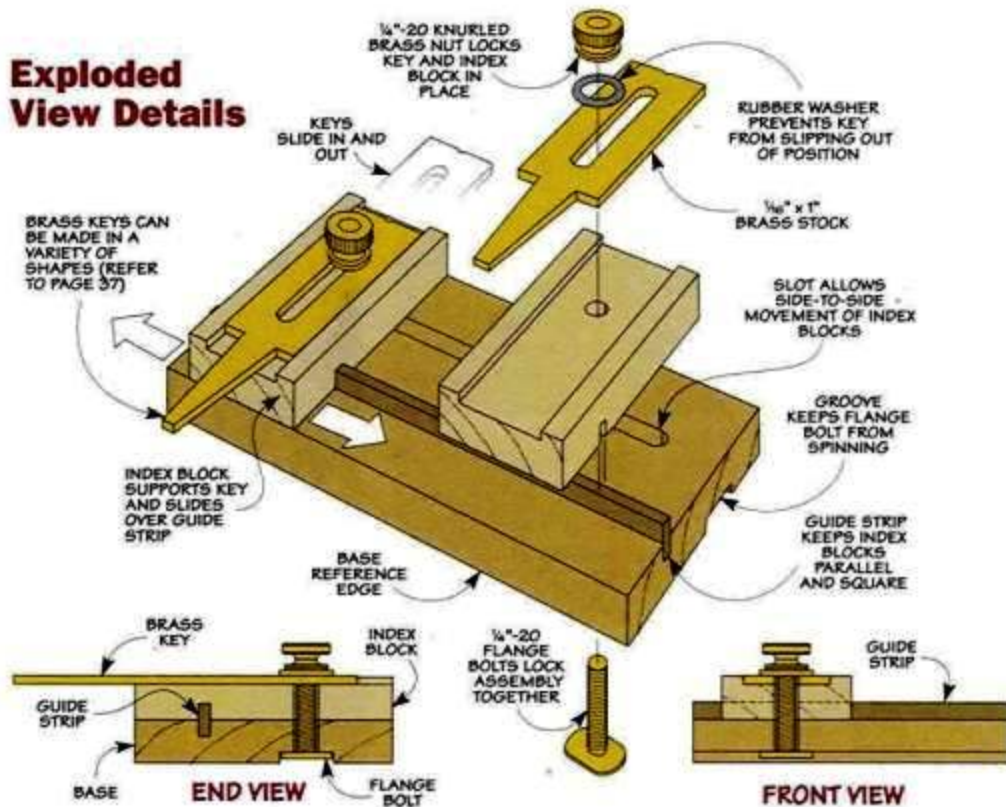

fits snugly in the groove. Then, to cut them to length, I used an auxiliary fence on my miter gauge to help support the workpiece.

**Test Fit.** With all the wood parts complete, now is the time to sand them smooth, test their fit, and make any adjustments. You want the flange bolts to slide freely along the slot. And the index blocks should seat over the

guide strip and move side to side without a lot of effort.

To complete the base and index blocks, I applied a coat of oil and paste wax to all the wood parts. The oil makes the grain "pop" and the wax ensures the index blocks will slide easily for smooth operation. Once that's done, you can turn your attention to making the brass keys.

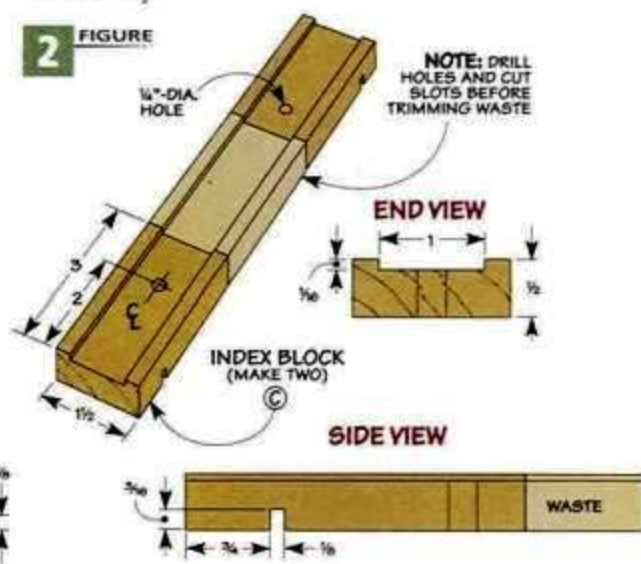
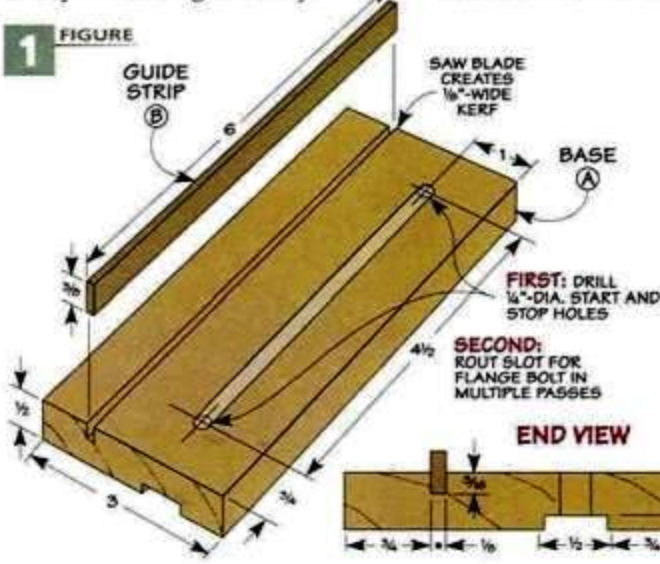

# making the Brass Keys

With the wood pieces completed, the only thing left to do is make the brass keys. Making the keys is the more interesting part of this project. It's an opportunity to give the tool some "polish." You can start by making the keys for laying out dovetail joints like you see in the left margin. For other useful options, check out the box on the bottom of the opposite page.

**Creating a Slot.** Like the index blocks, it's safer to work with the brass as a long piece, as shown in Figure 3. The first step in making the keys is forming the slot that runs down the middle.

What I like to do is drill the holes at the ends of the slot (Figure 3). Then it's just a matter of drilling a few holes between them to remove some of the waste. I used a fence to keep the drill bit from grabbing and spinning the brass. And it's always a good idea to clamp the workpiece any time you're drilling or cutting metal in the workshop.

You'll find that a round file works great to remove the waste between the holes. And a flat file makes quick work of smoothing out the edges of the slot. Now



▲ **Angled Cuts.** Use an auxiliary fence with a shallow dado and clamp to hold the brass in place.



▲ **Final Cuts.** A zero-clearance insert makes trimming away small pieces easier and safer.



▲ **Filing a Notch.** A triangular file is ideal for forming the small notch in the end of the brass keys.

you're ready to cut the angle on the ends of the blanks.

**Cutting Jig.** The nice thing about cutting brass is that it doesn't require any special tools. It's soft enough so that you can cut it with a standard carbide-tipped saw blade. But to make the cut safely, you'll want to make an auxiliary fence to fit your miter gauge.

Figure 4 shows the auxiliary fence I used to hold the key in place. The fence is just a scrap piece with a shallow dado. I made sure to clamp the brass blank in place

before making any cuts. There's just one more step before you can polish up the keys.

**Guide Notches.** The last step in forming the keys is an easy one. You can see in the photo above a small notch that's filed in the square end of the key. This notch comes in handy for holding your pencil or a marking knife while striking a line.

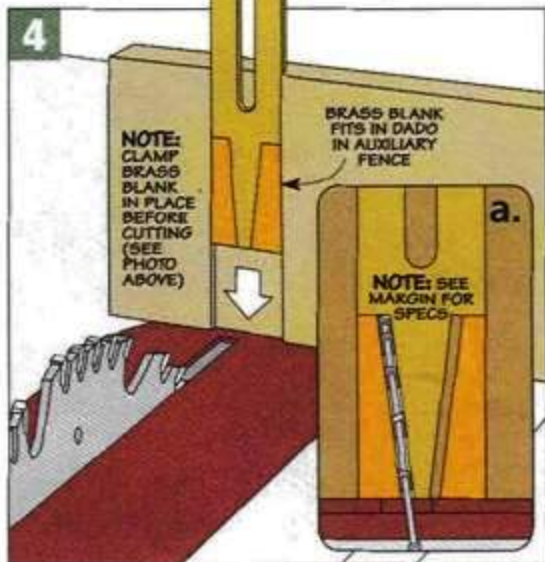
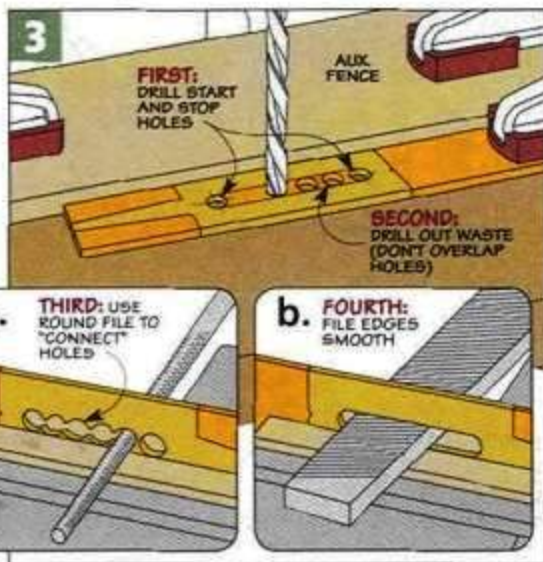
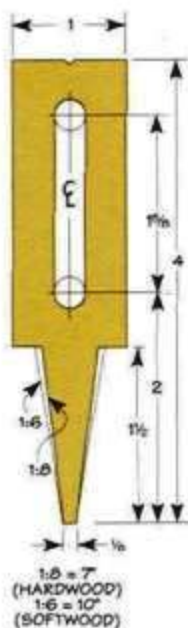

A couple of passes with a triangular file is all it takes to form a shallow notch. Now there's only one more thing left to do.

To make the keys look and work smoothly, you'll want to smooth the edges and polish the faces. You can see how I did this in Shop Shortcuts on page 16.

**Using the Tool.** Using the layout tool is just a matter of loosening the nut to move the index blocks and keys. The problem was the keys wanted to slip out of place. But an ordinary rubber washer between the nut and the key provides enough "grip" to let me move the index block but still hold the key in place without it slipping.

Now that everything's together, you can start to put the tool to use. The first thing I tried was laying out dovetail joints (main photo, page 36). The index blocks establish the spacing of the dovetails. And the brass keys determine the size of the pins and tails. The square end of the keys came in handy for scribing



▲ **Locating Screw Holes.** Use the notch to hold the pencil tip while sliding the tool along the edge.



▲ **Marking Mortises.** First, use the tool to mark the ends of the mortise (top photo). Then set each key to a different depth to mark the sides of the mortise (bottom photo).

the base of the pins and tails across the ends of the boards.

In the photos above, you'll see that this tool is a real time-saver for laying out mortises, too. You can set each key to mark the two cheeks of the mortise. That makes it really handy for mortises that are offset (not centered).

With just a little imagination, you'll find many other uses for

this tool. I soon discovered that by making some "custom" keys, I could use this tool for a lot of tasks in my shop (box below). If you're like me, it won't be long before it'll find a home in the top drawer of your tool chest. ▲

## Options: Keys



You can get creative with the shape of the brass keys to suit a wide range of tasks, as you can see in the photos.

You'll cut and shape them like you did for the dovetail keys. For curved "caliper" shapes, I use a scroll saw or coping saw fitted with a blade suitable for cutting brass.

For a finished look, file the rough edges and buff the keys to a shine. I also like to "joint" straight edges with a fine-cut file to create an edge that will help with marking a precise line on the workpiece.

As I've used the layout tool, I've made several sets of custom keys to have on hand.

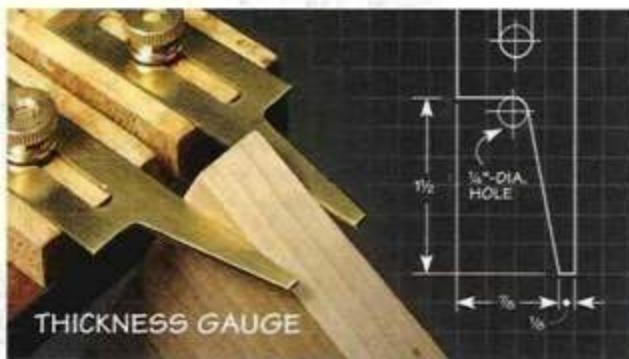

THICKNESS GAUGE

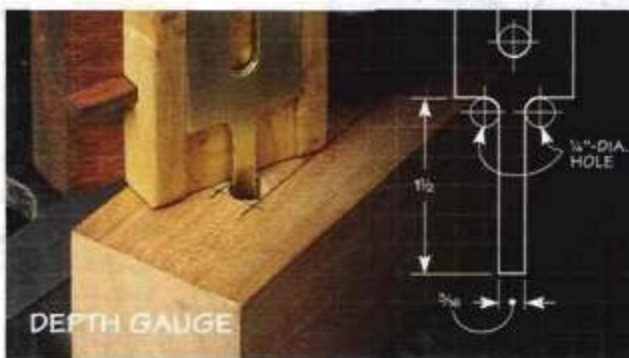

DEPTH GAUGE

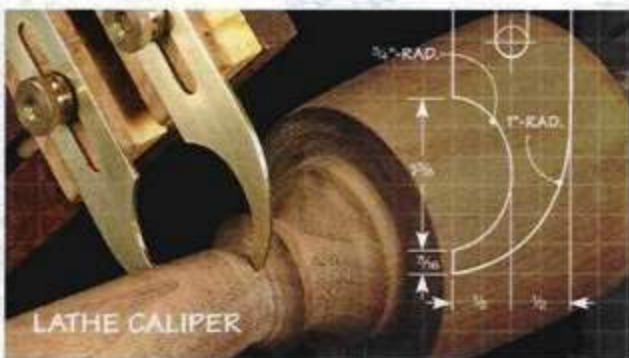

LATHE CALIPER

# putting Air Power to Work in your shop

Upgrade the performance and versatility of your air compressor with a piping system.

■ It's only been a few years since I bought an air compressor for my shop. But since then, it's become a tool I can't do without. The only problem is it isn't easy to move a "portable" compressor around. For a long time, I left mine in one place and used long hoses. However, they always ended up in a tangled mess.

**Fixed Piping.** A solution is to run piping around the shop. This way, you can have an air hookup wherever you need one.

But there's more to plumbing your shop for compressed air than just going out to the home center and buying a bunch of pipe. It'll take some planning and a little "inside" information on just what to include to get the best results.

**The Right Material.** The first thing to think about is the type of piping to use. A stop in the plumbing aisle at your local

home center has a number of options—galvanized iron, black iron, and copper. (Don't bother being tempted by low-cost PVC. It's brittle and any break in a line under pressure will cause it to shatter.)

**Copper Works Best.** Of the suitable choices, my preference is copper for a number of reasons. First, it won't rust from any water in the line. Second, the smooth inside walls allows the air to flow freely for better efficiency. And you'll discover the

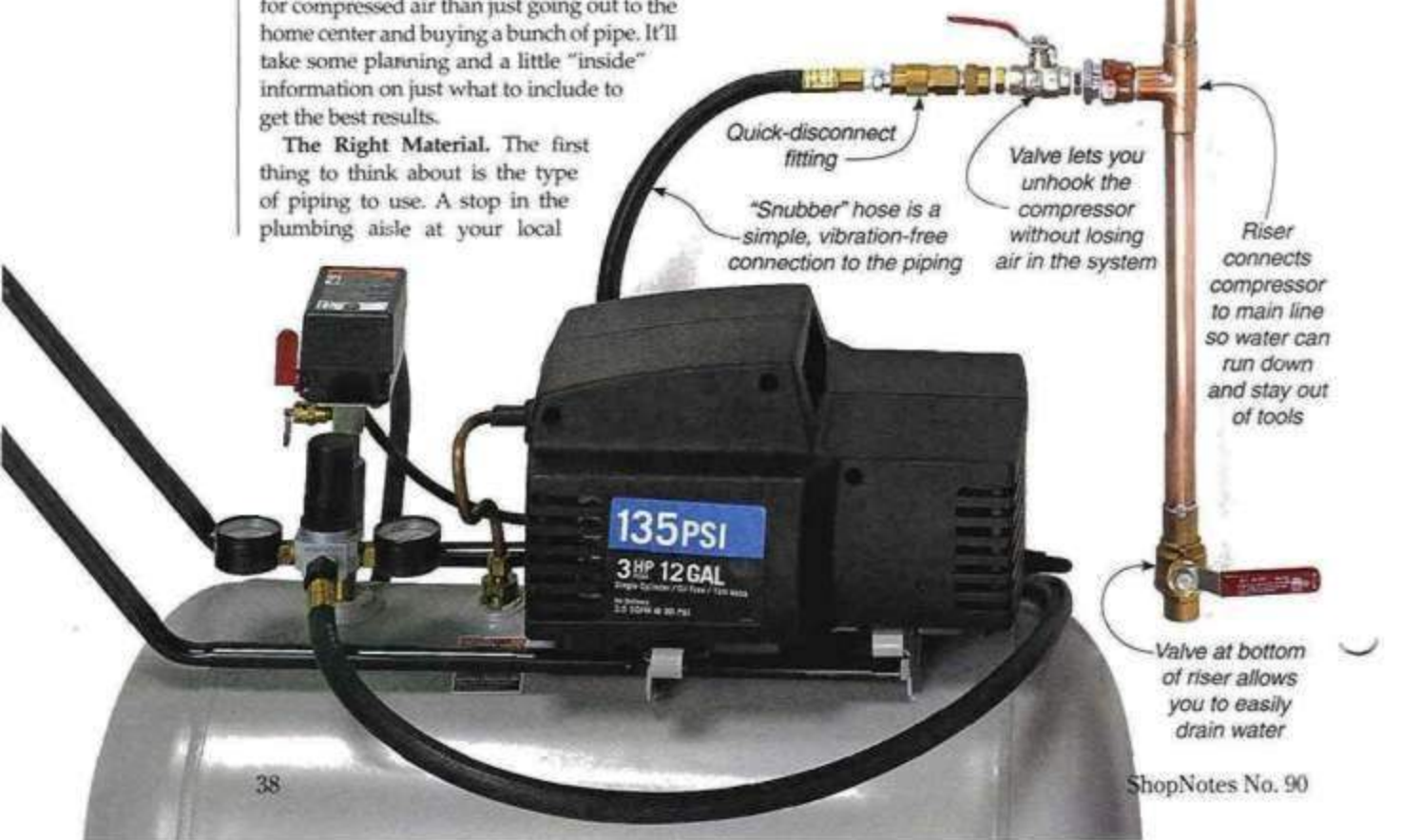

Split-ring standoff mount works for walls or ceilings

3/4"-dia. copper pipe provides extra air capacity

Quick-disconnect fitting

"Snubber" hose is a simple, vibration-free connection to the piping

Valve lets you unhook the compressor without losing air in the system

Riser connects compressor to main line so water can run down and stay out of tools

Valve at bottom of riser allows you to easily drain water

Running main line high on wall or ceiling avoids damage

► **Basic Tools.** To solder copper, you only need these simple tools and supplies.



third advantage when you install the piping in your shop. Copper is a lot lighter than iron and it's pretty easy to work with.

There are only a couple downsides of copper. Yes, you do need to solder the joints. But this is an easily mastered skill. The other downside is the cost. So if you'd rather consider a less-expensive option, just take a look at the box below.

**Plan the Layout.** Once you've decided on the type of piping, the

next step in the process is figuring out the layout of your system. That means finding a place for the compressor, determining where the main line of piping should run, and the number and location of branches or drops you want.

In the photos on these two pages and the next, you'll see a sample setup that shows the basic components of a compressed-air run.

**Compressor Connection.** For now, let's concentrate on the main line. Since you no longer need the compressor close to your work, you can move it to an out-of-the-way corner or even in a different room to keep the noise down.

To connect the compressor to the piping system, you'll want to use a flexible "snubber" hose (photo on the opposite page). The most important reason to do this is to prevent vibration from the compressor from transmitting to the pipe. This vibration can weaken the solder joints over time.

**Eliminating Water.** The main line of the system that the compressor connects to runs vertically to the ceiling, then across the shop to the individual drops. The reason for this is water control. Water is

the biggest enemy of any tool. So the system is designed to capture and eliminate water.

The first way it does this is to allow water (or condensation) from the compressor to trickle down to a valve at the bottom of the riser. Here it can be easily drained out.

Then, the overhead main line is sloped about 1" for every 10'. Any additional water vapor that condenses out of the air will then run to another vertical pipe and valve at the end of the system.

**Choosing the Size.** For most shops, 1/2"-dia. pipe will work just fine. But I chose 3/4"-dia. pipe for the main run. The reason for this is that a larger pipe for the main line effectively increases the "tank" size of the air compressor.

There's one other thing to mention about copper pipe. It comes in several wall thicknesses. The thinnest, size "M," should only be used for water. Size "L" has thicker walls and is right for a compressed air system (right margin photo). You can find it at most home centers.

That takes care of the main line. All that remains are the individual drops that go to each tool. For more on this, just turn the page.



▲ **Thick Walls.** Size "L" pipe (left) has thick walls for use in air systems. Avoid size "M" (right).

## Iron Pipe: A Lower-Cost Alternative

While copper is my choice for compressed air pipe, it can be expensive. So you might consider iron pipe (black or galvanized) as a less-expensive alternative.

Besides cost, iron pipe is pretty simple to work with. Since there are only threaded connections, all you need is some Teflon tape and a pipe wrench. This does mean you'll have to plan your system around available pipe lengths, though.

(Or you can pay extra to have the pipe custom cut and threaded.)

One disadvantage of threaded connections is you'll need to at least partially assemble the system before mounting it in your shop. Another is that it can be difficult to add on to the system later.

There's another downside to consider. The inside of iron pipe will develop rust and scale over time. To keep it under control,

Threaded fittings make it easy to build an air line



Teflon tape seals joints

you'll need to drain the water daily and replace filters regularly.

By the way, galvanized pipe only refers to the outside coating, the inside will still corrode. So stick to black iron — it's cheaper.



Iron pipe comes in many ready-to-use lengths

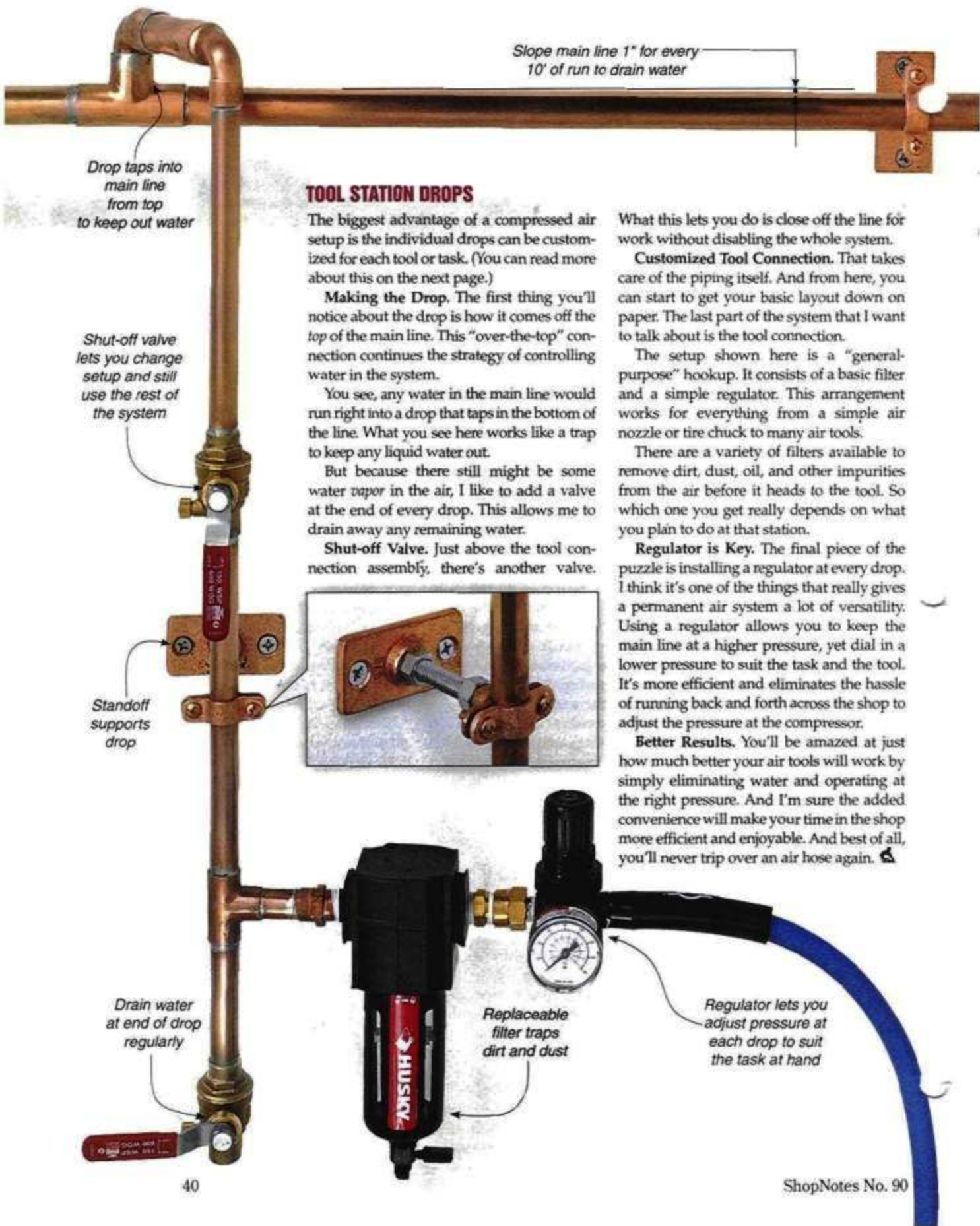

## TOOL STATION DROPS

The biggest advantage of a compressed air setup is the individual drops can be customized for each tool or task. (You can read more about this on the next page.)

**Making the Drop.** The first thing you'll notice about the drop is how it comes off the top of the main line. This "over-the-top" connection continues the strategy of controlling water in the system.

You see, any water in the main line would run right into a drop that taps in the bottom of the line. What you see here works like a trap to keep any liquid water out.

But because there still might be some water vapor in the air, I like to add a valve at the end of every drop. This allows me to drain away any remaining water.

**Shut-off Valve.** Just above the tool connection assembly, there's another valve.

What this lets you do is close off the line for work without disabling the whole system.

**Customized Tool Connection.** That takes care of the piping itself. And from here, you can start to get your basic layout down on paper. The last part of the system that I want to talk about is the tool connection.

The setup shown here is a "general-purpose" hookup. It consists of a basic filter and a simple regulator. This arrangement works for everything from a simple air nozzle or tire chuck to many air tools.

There are a variety of filters available to remove dirt, dust, oil, and other impurities from the air before it heads to the tool. So which one you get really depends on what you plan to do at that station.

**Regulator is Key.** The final piece of the puzzle is installing a regulator at every drop. I think it's one of the things that really gives a permanent air system a lot of versatility. Using a regulator allows you to keep the main line at a higher pressure, yet dial in a lower pressure to suit the task and the tool. It's more efficient and eliminates the hassle of running back and forth across the shop to adjust the pressure at the compressor.

**Better Results.** You'll be amazed at just how much better your air tools will work by simply eliminating water and operating at the right pressure. And I'm sure the added convenience will make your time in the shop more efficient and enjoyable. And best of all, you'll never trip over an air hose again. 



## Drops: 2 Setups

### AIR TOOLS

The air tool connection setup shown on the facing page should work fine for most shop tasks. But some of the air tools I have require a slightly different setup. The key difference is if the tool requires lubricating oil while it's in use. (Check with the owner's manual if you're unsure.) So I customized one of the drops in my system to work only with these tools.

**Automatic Oiler.** To take care of these tools and help them last longer, I include an inline oiler, like you see below. It's a small reservoir that releases a tiny droplet of oil whenever the tool is used.

This is a no-hassle way to keep your tools in top shape. It's best to place the oiler as close to the tool as possible, so that no oil contaminates the inside of the hose, as shown in the photo below.

**Filter Upgrade.** Because these tools are usually more "air hungry," I upgraded the filter both in size and quality to make sure no dust or grit gets into the tool.

Just be sure to check and replace the filter cartridge frequently if you use the tool station often. A clogged filter can decrease the performance (and life) of your air tools and equipment.



▲ **Foolproof Tool Lubrication.** An inline oiler releases a small amount of oil into the tool to automatically lubricate it every time it's used.

www.ShopNotes.com

### SPRAY FINISHING

Another situation that you might want to consider setting up for is spray finishing. The advantage of this is that you can use some top-quality, fast-drying finishes and get flawless results in a short time. But here again, you'll need to take some extra steps to make efficient use of the spray gun and get the best results on your projects.

**Removing Oil and Water.** The biggest issue with spray equipment is eliminating oil and water from the air before it gets to the gun (and on to the project). The piping helps a lot with this, but you can get additional water and oil filters and driers that will trap these contaminants and remove them from the air, as you can see in the photo above. Of course, you'll still want to add a good dust and debris filter as well.

**Air Needs.** There's one other thing I want to mention about spray equipment. No matter what kind of spray system you use, you want to make sure your equipment has the right combination of pressure and volume. So I find it's best to locate the spraying station closer to the compressor for the best results.

▲ **Remove Oil and Water.** Driers like this can collect any remaining oil and water before they have a chance to contaminate a finish.

## Drain Extension

I know you're supposed to drain the air tank on a compressor daily. But the drain valve on my air compressor is located on the bottom of the tank, where it's difficult to reach. So I added an extension to the drain valve. Some inexpensive pipe fittings bring the valve out where I could reach it more conveniently, as shown in the drawings.

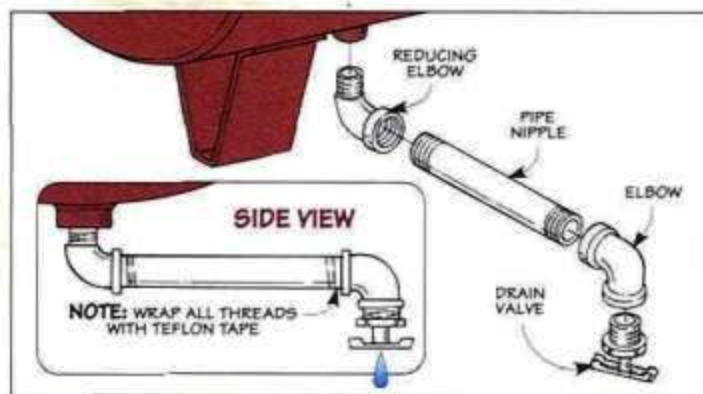

**SHOP  
TIP**

# 5 shop upgrades

## Space-saving Worksurfaces

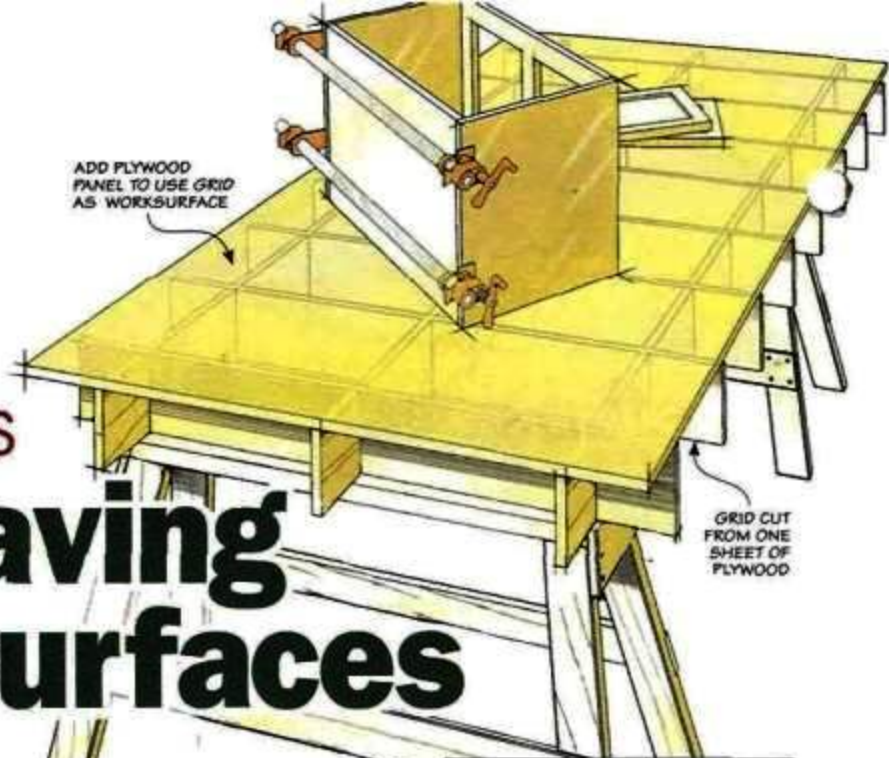

### MULTI-PURPOSE GRID

I've found it's easier to cut sheet goods into smaller parts with a circular saw rather than wrestle with them on my table saw. But sawhorses just don't provide the necessary support.

My solution is the knock-down grid you see at right. It's nothing more than a set of interlocking strips that form a solid platform. And all you need to make the grid is a single sheet of plywood.

Once the grid is assembled, it provides full support for making cuts on sheet goods. But the grid has other uses as well.

For glueups, parts can be clamped to the top or through the openings vertically. Or throw a sheet of plywood or MDF on top and use it as an extra workbench.

And when you're finished with it, the grid breaks down and stacks neatly against the wall.

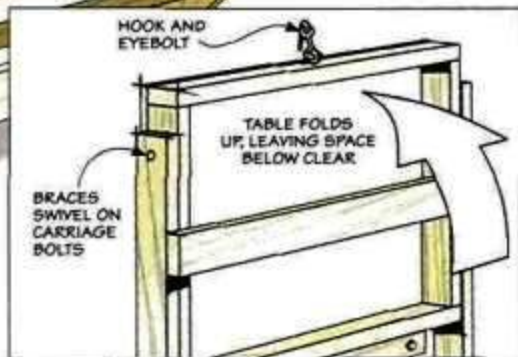
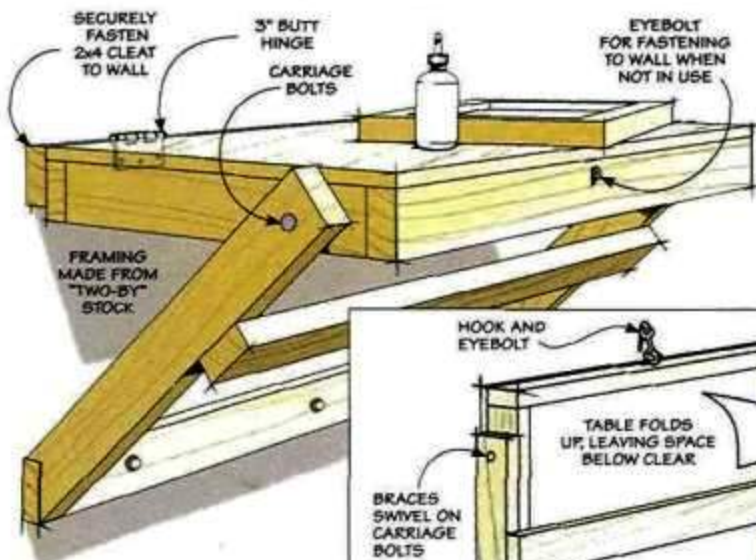
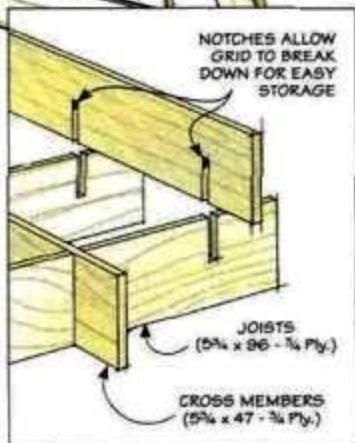

### FOLD-UP WORK TABLE

Most small shops don't have a lot of wall space to spare. But it doesn't take much space to add this handy fold-up work table to your shop.

And it can be used for more than light-duty work. A solid 2x4 frame and a 3/4" plywood top make it rugged enough for the toughest tasks. And because it's bolted to the wall, it has a lot of stability. You can use it as a work station for a benchtop tool, project assembly, or finishing.

Since it's hinged to fold up, not down, it leaves the floor space below the work table clear (inset drawing). And it's quick to set up. Just unhook the table, brace the legs against the bottom cleat, and it's ready to go.

Then, once the job is done, all you have to do is simply fold the work table up and latch it against the wall to get it out of the way.

## TABLE SAW COVER ▶

When you need an extra work surface, a natural place to turn is your table saw. But it's not exactly the best surface to work on because the miter slots, blade opening, and wings are not smooth and even.

The solution is a simple one. All you need to do is make a cover that slips over the top of your table saw and doubles as a work surface (drawing at right).

The cover is made out of a piece of  $\frac{1}{4}$ " hardboard because of its smoothness and durability. To hold it in place on your table saw, the cover is surrounded by a rabbeted apron of hardwood edging. You'll want to size the cover so the apron fits just over the top of your

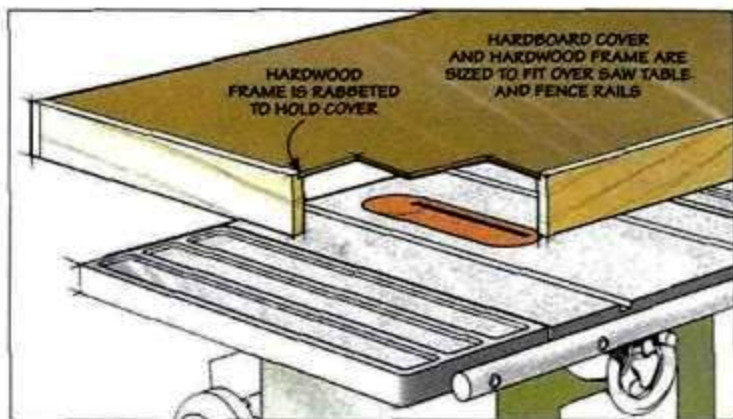

table saw, including the rails for your rip fence.

Finally, when you're not using it, you can simply lift it off your table saw and hang it on the wall.

## INSTANT TABLE ▶

Another easy table to set up is the one you see at right. It uses  $\frac{3}{4}$ " plywood as a work surface and pipe clamps as legs. A nice thing about it is its "adjustability."

Any size scrap of plywood up to a half sheet can be used for a tabletop (anything larger might

sag in the middle). And each pipe clamp can be adjusted separately to keep the table level.

When you're finished, put the clamps back in the clamp rack and the plywood back in the storage bin — no extra room is needed to stow this work surface away. ▲

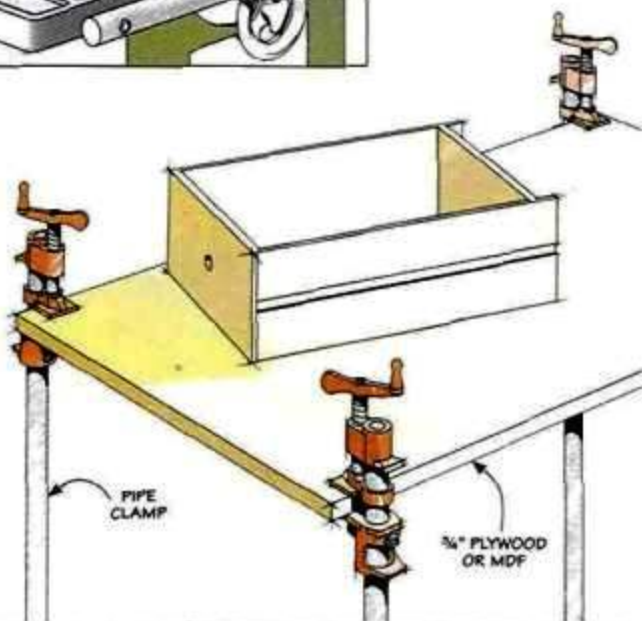

## Revolving Finish Station

One of the biggest challenges in a small shop is having room to apply finish to a project. I needed something that wouldn't take up much room but would still provide easy access to all sides of the project. The station you see here is the solution.

First, the top sits on a lazy Susan. This allows you to rotate the project and apply finish easily on all sides. Second, the hinges allow you to set the station up and tear it down quickly. And third, it can be set up in a corner of my shop out of the way and without taking up a lot of valuable space.

The base consists of two side panels made from  $\frac{3}{4}$ " plywood and connected by a hinge. Another hinge connects one side panel assembly to the turntable, which is made up of two plywood disks and the lazy Susan (far right drawing).

When you set the station up, swing the two side panels open. The top will rest on

the side panels and fit down onto a dowel (drawing below). The dowel acts as a safety catch to lock the station open and adds stability. When you're done with the station, all you have to do is lift the top up, fold the panels together, and hang it on a wall hook, as you see in the drawing below.

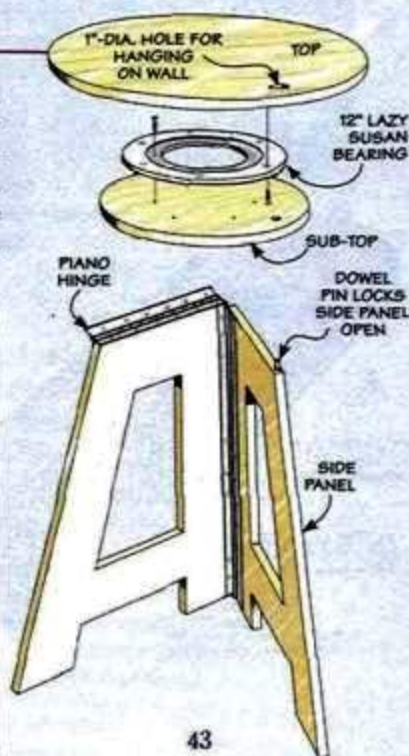
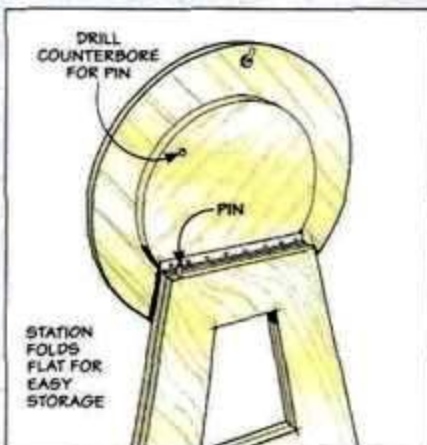

## MASTERING THE Table Saw



# Tough Cuts Made Easy

Here are 10 great tips and tricks for making safe, accurate cuts on even the smallest workpieces.

**NOTE:** USE YOUR SAW'S INSERT AS A PATTERN TO CUT A ZERO-CLEARANCE INSERT PLATE

A table saw is great for ripping and crosscutting most "normal-size" workpieces. But as the size of the pieces gets smaller, a table saw starts to seem like way too much tool for the job. Don't get me wrong — a table saw is still my first choice for making clean and accurate cuts on small workpieces. You just need to approach these cuts in a different way to get the job done well and, even more importantly, safely.

Basically, handling small pieces on the table saw is all a matter of control. But this is easier said than done. First, as the pieces get smaller, they become less rigid, so achieving a smooth, controlled cut is more difficult. Second, just holding onto the workpiece is a challenge that's likely to bring your fingers closer to the blade. Still, cutting small pieces isn't a new problem, and there are a number of good ways to deal with it. On the following pages, you'll find a few of my favorites.

### ◀ ZERO-CLEARANCE INSERT

Anytime you're working with small pieces on the table saw, the narrow opening in the blade insert begins to look like the Grand Canyon. It's very easy for pieces to fall right through along with the sawdust or, worse yet, get jammed between the blade and the insert.

To eliminate this possibility, I often install a zero-clearance insert in place of the standard insert

before attempting these cuts. My favorite insert is a simple shop-built version with a built-in splitter, as shown at left. It closes up the gap around the blade and the splitter ensures that a workpiece won't bind while being cut. You'll get much cleaner, trouble-free cuts. And there's a bonus — all it takes to build the insert is a piece of  $\frac{1}{2}$ " MDF and a small scrap of hardwood.

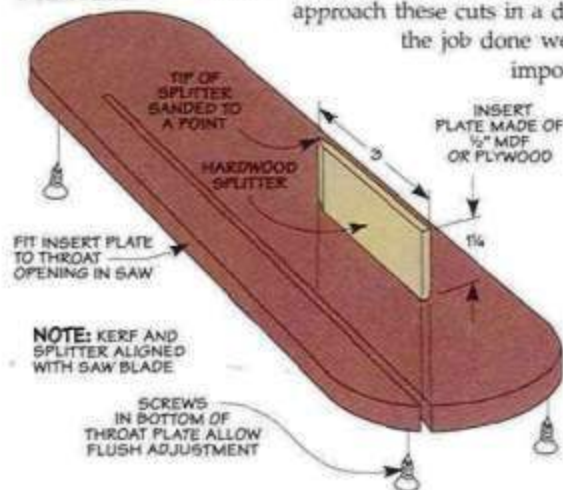

## THE PERFECT PUSH BLOCK ▶

To safely rip small pieces on the table saw, you really need the right kind of push block. There's usually very little space between the blade and the fence for a simple push stick to pass. And then there's the problem of controlling the flexing and vibration that usually occurs.

For years, my favorite push block for general ripping has been a simple, notched "two-by" block. This sacrificial push block hooks

over the back end of the workpiece and then passes right over the saw blade giving me great control.

The same idea in a different size works great for ripping thin pieces. As you see at right, this push block is made from a piece of  $\frac{3}{4}$ " MDF. A shallow notch at opposite ends of each side provides the push. But the key is the long edge that allows you to bear down on the workpiece and control the flex and vibration.

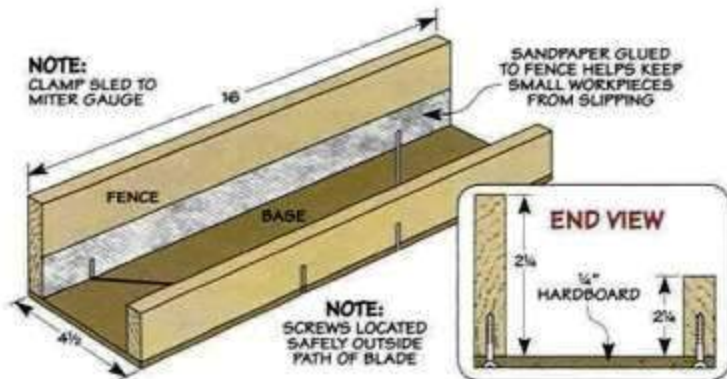

## WORK BIG, THEN SMALL ▶

Sometimes, when making a small part, a single cut on the table saw won't get the job done. For example, a molding may require a routed or rabbeted edge. But when the finished size is only  $\frac{1}{4}$ " or  $\frac{1}{2}$ " square, the pieces are just too small to cut on the table saw or rout safely.

The drawing at right shows how to avoid this problem. I first do

all the shaping at the table saw or router table on an oversize workpiece. A larger piece is easier to get a good grip on and you're guaranteed better results. Another plus is that you can often work on both edges of the workpiece and speed up the task. Once the hard part is done, you can set up the saw to cut the pieces to final size.



▲ **Small Parts on a Sled.** Here, a piece of plywood and a couple of cleats position the small pieces and make angled cuts a breeze.



▲ **The Right Push.** This simple push block gives you complete control when ripping small, thin pieces.

## ◀ MITER JIG

How do you cut clean, accurate miters on small, flexible, hard-to-handle moldings? It's a tough one.

My answer is the simple miter jig you see in the main photo and the drawing at left. (It's also great for crosscuts.) The sled, clamped to the miter gauge, carries the workpiece past the blade and provides the control and stability you need to get perfect results.

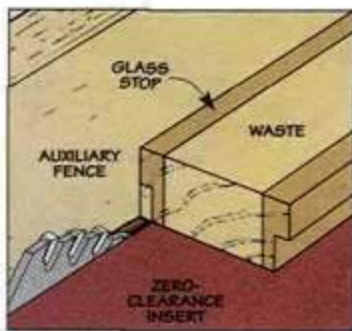

## ◀ SMALL PARTS SLED

Making cuts on small, odd-shaped pieces can leave you searching for a good solution. Often, the cut isn't a simple rip or crosscut. In many cases you may not have a straight or square surface to register against the rip fence or miter gauge.

A good way to get around this challenge is to mount the workpiece on an easy-to-handle sled to make the cut, as shown at left. The sled holds the workpiece in the right orientation so your only worry is feeding it through the blade.

ShopNotes

GO ONLINE EXTRAS

Go to our website  
**ShopNotes.com**  
and view a video  
that shows how  
to make a zero-  
clearance insert  
and splitter.

## SMALL PARTS CLAMP ▶

Cutting small parts on the table saw doesn't always involve making a lot of repetitive cuts or identical pieces. Often all I need to do is cut or trim one or two short pieces to length. Or possibly cut several small pieces to size that are each a little different. For a long time, I struggled with making these crosscuts cleanly and accurately without risking my fingers. The solution turned out to be the simple clamping jig you see at use in the photo at right.

This small parts clamp attaches to the miter gauge of the table saw. It holds the workpiece firmly between the two jaws so all I have to worry about is sliding the miter gauge past the blade.



▲ **Tight Between The Jaws.** The jaws of the clamp can tightly grip even the smallest workpiece and keep your hands at a safe distance.

**Building the Clamp.** As you can see in the drawings below, the construction is pretty simple. Basically, the clamp consists of a back jaw, an

adjustable front jaw, and a slotted spreader that connects them.

You start by cutting the front and back jaw to identical size from  $\frac{3}{4}$ "-thick hardwood. Then you drill matching holes at the "blade" end of the jaws to hold the carriage bolt that tightens the clamp.

Once the slot is cut in the spreader, you can screw it to the opposite end of the front jaw. The slot fits over a hanger bolt installed in the end of the back jaw. Both ends of the clamp are tightened down with wing nuts and washers.

**Using It.** Putting the clamp to use doesn't need much explanation. First, you adjust the jaws to loosely fit the workpiece. Then line up your cut mark on the workpiece with the blade and tighten the wing nuts. Making the cuts is just a matter of sliding the miter gauge past the saw blade.

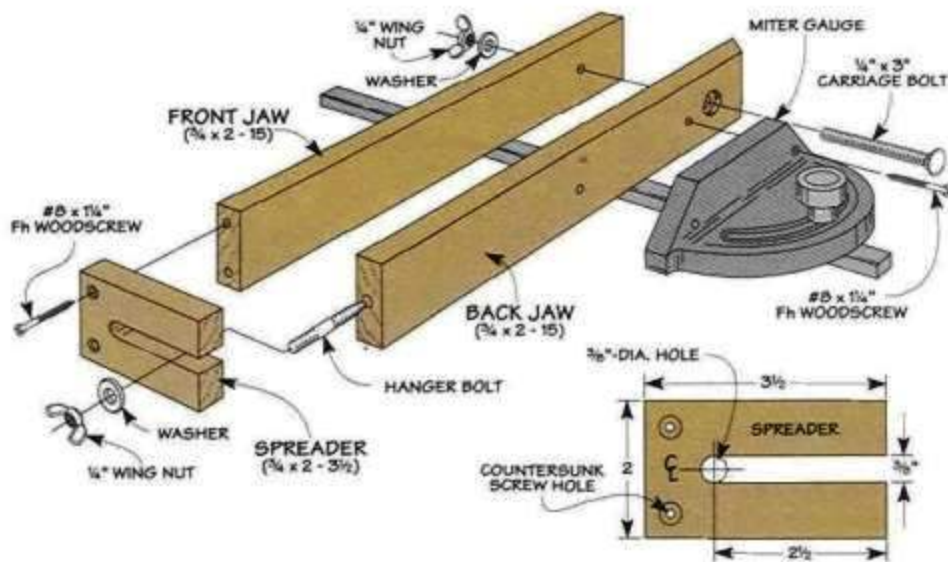

## DOWEL PIN JIG ▶

The dowel cutting jig you see in the drawing at right makes the job of cutting short, accurate lengths of dowel an easy task.

The jig is simply a block with a hole drilled through it to fit the dowel. The block is clamped to the auxiliary fence on the miter gauge. The distance between the end of the block and the saw blade matches the desired length of the dowel pieces. You simply feed the dowel into the block, cutting off piece after piece to the same length.

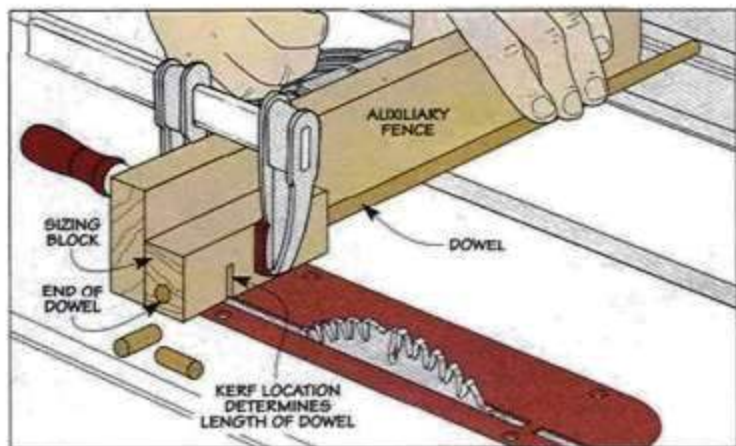

## RIPPING THIN STRIPS

Ripping a thin strip with the workpiece trapped between the fence and the blade makes feeding difficult and can lead to burning and kickback. But then the safer route of cutting to the outside of the blade involves resetting the fence after each cut with less accurate results.

A good solution to the problem is shown in the drawing at right. The edge of a wide jig rides against fence while a notch in the opposite edge pushes the workpiece past the blade. Once you're set up, it's easy to cut identical strips.

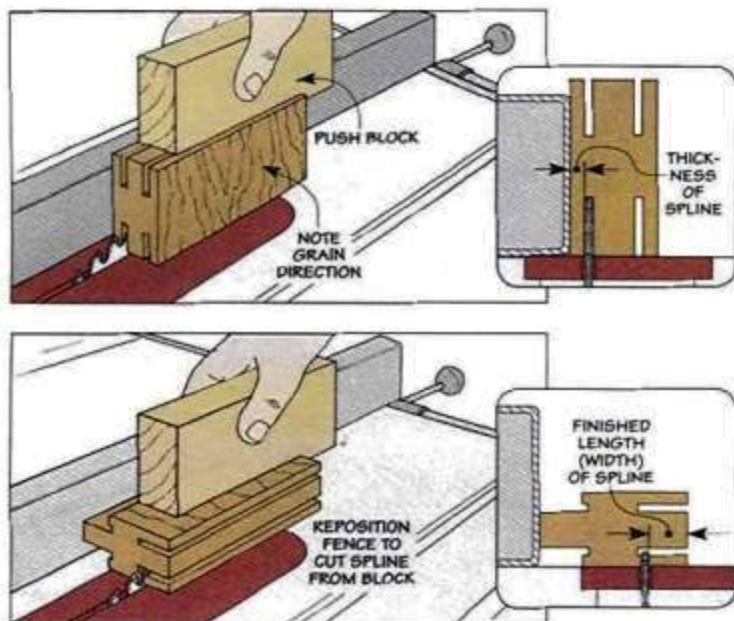
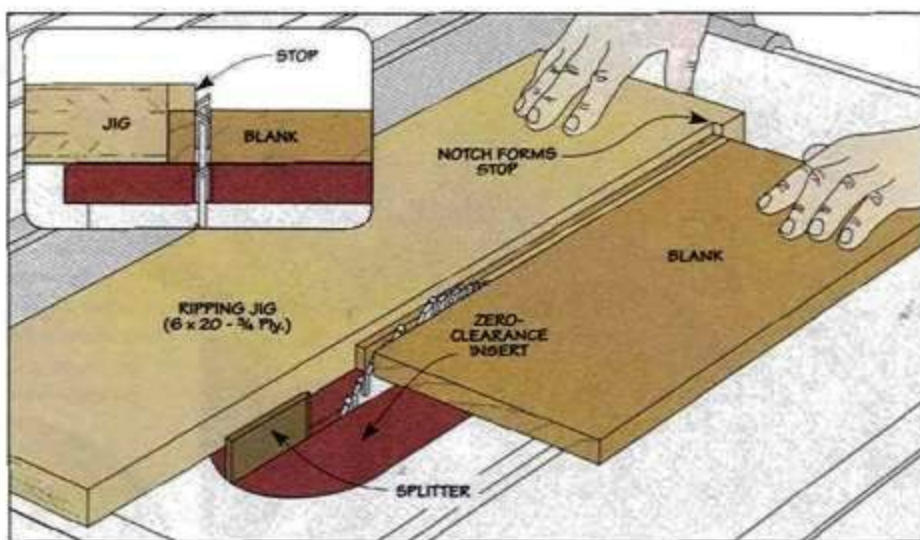

## CROSSGRAIN SPLINES

A hardwood spline adds loads of strength to a miter joint. The catch here is making small splines that do the job effectively. First, the splines need to fit pretty snugly in the grooves in the mitered faces. Second, to provide maximum strength, the grain of the splines should run across the miter joint.

The key to making small, accurate splines is to not try to work on them individually. Instead, I start by using the rip fence and a push block to accurately "thickness" a pair of splines on each end of a short blank (upper drawing). Then the fence is carefully reset to cut the splines to exact length (lower drawing). And all without having to handle them.

## STAND-OFF BLOCK

Crosscutting short, identical workpieces on the table saw is tricky. Clamping a stop block to the miter gauge to register the length brings your fingers too close to the blade. But then using the rip fence as a length stop is inviting kickback.

The photo at right shows the easiest and safest solution to the problem. The way it works is that a stand-off block is clamped to the rip fence in front of the blade. The block acts as a length stop while leaving plenty of clearance to avoid any chance of kickback.

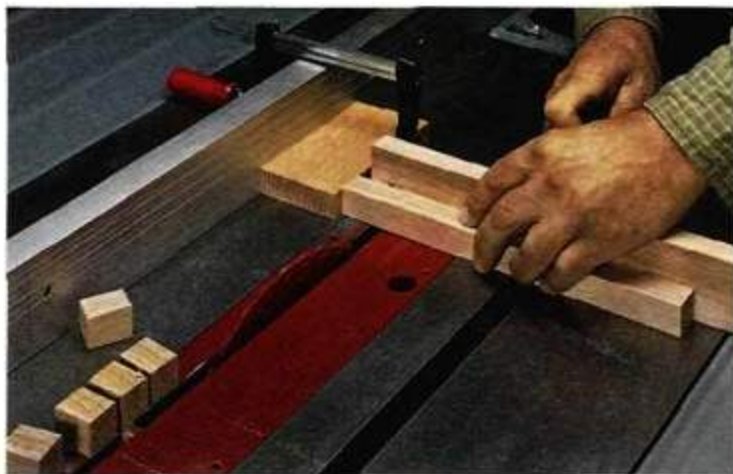

**GREAT**  
Gear

## 20 cool tools Under \$50

There's no doubt about it, woodworking can be a fairly expensive hobby, especially when you consider the cost of some of the major power tools in the average workshop. But fortunately, not every woodworking tool is expensive. There are plenty of cool tools for woodworkers that won't break the bank.

Here's a look at some of our favorite tools under \$50. Some of these are tools that I use almost every time I'm in the shop. Others are simply "nice to have." But all of them make woodworking more enjoyable.

So whether you're shopping for a gift for yourself or simply need to give someone else an idea of what to get you, here are some great alternatives to more socks and ties. All of these items are commonly available through many woodworking mail-order sources. And many of them are available for purchase online at [www.WoodsmithStore.com](http://www.WoodsmithStore.com).

### 1 Starrett Pro-Site Protractor

This tool is the perfect companion for your miter saw. You can use it to transfer angles directly to your saw. If you're making a miter joint, a scale on the protractor "does the math" for you and tells you what angle to set your miter saw for each half of the joint, or to cut a complementary angle. \$45.



48

### 2 Saw Jaw

For years, woodworkers have used a scrap of wood to keep their saw blade from turning while loosening the arbor nut. Here's an improvement over that. The *Saw Jaw* works like an oversize wrench. It fits around your saw blade, holding it stationary while you loosen the arbor nut. Plus, it protects the carbide teeth at the same time. \$16.



### 3 Micro-Jig Splitter

The *Micro-Jig* splitter is a clever device that snaps into a zero-clearance table saw insert, right behind the blade. It reduces the chances of kickback by preventing your workpiece from pinching the back of the blade. The splitter comes with everything you need for a foolproof installation on your own zero-clearance insert. \$15.



### 4 Hock Plane Iron

If you use a hand plane in your shop and haven't tried a *Hock* replacement iron, you don't know what you're missing. These irons are thicker, giving you a smoother cut with less chatter. They're available for most sizes of bench and block planes. \$36 to \$43.



ShopNotes No. 90





## 5 General Digital Caliper

I've used a dial caliper in my shop for years. It's great for taking precise measurements. But a few years ago, I made the switch to a digital caliper. The digital readout eliminates any "user error." It also saves me from having to strain to read the scale. \$40.

## 9 Starrett 4" Double Square

I use this square more than any other in my shop. The adjustable head is ground square on both faces. You can use it not only as a square, but as a depth gauge, or to set up your tools. Plus, it's just the right size to tuck into the pocket of a shop apron. \$50.



## 6 Veritas Set-Up Blocks

This assortment of set-up blocks is ideal for positioning fences, setting up blades and bits, and checking the width of dadoes and grooves. The set includes five gauge blocks of different thicknesses as well as a "1-2-3 block" (named for its dimensions — 1" x 2" x 3"). \$40.

## 10 Fenner Power Twist Belt

One of the quickest and most dramatic upgrades you can make to your table saw (or any other belt-driven power tool) is to replace the standard rubber V-belt with a link belt. This belt runs smoother and won't take a set, so it helps reduce the vibration from your table saw. Plus, it lasts longer than a standard V-belt. \$26.



## 7 Lie-Nielsen Cabinet Scrapers

These cabinet scrapers are made from a high grade of Swedish tool steel, so they really take and hold an edge. There are two scrapers in the set. The thinner one is more flexible, so it's great for corners and tight areas. And the thicker scraper is good for smoothing large surfaces. \$15.

## 11 Stanley Nailsets

These are the ultimate in nailsets. They feature hardened steel tips that are long-lasting and won't deform. And they have cushioned grips to absorb the shock from your hammer blows. The tips are cupped to prevent them from slipping. They're sold in a color-coded set of three different diameters. \$9.



## 8 Veritas Saddle Square

Saddle squares are used to transfer layout lines between two perpendicular surfaces (from the edge of a workpiece to the face, for example). It's a simple tool, but one that you'll find yourself using all the time. \$13.

## 12 Peltor Earmuffs

I always hated wearing ear plugs or hearing protection of any sort until I purchased a pair of these Peltor earmuffs. They are so comfortable and light that you almost forget you have them on. And they do a great job at filtering out noise that could damage your hearing. \$15 to \$30.





### 13 Bahco Carbide Scraper

At first glance, this looks like an ordinary paint scraper. But this scraper has a replaceable carbide blade, so it lasts and lasts. And while it does a fantastic job at scraping paint, I keep one in my shop for scraping dried adhesive off glued-up panels. I especially like the knob at the front of the scraper because it allows me to get a good grip on the tool and really bear down as I'm scraping. \$23.



### 14 Warrington Hammer

When it comes to building furniture, I don't have much use for a typical claw hammer. But this Warrington-pattern hammer is a different story. It's just the right size for driving brads. One end is flattened to make it easier to start the brad without whacking your thumb. The other end is shaped like a traditional hammer for driving the brads home. \$17.



### 15 Dead-Blow Mallet

A dead-blow mallet is ideal for all kinds of assembly tasks. The head of the mallet is weighted with lead shot to give each blow more force but with less bounce. The entire mallet is covered with a smooth, non-marring urethane coating to prevent damage to wood. It's great for persuading a stubborn joint to go together or for striking chisels. \$20.



### 16 Veritas MK. II Honing Guide

This honing guide makes sharpening almost foolproof. It can handle chisels and plane irons up to 2 $\frac{7}{8}$ " in width. It includes a registration jig that makes it very easy to hone a precise bevel angle on the edge of your tool. And then with a simple turn of a knob, you can add a micro-bevel for the ultimate edge. \$50.

### 17 Flush-Cutting Saw

Also known as a *kugitiki*, this flush-cutting saw is ideal for trimming dowels or plugs flush with the surface of a project. The blade is extremely thin and flexible, allowing you to work in tight quarters. And the teeth have no set, so you don't have to worry about scratching your workpiece. \$25.



### 18 Starrett Center Punch

A spring-loaded center punch is a great tool to have for laying out hole locations in metal or wood. Just set the punch right where you want to mark and push down on the top until you hear a click. The punch will leave a dimple in the workpiece, letting you know precisely where to position your drill bit. \$27.



### 19 Vix Bits

Vix bits are great for drilling holes for hinge screws. A spring-loaded sleeve automatically centers the bit in the screw holes of your hinges or other hardware. They're sold individually in several sizes for different screw sizes. \$13 each.



### 20 Weldon Countersinks

These countersink bits work better than any others that I've tried. The secret is in the design. The single-flute cutting edge leaves a perfectly smooth countersink in wood or metal. The set of four bits shown handles screw sizes ranging from #4 to #10. \$30.



# Sources

## ALL-PURPOSE LAYOUT TOOL

Finding the materials to build the all-purpose layout tool on page 34 should be pretty easy. You may be able to pick up all of the material you need at a local hardware store.

The only problem I ran into was finding the brass strips and the knurled thumb nuts. If you can't find them locally, *McMaster-Carr* can help you out.

For the brass strip, ask for part number 8859K91. And the knurled nuts are part number 92741A160. The company's contact information can be found in the right margin.

Instead of using knurled thumb nuts, you could switch to brass wing nuts, which are a common item in most hardware stores.

## ROLL-AROUND WORK CART

The roll-around work cart on page 18 requires quite a bit of hardware. The nice thing about this is you can find most of it, including the EMT conduit used for the handles, at a hardware store or home center. But there are a few items that you'll probably have to order.

The heavy-duty, 1 1/4" x 5" locking swivel casters (WC-88) came from *Reid Tool*. For the drawer handles, I used extruded aluminum pull material from *Woodworker's Hardware* (KV0822). It comes in 8-

long pieces that you simply cut to the length you need.

The full-extension drawer slides can be obtained from *Rockler*. You'll need four pairs of the 14"-long drawer slides (32474) and four of the 18" slides (32490) as well. You can also order these drawer slides from the *Woodsmith Store* (see margin).

## DRILLING GUIDE

When it comes to installing hardware, accuracy is the key to getting the best results. And anything that speeds up the hardware installation while still maintaining accuracy, well, that's a bonus.

The *True Position Drill Guide* highlighted on page 14 combines both speed and accuracy. You can get the guide and all its accessories from the manufacturer, *Precision Casework*, or from *Mockett Hardware*. The contact information for both companies is listed in the margin.

## 3-IN-1 MULTI-TOOL

The multi-tool on page 28 will make your palm router more versatile. Before you start building, there are a few parts you'll need to order.

The first thing I did was pick up a 12" x 16" sheet of 1/4" phenolic material from the *Woodsmith Store*. But you can also order it directly from *Leecraft* (BK-2). The only thing

to be aware of is the color may vary depending on when you order.

Most of the other parts came from *Reid Tool*: the tapered knob (DK-913); the 1/4"-20 T-knob (DK-222); the 1/4"-20 x 1", three-point knobs (RK-305); and the 1/4"-20 threaded inserts (EZ-12).

The brass strips can be purchased at most hardware stores or arts and crafts retailers. Finally, *Rockler* carries the bit guard (67157) for the fence.

## TOOL STEEL

Several sources are available for ordering chisels and plane irons made from the different types of tool steel described on page 12.

*Hock Tools*, *Lee Valley*, and *Tools for Working Wood* all carry replacement irons made from O1 and A2. *Lee Valley* and *Tools for Working Wood* carry chisels as well. *Tools for Working Wood* also carry chisels made from D2 steel.

## SHOP AIR PLUMBING

Outfitting your shop for compressed air isn't all that difficult. You can find the copper pipe, fittings, and wall mounts at a hardware store or home center.

You should also be able to find the filters and air hose fittings at those locations as well. 

## MAIL ORDER SOURCES

**Woodsmith Store**  
800-444-7527  
woodsmithstore.com  
*Drawer Slides, Phenolic*

**Rockler**  
800-279-4441  
rockler.com  
*Drawer Slides*

**Lee Valley**  
800-871-8158  
leevalley.com  
*Tool Steel,  
Replacement Plane Irons*

**Reid Tool**  
800-253-0421  
reidtool.com  
*Casters, Knobs,  
Threaded Inserts*

**McMaster-Carr**  
630-600-3600  
mcmaster.com  
*Brass Strips, Knurled  
Thumb Nuts*

**Woodworker's Hardware**  
800-383-0130  
wwhardware.com  
*Drawer Pull Material*

**Precision Casework**  
888-790-7565  
precisioncasework.com  
*Drill Guide*

**Mockett Hardware**  
800-523-1269  
mockett.com  
*Drill Guide*

**Hock Tools**  
888-282-5233  
hocktools.com  
*Replacement Plane Irons*

**Tools for Working Wood**  
800-426-4613  
toolsforworkingwood.com  
*Replacement Plane Irons*

**Leecraft**  
770-983-1797  
*Phenolic*

## ShopNotes Binders

### Keep your issues organized!



As you build your *ShopNotes* library, here's a way to keep your issues organized. Each binder features durable vinyl covers and easy-to-read perforated number tags. Snap rings with a quick-open lever make it easy to insert and remove issues. And there's an extra pocket inside for storing notes. Each binder holds a full year (6 issues) of the new, expanded *ShopNotes*.

Visit [www.ShopNotes.com](http://www.ShopNotes.com) to order these binders, or call 1-800-444-7527.

**ShopNotes Binder**

○ 701950-SN90 (Holds 6 issues).....\$12.95

## Scenes from the Shop

▼ **3-in-1 Multi-Tool.** A palm router is the perfect choice for many shops. To get more out of one, you may want to consider the multi-tool shown here. Although it's great for working with small pieces, additional features allow you to joint an edge or rout a mortise, as shown below. For more on this multi-tool, along with detailed instructions for building it, turn to page 28.



▼ **Panic-Free Glue-Ups.** Does gluing up a solid-wood panel give you a headache? With the simple step-by-step process detailed on page 26, you'll end up with a perfectly flat panel without the hassle.



▲ **All-Purpose Layout Tool.** Accurate layout is a key part of successfully building a project. Whether it's dovetails or a mortise like you see above, this versatile layout tool handles it with ease. Step-by-step plans start on page 34.