

TABLE SAW WORKCENTER

WITH SPACE-SAVING ROUTER TABLE & SUPER STORAGE SYSTEM



ShopNotes

Vol. 15 Issue 89

www.ShopNotes.com

BUILD A \$100 ROCK-SOLID WORKBENCH

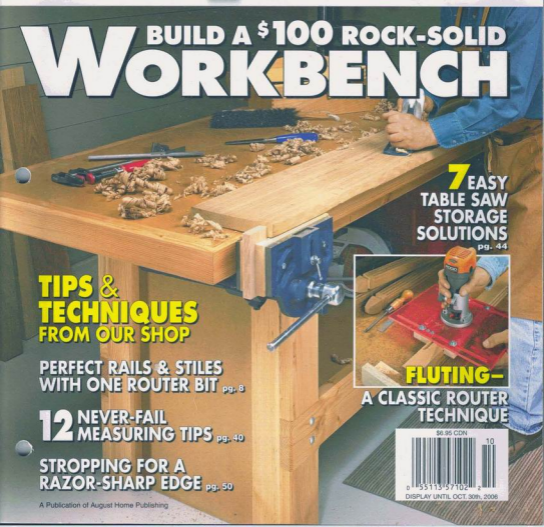

**TIPS &
TECHNIQUES
FROM OUR SHOP**

**PERFECT RAILS & STILES
WITH ONE ROUTER BIT** pg. 8

**12 NEVER-FAIL
MEASURING TIPS** pg. 40

**STROPPING FOR A
RAZOR-SHARP EDGE** pg. 50

**7 EASY
TABLE SAW
STORAGE
SOLUTIONS**
pg. 44



**FLUTING—
A CLASSIC ROUTER
TECHNIQUE**



Contents

Features

dream shop project **Table Saw Workcenter** **16**

Upgrade your contractor's saw by building this custom workcenter. With a large worksurface, loads of storage, dust collection, and a handy built-in router table, you'll be able to handle any project. Plus, there's an optional table for extra outfeed support and even more storage.

hands-on technique **5 Shop-Made Pulls** **28**

Want a new look for your shop cabinets and projects? With just a little time and some scrap wood, you can make all the pulls you need.

weekend workshop **Heavy-Duty Workbench** **30**

This workbench has it all — a rock-solid base, large top, and it's inexpensive to make. All you need are a few sheets of MDF, some "two-by" stock, and a handful of hardware.

best-built jigs & fixtures **Palm Router Fluting Jig** **36**

Adding flutes is a great way to dress up a project. This shop-made jig makes it easy to rout consistent flutes quickly.

Departments

Readers' Tips **4**

router workshop **Perfect Rails & Stiles — One Bit** **8**

Creating a rail and stile joint doesn't have to be a lot of work. We'll show you how with a slot-cutter bit and one fence setting.

materials & hardware **Working with Plastic Laminate** **10**

Here's what you need to know to get the best results when you use plastic laminate on your projects, shop jigs, and fixtures.

jigs & accessories **Upgrade Your Jointer** **12**

Looking to get less tearout and smoother cuts with your jointer? A spiral cutterhead might be the answer you're looking for.



Table Saw Workcenter page 16



One-Bit Joinery page 8



Palm Router Fluting Jig page 36

Cutoffs

It's no secret. When it comes to making shop projects, I like using MDF (medium-density fiberboard). It's flat, durable, and best of all — inexpensive. Right now, a full-size sheet goes for about \$20 (or less) at the local home centers. In this issue, we're featuring two projects that take advantage of this versatile material.

For starters, check out the workbench in the photo at left. Here the idea was to design an easy-to-build bench that used a minimum of materials and hardware. Now, with just three sheets of MDF, some 2x6's, and a handful of hardware, you can build a rock-solid workbench in a weekend — all for less than \$100 in materials.

The other project in this issue that makes use of MDF is the Table Saw Workcenter on page 16. In this case, we took advantage of another property of MDF — its smooth surface. This makes it great for painting or for use as a substrate for plastic laminate. On page 10, we've even included some tips for applying laminate.

Speaking of tips, if you haven't already signed up for our free woodworking E-tips, I invite you to do so. Not only will you receive a woodworking tip by email each week, but you'll also have the opportunity to give us your input on what kind of projects and articles you'd like to see. Plus, from time to time, you'll get updates and sneak previews on what's appearing in future issues of ShopNotes.

FREE TIPS BY EMAIL

Sign up to receive a
free shop tip by
email every week.

Visit us on the Web at
ShopNotes.com

Click on
"FREE TIPS by Email"

Tom

ShopNotes

GO ONLINE
EXTRAS

This symbol lets you know there's more information available online at www.ShopNotes.com

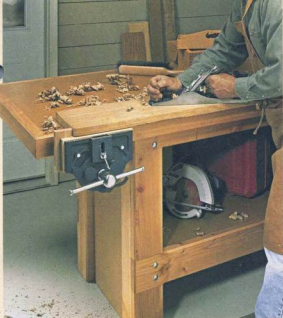

Heavy-Duty Workbench

page 30

Shop Short Cuts _____ 14

Shop-tested tips and techniques to solve your woodworking problems.

in the shop

12 Tips for Measuring & Marking _____ 40

Measuring and marking is an essential skill for successfully building any project. Here are a dozen foolproof tips for doing it right.

setting up shop

Easy-to-Build Table Saw Storage _____ 44

Need more storage? You'd be surprised how easy it is to create some around your table saw.

mastering the table saw

Table Saw Molding Head _____ 46

With a molding head and just a few cutters, you can easily create a wide range of profiles.

ultimate garage

Taking off the Chill _____ 48

Woodworking in a cold shop isn't fun. Learn all you need to know about adding a little heat.

Q&A _____ 50

Sources _____ 51

Tips for Your Shop

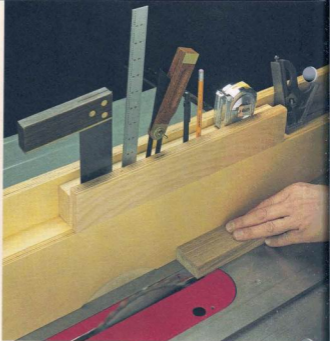

Table Saw Fence Tool Caddy

To make it easier to cut raised panels, I built the auxiliary fence from Issue No. 87 for my table saw. And then I added the tool caddy you see in the photo above to organize my layout and marking tools.

The caddy sits atop the auxiliary fence and has slots for keeping rulers, squares, and a bevel gauge securely in place. An opening at

one end allows you to store your combination square. I also drilled holes to hold pencils so they would always be in easy reach. There's even a ledge along the top to hold a measuring tape and other items.

The caddy is built using $\frac{3}{4}$ " plywood. I began by cutting dadoes sized to hold my square, ruler, and

bevel gauge as well as a notch for the combination square in an oversized piece of stock. Next, trim the stock to make two spacer blocks that form tool slots when the blocks are glued together. Then add another wide spacer block to create a ledge for the measuring tape. Finally, secure the caddy to the fence with glue.

Riley Maxey
Delaware, Ohio

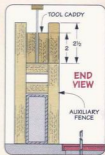
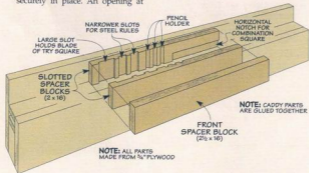

Bin Label Holders

Storage bins are a great way to organize small parts around the shop. To identify the contents of each bin, I built the label holders you see in the photo below.

They're easy to build. Start with a strip of hardwood planed down to $\frac{3}{16}$ " thick. Next, cut a groove in the strip using your router and a $\frac{1}{2}$ " dovetail bit. Just set your fence and make a pass (drawing at right). Then flip the piece around and make a second pass. Finally, glue the holder to the bin and insert the label.

Tim Wilson
Austin, Texas

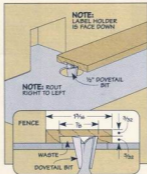

Submit Your Tips

If you have an original shop tip, we would like to hear from you and consider publishing your tip in one or more of our publications. Just write down your tip and mail it to: *ShopNotes*, Tips for Your Shop, 2200 Grand Avenue, Des Moines, Iowa 50312. Please include your name, address, and daytime phone number (in case we have any questions). If you would like, you can FAX it to us at 515-282-6741 or simply send us an email message at: shopnotes@shopnotes.com. We will pay you \$200 if we publish your tip.

The Winner!

Congratulations to Tom Slatky of Lena, Wisconsin. His tip on building a sandpaper organizer was selected as winner of the *Porter-Cable* router just like the one shown at the right. The organizer stores different grits of orbital sandpaper in a way that keeps them flat and ready for use.

To find out how you could win a *Porter-Cable* router check out the information above. Your tip just might be a winner.



PUBLISHER Donald B. Peschke

EDITOR Terry J. Strohm

SENIOR EDITORS Bryan Nelson, Vincent Ancona
ASSOCIATE EDITORS Phil Huber, Ted Raffe
ASSISTANT EDITORS Ron Johnson, Mitch Holmes,
Randall A. Masey, Dennis Perkins

EXECUTIVE ART DIRECTOR Todd Lambirth

ART DIRECTOR Cary Christensen

SENIOR GRAPHIC DESIGNER Jamie Downing

SENIOR ILLUSTRATOR Roger Reiland

ILLUSTRATORS David Kallemyn, Peter J. Larson

CREATIVE DIRECTOR Ted Kralciak

SENIOR PROJECT DESIGNERS Ken Munkal,

Kent Welsh, Chris Fitch

PROJECT DESIGNERS/BUILDERS Mike Donovan,

John Doyle

SHOP CRAFTSMEN Steve Curtis, Steve Johnson

SR. PHOTOGRAPHERS Crayola England, Dennis Kennedy

ASSOCIATE STYLE DIRECTOR Rebecca Cunningham

ELECTRONIC IMAGE SPECIALIST Allan Ruhnik

VIDEOGRAPHERS Craig Ruepfecker, Mark Hayes

ShopNotes (ISSN 1082-9096) is published bi-monthly (Jan., March, May, July, Sept., Nov.) by August Home Publishing, 2200 Grand Ave., Des Moines, IA 50312. *ShopNotes* is a registered trademark of August Home Publishing. ©Copyright 2006 by August Home Publishing. All rights reserved. Subscriptions: Single copy: \$4.95. One year subscription (6 issues): \$27.95. Canada/International add \$10 per year, U.S. funds. Canadian Subscriptions: Canada Post Agreement Number 4002091. Send change of address information and blocks of undeliverable copies to: P.O. Box 961, Sharon, Maine, March/Apr, US 14786. Canada: 101 9407 1473 EXT.

Periodicals Postage Paid at Des Moines, IA and at additional mailing offices. Postmaster: Send change of address to *ShopNotes*, P.O. Box 37100, Boone, IA 50007-2100.

www.ShopNotes.com

ONLINE SUBSCRIBER SERVICES

- ACCESS your account
- CHECK on a subscription payment
- TELL US if you've missed an issue
- CHANGE your mailing or e-mail address
- RENEW your subscription
- PAY your bill

Click on "Subscriber Services" in the list on the left side of our home page. Menus and forms will take you through any of the account-maintenance services you need.

HOW TO REACH US:

FOR SUBSCRIPTIONS, ADDRESS CHANGES OR QUESTIONS, WRITE OR CALL:

Customer Service

2200 Grand Ave., Des Moines, IA 50312
800-333-8854 8 a.m. to 5 p.m. CT

OR SEND AN E-MAIL TO:
orders@shopnotes.com

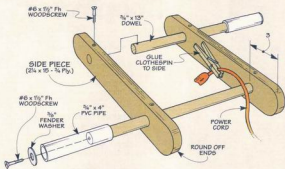

Power Cord Reel

This simple hand reel is a great way to store a long power cord. To wind up the cord, you just "pedal" the reel like a bicycle (photo above). Once the cord is wrapped up, it won't get tangled, so it's ready to go when you need it. (This reel can hold a 50' power cord.)

The reel is easy to build. Simply connect a pair of dowels to two plywood sides, as shown in drawing above. Besides providing a rigid support to wrap the cord around, the dowels act as handles to make it easy to roll up the cord.

The dowels fit in holes drilled near the ends of each side. It's a good idea to round off both ends of the side pieces. This keeps the power cord from getting tangled or snagged as you wrap it up.

To assemble the reel, it's just a matter of inserting the dowels in the holes in the sides. The handles are formed by extending one end of each dowel past opposite sides of the reel. (The other end of each dowel is flush with the side.)

After screwing the dowels to the side, I slipped a short length of PVC

pipe over each one. The pipe spins freely on the handles which makes it easy to wind up the cord. (I cut the pipes $\frac{1}{8}$ " shorter than the handles.)

Next, to prevent the pieces of pipe from slipping off, I placed a fender washer over the end of each one and screwed it in place.

All that's needed to complete the cord reel is to glue a clothespin to one side. Clipping the end of the power cord in the clothespin frees up your hands to crank the reel.

Wallace E. Delo
Buffalo, New York

Retractable Chuck Key

I'm always misplacing the chuck key to my drill press. So I fastened it to a retractable key chain that's attached to the column of the drill press (photo at right).

The key chain is held in place with a hose clamp. And it's connected to the chuck key by a short dowel to give you more leverage.

A hole drilled in one end of the dowel accepts the handle of the chuck key. (I used epoxy to hold it in place.) After screwing an eye hook in the opposite end, you can simply slip it onto the ring at the end of the key chain and it's ready for action when you need to use it.

Gary Vorgert
Epping, North Dakota

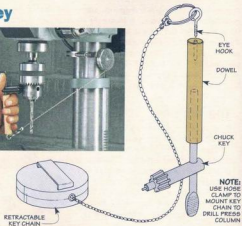

Sandpaper Organizer

Each time I changed sandpaper on my random orbital sander, it meant searching to find the right disk. And when I found one, it was often bent or curled up. So I built the sandpaper organizer shown at right.

The organizer lets me store three different grits of sandpaper. It takes up very little space and keeps the disks flat.

To build the organizer, cut four round plates from $\frac{3}{4}$ " MDF. Then use a hand saw to cut an alignment mark on the edge of each plate.

Next, drill $\frac{3}{8}$ "-dia. holes in the top plate (Top View below). You can then use it as a template for

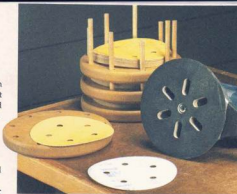

locating the $\frac{1}{4}$ "-dia. through holes in each plate that accept the alignment dowels. As you can see in the drawing at left, there are three in each plate. Finally, drill $\frac{3}{8}$ "-dia. holes in the plates for each of the dowels to slide through.

To use the organizer, place sandpaper on the bottom plate. Next, line up the saw kerf on the edge of the second plate with the top plate and slide the second plate over the dowels. Then continue to add sandpaper and plates until it's filled.

Tom Slatky
Lena, Wisconsin

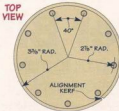
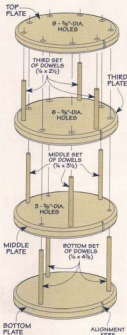

Quick Tips



▲ **Chad Eider** of Monroe, GA, cuts old leather belts to use as shims and clamping pads between his clamps, tools, and workbench. The leather allows him to clamp the tool securely to the bench and cuts down on vibration and noise.



▲ To save space and extend shelf life when bulk glue bottles run low, **Serge Duclos** of Delson, Canada transfers the glue to water bottles and labels them for storage.



▲ **Larry Crum** of Appleton, WI, ties a series of loops in a cord that hangs from the ceiling (inset photo). He then slips clamps into the loops to store them out of the way.

perfect rails and stiles with **One Router Bit**

Use your slot-cutting bit to make stub tenon and groove joints.



When I make simple doors with plywood panels, I usually turn to my table saw to cut the grooves for the panel and to form the stub tenons. But lately, I've been using a slot-cutting bit in my router table. I can get flat-bottom grooves and nice, clean joint lines on the tenons like you see in the photo below.

It only takes a little set-up time to cut the grooves (inset photo above). And a simple, easy-to-build router sled helps you form the stub tenons, as you can see in the main photo above. Here's what you need to know to get some extra use out of that slot-cutting bit in your collection of router bits.

The Right Width. One of the things that can keep you from getting a good fit with a plywood panel is the thickness can vary. What I mean is that $\frac{3}{4}$ " plywood is more often than not a little thinner than that. So, to get a snug fit, I use a slot-cutting bit that cuts a groove slightly narrower than the thickness of my plywood. This lets me sneak up on a tight fit. For example, with $\frac{3}{4}$ " plywood, I'll use a bit that cuts a $\frac{3}{8}$ "-wide slot.

When you install the bit in your router table, set the height of the bit so it's close to being centered on the thickness of the workpiece. This gives you a good starting point for fine-tuning the final width of the groove. Next, adjust the fence on the router table to set the depth of the groove (Figure 1).

Groove Depth. The nice thing about setting the depth of the groove is it automatically sets the length of the stub tenons. This means you won't have to reset the



▲ **Dual-Purpose.** With one bit, you can create grooves and stub tenons for simple frame and panel



▲ **Perfect Joints.** The size of the stub tenons and grooves are easy to set up on your router table using a slot-cutting bit.

ROUTING THE GROOVE

I find it easier to make the groove first then size the stub tenons to fit. But there are a couple of challenges with creating a groove for a panel. The first challenge is getting a snug fit. The panel often ends up too loose or too tight in the groove. Another challenge is getting the groove centered on the workpiece. The good news is with the right setup, an ordinary slot-cutting bit will solve both problems.

ShopNotes
GO ONLINE
EXTRAS

View a video of this technique by going to our website at:
ShopNotes.com

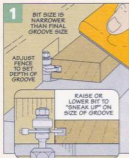

location of the fence. I like to make the grooves about $\frac{5}{16}$ " deep.

Rout Grooves First. Once everything is set up, you can make some test cuts. Then, you can verify the depth of the groove is what you want and is roughly centered on the thickness of the workpiece.

Next, I'll flip the test piece end-for-end and make another pass. This automatically centers the groove on the thickness of the piece, as in Figure 1. Now you can check the fit of the panel. You may need to tweak the height of the bit and make some more test cuts until you get a good fit. Then rout a groove on all the rails and stiles.

STUB TENONS

Now that you have the grooves cut, you can set up to cut the stub tenons on the rails to fit. What's nice is you've already determined the length of the tenon by setting the

fence for the depth of the groove. This means you can concentrate on sizing the stub tenons.

Adjust Bit Height. To do this, you can use the groove on a workpiece as a set-up gauge. I adjusted the height of the bit so that the top of the cutting edge was just shy of the shoulder of the groove, as you can see in Figure 2.

Use a Sled. To form the tenon, you'll be routing the end grain. But one of the problems with routing end grain is the likelihood of tearout. That's why I like to back up the cut with a router sled (see box below). Another benefit is it also helps hold the workpiece square to the fence.

Two Passes. If you look at the bottom two drawings on the right, you'll see that I make the cheeks of the tenon in two passes per side. That's because the slot-cutting bit isn't wide enough to form the cheeks of the tenons in one pass.

The first pass is a light cut made with the workpiece "elevated" on a $\frac{1}{8}$ " hardboard platform (Figure 3). Next, flip the workpiece and repeat the cut on the other side. Now, rotate the sled 180° and make a second pass on each side with the workpiece resting on the router table, as shown in Figure 4.

Once you get the hang of it, it doesn't take much time at all to make stub tenons and grooves. Plus, you've found another use for that slot-cutting bit. 

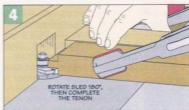
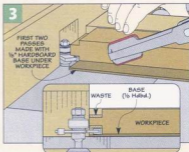
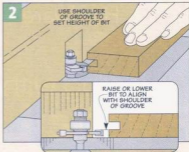

Routing Stub Tenons: Tenoning Sled

To rout the stub tenons on the ends of the rails, you need to keep the workpiece square to the router fence. And you need to make two passes on each side of the workpiece to create the tenon. This simple sled does the job.

The base is made from $\frac{1}{8}$ " hardboard. On one end of the sled, the hardboard base extends out past a fence to make a platform for the workpiece. This elevates the workpiece to make the initial cut on the face to form the tenon. The fence at the opposite end of the sled is flush with the hardboard. It's used to make the final cut on each face of the workpiece to complete the tenon.

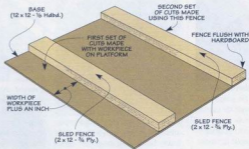

working with **Plastic Laminate**

Applying an attractive, durable surface isn't all that difficult. A few tips make it even easier.

■ When most people think of plastic laminate, kitchen countertops often come to mind. But for a woodworker, plastic laminate is a great material for shop jigs and fixtures.

Laminate has a lot of things going for it. First, it can be trimmed to almost any size with woodworking tools. And once it's glued down to a substrate (typically plywood or MDF), it creates a rock-solid surface that resists moisture and wear encountered in the shop.

It's smooth, slick surface makes it ideal for table tops or jigs where you don't want a lot of friction. And best of all, it's inexpensive and widely available.

Finally, laminate is easy to work with. There are three simple steps — cutting, gluing, and trimming.

CUTTING

Plastic laminate can be cut to size a number of ways — with a utility knife, hand saw, or power tools.

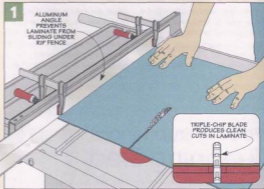

I like to use the table saw when working with larger pieces. A combination blade works fine. But to prevent chipping of the laminate, it's best to use a triple-chip blade.

The only real challenge you might encounter is the tendency of the thin laminate to slip underneath the rip fence. You can prevent this

by clamping a long piece of aluminum angle to your rip fence like you see in Figure 1.

Cutting Small Pieces. It's often difficult to cut small pieces on the table saw. So I use a pair of tin snips (photo at left). If you take small bites without closing the jaws completely, they make a nice, clean cut.



▲ Narrow Strips.

Tin snips work great for cutting narrow strips and odd shapes of plastic laminate.



▲ **Apply Glue.** For best adhesion, apply two coats of contact cement to the laminate and the substrate.



▲ **J-Roller.** Use a roller over the entire surface to apply pressure and eliminate air pockets.

Right Size. It's a good idea to cut the laminate a bit larger than the substrate (about $\frac{1}{4}$ " - $\frac{3}{8}$ " on all sides). This way, it's easier to glue down and you can trim it flush with a router later.

GLUING

After cutting the laminate to size, it's ready to be glued to the substrate. Wood glue works fine, but if you're gluing large sheets, I find contact cement works best. To ensure the strongest bond, I apply two coats to both the back of the laminate and the substrate, letting each coat dry before "sticking" the laminate to the substrate (photo above).

You'll need to be careful at this point, since once you put the laminate and substrate together, you

can't move them. I use old Venetian blinds (main photo on opposite page) to keep the laminate from making contact. Then starting at one end, I remove the strips one by one while pressing the laminate down.

Finally, use a J-roller, like you see in the photo above, over the surface. This applies pressure and removes air pockets for a smooth surface.

One thing you'll need to consider is once you glue the laminate to one surface, that side of the workpiece will be less affected by humidity than the other side. This can cause the workpiece to warp.

So if the substrate is thin or can't be secured to an underlying structure, you may want to apply laminate to both sides. If the face isn't going to be visible, you can

save some money and apply "backer laminate", as you see in the photo at right.

Edges. I only laminate the top and bottom of most projects. But depending on the look you want, you can also laminate the edges. To do this, you'll want to start with the edges (Figure 2). This way, the laminate on the top will overlap the edges after trimming, leaving a less noticeable joint line (Figure 3). Plus, items dragged across the surface are less likely to catch on the edge.

TRIMMING

The only thing left is to trim the edges. A router or laminate trimmer with a carbide-tipped flush trim bit works well. But I like to use a beveled bit to get a little "softer" edge.

As you do this, you'll need to be sure to keep the bearing of the bit clean. Glue can build up while routing and freeze up the bearing, causing it to spin along with the bit. This can scratch the laminate, like you see in the photo at right.

Another way to clean up the edges is to use a fine-cut flat file. You can find these files at most home centers or laminate retailers. Just be sure to file into the laminate as shown in the photo below. Don't pull the file along the edge or you may chip the laminate.

That's it. It's just that easy to add a smooth, durable surface to any jig or fixture. Once you try it you'll look for more ways to use it. ☺

▲ **Backer Laminate.** Use less expensive backer laminate on the back side to help prevent warping.



▲ **Bearing Scratches.** To prevent scoring of the laminate, check the bearing of the router bit frequently for glue buildup.

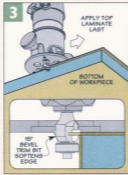
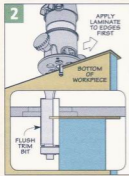

▲ **Filing Edges.** Downward and outward strokes of a flat mill file make smooth edges.



upgrade your Jointer Cutterhead

Smoother cuts and easier blade changes make a spiral cutterhead worth the effort.

▼ **Chop or Slice?** The top board was jointed with conventional knives; the bottom board with a spiral cutter.

Starting with flat, square stock makes building a project a lot easier. That's why a jointer is a "must-have" piece of equipment.

But a jointer has some limitations. It can tear out rather than slice wood fibers, especially when working with figured woods.

The problem is, on a conventional jointer cutterhead, the knives are square to the board, creating

a chopping cut. While this design is easy to manufacture, it may not give the best results. And even with this simple design, changing knives can be a chore.

Spiral Design. To address these shortcomings, manufacturers have developed replacement cutterheads using a spiral design, placing knives or cutters angled around the cylinder. The advantage of this



SUNHILL SPIRAL

approach is it produces a shearing, rather than a chopping cut. It's the same idea as skewing your block plane to make a smoother cut. The good news is, after-market spiral cutterheads are now available for most 6" and 8" jointers.

In addition to the spiral design, each of the manufacturers incorporates indexed knives for hassle-free replacement. But that's where the similarities end. When it comes to spiral design, each company has taken a different approach.

Basic Spiral Design. The first approach, by Sunhill, is a "true spiral" design. That is, each of the three high-speed steel knives fits in an angled groove in the cutterhead. The photos at the top of this page show the design.

To wrap around the spiral, the knives are thin and very flexible. Nevertheless, they hold up well in most woodworking applications. The downside is, if you get a nick in the blades you'll need to replace all three. Since the knives are indexed, you can't shift them to either side as you would with a conventional cutterhead.

Staggered Blades. The other two designs shown here take a different approach. Instead of long blades, they use a series of small insert cutters attached to the cutterhead with a countersunk screw.

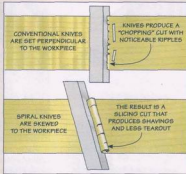
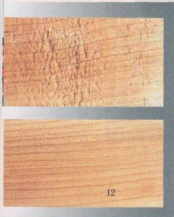

WOODTEK

BYRD TOOLS SHELIX

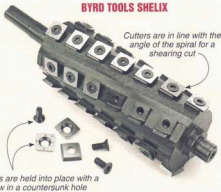

The inserts overlap each other between rows to provide a continuous cut. You can see what I'm talking about in the photos above.

One big advantage to this type of design is each insert has four cutting edges. So if you nick a cutter you only need to rotate the damaged edge a quarter turn to expose a fresh edge. A second benefit is the inserts are made from carbide, giving you a longer-lasting cutting edge. Plus, it's also suitable for working with MDF or plywood.

"V" Pattern. The first example, from Woodtek, positions six rows of cutters in a "V" shape on the cylinder. While this arrangement produces a smoother cut than a

conventional cutterhead (there is a shearing effect due to the spiral pattern) it still positions the cutting edge square to the board.

Shelix. The third option incorporates the best of both worlds. The *Shelix* head from Byrd Tools has six rows of insert blades, also slightly offset for a continuous cutting action. But unlike the *Woodtek*, the cutting edges follow a spiral pattern around the axis of the cutterhead. The difference is noticeable. It produces the smooth, shearing cut of a true spiral blade and has the durability that only carbide cutters can provide.

Cost. Of course, all these benefits come at a price. The *Sunhill* spiral

head is a great value at \$149 for a 6" jointer. Replacement knives cost \$18.95 for a set of three.

The *Woodtek* and *Byrd* heads each sell for more than twice that (\$320), but the carbide inserts mean you'll get longer life from the blades. Replacement inserts for either of these heads run about \$27 for a box of 10. But remember you'll need four boxes to replace the entire set. Refer to page 51 for sources.

If you feel like you could be getting better results from your jointer, one of these replacements may be the answer. And don't worry about changing out a cutterhead. As you can see in the box below, the process isn't all that difficult. 

Replacement: Installation

There's no reason to be intimidated by the thought of upgrading the cutterhead of your jointer. The upgrade isn't hard and it doesn't take too long. The instructions that came with the different cutterheads were all very detailed and easy to understand. But it's still a good idea to have the manual for your jointer handy, in case you need a little more information.

The drawing at right gives you an idea of what's involved. First, you'll need to remove the blade and pulley guards, and the fence assembly. Then you'll have to lower the infeed and outfeed tables to remove the pulley and bolts, and finally the cutterhead itself. Again, your manual will have the best information.

All that remains is to replace the head and put it all back together. After you've reset the height of the infeed and outfeed tables, you'll be up and running.

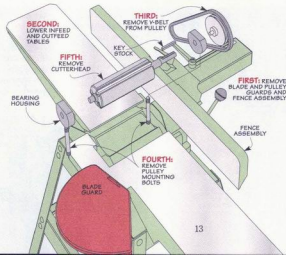

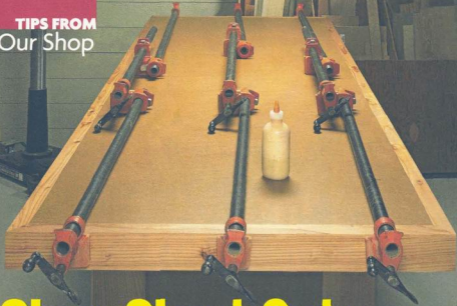

Shop Short Cuts

Building a Large Benchtop

■ A large workbench like the one on page 30 presents a couple challenges — building the layered top and then adding the edging.

Layering the Top. The trick with the top is keeping all the layers flush with each other as you glue

them up. To do this, I used screws to keep everything aligned and act as “clamps.” Plus, working in stages makes things less hectic.

I started by cutting the top two layers to final size. Then, after clamping them together with the edges flush, I pre-drilled all the holes for the screws.

With the screw holes complete, you can separate the two layers and spread on some glue. A slow-

set glue works best here. Then it's just a matter of “clamping” the two layers together using the screws.

To build up the other layers, I followed a similar process. First, I glued up and installed the two long strips along the outside edges of the top. Then, I sized a filler block to fit in between, gluing and screwing them in place. Be sure to stagger the screws to avoid interfering with the screws in the top.

Add the Edging. At this point, you're ready to add the edging. My problem was none of the clamps I had spanned the length of the top. If you have pipe couplers, you can simply “make” longer clamps.

For my top, I tried something different (photo above). Instead, I connected the clamps in series to create “longer” clamps that reached from one end to the other.

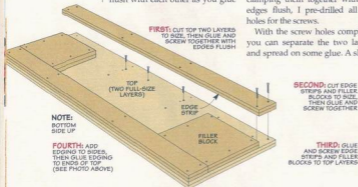

Clearance for a Table Saw Motor

It isn't difficult to wrap a top around a contractor's table saw (page 16). The problem comes when you want to tilt the blade to 45°.

In many cases, any surface that extends past the back edge will prevent the motor from tilting. The problem could be the thickness of the top or even the aprons and cleats used to build it. To solve this problem, you'll need to provide space for the motor (or other parts), as in the photo at right.

Once you have the top in place, simply tilt the saw blade, checking for any interference as you go. The first thing I had to do was cut a notch in the cleat running along the back edge of my table.

With the notch cut out, a little more tilting showed me I had a small problem where the capacitor on my motor contacted the bottom surface of the table. Drilling a shallow counterbore provided the needed clearance there.



Creating a Seamless Edge with T-Molding



T-molding can really dress up and protect the edge of a shop project. The trick to getting a smooth, clean look is to wrap the molding evenly around the corners of the project to create a seamless edge.

The problem is the spine on the backside of the molding. It makes it hard to bend around tight curves, like the top of the workcenter on page 16. To provide clearance, you'll need to make a couple relief cuts in the spine (inset photo). This way, the molding will bend smoothly in place. 

Making a Custom Scraper

One solution for getting a clean cut with a router is to keep it moving. But if you're using the fluting jig on page 36 to create "stopped" flutes, you can't do that. Once you stop moving the router, the spinning bit can burn the ends of the flutes (photo at right).

I usually get rid of burn marks with a sanding block or cabinet scraper. But it's nearly impossible to clean up the rounded end of the flute with a sandpaper block or traditional scraper.

To solve this problem, I made a custom scraper from an old hacksaw blade (Figure 1). After drawing the flute profile on one end, you can shape it with a grinder (Figure 2). Finally, to create a sharper edge, use a file to put a slight bevel around the profile.

Now the scraper can be used to quickly clean out the ends of the flutes. Just be careful not to deepen the flutes — a light scraping is all that's needed.

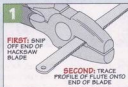



table saw Workcenter

Take a contractor's saw, a router, a few sheets of MDF, and a handful of hardware and turn it into this super workcenter.

■ For me, the most satisfying shop projects are the ones I know I'll put to use day in and day out. And if there was ever a project that fit this bill, it's the table saw workcenter you see in the photo above.

This project has a long list of features. The workcenter is designed around a standard contractor's saw. And it will accommodate just about any saw on the market. (Ours is a *Delta*, with a heavy-duty *Bisemeyer*

rip fence). As you can see, the table of the saw is surrounded by a huge worksurface that makes crosscutting or ripping workpieces (large or small) a breeze.

Off to the right, you'll find a large and stable router table with all the extras — drop-in insert, miter gauge slot, and an easy-to-adjust fence. And basically, the entire lower part of the workcenter is dedicated to valuable storage.

Now you might think that a project with this many highlights would be difficult, time-consuming, and expensive to build. Not so. A combination of modular casework, simple but sturdy joinery, and inexpensive materials keeps both the work and the cost to a minimum.

And believe it or not, you can make a good thing even better by adding the outfeed stand on page 26 to the workcenter.

Exploded View Details

OVERALL DIMENSIONS:
37 $\frac{1}{4}$ "D x 64 $\frac{1}{4}$ "W x 34 $\frac{1}{4}$ "H

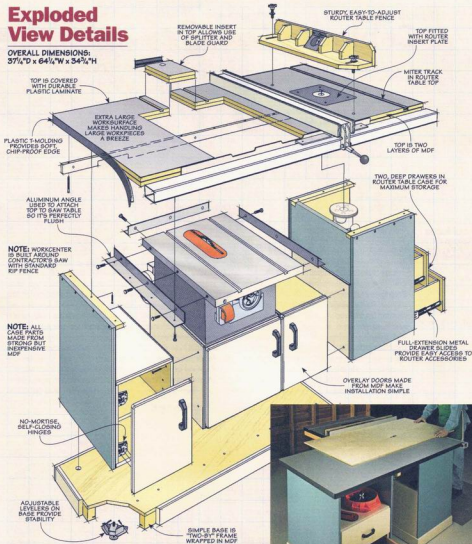

NOTE: MODULAR
CASE DESIGN MAKES
ASSEMBLY GO QUICKLY

► **Optional Outfeed Stand.** Easier cuts and more storage are a couple of the benefits you'll get from this outfeed stand. You'll find the details on page 26.



building the Cabinet

As you can see here, your first job is to build the main cabinet that supports the table saw and router table. Take a look at the drawing at right and you'll see that the cabinet consists of a stack of four, short MDF cases fastened to a long, continuous base. You'll find that this simple, modular assembly makes the work go fast and easy without sacrificing a bit of strength. The best plan is to tackle the cases first, then build the sturdy base to fit them.

Getting Started. Other than size and a few important interior details, the four cases are built identically. You'll find the biggest differences in the case that supports the table saw, so I saved it for last.

Easy Joinery. My goal was to build the cases solidly, but also to keep the joinery as straightforward as possible. So take a quick look at Figures 2 and 3 below, and you'll see how the two storage cases and the router table case are put together. Basically, once the parts are cut to size, all you'll have to do to complete the joinery is install a dado blade on the table saw and start cutting rabbets.

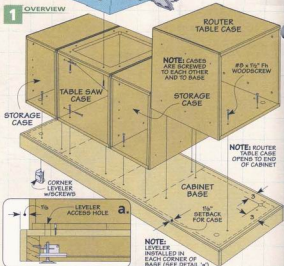

Figure 2a shows how the case sides are rabbeted to hold the top and bottom. And then if you look at Figure 3a, you'll see that the sides, top, and bottom are all rabbeted to capture the back panel.

A Few Details. Before gluing the cases together, there are a couple of interior details to take care of. First, you'll need to drill shelf pin holes

in the two storage cases for the shelves you'll add later. Second, notice that these three cases have a series of countersunk screw holes on the sides and bottoms (Figures 2 and 3). When the time comes, these holes will be used to fasten the cases together and to the base.

There's one last thing. To be certain the workcenter was good and

2 FIGURE

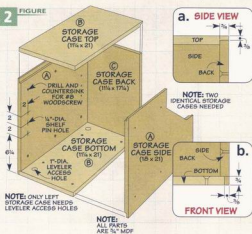

3 FIGURE

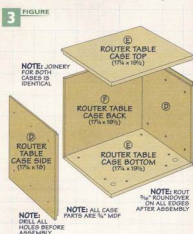

stable when set in place, I planned to add levelers to the corners of the base. This means you'll need access to the levelers to adjust them. For this purpose, I drilled access holes in the router table case and the left storage case (and later the base).

Now, the cases are ready for glue and clamps. And once the assembly is completed, all the outside edges of the cases are rounded over.

Table Saw Case. I had one requirement for the table saw case that made building it a bit more involved — dust collection. Figure 4 at right shows how it works. As you can see, the top of the case has a large cutout. I did this by drilling holes at the corners and then removing the waste with a jig saw.

Divider. Below the cutout, an angled divider funnels the dust to the back of the case. It's held in place by a pair of angled cleats.

It works best to add the divider after the case is assembled. First, cut the parts to size and then screw the cleats and the divider together. Then you can slide the assembly into the case from the front, and fasten it in place from above.

Finally, rather than cut a dust port directly into the back panel, I opted for a large cutout, covered with a separate dust port panel. This will give you better access to the dust chamber when needed.

The Base. Once all four cases are complete, you can build the base that connects them. Like the cases, it's pretty basic, but there's one point I should mention up front. The base is sized to hold the four cases and the end panels that support the top, along with the overlay doors and drawers. When everything is in place, the goal is an even $\frac{3}{8}$ " reveal all the way around.

You start the base by building a sturdy frame from "ripped down" two-by stock (Figure 5). The only detail you'll need to worry about is a saw kerf running around the inside perimeter. This gives extra support to the levelers you'll add (Figure 5a). I relied on woodscrews to assemble the frame.

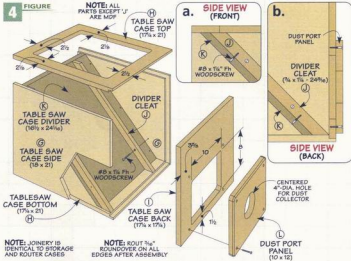

Once the frame is assembled, you can wrap it with an MDF skirt and top. The skirt pieces are butted at the corners and the top is cut to fit inside the skirt. With this done, I drilled an adjustment hole in each corner and then installed the levelers. Finally, I routed a roundover on the top edges and the corners.

Put It All Together. Now you're ready to screw all the cases and the

base into one assembly. And here, you just want to make sure you get everything aligned properly. First, I set the cases in place on the base and fastened them together. The four cases should be flush across the front (this will be the side of the router table case). Now, when you fasten the cases to the base, simply leave an even, $1\frac{1}{8}$ " setback on each end and across the front.

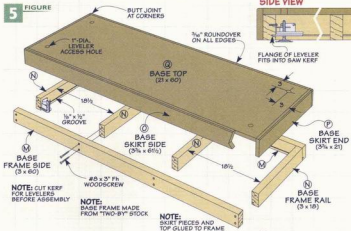

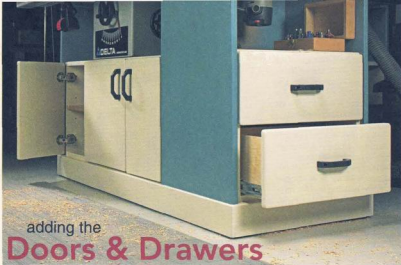

At this point, the cases and the base are joined into one assembly, but one of the major features of the workcenter — its generous storage — still needs more work. The three front cases simply need doors and shelves. But I had other ideas for the router table case. Here, easy access to my ever-growing collection of router bits and accessories was my number one goal. A couple of deep drawers are the answer.

Simple Doors. I took on the easier challenge of making the

overlay doors first. As you can see in Figure 6, I certainly didn't get fancy here. I started by cutting panels of MDF to overlap the openings in the cases by $\frac{1}{2}$ " on all sides. And then after rounding the sharp corners, I routed a roundover on the outside edges. Other than adding the hardware, you're done.

Mounting the Doors. To install the doors, I turned to some self-closing, no-mortise hinges. As you can see in the margin photo at left, they look a little intimidating, but

actually, I found that they were pretty easy to install.

There are a couple of helpful tips I can share with you. First, these hinges are designed to be used on both inset and overlay doors. For the overlay doors here, you want to attach the hinge plate with the long arm to the case (Figure 6b). This will give you the right "swing."

Second, the hinges have slotted screw holes for horizontal adjustment, but not much in the way of vertical adjustment. So to help me get the vertical position correct, I drew corresponding centerlines for the hinge plate on both the door and case. This way you can simply center the middle screw hole of the hinge plate on this line.

Details. A couple more details and you can move on to the drawers for the router table case. You won't need catches on the doors, but you will need pulls. I ordered some durable, hard plastic pulls for this job. They simply screw to the face of the door. And finally, I cut a couple of MDF shelves to size for the two storage cases (Figure 6a).

The Drawers. The two drawers I built for the router table case are likewise, no frills. As you can see in Figure 7, they're just sturdy boxes with false, overlay fronts.



▲ Easy Installation.

These no-mortise hinges make installing the doors a quick and easy job.

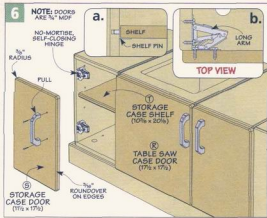

Full-extension slides give you easy access to everything inside.

The Details. A quick overview will be all you'll need to build the drawers. The sides, fronts, and backs are all cut from stable, $\frac{1}{2}$ " Baltic birch plywood. And since the plan calls for metal slides, remember to allow $\frac{1}{2}$ " clearance between the case sides and both sides of the drawers (Figure 7c).

The Joinery. The joinery on the boxes is a basic tongue and dado. You'll start by cutting a $\frac{1}{4}$ "-wide dado in both ends of the sides. Then cut a matching tongue on each end of the front and back to create a rigid joint (Figure 7a). A groove in all four pieces holds a $\frac{1}{8}$ " plywood bottom (Figure 7b).

Fronts. Once the drawer boxes were assembled, I cut the false fronts to size and gave them the same treatment as the doors — rounded corners and a roundover on the outside edges (Figure 7d).

But before adding the fronts, you'll want to install and adjust the slides. Then, I used carpet tape to locate the fronts on the boxes and drill the screw holes used to attach them. Finally, remove the carpet tape, refasten the fronts, add the pulls, and you're done.

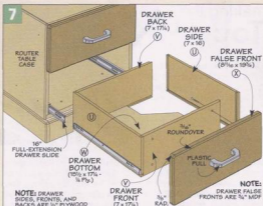

NOTE: DRAWER SIDES, FRONTS, AND BACKS ARE $\frac{1}{2}$ " PLYWOOD

NOTE: DRAWER FALSE FRONTS ARE $\frac{3}{8}$ " MDF

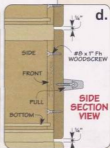

Materials & Hardware

- | | | | | | | |
|---|---------------------------|---|----|----------------------------|--|---|
| A | Stor. Case Sides (4) | 18 x 21 - $\frac{3}{4}$ MDF | V | Dwr. Fronts/Backs (4) | 7 x 17 $\frac{1}{2}$ - $\frac{1}{2}$ Ply. | • (6) $\frac{3}{16}$ " T-Nuts |
| B | Stor. Case Tops/Btms. (4) | 11 $\frac{1}{4}$ x 21 - $\frac{3}{4}$ MDF | W | Dwr. Bottoms (2) | 15 $\frac{1}{2}$ x 17 $\frac{1}{2}$ - $\frac{1}{4}$ Ply. | • (1) 1 $\frac{1}{2}$ " x 15" T-Molding |
| C | Stor. Case Backs (2) | 11 $\frac{1}{4}$ x 17 $\frac{1}{2}$ - $\frac{3}{4}$ MDF | X | Dwr. False Fronts (2) | 8 $\frac{3}{8}$ x 19 $\frac{1}{2}$ - $\frac{1}{4}$ MDF | • (2) $\frac{3}{16}$ " x 2" Studded Knobs |
| D | R.T. Case Sides (2) | 18 x 17 - $\frac{3}{4}$ MDF | Y | Left Top Section (1) | 20 $\frac{1}{2}$ x 37 - $\frac{1}{2}$ MDF | • (2) $\frac{3}{16}$ " Flat Washers |
| E | R.T. Case Top/Btm. (2) | 17 $\frac{1}{2}$ x 19 $\frac{1}{2}$ - $\frac{3}{4}$ MDF | Z | Right Top Section (1) | 37 $\frac{1}{2}$ x 37 - $\frac{1}{2}$ MDF | • (1) Dust Collection Hood |
| F | R.T. Case Back (1) | 17 $\frac{1}{2}$ x 19 $\frac{1}{2}$ - $\frac{3}{4}$ MDF | AA | Left Side Panel (1) | 21 $\frac{1}{4}$ x 29 $\frac{1}{2}$ - $\frac{1}{4}$ MDF | • (1) Miter Track |
| G | T.S. Case Sides (2) | 18 x 21 - $\frac{3}{4}$ MDF | BB | Left Side Panel Cleat (1) | $\frac{1}{4}$ x 11 $\frac{1}{2}$ - 21 $\frac{1}{4}$ | • (8) Shelf Support Pins |
| H | T.S. Case Top/Btm. (2) | 17 $\frac{1}{2}$ x 21 - $\frac{3}{4}$ MDF | CC | R.T. Side Panels (2) | 18 x 29 $\frac{1}{2}$ - $\frac{1}{4}$ MDF | • (4) #6 x $\frac{1}{4}$ " Fh Woodscrews |
| I | T.S. Case Back (1) | 17 $\frac{1}{2}$ x 17 $\frac{1}{2}$ - $\frac{3}{4}$ MDF | DD | R.T. Side Panel Cleats (2) | $\frac{1}{4}$ x 11 $\frac{1}{2}$ - 17 $\frac{1}{2}$ | • (24) #8 x 3" Fh Woodscrews |
| J | T.S. Case Cleats (2) | $\frac{3}{4}$ x 1 $\frac{1}{4}$ - 24 $\frac{3}{4}$ | EE | R.T. Case Partition (1) | 20 $\frac{1}{4}$ x 11 $\frac{1}{2}$ - $\frac{1}{4}$ MDF | • (2) #10 x $\frac{1}{2}$ " Sheet Metal Screws |
| K | T.S. Case Divider (1) | 16 $\frac{1}{2}$ x 24 $\frac{3}{4}$ - $\frac{3}{4}$ MDF | FF | Splitter Insert (1) | 6 x 10 - 1 $\frac{1}{2}$ MDF | • (53) #8 x $\frac{1}{4}$ " Fh Woodscrews |
| L | Dust Port Panel (1) | 10 x 12 - $\frac{3}{4}$ MDF | GG | Splitter Insert Cleat (1) | $\frac{1}{4}$ x 10 - $\frac{1}{2}$ - 6 | • (10) #8 x $\frac{1}{4}$ " Rh Woodscrews |
| M | Base Frame Sides (2) | 1 $\frac{1}{2}$ x 3 - 60 | HH | Top Cleat (1) | $\frac{1}{4}$ x 2 - 63 | • (46) #8 x $\frac{1}{4}$ " Fh Woodscrews |
| N | Base Frame Rails (4) | 1 $\frac{1}{2}$ x 3 - 18 | II | Fence Base (1) | $\frac{1}{4}$ x 6 - 30 | • (2) 1 $\frac{1}{2}$ x 1 $\frac{1}{2}$ - 4" Alum. Angle ($\frac{1}{4}$ " Thick) |
| O | Base Skirt Sides (2) | 3 $\frac{1}{4}$ x 61 $\frac{1}{2}$ - $\frac{3}{4}$ MDF | JJ | Fence Face (1) | $\frac{1}{4}$ x 4 - 30 | • (2) 48" x 72" Plastic Laminate (Face/Backer) |
| P | Base Skirt Ends (2) | 3 $\frac{1}{4}$ x 21 - $\frac{3}{4}$ MDF | KK | Fence Braces (4) | $\frac{1}{4}$ x 3 - 3 | • (6) $\frac{3}{16}$ " x 1" Lag Screws |
| Q | Base Top (1) | 21 x 60 - $\frac{3}{4}$ MDF | | | | • (8) #8 x $\frac{3}{4}$ " Sheet Metal Screws |
| R | T.S. Case Door (1) | 17 $\frac{1}{2}$ x 17 $\frac{1}{2}$ - $\frac{3}{4}$ MDF | | | | • (4) #6 x $\frac{3}{4}$ " Fh Woodscrews |
| S | Stor. Case Doors (2) | 11 $\frac{1}{4}$ x 17 $\frac{1}{2}$ - $\frac{3}{4}$ MDF | | | | • (8) #8 x 1" Fh Woodscrews |
| T | Stor. Case Shelves (2) | 10 $\frac{3}{8}$ x 20 $\frac{1}{2}$ - $\frac{3}{4}$ MDF | | | | • (1) Router Table Dust Port |
| U | Dwr. Sides (4) | 7 x 16 - $\frac{1}{2}$ Ply. | | | | |

making the Top

The table saw and router table top is where the work will get done. So I was looking forward to starting on this part of the project.

A Quick Look. First, I'll give you a general overview. Take a look at Figure 8 below, and you'll see that the top consists of two main sections. Each is made up of a double-thickness of MDF with plastic laminate on both sides.

Both sections wrap around the back of the saw table. And a gap between them provides a space for the splitter and blade guard. It can be filled with a "pop out" insert (Figure 10). Finally, the top is attached to the saw table by way of aluminum angle bolted to the saw table (Figure 8a). I'll cover the rest of the details along the way.

A New Base. Before getting started, I took my saw off its stand and moved it to its new home on the workcenter cabinet. This way, when the top is ready to install, everything will be in place.



Get Started. I started by gluing up an oversized, two-layer, MDF panel for each top section. Then before applying the laminate, you'll want to cut the sections to final size and shape. The less opportunity to chip the laminate, the better.

You really have two jobs here. First, cutting each section to overall size, then making the L-shaped cutouts that allow the sections to wrap around the saw table.

I was able to do some of this work at my table saw. But the large size of the right section and the notches presented a problem. The solution is to first rough cut the pieces to size and then use a router with a

straight bit installed and a straight-edge to trim them accurately.

Plastic Laminate. Now you can apply the plastic laminate and trim it flush. You'll want to be sure to apply a backer laminate to the underside to keep the top "balanced" and flat. But don't worry about the edges, they get a different treatment later. Take a look at the article on page 10 for more information on working with laminate.

Miter Gauge Slots. You'll notice in Figure 8, that the miter gauge slots extend into the top. Since this is just for clearance, I routed over-size slots and didn't worry about perfect alignment.

Clearance. One more thing and the top sections are ready to install. In order for the top to fit over the aluminum angle and snug to the saw table, you'll need to rout a deep, narrow rabbet around the L-shaped cutouts (Figures 8a and 8b). You'll also need to counterbore for the heads of the bolts, but this can wait until the angle is installed.

Side Panels. Before installing the new top, the cabinet below needs one more addition. In Figure 9 you'll see how three MDF side panels are screwed to the cabinet to help support the top — one on the left end and one on either side of the router table case.

The panels rest on the cabinet base. A hardwood cleat at the top of each panel is used to fasten the top down. An upper partition at the back of the router table case adds additional support and helps control the dust from the router.

8 FIGURE

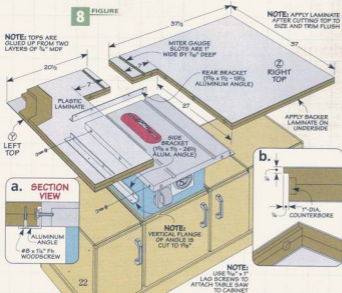

It's important that the panels support the top level with the saw table. Figure 9a shows how to find the height of the panels. Just measure from the top of the base to the top of the saw table and then subtract the thickness of the new top.

New Top. Once the side panels are in place, you can take the extension wings and fence off the saw and switch to the new top.

The aluminum angle used to attach the top is fastened to the saw table using the bolts and threaded holes that held the extension wings. To allow easy adjustment of the height of the angle, I drilled the bolt holes oversize. Figure 9b shows how to adjust the angle for a flush fit of the top. Once the aluminum angle is attached and adjusted, the two top sections can be set in place and screwed down.

Final Details. All that's left are a few loose ends (Figure 10). First comes the splitter insert that fills the gap at the back of the top. It's sized to fit snugly in its pocket and has laminate on both sides. I added a finger hole to remove it and a cleat keeps it in place (margin photo).

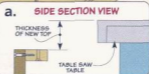
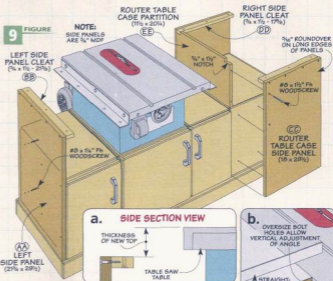

Top Cleat. The back edge of the insert rests on a long cleat that's screwed to the underside of the top (Figure 10b). This cleat's main purpose is to connect the top sections and keep them flat and true.

You'll notice that the cleat has a good-size notch cut into it. This provides clearance for the motor when the blade is tilted to 45°. Turn to Shop Shortcuts on page 14 for more details on this.

T-Molding. The last item is the top edging. For this I turned to easy-to-install and chip-proof, plastic T-molding. But before starting on this, decide whether you plan on building the outfeed stand on page 26. If so, hold off and install all the T-molding at once.

Installation. The first thing to do is round all the corners of the top so the molding will bend around them. The T-molding is held in place by a flange that fits a slot in the edges of the top (Figure 10a). So routing this narrow, centered slot is the next job. You can mark the ends of the rip fence rail and stop the slots there.

Installing the T-molding on the top is as easy as pressing or lightly tapping it into place. You'll find the simple technique I used to bend it around the corners in Shop Shortcuts on page 14.

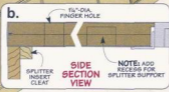
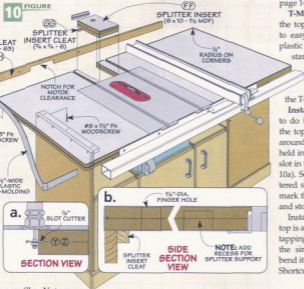

▲ Splitter Insert. Removal of the "pop out" insert makes way for installation of the splitter and blade guard.

Step-by-Step: Insert Plate

An insert plate should fit snugly in the router table top and be perfectly flush with the surface. The drawings below show how I got this done.

Basically, you'll need to make an accurately sized, rabbeted cutout in the top of the workcenter (photo at right). The rabbeted pocket that holds the insert is $\frac{1}{8}$ " deeper than the thickness of the insert. Then a screw installed in each corner allows you to adjust the height of the insert (Figure 12a on page 24). Be sure to note that the insert plate is centered over the case below.

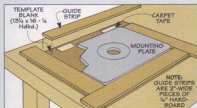

1. Start the Template. To install the insert, you'll need to make a hardboard template. First, place the insert on the template blank and wrap it with guide strips.

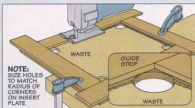

2. Remove the Waste. After drilling a hole in each corner that matches the corner radius of the insert, remove the waste, cutting to the inside of the strips.

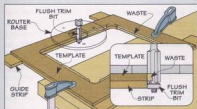

3. Flush Trim. To complete the template, smooth the rough cuts between the holes with a router and flush-trim bit. Notice I flipped the assembly over.

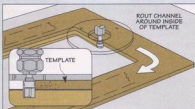

4. Start the Cutout. Next, with the template held in place on the top by carpet tape, I routed a narrow channel around the inside of the template.

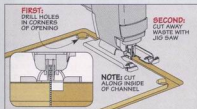

5. Complete the Cutout. After drilling starter holes in the corners, complete the cutout with a jig saw. Just cut along the inside edge of the channel.

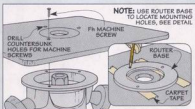

6. Mount the Router. Finally, you can mount the router to the insert using the router base plate as a template to locate the screw holes.



▲ **Dado Bit.** I used a short, dado bit with a top-mounted bearing to rout the pocket for the insert plate.

optional

Outfeed Stand

I'm sure you'd agree that the large top of the workcenter is a big plus. But when cutting up sheet stock or ripping long boards, you also want steady outfeed support. And that's where the outfeed stand, shown in the photo at right, comes in.

Outfeed Plus. Although offering safe, stable outfeed for ripping and cuts on large panels is its main duty, the outfeed stand also gives you three different types of storage. Below the top is a deep "pass-through" storage area where the tools you use often will be close at hand. The case that forms the lower part of the stand is divided down the middle. On the left, you'll find open shelving, while on the right side of the case I added a couple more drawers. And a "bonus" is that the top can do double-duty as an extra worksurface.

Building the Stand. One other important benefit here is that, just like the main cabinet, the outfeed stand is designed to go together quickly and easily. In general, the



construction of the cabinet and its top is identical to the main cabinet you've already seen — only the size and a few details are different. So, a quick overview of the basic construction should be all you need.

The Case. You'll start by building a simple case out of MDF, as shown in Figure 13. The joinery is identical to that used on the cases for the main cabinet. Rabbits in the sides capture the top and bottom (Figure 13a). But there is one new twist here. As mentioned before, to

make the case a bit more practical, I added a vertical divider. An MDF panel dadoed into all four case parts handles this job (Figure 13b).

As you can see in the drawing, the divider is offset toward the open, shelf side of the case. This makes room for deeper drawers and keeps the shelves narrower and more accessible.

That's it for the joinery. But before the case is assembled you have some holes to drill. The case sides need shelf pin holes, the sides and bottom have countersunk assembly holes, and finally, the bottom gets leveling access holes.

The Base. Building the base is basically a repeat of the base for the main cabinet — a frame made from "two-by" stock wrapped in MDF (Figure 14). And don't forget that the base needs to be sized to hold a couple of side panels and the overlay drawers fronts, as well as the case. The levelers on the base are important. They make it easy to align the top of outfeed stand with the top of the workcenter.

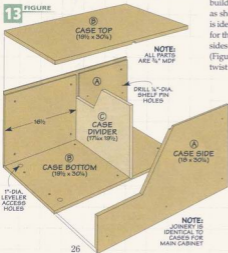

Side Panels. Once the case and base are assembled, you can add the side panels, as shown in Figure 14. Again, the details are all the same. Here, you can cut the panels to the same height as the panels you made for main cabinet. After rounding over the long edges and attaching the cleats, the panels are simply screwed to the case sides.

The Top. Now the cabinet is ready for a top. Figure 14 gives the details. It's basically just a smaller, simpler version of the top for the workcenter — a double layer of MDF with laminate on both sides and T-molding on the edges.

Remember that one long edge of the top butts against the back edge of the main top. So these two corners are left square and there's no T-molding on this edge. But you will need a cleat along this edge to mate with the cleat across the back of the main top. These two cleats tie the two tops together, as shown in Figure 14a. Hex bolts, washers, and nuts create a snug joint.

Near the End. All you have left to build are a pair of drawers for the deep side of the cabinet and a shelf for the shallow side. The drawers, shown in Figure 15 and 15a below, should look pretty familiar. In fact, they're identical

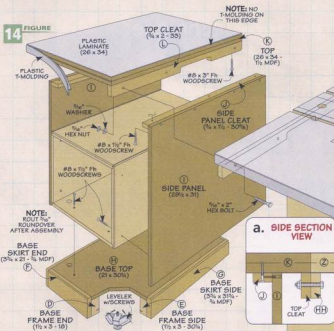

to the drawers built for the router table case. You'll find all the details you need on page 20.

The last step is to move the stand into position, level it up, and bolt it in place (Figure 14a). Then it can start earning its keep. **A**

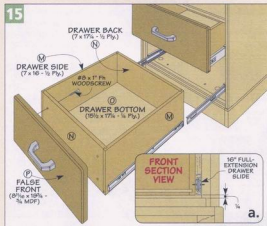

Materials & Hardware

A Case Sides (2)	18 x 30 1/4 - 1/4 MDF
B Case Top/Bottom (2)	19 1/2 x 30 1/4 - 1/4 MDF
C Case Divider (1)	17 1/4 x 19 1/2 - 1/4 MDF
D Base Frame Ends (2)	1 1/2 x 3 - 18
E Base Frame Sides (2)	1 1/2 x 3 - 30 1/4
F Base Skirt Ends (2)	3 1/2 x 21 - 1/4 MDF
G Base Skirt Sides (2)	3 1/2 x 31 1/2 - 1/4 MDF
H Base Top (1)	21 x 30 1/2 - 1/4 MDF
I Side Panels (2)	29 1/2 x 31 - 1/4 MDF
J Side Panel Cleats (2)	1/4 x 1 1/2 - 30 1/2
K Top (1)	26 x 34 - 1 1/2 MDF
L Top Cleat (1)	1/4 x 2 - 33
M Drawer Sides (4)	7 x 16 - 1/2 Ply
N Drawer Fronts/Backs (4)	7 x 17 1/4 - 1/2 Ply
O Drawer Bottoms (2)	15 1/2 x 17 1/4 - 1/2 Ply
P Drawer False Fronts (2)	8 1/2 x 19 1/2 - 1/4 MDF
Q Case Shelf (1)	12 1/4 x 18 1/2 - 1/4 MDF

- (4) Corner Levelers
- (2) 4 1/2" Long Handles
- (2 pr.) 16" Full-Extension Drawer Slides w/Screws
- (4) Shelf Support Pins
- (2) 48" x 48" Plastic Laminate (Face/Backer)
- (1) 1 1/2" x 30" T-Molding
- (12) #8 x 3" Fh Woodscrews
- (20) #8 x 1 1/2" Fh Woodscrews
- (12) #8 x 1 1/4" Fh Woodscrews
- (3) 1/2" x 2" Hex Bolts w/Nuts & Washers
- (8) #8 x 1" Fh Woodscrews

5 Shop-Made Pulls

Why buy pulls when you can make your own? All it takes is a little shop time and a step-by-step approach.

■ When it's time to choose drawer or door pulls for a project, there's an option that's often overlooked. Rather than buy something off the shelf or order from a catalog, save the cash and make you own pulls.

Shop-made pulls have some neat advantages. I like the fact that you're not limited to what's commercially available. When the work stays in the shop, you can better match the style, size, and wood of the pull to the project. You use up some scrap wood and get unique-looking, custom pulls out of the bargain.

So to get you started, here's the step-by-step process for five great-looking, easy-to-make pulls.



1

One of the big benefits of this simple recess pull is that it's very easy to make in multiples. You start by cutting a long, 1 1/4"-wide blank from 3/4"-thick stock. Next, you take the blank to the router table to rout a roundover on the top outside edge (upper drawing). You follow this with the cove that forms the finger recess (middle drawing).

The next step is the table saw to cut the blank into individual pulls, as shown in the lower drawing. A 20° bevel on the ends adds the perfect touch.



2



The real key to making this "cut-out" pull is doing things in the right order. I started by laying out the pulls on an extra-wide blank and drilling pairs of holes (upper drawing). You'll get two pulls from each section. After ripping the blank down the center, the cutouts are completed by removing the waste between the holes on the band saw (left lower drawing).

Then, before cutting the individual pulls from the blanks, you'll want to bevel the sides on the table saw, as shown in the lower right drawing.



3



If you need a pull that's easier to grip, this hefty oak dowel pull is the answer. Here, you have two different parts to make — the rounded end brackets and the "tenoned" dowel that's glued in between.

The brackets are made in pairs from a thick blank, as shown in the upper and middle drawings. This way, they'll turn out identical. You'll want to

round the ends of the brackets on the band saw before drilling the holes for the tenons and finally cutting the brackets to size.

The tenors on the ends of the dowel are made by rotating the dowel over the table saw blade. An auxiliary fence attached to the miter gauge acts as a back support while the rip fence is the end stop. I left the tenors a hair oversize and sanded them to fit.



4



A length of 1"-dia. dowel and a 3/4"-dia. core box bit will allow you to make a bunch of these finger pulls in short order. The router table setup I used is shown in the left drawing below. A V-block and the miter gauge are used to feed the dowel over the raised bit and create a groove on each side. Then you move to the table saw, cut the pull loose, and repeat the process. You'll want to check out the box below to mount these pulls.

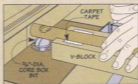

5



Making this wood and aluminum pull starts by cutting a 4"-long section of 1"-square aluminum angle and buffing it out. The next step is to drill and countersink a pair of mounting holes for some woodscrews in one face of the angle (upper drawing).

The 3/4"-dia. dowel that provides a grip is kerfed to fit over the angle. The lower drawing shows how a block with a "stopped" hole holds the dowel while you run it through the saw. Finish up by gluing the dowel in place with epoxy.

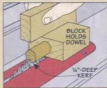

Easy Mounting With: Threaded Inserts

Many pulls can be installed with ordinary woodscrews. But sometimes this isn't the best option. The problem is that a woodscrew won't hold well in end grain or can split a pull with a small mounting surface. The pulls in the photo are good examples. And as you see, the solution is to add threaded inserts to the pulls and use machine screws.

You'll find that press-in inserts are the easiest to install and still provide plenty of grip. Two types are shown at right. Both require a hole less than 1/4" in diameter.

To use with the inserts, you'll need 8-32 thread pull screws (top). If you're not sure of the length you need, try the one-size-fits-all "break away" screws (bottom).





weekend
workshop

heavy-duty Workbench

With \$100
and a weekend,
you can build a
workbench that will
last a lifetime.

■ What goes into a great workbench? Most of us would agree it has to have a number of key features.

For starters, the base must be sturdy — no wobbling allowed. And it must have a large, flat work-surface that's rugged enough to stand up to years of hard use.

Storage would be helpful. And to keep the cost down, it should be built out of materials that you can get anywhere. Finally, it would be great if you could put it together in a short time, like a weekend.

Sound too good to be true? I thought so, too — but all these must-have features are built into the workbench pictured above.

The secret to the strength of the workbench is selecting the right materials. The base is built from "two-by" stock, and the top, shelf, and end panels are made from MDF. I chose these materials for their sturdiness, low cost, and ready availability. This means you can get everything you need in just one trip to your local home center.

The joinery is about as simple as it gets — glue and screws. But each piece builds on the previous one to create a rock-solid bench that will stand up to heavy use. This construction also means that building the bench won't take a lot of time.

Finally, as good as this bench is, you can make it even more versatile by adding a bolt-on woodworking vise that's easy to install as well.

For the money, this is one rock-solid workbench that will give you years of hard-working service.

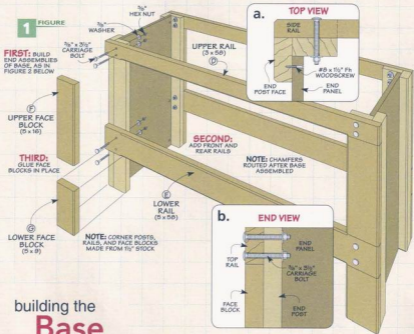

building the Base

As you can see in Figure 1 above, the base consists of two end assemblies connected by four rails. And to keep things simple, the base is built in sections. I started with the end assemblies first.

End Assemblies. Unlike a traditional workbench with four legs, the two end assemblies act as the bench's legs. This does two things: First, it gives the bench a rigid base, and second, the joinery is simple.

A quick check of Figure 2 shows that the each end assembly is made up of a pair of corner posts connected by an MDF panel. Each "post" consists of two identical pieces that wrap around the MDF panel. To make the posts, all you have to do is line up the parts along the edge and glue them together.

When the glue is dry, the corner posts will then be ready for the MDF panels (Figure 2a). Adding the panels is a good way to ensure the assemblies stay square and stable.

The panels run the full length of the corner posts and are glued and screwed in place. With that done, you're ready to attach the rails.

Rails. The rails connect the end assemblies to create a sturdy base.

After cutting them to size, line up the rails flush with the edges of the end assemblies. Some glue and a pair of carriage bolts hold each end of the rail to the end assemblies (Figures 1 and 1a). To provide a

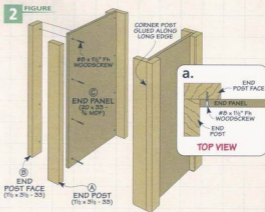

flat, solid surface for the benchtop, the upper rails are even with the tops of the corner posts. You can see this in Figure 1b.

Face Blocks. Carriage bolts reinforce the joints pretty well, but for even more stability, I added face blocks between the rails. The blocks act like the shoulders of a mortise and tenon joint to give the framework more stability and prevent it from rocking side to side.

With the base assembled, you can soften the outside edges by routing a $\frac{1}{4}$ " chamfer along the edges (see lower right photo). When you get near the carriage bolts with your router, you should take the bolts out temporarily so they won't interfere with your router.

Cleats. At this point, the base is almost complete. So now's the time to add the cleats that will hold the benchtop and lower shelf in place.

After cutting the cleats to size, I drilled and countersunk two sets of holes in them, like you see in Figure 3. The first set of holes is for the screws that hold the cleats to the rails. The second set is used for the screws that attach the benchtop and shelf to the cleats.

The top cleats align flush with the rail's top edges. But the lower

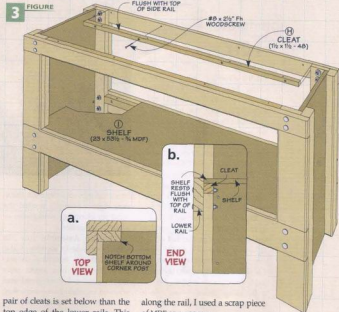

pair of cleats is set below than the top edge of the lower rails. This allows the shelf to sit flush with the lower rails and helps protect the edges of the MDF shelf. You can see this illustrated in Figure 3b. To get the cleats positioned correctly

along the rail, I used a scrap piece of MDF as a spacer.

Bottom Shelf. There's one final task before moving on to the benchtop. The bottom shelf has to be cut to size, and the corners notched to fit around the posts (Figure 3a). Then, you can attach the shelf by installing screws through the cleats into the shelf.

Materials & Hardware

BASE

A End Posts (4)	$1\frac{1}{2}$ x $3\frac{1}{2}$ - 33
B End Post Faces (4)	$1\frac{1}{2}$ x $3\frac{1}{2}$ - 33
C End Panels (2)	20 x 33 - $\frac{1}{4}$ MDF
D Upper Rails (2)	$1\frac{1}{2}$ x 3 - 58
E Lower Rails (2)	$1\frac{1}{2}$ x 5 - 58
F Upper Face Blocks (4)	$1\frac{1}{2}$ x 5 - 16
G Lower Face Blocks (4)	$1\frac{1}{2}$ x 5 - 9
H Cleats (4)	$1\frac{1}{2}$ x $1\frac{1}{2}$ - 48
I Shelf (1)	23 x $53\frac{1}{2}$ - $\frac{3}{4}$ MDF

TOP

J Top Layers (2)	29 x 85 - $\frac{3}{4}$ MDF
K Top Edge Fillers (4)	6 x 85 - $\frac{3}{4}$ MDF
L Top End Fillers (4)	17 x $17\frac{1}{2}$ - $\frac{3}{4}$ MDF
M Front/Back Edging (2)	$1\frac{1}{2}$ x 3 - 88
N End Edging (2)	$1\frac{1}{2}$ x 3 - 32

VISE

O Vise Spacer (1)	4 $\frac{1}{4}$ x 9 - $\frac{1}{4}$ Hdbd.
P Vise Faces (2)	$\frac{1}{2}$ x 4 $\frac{1}{4}$ - 9

- (71) #8 x $1\frac{1}{2}$ " Fh Woodscrews
- (24) #8 x 2" Fh Woodscrews
- (40) #8 x 2 $\frac{1}{2}$ " Fh Woodscrews
- (16) $\frac{1}{4}$ " x $3\frac{1}{2}$ " Carriage Bolts
- (1) 9" Bolt-on Vise
- (4) $\frac{3}{8}$ " x 3" Lag Screws
- (2) $\frac{1}{4}$ " x 1" Lag Screws
- (2) Machine Screws (For Vise Face)
- (4) $\frac{1}{2}$ " Flat Washers



To see a cutting diagram for this workbench, go to our website: ShopNotes.com

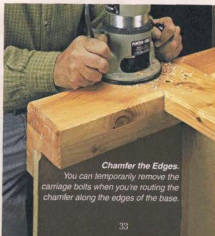

Chamfer the Edges.

You can temporarily remove the carriage bolts when you're routing the chamfer along the edges of the base.

adding the Top

All the effort put into building a strong base for the workbench would be wasted if it didn't have a sturdy, flat benchtop to match. If you take a look at Figure 4, you can see how I did this.

The first thing to note is that the top is made from "two-by" stock and MDF. Why MDF? For starters, it provides a smooth, flat surface. Second, it's heavy, which adds to the stability of the workbench. And finally, MDF is affordable.

Layers. As you can see in Figure 4, four layers of MDF are used to create a thick top. But not all the layers are full pieces of MDF, however. Only the two top layers are full size. The bottom two layers are made from pieces of MDF.

By using pieces, I was able to get these extra "layers" from a single sheet of MDF. Installing these pieces just along the edges of the

Flat Top. The benchtop has four layers of MDF, keeping the top flat and giving it strength.

benchtop provides the extra thickness right where it's needed the most for clamping workpieces or adding accessories.

Benchtop Assembly. Just like I built the base in sections, I also assembled the benchtop in sections. The top two layers were cut to size and then glued and screwed together. In the same way, the bottom two layers (assembled from pieces) were completed. Once that's done, you can assemble the

entire benchtop. The only trick here is keeping all the edges flush. To see how I did this, turn to Shop Short Cuts on page 14.

Edging. MDF edges aren't all that durable. So to protect the edges of the benchtop and to give the workbench a more finished look, I attached edging made from "two-by" stock, as in Figures 4 and 4a. And to provide a clean, finished look, this edging is wrapped around the top with mitered corners.

4 FIGURE

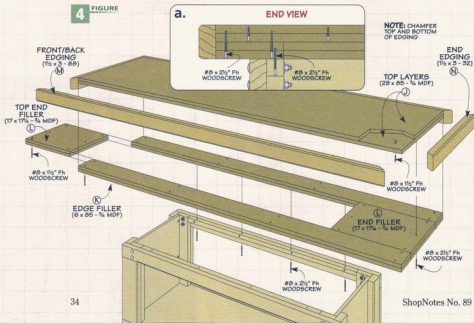

The challenge here is clamping the edging in place across the long top. Shop Short Cuts (page 14) shows a handy way of doing this if you don't have long clamps available.

Installing a Vise. The workbench is ready to use at this point. But to make the bench even more versatile, you can add a bolt-on vise like the one shown on the opposite page.

This type of vise only requires four lag screws to attach it to the benchtop (Figure 5a). Depending on the size of the vise, you may have to install a spacer between the rear jaw and the benchtop.

This spacer keeps the metal edge of the vise lower than the benchtop (Figure 5a), preventing any interference with a workpiece or possible damage to a tool. My spacer was simply a piece of $\frac{1}{4}$ " hardboard.

I also added a set of wood faces to the metal jaws. These faces provide a more secure grip without damaging the workpiece.

For a "cleaner" vise installation, there's another mounting option that buries the rear jaw of the vise behind the front edging strip of the

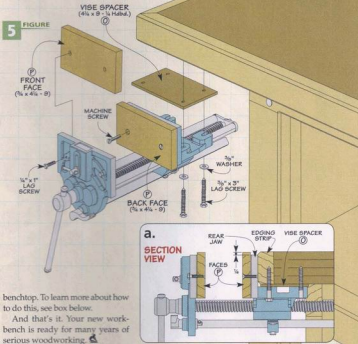

benchtop. To learn more about how to do this, see box below.

And that's it. Your new workbench is ready for many years of serious woodworking.

Optional Vise Mounting



Another way to mount a woodworking vise is to bury the rear jaw behind the edging, like you see in the above photo. This allows you to clamp long pieces flat against the front of the workbench.

Installing the vise this way requires a little planning. Before you attach

the edging, you'll need to rout a "pocket" in the edging that will house the rear jaw (detail 'a').

Once the edging is installed, you can slip the rear jaw of the vise into the pocket and bolt it securely to the benchtop from underneath with lag screws. Here again, you'll need to place a spacer between the vise and

benchtop (detail 'a').

The final detail is to add a wood face to the front jaw. To match the look of the edging, the thickness of the wood face is the same thickness as the edging. The face is also longer to provide more clamping surface against the edge of the bench.

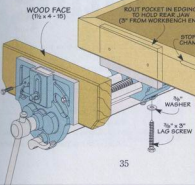
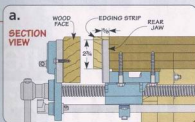
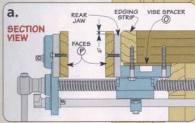

best-built
jigs & fixtures

palm router Fluting Jig

■ Fluted legs or trim pieces can add a classic look to a project. But the challenge is making flutes that are straight and evenly spaced. To solve those problems, I made this fluting jig (shown above). It's designed to fit a palm router or laminate trimmer.

As you can see, the jig is pretty simple. It's just a baseplate made from a piece of acrylic. A set of hardwood spacers makes it easy to position the flutes evenly across a workpiece, see inset photo. And using the jig with my palm router makes it easy to handle.

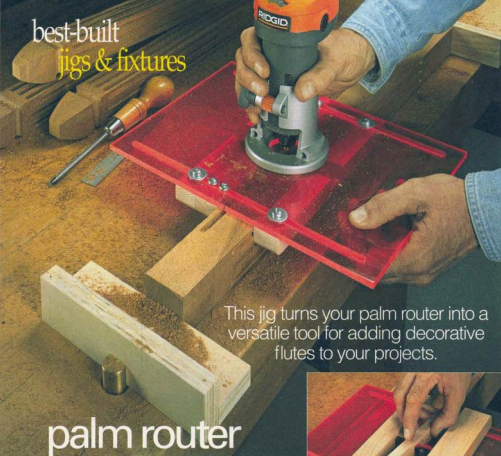

This jig turns your palm router into a versatile tool for adding decorative flutes to your projects.

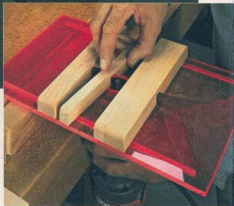

I like this jig because it's versatile. What I mean is you can make the spacers wider or narrower to adjust the spacing of the flutes (more on that later).

This is one of those simple projects that you can put together in an evening. But it's a handy jig you'll use for years to come to add appeal to your projects.

building the Fluting Jig

As I mentioned, this jig only has a few parts (drawing at right). The main component is the baseplate that's made to accept a palm router (or laminate trimmer).

The Jig Baseplate. After cutting the baseplate to size, I routed the slots for a pair of outside edge guides and a set of spacers. These slots let you reposition the guides and spacers for routing the flutes. I drilled the end holes for the slots first. Then a couple of passes with a $\frac{1}{8}$ "-dia. straight bit finished the slots (Figure 1).

Now you can use your router's baseplate as a template to mark the mounting hole locations. Then, drill and countersink the holes. A hole saw will create a nice center hole for the bit. After you attach the router, scribe a centerline on the bottom of the baseplate in line with the center of the collet.

Edge Guides and Spacers. The two edge guides and the spacers are all identical except for their width. You can make them from a single piece of extra-wide stock, like you see in Figure 2.

After cutting the blank to length, I routed a roundover on one side of each end. Then I cut a deep dado on the opposite side.

This dado allows you to slide the spacers past the router bit without having to adjust the depth of the bit.

The last step is to rip the piece to width (Figure 2). The spacers determine the center-to-center

Exploded View Details

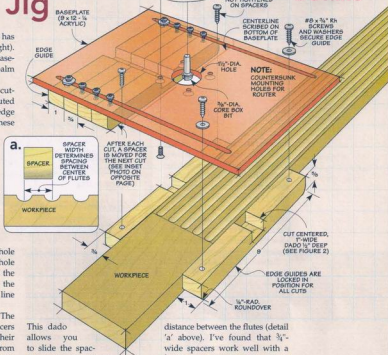

AFTER EACH CUT, A SPACER IS MOVED FOR THE NEXT CUT (SEE INSET PHOTO ON OPPOSITE PAGE)

CUT CENTERED, 1"-WIDE DADO $\frac{1}{2}$ " DEEP (SEE FIGURE 2)

EDGE GUIDES ARE LOCKED IN POSITION FOR ALL CUTS

$\frac{1}{8}$ "-RAD. ROUND-OVER

distance between the flutes (detail 'a' above). I've found that $\frac{3}{4}$ "-wide spacers work well with a $\frac{3}{8}$ "-dia. core box bit. But what's nice is you can make sets of spacers of varying widths, depending on your needs. Finally, you can fasten the edge guides and spacers, as shown above.

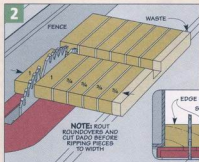
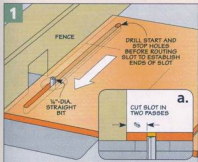

using the Fluting Jig

Once you have the router securely mounted to the jig baseplate, you can set up for your first cut.

Position Edge Guides. The first thing you need to do is determine the position of the two edge guides. One of them will ride along the edge of the workpiece when routing the first flute. To do this, loosen the screws and arrange the edge guides and spacers as shown in Figures 1 and 1a. Now you can align the centerline of the jig with the centerline of the first flute and slide the spacers and edge guides against the workpiece (Figure 1).

Tighten Edge Guides. As you can see in the Figure 1a, this sandwiches the workpiece between both edge guides and all the spacers. Once the jig is aligned, you can tighten the two edge guides in place. What you're looking for is a smooth, sliding fit of the jig along the workpiece without any side-to-side play or binding.

The last thing to do before you start routing is to set the depth of

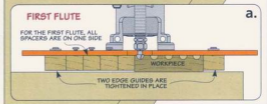
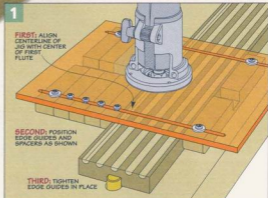

the router bit. This will determine the depth and width of the flutes.

ROUTING THE FLUTES

On some projects, you want the flutes to continue all the way to the end of the workpiece, as shown in the photo above. Since the jig is already set up, you can start

cutting the first flute. Start at one end of the workpiece and move the jig in a continuous motion to the opposite end for a smooth cut.

Spacing. Now, the spacers make it easy to rout the rest of the flutes accurately. Just flip the jig upside down and slide one of them to the opposite side, like you

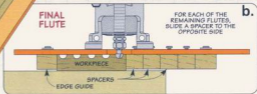
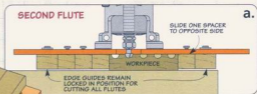
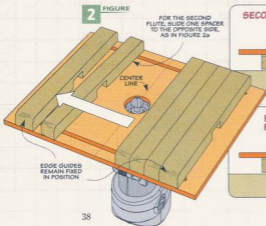

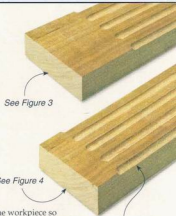
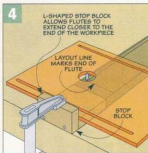
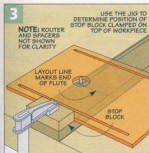

Note: For a half-flute look, just trim the edges

see in Figure 2. Now you can rout the second flute (Figure 2a). Then it's just a matter of repeating the process for each of the remaining flutes, as shown in Figure 2b.

STOPPED FLUTING

Stopped fluting can be a nice detail. This is where the fluting doesn't go all the way to the end of the workpiece (upper right photos). The key to doing this accurately is using a stop block.

Stop Blocks. The first thing I like to do is mark a line on the

workpiece where I want the fluting to start and stop. Then, I'll use the fluting jig to help determine what kind of stop block I need.

Figures 3 and 4 above, and the main photo on page 36, show some options. For example, you can clamp a stop block on top of the workpiece. Or you can fabricate an L-shaped block to

"extend" the workpiece so the flutes stop closer to the end.

It's not uncommon to get burning at the end of the flutes. Shop Shortcuts on page 14 shows a trick to clean up any burn marks.

You can be even more creative with fluting. The box below shows you how you can make tapered flutes for a different look.

How to make Tapered Flutes



You can get even more creative with fluting by building the ramp shown on the right. It lets you create tapered — or "feathered" — ends on the flutes like you see in the photo above. You can build the ramp using scrap lumber and a few pieces of hardware.

The idea is that the two sides of the ramp hug the workpiece and raise the fluting jig and bit to create a tapered cut. If you want the tapered fluting at both ends of the

workpiece, you'll need to make two ramps — one for each end.

To position the ramp, I first draw a line on the workpiece where I want the flutes to end. With the router off, move the ramp and fluting jig until the bit just touches the line, then clamp the ramp securely in place before routing.

Now you can align the jig for your first flute and start routing. Then you can cut the remaining flutes for a decorative touch.

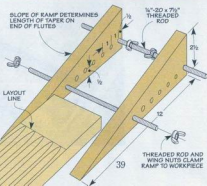

12 tips for Measuring & Marking

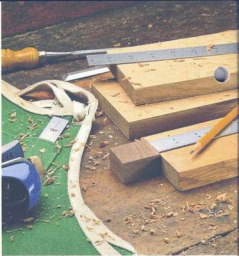

■ “Measure twice — cut once.” I’ve followed those words of wisdom ever since I began woodworking. But over the years, I’ve learned a few other things that have helped

me get accurate and consistent results time after time.

On the next few pages you’ll find a dozen ideas that are sure to be useful in any shop. Some involve

using the right tool, while others focus on technique. And no matter what kind of projects you build, you can put most of them to work in your shop right away.

1 Etched vs. Stamped ▶

It’s hard to pass up a bargain, but when it comes to measuring tools I buy the best I can afford. And one of the biggest differences between high-quality measuring tools and cheaper models is the use of etched lines rather than stamped marks.

The practical benefit of etched lines is that they’re finer, allowing more definition between small measurements. I like them because they’re easier to read in normal lighting. These tools usually cost a little more, but they’re worth the investment.

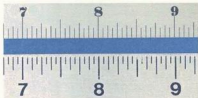

▲ **Finer Lines.** The fine etched lines in the top photo extend all the way to the edge of the rule, making them easier to read than the stamped lines of the lower one.



2 ◀ One Tape per Project

It’s tough to beat a tape measure for ease of use and convenience. I have several in my shop. But I’ve learned that using different tapes on a project can lead to serious measurement errors. The problem is tapes can differ in their readings for a couple of reasons.

First, if the hook on the end is bent or damaged, it can throw off the starting point of the measurement. Second, the tapes themselves can be printed with small deviations in the measuring marks. But if you stick to one tape measure throughout a project, you’ll be sure to get consistent results.

3 Check Square ▶

It's tempting to assume that framing squares are, in fact, perfectly square. Unfortunately, that's not always the case. It doesn't take much more than a drop off the bench to distort a blade.

Any distortion is magnified down the length of the blade and will result in a loss of accuracy that can ruin a project. The good news is there's an easy way to test your tools. The drawing at right shows you how to determine whether your square is actually square.

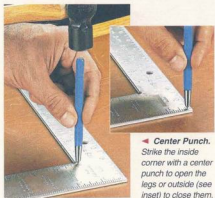
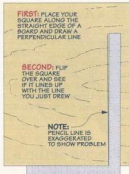

4 Accuracy with Fractional Calipers ▼

If you've ever tried to measure the thickness of a board or the width of a dado with a tape measure, then you know it's a challenge to get accurate results. Even with a good steel rule, it's still tough.

For these measurements, I reach for a caliper. A caliper is designed for that kind of job — and it's far more precise than most woodworking tools. But not just any caliper will yield easy-to-read results. Because I use fractional measurements in my projects, I prefer to use a fractional, rather than decimal, caliper. A fractional caliper has marks in $\frac{1}{64}$ " increments. So you don't have to "do the math" to find the dimension you're looking for.

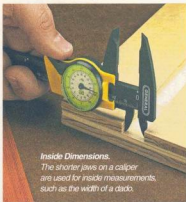

5 ◀ Marking Knife

When it comes to laying out marks for cutting joinery, a pencil line is often too thick. For precision work, I reach for a sharp marking knife.

Not only does the knife lay down a fine line, but the mark is durable and won't smudge or fade as you handle the piece. Another benefit for joinery work is the line also provides a handy "groove" for placing a chisel or saw blade. That's especially useful if you're squaring up the sides of a mortise after drilling out the waste. The line keeps your cuts square.



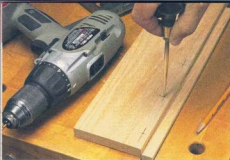

6 ◀ Awl for Marking Starter Holes

When it comes to laying out hole locations, I reach for an awl. It's especially handy if you're drilling the holes with a hand drill rather than at the drill press. The awl leaves a small indentation which serves as a starter for a drill bit.

By placing the tip of the drill bit in the awl mark, you avoid the

possibility of the bit wandering off the mark and scratching the surrounding stock. It also guarantees a more precise hole location than if you had just made an 'x' on the stock with your pencil. Another nice thing is the mark will survive sanding. So you can preserve the layout if you pre-finish the part.

7 Use a Drill Bit for Precise Setup ▶

Setting the fence of your router table to an exact distance from the bit can be a real chore. However, since drill bits are precisely machined to a specific diameter, you can use them as reliable measuring tools — just like a set of brass set-up blocks.

For instance, if you need a dado $\frac{3}{8}$ " from the edge of a board, just lay a $\frac{3}{8}$ "-dia. drill bit between the fence and the cutting edge of a router bit. This guarantees the dado will be where you need it without a lot of fussy measuring in tight spaces.



8 ◀ Mark Properly with a Straightedge

It may sound like splitting hairs, but the way you hold your pencil or marking knife against a straightedge as you make a mark can make a big difference. If you want to put a line on an exact measurement, you'll need to be sure the tip of your pencil or knife is not angled away from the edge of the square or rule, as in the far left photo.

A simple way to ensure consistent layout marks is to hold the point against the straightedge, as shown in the photo at left.

Another rule of thumb is to pull the pencil toward you, rather than try to push it along the straightedge. Pushing the tip can cause it to catch on the grain of the wood and jump away from the line.

9 Label Drawers ▶

No matter how many times I've built a set of drawers, it's easy to get confused and mix up the pieces. The time-tested method of marking the matching corners remains the surest way to avoid this mistake. Once you've laid out your pieces, just label both sides of each corner with a letter or a number. (I like to underline them as well.) This makes it easy to match them when it's time to assemble the parts. Make sure that all marks are oriented the same way, so you can tell which edge is the top and bottom of the pieces.

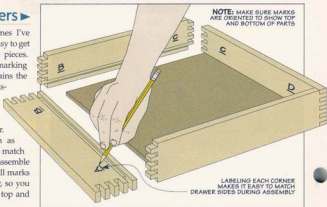

10 Cabinetmaker's Mark ▶

When laying out and grain matching boards for a panel or tabletop, I use a cabinetmaker's mark to clearly identify the arrangement of the pieces. The great thing about it is it's quick, easy, and guarantees you'll reassemble the pieces in the right order.

As you can see in the drawing, a 'V' marked on the face of the boards lines up in two different places. The two marks make it very easy to see when you've perfectly assembled the parts.

Another nice thing is the marks don't have to be thin to be accurate. For that reason, I usually use chalk to make the triangle since it's highly visible, even on dark woods, and is easy to remove when I'm done.

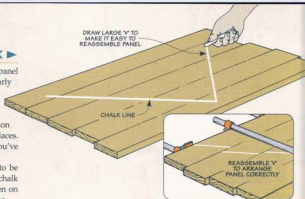

11 ◀ Mark Jointed Edges

Most woodworking projects begin by milling your stock flat and square. That means heading to the jointer with a pile of boards and running them through, one after another, to create a flat and square reference face and edge. The problem is, when it's time to square the opposite side, it's often hard to tell which edge or face of a board you've just flattened.

The easy solution is to mark each freshly jointed surface as you go. It only takes a second, but a quick pencil mark can save you a lot of head scratching down the road. This way, when it comes time to cut or plane the opposite side parallel, you can tell at a glance which side goes against the fence of your table saw or face down through the planer.

12 Don't Measure At All ▶

From time to time, no matter how careful you are, you'll make a mistake reading tapes and rules. For me, this usually happens when I'm trying to read the marks upside down or with the tape in an awkward position. Other times I'm just in a hurry and get the measurements transposed. The fact of the matter is, there are times when the best thing to do is leave your tape on the bench and not measure at all.

A good example of this is fitting an inset cabinet door. Of course you'll want to begin by building the door to a rough size using the dimensions from your plans. But when you've completed the case or frame for the door, why not just hold the rough-sized piece up to the opening and mark the edge showing the exact height and width? This way, you'll be sure to have the correct dimension. Then you can use a square and transfer those edge marks to the face of the piece and have your layout. After that, it's just a matter of going to the table saw and cutting the door or drawer front to the layout lines for a perfect fit. 🛠️

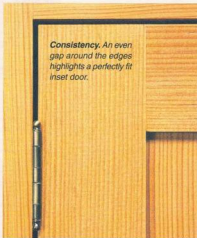

easy-to-build Table Saw Storage

Here are a few low-cost ideas to organize your accessories.

FLIP-TOP EXTENSION WING

The stamped steel extension wings that came with my table saw are barely functional. They do offer some added workpiece support — but that's about it.

I wanted to replace them with a smooth, flat surface. At the same time, it could be a great way to add some storage. In the drawing at right, you can see how it works. Instead of a simple wing, there's a wide shallow box that holds spare blades, wrenches, throat plates — whatever else you might need.

The box is built from $\frac{3}{4}$ " plywood and is sized to fit between the fence rails. The top of the box is attached with an ordinary piano hinge. I added a divider to keep smaller tools separate from the main compartment.

Although the construction is pretty basic, there are a couple of things to note before you get started. First, it's a good idea to

keep the box fairly shallow. That not only keeps the weight down, but also makes it easier to find your accessories. Second, you'll want to design the box so that it won't interfere with any saw controls located on the side of the saw cabinet.

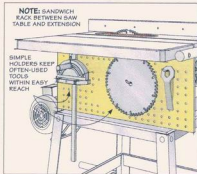
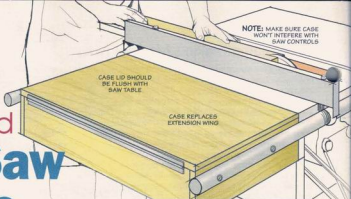

PEGBOARD RACK

After seeing just how handy a pegboard rack near my workbench can be, it got me thinking about putting up racks in other parts of the shop. And it was only natural to think about using pegboard to tame the clutter around my saw.

But if your table saw is located in the center of the workshop like mine, walking back and forth to a wall rack can get old in a hurry. However, that doesn't mean you need to give up on the idea.

If you take a look at the drawing, you can see a simple solution.

Here, a small section of pegboard is sandwiched between the saw table and an extension wing. The idea behind this rack is to provide a place for only the things you reach for most often.

A combination of customized, shop-built holders along with some standard metal hooks allows you to customize the rack to suit your work habits and keep some frequently used items within arm's reach. Best of all, you can probably add this handy rack to your saw in about an hour.

Table Saw



table saw Molding Head

Turn your table saw into a shaper with this cutterhead and a handful of different knife profiles.

■ When it comes to making moldings, the first tool that comes to mind is probably a router table or a shaper. But with one simple accessory, you can make all sorts of moldings — on your table saw. All you need is a molding head and a few sets of knives (photo above).

A molding head is nothing more than a heavy steel disk that mounts in your table saw like a saw blade. It holds a set of replaceable, high-speed steel knives. And this feature allows you to swap out the knives to cut different profiles of moldings. So the molding head turns your table saw into a shaper.

Versatility. The great thing about molding heads is their versatility. To start with, there's a wide variety of knife profiles available. But that doesn't mean you have to buy a lot of knives. Most knives can be used to create several profiles by exposing different parts of the cutting edge. And by combining profiles from different knives, you can create many complex moldings.

Molding Profiles. To give you an idea of just how versatile a molding head is, take a look at the moldings shown with just four different knife profiles. (These are the basic profiles that came with the molding head, refer to Sources on page 51 for more information.)

Using a Molding Head. If you've never used a molding head, there are a few things to know. To start with, you'll need a couple of insert plates for your table saw.

The first is a molding head insert. (This can be purchased or shop-made.) The molding head insert has a short, wide opening to accommodate the width of the molding head knives.

For profiles that are cut with the workpiece standing on edge, you'll want to use a zero-clearance insert to prevent the workpiece from falling into the insert opening.

Finally, it's a good idea to attach an auxiliary fence to your table saw rip fence. This allows you to bury the knives in the fence so you can safely use just a portion of the profile (photo at left). You may have to move the fence from the left to the right side of the molding head to get the profile you're after.

With a little creativity and some experimenting, you can make a wide variety of moldings to dress up just about any project. 🛠️



▲ **Auxiliary Fence.** Burying the knives in an auxiliary rip fence allows you to shape the edge of a board using just a portion of the knife profile.

6 Decorative Profiles

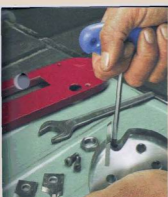

▲ Installing the Knives. Each knife is secured to the cutterhead with a sockethead set screw.

QUARTER ROUND A quarter round (roundover) is one of the simplest profiles you can make with a molding head. Simply bury the cutter in an auxiliary fence and cut a roundover on the edge of the board. You can create a shoulder (or fillet) along the edges of the roundover by raising the height of the molding head and repositioning the fence.

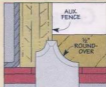

CENTER BEAD One of the advantages of a molding head is that you can cut a profile in the center of a wide board (something you can't do with most router bits). This feature allows you to make your own beaded board using a beading cutter. Simply use the fence to position the bead on the center of the board (or anywhere else you choose).

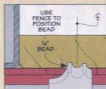

TWIN BEAD Beads can also be cut on the edge of a board. This detail is often used on dividers between drawers or on the edges of shelves. With a zero-clearance insert installed in your table saw, you can run a workpiece through the saw on edge to create a single bead. Or you can flip the workpiece around to create a second bead, and then remove the waste in between with a different cutter profile.



FLUTING Fluting is just as easy to accomplish with a molding head as beading. You start by adjusting the height of the molding head so that just the tip of the knife is exposed. Then simply run the workpiece over the cutter to create the flute. To make additional flutes, simply move the rip fence over an equal distance after each pass to keep the spacing between the flutes consistent.

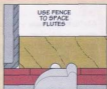

BULLNOSE A modified bullnose profile can be used on the edge of a table or cabinet to provide a visually appealing, softened edge. Start by easing the top edge of the workpiece using a "thumbnail" cutter. Then flip the workpiece over and cut a 1/4" roundover with a shoulder along the bottom edge. You may have to do a little sanding where the two profiles meet to form a smooth transition.

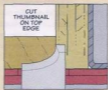

THUMBNAIL A "thumbnail" profile is commonly used on the edge of tabletops. This profile is created in three separate steps, using three different cutters. Start by cutting the thumbnail profile with a shoulder on the top edge.

Next, use a fluting cutter to create a small cove along the edge of the shoulder. Then flip the workpiece over and cut a 1/4" roundover along the bottom edge. Adjust the height

of the molding head so the roundover transitions smoothly into the curve of the thumbnail. Again, you

may have to do a little sanding, but when you're done, you'll have a classic, decorative profile.



shop heating Take Off The Chill

Make woodworking in the cold a bit more comfortable with electric heat.



■ My first shop was in the corner of the garage. Unfortunately, like most garages, it got too cold to spend much time doing woodworking when winter came around.

The nice thing is that doesn't have to be the case. Don't worry — I'm not talking about installing an elaborate system to keep an entire

shop warm. Heating just a little space may be all you need. And since most shops have electrical power, heaters that simply plug in are a quick and easy way to take the chill out of your shop.

Benefits. There are a number of benefits to using electric heaters in your shop. Flip the switch and get near-instant heat. Plus, you can plug one in anywhere there's an outlet.

Most heaters can be mounted overhead, on a wall, or even set up on your workbench. (A tip-over switch shuts the unit off if it's knocked over.)

Planning. Before you buy a "space" heater, do a little planning first. To start with, small electric heaters aren't designed to warm up a large shop. So, it's best to concentrate the heat you need into a smaller work area.

One way to do this is to move your tools a little

closer to each other. You might lose some elbow room, but only having to heat a small area more than makes up for the inconvenience.

And keep in mind that not all woodworking requires balmy conditions. Glueups and finishing are the most finicky. So, it's a simple matter to concentrate the heat where you're completing those tasks.

Once you've determined exactly where you need some heat, the next step is to select a heater suited to the task. As you might imagine, you have a few choices.

RADIANT HEATERS

One of the simplest heaters to use is a radiant heater, like the one pictured above. Also known as an infrared or quartz heater, it has a reflector panel behind the heating elements to direct heat toward objects in the room (Figure 1).

Think about an asphalt street during the summer. As the sun beams down on it, the pavement gets so hot you can see the heat rising ("radiating") from the road.

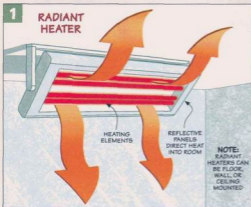

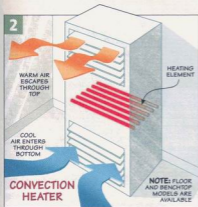

The same principle applies when using a radiant heater. As the radiant heat warms a tool, the tool radiates some of the heat back out. This warms the air around the tool, resulting in a warmer shop.

And, since the tools themselves heat up, the shop will continue to stay comfortable for a bit even after the heater is turned off.

CONVECTION HEATERS

Convection heaters take a different approach and work like baseboard heaters in many homes.

As the unit heats the air, the warm air inside rises. As it does, cooler air is drawn in to replace it (Figure 2). That cooler air is then warmed, rises, and the cycle repeats itself.

Beat the Cold with a Heated Mat

No matter how much heat you pump into your shop, a concrete shop floor will stay cold for a long time. And when your feet are cold, it makes it almost impossible to work comfortably on any task.

A simple anti-fatigue mat is one way to keep your feet off the floor. But in most cases, it doesn't provide enough insulation to help much. A better option is to use a rubber mat with a built-in heating element (available at many office supply stores). These mats are waterproof and comfortable to work on. And once it's plugged in, the mat starts heating up. So it's a quick and easy way to stay warm — and keep you in the shop.

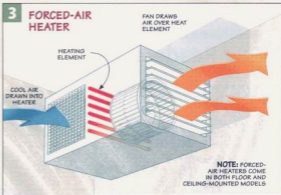

A convection heater can take a little longer to warm an area. To heat things a little faster, some models use a small fan to increase the airflow. This helps while the fan is running, but once the unit is turned off, the shop will cool down more quickly than one equipped with a radiant heater.

FORCED-AIR HEATERS

Unlike a convection heater with a small fan, a forced-air unit uses a larger blower to really move air over the heating element (Figure 3).

This will heat up an area quickly. And like a convection heater, the unit cools down quickly — resulting in a shop that cools down more quickly as well.

Sawdust. One of the downsides of a forced-air heater is it can stir up sawdust, so you'll want good dust collection to minimize the problem. And in general, it's good practice to keep sawdust in check when using any type of electric heater.

Availability. Prices for small electric heaters start at about \$50, and they're available just about anywhere. Forced-air heaters are usually a bit more expensive and to find one you may have to go to a home center or order online.

Still, electric heat is a great way to inexpensively warm up a shop. Another option for taking off the chill is to simply keep your feet a little warmer. For more on this, check out the box below. 





questions from
Our Readers

stropping for a Razor- Sharp Edge

A woodworking neighbor told me I need to strop my tools to get a sharp cutting edge. Other friends say it's a waste of time. Who's right?

David Scroggins
Henderson, Nevada

■ Every woodworker I know has an opinion about the "best" technique for sharpening. And often the debate centers on what constitutes the "sharpest" cutting edge. Stropping is considered by many to be the final step in producing the ultimate, razor-sharp edge.

What is Stropping? Stropping takes place after the normal sharpening steps of grinding and honing.

Traditionally, a blade is stropped by pulling the bevel across a firm piece of leather. Stropping removes the nearly microscopic strands of metal that remain on the cutting edge of a blade after the wire edge, or burr has been honed away.

Here again, there are a number of opinions about the proper technique. Some woodworkers prefer to charge the leather strop with abrasive compounds. But others argue that stropping is not really meant to abrade the metal. Instead, it is intended to burnish the edge by bending the strands until the metal fatigues and they fall off.



▲ **Buffing Wheel.** A wheel charged with different grades of abrasive compound can polish the edge of a gouge in no time.



▲ **Small Profiles.** Paring chisels and carving knives can be made razor sharp on an inexpensive, profiled strop.



When to Strop. There's no doubt that stropping produces a razor-sharp edge. But I've found it to be overkill for most common woodworking tools. The fact is, waterstones, oilstones, or sandpaper on glass all produce an edge sharp enough for most woodworking needs. If you're using any of these methods and your sharpening tasks are limited to plane irons and bench chisels, there's very little to be gained by stropping. There are, however, exceptions to every rule.

Carving Tools. If you're a carver, stropping may be the best method of keeping your tools ready to go. Many carving knives use very thin blades that simply can't be ground on anything but the finest honing stones without removing too much metal from the blade.

In this case, charging a leather strop with an abrasive stick, shown in the photo above, may be the answer. Stropping will leave the blade polished and razor-sharp, as shown in the inset box.

Only you can decide what's "sharp enough" for your needs. If you want better results than your current method provides, you may want to give stropping a try. 

Sources

ROUTER FLUTING JIG

You can find the hardware you'll need to build the router fluting jig on page 36 at a local hardware store or home center. But you'll probably need to order a sheet of acrylic for the base plate. The $\frac{1}{4}$ "-thick, fluoroscent orange acrylic (86205) was ordered from *United States Plastic*. You'll find contact information in the margin.

SPIRAL CUTTERHEADS

Spiral cutterheads, like those shown in the article on page 12, are a great way to upgrade your jointer. The *Sunhill* and *Byrd Shelix* cutterheads came from *Sunhill Machinery*. I ordered the *Woodtek Staggered Cutterhead* from *Woodworker's Supply*.

TABLE SAW WORKCENTER

Much of the hardware you'll need to build the table saw workcenter on page 16 can be found at your local hardware store or home improvement center. But there are a few items you'll need to order to be able to complete the project.

The corner levelers (31217) for the cabinet, spring hinges (28845) for the doors, and 16" *Accuride* drawer slides (32482) all came from *Rockler*.

The $\frac{3}{8}$ " x 2" star knobs (DK-685) for the router table fence as well

as the drawer handles (DUH-50) were ordered from *Reid Tool*.

In order to complete the router table, you'll need a few other items. The phenolic router plate (147) came from *Woodhaven*. And I picked up the dust collection port (715115) at the *Woodsmith Store*. A router table dust collection port (35317) is also available from *Rockler*.

You'll also need a miter gauge track for the router table. The *Rousseau* (0048) miter gauge track came from the *Mike's Tools*.

To give the top of the workcenter a nice finished edge, you'll need to install some T-molding. I ordered the 1 $\frac{1}{2}$ " black T-molding (#6) from *T-Molding.com*. You can find contact information in the margin at right.

WORKBENCH

You can find almost all of the materials needed to build the workbench on page 30 at your local hardware store or lumberyard. But the vise I used to complete the project is a 9" quick-release wood vise (22876) from *Rockler*.

MOLDING HEADS

A molding head and cutter set, like the one in the article on page 46, can add versatility to your table saw. The one featured is a molding head and cutter set (34-813) made by *Delta*.

It includes a molding head, Allen wrench, and four sets of cutters. I ordered mine from *Mike's Tools*, but they're also available through *Amazon.com* and *Woodworker's Supply*. You'll find contact information in the margin.

SHOP-MADE PULLS

The drawer pulls shown on page 28 are easy to make and can save you some money. But you might need a few pieces of hardware in order to mount them.

Screws and threaded inserts are available at hardware and wood-working stores. But when I'm not sure of the length of the screw I'll need, I use a segmented, breakaway screw (35535) from *Rockler*. The rib-type, press-in threaded inserts (5645) can be found at *Woodhaven*. The split-type threaded inserts are available at *Woodworker's Supply*.

STROPPING

Stropping can be a great final step to achieving a razor-sharp edge on your tools. But to do this you'll need to use a good strop.

You can find leather straps at many woodworking stores and hardware stores. The leather honing strop (22698) and the power strop (20703) shown on the opposite page came from *Rockler*.

MAIL ORDER SOURCES

Woodsmith Store
800-444-7527
Dust Collection Port

Rockler
800-279-4441
800-279-4441

Corner Levelers, Drawer Pull Screws, Drawer Slides, Dust Collection Port, Spring Hinges, Star Knobs, Strapping Supplies, Threaded Inserts, Wood Vise

Woodhaven
800-344-6657
woodhaven.com

Router Plates, Press-In Threaded Inserts

Reid Tool
800-253-0421
reidtool.com

Drawer Handles, Knobs

Mike's Tools
714-558-8360
mikestools.com

Delta Molding Head and Cutter Set, Rousseau Miter Gauge Track

Woodworker's Supply
800-645-9292
woodworker.com

Delta Molding Head and Cutter Set, Woodtek Staggered Cutterhead

T-Molding.com
866-422-5815
t molding.com

T-molding

U.S. Plastic Corp.
800-809-4217
usplastic.com

Acrylic Sheet

Amazon.com
Delta Molding Head and Cutter Set

Sunhill Machinery
800-929-4321
sunhillmachinery.com

Sunhill and Byrd Shelix Spiral Cutterheads

Lee Valley
800-871-8158
leevalley.com

Quartz Radiant Heater

ShopNotes Binders

Keep your issues organized!



As you build your ShopNotes library, here's a way to keep your issues organized. Each binder features durable vinyl covers and easy-to-read perforated number tags. Snap rings with a quick-open lever make it easy to insert and remove issues. And there's an extra pocket inside for storing notes. Each binder holds a full year (6 issues) of the new, expanded ShopNotes.

Visit www.ShopNotes.com to order these binders, or call 1-800-444-7527.

ShopNotes Binder
○ 701950-SN89 (Holds 6 issues).....\$12.95

Scenes from the Shop

▼ **Workcenter.** Get more out of your table saw with the custom workcenter shown below. Extra-large tops, along with an optional outfeed table, give you solid support for just about any size workpiece. And the built-in router table provides convenient, ready access. Plus the cabinets under the table saw, outfeed table, and router table offer plenty of storage close at hand. The step-by-step plans begin on page 16.

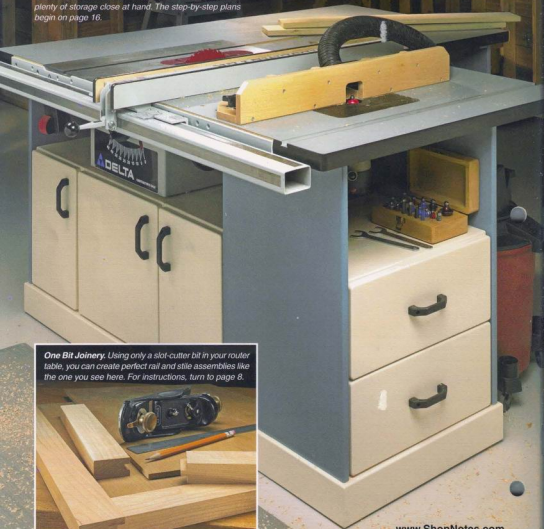

One Bit Joinery. Using only a slot-cutter bit in your router table, you can create perfect rail and stile assemblies like the one you see here. For instructions, turn to page 8.

