

MUST-HAVE ROUTER TABLE UPGRADES & ADD-ONS

ShopNotes

Vol. 15 Issue 87

www.ShopNotes.com

**BUILD
YOUR OWN**

ROUTER TABLE SLED

SAFE, PRECISE, ACCURATE!

PLUS
**EASY
RAISED
PANELS
ON YOUR
TABLE SAW**

**SIMPLE SHOP
STORAGE**
**3 QUICK
SOLUTIONS**

ALSO:

**THE ULTIMATE
PLYWOOD WORKSTATION**

**Save Space + 6 Easy-to-Build
Save Time Upgrades
Save Money**

\$6.95 CDN



0 55113 57102 2 06

DISPLAY UNTIL JULY 4, 2006

A Publication of August Home Publishing

Contents

Features

best-built jigs & fixtures

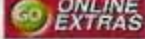
Router Sled  **16**

This sled makes it easy to cut precision joinery on the router table — quickly and safely.

hands-on technique

Tenons on the Band Saw **20**

Get more from your band saw. We'll show you how to set up for cutting perfect tenons.

weekend workshop

Custom Sanding Block **22**

This handy tool keeps a firm grip on your sandpaper and fits into tight corners.

storage solution

Hobby Chest  **26**

Combine a tool chest and small workbench into one compact package.

weekend workshop

Knock-Down Workstation **32**

No matter what the task, you can set up or take down this workstation in minutes.

Departments

Readers' Tips **4**

router workshop

Router Table Edge Jointing **8**

Put a clean, square edge on any workpiece with this simple router table technique.

materials & hardware

Choosing Plywood for the Shop **10**

Take a look at a few plywood choices you may not know about.

jigs & accessories

Working with Metal Detectors **12**

Protect your bits and blades. Find out how to put metal detectors to work in your shop.

Shop Short Cuts **14**

Shop-tested tips and techniques to solve your woodworking problems.

hands-on technique

Mastering the Hand Scraper  **24**

Learn the simple process that will have your scraper taking fine shavings in minutes.



Router Sled

page 16



Knock-Down Workstation

page 32



Custom Sanding Block

page 22

Cutoffs



Hobby Chest

page 26

in the shop

What to Look for in Router Lifts _____ 38

With these precision lifts, you'll never have to reach under your router table again.

setting up shop

Small Parts Storage _____ 42

A few of these drawer inserts can help you take control of your shop storage.

mastering the table saw

Perfect-Fitting Raised Panels _____ 44

Raised panels on the table saw? We'll show you just how straightforward it is.

great gear

What's New in Pipe Clamps _____ 46

New features and a few accessories will make this old shop standby more essential than ever.

ultimate garage

Tile Floors _____ 48

A simple upgrade that will make working in your garage more comfortable.

Q&A _____ 50

Sources _____ 51

In this issue, we have a couple of projects that prove, when it comes to woodworking, you can take it with you.

For starters, check out the Knock-Down Workstation featured on page 32. This entire dual-height workstation is easy to build and inexpensive. All you need is one sheet of plywood and some two-by material. Then, once the basic project is complete, you can add up to six different accessories. Each one is portable, practical, and will help you get the most out of your tools no matter where you need to work.

While I'm on the subject of portable, be sure and take a look at the Portable Hobby Chest that begins on page 26. It's part workbench, part toolbox, all rolled into one.

Router Table Upgrades. It's no secret — I think a router table is a "must-have" tool for any shop. But we're always looking for ways to make it better. So we've put together three upgrades to make this tool work harder.

The first is the Router Sled shown on the front cover. This shop-built jig allows you to make safe, precise cuts every time.

Second, if you've ever wanted an easy, accurate method for raising and lowering your router, be sure to read the article on page 38. There you'll find the inside story on router lifts.

Finally, on page 8, we'll show you how to turn your router into a jointer. All you need is a strip of brass and a carbide straight bit.

Tom

ShopNotes

GO ONLINE EXTRAS

This symbol lets you know there's more information available online at www.ShopNotes.com

Tips for Your Shop

Rolling Tool Tower

My shop is small so I need to use the space efficiently. That's why I built the tool tower you see in the photo below. The tower allows me to stack tools that would otherwise be stored in many other places throughout my shop.

I sized the tower so my air filter could sit on the top shelf. This way, the air filter can be quickly moved anywhere it might be needed.

The shelf just below the top is adjustable. It can be easily raised or lowered as needed to accommodate items of various sizes.

I use the middle shelf to store my planer. The height of this shelf and the open sides are positioned so I can pass stock through the planer as well as store it when not in use.

The tower is simple to build. First cut four pieces of MDF to size for the shelf platforms. Each shelf sits in a rabbet along the edge of a sturdy frame, like you see in Figure 1 below. The end of each frame piece is mitered at 45° and then glued together. The shelf and framework provide stability as well as a place

for securely attaching long upright supports with screws at each of the corners, as shown in Figure 1a.

Two 2x4's provide the base for the tower. I extended the base past the width of the tower for greater stability (Figure 2). You'll want to add large casters to the ends of the base before screwing the base securely to the bottom shelf frame (Figure 2a).

After installing the adjustable shelf pins, add the shelf and the tower is ready to use.

*Joshua Perkins
Papillion, Nebraska*

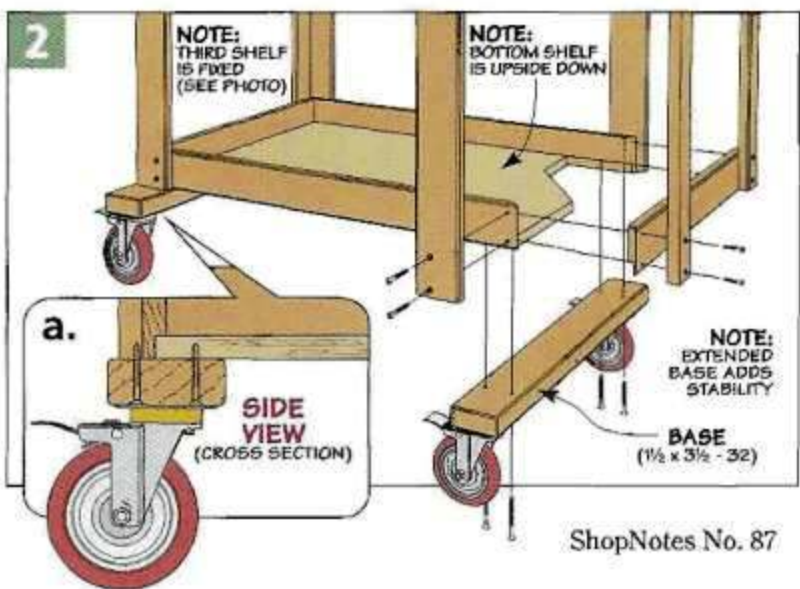
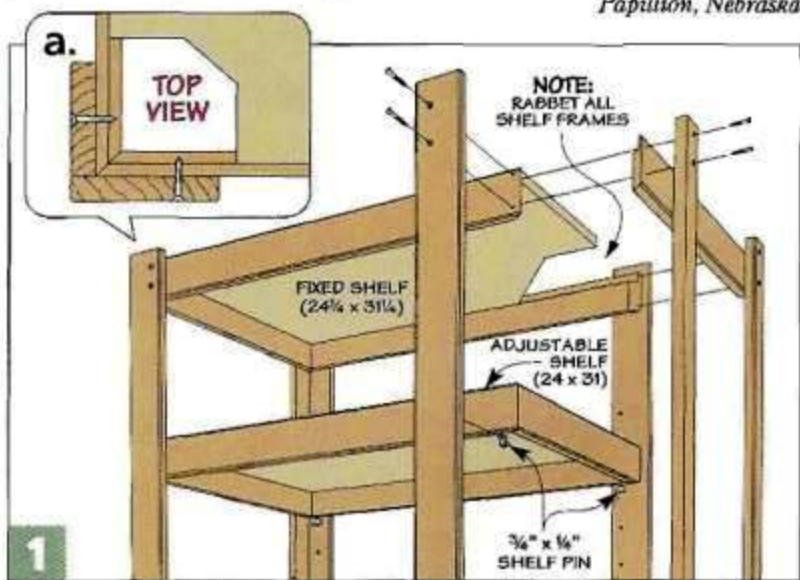

Dowel Drilling Jig

Drilling a centered hole in a dowel can be a challenge. It's hard to get the drill bit centered and keep the dowel from turning as the hole is drilled. To make it easier, I built the jig shown below.

Build the jig by first drilling a hole the diameter of the dowel in a piece of hardwood to make a clamp. Then just cut a saw kerf through the hole from the end.

Using the jig is simple. Begin by centering the dowel under the bit. To do this

clamp a piece of scrap wood to the table and drill a hole to fit the dowel. Then change out the bit to the size needed.

Next, slip the dowel into the hole in the scrap wood. Then slip the clamping jig over the dowel and squeeze the kerf together with a small clamp. Now you can clamp the jig in place and drill the hole in the center of the dowel.

Frank Penicka

Mount Pearl, Nfld., Canada



Submit Your Tips

If you have an original shop tip, we would like to hear from you and consider publishing your tip in one or more of our publications. Just write down your tip and mail it to: *ShopNotes*, Tips for Your Shop, 2200 Grand Avenue, Des Moines, Iowa 50312. Please include your name, address, and daytime phone number (in case we have any questions). If you would like, you can FAX it to us at 515-282-6741 or simply send us an email message at: shopnotes@shopnotes.com. We will pay up to \$200 if we publish your tip.

The Winner!

Congratulations to Tom Neal of Bosque Farms, New Mexico. His tip on making a digital set-up gauge was selected as winner of the *Porter-Cable* router just like the one shown at the right. His set-up gauge is simple to build and provides accurate measurements that are easy to read.

To find out how you could win a *Porter-Cable* router check out the information above. Your tip just might be a winner.



PUBLISHER Donald B. Peschke

EDITOR Terry J. Strohman

SENIOR EDITORS Bryan Nelson, Vincent Ancona

ASSOCIATE EDITORS Phil Huber, Ted Raife

ASSISTANT EDITORS Ron Johnson, Mitch Holmes,
Randall A. Maxey, Dennis Perkins

EXECUTIVE ART DIRECTOR Todd Lambirth

ART DIRECTOR Cary Christensen

SENIOR GRAPHIC DESIGNER Jamie Downing

SENIOR ILLUSTRATOR Roger Reiland

ILLUSTRATORS David Kallermyn, Peter J. Larson

CREATIVE DIRECTOR Ted Kralicek

SENIOR PROJECT DESIGNERS Ken Munkel,
Kent Welsh, Chris Fitch

PROJECT DESIGNERS/BUILDERS Mike Donovan,
John Doyle

SHOP CRAFTSMEN Steve Curtis, Steve Johnson

SR. PHOTOGRAPHERS Crayola England, Dennis Kennedy

ASSOCIATE STYLE DIRECTOR Rebecca Cunningham

ELECTRONIC IMAGE SPECIALIST Allan Ruhnke

VIDEOGRAPHERS Craig Rueggeger, Mark Hayes

ShopNotes (ISSN 1062-0636) is published bimonthly (Jan., March, May, July, Sept., Nov.) by August Home Publishing, 2200 Grand Ave., Des Moines, IA 50312. *ShopNotes* is a registered trademark of August Home Publishing. ©Copyright 2006 by August Home Publishing. All rights reserved. Subscriptions: Single copy: \$4.95. One year subscription (6 issues): \$27.00. Canada/International add \$10 per year. U.S. funds.

Canadian Subscriptions: Canada Post Agreement Number 40028207. Send change of address information and blocks of undeliverable copies to P.O. Box 881, Station Main, Markham, ON L3P 8M6. Canada BN S4907-5473 RT

Periodicals Postage Paid at Des Moines, IA and at additional mailing offices. Postmaster: Send change of address to *ShopNotes*, P.O. Box 37102, Boone, IA 50007-2100.

www.ShopNotes.com

ONLINE SUBSCRIBER SERVICES

- **ACCESS** your account
- **CHECK** on a subscription payment
- **TELL US** if you've missed an issue
- **CHANGE** your mailing or e-mail address
- **RENEW** your subscription
- **PAY** your bill

Click on "Subscriber Services" in the list on the left side of our home page. Menus and forms will take you through any of the account-maintenance services you need.

HOW TO REACH US:

FOR SUBSCRIPTIONS, ADDRESS CHANGES OR QUESTIONS, WRITE OR CALL

Customer Service
2200 Grand Ave., Des Moines, IA 50312
800-333-5854 8 a.m. to 5 p.m. CT

OR SEND AN E-MAIL TO:
orders@shopnotes.com

AUGUST HOME
PUBLISHING COMPANY

Printed in U.S.A.



Drill Press Table Upgrade

I wanted to add a table and fence to my drill press. But I didn't want to spend a lot of money. So I built the simple drill press table with a replaceable insert and fence you see in the photo above. The fence is adjustable and has a sliding stop.

Table. The table is two layers of $\frac{3}{4}$ " plywood that are glued together. A dado on the top side at

each end holds T-tracks for attaching the fence. Two bottom side T-tracks attach the table to the drill press, like you see in detail 'b' and the inset photo above.

Fence. The fence is nothing more than a length of aluminum angle. Slotted holes at each end accept a pair of T-track bolts from the table so you can quickly mount and

adjust the fence to meet almost any drilling challenge.

Stop Block. To help position and hold the workpiece, I added a stop block to the fence as was used in Issue No. 63. It's simply a block of wood attached to an aluminum bracket. A knob and T-nut, are used for adjusting the block and securing it in position on the fence (detail 'a').

Len Urban

Rancho Mirage, California

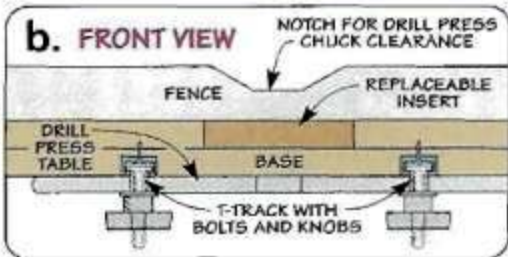
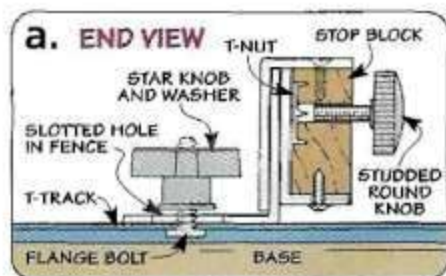
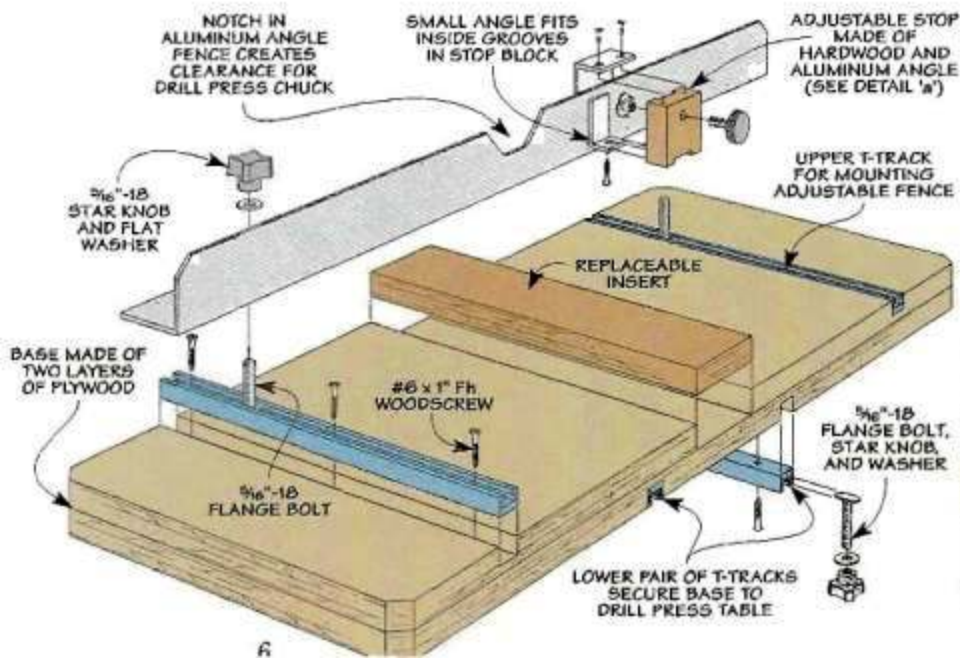

Digital Set-up Gauge

I got tired of "eyeballing" it whenever I needed to check the height of a saw blade or fence setting. So I modified the set-up gauge from Issue No. 69 slightly to accept an inexpensive digital caliper.

The set-up gauge is easy to build. You'll want to start with a 6½"-square piece of ¾" plywood.

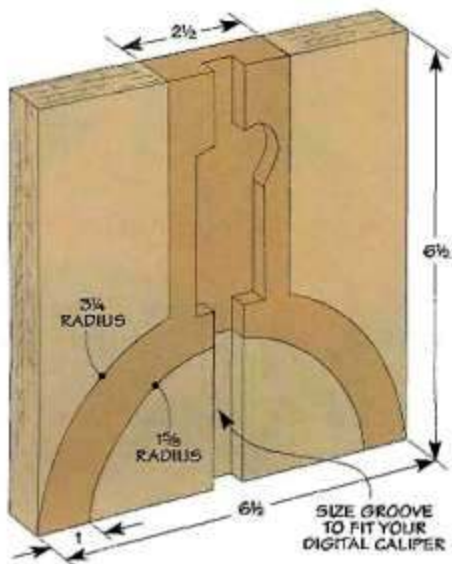

Next, lay out the legs and the body of the gauge on the workpiece (see drawing at left). Then mark the centerline on the square.

Now, you'll need to make a place for the calipers to rest in the body of the set-up gauge. To do this, lay your caliper on the centerline and use a pencil to draw the outline of the caliper measuring arm and digital readout.

To cut out the area the caliper sits in, I used my table saw and a dado blade to cut a ¾" groove down the centerline of the workpiece. Then a router and a ¼"-dia. straight bit easily removed the remaining waste around the digital readout.

Finally, use your band saw to cut out the legs and body of the gauge. You can round off the edges with sand paper or your router.

All that's left to do now is cut off the head of the caliper so only the arm



remains. Then use instant glue to secure the caliper into the cutout.

Using the set-up gauge is quick and easy. Simply place the gauge in position and zero out the digital reading. Then move the arm into position and look at the digital readout to find the measurement.

*Tom Neal
Bosque Farms, New Mexico*

Quick Tips



▲ Phillip Jacobs of Saint Paul, MN, mounts pegboard near his drill press to store the wheels and brushes he uses. The ¼" shank of many of these accessories fit neatly into the holes. For accessories with a larger shank, he simply enlarges the hole with a drill.



▲ Whenever screws need to be driven into end grain or MDF, Dan Shallenberger of Xenia, OH, fills the hole with instant glue and lets it soak in to strengthen the wood.



▲ James Lannom of Bonita, CA, uses rubber bands to clamp up edging. He simply stretches the rubber band over the edging and adds a spring clamp to hold it securely in place.



router table Edge Jointing

Put a smooth, straight edge on almost any workpiece. All you need is a straight bit and a simple fence.



■ A straight and square edge on your workpieces is one of the starting points for most woodworking projects. And one of the first power tools you'd think of to do this is a jointer. But you can also get great

results with a router table. And when using a carbide straight bit, you can put a smooth edge on materials that would be hard on steel jointer knives. I find this technique is ideal for use on small

parts, plywood, MDF, particleboard and even plastic.

The Fence. One of the things I like about jointing with the router table is that it doesn't take a lot to make it work. All you need to do is create an "outfeed table" on one side of an auxiliary fence.

I did this by attaching a thin strip of brass to an auxiliary fence made from a piece of $\frac{3}{4}$ " plywood, as shown in the left drawing. The thickness of the strip you use determines the depth of the cut. You can find the brass at most hobby or hardware stores. I like to use .032"-thick brass. This way, I can take as thin of a cut as possible.

The Bit. Another thing that makes this technique a favorite of mine is that it doesn't take a specialized bit to do the job — just an

▲ **Straight Bit.**
A $\frac{1}{2}$ "-dia. shank bit will produce the cleanest cuts.

1 FIGURE

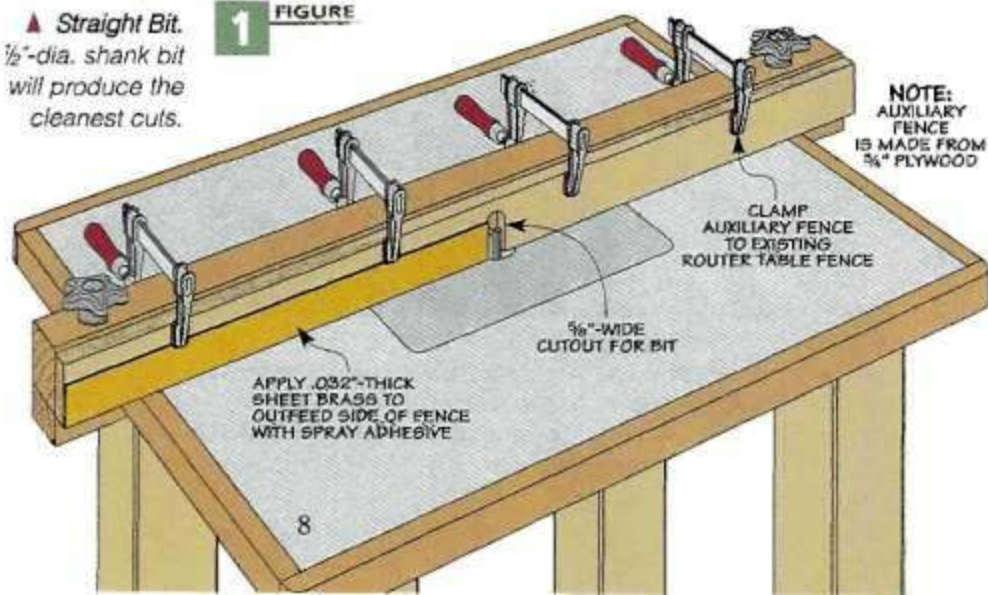

NOTE:
AUXILIARY
FENCE
IS MADE FROM
 $\frac{3}{4}$ " PLYWOOD

Technique: Jointing Setup

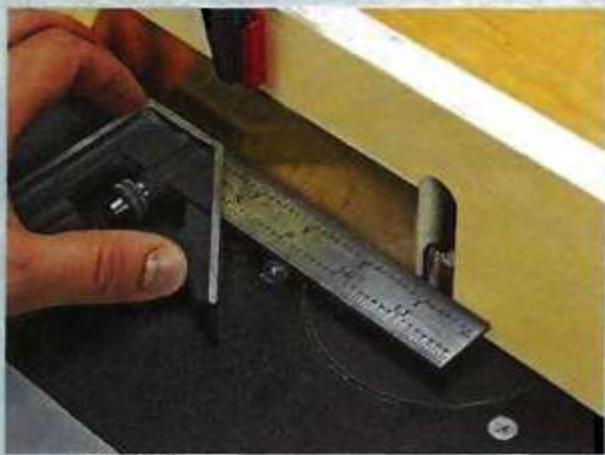
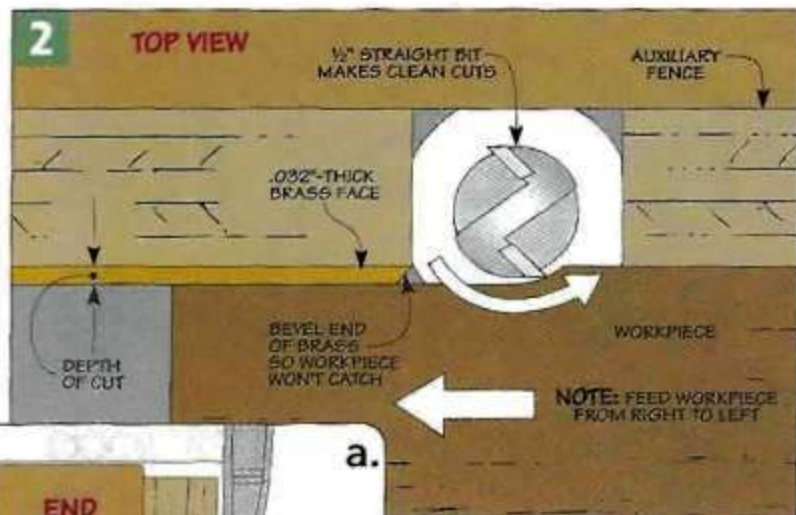

▲ **Set Up the Fence.** Clamp the auxiliary fence to the router table fence. Then place a combination square against the "outfeed" side. Adjust the fence until it's flush with the outside cutting edge of the bit.



▲ **Set the Bit Height.** Once the fence is in position, the next step is to set the height of the bit. To do this, you can use a workpiece as a set-up gauge. Set the bit about $\frac{1}{8}$ " above the thickness of the workpiece.



▲ **Jointing the Edge.** After jointing the first few inches, position your left hand to hold the workpiece firmly against the "outfeed" side of the fence. Padded push blocks provide a firm grip on the workpiece.

ordinary straight bit. I like to use a bit with a $\frac{1}{2}$ "-dia. shank. The extra mass and stiffness of this bit helps prevent vibration and deflection.

The Setup. With the bit in your router, you can set up the router table for jointing. This is really very simple. Start by clamping the auxiliary jointer fence onto your existing router fence, making sure that the bit is centered in the fence opening.

The next step is to set the position of the fence. The goal here is to have the outfeed side of the fence fully support the workpiece after it passes the bit, as you can see in the drawing above. This means you want the outfeed (left) side of the fence flush with the outside cutting edge of the bit. To do this, I hold the blade of a combination square against the outfeed side and then slide the fence up to the bit, as shown in the top photo at right.

With the router turned off, I rotate the bit to make sure the fence is in line with the outside edge. You'll know you have it right when

you feel the bit just "tick" against the edge of the square.

The final step in the process is to adjust the height of the bit. There's nothing too complicated about this. I like to use the workpiece itself as a set-up gauge, as you can see in the middle photo at right.

The Cut. With the router table set up, you're ready to start. But before routing one of your actual workpieces, it's a good idea to do a test cut to double-check the fence setting and make adjustments.

To control the workpiece, I use a pair of rubber-bottomed push pads for a firm grip. These pads also keep my fingers away from the bit when jointing small parts. Begin by using the push pads to hold the workpiece against the infeed side of the fence and move the piece into the bit (photo, opposite page).

Then, after you've routed a few inches, you want to slide your left hand on the outfeed side to hold the workpiece against the fence. At this point, you'll use your right hand to push the workpiece past the bit. You can see this in the bottom photo at right.

After a pass across the bit, take a look at the edge of the workpiece. You may need to take another pass or two to get a perfectly clean, square edge along the whole length of the workpiece. Now, you're on your way to getting tighter-fitting joints and better-looking projects. 🛠️

choosing Plywood for the Shop

Learn about plywood options that are great for projects around the shop.

Over the years, I've used a lot of plywood for jigs, fixtures, and other shop projects. You already know there are many types of plywood to choose from. But how do you know which ones are best for use around the shop? To find out, let's take a look at a few different ones you might want to consider.

BIRCH PLYWOOD

One type of plywood I use a lot of is birch. But what can be confusing is that all birch plywoods are not the same. So what's the difference?

Cabinet Grade. If you look at the photo below, you'll see a sample of cabinet-grade (or "domestic") birch plywood. It's widely available at most lumber yards and home centers.

Look closely and you'll see a very thin outer veneer of birch on the faces. But what's on the inside? The core of cabinet-grade birch plywood is actually made of fir, like most construction-grade plywood.

There are a couple of problems with using domestic birch plywood in the shop. First, it has relatively few plies. And since fir is a softwood, it's not as strong and doesn't hold screws as well as some other types of birch plywood. I've also found those inner plies can have a few voids.

Domestic birch may not be the best choice for shop projects. For durability and strength, I turn to Baltic birch plywood.

Baltic Birch. When you say "Baltic birch," most people think of a plywood with many thin plies like you see in the photo above. These layers are assembled with alternating grain directions, like conventional plywood, using interior-grade glue. The difference is that all of the plies are made from birch (photo below).

This type of construction makes a strong and stable sheet of plywood. It's a much stronger material than domestic birch plywood. The inner plies are void-free and it does a great job of holding screws. That's why I like to use Baltic birch for projects like the hobby chest on page 26 and for jigs like you see in the top left photo on the next page.

Another great benefit of using Baltic birch is that it's available in a wide variety of thicknesses (top right photo, opposite page). But there's something you should know about thickness. Plywood imported from other countries is measured in millimeters. You'll have to take this into consideration when you purchase your plywood.

A close cousin to birch plywood I'll sometimes use is Finnish birch-

◀ **Cabinet-Grade Birch Plywood.** The only birch used in this product is on the front and back face veneer. These outer veneers are very thin and the core plies may have some voids.

◀ **Arauco Plywood.** Imported from South America, the inner plies and faces of this product are made from radiata pine cut from managed forests.

◀ **Baltic or Finnish Birch.** Known for its many thin plies, this plywood is dense, straight, stable, and easy to work with. It's imported from the northern Baltic region of Europe.

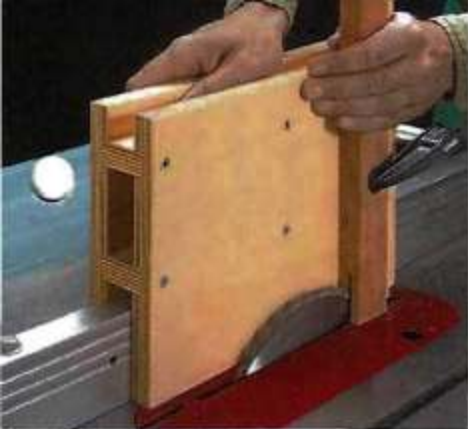

plywood since it looks and works a lot like Baltic birch. To know the difference, let's look at their history.

History. Before World War II, what we now call "Baltic" birch was called "Russian" birch. It was made in the Baltic region, including Finland. After the U.S. entered the war, the product became known as "Baltic" birch.

After the war, Finland took over their plywood production from Russia. And that's where "Finnish" birch plywood comes into play.

Finnish Birch. Finland soon made improvements to their birch plywood. As I said, Finnish plywood looks the same as Baltic birch. But Finnish birch typically has better quality face veneers and inner plies than Baltic birch. And what might be most important is that the veneers in Finnish plywood are put together using exterior-grade glue. As you might expect, these differences mean that Finnish birch can cost more than comparable Baltic birch.

ANOTHER OPTION

When I built the workstation (page 36), I didn't need all the strength

(and expense) of Baltic birch plywood. But I wanted something a little stronger than the typical cabinet-grade birch plywood. I found a plywood product called *Arauco*.

Arauco is the name of the company in South America that makes a plywood from radiata pine trees (see photo at the bottom of opposite page). You'll see that *Arauco* plywood has seven plies. It's stronger than domestic birch and less expensive than domestic or Baltic birch. The downside is its face veneers are less attractive and may contain some defects or patches.

So there are a number of plywood options for shop projects. It all depends on your needs. 🛠️

▲ **Variety.** Baltic birch plywood is commonly available in thicknesses from 1/8" to over 1".

Durable and Attractive: Phenolic-Faced Plywood

As I was looking around for plywood to use for some shop projects, I found something that's almost ideal. I wondered why I hadn't noticed it before. It's a unique product — phenolic-faced plywood.

If you look at the photos below, you'll see what looks like Baltic birch plywood with a thin coating on the faces. This tough coating is a plastic material (phenolic) over Finnish birch (exterior grade) plywood.

What I found out was that it was originally engineered for concrete forms. Its coating was designed to withstand the abrasion and moisture from concrete.

And since this coating is slippery, it releases from the concrete easily. This plywood has great properties for making jigs and fixtures — durability and low-friction. An extra benefit is that it looks great, too.

Manufacturers make this product available in a variety of colors and thicknesses, but I had a hard time finding retail sources for it. The good news is that *Woodcraft* carries this specialty plywood. It's available in 2'x4' sheets in 1/2" and 3/4" thicknesses in a green color like you see in the photos (see Sources). I'm sure you'll find lots of uses for it in the shop.



Great for Jigs and Fixtures. Durability and less friction make this an ideal product for lots of shop uses.



▲ **Water-Resistant.** A thin phenolic film protects the faces. You'll want to seal the edges for exterior use.





▲ **Knot or Nail?** What looks like a knot might actually be a broken nail or screw. Don't take chances.

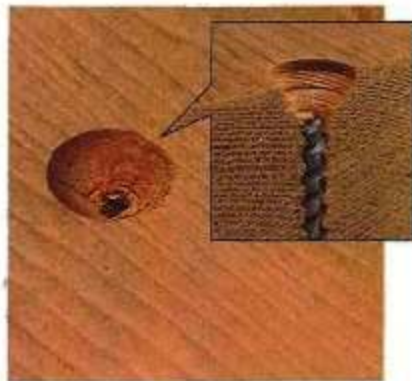

▲ **Hidden Screw.** Workpieces from old projects can have some hidden surprises beneath the surface.



▲ **Before & After.** Reclaimed lumber can be a great source for project lumber.

Fine Tuning. When trying out the metal detectors, I learned that some are more sensitive than others. One might detect a small nail but another detector would miss it. Sometimes you can adjust the sensitivity by "fine-tuning" it. The detectors I used had a small screw adjustment for this.

THE TECHNIQUE

The key to finding metal in wood has a lot to do with technique.

Scan and Repeat. There are a few things to keep in mind when using a metal detector. First, you'll want to make sure that the workpiece you're scanning is several

feet away from other metallic objects like tools and benches. A common mistake is to lay the workpiece on top of a planer or table saw while scanning. And you should remove your jewelry. It can set off the metal detector, too.

Next, you'll want to scan all sides of your workpiece. And if you're jointing or planing, you should scan it before you start, then after every pass. That way, if there's metal buried in the workpiece, you're more likely to find it.

When scanning, make overlapping circles (see Figure 2). And take it slow. It's time well spent to catch anything that can harm a tool.

Metal Removal.

So what do you do when the detector starts beeping? First, I'll mark the area with a pencil. If you can see the metal, you can sometimes remove it with your pliers. If you can't see it, but know the general area it's located, use an old chisel and gently work the surface down. Keep scanning until you see metal. Then you can remove it.

Removing metal can be a tedious operation, but the cost of a metal detector and time spent can save your tools. ⚡

Looking at Options: Metal Detectors

There are quite a few manufacturers of metal detectors, but *Wizard Industries, Inc.* dominates the market for woodworkers (see Sources). Here are three models that are geared for workshop use.

Wizard III. This metal detector (top photo) will look familiar to you. It's the same type used in airports. It's great for the noisy shop because it includes a vibrating feature and a headphone jack. And I think it does the best job of detecting metal objects in lumber.

Wall Wizard. This is a multipurpose detector (middle photo). It not only detects metal objects in lumber, but also detects metal fasteners in wall studs. And it can also

detect electrical currents, static electricity, and broken or missing insulation from electrical wiring.

Little Wizard II. For small workpieces or occasional use, this detector (bottom photo) is a good choice. Its unique shape and small size make it handy to use around the home workshop.

All of these detectors require a 9-volt battery that you'll have to supply separately.



Lumber Wizard III. (\$100)
A large scan area makes quick work of finding metal in wood.



Wall Wizard. (\$20) Multifunction scanner for home and shop.



Little Wizard. (\$20)
Compact size and features LED lights and sound.

Shop Short Cuts



Making the Laminated Legs

I made sturdy legs for the knock-down workstation project on page 32 by gluing together two pieces of $\frac{3}{4}$ " plywood. A cutout in the center of the panels reduces the weight and keeps them easy to manage.

The challenge here is sizing the "double-thickness" leg panels and creating a nice, smooth cutout without a lot of hard work. As you can see in the photo above and the drawings below, I accomplished this by shaping one layer at a time.

First Layer. The process goes like this. First, for each leg panel, I cut one piece of plywood to final size. Then I rounded the corners with a jig saw and sandpaper.

Next, you can lay out the center cutouts. With this completed, I started the cutout by using a 2"-dia. Forstner bit (or a hole saw) to drill a hole in each corner. Then, cutting to the inside of the layout lines, the waste can be removed with a jig saw. Finally, Figure 1 shows how to

clean up the cutout with a pattern bit in the router and a straightedge.

Second Layer. The second layer of plywood should be cut slightly oversize. And after rough-cutting the opening in the second panel, glue the completed piece and the rough-cut piece together. The cutout allows you to clamp around the inside as well as the outside.

The last step is to use a pattern bit to flush trim the oversize panel, as in Figure 2 and the photo above.

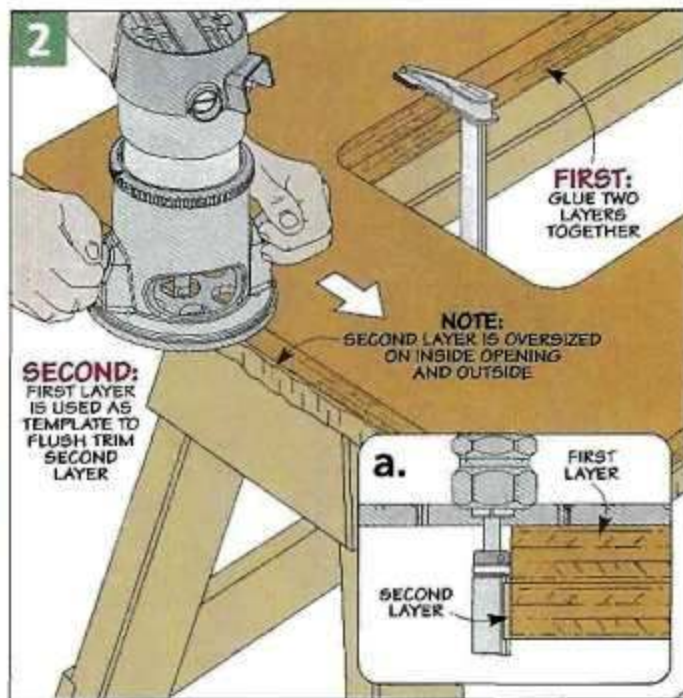
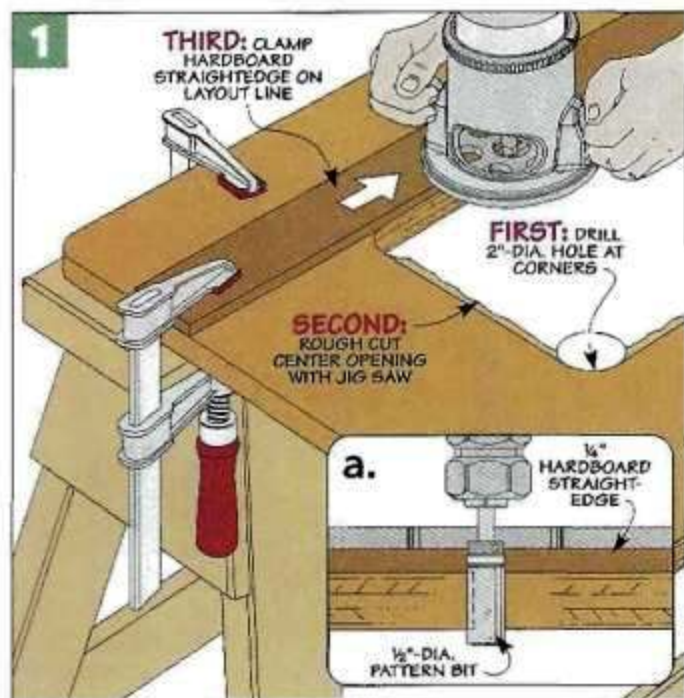

Magnetic Catches

The magnetic catches I used on the hobby chest work great to hold the drawers in place. Each catch consists of a round cup that holds a magnet, and a washer that's attracted to it. I fastened the cup to the back of the case, the washer to the drawer back (right drawings).

Installing the washers on the drawer backs is easy. But the tight space inside the case makes aligning the cup and magnet with the washer a challenge. Detail 'b' at right shows the trick I used. The cup screw is inserted in its hole and the magnet placed over it. Then I stuck the magnet to the washer on the back of the drawer and pushed the drawer into its opening. When the point of the screw hits the back of the case, it leaves a dimple. I used an awl to enlarge this dimple and then was able to reach in and screw the cup in place.

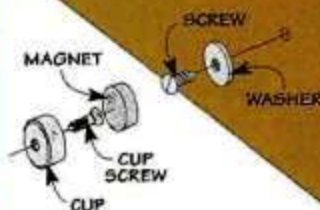
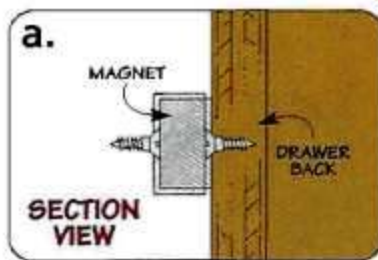
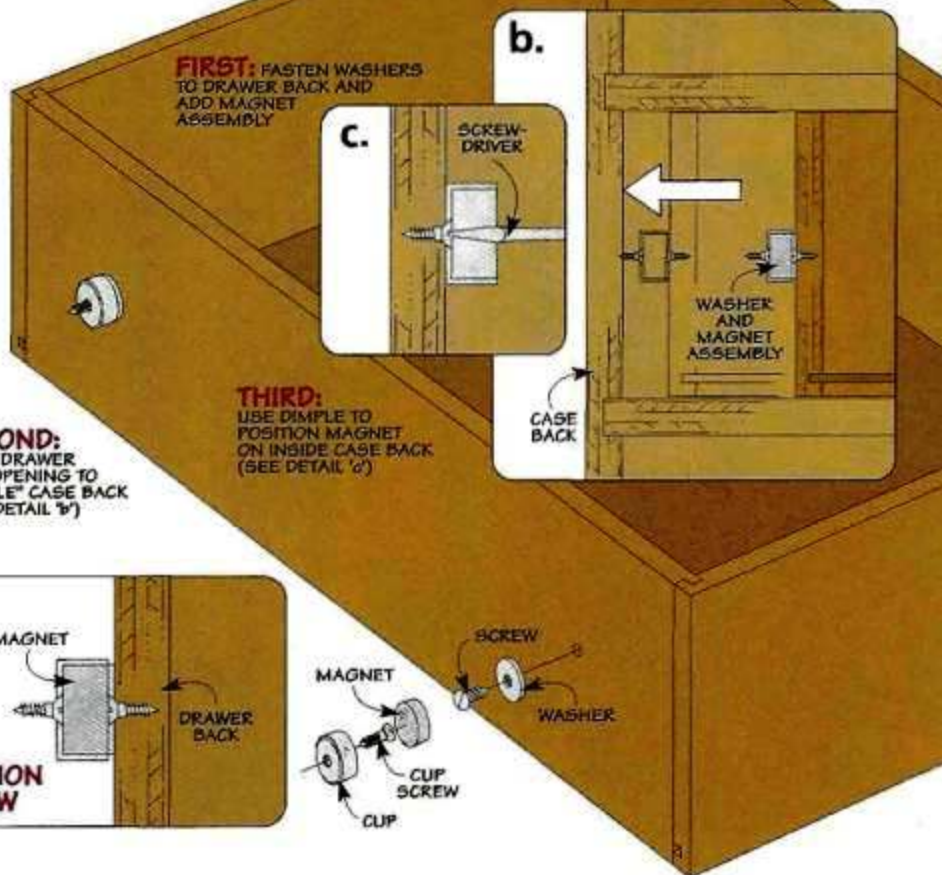

Hobby Chest: Installing the Top

Here's a good way to make and install the two-piece plywood top of the hobby chest from page 26.

First, I cut the two pieces of $\frac{1}{2}$ " plywood for the top to finished size. Then I stuck them together with carpet tape with the edges aligned. Now you can lay out and drill the $\frac{3}{4}$ "-dia. dog holes, as in Figure 1. Next, after rounding the four corners, I chamfered the top

and bottom of the dog holes and all the edges of the top (Figure 1a).

At this point, you can pop the pieces apart and attach the bottom piece to the case (Figure 2). Finally, all that's left to do is glue the top layer to the bottom layer. Figure 3 shows how you can insert waxed sections of $\frac{3}{4}$ " dowel into the four corner dog holes to keep the two layers perfectly aligned.

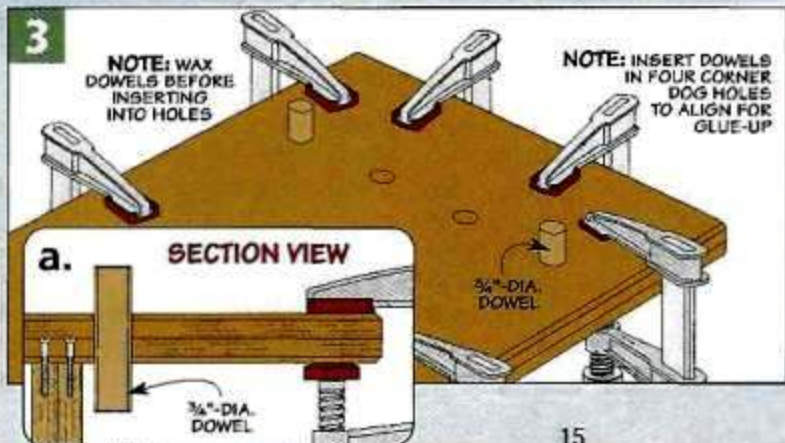
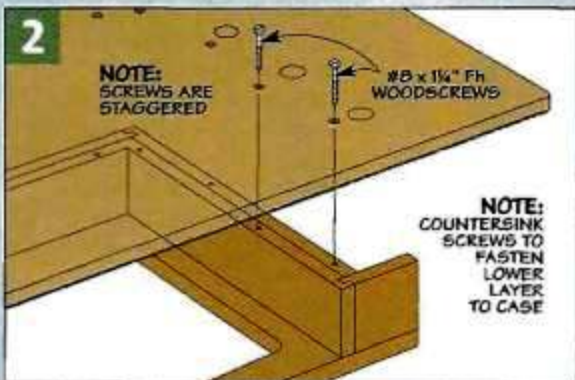
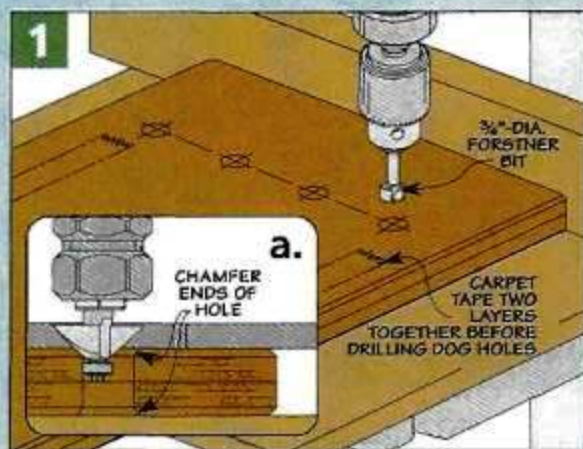

best-built
jigs & fixtures

router Table Sled

Packed with features, this sled makes it easy to rout perfect-fitting joints.

■ A router table is a great tool for producing tight, crisp joints; whether it's grooves, tenons, or even using the specialized "stile and rail" bit sets. But routing across the grain of a workpiece can be a problem. The biggest challenges are preventing tearout and keeping a narrow workpiece square to the bit.

The sled you see above meets both of these challenges. Right behind the workpiece, you'll find an MDF backing strip that supports the workpiece to eliminate tearout.

Another thing I really like about this sled is the hold-down. It's an amazingly simple clamp that locks the workpiece firmly in place.

Materials

A	Platform (1)	11½ x 15 - ½ Ply.
B	Fence (1)	1¾ x 3¾ - 11½
C	Backing Strip (1)	1½ x 13 - ¾ MDF
D	Filler (1)	¾ x ¾ - 6
E	Support (1)	¾ x 2½ - 4¼
F	Handle (1)	4¾ x 6¾ - ¾ Ply.
G	Handle Faces (2)	6 x 4 - ¼ Hdbd.

Hardware

- (1) ¾" x ¾" - 6" Steel Tube
- (1) ¾"-16 x 3¼" Threaded Rod
- (2) ¼"-20 x 2¼" Threaded Rods
- (2) ¼"-20 Aluminum Knobs
- (1) ¾"-16 Aluminum Knob
- (2) ¾"-16 Swivel Pad
- (2) ¼"-20 Threaded Inserts
- (1) ¾"-16 Threaded Insert
- (9) #6 x ½" Fh Woodscrews
- (2) #8 x 2" Fh Woodscrews
- (7) #8 x 1½" Fh Woodscrews
- (7) #10 x ¾" Fh Woodscrews
- (1) 15" Miter Bar
- (1) 1½" x 1½" - 11½" Aluminum Angle (½" thick)

Exploded View Details

OVERALL DIMENSIONS:
15"D x 13"W x 6 3/4"H

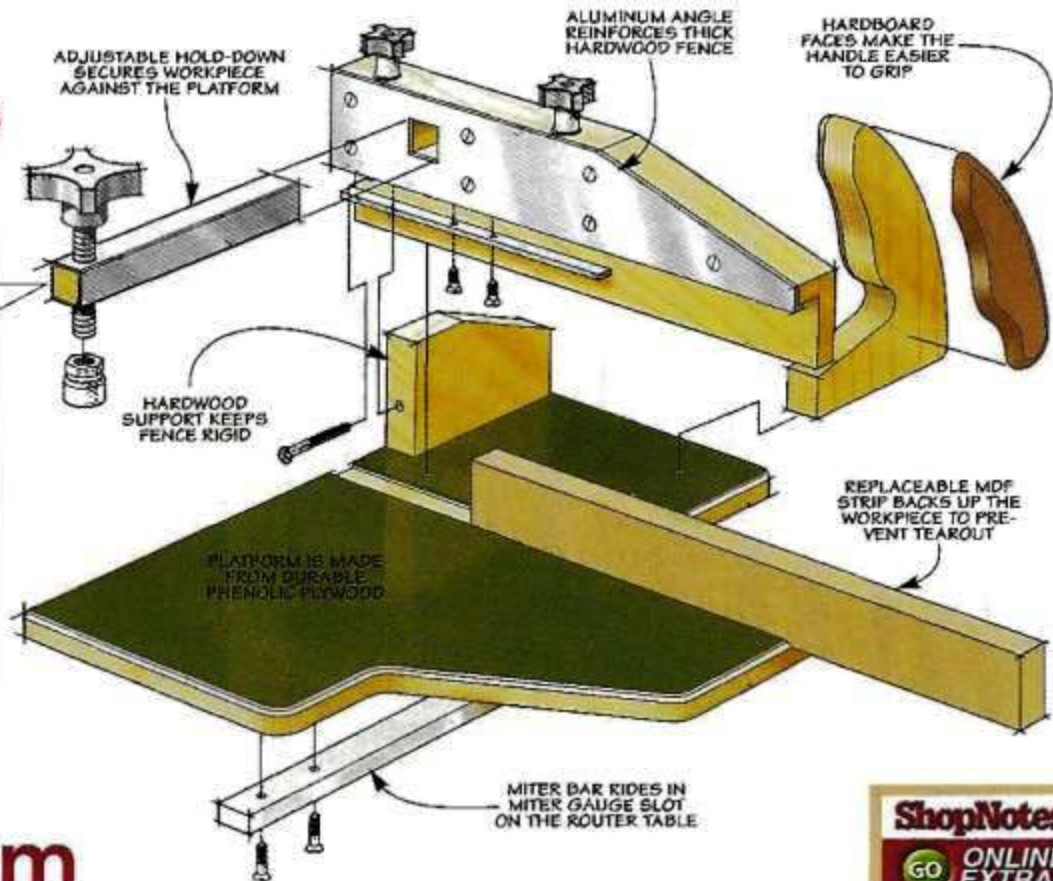
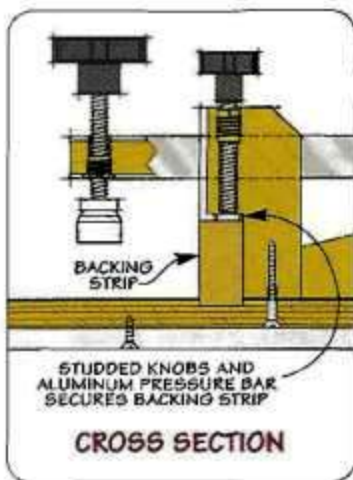

a plywood Platform

I began building the sled with the large platform. And there are a couple details worth mentioning.

The first is the material. We used phenolic-faced 1/2" plywood for the platform. This tough plywood has a smooth surface that's great for jigs. (For more on this, turn to page 10.) But you can just as easily use standard 1/2" plywood if you wish.

Dado. The other detail that I want to talk about is a dado that runs across the platform. It's sized to hold a backing strip for the

workpiece. It's a good idea to cut this dado while the platform is still square. Once the dado is cut, you can shape the platform (Figure 1).

After shaping the platform, I took it over to the router table and routed a chamfer on all the top edges — except for the long side that faces the router bit.

Miter Bar. The sled is guided by a bar that fits in the miter gauge slot of the router table. To prevent the platform from contacting a router bit, I positioned the edge of the

platform 1" away from the center-point of the bit and parallel to the miter slot. A strip of carpet tape will temporarily fix the position of the miter bar so you can screw it in place. In Figure 2, you can see how I used the edge of the table and fence to position the platform.

ShopNotes
GO ONLINE EXTRAS

To see the router sled in action and pick up a few tips on setting it up for use, go to:
www.ShopNotes.com

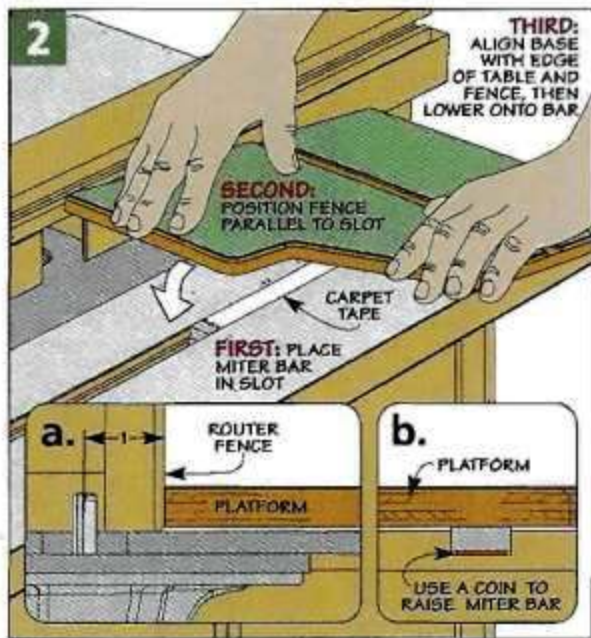
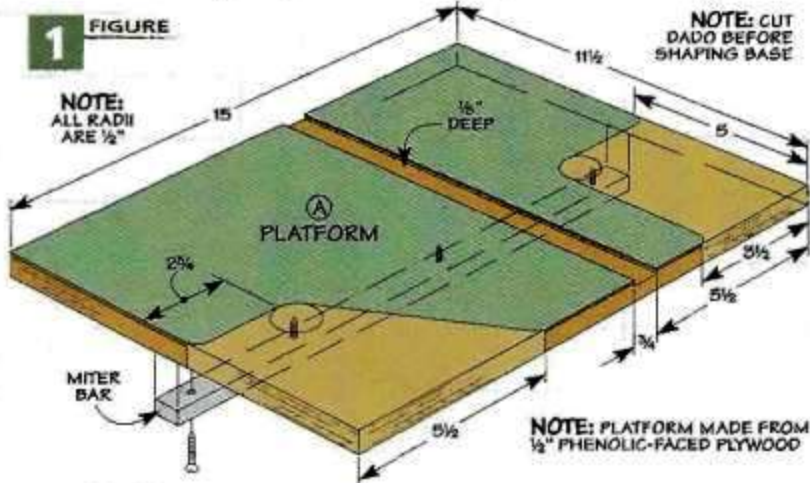

building the Fence



With the platform of the sled complete, the next section to build is the fence assembly. This is made up of four pieces — the fence, a backing strip, a support, and a hold-down (Figures 3 and 6). The fence also has a hold-down arm that makes it easy to secure a workpiece to the sled.

Fence. The main portion of the fence is a thick, hardwood block. Actually, it's two pieces that are glued together (Figure 4). In the lower piece, I cut a square notch sized to fit the hold-down. Now, it would have been easier to simply drill a round hole and use a round arm on the hold-down. But I didn't want the hold-down to rack or twist, so I used square tubing.

Along the front face of the fence I cut a wide rabbet in the bottom edge. This rabbet provides a space for the MDF backer strip. (Since these strips are designed to get chewed up, it's a good idea to make a bunch of them at one time.)

Aluminum Face. The thick hardwood fence is pretty rigid. But tightening the hold-down will exert a lot of upward pressure, which could split the fence body. To prevent this from happening, I

3 OVERVIEW

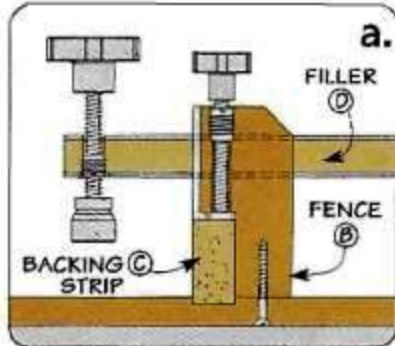
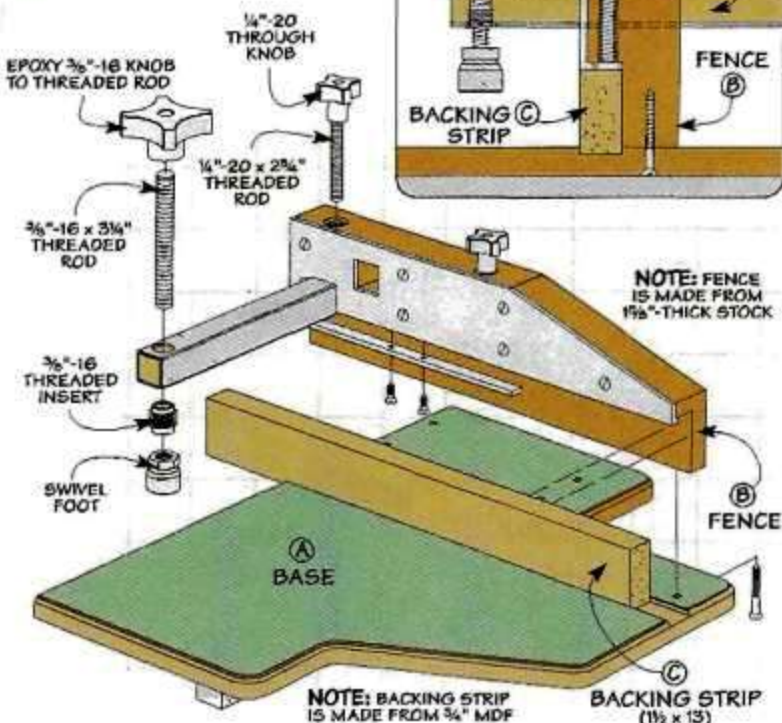

▲ A Square Hole. To complete the hole in the fence face, first drill out the waste (top photo). Then file it flush with the fence.

reinforced the fence with an aluminum face. It's cut from a section of aluminum angle. I trimmed off one side of the angle at the table saw so all that was left was a narrow lip, as shown in Figure 5.

The only trick now is, how do you drill a square hole in the face? The answer is an easy, two-step process. After attaching the face, I

took the fence over to the drill press to drill a starter hole in the aluminum (upper margin photo at left). Then at the workbench, I used a file to clean up the hole (lower photo). The sides of the hole in the fence guide the file for a flush fit.

Pressure Bar. There are just a few things left to do on the fence. From the cut-off section of the aluminum

4 FIGURE

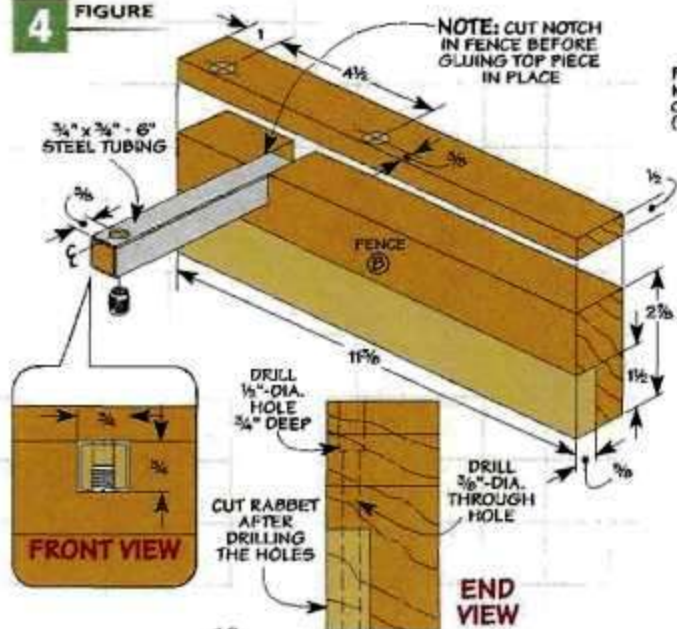

5 FIGURE

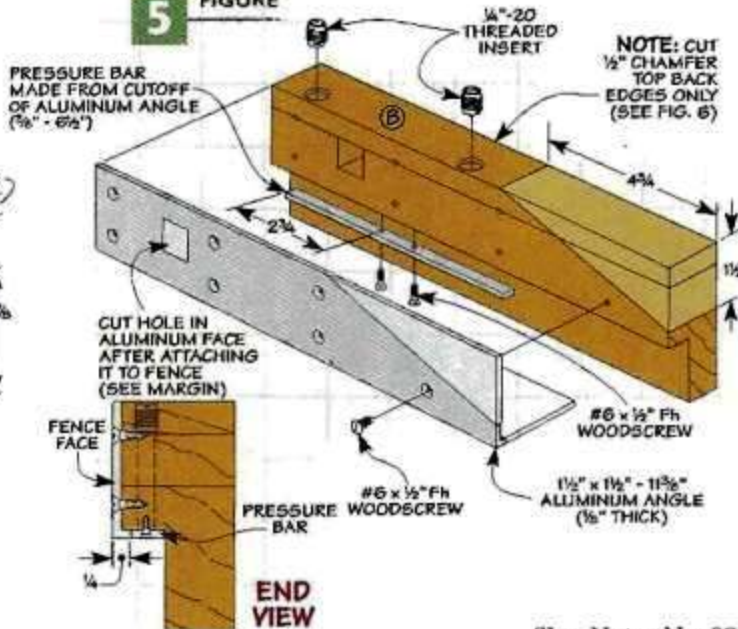

angle, I trimmed a piece to lock the backing strip in position (Figure 5). A pair of knobs mounted in threaded inserts in the fence forces each end of the pressure bar down to hold the backing strip tight.

Two other details — a gentle angle and a chamfer — are all that's left (Figures 5 and 6). Now, you can screw the fence to the platform.

Simple Hold-Down. One of the most interesting features of the sled is the hold-down. Part of what makes it so interesting is how simple it is. It consists of an arm made from a piece of square tubing. At one end of the arm is a clamp, as in Figures 3 and 3a.

The hold-down slides easily in the hole in the fence to adjust its position. But then locks in place as soon as you tighten the clamp.

Because of the pressure generated by the hold-down, I wanted to make sure the arm wouldn't bend or flex. So I used a piece of steel tubing. Then to provide a solid anchoring point for a threaded insert that's used to adjust the

6 FIGURE

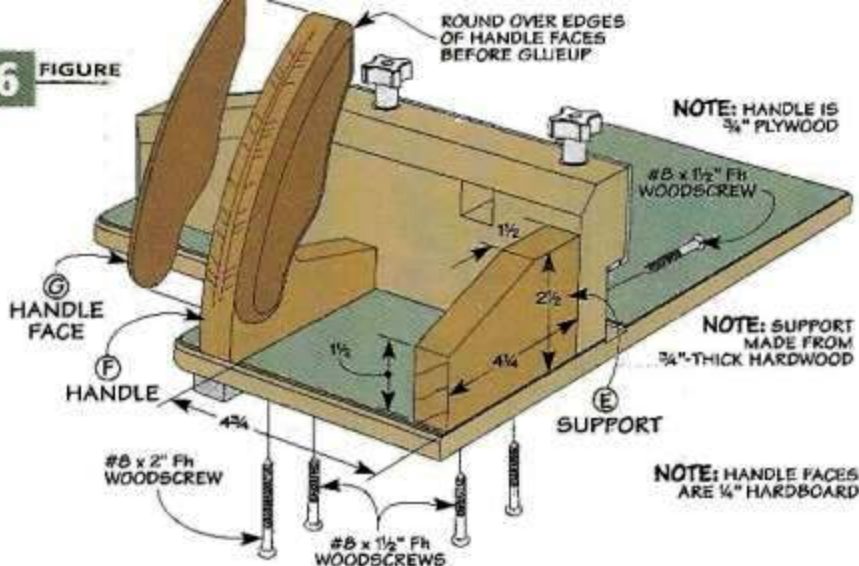

clamp, I cut a filler to fit inside the tubing. It's glued in place with epoxy. All that's left to complete the hold-down is to epoxy a knob to a piece of threaded rod. Then twist a swiveling foot on the other end.

Support. At this point, there are just two parts left to complete the sled — a support and a handle. The aluminum face I mentioned earlier will keep the fence from splitting. But I also wanted to prevent the

fence from tilting out of square during use. So I added a support behind the fence, as in Figure 6.

Handle. Finally, I made a plywood handle that's attached to the sled behind the fence. A pair of hardboard "cheeks" makes the handle more comfortable to grip.

The sled is now ready for use. In the box below, you'll find a few set-up tips to get the best results with the router sled. 

Using the Sled: Set-up Tips



▲ **Set Backing Strip.** Align the backing strip with the bit and plunge it into the spinning bit. When it touches the bearing, lock the strip down.



▲ **A Stop Block.** I clamped a stop block to the router table fence using the backing strip as a guide. The stop block makes workpiece set-up quick.

Handle Pattern

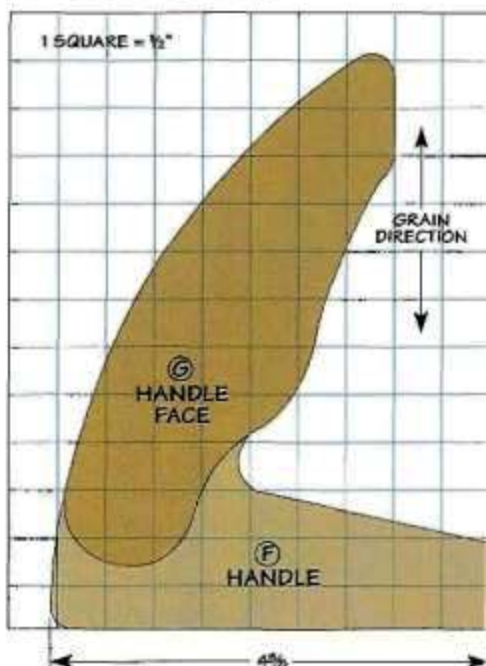

Cutting Tenons

on the
band saw

Simple to set up, easy to use, and dead-on accurate.

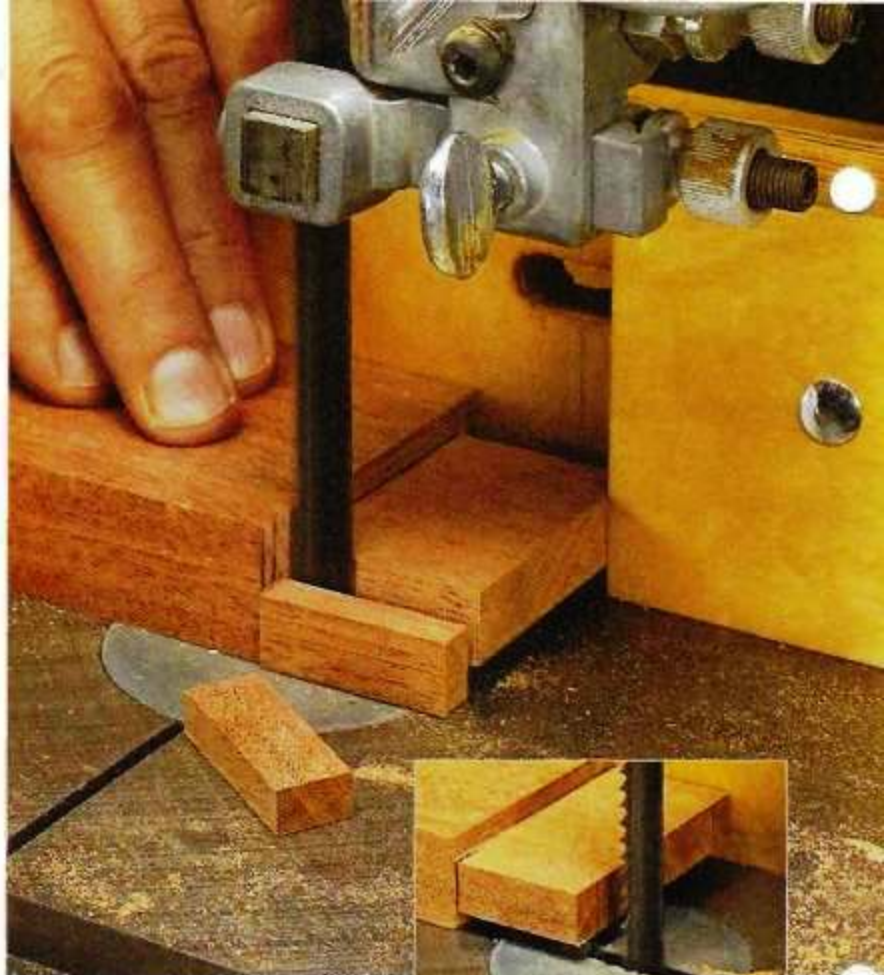

■ The mortise and tenon joint is great for building a rock-solid assembly. So, there are a lot of furniture projects that call for mortise and tenon joinery. I've tried several different ways to cut tenons. But I've found that with a simple fence and stop block, the band saw is one of the

quickest, easiest, and most reliable methods. And, with the exception of cutting them by hand, I think it's also the safest.

That's why you may want to give this method a try. You can build

the fence and stop block shown at the bottom of the next page in no time. They make this an easy operation by keeping the cuts accurate while holding the stock flat on the table.

Start With a Well-Tuned Saw. A tight-fitting joint depends on accurate cuts. So, it's a good idea to

begin by checking out your band saw. First, make sure the table is square to the blade and the miter gauge is square to the miter slot. For this operation, I get the best results with a 6 TPI 1/2" blade. And I keep the blade guide low to prevent the blade from drifting.

Mortises First. I like to cut my mortises first, because I find it easier to fit a tenon to a mortise than vice-versa. Then, I can lay out

a tenon on a piece of scrap cut to the same size as the workpieces. Using this piece allows me to accurately set up the fence and stop block for the rest of the cuts.

Shoulders. The shoulder cuts determine the length of the tenon and are visible when the pieces are joined. By cutting them first, you ensure a square and tight fit. If you

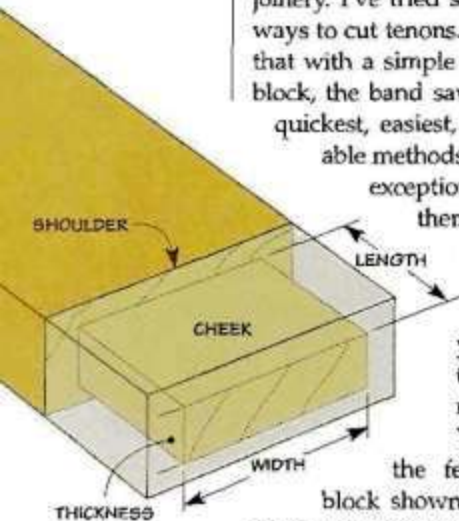

▲ **Side Shoulders.** Using the miter gauge, cut to the layout line and set the stop block.



▲ **Top/Bottom Shoulders.** Use the same technique to make the remaining shoulder cuts.

accidentally go past the line on the shoulder cut, it's not visible since it will be inside the mortise.

So, with your stock against the miter gauge, as shown at the bottom of the opposite page, set your fence as the stop for the tenon length. Then, with the blade on the waste side of the layout line for the shoulder, make the cut slowly and stop just after the line. Finally, turn off the saw, and lock the stop block in position to limit the depth of the remaining shoulder cuts.



▲ *Cutting the Cheeks.* This time, carefully cut just to the shoulder line. This leaves a crisp edge on the shoulders.

Now you can make those cuts on the remaining pieces. If the top and bottom shoulders are the same depth, you can complete them all by simply rotating the piece and cutting the shoulders in all four faces. If not, use the same method to reset the stop block and make the top and bottom cuts.

Cheeks. Cutting the cheeks is a similar process, but you won't need the miter gauge. Set the fence so the blade cuts on the waste side of the layout mark, then slowly cut just to the shoulder line. As before, turn the saw off, and lock the stop block in position.

Now is a good time to test fit the thickness of the tenon. I like to leave it a hair thicker than the mortise. This way, I can smooth the cheeks by taking a pass with a plane or sanding block, removing the saw marks while sneaking up on a nice, tight fit. Smoothing the cheeks also eliminates voids that can weaken the glue bond.



▲ *Check Fit in Mortise.* Test the tenon fit throughout the process to find the best setup for the fence and stop block. Plane or sand off saw marks for final fit.

If the thickness is correct, you can go ahead and make the cheek cuts on the rest of the workpieces. Then, you can leave the stop block in place and reset the fence to cut the tenon to width using the same technique.

You'll find this method of cutting tenons to be both easy and accurate. And it's versatile enough to accommodate tenons on projects of just about any size. Once you give it a try, you just might be hooked. ▲

Shop-Made: Fence and Stop Block

Cutting tenons on the band saw is quick, easy, and accurate using this fence and stop block. As you can see in the illustration at right, the plywood fence is attached to a base that can be adjusted and clamped to the table. A cleat registers the base square to the table.

I made the fence and stop block 3" tall. That's tall enough to handle most tenons, but low enough to keep the blade guides close to the work. To cut the slot for the stop block, drill a pair of $\frac{3}{8}$ "-diameter holes in the fence and remove the waste in between with a jig saw. Then, drill a hole at the same height in the stop block for the bolt. The 6"-wide base is the same length as the fence.

At this point, you're ready to assemble the fence. Begin by attaching the cleat to the front edge of the base. Then, attach the fence to the side of the base with countersunk screws. A carriage bolt through the slot with a star knob makes adjustments quick and easy.

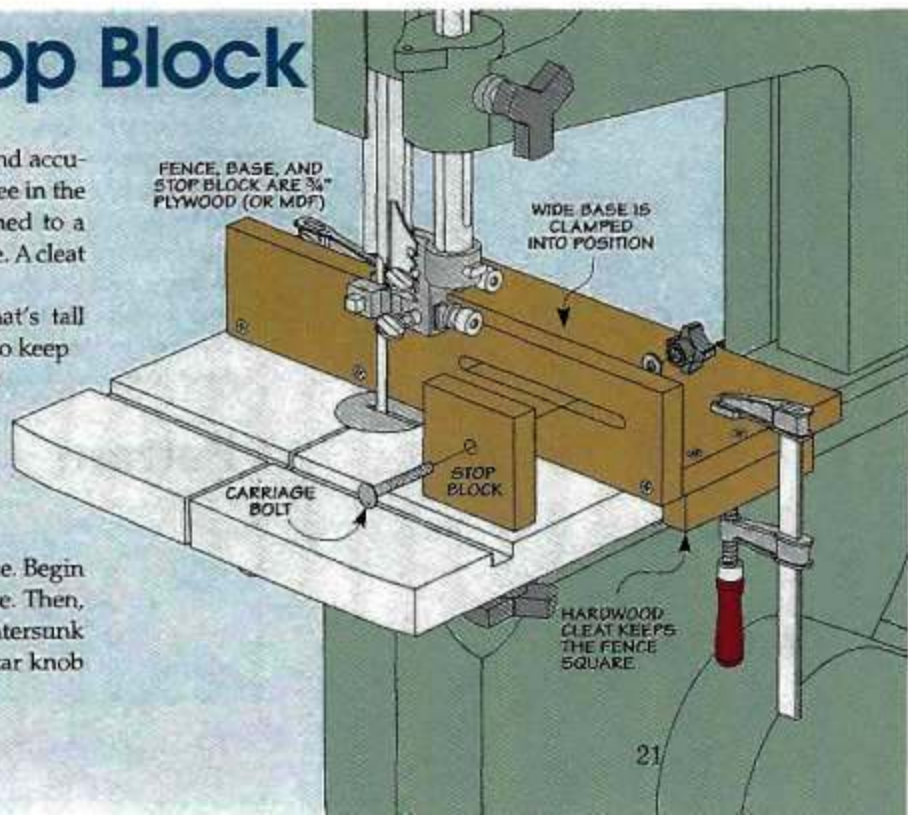

custom Sanding Block

Some scrap wood and a few simple steps are all it takes to build this basic, must-have shop tool.

1 FIGURE

FIRST: CUT INSIDE CURVE, THEN GLUE TWO PIECES TOGETHER TO FORM THE BLOCK

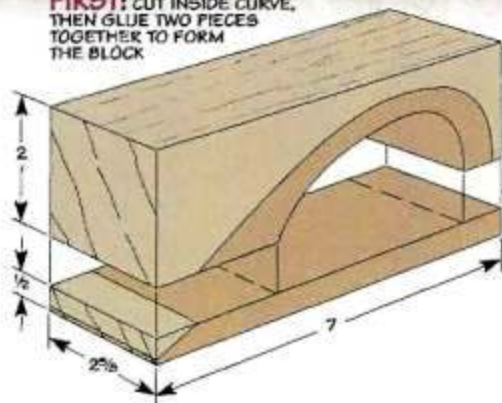

SECOND: CUT TO FINAL SHAPE AND CUT DADO ON FRONT OF BLOCK

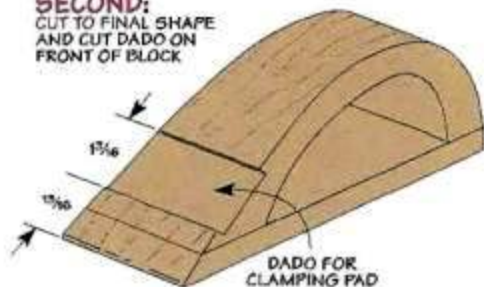

One of the most basic tools every shop needs is a simple sanding block. I've used everything from a piece of scrap wood to a specially manufactured block to get the job done. But none of them ever really had the features I needed, so I built the custom sanding block you see in the photo above.

This sanding block provides a good secure grip and still fits comfortably in my hand. Plus, the size and shape provide good visibility of the surface being sanded and allow me to get into even the tightest corners with ease.

It's made from pine so it's lightweight. This means less fatigue during long periods of sanding. And finally, the block lets you use either standard or self-adhesive sandpaper.

Shaping the Block. Building the sanding block is a snap. All you'll need are two pieces of pine — one 1/2"-thick piece for the base and a second 2"-thick piece to form the handle. Then you'll need to clamp the blocks together and trace the pattern shown below on to them.

I made a trip to the band saw to cut the inside curve for the handle. Then it was a simple matter to glue

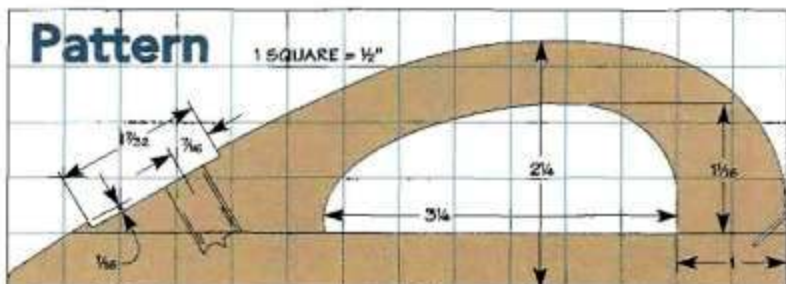

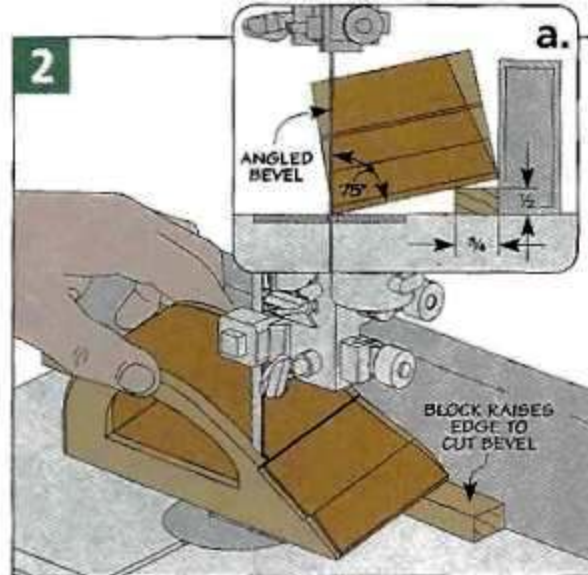

the two pieces together, like you see in Figure 1. Now you can use the band saw again to cut the outside shape of the top of the block. Finally, sand the top and bottom to provide a smooth look and feel.

Clamping Pad Dado. To keep the sandpaper tightly stretched over the block, you'll need to secure the sandpaper in place at the front. For this, all you need to do is cut a shallow dado to hold the clamping pad across the front of the block. I did this by making two shallow cuts at the band saw to define the edges and then cleaning out the waste with a sharp chisel.

Bevel the Sides. Since one of the goals of this project was to be able to sand into a corner without my fingers getting in the way, I beveled the sides of the block. This was easy. I just used a small piece of scrap to raise one edge of the sanding block to the desired bevel angle, like you see in Figure 2, and then cut both sides with a couple of quick passes of the band saw. Once this is done you're ready to make a clamping pad to hold the sandpaper in place at the front of the block.

Clamping Pad. Since you've already cut the dado, all you need to do is install a threaded insert to hold a clamping pad and knob in place. I used my drill press to first drill a hole at 90° to the dado as shown in Figures 3 and 3a. Then install the threaded insert (Figure 3b).

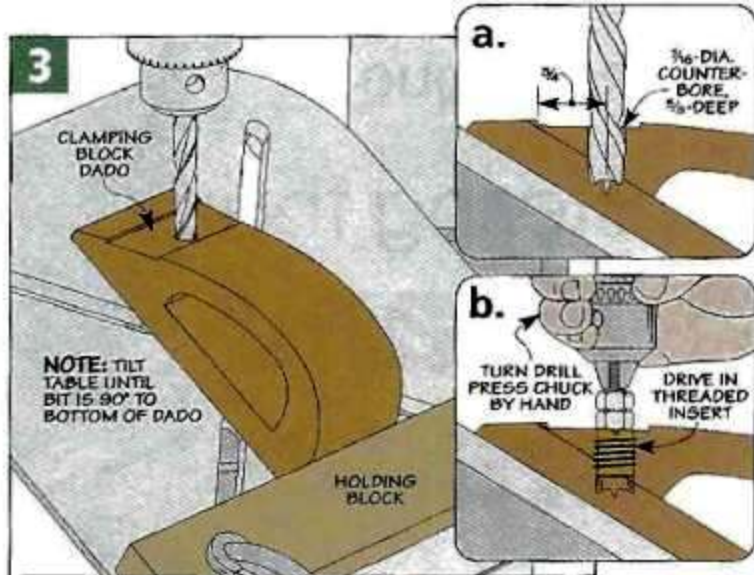

For the clamping pad, I used a piece of 1/4" hardboard that I cut slightly narrower (1/32") than the dado. To provide some "grip" so the sandpaper wouldn't slip around during use, I added a small piece of sandpaper along the lower edge of the clamping pad.

Back Sandpaper Slot. You'll also need to hold the sandpaper in place at the back of the block. This is done by simply cutting a small slot at the back of the block as shown in Figure 4a. You'll find a thin-kerf hand saw works great for this. Just make a cut at 45° and then pass a piece of sandpaper through the slot a few of times until the sandpaper slides easily in place.

Cork Base. I added a cork base to the bottom of my block. The cork provides a nice base and helps keep the sandpaper from slipping around as you sand. You can use other materials, such as felt or rubber, for this as well.

I used a spray adhesive to attach the cork. This way, I didn't have to worry about any glue squeezing through the porous cork when I attached it to the sanding block.

Using the Block. Now, all that's left is to install the sandpaper. Since the block accepts a quarter sheet of sandpaper, this is easy. Just trim the sheet, slip one end in the back groove, and secure the other end under the front clamping pad. 

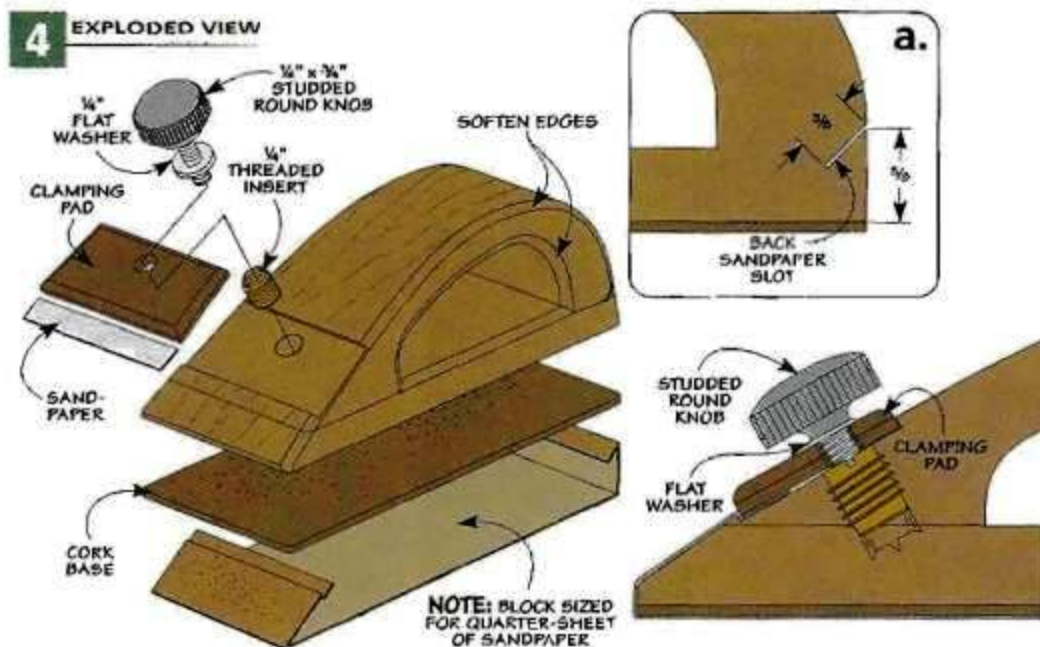

mastering the Hand Scraper

Success with a hand scraper is as easy as one, two, three.



- For such a simple tool, a hand scraper (also called a cabinet or card scraper) can be incredibly useful. And in that spirit, I've always taken the approach that putting a hand scraper to work should be just as simple as the tool itself. The technique I use takes a few minutes preparation and you're ready to go.

Why a Scraper? A scraper is nothing more than a thin, rectangular piece of flexible steel. It works kind of like a cross between a hand plane and sandpaper. A scraper will lift fine shavings (and a little dust) from the wood surface without the worry of tearout. So, it's easier to use than a handplane, but it does the job a lot faster than sandpaper. I often reach for a scraper to remove planer or saw

marks on difficult wood, to smooth panels, or "flush out" plywood edging, as shown above.

The Burr. When you run your finger across the edge of a well-sharpened hand scraper, you'll feel an "invisible" hook or burr (drawings on opposite page). This is what makes a scraper work. When drawn across a surface, the burr digs in, and then peels back a fine shaving. So, when you "sharpen" a hand scraper, your goal is to form a crisp burr on the edge.

Three Quick Steps. The photos below along with the photo and drawings on the opposite page, show the tools and steps I use to create the burr. As you can see, all the work is done with the scraper clamped in a bench vise. A mill file,

a medium-grit stone, and a burnisher are the only tools needed.

File. First, you need to remove the old, dull burr and make sure the edge of the scraper is straight and square. All this takes is several quick passes over the edge with a mill file. Time? Maybe 30 seconds.

Hone. Next, I pick up the stone to quickly hone the edge. This step simply removes your filing marks and ensures that the burr formed next will be crisp and sharp.

The Burr. Now, you can use the burnisher (just a hardened steel rod) to draw the burr on the edge. First, lubricate the edge with a drop of oil. Then a half dozen back and forth strokes, with increasing pressure, flares the edge. Next, by tilting the burnisher, the flared edges are "rolled" over and the sharp hook is formed.

A simple touch of the finger tells me when the scraper is ready. Honestly, from start to finish, I never spend more than a few minutes creating the burr. Finally, the box on the opposite page will help you put your scraper to work.

◀ **A Quick Hone.** A medium-grit stone will smooth any roughness on the edge left by the file.

ShopNotes
GO ONLINE
EXTRAS

Check out our website at ShopNotes.com to view a video on sharpening and using a scraper.



Start Fresh. The first step in sharpening a scraper is to take several passes across the edge with a file to remove the old burr and square the edge.

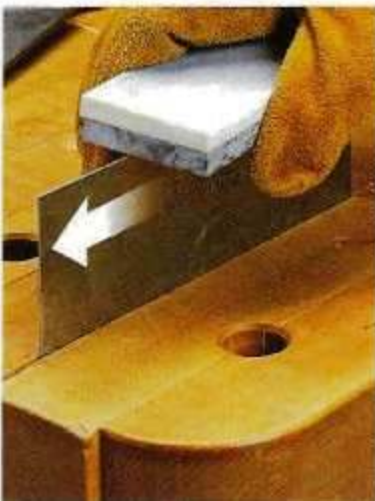

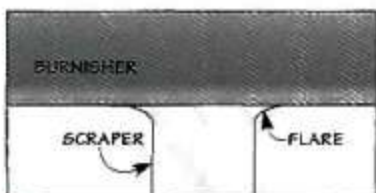

1 Flare the Edge. Long strokes with the burnisher held square to the face will flare the edge.

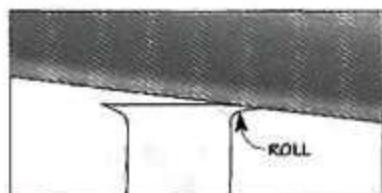

2 Roll the Burr. Now, tilt the burnisher very slightly to begin to roll the flared edge.

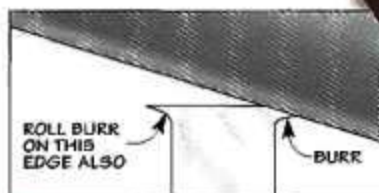

3 Sharp Hook. Finally, a couple of light strokes at a steeper angle will create a sharp hook.

▲ **Simple Tools.** A few simple tools make a quick job of creating a sharp burr on the edge of your scraper.

How To: Handle a Scraper

There's really no single way to use a scraper. But, a few pointers will help you get better results.

A Slight Bow. Using a scraper is a two-handed job. The main reason for this is that the flexible scraper works best when forced into a slight bow (lower right drawing). This bowed shape concentrates the scraping action over a smaller area and reduces the effort involved. It also keeps the corners of the scraper from gouging the wood.

Push or Pull. Some woodworkers like to "crown" the blade away from their bodies and push it across the wood (middle drawing). Others, myself included, find it easier to pull the scraper (top drawing). This method makes bending the scraper a bit more work, but for me, it's easier to see and control the cut.

Two Angles. When you draw a scraper across a workpiece, there are a couple angles to think about.

The first is the pitch or cutting angle of the blade (detail 'a' at right). The second is the angle of the long scraper edge in relation to the grain direction. The good news here is that neither angle is critical.

The cutting angle is usually somewhere between 45° to 60° to vertical. But basically, it's whatever angle seems to work best. The burr you form isn't always going to be the same size and shape. So basically, it's just a matter of feel. Fine shavings let you know it's right.

As the drawing shows, the scraper blade is held slightly skewed to the grain direction. This way, the scraper is more likely to hit the high spots and skip over the low spots. To avoid creating ridges, I alternate angling the blade from one side to the other.

You'll find that the learning curve for success with a scraper is a pretty small hill to climb. And it's definitely worth the effort.

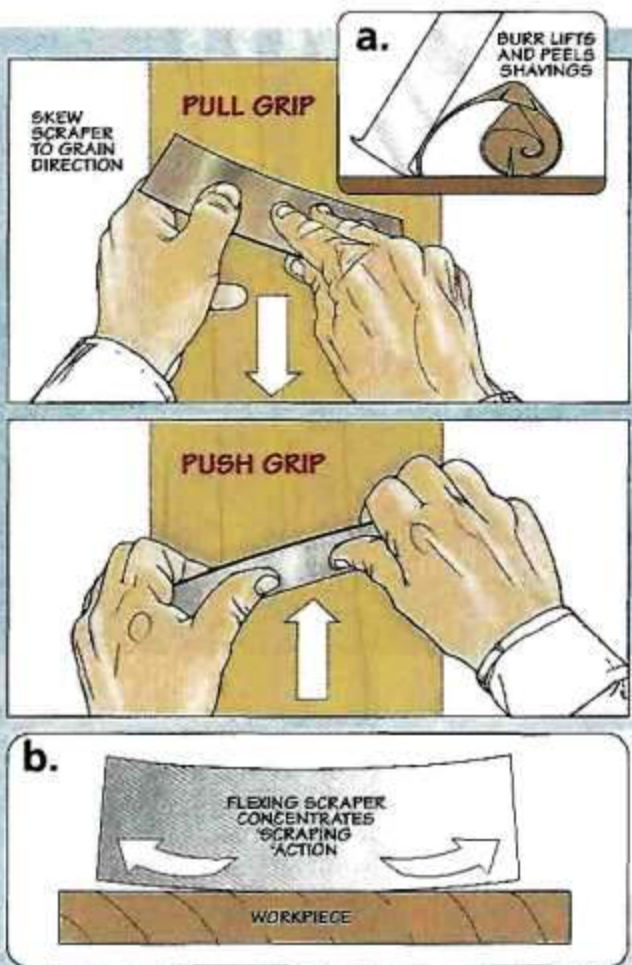

storage
solution

portable Hobby Chest

Take your favorite hobby on the go with this combination storage chest and portable workbench.

■ There's no question that a workshop, no matter how small, can be a great place to unwind and spend a few hours. But sometimes — especially if you're traveling — it's not always practical to get into your shop. The idea behind this hobby chest is to provide you with a "workshop" that you can take anywhere, whether it's just into another room of the house or across the country. It not only offers you several handy worksurfaces, but also provides you with plenty of drawers to

store all the tools and supplies that go along with your hobby (whatever that may be).

But the most interesting aspect of this project is the slide-off top. When the hobby chest is placed on an average table, the top is at just the right height for working while you're standing. But if you remove the top from the case and set it on the same table, you now have a worksurface that's at the perfect height for sitting down. It's like getting two projects in one.

Exploded View Details

OVERALL DIMENSIONS:
14½"D x 25"W x 12¾"H



To download a free cutting diagram for the portable Hobby Chest, go to: www.ShopNotes.com

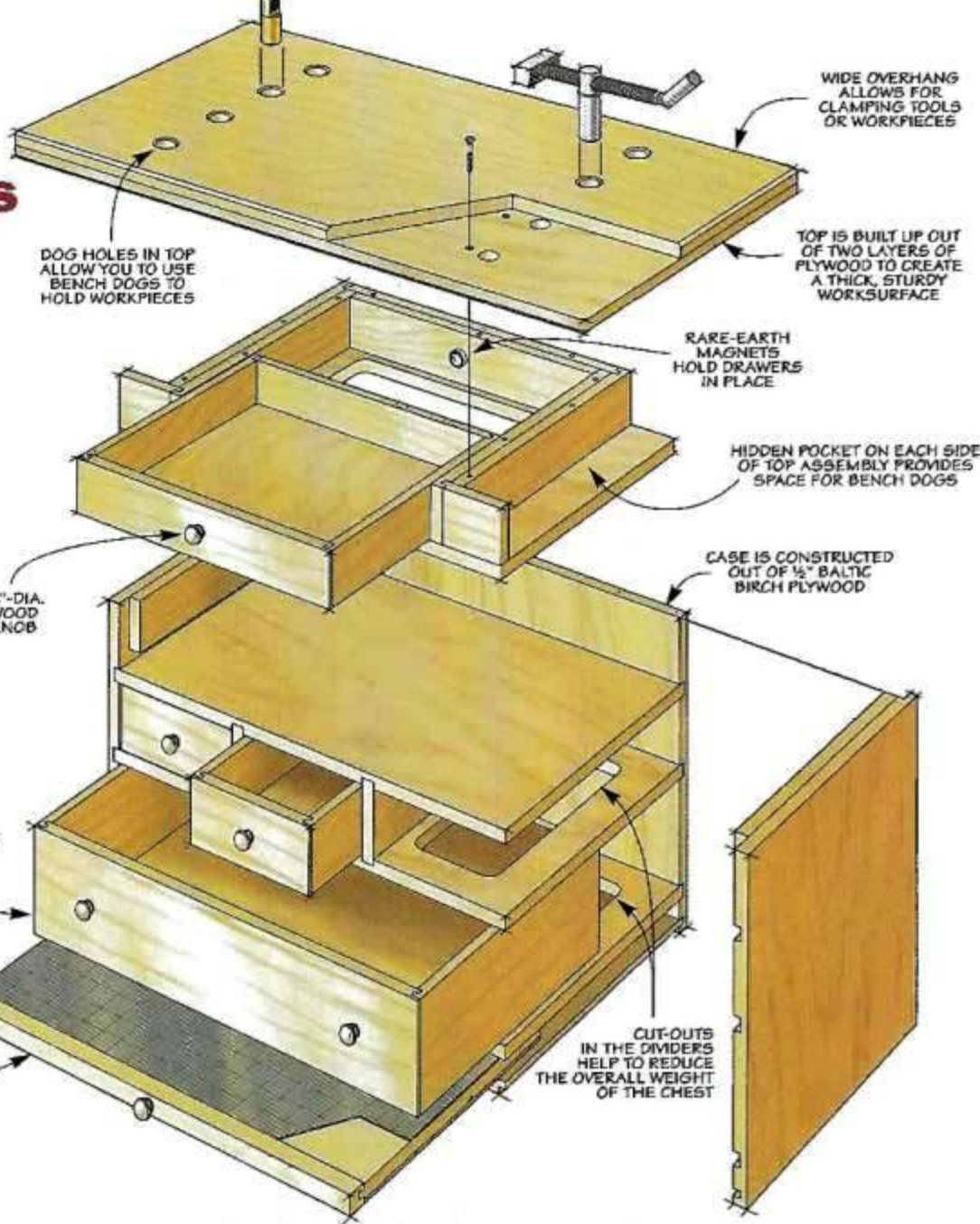

◀ **Removeable Top.** The top of hobby chest can be removed and used separately.

1 FIGURE

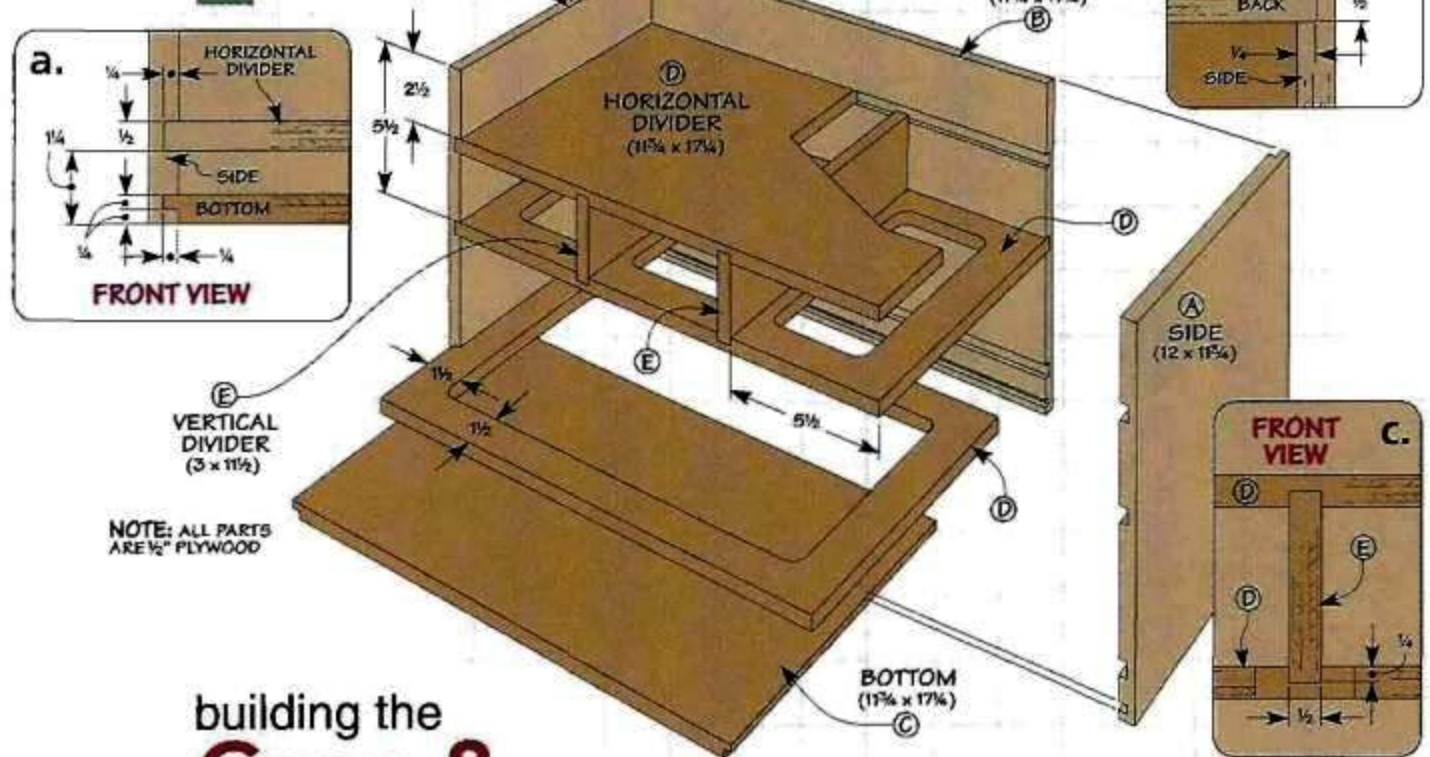

building the Case & Drawers

The hobby chest can be broken down into two main sections — the case and the removeable top. As you can see in the drawing above, the case starts off as nothing more than an open box with a few dividers. Later, drawers and a pull-out tray are added.

To create a strong yet fairly light-weight hobby chest, I used 1/2" plywood for all the case parts. I began by cutting the sides and back to size. A narrow groove is cut near the lower edge of each piece for the case bottom (detail 'a'). And three wider grooves are cut in each piece for the horizontal dividers. Then a rabbet is cut along the back edge of both side pieces to hold the case back (detail 'b').

Case Bottom & Dividers. The case bottom and the horizontal dividers start off as identically sized plywood panels. But as you can see in Figure 1 above, each one gets a slightly different treatment.

The case bottom is rabbeted on three edges to fit into the grooves in the case sides and back (detail 'a'). You can cut these rabbets on the table saw using a dado blade.

The three horizontal dividers simply fit directly into the grooves you cut earlier. But the upper two dividers each receive a pair of dadoes for a couple of vertical dividers that will be added later.

Once these dadoes are cut, the last step before assembly is to make some cut-outs in the lower and middle dividers. The purpose of these cutouts is simply to reduce the weight of the hobby chest — making it easier to carry around.

Assembly. At this point, you can glue up the outer case and horizontal dividers. Once these pieces are assembled, you can measure and cut the two vertical dividers that fit in the upper opening (see drawing). These are glued in place.

Materials & Hardware

CASE		TOP ASSEMBLY			
A	Sides (2)	12 x 11 3/4 - 1/2 Ply.	Q Base (1)	11 1/2 x 16 3/4 - 1/2 Ply.	
B	Back (1)	11 3/4 x 17 1/4 - 1/2 Ply.	R	Side Walls (4)	2 x 11 - 1/2 Ply.
C	Bottom (1)	11 3/4 x 17 1/4 - 1/2 Ply.	S	Inner Back Wall (1)	2 x 11 - 1/2 Ply.
D	Horizontal Dividers (3)	11 3/4 x 17 1/4 - 1/2 Ply.	T	Side Wings (2)	2 x 2 3/8 - 1/2 Ply.
E	Vertical Dividers (2)	3 x 11 1/2 - 1/2 Ply.	U	Outer Back Wall (1)	2 x 12 1/2 - 1/2 Ply.
F	Sm. Drawer Fronts (3)	2 7/16 x 5 3/16 - 1/2 Ply.	V	Top Layers (2)	14 1/2 x 25 - 1/2 Ply.
G	Sm. Drawer Backs (3)	3/8 x 2 7/16 - 4 13/16	W	Cleats (2)	2 x 11 - 1/2 Ply.
H	Sm. Drawer Sides (6)	3/8 x 2 7/16 - 11 1/8	X	Drawer Front (1)	1 5/16 x 10 15/16 - 1/2 Ply.
I	Sm. Dr. Bottoms (3)	4 13/16 x 10 3/4 - 1/8 Hdbd.	Y	Drawer Back (1)	3/8 x 1 15/16 - 10 9/16
J	Lg. Drawer Front (1)	3 3/16 x 16 11/16 - 1/2 Ply.	Z	Drawer Sides (2)	3/8 x 1 15/16 - 10 1/8
K	Lg. Drawer Back (1)	3/8 x 3 15/16 - 16 5/16	AA	Drawer Bottom (1)	9 3/4 x 10 9/16 - 1/8 Hdbd.
L	Lg. Drawer Sides (2)	3/8 x 3 15/16 - 11 1/8			
M	Lg. Dr. Bottom (1)	10 3/4 x 16 3/4 - 1/8 Hdbd.			
N	Tray (1)	10 3/4 x 16 11/16 - 1/2 Ply.			
O	Tray Surface (1)	10 1/2 x 16 11/16 - 1/8 Hdbd.			
P	Tray Edging (1)	3/4 x 1 11/16 - 16 11/16			

- (22) #8 x 1 1/4" Fh Woodscrews
- (7) 3/8"-dia. Shaker Knobs
- (7) 3/8"-dia. Magnets w/Cups & Washers
- (14) #4 x 3/8" Fh Woodscrews
- (1) Self-Healing Cutting Mat

Drawers. With the case complete, you can move on to making the drawers. Like the case, I designed the drawers to keep the weight down as much as possible. The drawer fronts are $\frac{1}{2}$ " plywood (to match the rest of the case). But the drawer sides and back are $\frac{3}{8}$ "-thick hardwood.

As you can see in Figure 2, there are three small drawers and one large drawer. Except for the difference in size, all the drawers are constructed identically. The drawer front is connected to the sides with a locking rabbet joint (Figure 2a). And the drawer back uses a simpler tongue and dado joint. A groove on the inside face of each drawer piece holds a hardboard bottom.

There's one thing to point out when you're cutting out the parts for the drawers. If you look at Figure 2, you'll see that the drawers are held in place by some rare-earth magnets that are mounted to the back of the case. (These magnets prevent the drawers from sliding out while transporting the hobby chest.)

You'll need to take the thickness of the magnets and washers into account when sizing the length of the drawer sides. The goal here is for the drawer fronts to end up

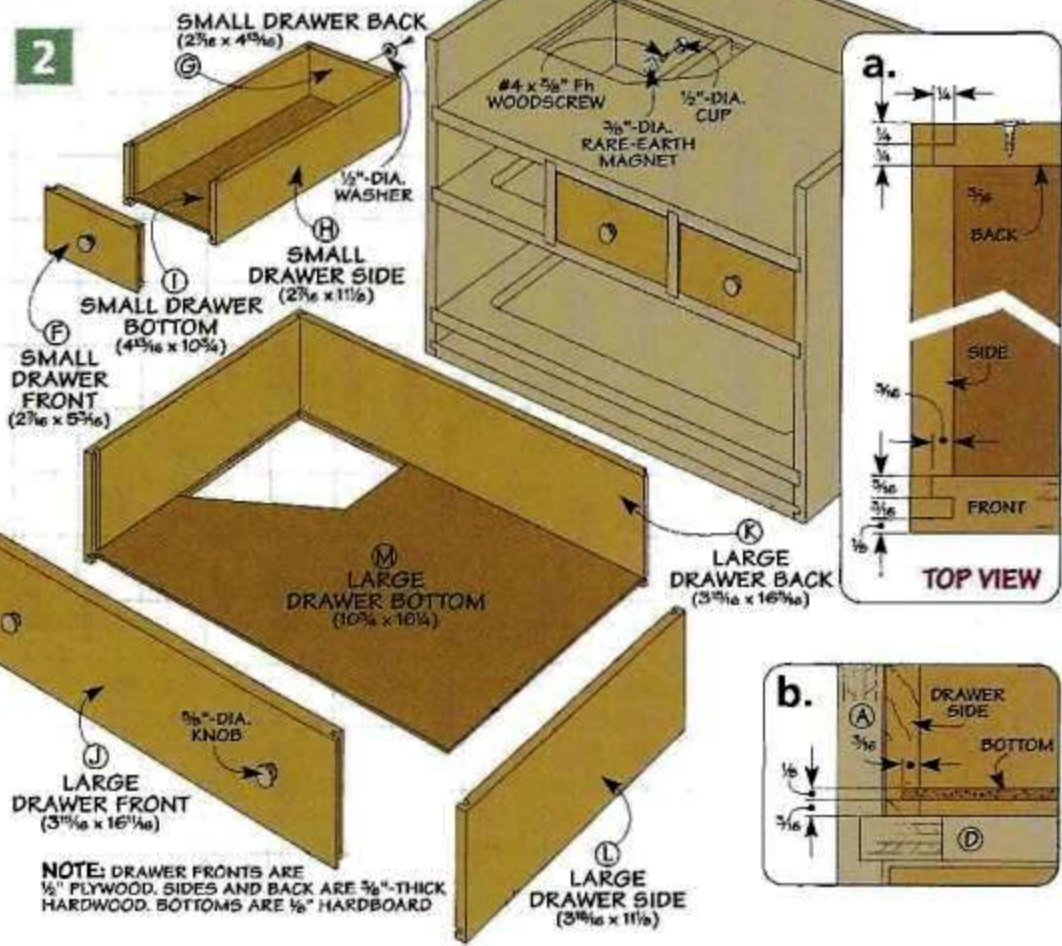

flush with the front edges of the case when they are closed.

Pull-out Tray. In addition to the drawers, the case also holds a pull-out tray, as shown in Figure 3. This tray is nothing more than a $\frac{1}{2}$ " plywood panel that gets sandwiched between a cutting mat and a piece

of hardboard (see the box below). A tongue is cut on the front edge of the tray to accept a piece of hardwood edging.

After the drawers and tray are assembled, you can add the washers and rare-earth magnets. For more on this, see page 15.

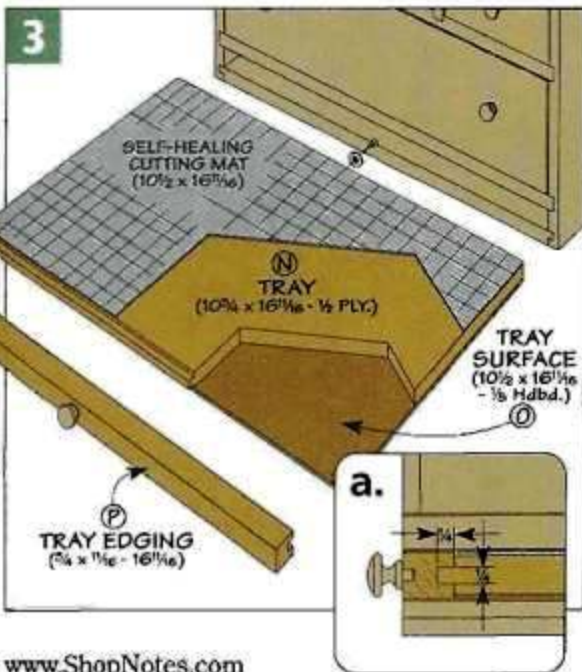

Two-Sided Tray

The pull-out tray features two different worksurfaces. One side of the tray is covered with a self-healing cutting mat. (I was able to purchase my mat from a hobby store). This side is great for cutting out patterns or small parts with an X-acto knife. The soft mat cushions the workpiece and prevents the blade from dulling.

The other side of the tray is covered with a layer of tempered hardboard. This side is ideal for painting or finishing small projects — or any other task that requires a hard, smooth worksurface.

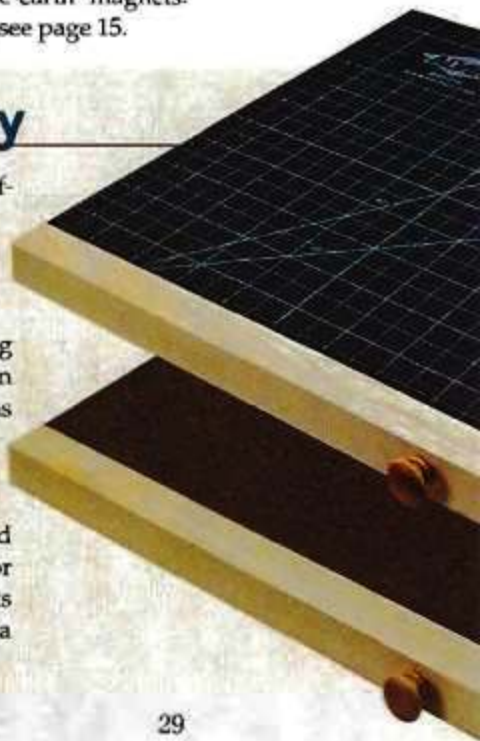

slide-out Workbench Top

In a lot of ways, this hobby chest resembles a miniature workbench. The case is like the base of the bench. So all it needs now is a top. And when it came to designing that top, I patterned it after the top on a full-size workbench.

To start with, I made it extra thick and beefy. And there are two rows of dog holes that allow you to clamp up workpieces. But the most interesting thing about the top is that it's removable (see photo). It slides off the case so you can use it on top of a table or counter.

The top starts off with a plywood base that's sized to fit in

between the sides and back of the case. Like the case dividers, a large cut-out in this base helps to reduce the weight of the top (Figure 4).

Support Walls. To create some room for bench dogs, the top sits on a raised platform. As you can see in Figure 4 below, the top itself rests on some plywood support walls. Doubling up on the supports provides a more stable base for the top, and allows you to attach it securely. This support assembly is roughly U-shaped to create an opening for a drawer that is added later.

I made the inner walls of the support assembly first. At the back,



▲ **Bench Dogs.** A hidden pocket on each side of the top provides clearance space for bench dogs.

they're simply butted together to create the U-shape. But at the front of the base, I added a couple of side wings to fill the space between the support walls and the sides of the case. These wings are joined to the

4 FIGURE

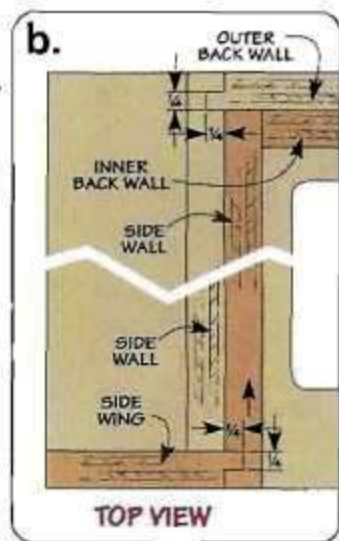
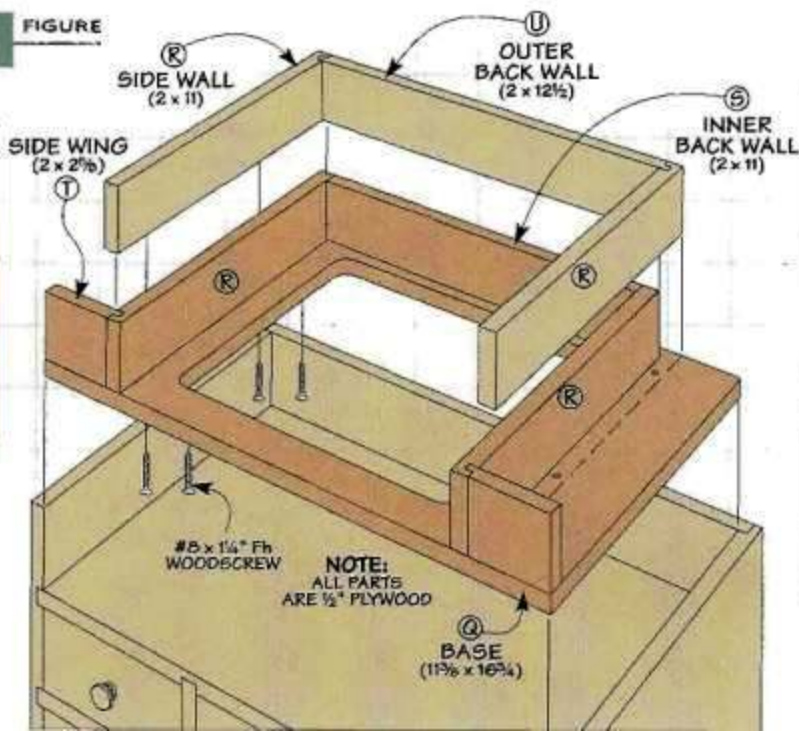
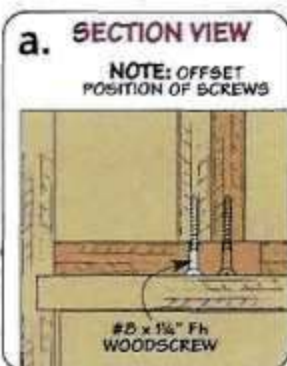

support walls with tongue and dado joints, as shown in Figure 4b.

After screwing the walls to the base, you can add the outer support walls. I sized these pieces to fit around the inner walls, and used the same tongue and dado joint to hold them together. Then the outer walls are also screwed to the base.

Cleats. Once the base assembly for the top is complete, you can add a couple of cleats to the sides of the case, as shown in Figure 5 below. These cleats lock the top in place, preventing it from just lifting off the case (Figure 5a). They also allow you to lift the hobby chest up by grasping the sides of the top.

The cleats are just a couple of pieces of $\frac{1}{2}$ " plywood that are cut to fit between the back of the case and the side wings of the top assembly. They are simply glued to the inside faces of the case.

Adding the Top. The top itself is made up of two layers of $\frac{1}{2}$ " plywood. But because I didn't want to have exposed screwheads in the top, I screwed the bottom layer of the top down to the support assembly first. Then I glued the top layer to the bottom layer. This means that you have to drill the

Add-On Accessories

To make the hobby chest more versatile, I added a couple of accessories. The *WonderPup* by Veritas allows you to clamp a workpiece between bench dogs using the holes in the top of the hobby chest (photo below).

The second accessory I added was a small, clamp-on machinist's vise (see photo at right). To locate sources for both of these items, turn to page 51.



dog holes and chamfer the edges *before* you attach the top. For more information on what's involved in making the top, see page 15.

Drawer. The last step in completing the hobby chest is to make a drawer for the top assembly. This drawer is sized to fit in the opening between the support walls. The joinery and construction are

identical to the drawers you built for the case. And just like the other drawers, I added a washer and rare-earth magnet to keep the drawer closed when carrying the hobby chest around.

Finish. To complete the chest, I wiped on a couple coats of finish. Then for a final touch, I added a couple of accessories, as shown above.

5 FIGURE

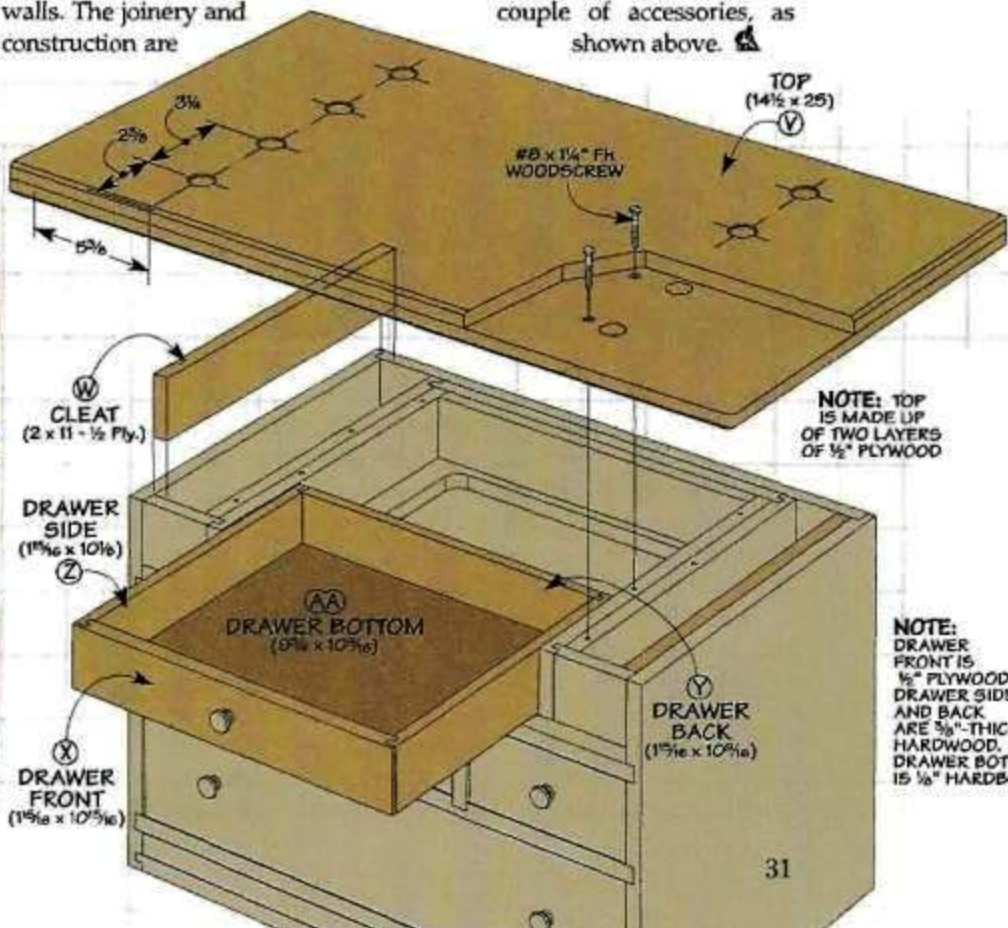
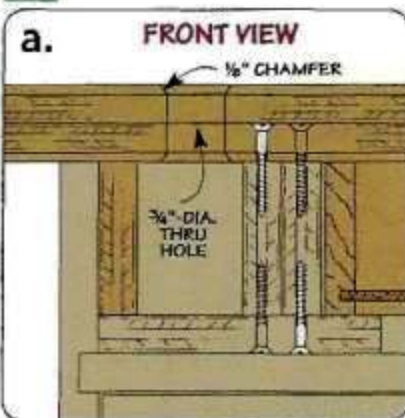

knock-down Workstation

Rock-solid, practical, and inexpensive — a versatile workstation you can make from one sheet of plywood.

■ I don't think a woodworker can ever have enough work space. But building a permanent bench or table just makes the shop more crowded. That's where this multi-purpose workstation comes to the rescue.

This knock-down workstation can be made in a few hours. It's simple, yet the strong design makes it useful around the shop, house, or outdoors. You can set up a workstation in almost no time at all. And it can be assembled at two different heights. Use it in the low position as an assembly table or finishing table. Or for cutting sheets of plywood down to size with your circular saw. At the high position, you'll have another workbench or miter saw station. Add the practical accessories on the following pages and you can set up shop almost anywhere.



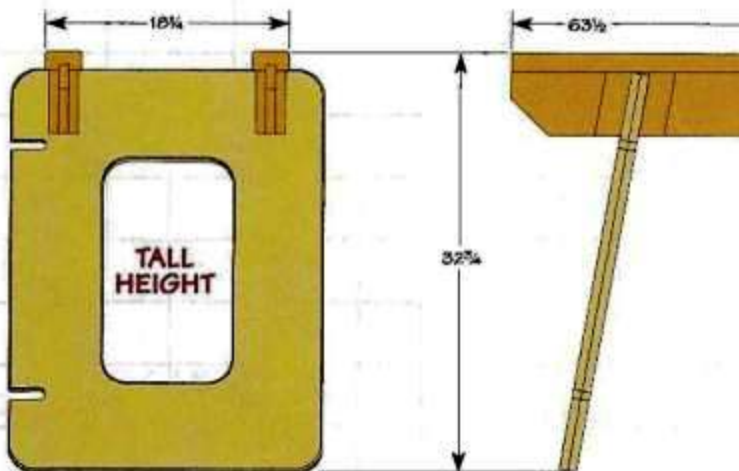
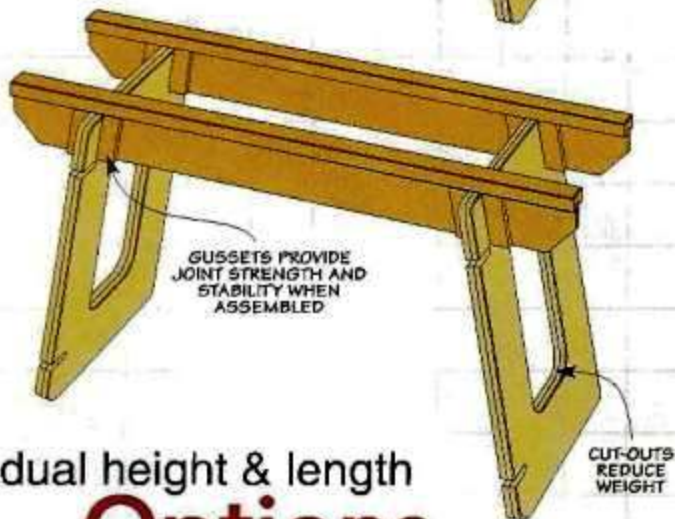
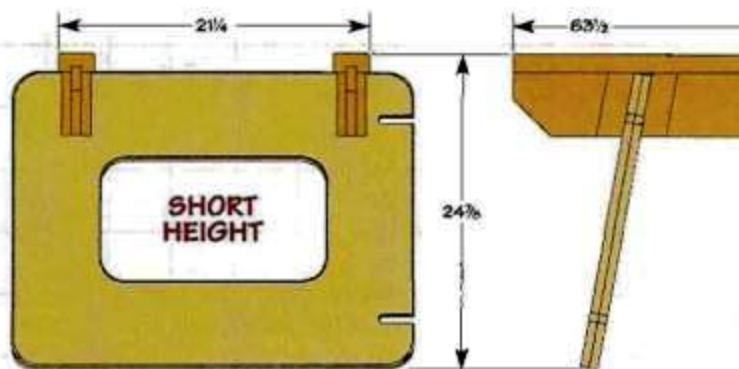
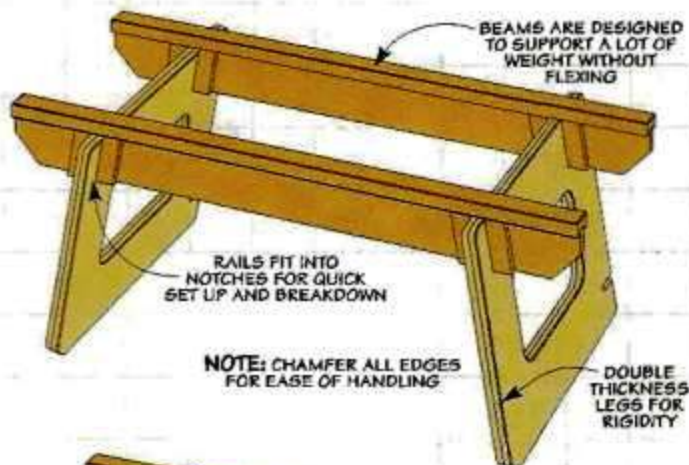

dual height & length Options

Take a look at the drawings on this page and you'll see how versatile this workstation really is. The two rectangular legs are connected by rails that fit into notches. The legs are notched on two sides to create two working heights. And they're laminated for added strength.

You can make a set of long rails, short ones, or both in four different configurations—all from one sheet of plywood and some dimensional stock (cutting diagram below).

Building this workstation isn't difficult. You'll need a circular saw or table saw to cut the plywood

down to size. And you'll need a drill, router, and jig saw to shape the legs and make the notches in the legs and rails. Since the legs are laminated, Shop Shortcuts on page 14 shows you how to make them. You'll see how all the pieces go together starting on page 34.

Cutting Diagram

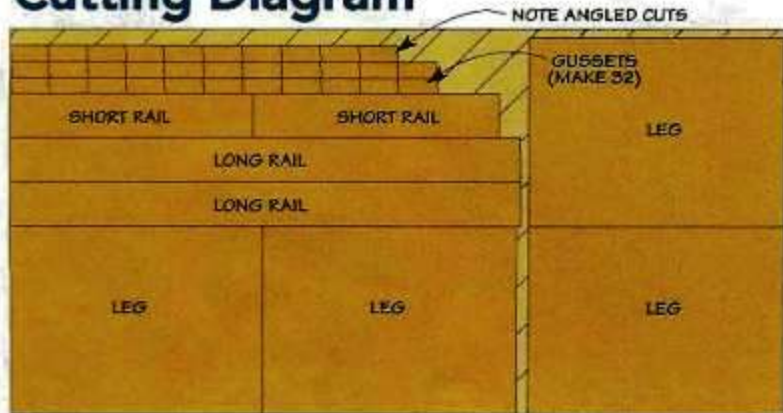

48" x 96" - 3/4" PLYWOOD

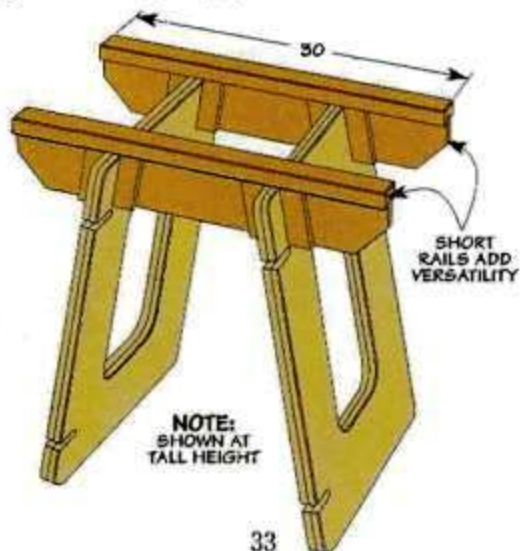

Legs & Rails

If you follow the cutting diagram on the previous page, you can cut all the parts to their rough size. Then you can start on the legs.

Laminated Legs. The legs are made up of two thicknesses of plywood (drawing below). To make the legs lighter and easier to clamp during glue-up, I cut out the center portion on the four pieces. But there's a trick to getting good

results. Shop Shortcuts on page 14 will show you how. Once the legs are cut to shape, you can route a roundover on the edges.

Now you can turn your attention to the notches for the rails.

Notches. Each of the legs has two pairs of notches (see below). The best way I found to form the notches was to first drill a 3/4"-dia. hole at the base of the notch, as in Figure 1a below. Then you can cut out the waste with a jig saw.

Rail Assemblies. The rails are a vertical piece of plywood with a 1 1/2"-thick cap shown in Figure 2a.

They're built almost like an I-beam for strength.

Start by trimming the rails to width and length, and cut off the bottom corners. Then mark the location for the notches. Note that these notches are angled at 80° from the bottom edge. These "splay" the base of the legs out, making the platform more stable. You'll make the notches like you did for the legs by drilling a hole and cutting out the waste with a jig saw. But you'll need to make these notches 1 1/2" wide to fit the legs.

Rail Cap. For the rail cap, I ripped a 2x4 to width and cut a 3/4" dado on the bottom side to fit over the rail. Chamfer all the edges and glue it in place.

Gussets. The gusset pieces are angled to provide support for the legs when the workstation is assembled. I glued and screwed them in place for extra strength.

1 FIGURE

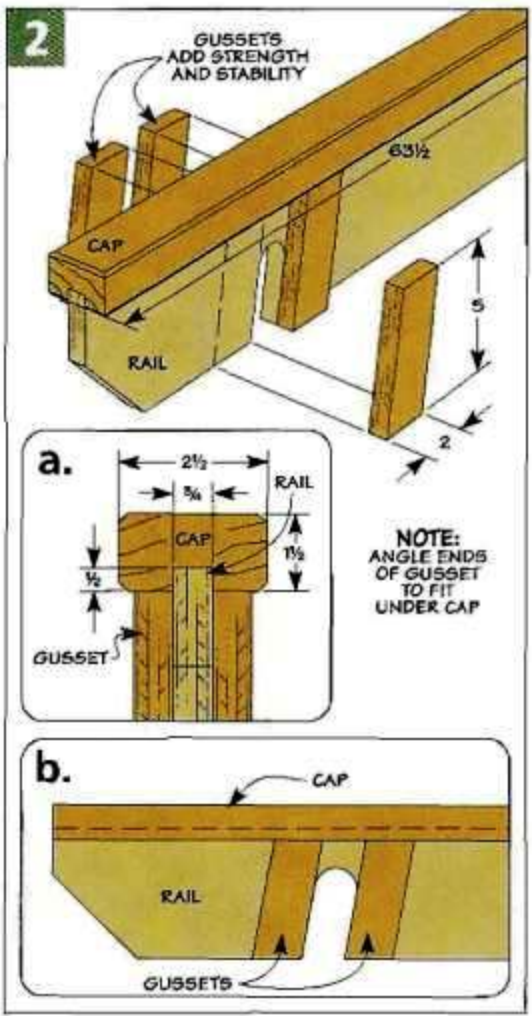
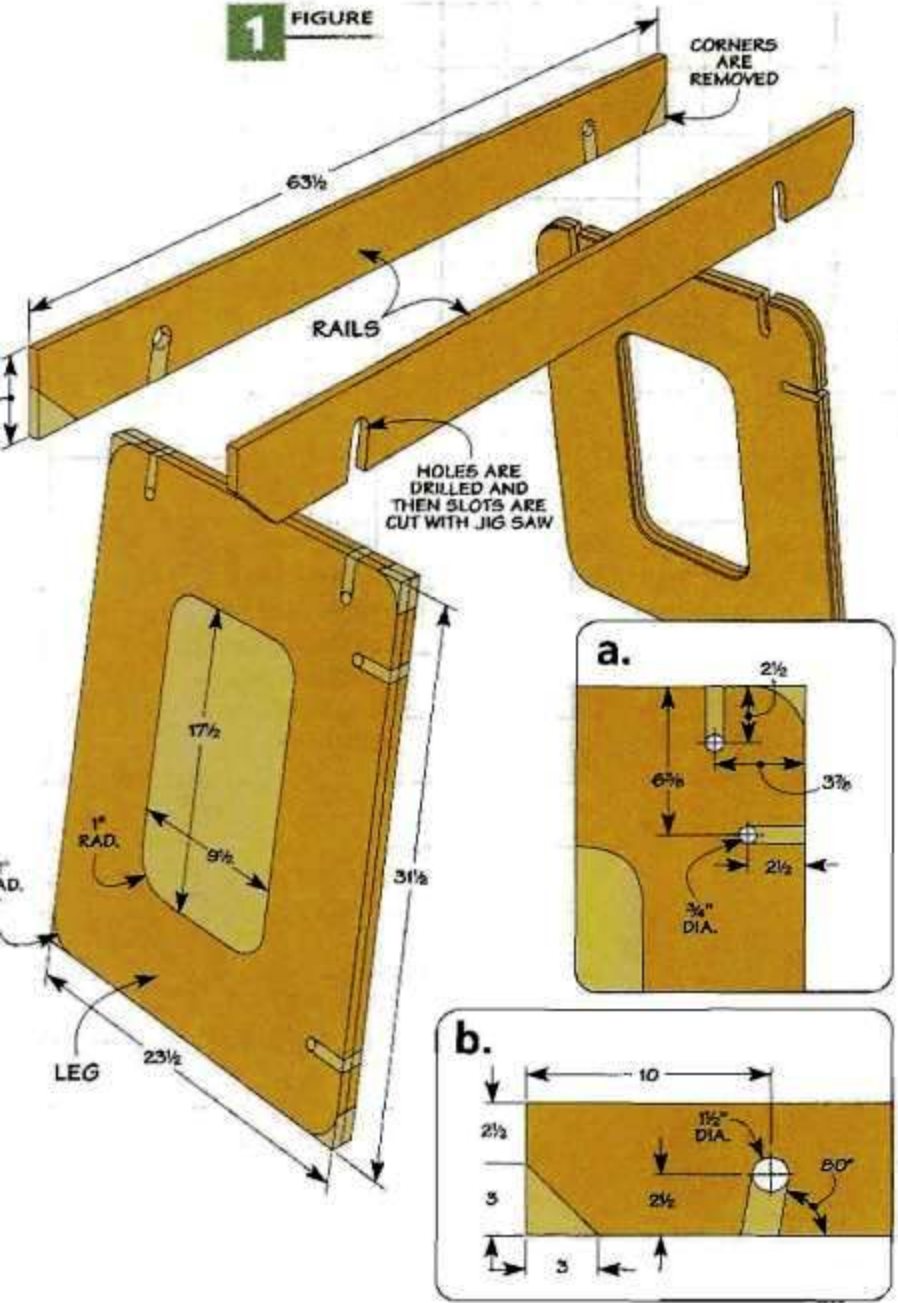

easy-to-build Worksurfaces

By itself, the workstation is great for projects around the shop and house. But the accessories shown on the next few pages make it even more versatile and useful.

Worksurface. The first accessory I added was a simple worksurface. It's just a piece of plywood with some cleats to hold it in place on the rails (see detail 'a' at right). If you want to use the worksurface at both heights, you'll need two sets of cleats as shown in the drawing.

It makes a great assembly or finishing table for projects. Or a handy workbench when I need a little extra elbow room to work.

Sacrificial Supports. When I need to cut a sheet of plywood down to size, I'll usually use my circular saw. With a set of sacrificial supports, you can safely cut through the plywood and also support the workpiece for a cleaner — and safer — cut. Each one is just a 2x4 with cleats added to the bottom like the ones on the worksurface above (detail 'a' at right).

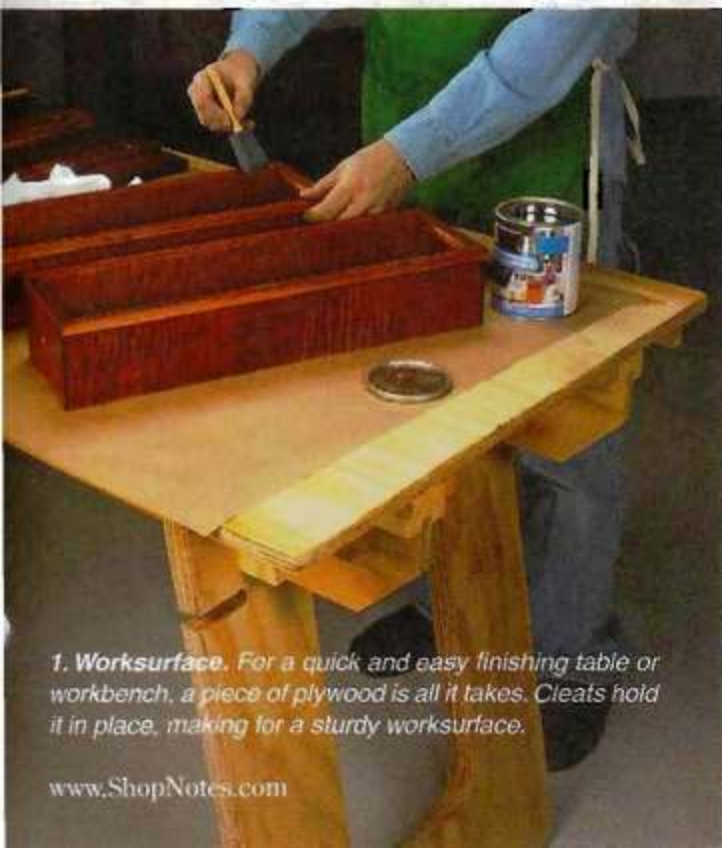
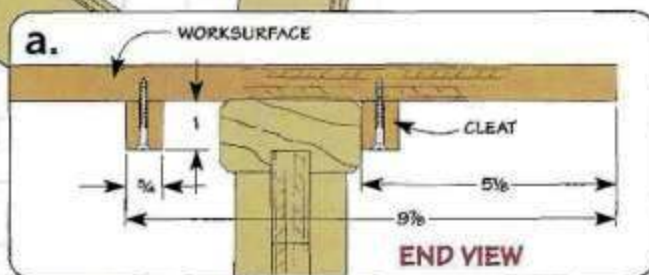
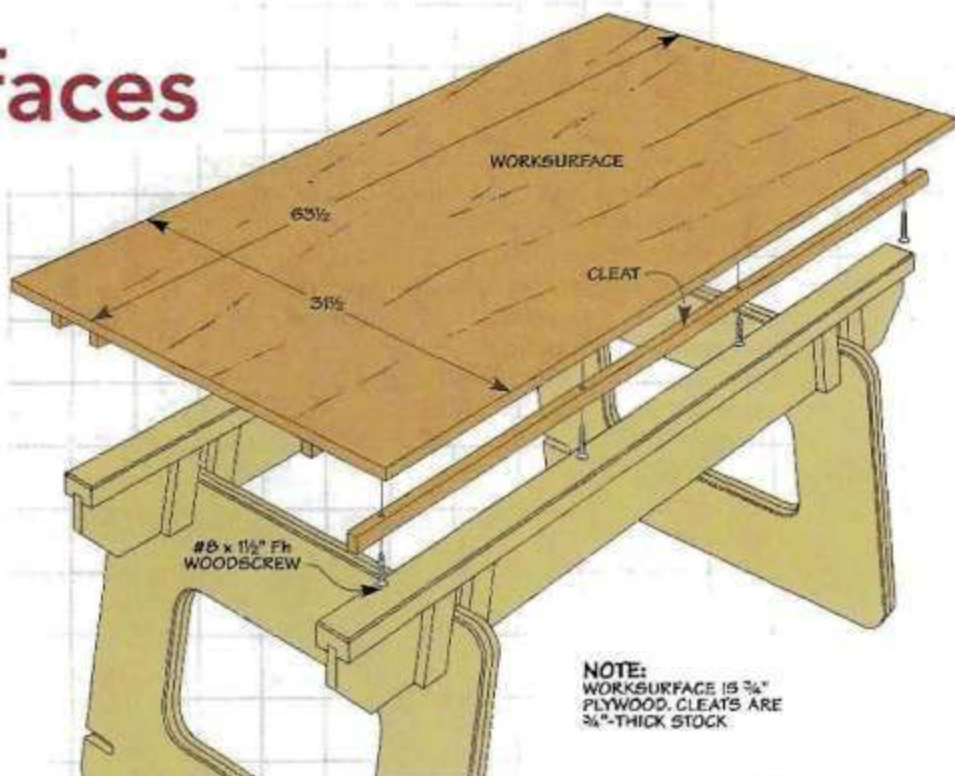

1. Worksurface. For a quick and easy finishing table or workbench, a piece of plywood is all it takes. Cleats hold it in place, making for a sturdy worksurface.



2. Sacrificial Supports.

Cutting plywood with a circular saw can be a chore without proper support. Simple 2x4 supports turn your workstation into a panel-cutting bench.

miter saw & planer Tool Stands

All it takes is a platform and a couple of outfeed supports to set up a portable workstation for my miter saw or portable planer.

Miter Saw Station. The platform for my miter saw is nothing more than a piece of $\frac{3}{4}$ " plywood sized to fit the base of my saw. Cleats on the bottom fit along the rails of the workstation. And I added some cleats on top to keep the saw and planer from sliding around (see detail 'a' at right).

The outfeed supports are easy to make (detail 'b'). The only trick is to make them the same height as your saw's table.

Planer Platform. The platform for my portable benchtop planer is a little different. It's also made from $\frac{3}{4}$ " plywood and I still put cleats on the bottom. But instead of top cleats, it uses L-shaped blocks to hold the planer in position (see detail in bottom right photo).

To accommodate these L-blocks, size your platform at least four inches larger than your planer's base in both directions.

Like the outfeed supports for the saw above, the height should match your planer's table height.

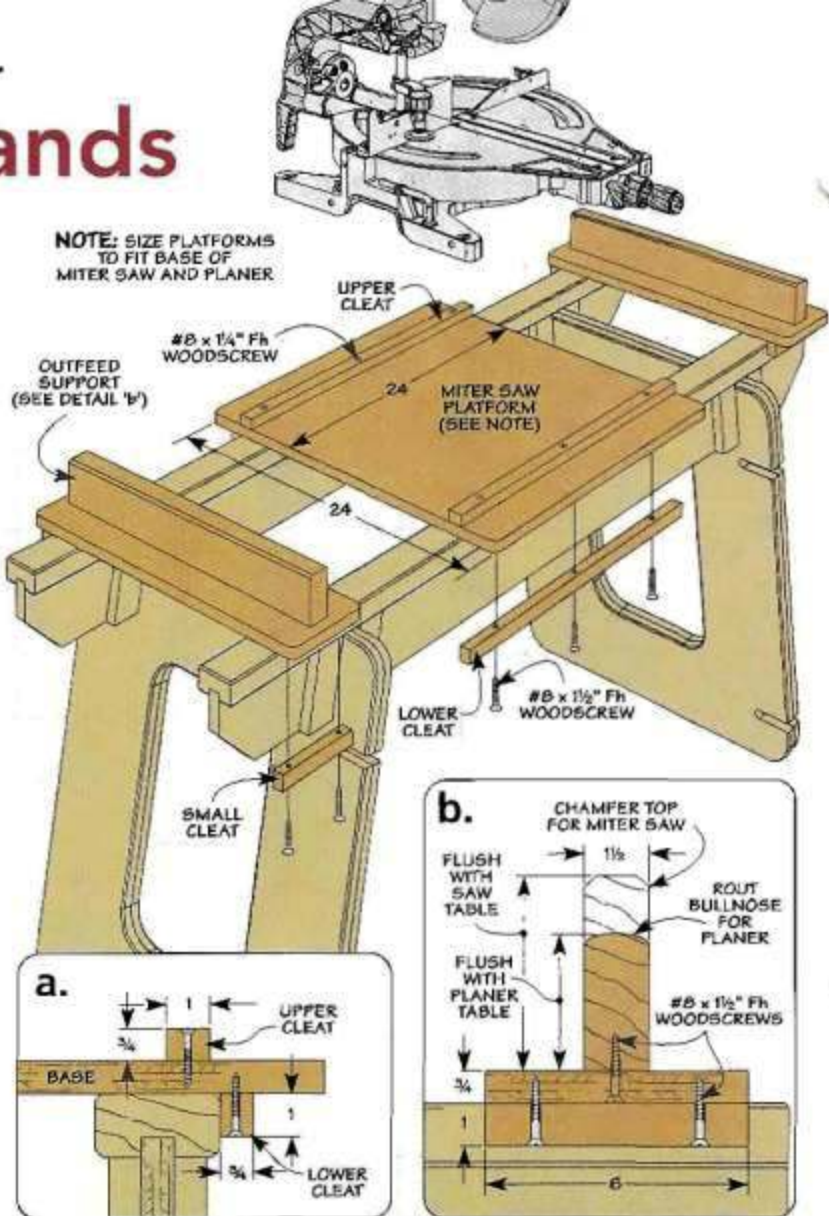

3. Planer Stand. A stable worksurface and outfeed support are necessities when using a portable planer. You get both with this easy-to-make accessory.

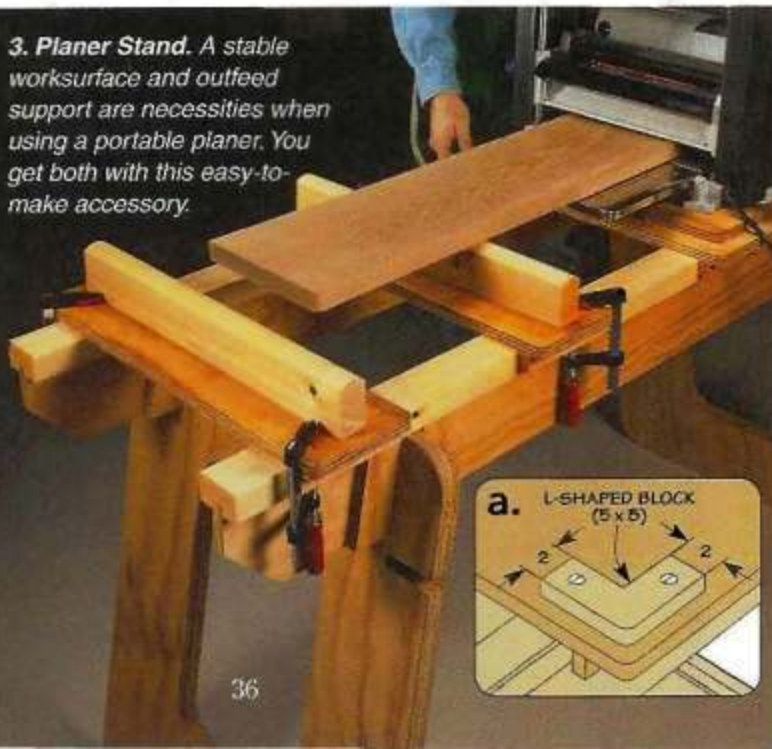

4. Miter Saw Stand. Portability and quick setup make this accessory a must-have for the shop. A solid platform and outfeed supports make for accurate cuts.





5. Table Saw Stand. Benchtop table saws gain capability with quick setup and an outfeed support.

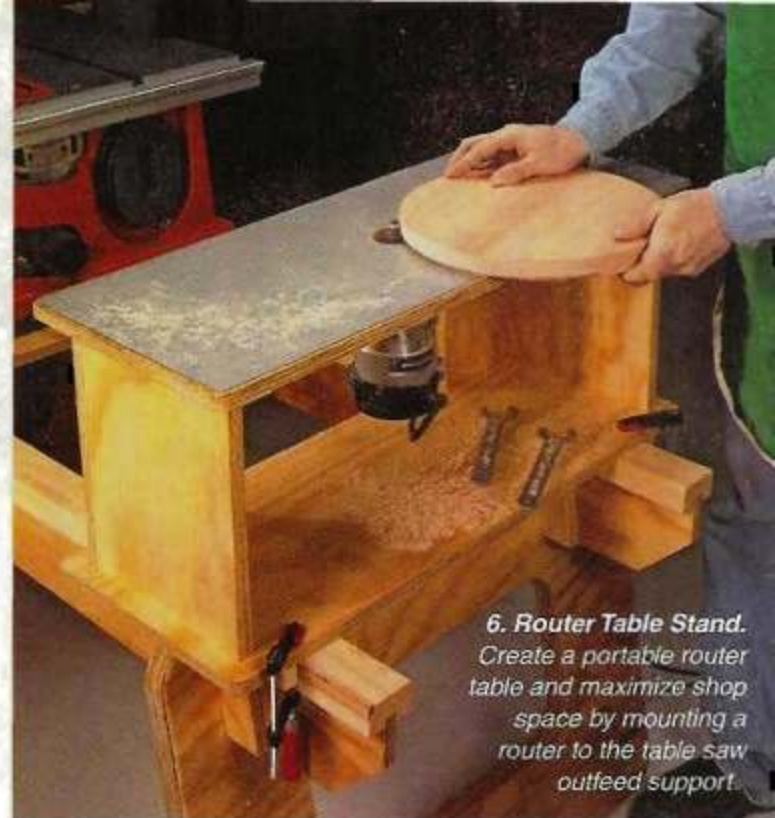

6. Router Table Stand. Create a portable router table and maximize shop space by mounting a router to the table saw outfeed support.

dual-function Outfeed Table

With this platform and outfeed table, I can use my benchtop table saw anywhere. And to make it even more useful, I mounted a router to the outfeed support.

Table Saw Platform. The base for the benchtop table saw is just a piece of $\frac{3}{4}$ " plywood with cleats on the bottom like the other bases on page 36. You'll have to size your platform 4" larger than the base of your saw to accommodate the four L-shaped blocks in each corner (see opposite page). I screwed the blocks in place then rounded the corners with a 1" radius.

Outfeed Support. The outfeed support shown on the right doubles as a router table. The key is to make the final height the same as the height of your saw table.

Detail 'a' on the right shows how the outfeed support is just a bottom and top piece connected by a pair of end and back pieces.

To mount your router, use your router's base plate as a template for locating the screw holes.

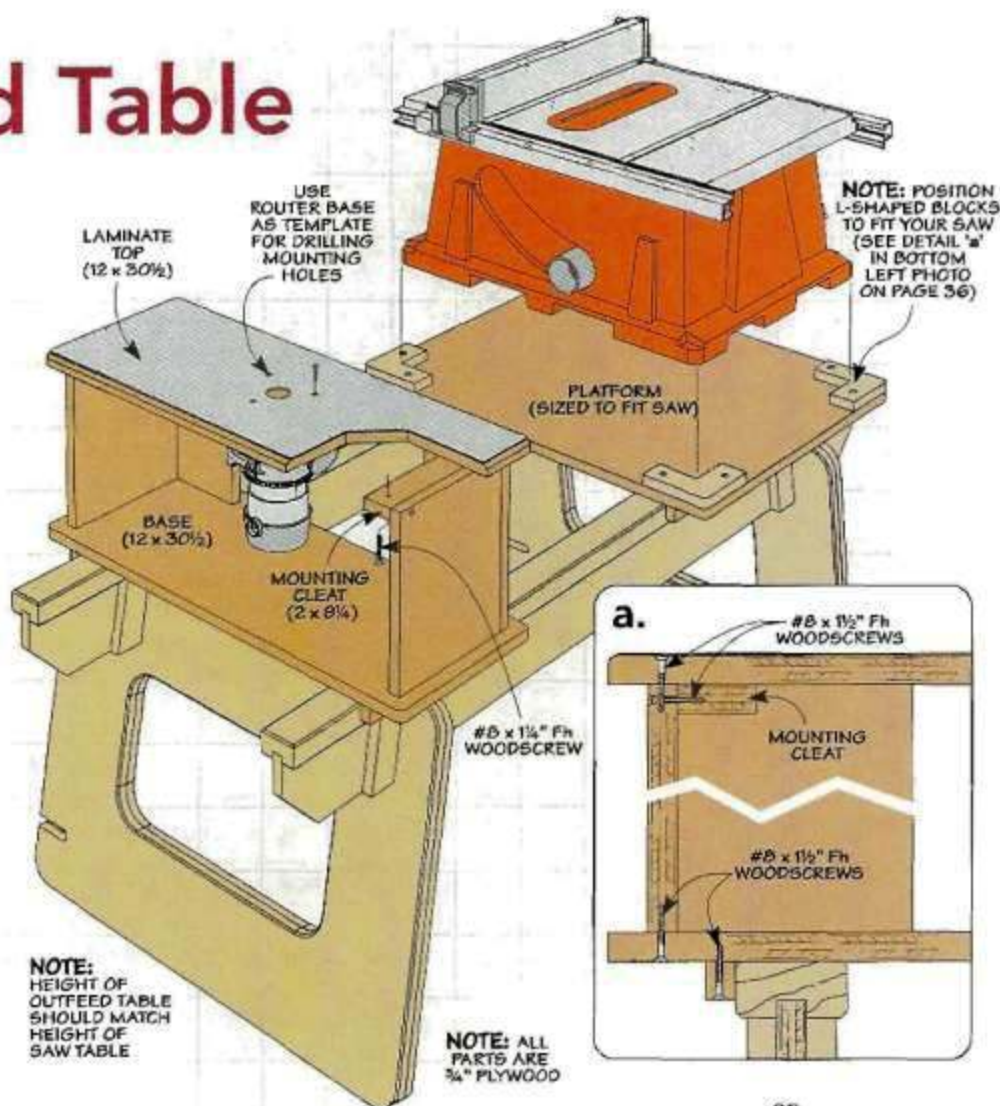

looking at Router Lifts

All router lifts are not created equal. Here's the information you need to decide what's right for your shop.

My router table gets quite a workout. In fact, it sees action in almost every project I build. So, when a product promises to make working at the router table easier and more accurate, it gets my attention. Router lift manufacturers claim they can help on both counts.

To evaluate these claims, I looked at a few of the router lifts on the market today. With so many to choose from — currently there are more than a dozen — it can be pretty confusing trying to find one that's right for your shop.

Let me say at the outset, every one of these lifts is a precision-machined tool. Each came with well-written and illustrated installation instructions. And they all do their jobs as advertised.

The differences in the router lifts can be found in their features and in the type of router they'll accommodate. So, your decision can depend on what router you currently have, which features you need for the work you do, and of course, your budget. The good

news is, there's a router lift for every router and budget.

Universal Lifts. *JessEm* started the router lift boom with the original *Rout-R-Lift*, shown below. The *Rout-R-Lift*, its clone, the *Jet XACTA Lift*, and *Woodpecker's Unilift* will accept virtually any router. This flexibility is possible because the router base mounts directly to a plate on the lift mechanism. This plate is attached to machined steel posts and is raised and lowered with a drive screw. You make height adjustments above the table

▲ **Fixed-Base Lift.** *JessEm's Mast-R-Lift* holds the motor housing of a fixed-base router in its carriage. It also features a direct-drive height adjuster.

► **Universal Lift.** The original *JessEm Rout-R-Lift* remains a top seller because it accepts both plunge or fixed-base routers.





▲ **Changing Bits.** Since universal lifts can not raise the router high enough above the table for bit changes, the lift must be removed.

by turning a removable crank that connects to the drive screw via a cogged rubber belt or a chain.

Woodpecker's *Unilift* also offers a universal mounting plate which will accept plunge or fixed-base routers. The lift plate travels on four machined steel posts for increased stability. The *Unilift* uses a chain rather than a belt to drive the height adjustment mechanism.

Fixed-Base Router Lifts. A different class of lifts accepts a fixed-base router. Though very different in features and design, all the fixed-base lifts operate in a similar fashion. The motor is removed from its base and is housed in a collar which travels on machined posts. The drive screws move the collar and motor to the desired height. The greatest advantage to these lifts is that they can raise the motor high enough to expose the collet and lock nuts for bit changes.

Most of these lifts are built to accommodate the 3/4 horsepower, *Porter Cable 7518* router. Its power and variable speed controls make it a great choice for a router table. (In fact, tipping the scales at 15 pounds, it's a challenge to use it anywhere else). With the aid of adapter sleeves, the lifts will accept most popular routers, though. Adapters are priced between \$20 and \$32, so remember to factor that cost into your comparisons.

Plates. If you already have a router table and a plate insert, the different plate sizes might influence your decision. Most have a "standard" size of 9 1/4" x 11 3/4", but there are a few exceptions. *Bench Dog's Pro-Lift* is slightly smaller, built specifically for their line of tables and tops. *Rockler* also uses their own standard of 8" x 11" throughout their line of router products. Templates can be purchased for each of the various plate sizes, however, so you can easily build your own top and rout the opening to fit the lift you choose.

Size isn't the only difference in the plates. They're also made from different materials. Most are made from aluminum or phenolic, but *Bench Dog's Pro Lift*, below right, has a nickel-plated steel top, sure to stand up even in industrial applications. For home shop use, any of

these plates will be up to the task. Your table top may require some reinforcement to prevent sagging.

Direct Drive. Another great feature of the fixed-base lifts is direct drive height adjustment. Instead of relying on a belt or chain, the lift crank attaches directly to the lead screw. The advantage to direct drive is the reduction of backlash, the "slop" you sometimes get in the lift with a belt or chain.

Other Features. Interestingly, the two least expensive fixed-base lifts incorporate one of the best features. Both *Woodhaven's EZ Lift* and *Rockler/JessEm's Router Lift FX* provide quick-release mechanisms so you can easily remove your router for hand-held operations—a great feature for the one-router shop. For the others, you'll want to dedicate a router to the lift, since they make it a hassle to remove and to reinstall.

▲ **An Easier Way.** With a few turns of the crank, you can raise the router high enough to access the collet for bit changes above the table.

▼ **Acme Lead Screw.** Instead of belts, chains, or conventional thread stock, *Bench Dog* uses a precision Acme lead screw to move the carriage.

Belt Drive. The cogged drive belt on the *Rout-R-Lift* connects the height-adjustment crank to the lift screw.





▲ The JessEm Rout-R-Lift. One full turn of the crank equals 0.05", with increments marked on the plate.

► Mast-R-Lift. This scale uses conventional woodworking fractions rather than decimal inches.



Bench Dog's ProLift. This lift includes a fine adjustment gauge with an easy-to-read scale.

it's all about Accuracy

There are a few other things that make some of these lifts more user friendly. Most of them have plate levelers, for instance. They allow you to adjust the plate flush to the surface of your table. A few manufacturers build this feature into their tables instead. The absence of levelers means you'll have to use shims to keep the plate flush.

Accurate Adjustments. Finally, the feature most talked about by the manufacturers is accuracy. While some provide scales in $\frac{1}{64}$ " increments, others boast lift mechanisms accurate to within 0.001". Every company has a different system (see photos above.) On each one, however, one full revolution of the lift screw will raise the router a precise height. While each approach is slightly different, I found all the lifts I sampled to be both accurate and reliable.

Jointech raises the bar for precision measurement with their *Smart Lift Digital Router Lift* (below). The digital readout takes the guesswork out of bit setups.

How Much Is Enough? Precision comes from your own

attention to detail, persistence, and experience as a craftsman. A router lift can make your work easier, though, by giving you more exact control of the router from a comfortable position above the table. That beats constantly bending over and messing around underneath.

One great advantage of precision measurements is how they can drastically reduce set-up times for your commonly used bits. By taking advantage of the ability to zero out a bit height and return it to that position with dead-on accuracy, you won't have to struggle with finding exact profiles anymore. You can record the height of your bits and eliminate the need for endless test pieces. This feature alone may be worth the price. ▲

► **Guaranteed Accurate to 0.001".** The Jointech SmartLift Digital features the Absolute Encoder, from Accurate Technology. The sensor attaches to the carriage, sending precision measurements to the digital display.



BRAND	PRICE	PLATE SIZE	PLATE MATERIAL	LIFTING MECH.	ABOVE TABLE BIT CHANGE	PLATE LEVELERS	VERT. TRAVEL
FIXED-BASE ROUTER LIFTS							
Bench Dog	\$325.00	8 1/4 x 11 3/4	Steel	Direct	Yes	No	6
Pro-Lift	Fits PC7518; adapters \$20. Scale can be zeroed out. Cooling fins dissipate heat.						
JessEm	\$270.00	9 1/4 x 11 3/4	Aluminum	Direct	Yes	Yes	3 3/4
Mast-R-Lift	Fits PC7518; adapters \$30.						
Jointech	\$429.00	9 1/4 x 11 3/4	Aluminum	Direct	Yes	Yes	3 3/4
SmartLift Digital	Fits PC7518; adapters \$25. Scale can be zeroed out. Cumulative digital readout of actual carriage movement. Sealed gears with scrubbers.						
Jointech	\$299.00	9 1/4 x 11 3/4	Aluminum	Direct	Yes	Yes	3 3/4
SmartLift Pro	Fits PC7518; identical to Smartlift minus digital readout.						
Woodpecker	\$289.00	9 1/4 x 11 3/4	Aluminum	Chain	Yes	Yes	4
Precision Router Lift	Fits PC7518; adapters \$25. Automatic brake locks position. Choice of 1/16" or 1/32" pitch lift screw.						
Woodhaven	\$165.00	9 1/4 x 11 3/4	Phenolic	Direct	Yes	No	3 3/4
EZ Lift	Fits PC7518. Most affordable. Quick-release knob for easy removal.						
Woodhaven	\$165.00	9 1/4 x 11 3/4	Phenolic	Direct	No	No	3 3/4
EZ Lift for 3.5" Motors	Identical to EZ Lift, but this one accepts PC 690, 892; Bosch 1617, 1618; DeWalt 616, 618. Adapters \$32 for others.						
JessEm	\$179.00	8 X 11	Phenolic	Direct	No	Yes	3
Rockler Router Lift FX	Quick-release lever for easy removal. Accepts more routers than any other without adapter. (PC 690, 890; Bosch 1617, 1613; DeWalt 610, 618)						
UNIVERSAL ROUTER LIFTS							
JessEm	\$200.00	11 3/4 x 14 3/4	Aluminum	Belt	No	Yes	2 1/2
Rout-R-Lift	The original router lift. Will accept virtually any router.						
Jet	\$285.00	11 3/4 x 14 3/4	Aluminum	Belt	No	Yes	3 1/2
XACTA Lift	Clone of the JessEm Rout-R-Lift. Will accept virtually any router. Price includes fence and dust-collection port.						
Woodpecker	\$289.00	9 1/4 x 11 3/4	Aluminum	Chain	No	Yes	3 1/2
Unilift Router Lift	Only four-post router lift. Choice of 1/16" or 1/32" pitch lift screw. Accepts over 20 popular routers without adapter.						

Low-Cost: Plunge Router Option

Two companies offer a package to replace the lift mechanisms of most popular plunge routers. By retrofitting a plunge router with either one of these kits, you'll be able to make fairly accurate bit height adjustments above the table.

Router Technologies' Router Raizer, shown below, is a kit that replaces the lift screw and incorporates a crank for adjustments. The kit includes a variety of hardware and takes about an hour to install.

Then, you simply drill a hole in your mounting plate to accommodate the crank, (they provide a template to place the hole) and you have basic above-the-table height adjustment for around \$90.

The *Plungelift Router Lift* (\$149) from Woodpecker is a similar design, replacing your plunge router's lift screw with a precision lead screw. Woodpecker goes a step further by including a mounting plate with predrilled holes for eight of the most popular plunge routers.

▼ *The Router Raizer. Installs easily and provides a low-cost above-the-table height adjustment.*



◀ *The Hardware. Included in the kit are the parts and pieces to fit a variety of plunge routers.*





dividing drawers for

Small Parts Storage

These simple solutions can clear up the clutter and get your shop drawers organized now.

■ The secret to good organization is to divide and conquer your storage space. And one of the easiest ways to maximize storage space in the shop is to take control of the chaos in your shop drawers.

Shallow Drawers. A drop-in grid system (pictured above) is an ideal way to organize shallow drawers.

The system consists of identical strips made from 1/4"-thick hardwood, as in Figure 1. The strips are notched so they interlock to form a secure grid. Then, it's just a matter of fitting them together and slipping the grid into the drawer (Figures 2 and 2a).

Deep Drawers. A simple grid system works well for shallow drawers, but it's all too easy for stuff to get lost in deep drawers. To solve this problem, I like to divide each deep drawer into two layers (drawing on opposite page). For the bottom layer, I made a divided box. When you measure for the box, you'll want to leave a 1/16" gap between the box and the drawer. This way you can take the box out if you ever need to.

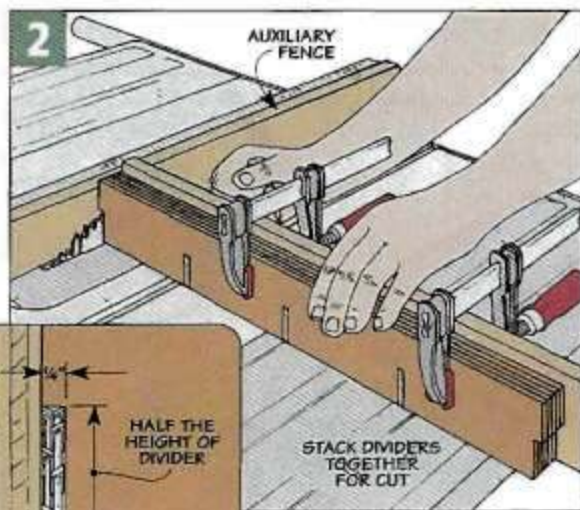
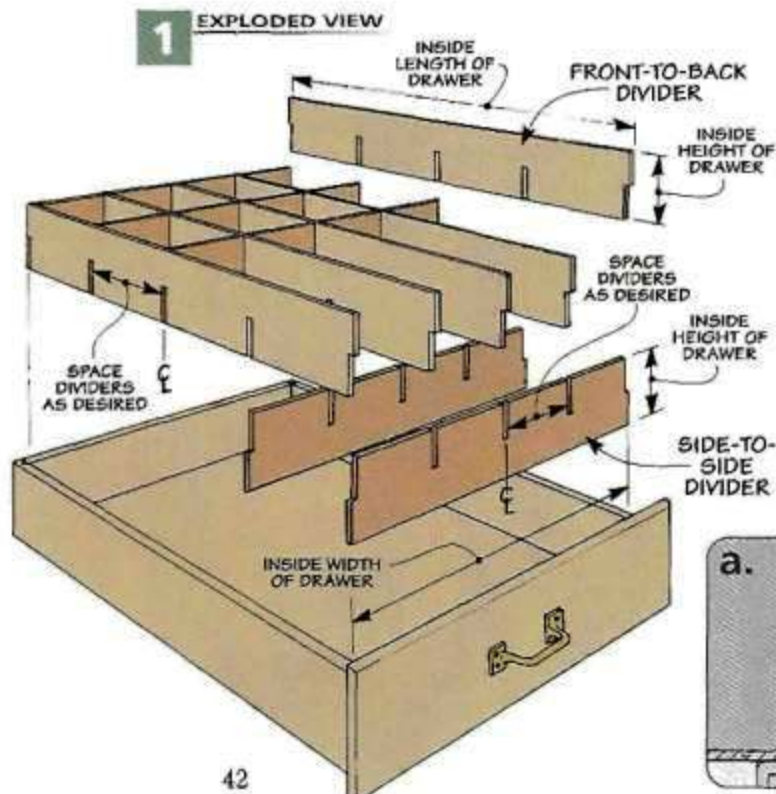

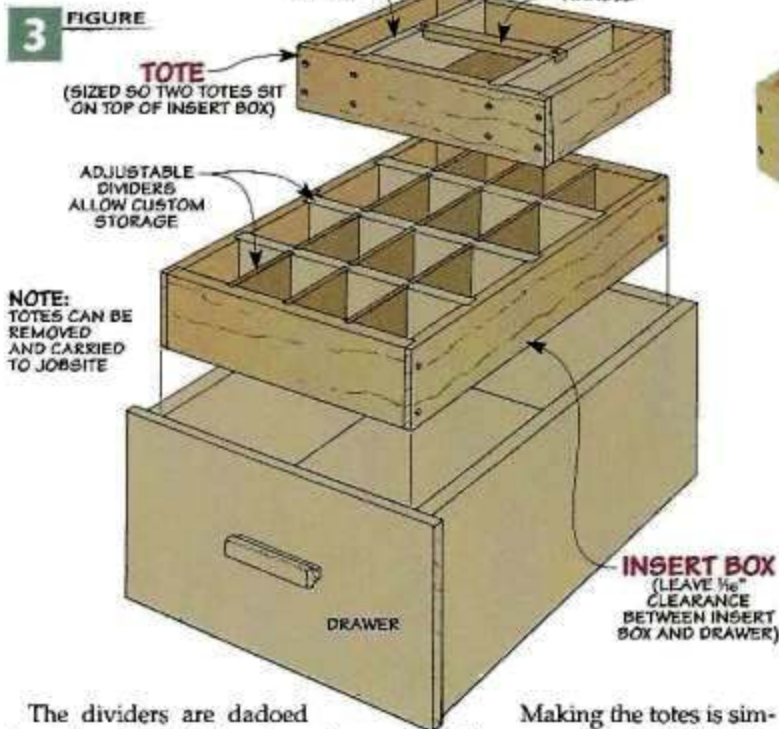

The dividers are dadoed into the sides of the insert box (Figure 3). They also accept subdividers, so you can customize the box for whatever you need to store.

The Totes. To take advantage of the space above the box, I made some totes to rest on top. Each tote has a pair of fixed dividers and a handle. Besides making it easy to organize small items, you can remove a tote from the drawer and take it right where it's needed.

Making the totes is similar to making the divided box. But there are some things to keep in mind while building them.

It's a good idea to allow a $\frac{1}{16}$ " gap between the totes. This makes it easy to slip one tote in place while the other is in the drawer.

You'll also notice that the rabbets and dados for the tote dividers are cut in the front and back pieces, not the sides like in the divided box. And don't forget to cut notches for

the wood handle and the groove for the $\frac{1}{4}$ " hardboard bottom.

Made to Order. The nice thing about either of these storage solutions is that you can build any combination of grids, divided inserts, and totes. This way, you can simply mix and match them to customize all of the drawers in your shop. And in the box below, you'll find out how to keep even the smallest stuff tidy. 

▲ Deep Drawers. A divided box, combined with a couple of totes, makes finding what you need quick and easy.

Watchmaker's Cases

A good option for storing small hardware is to use "watchmaker's cases" (see photo at right). But to keep them organized in drawers, I made a couple of inserts with cutouts in them to hold them in place.

Sizes and Shapes. The photo at right shows round cases of different sizes. After cutting a $\frac{1}{4}$ " hardboard insert to fit the drawer (remember the $\frac{1}{16}$ " clearance), arrange the cases on the hardboard and trace their shapes. Then, you can cut the holes.

Upper Insert. Now, you could just use one insert and set it on the bottom of your drawer. But the

cases I used weren't very tall. So, I built a second insert to set on top of the bottom insert.

The upper insert is only half the length of the drawer, so you can slide it out of the way. To keep the cases from falling through, you'll want to attach it to a base made from MDF or plywood.

Runners. To provide clearance between the upper and lower inserts, I added runners to the bottom edges of the upper insert. You'll just need to make sure the runners are high enough to clear the cases on the bottom. For sources to get the watchmaker's cases, turn to page 51.

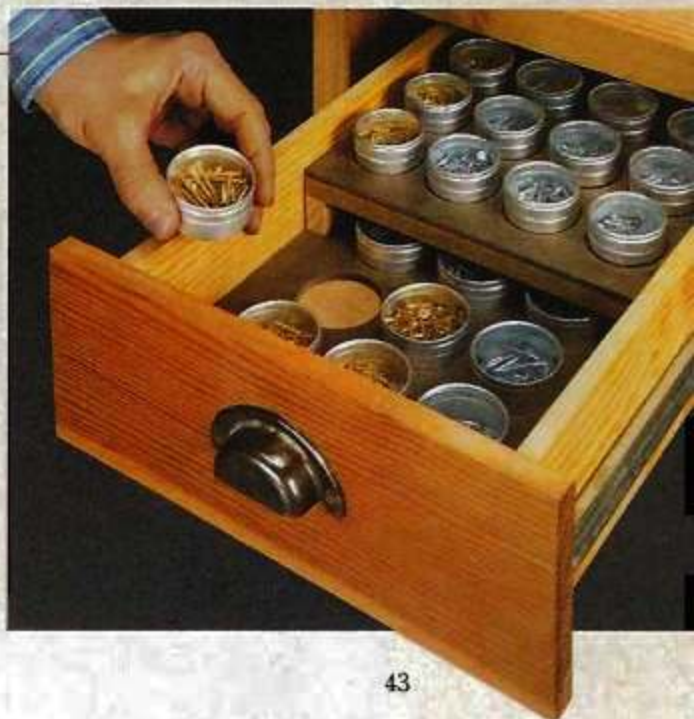

MASTERING THE Table Saw

cutting a
perfect-
fitting

Raised Panel

Make your cabinets stand out with raised panels cut on your table saw.

- One of the simplest cabinet doors to make is a frame and flat panel door. You build the frame and slide a $\frac{1}{4}$ " plywood panel into it. But what if you wanted to dress that door up a little bit more?

One way to make the door stand out is to substitute a raised panel for

the flat one. And you can add this traditional detail by cutting the panel to final size. To do that, dry-assemble the door frame and measure the distance between the grooves. Cutting the panel $\frac{1}{16}$ " narrower will allow it to move with humidity changes.

The first step is to bevel the edges of the panel to raise a "field" in the center (left drawing). The second step is cutting a rabbet along the back edge of the panel to so it fits in the door frame (detail 'a').

CREATING THE FIELD

Before working on the raised field, you need to cut the panel to final size. To do that, dry-assemble the door frame and measure the distance between the grooves. Cutting the panel $\frac{1}{16}$ " narrower will allow it to move with humidity changes.

With the panel cut, you're ready to make the raised field. The first thing you'll need to do is set your rip fence and saw blade.

Setup. What's important here is to tilt the blade *away* from the fence to prevent trapping the

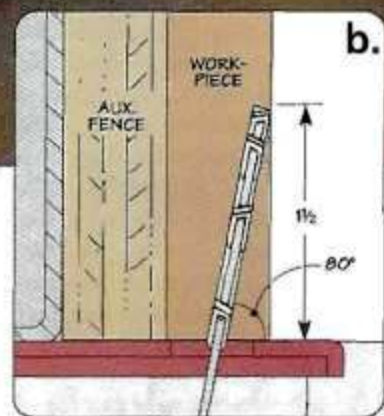

waste between the blade and the fence. And because the panel will be standing on edge during the cut, you'll want to use a zero-clearance insert and a tall auxiliary fence to provide solid support (see box on opposite page).

I've found that tilting the blade 10° and raising it $1\frac{1}{2}$ " will give you a nice-looking panel. Then, to add a three-dimensional feel to the panel, I like to set the fence so the blade will leave a $\frac{1}{8}$ " shoulder between the field and the bevel (detail 'b').

Making the Cut. Now, it's just a matter of making a bevel cut on each edge of the panel. Since the end grain is more likely to tear out

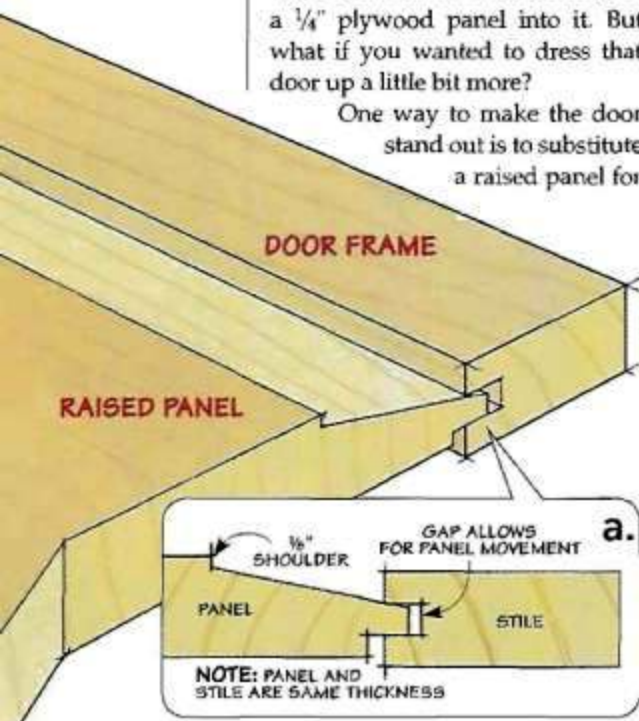

near the end of the cut, it's a good idea to cut these edges first. Any tearout will be removed when you cut the other two edges.

To keep the panel firmly against the fence I also like to use a tall featherboard. The box below shows how to build it.

Cleaning Up. After you make the cuts, it's not unusual to find saw marks on the bevels. Plus, the shoulder isn't square to the face of the panel. A simple way to fix both problems is to use the beveled sanding block shown in Figure 1. As you sand away the swirl marks, it squares up the shoulder of the field at the same time (Figure 1a).

CUTTING THE RABBET

At this point, you're halfway through creating a raised panel. You'll notice that the edge of the panel is too thick to fit into the groove of the door frame. That's where the second step of the process comes in — cutting a

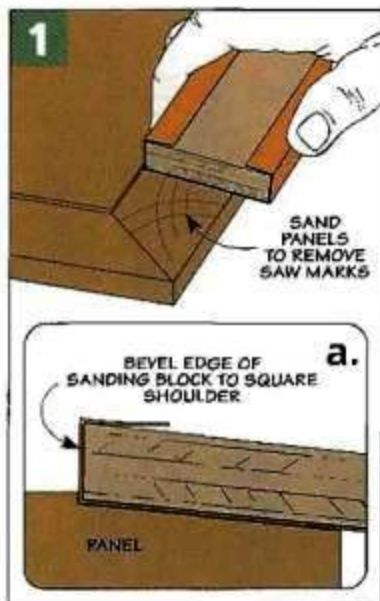

rabbet along the back edges of the panel to get a nice fit (Figure 2).

The rabbet is sized so the panel can slide into the frame, but not so loose that it rattles around. The best way to fit the panel is to "sneak up" on the depth of the rabbet until you

the panel just slips into place. The rabbet also should be as wide as the groove is deep to allow the panel to expand and contract (Figure 2a).

And that's it — two simple steps and your new raised panel is ready for the door frame. 🛠️

Two Shop-Made Accessories

Cutting a raised panel on a table saw requires you to stand the panel on edge when making the cuts. The two accessories shown here will provide solid support and help make the task go smoother.

Featherboard. The featherboard shown at left keeps your fingers out of the way while pressing the panel firmly against the fence. It's made from a strip of $\frac{1}{8}$ " hardboard that's held in place by an L-shaped block attached to a hardwood runner.

Auxiliary Fence. The auxiliary fence on the right should fit snugly over your table saw fence. It should be tight enough that the fence won't slide as you push the panel. You can add a cap to one end of the auxiliary fence to also keep it from slipping. The taller side of the fence should be high enough to keep the panel stable while it passes through the blade.

FEATHERBOARD

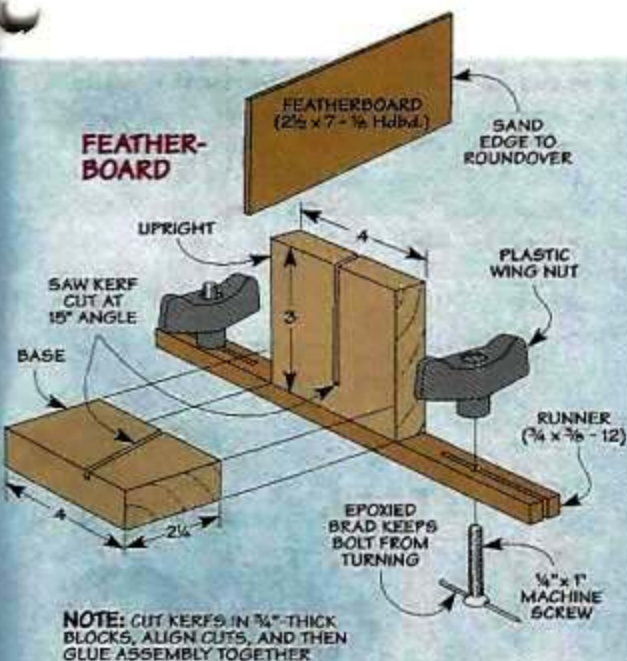

NOTE: CUT KERFS IN 3/4"-THICK BLOCKS, ALIGN CUTS, AND THEN GLUE ASSEMBLY TOGETHER

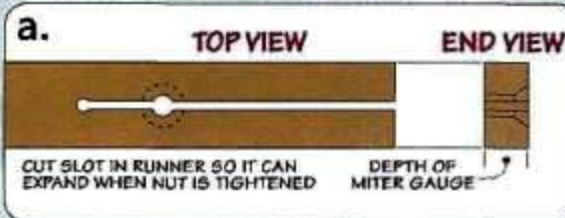

AUXILIARY FENCE

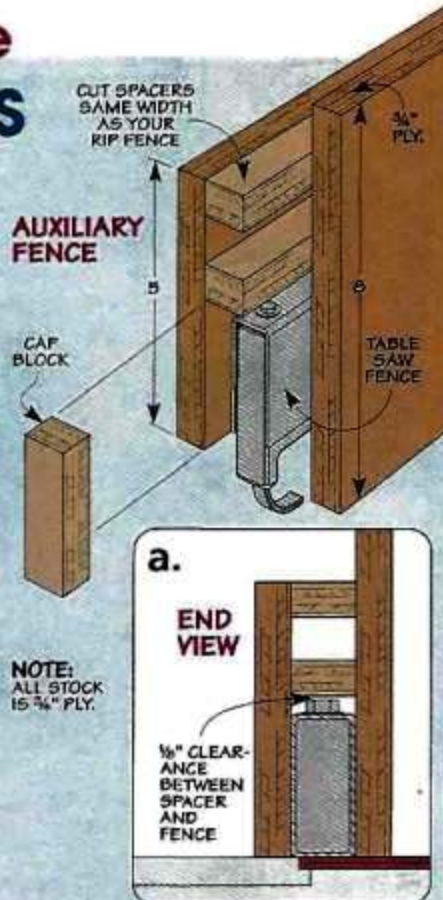

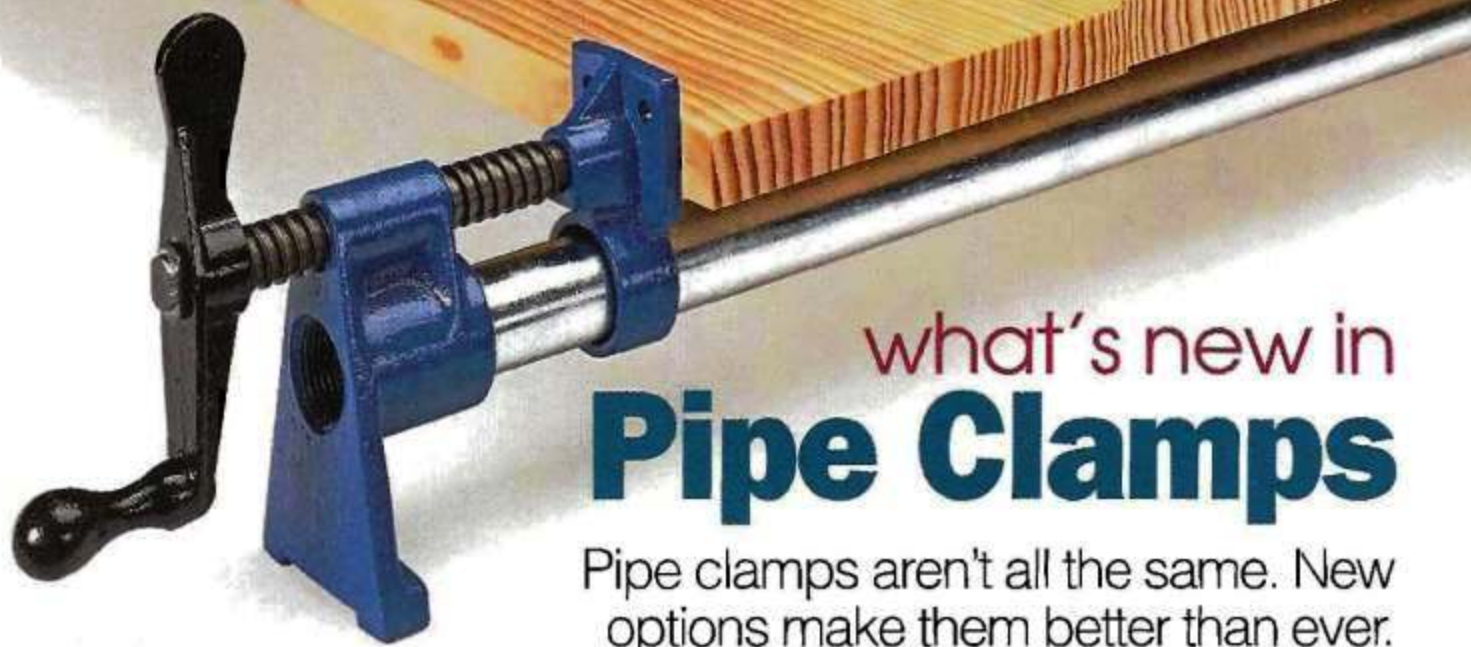

what's new in Pipe Clamps

Pipe clamps aren't all the same. New options make them better than ever.

■ Pipe clamps continue to be a basic clamping solution for many woodworkers. They're quick to make, inexpensive, and easy to use.

The Shop Standard. The orange *Pony* clamp you see in the left photo is the one most woodworkers think of whenever pipe clamps are mentioned. It consists of two pieces that fit right over the pipe. The

first piece, or head fixture, screws to threads at the end of the pipe. A handle attached to a threaded shaft allows you to apply clamping pressure. The other piece is an end fixture that slides over the opposite end of the pipe. This part has a series of metal clutch plates that bite against the pipe at an angle to hold the fixture securely in place.

Pipe clamps have always looked much the same. But recent innovations have changed all this.

You'll also find larger clutch plates on the clamp. This makes it easier to squeeze them together when you make adjustments.

The foot of the clamp is wider and longer. This gives them more stability and raises the pipe higher. So it's easier to turn the handle.

Sure-Foot Clamp. The *Rockler* clamp you see in the main photo above is a lot like the standard pipe clamp I mentioned earlier. But this



NEW FEATURES

The blue clamp you see in the left photo is the *Irwin Quick-Grip Clamp*. What I like most about this pipe clamp is it eliminates the need to have any threads at all on the pipe. Instead, a set of clutch plates on each clamping fixture grabs onto the pipe to hold both fixtures in place. This means you can cut a pipe to any length and start using the clamp right away — without having to rethread the end of the pipe.



▲ **Clamp Storage.** To quickly store the *Rockler* clamp all you need to do is hang it by the built-in lip on the foot.



clamp has a few added features you'll find useful. First of all, the foot on the clamp is extra-wide. I especially like this because it means the clamps are more stable. So when you set several of them up, they aren't as likely to tumble over.

Another great feature of this clamp is the pre-drilled holes in each clamping face. This makes it easy for you to attach oversized pads, cauls, or other types of fixtures to the clamps to handle unique clamping challenges.

Finally, pipe clamps aren't always easy to store. But as you can see in the photo at the bottom of the

previous page, the *Sure-Foot* clamp has a feature that helps you solve this problem. A small lip designed into the foot makes it easy to hang the clamp on the wall.

If you're looking to buy new pipe clamps, you can choose the newer ones that best meet your needs. But to make better use of the ones you already have, you'll find a few simple clamp upgrades can really make a big difference.

UPGRADES

As I mentioned before, pipe clamps with wider feet are more stable. So what do you do if you already have pipe clamps with narrow feet? Simple accessories can help you out.

Clamp Saddles. The wide-based brackets on the saddles in photo A hold the pipe securely in position and prevent the clamps from



moving around and turning over. A thumb screw lets you secure the pipe in the saddle, allowing you to place the pipe right where you want it.

Conversion Pads. If your current clamps have narrow feet, you can quickly make them wider. Just slip the *Sure-Foot* conversion pads over the face of your current fixtures, like you see in photo B. This way, you get wider feet and workpiece protection.

Zinc Pipe. Finally, one of the drawbacks to pipe clamps is they can leave marks on your workpiece. The black marks you see in the photo above result when the glue and black pipe react with the tannin in the wood, especially oak.

To solve this problem you can use zinc-plated pipe (see margin photo) to protect the wood. Don't be tempted to try galvanized pipe from the home center though. The fixtures can slip on the pipe, making clamping difficult.

Pipe clamps will always be a mainstay in my shop. But with the addition of a few new clamps and some simple accessories, they're now better than ever. 🐶



▲ **A Better Pipe.** To eliminate the marks that occur when you use black pipe (top photo), switch to zinc-plated pipe (lower photo).

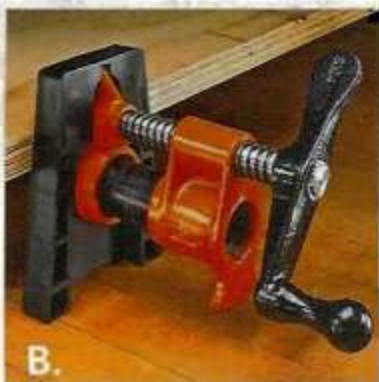
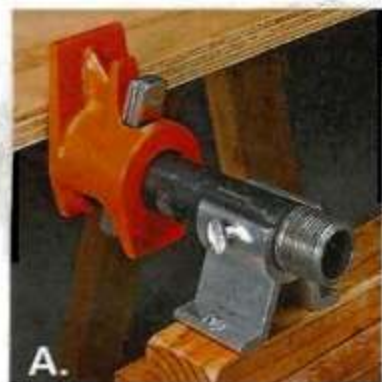

Pivot your work with: Bessey Maxis

If you need to add a little more versatility to your pipe clamps, you might want to take a look at the *Bessey Maxis Vario-Pivot* clamp. This set includes two clamps, like the one shown in the photo at right. These clamps easily attach to almost any bench top, assembly table, or sawhorse. The clamps have a band for attaching the pipe as shown in the photo below right (*K-Body* bar clamps can also be used). Once installed, the pipe clamp travels 3" horizontally and 6" vertically. Plus, you can move it through a 270° arc.

You can use this clamp whenever you need to stand a long workpiece on end

and secure it in position for edge banding, like you see in the photo below. It's also helpful for end drilling and planing a workpiece. And the ability to rotate the clamp makes shaping a handle or chair leg a whole lot easier.



Range of Motion. The fixtures allow you to rotate the workpiece as well as move it up and down.



Wide Jaws. Large, 4-3/8" jaws allow you to quickly attach the clamp to almost any workbench, table top or sawhorse.

Garage

upgrade to a Tile Floor

Interlocking tiles are a quick and easy way to improve the look and feel of your shop.

■ One of the more unpleasant things about working in a shop is spending all that time on a concrete floor. It's hard on your feet and legs, and it never really looks good — especially once cracks start developing or the car leaks a bit of oil.

▼ **Hard Plastic.** Polypropylene tiles like these are tough, inexpensive, and easy to use and install.

But there is a solution. You can turn to interlocking tile flooring. This flooring provides a number of advantages — anywhere you use it.

For starters, tile floors cover up that old concrete, cracks and all, to create a smoother, flatter surface. As the tile goes down, it brightens up the whole area, making it more comfortable to work in.

Besides being easy on your body, the tiles



provide a measure of protection for any tool you might drop.

Don't let the colorful look of these tiles fool you. They're tough enough to drive on. And best of all, you can install a tile floor in a matter of hours — without dealing with chemicals or drying time.

RIGID PLASTIC

The most common interlocking tiles you're likely to run across are the three shown at left. Made from a

tough, polypropylene plastic, each ½"-thick, 12"-square tile features an interlocking hook and loop system that simply snaps together (see box on opposite page).

Controlling Spills. The interlocking nature of these tiles does have a downside. Spills have a tendency to seep through the seams.

To prevent any spill from being trapped, grooves and notches are designed into the bottom to allow the material to flow out (lower left

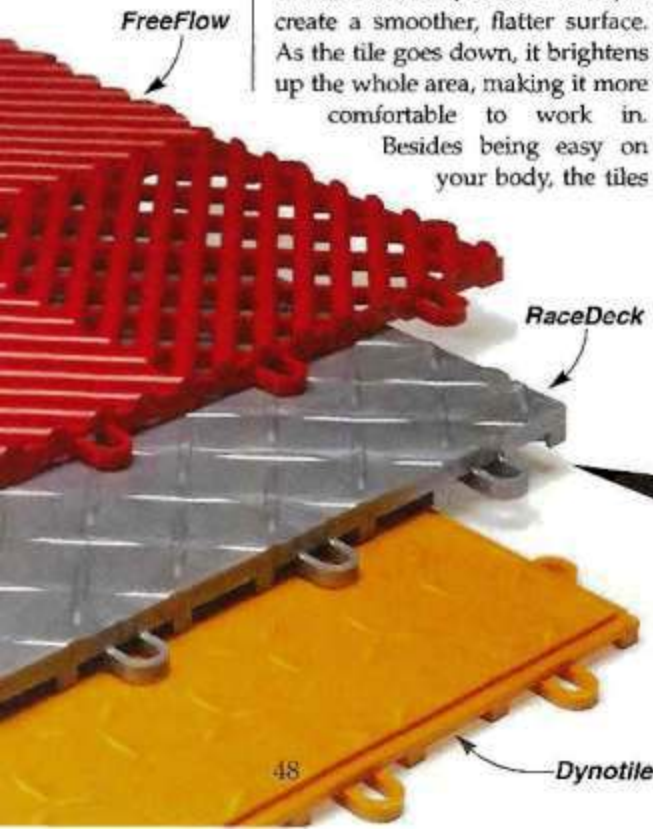

▲ **Drainage.** The grid design on the bottom of this tile ensures that any water that seeps through can flow out.



▲ **Easy Cleanup.** The FreeFlow tile allows dust and debris to fall through, but cleanup is a snap.

photo). Of the rigid tiles, the *Dynotile* features an overlap design along the edges to provide a leak-resistant surface.

Rigid plastic tiles, like the *RaceDeck* and *Dynotile*, have a tendency to be a bit noisy as you walk around on them. If you'd like a quieter shop, you may want to consider using *FreeFlow* tile. Although it's made from rigid plastic, the open design seems to provide a little "give" to mute the sound. Plus, dust and debris fall right through, so you can clean up later (lower right photo opposite page).

PVC PLASTIC

A second type of interlocking tile creates a totally different floor surface. Instead of thicker, hard tiles, this floor system is made from 1/4"-thick, flexible PVC (photos at upper right). But that doesn't mean they're lightweights. These tiles stand up to most chemicals and parked cars without leaving a mark.

Another thing that sets the PVC tiles apart is that they're self-sealing. The edges come together like a



Self-Sealing.
The interlocking design of the *Tuff-Seal* makes a virtually waterproof floor.

sandwich bag. These floors end up looking more like a continuous sheet. The result is a shop floor that's easy to keep clean and won't leak liquids to the concrete below.

Like the tiles on the opposite page, the *Resilia* flooring is 12" square. But the *Tuff-Seal* (main photo on opposite page and above) is 18" square, while the *Lock-tile* is just a bit larger (19 5/8"). So laying down even a large floor goes pretty quick.

Pick a Pattern. Other than the *FreeFlow* and *Dynotile* flooring, all the tiles can be ordered in different surface textures — the coin (or raised disk) and diamond plate are two of the most popular. And most come in a wide range of colors —

Resilia

Tuff-Seal

Lock-tile

making it easy to create a one-of-a-kind floor.

Cost. Of course, having the nicest shop floor in the neighborhood comes at a price. The rigid tiles will set you back around \$3 a square foot, while the PVC tiles range from just under \$4 to almost \$5 a square foot. (See Sources on page 51).

Still, the look and feel might be worth it. If you're not sure, keep one other thing in mind — if you ever move, you can simply pull up the tiles and take them with you — try that with any other type of floor. 🛠️

▲ **Flexible PVC.**
The PVC material used for these tiles is easy on your feet and quieter than solid plastic tiles, but it's still tough enough to drive a car on.

Tips for Installing the Tile



The best thing about all these tiles is how easily and quickly you can install them. Just snap or tap them together, as shown in the upper left photo. And if you need to fit a tile around a wall or corner, simply trim them on the table saw. The table saw works on the flexible PVC tiles as well, but a straight-edge and a sharp utility knife handle the job easily.

Finally, you don't need to tile the entire garage. You can use the tiles to create a smaller work area. Individual trim pieces or cut-to-fit rolls of trim, like you see in the photos at right, make it easy to smooth the transition between the tiled and untiled areas.

► **Trim Pieces.** Individual edging strips and corners simply snap in place like the tiles.

▼ **Long Rolls.** To add the edging shown below you cut it to length, miter the corners to fit, and then slip it under the edge of the tile with a bit of adhesive.

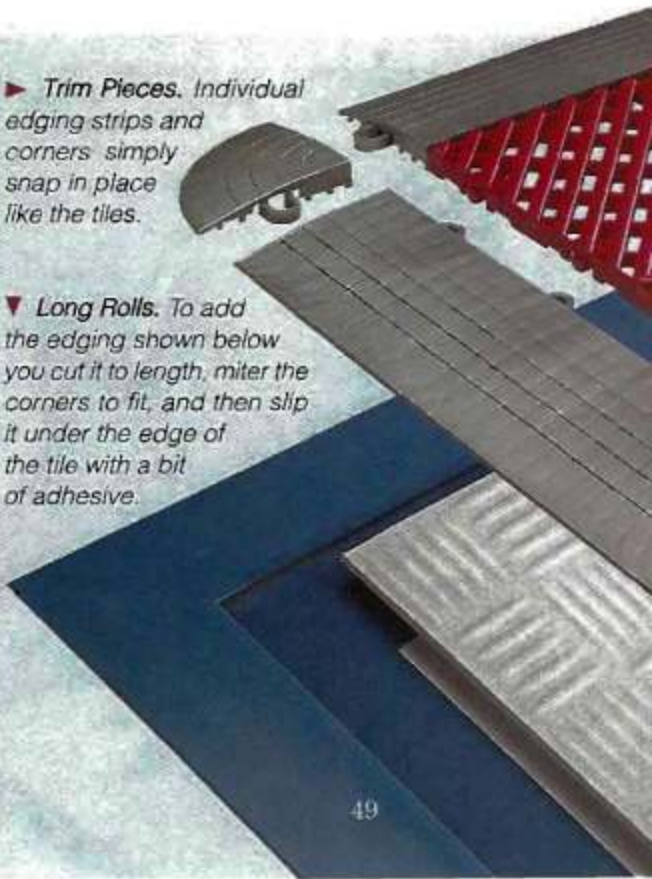

questions from
Our Readers

getting a grip with Carpet Tape

I've noticed you use carpet tape quite often to hold things together. My results with carpet tape have been mixed. Any thoughts on getting better results?

Tom Weber
Chattanooga, TN

Double-sided tape, or carpet tape, is the perfect choice for shop tasks where you need a temporary "clamp" that won't get in the way. I use it for all sorts of tasks, as shown above and in photos A, B, and C.

Start with the Tape. Getting the best results isn't all that big of a chal-

lenge. The first step is using the "right" carpet tape (lower photo). Most carpet tape will have either a film (far left roll) or paper base (center roll). And as long as the surfaces you're joining are smooth and clean, they work just fine. But there are times when I want a rock-solid grip. That's when I turn to either a cloth or fiberglass carpet tape. Just be aware — this tape is so strong it can pull out wood fibers as you separate your workpieces.

Using Carpet Tape. Besides the right carpet tape, there are a few things you can do to ensure the best results any time you use it.

For starters, don't use too much. I find that cutting a 3" to 4" strip and applying it every 6" to 8" works best. It's enough tape to hold securely, yet you can still pull the pieces apart. And before you pull the backing off the tape, firmly press it into place by hand or with a small roller.

As you peel the backing off the tape, make sure the corners don't fold back over

on themselves. You don't want to create a "lump" and prevent the parts from coming together.

After completing your work, all that's left to do is separate the parts. Instead of pulling them apart, I've found they separate better if you twist them. And if all else fails, adding a little lacquer thinner to the joint will dissolve the adhesive. 

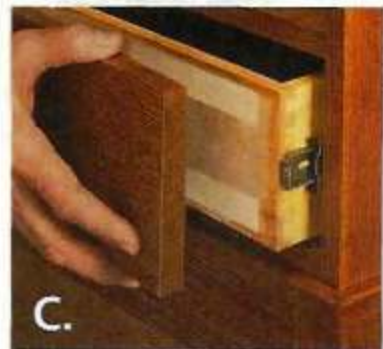

Paper-based tape is an all-purpose shop workhorse

Fiberglass tape provides the ultimate, rock-solid grip

Thin film-based tape is fine for light-duty applications

Sources

ROUTER TABLE SLED

Most of the hardware for the router sled on page 16 came from a local hardware store. But the large knob (STT-8T), two small knobs (STT-2T), and swivel pad (RP-3) came from *Reid Tool*. I used a *Kreg* miter bar to guide the sled, but any metal or wood runner will work. For the platform I used a heavy-duty, phenolic-faced plywood from *Woodcraft*. Sources are listed in the margin.

PLYWOOD

The Baltic and Finnish birch plywoods shown on page 10 are available from many woodworking supply stores, as well as online sources (see margin). If you're interested in the *Arauco* plywood, check your local home centers and lumberyards. Finally, phenolic-faced plywood is tough to find. Your best bet for that is *Woodcraft*.

HOBBY CHEST

Building the hobby chest shown on page 26 only requires a handful of hardware. The Shaker knobs (KP-B065) we used on the drawers are available from *Woodworks Ltd.* (see margin). And the rare-earth magnets (99K32.03), cups (99K32.52), and washers (99K32.62) came from *Lee Valley*, along with the *Veritas Wonder Pup* and *Bench Pup*.

Finally, the cutting mat we added to the pull-out tray came from a local hobby store. The small clamp-on vise (427-8602) we used is available from *Enco*.

ROUTER LIFTS

We took a look at a number of router lifts you can use to make working at your router table easier and give it more capability. You'll find contact information for each manufacturer below:

Router Technologies
866-266-1293
www.routertechnologies.com

Bench Dog
800-786-8902
www.benchdog.com

JessEm
866-272-7492
www.jessem.com

JoinTech
800-619-1288
www.jointech.com

Woodhaven
800-344-6657
www.woodhaven.com

Woodpeckers
800-752-0725
www.woodpeck.com

METAL DETECTORS

The *Wizard Industries* metal detectors like the ones featured on page 12 might seem like a shop luxury.

But it'll easily pay for itself if it saves a saw blade or set of planer or jointer knives. Company contact information is listed in the margin.

TILE FLOORING

Installing tile flooring is a great way to upgrade the look and feel of a concrete floor. To get more information about the tiles featured in the article on page 48, contact the sources listed below:

Flooring Adventures LLC
(Tuff-Seal) 877-779-2454
www.tuffsealtile.com

SnapLock Industries, Inc.
(FreeFlow & RaceDeck)
800-457-0174
www.snaplock.com

Evertile Flooring Co.
(Lock-Tile) 888-562-5845
www.locktile-usa.com

Floor Surfaces, Inc.
(Resilia) 805-963-4250
www.floorsurfaces.com

Dynotile
(Dynotile) 866-605-8700
www.dynotile.com

PIPE CLAMPS

Pipe clamps are a shop necessity. On page 46, we showed you what's new along with a few additions to get more out of your clamps. For sources, check out the margin information at right. 

MAIL ORDER SOURCES

Woodsmith Store
woodsmithstore.com
800-444-7527

Baico Scrapers, Lie-Nielsen Scrapers, Two Cherries Scrapers, Kreg Miter Bar, Sure-Foot Pipe Clamps & Pads, Veritas Bench Pups & Dogs, Veritas Scraper Burnisher

Rockler
800-279-4441
rockler.com

Baico Scrapers, Metal Detectors, Miter Bar, Sure-Foot Pipe Clamps & Pads, Zinc-Plated Iron Pipe

Lee Valley
800-871-8158
leevalley.com

Bessy Maria Vario-Pivot Clamp, Pony Pipe Clamps, Saddles, Ravo-Earth Magnets & Accessories, Veritas Bench Pups & Dogs, Veritas Scraper Burnisher

Watchmaker's Cases

Reid Tools
800-253-0421
reidtool.com

Knobs, Stivel Foot

McMaster-Carr
630-600-3600
mcmaster.com

Brass Sheet Stock

Woodcraft, Inc.
800-225-1153
woodcraft.com

Baico Scrapers, Lie-Nielsen Scrapers, Finnish Birch & Phenolic-Faced Plywood

Lie-Nielsen
800-327-2520
lie-nielsen.com

Scrapers

Enco, Inc.
800-873-3626
use-enco.com

Vises

Wizard Industries
866-781-8033
wizarddetectors.com

Metal Detectors

Woodworks Ltd.
800-722-0311
craftparts.com

Wood Knobs

Irwin Industrial Tools
800-464-7946
irwin.com

Vises

ShopNotes Binders

Keep your issues organized!

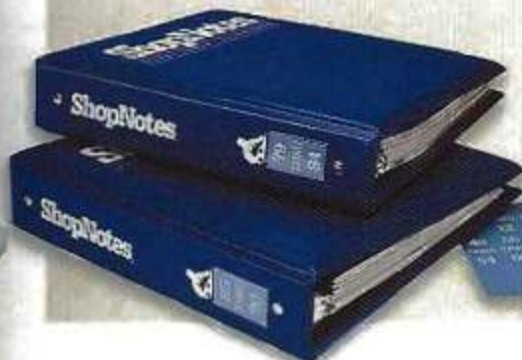

As you build your *ShopNotes* library, here's a way to keep your issues organized. Each binder features durable vinyl covers and easy-to-read perforated number tags. Snap rings with a quick-open lever make it easy to insert and remove issues. And there's an extra pocket inside for storing notes. Each binder holds a full year (6 issues) of the new, expanded *ShopNotes*.

Visit www.ShopNotes.com to order these binders, or call 1-800-444-7527.

ShopNotes Binder

○ 701950-SN87 (Holds 6 issues).....\$12.95

Scenes from the Shop

Hobby Chest. With a removable workbench top and plenty of storage space, you'll have everything you need for a workshop on the go. The plans begin on page 26.

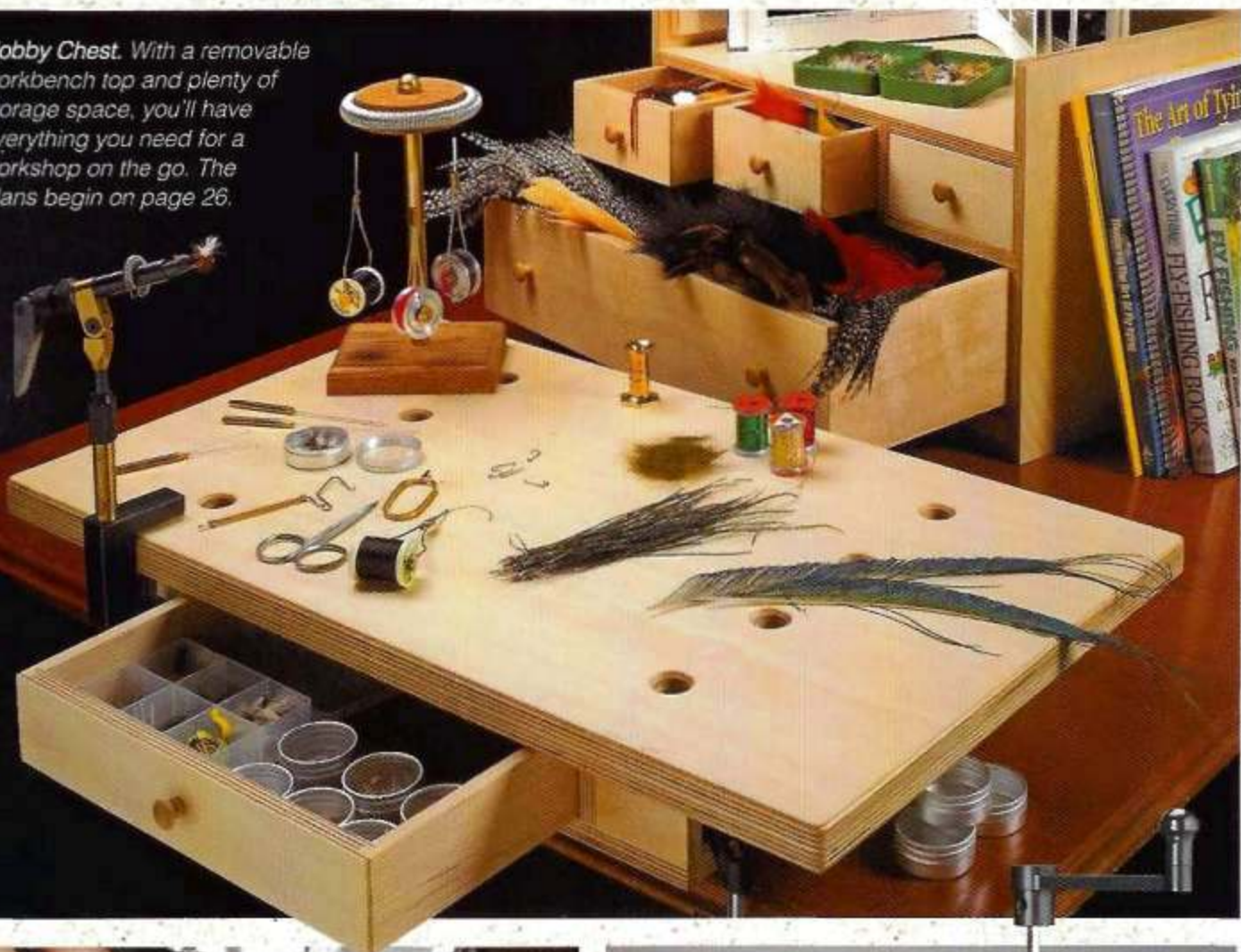

▲ **Cutting Tenons on the Band Saw.** With our simple setup, you'll learn just how straightforward it is to cut accurate tenons on the band saw. Read the article on page 20.



► **Router Lifts.** Take an under-the-table look at how router lifts work. Then find out the features that are available for this valuable addition. The article starts on page 38.