

**LASERS**  
In Your Shop

**Great Garage & Shop Upgrades**

# ShopNotes

Vol. 14 Issue 81

www.ShopNotes.com

## ULTIMATE SHARPENING STATION

### EXCLUSIVE DESIGN FEATURES:

- Expandable Worksurface
- Built-in Water Basin
- Easy-access Storage

## POWER UP YOUR DRILL PRESS:

- Spindle Sander
- Circle Cutters
- Twist Bits

## TOP-NOTCH TABLE SAW TECHNIQUES:

- Precise Pattern Cutting
- Perfect Half Laps



A Publication of August Home Publishing

# Contents

## Features

### storage solutions

#### Ultimate Sharpening Station **GO ONLINE EXTRAS** 16

This sharpening station features a sliding top, ample storage, and a basin for water. Everything you'll need to keep your tools in top shape.

### weekend workshop

#### Sharpening Stone Holder 24

This stone holder is a great sharpening accessory. It's adjustable and the wedge clamp that holds the stone in place is simple and fast.

### fine tools

#### Japanese Saw Handle Upgrade 28

We'll show you how to cut and fit a new handle for your Japanese saw that not only looks good, but feels good as well.

### technique

#### Great Results With a Circle Cutter 30

Cut a perfect hole or disk — once you know how to put this tool to work for you.

### best-built jigs & fixtures

#### Adjustable Spindle Sander 32

Sanding curved edges was never so easy. This spindle sander uses common sanding sleeves that slip over shop-made drums.

## Departments

#### Readers' Tips 4

### router workshop

#### Get a Grip on Collets 8

**NEW!**

Small size, big job. Learn all you need to know about router collets.

### materials & hardware

#### Going Mobile with Casters 10

**NEW!**

Want to make your shop "mobile"? Learn the key to buying and using casters.

### jigs & accessories

#### All About Twist Bits 12

**NEW!**

Confused by the wide variety of twist bits? We'll help you sort out the differences.

#### Shop Short Cuts 14

**NEW!**

Shop-tested tips and techniques to solve your woodworking problems.



Spindle Sander

page 32



Laser Guides

page 46



Stone Holder

page 24



Ultimate Sharpening Station

page 16

**hands-on technique**

**Perfect Half Laps on the Table Saw** 26

**NEW!**

*Half-lap joints are easy to make, incredibly strong, great for face frames, and much more.*

**in the shop**

**Getting Connected with Air** 38

**NEW!**

*The key to getting the most from your air compressor is choosing the right hoses and fittings.*

**setting up shop**

**Breathe Right for Safe Finishing** 42

**NEW!**

*Protecting your health is important. Here's what you need to know about respirators.*

**mastering the table saw**

**Table Saw Pattern Cutting** 44

**NEW!**

*Need help making hard-to-cut, identical parts? The secret is pattern cutting on the table saw.*

**GO ONLINE EXTRAS**

**great gear**

**Miter Saw Upgrade — Laser Guides** 46

**NEW!**

*For accurately lining up a cut on your miter saw, you can't beat a laser.*

**ultimate garage**

**Precision Parking Systems** 48

**NEW!**

*Stop your car at the same spot — every time. All you need is a high-tech parking system.*

**Q&A** 50

**Sources** 51

# Cutoffs

In this issue, we have several projects that can make a big improvement in the way you work. First off, there's the sharpening station that appears on page 16. It features plenty of storage and an easy-to-clean worksurface. But what really sets this project apart is the sliding top. Just pull it to the side to access an inset tub for storing and cleaning waterstones.

The shop-built spindle sander on page 32 is another great addition to your shop. It fits onto your drill press and uses extra-long, 5½" sleeves. And the adjustable worksurface allows you to get the most out of each sleeve.

But it doesn't take a big project to make a big difference in the way you work. If you're looking for a couple of quick projects, be sure to check out the article on upgrading a Japanese hand saw on page 28. And the sharpening stone holder on page 24 makes it easier to get a sharp edge on all your tools.

## HELP WANTED

We're looking for someone to join our editorial team. This is a full-time, staff position here in Des Moines, Iowa. So if you're an experienced woodworker, interested in writing, and would like to share your knowledge with others, I would like to hear from you.

Send a resume highlighting your experience to: HR, August Home Publishing, 2200 Grand Ave., Des Moines, IA 50312. Or visit our website at [www.AugustHome.com](http://www.AugustHome.com) for more information about this position.

*Temy*



This symbol lets you know there's more information available online at [www.ShopNotes.com](http://www.ShopNotes.com)

from our  
Readers

# Tips for Your Shop

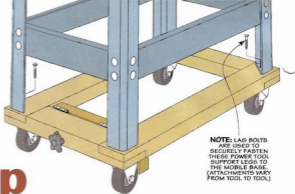

## Shop-Built Mobile Tool Base

My shop is small, so I need to be able to easily move my power tools. But manufactured tool bases are a bit more than my budget allows.

So I built a mobile tool base out of some scrap stock. All hardware can be found at any home improvement center or hardware store. And it goes together quickly and easily.

First you'll want to measure the base of the tool it's going to support. And then cut the four 2 x 4's so they fit these dimensions.

The base frame is made by simply making half-laps at each corner, like you see in the illustration below. The half-lap joints make a strong level support surface for the tool.

Since it's important to lock the mobile base in position when I use the tool, I made a simple brake by mounting a pair of hinges at one end of the base and attaching a

brake piece. This way the brake piece can drop down and make full contact with the caster wheels.

The brake adjustment is nothing more than a hole drilled through one end of the base and the hinged 2 x 4. A T-nut, threaded rod, and star knob (see illustration side view below) were added to complete the adjustment assembly. Then by tightening the knob, the wooden brake is pulled against the caster wheels with enough force to keep the wheels locked in place.

Finally, I used lag screws to attach the tool securely to the base. Just be sure it's securely fastened before you try to move it.

Now it's a snap to move. A few twists of the knob is all it takes to release the brake. And then, after I move it to where I want it, I can easily lock the brake in place again.

*Guy Gerard  
Orlando, Florida*

### Free Tips ON THE WEB

Get more wood-working tips **free**.

Visit us on the Web at [ShopNotes.com](http://ShopNotes.com)

Sign up to receive a free shop tip by email every week.

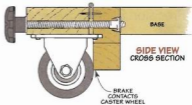
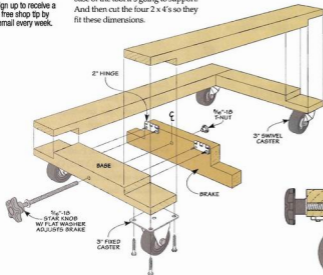



## Simple Dowel Pin Cutting Jig

Cutting multiple short dowel pins can be tedious work. So I made a simple dowel pin cutting jig to speed things up.

This jig only takes a few minutes to make and set up on your table saw. Then it's easy to quickly cut dowels to equal length without measuring.

It's simply a block of wood with a hole drilled through it the same size as the dowel to be cut (see drawing below). The block is then clamped to an auxiliary fence on the miter gauge.

To use the jig, first cut a kerf in the block at the desired length of the dowel. Next, pass the dowel into the hole. Position it flush with the end of the hole and make a cut. Then you can quickly push it through again to cut the next dowel pin to the same exact length.

I made blocks to accommodate several dowel sizes. That way I'm ready to size dowel pins when the need arises.

Len Urban

Rancho Mirage, California

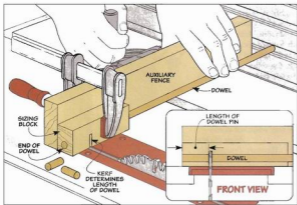

## Submit Your Tips

If you have an original shop tip, we would like to hear from you and consider publishing your tip in one or more of our publications. Just write down your tip and mail it to: ShopNotes, Tips for Your Shop, 2200 Grand Avenue, Des Moines, Iowa 50312. Please include your name, address, and daytime phone number (in case we have any questions). If you would like, FAX it to us at 515-282-6741 or send us an email message at: shopnotes@shopnotes.com. We will pay up to \$200 if we publish your tip.

## The Winner!

Congratulations to Guy Gerrard of Orlando, Florida. His tip on making a shop-built mobile tool base was selected as winner of the Porter-Cable router just like the one shown at the right. His mobile tool base is easy to build and uses readily available, inexpensive materials.

To find out how you could win a Porter-Cable router just check out the information above. Your tip might just be a winner.



PUBLISHER Donald B. Peschke

EDITOR Tony J. Srothman

SENIOR EDITORS Bryan Nelson, Vincent Ancona

ASSOCIATE EDITORS Phil Huber, Ted Rife

ASSISTANT EDITORS Ron Johnson, Mitch Holmes

EXECUTIVE ART DIRECTOR Todd Lambirth

ART DIRECTOR Cary Christensen

SENIOR GRAPHIC DESIGNER Jamie Downing

SENIOR ILLUSTRATOR Roger Reiland

ILLUSTRATORS David Kallertyn, Peter J. Larson

CREATIVE DIRECTOR Ted Krulick

SENIOR PROJECT DESIGNERS Ken Munkel, Kent Welsh,

Chris Fitch

SHOP CRAFTSMEN Steve Curtis, Steve Johnson

SR. PHOTOGRAPHERS Crayola England, Dennis Kennedy

ASSOCIATE STYLE DIRECTOR Rebecca Cunningham

ELECTRONIC IMAGE SPECIALIST Allan Ruhnke

VIDEOGRAPHERS Craig Rueggerger, Mark Hayes

ShopNotes® (ISSN 1090-8906) is published bi-monthly (Jan., March, May, July, Sept., Nov/Dec) August Home Publishing, 2200 Grand Ave., Des Moines, IA 50312. ShopNotes is a registered trademark of August Home Publishing. © Copyright 2005 by August Home Publishing. All rights reserved. Subscription Single copy: \$4.95. One year subscription (6 issues): \$27.95.

Canada Post International will \$30 per year. U.S. funds. Canadian Subscriptions: Canada Post Agreement Number 40082011. Send change of address information and blocks of undeliverable copies to PO Box 981, Station Main, Markham, ON L3P 8M5.

Canada: (519) 469-9476 RT. Periodicals Postage Paid at Des Moines, IA and at additional mailing offices. Postmaster: send change of address to ShopNotes, P.O. Box 37075, Boone, IA 50037-0755.

www.ShopNotes.com

## ONLINE SUBSCRIBER SERVICES

- **ACCESS** your account
- **CHECK** on a subscription payment
- **TELL US** if you've missed an issue
- **CHANGE** your mailing or e-mail address
- **RENEW** your subscription
- **PAID** your bill

Click on "Subscriber Services" in the list on the left side of our home page. Menus and forms will take you through any of the account-maintenance services you need.

## HOW TO REACH US:

FOR SUBSCRIPTIONS, ADDRESS CHANGES OR QUESTIONS, WRITE OR CALL.

Customer Service  
2200 Grand Ave., Des Moines, IA 50312  
800-333-5854 8 a.m. to 5 p.m. CT

OR SEND AN E-MAIL TO:  
orders@shopnotes.com

AUGUST HOME  
PUBLISHING COMPANY

Printed in U.S.A.



## Adjustable Outfeed Roller

I like to use outfeed support when working with long stock. The problem is the support is never in the place I need it.

So I built an adjustable outfeed roller, like you see in the photo at the left, and attached it to a small, roll-around shop cabinet.

The adjustment arm is simply two pieces of 2 x 4 stock sized to fit the side of the cabinet (see illustration at right). A steel pin on one piece glides in a groove on other piece for stability. And a carriage bolt with a knob locks the roller support at the desired height.

I made the roller using a steel rod and a section of PVC pipe with the ends capped. Then I secured it to the top of the adjustment arm.

Now, I have outfeed support where I need it. And it drops down out of the way when not in use.

Angie Mickko  
Waymart, Pennsylvania

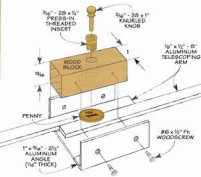
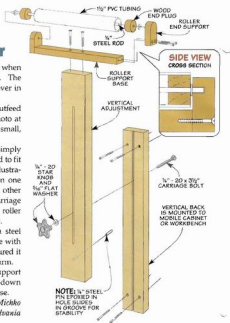

## Telescoping Drawer Gauge

Measuring the width for drawer bottoms can be a challenge. I usually measure several times just to make sure I get it right.

Then I made the simple drawer gauge shown in the photo below. Now, I don't have to worry about the "numbers." The gauge always shows me the exact distance.

It's made from two pieces of aluminum angle joined together by a small wood block (see end view at left). The telescoping arms are two pieces of flat aluminum bar stock

set side by side. A knurled knob, pressed-in threaded insert, and a penny sets and adjusts the arms.

It's easy to use the gauge to set up your table saw for the cut. Just slide the measuring rods until each arm touches the bottom of the groove in the drawer sides. Then tighten the knob to secure the arms.

Next place the end of one arm against the blade and the other arm against your rip fence. Lock the fence in position and make the cut.

Robert Fox  
Albany, Oregon

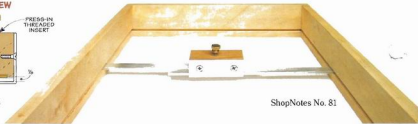
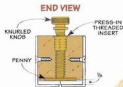

## Pull-Out Storage Case

I never seem to have enough storage space in my shop. This is especially the case when it comes to screws, fasteners, and other odds and ends. Things I need close at hand but don't use every day.

So, to store these and other small items, I built a pull-out storage case, like you see in the photo at right. The case is large enough to hold a couple of small plastic storage cabinets with lots of drawers (the kind you find at hardware stores and home centers). I also added a few shelves to store other items.

Since I wanted to be able to move the case, I placed it on wheels (see inset at right). A handle attached to the side lets me simply pull it out to get to the items I need and then push it back out of the way again.

The case fits nicely against the wall next to my workbench. It worked so well that I built a couple more cases and rolled them next to one another. Now I have lots of storage in a space that would have gone to waste.

*Arnold Johnson  
Brooklyn Center, Minnesota*

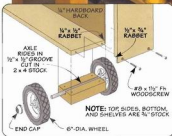
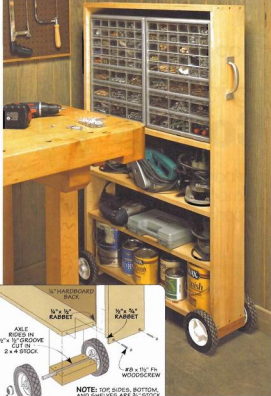

## Quick Tips



▲ To secure wood plugs, David Richards of Rochester, MN, uses the same finish he plans to use on the project. Just dip the plug into the finish and insert it in place. It's fast and you won't see any glue lines.



▲ Ken Munkel of Des Moines, IA, applies 2" masking tape to his table saw or router table fence whenever he needs to increase the width of his dado cuts by "just a hair." The tape can be quickly removed after the cut.

ROUTER  
Workshopget a grip on  
**Collets**

Often overlooked, this router component plays an important role.

One of the key parts of any router is the mechanism that holds the bit in place — the collet. It's easy to change router bits without even giving this part a second thought. But once the bit slips or is hard to get in or out, it's sure to get your attention.

**How it Works.** The illustration above shows you how a typical collet works. As you can see, it's a tapered sleeve that's precisely machined to fit in a socket in the end of the arbor. Then as you

tighten the nut that fits on the end of the arbor, the collet squeezes the shank of the bit and holds it firmly in place. This means that anything that interferes with these parts (like debris and burrs) affects how well the collet holds onto the bit.

You'll find that most collets work in a similar manner. But some collets are made just a little bit different than others.

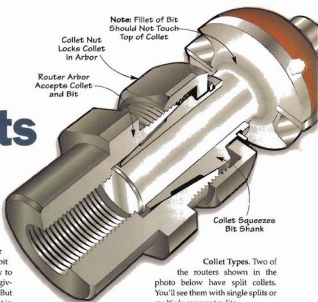

**Collet Types.** Two of the routers shown in the photo below have split collets. You'll see them with single splits or multiple segment splits.

As a rule, more segments tend to grip the bit more uniformly. But the greatest advantage of this type of collet is that if it wears out, it's easy to take it out and replace it with a completely new one.

The other type of collet you'll see is like the one on the router in the upper right in the photo below. This collet is machined right into the router arbor or motor shaft. You'll usually find these on less expensive routers. The problem with this one is that when the collet becomes damaged or wears out, you'll have to replace the entire router and not just the collet.

**Collet Sizes.** You'll usually find collets in either  $\frac{1}{8}$ " or  $\frac{1}{2}$ " diameters to match the shank of the bit. Some manufacturers will ship routers with both sizes or with a  $\frac{1}{2}$ " collet and include a  $\frac{1}{4}$ " reducer.

Both sizes get the job done. But I like to use the larger  $\frac{1}{2}$ "-dia. size because it has a lot more surface area to grab onto the bit. Whichever size you use, you'll find there are a few things you need to know before you're ready to put the bit into the collet.

**Bit Installation.** For the collet to securely grip the bit, you'll want to get as much of the bit shank in the collet as you can. But be sure you don't put it in too far. If it goes in as far as the curve in the fillet at the top of the shank, the collet won't be able to grip the shank tightly and the bit is likely to slip.

Sometimes you can install the bit properly and it still slips in the collet. That's when you need to make sure the collet and the bit are clean and free of defects.

**Keep it Clean.** Because of its location, wood chips and sawdust can get lodged in the collet. When this happens the collet can't get a firm hold on the bit. So the solution

is to keep the end of the arbor and the collet clean and free of debris.

First, you'll need to loosen the collet nut and remove the collet from the arbor. You may need to remove a snap ring to separate the collet from the nut.

Then clean out the inside and outside of the collet as well as the end of the arbor. I like to use a brass gun-cleaning brush or a nylon brush so I don't scratch the metal surfaces (see photo above right).

Now is also a good time to check the inside of the collet and look for any burrs or abrasions. If present, they can interfere with the ability of the collet to grip the bit securely. Small burrs can be carefully



◀ **Clean the Collet.** Gently push a brass wire or nylon brush through the opening to remove debris from the collet.

removed with a small half-round file, like you see in the photo below.

Once you're sure everything is clean and smooth, you can put the collet back in the router. At this point I like to add a small amount of white lithium grease to the arbor threads to help the nut turn smoothly. But don't apply any to the inside of the collet. It might cause the bit to slip.

Finally, give the the shank of the bit a quick once-over before you put it in the collet. I like to keep a little steel wool handy to help me out here. It works great for removing any rust, resin, or small burrs you might find on the shank. That way the collet has a smooth surface to grab onto.

**Replace the Collet.** Sometimes you'll do all these things and the bit still slips. That's usually a sign it's time to get rid of the old collet and replace it with a new one. ▶



▶ **Thread Lubrication.** Lubricating the arbor threads makes it easier to loosen and tighten the collet nut.



▶ **Burr Removal.** Small burrs inside the collet can be carefully removed using a small, half-round file.

## Collet Wrenches

It takes two wrenches to loosen and tighten the collet on my router. One wrench prevents the spindle from turning while the other (shown in red in photo) turns the collet nut.

So the way I make bit changes is like you see in the photos at right. With this method, one hand is all I need to make the change.

Since I am using only one hand, it keeps me from slamming my knuckles together when the nut breaks free. And I'm less likely to over tighten the collet.



▶ **Loosen Collet.** Place one wrench (red handle) on the left side and the other wrench on the right side. Then squeeze the wrenches together.



▶ **Tighten Collet.** Position one wrench (red handle) on the right side with the other wrench to its left. Then squeeze with one hand.

**SHOP  
TIP**

going  
Mobile

The right casters can add versatility to any shop.

When I design a project that includes casters, I put a lot of thought into what kind of caster to use. There's more to casters than just finding the lowest price at the neighborhood hardware store.

**Types of Casters.** Casters come in two basic types: fixed and swivel. The fixed caster (sometimes called "rigid") is really quite simple. If you look at the left photo,

you can see that it's essentially a wheel on an axle, which is riveted to a pair of "horns," or side brackets. The brackets are attached to a mounting plate so you can fasten the caster to your project. There's not much to the wheel either. It simply rolls forward and backward, just like the rear wheels of your car do.

The other type is called a swivel caster, which is a big upgrade over the fixed. It has the same basic setup, except that a ring of ball bearings is sandwiched between the wheel assembly and the mounting plate (see photo at right). Those bearings allow it to rotate 360°, improving maneuverability quite a bit.

**Locking Swivel.** With swivel casters, you can move your projects and tool stands around the shop with ease. But what do you do to

prevent them from rolling once they're where you want them?

If you look at the lower photos again, you'll see a butterfly-shaped lever on the side of the wheel.

The lever is actually a cam-style compression brake. Pressing the "ON" side down causes the housing to squeeze against the wheel, preventing the wheel from rolling. Stepping on the opposite end of the wing releases the wheel. In the "locked" position, the caster can still swivel, but it can't roll. So, while this caster is "officially" a locking swivel, that's a bit of a stretch.

These two types of casters have been the shop standard for years. Then, a better design came along.

**Double-Locking Swivel.** A caster with a double-lock not only prevents

the wheel from rolling, but also stops it from swiveling.

The way this caster works is pretty interesting. The first thing you'll notice is that the brake lever has been moved behind and on top of the wheel (photo above). Now, if you peek underneath the lever (photo on opposite page) while pressing down on it, you'll see the brake shoe come in contact with the wheel to stop it from rolling.

If you look at the front of the wheel while pressing the lever, you'll see the swivel brake shoe slide in and mesh with the bearing retainer ring that has "teeth" cut into it. This is the mechanism that prevents the caster from rotating.

## Fixed



▲ **Fixed Caster.** Fixed casters only roll forward and backward, but provide good stability.

## Swivel with Locking Brake

▶ **Locking Caster.** The cam-style compression brake stops the wheel from rolling, but still allows the caster to swivel.



## Anatomy of a Double-Locking Swivel

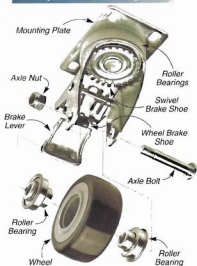

What I like about this caster is how easy it works. With just a tap of your toe, you can prevent the wheel from rolling and the swivel from rotating, resulting in a truly locked caster that's as stable as any fixed stand in my shop. Another quick tap with your toe releases the brake and swivel, and it's ready to move.

Other things that set these casters apart is the variety of sizes and materials available. For example, I like to use larger wheels, like the big red one on the opposite page, because they roll and steer easier than smaller wheels do. Plus, they don't get stuck on small debris and scratch my shop floor. I also like casters with wheels that turn on roller bearings, like the one above. The wheels seem to last longer and roll more smoothly than wheels without bearings.

**Configurations.** Now that you understand the basics, you might be wondering which casters to use where. What you'll find is that different combinations and configurations produce surprisingly different results when you're trying to move stuff around. In the past, I always stuck a pair of swivels in the front and a pair of fixed in the back (think back to your car). But this setup wasn't always the best. The box on the right shows different setups I've found useful over the years, along with the advantages and disadvantages of each.

So, you see, casters aren't just wheels you stick on the bottom of a tool or stand. You need to think about what you want them to do, and get the right casters in the right combination to do the job right. 🛠️

## Picking caster combinations

### 2 Fixed 2 Swivel



This setup is what most people are familiar with — it steers like the family car does. It provides good stability, and it's easy to keep straight as you push it across your shop. It's not the best setup, though, when you have to maneuver in tight spaces and "parallel park."

**PROS:** Drives like you're used to  
**CONS:** Needs room to maneuver

### 2 Fixed 2 Swivel



Although this arrangement looks odd, it's how a lot of home center lumber carts are configured. It provides a tight turning radius and is fairly stable. Center the load over the fixed casters for the best maneuverability and stability. It tends to "rock" along the center fixed casters on uneven surfaces and loads.

**PROS:** Good turning and stability  
**CONS:** Tends to rock back and forth

### 4 Swivel

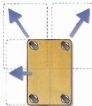

If you have a crowded shop, this may be the best setup for you. It has a really tight turning radius, sort of like a swivel office chair. You can spin it 360° and change directions instantly. It's not good for longer distances because it's hard to get all the swivel casters heading in the same direction at the same time.

**PROS:** Good for tight spaces  
**CONS:** Hard to keep straight

### 2 Fixed 1 Swivel

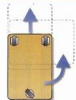

Here's the tricycle version of caster setups. It works great moving light loads around in tight spaces. It's not very stable, however, and can tip over easily if you turn too sharply and there's too much weight over the swivel caster. Be careful on uneven floors too.

**PROS:** Light loads in tight spaces  
**CONS:** Less stable, easy to tip over

JIGS &  
Accessoriesall  
about **Twist Bits**

You can count on twist bits to get the drilling job done — if you have the right bit.

■ If there's one thing I have a lot of in my shop, it's twist bits. That's because they're inexpensive, come in so many sizes, and will drill a hole in almost any kind of material. They're truly the jack-of-all trades when it comes to drilling a hole.

Although I use them all the time, I don't usually think about what a complex tool they really are. Their

design makes them both versatile and easy to use. It's worth taking a little time for a closer look.

**How They Work.** If you look closely at the twist bit drawing on the opposite page, you'll notice that the tip of the bit has a sharp chisel edge or web running across the point. And the leading edge of this web forms a sharp cutting lip.

What this means is that as the point of the bit penetrates, the chisel edge of the web bites into the material and the cutting lips begin to scoop out the waste — making chips. These chips are then channeled into the flutes along the side of the bit and carried to the top of the hole where they're ejected.

Once the hole is started, the side of the bit goes to work. The sharp-edged margin, that runs along the *land* of the bit, acts like a scraper and reams the hole to size.

As you might guess, the bit point is quite important when it comes to drilling. So it deserves some real consideration whenever you go about choosing a twist bit.

**Point Angle.** One thing that isn't always obvious is that twist bits don't all have the same point shape. Some are more angled than others. So you'll want to match the angle at the point of the bit to the material you'll be drilling.

If you're going to be drilling in softer materials like wood and plastic, point angles (see illustration at right) ranging from 60° to 118° work well. But if you're going to be drilling both wood and soft metals, like brass, look for all-purpose bits that are ground to 118°. And for harder metals, such as steel, you'll want to use flatter bits having a point angle of 135° to 143°.

**Point Types.** One problem you'll find when using twist bits is that



▲ **Plain Point.** You'll find this is the most common point on twist bits. It's difficult to center and wanders easily as you begin to drill.



▲ **Split Point.** The tip is split at the center. This makes starting the hole easier and keeps the bit from wandering as drilling begins.



▲ **Pilot Tip Design.** The pointed tip starts drilling on contact without wandering. It also won't lock-up when it breaks through the hole.



## High-Speed Steel

The most common general-purpose bit



## Black-Oxide Coated

Coated to reduce heat buildup during drilling

## Titanium-Nitride Coated

Coating increases bit hardness and reduces friction

## Cobalt Bit

Used for drilling stainless steel

they tend to skate around as you begin drilling. The result is often a hole that's slightly off-target and a scratched drilling surface. This is especially the case when using twist bits in a hand drill.

To solve this problem, special bit points (see photos on page 12) have been developed. They're designed to make it easier to start the hole and reduce bit wandering. They work well in wood, plastic, and

soft metals, but sometimes any type of bit will need a little help.

**Drilling Techniques.** If you don't have one of these specially tipped bits, you can always use a center punch before starting to drill the hole (see margin at right). This makes a small "dimple" in the material that helps the drill bit get started in the right spot.

And when drilling larger holes, it's often helpful to start with a smaller bit first. The smaller hole then centers the larger bit easier and prevents it from wandering as you begin to drill.

**Bit Composition.** Most twist bits are made of high-speed steel which stays sharp longer than carbon tool steel. Plus, it stay sharp and retains it's hardness at high temperatures.

While this is important, the main thing you'll notice is that twist bits come in a variety of colors (see photo above). These colors are a result of coatings applied to the bit.

**Bit Coatings.** These coatings are applied to the bit to give it better performance. Two of the coatings

you'll run across most often are black oxide and titanium nitride.

**Black Bits.** Black-colored bits are coated with black oxide. Since heat significantly reduces the life of the bit, black oxide is applied to the bit to reduce heat buildup — especially during extended drilling. So less heat buildup means that the bit will last longer.

**Titanium Bits.** Titanium nitride coated bits are easily identified by their bright, gold color. This coating increases the hardness of the bit and serves as a lubricant for the bit as well.

Either of these coatings is a good idea if you frequently drill metal. But they don't offer you any real advantage if all you're drilling is wood and other soft materials.

**Alloy Bit.** One type of metal that requires a special bit for effective drilling is stainless steel. You'll need to use a bit made of cobalt to get the best results (right bit at top of page).

The reason for this is the cobalt alloy. It's highly heat resistant. So it's able to stand up to the heat that comes with drilling in stainless steel. The heat generated would quickly dull most bits.

As you can see there's more to twist bits than meets the eye. The key is to match the bit to the drilling job you have to do.

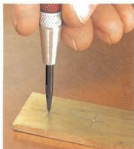

**▲ Center Punch.** Use a punch to make a starting point for the bit. This makes it easier to start the hole and keep the bit from wandering.

## BIT ANATOMY

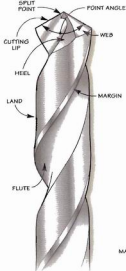

## TOP VIEW

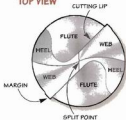

## Shortcuts

## Routing a Perfect Opening

To fit the plastic tub into the top of the sharpening station on page 16, you have to cut a large hole in the sub-top. After all the work on the sharpening station, getting a perfect fit the first time is important.

The key to getting it right is to use a template to cut the hole, like you see in the drawing at right. This way, you can fine-tune the fit of the template before you cut the opening in the sharpening station.

**Make the Template.** To create the template, I started by using the top of

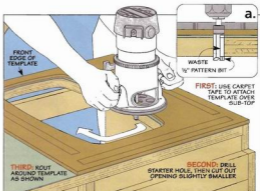
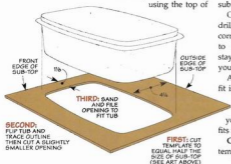

the tub to trace an outline on a piece of hardboard. The hardboard is sized to match the depth of the sub-top, but it's only half as wide.

Once you've traced the outline, drill a starter hole near an inside corner. Then you can use a jig saw to remove most of the waste, staying just inside the layout line you traced off the tub.

At this point, creating a perfect fit is just a matter of sanding and filing the inside edge of the template. Be sure to check your progress until the tub just fits into the opening.

**Cutting the Opening.** With the template complete, you're ready to

cut the opening. This starts with locating the template flush with the front, back, and left side of the sub-top, like you see in the drawing above. Then you can trace around the inside edge to transfer the location of the opening to the sub-top.

The next step is to drill a starter hole and remove the waste by cutting just inside the layout line. Once that's complete, you can use carpet tape to attach the template to the line you traced earlier.

Now all that's left is to rout clockwise around the template with a router and pattern bit, as shown above. This will leave a clean opening that fits the tub perfectly.

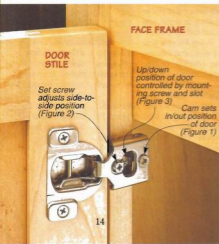

## Adjusting a European Face Frame Hinge

I used a unique hinge on the doors of the sharpening station — a  $\frac{3}{8}$ "-overlay European hinge, like the one shown at left. Unlike most European hinges, this one is designed for use on a face frame.

The part of the hinge that attaches to the door fits into a large counterbore in the door stile. And the cabinet side of the hinge mounts to the edge of the face frame.

As you mount the hinge to the face frame, be sure the door is centered over the opening as close as

possible. Then screw through the center of the slot to mount the hinge. Once you have both hinges in place, you're ready to fine-tune the position of the door.

The photo at left and the drawings at right will give you all the information you'll need to adjust the position of each door. Start by adjusting the door for clearance (Figure 1), then make sure each door is level, as in Figure 2. Finally, just double-check the vertical position, as illustrated in Figure 3.

## Making Spindle Sander Inserts

The spindle sander on page 32 features a custom-fit insert for each sanding drum. Each insert is sized to fit around the drum with a little clearance for dust extraction. The hard part is getting each insert to fit snug in the opening in the table top.

To accomplish this, I set up to cut all the sanding drum openings first. Then I used a few scrap blanks to fine-tune the outside diameter for a snug fit.

**Make the Blanks.** The first step is to cut the inserts and scrap blanks to size from  $\frac{1}{4}$ " hardboard, as shown in the drawing below. Then, set up an auxiliary table on your drill press with a fence and a stop block, as in the photo.

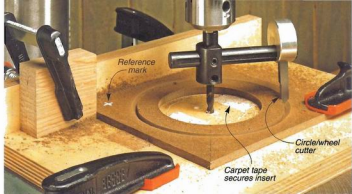

You'll want to position everything to roughly center the blank under your circle cutter. To make sure you put the blank back the same way for cutting the insert free, make a small 'X' in one corner of each blank. Then, drill a hole

in each blank about  $\frac{1}{8}$ " larger than each size sanding drum.

With the holes for the drums cut, you're ready to cut the inserts free. Here's where you use the test blanks to fine-tune the circle cutter.

Once the test insert fits, you can reinstall each blank and cut the inserts to size. 

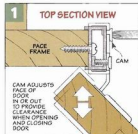
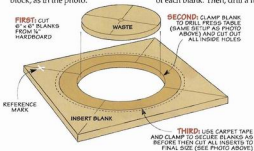

▲ **Door Clearance.** A cam installed in the hinge mount allows you to move the face of the door in and out to provide clearance to open and close the door.

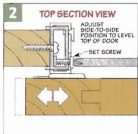

▲ **Side to Side.** Now, adjust the side-to-side position of the door. Since each hinge adjusts separately, it makes quick work of leveling the top of the door.

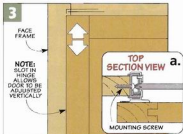

▲ **The Last Step.** Next, you'll need to adjust the large door so it aligns with the top edge of the upper drawer. Finally, adjust the small door so its bottom edge matches the large door.



# ultimate Sharpening Station

With plenty of storage and a slide-out worksurface, this station will keep your sharpening supplies ready for action.

For me, sharpening tools is a little like going to the dentist — even though I know I should do it, I tend to put it off for as long as I can. And I think one of the main reasons for this is that I don't want to have to stop in the middle of building a project, clear off my bench, and drag out my sharp-

ening supplies. That's where this sharpening station comes in. It gives you a dedicated sharpening area that's ready to go at a moment's notice.

So what makes this cabinet a "sharpening" station? First, it has plenty of storage for all your sharpening tools — sharpening

stones, jigs — even a grinder. But more important, it features a sliding top that opens to reveal a drop-in plastic tub. You can fill the tub with water and use it with your waterstones — just like a sink. Then simply empty out the tub and slide the top closed when you're done sharpening.

# Exploded View Details

OVERALL DIMENSIONS:  
22½" D x 36" W x 44½" H

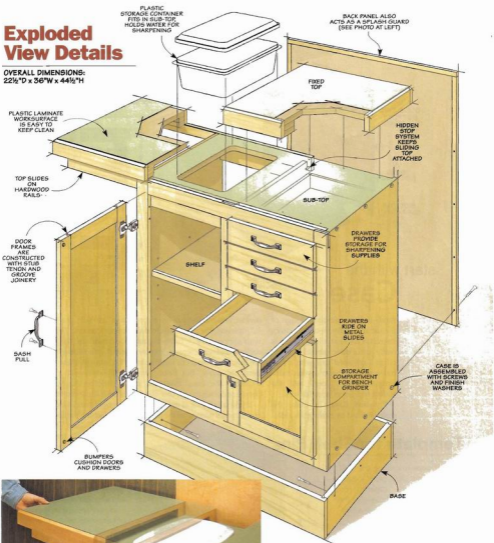

To download a free cutting diagram for the Sharpening Station, go to: [www.ShopNotes.com](http://www.ShopNotes.com)

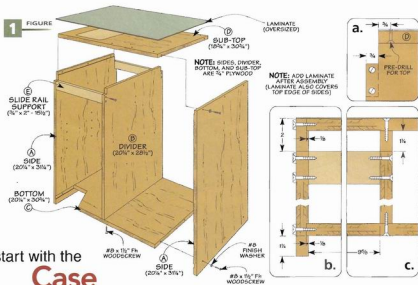

## start with the Case

Aside from the unusual design of the sliding top (more on this later), the rest of the sharpening station is really just a basic cabinet. It starts off as a plywood case with a face frame and a sub-top covered with laminate. Later, you'll add the sliding top, doors, and drawers.

**Plywood Case.** To make the case, I started by cutting the sides,

divider, bottom, and sub-top out of  $\frac{3}{4}$ " plywood. The case is assembled with simple joinery (rabbets and dados) and some screws. You can see how these pieces fit together in detail 'b' above. But before you assemble the case, there are a couple of details to take care of.

If you take a look at the drawing above, you'll notice that the divider

and left side are notched in the upper corners. This is to provide clearance for the rails that will attach the sliding top to the case. You can cut these notches on the table saw or with a jig saw.

The other thing you'll need to do is drill some countersunk holes in the right-hand side of the sub-top for attaching the fixed top that will be added later (Figure 1a). It's easier to drill these holes now, before the case is assembled. When this is done, you can go ahead and glue and screw the case together.

**Slide Rail Supports.** With the case assembled, the next step is to add a couple of slide rail supports. These are nothing more than a pair of hardwood pieces that will support the rails of the sliding top. They're cut to fit between the divider and the left side, as shown in Figure 1. Then they're simply screwed in place, as illustrated in Figures 1b and 1c.

**Sub-top Laminate.** Another detail to take care of at this point is to apply plastic laminate over the sub-top and top edges of the sides.

## Template for Shelf Pins

When it came to drilling the shelf pin holes, my drill press simply didn't have the capacity. So instead, I drilled the holes after the case was assembled, using a template and a hand-held drill.

The template is just a piece of plywood with two rows of evenly spaced holes (see drawing at right). To use the template, simply place it against the side of the case, flush with the front edge. After drilling the first two rows of holes, slide the template flush to the back of the case and drill the third row. Then repeat the process on the divider.

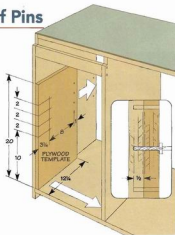

I cut the laminate slightly oversized, and then just flush-trimmed it after it was glued down. Shop Note: You'll need to remove the screws and finish washers on the case sides to flush trim the ends.

After the laminate is in place, you can cut out the opening for the plastic tub with a jig saw. (For more on this, see page 14.)

**Shelf Pin Holes.** Before moving on to the back and face frame, you can drill three sets of shelf pin holes in the left side and divider of the case. This will provide plenty of support for the deep shelf added later. The box on the opposite page will show you how.

### ADD A BACK & FACE FRAME

Once you've completed the cutout, all you have left to do is make a back and a face frame (Figure 2). And after this is done, you'll add a base to complete the case.

**The Back.** The back couldn't be much simpler. It's just a large piece of plywood with some hardwood edging on the top and sides. I made the back taller than the rest of the case for a couple of reasons. First, it creates a "backsplash," just like you'd see in a kitchen or bathroom. And second, it provides a ledge for attaching a worklight.

**Face Frame.** The face frame is pretty straightforward to build. It consists of two rails and three stiles — all joined with half laps. (For more on cutting half laps, you can read the article on page 26.)

The real trick in making the face frame is to size it correctly. The

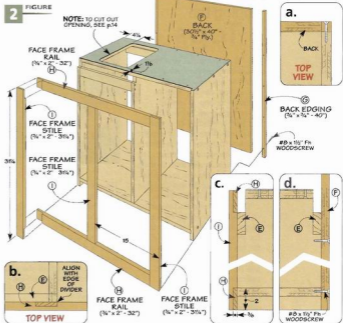

overall size of the frame should match the front of the case, minus the laminate on top. But you also want to pay close attention to the location of the center stile. It should be positioned so that the right edge is flush with the face of the divider, as shown in Figure 2b.

**Adding the Base.** The last step to complete the case is to add a base. As you can see in Figure 3,

this is nothing more than a front, back and two sides that are joined together with tongue and dado joints. The only tricky thing about making the base is sizing it so that it fits into the recess in the bottom of the case. To do this, I cut the front and back of the base first, sizing the pieces to fit between the sides of the case. (It's a lot easier to do this with the case flipped upside down.) Then after cutting dadoes in the ends of these pieces, I set them in place in the bottom of the case and measured for the length of the base sides.

After cutting a tongue on each end of the base sides, you can glue the base up and screw it in place to the sides of the case (Figure 3a). Now you're ready to move on to making the sliding top.

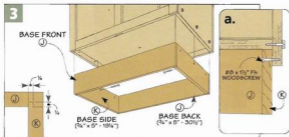







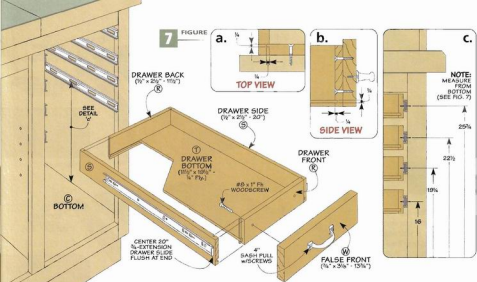

## making the Drawers

At this point, the case is more or less complete. All you have to do now to finish the sharpening station is add the drawers and doors. Let's start with the drawers.

**Simple Drawers.** If you take a look at Figure 7, you'll see that

there's nothing complicated about the drawers. Each one is made up of a front, back, and two sides, joined with simple tongue and dado joints. A groove on the inside face of each piece holds a plywood drawer bottom. Finally, a hardwood false front is added to each drawer.

One feature that makes building the drawers go quickly is that

they're all the same size. So you can make them in assembly-line fashion, cutting out the parts first and then working on the joinery.

Another thing about the drawers that deserves mention is how they're mounted in the case. Each drawer travels on a pair of 3/4-extension metal drawer slides. These drawer slides are designed to be mounted on the inside faces of the case side and divider flush with the face frame.

But if you take look inside the case, you'll see that the outer stile of the face frame overlaps the right side panel of the case. So in order to provide a flush surface for mounting the drawer slides, you'll have to add a filler panel to the inside of the case. For more on this, see the box at left.

**Add False Fronts.** After all the drawers are assembled and mounted on their metal drawer slides, you can go ahead and add the false fronts. Waiting to add the false fronts until after the drawers are in the case means you can "tweak" the false fronts so that you end up with perfectly even gaps (1/8") between each drawer.

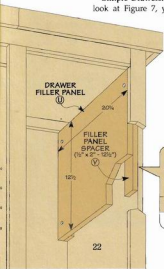

## Filling in the Space

In order to create a flat surface that is flush with the edge of the face frame, I added a filler panel to the right side of the case.

The filler is just a plywood panel cut to fit between the face frame and the back of the case. A pair of hardwood blocks are planned to fit and then sandwiched between the filler panel and the side of the case. This brings the panel flush with the inside edge of the face frame.

Once this filler panel is screwed in place, you can install the drawer slides and add the drawers to the case.





sharpening

# Stone Holder

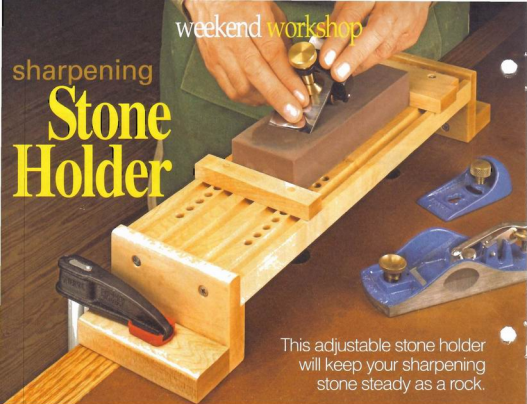

This adjustable stone holder will keep your sharpening stone steady as a rock.

■ If you've ever tried to do any sharpening on top of your workbench, you probably know how frustrating it can be. First, with the sharpening stone sitting on the surface of the bench, there's just not enough knuckle room to sharpen comfortably. Then there's the mess it creates. And most annoying of all, I feel like I'm chasing the stone all over the bench as it slides around while I'm sharpening.

Fortunately, this sharpening stone holder solves all those problems. The stone rests on a wide platform and is held in place by a simple system of wedges and cleats. Flutes in the platform catch any slurry that may run off the stone, keeping your workbench from getting messy. And a pair of

supports lift the platform and stone up off your workbench to a more comfortable working height.

**Platform.** To make the stone holder, I started with the platform. As you can see in the drawing on the opposite page, this is nothing more than a piece of hardwood. The flutes are made on the router table, using a core box bit. Then two rows of holes are drilled in the platform to hold an adjustable cleat that is added later.

**Add the Supports.** The platform rests on a pair of L-shaped supports. As the drawing

on the opposite page shows, there's not much to making the supports. Each one is made up of two pieces — a vertical leg and a horizontal foot. The feet allow you to clamp



▲ **Wedges Hold the Stone Tight.** A pair of wedges hold the sharpening stone tightly against an adjustable cleat at the other end.

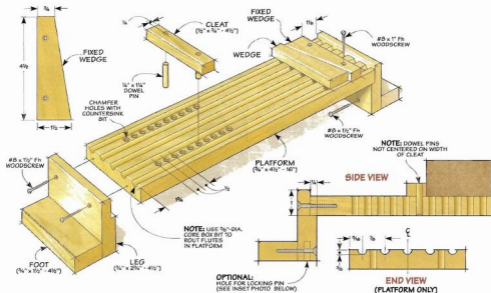

the stone holder to the top of your bench. And a rabbet cut along the top edge of each leg holds the platform. Once the supports are assembled, they can be glued and screwed to the platform.

**Wedge & Cleat System.** The last part of the stone holder to make is the wedge and cleat system that holds the stone in place. The principle behind this is about as basic as it gets. At one end of the stone, an adjustable cleat serves as a stop. Then at the other end, a pair of opposing wedges are used to hold the stone tightly against the cleat.

The adjustable cleat is nothing more than a narrow piece of hardwood with a couple of dowel pins that fit into the holes in the platform. But the thing to note here is that the dowel pins aren't centered on the width of the cleat (see Side View drawing above). This way, you can get two different cleat positions out of each pair of holes by simply turning the cleat around. This allows you to accommodate sharpening stones ranging from 6" to more than 10" in length.

After making the cleat, I cut the two hardwood wedges. The fixed wedge gets screwed to the top of the platform, as shown. The adjustable wedge just fits in between the stone and the fixed wedge.

**Finish.** Finally, to seal the wood and protect the stone holder from the water and inevitable slurry that is created while sharpening, I brushed on three coats of an outdoor, spar varnish.

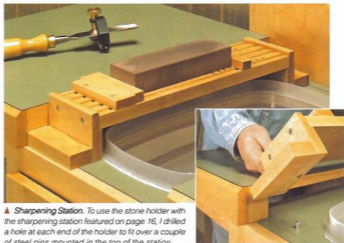

▲ **Sharpening Station.** To use the stone holder with the sharpening station featured on page 16, I drilled a hole at each end of the holder to fit over a couple of steel pins mounted in the top of the station.

# perfect Half Laps on the table saw

Versatile, strong, and easy. Half laps are the ultimate no-fuss table saw joint.

■ Half laps are high on my top ten joint list. For cabinet face frames, doors, case web frames, or any place you need a strong, rigid frame, half laps can take on the job. But the best thing about half-lap joints is that cutting them doesn't require any tricky setups or a lot of fussy work. All you need to cut perfect-fitting half laps in a short amount of time is a table saw and a dado blade.

**Just Like it Sounds.** A half lap joint looks just like you'd expect. Half the thickness of each workpiece is cut away so that the two pieces overlap with flush faces. As you see in the lower left drawing,

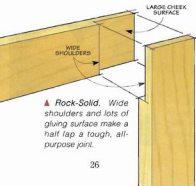

you get a large amount of gluing surface and the deep shoulders keep the joint square and rigid.

**The Goals.** There are two things you want to get right when cutting half laps. First, to end up with perfectly flush faces, the depth of the cuts needs to be on the money. Next, when the joint is assembled, the frame pieces should be square with the outside edges flush. This simply means the cheeks of the joint have to be cut to the right length and with square shoulders.

## SETTING UP

When it comes to half laps, the key to success is to keep things in order. And the first task is to cut all the parts to size. If you get this done all at once, you can set up the saw for cutting the joinery and not waste time switching back and forth from one setup to another.

When you're sizing the parts for a half-lap frame, keep a couple things in mind. First, to end up with equal halves and flush faces, all your stock has to be the same thickness. And next, remember this: since each half of the joint has a full overlap, all the parts of a half

lap frame run full length. This makes sizing the parts foolproof.

Once your parts are cut and stacked, you can set up for half laps by simply installing a wide, stack dado on the table saw and a fresh auxiliary fence on the miter gauge to back up the cuts.

**Find the Depth.** When I'm ready to start on the joinery, I set the workpieces aside for a bit. First, I use a couple of cutoffs that are the exact thickness of my workpieces to adjust the blade height. Figure 1 above shows how this works.

Make a quick "halfway point" mark on each piece and then set the dado blade a little bit below the mark. After you make a cut across the end of each piece, simply overlap them to check the result.

Raise the blade slightly and repeat the process until the faces fit flush, as in Figure 1a. Remember that since you're cutting both pieces, the blade adjustment is doubled, so take it in tiny steps.

And be sure to keep firm downward pressure on the pieces as you make the cuts. You don't want the workpiece to ride up on the blade and give you a false test result.

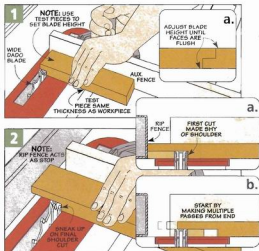

**Cut the Cheeks.** At this point, you can set aside the test pieces and turn to the actual workpieces. With the depth set, the only trick now is to cut the cheeks of the joint square and to the right length.

An easy way to get this done is shown in Figure 2 at left. The miter gauge and auxiliary fence will ensure a clean, square shoulder while the rip fence acts as a stop to help you cut the joints to the right length.

First, set the rip fence so that the distance from the outside edge of the blade to the fence is about  $\frac{1}{8}$ " shy of the final cheek length. Then pick up one of the workpieces and make your first pass, as shown in Figure 2a. Slide the workpiece back and maintaining steady downward, start rubbing away the waste from the end, as shown in Figure 2b.

**Test Fit.** When all the waste has been turned to saw dust, do a quick test by lapping the workpiece over its mating piece. Since the fence

isn't set to cut the cheek to final length, the end won't be flush. But now it's easy to see how far to cut back the shoulder for a perfect fit. Just sneak up on the final cheek length by adjusting the fence away from the blade until the fit is flush.

Now that you've used the first piece to fine tune the setup, you can go ahead and cut the remaining joints. When all the pieces are equal width, this one setup will do the job.

**The Glueup.** The only catch to half laps is that gluing up the frame requires a few extra clamps. On a half-lap joint, neither piece is "captured," so this means you need to clamp the pieces in all directions. The photo above shows this clearly.

First, loosely clamp across the frame both ways. Next, apply a short clamp over the joint to pull the cheeks together. Tighten all the clamps, check for square, and that's it. A perfect half-lap frame.

**▲ More Clamps.**  
Assembling a half-lap frame is easy with the help of a few extra clamps.

## In the Middle: Half Lap

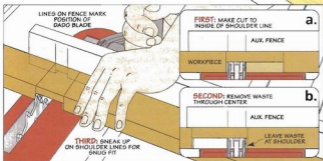

**T-Joint** ▶  
Half laps are a great way to create a strong joint in the middle of a rail or stile.

Half laps are also a great way to join two pieces together in a T-joint, as shown in the drawing at right.

To do this, the half lap on the end of the first piece goes just the same. Then lay this half lap over

the mating piece to mark a layout of the other half of the joint.

To cut this part of the joint, I don't use the rip fence. It would be too far from the blade to make a reliable stop. Instead, you can mark

the lines of the dado blade cut on the auxiliary fence to act as your guides. With this extra help, you can simply follow the steps in the drawings above to complete a snug-fitting joint.

japanese

# Saw Handle Upgrade

All it takes to dress up the handle of your Japanese saw is a few hardwood scraps and a little time.

What I like the best about this project is it doesn't take a lot of time and it's a good way to use up some hardwood scraps I had squirreled away. I made my handle from contrasting woods, but feel free to use this technique to make a handle any way you like.

The type of Japanese saw I used is called a *dozuki*, or back saw. These saws have a steel back that supports the thin blade. The back can run the full length of the blade or just part way, like the one you see here. This handle design will work great with both types of saw.

In the original handle, the blade and back slip into a pocket cut in the softwood handle. They're held in place by a retaining screw. To make the new handle, you'll need to pull out both the blade and back.

Sandwich. The drawings on the opposite page give you a pretty good idea about how I made the handle. It's a sandwich made from a pair of sides or cheeks glued to a center spine. But there are a few details I'd like to point out.

**Spine.** The first detail is the spine. It's the most important piece of the handle. So I took a little extra care to make sure everything was just right before moving on.

I made the spine from a piece of hardwood. And the reason is simple. For the screw that holds the blade and back in place, you'll need to "tap" threads in the spine. In softer wood, the threads will likely strip out rather quickly.

After selecting the material for the spine, the next thing to look at is its thickness. The thickness of the spine should be a perfect match to that of the saw back, as shown in the End View on the opposite page. If it's too thin, sliding the saw blade and back into place could cause the handle to split. If the spine is too thick, the blade and back won't fit snugly and they'll fall out easily.

At this point, the width of the spine isn't critical. To make the handle easier to shape later on, I made it extra-wide (about  $\frac{1}{8}$ ").

There's just one final detail to note on the spine. And that is a notch that gets cut in one end. Once the cheeks are glued in place, this notch forms the pocket where the blade and back will rest. I used the saw back as a pattern to lay out the notch on the spine, as shown in the Side View on the opposite page.

**Cheeks.** Once you have these details taken care of, making the

There's no doubt about it. I really like the way my Japanese saw works. The razor-sharp blade cuts quickly on the pull stroke and leaves a narrow kerf. And it leaves a smoothly cut surface that's perfect for precise joinery.

The saw has all the makings of a high-quality tool — except for the handle, that is. So I decided to dress it up with a new one that looks as good as the saw cuts, like you see in the photo above.





rest of the handle is a snap.

The only other parts to make are the cheeks. And as I mentioned earlier, you can make these any way you choose. I made each cheek out of three parts — a long side with contrasting beveled blocks glued on each end, as illustrated in Figure 1. Here again, like the spine, I left the cheeks extra-wide for shaping.

**Retaining Screw.** Before moving on to shaping the handle, there's one thing left to do. I drilled the hole for the retaining screw in the spine while the blank was still square. This makes it a lot easier to drill an accurate hole. The blade and back come in handy here as a guide for locating the hole position, as you can see in Figure 2.

This pilot hole should be a little smaller than the screw so that it can cut threads in the spine. Once this is done, you can shape the handle. The box below gives you the details you need.

After applying a few coats of finish (I used spray lacquer), you're ready to put your "new" fine tool to use. 🛠️

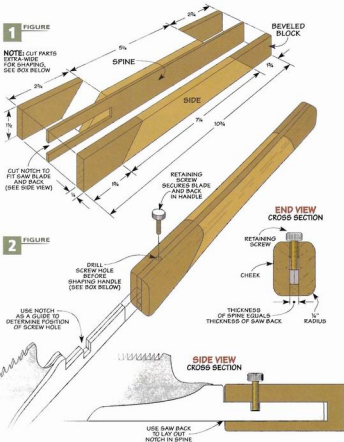

## Curved for Comfort

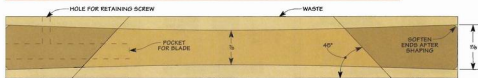

To make the new saw handle more comfortable to use, I cut a slight curve on the long edges. As you can see in the drawing above, I didn't take much off, but it's enough to give the handle a sure, easy grip. The cuts are made at the band saw, after first laying them out on the

workpiece. You'll notice I'm working with an extra-wide blank. This makes it easier to get an even curve on both sides with no flat spots. After cutting the curves, I sanded them smooth before routing a  $\frac{3}{8}$ " roundover, as shown in the End View above.

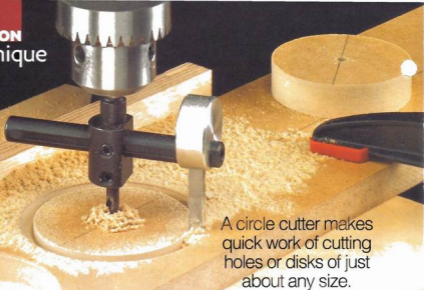

A circle cutter makes quick work of cutting holes or disks of just about any size.

## getting great results with a **Circle Cutter**

■ Cutting a large, circular hole is a challenge. You can try to find a Forstner bit the right size. But if you have more than a couple different sizes to drill, that can get expensive. And it's impossible to find a Forstner bit any larger than 4". The solution — a simple circle cutter.

**How It Works.** As you can see in the photo above, a circle cutter,

or wing cutter as it's sometimes called, looks quite a bit different from most other drill bits. And it works differently as well. You can see what I'm talking about in the left drawing below.

Instead of a cutting edge that removes all the waste to form a hole, a circle cutter only cuts a narrow, circular groove through the workpiece.

To do this, there's a cutter attached to the end of an adjustable arm. It's the arm that allows you to set the cutter for a wide range of sizes (see photo on opposite page and refer to sources on page 51). Note: Circle cutters have a maximum depth of cut of about  $\frac{3}{8}$ ".

**Holes & Wheels.** There is one thing I should mention at this point. When you're shopping for a circle cutter, you'll find two types, like the ones at the top of the opposite page. The cutter on the left does a good job cutting holes. But if you need to cut both holes and disks (or wheels), you'll want to consider the circle cutter on the right.

You might be asking yourself, "If I cut a hole, doesn't that leave me with a disk once I'm done?" That's true, but the disk will have a rough edge and ridge of waste on the bottom that isn't completely cut free.

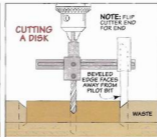
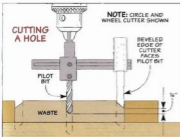

**Double Cutter.** To avoid this problem, the circle cutter at the far right has two cutting edges. With the bevel facing in (left drawing on opposite page), you can cut a hole with a smooth edge. And if you flip the cutter end for end (right drawing), you can cut a disk that's just as smooth.

Sure, you can use a single-edged cutter to make a wheel. Just be prepared for a rougher edge that needs a little extra sanding.

### USING A CIRCLE CUTTER

Using a circle cutter seems simple enough — adjust the arm so the cutter matches the size of the hole (or disk) you want and start cutting. But there are a few things you'll want to keep in mind.

For starters, always use a circle cutter in a drill press. It just isn't safe to use one in a hand-held drill. Then to minimize vibration and stress on the cutter, set the pilot bit so it enters the workpiece before the cutter (left drawing on opposite page).

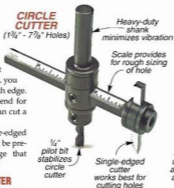

### CIRCLE & WHEEL CUTTER (1 1/4" - 6 1/4" Holes, 3/4" - 6 1/4" Disks)



Then before you start to make a cut, check to see that your drill press is set to its lowest speed. Speeds above 500 RPM cause the cutter to vibrate more, resulting in a rougher cut. Plus, the heat that results will dull the cutter more quickly.

I've never found the scale on a circle cutter to be very accurate (if it has a scale at all). So once you have the cutter set, make a test cut. This way, you can fine tune the setting.

For a few more handy tips to help you get better results, check out the box at the lower left.

**Sharpening a Cutter.** But those tips won't be of much use if the cutter you're using is dull. To learn more about how to sharpen a cutter, take a look at the box below.

Once the cutter is sharp, you'll find that using a circle cutter to make a hole or disk of just about any size will be a snap. 

## Quick Tips

*Never use a circle cutter with a hand-held drill*

*Set the drill press to 500 RPM, or less if possible*

*Avoid loose fitting clothing and always wear protective goggles*

*Securely tighten the set screws for the pilot bit, cutter, and adjustable arm*

*Clamp workpiece securely to the drill press table*

*Make sure the pilot bit engages workpiece first*

*Make a test cut to check circle size, then readjust the cutter as required*

*Sharpen cutter often (see box at right)*

## Getting a Better Edge: Sharpening the Cutter

Although it's called a circle cutter, the actual process is really a scraping action. This generates a lot of heat and can dull a cutter very quickly — and forcing the cutter to work by applying more pressure with the drill press isn't the answer.

Instead, it's better to keep the cutter in tip-top shape. The nice thing is it doesn't take a lot of work to do this.

The important thing is to think of the cutter just like you would a chisel. The cutting edge is formed by the back and bevel coming

together in a nice sharp edge. So the first thing to do is flatten the back of the cutter (left photo).

Once the back is flat, all that's left to do is hone the bevel. I do this by drawing the cutter toward me, as in the right photo.



**▲ Flatten & Hone.** The first step in sharpening the blade of a circle cutter is to flatten the back (left photo). Once that's



complete, you can hone the bevel. I find it works best to do this by holding it flat against the stone and drawing it back (right photo).

best-built  
jigs & fixtures

# adjustable Spindle Sander

Turn your  
drill press into  
a heavy-duty  
sander for smooth-  
ing curved edges.

■ Anything that makes the task of sanding even remotely bearable is a plus in my book. And that's a good reason to take a look at the spindle sander shown at right.

As you can see, this spindle sander clamps to the table of your drill press. The table of the spindle sander adjusts up and down so you can make full use of a set of tall ( $5\frac{1}{2}$ " ) sanding sleeves. The sleeves fit over shop-made drums that are powered by the drill press. All you have to do is slip the top of the drum into the chuck and lock it in place.

And for the really nice feature — you won't have to worry about stirring up a lot of sanding dust. There's a dust port on the back side of the base for hooking up the hose of your shop vacuum.



## Materials

A	Baseplate (1)	9 x 10 - 1/2 Ply.
B	Base Front/Back (2)	8 1/4 x 6 - 1/4 Ply.
C	Base Ends (2)	3 1/4 x 6 - 1/4 Ply.
D	Bearing Support (1)	2 1/2 x 2 3/4 - 1/4 Ply.
E	Table Front/Back (2)	10 x 6 - 1/4 Ply.
F	Table Ends (2)	5 x 6 - 1/4 Ply.
G	Dust Port (1)	3/4 x 3/4 - 1/4 Ply.
H	Top (1)	12 x 16 - 1/4 Ply.
I	Table Inserts (5)	4 1/4 x 4 1/4 - 1/4 Hdbd.
J	3/4"-Dia. Drum Cores (6)	1/4 x 1/4 - 1/4 MDF
K	1"-Dia. Drum Cores (6)	1 x 1 - 1/4 MDF
L	1 1/2"-Dia. Drum Cores (6)	1 1/2 x 1 1/2 - 1/4 MDF
M	2"-Dia. Drum Cores (6)	2 x 2 - 1/4 MDF
N	3"-Dia. Drum Cores (6)	3 x 3 - 1/4 MDF

## Hardware

- (12) #8 x 1 1/2" Fh Woodscrews
- (2) 3/8" T-Nuts
- (2) 3/8" x 1 1/4" Fender Washers
- (2) 3/8" x 1 1/2" Studded Knobs
- (1) 1/2" Flange Bearing
- (5) 3/4"-20 x 7 1/2" Threaded Rods
- (5) 3/4"-20 Coupling Nuts
- (5) 3/4"-20 x 1/2" O.D. x 1/2" Threaded Nylon Spacers
- (6) 3/4" x 1" Fender Washers
- (4) 3/4" Flat Washers
- (1) 12" x 16" Plastic Laminate
- (1) 12" x 16" Neoprene Rubber (1/4" Thick)

## Exploded View Details

OVERALL DIMENSIONS:  
12"D x 16"W x 7 1/2"H (TOP LOWERED)  
12"D x 16"W x 11 1/2"H (TOP RAISED)

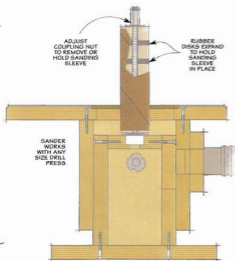
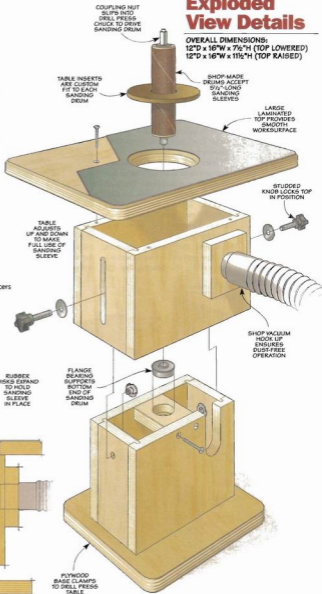

SIDE VIEW CROSS SECTION



fit the end of your shop vacuum hose. After assembling the table, you can add a dust port with a matching hole (Figure 1).

**Add the Top.** All that's left to complete the table is to add the top you see in Figure 3. After cutting the top to size, the next step is to add a rabbetted opening to support the sanding drum inserts.

To do this, you'll need to drill a hole in the top that's centered side to side. But to provide more working room at the front of the top, the hole is positioned closer to the back (Figure 3). (For more on drilling large holes, turn to page 30.)

Once you have the hole drilled, you can screw the top in place. To provide a smooth work surface, I added some plastic laminate and then chamfered the edge, as illustrated in Figure 3b.

**Supporting the Insert.** The next step is to create the ledge that the sanding drum insert rests on. I used a rabbeting bit to create a  $\frac{1}{8}$ "-wide

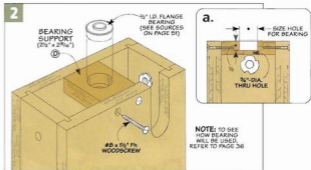

ledge. Note: You'll need to drill an access hole through the laminate for the bit. And be sure to adjust the cutting depth to match the thickness of the hardboard you plan to use for the inserts.

All that's left at this point is to make the hardboard inserts, like you see in the photo at right. For more on this, turn to page 15.



▲ **Custom-Fit Inserts.** To provide solid support for the workpiece and ensure good dust collection, you'll need to custom fit each insert to the table and sanding drum. To learn more about how to do this, turn to page 15.

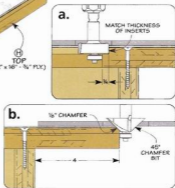
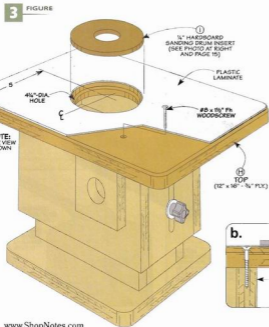

## Layered Sanding Drums



▼ **Sanding Drums.** Sanding sleeves come in a wide range of diameters, lengths, and grits. The 5 1/2"-long set shown below consists of a 3", 2", 1 1/2", 1", and 3/4"-dia. sleeve for handling just about any task.

With the base and table of the spindle sander complete, all that's left to do is make the drums that the sanding sleeves fit over.

Sanding sleeves come in all sorts of sizes, lengths, and grits. (For sources of sanding sleeves, turn to page 51.) In the photo above, you can see the set of five sizes I made. The drawing below shows how a sanding drum goes together.

**Layer by Layer.** The drum is really nothing more than a "layer cake" formed by alternating MDF disks and rubber gaskets. The key to how well the sanding drum works is the rubber gaskets.

After the sanding sleeve is slipped over the drum assembly, you tighten the coupling nut at the top. This squeezes the MDF disks

against the gaskets just enough to make them bulge slightly. They press against the inside of the sanding sleeve to lock it in place, as in the detail below.

**Setting Up for Sanding.** There isn't much to setting the spindle sander up for sanding. You simply slip the coupling nut into the chuck of your drill press and tighten it down. Then, to support the bottom end of the sanding drum, simply raise your drill press table until the nylon spacer at the bottom of the sanding drum slips into the bearing in the base, like you see in the margin photo at left.

After locking the drill press table in place and clamping the base of the spindle sander to it, you're ready to sand. As I mentioned before, you can make full use of the sanding sleeve by simply loosening the knobs on the table and adjusting it up or down as necessary.

For the step-by-step process for building a sanding drum, take a look at the opposite page. It'll cover everything you need to know to make each sanding drum.



▲ **Solid Support.** To support the bottom of the sanding drum, the nylon spacer fits into a flange bearing.

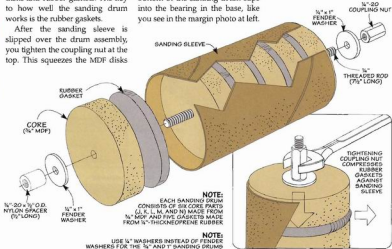

**NOTE:** EACH SANDING DRUM CONSISTS OF SIX CORE PARTS (J, K, L, M, AND N) MADE FROM 3/4\"/>

**NOTE:** USE 1/2\"/>



# Step-by-Step Drum Assembly

The first step in making a sanding drum is to cut a set of MDF disks to form the core. You'll need six disks for each 5½"-long sanding sleeve.

**MDF Core.** For an easy fit, I used a circle cutter to size the MDF disks so they just slipped inside the sanding sleeve (top left photo below). For more on using a circle cutter, turn to page 30.

**Working with Rubber.** The next step is to cut a set of rubber gaskets. I found it almost impossible to cut perfectly circular gaskets from the ¼"-thick neoprene rubber material I used. (For sources, see page 51). So instead, I cut oversized squares and then punched a hole for the drive shaft in the center of each gasket (top right photo below).

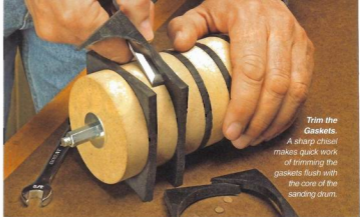

**Trim the Gaskets.**  
A sharp chisel makes quick work of trimming the gaskets flush with the core of the sanding drum.

**Assembly.** To assemble the drum, cut a piece of ¼" threaded rod to length (7½"). Then use epoxy to glue a single MDF disk and washer in place, leaving room for the nylon spacer (lower left photo).

The rest of the drum goes together by gluing alternating layers of MDF and rubber gaskets. Just be sure you don't glue these to the

drive shaft. This way, when you tighten the coupling nut, the "loose" MDF disks and gaskets will compress without any problem.

After adding a washer and coupling nut at the top, you're ready to trim the gaskets flush. To do this, I "snugged up" the coupling nut just a bit and then used a sharp chisel, like you see in the photo above. 



▲ **Size the Disks.** The first step in building a sanding drum assembly is to use a circle cutter to size the MDF disks so they just slip inside the sanding sleeve.



▲ **The Gaskets are Next.** After cutting squares of rubber to size, create a hole for the drive shaft with a hollow steel punch.



▲ **Assemble the Drum.** To assemble the drum, start by gluing a washer and MDF disk in place near the end of the drive shaft. Then screw the nylon spacer in place.



▲ **One Layer at a Time.** Next, build up the assembly by alternating the rubber gaskets with the MDF disks and gluing them together with contact cement.

Getting  
Connected

There's more to getting air from your compressor to an air tool than you might think.

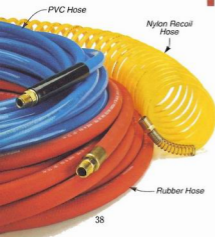

Getting your first air compressor and air tool is exciting. But in all the excitement, you might not give much thought to a couple key things that really affect how much you enjoy using your compressor. And that's the air hose and fittings that actually move the air from the compressor to the tool.

**An Inexpensive Start.** The most visible part of that connection is the air hose. And it's probably the thing you'll wrestle with the most — literally. Especially if you buy a compressor kit and the hose they throw in is like the blue hose at left.

This inexpensive hose is made from polyvinyl chloride (PVC) — the same kind of material you'll find in inexpensive garden hoses

and other plastics. It's low-cost and tough as nails. You can drag it around the shop and give it quite a bit of abuse without worrying about damaging it.

But there's one drawback. No matter how neatly you try to roll it out, it has a "memory" that makes it want to coil right back up. And in cold weather, it gets so stiff that using it is a big hassle.

**The Recoil Advantage.** One hose you should consider adding to your system is the yellow, nylon recoil hose shown at left. This hose relies on its memory to do its job.

A recoil hose looks like a giant spring. And it's this "spring" memory that makes a recoil hose self-retracting. This keeps it out of

the way when don't need it. But it easily uncoils when you do. (I have mine hanging over my workbench.)

One thing to be aware of is that a recoil hose won't stretch out completely. At best, it'll probably stretch a little over half its length. Pull much more and you'll likely kink it.

**Upgrade to Rubber.** Like a PVC hose, a rubber hose (red hose on opposite page) is tough and durable. But there is an important difference. A rubber hose tends to lay out straighter and stay that way — even in cold weather. A rubber hose will cost a little more, but it's worth it to me.

In a woodworking shop, a rubber hose will probably last forever. But if you ever have to replace a hose (or just decide you need to add to your collection), check out the box below for the latest in air hoses.

**How Long?** Something I haven't mentioned yet is what length hose to buy. Air hoses range from 10' to over 100'. You'll need to choose a hose that reaches anywhere you need air. But

it's best to go with a short hose if at all possible. It's a whole lot lighter to haul around and it won't get tangled up underfoot as much.

But don't be tempted to move your compressor closer and hook up an extension cord. This just makes the compressor motor work harder. Instead, leave the compressor where it's at and use the right length hose.

Along the same lines, 3/4" (I.D.) hoses work just fine for most air tools. But if you plan to use a real air hog, like a sander, or need to run a hose more than 50', go with a 3/8" or larger hose. This will keep the air pressure from dropping too much.

**Fixing a Hose.** Almost any hose can spring a leak — usually right in the middle of something important. Fortunately, repairing a hose doesn't take much work. All you need is an inexpensive repair kit (see right).

**Final Connections.** Once you have a hose, all that's left to get are the fittings that connect things together. Turn the page to learn more.

## on the mend: Hose Repair



▲ **Hose End Repair.** A barbed-end fitting and hose clamp make quick work of repairing the end of a hose.

▲ **Joining the Middle.** For fixing the middle of a hose, a double-barbed coupler and a pair of hose clamps are all you'll need.

▲ **A Clean Fix.** A barbed-end fitting and threaded ferrule make for a clean hose end repair. ▼

▼ **Smooth Repair.** You won't catch anything on the coupler and threaded ferrules that connect these two hose sections. ▼

## what's new: Buying a Better Hose

If you're thinking about replacing a hose or two (or you're just starting out), you might want to give the FLEXEEL hose shown below some serious consideration. (For sources, see page 51). Now, you might be wondering what makes this new hose so much better.

Well, for starters, it's about half the weight of a rubber hose. Now that might not seem like a big deal, but hauling a heavy hose around or coiling it up to store can be a hassle. And don't think the light weight means light duty.

This hose is

made from reinforced polyurethane. So it's almost impossible to kink and it's virtually crush-proof. Since the hose is translucent, you can actually see the braiding that reinforces the hose.

Plus, you don't have to worry too much about the "memory" that most hoses seem to have. With the FLEXEEL you can "release" most of the memory by pulling on the hose until it "crackles." I know. It sounds strange, but it works. And in cold weather, the hose stays just as flexible and easy to work with.

Of course, there are a couple downsides. The hose costs more (about double) than a rubber hose. And a hot ember or ash can damage the hose by melting through it. So it's not good for any area where welding or other "hot" jobs are going on. Even so, repair is quick and clean, as shown in the photos at right.

## the right Fittings for air



▲ A (Aero)



▲ IM (Industrial)



▲ T (Tru-Flate/  
Automotive)



▲ Lincoln

The other half of connecting your compressor to an air tool is the fittings. Sure, you could connect the hose straight to the compressor and tool. But that's not a good idea.

For starters, it "locks" everything together. So changing over to another air tool is a hassle. But the bigger reason not to do this is the tool will always be pressurized — which isn't safe.

**Quick Disconnects.** Instead, you'll want to invest in quick-disconnect fittings — plugs and couplers. A quick disconnect makes it fast and easy to change from one tool to another, yet still ensures a leak-free system.

A plug (photos at left) is the male end of the connection. It slips into a female coupler (margin on opposite page) and locks into place.

### PLUGS

The important thing to know is that a plug is a straight-through (hollow) fitting. Air flows through one end of the fitting and back out

the other end. And it's important that a plug does this.

This way, whatever has a plug on it won't remain pressurized once you disconnect the air hose. That's the reason you should always install a plug in each air tool you have. (For making sure you have air-tight fittings, check out the box below.)

So if you inadvertently pull the trigger on a nailer as you pick it up to put it away, you won't need to worry about firing one last brad somewhere you hadn't intended to.

**Selecting a Plug.** You would think that selecting a plug would be simple. Any hardware or tool store will carry them — lots of them. And that's the problem.

With all the sizes, names, and letter designations out there, it can get pretty confusing. I use 1/8" fittings for my system. But just like hoses, you can use bigger fittings to allow for more air flow.

As for the names and letter designations, the main thing to keep in

mind here is that most of this came about from the original designers of the "interchanges."

So what exactly is an interchange? It's really nothing more than the external design of the plug and the internal design of the coupler it connects to. This is really easy to see on the plug, as the margin photos show.

And why so many? Originally, each manufacturer came up with their own design — essentially forcing you to always buy their "system." But these days, you'll find that many manufacturers make some version of each design. So this really isn't an issue any more.

What's more important to understand is that the designs are rarely interchangeable (more on this later). So it's important to choose one design and stick with it when you go about selecting both your plugs and couplers.

### COUPLERS

Unlike the plug, the coupler is a single-shutoff fitting. An internal valve shuts off flow on the pressurized side of the system when the plug is removed. This way, all that pressurized air isn't lost.

## air-tight connections: Keeping It Leak-Free

The best fitting and coupler there is won't be of much use if air leaks out where they connect to a tool or hose. To create a tight seal, you have a couple options.

If you've ever done any work with galvanized or black pipe, you probably have a can of pipe joint compound (photo at left) in your cabinet. And it works fine for sealing threads (right photo). But it can be a bit messy.

That's why I like to use Teflon tape (lower left photo). Simply wrap it around the threads clockwise and you're good to go (far right photo).



**Joint Compound.**

A couple dabs of joint compound will seal the threads when you screw the fitting in place.



**Teflon Tape.** A couple clockwise wraps of Teflon tape is a clean and easy way to seal any fitting.

As you might expect, the compressor will have a coupler installed. So that means you'll need to install a plug on one end of the hose (to mate to the compressor) and a coupler at the other end (to connect to the tool).

**Choosing a Coupler.** Once you've decided on a plug design, you've simplified the process of choosing a coupler — just match the size and design. Some couplers will have the design stamped on the sleeve (far right photo). So matching it up shouldn't be a problem.

If it doesn't, just slip the plug into the coupler and make sure it connects firmly. (There's nothing

more frustrating than getting back to the shop and finding out the plug and coupler don't mate when you really need them to.)

To make the connection, most couplers require you to hold the hose in place with one hand and pull the sleeve back. Then you push the plug in with your other hand and release the sleeve to lock the plug in place. It's almost as bad as trying to pat your head and rub your stomach at the same time.

**The Push Alternative.** That's why I like push-to-connect couplers. Instead of pulling back on the sleeve, you just push the plug into the coupler until it locks. Quick, simple, and a lot less hassle. To disconnect either type, just pull back on the sleeve and the plug "pops" free.

I mentioned earlier about sticking to one plug type. If you want more flexibility, you can use a universal coupler (see photo above). With it, the three major plug designs — the A, M, and T — will all lock in place securely.

**Standard Coupler.** With a standard coupler, pull back the sleeve to connect the plug ▼



▲ **Universal Coupler.** This universal coupler has a push-to-connect sleeve.



▲ **Stay Connected.** Some couplers (left) can disconnect if you catch the edge of the sleeve. A drag ring (right) or raised edge prevents this.

**Avoid the Disconnect.** Most couplers can disconnect if you catch the edge of the coupler as you drag it around. This isn't something you want happening in the middle of a task like spraying on a finish. A drag ring, as in the photo at left prevents this from happening.

**Final Details.** Hoses, plugs, and couplers are the key to a smoothing running compressed air system. And once you're set up, your compressed air system will work just fine. But there is one last thing you might want to add — and that's a swivel fitting. To find out more, check out the box below. 📦

## accessorize: Adding Flexibility



A hose and a couple fittings will get air from your compressor to your air tool. But there is one accessory I think you might want to take a look at. And that's a swivel fitting, like the ones at left.

One of the annoying things about using an air tool is that

once it's connected to the air hose, it always feels like there's a big weight hanging off the back end. Even a small change in the position of the tool forces you to swing the hose right along with the tool.

To solve this problem, I've added a swivel fitting to the end of most of my air tools. There are all kinds of styles, like you see at right. But each one is designed to allow you to change the position of the tool (within a small range) without the air hose feeling like it's a big drag on the end of the tool.



# breathe right for Safe Finishing

Finishing a project safely is just as important as operating your tools safely.

■ The work you do in the shop puts a number of different things into the air. And some of these materials can pose health risks if you don't properly protect yourself.

I use respiratory masks for two types of health hazards — dust and harmful vapors. And a different mask design is needed to guard against each these hazards.

**Types of Protection.** Dust and sawdust floating in the air require the most basic type of filter. It's nothing more than a thin cloth-like material. And it works like putting

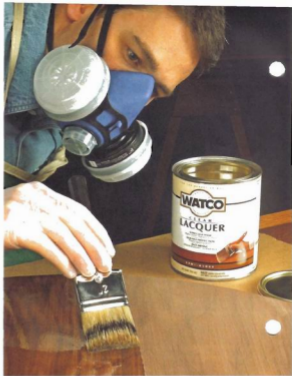

a handkerchief over your nose and mouth on a dusty day.

But when chemicals are present, you need something different. That's because chemicals often exist in the form of mists or vapors. And depending on the finishing material

or solvent being used, the risks can range from minimal to serious. So this is where you'll need to use a good respirator mask.

## TWO-STAGE PROTECTION

Most respirators, like those shown in the photos at left, provide two stages of protection. The first stage consists of a pre-filter that captures larger particles, like pigments and dust. It prevents them from clogging up the filter used in the next stage.

The second stage of protection is a small cartridge like you see in the illustration at the top of the next page. It's filled with small pieces of activated charcoal.

**Activated Charcoal.** This material is simply burned wood (carbon) that's been treated with a high concentration of oxygen. Treating it



with oxygen opens up millions of tiny pores in the pieces of charcoal. These pores play the important role of filtering out chemicals.

Activated charcoal is used because it's good at attracting organic (carbon-based) impurities. So when they pass next to the surface of the charcoal, they bond to it and become trapped in the pores in the charcoal. Once all the porous binding sites are filled, the charcoal filter stops working. That's when it needs to be replaced.

But there are many chemicals that aren't attracted to the charcoal—so they pass right on through. That's why you want to make sure you choose the right cartridge for the job.

### CHOOSING A CARTRIDGE

When choosing a cartridge, it's always important to read the label on the finish you'll be using. That way you'll know which gases, vapors, or chemicals the respirator cartridge needs to filter out.

The cartridge used for most finishing tasks should be rated for organic vapors and gases, lacquers, paints, and enamels. You'll find these black cartridges at most paint stores and home improvement centers (see color code chart at right).

**Be Aware.** These cartridges may not provide adequate protection from things like ammonia that's commonly used in wood fuming. Also, some furniture strippers and finishes contain methyl chloride, which may not be filtered out by this respirator cartridge.

You should also be cautious when using urethane finishes. These compounds are odorless. So they may not be detected if the filter becomes saturated or the respirator leaks.

If you're going to be using one of these finishes, your safest bet is to contact the manufacturers directly. They'll be able to recommend the specific cartridge you'll need for the finish or solvent you're working with. But even if you have the right cartridge, you still won't be protected unless the respirator fits on your face correctly.

### CARTRIDGE CROSS SECTION

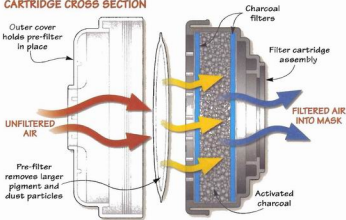

▲ **Filter Cartridge.** Air enters through a pre-filter where large pigment and dust particles are taken out. It then passes through carbon filters and activated charcoal to remove the chemicals before entering the mask.

### THE RIGHT FIT

The first thing you'll need to do is adjust the straps so that the face piece fits snugly on your face (an almost impossible task if you have facial hair). Be sure it doesn't leak around the face piece and that you can breathe in and out easily.

You shouldn't smell finishing odors while wearing the respirator. If you do, first try readjusting the mask. If the odor persists, you may need to replace the cartridge. And if that doesn't solve the problem, consider replacing the respirator.

**Proper Care.** A respirator should last you a long time. But you must

maintain it and store it properly to ensure that it always works right.

It only takes a little bit of time to keep your respirator in good shape. First, remove the cartridges and give the mask a good washing with mild soap after each use. It's important to rinse the mask thoroughly so that any detergent residue is removed. That way it won't harm the mask or irritate your skin the next time you use it.

Finally, dry it off completely. Then store it in a plastic bag away from temperature extremes, moisture, and vapors (remember how it works). That way it's ready to go the next time you need to use it.

## Cartridge Color Coding

*All manufacturers use the same color coding for cartridge protection. You should change the cartridge any time you taste or smell a substance, or if your throat or respiratory system becomes irritated.*

Organic Vapors	BLACK
Organic Vapors/Acid Gas	YELLOW
Acid Gas	WHITE
Ammonia Gas	GREEN
Particulate HEPA(P100)	MAGENTA
<small>Not for gas and/or vapors</small>	

# MASTERING THE Table Saw

get top-notch results with

## Pattern Cutting

Have you ever faced the task of making multiple copies of an odd-shaped workpiece and not had any idea how to get the job done? So you stand staring at a pile of wood and hope that a sudden inspiration will provide the solution. Well it could be that the answer you're looking for is the table saw trick of pattern cutting.

This technique allows you to duplicate straight-edged work-

pieces on the table saw accurately and quickly. The large dividers and shelves of a corner cupboard, as shown in the photo above, are a good example. But any hard-to-cut workpiece with straight sides is fair game for pattern cutting.

**The Secret.** The thought of pattern cutting on the table saw might sound a bit odd. But just think of it as template routing on the table saw. If you take a look at the drawing at left, you'll get the idea.

You start by clamping a simple pattern-cutting fence to the rip fence of your table saw. The horizontal arm of the fence is aligned directly above the blade of the saw to act as a "rub" guide. A pattern attached to the workpiece follows the edge of the guide arm to "steer" the workpiece past the blade. The result is a flush cut that creates a perfect copy of the pattern. The advantage to this technique is that all you need is a master pattern and one simple setup.



▲ **Flush with the Blade.** A square can take some of the guesswork out of adjusting the fence.

**The Fence.** The first item on the pattern-cutting "checklist" is the guide fence. If you take a close look at the photo above and the drawing at left, you'll be able to put one together pretty easily. So I'll just give you a few pointers.

It's a good idea to make the fence about the same length as your rip fence. I like the long, steady guide surface this gives me. And when I'm pattern cutting, it's usually on  $\frac{3}{4}$ "-thick stock. So the guide arm is attached to the upright about about  $\frac{7}{8}$ " from the bottom.

The cutoffs from the workpieces will fall harmlessly between the upright and the saw blade. Usually these will only be narrow strips. But even so, you need plenty of

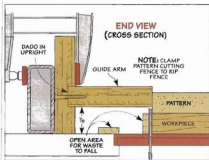



room for them. A 4"-wide guide arm creates the space you'll need. Finally, notice the window just opposite the blade. This lets me see when I need to do a little house-keeping and clean out the cutoffs.

**The Pattern.** Next comes the pattern. This should be made to the exact size and shape of the parts you want to duplicate. Plywood or MDF works great. Keep in mind that once you make the pattern, the hard work is over, so take the time to get it right. Extra time here will be more than made up for later on.

### SETTING UP

With the fence and the pattern in hand, you're ready to get set up. When you install the fence on the saw, the edge of the guide arm needs to be directly above the outside edge of the blade. A square helps get it close (inset photo at left). But I like to start out with the blade set a little behind the edge of the guide arm and then readjust it after a test cut. Hitting it dead-on may take a little trial and error.

With the fence in place, I don't start cutting on the table saw right away. First I make a quick trip to

the band saw to rough cut the workpieces. If you only have to trim off a little bit of waste, the cuts go easier and you won't have to clean out the cutoffs quite as often.

There are several ways to fasten the pattern to the workpiece. If you don't want to leave any marks, a few strips of carpet tape will do the job, as shown in the drawing above. When the workpieces are especially large or have a face that won't show, I'll tack or screw the pattern in place. But regardless of the method you use, make sure the attachment is good and solid.

### MAKING THE CUT

Making the cut is pretty routine. Butt the pattern firmly against the guide arm well in front of the blade and then slide it forward. If the feed is stiff, some wax on the pattern and guide will help.

Feeding the pattern and workpiece along the guide arm may be a little awkward at first. If the pattern

wanders

away from the fence and the cut isn't smooth and straight, don't worry—all you need to do is make a second pass. Remember, with the fence in place, you can't cut too deeply.

As you cut around the pattern, use the same, steady feed rate you would for any other cut. Even when the cutting is easy, don't go too fast. Keep an eye on the scraps building up under the guide arm and clean them out when needed.

You might find that it takes you longer to get set up than to actually cut the workpieces. But all in all, the job will get done quicker, easier, and much more accurately. And that's a good enough reason for me to use pattern cutting. 

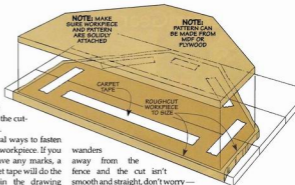

**ShopNotes**  
GO ONLINE EXTRAS  
To view a video on using this table saw technique, go to: [ShopNotes.com](http://ShopNotes.com)

## Square an Edge

Sometimes, all you need to do is cut one straight, square edge across the end of a panel. But manhandling a large panel through the saw guided by the miter gauge can be a challenge at best. But as you see in the photo at right, the pattern cutting fence and a straight cleat will help you get the job done.

Just set up the fence as you would for a pattern cut. Then carpet tape or tack the cleat to the workpiece with the straight edge right on the line of the cut. As you feed the panel into the blade, the cleat rides along the guide arm and the result is a straight, square cut.



*Square up the End. This simple setup can be used to make a straight, square cut across the end of a large plywood panel.*



miter saw upgrade

# Laser Saw Guides

Like most woodworkers, I'm always looking for that something extra that will improve my skills. Lasers are popping up on all sorts of tools nowadays, so I wanted to see how well saws with lasers really work. But I didn't want to outfit my shop with a new miter saw. Fortunately, there is an add-on laser kit by *Laserkerf* that will attach to most miter saws.

**How It Works.** The laser unit itself is about the size of a Zippo lighter (see the photo at right). Looking at the front of the box, you can see the laser. When the laser is on, it looks like a red cat's eye peering out, as shown in the photo at the top of this page. The black band around the front provides extra protection against dust.

The standard model comes with an AC adaptor, but I liked the one

powered by two AA batteries. I have one less cord in my shop to worry about and don't have to move my saw around. The kit comes with plastic ties to help keep the wires secure and out of the way.

I also like the on/off switch that you also see in the photo below. It

can be mounted almost anywhere on your saw (within reach of the wire, of course). I mounted mine near my saw's trigger, where it's safely away from the spinning blade. I can turn the laser on and then use both hands to get everything aligned before turning the saw on and making the cut.



**Easy Installation.** This laser unit is pretty much one-size-fits-all. Mounting brackets and wedges are available so the laser will fit most miter and radial arm saws. The brackets and wedges attach with adhesive tape that is essentially permanent after a couple of days — no drilling required.

**Laser Alignment.** Before you stick the laser on your miter saw, you need to build the alignment jig that is pictured in the photo on the right. The kit comes with instructions on how to build and use it. There are two things to remember. First, don't cut completely through the jig. And, second, don't unclamp the jig until you've completed the alignment process.

When you attach the unit, you'll want to align it as close as you can on the first try. But don't worry if you're not exact, because the laser has two adjustments to help you fine-tune the alignment.

Underneath the black band is an angular adjustment ring, which

helps rotate the beam vertically through the kerf slot. Sticking out the side of the box is a horizontal adjustment knob, which moves the beam left or right. Once you get the beam shooting through the slot and filling the kerf on the horizontal board, you're set to go. And because the laser mounts to the saw body, its alignment should stay true at any angle you need. But I'd hold onto the jig so you can double-check the alignment from time to time.

**The Beam.** Another thing I like about this laser is the kerf-wide beam it shoots across my stock. While the beam width itself is not adjustable, the laser is available in two widths — one to match the standard 1/8"-wide kerf and one to match thin kerf blades, whichever you use. So, not only do you know which side of your layout line the



blade will cut, but you can also tell exactly how much wood the saw blade will eat up in making the cut.

Now with the laser on my miter saw, I don't have to "eye-ball" the cuts anymore. The laser not only improves my accuracy with my miter saw, it also makes the cuts easier, faster, and safer.

To find out where to get this add-on, as well as the blade-mounted laser below, turn to page 51. 

**▲ Straight Shooter.** Use this jig to ensure the laser beam lines up with the blade.

## Blade-Mounted Laser Guides

As you can tell by its name, this laser guide doesn't mount on the arm of your saw — it's attached to the outside of the blade. Made by *Aerger Products*, this design allows the guide to work on many miter and radial arm saws, but I like to use it on my hand-held circular saw (see photo at right).

This laser easily mounts to the saw just by replacing the blade's outside washer with the laser unit. The kit even comes with extra batteries and also longer mounting bolts just in case the unit is too deep for your saw's original bolt to work (photo at far right).

The laser turns on when the blade reaches 500 RPM and spins so fast that it appears as one continuous line on your stock. The beam width is thinner than the width of the saw blade, and because there's

no adjustment, you'll have to practice until you know how the beam lines up with your layout line.

I had to adjust my position to see the laser, because the beam lights up right in front of the blade, rather than in front of the shoe. But once I got the hang of the different view, I really like using the laser.



**▶ What You Get.** The kit comes with the laser unit, different-sized mounting bolts and Allen wrenches, and extra batteries.



**◀ Spinning Laser.** Because the unit spins with the blade, the beam makes a line on both the horizontal and the vertical surfaces of the workpiece.

# ULTIMATE Garage

precision

# Parking

These high-tech systems make it easy to park your car in the right spot every time.

- My garage is home to much more than the family car. It holds everything from my woodworking tools to gardening tools, ladders, bikes — you name it and it's in there.

And with all this other stuff, there isn't much room for the car. This means parking can be a bit of hassle. You have to inch the car in until it's in just the right place so the garage door can close.

In the past, I've tried the old tennis-ball-on-a-string trick to make parking foolproof. Although it does make parking simpler, it can be a pain when the car is out of the garage. It's too easy to walk into and gets in the way when I'm working inside the garage.

But I came across a few unique products that do the job without being a nuisance. Three of the parking systems shown here use lasers to line up the car in the right

spot every time. But each one takes a little different approach to activating the laser light.

A fourth system, shown in the box on the opposite page, doesn't use a laser at all. Best of all, these cutting-edge parking systems cost less than \$35. To find out where to get them, take a look at page 51.

Each system consists of two parts. The first part is a sensor or switch that activates the laser. The other part of the system is the laser emitter. The emitters are connected to the sensors by a cord. This lets you position the laser light where it will be most visible in your car. In any case, the laser lights stay lit for about a minute or two before automatically turning off.

## LASER PARK SET

The first system I looked at was the *Laser Park Set*, as shown in the photos at left and below. The laser in this compact unit is activated by the vibration of the automatic garage door opener.

Even though the vibration sensor is pretty sensitive, I found it worked best when it was attached directly to the garage door opener. You can even adjust the sensitivity with a dial on the back, as you can see in the inset photo.

**Adjustable.** If the opener isn't a convenient spot for the emitter, you can remove it and use a longer cord that comes with the unit to mount it in a suitable location.

Another feature of the *Laser Park Set* I liked is the extra connection port. This enables you to connect another laser to the same sensor to park a second car. All in all, this system was easy to install and can be adjusted quickly.

## EZPARK

The second system I looked at took a more conventional approach to turning on the laser. Instead of vibration, the *EZPARK* uses a contact switch that gets mounted near the end of the rail on a garage door track, as shown in the left inset photo above. Unlike the other

## Laser Park Set

(vibration activated)



Removable emitter can connect to sensor with longer cord

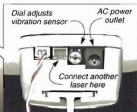

Adjustable Laser. Aim the laser to hit a visible spot on your car when it's parked in the garage.

## EZpark (switch activated)



Adjust laser "dot" size so it's easy to see



▲ **Contact Switch.** Mount the switch on the door track to turn on the laser when the door opens.

systems, this one doesn't require you to have an automatic garage door opener for it to work.

**Dual Purpose.** There are two benefits to this system. First, it shows you where to park. And, if you have an automatic door opener, you can use it as a guide to let you know the door is completely open and it's safe to leave.

I found that the laser in the EZpark system shines a pretty large "dot" on the car, which made it easy to see even with the garage

## Car Stop (light activated)



Thumb wheels let you aim laser



▲ **Light Sensor.** The laser in the Car Stop is activated when the light on the garage door opener turns on.

light on. But since you can't aim the laser, as shown in the left photo above, you'll need to take extra care when you position it.

### CAR STOP

The final laser parking system is the Car Stop. What sets this unit apart is how the laser is activated. In this case, a light-sensitive switch is what does the job. In the right inset photo above, you can see the round light sensor. By attaching this to the garage door light cover, the unit will only turn on when the door opens or closes.

I found I could easily fine-tune the laser setting with the pair of thumb wheels located on the emitter unit (right photo above).

**One Weakness.** All of these systems set up quickly, work great, and are pretty inexpensive. About the only weakness I found with them is the timing. When I need to work in the garage, I'll often back the car out and leave it outside while I work inside the garage with

the door open. When I pull the car back in later, none of the laser systems will still be active. But overall, these parking solutions take a lot of the headache out of parking your car in a crowded garage. 🚗

## Ultra-Sonic: Park-Zone

A fourth parking system doesn't use lasers at all. Instead, the Park-Zone has an ultra-sonic emitter/sensor that measures the distance to the car as it approaches. A miniature traffic light lets you know when to stop. When your car first enters the garage, the light will turn green. As it moves forward, the green light will change to yellow and finally red. Best of all, it stays active all the time without relying on the garage door opener.

▲ **Precision Parking.** Laser parking systems make it easy to park your car in the same place every time.

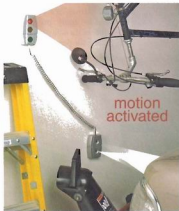

## questions from Our Readers

# using cauls to Put on the Squeeze

*I've read about using cauls as a way to get better results when assembling a project or gluing up a panel. What exactly are cauls and how do I use them?*

Ben Nelson  
West Des Moines, IA

■ Cauls are really just a fancy name for a set of clamping bars that help you glue up a cabinet assembly or solid wood panel more accurately.

Let's say you're gluing up a case with a shelf or divider located several inches in from the top or bottom. Without specialized clamps, it's almost impossible to apply pressure to the center of the side panel. Instead of pulling the panel tight against the

edge of the shelf or divider, the side will bulge out slightly.

**Cauls Solve the Problem.** To solve this problem, you can use a set of cauls to apply pressure evenly across the sides (photo above). For this to work, the cauls are shaped with a slight curve or taper (detail drawing). When the clamps are tightened, pressure is applied to the center of the panel first, pulling it in tight.

**Making Cauls.** Making a caul isn't difficult. Start by cutting a length of stock (I like to use 1½"-square maple) that will span your assembly or panel. Then just make a gentle curve along one edge.

How much? In general, I've found that tapering the caul 1/16" or so works out just about right, as you can see in the drawing above. I like to use a hand plane to

shape the caul. But you can sand the taper just as easily.

Now, a 1/16" isn't that much of a curve. And when you're in a hurry gluing up a project, it can be hard to tell which edge to place against the workpiece. So it's a good idea to mark which way the caul goes with an arrow for easy identification.

**Flat Panels Too.** Cauls also work great for gluing up flat panels. In this case, applying pressure at the center of the panel isn't necessary, so I just use cauls that are straight, without any taper or curve.

What's more important is keeping the panel flat while you clamp the boards together. The trick is to sandwich the boards between cauls to form a flat panel. Then you can add the clamps, like you see in the photo at left.

Finally, when you glue up a panel, you'll want to apply a couple coats of wax to your cauls (or packing tape, as in the inset photo). This way, you won't have to worry about gluing the cauls in place. 🐿

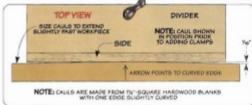

**Flat Panels.** Cauls with straight edges keep a panel flat during glueup. And packing tape (inset) keeps them from sticking.

# Sources

## CASTERS

You can find casters at most hardware stores and home centers. But for a complete range of casters to suit almost any need, check with *Dunn & Company*. Their contact information is listed in the margin along with a few other mail-order sources that carry the locking, swivel casters we featured in the article on page 10.

## TWIST BITS

The article on page 12 shows how a twist bit works. Twist bits are available at any hardware store, home center, or the sources in the margin.

## SHARPENING STATION

You should be able to find the 4" sash pulls, shelf supports, finish washers, screws, and bumpers for the sharpening station on page 16 at a hardware store or home center.

The plastic tub I used is a 2.4-gallon Rubbermaid *Servin' Saver Plus* container (#4025). You should be able to find this container or something similar at any store that carries household items.

I ordered the *Accuride* 20" 3/4" extension drawer slides (39364) and *Blum* 3/8" overlay face frame hinges (55902) from *Rockler*. They're also available from the *Woodsmith Store*.

## CIRCLE CUTTERS

Many home centers and most woodworking catalogs sell one or both types of circle cutters shown in the article on page 30. If you have trouble locating a cutter locally, check out the margin sources.

General makes a circle cutter (No. 6) that does both holes (1 1/2" to 6 1/4") and wheels (3/4" to 6 1/4"). They also make a standard circle cutter (No. 55) that cuts holes from 1 1/4" to about 8". And if you only need holes up from 3/8" to 4", the *General* No. 4 will do the trick.

## AIR HOSES & FITTINGS

Air hoses and fittings are available at just about every hardware store, home center, auto parts store, and tool center. But for a one-stop shop, check with *Bob's Tools* (see margin). They carry most of the items shown in the article on page 38.

## SPINDLE SANDER

You'll find most of what you need for the spindle sander at a local hardware store or home center. The only items you might have trouble locating are the flange bearing that supports the drum and the neoprene rubber used for the gaskets.

The flange bearing (6384K363) is available from *McMaster-Carr*. They also have the 12" square sheet

of neoprene rubber (9455K15). *Reid Tool* also has a bearing that will work (NB-1070). Just be sure to have either bearing in hand before you drill the flange support block.

Finally, we picked up our sanding sleeves at the *Woodsmith Store*. But there are a couple other sources listed in the margin that you can order sleeves from.

## LASER GUIDES

The saw-mounted laser cutting cutting guide featured on page 46 is available from *Laserkerf* (see margin). Be sure to check with them to ensure it will work with your miter saw.

And if you'd like to try the *Atvenger* arbor-mounted laser guide, check with the two sources we listed in the margin.

## PARKING SYSTEMS

A parking system is a sure way to protect your tools by putting your car in the same spot every time. These systems are available at garage specialty stores, some home centers, and the margin sources.

*Griot's Garage* carries a number of different parking systems — the *Park Zone*, *Car Stop*, and *Laser Park Set*. *Amazon* also carries the *Park Zone*. And the *EZpark* system is made by *Peterson Manufacturing*.

## MAIL ORDER SOURCES

Similar project supplies may be ordered from the following companies:

**Woodsmith Store**  
800-835-5084

*Air Hoses & Fittings, Blum Hinges, Casters, Circle Cutters, Drawer Slides, Knobs, Sanding Sleeves*

**Rockler**

800-279-4441  
www.rockler.com

*Atvenger Arbor-Mounted Laser Guide, Blum Hinges, Casters, Circle Cutters, Knobs, Drawer Slides, Sanding Sleeves*

**Reid Tool**  
800-233-0421  
www.reidtool.com

*Casters, Knobs*

**Dunn & Company**  
800-278-3866

www.dunnco.com

*Casters*

**Amazon**

www.amazon.com

*Atvenger Arbor-Mounted Laser Guide, Park Zone*

**McMaster-Carr**  
630-833-0300

www.mcmaster.com

*Flange Bearing, Knobs, Neoprene Rubber*

**Laserkerf**  
859-494-0790

www.laserkerf.com

*Saw-Mounted Laser Guide*

**Woodworker's Supply**  
800-645-9292

www.woodwork.com

*Sanding Sleeves*

**Griot's Garage**  
888-345-5789

www.griotsgarage.com

*Car Stop, Laser Park Set, Park Zone*

**Bob's Tools**  
888-845-7500

www.bobstools.com

*Air Hoses & Fittings*

**Peterson Manufacturing**  
816-765-2000

www.pmgib.com

*EZpark*

**Pedestal Corp.**  
620-343-2366

www.pedestalcorp.com

*Car Stop*

## ShopNotes Binders

Keep your issues organized!



As you build your ShopNotes library, here's a way to keep your issues organized. Each binder features durable vinyl covers and easy-to-read perforated number tags. Snap rings with a quick-open lever make it easy to insert and remove issues. And there's an extra pocket inside for storing notes. Each binder holds a full year (6 issues) of the new, expanded ShopNotes.

To order these binders, call 1-800-347-5105.

**ShopNotes Binder**

○ 701950-SN81 (Holds 6 issues).....\$12.95



www.ShopNotes.com

## Scenes from the Shop

*Precision Sanding. Sanding curved edges is always a chore. But with the spindle sander shown here, you can turn your drill press into a precision sanding station. There are five different size sanding drums that accept long sanding sleeves to give you a lot of sanding area. And a handy shop vacuum hookup ensures you won't be breathing in any dust while you work.*





# Ultimate Sharpening Station

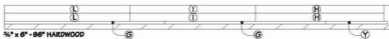

## Materials

A	Case Sides (2)	20 $\frac{1}{4}$ x 31 $\frac{1}{4}$ - $\frac{1}{4}$ Ply.	P	Top Front/Back Edging (4)	$\frac{1}{4}$ x 2 $\frac{1}{2}$ - 18
B	Case Divider (1)	20 $\frac{1}{4}$ x 28 $\frac{1}{2}$ - $\frac{1}{4}$ Ply.	Q	Top Side Edging (4)	$\frac{1}{4}$ x 2 $\frac{1}{4}$ - 20
C	Case Bottom (1)	20 $\frac{1}{4}$ x 30 $\frac{1}{4}$ - $\frac{1}{4}$ Ply.	R	Drawer Fronts/Backs (8)	$\frac{1}{2}$ x 2 $\frac{1}{2}$ - 11 $\frac{1}{2}$
D	Case Sub-Top (1)	18 $\frac{1}{4}$ x 30 $\frac{1}{4}$ - $\frac{1}{4}$ Ply.	S	Drawer Sides (8)	$\frac{1}{2}$ x 2 $\frac{1}{2}$ - 20
E	Slide Rail Supports (2)	$\frac{1}{4}$ x 2 - 15 $\frac{1}{2}$	T	Drawer Bottoms (4)	11 $\frac{1}{2}$ x 19 $\frac{1}{2}$ - $\frac{1}{4}$ Ply.
F	Case Back (1)	30 $\frac{1}{2}$ x 40 - $\frac{1}{4}$ Ply.	U	Drawer Filler Panel (1)	12 $\frac{1}{2}$ x 20 $\frac{1}{4}$ - $\frac{1}{4}$ Ply.
G	Back Edging	$\frac{1}{4}$ x $\frac{1}{4}$ - 120 (rgh.)	V	Filler Panel Spacers (2)	$\frac{1}{2}$ x 2 - 12 $\frac{1}{2}$
H	Face Frame Rails (2)	$\frac{1}{4}$ x 2 - 32	W	False Fronts (4)	$\frac{1}{4}$ x 3 $\frac{1}{2}$ - 13 $\frac{1}{4}$
I	Face Frame Stiles (3)	$\frac{1}{4}$ x 2 - 31 $\frac{1}{4}$	X	Shelf (1)	15 $\frac{1}{4}$ x 19 $\frac{1}{4}$ - $\frac{1}{4}$ Ply.
J	Base Front/Back (2)	$\frac{1}{4}$ x 5 - 30 $\frac{1}{2}$	Y	Shelf Edging (1)	$\frac{1}{4}$ x $\frac{1}{4}$ - 15 $\frac{1}{4}$
K	Base Sides (2)	$\frac{1}{4}$ x 5 - 19 $\frac{1}{4}$	Z	Large/Small Door Rails (4)	$\frac{1}{4}$ x 2 - 10 $\frac{1}{2}$
L	Sliding Top Rails (2)	$\frac{1}{4}$ x 2 - 31 $\frac{1}{4}$	AA	Large Door Stiles (2)	$\frac{1}{4}$ x 2 - 28
M	Top Panels (2)	16 $\frac{1}{2}$ x 20 - $\frac{1}{4}$ Ply.	BB	Large Door Panel (1)	10 $\frac{1}{2}$ x 24 $\frac{1}{4}$ - $\frac{1}{4}$ Ply.
N	Sliding Top Spacers (4)	1 $\frac{1}{2}$ x 16 $\frac{1}{2}$ - $\frac{1}{4}$ Ply.	CC	Small Door Stiles (2)	$\frac{1}{4}$ x 2 - 15
O	Fixed Top Spacers (4)	2 $\frac{1}{2}$ x 16 $\frac{1}{2}$ - $\frac{1}{4}$ Ply.	DD	Small Door Panel (1)	10 $\frac{1}{2}$ x 11 $\frac{1}{4}$ - $\frac{1}{4}$ Ply.

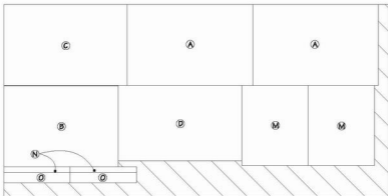

48" x 86" -  $\frac{3}{4}$ " PLYWOOD

← GRAIN DIRECTION →

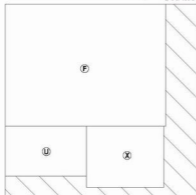

48" x 48" -  $\frac{3}{4}$ " PLYWOOD

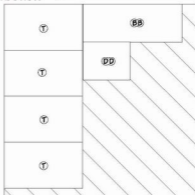

48" x 48" -  $\frac{3}{4}$ " PLYWOOD