

**DUST  
COLLECTOR**  
EASY UPGRADES

**Special Weekend Projects Issue**

# ShopNotes

Vol. 13

www.ShopNotes.com

Issue 78

## WORKSHOP IN A WEEKEND

**5** Money-Saving  
Plywood Projects

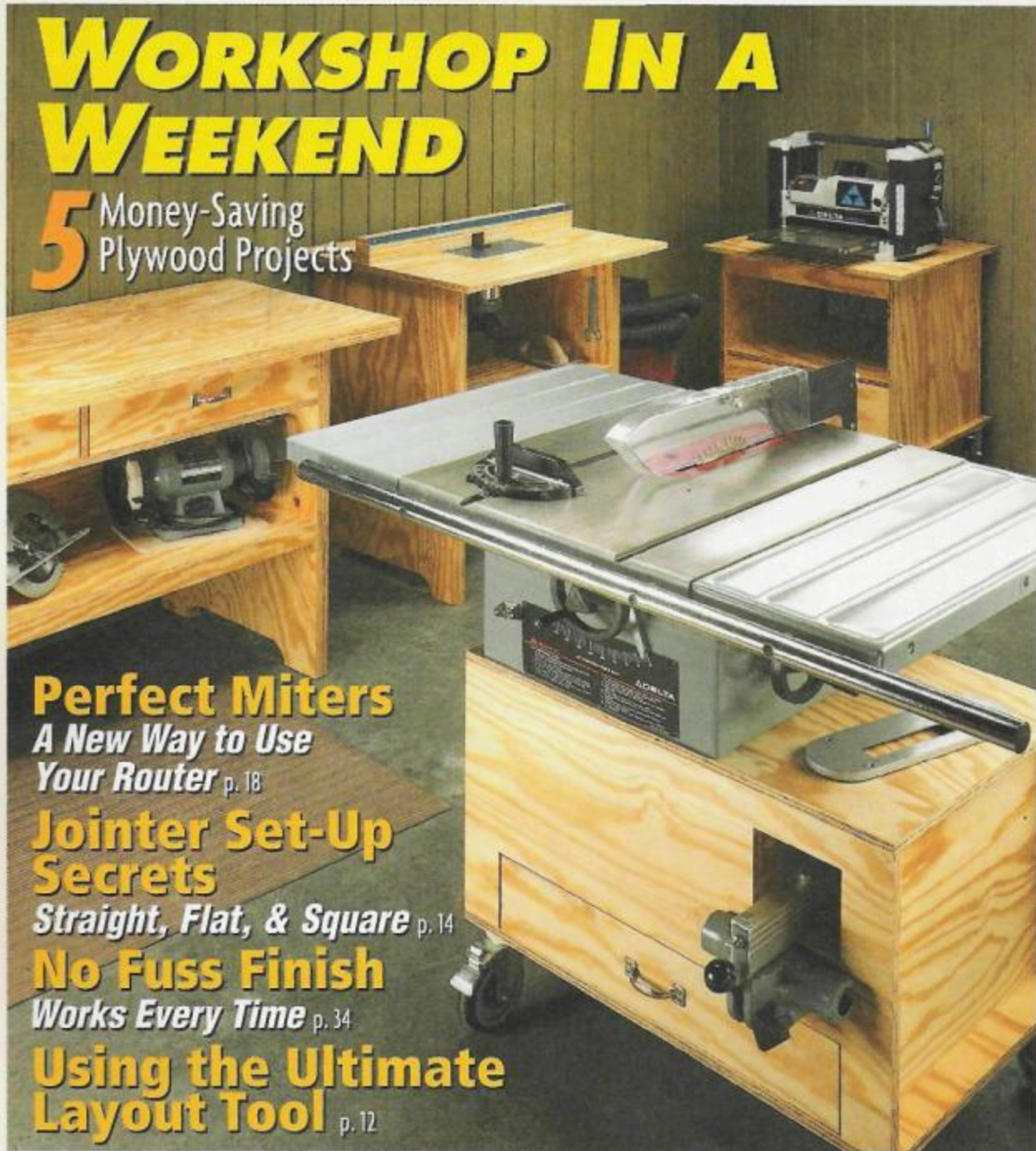

### Perfect Miters

*A New Way to Use  
Your Router* p. 18

### Jointer Set-Up Secrets

*Straight, Flat, & Square* p. 14

### No Fuss Finish

*Works Every Time* p. 34

### Using the Ultimate Layout Tool

p. 12



# ShopNotes

Issue 78

Nov./Dec. 2004

**PUBLISHER** Donald B. Peschke  
**EDITOR** Terry J. Strohman  
**SENIOR EDITORS** Bryan Nelson  
 Vincent Ancona  
**ASSOCIATE EDITOR** Phil Huber  
**ASSISTANT EDITOR** Ron Johnson  
**ART DIRECTOR** Cary Christensen  
**SR. GRAPHIC DESIGNER** Jamie Downing  
**SENIOR ILLUSTRATOR** Roger Reiland  
**ILLUSTRATORS** David Kallemyn  
 Peter J. Larson  
**ELEC. IMAGE SPECIALIST** Allan Ruhnke

**CREATIVE RESOURCES:** *Creative Director:* Ted Kralliek • *Sr. Project Designer:* Ken Muskal, Kent Welsh, Ryan Mlinick, Chris Fitch • *Shop Craftsmen:* Steve Curtis, Steve Johnson • *Sr. Photographer:* Craycia England • *Photo Intern:* Julia Adlisson

**SPECIAL PUBLICATIONS:** *Covr. V.P.:* Douglas L. Hicks • *Art Dir.:* Douglas A. Flint • *Sr. Graphic Designer:* Chris Glowacki • *Graphic Designer:* Lindsay Ross • *Videoographer:* Mark Hayes, Jr. • *Sr. Editor:* Craig Ruessinger • *Assoc. Editor:* Joel A. Hess

**CIRCULATION:** *Circ. Oper. Director:* Sandy Baum • *Circ. Marketing Dir.:* Wayne J. Klingbeil • *Strategic Business Analysts:* Kris Schlemmer • *Circ. Marketing Analyst:* Patrick Walsh • *Renewal Mgr.:* Paige Rogers • *Circ. Marketing Assoc.:* Christine Forrest • *Circ. Fulfillment Mgr.:* Stephanie Porinush • *Sr. Graphic Designer:* Robin Friend, Randy Shebok

**CORPORATE SERVICES:** *VP of Finance:* Mary R. Scheve • *Controller:* Craig Skille • *Dir. Financial Analysis:* Lesia Smith • *Sr. Acct.:* Laura J. Thomas • *Acct. Payable:* Mary J. Schultz • *Acct. Receivable:* Margo Petras • *Prod. Dir.:* George Cameliara • *IT Manager:* Brian VanHeuverswyn • *Electronic Pub. Dir.:* Douglas M. Lidster • *Sys. Admin.:* Chris Schwanebeck • *P.C. Maint. Tech.:* Robert D. Cook • *Assoc. Style Dir.:* Robeca Cunningham • *New Media Mgr.:* Gordon C. Galpe • *Multimedia Art Dir.:* Eugene Pedersen • *Web Server Admin.:* Carol Schoepfler • *Web Content Mgr.:* David Briggs • *Multi-media Designer:* Kara Blessing • *Web Prod.:* Terry Walker • *Web Pub. Asst.:* Justin Graca • *Research Coord.:* Nicholas A. Jaeger • *Prof. Dev. Dir.:* Michael Sigel • *Benefits Specialist:* Jennifer Westover • *Hiring Specialist:* Jessica Teasor • *Facilities Mgr.:* Kurt Johnson • *Office Manager:* Joanne Johnson • *Admin. Asst.:* Brandi Hammond • *Mail Room Clerk:* Lou Webber

ShopNotes® (ISSN 1062-9696) is published bimonthly Jan., March, May, July, Sept., Nov. by August Home Publishing, 2200 Grand, Des Moines, IA 50312.

ShopNotes® is a registered trademark of August Home Publishing ©Copyright 2004 by August Home Publishing. All rights reserved. Subscriptions: Single copy: \$4.95. One year subscription (6 issues), \$27.95. Canada/International add \$10 per year, U.S. funds.

Canadian Subscriptions: Canada Post Agreement Number 40088201. Send change of address information and blocks of undeliverable copies to PO Box 881, Station Main, Markham, ON L3P 8M6.

Periodicals Postage Paid at Des Moines, IA and at additional mailing offices.

Postmaster: Send change of address to ShopNotes, P.O. Box 37103, Boone, IA 50037-2103.

Online Customer Service. [www.ShopNotes.com](http://www.ShopNotes.com)

- Access your account
- Check a subscription payment
- Tell us if you've missed an issue
- Change your mailing or email address
- Renew your Subscription
- Pay your bill

Email: [shopnotes@shopnotes.com](mailto:shopnotes@shopnotes.com)

Write to ShopNotes, P.O. Box 842, Des Moines, IA 50304 or call 1-800-333-5075, 8:00 am to 5:00 pm, Central Time, weekdays. Or send an email to: [orders@shopnotes.com](mailto:orders@shopnotes.com)

**AUGUST HOME**  
PUBLISHING COMPANY

Printed in U.S.A.

## EDITOR'S NOTE

# Cutoffs

As the days get shorter, it seems like I'm constantly running behind on getting my projects done. Consequently, I'm always on the lookout for shop projects that can make things go easier and faster.

**Plywood Projects** – The five plywood projects featured in this issue do just that. For starters, each project (table saw stand, router table, multi-tool stand, workbench, and a pair of assembly boxes) can easily be built in a day or two. Each project takes just one or two sheets of plywood, a handful of screws, and some basic, but rugged joinery.

Although these projects are easy to build, you'll find they still have quite a few great features. Whether it's some added storage space, extra worksurfaces, or the ability to quickly roll tools around your shop, you'll find that these projects will make your shop more efficient and you'll get things done faster. Best of all, you won't be spending a lot of time (or money) in the process.

**Miter Trimmer** – Another great project you won't want to miss is the router miter trimmer on page 18. We all shoot for accurate results in our joinery, but it can be difficult to achieve. But with this simple jig (and a router), you can "dial-in" the accuracy for tight-fitting miter joints every time. That means you'll spend less time fussing and more time building great-looking projects.

**Framing Square** – If you're like me, you probably have a framing square somewhere in your shop that doesn't get much use. But with a few simple additions, you can turn a basic square into a top-notch layout tool you'll reach for more often. To see more, turn to page 12.

## FREE TIPS

And speaking of improving your shop, you can have time-saving secrets, solutions, and techniques sent right to you. Just go to [www.woodworkingtips.com](http://www.woodworkingtips.com) to sign up. You'll get a new tip each week.

Terry

## STATEMENT OF OWNERSHIP, MANAGEMENT, AND CIRCULATION

(Required by 39 U.S.C. 3685)

1. Publication Title: ShopNotes; 2. Publication No.: 1062-9696; 3. Filing Date: September 13, 2004; 4. Issue Frequency: Bimonthly; 5. No. of Issues Published Annually: 6; 6. Annual Subscription Price: \$27.95; 7. Complete mailing address of known office of publisher: 2200 Grand Avenue, Des Moines, IA 50312-2103; 8. Complete mailing address of the headquarters or general business office of the publisher: 2200 Grand Avenue, Des Moines, IA 50312-2103; 9. Full names and complete mailing addresses of publisher, editor, and managing editor: Publisher: Donald B. Peschke, 2200 Grand Avenue, Des Moines, Iowa 50312; Editor: Terry Strohman, 2200 Grand Avenue, Des Moines, Iowa 50312; 10. Owner: August Home Publishing Company, 2200 Grand Avenue, Des Moines, Iowa 50312; Donald B. Peschke, 2200 Grand Avenue, Des Moines, Iowa 50312; 11. Known bondholders, mortgagees, and other security holders owning or holding 1 percent or more of total amount of bonds, mortgages or other securities: None; 12. Does not apply; 13. Publication Title: ShopNotes; 14. Issue Date for Circulation Data Below: August/September 2004 (6/15); 15. Issue or issue date of circulation data.

	Average no. copies each issue during preceding 12 months	Average no. copies of single issue published nearest to filing date
A. Total number of copies (net press run)	216,594	197,494
B. Total paid circulation		
1. Paid circulation outside the United States (based on Form 3541)	152,790	142,231
2. Paid circulation in the United States	0	0
3. Sales through dealers and carriers, street vendors, counter sales, and other non-USPS paid distribution	22,870	25,645
4. Other classes mailed through the USPS	0	0
C. Total paid and/or requested circulation	175,660	167,876
D. Free distribution by mail, outside the United States, and other free copies		
1. Outside country or stated on Form 3541	78	82
2. In-country or stated on Form 3541	0	0
3. Other classes mailed through the USPS	0	0
E. Free distribution outside the United States or other free mail	0	0
F. Free in-country distribution	78	30
G. Total free distribution	78	30
H. Total distribution	175,738	167,906
I. Copies not distributed	38,856	29,588
J. Total (Sum of lines G, H, and I)	214,594	197,494
K. Percentage paid and/or requested circulation	81.2%	85.1%
L. Publication of Statement of Ownership: Will be printed in the Nov./Dec. 2004 (376) issue of this publication.		
17. I certify that all information furnished on this form is true and correct.		

Signed: Terry Strohman, Editor

On occasion, we allow companies whose products and services may be of interest to you to send advertising mail to our subscribers. We are careful to choose ethical companies that have a reputation of providing interest to our subscribers. If you do not wish to receive such mail, please advise us at ShopNotes, 2200 Grand Avenue, Des Moines, IA 50312.

# Contents

## Features

### Upgrade Your Dust Collector \_\_\_\_\_ 6

Looking to super-charge your single-stage dust collector? We'll show you a few handy add-ons that will help you keep your shop cleaner and save you time.

### A New Angle on Framing Squares \_\_\_\_\_ 10

There's more to this handy tool than meets the eye. Take a look at some unique "skills" in your framing square.

### Ultimate Layout Square \_\_\_\_\_ 12

With just a few simple changes, you can turn your framing square into a tool you'll be reaching for more often.

### Jointer Tune-Up \_\_\_\_\_ 14

Our straightforward techniques will have your jointer running better than new, so you can create perfectly flat, straight, and square stock with ease.

### Router Miter Trimmer \_\_\_\_\_ 18

Don't settle for poor-fitting miter joints. With this easy-to-build jig and a hand-held router, you can dial-in accuracy for miter joints that fit perfectly.

### 5 Plywood Shop Projects \_\_\_\_\_ 22

You can build each of these essential shop projects in just a few hours from one or two sheets of plywood.

## Departments

### Readers' Tips \_\_\_\_\_ 4

Shop-tested tips to solve common woodworking problems.

### Shop Talk \_\_\_\_\_ 32

Every shop needs a precision straightedge (or two) to keep tools tuned and to build projects that are flat and square.

### Tool Chest \_\_\_\_\_ 34

The perfect finish? It just might be. We'll show you the one we turn to almost every day for fast, consistent, high-quality results for all our shop projects — and furniture projects too.

### Sources \_\_\_\_\_ 35

Mail-order sources and supplies to help you complete the projects featured in this issue.



Layout Square page 12



Jointer Tune-Up page 14



Router Miter Trimmer page 18



5 Plywood Projects page 22

# Readers' Tips

## Portable Outfeed Table

### Free Tips ON THE WEB

Get more wood-working tips free.

Visit us on the Web at  
**ShopNotes.com**

Sign up to receive a  
free shop tip by  
email every week.

Whenever I cut sheet goods or other large pieces on my table saw, I have to find someone to help me safely make the cuts. This means delaying the start of many projects.

To solve this problem, I built an outfeed table like the one illustrated below to use with my table saw. This outfeed table has rollers to move the wood along easily and is big enough to handle a full sheet of plywood.

I can also place the table along one side of my table saw and use it as an extension when crosscutting wide stock or sheet goods. But best of all, the table is portable and folds up flat

for easy storage when it's not in use.

To build the table, I used half-lap joints for the upper framework. Notches cut in the top of the frame secure shelf pins (see margin photo below) that hold the rollers.

The rollers are made of PVC pipe cut to length with a wood plug in each end. A 1/4"-dia. hole drilled in the center of each plug accepts the shelf support pin that serves as the axle for the rollers (see detail 'a').

To match the table to the height of the table saw, a wide support spacer was built using lap joints. This spacer is placed between the upper

framework and the legs and secured with wood screws as shown below.

To find the height needed for the spacer, I measured the height from the floor to the top of my table saw. Then I subtracted the thickness of the outfeed table and the table legs.

Before adding the pedestal-style folding table legs, you'll want to add 1" shims to one end of the table base, like you see in detail 'b' below. Then cut 1" off both of the legs on that same end. This lets the legs fold up flat for easy storage and still sit nice and level whenever you need to use it with your table saw.

Richard Beal  
Fort Polk, Louisiana

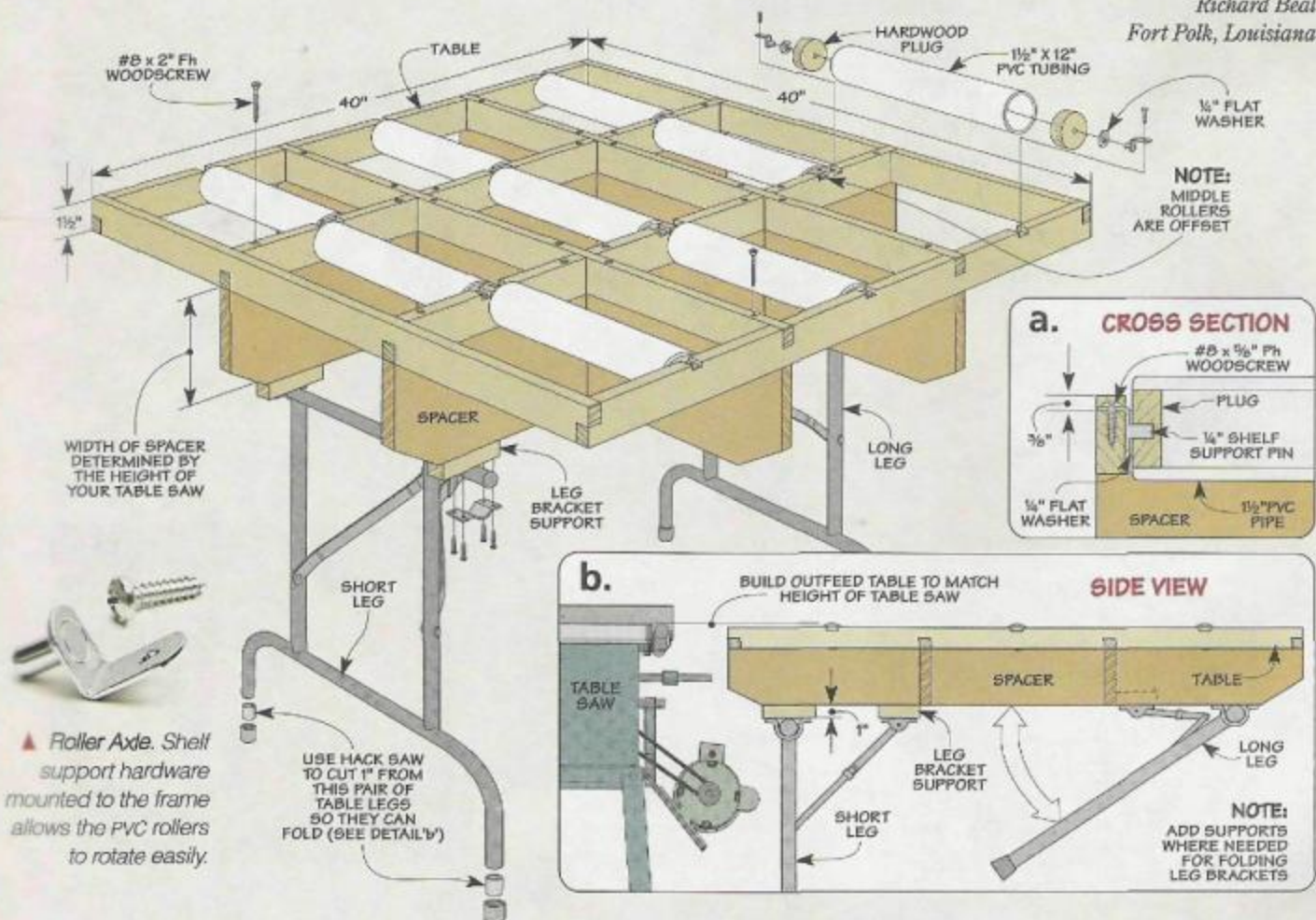

## Quick Tips

Mike Moeller of Loup City, NE turns his hammer into a non-marring mallet by adding a rubber table leg tip to his hammer.



To store his pipe clamps, Michael Schutz of Olympia, WA hangs vinyl covered ladder hooks from the ceiling of his shop.



▲ Louis Luersen of Granbury, TX slips a straight spring and a small hose clamp over his compressor hose to prevent air hose kinks.

## Wood Plug Drill Press Jig

■ Cutting wood plugs can be a tedious and time-consuming task. So I built a jig to make it easier.

This jig cuts plugs in long rows on thin strips of wood, so there's minimal waste left around each plug. And once the plugs are cut, they can be stored on the long, thin strip or cut from the strip using a bandsaw.

The jig, shown in the photo on the right, is made up of two parts. The first part is a small (6" x 12") plywood base that gets clamped to the drill press table for stability. The second part is a hardwood fence that prevents lifting of the workpiece and

guides the plug stock and the plug cutter.

To make the fence, I cut a wide rabbet on the bottom edge. You'll want to be sure the height of the rabbet is greater than the length of plug you want to make.

Finally, glue the fence to the base so the rabbet faces forward. Then use your plug cutter to cut a guide hole in the top fence.

To center the plug cutter over the plug stock, you'll want to place the guide hole along the back edge of

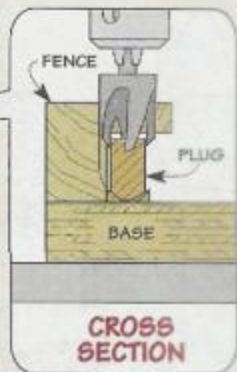

the rabbet and cut away a small amount of fence as shown in the margin detail. Now slip your stock in the jig and you're ready to go.

David Richards  
Rochester, Minnesota

## Table Saw Accessory Board



■ The table saw in my shop gets a lot of use. And I often waste a lot of time looking for the accessories I need whenever I use my saw.

So I built the quick storage rack you see in the photo on the left. All it took was a piece of pegboard cut to the size of the legs of the stand and some pegboard hooks to get everything well organized.

I attached the pegboard rack right to the legs of my table saw with a screw and a wooden cleat at each corner.

## Send in Your Tips

To share your original tips and solutions to problems you've faced, send them to: *ShopNotes*, Attn.: Readers' Tips, 2200 Grand Ave., Des Moines, IA 50312. (Or if it's easier, FAX them to us at: 515-282-6741.)

We'll pay up to \$200 depending on the published length. Please include a daytime phone number so we can call you if we have any questions.

Now whenever I need any table saw accessory, I can always find it within safe and easy reach.

Marvin Robinson  
Arlington, Texas

# Upgrade your Single-Stage Dust Collector

*Better dust collection, a cleaner shop, and cleaner air — they're only a few upgrades away.*

**A**fter I outfitted my shop with all the "real" tools, I finally got around to buying a single-stage dust collector. I dutifully rolled it around my shop, hooking it up to whatever dust-producing tool I happened to be using.

Although a single-stage dust collector is a great way to collect dust and chips, it does have a few downsides. For starters, emptying a load of dust and chips can be a pain. Plus, you have to keep in mind that everything that enters the dust hose goes through the collector itself — dust, chips, and the occasional bit of metal or large scrap piece. And finally, even if you use your dust collector all the time, there still seems to be a haze of dust everywhere.



The nice thing is, there are a number of ways to solve, or minimize, these problems and improve the performance of your dust collector.

### SEPARATOR

As I mentioned, anything that enters the hose goes through the dust collector — hitting the impeller. Not only is this hard on the dust collector, it makes me cringe every time I hear the clatter. One solution you can use to solve this problem is to add a chip separator like the one you see below.

A chip separator fits over a standard metal garbage can and collects the larger chips and debris *before* it all gets to the dust collector. It does this by slowing the air down and allowing the heavier stuff to “fall” out of the airflow before it moves on through the system. This protects your dust collector and ensures that it will last longer.

Since most of the dust and chips end up in the garbage can, you won't have to change the dust collector bag that often — which means less hassle and mess. Plus, when you do have to empty the garbage can, it's quite a bit easier.

Although the chip separator removes most of the dust and chips before it gets to the dust collector, there may still be a light coating of dust that settles on all the tools and surfaces in your workshop.

*Separator. A separator is an inexpensive way to turn your dust collector into a two-stage system and remove dust and chips before they get to the collector.*



### FINER FILTRATION

The fine dust still ends up all over the shop because most filter bags aren't designed to capture the really small particles of dust. They'll usually filter particles down to 30 microns.

A micron is one thousandth of a millimeter or about 50 times smaller than a human hair. But fine dust particles are even smaller, so they're forced right out the bag.

So what can you do about it? One of the simplest things you can do is to upgrade your standard filter bag.

The fine filter bag you see in the center photo below will trap dust down to a size of about 5 microns. You can even get filter bags that will remove particles down to 3 microns.

In most cases, you'll have to replace the lower bag with a plastic one to force the air through the finer filter bag on the top. The upside — no messy bag to empty. Simply remove the plastic one, toss it in the trash, and put on a new one.

### CANISTER FILTER

To deal with really fine dust, there is another option. And that's to skip filter bags altogether and

switch to a canister filter, like you see below. Canister filters are one of the more recent additions to the dust collection world. And one of the best.

You can find canister filters that capture dust in the 2 micron range or less. And the pleated design creates a filtering area more than six times that of a bag, so it's less likely to suffer from reduced performance as dust accumulates on the inside.

**Cleaning** — To clean the canister, you simply rotate the handle at the top. This turns a pair of paddles inside (inset photo) to knock the dust free, restoring full performance.

As you can see, there are a number of options for easily upgrading your dust collector so your workshop and the air you breathe are cleaner.



▲ **Filter Bags.** A finer filter bag will capture more of the small dust particles, keeping your shop cleaner and less of a health hazard.



▲ **Canister.** The design of a canister filter (top) traps most of the dust and increases the filtering area for better overall performance.

## Top-of-the-Line Ductwork

The key to controlling dust in the workshop is to collect it at the source and deliver it to your dust collector.

**Simple & Easy** - To do this, you'll need a system of ductwork and fittings. I've seen everything from shops with flex hose running all over the place, to shops that use PVC pipe and fittings to get the dust and chips from a shop tool to the collector.

Flex hose and PVC are used often for the simple reason that they're inexpensive and easy to work with. Unfortunately, they have downsides. With flex hose, the dust collector has to work hard to overcome all the "drag" and inefficiency associated with the hose. PVC has a similar problem and tends to generate static electricity charges.

**Metal Ductwork** - To avoid all these problems, it's best to use metal ductwork for a dust collection system.

Now I'm not talking about the pipe used for heating, ventilating, and air conditioning (HVAC) you see at the local home center. It's designed for carrying air around your home, not dust and chips. And it's pretty light gage, so it damages easily and the suction of a powerful dust collector can cause the ductwork to collapse.

But not all metal duct is the same. The type I'm talking about is the kind you see in the photo at left. This

ductwork (from *Jet*, see page 35) is heavy-duty, so you can be sure it will handle anything that passes through your dust collection system.

One of the nice design features of this system is the way all the ductwork and fittings go together. You can install an entire dust collection system without ever having to cut a single piece of metal.

The reason this works is that instead of pipe and fittings that slip into one another, the ends of the pieces are rolled and butt together. You can see what I'm talking about in the photo below.

**Quick-Connect Clamp** - A lever clamp securely locks the two rolled ends together (lower part of photo). And a foam seal around the inside of the clamp ensures an air tight fit.

Besides the 4"-dia. fittings shown, there are fittings, reducers, and ductwork available in 5", 6", and larger diameters. There's even a floor sweep available (margin photo), so you'll never have to bend over and use a dustpan again.

Of course, a system like this isn't cheap. The clamps, fittings, and pipe start around \$10 apiece and can run to more than \$100. But like adding any quality tool to your shop, a top-of-the-line dust collection system is worth considering. 🛠️

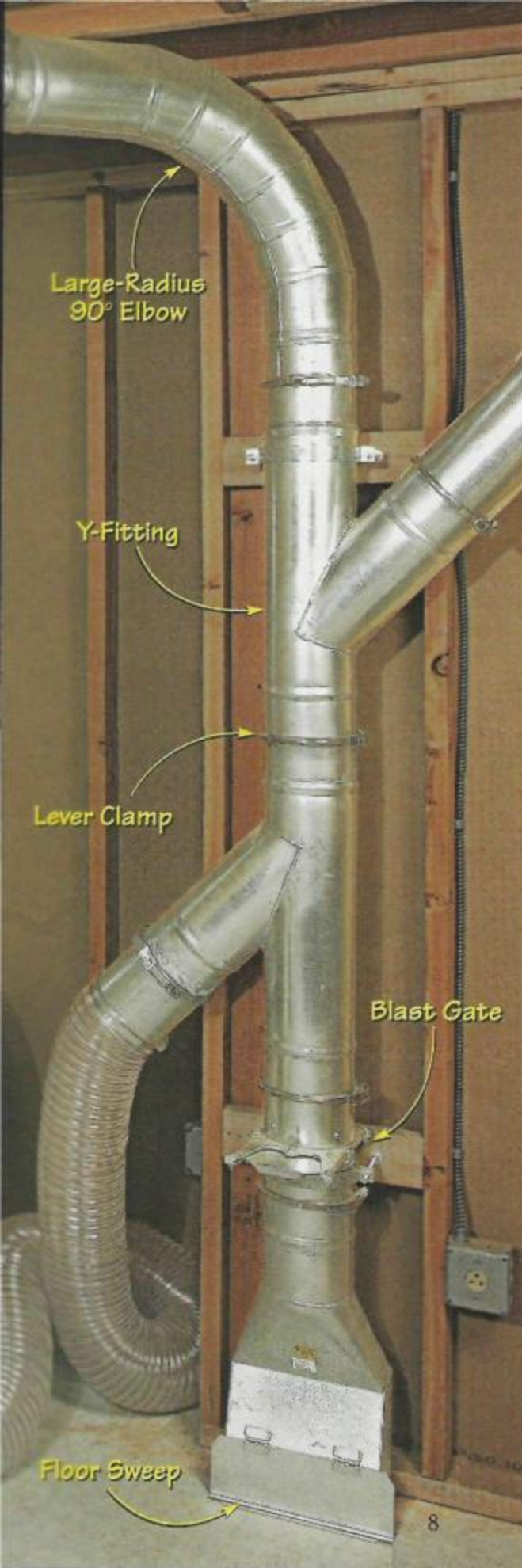



# Easy On with Remote Control



▲ **Control Box.** Opening a blast gate sends a low-voltage signal to this control box to automatically turn the dust collector on (or off).

The best dust collector in the world won't do you much good if you don't turn it on every time you use one of your shop tools.

And that's the biggest problem with any dust collection system. For starters, it's a hassle to roll the dust collector over to the shop tool you're using and hook it up. Then you have to remember to turn it on once you start and then turn it off when you're done.

It's an even bigger hassle with a central dust collection system. The dust collector always seems to be in a far corner on the other side of the shop. So it's all too easy to say, "I'm only going to make one cut," and



**Wired Blast Gate.** A relay switch on this blast gate connects directly to the control unit to automatically turn the dust collector on or off (see photos below).

simply not turn the collector on. After awhile, it starts to become a habit.

**Automatic Operation** – To get around this, you'll want to consider upgrading your dust collection system to make the whole process more automatic. And there are two ways you can do this.

Some companies manufacture a system for dust collectors that works like a TV remote control. Simply push a button and the collector turns on, hit the button again, and off it goes. But like a TV, keeping track of the remote control is a hassle.

**Wired System** – A better way to go automatic is to use a system that doesn't involve a hand-held remote. Instead of a hand-held unit, the blast gates are wired to a control box, like the one you see in the upper left photo. The control unit comes in models to handle either 110-volt or 220-volt dust collectors. (Available from Penn State Industries at [www.pennstateind.com](http://www.pennstateind.com).)

With this system, all you have to do is remember to open the blast gate to your tool. Since this is usually right by the tool, it's hassle-free. Any time you open a blast gate (upper photo at right), a microswitch causes a low-voltage signal to be sent to the control box, turning on the dust collector. Once you're done, unlatch the blast gate and a spring snaps it closed (lower photo), shutting off the dust collector.



▲ **Send a Signal.** With the gate open (top), a microswitch "signals" the dust collector to turn on. Once closed (bottom), the collector shuts off.

It doesn't get much simpler, or more convenient than that. The hardest part of the process is installing the blast gates and then connecting each blast gate to the wiring that runs to the control unit.

**Easy Expansion** – And if you need to add a tool to your dust control system, you can easily add another blast gate and simply connect it to the existing wiring.

There is one thing to keep in mind though. The blast gates only allow you to hook up to 4" ductwork. But that shouldn't be a problem since that's typically the standard port size for most stationary power tools. ☞

# A New Angle on Framing Squares

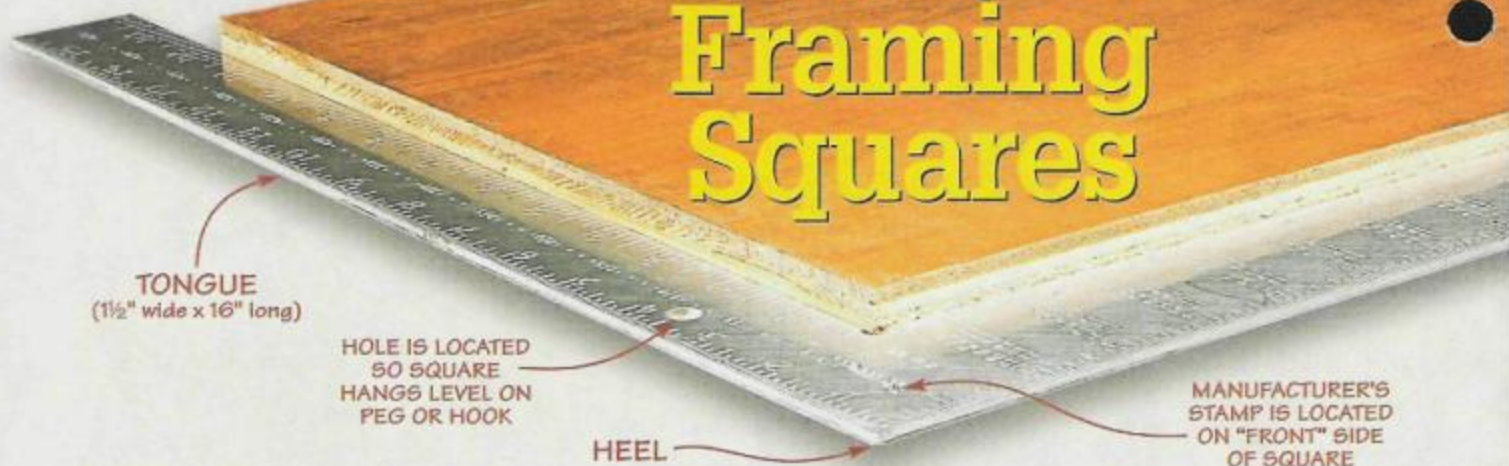

**TONGUE**  
(1½" wide x 16" long)

HOLE IS LOCATED  
SO SQUARE  
HANGS LEVEL ON  
PEG OR HOOK

HEEL

MANUFACTURER'S  
STAMP IS LOCATED  
ON "FRONT" SIDE  
OF SQUARE

**F**raming squares are one of those tools that are so common you probably don't give them a second thought. Sure, they're great for checking large cases and assemblies. But there's a lot more to framing squares than meets the eye.

**History** - The framing square has been around for almost two hundred years. The first squares were hand-forged from iron. Later, manufactured steel squares became the norm. Today, most framing squares are made out of aluminum. Aluminum squares have the advantages of being lighter and not prone

to rust like steel squares do.

**Size** - Early on, there wasn't much consistency in the size of squares from one manufacturer to another. But as framing became standardized throughout the construction industry, so did the framing square. Eventually, framing square manufacturers arrived at a "standard" size (16" x 24") that is still in use today. (See photo above for some "square" terminology.)

**Markings** - If you take a close look at a framing square, you'll notice that it's covered with more

markings and numbers than the timetable at Grand Central Station. To start with, the edges of the square have inch markings in various scales (1/8", 1/10", 1/12" and 1/16", etc.). These are used just like you would an ordinary steel rule.

In the center of the square, stamped on both sides, are several mysterious-looking sets of numbers. Before the days of calculators and electronic measuring devices, an experienced carpenter could use these tables to determine everything from how long to cut a hip rafter to how to lay out an octagon.

Reading and using these tables takes a little practice, particularly if you aren't doing it on a daily basis. (There are actually entire books devoted to using a framing square.) And while most of the tables pertain

to house framing, there is one table that a woodworker may find useful. That's the table for measuring board footage (see photo below).

To use the board footage table, start by locating the column of numbers underneath the 12" mark on the edge of the square. This column represents the length of the board in feet. Find the length that matches the board in question and follow the line to the left or right until you arrive at the column that is directly underneath the number matching the width of the board in inches. The result will be the board footage.

For example, say you have a board that's 14' long and 10" wide. First, find the length of the board (14') under the 12" mark on the edge of the square (see photo below). Now follow that line over

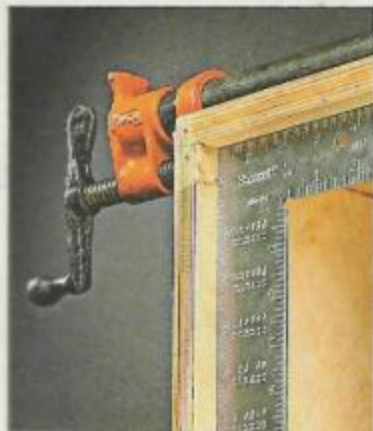

▲ **Square it Up.** A framing square is the perfect tool for checking large cases or frames for square.

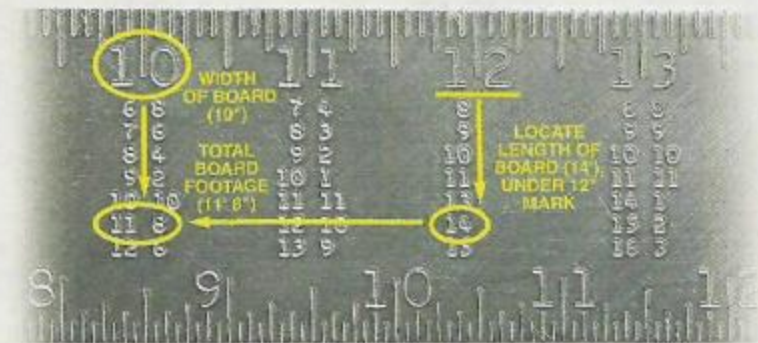

▲ **Board Footage Table.** By using this table (usually found on the back of the blade) you can determine the number of board feet in a given piece of lumber (in this example, a board that is 14' long and 10" wide).

until you're under the 10" mark. The result — 11 ft. 8 in. (or 11<sup>2</sup>/<sub>5</sub> ft.) — is the board footage. Note: This table is designed for 1"-thick lumber. For 8/4 stock, multiply the result by 2.

**Other Uses** — Aside from doing all sorts of cool calculations, framing squares have a lot of practical uses in the shop. I use mine all the time to check large assemblies for square. It also comes in handy for laying out lines on plywood or wide boards. But there are some other less-obvious things that squares can do that you might not have been aware of.

Believe it or not, you can use a square to draw a circle. Start by driving a couple of nails at the ends of the diameter of the circle. Then use the square to guide your pencil (see upper photo at right). Just swing the square around to draw two half-circles, keeping the edges of the square in contact with the brads.

With the addition of a couple of stair gauge stops, you can also use

your square to lay out angles, see lower photo above. This is especially handy for laying out stair stringers.

**Truing a Square** — Unlike other tools, framing squares don't require much care. But since they tend to get dropped a lot, it's a good idea to

periodically check yours to make sure it's still square (see box below). If it's not, you can spread the legs of the square slightly by making a punch mark near the inside corner. To close up the legs, make a punch mark near the heel, see photos below. 

**BLADE**  
(2" wide x 24" long)

**Making Circles.** In a pinch, you can use a framing square to lay out a circle.

◀ **Stair Gauges.** A pair of inexpensive stair gauges (available at most hardware stores) allows you to lay out angles and stair stringers with your framing square.



## Is Your Square Square?

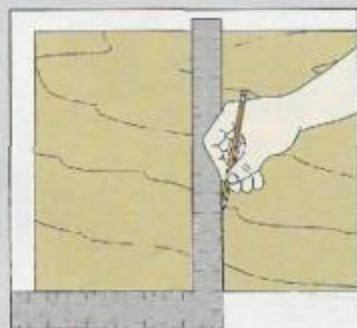

**First:** To check the accuracy of your square, place it along the straight edge of a board and draw a perpendicular line.

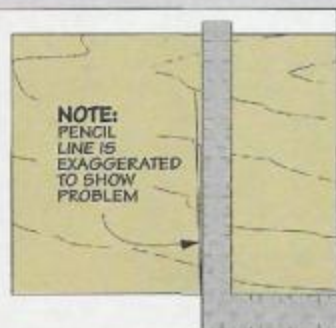

**Second:** Now flip the square over and check to see if it lines up with the pencil line you just drew. If not, see photos at right.



◀ **Center Punch.** Strike the inside corner of the square with a center punch to open up the legs or the outside corner (inset) to close them.



# Ultimate Layout Square

*The perfect layout tool  
for "big" projects.*

**W**hen it comes to working with wide boards or large plywood panels, a framing square is just the right size. The only problem is that the thin, metal body of a framing square can be difficult to hold against the edge of a workpiece.

But this "problem" became the inspiration for the project shown in the photo above. The idea was to take an aluminum framing square and turn it into the ultimate layout tool.

Now I'll admit that the result looks a little bit like an over-sized Swiss army knife. But after giving this tool a try in my own shop, it quickly became one of my favorites.

As you can see in the Exploded View drawing on the opposite page, there really isn't much to this project. To make it easier to register the tongue of the square against the edge of a workpiece, I sandwiched it between a pair of wood "cheeks." Then I added a couple of extra

features — a bevel gauge for laying out angles (see photos above) and a slide-out tab to support the square when using it as a layout tool (see photos below).

**Cheeks** — To make the cheeks, I started by cutting two strips of wood to match the width of the tongue of my square ( $1\frac{1}{2}$ " ). Before attaching the cheeks to the square, however, I did all the machining.

First, I cut a shallow, stopped recess on the inside face of the short

cheek to serve as a pocket for holding the bevel gauge blade that is added later. I cut this recess on the table saw (but you could use a router table). Since the saw blade leaves the end of the recess rounded, you'll have to square up the end with a chisel.

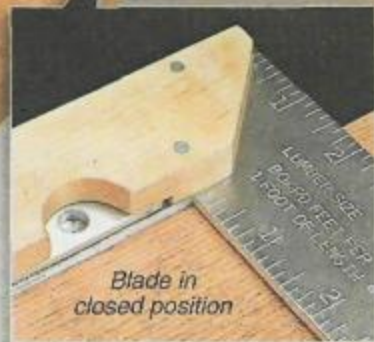

◀ **Slide-Out Tab.** A tab at one end of the tongue supports the square along the edge of the workpiece.

Next, I mitered the end of each cheek (see drawings at right). Then I routed a finger grip on the outside face of each cheek with a core box bit. I also made a small cutout in the short cheek to make it easier to pull out the bevel gauge blade (see short cheek drawing at right and inset photo on opposite page). Finally, I drilled a hole and installed a threaded insert near the end of the long cheek and rounded off the end.

The cheeks are glued to the framing square with epoxy and then pinned in place. I started with the long cheek. Once it was glued in place, I drilled four holes along the inside edge, through the cheek and the framing square (see detail 'a' in exploded view). To lock the cheek in place, I used "pins" cut from 16d finish nails. I drove the pins into the holes and peened over the ends with a ball-peen hammer. Then I filed the pins flush with the surface.

Once the long cheek is in place, you can add the short cheek. The process is exactly the same. The only difference is that the pins you'll use here pass through both cheeks

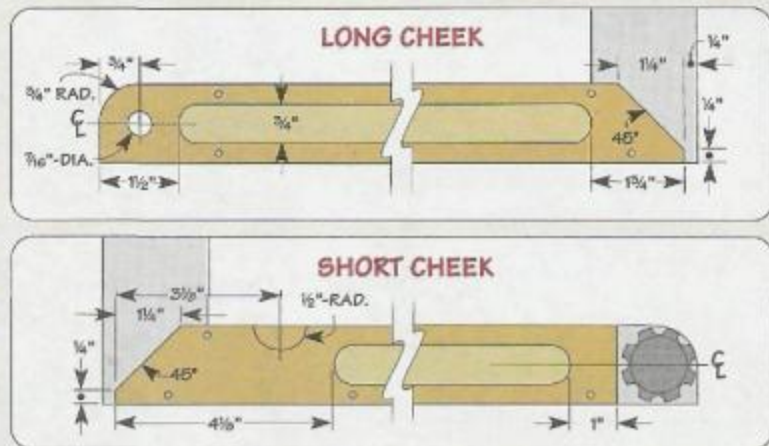

**▲ Locking Knob.**  
To make the locking knob for the layout square, a cap screw is press-fit into a blind hole in the center of the knob.

as well as the square. Take a look at detail 'b' in the exploded view to see what I'm talking about.

**Blade and Tab** – All that remains to complete the layout square is to add the bevel gauge blade and the slide-out tab. These are both cut from 1/8"-thick aluminum bar stock. The bevel gauge blade is mitered at 30° at one end. The other end is cut and filed to shape. Then a couple of holes are drilled in the blade — one is for the knob (see details below and photo in margin) and the

other is to make it easier to pull the blade out of the recess (see inset photo on opposite page).

The tab is slotted to allow it to slide in and out. After you've made the slot, you can attach the tab and bevel gauge blade with the knob and washer and go to work.

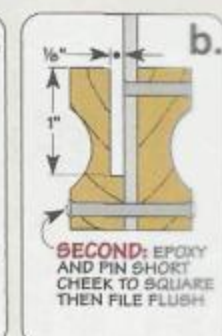
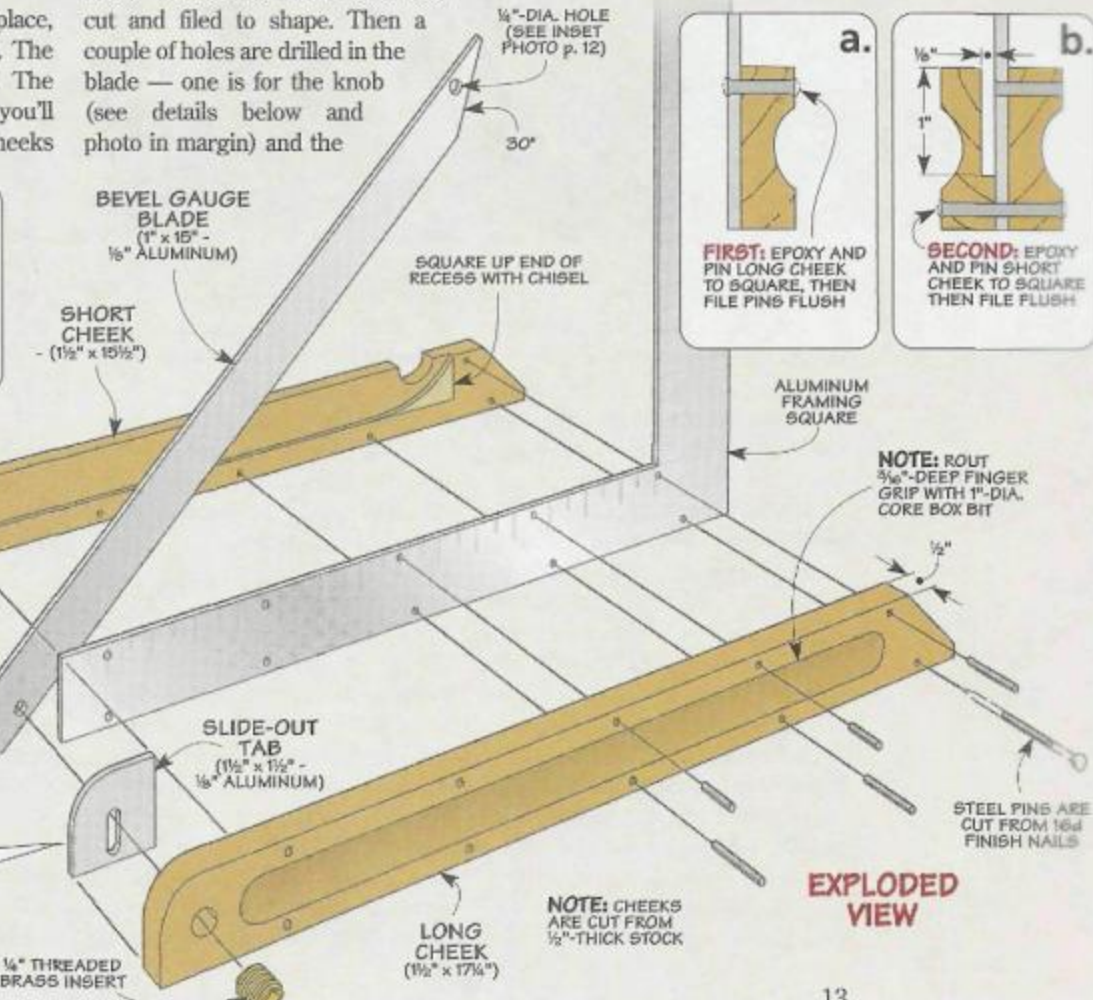
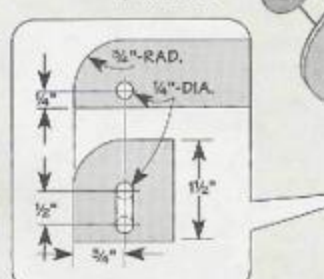
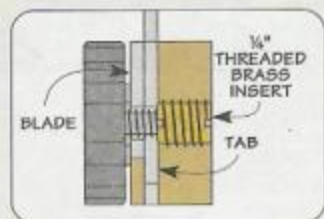

**EXPLODED VIEW**

A close-up photograph of a person's hand in a denim shirt operating a Delta jointer. The hand is on a black handle, adjusting a red handwheel on the machine. The jointer is a large, industrial-grade metal tool with a prominent 'DELTA' logo on its side. The background is dark, making the machine stand out.

## Tuning Up Your Jointer

*Stock that's flat,  
straight, and square —  
every time? It's only  
steps away with a  
well-tuned jointer.*

**A** jointer is arguably one of the most, if not the most, critical shop tools when it comes to preparing stock for a project. Without a well-tuned jointer, getting stock that's flat, straight, and square is just about impossible.

So what does it take to get great results? Not all that much. With a few standard shop tools and a spare afternoon, you can make sure your jointer's table and fence are in good working order and set properly. Then you can finish up by setting the knives on your jointer for a perfect cut.

**Reference Owner's Manual** — Before you get started though, take some time to dig out your owner's manual. Although most jointers are built and operate in the same basic manner, the manual that came with your jointer should provide detailed

drawings and figures to help orient you to the parts and assemblies that relate to the tune-up procedure and photos that follow.

**Start Out Safe** — Before you start, be sure to unplug your jointer and then remove the cutterhead guard to provide easy access to the cutterhead and tables.

### **INFEED & OUTFEED TABLES**

The heart and soul of a jointer are the infeed and outfeed tables. The tables provide the reference surfaces for accurately flattening the face or edge of a workpiece.

**Check for Flatness** — So the first thing you'll want to do is check that each table is flat. To do this, you'll need an accurate straightedge, like the one shown in the photo at the top of the opposite

page. (For more on precision straightedges, refer to page 32).

To see how flat the table is, simply lay the straightedge along one edge. If you can see a slim sliver of light anywhere between the table and straightedge, you probably have a gap of a couple thousandths of an inch, which isn't much to worry about.

Be sure to check along the opposite edge of the table too. And then check for any twist by laying the straightedge diagonally across the corners.

**Judging the Gap** — So how much gap is too much? Well, that's open for debate, but a feeler gauge will tell you exactly what the gap is. I don't like to see much more than 0.010". Anything larger can result in inconsistent results. Correcting a problem like this will probably require a visit to a machine shop. The nice thing is, your

tables will most likely check out okay. What's more likely to be a problem is how the tables relate to each other.

**Are the Tables Parallel?** – What's really important is for the two tables to be parallel to each other. This way, the workpiece will rest perfectly flat against the infeed table while it passes over the cutterhead and remain flat against the outfeed table as you complete the cut.

Here again, you'll need your straightedge to check the relationship. Only this time, you'll need to lay the straightedge *across* the two tables to check for any gaps. And don't forget to check diagonally too.

It's best to start with the straightedge flat against the infeed table and then raise or lower the table until the straightedge just touches the outfeed table (photo at right). This way, you can check for any gaps at the outfeed end.

The most likely problem will be that the end of the outfeed table "sags" a little bit. If that's the case, the first thing I do is check whether the gibs in the dovetailed ways are snug on both tables (see drawing below).

Over time, you'll have some wear on the gibs as the tables are adjusted up and down. This "looseness" can result in a little sag on either table.



▲ **Checking the Alignment.** A precision straightedge and feeler gauge allow you to check whether the outfeed table sags (top). Snugging up the gib may help remove the sag (inset).

After snugging up the gibs (inset photo above), check the tables one more time with your straightedge.

Just don't tighten the gibs too much to correct any sag. You still need to be able to adjust the table smoothly. If there's still some sag, you can try to correct it with a little shimming. For more on how to do this, check out the box below.

**Check the Fence** – While you have your straightedge handy, you'll

want to take a minute to check the fence. The fence provides the reference surface for squaring the edge of a workpiece. So it's important that it be just as flat as the tables.

If the fence is twisted or bowed too much, there isn't any way to correct it on the jointer. You can probably live with a small bow. But if there's any excessive twist, you'll probably want to take the fence to a machine shop and have it corrected.

## Taking out the Sag

After snugging up the gibs on your jointer, you may find that the infeed and outfeed tables still sag a little. To solve this problem, you might want to try adding shims.

You can shim either table, or both if necessary, but it's best to shim just the outfeed table. This way, you don't have to worry about the shims working their way loose as you adjust the infeed table to change the depth of cut.

The goal here is to add shims to the lower ends of the dovetailed ways (see photo and drawing) to "lift" the end of the outfeed table. And keep in mind that you'll probably have to experiment a bit to get things just right.

Start by loosening the gib, then have a friend gently lift the end of the outfeed table so you can slip the shims in place. (I picked up some brass sheet stock at a local hardware store.) After snugging up the gib, check the tables with your straightedge again. As I mentioned, a little trial and error may be necessary to get things just right.

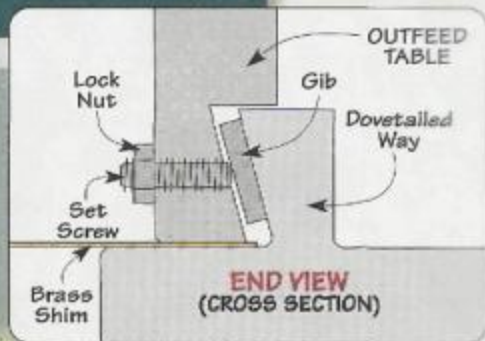
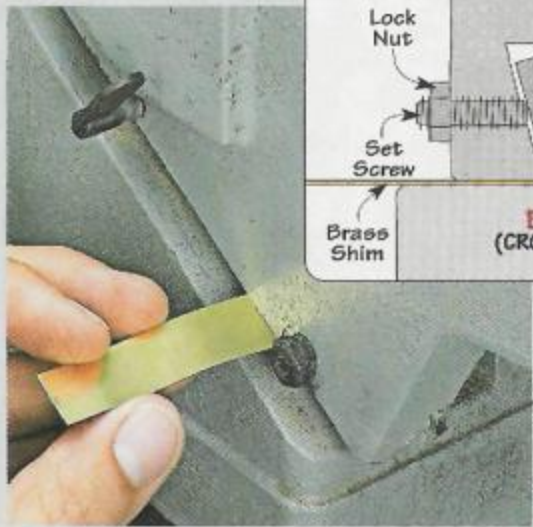

OUTFEED TABLE

Gib

Knife

Cutterhead

INFEED TABLE

## Changing & Setting the Knives

Once you have the tables aligned so they're parallel with each other, you've won half of the tune-up battle. The other half is ensuring that you have sharp jointer knives installed in the cutterhead and that they're adjusted properly.

**Jointer Knives** – It goes without saying that to get good results with your jointer, you need sharp knives. So if you've been using your jointer for some time, it's probably a good idea to sharpen the knives.

One thing you might want to consider is keeping an extra set of knives handy for your jointer. This way, when the set in the jointer begins to dull or gets nicked, you can swap them out for a fresh set. This

gives you time to send the other set out to be sharpened without having to worry about having your jointer out of commission.

**Top Dead Center** – The secret to installing a set of jointer knives is simple. The knives have to be perfectly level with the outfeed table when the cutting edge is at its peak.

Finding the peak, or top dead center (TDC), isn't all that difficult. The photo at the lower left shows how to use a metal rule to find TDC using the cutterhead as a reference and allowing you to mark the position on the fence.

**Remove One Knife** – Once you've located TDC, you can carefully rotate the cutterhead to position

one of the knives so the cutting edges lines up with your TDC mark. Then "lock" the cutterhead in place with a wood wedge, as in the upper photo on the opposite page.

At this point, you can remove the knife. The knife is held in place by a metal gib. Removing the knife is just a matter of loosening the bolts that hold the gib in place. The drawing at the lower left shows how this works.

You'll probably notice some dust and pitch buildup on the knife and gib when you lift them out. Set the knife aside and take a moment to clean the gib and cutterhead with a rag and some mineral spirits.

**Install New Knife** – Now you're ready to install a new knife. Start by

placing the gib back in the slot and then carefully slip a new knife between the cutterhead and gib. Just be sure that the bevel is facing the outfeed table.

Once the knife is in place, position it so the end is even with the end of the cutterhead. With some jointers, the ends of the knives may project slightly past each end of the cutterhead.

With the knife in place and resting on the leveling screws, snug up the gib

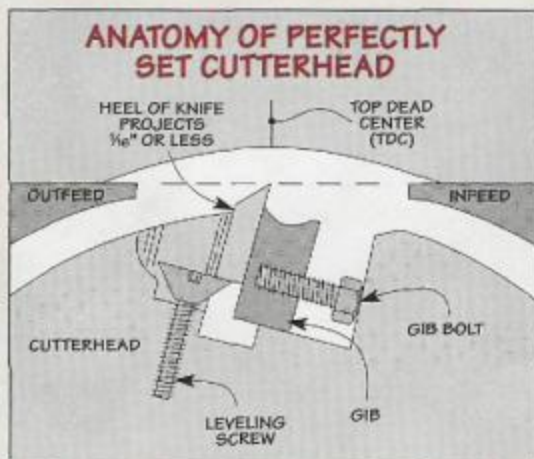



Now, take a look at how far the back edge of the knife, or heel, sticks out past the cutterhead. To provide solid support for the knives, you don't want this to be any more than  $\frac{1}{16}$ " , as in the drawing on the opposite page. Adjust the leveling screws to raise or lower the knife as required.

Next, you'll need to align the knives with the outfeed table. I start by adjusting the height of the outfeed table so it's roughly at the same height as the knife. (A straightedge makes quick work of this.)

**Dial Indicator** – The method I like to use for setting the knives to exactly match the outfeed table requires a dial indicator and holder (I use a magnetic base, but a shop-made base will work just as well.)

The first step is to "zero out" the dial indicator. To do this, rest the tip on the outfeed table and adjust the indicator to read zero (photo at near right). From this point on, don't adjust the arms of the base or the dial of the indicator. This will ensure that your reference point remains the same.

Now, position the tip of the dial indicator on the edge of the knife near

the fence (center photo). If the indicator stills reads zero, the cutting edge matches the outfeed table. If not, adjust the leveling screw so the indicator reads zero. To check the other end of the knife, reposition the dial indicator and adjust the leveling screw as required (far right photo).

Once the knife reads zero at each end (check both ends again after any adjustment), tighten the gib bolts securely. I do this a little at a time by working from the center out until all the bolts are tight.

You also need to adjust the other two knives. To do that, simply repeat the process, working with one knife at a time. Other than taking care of a few final details (more in the box below), your jointer is tuned up and ready for use.

**Nicked Knives** – One last thing. There's probably nothing more frustrating than running a workpiece across your jointer and nicking a

newly installed set of knives. Instead of replacing the whole set, you can solve the problem by simply shifting one of the knives slightly.

Doing this offsets the nick on each knife just a bit, resulting in a smooth cut. It's a good idea to use the knife-setting process to double-check that the knife you shift is still aligned with the outfeed table. 



◀ **Knife Adjustment.** With the dial indicator zeroed out (left), place the indicator tip on one end of the knife and adjust the height of the knife until the indicator reads zero (center). Repeating this process at the other end of the knife shows it needs to be lowered (right).

## Final Details

Now that the knives are set, the hardest part of the jointer tune-up is behind you. All that's left to do at this point is complete the adjustments on a few final details.

**Set the Depth of Cut** – Although I don't depend on my jointer's depth of cut indicator to precisely set how much material the jointer removes, I still like it to be close. So it's a good idea to set the infeed table to match the outfeed table and then reset the indicator to zero (right photo).

**Set the Stop** – One other setting you should double-check is the stop for positioning the fence square to the tables. A machinist's square makes quick work of this, as you can see in the center photo.



Then zero-out the fence angle gauge if your jointer has one. If your jointer has stops for  $45^\circ$  and  $135^\circ$ , set those too.

**Reinstall the Guard** – Finally, completing the tune-up is just a matter of reinstalling the guard for

the cutterhead, as in the far right photo. What's important here is to adjust the spring so there's enough tension to swing the guard all the way back to the fence. But you don't want the tension so tight that the guard "slams" into the fence.

*With a hand-held router and this jig, you can make perfect-fitting miters in no time at all.*

Getting a miter joint to fit perfectly may seem like a simple task. Just cut the two pieces at 45° and put them together. What could possibly be easier than that?

But if you've ever made mitered frames, you know it can take a lot of fussing to get the mitered ends to match up perfectly. No matter how careful you are, there's always some trimming that needs to be done. That's where this router miter trimmer comes in handy.

This jig accepts stock up to 3" wide so its not just for making frames. And trimming with the router means the miters are always cut smooth and accurate.

One of the great features about this miter trimmer is the fact that you can make small adjustments whenever needed. You can slightly increase or decrease the trim angle to fit the situation. This makes it easy to trim almost any miter joint so you get just the right fit.

But best of all, the trimmer is easy to build and easy to use. Since it's portable, you can use it in your shop or take it to the job site.

## Router Miter Trimmer



▲ **Angle Adjustment.** Fine tuning the jig is easy. A few turns of the knobs and the adjustment is made. The center stop lets you quickly return to the original, 45° setting.

The trimmer consists of a base panel, a router guide assembly, and some adjustment components. The base panel is the first task.

**Base Panel** – For the base panel (A), I used a piece of 1/2" plywood. At the back of the plywood panel, I added a backstop (B) and a 36" piece of T-track to receive the hold down clamps as shown in Figures 1 and 1a at the right.

Next, a filler block (C) is added in the space between the end of the T-track next to the backstop to prevent workpiece tearout. The end of this filler block will be trimmed at 45° the first time you use the jig.

Before moving on to the guide assembly, center a 5/16" hole in the backstop. This hole will hold a carriage bolt that allows the router guide assembly (made later) to pivot to fine tune angle settings.

**Guide Assembly** – The heart of the miter trimmer is the router guide assembly (Figure 2). As you can see, it consists of a router base, sandwiched between the router guide, and an adjustment block.

Begin by cutting a piece of 1/2" plywood for the router base (D). I made it a little wider so the edge could be trimmed off with the first pass of the router, as shown in

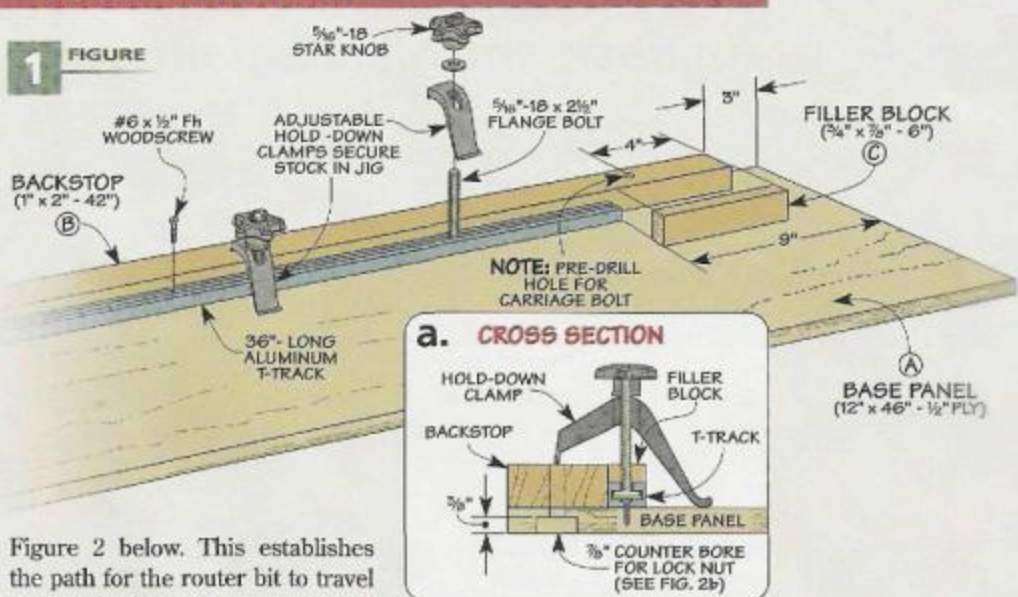

Figure 2 below. This establishes the path for the router bit to travel accurately along the router guide.

Next, the adjustment block (E) is cut from a piece of 7/8" thick stock. One end is cut at 45° to allow the workpiece to slide through. I cut two grooves perpendicular to one another in the opposite end of the block, as shown in Figure 3.

The wider groove captures the threaded adjustment rod and the narrow groove will hold an aluminum flip stop. The adjustment block is then secured with three screws to the router base.

The router guide (F), that directs the router base plate, is cut

from a 7/8" thick piece of stock and glued to the top of the router base. To complete the guide assembly drill a counterbored 5/16" hole through the guide and base. A carriage bolt can then be used to attach the guide assembly to the backstop and base panel.

All that's left now is to mount the router support (G). You'll want to be sure it is positioned at a 45° angle to the backstop, as shown in Figure 2a. This will help orient the location of the adjustment components that are built next.

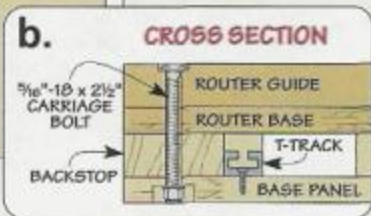
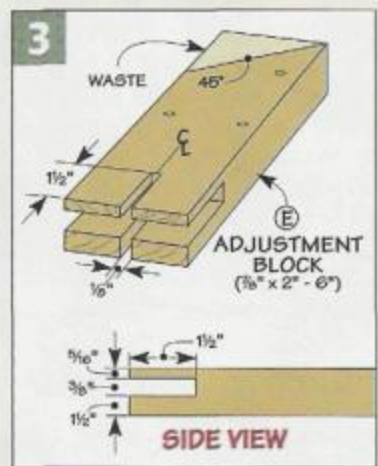
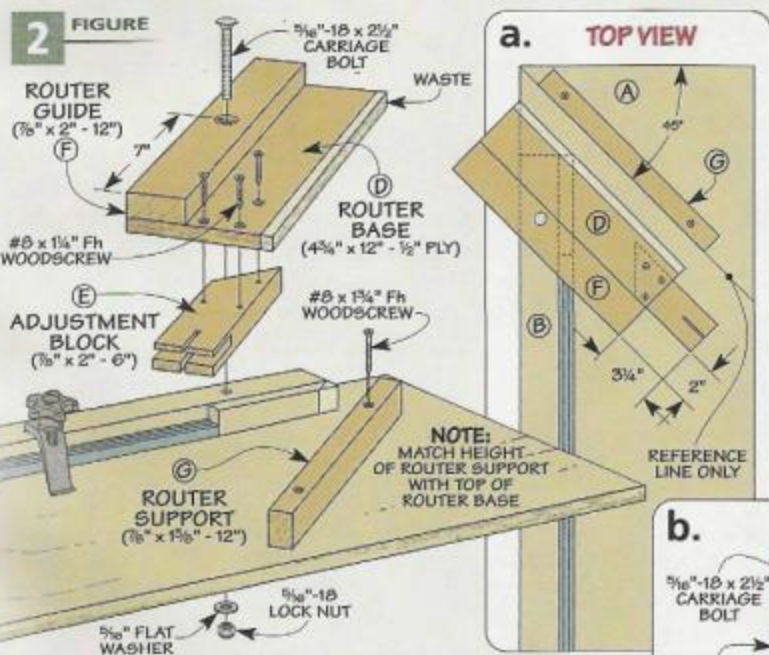

ShopNotes To view a video on how to use this router miter trimmer, go to: [www.ShopNotes.com](http://www.ShopNotes.com)

# Adjustment Mechanism

With the guide assembly in place, the next parts to add are the adjustment components. Using a few small wooden blocks, an aluminum center stop and a few screws, it's easy to build the adjustment mechanism for the trimmer.

**Adjustment Rod** - First you'll want to make the two *rod holder blocks (H)* that capture the threaded adjustment rod. Next, drill and countersink a pilot hole in the top of each of these blocks. Then make a second,  $\frac{1}{4}$ "-deep hole centered on the inside of each block to hold the adjustment rod (Figure 4a).

Before assembling the adjustment rod, you'll want to fashion a center stop out of a piece of aluminum, as shown in Figure 4. Once you've made the center stop, slide it on the threaded adjustment rod followed by a washer and a knob on each side of the stop. Then place a rod holder block over each end of the threaded rod.

Finally, orient the rod holder blocks so they are 90° to the router support. Then fit the threaded rod and the aluminum stop into grooves in the adjustment block, as is shown in Figures 4 and 4a.

**Stop Block** - The final thing you'll need to do is to add a *stop block (I)* to act as a guide for centering the trimmer at a 45° angle. The top view in Figure 4 shows you the correct placement. Next, insert a screw in the center of the end of the stop block. You can adjust this screw so

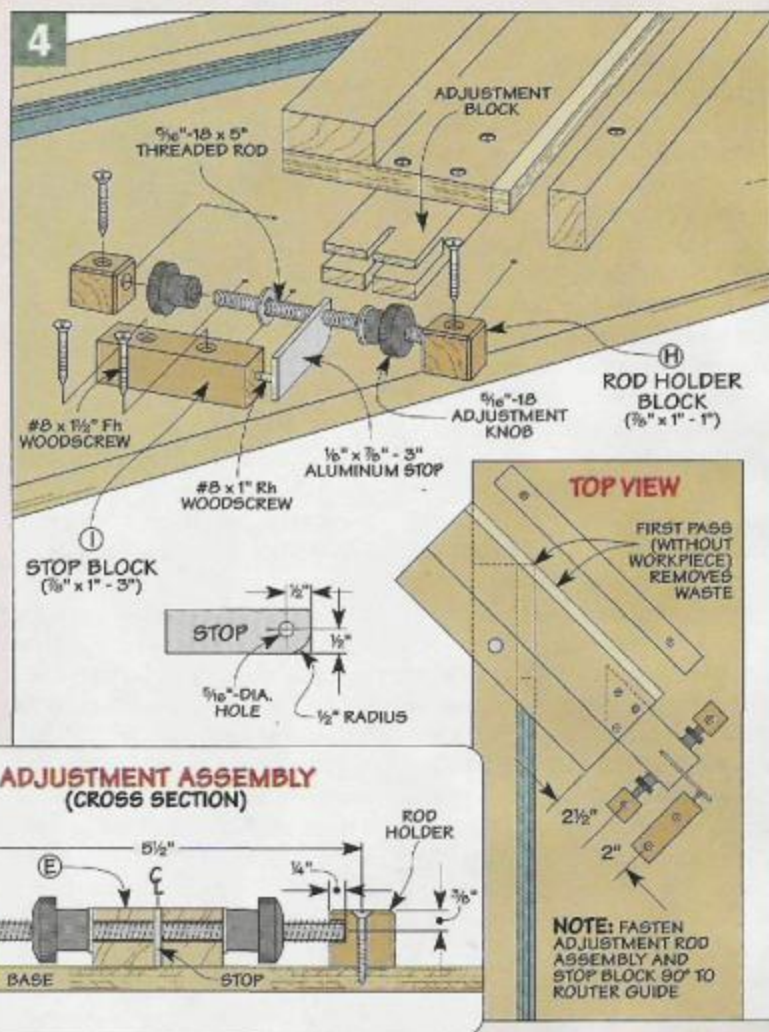

that the aluminum stop rests against it when the trimmer guide is positioned at a 45° angle.

**Using the Trimmer** - To use the router miter trimmer, simply place one end of a mitered board in position along the T-track and tighten the hold down clamps. Next, position your router so it

rests on top of the router support and against the router guide. Then just turn on the router and pass it from left to right along the guide.

Trimming the other end of the workpiece is simple, just flip the board over and repeat the process. It's that easy to make miter joints with a perfect fit every time. 

## Materials & Hardware

A Base Panel (1)	12 x 46 - $\frac{1}{2}$ " Ply.	I Stop Block (2)	$\frac{7}{8}$ x 1 - 3	• (1) $\frac{5}{16}$ " x 2 1/2" Carriage Bolt
B Backstop (1)	$\frac{7}{8}$ x 2 - 42	• (1) Stop $\frac{1}{8}$ " x $\frac{7}{8}$ " Aluminum (3" long)		• (1) $\frac{5}{16}$ " Lock Nut
C Filler Block (1)	$\frac{7}{8}$ x $\frac{3}{4}$ - 6	• (2) $\frac{5}{16}$ " - 18 Adjustment Knobs		• (5) $\frac{5}{16}$ " Flat Washers
D Router Base (1)	4 3/4 x 12 - $\frac{1}{2}$ " Ply.	• (1) $\frac{5}{16}$ " - 18 x 5" Threaded Rod		• (3) #8 x 1 1/4" Fh Woodscrews
E Adjustment Block (1)	$\frac{7}{8}$ x 2 - 6	• (1) #8 x 1" Rh Woodscrew		• (4) #8 x 1 1/2" Fh Woodscrews
F Router Guide (1)	$\frac{7}{8}$ x 2 - 12	• (2) $\frac{3}{16}$ " - 18 Star Knobs		• (2) #8 x 1 3/4" Fh Woodscrews
G Router Support (1)	$\frac{7}{8}$ x 1 3/8 - 12	• (2) $\frac{5}{16}$ " x 2 1/2" Flange Bolts		• (1) T-Track (36" long)
H Rod Holder Block (2)	$\frac{7}{8}$ x 1 - 1			

# Fine-tuning your Miter Trimmer

If you've ever tried to fit a miter that was just a little bit off, you know how difficult and frustrating it can be. First, you trim a little off of one end and then the other and the miter still doesn't match up.

Well, one of the great features of this router miter trimmer is that it's easy to make micro-adjustments to the angle. This allows you to trim both sides of the miter joint with the same setting, resulting in a perfect fit.

**Basic Miter Setting** – The first thing that you'll want to do is to set the trimmer to cut a 45° miter. To do this, just set your guide assembly to the desired angle and make some test passes. Once you have the angle you want, adjust the stop screw until it touches the aluminum stop when it's in the down position as shown in the photo below. This will give you a reference point when you need to return to the 45° position.

**Increasing or Decreasing the Angle** – In order to make the miter match up correctly, you'll sometimes find you need to cut an angle slightly greater or slightly less than 45°. This is usually a difficult task but can be easily accomplished using the miter trimmer.

This is done by simply raising the aluminum stop and making adjustments with the two adjustment

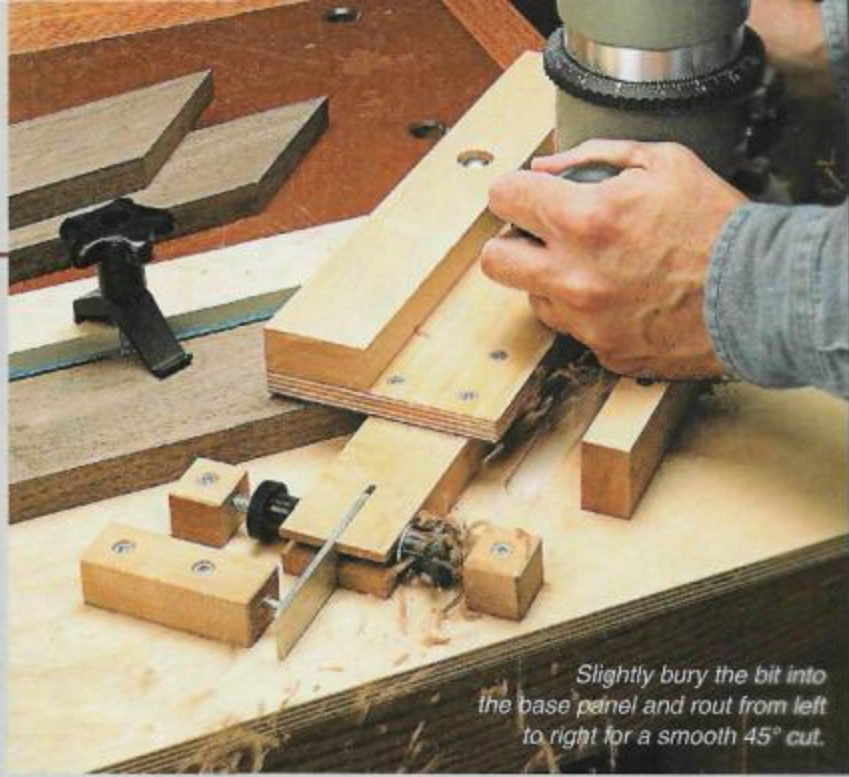

*Slightly bury the bit into the base panel and rout from left to right for a smooth 45° cut.*

knobs (bottom right photo). If the tips of the miter are open, you'll need to move the adjustment knobs to the right (less than 45° angle) and if the heel of the miter is open you'll need to move the adjustment knobs to the left (greater than 45° angle). That's all there is to fitting miters with the router miter trimmer. 🛠️

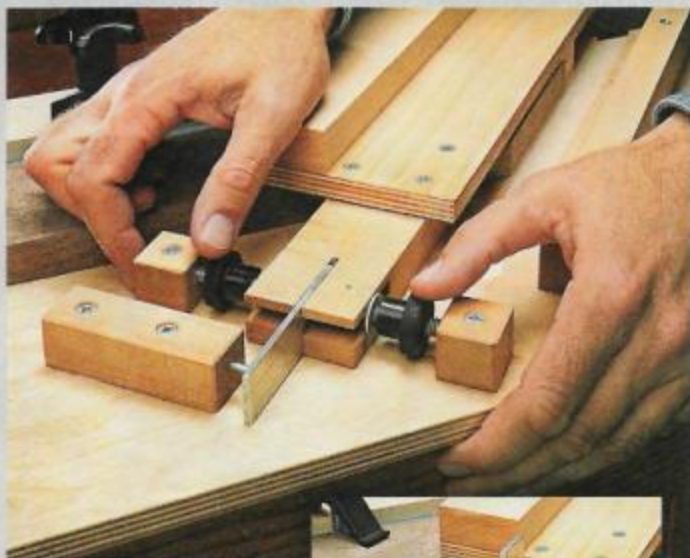

▲ **Fine Tuning for a Perfect 45° Cut.** With the guide assembly at 45°, set the screw until it touches the aluminum stop (see insert). Then it's easy to return to this position by just flipping the stop down and adjusting the knobs.



▲ **Plus or Minus 45° Cuts.** Whenever you need to cut an angle greater or less than 45° to square up a miter joint, simply lift up the aluminum guide stop. Then adjust the two knobs to change the miter angle for trimming.



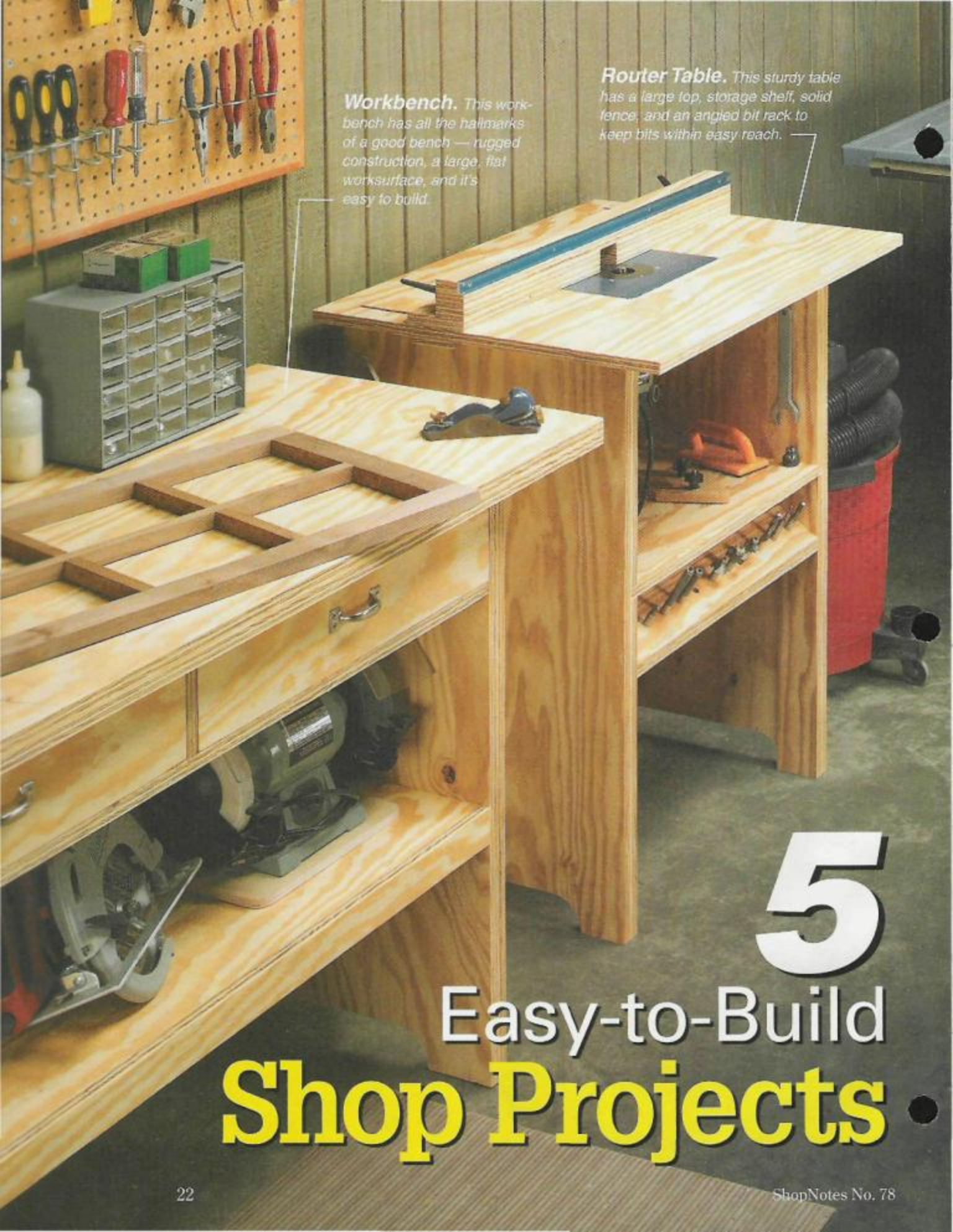

**Workbench.** This workbench has all the hallmarks of a good bench — rugged construction, a large, flat worksurface, and it's easy to build.

**Router Table.** This sturdy table has a large top, storage shelf, solid fence, and an angled bit rack to keep bits within easy reach.

# 5

## Easy-to-Build Shop Projects

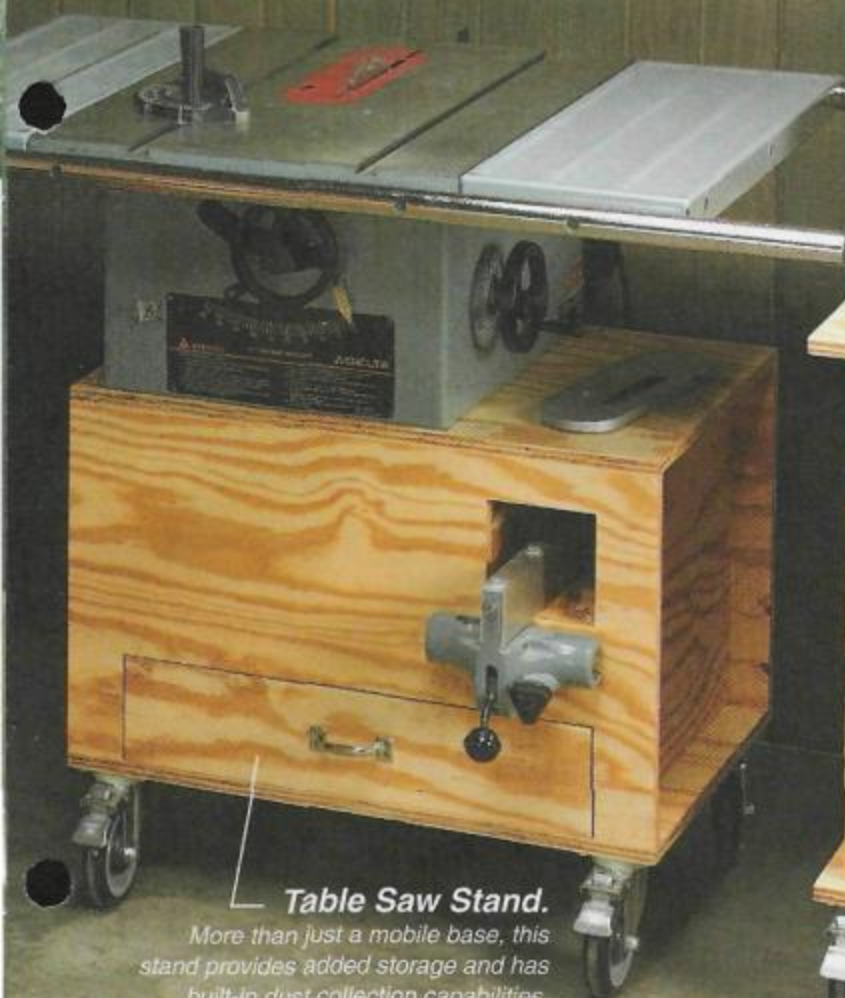

### **Table Saw Stand.**

*More than just a mobile base, this stand provides added storage and has built-in dust collection capabilities.*



**Tool Stand.** *A roll-around stand for power tools features an open shelf and a drawer to keep needed tools and supplies close at hand.*

*You can build five essential shop projects this weekend with just seven sheets of plywood and a box of screws.*

**D**on't get me wrong, I like building projects for my shop the same as anybody. But sometimes, I don't want to spend a huge amount of time or money building them. The problem is, "quickie" projects tend to be second-rate, slap-together contraptions that don't do the job well and won't last long.

But that's not the case with the workbench, router table, table saw stand, tool stand, and assembly boxes you see in the photo above. I wanted projects that were strong, easy to build, and made the most of the space in my small shop.

**Simple Materials** - To start with, they're all built from one or two sheets of run-of-the-mill  $\frac{3}{4}$ " fir plywood. You can find it at any home center and it's pretty inexpensive.

The joinery is pretty basic too — just butt and rabbet joints fastened with glue, screws, and nails. That means assembling each project is just a matter of cutting the parts to size and fastening them together.

Although they're not fancy, these simple projects have enough features, added storage, and flexibility to make spending time in your shop easier and more enjoyable.

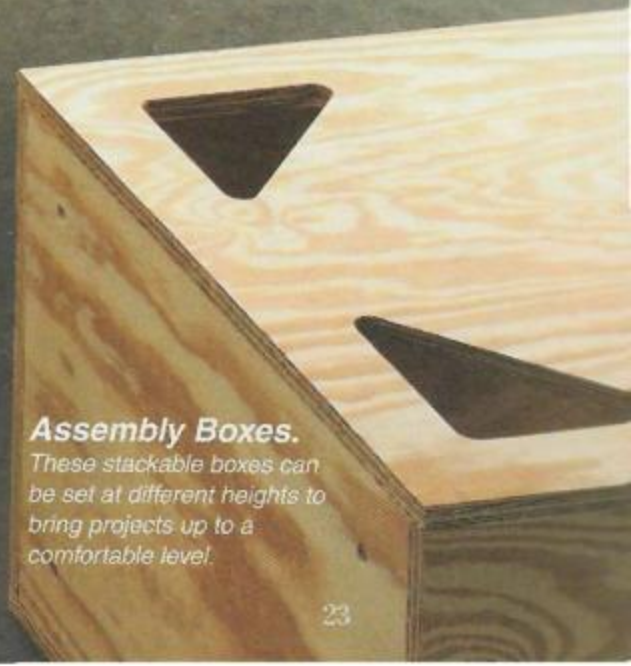

### **Assembly Boxes.**

*These stackable boxes can be set at different heights to bring projects up to a comfortable level.*

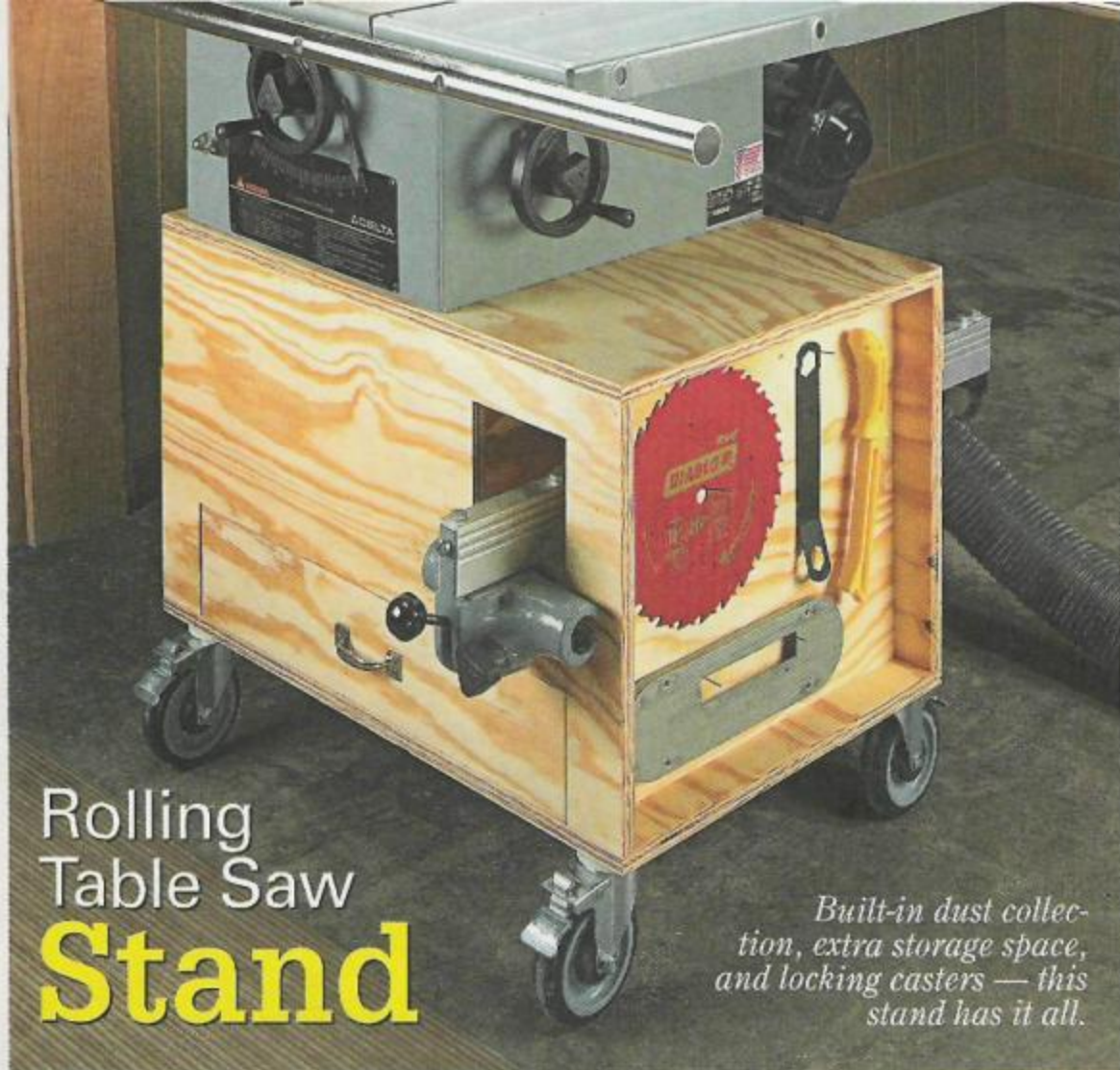

## Rolling Table Saw Stand

*Built-in dust collection, extra storage space, and locking casters — this stand has it all.*

If there's one thing I could change about my table saw, it would be the metal stand that came with it. The stand isn't very efficient — it's not easy to move the saw around, and there's no storage. And the open base just lets the chips and sawdust fall right to the floor.

The table saw stand shown above overcomes all these weaknesses without taking up much more space than the metal stand.

**Ample Storage** — For starters, the stand is packed with storage options. On each end of the stand there's a shallow recessed area. With a few nails or screws, you can turn it into a storage rack for spare blades, inserts, and wrenches. This keeps everything easy to get at. And since the ends are recessed, the accessories won't get knocked off. A drawer in the bottom of the stand provides protected storage for other

items. One of the things I like best is the small cubby on one side of the stand. It's designed to hold the rip fence for those times I need to take it off the saw while crosscutting large panels and long stock.

**Added Features** — The added storage alone would be reason enough to build this stand. But there

are two other features to mention. First, the table saw stand is mounted on heavy-duty, locking casters. The casters are large enough to roll smoothly over extension cords, wood chips, or anything that might be laying around on the floor. And all four wheels lock down so the stand is rock-steady during use.

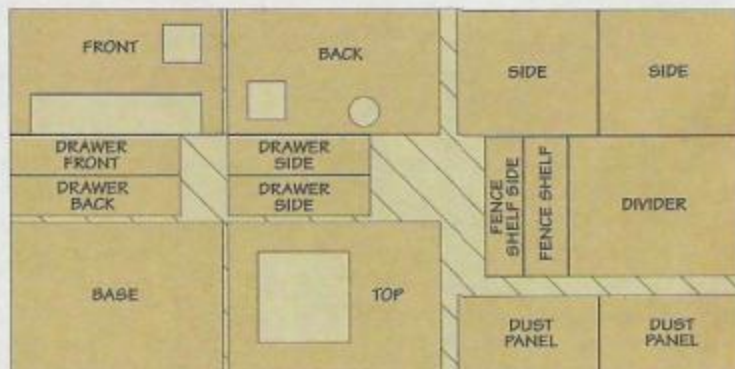

**CUTTING DIAGRAM** (48" x 96" - 3/4" PLYWOOD)

Also needed: 18 1/4" x 21 3/8" - 1/4" Hardboard for DRAWER BOTTOM



The other feature worth noting is that the stand has a built-in dust collection capability. Dust and chips fall from the saw into a V-shaped hopper where they can be drawn out through the hole in the back, as you can see in the drawing at right.

**Building the Stand** – The stand is built with basic joinery (butt joints, nails, and screws) and just one sheet of plywood. The cutting diagram on the opposite page will show you how to make the most of the plywood.

I started building it from the inside out by cutting the sides and divider to size and screwing them together into an H-shaped assembly.

Next, cut the front and back panels. Although they are the same size, there are a couple of differences. On the front panel, there's a cutout for the drawer at the bottom and a square hole cut near one corner for the rip fence cubby. You'll need to cut a matching hole on the back panel. The second hole in the back panel is a round one. I sized this to match my dust collector hose (4"), as in the 'front view' below.

**Dust Collection** – After gluing and nailing the front and back in

### Hardware

- (12) #8 x 1½" Fh Woodscrews
- (4) 5" Locking Casters w/Screws
- (1) Sash Pull w/Screws
- (60) 1½" Brads

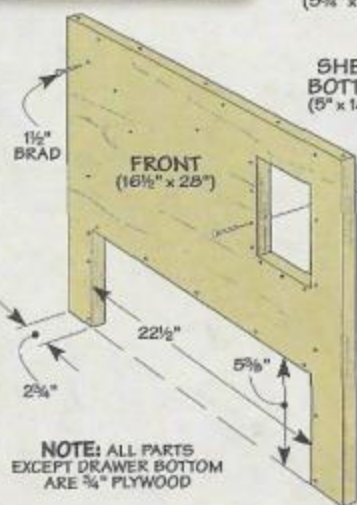

NOTE: ALL PARTS EXCEPT DRAWER BOTTOM ARE ¾" PLYWOOD

1 FIGURE

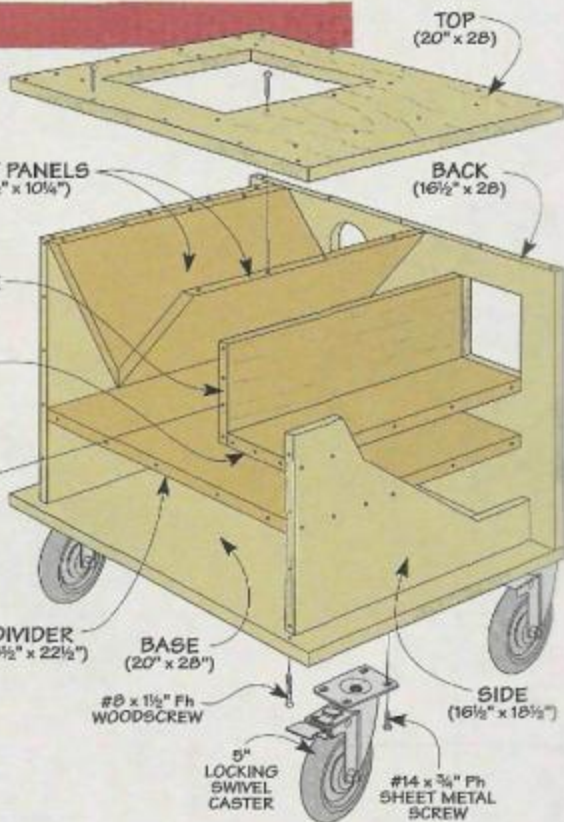

place, you can cut out the top and bottom panels. They're identical except for a hole cut in the top to let chips and sawdust fall through. A pair of dust panels are mitered into a V-shaped collector that's nailed under the hole in the top panel.

Before nailing the top in place, I cut out and attached a shelf side and bottom for the rip fence holder. At this point, the top and bottom can be

nailed to the case. And finally, I screwed the casters in place.

**Basic Drawer** – The last thing to make is the drawer. To keep things simple, I used basic rabbet joints. (I used the same joinery dimensions on all the drawers for the projects that follow.) A groove near the bottom of each part is sized to hold a ¼" hardboard bottom. A standard sash pull serves as the handle.

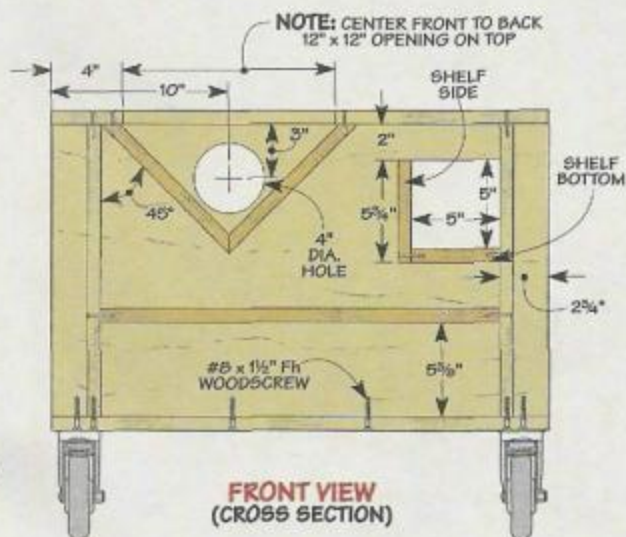

2 FIGURE

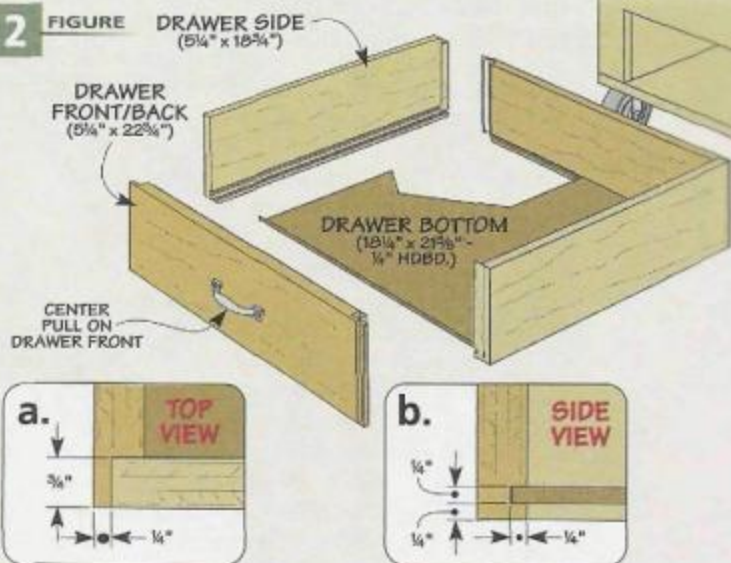

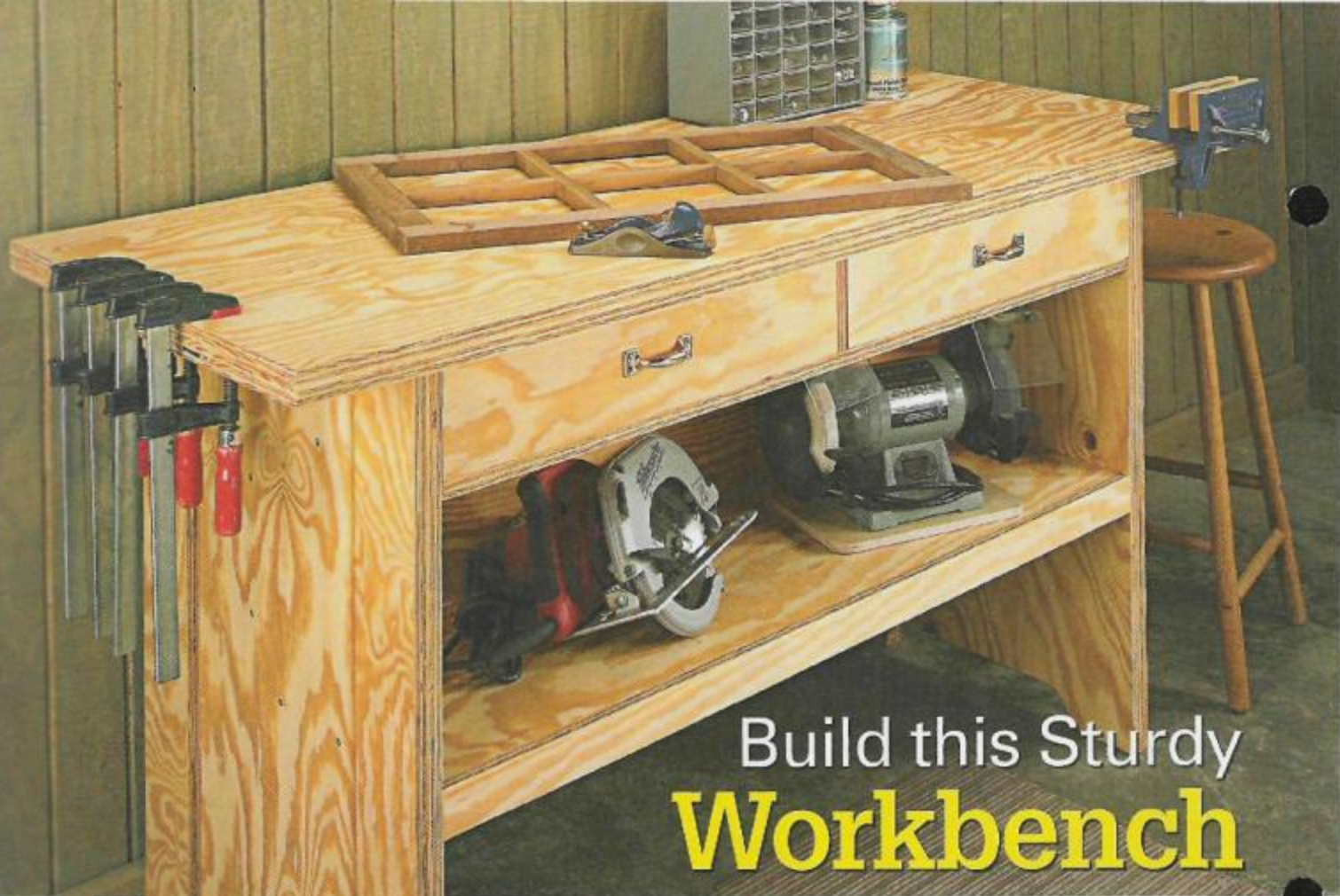

## Build this Sturdy Workbench

*Two sheets of plywood,  
some screws, and  
simple joinery create  
one super-strong  
workbench.*

**W**hether I'm assembling a project, repairing a piece of furniture, or fitting joints, a workbench needs to have a few important qualities.

For one, it needs a large, flat worksurface. A good workbench also needs to be strong and rigid enough to stand up to serious pounding, planing, and

everyday wear and tear. Finally, it needs to provide some storage for my small shop.

The workbench in the photo above has all these features. Plus, it adds a couple more — it's easy to build and it's inexpensive. Except for the drawer bottoms, you can build this sturdy bench from just two sheets of  $\frac{3}{4}$ " plywood. The cutting diagram, shown at right, will show you the best way to maximize the sheets.

**Basic Construction** — What makes this bench so simple to build is that there's no complicated joinery. It's just run-of-the-mill butt joints, glue, and screws. You may be thinking this is a recipe for a wobbly bench, but as you'll see, the parts interlock to form a surprisingly rugged, wiggle-free workbench.

The workbench is made up of four assemblies: the inner case, the legs, the top, and the drawers. Each section (except the drawers) reinforces the others and adds

to the overall stoutness of the bench. Once it's loaded up with tools and supplies, there's enough mass to keep it from shifting around while you're working at it.

**Strong Case** — The first assembly to make is the inner case. This forms the backbone that the rest of the bench is built around. The case serves a couple of purposes.

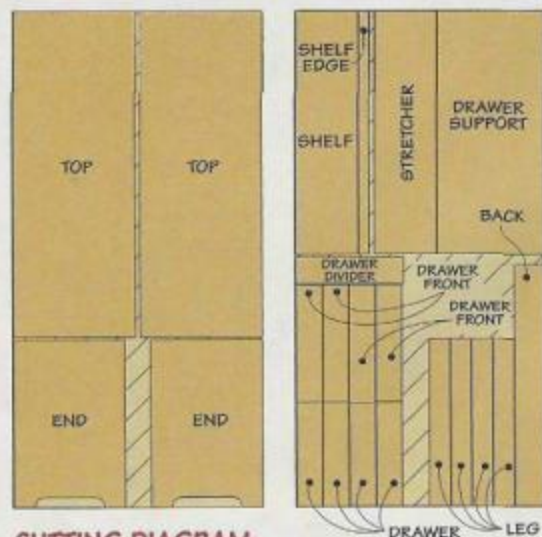

### CUTTING DIAGRAM

48" x 96" -  $\frac{3}{4}$ " PLYWOOD (TWO SHEETS)

Also needed: Two 19 $\frac{1}{2}$ " x 22" -  $\frac{1}{4}$ " Hardboard DRAWER BOTTOMS

First, the case strengthens the bench. And second, it provides some extra storage space — a wide shelf and two drawers.

In everyday use, a workbench is subjected to forces that can cause racking and twisting. To resist these forces, the case of this bench is built up of vertical and horizontal panels similar to an I-beam.

You can see what I mean in the drawing below. The drawer support and shelf form the top and bottom of the "I." The stretcher serves as the body. This creates a rigid frame that won't bend or rack.

On top of this assembly are the back panel and drawer divider. They form the space for the two drawers that are added later. To beef up the shelf and keep it from sagging, a wide, plywood edging is applied to the front of the shelf.

**Sturdy Legs** — Attached to each end of the case are the leg assemblies. Each assembly consists of a solid plywood panel with applied legs. The end panels anchor each part of the case together make the whole bench more rigid. A small cutout at the bottom of the panel creates individual feet for the bench to rest on. Once the bench is assembled, the narrow legs are added to strengthen the end panels.

**Thick Top** — As I mentioned earlier, the top of the bench is made up of two layers of plywood. This extra mass helps keep the bench from shifting in use. When selecting the plywood for this part of the workbench, I picked the smoothest and flattest piece I could find. The top is attached in two steps.

First, the bottom layer is screwed and glued to the inner case and leg assemblies. Like the end panels, this locks the other three assemblies together as a single unit. Next, the top layer is slightly oversized and trimmed it with a hand-held router and a flush trim bit after it was glued in place.

**Drawers** — That pretty much takes care of the bench. All that's left is to add the two drawers. They're built with rabbet joints. A groove cut near the bottom of all the parts holds a hardboard bottom.

**Hardware**

- (71) #8 x 1 1/2" Fh Woodscrews
- (2) Sash Pulls w/Screws

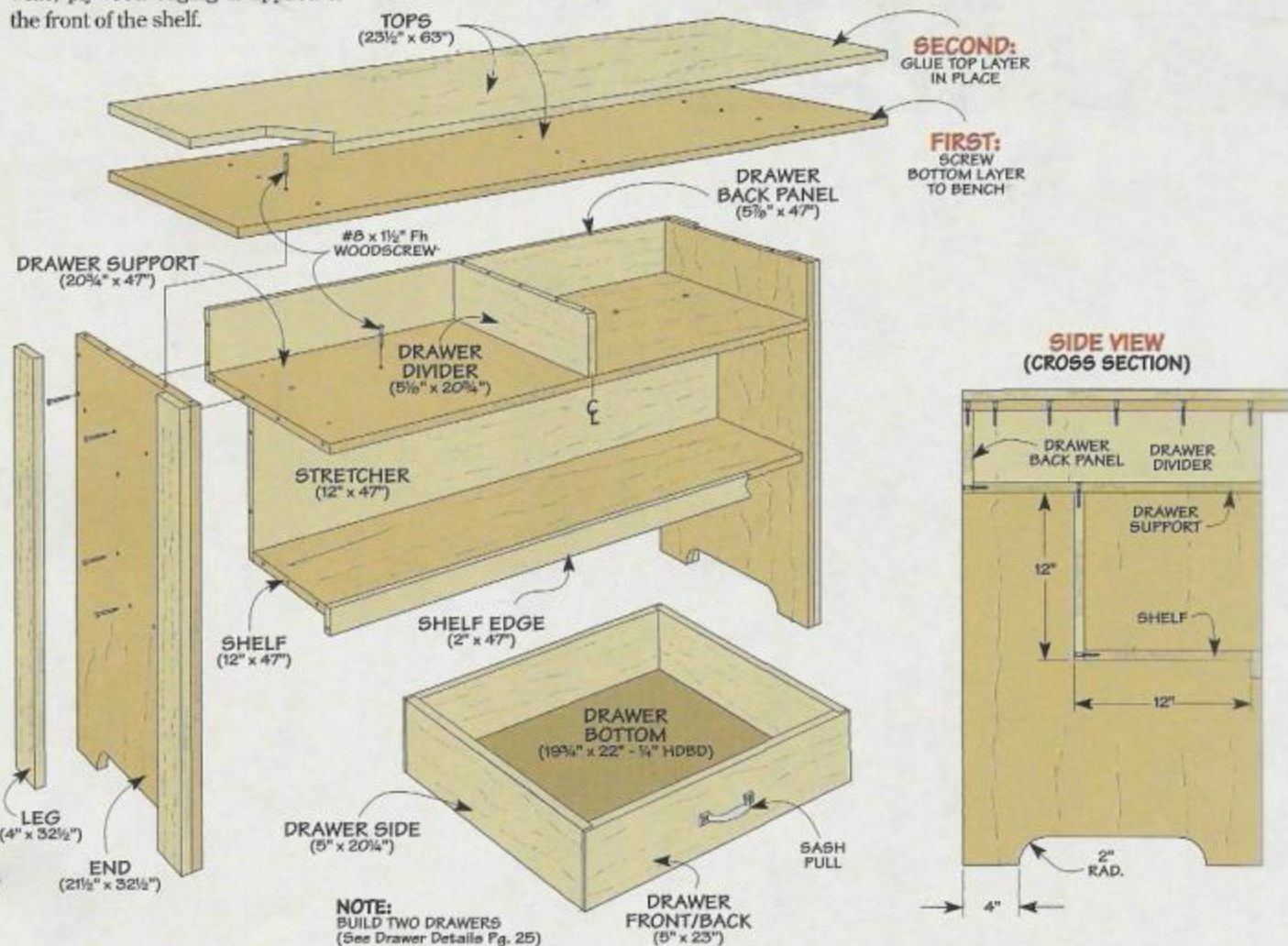

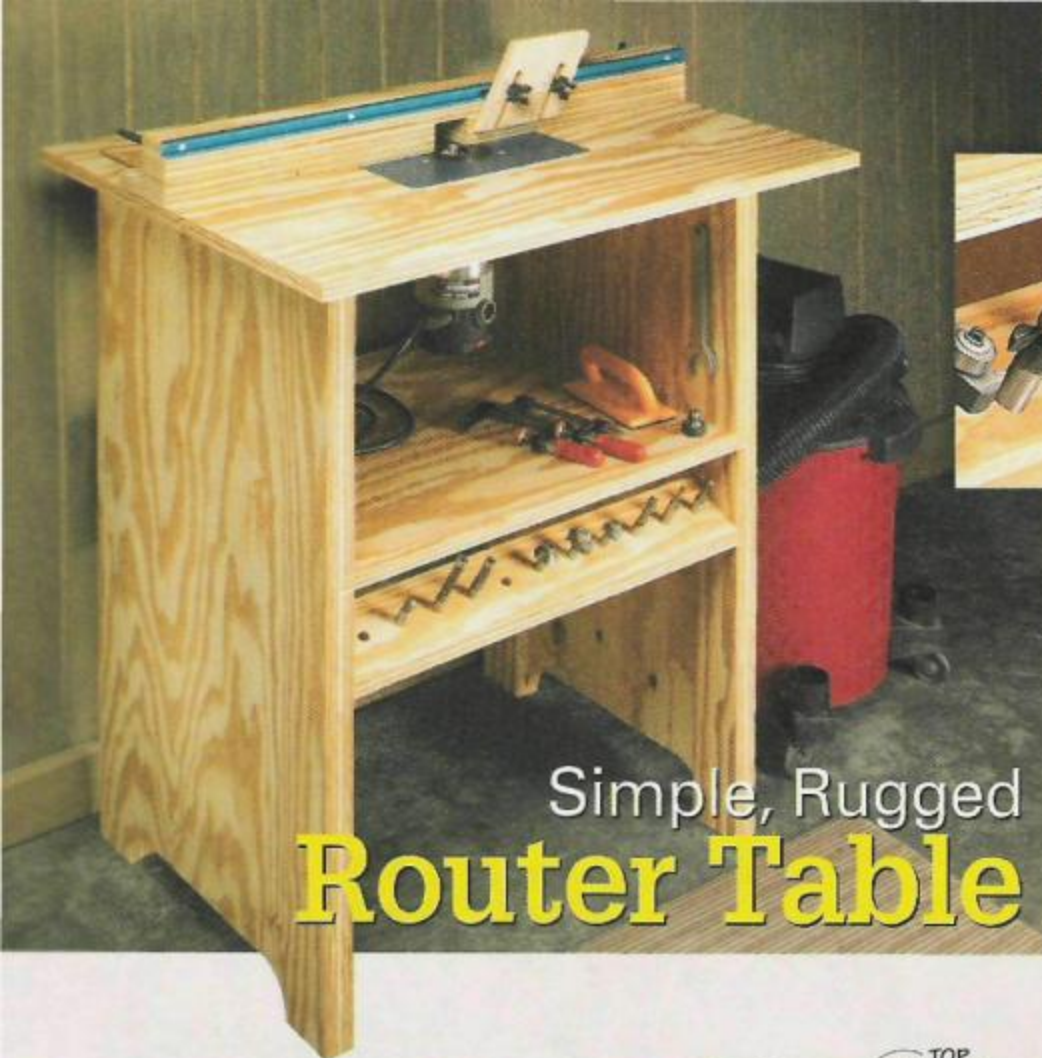

## Simple, Rugged Router Table

▲ **Bit Rack.** With the angled bit rack, you can quickly see and pick out the one you're looking for.

It's easy to see why this router table is such a shop workhorse. For starters, there's the simple, rugged construction. This means you won't spend a lot of time building it. Then there's the large top and fence that are capable of handling just about any project. Finally, there's even a rack for keeping your bits within easy reach.

**Sturdy Construction** - You'll notice in the drawing below that the router table shares some rock-solid construction features with the workbench. It's made up of a center box supported by four legs, and a pair of braces. This assembly is then sandwiched between two end panels.

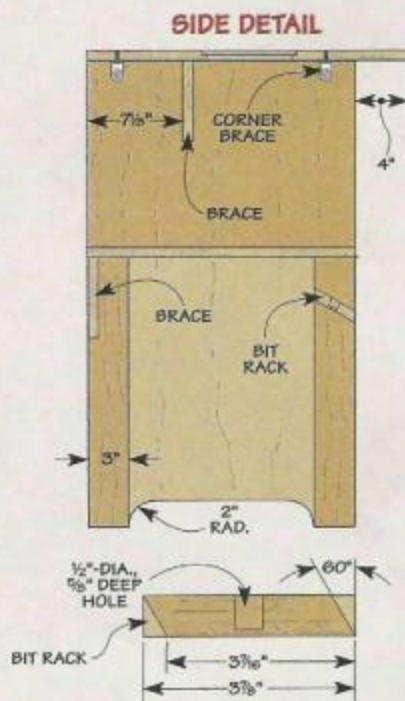
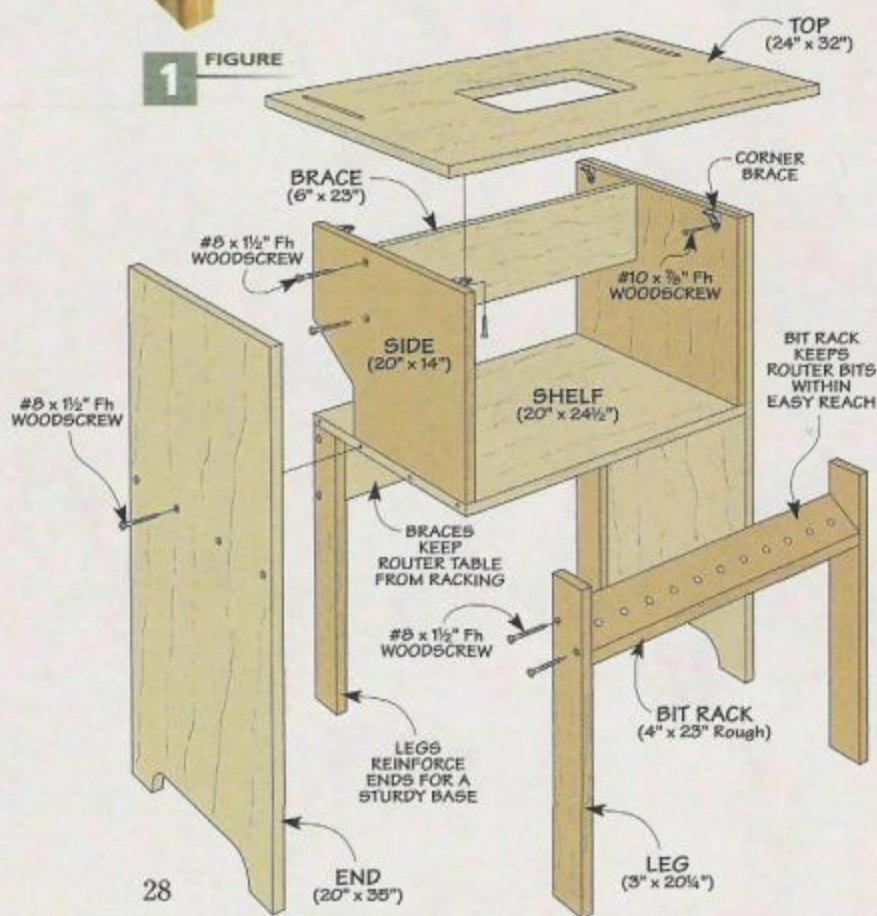

**Case** – The center box consists of a shelf and two sides. A brace is screwed to the sides of the box near the top. The brace serves two purposes. First, it prevents the router table from racking. Second, the brace supports the table top and keeps it from sagging, as shown in the ‘side detail’ on the opposite page.

A second brace is located just under the box at the back of the table. It’s screwed to two legs that serve to beef up the end panels that are added later. At the front of the table, another pair of legs are added. But instead of a brace, I screwed an angled bit rack between them, as shown in the detail on the bottom right of the opposite page. Not only does it help strengthen the table, but it keeps router bits close at hand.

Now, the end panels can be cut, glued, and screwed to the center assembly. Like the workbench, a cutout at the bottom of the end panels forms the feet that give the router table a firm stance.

**The Big Top** – With the base complete, I turned to the top where all the work takes place. Basically, it’s just a large panel that’s cut to shape. But there are a couple important details I want to mention.

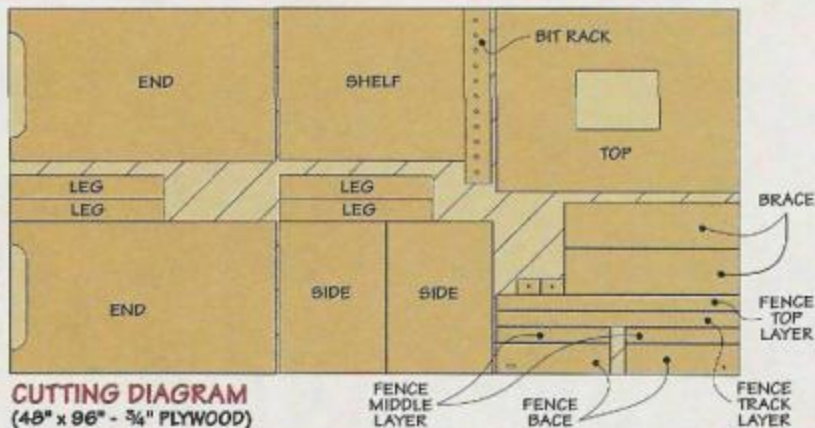

**CUTTING DIAGRAM**  
(48" x 96" - 3/4" PLYWOOD)

The first detail is a slot near each end of the table (drawing below). They’re used to adjust the fence and secure it to the table.

The other detail to note is the hole for a router insert plate. (You’ll want to size the opening to fit your insert plate.) The hole is cut in two steps. First, cut a rough opening for the router to drop into that’s slightly smaller than the size of the plate. Second, rout a rabbet around the edge of the hole that’s sized to hold the insert plate flush with the top of the table. The top can then be attached to the base with metal corner braces (drawing below and side detail on the opposite page).

**Simple Fence** – The final part of the router table is the fence (drawing below). This isn’t your typical L-shaped fence. It’s a solid beam built up from four layers of plywood. It’s attached to the table with a pair of ratchet knobs, washers, carriage bolts, and pinch blocks. To prevent the fence from binding, I cut a short slot in one end of the fence base. This gives the fence a little wiggle.

At the top of the fence, I added some T-track for attaching stop blocks, bit guards, and featherboards, like you see in the main photo. You can make your own accessories or find some at [www.ShopNotes.com](http://www.ShopNotes.com).

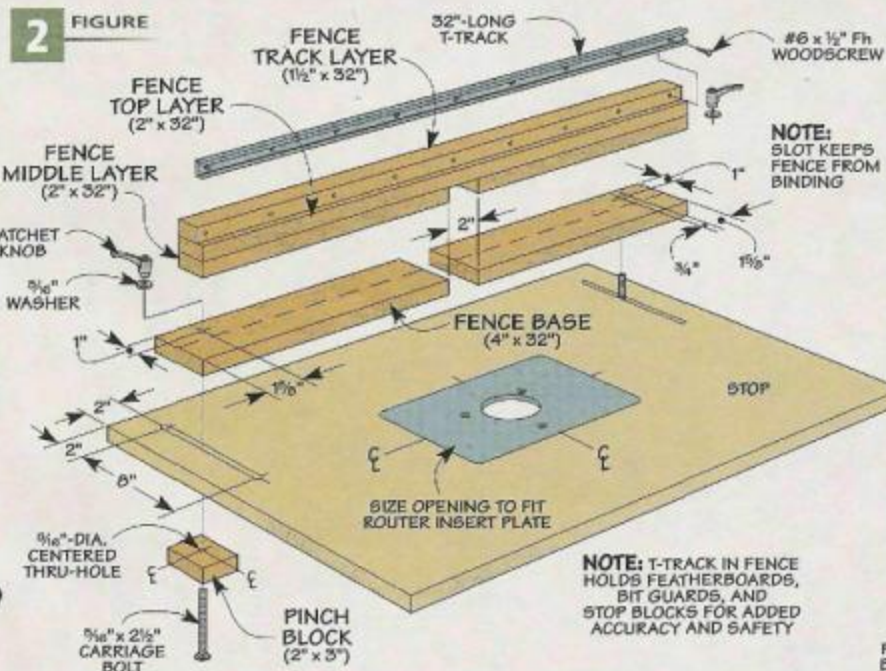

- Hardware**
- (20) #8 x 1 1/2" Fh Woodscrews
  - (4) Corner Braces w/Screws
  - (1) Router Plate
  - (2) Ratchet Knobs
  - (2) 5/16" Washers
  - (2) 5/16" x 2 1/2" Carriage Bolts
  - (1) 32" T-Track (w/screws)

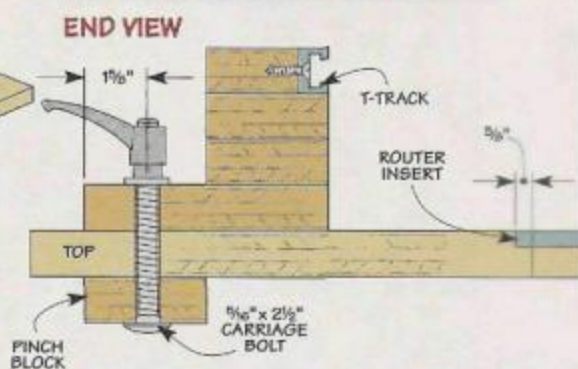

**T**here just never seems to be enough surfaces close by to set down tools, store parts, or accessories. That's where this multi-tool stand comes in. It has a large work area on top that's big enough for most benchtop tools, like the planer you see in the photo.

The stand also has an open shelf below the top to hold parts at the ready. Another great feature is a drawer at the bottom that holds supplies and accessories right where you need them. Finally, a set of heavy-duty casters means the cart can go anywhere without getting hung up on chips or extension cords.

**Building the Cart** - The core of the stand consists of two sides supported on the bottom by a pair of shelves. A back panel creates a space that will house a drawer, as shown in detail 'b.' The upper shelf also serves as the second worksurface.

The top of the stand is braced by top supports. This forms a sturdy core that can stand up to anything.

To this core, I added a top and bottom panel. The top is a bit larger to

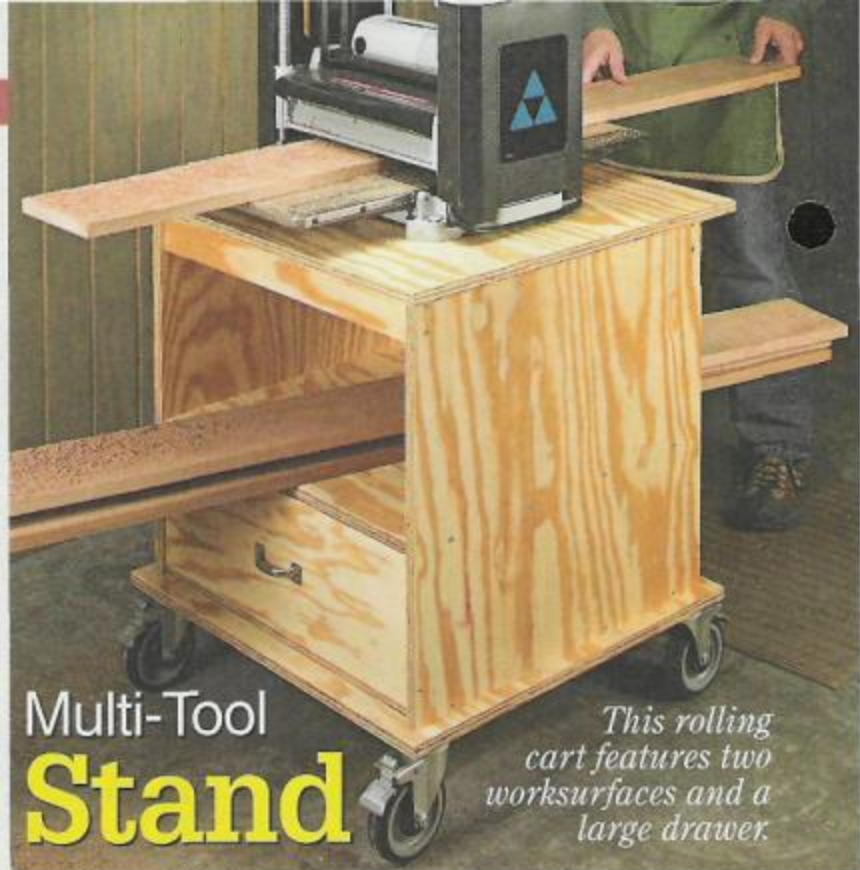

# Multi-Tool Stand

*This rolling cart features two worksurfaces and a large drawer.*

give you a worksurface as large as possible. It's attached with metal corner braces (detail 'a').

The base serves to support the stand and provide a place to attach the casters. It's simply glued and screwed to the lower shelf.

**A Basic Drawer** - I added a drawer to the bottom of the stand to hold frequently needed items. Since it's fully enclosed, the drawer keeps things pretty clean and dust free. The drawer is built from the same  $\frac{3}{4}$ " plywood as the rest of the stand and uses simple rabbet joinery. It's sized to fit the opening below the shelf. To keep the drawer operating smoothly, I rubbed some wax on the bottom of the drawer sides.

## Hardware

- (32) #8 x 1½" Fh Woodscrews
- (4) Corner Braces w/Screws
- (1) Sash Pull w/Screws
- (4) 5" Locking Casters w/Screws

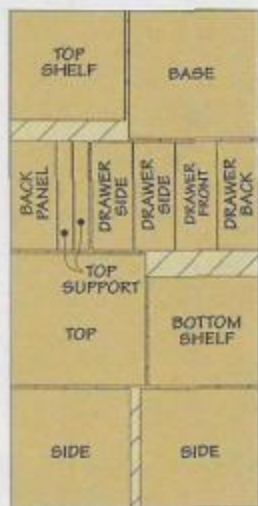

### CUTTING DIAGRAM

48" x 96" -  $\frac{3}{4}$ " PLYWOOD

Also needed:  
20" x 20½" -  $\frac{1}{4}$ " Hardboard for DRAWER BOTTOM

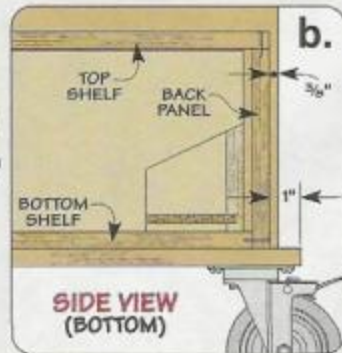
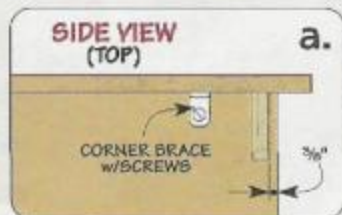
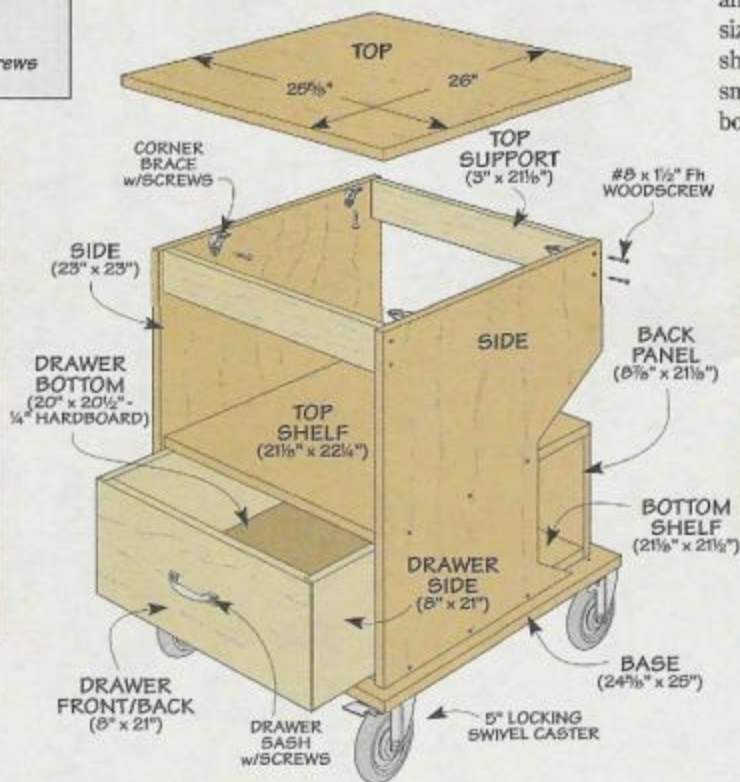

# Adjustable, Stackable Assembly Boxes

The final plywood shop helpers are probably the easiest to make. These two boxes are like big shop dice. You can roll any combination of heights to suit the job at hand. In fact, I think they're more handy than a pair of sawhorses.

What makes them so great is that they can be positioned at several different heights or even stacked, as you can see in the margin at right. This makes it a lot easier to position a workpiece or project at a comfortable height for assembly or finishing, as in the photo at right.

**Building the Boxes** - The construction is pretty straightforward. In

the cutting diagram below, you can see how to get two boxes from  $1\frac{1}{2}$  sheets of plywood. The parts are simply cut to size and glued together. The short and long sides can be glued and clamped together into a simple frame. (Be sure they're square.) Next, you can glue on the top and bottom. They are sized to overlap the side frame assembly, as illustrated in the drawing below.

**Bolt Together** - To make the boxes more versatile, they can be bolted together. To do that, knobs fit into holes from one box and into threaded inserts installed in the other box (detail 'a'). But for this

work, you need to take extra care in locating the holes to be sure they'll line up.

In order to use the knobs, you'll need to cut a few openings in the top panel of each box. You can see the dimensions I used in detail 'a' as well.

Besides making it easier to connect the boxes, I've also found the holes provide another benefit. You can slip in a clamp head to secure a workpiece to the surface, as shown on the back cover.

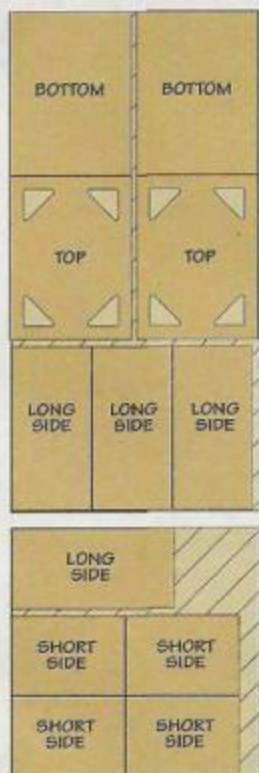
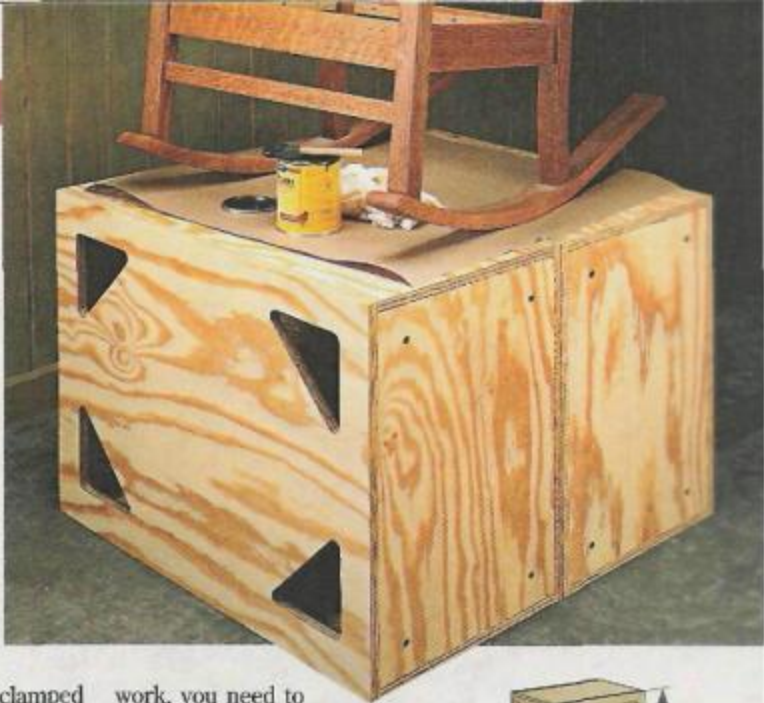

## CUTTING DIAGRAM

48" x 96" -  $\frac{3}{4}$ " PLYWOOD (1 SHEET)  
48" x 48" -  $\frac{3}{4}$ " PLYWOOD ( $\frac{1}{2}$  SHEET)

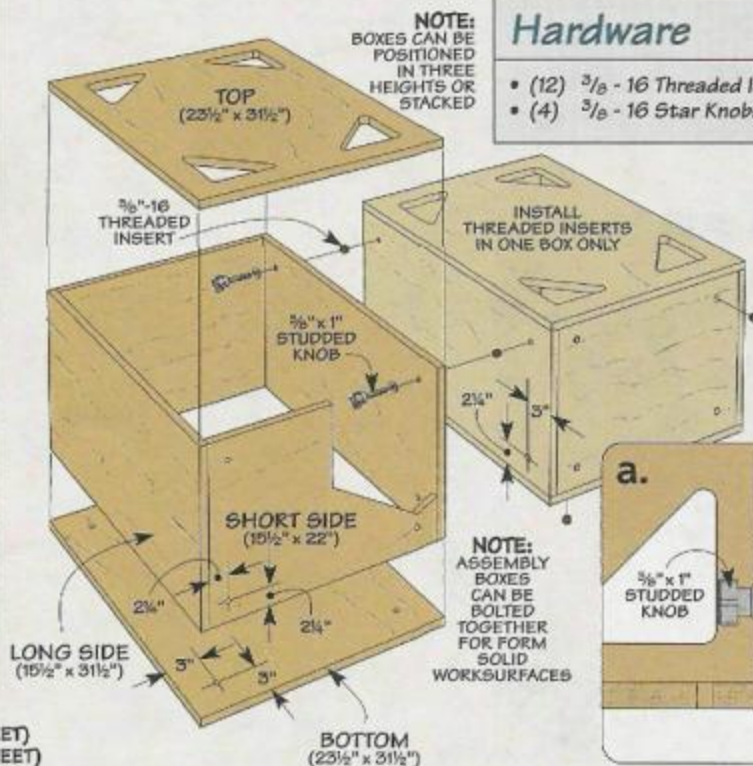

## Hardware

- (12)  $\frac{3}{8}$ " - 16 Threaded Inserts
- (4)  $\frac{3}{8}$ " - 16 Star Knobs

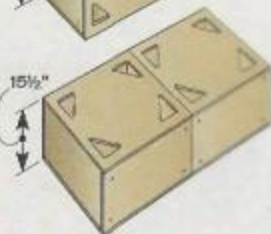
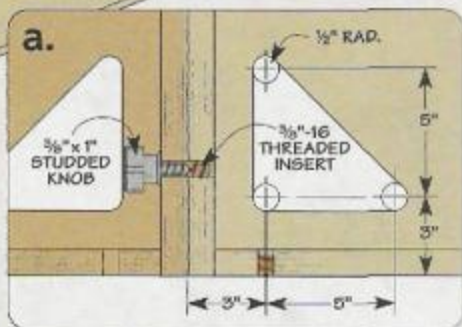

Looking for an extra "edge" when it comes to woodworking? You can get one with a precision straightedge.

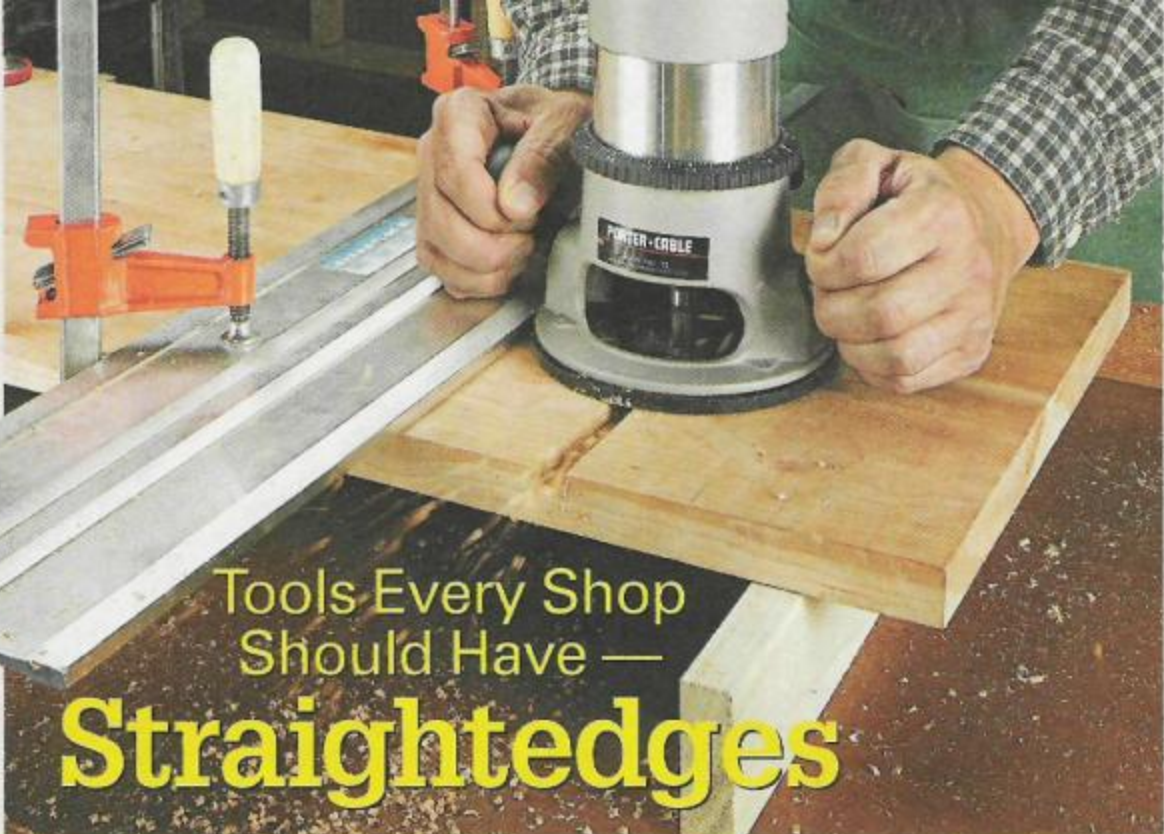

## Tools Every Shop Should Have — Straightedges

**M**ost woodworking projects require straight edges and flat surfaces. The challenge is verifying that an edge is straight or ensuring that a surface is flat before continuing on with your project.

A sure-fire way to give yourself an "edge" in these areas is to keep a straightedge (or two) handy any time you're working in the shop. Plus, you'll be able to use them as handy layout tools and guides.

**Straightedges** — Straightedges can be just about anything, from

short wood strips you make in your shop to precisely machined metal. As a matter of fact, you may already have straightedges in your shop you're not even aware of.

**Shop Rules** — For example, I have a set of steel shop rules in 6", 12", and 18" lengths. As you'd expect, they get used all the time for a wide variety of measuring and layout tasks. But as shown in the photo below, you can use the precision edge on a metal rule to check whether a glued-up panel is flat or not.

You'll find shop rules made of either aluminum or steel. And they range in length from 6" to well beyond 4'. The nice thing is, shop rules can be quite accurate as straightedges. Many are straight to within hundredths of an inch over their length, while shorter rules are within thousandths of an inch — plenty accurate for most tasks.

As a matter of fact, I have a 36" aluminum rule that gets used more often as a straightedge than it does as a measuring or layout tool.

◀ **Flat or Not?** You can use a shop rule as an accurate straightedge to check whether a glued-up panel is flat — before the glue dries.

**The Ultimate Edge** — Using a shop rule as a straightedge works fine for a lot of what I do in my shop. But for work that requires more accuracy, like checking tool beds and fences for flatness or tuning up tools used to machine workpieces flat and square, you'll want to consider a machined straightedge.

Accurate to a few thousandths of an inch over their entire length, a machined straightedge is the best choice where accuracy is critical. The 24" steel straightedge I use most often (see upper photo on the opposite page) is accurate to within 0.002" over its length.

I find that a 24" straightedge handles most of my needs. But you can find straightedges in many lengths. You can even special order straightedges in just about any length you'd like — for a price. (More on this later.)

Whether you get an aluminum or steel straightedge is a personal choice. Aluminum is lighter and handier around the shop. But a hardened steel straightedge will hold up better in use, especially if you do a lot of veneer work. A hardened steel straightedge won't be damaged by a knife cut that wanders as you're trimming a piece of veneer to size.

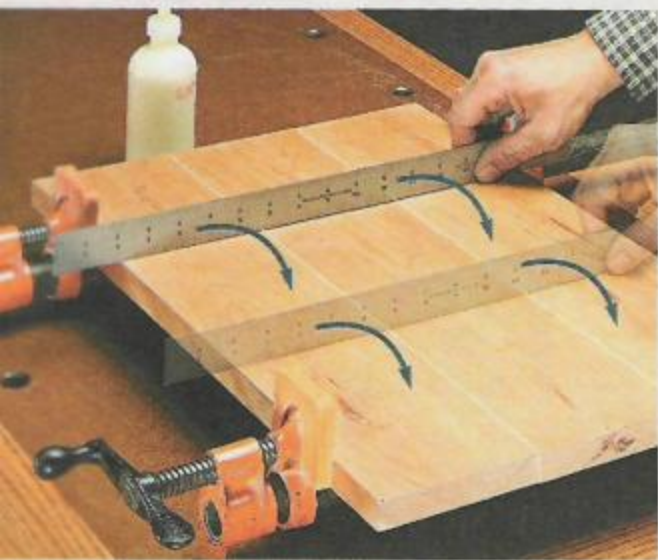



**Reference Check.** Flat reference surfaces are a must for most machine and hand tools. A precision straightedge makes it easy to check.



Some straightedges even make great tool guides, like the aluminum model from *The Pinsky Edge* shown in the main photo. This straightedge was developed for companies working with solid-surface countertops, like Corian®, where accuracy to thousandths of an inch is critical. That kind of accuracy comes in handy in the woodworking shop as well for checking machine tables and fences.

tool rack along with all my other woodworking tools.)

**Shop-Made Straightedges** – So is a metal straightedge the only choice? Not at all. I use shop-made straightedges in my shop fairly often — both short and long versions.

For tasks where you need a long straightedge, you can make one from a piece of jointed hardwood or simply rip a strip off a piece of plywood.

**Take Care** – Whether your straightedge is made of steel or aluminum, keep in mind that it's a precision tool.

A straightedge can lose its accuracy if you drop it. So be sure to care for and store it just like any of your quality tools. (I hang mine on my

They work great for checking large assemblies like cabinets and table tops where accuracy to thousandths of an inch isn't as critical.

There's even a handy set of straightedges you can make in your shop that are used in pairs — winding sticks. These "tools" are lifesavers when it comes to gluing up panels or assembling frames. For more on winding sticks, check the box below.

**Finding a Straightedge** – Obviously, shop-made straightedges can be practically free. You probably have what you need to make them in your scrap pile. If you'd like a metal straightedge, you'll have to buy one.

Unfortunately, rules are about the only thing you'll find locally. To get a machined straightedge, you'll most likely have to mail-order it. You can find a list of sources on page 35. Just keep in mind that their cost is reflective of their length and accuracy. You can expect machined straightedges in the 18" to 36" range to run anywhere from \$40 to \$100. 🛠️

## Checking for Twist

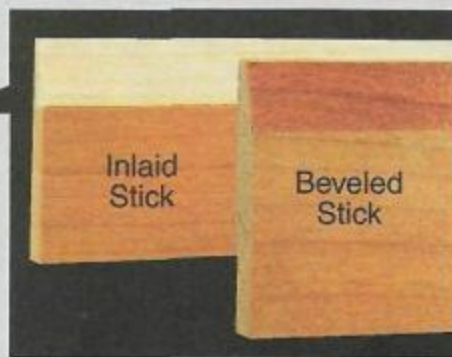

◀ **Do the Twist.** With a pair of shop-made winding sticks, any twist becomes obvious when you sight across the tops of the sticks.

One of the most difficult things to deal with is a workpiece or assembly that's twisted. It affects everything else you do to a project. But you don't have to battle twist. During glue up, a pair of shop-made winding sticks can easily be used to check for twist in anything from a small panel to an 8'-long table. This

way, you can "tweak" the clamps a bit to take out the twist.

Winding sticks are just a pair of strips that are milled flat and parallel. To provide contrast when sighting across the sticks, one strip can be inlaid with a contrasting wood, like the maple inlay you see in the inset photo above.

If the top edges of the two winding sticks are parallel, then the workpiece is flat. Just be sure to check the assembly at a couple different points on the workpiece or assembly. Note: Beveling the edges of the winding sticks will make them easier to use as straightedges for drawing layout lines.

# General Finishes Arm-R-Seal

For shop projects, General Finishes Arm-R-Seal is the perfect choice.

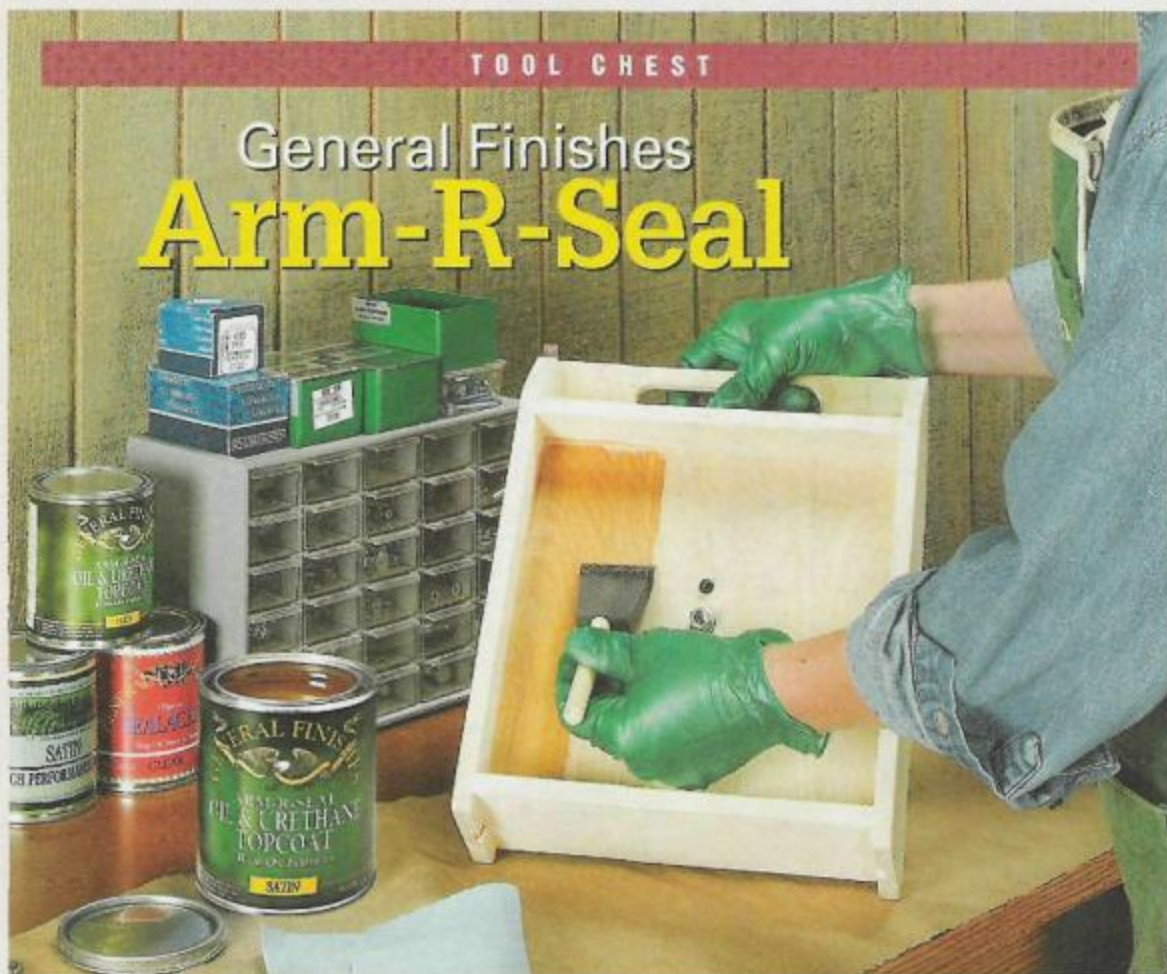

**A** lot of people are surprised that I put as much work into applying a finish to a shop project as I do one of my furniture projects. They often ask why I do the "extra" work.

Well, there are a number of reasons. For starters, a finish seals a project from the dust, dirt, and grime that's always present in a shop. This means your storage cabinets, jigs, and shop-made tools will last longer and stay more accurate over the long haul. And for jigs, a finish ensures that the jig will work smoothly and prevent workpieces (or the jig) from hanging up during use.

So what's the "tool" I use to finish my shop projects? Simple — *General Finishes Arm-R-Seal*.

Arm-R-Seal is about as easy to use as it gets. Plus, you can change the look and amount of protection on the project simply by adding more coats.

**Easy Application** — As for ease of application, Arm-R-Seal is practically foolproof. All you have to do is wipe it on with a clean cloth or brush it on, like you see above.

Once you have a thin to moderate coat applied, simply wipe off the excess using smooth even strokes. Don't apply too much pressure though, it can result in streaks that show up after the finish dries.

**Done in a Weekend** — Arm-R-Seal doesn't dry as quickly as some types of finish, like lacquer. But you'll still find that under good drying conditions, your project will be ready to handle in as little as six hours. Then after a little light sanding, you can apply the next coat. Even with the time you'll have to wait between coats, you can still get all your finish coats in over a weekend.

**Build It Up** — Arm-R-Seal is an oil and urethane mix. So you can control the overall look and "build" of the finish. To get more protection, just apply additional coats.

I typically apply three coats of finish for most of my shop projects. This provides just the right amount of protection for shop cabinets and storage projects. But for my fine shop-made hand tools, or jigs and fixtures that will see a lot of wear and tear, I like to build up the finish with additional coats (see margin photo).

**All-Around Finish** — With all that *General Finishes Arm-R-Seal* has going for it, you might think it's the perfect finish. And you could be right. It's ease of use and the protection it offers make it a great choice for any type of project. I use Arm-R-Seal for most of my furniture projects too.

**Availability** — You can find *General Finishes Arm-R-Seal*, at many woodworking stores and through mail-order catalogs. You'll find a couple of these sources listed in the margin on the opposite page.

You can also find a dealer near you by contacting *General Finishes* at 1-800-783-6050, or just visit them at [www.generalfinishes.com](http://www.generalfinishes.com).



▲ **Protection.** You can "build up" the finish by starting with one coat (left) and adding more (five coats on right).

# Sources

## Framing Square

■ Finding a framing square isn't hard — they're available at just about every hardware store and home center. Before buying one, it's a good idea to check that it really is square. Some may not be square, so it doesn't hurt to check it out.

As for the modifications to turn an ordinary framing square into a giant layout tool, you should be able to

find the material for the hardwood checks in your scrap bin. You can pick up the rest of the hardware, the aluminum bar stock, cap screw, knob, and washer, at a hardware store.

The cap screw and knob may be harder to find. Both *Reid Tool* and *Lee Valley* have them in stock, see the margin at right for contact information.

## Router Miter Trimmer

■ One of the best features of the router miter trimmer is that it doesn't take much in the way of materials or hardware to build. Some of the hardware, like the threaded rod and aluminum bar stock, you should be able to find locally.

The hardest-to-find items are the hold-downs and T-track. These I ordered from *Rockler*. The T-track comes in several lengths. I used a 36"-long piece (21746) for the miter trimmer.

The mini hold-down clamps come as a kit (25169), which includes toilet bolts and knurled knobs. I ended up using these knobs for the adjustment mechanism and bought two additional star knobs (23812) for the hold-downs, all from *Rockler*.

The bit I used was a 3/4"-dia. straight bit (1/2" shank) from *Amana* (45440). It has 1 1/4"-long flutes, which should be long enough to handle most jobs.

## Dust Collector Upgrades

■ You can find a number of sources in the margin that carry a wide range of dust collection accessories to upgrade your single-stage dust collector and improve the overall efficiency of your system.

## Plywood Projects

■ Most of the hardware needed for the plywood shop projects can be found at a local hardware store or home center. I did splurge on the locking casters (31845) to be sure they

And if you're thinking about adding a complete dust collection system, a company called *Air Handling Systems* is a great source of design information as well as ductwork, fittings, and flex hose.

were rock-solid when locked down. You can order them from *Rockler*. On the router table, the insert plate (35265), T-track (21746) and corner braces (33605) also came from *Rockler*.

## Precision Straightedges

■ As mentioned in the article on page 32, you should have a straightedge or two for layout work, to use as tool guides, and for checking the accuracy of tools and machines.

**Manufacturers** — *The Pinsky Edge* has aluminum models in six different lengths from 31" (\$95) to

150" (\$285), while *Bridge City Tools* offers a 24" hardened steel straightedge (SE-24) that runs \$59.

*Starrett* has too many models to mention. But you can find out more about them by giving them a call or visiting their website. For even more sources, check out the margin. 🐶

## SHOPNOTES PROJECT SUPPLIES

We now feature hardware from **ROCKLER** in many of our new project kits. To order, please use our toll-free order line, see below. It's open Monday through Friday, from 8 AM to 5 PM Central Time. Before calling, please have your VISA, MasterCard, Discover, or American Express card ready.

If you would prefer to mail in an order, please call the toll-free phone number below for more information concerning shipping charges as well as any applicable sales tax.

**1-800-347-5105**

## ShopNotes on the web

- "Online Extras" - Plans, Patterns, & More
- Over 100 Woodworking Tips Online
- Visit Our Woodworking Shop Tours Gallery
- Project Plans You Can Download
- Catalog of Project Kits, Tools, Jigs, & Plans
- Forums for Woodworking, Tools, & Classifieds
- Links to Other Woodworking Sites

**www.shopnotes.com**

### Online Customer Service

Click on Subscriber Services at [www.shopnotes.com](http://www.shopnotes.com)

- Access your account status
- Change your mailing or email address
- Pay your bill
- Renew your subscription
- Tell us if you've missed an issue
- Find out if your payment has been received

Similar project supplies may be ordered from the following companies:

**Rockler**  
800-279-4441  
[www.rockler.com](http://www.rockler.com)

*Casters, Corner Braces, Dust Collector Accessories, General Finishes Products, Knobs, Router Inset Plate, T-Track, Threaded Inserts*

**Jet**  
800-274-6848

[www.wmhtoolgroup.com](http://www.wmhtoolgroup.com)  
*Dust Collector Accessories*

**Air Handling Systems**  
800-367-3828

[www.airhand.com](http://www.airhand.com)

*Dust Collection System Design & Accessories*

**Bridge City Tool Works**  
800-253-3332

[www.bridgecitytools.com](http://www.bridgecitytools.com)

*Straightedges*

**Lee Valley**  
800-871-8158

[www.leevalley.com](http://www.leevalley.com)

*Cap Screws, Knob, Straightedges*

**Woodsmith Store**  
800-835-5084

[www.woodsmithstore.com](http://www.woodsmithstore.com)

*Casters, Corner Braces, Dust Collector Accessories, General Finishes Products, Router Bits, Router Inset Plate, Straightedges, Knobs, T-Track*

**Reid Tool**  
800-253-0421

[www.reidtool.com](http://www.reidtool.com)

*Cap Screws, Knob*

**Pinsky Edge**  
800-874-6753

[www.pinsky-edge.com](http://www.pinsky-edge.com)

*Straightedges*

**Starrett**  
978-249-3551

[www.starrett.com](http://www.starrett.com)

*Straightedges*

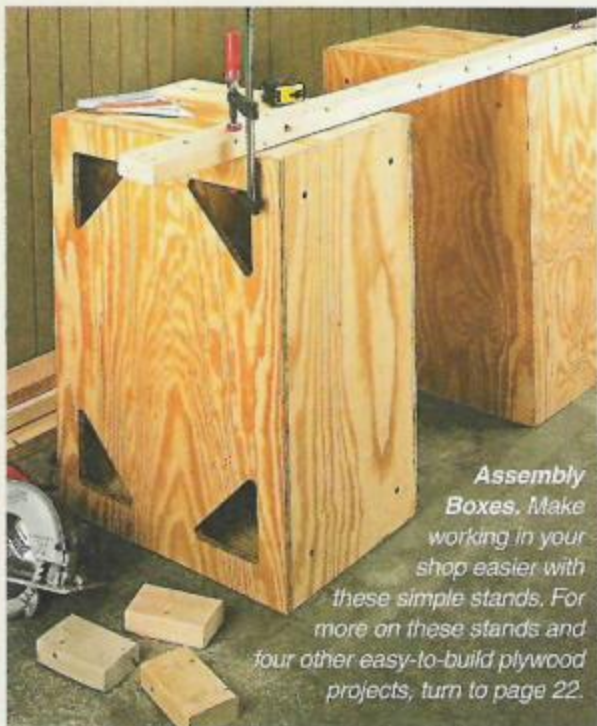

**Assembly Boxes.** Make working in your shop easier with these simple stands. For more on these stands and four other easy-to-build plywood projects, turn to page 22.



**Layout Square.** Turn your framing square into a precision layout tool. All it takes are a few simple additions. Plans start on page 12.

## Scenes from the Shop

**Router Miter Trimmer.** You can end miter joint gaps. This simple jig and a hand-held router are all it takes for perfect-fitting joints. Detailed instructions begin on page 18.

