

**3 All New
Shop Projects**

SHOP-TESTED CLAMPING TIPS & TECHNIQUES

ShopNotes

Vol. 11

Issue 64

Exclusive:

Router Mortising Jig

- **Easy-to-Use**
- **Inexpensive**
- **Accurate**

• **END WORKBENCH
CLUTTER**
**SPACE-SAVING
STORAGE**

• **EASY-TO-BUILD
HARDWARE
STORAGE CABINET**

• **SHOP SECRETS TO A
PERFECT PAINT FINISH**





ShopNotes

Issue 64

July 2002

PUBLISHER Donald B. Peschke

EDITOR Terry J. Strohman

ASSOCIATE EDITORS Bryan Nelson

Vincent Ancona

ART DIRECTOR Cary Christensen

SR. GRAPHIC DESIGNER Kurt Schultz

SENIOR ILLUSTRATORS Roger Reiland

Mark Higdon

CREATIVE RESOURCES

Creative Director: Ted Kralliek • *Project Developer:* Ken Munkel • *Sr. Project Designers:* Kent Welsh, Ryan Mirmick • *Project Designer:* Chris Fitch • *Shop Craftsmen:* Steve Curtis, Steve Johnson • *Senior Photographer:* Crayola England

SPECIAL PUBLICATIONS

Corp. VP: Douglas L. Hicks • *Art Director:* Douglas A. Flint • *Sr. Graphic Designer:* Chris Glowacki • *Graphic Designers:* Vu Nguyen, Jonathan Eike • *Associate Editor:* Craig Baesgegger • *Asst. Editor:* Joel A. Hess

CIRCULATION

Subscriber Services Director: Sandy Bann • *New Business Dir.:* Wayne J. Klingbeil • *Circulation Marketing Analyst:* Kris Schlemmer • *Assoc. Circ. Marketing Analyst:* Paula M. DeMatteis • *Revenue Manager:* Paige Rogers • *Sr. Graphic Designers:* Mark Hayes, Robin Friend • *Billing & Collections Mgr.:* Rebecca Cunningham • *Multimedia Promotion Mgr.:* Rick Jenkins • *Promotion Analyst:* Patrick Walsh

CORPORATE SERVICES

VP of Finance: Mary R. Scheva • *Controller:* Robin K. Hutchinson • *Sr. Acct.:* Laura J. Thomas • *Accts. Payable:* Mary J. Schultz • *Accts. Receivable:* Margo Petras • *Prod. Dir.:* George Christlars • *Electronic Pub. Dir.:* Douglas M. Lidster • *Systems Admin.:* Chris Schwanebeck • *P.C. Maint. Tech.:* Robert D. Cook • *Pre-Press Image Specialist:* Troy Clark, Minnie Johnson • *New Media Mgr.:* Gordon C. Galpe • *Multimedia Art Dir.:* Eugene Pedersen • *Web Server Admin.:* Carol Schoopler • *Web Content Mgr.:* David Briggs, Sue M. Moo • *Web Designer:* Kara Blessing • *Prof. Dev. Dir.:* Michal Sigel • *H. R. Asst.:* Kirsten Knele • *Receptionist:* Jeanne Johnson • *Mail Room Clerk:* Lea Webber

MAIL ORDER

Operations Director: Bob Baker • *Customer Service Mgr.:* Jennie Elias • *Warehouse Supv.:* Nancy Johnson • *Buyer:* Linda Jones • *Admin. Asst.:* Nancy Downey • *Tech. Rep.:* John Audette • *Sr. Cust. Serv. Rep.:* Anna Cox, Deborah Rieh, April Revell • *Cust. Serv. Rep.:* Tammy Truckenbrod, Valerie Jo Riley, Kim Harlan • *Warehouse:* Sylvia Carey

WOODSMITH STORE

Manager: Dave Larson • *Asst. Mgr.:* Tim Theles • *Sales Staff:* Wendell Stone, Jim Barnett, Larry Morrison, Gregory Kautsarich, Mark Johnson • *Office Mgr.:* Vicki Edwards

ShopNotes® (ISSN 1062-9606) is published bimonthly (Jan., March, May, July, Sept., Nov.) by August Home Publishing, 2200 Grand, Des Moines, IA 50312.

ShopNotes® is a registered trademark of August Home Publishing © Copyright 2002 by August Home Publishing. All rights reserved. Subscriptions: Single copy: \$4.95. One year subscription (6 issues), \$27.95. Canada/International add \$10 per year, U.S. funds.

Periodicals Postage Paid at Des Moines, IA and at additional mailing offices.

Postmaster: Send change of address to ShopNotes, P.O. Box 37103, Boone, IA 50037-2103.

Subscription Questions? Write to: ShopNotes Customer Service, P.O. Box 842, Des Moines, IA 50304-0961. Or call 1-800-333-5854, 8:00 am to 5:00 pm, Central Time, weekdays. FAX 515-283-0447

Email: ShopNotes@shopnotes.com
Internet: http://www.shopnotes.com

PRINTED IN U.S.A.

Cutoffs

One thing I enjoy about woodworking is being able to use tools. Hand tools or power tools — it doesn't really matter. But the thing I like the most is being able to spend some time down in the shop building something that takes a hard-working tool and makes it perform even better than it did before.

I guess that's why I'm so excited about the feature project in this issue — it's a shop-built jig for making mortises with a plunge router.

Now I know making mortises with a plunge router isn't a new idea. Woodworkers have been doing it for years — for good reason. A plunge router can be used to cut a perfect, smooth-sided mortise in seconds. But there's more to making mortises than getting a quick, clean cut.

Typically, you want the mortise centered *exactly* on the thickness of the workpiece. Then you want to be able to start and stop the mortise *precisely* in the correct locations. And to top it all off, you need to be able to

repeat this process over and over again on several workpieces.

This new jig makes it easy to do all of these things and more. For starters, it prevents any side-to-side movement of the router. This means your mortises will be perfectly straight *and* parallel with the sides of the workpiece.

A sliding platform makes it easy to center the router bit exactly on the thickness of the workpiece. And a couple of easy-to-adjust stops are all it takes to make sure your mortises will be precisely the right length, each and every time.

The other thing I like about this jig is how simple and inexpensive it is to build. All it takes is a few pieces of plywood, three small clamps, some knobs, and a handful of screws.

If you have a plunge router, you'll be amazed at how quickly and accurately you can make mortises. And if you've been thinking about buying a new router, this jig might be the perfect reason for taking the "plunge."

Terry

Be included, as a part of the
Woodworking Shop Tours

On the Web

Visit other ShopNotes subscribers' workshops and see photos of the shop projects they've built. It's all online at Woodworking Shop Tours on the ShopNotes web site:

www.ShopNotes.com

We want you to be part of our shop tours! To submit photos of your favorite ShopNotes projects or views of your shop, just follow the instructions you'll find on our web site.



Contents

Features

Wall-Mounted Drill Press Shelf _____ 6

Open up space on your workbench by moving your drill press to this handy, wall-mounted shelf. Then add an optional storage rack that keeps all your drilling accessories close at hand.

Painting a Hammered Finish _____ 12

One of the best ways to finish MDF is with paint. Learn how to spray or roll on a "hammered" finish in an afternoon and give your shop projects a professional-quality look.

Plunge Router Mortising Jig _____ 14

This shop-made mortising table lets you rout perfect mortises with a hand-held plunge router. You can set up the table and make identical mortises time after time in less than a minute.

Hardware Storage Cabinet _____ 22

All your hardware stored and organized in one spot? With this hardware storage cabinet and a set of plastic storage bins, you'll never have to hunt for hardware again.

Shop-Built Drawer Dividers _____ 29

Eliminate cluttered drawers forever with a set of custom dividers you can make in your own shop.

Cabinet Clamping Tips _____ 30

Clamping large cabinet projects can be a daunting task — especially if you don't have a lot of clamps. We show you how to clamp a large assembly with just a few clamps.

Departments

Readers' Tips _____ 4

Shop-tested tips to solve common woodworking problems.

Shop Talk _____ 32

When it comes to joining pieces of MDF together, a few tips and techniques will ensure quality results and solid assemblies.

Tool Chest _____ 34

There's an old saying that good things come in small packages. And our featured tool is a perfect example.

Sources _____ 35

Mail-order sources and supplies to help you complete the projects featured in this issue.



Drill Press Shelf page 6



Router Mortising Jig page 14



Storage Cabinet page 22

Readers' Tips

Cutting Multiple Pieces

■ I've made and sold the same wood items for fifteen years. In order to speed up the production process, I came up with this method for creating duplicate parts without having to re-measure every time I need to make a run of a certain part. My trick is to use stop blocks that automatically set up the workpiece for the cut I need.

I started by making a simple crosscut sled for my table saw. It's nothing more than a piece of plywood with a fence and a runner. Then I drilled a row of evenly-spaced holes in the sled, just in front of the fence, as you see in the drawing.

Each stop block is just a block of wood with a couple of dowel pins glued into holes drilled in the block (see drawing in margin). The holes are spaced to match the hole spacing in the sled.

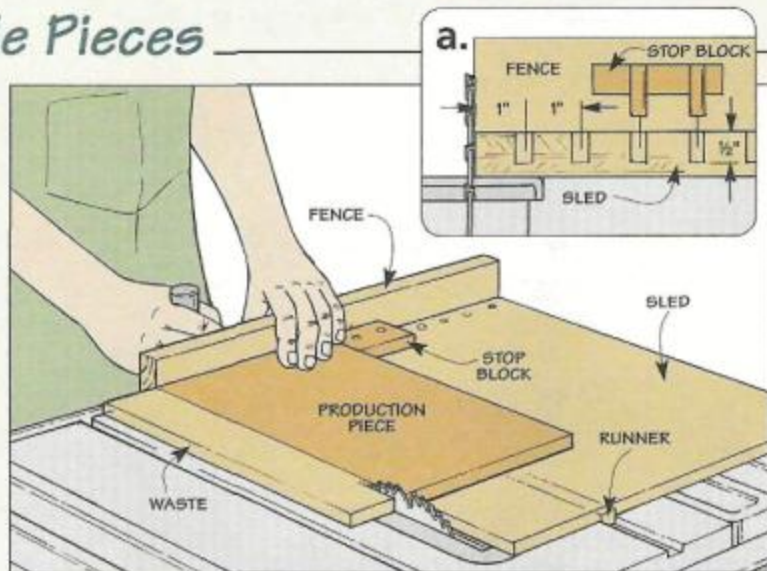

I make a custom-sized stop block for each part that I create. Then I label the stop block so that I know what part it is for and which holes it fits into on the sled.

Whenever I need to make more of

a certain part, I simply grab the particular stop block and mount it to the sled. This way I always know that the pieces will be the same size.

*Shirley Weismann
Rolling Meadows, Illinois*

Router Circle-Cutting Jig

■ My router didn't come with a circle-cutting jig, so I decided to make my own out of a few pieces of hardware. I started by making a pivot block from a small piece of wood. A short length of $1/4$ "-dia. dowel is glued into a hole in the bottom of the block to serve as a pivot point.

A hole drilled through the center of the block allows it to slip over a length of $3/8$ "-dia. threaded rod. A couple of nuts and washers secure the block to the threaded rod (see detail). The end of the rod fits into a hole in the base of the router and is held in place with a machine screw.

To use the jig, first mark out the center of the circle you want to cut and drill a shallow, $1/4$ "-dia. hole for the pivot pin of the jig. Then slide the block of the jig along the

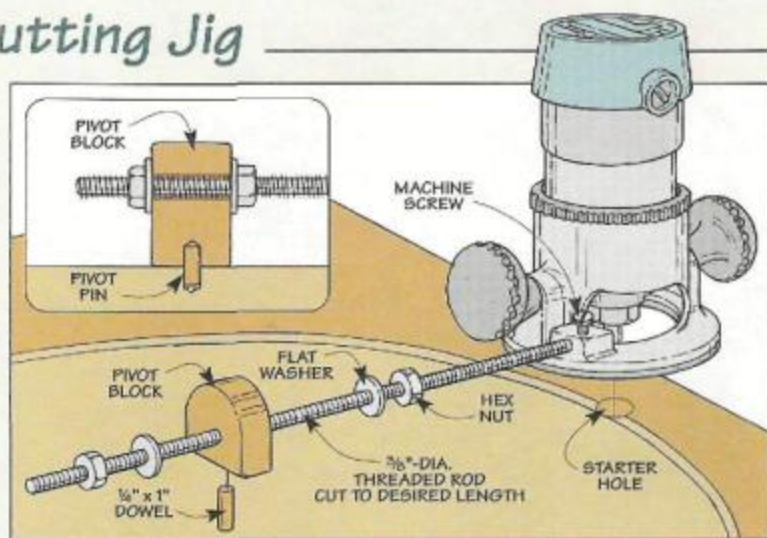

threaded rod to match the radius of the circle and lock it in place with the nuts and washers.

To rout the circle, drill a starter hole on the edge first, then lower the

router bit into the hole and rout the circle in multiple passes, lowering the bit $1/4$ " between each pass.

*Jon T. Keith
Wheeling, Illinois*

Free Tips ON THE WEB

Get more wood-working tips **free**.

Visit us on the Web at
ShopNotes.com

Sign up to receive
a free shop tip by
email every week.

Quick Tips



▲ **Michael Mata**, of Plymouth, MA, countersinks a magnet into the end of his hammer handle so he doesn't have to stick his hand into a pocket full of nails.



▲ To avoid tripping over power cords, **Emery Aranda**, of El Cajon, CA, uses eye bolts and spring-loaded snaps to route the cords overhead.



▲ To make a quick rack for small tools or router bits, **Thomas Heyob**, of Cornelius, OR, uses small sections of "egg crate" light diffusers for fluorescent light fixtures.

Thread-Sizing Gauge

■ Over the years, I've managed to accumulate quite an assortment of nuts, bolts, and fasteners of all sizes. Unfortunately, they all seem to wind up in one big glass jar, making it almost impossible to find the size that I need. So I finally decided to sort them out.

To identify all the hardware, I made this convenient thread gauge. It's just a block of wood with various sizes of bolts. The bolts range in size from #4-40 to 1/2"-13. I marked the thread size right next to each bolt. And in front of each bolt, I drilled a hole that matches the diameter of the fastener.

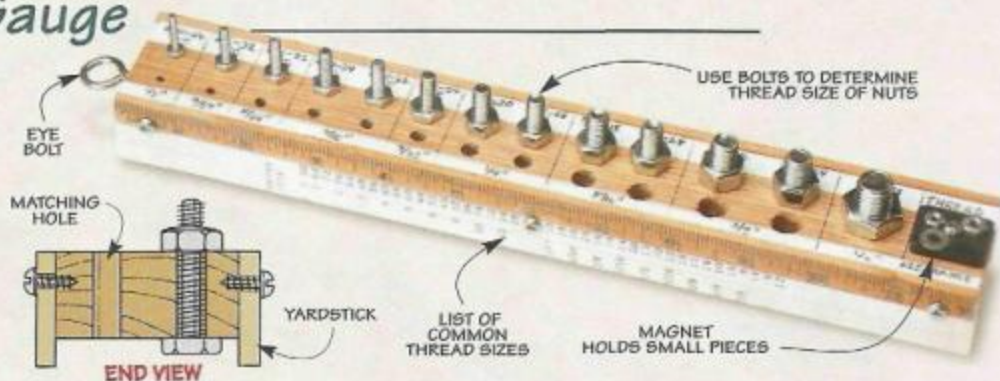

I also cut a couple of pieces from a yardstick and screwed them to the sides of the gauge. A small magnet on the end of the jig holds loose nuts, washers, etc. And an eye bolt on the end allows me to hang the gauge up

on the wall. Now when I run across a lone bolt, machine screw, or nut, I no longer have to try and guess the length or thread size.

*Dana Craig
Norwood, Massachusetts*

Your Tape is Ringing

■ I've always had a problem with tape measures falling off my belt when I move around. The clip on the back of the tape measure just isn't strong enough. So I came up with a solution that works much better.

I replaced the standard clip with a clip from a cell phone. (You can purchase these at office supply stores.) This clip locks the tape securely in place on my belt but still allows me to remove it quickly and easily.

*Attilio Lucchese
Courtice, Ontario*



Send in Your Shop Tips

If you have a unique shop tip, we'd like to consider featuring it in one or more of our print or electronic publications.

We'll pay up to \$200 for a tip we publish. Just write down the tip and mail it to *ShopNotes*, Attn.: Readers' Tips, 2200 Grand Ave., Des Moines, IA 50312. Or FAX it to 515-282-6741, or send us an e-mail at shopnotes@shopnotes.com. Please include your name, address and daytime phone number in case we have any questions.

Wall-Mounted Drill Press Shelf

Reclaim the top of your workbench and add some valuable storage space with this handy drill press shelf and storage rack combo.

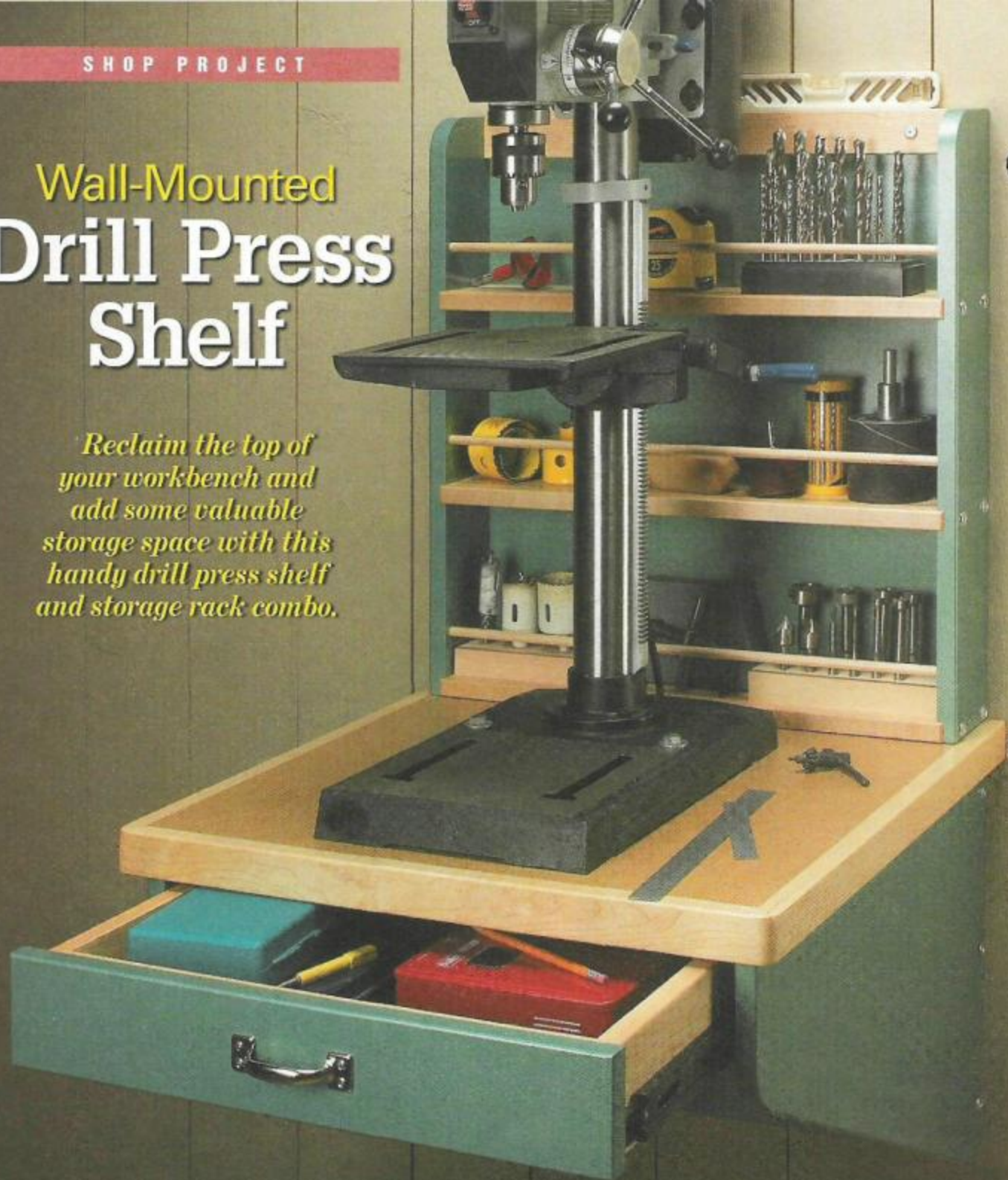

Benchtop tools can be a real life-saver in a small shop that is short on floor space. But once you acquire more than a couple of these tools, you'll be facing a new problem — a shortage of benchtop space.

This wall-mounted shelf is one solution. It allows you to get your drill press off the top of your bench, without taking up any precious floor space in the shop. But this shelf is more than just a perch for your drill press. A

drawer underneath the top offers plenty of storage for drill bits and a chuck key. And an optional storage rack is the perfect place to put drill press accessories like sanding drums and hole saws.

As you look at the photo above, you might be wondering about the finish we used. To give this shelf the protection that a shop environment demands, we used a special kind of paint. For more, see page 12.

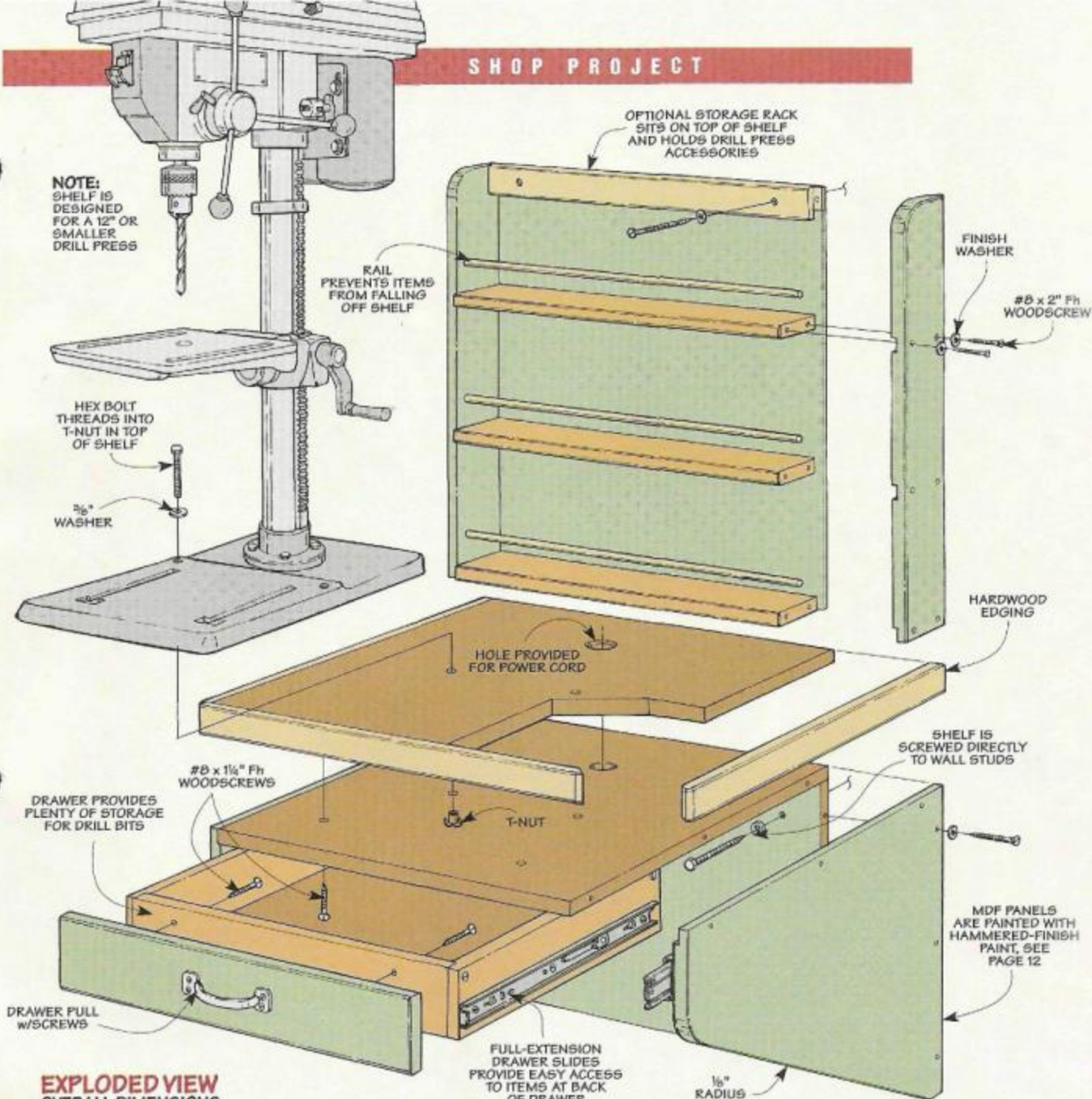

EXPLODED VIEW
OVERALL DIMENSIONS:
23"W x 24"D x 40"H

Materials

Shelf

A Sides (2)	16 x 23 ¹ / ₄ - ³ / ₄ MDF
B Sub-Top (1)	20 ¹ / ₂ x 23 ¹ / ₄ - ³ / ₄ MDF
C Back (1)	15 ¹ / ₄ x 20 ¹ / ₂ - ³ / ₄ MDF
D Top Panel (1)	21 ¹ / ₂ x 23 ¹ / ₄ - ³ / ₄ MDF
E Top Edging (1)	³ / ₄ x 1 ¹ / ₂ - 78 (rgh.)
F Drawer Front/Back (2)	³ / ₄ x ³ / ₄ - 18
G Drawer Sides (2)	³ / ₄ x ³ / ₄ - 16
H Drawer Bottom (1)	15 x 18 - ¹ / ₄ Hdbd.
I False Front (1)	3 ¹ / ₂ x 19 ⁷ / ₈ - ³ / ₄ MDF

Storage Rack

J Sides (2)	4 x 23 ¹ / ₄ - ³ / ₄ MDF
K Shelves (3)	³ / ₄ x 3 ⁷ / ₈ - 20 ¹ / ₂
L Shelf Rails (3)	³ / ₈ -dia. x 20 ³ / ₄
M Hanger Strip (1)	³ / ₄ x 1 ³ / ₄ - 21
N Back (1)	21 x 22 - ¹ / ₄ Hdbd.

Note: For a complete cutting diagram for this project, please turn to page 11.

Hardware

- (35) #8 x 2" Fh Woodscrews
- (10) #8 x 1¹/₄" Fh Woodscrews
- (6) #8 x ³/₄" Fh Woodscrews
- (2) #8 x 3" Fh Woodscrews
- (20) #8 Finish Washers
- (4) 1⁴" x 3" Lag Screws
- (4) 1⁴" Washers
- (2) ³/₈" T-Nuts
- (2) ³/₈" Hex Bolts
- (2) ³/₈" Washers
- (1) 4" Drawer Pull w/Screws
- (1 Pr.) 16" Full-Extension Drawer Slides w/Screws

Shelf

There are two main components to this project — the shelf and an optional storage rack. Since the storage rack will sit on top of the shelf, I decided to build the shelf first.

As you can see in Figure 1, the shelf starts out as little more than an open frame. When it's complete, it will provide a support base for the top of the shelf and also hold a drawer. But for now, you can start by cutting the pieces for this base to size from $\frac{3}{4}$ " MDF (medium-density fiberboard). You'll need a pair of *sides* (A), a *sub-top* (B), and a *back* (C).

Rabbets — The sub-top and back are held in place by rabbets cut on the sides of the base. There's nothing unusual about how these rabbets are made — I simply cut them on the table saw using a dado blade. But when laying them out on your workpieces, keep in mind that you will be making a right-hand side and a left-hand side.

After cutting the rabbets, you can lay out the profile on the side pieces, as shown in Figure 1. Then the profile can be cut and sanded smooth.

As you can see in Figures 1a and 1b, the base is assembled with glue,

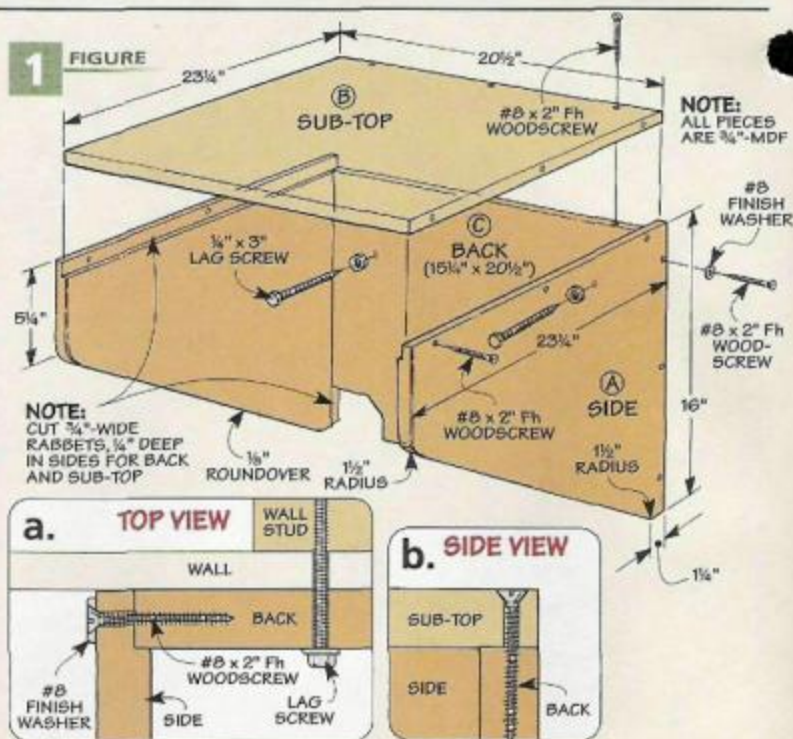

screws, and finish washers. (For more on using screws with MDF, see the article on page 32.)

Note: If you are painting this project, you might want to paint the pieces *before* assembling them. And if you are using a hammered-finish

paint (like I did), you might want to read the article on page 12 first.

Top — There's not a whole lot to making the top of the shelf. It's just an MDF *top panel* (D) with some hardwood edging glued around the front and sides (Figure 2).

Before adding the edging, however, I set the top panel on my workbench and positioned my drill press on the panel to mark out the location of the mounting bolts. The drill press should be centered from side to side. And the front of the drill press base should be about an inch away from the front edge of the top panel.

Once you've finished marking out all the hole locations, you can go ahead and add the *top edging* (E). The edging is mitered and glued in place around the top panel. Then the corners are radiused, and the front and side edges are rounded over.

As you can see in Figure 2, the top is screwed to the base from below. Once this is done, the holes you laid out earlier can be drilled through both the top panel and the sub-top. T-nuts are mounted to the bottom of the sub-top for the mounting bolts.

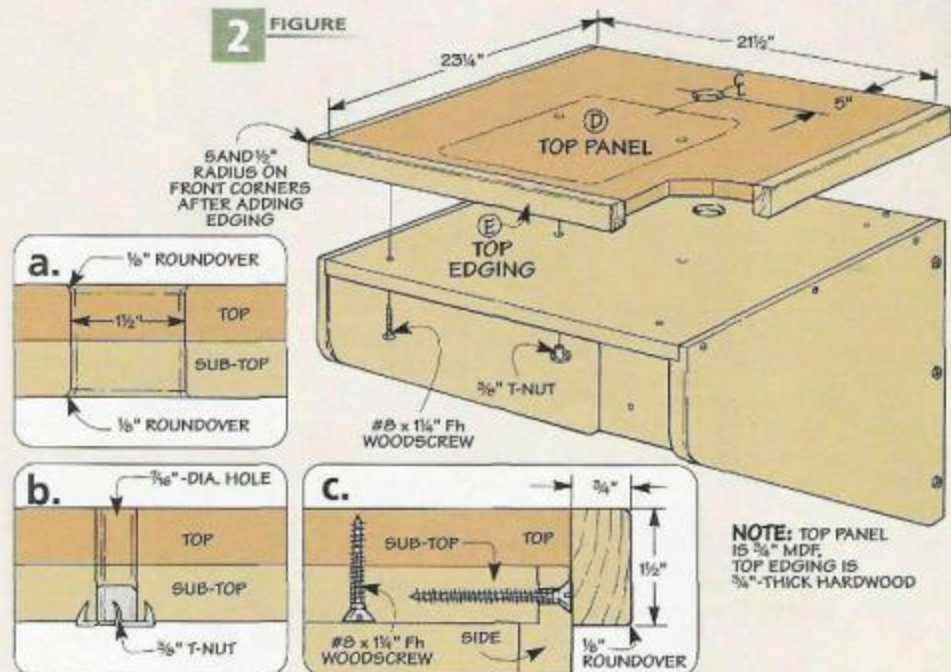

You'll also need to drill a large hole for the cord near the back of the shelf, which is shown in Figure 2a. To prevent the edge of this hole from fraying the cord, I rounded over the inside edge of the hole on both the top and the bottom (Figure 2a).

At this point, the shelf can be mounted to the wall studs of your shop with 3"-long lag screws and washers (Figures 1 and 1a).

DRAWER

To hold drill bits and other small items, a drawer is mounted below the top of the shelf. The drawer isn't complicated. It's constructed with rabbit joints and screws. I decided to use 3/4"-thick hardwood for the *drawer front* and *back* (F) and the *drawer sides* (G). Later, a false front made out of MDF will be added.

After cutting the drawer pieces to size, the ends of the drawer sides can be rabbeted to hold the drawer front and back. Then a groove can be cut along the inside face of each drawer piece to hold a hardboard drawer bottom. Finally, I routed a small roundover on the top, outer edge of each drawer side.

After cutting the *drawer bottom* (H) to size, the drawer can be assembled. I drilled countersunk pilot holes in the drawer sides, and then glued and screwed them to the drawer front and back.

Drawer Slides - The drawer travels on full-extension, metal

3 FIGURE

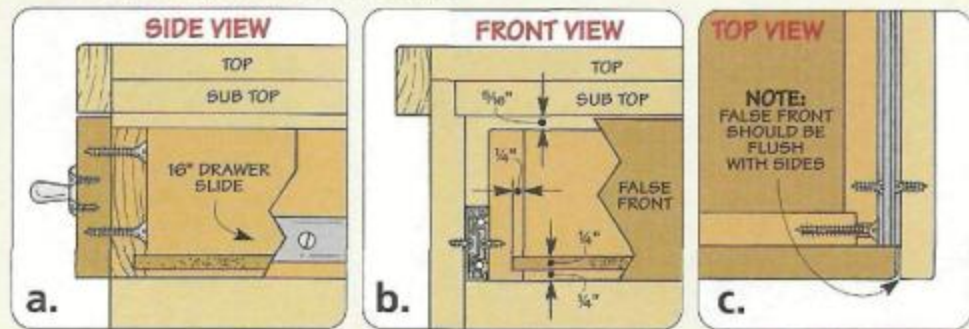
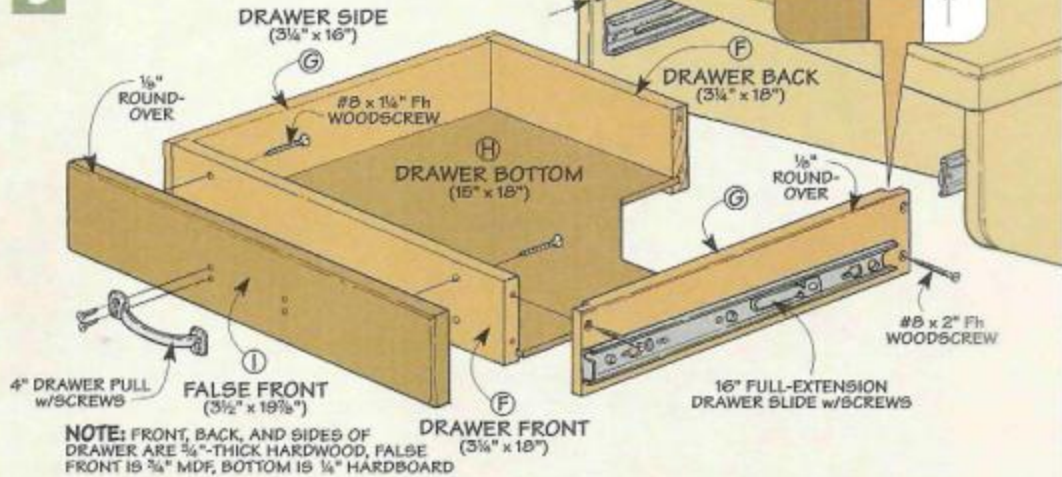

drawer slides (see photo below). This allows you to easily reach items at the back of the drawer. And no matter how weighted down the drawer gets with drill bits, it will always open smoothly on the ball-bearing slides.

If you've never installed this type of drawer hardware before, don't worry. It's not difficult. The drawer

slides come apart into two pieces. One piece is screwed to the side of the base. The other half is screwed to the side of the drawer, as you can see in Figures 3a and 3b. The slides are positioned flush with the bottom edge of the drawer.

False Front - After the drawer is mounted in the base, you can add the *false front* (I). This is just a piece of MDF that has been rounded over on the front edges. (It also gets painted with the same hammered-finish paint that I used on the base of the shelf.) The false front is simply screwed to the front of the drawer. Just make sure that it's centered side-to-side in the drawer opening.

Drawer Pull - The last step to complete the drawer is to add a drawer pull. I just centered this on the front of the drawer and screwed it in place (Figures 3 and 3a).

◀ **Drawer.** The drawer rides on full-extension drawer slides, making it easy to reach items at the back.



Storage Rack

The storage rack is really an optional part of this project — you don't have to build it at all. But I find it to be a handy place to organize all those odd-size accessories right next to the drill press.

Like the shelf and drawer, the storage rack is built out of MDF and hardwood. I started by making the two sides (J). These are cut to size from $\frac{3}{4}$ "-thick MDF. Then dadoes are cut on the inside face of each side piece to hold the shelves, as shown in Figures 4 and 5. And a rabbet is cut along the back edge for the back.

In addition to the dadoes for the shelves, you'll need to drill a shallow hole above each dado, as shown in the margin drawing at left. These holes will hold dowels that serve as rails for the shelves.

After all the joinery is complete, the upper, front corner of each side is rounded (radiused), and the outer edges are rounded over. Shop Note: The back and inside edges are not rounded over.

Shelves — There's not much to making the shelves. Each shelf (K) is cut to size from $\frac{3}{4}$ "-thick hardwood. Then the front edges are rounded over.

You'll also need to make three shelf rails (L). These rails help to keep small items from vibrating off the shelf when the drill press is running. I simply cut these rails to length from some $\frac{3}{8}$ "-dia. hardwood dowel stock.

Hanger Strip — The last piece to make before assembling the rack is the hanger strip. This is a narrow piece of wood that runs across the top of the rack and provides a means of attaching it to the wall.

The hanger strip (M) is cut from $\frac{3}{4}$ "-thick hardwood stock. In Figure 6, a rabbet is being cut along one edge to hold a hardboard back that



▲ **Guard Rail.** Like the guard rail on a highway, the shelf rails on this storage rack prevent items from falling off the edges of the shelves.

will be added to the rack later. Then in Figure 7, tongues are being cut on the ends of the hanger strip to fit in the rabbets that you cut earlier on the sides of the rack. The two front edges of the strip are rounded over, and then a couple of holes are drilled in the hanger strip for the screws that will be used to mount the storage rack.

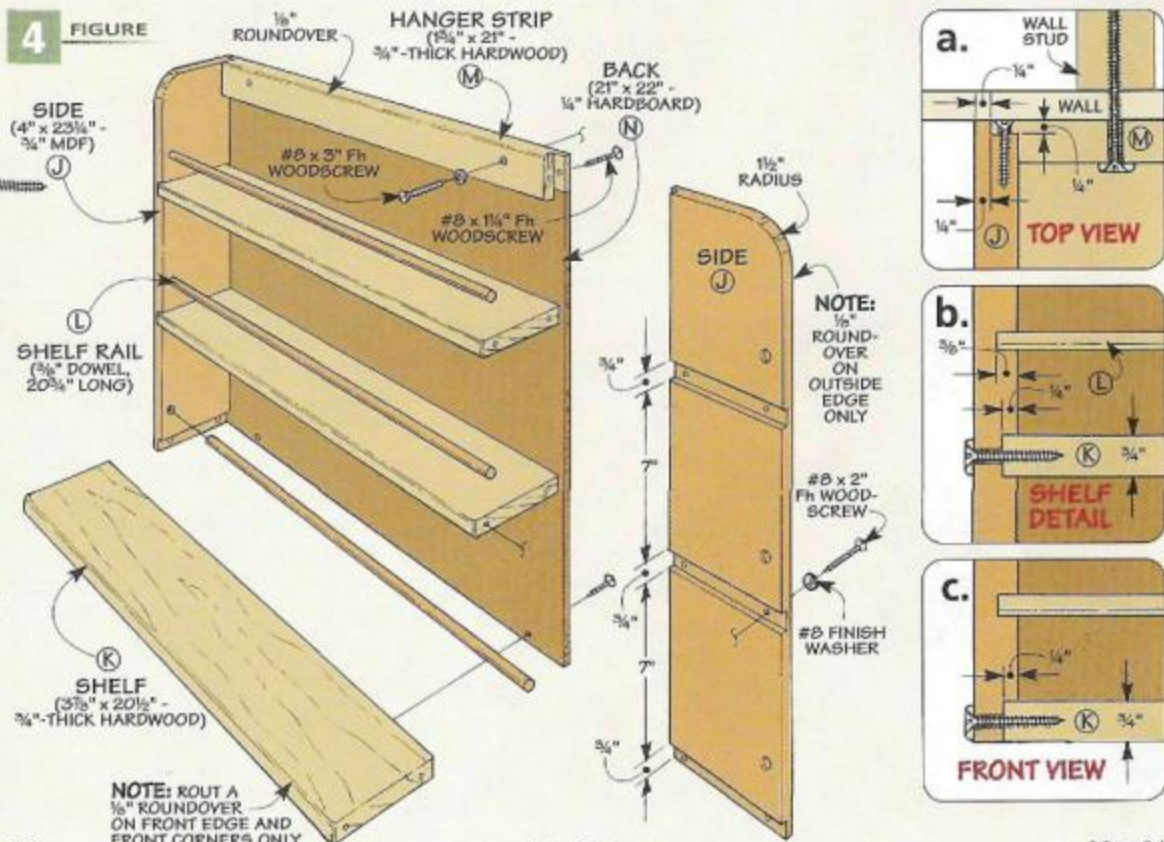

Assembly – The rack is assembled with glue and screws. First, I assembled the sides, shelves, and rails. The rails are simply glued in place. But the shelves are glued and also screwed in place, using wood-screws and finish washers (Figure 4b). The hanger strip is glued and screwed to the sides from the back.

Back – The last piece to add to complete the storage rack is the *back (N)*. This is just a piece of 1/4" hardboard that is cut to fit in the rabbeted opening in back of the rack. It gets screwed in place to the back edges of the shelves.

Mounting the Rack – The rack just sits on top of the shelf. But to keep it from moving around, it is also fastened to the wall through the hanger strip, using woodscrews and finish washers. Once it is screwed in place, you can set your drill press on the shelf and fasten it down with a couple of hex-head bolts and washers. Fish the cord through the large hole in the top of the shelf and plug it in. Now you are all set for your next drilling task. ▲

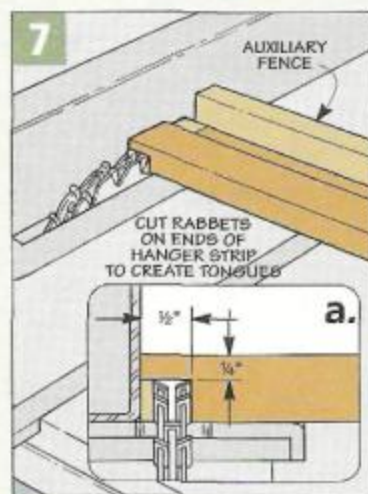
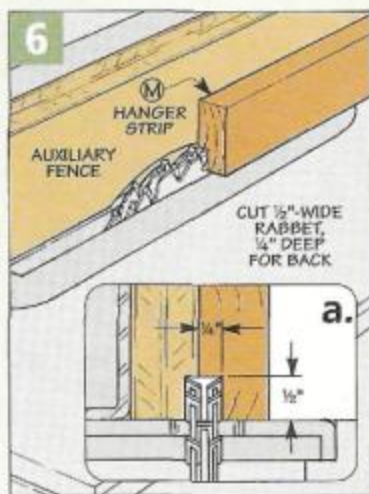
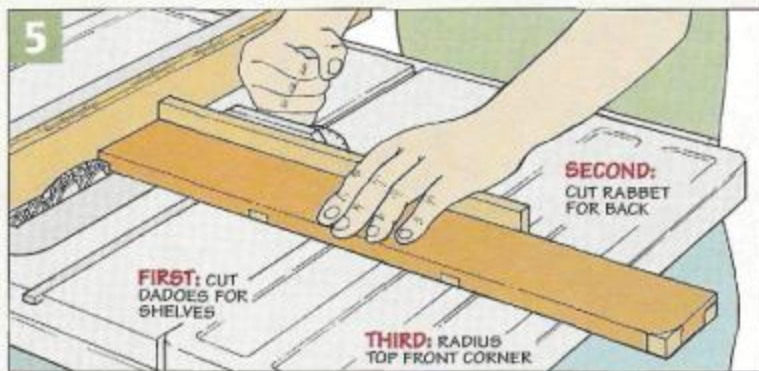

▲ **Tongue Detail.** Tongues cut on the ends of the hanger strip fit into the rabbets in the sides of the storage rack.

Cutting Diagram

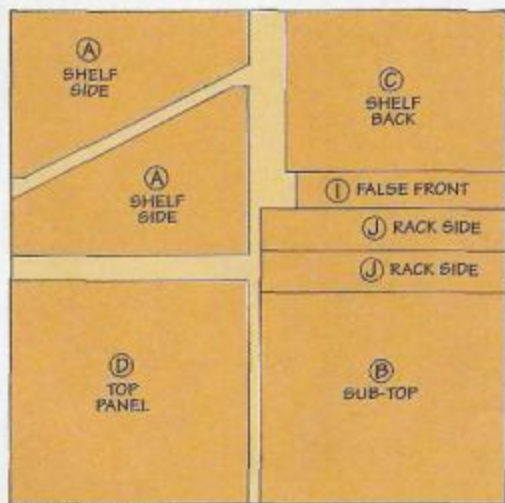

3/4" x 49" x 48 1/2" MDF



1/4" x 24" x 48" HARDBOARD

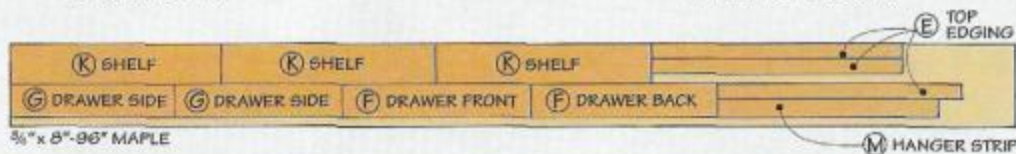

3/4" x 8" x 96" MAPLE

Painting a “Hammered” Finish



You're probably already familiar with hammered-finish paints. For years, they have been used on everything from toolboxes to appliances. They give the surface of an object the look of metal that has been lightly hammered all over (see inset photo).

Typically, hammered-finish paints are used on objects made out of metal. But we wanted to achieve that same “hammered” look on the MDF used to build the drill press shelf on

page 6. This meant that we had to take a few extra steps in preparing the project for paint, as you'll see shortly.

Hammered-finish paints come in several colors. And you'll find these in both spray cans and quart cans at hardware stores and home centers. (Locally, I paid about \$6 for a spray can and \$8 for a quart of paint.)

Hammered-finish paints provide a tough, durable surface — perfect for a shop environment. And unlike

some specialty finish paints, they are pretty easy to apply. That's because the hammered look is “built-in.” Within seconds of applying the paint, you'll start to see the “hammered” appearance taking affect.

Preparation – The key to any successful paint job is in the initial preparation of the surface. Although MDF takes paint quite well because it is so smooth, it pays to take a few minutes to sand all the edges to remove any saw blade marks. Sanding also removes any “fuzz” or fibers that may be present on the edges of the MDF.

Masking Off – The other thing you'll want to do is mask off the areas that you don't want painted. This includes any gluing surfaces, like rabbets, grooves, and dadoes. I prefer to use a low-tack masking tape so that the tape is easy to remove after the painting is finished.



Sand Edges. Make sure the edges of the MDF are smooth by sanding them with 220-grit sandpaper and a sanding block.



Masking. To avoid getting paint on glue surfaces, mask off all the dadoes, grooves, and rabbets with masking tape.

Spray

For the most consistent-looking hammered finish, spray paint is the way to go. It's easy to use and minimizes clean up. Before applying the paint, however, I primed all the surfaces. The primer helps to seal the surface of the MDF so it doesn't absorb all the paint. This is especially important on the edges, which are more porous than the faces.

As you can see in Steps 1 and 2, I primed the edges first and then the faces. Because the edges tend to soak up a lot of primer, I applied three coats to these areas, sanding lightly with 400-grit sandpaper between each coat.

Paint – Once the primer is dry, you can apply the paint. Here again, I started with the edges and then painted the faces (Steps 3 and 4).

In order for the hammered effect to work, you have to put on a fairly "wet" coat of paint. This is the only trick to using this paint. You have to spray on a healthy coat, but you don't want to spray it on so thick that it runs. It's a good idea to practice on a piece of scrap first.

Second Coat – Once the first coat is dry (10 to 15 minutes), you can spray on a second coat. One



Step 1. Using a gray primer, spray the edges of the MDF first. Apply at least three coats to seal the edges.



Step 2. Because the faces don't absorb the primer as much as the edges, a single coat is fine here.



Step 3. Once the primer is dry, you can spray on the hammered finish paint, starting with the edges.



Step 4. In order for the "hammered" finish to work, you have to apply a generous coat of paint.

thing to be aware of when using hammered-finish paint is that you have a limited "window" of opportunity to re-coat. According to the

directions on the spray can, if you don't apply the second coat within an hour of the first, you should wait 10 days before re-coating.

Roller

Hammered-finish paints can also be rolled on with a paint roller. This method is a little more economical, particularly if you have a large surface to cover. The steps involved are the same as in spraying the paint.

To begin with, I primed all the surfaces, rolling on additional coats of primer on the edges.

Next, the paint can be applied. To spread the paint out smoothly, I like to use either a foam roller or a roller with a short nap. Make sure you load the roller up before you start rolling on the paint. Just like with the spray paint, you want to put down a substantial coat. And again, start with the edges and then move on to the faces of the workpiece (Steps 1 and



Step 1. After priming the workpiece, roll the paint onto the edges first, using a short-nap roller.



Step 2. After covering the edges, roll the paint on the faces, making sure to lay down a good, "wet" coat.

2). Once the first coat is dry, you can apply a second coat.

Safety Note: As with any paint containing potentially harmful vapors, you should always wear a respirator

when working with hammered-finish paints. And make sure you have plenty of ventilation, regardless of whether you are spraying or rolling on the paint. 🐶

Plunge Router Mortising Jig

Transform your router into a precision tool for creating fast, accurate mortises.

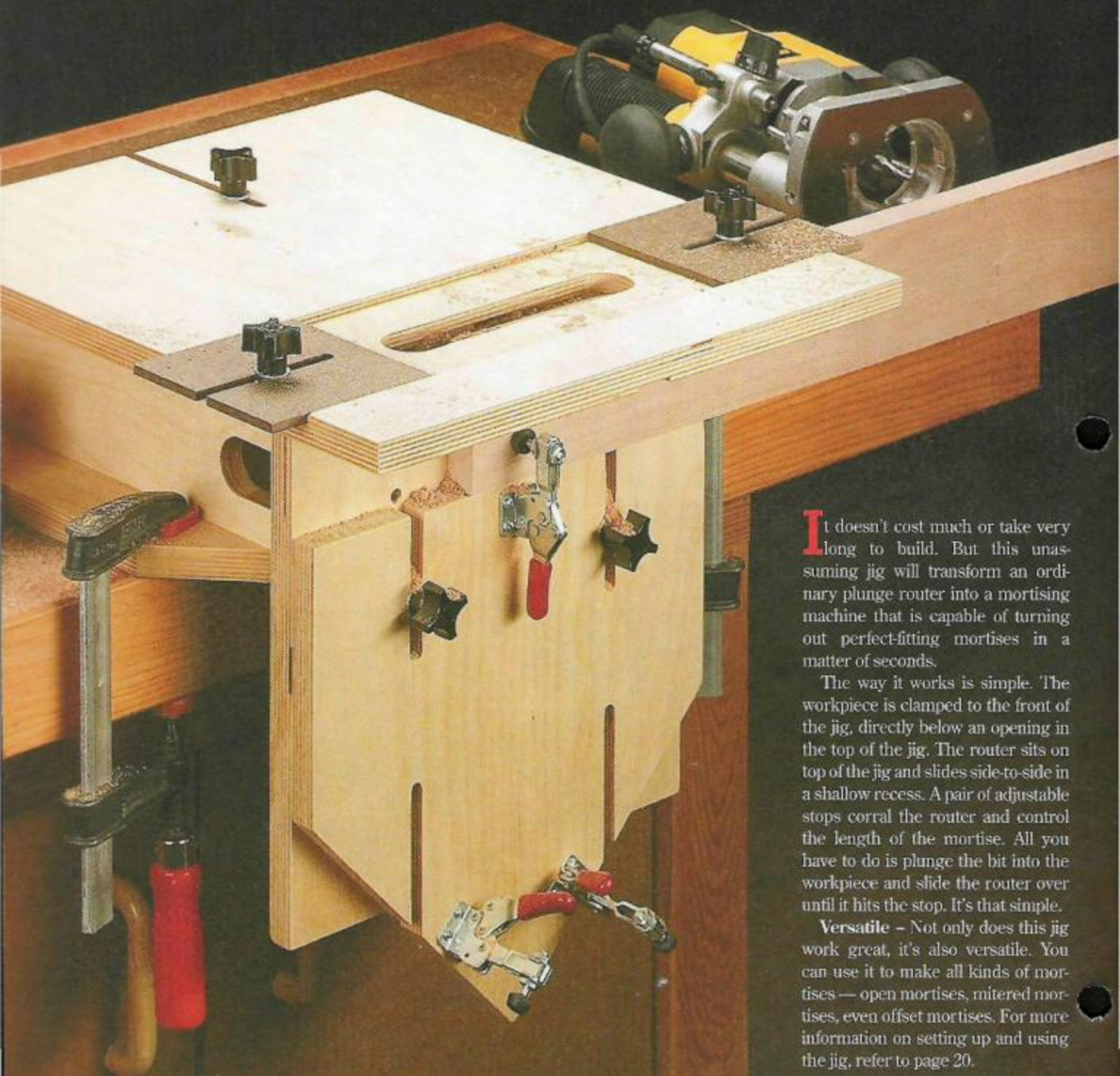

It doesn't cost much or take very long to build. But this unassuming jig will transform an ordinary plunge router into a mortising machine that is capable of turning out perfect-fitting mortises in a matter of seconds.

The way it works is simple. The workpiece is clamped to the front of the jig, directly below an opening in the top of the jig. The router sits on top of the jig and slides side-to-side in a shallow recess. A pair of adjustable stops corral the router and control the length of the mortise. All you have to do is plunge the bit into the workpiece and slide the router over until it hits the stop. It's that simple.

Versatile – Not only does this jig work great, it's also versatile. You can use it to make all kinds of mortises — open mortises, mitered mortises, even offset mortises. For more information on setting up and using the jig, refer to page 20.

EXPLODED VIEW
OVERALL DIMENSIONS:
16"W x 20"D x 21"H

STAR KNOBS ALLOW YOU TO MAKE ADJUSTMENTS BY HAND — NO WRENCH OR SCREWDRIVER REQUIRED

ROUTER PLATE SLIDES BACK AND FORTH TO POSITION MORTISE ON THICKNESS OF WORKPIECE

LENGTH OF MORTISE IS PRE-DETERMINED BY ADJUSTABLE STOPS

RECESS IN PLATE GUIDES ROUTER IN STRAIGHT LINE

LARGE OPENING OFFERS CLEAR VIEW OF WORKPIECE AND MORTISE

GUIDE STRIP KEEPS SLIDING PLATE IN PERFECT ALIGNMENT WITH FIXED PLATE

BASE OF JIG CLAMPS TO TOP OF WORKBENCH

NOTCH ALLOWS YOU TO CLAMP A STOP BLOCK TO FRONT OF JIG (REFER TO PAGE 20)

FOUR SETS OF MOUNTING HOLES IN FIXED PLATE ALLOW YOU TO MORTISE WORKPIECES UP TO 8½" IN WIDTH

NOTE:
FOR STEP-BY-STEP INSTRUCTIONS ON USING THE JIG, TURN TO PAGE 20

TOGGLE CLAMP HOLDS WORKPIECE IN PLACE WHILE ROUTING MORTISE

SLIDING PLATE CAN BE ROTATED TO HOLD MITERED OR VERTICAL WORKPIECES (REFER TO PAGE 20)

ShopNotes

ON-LINE EXTRAS

To download a free Cutting Diagram for the Mortising Jig, go to www.shopnotes.com.

Materials

A Bottom (1)	16 x 12 - ¾ Plywood
B Top (1)	12 x 12 - ¾ Plywood
C Sides (2)	3 x 12 - ¾ Plywood
D Router Plate (1)	16 x 17 - ¾ Plywood
E Router Plate Guide Strip (1)	1 x 9 - ¼ Hardboard
F Stops (2)	4 ¼ x 4 ½ - ¼ Hardboard
G Fixed Plate (1)	12 x 12 - ¾ Plywood
H Sliding Plate (1)	12 x 12 - ¾ Plywood
I Sliding Plate Guide Strip (1)	1 x 12 - ¼ Hardboard

Hardware

- (20) #8 x 1 ¼" Fh Woodscrews
- (11) ¼" T-Nuts
- (2) Star Knobs (with ¼" x ¾" threaded stud)
- (3) Star Knobs (with ¼" x 1 ½" threaded stud)
- (5) ¼" Washers
- (3) Toggle Clamps (De-Sta-Co No. 213-U)
- (12) #6 x ¾" Rh Woodscrews (for Toggle Clamps)

Base

Despite its versatility, this mortising jig isn't really all that complicated to build. It's built almost entirely out of $\frac{3}{4}$ " plywood.

At the heart of the jig is a box-like base that gets clamped down to the top of your workbench. A plate is attached to the top of the base. This plate has a wide, shallow recess to hold your router. It can be adjusted forward and back to accommodate workpieces of varying thicknesses or to create an offset mortise.

Also attached to the plate are a pair of adjustable stops that allow you to automatically control the length of each mortise. Take a look at Figure 1 to get a better idea of what I'm talking about.

Base - To build the base of the jig, I started by cutting a *bottom* (A), a *top* (B), and two *sides* (C) from $\frac{3}{4}$ " plywood. The dimensions for these parts are shown in Figure 2.

To avoid scraping your knuckles on any sharp corners, the front corners of the base are mitered. You can see this in Figure 2 below. And Figure 2a shows the short, rounded notch that is cut at the front of each side piece. (These notches allow you to clamp a stop block to the front of the jig for multiple pieces, see p. 20.)

The base top is just a square piece of plywood. But it has a shallow groove routed down the center, just

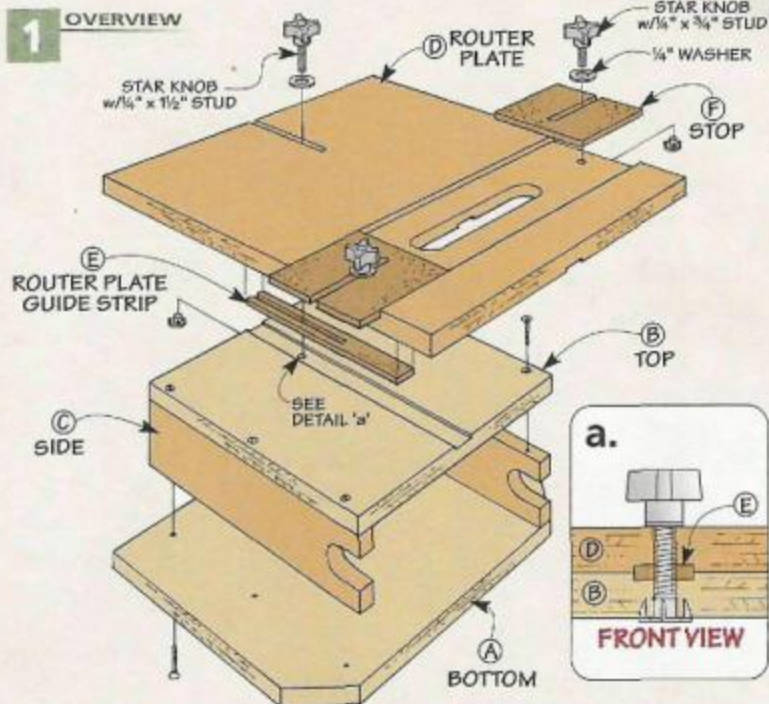

as you see in Figures 3 and 3a. This groove will be used to guide the router plate that is added later. Once the groove is routed, a hole is drilled right in the center and a T-nut is installed in the side opposite the groove, see Figures 2 and 2b.

Assembly - The base of the jig is simply screwed and glued together. To do this, I clamped all the pieces together first, without any glue. Then I drilled counter-sunk pilot holes for all the screws.

Once this was done, I disassembled the base, applied the glue, and installed the screws.

Router Plate - Making the *router plate* (D) involves a few more steps than the base. The plate starts out as a rectangular piece of plywood, as shown in Figure 4. Then a $1\frac{1}{4}$ "-wide by $7\frac{1}{4}$ "-long slot is cut near the front edge of the plate for the router bit. This opening is centered from side to side on the router plate. I made

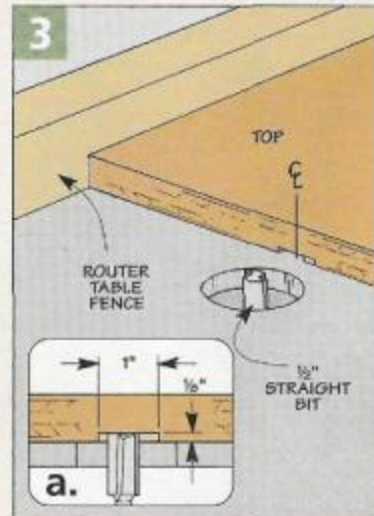
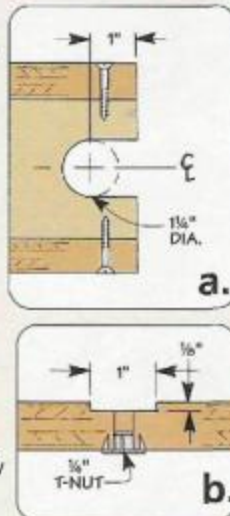
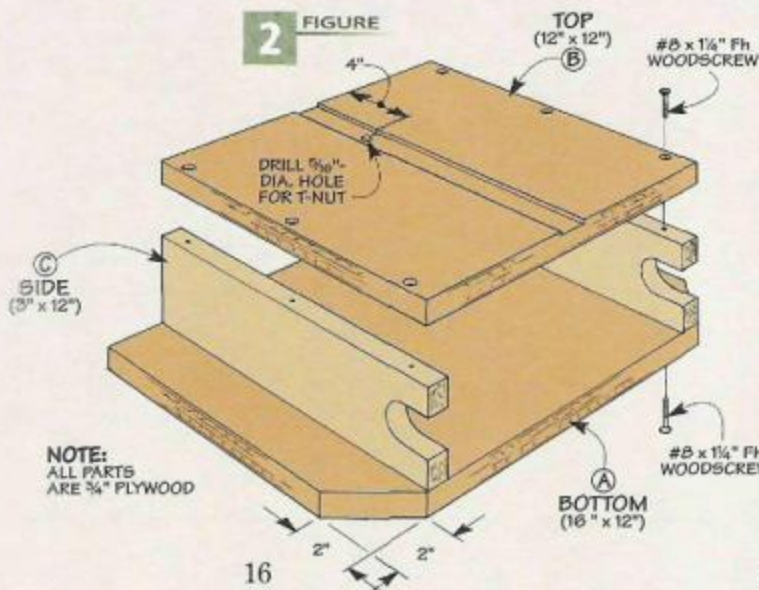

this opening by drilling a couple of holes with a Forstner bit and then cutting out the waste in between with a jig saw. Figure 4a shows the location of this opening.

The next step is to create a shallow recess on the top of the plate to hold your router. This recess guides the base of the router in a straight line, giving you nice, straight mortises.

In order for the router to slide freely, the recess needs to be smooth and flat. So I decided to make the recess on the router table, routing it in several passes with a 1/2" dia. straight bit.

As you can see in Figure 4b, the trick here is to size the recess to just fit your router base. And make sure the recess is centered over the router bit opening.

Guide Strip - Once the recess for the router is finished, you can *route a groove on the opposite face of the router plate for a guide strip* (Figure 5). This groove is identical to the one you made on the base top earlier (Figure 3), and it runs right down the center of the router plate.

The *guide strip (E)* is just a piece of 1/4" hardboard. It's glued into the groove, flush with the *back* edge of the router plate. Note: The guide strip will stop short of the opening in the plate for the router bit.

After gluing the guide strip in place, you'll need to cut a slot in the router plate to allow it to be adjusted back and forth. I did this by drilling a hole at the end of the slot and then

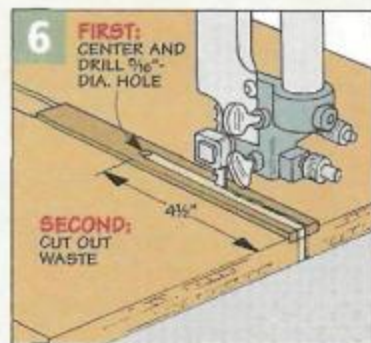
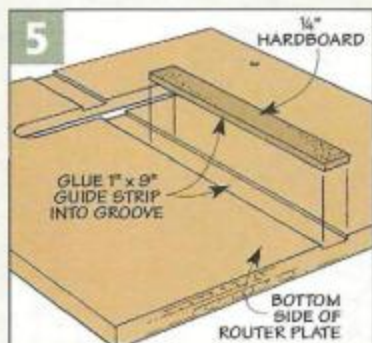
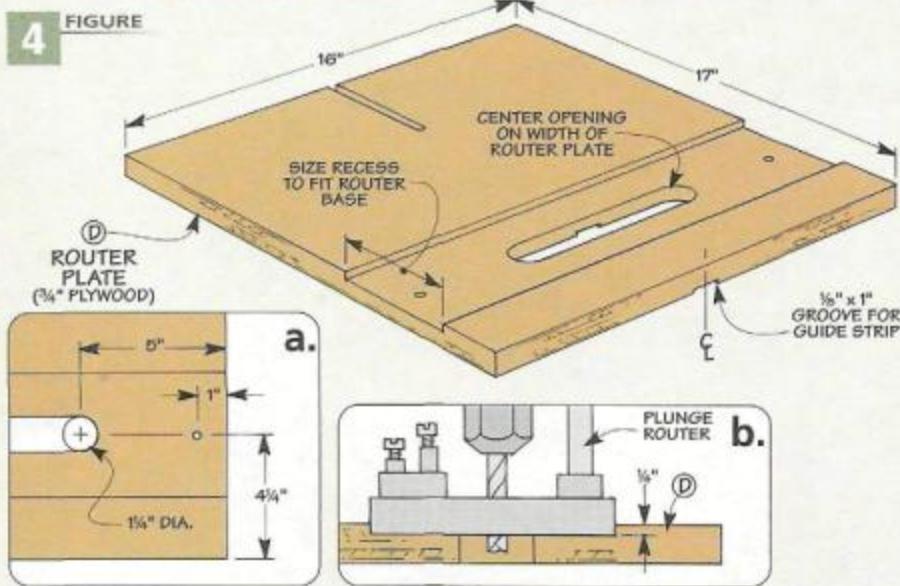

cutting out the waste on a band saw, as shown in Figure 6. But you could also rout the slot on a router table.

Stops - The last pieces to be added to the base are a pair of stops. Adjusting the stops in or out will allow you to set the length of the mortise. These *stops (F)* are made from 1/4" hardboard and are sized to fit in the

recess you cut for the router base, as you see in Figure 7. A slot is cut in each stop to allow it to be adjusted.

Each stop is held in place with a knob with a threaded stud. The knob threads into a T-nut that is mounted in the bottom of the router plate, just as you see in Figure 7. In order to keep the T-nut flush with the surface of the router plate, you'll need to drill a shallow counterbore before drilling the hole for the T-nut. You can see what I'm talking about by taking a look at Figure 7a.

The router plate simply sits on top of the base with the guide strip in the groove on the base top. Then another knob with a threaded stud is used to hold the router plate in position, as shown in Figure 1a.

At this point, the base of the jig is complete. All that is left now is to make the front section of the jig that holds the workpiece.

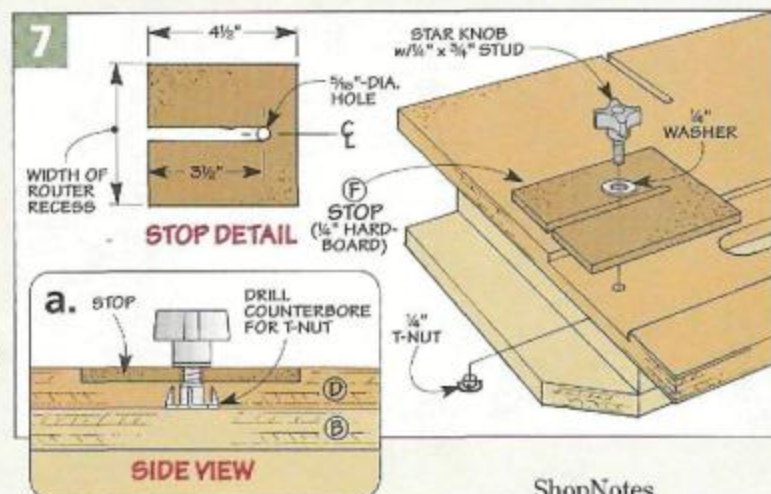

Front

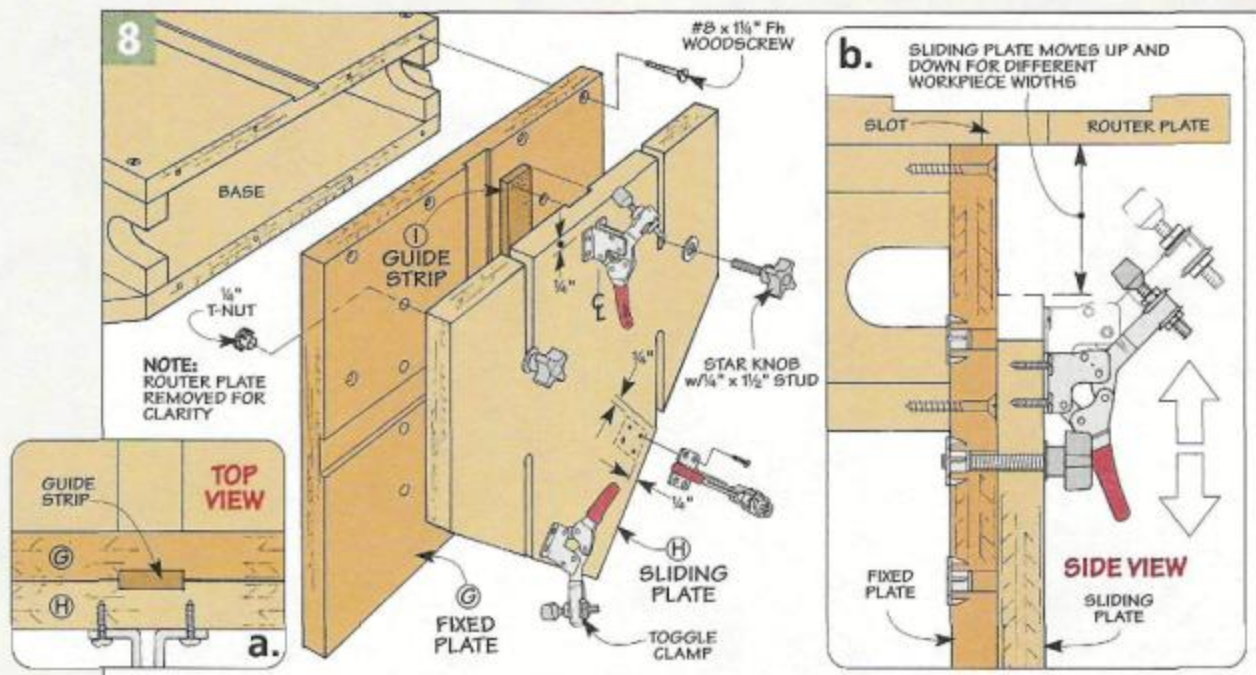

Now that the base is complete, you can start making the front section of the jig that holds the workpiece. As you can see in Figure 8, this section is made up of two plywood plates. A fixed plate is screwed directly to the front of the jig base. And a sliding plate travels up and down (or side to side) in grooves in the fixed plate.

The sliding plate allows you to accommodate different sizes of workpieces. To cut a mortise on the end of a mitered workpiece, the

sliding plate can be turned around (so the pointed end is up). Or you can rotate the sliding plate 90° in order to cut a mortise on the end of a workpiece. Toggle clamps attached to the sliding plate are used to hold the workpiece in place while the mortise is being routed (see p. 21).

Fixed Plate – I made the fixed plate first. As shown in Figure 9, the *fixed plate* (G) is just a square piece of plywood with a couple of shallow grooves that cross in the center of

the piece. These grooves will be used to help guide the sliding plate that is added later.

Like the grooves in the base, I made these grooves on the router table (Figure 10). The first one is centered on the *length* of the workpiece. Then a second groove is centered on the *width* of the piece. To center these grooves, I routed them in multiple passes, flipping the workpiece between each pass. Figure 10a shows a detail of the grooves.

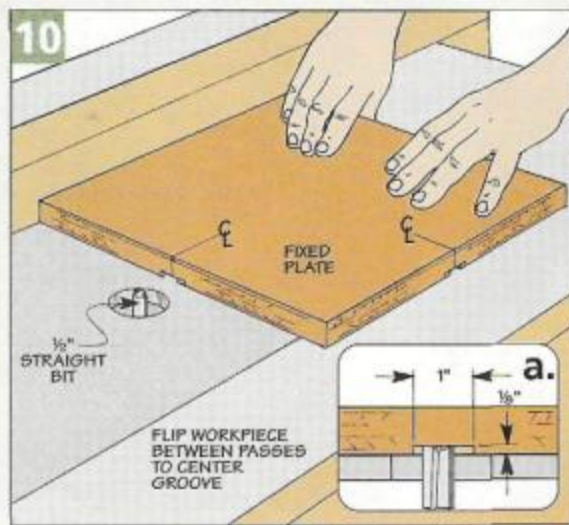
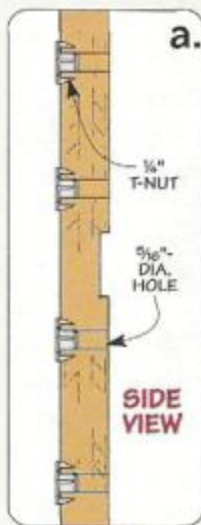
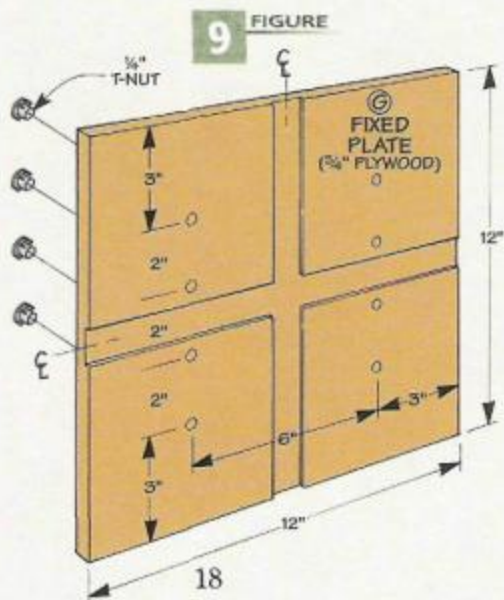

The sliding plate will be held in place with a couple of knobs that thread into T-nuts in the fixed plate. But in order to provide a range of adjustments for different sizes of workpieces, I installed four pairs of T-nuts in the fixed plate. You can see the locations for these in Figure 9. After drilling a hole for each T-nut, simply hammer the T-nuts in place on the back of the fixed plate. (The back of the plate is the side *without* the grooves.)

At this point, the fixed plate can be attached to the base of the jig. It is simply screwed in place with eight woodscrews, as you see in Figure 8.

Sliding Plate – Like the face plate, the *sliding plate* (H) also starts out as a square piece of plywood (Figure 11). But the sliding plate is a little more involved.

To start with, a pair of slots are cut on each end of the plate to allow it to slide up and down (see the photo in the margin). The location of these slots is shown in Figure 11. The important thing to keep in mind is that the spacing between each pair of slots is the same as the spacing between the two rows of T-nuts in the fixed plate.

To cut the slots, I drilled a hole at the end of each slot. The I cut away the waste with a band saw.

After cutting the slots, a shallow groove is routed down the center of the sliding plate. This groove is identical to the ones you routed on the fixed plate. It will hold a guide strip that will also fit into the grooves in the fixed plate.

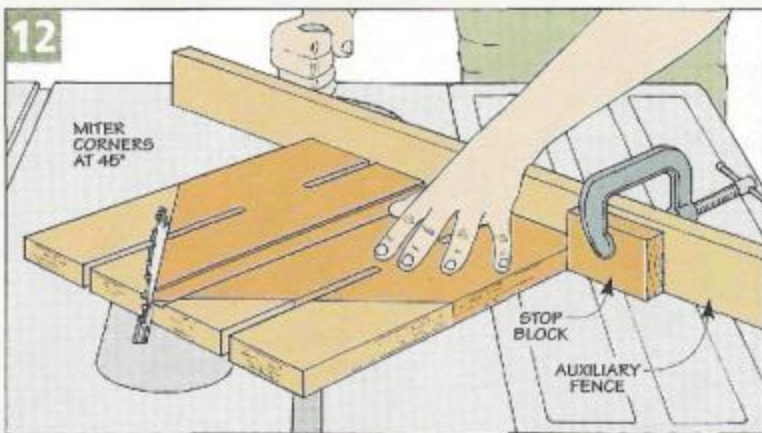
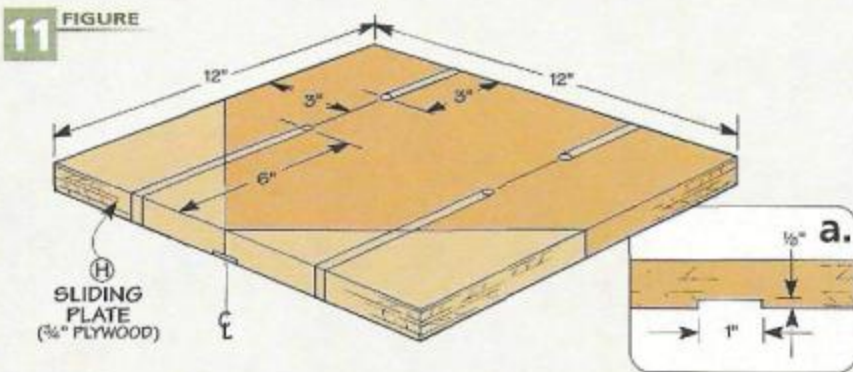

To hold mitered workpieces, two of the corners of the sliding plate are mitered at a 45° angle. This is done on a table saw, using the miter gauge and an auxiliary fence, as you see in Figure 12. Clamping a stop block to the auxiliary fence allows you to simply flip the workpiece over to miter the opposite corner.

Guide Strip – The *guide strip* (I) is nothing more than a piece of 1/4" hardboard. It's cut to size and glued into the recess on the sliding plate. Then after the glue is dry, you can

sand or trim the end of the strip flush with the mitered edges of the plate, as shown in Figure 13a.

Toggle Clamps – The last step to complete the sliding plate is to add the toggle clamps, see photo in margin. These clamps are used to hold a workpiece down to the top of a workbench or other flat surface. (For more on toggle clamps, see Sources on page 35.)

There are three toggle clamps used on this jig. These are simply screwed to the sliding plate. If you take a look at Figure 8, you can see where the clamps are positioned on the plate.

After the toggle clamps are installed, the sliding plate can be added to the fixed plate. It is held in place with a pair of star knobs with threaded studs and a couple of washers, as you can see in Figure 8.

Once the clamp plate is in place, the jig is ready to be put to work. All you need to do is clamp it down to your workbench. For more information on using the jig, see page 20.



▲ **Adjustable.** Slots in the sliding plate allow you to adjust the jig for different size workpieces. And a toggle clamp holds the workpiece securely in place.

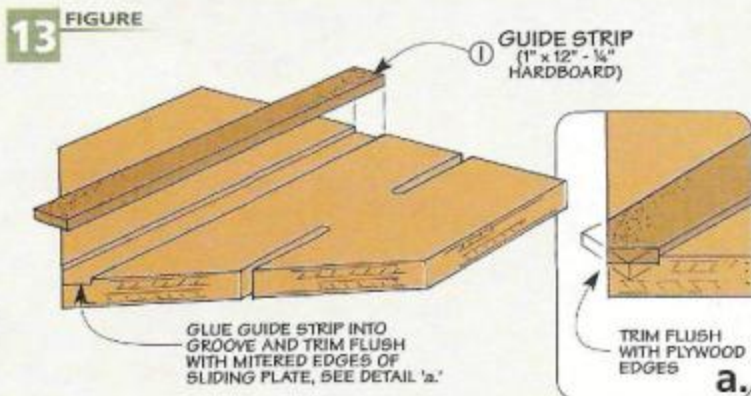

Using the Jig

Once you try this jig, I think you'll be amazed not only with the results, but at how easy it is to set up and use. There are just a few simple steps.

Layout – The first step is to lay out the mortise on your workpiece. If you are making identical mortises on identical workpieces, you only need to lay out one mortise — once the stops on the jig are adjusted for the first mortise, the rest will fall into place automatically.

Jig Setup – With the jig clamped to your bench, loosen the two knobs

on the front face of the jig and bring the sliding plate up to trap the workpiece against the router plate, as you see in Step 1. Tighten the knobs and clamp the workpiece to the jig with the toggle clamp.

Now loosen the knob at the back of the jig and adjust the router plate so the opening is centered over the mortise (see Step 2 and the box shown at left).

In Step 3, the stops are being adjusted to control the length of the mortise. To do this, place the router in the recess of the jig so the bit is directly over one end of the mortise. Then slide the stop up against the router base and tighten the knob. Now repeat this procedure for the stop at the other end of the mortise.

Routing – At this point, you're ready to start mortising. The mortise is made in a series of passes, removing about $\frac{1}{4}$ " of material at a time. Start with the router against the left-hand stop, turn the router on and

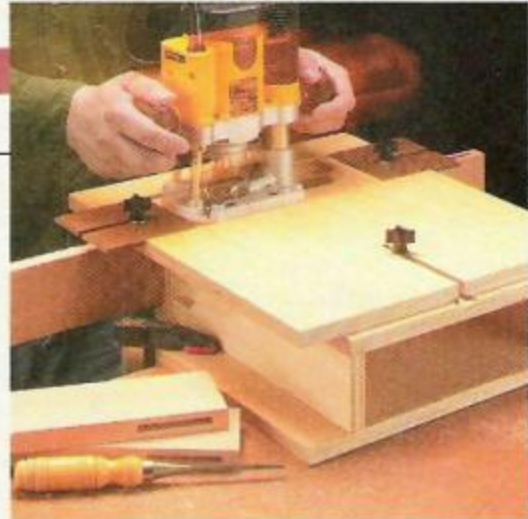

▲ **Lightning-Fast Mortises.** To rout a mortise, all you have to do is plunge the bit into the workpiece and move the router over until it hits the stop.

plunge it into the workpiece about $\frac{1}{4}$ ". Move the router to the right until it contacts the opposite stop. Now increase the depth of cut and repeat the process until you reach the full depth of the mortise.

Stop Block – Before removing the workpiece from the jig, you may want to clamp a stop block to the front of the jig (see Step 4). If you're making multiple mortises on the ends of identical workpieces, this will allow you to slide the next workpiece right into place.

When you're finished routing all the mortises, you might want to come back with a chisel and square

Centering the Router Bit

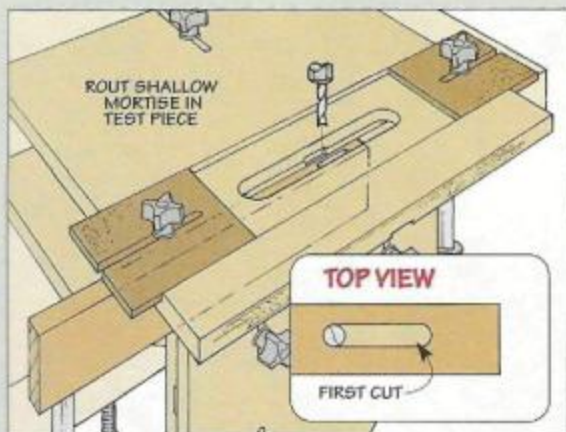

1 To see if the router bit is centered on the thickness of the stock, make a mortise in a test piece of the same thickness as your workpieces.

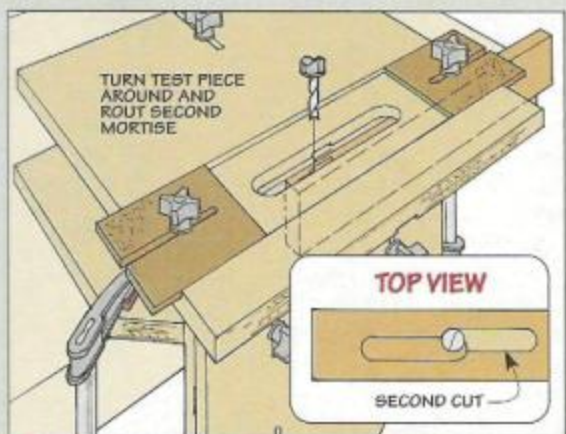

2 Now turn the test piece around and rout a second mortise. The two should line up. If they don't, adjust the router plate and try again.

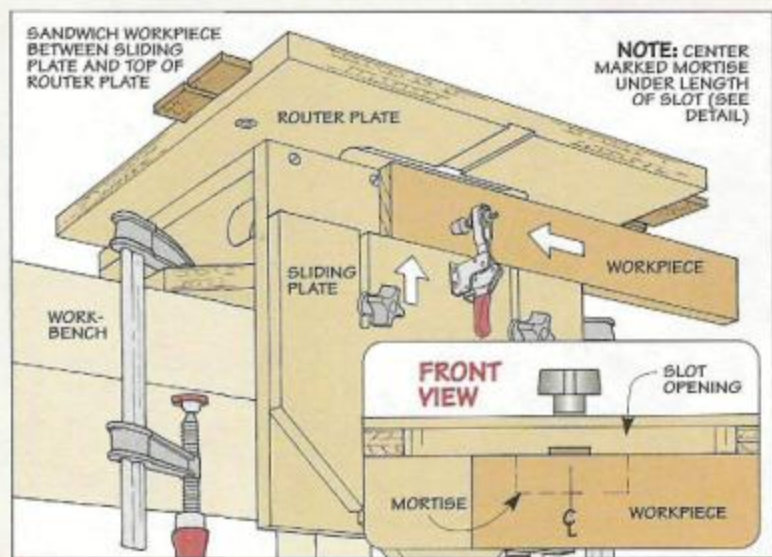

1 Sandwich the workpiece between the sliding plate and the router plate and use the toggle clamp to secure the workpiece.

up the ends of each mortise to match your tenons. Or the shoulders of the tenons can be rounded over later with a rasp or file.

One last suggestion. Although you can use an ordinary straight bit for routing mortises, I find that I get better results using a spiral upcut bit (see photo in margin). With a straight bit, the wood chips tend to pile up inside the mortise, making the bit (and the router) work harder. A spiral upcut bit pulls the chips up and out of the mortise as it cuts, leaving you with a cleaner mortise.

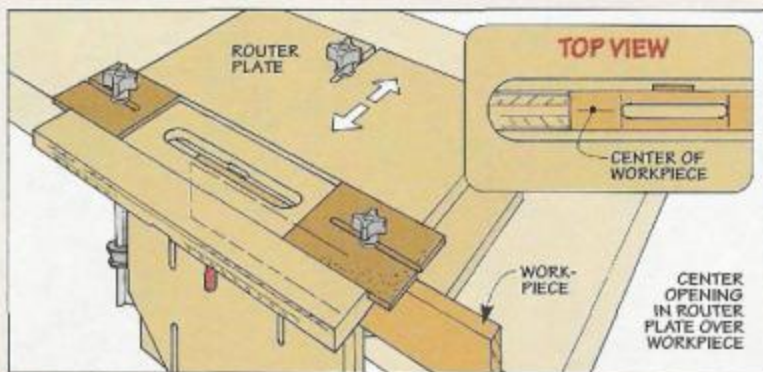

2 With the workpiece in place, move the router plate forward or back until the opening in the plate is centered over the mortise laid out on the workpiece. Then tighten down the knob.



▲ **Spiral Upcut Bit.** For routing mortises, a spiral upcut bit is a good choice because it pulls the chips out of the mortise, giving you a cleaner cut.

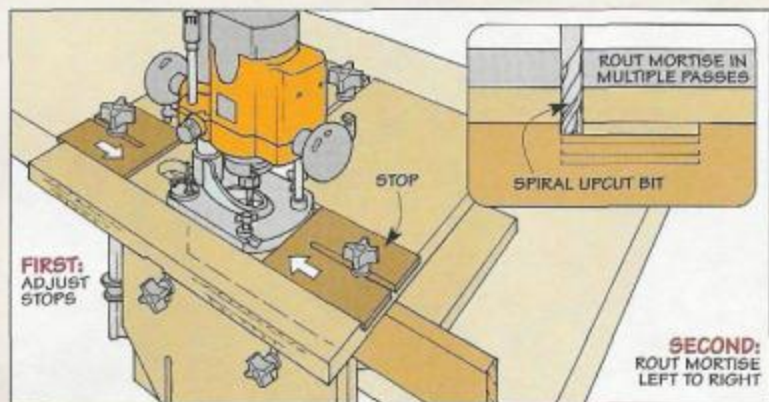

3 Adjust the stops in or out to establish the length of the mortise. Then plunge the bit into the workpiece and rout the mortise in multiple passes, removing no more than 1/4" of material at a time.

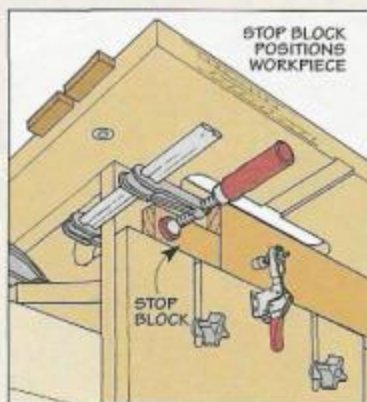

4 A stop block clamped to the jig makes the setup for duplicate workpieces automatic.

Other Features

One of the features of this jig is that it can be used to make mortises on the end of a workpiece as well as on the edge. All you have to do is remove the two knobs holding the sliding plate in place and rotate it 90°, as shown in the first photo at right.

Routing a mortise in the end of a workpiece allows you to create a "loose" tenon joint. In this type of joint, the mating pieces both end up with a mortise. Then a small block of wood (the "tenon") is cut to fit in the mortises and is glued into place.

You can also make a mortise on the end of a mitered workpiece, which is great for strengthening mitered frames. All you have to do is turn the sliding plate around so the pointed end is up. Then set your workpiece against one of the two mitered edges of the plate and clamp it in place, see the second photo at right.



▲ **Vertical Workpieces.** To rout a mortise on the end of a workpiece, simply rotate the sliding plate 90° to the base.



▲ **Mitered Workpieces.** For mortising mitered workpieces, the sliding plate can be turned upside down.



Hardware Storage Cabinet

Store all your hardware (and a little bit more) in this classic, old-fashioned hardware storage cabinet.

When it comes to storing hardware, it's hard to beat the practicality of plastic bins. But the problem then becomes, how do you organize the organizers? This project solves that dilemma.

Drawers & Storage Bins – As you can see in the photo above, the cabinet is loaded with storage space. Four upper drawers accept a total of 64 small plastic storage bins. And the two bottom drawers hold a total of 12 larger bins.

I sized the drawers (and therefore the cabinet) to fit the *Akro-Mils* storage bins I used (refer to Sources on page 35). Whether you use these bins or another type, it's best to have them on hand before you start to size the drawers and cabinet to fit.

Drawer Slides – Plastic storage bins aren't the only modern conveniences in this cabinet. The drawers ride on full-extension slides that allow you to access the entire contents of each bin easily.

These modern conveniences are "wrapped" in a cabinet with an old-fashioned look that showcases the solid woodworking that goes into building it — stub tenon and groove joinery for the frame and panel sides, and lap joints for the face frame.

Option – And if you're looking for a little more woodworking, you can build shop-made dividers for organizing the contents of each drawer (instead of using the storage bins). Details for this begin on page 29.

EXPLODED VIEW
OVERALL DIMENSIONS:
22³/₄"W x 24¹/₄"D x 42¹/₂"H

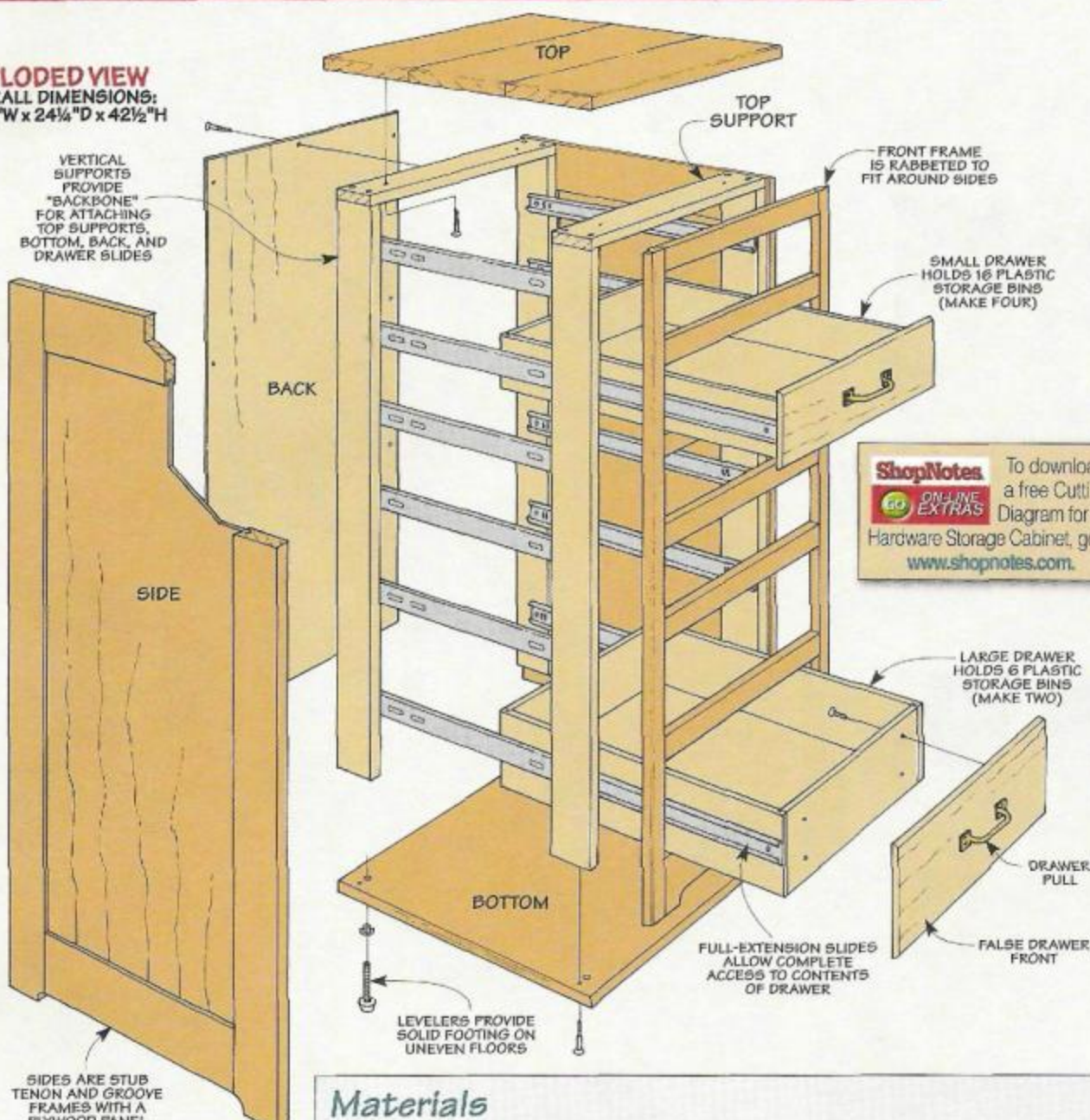

ShopNotes To download a free Cutting Diagram for the Hardware Storage Cabinet, go to www.shopnotes.com.

ON-LINE EXTRAS

Hardware

- (24) #8 x 1" Fh Woodscrews
- (4) #8 x 1¹/₄" Fh Woodscrews
- (12) #8 x 1¹/₂" Fh Woodscrews
- (4) ⁵/₁₆"-18 T-Nuts
- (4) ⁵/₁₆"-18 x 1¹/₂" Leveler Glides
- (10) #6 x 1" Fh Woodscrews
- (6 Ft.) 22" Drawer Slides w/screws
- (6) 4" Drawer Pulls w/screws
- (12) Knobs w/screws (Optional)
- (6) Label Holders w/screws (Optional)

Materials

Cabinet

A Side Stiles (4)	³ / ₄ x 3 ¹ / ₂ - 41 ¹ / ₂
B Side Rails (4)	³ / ₄ x 3 ¹ / ₂ - 17
C Side Panels (2)	17 x 34 ¹ / ₄ - ¹ / ₄ Ply.
D Narrow Front Rails (6)	³ / ₄ x 1 ¹ / ₂ - 20 ³ / ₄
E Wide Front Rail (1)	³ / ₄ x 3 ¹ / ₂ - 20 ³ / ₄
F Front Stiles (2)	³ / ₄ x 1 ³ / ₄ - 41 ¹ / ₂
G Vertical Supports (4)	1 x 3 ¹ / ₄ - 39 ¹ / ₄
H Top Supports (2)	³ / ₄ x 3 ¹ / ₄ - 20 ³ / ₄
I Bottom (1)	20 ³ / ₄ x 23 - ¹ / ₂ Ply.
J Top (1)	1 x 24 ¹ / ₄ - 22 ³ / ₄
K Back (1)	20 ³ / ₄ x 40 ³ / ₄ - ¹ / ₄ Ply.

Drawers

L Small Fronts/Backs (8)	¹ / ₂ x 3 ¹ / ₂ - 17 ¹ / ₄
M Small Sides (8)	¹ / ₂ x 3 ¹ / ₂ - 23
N Large Fronts/Backs (4)	¹ / ₂ x 5 ¹ / ₂ - 17 ¹ / ₄
O Large Sides (4)	¹ / ₂ x 5 ¹ / ₂ - 23
P Bottoms (6)	17 ¹ / ₄ x 22 ¹ / ₂ - ¹ / ₂ Ply.
Q Small False Frts. (4)	³ / ₄ x 4 ³ / ₄ - 19 ¹ / ₄
R Large False Frts. (2)	³ / ₄ x 6 ¹ / ₂ - 19 ¹ / ₄
S Small Side-to-Side Dvdrs. (20)	¹ / ₄ x 3 - 16 ³ / ₄
T Small Frt.-to-Back Dvdrs. (20)	¹ / ₄ x 3 - 22
U Lrg. Side-to-Side Dvdrs. (10)	¹ / ₄ x 5 - 16 ³ / ₄
V Lrg. Frt.-to-Back Dvdrs. (10)	¹ / ₄ x 5 - 22

Note: For this project, you'll need 1 sheet of ¹/₄" plywood, 1 sheet of ¹/₂" plywood, 20 sq. ft. of ¹/₂"-thick stock, 20 bd. ft. of ³/₄"-thick hardwood, 14 bd. ft. of 1"-thick hardwood, and 30 sq. ft. of ¹/₄"-thick stock or hardboard (for the optional dividers).

Sides & Front

Forming the shell of the cabinet begins with making a pair of frame and panel sides that join to a face frame, as you can see in Figure 1.

These pieces provide the support for adding the top, bottom, and back that are built later.

Stiles & Rails - I started on the sides by cutting the $\frac{3}{4}$ "-thick hardwood *side stiles* (A) and *rails* (B) to final size (Figure 1). Then to ensure that the cabinet would rest firmly on an uneven floor once it was assembled, I created a "foot" at each corner at the bottom of the cabinet.

To do this, I clamped the two stiles together and then used a $1\frac{1}{2}$ "-dia. Forstner bit to create circular cutouts on the inside corner of each stile (see upper margin photo and Figure 1a).

Stub Tenons & Grooves - After shaping the foot of each stile, you're ready to cut the stub tenon and groove joinery that holds the stiles and rails together. As you can see in Figure 2, the groove for this joint needs to be sized to accept the $\frac{1}{4}$ " plywood *side panel* (C). So you'll want to be sure to cut the groove first.

There are two things to keep in mind here as you cut the groove.

▲ To form the "feet" at the end of the side stiles, slide them together and use a scrap piece across the ends for support.

▲ For the "feet" on the wide rail, a scrap piece again provides support for the drill bit during the cut.

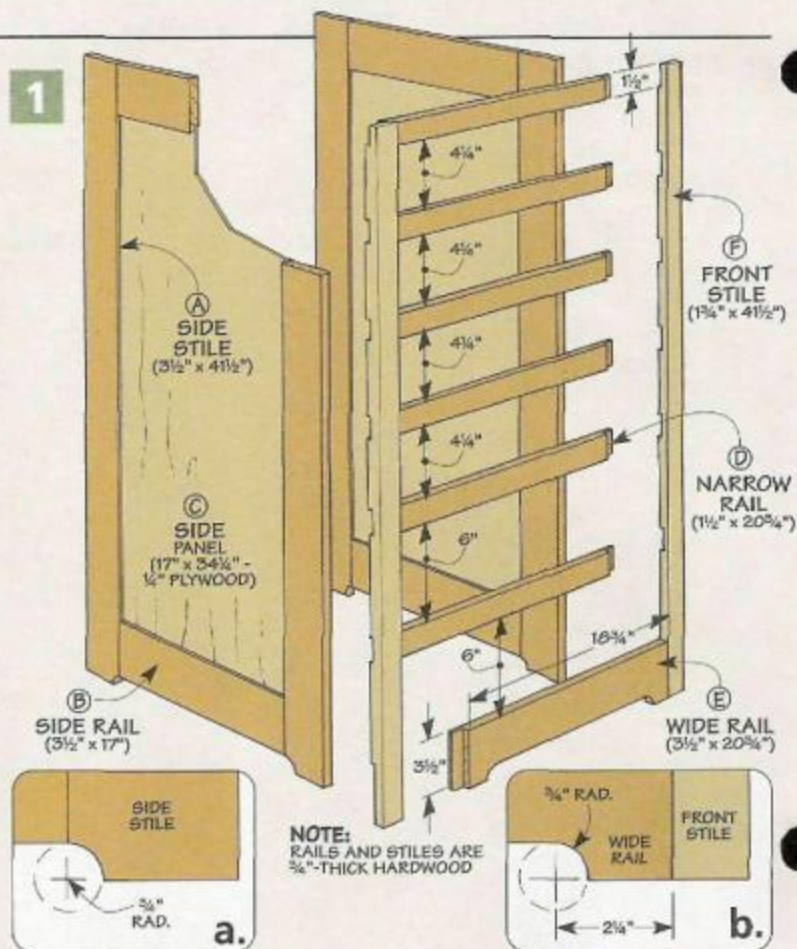

First, the groove needs to match the actual thickness of the $\frac{1}{4}$ " plywood. (It's usually a little undersized.) And second, you'll want to make sure the groove is centered on the edge of the rails and stiles. This makes it easier to cut the tenons to fit.

Centering the groove isn't as diffi-

cult as you might think. Instead of using a dado blade set to match the thickness of the plywood, I simply use my regular saw blade. Then to create a centered groove, I start by roughly centering the blade on the workpiece and making a single pass, as illustrated in Figure 2a.

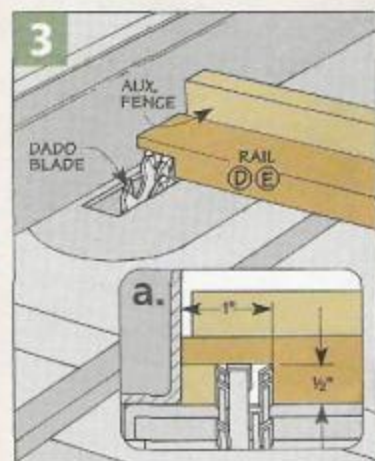
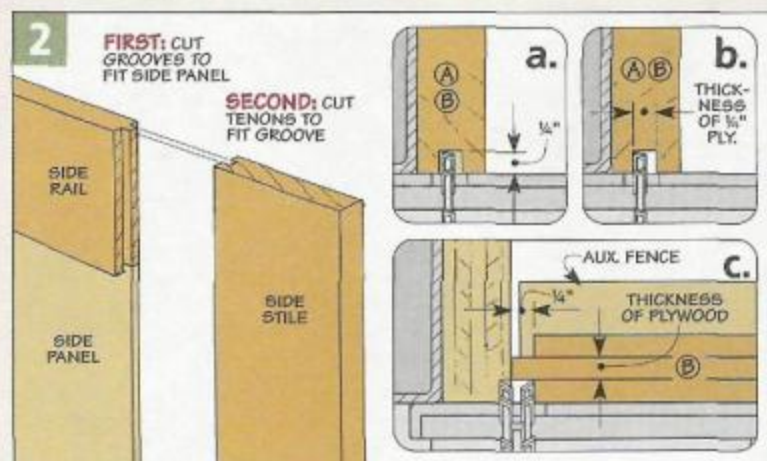

To complete the groove, just flip the workpiece end for end and make a second pass (Figure 2b). A quick trial fit of the panel will let you know if the groove is wide enough. If it's not, just nudge the fence a bit closer to the blade and make two more passes. Once you have a good fit, you can cut the remaining grooves.

Stub Tenon - With the grooves complete, you can cut the tenons on the ends of the rails to match (Figure 2c). Once again, this is just a matter of sneaking up on the fit.

Assembly - Now that the tenons are complete, you can glue the stiles, rails, and panels together to form the sides. Just be sure to align the lower edge of the bottom rail with the top of the circular cutout in each stile (Figure 1a). For tips on assembling a frame and panel, refer to page 30.

Front Frame - At this point, you can let the sides dry and concentrate on the front frame of the cabinet. Like the sides, the face frame is made up of stiles and rails, as shown in Figure 1. But they're held together by lap joints that create openings for the drawers.

Rails - I started by cutting the rails (D, E) to final size from $\frac{3}{4}$ "-thick hardwood. Once that's complete, you can cut rabbets on the ends of each rail to form half of the lap joint (Figure 3). What's important here is that the shoulder-to-shoulder distance be identical ($1\frac{3}{4}$ ") on each rail so the size of the drawer openings is consistent (Figure 1).

At this point you can set the

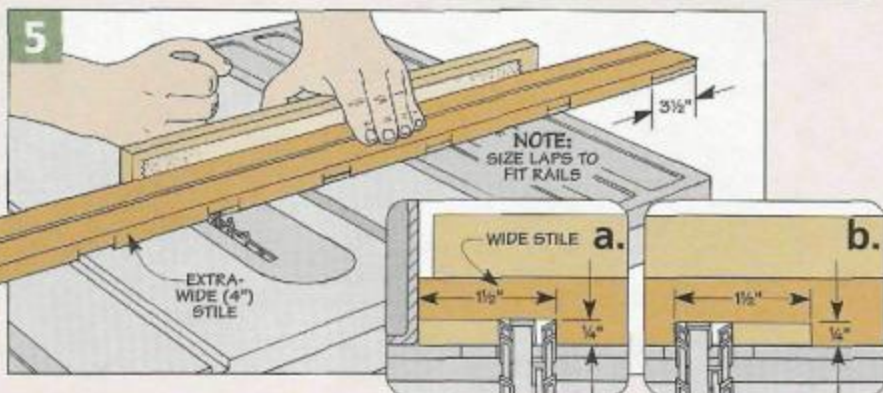
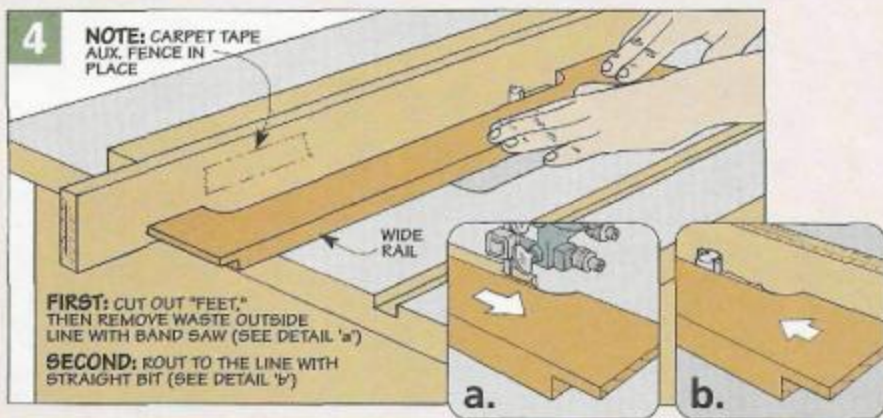

narrow rails aside and complete a little shaping work on the wide rail (E) at the bottom of the cabinet.

Foot - Like the sides of the cabinet, the front frame has a "foot" on each side. But this time, the foot is cut in the bottom rail. To form the circular part of the cutout, I used a technique similar to the one I used for the sides. You can see this in the lower margin photo on the opposite page.

Shape Wide Rail - Completing the foot is just a matter of using a band saw to remove most of the

waste (Figure 4a) and then cleaning up the edge with a straight bit on the router table (Figures 4 and 4b).

Stiles - With all the rails complete, you're ready to work on the stiles (F). I found it easiest to start out with an extra-wide (4") workpiece (Figure 5). Cutting the lap joints in a single piece ensures they'll be aligned perfectly across each stile. I used the rails to verify the width and depth of each lap joint as I cut them to size (Figures 5, 5a and 5b). Then I cut the stiles to final width ($1\frac{3}{4}$ ").

Assembly - Now that the lap joints are complete, you're ready to assemble the front frame (Figure 6). (For a few tips and techniques on assembling the frame with just a few clamps, refer to page 30.)

As you assemble the frame, you'll notice that the rails don't extend all the way to the edges of the stiles. Don't worry. After the frame is assembled (and the glue is dry), you'll be cutting rabbets that are even with the ends of the rails to accept the sides.

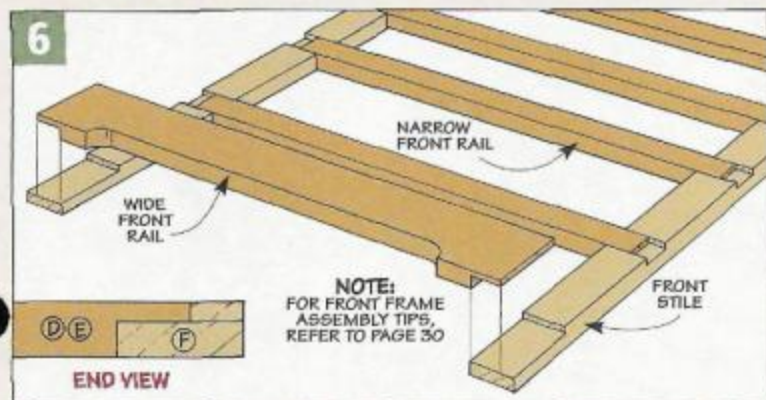

Top, Bottom & Back

Now that the sides and front frame are complete, you're ready to start assembling the cabinet, as shown in the Overview in Figure 7.

Attach Sides – However, before you can attach the sides, you'll need to cut a rabbet along the back edge of the front frame (Figure 8).

There's nothing tricky about cutting the rabbet. I used a dado blade and "buried" it in an auxiliary fence attached to the face of my rip fence (Figure 8a). Then it's just a matter of sneaking up on the width of the rabbet so the sides are flush with the outside of the frame.

Assemble Sides & Frame – With the rabbet cut in the front frame, you're ready to attach the sides. To make this easy to do with a limited number of clamps, refer to the article on page 30.

Rout Roundover – Once the sides are attached, carefully rest the assembly on its "back" and rout a $\frac{1}{2}$ " roundover along the front edge, as shown in Figure 9. Besides softening the corner, this also makes the joint line along the side less visible.

Vertical Supports – Because the cabinet will be very heavy with all the drawers loaded with hardware, it needs to be solid. To ensure this, I added some "backbone" by installing a set of four vertical supports, like the ones you see illustrated in Figure 10.

These supports will be used later to attach the slides for the drawers. But they also provide a convenient

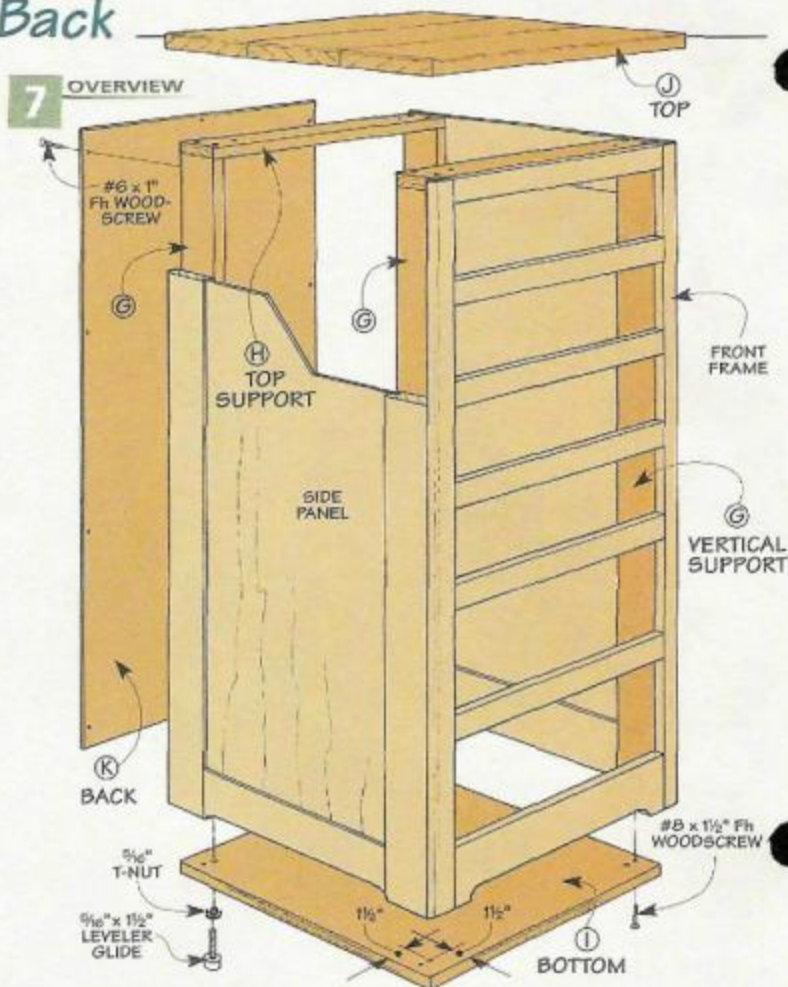

way to attach the top, bottom, and back of the cabinet as well.

To ensure the drawer slides line up flush with the inside edge of the drawer openings, the *vertical supports* (G) are made from 1"-thick stock. And they're cut to length to provide clearance for attaching the top supports and bottom of the

cabinet (Figures 10, 10a, and 11).

Gluing the front vertical supports in place is just a matter of butting them into the corners, as you can see in Figure 10b. And the vertical supports at the back of the cabinet are set in to create a "rabbet" for the back of the cabinet, as shown in Figure 10b.

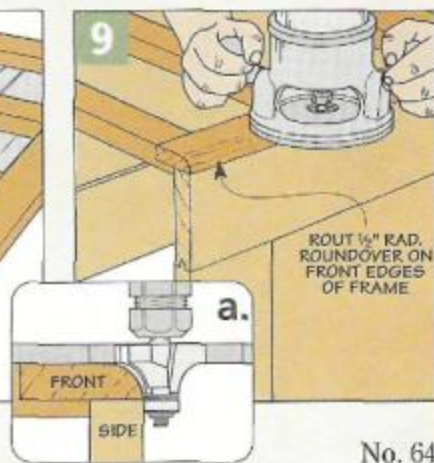
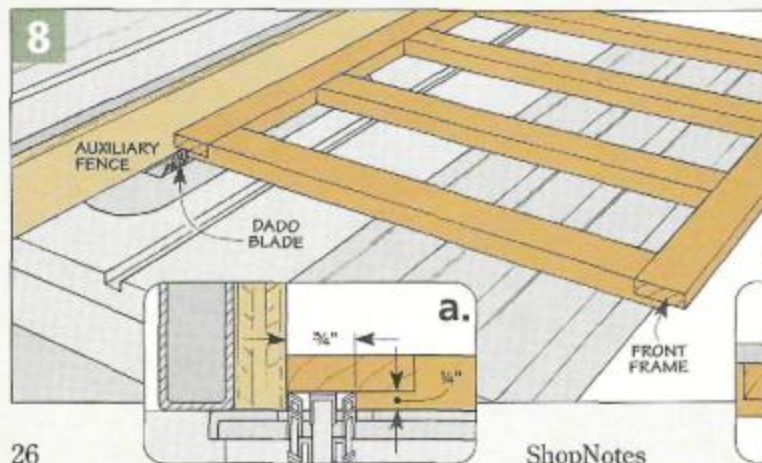

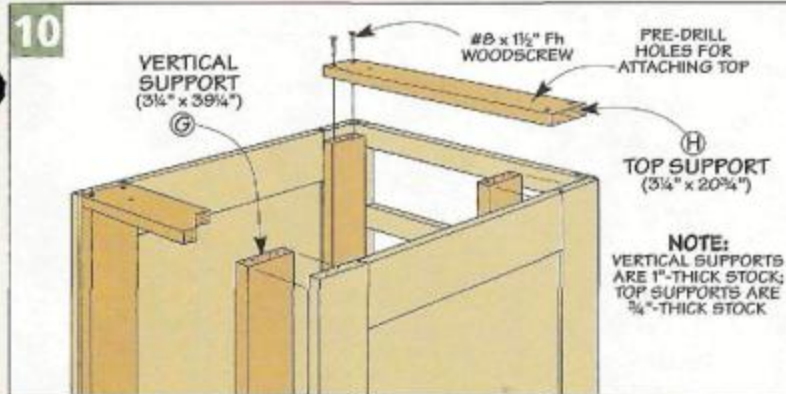

While I was at it, I added a pair of top supports (H) made from $\frac{3}{4}$ "-thick hardwood (Figure 10). Before screwing them in place (Figure 10a), I drilled a pair of holes in each support for attaching the top.

Bottom – With the top supports in place, you can turn your attention

to the bottom of the cabinet. Besides enclosing the base of the cabinet, the bottom provides a mounting point for a set of levelers.

After cutting the bottom (I) to size from $\frac{1}{2}$ " plywood, I drilled two sets of holes, as you can see in Figures 7, 11, and 11a. One set of

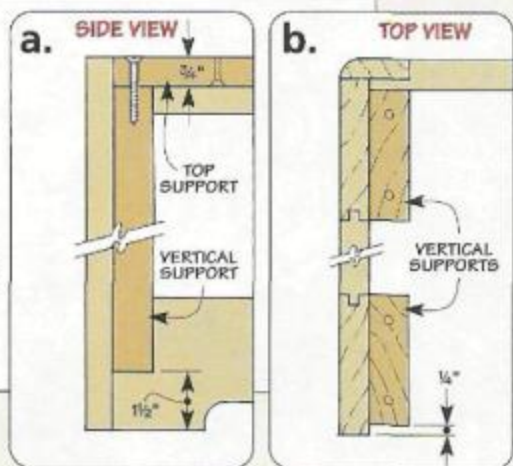
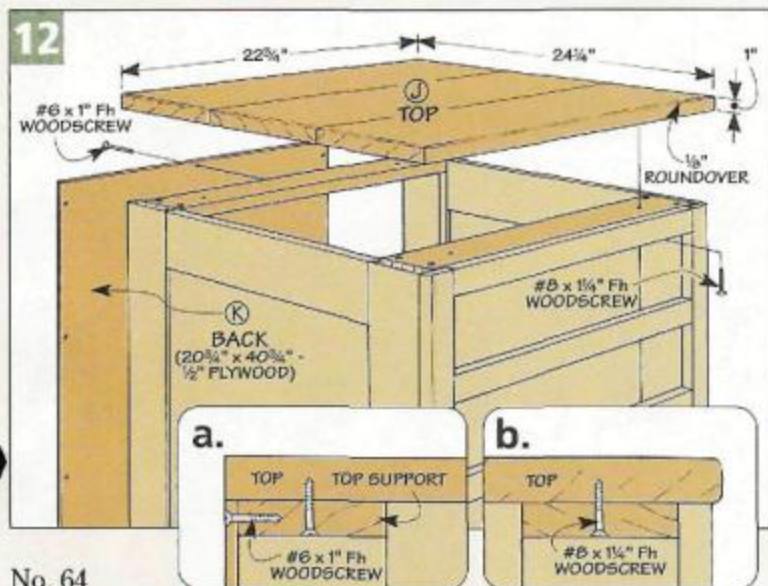
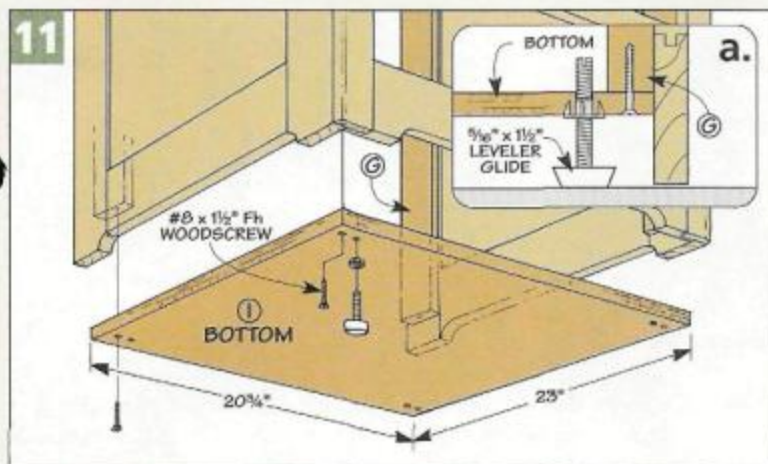

holes is used to attach the bottom to the supports installed earlier.

The other set of holes is part of a shop-made leveling system. Since I wasn't able to find a set of low-profile levelers that were inexpensive and adjustable, I decided to make my own using a set of T-nuts and glides.

That took care of the inexpensive and low profile criteria. To make them easily adjustable from inside the cabinet, I cut a slot in the top of each glide (see margin). Once that's complete, drill the holes for the T-nuts, tap them in place and then thread in the levelers.

Top – There are only a couple things left to complete the cabinet — adding the top and back. I concentrated on the top first since it's easier to install without the back attached to the cabinet.

The top (J) is just a 1"-thick panel I glued up from several narrower boards (Figure 12). After the glue dries, you can trim the top to final size. Then rout a small roundover ($\frac{1}{8}$ ") on all the top and bottom edges except the back, as in Figure 12a. Finally, screw the top in place so it's centered side to side and flush at the back (Figure 12a).

Back – All that's left to do is add the back. The back (K) is a piece of $\frac{1}{4}$ " plywood that's sized in width to fit between the sides of the cabinet. And it's cut to length so it's flush with the lower edge of the bottom. Once the back is cut to size, you can screw it in place (Figures 12 and 12a).

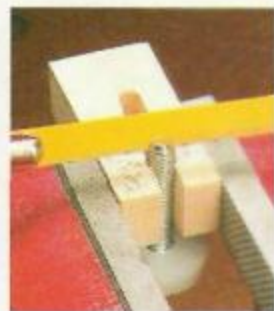

▲ **Adjustable Levelers.** Cutting a slot in the top of a glide with a hacksaw creates an adjustable leveler.

Drawers



With the basic cabinet complete, you can move on to building the drawers that hold the bins used to organize the hardware (see photo and Figure 13).

As I mentioned before, I sized the drawers to accept plastic storage bins (refer to page 35 for Sources). But if you'd rather make your own organizing system, check out the shop-made dividers on the opposite page.

Drawers – The drawers are built from $\frac{1}{2}$ "-thick stock. After planing your stock down to size, you can cut the *drawer fronts/backs* (L, N) and *sides* (M, O) to the dimensions shown in Figure 13 and the margin.

What's important here is to end up with a $\frac{1}{2}$ " space on each side of the drawer for installing the full-extension metal drawer slides (Figure 13c). Full-extension slides make it easy to reach the entire contents of the drawer.

Tongue & Dado Joinery – The joinery for the drawers is quite simple. A single kerf cut in the ends of each side accept tongues cut on the ends of the fronts and backs (Figures 13 and 13a).

Before assembling the drawer, you'll need to cut a $\frac{1}{4}$ "-wide groove along the bottom edge of all the drawer pieces to hold the bottom (Figure 13b). And since it will be difficult to do once the drawer is assembled, it's best to drill a set of countersunk screw holes in the front for attaching the false fronts.

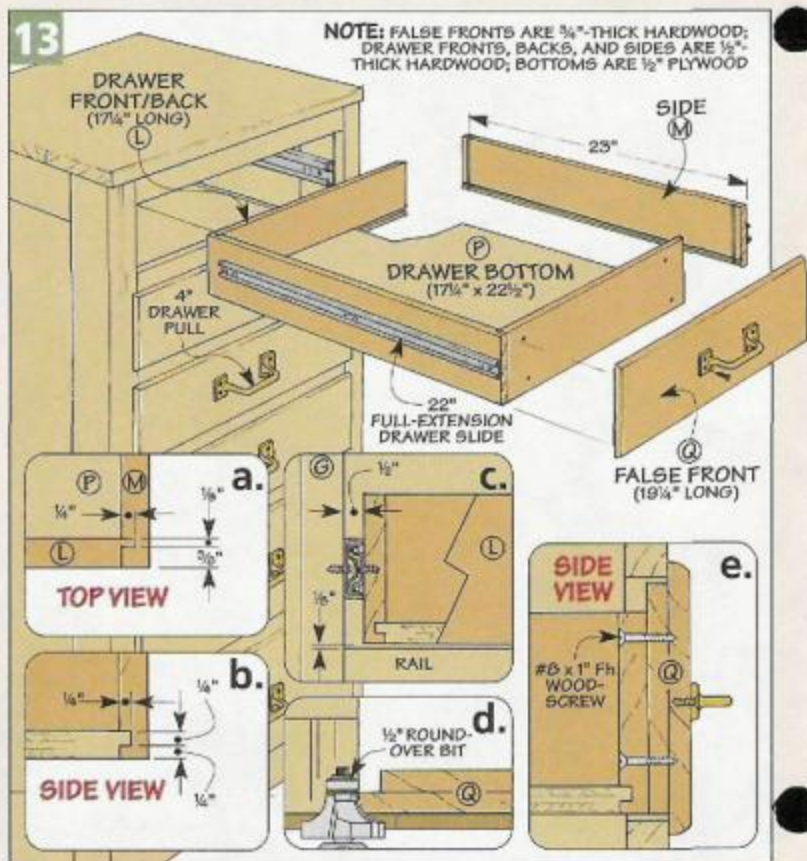

Now you can cut the *drawer bottom* (P) to size from $\frac{1}{2}$ " plywood. ($\frac{1}{2}$ " plywood makes a heavy-duty bottom for supporting a drawer full of hardware.) After cutting a $\frac{1}{4}$ " tongue around the edges of the bottom to fit the groove (Figure 13b), you can glue up each drawer.

Install Drawers – At this point you're ready to add the slides and install the drawers in the cabinet. Just keep in mind that the goal is to position each drawer $\frac{1}{8}$ " above each rail (Figure 13c). This provides the clearance above the drawer for the bins and hardware.

False Fronts – All that's left at this point is to make the *false fronts* (Q, R) shown in Figure 13 and the margin. A rabbet is cut around the edges of the false fronts to create a lip that overlaps the drawer opening (Figure 13e and margin). Then a

half-bullnose is routed around the outside to ease the edges (Figure 13d).

Finish – After screwing the false fronts in place, I stained the cabinet with a mix of three tablespoons of Van Dyke brown artist's colors and a quart of linseed oil. Then I topped it off with a few coats of a wipe-on varnish.

Finally, I added a pull to each drawer (Figure 13). But you might also want to consider the brass hardware shown below.

SMALL DRAWER DETAIL

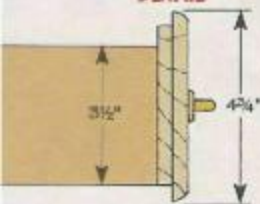

LARGE DRAWER DETAIL

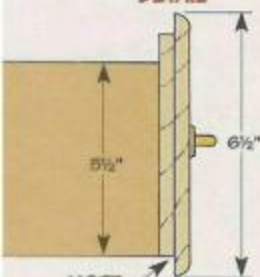

NOTE: CUT $\frac{3}{8}$ " x $\frac{1}{8}$ " RABBET ON ALL FOUR EDGES

Hardware Option.

A brass label holder (and knobs) makes it easy to identify the contents of each drawer.



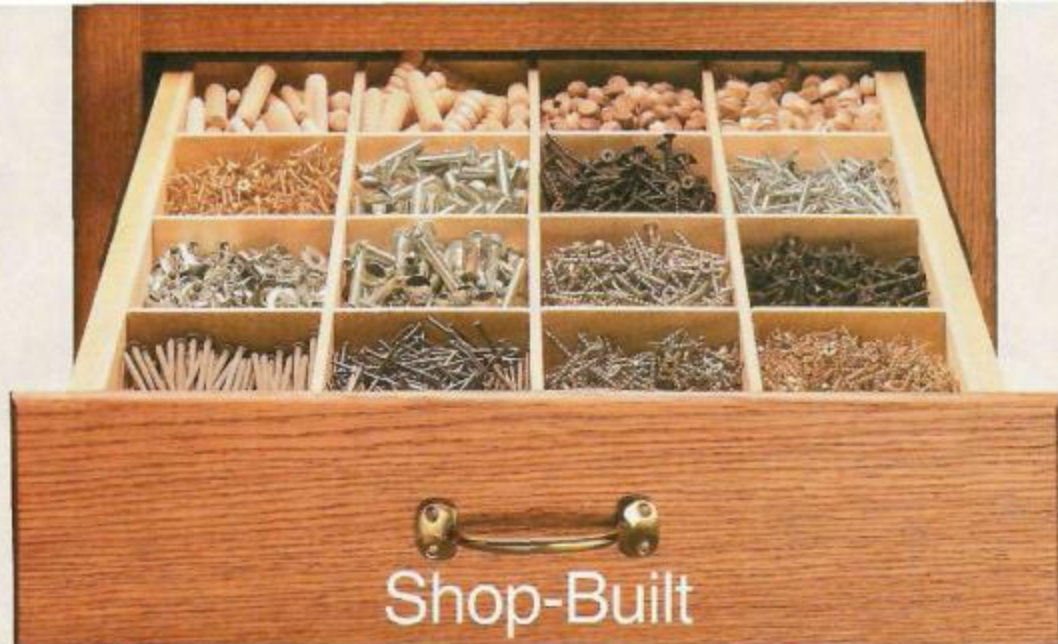

Turn the jumbled contents of any drawer into a model of organization with these shop-built drawer dividers.

Shop-Built Drawer Dividers

You don't need to build an entire cabinet to get organized. Shop-built drawer dividers are a great way to organize the contents of any drawer.

Divider System – The dividers consist of an interlocking system (Figure 1) that can be made from 1/4"-thick stock or 1/4" hardboard. Regardless of the material, what's important is that all the dividers must be the same *thickness* to ensure they lock together securely.

Size Dividers – To start, cut the dividers to width (height) to match the distance from the drawer bottom to the top edge of the drawer sides (Figure 1). Then for each drawer, cut

five *side-to-side* (S, U) and *front-to-back* (T, V) dividers to length to match the inside dimensions of the drawers.

Auxiliary Fences – Before cutting the joints, I added an auxiliary fence to my miter gauge. Besides providing solid support for the dividers, it prevents chipout on the back side as you make the cut. A second auxiliary fence prevents the blade from "shaving" the rip fence.

Then to ensure the joints were cut identically, I stacked all the same length pieces for each drawer together. After clamping them to the auxiliary fence, you can make the cuts as shown in Figure 2.

Cut Joints – After installing a dado blade in your table saw to match the thickness of the dividers, you can cut a notch at each end of the dividers (Figure 2a). Then after cutting a centered notch in each piece, you can cut a pair of notches on each side of the center notch. Note: I only cut centered notches for the large drawers.

Once all the notches are cut, it's just a matter of sliding the dividers together and slipping the assembly into the drawer. Then all that's left to do is gather up all your boxes of hardware and organize each drawer to suit your needs. 🛠️

1 OVERVIEW

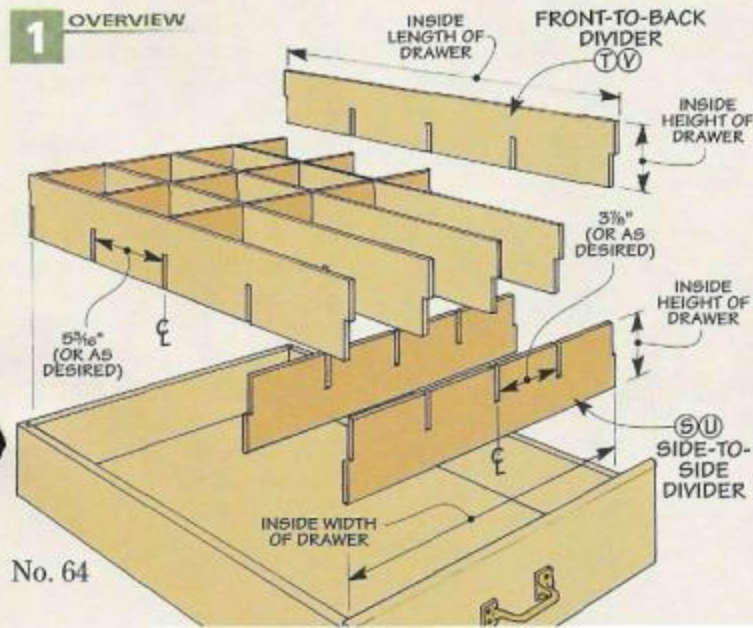

No. 64

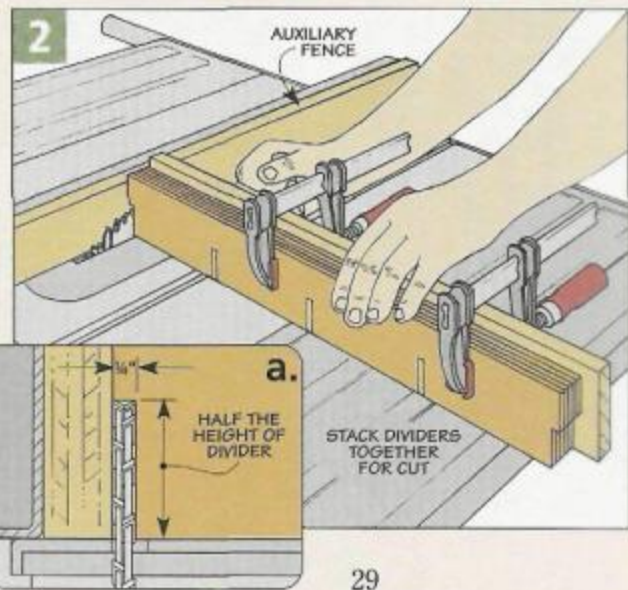

29

Tips and Techniques for Carcase Clamping

When it comes time to assemble a large carcase (like the Hardware Cabinet on page 22), I never seem to have enough clamps. But the truth is, you *don't* always need a lot. With just a few clamps, you can use the tips and

techniques that follow any time you need to assemble a large project.

Preparation – Before you start rounding up your clamps, one of the first things you'll need is a large, flat surface to work on. If it's not, you'll have to work that much harder to get

your assembly flat *and* square.

I like to use my workbench, as you can see in Figure 1. It's a natural assembly area. But that's not always best for large or tall projects. In that case, I lay down a piece of plywood on my shop floor. (I use shims to even out any low spots in the floor.)

Frame & Panel Assembly – Typically, a frame and panel doesn't require a lot of clamps. As a matter of fact, two will usually do the trick. And even though clamping it is a simple task, it's still a good idea to spend a little time dry assembling everything to check for problems.

One problem you might notice is that the stiles and rails “pop up” a bit as you apply clamping pressure. To avoid this problem, you'll want to make sure the pressure is centered on the *thickness* of the workpiece (Figure 1). To do this, I use rounded clamping blocks the same thickness as the workpieces (Figure 1a).

Another area of concern with a frame and panel assembly is ensuring that it ends up square. Checking for this is easy — just measure diagonally from corner to corner (Figure 1).

If these dimensions are the same, the assembly is square. But it's not unusual to be a little off. If that's the

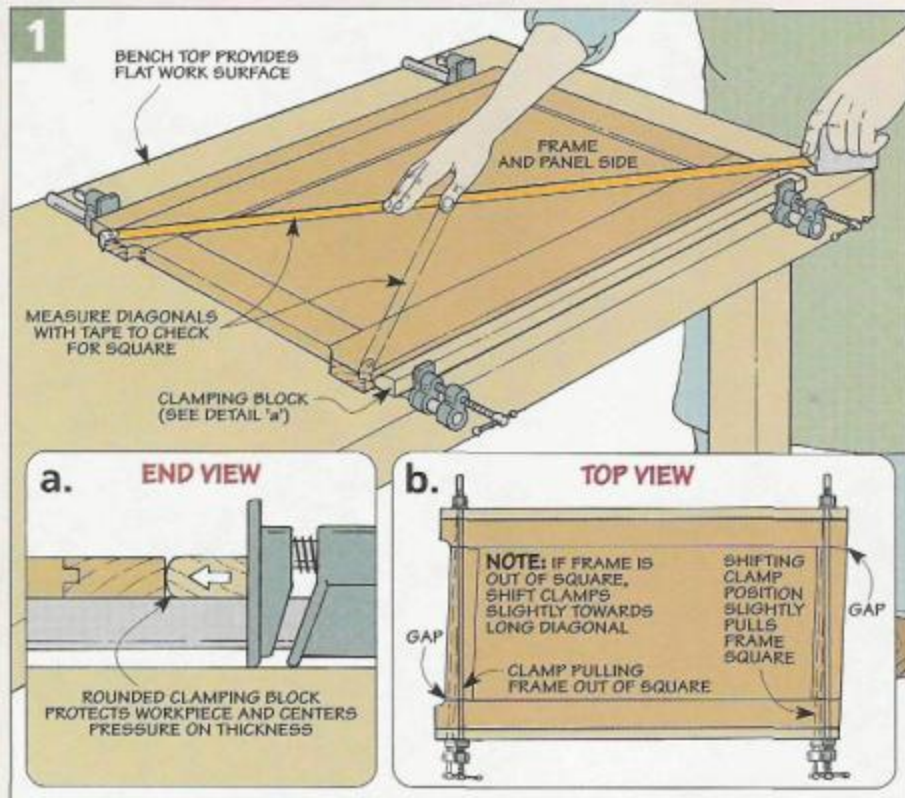

case, don't worry. All it takes to square things up is to shift the clamping pressure slightly (Figure 1b).

Face Frames – Another large assembly that's similar to a frame and panel is a face frame. But instead of a panel, there's usually a few more rails (and therefore joints) making up the assembly.

Trying to glue the entire assembly at once often results in running out of both clamps and time. To take the "pressure" off, I only glue *one* rail at a time.

To see how to do this, take a look at Figure 2. The key is *dry* assembling the frame. Besides keeping everything aligned and square, it allows you to remove one rail at a time.

This makes it easy to apply glue to the ends of the rail and then slip it back in place. Once you've done that, place a pipe clamp across the rail and pull the joint tight. Finally, add a clamp across each lap joint to lock the rail in place.

At this point, it's a simple matter to remove the pipe clamp and repeat this process, "leapfrogging" your way down the frame. And don't worry if

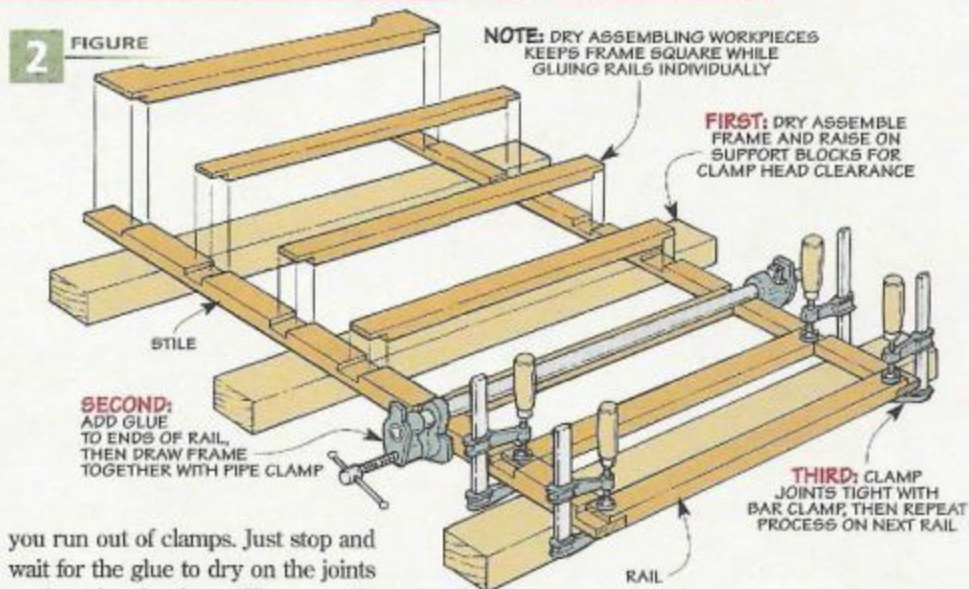

you run out of clamps. Just stop and wait for the glue to dry on the joints you've already done. Then simply start up right where you left off.

Bringing It All Together – The last challenge in assembling a project is bringing all the parts together.

As I mentioned before, I find it easier to assemble large (or tall) projects on the floor. Besides not having to reach so high above my workbench, I don't have to worry about moving it off my workbench later.

Another challenge is trying to

hold a number of pieces in position while you work. To give myself a "third hand," I used a handscrew as a wide base to hold one (or more) of the pieces in position, as in Figure 3.

When you're only assembling a couple parts (like the single side and frame in Figure 3), it's not unusual for the assembly to "pinch" together.

To solve this problem, I use a little trick that involves making a "framing" square from a scrap of plywood (Figure 3). Once it's clamped in place, it squares up the side and front frame *and* holds them in position.

With all the problems worked out, all that's left is to start gluing up the assembly. The idea here is to apply glue to the joint (see margin for a handy tip) and then get the joint tight with as few clamps as possible.

Here again, I "leapfrog" from the bottom of the assembly to the top. Starting with a pipe clamp, I bring the two parts together. Then I use a bar clamp across the two pieces to pull them tightly together.

Clamping the rest of the assembly is just a matter of moving the pipe clamp up a bit and repeating the process. (You can do this for the other side once the glue dries.)

As you can see, you don't need a shop filled with clamps to assemble a large project. With the tips and techniques shown here, success is often just a handful of clamps away.



▲ Cleaner Glue-ups. You'll have less glue squeeze out on the inside of the cabinet if you only spread the glue to the corner of the rabbet.

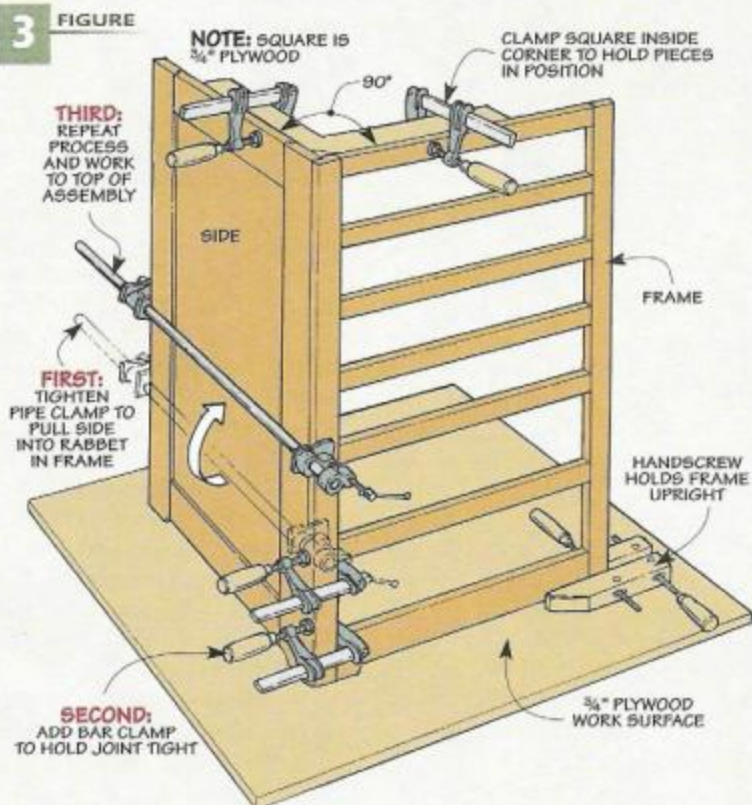

Shop Talk

When it comes to assembling MDF projects, the secret to success is choosing and using the right fastener.

One of the materials we use around the shop a lot is medium-density fiberboard (MDF). It's flat, stable, and a consistent thickness. MDF also machines well for clean, crisp edges and joints. All these great qualities make it sound like the perfect material. But unfortunately, it's not quite "perfect." Unlike other materials, MDF doesn't have grain or plies, which tend to help the screws "grab." That's not to say you can't use screws with MDF. I use them all the time. But I've learned a few tricks when it comes to using them successfully.

Screw Type – For years, I assembled projects with traditional wood-

screws with straight shanks and tapered threads, like the one shown in the left drawing below. Whether I was using them in solid wood or plywood, they worked great.

But I had problems using them with MDF. Sometimes the tapered threads on the woodscrew would split the MDF like a piece of firewood. And even if the MDF didn't split, I often had trouble just drawing the two pieces together tightly without stripping out the threads.

To solve these problems, I made a couple changes. First, I switched the type of fastener I use. And second, I spend a little more time on the technique of drilling and assembling the workpieces.

Sheet Metal Screw – Instead of a traditional woodscrew, I switched to a sheet metal screw (see right drawing below). Although it doesn't look a lot different, I've had more success using them with MDF.

The nice thing about sheet metal screws is they're not tapered. Since the whole shank is straight, it isn't as likely to split the workpiece. And the threads are a little sharper, so they tend to cut into the MDF better.

Technique – As you may have guessed, there's more to the process of joining two pieces of MDF than just switching to a different screw. It's also important to drill two holes — a shank hole and a pilot hole.

The shank hole is drilled in the top piece, and the pilot hole is drilled in the bottom piece, as illustrated in Figures 1 and 3.

Drilling the Shank Hole – The key to drilling the shank hole is to size it so the top piece pulls tightly down to the bottom workpiece. For this to work, you don't want the screw threads to grab the top piece at all.

The first thing I do is find a drill bit that matches the outside diameter of the threads, like you see in the detail in Figure 1. This way, the screw will just slip through the hole without any play (Figure 1).

Countersink – Once you have the shank hole drilled, you can go ahead and countersink it for the head of the screw (Figure 2). Just like the shank hole, it's important to properly size the countersink.

To determine the correct depth to drill the countersink, turn the screw upside down and fit the head into the countersink. The screw will be flush with the surface when the head just fits into the countersink.

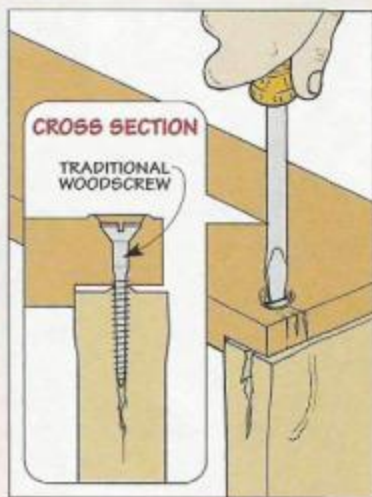

▲ PROBLEMS

- Tapered woodscrew splits MDF near edges and causes bulging on the face of the workpiece.
- Shallow countersinks and over-driving screw "lifts" edge of hole.
- Wood fibers "pull" away from bottom workpiece and prevent them from joining together.

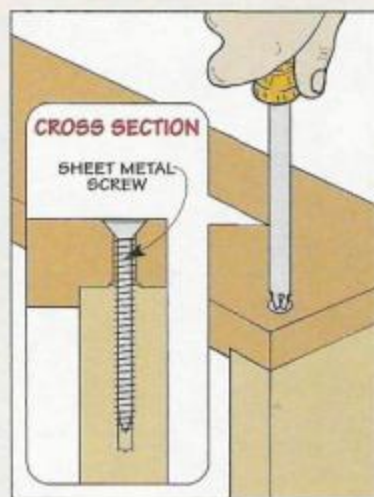

▲ SOLUTIONS

- Sheet metal screws and properly-sized shank and pilot holes prevent splitting and bulging of workpiece.
- Longer screws provide extra holding power in MDF.
- Countersinks at both ends of shank hole allow screw to pull joint together tightly.

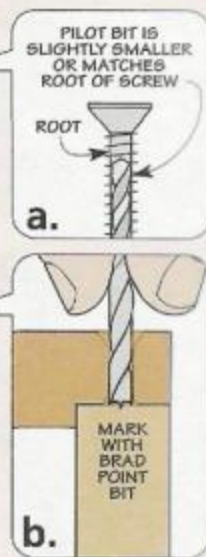
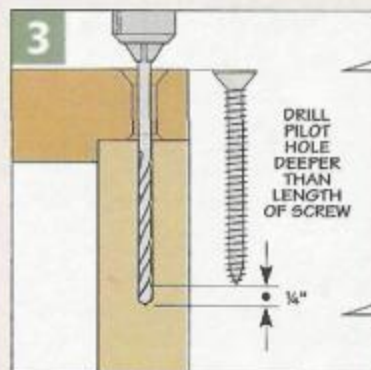
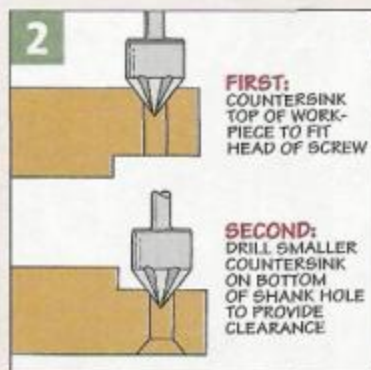
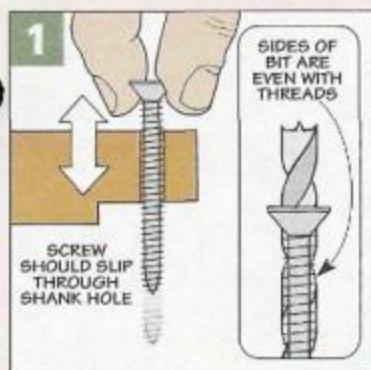

While I'm at it, I flip the workpiece over and drill a smaller countersink where the shank hole exits the top piece. So why countersink something you don't see? The main reason is it's easy for the fibers in the bottom workpiece to "lift" up. This keeps the top and bottom workpieces from pulling together tightly, as you can see in the far left drawing on the opposite page. Drilling a small countersink provides a clearance area for the fibers.

Sometimes I'm looking for a little different appearance on a project than

just a plain countersink. The box below shows a couple options I use.

Drilling the Pilot Hole - With the countersinks complete, all that's left to do is drill the pilot hole (Figure 3). This anchors the threads of the screw and prevents splitting.

There are two important things to remember here. First, the pilot hole needs to be the right diameter. And second, it needs to be the right depth.

Diameter of Pilot Hole - The pilot hole should be about the same size (or a hair smaller) than the root diameter of the screw.

Here again, an easy way to determine the right size bit is to hold it up in front of the screw until you find one that allows the root to just barely show on both sides of the bit (Figure 3a). Note: Since it's hard to find a brad point bit the right size, I like to use a regular twist bit for pilot holes.

With the bit sized, you're ready to drill the pilot hole. To ensure the pilot hole is centered properly, I mark the location using the same brad point bit I used for the shank hole. All you need to do is hold the two pieces in position (I like to clamp them any time I can) and give the bit a little tap or twist to mark the precise centerpoint for the pilot hole, as shown in Figure 3b.

Depth of Pilot Hole - With the pieces still held together, you can drill the pilot hole. How deep should it be? In MDF, I drill the pilot hole just *past* where the tip of the screw will end up (Figure 3).

This way, I don't have to worry about the end of the screw splitting the MDF deep in the hole and "bulging" out the side of the workpiece. Note: For extra holding power, I like to use screws that are 1/2" - 3/4" longer than I would typically use for solid wood or plywood.

Final Assembly - All that's left at this point is to screw the pieces together. But there's one last thing. A power drill can easily strip the threads in MDF, ruining all the work that went into sizing everything properly. So instead of driving the screw all the way home under power, I switch to a screwdriver and "snug up" the screw for a perfect fit. 

Optional Fasteners

Instead of countersinking the head of the screw in MDF, there are a couple other options: sheet metal screws with finish washers (left photo and drawing) and Confirmat screws (right photo and drawing). Note: It's still a good idea to countersink the *bottom* side of the workpiece.

Finish Washer - A finish washer has a built in "countersink" and provides a wider bearing surface for the head of the sheet metal screw. Plus, it adds a unique look to the project. (We used it on the Wall-Mounted Drill Press Shelf on page 6.)

Confirmat Screw - A Confirmat screw also has a wide bearing surface. This keeps it from pulling into the workpiece. And deep, widely-spaced threads won't pull out of the workpiece as easily. This makes them perfect for knock-down assemblies.

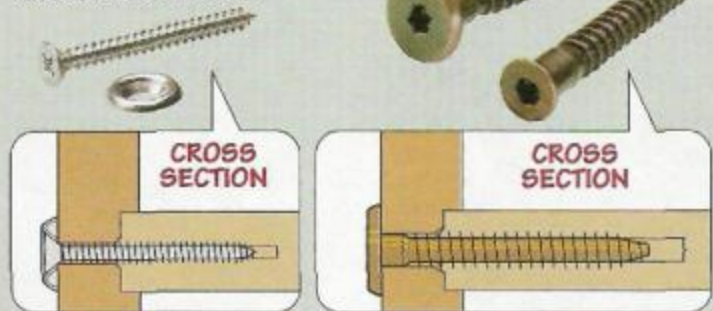

Tool Chest

Does a woodworker really need another square? Since I've been using the *Universal Square* from *Bridge City Tools*, the answer is yes.

I've used a similar-looking tool for a lot of construction projects. But unlike that tool, this aluminum square is flawlessly machined and has just the right features that make it a great tool for woodworking.

The Basics – For starters, the square is machined flat with a cove down the center to form a solid base. So I can rest it right next to the saw blade and verify it's set to 90°. And the matte black finish and white lettering make it very easy to read. (A great feature for my aging eyes.)

Height Gauge – But there's more to the *Universal Square* than just checking a saw blade for 90° (or 45°). I can also set the height of

the saw blade (or a router bit) because the outside edge has a scale with $\frac{1}{32}$ " increments (Photo A). So setting the right height for something like a dado blade on the first attempt is a piece of cake.

Protractor – And when laying out an angle, I don't have to track down my old plastic protractor (Photo B). Along the angled side of

Bridge City Tools Universal Square

Universal is a great description for the capabilities built into this square.

the square you'll find divisions in single degree increments.

Centering Rule – The capabilities don't stop there. The *Universal Square* also makes finding and laying out the center of a workpiece (like the mortise shown in photo C) a simple task.

Thickness Gauge – Finally, photo D shows one of the uses I make most frequently — checking the thickness of stock when it comes out of the planer. The wide base makes it easy to butt against the workpiece so I can easily read the thickness along the rule next to the open slot.

Availability – The *Universal Square* comes in 3", 4", and 6" sizes. So choosing just one might be the biggest problem. (The 6" size is great for guiding a circular saw or jig saw when making a crosscut.) And if you'd like, you can also buy the squares with metric graduations. (See margin for sources).

I chose the 3" *Universal Square*. It has all the features of the two larger squares, but its small size makes it the perfect tool to carry around in the pocket of your apron.

Cost — Depending on the size of the *Universal Square*, the cost will range from \$33 (3") to \$56 (6"). At first, this may seem a bit extravagant. But considering the *Universal Square* takes the place of three or four tools, I think it's worth it. 

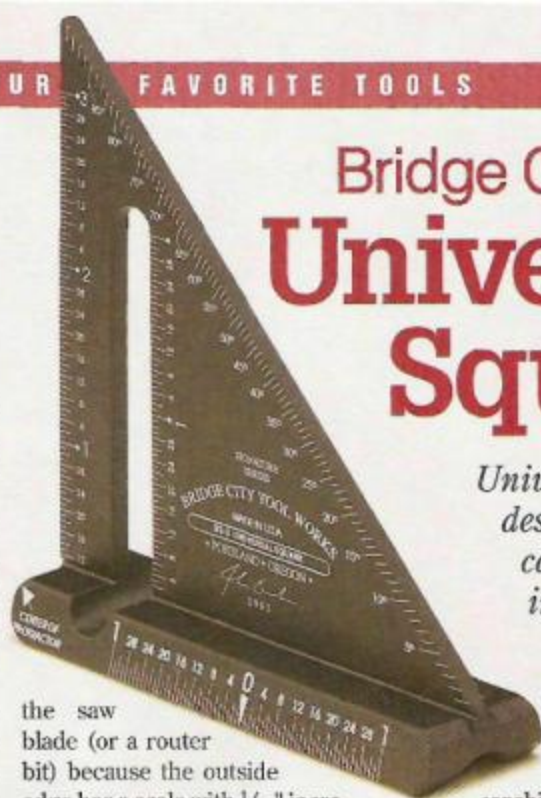

Sources

• *Bridge City Tools, Inc.*
bridgecitytools.com
800-253-3332

• *Woodemith Store*
800-835-5084

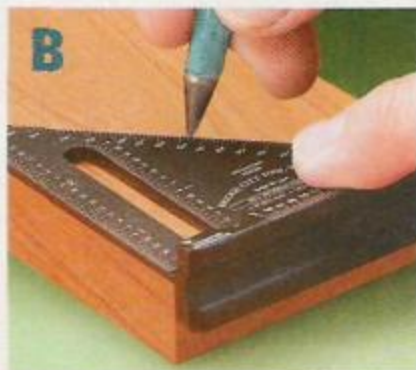
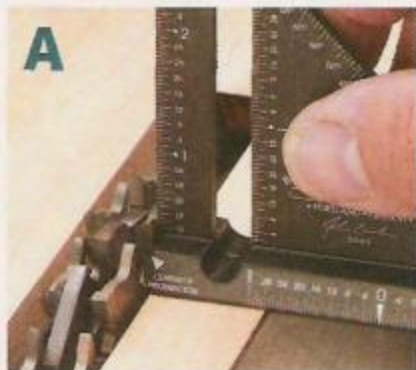

Sources

Drawer Slides

One of the best ways to increase the useable space in a drawer is to install them with full-extension drawer slides, like the one shown at right.

The secret is a system of telescoping steel "channels" that cantilever the drawer as you open it. These channels ride on ball bearings,

so you'll get smooth, silent operation. And don't worry about sagging. The slides carry loads ranging from 75 to 150 pounds — strong enough for a drawer full of tools or hardware.

Brands — We used Accuride slides with a black finish for our projects. But you'll find other brands and

finishes (white and bright metal) available in lengths ranging from 10" to 28" at home centers, through woodworking catalogs, as well as the sources listed in the margin.



MAIL ORDER SOURCES

Akro-Mils, Inc.
800-253-2467
www.akro-mils.com
Storage Bins

McFeeley's
800-443-7937
www.rockler.com
Drawer Slides,
Storage Bins

Rockler
800-279-4441
www.rockler.com
De-Sta-Co Clamps,
Drawer Slides,
Leveler Glides,
Storage Bins

McMaster-Carr
630-833-0300
www.mcmaster.com
Drawer Slides,
Storage Bins,
Toggle Clamps

Van Dyke's Restorers
800-558-1234
www.vandykes.com
Cabinet Hardware

Woodsmith Store
800-835-5084
Mortising Jig
Hardware, De-Sta-Co
Clamps, Drawer
Slides

Storage Cabinet Hardware & Bins

Besides the drawer slides, there are a few other things you'll need for the Hardware Storage Cabinet on page 22.

Levelers — For starters, I used leveler glides (Part No. 24257) from Rockler (see margin) to make it easy to level the cabinet.

Hardware — For the drawers, I used 4" brass sash pulls (upper left) from a local home center. But if you'd like something different, Van Dyke's has brass label holders (Part No. CH-02005501) for identifying the contents of each drawer, along with 1"-dia. brass knobs (Part No. CH-02002542).

Plastic Storage Bins — When I designed the cabinet drawers, I sized

them specifically for the small (Part No. 30-210) and large (Part No. 30-230) Akro-Mils storage bins shown below. Other brands may not fit the drawers exactly. These bins (or similar ones) are available from home centers and the sources at right.



Mortising Jig Hardware

Considering the capabilities of the Plunge Router Mortising Jig (page 14) in this issue, it's surprising how little hardware it actually takes to build it.

Clamps — The key to the jig is the three De-Sta-Co toggle clamps (Part No. 213-U) that hold the workpiece in place as you rout the mortise. These clamps (or similar ones) are available from home centers,

woodworking catalogs, and the sources listed in the margin.

Knobs — Locking the sliding platforms in place on the Mortising Jig requires knobs with two different length threaded studs. Both of the knobs are available from the Woodsmith Store (see margin for number). The part numbers you'll need for ordering them are 1065202 (3/4") and 1065203 (1 1/2").



ShopNotes

on the web

- "Online Extras" - Plans, Patterns, & More
- Over 100 Woodworking Tips Online
- Forums for Woodworking, Tools, & Classifieds
- Visit Our Woodworking Shop Tours Gallery
- Project Plans You Can Download
- Catalog of Project Kits, Tools, Jigs, & Plans
- Links to Other Woodworking Sites
- Order ShopNotes & Woodsmith Back Issues

Online Customer Service

Click on Subscriber Services at
www.shopnotes.com

- Access your account status
- Change your mailing or email address
- Pay your bill
- Renew your subscription
- Tell us if you've missed an issue
- Find out if your payment has been received

www.shopnotes.com

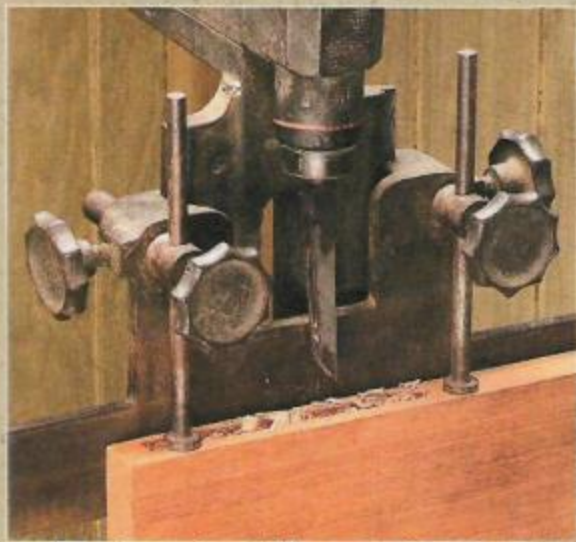

Scenes from the Shop

This early Barnes mortising machine is a classic example of 19th and early 20th century foot-powered tools.

To use this machine, a beveled bit is lowered into a board by stepping on a spring-loaded foot pedal. Two adjustable rods keep the board from lifting as the bit is withdrawn (see the inset photo above). To take each additional bite, the board is simply repositioned along the fence. In order to cut a square edge on both ends of the mortise, a handle on top of the shaft rotates the bit 180°.

Mortiser courtesy of John Trier.

Plunge Router Mortising Jig

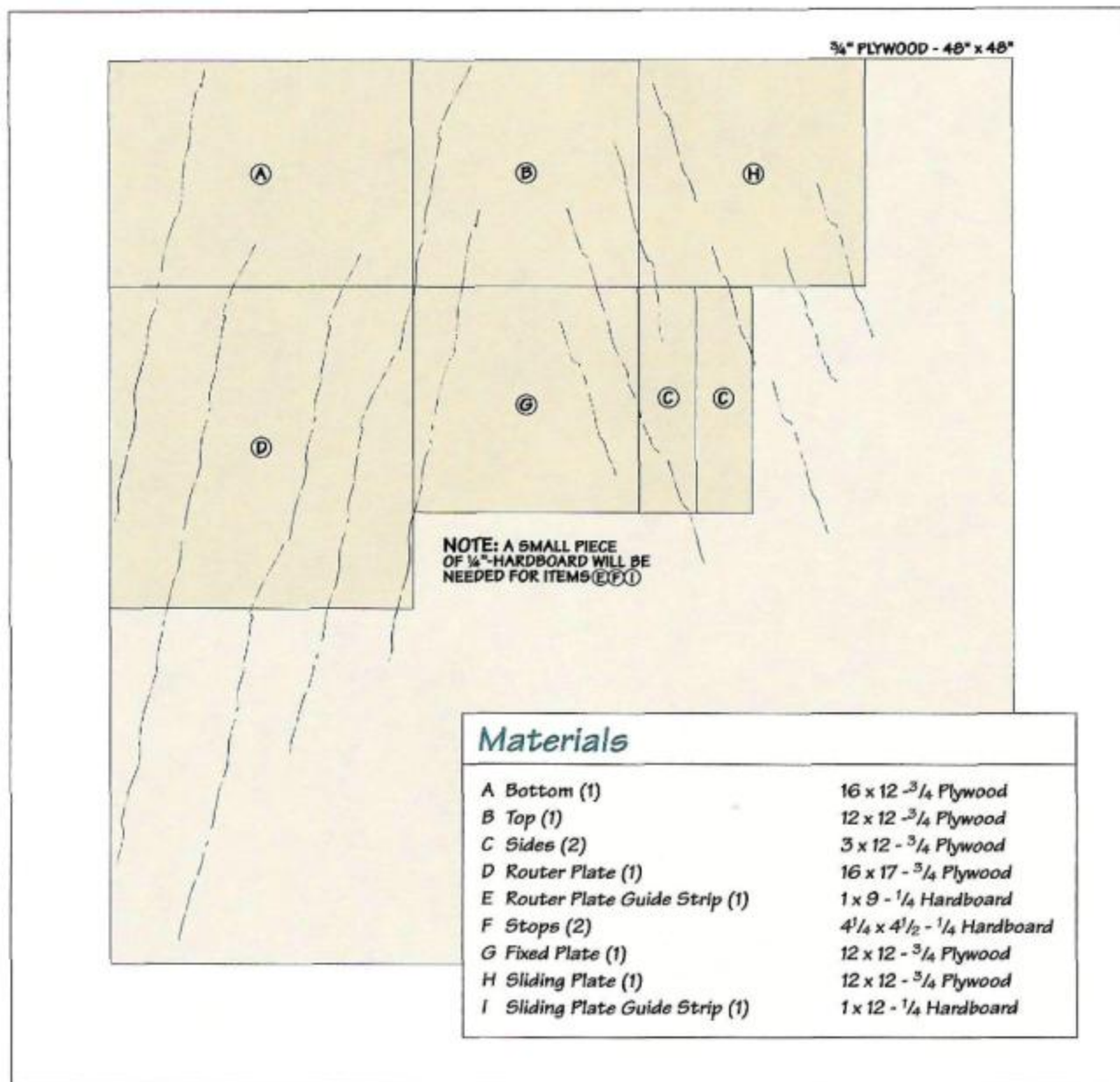

Storage Cabinet

Materials

Cabinet

A Side Stiles (4)	$\frac{3}{4} \times 3\frac{1}{2} - 41\frac{1}{2}$
B Side Rails (4)	$\frac{3}{4} \times 3\frac{1}{2} - 17$
C Side Panels (2)	17 x $34\frac{1}{4} - \frac{1}{4}$ Plywood
D Narrow Front Rails (6)	$\frac{3}{4} \times 1\frac{1}{2} - 20\frac{3}{4}$
E Wide Front Rail (1)	$\frac{3}{4} \times 3\frac{1}{2} - 20\frac{3}{4}$
F Front Stiles (2)	$\frac{3}{4} \times 1\frac{3}{4} - 41\frac{1}{2}$
G Vertical Supports (4)	1 x $3\frac{1}{4} - 39\frac{1}{4}$
H Top Supports (2)	$\frac{3}{4} \times 3\frac{1}{4} - 20\frac{3}{4}$
I Bottom (1)	$20\frac{3}{4} \times 23 - \frac{1}{2}$ Plywood
J Top (1)	1 x $24\frac{1}{4} - 22\frac{3}{4}$
K Back (1)	$20\frac{3}{4} \times 40\frac{3}{4} - \frac{1}{4}$ Plywood

Drawers

L Small Fronts/Backs (8)	$\frac{1}{2} \times 3\frac{1}{2} - 17\frac{1}{4}$
M Small Sides (8)	$\frac{1}{2} \times 3\frac{1}{2} - 23$
N Large Fronts/Backs (4)	$\frac{1}{2} \times 5\frac{1}{2} - 17\frac{1}{4}$
O Large Sides (4)	$\frac{1}{2} \times 5\frac{1}{2} - 23$
P Bottoms (6)	$17\frac{1}{4} \times 22\frac{1}{2} - \frac{1}{2}$ Plywood
Q Small False Fronts (4)	$\frac{3}{4} \times 4\frac{3}{4} - 19\frac{1}{4}$
R Large False Fronts (2)	$\frac{3}{4} \times 6\frac{1}{2} - 19\frac{1}{4}$
S Small Side-to-Side Dividers (20)	$\frac{1}{4} \times 3\frac{1}{2} - 17\frac{1}{4}$
T Small Front-to-Back Dividers (20)	$\frac{1}{4} \times 3 - 22$
U Large Side-to-Side Dividers (10)	$\frac{1}{4} \times 5 - 16\frac{3}{4}$
V Large Front-to-Back Dividers (10)	$\frac{1}{4} \times 5 - 22$

NOTE: Cutting Diagram For Optional Dividers Not Shown

