

**5 All New  
Shop Projects**

PERFECT CROSSCUTS - **SHOP SECRETS REVEALED**

# ShopNotes

Vol. 11

Issue 63

## Space-Saving **ROUTER STORAGE SYSTEM**

Choosing a  
Table Saw—  
What you need to Know

Discover the  
Best Sharpening  
Solution

New Lightweight  
Crosscut Sled with  
2 Optional Features

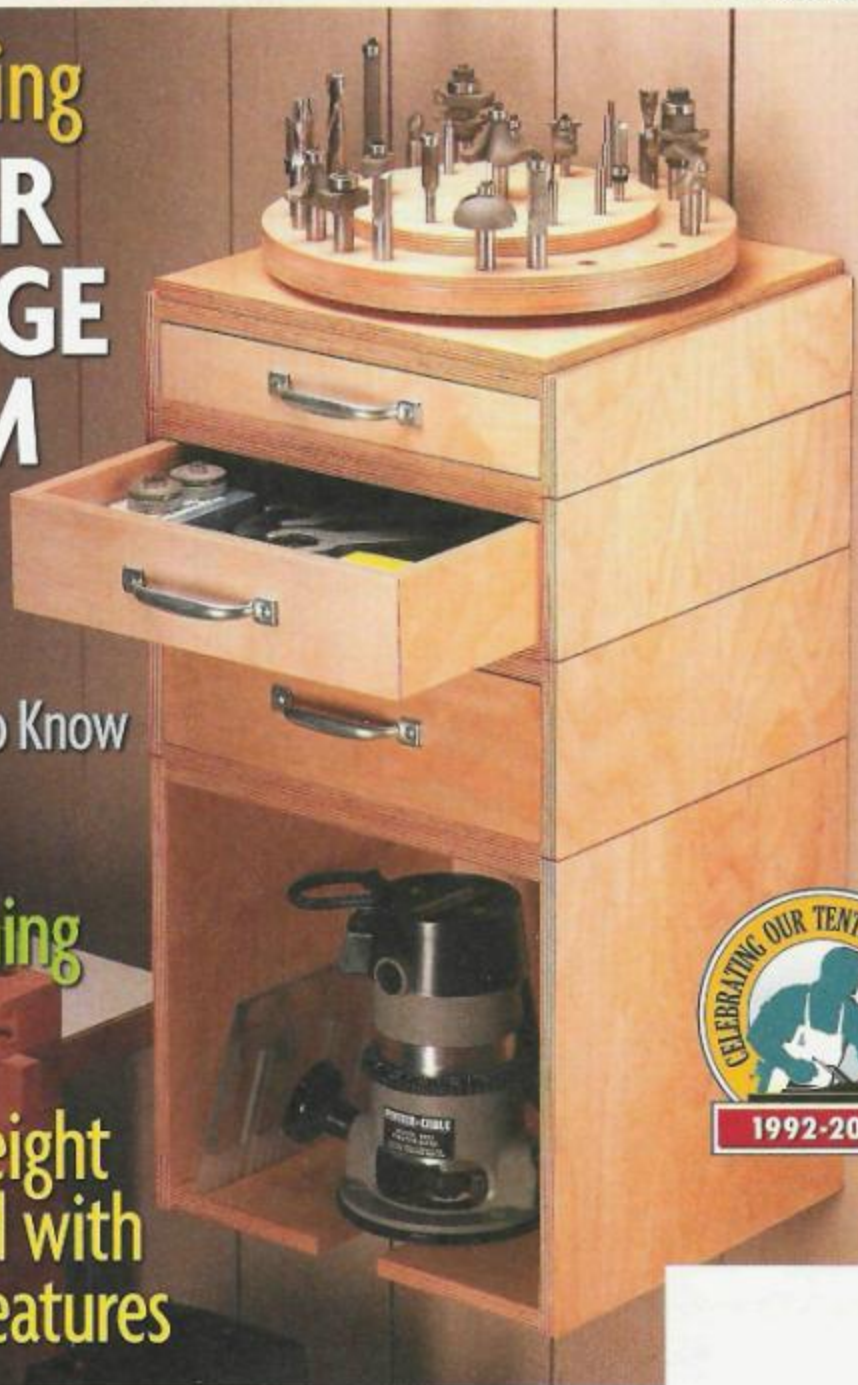



# ShopNotes

Issue 63

May 2002

**PUBLISHER** Donald B. Peschke

**EDITOR** Terry J. Strohmman

**ASSOCIATE EDITORS** Bryan Nelson

Vincent Ancona

**ART DIRECTOR** Cary Christensen

**SR. GRAPHIC DESIGNER** Kurt Schultz

**SENIOR ILLUSTRATORS** Roger Reiland

Mark Higdon

## CREATIVE RESOURCES

*Creative Director:* Ted Kralovic • *Project Developer:* Ken Munkel  
• *Sr. Project Designer:* Kent Welsh, Ryan Minick • *Project Designer:* Chris Fitch • *Shop Craftsmen:* Steve Curtis, Steve Johnson • *Senior Photographer:* Crayola England

## SPECIAL PUBLICATIONS

*Corp. V.P.:* Douglas L. Hicks • *Art Director:* Douglas A. Flint • *Sr. Graphic Designer:* Chris Glowacki • *Graphic Designer:* Vu Nguyen • *Associate Editor:* Craig Ruessogger • *Asst. Editors:* Joel A. Hess, Joseph E. Irwin

## CIRCULATION

*Subscriber Services Director:* Sandy Baum • *New Business Dir.:* Wayne J. Klingbeil • *Circulation Marketing Analyst:* Kris Schlemmer • *Assoc. Circ. Marketing Analyst:* Paula M. DeMatteis • *Revenue Manager:* Paige Rogers • *Sr. Graphic Designer:* Mark Hayes, Robin Frensch • *Billing & Collections Mgr.:* Rebecca Cunningham • *Multimedia Promotion Mgr.:* Rick Jenkins • *Promotion Analyst:* Patrick Walsh

## CORPORATE SERVICES

*V.P. of Finance:* Mary R. Scheve • *Controller:* Robin K. Hutchison • *Sr. Acct.:* Laura J. Thomas • *Accts. Payable:* Mary J. Schultz • *Accts. Receivable:* Margo Petrus • *Prod. Dir.:* George Chmielarski • *Electronic Pub. Dir.:* Douglas M. Likster • *System Admin.:* Chris Schwarneck • *P.C. Maint. Tech.:* Robert D. Cook • *Pre-Press Image Specialist:* Troy Clark, Minnie Johnson • *New Media Mgr.:* Gordon C. Gasppe • *Multimedia Art Dir.:* Eugene Pedersen • *Web Server Admin.:* Carol Schöppeler • *Web Content Mgr.:* David Briggs, Sue M. Moe • *Web Designer:* Kara Blessing • *Prof. Dev. Dir.:* Michal Sigel • *H. R. Asst.:* Kirsten Koole • *Receptionist:* Jeanne Johnson • *Mail Room Clerk:* Lisa Webber

## MAIL ORDER

*Operations Director:* Bob Baker • *Customer Service Mgr.:* Jennie Enos • *Warehouse Supr.:* Nancy Johnson • *Buyer:* Linda Jones • *Admin. Asst.:* Nancy Downey • *Tech. Rep.:* John Audette • *Cust. Serv. Team Leader:* Tammy Truchenhead • *Sr. Cust. Serv. Rep.:* Anna Cox, Deborah Rich, April Revell • *Cust. Serv. Rep.:* Valerie Jo Riley, Kim Harlan • *Warehouse:* Sylvia Cury

## WOODSMITH STORE

*Manager:* Dave Larson • *Asst. Mgr.:* Tim Thelen • *Sales Staff:* Wendell Stone, Jim Barnett, Larry Morrison, Gregory Kaularich, Mark Johnson • *Office Mgr.:* Vield Edwards

ShopNotes® (ISSN 1062-9696) is published bimonthly (Jan., March, May, July, Sept., Nov.) by August Home Publishing, 2200 Grand, Des Moines, IA 50312.

ShopNotes® is a registered trademark of August Home Publishing ©Copyright 2002 by August Home Publishing. All rights reserved. Subscriptions: Single copy: \$4.95. One year subscription (6 issues), \$27.95. Canada/International add \$10 per year, U.S. funds. Periodicals Postage Paid at Des Moines, IA and at additional mailing offices.

Postmaster: Send change of address to ShopNotes, P.O. Box 37103, Boone, IA 50037-2103.

Subscription Questions? Write to: ShopNotes Customer Service, P.O. Box 842, Des Moines, IA 50304-9961. Or call 1-800-333-5854, 8:00 am to 5:00 pm, Central Time, weekdays. FAX 515-283-0447  
E-Mail: ShopNotes@shopnotes.com  
Internet: http://www.shopnotes.com

PRINTED IN U.S.A.

## EDITOR'S NOTE

# Cutoffs

One afternoon a few weeks back, Steve Johnson (our shop craftsman) stopped me on the way down to the shop. He mentioned he'd been working on something new and wanted me to take a look.

When I walked over to his bench, I was a bit surprised. It looked more like a science experiment than a woodworking project. There were a number of small syringes filled with some sort of colored paste and several thick blocks covered with a dark gray film. The only thing I recognized was a honing guide, so I assumed it had something to do with sharpening.

But before I could ask the first question, Steve handed me a chisel. All it took was one look at the polished edge, and he had my attention — I wanted to know more.

What I found out was that the small syringes were filled with a paste made from finely ground, man-made industrial diamonds. And the blocks were "stones" made from pieces of MDF. To use this system, the idea is to dab a small amount of paste on a MDF stone and then rub

the chisel or plane iron back and forth to hone the edge. After Steve explained the process, I couldn't wait to give it a try.

When I did, there were a couple of surprises. First, I found with the diamond paste I was able to polish the steel to a flawless, mirror-like finish.

The other surprise was how quickly I was able to get a razor-sharp edge that sliced effortlessly though a workpiece. If this sounds like the sharpening solution you've been looking for, check out the complete story on page 9.

Once you have your chisels honed to perfection, you'll probably find yourself using them more often (I know I do). So we have plans for a chisel rack that mounts near your workbench. This puts your chisels right where you need them. And the unique design of the rack holds them securely in place and protects those newly sharpened edges. For more on how we did this, see page 6.



Terry

Be included, as a part of the  
**Woodworking Shop Tours**

On the Web

Visit other ShopNotes subscribers' workshops and see photos of the shop projects they've built. It's all online at Woodworking Shop Tours on the ShopNotes web site:

[www.ShopNotes.com](http://www.ShopNotes.com)

We want you to be part of our shop tours! To submit photos of your favorite ShopNotes projects or views of your shop, just follow the instructions you'll find on our web site.



# Contents

## Features

### Chisel Rack \_\_\_\_\_ 6

Our new chisel rack makes use of a unique design (and a secret method) to keep chisels easily accessible and on display.

### Sharpening with Diamond Paste \_\_\_\_\_ 9

Put a razor-sharp cutting edge on any plane iron or chisel in minutes with this new sharpening method.

### Table Saw Accessory Shelf \_\_\_\_\_ 12

Keeping table saw accessories organized and close at hand has always been a problem — until now.

### Crosscut Sled \_\_\_\_\_ 16

A lightweight crosscut sled that's dead-on accurate? You bet. Plus, a couple optional accessories to make it even more useful.

### Crosscutting Tips \_\_\_\_\_ 21

Get better crosscuts in minutes. We offer a few tips from our own shop for smooth, accurate crosscuts time after time.

### Router Storage System \_\_\_\_\_ 24

Besides keeping your router bits organized and accessible, this storage system expands as your needs grow.

### Spade Bit Tote \_\_\_\_\_ 30

Keep your spade bits stored and ready to go with this handy tote that you can make in an afternoon.

## Departments

### Readers' Tips \_\_\_\_\_ 4

Shop-tested tips to solve common woodworking problems.

### Shop Talk \_\_\_\_\_ 32

Want to know the "in's and out's" of table saws? We cover the basics from benchtops to cabinet saws.

### Tool Chest \_\_\_\_\_ 34

This issue's tool is the perfect example of getting what you pay for. When it comes to the "details," this tool has it all.

### Sources \_\_\_\_\_ 35

Mail-order sources and supplies to help you complete the projects featured in this issue.



Chisel Rack

page 6



Diamond Paste

page 9



Table Saw Crosscut Sled

page 16



Router Storage System

page 24

# Readers' Tips

## Five-Minute Spray Booth

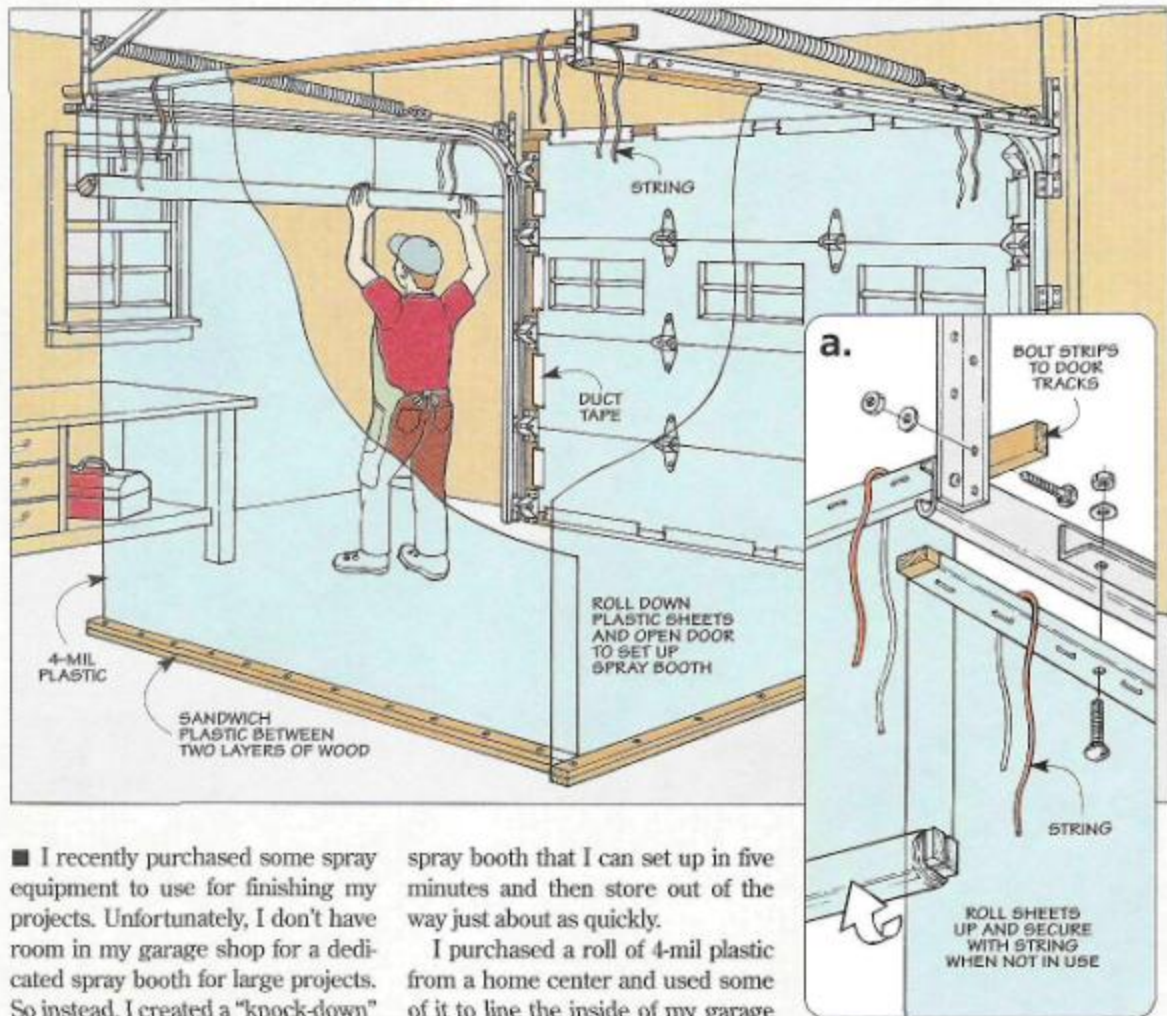

■ I recently purchased some spray equipment to use for finishing my projects. Unfortunately, I don't have room in my garage shop for a dedicated spray booth for large projects. So instead, I created a "knock-down"

spray booth that I can set up in five minutes and then store out of the way just about as quickly.

I purchased a roll of 4-mil plastic from a home center and used some of it to line the inside of my garage door by attaching it with duct tape. Then I cut sheets of plastic for the sides and back of the spray booth.

To hang the plastic sheets, I stapled each one to a 1½"-wide strip of wood and then bolted the strips to the tracks of the garage door. The strip holding up the "back" wall of the spray booth rests across both tracks, as shown in drawing above.

The bottom edge of each sheet is sandwiched between two strips of wood. This helps to weigh down the plastic sheets and makes it easier to roll the "walls" up when you're done.

### Send in Your Shop Tips

If you have a unique shop tip, we'd like to consider featuring it in one or more of our print or electronic publications.

We'll pay up to \$200 for a tip we publish. Just write down the tip and mail it to *ShopNotes*, Attn.: Readers' Tips, 2200 Grand Ave., Des Moines, IA 50312. Or FAX it to 515-282-6741, or send us an e-mail at [shopnotes@shopnotes.com](mailto:shopnotes@shopnotes.com). Please include your name, address and daytime phone number in case we have any questions.

To use the spray booth, I simply roll down the plastic sheets. (The corners can be folded over to seal the booth.) Then I raise the garage door to create a "ceiling" for the booth. The booth helps to contain the finish and prevents overspray from getting all over everything else in the garage. When I'm finished spraying, I just roll the walls up and tie them up with some string, see detail drawing above.

*Chuck Steger  
Bossier City, Louisiana*

## Quick Tips

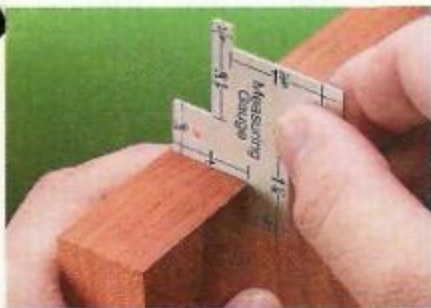

▲ **Steve Wargo**, of North Olmsted, OH, uses an inexpensive, 14-in-1 measuring device purchased at a fabric store as a thickness gauge when planing stock.



▲ When drilling holes by hand, **Dana Craig**, of Norwood, MA, uses this handy shop-made drilling guide to keep the drill bit square to the workpiece.

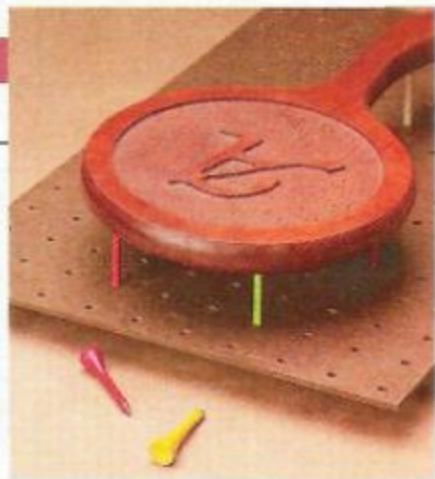

▲ **Roger Lynne**, of Bloomington, MN, uses golf tees and  $\frac{1}{8}$ " pegboard to construct a drying rack for finishing small projects and pieces.

## Scroll Saw Blade Holder

■ I use my scroll saw a lot, and I go through a lot of blades. So I came up with this convenient way of storing my blades while still keeping them close at hand so I don't have to get up every time I need a new blade.

My solution is to make a blade storage tube out of PVC pipe, see drawing at right. I simply cut a length of  $\frac{1}{2}$ " pipe and then cement an end cap on one end. A second end cap can be slipped over the other end of the tube for use as a lid (don't cement this one in place).

To hold the blade storage tube, I use a couple of spring clips (the kind used to hang brooms or mops on the wall). Just mount the spring clips to

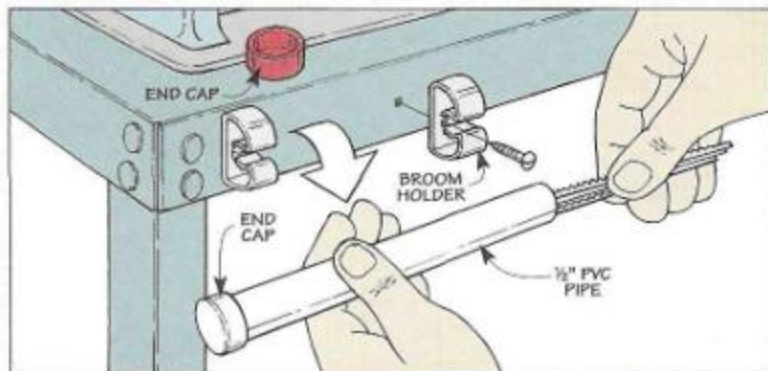

the side of your scroll saw stand with a couple of sheet metal screws, see drawing. Then pop the blade storage tube into the spring clips.

One other thing. I used a red felt

marker to color the lid of the storage tube so that I would know which end cap to pull off.

*Herb Matthias  
Fort Wayne, Indiana*

## Drain Valve Extension

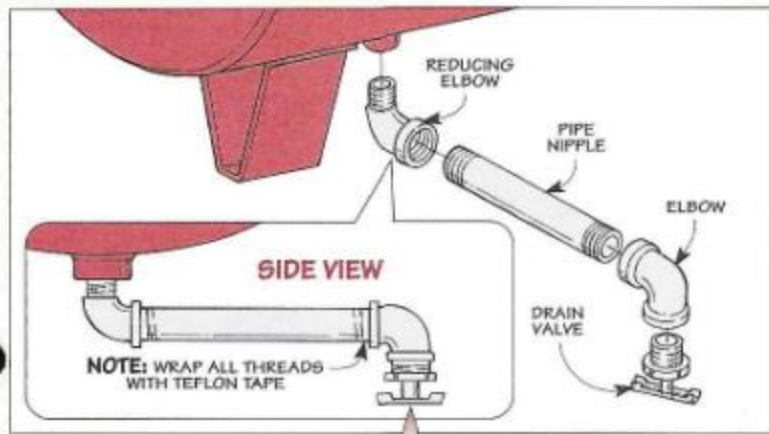

■ I know that you're supposed to drain the air tank on a compressor regularly. But the drain valve on my air compressor is located on the bottom of the tank, where it's difficult to reach. So I added an extension to the drain valve. I simply removed the existing drain valve from the tank. Then I added some galvanized pipe fittings to bring the valve out where I could reach it more conveniently, see drawing.

*Jay L. Van Epps  
North Creek, New York*

Free Tips  
ON THE WEB

Get more wood-working tips free.

Visit us on the Web at [ShopNotes.com](http://ShopNotes.com)

Sign up to receive a free shop tip by email every week.

# Magnetic Chisel Rack

I've never been very happy with the chisel rack that has hung in my shop for years. The chisels simply dangle loosely in the rack, occasionally knocking against one another. And nothing protects the edges of the blades from damage.

This chisel rack is remarkably different. For one thing, the chisels all stand straight up, like a row of soldiers at attention. And the edges of the chisels are protected by a shallow, V-shaped trough, where they are out of harm's way.

But the thing that's really amazing about this chisel rack is what you don't see. When you look closely at the rack, there doesn't appear to be anything holding the chisels up. The "secret" is magnets. Behind each chisel, sandwiched between the two plates of the rack, is a wafer-like, rare-earth magnet. These powerful magnets are strong enough to hold even the largest chisel in place. And yet, when you want to remove a chisel from the rack, all you have to do is pull it straight out.

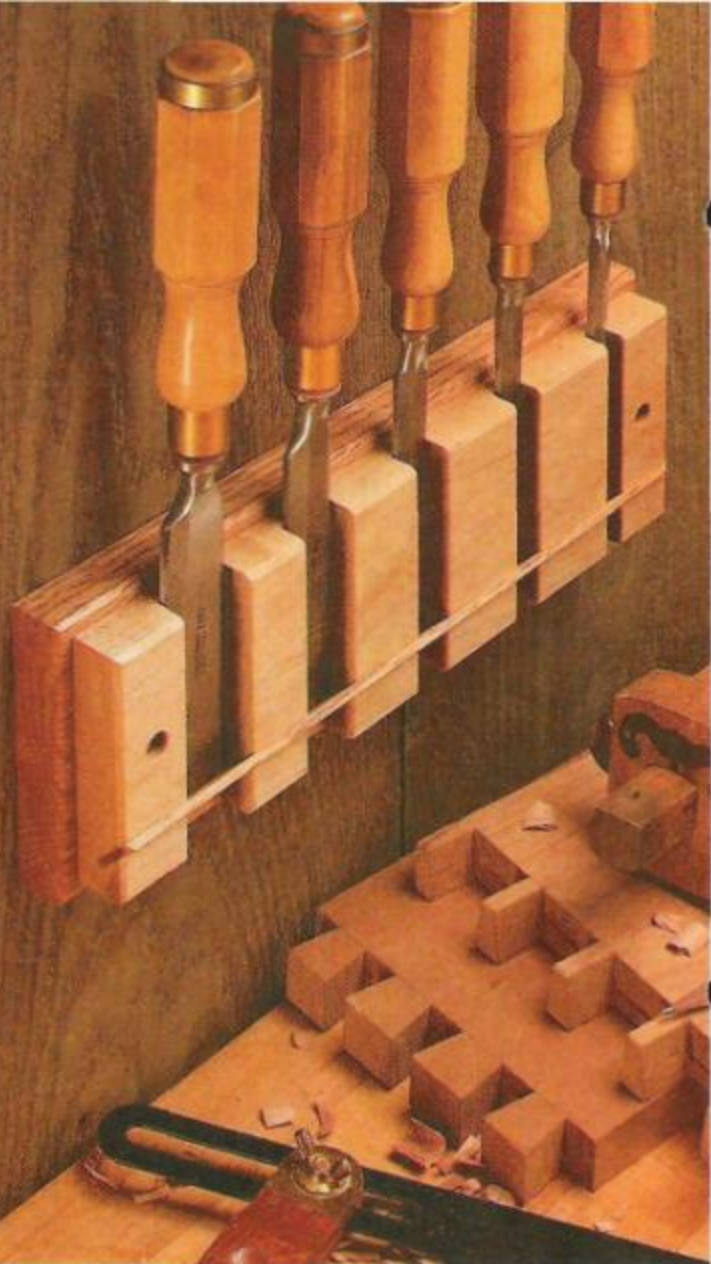

END VIEW  
(CROSS SECTION)



TIP OF CHISEL FITS IN GAP CREATED BY CHISEL REST

1 EXPLODED VIEW

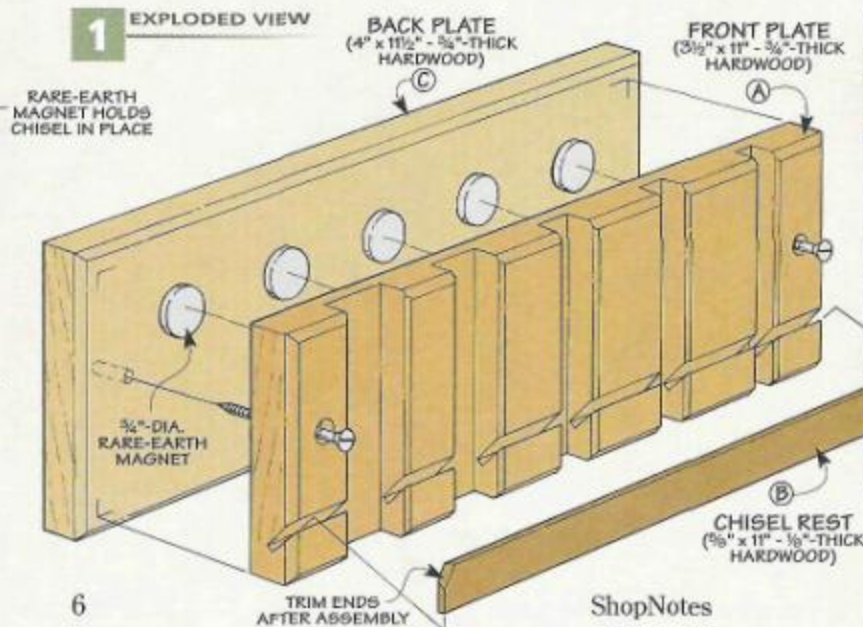

6

TRIM ENDS AFTER ASSEMBLY

ShopNotes

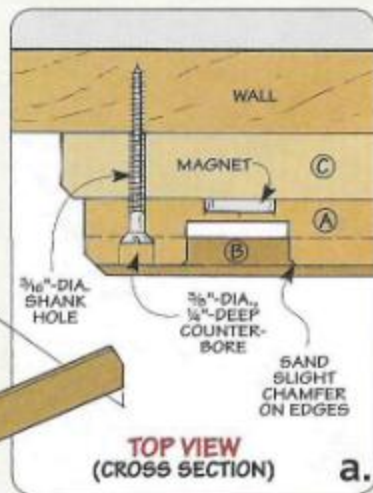

TOP VIEW  
(CROSS SECTION)

a.

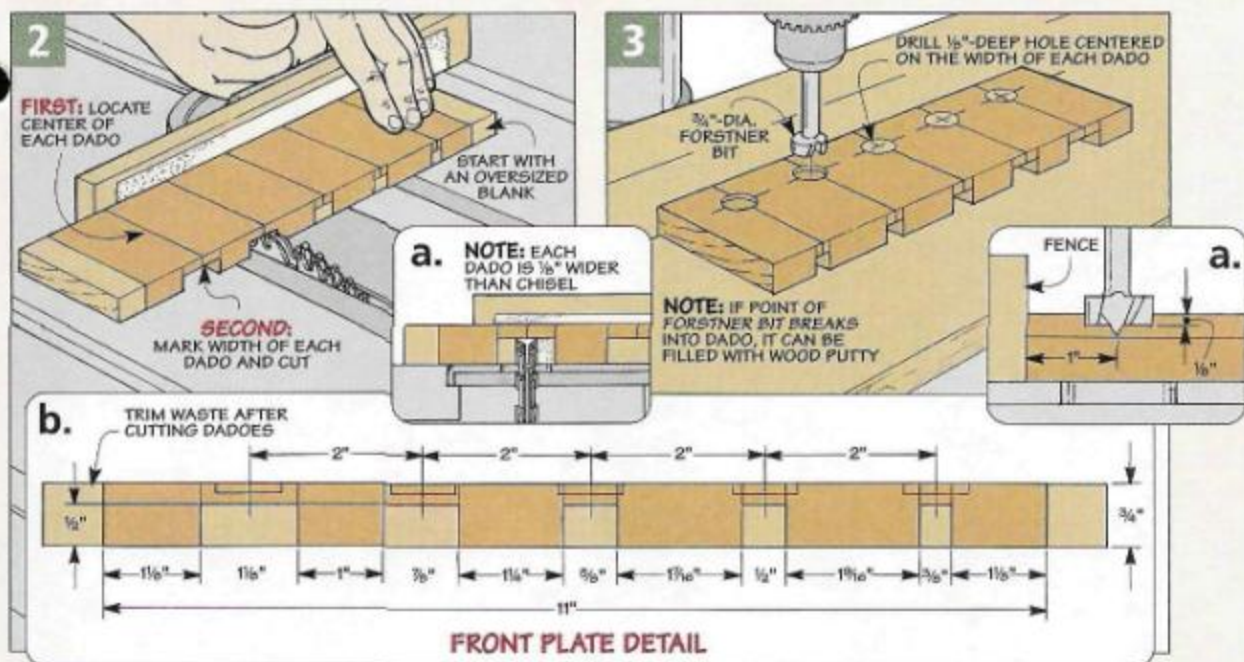

There are only three pieces to this chisel rack. In fact, it's a great project to use up some of those scrap wood pieces that you have stashed away.

I started by making the *front plate (A)*. The final length of this piece will depend on the number and widths of your chisels, as shown in Figure 2b. But I started with an extra-long blank. Then I cut the dados that will hold the chisels (Figure 2). Each dado is sized so it is  $\frac{1}{8}$ " wider than the chisel it will hold. And the dados are positioned two inches on center so that all the handles will be evenly spaced when the chisels are placed in the rack.

After cutting the dados, I sanded a small chamfer on the inside edges of each opening, just like you see in Figures 1 and 1a. Then the ends of the front plate can be trimmed off  $1\frac{1}{8}$ " from the edge of the nearest dado, as shown in Figure 2b.

The rare-earth magnets will be housed in shallow counterbores on the back of the front plate. These recesses are created with a Forstner bit on the drill press. Just drill a shallow hole centered over the back of each dado, as you see in Figure 3. The diameter and depth of the holes should match the diameter and thickness of the magnets.

With all the holes drilled, the next step is to chamfer the edges of the front plate on a router table. You can see this being done in Figures 4 and 4a. Because of the dados cut in the plate, you can't rely on the bearing alone to guide the bit when making the chamfer. So you'll want to use a fence on your router table as well.

**Chisel Rest** – Although the magnets will hold the chisels in the rack, I added a narrow strip of wood to the front plate to serve as a stop or rest for the chisels. When you place a chisel in the rack, the rest contacts

the bevel of the chisel and pins it to the front plate of the rack.

The *chisel rest (B)* is just a narrow strip of stock. It fits into an angled saw kerf cut into the front plate. To make this kerf, simply tilt your saw blade  $45^\circ$  (Figure 5).

After making the kerf, the rest can be glued in place. Before you move on to making the back plate, however, there is just one more detail to take care of. Using a sharp chisel, trim the ends of the rest flush with the chamfer on the ends of the front plate, refer to Figure 1.

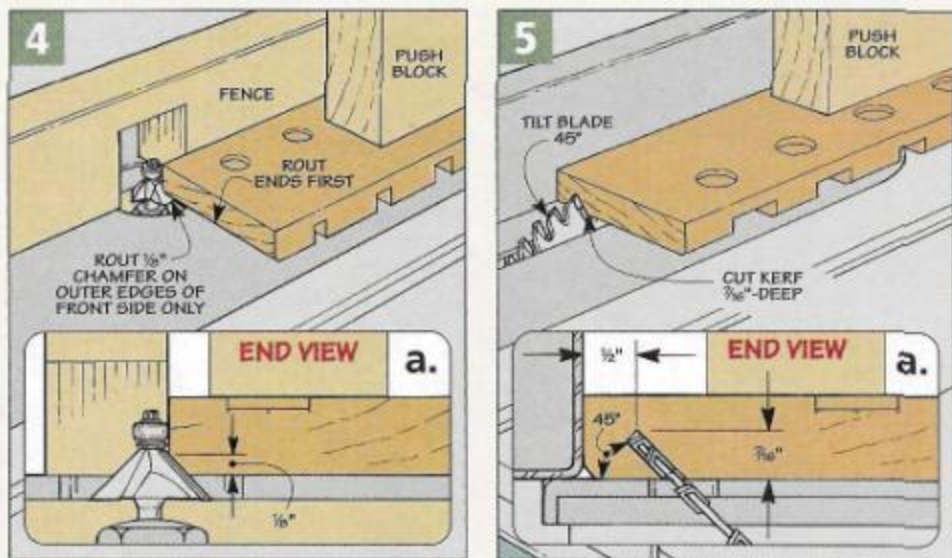

## Back & Assembly

At this point, you've got the most difficult part of making the chisel rack out of the way. All that's left now is to add a back and the magnets and hang the rack up.

The *back plate* (C) is made from a piece of  $\frac{3}{4}$ "-thick stock as shown in Figure 6. (I used a different species of wood to contrast with the front plate.) After cutting the back plate to size, a chamfer is routed all around the front. This chamfer is the same size as the one you routed earlier on the front plate ( $\frac{1}{8}$ ").

**Assembly** - Before gluing the two plates together, insert a rare-earth magnet into each recess on the back of the front plate. The magnets will be trapped between the two plates, so you don't have to worry about gluing them in place.

Gluing the two plates together can be tricky. If you try to clamp them together, the glue will make them slip around like they are on ice. So before I applied the glue, I drove

6 FIGURE

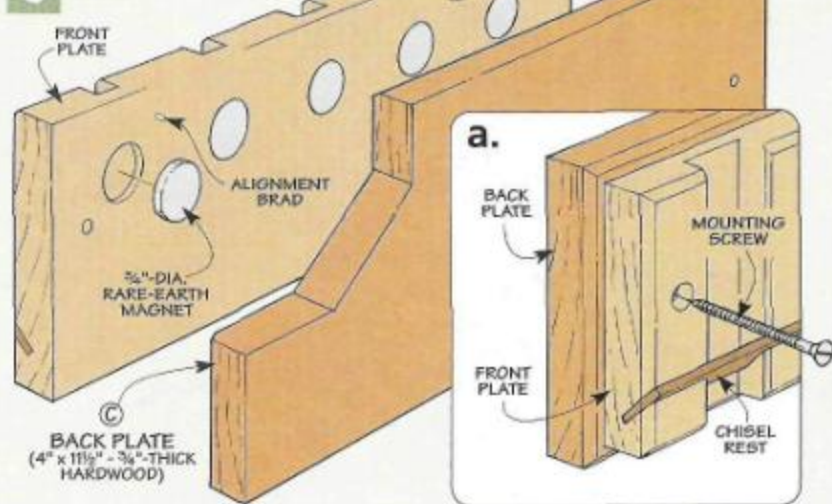

▲ **Rare-Earth Magnets.** Roughly the size of a nickel, these rare-earth magnets have incredible holding power. See page 35 for sources.

some brads into the front plate, leaving about  $\frac{1}{4}$ " of each brad sticking out. Then I snipped off the heads of the brads (Figure 6). When you clamp the plates together, the brads will bite into the back plate and prevent the two pieces from slipping.

**Mounting the Rack** - The easiest way to mount the chisel rack is to screw it directly to the wall. Just drill a mounting hole at each end, as shown in Figures 1a and 6a. Once the rack is attached to the wall, you can set your chisels in place. 🛠️

## Non-Magnetic Chisel Rack

You don't have to buy magnets to be able to build this chisel rack. Here's an alternate version that is identical to the rack above, except this one uses a retaining strip instead of magnets to hold the chisels in place, as you can see in the photo at right.

All you have to do is cut a  $\frac{1}{4}$ " x  $\frac{1}{8}$ " groove across the front plate, as shown below. Then glue a *retaining strip* (D) into the groove. You can use a chisel to trim the ends of the retaining strip flush with the chamfer on the ends of the front plate.

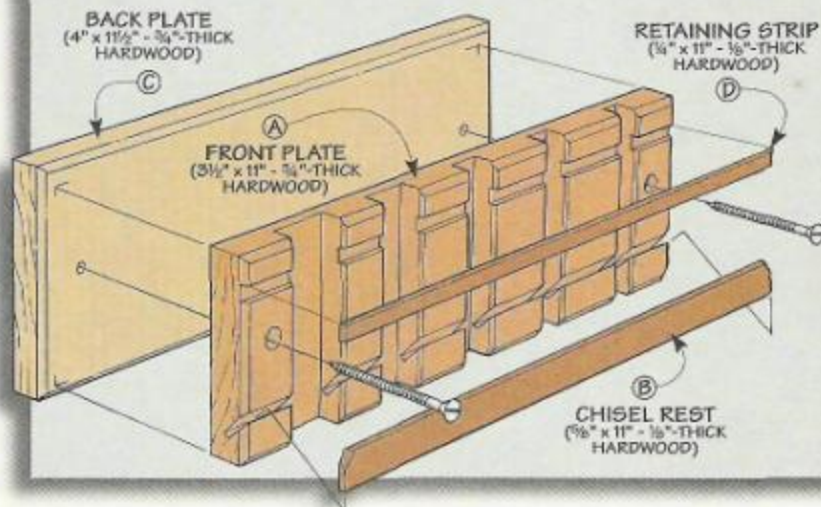



# Sharpening with Diamond Paste

*Once you try it, you'll see why we say this new sharpening system is truly on the "cutting edge."*

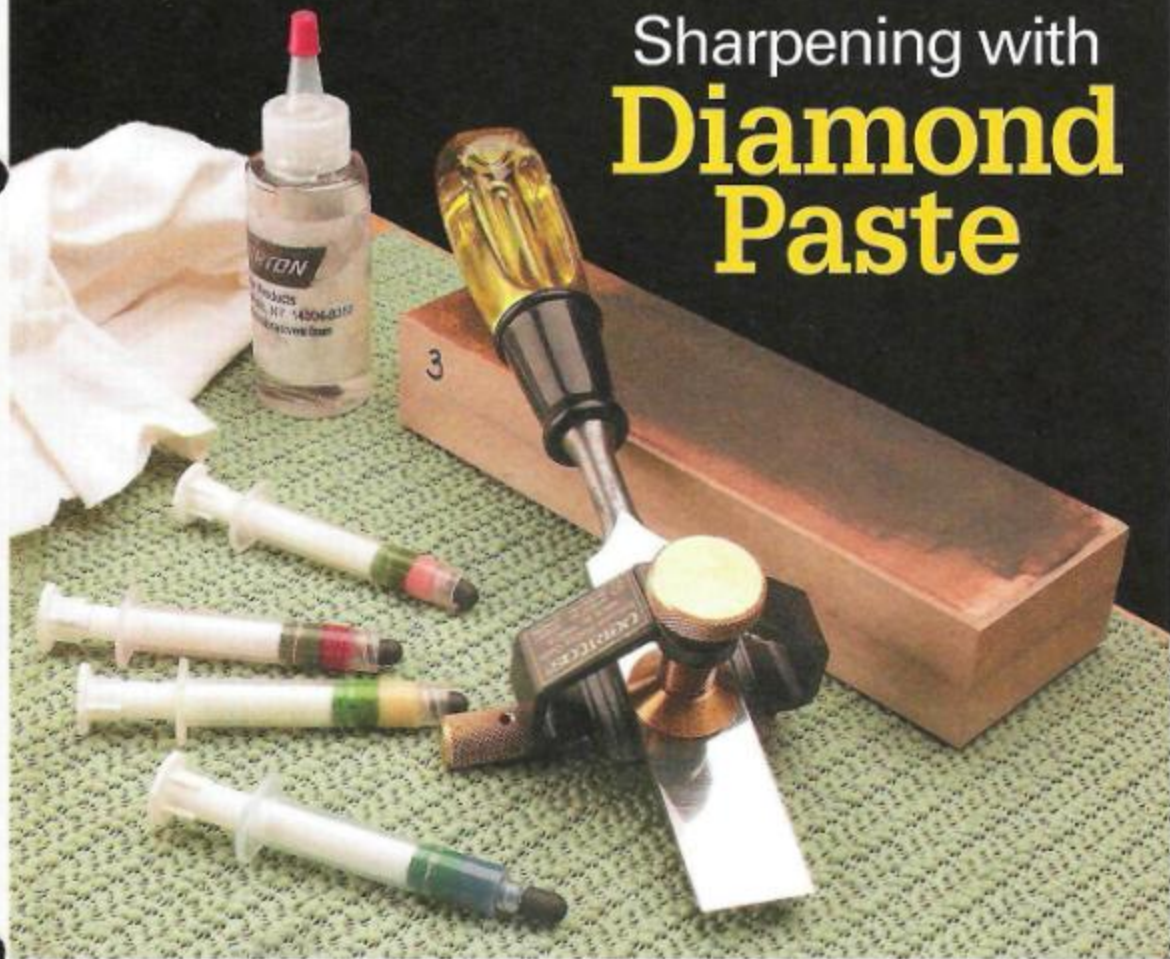

**S**harpening chisels, plane irons, and other wood-working tools used to be a chore that I would put off for as long as possible. But recently, I've discovered a fairly new way of sharpening that gives you an amazing, razor-sharp edge with less mess and less fuss and in half the time of waterstones or other traditional sharpening methods. The "secret" behind this new sharpening system is a material you may not be familiar with — diamond paste.

Why does diamond paste work so well? It all has to do with the fact that diamonds are the hardest substance known to man. So they can cut and polish the toughest steels faster and with less work than anything else. And the edge that you get with diamond paste seems twice as sharp as anything you can get with waterstones or oilstones.

Not only does diamond paste work better and faster, it takes a lot of the drudgery out of sharpening. There's no more endless rubbing back and forth over messy sharpening stones. Just a few minutes using the diamond paste, and you're done.

**What is Diamond Paste?** — Diamond paste is made up of finely ground particles of industrial diamonds. The particles are sorted by size and then mixed with a paste-like substance (referred to as the "carrier"). Because they are so small, the diamond particles are measured in *microns*. (A single human hair is about 100 microns thick.) The larger the particles, the coarser the diamond paste. Although diamond paste is available in a wide range of grits, I use only four — 30-micron, 15-micron, 6-micron, and 3-micron.



*Razor-Sharp in Record Time. Diamond paste will give you an unbelievably sharp, mirror-like edge in half the time.*

You'll also need a lubricant. The lubricant helps keep the diamond particles evenly dispersed while you are sharpening. You can purchase a special lubricant for use with diamond paste, or you can use a light-weight oil. The only other materials you'll need are some scraps of MDF (medium-density fiberboard) for the sharpening "blocks."

You can buy a pre-packaged kit that contains the four grits of diamond paste, lubricant, and MDF blocks. Or you can save some money by purchasing the diamond paste and lubricant separately and making your own MDF blocks. (See page 35 for sources.)

## Using Diamond Paste



**1** Flatten the back of the tool using sandpaper on a piece of plate glass. A rubber shelf liner prevents the glass from slipping.



**2** Carefully squeeze out a few small dabs of the diamond paste onto the surface of the block. You don't need much.



**3** Start rubbing the back of the tool back and forth on the block, working the diamond paste into a black slurry.



▲ **Lubricant.** Before applying the diamond paste for the first time, work a few drops of the lubricant into the MDF block.

No matter how you sharpen a tool, both the bevel *and* the back of the tool have to be perfectly flat and smooth in order to get a razor-like edge. So I start by flattening the back. This is something you will only have to do one time (the first time you sharpen the tool). For subsequent sharpenings, you'll only have to worry about sharpening the bevel.

**Sandpaper** – Although the diamond paste cuts quickly, its real purpose is in the final polishing of the steel. To quickly flatten the back, I use sandpaper instead. I start with a

piece of 150-grit, silicon-carbide sandpaper and a piece of plate glass.

The plate glass is an important part of the process. It provides a nearly-perfect flat surface to back up the sandpaper. Spray adhesive can be used to stick the sandpaper to the glass. Then just start rubbing the back of the tool back and forth over the sandpaper, pressing down firmly the whole time, see Step 1. A spritz of water from a spray bottle will help to keep the sandpaper from clogging up with metal shavings.

You may have to spend a bit of time

on the 150-grit paper to grind down all the high spots on the back of the tool. (Be sure to switch to a fresh piece of sandpaper as soon as the one you're using starts to wear out.)

As you examine the tool, you will start to see a pattern of scratches emerging. Once these scratches evenly cover the entire width of the back, you can move on to 220-grit paper and repeat the process. (You shouldn't have to spend nearly as much time on the 220-grit paper as you did on the 150-grit.)

After the 220-grit, switch to 400-grit paper. By the time you finish with this grit, the back of the tool should have an even, dull-looking appearance. Now you're ready to start using the diamond paste.

**Diamond Paste** – Just like the sandpaper, you will be using progressively finer grits of diamond paste to gradually polish the back of the tool (see margin at right). But instead of plate glass, the diamond paste is used on MDF. I glue up two layers of  $\frac{3}{4}$ "-thick MDF into blocks about  $2\frac{1}{2}$ " wide and 8" long. (You'll need to make a separate block for each grit of diamond paste.) I like to label the side of the block with the grit so that I don't get them mixed up. And chamfering the edges of the block will help to prevent the tool you are sharpening from catching

## Honing Guide

▼ **Honing Guide.** The wide roller on this honing guide makes it stable, even when sharpening narrow tools.

In order to get a flat, smooth bevel, the tool has to be held at a consistent angle throughout the sharpening process. While it's possible to do this by hand, I find it a lot less frustrating to use an adjustable honing guide.

A honing guide holds the tool at a fixed angle. For most chisels and plane irons, I use a 30° bevel angle (unless I'm creating a micro-bevel, see box at right.)

The Veritas honing guide and angle jig (shown here) are available from Lee Valley (1-800-871-8158) for just over \$30. The guide has an adjustment feature that allows you to create a micro-bevel with a simple turn of a knob.

### Angle Jig. ▶

The angle jig allows you to position the tool to one of five pre-set angles.



**4** After you've polished the back with all four grits of the diamond paste, you should have an even, mirror-like surface.



**5** To sharpen the bevel of the tool, start with the sandpaper again. I use a honing guide to hold the tool at a fixed angle.



**6** After the sandpaper, the bevel can be polished with diamond paste, working through all four grits like you did with the back.

the edge and digging into the block.

To use the diamond paste, start by applying a few drops of lubricant to the MDF block and gently smear it around, as shown in the photo in the margin at left. Then apply four or five BB-sized dabs of the 30-micron paste to the block. As you can see in Step 2, you don't need to use much.

Now start rubbing the tool back and forth over the block, like you see in Step 3. As you do this, the diamond paste will mix with the lubricant and turn into a black slurry. Don't wipe this off – this is what contains the diamond particles. If the paste starts to dry out, try adding a drop or two of the lubricant.

As with the sandpaper, check your progress by examining the pattern of scratches on the back of the tool. The diamond paste cuts quickly, so you won't have to spend a lot of time on each grit. When the back looks evenly polished (a dull, matte-looking surface), wipe off the tool and move on to the 15-micron paste. Then proceed to the 6 and finally the 3, using a new MDF block for each.

Note: It's important to wipe off any remaining diamond paste from the tool *before* moving on to the next grit. If you don't, the diamond particles from the coarser paste will contaminate the finer paste, leaving scratches on the surface of the tool.

For the same reason, I use a fresh shop towel each time I wipe off the tool.

By the time you finish with the 6-micron paste, you'll really start to notice the shine. And the final polishing with the 3-micron paste will leave the back of the tool looking like a mirror, see Step 4.

**Bevel** – The process for sharpening the bevel of the tool is the same as for the back. The only difference is that I like to use a honing guide to hold the tool at a consistent angle (see box on opposite page).

Shape the bevel using the sand-

paper and plate glass, as you see in Step 5. Then you can polish the entire bevel using the diamond paste, as in Step 6. Or you can change the angle of the honing guide to create just a small "micro-bevel" using the diamond paste. (See the box below for more information on this.)

**Results** – Apart from the mirror-like shine, you'll really be amazed at how easily your chisels and plane irons cut when sharpened with diamond paste. Once you give it a try, I think you'll agree it's a quick, clean way to a razor-sharp edge. 

30-micron  
(coarse)

15-micron

6-micron

3-micron  
(fine)

**Color-Coded.** Diamond paste is often supplied in plastic syringes. To help distinguish between the various grits, the paste is color-coded.

## Micro-Bevel

When you think about it, there's really no need to polish the entire bevel of a tool when only the edge is doing the cutting. That's why I like to create a "micro-bevel" on most of my edge tools.

The process is pretty simple. First, I grind a primary bevel on the tool using the sandpaper. (I usually grind this bevel at a 25° angle.) Then I use the diamond paste to hone a very small, secondary bevel on the edge of the tool, this time at 30°. This micro-bevel doesn't have to be very wide. I usually shoot for about 1/16".

The nice thing about the micro-bevel is that when the tool gets dull, you only have to touch up the edge, rather than

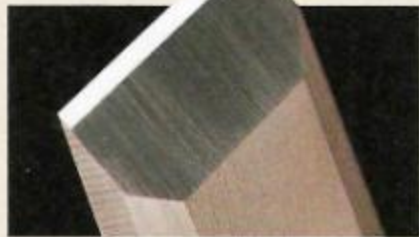

the entire bevel. This speeds up the sharpening process quite a bit.

After repeated sharpenings, the micro-bevel will get wider and wider. When the micro-bevel gets to the point where it is about half the width of the entire bevel, I just grind a new primary bevel (at 25°) and start all over again.



## Table Saw Accessory Shelf

**Accessory Storage.** ▶  
Keep accessories in reach with a handy storage drawer and miter gauge shelf.



**Fence Storage.** ▶  
An open wing provides convenient storage for the rip fence when it's not in use.



**Dust Collection.** ▶  
An optional hood attaches to the shelf to make dust collection a snap.

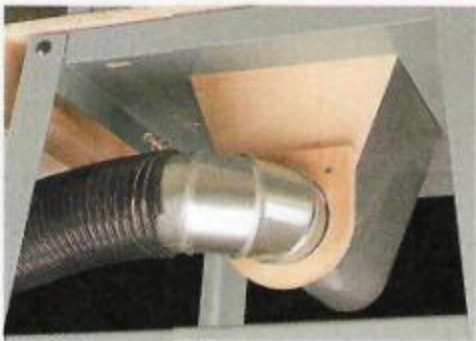

*Make your table saw work harder — in an afternoon. All it takes is this handy accessory shelf.*

**G**etting more out of the tools you already own is one way to make them work harder. It's one of our main goals when we design a project. And the accessory shelf added to the contractor-style table saw shown above is a perfect example. It's a practical, easy-to-build project you can complete in an afternoon that provides plenty of storage — something often lacking around a table saw.

To accomplish this, the accessory shelf consists of a rectangular piece of plywood sandwiched between the cabinet of the table saw and its stand. The plywood sticks out past the sides of the cabinet to provide a convenient spot for storing your miter gauge, rip fence, and other commonly used accessories.

**Miter Gauge & Accessory Storage** — As you can see in the upper photo at left, there's a covered slot for the miter gauge to slide into on the left side of the shelf, keeping it close at hand. And a drawer right underneath provides storage for wrenches, push blocks, featherboards, and other accessories.

**Rip Fence Wing** — Finding a place to store the rip fence when you don't need it can be a hassle. But not any more. On the right side of the shelf there's an open wing for storing the rip fence out of the way (center photo at left).

**Dust Collection** — And finally, if you're tired of all the dust piling up below your table saw (where it's a pain to sweep up), there are a couple options for adding dust collection. Our shop-built version is shown in the lower photo at left. But you can also add a store-bought dust hookup. (For more on this, refer to page 15.)

**THE SHELF**

Sizing the shelf to fit your table saw is the key to this project. To do this, the first step is to measure the width and depth of your table saw stand.

But don't remove your table saw from the stand to do this. You'll need the table saw to build the shelf. Like most projects, I assembled the shelf on my bench and then attached it later once it was complete.

**Size Shelf** – The shelf is cut to length to match the depth of the stand (Figure 1). But determining the width takes a little more work.

To account for the wings on either side of the shelf (plus 1½" clearance for stands with splayed legs), you'll need to add 14½" to the width of your stand. (For my shelf, the final dimensions were 34" x 22".)

**Miter Gauge Slot** – After cutting the shelf (A) to final size from ¾" plywood, you can turn your attention to the top of the shelf. All that needs to be done here is to cut a groove to match the width and depth of your miter gauge bar, as shown in Figure 1a. (Mine was ¾" wide and ⅜" deep.) Note: For miter gauge bars with washers on the ends, see the margin.

Finally, to ease the sharp edge at the front of the shelf, I routed a ¼" chamfer along the upper edge.

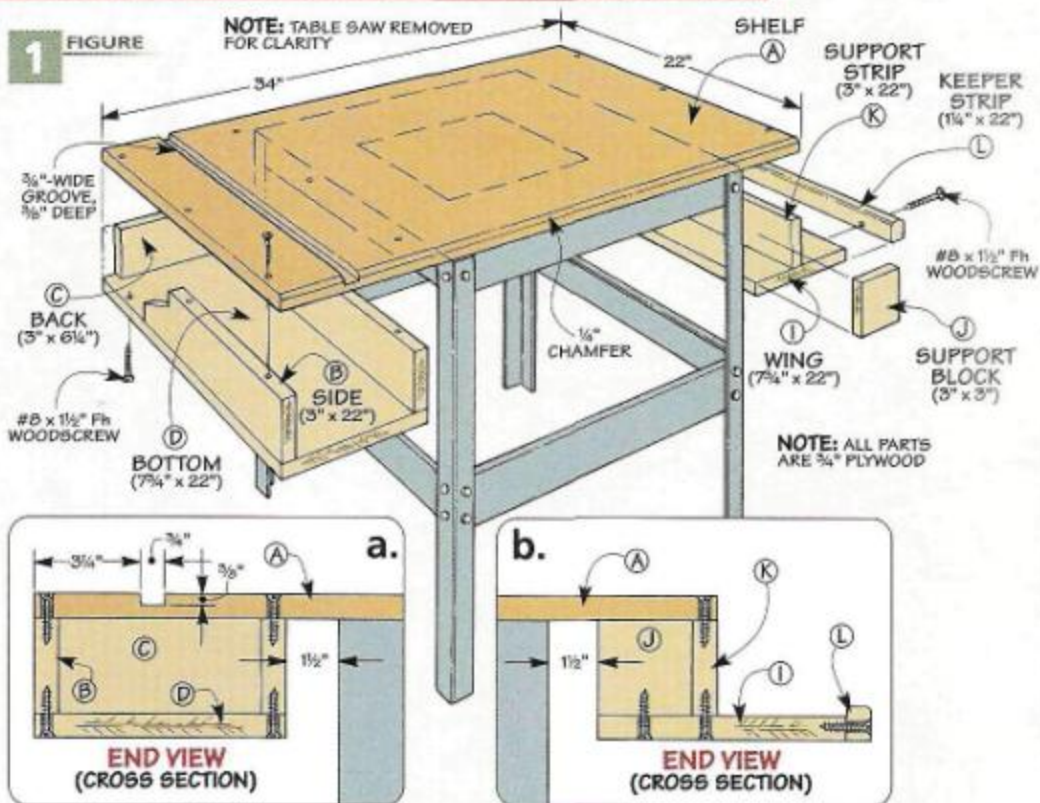

**Drawer Opening** – At this point, you're ready to build the drawer. But first, to create its opening you'll need to add four pieces. After cutting the sides (B), back (C), and bottom (D) to size from ¾" plywood, you can glue and screw them together and to the bottom face of the shelf to create an opening for the drawer (Figure 1a).

**Drawer** – Now you'll need to determine the size of the drawer parts. To allow the drawer to slide freely, I allowed a 1/16" gap side-to-side and 1/8" top-to-bottom. Then after allowing for the rabbet joinery, I cut the front/back (E) and sides (F) to size from 1/2" plywood (Figure 2).

To hold the 1/4" hardboard drawer bottom (G) in place, you'll need to cut a 1/4" x 1/4" groove near the bottom edge of each piece. Then before assembling the drawer, drill a couple shank holes in the front for the screws that attach the false front.

The false front (H) is cut to size from 3/4" plywood. It fits flush with the sides and bottom of the case, but it rests just below the groove cut in the shelf (Side View in Figure 2). After attaching a handle, you can screw the false front in place.

**Rip Fence Wing** – After sliding the drawer in place, you can add the wing for the rip fence. The wing (I) is a piece of 3/4" plywood that's held in place by a pair of support blocks (J) and a support strip (K) (Figures 1 and 1b). And a keeper strip (L) keeps the rip fence from sliding off (Figure 1b).



**▲ Washer Groove.** The washers attached to some miter bars keep it secure in the miter slot. But to store the miter gauge, you'll need to cut a wider groove in your shelf.

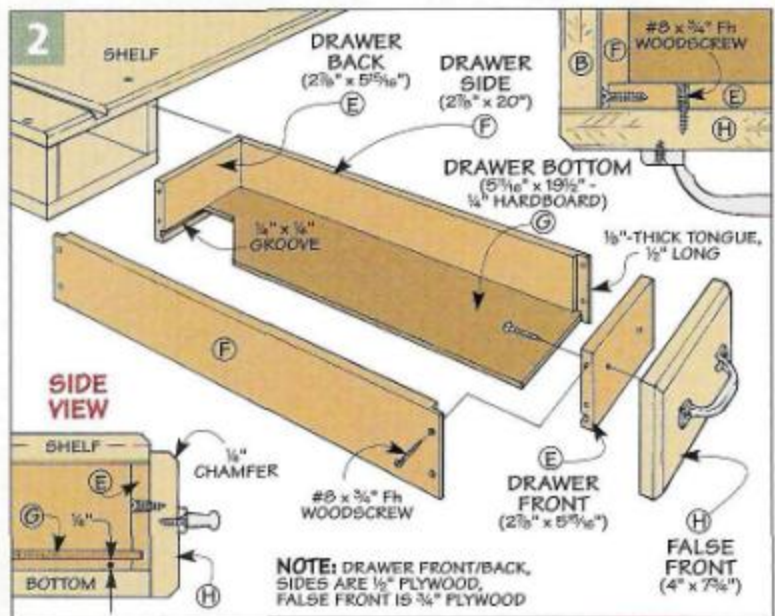

## Mount the Shelf

With the shelf complete, you're ready to remove the table saw cabinet from the stand and "slip" the shelf in between.

But first you'll need to make a cutout in the center of the shelf. This provides a way for the sawdust and chips to fall through. Or if you want, you can add a dust collection system. But more about that in a bit.

**Dust Opening** – Determining the size of the opening is an easy task. Start by placing the shelf on the table saw stand, making sure it's centered evenly side-to-side and flush at the front and back (Figure 3).

Now, reach under the stand and trace the outline of the opening in the stand onto the bottom of the shelf. Note: It's best to limit the size of this opening to 10" x 10". This keeps the "frame" of the shelf solid. Also, while you're "under" the stand, it's a good idea to locate the mounting holes for the table saw.

After tracing the opening, drill a couple starter holes and then cut out the opening (Figure 3a). Finally, drill the mounting holes through the shelf.

**Dust Collection** – At this point, you need to decide if you're going to install a dust collection system. There are a couple options here. You can simply purchase a plastic dust hood. Or you can build a shop-made

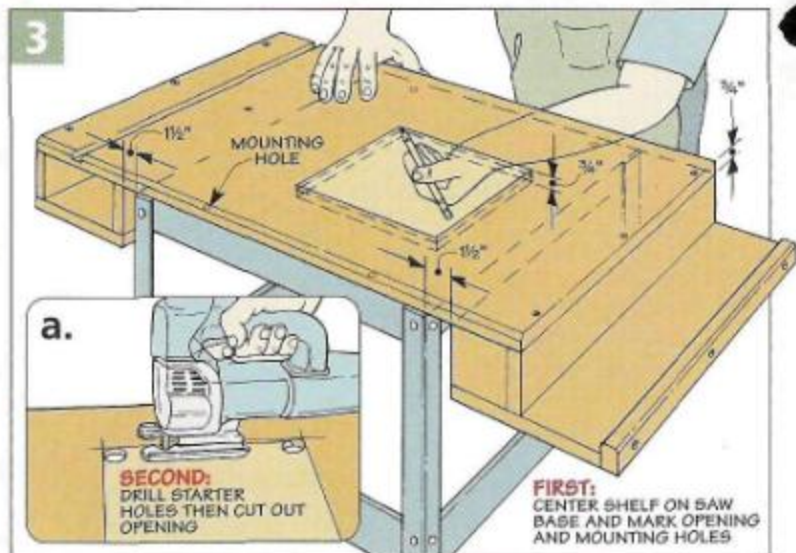

version. For more information on either option for collecting dust, take a look at the opposite page.

**Mount Shelf** – Mounting the shelf is just a matter of lining up the mounting holes in both the stand and shelf and then bolting the saw in place (Figures 4 and 4a). Note: You may need longer bolts due to the added thickness of the shelf.

**Miter Gauge Cover** – There's one last thing to do to complete the shelf. And that's to add a miter gauge cover to the left side. Besides acting as a stop to keep the miter gauge in place, it also makes a convenient

storage area for larger table saw accessories (like a dado set) that won't fit inside the drawer.

The cover (M) is just a rectangular piece of 3/4" plywood that's screwed to the left side of the shelf (Figure 5). It's sized so it's flush with the outside edge of the shelf and butts against the side of the saw cabinet.

To determine the length, I placed my miter gauge in the groove so the bar was even with the front edge of the shelf. Then after measuring from the face of the miter gauge to the back of the shelf, I cut the cover to size and screwed it in place.

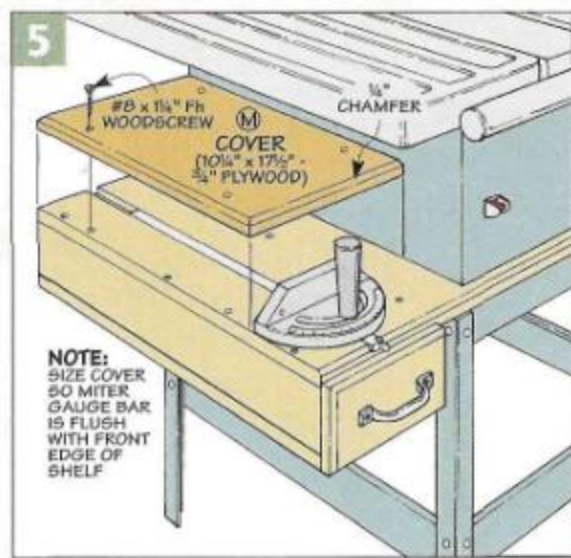
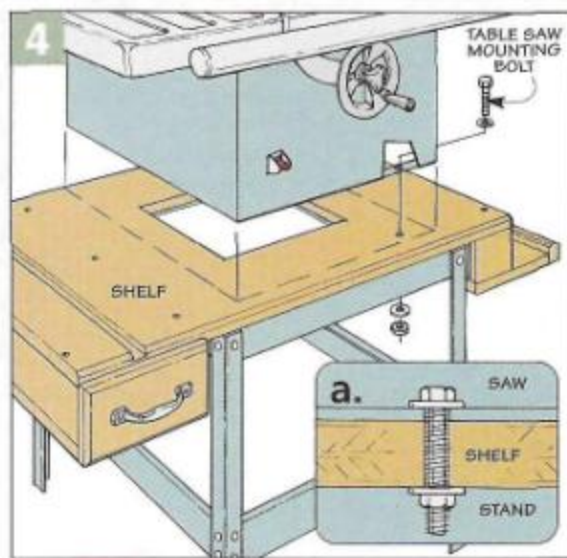

## Optional Dust Collector

Although you can let the dust and chips from the table saw fall to the floor (and settle on everything in the shop), it's much better to collect them first — not sweep them up later. So you might want to think about adding a dust collector to the shelf.

There are a couple ways to go about this. First, you can purchase a dust hood that fits the opening in the shelf (see the box below). Or you can use up some of the plywood scraps left over from the accessory shelf and build a shop-made version like the one shown in the photo at right (shelf ghosted for clarity).

**Front/Back** — As you can see in Figure 6, the dust collector starts out as a *front/back* (N) made from

10" x 11" pieces of  $\frac{3}{4}$ " plywood. (They're cut to width to fit the opening in the shelf.) The next step is to lay out a "V" shape on each one. This "funnels" the dust and chips to the bottom of the dust collector.

Once you've laid out the shape, you'll need to cut a hole in the back for hooking up the dust hose. I used a band saw (you could use a jig saw) to shape the opening as I cut both the front and back to final shape.

**Add Panel** — To create the dust collector, I wrapped the front and back with a sheet metal panel, as you can see in Figure 7. To size the panel, measure from the top corner of the front, around the V-shape to the opposite corner. (My sheet metal



panel was 10" wide and  $23\frac{1}{2}$ " long.)

Now it's just a matter of wrapping the front and back with the panel and tacking it in place with a few brads. (It's a good idea to predrill the sheet metal panel for the brads.)

At this point, you can slip the dust collector in place and screw it to the shelf, as shown in the photo above. Note: You may need to sand the edges of the shelf opening slightly to allow the dust collector to fit.

**Collar** — Finally, to provide a smooth transition into the dust collector, I used a  $\frac{3}{4}$ " plywood collar (O) to attach an adjustable, 4"-dia. metal elbow, as illustrated in Figure 8.

Here again, I used a band saw to cut the opening. This created a kerf at the top that allowed me to "pinch" the elbow for a tight fit. After tacking the elbow in place, the collar is simply screwed to the back of the dust collector (Figure 8a).

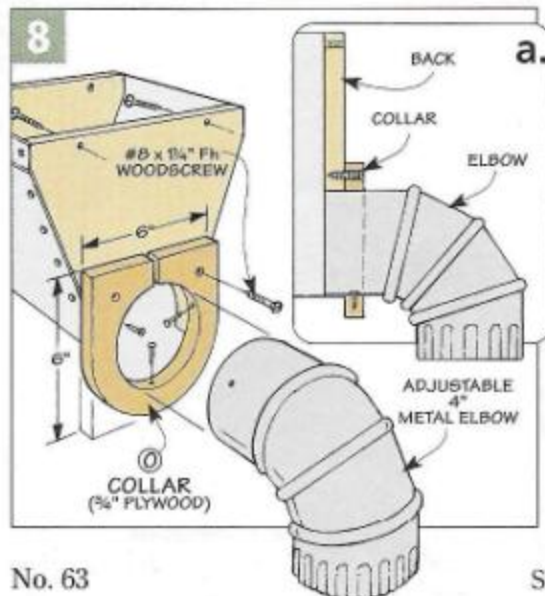
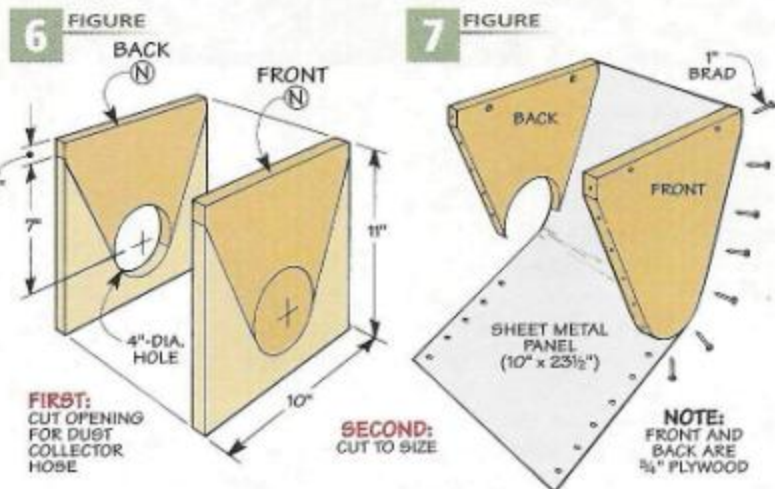

## Dust Hood

If you don't want to build the dust collector, you can use a plastic dust hood designed for a table saw, like the one shown in the photo at right.

The hose from the dust collector attaches easily to the hood, which is then screwed to the table saw shelf.

The hoods come in different sizes, so be sure to order one that will fit your opening. (My 10"-square opening required a 12" x 12" dust hood.) Refer to page 35 for sources of dust collection components.





## Table Saw Crosscut Sled

*Big results in a small package. Reach for this lightweight sled and make perfect crosscuts every time.*

**Y**ou can see from the photo above that this isn't a typical crosscut sled. For starters, most crosscut sleds are heavy — so they tend not to get used as much as they should. But with the aluminum fence and the cutouts in the base, this sled is smaller and lightweight, so you'll want to use it all the time.

But don't let the size of this sled fool you. It's dead-on accurate and works "big." As a matter of fact, you can make perfectly square cuts on workpieces much wider and longer than you can on a typical miter gauge.



**Stop Block.** Easy to adjust and rock solid, this stop block makes cutting workpieces to identical length easy.

**Stop Block** — Perfect cuts are great. But it's just as important to be able to cut a number of workpieces perfectly square *and* identical in length. So there's a handy stop block that slips onto the fence quickly and locks securely in place (see left photo).

**Miter Bar** — As I mentioned, this sled is lightweight. But one area I sacrificed lightness in return for accuracy was the miter bar. Now you could just use a hardwood strip. But often it becomes too loose (or too tight) as the strip changes size depending on the humidity level.



**Miter Bar.** Adjustable ball bearings keep this miter bar (and the sled) running firm and true in the miter slot.

Instead, I bought a steel bar similar to the one you'd find on the miter gauge that comes with most table saws. The main difference is in the fit — it's perfect. That's because the bar has a set of spring-loaded ball bearings along the edge (see right photo). You can adjust them to provide a snug fit in any miter slot. For more information, refer to page 35.

If the accuracy and ease of use aren't enough to sell you on this crosscut sled, you may want to check out the optional accessories detailed on page 20. First, there's a simple platform for supporting cut-offs. And then for cutting long workpieces (like table legs) to identical lengths, there's a longer fence.

**Alignment Check** — It's no good building a precision crosscut sled if the table saw itself isn't aligned accurately. So the first thing to do is check that the saw blade is perfectly parallel to the miter slot.

The owner's manual for your saw should explain how to check for this and adjust it if necessary. For a little more information on the process I use to make this check, you can refer to the article on page 21.



**Sled Accuracy** – With the table saw aligned, you're ready to build the sled (Figure 1). The accuracy of the sled depends on cutting the base with a perfect 90° corner, as shown in Figure 2. Once that's complete, the accuracy is built right in.

But if you're building this sled, it's probably because you don't trust your current miter gauge to make a crosscut that accurate. So how do you go about creating the 90° corner?

The answer is one you've probably heard before — trial and error. You simply make a test cut, and then check the corner to see how square it is. Note: You may have to adjust the miter gauge a few times to end up with a perfect corner.

**Base** – I started by ripping the base (A) to final width (12<sup>1</sup>/<sub>8</sub>" ). But I cut it extra-long. (My base was 26" long.) This way, there was a little extra material for making the test cuts.

Then to provide solid support for the test cuts, I attached an auxiliary fence to my miter gauge (Figure 2). Note: A strip of sandpaper attached to the fence prevents the workpiece from slipping during the cut.

Now you're ready to make a test cut and check the corner with a square. (I used a framing square.) If

**1 OVERVIEW**

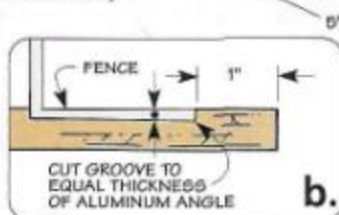
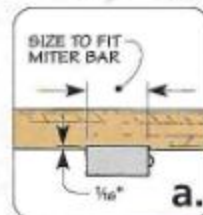
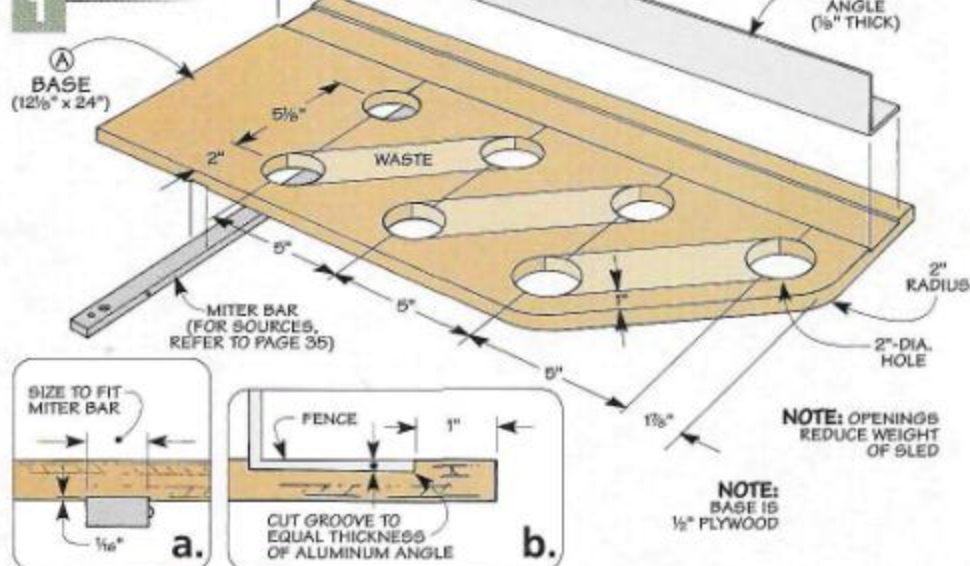

it's not right on, simply "tweak" the setting on your miter gauge a bit and make another test cut. Just continue this until you're satisfied that the corner is square.

Once that's complete, you don't want to forget which corner is the "square" one. So it's a good idea to make a mark in that corner for reference. Now just flip the base end for end and trim it to final length (24").

Completing the rest of the work on the base will go fairly quickly at

this point. It's just a matter of cutting a dado to fit the miter bar and then cutting a groove for the fence (Figures 1a and 1b).

But before you install a dado blade to do this, it's important to measure the distance from the edge of your saw blade to the edge of the miter slot, as illustrated in Figure 3a. This measurement is where the dado for the miter bar will start. This will position the sled right next to the saw blade to help support the workpiece.

**Cut Dado** – Now you're ready to cut the dado. But don't try to get an exact fit on the first try. It's best to install a narrower dado blade (1/2") and then sneak up on the fit by making multiple passes (Figure 3b). Just remember to keep the "short" leg of the 90° corner against the rip fence for this cut.

**Cut Groove** – The next step is to cut the groove in the top of the base for the fence (Figure 1b). Here again, I made sure the "long" leg of the 90° corner was against the rip fence for this cut. And sneaking up on the width of the groove ensures a perfect fit for the fence.

**Shape Base** – All that's left to complete the base is to do some final shaping. As you can see in Figure 1, this is just a matter of trimming one of the corners and cutting a few openings in the base.

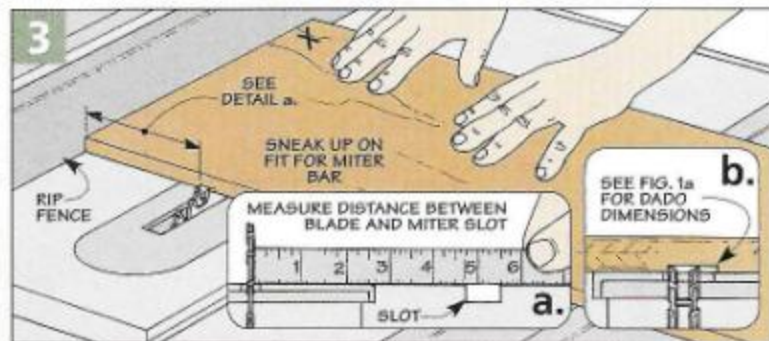
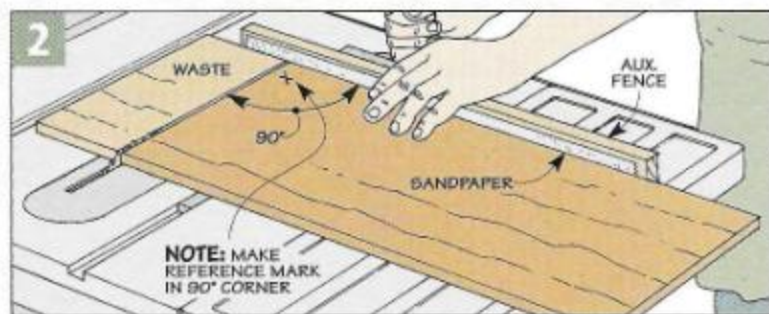

# Hardware & Stop Block

At this point, the sled base is ready to accept the miter bar, fence, and hardware that make it functional. Once that's complete, you can add a stop block to allow you to cut multiple workpieces to identical length.

## MITER BAR & HANDLE

As I mentioned before, I used an after-market miter bar to accurately guide the sled on the table saw. In addition, to provide a convenient grip during use, I added a tall, tapered handle. You can find out more about both of these products by turning to Sources on page 35.

**Mounting Holes** - The miter bar rests in the dado cut earlier in the bottom of the base. But to hold it in place, you'll need to drill a couple holes through the base.

The center of the miter bar is secured by a screw that passes through a countersunk hole in the base of the sled (Figures 4 and 4a). And the end of the miter bar near the fence is held in place by a studded handle (Figure 4b).

Both holes are centered on the width of the dado and located to match the spacing on the miter bar, as you can see in Figures 4 and 4a.

**Attach Miter Bar** - After you've drilled the holes, you can countersink the one in the "center" of the sled and attach the miter bar with a flathead machine screw.

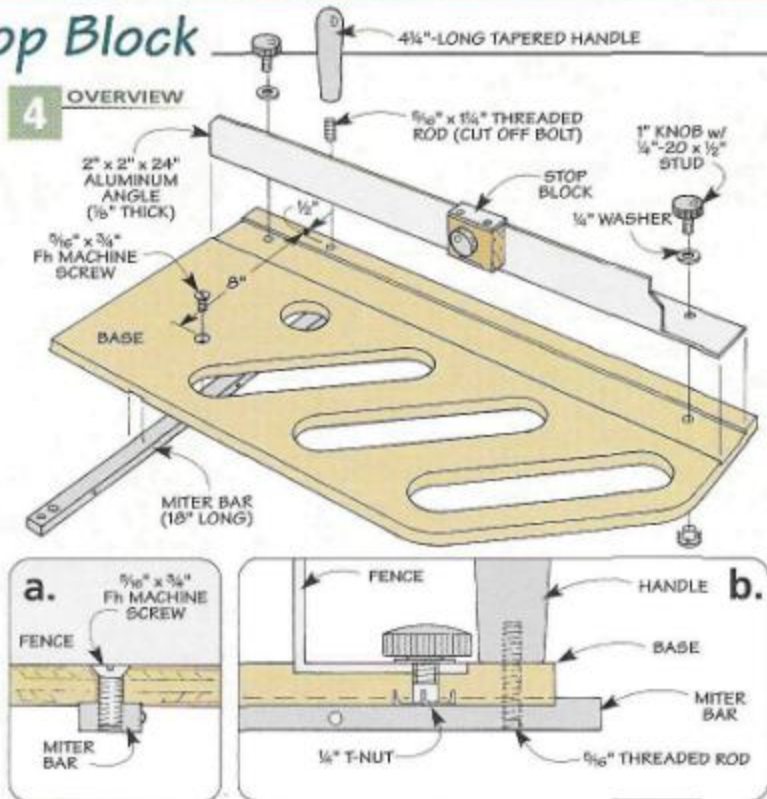

Attaching the end of the miter bar with the handle requires a little more work. That's because the handle I used didn't have a threaded nut on it. Instead there was a brass insert in the bottom of the handle.

To create a "stud," I cut off a short ( $1\frac{1}{4}$ ") length of threaded "rod" from the end of a long bolt. Note: To "clean" up the threads on the end of the stud you just cut, simply thread a nut on the good end and then turn the nut off the cut end.

Now you can thread the "stud" into the handle (with a little epoxy to secure it) and then attach the handle to the sled and miter bar (Figure 4b).

## FENCE

With the miter bar and handle installed, the next step is to cut the fence to size and attach it to the base. The fence provides solid support for the workpiece as you make a cut.

**Cut to Size** - The fence is nothing more than a piece of 2" alu-

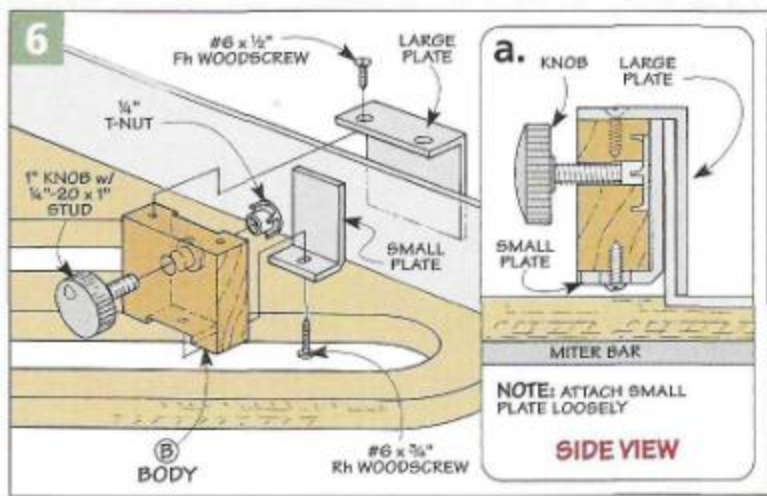
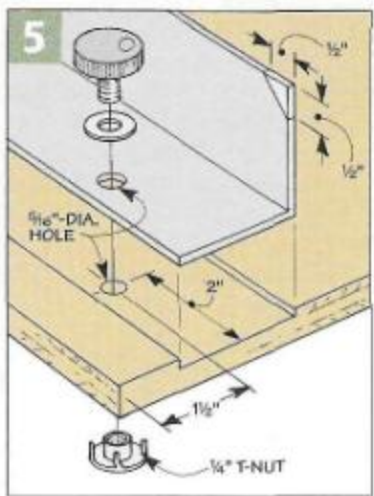

minum angle cut to match the length of the base (24"), as shown in Figure 4. I used a carbide-tipped saw blade to do this. But it's just as easy to cut it with a hacksaw and file the ends smooth. Regardless of which method you use, it's a good idea to "knock off" the two outside corners to ease the sharp points (Figure 5).

**T-Nuts & Counterbores** - The fence is held in place with a couple of studded knobs. These knobs fit into T-nuts that rest in counterbores drilled in the bottom of the base, as illustrated in Figure 4b.

To provide clearance for the knob on the stop block (added later), the mounting holes (and counterbores) are located near the back edge (Figure 4b). After drilling the counterbored holes, you can install the T-nuts and then drill matching oversized holes in the fence (Figure 5).

Attaching the fence is just a matter of tightening the studded knobs into the T-nuts. To ensure the knobs don't project through the bottom of the base, you may need to cut off some of the threaded portion.

### STOP BLOCK

Adding a stop block to the crosscut sled is a great way to ensure you can cut a number of workpieces to identical length — like when you're making table legs. You can install (or remove) it quickly with the turn of a knob. And once it's locked in place, it's solid. So it won't shift during use.

To accomplish this, the stop block is designed so that as you tighten the

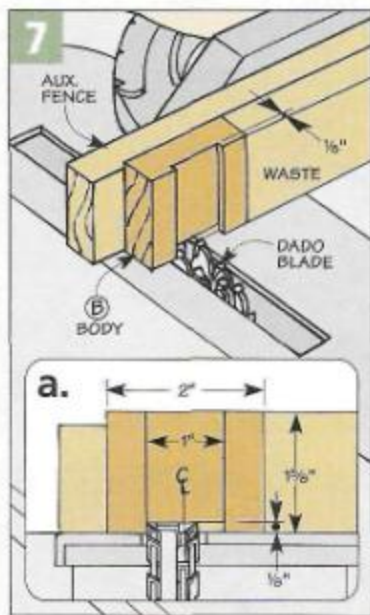

knob, the fence is "clamped" between two aluminum plates, as shown in Figures 6 and 6a.

**Oversized Blank** - It's pretty obvious that the stop block is small. So I started with an extra-long 3/4"-thick hardwood blank to make the body (B) of the stop block (Figure 7). This way, I could do as much work as possible on a larger workpiece.

After attaching an auxiliary fence to my miter gauge to prevent chipout, I cut a pair of dados in the blank (Figure 7a). These dados accept a smaller aluminum plate that wraps around the block keeping it aligned as the stop block is locked in place.

To attach the knob to the stop block, there's a T-nut installed in the body. The T-nut fits into a counter-

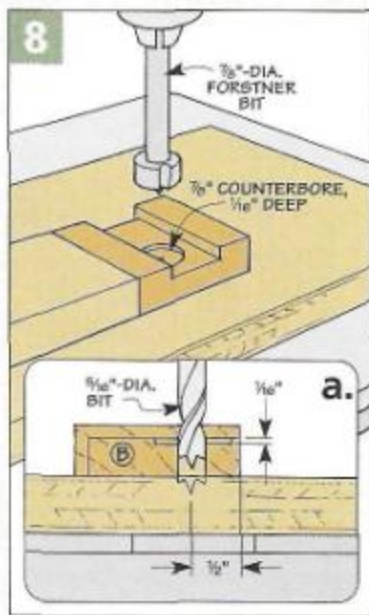

bore drilled in the backside of the body (Figures 8 and 8a).

Once the T-nut is installed, you can cut the body to final length and then turn your attention to the two aluminum "clamping" plates.

**Plates** - Although I cut the fence to size on the table saw, I wasn't really comfortable cutting the clamping plates the same way. They were just too small. Instead, I used a hacksaw to make the cuts.

But like the body of the stop block, I started with extra-long workpieces. This made it easy to clamp them in a vise and cut them to the sizes shown in Figures 9 and 10.

The hacksaw left the edges a little rough and uneven. But they were easy enough to smooth with a file. While I was at it, I filed a chamfer on the outside corner of the small plate (Figure 10a). This allows the stop block to slide easily over the top of the fence when it's installed.

After drilling a few mounting holes, you can screw the plates to the body and add the knob (Figure 6a). Note: The small plate is attached loosely so it can slide freely.

At this point, the sled is ready to make dead-on accurate crosscuts. But you may want to take a look at the next page for a couple of options that add even more capability.



▲ **Stop Block.** For thin materials, the stop block can be reversed, allowing you to butt the workpiece against the clamping plate.

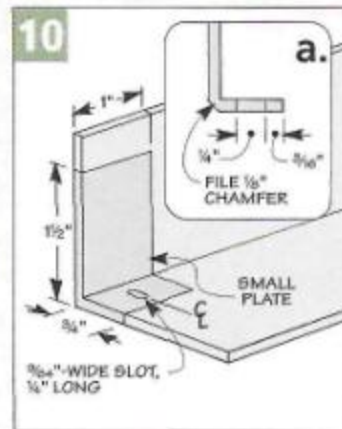
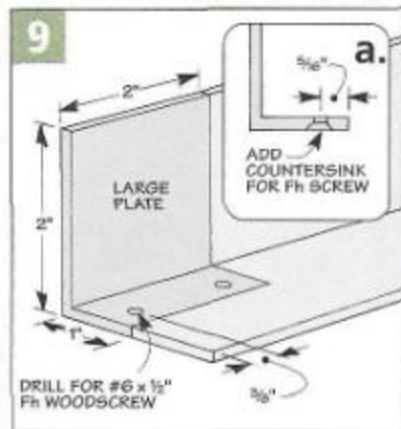

## Optional Accessories

After completing the stop block on the previous page, you're ready to start cutting. But if you're looking for a couple accessories to make the crosscut sled even more versatile, take a look at the two options at right.

### LONG FENCE

Although the short fence (and stop block) will handle most crosscuts, there are times when I need to cut longer pieces to identical length (see upper photo at right).

If you purchased a 6'-long piece of aluminum angle like I did, there's more than enough extra to make a longer fence (43"). Other than the length, the only difference is the back corner of the far edge of the fence is "knocked off" just like the upper corners.

### CUTOFF TABLE

The crosscut sled is great for cutting wide panels. But the portion of the panel to the right of the blade isn't supported. So it tends to bind against the blade or cause chipout.

**Cutoff Table** - To solve these problems, I added a fixed table to the right side of the table saw to support the cutoff, as you can see in the lower photo at right.

The *cutoff table* (C) is nothing more than a large piece of 1/2" ply-



wood, as you can see in Figure 11. It's sized to cover the entire surface of the table saw to the right of the saw blade. (My table was 20" x 27".)

To make it easy to position the table, I cut a 1/8"-deep groove in the bottom of the table and then glued in

a 1/2" plywood *runner* (D), as illustrated in Figures 11 and 11a.

Then to prevent the table from shifting as you make a cut, there's a large washer screwed to each end of the runner (Figure 11b). This way, the table is "locked" in place. 

### Hardware

- (1) 18"-Long Adjustable Miter Bar
- (1) 5/16" x 3/4" Fh Machine Screw
- (1) 5/16" x 1/4" Threaded Rod (For Handle)
- (1) 4 1/4"-Tall Handle w/ 5/16"-18 Brass Insert
- (3) 1/4" Short Barrel T-Nuts
- (3) 1" Round Knobs w/ 1/4"-20 x 1" Stud
- (2) 1/4" Washers
- (1) 1/2" x 2" x 2" Aluminum Angle (24" Long)
- (1) 1/2" x 2" x 2" Aluminum Angle (2" Long)
- (1) 1/2" x 2" x 2" Aluminum Angle (1" Long)
- (3) #6 x 3/4" Rh Woodscrews
- (2) #6 x 1/2" Fh Woodscrews
- (1) 1/2" x 2" x 2" Aluminum Angle (43" Long)
- (2) 3/16" x 1" Fender Washers

*Note:* You'll need a half sheet of 1/2" Baltic Birch plywood, a strip of 3/4"-thick hardwood, and a 6'-long piece of 2" x 2" aluminum angle (1/2" thick) to build the crosscut sled and accessories.

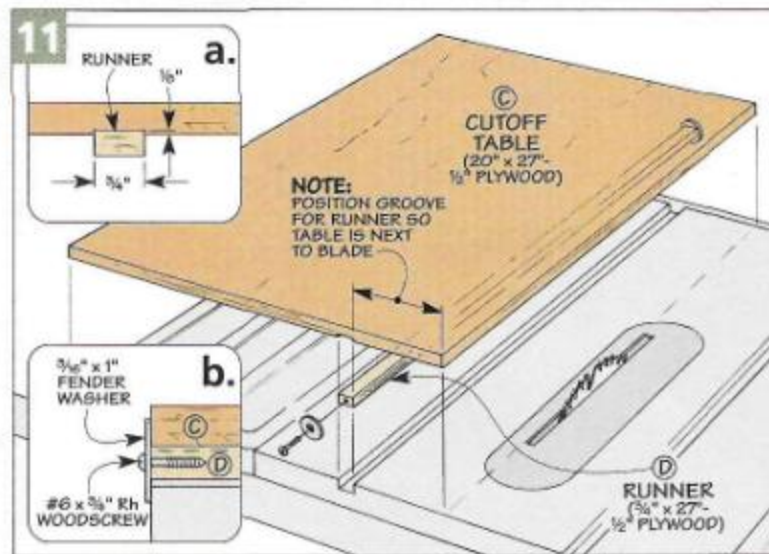

# Secrets of Great Crosscuts

*Here's what I do to make accurate crosscuts — time after time.*

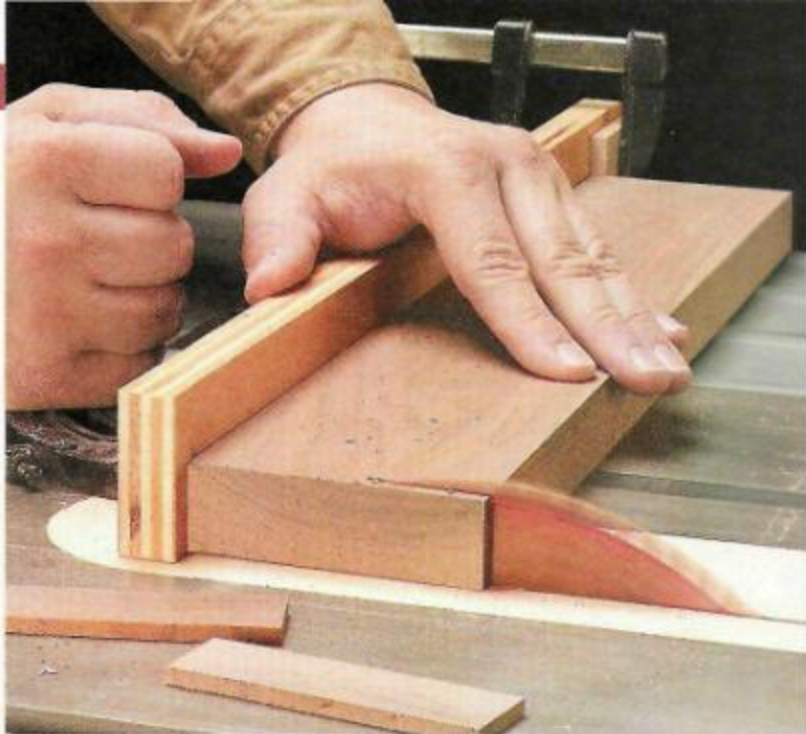

**W**oodworking doesn't get much more basic than a crosscut. So why is it that cutting a perfectly square edge without burn marks or chipout is so difficult?

Making a crosscut sled (page 16) is one way to get better crosscuts. But you don't have to build a sled to get good results. Most crosscut problems can be solved by starting with the right setup. So regardless of whether you use a sled or not, you'll want to take some time to check the setup of your table saw.

**Blade Alignment** – The most often overlooked problem is that the saw blade may not be parallel to the miter slot — an absolute must for accurate crosscuts.

To check this, I like to raise the blade as high as possible and then mark a single tooth. Next, I place a combination square in the miter slot and adjust the rule on the square so it just touches the side of the marked tooth (left photo below).

Next, slide the square to the back and rotate the blade backward until the marked tooth aligns with the square. If it touches the rule just as it

did before, the slot and blade are aligned.

If not, you'll need to adjust the table saw trunnions. This is the assembly that holds the saw arbor to the bottom of the table. (It's best to check your owner's manual for more on adjusting the trunnions).

**Checking the Blade** – Besides aligning the saw blade to the miter slot, it's important to make sure it's square to the table.

What you want to do is verify that the *tilt* angle of the blade is set at 90°. And you can't necessarily rely on the table saw's indicator for accuracy here.

A better way to check this is to remove the insert plate to expose the saw blade (center photo below). Then using the combination square, extend the rule below the surface of the table. I've found that using the entire surface of the saw blade provides a more accurate reading than just checking the top part of the blade.

**Miter Gauge** – Even a perfectly aligned saw blade isn't going to

make an accurate cut if the head of the miter gauge isn't 90° to the slot. Here again, the miter gauge settings are only good for *rough* positioning.

For a more accurate setting, use a square to set the miter gauge (right photo below). Just make sure the blade isn't resting against the teeth of the saw blade.

**Zero Clearance Insert** – The last part of the setup you might want to consider is adding a zero clearance insert. As the name implies, a zero clearance insert provides a "tight" fit around the blade, virtually eliminating chipout on the bottom side of a workpiece. (A plywood version is shown in the photos below.)

With the setup complete, you can turn the page to learn a few more tips on making better crosscuts.



▲ **Alignment.** Verify that the saw blade is parallel to the miter slot by checking the position of a single tooth at both the front and rear of the table saw.



▲ **Square the Blade.** Using a combination square, check that the saw blade is square to the table.



▲ **Miter Gauge Check.** Finally, adjust the head of the miter gauge so it's square to the blade.

## Better Crosscuts (Cont'd)

At this point, you're almost ready to test the setup. But before you do that (and if you're not building the crosscut sled on page 16), there's one last thing I'd recommend — add an auxiliary fence to your miter gauge.

### AUXILIARY FENCE

An auxiliary fence is nothing more than a straight, flat piece of wood (a strip of  $\frac{3}{4}$ " hardwood or plywood) attached to the face of the miter gauge, as shown in Figure 1. An auxiliary fence improves the quality of the crosscut in three ways.

**Support** — First, it provides extra support for the workpiece, preventing it from pivoting during the cut. This is particularly helpful on long, wide pieces that tend to drag on the table saw surface.

**Wander** — Second, an auxiliary fence can prevent the tendency of a spinning saw blade to shift the workpiece, causing a bad cut. (This is sometimes called wander, or creep.)

The most common way to prevent wander is to attach a strip of sandpaper to the face of the auxiliary fence. The sandpaper provides extra "grip" and keeps the workpiece from slipping along the fence.

**Tearout** — Finally, an auxiliary fence works like a zero clearance

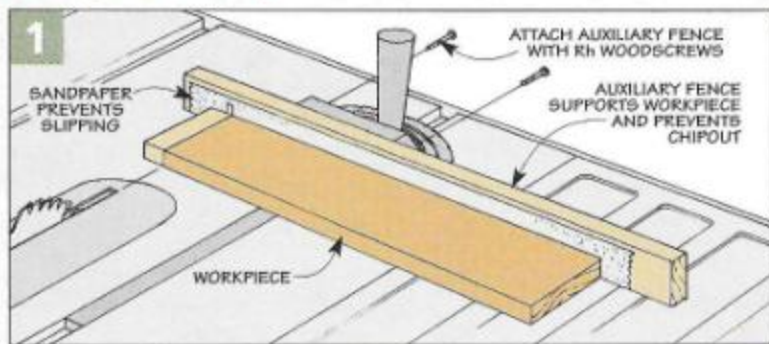

insert — it helps reduce tearout on the back edge of the workpiece. All you need to do is extend the fence so it's in the path of the blade. This way, the fence supports both the workpiece and the waste piece, reducing the chance of the grain tearing out.

### DYNAMIC TEST

With an auxiliary fence installed, you're finally ready to test the setup of the miter gauge and saw blade with a couple *dynamic* tests. I know. This sounds fancy, but it's really nothing more than turning the saw on and making a cut.

The first check I do is to make a crosscut on a piece of wide scrap that's had the edges jointed and ripped parallel to each other, as illustrated in Figure 2. (I like to use a scrap at least 6" wide since it helps

"magnify" any error.)

Once you've made the cut, stand the pieces on edge. Then flip the cut off piece over and butt the ends together, as you can see in Figure 2a. If there's any gap where the two ends meet, the saw blade isn't quite square yet and needs to be re-adjusted. Note: The "difference" you see is twice the actual error.

After readjusting the saw blade (or miter gauge), you're ready to make another check to verify the saw blade is at 90° to the table. Here again, you'll need a scrap piece.

Only this time, I use a scrap of "two-by" material that has had the faces jointed and planed parallel. In this case, a *thicker* workpiece helps "magnify" any error.

As before, you're going to make a test cut like the one shown in Figure

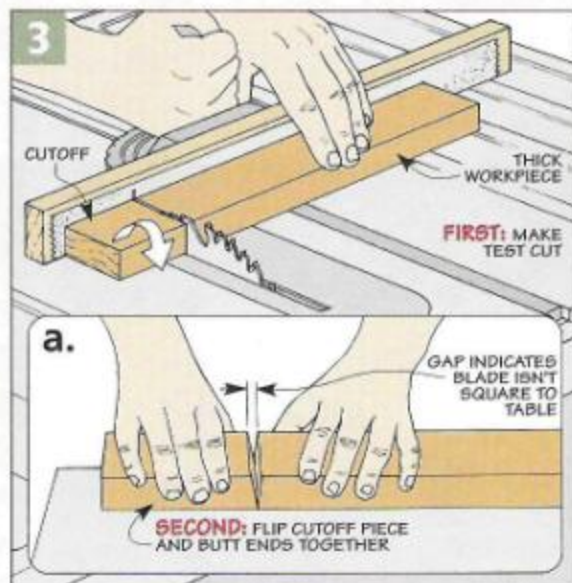
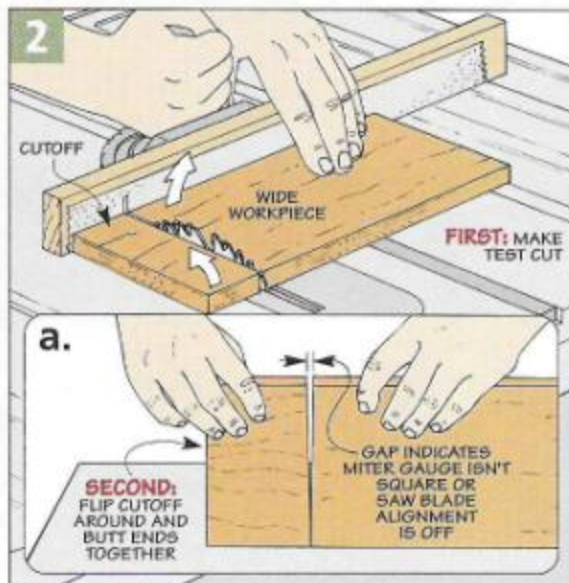

3. But this time, all you need to do is flip the cutoff piece over before butting the ends together (Figure 3a). And just like before, any gap at the top (or bottom) indicates a need to adjust the tilt of the saw blade.

### STANDARD PROCEDURES

Once you're sure the table saw and miter gauge are set up accurately, there are a couple simple procedures you can use to help ensure clean, accurate crosscuts.

First, always crosscut the workpiece with the good face up. This way, any chipout will be on the side that usually isn't seen. But sometimes it's important that both sides be cut cleanly. That's where a zero clearance insert comes in handy. It helps prevent chipout on the bottom side of the workpiece.

Second, you can often ruin a perfect crosscut by pulling the workpiece back along the side of the saw teeth after making a cut. Instead, slide the workpiece away from the blade after the cut. Then you can pull the miter gauge and workpiece back.

**Repetitive Cuts** – Finally, being able to make a perfect crosscut isn't of much use if you can't repeat it on a number of workpieces so they're all cut to the the same length.

Marking each piece with a pencil, and then hoping all the marks *and*

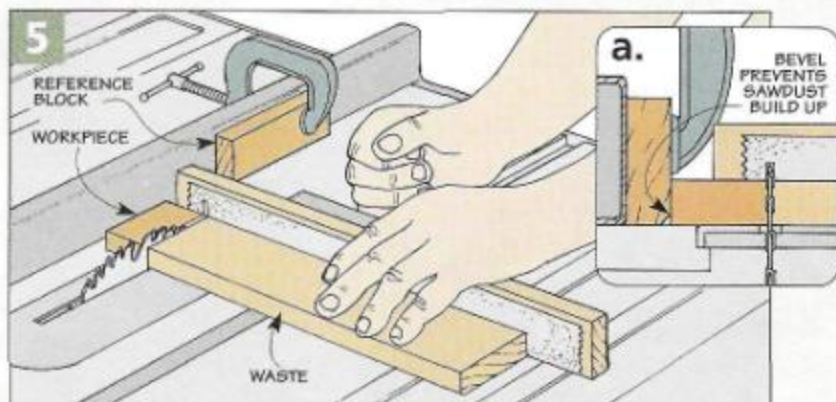
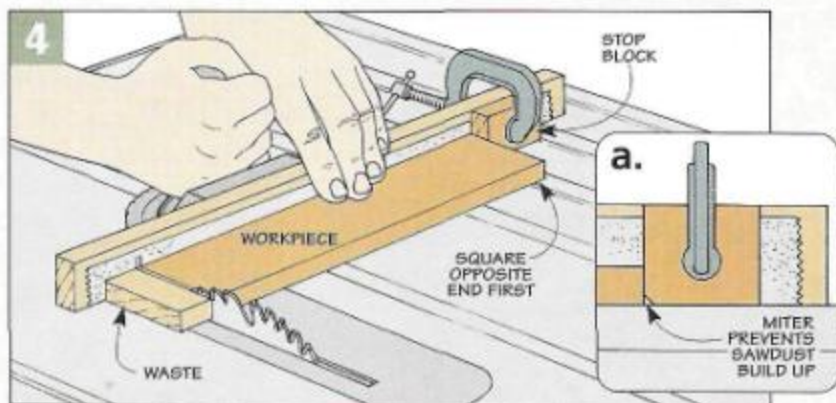

cuts are accurate is nearly impossible. Instead, I make repetitive cuts by using a two-step procedure, as you can see in Figures 4 and 4a.

The first cut is made with a stop block positioned so the piece is cut slightly (about  $1\frac{1}{2}''$ ) longer than the finished length you want. (This

ensures that both ends of each workpiece will end up perfectly square.)

Then, all you need to do is reset the stop block, flip each piece end-for-end, and cut them all to final length, as in Figure 4. By using the same setup (and pushing the workpiece against the stop block), you can be sure they're all exactly the same length with perfectly square ends.

**Short Pieces** – I'm not quite as comfortable using this procedure to cut short pieces all the same length. So instead, I clamp a scrap piece to the rip fence and use it as a reference block (Figures 5 and 5a).

It's okay to use the rip fence along with the miter gauge as long as the block provides enough clearance so the cutoff can't bind between the blade and fence. It also helps if the auxiliary fence extends to support the cutoff piece and pushes it all the way through and beyond the saw blade.

**Crosscut Blade** – Finally, if you really want a glass-smooth cut, you can install a *crosscut* blade. For more on this, see the box at left. 🛠️

## Crosscut Blade

One way to a more perfect crosscut is to use a dedicated crosscut blade (see photo at right).

**Teeth** – So what makes a crosscut blade work so much better? The main reason has to do with the number and design of the teeth on the saw blade.

A crosscut blade has more teeth than a typical saw blade. (Mine has 80). Plus, the teeth are ground with alternate, top bevels. These two things allow the blade to make tiny shearing cuts — resulting in a super-smooth cut.

**Teflon** – You might also notice a slick coating on some crosscut blades. This minimizes any heat buildup resulting in less burning and a smoother cut. For sources of crosscut blades, refer to margin on page 35.

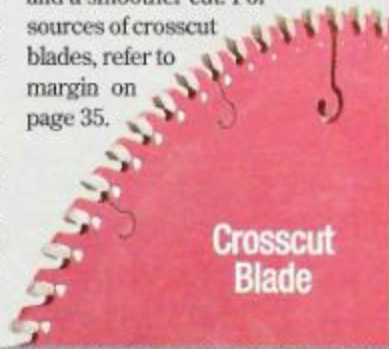

# Wall-Mounted Router Storage System

*With a handy, revolving bit carousel on top and drawers below, this expandable storage system is the answer to all your router storage needs.*



**T**his project grew out of a simple need — to provide a convenient place to store router bits. The most common solution might be to just drill a few rows of holes in a board. But there's a problem with this arrangement. It seems like the bit you need is always at the back, forcing you to reach over all the other bits (hopefully without getting cut or scratched in the process).

**Carousel** — The answer to this problem was really pretty simple. Instead of just a board, the router bits fit into holes drilled in a round, double-decker tray, or "carousel." This carousel rotates on a lazy-Susan, making it easy to find the bit you are looking for. And although the carousel doesn't take up much space, it can hold 37 individual bits.

But after coming up with the idea for the carousel, we started thinking about how nice it would be to have room to keep other router accessories. Pretty soon, what had started

as a project just for storing bits expanded into the storage system shown here.

But the nice thing is that this project can still be as simple or as elaborate as you wish to make it. That's because we designed it to be modular. Each section stacks on top of the one below it. So you can build just the router bit carousel and a drawer, like you see in the inset photo above. Or you can build the whole thing, which includes three drawers and a storage compartment for your router.



**Carousel**

A Large Disks (2)	12 x 12 - 1/2 Ply.
B Small Disk (1)	8 x 8 - 1/2 Ply.
C Base (1)	12 1/4 x 12 1/4 - 1/2 Ply.

**Drawer Units**

D Case Tops/Bottoms (6)	12 1/4 x 12 1/4 - 1/2 Ply.
E Small Case Sides (2)	3 x 12 1/4 - 1/2 Ply.
F Medium Case Sides (2)	4 x 12 1/4 - 1/2 Ply.
G Large Case Sides (2)	5 x 12 1/4 - 1/2 Ply.
H Small Case Back (1)	2 3/8 x 12 - 1/2 Ply.
I Medium Case Back (1)	3 3/8 x 12 - 1/2 Ply.
J Large Case Back (1)	4 3/8 x 12 - 1/2 Ply.
K Small Drawer Frt./Back (2)	2 1/8 x 11 5/8 - 1/2 Ply.
L Medium Drawer Frt./Back (2)	3 1/8 x 11 5/8 - 1/2 Ply.
M Large Drawer Frt./Back (2)	4 1/8 x 11 5/8 - 1/2 Ply.
N Small Drawer Sides (2)	2 1/8 x 11 1/2 - 1/2 Ply.
O Medium Drawer Sides (2)	3 1/8 x 11 1/2 - 1/2 Ply.
P Large Drawer Sides (2)	4 1/8 x 11 1/2 - 1/2 Ply.
Q Drawer Bottoms (3)	1 1/4 x 11 5/8 - 1/4 Hdbd.

**Router Compartment**

R Top/Bottoms (2)	12 1/4 x 12 1/4 - 1/2 Ply.
S Sides (2)	12 1/4 x 12 1/4 - 1/2 Ply.
T Back (1)	12 x 11 1/4 - 1/2 Ply.

**Hardware**

- (1) 6" Lazy-Susan
- (8) #6 x 3/8" Rh Sheet Metal Screws
- (3) 4" Drawer Pulls w/Screws
- (optional) 1/4" I.D. x 1/2" O.D. - 1/2" Nylon Bushings

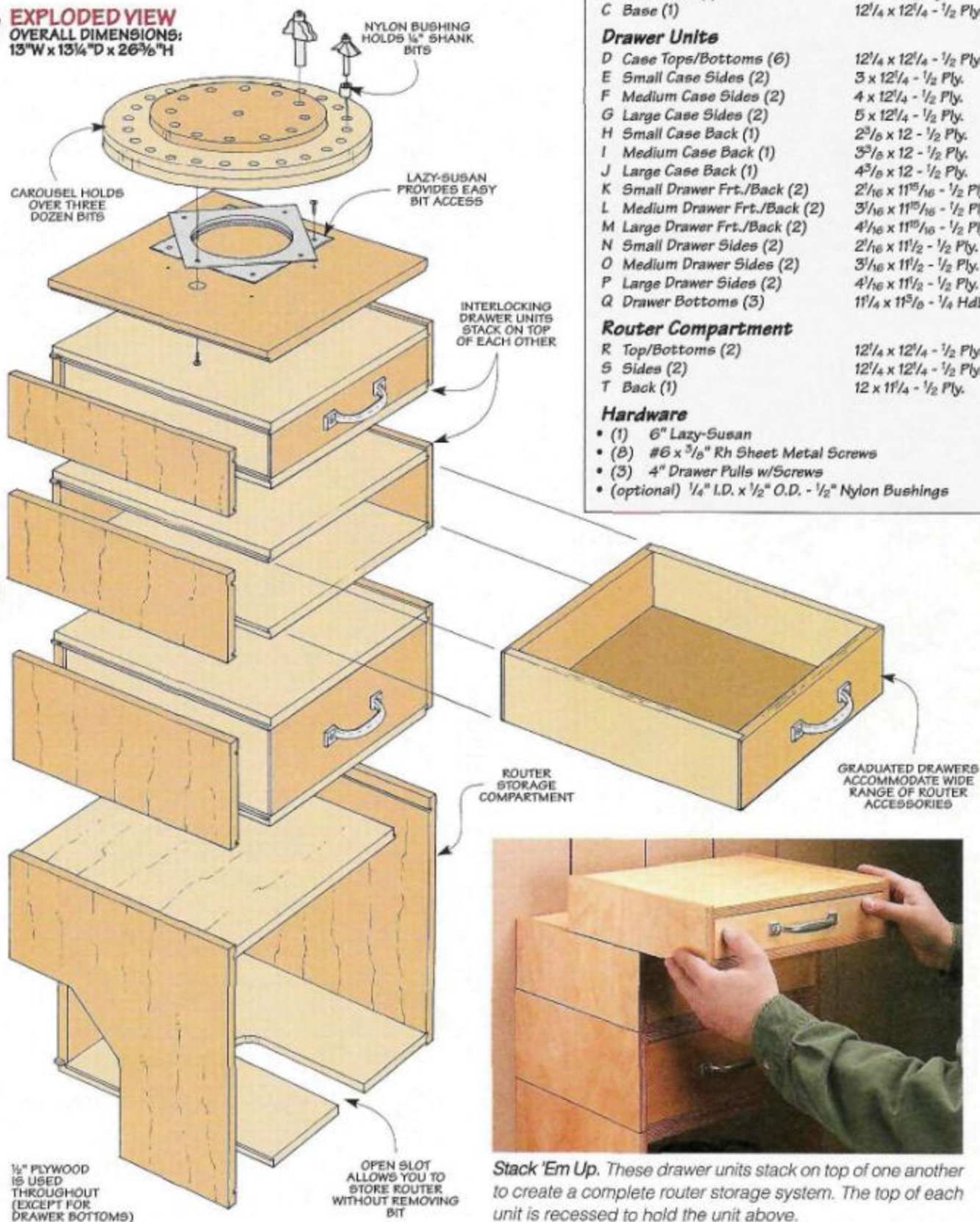
**EXPLODED VIEW**  
OVERALL DIMENSIONS:  
13"W x 13 1/4"D x 26 3/8"H

**Stack 'Em Up.** These drawer units stack on top of one another to create a complete router storage system. The top of each unit is recessed to hold the unit above.

## Router Bit Carousel



**Nylon Bushing.** In order to accommodate  $\frac{1}{4}$ " shank router bits, a nylon bushing can be used to reduce the size of the hole.

This storage center is made up of three main sections — a carousel, a set of drawers, and an open router storage compartment. The carousel is really the heart of the project. It can store over three dozen router bits. And the top of the carousel revolves to make it easier to find the bit you're looking for. Since this project is expandable, you can start off by making just the carousel if you want. Then build the other components as your storage needs grow.

As you can see by looking at the overview drawing in Figure 1, there aren't a whole lot of parts to the carousel. The round, revolving tray is a "sandwich" made up of three layers of  $\frac{1}{2}$ " plywood. (I used Baltic birch.) The square base of the carousel is just a single layer of plywood. And in between the two sections is the lazy-Susan hardware that allows the top to rotate.

To build the carousel, start by cut-

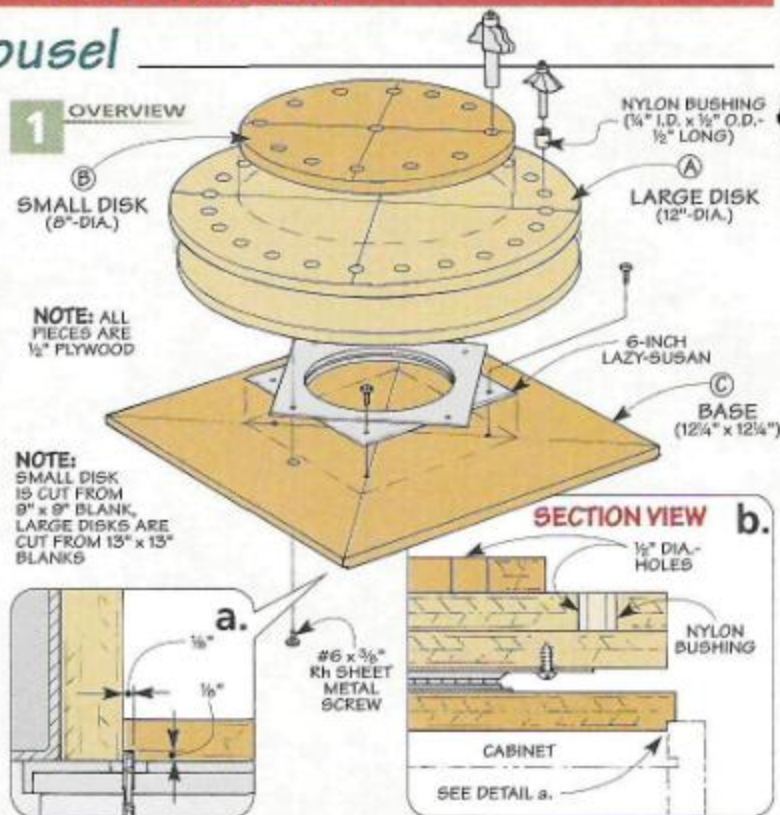

**NOTE:** ALL PIECES ARE  $\frac{1}{2}$ " PLYWOOD

**NOTE:** SMALL DISK IS CUT FROM  $9" \times 9"$  BLANK, LARGE DISKS ARE CUT FROM  $13" \times 13"$  BLANKS

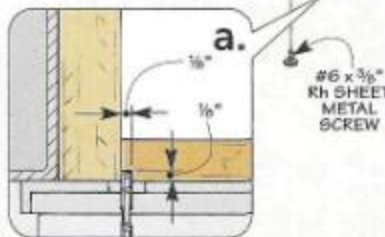

ting three square, oversized blanks for the two large disks (A) and one small disk (B) that make up the tray. Now draw diagonal lines across each blank to locate the center. Then use a compass to draw an 8"-dia. circle on the small blank and a 12"-dia. circle on one of the large blanks.

You can lay out the holes for the router bits using the pattern shown in Figure 2. This pattern is one-fourth of the actual size. So you'll need to make a photocopy of it at 200%. Then make a photocopy of

the copy, again at 200%.

The holes on the outer track of the pattern are for the large blank, and the holes on the inner track are for the small blank. I used an awl to mark the hole locations through the pattern, as shown in Figure 2. (Note: Only one of the large blanks will be drilled with holes. The other one can be set aside for now.)

I have a mix of  $\frac{1}{2}$ " and  $\frac{1}{4}$ " router bits. But instead of drilling two different sizes of holes, I made all the holes  $\frac{1}{2}$ ". Then I used nylon bushings to hold my  $\frac{1}{4}$ " bits, as seen in the photo in margin at left. This way, you'll be able to accommodate any size bit you might add later.

The holes are drilled all the way through the plywood (Figure 3). This way, when the disks are glued together, the router bits will rest solidly on the layer below.

After I drilled the holes, I noticed that some of my  $\frac{1}{2}$ " shank router bits fit rather snug in the  $\frac{1}{2}$ "-dia. holes. So before going any further, I wrapped some sandpaper around a dowel and quickly sanded each hole to enlarge the opening slightly.

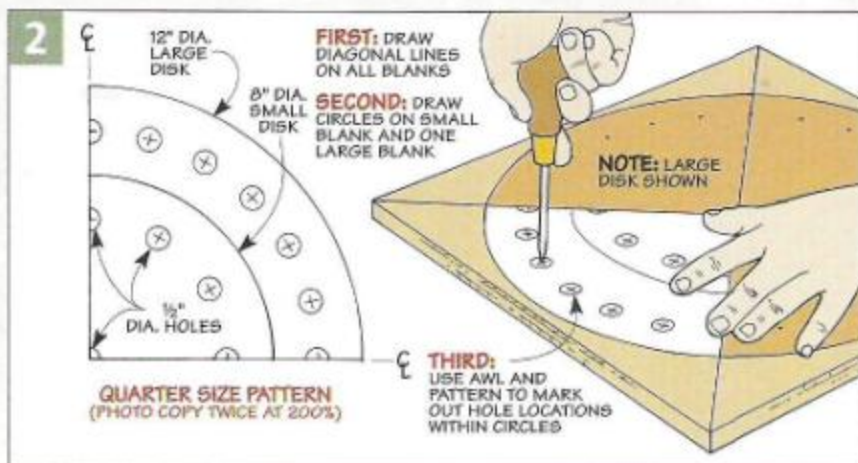

**QUARTER SIZE PATTERN**  
(PHOTO COPY TWICE AT 200%)

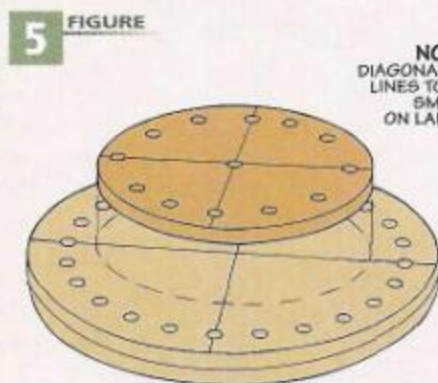
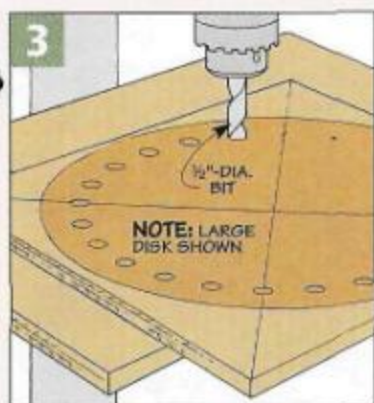

The disks can be cut from the blanks on a band saw (Figure 4). Before cutting out the two large disks, I glued the blanks together. Just make sure that when you do this, the diagonal lines you drew on both blanks are facing out. (You will need these layout lines later when mounting the lazy-Susan hardware.) You also want to keep the glue away from the holes in the top blank.

The band saw left the edges of the disks a little rough, so I sanded them smooth. Then the small disk is glued down to the top of the other two disks, as shown in Figure 5.

**Base** – The base (C) of the carousel is just a square piece of 1/2" plywood, as shown in Figure 1. A small rabbet is cut along each side of the base to allow it to stack on top of the other components of the storage cabinet (Figure 1a). Note: If you are only building the carousel, you can skip cutting these rabbets.

**Lazy-Susan** – The upper section of the carousel swivels on a lazy-Susan

(see page 35 for sources). As you can see in Figure 6, this hardware is nothing more than a couple of metal plates that ride on ball bearings.

To mount the lazy-Susan, start by centering it on the bottom of the upper section of the carousel, just like you see in Figure 6. You can use the diagonal lines drawn earlier on the bottom disk to help center the screw hole locations and drill pilot holes for the mounting screws.

The next step is to flip the lazy-Susan over and lay out the holes on the base of the carousel, as shown in Figure 7. Again, you can use the diagonal lines to help center the lazy-Susan hardware.

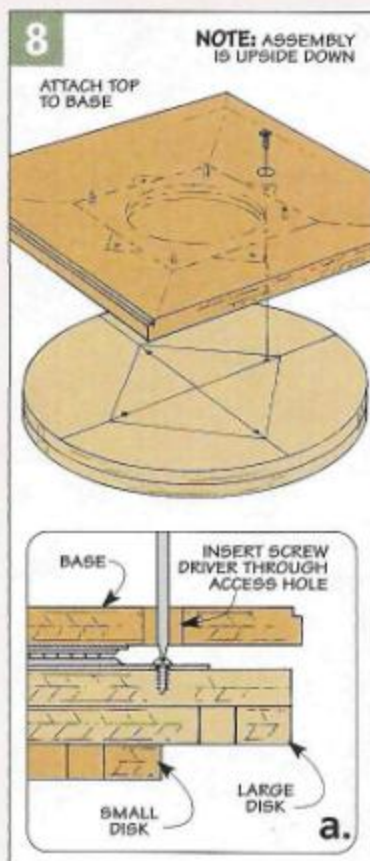
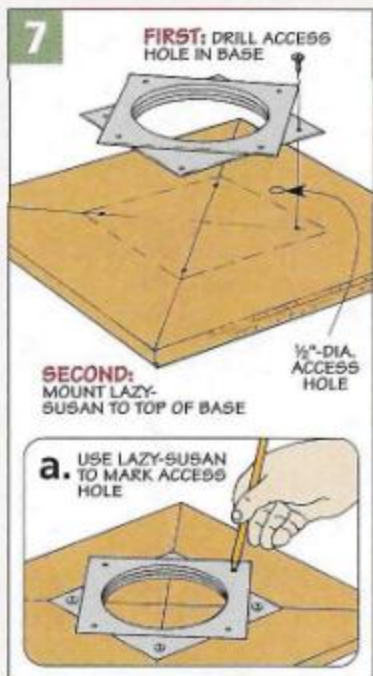
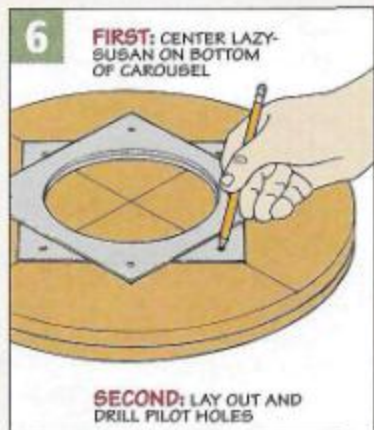

**Access Hole** – As you can see in Figure 7a, you'll also need to lay out and drill an access hole in the base. This 1/2"-dia. hole will allow you to insert a screwdriver through the base to attach the lazy-Susan to the top. Once this is done, the lazy-Susan can be attached to the base.

Finally, the upper section of the carousel is attached, just like you see in Figures 8 and 8a. For a tip on inserting the screws into the pilot holes, see photo in the margin at right.



**Glue Stick Trick.** To hold the screws to your screwdriver while installing the lazy-Susan, try using a dab of glue from a glue stick.

## Drawer Units

The carousel provides plenty of storage for router bits. But it won't hold your other router accessories — things like wrenches, bushings, collets, and router base plates. For these items, the drawer units shown here are just the ticket.

If you take a look at Figure 9, you can see that each drawer and case is a separate unit. So you can choose to build just one or two of the drawer units for now and add more later as you need them. You'll also notice that the drawers are each a different size (height). But aside from this difference, the construction of the drawers is the same.

The interesting thing about these drawer units is the fact that they stack on top of one another. The sides of the drawer case extend past the top, creating a lip on each side. These lips help to lock the next drawer unit above in place, as you can see in Figure 9a.

**Cases** — I started building the drawer units by making the cases. Each one has an identical *top* and *bottom* (D), a pair of *sides* (E, F, G), and a *back* (H, I, J). All of these

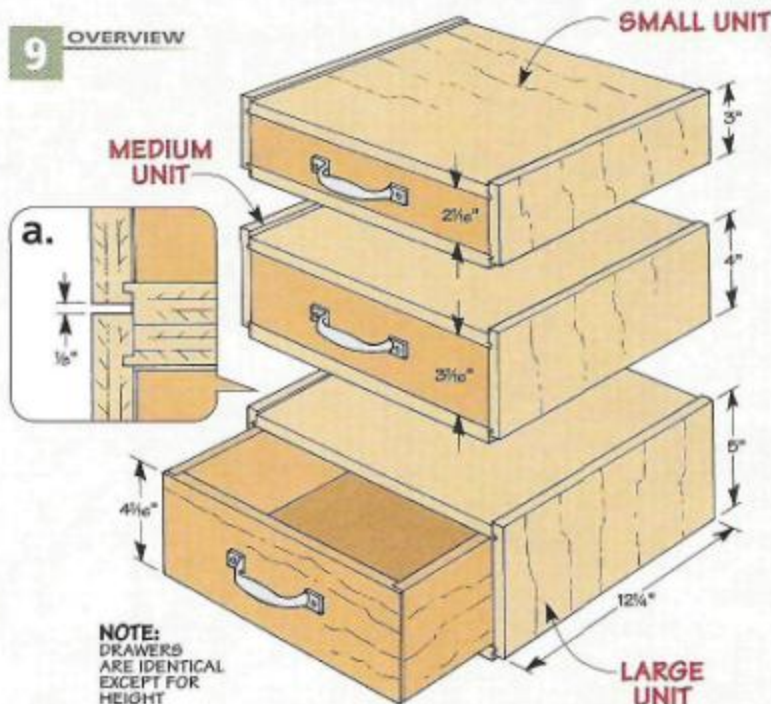

pieces are cut from 1/2" plywood.

Each case is joined with tongue and groove (or dado) joints. Tongues cut on the ends of the top and bottom fit into dados cut in the sides. But if you take a look at

Figure 10a, you'll see that the tongues and dados are slightly offset. This is what creates the "lip" on the sides of the case that I mentioned earlier. And the sides of each case also stop short of the bottom, creating a notch that runs along the side of each case. This allows the bottom of the case to lock into the top of the case beneath it.

I found it easiest to cut the dados first and then cut the tongues to fit. The dados are only 1/8" wide, so you can make them by cutting a kerf with an ordinary saw blade. You'll need to cut two dados on each side — one to hold the top and one to hold the bottom. But the location of these dados is slightly different. Take a good look at Figure 10a to see what I'm talking about.

Tongues are then cut on both the top and bottom pieces to fit in the dados on the side pieces. The tongues are identical on both the bottom and the top pieces, so you only need to make one setup on your table saw.

The back of the case is also held in place with tongue and groove joints.

**SIDE VIEW  
(CROSS SECTION)**

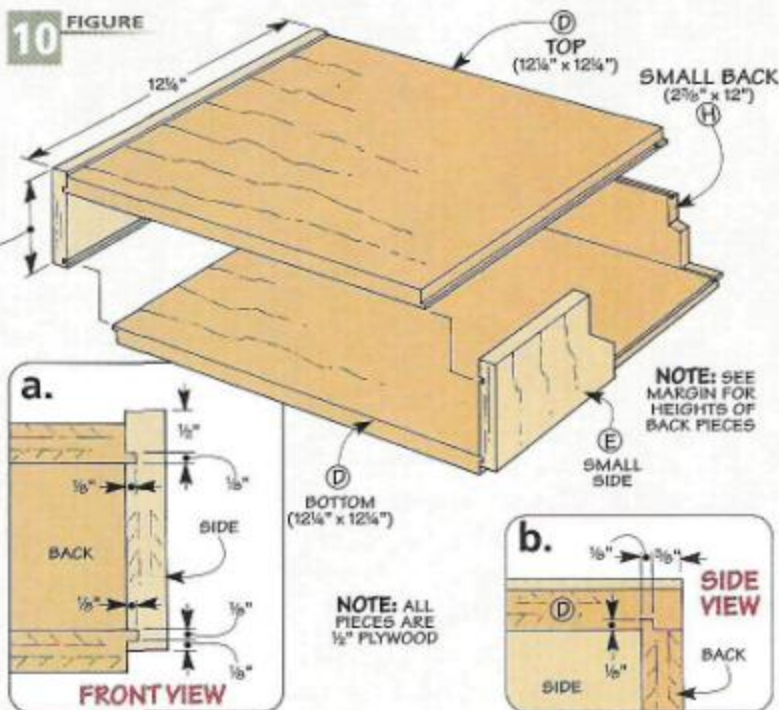
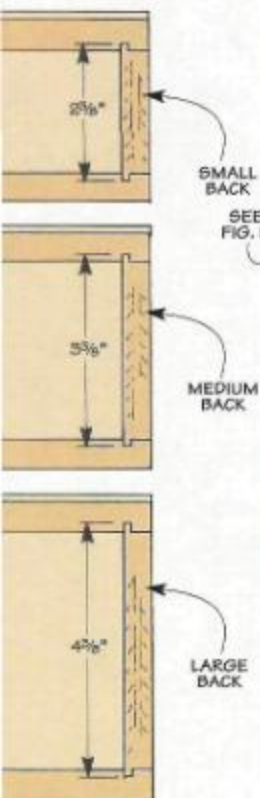

A groove is cut near the back edge of both the top and the bottom of the case. Then tongues are cut on the back of the case to fit these grooves. For a closer look, see Figure 10b. (The ends of the back simply butt against the sides of the case.)

After cutting all the tongue and groove joints, you can assemble the cases. They are simply glued together and clamped up along the sides and back. The tongue and groove joints should help to square up the openings in the cases.

**Drawers** - Once all the cases are completed, you can start making the drawers to fit inside them. I sized each drawer slightly smaller than its opening, in order to leave a  $\frac{1}{16}$ " gap on the sides and at the top of the drawer.

From looking at Figure 11, you can see that the drawers couldn't be much simpler. They are made up of a *front* and *back* (K, L, M) and two *sides* (N, O, P). The ends of the front and back are rabbeted to hold the sides (Figure 11b). And a groove is cut on the inside face of

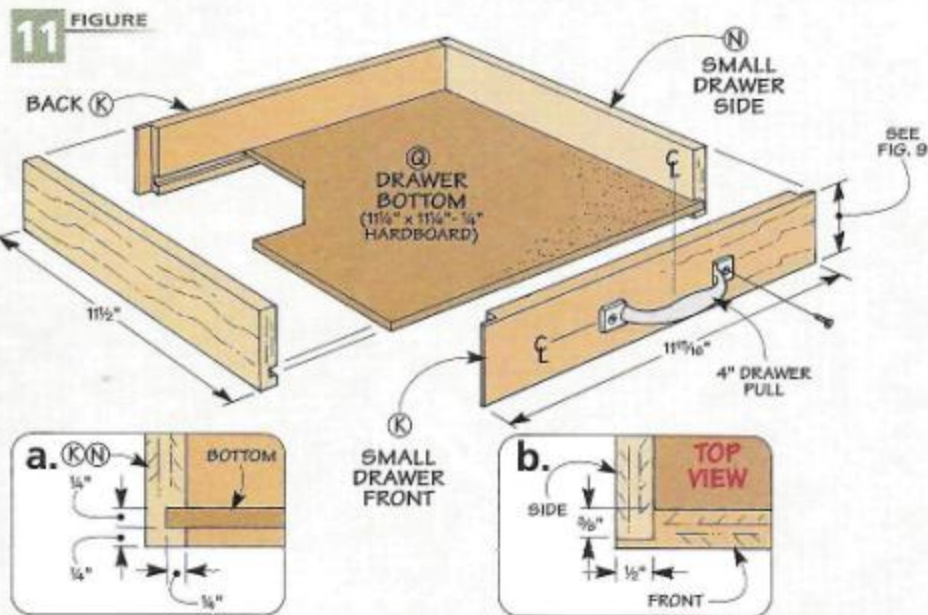

all four pieces to hold a  $\frac{1}{4}$ " hardboard bottom (Q). You can see this groove in Figure 11a.

**Pulls** - After the drawers are assembled, a pull can be added to the front of each one. These should be centered on the drawer fronts from top-to-bottom and side-to-side.

One note on attaching the drawer pulls. I found that the screws that came with the pulls I used were a hair too long. So I had to file a little bit off the end of each screw (about  $\frac{1}{8}$ ") so that they wouldn't break through the inside of the drawer fronts.

## Router Compartment

The last component of the storage cabinet is the router compartment. It's just an open box that holds the router. Like the drawer cases, it's made up of a *top* and *bottom* (R), a couple of *sides* (S), and a *back* (T). The only difference is the location of the dadoes in the sides that hold the bottom (Figure 12c).

Before assembling the compartment, I cut a slot in the bottom. This slot allows you to leave a router bit chucked up in the router when you store it in the compartment.

To make the slot, just drill a hole in the center of the bottom panel and then cut out the rest of the waste with a sabre saw or band saw.

After the compartment is assembled, it can be screwed through the back directly to the wall. Then the drawer units and carousel can be stacked on top of it.

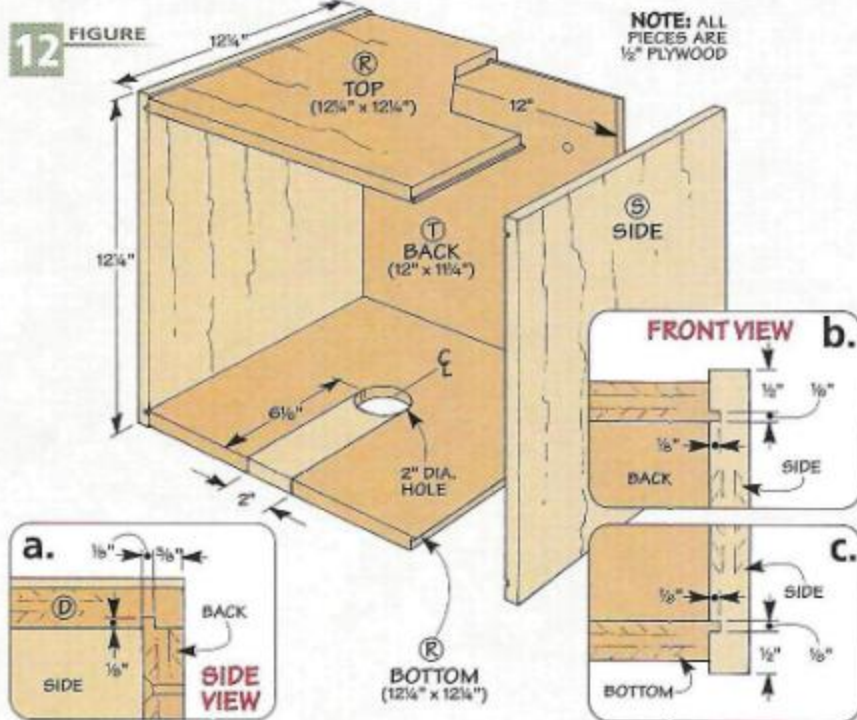

# Spade Bit Tote

*This handy tote will keep your spade bits safe and accessible — wherever you need to take them.*

**M**any drill bit sets come with a cheap plastic case that often falls apart. So when I saw the pictures for a spade bit tote sent by Gerrit De Boer from Grandville, Michigan, I wanted to pass it on.

What makes this spade bit tote unique is that the bits are stored in tilt-out, removable holders, as you can see in the photo.

Besides keeping the spade bits in order (and separated to avoid damaging any of the edges), you can tote the entire set (or a single holder) right where you need it.



## CASE

I started on the tote by making the case that the holders slip into. Note: The tote is sized for a 12-piece set with bits up to 6<sup>3</sup>/<sub>4</sub>" long.

The 1/2" plywood top/bottom (A) and sides (B) are cut to the final sizes shown in Figure 1. They're sized to

fit all three holders (and bits) inside the case with a little "wiggle" room and to allow for the joinery that holds the case together.

**Joinery** – There isn't much to the joinery. First, there's a rabbet cut at each end of the top/bottom. And shallow (1/4") grooves near the back edge of each piece hold the 1/4" hardboard back (C) in place (Figure 1a).

**Holder Slots** – Before gluing the case together, you'll need to create the slots that allow the holders to tilt forward and slide out of the case.

Creating the slots is a three-step process. I started by cutting a dado in the two sides. Then to form the bottom of the slots that the holders drop into, drill three shallow (1/4") counterbores in each side just below the dado, as illustrated in Figure 1a. Finally, complete the slot by removing the waste with a chisel and then chamfering the corners slightly.

**Hinge Notches** – There's one last thing to do before gluing the case together. And that's to cut two notches in one side to accept the door hinges (Figure 1).

After gluing the case together, you'll need to add a small 1/2"-square stop (D) flush with the front edge of the bottom, as you can see in Figure 1. This stop keeps the holders from tipping too far forward when you want to remove a bit.

## 1 OVERVIEW

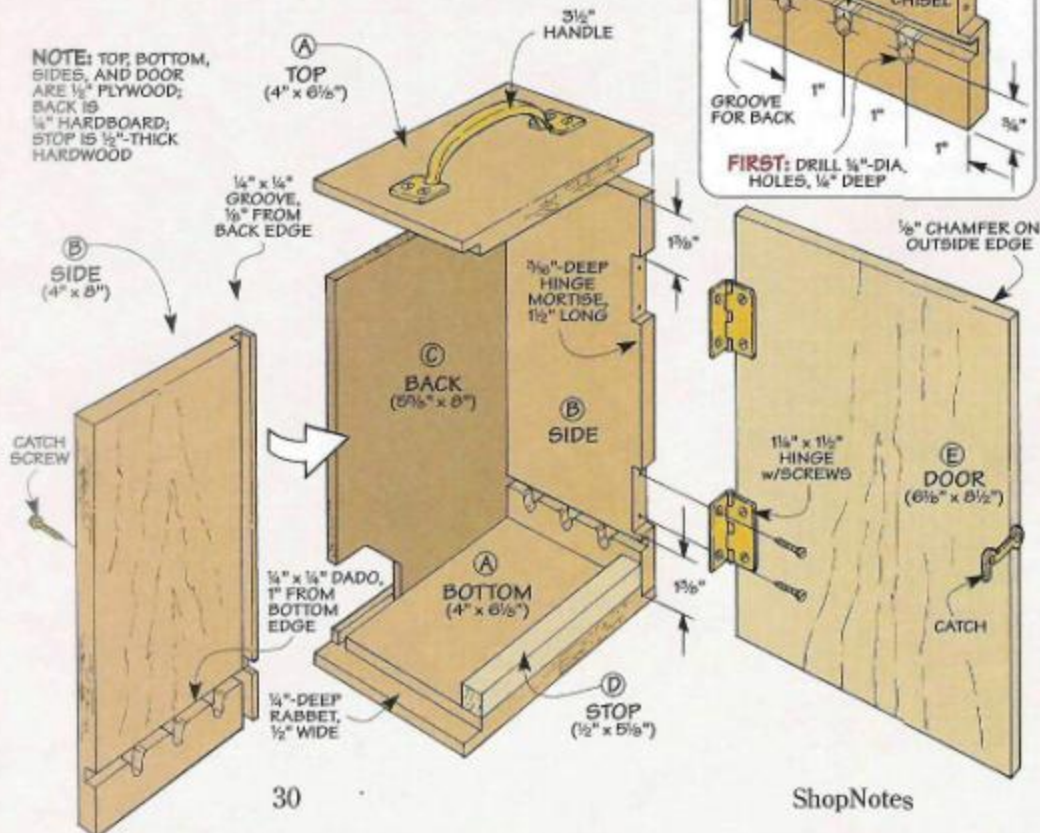

Finally, all that's left to complete the case is to cut a door (E) to size to match the outside dimensions of the case. After sanding a small chamfer around the outside edge, attach the door to the case. Then add a handle and catch (Figure 1).

**HOLDERS**

With the case complete, you're ready to make the holders for the spade bits. Other than the number of holes in each holder, they're identical. Each one consists of a top (F) and bottom (G) connected by a pair of dowels, as in Figure 4.

The problem is the parts are rather small to work with. So I started with a 2<sup>5</sup>/<sub>8</sub>"-wide blank cut extra-long (Figure 2). This makes it easier to work with.

**Drill Holes** – The first step is to lay out and drill the holes for each bit. The holes start 1" in from each "end." And then they're spaced evenly in between (Figure 2).

**Groove** – To prevent the bits from spinning in place and nicking an edge, the "head" of each bit fits into a groove cut along the top edge (see Bit Cross Section in Figure 4). Finally, to allow the holders to tip forward, rout (or sand) a small roundover along the lower edge (Figure 2).

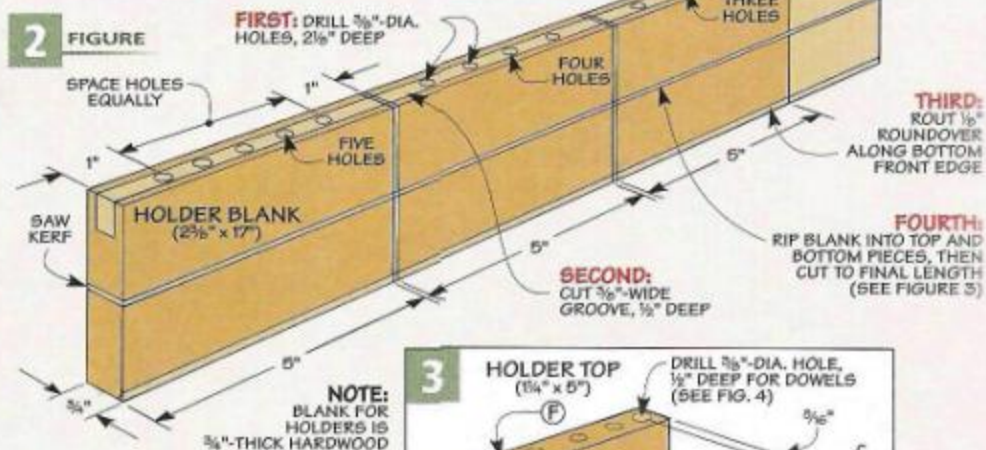

**Cut to Size** – Now you're ready to cut the holders to final size. To do this, first rip the blank to form a top and bottom half. Then crosscut the pieces to final length (Figure 2).

To connect the top and bottom of each holder, you'll need to add a pair of dowels. They fit into counterbores drilled in the mating faces of the top and bottom (Figure 3 and Dowel Cross Section in Figure 4). But before gluing the dowels in place, the bottom piece needs a little more work.

First, to make it easy to guide the shank of the bit into the bottom piece, I chamfered the holes, as shown in Figure 3. And then to allow each holder to pivot, I added a pin at each end of the bottom piece, as

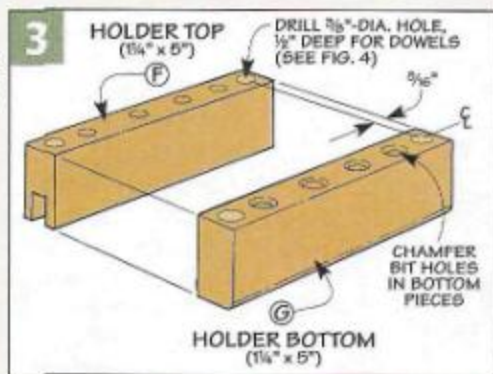

shown in Figure 4a. The pins are just small dowels sized to provide 1/16" clearance between the end of the dowel and the dado in the case.

**Assembly** – Once that's complete you can glue the top and bottom pieces of each holder together. After the glue dries, you can slip your bits into the holders and then slide the holders safely inside the case.

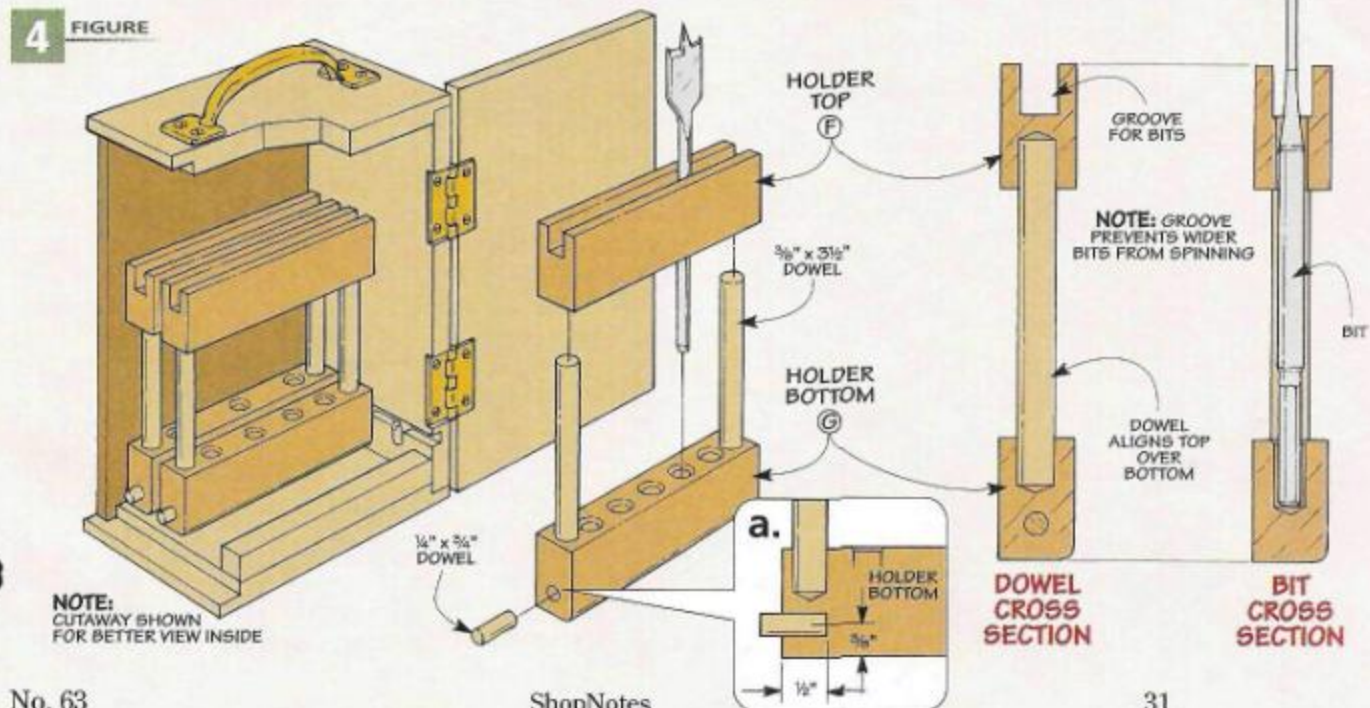

# Shop Talk

## Choosing the Right Table Saw

**W**hich table saw should I buy? It's probably one of the most frequently-asked questions among woodworkers. This isn't surprising, given the fact that the table saw is the heart of most woodworking shops. (And it's also probably one of the more expensive tool purchases you will make for your shop.)

Whether you're just starting out or are looking to upgrade from the saw you already own, shopping for a table saw can be almost as intimidating as shopping for a used car. There's a dizzying array of brands and models on the market, not to mention options and accessories. But before you start comparing specific models, you need to know the type of saw you're looking for.

Essentially, there are three basic types of saws — benchtop, contractor's, and cabinet saws. And despite what you might think, there is a lot more to consider than price alone. While all of these saws will cut wood, each one serves a slightly different purpose and has its own strengths and weaknesses. The trick is to determine

which type is best for *you*.

You can start by asking yourself what kind of woodworking you plan on doing. If you're going to be making birdhouses and small boxes

exclusively, shelling out the money on a cabinet saw is probably overkill. On the other hand, if you plan on building a lot of projects using sheet goods, you'll probably find yourself quickly frustrated with a benchtop saw.

Beyond this, however, there are some key features that separate the three types of saws, and we've outlined these below. Armed with this information, you will be able to make a better-informed decision before plunking down your hard-earned cash.

Finally, keep in mind that the table saw doesn't make the woodworker. There are plenty of very talented woodworkers who turn out large, beautiful projects with small, modestly-priced table saws. By the same token, even the best saw available won't do you much good unless you take the time to learn and develop the skills to use it properly.

### Benchtop Saw

When benchtop saws first arrived on the scene, they seemed to be marketed primarily to the construction and building trades. But I've met a large number of woodworkers who turn out some pretty amazing projects on benchtop saws.

The two main things that benchtop saws have going for them

is their portability and their price. Many benchtop saws are small enough and light enough to toss in the trunk of a car and take with you anywhere. And you can purchase a benchtop saw for as little as \$100 (although fancier models with more features sell for upwards of \$500).

**Motor** — A common trait of benchtop saws is they operate on universal motors (the same kind of motor that you'll find on your router). On some benchtops, the blade mounts directly to the shaft of the motor. On others, power is transferred from the motor by a small, flat, rubber belt.

Universal motors are louder and typically less powerful than comparable induction motors. And this is probably the biggest drawback of a benchtop saw. For cutting up framing lumber or thin hardwoods they're fine. But benchtop saws aren't designed for heavy-duty cutting day-in and day-out. And if the

motor on a benchtop burns out, it's often cheaper to buy a new saw than to have the motor repaired.

**Lightweight** — Benchtop saws also tend to have more plastic and lighter-weight metal parts on them than larger saws. The small, aluminum table tops on most bench saws help to keep the weight of the saw down but also make it difficult to work with sheet goods or large stock.

Another thing to look at if you are considering a benchtop saw is the rip fence. Many of the fences on benchtop saws leave a lot to be desired. Some of the more expensive benchtops have decent fences, but the prices of these saws can easily approach the price of a low-end contractor's saw.

Despite their limitations, a lot of woodworkers find that a benchtop saw suits their needs just fine. Just keep in mind that a benchtop saw probably won't last as long and definitely won't be able to do everything that a larger saw can.

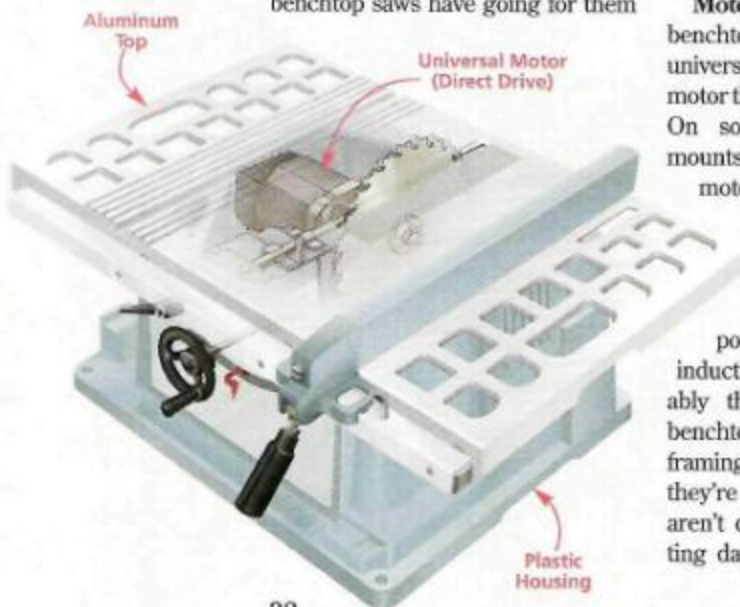



## Contractor's Saw

I'd be willing to bet that you'll find more contractor's saws in home woodworking shops than any other type of saw. That's probably because they strike a good balance between performance and price.

Costing anywhere from \$350 to \$800 (depending on options), contractor's saws fall in between benchtops and cabinet saws. But in terms of performance, they are a dramatic step up from benchtop saws.

**Power** – The most noticeable difference is in the power of the saw. Contractor's saws use an induction motor (typically rated at 1½hp). This provides a lot more power than the universal motors on benchtop saws.

Another difference is the way in which the motor is mounted. On most contractor's saws, the motor hangs off the back of the saw, and power is transferred to the blade through pulleys and a V-belt. So if the motor ever fails, replacing it is not a problem.

## Cabinet Saw

Cabinet saws get their name from the fact that the saw and motor are enclosed within a cabinet-type base. Smooth-running and loaded with power, once you've tried a cabinet saw, it's difficult to go back to using anything less. There are several factors that go into making a cabinet saw such a joy to use.

For one thing, most cabinet saws have large (3 hp or more), heavy-duty motors. This gives you plenty of power for cutting through thick hardwoods without having to worry about bogging down the motor.

**Enclosed Motor** – Just as important as the size of the motor is the way in which it is mounted. Instead of hanging off the back of the saw, the motor on this saw hangs underneath the table top, entirely enclosed within the cabinet. A set of two or three V-belts are used to transfer power smoothly and efficiently to the blade arbor. And the enclosed

**Size** – The contractor's saw also has a larger table, which is a real plus when working with sheet goods. But it also means that the saw will take up more space.

Contractor's saws are usually sold with an open metal stand. These stands tend to flex and vibrate, which can cause the saw to shift out of alignment over time. And since the back and bottom of the saw are open, dust collection can be difficult.

**Rip Fence** – One of the big benefits of a contractor's saw is that there are a wide assortment of aftermarket accessories available, such as rip fences, table extensions, and blade guards. Adding an aftermarket rip fence (some saws now come with one from the factory) will greatly improve the accuracy (and your enjoyment) of the saw.

**Durability** – If you take a look under the top of a contractor's saw, you'll notice more differences. Most

contractor's saws have a cast iron trunnion assembly (the part that supports the saw arbor and allows the blade to tilt). Unlike aluminum or zinc, cast iron will last for decades.

For a home shop, a contractor's saw will do just about anything you could ask of it. And as an added plus, contractor's saws usually hold their value fairly well, making it easier if you decide to upgrade to a cabinet saw later on.

cabinet makes it easier to hook the saw up to a dust collector.

Cabinet saws have beefier trunnions and internal parts. Because of their heavier, more robust components, cabinet saws run smoother and require less frequent adjusting than either contractor's saws or benchtops.

While there may not be many downsides to owning a cabinet saw, there are a few. For one thing, they are heavy. This makes it difficult to move the saw around, which may be an issue if you have a small shop or you share shop space with the family car (although a mobile base can solve this problem).

**Voltage** – Additionally, most cabinet saws require 220-volt power. If you don't already have a 220-volt line in your shop, you will have to hire an electrician to install one.

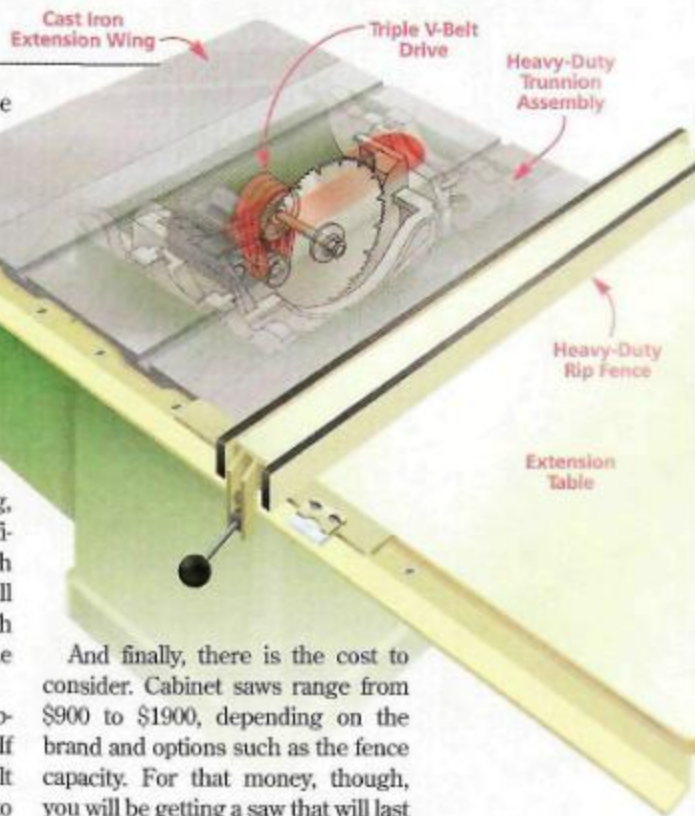
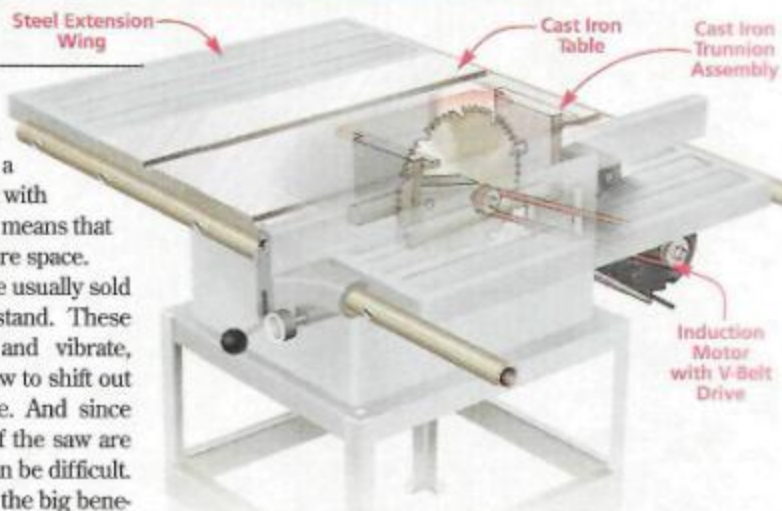

And finally, there is the cost to consider. Cabinet saws range from \$900 to \$1900, depending on the brand and options such as the fence capacity. For that money, though, you will be getting a saw that will last a lifetime, if not longer. 🛠️

# Tool Chest

When it comes to handling a wide variety of tasks, this detail sander has what it takes to get the job done.



## Fein MultiMaster

### Sources

- Fein Power Tools, Inc.:  
feinusa.com  
800-441-9878
- Japan Woodworker:  
japanwoodworker.com  
800-537-7520
- Klinge par'e:  
woodworkingshop.com  
800-228-0000

**S**anding is a chore. Especially when you need to work in tight areas, like between the chair spindles above, or sand into a corner, as you can see in the photo below. To solve this problem, I took a chance on a purchase that seemed a bit extravagant at the time — the *MultiMaster* detail sander from *Fein*.

But that purchase has paid for itself many times over since then. The *MultiMaster* offers precision control and smooth operation for a

wide variety of detailed sanding tasks.

Unlike other detail sanders I've used, the *MultiMaster* is a solidly-built, dependable machine. For starters, a quick turn of the dial allows you to adjust the speed of the sanding head (photo at left) from 12,000 oscillations per minute to 21,000.

At these speeds, you'd probably expect some hand-numbing vibration with any extended use. But that isn't the case. The *Fein MultiMaster* runs so smoothly, it's not at all unusual to have to double-check the setting just to know where it's at.

And the quality literally extends all the way to the power cord. It's a 14-foot long rubber cord that makes it easy to reach just about anywhere.

**Accessories** — But as you can guess by the name, you can do more than just sand with the *MultiMaster*. With the accessories that come with it (or the wide variety you can purchase separately), it's hard to come up with a task it can't handle.

A rigid scraper blade and flush-cut blade come as standard accessories. And changing to either one is just a

matter of loosening a single Allen screw with the provided wrench. The rigid scraper excels at removing old paint and wallpaper. And the flush-cut blade makes quick work in close quarters (like undercutting a door jamb).

If you're going to be doing a lot of sanding, there's even a dust extraction kit you can use to attach the *MultiMaster* to a shop vacuum for extremely clean sanding.

And for really heavy-duty work, consider a Professional Kit. This kit includes a smooth-cutting knife blade as well as carbide-tipped grout and rasp blades (about \$60.00).

**Cost** — As you may have guessed, this kind of capability (and quality) comes at a price. The basic *MultiMaster* kit will cost you \$180 - \$200. And adding in a few accessories might add another \$100 or so. Is it worth it? Definitely.

The smooth operation and quality results speak for themselves. My *MultiMaster* works as well today as it did when I bought it a few years ago (and it gets more use than ever). It's a purchase I've never regretted. As a matter of fact, one of the guys here asked to borrow it just the other day — a sure sign of a great tool. 🛠️



Disk  
Oscillates



▲ The *MultiMaster*'s smooth operation makes it easy to sand into tight places like the corner of this frame and panel door.

# Sources

## Crosscut Sled Hardware

The quality of the hardware can make or break a shop-made jig or fixture. And the Crosscut Sled on page 16 isn't any different.

To ensure the sled was accurate (and stayed that way), I used a few pieces of hardware available from *Rockler* (see margin).

**Miter Bar** – One of the keys to the accuracy of the sled is the miter bar. The one I used (Part No. 36786, \$11.99) has spring-loaded ball bearings installed along the edge of the

bar (see photo at right). So it's easy to "snug up" the fit of the bar just by turning a few set screws.

**Handle & Knobs** – Accuracy is important, but if the crosscut sled isn't comfortable or easy to use, it's likely to gather sawdust under a bench somewhere. So I was particular when choosing the handle and knobs.

The handle (\$1.99) is tall (4<sup>1</sup>/<sub>4</sub>" ), and the tapered design makes it comfortable to use. The handle only

comes with a brass insert (5/16"-18), so depending on your use, you may need to glue a threaded rod into the insert to create a stud.

But that's not the case with the knobs. The ones I used (Part No. 34238, \$1.29 each) came with a 1"-long stud (1/4"-20). All I needed to do was cut off a bit of the threaded portion. Note: Similar hardware is available from other sources, see margin.



## MAIL ORDER SOURCES

**Beta Diamond Products, Inc.**  
800-975-9009  
www.betadiamond.com  
Diamond Paste

**Lee Valley Tools**  
800-871-8158  
www.leevalley.com  
Rare-Earth Magnets,  
Knobs & Handle,  
Crosscut Blades

**Rockler**  
800-279-4441  
www.rockler.com  
Miter Bar, Knobs,  
Handle, Dust Hood,  
Crosscut Blades

**Woodcraft**  
800-225-1153  
www.woodcraft.com  
Diamond Paste Kit,  
Dust Hood

**Woodsmith Store**  
800-835-5084  
Crosscut Blades,  
Dust Hood

## Diamond Paste

Sharpening a chisel or plane iron isn't a task I particularly looked forward to. It can be a long, messy process. But after trying out the diamond paste sharpening technique detailed on page 9, it's almost enjoyable.

That's because diamond paste makes the whole process go faster with less mess. And the nice thing is there isn't much to setting up a complete sharpening system.

*Woodcraft* (see margin) offers a complete kit to get you started. It includes four syringes with 1 gram of each grit (30, 15, 6, and 3 microns) of diamond paste and a bottle of lubricant (shown at left), as well as the MDF blocks you'll need. This is a complete kit that sells for \$70.

We also located a company called *Beta Diamond Products* (see margin) that sells diamond paste and lubricant separately. (You will need to make your own MDF blocks though.)

The same four grits are available for \$30, but each syringe contains 2 grams of paste (other quantities are available). The bottle of lubricant (4 oz.) sells for \$3.



## Rare-Earth Magnets

The "secret" to making the Chisel Rack on page 6 work is a set of magnets. But not just any magnets.

**Rare-Earth Magnets** – The ones we used are *rare-earth* magnets (see photo). They're incredibly strong for their size. As a matter of fact, the 3/4"-dia. magnets we ordered only come in a "clump" of five (\$5.75) — with instructions on a couple simple methods for separating them once you receive them (see margin for source).

**Sizes** – As I mentioned, we used 3/4"-dia. magnets for the chisel rack. But depending on your needs, rare-earth magnets are available in sizes ranging from 1/4" up to 1" in diameter.

Although we "trapped" the magnets in counterbores, they can also be glued in place. (Epoxy provides the best "grip.") Since these magnets can be used on a wide variety of projects around the shop, you might want to order a set (or two) just to have some on hand.



## ShopNotes

- "Online Extras" - Plans, Patterns, & More
- Over 100 Woodworking Tips Online
- Forums for Woodworking, Tools, & Classifieds
- Visit Our Woodworking Shop Tours Gallery
- Project Plans You Can Download
- Catalog of Project Kits, Tools, Jigs, & Plans
- Links to Other Woodworking Sites
- Order *ShopNotes* & *Woodsmith* Back Issues

### Online Customer Service

Click on Subscriber Services at  
[www.shopnotes.com](http://www.shopnotes.com)

- Access your account status
- Change your mailing or email address
- Pay your bill
- Renew your subscription
- Tell us if you've missed an issue
- Find out if your payment has been received

[www.shopnotes.com](http://www.shopnotes.com)

## Scenes from the Shop

*Made out of bird's-eye maple and wenge, the chisel rack shown here provides an elegant resting place for some very special chisels. This set of ten hand-made Japanese chisels feature genuine sharkskin-covered handles. See page 6 for plans on building a rack for your own chisels.*



## Wall-Mounted Router Storage System

### Materials

#### Carousel

A Large Disks (2)	12 x 12 - 1/2 Ply.
B Small Disk (1)	8 x 8 - 1/2 Ply.
C Base (1)	12 1/4 x 12 1/4 - 1/2 Ply.

#### Drawer Units

D Case Tops/Bottoms (6)	12 1/4 x 12 1/4 - 1/2 Ply.
E Small Case Sides (2)	3 x 12 1/4 - 1/2 Ply.
F Medium Case Sides (2)	4 x 12 1/4 - 1/2 Ply.
G Large Case Sides (2)	5 x 12 1/4 - 1/2 Ply.
H Small Case Back (1)	2 3/8 x 12 - 1/2 Ply.
I Medium Case Back (1)	3 3/8 x 12 - 1/2 Ply.
J Large Case Back (1)	4 3/8 x 12 - 1/2 Ply.
K Small Drawer Frt./Back (2)	2 1/8 x 11 5/8 - 1/2 Ply.
L Medium Drawer Frt./Back (2)	3 1/8 x 11 5/8 - 1/2 Ply.
M Large Drawer Frt./Back (2)	4 1/8 x 11 5/8 - 1/2 Ply.
N Small Drawer Sides (2)	2 1/8 x 11 1/2 - 1/2 Ply.
O Medium Drawer Sides (2)	3 1/8 x 11 1/2 - 1/2 Ply.
P Large Drawer Sides (2)	4 1/8 x 11 1/2 - 1/2 Ply.
Q Drawer Bottoms (3)	11 1/4 x 11 3/8 - 1/4 Hdbd.

#### Router Compartment

R Top/Bottoms (2)	12 1/4 x 12 1/4 - 1/2 Ply.
S Sides (2)	12 1/4 x 12 1/4 - 1/2 Ply.
T Back (1)	12 x 11 1/4 - 1/2 Hdbd.

24" x 48" - 1/4" HARDBOARD

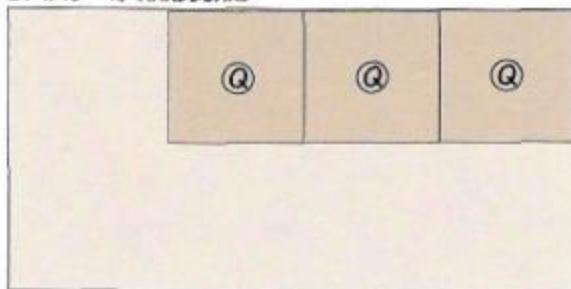

48" x 96" - 1/2" PLYWOOD

