

LEARN HOW TO
Sharpen Drill Bits
LIKE A PRO

SPECIAL: SPRAY FINISHING TIPS & TECHNIQUES

ShopNotes

Vol. 10

Issue 55

Dust Collection UPGRADE

Clear the air with this
shop-made separator
& 3-tool control box



Plus

◆ **Multipurpose Store-All**
Small-scale lumber yard on wheels

◆ **Two-Handled Push Block**
A must-have accessory for your router table



ShopNotes

Issue 55 JANUARY 2001

PUBLISHER Donald B. Peschke
EDITOR Tim Robertson
ASSOCIATE EDITOR Bryan Nelson
CONTRIBUTING EDITOR Joel Hess
ART DIRECTOR Cary Christensen
SR. GRAPHIC DESIGNER Kurt Schultz
SENIOR ILLUSTRATORS Roger Reiland
 Mark Higdon

CREATIVE RESOURCES

Creative Director: Ted Krulik • *Project Developer:* Ken Munkel • *Project Coordinator:* Kent Welsh • *Shop Manager:* Steve Curtis • *Shop Craftsmen:* Steve Johnson • *Senior Photographer:* Crayola England

SPECIAL PUBLICATIONS

Executive Editor: Douglas L. Hicks • *Sr. Graphic Designer:* Chris Glowacki • *Graphic Designers:* Vu Nguyen, April W. Janning • *Asst. Editors:* Craig Ruesgesser, Joel A. Hess

CIRCULATION

Subscription Services Director: Sandy Baum • *New Business Dir.:* Wade Klingbeil • *Circulation Marketing Analysts:* Kris Schlemmer, Paula DeMatteis • *Revenue Manager:* Paige Rogers • *Sr. Graphic Designers:* Mark Hayes, Robin Dowdell • *Billing & Collections Mgr.:* Rebecca Cunningham • *Prom. Mgr.:* Rich Jenkins

CORPORATE SERVICES

Director of Finance: Mary Schere • *Controller:* Robin Hutchinson • *Sr. Accountant:* Laura Thomas • *Accounts Payable:* Mary Schultz • *Accounts Receivable:* Margo Petrus • *Prod. Dir.:* George Chmelars • *Electronic Pub. Dir.:* Douglas M. Lalster • *Newsroom Admin.:* Chris Schweinbeck • *Pre-Press Image Specialist:* Tracy Clark, Marnette Johnson • *Prod. Coordinator:* Nicole Carrull • *New Media Mgr.:* Gordon C. Osippe • *Multimedia Art Dir.:* Eugene Pedersen • *Technology Analyst:* Carol Schaeppeler • *Web Content Mgr.:* Terry Walker, David Briggs • *H. R. Asst.:* Kirsten Kools • *Facilities Mgr.:* Julia Fish • *Receptionist:* Jeanne Johnson • *Mail Room Clerk:* Lou Webber

MAIL ORDER

Operations Director: Bob Baker • *Customer Service Manager:* Jennie Enos • *Warehouse Supv.:* Nancy Johnson • *Buyer:* Linda Jones • *Admin. Asst.:* Nancy Downey • *Tech. Rep.:* John Auletta • *Cost. Serv. Rep.:* Anna Cox, Tammy Truonbrod, Deborah Rich, April Revel, Valerie Riley, Linda Stepp • *Warehouse:* Sylvia Carey, Dan Spidle, Sheryl Knox, Al Voigt

WOODSMITH STORE

Manager: Dave Larson • *Sales Staff:* Wendell Stotz, Jim Barnett, Kathy Smith, Larry Morrison, Harold Cashman, Tim Thelen, Gregory Kautzrich, Mark Johnson, Joe Kucera • *Office Manager:* Vicki Edwards

ShopNotes® (ISSN 1062-9696) is published bimonthly (Jan., March, May, July, Sept., Nov.) by August Home Publishing, 2200 Grand, Des Moines, IA 50312.

ShopNotes® is a registered trademark of August Home Publishing ©Copyright 2000 by August Home Publishing. All rights reserved.

Subscriptions: Single copy: \$4.95. One year subscription (6 issues), \$27.95. Canada/International add \$10 per year, U.S. funds.

Periodicals Postage Paid at Des Moines, IA and at additional mailing offices.

Postmaster: Send change of address to ShopNotes, P.O. Box 37105, Boone, IA 50037-2105.

Subscription Questions? Write to: ShopNotes Customer Service, P.O. Box 842, Des Moines, IA 50304-0842. Or call 1-800-333-3884, 9:00 am to 5:00 pm, Central Time, weekdays. FAX 515-283-0447

E-Mail: ShopNotes@shopnotes.com

Internet: <http://www.shopnotes.com>

PRINTED IN U.S.A.

Cutoffs

Can't you leave well enough alone? It seems like I've heard that question as long as I can remember. To be honest, the answer is no, I *can't*. Come to think of it, most woodworkers I know *can't* either. Which isn't really a bad thing.

It's one reason we're always looking for a way to improve the quality of what we do. Making a joint that fits a bit tighter and looks a *lot* better. Applying a smoother finish. Or building a jig to make a tricky cut safer or more accurate.

Now don't get me wrong. The goal *isn't* to come up with the perfect woodworking technique or to build a perfect project. It's the *process* of starting with something that already works and then making it even better.

Dust Collection Upgrade – The dust collection upgrade featured in this issue is a good example. The idea for this project started with a portable dust collector we bought for the shop awhile back. It's a small, roll-around unit, the type that's designed to connect to one tool at a time.

Well the dust collector works fine. But to be honest, I get lazy sometimes, and I don't *always* connect the dust collector before using a tool, especially if I only need to make one or two cuts. So I end up sweeping up chips or breathing dusty air anyway.

A bigger problem is the bag itself. It fills up fast, and it's a dusty chore to empty. Plus, putting it back on is a real juggling act that requires three hands.

The point of all this is that even though the dust collector does its job, there's room for improvement. That's where the dust collector upgrade comes in. It consists of two separate projects: a *chip separator* and a *dust control box*.

Chip Separator – To avoid having to empty the bag as often, the *chip separator* captures large chips *before* they get to the dust collector. These chips are deposited in a trash can which is quicker and easier to empty than the dust collector bag.

Control Box – The second project is a *dust control box*. It provides a way to connect *three* tools to the dust collector at the same time. So there's no need to constantly switch the dust hose from one tool to another.

Most woodworkers I know can't leave well enough alone . . . which isn't a bad thing.

Instead, there are three blast gates that control the flow of air at each individual tool.

When you pull out a blast gate, it's like flipping a switch that allows chips and dust produced by the tool to be pulled *through* the control box and *out* to the dust collector.

Low-Tech, High-Performance – Just one more note. You won't have to invest a lot of money in material to build these projects. Made of plywood and plastic, they're a low-tech solution for a high-performance dust collection system.

More Improvements – Of course, striving to make improvements doesn't apply just to woodworking. It's a big part of woodworking *magazines* as well.

We're always looking for ways to make *ShopNotes* a better magazine. One way to do that is to find out what you like (or don't like) about this issue of *ShopNotes*. We'd also like to find out more about the type of projects and techniques you'd like to see in upcoming issues.

To accomplish that, we've posted a short questionnaire on our web site. By visiting us at www.ShopNotes.com and filling out the questionnaire, you'll help us make a good thing better. (You'll also have a chance of winning a free router.) I look forward to hearing from you.

Tim

Contents

Features

Two-Handled Push Block _____ 6

Two handles, two clamps, and two replaceable backer boards — together they make a handy push block for the router table that eliminates end-grain chipout.

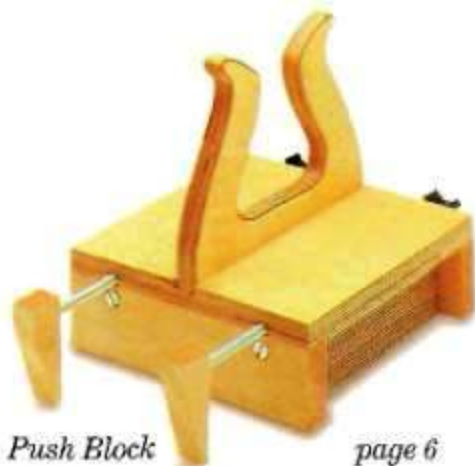

Push Block

page 6

HVLP Spray Systems _____ 10

A high-volume, low-pressure (HVLP) system makes it quick and easy to spray on a glass-smooth finish. Is it right for you? To find out, we take a look at two types of HVLP systems.



Spray Finishing

page 12

Spraying a Flawless Finish _____ 12

There's more to spraying a perfect finish than squeezing the trigger on a spray gun. We show you practical tips and techniques to ensure a professional-looking finish.

Dust Collector Upgrade _____ 16

Take a good thing and make it better. That's the idea behind these two shop-built projects designed to improve the performance of a portable dust collector.



Dust Collector Upgrade page 16

In-Line Chip Separator _____ 18

Don't get caught holding the bag — on your dust collector that is. This separator captures the large chips produced by your tools and deposits them in a trash can.

3-Tool Dust Control Box _____ 21

Tired of switching a dust hose from one tool to another? Build a control box and connect three tools at once.

Roll-Around Store-All _____ 24

It's like having a lumber yard in your shop. Storage for long boards, short cutoffs, and sheet material. Also, an optional guide for cutting large panels into manageable-sized pieces.



Roll-Around Store-All page 24

Departments

Readers' Tips _____ 4

Shop-tested tips to solve common woodworking problems.

Tool Talk _____ 30

Twist bits dull? Get them sharper than new with Drill Doctor.

Sources _____ 31

Sources and supplies for building the projects in this issue.

Readers' Tips

Rule Guide

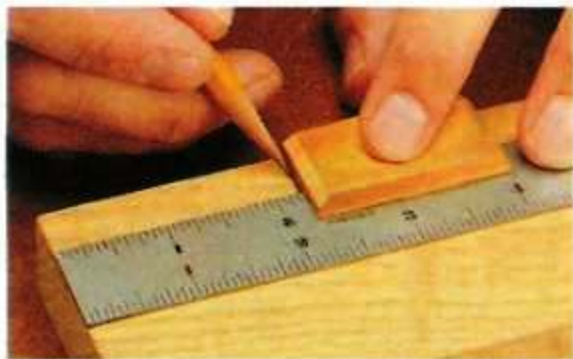

■ A metal rule is great for measuring, but it can be difficult to use for layout work. The problem is the *thickness* of the rule itself. It creates a "step" between the surface of the rule and the workpiece that can make transferring a mark less than accurate.

My solution is the simple *rule guide* shown above. It's a small wood block that makes it easy to accu-

ately lay out a line. You simply align the end of the block with the desired increment on the rule. Then mark the line, using the block as a guide.

To allow the rule guide to sit flat on a workpiece, the bottom edge is rabbeted to fit over the metal rule (Figure 1). Since the rule guide is fairly small, it's best to cut this rabbet in an extra-long piece (Figure 2).

I also added a small magnet to hold the rule guide in place, yet still allow it to slide along the metal rule. The magnet fits in a hole that's drilled in the rabbeted edge of the strip.

After cutting the rule guide to length, it's just a matter of sanding a bevel on each end to ease the sharp edges and then gluing in the magnet. (I used epoxy.)

Richard Hoffman
Colorado Springs, Colorado

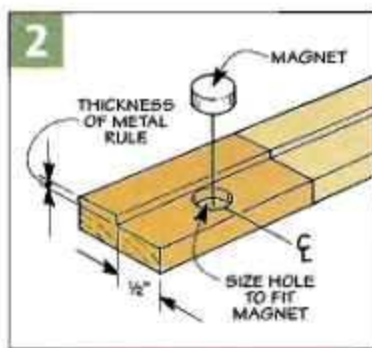
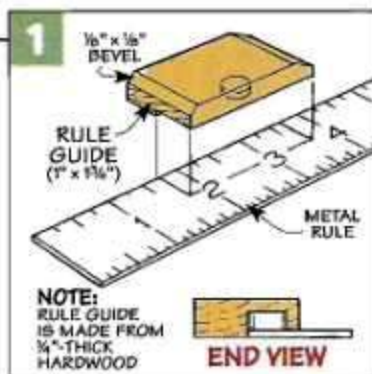

Free Tips ON THE WEB

Get more wood-working tips **free**.

Visit us on the Web at ShopNotes.com

Sign up to receive a free shop tip by email every week.

Replaceable Fence Insert

■ I couldn't be more pleased with the Adjustable Miter Gauge Fence featured in *ShopNotes* No. 53. It definitely helps me make quick, accurate setups when crosscutting on the

table saw. To reduce chipout, I even added a hardboard *fence insert* that can be easily replaced when it gets chewed up (Figure 1).

To make the insert replaceable, it

fits into a dovetail-shaped recess near the end of the fence (Figure 2). Note: To accommodate the insert I made my fence 3" longer than the plans called for.

All that's needed to cut the recess is a dovetail bit and a table-mounted router (Figure 2a). After removing all of the waste material, it's just a matter of cutting an insert to fit. (While you're at it, you may want to make several extra inserts.)

To make the inserts, start with a long strip of hardboard that's about 1/4" wider than needed. Then use the same dovetail bit to bevel both edges of the strip, sneaking up on the final width to create a smooth, sliding fit. Finally, cut each insert to length to match the height of the fence.

Rich Wagner
Hadley, Massachusetts

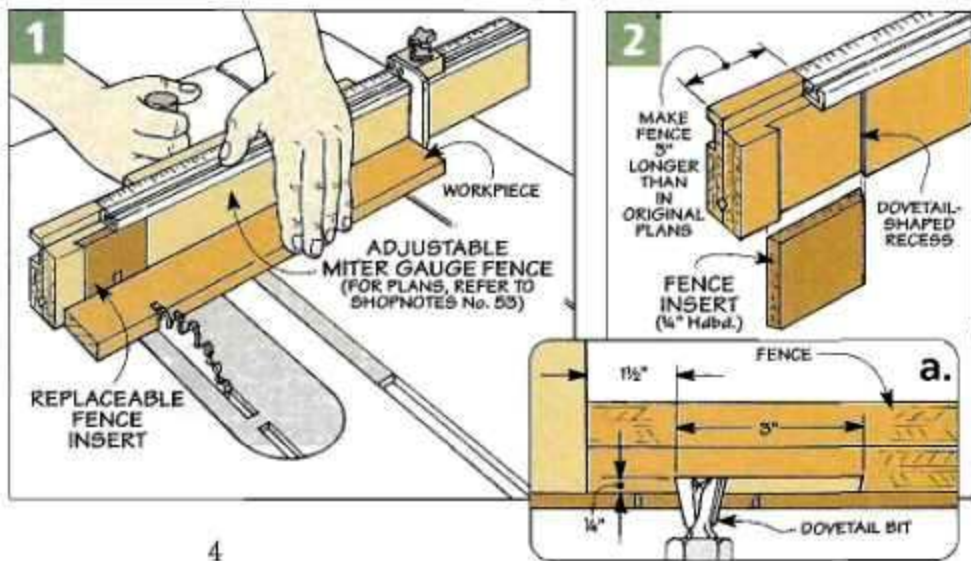

Table Alignment Tip

■ When crosscutting (or cutting a dado) on a radial arm saw, the table must be parallel to the arm. Otherwise, the depth of cut will vary from one edge of a board to the other.

To check the alignment, it requires rotating the head of the saw so the arbor points straight down, as shown at right. Ideally, the end of the arbor should just graze the table as you pivot the arm (or slide the head back and forth).

If it doesn't, most owner's manuals will recommend loosening the brackets that connect the table to the saw and using a mallet to tap it up or down. The problem is it's difficult to control the amount of movement.

To make a more accurate adjustment, I install a T-nut and a socket head set screw in the table over each corner of the metal saw base. This

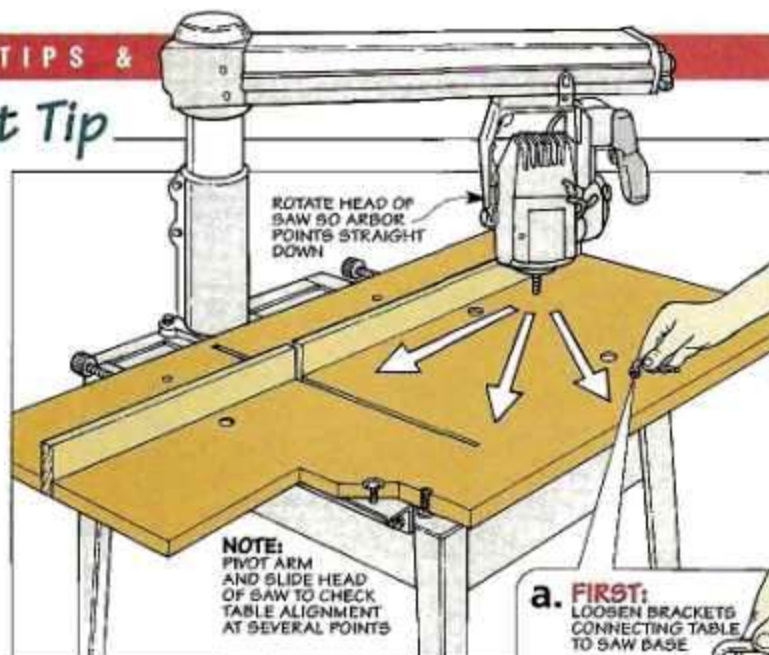

way, all I have to do is "tweak" the screws to raise or lower the table in precise increments.

Chet Bisio

Shelby Township, Michigan

Plans Hanger

■ To keep woodworking plans and tool manuals in reach, I made a hanger that fits into a bracket under my bench.

The *hanger* consists of a metal ring assembly from an old three-ring binder that's mounted to a strip of 1/4" hardboard with machine screws. (See drawing and detail.)

To hold the hanger, it fits into a T-shaped slot that's formed by a two-part *bracket*. Each part of the bracket is a rabbeted wood strip that's screwed to the bench.

Marty Burger

Northfield, Minnesota

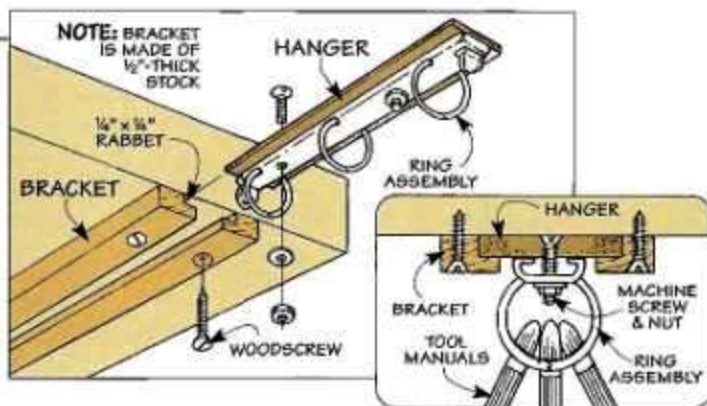

Quick Tips



▲ Here's a quick way to seal an open tube of caulk so it won't dry out. *Jim Labyak* of Kenmore, WA pushes the tip into a wax ring.



▲ To keep his shop vacuum from tipping, *Chuck Pierce* of Lugoff, SC puts a weight in it. A string lets him pull out the weight before emptying.

Send in Your Shop Tips

If you have a unique shop tip, we'd like to consider featuring it in one or more of our print or electronic publications.

We'll pay up to \$200 for a tip we publish. Just write down the tip and mail it to *ShopNotes*, Attn.: Readers' Tips, 2200 Grand Ave., Des Moines, IA 50312. Or FAX it to 515-282-6741, or send us an e-mail at shopnotes@shopnotes.com. Please include your name, address and daytime phone number in case we have any questions.

Two-Handled Push Block

A handy accessory for your router table that puts an end to end-grain chipout.



Replaceable Backer Board

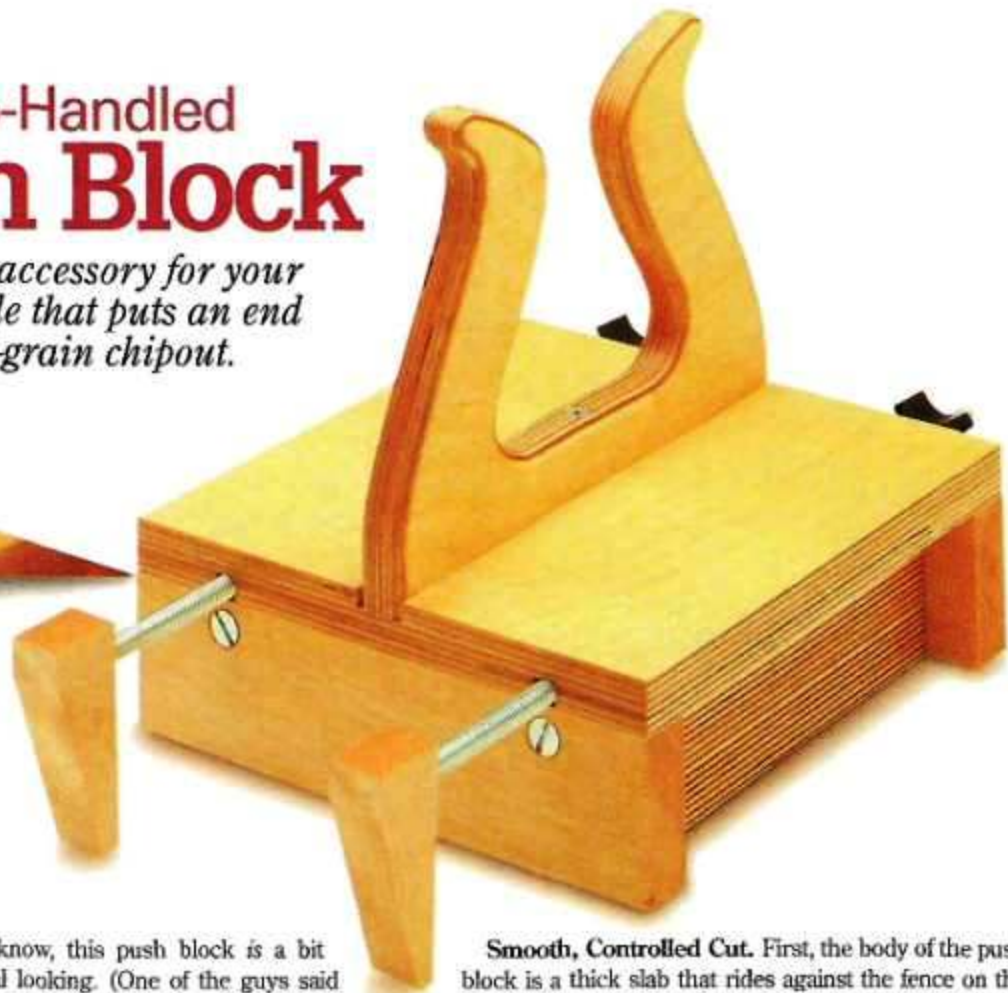

Okay I know, this push block is a bit unusual looking. (One of the guys said the two handles reminded him of Dr. Doolittle's push-me-pullyou.) But don't let its appearance fool you.

This push block is one of the handiest accessories I've added to my router table in a long time. As you can see in the photos below, it's designed to be used when routing the end of a board. So why not just use a miter gauge?

One reason is you don't have to worry about setting the fence parallel to the miter gauge slot. But there are several other advantages as well.



This push block is ideal for routing the end of a board. With the work clamped against a replaceable wood block, it stops end-grain chipout once and for all.



Smooth, Controlled Cut. First, the body of the push block is a thick slab that rides against the fence on the router table. With this hefty block providing support behind the board, it produces a smooth, controlled cut.

Built-In Clamps – To prevent the workpiece from twisting during a cut, there are two built-in clamps that can be used to “snug” it against the push block.

The handy thing about these clamps is they can be removed and turned end for end. This way, you can clamp a workpiece against the front or the back of the push block. (That's where the two handles come in — they provide a comfortable grip from either side.)

This dual-directional design is especially handy when using a matched set of stile and rail bits to make a solid wood frame. (For information about these bits, see page 7.)

No Chipout – Regardless of whether you're using stile and rail bits, cutting a tenon with a straight bit, or routing a profile on the end of a board, you won't have to worry about chipout. The reason has to do with a pair of replaceable backer boards, as shown in the inset photo above.

To prevent tearout, these boards support the wood fibers where the bit exits the cut. When the backer boards get chewed up with use, it's a simple matter to make new ones.

Stile & Rail Bits

A router table and a matched set of stile and rail bits. That's all it takes to cut the joinery *and* to create the decorative profile in the frame pieces of a cabinet door.

Notice in the photo at right that the stile bit is used to rout the inside edge of *each* piece (stiles *and* rails). The rail bit is more aptly named. It's used only to rout the *ends* of the rails.

Using the Push Block – It's *this* step (routing the ends of the rails) where the two-handled push block comes in handy. With a backer board on each side of the push block, you can provide support for the workpiece when routing *both* ends of the rails. This prevents the end-grain wood fibers from tearing or splintering. (For information about how this works, check out the photos below.)



◀ **A. Stile Bit**

B. Rail Bit ▶

When using a matched set of router bits, the stile bit creates a decorative profile and a groove in the edge of all four frame pieces.

A rail bit is used to rout both ends of the rails only. It forms a tongue and a coped profile that allows the rails to fit into the stiles.

Using the Push Block



1 The first step is to use the stile bit to rout a decorative profile and a groove in the edge of all four frame pieces.



2 After clamping a rail to the push block, the mating tongue and coped profile are routed on one end using the rail bit.



3 Since the rail was supported by the backing board at the point the bit exited the cut, you get a clean, crisp cut.



4 To prevent chipout in the opposite end, turn the push block 90° and use the rail bit to rout the uncut backing board.



5 Now fit the edge of the rail (the one routed earlier with the stile bit) into the mating profile in the backing board.



6 After clamping the rail in place, rout the opposite end with the rail bit. Here again, the backing board prevents chipout.

Making the Push Block

In spite of its unusual appearance, this push block is a snap to build. In fact, you can probably build it in the morning and use it by the afternoon.

THE BODY

As you can see in Figure 1, the thick slab that forms the *body* of the push block provides a mounting surface for the handle. Plus it holds the *backer boards* and *clamps*.

Layer Cake - To create this solid block, the body is made up of four pieces of 3/4" plywood that are built up like a layer cake. (I used Baltic birch.)

Notice that the *top* overhangs the bottom three pieces (the *core*) all the way around. This way, the backer boards form a smooth, flat clamping surface in front and back (Figure 1a). The overhang on the sides creates a recess that prevents the core from getting chewed up by the router bit.

Top - I began work by cutting the *top* (A) to final size (Figure 2). Two grooves in the bottom of this piece hold a pair of metal rods that are part of the clamping system (Figure 2a). There's also a shallow groove in the top to accept the handle.

Core - The next step is to add the three *core pieces* (B). These are oversize pieces that are glued face-to-face. Don't worry if they slip out of

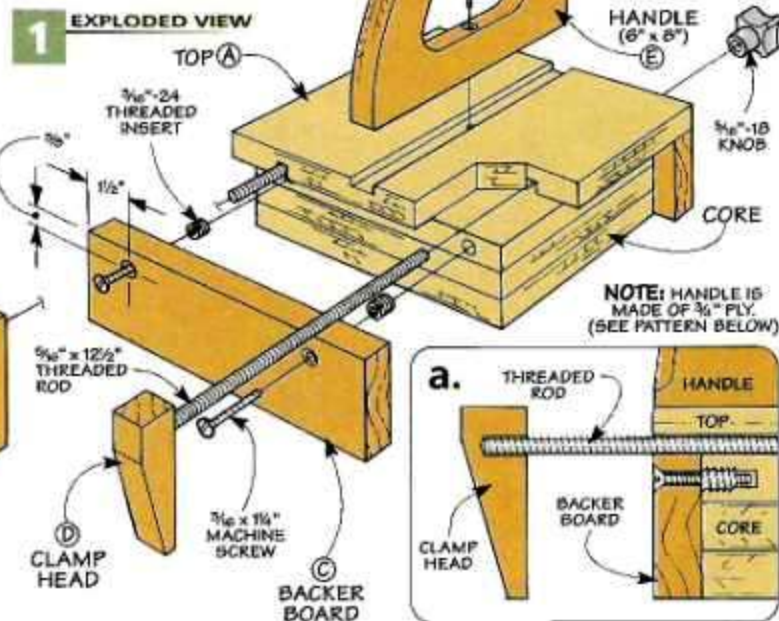

NOTE: HANDLE IS MADE OF 3/4\"/>

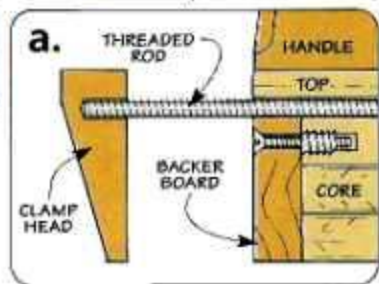

alignment when tightening the clamps. They'll be trimmed flush later.

Glue on Top - But first, you'll want to glue on the top. There's nothing critical about its exact location. Just be sure it overhangs all four sides of the core so you can use it as a reference when "truing" the core.

True Up Core - This is accomplished by making *two* series of passes on the table saw, one with the body of the push block lying flat, and the second with it standing on edge. Note: To provide extra support for

the workpiece, I attached a tall, auxiliary fence to the rip fence.

To make the *first* series of passes, start by adjusting the height of the blade to match the thickness of the core (Figure 3a). Then set the fence to make a 3/4"-wide cut (the width of the overhang). Now turn on the saw, set one edge of the top against the fence, and push the workpiece through the blade. Repeating this process on the other three sides creates a single saw kerf all the way around.

To remove the waste, you'll need to make a *second* series of intersecting cuts. To do this, lower the saw blade and reposition the fence (if needed). Then with the workpiece standing on edge, make four passes, rotating the workpiece a quarter turn each time (Figures 3 and 3b).

BACKER BOARDS

With the body of the push block complete, it's time to add the *backer boards*. They provide support directly in back of a workpiece which prevents tearout where the bit exits the cut.

The *backer boards* (C) are 3/4"-thick hardwood blocks attached to the front and back of the body. Since they'll get chewed up by the router bit, it's a good idea to make several



NOTE: 1" x 1" GRID PATTERN SHOWN

DRILL COUNTERSUNK SHANK HOLE FOR #6 x 2" WOODSCREW

HANDLE PATTERN
HALF PATTERN SHOWN
(ENLARGE 200%)

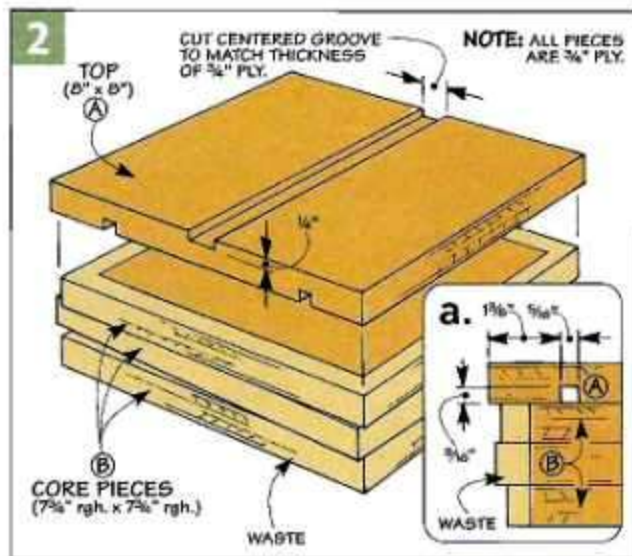

NOTE: ALL PIECES ARE 3/4\"/>

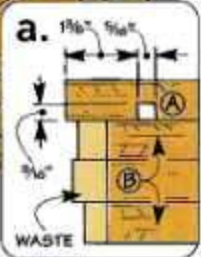

extras and replace them as needed.

Each backer board is held in place with two machine screws that thread into inserts in the body (Figures 1 and 1a). To make sure the holes line up, I pre-drilled countersunk shank holes in the backer boards and used the method shown in Figure 4.

Start by clamping one backer board in place. (Slip the other one underneath to keep the block from tipping.) Then mark the location of the inserts by lowering a drill bit into the holes in the backer board (Figures 4 and 4a) After removing the backer board, I drilled holes for the inserts (Figure 4b) and installed them as shown in the margin.

CLAMPS

Now you can turn your attention to the two clamps. Each clamp consists of a wedge-shaped block (the clamp head) which is attached to the end of a metal rod (Figure 1). Tightening a knob on the rod pulls the clamp head toward the push block and holds the workpiece against the backer board.

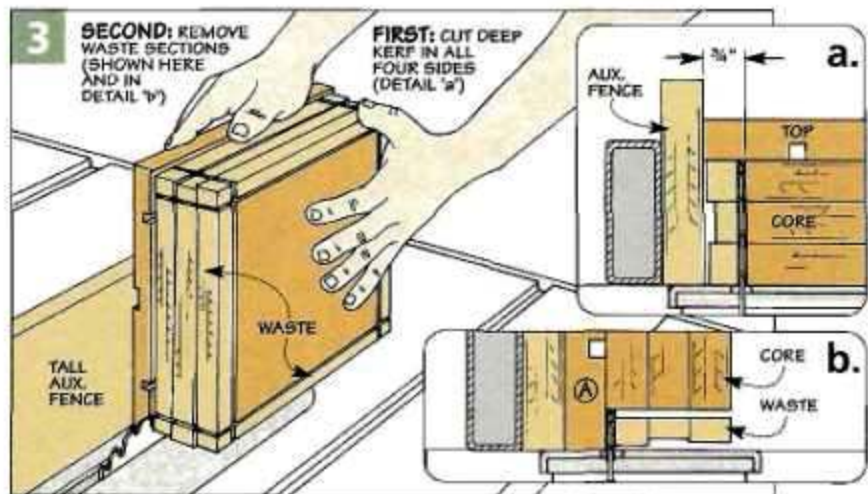

The clamp heads (D) are 3/4"-thick hardwood blocks that are only about as big as a bite-size candy bar. So to make it easier to work on them, I made both clamp heads from an extra-long piece that's ripped to final width (Figure 5). After drilling holes for the threaded rods, a band saw (or jig saw) makes quick work of cutting the tapered edge on each clamp head. Then just sand them smooth and use

a hand saw to cut them to final length.

Install Rod - All that's needed to complete the clamps is to install the threaded rods. The length of these rods determines how wide a board you can clamp. I made mine 12 1/2" long which allows me to clamp boards up to 3 1/2" wide. After cutting the rod to length, adding a dab of epoxy to the clamp head is all it takes to hold it in place.

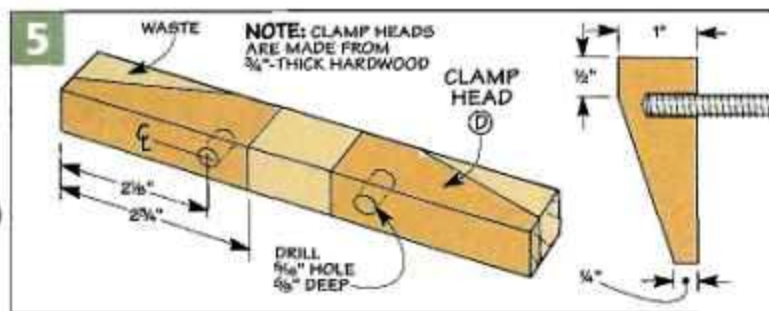
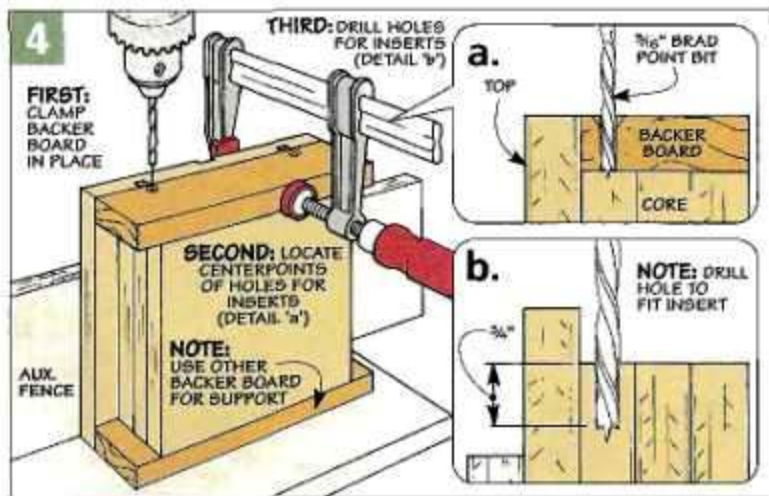

HANDLE

Once the clamps are installed, the final step is to add the handle. With its two separate grips, this handle provides a comfortable way to push a workpiece past the router bit from either end of the push block.

The handle (E) is made from 3/4" plywood (Figure 1). Here again, I used Baltic birch because it's relatively free of voids. As with any plywood, the grain direction of each individual ply runs at right angles to the one next to it. This creates a strong, sturdy handle that resists breaking.

To provide a comfortable grip, I experimented with several different handle shapes before choosing the one shown in the Pattern on page 8. You may want to modify it to fit your hand better. Either way, just lay out the handle and cut it to shape with a band saw or jig saw. Routing a small roundover on the exposed edges helps to "ease" the sharp corners. Finally, secure the handle with glue and a single screw.



▲ To prevent an insert from going in crooked, tighten a cutoff bolt with a "jam" nut in the drill press and turn the chuck by hand.

High-Volume, Low-Pressure Spray Systems

Looking for the perfect finish? An HVLP spray system could be just the ticket. Here's what you need to know to find out.



There are two reasons that professional woodworking shops use a spray system to apply a finish. It's fast. And it produces a glass-smooth finish.

That's great, *if* you're a professional cabinetmaker. But how do you spray a smooth finish at home?

HVLP – One way is to use a high-volume, low-pressure (HVLP) spray system. With this type of system, the spray gun “atomizes” the finish into a

fine mist. This eliminates brush marks. Plus you end up with a much more even, consistent coverage.

Soft Spray – The biggest advantage of this high-volume, low-pressure air is it creates a “soft” spray. Not as much finish bounces off the project as with a conventional (high-pressure) spray system. As a result, you end up with *more* finish on the project and *less* overspray in the finishing area. This reduces the amount of finish you need to use, which saves a considerable amount of money.

Two Types – There are two types of HVLP systems. One uses a *turbine* to supply air to the spray gun, as shown at left. The other type is a *conversion* system where the air is supplied to the spray gun by a compressor. (Refer to photo on page 11.)

TURBINE SYSTEM

Okay I know, a turbine sounds like something you'd find in a jet engine more than in the shop. But it's really nothing more than a fan (or a series of fans) that are driven by an electric motor. These fans force air to the spray gun through a large-diameter hose.

The number of fans (stages) deter-

mines the amount of air and pressure produced. The more stages, the higher the volume of air and pressure, and the easier it is to atomize “heavy” finishes (like a water-based polyurethane). Note: If you're planning on spraying water-based finishes, you'll need at least a three-stage system to produce good results.

Cost – Of course, the more stages a turbine has, the higher the cost. You can expect a two-stage system to start around \$180. If you get a turbine with three stages (or more), it can cost as much as \$500.

CONVERSION GUN

The second way to set up a high-pressure, low-volume spray system is to use a conversion gun. This is just a spray gun with a regulator that's connected to an air compressor.

Unlike a turbine which produces a constant stream of air at a specific pressure, the regulator on a conversion gun allows you to adjust the air pressure from about 4 to 10 PSI. This lets you vary the pressure to match the type of finish you're spraying.

Another benefit to a conversion gun is that if you already have an air



▲ **Turbine.** A turbine-style HVLP system is a lightweight, portable unit that produces clean, dry air to atomize the finish from the spray gun.

compressor, it can be a less expensive way to end up with a quality HVLP system. The cost of conversion guns ranges from \$170 to \$350.

There is one thing to keep in mind about a conversion system. To avoid contaminating the finish, the air from the compressor needs to be filtered to remove dust, oil, and water. To do this, you can install either a permanent or a disposable filter, like those shown in the photos at right.

THE SPRAY GUN

Regardless of the type of system, the spray gun is quite similar. Notice in the drawing below that it has large air passages to deliver the high volume of air needed to atomize the finish.

The spray gun is attached to a cup that holds the finish. The finish is either forced out of the cup (pressure feed) or it's "pulled" out by the vacuum created by the rushing air (siphon feed).

No matter how the finish is fed to the spray gun, the process of atomizing it is the same. As you squeeze the trigger, air flows through the gun and out the air cap.

Pulling the trigger back even further withdraws the needle from the fluid nozzle which allows the finish to flow out the tip of the nozzle. As the air hits the finish, it atomizes it into a fine mist.

You can adjust how far the needle moves and how much finish comes out by turning the fluid flow knob at the back of the spray gun.

Spray Pattern - All spray guns allow you to control the shape of the spray pattern. You can adjust it for a horizontal, vertical, or round pattern, as shown in the margin. To change the pattern, all you need to do is rotate the horns on the air cap. Note: Some spray guns also have an air flow knob on either the back or side. Adjusting this knob provides additional control over the shape and size of the pattern.

So how do you know which pattern to use? If you're spraying a horizontal surface like a table top, you'll want to use a vertical pattern to provide even

coverage. But if you're spraying the side of a tall cabinet, a horizontal pattern works better. Here again, it provides consistent coverage as you make long passes down the side of the cabinet. Finally, when spraying irregular surfaces (like the rungs of a chair for example), I switch to a small, round spray pattern.

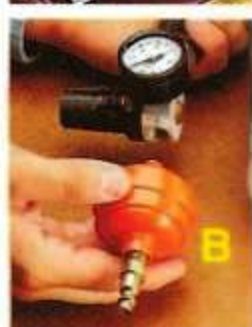

▲ Conversion Gun. With a conversion gun, air is supplied by a compressor. To avoid contaminating the finish, it's important to remove moisture from the air by installing a permanent trap (A) or disposable filter (B).

3 TYPES OF SPRAY PATTERNS

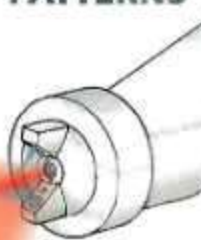

Horizontal (rotate horns up and down)



Vertical (turn horns side to side)



Round (horns are diagonal)

SPRAY GUN ANATOMY

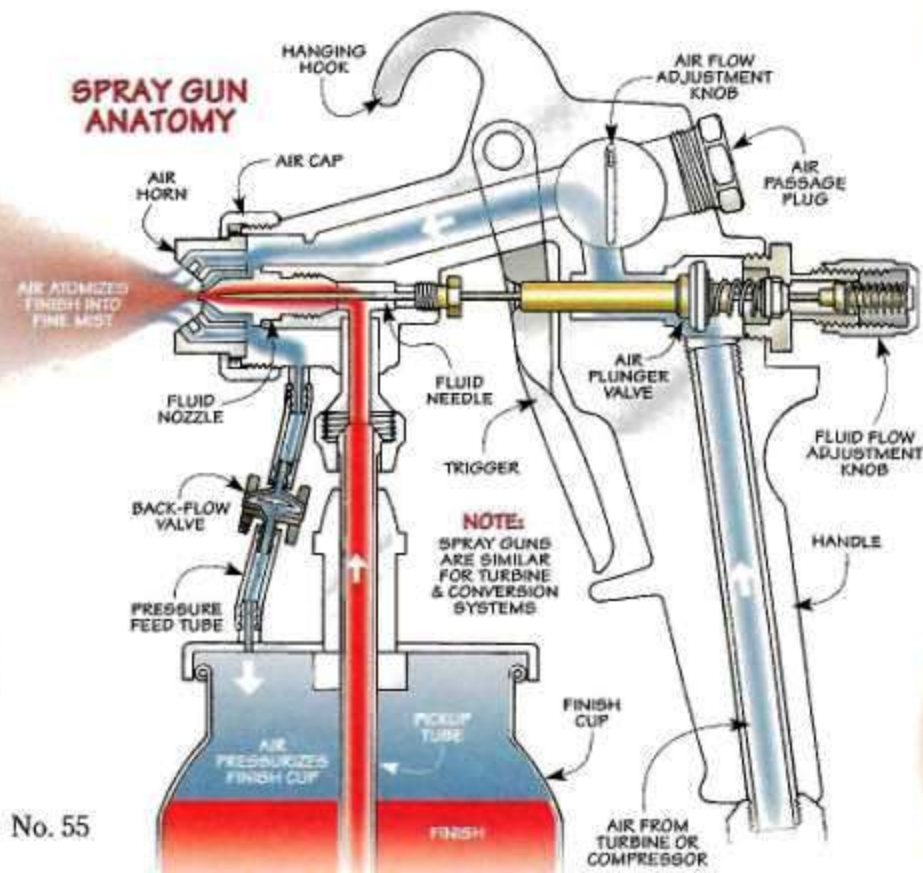

Spraying A Flawless Finish

Simple techniques to spray a finish that rivals the pros.

Squeeze the trigger on a spray gun and a fine mist of finish sprays out. That much is simple. But there's more to spraying a finish than "point and shoot." To spray a smooth, even coat of finish, it takes some preparation, practice, and an understanding of a few basic techniques.

CAREFUL PREPARATION

One of the simplest things you can do to get good results is to carefully prepare the work area, the project, and the finish.

Work Area – The ideal place to spray is in a special booth that exhausts overspray and finish vapors from the air. With finishes that have flammable solvents, that's really the only option. But if you're spraying a water-based finish, any clean, well-ventilated area will work.

Good lighting is also important. To make it easy to see runs or sags, set up a task light that "glances" across the surface of the workpiece at a low angle.

Also, don't forget to round up safety gear. When spraying any type of finish, I make it a point to wear goggles and a respirator like those shown at left.

Sand the Project – A sprayed finish will magnify any irregularities on the surface of the workpiece. So I sand the entire project using progressively finer grits of sandpaper (120 to 180-grit). Note: Be sure to vacuum all the sanding dust from the project and the finishing area.

Thinning the Finish – The next step is to prepare the finish. There's more to this than opening the can and



pouring it into the cup. Many finishes are too thick (viscous) to be sprayed easily, so they need to be thinned first. The type of thinner depends on the finish you're spraying. Just use the appropriate solvent for that finish.

As for the amount of thinner, most manufacturers include recommendations for that along with a cup to measure the viscosity. (See photo A below.) In a pinch, stir the finish with a stick. If it's thinned properly, a drop of finish should drip off the stick about once a second.

Strain Lumps – Once the finish is thinned, strain it through a filter before pouring it into the cup of the spray gun. This removes any lumps or contaminants that might clog the spray gun. To do this, I use a disposable paper filter with a nylon mesh, as in photo B.

PRACTICE MAKES PERFECT

After filling the cup with finish, you're ready to start spraying — but not on the project. You'll definitely want to practice on a scrap piece of plywood or cardboard first to get the smoothest possible finish.

Adjust Mix – The goal is to adjust the "mix" of air and finish until you get a wet, even coat that flows smoothly together. This requires adjusting the control knobs for the air and finish on the spray gun. Note: If you're using a turbine system that has a fluid control adjustment only, you may need to thin the finish to get the best results.

Keep in mind that every time you



▲ For safety when spraying, be sure to wear goggles and a cartridge-style respirator with two filters.



A. **Viscosity Check.** A properly thinned finish flows through a viscosity cup in a specific time.



B. **Strain the Finish.** After thinning the finish, filter it through a strainer to remove any lumps or impurities.

make one adjustment, it also affects the other. For example, increasing the air pressure can cause the finish to be broken into droplets that are *too* fine, causing a "dry" or rough surface. So you'll need to open the fluid control knob to allow more finish to come through.

It may take awhile (and quite a bit of scrap material) to get the spray gun adjusted properly. But don't get discouraged, it's time well spent. The payoff comes when spraying the "real" project.

SPRAYING A HORIZONTAL SURFACE

As a starting point, let's take a look at the easiest type of surface to spray — a horizontal surface like the shutters at right or the table top shown in the drawing below.

Least Visible Areas — The first step is to spray the *least* visible areas first (the *edges* of the table top). This way, any overspray lands on bare wood which will be covered up when you spray the top. To see what I mean, imagine what would happen if you sprayed the top first. The overspray from the edges would land on the *finished* top, producing a rough surface.

Spray the Top — With the edges complete, spray the top by making *two* series of passes. Notice that the first series of passes is made along the length of the top. Then to ensure even coverage, a second series of perpendicular passes is made to "double-coat" the top.

Trigger First & Last — To avoid "pooling" the finish at the edges of the workpiece, I use a *trigger-first-and-last* technique. The idea is to pull the trigger first, *before* you move the spray gun across the end (or edge) of a workpiece. Then make a smooth pass all the way across, but don't release the



Horizontal Surfaces — When spraying workpieces like these shutters, set them up so you're spraying a horizontal surface whenever possible. Together with a properly adjusted spray gun, this helps minimize drips, runs, and sags.

trigger until *after* the spray gun is past the opposite side.

More Spray Techniques — To produce an even coat across the entire workpiece, point the nozzle of the gun so it's perpendicular to the workpiece and about 6" to 8" away from the surface. There's a tendency to pull the spray gun farther away from the surface. But this produces a rough, textured surface like an orange peel.

Another thing to note is that the finish is concentrated near the *center* of a spray pattern. So to ensure even coverage across the entire surface, overlap each pass by about fifty per cent. Also, keep the spray gun moving at a slow, steady pace (about 3" to 4" per second works best for me).

Finally, resist the tendency to sweep the spray gun back and forth in an arc. This will produce a finish that's too heavy in the center of the project and too thin at the edges.

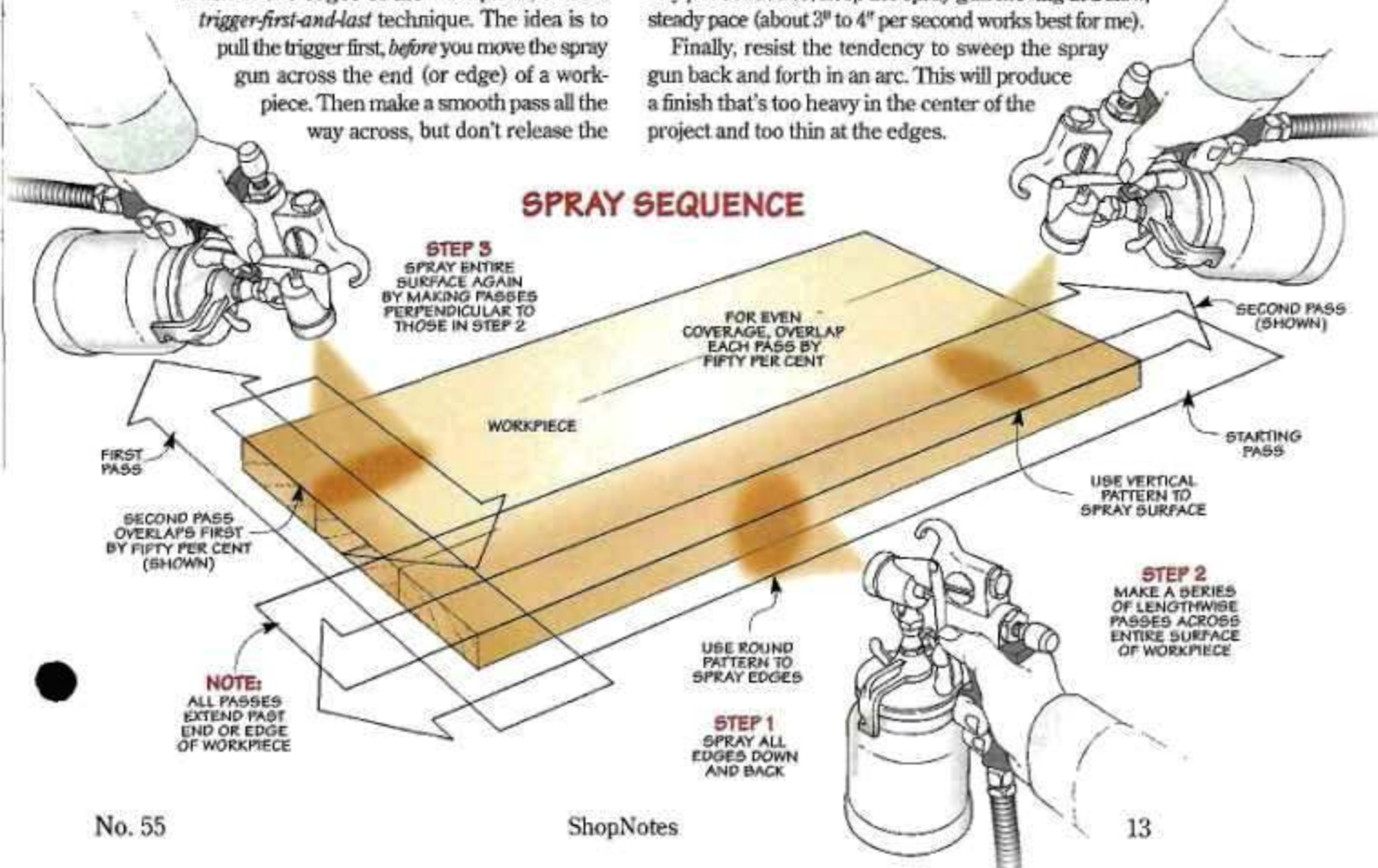

Beyond the Basics

Spraying a flat, horizontal surface is one thing. But some projects present more of a challenge.

SMALL PROJECTS

Take a small project for example. It's a hassle to drag the heavy hose on the spray gun *around* the project. A better solution is to set the project on a turntable and spin it around as you spray the finish. (To make a simple turntable, take a look at the box below.)

CORNERS

Another area that needs special attention when spraying a finish are the *corners* of a project.

Inside Corner – An inside corner of a drawer or a cabinet is especially tricky. That's because the finish sprayed on the adjacent sides of the corner tends to "funnel" inward. This causes a build-up of finish in the corner.

To prevent this, don't spray directly into the center of the corner. Instead, aim the gun so the center of the spray pattern is shifted to one side, as shown in Figure 1. Then make two passes, one on each side.

With each pass, there's a smaller amount of finish laid down in the corner. But once both passes are completed, there's a slight overlap. The

end result is it deposits just the right amount of finish in the corner.

One thing you may notice is the finish "bounces back" as you spray into the corner, creating a foggy cloud. To minimize this, reduce the airflow (if possible) and fluid flow from the spray gun.

Outside Corners – If you're spraying an outside corner, it's difficult to avoid *over-spraying* one of the adjacent sides that's already finished. So I spray *both* sides at the same time.

To do this, start by rotating the horns on the air cap to form a horizontal spray pattern. Then point the nose of the gun directly at the corner and spray from top to bottom, as in Figure 2. This "splits" the spray pattern on both sides of the corner.

VERTICAL SURFACES

It makes sense that when spraying a *vertical* surface, the finish is more likely to run or sag. Fortunately, there's an easy fix.



Lighter Coats – All that's needed is to adjust the spray gun to apply a lighter coat. You'll have to spray more coats to get the same thickness of finish. But that's not a big deal.

Direction – Another consideration is the *direction* to move the spray gun. As a rule, you'll want to work in the *longest* direction possible. On a tall cabinet, this means spraying from top to bottom, as shown in the photo above. Note: You'll also have better results if you adjust the spray gun for a horizontal spray pattern.

Finishing Turntable

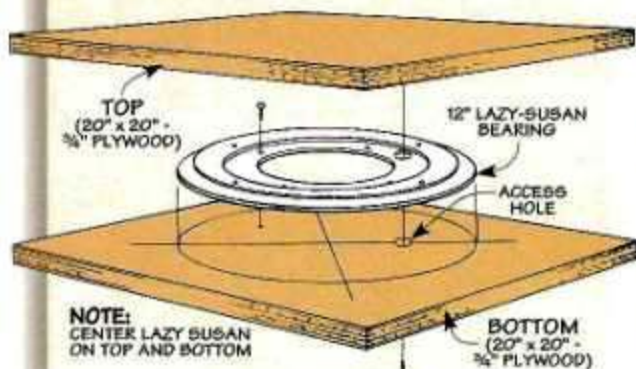

▲ A turntable makes it easy to spray small projects. Just put it on the turntable and give it a spin. This turntable is nothing more than a lazy-Susan bearing sandwiched between two pieces of plywood.

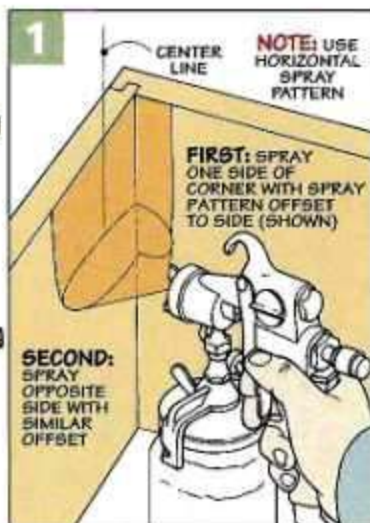

▲ **Inside Corner.** To avoid excess finish in the corner, spray to each side of the corner with a small overlap.

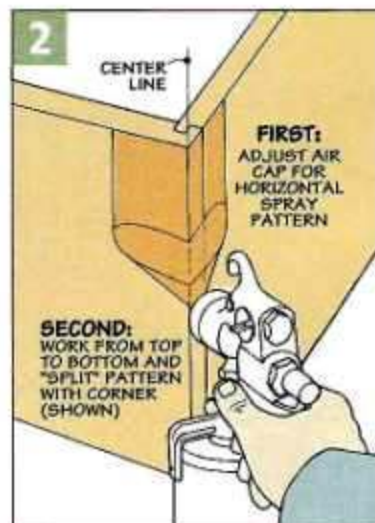

▲ **Outside Corner.** Splitting the spray pattern around an outside corner ensures smooth, even coverage.

Clean-Up

There's nothing worse than picking up a spray gun that spits and sputters (or doesn't spray at all). More often than not, the problem is it's clogged with dried finish. That's why it's important to thoroughly clean the spray gun after each use.

Remove Excess Finish – Start by removing the cup and pouring the remaining finish back into its container. Then squeeze the trigger on the spray gun to drain any finish left in the pickup tube.

Rinse Spray Gun – The next step is to “rinse” out the spray gun. A quick way to do this is to fill the cup half full with the appropriate solvent for that finish. Then spray the solvent into a jar or can for about ten seconds.

Now just remove the cup and drain the pickup tube again. You may need to do this a couple of times until clean solvent runs out of the pickup tube.

Note: The residue of water-based finishes can corrode aluminum parts. So be sure to thoroughly clean *and* dry these parts.

Disassemble Gun – This gets rid of most of the finish. But in order to clean the individual parts, you'll have to disassemble the spray gun. Start by removing the air cap, fluid nozzle, and fluid needle. You can simply unscrew the cap and nozzle from the gun. But to remove the needle, you'll have to unscrew the fluid flow knob at the back of the spray gun.



Once these parts are removed, just soak them in a jar of solvent for awhile.

Clean Fluid Passages – After taking the gun apart, clean the pickup tube and nozzle opening. A nylon bristle brush dampened in solvent comes in handy here. Just poke a brush into each end of the passages to clean these hard-to-reach areas. (Refer to photos above and below left.) **Note:** The brushes are part of a cleaning kit for spray guns available at many auto parts stores.

Reassemble Gun – Now it's time to reassemble the spray gun, starting with the needle. But before slipping it in place, rub on a light coat of petroleum jelly (center photo below). This

ensures that the needle will move smoothly the next time you use the spray gun. Once that's complete, just thread on the fluid control knob.

At this point, all that's left to do is reinstall the fluid nozzle and air cap. These parts can get gunked up, so it's important to get inside the tiny openings and remove any dried finish. The problem is the openings are easily scratched or deformed. To prevent that, I stick in a toothpick and work it back and forth.

Here again, apply a dab of petroleum jelly to the threads on the fluid nozzle and air cap. After reinstalling these parts, just wipe the gun with a cloth dampened in solvent. 



▲ **Clean Passages** – To clean gunk from the fluid passages, stick a brush inside and work it around.

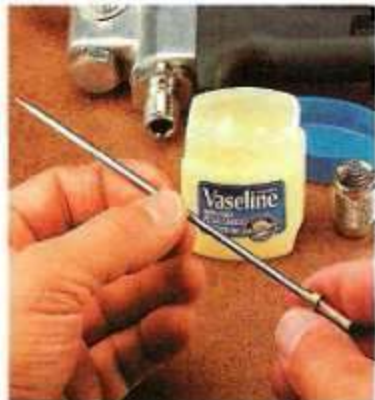

▲ **Lube** – Rubbing petroleum jelly on the fluid needle ensures it will move easily the next time you spray a finish.



▲ **Cleaning Kit**. With its assortment of nylon bristle brushes and toothpicks, this handy kit makes it easy to clean a spray gun.

Dust Collector Upgrade

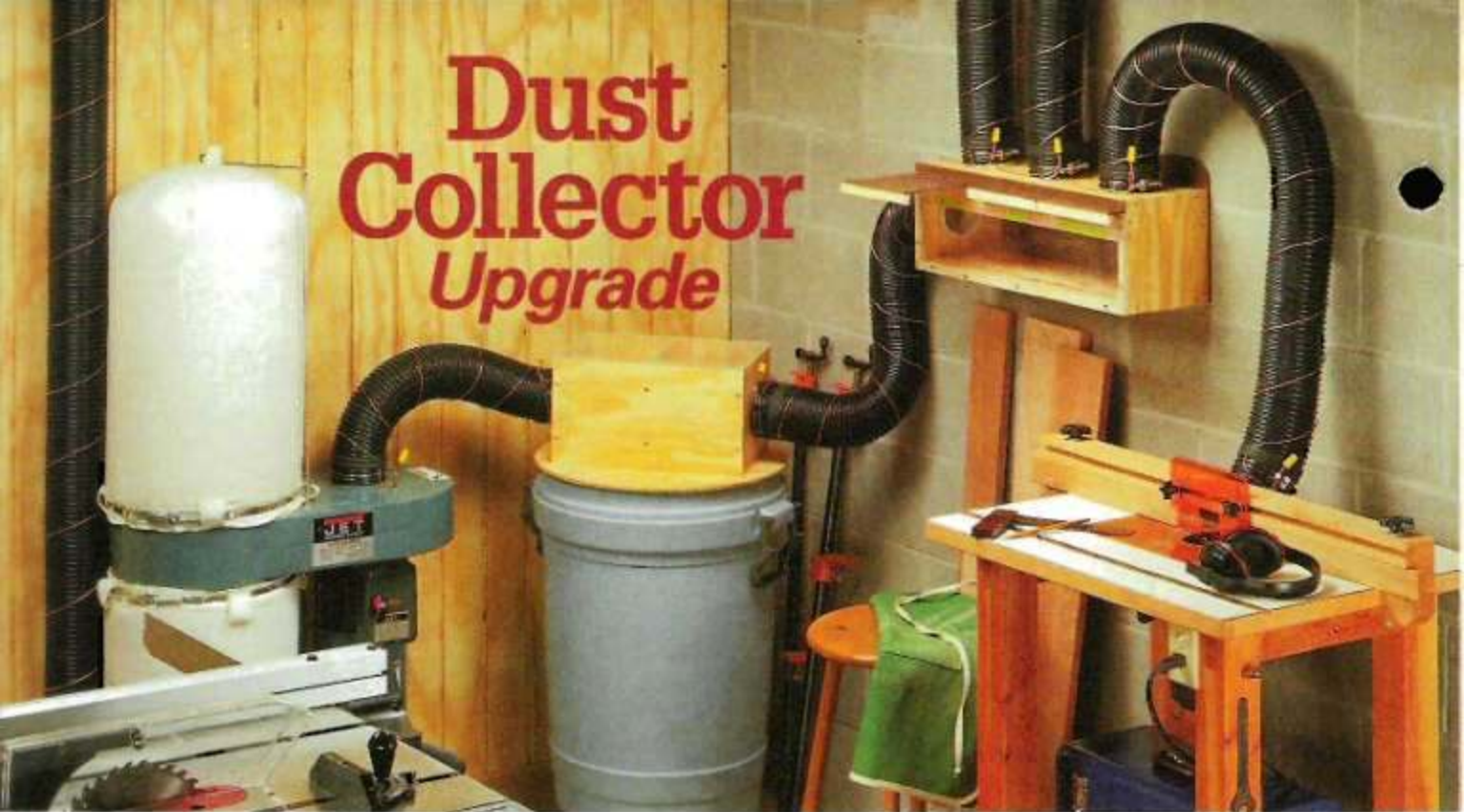

Want to spend more time making dust and less time cleaning it up? Build this simple chip separator and dust control box.

Several years ago, I purchased a portable dust collector for the shop. It's a small, roll-around unit that hooks up to one tool at a time.

Now there's no question that this dust collector has helped keep the shop (and the air) cleaner. Even so, I've never been completely satisfied with the whole dust collection setup.

First of all, constantly switching the hose from one tool to another is a nuisance. Also, the bag that holds the chips and dust fills up quickly. Emptying the bag is a messy job, and it requires *three* hands to put it back on.

To help solve these problems, I built two simple projects: a *chip separator* and a *dust control box*.

CHIP SEPARATOR

If you look at the photo above, you can see the *chip separator* sitting in the corner. I know, it looks suspiciously

like a plywood box sitting on a trash can. But as you can see in the drawing on page 17, there's more to it than that.

The chip separator is connected to two flexible hoses. One hose is connected to the dust collector. The other hooks up to the dust control box. Note: If you build *only* the chip separator, run one hose to the collector and the other to the tool.

Either way, as air, chips, and dust are drawn into the chip separator, they hit a baffle that extends down into the trash can. This baffle *slows down* the air, so the big chips settle out and are deposited in the trash can. The fine dust particles get carried around the baffle and on to the dust collector.

One advantage to this is you don't have to empty the bag on the dust collector nearly as often. Just empty the trash can instead (Photo A). Also, since large chips and slivers of material are captured in the trash can, I don't have to worry about them damaging the fan blades in the dust collector.



A. Chip Separator. Just lift off the chip separator to empty the trash can. A plastic "window" lets you see when the trash can is full.

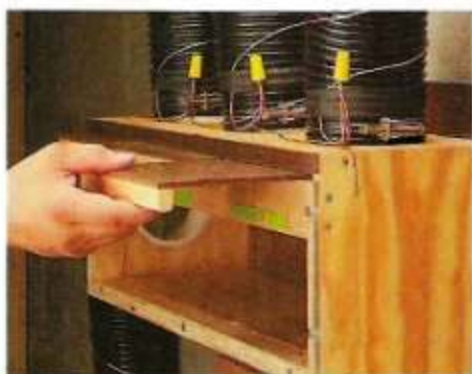

B. Dust Control Box. To direct dust and chips from the tool you're using to the dust collector, simply slide open the blast gate for that tool.

DUST CONTROL BOX

To avoid having to swap the hose on the dust collector from one tool to another, I also built a *dust control box* that lets me hook up *three* tools at once. It's the wall-mounted box with three hoses coming out of the top. Each hose is hooked up to a separate tool.

So if you want to use the router table for example, simply slide open the appropriate blast gate (Photo B). This draws dust and chips from the router table and directs them to the chip separator and dust collector.

AIR FLOW DIAGRAM

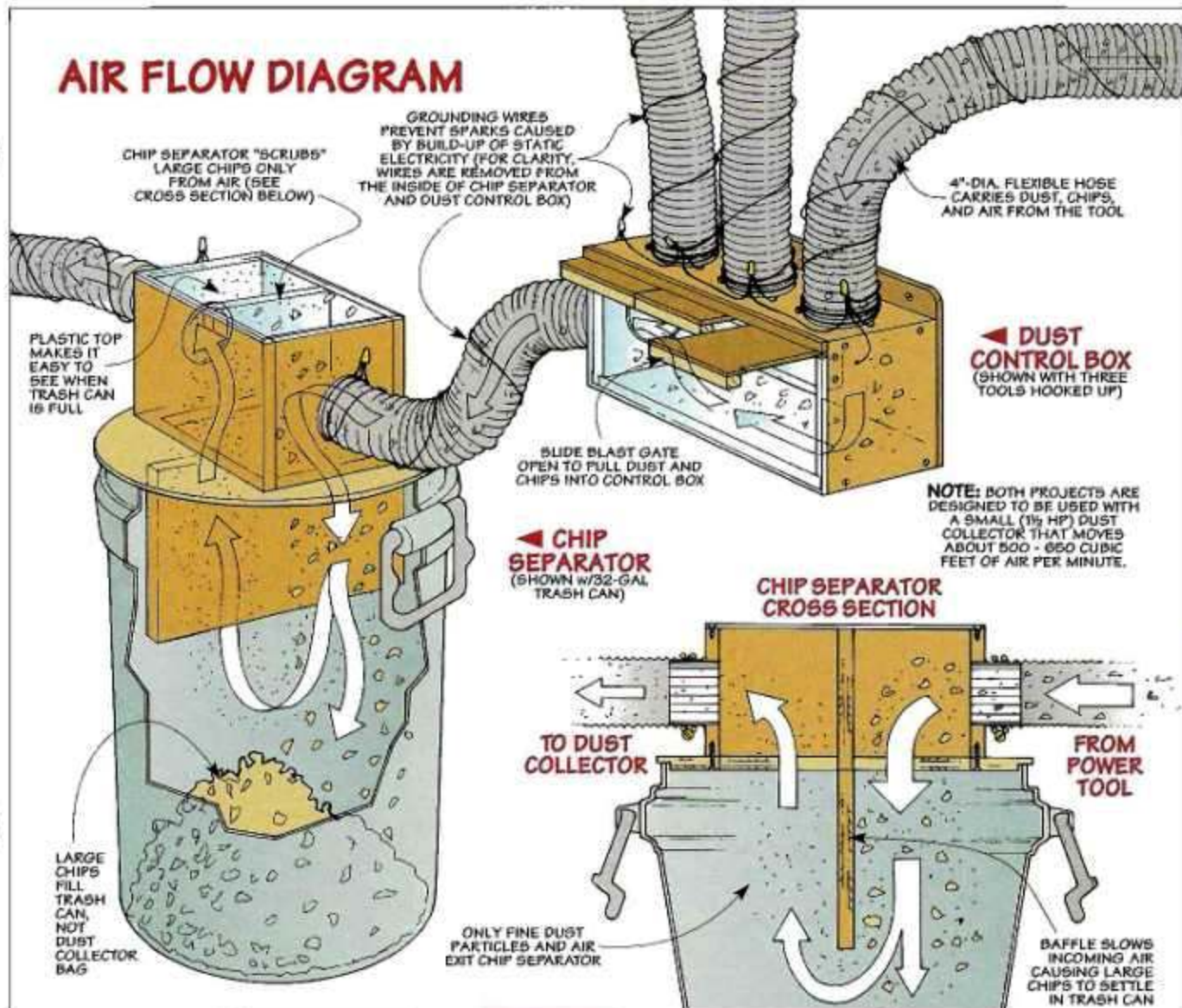

Dust Collection Hook-Up Hints

It's easy to hook up a small dust collection system that includes the *chip separator*, *dust control box*, and a portable *dust collector*.

Flexible Hose – To carry dust, chips, and air from one part of the system to another, I used 4"-dia. *flexible hose*. The hose fits over plastic dust ports in the chip separator and dust control box (Photo A), and it's secured with a wire hose clamp. (Instructions for making these ports out of PVC pipe begin on page 20.)

Since the hose bends easily, it doesn't require a bunch of different fittings. Simply cut a length of hose and run it between each part of the system. There is one thing to keep in mind however. The longer the hose, the more pressure is lost, and the less suction you get at the tool. So keep each run as short as possible.

Grounding Wire – One last note. This type of hose builds up static electricity. In a worst case, this could cause a spark that ignites the dust particles inside. To prevent that, I grounded the entire system with copper wire, as shown in Photo B and on page 23. (For sources of wire and other supplies, refer to page 31.)



▲ **Hookup** – To hook up this system, just fit a flexible hose over each dust port and secure it with a wire hose clamp (Photo A). Then ground the system with copper wire (Photo B).

One look in the "window" of this chip separator says it all. A blizzard of dust and chips swirl into one side, and fine dust particles exit the other. No, this disappearing act isn't magic. It's a simple matter of letting the chips fall where they may. In this case, that means into a trash can.

The secret is a T-shaped baffle that deflects incoming air and chips (Figure 1). This slows down the fast-moving air, causing heavy chips to settle in the trash can. With the big chips removed, only the fine dust particles are drawn into the dust collector.

Trash Can – Just a note about the trash can. Be sure it's made of *rigid plastic* (not soft vinyl). Otherwise, the vacuum created by the dust collector can make it collapse inward. (I used a 32-gallon Rubbermaid trash can.)

Base – In use, the plastic lid of the trash can is removed, and it's replaced with a plywood disk that serves as the *base (A)* of the chip separator (Figure 1). Besides enclosing the trash can, the base acts as a mounting surface for the baffle and a box that's added later.

The base starts out as a square blank that's $1\frac{1}{2}$ " larger than the *inside*

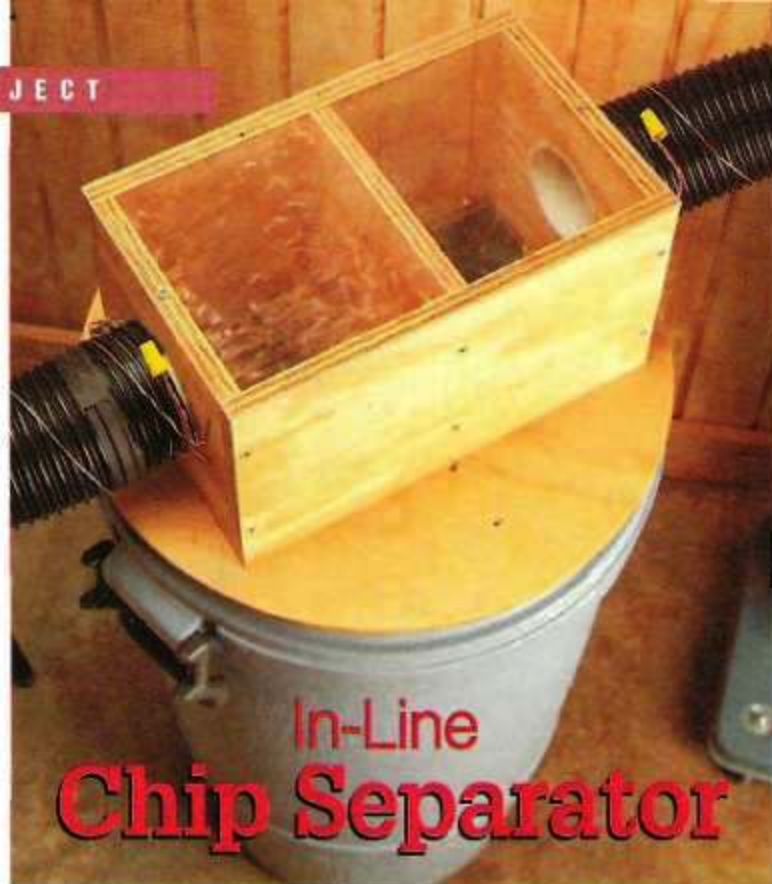

diameter of the trash can. This provides enough material to create a lip that rests on the trash can (Figure 1a).

After laying out the centerpoint of the blank, the next step is to draw a

circle of the desired diameter (20" in my case). Then use a jig saw (or band saw) to cut the base to rough shape. To cut it to final size (and to form the lip on the base), I used a simple jig.

Circle-Cutting Jig – This jig makes it easy to rout a circle using a hand-held router and a straight bit. The router is mounted to one end of a piece of hardboard (Figure 2). At the opposite end, a pivot pin lets you swing the router in an arc, cutting a perfect circle. (I used a nail as a pivot pin.)

There are *three* separate holes (pivot points) for the nail (Figures 2 and 2a). This allows you to rout three different-size circles — one to trim the base to size, and the other two to rout a rabbet that forms the lip.

Trim Base – The final size of the base is determined by the location of the *outermost* hole. To find the centerpoint of this hole, you need to know the radius of the base (10" in my case). Then drill a hole that same distance from the *inside* edge of the router bit. Note: You'll also need to drill a centered hole in the base to hold the nail.

To trim the base to size, start by setting the jig in place and installing the pivot pin. Then lift up on the router.

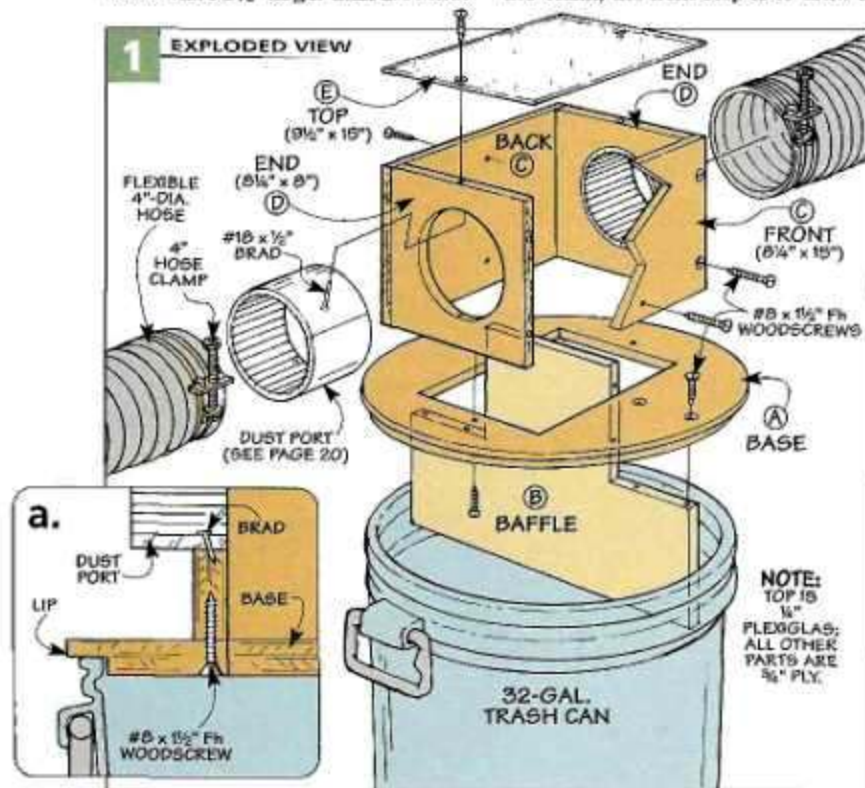

(You don't want the bit to contact the workpiece when you first turn on the router.) Now flip on the switch, lower the bit into the workpiece, and rout in a counterclockwise direction to trim off the waste (Figure 2b)

Rout the Rabbet – The next step is to rout the rabbet that forms the lip in the base. The basic process is the same. Only this time, the bit is adjusted for a $\frac{3}{8}$ " depth of cut. Also, you'll need to make *two* passes, removing a portion of the material with each pass.

To do this, start by locating and drilling the two inner holes (Figure 2a). The centerpoints of these holes are $\frac{3}{8}$ " apart. This way, after making both passes (Figures 2c and 2d), you'll end up with a $\frac{3}{4}$ " wide lip.

Cut Opening – To complete the base, you'll need to cut an opening for chips to pass through (Figure 3). After laying out the opening and drilling a hole near each corner, a jig saw makes quick work of removing the waste.

Baffle – Now you're ready to add the plywood *baffle* (B). If you look at Figure 3, you can see that the corners of the baffle are notched so it fits up into the opening in the base. Note: If your trash can has angled sides, you'll also have to taper the lower edges of the baffle to fit.

Connection Box – After fastening the baffle to the base with screws, I set about making a *connection box*. As you can see in Figure 1, it's a plywood box with a plastic top. A plastic port in

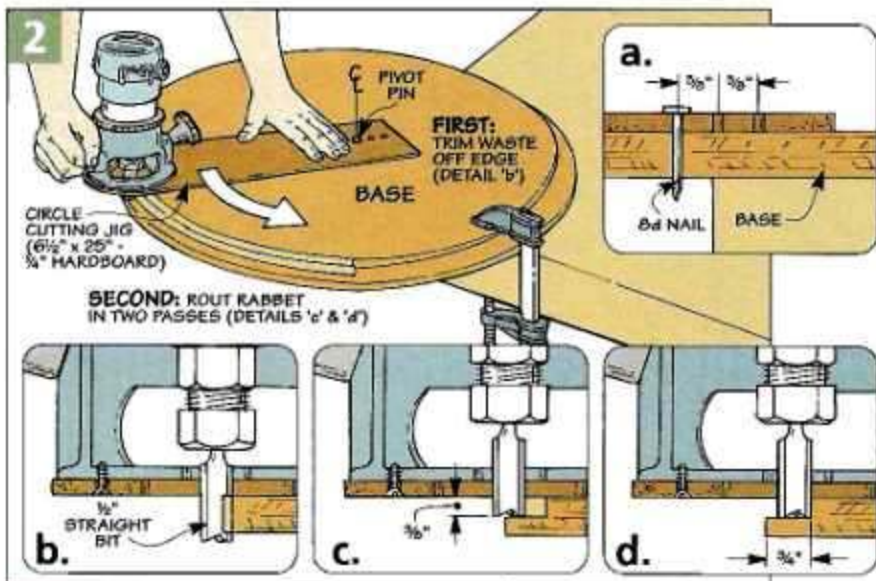

each end provides a way to hook up two hoses, one coming from the control box (or tool), and the other leading to the dust collector.

The box consists of a *front/back* (C) and two *ends* (D) that are assembled with butt joints. These pieces are sized so the *inside* of the box fits flush with the opening in the base.

To hold the dust ports, you'll need to cut a hole in each end piece. It's sized to match the *inside* dia. of the hose (Figure 4a). Since the ends are fairly small, it's best to cut the holes in an extra-long piece. I used a circle cutter chucked in the drill press (Figure 4). But you could cut them with a jig saw and sand the edges smooth.

Dust Ports – After cutting the end pieces to final length, it's time to add the *dust ports*. These are short pieces of 4"-dia. PVC pipe with a small section removed so they fit into the holes. (For more on this, see page 20.)

Once the dust ports are completed, you can install them in the ends. Each port is held in place with a couple of brads (Figure 1a). It's best to pre-drill the holes for the brads. Then install the dust ports and tap in the brads.

Assembly – Now all that's left is to screw the box together and add a $\frac{1}{4}$ " Plexiglas *top* (E). After screwing the top in place, just slip the box over the baffle. To hold it securely, the box is screwed to the baffle *and* the base.

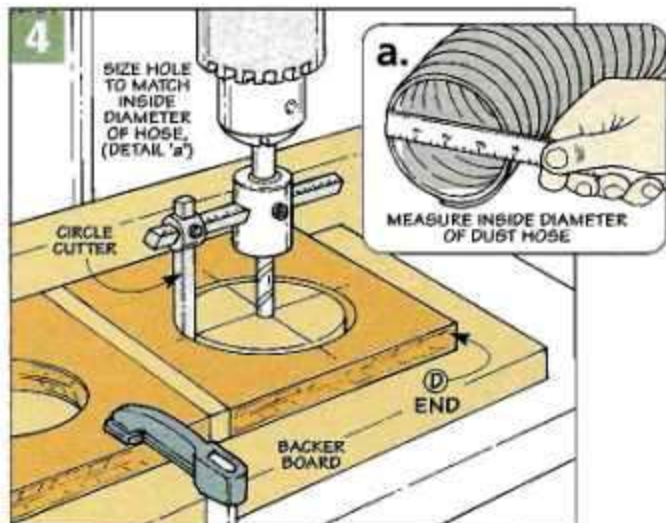
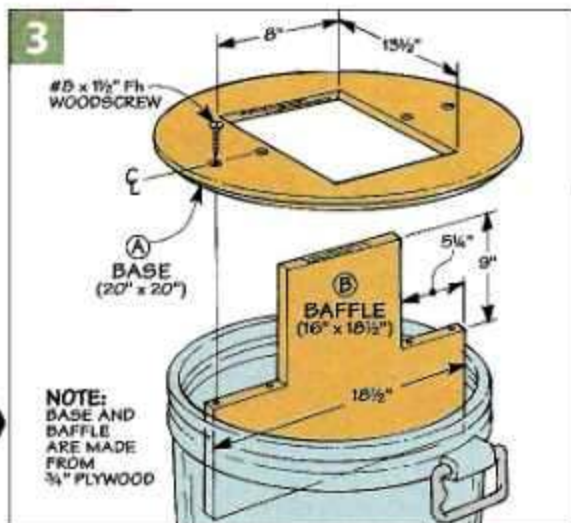

Plastic Dust Ports

Each part of this dust collection system is connected by a flexible hose that fits over a *plastic dust port*. At first, I considered buying manufactured dust ports, but they cost about six dollars each. So I decided to make my own.

PVC Pipe – Each dust port is made from 4"-dia. plastic PVC pipe. I used thick-walled (Schedule 40) pipe which is available at most home centers.

One thing to note is the outside diameter of this pipe is *larger* than 4". (It's actually about 4 1/2".) As a result, it won't fit into the holes in the chip separator or dust control box. (These holes are slightly *smaller* than 4".)

The solution is to *reduce* the diameter of the pipe. This isn't as difficult as it sounds. Basically, the idea is to remove a small piece of material from each dust port and then glue the ends together, as shown in the photo above.

Cut to Length – The first step is to cut a 2 1/2"-long piece of pipe for each dust port. (I made six ports altogether.) To cut the ends square, I used a simple process that involves first *scoring* the pipe on the table saw, as shown in Step 1



below and then cutting the rest of the way through with a hack saw. This will leave a small "nib" on the end of the pipe, but it can be quickly sanded off.

Remove Waste – Once the pieces are cut to length, it's time to remove the waste piece from each dust port. A band saw makes quick work of this (Step 2). The tricky part is figuring out how large a piece to cut out.

To do this, I used a strip of paper as a "measuring tape." Start by fitting the paper around the inside of the hole and drawing a line at the end of the strip (detail 'a'). Then

wrap the paper around the dust port and mark the locations of the end of the strip and the layout line on the pipe (detail 'b').

Glue-Up – After removing the waste piece, the last step is to glue the ends of the dust port together. The problem is the pipe is rigid and stiff. This makes it hard to squeeze the dust port together, and there's quite a bit of pressure that makes it want to spring open.

An easy way to make it bend easily is to cut a series of kerfs around the inside of the pipe (Step 3). Then tighten one of the hose clamps around the dust port to draw the ends *close* together (about 1/4" apart). Now just brush on some PVC cement and quickly tighten the clamp until the ends meet.

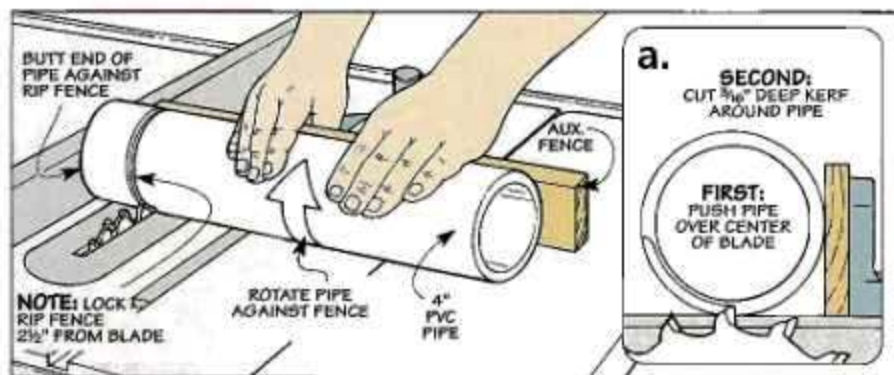

1 To make each dust port, the first step is to "score" the pipe on the table saw. After adjusting the blade height to make a 3/8"-deep cut (detail 'a'), use a miter gauge to push the pipe into the blade. Then rotate the pipe to cut a kerf all the way around.

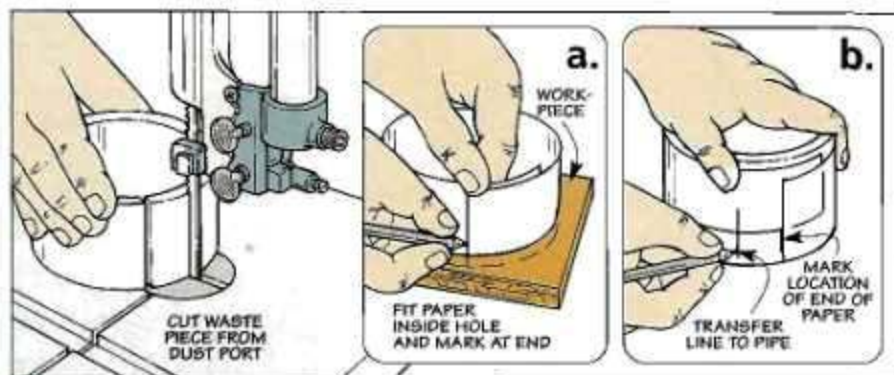

2 The next step is to cut the waste piece from the dust port. To determine the size of this piece, use a paper strip to "measure" the circumference of the hole in the work-piece (detail 'a'). Then just transfer this measurement to the dust port (detail 'b').

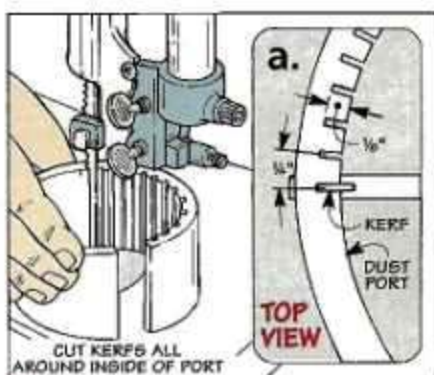

3 Before gluing the dust port together, cut a series of kerfs to make it easy to squeeze it closed with a hose clamp.

It only takes a minute to connect the hose on a dust collector to a tool. Not a big deal at all. Even so, constantly switching the hose from one tool to another gets to be a hassle.

That's why I like this dust control box. I can use it to connect three tools to the dust collector at the same time. But I can still collect dust and chips produced by each individual tool.

Blast Gates - The key is a set of three blast gates that are like on/off switches. Each gate controls the flow of air at a single tool. When you pull out a blast gate, chips and dust from that tool only are drawn into the control box and then carried out the end to the chip separator. Closing the gate shuts off the flow of air at the tool.

Case - The blast gates are housed in a wall-mounted case. As you can see in Figure 1, the case starts out as a top/bottom (A) and two end (B) pieces made from 3/4" plywood.

To connect the hoses from the tools, you'll need to cut three holes in the top to hold the dust ports. (The size of the holes and the dust ports are identical to those on the chip separator.) There's also a hole in one end for a single dust port. The hose from the chip separator fits over this port.

Rabbit Joints - The case is assembled with simple rabbit joints. As Figure 1 shows, the top and bottom



Three-Tool Dust Control Box

fit into rabbets in the end pieces. But the thing to pay close attention to is the width of the rabbets.

Notice in the Front View in Figure 1 that the lower rabbet is cut to fit the bottom of the case. But to form a slot that allows the blast gates to slide in and out, the upper rabbet is wider. It's sized to match the combined thickness of the top plus the 1/4" hardboard panels on the blast gates.

Assembly - Once the joinery is complete, you can assemble the case. Here again, the dust ports are secured

with brads. As for the case, it's held together with screws. Just be sure the top is flush with the upper edge of the end pieces. This way, the blast gates should slide into the slots in the case without binding.

Back - To enclose the rear of the case, I added a hardboard back (C). It matches the length of the case. But it's taller (wider), so it sticks up above the case. This provides a convenient "tab" for the mounting holes. Note: To make it easy to install two guides later, set the back aside for now.

Tired of switching dust hoses from one tool to another? Build a three-tool control box — it's an open and shut case.

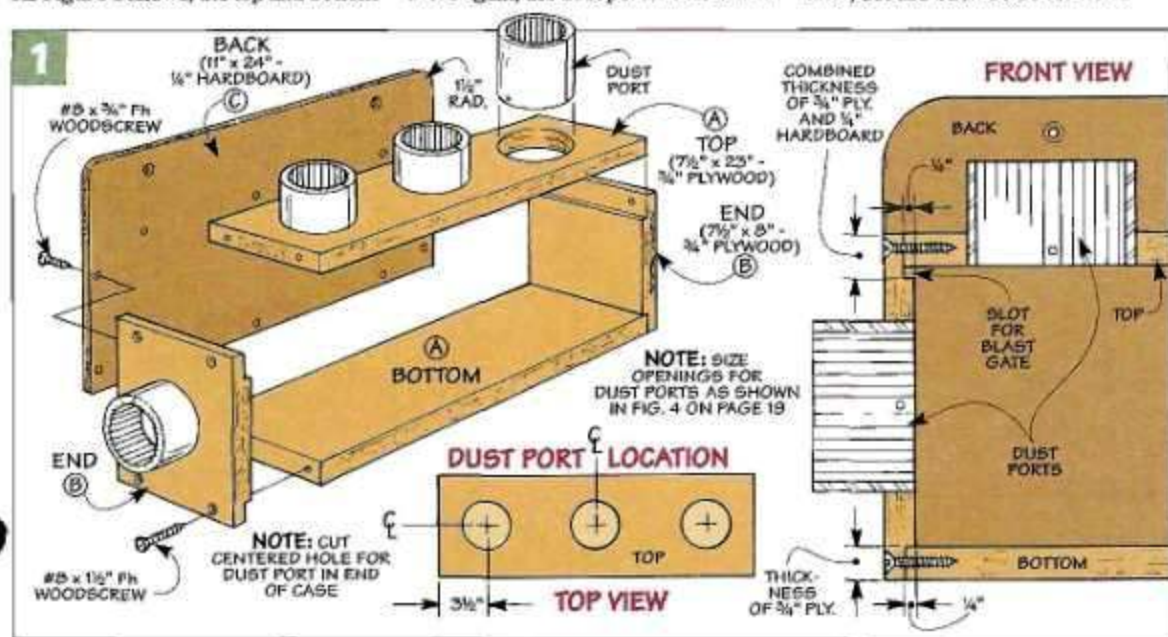

Blast Gates

Once the case for the dust control box is complete, you can turn your attention to the three blast gates. As you can see in Figures 2 and 2a, the blast gates are located directly below the dust ports in the control box. This way, when you slide one of the gates open, chips and dust are pulled down into the control box.

Guides – To allow the gates to slide smoothly, there are two hardwood *guides* (D) attached to the top of the control box (Figure 3). Notice that these guides are rabbeted on each edge (Figure 3a). Together with the slot in each end of the box, the rabbets form a track that lets you slide the gates in and out (Figure 3c).

In addition to the rabbets, you'll also need to cut a notch in one end of each rail (Figure 3b). It holds a long wood rail that's added later.

Now it's time to attach the guides to the top of the box. To do this, I found it easiest to turn the case upside down. Also, to prevent the blast gates from binding, it's important that the guides are parallel to each other and square to the front edge of the case. You'll also want to space them evenly apart to create equal-sized openings for the gates. Then it's just a matter of gluing

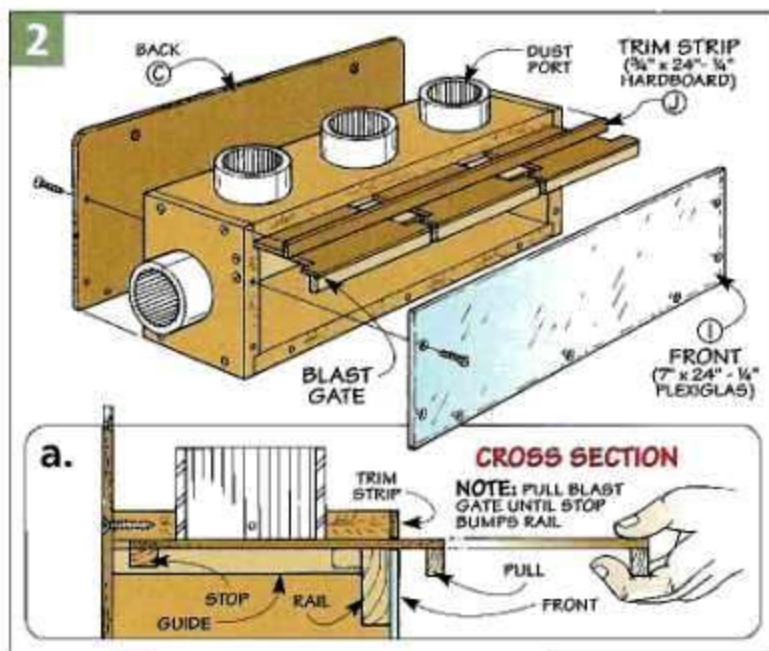

▲ To see which blast gate controls the air flow at each tool, I labeled the front of the box with self-adhesive letters.

and clamping the guides in place.

Blast Gates – The next step is to add the blast gates. Each blast gate consists of three parts: a *sliding panel*, a *pull*, and a *stop* (Figure 3).

The *sliding panel* (E) is just a piece of 1/4" hardboard that controls the flow of air into the box. Notice in Figure 3 that it's notched on each edge to form a T-shaped panel. The narrow part of

this panel is sized to slide smoothly between the guides without any side-to-side play. As for the two "ears," they contact the ends of the guides (or the case) when you close a gate. This way, the dust port is completely covered.

After cutting the notches, I added a *pull* (F) to make it easy to open and close the gate. This is just a narrow strip of hardwood with a small (1/8") roundover on each of the exposed edges. Safety Note: It's best to rout the roundovers on an extra-wide strip and then rip the strip to final width.

Once the pull is glued in place, all that's left to do is add a *stop* (G). This is a small wood block that's glued flush with the back edge of the panel. When you open the blast gate, the stop hits a rail which prevents the blast gate from being pulled all the way out.

Rail – Now you can turn your attention to the *rail* (H). It's a long strip of 3/4"-thick hardwood that spans the top of the case (Figure 4). The rail provides a contact point for the stops on the blast gates (Figure 2a). Plus it forms a slot in front of the control box that lets you slide the gates in and out.

The thing to pay attention to is the up and down location of the rail. To prevent the blast gates from binding,

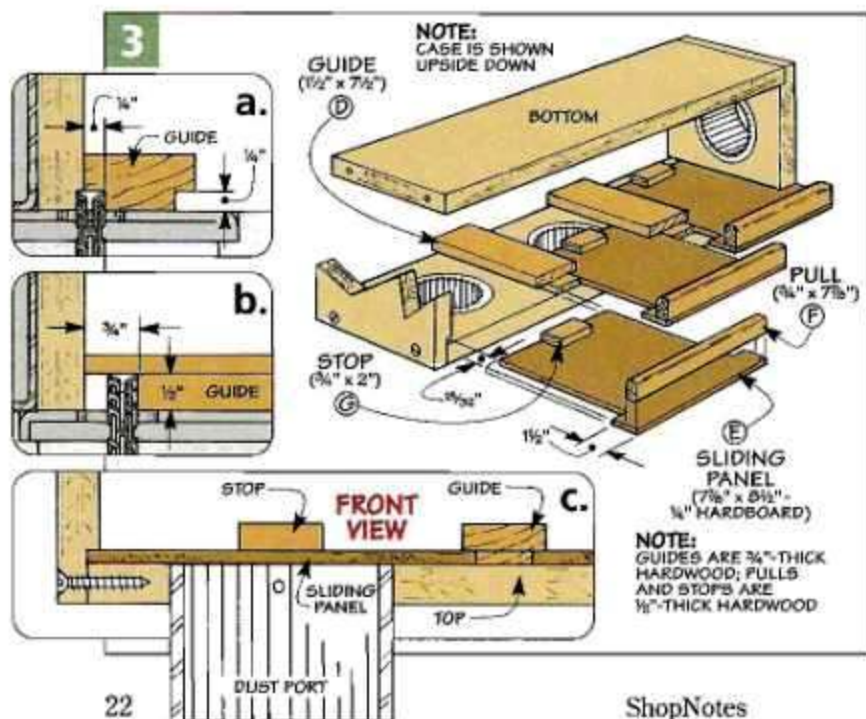

you don't want the rail to fit too tightly against them. Also, don't forget to slip in the blast gates *before* attaching the rail. (The rail will trap them inside.)

Once again, it's easiest to turn the case upside down to position the rail. Start by setting the rail in the notches cut earlier in the guides (Figure 4). Then after raising it just a hair above the blast gates with a paper shim, screw the rail to the ends of the case.

Enclosing the Case – At this point, the dust control box is almost complete. Now it's time to enclose the front and back of the box.

As with the chip separator, the *front* (D) is 1/4" Plexiglas (Figure 2). This way, if a chunk of material gets clogged in the dust ports, it makes it easy to find the problem at a glance. After cutting the front to size, it's

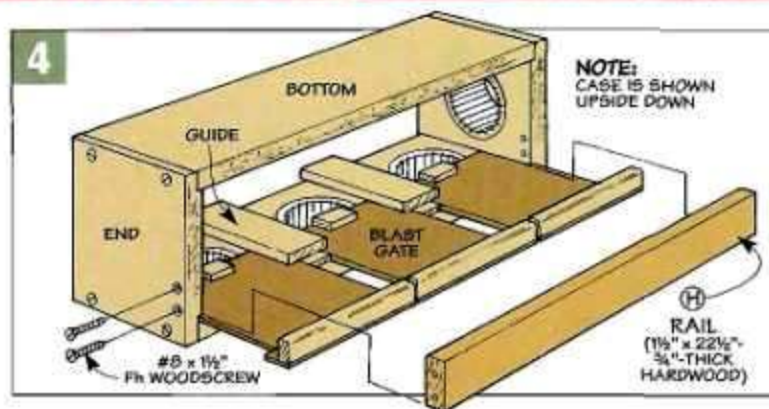

screwed in place. Just be sure it doesn't pinch against the blast gates.

The same thing applies to the *trim strip* (J) that covers the exposed plywood edge above the blast gates. It's a 1/4" hardboard strip that's glued in place. Finally, the back (C) that was made earlier can be screwed in place.

Hook-Ups – After completing the control box and chip separator, it's just a matter of arranging them in your shop and connecting them with flexible hose. (For more on this, see page 17.)

GROUNDING THE SYSTEM

Once you establish the basic setup, there's one final thing to do. To prevent a spark caused by a build-up of static electricity, it's important to ground the entire system (Figure 5).

Grounding Path – The idea is to establish a continuous *grounding path* from one end of the system to the other. This means starting at each tool, going *through* the chip separator and dust control box, and completing the path at the dust collector.

Stranded Wire – All that's needed to do this is some uninsulated copper wire. I used 16-gauge, stranded wire. (See page 31 for sources of the copper wire and other grounding supplies.)

One wire is attached to the metal housing of each tool *and* to the dust collector. (I used a crimp-on connector and screw to do this.) You'll also need to run a wire through the chip separator and dust control box. This requires drilling a small hole in the ends and stapling the wire inside.

Finally, I used *two* wires for each section of hose. One wraps around the *outside* of the hose like stripes on a candy cane. (I used electrician's tape to hold it in place.) The other runs through the *inside* of the hose. Note: Feed this wire *between* the hose and the dust port as you slip the hose in place. To complete the grounding system, just connect the ends of the wires as shown in the margin.

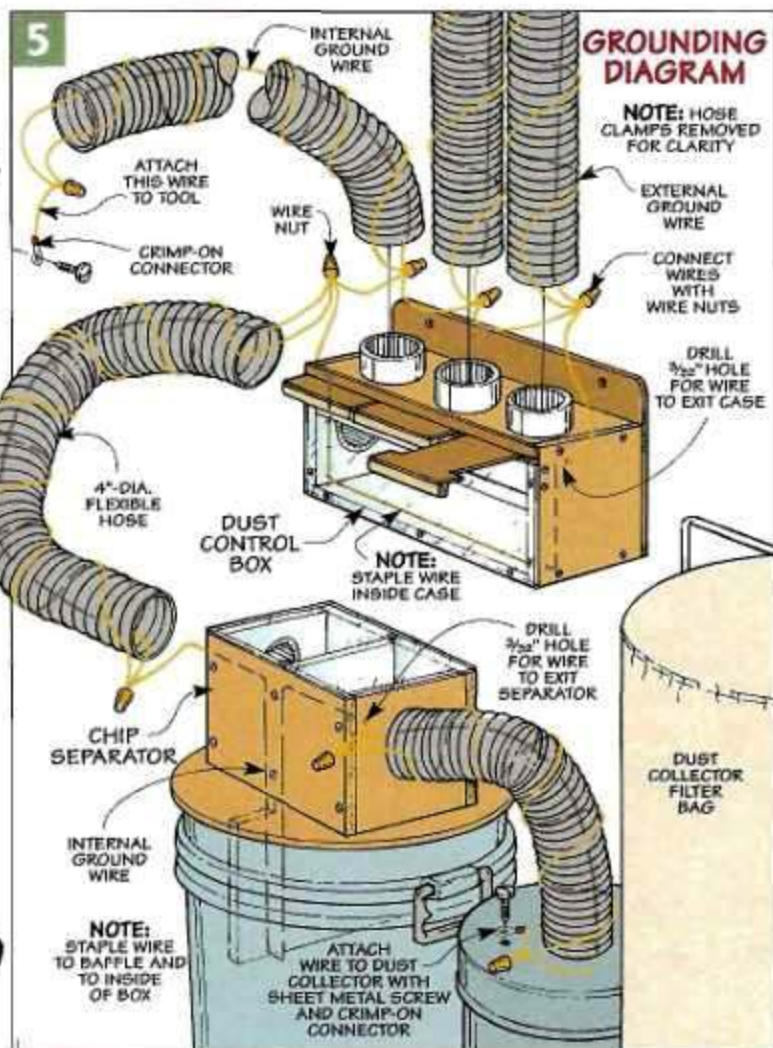

▲ To complete the grounding path, "tie" the ends of the wires together with wire nuts.

Lumber storage for the long and short of it — and everything in between. There's even a place for sheet material.



Roll-Around Store-All for lumber & plywood

Here, there, and everywhere. That's one method for storing lumber and plywood. Long boards are often stacked on the floor, short pieces of wood get buried in a pile somewhere else, and sheet material is usually just leaned against the wall.

The only problem with this type of storage "system" is it's a hassle to sort through everything to find the piece you need. So I'm always on the lookout for a better way to store lumber.

One of the best solutions I've seen is the roll-around store-all shown above.

It's based on an idea that was sent in by Tom Staggs of Paw Paw, Michigan. As you can see, there's plenty of storage. But just as important, this store-all provides a great way to *organize* lumber and sheet material.

You can slide long boards into the open-ended compartments in the A-shaped "tower," and shorter pieces of wood fit into a row of bins on the side. The other side holds full and partial sheets of material.

Panel-Cutting Guide – But there's more to this project than storage. As an option, you may want to add the panel-cutting guide that's shown at left. It makes it easy to cut sheet material into pieces of manageable size.

Editor's Note: The plans for building this cutting guide were originally featured in *ShopNotes* No. 48 which is available from the source listed in the margin. Instructions for mounting it to the lumber cart begin on page 28.

PLATFORM

The first step in making the store-all is to build a large platform that provides support for the tower and the storage bins. Since the store-all is quite



Panel-Cutting Guide ▶ Mounting this optional panel-cutting guide to the lumber cart provides a quick, easy way to cut large sheets of material to manageable size. The step-by-step plans for this project were originally featured in *ShopNotes* No. 48. You can order this issue by calling 800-347-5105. Or, visit us at PlansNow.com to purchase the plans only.

heavy when it's loaded, this platform has to be strong and rigid enough to carry the weight.

To accomplish this, the foundation of the platform consists of a set of five wood rails (A) that are covered with a plywood base (B), as shown in Figure 1. After positioning two of these rails flush with the ends of the base, they're screwed in place. The other three rails are spaced equally apart and fastened with screws as well.

Bins – Once the foundation for the platform is complete, you can turn your attention to the bins. The openings for these bins are formed by a set of six plywood dividers (C).

Notice in the Divider Detail in the margin that the *inside* edge of each divider tapers from top to bottom. This will allow the dividers to fit against the angled sides of the tower when it's added later. The table saw makes quick work of cutting the tapered edges. All you need is a sled to hold the workpiece, as shown in the box below.

To complete the dividers, I cut a curved "scoop" in the top edge of each piece. Besides removing the sharp, outside corner, this makes it easy to see what's inside the bins.

Add the Side – To hold the boards in the bins, the outside of the store-all is enclosed by a tall (wide) side (D)

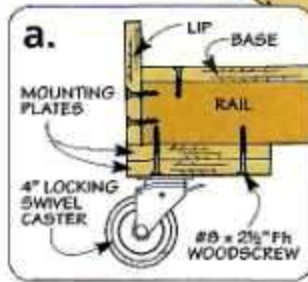
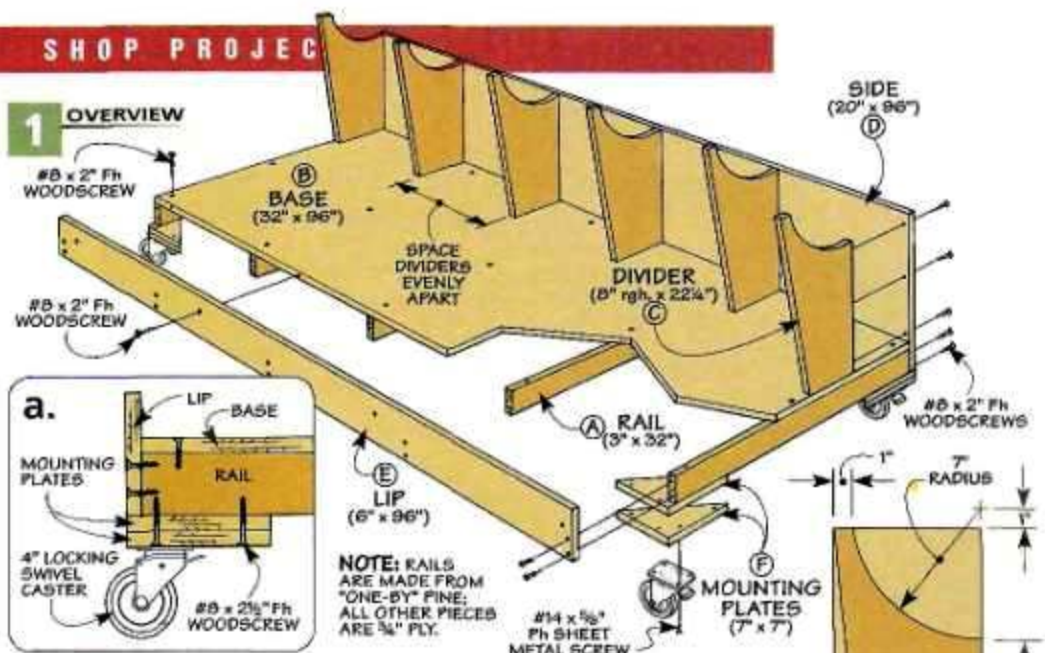

piece made of $\frac{3}{4}$ " plywood (Figure 1). It's cut to match the length of the store-all and then screwed to the ends of the rails. Then after locating the dividers so they're spaced equally apart, they're attached to the side with screws as well.

Lip – The side of the platform *opposite* the dividers also needs some work. To prevent pieces of sheet material from slipping off the cart, I added a plywood lip (E). This is just a long, narrow strip that's attached to the ends of the rails and the base with screws (Figure 1a).

Install Casters – There's one more thing to do to complete the platform. That's to install a set of four locking swivel casters. To support the weight of the store-all, I purchased casters that are designed to hold 400 pounds each. (For a source of inexpensive casters, refer to page 31.)

Each caster is attached to a thick, triangular mounting plate (F). It's made by gluing up two pieces of $\frac{3}{4}$ " plywood. After trimming the mounting plates at a 45° angle, they're screwed to the corners of the platform. Then just screw the casters in place.

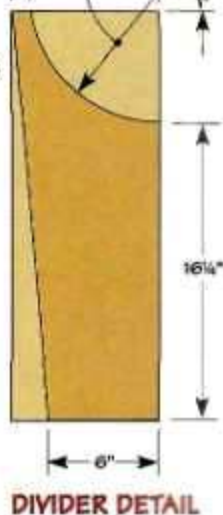

Taper-Cutting Sled

To make a long, tapered cut on the table saw, I use a simple sled to carry the workpiece through the saw blade. This sled is especially handy when making multiple pieces (like the dividers for the lumber cart) because it ensures identical tapers.

The sled consists of a plywood base and a wood runner that slides in the miter gauge slot. You'll want to start with an extra-wide base. It should be wide enough to hold the divider, a cleat (added later), plus about 1" of waste material.

Before removing the waste, you'll need to attach the runner. It's screwed in place so the base extends about 1" past the blade. Then slide the sled through the blade to trim the edge (Figure 1). This



creates a *reference edge* that's used to position the workpiece on the sled.

To do this, align the layout line on the workpiece with the reference edge. Then without moving the piece, attach two

wood cleats to the sled (Figure 2). These cleats will prevent the workpiece from shifting as you slide the sled past the blade. This way, the blade cuts a perfect taper every time — exactly on the line.

The Tower

Once the platform is complete, it's time to add the tower. As you can see in Figure 2, this is a tall, A-shaped unit with two angled side panels and a set of four shelves. One side panel encloses the back of the bins; the other provides a large, flat surface to lean sheet material against.

Side Panels – Each side panel (G) is made from a full sheet of $\frac{3}{4}$ " plywood. Notice in Figure 3a that the bottom edge of each sheet is beveled at a 5° angle. This way, the side panels will sit flat on the base of the platform when the tower is assembled.

There's only one problem. These large sheets are quite awkward to handle on a table saw. So I clamped them to a pair of sawhorses and cut the bevels with a circular saw instead.

To produce a straight, accurate cut, it's a good idea to clamp a straightedge to the workpiece as a guide, as shown in Figure 3. Then with the saw base tilted 5°, hold it firmly against the straightedge and rip a bevel along the entire length of the side panel.

Cleats – After cutting both bevels, the next step is to add four wood cleats (H) to each side panel (Figures 2 and 2a). These are long, narrow strips of "one-by" stock (pine) that provide support for the shelves.

To make the shelves sit flat, the top edge of each cleat is beveled at a 5° angle. A table saw makes quick work of cutting these bevels. But before you get started, check out the direc-

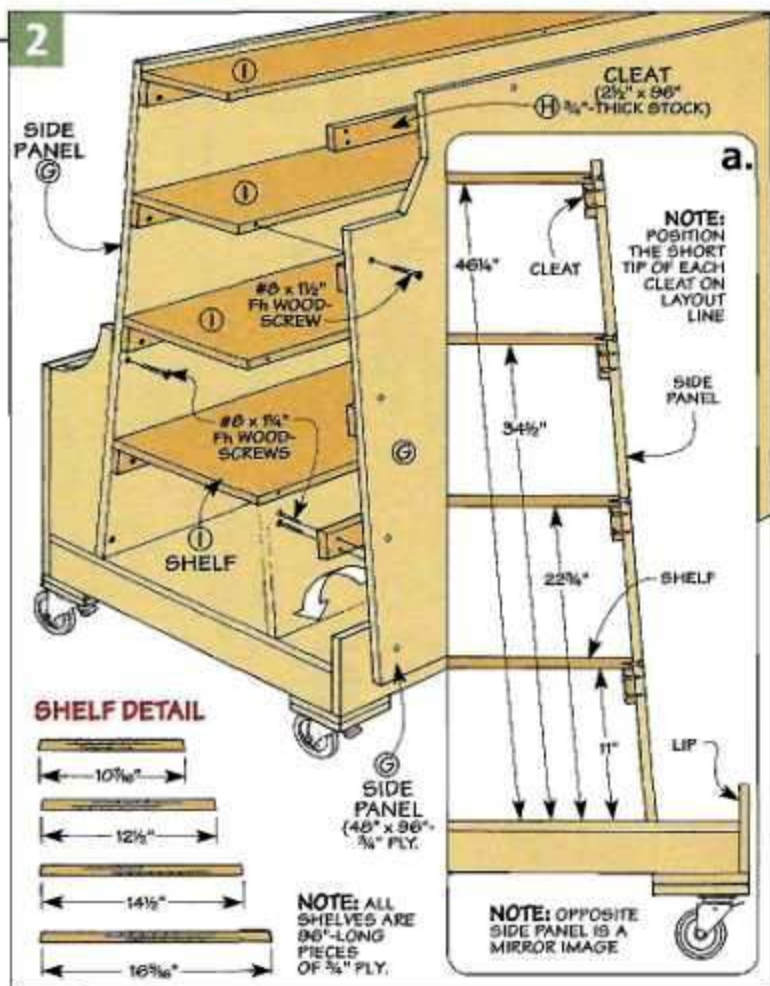

tion in which the saw blade tilts.

Tilt Direction – On many table saws, the blade tilts to the right. This means that it tilts *toward* the rip fence (if the fence is on the right side of the blade). The problem with this type of setup is there's a chance the work-

piece will get pinched between the blade and the fence which can cause it to burn or bind. To prevent this, be sure to move the rip fence to the *left* side of the saw blade. Note: If the blade on your saw *does* tilt to the left, position the fence on the *right* side.

Rip Bevels – Now you're ready to rip the bevel on each cleat. Start by tilting the blade 5° (Figures 4 and 4a). Then after locking the fence in position, rip a 2 1/2"-wide strip (to the long tip of the bevel).

Attach Cleats – After completing the bevels, the next step is to attach the cleats with glue and screws. The locations of the cleats are shown in Figure 2a. But the glue will have a tendency to make them slip out of alignment. To avoid that, I pre-drilled all the holes for the screws, brushed on a thin layer of glue, and installed the screws to "clamp" the cleats in place.

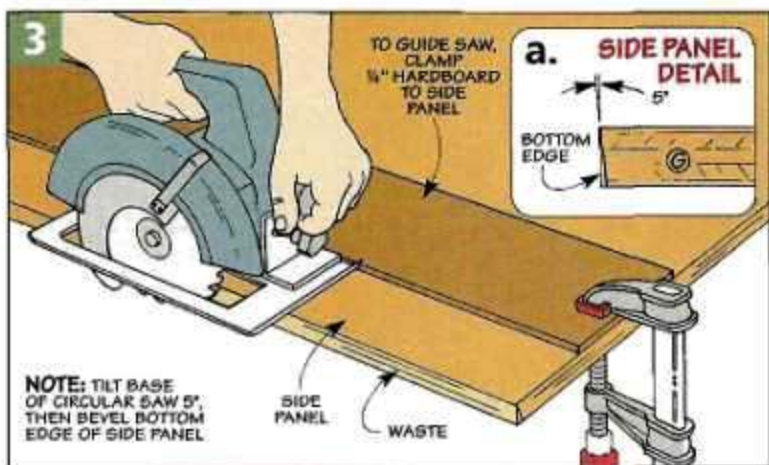

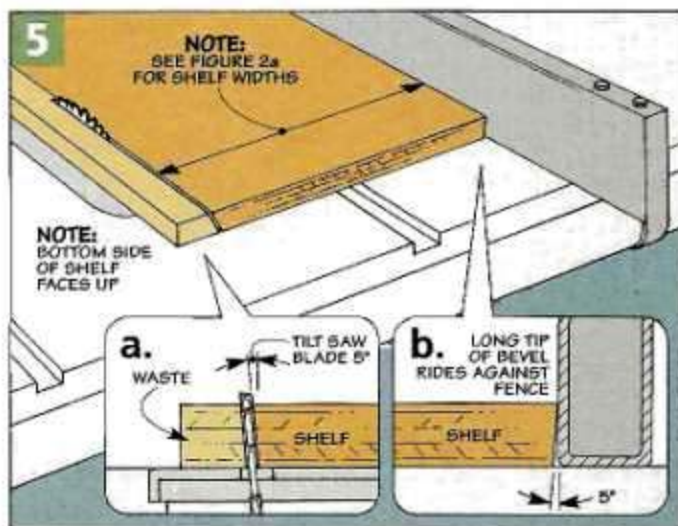
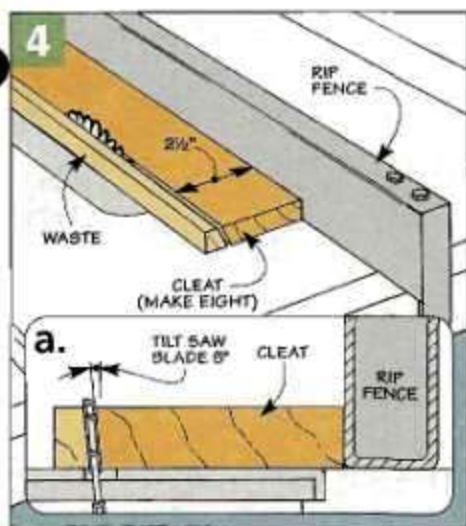

Shelves – Now you're ready to add the shelves (1). These are pieces of $\frac{3}{4}$ " plywood that run the entire length of the cart. Notice in Figure 2 that the shelves get progressively wider from the top to the bottom of the cart.

Regardless of its width, each shelf is beveled on *both* edges so it fits against the angled side panels. To end up with shelves of the desired width, you'll want to start with extra-wide pieces. Note: The dimensions shown in Figure 2 indicate the final width at the *bottom* of the shelf (between the long tips of the bevels).

Here again, tilt the saw blade 5° to

cut the bevels. As before, position the rip fence on the table saw so the blade tilts *away* from it. Then rip the bevel on the first edge, as in Figure 5a.

After repositioning the fence to cut the shelf to final width, you can turn the workpiece end for end and rip the bevel on the opposite edge (Figures 5 and 5b). Notice that in this case, the long tip of the bevel rides against the rip fence. This way, it can't work its way underneath the fence which can cause the workpiece to kick back.

Assemble Tower – After completing all four shelves, you're ready to assemble the tower. Since some of

the pieces are quite large, they can be a bit awkward to handle. So it's a good idea to get a friend to help.

The first step is to attach the side panel that encloses the back of the bins. To do this, set it on the base of the platform and then slide it against the dividers. (The tapered edges of the dividers will establish the angle of this side panel.) After clamping it in place, just screw the panel to the dividers, as shown in photo A below.

When it comes to installing the *second* side panel, things get a bit tricky. That's because the bottom edge of this panel has a tendency to "kick out" toward the lip of the platform, at least until the shelves are secured.

To prevent this, I used a long, scrap piece as a temporary spacer (Photo B). Together with the shelves, this spacer establishes the angle of the side panel. I found that a 6"-wide spacer worked out just right.

With the spacer in place, it's just a matter of setting the side panel against it, sliding in the bottom shelf, and securing it with screws. Then work your way toward the top of the tower, installing one shelf at a time.

Rewards – After completing the store-all, loading it with lumber and plywood is definitely a satisfying task. And adding the panel-cutting guide shown on the next page is also a plus. But the real reward is the new sense of order and organization that this store-all brings to the shop.

Shop Tip



▲ When storing long boards, label the end of each piece so you can see the size and type of wood at a glance.



Tower Assembly. To assemble the tower, clamp one side panel to the dividers and screw it in place (photo A). Then set the second panel against a spacer, slide in the shelves, and secure them with screws (photo B).

Mounting the Panel-Cutting Guide

One way to make this store-all even more versatile is to add the panel-cutting guide that was featured in *ShopNotes* Issue No. 48. It makes it a snap to cut large sheets of material into pieces of manageable size.

If you turn to page 24, you'll see that this panel-cutting guide is a large, wood grid that tilts out at an angle. The grid holds the workpiece at a convenient angle when making a cut. To ensure straight, accurate cuts, it has two separate fences that are used to guide a circular saw. (A long fence is used for ripping, and there's a short fence for making crosscuts).

Mounting Assembly – Originally, the panel-cutting guide was designed to be mounted to a wall. To hinge it to the store-all, I added the *mounting assembly* shown in the photo at right. This is a long, ladder-like unit fastened to the top of the store-all.

Construction – To provide rigid support for the panel-cutting guide, the mounting assembly is made entirely of "two-by" material. As you can see in Figure 6, two long *stretchers* (J) run the length of the store-all, and there are four short *support arms* (K) cantilevered out over the top.



▲ **Mounting Assembly.** Made of "two-by" material, the mounting assembly for the panel-cutting guide is fastened to the top shelf of the store-all. The guide is hinged to four short crosspieces so it can be tilted out at an angle.

By securing the panel-cutting guide to these overhanging support arms, it's held *away* from the store-all. This provides plenty of room to hold sheets of material behind it.

Joinery – The mounting assembly is held together with rabbet and dado joints. This requires cutting a rabbet in one end of each support arm to fit over a stretcher (Figure 6a). There's

also a dado near the middle of each arm that fits over the second stretcher.

One thing to note is that the *location* of these dados determines the distance between the stretchers. Ideally, the stretchers should be far enough apart so they fit snugly between the side panels (Figure 6a).

Assembly – After cutting all the joinery, the mounting assembly is

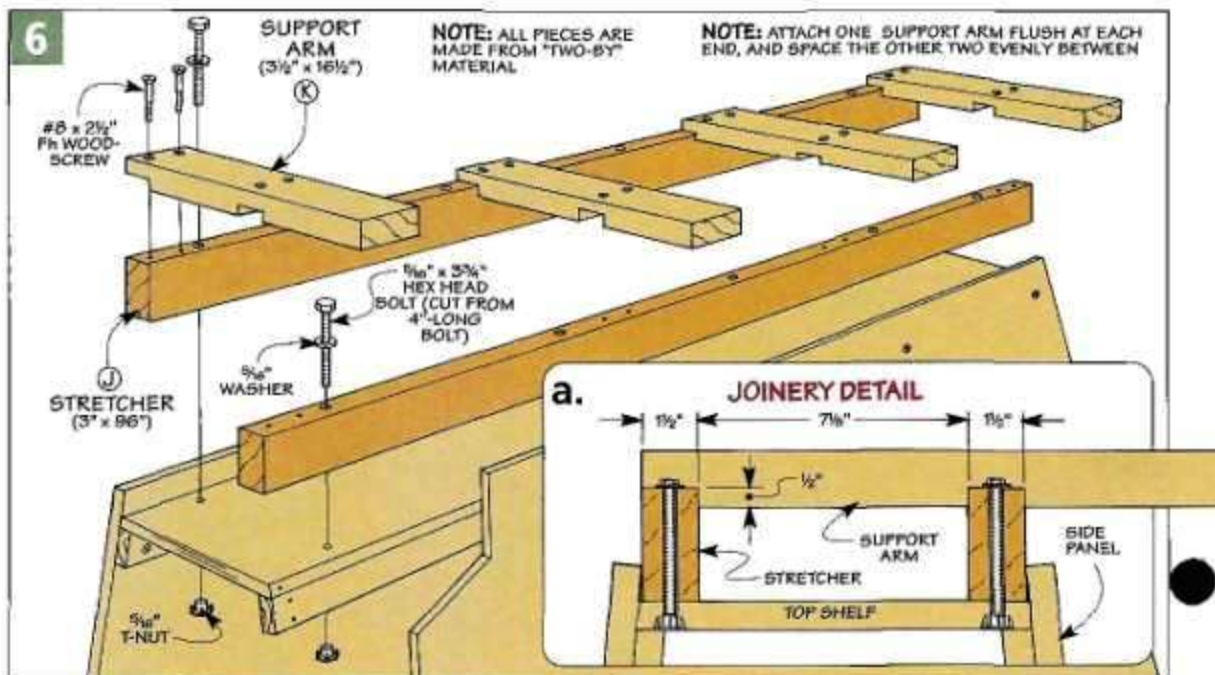

glued and screwed together to create a strong, rigid unit. As you can see in Figure 6a, this unit is secured to the store-all with bolts that pass through holes in the stretchers and then thread into T-nuts in the top shelf.

To simplify the assembly, it's important that the holes for the bolts and T-nuts align. An easy way to accomplish this is to lift the mounting assembly into place and clamp it to the top shelf (Figure 7). Then use a hand-held drill to drill holes through the stretchers and the shelf (Figure 7a). Note: These holes are centered on the thickness of the stretchers and sized to fit the T-nuts.

In order to install the T-nuts, you'll need to remove the top shelf of the tower. Also, to allow the shelf to sit flat on the upper cleats, the head of each T-nut has to be recessed in a shallow pocket. This is just a matter of flipping the shelf over and drilling a counterbore, as shown in Figure 7b. Then, after installing the T-nuts, you can reattach the shelf and secure the mounting assembly.

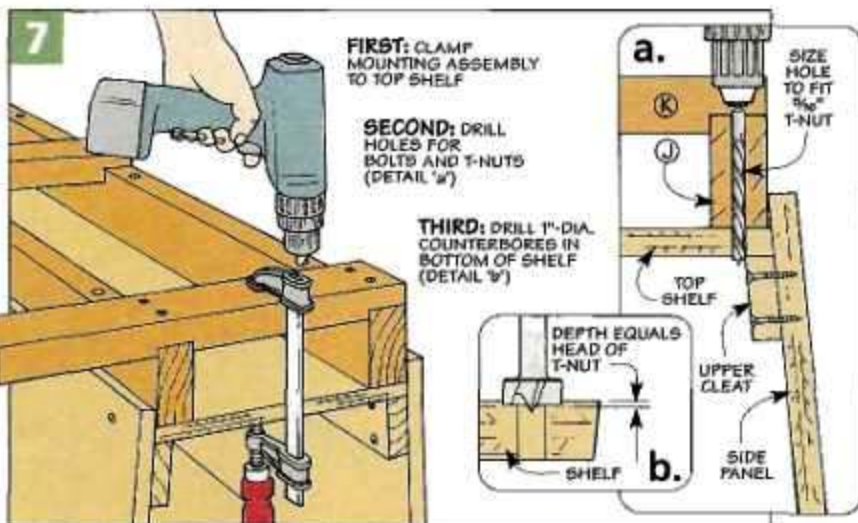

Attach Panel-Cutting Guide – Once that's accomplished, it's time to attach the panel-cutting guide to the support arms. It's held in place with four butt hinges.

A look at Figures 8 and 8a shows how the hinges are mounted. One leaf of each hinge is screwed to the top of the support arm. But before attaching the other leaf, you'll need to

provide a solid mounting surface.

All it takes to do that is to add a *mounting cleat* (L) to the panel-cutting guide (Figure 8). This is a strip of "one-by" stock (pine) that runs the length of the guide. After ripping the strip to width, it's screwed flush with the ends of the guide.

With the mounting cleat in place, you can attach the second leaf of the hinge. Notice in Figure 8a how the hinge aligns with the bottom edge of the cleat. This requires propping the panel-cutting guide up off the floor, temporarily clamping it to the cart, and then screwing the hinge in place.

At this point, it's possible to tilt the panel-cutting guide at an angle when making a cut. But there's no way to hold it there yet.

Pivot Blocks – That's the job of the two *pivot blocks* (M) attached to the lower part of the panel-cutting guide (Figures 9 and 9a). These blocks can be pivoted downward to prop the panel-cutting guide at an angle. To fold it flat for storage, just rotate the blocks upward.

The blocks are made from scrap pieces of "one-by" stock (pine). A notch in one end of each block fits over the lip of the platform (Figure 9a). And there's a hole drilled in the opposite end. It accepts a knob that threads into a T-nut installed in the panel-cutting guide (Figure 9b). To lock each block in place (or pivot it up and down) just tighten (or loosen) the knob.

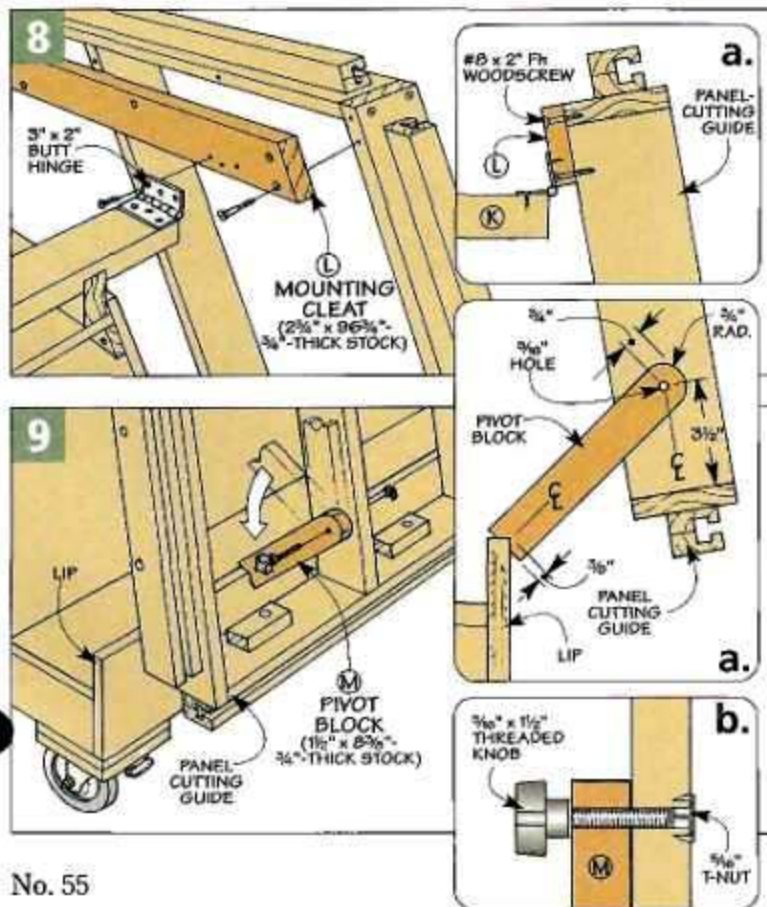

Tool Talk

TOOLS OF THE TRADE

Drill Doctor

It's a curious thing about twist bits. Even when one gets too dull to drill a hole, I still can't bring myself to throw it away. So like a lot of woodworkers, I stick it in a can filled with a bunch of other dull bits.

Now it's not that I haven't *tried* sharpening twist bits, but I often get mixed results. When I sharpen them freehand on a bench grinder, it's all too easy to grind the tip of the bit off-center and end up with an irregular-shaped hole. And even a slight change in the cutting angle can cause

the bit to smoke or require a lot of pressure to drill a hole.

The most common solution is to buy a new bit. That's not a big deal with small-dia. bits ($\frac{1}{4}$ " or less) that only cost a few bucks. But some of the larger bits cost \$10 to \$15 apiece, and *that* gets to be expensive.

So when I saw a new tool called the *Drill Doctor* that's specially designed

for sharpening twist bits, I was intrigued. The only problem is it was a bit pricey (about \$77 at the local home center). Even so, I figured it might save money in the long run, so I decided to buy one and give it a try.

At first glance, the *Drill Doctor* looks more like a camera than a sharpening tool. As you can see in the photo above, it has a plastic housing and two round openings (tubes). The tube in the side is used to *align* the drill bit, and the one on the end to *sharpen* it. For both operations, the bit is inserted in a chuck that's included with the *Drill Doctor*.

Insert Bit – My first instinct was to tighten the bit in the chuck like I do in a regular drill. But actually, the goal is *not* to tighten the chuck all the way, at least not at first. To align the bit, it has to be loose enough to slip back and forth in the chuck.

Align Bit – The whole idea in aligning the bit is to determine how far it should stick out of the chuck. To do this, start by pushing in a spring-loaded bar to spread a pair of metal *arms* apart. (Refer to the drawing and detail 'b' at left.) Then insert the chuck into the alignment tube until the bit contacts a *stop*.

When you release the bar, the arms grab the bit and position it in the chuck. There's just one small wrinkle. To ensure proper alignment, the arms must pinch the *thinnest* part of the bit (around the flutes). So you may need to rotate the bit until the arms click into place. (There's a "window" in the top of the housing that lets you look inside.) It's at *this* point that you can tighten



Drill Doctor Model 250

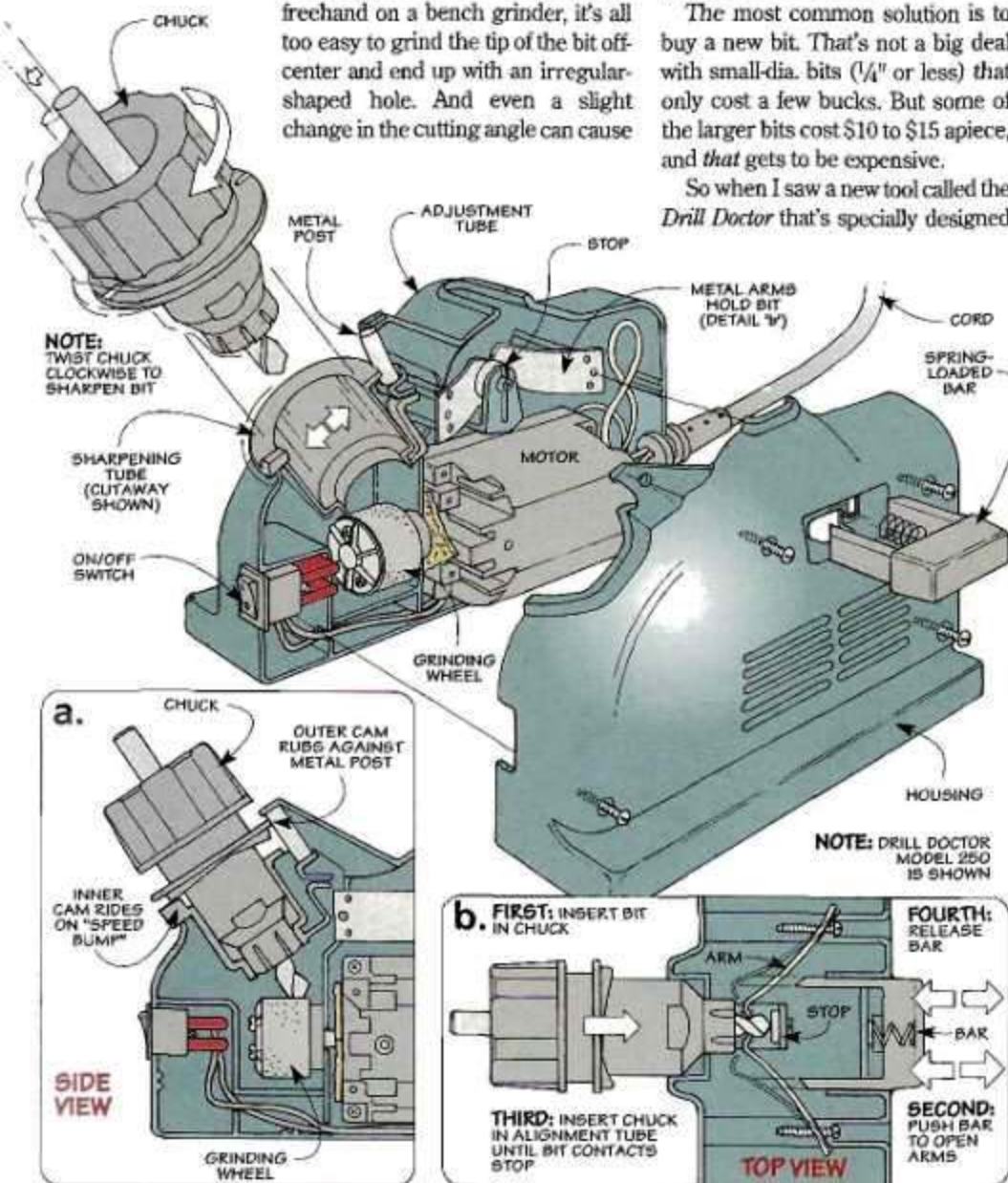

the chuck securely and then remove it from the tube.

Sharpening a Bit – Once the alignment is taken care of, sharpening the bit is almost automatic. Just flip the switch, insert the chuck into the sharpening tube, and then give it a few twists, as shown in the photo at right. The entire process takes less than half a minute.

Bit Size – Depending on the size (and condition) of the bit, the number of turns will vary. An 1/8" bit may only require three or four twists while a 1/2" bit may take a dozen or more. Note: The *Drill Doctor* (Model 250) is designed to sharpen bits that range in size from 3/32" up to 1/2".

As you sharpen, each rotation of the chuck produces a zzzzt, zzzzt sound. That's the sound of the grinding wheel as it removes a small amount of material from the tip of the bit. Since most twist bits are made of high-speed steel which is

quite hard, the grinding wheel is embedded with tiny diamond particles to cut the metal.

One thing I noticed when sharpening a bit is the chuck rocks back and forth. A close look at detail 'a' will explain the reason why.

A Couple of Cams – There are two *cams* molded into the plastic chuck. An *outer cam* rubs against a metal post. And an inner cam directly below it rides against what looks like a small "speed bump" on the top edge of the sharpening tube.

As you rotate the chuck, these cams rock it back and forth, and they move it up and down. This motion causes the bevels on the end of the bit to contact the grinding wheel at the correct angle. Note: It grinds a standard, off-the-shelf twist bit to a 118° point, as shown at right.

A Test – Now I didn't actually check the angle, but I *did* drill holes with each bit I sharpened. Not just in



▲ **Twist & Sharpen** – A few twists of the wrist. That's all it takes when using the *Drill Doctor* to sharpen a standard twist bit to a 118° point.



STANDARD TWIST BIT DETAIL
(118° POINT ANGLE)

wood, but in metal and plastic too. The results were impressive. With just a small amount of downward pressure, the bits drilled clean, perfectly *round* holes. And if the thin ribbons of waste spiraling upward were any indication, the bits were even sharper than new. 🛠️

Sources

PRODUCT INFORMATION

Hardware & Supplies

To make it easy to round up the hardware and supplies that you'll need to build the projects featured in this issue, we've put together a number of convenient mail-order sources.

HVLP Spray Systems

To produce a glass-smooth finish like those applied at a professional cabinetmaker's shop, try using a high-volume, low-pressure (HVLP) spray system. The article on page 10 shows two types of HVLP systems. To find a local dealer for these systems (or to order direct), contact the following manufacturers and mail order sources:

- Apollo 800-578-7606
- Campbell Hausfeld 800-626-4401
- Highland Hardware 800-241-6748
- Wagner 800-328-8251

Heavy-Duty Casters

The Store-All featured on page 24 holds long boards, shorter pieces of wood, and even sheet material. When it's fully loaded, it's definitely a heavy unit, but it's *not* a permanent fixture.

That's because a set of four heavy-duty casters support the weight and make it easy to roll around. We used locking swivel casters that hold 300 lbs. each. You can order these casters (Part No. 2370T57) from McMaster-Carr by calling 630-833-0300.

Rail & Stile Router Bits

When building a frame and panel door with rail and stile bits, our Two-Handled Push Block (page 6) is bound to come in handy. Rail and stile bits are available at many woodworking stores and from:

- Woodcraft 800-225-1153
- Woodhaven 800-344-6657
- Woodsmith Store 800-835-5084



▲ Dust Collector Hook-Ups

The Chip Separator and Dust Control Box (page 16) are part of an efficient system that's connected to a dust collector.

The 4"-dia. flexible hose and 4" wire hose clamps shown above make it quick and easy to hook it up. We recommend grounding the system with copper wire, crimp-on connectors, and wire nuts. Grounding kits are available from:

- Woodcraft 800-225-1153
- Woodsmith Store 800-835-5084

Scenes from the Shop

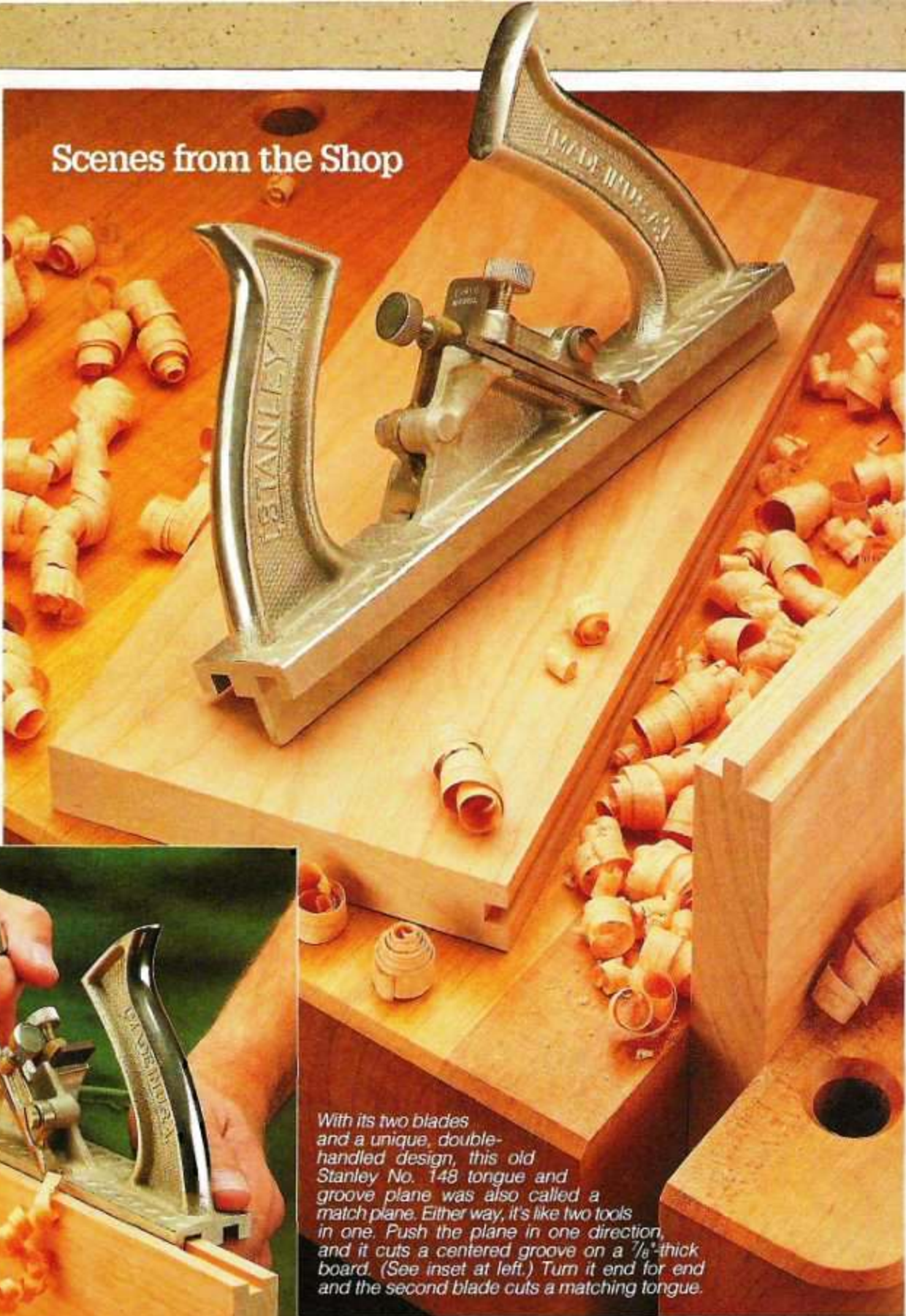

With its two blades and a unique, double-handled design, this old Stanley No. 148 tongue and groove plane was also called a match plane. Either way, it's like two tools in one. Push the plane in one direction, and it cuts a centered groove on a $\frac{7}{8}$ "-thick board. (See inset at left.) Turn it end for end and the second blade cuts a matching tongue.

ShopNotes Cutting Diagram

Roll-Around Store-All for lumber & plywood

Materials

A Rails (5)	$\frac{3}{4}$ " x 3" - 32 Pine	G Side Panels (2)	48" x 96" - $\frac{3}{4}$ " Plywood
B Base (1)	32" x 96" - $\frac{3}{4}$ " Plywood	H Cleats (8)	$\frac{3}{4}$ " x 2 $\frac{1}{2}$ " - 96 Pine
C Dividers (6)	8" rgh. x 22 $\frac{1}{2}$ " - $\frac{3}{4}$ " Plywood	I Shelves (4)	10 $\frac{1}{2}$ " x 96" - $\frac{3}{4}$ " Plywood
D Side (1)	20" x 96" - $\frac{3}{4}$ " Plywood		12 $\frac{1}{2}$ " x 96" - $\frac{3}{4}$ " Plywood
E Lip (1)	6" x 96" - $\frac{3}{4}$ " Plywood		14 $\frac{1}{2}$ " x 96" - $\frac{3}{4}$ " Plywood
F Mounting Plates (8)	7" x 7" - $\frac{3}{4}$ " Plywood		16 $\frac{1}{2}$ " x 96" - $\frac{3}{4}$ " Plywood

1 x 8 x 96 #2 Ponderosa Pine



1 x 6 x 96 #2 Ponderosa Pine (4 Boards)



$\frac{3}{4}$ " x 48" x 96" FIR FLYWOOD (2 SHEETS)



3/4 x 48 x 96 FIR PLYWOOD

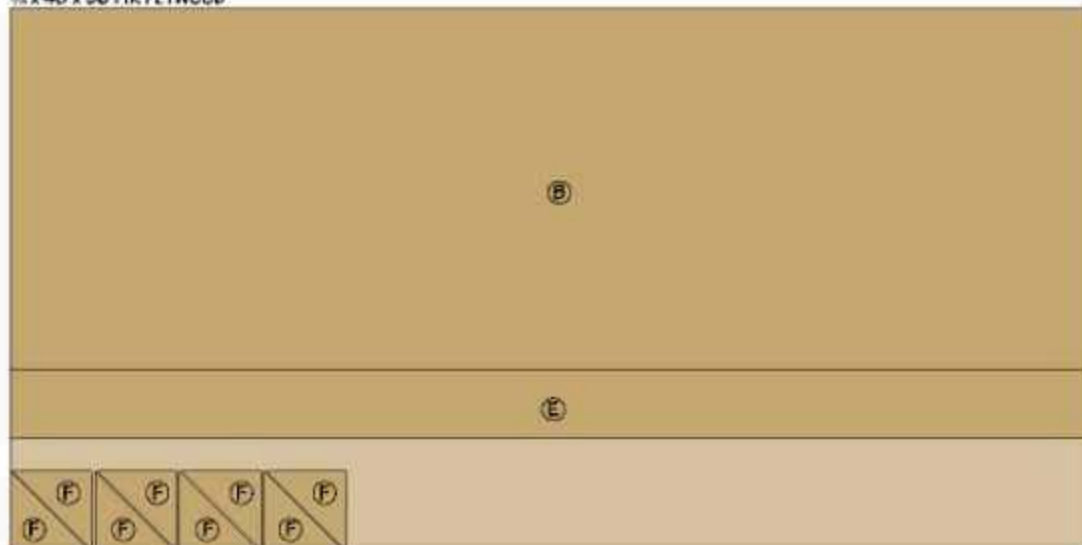

3/4 x 48 x 96 FIR PLYWOOD

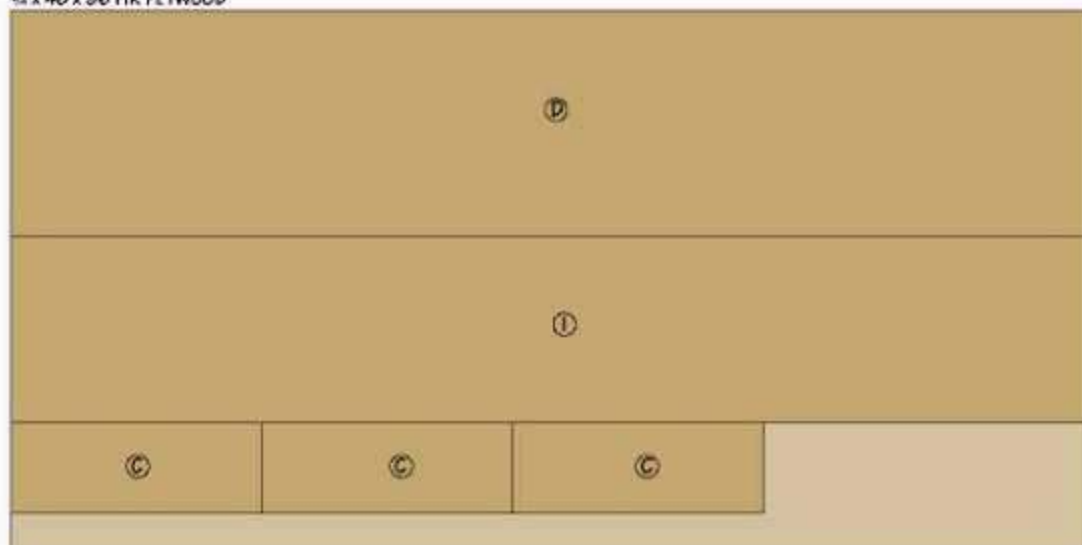

3/4 x 48 x 96 FIR PLYWOOD

