

SPECIAL ISSUE: BOWL TURNING BASICS

# ShopNotes

Vol. 9

Issue 53

Build this adjustable

## Miter Gauge Fence

and ensure quick, accurate setups



**Plus 3 GREAT WEEKEND PROJECTS:**

- ◆ Portable Workbench
- ◆ Drill Bit Storage System
- ◆ Easy-to-build Edge Sanding Jig



# ShopNotes

Issue 53 September 2000

**PUBLISHER** Donald B. Peschke

**EDITOR** Tim Robertson

**ASSOCIATE EDITORS** Tom Begnal

Bryan Nelson

Joel Hess

**CONTRIBUTING EDITOR**

**ART DIRECTOR** Cary Christenson

**SR. GRAPHIC DESIGNER**

Roger Reiland

**SENIOR ILLUSTRATORS**

Mark Higdon

## CREATIVE RESOURCES

*Creative Director:* Ted Kraicek • *Project Developer:* Ken Munkel • *Project Coordinator:* Kent Wehn • *Shop Manager:* Steve Curtis • *Shop Craftsmen:* Steve Johnson • *Senior Photographer:* Crayton England

## SPECIAL PUBLICATIONS

*Executive Editor:* Douglas L. Hieks • *Sr. Graphic Designer:* Chris Glowacki • *Graphic Designers:* Vu Nguyen, April W. Jansing, Stacey L. Krull • *Asst. Editors:* Joe Irwin, Craig Rongegger, Joel A. Hess

## CIRCULATION

*Subscription Services Director:* Sandy Baum • *Circulation Marketing Analysts:* Kris Schlemmer, Fasha DeMatteis • *Revenue Manager:* Paige Rogers • *Sr. Graphic Designers:* Mark Hayes, Robin Dowdell • *Billing & Collections Mgr.:* Rebecca Cunningham • *Print. Mgr.:* Rick Jenkins • *New Bus. Mgr.:* Todd L. Berle • *Asst. Sub. Mgr.:* Joy Krause

## CORPORATE SERVICES

*Controller:* Robin Hutchinson • *Sr. Accountant:* Laura Thomas • *Accounts Payable:* Mary Schultz • *Accounts Receivable:* Margo Poteus • *Prod. Dir.:* George Chmielarski • *Electronic Pub. Dir.:* Douglas M. Ladner • *Network Admin.:* Chris Schwanebeck • *Pre-Press Image Specialist:* Troy Clark, Minnie Johnson • *Prod. Coordinator:* Noelle Carroll • *New Media Manager:* Gordon C. Guippe • *Multimedia Art Dir.:* Eugene Pedersen • *Technology Analyst:* Carol Schoeppler • *Web Site Product Specialist:* Adam Best • *Web Content Manager:* Terry Walker, David Briggs • *H. R. Asst.:* Kirsten Koels • *Facilities Mgr.:* Julia Fish • *Administrative Asst.:* Sherri Ribbey • *Receptionist:* Jeanne Johnson • *Mail Room Clerk:* Lou Webber

## MAIL ORDER

*Operations Director:* Bob Baker • *Customer Service Manager:* Jennie Enos • *Warehouse Supv.:* Nancy Johnson • *Buyer:* Linda Jones • *Admin. Asst.:* Nancy Downey • *Tech. Rep.:* John Andette • *Cont. Serv. Rep.:* Anna Cox, Tammy Truckenbrod, Deborah Rich, April Revell, Jeannette Rankin • *Warehouse:* Sylvia Carey, Dan Spidle, Sheryl Knox

## WOODSMITH STORE

*Manager:* Dave Larson • *Sales Staff:* Wendell Stone, Jim Barnett, Kathy Smith, Larry Morrison, Harold Cushman, Tim Randall, Tim Theisen • *Office Manager:* Vicki Edwards

ShopNotes® (ISSN 1062-0696) is published bimonthly (Jan., March, May, July, Sept., Nov.) by August Home Publishing, 2200 Grand, Des Moines, IA 50312.

ShopNotes® is a registered trademark of August Home Publishing ©Copyright 2000 by August Home Publishing. All rights reserved.

Subscription: Single copy: \$4.95. One year subscription (6 issues): \$21.94. Canada/International add \$10 per year. U.S. funds.

Periodicals Postage Paid at Des Moines, IA and at additional mailing offices.

Postmaster: Send change of address to ShopNotes, P.O. Box 27108, Boone, IA 50037-2108.

Subscription Questions? Write to: ShopNotes Customer Service, P.O. Box 842, Des Moines, IA 50304-0861. Or call 1-800-333-5854, 8:00 am to 5:00 pm, Central Time, weekdays. FAX 515-288-0447.

E-Mail: ShopNotes@shopnotes.com

Internet: http://www.shopnotes.com

PRINTED IN U.S.A.

# Cutoffs

**R**ust never sleeps. I'd heard it a hundred times before, but it never sunk in — until I moved to an area with hot, humid summers.

After unpacking boxes of tools, I set up shop in a single-car garage. It smelled a bit musty and damp. But at least everything fit (except for the car). More important, my tools were safe and secure. Or so I thought.

A few days later, I noticed that my chisels were peppered with tiny spots of rust. Then I discovered that my bench planes had rusted too. There was even a rusty film beginning to form on the cast iron top of my table saw.

Needless to say, I was discouraged. But there was no sense feeling sorry for myself. After all, there *are* rust removal products for just that sort of thing.

**Pink Milk Shake** — The one I used was a pink, chemical remover with the consistency of a milk shake. It looked like something you'd take for a queasy stomach, but it was anything *but* medicinal. The label was loaded with cautions. (Not exactly an environmentally friendly product.) So after applying the pink slime and wiping it off with wet rags, I was left with a gooey, toxic mess to get rid of.

To make matters worse, the rust remover had turned my tools an ugly, battleship-gray color. So to restore their shiny appearance, I resorted to using some old-fashioned elbow grease and *sanded* the metal surfaces.

It was a workout, but I was pleased with the results — temporarily. The shiny surfaces were nothing but an open invitation to rust. And with the high level of humidity in the shop, a rusty haze reappeared overnight.

**Lesson Learned** — To make a long story short, I had to go

through the entire process all over again. Only this time, I'd learned my lesson. After removing the rust, I tried several things to seal out moisture — paste wax, spray-on coatings, and even a desiccant in what looked like a sardine can.

Fortunately, they worked well, and I eventually came to accept the fact that it was just going to take more maintenance to keep my tools free of rust.

But ever since then, I've been on the lookout for an easier way to get a handle on the problem of rust. I finally found it.

**Rust Blocker** — It's a product called *Rust Blocker* that's manufactured by a company with an unusual name — *Bullfrog* (more about that later).

The idea is to put the *Rust Blocker* in an enclosed area like the drawer of a tool cabinet. Inside, it emits tiny particles that "migrate" toward metal surfaces and bond *with* the metal. This creates a shield that seals out moisture and air.

I know, it sounds far-fetched. I was a bit skeptical myself. So I stuck a strip of the *Rust Blocker* inside a drawer in my tool chest. It's been there about a year now, and I haven't seen a speck of rust. Better yet, there's no maintenance until the strip "wears out." (It lasts about a year, so I'll be replacing it soon.) Note: We've included an article on *Rust Blocker* on page 30.

**Bullfrog** — Oh, I almost forgot. I was curious about why the company is called *Bullfrog*. So I called Paul Ginther, the owner of the company. He told me that the inspiration for the name came from his daughter who had done a science project on bullfrogs.

As it turns out, bullfrogs are a good indicator of the health of an ecosystem. And since *Bullfrog* products are non-toxic and safe for the environment, the name fit perfectly.



*Tim*

# Contents

## Features

### Edge Sanding Jig \_\_\_\_\_ 6

Convert your portable belt sander into a handy edge-sanding tool with this simple, shop-made jig.

### Bowl Gouge Basics \_\_\_\_\_ 10

Whether you're shaping the outside of a bowl or scooping out the inside, knowing how to use a bowl gouge is the key to success. We'll show you the basics.

### Turning a Bowl \_\_\_\_\_ 12

You don't have to be a master to turn a bowl on the lathe. With our simple, step-by-step approach, you can turn a bowl from start to finish in an afternoon.

### Miter Gauge Fence \_\_\_\_\_ 16

Quick, accurate setups. That's what you get when you build this adjustable miter gauge fence. It features a sliding fence and two stops that guarantee precise cuts every time.

### Drill Bit Storage \_\_\_\_\_ 24

Organize your drill bits with a set of custom hangers. Then hook them on a wall-mounted cleat next to your drill press or take them with you when working away from the shop.

### Power Sanding Systems \_\_\_\_\_ 28

Sanding a bowl that's been turned on the lathe doesn't have to be a chore. These two power sanding systems remove material fast and produce a smooth, consistent surface.

## Departments

### Readers' Tips \_\_\_\_\_ 4

Our readers offer their own shop-tested tips dealing with some of the most common woodworking problems.

### New Products \_\_\_\_\_ 30

Get a handle on the problem of rust with Rust Blocker.

### Sources \_\_\_\_\_ 31

Mail-order sources and supplies to help you build the projects featured in this issue.



Edge Sanding Jig page 6



Turning a Bowl page 12



Miter Gauge Fence page 16



Drill Bit Storage page 24

# Readers' Tips

## Portable Workbench

After seeing the knock-down workbench in issue No. 52 of *ShopNotes*, I thought you might be interested in a similar version of a portable workbench that I built several years ago.

To simplify the construction of the bench, the top and frame are made of  $\frac{3}{4}$ " plywood, and I used 2x4s for the legs. The splayed legs make the workbench look a bit like an oversize sawhorse. But there's a big difference.

Instead of being permanently attached, the legs fit into deep pockets under the bench. (See photo in margin.) After slipping each leg into its pocket, you simply insert a dowel to "lock" it in place.

Once a job is completed, the legs can be knocked down for storage. Just pull out the dowels, remove the legs, and set them in the notched supports underneath the bench. (See inset photo.) This makes it easy to carry the bench out to the driveway or backyard or to a friend's house to help on a project.

▲ To set up the workbench, slip the legs into pockets underneath the top and "lock" them in place with a dowel.



**Construction** - As you can see in the drawing, this bench is quite simple. To create a stable worksurface, the legs are splayed out to the side. This requires beveling both ends of each leg at a 15° angle.

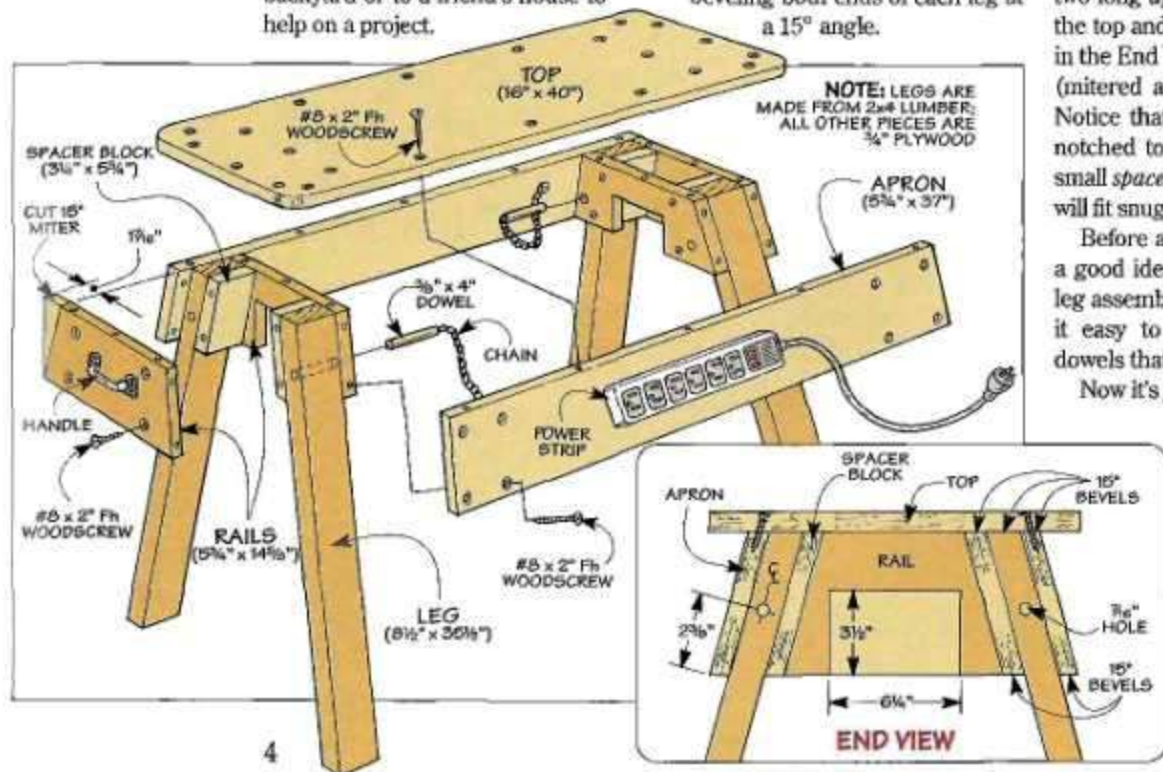

To prevent the bench from racking, the legs are connected by two long *aprons* that are beveled on the top and bottom edges, as shown in the End View. And four short *rails* (mitered at each end) add rigidity. Notice that the two inside rails are notched to hold the legs. Finally, a small *spacer block* is sized so the legs will fit snug (not tight) in the pockets.

Before assembling the bench, it's a good idea to "dry clamp" the two leg assemblies together. This makes it easy to drill the holes for the dowels that hold the legs in place.

Now it's just a matter of gluing and screwing the bench together and adding the *top*. After screwing it in place, I secured each dowel with a short chain. Then I mounted a power strip and a couple of handles.

Randy Hoy  
Adel, Iowa

## Sharpening Guide

■ I use sandpaper to sharpen my chisels. By "sanding" the bevel of the blade flat and smooth, it produces a sharp edge in minutes.

The key to getting a perfectly flat bevel is to hold the chisel at a consistent angle as you sharpen. To do this, I clamp the chisel to a simple sharpening guide. (See photo at right.)

As you can see in the drawing, the guide starts off as a pair of wedge-shaped *support blocks* that hold the *top* at a 25° angle. To square up the chisel (and keep it from shifting), it sits against a wood *cleat* that's glued into a *dado* in the top.

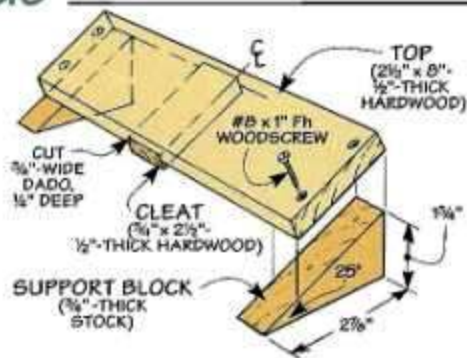

To set up the guide, place the chisel against the cleat and slide it down until the bevel is resting on a *flat* surface (not on the sandpaper). Then clamp the chisel in place and "scrub"

it back and forth across the sandpaper. Note: I start with 180-grit sandpaper and work up through 400 grit.

*Ellwyn Smith*  
Peoria, Arizona

## Quick-Change Clamp



■ Switching the flexible hose on a portable dust collector from one tool to another is a nuisance. I'm always fiddling with a screwdriver, loosening and tightening the hose clamp

that holds it in place.

To speed things up, I made my own hose clamp from a clothes hanger and a scrap of wood. (See photo at left.) This clamp fits around the hose and then snaps tight like the wire clip on an old-fashioned canning jar.

The two wire parts of the clamp are pretty simple. Just bend the wire into a double loop for the *body* of the clamp and make a *clip* to fit around it. Both parts fit into a wood *handle* that

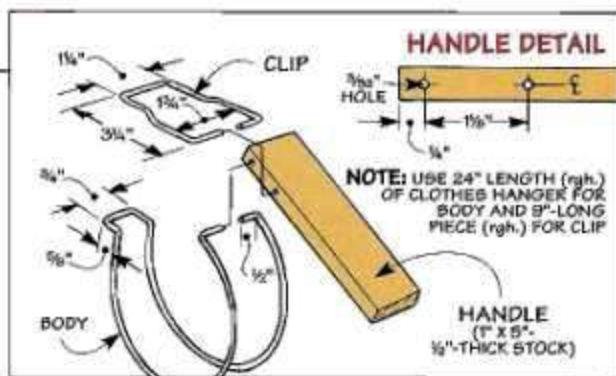

makes it easy to open and close the clamp. Note: This clamp is sized for a 4" dia. hose. To adjust the fit, simply change the length of the clip.

*Attilio Lucchese*  
Courtise, Ontario

## Quick Tips



▲ To keep accessories for his shop vacuum organized, Jim Vrooman of Meridian, ID fits them over film canisters held in place with epoxy.



▲ When installing hinges on a door, Bob Dunn of Norwalk, IA places it on a carpet sample to protect the finish from scratches.

## Send in Your Shop Tips

If you have a unique shop tip, we'd like to consider featuring it in one or more of our print or electronic publications.

We'll pay up to \$200 for a tip we publish. Just write down the tip and mail it to *ShopNotes*, Attn.: Readers' Tips, 2200 Grand Ave., Des Moines, IA 50312. Or FAX it to 515-282-6741, or send us an e-mail at [shopnotes@shopnotes.com](mailto:shopnotes@shopnotes.com). Please include your name, address and daytime phone number in case we have any questions.

# Edge Sanding Jig

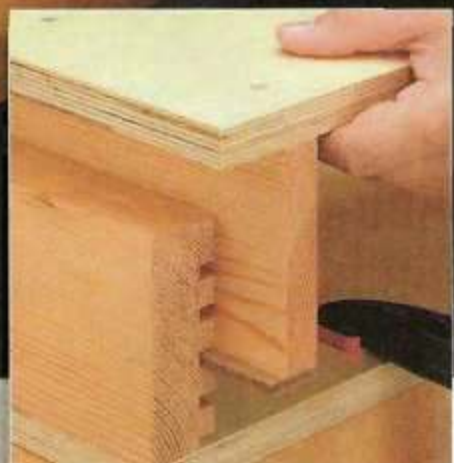

Get even more use from your belt sander by converting it into a handy edge-sanding tool.

**A** belt sander is a great tool for removing a lot of material quickly. But usually, it's limited to sanding only the *face* of a board.

That's not to say I haven't tried using it to sand the *edge* of a workpiece. Unfortunately, the results were often

less than satisfactory. Even with the workpiece clamped securely in place, it was difficult to hold the belt sander steady enough to prevent it from tipping. So I usually ended up gouging the edge of the workpiece or rounding over the corners.

The solution is simple — hold the belt sander in place and move the workpiece instead. That's the idea of the edge sanding jig shown above.

The belt sander is secured to a mounting platform with two quick-release hold-downs. A table in front of the belt sander creates a flat, stable worksurface. As you can see in the inset photo above, the height of the table can be adjusted to use the full width of the sanding belt.

## MOUNTING PLATFORM

I began by making the mounting platform. In addition to providing a way to clamp the jig to a bench, it's made up of a number of custom-fit blocks that support the belt sander.

**Base** — The foundation of the platform is a  $\frac{3}{4}$ " plywood *base* (A). As you can see in Figure 1, it serves as a mounting surface for the wood blocks that are part of the support system for the sander. Three of the blocks (two *support blocks* and a *leveling block*) form a "tripod" that holds the sander flat.

**Contact Points** — But first, you'll need to establish *three* contact points

## 1 OVERVIEW

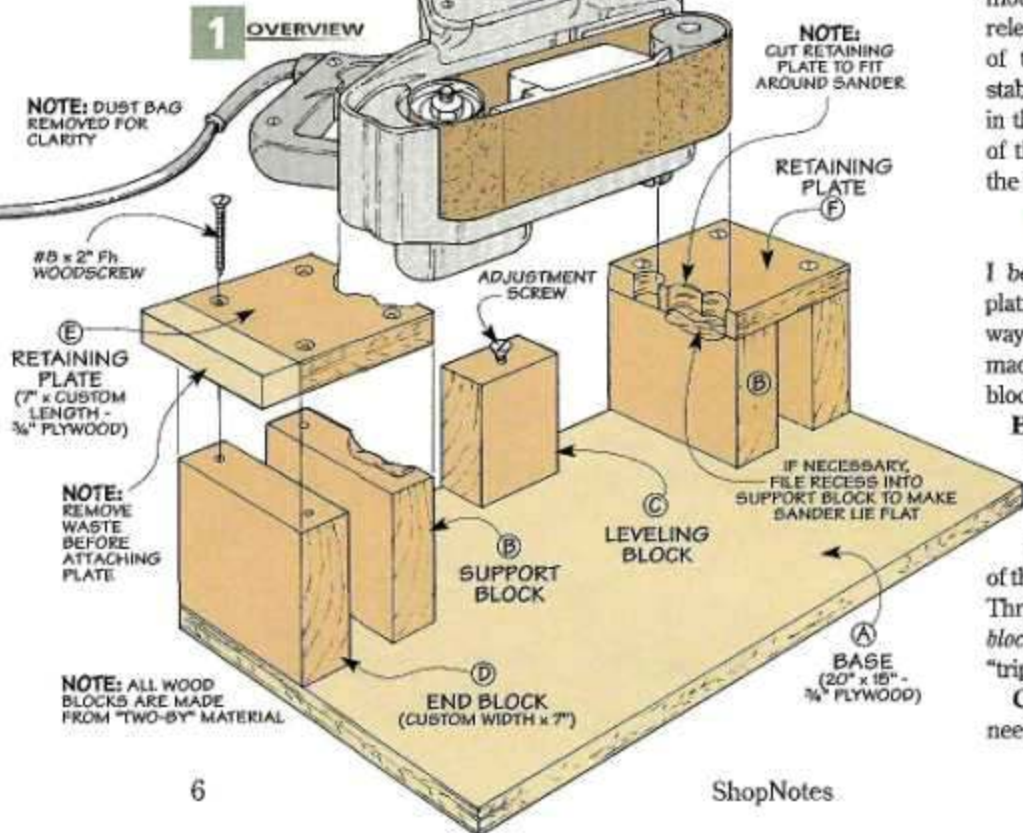

on the sander that will rest on the blocks (or in the case of the leveling block, on an adjustment screw). The idea is to select one point near the front and rear end of the sander and one near the top. (These are the blue-tinted areas in Figure 2.)

**Support Blocks** – Now you're ready to make the two support blocks (B) that fit under the front and rear contact points. These are scrap pieces of "two-by" material that raise the belt sander up above the base.

The thing to be aware of is the distance between the base and the sanding belt. To use the full range of adjustment that's built into the table, the bottom edge of the belt must be  $4\frac{1}{8}$ " above the base (Figure 3a).

An easy way to accomplish this is to temporarily prop up the belt sander at the correct height. Then rip each support block (B) to width so it fits snugly against its contact points. Note: The width (height) of each block may vary depending on your sander. As for length, I cut them both 7" long to provide room for the table (Figure 3).

Before attaching the support blocks, be sure to check whether the sander sits flat. The irregular shape

2 FIGURE

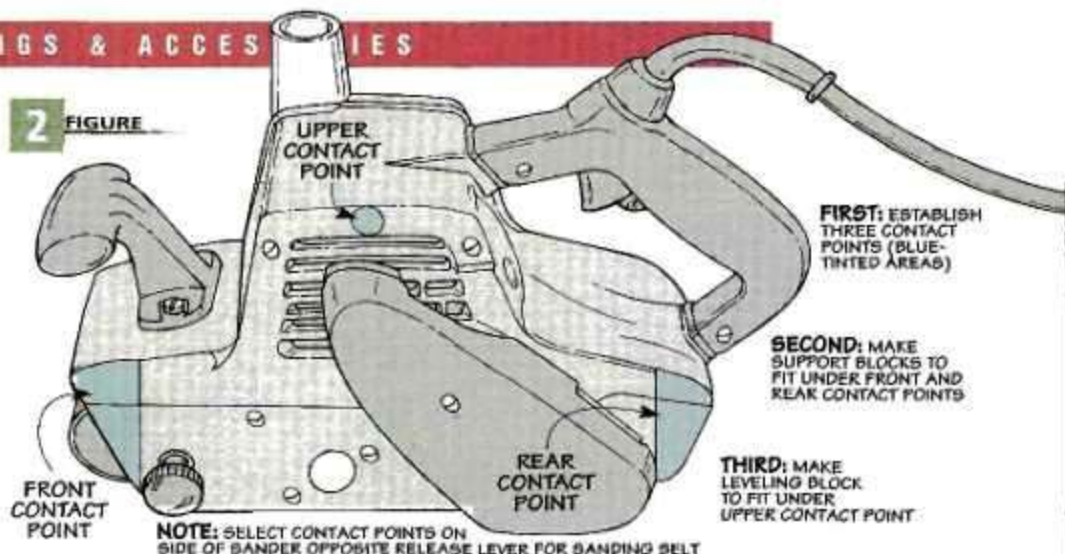

of the housing on my sander made it rock back and forth on the blocks. So I filed the top edges of the blocks to make it lie flat, as shown in Figure 1.

Now it's time to attach the support blocks to the base. The idea is to locate the blocks so the platen on the belt sander is centered on the length of the base (Figure 3). Then position the blocks flush with the back edge of the base and screw them in place.

**Leveling Block** – At this point, you can add the leveling block (C). (This is the block with the adjustment screw.) Later, all you'll need to do to square the sanding belt to the table

is to "tweak" the screw up or down.

To allow room for adjustment, you'll want to rip the leveling block to width so it sits  $\frac{1}{8}$ " below the upper contact point (Figure 3b). After cutting it to length (3"), screw the leveling block to the base and install the adjustment screw.

**End Blocks** – With the three main supports in place, the next step is to add two end blocks (D). As you can see in Figure 1, these blocks provide a mounting surface for two retaining plates. To ensure that these plates sit flat and level, each end block is identical in size to the nearest support block. Here again, they're simply screwed in place.

**Retaining Plates** – Now all that's left is to add the two retaining plates (E, F). These are pieces of  $\frac{3}{4}$ " plywood that trap the ends of the belt sander and prevent it from moving from side to side.

To accomplish this, the inside edge of each plate is cut to shape so it fits around the housing (and handle) of the sander. As you can see in the margin, a simple layout "tool" makes it easy to determine the shape.

It's best to lay out the shape on an extra-long workpiece. Then after cutting and filing it to shape, trim the plates to length and screw them in place.



▲ To "copy" the irregular shape on the end of the sander, wrap a short length of solder around the housing.

3

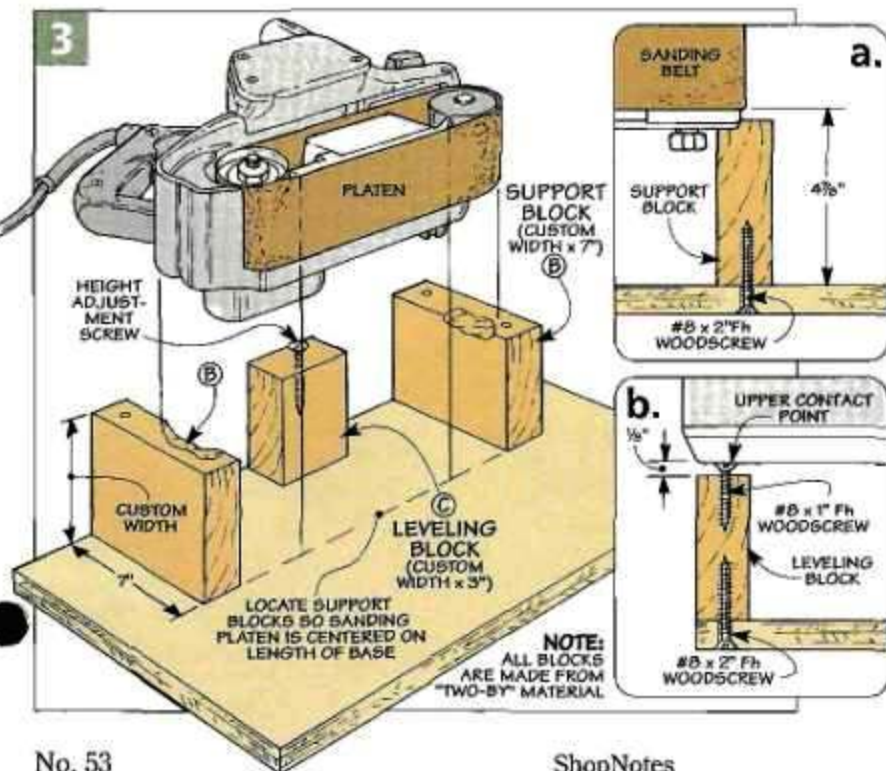

## Table &amp; Hold-Downs

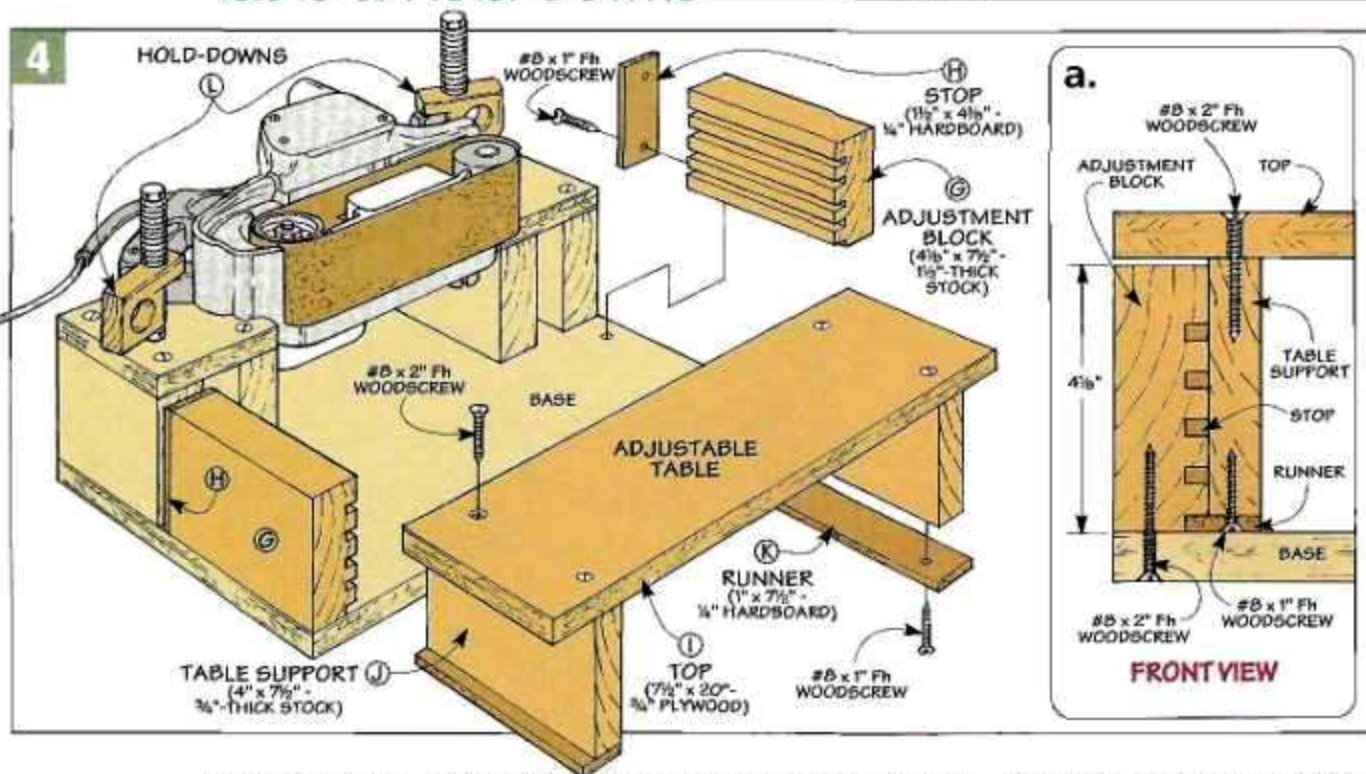

With the mounting platform complete, you're well on your way to completing the edge sanding jig. But you wouldn't want to use it just yet.

As you can see in Figure 4, it still needs an *adjustable table* to provide support for the workpiece as you sand. In addition to the table, a

couple of *hold-downs* are a must so the sander stays put.

## ADJUSTABLE TABLE

The table provides a flat, stable work surface. Plus it can be adjusted in height. This way, when a strip of the sanding belt gets worn, you simply raise (or lower) the table to use another part of the belt.

To accomplish this, the table slides in and out of grooves in two wood blocks (Figure 4). To adjust the height of the table, just move it from one set of grooves to another — like changing a rack in the oven.

**Adjustment Blocks** — I began by making two *adjustment blocks* (G). These are nothing more than scrap pieces of "two-by" stock with a series of evenly-spaced grooves.

As you can see in Figures 5 and 5a, a 1/4" dado blade mounted in the table saw makes quick work of cutting the grooves. Notice that the bottom "groove" is actually a rabbet until the block is attached to the base. In any event, an auxiliary fence will prevent the blade from cutting into the rip fence as you rabbet the bottom edge.

Then move the fence in even increments to cut the remaining grooves.

**Add Stop** — The next step is to add a 1/4" hardboard *stop* (H) to the back of each adjustment block. These stops cover the openings at the ends of the grooves. When you slide the table into the grooves, two runners (added later) will hit the stops and position the table at the correct distance from the sander.

After cutting the stops to size, they're glued and screwed in place. Then attach the adjustment blocks to the base with glue and screws.

**Top** — At this point, you're ready to add the *top* (I) of the table. As you can see in Figure 4, the top is a piece of 3/4" plywood that's cut to width (depth) to match the length of the adjustment blocks. As for length, it equals the length of the base.

The top is attached to a couple of *table supports* (J) made of "one-by" stock. To form a lip that sticks out past the sides of the table supports, I added a hardboard *runner* (K). This runner slides into the grooves in the adjustment blocks and supports the table at the desired height.

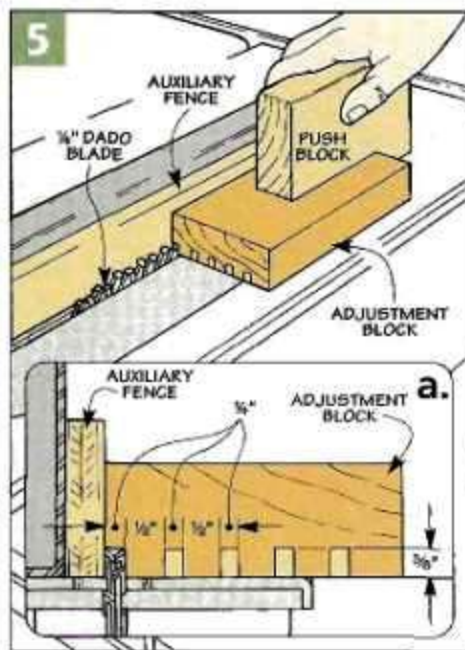



**Attach Top** – After screwing the runners to the table supports, you're ready to attach the top. Start by fitting the runners into the bottom grooves in the adjustment blocks. Then with the table supports against the blocks, position the top so it's flush all around and screw it in place, as shown in Figure 4a.

**HOLD-DOWNS**

After completing the table, the next step is to add the two hold-downs. They're used to secure the sander to the jig. Plus, they make it easy to quickly *remove* the sander when you want to use it in a hand-held position.

As you can see in Figure 6, each *hold-down (L)* is a whistle-shaped block of hardwood with a large finger-hole in the side. The hold-down is held in place with a long bolt. Notice that there's a spring captured between the head of the bolt and the hold-down. This spring is the key to producing the clamping pressure.

To see how this works, look at the photo in the margin. As you lift the hold-down, it squeezes the spring. By rotating it a quarter turn and then releasing it, the spring presses down against the hold-down which clamps the belt sander in place. To "release" the sander, just reverse the process.

The hold-downs are fairly small. So to avoid working with small pieces, I made both of them from an extra-long strip. As you can see in Figure 7, all that's needed to make the hold-downs is to follow a simple sequence

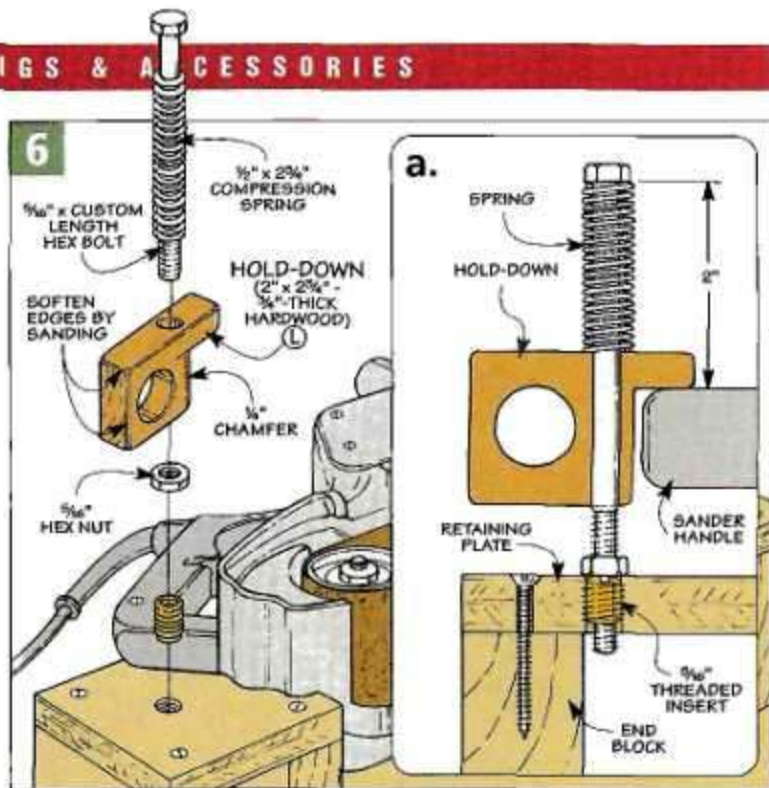

of steps. The thing that's a bit trickier is determining the *length* of the bolt used to hold them in place.

**Clamping Surface** – To do this, you'll need to decide which points on the belt sander you want the hold-downs to press against. On my sander, the front and back handles provided a convenient clamping surface.

Once you know the two clamping surfaces, you can figure out the length of the bolts. The idea here is simple. When each bolt is installed, the head should be 2" above the clamping surface (Figure 6a). This accounts for the compressed length of the spring (1 1/4"), the width of the

"arm" that extends over the sander (1/2"), plus 1/4" clearance above the sander to lift the hold-down.

**Install Inserts** – To accept the bolts, you'll need to install a couple of threaded inserts in the mounting platform. The location of the inserts determines the position of the hold-downs. So take a minute to locate the hold-downs carefully.

First of all, you want them to be close enough to the sander so they have enough "reach" to apply pressure. At the same time, they need to pivot freely. To prevent them from binding, I chiseled 1/4" chamfers on the notched end of each hold-down (see margin photo).

**Assembly** – Once the inserts are installed, you're ready to assemble the hold-downs. Start by slipping the springs over the bolts. Then, after fitting each bolt through the hole in the hold-down, there's one more thing to do. That's to add a nut to the end of each bolt before threading it into the insert. Tightening this nut "jams" it against the plate and locks the bolt in place.



▲ A spring-loaded hold-down "locks" the belt sander in place. To release the sander, simply lift the hold-down and rotate it out of the way.

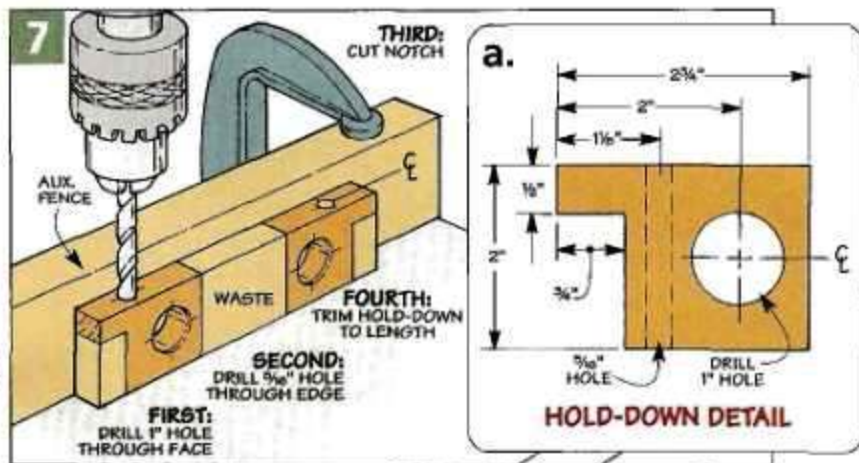

**Hardware**

- (9) #8 x 1" Fh Woodscrews
- (26) #8 x 2" Fh Woodscrews
- (2) 1/2" Hex Bolts
- (2) 1/2" Hex Nuts
- (2) 1/2" Inserts
- (2) 1/2" x 2 3/4" Springs

# Bowl Gouge Basics

**W**hen turning a bowl on the lathe, there's one tool that's indispensable — a bowl gouge.

Whether you're turning the outside of the bowl shape, scooping out the inside, or making a light, clean-up pass, most of the work is accomplished with a bowl gouge.

Best of all, a bowl gouge isn't difficult to learn how to use. All it takes is an understanding of the basic cutting technique and some practice.

**Thick Blade & Deep Flute** — If you look at the photo in the margin, you'll see that a bowl gouge has a thick, beefy blade and a deep, U-shaped flute. The reason is simple. When you push the cutting end of the gouge past the toolrest to reach inside a bowl, the heavy blade helps produce a smooth, chatter-free cut.



And the deep flute quickly removes large amounts of waste material.

**Size** — The distance between the sides of the flute determines the size of the gouge. They range in size from  $\frac{1}{4}$ " to  $\frac{5}{8}$ ", but I've found that a  $\frac{1}{4}$ " and a  $\frac{1}{2}$ " gouge handle most jobs.

**Bevel** — The bevel on a bowl gouge also makes it particularly suited to turning a bowl. It's quite short which reduces the chance of the cutting edge from digging into the end grain of a bowl. Also, notice how the bevel "wraps" around the tip of the blade. When sharpening a bowl gouge, this shape makes it a bit of a challenge to turn a consistent bevel. But don't worry, we've included some informa-

tion in the box on the next page that will help you get a sharp edge.

**Rub the Bevel** — But a sharp edge isn't enough by itself. The secret to producing a crisp, clean cut is to keep the bevel of the gouge rubbing continuously against the spinning blank.

To do this, start by "easing" the cutting edge of the gouge into the blank. A look at Figure 1 will show you what I mean. The handle is held quite low, so only the *heel* of the bevel is riding against the workpiece (Figure 1a). Notice that the cutting edge isn't in contact with the wood at this point.

To begin cutting, slowly raise the handle until the cutting edge begins to slice off a thin shaving of wood (Figure 1b). Now smoothly rotate the gouge to the side so the flute faces the desired direction of travel (Figure 1c). To keep the bevel rubbing, swing the handle to the side and slide the gouge across the toolrest to complete the cut.

Once you're comfortable making the basic cut, there's one more thing to consider. To create a smooth surface, you go about things differently depending on whether you're working on the *outside* or *inside* of a bowl.

**Outside** — To avoid tearout when shaping the outside of a bowl, the idea is to work from a *small* to a *large* diameter, as shown in the upper left drawing on page 11. Notice how the wood fibers in front of the cut are

▲ A little know-how and some practice. That's all it takes to learn how to use a bowl gouge like a pro.

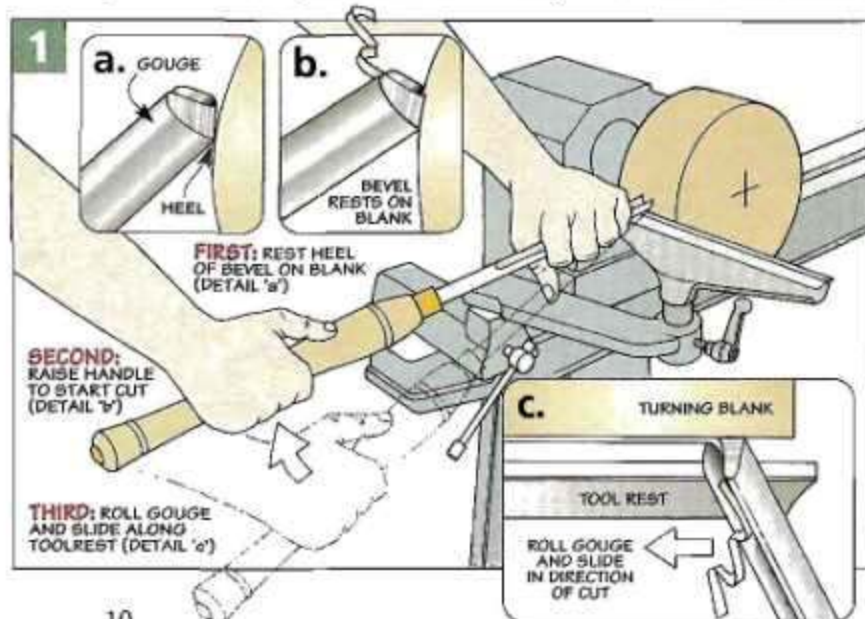

supported, so they don't tear out.

With that in mind, the bowl is turned to shape by making a *sequence* of cuts. The initial cuts can be quite heavy — you're just removing waste material. But to create a smooth surface, make the final shaping cut in one continuous pass, working from the base to the rim of the bowl.

**Inside** — To hollow the inside of the bowl, the process is similar. You remove the waste by making a series of scooping cuts, as shown in the drawing at the far right.

But this time, to avoid tear out, the idea is to make each cut from a *large* to a *small* diameter. As a result, the point that the gouge enters the wood is closer to the rim, and then you cut toward the center.

Just a note here. You may find that the gouge wants to "skid" along the face of the blank at the start of a cut. To prevent that, place the gouge on its side with the flute facing the center of the bowl and plunge it firmly into the blank. 

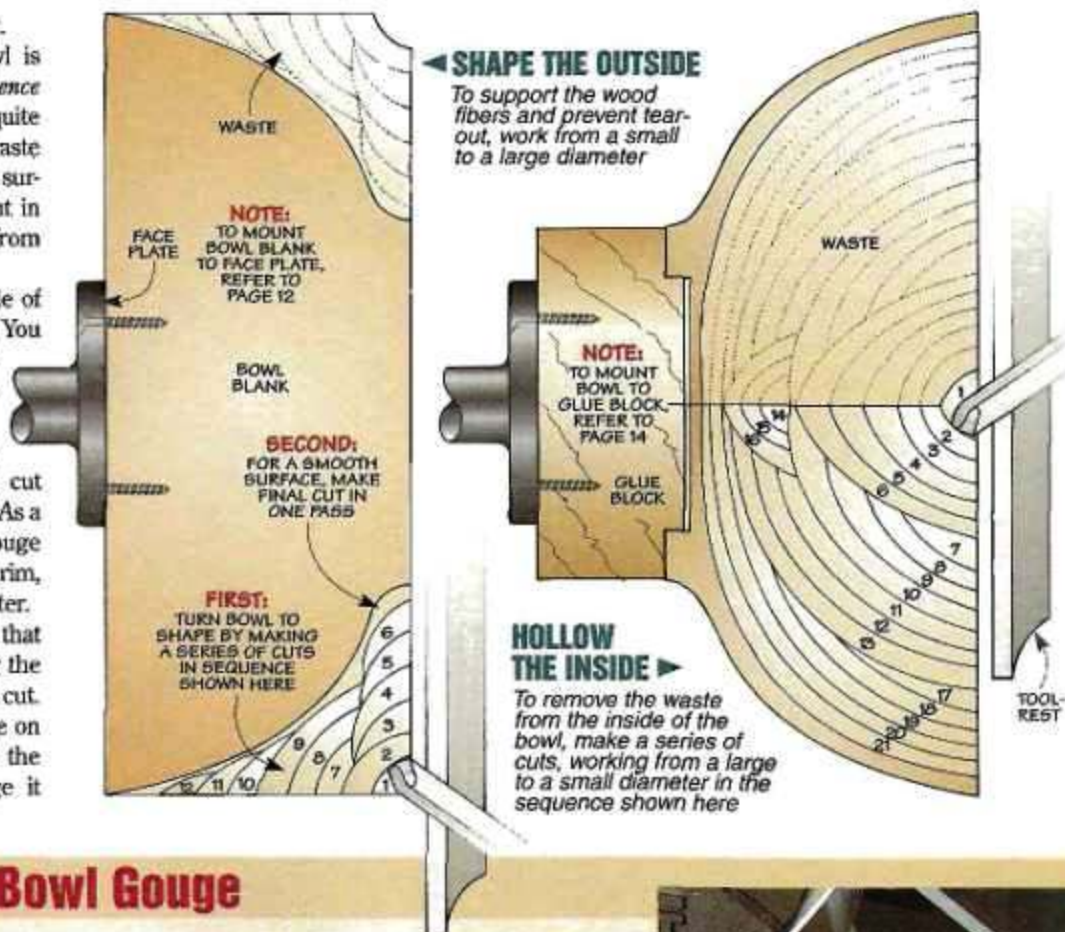

## Sharpening a Bowl Gouge

When sharpening a bowl gouge, the goal is simple — a smooth, *even* bevel all the way around the tip. It's possible to grind the entire bevel in one continuous movement. But to be honest, I've had better results grinding *one* side of the bevel at a time.

The key is to roll the gouge *smoothly* as you grind. To accomplish that, I clamp a simple toolrest to my grinder. It's just a wood block with rounded edges, as shown at right. A hardboard base

glued to the block makes it easy to clamp the rest to the grinder.

**First Side** — With the toolrest in place, you're ready to grind the first side of the bevel. Note: I use a pink, aluminum-oxide grinding wheel.

Start by placing the gouge on the toolrest. At this point, the handle should be held low and perpendicular to the toolrest. Then slowly raise the handle until the bevel contacts the grinding wheel (detail 'a'). You'll know when it's in the right position by the sparks spilling over the cutting edge and down the flute.

Now rotate the handle to roll the gouge on its side, as shown in the drawing and detail 'b.' At the same time, lower the handle and swing it to the side in a smooth, continuous motion. As you do this, notice in detail 'c' that the gouge slides forward on the toolrest a *short* distance — just enough to keep the bevel in contact with the grinding wheel.

**Second Side** — Once the first side is complete, simply grind the second side of the bevel to match.

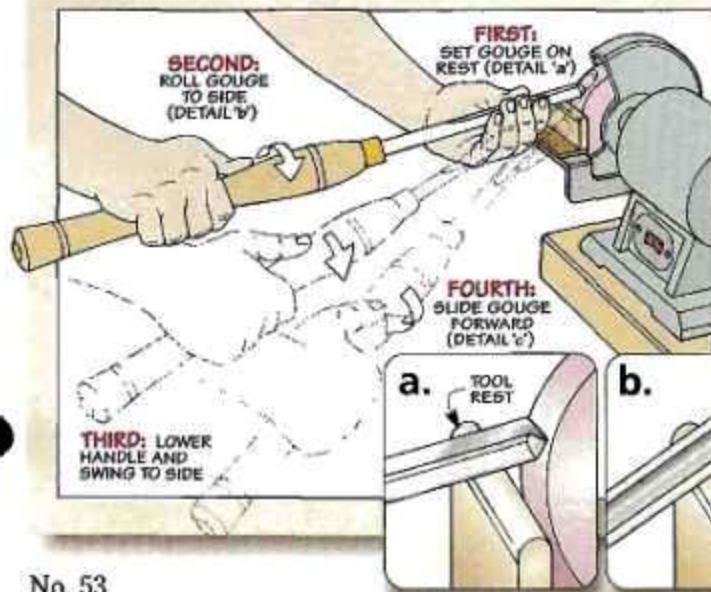

# Turning a Bowl

From blank to bowl  
in an afternoon

**I**t happens every time I turn a bowl on the lathe. As thin ribbons of wood fly off the lathe and pile up around my ankles, I'm always fascinated to see how quickly the bowl takes shape. In fact, it usually only takes a couple of hours to "turn" a thick block of wood into a beautiful bowl.

**Bowl Blanks** – The first step is to find (or buy) a thick chunk of wood. To make the bowls shown in the photo at right, I purchased pre-cut, square bowl blanks. (These blanks are available in a wide variety of sizes and types of wood from many wood-working stores and from the sources listed on page 31.)

**Mounting the Blank** – Regardless of the size of the blank, the important thing is to mount it securely on the lathe. Even a small bowl blank can make the lathe wobble and shake like a washing machine that's out of balance. Worse yet, when you turn on the lathe, the blank could fly off if it's not mounted properly.

Fortunately, there's a simple way to prevent this from happening. As you can see in the photos below and on page 13, it's all in how you mount the blank to the faceplate.

To do this, start by planing a flat mounting surface for the faceplate (Step 1). Then after laying out the bowl with a compass, cut the blank to rough shape and screw on the faceplate (Steps 2, 3, and 4). To hold the blank

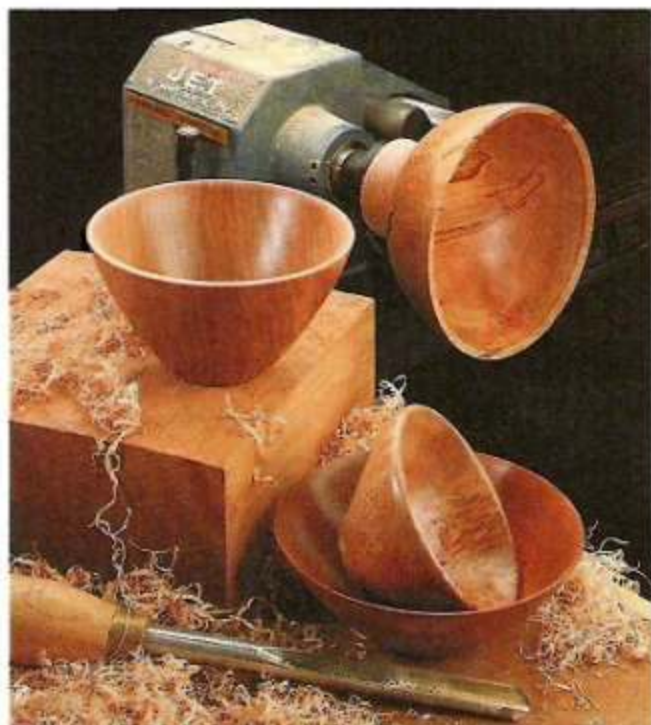

securely, use fairly long ( $1\frac{1}{4}$ " ) sheet metal screws. And don't worry about the screw holes. They'll "disappear" when you hollow out the inside of the bowl.

The next step is to tighten the faceplate on the spindle of the lathe. At this point, the blank may look like it's mounted securely. But you'll want to check it just to be sure. To do this, set the lathe to run at *slow* speed (about 600 RPM). Then stand to the side and flip the switch on the lathe *quickly* on and off to make sure the blank stays on.

**Truing Up the Blank** – One thing you may notice is that the blank *appears* to wobble (even though it's securely attached to the faceplate). That's because the faceplate isn't *perfectly* centered on the blank. So you'll want to "true up" the outside and face of the blank with a bowl gouge (Steps 5 and 6).

## Mounting the Blank



**1** The first step in mounting the bowl blank is to plane a flat surface to secure the faceplate.



**2** After locating the center of the blank, draw a circle slightly larger than the desired bowl diameter.



**3** Use a band saw to cut the blank to rough shape. Stay close to the line to ensure a balanced blank.

## SHAPING THE OUTSIDE

Now it's time to turn the outside of the bowl to shape. The question is *what* shape. I'd recommend looking around for shapes that appeal to you, perhaps a piece of pottery or another bowl. In any case, it's a start. As you turn, you'll probably end up experimenting with the shape anyway.

Having said that, there's one rule of thumb that usually makes the proportions come out just about right. That's to keep the base of the bowl about one third the size of the rim.

**Turn to Shape** - With that in mind, you're ready to turn the bowl to shape. Start by setting the toolrest up close to the bowl (and roughly centered up and down). Then turn on the lathe, grab a bowl gouge, and make a series of smooth, sweeping cuts to turn the bowl (and base) to shape, as shown in Step 1. (For detailed instructions on using a bowl gouge, turn to the article on page 10.)

**Base** - Since the face of the blank is already trued up, the bowl should sit flat on the base when you take it off the lathe. The problem is the bowl is likely to change shape as the wood dries, which will make it rock back and forth on the base.

To prevent that, I use a bowl gouge to turn a 1/4"-deep recess in the base (Step 2 and detail 'a'). Following up with a scraper squares up the recess (detail 'b'). This will



**1** Using smooth, sweeping cuts, work from the base of the bowl to the rim to turn it to shape.



**2** Now cut a recess in the base with a bowl gouge (detail 'a') and square it up with a scraper (detail 'b').



**3** To smooth the surface, sand the spinning bowl by hand using progressively finer grits (80 to 320-grit).



**4** With the lathe off, apply a coat of finish and let it soak in. Then turn the lathe on and buff the finish.

make it easy to remount the bowl when hollowing out the inside later.

**Sanding** - Now it's just a matter of sanding the bowl to remove the tool marks and smooth out any torn end grain. You can do this by hand as in Step 3 above. Or you may want to try a power sanding system. (For more on this, refer to page 28.)

**Finish** - Before removing the bowl, take a minute to apply a finish, as shown in Step 4. What works well here is to rotate the bowl *by hand*. Then turn on the lathe and buff the finish with a soft cloth. Note: To provide a good glue surface for remounting the bowl later, don't apply a finish to the recess in the base.



**4** Once the waste is removed, center the faceplate on the blank and then screw it in place.



**5** After mounting the blank, set the lathe to run at a slow speed (600 RPM) and "true up" the outside.



**6** Finally, reposition the toolrest and flatten the face of the blank before you begin shaping the bowl.

## Hollowing the Inside

With the outside of the bowl turned to shape, you're ready to hollow the inside. But first you'll need to turn the bowl around and remount it to the lathe. To do this, I used the shop-made glue block shown in the box below.

**Mount Bowl** – After remounting the bowl on the lathe, it's a good idea to give it a firm "tug" to check the glue joint. Then with the lathe set to a slow speed, stand to the side and flip the lathe quickly on and off to ensure that the bowl is secure.

**Remove Waste** – After checking that the bowl spins smoothly, increase the speed of the lathe (1200 RPM) and start hollowing out the inside. To prevent the gouge from skidding along the face, roll the gouge on its side with the flute facing the center of the blank as you start the cut (Step 1).

At this point, you can remove the waste by making a series of cuts,



**1** Take small "bites" out of the inside as you work from the outside of the bowl to the center.

always working from a large to a small diameter. To do this, start each cut closer to the rim and then cut deeper into the bowl.

Remember, the bowl is glued on now. So you don't want to be as aggressive in removing the waste as when you shaped the outside. Plus, a lighter



**2** For a consistent wall thickness, work from the rim to the center of the bowl in a single, sweeping cut.

cut will leave a smoother surface.

As you near the rim of the bowl, the goal is to maintain a consistent wall thickness by matching the shape of the outside of the bowl.

**Sand & Finish** – Here again, once the inside is hollowed out, sand the surface smooth and wipe on a finish.



▲ After applying "instant" glue to the tenon on the glue block (top), spray the accelerator in the recess (bottom) and press the bowl quickly into place.

## Making a Glue Block

It's easy to secure the base of a bowl to the lathe so you can hollow out the inside. All it takes is a *glue block*.

**Glue Block** – This is nothing more than a glued-up hardwood block that's screwed to the faceplate and turned to a cylinder. (I glue up pieces of  $\frac{3}{4}$ "-thick stock.) As with the bowl blank, you'll need to turn the glue block so it's flat on the face.

**Cut Tenon** – The next step is to create a short tenon to fit into the recess in the base of the bowl. This tenon centers the base of the bowl on the glue block. This way, the bowl will run "true."

When turning the tenon, the goal is to get it to fit



into the recess with a snug fit. The best way to do this is to start with a tenon that's *larger* than the diameter of the recess. This way, as you sneak up on the final size of the tenon, you can test fit the bowl for a perfect fit, as shown in the photo above.

There's one more thing to keep in mind — the *length* of the tenon. To ensure the base of the bowl sits flat against the glue block, the tenon should be slightly shorter ( $\frac{1}{16}$ " ) than the depth of the recess (see detail).

**Mount Bowl** – At this point, you're ready to attach the bowl. To do this, I use "instant" glue and an accelerator to make the glue dry quickly (see margin photos). Instant glue and accelerator are available from the sources listed on page 31.

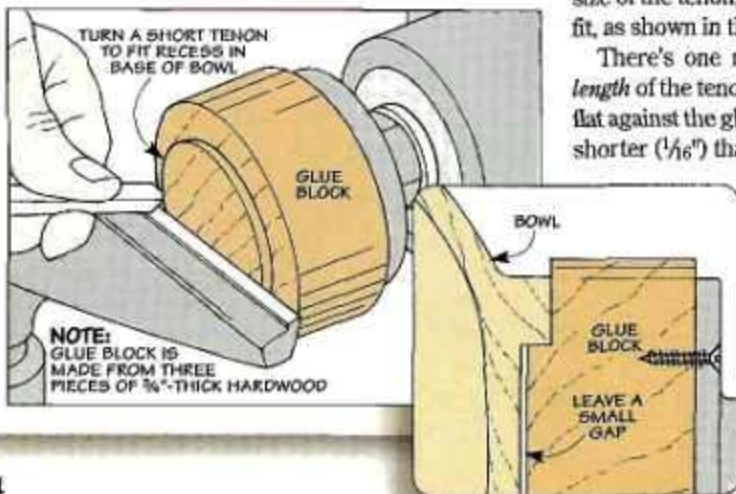

## Turning the Base

At this point, the bowl is nearly complete. All that's left to do is separate the bowl from the glue block and then clean up the base.

**Remove Bowl** – Removing the bowl is easy. Simply use a parting tool to cut most of the way through the waste just below the base of the bowl (Step 1). Then, stop the lathe and use a hand saw to cut through the remaining waste (Step 2).

This will leave the base unfinished with some of the waste from the glue block still attached. To clean this up, you'll need to remount the bowl to the lathe. Since the inside and outside of the bowl are completed, you don't want to use a glue block here.

**Jam Chuck** – That's where a jam chuck comes in handy. The box below provides a simple process for creating a jam chuck to mount the bowl.

**Clean Up Base** – Once the bowl is secured in the jam chuck, use a light touch to remove the waste and reshape the base (see Step 3 and detail). Finally, sand and finish the base to match the rest of the bowl.



**1** With the inside complete, use a parting tool to cut part way into the glue block just below the base.



**2** After stopping the lathe, use a hand saw to cut through the remaining waste and remove the bowl.

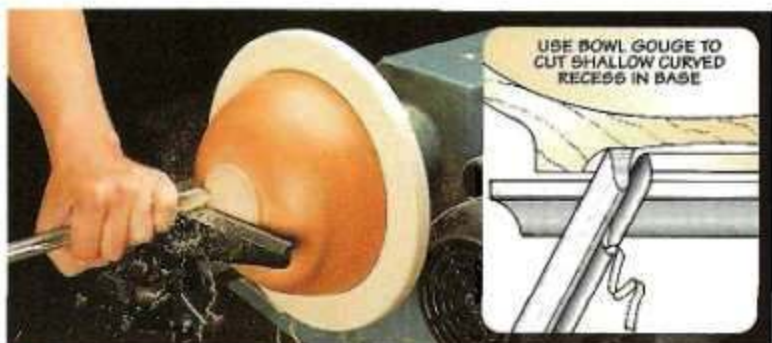

**3** After remounting the bowl with a jam chuck, use the bowl gouge to remove the waste left over from the glue block. Then turn the base to final shape (see detail), sand, and apply a finish.

## Jam Chuck

Like a glue block, a *jam chuck* is used to remount a bowl to the lathe. What's different about a jam chuck is that instead of gluing the bowl onto a tenon, you cut a *groove* to hold the rim of the bowl.

There's nothing complicated about making a jam chuck. I just cut a plywood disk and then attach it to a

faceplate. (I use a piece of  $\frac{3}{4}$ " plywood.)

**Cut Groove** – To hold the rim of the bowl, you'll need to cut a shallow groove in the disk with a scraper. The idea is to make the groove match the outside diameter of the bowl and wide enough to accept the rim of the bowl.

The trick to holding the rim tight is to slightly *taper* the groove, as shown in the detail. Here, it's best to start with a groove that's *smaller* than the bowl. This way, you can sneak up on the final size of the groove (and the taper) and test fit the bowl as you go (see photo above).

Once the bowl fits snug and bottoms out on the groove (see detail), you're ready to make the final cuts on the base to complete the bowl.

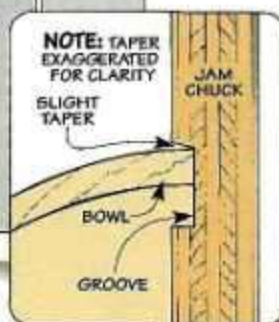
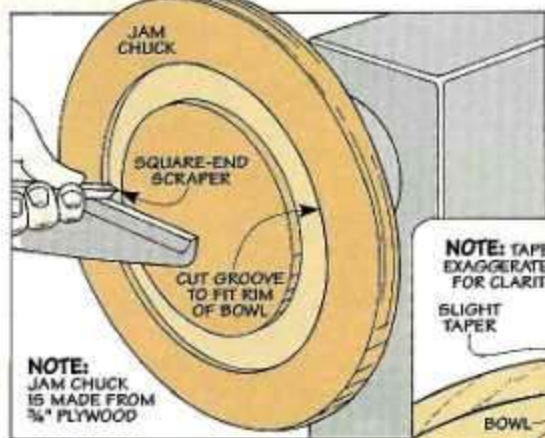
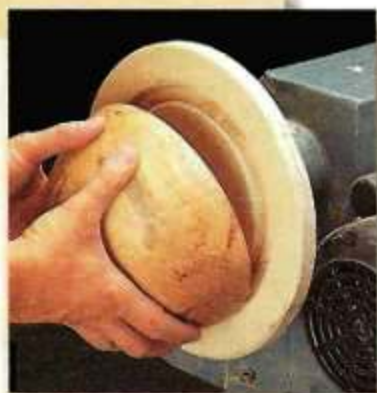

# Adjustable Miter Gauge Fence

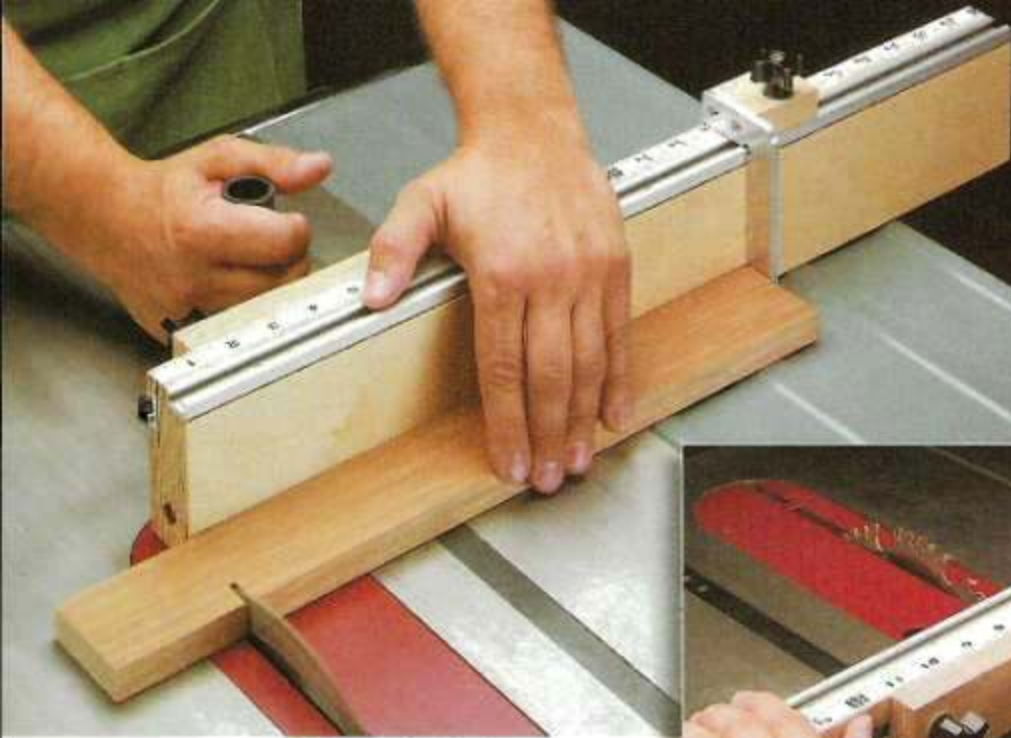

*An adjustable fence and two simple stops provide quick, accurate setups when using a miter gauge.*

One of the simplest accessories you can add to the miter gauge on your table saw is an auxiliary fence. It provides more support for a workpiece than the miter gauge by itself. Plus, you can clamp a wood block to it to make repeat cuts.

So how do you improve on a good thing? Two ways.

First of all, make it *adjustable* from side to side. This way, when you tilt the head of the miter gauge to make an angled cut, the fence can be quickly repositioned to provide support up close to the saw blade.

The second improvement is to add a couple of stops. Ideally, these stops could be set up

quickly and accurately *without* having to fiddle with clamps.

**T-Track** – Well, it sounded like a great idea. And as it turns out, I had just the right thing to make it work — a couple of strips of extruded aluminum, each with a slot that holds a T-shaped bolt (T-track).

*Editor's Note:* This is a manufactured product that we've used on several projects in the past. (For more information about T-track, refer to page 17.)

**Adjustable Fence** – With T-track in hand, I

set about making the adjustable fence that's shown above. It provides all the support that's needed to prevent a board from twisting during a cut. But it's the two improvements I mentioned that set this fence apart.

For example, a strip of T-track in the back of the fence makes it adjustable. As you can see in the inset photo, loosening two lock knobs lets you slide the fence from side to side.

**Stop Block** – The second strip of T-track is attached to the top of the fence. If you look at photo 'A' at left, you can see that this strip acts as a guide for an adjustable *stop block*. This stop block makes it quick and easy to crosscut one (or multiple) workpieces to identical length.

One thing to note here is the L-shaped, metal stop. To prevent the stop from flexing, it's made from a thick, aluminum plate. If you haven't worked with this material before, don't worry. We've provided step-by-step instructions on page 21.

**Extension Stop** – There's also a metal stop that extends out from the *body* of the fence (Photo B). When working with long pieces (up to 41½" long), this stop provides a quick, accurate way to cut them to length.



**A. Stop Block.** By sliding this stop block to the desired mark on a measuring tape, it's quick and easy to cut boards accurately to length.

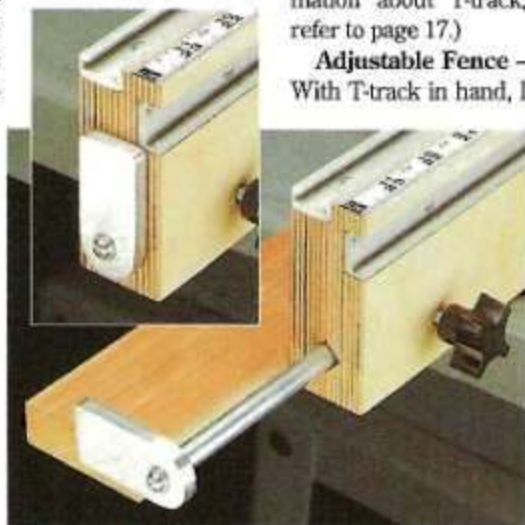

**B. Extension Stop.** Simply extend the stop on the end of the fence to cut multiple pieces up to 41½" long. Then slide it into the fence for storage (inset).



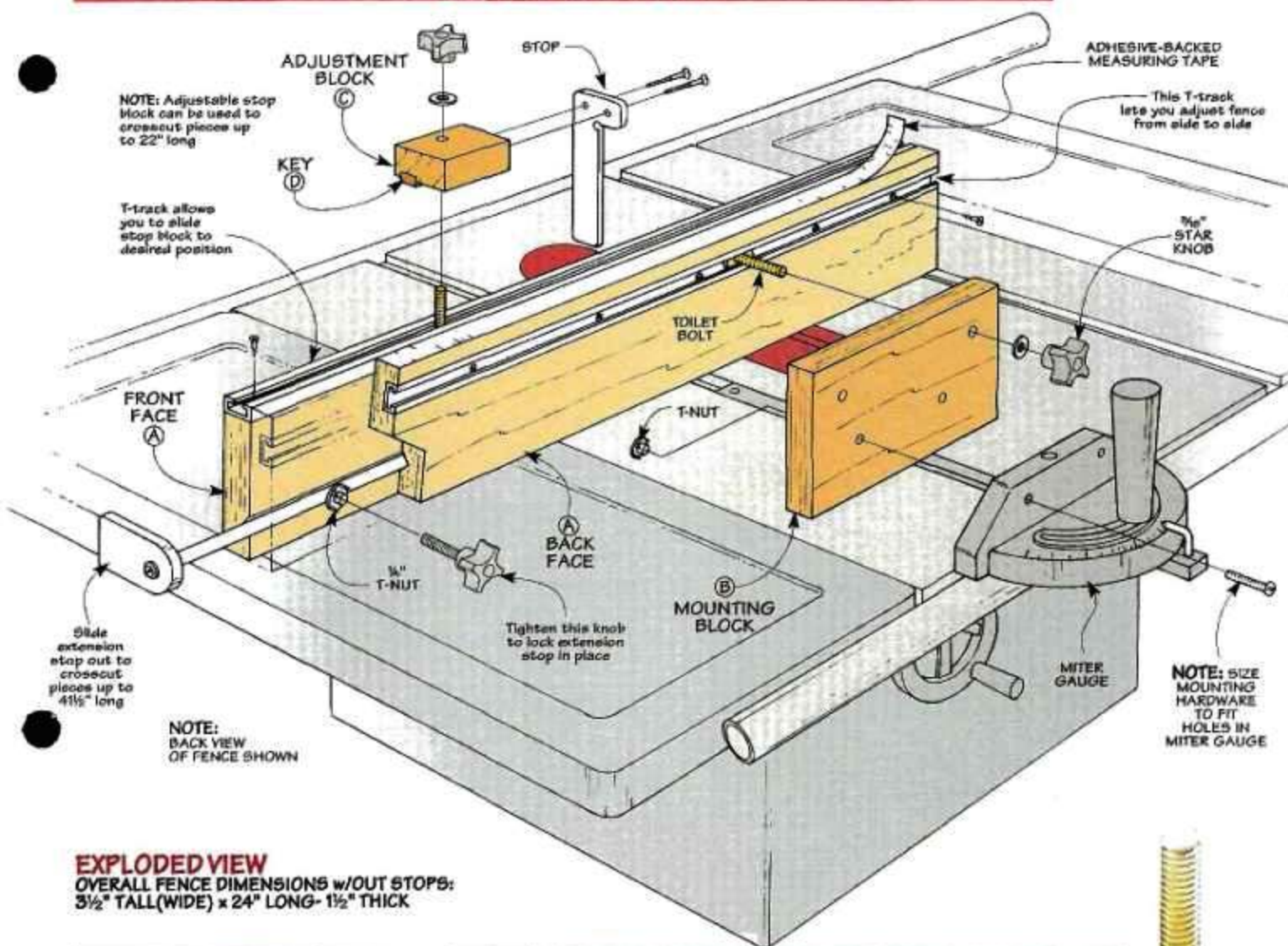

**EXPLODED VIEW**

OVERALL FENCE DIMENSIONS w/OUT STOPS:  
3½" TALL(WIDE) x 24" LONG- 1½" THICK

**Materials & Hardware**

- |                        |                     |
|------------------------|---------------------|
| A Front/Back Face (2)  | 5½ x 24 - ¾ Plywood |
| B Mounting Block (1)   | 3½ x 7½ - ¾ Plywood |
| C Adjustment Block (1) | ¾ x 1½ - 2          |
| D Alignment Key (1)    | ¾ x 2 - ¼ Hardboard |
- (2) 24"-long Aluminum T-Tracks
  - (14) #6 x ½" Fh Woodscrews
  - (1) ¼" T-Nut (w/ short barrel)
  - (1) ¾" x 20" Steel Rod (zinc plated)
  - (1) 8-32 x ½" Rh Machine Screw
  - (1) #8 Flat Washer
  - (1) ¼" Star Knob (w/ ¾"-long threaded stud)
  - (1) 3" x 5" Aluminum Plate (¼" thick)
  - (1) 72"-long Measuring Tape (reads right to left)
  - (3) ⅝" x 1¼" Toilet Bolts
  - (3) ⅝" Flat Washers
  - (2) #8 x 1" Fh Woodscrews
  - (3) ⅝" Star Knobs (w/ thru hole)

**T-Track**

If you're building a jig and you want to make it adjustable, this aluminum T-track is a quick, easy way to do it.

The key is a slot in the track that accepts the head of a T-shaped bolt (toilet bolt). By slipping an accessory (like the stop block on the miter gauge fence) over the bolt, you can slide it along the track. Then just tighten a knob on the bolt to lock it in place.

This T-track is made by extruding aluminum, a process that produces a strong, durable product. It's available in 32" lengths with pre-drilled mounting holes to speed up installation. If you want to use shorter lengths, you can easily cut the track with a carbide-tipped saw blade (or simply use a hack saw). Note: A source for T-track is listed on page 31.

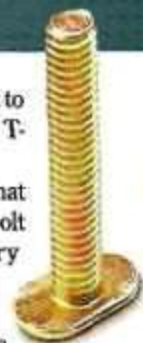

# Fence

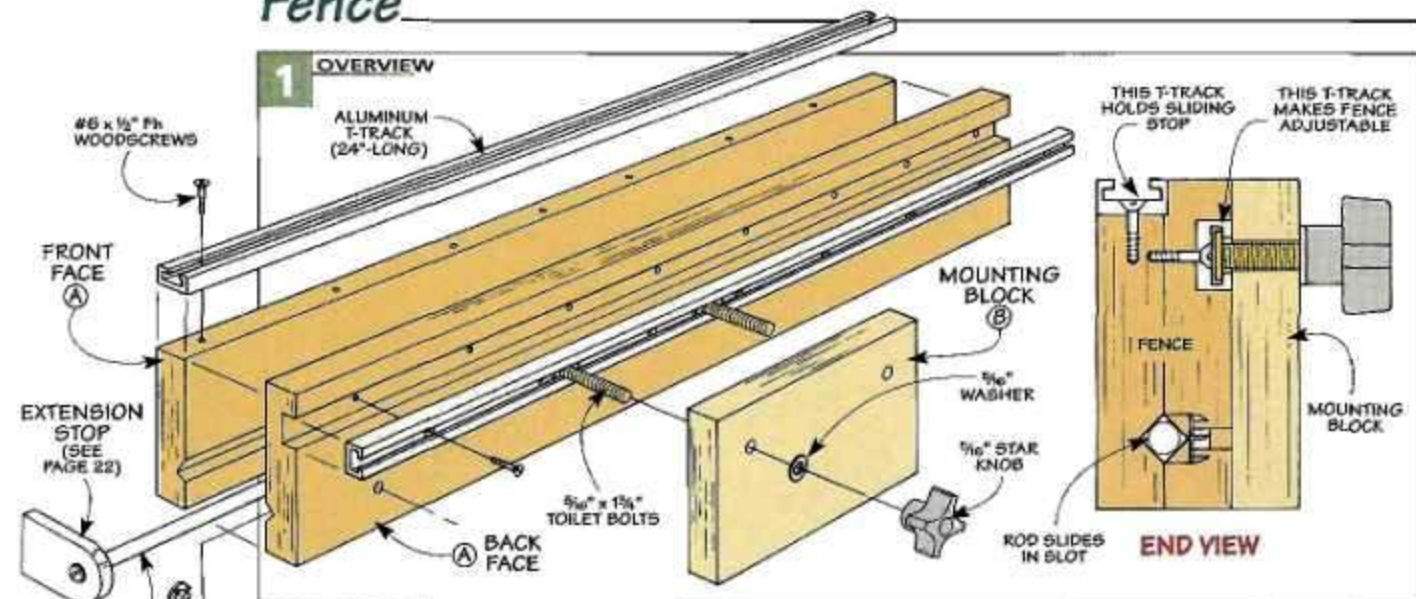

The main job of this miter gauge fence is simple — it provides support for a workpiece as you push it through the saw blade. But a look at Figure 1 shows there's more to it than that.

To make the fence adjustable, there's a strip of aluminum T-track housed in the back of the fence. A second strip attached to the top edge serves as a track for an adjustable stop. Finally, there's an extension stop attached to a sliding metal rod.

**Two Faces** — To create a slot that allows the rod to slide in and out, the fence is made up of a *front* and *back face (A)*, as shown in Figure 2. I used 3/4" Baltic birch plywood for both faces. It's a flat, stable material that resists warping and twisting.

**Slot** — After cutting the faces to size, the next step is to make the slot for the rod. It's formed by two V-shaped grooves, one in the inside face of each fence piece. The goal is to

get the rod to fit snugly inside the slot, yet still slide easily. The best way I found to accomplish that is to use a table-mounted router with a V-groove bit and "sneak up" on the perfect fit.

To do this, start by setting the fence 3/4" away from the tip of the bit (Figure 2a). Then adjust the height of the bit to make a shallow cut (about 3/16" deep). After routing both halves of the fence, clamp the pieces together and check the fit. If necessary, raise the bit just a hair and rout each piece again. Continue like this until the rod slips in with a smooth, sliding fit.

**T-Nut** — Once you're satisfied with the fit, the next step is to install a T-nut in the *back* face of the fence (Figures 2 and 2d). Later, it accepts a knob that locks the rod in place.

The head of the T-nut fits in a counterbored hole centered on the width of the V-groove (Figure 2b). The thing to be aware of is the *depth* of this hole. To prevent the rod from hitting the T-nut, drill the hole deep enough to recess the head *below* the groove. Now just drill a shank hole (Figure 2c) and install the T-nut as shown in the photo at left.

**Glue-Up** — At this point, you're ready to glue up the fence. All that's needed here is a *thin* film of glue. If the glue squeezes into the grooves, it will be hard to remove from the slot.



▲ A hammer is too big to fit down into the pocket that holds the T-nut. So I installed the T-nut by tapping a dowel against the head.

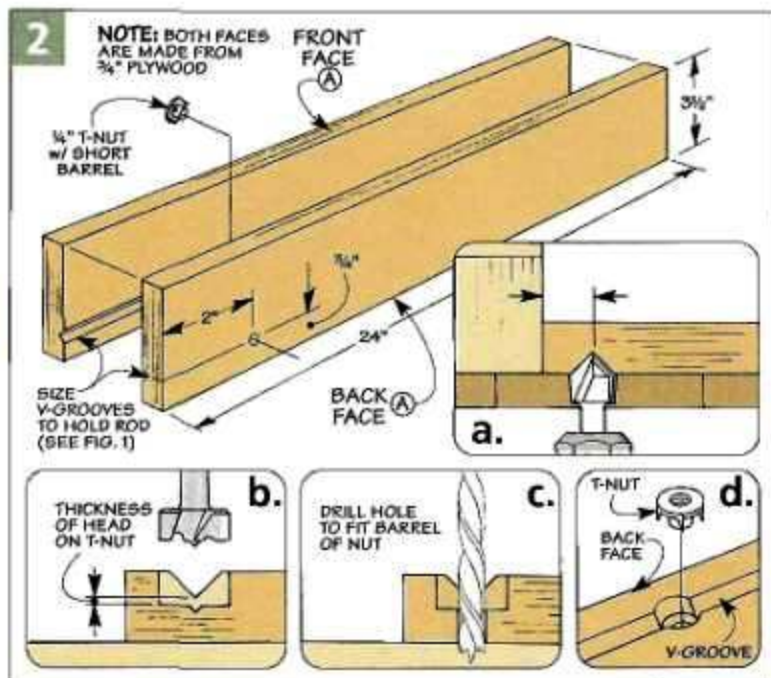

Plus, any dried glue could cause the rod to bind. When clamping the fence together, the pieces may slip out of alignment. So be sure to check that they're flush all around and make any adjustments *before* the glue dries.

**T-track** – Once the fence is glued up, you can turn your attention to the two strips of aluminum T-track. They're simply cut to length to match the length of the fence.

As you can see in Figure 1, one of the strips of T-track fits in a groove in the back of the fence. The other strip sits in a rabbet in the top edge.

A dado blade mounted in the table saw makes quick work of cutting the groove. It's set up to match the width of the T-track (Figure 3a). As for the depth of cut, adjust the height of the blade so the track will sit flush with the fence. Then lock the rip fence and make a single pass to cut the groove.

The next step is to cut the rabbet. It's best to do this with the wide part of the fence face down on the table saw, as shown in Figures 3 and 3b. (This provides more support than standing the fence on edge.)

The rabbet is cut with the fence up close to the blade. So to avoid cutting into the fence, you'll need to "bury" part of the blade in an auxiliary fence. Note: I adjusted the fence to make a  $\frac{3}{8}$ "-wide cut. Now just turn on the saw and guide the workpiece over the blade with a push block.

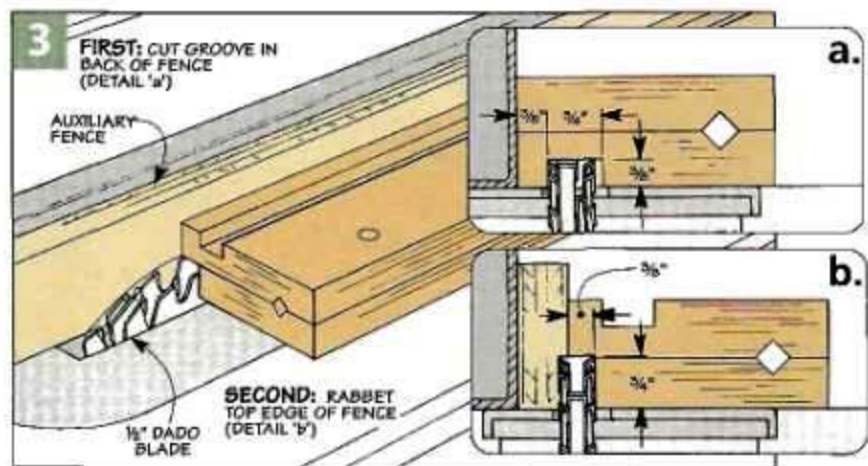

**Mount Fence** – At this point, it's just a matter of screwing the pieces of T-track in place and then mounting the fence to the miter gauge. Actually, the fence isn't attached *directly* to the miter gauge. As you can see in Figures 4 and 4b, it's fastened to a  $\frac{3}{4}$ " plywood *mounting block* (B) that's secured to the miter gauge.

To make the fence adjustable, there are two toilet bolts that slide in the T-track in back of the fence. These bolts pass through holes in the mounting block. Loosening (or tightening) a knob on each bolt allows you to slide the fence along the mounting block (or lock it in place).

Just a note about attaching the mounting block. It's held in place with machine screws that thread into T-nuts in the mounting block (Figure

4b). To allow the fence to fit tightly against the mounting block, the head of each T-nut is recessed slightly.

This recess is formed by drilling a counterbore. The problem is finding the centerpoint of this counterbore. That's because it's in the side of the mounting block that's *opposite* the side that fits against the miter gauge.

The solution is to use the existing holes in the miter gauge as a template and mark the centerpoints on one side with a brad point bit (Figure 5a). Then drill small ( $\frac{1}{16}$ ") pilot holes. The points where the bit cuts through establish the centerpoints on the opposite side.

Now you can drill the counterbored shank holes that hold the T-nuts. After adding the T-nuts, it's just a matter of installing the fence.

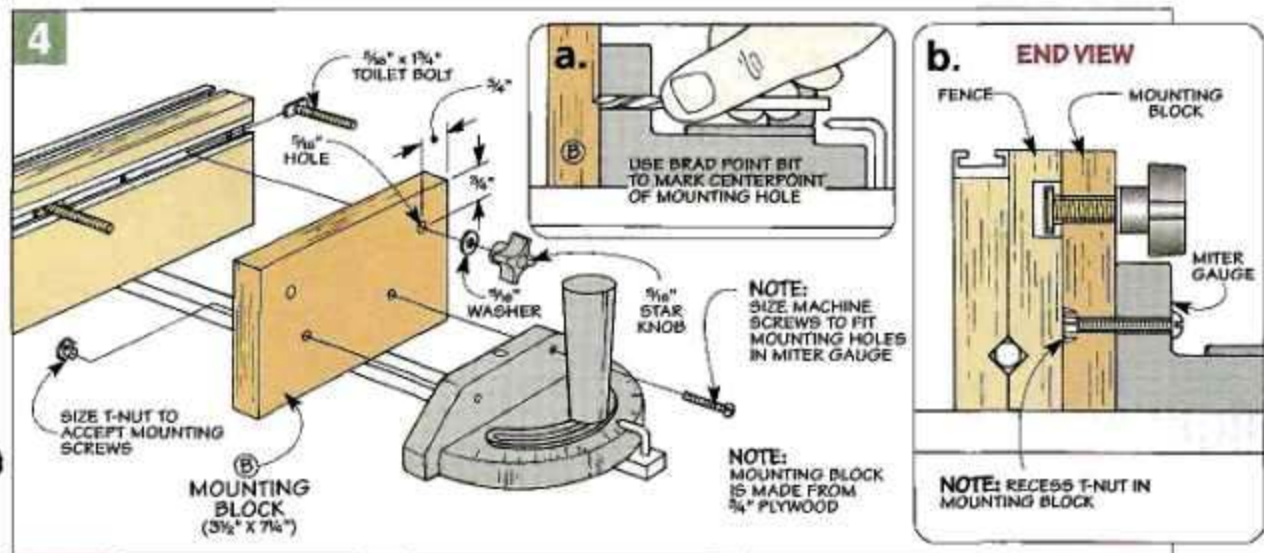

# Stop Block



▲ To produce accurate results, this adjustable stop combines a rigid, L-shaped arm made of aluminum with a sliding wood block.

One of the handiest things about this miter gauge fence is the adjustable stop block shown at left. When you need to crosscut a piece to length (or make multiple cuts), this stop block is quick and easy to set up, and it ensures accurate results.

**No Measuring** – One nice thing about setting up this stop block is there's no need to measure. That's because there's a measuring tape attached to the top of the fence. To set up a cut, simply slide the stop block until it aligns with the desired mark on the measuring tape. Then tighten a knob to lock it in place. The stop block consists of two main parts: a wood block that slides along the T-track in the top edge of the fence and a metal, L-shaped stop.

## SLIDING BLOCK

I began by making the block that slides in the T-track. It's made up of two separate pieces: an *adjustment block* and an *alignment key*.

**Adjustment Block** – As you can see in Figure 5, the *adjustment block* (C) is a small piece of  $\frac{3}{4}$ "-thick hardwood that provides a mounting surface for the stop. (I used maple.)

Notice there's a shallow groove in the bottom of this block that holds an alignment key (added later). Since the adjustment block is fairly small,

it's safest to cut this groove in an extra-long workpiece that's ripped to width, as shown in Figure 6 below.

It only takes a minute to set up the table saw to cut the groove. Start by positioning the rip fence  $\frac{3}{16}$ " away from the saw blade (Figure 7a). Then, after locking the fence in place, adjust the height of the blade to make a  $\frac{3}{16}$ "-deep cut.

Now just turn on the saw, set the workpiece against the fence, and push it across the blade with a block. To

remove the rest of the waste, you'll need to make a couple more passes at least, nudging the fence away from the blade between each pass.

**Alignment Key** – After trimming the adjustment block to length, the next step is to add the *alignment key* (D). It's a short strip of  $\frac{1}{4}$ " hardwood that fits into the groove in the adjustment block. In use, the key fits down into the slot in the T-track and prevents the stop from twisting as you slide it back and forth.

After gluing the key in the groove, the next step is to provide a way to "lock" the stop block at the desired location on the track. This is accomplished with a toilet bolt.

The head of the toilet bolt slips into the T-track while the shank passes through a hole in the adjustment block (Figures 5a and 5b). By threading a knob on the bolt, it pinches the head against the T-track which "clamps" the stop block in place.

As you can see in Figure 7a, the hole that accepts the toilet bolt is

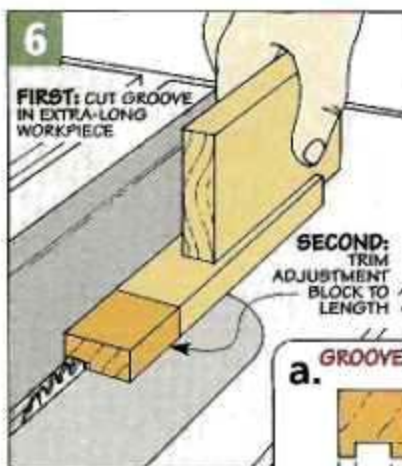

20

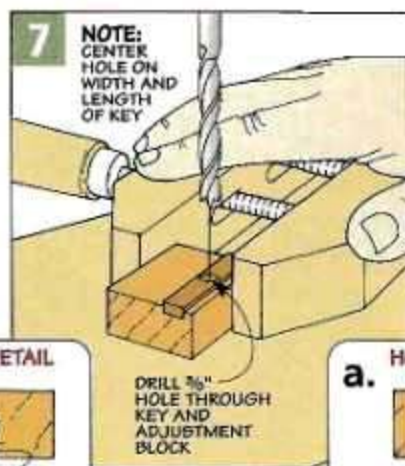

ShopNotes

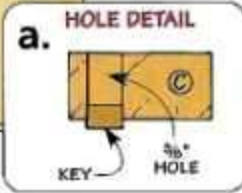
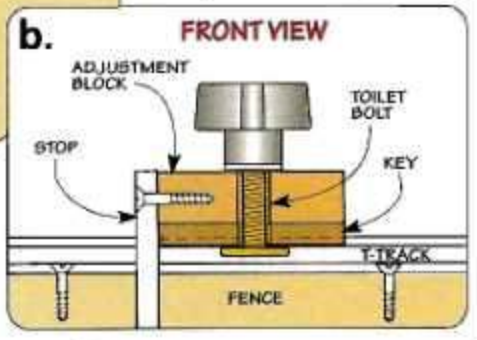
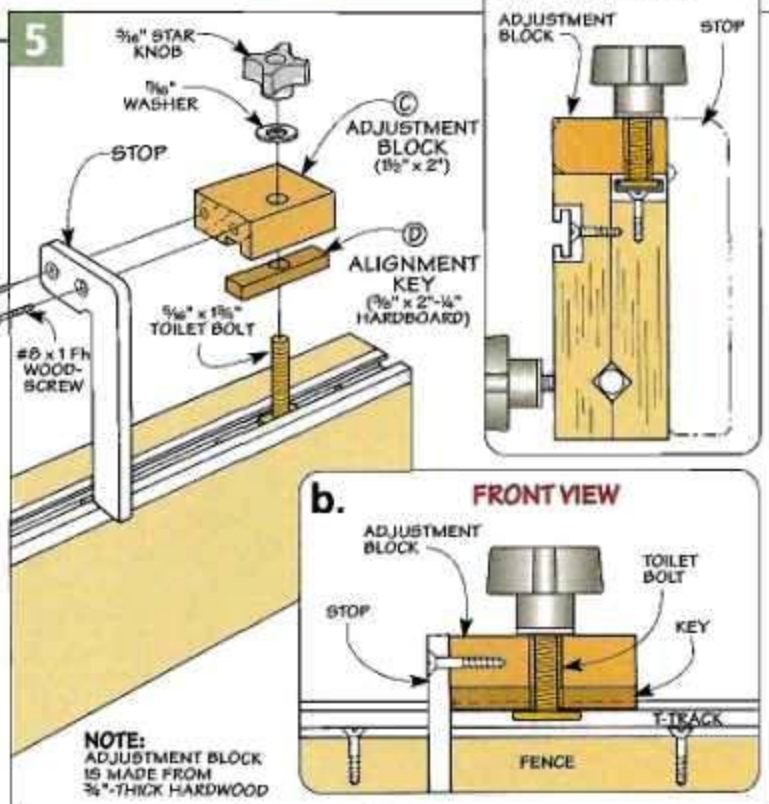

No. 53

slightly oversize. (It's a  $\frac{3}{8}$ "-dia. hole for a  $\frac{5}{16}$ " bolt.) This will provide a small amount of "play" in the bolt — just enough to allow the stop block to slide easily in the track. Note: I clamped the adjustment block in a handscrew to hold it steady when drilling the hole (Figure 7).

### STOP

With the sliding block complete, the next step is to add the stop that hangs in front of the fence.

To produce accurate results, I wanted to make sure the stop didn't flex when I butted the end of a board against it. But I didn't want a large, bulky stop either.

**Aluminum Plate** — After checking around a bit, I found the ideal material to make a rigid, compact stop — a  $\frac{1}{4}$ "-thick plate of solid aluminum. It doesn't take a large piece of aluminum to provide enough material for the adjustable stop *and* the extension stop. I bought a 3" x 5" plate from a machine shop for a couple of bucks.

**Lay Out Shape** — With plate in hand, it's just a matter of laying out the shape of the stops, as shown in Figure 8. Since pencil lines might rub off, I'd recommend using a fine-tipped, permanent marker. Note: For the dimensions of the extension stop and the location of the mounting holes, refer to Figure 10 on page 23.

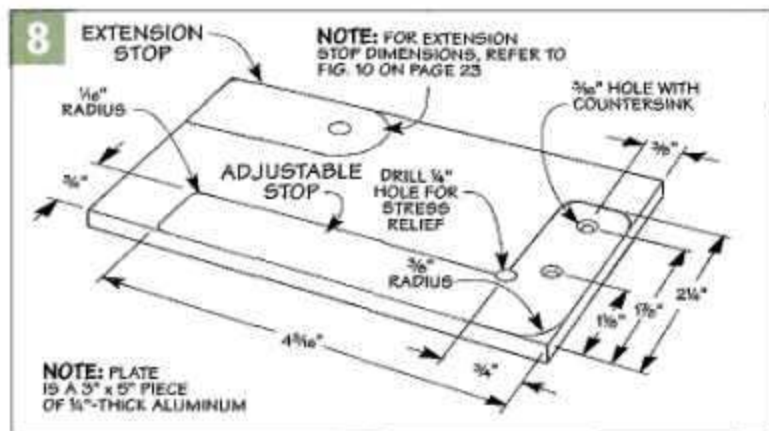

**Locate Holes** — You'll also want to mark the centerpoints of the mounting holes. While you're at it, mark the location of a small, "stress relief" hole in the inside corner of the arm.

**Drill Holes** — Since aluminum is fairly "soft," drilling the holes should go quickly. (Refer to Step 1 below.) Just be sure to make a dimple with a punch first to prevent the tip of the bit from skidding across the plate. Also, don't forget to clamp the plate securely to the drill press table — you don't want it spinning around as you drill the holes.

**Cut to Shape** — The next step is to cut the stops to *rough* shape. After tightening the plate in a vise, a hack saw is all that's needed here (Step 2). To minimize the amount of clean-up,

try to cut about  $\frac{1}{16}$ " to the waste side of the lines. The remaining material can be quickly removed with a disk sander (or a file). As you can see in Step 3 and Figure 8 above, I also sanded a gentle radius on the corners to "ease" the sharp edges.

**Sand the Sides** — If the sides of the stop are scratched or dirty, you may want to sand them as well. I attached strips of sandpaper (120 up to 300-grit) to a flat surface and then "scrubbed" the stops back and forth to produce a smooth, satin finish.

**Assembly** — Now it's just a matter of assembling the stop block. After drilling pilot holes in the adjustment block, the stop is simply screwed in place. Then slide the toilet bolt into the T-track, slip the stop block over it, and thread on the knob.

## Making the Stops



**1 Drill Holes.** After laying out both stops on the aluminum plate, clamp it securely to the drill press table. Then use a twist bit to drill the holes.



**2 Cut to Shape.** A hack saw slices easily through the aluminum when cutting the extension stop (lying on the vise) and the L-shaped stop to shape.



**3 Sand the Corners.** To create a gentle radius on the corners, sand them smooth with a disk sander. Or if you prefer, use a file and sanding block.

## Extension Stop



▲ To cut extra-long pieces to length, just loosen a lock knob and then slide the extension stop out of the fence.

To make repeat cuts accurately when working with long pieces (up to 41½" long), I added an extension stop. As you can see in the photo above, the extension stop slides out from the end of the fence. Once you finish a cut, just push the metal rod that holds the stop back into the body of the fence for storage.

There's nothing complicated about the extension stop. As you can see in Figure 9, it consists of two parts: a steel rod and a short, flat stop. As it turns out, most of the groundwork for these parts is already complete.

**Stop** – Take the stop for instance. It's the small metal block with a

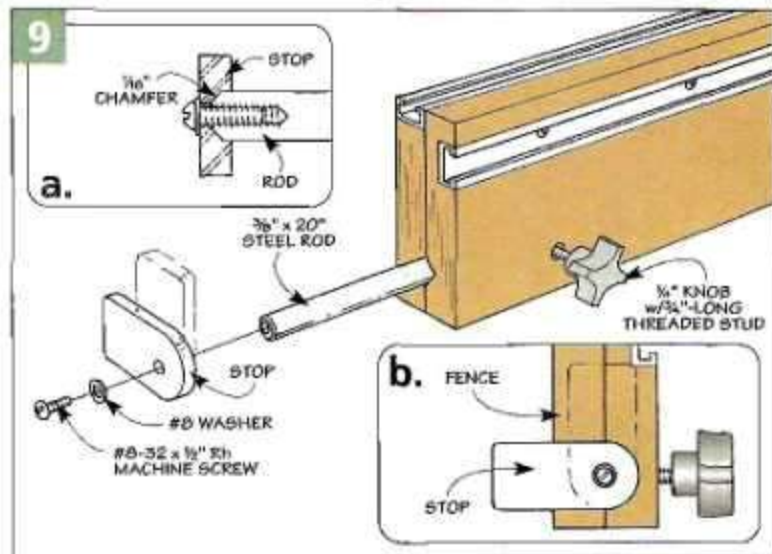

curved end that was made earlier from the aluminum plate. Notice in Figure 9 how the stop can be pivoted up and down. That's because it's fixed onto the end of the rod which rotates inside the slot.

When the rod is extended, the idea is to swing the stop down so it

sticks out in front of the fence (Figure 9b). In this position, it provides a rigid support that won't flex when you butt the end of a board against it. When you slide the rod back into the fence, rotate the stop to the "up" position so it's out of the way, stored neatly against the end of the fence.

**Pocket** – If you look at Figure 10, you'll see there's a counterbored shank hole in the stop. It forms a pocket that fits over the end of the rod. I use a Forstner bit to drill a flat-bottomed counterbore. But since the stop is metal, I had to use a twist bit instead. The result is a counterbore that's beveled on the bottom.

That's okay, but there is one thing to keep in mind — the depth of the hole. To "seat" the rod securely in the stop, you'll want to drill the hole deep enough to create a shoulder that's at least 1/8" deep (Figure 10a). Then follow up by drilling a shank hole for a machine screw that's used to hold the stop in place.

**Steel Rod** – At this point, you can turn your attention to the rod that slides in and out of the fence. It's a 3/8"-dia. steel rod that's housed inside the slot in the fence. (I picked up a steel rod at a home center and then cut it 20" long with a hack saw.)

While you're at it, it's a good idea

## Tapping Threads

Occasionally, the threaded part I need to assemble a project isn't available. The rod on the extension stop is a good example. A hole in the rod needed to be threaded to accept a screw.

**Tap** – So I used a tap to cut the threads. This is a special tool designed to cut threads inside a hole. The tap is tightened into a wrench with a T-handle. (These tools are available at most

hardware stores.)

**Pilot Hole** –

The first step is to drill a pilot hole for the tap. The size of this pilot hole is usually marked on the side of the tap.

**Tap Threads** – To avoid cutting the threads crooked, the important thing is to get the tap started straight. You'll also want to apply a few drops of oil as a lubricant.

After setting the tap in the hole, twist it slowly and evenly in a clockwise direction, applying pressure downward, as shown at left. As the tap begins to cut, a burr will form which will make it harder to turn. To clear this burr, back out the tap. Then repeat the process to cut the threads to the desired depth.

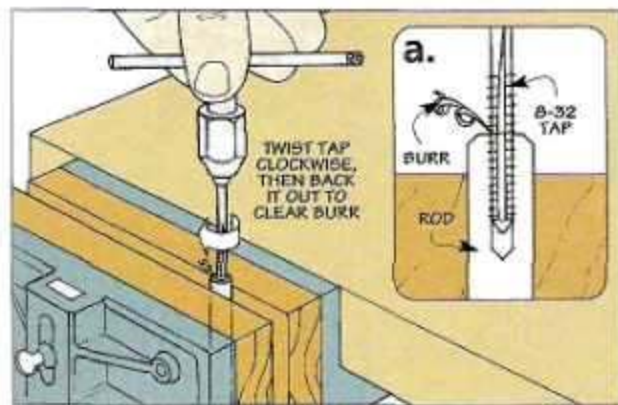

to file a small ( $\frac{1}{16}$ " ) chamfer on one end of the rod. This chamfer will make it easier to fit the rod into the pocket in the stop.

As I mentioned, the stop is attached to the rod with a machine screw. This requires drilling a centered hole in the end of the rod and then tapping threads in it to accept the screw. An easy way to locate this hole is to set the stop over the end of the rod and use it as a template.

To do this, tighten the rod in a vise so the end sticks up above it by a small amount. Just how much the rod should project is a trial and error process. What you're looking for is to have the stop sitting flat on the vise, as shown in Figures 11 and 11a. This way, the vise provides a solid platform for the stop as you drill the pilot hole. Note: I drilled a pilot hole with a No. 29 twist bit (or you can substitute a  $\frac{3}{64}$ " bit).

**Tap Threads** – Now it's just a matter of tapping threads in the hole to accept the machine screw that fastens the stop to the rod. (I used an 8-32 tap.) Note: For more

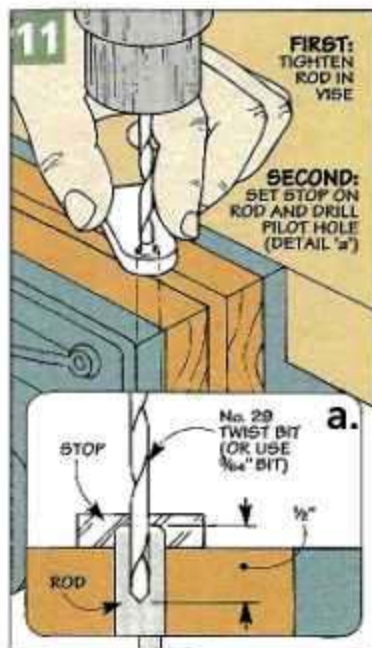
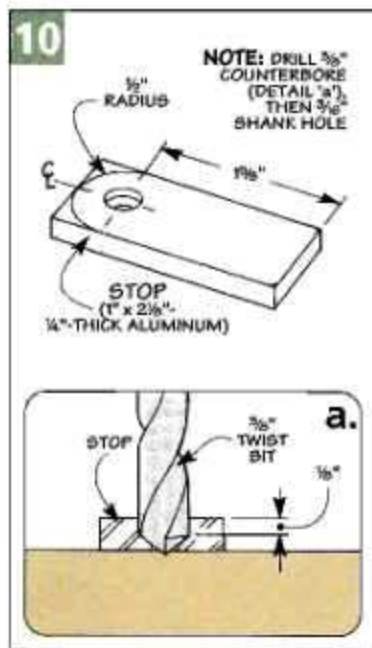

information about tapping threads, refer to the box on page 22.

**Assembly** – Just a couple of notes about assembling the stop. To prevent the screw that secures it to the rod from loosening, I applied some *Loctite* to the threads before

installing the stop. Then, after slipping the rod into the slot, thread a studded knob into the T-nut that was installed earlier in the back of the fence. Tightening (or loosening) the knob allows you to lock the stop in place or slide it in and out.

## Setup



Setting up the miter gauge fence is a simple, two-step process.

**Measuring Tape** – The first step is to install a measuring tape. Since I usually place the miter gauge to the left of the saw blade, I used an adhesive-backed measuring tape that reads from right to left, as shown above.

Before attaching the tape, there's one thing to mention. To avoid cutting into the fence, I wanted it to be  $\frac{1}{16}$ " away from the blade when making a  $90^\circ$  cut. So to produce accurate readings, I trimmed  $\frac{1}{16}$ " from the end of the tape (Figure 12a) and then applied it to the fence (Figures 12 and 12b).

**Reference Line** – To make it easy to return to that setting (after repositioning the fence to cut a miter for instance), it's a good idea to mark a reference line on the fence. To do this, loosen the lock knobs, slide the fence to within  $\frac{1}{16}$ " of the blade, and mark a line (Figures 13 and 13a).

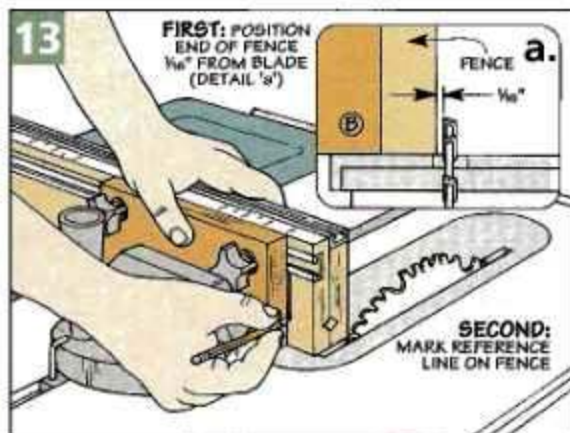
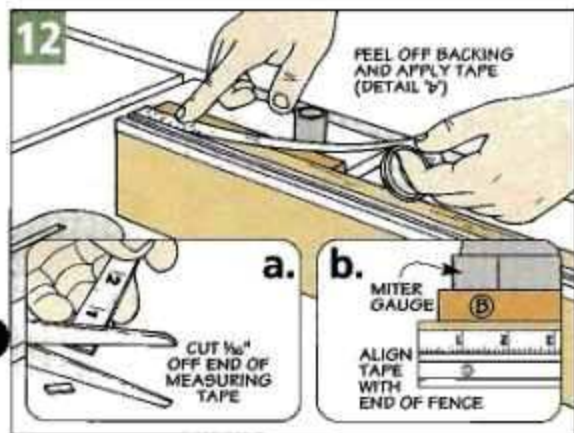

▲ To produce accurate cuts, align the stop block precisely with the desired mark on the measuring tape.

# Wall-Mounted Drill Bit Storage

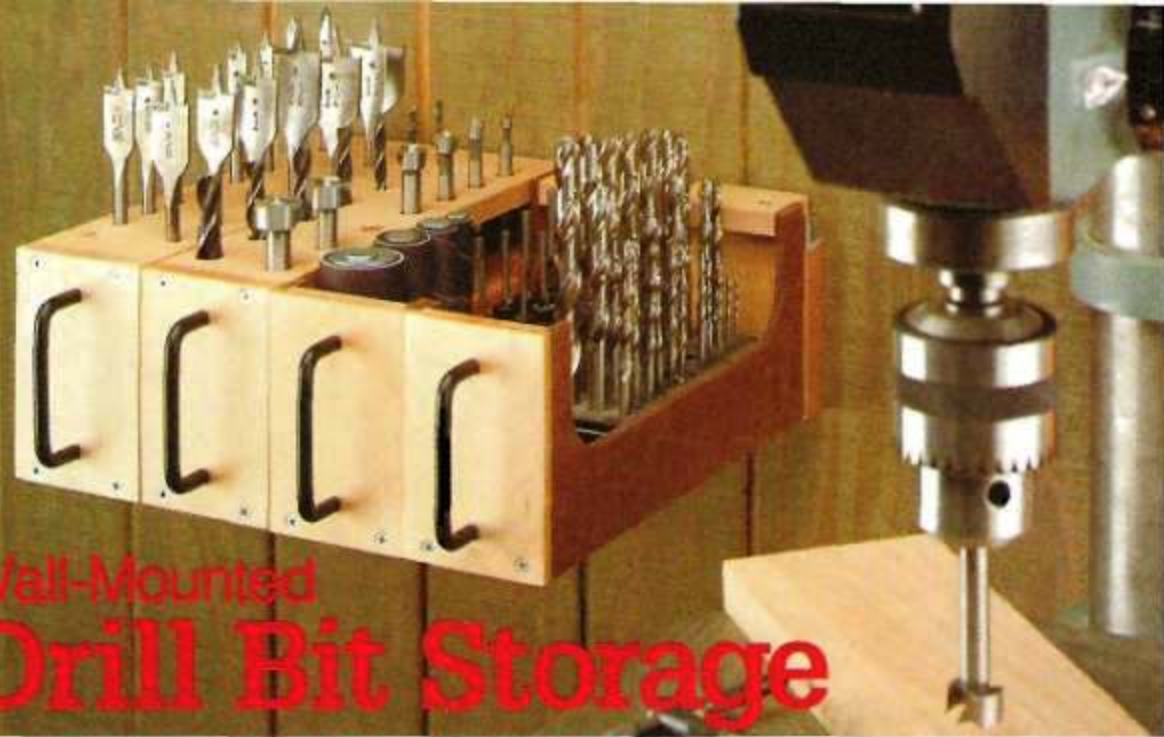

*If your drill bits have a habit of disappearing into a "black hole," build this handy storage system to keep them close by.*

**L**ike many woodworkers, I keep my drill bits and accessories next to the drill press. After all, that's where I use them most often.

The only problem is I frequently need to drill holes somewhere else, like in a project I'm building at the bench or in the back yard. So I end up carrying a

handful of bits back and forth.

That's why I built the simple storage system shown above. It's made up of four individual hangers that organize my drill bits and accessories. To provide easy access to the bits when I'm using the drill press, the hangers hook onto a wall-mounted cleat. (See photo on page 25.) If I

need to take the bits with me, I just lift one of the hangers off the cleat.

**Two Types of Hangers** – Since I have several kinds of drill bits, I made two different types of hangers. Two racks hold my brad point bits, Forstner bits, and spade bits. And there are two bins for my twist bits, combination bits and sanding drums.

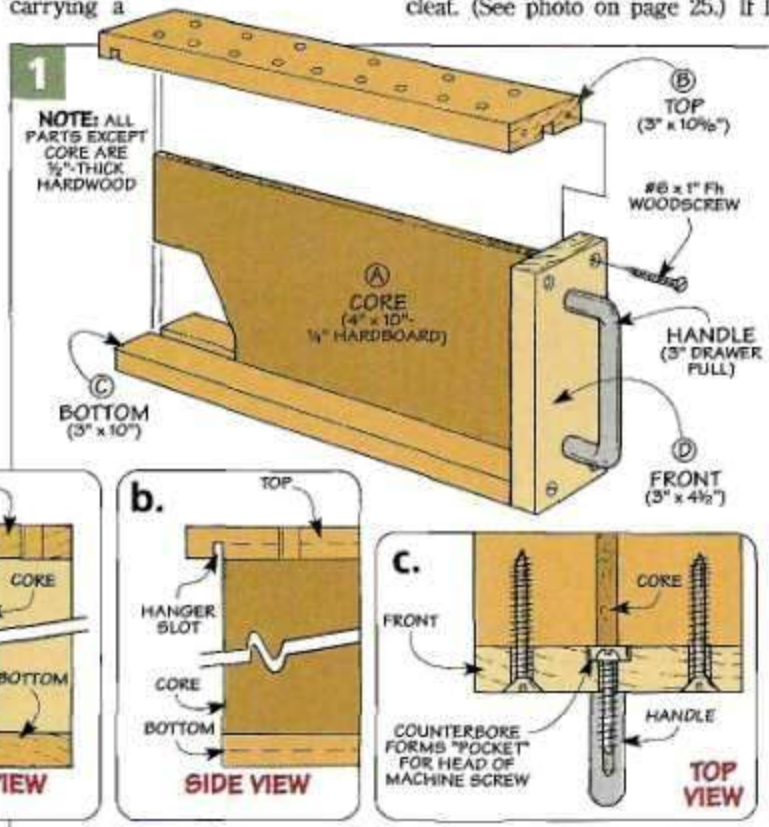

## RACKS

I began by making the two racks. As you can see in Figures 1 and 1a, each rack is shaped like a mini I-beam with storage on each side for bits. A wood block attached to the front end of the rack adds rigidity, plus it provides a mounting surface for a handle.

**I-Beam** – Each of the I-beams consists of a  $1/4$ " hardboard core (A) that's sandwiched between a top (B) and bottom (C) made of  $1/2$ "-thick hardwood strips. (I used maple.)

These strips are identical in width (3"), but the top is  $5/8$ " longer than the bottom. This creates an overhanging lip that extends past the end of the rack. Notice in Figure 1b that there's a slot in this lip that provides a way to hang the rack on a metal rail attached to the cleat.

The slot is formed by cutting a dado near one end of each top piece. To cut the dado the same distance from the end in each piece, I used the setup on the table saw shown in



Figures 2 and 2a. Start by locking the fence  $\frac{1}{2}$ " from the *inside* of the blade. Then butt the end of the workpiece against the fence, and use the miter gauge to push it across the blade.

**Groove** – The next step is to cut a groove in the top and bottom piece to accept the hardboard core (A). To create a friction fit, I found it best to “sneak up” on the final width of the groove, as shown in Figures 3 and 3a.

To do this, lock the rip fence in place so the saw blade is *roughly* centered on the width of the workpiece. Then make *two* passes, turning the workpiece *end for end* between each one. At this point, check the fit of the core piece in the groove. If it fits too tightly, nudge the fence away from the blade and repeat the process.

**Drill Holes** – The next step is to drill holes in each top piece so you can slip bits in and out. When laying out these holes, be sure to allow for some finger room between the bits.

Also, to make it easy to remove bits (or put them back in), I drilled each hole  $\frac{1}{32}$ " larger than the shank of the bit that fits in it. Note: To hold my longest brad point bit, I also drilled a single hole in the bottom (C) of one rack. (See photo below.)

**Front** – Now you're ready to add the *front* (D) piece for each rack. It's a  $\frac{1}{2}$ "-thick hardwood block with a handle attached for easy carrying. I used a drawer pull

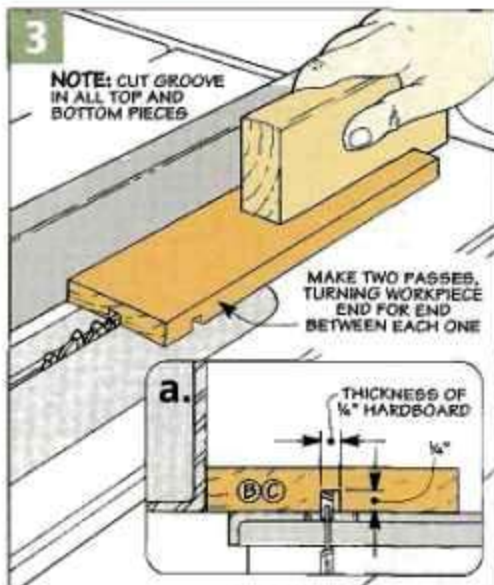
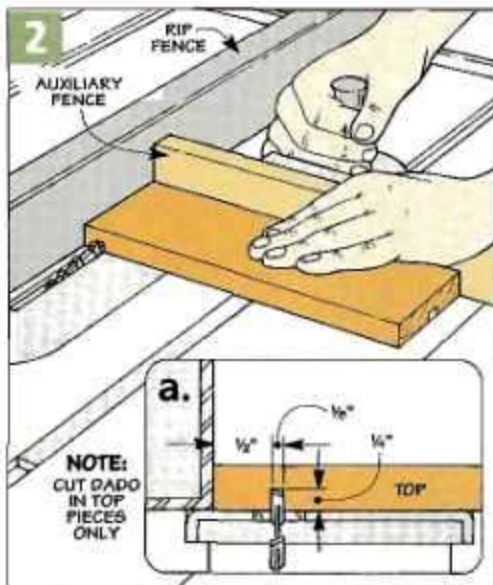

as a handle and drilled a couple of counterbored shank holes for the machine screws that hold it in place. This creates a pocket for each screw head that allows the front of the rack to fit tightly against the end of the core piece (Figure 1c).

**Assembly** – After installing the handle, it's just a matter of gluing up the three pieces that form the I-beam. Then simply attach the front with glue and screws.

**Riser Blocks** – At this point, all that's left is to add a *riser block* to both sides of each rack. As you can see in Figure 4, these are scrap pieces of “two-by” material with a series of holes to hold the

bottom ends of the bits. Note: I planed the stock to a thickness that allowed the riser blocks to fit flush with the outside of the rack.

To provide easy access to the bits, I wanted them to stick up an equal amount. So in order to align the tips of my brad point bits, I used a band saw to cut “stair steps” in that riser block. As for my Forstner bits, it was just a matter of ripping a block to width and gluing on one “step” for my shortest bit. The blocks that hold my spade bits are identical in width.

Now it's just a matter of drilling holes in the blocks that align with the holes in the top of the rack. Then glue the blocks in place.

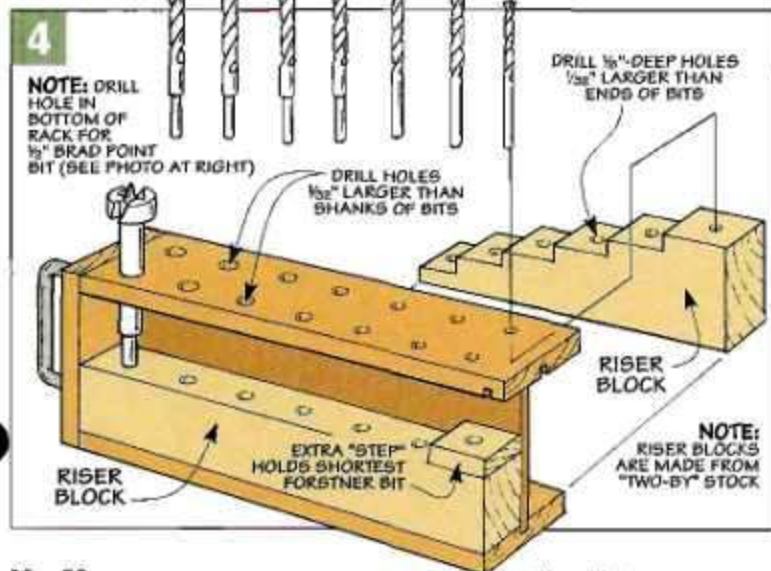

▲ **Removable Hangers.** Each hanger hooks onto a metal rail attached to a wall-mounted cleat. To drill a hole in a project at the bench (or around the house), simply lift the hanger off the rail and take the bits with you.

# Bins

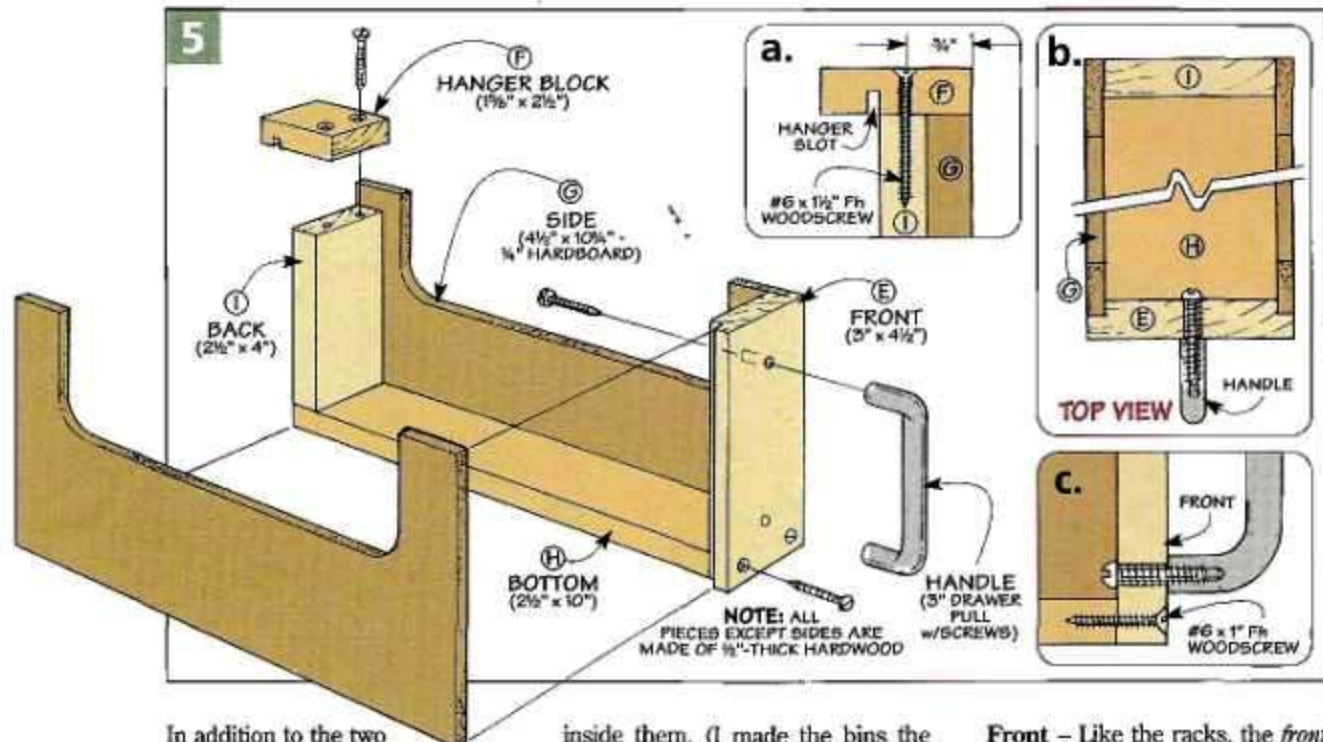

In addition to the two racks, I made a couple of storage bins to hang on the cleat. As you can see in the photo on the next page, each bin is a narrow container that can be used to hold a variety of drill bits and accessories.

**Size** – As with the racks, you may want to modify the size of the bins depending on what you plan to put

inside them. (I made the bins the same size as the racks.)

**Construction** – It won't take long to build the bins. As Figure 5 shows, each bin is an open box that's made up of a hardwood *front*, *back*, and *bottom* piece and a pair of hardboard *sides*. Also, a short *hanger block* attached to the back provides a way to hook the bin on the cleat.

**Front** – Like the racks, the *front* (E) of each bin is made from 1/2"-thick hardwood. But this time, the front is rabbeted on each edge to hold the sides of the bins (Figure 5b).

This requires working with a fairly small piece — too small to cut it safely on the table saw. So I mounted a rabbet bit in the router table and used it instead (Figures 6 and 6a).

Setting up the router table is a simple two-step process. First, set the fence so the width of the rabbet will match the thickness of the material used for the sides (1/4" hardboard). Second, adjust the height of the bit to cut a 1/4"-deep rabbet.

Now turn on the router, place the edge of the workpiece against the fence, and use a scrap block to push it across the bit (Figure 6).

**Hanger Blocks** – Once the front pieces are completed, you can turn your attention to the *hanger block* (F) for each bin. It's a short, 1/2"-thick hardwood block with a slot in the bottom that hooks onto the rail on the cleat (Figures 5 and 5a).

A look at Figure 7a shows that the size and location of this slot is the same as the one in the top of each

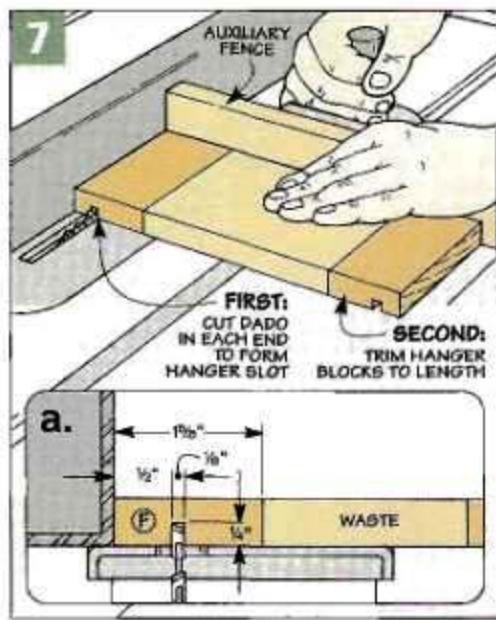
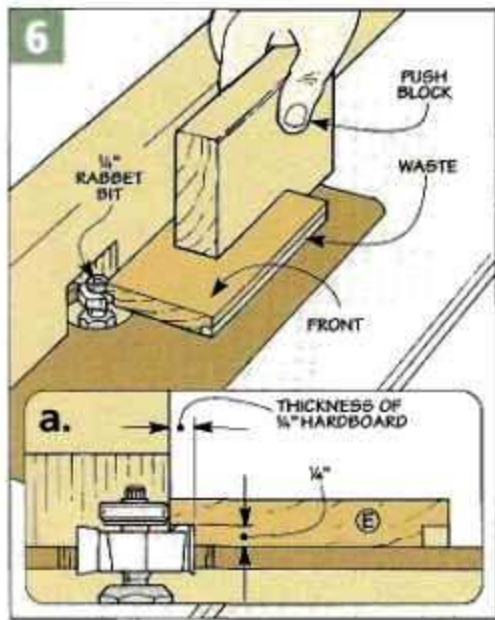

rack. But once again, the hanger blocks are fairly small. So it's best to start with an extra-long piece and cut a dado in each end to form the slot, as shown in Figure 7. Then trim each hanger block to length.

**Add the Sides** – At this point, it's time to add the *sides (G)* of the bins. To see at a glance what's inside the bins, the sides are scooped out to form a long, deep notch. It only takes a few minutes to make these notches.

After cutting blanks for the sides (two for each bin), lay out the notch

and use a band saw (or sabre saw) to cut about  $1/8"$  to the waste side of the line. The rest of the material can be removed using a drum sander chucked in the drill press (Figure 8).

To sand the entire thickness of the workpiece, you'll need to "bury" the lower part of the drum sander in a hole that's cut in an auxiliary table. (I attached a piece of plywood to the drill press table.) You'll also want to locate a *straight* piece of wood to use as a fence. After notching it to fit around the drum sander, position

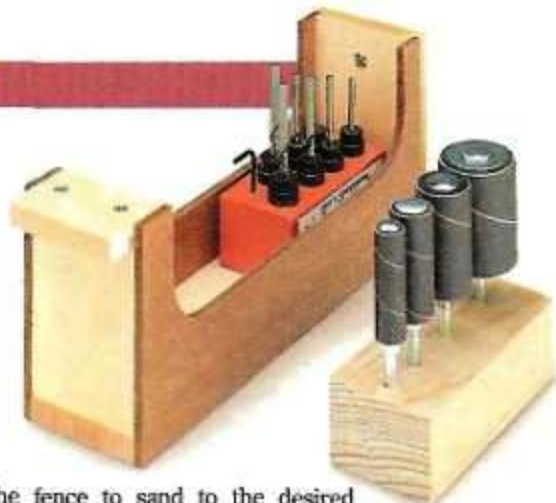

▲ One of the simplest ways to organize drill bits and accessories is to store them in wood blocks that fit inside the bins.

the fence to sand to the desired depth and clamp it in place.

To produce identical notches, it's a good idea to carpet-tape the two sides together. Then, after turning on the drill press, start at the *right* end of the notch and push the workpiece into the drum sander until the "feet" contact the fence. Now slowly feed the workpiece from left to right to sand the edge smooth.

**Bottom & Back** – To complete each bin, I added a hardwood *bottom (H)* and *back (I)*. These pieces are assembled with ordinary butt joints. But first, be sure to pre-drill holes in the front (E) for the machine screws that hold the handle (Figure 5c). Then simply assemble the bins with glue and screws.

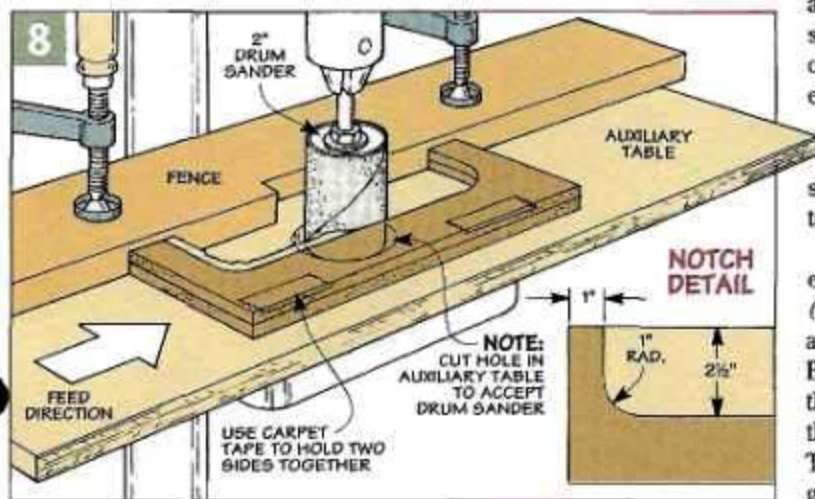

## Wall-Mounted Cleat

As you can see in the photos below, the racks and bins hang on a simple *cleat* that mounts to the wall.

To provide rigid support, the cleat consists of two parts: a hardwood *mounting plate (J)* and a metal rail made from aluminum angle bracket

(Figure 9). After drilling three shank holes in the rail, it's simply screwed to the top edge of the cleat.

**Determine Length** – Just a note about the length of the cleat. To hold all four hangers, the cleat shown here is 12" long. Since I planned to

screw the cleat directly to a wall covering made of fir plywood, I didn't have to worry about the screws hitting the wall studs. If you plan to fasten the cleat to wallboard, be sure to make it long enough to anchor it in the studs. 🛠️

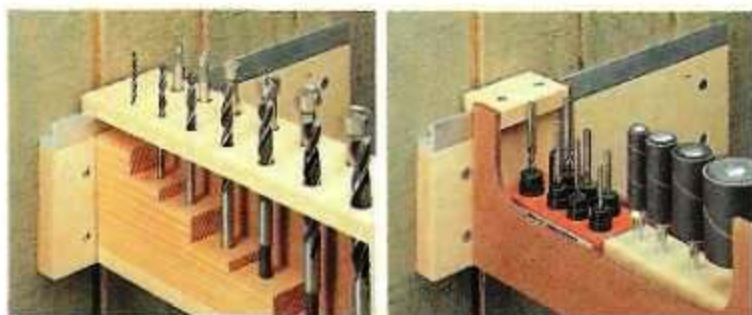
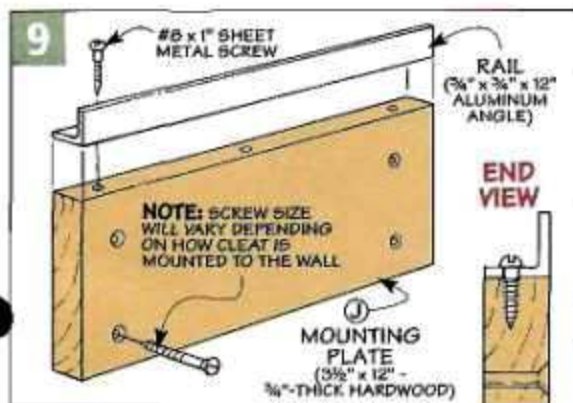

▲ **Cleat.** A two-part cleat that's made up of a hardwood mounting plate and a metal rail lets you hang each of the racks (left) and bins (right) on the wall. Just be sure to anchor the cleat securely to the wall.

# Power Sanding Systems

*A faster way of sanding . . . and a consistently smooth surface. Two reasons to sand a bowl with a power sander.*

There's nothing I like better than spending a few quiet hours turning a bowl on the lathe. What I don't like is all the sanding required to produce a smooth surface.

The problem has to do with the end grain surfaces of the bowl. Even when you use sharp tools and the proper turning technique, it's not unusual to tear out the wood fibers or end up with a slightly "fuzzy" surface.

**Power Sanding** - One way to save time when sanding the surface of the bowl is to use a *power sanding*



system. As you can see in the photo above, the idea of this system is simple. A sanding disk and a hand-held drill are used to sand the bowl as it spins around on the lathe.

Although it's a bit noisy, it's a *fast* method of sanding. (I can usually sand an average-sized bowl in about

twenty minutes.) Plus, it produces a consistently smooth surface — something I don't always get when sanding by hand.

**Two Types** - There are two basic types of power sanding systems. To mount the sanding disks, each one has a special *holder* that's tightened in the drill chuck. But the holders (and disks) are quite different from each other. So if you're considering buying a power sanding system, it's worth comparing the two types.

## POWER-LOCK

The most unique thing about the *Power-Lock* system is how the sanding disks attach to the holder.

**Snap-in Disks** - To see how this works, take a look at the two upper photos in the box at left. Each sanding disk has a ring of plastic tabs that snap into a recess in the holder. These tabs "lock" the disk in place, so they won't come loose while you're sanding. Yet it's still easy to change disks — just pull off one disk and snap another one in place.

**Rubber Backing Pad** - The sanding disks are backed by a flexible rubber pad. This allows the disks to follow the contours of the bowl. And since the pad is quite firm, you can actually sand aggressively enough to do a bit of shaping on the bowl.

**Cost** - The only drawback to this system is the cost. A kit that includes three sizes of holders (1½", 2", and 3" dia.) and a 150 sanding disks costs \$72.95. Replacement disks range from thirty-five to seventy-five cents depending on their size. Note: You

## POWER-LOCK



*Power-Lock.* The locking tabs on these sanding disks snap into a recess in a rubber backing pad. Although it's flexible, the pad is firm enough for minor shaping.

## HOOK & LOOP

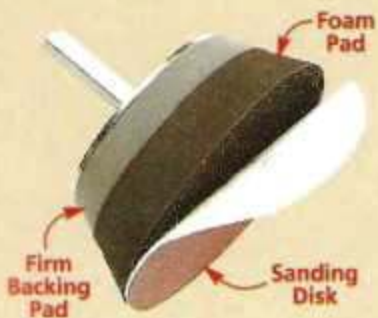

*Hook & Loop.* It only takes a second to change disks with this interlocking hook and loop system. Just press the disks (the loop) onto a soft, foam pad (the hook).

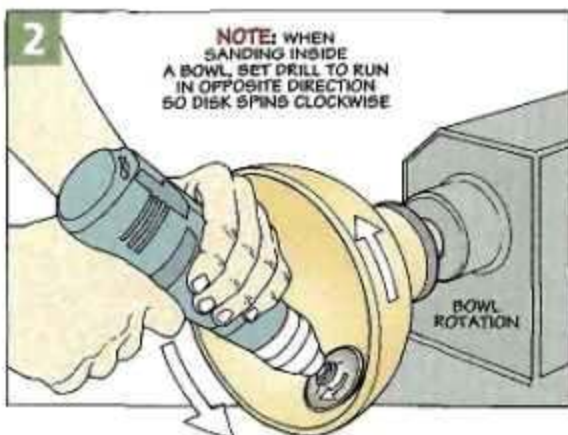
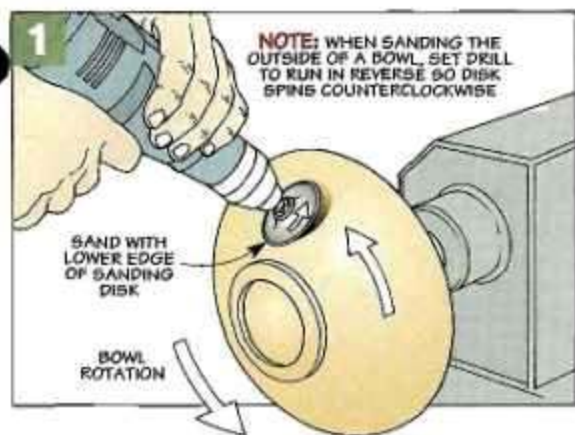

can also buy holders individually. (For sources, see page 31.)

### HOOK & LOOP

The second power sanding system might look familiar. The sanding disks are attached to the holder using an interlocking hook and loop system (hook and loop is similar to *Velcro*).

As you can see in the two lower photos on page 28, the holder has a soft, foam pad with hundreds of tiny "hooks." And the back of each sanding disk is filled with a fuzzy white material (the loops) that stick to the pad like a cocklebur. This makes it quick and easy to change disks. Just pull off one disk, slap on another, and then continue sanding.

**Foam Pad** – The foam pad is quite soft, so it conforms to the shape of the bowl as you sand. That doesn't mean you can't sand aggressively. It's

just not designed to do any shaping.

**Cost** – One thing you'll find is this system is less expensive (about \$60). This includes a 2" and 3"-dia. holder and 140 sanding disks. The nice thing about these disks is they only cost about half as much as the disks for the *Power-Lock* system — a big plus if you do a lot of sanding.

### POWER SANDING BASICS

Regardless of the system you use, the basics of using a power sanding system are pretty straightforward.

**Cordless Drill** – First of all, you'll want to use a *cordless* drill. That way, you won't have to worry about a power cord getting wrapped around a spinning bowl.

**Lathe Speed** – Another thing to take into consideration is the *speed* of the lathe. As a rule, I set the lathe to run at the same speed as when

turning the bowl to final shape.

**Disk Rotation** – Finally, be aware of the direction that the sanding disk is spinning around. To provide better control, the idea is to make the disk spin *opposite* the rotation of the bowl.

For example, if you're sanding the outside of a bowl, run the drill in reverse (Figure 1). This way, the sanding disk spins counterclockwise (against the rotation of the bowl). To sand the inside of a bowl, set the drill so the disk spins clockwise (Figure 2).

Either way, to remove material quickly, apply pressure against the bowl with the lower edge of the sanding disk. Then sweep the disk back and forth across the bowl.

Since these sanders are aggressive, be prepared for a cloud of dust. Also, it's a noisy process, so wear hearing protectors. (For a quieter "power" sander, see the box below.)



▲ The grit sizes on the sanding disks are hard to see. So to avoid using the wrong disk, I write the grit size on the back with a permanent marker.

## Grip-A-Disc Shear Sanding Tool

When smoothing the surface of a bowl, this *Grip-A-Disc Shear Sanding Tool* offers the best of both worlds — aggressive sanding *and* quiet operation.

Instead of a noisy drill, the sanding disk on this tool is "powered" by holding it against the spinning bowl. Surprisingly, this produces a smooth surface almost as quickly as a power sander.

To accomplish this, the sanding disk is attached to a holder that's mounted in a free-spinning arbor. Here again, an interlocking hook and loop system lets you change disks quickly.



**Angled Head** – Another thing I like about this sanding tool is the head can be tilted at an angle, as shown at right. By pivoting the head to one of nine angles, it makes it easy to sand hard-to-reach areas deep inside a bowl or under the rim.

**Cost** – The sanding tool costs about \$50 which includes a single 1½"-dia. holder and ten disks. (See page 31 for sources.)

# New Products



## Bullfrog Rust Blocker

■ It used to be a habit to give the tools in my toolbox a "once-over" every time I opened it. I'd check to see if any surface rust had started to form. This way, I could take care of the rust before it got worse.

But after trying out the three *Bullfrog* Rust Blocker products shown above, it's one habit I've quit. That's because Rust Blocker products *prevent* the rust from forming in the first place.

**How It Works** – To do this, Rust Blocker products contain vapor corrosion inhibitors (VCIs). I know, it sounds like something from a science fiction movie. But these VCIs are just tiny particles that are emitted from the product like a time-release capsule. As you can see in the photo of the package in the margin, the particles create a protective "umbrella" that seals moisture and air away from metal.

The VCIs actually bond to metal surfaces. But they don't affect the look and feel of your tools. Plus, you won't

have to worry about the VCIs leaving behind any residue that might affect the finish on a project. Last but not least, they're non-toxic and safe for the environment as well.

**Three Forms** – As you can see in the photos below, Rust Blocker is available in three forms: a short foam *strip* with an adhesive-backing, a small *cup*, and a perforated *shield*. They're designed to be used in an enclosed area. The size of this area determines which Rust Blocker you need to provide the necessary protection.

Regardless of which Rust Blocker you use, it starts to work as soon as you open the package. As a result, it won't last forever. To provide continuous protection, you'll need to replace it about once a year.

**Cost** – So how much do they cost? A set of six strips or a single cup is about \$7, and the perforated shield costs around \$10. In my book, that's a small price to pay to keep tools from rusting. (For sources, see page 31.)



▲ *Bullfrog* products emit microscopic VCIs to create a protective umbrella on metal surfaces.



**A. Strip.** To provide protection from rust in a small area (less than one cubic foot), use a Rust Blocker strip.



**B. Cup.** The small cup attached to the inside of this tool cabinet will handle areas up to ten cubic feet.



**C. Shield.** A perforated shield seals metal surfaces in large areas (up to 100 cubic feet) as in this toolbox.

## Spray Lubricant & Rust Blocker

If you let rust get the upper hand on tools with moving parts, the rust can "weld" the parts together. (The rusted hand drill shown at right is a perfect example.)

That's why I was interested in this *Bullfrog* Spray Lubricant and Rust Blocker. It loosens parts that are stuck together. Plus it helps prevent the parts from rusting again.

To accomplish this, it works in a similar way to the other Rust Blocker products. After spraying on the lubricant, it coats the metal with VCIs that protect against rust and corrosion for up to a full year.

Here again, the spray lubricant is non-toxic, and it's safe for the environment as well. (For sources of *Bullfrog* products, see page 31.)



# Sources

## PRODUCT INFORMATION

*ShopNotes Project Supplies is offering some of the hardware and supplies needed to build the projects in this issue. We've also put together a list of other mail-order sources that have similar hardware and supplies.*



### ▲ Power Sanding Systems

A power sanding system is a quick and easy way to sand a bowl on the lathe. The hook and loop and *Power-Lock* systems shown above and described in the article on page 28 use circular disks of sandpaper that attach to a holder. The holder fits into the chuck of a variable-speed, reversible drill.

Depending on your needs, each power sanding system can be purchased as a complete kit. Or you can simply buy the holders and sanding disks individually as you need them. The margin lists sources for both power sanding systems as well as the Grip-A-Disc Shear Sanding tool featured on page 29.



### ▲ Glue & Accelerator

In the article on page 12, we describe a technique for mounting a partially-turned bowl to a wood block. To attach the bowl securely without screws, we used an "instant" glue (above right). An accelerator (above left) speeds up the drying process so you can turn almost immediately. For sources, see the margin.



### ▲ Bowl Blanks

Turning a bowl like the one shown on page 12 starts with a bowl blank. One way to obtain a bowl blank is to buy one that's already cut to size. As you can see in the photo above, blanks are available in a number of different sizes (and types of wood). To prevent checking, the blanks are sealed on the edges and ends. Sources for bowl blanks are listed in the margin.



### ▲ Miter Gauge Fence Kit

*ShopNotes Project Supplies* is offering a complete hardware kit to build the Miter Gauge Fence featured on page 16. The kit includes all the hardware required to build the fence. All you need to supply is the plywood. If you want, you can purchase 32"-long pieces of T-track separately to build this project or other shop jigs and fixtures.

#### MITER GAUGE FENCE KIT

6853-100.....\$45.95

#### SINGLE T-TRACK, 32"-LONG

4502-024.....\$12.95

#### ON-LINE CUSTOMER SERVICE

- Access information about your subscription account.
- Find out if your payment has been received.
- Change your mailing address or your email address.
- Renew your subscription.
- Pay your bill.

[www.ShopNotes.com](http://www.ShopNotes.com)



### ◀ Rust Blocker

The war against rust never seems to end. But you can certainly win a few more of the battles by adding the *BullFrog* Rust Blocker products shown on the opposite page to your arsenal of weapons. To locate a dealer near you or to order direct, call *BullFrog* at 1-800-854-3146.

## MAIL ORDER SOURCES

**Craft Supplies**  
800-551-8876

*Bowl Blanks,  
Glue & Accelerator,  
Power Sanding,  
Grip-A-Disc*

**Lee Valley Tools**  
800-871-8158

*Glue & Accelerator,  
Bowl Blanks*

**Packard Woodworks**

800-683-8876

*Bowl Blanks,  
Glue & Accelerator,  
Power Sanding*

**Woodcraft**

800-225-1153

*Power Sanding*

## FREE Online Tips

If you'd like even more woodworking tips, the solution is simple. Just visit us at our website and sign up to receive a free tip via email every week.

[www.ShopNotes.com](http://www.ShopNotes.com)

## WoodNet

- 101 Woodworking Tips Online
- Woodworking Techniques
- Project plans you can download
- WoodNet Forum
- Power Tool Reviews

[www.AugustHome.com](http://www.AugustHome.com)

## Scenes from the Shop

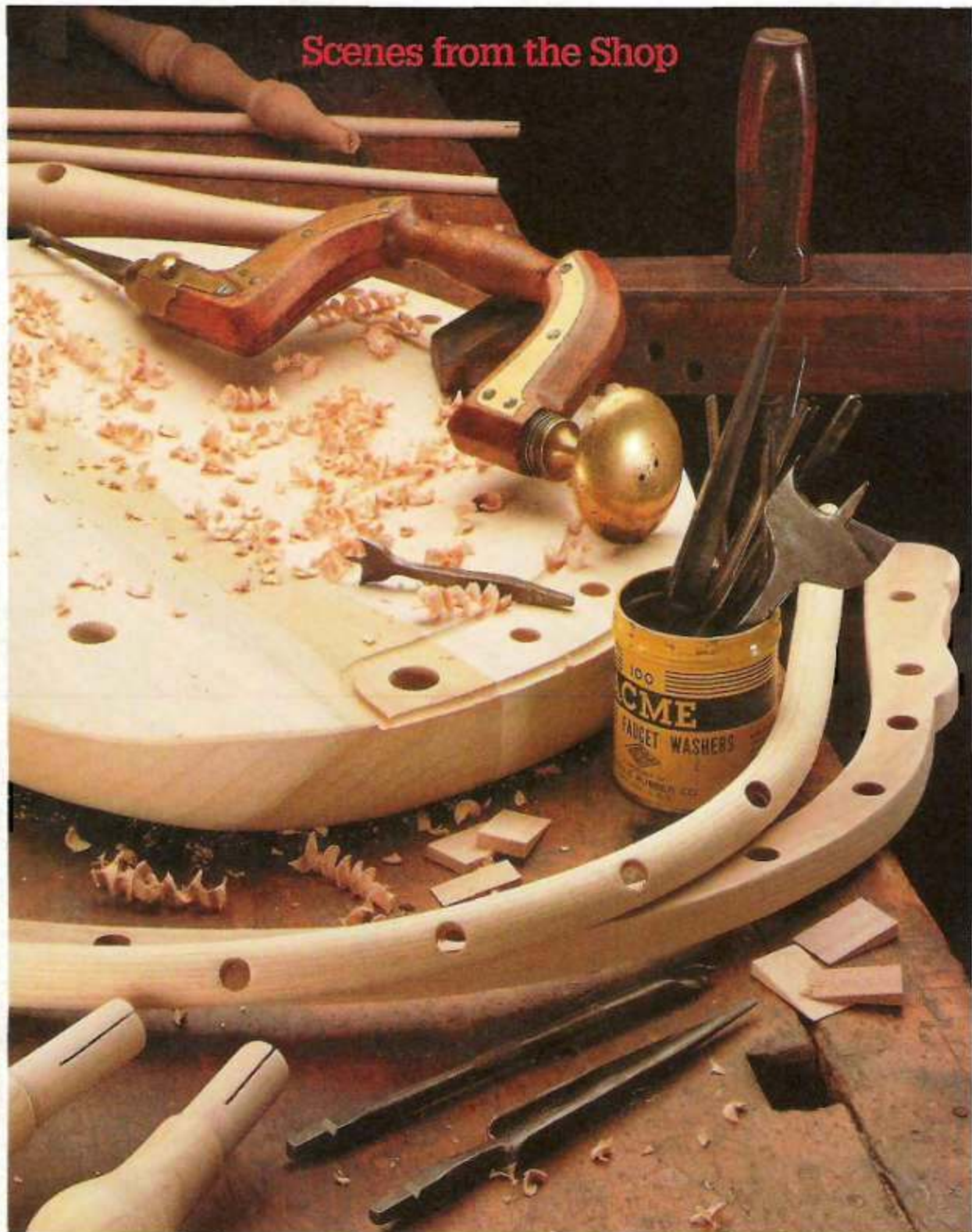

▲ In years past, a chairmaker used a wood brace and an assortment of bits to drill holes. The curved arm of this brace is made of solid beech, and it's strengthened by

thin, brass plates. To change bits, simply push a button on the side of the brace. This moves a spring-loaded latch inside the chuck that grips a notch in the end of the bit.