

# ShopNotes

Vol. 9

Issue 51

## Band Saw UPGRADE



### Features:

- ◆ Shop-built table provides support for extra-long workpieces
- ◆ Precision fence adjusts quickly and locks securely

- Hanging Storage Rack for Jigs
- Assembly Tips
- Fold-Out Magazine Rack
- Resawing Thick Stock

# ShopNotes

Issue 51

May 2000

**PUBLISHER** Donald B. Peschke  
**EDITOR** Tim Robertson  
**ASSOCIATE EDITOR** Tom Begnal  
**ASSISTANT EDITOR** Bryan Nelson  
**ART DIRECTOR** Cary Christensen  
**SR. GRAPHIC DESIGNER** Kurt Schultz  
**SENIOR ILLUSTRATORS** Roger Reiland  
 Mark Higdon

#### CREATIVE RESOURCES

**Creative Director:** Ted Kralicek • **Project Developer:** Ken Munkel • **Senior Project Designer:** Kevin Koyle • **Project Coordinator:** Kent Walsh • **Shop Managers:** Steve Carter • **Shop Craftsmen:** Steve Johnson • **Senior Photographer:** Cecelia England

#### SPECIAL PUBLICATIONS

**Executive Editor:** Douglas L. Heis • **Sr. Graphic Designer:** Chris Givens • **Graphic Designer:** Vu Nguyen, April W. Janning, Stacy L. Krul • **Asst. Editor:** Jon Irwin, Craig Hestegager, Joel A. Hess

#### CIRCULATION

**Sub. Serv. Dir.:** Sandy Baum • **New Bus. Dir.:** Gloria Butler • **Circ. Marketing Analyst:** Kris Schenauer • **Creative Mgr.:** Melinda Hallauer • **Business Mgr.:** Paige Rogers • **Sr. Graphic Designer:** Mark Hayes, Robin Dowdell • **Billing Mgr.:** Rebecca Cunningham • **Prod. Mgr.:** Rick Jenkins • **New Bus. Mgr.:** Todd L. Bierke • **Asst. Sal. Mgr.:** Joyce Krause

#### CORPORATE SERVICES

**Controller:** Robin Hutchinson • **Sr. Accountant:** Laura Thomas • **Accounts Payable:** Mary Seidels • **Accounts Receivable:** Margo Petrus • **Prod. Dir.:** George Chmelars • **Electronic Pub. Dir.:** Douglas M. Laska • **Network Admin.:** Kris Schwanzbeck • **Pre-Press Image Specialist:** Troy Clark, Michelle Johnson • **New Media Manager:** Gordon C. Galper • **Multimedia Art Dir.:** Eugene Pedersen • **Technology Analyst:** Carol Schoppert • **Web Site Product Specialist:** Adam East • **Web Content Manager:** Terry Walker, David Briggs • **H.R. Asst.:** Kirsten Koala • **Facilities Mgr.:** Julia Paul • **Administrative Asst.:** Sherri Ribbey • **Receptionist:** Jeanne Johnson • **Mail Room Clerk:** Lou Webber

#### MAIL ORDER

**Operations Director:** Bob Baker • **Customer Service Manager:** Jimmie Bross • **Warehouse Supv.:** Nancy Johnson • **Buyer:** Linda Jones • **Admin. Asst.:** Nancy Downey • **Tech. Rep.:** John Auletto • **Conf. Serv. Rep.:** Anna Cox, Tammy Trukenbrod, Deborah Cary, Dan Ewell, Jeannette Rankin • **Warehouse:** Sylvia Ribey, Dan Spidie, Cheryl Kunk

#### WOODSMITH STORE

**Manager:** Dave Larson • **Sales Staff:** Wendell Stone, Jim Barnett, Kathy Smith, Larry Morrison, Harold Cashman, Tim Rundell, Tim Deiss • **Office Manager:** Vicki Edwards

ShopNotes® (ISSN 1092-0696) is published bimonthly (Jan., March, May, July, Sept., Nov.) by August Home Publishing, 2200 Grand, Des Moines, IA 50312.

ShopNotes® is a registered trademark of August Home Publishing. ©Copyright 2000 by August Home Publishing. All rights reserved.

Subscriptions: Single copy: \$4.00. One year subscription (6 issues): \$21.84. Canada/International add \$10 per year, U.S. funds.

Periodicals Postage Paid at Des Moines, IA and at additional mailing offices.

Postmaster: Send change of address to ShopNotes, P.O. Box #7198, Boone, IA 50007-0198.

Subscription Questions? Write to: ShopNotes Customer Service, P.O. Box 842, Des Moines, IA 50304-0842. Or call 1-800-333-3034, 9:00 am to 5:00 pm, Central Time, weekdays. FAX 515-283-4447.

E-Mail: ShopNotes@shopnotes.com

Internet: <http://www.shopnotes.com>

PRINTED IN U.S.A.

# Cutoffs

Recently, I stopped by to visit Adolph, an old woodworking friend of mine. As usual, he was hunched over his bench, busily working on a project of some kind. When I took a closer look, I noticed he had clamped a hammer in the vise and was scraping the wood handle.

At first, it didn't occur to me to ask *why* he was scraping the handle. The thing that intrigued me was *how* he was doing it.

**Glass Scraper** - Instead of using a metal hand scraper, he was peeling off thin, lacy shavings with a piece of broken glass. It surprised me at first. But there was no getting around the fact that the jagged pieces of glass had a keen cutting edge.

Well, I couldn't wait to try it out, and it didn't take long to get the hang of it. After experimenting a bit, I was making shavings like I'd been using glass scrapers all my life. (If you try this at home though, I'd recommend wearing a pair of gloves.)

"Neat trick," I said, "But why go to all the trouble of scraping the handle on a hammer?"

"It's simple," he said. "I just finished putting a new handle on this hammer. It works okay, but it feels dead. By making the neck of the handle *thinner*, it gives it more spring and bounce. So I can whip the head of the hammer, get the job done quicker, and use a lighter hammer to boot."

Now to be honest, I didn't rush out and scrape the handles on all my hammers. But it got me thinking. A hammer is one of those tools that often gets taken for granted. In fact, the first thing that comes to mind is the old standby - a wood-handled



hammer with a curved claw.

**Must-Have Hammers** - Although a claw hammer is fine for general purpose work, it's not always the best tool for the job. Here in our shop, we use several different types of hammers for everything from nailing on the back of a cabinet to adjusting stationary tools. So we decided to take a look at these "must-have" hammers in the article beginning on page 12.

**Band Saw Table & Fence** - We're also featuring two simple projects in this issue that will help you improve the performance of your band saw. To provide better support for big workpieces, there's a large auxiliary table that mounts to the cast iron table of the band saw. And an adjustable fence will help you get more accurate results.

**Project Designer** - One final note. We're looking for someone who is enthusiastic about woodworking and home improvement to join our project design team here at August Home Publishing. This would involve designing projects for *ShopNotes* and two of our companion publications, *Woodsmith* and *Workbench*. If you're interested in this position, send a cover letter and resume to Ted Kralicek, 2200 Grand Ave., Des Moines, IA 50312.

Tim

# Contents

## Features

### Jig Storage Rack \_\_\_\_\_ 6

This ceiling-mounted rack provides the perfect solution for storing large or odd-sized jigs and fixtures. They're suspended from wire hangers that are bent to shape using a simple jig.



Jig Storage Rack page 6

### Four "Must-Have" Hammers \_\_\_\_\_ 12

Here's a close look at four different types of hammers that are useful to have in your shop. Also, step-by-step instructions for repairing or replacing damaged handles.

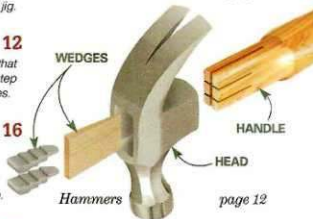

page 12

### Band Saw Upgrade \_\_\_\_\_ 16

Two shop-made accessories to help you get the most out of your band saw. An auxiliary table provides rock-solid support for large workpieces. And an adjustable fence makes it easy to produce accurate cuts every time.

### Resawing on a Band Saw \_\_\_\_\_ 24

Learn how to cut thick wood into thin stock on the band saw. Here are some simple tips, jigs, and techniques that will have you resawing lumber to uniform thickness in no time.

### Fold-Out Magazine Rack \_\_\_\_\_ 28

Do the plans in your woodworking magazines get covered up with clutter as you work? This shop-made rack holds them up off the bench and folds out for easy viewing.



Band Saw Upgrade page 16

## Departments

### Readers' Tips \_\_\_\_\_ 4

Our readers offer their own shop-tested tips dealing with some of the most common woodworking problems.

### Assembly Tips \_\_\_\_\_ 10

These five great tips ensure a squared-up assembly when you're gluing up a project.

### Sources \_\_\_\_\_ 31

Mail-order sources and supplies to help you build the projects featured in this issue.



Magazine Rack page 28

# Readers' Tips

## Miter Gauge Setup

■ Here's a quick way to set the miter gauge on your table saw to 45°. All it takes is a framing square and a little geometry. The idea is to form a right *isosceles* triangle using the framing square and miter gauge slot. (An isosceles triangle has two equal sides.)

Start by setting the framing square on top of the table saw. Now align the *same* increment on each leg of the

square with the edge of the miter gauge. (The 6" increment is shown in the drawing at right.)

Next, loosen the lock knob and gently snug the head up against the framing square as shown in the photo at left. The miter gauge is now set to exactly 45°. So after tightening the lock knob, you're ready to cut a perfect 45° miter.

Note: For accurate results, the saw blade must be parallel with the miter gauge slot. Also, check to make sure your framing square is truly square.

Bob Adams  
Greenville, North Carolina

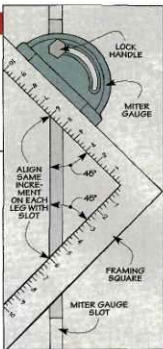

## Soaking Tube

■ I've made several of the fishing nets featured in *ShopNotes* No. 34. As you suggested, soaking the thin wood strips that make up the frame makes it easier to bend them around a form.

The only problem is the strips are over six feet long, and I didn't have a container that would keep them

completely immersed in water.

The solution occurred to me as I was working on a plumbing project — a long piece of PVC pipe with a cap glued on one end. As shown at left, you simply slip the strips into the pipe and stand it on end. (I use rubber straps to keep it from falling over.)

Now fill the pipe with water, and fit another cap (no glue) over the top. (This prevents the strips from bobbing up out of the water.) After letting the strips soak overnight, carry the pipe outside and dump out the water.

Bob Baker  
Des Moines, Iowa

## Driver Bit Face-Lift

■ It's frustrating when the tip of a Phillips driver bit gets chewed up and starts to slip in the screw head. Fortunately, there's an easy fix.

Rather than throw it away, touch the tip of the bit to a grinding wheel to remove the rounded shoulders. The sharp corners on the restored bit will engage the recess in the screw head and prevent the bit from slipping.

John Connors  
Omaha, Nebraska

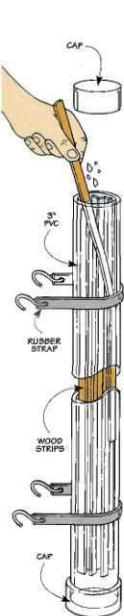
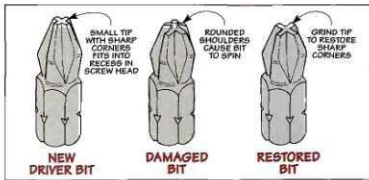



## Quick Tips



▲ Wax touch-up sticks come in handy when repairing a finish. To prevent the sticks from drying out, Dave Batzdorf of Candia, NH stores them in a plastic bag.



▲ To make a knob for a small shop drawer, Tom Blackwood of Crystal Lake, IL simply cuts the turned end off a clothespin and screws it in place.



If you ever grab the wrong screwdriver by mistake, try using this tip from G. Ross Darnell of Idaho Falls, Idaho. He just marks the type of tip (flat, Phillips, or square-drive) on the handle with typists' correction fluid.

## C-Clamp Handle



■ I often use a C-clamp when setting up a tool. But sometimes the sliding bar used to tighten the clamp gets in the way. Before each turn, I have to slide the bar all the way to the opposite side. That's a pain.

To solve the problem, I cut both

ends off the sliding bar and attached a wood handle to the remaining "stub." Now I can tighten the clamp with a few quick turns. (See photo.)

As shown in the drawing, the handle is just a dowel with a hole drilled in the end to accept the threaded screw. I also cut a notch in the handle to fit the stub.

After shaping the handle for a comfortable grip, a bit of epoxy is all that's needed to secure it to the clamp. But first, wrap the handle with tape to prevent the epoxy from leaking.

Adolph Peschke  
Des Moines, Iowa

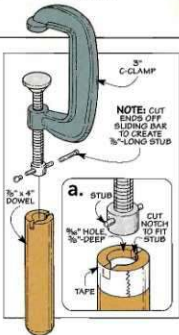

## Dry-Erase Board

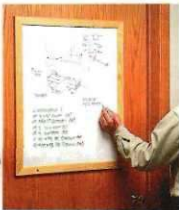

■ To sketch out an idea for a project or jot down a list of supplies, I made my own "dry-erase" board and screwed it to the door of my shop.

It's just a piece of Tileboard surrounded by a wood frame. Tileboard is 1/8" hardboard that's covered with melamine on one side. (It's available at most home centers.)

To make it easy to clean the board, be sure to use "dry-erase" markers. (You can buy these at most art stores.)

Kevin M. Bevins  
Summerville, South Carolina

## Send in Your Shop Tips

If you have a unique shop tip, we'd like to consider featuring it in one or more of our print or electronic publications.

We'll pay up to \$200 for a tip we publish. Just write down the tip and mail it to *ShopNotes*, Attn.: Readers' Tips, 2200 Grand Ave., Des Moines, IA 50312. Or FAX it to 515-282-6741, or send us an e-mail at [shopnotes@shopnotes.com](mailto:shopnotes@shopnotes.com). Please include your name, address and daytime phone number in case we have any questions.

### FREE Online Tips

If you'd like even more woodworking tips, the solution is simple. Just visit us at our website and sign up to receive a free tip via email every week.

[www.ShopNotes.com](http://www.ShopNotes.com)

# Jig Storage Rack



*Build this handy rack to hang jigs and fixtures . . . and learn how to make your own dowels in the process.*

Over the years, I've made all kinds of different jigs and fixtures to use with my tools. And like most woodworkers, I hang the jigs on the wall or stack them on a shelf until I'm ready to use them again.

Although this "system" works okay, there are a couple of drawbacks. For one thing, it takes up valuable space. Also, because the jigs are all different sizes and shapes, there never seems to be good way to store them.

To solve both problems, I made a

storage rack that attaches to the ceiling joists. As you can see in the photo above, the jigs hang from the rack like ornaments on a Christmas tree.

The jigs are suspended on metal hangers that hook onto the rack. Hanging the jigs like this not only takes advantage of the unused space near the ceiling. It also provides a lot of flexibility when it comes to arranging large or odd-shaped jigs.

**Hangers** – Just a note about the hangers. They're not something you'll

find at a hardware store. (At least not the *completed* hangers.) But don't worry, the hangers are easy to make. I used heavy-gauge wire and bent the hangers to shape using a simple jig. (For more information about this bending jig, turn to page 8.)

## RACK

At a glance, the rack looks like a set of monkey bars. If you look at Figure 1, you'll see that it's made up of two wood rails connected by dowels.

**Rails** – I began work by making the two rails (A). Each rail is a piece of "1 by" stock (pine) that's ripped to a width of 2 3/4". It pays to be a bit picky when selecting the lumber for the rack, it's best to use straight-grained lumber that's relatively free of knots.

After ripping the rails to width, it's just a matter of cutting them to length. The rails shown here are 56" long which allows them to span joists that are either 16" or 24" apart.

**Drill Holes** – The next step is to drill a series of 3/4" dia. holes in each rail to hold the dowels. To prevent the rack from twisting, it's important that the holes in each rail align. So as you can see in Figure 2, I used carpet tape to hold the rails together and then clamped a fence to the drill press table to position them accurately.

**Crossbars** – After drilling the holes, you can turn your attention to the crossbars (B) that connect the

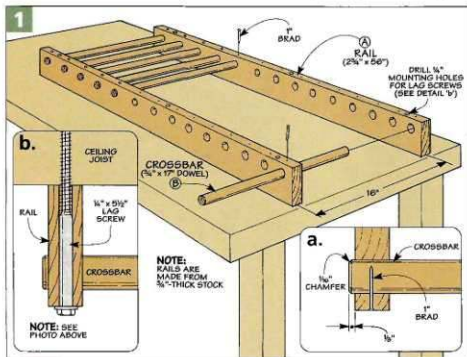

rails. To make it easy to hook the hangers on the rack, I used dowels for the crossbars.

At first, I thought about buying the dowels. But there are quite a few (fourteen altogether). Also, to provide plenty of strength, I wanted to use *hardwood* dowels. The only problem was the cost. (A  $\frac{3}{8}$ " maple dowel that's 36" long costs about \$2.40.)

So I made my own dowels as shown in the box below. Besides saving money, this gave me a chance to use some scrap pieces of wood that had been piling up in the shop.

With dowels in hand, the next step is to cut them to length. The dowels shown here are 17" long. This way, if your ceiling joists are 16" apart, the rack can be mounted *parallel* to the joists. If they're farther apart, just mount the rack *across* the joists.

**Sand Chamfers** – Before assembling the rack, there's one last thing to do. That's to sand a chamfer on both ends of each dowel. This eases the sharp edges, plus it will make it easier to assemble the rack.

To produce consistent chamfers on each dowel, I clamped a simple fence with a stop to the table of the disk sander. As you can see in Figures 3 and 3a, the fence is just a scrap piece of wood, and a dowel glued into a hole in the edge of the fence acts as a stop.

The idea is to position the fence at a 45° angle to the sanding disk. Also, check that the stop is close enough to the disk to produce a  $\frac{1}{16}$ " chamfer before clamping the fence in place.

Now turn on the disk sander, hold the dowel against the fence, and slide it forward. When it contacts the stop, rotate the dowel *counterclockwise* to sand the chamfer all the way around.

**Assembly** – After sanding all the chamfers, you can assemble the rack. Start by slipping the dowels into the holes in the rails. Then to prevent the dowels from rotating inside the holes, nail a couple of brads in each dowel as shown in Figure 1a. Once the rack is assembled, it's just a matter of drilling holes in the rails and mounting the rack to the joists with lag screws (Figure 1b).

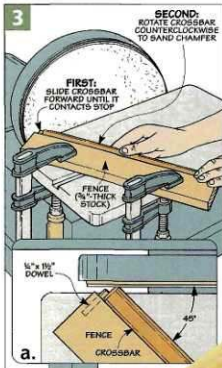
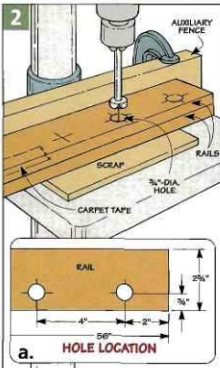

## Making Dowels

It's easy to make a dowel. All that's needed is a scrap piece of wood and a round-over bit.

**Setup** – Start with a blank that's the same width and thickness as the desired diameter of the dowel. For example, to make a  $\frac{3}{4}$ " dowel, use a piece of  $\frac{3}{4}$ " x  $\frac{3}{4}$ " stock.

The next step is to mount a  $\frac{3}{16}$ " round-over bit in the router table as shown in the drawings below. (The radius of the bit should be half the diameter of the dowel.) To get consistent results, the cutting edge of

the bit needs to be flush with the table and fence.

(I attached an auxiliary fence to "close" the opening around the bit.)

**Rout Corners** – After clamping a featherboard to the table, rout the waste off each corner of the blank. Then lightly sand the dowel to remove any mill marks.

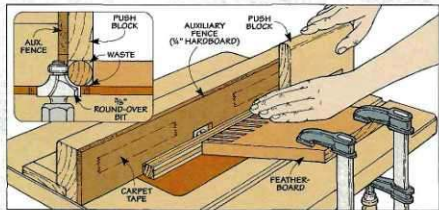





from slipping, I drilled a counterbore and pilot hole next to the groove and installed a washer and screw. As you can see in Figure 5, tightening the screw "clamps" the washer tightly against the wire.

**Lay Out** – At this point, you can lay out the curved shape on the end of the arm as shown in the Pivot Arm Detail in Figure 4. To produce the curved hook at the top of the hangers, the idea is to create a rounded knob that "blends" smoothly into a large, curved recess.

After laying out the basic shape with a compass, you'll need to drill a hole that's centered on the location of the round knob. This hole accepts the nail that serves as a pivot point for the arm.

Now you're ready to cut the arm to shape. A band saw (or sabre saw) makes quick work of removing the bulk of the waste. Then carefully sand up to the layout lines.

**Support Block** – Once the arm is completed, the next step is to add a short support block (E). This is just a scrap piece of  $\frac{3}{4}$ "-thick hardwood that provides a mounting surface for a plastic plate that's added next.

**Top Plate** – After gluing the support block in place, it's time to add the top plate. It's a piece of  $\frac{1}{8}$ "-thick Plexiglas that provides rigid support for the shank of the nail and the bolt.

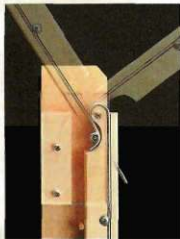

**A. Hook.** To form the hook at the top of the hanger, swing the pivot arm all the way around until it contacts the stop.

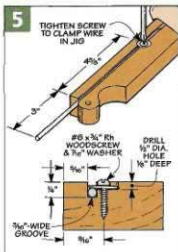

The nice thing about the clear Plexiglas is it makes it easy to see the hole in the arm when you slip the nail in place. After drilling holes to accept the nail (and bolt), just screw the top plate to the support block.

### MAKING THE HANGERS

With the bending jig complete, you're ready for the easy part — making the hangers.

**Cut Wire To Length** – Start by cutting a short length of wire for each hanger. I found that a 10" piece produced a hanger about 6" long which worked fine for me. One thing to be aware of is that when you cut the wire, it forms a sharp burr on the

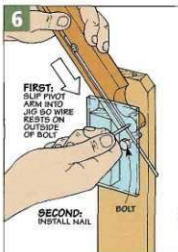

end. This burr will make a deep scratch on the arm as you bend the hanger. Plus it makes it difficult to fit the wire into the groove in the arm. So be sure to file off the burr.

**Insert Wire** – The next step is to work the wire down into the groove in the arm. (You'll need to straighten the wire to do this.) To produce the curved hook, the wire needs to project about 3" past the end of the groove as shown in Figure 5. Also, don't forget to tighten the screw that holds the wire in place.

**Install Pivot Arm** – At this point, you can tighten the jig in a vise and install the pivot arm. To do this, slip the arm between the base and the top plate and fasten it with the nail (Figure 6).

**Bend the Hook** – At this point, you're all set to bend the curved hook at the top of the hanger. The idea here is to swing the arm all the way around in a smooth, continuous motion until it contacts the stop. As you can see in photo 'A' at left, this provides all the leverage that's needed to mold the wire around the curved part of the arm.

**Angled Bend** – Now all that's left is to make the angled bend at the opposite end of the hanger. To do this, remove the wire from the arm and slip the straight end into the hole in the top end of the jig. Then simply bend the wire around the angled corner of the jig as in photo 'B.'

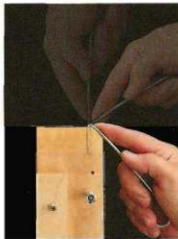

**B. Angled Bend.** Now fit the straight end of the wire in the hole and bend it around the angled corner of the jig.

# 5 Great Assembly Tips

## Frame & Panel Jig

■ Gluing up a frame and panel door so it ends up perfectly square can be difficult. The pieces always seem to slip out of square during glue-up.

To prevent this, I built the simple jig shown in the photo at right. It provides an accurate reference that makes it easy to square up the door.

A glance at the drawing shows that the jig consists of a plywood base that supports the door and two wood cleats that form a square corner. It's important that the cleats are 90° to each other. So start by attaching one cleat with glue and screws. Then use a framing square to position the second cleat as you glue and screw it in place.

To use the jig, start by placing each clamp directly over (and parallel to) the rails of the frame. Then, adjust the pressure and position of the clamps until the frame sits square in the jig.

Note: To prevent glue from sticking to the jig, I brushed on several coats of a polyurethane finish.

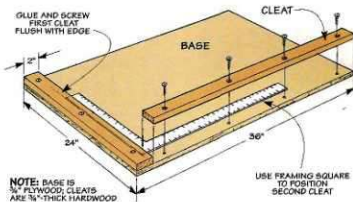
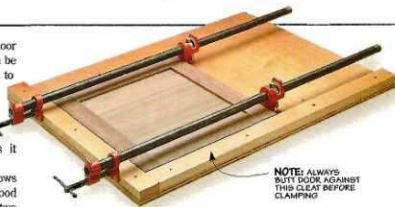

## Squaring a Mitered Corner

■ For some projects, like the mitered box shown in the drawing at right, a band clamp is the easiest way to hold the project together while the glue dries. But there is one small problem. The mitered corners tend to slip out of alignment as the clamp is tightened.

So in addition to the band clamp, I clamp short pieces of aluminum angle bracket to the *inside* of each corner to draw the miter together.

As you can see in the detail, filing a slight roundover on the outside corner of the bracket provides room for glue squeeze-out.

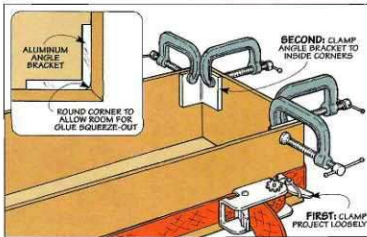

## Clamping Squares

■ The problem with assembling a large project is it's hard to keep it from racking after you add the glue and then try to screw it together.

As shown in the drawing at right, I solved this problem by making several plywood "clamping squares" that resemble a framing square.

When clamped in place, they square up the cabinet and hold the pieces in position.

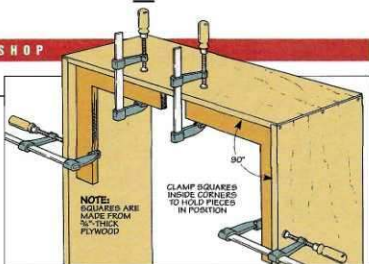

## Miter Joint Corner Clamp

■ It's a challenge gluing miter joints. There just isn't an easy way to clamp them together. The store-bought clamps I've tried in the past didn't always pull the joint together. So I came up with a shop-built corner clamp that uses wedges to push (or press) the mitered pieces together.

Looking at the photo and drawing

below, you can see that this corner clamp uses a piece of plywood for a base. Then a square block and two cleats are glued and screwed on top.

What's important here is that the inside corner of the square block is exactly 90°. Then align the inside edge of each cleat parallel with the inside edges of the block.

A pair of wedges sized to fit between the workpiece and the cleat does all the work. They apply pressure in two directions at the same time. When the inside wedge (the one contacting the mitered piece) is tapped forward, it pushes the joint tighter together and firmly holds the pieces in place while the glue dries.

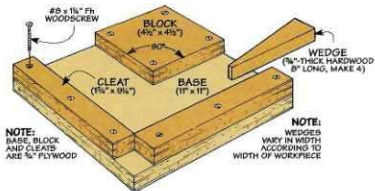
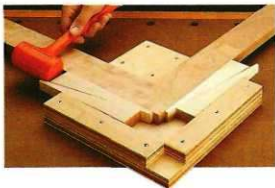

## Plywood Insert

■ Another way to square up a case is shown in the drawing at right. This method uses an insert made from a scrap of plywood that's sized to fit the *inside* of the case. To provide room for glue squeeze-out, I trimmed each corner of the insert at an angle.

To help hold the insert in place while you add the clamps, screw a pair of cleats across the top of the insert. After setting the insert in place, tightening the clamps squares the box around the insert.

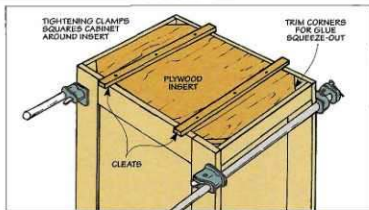

# Four “Must-Have” Hammers

There are “striking” differences between these four hammers. That’s why each one of these simple hand tools has earned its place in my toolbox.

## Claw Hammer

▲ **Claw Hammer.**  
For general purpose work, there’s no more versatile tool than an ordinary claw hammer.

Since a claw hammer is such a common tool, it’s easy to take for granted. But when it comes to driving in nails, yanking them out, knocking parts of a project together, or prying them apart, it’s hard to imagine a more versatile tool.

**Claws** – As you can see in the box below, there are two types of claw hammers: *straight* and *curved*.

A *straight claw* comes in handy when I’m working on a remodeling project. I just drive the claw between

two parts that are nailed together and rip them apart. But a *straight claw* isn’t much good for pulling out nails.

That’s where the *curved claw* comes in. When you apply pressure on the handle, the curved claw rocks back against the workpiece and levers out the nail. As you can see in the photo at right, placing a block under the claw provides even more leverage for pulling out long nails.

**Weight** – If you’re looking for a new claw hammer, one thing to consider is the *weight* of the head. They range in weight from 7 to 28 ounces. Although I can drive nails faster with a heavy hammer, it puts more strain on my arm, wrist, and hand. So I use a 16-ounce hammer for most work.

**Handle** – Another thing to keep in mind is the type of material used for the handle. I prefer a wood-han-



dled hammer. It’s resilient enough to absorb the shock of the blow. The only drawback is the hammer head eventually loosens up on the handle.

That’s not a problem with a fiberglass handle or a steel-bodied hammer. Just be sure they have a good quality rubber (or leather) grip to help cushion the blow.

## Which Claw?

A *straight claw* is great for ripping apart boards that are nailed together. But when pulling nails, you’ll get more leverage with a *curved claw*.



## Warrington Hammer

Here’s a hammer that I keep right by my bench. It’s called a *Warrington* hammer, and instead of a claw, it has a flat, wedge-shaped *cross peen* on the end of the head. After doing some checking around, I found out it’s named after the town in England where it was first manufactured.

**Cross Peen** – So what’s the big deal about a cross peen? In a word, it’s a finger-saver. To understand why, take a look at the photo at right. When I’m assembling a project with small nails or brads, the head of the nail barely sticks up above my fingers. So I often end up hitting my fingers instead of the nail.

But with this hammer, the cross peen slips *between* my fingers. As a result, I can tap the nail to get it started without hitting my fingers. Then I just flip the head around and use the striking face on the opposite end to drive in the nail.

**Side Strikes** – Another unusual thing about this hammer is there’s a striking face on *each side* of the head as well. These *side strikes* make it easy to pound in a nail when I’m working in close quarters.

**Weight** – Here again, Warrington hammers are available in a range of weights (3½, 6, 10, and 12-ounce sizes). I prefer a 6-ounce hammer. It’s just right for tasks like nailing on the



back of a cabinet or the wood strips used to hold a piece of glass in a cabinet door. Note: These hammers are available at some woodworking stores and from the sources on page 31.



▲ **Warrington.**  
A wedge-shaped cross-peen makes a Warrington hammer a great tool for driving small nails.



## Magnetic Tack Hammer



A simple idea that saves a lot of time and frustration. That's the reason I like this magnetic tack hammer. It makes it easy to hold a workpiece in position with one hand — and drive in a small nail or brad with the other.

**Split End** — If you take a look at the photo at left, you can see how this works. The tack hammer has a long slot in the head and a narrow "split" at the end. This split is what allows the end to be magnetized.

**Third Hand** — The magnetized end of the hammer holds the brad like a "third hand." As shown here,

this frees up one hand to stretch a web tightly across the chair rungs. A quick rap of the hammer sets

the tip of the brad in the rung. Then flip the head of the hammer and drive in the brad with the square end.

**Styles** — Just a note about different styles of tack hammers. Instead of the square striking face as shown above, some tack hammers have a round face. But I haven't found that the shape makes much difference.



**Tack.** ▲ A magnetic tack hammer lets you start tiny nails (or brads) with one hand.

## Ball-Peen Hammer



I often need a hammer designed for working with *metal*. That's when a ball-peen hammer comes in handy.

**Rounded Ball** — One thing that makes a ball-peen hammer so useful is the rounded *ball* on the end of the head opposite the striking face.

The ball is ideal for shaping soft metal. A good example is shown at left. The wood and metal parts of this project are held together with short pieces of brass rod. Here, the ball is being used to peen the ends of the rods over like a mushroom to draw the pieces together.

**General Purpose** — But aside from the ball, this hammer is a great general purpose tool. I use it for everything

from striking punches and cold chisels to setting the depth of a plane blade and knocking parts of a tool into alignment.

**Weight** — Once again, ball-peen hammers are available in a range of weights (4 to 32 ounces). I've found that an 8-ounce hammer like the one shown above handles most jobs.



**Ball-peen.** ▲ Whether you're shaping soft metal or knocking parts of a tool into alignment, a ball-peen hammer is just the ticket.

## Long-Nosed Claw Hammer

Quite frankly, this hammer *looks* funny. It has a long "nose," short claws, and a machined striking face on each side of the head (like a Warrington hammer).

But when I used it to help build a deck recently, I was impressed.

**Nose** — On several occasions, I had to pound nails into pieces that were partially obstructed by other parts of the deck. That's when the long nose came in handy — it provided the extra "reach" I needed.

**Nail Slot** — Another feature I liked is a recessed groove in the nose that holds a nail. With the nail in the groove (a magnet keeps it from falling out), I was able to hold boards in position with one

hand then start and drive nails with the other.

**Cat's Paw** — Even the claws are different. To dig out embedded nails (inset photo), the claws taper to a sharp point like the claws of a cat. And since the claws are quite short, it also increases leverage when pulling a nail.

**More Details** — In addition to all that, this hammer has a 13" long fiberglass handle, a 20-ounce head, and a rubber grip. All in all, it adds up to an excellent framing hammer. (A mail-order source is listed on page 31.)



## Quick Fixes

Let's face it. A hammer gets beat up with use. So it's bound to need a few fixes to keep it in "swing."

**Check the Face** – Over time, the striking face of a hammer gets dented or dinged. And sometimes rust and dried-on gunk accumulate on the face. Either way, it can make it hard to hit a nail squarely on the head.

All that's needed to clean up the face is a few *light* strokes with a file (Photo A). I also make it a point to "rough up" the face with sandpaper (120-grit). Since my aim *has* been known to be less than perfect, this helps prevent a misplaced blow from glancing off the head of the nail.

**Sharpen the Claws** – The claws of a hammer may also need attention. Pulling a lot of nails can round over the inside edges of the claws which means they won't grip as well.



▲ A utility knife is all it takes to trim off the frayed wood fibers at the base of the head.



1 To reseat the head of a hammer, start by rapping the end of the handle on a solid surface.

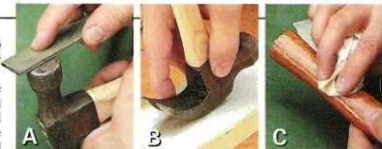

▲ **Tune-Up.** It only takes a minute to "tune up" a hammer. After filing the face smooth (Photo A), sharpen

the claws with sandpaper (Photo B). Then apply oil to keep the wood handle from drying out (Photo C).

The solution is to "sharpen" the claws. An easy way to do this is to rock the head back and forth on a sanding block until the edges are nice and sharp (Photo B).

**Oil Handle** – To improve the grip of the hammer, it's also a good idea to clean off any dirt and grime on the handle. Then after lightly sanding the handle, apply a couple

coats of linseed oil to keep the wood from drying out (Photo C).

### FIXING A LOOSE HEAD

Even with proper care, the wood handle may shrink and cause the head of the hammer to loosen up. This is annoying at best. But if the head flies off the handle, it's downright dangerous. So the few minutes it takes to fix a loose head is time well spent.

**Reseat the Head** – The idea is to *reseat* the head by driving it farther down on the handle. As you can see in Step 1 at left, several good solid raps on the end of the handle will set the head tightly in place.

**Drive in Wedges** – The next step is to use a punch to drive the metal wedge (or wedges) further down into the handle, as shown in Step 2. Be sure to set the wedge *below* the top of the head. This way, you won't have to worry about cutting into the wedge when trimming off the waste at the top end of the handle (Step 3).

**Trim Silvers** – One thing to note about this process is it may fray the wood fibers at the base of the head. If so, just trim off the wood slivers as shown in the margin.



2 To secure the head on the handle, drive the metal wedge below the top of the head.



3 Now trim off the waste sticking up above the head. Then sand the end of the handle flush.

### REPLACING A HANDLE

If the handle on a hammer cracks (or breaks), it's easy to replace. But first, you'll need to buy a new handle.

**Selecting a Handle** – There's a good selection of wood handles at most home centers. Usually, they're made of hickory which is a strong, resilient wood that helps absorb the

shock of a blow. I just pick a handle that's closest in size to the old handle. Most handles come with a hardwood wedge and one (or two) metal wedges, as shown in the drawing at right.

**Tapered Eye** – As you can see, there's a tenon on the end of the handle that fits into an opening in the head. (This opening is the *eye* of the hammer.) The eye is tapered on the sides *and* ends. This way, when you drive in the wedges, it spreads the tenon apart and creates a "jam" fit.

**Remove Old Handle** – Since it's such a tight fit, the only way to remove the old handle is to push it out the *top* end of the eye. To do this, simply saw off the handle below the head and then drive out the remaining waste, as shown in Step 1 below.

**Fit the Tenon** – The next step is to fit the tenon on the handle into the head. It doesn't have to be a snug fit. (The wedges will take care of that.) Even so, you want it to fit all the way in until the *shoulder* of the tenon "bot-

tombs out" against the head.

To accomplish that, slide the handle into the eye as far as it goes. If it rubs against the sides (or ends), remove the handle and file off a small amount of material (Step 2). Then just continue this trial and error process until you get a good fit.

**Trim Handle** – If you're satisfied with the fit, seat the head on the handle as before.

Then mark and remove the waste at the top end of the handle as in Step 3.

**Cut Kerfs** – Before installing the wedges, there's one more thing to do. That's to remove the handle and cut two kerfs for the metal wedges, as shown in Step 4. (The kerf for the wood wedge will already be cut in a new handle.) The kerfs will make the wedges easier to install and prevent them from "following" the grain of the handle.

**Install Wedges** – Now all that's left is to slide the handle back into

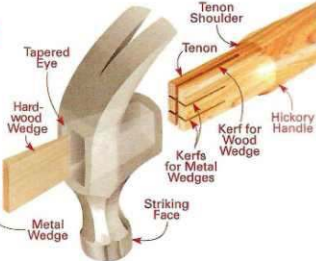

the head and install the wedges. Start with the wood wedge, tapping it in as far as you can (Step 5).

After trimming off the excess, it's just a matter of driving in the metal wedges. To spread the handle apart evenly, alternately tap one wedge, then the other, as shown in Step 6. Don't worry if the wedges don't go all the way in. Just trim off the excess with a hack saw and file them flush with the top of the head. 



**1** To remove the waste in the eye, place the head over an open vise and use a bolt as a punch.



**2** A file will help speed up the process of fitting the tenon on the handle into the eye of the head.



**3** With the head "seated" on the shoulder of the tenon, mark the waste at the top end of the handle.



**4** After trimming off the waste, cut kerfs for the metal wedges at 90° to the kerf for the wood wedge.



**5** Now fit the head back onto the handle, tap in the wood wedge as far as it goes, and trim the waste.



**6** To spread the handle apart evenly inside the head, alternately tap the metal wedges into place.

# Band Saw Upgrade

*Make your band saw even more versatile by building this large, auxiliary table and a precision fence.*

I only had one regret after building this auxiliary table and fence for my band saw — I wish I'd done it sooner. If you take a look at the photo above, it's easy to see why.

**Large Worksurface** — First of all, the table creates a large work-surface that's about *three* times larger than the cast iron table on my band saw. This provides plenty of extra support when making a curved cut. Plus I can rip (or resaw) a long board without having it tip off the back edge of the saw.

The table is designed to mount to the cast iron table on the band saw. By looking underneath the band saw as in the inset photo above, you can see how this works.

To keep the auxiliary table from shifting around, a simple system of wood cleats surrounds the cast iron table. Tightening a set of small wood blocks against the cleats holds the auxiliary table securely in place.



**Adjustable Fence** — As much as I like the large table, the thing that's made an even more significant improvement to my band saw is an adjustable fence. It provides a quick way to produce a straight, accurate cut. And I don't need to fiddle with clamps to lock the fence in place.

The fence rides on a metal rail that attaches to the front of the table. To position the fence, simply slide it along the rail until it's the desired distance from the band saw blade. Then as you can see in photo 'A' below, turning a single knob allows you to lock the fence securely on the rail.

This fence also solves another nagging problem that often crops up when working on a band saw. That's the tendency of the blade to "pull" the workpiece at an angle during a cut. (This is called drift.) To compensate for this, the metal rail can be adjusted so the fence matches the angle of drift.

**Stop/Pivot Block** — Just one more note about the fence. There's a T-shaped slot on the front of the fence that accepts a simple accessory. As you can see in the photos at left, it serves two different purposes.

First, it acts as a stop which comes in handy when cutting tenons. Second, the rounded edge of the block can be used as a pivot point when resawing. (For more information on resawing with a pivot block, refer to page 27.)



**A. Fence Clamp.** The band saw fence has a built-in clamp that's locked in place with a plastic knob.



**B. Stop/Pivot Block.** An adjustable block does double duty as a stop (left) and a pivot block when resawing (right). Tightening a knob clamps the block on the fence.



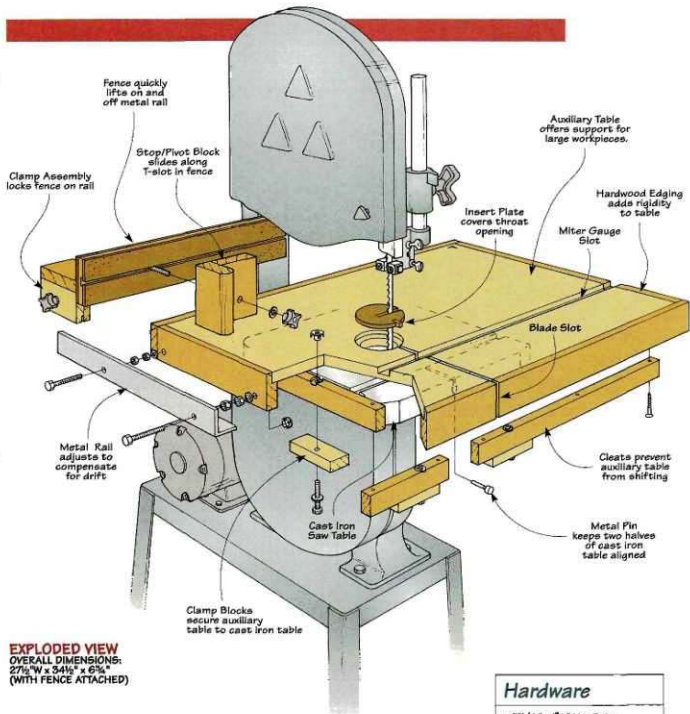

**EXPLODED VIEW**  
**OVERALL DIMENSIONS:**  
 27½" W x 34½" x 6¾"  
 (WITH FENCE ATTACHED)

## Materials

### Auxiliary Table

A Top (1)	22½" x 31½" - ¾" MDF
B Fronts/Back Edging (2)	¾" x 2½" - 22½"
C Side Edging (2)	¾" x 2½" - 32"
D Long Cleats (2)	¾" x 3¼" - 30½"
E Short Cleats (2)	¾" x 1¼" - 14"
F Clamp Blocks (6)	¾" x 1½" - 4"
G Insert Plate (1)	2½" x 2½" - ¼" Hdbd
H Alignment Key (1)	½" x ¼" - ¾"

### Adjustable Fence

I Core Piece (1)	½" x 3" - 20"
J Faces (2)	3" x 2½" - ¼" Hdbd
K Fence Support (1)	1½" x 4" - 10"
L Rear Jaw (1)	½" x 2½" - 4"
M Front Jaw (1)	¾" x 2½" - 4"
N Support Block (1)	¾" x 3" - 4"
O Stop/Pivot Block (1)	¾" x 2" - 4"

## Hardware

- (5) ¼" x 1½" Hex Bolts
- (2) ¼" x 1½" Machine Bolts
- (2) ½" Lock Nuts
- (2) ¼" Hex Nuts
- (8) ¾" Washers
- (12) #8 x 1½" Fh Woodscrews
- (2) #8 x 1½" Fh Woodscrews
- (1) ¼" x 1½" Toler Bolt
- (1) ¼" Star Knob w/thru hole
- (1) ¼" Star Knob w/¼" stud
- (8) ¼" T-Nuts (w/prongs)
- (1) 1½" x 1½" - 17½" Angle Iron (½" thick)

## Table

There were a couple of challenges when it came to designing the table. First, it had to be rigid enough to support a heavy workpiece. At the same time, I wanted a simple way to attach it securely to the band saw.

To get an overview of the solution, take a look at Figure 1. For starters, the table is made of  $\frac{3}{4}$ " medium-density fiberboard (MDF) that's surrounded by wide strips of hardwood. Attached to the bottom of the table are narrow cleats that fit over the cast iron table like the lid on a trash can. Mounting a set of small blocks to the cleats holds the table in place.

With the table in this position, it doesn't butt up against the column of the band saw. Instead, the table sits about 1" away as shown in Figure 2. This space provides plenty of clearance to tilt the table.

**Table Size** – The first step in building the table is to determine its overall size. Of course, it should be big enough to provide support for a large workpiece. But don't get carried away. If the table is too wide (or long), it will be a hassle to work around.

**Design Note:** The table shown here is  $23\frac{1}{2}$ " wide by 32" long. It's sized for a 14" band saw (the dis-

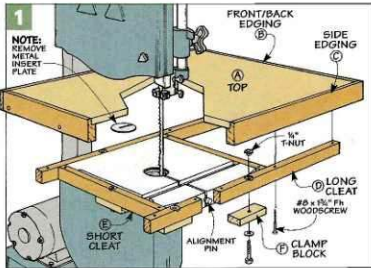

tance from the band saw column to the blade). Depending on your band saw, you may want to modify the size.

**Start with the Top** – With that in mind, you're ready to get started on the top (A) of the table. As I mentioned, it's made from  $\frac{3}{4}$ " MDF. This is a flat, stable material that won't warp or twist, so it's ideal for the top.

If you look at the Side View in Figure 2, you'll notice the top fits into rabbets in the edging strips. The rabbets are  $\frac{3}{8}$ " wide, so you'll want to

cut the top  $\frac{3}{8}$ " smaller than the overall size of the table in width and length (twice the width of the rabbets).

**Add the Edging** – The next step is to add the front/back (B) and side edging (C) strips. These are pieces of  $\frac{3}{4}$ "-thick hardwood that cover the exposed edges of the top. Plus, they add rigidity to the table. You can go ahead and cut the rabbets in the top edge of each strip to hold the top. Then, to allow the edging strips to fit together, you'll also need to cut a rabbet in both ends of each piece as shown in the Top View in Figure 2.

At this point, you're almost ready to attach the edging. But first, to accept a pair of T-nuts that are part of the fence system, it's easiest to drill two holes in the strip of edging that attaches to the front of the table.

**Cleats** – After tapping in the T-nuts and gluing on the edging, you can turn your attention to the cleats. The goal is to get the cleats to fit snugly around all four sides of the cast iron table. Figure 3 shows an easy way to do this. Just turn the auxiliary table upside down and use the band saw's cast iron metal table as a guide to position the cleats.

This requires removing the metal table from the band saw. (I only had to unscrew two knobs to do this.) Then lift off the table and set it

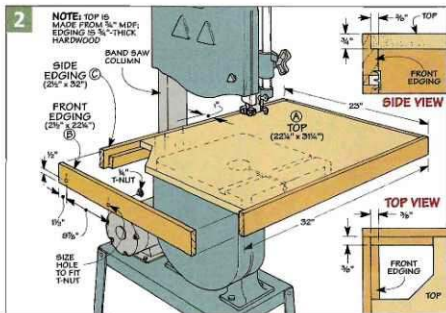

upside down on the auxiliary table as shown in Figures 3 and 3b.

With the table in this position, it's time to add the cleats. One thing to note is the *width* of the cleats. As you can see in Fig. 4a, they're narrower (shorter) than the height of the cast iron table. (I made them  $1/16$ " narrower.) This way, when the clamp blocks are installed later, they'll exert pressure against the metal table.

Now it's just a matter of ripping enough  $3/4$ "-thick hardwood stock to width for the cleats and then cutting them to length. Two *long cleats* (D) span between the front and back edging strips, and two *short cleats* (E) are cut to fit between them. Note: Later, the long cleat on the side of the table with the narrow blade slot will be separated into two pieces, but don't cut it just yet. There's still some work to do on the cleats.

**T-Nuts** – First of all, to accept bolts that apply pressure on the clamp blocks, you need to install several T-nuts. Notice in Fig. 3a that the head of each T-nut sits in a recess formed by drilling a counterbore in the top edge of the cleat. You also need to drill a shank hole that's sized to accept the barrel of the T-nut. Note: You'll need to install *two* T-nuts in the long cleat that spans the blade slot, one on each side of the slot.

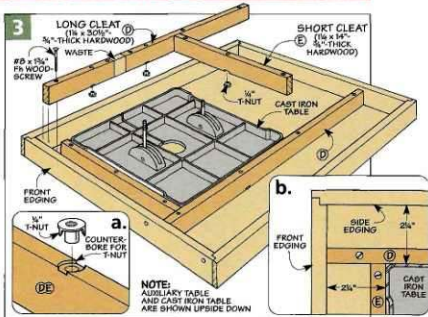

Before attaching the cleats, there's one more thing to do. As I mentioned earlier, a section of the long cleat next to the blade slot has to be removed. This will provide clearance when you install (or remove) the pin that keeps the two halves of the metal table aligned. To provide plenty of knuckle room, I trimmed off a  $1 1/2$ "-long section that's centered on the blade slot.

**Install Cleats** – Now you're ready to install the cleats. Be sure to

tap the T-nuts in first. Then just screw the cleats to the table.

**Clamp Blocks** – With the cleats in place, you can turn your attention to the *clamp blocks* (F) that are used to secure the auxiliary table to the cast iron table on the band saw. These clamp blocks are highlighted in Figure 4. They're just scrap pieces of  $3/4$ "-thick hardwood that exert pressure against the metal table.

All it takes to produce this pressure is a simple bolt. As you can see in Figure 4a, the bolt passes through a hole drilled in each clamp block and threads into the T-nut in the cleat. Tightening the bolt pinches the clamp block against the metal table which holds the auxiliary table firmly in place.

**Layout** – After installing all the clamp blocks, I took a minute to mark the centerpoint of the throat opening on the auxiliary table. (This is shown in Figure 4c.) Later, this will ensure that the hole that forms the throat opening in the auxiliary table aligns with the opening in the metal table.

While you're at it, mark the location of the blade slot on the auxiliary table. This is just a matter of drawing a pencil line that's centered on the existing blade slot (Figure 4b).

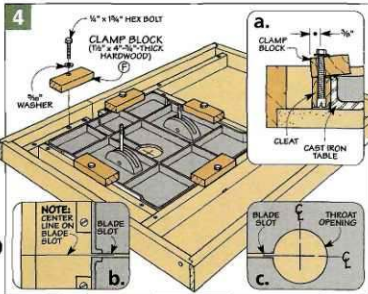

## Insert Plate

Aside from its large size, this auxiliary table has a number of things in common with the cast iron table. A quick glance at Figure 5 will show you what I mean.

As with the metal table, a circular throat opening provides clearance when changing blades. To prevent small pieces from tipping into this opening, a removable insert plate fits down into a recessed lip.

You'll also notice a long, narrow kerf that lets you slip the blade in and out of the opening. In addition, there's a groove in the top of the table that holds the miter gauge.

**Note:** Be sure to remove the clamp blocks and cast iron table before making any of these cuts.

**Throat Opening** – There isn't anything tricky about making the throat opening, especially since you've already located the centerpoint of the opening. (It was marked earlier on the bottom of the table.) So all that's needed is to drill a large hole through the table.

The best way I found to do this is to use a hole saw chucked in a hand-held drill as shown in Figure 6. I bought a 3"-dia. hole saw just for this purpose. Although it cost about twelve dollars, the hole saw produced a nice, clean cut. Just be sure

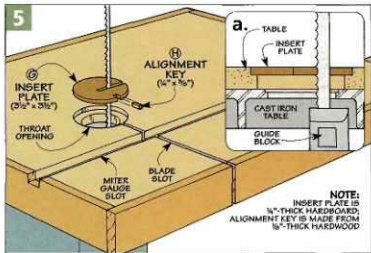

▲ A disk-shaped insert plate covers the throat opening. To prevent it from rotating, a wood "key" fits into the blade slot.

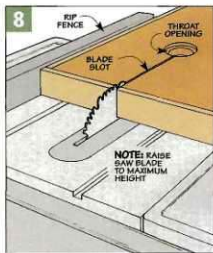
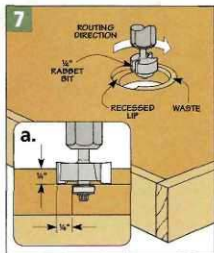
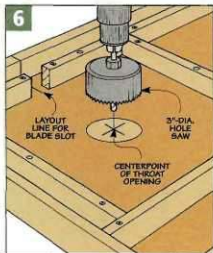

to use a backing board underneath so there's no tearout on the top surface of the table. (For sources of hole saws, refer to page 31.)

Even with a backing board, the rim of the hole may be a bit fuzzy. But that's okay. Any roughness will be cleaned up when making the lip that holds the insert plate.

As shown in Figure 7, I used a 1/4" rabbet bit in a hand-held router to form the recessed lip. The idea is to adjust the depth of cut to match the thickness of the material used for the insert plate. (I used 1/4" hardboard.) Notice in detail 'a' of Figure 7 that the bearing of the bit rides against the side of the hole while the cutting

edge creates the recessed lip.

**Blade Slot** – Once the throat opening is complete, the next step is to make the narrow slot that lets you slip the blade in and out of the table. To prevent the blade from twisting, it's important that this slot aligns with the one in the cast iron table underneath. So carefully extend the layout line for the blade slot (marked earlier) to the outside face of the edging on the side of the table.

As shown in Figure 8, I used the table saw to cut the blade slot. A single kerf is all that's needed to provide clearance for the blade.

To produce an accurate cut, position the rip fence so the kerf is centered



on the layout line. Then lock the fence and raise the blade all the way up. After turning on the saw, hold the table against the fence and slide it forward until the blade cuts into the throat opening. Now turn off the saw and wait until the blade stops spinning before backing out the table.

**Insert Plate** - After cutting the blade slot, the next step is to add the insert plate. This is a  $\frac{1}{4}$ " hardboard disk that fits into the recessed lip in the throat opening.

At first, it might seem difficult to make a disk that's the exact size and shape of the opening, but it's really quite simple. To get started, all you need is a square blank that's the same size as the diameter of the opening. (I cut a  $3\frac{1}{2}$ "-square blank and then used a compass to draw a circle of that same diameter.)

If you look at the Insert Plate Detail in Figure 9, you'll notice there are two saw kerfs in the blank. A long kerf creates an opening for the saw blade. Later, the short kerf holds a wood alignment key that fits into the blade slot in the table.

Each kerf is centered on one side of the blank. A quick glance at Figure 9 shows an easy way to accomplish this. Just set the blank against a block that's clamped to an auxiliary fence on your miter gauge. After clamping the blank in place, adjust the blade to the correct height to cut one kerf. Then reposition the blank, reset the blade height, and cut the second kerf.

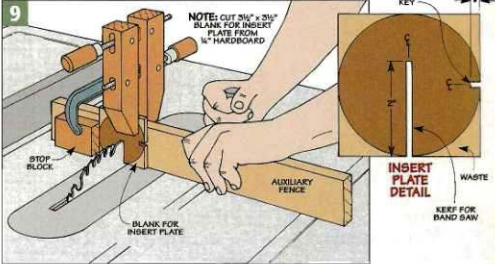

**Cut Insert to Shape** - Now it's just a matter of cutting the insert plate to fit the opening. To get a good fit, start by cutting it to rough shape first with the band saw. Then carefully sand up to the layout line, checking the fit frequently until the insert plate (G) fits just right.

**Alignment Key** - To prevent the insert plate from rotating in the throat opening, I added an alignment key (H). It's just an  $\frac{1}{8}$ "-thick scrap of hardwood that fits into the short kerf in the insert plate. The idea here is to cut the key to length so it extends about  $\frac{1}{4}$ " past the edge of the insert plate. Once the key is glued in place, the end that sticks out fits into the blade slot and holds the insert plate so it can't turn. (The photo on page 20 gives you an idea of how the key

"locks" the insert plate in place.)

**Miter Gauge Slot** - All that's left to complete the table is to cut a slot that accepts the bar of the miter gauge. As shown in Figure 10, a table saw and dado blade make quick work of this. But before you get started, there are a couple of things to consider.

First, when determining the location of the slot, be sure to check for clearance between the head of the miter gauge and the blade. I made it a point to align the slot in the auxiliary table with the slot in the cast iron table as shown in Figure 10a.

Another thing to keep in mind is the size of the slot. To match the thickness of the miter gauge bar, it's  $\frac{3}{8}$ " deep. As for width, the goal is to create a smooth, sliding fit without any play. To ensure a good fit, you'll want to make a test cut first before cutting the slot in the table.

**Mount Table** - Once the miter gauge slot is completed, you're ready to mount the auxiliary table on the band saw. Just a note here. It's a good idea to remove the metal throat plate on the band saw. This will prevent dust from piling up between the two tables. Then simply set the auxiliary table in place and tighten the clamping blocks.



▲ To produce accurate results, the miter gauge bar should slide smoothly in the slot without any "play."

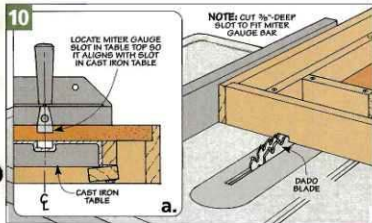

## Adjustable Fence

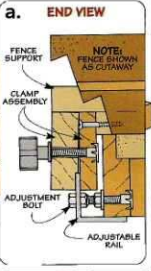
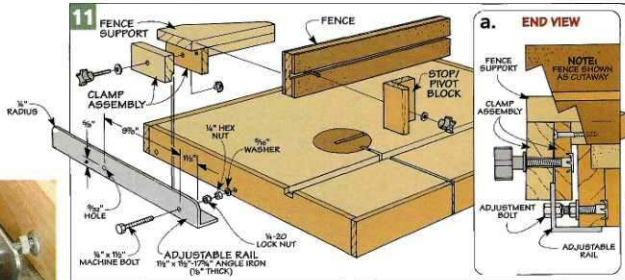

▲ The bolts that hold the rail to the table are also used to adjust it. Here, a quick turn of one of these bolts adjusts the fence for drift.

It's easy to get spoiled by the fence on this band saw table. It adjusts quickly, locks tight, and provides sturdy support for a workpiece. But there's more to it than that. If the blade isn't cutting in a perfectly straight line (drift), the fence can be adjusted to compensate. (For more about this, look at the box below.)

**Adjustable Rail** - The key to making this work is an adjustable rail

attached to the front of the table. As you can see in Figure 11, the rail is a piece of angle iron with the sharp, upper corners rounded with a file.

To make the rail adjustable, it's held in place with two bolts that pass through holes in the angle iron and into the T-nuts already installed in the table (Figure 11a). There's a lock nut on each bolt that's "snugged" against the rail. This way, when you

adjust the bolt, it moves the rail in or out (see margin). Tightening a hex nut against the table prevents the rail from accidentally getting bumped out of adjustment.

## FENCE

After installing the rail, you can concentrate on the fence.

**Size** - To provide plenty of support, the fence is 3" tall. It's also fairly short (20"). In fact, the fence only extends a short distance past the back of the blade. But since it only needs to guide the workpiece up to the blade, that's all that's needed.

**Three Layers** - One thing you'll notice in Figure 12 is the fence consists of three layers of material: a 1/2"-thick hardwood core sandwiched between two 1/4" hardboard faces.

There are two reasons for this layered type of construction. First, it makes it easy to create a T-shaped slot in the fence. (Later, this slot accepts a toilet bolt that lets you attach an accessory to the fence.) Second, it reduces the chance of the fence warping or twisting with changes in humidity.

To form the T-slot, start by cutting a wide, shallow groove in the core (1) as shown in Figure 12a. In order to center the groove, I made two

## Adjusting the Fence

One of the handiest features of this band saw fence is an adjustable rail. By moving the end of the rail in or out, you can change the angle of the fence to compensate for drift.

**Trial Cut** - To figure out the angle of drift, you'll need to make a trial cut. (We've included more information about this in the article on page 26.)

**Adjust Fence** - Once you know the angle of drift, simply "back off" the nut from the band saw table and turn the adjustment bolt. As you can see in the detail, this moves the rail closer to (or farther from) the table. It's this movement that changes the angle of the fence. To "lock in" the adjustment, simply retighten the nut.

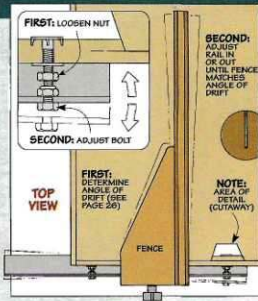

passes, flipping the workpiece end for end between each one. Then just glue on both faces (J), trim the edges flush, and complete the T-slot as shown in Figure 12b.

**HEAD**

Although the fence is complete, there's no way to connect it to the rail. That's where the *head* comes in. If you look at Figure 11, you'll see it consists of two parts: a triangular-shaped *support* attached to the back of the fence and a two-part *clamp assembly* that locks the fence on the rail.

**Fence Support** – To add rigidity, the *fence support* (K) is a thick block that's made by gluing up two pieces of 3/4" thick hardwood (Figure 13). A rabbet in the wide end of the support holds the clamp assembly. Also, to provide clearance for the column of the band saw, the fence support tapers toward the narrow end. I used the band saw to cut the support at an angle and then rounded the outside corner on the narrow end.

**Clamp Assembly** – After gluing on the fence support, you're ready to add the clamp assembly that locks the fence on the rail. As shown in Figure 13, it consists of two blocks: a *rear jaw* (L) made of 1/2" thick hardwood and a 3/4" thick *front jaw* (M).

One thing to note is there's a shallow rabbet in the front jaw. Notice in Figures 11a and 13a that

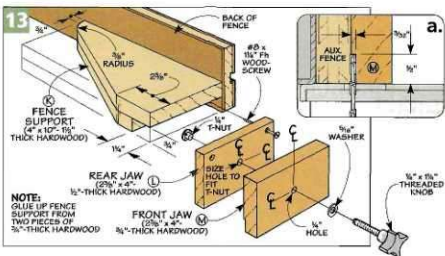
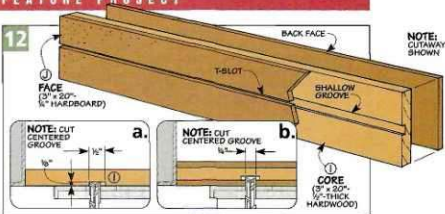

this rabbet is slightly *thinner* than the thickness of the rail. This way, when you tighten a knob, the two jaws pinch against the rail.

All that's needed to apply this pressure is a T-nut and a threaded

knob. The T-nut fits into a hole drilled in the rear jaw, and the knob passes through a hole in the front jaw and threads into the T-nut.

As far as mounting the clamp assembly, all that's needed is to screw the rear jaw to the fence support. Then thread the knob loosely in place to attach the front jaw.

**Stop/Pivot Block** – With the fence completed, I added a simple accessory. It does double duty as a *stop block* when cutting tenons and as a *pivot point* when resawing. To make it adjustable, it's attached to the fence with a toilet bolt that slides in the T-slot.

This accessory consists of two hardwood blocks: a sliding *support block* (N) and a *stop/pivot block* (O) with a radius on one edge (Figures 14 and 14b). After drilling a hole in the support block and routing a bullnose on the stop/pivot block (Figure 14a), the two blocks are glued together.

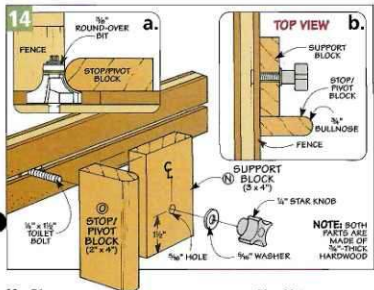

# Resawing on the Band Saw

*All it takes to make thin stock from a thick board is a band saw, a sharp blade, and a little know-how.*

**W**here do you get *thin* wood? If you're building a project requiring *thin* stock (less than  $\frac{3}{4}$ " thick), one of the quickest and easiest ways is to make your own by resawing a thick piece into two (or more) thin pieces.

Resawing is a lot like ripping. Only instead of placing the board with its wide face *down*, you stand it on *edge* and make the cut through the width of the piece.

**Thin Stock** - The biggest advantage of resawing your own lumber is it's an inexpensive (and readily available) source of thin stock. A good example is the thin, curved sides of the Shaker boxes shown in Photo 'A' below. They're made of  $\frac{1}{8}$ "-thick hardwood which is almost impossible to find at most lumberyards. And if you buy thin wood through a woodworking catalog, you'll probably pay a premium price.

**Bookmatching** - But making thin stock isn't the only reason to resaw. Photo 'B'



**A. Thin Stock.** The thin, curved sides of these Shaker boxes are simply resawn from thick stock.



**B. Bookmatching.** A resawn board can create a dramatic grain pattern with a mirror image on each side.



shows the striking grain pattern that can result when you resaw a board, open the two pieces like a book, and then edge-glue them together. (This is called bookmatching.) On the bookmatched panel of this chisel case, the pattern on the left side of the joint line looks like a mirror image of the pattern on the right.

Although there are several ways to resaw stock, I prefer using a band saw. As you can see in the photo above, it's an ideal tool for producing uniformly thin slices of wood. (It's shown here with the band saw table and fence featured on page 16.)

**Reduces Waste** - One of the benefits of using a band saw is the blade cuts a kerf that's only about half as wide as a table saw blade, so there's less waste. It may not seem like much. But if I'm working with highly-figured wood, getting one additional piece from a board is a big plus.

**Eliminates Kickback** - But the most important reason for using a band saw is safety. Since a band saw blade cuts with a continuous *down* stroke, it holds the workpiece against the table during the cut. So there's no chance for kickback like with a table saw.

## BAND SAW SETUP

Before you get started resawing, it's worth taking a few minutes to check that your band saw is running properly.

**Blade** - As a rule, I use a wider blade for resawing than for routine band sawing. A  $\frac{1}{2}$ "-wide blade is stiff enough to hold its shape while cutting through wide stock. As a result, it won't twist like a narrow blade.

Another thing to consider is the *tooth pattern* of the blade. What I've found works best is a blade with a *hook-tooth* pattern as shown in the box on page 25.

**Tracking** - After installing the blade, check to see if it "tracks" (shifts) toward the front or back edge of the wheels. To do this, start by increasing the blade tension



until the blade is stretched tight between the wheels. (Final tension is applied later.)

Now turn one of the wheels by hand a few times. If the blade tracks true, go ahead and tension the blade all the way. If the blade shifts, it's easy to correct. Most saws have a tracking knob (or screw) that lets you tilt the angle of the upper wheel. Just "tweak" this knob until the blade tracks evenly on both wheels.

**Apply Tension** – At this point, you can apply full tension to the blade. This is accomplished by raising the upper wheel to stretch the blade. Most band saws have a tension gauge which indicates an approximate setting. But these indicators usually aren't very accurate.

So how do you know if the blade is properly tensioned? The secret is to slowly increase the tension, "pluck" the blade like a guitar string, and *listen* to the sound. When it's properly tensioned, the blade will produce a clear, low tone.

**Thrust Bearings** – Once the blade is tensioned correctly, the next step is to adjust the thrust bearings. As you can see in Figure 1, there are

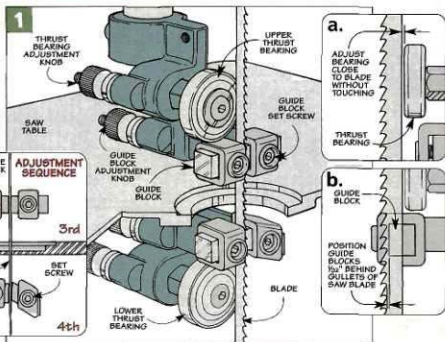

two thrust bearings, one above the table and one below.

The thrust bearings prevent a workpiece from pushing the blade *backwards* as you make a cut. This way the teeth can't come in contact with the guide blocks and ruin the blade.

As shown in Figure 1a, the thrust bearings are adjusted by moving them forward until they *almost* touch the back of the blade. (A gap about

the thickness of a piece of a paper is just right.) The blade should only touch the bearings and cause them to spin when it flexes back during a cut.

**Guide Blocks** – After tightening the thrust bearings, the next step is to adjust the guide blocks. There are two pairs of blocks (one above the table, and one below) that keep the blade from twisting during a cut.

For the blocks to do their job, they need to support as much of the blade as possible. As shown in Figure 1b, the idea is to move them forward so the front edge of each block is about  $\frac{1}{2}$ " behind the gullets of the teeth.

You'll also want to bring each guide block in close to, but not touching the blade. Notice in the margin that a slip of paper comes in handy here as well.

There's another thing to keep in mind as you adjust the guide blocks. If you set one pair of guide blocks first, and then the other pair, it's possible to shift the blade slightly to the left or right. Even a small amount of misalignment can cause the blade to bind or overheat. So I make it a point to adjust the upper and lower guide blocks on one side of the blade first, and then the other (Figure 1c).

## Hook-Tooth Blade

When resawing on a band saw, I use a  $\frac{1}{2}$ "-wide hook-tooth blade like the one shown here.

**Tooth Pattern** – One reason is a hook-tooth blade cuts more aggressively than a "standard" blade. If you look at the teeth on this blade, you'll see why—they point down a little (usually about  $5^\circ$  to  $10^\circ$ ). This creates a shearing cut that removes material quickly.

**Teeth per Inch** – Another thing to note is this blade only has *three* teeth per inch. Each tooth takes a big "bite," so to prevent the blade from bogging down, there has to be a way to remove the waste.

**Gullets** – That's the job of the deep, rounded gutlets between the teeth. By scooping out the waste, the gutlets allow the blade to cut quickly without getting too hot. (For mail-order sources of hook-tooth blades, refer to page 31.)

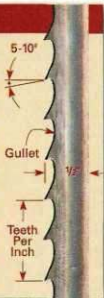

## Shop Tip



▲ To set the guide blocks quickly and accurately, use a slip of paper as a spacer.

## Fence Setup



At this point, the blade is installed and properly adjusted. Now all that's needed is to set up a fence to provide support for the workpiece. (If you only need to cut a few pieces, you may want to use a pivot block instead, as shown in the box on page 27.)

**Tall Fence** – When you resaw, the board rests on its edge. So the fence needs to be tall enough to keep it from tipping. The fence can be a simple scrap piece of wood clamped to the band saw table. Or you may want to build the fence and table that are shown here. (For step-by-step plans, turn to page 16.)

No matter which fence you use, the important thing is that the *face* of the fence is *parallel* to the blade. This will produce a resaw piece that's uniform in thickness across its width *and* from one end to the other.

So how do you end up with a piece that's consistent in thickness instead of a wedge-shaped board? The best way is to start by squaring up the table and fence, as shown in the photos in the margin.



▲ To ensure accurate results, square the table to the blade (upper photo). Then square the fence to the table (lower photo).

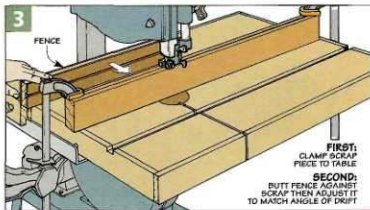
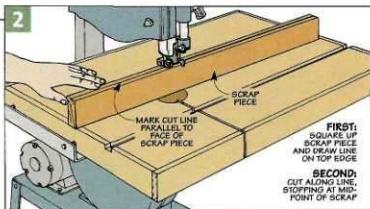

**Dealing with Drift** – Even after squaring up the table and fence, it still won't guarantee a straight cut. Almost every band saw blade I've used has an annoying tendency to "pull" the

workpiece at an angle when making a cut. (This is called drift.)

The problem is the teeth on the blade are bent outward (set) more on one side than the other. This causes

the blade to cut more aggressively on that side of the kerf, and this leads the workpiece off course.

There's no cure for an uneven set. But there is a simple solution. All you need to do is determine which way the blade is leading and then set the fence to match the angle of drift.

**Test Cut** – To do this, make a test cut in a scrap piece of wood *without* using the fence (Figure 2). Start by jointing one edge of the piece and marking a pencil line on the opposite edge. Then set the jointed edge on the table and cut along the line.

If the blade drifts to the right or left of the line, swing the tail end of the piece *toward* the direction of drift. Then continue feeding the workpiece steadily into the blade until you reach the approximate halfway point.

Now stop, turn off the saw, and without moving the scrap, clamp it to the table as shown in Figure 3. This is the "drift angle" of the saw blade. At this point, you can butt the fence

## Resaw Featherboard

To ensure a straight cut when resawing, I made a featherboard that applies *gentle* pressure against the workpiece and holds it flat against the fence.

As you can see in the drawing below, the *featherboard* is a piece of  $\frac{1}{8}$ "

hardboard with flexible "fingers" that are formed by bandsawing a number of thin kerfs. I also sanded a bevel on the end of the featherboard. It allows the workpiece to slide smoothly between the fence and featherboard.

The featherboard is attached to an L-shaped assembly made of  $\frac{1}{2}$ "-thick hardwood. A wide *base* provides a clamping surface, and a *support block* holds the featherboard at an angle, as shown in the detail.

After cutting this angled kerf, it's just a matter of screwing the support block to the base and then gluing in the featherboard.

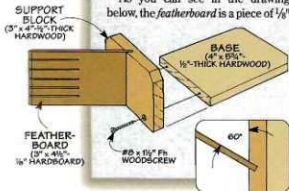

against the scrap and adjust it to match the angle of drift. (To see how to adjust this hand saw fence, turn to page 22.)

**Check Setting** – Before you start resawing the “real” workpieces, it’s a good idea to check the fence setting by making another test cut. Even though the fence is at an angle to the blade, the blade should cut straight along the line. If not, readjust the fence and try again. The important thing is to *find* the correct angle, *adjust* the fence, and *stay* with it.

### READY TO RESAW

Once the fence is adjusted, you should be able to resaw a straight line without worrying about drift.

**Stock Preparation** – Even so, to get accurate results, make sure the stock is flat, straight, and square. I joint the *face* of the piece that slides against the fence as well as the *bottom edge* that rides on the table.

**Guide Assembly** – Also, to provide as much support for the blade as possible, lower the upper guide assembly as close to the workpiece as you can, but still high enough so you can see the kerf. This reduces the chance of the blade bowing in the middle of a cut. Note: If you’re resawing narrow stock, try using the tip shown in the margin.

**Set Fence** – Now it’s just a matter of setting the fence at the correct distance from the saw blade. The location of the fence determines the thickness of the resawn piece. To pro-

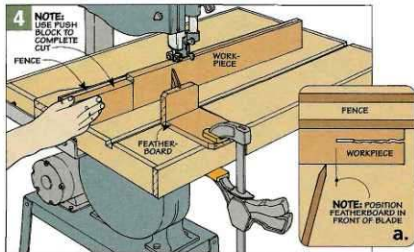

vide “extra” material for planing off the ridges left by the saw blade, I set the fence  $\frac{1}{16}$ ” farther from the blade than the desired thickness.

**Featherboard** – After locking the fence in place, it’s a good idea to clamp a tall featherboard to the band saw table, as shown in Figures 4 and 4a. The featherboard exerts even pressure that holds the workpiece flat against the fence. (For details about making this featherboard, refer to the box on page 26.)

**Making The Cut** – At this point, it’s just a matter of placing the edge of the board flat on the saw table and feeding it into the blade. As you can see in the photo on page 24, I push the board from behind with one hand, and guide it along the side with my other hand.

**Slow & Steady** – There’s no need to hurry here. The key to success is a slow, steady feed rate. If you push the board too fast, the blade can flex and create a “barrel” cut. If you stop sawing, it makes a wider kerf.

So how do you know if the feed rate is correct? Once again, *listen* to the sound of the saw blade. It should make a smooth, rasping sound as it cuts through the wood. You’ll know if you’re pushing too fast — the sound will change to a high-pitched squeal.

The point is to let the blade do the work — use your hands just to guide the board and feed it through the blade. Speaking of hands, be sure to keep them well away from the blade at the end of the cut. I use a scrap of wood as a push block when resawing the last few inches of the board.

### Shop Tip



▲ When resawing narrow (short) stock, carpet-tape a long scrap to the fence to provide clearance for the guide assembly.

## Resawing with a Pivot Block

If you only need to resaw a few pieces, it’s quicker to use the pivot block than to adjust the fence for drift.

**Setup** – To get a straight cut, start by marking a line along the top edge of the workpiece. As shown in the detail at right, the idea is to slide the pivot block along the fence so the “high” point of the radius aligns with the leading edge of the blade. Note: The distance between the pivot block and the blade equals the desired thickness of the piece, plus  $\frac{1}{16}$ ”.

**Making the Cut** – Now just turn on the saw, and feed the workpiece into the blade, holding it against the pivot block as you make the cut. If the blade “drifts” off the line, simply swing the tail end of the workpiece in that direction.

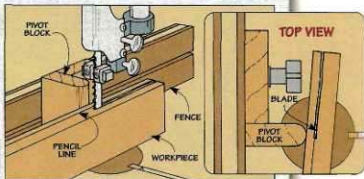

**T**here was quite a bit of kidding when I told the guys I was making a magazine rack for the shop. Someone even suggested bringing in an easy chair to go with it.

But sitting down for a comfortable "read" isn't what I had in mind. What I really wanted was a way to keep the plans in my woodworking magazines up off my bench. This way, they wouldn't get buried under a pile of clutter in the middle of a project.

**Fold-Out Rack** – The solution was a simple, wall-mounted rack. As you can see in the photo at right, the rack folds out and holds the plans at an angle so they're easy to see. A clear piece of plastic covers the plans so I don't have to shake dust and chips out of my magazines any more.

**Two Trays** – A closer look at the rack shows that it has two separate trays. The front tray lets you spread open a magazine behind the plastic cover. And the rear tray provides a handy place to hold more magazines or tool manuals. If you're not using the rack, the front tray folds up behind the rack, as shown in the margin.

If you look at Figure 1, you'll see that each tray is *almost* identical.



(They have different sized backs, but more on that later.) Each tray is made up of a U-shaped frame enclosed by a hardboard back and a plastic cover.

**Make the frames** – I began by making a frame for each tray. It con-

sists of a *bottom* (A) and two *sides* (B) made of 3/4"-thick hardwood. To simplify the joinery used to assemble the frames, it's best to start with extra-long pieces that are ripped to width.

**Rabbets** – If you take a look at Figures 1 and 1a, you'll see that the back and cover of each tray fit into rabbets in the frame pieces.

Figure 2 shows a quick way to cut these rabbets. Just mount a dado blade in the table saw and "bury" part of it in an auxiliary fence. To get consistent results, it's a good idea to use a featherboard to press the workpiece against the fence.

As shown in Figure 2a, the depth of both rabbets is the same (3/8"). But the width is different. To hold the hardboard back, you'll need to cut a 1/4"-wide rabbet. Then after completing the rabbets for the back, nudge the fence closer to the blade, reset the featherboard, and cut 1/8"-wide rabbets to hold the plastic cover.

**Miter Joints** – The frames are assembled with simple miter joints. To ensure that each tray ends up identical in size (and that the miter joints fit tightly together), it's important that all the sides are identical in

▲ The front tray folds up for compact storage, so the rack isn't in the way when you're not using it.

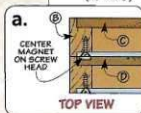
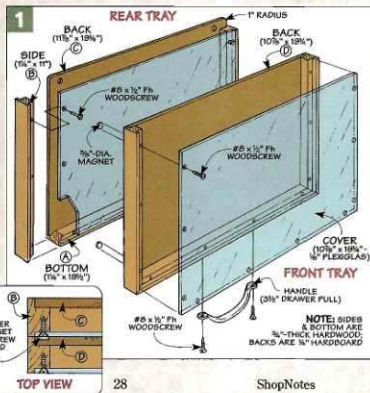

TOP VIEW



length and that the bottom pieces of the trays are equal in length as well.

As you can see in Figure 3, an easy way to accomplish this is to tilt the head of the miter gauge to 45° and then clamp a stop block to a fence attached to the miter gauge. (The fence prevents chipout on the back of the frame piece.) After mitering all the sides to length, the same idea can be used to cut the miter on each end of the bottom pieces.

**Assembly** – The next step is to assemble the frame. There's just one small problem. Since there's no frame piece across the top, how do you glue and clamp it together without racking the corners out of square?

The trick is to "clamp" the frame together with masking tape, as shown in Figures 4 and 4a. Start by taping the mitered ends of the frame pieces tip to tip. Then apply glue and "fold" the pieces together. Now hold a square in one corner and run a long strip of tape across the top of the frame. (Be sure to check the opposite corner too.) To square up the frame, reposition the tape by pulling it tighter or loosening it up a bit.

**Backs** – To enclose the back of the frames and add rigidity to the trays, I added two hardboard backs (C, D). They're cut to fit between the shoulders of the rabbets in the frames, so they're identical in length. But the back (C) of the rear tray is 1" taller (wider). As a result, it sticks up above the top of the tray. Drilling a pair of holes near the top edge of this

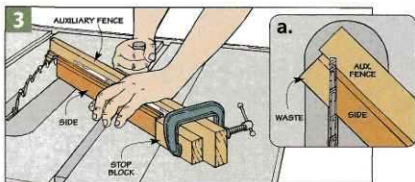
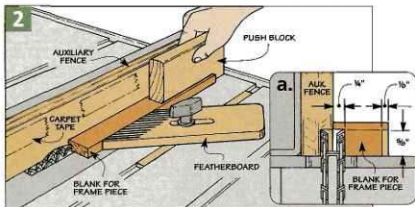

back piece will provide a convenient way to mount the rack on the wall.

**Covers** – After gluing on the back pieces, it's time to add the plastic covers. These are pieces of 1/8"-thick Plexiglas that fit between the sides and flush with the top of the frame.

The plastic is easy to cut on the table saw. But to keep it from getting scratched, don't peel off the paper backing yet. As you can see in the margin, the paper also makes it easy

to lay out the holes for the screws used to attach the covers.

**Magnets** – After screwing the covers in place, I added four small magnets to the front tray. (You can see these magnets in Figures 1 and 1a.) When the front tray is folded up, the magnets contact the screw heads that hold the cover on the rear tray. So when you close the rack, the front tray "clicks" into place.

To ensure that the tray stays put, I used special magnets called *rare earth magnets*. These magnets are quite strong. Even the small (3/8"-dia.) magnets I used have an amazing amount of holding power. (For sources, see page 31.)

The magnets fit in counterbored holes drilled in the back of the front tray. You want the holes to be shallow enough that the magnets sit slightly "proud." Then just use epoxy to hold the magnets in place.

**Handle** – To complete the front tray, I added a handle. It's just a drawer pull that's screwed to the bottom of the tray (Figure 1).

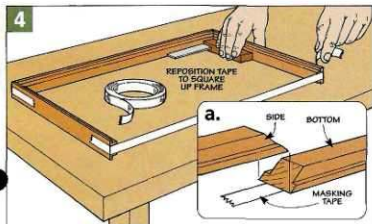

▲ To make it easy to see your layout lines, leave the paper backing on the Plexiglas.

## Pivot Arms

One of the handiest things about this magazine rack is the front tray tilts out at an angle to make your plants easy to see. This doesn't require any fancy hardware. Instead, the trays are connected by two wood *arms* on each side that pivot up and down as you open (or close) the rack.

Notice in Figure 5 that the lower arm is *longer* than the upper arm. The reason is simple. As you pull the tray open, the long (lower) arms swing down and allow it to "kick out" at the bottom. At the same time, the short (upper) arms limit how far the top of the tray can tilt. This is what establishes the angle of the tray.

**Arms** – Except for the difference in length, the *upper (E)* and *lower arms (F)* are identical. They're made from  $\frac{1}{4}$ "-thick hardwood that's ripped to a width of  $1\frac{1}{4}$ ". After cutting the arms to length, the next step is to drill a mounting hole near each end.

For smooth operation, it's important to locate these holes accurately. As you can see in Figure 6, an easy way of doing this is to clamp a fence to the drill press table and use a stop block to position each arm. Then after drilling a hole near one end of each arm, flip it end for end to drill the second hole.

**Shape Corners** – There's one thing left to do to complete the arms.

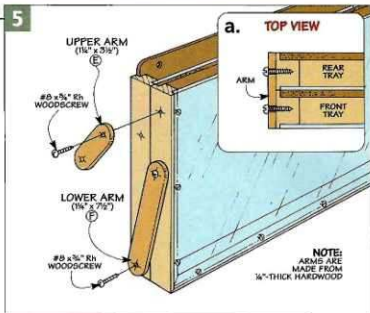

That's to remove the sharp corners by cutting a gentle radius on each end and sanding the edges smooth.

**Attach the Arms** – Now you're ready to attach the arms to the trays. They're held in place with ordinary woodscrews. The tricky part is to *accurately* locate the screw holes so the tray won't bind.

To do this, start by drawing a centerline down each side of both trays as shown in Figure 7. Then after marking and drilling pilot holes in the *rear* tray, screw the arms in place.

To locate the holes in the *front*

tray, stack the two trays together so they're flush all the way around. Then raise each arm, peek through the hole at the end until it aligns with the centerline, and mark the hole location. Now just drill pilot holes and screw the arms in place.

**Mount Rack** – All that's left is to mount the rack to the wall. This is just a matter of screwing the back of the rear tray to the wall studs. Once the screws are installed, you can fill the rack with your favorite woodworking magazines and get a whole new "slant" on your project plans.

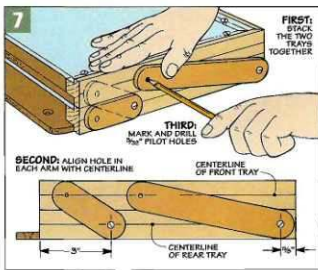
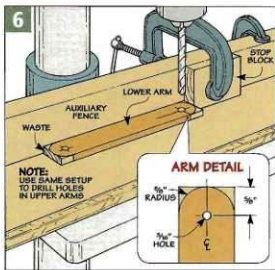

**Hardware & Supplies**

To make it easy to round up the hardware and supplies that you'll need to build the projects featured in this issue, we've put together a number of convenient mail-order sources.

**▲ Rare-Earth Magnets**

The Fold-Out Magazine Rack featured on page 28 has two trays that hold woodworking magazines and tool manuals.

In the folded position, the trays are held together with strong, rare-earth magnets. These magnets are available from the source listed in the margin.

**▲ Hole Saw & Arbor**

A hole saw comes in handy when creating the throat opening for the Band Saw Table shown on page 16. We used a 3" hole saw manufactured by Starrett and a 3/8" arbor that's chucked in a hand-held drill. These hole saws range in size from 3/4" to 3 3/8" in diameter. Hole saws (and arbors) are available at many hardware stores and home centers or from the sources listed in the margin.

**WoodNet**

- 101 Woodworking Tips Online
  - Woodworking Techniques
  - Project plans you can download
  - WoodNet Forum
  - Power Tool Reviews
- [www.WoodNet.net](http://www.WoodNet.net)

**▲ Heavy-Duty Wire Hangers**

The ceiling-mounted rack that's featured on page 6 is a great way to store awkward-sized jigs and templates. They're simply hung from the rack with hangers made from heavy gauge wire. We used nine-gauge wire and a simple bending jig to make the hangers.

This wire is available at many hardware stores and from some farm supply companies. We purchased a fifty-foot coil of wire for about five dollars.

**◀ Long-Nosed Claw Hammer**

The long-nosed claw hammer that's shown on page 12 makes it easy to drive nails in hard-to-reach places. This hammer also has several other practical features that most claw hammers don't have. A source for this hammer is listed in the margin.

**◀ Warrington Hammer**

For driving brads or small finish nails, it's handy to use a hammer with a straight peen on one end. (This type of hammer is called a Warrington hammer.) The peen lets you start the brad without hitting your finger. These hammers are available with heads of four different weights (3#, 6, 10, and 12 oz.). Sources are listed at right.

**ON-LINE CUSTOMER SERVICE**

- Access information about your subscription account.
  - Find out if your payment has been received.
  - Change your mailing address or your email address.
  - Let us know if you haven't received your issue.
  - Renew your subscription and pay your bill
- [www.ShopNotes.com](http://www.ShopNotes.com)

**MAIL ORDER SOURCES**

**Eagle America**  
800-872-2511  
*Band Saw Blades*

**Garrett Wade**  
800-221-2942  
*Warrington Hammers*

**Lee Valley**  
800-871-8158  
*Long-Nosed Hammer,  
Warrington Hammers,  
Rare-Earth Magnets*

**McFeeley's**  
800-443-7937  
*Hole Saws*

**Rockler**  
800-279-4441  
*Hole Saws*

**Trend-lines**  
800-767-9999  
*Band Saw Blades*

**Woodworker's Supply**  
800-645-9292  
*Band Saw Blades*

**Hook-Tooth Band Saw Blade**

In the article on page 24, we've provided tips and techniques for using a band saw to make thin boards from thick stock (resawing). For best results when resawing, we recommend using a 1/2"-wide, hook-tooth band saw blade with three teeth per inch. This blade cuts aggressively.

And the large gullets remove material quickly. Hook-tooth blades are available at many woodworking stores and from the sources listed in the margin.

## Scenes from the Shop

In many shops, you'll find ▶ an interesting assortment of hammers. The claw hammer (center) remains the standby for general purpose work. But the wedge-shaped peen on the Warrington hammer (back) is better suited for driving small brads without hitting your fingers. And the round ball on the end of the ball-peen hammer (front) makes it ideal for working with soft metal.



◀ When adjusting tools and machinery, the solid heads on these mallets won't bounce back or mar the surface. While the plastic-headed mallet (in back) is fine for lightweight work, the cast lead mallet (center) and copper mallet (front) help "persuade" heavier tools.

Each of these hammers is ▶ designed for a specific craft. A hammer that's used to form sheet metal (upper left) and the farrier's hammer for shoeing horses (lower left) are two examples. The half-dollar sized face on the cobbler's hammer (upper right) and the long nose and claw on the upholsterer's tack hammer (lower right) are also "striking" examples that form follows function.

