

# ShopNotes

Vol. 9

Issue 49

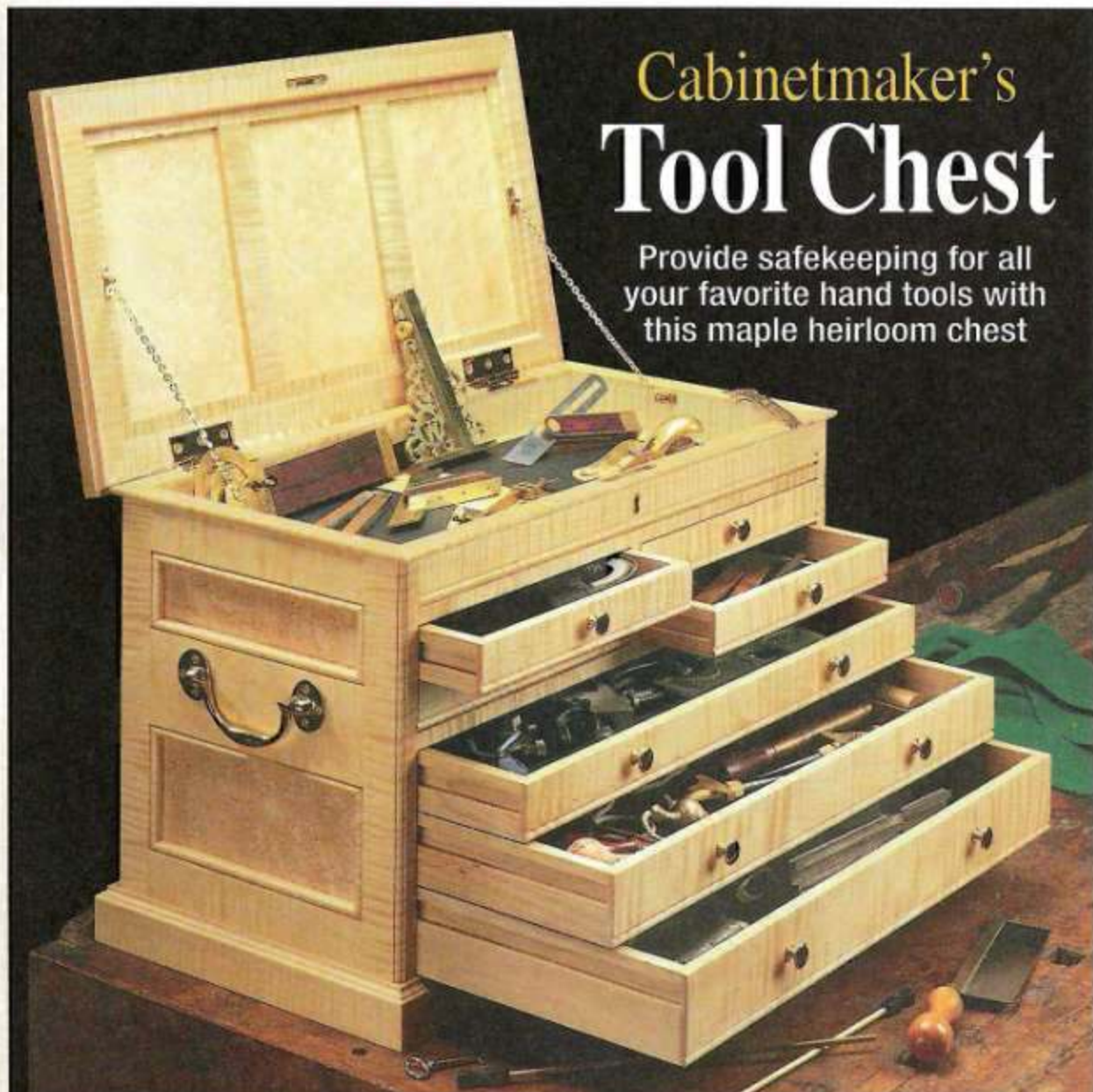

## Cabinetmaker's Tool Chest

Provide safekeeping for all  
your favorite hand tools with  
this maple heirloom chest

- Lathe Disk Sander
- Veneering Small Panels
- Table Saw Dust Collector
- Full-Mortise Lock



# ShopNotes®

Issue 49

January 2000

**PUBLISHER** Donald B. Peschke  
**EDITOR** Tim Robertson  
**ASSOCIATE EDITOR** Tom Bagnol  
**ASSISTANT EDITOR** Bryan Nelson  
**ART DIRECTOR** Cary Christensen  
**SR. GRAPHIC DESIGNER** Kurt Schultz  
**SENIOR ILLUSTRATORS** Roger Reiland  
 Mark Higdon

#### CREATIVE RESOURCES

*Creative Director:* Ted Kralovek • *Project Developer:* Ken Munkel • *Senior Project Designer:* Kevin Boyle • *Project Coordinator:* Kent Welch • *Shop Manager:* Steve Curtis • *Shop Craftsmen:* Steve Johnson • *Senior Photographer:* Grayola England

#### SPECIAL PUBLICATIONS

*Executive Editor:* Douglas L. Hideo • *Art Director:* Steve Lueder • *Sr. Graphic Designer:* Chris Glowacki, Cheryl L. Simpson • *Asst. Editors:* Jon Irwin, Craig Rungegger • *Graphic Designer:* Vu Nguyen

#### CIRCULATION

*Sub. Serv. Dir.:* Sandy Basso • *New Bus. Dir.:* Gensla Battles • *Circ. Marketing Analyst:* Kris Schlemmer • *Creative Mgr.:* Melinda Halfer • *Revenue Mgr.:* Paul Rogers • *Sr. Graphic Designer:* Mark Hayes • *Billing Mgr.:* Rebecca Cunningham • *Prod. Mgr.:* Rick Jandura • *New Bus. Mgr.:* Todd L. Bierle • *Asst. Sub. Mgr.:* Joy Krause

#### CORPORATE SERVICES

*Controller:* Robin Hutchinson • *Sr. Accountant:* Laura Thomas • *Accounts Payable:* Mary Schultz • *Accounts Receivable:* Margo Petrus • *Prod. Dir.:* George Christlars • *Electronic Pub. Dir.:* Douglas M. Lidster • *Network Admin.:* Chris Schwanebeck • *Prod. Assistant:* Susan Kueve • *Pre-Press Image Specialist:* Troy Clark, Marnette Johnson • *New Media Mgr.:* Gordon C. Gaippe • *Multimedia Art Dir.:* Eugene Pedersen • *E-Commerce Analyst:* Carol Schoeppler • *Web Site Editor:* Holly Kilburn • *Web Site Product Specialist:* Adam Best • *H. R. Asst.:* Kirsten Koels • *Admin. Asst.:* Julia Fluh, Sherri Ribbey • *Receptionist:* Jeanne Johnson • *Building Maintenance:* Ken Griffith • *Mail Room Clerk:* Lois Webber

#### MAIL ORDER

*Operations Dir.:* Bob Balzer • *Cust. Serv. Mgr.:* Jennie Enos • *Warehouse Supv.:* Nancy Johnson • *Buyer:* Linda Jones • *Admin. Asst.:* Nancy Downey • *Trck. Rep.:* John Audette • *Cust. Serv. Reps.:* Anna Cox, Tammy Truckenbrod, Deborah Rich, April Revell, David Ganner • *Warehouse:* Sylvia Carey, Dan Spalls, Eric Tullis, Sheryl Knox

#### WOODSMITH STORE

*Manager:* Dave Larson • *Assistant Manager:* Paul Schneider • *Sales Staff:* Pat Lowry, Wendell Stone, Jitz Barnett, Kathy Smith, Larry Morrison, Harold Cushman • *Office Manager:* Vicki Edwards

ShopNotes® (ISSN 1062-0696) is published bimonthly (Jan., March, May, July, Sept., Nov.) by August Home Publishing, 2200 Grand, Des Moines, IA 50312.

ShopNotes® is a registered trademark of August Home Publishing ©Copyright 2000 by August Home Publishing. All rights reserved.

Subscriptions: Single copy \$4.99. One year subscription (6 issues), \$21.94. Canada/International add \$10 per year, U.S. funds.

Periodicals Postage Paid at Des Moines, IA and at additional mailing offices.

Postmaster: Send change of address to ShopNotes, P.O. Box 21105, Boone, IA 50037-2105.

Subscription Questions? Write to: ShopNotes Customer Service, P.O. Box 842, Des Moines, IA 50304-8951. Or call 1-800-333-2854, 8:00 am to 5:00 pm, Central Time, weekdays. FAX 515-283-0447

E-Mail: ShopNotes@shopnotes.com

Internet: http://www.shopnotes.com

PRINTED IN U.S.A.

# Cutoffs

One of the last things I do before we send out an issue of *ShopNotes* is to add the date above the masthead. (That's the long list of names on the left.) Now usually, I don't give it a second thought. But this time, I hesitated a bit.

As I typed in the year "2000," the string of zeroes looked odd and out of place. Then it hit me. The *new year, new century*, and *new millenium* had always seemed like eons away. Now the twenty-first century had blown in like a gust of wind.

What changes will it bring about? I'm not really sure. But I do know one thing. Whatever changes *are* in store are likely to happen faster and faster.

Well, call me a stick-in-the-mud if you want. But the more things speed up, the more I find myself wanting to *slow down*. (Some folks say I'm just getting old.)

The best way I've found to do that is to spend a few quiet hours in the shop. It's a great way to slow down, unwind, and create something at a *leisurely* pace.

**TOOL CHEST.** I guess that's what's so enjoyable about building the tool chest that's featured in this issue. It's one of those projects where it's easy to lose track of time completely.

Take something as simple as selecting the lumber for the tool chest. An entire morning can slip by while you sort through stacks of lumber, turning each board over and over, looking for pieces with just the right figure or color.

And there's no need to rush when selecting the hardware for the tool chest. What better way to spend an evening than poring over woodworking catalogs, looking for pieces of hardware appropriate for an heirloom chest?

In fact, I was paging through one of my own "wish books" when I came across just the pieces of hardware I

wanted — solid brass hinges, heavy-duty chest handles, and a full-mortise lock with an old-fashioned key. (That's the key I've been carrying around for the past few weeks in the photo below.)

But let's face it. The most rewarding thing about building this chest is spending time in the shop, carefully fitting each piece together, and lingering over every single detail.

In fact, it's getting totally absorbed by these details that's the best part — making a strip of bead molding and applying it to the chest, lining the drawers with leather, gluing a wood plug in a brass knob and then "turning" it to shape on a drill press.

Somewhere in this process, an interesting thing happens — time loses its importance.

What begins to matter more are things like patience and pride. Not a boastful type of pride. But pride in workmanship, in making something as good as it can possibly be. It's a satisfying feeling.

Now I know, I've talked quite a bit about the tool chest. But believe it or not, there's a lot more to say. For the rest of the story, turn to page 16.

**LATHE DISK SANDER.** Another project in this issue that's definitely worth a closer look is a shop-made disk sander that mounts to a lathe. As a disk sander, it's a great way to remove stock quickly or sand a workpiece to shape. And when you want to turn a workpiece on the lathe, it only takes a minute to remove the disk sander.

**TABLE SAW DUST COLLECTOR.** One final note. Before you build another project of *any* kind, be sure to check out the table saw dust collector that's shown on page 28. It's the simplest solution I've seen yet for collecting the dust produced by a table saw.

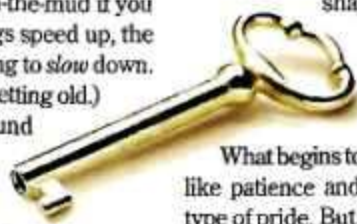

*Tim*

# Contents

## Features

### Lathe Disk Sander \_\_\_\_\_ 6

*It's easy to convert your lathe into a disk sander. This shop-made tool features a large sanding disk that removes stock quickly and a tilting table to support the workpiece.*



Lathe Disk Sander page 6

### Veneering Small Panels \_\_\_\_\_ 12

*From making crisp, clean cuts in veneer to gluing and clamping it in place, these helpful tips show you how to apply veneer to small, hardboard panels.*



Veneering Panels page 12

### Full-Mortise Lock \_\_\_\_\_ 14

*There's no mystery to installing a full-mortise lock. All you need is a little patience, a careful layout, and our step-by-step instructions.*

### Cabinetmaker's Tool Chest \_\_\_\_\_ 16

*This figured maple tool chest is constructed of simple frame and panel assemblies. With seven drawers and storage under the lid, it's designed to hold your favorite hand tools.*



Tool Chest page 16

### Table Saw Dust Collection \_\_\_\_\_ 28

*Get the most out of your dust collector. Together with a few scrap pieces of material, you can quickly create an efficient dust collection system for your table saw.*



Dust Collection page 28

## Departments

### Readers' Tips \_\_\_\_\_ 4

*Our readers offer their own shop-tested tips dealing with some of the most common woodworking problems.*

### Tool Talk \_\_\_\_\_ 30

*Tips and talk about tools of our trade. In this issue, we look at a micro-adjustable edge guide that attaches to a router.*

### Sources \_\_\_\_\_ 31

*Information and mail-order sources for the hardware and supplies used to build the projects in this issue.*

# Readers' Tips

## Sanding Long Notches

Occasionally, I build a project that requires cutting a long notch in a piece. That's the easy part. (I just use a sabre saw.) The trick is sanding the rough edge straight and smooth. If I

use a drum sander in the drill press, I often end up with a scalloped edge.

To prevent this, I use a long fence that's notched to fit around the drum sander, see drawing. With the "feet"

of the workpiece riding against the fence, it's easy to sand a straight edge.

**SETUP.** To sand the entire thickness of the edge, you'll also need a base with a hole cut in to accept the drum sander, see detail 'a.' After clamping the base to the drill press table, lower the drum sander into the hole and lock the quill. Then position the fence to sand to the desired depth and clamp it in place, see detail 'b.'

Now just turn on the drill press, and push the workpiece into the drum sander until it contacts the fence. Note: Start at the right end of the notch. Then slowly feed the workpiece from left to right.

Leon Schleusener  
Tomah, Wisconsin

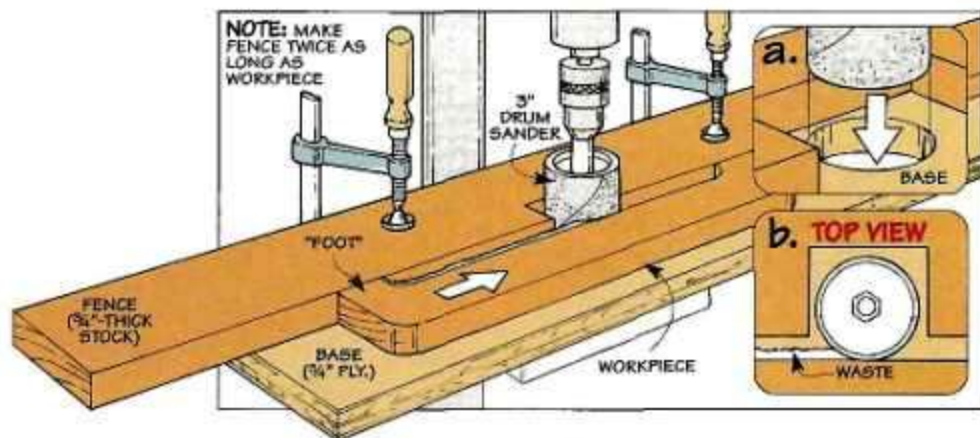

## Miter Gauge Extension

Using a miter gauge to cut multiple pieces to length on a table saw is easy — if the pieces are fairly short. I just clamp a stop block to a wood fence attached to the miter gauge.

But if the pieces are long, I've always had trouble cutting them to identical lengths. Unless I use an extremely long fence, there's no place to clamp a stop block. And such a

long fence would just get in the way most of the time.

So in order to cut long pieces to length quickly and accurately, I added a removable extension rail to the wood fence and then made a stop block to fit on the rail, see drawing.

**EXTENSION RAIL.** The extension rail is a thick piece of aluminum bar stock that attaches to the back of the wood fence. (You'll find bar stock at most home centers.)

To hold the rail in place, I cut two notches in the bottom edge of the aluminum bar to fit over screws installed in the fence. Tightening the screws secures the rail to the fence.

**STOP BLOCK.** Next, I added a sliding stop block. It's a thick hardwood block with a wide kerf that fits over the rail. After positioning the stop block on the rail, just tighten a knob into a threaded insert to lock it in place.

Bob Anderson  
Omaha, Nebraska

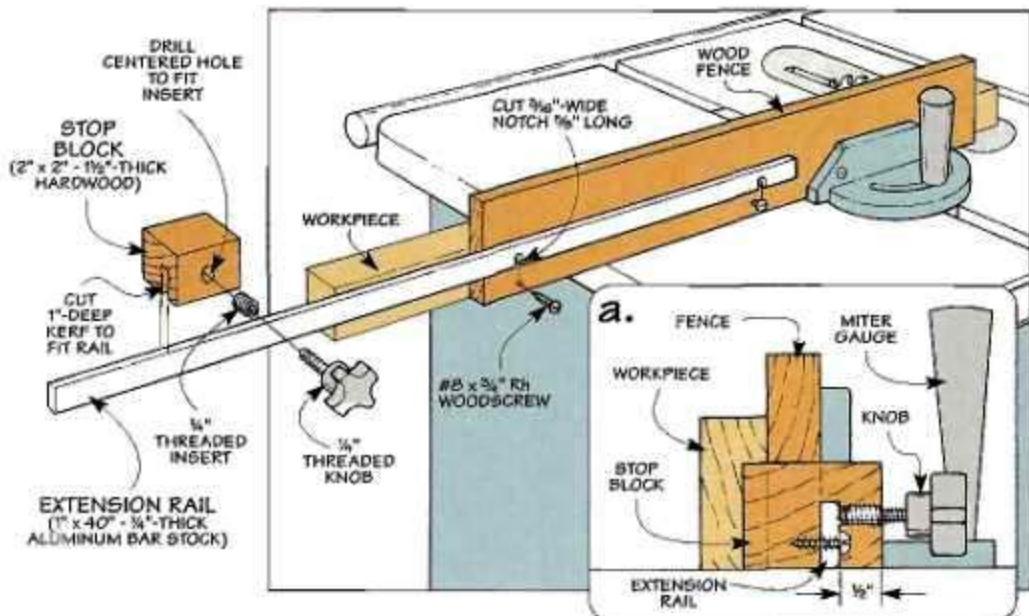

## Quick Tips

■ After rubbing a dried finish with steel wool, it's hard to clean up the tiny metal fibers that remain on the surface. My solution is to stick a magnet in a plastic bag and "sweep" it across the surface, see photos below. The metal slivers that stick to the bag are easy to remove. Just hold the bag over a trash can and remove the magnet.

*Keith Mulford  
Arlington Heights, Illinois*



■ When cutting delicate parts on a scroll saw, it's frustrating if a small piece breaks off. The problem is it isn't fully supported over the blade opening in the saw table.

To add extra support, I make a "zero-clearance" insert by poking the end of the blade through a business card (inset photo) and taping the card to the table, see photo.

*Rick Hutcheson  
Grimes, Iowa*



## Custom Fit Dado Joint

■ In *ShopNotes* No. 45, you showed a method of cutting a dado joint on the table saw *without* using a dado blade. It uses two spacer blocks to establish the width of the dado.

That method works fine. In fact, I

use a similar technique with a slight twist. A screw installed in one of the spacer blocks makes it easy to "fine tune" the width of the dado and create a custom fit joint.

The idea is to clamp the two blocks

to the rip fence so they're offset, see Fig. 1. (Place the block with the screw against the fence.) To cut one side of the dado, butt the workpiece against the block closest to the blade and make a pass, see Fig. 1a. Now set the workpiece against the screw and make a second pass to cut the other side of the dado, see Figs. 2 and 2a.

After removing the waste material in between, test fit the dado joint. If it's too tight (or too loose), simply adjust the screw in or out, see Fig. 2b.

*Phil Pratt  
Marco Island, Florida*

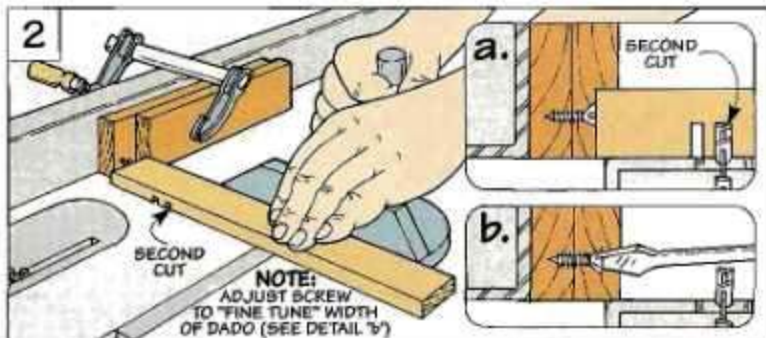
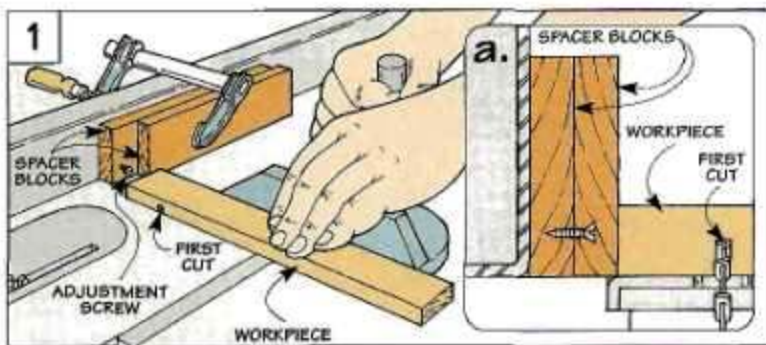

### Send in Your Shop Tips

If you have a unique shop tip, we'd like to consider featuring it in one or more of our print or electronic publications.

We'll pay up to \$200 for a tip we publish. Just write down the tip and mail it to *ShopNotes*, Attn.: Readers' Tips, 2200 Grand Ave., Des Moines, IA 50312. Or FAX it to 515-282-6741, or send us an e-mail at [shopnotes@shopnotes.com](mailto:shopnotes@shopnotes.com). Please include your name, address and daytime phone number in case we have any questions.



## Lathe-Mounted Disk Sander

*By mounting this shop-made disk sander to your lathe, you get two tools in the space of one.*

**O**ne of the best ways to save space in a shop is to use *one* tool to accomplish *two* jobs. That's the idea behind the lathe-mounted disk sander that's shown above.

As a disk sander, it makes quick work of sanding to a line or trimming the mitered end of a workpiece to get a perfect fit. And when you want to turn a project on the lathe, it only takes a minute to remove the disk sander.

**SLOW SPEED.** Besides doing double duty, mounting this disk sander to a lathe has another advantage. Since the speed of the lathe is adjustable, the sanding disk can be set to spin at a relatively slow speed. (I set mine around 750 rpm's.) This way, the wood isn't as likely to burn as with other disk sanding accessories I've used. (For example, a sanding disk mounted on the arbor

of a table saw spins at 3,000 rpm's.)

**DISK & TABLE.** The disk sander is made up of two main parts. A *sanding disk* provides a hard, flat surface to attach the sandpaper. And an *adjustable table* supports the workpiece.

To sand a bevel on the edge of a workpiece, the table is designed to tilt from 0° to 45°, see photo 'A' at left. As another option, you may want to build a simple jig that slides across the table and allows you to sand perfect circles, see photo 'B.'

### A. Tilting Table. ▶

*Sanding a bevel on the edge of a workpiece is a snap with this disk sander. Just tilt the table to the desired angle and tighten a knob to lock it in place.*



### B. Circle Sanding Jig. ▶

*By adding a simple circle sanding jig that slides across the table, you can sand perfectly round disks in a matter of minutes.*



### SANDING DISK

At first, I considered using a store-bought sanding disk. But as I was rummaging around in the scrap bin, I found the ideal material to make my own sanding disk — Medium-Density Fiberboard (MDF).

**MDF.** The nice thing about MDF is it's a hard, durable material that will stay flat in use. To add rigidity to the sanding disk, I used  $\frac{3}{4}$ "-thick MDF. (It's available at many lumberyards and home centers.)

**FACEPLATE.** I also needed a way to secure the sanding disk to the lathe. The solution was to attach a faceplate to the disk and then mount it on the lathe. (I used a 6" faceplate.)

**DISK SIZE.** But before attaching the faceplate, it's best to cut the disk to rough size. It's easy to establish

the size of the disk, at least in theory. Just measure the distance from the bed of the lathe to the centerpoint of the spindle. Then make the diameter of the disk twice that size. (This is the "swing" of the lathe.)

The only problem is a disk of that size would contact the lathe bed. This means that the disk has to be a bit smaller. To accomplish that, I started with a square blank that's  $\frac{1}{8}$ " smaller than the swing of the lathe. (In my case, the lathe has a 12" swing, so I cut an 11 $\frac{7}{8}$ " square blank.)

**LAYOUT.** The next step is to lay out two circles on the blank. A large circle establishes the size of the disk, see Fig. 1. And a small circle will be used to position the faceplate. Note: To find the centerpoint of both circles, just draw two diagonal lines across the corners of the blank.

After scribing the circles with a compass, you can use a band saw (or sabre saw) to cut the disk to rough shape. Once again, to ensure there's enough clearance to mount the disk on the lathe, stay as close as possible to the layout line. After roughing out the basic shape, it's just a matter of

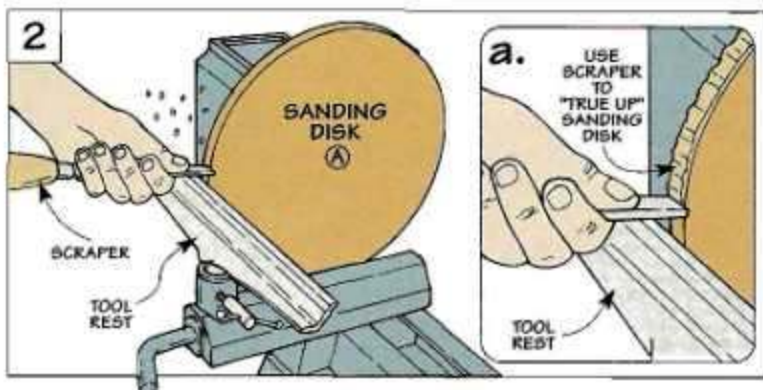
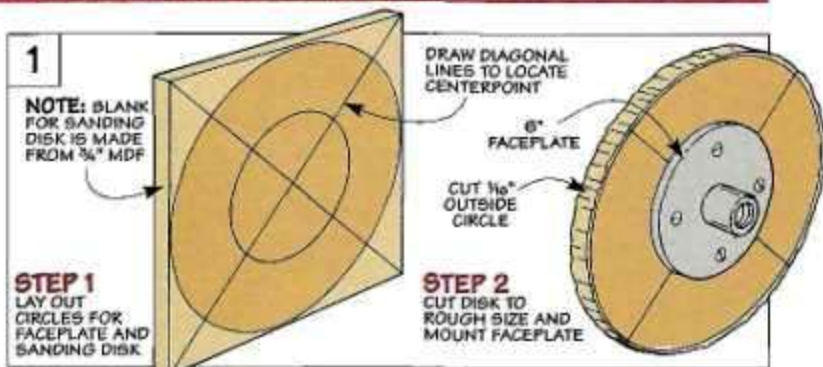

screwing the faceplate to the disk. **"TRUE UP" DISK.** No matter how carefully you position the faceplate, it probably won't be perfectly centered on the disk. So you'll need to "true

up" the sanding disk (A) so it spins without wobbling. To do this, mount the faceplate on the lathe and use a scraper to clean up the rough edge of the disk, see Figs. 2 and 2a.

## Installing Sandpaper Disks

It only takes a few minutes to install a sandpaper disk. Especially the peel-and-stick type of disks that have a pressure-sensitive adhesive on the back, see photo at right.

**DISK SIZE.** These sandpaper disks range in size from 5" to 12" in diameter. Just make sure that the disks you buy cover the entire surface of the MDF sanding disk. (For Sources, see page 31.)

**GRIT SIZE.** You'll also find sandpaper disks in a wide range of grit sizes, from 36-grit to 320-grit. But there's no need to have every single one of these grit sizes on hand. Either an 80, 100, or a 120-grit sandpaper disk works fine for most of my work.

**APPLY FINISH.** Before you attach the first sandpaper disk, there's a bit of ground-work to do. That's to apply a finish to the MDF sanding disk, see photo 'A.'

The finish helps seal the surface of the MDF. This makes it easy to peel off the used

sandpaper disks. Plus it prevents chunks of material from tearing out of the MDF. Note: To prevent the sanding disk from warping, I brushed on three coats of polyurethane to the edge and both sides.

**TRIM DISK.** One thing you may find when you stick on a new sandpaper disk is it hangs over the edge. This overhanging material can cut like a sharp knife, so it's a good idea to trim the excess flush to the edge of the sanding disk, see photo 'B.'



## Base & Table

The foundation of this disk sander is a wedge-shaped *base* that mounts securely to the bed of the lathe, see drawing at right. In addition to providing support for an adjustable table, the base has a hook-up for a shop vacuum, see margin.

### BASE

At first, the angled shape of the base might seem a little unusual. But there's a simple explanation. It provides the clearance that's needed when you tilt the table at an angle.

**BOTTOM.** I began by making the *bottom (B)* of the base from a piece of  $\frac{3}{4}$ " MDF, see Fig. 3. To provide a way to hook up the disk sander to a shop vacuum, there's a large hole in the base that's cut to fit the end of the hose. You'll also need to drill a hole for a carriage bolt that's part of a clamp head added later.

**ENDS.** The next step is to add two triangular *end (C)* pieces to support the angled side of the base, see Fig. 3. There's a hole drilled near the tip of *one* of these end pieces, see End View. Later, this hole will accept a T-nut that's used when locking the table at an angle.

**SIDE.** Before attaching the ends, I added the angled *side (D)*. It's

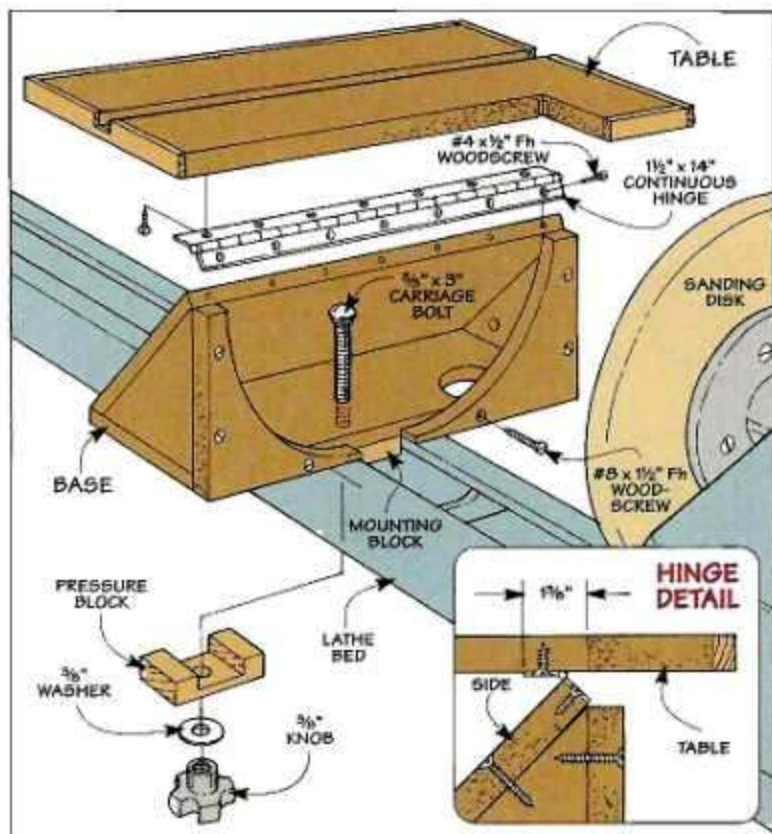

▲ To collect the dust produced by the disk sander, the hose on a shop vacuum fits into a hole in the base.

nothing more than a piece of MDF that's beveled on the lower edge to fit against the bottom of the base.

**ASSEMBLY.** The side, ends, and bottom are held together with glue

and screws. Just make sure to slip the carriage bolt in place *before* attaching the side. Since it sits at an angle, there's not enough clearance inside the base to install the bolt later.

**CLAMP HEAD.** Now it's time to turn your attention to the clamp head that holds the base on the lathe bed. The clamp head consists of two parts. To keep the base square to the sanding disk, a *mounting block (E)* made of MDF fits in the opening in the lathe bed, see Fig. 4. And a hardwood *pressure block (F)* that's notched to fit around the mounting block locks the base in place.

To apply this pressure, a centered hole drilled in each piece fits over the bolt in the base. Tightening a knob on the end of the bolt pinches the pressure block against the lathe bed and secures the base firmly in place, see Clamp Head Detail in Fig. 4.

**DUST COVER.** At this point, all that's left is to add a curved *dust cover (G)* to the open side of the

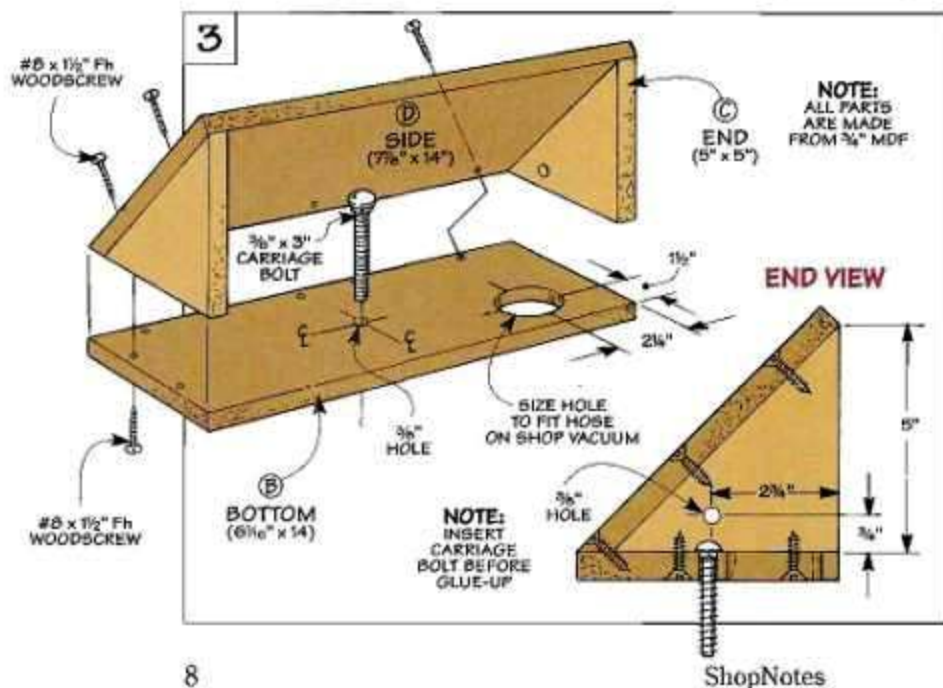



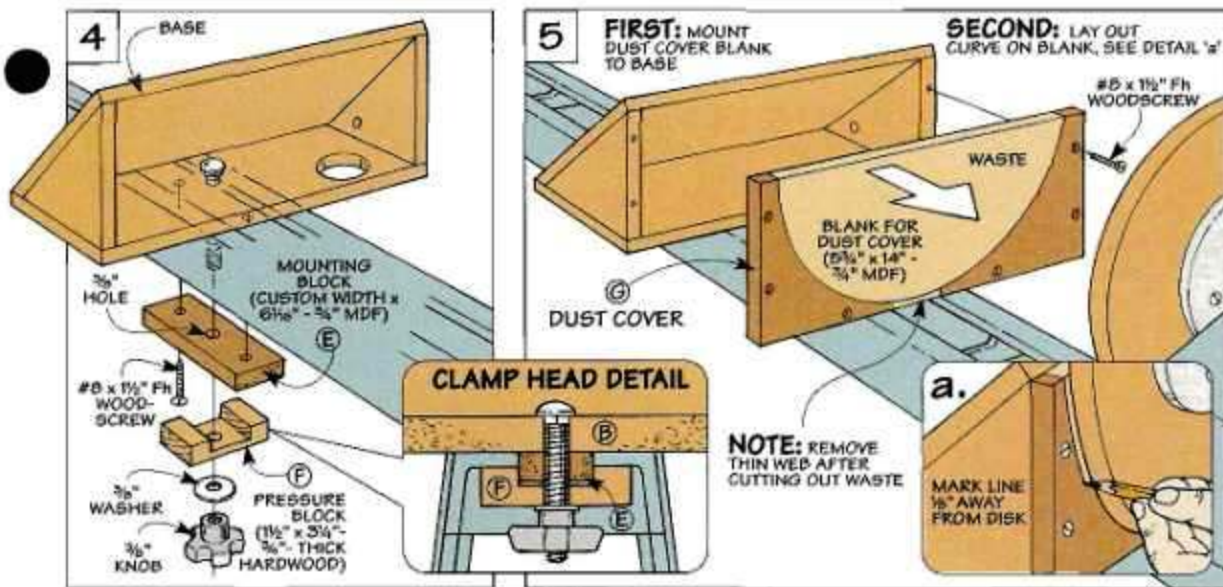

base, see Fig. 5. To prevent dust from escaping, the idea is to enclose the part of the opening that's *not* covered by the sanding disk.

The best way I found to accomplish that is to temporarily screw a rectangular blank to the base and butt it against the sanding disk. Then use the sanding disk as a template to lay out the curved shape of the dust cover, see Fig. 5a. Note: To provide clearance for the spinning disk, you'll want to draw the line about  $\frac{1}{8}$ " away from the disk.

After removing the blank, it's just a matter of cutting the dust cover to shape. I ended up with a thin "web" of material near the bottom of the dust cover. So I cut it into two parts and then glued and screwed each piece to the base.

**ADJUSTABLE TABLE**

With the base complete, it's time to concentrate on the adjustable table. The table provides a large, flat work-surface for sanding. Plus, it can be tilted to make it easy to sand a bevel on the edge of a workpiece.

To create a hard, durable surface, the *table (H)* is made from  $\frac{3}{4}$ " MDF, see Step 1 in drawing at right. Then it's "wrapped" with hardwood (maple) edging to protect the exposed edges.

**MITER SLOT.** After gluing on the edging, I cut a slot in the table to fit

the bar on my miter gauge. A dado blade mounted in the table saw makes quick work of cutting the slot.

**CUT NOTCH.** I also wanted as much support as possible when sanding irregular-shaped pieces, see photo at right. So I notched the back edge of the table to fit around the edge of the sanding disk.

**INSTALL HINGE.** The table is attached to the base with a contin-

uous hinge. To allow the table to tilt down without binding, the knuckle of the hinge needs to be set in from the edge of the table, see Step 2 below. (I located one leaf of the hinge  $1\frac{1}{8}$ " in from the edge and screwed it in place.)

The other leaf of the hinge is simply mounted to the top edge of the side as shown in the top drawing and Hinge Detail on page 8.



▲ To provide extra support for irreg- lar-shaped pieces, the table extends past the sanding disk.

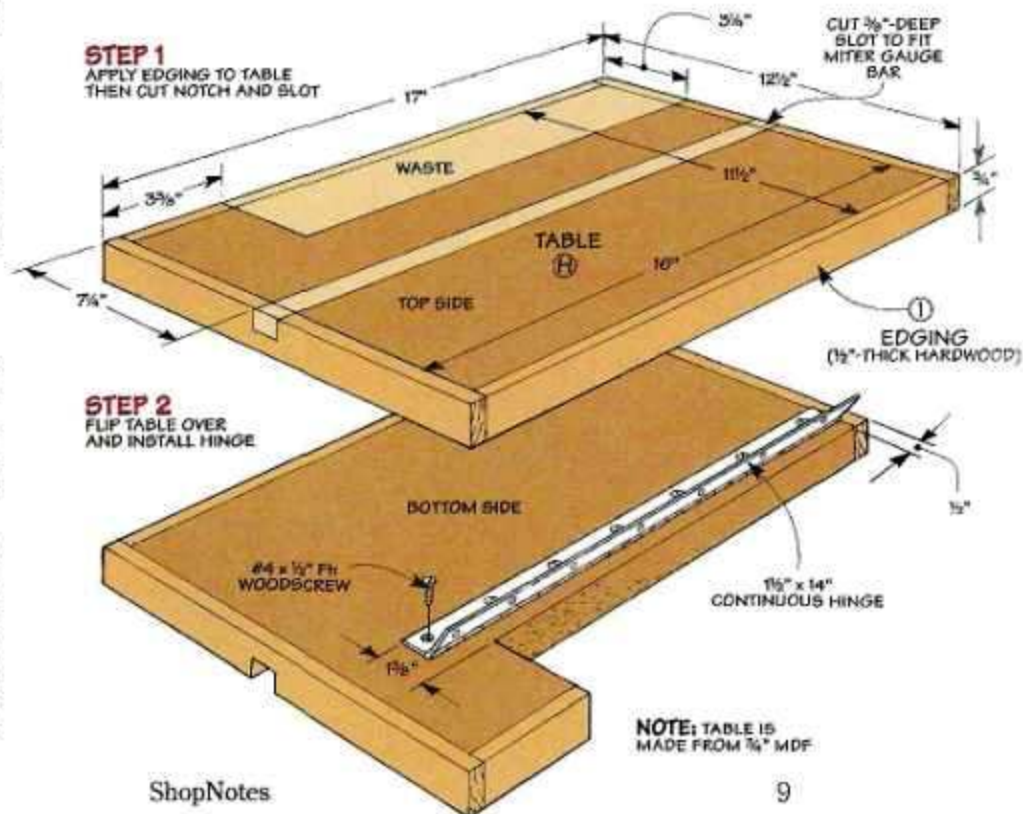

# Tilt Plate

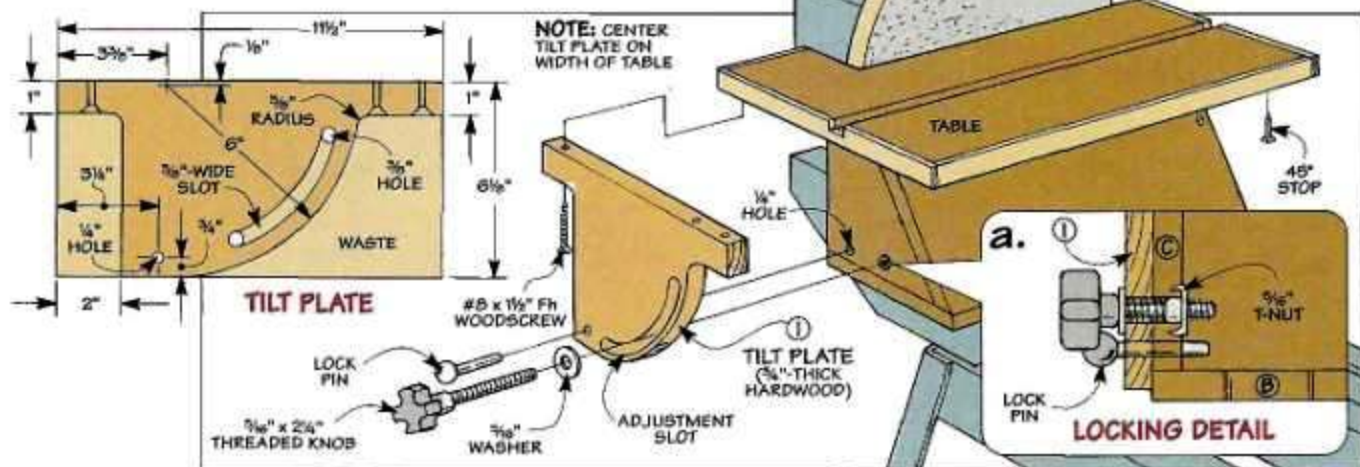

3/4"-dia. Plastic Ball Knob with 1/4" Threaded Insert



▲ All it takes to make the lock pin is a round, plastic knob (see page 31 for a source) and a bolt with the head and a portion of the threads cut off.

At this point, you can tilt the table to any angle between 0° and 45°. But there's no way to lock it in place. That's the job of the *tilt plate* (1), see drawing above. It works together with a knob to lock the table at the desired angle.

**TILT PLATE.** The tilt plate starts out as a rectangular blank of 3/4"-thick hardwood. To accept a metal pin that's added later, you'll need to drill a hole near the bottom edge of the tilt

plate. Also, cutting a notch on one side of the plate and an arc on the other side forms two "ears" that are pre-drilled for mounting screws. Note: The adjustment slot is cut later.

To attach the tilt plate, you'll want to center it on the width of the table and butt it against the base. Then after clamping it in place, install the mounting screws.

**LOCK PIN.** Now you're ready to add a lock pin to hold the table

square to the sanding disk, see margin. To install the pin, start by squaring the table to the sanding disk, see Fig. 6. Then clamp the table in this position and use the hole in the tilt plate as a guide to drill a hole through the end of the base, see Fig. 6a. Now just push the pin into place, see Fig. 6b.

**ADJUSTMENT SLOT.** The next step is to cut the curved adjustment slot. It provides clearance for the knob that's used to lock the table at an angle. Later, this knob threads into a T-nut that fits in the hole drilled earlier in the base, see detail 'a' above.

But before installing the T-nut, the hole comes in handy when laying out the location of the adjustment slot. To mark one side of this slot, hold the tip of a pencil at the *top* of the hole, pull the lock pin, and tilt the table all the way down, see Figs. 7 and 7a. Then with the pencil at the *bottom* of the hole, repeat the process to lay out the other side of the slot.

To complete the slot, you'll have to remove the tilt plate. Then drill a hole at each end of the layout lines and cut the slot with a sabre saw.

**45° STOP.** After reinstalling the tilt plate, I added a 45° stop. It's just a screw installed in the bottom of the table. The location of the screw isn't critical. Just be sure that when the table is tilted down, the head of the screw contacts the base, see Fig. 7b. Adjusting the screw lets you "fine tune" the angle of the table to 45°.

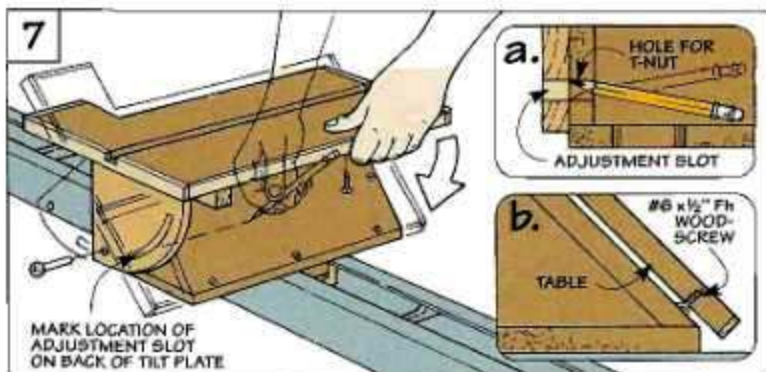
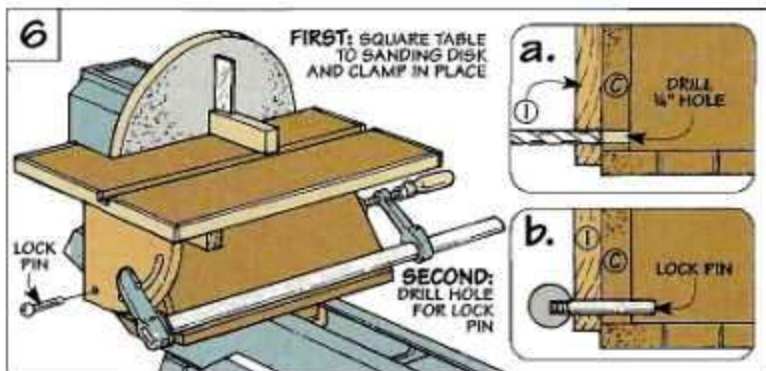

# Circle-Sanding Jig

As an option, you may want to add a circle-sanding jig to the disk sander, see photo. This jig makes it easy to sand a perfectly round circle up to 20" in diameter.

The way it works is simple. Start by fitting a rough-cut disk over a nail that serves as a pivot pin. (You'll have to drill a hole in the bottom of the disk for the nail.) Then all you need to do is slide the jig forward and rotate the disk to sand the edges smooth.

The jig consists of three parts: a large *platform* that supports the workpiece, a hardwood *guide* that rides against the table, and a *stop block* that establishes the final diameter of the disk, see Fig. 1.

**PLATFORM.** The platform is a square piece of  $\frac{3}{4}$ " MDF with a series of holes drilled in it to hold the nail. (I snipped the head off a finish nail.) So which hole do you use? That depends on the size of the disk.

The goal is to position the nail so there's as much support as possible for the disk, yet still have it extend beyond the leading edge of the platform. (Remember, you want to sand the disk, not the platform.)

**GUIDE.** The next step is to add the *guide*. It's a piece of  $\frac{3}{4}$ "-thick hardwood that keeps the platform square to the sanding disk. To form a handhold, there's a large slot near the lower edge of the guide, see Guide Detail in Fig. 1. A smaller slot makes the stop block adjustable.

**STOP BLOCK.** After attaching the guide with glue and screws, I added the hardwood stop block. It's held in place by tightening a knob on a bolt that passes through a hole in the stop block and the small slot in the guide.



**SETUP.** It only takes a minute to set up the jig. Start by placing it on the table so the distance between the nail and the sanding disk equals the desired radius of the circle, see Fig. 2. Then butt the end of the stop block against the table and tighten the lock knob.

Before putting the rough-cut disk on the nail, you'll need to move the jig away from the sanding disk. Then turn on the lathe and slide the jig forward until the stop block contacts the table, see Fig. 3. Now simply rotate the disk by hand to sand it smooth. 

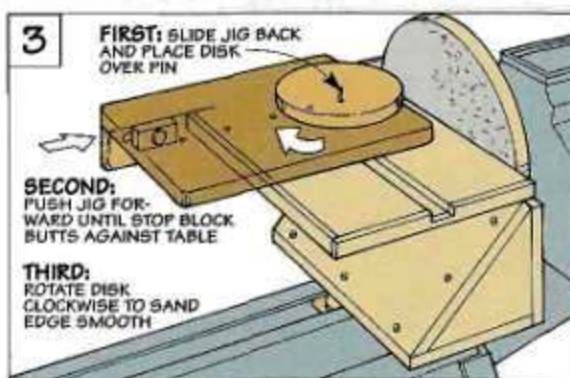
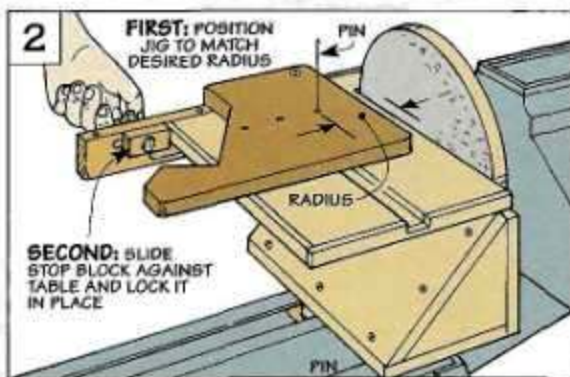
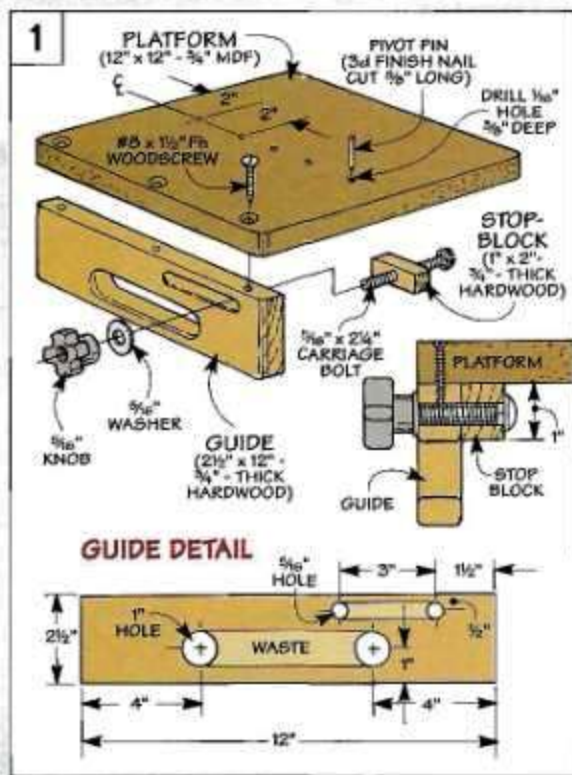

# Veneering Small Panels

**W**hen building the Cabinetmaker's Tool Chest that's featured on page 16, I decided to use veneer for a couple of reasons.

First, it allowed me to make the small panels in the tool chest out of *hardboard*. Besides reducing the weight of the chest, hardboard is more stable than solid wood. As a result, I was able to cover the hardboard panels with veneer and glue them into a frame — without worrying about wood movement splitting the joints apart.

As an added benefit, covering the panels with veneer provided a wide range of options when it came to determining the appearance of the tool chest. (I used bird's-eye maple veneer I'd been saving for a special project.)

**VENEER.** Veneer is nothing more than a very thin slice of wood (often only 1/32" thick). But once the veneer is glued to a core piece (the hardboard), it's difficult to tell it apart from a solid wood panel.

Although you can buy peel-and-stick veneer with a pressure-sensitive adhesive on back, I chose traditional veneer. This is the type of veneer that needs to be glued to a core piece. It's available in dozens of wood species as well as a number of highly-figured varieties. (For sources, refer to page 31.)

*Two layers of veneer . . . and a small piece of hardboard. That's all it takes to create the appearance of a solid wood panel.*



As a rule, veneer comes in pieces of random width and length. Because of this, you often have to edge-glue pieces together to cover a large surface.

But applying veneer to small panels is considerably easier. They can usually be covered without having to match or "piece" sheets of veneer together.

Another advantage of working with small pieces of veneer is it doesn't require any specialized clamps or presses. In fact, a few standard bar clamps provide all the pressure that's needed, see photo above.

## CUTTING VENEER

You won't need any special tools to *cut* the veneer either. A utility knife and straightedge work just fine.

**GRAIN PATTERN.** But before making a single cut, pay attention to the grain pattern and color of the veneer. Sometimes the grain is so "wild," it's difficult to visualize how the veneer will look once it's applied to the panel.

**PICTURE FRAME.** One way to simplify things is to make a "picture frame" out of posterboard. By sliding the frame across the sheet of veneer, you can see exactly how the panel will look once it's covered with veneer.

Occasionally, you'll "zero in" on an area only to find a split or crack in the veneer. Fortunately, there's an easy fix, see box on page 13.

**MAKING CLEAN CUTS.** After marking the desired section, you're ready to cut the veneer from the sheet. This can be a challenge. Veneer splits easily. And even with a sharp blade, it's possible to tear the wood fibers.

To prevent tearout when cutting *across* the grain, lightly score the wood fibers first. Then snap the veneer along the score line. When cutting *with* the grain, the blade may "follow" the grain line. So hold it firmly against the straightedge to prevent it from wandering.

**OVERSIZE PIECES.** No matter how careful you are, there's still likely to be some chipout. So to end up with a crisp, clean edge, it's best to start with an oversize piece

## Gap Filling Glue



With a name like "202 GF," I expected this glue to be special. I wasn't disappointed.

**EXTRA THICK.** First of all, it has the consistency of a milk shake. So unlike yellow woodworker's glue, it stays on the surface of the wood instead of soaking in. This makes it ideal for working with veneer. Since the glue doesn't penetrate, it's not as likely to cause problems when applying a finish.

**GAP FILLING.** This glue also comes in handy when building cabinets or furniture projects. Say you've got a joint that's slightly loose for instance. The solids in the glue act as a "gap filler" that helps strengthen the joint. (That explains the 'GF.' But what about the 202? It's just the manufacturer's code number.)

**EASY TO REMOVE.** Another thing I like about this glue is it chips easily when it's dry. So all it takes to remove any glue that squeezes out is a few strokes with a cabinet scraper. (See margin for sources.)

## SOURCES

**Garrett Wade**  
800-221-2942  
*Gap Filling Glue*

**Lee Valley**  
800-871-8158  
*Veneer Tape,  
Gap Filling Glue*

**Rockler**  
800-279-4441  
*Veneer Tape*

**Constantine's**  
800-223-8087  
*Veneer Tape*

of veneer (about  $\frac{1}{2}$ " longer and wider than the desired size of the panel). Then glue it onto a core piece that's about  $\frac{1}{8}$ " larger than the veneer. This way, when the panel is trimmed to size, any small splits near the edge are removed.

### GLUING & CLAMPING

Once the veneer is cut to rough size, the next step is to glue it onto the core piece. I use a simple "press" to glue the veneer down flat, see photo at right. Note: To ensure the panel stays flat, it's best to veneer both sides of the core piece.

**GLUE.** Another thing to consider is the type of glue. Yellow woodworker's glue works fine with tight-grained woods like cherry or maple.

But with open-grained woods like oak or mahogany (or highly-figured wood), the glue may "bleed" through the surface of the veneer. When the glue dries, it can cause an ugly spot that won't accept a stain (or finish). So I use a special type of glue that doesn't absorb into the wood fibers, see box on page 12.

Regardless of the type of glue, the key is to apply a thin, uniform layer. If there's a dry spot, the veneer may lift and form a "bubble." On the other hand, a puddle of glue may form a dried lump that can't be removed without sanding through the veneer. So I use a glue bottle with a roller to apply a thin, even film of glue.

One thing to be aware of is to



**VENEER PRESS**

apply glue to the core piece only (not the veneer). The moisture in the glue will cause the veneer to wrinkle up like bacon in a frying pan.

This moisture can also cause the veneer to curl a bit when you position it on the core piece. But dampening the top side of the veneer should make it lie flat, see margin.

**TAPE.** After covering both sides of the core piece, it's a good idea to tape the veneer in place. The tape prevents the veneer from slipping around on the core piece once the clamping pressure is applied. Note: I use drafting tape because it's easier to remove than masking tape.

### CLAMPING BLOCKS.

When clamping the veneer to the core piece, the goal is to distribute the pressure evenly across the entire surface. An easy way to do this is to slip the panel between two plywood blocks and clamp the "layer cake" together, see photo above. Note: Slipping in a couple of pieces of wax paper will prevent the panel from sticking to the clamping blocks.

**DRY TIME.** Once the glue sets up (in about an hour), you can remove the panel from the clamping blocks. It will still feel damp to the touch. So stand the panel on edge to allow air to circulate around it. When the panel is completely dry (overnight is best), just trim it to final size. 



**▲** If the veneer curls up when you place it on the core piece, mist it lightly with water to make it lie flat.

## Repairing Veneer

If a piece of veneer is split, trying to fix it might seem like a hopeless task, see inset photo. But it's really quite simple to make a repair that's nearly invisible.

**VENEER TAPE.** To do this, I use a special type of tape called *veneer tape*. Basically, it's a perforated strip of paper that's as thin as an onion skin, see photo at right.

The tape isn't sticky like you'd expect. But the side with the adhesive is shinier than the other. Moistening the shiny side makes the adhesive a bit gummy so you can

stick the tape to the veneer.

**SEAMLESS JOINT.** But first, squeeze the edges of the veneer together to create a "seamless" joint. (The holes in the tape make it easy to see if the edges shift out of alignment.) Then run a strip of tape along the joint line.

**REMOVE TAPE.** After gluing the taped-up veneer to the core piece, scrape (or sand) the veneer to remove the tape. (For sources of veneer tape, see margin on page 12.)

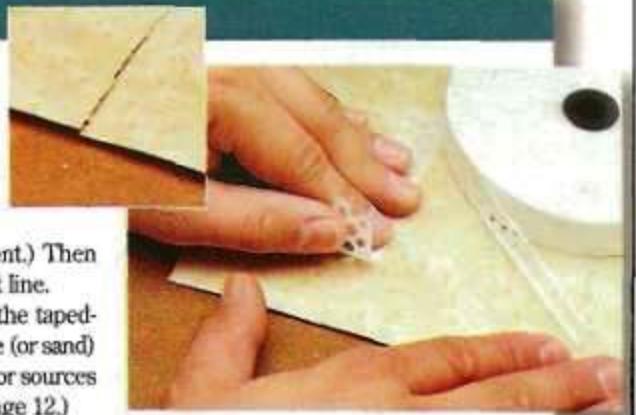

# Full-Mortise Lock

One of the challenges in building the tool chest that's featured on page 16 is installing the lock. To latch the lid securely, each part of the lock must be accurately aligned. Plus, it requires cutting mortises in the chest *after* it's nearly completed.

Now I'll admit this can be a bit nerve-racking. But a careful layout and a simple wood block make it a fairly straightforward task.

The lock I used has three main parts: the *lock body*, a brass *escutcheon*, and a *catch plate*, see drawing at right.

**LOCK BODY.** The body of the lock is housed in two mortises cut in the top edge of the case. A long, shallow mortise accepts the mounting flange on the lock body. And a short, deep mortise holds the lock mechanism.

Start by laying out the mortise for the mounting flange, see Step 1 below. To cut this mortise, I used a

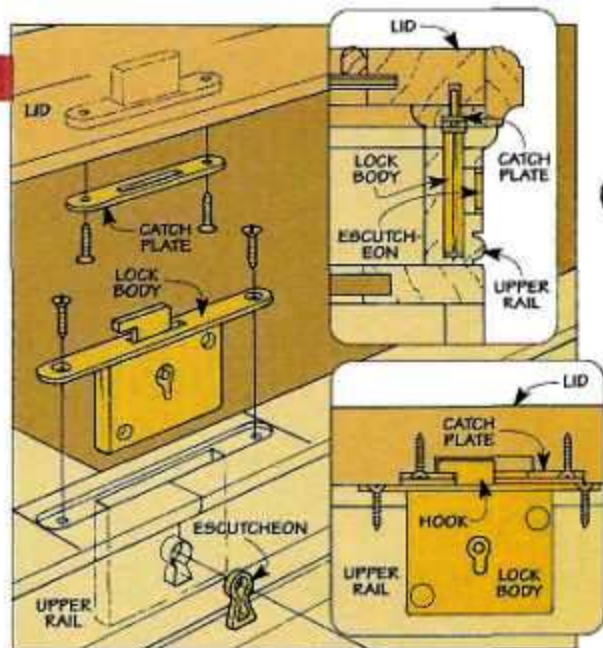

handheld drill and a brad point bit with a stop collar. The only problem is trying to hold the drill bit perpendicular to the top of the case.

The solution is a thick, hardwood *guide block* with a groove that fits over the edge of the case, see Step 2. A hole in the block guides the drill bit. The idea is to locate this hole

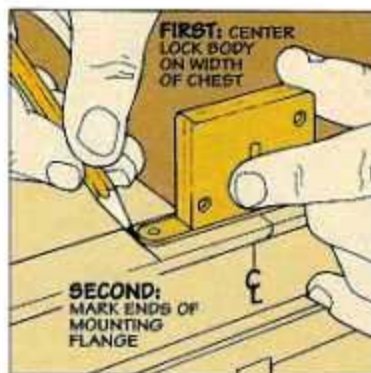

**1** Start by centering the lock body on the width of the case and marking the ends of the mortise.

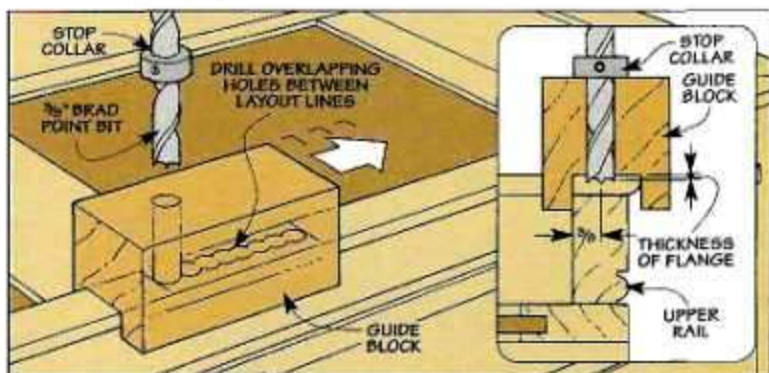

**2** After aligning the hole in the guide block with the layout line, cut the mortise by drilling a series of overlapping holes with a handheld drill and brad point bit. Then clean up the ridges with a chisel.

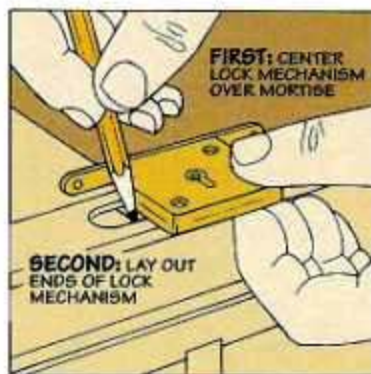

**3** Now you can lay out the location of the deep mortise that will hold the lock mechanism.

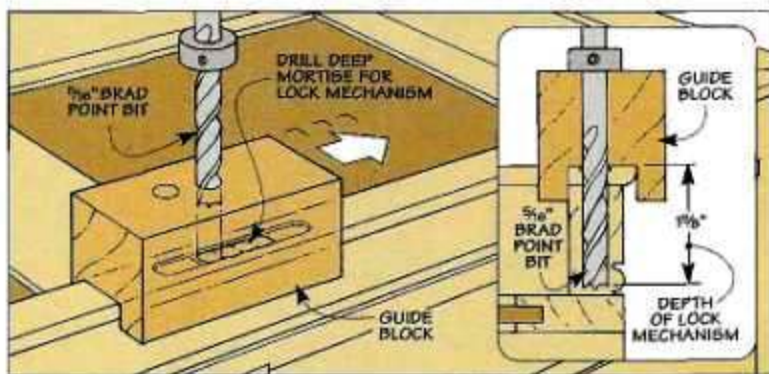

**4** After drilling a smaller ( $\frac{5}{16}$ ") hole in the guide block, drill a series of deep holes to form the mortise for the lock mechanism. Then pare off the remaining waste with a chisel, see photo above.

so the mortise is centered on the thickness of the *upper rail* (not the trim piece on top of the case). After aligning the guide block, it's just a matter of drilling a series of overlapping holes. Note: Shining a flashlight in the hole makes it easy to align the guide block.

Once the flange fits in the mortise, you can lay out the deep mortise for the lock mechanism, see Step 3. To cut this mortise, I drilled a smaller hole in the guide block (to match the thickness of the mechanism) and used the same process as before, see Step 4.

**ESCUTCHEON.** After squaring up the mortise, it's time to add the *escutcheon*. I know, it has a funny-sounding name. Especially since it has such a simple job. It's really just a brass keyhole that prevents the key from wearing against the case.

The escutcheon fits in a keyhole-shaped opening in the upper rail. To ensure a good fit, I started by creating an opening that's just large enough to accept the key, see Step 5. This requires drilling a hole in the upper rail and then filing a short slot.

Once the key fits in the opening, you can lay out the shape of the keyhole, see Step 6. Then file up to the line, checking the fit frequently. When you're satisfied with the fit, press the escutcheon in place, see margin.

**CATCH PLATE.** All that's left is to mortise the catch plate into the lid. Here again, a shallow mortise accepts the plate, and a deep mortise provides clearance for a hook in the lock.

To determine the location of the

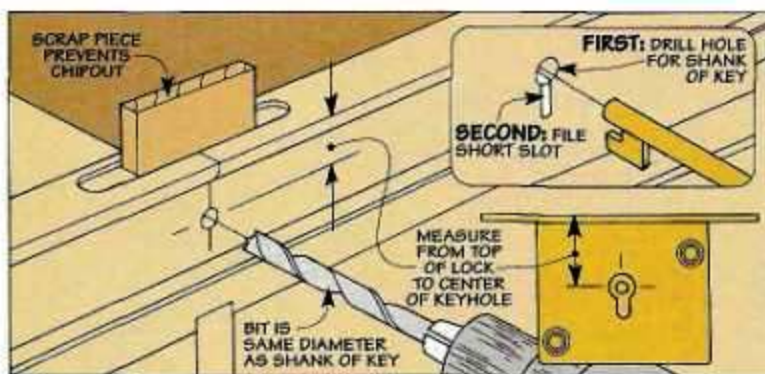

**5** To create the opening for the *escutcheon*, start by drilling a small hole in the upper rail to accept the shank of the key. Then file a short slot that's just large enough so you can slip the key in the opening.

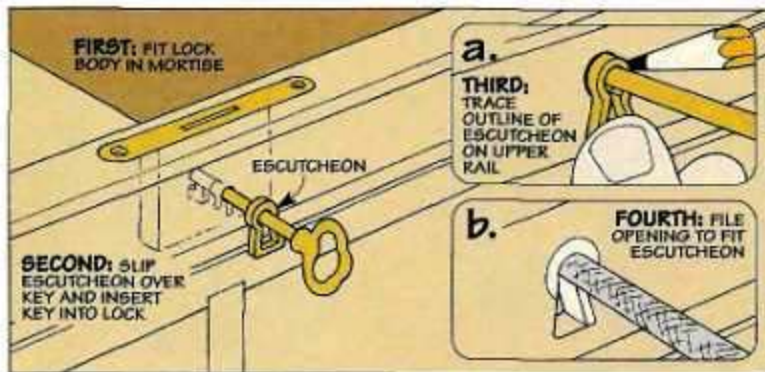

**6** After fitting the lock body in its mortise, slip the escutcheon onto the key. Then insert the key and trace around the escutcheon. Finally, file the opening so the escutcheon fits snug.

catch plate, start by attaching it to the lock with small pieces of carpet tape, see Step 7. You'll also want to attach a large piece of tape to the lid. Then close the lid and press down firmly. When you open the lid, the catch plate should be in its proper location, stuck to the large piece of tape.

After removing the lid and scoring around the catch plate (Step 8), it's just a matter of cutting the two mortises, see Step 9. Here again, I used two different-sized bits to drill the mortises. Note: To ensure the hook draws the lid down tight, it's best to recess the catch plate about  $\frac{1}{16}$ ".

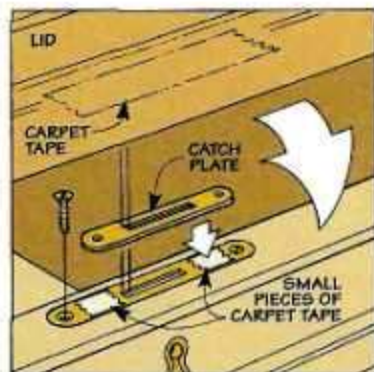

**7** Small pieces of carpet tape hold the catch plate in place. A large piece "pulls" it to the lid.



**8** After removing the lid of the tool chest, use a utility knife to mark the location of the catch plate.

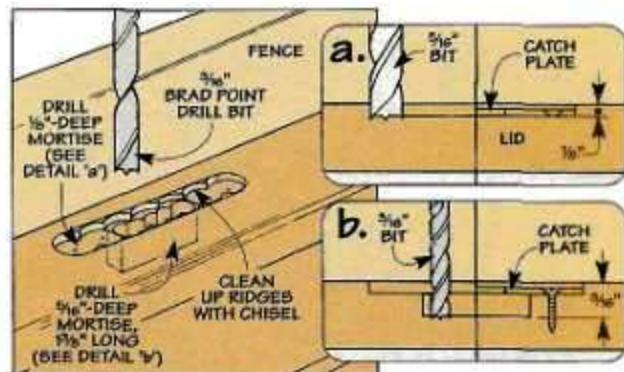

**9** Finally, drill the two mortises in the lid to hold the catch plate and provide clearance for the hook.



▲ To make it easy to install the escutcheon, use an ordinary C-clamp to apply even pressure.

# Cabinetmaker's Tool Chest

*This classic tool chest is designed to hold your favorite hand tools for generations to come.*

**R**ecently, there's been quite a bit of talk around here about a "treasure chest" in the shop. One look at this cabinetmaker's tool chest makes it easy to see why.

With its figured wood and solid brass hardware, the chest provides safekeeping for your fine hand tools. Perhaps it will even become an heirloom that gets handed down from one generation to the next.

But the real treasure isn't the chest, or even the tools inside. It's all the interesting woodworking challenges that building a chest like this presents.

**FRAME & PANEL.** The main case is made up of several frame and panel assemblies, see Exploded View on page 17. The frames are solid wood. (I used curly maple for the frames and drawer fronts.) But the panels only *appear* to be solid wood. They're actually pieces of hardboard covered with veneer on both sides. (I used bird's-eye maple veneer.)

**BEADS.** Another interesting part of building this chest is making two types of decorative beads, see photos at right. One bead is routed on the drawer fronts. The other is a strip of *bead molding* that's applied to the panels.

**HARDWARE.** Of course, a beautiful tool chest deserves some special hardware. The solid brass drawer knobs have a wood plug that's "turned" to shape on a drill press, see photo 'A' below. Also, heavy-duty handles allow you to get a good grip when carrying the chest, see photo 'B.'



**Drawer Bead**

**Bead Molding**

**LOCK SYSTEM.** I should mention the neat, two-part system used to lock the drawers and lid. To "lock" the drawers, simply slide a brass rod down through the chest, see photo 'C.' And a full-mortise lock and key secure the lid. There's even an old-fashioned brass escutcheon (keyhole) mortised into the chest.



**A. Knob.** A solid brass knob with an ebony plug highlights the drawers.



**B. Chest Handle.** To avoid pinching your fingers against the case, there's a built-in stop on the ends of the handles.



**C. Lock System.** When closing up shop, slide a brass rod down through the chest (left) to lock the drawers. Then secure the lid with a full-mortise lock and key, see photo at right.





**EXPLODED VIEW**

OVERALL DIMENSIONS:  
(25"W x 15<sup>3</sup>/<sub>16</sub>"H x 13"D)

**NOTE:**  
Back, sides, and lid are made up of veneered panels surrounded by solid wood frames

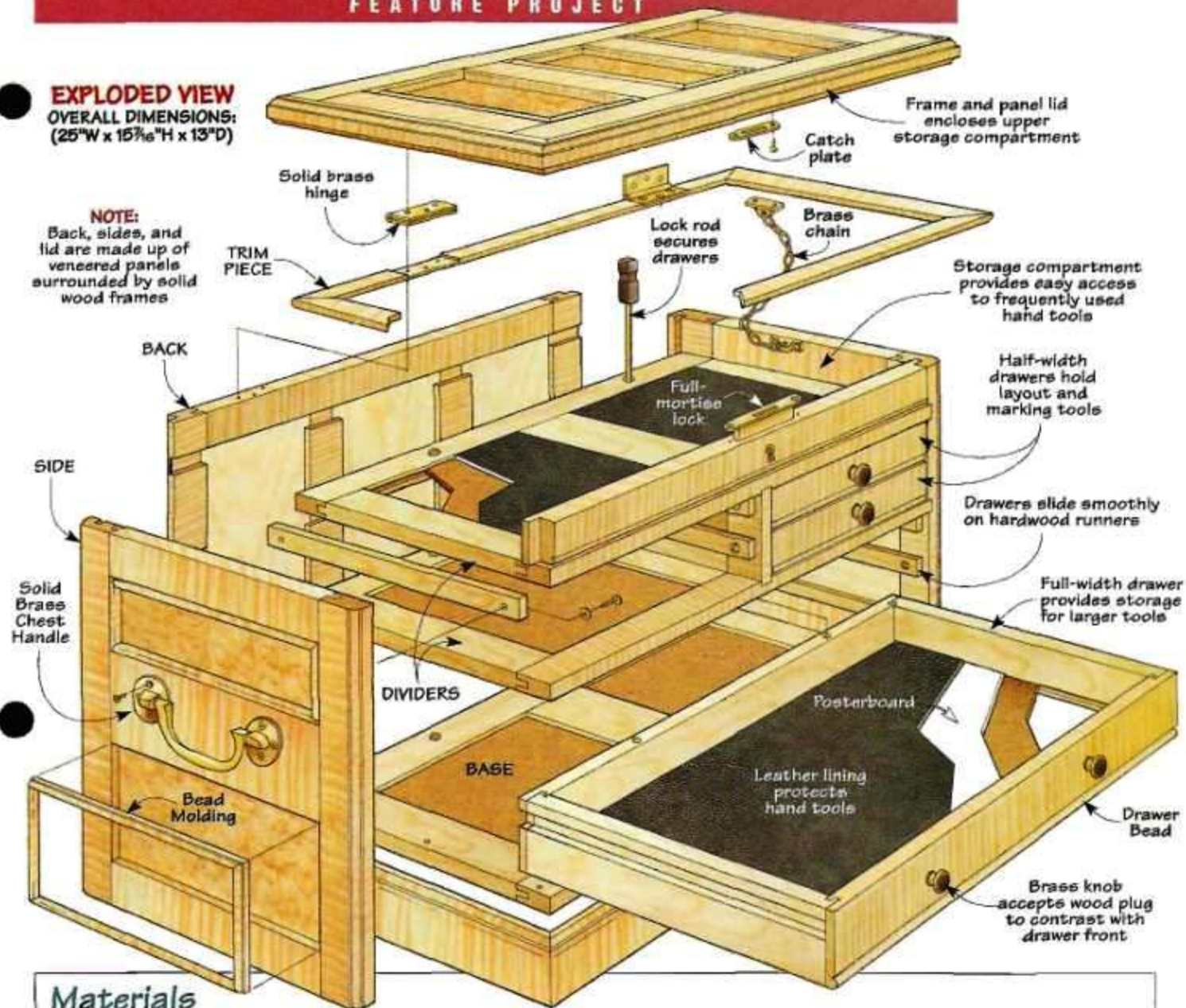

**Materials**

**Sides**

- A Upper Panels (2) 3<sup>3</sup>/<sub>16</sub> x 9<sup>3</sup>/<sub>4</sub> - 1/8 Hdbd.
- B Lower Panels (2) 4<sup>3</sup>/<sub>4</sub> x 9<sup>3</sup>/<sub>4</sub> - 1/8 Hdbd.
- C Stiles (4) 3/8 x 1 1/2 - 12<sup>1</sup>/<sub>16</sub>
- D Rails (4) 3/4 x 1 1/2 - 9<sup>3</sup>/<sub>4</sub>
- E Inner Rails (2) 3/4 x 3 - 9<sup>3</sup>/<sub>4</sub>
- F Bead Molding 3/8 x 5/16 - appr. 25 lin. ft.

**Back**

- G Back Panels (3) 6<sup>3</sup>/<sub>4</sub> x 10<sup>3</sup>/<sub>16</sub> - 1/8 Hdbd.
- H Outer Stiles (2) 3/4 x 1 - 12<sup>1</sup>/<sub>16</sub>
- I Inner Stiles (2) 3/4 x 1 1/2 - 10<sup>3</sup>/<sub>16</sub>
- J Rails (2) 3/4 x 1 1/2 - 21<sup>1</sup>/<sub>4</sub>

**Dividers**

- K Stiles (4) 1/2 x 1 1/2 - 9<sup>3</sup>/<sub>4</sub>
- L Center Stiles (2) 1/2 x 3 - 9<sup>3</sup>/<sub>4</sub>
- M Front Rails (2) 1/2 x 1 1/2 - 22<sup>3</sup>/<sub>4</sub>
- N Back Rails (2) 1/2 x 1/8 - 22<sup>3</sup>/<sub>4</sub>

**Base**

- O Panels (4) 9/16 x 9<sup>3</sup>/<sub>4</sub> - 1/4 Hdbd.
- P Stiles (2) 1/2 x 1 1/2 - 3<sup>3</sup>/<sub>16</sub>
- Q Rails (2) 1/2 x 1 1/2 - 9<sup>3</sup>/<sub>16</sub>
- R Panel (1) 1<sup>3</sup>/<sub>16</sub> x 9<sup>3</sup>/<sub>16</sub> - 1/4 Hdbd.
- S Upper Rail (1) 3/4 x 1 1/2 - 23
- T Runners (14) 1/4 x 5/8 - 11

**Large Drawers**

- U Stiles (2) 1/2 x 1 1/2 - 9<sup>3</sup>/<sub>16</sub>
- V Center Stile (1) 1/2 x 3 - 9<sup>3</sup>/<sub>16</sub>
- W Rails (2) 1/2 x 1 1/2 - 23<sup>3</sup>/<sub>16</sub>
- X Panels (2) 9<sup>1</sup>/<sub>16</sub> x 9<sup>3</sup>/<sub>16</sub> - 1/4 Hdbd.
- Y Frt./Bk. Aprons (2) 1/2 x 1<sup>3</sup>/<sub>4</sub> - 24<sup>7</sup>/<sub>16</sub>
- Z Side Aprons (2) 1/2 x 1<sup>3</sup>/<sub>4</sub> - 12<sup>7</sup>/<sub>16</sub>
- DD Front/Backs (2) 1/2 x 1<sup>3</sup>/<sub>4</sub> - 22<sup>1</sup>/<sub>16</sub>
- EE Sides (2) 1/2 x 1<sup>3</sup>/<sub>4</sub> - 10<sup>3</sup>/<sub>4</sub>
- FF Front/Backs (2) 1/2 x 2<sup>1</sup>/<sub>16</sub> - 22<sup>1</sup>/<sub>16</sub>
- GG Sides (2) 1/2 x 2<sup>1</sup>/<sub>16</sub> - 10<sup>3</sup>/<sub>4</sub>
- HH Front/Backs (2) 1/2 x 2<sup>5</sup>/<sub>16</sub> - 22<sup>1</sup>/<sub>16</sub>
- II Sides (2) 1/2 x 2<sup>5</sup>/<sub>16</sub> - 10<sup>3</sup>/<sub>4</sub>
- JJ Bottoms (3) 21<sup>1</sup>/<sub>16</sub> x 10<sup>3</sup>/<sub>16</sub> - 1/4 Hdbd.
- KK Handles (2) 1/2 x 1/2 - 1 1/2

**Small Drawers**

- AA Front/Backs (8) 1/2 x 1 1/2 - 10<sup>2</sup>/<sub>16</sub>
- BB Sides (8) 1/2 x 1 1/2 - 10<sup>3</sup>/<sub>4</sub>
- CC Bottoms (4) 10<sup>1</sup>/<sub>4</sub> x 10<sup>3</sup>/<sub>16</sub> - 1/4 Hdbd.

**Lid**

- LL Panels (3) 6<sup>3</sup>/<sub>4</sub> x 9<sup>3</sup>/<sub>4</sub> - 1/8 Hdbd.
- MM Stiles (4) 3/4 x 1 1/2 - 9<sup>3</sup>/<sub>4</sub>
- NN Rails (2) 3/4 x 1 1/2 - 24
- OO Frt./Bk. Edging (2) 3/4 x 1 - 25
- PP Side Edging (2) 1/2 x 1 - 13
- QQ Trim Pieces 1/4 x 1<sup>1</sup>/<sub>16</sub> - appr. 13 lin. ft.

# Case

I began work on the tool chest by building a U-shaped case. It consists of two *sides* and a *back* that are made up of small, veneered panels surrounded by solid wood frames.

**PANELS.** The panels (A, B, and G) start out as pieces of  $\frac{1}{8}$ " hardboard, see Fig. 1. Then to create the appearance of solid wood, they're covered with veneer. Note: To keep the panels from warping, it's best to apply veneer to *both* sides.

I glued bird's-eye maple veneer to one side of each panel. It creates a dramatic look on the "show" side of the panel. But the other side will be hidden, so I used plain maple veneer. (For information on veneering panels, see page 12.)

**FRAMES.** The next step is to "wrap" the panels with frames made of  $\frac{3}{4}$ "-thick hardwood. The frames are made up of several vertical *stiles* (C, H, and I) and horizontal *rails* (D, E, and J), see Fig. 1.

**STUB TENON & GROOVE.** These frame pieces are assembled with stub

tenon and groove joints. Unlike a traditional mortise and tenon, this type of joint doesn't have a "true" mortise.

Instead, there's a groove in the frame piece that houses a short (stub) tenon. This groove also holds the panel. Note: There's a groove in *each* edge of the *inner* rail and stiles.

**OFFSET GROOVES.** One thing to be aware of is that the grooves are offset toward the *inside* face of the

frame pieces. The reason is simple. The offset grooves recess the panels far enough into the frames so when the bead molding is added later, it will sit flush with the frame.

**GROOVE WIDTH.** Another consideration is the *width* of the grooves. This is determined by the thickness of the panels.

The goal is to get the panel to slide into the groove with a "friction fit." An easy way to accomplish that is to use a combination saw blade and cut each groove by making two passes.

Start by locking the rip fence on the table saw so it's  $\frac{3}{8}$ " away from the inside of the saw blade, see Fig. 1a. Then, after making one pass on each frame piece, nudge the fence (away from the blade) and make a second pass to sneak up on the final width of the groove.

**CUT TENONS.** Now you're ready to cut the stub tenons. The tenons need to be offset by the same amount as the grooves. Otherwise, the frame pieces won't fit flush with each other.

So start by setting the height of the saw blade to match the offset and cut the first cheek, see Fig. 1b. Now lower the blade and flip the workpiece over to cut the second cheek. Continue raising the blade in small

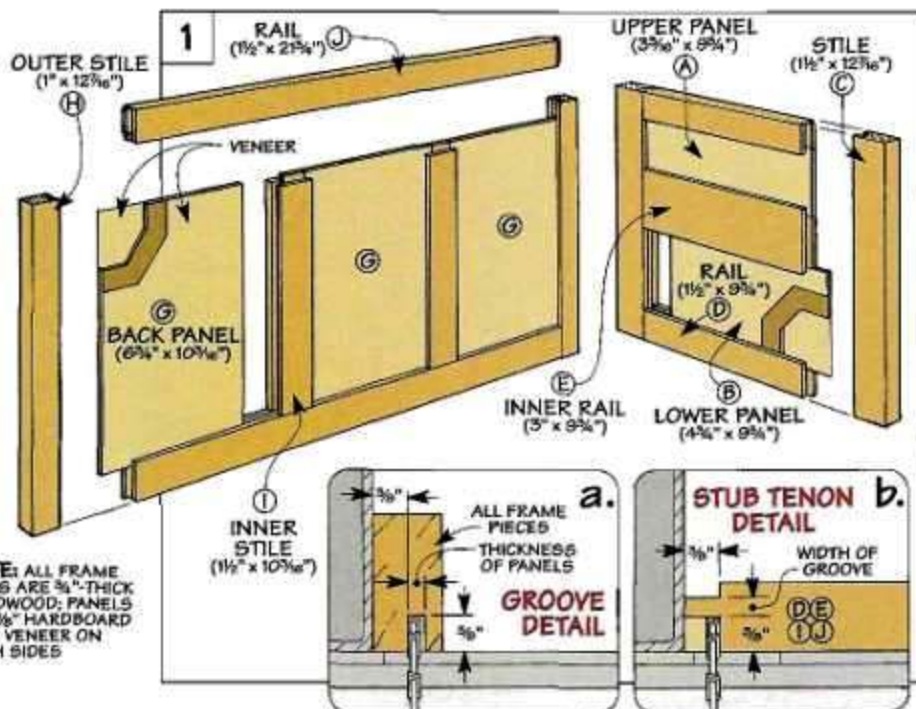
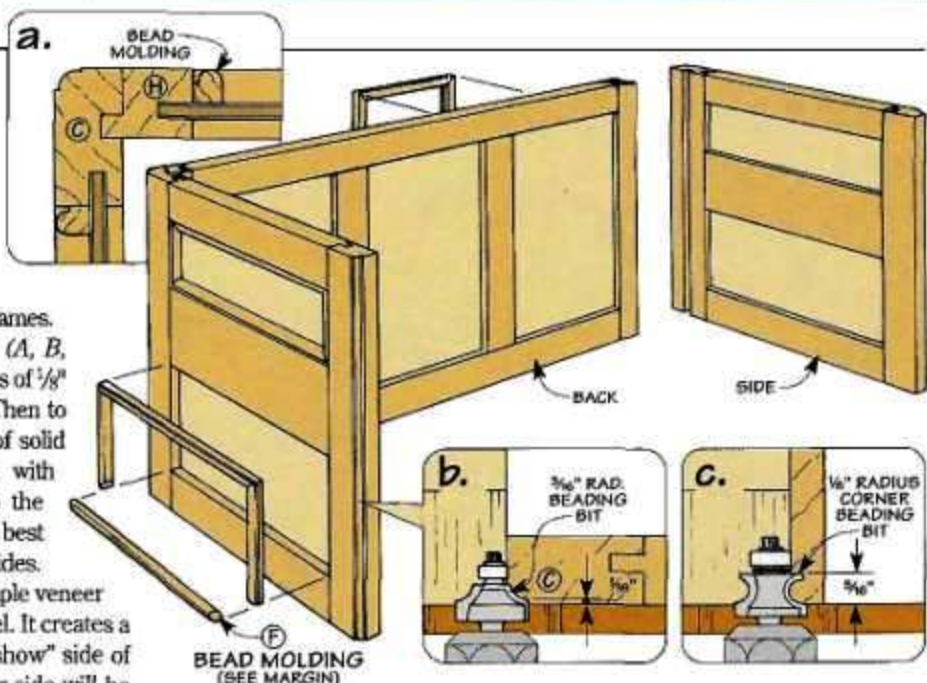
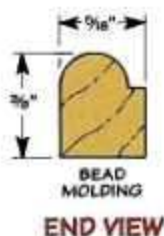

increments and making additional passes until you sneak up on the final thickness of the tenon.

**GLUE-UP.** After cutting all the stub tenons, you can glue up the sides and back. Just remember to orient the "show side" of the panels toward the *outside* of the frame.

**TONGUE & GROOVE.** Once the glue dries, the next step is to cut the joinery that's used to assemble the sides and back. To do this, I used a simple tongue and groove joint, see detail 'a' on top of page 18. This is a two-step process.

The first step is to cut a groove in the back stile of each side, see Figs. 2 and 2a. Once again, I made two passes, repositioning the rip fence between passes.

The second step is to rabbet each end of the back to form a tongue that fits the groove. To do this, I "buried" a dado blade in an auxiliary fence and made a single pass to cut the rabbet, see Figs. 3 and 3a.

**CORNER PROFILE.** Once the joinery was complete, I routed a decorative profile on each outside corner on the sides, see detail 'b' in drawing on page 18.

**BEAD MOLDING.** In addition to the routed profile, I applied strips of

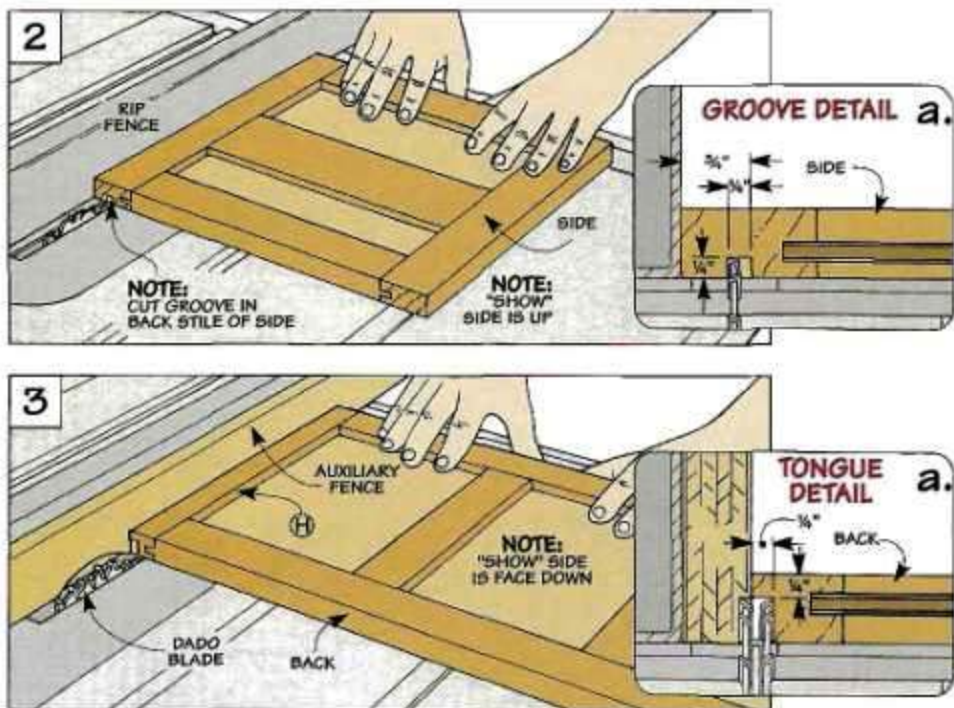

bead molding (*F*) around the panels. These are narrow strips of hardwood (curly maple) with a decorative bead that's routed with a beading bit, see detail 'c.'

For safety, I made the molding by routing both edges of an extra-wide workpiece. Then I used a simple jig to rip the strips of molding to a con-

sistent width, see box below. After ripping both edges, just rout another set of beads and repeat the process.

While you're at it, it's a good idea to make extra molding to use on the lid of the tool chest. (I made twenty-five linear feet.) After mitering the strips of bead molding to length, they're simply glued in place.

## Ripping Narrow Strips

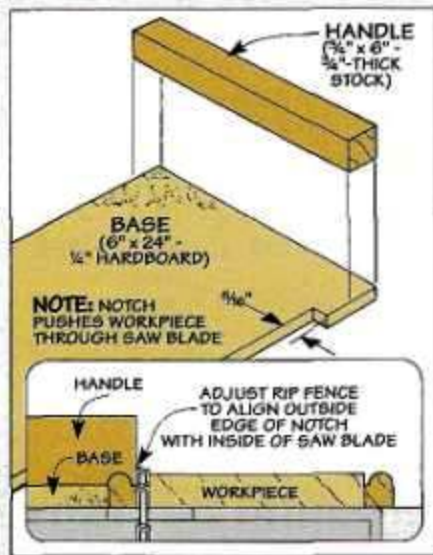

When ripping narrow strips of material (like the bead molding on the tool chest), I use a simple jig that rides against the rip fence on the table saw, see photo. It ensures that each strip is identical in width.

The jig consists of two parts. A hardboard *base* has a notch that's sized to match the width of the strip, see drawing. And a wood *handle* is glued to the base.

**SETUP & USE.** To set up the jig, start by positioning the rip fence so the outside edge of the notch aligns with the inside of the saw blade, see detail. After fitting the workpiece in the notch, push the jig past the saw blade to rip the first strip of molding.



To rip the molding from the opposite edge, there's no need to reposition the rip fence. Just flip the workpiece end for end and repeat the process. **Safety Note:** To keep your hands well away from the blade, it's best to use a workpiece that's at least 3" wide.

## Rail & Dividers

The inside of the case is divided to form an upper storage compartment and the openings for the drawers. To do this, I added an *upper rail*, a pair of large *horizontal dividers*, and a small *vertical divider*, see drawing at right.

The upper rail and horizontal dividers fit into a series of grooves and dados that are cut in the sides and back of the case, see Fig. 4.

**STOPPED GROOVES.** But before you get started, there's one thing to be aware of. To accept the upper rail, you'll need to cut a short, *stopped groove* in the front stile of each side, see Fig. 4. I used a table-mounted router and a  $\frac{1}{4}$ " straight bit to do this. But since the sides are mirror images, it requires two different setups.

Start by positioning the fence and clamping a stop block to it, see Fig. 5. Then with the side riding against the fence, slide it forward until it hits the stop block. Note: Wait for the bit to stop spinning before lifting the side.

To cut the groove in the second side assembly, you'll need to reposition the stop block, see Fig. 6. Then lower the side onto the spinning bit and slide it forward until the bit cuts through the top edge of the side.

**DADOES.** The next step is to cut the dados that hold the horizontal dividers. I used a table-mounted

router here as well. But this time, I installed a  $\frac{1}{2}$ " straight bit and adjusted it for a shallow ( $\frac{1}{8}$ ") cut, see Fig. 4a.

Once again, the dados in the *sides* are stopped short of the back edge. This way, the ends of the dados won't be visible when the case is assembled.

To rout these stopped dados, I used the same basic method. The only difference is the stop blocks are clamped farther from the bit.

But when it comes to routing the

dadoes in the *back* of the case, there's no need to use stop blocks. That's because the dados go all the way through.

### DIVIDERS

Now you can turn your attention to the two *horizontal dividers* and the *vertical divider*. Like the sides and back of the case, each divider is a simple frame and panel assembly that's held together with stub tenon and groove joints. But there are a few differences worth noting.

**FRAMES.** First of all, the *stiles* (K, L, and P) and *rails* (M, N, and Q) that make up the frames are  $\frac{1}{2}$ "-thick hardwood instead of the  $\frac{3}{4}$ " stock I used for the sides and back.

Most of these frame pieces will be hidden inside the case. But the *front edge* of each frame will be exposed once the case is assembled. So when making the rail (or stile) that's visible in front, it's worth taking some time to select the wood that complements the grain pattern in the rest of the chest.

**PANELS.** Another difference in the dividers is that the *panels* (O and R) are made of  $\frac{1}{4}$ " hardboard instead of  $\frac{1}{8}$ " material. And since the

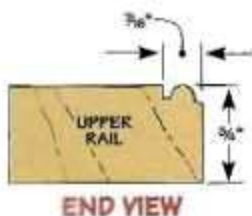

END VIEW

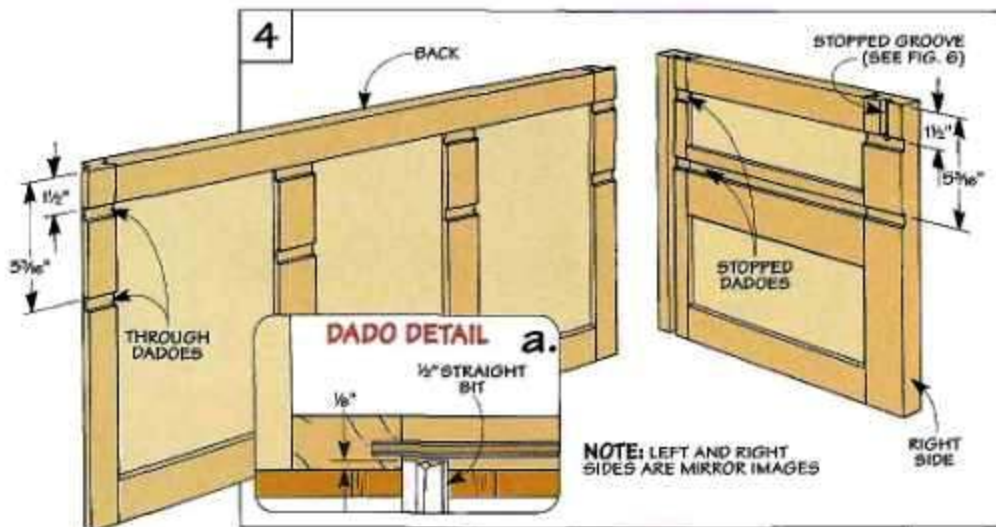
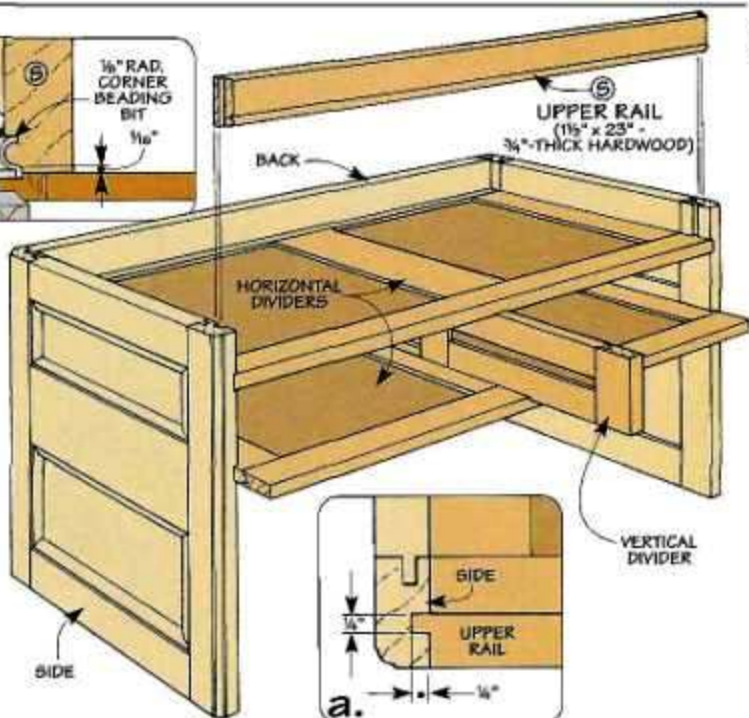

panels will be covered up, there's no point in applying veneer.

**GROOVES.** The panels fit in grooves that are centered on the thickness of the frame pieces. Cutting a centered groove is easy. Just set the rip fence so the blade is roughly centered on the workpiece, see Fig. 7a. Then make two passes, flipping the piece end for end between each pass. If you need to widen the groove, nudge the rip fence and repeat the process.

**STUB TENONS.** Of course, the stub tenons will have to be centered on the thickness of the frame pieces as well. Once again, it's best to make two passes (one on each side), see Fig. 7b. If necessary, repeat the process until the tenon fits in the groove.

**CUT DADOES.** After gluing up all the dividers, the next step is to cut a dado in each horizontal divider. These dados are centered on the length of the horizontal dividers, see Fig. 7. And they're sized to accept the vertical divider, see Fig. 7d.

**DRILL HOLES.** The second thing is to drill two countersunk shank holes in the back rail of each horizontal divider, see Figs. 7 and 7c. Later, these holes accept a brass rod that's used to lock the drawers.

### UPPER RAIL

Once the dividers are complete, you can add the upper rail. It spans the opening in front of the case and

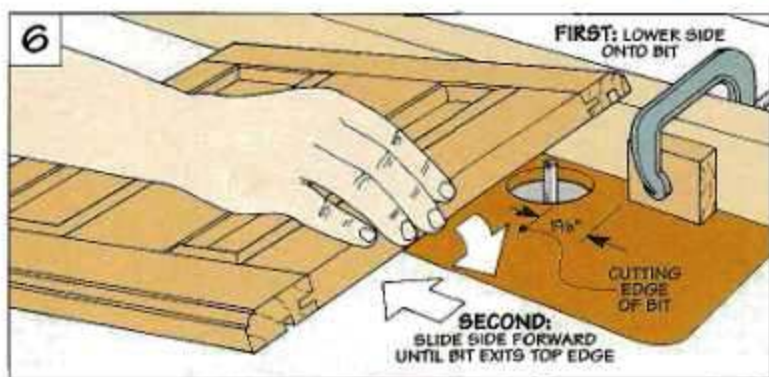
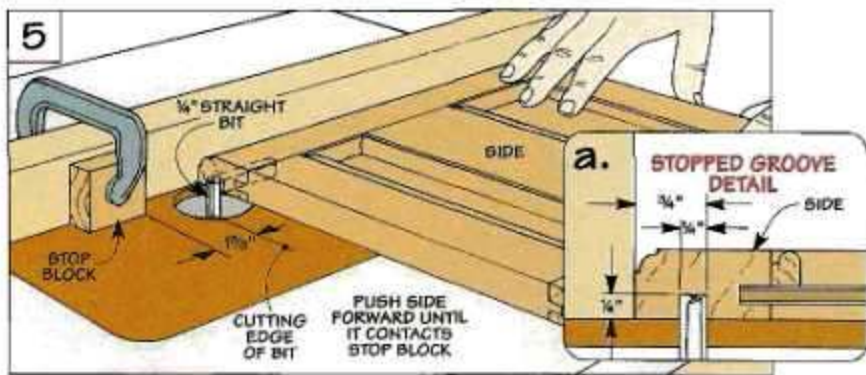

encloses the storage compartment.

The upper rail (S) is a narrow strip of 3/4"-thick hardwood that's cut to the same length as the back of the case, see drawing on page 20. It's also joined to the sides the same way as the back — with a tongue at each end that fits into the grooves in the sides, see detail 'a'.

**BEAD.** There's just one more thing to do. That's to rout a bead

along the bottom edge of the rail, see detail 'b' on page 20. I used the same router bit here as when making the bead molding. But there's a twist.

To create a "shadow line" between the rail and the divider, I adjusted the height of the bit to form a shoulder along the bottom of the bead. This shadow line is designed to imitate the gap between the drawers which will be added later.

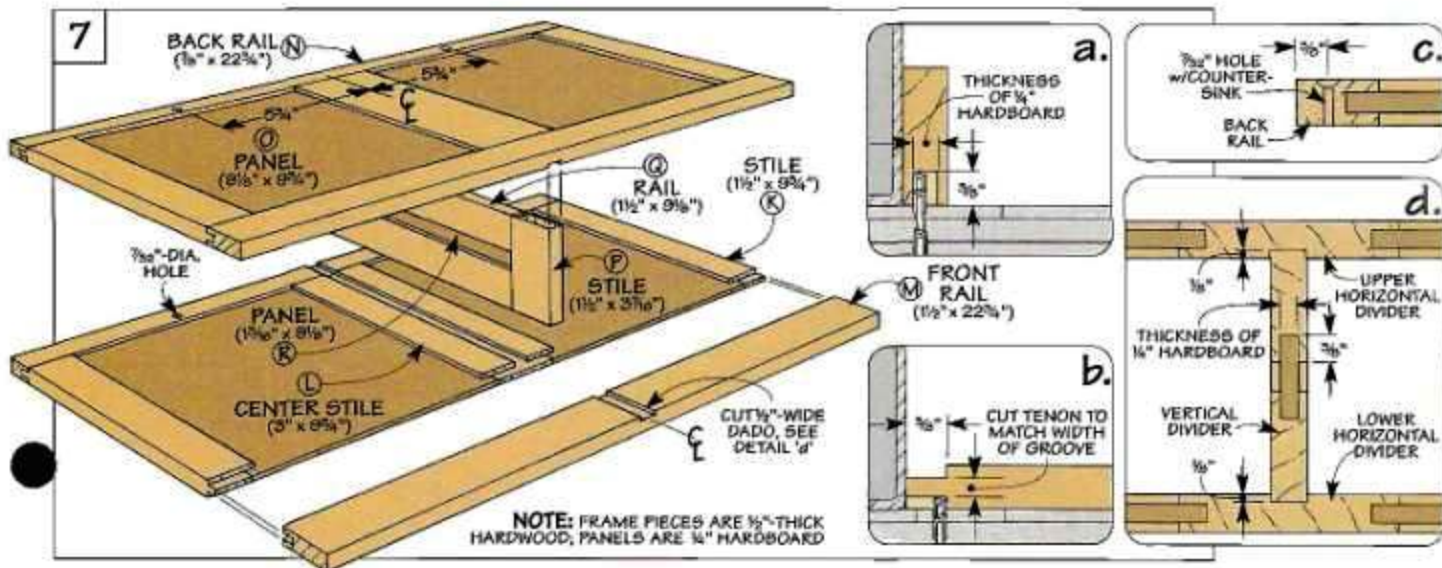

## Runners

The drawers in this tool chest slide on hardwood runners screwed to the sides and the vertical divider, see drawing at right. It's best to mount these runners *before* assembling the case — while there's room to work.

The runners (*T*) are thin, narrow strips of hardwood, see Fig. 8. (I made fourteen runners altogether, two for each of the seven drawers.) So I started by planing enough stock for all the runners to a thickness of  $\frac{5}{8}$ " (the final width of the runners). Then I ripped fourteen  $\frac{1}{4}$ "-thick strips.

**MOUNTING HOLES.** After cutting the runners to size, the next step is to drill a hole near each end to accept a mounting screw. One thing to note is the holes are set in a different distance from each end of the runner. This way, when it's time to mount the runners to the vertical divider, you can flip two of them end for end to prevent the screws from hitting, see details 'c' and 'd' at right.

Aside from their location, the holes are identical, see End View in Fig. 8a. A counterbore creates a "pocket" for a washer and the head of a screw. And oversized shank holes make the runner adjustable.

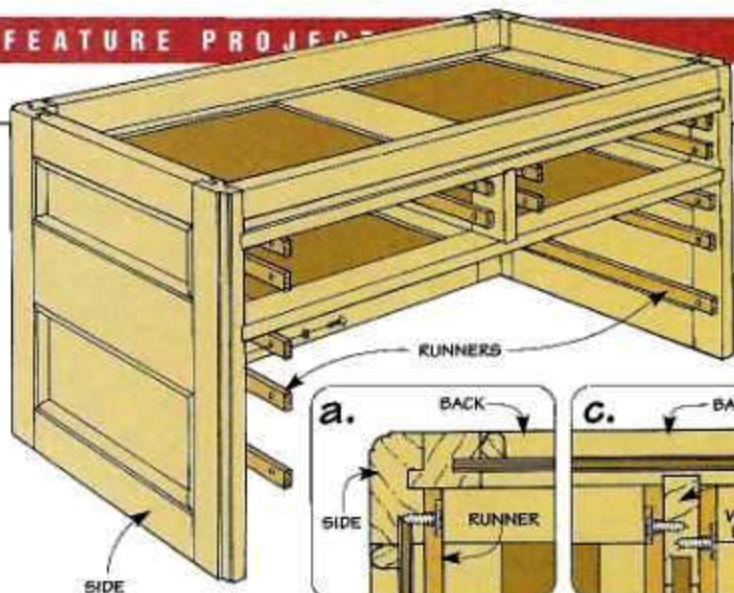

**INSTALL RUNNERS.** Now you're ready to install the runners. Even though the mounting holes provide some adjustment, it's still important to pay attention to the alignment of the runners.

The goal is to locate each pair of runners so the *top* edges are level. (That's because the drawers will rest on the *top* edge of the runners.) This will ensure an even gap above and below each drawer.

**ALIGNMENT BLOCKS.** To accomplish that, I dry-assembled the case and used two scrap blocks to align

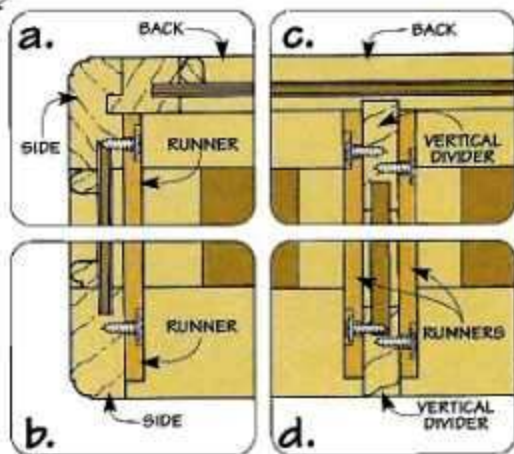

the runners inside the case, see Fig. 9. These are just pieces of MDF with grooves that hold the runners.

The idea here is to locate the grooves the same distance from the *top* of the blocks as the distance of the runners *below* the dividers. This will ensure that the runners are positioned accurately in the case.

To make this work, you'll need to cut each block to fit snug in either the large or small drawer opening. Also, the depth of the grooves is slightly *less* than the thickness of the runners which means the runners will sit just a bit "proud."

The reason for this is simple. After "loading" the runners in the grooves (flush with the back edge of the blocks), a strip of carpet tape is applied to each end, see Fig. 9a. This way, when you press the blocks against the sides (or vertical divider), the tape sticks each runner in its correct position. Note: The blocks should be flush with the front of the case.

To install the rest of the runners, you can use the same alignment blocks. But you'll need to flip them end-for-end to locate the runners in the opposite side (or on the other

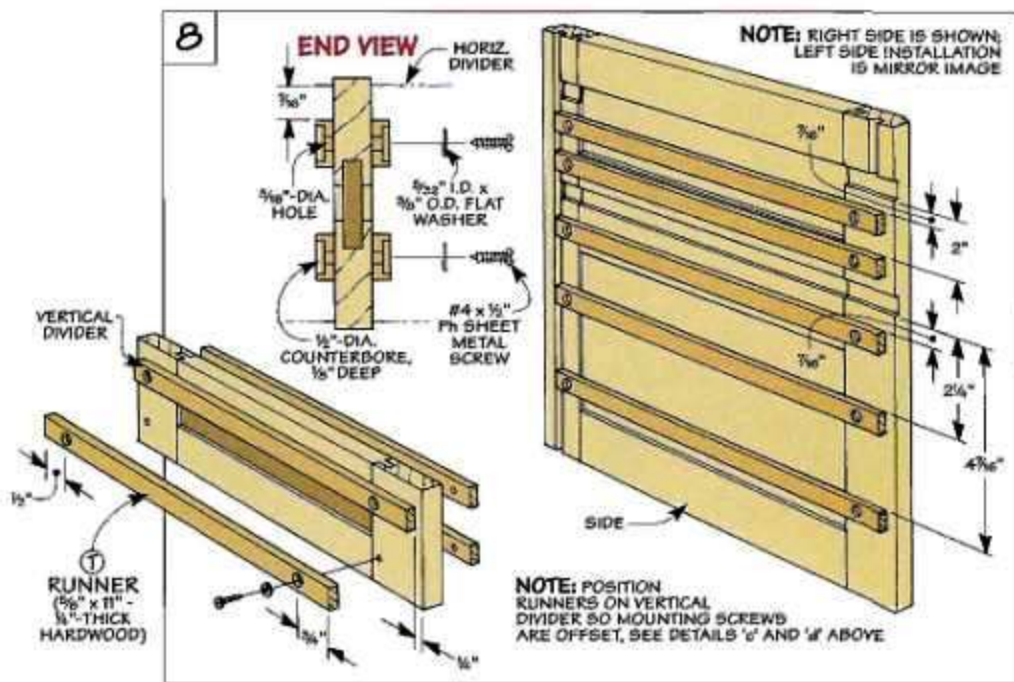

side of the small drawer opening).

**DISASSEMBLE CASE.** Now you can disassemble the case and mark the location of the pilot holes for the mounting screws. Before removing the runners to drill the holes (and take off the tape), score a line that shows their location, see Fig. 9b. This line comes in handy when repositioning the runners to screw them in place. Note: Don't forget to position the runners on the vertical divider so the mounting screws are offset.

**GLUE UP CASE.** Once the runners are installed, you can glue up the case. It's a good idea to practice this a few times by *dry assembling* the case. Then use a slow-setting glue to provide plenty of working time.

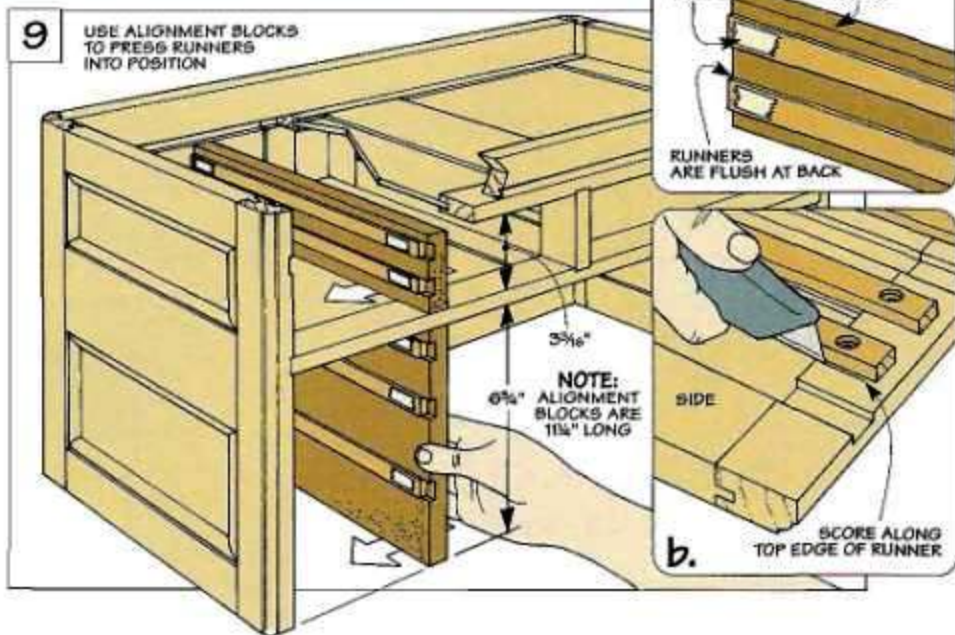

## Base

Once the case is glued up, you can turn your attention to the base that it sits on. The base is a frame and panel assembly that's simply wrapped with a decorative apron, see Fig. 10.

**FRAME & PANEL.** This frame and panel assembly is identical to the horizontal dividers except for two things — it's longer and wider. This way, the apron will extend beyond the case all the way around.

As before, the *stiles* (U, V) and *rails* (W) are assembled with stub tenon and groove joints, see Fig. 11. And the grooves are sized to accept 1/4\"

After gluing up the frame and panels, the next step is to drill shallow (stopped) holes to accept the lock rods that are added later, see Figs. 11 and 11a. While you're at it, it's a good time to drill mounting holes for screws in the bottom of the base.

**APRON.** Now it's just a matter of adding the apron. To do this, I routed a decorative profile on extra-long strips of hardwood, see Fig. 10a. Then I mitered the *front/back* (Y) and *side apron* (Z) pieces to length and glued them around the frame, see margin.

**ATTACH BASE.** At this point, all that's left is to center the base on the case and screw it in place, see Fig. 10b.

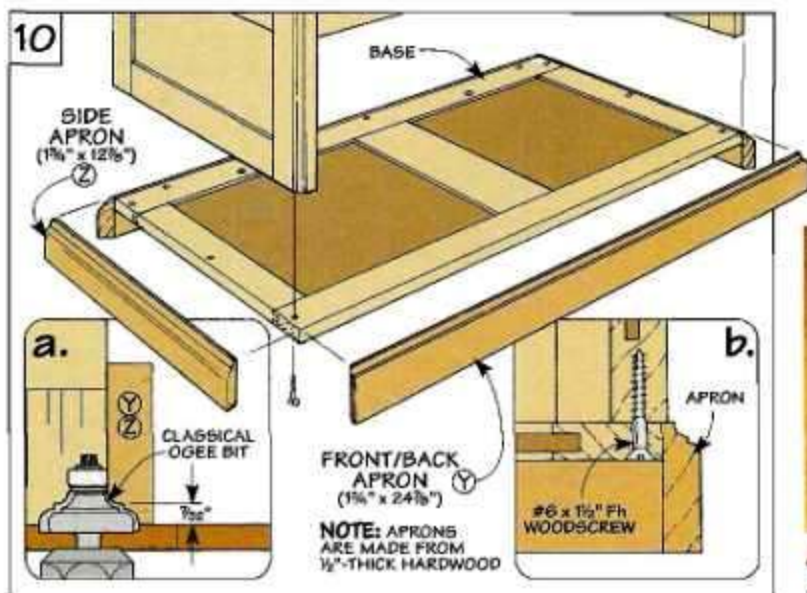

▲ When gluing the apron to the base, a corner block made from scrap protects the fragile tips of the miters.

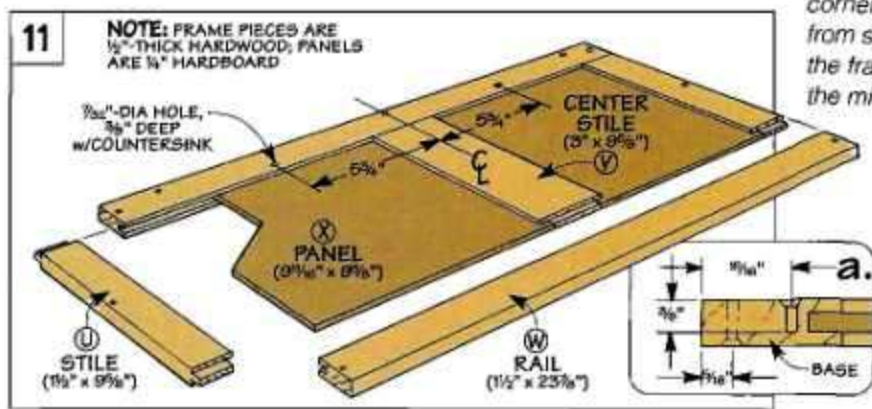

# Drawers

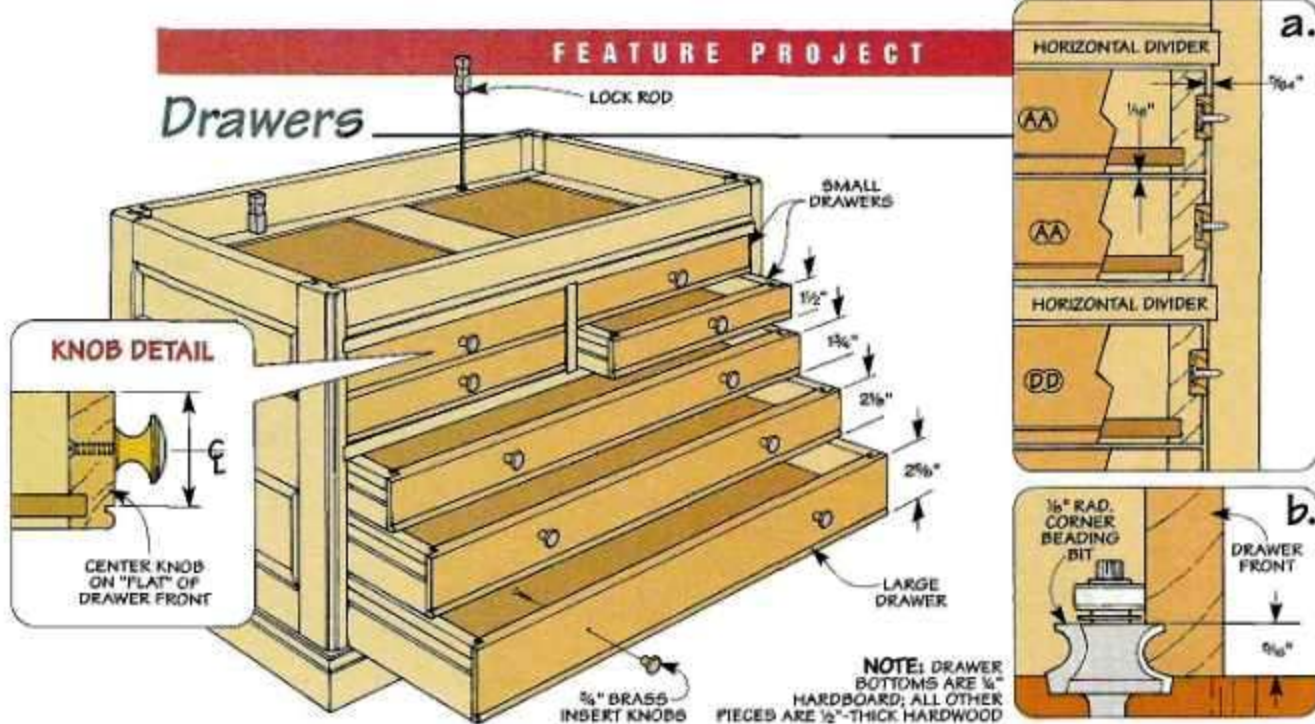

Since hand tools come in all different sizes and shapes, I designed this chest with different-size drawers.

The upper part of the case holds four half-width drawers that are all the same height, see drawing above. And there are three full-width drawers in the lower part of the case that get progressively taller from top to bottom.

To strengthen the drawers, they're

assembled with simple locking rabbet joints. With this type of joint, there's a tongue on the drawer front (and back) that fits into a kerf in the side piece, see Fig. 12a. The tongue forms a strong, interlocking connection that won't pull apart.

**THICKNESS STOCK.** To ensure accurate results when cutting the joinery, I started by planing all the

wood for the drawers to a thickness of 1/2". Before cutting any of these pieces though, you'll need to determine the size of the drawers.

**SIZE.** The overall height of the drawers is sized to create a 1/16" gap above and below each drawer, see detail 'a' above. But I allowed a little "extra" on the sides to allow the drawers to slide smoothly. As for length (depth), each drawer sits flush with the front of the case when it's slid all the way in against the back.

With that in mind, start by ripping the front/back (AA, DD, FF, HH) and side (BB, EE, GG, II) pieces to final width, see Fig. 12 and drawing above. Then after taking the joinery into account, crosscut each piece to final length.

**LOCKING RABBETS.** Now it's just a matter of cutting the locking rabbet joints. This requires standing the front and back pieces on end to cut a kerf. (I use a support block to hold the workpiece steady.) Then just trim the tongue to length, see Fig. 12a. To complete the locking rabbet joint, all that's left is to cut a kerf in the side of the drawer.

**CUT GROOVES.** The next step is to cut a groove near the bottom inside edge of each drawer piece. These grooves are sized to accept the 1/4" hardboard drawer bottoms (CC and JJ), see Figs. 12 and 12c.

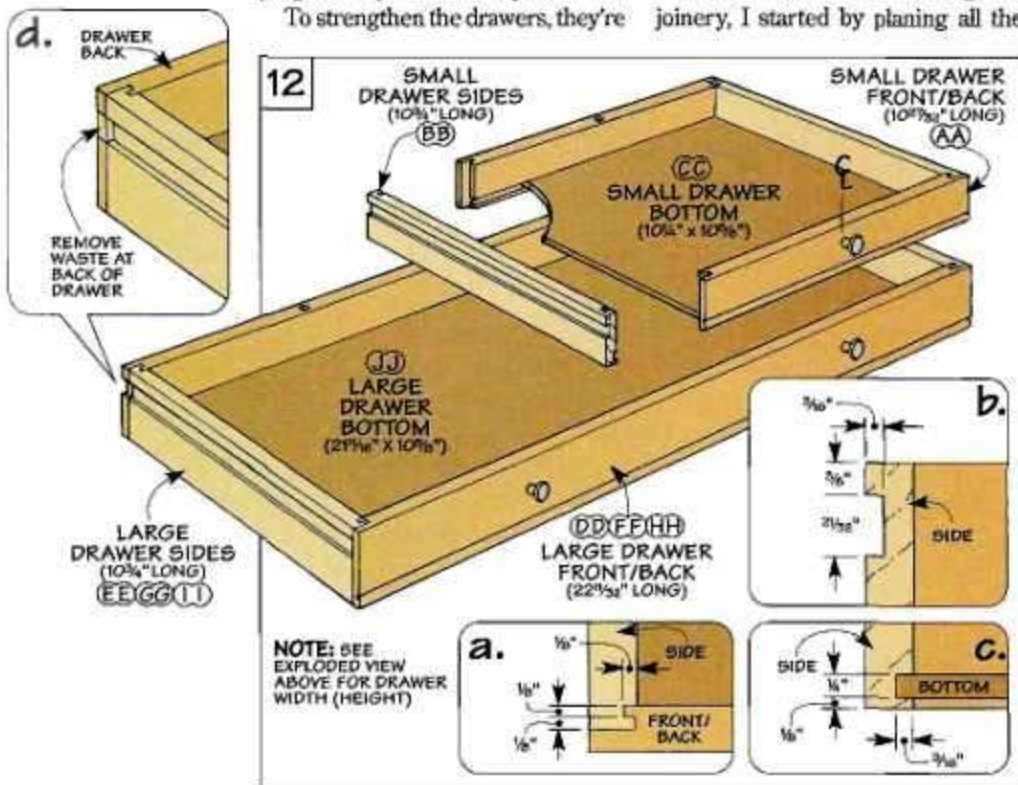

NOTE: SEE EXPLODED VIEW ABOVE FOR DRAWER WIDTH (HEIGHT)



To fit the drawer over the runners, you'll also need to cut a wide groove in the *outside* face of each side piece. I cut these grooves  $\frac{1}{32}$ " wider than the runners to create a smooth, sliding fit.

**ROUT BEADS.** There's one more thing to do before assembling the drawers. That's to rout a decorative bead in each drawer front, see detail 'b' on the top of page 24. It matches the profile of the bead molding on the sides and back of the case.

**NOTCHES.** After gluing up the drawers, the back piece will cover the end of the groove that fits on the runners. So you won't be able to install the drawer until you notch the back, see Fig. 12d. A handsaw and chisel make quick work of this.

**KNOBS.** Next, I added some fancy brass knobs. These knobs have a shallow recess that lets you insert a wood plug. (I used ebony to contrast with the maple chest). The plugs are held in place with epoxy and "turned" to shape on a drill press, see margin and Sources on page 31.

The mounting holes for the knobs are centered on the "flat" between the top of the drawer front and the bead, see Knob Detail on page 24. I also cen-

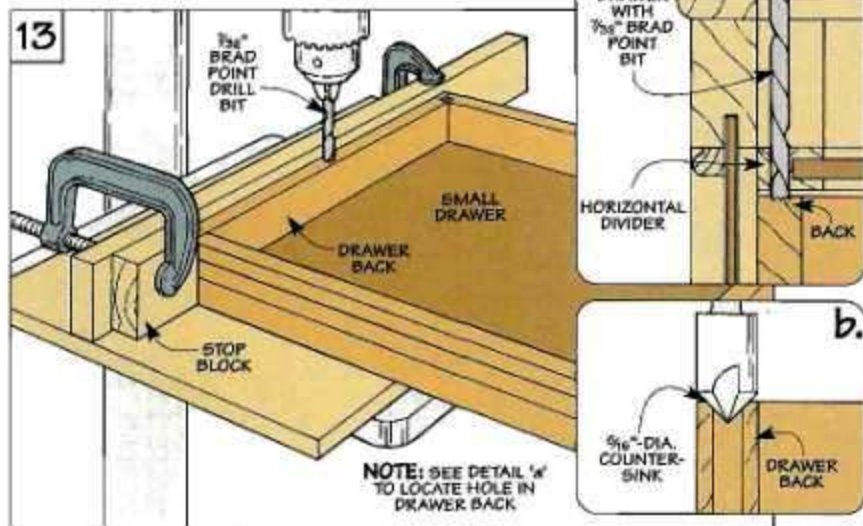

tered these holes on the *width* of the small drawers and lined up the holes in the large drawers underneath.

**LOCK ROD**

One of the most unique things about this tool chest is a pair of brass rods that "lock" the drawers. To do this, simply slide the rods down through holes in the dividers and the drawers.

**DRILL HOLES.** This requires drilling a *single* hole in the back of each small drawer and *two* holes in the large

drawers. To locate these holes, start by installing the upper two drawers. Then insert a brad point bit in each hole in the divider and make a dimple in each drawer, see Fig. 13a.

To drill the holes accurately, I clamped a fence to the drill press table and used a stop block to position the drawers, see Fig. 13. The idea is to use one setup to drill a hole in each of the two small drawers on the *left* side of the case. Then use the same setup to drill the hole on the *left* side of each large drawer.

For the drawers on the right side of the case (and the second hole in the large drawers), clamp the stop block to the opposite end of the fence and repeat the process. It's also a good idea to countersink each hole, see Fig. 13b. This makes it easy to "find" the hole as you slip the lock rod in place.

**LOCK RODS.** Now all that's left is to add the two lock rods. Each rod consists of two parts: the brass *rod* and a wood *handle*, see Fig. 14a. (I picked up brass rods at a hobby shop.)

**HANDLE.** After cutting the rods to length, I added the *handle* (KK). It's a  $\frac{1}{2}$ " square block of hardwood (ebony) that's sanded to provide a comfortable grip, see Fig. 14. Note: Since the handle is quite short, I started with an extra-long piece. After cutting the handle to length, just drill a hole in the end (Fig. 15) and use epoxy to hold the rod in place.



▲ With the knob threaded onto a rod chucked in the drill press, the wood plug is simply filed and sanded to shape. (Two "jam" nuts hold the knob in place.)

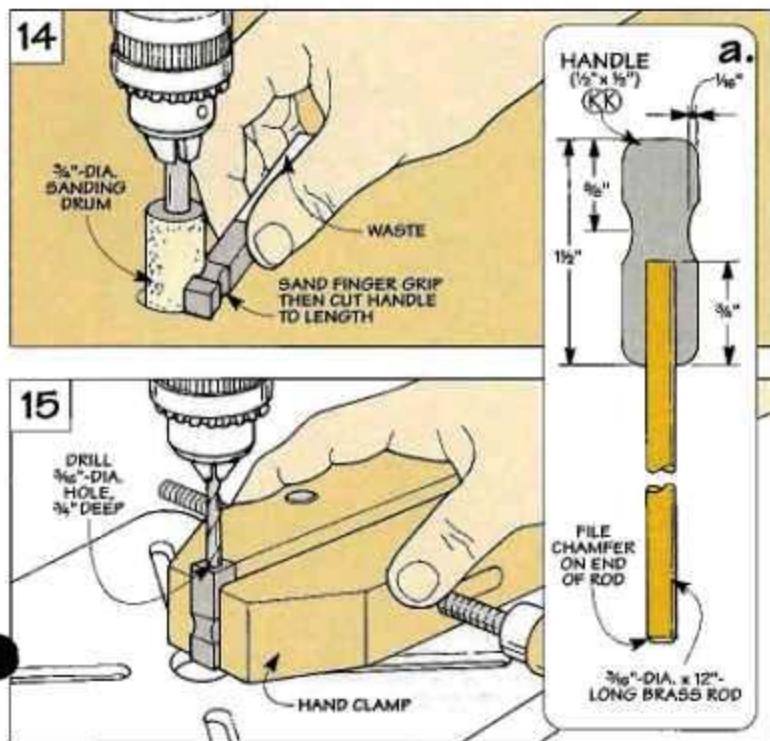

## Lid

All that's left to complete the tool chest is to add a lid that encloses the storage compartment, see Fig. 16.

**PANELS.** Like the sides and back of the case, the lid consists of  $\frac{1}{8}$ " hardboard panels (LL) surrounded by a wood frame, see Fig. 17. Here again, both sides of the panels are covered with veneer. Only this time, I glued bird's-eye maple veneer to *each* side so the panels look good inside and out.

As before, the *stiles* (MM) and *rails* (NN) are assembled with stub tenon and groove joints, see Figs. 17a and 17b. And once again, the grooves that hold the panels are offset toward the inside of the frame to create a recess for strips of bead molding, see Fig. 18. (This is the extra bead molding made earlier.)

**EDGING.** After gluing on the bead molding, the next step is to "wrap" the outside of the lid with hardwood edging (OO and PP). Besides creating a decorative profile, the edging makes the lid appear thicker than it actually is.

To make the edging, I started by planing a piece of hardwood to a thickness of  $\frac{1}{2}$ ". Then, after ripping 1"-wide strips, I routed a *different* decorative profile on each edge.

The profile on the top edge matches the corners on the sides of the case. So I routed this edge with a beading bit in a table-mounted router, see Fig. 18a. Then, to create a smooth transi-

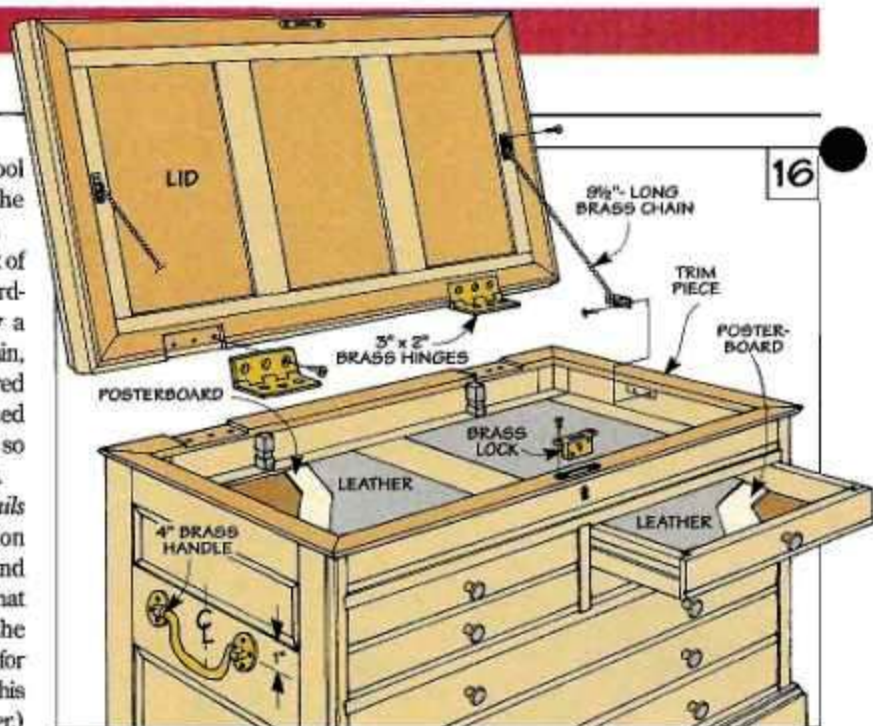

16

## Hardware

- (12) #6 x  $\frac{1}{2}$ " Brass Fh Wood screws
- (1 Pr.) 4" Brass Chest Handles
- (1) Brass Lock
- (1)  $\frac{1}{2}$ " Escutcheon
- (2) 9 $\frac{1}{2}$ "-long Brass Chains
- (1 Pr.) 3" x 2" Brass Hinges
- (12) #8 x  $\frac{5}{16}$ " Brass Fh Wood screws
- (10)  $\frac{3}{4}$ " Knobs w/Wood Inserts
- (2)  $\frac{3}{16}$ "-dia. x 12" Brass Rods
- (9) #6 x  $\frac{1}{2}$ " Fh Wood screws
- (2B) #4 x  $\frac{1}{2}$ " Ph Sheet Metal Screws
- (2B)  $\frac{5}{32}$ " I.D. x  $\frac{3}{16}$ " O.D. Flat Washer

tion between the lid and the case, rout a cove in the bottom edge, see Fig. 18b. After mitering the edging to fit around the lid, it's glued in place.

**TRIM PIECES.** In addition to the edging, I also added *trim pieces* (QQ) to the bottom of the lid and top of the case, see Figs. 19 and 19a. These are thin, hardwood strips with a roundover routed on one edge, see Fig. 19b.

The trim pieces on the lid create a flat mounting surface for the hinges. They're just mitered to length to fit inside the lip created by the edging and glued in place. After mitering

the strips for the case, they're glue flush with the inside edge.

## INSTALL HARDWARE

I spent quite a bit of time looking at hardware as I was designing this tool chest. Some of it was purely functional which didn't seem right for such a nice chest. What I wanted was hardware that was functional *and* beautiful.

Fortunately, I found just what I was looking for while paging through a woodworking catalog — solid brass hardware made with old-fashioned, quality craftsmanship. (We've listed a source for this hardware on page 31.)

**HINGES.** All you have to do is pick up one of the hinges to see what I mean. It has a nice, reassuring heft. And the leaves of the hinge are thick slabs of polished brass.

The hinges fit in mortises cut in the case and lid, see Fig. 20. After laying out the location of the mortises on the *case*, a hand-held router and  $\frac{1}{2}$ " straight bit make quick work of removing most of the waste. After routing up close to the layout line, use a chisel to pare away the remaining waste.

Once the hinges fit in the case you can lay out the mortises in the *lid*. To do this, set the lid on the case so it's centered in both directions

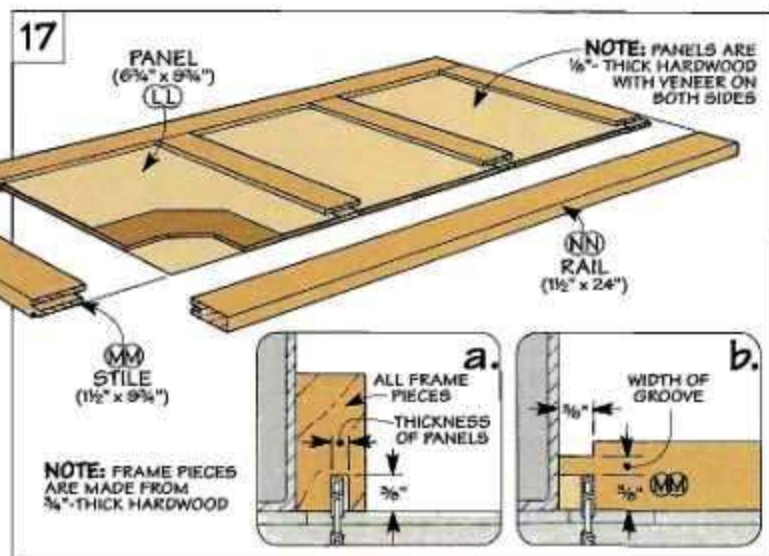

and mark the ends of the mortise, see margin. Then remove the lid and lay out the long edge of the mortise. Note: This edge is set in from the rounded edge of the trim strip.

Now you're ready to rout the mortise. Here again, you'll want to chisel the remaining waste until the hinge fits the mortise like a hand in a glove.

**CHAINS.** To hold the lid open (and keep it from falling back), I added a pair of brass chains, see Figs. 21 and 21a. The idea is to locate the chains so the lid is tilted back at a slight angle. This provides easy access to the tools in the storage compartment without having to constantly open and close the lid.

**ADD LOCK.** After installing the chains, I added a lock to secure the lid. The lock I chose has three parts that are mortised into the case. (For step-by-step instructions on installing a full-mortise lock, see page 14.)

**HANDLES.** When this chest is loaded with tools, it's quite heavy. So in order to get a good grip when carrying it around, I mounted a pair of heavy-duty brass handles to the wide rails on the sides, refer to Fig. 16.

Each handle is centered on the length of the rail. But it's offset toward the top. This way, the handle won't hang down below the rail.

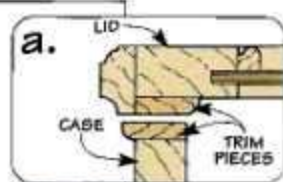
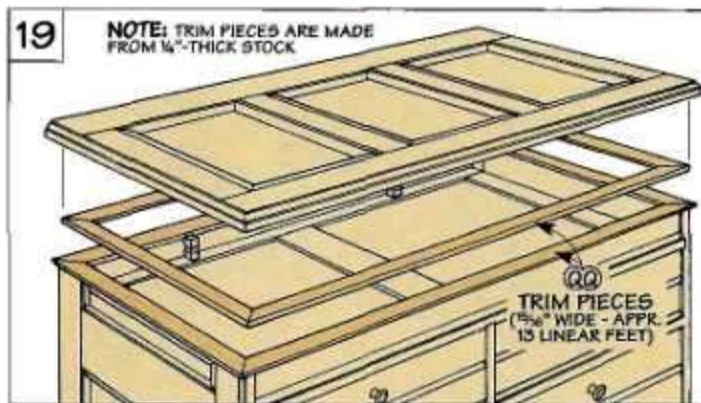
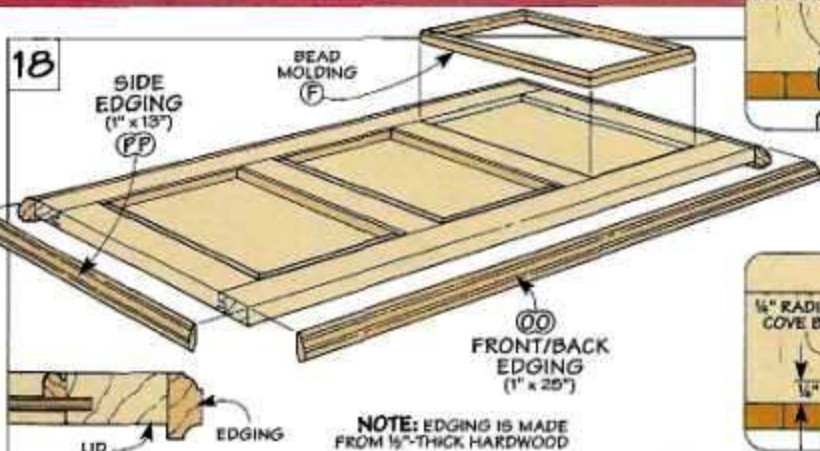
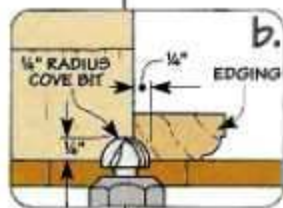
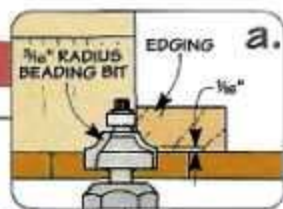
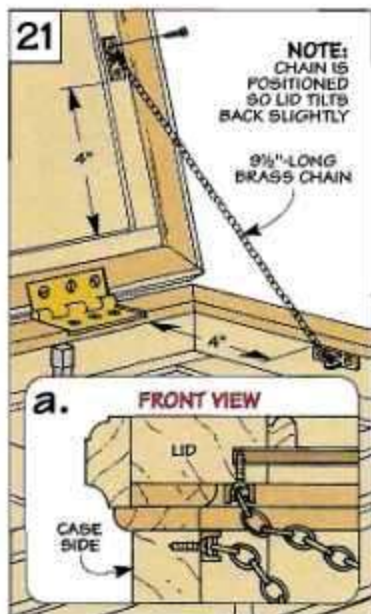
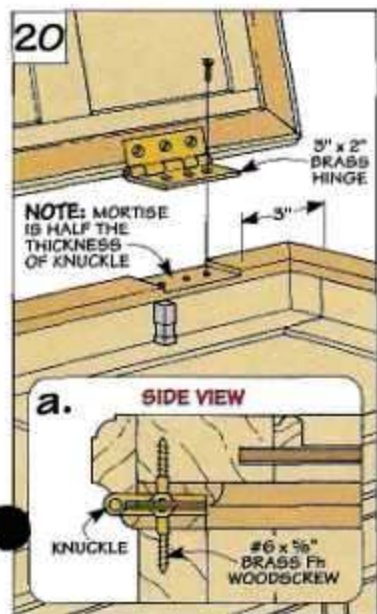

**FINISH.** At this point, I removed all the hardware and applied a finish. Three coats of a wipe-on oil finish emphasized the dramatic swirl marks in the bird's-eye maple and made the "ribbons" in the

curly maple shimmer. And a coat of paste wax gave the chest a smooth, silky appearance.

**LEATHER.** Finally, to protect my favorite hand tools, there was one last thing I'd been wanting to try. That was to add *leather* lining to each of the drawer bottoms and the two recesses in the upper storage compartment.

At first, I thought that finding the leather might be a problem. But after checking around at a local leather store, I found two *deerskins* that worked just fine.

The leather is mounted to posterboard that's cut to fit inside the drawers and the recesses in the storage compartment. Note: I used two pieces of posterboard for each recess to make the leather flush with the frame.

Now it's just a matter of cutting oversize pieces of leather and using a spray-mount adhesive to attach them to the posterboard. After trimming the edges of the leather flush with the posterboard, simply press it in place. 



▲ To lay out the location of the hinge on the lid, simply score a line using the mortise in the chest as a guide.

# Table Saw Dust Collection

*It's hard to imagine a simpler way of collecting the dust and chips produced by a table saw.*

Sometimes it seems like collecting the dust produced by a table saw is a losing battle. Even if you're only cutting a few pieces, it can still fill the air with a cloud of dust that settles over the entire shop.

To solve this problem, I added a simple *baffle system* inside the metal saw cabinet, see drawing below. It's designed to be used with a dust collector to catch the chips and dust suspended inside the cabinet.

The secret to making this work is the baffles are *angled* to control the flow of air inside the saw cabinet. When you turn on the dust collector, air rushes in the back of the cabinet and "sweeps" across the baffles, drawing dust and chips down into the hose leading to the dust collector, see Air Flow Detail below.

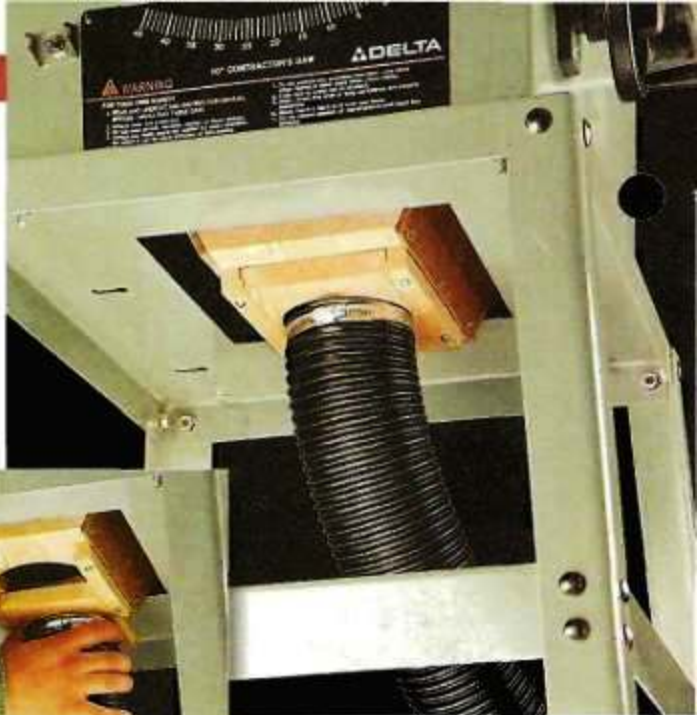

is a piece of  $\frac{1}{4}$ " hardboard that's notched to fit around any obstructions inside the saw cabinet, see Fig. 1.

Depending on your saw, the size of the baffles will vary. Determining their *length* is easy. Just measure the *inside dimension* of the saw cabinet. (This is dimension 'A' in Fig. 1.)

But figuring out the *width* of the baffles is trickier. It depends on the angle of the baffles. The exact angle isn't critical. I "eyeballed" it by using

To hook up the dust collector hose, it's attached to a wood plate that slides in place under the baffles, see photos above. The nice thing about this plate is it makes it easy to adapt this type of hook-up to other tools as well. (To see two other options, turn to the back cover.)

**BAFFLES.** There's nothing complicated about the *baffles (A)*. Each one

**CUTAWAY**  
(REAR VIEW)

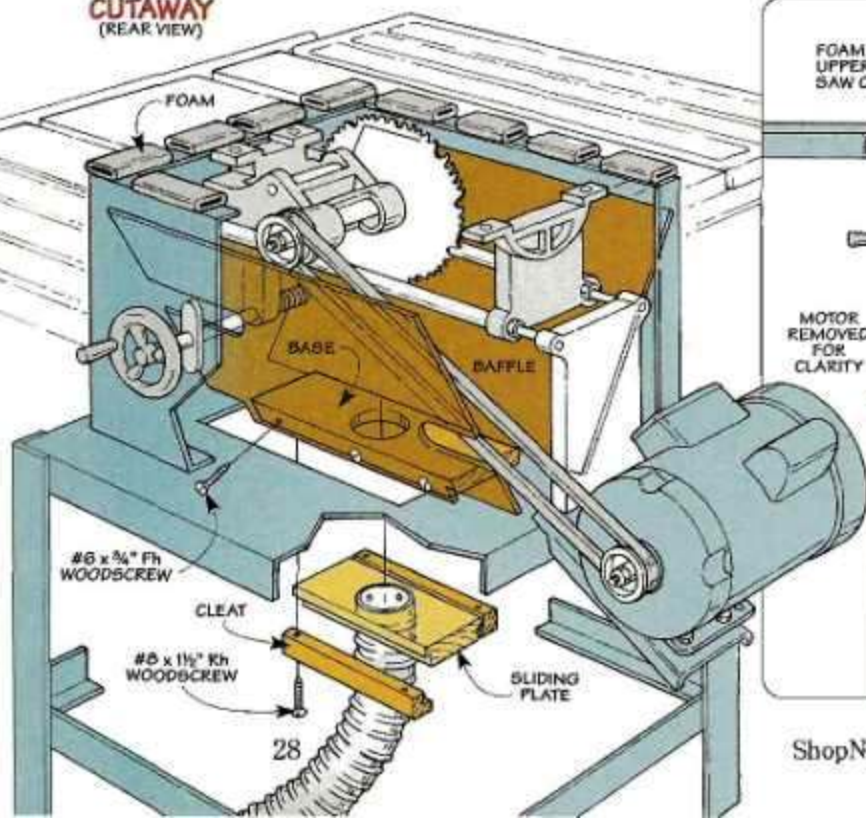

**AIR FLOW**  
**DETAIL**

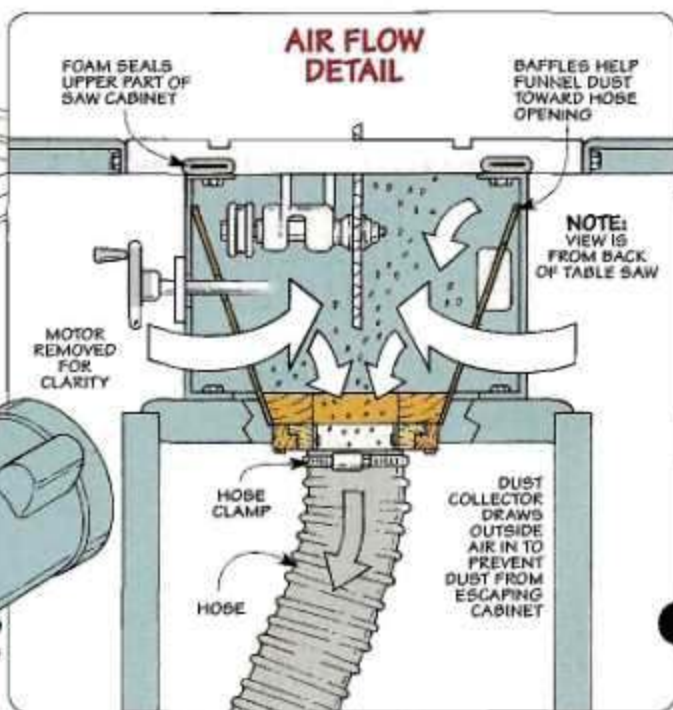

a metal rule and two strips of wood that are temporarily carpet-taped to the cabinet, see Figs. 1 and 1a. With the strips in place, measure the distance from the upper corner of the cabinet to the top edge of the strip. (That's dimension 'B' in Fig. 1.)

**NOTCHES.** The next step is to notch the lower corners of each baffle. This creates a tongue that fits down through the opening in the bottom of the cabinet. (Dimension 'C' shows the length of the tongue.)

I also had to notch the baffles to fit around the rod on the tilt mechanism, the electrical box for the on/off switch, and the drive belt. Shop Tip: To get a good fit, make posterboard templates of the baffles first. Then it's just a matter of cutting the baffles to match the templates.

**INSTALL Baffles.** At this point, you're ready to fit the baffles into the cabinet. You'll need to remove the motor to do this. But don't take off the wood strips yet. They hold the baffles in place while you work on the base.

**BASE.** The base (B) is nothing more than a piece of 3/4"-thick stock that's beveled to fit between the baffles, see Figs. 1 and 2. (I used pine.) To allow dust to pass through the

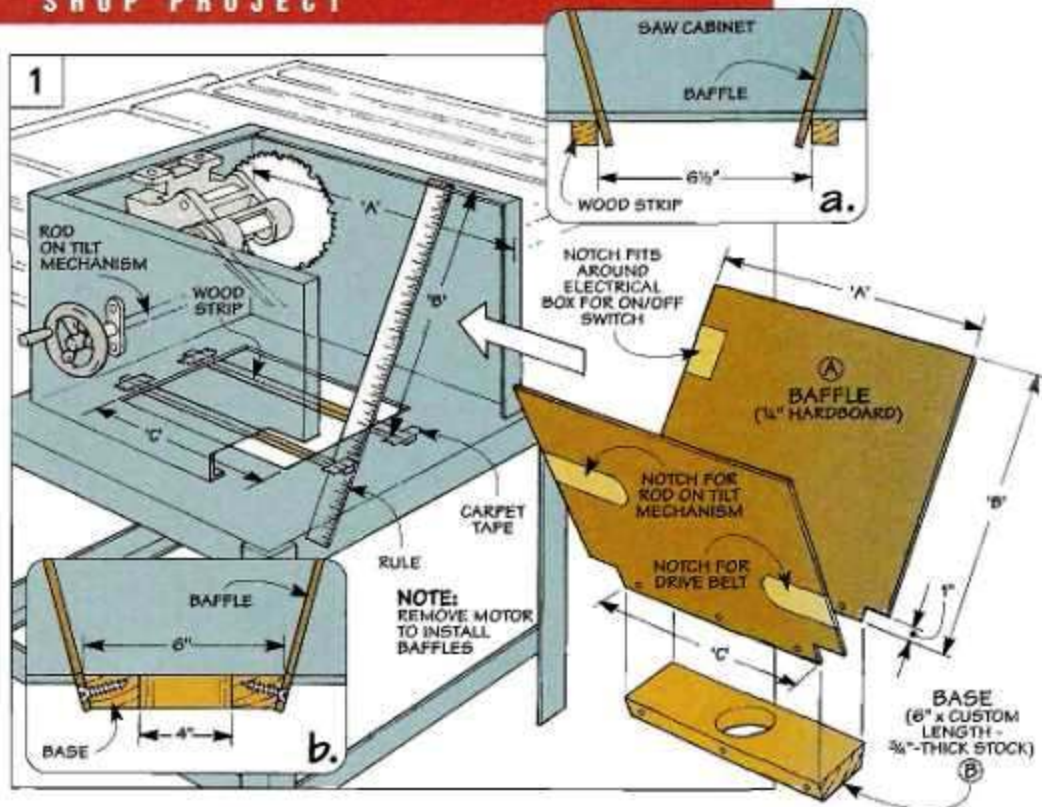

base, you'll need to cut a large hole that's sized to match the diameter of the dust collector hose.

**HOOK-UP.** Before the base is installed, it's easiest to add the hook-up for the dust-collector hose. It consists of two parts: a sliding plate (C)

that's connected to the hose and a pair of L-shaped cleats (D) attached to the base, see Fig. 2.

The plate simply slides in and out on the cleats. To accomplish this, there's a lip on each cleat that's formed by rabbeting one edge. A matching rabbet in each edge of the sliding plate allows it to fit on the cleats.

To hook up the hose, I made a short connector from a piece of metal flashing and attached it to the sliding plate. It's simply wrapped around a large hole that's cut in the sliding plate and tacked in place.

**ASSEMBLY.** Now you can assemble all the pieces. The goal is to position the cleats on the base so the sliding plate moves freely without binding. After gluing and screwing the cleats in place, just screw the base to the baffles. (You'll have to remove the wood strips first.) Then attach the hose with a hose clamp.

**FOAM.** All that's left is to seal the openings between the metal cabinet and the table, see margin. The type of foam that's used to "wrap" water pipes is just the ticket here.



▲ To seal the upper part of the cabinet, stuff in short pieces of foam insulation between the "ribs" of the cast iron table.

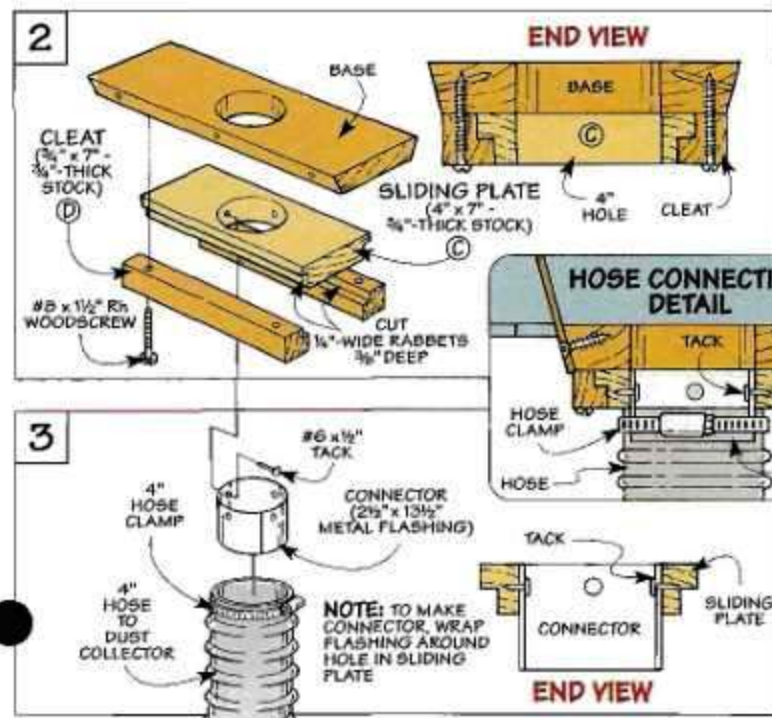

# Tool Talk

TOOLS OF THE TRADE

## Micro-Fence

■ There's no question about it, \$140 is a lot to pay for a fence that attaches to a hand-held router. So when I first heard about this fence (called the Micro-Fence), I was a bit skeptical.

Granted, the fence is micro-adjustable. So you can "fine tune" the position of the router bit in relation to the fence. But is it worth the money?

Well, my curiosity got the best of me. So I decided to buy a Micro-Fence and give it a try.

**PRECISION TOOL.** Right off the bat, the thing that impressed me is the Micro-Fence has the *look and feel* of a precision tool. The body of the fence is machined aluminum, and it slides flawlessly on two stainless steel guide rods, see photo above. And the knurled knobs are made of either solid brass or aluminum.

**MOUNTING BLOCK.** To attach the Micro-Fence to the router, you'll need to thread two short, metal pins in a mounting block, see margin. After fitting the pins into holes in the base of the router, the mounting block is secured with a couple of screws. Note: The hole locations will vary from one router to the next, so you'll need to specify the model of router when purchasing a Micro-Fence.

**VERSATILITY.** Another thing I like about the Micro-Fence is it's an extremely versatile tool. Depending on the type of work you're doing, there are *three* different fences: two wood fences, and a "fence" that uses plastic, half-round inserts for routing curves, see photos below.

**FENCE ADJUSTMENT.** No matter which fence you're using, adjusting it is a simple two-step process. First, slide the fence into *rough* position and then tighten the knob on each end of the adjustment block. Second, "dial in" the

exact position of the fence by turning a threaded knob.

**THREADED KNOB.** As you turn the threaded knob, it moves the fence in extremely tiny increments. To make it easy to see the amount of this movement, the knob also turns a *micrometer* that has increments etched into the surface. Each increment represents .001". (That's less than the thickness of a piece of tissue paper.)

**ODD-SIZED GROOVES & DADOES.** This precise adjustment is especially handy if you need to rout odd-sized grooves or dadoes (like when you're working with plywood that's less than its nominal thickness).

The idea is to rout a groove with a bit that's *smaller* than needed. (For example, I use a 1/2" straight bit for 3/4" plywood). Then after measuring the difference between the width of the groove and the *actual* thickness of the plywood, just dial in the difference and make a second pass.

**CONCLUSIONS.** Well, as I mentioned, I had my doubts about the Micro-Fence at first. It just seemed too expensive for a router fence, even if it *was* micro-adjustable.

But after using it awhile, I'm pretty fond of its quick, easy setup. Plus, it's dead-on accurate. Is the Micro-Fence for everyone? Probably not. But if you plan on doing a lot of edge-guided routing, it's well worth the cost. Note: Refer to next page for sources of the Micro-Fence. 🛠️

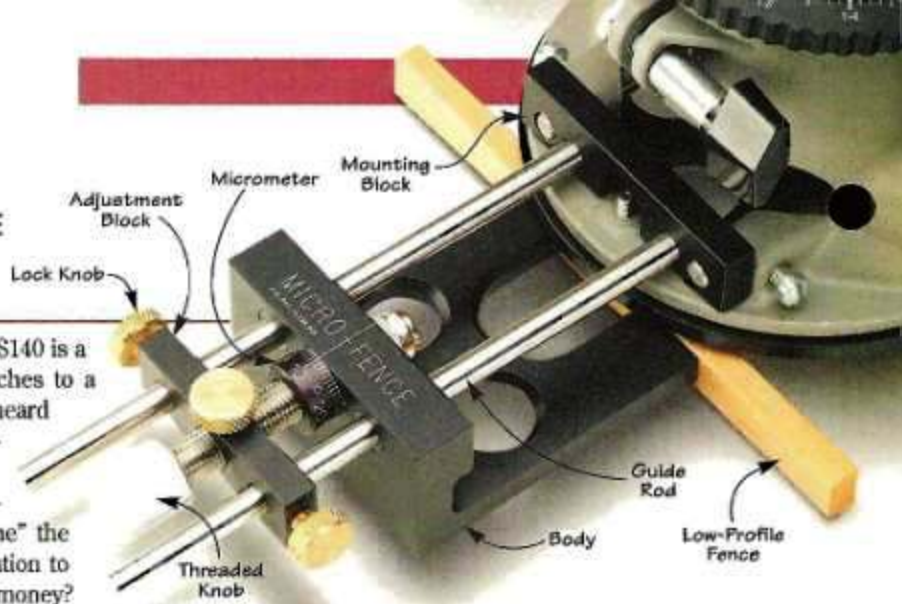

▲ To avoid marring the pins when threading them into the mounting bar, a small piece of rubber is included with the Micro-Fence.



▲ **Low-Profile Fence.** When the narrow, low-profile fence is mounted to the aluminum body, you can rout a groove (or dado) while the workpiece is clamped flat against a benchtop.



▲ **Wide Fence.** To rout a mortise with a fixed-base router, attach the wide edge guide. It provides more surface contact with the workpiece as you make a plunge cut.



▲ **Half-Round Inserts.** By mounting pair of plastic, half-round inserts to the aluminum body, you can even rout a groove parallel to a curved edge.

# Sources

## PRODUCT INFORMATION



### ▲ Shop-Made Lock Pin

The Latho-Mounted Disk Sander featured on page 6 has a lock pin that holds the table at 90° to the sanding disk. To make it easy to grab the pin, I used a plastic ball knob that threads into a cutoff bolt.

The knob we used is available from Reid Tool Supply Company. To order a knob call 1-800-253-0421 and ask for Part No. B-22.



### ▲ Micro-Fence

In the article on page 30, we take a close look at a Micro-Fence. This is a micro-adjustable fence that's used with a hand-held router. A knurled knob lets you quickly and accurately "dial in" the fence setting which positions the bit on the workpiece.

For mail-order sources of the Micro-Fence, see margin at right.



### ▲ Peel-and-Stick Sandpaper Disks

These disks make it easy to attach sandpaper to the Latho-Mounted Disk Sander (page 6). They have a pressure-sensitive adhesive on the back. So you just peel off the plastic backing and press the disk in place.

For extra durability, we recommend disks made with a heavy, cloth-backed material. These disks are available in sizes ranging from 5" to 12" in dia. and in grit sizes from 36 to 320-grit. (See margin for sources.)

### Figured Lumber & Veneer ▶

If you build the Cabinetmaker's Tool Chest featured on page 16, you may want to consider giving it a special touch by using highly-figured lumber and veneer. (We used curly maple hardwood and bird's-eye maple veneer for our tool chest.)

Figured wood and veneer are available at many woodworking stores and some lumberyards. There are also a number of mail-order sources. (We've listed some of them in the margin at right.)

One thing to be aware of is you may have to order a minimum amount of lumber (or veneer). To build our chest, you'll want at least 25 board feet of lumber and 10 square feet of veneer. This allows you to select pieces for the best grain or color.



## MAIL ORDER SOURCES

**Bob Morgan's**  
502-456-2545  
*Veneer*

**Certainly Wood**  
716-655-0206  
*Figured Lumber,  
Veneer*

**Constantine's**  
800-223-8087  
*Figured Lumber,  
Veneer*

**Klingspor's**  
800-228-0000  
*Sandpaper Disks*

**Lee Valley**  
800-871-8158  
*Brass Hardware*

**Micro-Fence**  
800-850-4367  
*Micro-Fence*

**Sandy Pond Hardwoods**  
800-546-9663  
*Figured Lumber*

**Woodcraft**  
800-225-1153  
*Figured Lumber,  
Sandpaper Disks*

**Woodhaven**  
800-344-6657  
*Micro-Fence*



### Brass Hardware

- (1 Pr.) 4" Brass Chest Handles #00A21.02
- (1) Chest Lock #12K04.01
- (1) 1/2" Escutcheon #00A03.01
- (1 Pr.) 3"x 2" Brass Hinges #00D03.04
- (10) 3/4" Brass Inset Knobs #05E01.07
- (2) 9 1/2"-long Small Link Brass Chains #00F04.01

### ▲ Cabinetmaker's Tool Chest Hardware

The tool chest that's featured on page 16 is such a special project, I felt it deserved some special hardware. So I selected the best quality hardware I could find.

For example, the hinges and handles are solid brass. The leaves of the hinges are almost 3/32" thick — nothing flimsy there. And the heavy-duty handles have a stop to keep the handle from pinching your fingers against the case.

The knobs are also solid brass. Plus they have a recess for a wood plug so you can customize the knob to complement (or contrast) with the chest. Together with the chains, escutcheon (keyhole), and lock, the hardware is actually one of the "treasures" in this chest. It's expensive, but it's worth it. (We paid about \$110.) All of the hardware shown above is available from Lee Valley. (See margin.)

### ON-LINE CUSTOMER SERVICE

- Access information about your subscription account.
  - Find out if your payment has been received.
  - Change your mailing address or your e-mail address.
  - Let us know if you haven't received your issue.
- [www.shopnotes.com](http://www.shopnotes.com)

### WoodNet™

- 181 Woodworking Tips Online
  - Woodworking Techniques
  - Project plans you can download
  - WoodNet Forum
  - Power Tool Reviews
- [www.augusthome.com](http://www.augusthome.com)

## Scenes from the Shop

*If you have a special collection, our cabinet-maker's tool chest is a great way to protect it from dust or damage. With its seven drawers and a storage compartment under the lid, the chest provides a fitting home for this collection of rocks and minerals.*

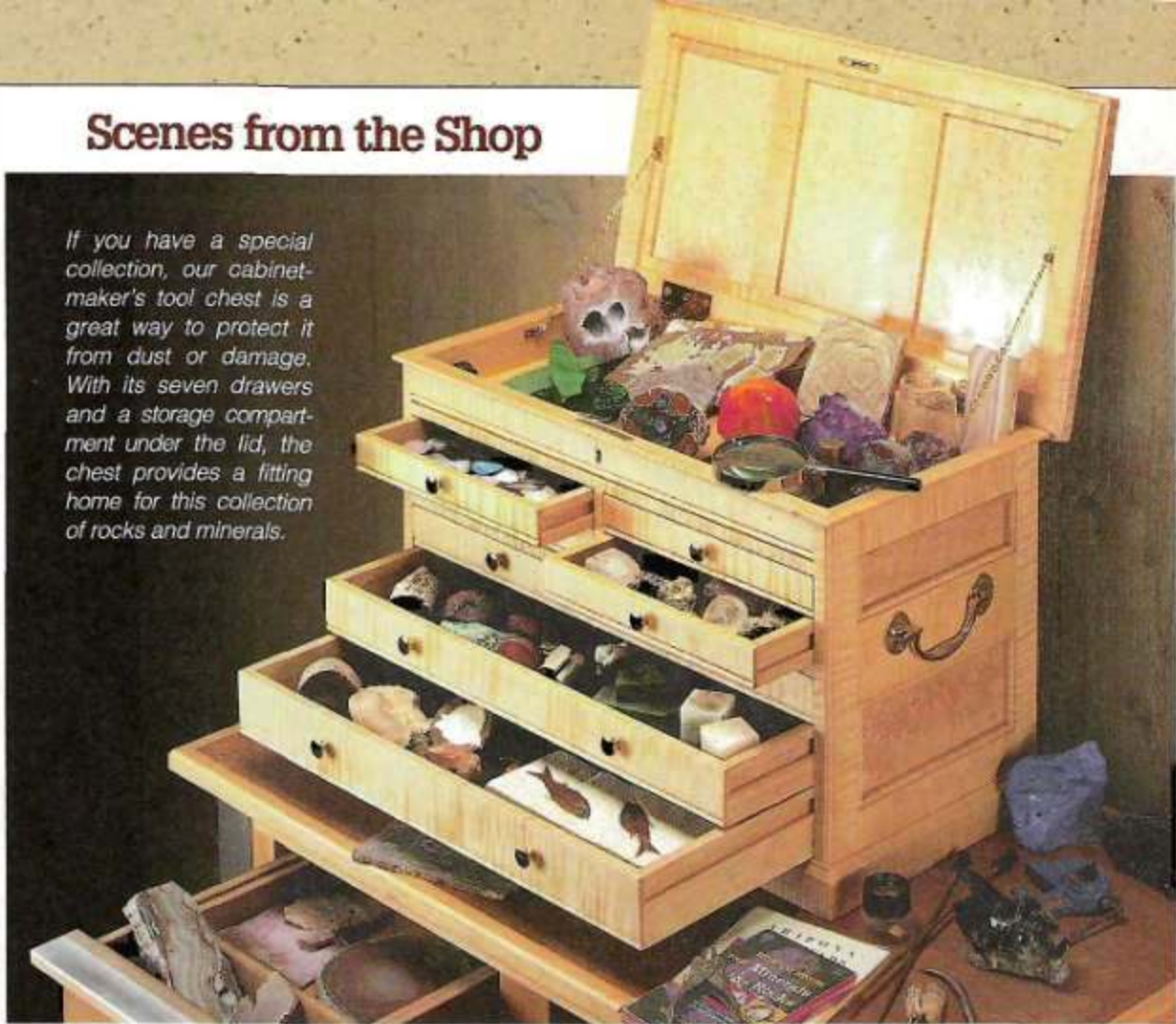

*These shop-made hook-ups provide a quick way to connect your dust collector to a jointer (left) or router table (right). The dust collector hose is attached to a wood plate that slides between a pair of cleats, just like the dust hook-up for the table saw featured on page 28.*