

Shop Tested
TIPS

TIPS • TOOLS • TECHNIQUES

ShopNotes®

Vol. 8 Issue 45

Benchtop Router Table

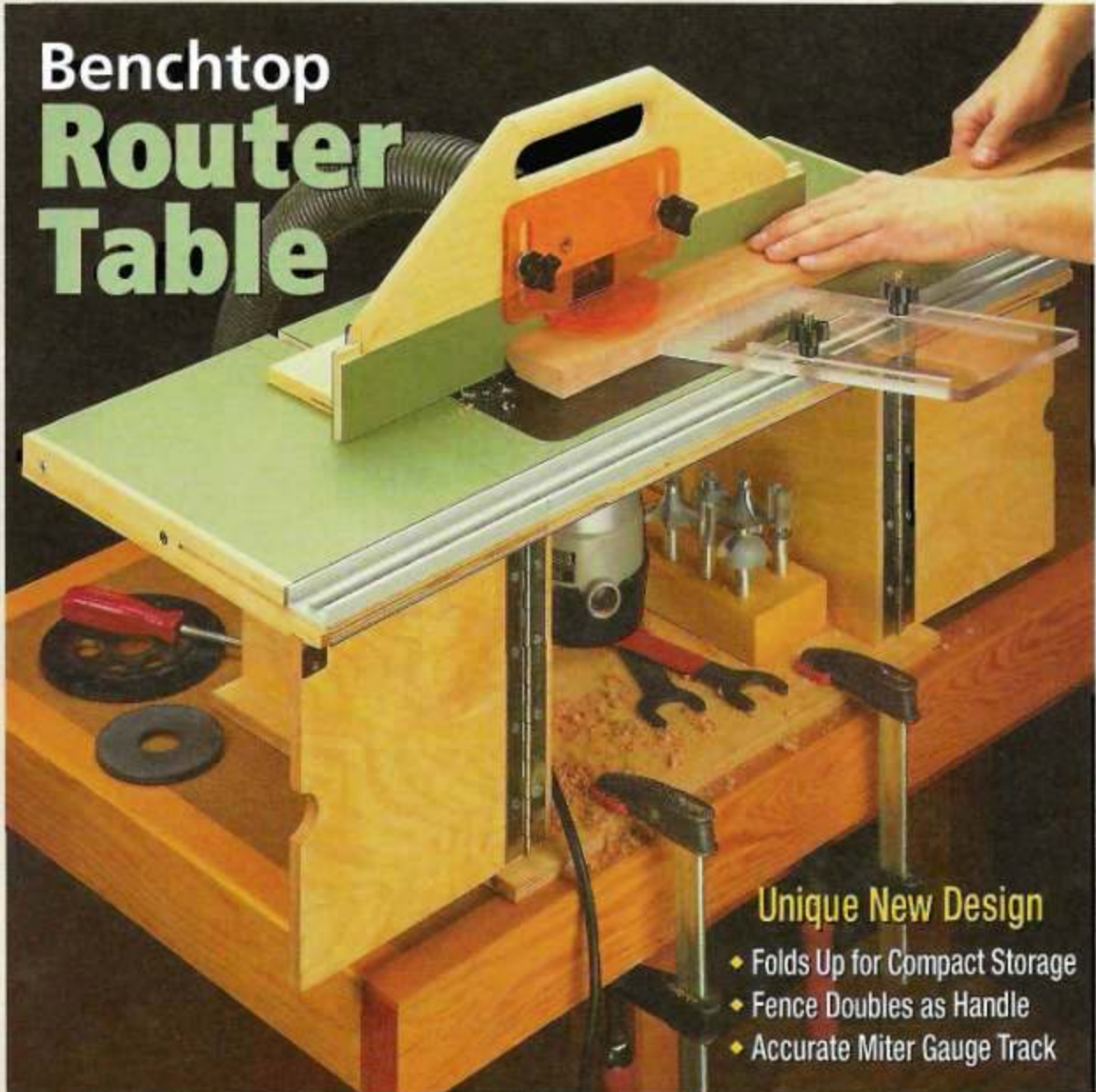

Unique New Design

- ◆ Folds Up for Compact Storage
- ◆ Fence Doubles as Handle
- ◆ Accurate Miter Gauge Track

- Socket Set Boxes ■ Custom Fit Dadoes
- Router Mounting Plates ■ Lumber Cart



ShopNotes

Issue 45

May 1999

PUBLISHER Donald B. Peschke
EDITOR Tim Robertson
ASSOCIATE EDITOR Tom Bernal
ASSISTANT EDITOR Bryan Nelson
ART DIRECTOR Cary Christensen
SR. GRAPHIC DESIGNER Kurt Schultz
SENIOR ILLUSTRATORS Roger Reiland
 Mark Higdon

CREATIVE RESOURCES

Creative Dir: Ted Kralovic • *Project Developer:* Ken Munkit • *Sr. Project Designer:* Kevin Boyle • *Project Coordinator:* Kent Welch • *Shop Mgr:* Steve Curtis • *Shop Craftsmen:* Steve Johnson • *Sr. Photographer:* Crayola England • *Photographer:* Roderick Kennedy

BOOKS

Executive Editor: Douglas L. Hicks • *Art Director:* Steve Lueder • *Sr. Graphic Designer:* Chris Glewacki, Cheryl L. Simpson • *Asst. Editor:* Joe Irwin, Craig Kneggegger

CIRCULATION

Sub. Serv. Dir: Sandy Baum • *New Bus. Dir:* Glenda Battles • *Circ. Marketing Analyst:* Kris Schermer • *Creative Mgr:* Melinda Halpern • *Business Mgr:* Paige Rogers • *Billing Mgr:* Rebecca Cunningham • *Prod. Mgr:* Rick Jenkins • *New Bus. Mgr:* Todd L. Bielek • *Asst. Sub. Mgr:* Joy Krause

CORPORATE SERVICES

Vice President of Planning & Finance: Jon Macarthy • *Controller:* Robin Hutchinson • *Sr. Accountant:* Laura Thomas • *Accounts Payable:* Mary Schultz • *Accounts Receivable:* Margo Putras • *Production Director:* George Camilars • *Electronic Publishing:* Douglas M. Lidster • *Network Administrator:* Chris Schwanebeck • *Production Assistant:* Susan Ruere • *Pre-Press Image Specialist:* Troy Clark, Minnie Bieghler • *New Media Manager:* Gordon C. Galpe • *Multimedia Art Director:* Eugene Pedersen • *E-Commerce Analyst:* Carol Schoeppler • *Web Site Editor:* Holly Kilborn • *Human Resources Assistant:* Kristen Koel • *Office Manager:* Julia Flah • *Receptionist:* Jeanne Johnson • *Building Maintenance:* Ken Griffith • *Special Projects Director:* Saville H. Inman

MAIL ORDER

Operations Dir: Bob Baker • *Cust. Serv. Mgr:* Jennie Koss • *Warehouse Supv:* Nancy Johnson • *Buyer:* Linda Jones • *Admin. Asst:* Nancy Downey • *Tech. Rep:* Matthew TeRonde • *Cust. Serv. Reps:* Anna Cox, Adam Best, Tammy Truckenbrod, Deborah Eich, April Reveil, David Gaumer • *Warehouse:* Sylvia Carvey, Dan Spidle, Eric Tullis, Sheryl Kuntz

WOODSMITH STORE

Manager: Dave Larson • *Assistant Manager:* Paul Schneider • *Sales Staff:* Pat Lowry, Wendell Stone, Jim Barnett, Kathy Smith, Larry Morrison • *Office Manager:* Vicki Edwards

ShopNotes® (ISSN 1062-0696) is published bimonthly (Jan., March, May, July, Sept., Nov.) by August Home Publishing, 2200 Grand, Des Moines, IA 50312.

ShopNotes® is a registered trademark of August Home Publishing ©Copyright 1999 by August Home Publishing. All rights reserved.

Subscriptions: Single copy: \$4.99. One year subscription (6 issues): \$21.94. Canada/Foreign add \$6 per year.

Periodicals Postage Paid at Des Moines, IA and at additional mailing offices.

Postmaster: Send change of address to ShopNotes, P.O. Box 37108, Boone, IA 50037-2108.

Subscription Questions? Write to: ShopNotes Customer Service, P.O. Box 342, Des Moines, IA 50304-0342. Or call 1-800-335-5854, 8:00 am to 5:00 pm, Central Time, weekdays. FAX 515-283-0447.

E-Mail: ShopNotes@shopnotes.com
 Internet: http://www.shopnotes.com

PRINTED IN U.S.A.

EDITOR'S NOTE

Cutoffs

Over the years, we've built a number of different tools for our shop. But the one that gets used most often is the router table that was featured in the very first issue of *ShopNotes*.

That's a long time ago (over seven years). So why bring it up now? It has to do with a conversation I had recently with a friend of mine.

He stopped by the shop recently while I was using the router table to make some strips of molding. And he mentioned that he'd always admired its large table top and adjustable fence.

But what surprised me is that he had never actually built the router table.

The base cabinet it was mounted on would have taken up too much room in his shop. (Sound familiar?)

Well, that got me to thinking. Why not build another router table? One that didn't take up any floor space.

What I had in mind was a small router table that clamped to a bench. Yet it would still incorporate all the features of our full-sized router table. In other words, a small router table that could handle large jobs.

It sounded like an interesting challenge. And we kicked the idea around with Ken (our project developer). The more we talked, the more excited we got about it. So we decided to build a prototype of the new router table.

Not long after that, Ken showed up carrying a small, compact box that looked like a plywood suitcase, see photo above. "What do you think?" he asked as he set the box down.

Then, with a gleam in his eye, he proceeded to raise a "wing" that was hinged

to one side of the box. At the same time, he reached into a hole in front of the box, opened a door, and swung it underneath the wing.

After repeating the process on the other side, one thing became clear. This was no small router table. In fact, the table had a "wingspan" that appeared to be a yard long. (Okay, it was only 32" long.) Even so, that's still 2" longer than our original router table.

I have to admit, the table is impressive. It's a beefy, 1"-thick slab that provides a rock-solid worksurface. (Take a look at the photo of the extended table on the back cover.)

FENCE. I was also curious about the fence. Since it doubled as a handle, it was unusual looking. But what I really wanted to know is how it compared with my old fence. (That fence had spoiled me just a bit.)

It didn't take long to find out. The fence is the same thickness (1") as the table, so it has a nice, solid feel. It slides smoothly across the table. And a simple, built-in clamp locks it in place.

Just one more thing about the fence, and then I'll stop. To change the size of the opening around the router bit, there are two faces in the fence that slide back and forth. Moving these faces as close to the bit as possible prevents a workpiece from tipping into the opening.

DELUXE VERSION. As you can see, I'm excited about our new router table. We even built a deluxe version. It uses the same basic design, but it has several additional features that make it even more versatile. (For more about this deluxe router table, refer to page 16.)



Tim

Contents

Features

Socket Set Storage Boxes _____ 6

Keep the tools in your socket sets organized with these handy storage boxes. You can customize each box to suit your needs. There's even a case to hold the boxes.



Socket Set Boxes page 6

Custom Fit Dadoes _____ 10

Two simple methods to cut an accurate, tight-fitting dado joint — without using a dado blade.



Custom Fit Dadoes page 10

Lumber Cart _____ 12

This shop-built cart provides plenty of storage for scrap pieces of wood and sheet materials. Plus, the top of the cart doubles as a convenient work surface.



Lumber Cart page 12

Benchtop Router Table _____ 16

Take a close look at this space-saving router table. It features a large table, an adjustable fence, and three different accessories. Yet it folds up into a compact box.

Mounting Plates _____ 28

Building a router table? To make it easy to change bits, attach your router to a removable mounting plate. We offer some practical suggestions on which one to buy.

Dovetail Jigs _____ 30

You can rout professional-looking dovetail joints every time with these two commercial dovetail jigs.

Departments

Readers' Tips _____ 4

Our readers offer their own shop-tested tips dealing with some of the most common woodworking problems.

Sources _____ 31

Hardware, project supplies, and mail order sources for the projects in this issue.

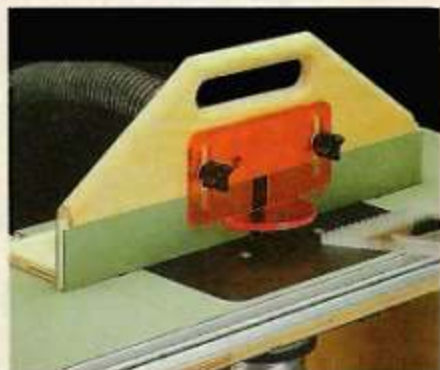

Router Table page 16

Readers' Tips



■ When edge gluing a solid wood panel, the boards always seem to shift up or down. So I often end up with a small "step" at the joint line.

To create a flat panel, I clamp *pressure bars* across the boards, see photo. The pressure bars are squeezed together by tightening wing nuts on the carriage bolts that extend through the bars.

The bars need to be pretty stiff,

Edge-Gluing Tip

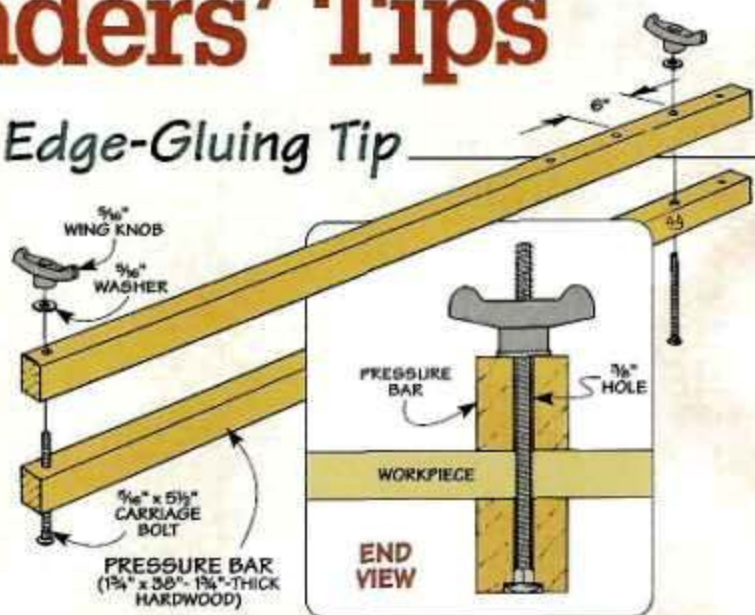

so I used 1 $\frac{3}{4}$ "-square stock, see drawing. Mine are cut long enough to accept panels up to 36" wide.

A few extra holes along one end allow me to move the bolts closer together when gluing narrower panels. And each hole is counter-bored so the bars can sit flat on my

workbench or the shop floor.

Before using the pressure bars, you'll want to apply a coat of paste wax to their inside faces. This prevents them from getting permanently glued to the boards.

John Lynch
Boston, Massachusetts

Quick-Release Featherboard

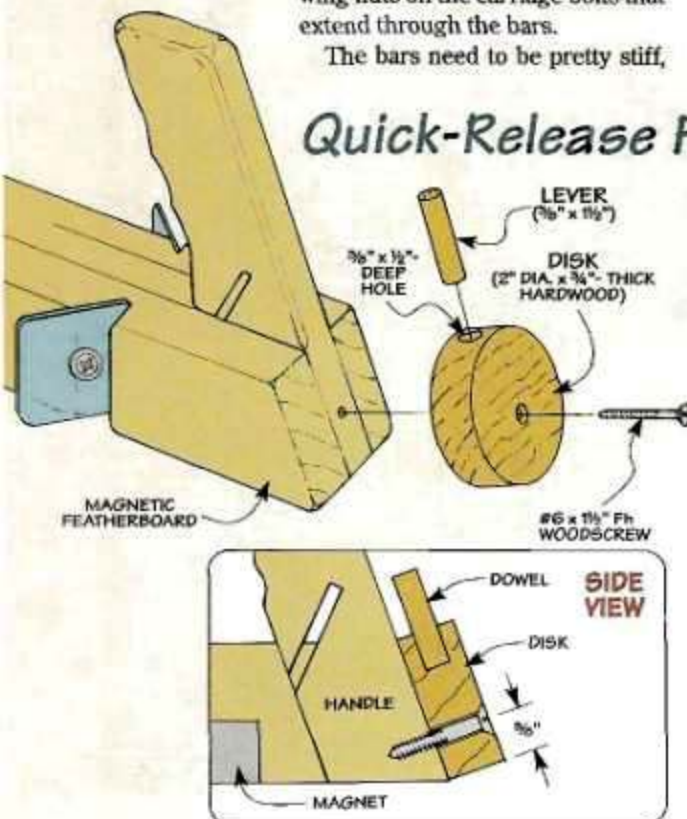

■ I often use a magnetic featherboard when I'm ripping stock on the table saw. As you might expect, the magnet grips pretty tightly. So it's not an easy task to lift the featherboard off the saw table.

But I recently came up with an almost effortless way to remove the featherboard. All that's needed is a hardwood *disk* to use as a "cam", see photo. To create a *lever* for the cam, I simply glued a *dowel* into the edge of the disk, see drawing.

The cam pivots on a short screw. But the screw isn't located in the center of the disk. Instead, it's offset slightly, see Side View. It's this offset that makes the cam work.



When you want to remove the featherboard, just pivot the disk about a quarter of a turn. That rotates the disk *below* the bottom edge of the featherboard and breaks the magnet's grip on the saw table.

Bob Wickstrom
Overland Park, Kansas

Quick Tips



▲ When Alan Smith of Utica, NY uses a rasp, he slips a rubber finger guard on the end to protect his fingers from the sharp teeth.



▲ To reduce vibration in her scroll saw, Martha Dawson of Squaw Valley, CA cuts pieces from an old mouse pad to put under the saw.



▲ To make an inexpensive "pull" for a small shop drawer, John Hershey of Mena, AR simply cuts a slot with a plate joiner and glues in a biscuit.

Repairing Tenons

■ Chairs get lots of tough use, so it's not uncommon to see spindles and rungs with broken tenons, see drawing. Rather than try to salvage a badly broken one, I often find it easier to simply cut off the entire tenon, see detail 'a.' After drilling a hole in the end and gluing in a dowel, I just trim the "tenon" to length, see detail 'b.'

Kevin Boyle
Des Moines, Iowa

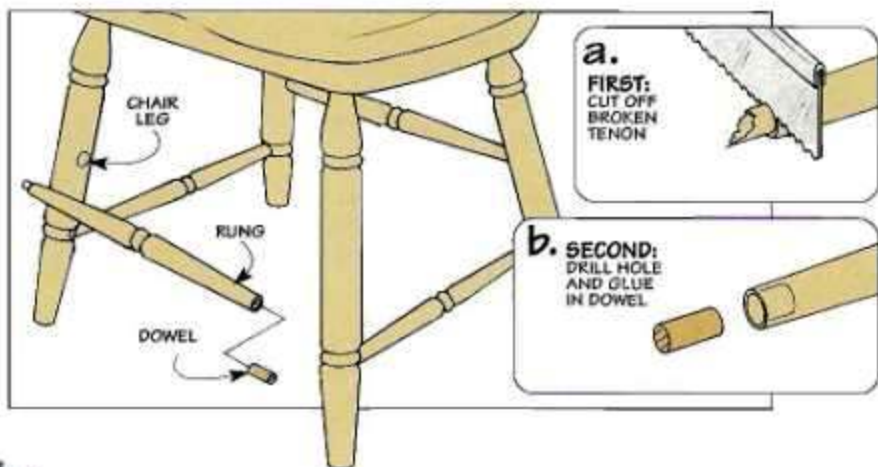

Fitting Dovetails

■ When cutting dovetails, I like my initial fit to be a bit tight. It's always easier to relieve a tight joint than try to deal with a loose one. To "fine tune" a joint that's too tight, I use a couple of tricks.

To make it easier to fit the pieces together, chisel a chamfer on the *inside* of each tail, see photo at left. You'll want to start the chamfers just short of the end, otherwise they show when you join the pieces.

Then sand the *inside* face of the pins until they fit into the tails just right, see photo at right.

Al Woods
San Jose, California

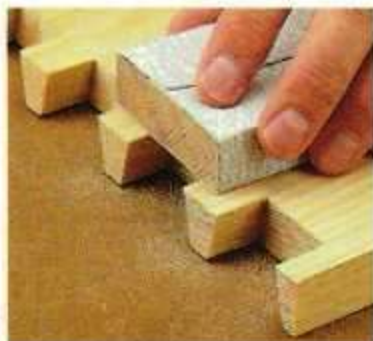
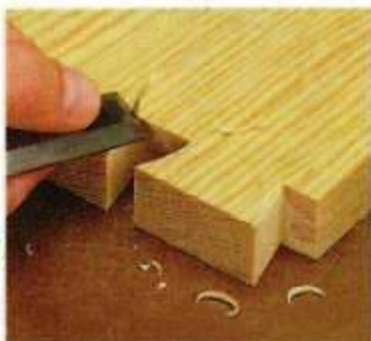

Send in Your Shop Tips

To share your original shop tips to problems you've faced, send them to: *ShopNotes*, Attn.: Readers' Tips, 2200 Grand Avenue, Des Moines, IA 50312. (Or if it's easier, FAX them to us at: 515-282-6741.)

We'll pay up to \$200 depending on the published length. Please include a daytime phone number so we can call you if we have any questions.

Socket Set Storage Boxes

Keep all your socket sets organized by customizing these simple storage boxes.

I've had a socket set for years. Actually, I have *three* socket sets — each with a different size ratchet ($\frac{1}{4}$ ", $\frac{3}{8}$ ", and $\frac{1}{2}$ "). At one time, each set had its own case. But those flimsy plastic cases fell apart a long time ago. So I'd just toss the sockets in a drawer. I know, it wasn't the best solution. The sockets rattled around like BB's in a tin can. And rummaging around the drawer to find the correct size socket was a pain.

Because of that, I decided to buy a case to hold the loose tools — one of those *fitted* cases with a space for each piece in the set. There was just one problem. The only cases I could find already *had* a full set of tools, and I certainly didn't need any more.

CUSTOM BOXES. The solution was simple. I made my own storage boxes, see photo above. The nice thing about these boxes is they're customized to fit the sockets, ratchets, and extension bars that go with that set. (There's one box for each set).

PEGS. To keep things organized, each socket fits on a wood peg. When you're cleaning up, the pegs make it easy to see if one of the sockets is missing. Once you close the lid, a piece of foam keeps the sockets from falling off the pegs — even if the box gets turned upside down. So the next time the box is opened, the sockets are lined up and ready to use.

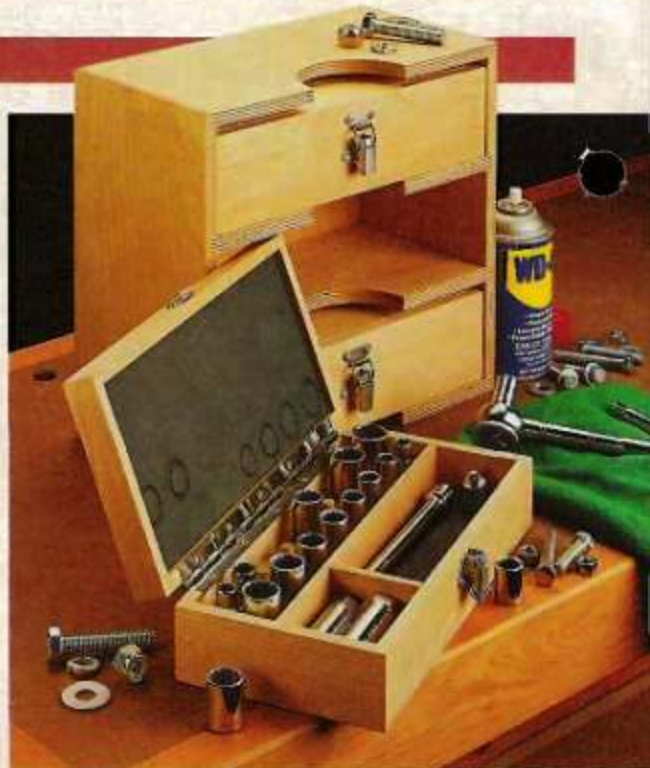

CASE. In addition to organizing my socket sets, I also wanted a place to put the storage boxes. So I built a plywood case to hold them.

BUILDING THE BOXES

Each of the boxes is made using a simple, two-step method: build an enclosed box, then cut it apart.

ENCLOSED BOX. To determine the size of the box, plan the *inside* dimensions to accept your *largest* size socket set. The box shown in the Exploded View below is long enough to hold my $\frac{1}{2}$ " ratchet and also eight metric and fractional sockets.

Since the boxes are bound to get knocked around, I

EXPLODED VIEW (BOX ONLY)

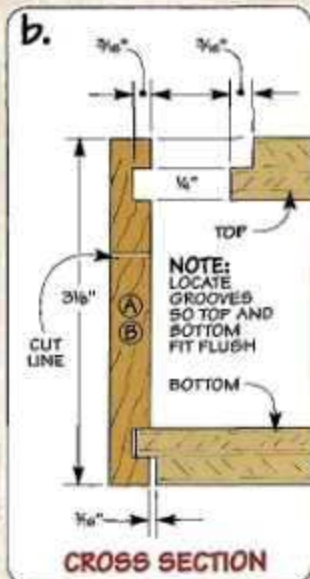
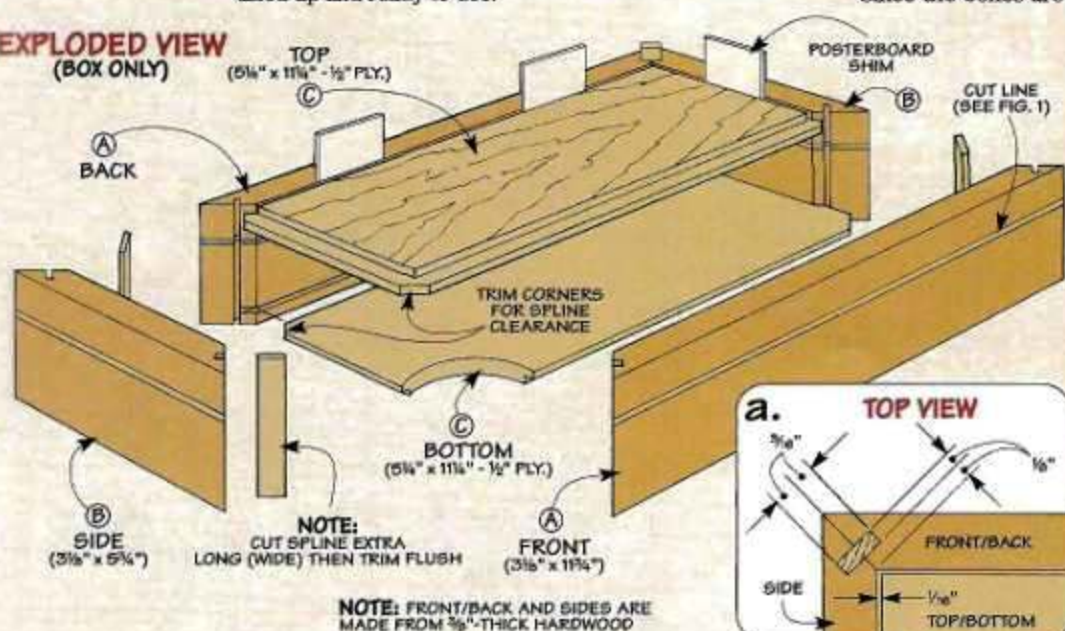

used $3/8$ "-thick hardwood (maple) for the *front/back* (A) and *sides* (B). These pieces are ripped to final width. But I cut them extra-long to start.

To accept a top and bottom (added later), you'll need to cut two grooves in each piece, see detail 'b' on page 6. Then just miter each piece to final length and cut splines to strengthen the joint, see box below.

TOP/BOTTOM. Now you can turn your attention to the *top* and *bottom* (C). These are pieces of $1/2$ " plywood (birch) that are cut slightly smaller ($1/8$ ") than the distance between the bottom of the grooves.

The top and bottom are rabbeted on all four edges. This forms a tongue that fits the grooves cut earlier. The idea is to cut the rabbets wide enough so there's a slight ($1/16$ ") "shadow line" all the way around the top and bottom, see detail 'a.' (I cut $3/16$ "-wide rabbets.)

GLUE-UP. Before gluing up the box, don't forget to "nip" the corners of the top and bottom at an angle.

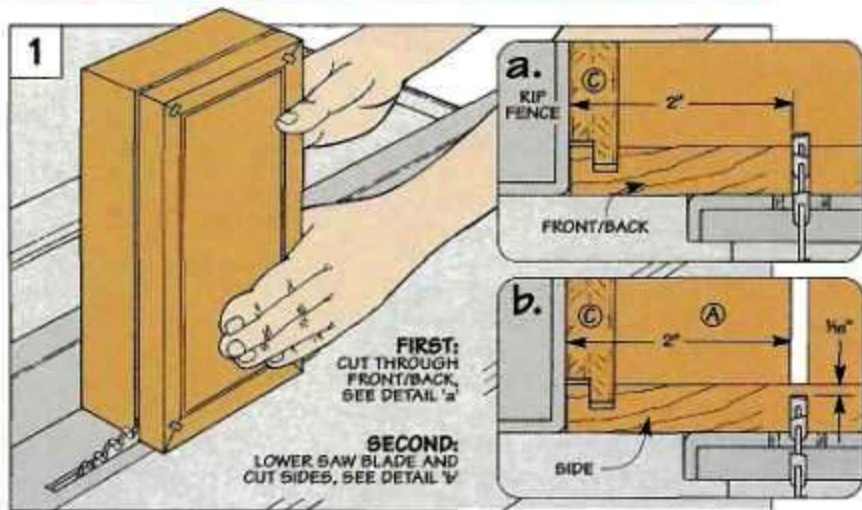

This provides clearance for the splines. Also, some posterboard shims will produce a uniform gap around the top and bottom.

CUT BOX APART. After gluing up the box and trimming the splines flush, you can cut the lid from the box. A table saw makes quick work of this, see Fig. 1. Start by raising the blade to cut *through* the thickness of

the box, see Fig. 1a. Then cut through the front and back only.

Before cutting the sides of the box, lower the blade so it *won't* cut all the way through, see Fig. 1b. This will leave a thin membrane that keeps the box intact and prevents it from "pinching" the blade. To separate the lid, cut the membrane with a hand saw and sand the edges smooth.

Splined Miter Joints

Adding a spline to a miter joint accomplishes two things. First, it produces a stronger glue joint than the end grain surfaces of the miters. Second, it prevents the miters from slipping out of alignment when they're clamped together.

CUT KERFS. The splines fit in kerfs in the mitered ends of the pieces, see photo. To cut the kerfs, tilt the saw blade to 45° and attach an auxiliary fence to the rip fence, see Fig. 1. Then, with the long tip of the miter riding against the auxiliary fence, use the miter gauge to push the workpiece through the blade.

SPLINES. The next step is to cut thin, hardwood splines to fit the kerfs. One thing to be aware of here is the *grain direction* of the spline. To produce a strong joint, the splines should be cut

so the grain runs *perpendicular* to the joint line.

An easy way to make the splines is to use a scrap from the project you're working on and cut it on the table saw.

Start by setting the rip fence so the blade will cut a spline of the desired thickness, see Fig. 2. Then raise the blade $1/8$ " higher than the width (length) of the spline and cut several kerfs. After repositioning the fence and lowering the blade so it just cuts into the kerf, it's a simple matter to trim each spline from the block, see Fig. 3.

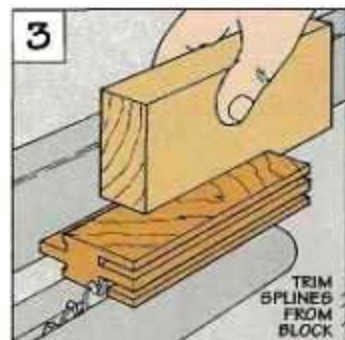
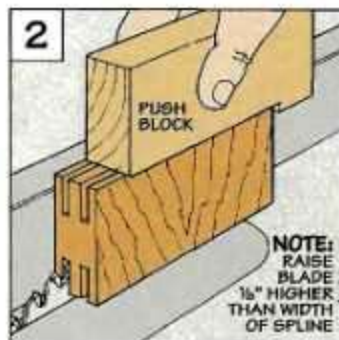
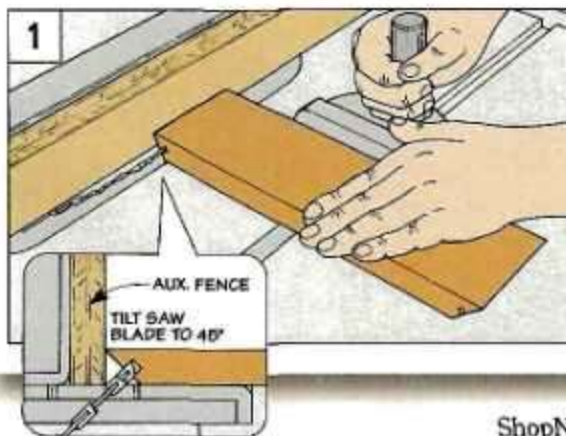

Customizing the Boxes

After cutting the storage boxes apart, they're basically complete — at least on the outside. Now it's time to customize the *inside* of the boxes.

HINGES. To simplify things when "fitting out" the boxes, start by installing the hinges that hold them together. (I used a continuous hinge.) Each hinge is recessed in a shallow notch in the box and lid, see drawing.

An easy way to cut these notches is to use a table-mounted router and a straight bit. You'll want to adjust the height of the bit to equal *half* the thickness of the knuckle on the hinge, see Figs. 2 and 2a. This will allow the lid to close completely.

Another thing to be aware of is that the notches don't extend *through* the sides of the box. Instead, they're "stopped" short to keep the notch (and hinge) from showing. This requires making a stopped cut.

To establish the beginning and end of this cut, clamp a pair of stop blocks to the fence, see Fig. 2. The idea is to locate the blocks so the notch will be about $\frac{1}{4}$ " shorter than the length of the hinge. (It's cut to final length later.)

ROUT NOTCH. Once the router table is set up, it only takes a minute to rout the notch. Just hold the lid (or box) at a slight angle and set it against the back stop block, see Fig.

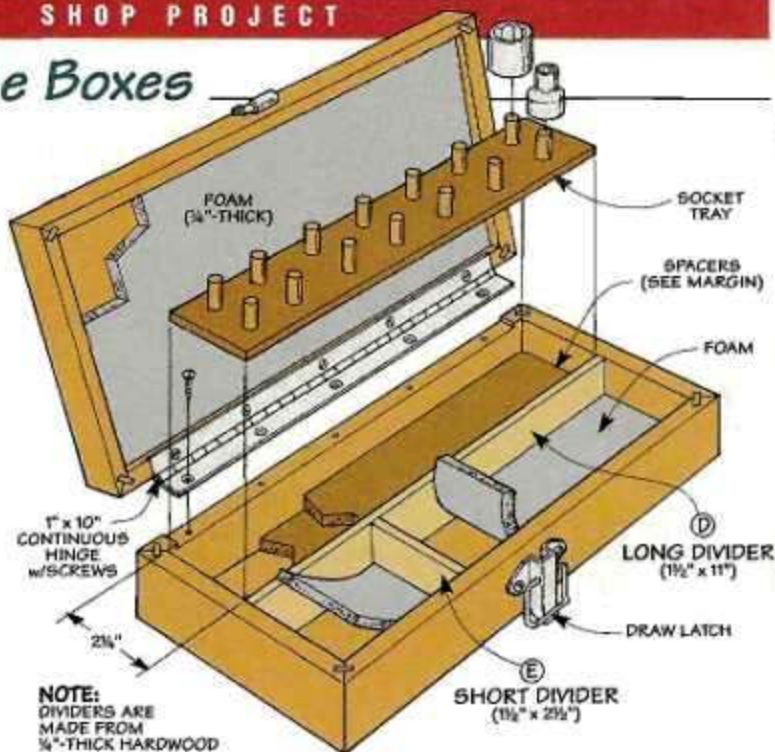

NOTE: DIVIDERS ARE MADE FROM $\frac{1}{4}$ "-THICK HARDWOOD

2. Now gently lower the lid onto the spinning bit and push it forward until it contacts the other stop block.

This removes the bulk of the waste, but there's still a sliver of material at each end of the notch. Paring away the waste with a chisel is all it takes to square up the end, see Fig. 2b.

LATCHES. After screwing the hinges in place, I added a draw latch to keep the lid on each box closed. The latch is simply mounted to the front of the box with screws.

DIVIDERS. Now you can turn your attention to the inside of the box. It's divided into individual compartments by thin strips of hardwood. A *long divider* (D) separates the sockets from the ratchet and extension bars. And a *short divider* (E) creates a handy place for small items. Note: My $\frac{1}{2}$ " ratchet is nearly as long as the box, so I didn't add a short divider to that box.

SOCKET TRAYS. After gluing the dividers in place, the next step is to add a *socket tray* (F) to each box, see Fig. 3. The tray is a strip of $\frac{1}{4}$ " hardboard with two rows of wood pegs — one to hold metric sockets, and the other for fractional size sockets.

PEGS. The pegs are short dowels that fit into the drive end of the sockets. To create a snug fit, the diameter of the dowels matches the size of the square openings in the sockets. (This means using $\frac{1}{4}$ " dowels for a $\frac{1}{4}$ " socket set, $\frac{3}{8}$ " for a $\frac{3}{8}$ " set, and so on.)

When it comes to determining the *length* of the pegs, things get a bit trickier. That's because the pegs extend all the way *through* the drive end of the large size sockets in a set, see End View in Fig. 3. But they "bottom out" in the smaller sockets.



▲ Three $\frac{1}{4}$ " hardboard spacers raise the $\frac{1}{4}$ " sockets just enough to compress the foam in the lid.



▲ The $\frac{3}{8}$ " sockets are taller, so all you'll need is a pair of $\frac{1}{4}$ " spacers.



▲ A single, $\frac{1}{8}$ " strip of hardboard builds up the $\frac{1}{2}$ " sockets high enough to "dent" the foam.

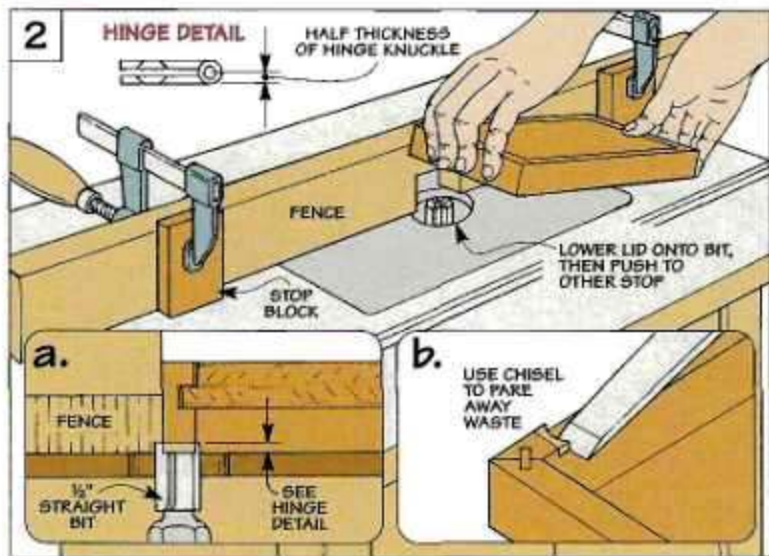

So to ensure that all the sockets sit flat on the tray, cut the pegs to length to fit the *smallest* socket in the set.

The pegs fit in holes drilled in the socket tray. To determine the location of these holes, simply arrange the sockets on the tray. There's nothing critical here. Just be sure the sockets won't extend past the edge of the tray. (I located the centerpoints of the holes $\frac{1}{2}$ " in from the edge.) Also, check that there's enough finger room between the sockets so you can grab them easily.

SPACERS. After drilling the holes and gluing in the pegs, I added a system of hardboard *spacers* (G), see Fig. 3. Together with a piece of foam installed in the lid, the spacers keep the sockets from falling off the pegs when the box is closed.

The way this works is simple. The spacers "build up" the height of the tray so the sockets compress the foam.

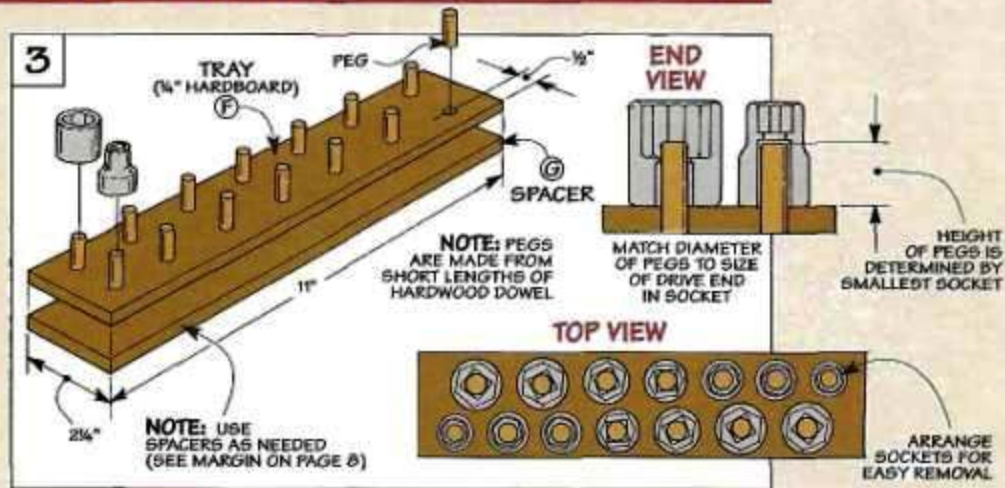

The foam makes the sockets stay put — even if the box gets turned upside down. Note: Depending on the size of your socket sets, you'll need to use a different number (or thickness) of spacers, see margin on page 8.

FOAM. All that's left to complete the boxes is to add the foam. I used

$\frac{1}{4}$ "-thick closed-cell foam that resists tearing. (For a source of closed-cell foam, see page 31.)

The foam is simply cut to fit in the lid and pressed into place. While I was at it, I also put foam in the bottom of each small compartment to keep tools from rattling.

The Case



The storage boxes keep all my socket sets organized. But I also wanted a place to put the *boxes*. So I built a simple plywood case to hold them, see photo above.

DEEP REACH. One nice thing about this case is it has several large, curved notches in front. These notches let you reach deep inside the case to get a firm grip on the boxes. (The boxes are quite heavy when full of tools.) This makes it easy to remove a box or slide it back into the case.

Besides the notches, there's some additional clearance built into the openings for the boxes. And the

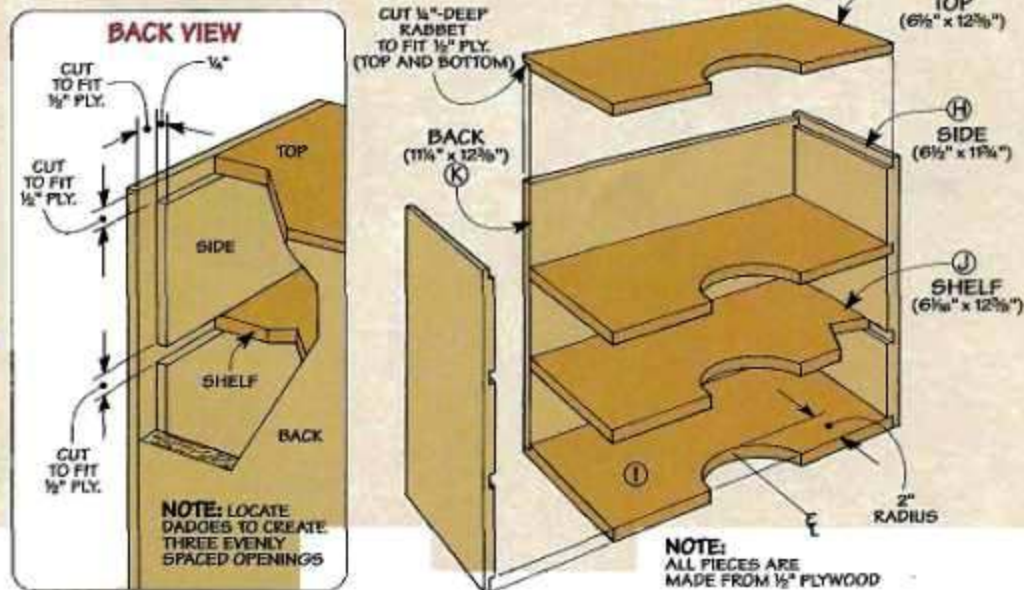

openings are sized so the boxes fit flush with the front of the case. There's $\frac{1}{4}$ " of clearance above each box and $\frac{1}{16}$ " on each side.

BUILDING THE CASE. To make the case, start by cutting the *sides* (H) to final size, see drawing above. The sides are rabbeted at each end

to accept the *top* and *bottom* (I). And a pair of dadoes in each side hold the *shelves* (J). You'll also need to rabbet the *sides*, *top*, and *bottom* for the *back* (K) of the case, see Back View.

After cutting and sanding the curved notches, it's just a matter of gluing up the case.

Custom Fitting Dado Joints



Recently, a friend of mine was building a project that was assembled with dado joints. He's just getting started in woodworking, and he doesn't have a dado blade. So he stopped by to borrow mine.

As luck would have it, I'd just sent

my dado blade out to be sharpened. So instead, I showed him a couple of simple methods for cutting dados that *don't* require using a dado blade — one on the table saw, and the other with a hand-held router.

The best thing about both of these

methods is they produce perfect-fitting dado joints — not too tight, and not too loose.

The secret is to use a simple system of spacers to establish the width of the dado. These spacers ensure a "custom fit" joint.

Table Saw Method

Here's a quick way to cut a dado on a table saw. It only requires a combination saw blade and two spacers. The spacers are used to establish the two sides of the dado. Then the material *between* the sides is wasted out.

SPACER THICKNESS. The key to making this work is the *thickness* of the spacers. The first spacer matches the thickness of the workpiece that fits into the dado. (A scrap piece from the project works fine.) And the second spacer equals the thickness of the blade. (I use a piece of 1/8" hardboard with a single strip of masking tape.)



FIRST SIDE. To cut the first side of the dado, start by clamping one spacer (the scrap from the project) to the rip fence, see Fig. 1. Then position the fence so the saw blade

aligns with the *near* side of the dado, see Fig. 1a. After locking the fence in place, butt the workpiece against the spacer and use the miter gauge to push it through the blade.

SECOND SIDE. The second side of the dado is cut with the rip fence in the same exact position. Only this time, you'll need to replace the first spacer with the one that matches the thickness of the blade, see photo above. With this spacer clamped in place, it's just a matter of making a second pass, see Fig. 1b.

REMOVE WASTE. All that's left to complete the dado is to remove the rest of the waste. To do this, just "nibble" away the waste by making as many passes as needed, see Fig. 1b.

RIDGES. One thing you'll notice about a combination blade is it leaves ridges on the bottom of the dado. If the end of the dado is going to be covered up, you can just leave the ridges. But if it's exposed, you may want to sand the bottom of the dado flat, see margin at left.



▲ To sand the bottom of a dado flat, use a block that's slightly thinner than the width of the dado.

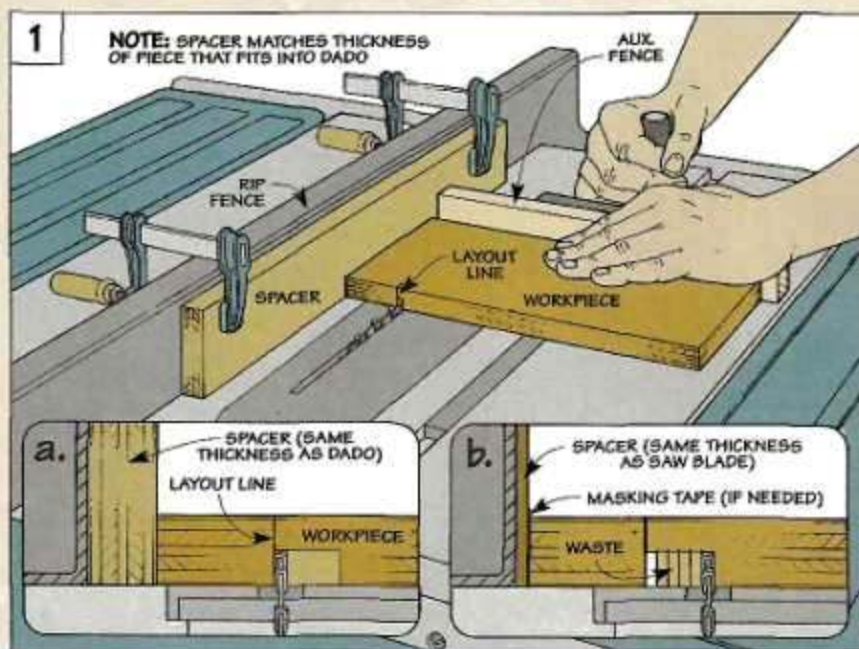

Routing Dadoes

Sometimes a workpiece is too large or awkward to handle on the table saw. In that case, it's best to clamp it to a bench and *route* the dadoes using a hand-held router and straight bit.

As with the table saw, using a spacer ensures a perfect fit. And a pair of simple guides produce straight, accurate cuts, see photo.

GUIDES. Each guide consists of two parts: a hardboard *base* that acts as a routing platform and a wood *fence* to guide the router, see Fig. 1. To rout a dado across the width of a full sheet of plywood, both pieces are 48" long. Also, it's best to start with an extra-wide base (6" in my case).

After gluing on the fence, the next step is to trim the base to final width. The idea here is to use the same router bit you plan to use when cutting the dadoes. (I used a 1/2" straight bit.) This creates two *reference edges* that establish the sides of the dado.

One thing to be aware of is the bit may not be perfectly centered in the base of the router. So be sure that the same side of the base is against the fence when trimming the base pieces to width. Shop Tip: Make a mark on the router base and keep it in contact with the fence at all times.



SETUP. Once the guides are complete, positioning them on the workpiece only takes a minute. Start by laying out the location of one side of the dado. Then align the reference edge of one of the guides along that mark and clamp the guide in place, see Fig. 2.

SPACER. To position the second guide, there's no need to lay out the other side of the dado. The spacer takes care of that. (Here again, use a scrap that matches the thickness of the piece that fits in the dado.) Just set the spacer against the guide that's clamped to the workpiece. Then butt the second guide against the spacer. Now clamp this guide to the work-

piece and remove the spacer.

ROUT DADO. At this point, you're ready to rout the dado. This is accomplished by making a series of shallow, overlapping passes.

To define one side of the dado (and remove part of the waste material), turn on the router and run it along the fence of the first guide in the direction shown in Fig. 3. Note: Don't forget to orient the mark on the router base toward the fence on the router base toward the fence.

After routing all the way across the workpiece, turn the router so the mark is oriented toward the fence on the second guide and then repeat the process. This produces a tight-fitting dado joint every time. 

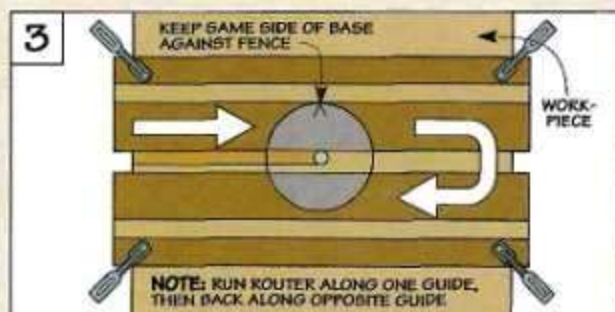
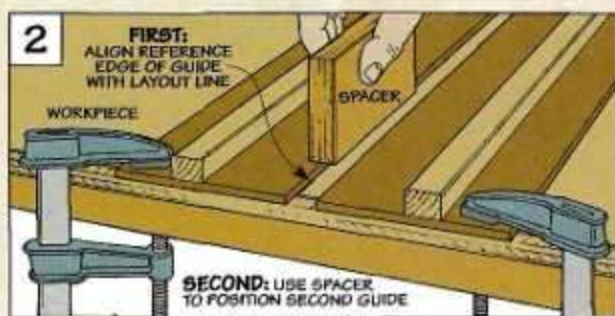
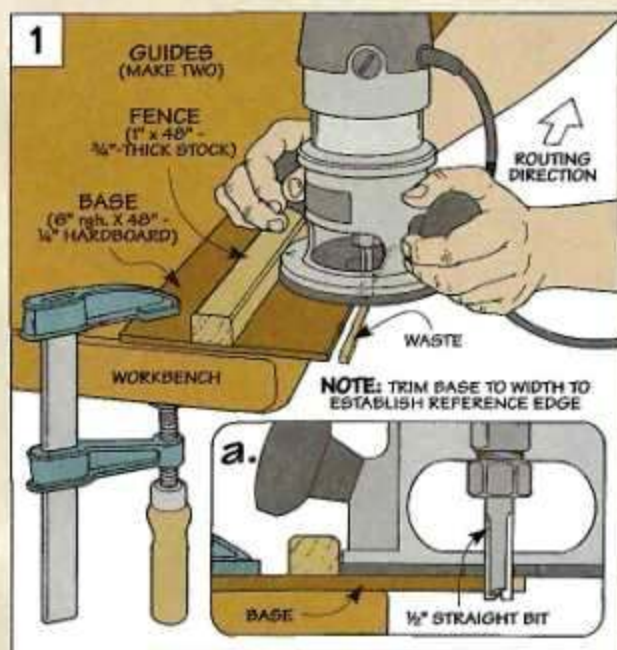

Lumber Cart



BINS FOR
LUMBER CUTOFFS



STORAGE BAY
FOR SHEET GOODS

Like most woodworkers, I've always had a hard time throwing away scrap pieces of material. Short chunks of wood usually get "squirreled" away in a corner. And I just lean the plywood cutoffs (and other sheet goods) up against the wall.

As nice as it is to have lots of scrap pieces, they *do* have a way of piling up. (And lately, the piles seem to be getting *larger*.) This makes finding the piece I need like looking for buried treasure without a map.

In order to keep all these scrap

pieces organized, I built a simple cart. This cart lets me see at a glance exactly which pieces I have. So now, instead of just accumulating more scraps, I've found myself *using* more of the material I have on hand.

The lumber cart is divided into two sides. The front side has a number of bins that hold short lengths of wood, see photo above left. And sheet goods are stored in a large "bay" on the opposite side, see photo above right. To provide access to either side, there's a set of heavy-duty casters mounted to the cart that make it easy to turn around.

BINS. The bins range in depth from 12" to 36". The nice thing about this is it's like having a built-in sorting system. Scrap pieces of similar lengths are stored in the same bin. So when you need a piece that's a certain length, it's just a matter of looking in the appropriate sized bin.

STORAGE BAY. Although the sheet goods in the storage bay aren't arranged by size, it only takes a few seconds to find the piece you need. You just "leaf" through the pieces like a stack of record albums.

WORKSURFACE. One more thing worth mentioning here is the large

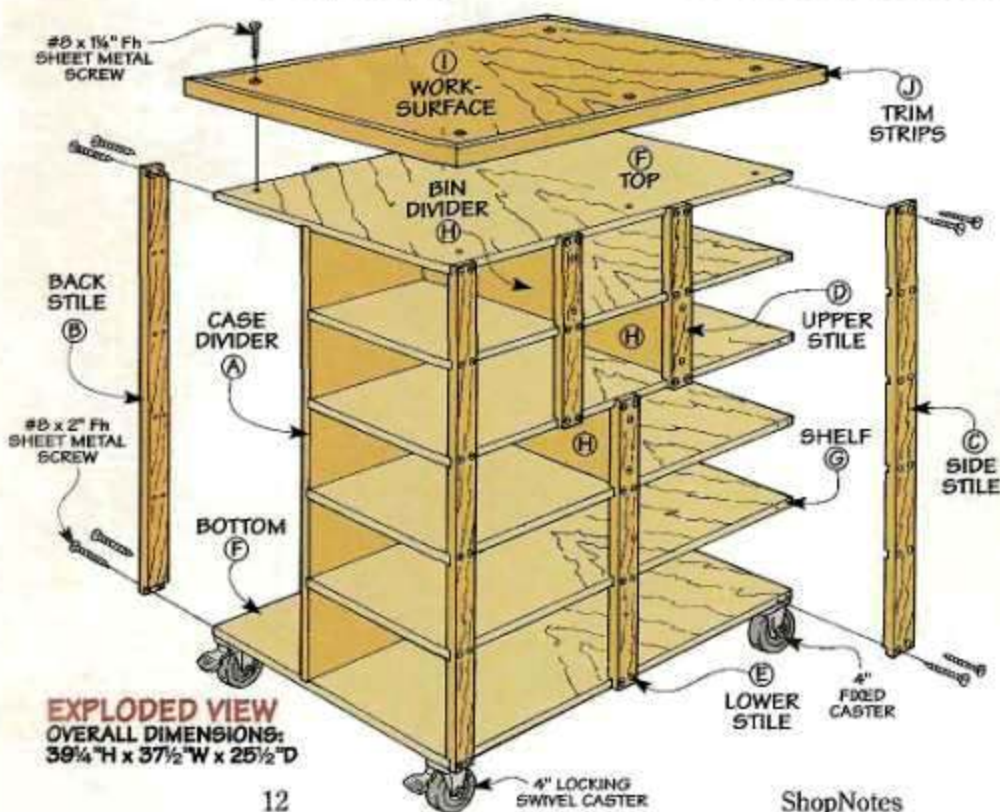

EXPLODED VIEW
OVERALL DIMENSIONS:
39 1/4" H x 37 1/2" W x 25 1/2" D

area on top of the cart. It's a great place to mount a tool or to use as an extra work surface.

CONSTRUCTION

There's nothing complicated about this lumber cart. It's made from inexpensive material. (I used one and a half sheets of $\frac{3}{4}$ " fir plywood with an 'AC' grade.) And it's assembled with dado and rabbet joints. (There are two simple techniques for cutting dados shown on page 10.)

DADOES. Most of the dados are located in the *case divider* and the *stiles* that are attached to the front of the case, see the Exploded View on page 12. In addition to supporting a set of *shelves*, the dados will make it easy to align the parts when assembling the cart.

Although the dados are relatively simple to cut, there are a *bunch* of them (sixteen altogether). So I used an old trick to speed up the process.

Start with an extra-wide piece that's cut to the final length ($34\frac{1}{2}$ " of the front stiles, see Fig. 1. After cutting the dados in this piece (Fig. 1a), it's separated into two parts — one for the case divider and the other for the front stiles, see Fig. 2.

TRIM CASE DIVIDER. One thing to be aware of here is that the *case divider* (A) is 1" shorter than the

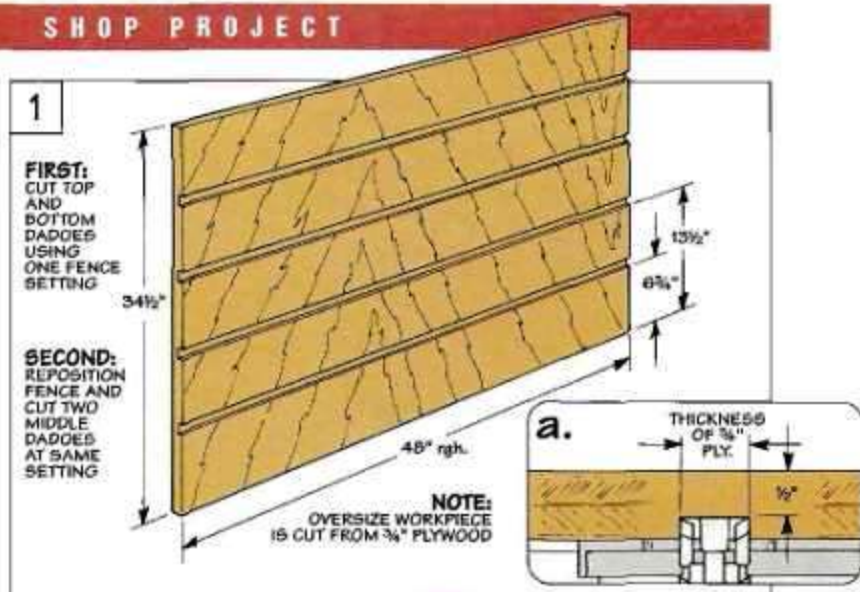

front stiles. So it needs to be trimmed to final length. Now it's tempting to remove *all* of this waste by making a single pass on the table saw. The only problem is that the dados in the case divider wouldn't align with the dados in the front stiles. So to ensure proper alignment, I trimmed $\frac{1}{2}$ " off the top *and* the bottom edge of the case divider, see Fig. 2.

STILES. Now you can turn your attention to the stiles. To provide support for the shelves, there are *five* stiles on the front of the cart, see Exploded View. And *four* stiles in back add rigidity to the cart.

The front stiles are made from the

piece separated earlier from the case divider. However, you'll need a second piece for the back stiles. Here again, I started with an extra-wide piece that's cut to final length, see Fig. 3.

There's no need to cut any dados in this piece. (There aren't any shelves in the back compartment.) But *both* pieces are rabbeted at each end to accept the top and bottom of the cart, see Fig. 3a.

Now it's just a matter of ripping the stiles to width. This completes the *back* (B) and *side* stiles (C). But you'll still need to crosscut the two *upper* stiles (D) and *lower* stile (E) to final length.

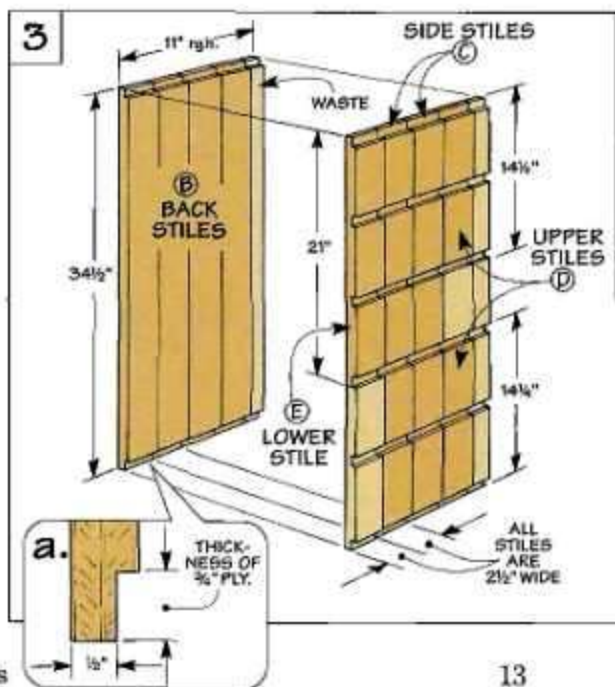
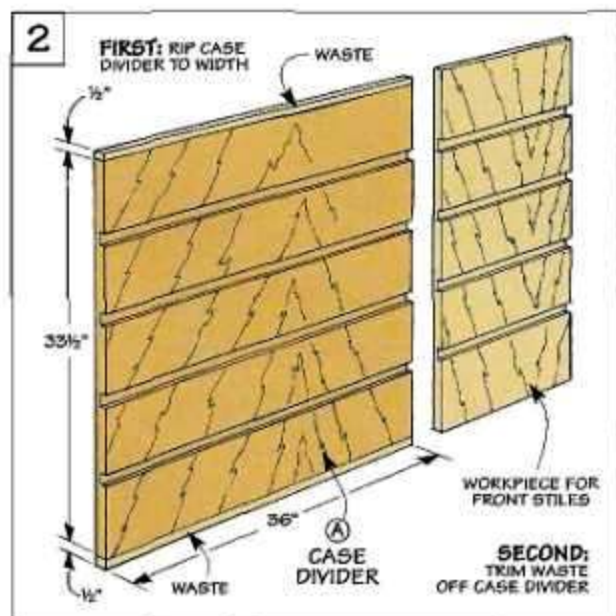

Bins and Storage Bay

At this point, the case divider and stiles are complete. Now you can turn your attention to the bins in the front of the case and the storage bay in back.

TOP & BOTTOM. The first step is to add a plywood top and bottom (F), see Fig. 4. To create a compartment on each side of the cart, the case divider (A) rests in dadoes cut in the top and bottom, see Figs. 4 and 4a. I tend to have more lumber cutoffs than sheet goods. So this dado is offset to one side. This provides more storage area on the front side of the cart.

With the dadoes complete, you're ready to start assembling the cart. Working with these large pieces can be a juggling act. So I found it best to do most of the assembly with the cart on its side.

I started by setting the case divider into the dadoes in the top and bottom to form a large, H-shaped assembly, see Fig. 4. Then I glued and screwed the top and bottom in place.

SHELVES. To form the separate bins, there are four shelves added to the front side of the cart. Later, dividers are added to "break up" the bins into different sizes.

The shelves (G) are nothing more than pieces of $\frac{3}{4}$ " plywood, see Fig. 5. They're cut to size so they're even with the front edges of the top and bottom. And just like the top and bottom, the shelves are glued and screwed in place.

ADD FRONT STILES. To support the shelves, the next step is to attach the stiles to the front of the cart, see Fig. 6. The side stiles (C) are glued and screwed flush with the top, bottom, and shelves. And the two upper stiles (D) are spaced evenly across the front of the cart. Finally, I centered the lower stile (E) on the

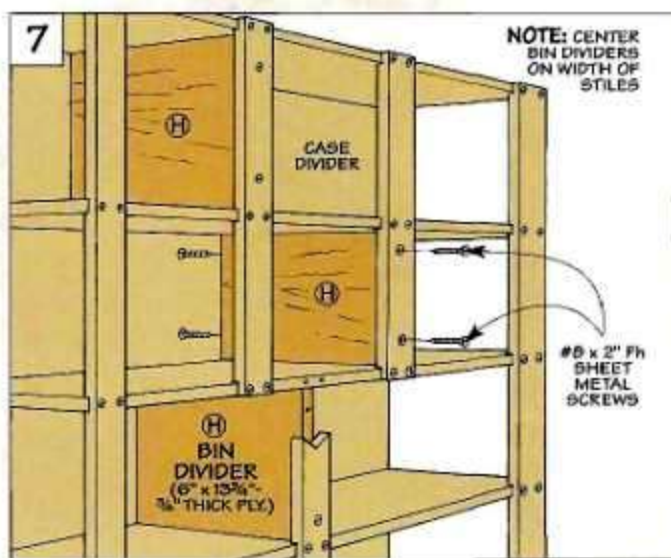
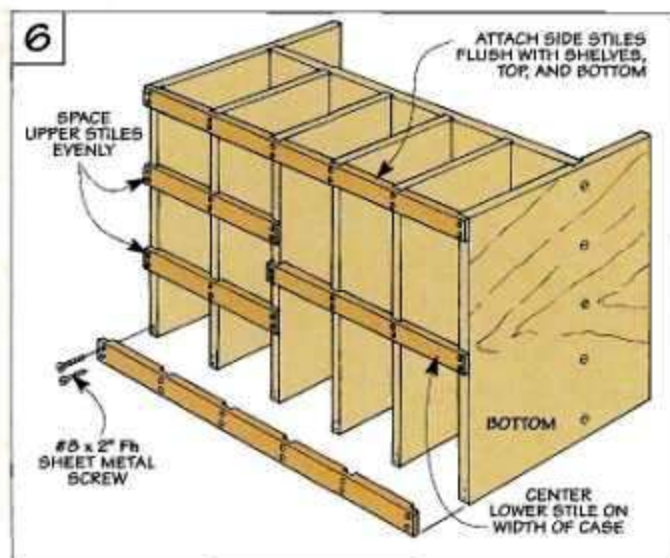
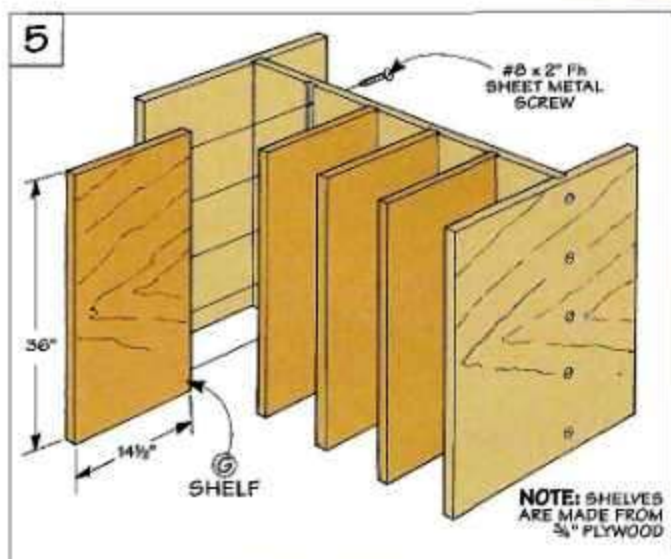
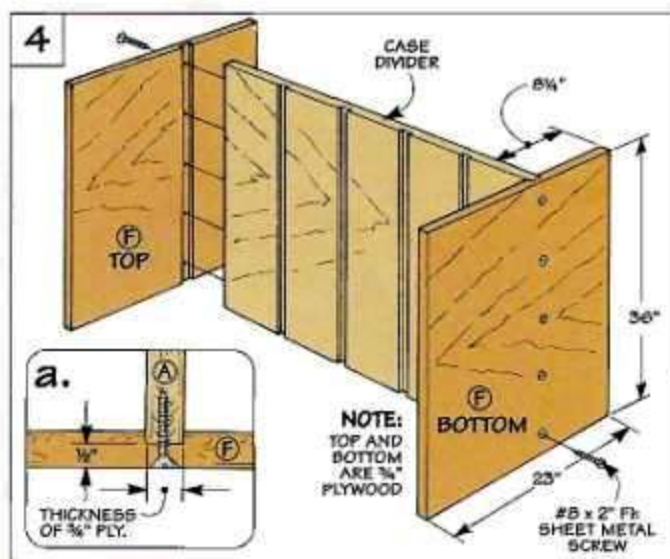

width of the cart.

BIN DIVIDERS. All that's left to complete the bins is to add three dividers to the top three shelves. The *bin dividers (H)* are pieces of $\frac{3}{4}$ " plywood that are sized in width to fit between the shelves, see Fig. 7. And they're cut to length so they slip between the case divider and the front stiles.

To position the dividers, I centered them on the width of the front stiles. Then I secured them by screwing through the front stiles and the back of the case divider.

STORAGE BAY. With the bin dividers in place, you can complete the storage bay at the back of the cart. All you need to do here is attach the back stiles (B), see Fig. 8. I spaced them evenly across the back of the cart.

ADD CASTERS. At this point, the lumber cart is ready for cutoffs and sheet goods. But for easy access to both sides for adding (or removing) material, I wanted to be able to move the cart around.

To make it easy to get at materials *and* still be out of the way, I added four casters to the bottom of the cart, see Fig. 9. There's a pair of fixed casters at one end of the cart and two swivel casters at the other end. This makes it easy to turn the cart around to get at all four sides. And I can easily push the cart into a corner or against a wall for storage. The swivel casters also lock in

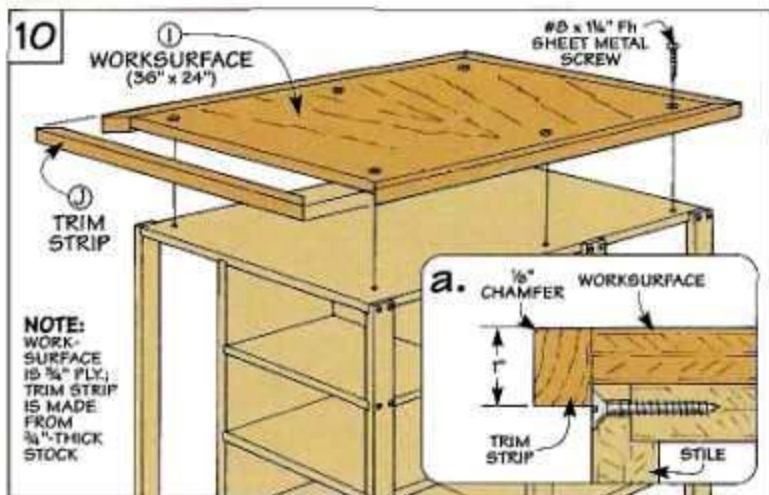
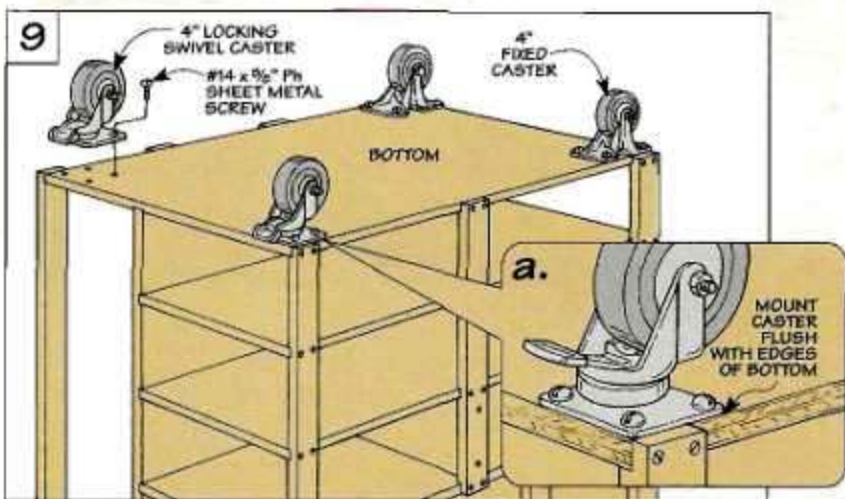
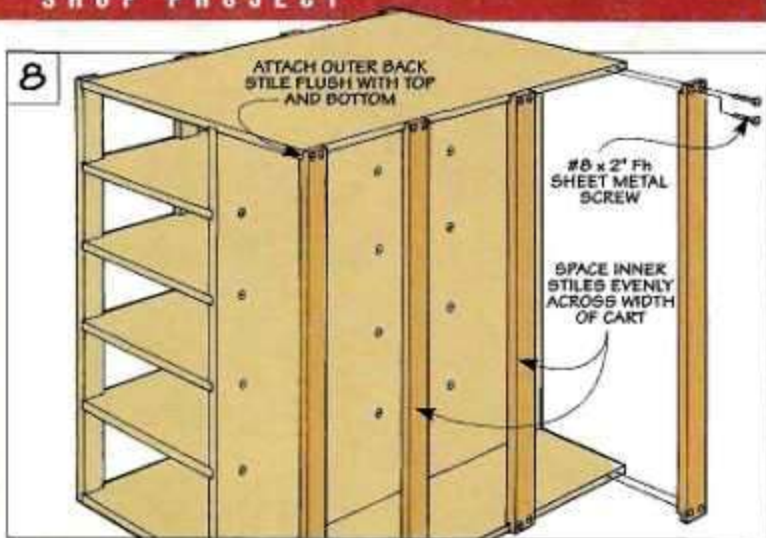

place, so I can use the cart as a stable work surface.

To make it easy to reach the locking lever on the casters, they're attached flush with the outside cor-

ners of the bottom, see Fig. 9a.

WORKSURFACE. The large top on the cart makes a great work area. Unfortunately, the exposed plywood edges have a tendency to splinter and catch on things. And the sharp corners at the top of each stile can make it a little uncomfortable to work around the top of the cart. To take care of both of these problems, I added a work surface, see Fig. 10.

The *worksurface (I)* is a piece of $\frac{3}{4}$ " plywood that's screwed flush with the ends of the cart and the face of the stiles, see Fig. 10. Then, to cover the exposed edges of the work surface, I added some *trim strips (J)*. These strips are simply mitered to length and then glued in place. Finally, to ease the sharp corners on the strips, I routed a small chamfer, see Fig. 10a. 

Benchtop Router Table



Let's face it. Not every shop has room for a large, stationary router table. That's the reason I like this benchtop router table.

Instead of taking up valuable floor space, the router table simply clamps to a bench, see photo above. And once a job is completed, it folds up into a compact box that's stored neatly out of the way, see inset photo.

With the router table folded up, it's only about as big as a picnic basket. But don't let its small size fool you.

LARGE TABLE. The "wings" on each side of the router table fold out to create a large, flat table, see photos below left. To provide support for the wings, just open

the doors and swing them underneath. The doors "click" into a shop-made catch with a reassuring sound.

FENCE. As much as I like the table, it's the *fence* that impresses me the most. It adjusts easily and locks down tight. And a pair of sliding faces let you change the size of the opening around the bit. The fence even doubles as a handle to make it easy to carry the router table.

ALUMINUM TRACK. Another handy thing about this router table is it has an aluminum track that runs along the front edge, see photos below right. Actually, it's *two* tracks in one. One part acts as a smooth, accurate slot for a miter gauge. The other lets you attach a featherboard.

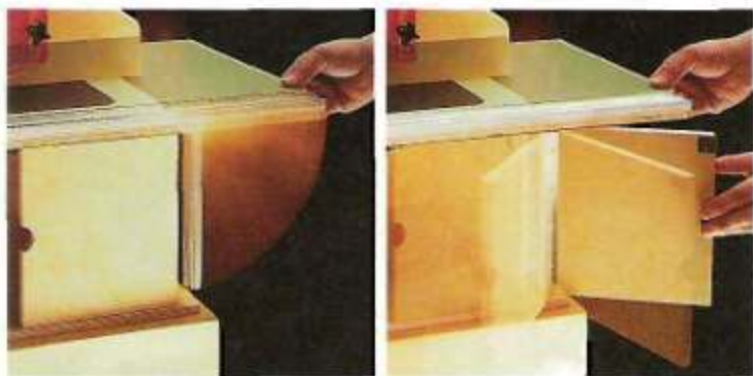

▲ **Extension Wings.** To set up the router table, simply lift the extension wing on each side, see photo at left. Then swing the door out to provide sturdy support underneath the wing, see photo at right.



▲ **Dual Track.** The aluminum track that runs along the front edge of the router table can be used to guide a miter gauge (left) or to attach a featherboard (right).

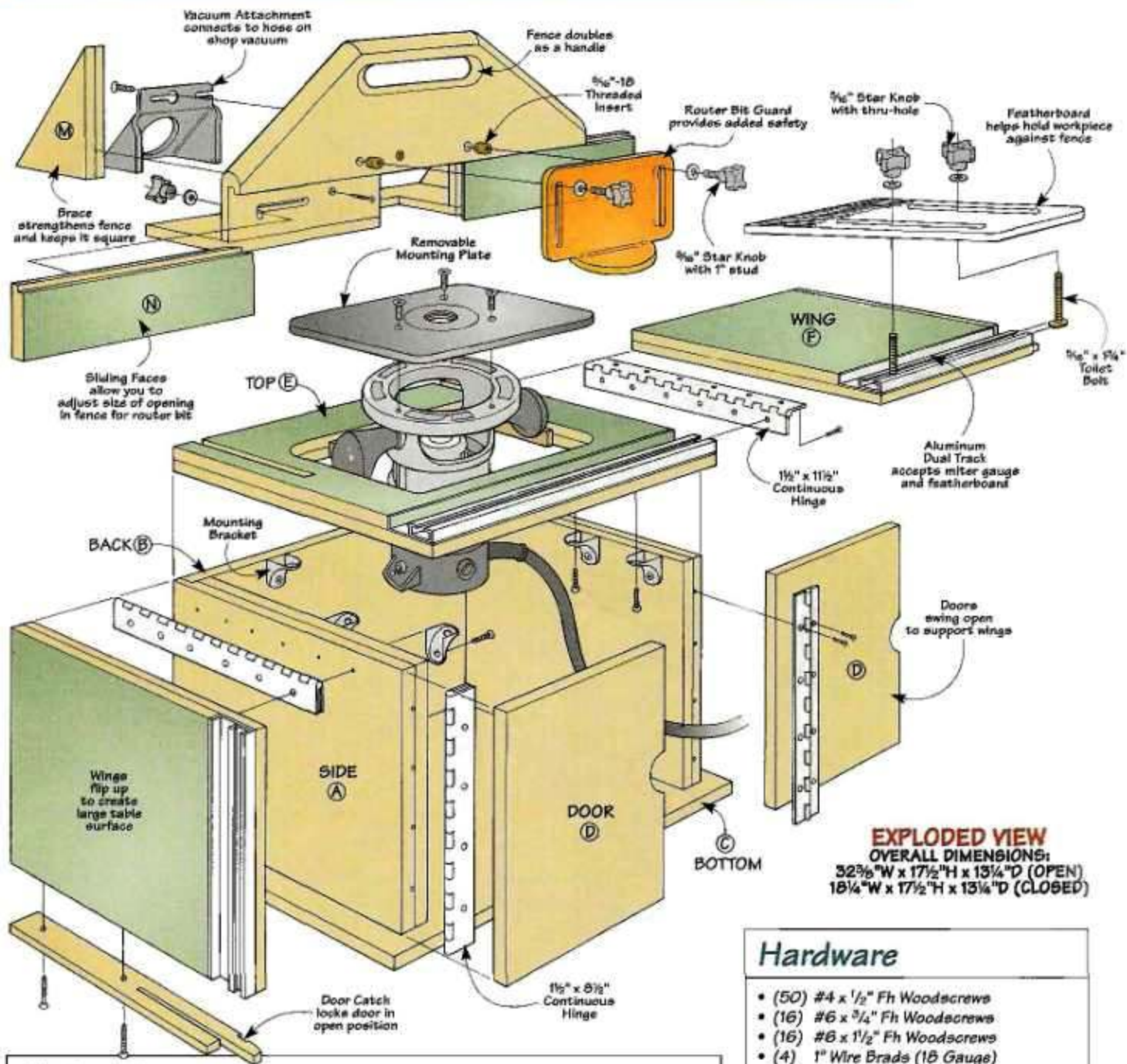

EXPLODED VIEW
OVERALL DIMENSIONS:
 32^{3/8}\"/>

Materials

Case

| | |
|----------------------|--|
| A Sides (2) | 8 ^{3/4} x 12 ^{1/2} - 1 Ply. |
| B Back (1) | 8 ^{3/4} x 15 ^{1/2} - 1/2 Ply. |
| C Bottom (1) | 13 ^{1/4} x 18 ^{1/2} - 1/2 Ply. |
| D Doors (2) | 8 ^{3/4} x 7 ^{9/16} - 1/2 Ply. |
| E Top (1) | 13 ^{1/4} x 16 - 1 Ply. |
| F Wings (2) | 13 ^{1/4} x 7 ^{1/8} - 1 Ply. |
| G Long Supports (2) | 1/4 x 1 ^{1/16} - 9 |
| H Short Supports (2) | 1/4 x 1 ^{1/16} - 6 |
| I Door Catches (2) | 3/16 x 1 ^{1/8} - 13 ^{1/4} |

Fence

| | |
|---------------------|---|
| J Back Fence (1) | 8 ^{3/4} x 18 ^{1/4} - 1/2 Ply. |
| K Front Fence (1) | 5 x 18 ^{1/4} - 1/2 Ply. |
| L Base (1) | 4 x 18 ^{1/4} - 1/2 Ply. |
| M Braces (2) | 3 ^{1/2} x 5 - 1 Ply. |
| N Sliding Faces (2) | 2 ^{1/2} x 9 ^{1/8} - 1/2 Ply. |

Note: All 1\"/>

Hardware

- (50) #4 x 1/2\"/>

Case

I began work on the router table by making the case. In addition to housing the router, the case provides a sturdy mounting platform for the table.

Design Note: We sized our case to hold a Porter Cable router (model 690). But depending on your router, you may need to modify the height of the case. Just be sure it's tall enough that you can adjust the height of the bit without having the router contact the bottom of the case.

U-SHAPED ASSEMBLY. The case starts out as a U-shaped assembly that consists of two sides and a back, see Fig. 1. Each side is glued up from two oversized pieces of 1/2" plywood. (I used Baltic birch.)

After trimming the sides (A) to final size, you'll need to rabbet the back, inside edge of each one to accept the back (B), see Fig. 1a. The

back is a piece of 1/2" plywood that's glued and screwed to the sides.

BOTTOM. The next step is to add a plywood bottom (C), see Fig. 1. The bottom is sized to extend an equal amount past the sides and front of the case. (It's flush at the back.) This provides several clamping surfaces that allow you to secure the router

table to a workbench.

DOORS. After attaching the bottom with glue and screws, I added a pair of doors (D), see drawing above and Fig. 2. Besides enclosing the front of the case, the doors have another (more important) job. When you swing the doors open, they hold up the "wings" of the router table.

To create a continuous, flat surface, the wings need to be supported at the same height as the center part of the table. This center part rests on the sides (A) and back (B) of the case. So making the doors the same height (width) as these pieces will prevent the wings from sagging.

Of course, this means that the doors will fit quite tightly in the opening when the top is added later. But that's okay. In fact, the goal is to size the doors so they'll just barely scrape against the top and bottom.

To do this, I made both doors from a single blank of 1/2" plywood, see Fig. 2. As I mentioned, it's ripped to width to match the height of the sides. And it's cut to length to match the distance from the outside face of one side to the other. (Later, when the blank is cut apart, this will leave an 1/8" gap between the doors.)

FINGER RECESSES. But first, it's best to make the finger recesses that are used to open the doors. This is just a matter of drilling a centered hole in the blank and crosscutting it

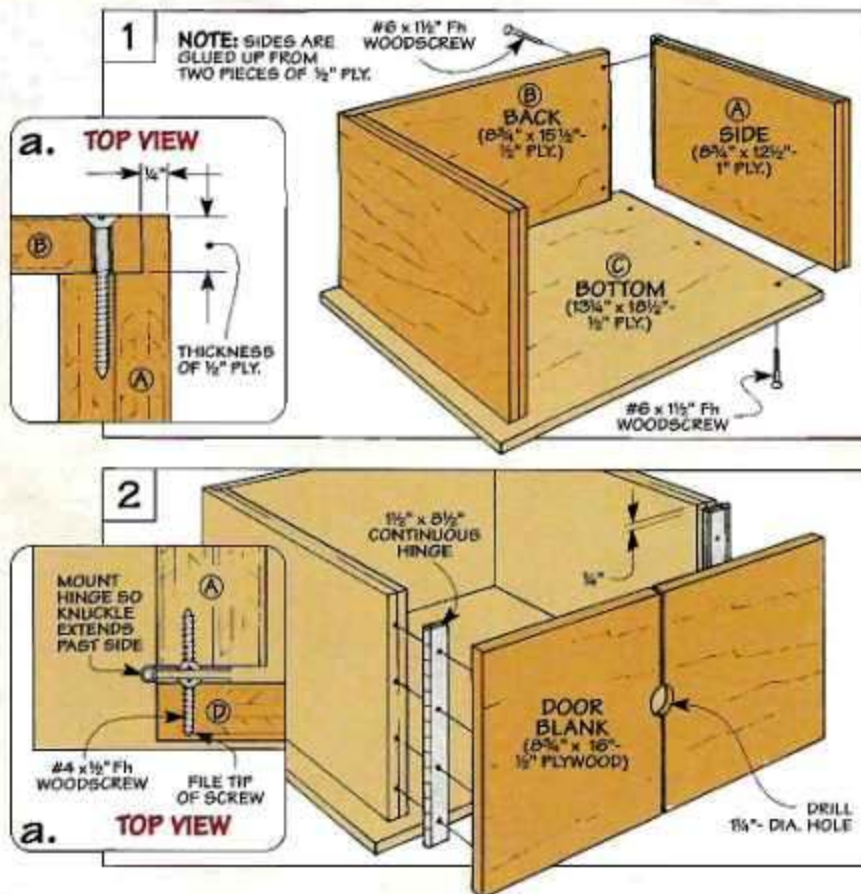
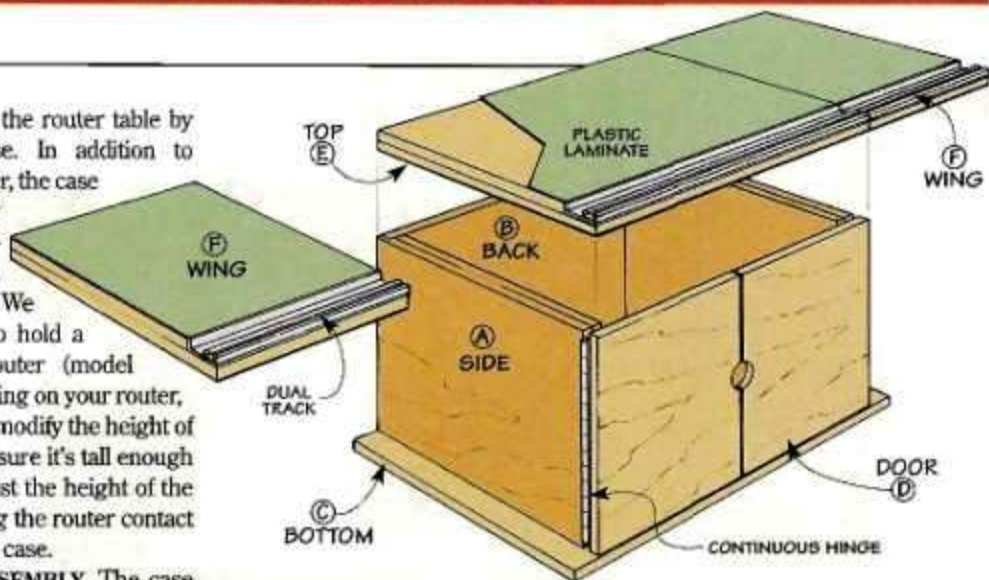

into two equal pieces.

INSTALL DOORS. All that's left to complete the case is to install the doors. They're held in place with a pair of continuous (piano) hinges, see Fig. 2a. One thing to be aware of here is that the hinges are located $\frac{1}{4}$ " below the top of the door and side. This provides clearance that keeps the wings from binding against the hinge.

THE TABLE

Once the hinges are screwed in place, you can turn your attention to the table. Basically it consists of three parts: a *top* (E) and two *wings* (F), see drawing on page 18.

GLUE UP BLANK. Here again, it's easiest to make all three parts from one blank. To create a thick, sturdy table, I glued up two pieces of $\frac{1}{2}$ " plywood, see drawing above right.

PLASTIC LAMINATE. But regardless of its thickness, the surface of the table will still get worn from sliding workpieces across it. So to produce a durable surface, it's a good idea to glue a piece of plastic laminate to the *top* of the blank.

While I was at it, I added another piece of plastic laminate to the *bottom* of the blank. Laminating both sides helps keep the table from warping.

TRACK SYSTEM. After trimming the laminate flush, I added an aluminum track system. This system consists of two parts: a wide, L-shaped piece, and a narrow mounting strip with a T-shaped slot, see margin.

Together, these parts form a slot for the miter gauge. And the

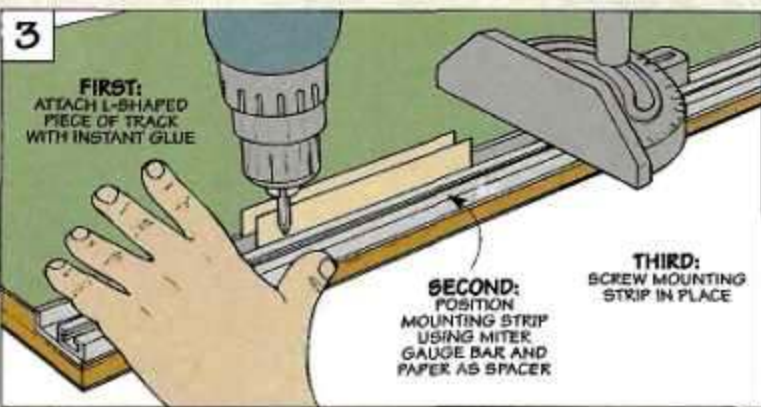
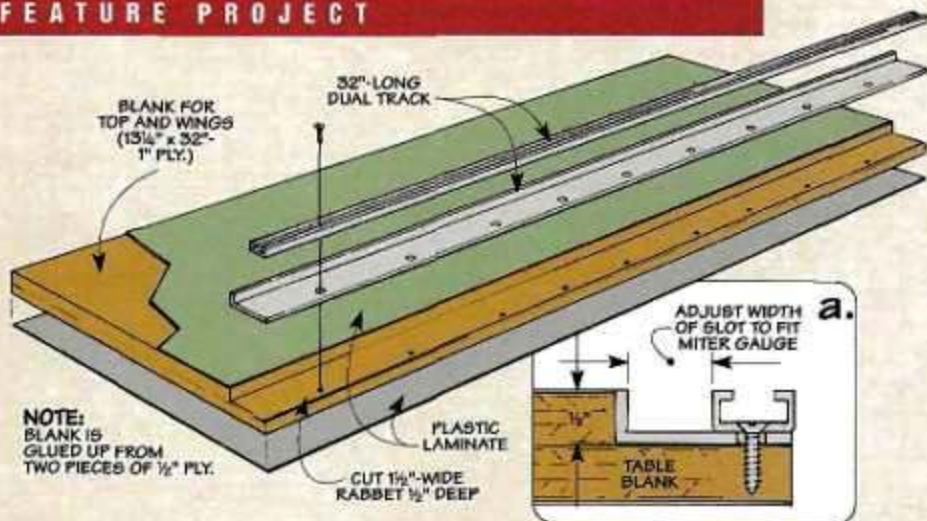

▲ This aluminum track system forms a slot to accurately guide a miter gauge. Plus the track makes it easy to attach a featherboard to the router table.

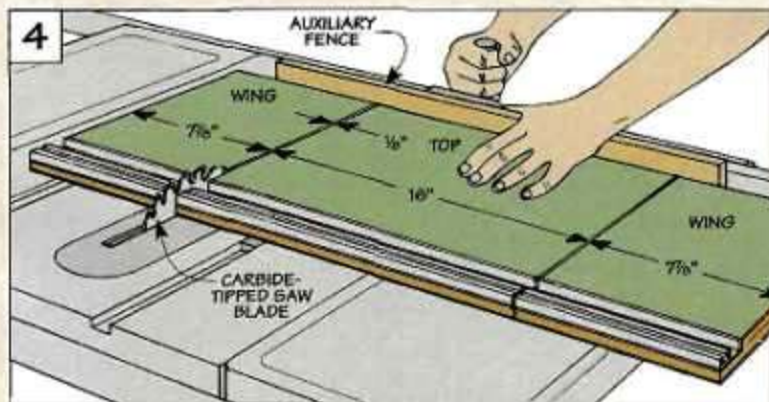

mounting strip makes it easy to attach a featherboard. Just slip the head of a toilet bolt into the T-slot and secure the featherboard with a knob.

Editor's Note: This track system is a product called *Dual Track* that has been specially manufactured for *ShopNotes*. It's available as part of a complete hardware kit for the router table, refer to Sources on page 31.

Of course, you can build the router table without using the track at all. In

that case, you may want to rout a slot in the blank for a miter gauge. Or just plan on using a squared-up block to push the workpiece past the bit.

INSTALL TRACK. There's nothing complicated about installing the track. The L-shaped piece fits in a rabbet that's cut in the edge of the blank, see detail 'a' in drawing above. Then, to position the narrow strip, I used the router bar on the miter gauge as a spacer. *Shop Tip:* Wrapping a single layer of paper around the bar will ensure a smooth, sliding fit.

CROSSCUT BLANK. After attaching the narrow strip with screws, it's time to crosscut the blank to form the three table pieces, see Fig. 4. A table saw and a miter gauge with an auxiliary fence make quick work of this. And as long as you use a carbide-tipped saw blade, there's no need to worry about cutting through the aluminum track. Aluminum is quite soft, and it cuts easily.

Mounting Plate

One nice thing about this router table is it makes it a snap to change bits. That's because the router is screwed to a mounting plate that fits into an opening in the table, see photo.

To provide easy access to the router, just lift the mounting plate out of the opening. Then change the bit and drop the mounting plate back in. Note: I used a mounting plate from *Woodhaven*. (For more information about mounting plates, see page 28.)

TEMPLATE. Regardless of the mounting plate, the challenge is to

cut an opening that allows it to fit nice and snug. To do this, I made a hardboard template, see Steps 1 through 3 below. The basic idea here is to cut an opening in the template so the mounting plate fits it like a picture in a frame.

CUT OPENING. Once you're satisfied with the fit, the time spent making the template pays off. By using it as a guide, you can cut an identical opening in the top (E) of

the router table, see Steps 4 and 5.

SUPPORT STRIPS. With the opening completed, it's just a matter of adding several hardwood strips to support the mounting plate, see Step 6. Then simply attach the router to the mounting plate, see Step 7.



Step 1

To make the template, start by cutting a $\frac{1}{4}$ " hardboard blank to the same size as the top (E) of the table. Then center the mounting plate on the blank and surround it with hardboard guide strips. The strips are simply butted against the plate and secured with carpet tape.

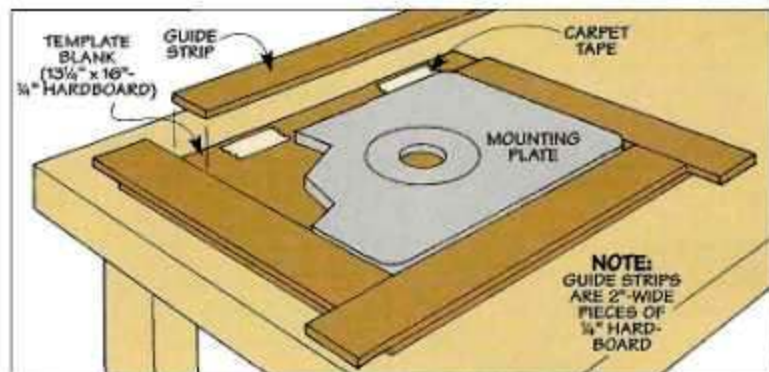

Step 2

After removing the mounting plate, the next step is to cut a rough opening in the template. To do this, drill a hole in each corner that just grazes the edges of the guide strips, see detail. Then remove the bulk of the waste with a sabre saw.



Step 3

Now flip the template over so the guide strips are on the bottom and clean up the rest of the waste with a handheld router and flush trim bit. To avoid changing the radius of the corners, stop routing just short of the corner holes. This leaves a ridge that's easily sanded smooth.

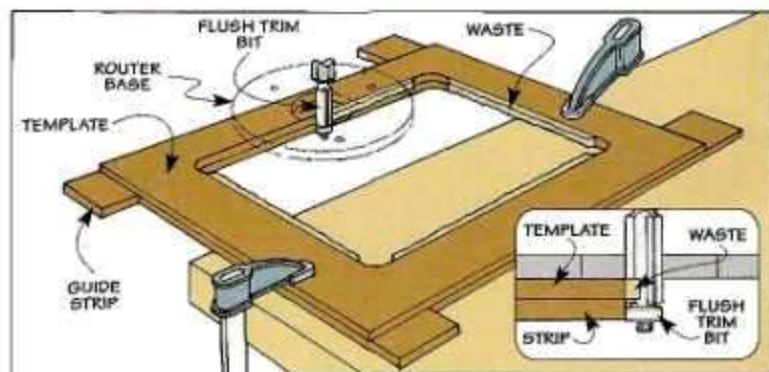

Step 4

Now you can use the template as a guide to cut the opening in the table top (E). After carpet-taping the template flush with the top, drill holes in the corners as before. Then cut the opening to rough size, staying about $\frac{1}{8}$ " to the inside edge of the template, see detail.

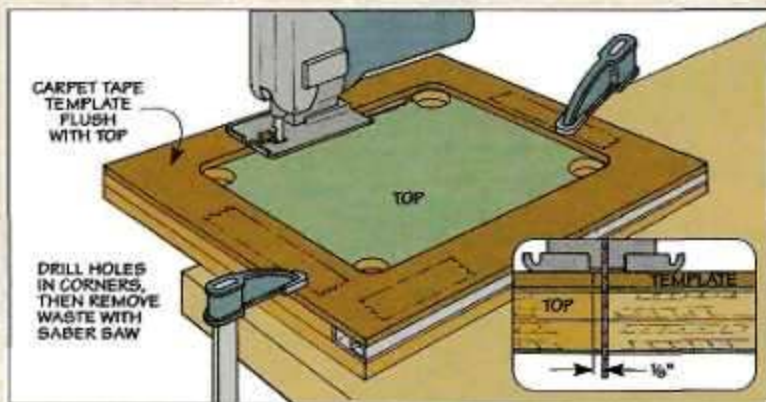

Step 5

At this point, it's just a matter of trimming the edges of the opening flush with the template. Here again, a handheld router and flush trim bit make quick work of this. Just flip the top so the template is on the bottom. Then clean up the waste by routing in the direction shown.

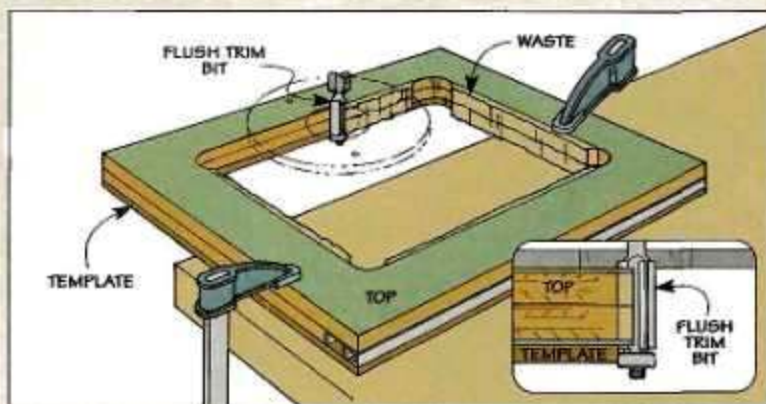

Step 6

Once the opening is complete, you'll need to add thin, hardwood strips to provide support for the mounting plate. To ensure that the mounting plate is flush with the top, place both parts face down on a flat surface. Then butt the strips against the plate and glue them to the top.

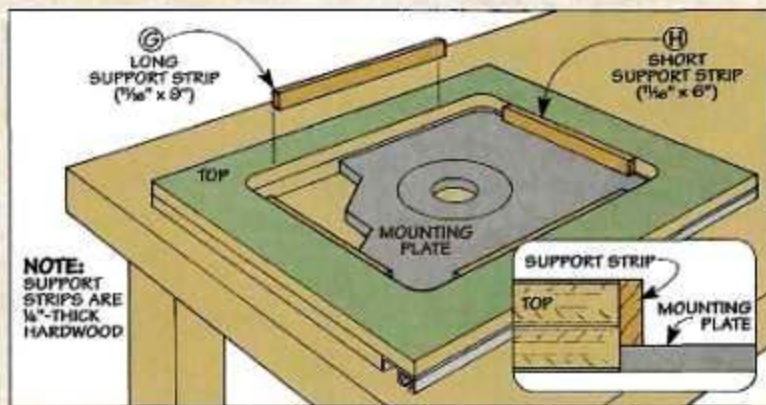

Step 7

All that's left is to attach the router to the mounting plate. This requires drilling holes for the machine screws that hold it in place. An easy way to locate the holes for the screws is to use the existing base on your router. (I used carpet tape to keep the base from shifting.)

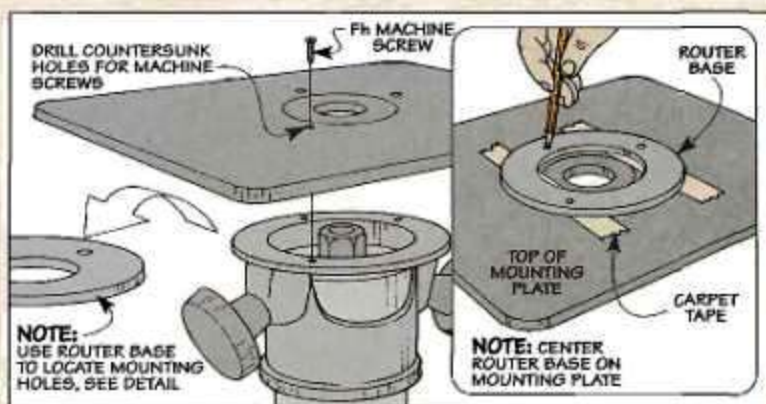

Assembly

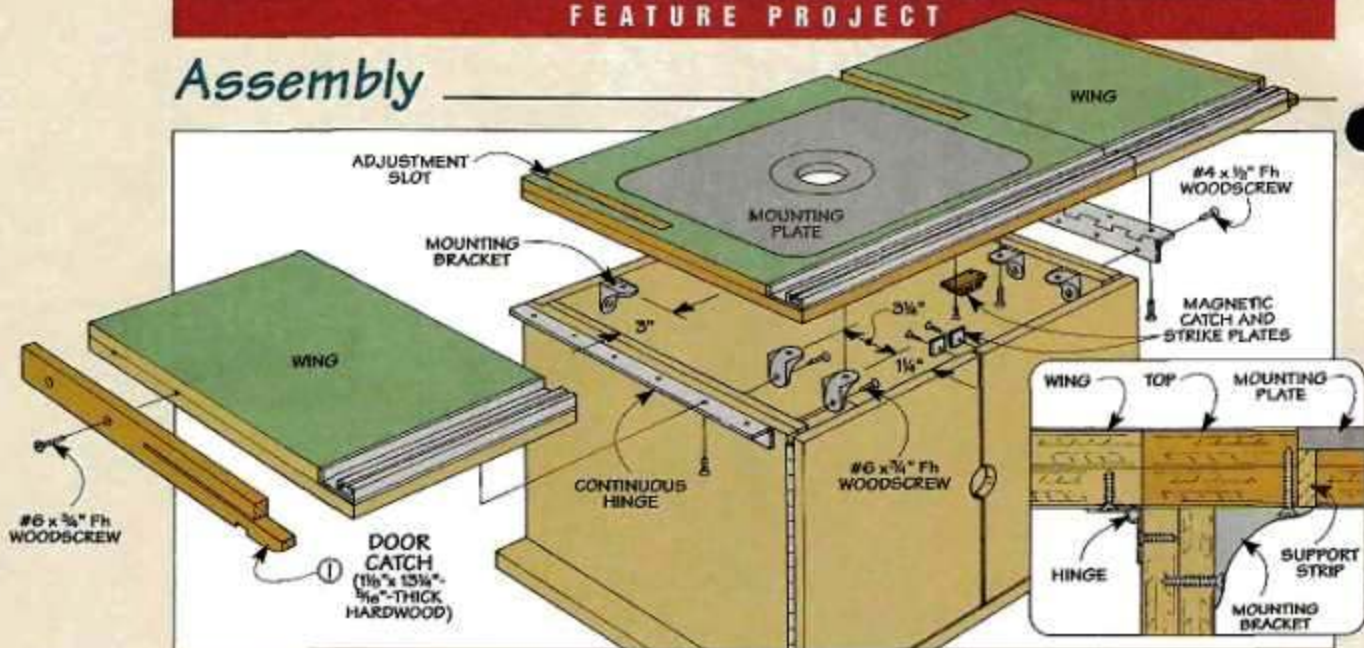

Assembling the table is a fairly straightforward process. But getting all three parts to form a continuous, flat surface does require some care.

ADJUSTMENT SLOTS. Before you get started though, there's still some work to do on the top (center) of the table. To make the fence adjustable

from front to back, you'll need to cut two slots that extend about halfway across the table, see drawing above.

Later, these slots accept a pair of toilet bolts. So each one is shaped like an upside-down 'T'. The narrow part of each slot accepts the shank of the bolt. And the head of the bolt fits

in a wide, shallow recess.

To cut the narrow part of each slot in a single pass, I mounted a dado blade in the table saw, see Fig. 5a. The blade will leave an arc at the end of the slot. But that's okay, as long as it's on the bottom of the table.

This means you'll need to mark the end of the slot on the *top* of the workpiece and then cut up to the line, see Fig. 5. To reduce the chance of kickback, turn off the saw and let the blade stop spinning before sliding the top back across the saw table.

To cut the narrow part of the slot in the opposite end, you could flip the workpiece over and use the same setup. But then the arc would be cut in the top surface of the table. So I moved the fence to the *opposite* side of the blade to cut this slot.

RECESS. Now you're ready to cut the shallow recess for the head of the bolt. The procedure is the same. Only here, I used a 5/8"-wide dado blade and set it for an 1/8"-deep cut, see Fig. 6a.

Since the blade won't extend all the way through the top, it won't be visible. So you'll need a reference mark to establish the end of the recess. A pencil mark on the rip fence that indicates the top (center) of the blade will work fine, see Fig. 6.

Now just turn on the saw and push the workpiece forward until the end of the slot aligns with the

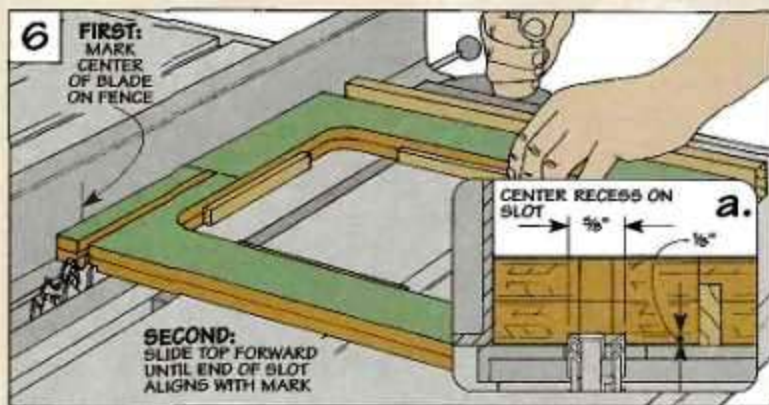
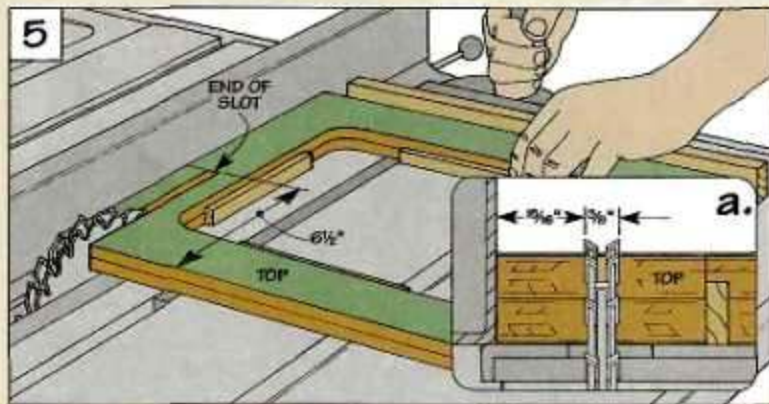

mark. As before, move the fence to the opposite side of the blade to cut the other recess.

MOUNT TOP. Once the adjustment slots are completed, you can mount the top. It's attached with six metal brackets, see the drawing on page 22. After positioning the top flush with the sides and back, the brackets are just screwed in place. I also added a magnetic catch and two strike plates to keep the doors closed.

ATTACH WINGS. The next step is to attach the wings. As with the doors, they're hinged to the case. But first, you'll want to make sure the aluminum track in the wings aligns with the track in the top. Also, it's important that the top surface of all three pieces is perfectly flush.

The best way I found to accomplish both things is to cut a scrap to fit snug in the track, see Fig. 7a. (It

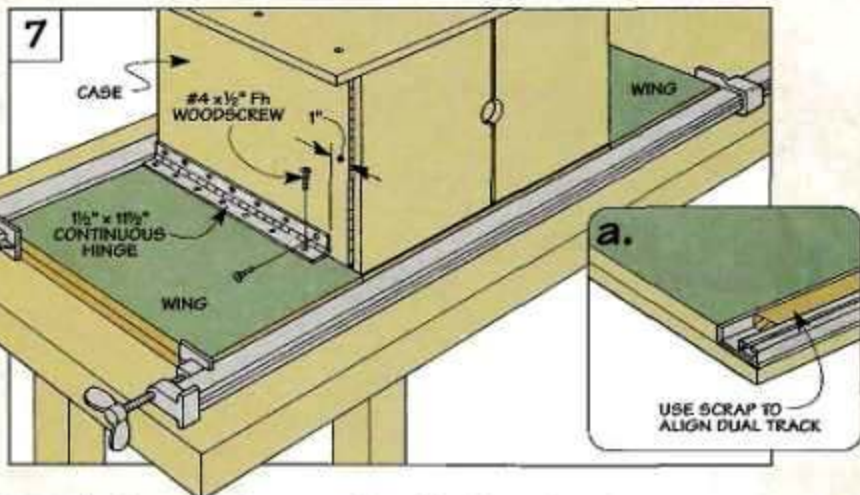

has to be long enough to span all three pieces.) Then turn the case and wings upside down on a flat surface and clamp them together, see Fig. 7.

Now it's just a matter of marking the location of the pilot holes for the mounting screws. To provide clearance for the doors, the hinges are set back 1" from the front edge of the

sides. Note: I used carpet tape to keep the hinges from shifting.

After carefully marking the centerpoints of the mounting holes, you can unclamp the wings and drill the pilot holes. Then just screw the hinges to the wings and sides.

CATCHES. To complete the table, I added a wood catch (1) to each wing, see Fig. 8. It's a thin strip of hardwood that "locks" the door in the open position. This prevents the door from swinging out from under the wing if it accidentally gets bumped.

FINGERS. To make this work, a kerf in each catch forms two "fingers" that flex like an old-fashioned clothespin. The lower finger tapers toward the end, and it has a small notch in the bottom edge, see Fig. 8a. This way, as you swing the door open, it contacts the tapered end of the catch and lifts up the lower finger. To secure the door, just open it a bit further. The lower finger drops down, and the notch "captures" the door.

Before attaching the catches, you'll need to trim the end of the upper finger. This allows the miter gauge to slide in and out of the track. Now glue and screw the catches to the wings. Just be sure not to apply glue to the lower finger.

ADJUSTMENT SCREWS. At this point, it's a good idea to flip up the wings, open the doors, and check the table to make sure it's flat and level. If necessary, you can install an adjustment screw in the bottom of each wing, see Fig. 9 and margin.

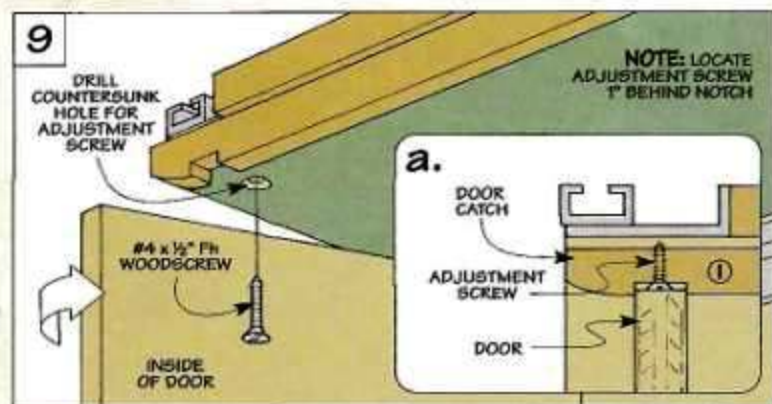
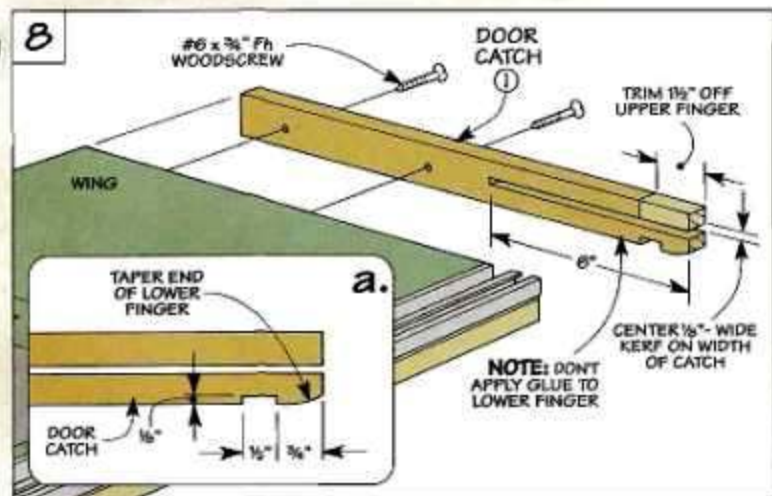

▲ An adjustment screw lets you "tweak" the wings to create a flat, level worksurface.

Fence



The most unique thing about this router table is that the fence doubles as a handle. But there's more to it than that.

A simple clamping system is used to lock the fence in place quickly and accurately. There's also an adjustable opening to accom-

▲ The two adjustment slots make it easy to slide the fence on and off the router table.

modate different sized router bits. The fence consists of three main parts: a tall, thick *body* with angled corners, a *fence support* that provides rigidity, and two *sliding faces* to adjust the size of the bit opening, see drawing.

BODY

Besides acting as the handle, the body of the fence houses the sliding faces.

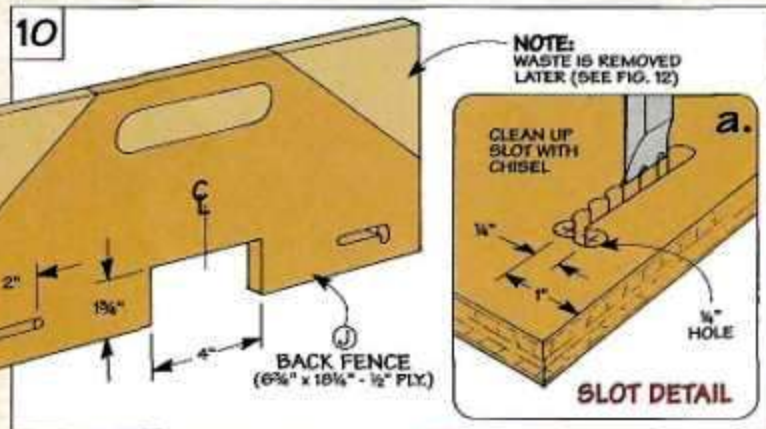
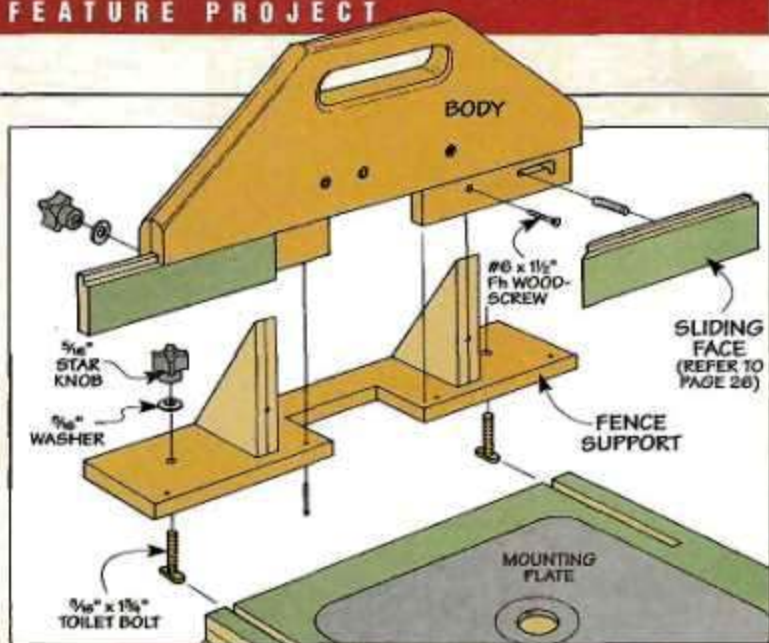

To support the weight of the router table and the router, the body needs to be sturdy and strong. So it's made up of two pieces of 1/2"-thick plywood. But I didn't glue these pieces together right away. Instead, I worked on one at a time. This made it easier to "build in" a recess for the two sliding faces.

BACK FENCE. I began by cutting the *back fence* (J) piece to final size, see Fig. 10. A wide notch in the bottom edge of this piece forms an opening that prevents the bit from chewing up the fence.

In addition to the notch, you also need to cut a pair of L-shaped slots, see Fig. 10a. The long part of each slot lets you adjust the sliding face. And later, the "leg" makes it possible to attach the sliding faces to the fence.

A quick way to cut these slots is to first drill a series of overlapping holes. Then just clean up the ridges with a chisel.

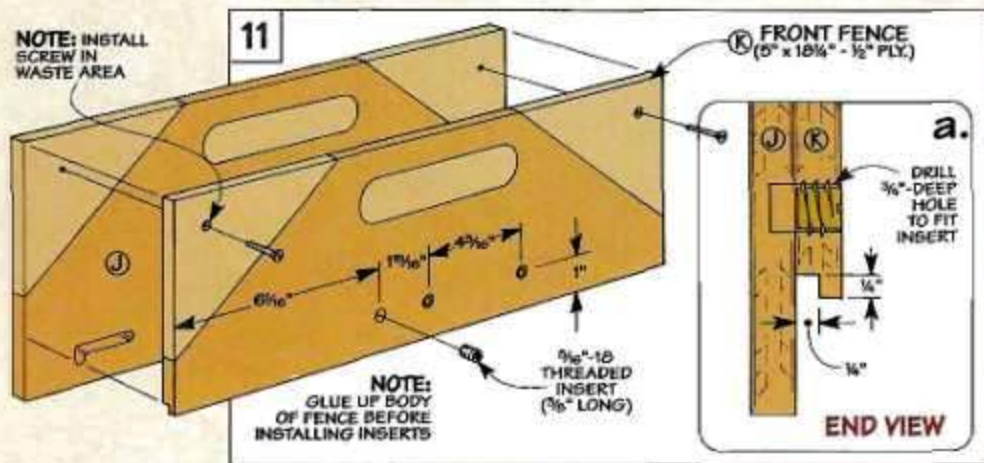

FRONT FENCE. Now you're ready to start on the *front fence* (K), see Fig. 11. It's the same length as the back, but it's narrower. The difference in widths forms the recess for the sliding faces. Cutting a rabbet in the bottom edge of this piece creates a lip that holds the sliding faces in the recess, see Fig. 11a.

GLUE-UP. The next step is to glue up the front and back fence pieces. This presents a bit of a problem. If the pieces slip out of alignment, the sliding faces will bind in the recess. To prevent this, I used a simple trick.

Start by first screwing the pieces

together (no glue) so the top edges and ends are flush, see Fig. 11. Note: Install the screws in the waste areas of the two upper corners. Now separate the pieces, apply glue, and reinstall the screws. This keeps the pieces from shifting around as you clamp up the assembly.

THREADED INSERTS. All that's left to complete the body is to install three threaded inserts, see Fig. 11a. These inserts are used when attaching accessories like a bit guard or featherboard.

HANDHOLD. Now you can turn your attention to the handhold. It's a long, wide slot at the top of the body, see Fig. 12. The ends of the handhold are established by drilling two large holes, and a sabre saw makes quick work of removing the rest of the waste. After smoothing the rough spots with a file, I routed a roundover on all the edges to provide a comfortable grip.

To "slim down" the profile of the fence (and reduce its overall weight), it's also a good time to cut the upper corners of the body at an angle. Here again, sand the rough surfaces smooth and round over the edges.

FENCE SUPPORT

To provide accurate results, the fence needs to be square to the table. And since this fence is used to carry the router table around, I wanted to make sure it *stayed* square. So I added a sturdy fence support.

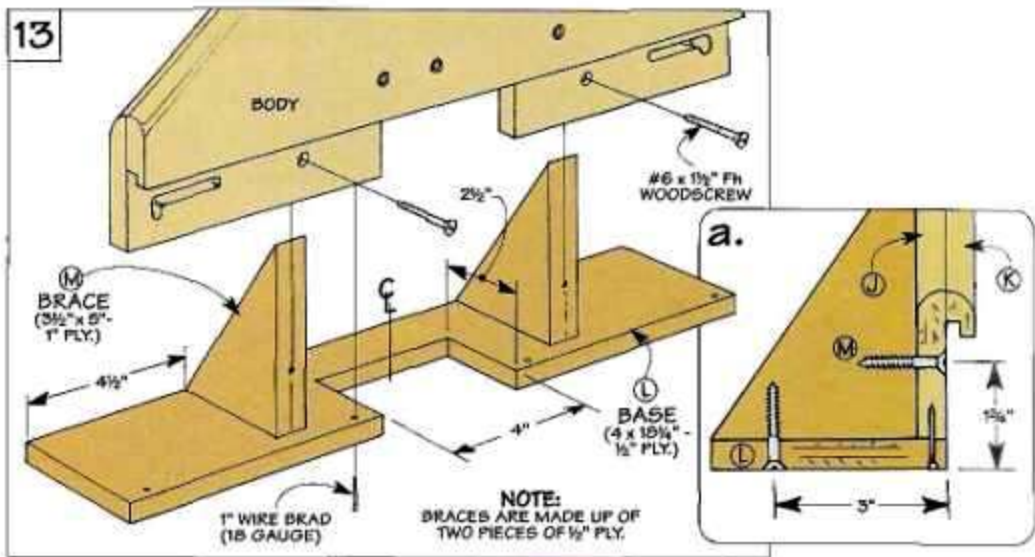
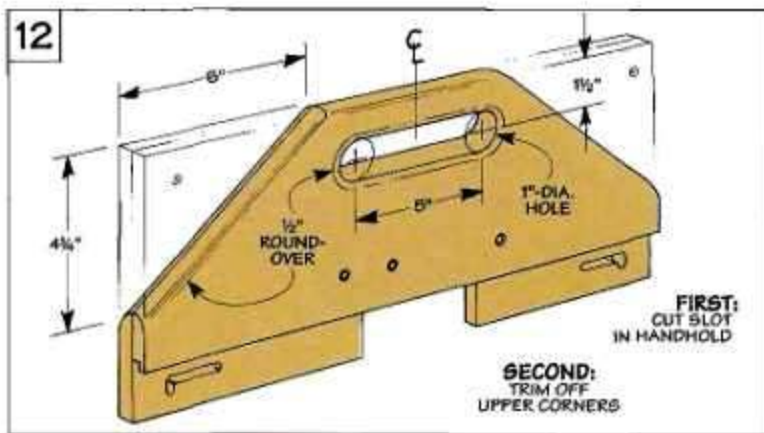

BASE. The foundation of the fence support is a 1/2" plywood base (L), see Fig. 13. As with the back fence (J), cutting a large notch in the base provides clearance for the router bit.

BRACES. Next, to hold the fence square to the base, I added two triangular braces (M). Each brace is made by gluing up two pieces of 1/2" plywood. The braces are held in place with glue and screws. But to simplify the assembly, I first glued and nailed the back fence (J) flush with the front edge of the base, see Fig. 13a.

MOUNTING HOLES. There's one more thing to do. That's to drill two mounting holes for the toilet bolts that are used to secure the fence to the table, see Figs. 14 and 14a.

To locate these holes, position the fence flush with the back edge of the table. Then, after checking that there's an equal overhang on each side, center the holes on the T-slots in the table. Now it's just a matter of drilling the holes and installing the bolts and lock knobs.

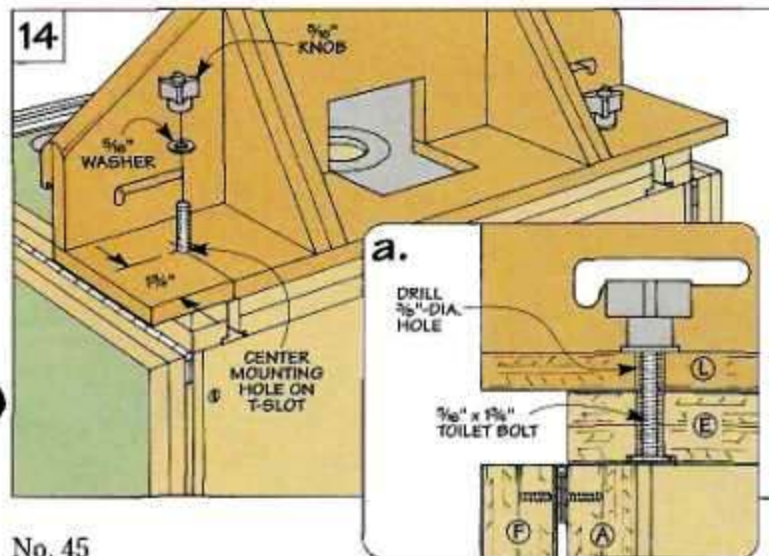

Sliding Faces

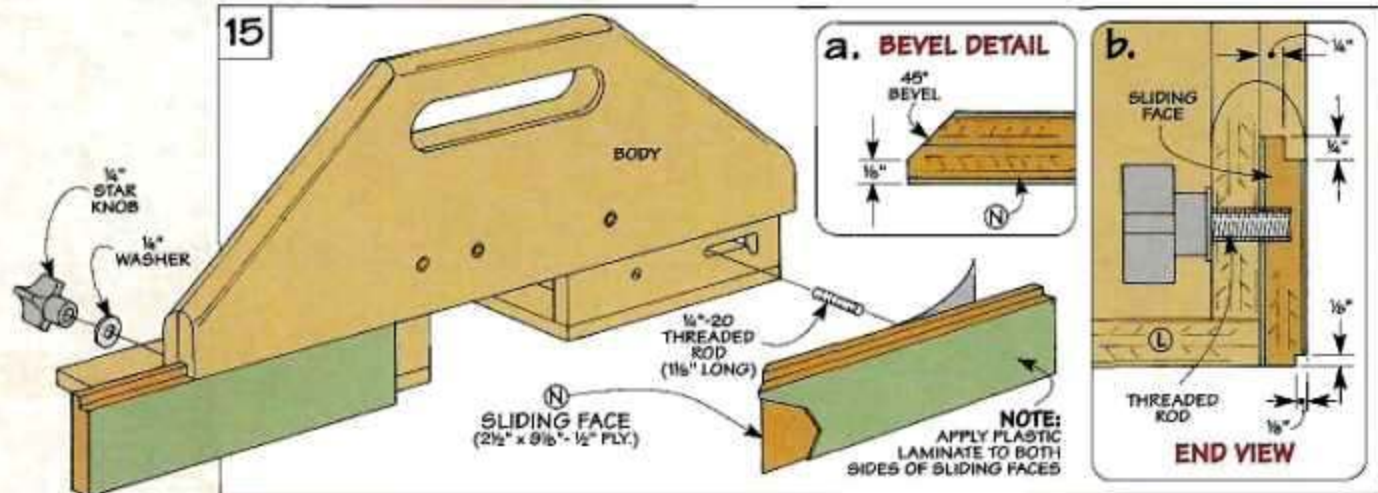

All that's left to complete the fence is to add two sliding faces, see photo.

Each of the *sliding faces* (N) starts out as a piece of 1/2" plywood, see drawing above. To create a durable surface, both sides are covered with plastic laminate. But don't apply the laminate yet. This would make the

sliding faces *thicker* than the front fence piece. As a result, there would be a slight "step" between the faces and body of the fence.

The solution is simple. Just use two layers of laminate as a "gauge" and mark the amount of material to remove, see Fig. 16a. Then slice it

off on the table saw, see Fig. 16.

BEVEL ENDS. After applying the laminate, you can cut a bevel on the *inside* end of each face, see detail 'a' above. The bevels provide clearance for large bits, so you can reduce the size of the opening even more.

CUT RABBET. In addition to the bevels, you'll also need to rabbet the top edge of each sliding face, see detail 'b.' This forms a lip that fits under the lip in the front fence (K). Together, they form an interlocking (sliding) joint that keeps the faces nice and flat against the fence.

DUST RELIEF. The bottom edge of the sliding faces is also rabbeted. It's just a small rabbet that provides some dust relief at the bottom of the fence.

THREADED ROD. Now all that's left is to add a short, threaded rod to each sliding face. These rods pass through the L-shaped slots in the fence. Tightening a knob on the end of each rod locks the face in place.

It's easy to lay out the location of the rods. Just slide each face into the fence so the ends are flush, see Fig. 17. (It should be snug along the top edge.) After marking around the slot, drill a hole in the end and glue in the rod with epoxy, see Fig. 17a.

To install the sliding face, insert the rod in the short "leg" of the slot. Then lift *up* on the face (so the top edge engages the fence), slide it *over*, and thread on a knob.



▲ To quickly adjust the fence opening for different size bits, just move the sliding faces in or out as needed.

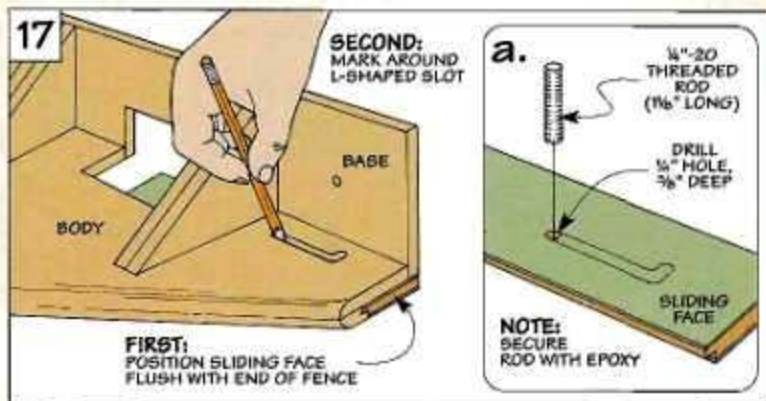
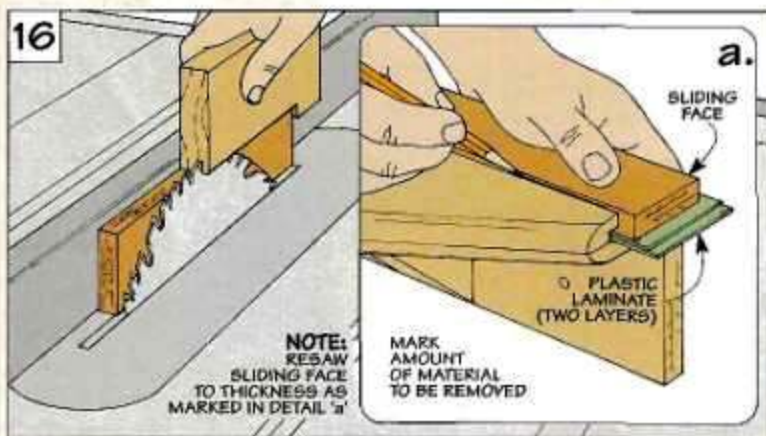

Accessories

After completing the router table, one of the first improvements I made was to add three simple accessories.

All three of these accessories can easily be made in a couple of hours, see photos below left. Or, if you prefer, durable plastic accessories are available as part of our hardware kit, see the photos below right and Sources on page 31.

FEATHERBOARD. One nice thing about the featherboard is it can be attached to either the fence or the aluminum track. To keep a workpiece flat on a table, mount the featherboard to the fence with knobs that thread into the inserts. Or secure it to the track with toilet bolts and knobs to hold the work against the fence.

The featherboard is a piece of $\frac{1}{2}$ "-thick hardwood with mitered ends and a pair of adjustment slots, see Fig. 18. To cut the slots that form the fingers, I tilted the blade on the table saw and clamped the featherboard to an auxiliary fence on the miter gauge.

ROUTER BIT GUARD. For safety, you should include a bit guard on the router table. This guard is designed to attach to the fence with knobs that thread into the two *outer* inserts.

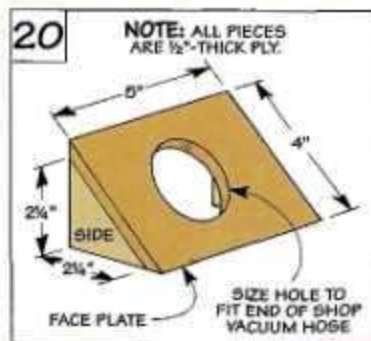
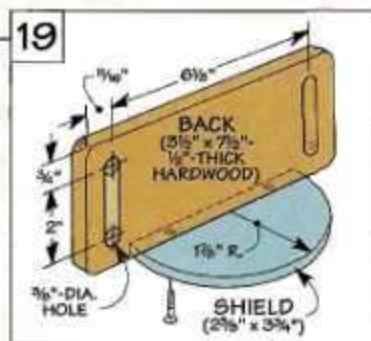
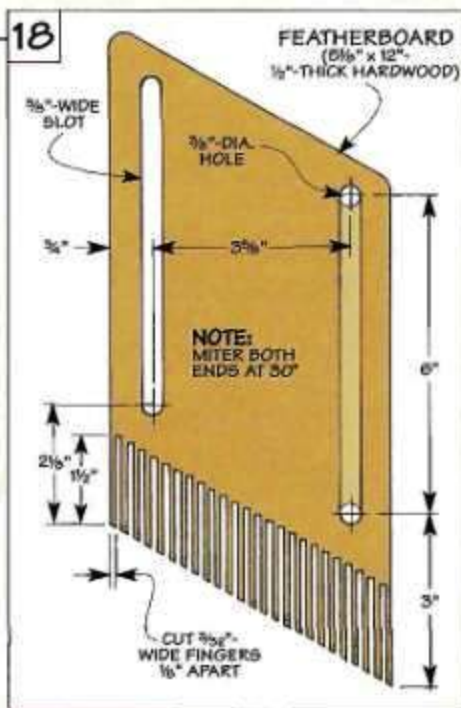

Note: You'll need to use the *middle* insert for the featherboard.

The guard consists of a hardwood *back* and a *shield* made from $\frac{1}{4}$ " polycarbonate plastic, see Fig. 19. After cutting two adjustment slots in the back, the shield is screwed in place.

VACUUM ATTACHMENT. Finally, I added a dust collection system that

attaches to the back of the fence and connects to a shop vacuum. It's made up of two *triangular sides* and a *face plate* with a hole cut to fit the vacuum hose, see Fig. 20. After beveling the face plate to fit against the fence and table, it's simply glued to the sides. Gluing the attachment to the fence holds it securely in place.



▲ **Shop-Made Accessories.** A few scrap pieces of material is all it takes to make a featherboard (left), router bit guard (upper right), and a vacuum attachment (lower right).

▲ **Plastic Accessories.** A plastic featherboard (left) and bit guard (upper right) use the same mounting system. The vacuum attachment (lower right) is screwed to the fence.

Router Table Mounting Plates

Selecting the right mounting plate can make a big difference in the performance of your router table.

Attaching a router to a separate mounting plate and then inserting that plate into an opening in the top of a router table just makes sense. To change bits, all you have to do is pull the plate out of the opening — the router comes right with it.

This saves a lot of fiddling around under the table with collet wrenches. And, you can leave the plate attached and still use it as a base for hand-held routing.

Although you can make your own mounting plate, there are a number of commercial versions available. And over

the last few years, several improvements have been made to them. So we decided to use one of these mounting plates in the benchtop router table that's featured on page 16.

While we were in the process of selecting a mounting plate, several questions came up.

What type of material should it be made of? Which accessories do you need? And what accounts for the differences in price? To find out, we took a look at five commonly available mounting plates, see the photos at left and in the margin on page 29.

FLAT & RIGID. To produce a consistent depth of cut, it's important for a mounting plate to be as flat as possible. (There is one exception to this, but more about that later.) Also, the mounting plate has to be rigid enough so it won't sag with the weight of the router.

PHENOLIC. To accomplish both things, the mounting plates from Woodhaven and Rousseau are made of $3/8$ "-thick phenolic. This is a strong, durable plastic that provides plenty of support for the router.

Although both plates are made of the same material, there is one difference between them. The Woodhaven mounting plate is as flat as a piece of glass. But the Rousseau plate is molded with a slight crown in the center.

Wait a minute, I thought it was supposed to be flat? This is where the exception comes in. The high point (crown) is next to the router bit. So even if your router table isn't perfectly flat, you'll still get consistent results.

POLYCARBONATE. In addition to the phenolic plates, we also purchased a $3/8$ "-thick polycarbonate plate from Eagle America. This is a clear, plastic plate that's virtually



unbreakable. Since you can see through the plate, it's handy when using the router in a hand-held operation.

The only drawback to polycarbonate is it flexes just a little. Over time, this may cause the mounting plate to sag (especially with a heavy router suspended from it). That's why I prefer a phenolic plate. Note: Eagle America also sells a $3/8$ "-thick phenolic plate.

REINFORCED PLASTIC. The mounting plate from Woodworker's Supply is also made of plastic. This plate is reinforced underneath by a number of plastic "webs." But even so, it's still slightly dished out in the center.

Another thing to note about this plate is it has a series of slots radiating from the center, see photo below left. These slots let you mount any size (or model) of router. Even so, I'd just as soon drill the mounting holes myself.

Drilling the holes is easy. The trick is locating them so the bit is centered in the opening. The Rousseau mounting plate is the only one to take that into consider-



▲ **Mounting Systems.** Slots in a plate (left) act as a universal mounting system for a router. But the rings (right) make it easier to center the bit in the opening.

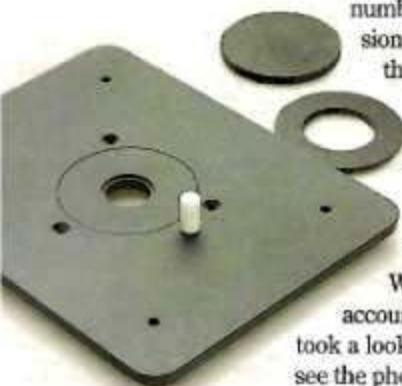

Woodhaven

Part No. 147
800-344-6657
\$49.99



Rousseau

Part No. RM 3509
800-635-3416
\$39

ation. You simply remove the base of the router and position it inside one of the concentric rings molded into the bottom. (See lower right photo on page 28.)

ALUMINUM. The final mounting plate (from the Rockler company) isn't plastic at all. It's a rigid piece of 1/4"-thick aluminum. Besides providing solid support, the metal plate is 1/8" thinner than the plastic plates. This provides an extra 1/8" of height adjustment for the bit.

For all practical purposes, this plate is machined dead flat. (It's within .003" of being perfectly flat.) Then a thin, protective (anodized) coating is applied that prevents the aluminum from leaving black marks on a workpiece.

INSERTS

There's more to these mounting plates than just holding the router in the table. They also keep a workpiece from tipping into the opening around the bit.

The key to making this work is a system of disk-shaped inserts that let you enlarge (or reduce) the size of the opening. You simply select an insert with a hole that's slightly larger than the bit. Then fit the insert into the mounting plate to "close" the opening around the bit.

SNAP-IN INSERTS. This is easy with the inserts in the Woodhaven and Rousseau mounting plates — they just snap into place. At first, I was a little skeptical that these inserts would stay put. But both of them fit nice and snug.

Also, the inserts are perfectly flush with the top surface of the mounting plate. So I don't have to worry about any "catches" as I'm sliding a workpiece across the router table.

SCREW-IN INSERTS. The inserts in the Eagle America, Rockler, and Woodworker's Supply mounting plates are held in place with machine screws. This works fine, but messing around with the tiny screws is a nuisance.

Here again, the Eagle America insert fit perfectly flush. But the Rockler and Woodworker's Supply inserts are recessed just a hair. It's not enough to cause a problem. (And it's better than sticking up above the mounting plate.)

HOW MANY INSERTS? To provide a fair comparison, it's also worth taking a look at the number of inserts that come with each mounting plate.

The Woodhaven and Eagle America mounting plates each come with three inserts which create four different

size openings. (This includes a blank which can be customized for a different sized bit.)

There's no blank with the Rousseau mounting plate. But the two inserts that "nest" together allow you to make three different size openings.

You'll be limited to two different size openings with the Rockler and Woodworker's Supply mounting plates. (They each come with only one insert.) Additional inserts cost about five dollars each.

PINS, BUSHINGS & LEVELERS

Although it's probably not going to make or break your decision as to which mounting plate to buy, another thing to keep in mind is whether there are any "extras."

STARTING PIN. Take a starting pin for instance. It comes in handy when routing an irregular-shaped piece with a piloted bit, see photo below left.

That's because the bit has a tendency to grab the workpiece at the beginning of a cut. Holding the workpiece against a starting pin provides more control. Note: The Woodhaven, Rousseau and Eagle America are the only mounting plates that include a starting pin.

GUIDE BUSHINGS. If you do a lot of template routing, you'll also want to check whether the insert accepts a guide bushing, see photo below right. The only way to do this with the mounting plate from Woodworker's Supply is to buy an adapter set which costs an additional \$17.95. With all the others, you can install a standard-size guide bushing in the smallest insert.

LEVELING SCREWS. One final note. You may need to level the mounting plate in the router table. That's when the leveling screws installed in the Rockler and Eagle America mounting plates come in handy.

CONCLUSIONS

Okay, so which mounting plate would I use? It's a toss-up between the Woodhaven and Rousseau. They're strong, rigid plates. And the snap-in inserts are a plus. My only quibble is the Rousseau inserts fit so tightly, I have to reach under the table and tap them out with a dowel.

The phenolic plate from Eagle America is also a good choice (not the polycarbonate plate). But at \$59.99, it's the most expensive. And the only additional features it has are the leveling screws. That's not enough to justify the cost for me.

I'd be satisfied with the Rockler mounting plate too. But it bothers me to have to pay for additional inserts.

The only mounting plate I'd steer clear of is the one from Woodworker's Supply. You get what you pay for with this inexpensive mounting plate. 🐿

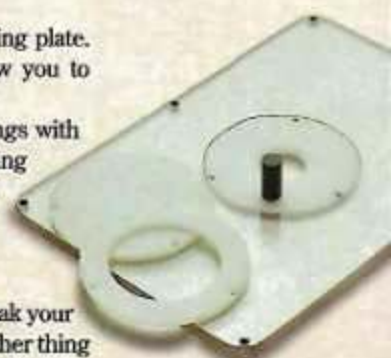

Eagle America

Part No. 415-0590

800-872-2511

\$59.99

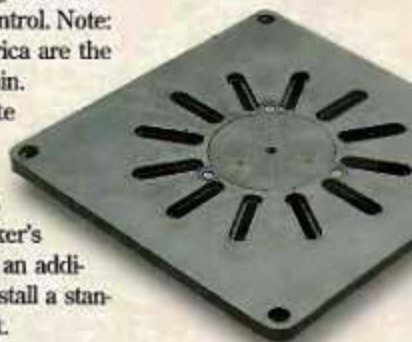

Woodworker's Supply

Part No. 126-490

800-645-9292

\$19.95



Rockler

Part No. 35265

800-279-4441

\$39.99



▲ **Starting Pin.** Using a starting pin prevents the bit from grabbing the workpiece at the beginning of a cut.



▲ **Guide Bushing.** If you do a lot of template routing, it's handy if the insert accepts a guide bushing.

Dovetail Jigs

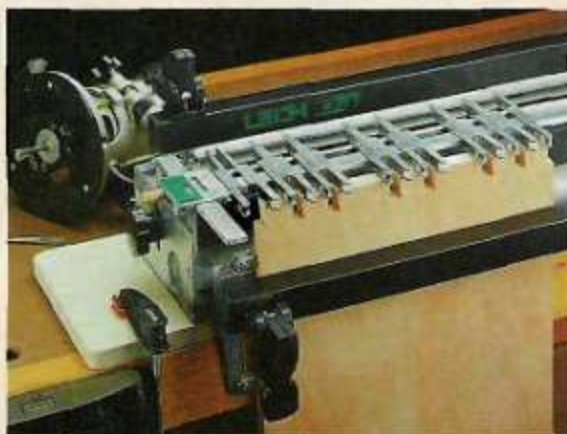

A. Leigh Jig. It's hard to beat the versatility of this jig. The unique design of the fingers lets you rout through-dovetails, half-blind dovetails, and sliding-dovetails.



B. Katie Jig. Sometimes simple is best. This Katie Jig allows you to rout through-dovetail joints quickly and accurately without the usual trial and error process.

It's easy to rout perfect-fitting through-dovetail joints with either one of these commercial jigs.

In *ShopNotes* No. 43, we featured a shop-made dovetail jig that allows you to cut through-dovetail joints with a handheld router. As a follow-up, we also took a close look at two manufactured dovetail jigs: the *Leigh Dovetail Jig* (see photo A above) and the *Katie Jig System*, see photo B.

LEIGH JIG

At a glance, the *Leigh Jig* looks a bit complicated. And I admit, the first time I used the jig, it took me an hour and a half to set up. But I was impressed with the tight-fitting dovetails it produced. And once I got the hang of it, things speeded up considerably.

The basic principle of this jig is simple. A workpiece is clamped vertically under a bar. (It accepts pieces up to 24" wide.) Then, to cut the tails and pins of the dovetail joint, you rout around a set of finger-shaped templates.

One side of each finger is *straight*. With a dovetail bit mounted in the router (and a guide bushing in the base), the straight side is used when routing the tails, see photo A.

To make the pins, it's just a matter of flipping the fingers around. This way, the opposite (tapered) side of each finger projects over the workpiece. Routing around these tapered

sides with a straight bit (and guide bushing) produces the wedge-shaped pins. Note: Both router bits are included with the jig.

ADJUSTABILITY. Another thing that's worth mentioning about the *Leigh* jig is the fingers are totally adjustable. By repositioning the fingers, you can vary both the size and the spacing of the dovetails.

VERSATILE. Besides being easy to adjust, the *Leigh Jig* is as versatile as it gets. In addition to through-dovetail joints, it allows you to rout half-blind dovetails and sliding-dovetails as well. Depending on the type of dovetail, you can rout workpieces that range in thickness from $\frac{5}{8}$ " to $1\frac{1}{2}$ ".

KATIE JIG

The second dovetail jig I used is called the *Katie Jig*. This one really intrigued me. That's because I'd heard it was designed to cut perfect dovetail joints straight out of the box.

SETUP. Well, I was just a bit skeptical. But with its easy setup, the *Katie Jig* was off to a great start. To establish the spacing of the dovetails, all that's needed is to position a set of aluminum guide forks along the top of the jig. Note: You can adjust the size of the dovetails by changing

the size of the guide forks. (These need to be purchased separately.)

After clamping the workpiece against the jig, the pins are formed by routing around the tapered ends of the guide forks with a bearing-guided straight bit. Then, using the exact same setup, the mating tails are created by routing around the notch in the opposite ends of the guide forks with a bearing-guided dovetail bit. Note: Both router bits are included with the jig.

Okay, so that's the theory. And I routed the pins and tails without a hitch. But the real test still remained. How well would they fit together?

Here, I was pleasantly surprised. The dovetails fit perfectly — exactly as promised. And the jig hadn't required any fiddling around whatsoever. All in all, it's an impressive tool. 

Sources

Leigh Dovetail Jig
Phone: 800-663-8932
Fax: 604-464-7404

Katie Jig System
Phone: 317-881-8601
Fax: 312-453-0667
e-mail: thampton@indy.net
web site: <http://www.katiejig.com>

Sources

PRODUCT INFORMATION

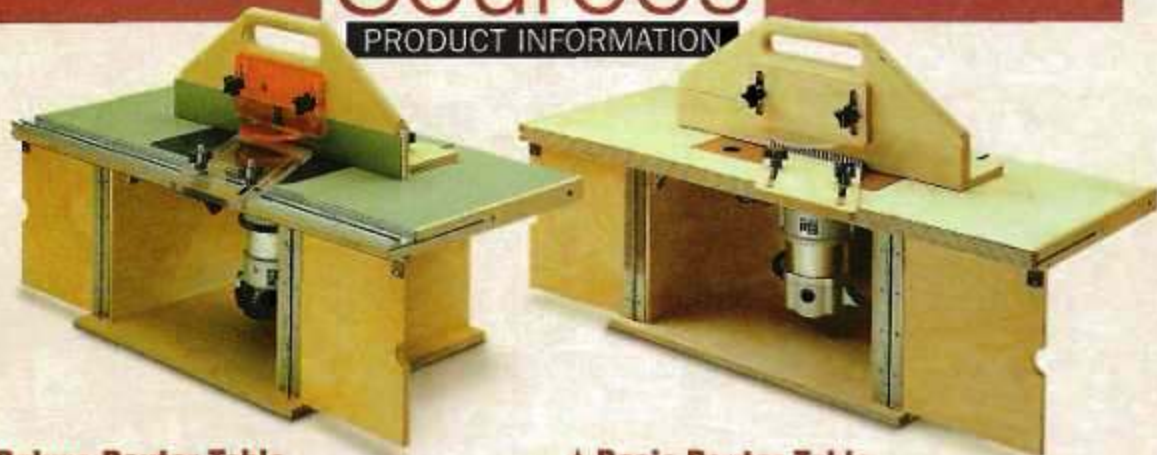

▲ Deluxe Router Table

The Benchtop Router Table featured on page 16 is perfect for a small shop. But it's also a great addition for *any* shop where space is limited.

Setting up the router table is easy. Just flip up the wings and swing out the doors to provide rock-solid support underneath. With its adjustable fence and a built-in clamping system, you can make fast, accurate setups. And when you fold up the table, the fence doubles as a handle.

ShopNotes Project Supplies is offering a complete kit with all the hardware you need to build the Router Table.

The kit includes the aluminum *Dual Track* and a $\frac{3}{8}$ "-thick phenolic mounting plate made by Woodhaven. In addition, there's also a featherboard, router bit guard, and a vacuum attachment made from durable plastic. All you need to supply is the plywood and plastic laminate.

DELUXE ROUTER TABLE KIT
6845-125.....\$156.95

▲ Basic Router Table

This Router Table uses the same basic design as the Deluxe version. But in order to simplify construction (and reduce the overall cost), there are a few minor differences.

For example, the table and sliding faces on the fence aren't covered with plastic laminate. And the accessories are made using only scrap pieces of material.

Another difference is the mounting plate. It's a $\frac{1}{4}$ "-thick phenolic plate that comes pre-drilled with a hole for the router bit and two finger holes.

Finally, we didn't install the *Dual Track* on this router table. So the featherboard is attached with knobs that thread into inserts installed in the table.

We're also offering a kit for the Basic Router Table. It includes all the hardware you need as well as the mounting plate and the knobs and inserts for the featherboard.

BASIC ROUTER TABLE KIT
6845-100.....\$26.95



◀ Socket Box Hardware

The Socket Set Storage Boxes (page 6) provide a handy way to keep sockets, ratchets, and accessories organized.

A foam lining in each box keeps sockets from rattling around. We used a sheet of closed-cell foam from *McMaster Carr* (Part No. 9349K9). The latches (Part No. 1889A34) are also available from *McMaster-Carr*. To order, you can call 630-833-0300.

Dual Track System ▶

The *Dual Track* system in our Deluxe Router Table consists of two, 32"-long pieces of aluminum. Together, they create a slot for a miter gauge *and* they provide a way to attach accessories.

Dual Track is available as a separate item from *ShopNotes Project Supplies*.

DUAL TRACK SYSTEM
7213-220.....\$26.95



NOW ON THE WEB!

WoodNet

- 101 Woodworking Tips Online
- Woodworking Techniques — Step-by-Step
- Project plans you can download
- WoodNet Forum — Woodworkers' Q & A
- Power Tool Reviews

Point your browser to: <http://www.anguthome.com>
Select "Woodworking" from the Welcome Page menu.

NEW

ON-LINE CUSTOMER SERVICE

- Access information about your subscription account.
- Find out if your payment has been received.
- Change your mailing address or your e-mail address.
- Let us know if you haven't received your issue.

www.shopnotes.com

TO PLACE AN ORDER CALL

800-347-5105

(KEY CODE: SN 45)

Scenes from the Shop



With its "wings" extended and doors swung open for support, this benchtop router table features a large, sturdy work surface. A removable mounting plate makes it easy to

change bits. And an adjustable fence doubles as a handle to make the router table portable. You can build this basic model or the "deluxe" version on page 16.



Whether you're working under the car or doing a job around the house, this simple storage box makes it easy to keep track of all the tools and accessories in a socket set. It's one of three boxes that we customized to fit different sized socket sets. (Plans begin on page 6.)