

ShopNotes®

Vol. 8

Issue 44

Editors Pick Best
**BENCHTOP
DRILL PRESSES**

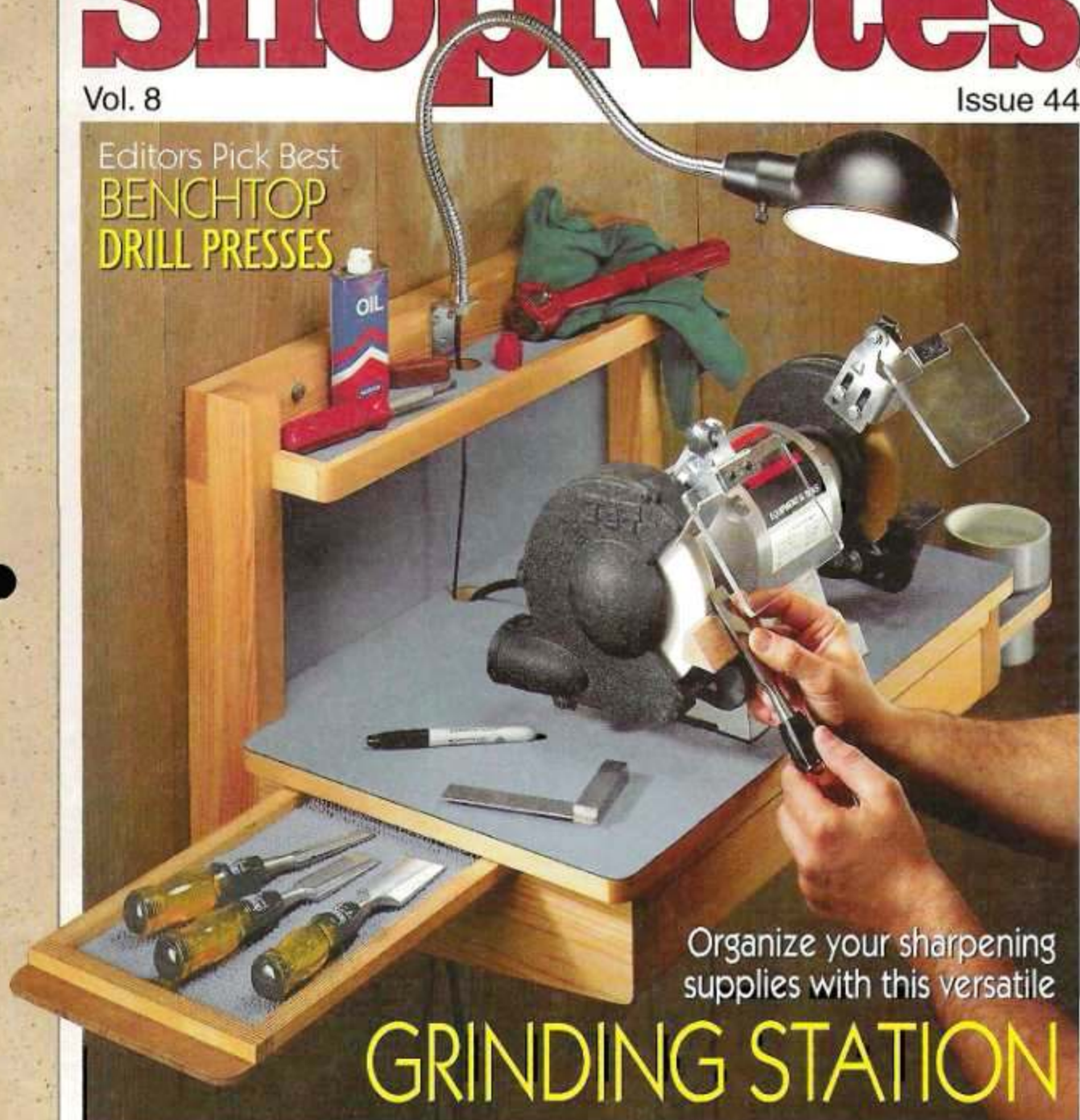

Organize your sharpening supplies with this versatile

GRINDING STATION

- Shop-Made Scratch Awl
- Dowel Storage Rack
- Using a Skew Chisel
- Grinding Wheel Basics



ShopNotes

Issue 44

March 1999

PUBLISHER Donald B. Peschke
EDITOR Tim Robertson
ASSOCIATE EDITOR Tom Begnal
ASSISTANT EDITOR Bryan Nelson
ART DIRECTOR Cary Christensen
SR. GRAPHIC DESIGNER Kurt Schultz
SENIOR ILLUSTRATORS Roger Reiland
 Mark Higdon

CREATIVE RESOURCES

Creative Director: Ted Kralecik • *Project Developer:* Ken Munkel • *Senior Project Designer:* Kevin Boyle • *Project Coordinator:* Kent Walsh • *Shop Manager:* Steve Curtis • *Shop Craftswomen:* Steve Johnson • *Senior Photographer:* Crayola England • *Photographer:* Roderick Kennedy

BOOKS

Executive Editor: Douglas L. Heltz • *Art Director:* Steve Lander • *Sr. Graphic Designer:* Chris Glawicki • *Asst. Editors:* Joe Irwin, Craig Ruespenger

CIRCULATION

Sub. Serv. Dir.: Sandy Buzan • *New Bus. Dir.:* Glenda Battles • *Revenue Mgr.:* Paige Rogers • *Billing Mgr.:* Robecca Cunningham • *Press. Mgr.:* Rick Jurdick • *New Bus. Mgr.:* Todd L. Bierie • *Asst. Sub. Mgr.:* Jay Krause • *Sr. Graphic Designer:* Cheryl L. Sheehan

CORPORATE SERVICES

V.P. of Planning & Finance: Jon Macurthy • *Controller:* Robin Hutchinson • *Sr. Acct. Laura Thomas* • *Accts. Payable:* Mary Schultz • *Accts. Rec.:* Margo Petrus • *Prod. Dir.:* George Chmielewski • *Fleet. Pch.:* Douglas M. Lohster • *Prod. Asst.:* Susan Rasve • *Pre-Press Image Spec.:* Troy Clark, Minnie Bingham • *New Media Mgr.:* Gordon C. Gaipe • *Multimedia Art Dir.:* Eugene Pedersen • *E-Commerce Analyst:* Carol Schlegel • *Web Site Editor:* Holly Kilborn • *H. E. Asst.:* Kristen Koels • *Office Mgr.:* Julia Fish • *Receipt.:* Jeanne Johnson, Sheryl Ribbey • *Bldg. Maint.:* Ken Griffith • *Special Projects Director:* Saville H. Inman

MAIL ORDER

Operations Dir.: Bob Baker • *Cust. Service Mgr.:* Jennie Eace • *Warehouse Supv.:* Nancy Johnson • *Buyer:* Linda Janis • *Tech. Rep.:* Matthew DeBande • *Cust. Serv. Rep.:* Ann Cox, Tammy Trachtenberg, Adam Best, Nancy Downey, Deborah Rich • *Warehouse:* Sylvia Cusvy

ShopNotes® (ISSN 1092-0896) is published bimonthly (Jan., March, May, July, Sept., Nov.) by August Home Publishing, 2200 Grand, Des Moines, IA 50312.

ShopNotes® is a registered trademark of August Home Publishing. ©Copyright 1999 by August Home Publishing. All rights reserved.

Subscriptions: Single copy: \$4.99. One year subscription (6 issues), \$21.99. Canada/Foreign add \$6 per year.

Periodicals Postage Paid at Des Moines, IA and at additional mailing offices.

Postmaster: Send change of address to ShopNotes, P.O. Box 97193, Boone, IA 50097-2193.

Subscription Questions? Write to: ShopNotes Customer Service, P.O. Box 842, Des Moines, IA 50394-3961. Or call 1-800-333-6564, 9:00 am to 5:00 pm, Central Time, weekdays. FAX 515-283-6447.

E-Mail: ShopNotes@shopnotes.com

Internet: http://www.shopnotes.com

PRINTED IN U.S.A.

WoodNet

NOW ON THE WEB!

- 101 Woodworking Tips Online
- Woodworking Techniques — Step-by-Step
- Project plans you can download
- WoodNet Forum — Woodworkers' Q & A
- Power Tool Reviews

Point your browser to: <http://www.augusthome.com>
 Select "Woodworking" from the Welcome Page menu.

EDITOR'S NOTE

Cutoffs

If it's in your way, put it away. As a kid, that was the rule that was intended to keep our garage from getting too cluttered up.

There's only one problem. For rules to work, you have to follow them. I found that out the hard way.

I laid my bike down on the garage floor. (After all, it wasn't in my way.) Still, it didn't prevent the bike from getting crumpled when my father backed over it with the truck.

As the years have gone by, I've come to realize the wisdom of that rule. But I have to admit, I don't always follow it as well as I should.

CATCH-ALL. For instance, there's one corner in my shop that's sort of a catch-all. (One of those places that the spiders like to hang out.)

It's the type of place where I put things and forget they're even there — odd lengths of threaded rod, strips of molding from an old project, and metal corner beads from the time I drywalled my kid's room. In front of this clutter was a plastic bucket with dowels sticking out of it like pencils in a jar.

So recently, I decided to do something about that corner. I slid out the bucket, brushed off the cobwebs, and sorted through the junk.

Well, the corner was cleaner alright. But as I set the bucket of dowels back in place, I realized I was up to my old tricks again. The dowels were out of the way. But what I really needed was some

method of organizing them — a better way to put them away.

DOWEL RACK. The solution was a rack that uses a simple "stairstep" design to organize dowels by length.

This rack works great for storing dowels. But it's also a good way to organize any long strips of material — like pieces of angle iron, threaded rod, or strips of molding. (For more on this Dowel Storage Rack, refer to the article beginning on page 6.)

GRINDING STATION. A similar thing happened with my grinder. It was sitting on the end of my bench where I'd been using it to sharpen my chisels.

So I picked up the grinder and turned around to put it away. In this case, "putting it away" meant sitting the grinder on a shelf that was already filled with too much stuff.

Once again, I was just moving things around to make it appear like they were organized. But they really weren't. In a day or two, I'd have to haul out the grinder again, lug it to the bench, and then repeat the entire process all over again.

This time, a better solution turned out to be a wall-mounted Grinding Station like the one shown on the cover. It's a permanent "home" for my grinder. And it has several additional features that simplify the job of sharpening tools.

Tim

NEW

ON-LINE CUSTOMER SERVICE

- Access information about your subscription account.
- Find out if your payment has been received.
- Change your mailing address or your e-mail address.
- Let us know if you haven't received your issue

www.shopnotes.com

Contents

Features

Dowel Storage Rack _____ 6

With four "stairstep" compartments, this shop-made storage rack makes it easy to organize dowels by length. Also, a set of drawers provides storage for all your doweling supplies.



Dowel Storage page 6

Using a Skew Chisel _____ 10

This versatile turning tool does it all — from making a glass smooth planing cut, to turning a bead. Here are some simple tips and techniques to show you how.



Skew Chisel page 10

Selecting Grinding Wheels _____ 14

The secret to sharpening a tool on a bench grinder is using the correct grinding wheel. Check out these handy guidelines for choosing the right one.

Grinding Station _____ 16

A sturdy mounting platform, a clean, well-lit sharpening area, and plenty of storage. That's what you get when you build this wall-mounted station for your benchtop grinder.

Benchtop Drill Presses _____ 22

Our editors test four benchtop drill presses — and the results are in. Find out which one is best. Also, a close-up look at a drill press designed especially for woodworkers.



Drill Presses page 22

Scratch Awl _____ 26

Each of these scratch awls has the look and feel of a finely crafted tool. Yet it only takes an hour or two to complete. Our step-by-step plans make it easy.

Departments

Readers' Tips _____ 4

Our readers offer their own shop-tested tips dealing with some of the most common woodworking problems.

New Products _____ 31

Three new products that are sure to come in handy in your shop. Plus, information on where to get them.



Shop-Made
Scratch Awls
page 26

Readers' Tips

Power Cord Reel

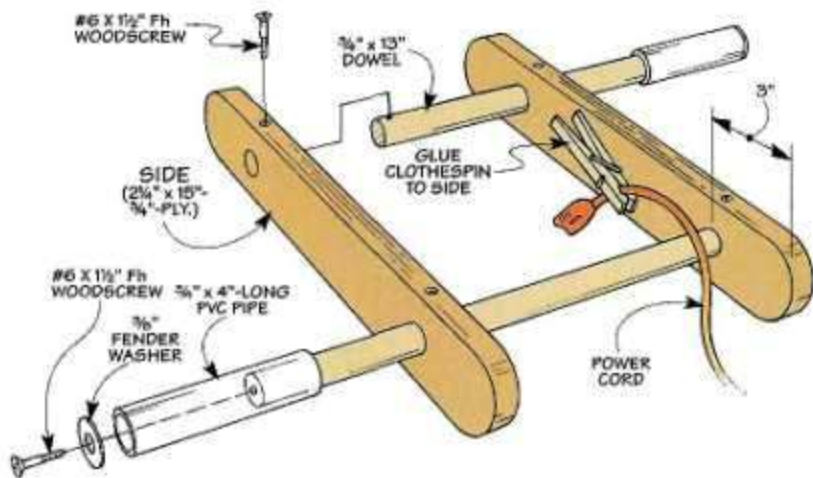

■ This simple hand reel is a nifty way to store a long power cord. To wind up the cord, you just “pedal” the reel like a bicycle, see photo. Once the cord is wrapped up, it won’t get tangled, so it’s ready to go when you need it. (This reel holds a fifty-foot-long power cord.)

The reel consists of two plywood *sides* connected by a pair of dowels, see drawing. Besides providing a rigid support to wrap the cord around, the dowels act as *handles* for the reel.

The dowels fit in holes drilled

near the ends of each side. It’s also a good idea to cut a curve on the ends of the sides. This keeps the power cord from getting snagged as you wrap it up.

To assemble the reel, it’s just a matter of inserting the dowels in the holes in the sides. The handles are formed by extending one end of each dowel past opposite sides of the reel. (The other end of each dowel is flush with the side.)

After screwing the dowels to the side, I slipped a short length of PVC pipe over each one. The pipe spins freely on the handles

which makes it easy to wind up the cord. (I cut the pipes $\frac{1}{16}$ ” shorter than the handles.)

Next, to prevent the pieces of pipe from slipping off, I placed a fender washer over the end of each one and screwed it in place.

All that’s needed to complete the cord reel is to glue a clothespin to one side. Clipping the end of the power cord in the clothespin frees up both your hands to crank the reel.

Wallace E. Delo
Buffalo, New York

Utility Saw

■ This simple utility saw really comes in handy when working in tight places. All that’s needed to make the saw is a reciprocating saw blade and a hardwood block for the handle, see drawing.

The blade fits in a kerf that’s cut in the handle. After shaping the handle to provide a comfortable grip, I used epoxy to hold the blade securely in place.

R. B. Himes
Vienna, Ohio

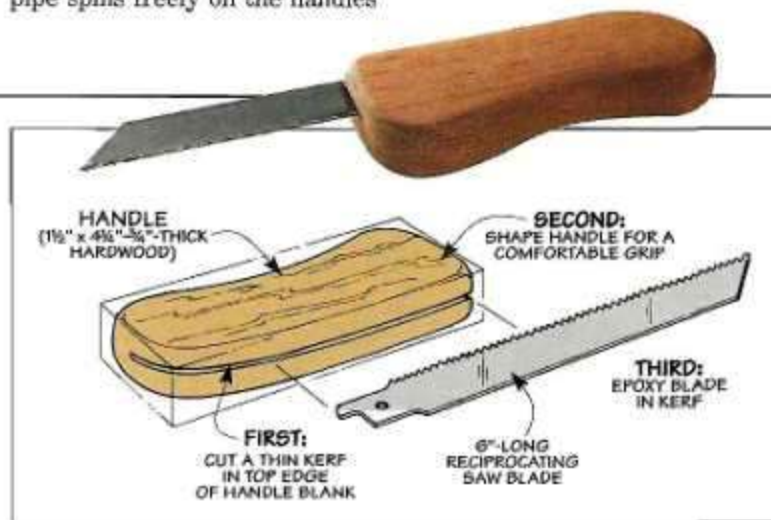

Quick Tips



▲ By applying hot glue to the edge of a chisel, **Alex Schultz** of Otley, IA forms a reusable cap that keeps it from getting nicked.



▲ To collect chips from his planer, **Don Zilliox** of Brevard, NC rolls it onto a tarp. Then he folds the tarp and empties the chips.



▲ To see at a glance what's inside his film storage containers, **Ed Page** of Erie, PA uses hot glue to attach a piece of hardware to each lid.

Cutting Threaded Rod

■ Cutting a threaded rod with a hacksaw can be a nuisance. If you clamp the rod in a machinist's vise, the metal jaws chew up the threads. And if you use a woodworker's vise, the threads mar the wood faces of the jaws.

The solution is simple — an ordinary hex nut. The trick is to cut a kerf through one of the "corners" of the nut, see Fig. 1 and detail below. Then just thread the nut onto the rod and clamp it in a machinist's vise.

As you apply pressure, the jaws of the vise pinch the nut tightly around the rod. This holds the rod securely without damaging the threads, see Fig. 2.

*Nathan Gutman
Simsbury, Connecticut*

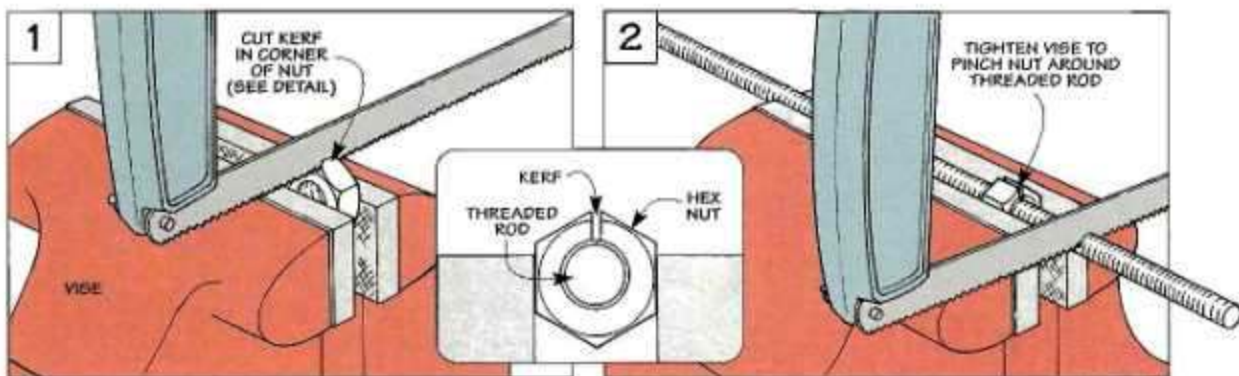

Table Saw Tip



■ Every time I crosscut a wide workpiece, the head of my miter gauge "clunks" against the front edge of the table saw. Over time, this knocks the miter gauge out of adjustment. So I filed a bevel in the table that allows the miter gauge to ride smoothly across.

*Bill Edwards
Kansas City, Kansas*

Send in Your Shop Tips

To share your original shop tips to problems you've faced, send them to: *ShopNotes*, Attn.: Readers' Tips, 2200 Grand Avenue, Des Moines, IA 50312. (Or if it's easier, FAX them to us at: 515-282-6741.)

We'll pay up to \$200 depending on the published length. Please include a daytime phone number so we can call you if we have any questions.

Dowel Storage Rack



▲ To remove a dowel, just slip it out of the bottom of the compartment. This way, even long dowels won't bump into anything above the rack.

Until recently, my only "system" for storing dowels was to stick them in a five-gallon plastic bucket. It worked okay. But often, the only way to find the dowel I needed was to dump them out and play a frustrating game of Pick-Up-Stix.

To solve the problem, I built a simple storage rack, see photo. With four narrow compartments that "stairstep" up from one side of the rack to the other, it organizes all my dowels by length.

The nice thing about this type

of system is I don't have to worry about the diameter of the dowel (or whether it's oak, maple or cherry). I just put the dowel in the compartment that suits its length.

For example, long dowels (24" to 36") are stored in the tall compartment on the left. And the compartment next to it holds 18" to 24"-long dowels. The last two compartments are used for 12" to

18"-long and 6" to 12"-long dowels.

Another nice thing about the compartments is they're open in front. So it's easy to sort through the dowels and grab the one you want, see photo in margin.

DRAWERS. But this rack does more than just organize dowels. A bank of drawers also provides plenty of storage for dowel pins, dowel centers, or a doweling jig.

THE CASE

The storage rack starts out as a simple plywood case that's divided into four compartments and three drawer openings, see Exploded View at left.

SIDES. Because of the staggered heights of the compartments, the only vertical pieces that are the same length are the two sides (A). Both sides are rabbeted to accept the bottom of the case, see detail 'c.'

Although the sides are identical in length, there is one thing that's different. The side on the right (as you're looking at the front of the case) has a number of dados that support three shelves and a pair of drawer guides.

DIVIDERS. The opposite ends of the shelves (and the other two

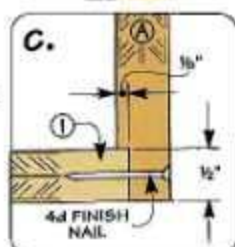
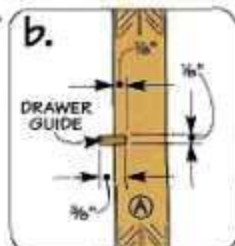
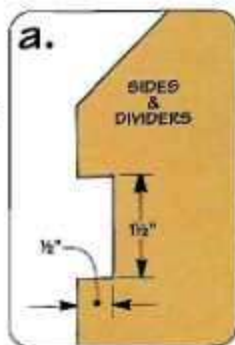
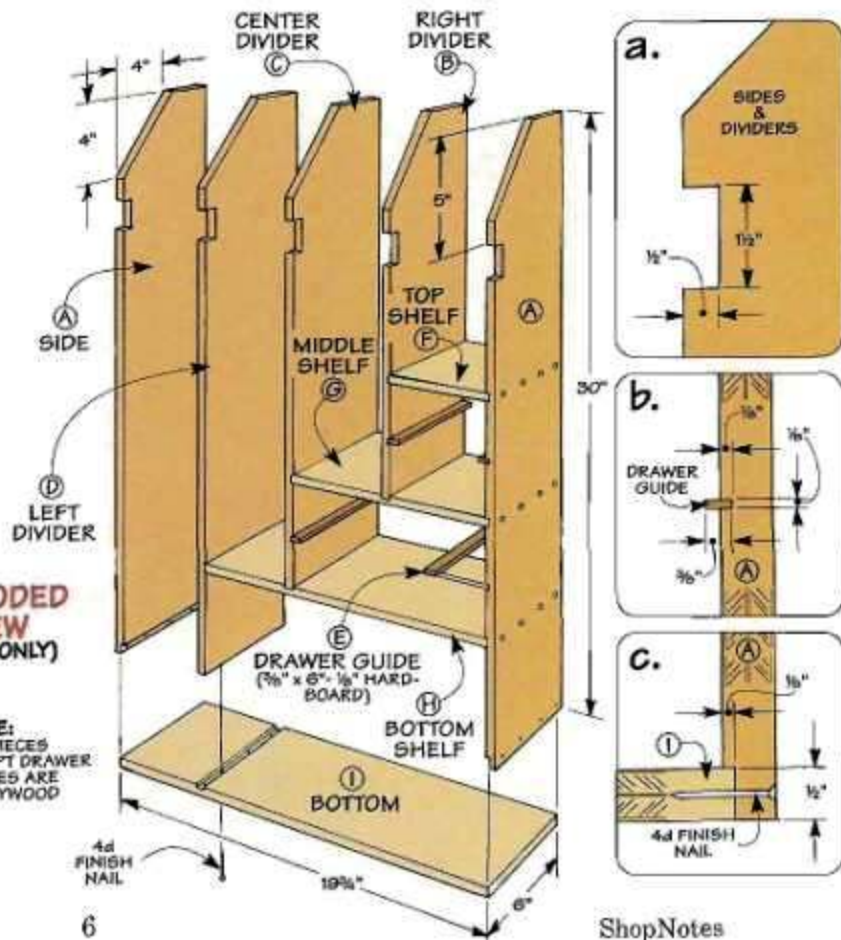

drawer guides) fit into matching dados in the *right (B)*, *center (C)*, and *left divider (D)*, see Fig. 1. So to ensure these dados align, it's best to cut them in pairs.

CUT DADOES. When cutting these dados, it's important to provide plenty of support for the workpiece — especially since the side and the dividers are fairly long.

So after setting up a dado blade in the table saw, I attached a long fence to the miter gauge. Also, clamping a stop block to the fence will ensure accurate results when cutting the three pairs of dados for the shelves, see Fig. 1.

The same type of setup works well when cutting the dados for the *drawer guides (E)*, see the Exploded View and detail 'b.' But the drawer guides are made from $\frac{1}{8}$ " hardboard. So here, a single pass with a combination saw blade is all that's needed. Once again, be sure to cut these dados in pairs, see Fig. 2.

CUT NOTCHES. After gluing in the drawer guides, the next step is to cut a wide notch near the top end of each piece, see Exploded View and detail 'a.' These notches accept a rail that's added later.

Also, to make it easy to see into the top of the compartments, I

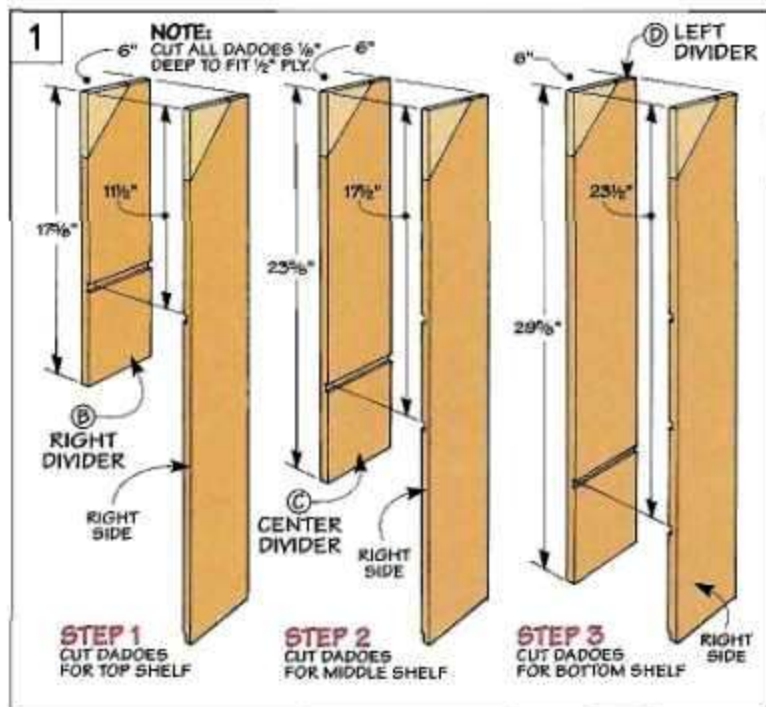

made an angled cut on the top corner of the sides and dividers.

SHELVES & BOTTOM. At this point, all the vertical pieces of the case are complete. To connect them, it's just a matter of adding the three *shelves (F, G, H)* and the *bottom (I)* of the case, see Fig. 3.

These pieces are all the same width. But they get progressively longer from top to bottom.

This way, each one acts as the bottom of one compartment. And it also helps to form one of the openings for the drawers.

After cutting them to final size, it's just a matter of cutting a dado in the three longest pieces. (There's no dado in the top shelf.) These dados make it easy to align the bottom ends of the dividers when assembling the case.

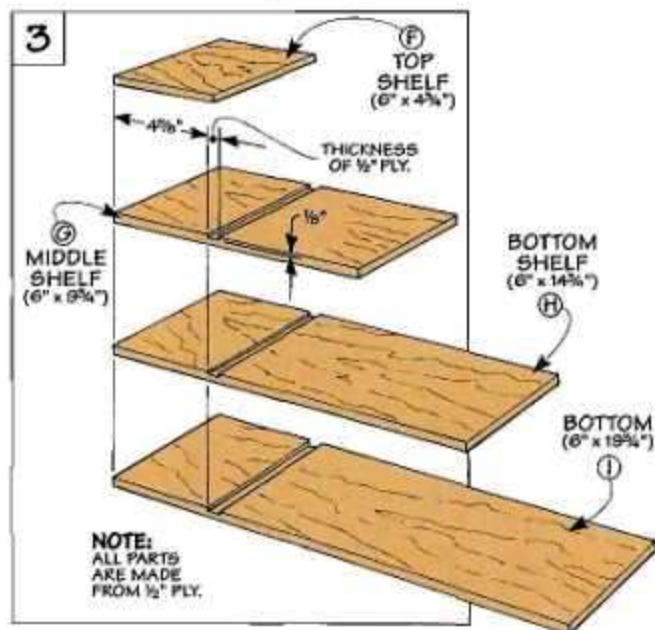
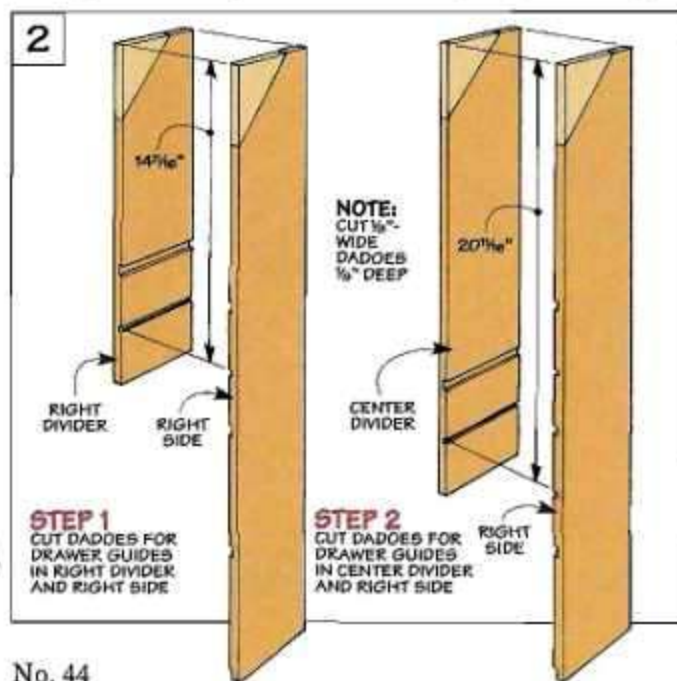

Assembling the Case

At this point, most of the pieces that make up the case are complete. Now it's just a matter of putting them together.

T-SHAPED ASSEMBLIES. I began by gluing and nailing three T-shaped assemblies together; see Fig. 4. The largest one is made up of the base (I) and left divider (D). And the middle assembly consists of the bottom shelf (H) and the center divider (C). Attaching the middle shelf (G) to the right divider (B) forms the smallest assembly.

Before connecting the three assemblies, it's best to attach the top shelf (F) to the right divider (B). Then after joining the two smaller assemblies with glue and nails, the large one is attached the same way.

With the "skeleton" now complete, you can attach the base and sides, see Fig. 5. These parts help stiffen the case, but they don't support the dividers.

RAIL. That's the job of a long rail (J) that spans the top of the case. The rail is just a strip of plywood that fits into the notches in the sides and dividers.

Before attaching the rail, you'll want to make sure that the dividers are spaced an equal distance apart. An easy way to do this is to cut a spacer to fit each of the first three compartments. (The top shelf keeps the right divider aligned.) Then glue and nail the rail in place.

KEEPER STRIPS. To prevent the dowels from kicking out at the bottom of the compartment, I added four keeper strips (K), see Fig. 6. These are nothing more than short pieces of plywood that are glued in place.

BACK. All that's left to complete the case is to add the plywood back (L). It's simply cut to fit the back of the case and then glued and nailed.

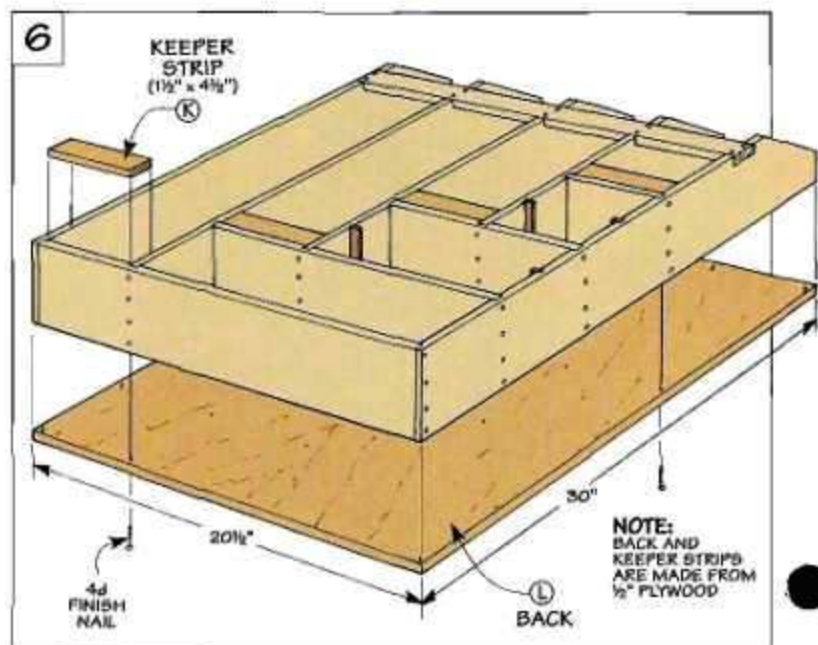
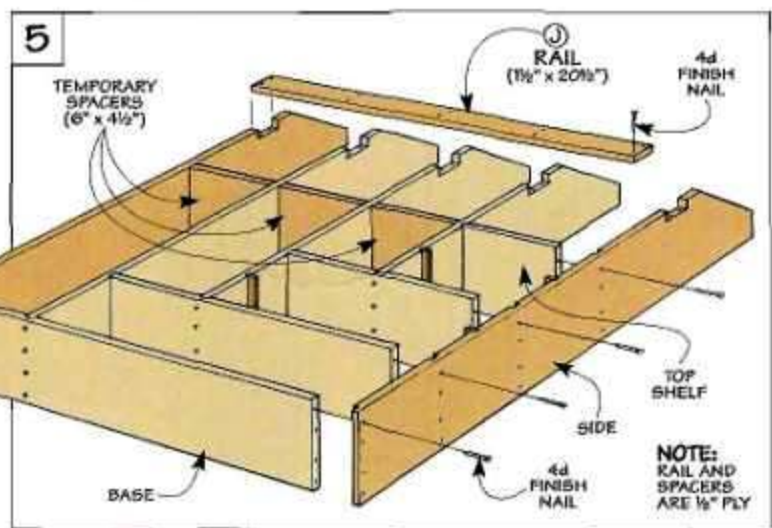
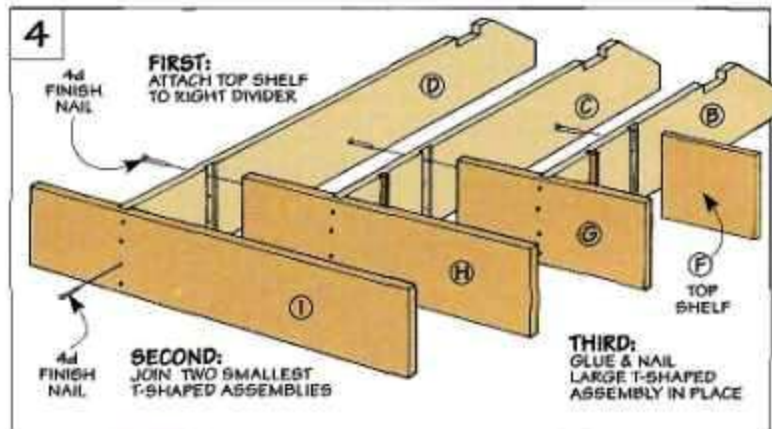

Building the Drawers

One of the most useful features of this dowel storage rack is a set of five drawers that hold all my doweling supplies, see photo.

The drawers fit into three openings in the lower right corner of the case. Since each of these openings gets progressively wider from top to bottom, there are three different sizes of drawers.

The narrow opening on top holds two shallow drawers, see Fig. 7. One of these drawers rests on the middle shelf (G), and the other slides in and out on the drawer guides.

The opening directly below these drawers also holds two shallow drawers. But since this opening is wider, the drawers are sized accordingly. Here again, one drawer is supported by the drawer guides while the other sits on the bottom shelf (H).

To store tall items, I made a single, deep drawer that fits in the large opening at the bottom. Unlike the other drawers, it's divided into compartments to help keep things organized.

DRAWER SIZE. When sizing the drawers, there are a couple of

things to take into consideration. First, all the drawers are designed to allow $\frac{1}{16}$ " of clearance between the case and the sides of the drawers. I also wanted a $\frac{1}{16}$ " gap between the drawer and the shelf (or drawer guides) above it.

Another thing to keep in mind is that the overall length of the drawers (from front to back) matches the depth of the opening. (In my case, this was 6".) This way, when you push a drawer all the way in, it's flush with the front of the case.

Regardless of their size, the drawers are all basically the same. The drawer fronts, backs, and bottoms are made from $\frac{1}{2}$ " plywood. And the sides and dividers are $\frac{1}{4}$ " hardboard.

RABBET JOINTS. The drawers are assembled with simple rabbet joints. The front and back (M, N, O) of each drawer is rabbeted at each end to accept the sides (P, Q), see Fig. 7a.

Also, each drawer bottom (R, S, T) fits in a rabbet in the bottom edge of the front and back, see Fig. 7b.

FINGER RECESS. With all the joinery completed, I cut a semi-circular notch in each drawer front, see Fig. 7c. These notches serve as finger pulls that make it easy to open the drawers.

DIVIDERS. There's just one more thing to do before assembling the drawers. To accept the dividers (U), you'll need to cut two narrow dadoes in the front and back of the large drawer.

ASSEMBLY. Now you're ready to assemble the drawers. This is just a matter of brushing a thin coat of glue on each of the mating surfaces and then clamping the drawers together. 



▲ The five drawers are sized to provide a variety of different storage options for your doweling supplies and accessories.

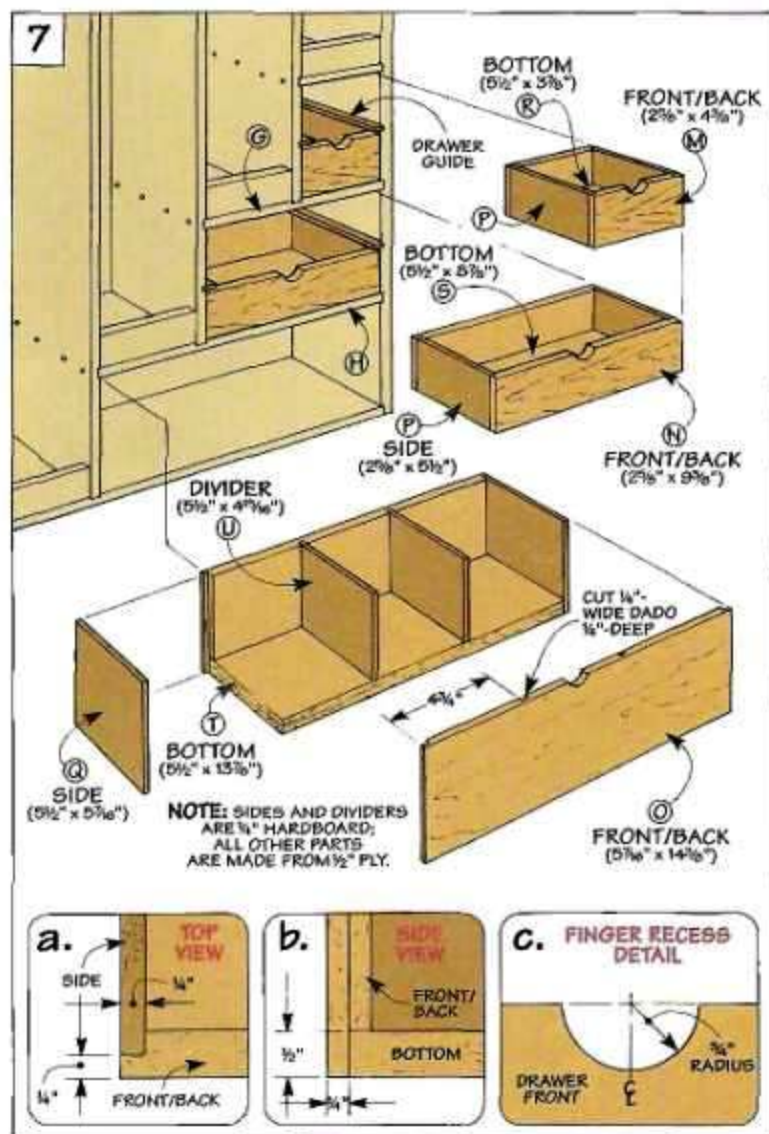

Tips on Using a Skew Chisel

Crisp, sharp details. And a glass-smooth finish. Two things you can depend on when using a skew chisel to turn a spindle on the lathe.

The reason is simple. The blade of a skew chisel is beveled on *both* sides like a knife. This forms a cutting edge that peels off shavings like the skin off an apple.

SKEWED EDGE. But it isn't a keen edge that makes a skew chisel such a versatile turning tool. It's the fact that the edge is angled (skewed) across the end of the blade, see drawing below.

This skewed edge makes it ideal for planing the *long grain* of a spindle, see photo above. Yet it also lets you cut a shoulder in stubborn *end grain* or turn a delicate bead. (For more on this, refer to pages 11 and 12.)

SIZE. Depending on the type of cut (and size of workpiece), there are several sizes of skew chisels.



▲ From planing a smooth finish to turning a bead, a skew chisel is a versatile turning tool.

They range in width from $\frac{1}{4}$ " up to 2". I've found that a $\frac{1}{2}$ " or $\frac{3}{4}$ " skew chisel is fine for most work.

TUNE & SHARPEN. Regardless of its size, it's worth taking a few

minutes to "tune up" a brand new skew chisel, see box below. And as with most hand tools, a sharp edge is the key to getting good results, see box on page 11.

SKEW ANATOMY



Tune-Up

The secret to using a skew chisel is to slide (or roll) it smoothly across the tool rest. But sometimes, the sharp, square corners of the chisel can cause a slight "hitch."

ROUNDROVER. To prevent this, it's a good idea to "tune up" a brand new skew chisel by grinding a roundover along the *short edge*, see photo.

Start by grinding several "flats" along the length of the edge. Then blend them together using silicon-carbide sandpaper, see



drawing at left and detail 'a.'

LONG EDGE. You may also want to knock off the corners on the *long edge*, see detail 'b.' This provides a more comfortable grip. And it keeps the edge from marring the tool rest.

Planing Cut

An easy way to create a satin smooth surface on a spindle is to “plane” across its length with a skew chisel, see photo at right.

SHORT POINT. To do this, the short point of the skew “leads” in the direction of the cut, see Fig. 1. But it’s not the short point (or the long point either) that does the actual cutting.

SWEET SPOT. It’s the “sweet spot” on the cutting edge of the

skew. This is the area *between* the short point and the center of the cutting edge, see Fig. 1a.

The best way to “find” this spot is to start with the handle quite low and the blade resting flat on the tool rest. Then, with the heel of the bevel rubbing on the spindle, rotate the handle slightly so the blade tips up on its *short* edge, see Fig. 1b.

The blade isn’t cutting yet at

this point. But that’s okay. To begin cutting, *slowly* raise the handle and slide the blade back just a bit on the tool rest. At first, this only creates dust. But if you raise the handle a bit more, it will start to produce thin, wispy shavings, see Fig. 1c.

To complete the cut, simply slide the blade smoothly and steadily across the tool rest.



▲ A planing cut (and a light touch) will produce a smooth surface that doesn’t need sanding.

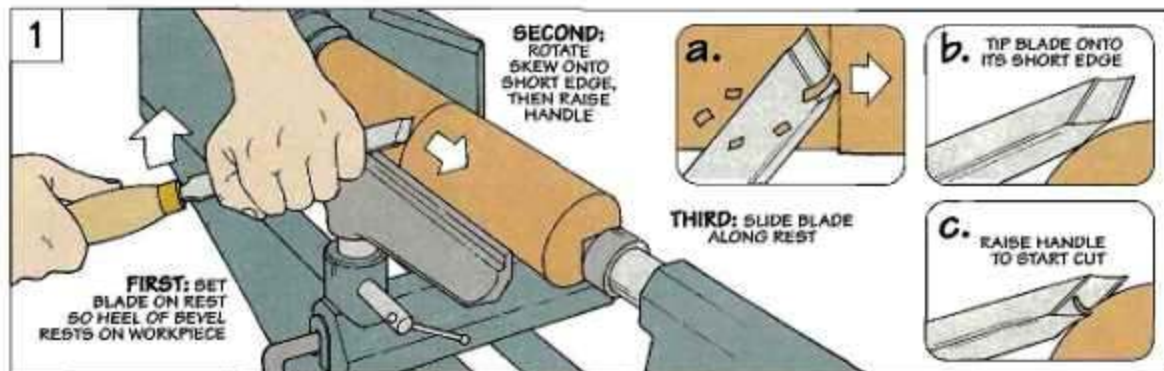

Sharpening a Skew Chisel

Sharpening a skew chisel is a simple two-step process: grinding the bevels on a wheel, then honing the edge on a sharpening stone.

FIRST, THE BEVELS. It’s easy to grind a bevel on each side of the blade. The trick is making sure the angle of the bevels is identical on both sides.

To accomplish this, I attach a wedge-shaped block to the tool

rest on the grinder, see Fig. 1. It holds the blade at an angle so the bevel rests flat on the wheel, see Fig. 1a. By moving the bevel gently across the wheel, you get a nice, even grind, see photo above left.

NOW THE EDGE. The second step is to hone the edge on a sharpening stone, see Fig. 2. To do this, place the bevel on the stone so it’s

resting on both the heel and the cutting edge, see Fig. 2a. Then make a series of short, back and forth strokes until the grinding marks on the edge disappear, see photo above right.

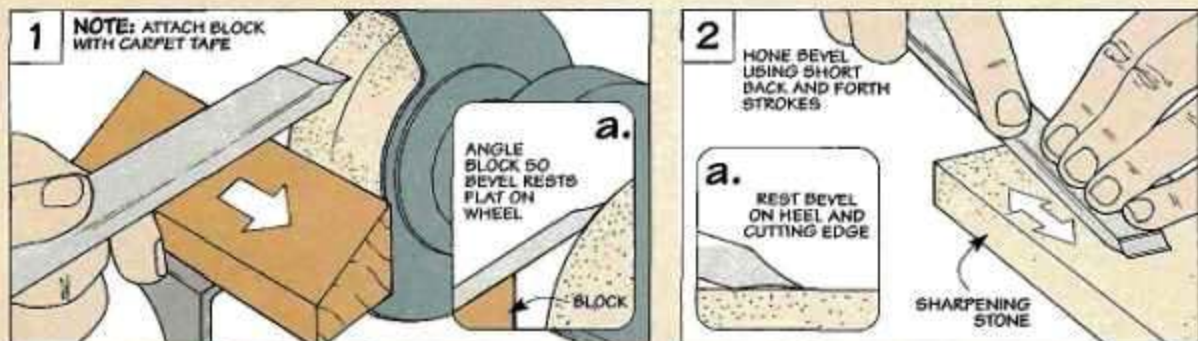

Facing Cut

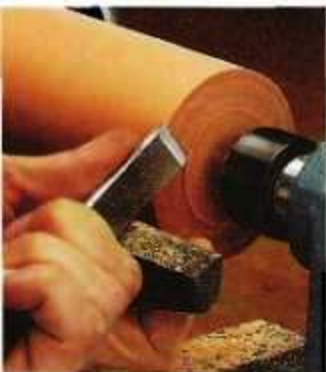

▲ Peeling off a sliver of wood with a facing cut makes it easy to square up the end of a spindle.

A skew chisel is also a great tool for making a deep cut in *end grain*. When facing (squaring up) the end of a spindle for instance, it severs the wood fibers to create a crisp, clean surface, see photo at left.

The thing that's different about a facing cut is the blade doesn't traverse the tool rest. Instead, it pivots like a seesaw to produce a slicing cut down into the wood.

UNDERHAND GRIP. To create a stable pivot point, an underhand grip works best, see Fig. 1. I've also found that wrapping my index finger around the bottom of the tool rest provides better control of the skew.

LONG POINT. With a facing cut, the business end of the skew is

the *long point* of the blade. The idea is to position the point just above the centerline of the spindle. So here again, hold the handle down low. Also, to provide clearance between the bevel and spindle, you'll need to angle the blade slightly to the side, see Fig. 1a.

ENTRY CUT. To make the entry cut, slowly raise the handle and push the blade forward at the same time, see Figs. 1 and 1b. The long point of the blade should follow a descending arc toward the center of the spindle, peeling off a thin (about $\frac{1}{32}$ ") sliver of material.

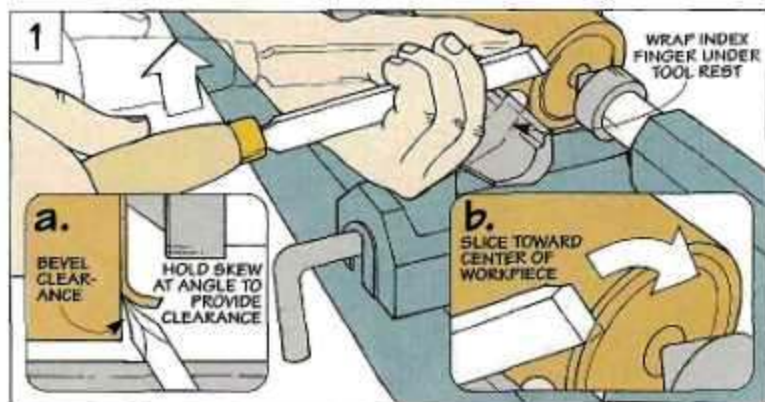

Turning a Bead



▲ The secret to turning the curved shoulders of a bead is to roll the skew chisel in one continuous motion.

Turning a bead with a skew chisel requires two things — *practice* and *patience*. Not because it's a particularly difficult technique. But because it blends several different movements into one continuous cut.

The bead is formed by rolling the skew — first to one side, then the other, see photo. But first, you'll need to provide some “shoulder

room” for the blade to work.

V-GROOVES

This clearance is created by cutting two V-shaped grooves — one on each side of the desired location of the bead.

LONG POINT. The grooves are formed by using the *long point* of the skew chisel. (It penetrates deeper than the short point.)

Here again, the entry point is just above the centerline of the spindle. (I use the same grip.)

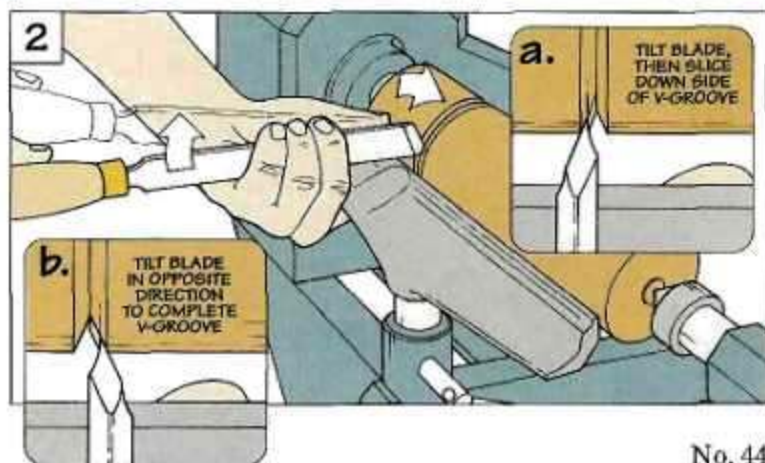
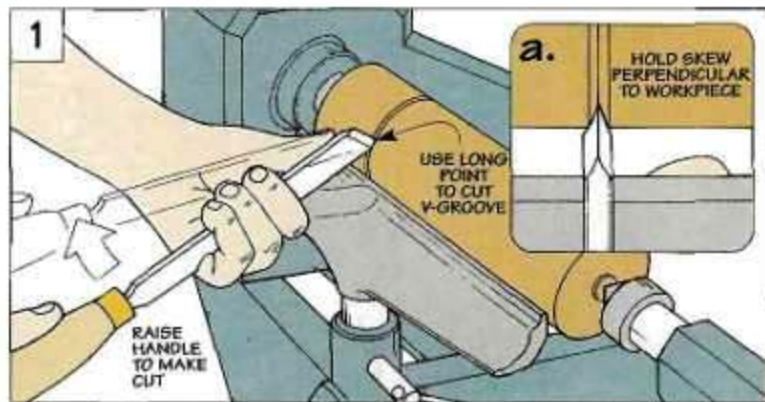

Only this time, hold the blade *perpendicular* to the workpiece.

To make a cut, raise the handle straight up and sweep the blade down into the spindle, see Figs. 1 and 1a. The entire process only takes a second. To avoid burning the blade, withdraw it when the long tip is “pointing” at the centerline of the spindle.

ENLARGE GROOVE. At this point, the groove still isn’t wide enough (or deep enough) to roll the bead. So you’ll have to enlarge it by making two more cuts — one on each side of the groove, see Fig. 2.

Basically, each cut is the same as the V-groove. Only here, tilt the blade a bit so you can slice down the side of the groove, see Figs. 2a and 2b. (I start each cut $\frac{1}{8}$ " from the rim of the groove.)

To clear out the waste, just work back and forth from one side of the groove to the other as if you’re chopping a notch in a log.

TURNING THE BEAD

Now you’re ready to turn the bead. It’s formed in two steps — first rounding one shoulder of the bead, then the other.

SMALL BITES. What works best is to round each shoulder by taking a series of small “bites.” With each bite, the blade starts out flat on its side, see Fig. 3. Then the *short point* is “feathered” into the wood as the skew is rolled on its edge.

To form the initial roundover, hold the handle low and angled away from the direction of cut, see Fig. 3a. Now roll the skew in the direction of cut by rotating the handle, see Fig. 3b. At the same time, raise the handle and push the skew forward, see Fig. 3c.

Once you’ve established a small roundover, it’s just a matter of increasing its size by making several more rolling cuts — each one beginning closer to the center of the bead, see Figs. 4 and 4a.

As before, ease the cutting edge into the wood and roll it into the bottom of the V-groove, see Figs.

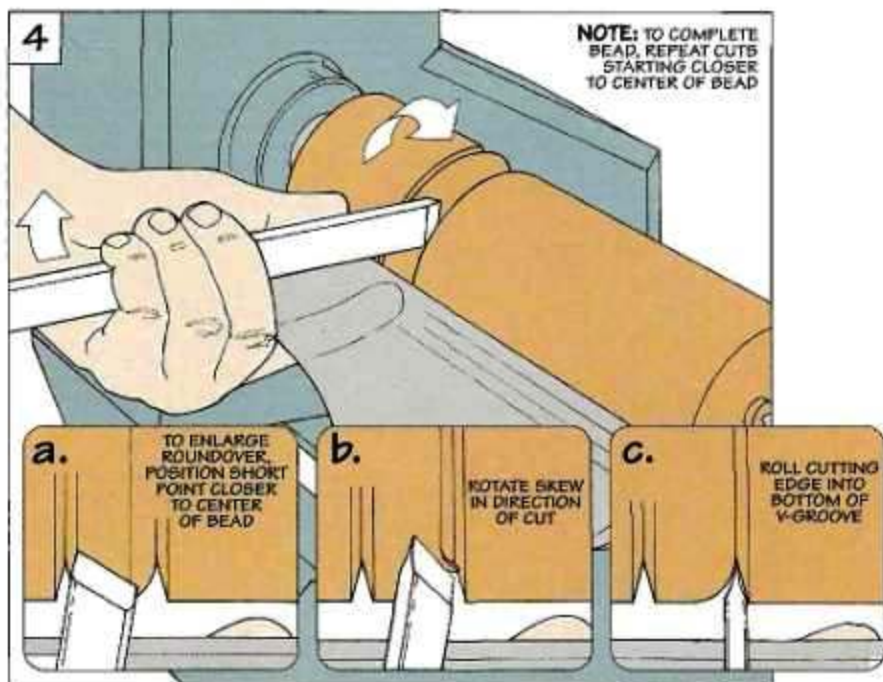
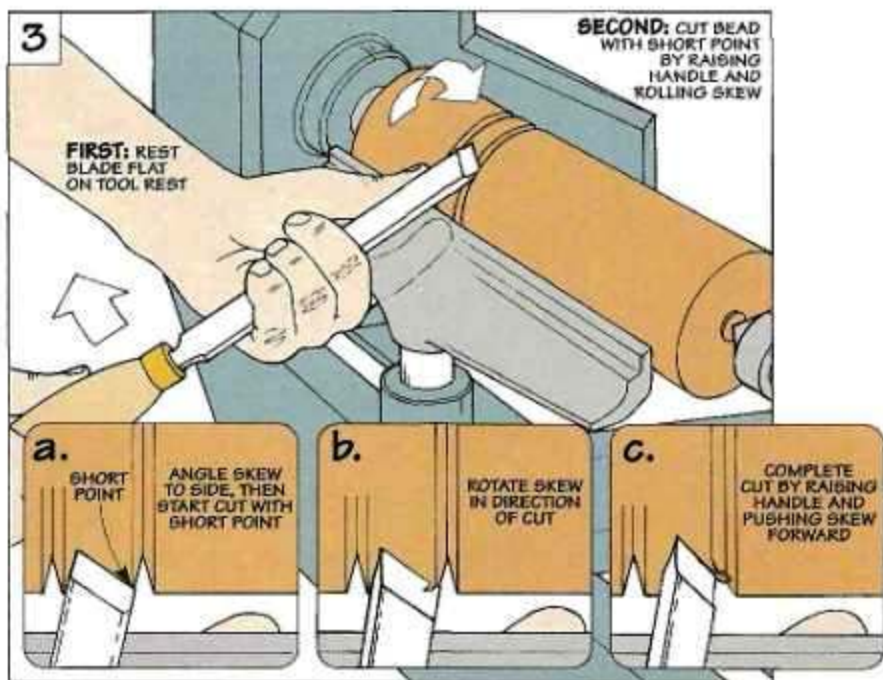

4b and 4c. But as the roundover increases in size, there’s a subtle difference. To keep the cutting edge in contact with the wood, slide the blade a short distance across the tool rest as you work your way around the bead.

COMPLETE BEAD. To turn the second shoulder of the bead, the

process is identical. But the skew is rolled in the opposite direction.

You may find it’s easier to turn a uniform bead on one side or the other (depending on whether you’re right or left-handed). But don’t worry. With practice, you’ll be turning nice, symmetrical beads in no time. 🐿

Selecting a Grinding Wheel

What's the secret to ending up with a razor sharp edge on a chisel? Start by using the right grinding wheel.

Using a bench grinder to sharpen a chisel or plane iron used to be a frustrating experience for me. In fact, sometimes it seemed I was just as likely to *burn* the tip of the tool as to get a sharp edge.

The first time it happened, I figured there was either something wrong with the grinder or the way I was going about sharpening the chisels. So I tried several things to correct it.

Still I was having problems. Even when I used a light touch and steadily moved the bevel across the grinding wheel, the blade turned blue. It wasn't until I'd ruined one of my best chisels that I finally discovered the real

culprit — the *grinding wheel*.

ALL-PURPOSE. The grinding wheel I'd been using was a gray, all-purpose wheel that had come with my bench grinder. This type of wheel works fine for sharpening a lawnmower blade or garden hoe. But it's not really intended for grinding the type of steel that's used in most chisels and plane irons.

That's because a gray wheel is a hard, slow-cutting wheel. So it tends to clog up with tiny bits of metal. As the grinding surface of the wheel fills with metal, it becomes "glazed."

When a grinding wheel is glazed, the chisel no longer comes in contact with as many of

the abrasive particles in the wheel. Instead, you get steel-to-steel friction. This friction can generate a lot of heat, quickly. So quickly that you can be grinding away and all of a sudden the tip of the tool turns blue.

TEMPER. The blue color indicates that the steel has lost its "temper." (Tempering is a heat treatment that makes the metal tougher, so it will hold an edge longer.) If the metal loses its temper, it won't stay sharp.

Fortunately, not all grinding wheels will cause heat to build up as rapidly. So the secret is to replace the gray wheel with one that's not as likely to draw the temper out of the tool.

WHITE WHEEL. One wheel that's especially good for that is a white, aluminum-oxide grinding wheel. This wheel cuts fast. And just as important, the binder or "glue" used on this type of wheel allows the abrasive particles to break away faster than the particles in an all-purpose wheel. This is good for two reasons.

First, the cutting surface doesn't get clogged up with bits of cut-off metal. Since it's not clogged up, the chisel (or plane iron) doesn't get as hot while grinding.

The second reason is that "fresh," sharp cutting edges are continuously being exposed. So the wheel cuts quicker and cooler.

But there's a tradeoff to using a white wheel. Since the abra-

Wide Grinding Wheel

At a glance, it looks like just another grinding wheel. But it's not. The face of the wheel is 1" wide (instead of $\frac{3}{4}$ " wide like most 6" grinding wheels).

I like the extra width because I can grind a bevel on a tool (like my $\frac{3}{4}$ " chisel) without having to move it back and forth across the wheel. The larger surface area is also handy for grinding turning tools.

To fit the wheel onto the arbor of a grinder (and still have room for the nut), the center of the wheel is "dished" out to form a shallow cup, see photo. (This wheel is available from the source listed on page 15.)



sive particles break away faster, the wheel also wears out faster. (In other words, it has a *soft bond*.)

On a wheel with a soft bond, you're more likely to wear a groove in the grinding surface when sharpening a tool. So if you're doing some heavy grinding (like reshaping the edge of a lathe tool for instance), a better choice would be a pink, aluminum-oxide wheel.

PINK WHEEL. The abrasive particles on a pink wheel don't break away quite as readily as on a white wheel. (A pink wheel has a slightly *stronger* bond.) So you don't have to worry as much about accidentally grooving the face of the grinding wheel.

Since a pink wheel is more resistant to wear, it's ideal for sharpening the high-speed steel used in many turning tools. (This type of steel is harder than the tool steel used in most chisels.)

WHICH GRIT? In addition to the color of the wheel, you'll also need to decide which grit to use. As with sandpaper, a coarse-grit wheel will leave a rough surface on the bevel, and fine grits will create a smoother surface.

The thing to keep in mind is that grinding the bevel is only

the first step of the sharpening process. To form the final cutting edge, you'll still need to hone the bevel on a sharpening stone.

Because of that, I'm not too concerned about the coarseness of the grind marks on the bevel. In fact, I *prefer* a wheel with a relatively coarse grit. It gets the job done quickly, so there's less chance for heat to build up in the tool. (I use a 60-grit wheel.)

CODE. So how do you know if a wheel is actually a 60-grit, aluminum-oxide wheel? One way is to look at a *code* that's printed on the paper washer on the side of the wheel, see photo above. The code has a lot of technical information. But you can find out all you need to know by "cracking" the first three parts.

ABRASIVE TYPE & GRIT. For example, the letter 'A' indicates that this wheel has abrasive particles made of aluminum oxide. And the '60' refers to the grit.

BOND GRADE. Another thing the code will tell you is the *grade* of the bond. Basically, this is the measurement of how easily the abrasive particles will break away.

With a *soft* bond grade, the particles separate relatively easy

Abrasive Material
(A=Aluminum Oxide)

6 x 3/4 x 5/8
A 60-K5VBE

Abrasive Grit Size
(60)

Bond Grade
(K)

Structure
(5)

Bond Type
(V)

Factory Code

Three of the ▲ most important things you need to know about a grinding wheel are contained in a code printed on the paper washer (in dark print).

(as with the white and pink wheels). But on a wheel with a *hard* bond (like the gray, all-purpose wheel), the particles are a little more stubborn.

To distinguish one grade from another, most manufacturers use a lettering system from 'A' to 'Z' (with 'A' being the softest and 'Z' the hardest.) Note: The white wheel I use has a bond grade of 'K' which is fairly soft.

Because of this, the abrasive particles separate fairly easily. And fresh cutting edges are continually exposed. So the wheel cuts cooler, heat doesn't build up, and it's no longer a "grind" to sharpen my tools. ▲

Sources

- **Craft Supplies**
800-551-8876
Grinding Wheels,
Wide Grinding Wheel,
Diamond Truing Tool
- **Garrett Wade**
800-221-2942
Grinding Wheels
- **Lee Valley Tools**
800-871-8158
Grinding Wheels
- **Woodcraft**
800-225-1153
Grinding Wheels

Truing Up a Grinding Wheel

The nice thing about the white and pink grinding wheels is they "shed" their abrasive particles as you grind. So they're not as likely to clog with metal. (They're more or less "self-dressing.")

Even so, you'll still need to *true up* these wheels. This squares up the face of the wheel across its width. And it knocks off any high spots. As a result, you can grind a nice, uniform bevel across the blade.

DIAMOND TRUING TOOL. One of the best ways I've found to true up a wheel is with a *diamond truing tool*, see photo at left. The diamonds are embedded



▲ With tiny bits of diamonds embedded in its head, this simple tool makes quick work of truing up a grinding wheel.

in a 1"-wide head that's placed against the face of the grinding wheel, see photo at right. This way, you can true up a wheel in a matter of seconds. (For sources, see margin at right.)



This versatile wall-mounted unit provides a complete workstation for your grinder.

Wall-Mounted Grinding Station

Sometimes a grinder is like a naughty kid — it ends up getting stuck in a corner.

More often than not, it's a dimly lit area that makes it hard to see when you're sharpening. And it's usually dirty and gritty from years of messy grinding jobs,

But this wall-mounted grinding station improves things considerably. In addition to providing a sturdy platform for a grinder, it has a long, flexible lamp that shines light right where it's needed.

PLASTIC LAMINATE. Of course, there's nothing to keep it from

getting covered with gunk. But that's okay. The exposed surfaces are covered with plastic laminate, see photo above. So a damp cloth is all it takes to clean it up.

A clean, well-lit work area is one thing. But there's more to this grinding station than that. To get a handle on the clutter that accumulates around a grinder, it has several types of storage.

STORAGE. Grinding wheels and sharpening supplies are stored in a drawer under the table, see photo A at left. And a narrow shelf up above holds small items that often get in the way. There's even a sliding tray that provides a temporary place to put tools you're working on, see photo B.

CUP. Finally, there's one more thing about this grinding station that's just plain fun — a shop-made plastic cup that's used to quench a hot chisel or plane iron.



A. Full-Extension Drawer. To provide easy access to accessories, the drawer in this grinding station is mounted on full-extension drawer slides.



B. Sliding Tray. A tray slides out of either side of the station to hold the tools you're working on.

EXPLODED VIEW
OVERALL DIMENSIONS:
(16"H x 26"W x 18"D)

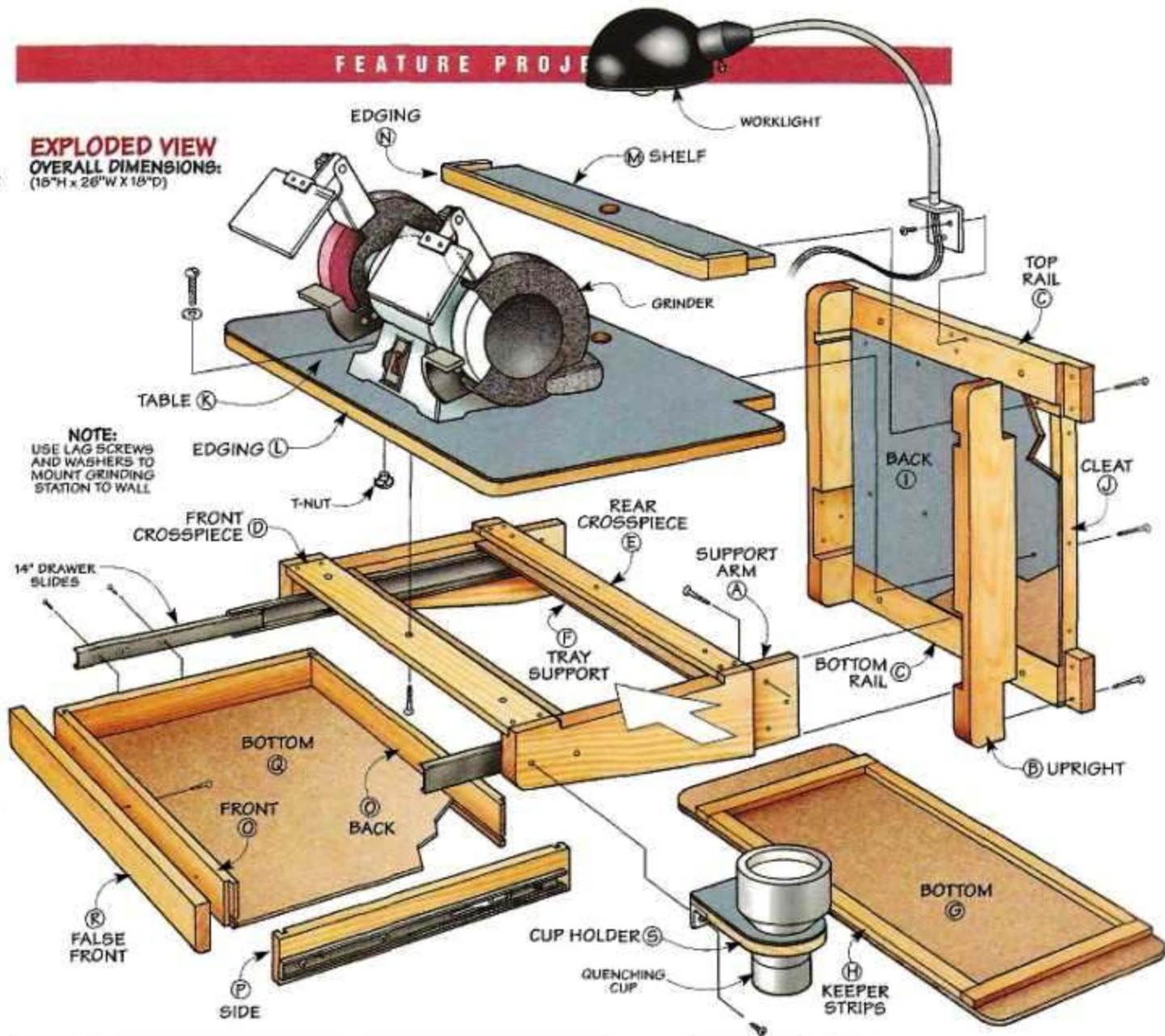

NOTE:
USE LAG SCREWS
AND WASHERS TO
MOUNT GRINDING
STATION TO WALL

Materials

Frame

- A Support Arms (2) 1 1/2 x 5 - 17 1/2
- B Uprights (2) 1 1/2 x 3 - 19
- C Top/Bottom Rails (2) 1 1/2 x 3 - 24
- D Front Crosspiece (1) 3/4 x 4 - 22 1/2
- E Rear Crosspiece (1) 3/4 x 2 - 22 1/2
- F Tray Supports (2) 1 1/2 x 21 - 1/4 Hdbd.

Sliding Tray

- G Bottom (1) 8 3/8 x 26 - 1/4 Hdbd.
- H Keeper Strip 15 1/2 x 6 Lin. Ft. - 3/4 Ply.

Back, Table, & Shelf

- I Back (1) 21 x 14 1/2 - 1/4 Hdbd.
- J Cleats (2) 3/4 x 1 1/2 - 13
- K Table (1) 16 x 25 - 3/4 Ply.
- L Edging 1/2 x 3/4 (5 Lin. Ft.)
- M Shelf (1) 3 1/2 x 22 - 3/4 Ply.
- N Edging 1/2 x 1 1/8 (3 Lin. Ft.)

Drawer

- O Front/Back (2) 1/2 x 2 3/8 - 19 1/2
- P Sides (2) 1/2 x 2 3/8 - 14
- Q Bottom (1) 13 1/2 x 19 1/2 - 1/4 Hdbd.
- R False Front (1) 3/4 x 2 1/8 - 20 1/8
- S Cup Holder (1) 4 x 6 - 3/4 Ply.

You can make all the parts for the Grinding Station from (1) 2 x 12 piece of Douglas Fir (eight feet long), one sheet of 3/4" Baltic Birch Plywood, one 1/4 sheet of 1/4" handboard, and a 24" x 48" piece of plastic laminate.

Note: The worklight we used for this Grinding Station is available from W. W. Grainger for \$33.44. To order, call 515-268-3460 and request Part Number 4PD33.

Hardware

- (1 Pr.) 14" Full-Ext. Drawer Slides
- (2) #8 x 1/2" Panhead Screws
- (2) #8 x 1 1/4" Panhead Screws
- (4) #8 x 3 1/2" Fh Woodscrews
- (8) #8 x 2 1/2" Fh Woodscrews
- (30) #8 x 1 1/4" Fh Woodscrews
- (17) #8 x 3/4" Fh Woodscrews
- (1) 1" x 1" - 4" Aluminum Angle (1/8" Thick)
- (1) 2"-Dia. PVC Pipe (1 1/2" Long)
- (1) 2"-Dia. PVC End Cap
- (1) 3"-Dia. x 2"-Dia. PVC Coupler

To order a kit that includes all of this hardware, call 800-347-5105. Note: Worklight not included.

Kit No. 6844-100.....\$33.95

Frame

I began work on the Grinding Station by making a sturdy wood frame. It consists of a pair of L-shaped brackets connected by two rails and a couple of crosspieces, see drawing. Note: I made all of the pieces from straight-grained Douglas fir.

L-SHAPED BRACKETS

To provide solid support for the grinder, each of the brackets consists of two interlocking parts: a horizontal support arm, and vertical upright.

SUPPORT ARMS. The two support arms (A) are quite simple. Each one is made from a piece of "two-by" material that's cut to final length and width, see Fig. 1.

To prevent the support arms from sagging under the weight of the grinder, they fit securely in the uprights. This requires cutting a wide rabbet at one end of each support arm, see Fig. 1.

In addition to the rabbet, I cut

a long, shallow notch in the top edge of each support arm. These notches will create an opening for the sliding tray on each side of the grinding station.

With the notch complete, there

are two more things to do. First, you'll need to rabbet the top inside edge of each support arm to accept the crosspieces. Then, to create a slimmer profile, I cut a gradual taper along the bottom edge.

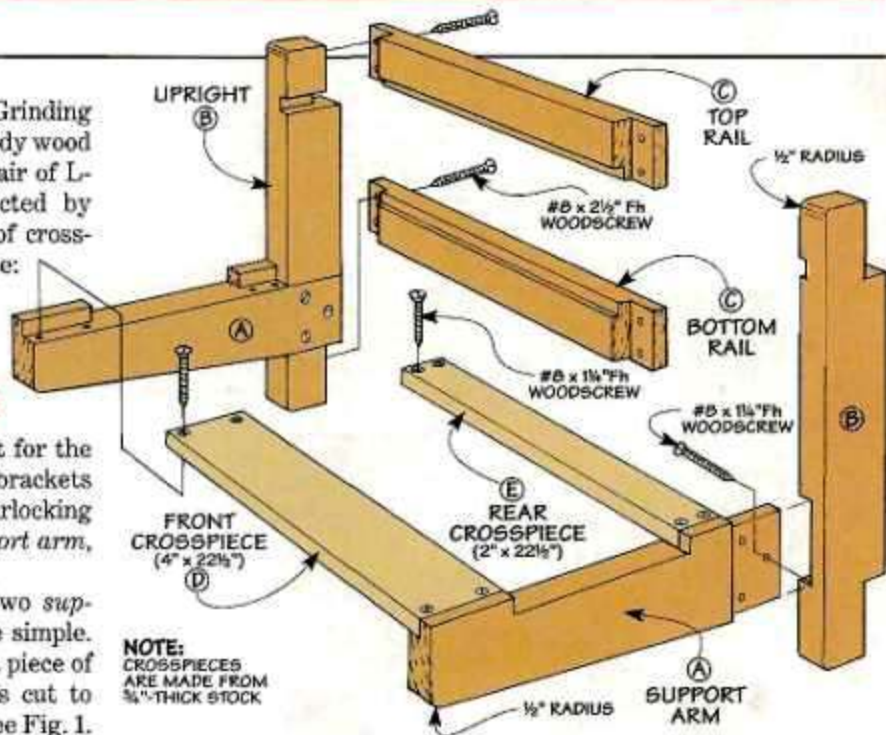

NOTE: CROSSPIECES ARE MADE FROM 3/4" THICK STOCK

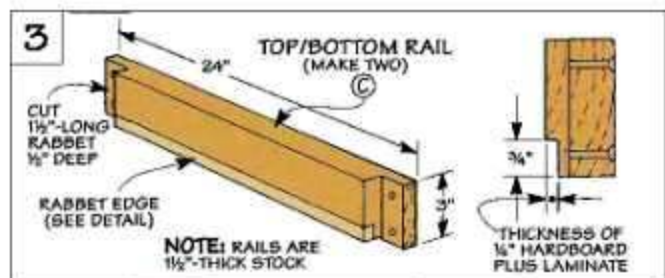
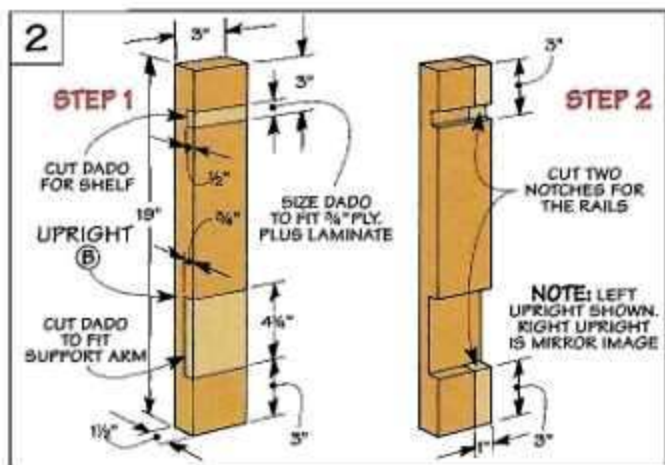
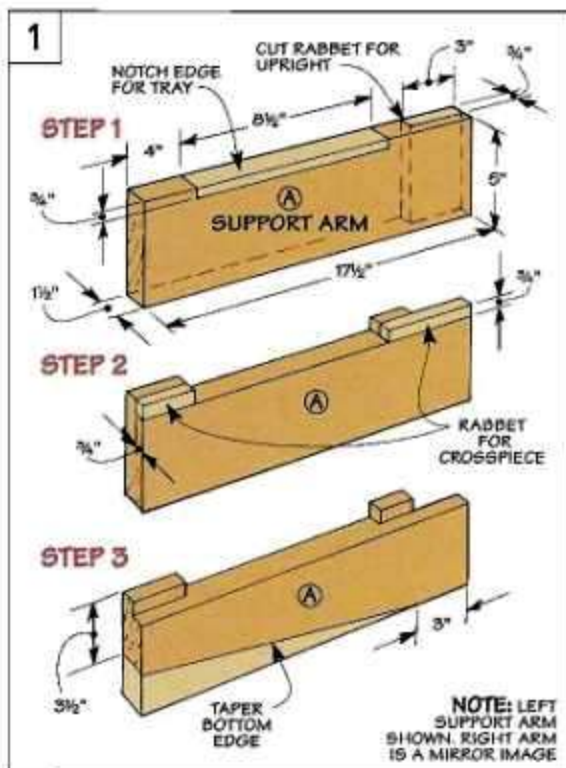

UPRIGHTS. With the support arms complete, you can turn your attention to the two uprights (B), see Fig. 2.

To accept the support arms, there's a wide dado cut in the inside face of each upright. Also, a narrow dado near the top holds a shelf that's added later.

With the dados complete, I notched both ends of each upright along the back edge. These notches will accept the rails that "tie" the uprights together.

ASSEMBLE BRACKETS. After sanding a radius on the outside corners of each upright and the bottom corners of the support arms, the brackets are ready for assembly. They're simply glued and screwed together.

RAILS. To join the brackets together, I added a top and bottom rail (C), see Fig. 3. The ends of each rail are rabbeted to fit into the uprights. And a shallow rabbet in the inside edge accepts a back that's added later.

CROSSPIECES. After gluing and screwing the rails in place, all that's left to complete the frame is to add the two crosspieces. Besides adding rigidity to the frame, these pieces form an opening for the sliding tray.

The crosspieces are identical in length. But their width is different. To guide the tray as it slides in and out, the front (D) and rear crosspiece (E) are

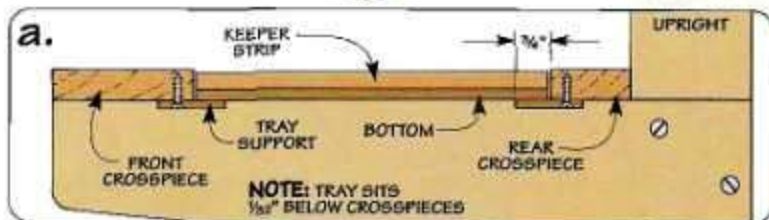
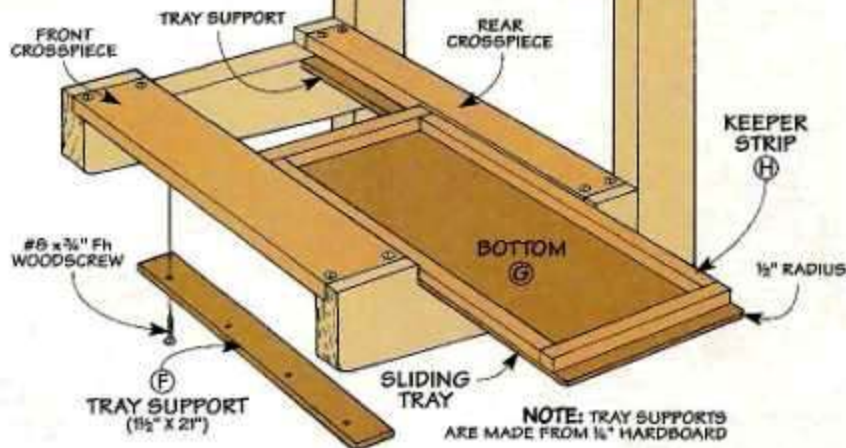

ripped to width to fit flush with the shoulders of the notches in the support arms, see drawing at top of page 18.

SLIDING TRAY

After gluing and screwing the crosspieces in place, the basic frame is complete. Now it's just a matter of adding the sliding tray, see drawing above and Fig. 4.

The tray is designed to be pulled out from either side of the grinding station. This way, it doesn't matter which wheel you're using on the grinder — there's still a convenient place for your tools.

TRAY SUPPORTS. To support the sliding tray, it rests on two tray supports (F) made from narrow strips of 1/4" hardboard, see drawing above. These strips extend past the inside edge of the crosspieces and are simply glued and screwed in place.

SLIDING TRAY. Now you can concentrate on the sliding tray. It's just a piece of 1/4" hardboard with a plywood lip on all four sides to keep tools from falling off.

BOTTOM. The bottom (G) of the tray is cut to fit between the notches on the support arms, see detail 'a' above. To make it easy to pull out the tray, it extends 1" past each support arm.

LIP. After sanding a gentle curve on the corners of the tray bottom, I added four keeper strips (H) to form the lip around the tray. These are narrow strips of 3/4" plywood that are laid on edge and attached to the bottom.

Besides ensuring that tools stay put, the strips also prevent the tray from tipping down when you pull it out. To make this work, the strips sit just below (1/32") the top surface of the crosspieces, see detail 'a' above.



▲ To keep tools from sliding around, I cut a piece of non-slip shelf liner to fit the tray.

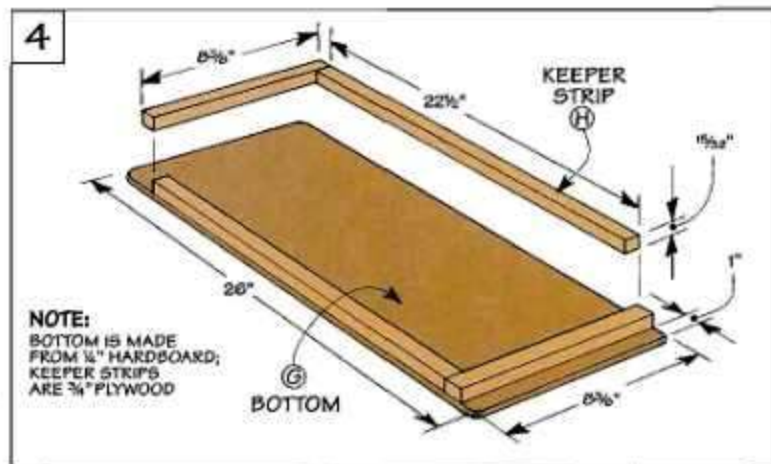

Back, Table, & Shelf

This grinding station won't do anything to reduce the mess that often results from grinding. But it sure makes it easier to clean it up.

That's because the back, table, and shelf are all covered with plastic laminate, see drawing at right. So you can simply wipe them off with a damp cloth.

BACK

Besides enclosing the rear part of the grinding station, the back also adds rigidity to the frame.

The *back* (I) is just a piece of $\frac{1}{4}$ " hardboard with a plastic laminate cover, see Fig. 5. It's sized to slip between the uprights and to rest in the rabbets that were cut earlier in the rails.

To produce a good fit, it's best to start with an oversize piece of hardboard. Then glue on a piece of laminate that's *smaller* than the hardboard but *larger* than the final size of the back. (I used contact cement.) After trimming the back to final size on the table saw, it's just screwed in place.

CLEATS. To provide additional support behind the back, I added two *cleats* (J), see Fig. 6. These

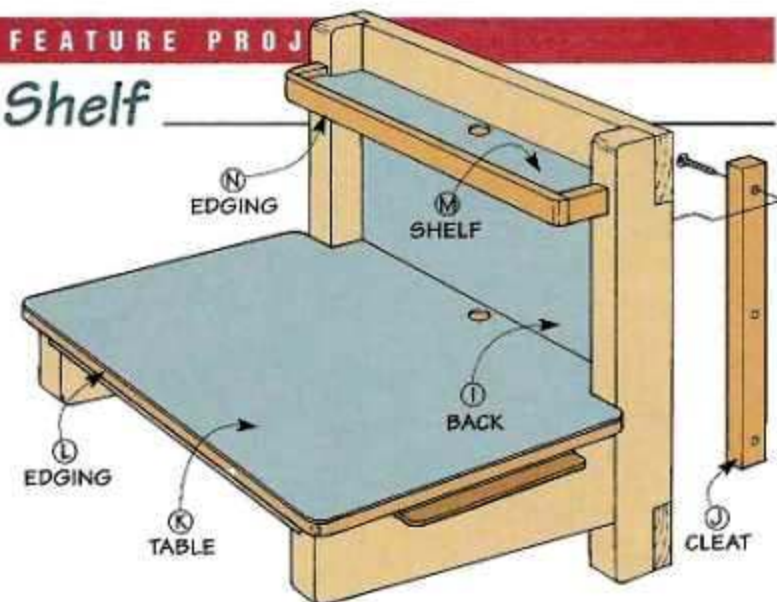

are $\frac{3}{4}$ "-thick strips that are glued and screwed to the uprights.

TABLE

Once the back is complete, you can turn your attention to the table. It provides a solid mounting platform for the grinder.

Like the back, the table is covered with plastic laminate. But I didn't apply the laminate right away. That's because the back corners of the table are notched to fit around the uprights, and I wanted to make sure the table fit just right before adding the laminate.

To accomplish this, the *table* (K) starts out as a piece of $\frac{3}{4}$ " plywood, see Fig. 7. Then to cover the edges of the plywood, I added $\frac{1}{2}$ "-thick strips of *edging* (L) to the front and ends of the table.

NOTCH CORNERS. After gluing on the edging, you can cut the notches in the back corner of the table, see Fig. 7b. The goal here is to size the notches so the table fits tightly against the back and around the uprights.

To do this, I used a sabre saw and then filed the edges smooth. While I was at it, I rounded the

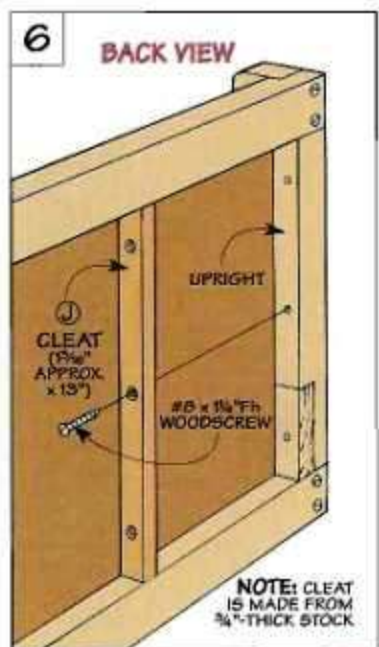
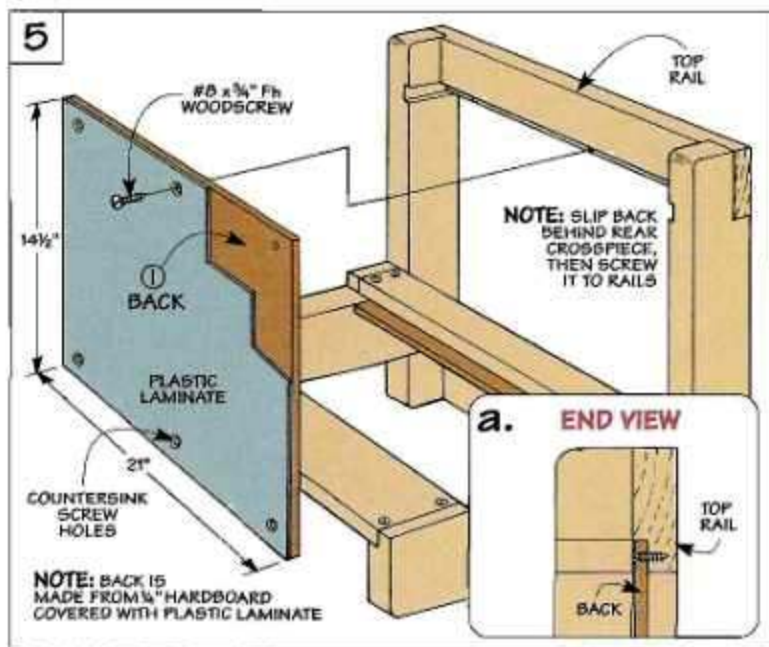

outside corners of the table, see Figs. 7a and 7b.

APPLY LAMINATE. Now it's just a matter of applying the laminate. This time the laminate is oversized and trimmed flush with a hand-held router and flush trim bit. A little work with a file will clean up the material left on the inside corners of the notches.

MOUNTING HOLES. Before attaching the table, it's best to locate the mounting holes for your grinder. To do this, center the grinder on the length of the table. Also, check for clearance in front so tool handles won't hit the table as you're sharpening. Then transfer the location of the holes in the grinder to the table.

The grinder is held in place with bolts that thread into T-nuts installed in the bottom of the table. These T-nuts slip into counterbored shank holes, see Fig. 8a. Note: Size the mounting bolts and T-nuts for your grinder.

HOLE FOR POWER CORD. After installing the T-nuts, I drilled a large hole near the back edge of the table. This hole will allow the power cord for the grinder to feed down through the table.

ATTACH TABLE. Now you can attach the table to the frame. It's held in place by driving screws up through the crosspieces and also through the back, see Fig. 8a.

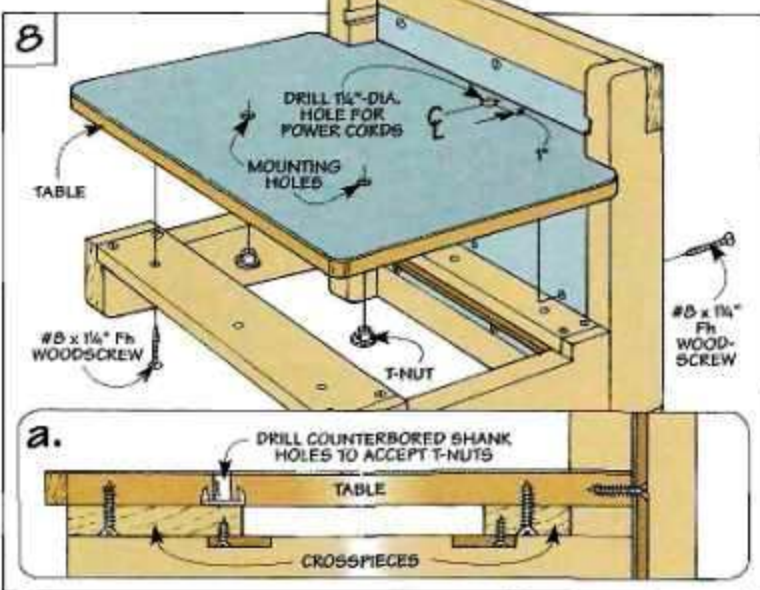
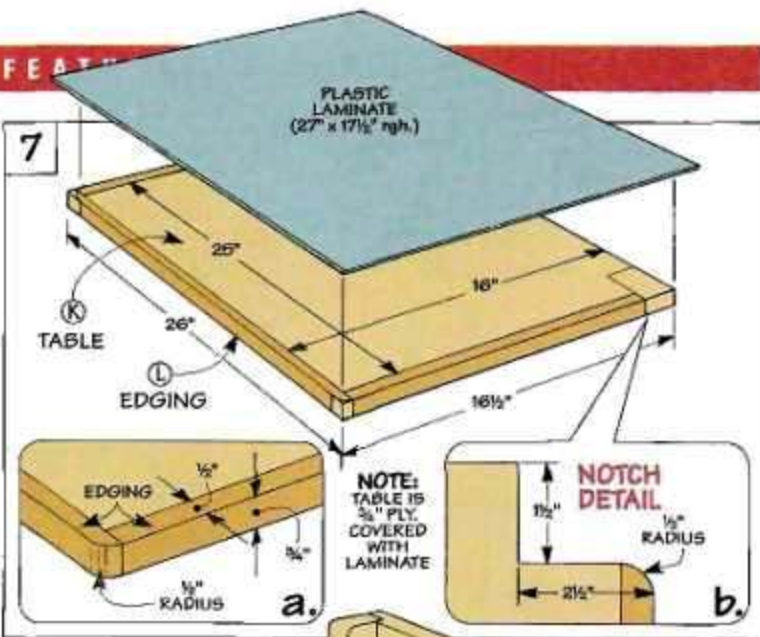

SHELF

All that's left is to add a shelf near the top of the grinding station to hold small items.

The shelf (M) is cut to fit between the dadoes in the uprights. Here again, it's covered with plastic laminate.

ADD EDGING. As with the table,

I applied 1/2"-thick strips of edging (N) to the front edge and ends of the shelf, see Fig. 9. But to form a lip that keeps things from falling off, these strips are wider than the thickness of the shelf.

The edging is cut to fit so when you set the shelf in place, the end pieces fit tightly against the uprights. After gluing on each strip, simply round the outside corners.

Before gluing and screwing the shelf in place, I drilled a large hole near the back edge. As before, this hole accepts a power cord. But this time, it's the cord for a worklight that's attached to the frame, refer to page 17.

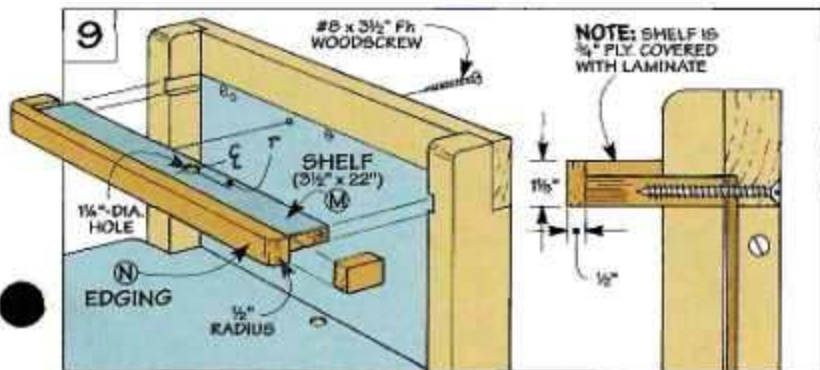

Drawer

One nice thing about this grinding station is that extra grinding wheels and sharpening accessories are always in easy reach. You just slide out the drawer that fits in the opening under the table.

To provide access to items in back, the drawer is mounted on a pair of full-extension drawer slides, see Fig. 10.

Note: It's best to have these slides in hand *before* determining the size of the drawer.

WIDTH. The slides I used required a $\frac{1}{2}$ " clearance on each side. So I built a 20"-wide drawer (1" less than the distance between the support arms).

LENGTH. Another consideration is the length (from front to back) of the drawer opening. The opening is designed to accommodate a 14"-long drawer. (This also provides clearance *behind* the drawer for the power cords on the grinder and worklight.)

LOCKING RABBETS. One final thing that affects the size of the drawer is the type of joinery that holds it together. For this drawer, I used a locking rabbet joint. It's a simple joint, yet it still provides plenty of strength.

At this point, it's just a matter

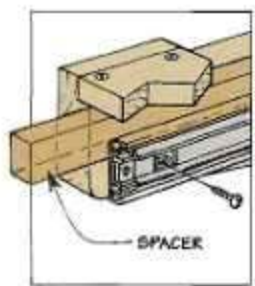
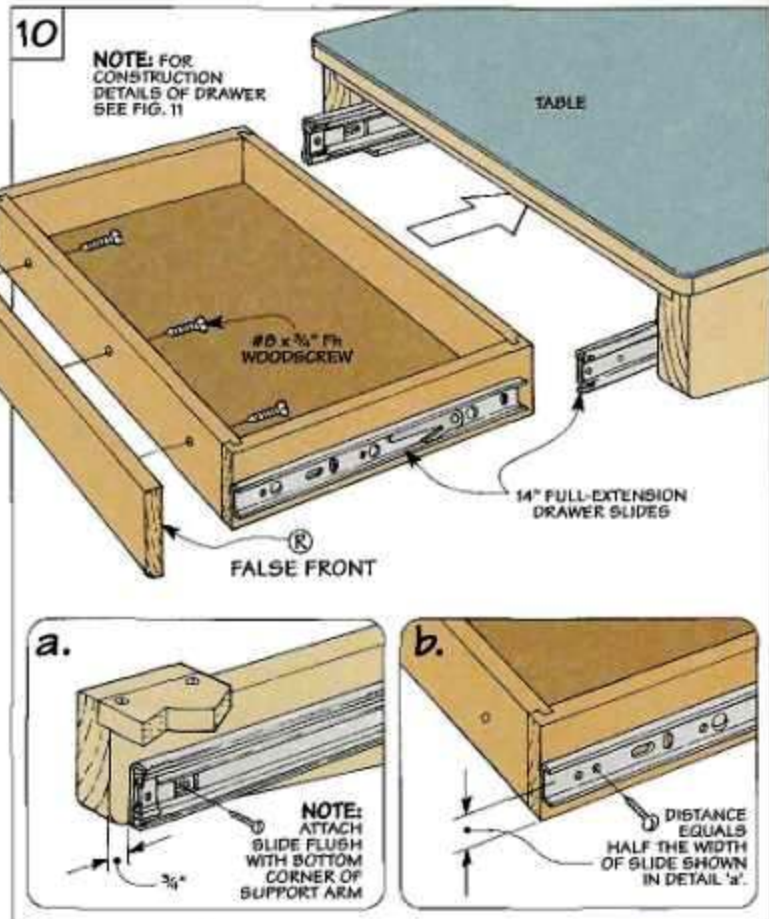

▲ To keep the drawer slide level during installation, slip a scrap under the crosspieces to act as a spacer.

of cutting the *front/back* (O) and *sides* (P) of the drawer to final size, see Fig. 11. (I used $\frac{1}{2}$ "-thick fir for all of these pieces.)

Now, you can concentrate on

the locking rabbet joints. The front/back pieces are rabbeted on each end to form a tongue, see Fig. 11b. This tongue fits in a matching dado that's cut in each side piece.

Before gluing up the drawer, you'll need to cut a groove in each piece for a $\frac{1}{4}$ " hardboard *bottom* (Q), see Figs. 11 and 11a. Also, it's a good idea to drill countersunk holes now for a false front that's added later.

DRAWER SLIDE. Now you're ready to add the full-extension slides. These slides have a release that lets you separate them into two parts.

One part of the slide is screwed to the inside of the support arm, see Fig. 10a and margin. The other part is mounted to the side of the drawer, see Fig. 10b.

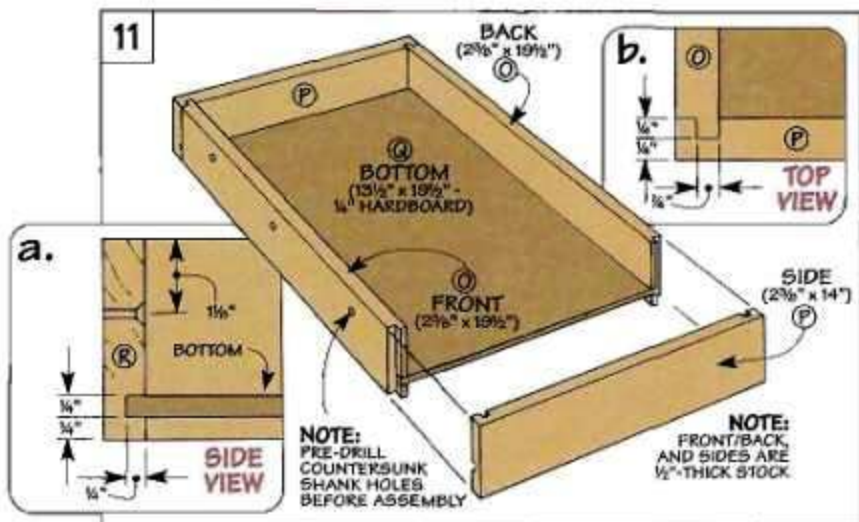

FALSE FRONT: All that's left to complete the drawer is to add a *false front (R)*, see Fig. 12. It's nothing more than a piece of $\frac{3}{4}$ "-thick fir that's attached to the front of the drawer.

The false front is sized to allow $\frac{1}{16}$ " clearance on the top and on each end, see Fig. 12a. I also wanted it to fit flush with the rounded corners on the ends of the support arms.

To match these corners, I routed a roundover on the bottom edge of the false front. Then, after using carpet tape to position it on the front of the drawer, it's just screwed in place.

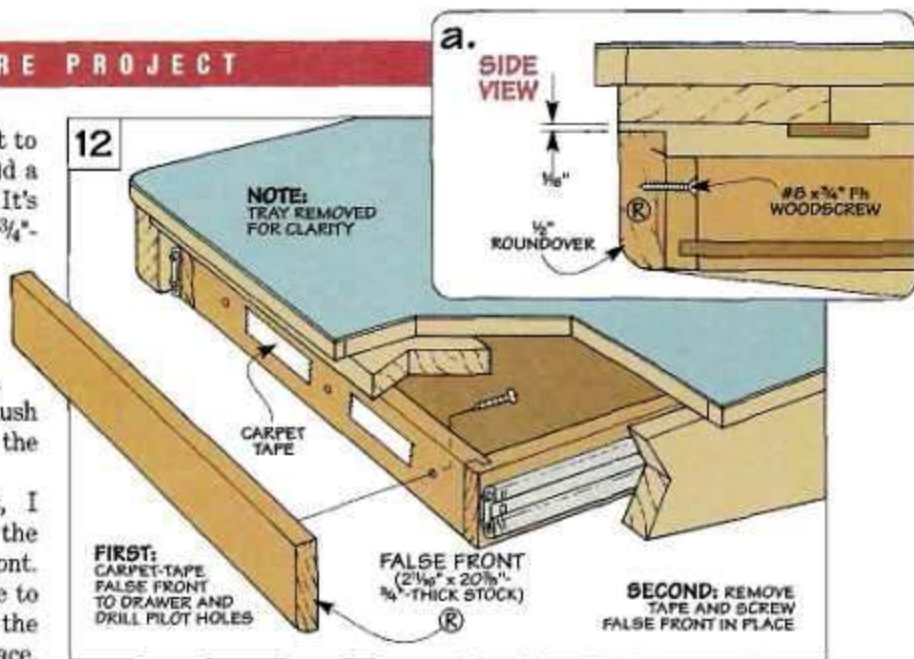

Quenching Cup

When grinding a chisel or plane iron, I usually just stick it in a tin can filled with water to keep the metal from overheating. But sometimes, I accidentally bump the can and spill water all over.

To prevent this, I made a quenching cup that fits into a holder attached to the grinding

station, see the photo at right.

CUP. The cup consists of three parts: a *coupler* and *end cap* made from PVC fittings and a *sleeve* that's cut from a length of PVC pipe, see Fig. 13. Gluing these pieces together forms a watertight seal. (I used PVC cement.)

Note: I also spray painted the

cup to give it the look of metal.

CUP HOLDER. The cup fits in a simple holder that's covered with laminate, see Fig. 13. This requires cutting a large hole to hold the cup. (I planned to use a circle cutter chucked in the drill press.)

But since the cup holder is fairly small (and I get nervous when the wings of a circle cutter are whizzing around), I applied the laminate to an extra-long piece of plywood that's ripped to final width. This way, it can be clamped securely to the drill press table when cutting the hole.

After cutting the *cup holder (S)* to final length, I used a band saw to cut a 2" radius on the end and sanded it smooth.

To allow the cup to nestle down into the holder, the next step is to rout a chamfer around the rim of the hole, see Fig. 13a.

Finally, to mount the holder, I rabbeted the end for a piece of aluminum angle. The angle is simply screwed to the holder and the support arm.



▲ As an option, you may want to add this handy quenching cup to the side of the grinding station.

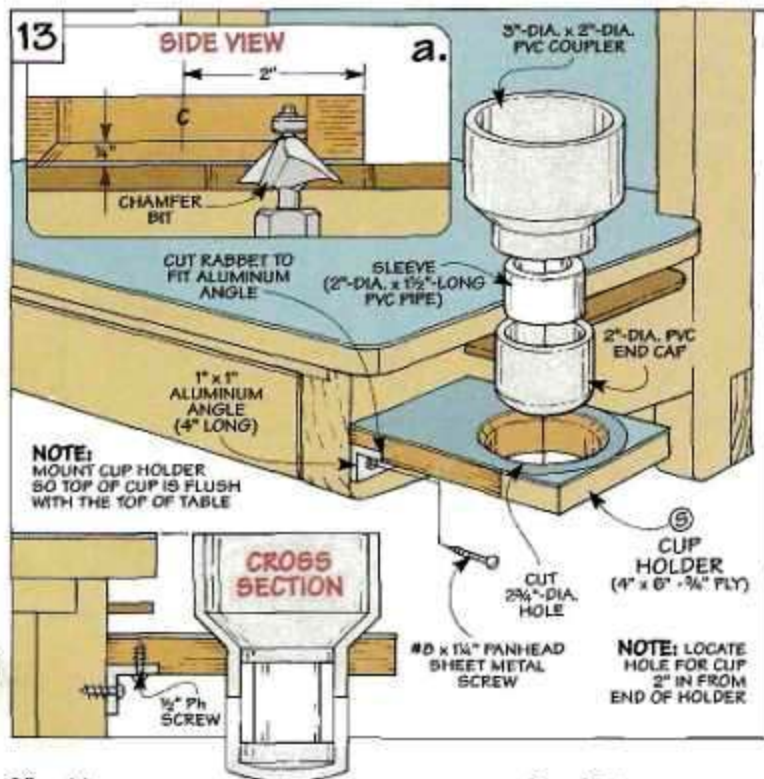



Bridgewood
BW1412B
800-235-2100

Powermatic
1140-A
800-248-0144

Grizzly
G1199
800-541-5537

Jet
JDP-14M
800-274-6848

Benchtop Drill Presses

At a glance, these benchtop drill presses all look remarkably alike. In fact, it almost appears as if each one was popped out of the same mold and painted a different color.

But in spite of the close similarity, there's one big difference between them — the cost. They range in price from \$219 to \$350.

So what accounts for this difference in price? And are the more expensive drill presses really worth the extra cost?

To find out, we bought and tested the four models shown above. *Editor's Note:* For a close look at another (more expensive) drill press that we tested separately, refer to page 27.

SHIPPING. When the drill presses arrived, two of the cardboard boxes were pretty beat up. Fortunately, the only damage was a small dent in the capacitor of the motor on the *Grizzly*.

But one thing that was a bit more irritating is that the cast iron table on the *Bridgewood* had rusted. Nothing that some elbow

grease couldn't fix. Still, it made me think twice before complaining about the thick, gooey coating that protected the tables on the other drill presses.

TABLES. After cleaning things up, I could see that the cast iron tables were all well-machined. It also gave me a chance to check out the two different types of tables we selected for this tool review. One table is designed for drilling metal, while the other is better suited for woodworking.

To catch lubricants when drilling metal, there's a trough running all the way around the metal-working table, see photos at top of page 25. And the slots don't extend all the way through the table.

But these "blind" slots present a problem for a

Selection Criteria

Each of the four drill presses we tested:

- Has a 14" drilling capacity (Swing)
- Ranges in price from \$219 to \$350
- Features cast iron table with rack & pinion adjustment

Drill Presses at a Glance

| Models Tested | Price | Quill Travel | Chuck Size | Quill Runout | Motor Size |
|-------------------|-------|----------------------------------|------------|--------------|------------|
| Bridgewood | \$219 | 3 ³ / ₈ " | 1/2" | .008" | 1/2 hp |
| Grizzly | \$280 | 3 ⁵ / ₁₆ " | 5/8" | .009" | 1/2 hp |
| Jet | \$319 | 3 ⁵ / ₁₆ " | 5/8" | .008" | 1/2 hp |
| Powermatic | \$350 | 3 ¹ / ₄ " | 1/2" | .004" | 3/4 hp |

woodworker. They make it difficult to attach an auxiliary table. So if you're working only with wood, one of the circular tables with slots that extend all the way through is a better solution.

Note: The *Powermatic* is the only drill press that offers both tables. (The cost is identical.)

SWING. After assembling the drill presses, I got a feel for how big (and heavy) they are. Each one has a 14" "swing." This means it's possible to drill to the center of a 14"-wide workpiece. That's a plus if you're building cabinets or furniture. (Some benchtop models only have an 8" swing.)

QUILL TRAVEL. Another thing I check is the maximum distance a quill will move *downward*. The farther it travels, the deeper the hole you can drill without adjusting the height of the table.

On these drill presses, there's only a fraction of an inch difference in the quill travel, see chart on page 24. So none of these drill presses has a real advantage in this area. But it's something to keep in mind if you're considering a different model.

CHUCK SIZE. Another thing to look for is the size of the chuck. As their name implies, the $\frac{1}{2}$ " chucks on the *Bridgewood* and *Powermatic* hold bits with shanks up to $\frac{1}{2}$ " in diameter.



Tables. To catch lubricants when drilling metal, there's a trough running around the table on the *Powermatic* (left). And the T-shaped slots used to attach a vise don't extend all the way through. A table with "open" slots (right) makes it easier to attach an auxiliary table.

That's fine for most jobs. But when working with metal, I occasionally need to use a twist bit that's *larger* than $\frac{1}{2}$ ". That's when the $\frac{5}{8}$ " chuck on the *Jet* and *Grizzly* would come in handy.

RUNOUT. Regardless of the size of chuck, the spindle it's mounted on has to spin "true." Any wobble (runout) is exaggerated at the tip of the bit — and that makes it difficult to drill holes accurately.

So we checked the runout on each drill press, see photo A below and chart on page 24. While the *Powermatic* had the least amount of runout, the other drill presses were quite acceptable.

MORE TESTS. But the numbers don't tell the "hole" story. The only way to get a feel for the overall performance of a drill press is to

drill holes — dozens and dozens of holes, with all types and sizes of drill bits. So that's what we did, see photos B, C, and D.

MOTOR SIZE. The thing I was curious about is how the size of the motor would affect the performance of the drill presses.

As it turned out, I couldn't bog down the $\frac{1}{2}$ hp motors on the *Jet*, *Grizzly*, and *Bridgewood* — even when boring large, deep holes. The $\frac{3}{4}$ hp motor on the *Powermatic* worked great, but it seems like overkill. (Plus, it adds to the cost.)

WORKLIGHT. One more note. When you're working at these drill presses, you won't have to strain your eyes. A bright worklight mounted in the head of each drill press completely eliminates the shadows, see margin.



▲ A 60-watt light in the head of each drill press makes it easy to see when positioning work under the bit.

Testing Procedures



A. Accuracy. To check runout (wobble) on each drill press, we used a dial indicator and a precision steel rod.



B. Performance. By drilling dozens of mortises with each drill press, we got a feel for overall performance.



C. Power. To see if the drill presses would bog down in a heavy cut, we bored a series of large, deep holes.



D. Accessories. Finally, we put each tool through its paces by using a variety of drill press accessories.

Adjusting Spindle Speed

It's one of the cardinal rules of drilling — match the speed of the spindle to the size of drill bit and type of material you're using.

Usually changing the speed of a drill press involves fiddling with belts and pulleys. So I was anxious to see if these drill presses made the job any easier.

BELTS & PULLEYS. When I "popped" the hoods to find out, they looked like what I expected — a system of V-belts and "step" pulleys. What's different is the number of belts and pulleys.

With three pulleys connected by two belts, the *Powermatic*, *Jet*, and *Grizzly* have as many as sixteen different speeds, see upper drawing and Chart below. But the *Bridgewood* only has two pulleys and a single belt, so it's limited to five speeds, see lower drawing.

Since I work with all types of material (from hardwood to metal and plastic), the additional speeds are a real plus for me. It's also important that there's a wide range of speeds.

That's the nice thing about the *Jet*. It runs *faster* at the top end of the range than any of the drill presses, yet it also has the *slowest* spindle speed, see chart.

REPOSITIONING BELTS. But that won't mean a thing if it's difficult to shift the belts from one pulley to another. That's where I noticed a big difference — especially on the drill presses with a center pulley.

On the *Jet* and *Grizzly*, the pulley is mounted on a pivot arm,

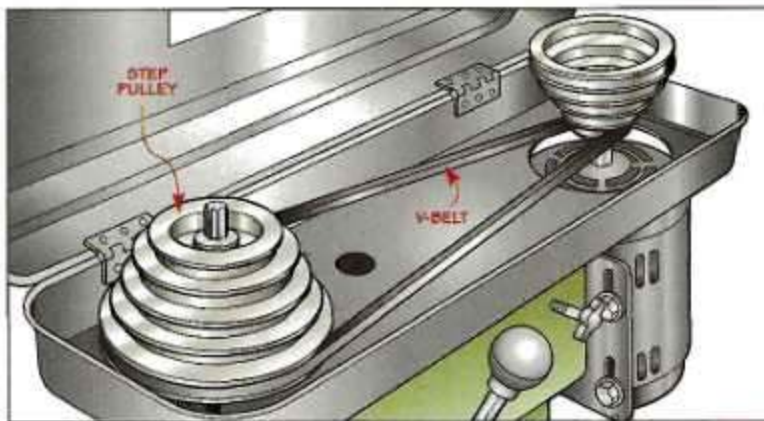
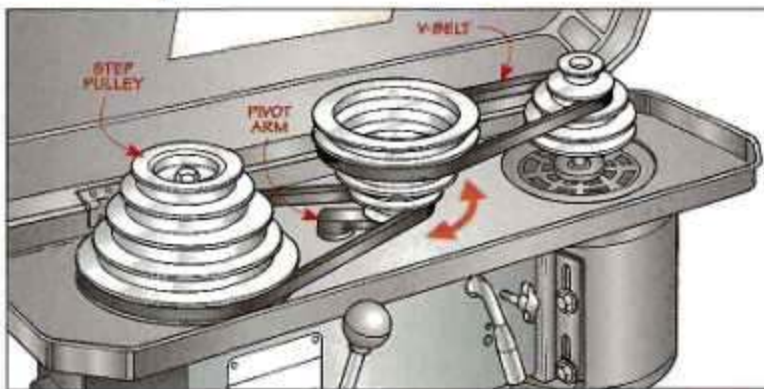

▲ A locking collar on the *Grizzly* and *Bridgewood* lets you quickly "dial in" the depth of hole.



▲ But tightening two nuts on a threaded post creates a more reliable depth stop on the *Jet* and *Powermatic*.

see upper drawing. When I move the motor toward the head to loosen the belt tension, this arm swings freely. So it only takes a minute to swap the belts around.

But it's a different story altogether on the *Powermatic*. The center pulley is mounted to a metal bar that's bolted to the head. So I have to loosen the bolts each time I change speed.

To make matters worse, the motor binds when I loosen the belt tension. As a result, there's

so little slack in the belts that fitting them onto the pulleys is a real finger torture.

CONCLUSIONS

Okay, so which drill press is best? And is spending more money really worth it?

As my first choice, I'd recommend the *Jet*. It runs smooth, and I like its wide range of speeds. Plus, it's easy to change belts.

But I wouldn't overlook the *Grizzly* either. It doesn't have the number (or range) of speeds like the *Jet*, but it's a solid tool. And it costs about \$40 less.

Although the *Bridgewood* is the lowest priced drill press, it's a good, utility tool. But the limited number of speeds puts it out of the running for me.

And the *Powermatic*? I'd kick myself every time I needed to adjust the speed of the spindle. For the price, I expected more.

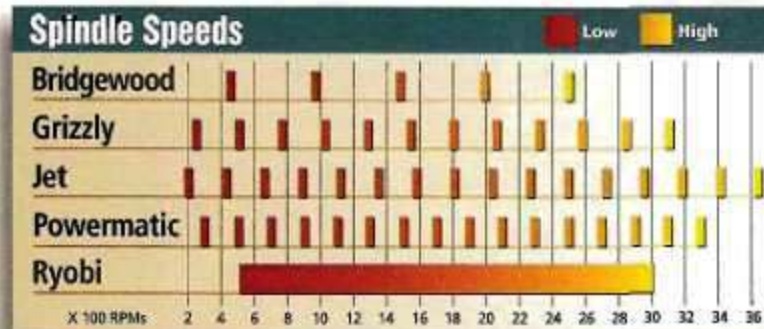

Wood Drilling System

You expect a lot from a drill press that costs \$400. So I was curious whether this *Ryobi Wood Drilling System* was worth the money.

DRILLING CAPACITY. One thing it has going for it right off the bat is a large drilling capacity. With an 18½" swing, it's bound to come in handy on large projects.

SPEED ADJUSTMENT. But what impresses me the most about it is how easy it is to adjust the speed. You simply turn a crank that's located on top of the head.

With this system, there's a *continuous* range of speeds. Even so, I wish it ran faster at the upper end of the range, see chart on page 25. It's a tad slow for small (⅜" and ½") drill bits.

Another detail I'd quibble about is the crank. It's made of plastic, so it seems like it's just a matter of time before it breaks. A beefy metal crank would be more reassuring — like the one on the side of the head assembly.

HEAD. This crank is used to raise and lower the head on the column, see photo A below. So instead of adjusting the height of the *table* (as with most drill

presses), the *head* travels up and down instead. It sounds a bit odd, but it's a convenient way of working at a drill press.

TABLE. The table on the *Ryobi* also sets it apart. It's twice as large as the tables on the other drill presses. So there's plenty of support when drilling a long workpiece. And when drilling an angled hole, you can tilt the table by loosening one knob, see photo B.

Still, I'm not completely satisfied with the table. It consists of a lightweight aluminum frame with a top made of MDF. The problem is there's no center support under the top. So there's a certain amount of "give" when I lower the bit into a workpiece.

FENCE. The *Ryobi* also has an adjustable fence that makes it easy to position a workpiece and provide support when drilling. Also, a flip-up stop is handy for drilling holes in multiple pieces.

HOLD-DOWN. There's even a hold-down for drilling holes in small pieces, see photo C. The only problem is I couldn't get it to work. As I tightened the hold-down, it just crept back up. So it

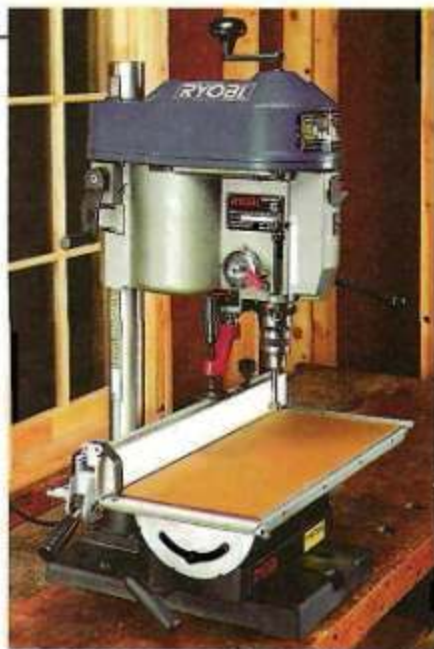

▲ This *Ryobi Wood Drilling System* incorporates several features that are designed with a woodworker in mind.

never applied any real pressure.

CONCLUSIONS. All in all, I'd say *Ryobi* has made some definite innovations. Some worked, and some didn't. Is it worth the money? I don't think so. I'd stick with a traditional (less expensive) drill press. And I'd add a shop-made table and fence. 🛠️



A. **Head.** The unusual thing about this drill press is you crank the head up and down — not the table.



B. **Tilting Table.** A tilting table and fence make it easy to support round stock or drill angled holes.



C. **Hold-Down.** The hold-down is a good idea. But since it won't tighten down, it's nearly useless.



Scratch Awl

I've always enjoyed making my own hand tools. Especially when it's a tool like this scratch awl that only takes an hour or two to complete.

But the most intriguing thing about this scratch awl isn't its simplicity. It's the process of working with both wood *and* metal to create a tool that's practical and nice looking as well.

HANDLE. The wood handle of the scratch awl is turned to shape on a lathe. (I used a chunk of spalted maple I'd been saving for just this type of special project.)

BLADE. But figuring out what to use for the long metal blade of the scratch awl (and how to secure it to the handle) was more of a challenge. The solution came about in an unexpected way.

I was buying a drill bit at the local hardware store when I came across an extra-long (6") twist bit, see margin. It was long enough for a blade. But it seemed like the flutes might present a problem.

That's when it occurred to me. By filling the flutes with epoxy and "twisting" the bit into the handle, the blade would be permanently attached to the handle, see drawings below. Then I could sharpen the blunt end of the bit to a fine point.

FERRULE. Using a drill bit as a blade was one thing. But I also wanted to cover the end of the handle with a metal ferrule. As it turns out, I found the answer in the plumbing department — a brass flare nut, see margin.

The nut would simply thread

onto the handle. And since the brass is quite soft, just a little work with a file would create a smooth transition.

PALM HANDLE

The handle of this scratch awl has a gently rounded knob that fits into the palm of my hand. When I'm starting a screw hole or marking a layout line, the shape of the handle provides a comfortable grip for me, see Pattern below. But you may want to experiment with your own shape.

BLOCK. To make the handle shown below, start with a 2"-square block that's 5" long. Note: It's important that the ends of the block are square.

To accept the blade of the scratch awl, you'll need to drill a hole in one



▲ A 6"-long twist bit and a brass flare nut provide two of the key ingredients for this scratch awl.

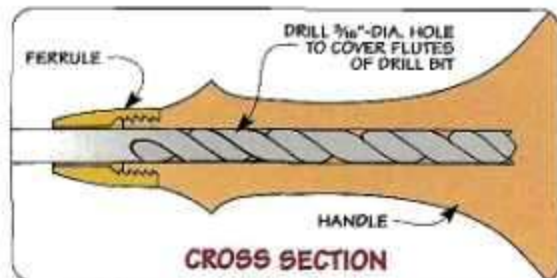

EXPLODED VIEW

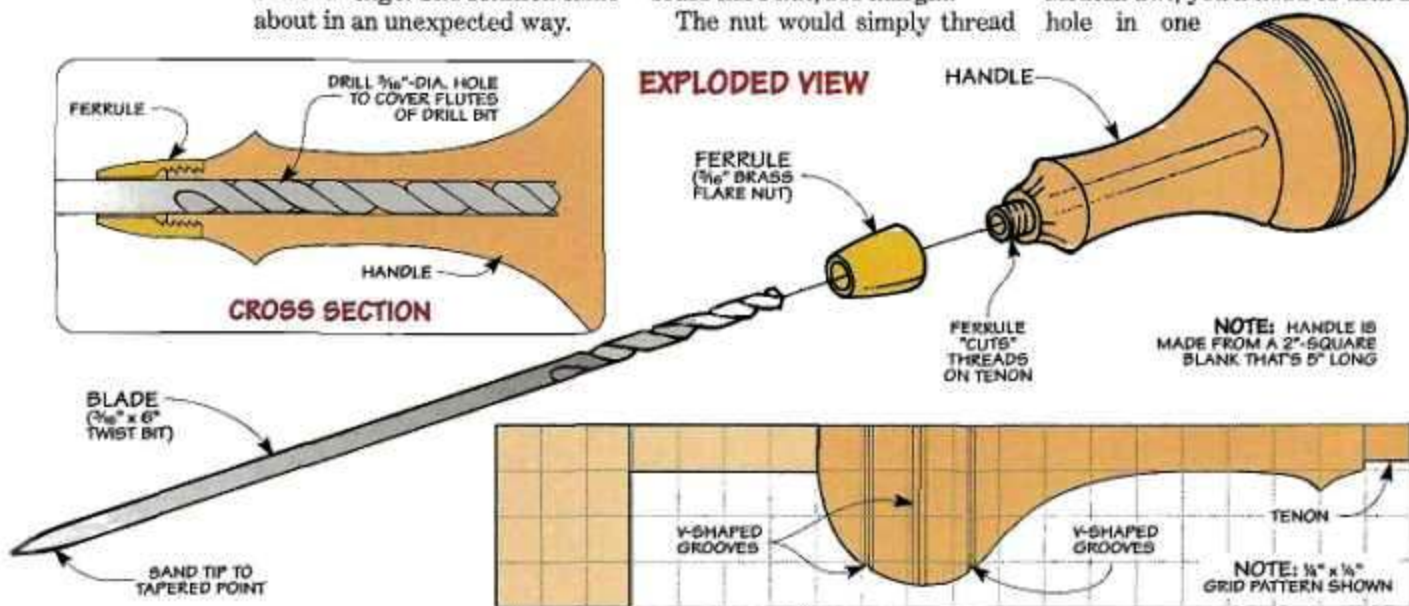

NOTE: HANDLE IS MADE FROM A 2"-SQUARE BLANK THAT'S 5" LONG

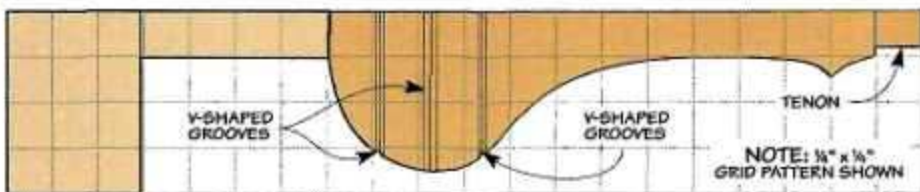

HALF-PATTERN (FULL SCALE)

end of the block. The diameter of this hole is sized to accept the twist bit that will be used as the blade. And it's deep enough to cover the flutes.

It's tempting to drill this hole with the long twist bit. But there's a problem. Any irregularity in the grain can "catch" the tip of a twist bit and cause it to wander.

If that happens, the blade on the scratch awl will be crooked when you put it in the handle. So to drill this hole straight into the blank, I used a brad point bit.

MOUNT BLOCK. Now you can mount the block on the lathe. It's oriented so the centerpoint on the tailstock fits into the hole in the block, see Step 1 below.

CUT TENON. After the initial roughing cuts, I turned a short

tenon on the end of the block that's supported by the tailstock, see Step 2. Later, this tenon will be sized to fit the ferrule. But for now, leave it a bit thick. (I turned a $\frac{3}{8}$ "-dia. tenon that's $\frac{1}{4}$ " long.)

HANDLE LENGTH. To establish the overall length of the handle, the next step is to make a parting cut near the end of the block that's closest to the headstock, see Step 2. It's best to leave about a $\frac{1}{2}$ " of thickness here. This provides plenty of support for the spinning block.

SHAPE HANDLE. Now it's just a matter of turning the handle to shape. The thick knob on the end of the handle is formed by rolling a spindle gouge — first to one side then the other, see Step 3. Note: You'll need to waste out

additional material to provide clearance for the spindle gouge, see pattern on opposite page.

The spindle gouge also makes it easy to shape the neck of the handle. It sweeps down from the knob, flares out to create a stop for your thumb, and then tapers toward the shoulder of the tenon.

FINAL DETAILS. To complete the handle (and add some visual detail), I used a skew chisel to cut a series of V-shaped grooves, see Step 4.

This is also a good time to lightly sand the handle and apply a finish. You don't need to remove the handle from the lathe to do this. But later, after removing the waste at the top of the handle, you'll need to complete the sanding and finishing.

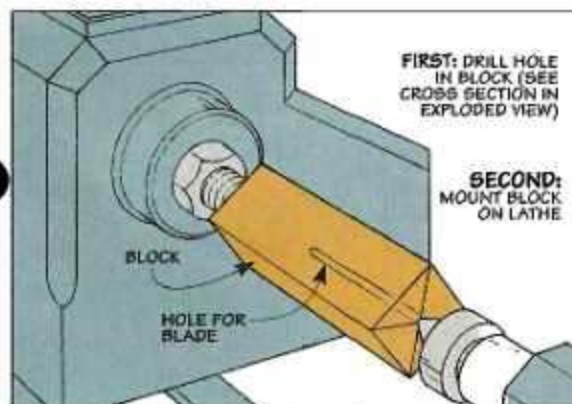

1 Start by drilling a hole in the end of a block to accept the blade. Then mount the block on the lathe so the centerpoint of the tailstock fits in the hole.

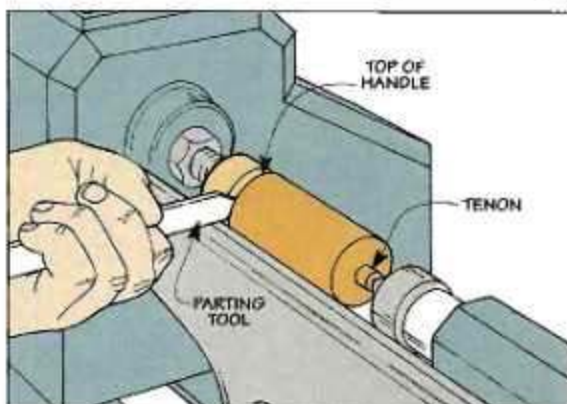

2 After roughing out the block, use a parting tool to turn a tenon on one end. Then cut in at the opposite end to define the top of the handle.

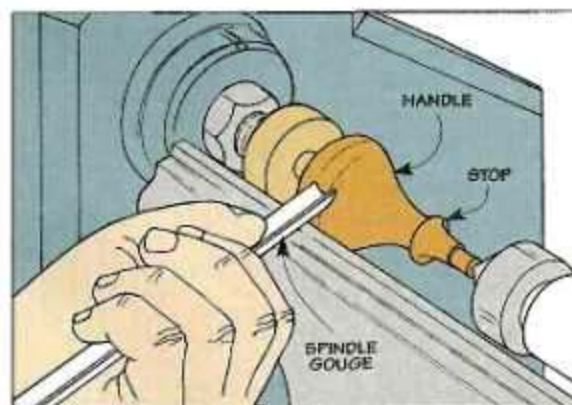

3 Using a spindle gouge, turn the handle to shape. To ensure a comfortable grip, stop the lathe frequently and check the feel of the handle.

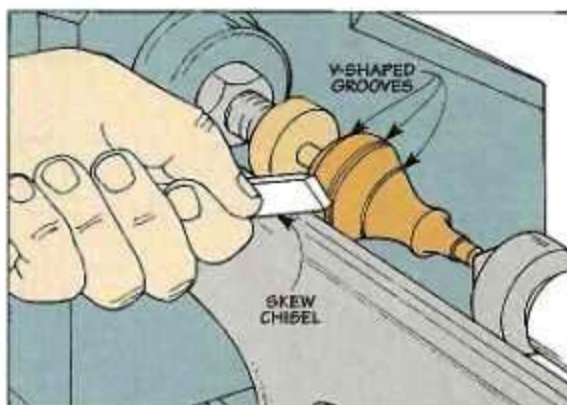

4 It's easy to add some visual detail to the thick part of the handle. Just use a skew chisel to cut a series of V-shaped grooves in the knob.

Adding the Ferrule



▲ After threading the flare nut onto the tenon so it's "finger tight," use a wrench to turn it the rest of the way.

Once the finish is dry, the next step is to add the brass ferrule. It prevents the end of the handle from splitting. Plus, it creates a smooth transition between the handle and the blade.

The ferrule is made by fitting the brass flare nut onto the tenon at the end of the handle. But the tenon is still a bit thick, so you'll have to shave off a small

amount of material, see Step 5.

The goal here is to remove just a whisker, checking the fit frequently. Continue this process until you can tighten the nut about halfway onto the tenon with your fingers. Then complete the job with a wrench, see margin.

FILE CORNERS. Once the flare nut is in place, it's just a matter of removing the "corners." An easy

way to do this is to remount the handle on the lathe and use a small triangular file, see Step 6. Note: Be sure to remove the tool rest.

One thing to be aware of is the "wall" of the nut is quite thin. So file off just enough material to round the corners. Then polish the ferrule smooth with progressively finer grits of sandpaper. (I went up to 600-grit sandpaper.)

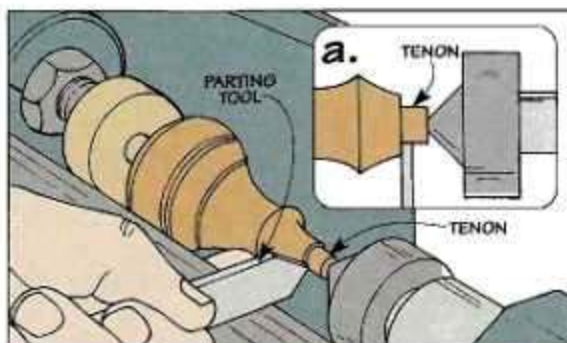

5 To size the tenon for the flare nut, shave off a small amount of material and check the fit. Continue the process until the nut threads halfway onto the tenon.

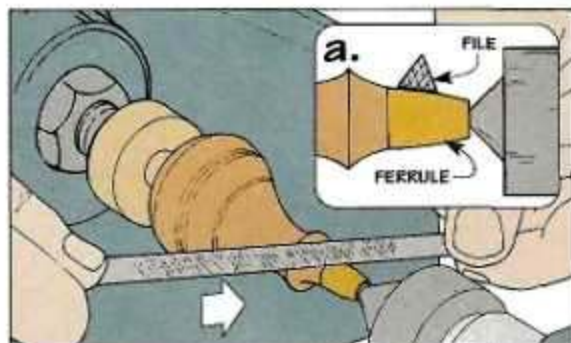

6 Once the flare nut is installed, remove the tool rest and remount the handle. Then turn on the lathe and file the corners using smooth, even strokes.

Installing the Blade



▲ To hold the blade of the scratch awl securely in place, fill the flutes of the twist bit with epoxy.

All that's left to complete the scratch awl is to add the long twist bit that's used as the blade.

REMOVE WASTE. But first, you'll need to take the handle off the lathe and remove the waste at the top end. (I used a handsaw.)

INSTALL BIT. After sanding the rough spot left by the saw teeth (and touching it up with finish), you can install the bit. To permanently secure the bit in the handle, start by coating the flutes with epoxy, see margin. Then simply "twist" the bit into the end of the handle, see detail 'a' in Step 7.

SHARPEN BLADE. When the epoxy cures, the next step is to sharpen the blade. An easy way to do this is to use a belt sander that's clamped in a vise, see Step 7. Note: Since this will create sparks, be sure to remove the dust bag on the sander.

The idea is to hold the blade at a slight angle to the belt while you rotate the handle. What you want to accomplish here is to sand a 1½"-long taper on the end of the bit that narrows down to a

fine point, see detail 'b.'

POLISH BLADE. Finally, I polished the entire length of the blade starting with 150-grit sandpaper and working my way up to 600 grit. ▲

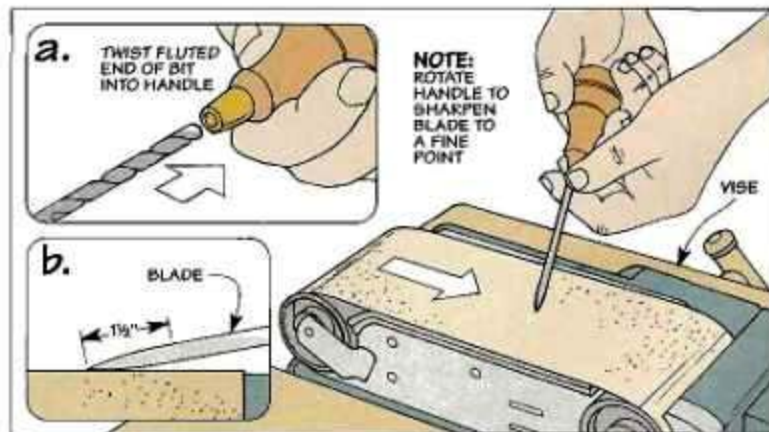

7 After using epoxy to secure the blade in the handle, it's easy to sharpen it to a fine point. Just clamp a belt sander in a vise and sand the end of the blade until it tapers to a sharp point.

New Products

Custom Floor Mat

■ Floor mats do a great job of providing a cushion when you're standing on a hard shop floor. But they're usually only available in a few different sizes.

That's why I like this floor mat, see photo above. It's called *Dri-Dek*. And it's sold in 12" x 12" squares that simply snap together.

This makes it easy to customize the mat to fit whatever size or shape you need.

To avoid tripping on the edge of the mat, you can also get tapered edging strips and corners, see inset photo. Here again, they just snap together.

Another thing I like about this

mat is it has a series of holes that allow dust to fall through. This way, I don't track as much dust into the house.

The only drawback is the mat is a bit expensive. We paid \$48 for a 24" x 36" mat. It includes six squares plus the edging strips and corners, see margin for Sources.



Dust Mask



■ I've never been completely satisfied with the paper masks that are used to filter dust. They don't conform to the shape of my face very well, so I end up breathing in dust. And the air I breathe out fogs up my safety glasses.

But this new dust mask (the *Dustfoe*) has a soft rubber seal

that fits tightly against my face. So no air leaks in or out.

In addition to the seal, this dust mask has a special filter that will capture even the finest wood dust. To install the filter, you simply fold it over a wedge-shaped insert, see inset photo. Then clip the insert into the mask.

Note: The *Dustfoe* costs about \$25 and comes with five extra filters, see margin for Sources.

Sources

Woodcraft
800-225-1153
Dustfoe

Rockler
800-279-4441
Jig-It
35 mm Drill Bit

Dri-Dek Corporation
800-348-2396
Dri-Dek

Hinge Drilling Jig

■ Most European-style hinges have a metal "cup" that fits into a hole in the cabinet door. To accept the cup, you need to drill either a 35mm or 40mm hole.

Usually, this requires a drill press to ensure accurate results. But this new drilling jig (*Jig-It*) accomplishes the same thing with a hand-held drill.

Basically, the jig consists of two parts: an alignment plate that clamps to the door and a ring-shaped collar that guides the drill bit, see photo. Note: The drill bit is *not* included.

When drilling a hole, the alignment plate establishes the location of the hole at the correct distance from the edge of the door. And the collar fits over a circular lip on the alignment plate.

These two interlocking parts ensure that the hole is centered inside the circular opening in the alignment plate. Also, the collar keeps the drill bit perpendicular to the workpiece.

The jig costs about \$30, see margin. It includes a spring and stop collar that lets you preset the depth of the hole.



Scenes from the Shop

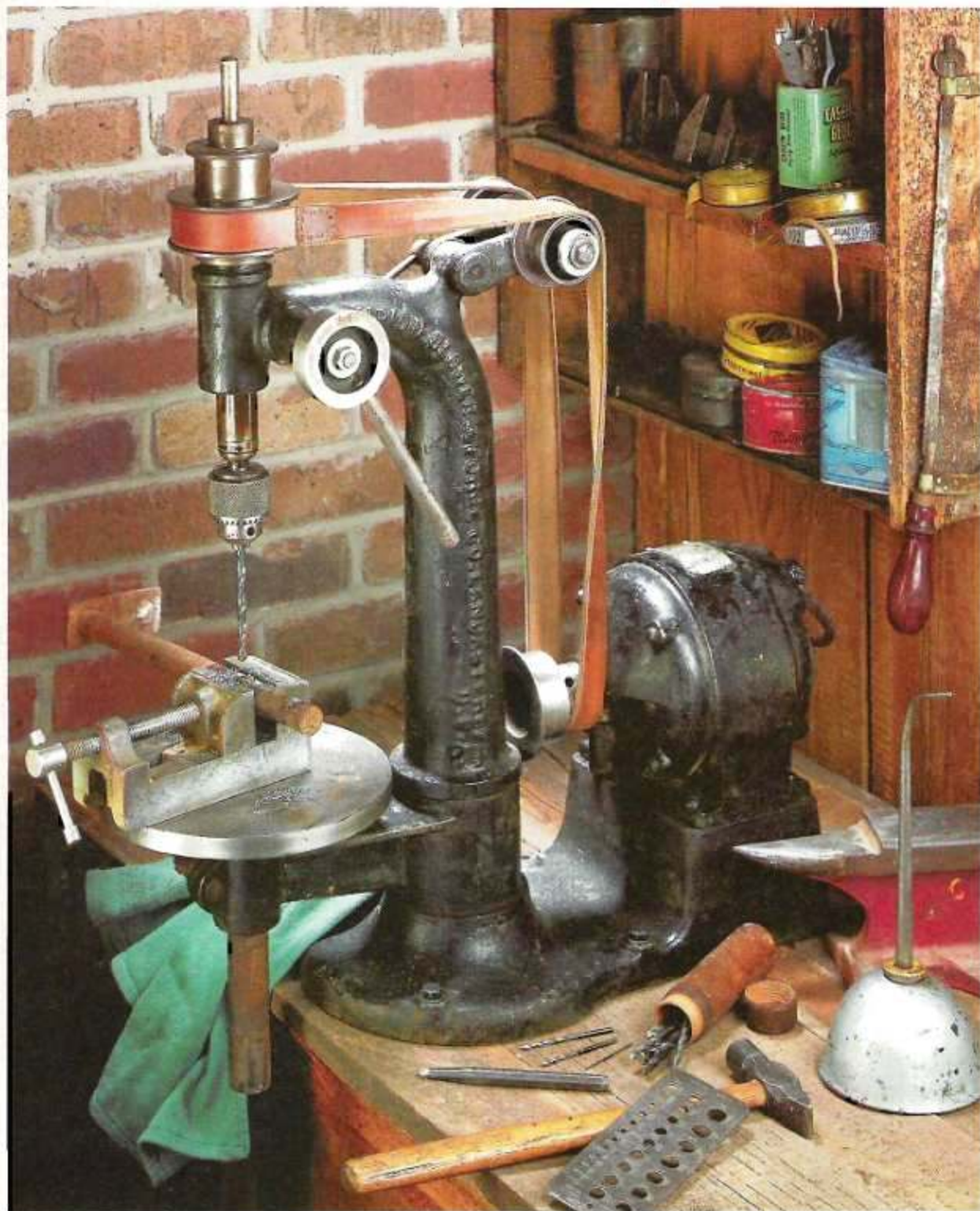

Built in the early 1900's by the Champion Blower and Forge Company, this cast iron drill press is a forerunner of today's benchtop models. It features a flat, leather

belt that transfers power from the motor to the spindle. Just like today's drill presses, the position of the belt on the pulleys determines the drilling speed.