

TIPS • TOOLS • TECHNIQUES

ShopNotes®

Vol. 8

Issue 43

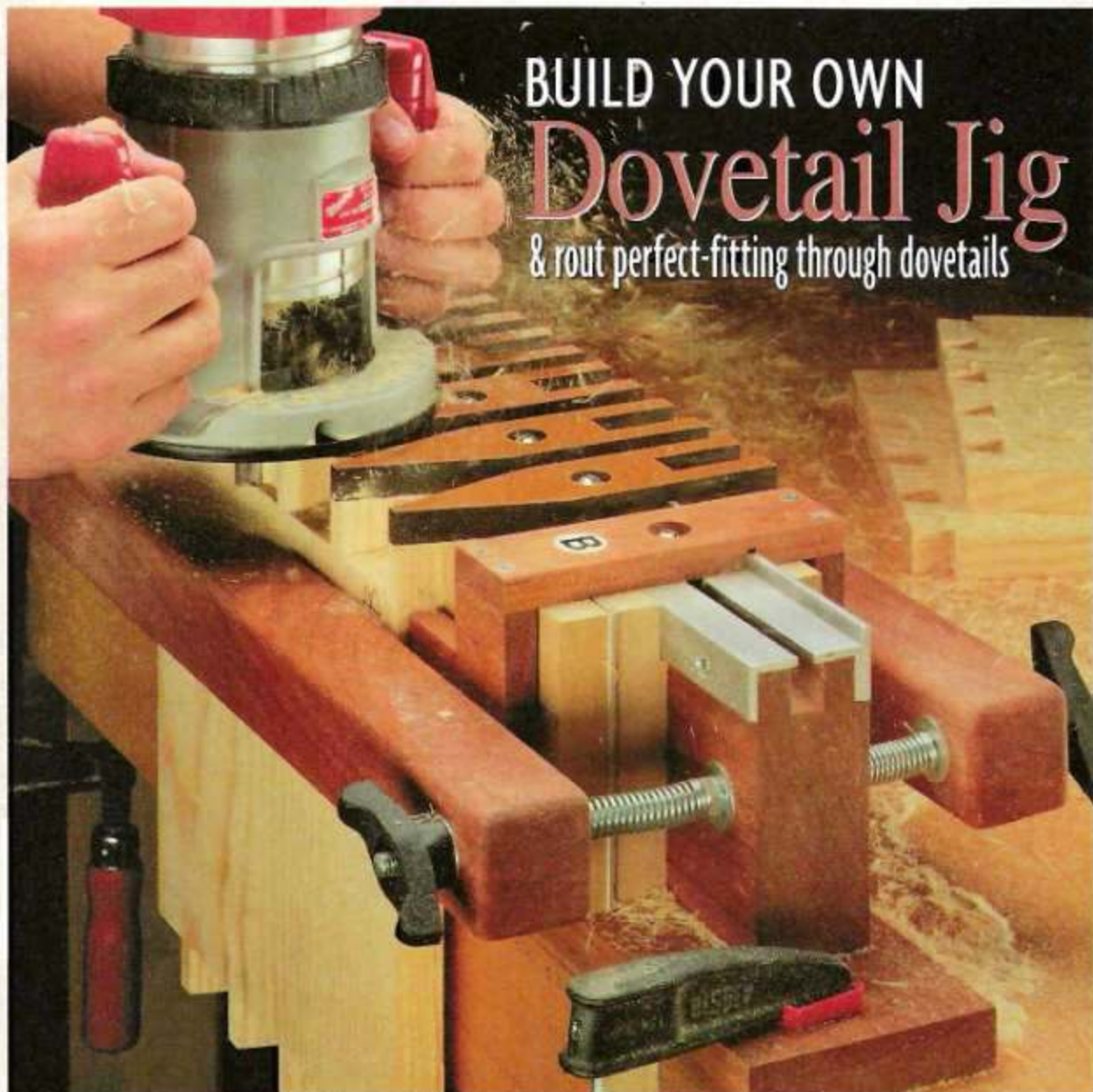

BUILD YOUR OWN
Dovetail Jig
& rout perfect-fitting through dovetails

- Working with Plastics
- Dovetailed Toolbox
- Steady Rest
- Buying Pine
- Shop-Tested Tips



ShopNotes

Issue 43

January 1999

PUBLISHER Donald B. Peschke
EDITOR Tim Robertson
ASSOCIATE EDITOR Tom Bognal
ASSISTANT EDITOR Bryan Nelson
ART DIRECTOR Cary Christensen
SR. GRAPHIC DESIGNER Kurt Schultz
SENIOR ILLUSTRATORS Roger Relland
 Mark Higdon

CREATIVE RESOURCES

Creative Director: Ted Kralliek • *Project Developer:* Ken Munkel • *Senior Project Designer:* Kevin Boyle • *Project Coordinator:* Kent Welsh • *Shop Manager:* Steve Curtis • *Shop Craftswoman:* Steve Johnson • *Senior Photographer:* Crayola England

BOOKS

Executive Editor: Douglas L. Hilde • *Art Director:* Steve Laeder • *Sr. Graphic Designer:* Chris Glowacki

CIRCULATION

Sub. Serv. Dir.: Sandy Baum • *New Bus. Dir.:* Glenn Battles • *Revenue Mgr.:* Paige Rogers • *Billing Mgr.:* Rebecca Cunningham • *Prom. Mgr.:* Rick Jenkins • *New Bus. Mgr.:* Todd L. Bierke • *Asst. Sub. Mgr.:* Jay Krause • *Assoc. Graphic Design Dir.:* Shale Etker • *Sr. Graphic Designer:* Cheryl L. Simpson

CORPORATE SERVICES

V.P. of Planning & Finance: Jon MacCarthy • *Controller:* Robin Hutchinson • *Sr. Acct.:* Laura Thomas • *Accts. Payable:* Mary Schultz • *Accts. Rec.:* Margo Petrus • *Prod. Dir.:* George Chambliss • *Elect. Pub.:* Douglas M. Lohster • *Prod. Asst.:* Susan Roewe • *Pre-Press Image Spec.:* Trey Clark, Minnie Biegler • *New Media Mgr.:* Gordon C. Gaippe • *Multimedia Art Dir.:* Eugene Pedersen • *H. R. Asst.:* Kirsten Koolo • *Admin. Asst.:* Julia Fain • *Receipts:* Jeanne Johnson, Sheryl Ribbey • *Bldg. Maint.:* Ken Griffith • *Special Proj. Dir.:* Saville H. Inman

MAIL ORDER

Operations Dir.: Bob Baker • *Mat'l Mgr.:* Mark Martini • *Cost. Service Mgr.:* Jessie Eason • *Warehouse Supr.:* Nancy Johnson • *Buyer:* Linda Jones • *Op. Asst.:* Tammy Akhni • *Tech. Rep.:* Matthew Telford • *Cost. Serv. Rep.:* Anna Cox, Tammy Truckenbrod, Adam Best, Nancy Downey, Deborah Rich • *Warehouse:* Sylvia Carey • *Quality Control Technician:* Frank Johnson

ShopNotes® (ISSN 1062-0696) is published bimonthly (Jan., March, May, July, Sept., Nov.) by August Home Publishing, 2900 Grand, Des Moines, IA 50312.

ShopNotes® is a registered trademark of August Home Publishing. ©Copyright 1998 by August Home Publishing. All rights reserved.

Subscriptions: Single copy: \$4.99. One year subscription (6 issues): \$21.94. Canada/Foreign add \$6 per year.

Periodicals Postage Paid at Des Moines, IA and at additional mailing offices.

Postmaster: Send change of address to ShopNotes, P.O. Box 97103, Boone, IA 50007-2103.

Subscription Questions? Write to: ShopNotes Customer Service, P.O. Box 842, Des Moines, IA 50304-3961. Or call 1-800-333-8884, 8:00 am to 5:00 pm, Central Time, weekdays. FAX 515-283-0447

E-Mail: ShopNotes@shopnotes.com

Internet: http://www.shopnotes.com

PRINTED IN U.S.A.

WoodNet

NOW ON THE WEB!

- 101 Woodworking Tips Online
- Woodworking Techniques — Step-by-Step
- Project plans you can download
- WoodNet Forum — Woodworkers' Q & A
- Power Tool Reviews

Print your browser to: <http://www.augusthome.com>. Select "Woodworking" from the Welcome Page menu.

EDITOR'S NOTE

Cutoffs

What's the best way to cut a dovetail joint? By hand? Or using a router and a dovetail jig? The answer is simple — it all depends.

HAND-CUT DOVETAILES. Cutting dovetails by hand certainly isn't the quickest way to do it. Nevertheless, there is something satisfying about being alone in the shop, working quietly with a hand saw and chisel, and getting the dovetails to fit together just right.

But I have to admit it. When there are a lot of dovetails to cut, I'm usually only interested in one thing — getting the job done as quickly as possible.

DOVETAIL JIGS. That's when a dovetail jig and a router come in handy. A couple of the niftiest dovetail jigs I've seen (shown below) are designed to cut through dovetail joints. (These are the traditional dovetails that you often see on a project like a blanket chest or a dovetailed box.)

Although these jigs do a great job, they can cost anywhere from

\$250 to \$350.

SHOP-MADE VERSION. That got me to thinking about building a shop-made version of a dovetail jig — one that wouldn't require a big investment in time and money. It had to be easy to build. And the dovetails would have to be accurate.

All in all, it sounded like an interesting challenge. How do you go about making a precision jig using ordinary tools and materials? The key is a special table saw technique that lets you accurately make a set of wedge-shaped fingers (page 16).

Editor's Note: Individual fingers of this type are the subject of two United States patents. The first patent (No. 4,428,408) is owned by Kenneth M. Grisley, President of Leigh Industries Ltd. The second patent (No. 5,832,977) is owned by R. Terry Hampton, President of Hampton House, Inc.

Tim



Leigh Dovetail Jig. It's hard to beat the versatility of this jig. The unique design of the fingers lets you rout through-dovetails, half-blind dovetails, and even sliding dovetail joints.

For more information or to place an order, contact Kenneth Grisley at 800-663-8932 or send a FAX to 604-464-7404.

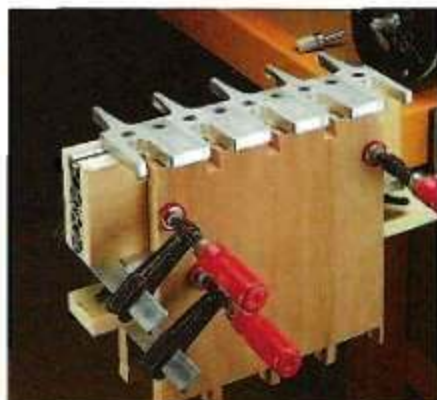

Katie Dovetail Jig. This Katie Jig lets you rout accurate, through-dovetail joints without the usual trial and error process.

For more information or to place an order, contact R. Terry Hampton at 317-881-8601 or send a FAX to 312-453-0667. You can email him at: info@katiejig.com or visit his web site at www.katiejig.com.

Contents

Features

Dovetailed Toolbox _____ 6

With its solid wood construction and strong dovetail joints, this sturdy pine toolbox is built to last. It also features two removable bins for organizing small tools.



Toolbox

page 6

Dovetail Jig _____ 16

This shop-made dovetail jig provides an easy way to rout perfect-fitting dovetail joints. The secret is a set of finger-shaped templates that establish the basic size and shape of the dovetails.



Working with Plastics page 14

Steady Rest _____ 26

If you're turning a long, thin spindle on the lathe, this steady rest provides all the support that's needed to keep it from flexing. A simple wood wedge ensures continuous contact as the spindle gets smaller in diameter.



Dovetail Jig

page 16

In the Shop

Plastics in the Woodshop _____ 12

Four different types of plastic that are sure to improve the performance of your woodworking jigs and fixtures.

Working with Plastics _____ 14

Here are some handy tips that will help you get good results when working with plastics.

Buying Pine _____ 30

Building a project out of pine? You can save money by knowing the different grades. Also, avoid problems by working around defects in the lumber.



Steady Rest

page 26

Departments

Readers' Tips _____ 4

Our readers offer their own shop-tested tips to some of their most common woodworking problems.

Readers' Tips

Dust Pick-Up

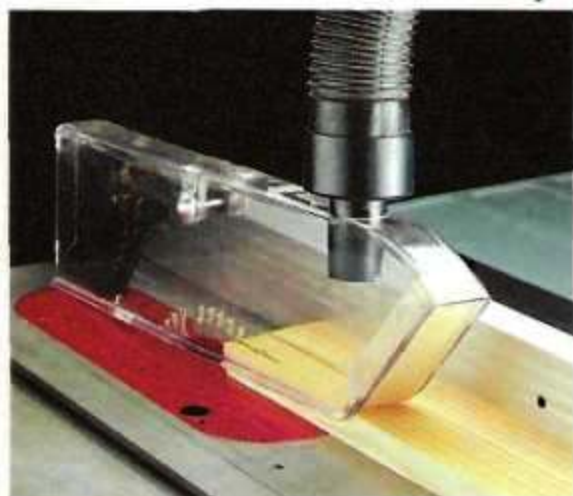

■ Even when I hook a dust collector up to my table saw, it still doesn't collect *all* the dust. There's always a certain amount that flies off the top of the spinning blade — filling the air with a cloud of fine dust particles.

To collect this dust, I connect the hose on my shop vacuum to the blade guard on the table saw, see photo above. This requires a simple adapter. (I used a Sears adapter, part number 16999.)

The small end of the adapter

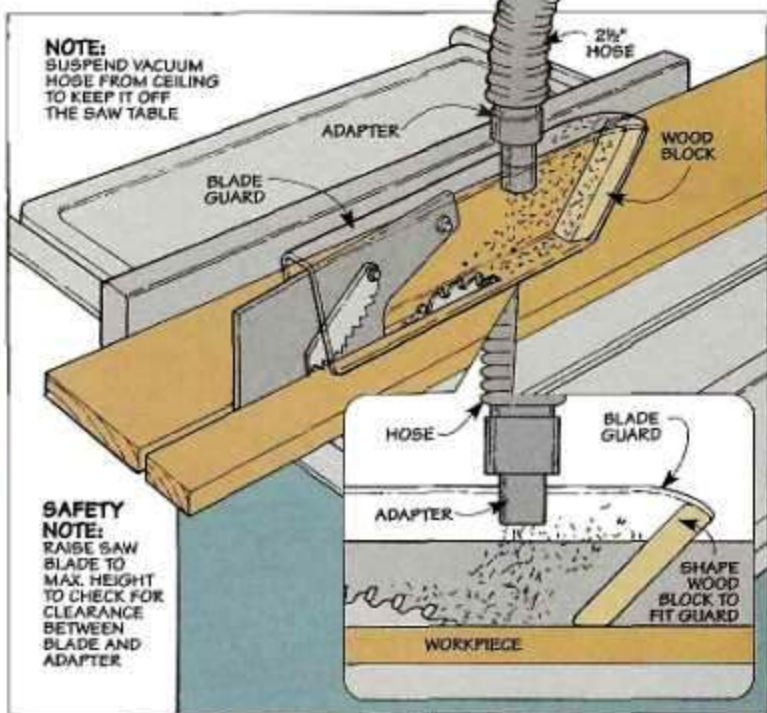

NOTE:
SUSPEND VACUUM
HOSE FROM CEILING
TO KEEP IT OFF
THE SAW TABLE

**SAFETY
NOTE:**
RAISE SAW
BLADE TO
MAX. HEIGHT
TO CHECK FOR
CLEARANCE
BETWEEN
BLADE AND
ADAPTER

has a taper, so it fits tightly into a hole drilled in the top of the blade guard. (I used a spade bit and a hand-held drill.) The hole is located near the front of the guard, well away from the sawblade, see drawing. Then the

wood block is attached to the guard with epoxy. Note: To keep the hose out of the way during cuts, I ran it straight up and tied it to a ceiling hook.

*Alan Schwartz
Pembroke Pines, Florida*

Vacuum Seal

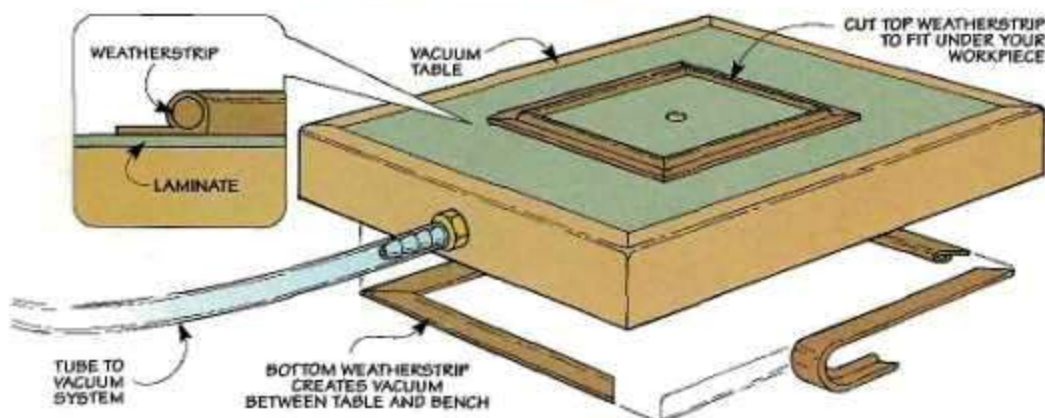

■ When building the vacuum table featured in *ShopNotes* No. 40, I experimented with a different material to form the vacuum seal.

Instead of foam backer rod, I used self-adhesive weatherstrip, see drawing. To prevent outside air from leaking into the vacuum area, simply miter the strips to length and press them in place.

*Bill Waters
Westlake Village, California*

Quick Tips



▲ To make a handy sanding block, R. Marques of Sao Paulo, Brazil cuts up the foam used to protect packages from damage.

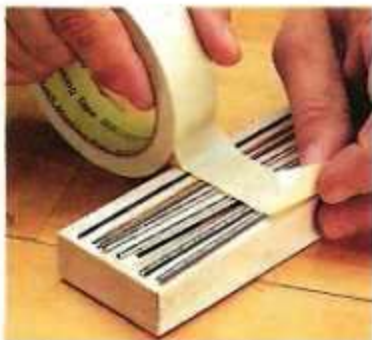

▲ When storing thin, fragile strips of banding, Kevin Boyle of Des Moines, IA tapes them to a board to keep them from breaking.



▲ By filling a cutter with silicone, W. Dudek of New Madison, OH can snip the head off a brad without having it fly across the shop.

Tool Tray

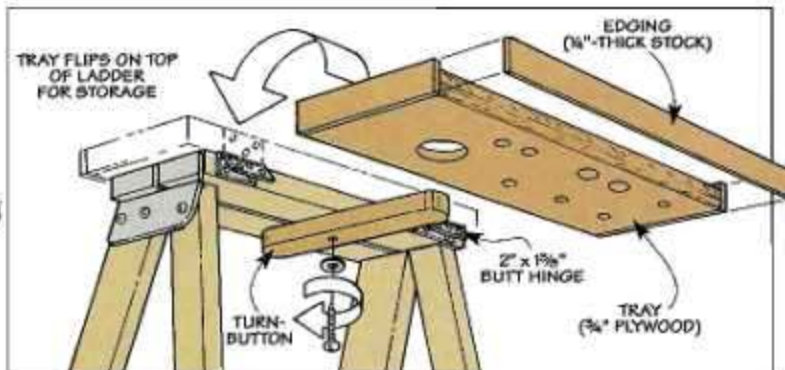

■ Sometimes I spend more time climbing up and down a ladder getting tools than I do working on the job itself. So to keep the tools within easy reach, I attached a plywood tray to the top of the ladder, see photo.

Several holes are drilled in the tray to accept the tools I use a lot. And to keep loose tools from rolling off the tray, I created a lip by adding wide edging to three of the edges.

A pair of hinges secures the

tray to the ladder. The wood turnbutton pivots out to support the tray when it's in the open position. And when storing the ladder, I just flip the tray on top.

John A. Kinney
Austin, Texas

Plastic Knobs



■ Here's an inexpensive way to make a plastic, T-shaped knob. All you need are a few parts from the hardware store: a 1/2 inch tee fitting, a 3/8 inch hex nut and two short pieces of 5/8 inch-dia. dowel. Just epoxy the nut and dowels into the tee fitting, then dip the knob in liquid plastic.

John Train
South River, Ontario

Send in Your Tips

To share your original tips and solutions to problems you've faced, send them to: *ShopNotes*, Attn.: Readers' Tips, 2200 Grand Ave., Des Moines, IA 50312. (Or if it's easier, FAX them to us at: 515-282-6741.)

We'll pay up to \$200 depending on the published length. Please include a daytime phone number so we can call you if we have any questions.

There's no getting around it — toolboxes take a beating. And when they get knocked around, there's always a chance your tools will get damaged too.

This sturdy, pine toolbox combines the strength of dovetail joints with solid wood construction.

But you don't have to worry about that with this toolbox. It's made entirely of solid wood. (I used pine to keep the weight down.) And the corners are held together with dovetail joints to create a strong, sturdy toolbox.

Okay, but it's still only a toolbox. So why go to the trouble of cutting dovetails? Actually, it's not much trouble at all. That's because I *routed* the dovetails using the jig that's featured on page 16.

Now this doesn't mean you have to build the dovetail jig to make the toolbox. It's also a perfect project to practice cutting dovetails by hand.

NESTING BINS. But there's more to this toolbox than just solid construction. To help organize small tools, there's a pair of shallow bins that "nest" in the top of the toolbox, see photo 'A' below.

The nice thing about these bins is you don't have to rummage around for small items that work their way to the bottom. And when you need to get a



tool that's stored underneath, a large notch makes it easy to lift the bins out of the toolbox, see photo 'B.'

CASE

I began work by building the case, see drawing below. In addition to supporting the bins, the case serves as a "well" for tools and supplies.

The case starts out as a pair of long *sides* (A) and two short *ends* (B), see drawing. These pieces are held together with dovetails. So the pins (on the



A. Nesting Bins. To provide easy access to small tools or pieces of hardware, a pair of long, narrow bins "nest" in the top of the toolbox.



B. Notch. A large notch lets you lift out the bins to remove the tools stored below. For small jobs that only require a few items, just take the bin with you.

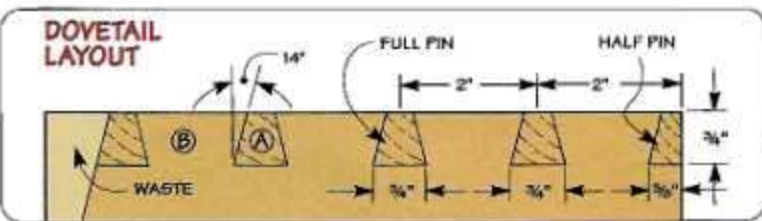
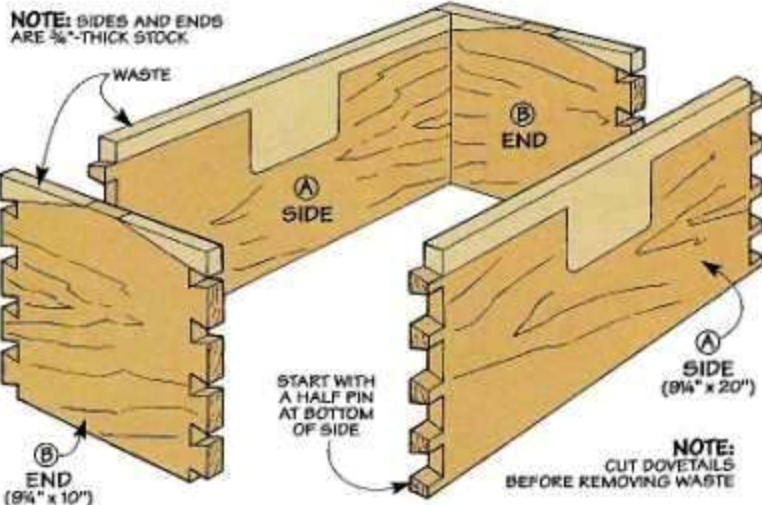

sides) and tails (on the ends) extend all the way through the adjacent piece. This means you can cut all the pieces to final length. But it's best to start with extra-wide pieces.

BEVEL SIDES. After cutting the dovetails, the waste on the sides is removed by beveling the top edge. To do this, tilt the saw blade to 14° (to match the angle of the pins), see Fig. 1a. Then set the rip fence to leave a full-width pin and rip the sides to width.

TAPER ENDS. The ends of the case taper from a 1½"-wide "flat" at the center down to the beveled edge on the sides, see Fig 1b. To lay out this angle, it's easiest to dry assemble the case. Then, after disassembling the pieces, cut the angle with a band saw.

NOTCHES. While you're at it, you can cut the notch as well. The bottom corners of the notch are formed by drilling two large holes, see Fig. 2. After using a band saw (or sabre saw) to cut the notch, rout a roundover on the outside edges only, see Fig. 2a.

BOTTOM. At this point, you can turn your attention to the bottom (C) of the case, see Fig. 3. It's a solid wood panel that's made by edge-gluing pieces of ½"-thick stock. You'll want to make the panel longer and wider than needed, then trim it to final size later.

The panel fits in grooves cut in the sides only. These grooves are located between the two lower pins, see Fig. 3a. This way, the ends of the grooves won't be visible when the case is assembled.

At this point, you can trim the bottom to final size. Just be sure to allow a little extra room for expansion and contraction.

BIN SUPPORTS. All that's left to complete the toolbox is to add two bin supports (D). These are thin strips of wood that are glued into grooves cut in the ends, see Fig. 3b. Here again, to cover the ends of the grooves, locate them between the top two tails.

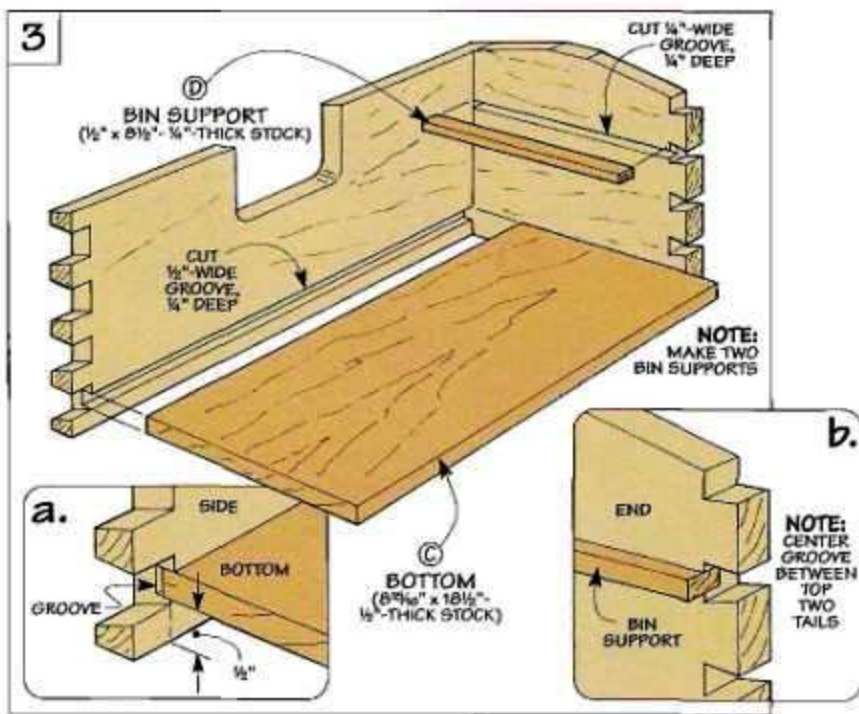
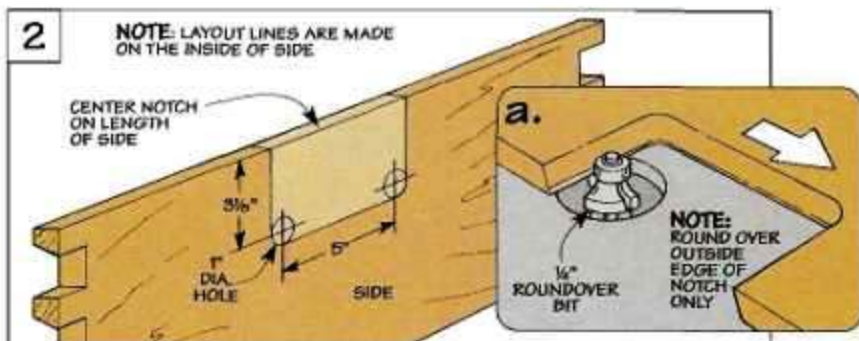
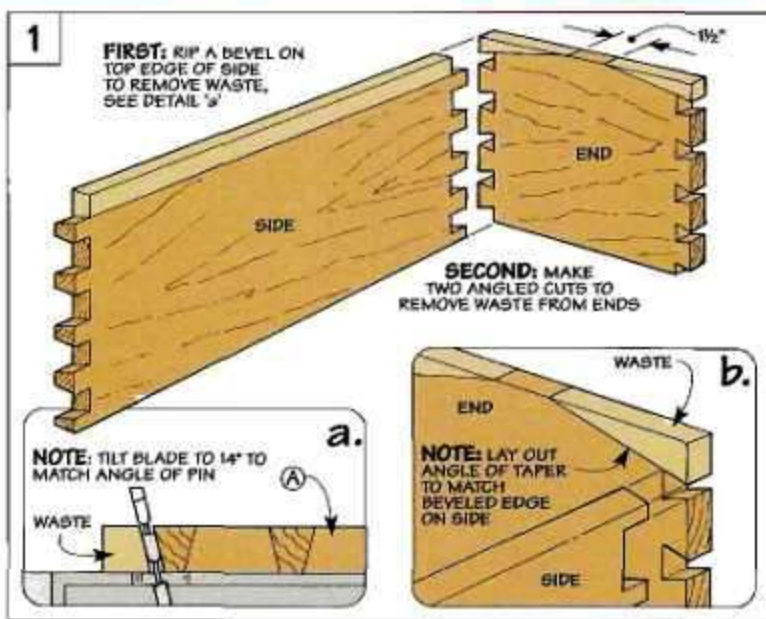

Handle

Before assembling the case, I set about making a sturdy handle to carry the toolbox, see drawing at right. To make it easy to reach in and remove a tool, the bottom of the handle is curved. And the top corners are angled to create a slim profile.

The handle has to support the weight of the tools (and the toolbox). So I made it from a 1½"-thick slab of pine. Note: I glued up two pieces of ¾"-thick stock, see Step 1 below.

Another thing that contributes to the strength of the handle is how it's joined to the case. To prevent it from pulling out, a thick tenon on each end fits into a mortise in the end of the case.

CUT MORTISES. To produce a tight fit, it's best to cut the mortises first, then size the tenons to fit. So start by laying out the location of each mortise, see detail 'a' in drawing above. A Forstner bit makes quick work of removing most of the material. Then simply pare away the remaining waste with a chisel.

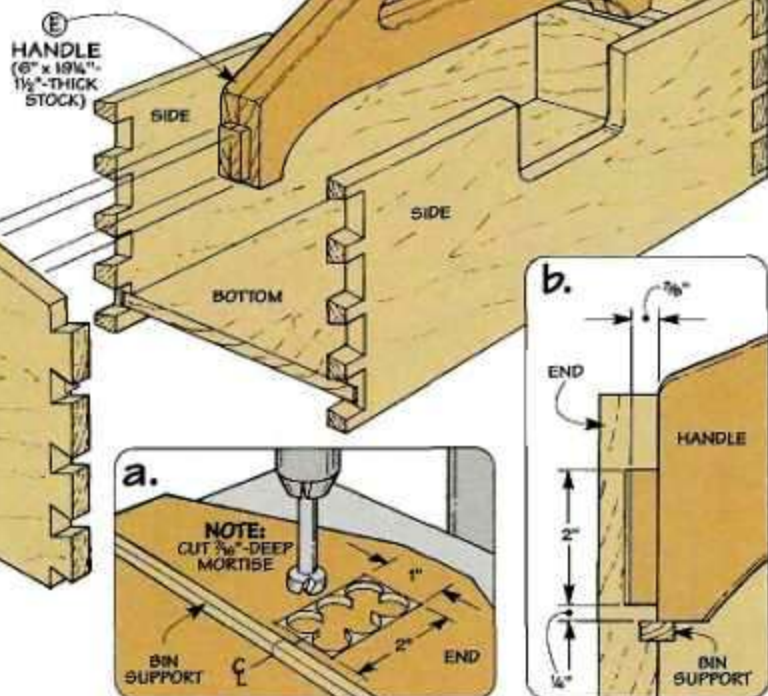

CUT TENONS. Now you can turn your attention to the tenons, see detail 'b.' The *thickness* of each tenon is established by making a cheek cut on both faces of the glued-up blank, see Step 1.

This is just a matter of placing the blank face down on the table saw and using a miter gauge to push it through the blade. To add extra support, it's best to attach a fence to the miter gauge. And

clamping a stop block to the fence ensures that all the shoulders of the tenons align.

When cutting the tenons to *width*, you'll need to stand the blank on end, see detail in Step 1. This presents a small problem. The tenons are only 2" wide, and if *all* the waste is removed, there's not much material left to support the workpiece.

So to prevent the blank from

STEP 1

GLUE UP BLANK AND CUT TENONS

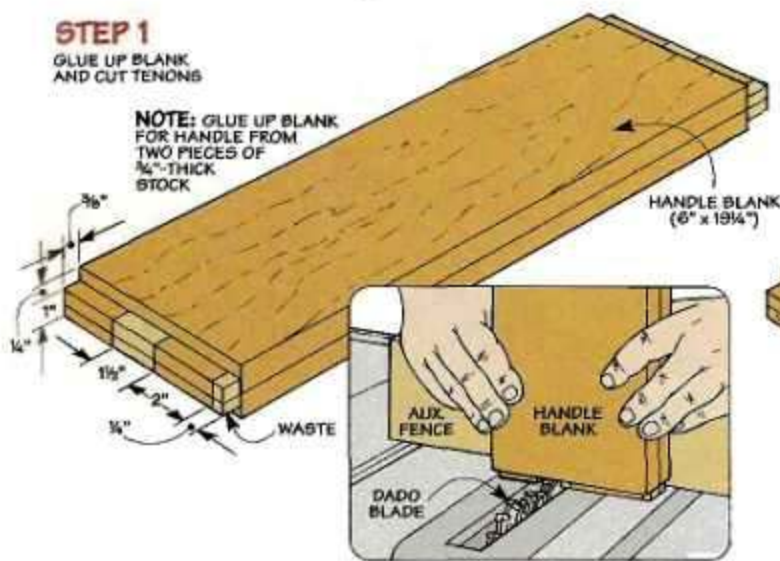

STEP 2

CUT SLOT FOR HANDHOLD

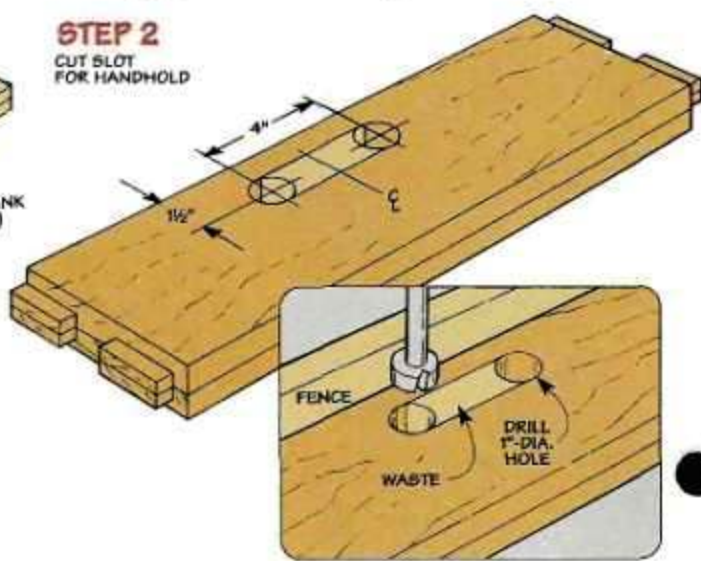

tipping, I made a $\frac{1}{4}$ "-wide cut to define the bottom shoulder of the tenon and a $1\frac{1}{2}$ "-wide cut to establish the top shoulder. This leaves enough material to support the blank. (It will be removed when the handle is cut to shape.)

HANDHOLD. After completing the tenons, I cut a long slot near the top edge of the blank as a handhold, see Step 2. The ends of the slots are formed by drilling two holes. Then, after using a sabre saw to remove the rest of the waste, file the edges smooth.

SHAPE HANDLE. Now you're ready to cut the handle to rough shape. To do this, simply lay out the basic shape and cut to the waste side of the lines, see Step 3. Note: Making the angled cuts removes the waste that was left when cutting the tenon.

ROUND EDGES. After sanding up to the layout lines, the handle is almost complete. But to provide a comfortable grip (and soften the look of the handle), it's a good idea to round over the sharp edges.

A table-mounted router and a roundover bit make quick work of this job. Rout around both sides of the handhold and the top and bottom edges, see Step 4. Just be sure not to round over the *ends* of the handle where it meets the case. I also left the

straight part of the bottom edge square. Note: It's best to file the top outside corners to "break" those edges.

GLUE-UP

After sanding the handle nice and smooth, you're ready to glue up the case.

DRY ASSEMBLY. As with any glue-up, things can get a bit hectic here. So you'll want to dry assemble the case (and handle) to see how they fit together. (I had to shave a little bit off the bottom edge of the handle where it rests on the bin supports.)

CLAMPING BLOCKS. While you're at it, it's a good idea to make a set of clamping blocks, see photo. These blocks are notched so they straddle the pins. This way, the blocks apply pressure against the tails only.

GLUE-UP. Now you can get started gluing up the pieces. Just brush a thin coat of glue on all the mating surfaces. (I used pre-mixed hide glue to provide more working time.)

Then place one of the end pieces on a flat surface. This

Shop Tip



▲ The notches in these blocks form pads that allow you to apply clamping pressure directly against the tails.

makes it easier to push the pins on the sides into the openings between the tails.

At this point, you can slide the bottom into the grooves in the sides. Don't use glue here. To allow the bottom to expand and contract with changes in humidity, it "floats" in the grooves. After inserting the handle, just tap the other end piece in place and clamp the box together.

STEP 3

CUT AND SAND HANDLE TO SHAPE

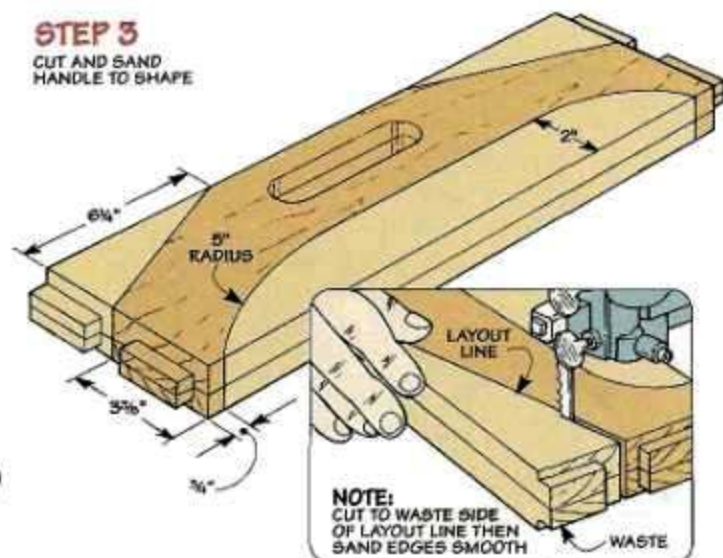

STEP 4

ROUND OVER SHARP EDGES

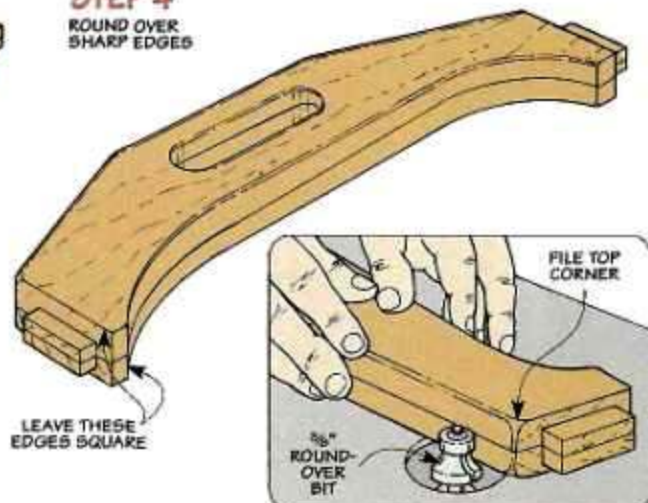

Tool Bins



▲ With its simple, wedge-shaped design and strong dovetail joints, this removable bin is a perfect complement to the toolbox.

One of the handiest things about this toolbox is a pair of long, narrow bins that hold small tools and supplies, see Fig. 4. These bins have a simple, wedge-shaped design that matches the angled profile of the toolbox, see photo. This way, when you set the bins in the toolbox, they form a gently sloping cover on each side of the handle, see Fig. 4a.

Like the case, the bins are held together with dovetail joints. So the *front* (F), *back* (G) and *ends* (H) of each bin are cut to final length, see Fig. 5. As before, it's best to start with extra-wide pieces.

PIN SPACING. The pins of the dovetail joints are cut on the front and back pieces. But the *spacing* between these pins is different, see End View below. Note: If you're using the dovetail jig, it requires two different setups to cut the pins.

HALF PINS & FULL PINS. The spacing of the pins isn't all that's different. The lower pin on each piece is only angled on one side, so it's called a *half pin*. And the top pin on the front (F) is a *full pin*. (It's angled on both sides.)

But the upper pin on the back (G) is a bit of both. It starts out as a half pin. (So cut one side only for now.) But later, ripping a bevel on the top edge creates a full pin.

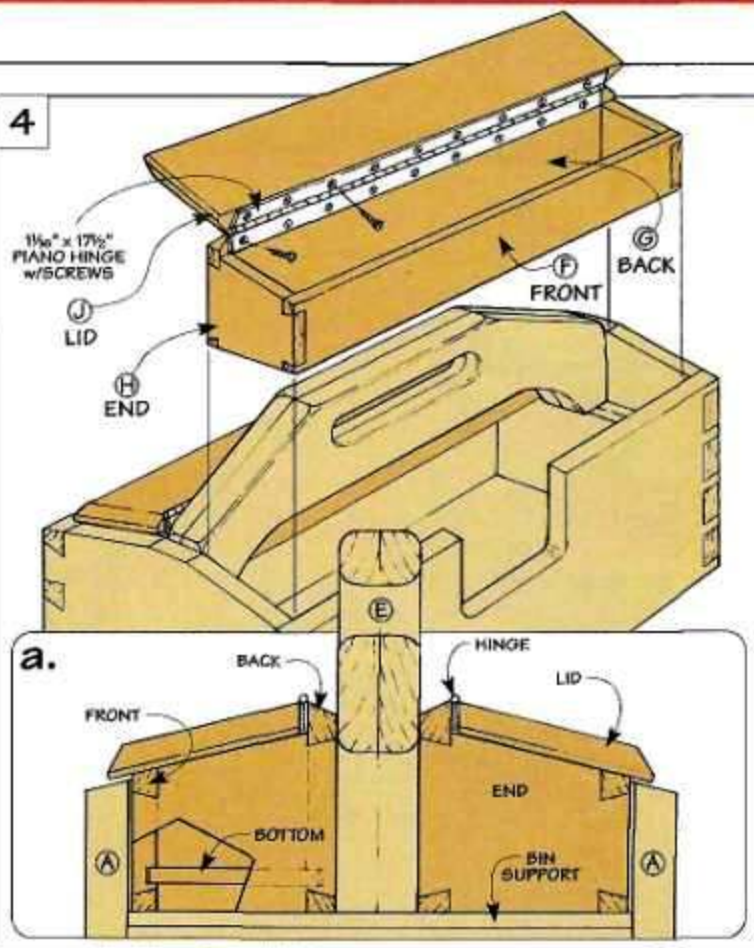

BOTTOM. After cutting the dovetails, the next step is to add the *bottom* (I), see Fig. 5. It's a piece of $\frac{1}{4}$ "-thick stock that fits in a groove cut in the front and back.

DRY ASSEMBLY. At this point, it's a good idea to dry assemble the bin and see if the parts fit together. It's also a perfect opportunity to lay out the angled shape

of the toolbox on the bins.

LAY OUT ANGLE. Besides getting the bins to match the angle of the toolbox, I wanted them to stick up above the case just a bit. This way, the lids (added later), will close tightly on the bins — not the toolbox, see Fig. 4a.

An easy way to accomplish both things is to set each bin in

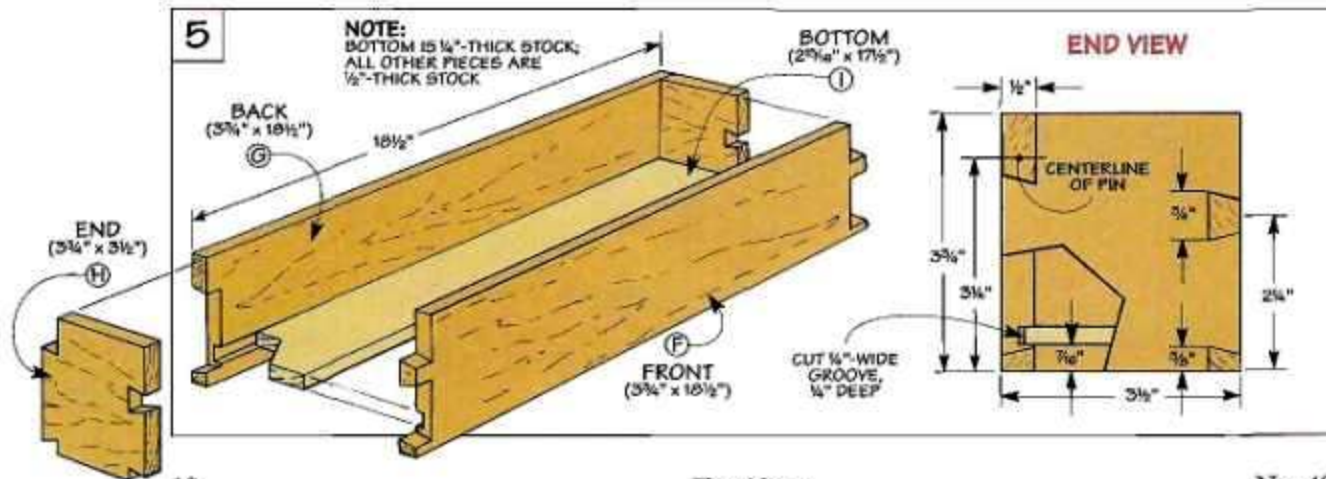

the toolbox. Then, with a metal rule lying on the toolbox, mark an angled line across each end (H) and the upper pin on the front (F), see Fig. 6. Note: The bevel on the back (G) is laid out later.

After disassembling the bin, a band saw (or sabre saw) makes quick work of making the angled cut on each end piece, see Fig. 6a.

But a table saw provides more accurate results when cutting the beveled edge on the front. To do this, tilt the blade to match the layout line on the pin, see Fig. 6b. Then position the fence so the blade aligns with the mark and rip the front to width.

LIDS. Now you're ready to add the lid (J), see Fig. 7. It fits flush with the ends of the bin. But it overhangs the front to form a wide lip, see Fig. 4a. This lip makes it easy to open the lid when the bin is sitting in the toolbox.

The lid starts out as a piece of 1/2"-thick stock that's cut to final length and rough width. To provide a smooth transition between the lid and the toolbox, I used a table-mounted router to rout a chamfer on both ends and the front of the lid, see Fig. 7a.

In addition to the chamfers, you'll need to rip a bevel on the back edge of the lid. This bevel allows the lid to fit tight against the back (G) of the bin so the two pieces can be hinged together.

BEVEL THE BACK. Before the hinge is installed, there's one

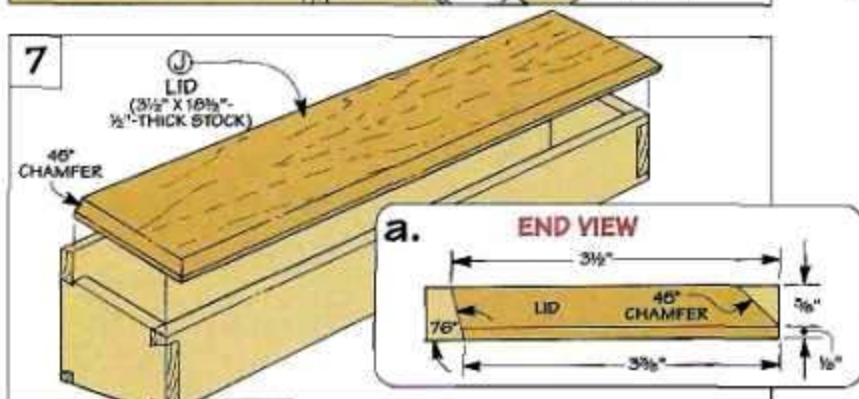
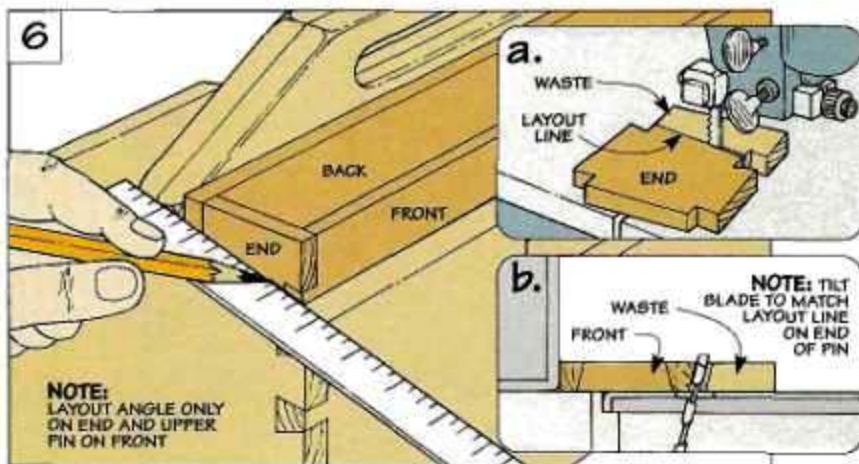

more thing to do. That's to bevel the top edge of the back (G). The idea of this bevel is to make the back appear to be part of the lid.

To do this, set the lid on the bin and extend the shoulder line of the chamfer to the back, see Figs. 8 and 8a. Then tilt the blade on the table saw to 31° and adjust the fence so the blade aligns with the layout mark. Ripping the bevel not only establishes the

width of the back. It creates the full pin mentioned earlier.

ASSEMBLY. At this point, you're ready to glue up the bins. I used the same procedure here as with the case. When the glue dries, simply hinge the lid to the back.

SAND CORNERS. But the upper corners of the back (G) are still square. So I sanded them to match the angle of the chamfers on the lid, see Fig. 9.

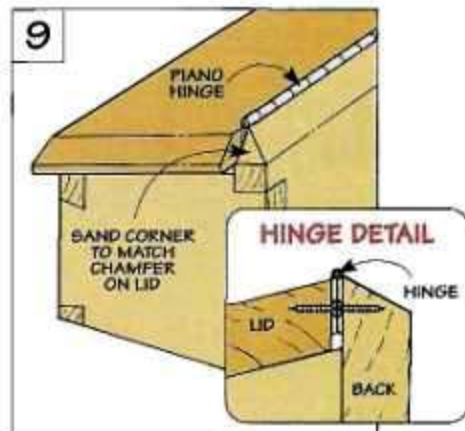
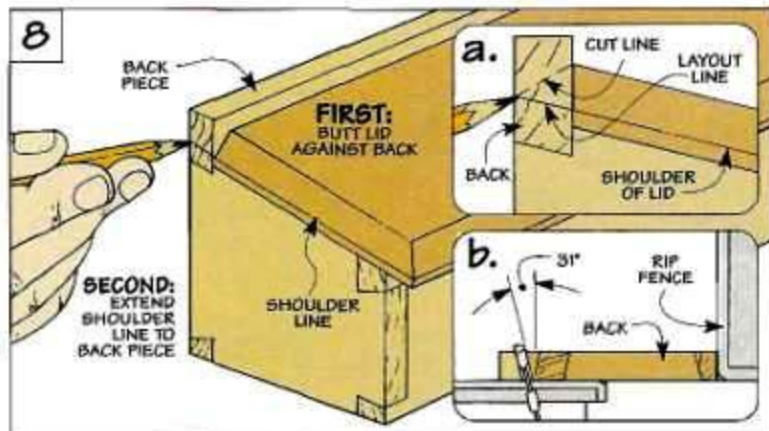

Plastics in the Woodshop

There's no question about it. A good jig makes woodworking easier. And often, only one thing is required to make that jig better — plastic.

Laminate

One type of plastic that gets a lot of use in my shop is thin, flexible sheets of *plastic laminate*, see photo at left. It's an inexpensive, commonly available material that's often used to cover the countertops in kitchens and bathrooms.

▲ You can find plastic laminate at most home centers. It's inexpensive. And it comes in a variety of colors.



A. Durability. Plastic laminate creates a tough, durable surface on the platen of this edge sander.

PAPER. So just what exactly is plastic laminate? Basically, it's made up of layer after layer of *paper*. Each layer is soaked in a plastic resin. Squeezing them together in a heated press permanently bonds the layers into a hard, durable plastic.

DURABLE. These sheets of plastic laminate provide an easy



B. Slick. This cutoff table rides on pieces of plastic laminate, so it slides smoothly without binding.

way to cover a large area with a tough, durable work surface. This makes it ideal for the top of a router table or any project where you need a wear-resistant surface, see photo 'A.'

To apply plastic laminate, you simply glue it to a subsurface. (I use contact cement.) Then trim the edges flush with a router and a flush-trim bit. Note: For smaller pieces of laminate, you can use yellow glue to apply it to the subsurface.

SLICK. Another thing I like about plastic laminate is it creates a smooth, slick surface. When you push a workpiece across a surface covered with laminate, it glides smoothly and easily. And applying laminate to parts that slide against each other reduces friction considerably, see photo 'B.'

Phenolic

A close "cousin" to plastic laminate is a plastic called *phenolic*. As with laminate, it's made from a number of layers of material soaked in resin. Here again, applying pressure and

heat bonds the layers together. This makes phenolic an extremely hard, durable material. (That's why we used it to make the fingers on the Dovetail Jig shown on page 16.)

Depending on the number of layers, this process produces different thicknesses of phenolic,

see margin. (It ranges in thickness from 1/8" to 1/2".)

RIGIDITY. The thicker pieces of phenolic are incredibly rigid. I use a 3/8"-thick phenolic plate for the insert on my router table, see photo 'C.' This way, I don't have to worry about the insert sagging from the weight of a heavy router.

HOLDS THREADS. Another advantage of phenolic is it holds threads better than some of the softer plastics. So accessories made of phenolic can be securely fastened to tools or jigs, see photo 'D.'

COST. The only drawback to phenolic is it's a bit expensive. I paid \$22 for a 3/8"-thick piece that's about 10" x 12" in size. (See margin for sources of phenolic.)

▲ Phenolic is available in several different thicknesses from the following mail-order sources:

- McFeely's
800-443-7937
- Woodhaven
800-344-6657
- Woodsmith
800-835-5084



C. Rigid. Phenolic is quite rigid, so this insert plate won't sag when you mount a router to it.



D. Holds Threads. Because it's so hard, phenolic holds threads well as in this painted crank.

UHMW

For the parts on some projects, laminate and phenolic provide a nice, smooth surface for things to slide easily. But there are times when that's still not slick enough. So when I need an almost friction-free surface, I



E. Runners. Jigs slide easily when they're guided by a runner made from a piece of UHMW plastic.

like to use a material called Ultra-High Molecular Weight (UHMW) plastic, see margin.

SELF-LUBRICATING. The thing that makes UHMW plastic so slick is its self-lubricating property. Parts slide along like they're on ice. But UHMW plastic isn't as fragile as ice —



F. Fences. To make a workpiece slide easily along an auxiliary fence, add a strip of UHMW plastic.

it's a tough, dense material. This makes UHMW plastic ideal for use as a runner in the miter slot of a table saw, see photo 'E.' UHMW plastic even comes in thin, self-adhesive strips that work great as a facing for an auxiliary fence, see photo 'F.'

STABILITY. UHMW plastic is also very stable, and it won't absorb moisture. So once you cut the runner to fit the miter slot, it won't bind (or get sloppy) with changes in humidity.

AVAILABILITY. As with phenolic, you won't find UHMW at the local home center or hardware store. But it is available from the mail-order sources listed in the margin.

▲ UHMW is the choice for a slick surface. It's available from the following:

- Lee Valley
800-871-8158
- Rockler
800-279-4441
- Woodworker's Supply
800-645-9292

Acrylics & Polycarbonates

One final group of plastics that I use frequently is acrylics and polycarbonates, see margin.

CLEAR. The main reason is they're clear (or lightly tinted). So it's easy to see exactly what's happening. I like to use them for safety guards, hairline indicators and router base plates, see photos below. Even though they look similar, there are a few key differences between the two plastics.

ACRYLIC. Acrylic is clear, strong and quite rigid, so it's often

used as a substitute for glass. The only problem is it can shatter.

POLYCARBONATE. So when I need something that's virtually unbreakable, I use polycarbonate. (It's even used in some safety glasses.) This makes polycarbonate best for a safety guard or cover where it might get hit by a chunk of wood or the edge of a blade or bit.

SCRATCHES. Regardless of which type you use, both acrylics and polycarbonates are similar in one way. They scratch easily. So after awhile, base plates and guards will be crisscrossed with fine scratch marks which makes

them hard to see through.

AVAILABILITY. The nice thing is acrylics and polycarbonates are fairly inexpensive. So you can make replacement parts whenever you need to.

You can usually find acrylics (like Plexiglas and Lucite) and polycarbonates (Lexan) at your local home center. But there are other sources.

For example, at a local company that manufactures plastics, I only paid seventy-five cents a pound for some scraps of clear plastic. For tinted versions, it's about twice as much.

▲ Acrylic and polycarbonate plastics come in a wide variety of sizes and colors, making it a very versatile plastic for the shop.



G. Guards. Because they don't shatter, polycarbonates work best for see-through guards.



H. Indicator. A hairline mark on a piece of acrylic makes it easy to precisely set a measurement.



I. Base Plate. An oversized piece of clear plastic makes it easy to see exactly where you're routing.

Working with Plastic

Cutting

It's easy to cut a piece of plastic to workable size. The trick is getting a smooth, clean cut.

SCORE & SNAP A quick way to do this with a thin ($\frac{1}{8}$ "-thick) piece of acrylic (or polycarbonate) is to score a line and snap it over the corner of a scrap, see photo 'A.'



Raising the saw blade about 1" above the plastic reduces the amount of heat that builds up and produces a smooth, clean cut.



A. Score & Snap. To cut thin pieces of plastic, simply score a line and snap it over a scrap.

LARGE PIECES. But for large (or thick) pieces, a table saw produces a more accurate cut. (I use a combination saw blade with carbide-tipped teeth.)

Once again, if you're working with acrylic or polycarbonate, the heat that builds up can melt the plastic and leave a rough surface. So something as simple as raising the saw blade can improve the quality of cut, see margin.

Heat can also be a problem when using a sabre saw to cut plastic. Even with the saw set to a slow speed, the kerf sometimes



B. Sabre Saw. When making a cut with a sabre saw, soapy water prevents the plastic from melting.

"welds" shut right in the middle of the cut. To prevent this, I apply a small amount of soapy water as a lubricant, see photo 'B.'

PLASTIC LAMINATE. Although plastic laminate isn't affected by heat as much, it can still be difficult to cut on the table saw.

Because the laminate is so thin, it tends to slide under the rip fence. So I clamp an L-shaped auxiliary fence to the metal rip fence, see photo 'C.' Note: An extra-long fence provides support in back of the saw that keeps the laminate from sagging.



C. Table Saw. An L-shaped fence keeps the plastic laminate from slipping under the rip fence.

Drilling

Drilling a hole in plastic is a pretty straightforward process. But there are a few things to keep in mind to get good results.

TWIST BIT. Although there are special bits available for working with plastic, a twist bit is all you

need. It cuts quickly in all types of plastic—*too* quickly sometimes.

That's because the steep cutting edges have a tendency to "grab" and pull the bit into the hole. This can cause the plastic to chip or crack. One quick fix for this is to grind a slight flat on the cutting edges, see margin.

DRILL SPEED. Another consideration is the *speed* of the drill press—especially when working with acrylic and polycarbonate. If the bit is spinning too fast, it *melts* the plastic instead of cutting it. (You'll know by the gummy globs it produces.)

To get around this, I adjust the speed of the drill press to about 500 rpms. This works fine on thin plastic ($\frac{1}{4}$ "-thick or less). But with thick pieces, heat is still a problem. So here again, it's a good idea to use a lubricant, see photo 'D.'

CUTTING THREADS. One more note. Occasionally, I use a tap to cut threads in plastic. (Phenolic holds threads quite well.) But as the tap starts to cut, it raises the plastic around the rim of the hole. To prevent this, chamfer the rim of the hole first, see photo 'E.'



Grinding a slight "flat" on the cutting edges of a twist bit produces a scraping cut that leaves a smooth, clean surface.



D. Lubricant. Soapy water acts as a lubricant that allows the drill bit to cut thin, feathery shavings.



E. Chamfer. Before cutting threads in plastic, chamfer the rim of a hole to ensure a flat, level surface.

Gluing

Occasionally, you may need to glue several pieces of plastic together. The best way to end up with a strong glue joint is to start with a clean, straight edge.

SAND OR SCRAPE. A few strokes with a sanding block will get rid

of the plastic "nibs" on the freshly cut edge. And a hand scraper makes quick work of removing the saw marks, see margin.

GLUE-UP. Once the edges are cleaned up, gluing the plastic pieces together is just the opposite of working with wood. That's because they're clamped together

before the glue is applied.

SOLVENT CEMENT. The most commonly available glue is a solvent-based cement. (It's available at most hobby stores.) This is a runny, watery mixture that "fuses" the plastic together, see photo 'F.' After applying a thin bead, the cement is drawn up into the joint like soda in a straw.

TWO-PART CEMENT. Another type of adhesive that produces an invisible joint line is a two-part mixture called *polymerized cement*. (You mix the two parts together like epoxy.)

This cement has the consistency of thick syrup. It's simply poured into the gap that's created by beveling one of the pieces, see photo 'G.'

Note: Both of these cements are designed to be used only with acrylic and polycarbonate.



F. Solvent Cement. For a tidy glue job, apply a thin bead of solvent cement with a needle applicator.



G. Polymerized Cement. For a strong joint, bevel one piece before applying polymerized cement.



An ordinary hand scraper makes quick work of removing saw marks from a piece of plastic.

Bending

Sometimes all I need is an L-shaped piece of plastic. In that case, I *bend* the plastic instead. (Note: You can only bend acrylics and polycarbonates.)

PROPANE TORCH. If I'm working with small pieces of plastic, I use a propane torch to heat the plastic. (This torch is the same type used for ordinary plumbing repairs.)

A torch provides plenty of heat. But it concentrates all that

heat in a small area which can cause the plastic to bubble.

To distribute the heat more evenly, I bought a flared tip to spread out the flame, see photo 'H.' After clamping the plastic between two scraps (one scrap has a roundover to match the desired bend), sweep the flame along the bend line.

Once the plastic is soft, bend it over the rounded scrap, see photo 'H.' After the plastic cools, you can remove the plastic from the form.

STRIP HEATER. To bend longer pieces of plastic, I switch to a strip heater, see photo 'I.' This heater is a long rubber strip that works like an electric blanket. Note: I bought my strip heater at the same company I got my plastic scraps from.

To use it, lay the strip down on a scrap and place the plastic on the strip across the "bend" line. Then, use a scrap to press the plastic down. Once the plastic softens, you simply bend it around a form and allow it to cool. 🐶



H. Propane Torch. After sandwiching the plastic between a scrap and a bending form, heat along the bend line (left). Once the plastic has softened, bend it over the form and allow it to cool (right).



I. Strip Heater. A strip heater makes it easy to create a uniform bend in a long piece of plastic.



To polish the rough edge on acrylic or polycarbonate, sweep the flame from a torch slowly across the surface.

Dovetail Jig



Perfect-fitting dovetails. That's what you get with this simple, shop-made jig.

There's a good reason dovetail joints have been around for centuries — they're incredibly strong. That's because the two basic parts (the pins and the tails) wedge tightly against each other to form a strong, interlocking joint. But let's face it. Cutting dovetails by hand can be a painstaking process. Even with a careful layout, it's difficult to make the precise, angled cuts that are required to produce a good fit.

That's what I like about this dovetail jig, see

photo above. It makes it easy to cut perfect-fitting through dovetails with a hand-held router. (This is the type of dovetail joint where the pins and tails extend all the way *through* the adjoining piece.)

FINGERS. The secret is a number of finger-shaped templates that attach to the top of the jig, see Exploded View on next page. These "fingers" establish the basic shape and size of the pins and tails.

TAPERED END. To make this work, one end of each finger is tapered. Routing around this tapered end with a straight bit produces a wedge-shaped pin, see "Pins" drawing on page 17. Note: A bushing mounted in the router guides the bit around the finger.

NOTCHED END. The opposite end of each finger has a deep notch. It's used to guide a dovetail bit when routing the fan-shaped tails, see "Tails" drawing on page 17.

SPACING. To change the *spacing* of the dovetails, the fingers slide back and forth on the jig. Positioning the fingers an equal distance apart creates evenly-spaced dovetails, see "Tails" drawing.

SIZE. It's also possible to change the *size* of the dovetails. All you need to do is make different widths of fingers. For example, the two wide pins in the center photo were formed by a pair of wide fingers.

And, depending on the project, you may want to combine fingers of different widths *and* adjust the spacing as well, see photo at near left.

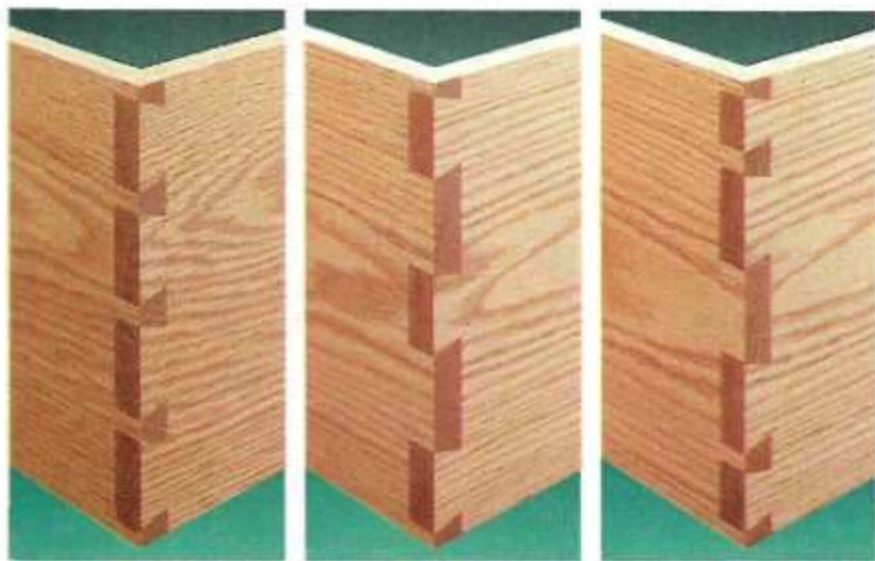

Dovetail Spacing & Size. Position the fingers an equal distance apart to create evenly-spaced dovetails (left).

Or use wide fingers to make wider pins (center). You can even vary both the size and the spacing (right).

Materials

A	Base Piece (1)	$\frac{3}{4}$ " x $3\frac{3}{4}$ " - 26 $\frac{1}{2}$ "
B	Body (1)	$1\frac{3}{4}$ " x 4" - 22 $\frac{1}{2}$ "
C	Pressure Bar (2)	$1\frac{3}{4}$ " x $1\frac{3}{4}$ " - 22 $\frac{1}{2}$ "
D	Filler Block (1)	$4\frac{1}{8}$ " x 18" - $\frac{3}{4}$ " MDF
E	Backing Blocks (4)	$4\frac{1}{8}$ " x 9" - $\frac{3}{4}$ " MDF
F	Fingers (6)	$1\frac{1}{2}$ " x 6" ($\frac{1}{2}$ " Phenolic)
G	Legs (4)	$\frac{1}{2}$ " x $1\frac{3}{4}$ " - 3"
H	Crosspieces (2)	$\frac{1}{2}$ " x $1\frac{1}{2}$ " - 5 $\frac{1}{4}$ "

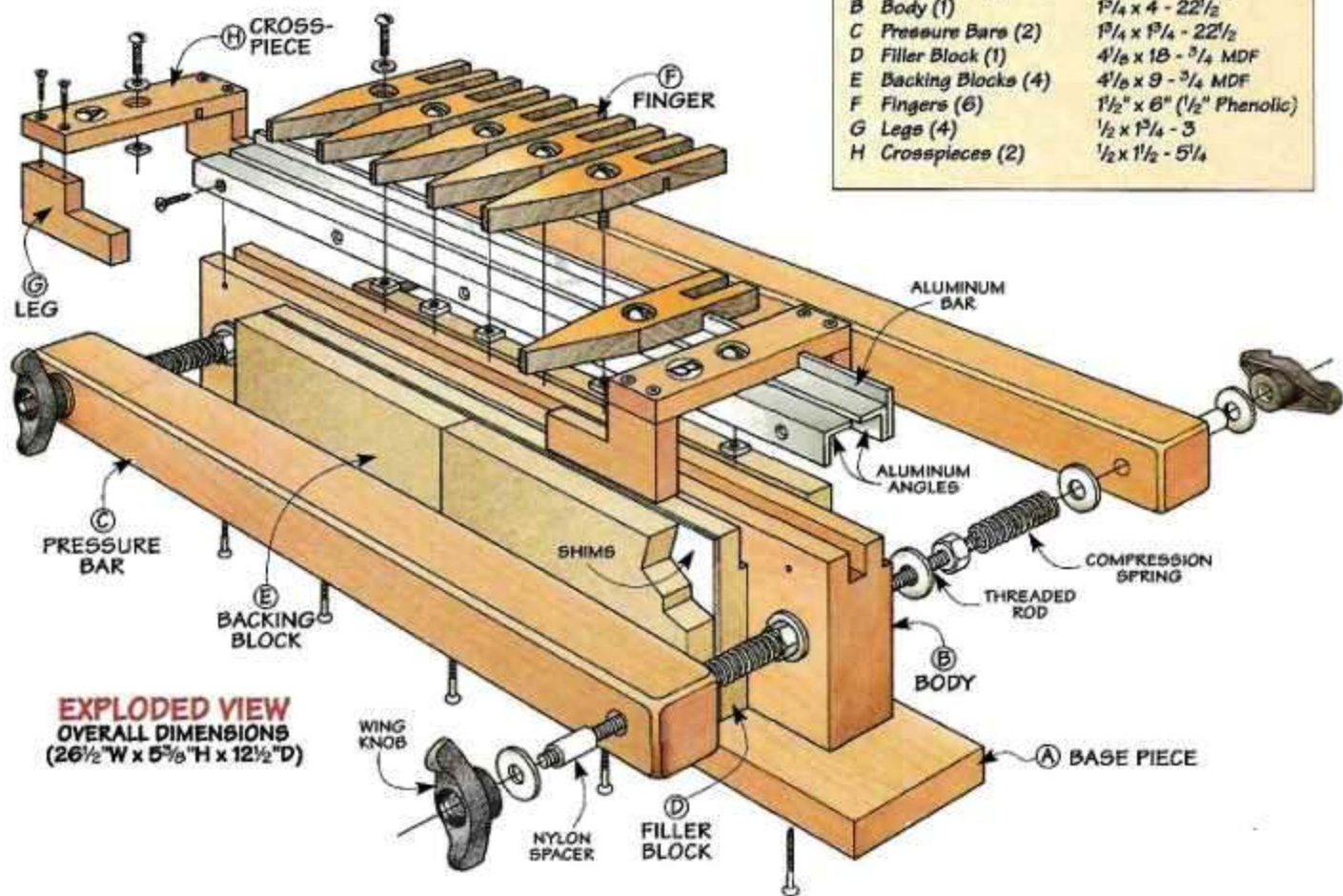

EXPLODED VIEW
OVERALL DIMENSIONS
(26 $\frac{1}{2}$ " W x 5 $\frac{3}{8}$ " H x 12 $\frac{1}{2}$ " D)

Hardware

- (5) #8 x 2" Fh Woodscrews
- (10) #6 x $\frac{1}{2}$ " Fh Woodscrews
- (8) #6 x 1" Fh Woodscrews
- (2) $\frac{3}{4}$ " x $\frac{3}{4}$ " - 22 $\frac{1}{2}$ " Aluminum Angles ($\frac{1}{8}$ " Thick)
- (1) 1" x 22 $\frac{1}{2}$ " Aluminum Bar ($\frac{1}{8}$ " Thick)
- (2) $\frac{3}{16}$ "-18 Threaded Rods (11 $\frac{3}{4}$ " Long)
- (4) $\frac{3}{16}$ "-18 Lock Nuts w/ Nylon Inserts
- (12) $\frac{3}{16}$ " Flat Washers
- (4) $\frac{3}{16}$ "-18 Wing Knobs
- (4) .328" I.D. x $\frac{1}{2}$ " O.D. Nylon Spacers (1" Long)
- (4) .47" I.D. x .5" O.D. Compression Springs (2 $\frac{1}{8}$ " Long)
- (8) 12-24 x 1" Rh Machine Screws
- (8) No. 12 Flat Washers
- (8) 12-24 Square Nuts

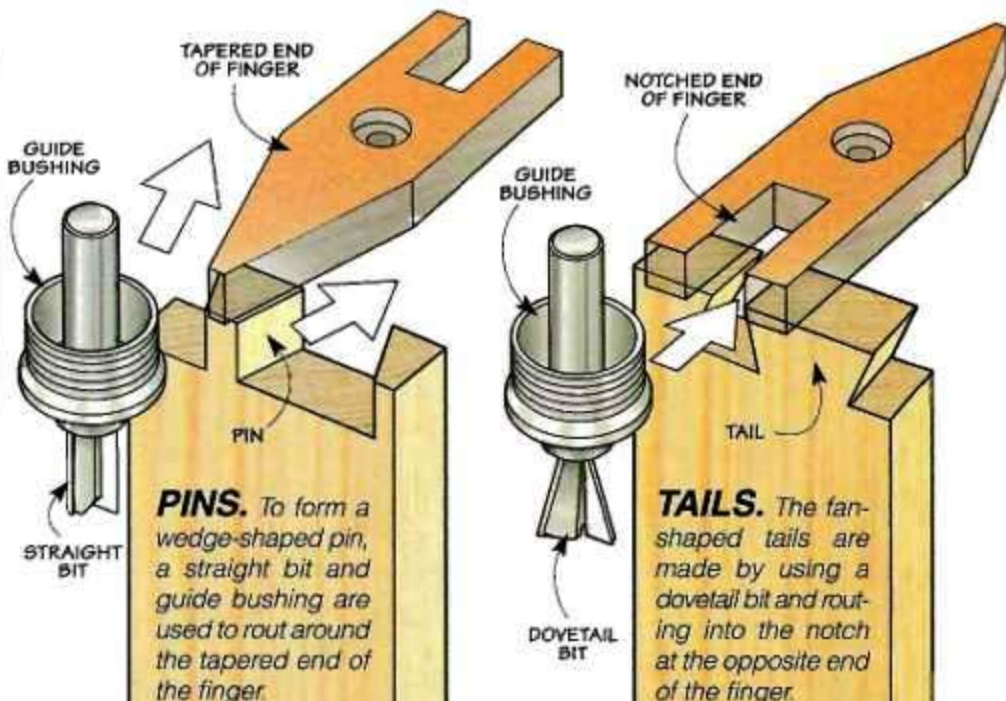

PINS. To form a wedge-shaped pin, a straight bit and guide bushing are used to rout around the tapered end of the finger.

TAILS. The fan-shaped tails are made by using a dovetail bit and routing into the notch at the opposite end of the finger.

Base

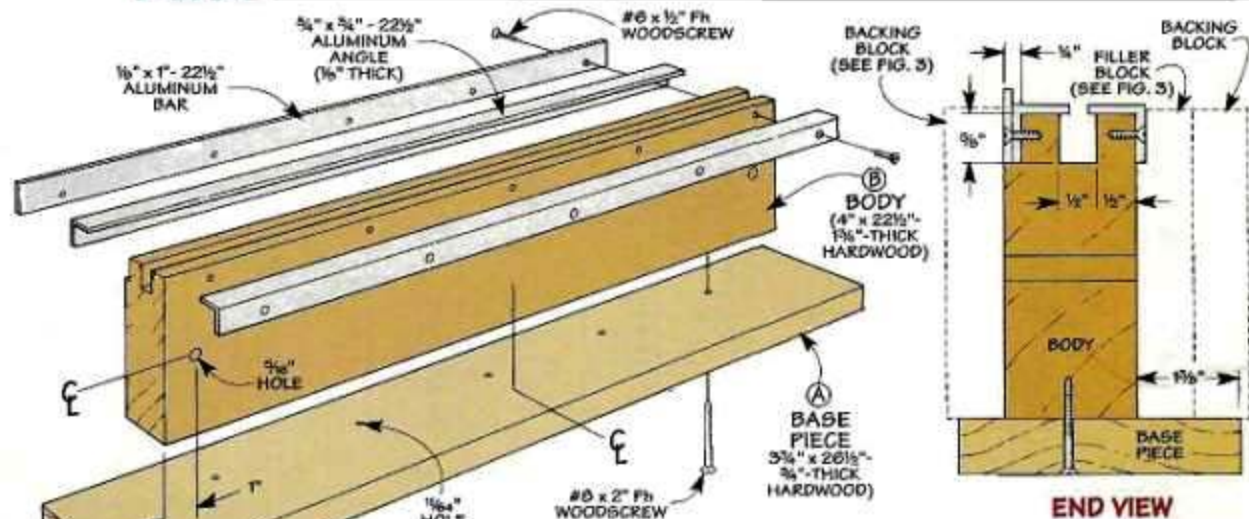

The foundation of the dovetail jig is a long, T-shaped base with a metal track running along the top edge, see drawing above.

BASE PIECE. To provide a clamping surface at each end of the jig, I began by making a long base piece (A) from $\frac{3}{4}$ "-thick hardwood. (I used cherry for all the wood parts of the jig.)

BODY. After cutting the base piece to size, you can turn your attention to the *body* (B) of the jig, see drawing above. It's a $1\frac{3}{4}$ "-thick slab that provides a solid

platform for the fingers and stops.

TRACK. To align the fingers and stops accurately (and to hold them in place), there's a metal track built into the top edge of the body. The track is made up of three pieces of aluminum: two pieces of aluminum angle (one on each side), and a flat bar.

The bar and one piece of angle fit in a rabbet cut in the top edge of the body, see End View above. Since the bar is wider than the angle, it sticks up above the body. This is what forms the track that aligns the fingers and stops.

In addition to the rabbet, there's a groove in the top edge of the body. It creates a recess for the machine screws and nuts used to secure the fingers and stops.

One thing to note is that the groove is *offset* toward the side of the body that's *not* rabbeted. This way, the pieces of aluminum angle form a lip that extends over the groove. As you tighten a finger (or stop), the nut used to secure it pinches against the lip.

INSTALL TRACK. To install the track, simply place one piece of angle in the rabbet. Then apply a few drops of instant glue to the bar and butt it against the angle. After drilling countersunk shank holes, the two pieces are screwed in place. The other piece of angle is screwed directly to the body.

DRILL HOLES. Once the track is in place, you'll need to drill a hole near each end of the body. These holes accept two metal rods that are added later.

ASSEMBLY. Now you're ready to assemble the base. The body is centered on the length of the base piece. But to allow for some blocks that are used to position the workpiece later, it's offset on the width, see End View above.

CLAMPING SYSTEM. After gluing and screwing the base together, I added a two-part system to

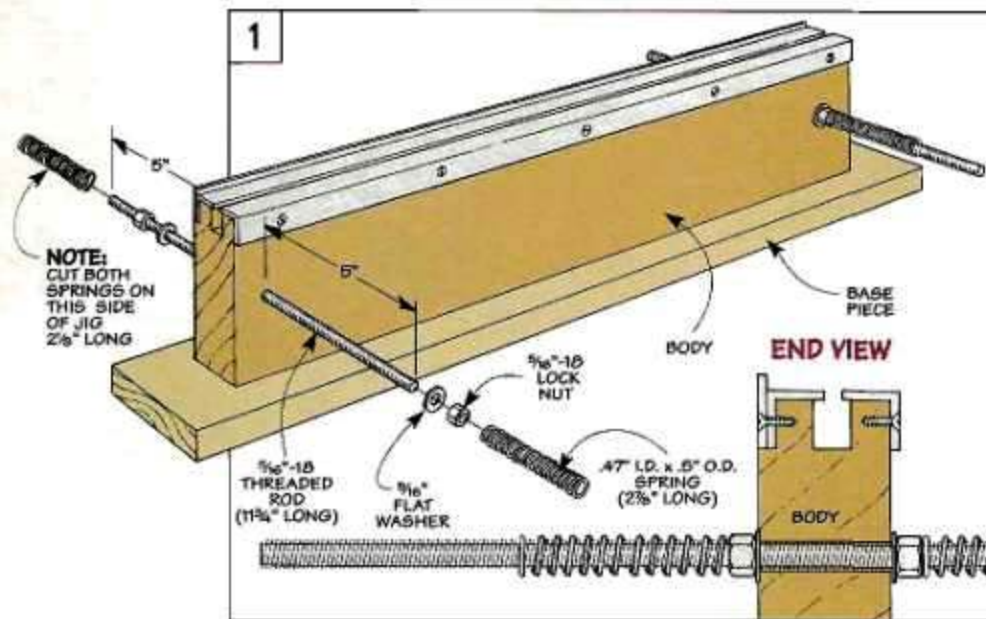

clamp the workpieces in the jig.

THREADED RODS. The first part of the system is a pair of threaded rods that pass through the holes in the body, see Fig. 1. These rods provide rigid support for two pressure bars, see Fig. 2.

After cutting the rods to length, it only takes a minute to secure them to the body. Just insert the rods in the holes so there's an equal amount sticking out from each side. Then slip a washer over each end and tighten a nut against the body, see Fig. 1.

SPRINGS. The next step is to install a spring on each end of the rods. When the pressure bars are loosened, the springs push against them which makes it quick and easy to remove a workpiece.

Since the body isn't centered on the width of the base piece, the springs on the narrow side are *shorter* than those on the opposite side. Note: I started with four springs of equal length. Then I filed a notch in two of them and snapped the springs to length.

PRESSURE BARS. The second part of the clamping system is a pair of long, thick *pressure bars* (C) that fit over the threaded rods, see Fig. 2. When you tighten wing knobs on the

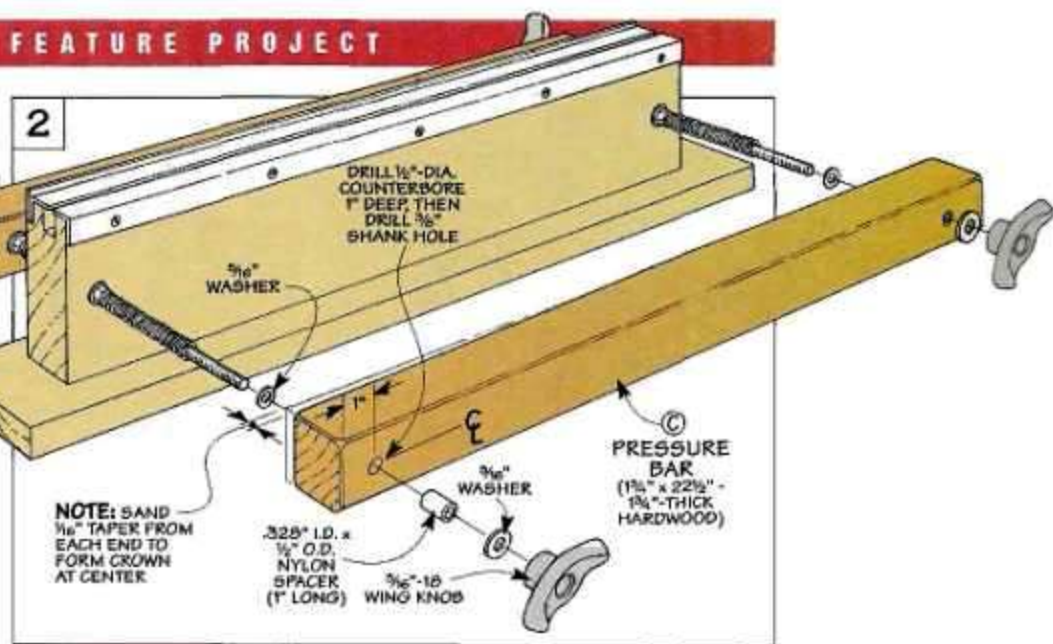

ends of the rods, the pressure bars clamp the workpiece in place.

To fit the pressure bars onto the rods, you'll need to drill a counterbored shank hole near each end. The counterbore accepts a nylon spacer that allows the pressure bars to slide smoothly.

TAPERS. Just one more note before installing the pressure bars. I sanded the *inside* edge of the bars so they taper from each end to a slight ($1/16$ ") crown in the center, see Fig. 2. The reason for this is simple.

As you tighten the wing nuts, the center of the bar contacts the

workpiece first. But applying a bit more pressure flattens the ends against the workpiece. This produces even pressure along the entire length of the bar.

BLOCKS. After installing the pressure bars, I added several blocks made from $3/4$ " MDF, see Fig. 3. These blocks aren't attached to the jig. They simply rest on the base piece between the workpiece and the body of the jig.

The thickness of the blocks establishes the position of the workpiece in relation to the fingers. In addition, it creates a slight overhang that allows the workpiece to extend past the base piece, see End View on page 18.

To make this work, a long *filler block* (D) is rabbeted to fit around the aluminum angle on the wide side of the base, see Figs. 3 and 3a. And two short *backing blocks* (E) rest against it. An identical pair of *backing blocks* (E) fit on the narrow side of the body.

In use, the backing blocks will get chewed up when the router bit cuts through the workpiece. So make plenty of extra replacement blocks. Note: To make it easy to replace the backing blocks, I made them half as long as the filler block.

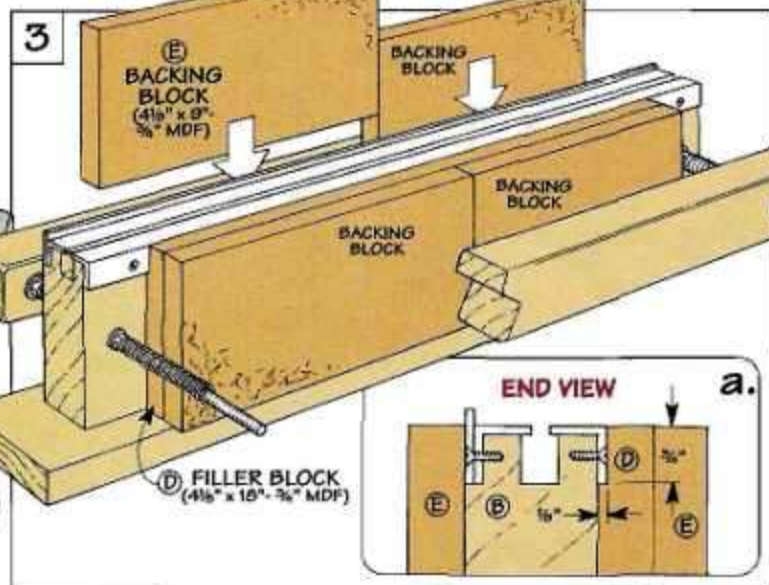

Fingers

The two basic parts of a dovetail joint (the pins and the tails) are established by a number of finger-shaped templates that slide along the metal track of the jig, see Fig. 4.

These *fingers* (*F*) are tapered on one end to produce the wedge-shaped pins. And a notch in the opposite end is used to form the tails.

PHENOLIC. To reduce wear on the fingers, I made them from a hard, durable plastic called *phenolic*. But a dense hardwood like maple would also work. (For more about phenolic, see page 12.)

FINGER SIZE. All the fingers are 6" long. But the width is going to vary depending on the size of the dovetails you want, see photos in margin.

Each finger starts out as a

simple, rectangular blank, see Fig. 4. You'll need one finger for each full-pin (and half-pin), plus one extra. The extra finger provides support for the router. (I made six 1½"-wide fingers and two 3"-wide fingers.)

KERF. To keep the fingers aligned, there's a narrow (1/8") kerf in each one that fits over the aluminum bar, see Fig. 4a. This kerf needs to be perfectly square to the long edge of the blank. So to ensure accurate results, I clamped a stop block to a fence on the miter gauge and cut each kerf.

DRILL HOLES. The fingers also need to lock securely on the track. So you'll need to drill a counterbored shank hole in each blank to accept a machine screw.

NOTCH. Now you're ready to cut the notch in each blank. This notch is centered on the width of the blank. And, in the case of the narrow fingers, it's sized to fit snugly around the guide bushing on the router, see Fig. 5a. (More about the wide fingers later.)

To accomplish this, attach a tall fence to the miter gauge and use a stop block to position the blank, see Fig. 5. The idea is to clamp the stop block in place so the blank is *roughly* centered on the blade. Then make two passes — first with one edge of the blank against the stop block, then the opposite edge.

At this point, the notch is probably still too narrow. If so, nudge the stop block and make



▲ It's easy to change the size of the pins. Just use a narrow finger (top) to form a narrow pin or a wide finger (bottom) for a wide pin.

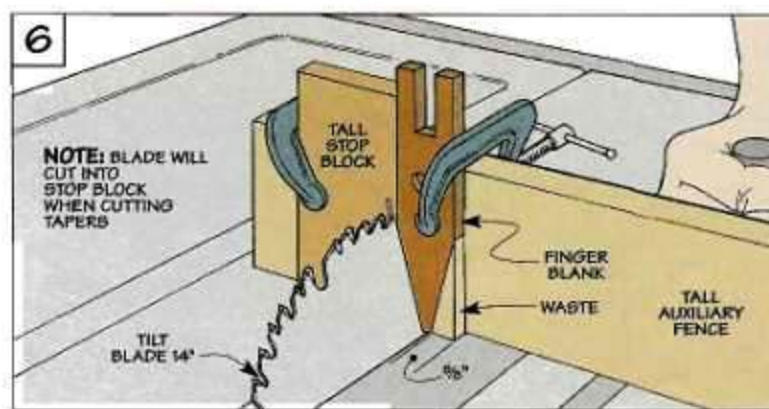
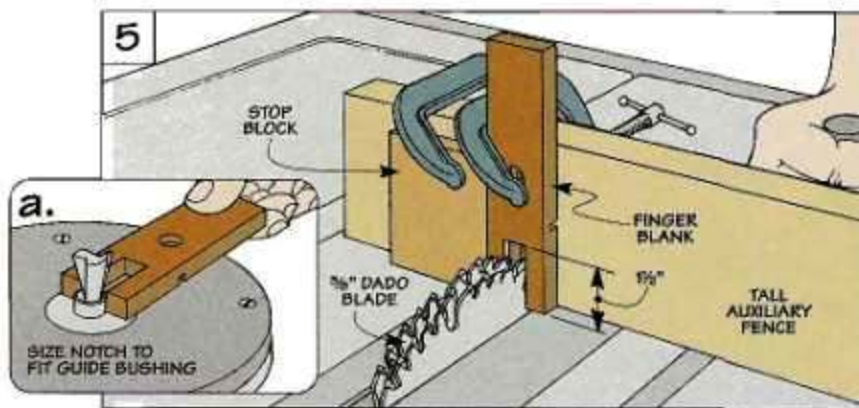
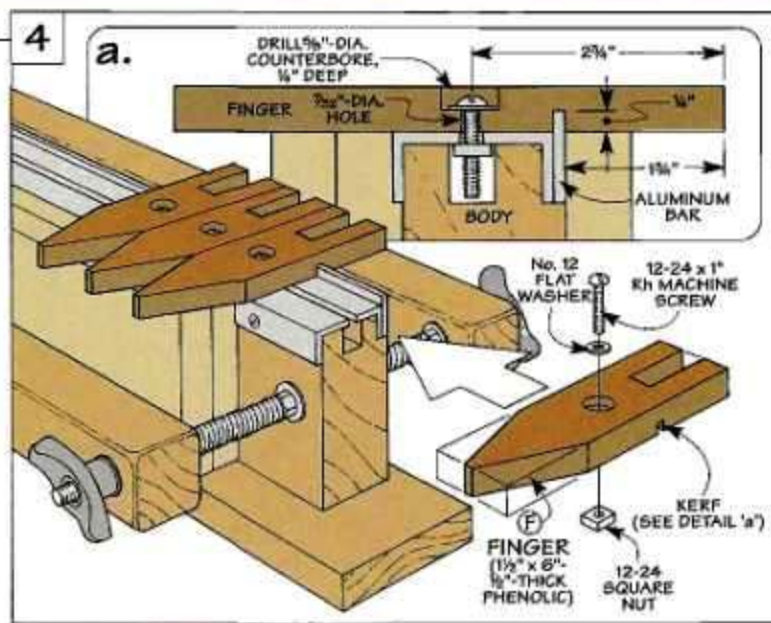

two more passes. After checking the fit, you may need to repeat the process until it fits just right. Then cut the notch in each remaining blank. Note: To cut notches in the wide fingers, use the same setup to establish the "legs." Then waste out the remaining material.

TAPERED END. Now it's just a matter of cutting the tapered end on each blank. Once again, it's centered on the width of the blank. So the same, two-pass method works well here. Only this time, the saw blade is tilted to 14° (the same angle as the dovetail bit), see Fig. 6.

Making the two angled cuts that form the tapered end of the finger is easy. The trick is determining the *final* width at the tip of the finger. If it's too wide, the pin won't fit. Too narrow, and the pin will be loose.

NEAR FIT. The solution is to create a *near fit* where the pins almost (but not quite) fit into the openings between the tails, see margin. Then later, use shims to "fine tune" the fit.

To create the near fit, start by cutting the tapered end of one finger a bit "fat." Then, to check the fit this produces, slide the finger onto the jig to make a test joint, see Fig. 7. Note: To sup-

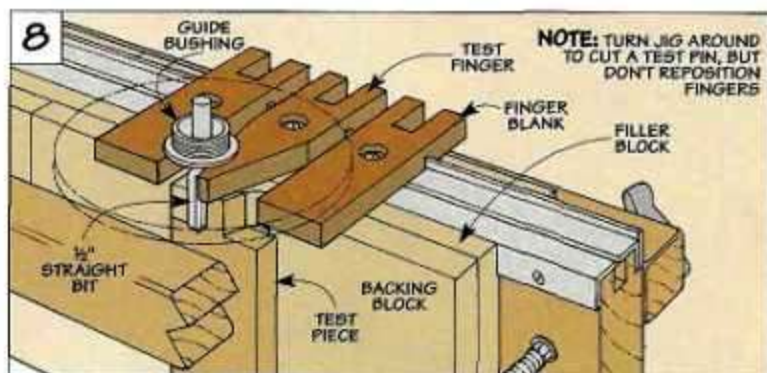
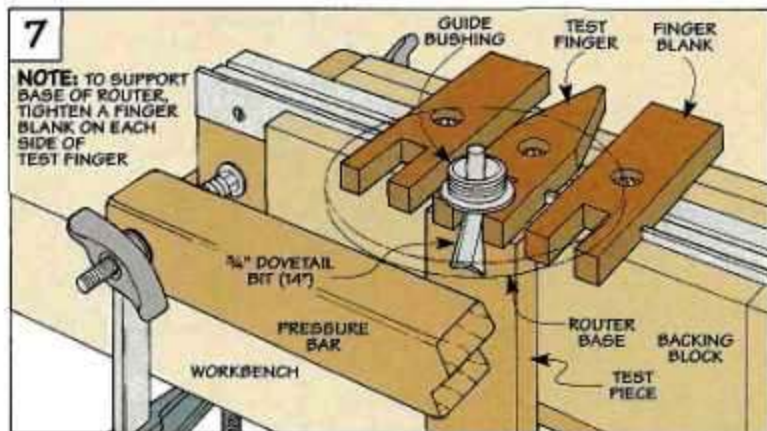

▲ To produce a "near fit," the pin should almost (but not quite) fit into the opening between the tails.

port the router, set one of the blanks on each side of the finger.

After tightening the finger (and blanks), just rout a tail in one test piece and a pin in another, see Figs. 7 and 8. (See page 24 for more on using the jig.)

Since the tapered end was wide to begin with, the pin prob-

ably won't fit. So you may need to go back to the table saw and shave a *very* small amount off each of the tapered sides. Don't get carried away here. (Remember, you're looking for a *near fit*.)

To see if you're getting closer, cut another test joint. You can use the same test "tail." But cut off the first test pin before routing another one.

Once you've achieved that near fit with one finger, cut the tapered ends on *all* the blanks. Note: Use this same setup to cut the tapers on the wide blanks.

SHIMS. Now all that's left is to add the shims. These are pieces of posterboard that fit between the filler block and the backing blocks, see Fig. 9. With each shim, the workpiece will be positioned farther out on the tapered end of the fingers. This means the pin that's cut will be a bit narrower. So once again, cut a test pin and use as many shims as needed to get a perfect fit.

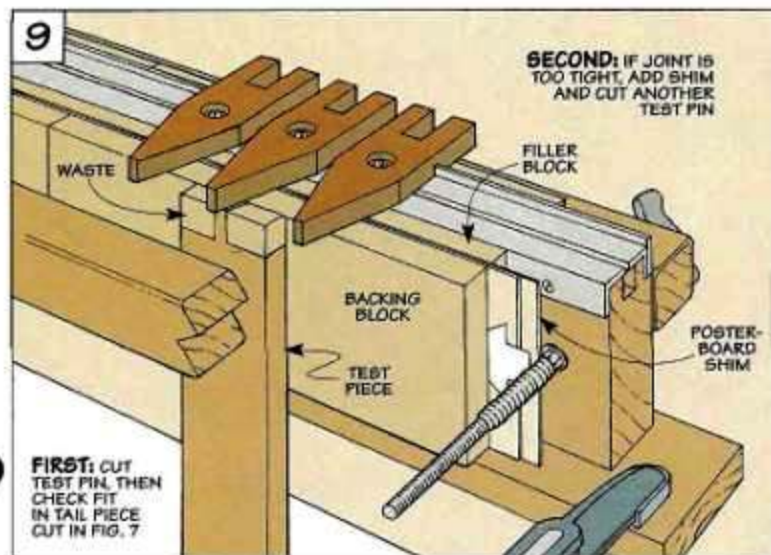

Adjustable Stops

All that's left to complete the jig is to add a pair of *adjustable stops*, see Fig. 9. Like the fingers, each stop slides along the metal track of the jig and locks securely in place, see photo.

The purpose of the stops is simple. In use, the bottom edge of the workpiece butts against the stop. This is what positions the workpiece from side to side.

But why do you need *two* stops? Well, say you're cutting the pins for example. One stop is used when routing one end of the workpiece. The other stop is used when cutting the pins in the opposite end.

The thing that complicates

matters a bit is that the mating piece (the "tail" piece) is routed on the *opposite* side of the jig. So you need a stop on that side as well — one that positions the workpiece in the exact same relationship to the fingers. This way, the pins and tails are sure to align.

TWO ENDS. The solution is a double-ended stop that fits over the body of the jig like a saddle. Each stop consists of two L-shaped *legs* (G) connected by a *crosspiece* (H), see Fig. 9.

The legs are notched to provide clearance for the router bit when working near the stop. Here again, a kerf in the crosspiece fits over the



track, see Fig. 9a. And a counter-bored shank hole accepts a machine screw that's used to secure the stop.

TRIM LEGS. After gluing and screwing the stops together, the legs may have shifted out of alignment. So to ensure they extend an equal amount, I trimmed the ends on the table saw, see Fig. 10.

LABEL STOPS. Finally, to make it easy to use the jig, I labeled one stop 'A' and the other one 'B.'

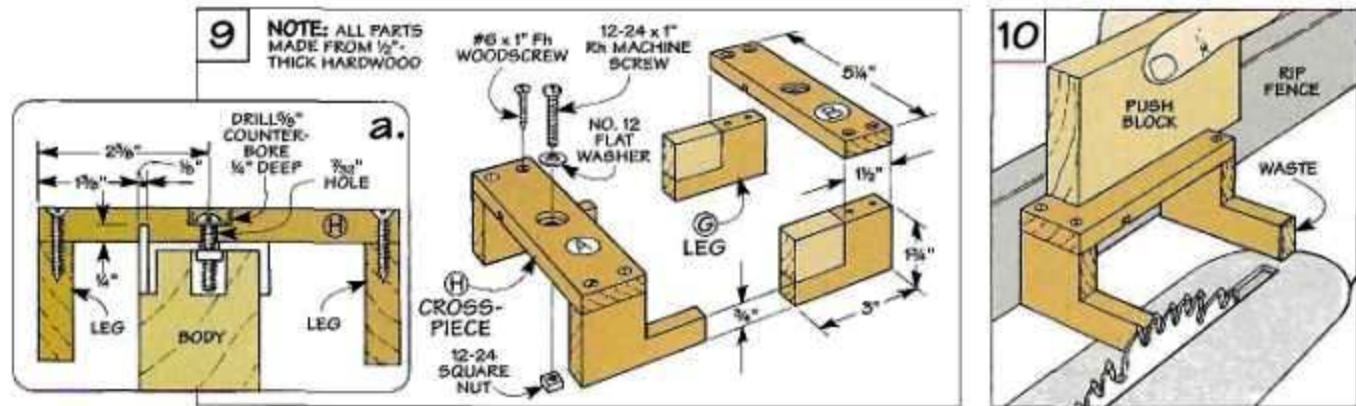

Setup

It only takes a few minutes to set up the dovetail jig.

LABEL PIECES. To avoid confusion later on, start by labeling the "pin" pieces and "tail" pieces, see Step 1. Then mark an 'X' on the *bottom* edge of each piece. In use, this edge is *always* against one of the stops.

Finally, label the two ends that form one corner with an 'A.' (It doesn't matter which corner.) The corner that's *diagonal* to this one is also an 'A' corner. (All the 'A' ends are routed with the workpiece against the 'A' stop.) The two remaining corners are the 'B' corners.

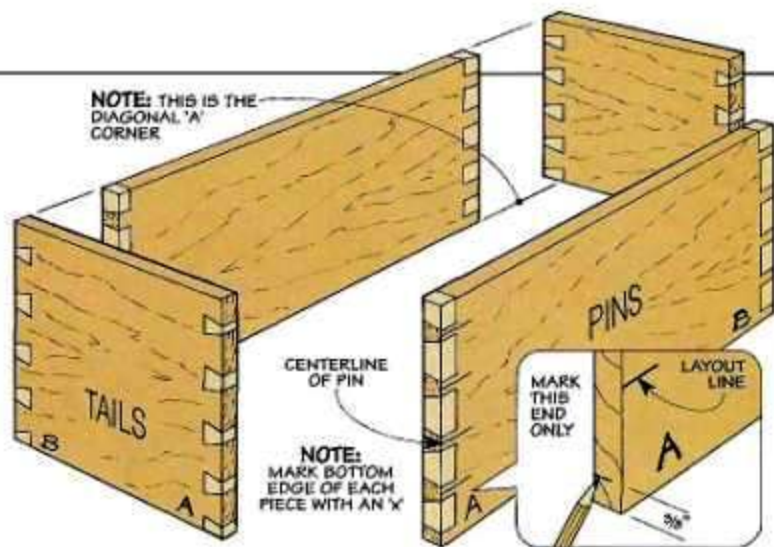

1 To make it easy to set up the jig (and avoid confusion when routing the dovetails), arrange all the pieces as they'll be when the project is assembled. Then label each of the pieces as shown.

LAYOUT. Now lay out the pin centerlines on one of the "pin" pieces. These centerlines are used to locate the fingers on the jig.

One thing to note here is that the *bottom* pin is only angled on one side. (It's called a *half pin*.) This means you'll only rout around *one* of the tapered sides of the finger. In order to position this finger later, simply lay out the *widest* part of this half pin, see detail in Step 1.

ADD STOP & FINGERS. Now slide the 'A' stop and a few fingers onto the track. (Their exact location isn't critical.) Just tighten them down so they don't shift when you put the workpiece in the jig.

To position the workpiece, slip it under the pressure bar and butt the bottom ('X') edge against the 'A' stop. Also, make sure the 'A' end is tight against the fingers. Note: For 1/2"-thick stock, place a scrap between the pressure bar and workpiece to keep the bar from hitting the stops.

FIRST FINGER. The next step is to position the finger that's *closest* to the stop. This finger forms the half pin. So one of the tapered sides extends over the edge of the workpiece. The other one aligns with the layout mark made earlier, see detail in Step 2. Note: Because of the thickness of the guide bushing, the pin will be cut slightly wide of the mark.

REMAINING FINGERS. Now slide the rest of the fingers on the track. (Remember, include one more finger than the number of pins.) Then center the tapered end of each finger over a layout line, see Step 3. Note: The "extra" finger supports the router when routing the 'A' end. But it's the finger that forms the half pin when routing the 'B' end. So position the extra finger to cut a half pin.

'B' STOP All that's left is to add the 'B' stop. It's located the same distance away from the nearest finger as the 'A' stop is from the finger closest to it, see Step 4.

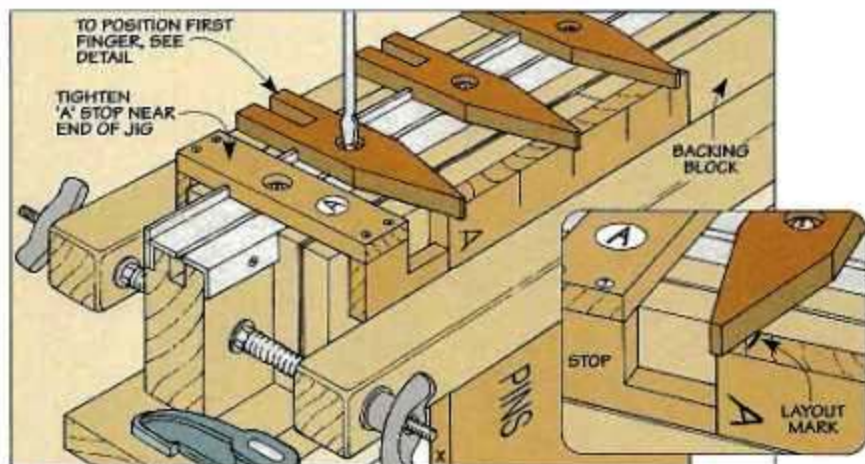

2 After clamping the workpiece in the jig, you can tighten the finger that forms the half pin. One tapered side of this finger overhangs the edge of the workpiece. The other side aligns with the layout mark.

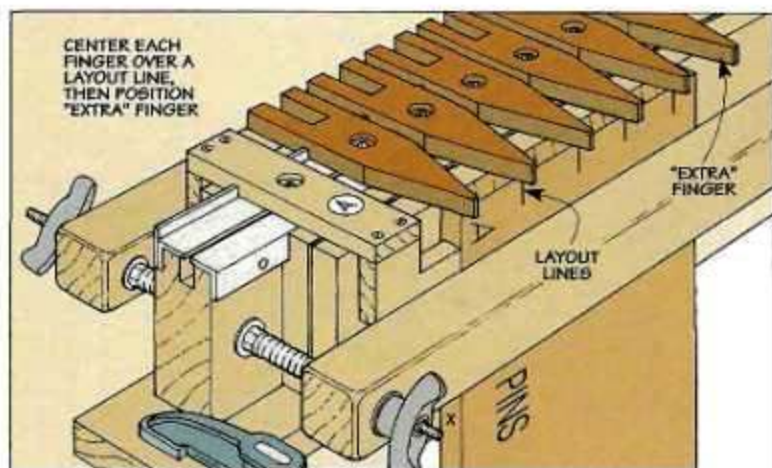

3 It only takes a few seconds to position the rest of the fingers. Just slide each finger one way or the other until the tapered end is centered on the layout line for the pin. Then lock each one in place.

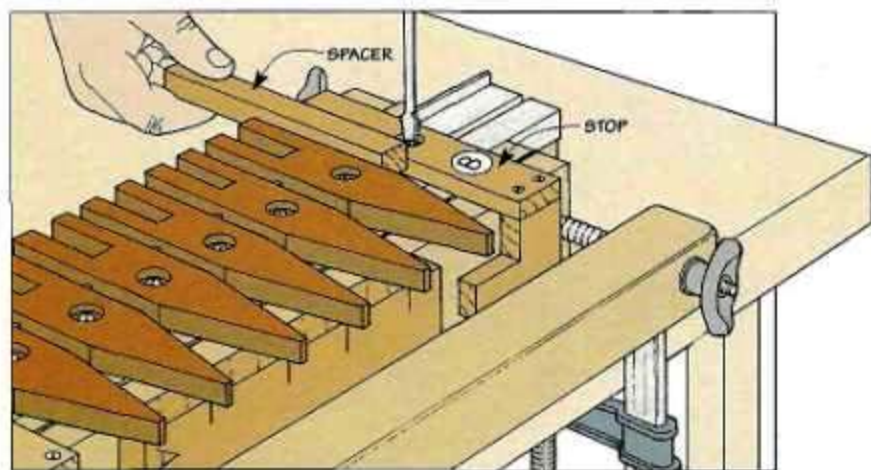

4 After cutting a scrap to fit between the 'A' stop and the nearest finger, it's used as a spacer to position the 'B' stop. This ensures that the dovetails on one corner align with those on the adjacent corner.

Routing the Pins

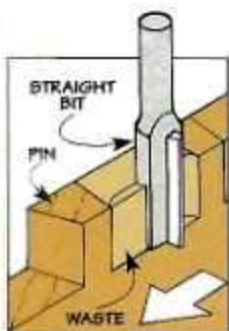

To reduce chipout, make a shallow "back cut" from right-to-left. Then complete the pins by routing in a standard (left-to-right) direction.

The pins of the dovetail joint are formed by routing out the waste material between the tapered ends of the fingers.

GUIDE BUSHING. To guide the router around the fingers, you'll need to install a guide bushing in the router base, see drawing at right. (I used a $\frac{5}{8}$ " bushing.)

STRAIGHT BIT. As the bushing rides against the fingers, the angled sides of the pins are cut with a straight bit. (A $\frac{1}{2}$ " straight bit works fine.)

One thing to be aware of is the length of the bit. Since the router rests on top of the fingers, the bit has to be long enough to

allow for the thickness of the fingers plus the full depth of cut.

DEPTH OF CUT. To set the depth of cut, simply extend the bit to equal the combined thickness of the workpiece and the fingers — and then "tweak" it $\frac{1}{32}$ " more. This will leave the pins a bit proud after assembly, but they're easy to sand flush.

CLAMP WORKPIECE. At this point, you can clamp the workpiece in the jig. Don't forget to check that it's oriented properly before tightening the pressure bar, see Steps 1 and 2 below.

ROUT PINS. Now you're ready to rout the pins. Making a

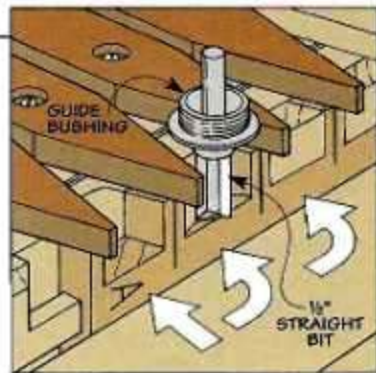

shallow "back cut" on the initial pass will reduce chipout on the outside face, see margin. Then waste out the material between the fingers. After cleaning out one socket, move on to the next until all the pins are routed.

STEP 1

Start by clamping the jig to the bench so the tapered ends of the fingers face forward. Now slip the 'A' end of a pin piece up under the pressure bar and set it firmly against the fingers. After butting the bottom ('X') edge against the 'A' stop, clamp the workpiece in place. Then rout out all the waste material between the fingers to form the pins.

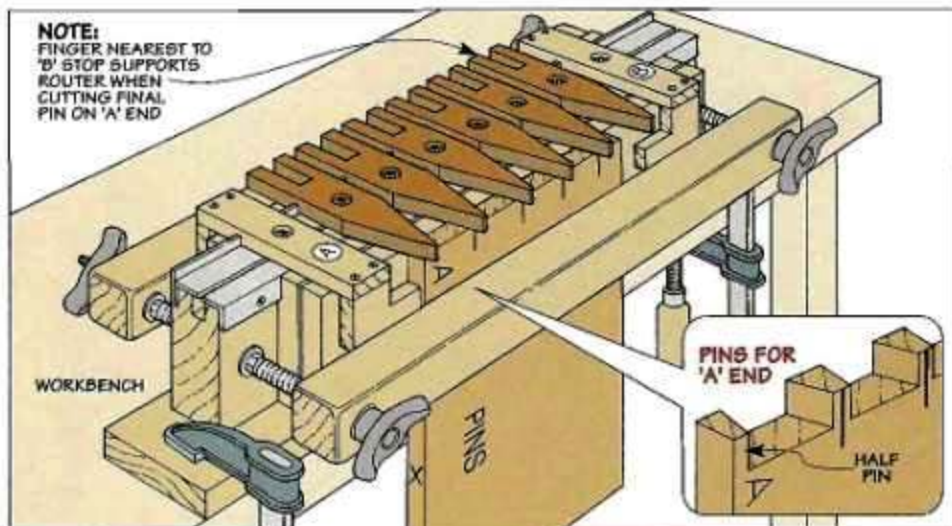

STEP 2

To rout the pins in the opposite ('B') end of the workpiece, just turn it end for end and butt the bottom ('X') edge against the 'B' stop. After routing all the pins in this end, repeat the entire process for the other "pin" piece. Note: To minimize chipout on the back side of the workpiece, replace the backing blocks when they get chewed up.

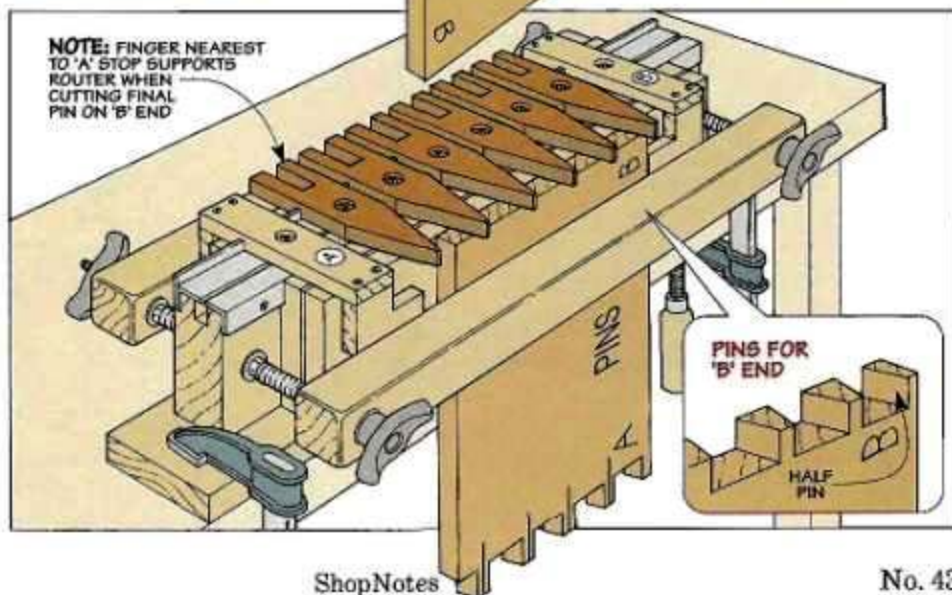

Routing the Tails

Once the pins are completed, you're halfway done. Now all that's left is to rout the tails.

The nice thing about this is you don't have to change the position of a single finger (or stop). Just turn the jig around so the notched ends of the fingers face forward, see Step 3 below.

BUSHING & BIT. The same guide bushing is used when routing the tails. Only this time, as the bushing rides against the sides of the notch, a dovetail bit cuts the angled sides of the tails, see drawing above. (I used a 3/4" dovetail bit with a 14° angle and set the depth of cut as before.)

TAIL PIECES. Here again, it's easy to orient each of the "tail" pieces in the jig, see Steps 3 and 4 below. Just be sure the letter on the end of the piece corresponds to the letter on the stop. As before, check that the bottom ("X") edge is against the stop.

ROUT TAILS. After clamping the workpiece in place, it's time to rout the tails. So set the router on top of the fingers, turn on the switch, and make a *sideways* plunge cut into one of the notches, see drawing above.

When the guide bushing contacts the end of the notch, turn off the router and wait until the

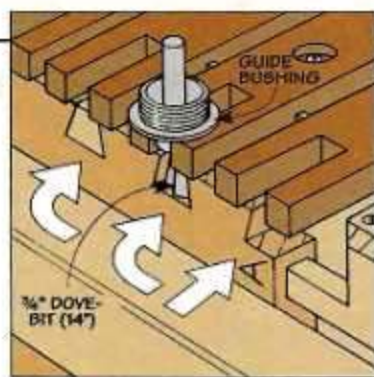

bit stops spinning before you pull it back out. This takes a few seconds. But I found it's a good way to keep the rotation of the spinning bit from flicking a chip off the *end* of the tail once the cut is completed. 

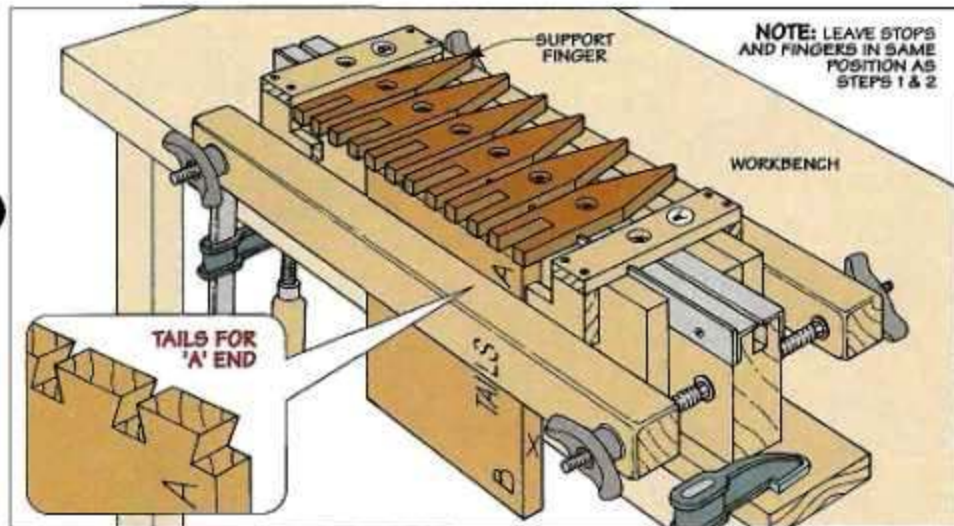

STEP 3

To rout the tails, clamp the jig to the bench so the notched ends of the fingers face forward. Once again, be sure the 'A' end is tight against the fingers and the bottom edge (labeled with an 'X') is butted against the 'A' stop. After tightening the pressure bar, make a sideways plunge cut into each notch to form the tails.

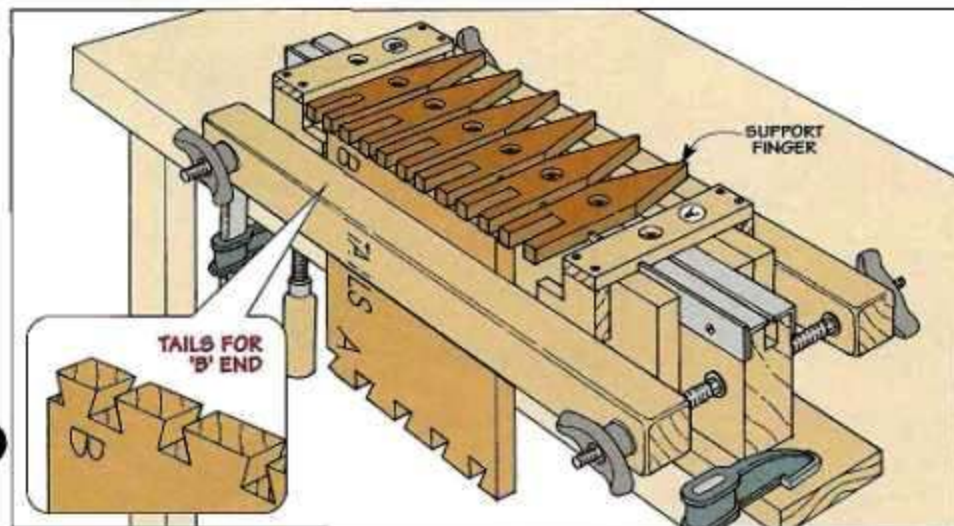

STEP 4

The tails in the opposite ('B') end are routed in the same way. Only this time, the bottom edge of the tail piece is butted up against the 'B' stop. After routing all the tails in this piece, repeat the process for the other "tail" piece. Once again, always keep a "fresh" backing block behind the workpiece to reduce chipout on the back side.

Steady Rest

When turning a spindle on the lathe, this steady rest provides the support needed to keep it from flexing.

Usually, wood is a stiff, rigid material. But when turning a long, thin spindle on the lathe, it gets a bit “rubbery.” As the spindle gets thinner, it flexes and bends away from the turning tool. This makes it hard to avoid digging into the spindle.

To prevent the spindle from flexing, I made a steady rest that attaches to the lathe bed, see photo. It supports the workpiece from behind, so it's easy to get a smooth, controlled cut.

SELF-ADJUSTING. One nice thing about this steady rest is it doesn't have to be constantly readjusted as you turn the spindle to a smaller diameter. Instead, it automatically adjusts to the size of the spindle.

WEDGE. The secret is a simple wedge that applies pressure against a tilting arm, see Exploded View and detail ‘a’ below. There's not a lot of pressure—just enough to hold a pair of ball



bearings gently against the spindle.

With the spindle cradled between the bearings, it won't bow out. And as the spindle gets smaller, the wedge gradually works its way down and tilts the arm forward, see detail ‘b.’ This keeps the bearings in continuous contact with the spindle.

L-SHAPED SUPPORT

I began work by making an L-shaped support. It consists of two feet with an upright brace sand-

Hardware

- (1) 1/4" x 3" Hex Bolt
- (5) 1/4" x 1/4" Hex Bolts
- (4) 1/4" Lock Nuts w/Nylon Inserts
- (1) 5/16" Flat Washer
- (1) 5/16" x 4" Carriage Bolt
- (1) 5/16" Star Knob
- (4) 1/4" Flat Brass Washers
- (2) 1/4" I.D. x 5/4" O.D. Ball Bearings

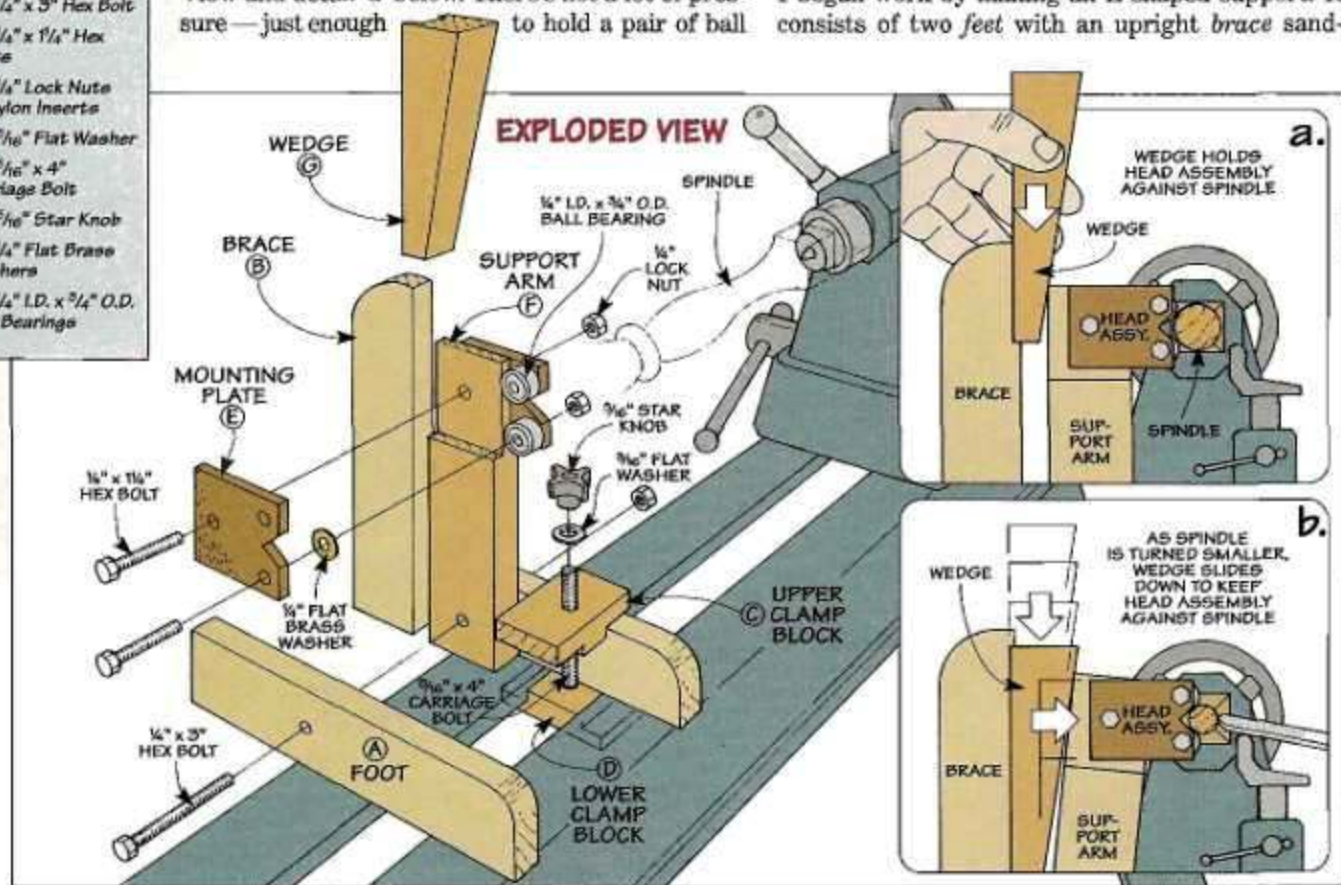

wicked between, see Fig. 1.

FEET The feet (A) are pieces of $\frac{3}{4}$ "-thick hardwood that rest on the lathe bed. (I used maple.) To accept a bolt that secures the arm later, you'll need to drill a hole in each foot. It's also a good idea to cut a gentle curve on each foot. This way, you won't have to worry about bumping into a sharp corner when working at the lathe.

BRACE Now you're ready to add the brace (B), see Fig. 1. It guides the wedge as it slips down between the brace and the arm. In addition, the brace prevents the arm from tilting back.

One thing to be aware of is the height (length) of the brace. It has to be tall enough to catch the tip of the wedge. To accomplish this, the brace is $1\frac{1}{2}$ " longer than the distance from the lathe bed to the center of the tailstock, see Fig. 1a. Here again, I cut a curve on the upper back corner of the brace before gluing it in place.

CLAMP HEAD

Once the support is complete, the next step is to add a clamp head to secure it to the lathe.

CLAMP BLOCKS The clamp head consists of two T-shaped blocks that work together to pinch the support against the lathe bed, see Fig. 2. This pressure is applied by tightening a knob on the end of a bolt that passes through each block.

KEY To prevent the blocks from spinning as you tighten the knob, one part of each block forms a "key." The key on the upper clamp block (C) fits between the feet, see Fig. 2a. And the lower clamp block (D) fits between the rails of the lathe, see Fig. 2b.

Since the clamp blocks are quite small, it's best to start with an extra-long piece. The keys are formed by cutting a rabbet and a dado at each end, see Fig. 3. Then just cut the clamp blocks to length and drill a centered hole in each one to accept the bolt.

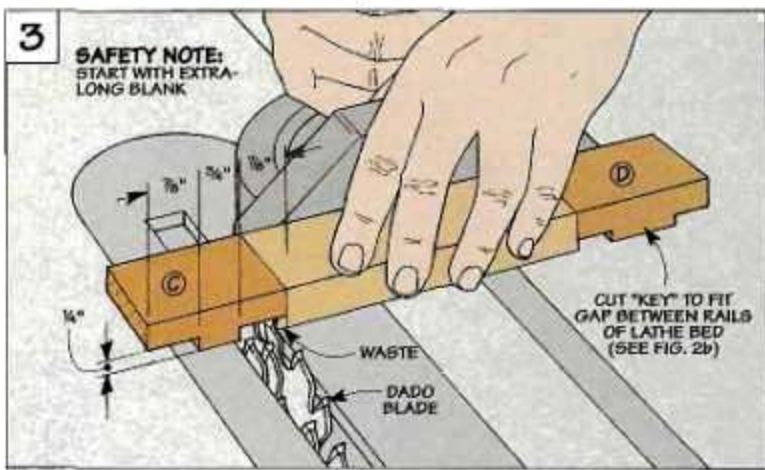
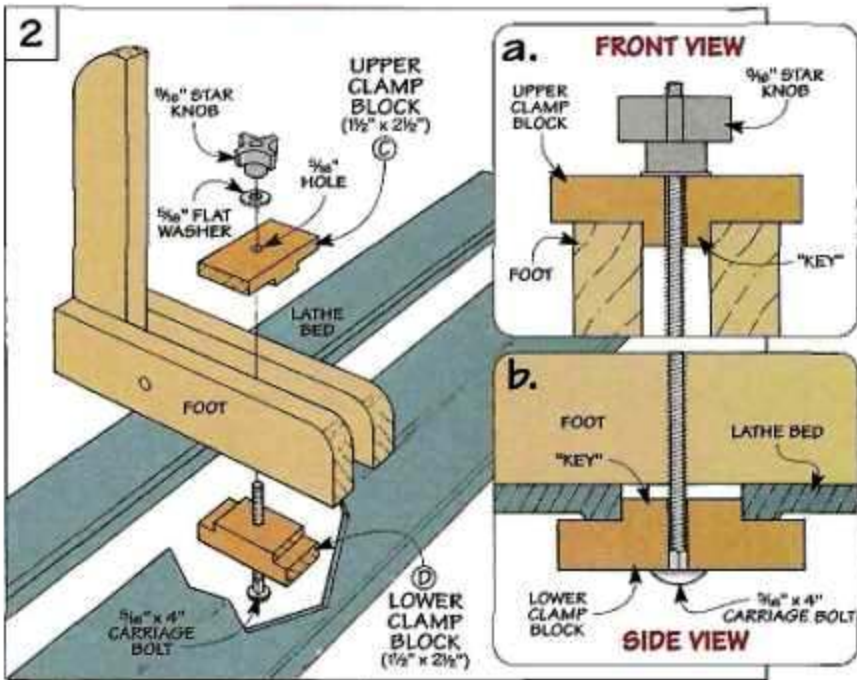
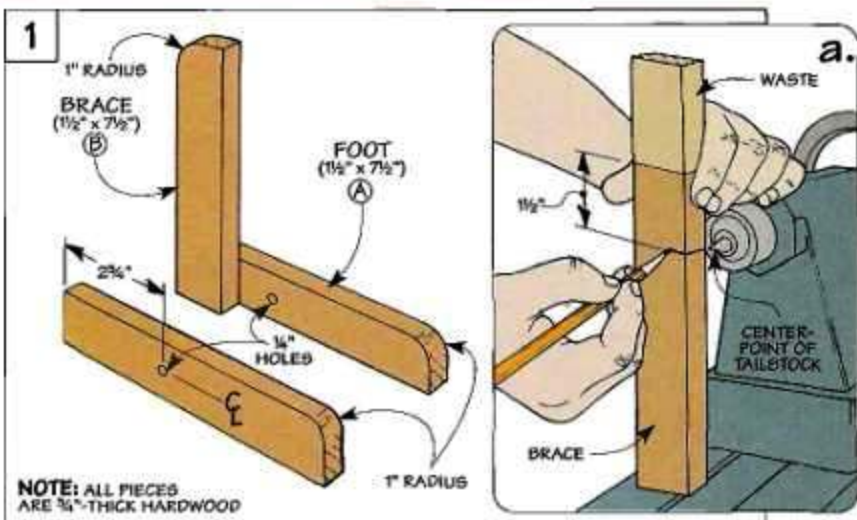

Support System

The steady rest uses a simple system to support the spindle. The heart of this system is a pair of ordinary ball bearings that ride against the spindle as it turns.

Note: I bought bearings from a bearing supply company, but they're available in many woodworking catalogs as well.

HEAD ASSEMBLY

The bearings are housed in a *head assembly* that's attached to a vertical arm, see Figs. 4 and 5. This assembly is made up of a pair of mounting plates that sandwich the bearings between them.

MOUNTING PLATES. These *mounting plates (E)* are pieces of $\frac{1}{4}$ " hardboard that are about the size of a matchbook, see Fig. 4a. To accept bolts that will be used to secure the bearings, you'll need to drill two holes near the front of each plate. And another hole near the back provides a way to attach the head assembly to the arm.

In addition to the holes, there's a small, V-shaped notch centered on each mounting plate. This notch provides clearance between the mounting plates and the spindle.

INSTALL BEARINGS. After cutting the notches, it's just a matter of installing the bearings between the mounting plates. Each bearing is held in place with a bolt

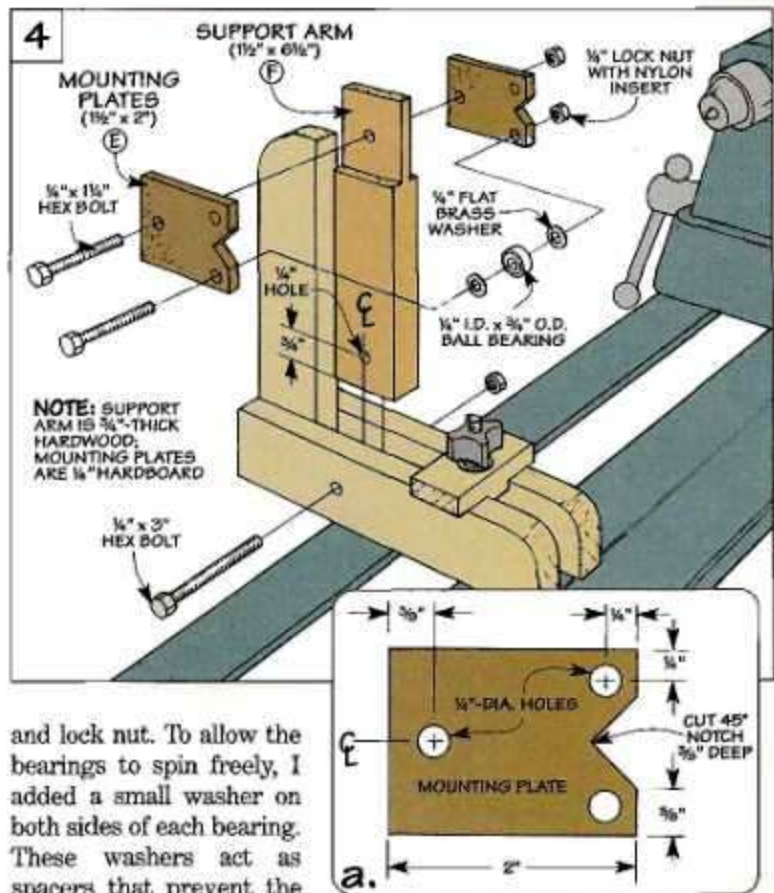

and lock nut. To allow the bearings to spin freely, I added a small washer on both sides of each bearing. These washers act as spacers that prevent the mounting plates from pinching against the bearings.

SUPPORT ARM

With the head assembly complete, the next step is to add a *support arm*, see Fig. 4. Besides providing a way to mount the head assembly, the arm raises it to a height that allows the bearings to

ride against the spindle.

That sounds fairly straightforward — but there's a catch. As you turn the spindle to a smaller diameter, the bearings need to remain in continuous contact with the spindle.

The solution is simple. As the spindle gets thinner, the support arm tilts forward and the head assembly pivots to keep the bearings right where you want them — against the spinning workpiece, refer to details 'a' and 'b' on page 26.

The *support arm (F)* starts out as a piece of $\frac{3}{4}$ "-thick hardwood that's cut 1" shorter than the brace (B), see Fig. 4. To secure the arm to the feet (and to provide a pivot point), a bolt passes through a hole drilled near the bottom end of the arm. And another hole in the top

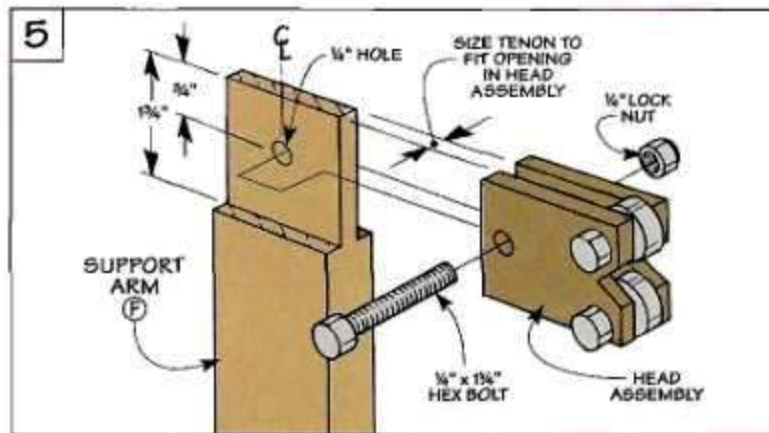

accepts a bolt used to secure the head assembly, see Fig. 5.

TENON. But before attaching the head assembly, there's one more thing to do. That's to cut a tenon on the top end of the support arm. The tenon fits between the mounting plates on the head assembly, see Fig. 5.

The idea here is to cut the tenon $\frac{1}{8}$ " longer than the width (height) of the mounting plates. This will provide clearance above the shoulder of the tenon that prevents the head assembly from binding.

Another thing to be aware of is the *thickness* of the tenon. What you're looking for here is a *loose* fit that allows the tenon to slip easily into place. This will allow the head assembly to pivot smoothly up and down.

ASSEMBLY. Once the tenon is completed, you can secure the head assembly and support arm. After installing the bolts that hold them in place, be careful not to overtighten the lock nuts.

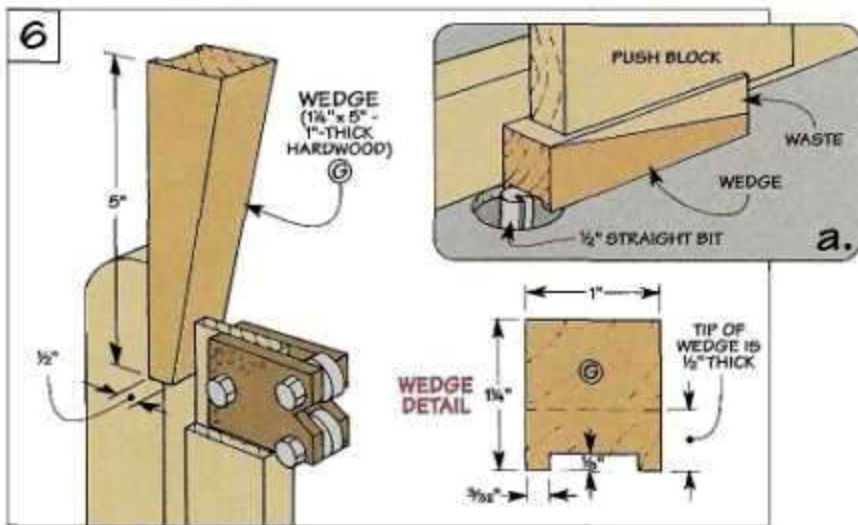

Again, you want both parts to move without binding.

WEDGE

All that's left to complete the steady rest is to add a hardwood wedge, see Fig. 6. As the spindle gets smaller in diameter, the wedge slips down between the brace and support arm. This tilts

the arm forward which holds the bearings in the head assembly against the spindle.

To guide the *wedge* (G), there's a groove in one edge that fits over the edge of the brace, see Wedge Detail in Fig. 6. I used a table-mounted router to cut this groove and then cut the wedge on a band saw, see Fig. 6a.

Using the Steady Rest

Using the steady rest is a simple three-step process, see photos below. But there are a couple things to keep in mind as you turn.

ROUGHING OUT. First, you'll need to rough out a cylinder so you have a round surface. This

way the bearings can make full contact with the workpiece. Then, you can lock the steady rest down and add the wedge.

GENTLE PRESSURE. The whole idea of the wedge is to provide *gentle* pressure to hold the bear-

ings against the spindle. But if you catch the edge of your tool on the workpiece, the workpiece may flex causing the wedge to drop too low. In that case, simply lift the wedge up and gently set it back in place. 



1 To set up the steady rest, slide it forward until the bearings contact the spindle. Then tighten the lock knob.



2 Now gently slip the wedge in place. The weight of the wedge applies all the pressure that's needed.



3 To reposition the steady rest closer to where you're turning, slide it along the lathe bed.

Buying Pine

If you're building a project out of pine, knowing what to look for can save you time and money.

You'd think it would be easy to walk into a lumberyard or home center and buy a pine board. But sometimes it gets confusing.

One way to simplify things is to keep in mind that most of the pine lumber you see can be divided into three main groups: *white*, *southern yellow*, and *western yellow*, see photos below.

WHITE PINE. As you'd expect, white pine is the lightest in color. It's also the most lightweight. One nice thing about white pine is it has a subtle grain pattern. And it machines well and takes a finish better than the other pines. That makes white pine ideal for making furniture.

SOUTHERN YELLOW. You'll also find southern yellow pine at some lumberyards. Besides the fact it's considerably yellower than white pine, it's also quite a bit heavier. And it's hard

as nails. (Don't try to drive a screw into it without drilling a pilot hole.)

The striking thing about southern yellow pine is the alternating bands of light-colored earlywood and darker latewood. Run your hand across the board and you can *feel* the difference in coarseness. This abrupt transition makes southern yellow pine more difficult to work and harder to finish.

WESTERN YELLOW. It goes without saying that the pines in the western yellow group are yellow. But there's not as dramatic a contrast between earlywood and latewood.

A good deal of the lumber you find at home centers falls in the western yellow group. (We built the toolbox in this issue using ponderosa pine which is one type of western yellow.) It's also an excellent choice if you're building "country-style" knotty pine furniture.

GRADE STAMPS. Even when you know what to look for, it's still sometimes hard to tell one pine from another. So look at the grade stamp imprinted (or stapled) on the board.

There's no doubt whatsoever if it's stamped "white pine." Some white pine will also be stamped 'IWP' which stands for Idaho White Pine.

Another grade stamp that's not obvious at first is SPIB. (No, it's not a soft drink.) It stands for the Southern Pine Inspection Bureau. So you'll know right away you're dealing with southern yellow pine.

Finally, you may see two back-to-back 'Ps'. That's ponderosa pine. Sometimes you'll see the 'Ps' combined with an 'LP' (for lodgepole pine). Either way, it's one of the western yellow pines.

SELECT & COMMON

Another thing to consider is the *grade* of the lumber. There are many different grades. But all you need to know is that they generally fall into two basic categories: select (or finish), and common.

As a rule, a board that's generally knot-free and consistent in color is assigned one of the "Select" or "Finish" grades. And if there are more knots (or the color is uneven) it's one of the "Common" grades.



▲ With its light color, white pine (top) is easy to distinguish from southern yellow pine (middle) and the western yellow pines (bottom).





◀ **Common.** A board that has one of the common grades has more knots, but it still has plenty of usable lumber.



◀ **Select.** Expect to find clear-grained lumber with few (if any) knots on a board assigned one of the Select grades.

COST. The thing to be aware of is that "Select" pine is considerably more expensive than "Common." So if you want to build a project out of clear pine, you may be surprised to find that it ends up costing as much as one made of oak or walnut.

The solution is simple. For the short pieces of a project, buy "Common" boards and cut around the knots. Buy "Select" only when you need long pieces.

DEFECTS

Besides working around the knots, there are also some defects that you'll want to avoid.

LOOSE KNOTS. Loose knots are easy to recognize, see photo 'A' below. They slide back and forth in the knothole. And in time they're likely to fall out, leaving a hole in your project. If the loose knots fly out when you're cutting or routing a board, they can be dangerous as well.



A. Loose Knots. A black ring around a knot is a sign that a knot will loosen up over time.

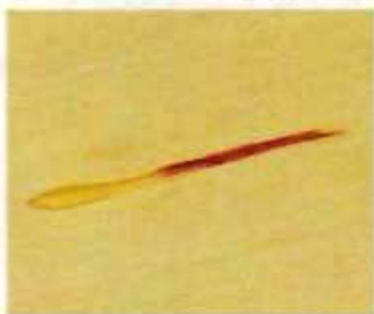

B. Pitch Pockets. These slits ooze sap which gums up saw blades and creates finishing problems.



C. Pith. It's the very core of the tree. But you'll find it much too soft to sand and finish.



D. Wide Growth Rings. It means a tree has grown fast. But at the cost of strength and appearance.

PITCH POCKETS. Another defect to steer clear of is pitch pockets, see photo 'B.' These are slits in the board that ooze sap. The sap gums up saw blades and router bits. And it can bleed through a finish long after the project is completed.

PITH. On some boards, the pith (core) of the tree runs lengthwise down the center, see photo 'C.' It's so soft you can dig it out with your fingernail — too soft to sand or finish. But there's usually straight-grained wood on each side of the pith. So if you're making narrow rails or stiles, cut out the pith to get the usable lumber.

WIDE GROWTH RINGS. One final note. Some boards have growth rings that are extremely far apart, see photo 'D.' This is the result of a tree that has grown too rapidly. These boards tend to be a bit punky, so they're not as strong. And I find the grain pattern is less desirable. ▲

Tips on Selecting Pine

- 1 Buy Common.** For small projects, buy common boards and cut around the knots. Buy select only if you need long, clear pieces.
- 2 Avoid Loose Knots.** A saw blade can fling loose knots out of the board. And they may fall out of a project after assembly.
- 3 Pitch Pockets.** The oozing sap in pitch pockets will gum up blades and bits. And it can bleed through a finish long after it dries.
- 4 Pith.** Cut out the pith that runs lengthwise down the center of a board to take advantage of straight-grained wood on each side.
- 5 Wide Growth Rings.** Steer clear of wide growth rings produced by fast growing trees. It reduces the strength of the lumber.
- 6 Check Grade Stamps.** If it's difficult to identify the type of pine by the grain, the grade stamps provide useful clues.

Scenes from the Shop

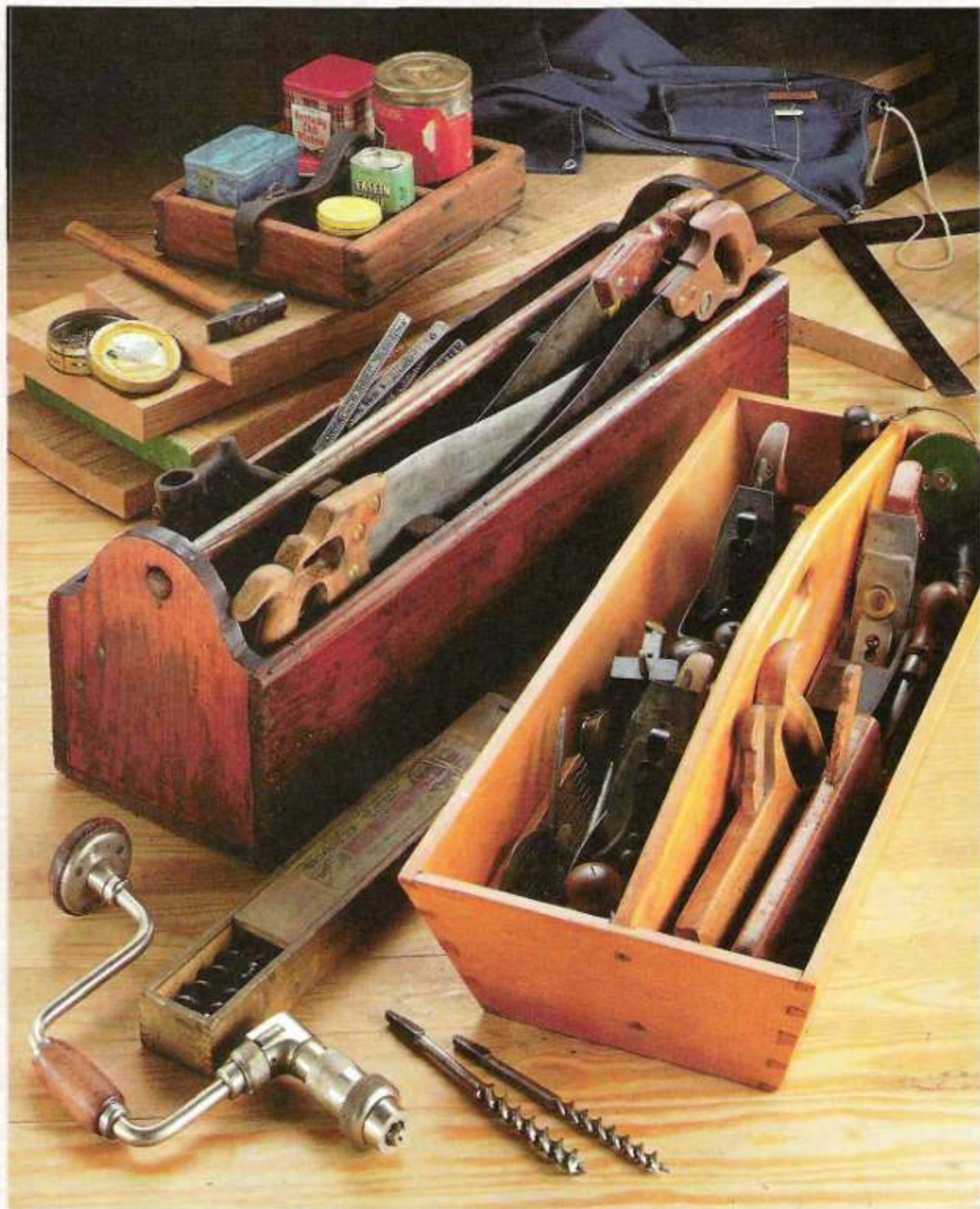

Woodworkers have been carrying their tools to the job for generations. And tool totes like these provided a practical way to do it. Whether it's a box of tins to hold

small parts, a long tote to protect handsaws from damage, or a dovetailed carry-all for hand planes, they're as individual as the craftsmen who made them.