

TIPS • TOOLS • TECHNIQUES

ShopNotes

Vol. 7

Issue 42

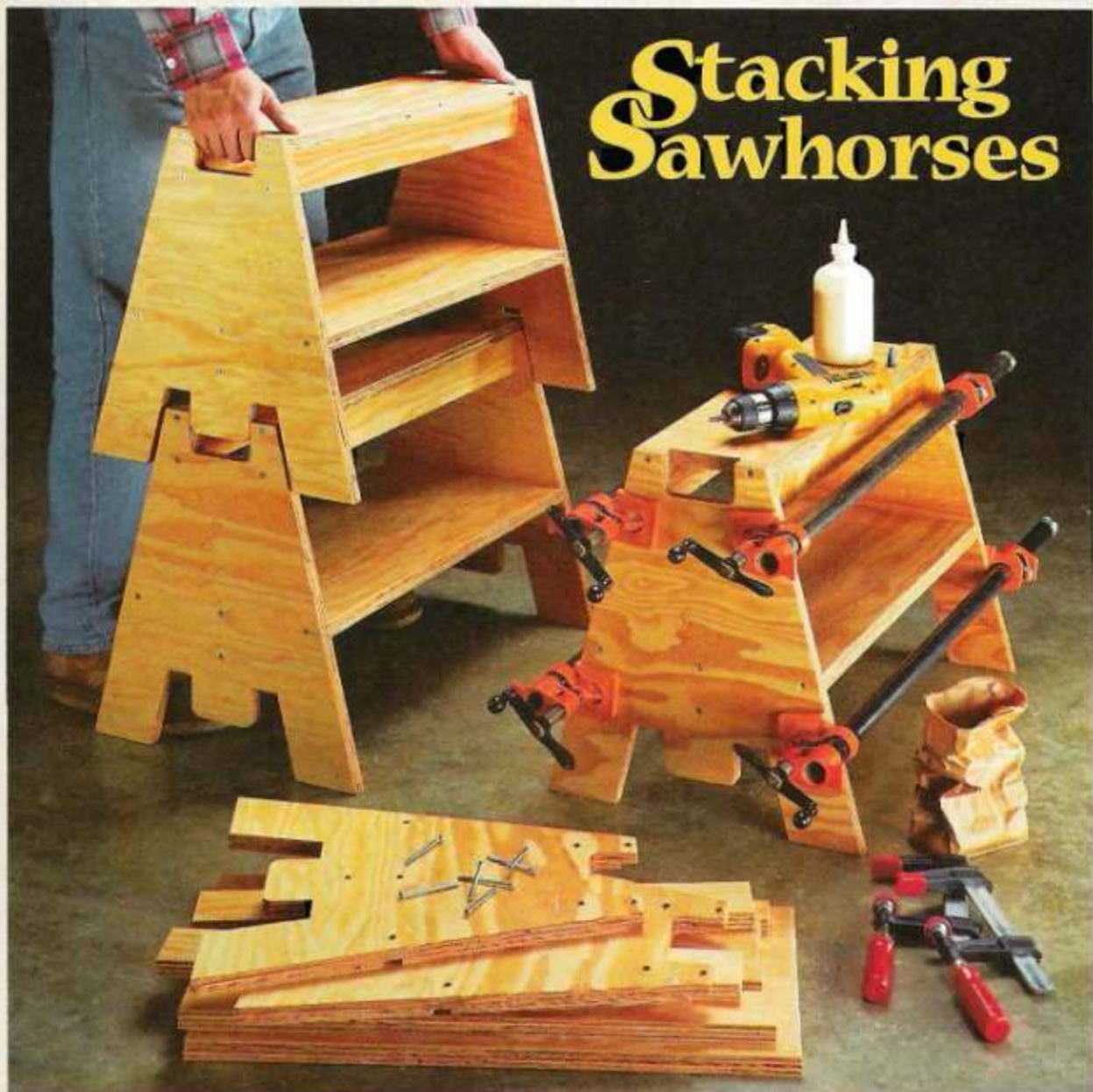

Stacking Sawhorses

- Pocket Hole Jig
- Tool Review: Miter Gauges
- Shop-Made Edge Clamps
- Spiral Router Bits



ShopNotes

Issue 42 November 1998

PUBLISHER Donald B. Peschke
EDITOR Tim Robertson
ASSOCIATE EDITOR Tom Bagnol
ASSISTANT EDITOR Bryan Nelson
ART DIRECTOR Cary Christensen
SR. GRAPHIC DESIGNER Roger Reiland
SENIOR ILLUSTRATORS Mark Higdon

CREATIVE RESOURCES

Creative Director: Ted Krashinsky • *Project Developer:* Ken Munkel • *Senior Project Designer:* Kevin Boyle • *Project Coordinator:* Kent Walsh • *Shop Manager:* Steve Curtis • *Shop Craftman:* Steve Johnson • *Senior Photographer:* Craylin England

BOOKS

Executive Editor: Douglas L. Hicks • *Art Director:* Steve Lander • *Sr. Graphic Designer:* Chris Glowacki

CIRCULATION

Sub. Serv. Dir.: Sandy Bman • *New Bus. Dir.:* Glenda Battles • *Retention Mgr.:* Paige Rogers • *Billing Mgr.:* Rebecca Cunningham • *Prod. Mgr.:* Blak Jundak • *New Bus. Mgr.:* Todd L. Blerle • *Asst. Sub. Mgr.:* Jay Krause • *Assoc. Graphic Design Dir.:* Stacie Rider • *Sr. Graphic Designer:* Cheryl L. Simpson

CORPORATE SERVICES

V.P. of Planning & Finance: Jon McCarthy • *Controller:* Robin Hutchinson • *Sr. Acct. Laura Thomas* • *Accts. Payable:* Mary Schultz • *Accts. Rec.:* Margo Petrus • *Prod. Dir.:* George Chmieloz • *Elect. Pub.:* Douglas M. Lillster • *Prod. Asst.:* Susan Ruave • *Pre-Press Image Spec.:* Troy Clark • *Minimette Biegler* • *New Media Mgr.:* Gordon C. Galippe • *Multimedia Art Dir.:* Eugene Pederson • *Network Admin.:* Chris Harrison • *H. R. Asst.:* Kristen Koole • *Admin. Asst.:* Julia Fish • *Receipt.:* Jeanne Johnson, Sheryl Kibbey • *Blkg. Maint.:* Ken Griffith • *Special Proj. Dir.:* Saville H. Inman

MAIL ORDER

Operations Dir.: Bob Baker • *Mail Mgr.:* Mark Mattison • *Cost. Service Mgr.:* Jennie Eason • *Warehouse Supv.:* Nancy Johnson • *Buyer:* Linda Jones • *Op. Asst.:* Tammy Akini • *Tech. Rep.:* Matthew TeRonde • *Cost. Serv. Reps.:* Anna Cox, Tammy Trukenbrod, Adam Best, Nancy Downey, Deborah Rich • *Warehouse:* Sylvia Carey • *Quality Control Technician:* Paula Johnson

ShopNotes® (ISSN 1062-9606) is published biweekly (Jan., March, May, July, Sept., Nov.) by August Home Publishing, 2590 Grand, Des Moines, IA 50312.

ShopNotes® is a registered trademark of August Home Publishing. ©Copyright 1998 by August Home Publishing. All rights reserved.

Subscriptions: Single copy: \$4.99. One year subscription (6 issues), \$21.94. Canada/Foreign add \$6 per year.

Periodicals Postage Paid at Des Moines, IA and at additional mailing offices.

Postmaster: Send change of address to ShopNotes, P.O. Box 37166, Boone, IA 50037-2166.

Subscription Questions? Write to: ShopNotes Customer Service, P.O. Box 842, Des Moines, IA 50304-9901. Or call 1-800-333-5854, 9:00 am to 5:00 pm, Central Time, weekdays. FAX 515-283-0447.

E-Mail: ShopNotes@shopnotes.com

Internet: http://www.shopnotes.com

PRINTED IN U.S.A.

Reprinted 2002

WoodNet

NOW ON THE WEB!

- 101 Woodworking Tips Online
- Woodworking Techniques — Step-by-Step
- Project plans you can download
- WoodNet Forum — Woodworkers' Q & A
- Power Tool Reviews

Print your browser to: <http://www.augusthome.com>
 Select "Woodworking" from the Welcome Page menu.

Cutoffs

Whenever we get visitors here at ShopNotes, one of the most frequently asked questions is, "Isn't it difficult coming up with ideas for the projects?"

Actually, coming up with the ideas is easy. (We've got a long wish list.) The hard part is making the ideas work.

Often, it seems there's some small obstacle or detail that we get bogged down in. We just can't seem to find the right solution.

When that happens, the best thing I've found is to step back, stop butting heads with the problem, and look for inspiration somewhere else.

STACKING SAWHORSES.

The sawhorses featured in this issue are a good example. The idea was to build a set of four short sawhorses that stack together.

This way, you could stack them together in pairs and use them like a standard height sawhorse. Or, use them individually to create a low assembly area.

It sounded like a great idea. There was just one small problem. We were struggling with a way to get these sawhorses to fit together securely without wobbling.

Then I got to thinking about a set of stacking wood figures I'd seen as a kid. So I started checking around some antique shops to try to find them. At each place, they knew just what I was talking about. But no one had any around.

I was just about ready to give up

when I decided to stop at one last place. There was stuff piled everywhere. And most of it looked like it hadn't been moved in years.

But when I described the figures to the lady who worked there, she nodded a bit and began picking her way through the narrow passageways. Then she stopped at a pile that looked just like all the rest and started rummaging around.

BILL DING. After a few minutes, she pulled out an old, musty box. Inside, under a thick layer of dust, was exactly what I'd been looking for — a set of stacking clowns called *Bill Ding*, see photo.

Well, I brought the clowns back to the office, and they were a big hit with all of the guys. They stacked and unstacked the figures. Over and over again. Each balancing stunt more impressive than the last.

What made this work is a simple system of interlocking parts that allowed each figure to hook securely onto the next.

TABS & NOTCHES. This concept provided just the inspiration we needed to get us back on track with our own stacking sawhorses. To lock them together, the sawhorses incorporate a similar type system of interlocking tabs and notches.

In the end, I couldn't be happier with our sawhorses. But what was even more satisfying is that a part of my past I'd long forgotten provided a clue to the solution.



Tim

Contents

Features

Edge Clamps _____ 6

These shop-made edge clamps are bound to come in handy when gluing hardwood edging on plywood.

Cutting Plywood _____ 10

Tips and techniques for cutting a full sheet of plywood down to size. Also, tricks on preventing chipout.

Tool Test: Miter Gauges _____ 12

Is it worth buying an "after-market" miter gauge for your table saw? We test four popular models to find out.

Pocket Hole Jig _____ 16

Make pocket hole joints quickly and easily with this simple jig. It features a tilting carriage to rout the pocket. And a built-in guide lets you drill the pilot hole accurately.

Stacking Sawhorses _____ 24

Practical and inexpensive — two reasons to build this set of stacking sawhorses. You can make four complete sawhorses using just a single sheet of plywood.

Spiral Upcut Bits _____ 30

It cuts sideways like a router bit. And it has the plunge cutting ability of a drill bit. That's what makes these router bits ideal for cutting deep mortises.

Departments

Readers' Tips _____ 4

Our readers offer their own shop-tested tips to some of the most common woodworking problems.

Shop Solutions _____ 28

Here's a selection of tips from the guys in our shop that will make it easy to build the projects in this issue.

Sources _____ 31

Hardware, supplies, and mail-order sources for the projects featured in this issue.

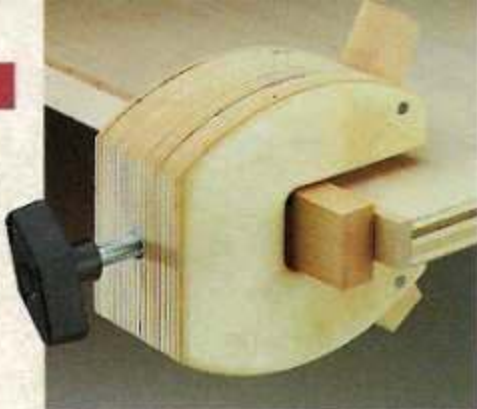

Edge Clamps *page 6*



Miter Gauges *page 12*



Pocket Hole Jig *page 16*

Stacking
Sawhorses
page 24



Quick Tips



■ When using pliers to make repetitive cuts, *Crayola England* of Des Moines, IA slips a length of garden hose over the handles. This opens the jaws automatically like they're spring-loaded.



■ Trying to lift an edge of the backing strip on a piece of carpet tape can be frustrating. So *Al Army* of Utica, NY first scrapes the backing strip with a scratch awl then peels it off.



■ Sabre saw blades have a way of getting lost in the shuffle. But *R.B. Himes* of Vienna, OH keeps all his blades organized and right at hand by hanging them on a shower curtain hook.

Dowel Cutting Jig

■ Cutting dowels to short lengths on the table saw can present problems. The dowel is likely to splinter. And the blade often launches the cut-off piece right back at the operator.

To solve the problem, I made a jig that's used with a handsaw. The jig makes it safe and easy to cut dowels to length. And it prevents splintering.

The jig can be used with $\frac{1}{4}$ ", $\frac{3}{8}$ " and $\frac{1}{2}$ " dowels. And it will cut dowel to lengths ranging from $\frac{1}{4}$ " to 2", in $\frac{1}{8}$ " increments.

It has just two parts: a hard-

wood body, and a hardboard stop that pivots on a screw. Three dowel holes are drilled along the edge. And kerfs cut with a back saw establish the dowel lengths.

The jig is easy to use. First, it's clamped in a vise. Then the dowel is inserted in a hole and butted against the stop. With the saw blade in the appropriate kerf, the dowel is cut to length, see Fig. 1. Then just flip the stop down and push out the cutoff dowel, see Fig. 2.

John Lynch
Omaha, Nebraska

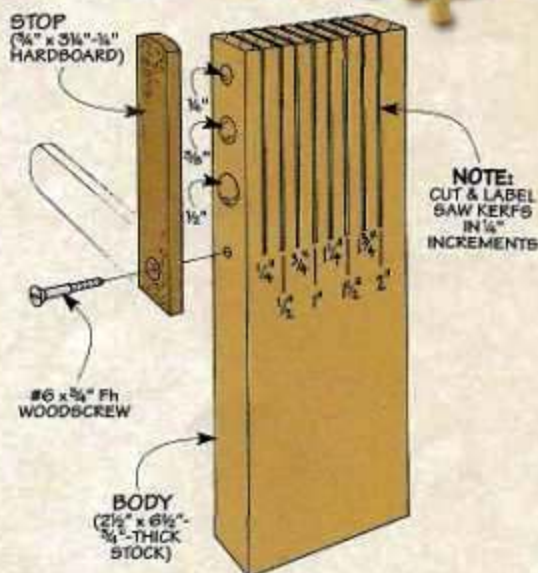
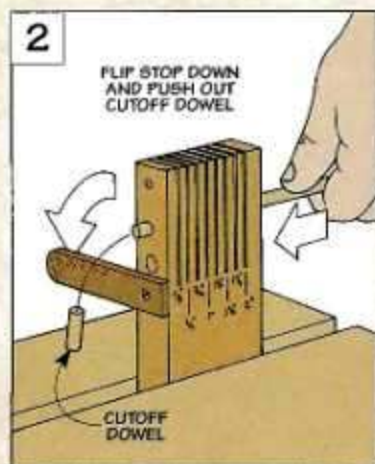
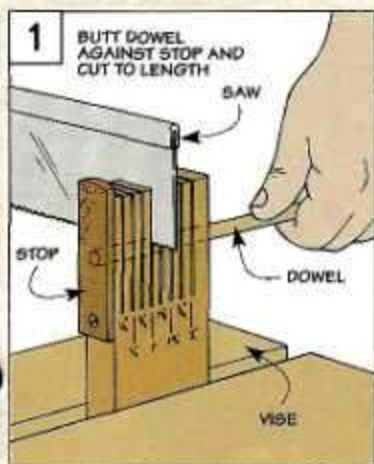

Send in Your Tips

To share your original tips and solutions to problems you've faced, send them to: *ShopNotes*, Attn.: Readers' Tips, 2200 Grand Ave., Des Moines, IA 50312. (Or if it's easier, FAX them to us at: 515-282-6741.)

We'll pay up to \$200 depending on the published length. Please include a daytime phone number so we can call you if we have any questions.

Edge Clamps



The unique design of these edge clamps makes it easy to apply hardwood edging.

Like most woodworkers, I build quite a few projects that use $\frac{3}{4}$ " plywood. So covering the exposed edges of the plywood with strips of solid wood edging has become a fairly routine matter.

In spite of that, gluing on these narrow strips of wood always seems to require more fiddling around than I'd like.

If it's a long piece for instance, I have to drag out an armload of heavy clamps to apply pressure

along the entire length of the strip. And even then, aligning the edging with one hand and positioning the clamps with the other is a bit tricky.

To simplify this process, I built a set of six small edge clamps, see photo above. These clamps make it easy to align the edging *and* apply pressure at the same time.

FINGERS. The secret is a pair of pivoting "fingers," see drawing below and inset photos above. When you slip the clamp in place, the fingers *lightly* grip the top and bottom surface of the plywood. Because of this, the clamp stays put. This lets you use both hands to position the edging.

But that's not all the fingers do. The more you tighten the clamp, the *harder* they grip. This anchors the clamp on the plywood so it doesn't slip back once the pressure is applied to the edging.

The nice thing about this is the edge clamps can be used when a pipe clamp (or bar clamp) won't work. The cabinet shown above is a good example. It's already assembled, and only one edge is accessible. But you can still fit the clamps over the "open" edge to apply the edging.

EXPLODED VIEW

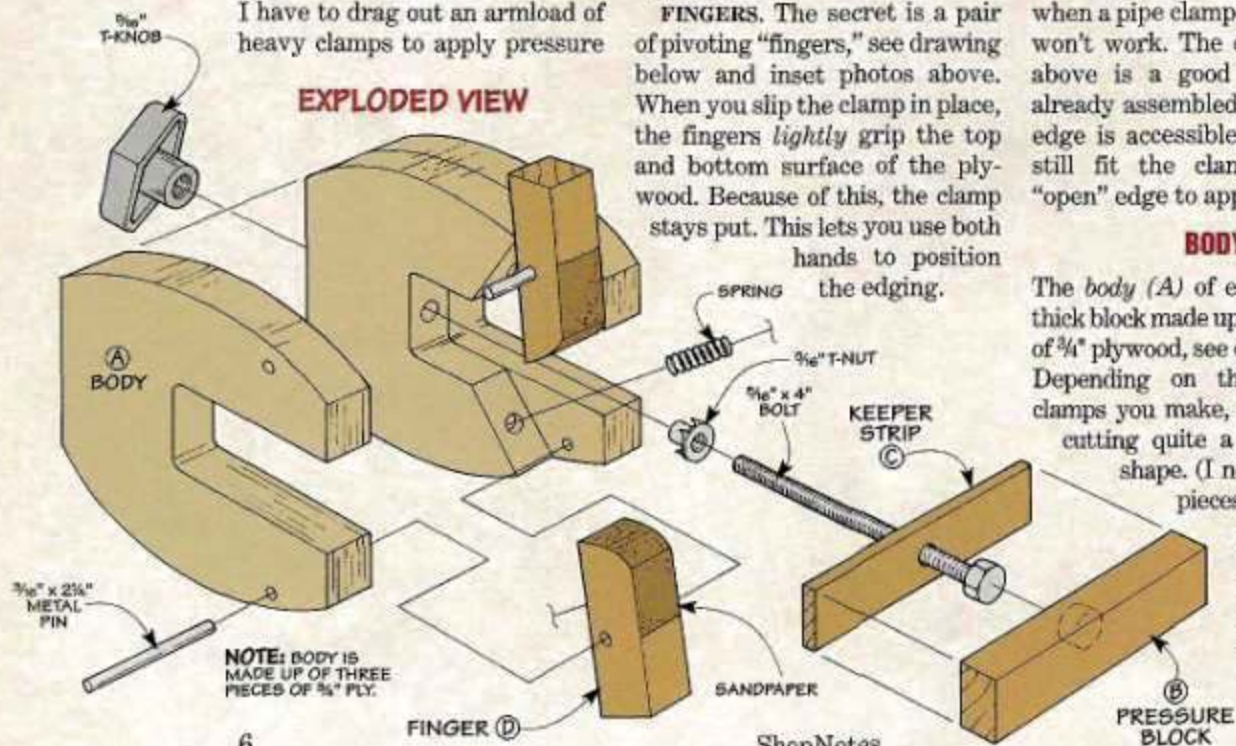

BODY

The *body* (A) of each clamp is a thick block made up of three layers of $\frac{3}{4}$ " plywood, see drawing at left. Depending on the number of clamps you make, it may require cutting quite a few pieces to shape. (I needed eighteen pieces to build my six clamps.)

TEMPLATE. To do this quickly (and to ensure that all the pieces are

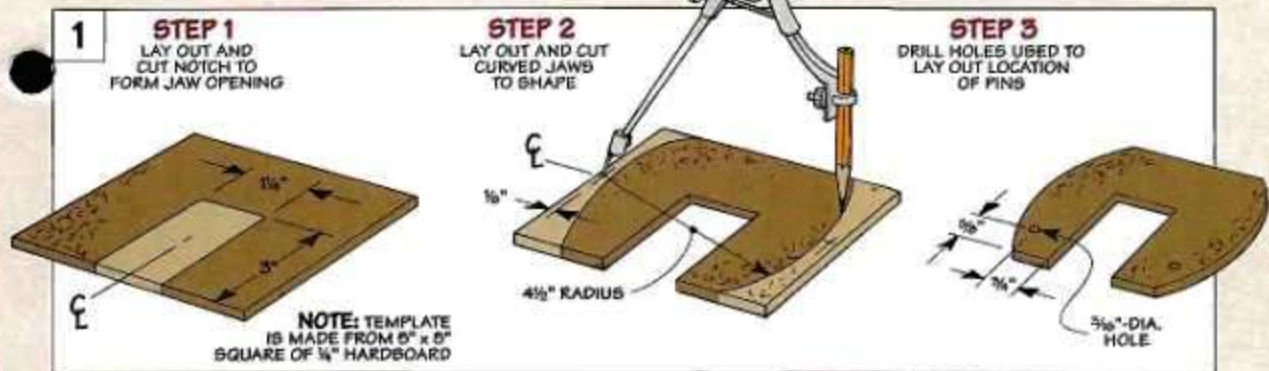

identical), I started by making a hardboard template, see Fig. 1. A wide notch in the template forms the "jaws" of the clamp. To reduce the overall size of the clamp, there's a gentle curve on the outside edge of each jaw.

The thing to be aware of here is the template will be used when routing the pieces to shape. So any "bumps" in the edge of the template will transfer to the workpiece. To avoid this, I hand-sawed the template to rough shape then sanded up to the line.

Once the edges are nice and smooth, the last thing is to drill a hole in each jaw. These holes are used to locate two pivot pins (added later) for the fingers.

BLANKS. With the template complete, the next step is to cut as many blanks as you need for the pieces of the body. (I cut 5" x 5" squares of Baltic birch plywood.)

There's no need to lay out the shape of the body on the blanks. It's easier to simply carpet-tape the template to the blank.

Before cutting each blank to shape, it's a good idea to drill holes near the inside corners of the notch, see Fig. 2. As you cut the piece to rough shape with a band saw (or sabre saw), the holes provide clearance so you can "turn the corner," see Fig. 3.

Note: Save one of the curved waste pieces. It will come in handy when working on the middle piece of the body later.

ROUT TO SHAPE. Now you're ready to rout the piece to final

shape. This is where the time spent making the template pays off. With a flush trim bit mounted in the router table, you can remove the excess waste in a matter of minutes, see Fig. 4.

TRIM JAWS. After repeating this process for the rest of the blanks, there's one more thing to do. To create an opening for the fingers, the jaws of the *middle pieces* only are trimmed at an angle.

But if you use the miter gauge on the table saw to do this, the

curved edges of the pieces will rock when you set them against the miter gauge. The solution is a simple jig that uses the curved waste piece that was cut earlier, refer to page 28. To set up this jig, you'll need to first lay out the angled lines on one of the pieces, see Fig. 5.

GLUE-UP. Now it's just a matter of gluing up the body of each clamp. Here, an assembly jig made of scrap pieces keeps the edges aligned, see page 29.

Hardware

- (1) 5/16" x 4" Hex Bolt (full thread)
- (1) 5/16" T-nut (w/prong)
- (1) 5/16" T-knob
- (2) 5/16" O.D. x 1 1/2" Springs (.025" wire diameter)
- (2) 5/16" x 2 1/4" Metal Pins

Note: The hardware on this list is for one edge clamp only.

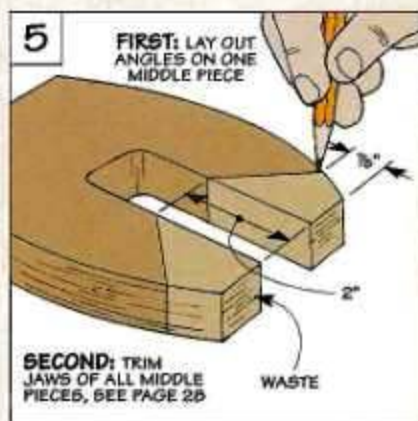
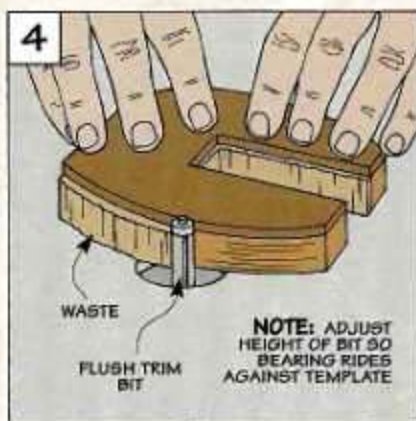
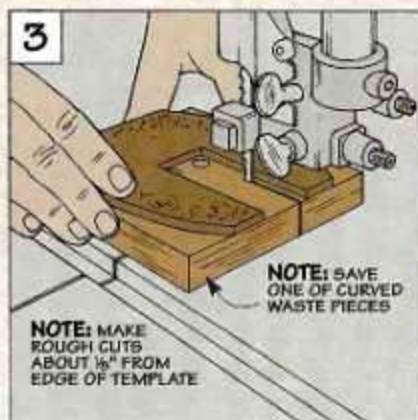
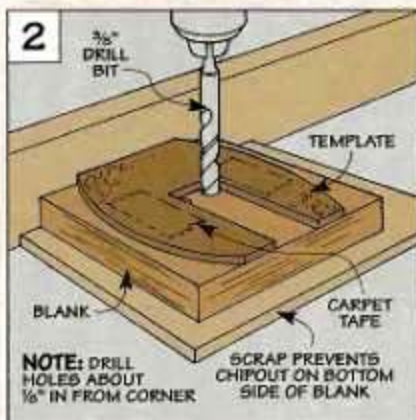

Clamping System

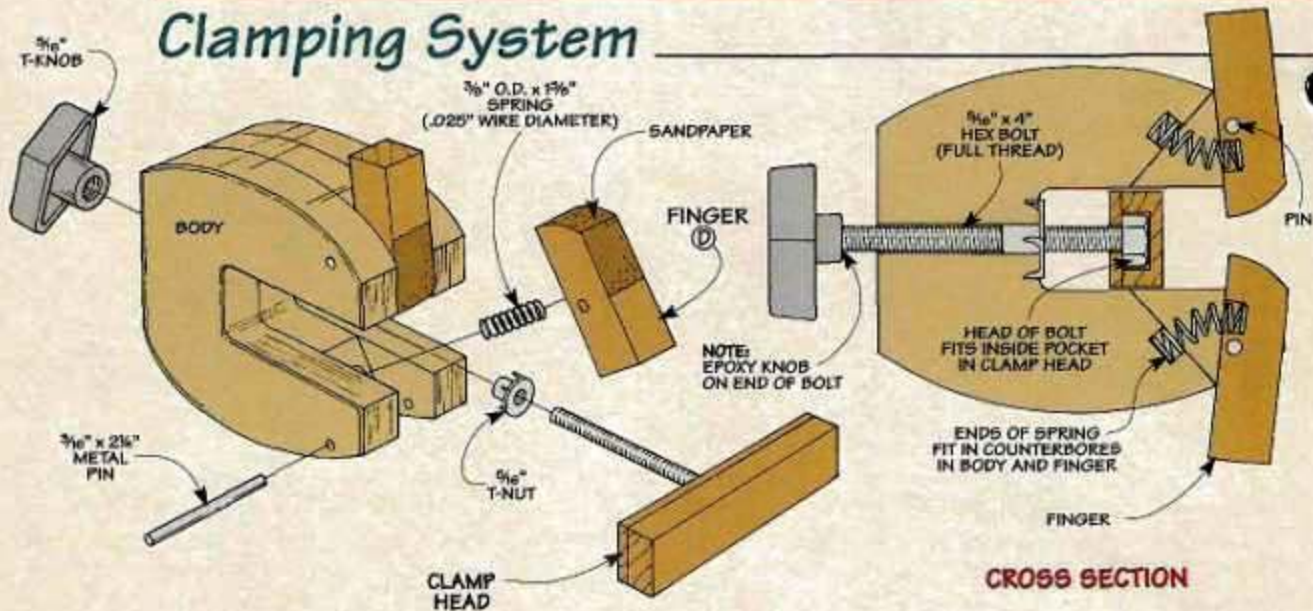

After gluing up the body of each edge clamp, I added a two-part clamping system. A *clamp head* applies pressure against the edging, see drawing. And two *fingers* hold the clamp in place.

CLAMP HEAD

The clamp head is a hardwood block that distributes the clamping pressure. This pressure is applied by a bolt that threads into a T-nut in the body of the clamp.

POCKET. But the head of the bolt could mar the edging when the clamp is tightened. So it's enclosed in a "pocket" inside the clamp head, see Cross Section.

To create this pocket, the clamp

head is made up of two pieces: a thick *pressure block* (B) and a thin *keeper strip* (C), see Fig. 6.

The bolt head sits in a counterbore that's centered in the pressure block. And a centered hole in the keeper strip fits over the threads of the bolt. Gluing the two pieces together captures the head of the bolt in the clamp head.

T-NUT. Before installing the clamp head, you'll need to add the T-nut that accepts the bolt. It fits in a centered hole in the end of the jaw opening. It's easiest to drill this hole from the opposite end of the clamp, see Fig. 6a. Note: Placing a scrap in the opening reduces chipout.

After tapping the T-nut into place, just thread the end of the bolt through the T-nut and out the opposite end. Then, after applying epoxy to the end of the bolt, thread on a plastic knob.

FINGERS

Once the clamp head is installed, you're ready to add the fingers. They hold the clamp securely in place as pressure is applied.

PIVOTING FINGERS. To make this work, the fingers pivot back and forth like flippers on a pinball machine. When you slip the clamp over the edge of the workpiece, the curved ends of the fingers pivot *inward*. This com-

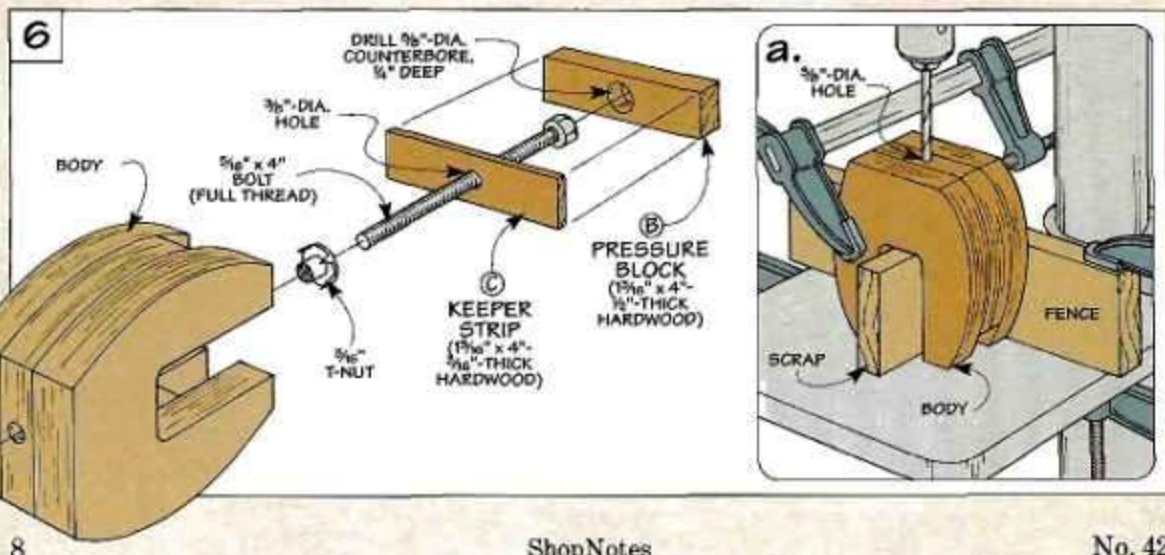

8

presses a spring which exerts pressure in the opposite direction. This pressure holds the clamp snug as you align the edging.

But the springs aren't strong enough to keep the clamp from slipping once pressure is applied. That's why the ends of the fingers are curved. As you tighten the clamp, the fingers rock slightly on their curved ends and squeeze the plywood between them.

CONSTRUCTION. Each *finger* (D) starts out as a short block of hardwood, see Fig. 7. To ensure that the curved ends are identical in shape, I butted the blocks together and marked a radius across each one, see Fig. 7a.

But why doesn't the curved end just rotate as you tighten the clamp? Because of the location of a pin that's used as a pivot point for each finger, see drawing on page 8.

CAM. The key is to drill the hole for this pin so it's *offset* toward the inside edge of the fingers, see Fig. 7. This way, the curved ends of the fingers act like cams — the more pressure you apply, the harder they grip.

In addition to the holes for the pivot pins, you'll also need to drill a counterbore in each finger. It traps one end of the spring when the clamp is assembled.

The other end of the spring fits in another counterbore in the body of the clamp. It's located in the *angled* end of the middle piece. So to keep the tip of the bit from slipping, I "leveled" the drilling surface by clamping the body at an angle, see Figs. 8 and 8a.

PIVOT PINS. Before assembling the clamp, you'll also need to drill a hole through each jaw to accept one of the pivot pins. The best way to locate these holes is to use the template once again.

To do this, start by aligning the template with the edges of the body. Then, to mark the center-points, tap a $\frac{3}{16}$ " brad point bit through the holes that are

already drilled in the template.

Next, to reduce chipout, you'll want to cut a scrap to fit between the jaws, see Fig. 9. Two more scraps support the body so it sits level while you drill the holes.

PINS. Now you're ready to add the pins. These are pieces of metal rod that are cut $\frac{1}{8}$ " longer than the height (thickness) of the body.

Before installing the pins,

make sure the springs are in place and that the holes in the fingers align with the holes in the body. Then just tap the pins into place, see Fig. 9a.

SANDPAPER. After filing and sanding the pins flush, all that's left is to glue sandpaper to each finger, see margin. (I cut strips from a sanding belt like the type used on a belt sander.)



▲ To produce a no-slip surface, I glued strips of cloth-backed sandpaper (100-grit) to the ends of the curved fingers.

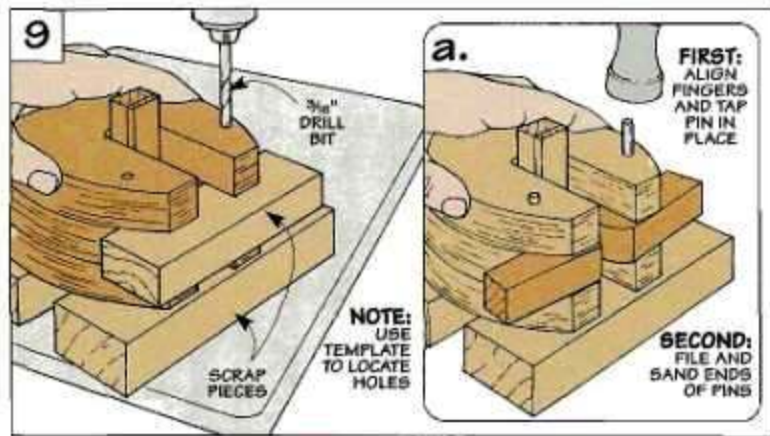
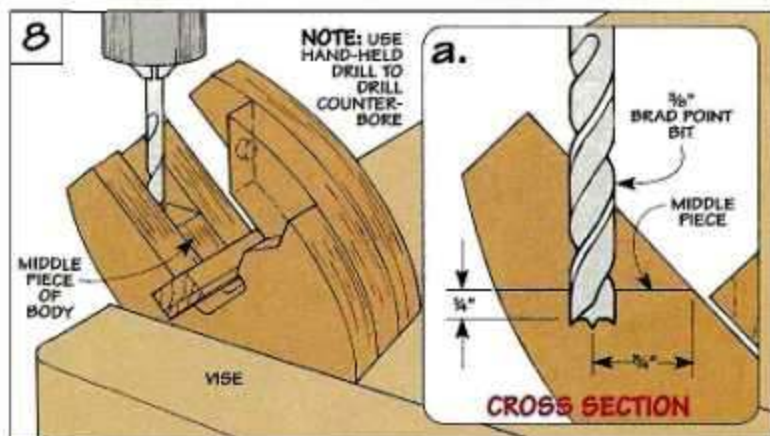
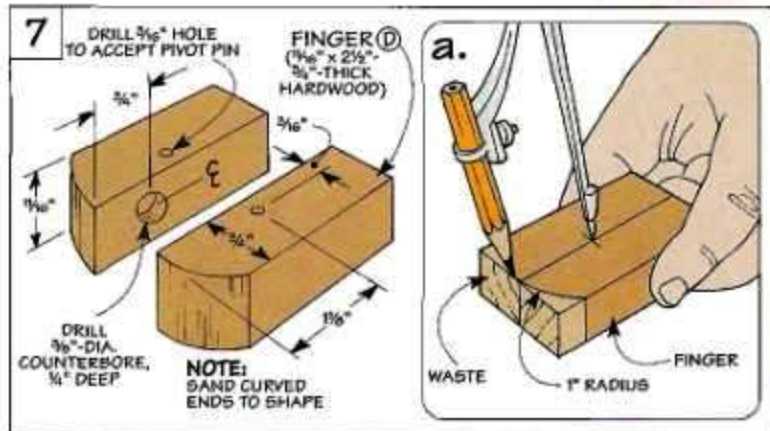

Cutting Plywood

Down-to-Size

Cutting a full sheet of plywood down to size can be a challenge. It's heavy and awkward. And even after you wrestle it into position to make a cut, the surface veneer has a frustrating tendency to chip out.

Fortunately, there are several things you can do to simplify the job — starting with the initial rough cuts.

ROUGH CUTS

Before making a single cut, the first step is to lay out the pieces on the plywood. As a rule, I allow $\frac{1}{4}$ " "extra" all the way around. This provides enough material to make a final clean-up pass later.

But just because the pieces are cut to rough size doesn't mean you want a *rough* cut. The goal is to end up with clean, straight edges that can ride against the rip fence on the table saw (or be placed against the miter gauge).

CUTTING GUIDE. To accomplish this, I use a simple cutting guide that clamps to the plywood and a circular saw, see Fig. 1. The guide consists of two parts: a hardboard base that serves as a platform for the saw, and a wood fence that guides the saw.

The nice thing about this cutting guide is it has a *reference edge* that aligns the saw blade with the layout line. By aligning this edge with the layout line, the blade makes a perfectly straight cut exactly where you want it.

To make the cutting guide,

start by gluing the fence to an extra-wide base. The reference edge is formed by running the base of the saw against the fence and trimming off the waste.

FOAM SUPPORT. You'll also need a way to support the plywood during the cut. The best way I've found to do this is to lay the plywood on a sheet of foam insulation, see Fig. 2. (It's available at most home centers.)

Besides providing support,

the foam lets you crawl onto the sheet of plywood. That's handy when you need just a bit more "reach" to complete a cut.

"GOOD" SIDE DOWN. One thing to be aware of is that the blade on a circular saw cuts on the *upstroke*. This means the *top* surface of the plywood is likely to splinter. So in order to reduce chipout on the "good" side of the plywood, you'll want to place it *face down* on the foam.



▲ To help reduce chipout, these inexpensive, steel saw blades have tiny, razor sharp teeth that remove small amounts of material.

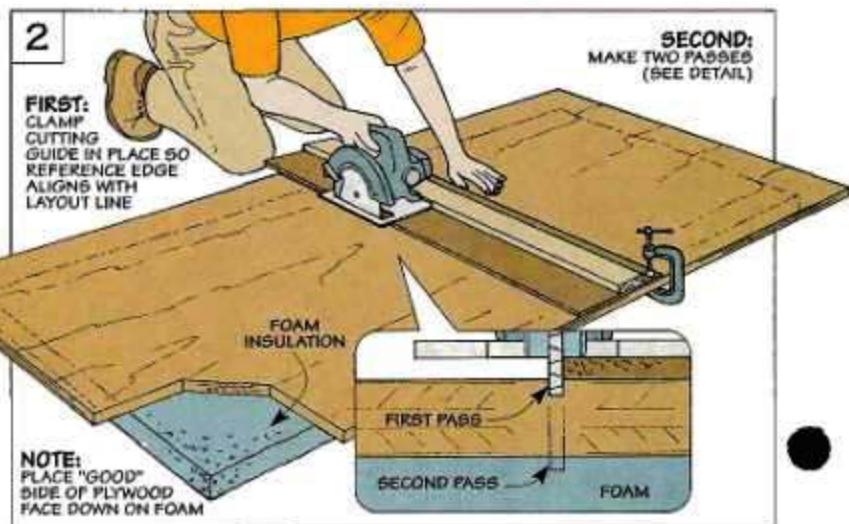
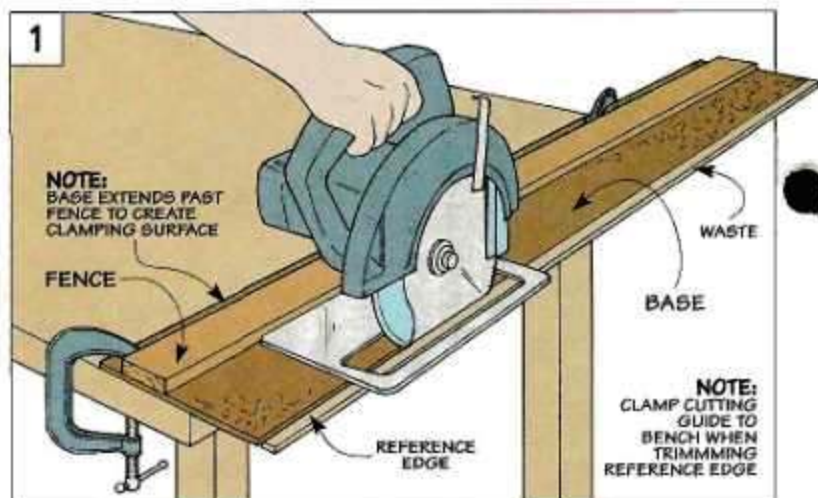

REDUCING CHIPOUT. But many times, you don't want *either* side to splinter. One way to reduce chipout is to use a blade that's specially designed for cutting plywood, see margin on page 10.

Another way to produce a clean cut is to make *two* passes. A shallow, first pass severs the fibers of the surface veneer, see detail in Fig. 2. This means that they *can't* splinter when making the second, full-depth pass.

FINAL CUTS

After making the preliminary rough cuts, the next step is to trim the pieces to final size. This usually calls for a series of cuts — not just one.

FACTORY EDGE. One reason is the "factory edge" of the plywood. You can usually count on this edge to be straight and true. But it often gets dented or nicked. So I usually trim it off.

To do this, adjust the rip fence on the table saw to make an extra-wide cut, see Fig. 3. Then, after readjusting the fence, run the "just-cut" edge against it and rip the piece to final width.

One thing that's different here is the blade on the table saw cuts on the *downstroke*. So the "good" side of the plywood faces *up*.

Even so, it's still a good idea to make a shallow pass first, then follow it up with a full-depth cut, see detail in Fig. 3.

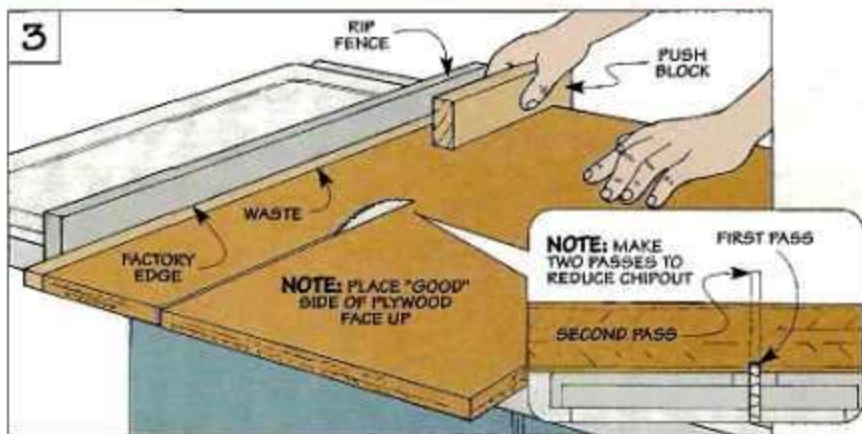

WIDE PIECES. There's another situation that often comes up when cutting pieces to final size — crosscutting a wide piece.

The problem is that a wide piece extends too far out in front of the table saw at the beginning of a cut. This means that the bar of the miter gauge isn't fully supported in the slot in the saw

table. As a result, you can't get an accurate cut.

SLIDING PLATFORM. The solution is a large sliding platform that provides extra support for the workpiece, see Fig. 4.

The platform consists of three parts. A plywood *base* carries the workpiece through the blade. The base is guided by a hardwood *runner* that slides in the miter slot of the table saw. As you make a cut, a *fence* keeps the workpiece square to the blade.

FLUSH TRIM. But sometimes a workpiece is too wide even for the sliding platform. That's when a hand-held router and a flush trim bit come in handy.

The idea here is to first clamp a straightedge to the workpiece so it aligns with the layout line, see Fig. 5. When you run the bearing of the flush trim bit against the straightedge, the bit cuts a clean, crisp edge. 

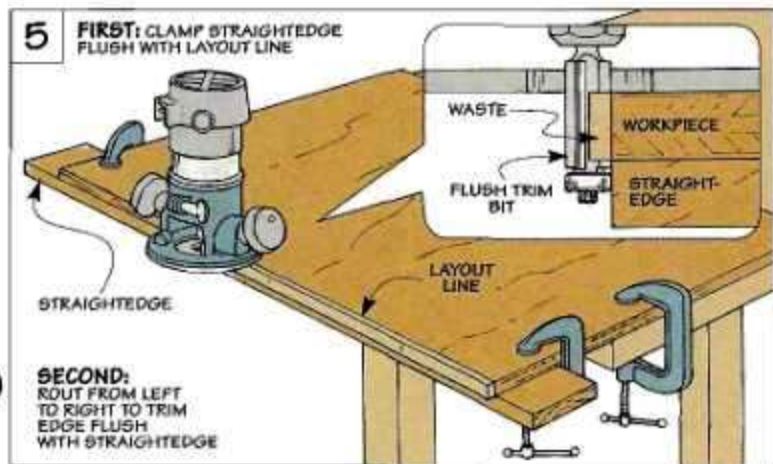



Tool Test: Miter Gauges

How We Selected the Miter Gauges

Each miter gauge we tested has an:

- Adjustable Head
- Long Support Fence
- Price: \$105 to \$170

Why would anybody spend over a hundred bucks for a miter gauge? Especially since it's a standard item that comes with most table saws.

That's what we wanted to know when we decided to test these "after-market" miter gauges. Are they really that much more accurate? And are the "extras" that go with them worth the cost?

To find out, we bought four of the most popular miter gauges, see photos below and on page 13.

One reason we selected these miter gauges is they all have a head that adjusts to any angle between 45° and 90°, see margin.

(Some models we considered were designed to cut *only* 45° or 90° miters.) Note: The Vega miter gauge is the only one we tested that includes a hold-down as a standard accessory.

TEST. With miter gauges in hand (and a lot of questions still to be answered), we rounded up a team of three woodworkers with different types and amounts of experience to test them.

While *Kent* is a professional cabinetmaker and woodworker, *Bryan* spends his spare time building projects in his home workshop. And *Kurt* has just finished building a house where he

made extensive use of his table saw and (of course) his old standby miter gauge.

Q: What are your first impressions of these miter gauges?

Bryan: The biggest thing is that there are two completely different styles of miter gauges.

Three of them (the Accu-Miter, Vega, and Inca) remind me of the miter gauge I use on my table saw at home. They have a tilting head that pivots on a *single* point. And the angles are laid out in an arc like a protractor.

But the Osborne miter gauge is definitely new to me. It's like a



Accu-Miter
803-798-1600
\$166.85



Vega
800-222-8342
\$144.95



Miter Bars. The adjustment slots in the miter bar of the Osborne (left) are handier than the loose blocks on the Inca (center). Even making a "dimple" produces a snug fit on the Vega and Accu-Miter (right).

big, triangular support that rides in the miter slot. One "leg" of the triangle has a telescoping arm that changes the angle of the fence.

This arm can be quickly attached to either end of the fence. This way, you can use the miter gauge in either one of the miter slots on the table saw.

Kent: This system seemed to work fine. The only problem is the end of the arm digs into my palm when I grab the handle.

Still, I *do* like the idea of a tall handle. Not because I need it when I'm making a cut. But because I'm always lifting the miter gauge on and off the saw table. And with some of these miter gauges, that's like picking up a dumbbell. (See chart above.)

Kurt: I wouldn't knock the weight too much. In fact, the extra heft is one of the things I *liked* about the Accu-Miter and Vega. Both of them have a nice, solid feel when I'm making a cut. And the Accu-Miter in particular feels (and looks) like a precision, well-machined tool.

Q: There's more to a miter gauge than weight. To produce an accurate cut, the miter bar has to glide smoothly in the miter slot without any "play." Is there any way to adjust how the bars fit in the miter slots?

Kurt: Some of the miter gauges have a pretty elaborate system to adjust the fit of the bar in the miter slot. The one that intrigued me was the Osborne. It has an adjustment slot at each end of the bar. (See photos above.) When I tighten an Allen screw in the slot, it spreads the bar apart. That makes for a nice, snug fit. And it only takes a second to adjust.

Kent: It's too bad the adjustment system for the bar on the Inca isn't thought out as well. It has four cylindrical blocks that fit in holes in one side of the bar. When you tighten Allen screws in the opposite side, they push the blocks against the miter slot.

These blocks work fine — as long as the end of the miter bar never sticks out past the saw

Miter Gauge Weights



table. But when I push the miter gauge forward, the blocks vibrate loose from the end of the miter bar. As a result, I can't even pull the miter gauge back because the blocks "catch" on the saw table. That seems downright dangerous.

Kurt: Those blocks are frustrating even when I'm *not* making a cut. Every time I tip the miter gauge, the blocks fall out of the holes onto the floor.

Kent: All that makes me think that sometimes simpler is better. The bars on the Vega and Accu-Miter are a good example. Each one has a straight, flat bar. To fit it into the miter slot, all I had to do was tap the side of the bar with a punch to make a little "dimple."

Bryan: One last thing. The miter bars on the Accu-Miter and Osborne both have a washer on the end. (See margin.) It comes in handy when you pull the miter gauge back to crosscut a wide workpiece.



▲ A large washer attached to the end of the miter bar keeps it from falling out of the T-shaped slot in a table saw.



Inca
888-593-2453
\$107.50



Osborne
717-368-1493
\$149.95

The Head

Q: You said earlier that these miter gauges use two types of systems to adjust the angle of the head. So how did they work out?

Bryan: At first, I thought I'd be more comfortable using a miter gauge with a protractor-style head. (See photos at right.) That's what I have on my miter gauge at home. So loosening the head, tilting it to the angle I want, and then locking it down is a pretty familiar routine.

But the more I used the Osborne, the more I liked it. It's just a matter of getting used to the idea that the "head" is really a combination of parts: a fence, the miter bar, and a telescoping arm that fits inside a sleeve. As the arm slides back and forth, it changes the angle of the fence.

Kent: The *type* of adjustment system doesn't matter to me. As long as I can easily set the head to the exact angle I want and then lock it securely in place.

That's why I had a bit of a problem with the head on the Inca. The angle markings on the scale are squished together and hard to read. (See drawings below.) And I have to depend on a pointer to indicate the angle.

The pointer just isn't accurate enough. So I have to make a bunch of test cuts to set the head



Head Styles. The Accu-Miter (left), Vega, and Inca have a traditional protractor-style head. But the Osborne uses a telescoping arm that connects the fence and miter bar to create a stable, triangular "head."

at the correct angle. What's worse is that when I tilt the head to make a cut at a different angle, I can't return to the original setting — that's frustrating.

Bryan: The other miter gauges solve that problem by establishing a number of *preset stops* at 22½°, 30°, 45°, and 90°. So I can make a 90° crosscut, tilt the head to cut a 45° miter, then set it back to 90°. And I never have to check the angle setting again.

Q: How does that work?

Kurt: The Accu-Miter has a spring-loaded pin that fits into holes in the head of the miter gauge. When I pivot the head to one of the preset stops, the pin pops into the hole.

That's handier than the Vega. It has a pin too — but no spring. So to make sure the head is tilted to the right angle, I have

to wiggle the pin to push it in.

Q: What if the pin drops into the hole for the 90° angle setting, but the cut is "off" just a bit?

Kent: No problem. After adjusting the head to make a perfectly square cut, you can shift the pin assembly so the indicator aligns with the mark for the 90° angle. This "zeroes out" the head which makes all the other preset angles accurate as well.

Q: What about the preset stops on the Osborne?

Kurt: It's a nifty system. It has a spring-loaded ball inside the sleeve. The ball fits into a small dimple on the bottom of the arm at each of the preset stops.

One thing about these preset stops is there's no way to adjust them. Fortunately, I didn't need to — they were right on the money.

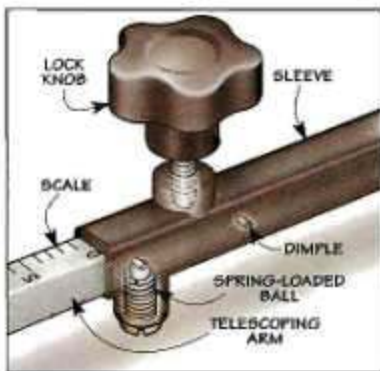
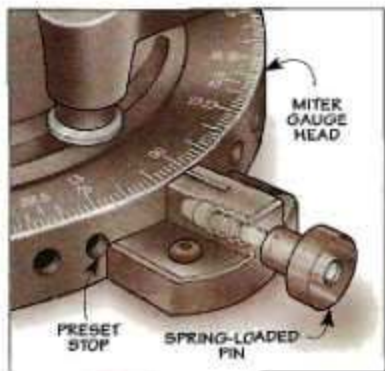
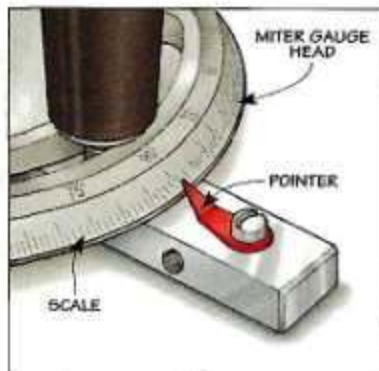

Angle Adjustment. A pointer and a hard-to-read scale on the Inca (left) makes cutting any angle a trial and error process. But a system of preset

stops on the Accu-Miter (center), Vega, and Osborne (right) allow you to make accurate cuts at the most commonly used angles quickly and easily.

The Fence

Q: The first thing I noticed about the fences on these miter gauges is they're made of two different types of materials. What gives?

Bryan: The fence on the Osborne is made of a hard, nylon composite material. (Refer to the bottom photo on page 13.) But the other three fences are made of extruded aluminum.

Kent: I wouldn't get too worked up about the material. As long as the fence is perfectly flat and it's square to the saw table, you'll get an accurate cut.

The Accu-Miter and Osborne both have fences that are flat and square. But the fence on the Vega had a "twist" in it. And I had to shim the fence on the Inca to square it up to the saw table.

Q: I'm always cutting pieces to identical lengths. So I'm curious about how the stops worked.

Kurt: First of all, the Osborne doesn't even have a stop. So I have to clamp a block to the fence.

Bryan: That's one advantage of the aluminum fences. They have a T-shaped slot that acts as a track for an adjustable stop. (See photos above.)

The nice thing about all these stops is I can flip them up out of the way. This makes it easy to square up one end of a board. Then I flip the stop down and



Stops. Unlike the solid stop on the Accu-Miter (left), the flip stop on the Inca (center) twists when you butt a board against it. A micro-adjustment on the Vega (right) is a good idea, but it loosens the stop.

use it to cut the piece to length. Along with a rule that comes with the Accu-Miter and Vega, the stop provides a quick, accurate way to cut pieces to length.

Kent: The stop on the Accu-Miter is a heavy-duty casting that doesn't budge when I butt the workpiece against it. This way, the length of the pieces won't vary.

I had to be more careful with the stop on the Inca. It twisted just a bit no matter how tightly I locked it down.

Bryan: One interesting thing about the stop on the Vega is it has a built-in micro-adjustment. But when I "tweak" the adjustment, it loosens the stop.

Kurt: That stop does come in handy though. It fits on an extension that slides in and out of the fence. (See photos and chart below.) This way, I can cut much longer pieces.

The Accu-Miter has a similar extension with a stop attached to the end. I'd use that a bunch.

Q: Okay, time to answer the question we started with. Are these miter gauges worth the money?

Kent: The only one I'd spend that much money on is the Accu-Miter. It's a well-machined tool. And it provides much more accurate cuts than my old miter gauge.

Kurt: I'd buy the Accu-Miter too. I'm sold on the convenience and accuracy of its preset stops. And I like the solid flip stop and the long fence extension.

Bryan: I like the Osborne. It's lightweight, yet the triangular head provides plenty of support for a workpiece. If it had a flip stop, I'd buy it in a heartbeat. But without that, I'd stick with the miter gauge I've already got.

Editor's Note: The folks at Osborne are currently working on a miter gauge that will include an aluminum fence and a flip stop. Once it's available, it will only cost about ten dollars more than the model we tested. 🐶

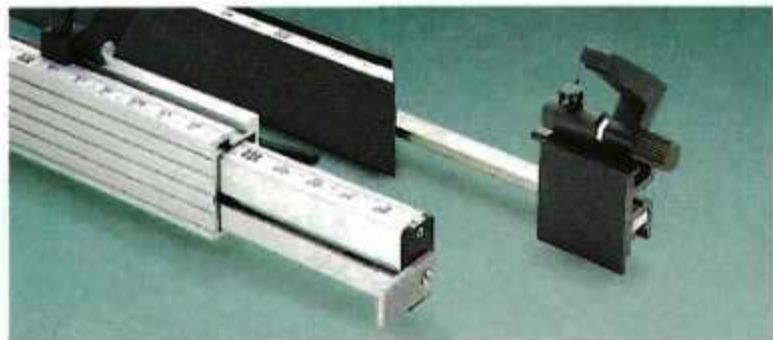

Fence Extensions. To cut long pieces to length, the flip stop on the Vega attaches to an extension that slides out of the fence (right). The Accu-Miter (left) has an extension with a stop attached to the end.

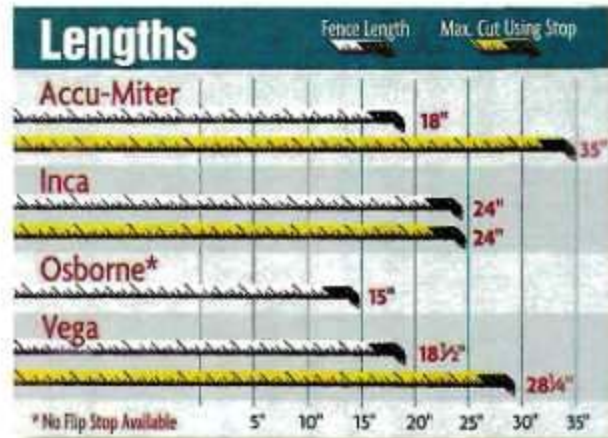



Pocket Hole Jig

A router and a hand-held drill. That's all it takes to make a pocket joint when you use this simple jig.

There are two good reasons for making a pocket hole joint. It's strong. And it's quick.

Basically, a pocket hole joint is a butt joint that's held together with screws. The screws are driven into angled holes (pockets) in one piece. And they're guided into the adjoining piece by a pilot hole drilled in the end of the pocket.

As simple as it is, making a pocket hole joint can be a bit tricky. When drilling the angled pocket, the tip of the bit tends to "skate" across the workpiece. Also, if the pilot hole isn't drilled at the correct angle, the screw may break through the "good" side of the workpiece when you assemble the project.

To get around this, there are several jigs available that are specially designed to make pocket hole joints. But they're fairly expensive. So I decided to make a pocket hole jig of my own, see photo above.

ROUT THE POCKET. This jig uses a *router* to cut the pocket quickly and accurately. The router is mounted to a carriage that tilts out like the bin on a corner mailbox, see Cross Section on page 17.

So with the workpiece clamped to the top of the jig, you just pull the handle of the carriage. As the router pivots forward, the bit scoops out a pocket in the bottom of the workpiece. (We used a spiral upcut bit.)

PILOT HOLE. The jig also makes it easy to drill the pilot hole — without having to guess if the bit is positioned at the correct angle. That's because there's a simple, built-in guide that directs the bit at just the right angle, see inset photo above.

ASSEMBLY. Once you've completed both parts of the operation, assembling the joint is a snap. Simply screw the pieces together. (For a look at some typical applications, see the photos below.)



Face Frames. If you're building a face frame, the pocket hole jig makes quick work of joining the rails and stiles.



Cabinets. The jig also makes it easy to cut the pockets and drill the pilot holes that are used to assemble this cabinet.



Furniture. After using the jig to cut the pockets in the base of this table, installing screws provides plenty of strength.

Hardware

EXPLODED VIEW
OVERALL DIMENSIONS:
12" W x 18" H x 12 1/4" D

- (14) #6 x 1" Fh Woodscrews
- (6) #6 x 3/4" Fh Woodscrews
- (4) #8 x 1" Fh Woodscrews
- (2) #8 x 1 1/4" Rh Woodscrews
- (2) 3/8" x 1 1/2" Cap Screws
- (2) 3/8" Lock Nuts
- (1) Toggle Clamp (De-Sta-Co No. 227)
- (1) 5/16" x 2 1/2" Cap Screw
- (1) 3/16" O.D. x 2" Copper Tube

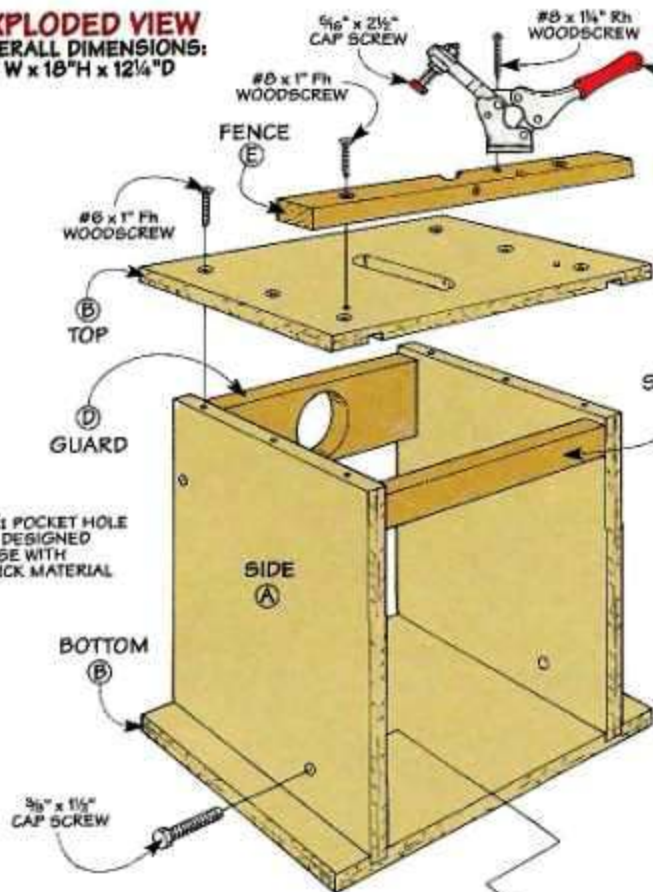

NOTE: POCKET HOLE JIG IS DESIGNED FOR USE WITH 3/4"-THICK MATERIAL

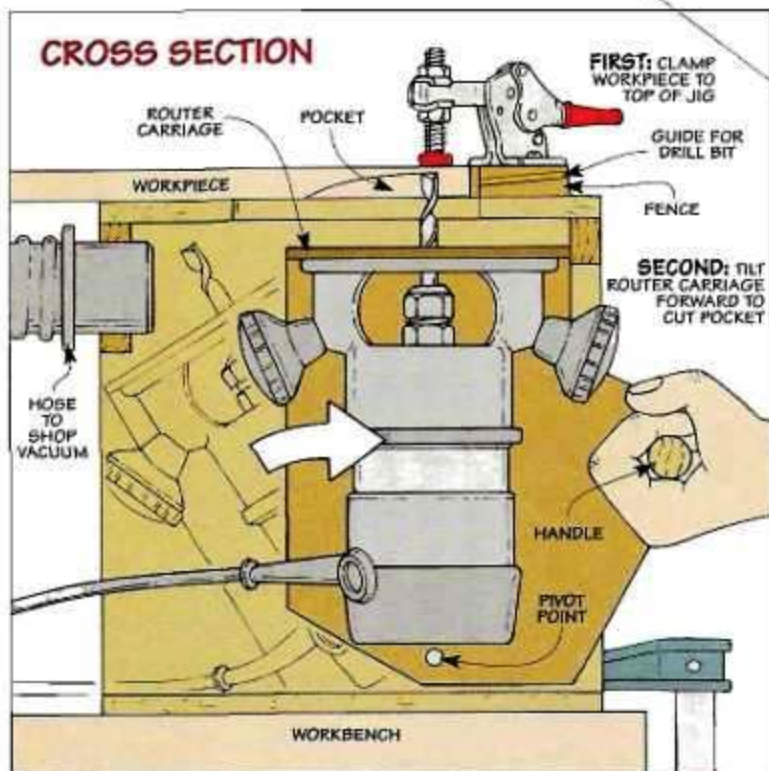
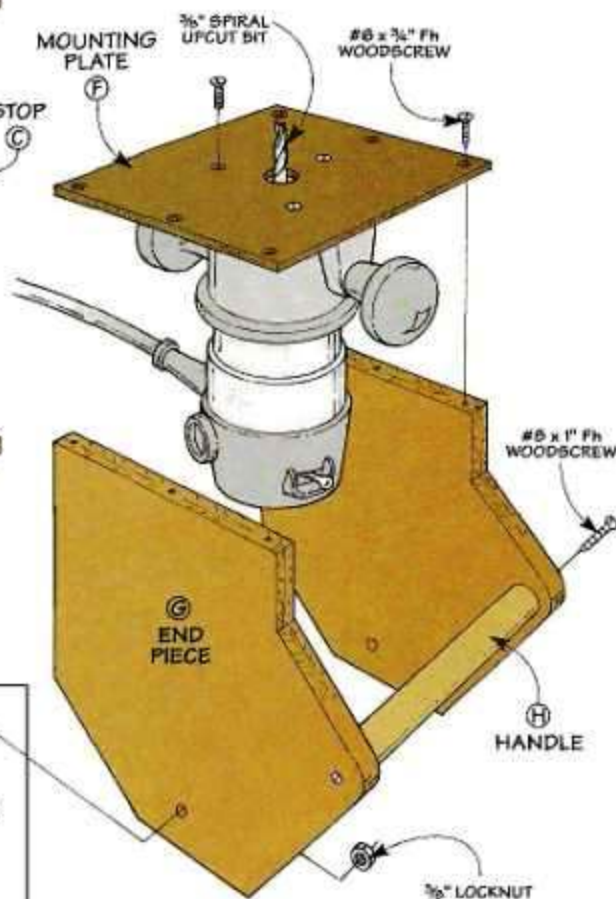

Materials

Base

- | | |
|------------------|------------------------------|
| A Sides (2) | 1 1/2 x 12 1/4 - 1/2 Plywood |
| B Top/Bottom (2) | 12 x 12 1/4 - 1/2 Plywood |
| C Stop (1) | 3/4 x 1 - B |
| D Guard (1) | 3/4 x 3 - B |
| E Fence (1) | 3/4 x 2 1/2 - 12 |

Router Carriage

- | | |
|----------------------|---------------------------|
| F Mounting Plate (1) | 7 x 8 - 1/4 Hardboard |
| G End Pieces (2) | 10 x 10 1/2 - 1/2 Plywood |
| H Handle (1) | 1-Dia. x 7 Dowel |

Note: For a complete hardware kit to build the Pocket Hole Jig, see Sources on page 31.

Base

I began work on the pocket hole jig by building the base. Together with a fence that's added later, the base supports the workpiece when making a cut. And it houses a carriage that holds the router.

To provide easy access to the router, the base is a plywood box that's open in front and back, see drawing. This box is quite simple — just two sides sandwiched between a top and bottom.

SIDES. Besides supporting the top, the *sides* (A) provide a way to attach the router carriage. This requires drilling a hole in each side for a cap screw that acts as a pivot point for the carriage.

To ensure that the carriage operates smoothly, it's important that these holes align. So I carpet-taped the sides together and drilled both holes at the same time.

TOP & BOTTOM. The next step is to add the *top* and *bottom* (B). To accept the sides, you'll need to cut a pair of grooves in each piece. These grooves are located so the top and bottom overhang the sides. This creates a clamping surface on the bottom that lets you secure the base to the bench.

CUT SLOT. Before gluing and screwing the base together, there's one more thing to do.

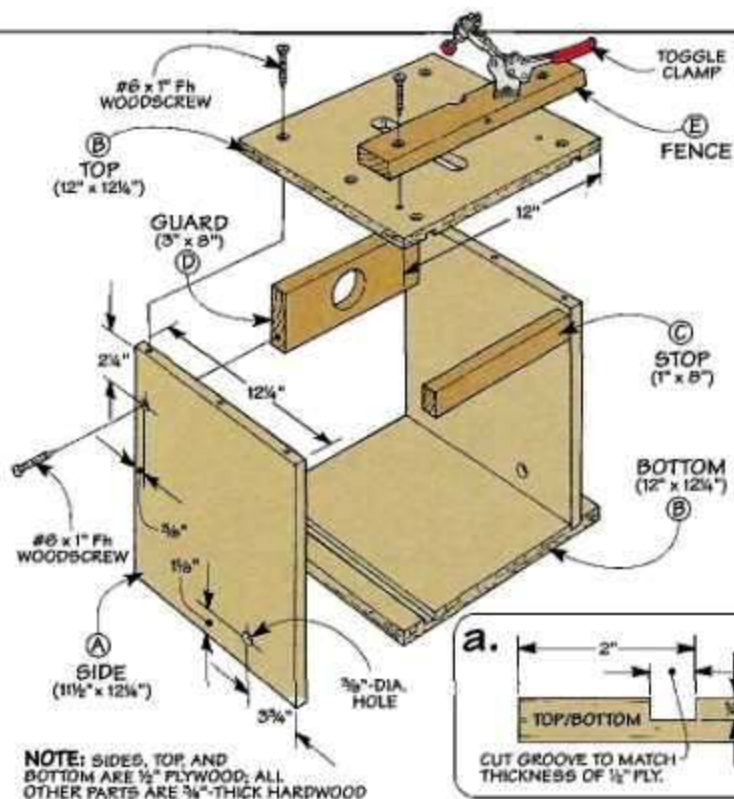

That's to cut a wide slot in the top, see Fig. 1. As you pull the carriage forward to cut the pocket, this slot provides an opening for the router bit to stick through the top.

STOP. To prevent the carriage from tilting out too far (and cutting the pocket all the way through the end or edge of a workpiece), I added a *stop* (C),

see Fig. 1. It's a narrow piece of hardwood (maple) that bridges the opening between the sides.

GUARD. After gluing on the stop, I also added a hardwood *guard* (D). It covers the exposed bit when the carriage is tilted back. But it also doubles as a hookup for a shop vacuum. This is just a matter of cutting a centered hole to fit the end of the hose on your shop vacuum. Then the guard is glued and screwed in place.

FENCE

With the base complete, you can turn your attention to the fence. It supports the edge of the workpiece as you make a cut. In addition, the fence has a built-in guide that allows you to accurately drill the pilot hole for the screw.

FENCE. The *fence* (E) is a piece of $\frac{3}{4}$ "-thick hardwood attached to the top of the base, see Fig. 2. One thing you'll notice about the fence is there's a curved notch on the inside edge (the one that supports the workpiece), see Fig. 3. It pro-

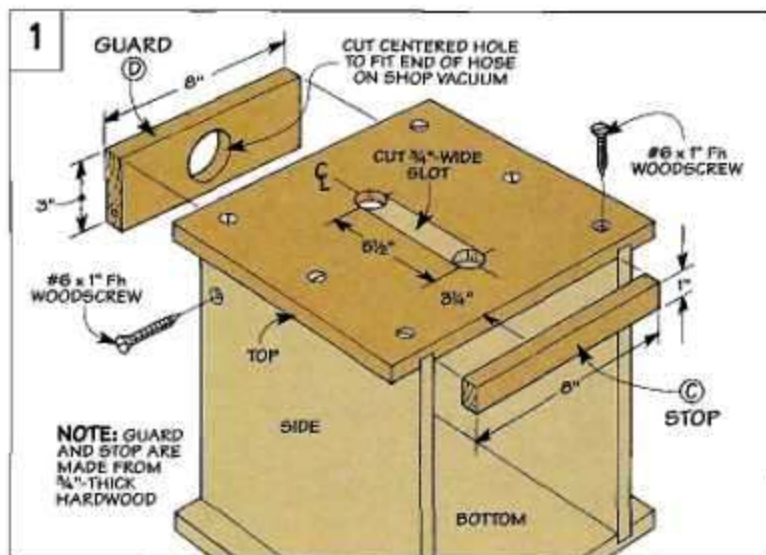

vides a relief area for the chips to fall through when drilling the pilot hole. This keeps the chips from jamming up against the fence.

GUIDE. After cutting the notch, you're ready to add the guide for the drill bit. It directs the bit into the workpiece at a slight (5°) angle.

The guide I used is a small piece of copper tubing, see margin. The inside diameter of this tubing is slightly smaller than the 1/8" bit used to drill the pilot hole. But that's okay. It's easy to ream out the tubing once it's installed.

The tubing fits into an angled hole in the fence. To drill this hole, you could tilt the metal table on your drill press. But that would involve some fiddling around.

So instead of adjusting the angle of the table, I tilted the workpiece instead. To do this, start by ripping a 5° bevel on the edge of the fence that's opposite the notch, see Figs. 3 and 3a. With the beveled edge resting on the table, it's easy to drill the hole at the correct angle.

Now you're ready to install the tubing. It's best to cut a piece about 1/8" longer than needed.

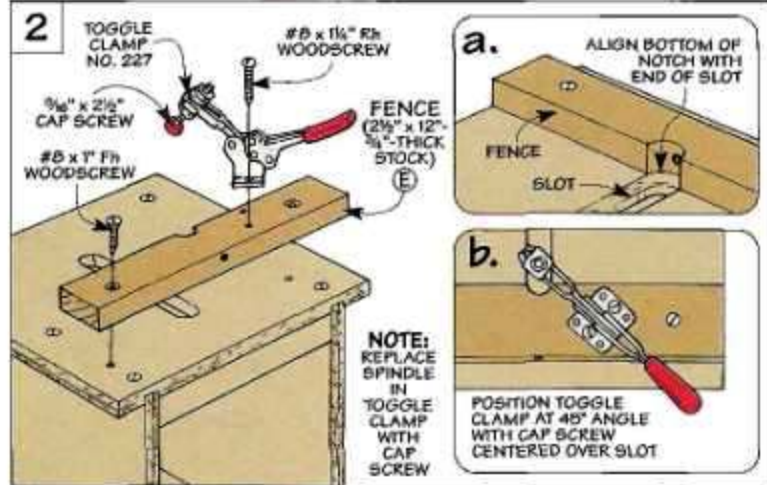
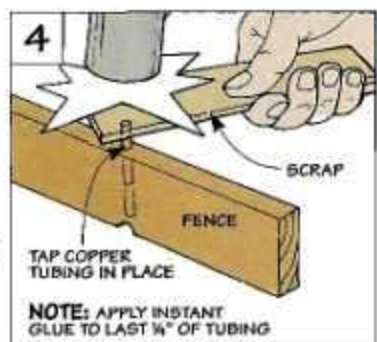
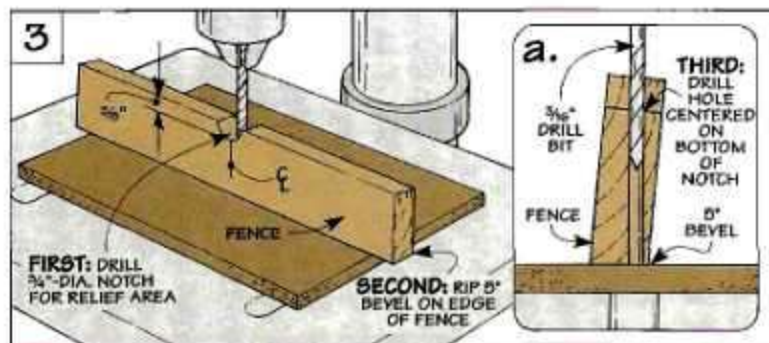

Then tap it into the hole until the end of the tubing is sticking up about 1/4", see Fig. 4. At this point, apply "instant" glue to the tubing and tap it in the rest of the way. Then file and sand the exposed end so it's flush with the fence.

ATTACH FENCE. Once the tubing is installed, you can attach the fence. It's screwed in place so the bottom of the notch aligns with the end of the slot, see Fig. 2a.

REAM TUBING. With the fence firmly attached, it's a good time to ream out the tubing, see Fig.

5. You'll need an 1/8" twist bit to do this. But one thing to be aware of is that a standard length bit is too short to extend all the way through the tubing.

So I used a 6"-long bit that I picked up at a local hardware store, refer to margin on page 23. Note: This is the same bit that will be used to drill the pilot holes.

TOGGLE CLAMP. All that's left to complete the fence is to add a toggle clamp, see Fig. 2. It holds the workpiece securely in place as you make a cut. The nice thing about this type of clamp is it provides a quick way to clamp (and unclamp) the workpiece.

But there was one drawback to the toggle clamp I used. It had a rubber tip on the end of the spindle that allowed the workpiece to shift as I routed the pocket. So I replaced the spindle with a cap screw, see Fig. 2 and margin at right.

After installing the cap screw, you can attach the clamp to the fence. It's positioned so the head of the cap screw is centered over the slot in the top, see Fig. 2b. This way, the clamp will apply pressure directly over the router bit.

One more thing. It's best to position the base of the clamp at an angle and to the side of the notch. This way, the handle of the clamp won't get in the way of the drill.



▲ The copper tubing we used as a guide for the drill bit is available from:

• Small Parts, Inc.
(Part No. E-HTC-3-6)
800-220-4242



▲ To prevent the head of the cap screw from denting the workpiece, I filed it flat and dipped it in liquid plastic.

Router Carriage

The heart of the pocket hole jig is a pivoting carriage that holds the router securely in place, see drawing. As you tilt this carriage forward, the router bit cuts the pocket in the workpiece.

To produce a smooth cut, the goal is to create a friction fit between the carriage and the base. Basically, this is a matter of "feel." When you pull the carriage forward, it should barely brush against the sides of the base.

MOUNTING PLATE. Getting the right fit depends on the size of a *mounting plate* (F) that's used to secure the router in the carriage, see Fig. 6. This is a piece of 1/4" hardboard that's cut to size to produce a sliding fit.

The mounting plate replaces the base on your router. So you'll need to transfer the mounting holes from the router base to the mounting plate, see Fig. 6a.

There are a couple of things to keep in mind here. First, be sure to locate the holes so the handles of the router aren't wedged

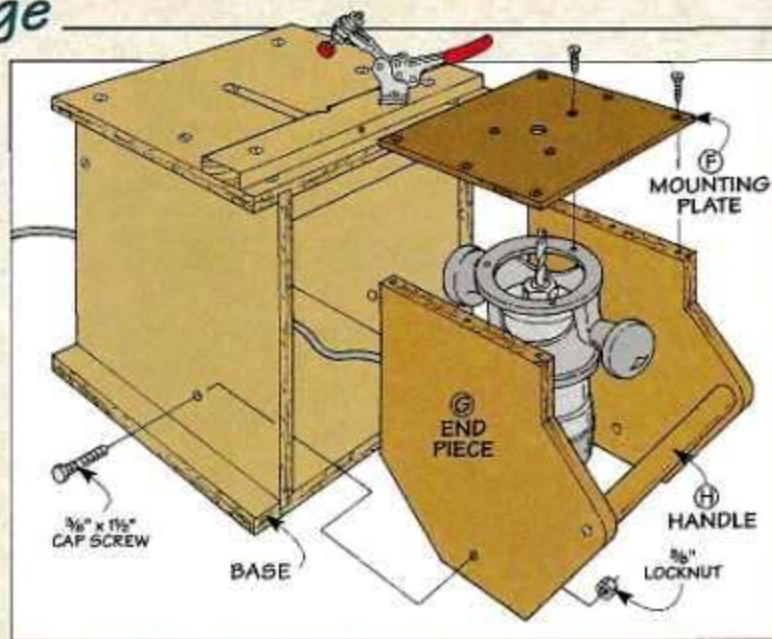

against the end pieces (added later), see drawing above. And second, you'll want to have easy access to the on/off switch on the router. Note: As an option, you can hook up an electrical switch, see box on page 21.

After drilling countersunk holes for the mounting screws, there's

one more thing to do. That's to drill a centered hole that allows the router bit to stick up through the mounting plate.

END PIECES. The next step is to add two plywood *end pieces* (G) to support the mounting plate and the router, see Fig. 7. The unusual thing about these

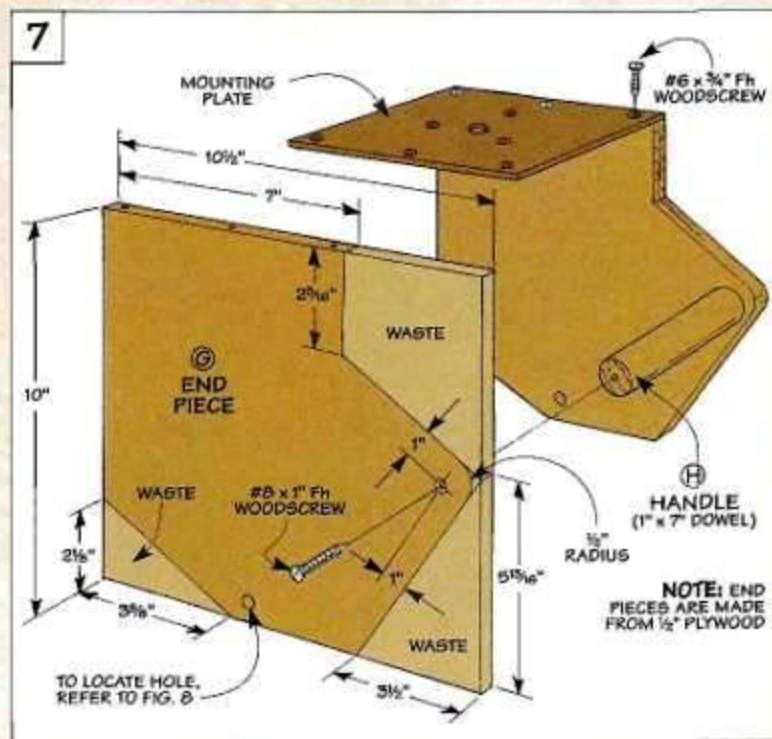
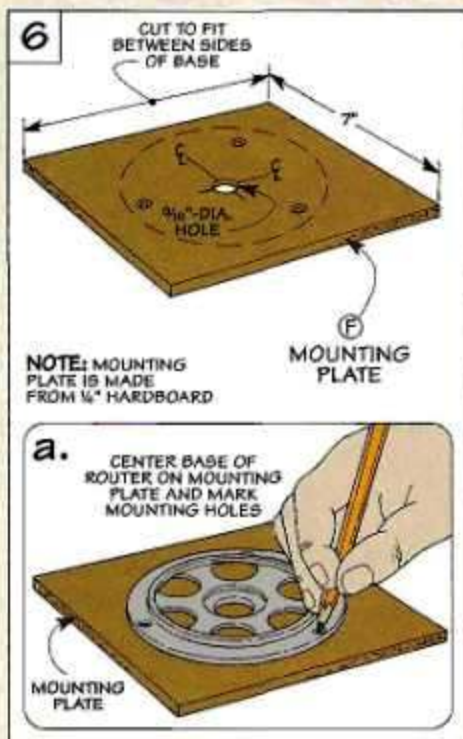

end pieces is their shape.

There's an angled notch in the upper corner of each piece. As you tilt the carriage forward, the vertical part of this notch contacts the stop (C) on the base. This establishes the *end* of the pocket in the workpiece.

Both of the bottom corners on the end pieces are cut at an angle as well. To allow the carriage to pivot near the bottom of the base, there's an angled corner in back. And the one in front gives the carriage a slimmer profile.

Since the end pieces work together, both of them need to be identical. An easy way to accomplish this is to carpet-tape two blanks together then cut and sand the pieces to shape. It's also a good idea to sand a radius on the sharp corner in front.

HANDLE. After screwing the mounting plate to the end pieces, I added a *handle* (H), see Fig. 7. It's nothing more than a dowel that's cut to fit and screwed between the end pieces.

PIVOT HOLES. At this point, you're just about ready to install

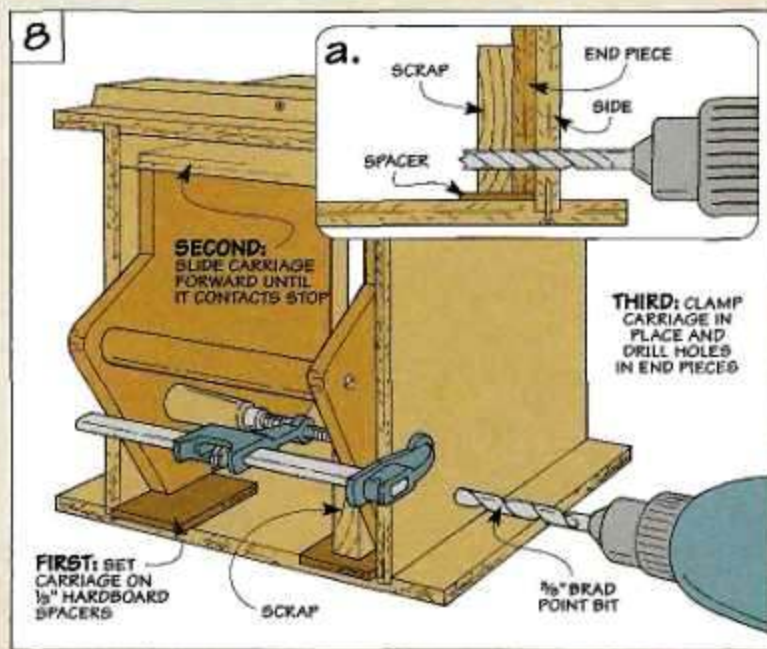

the carriage. But first, you'll need to drill holes in the end pieces for the two cap screws that act as pivot points.

To locate these holes, start by slipping the carriage into the base and setting it on a couple of 1/8"-thick spacers, see Figs. 8 and 8a. These spacers raise the car-

riage up just a bit so it won't bind.

Now slide the carriage forward until it contacts the stop. After clamping the carriage in place, you can use the holes in the base as a guide to drill the holes in the end pieces. Note: Clamping a scrap against the carriage prevents chipout on the inside face.

Electrical Hook-Up

Before using the pocket hole jig, you may want to consider a couple different ways to turn the router on and off.

ON/OFF SWITCH. If you only need to make a few joints, simply use the on/off switch on the router. But if you're doing a lot of work, it's quicker to flip a switch on the side of the jig.

SWITCH/RECEPTACLE. To do this, you'll need to run a short length of electrical cord (with a plug installed on one end) between a wall outlet and a switch/receptacle, see drawing.

Now just plug the power cord on the router into the switch/receptacle, and you're in business.

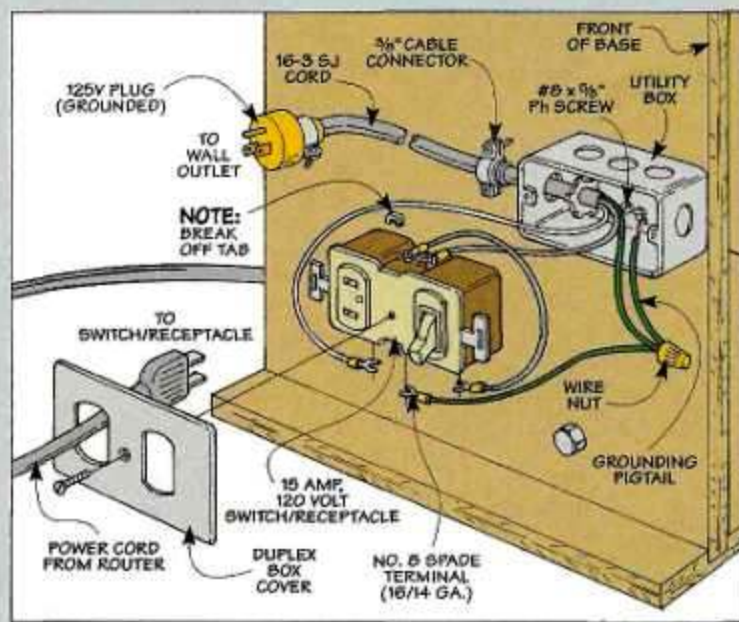

Electrical

- (1) 15 Amp, 120 Volt Switch/Receptacle
- (5) No. 8 Spade Terminals (16/14 ga.)
- (1) Utility Box
- (1) Grounding Pigtail w/Screw (12 ga.)
- (1) Wire Nut Connector (Yellow)
- (1) 3/8" Cable Connector
- (2) #8 x 3/8" Panhead Sheet Metal Screws
- (1) Box Cover (Duplex)
- (1) 15 Amp, 125 Volt Plug (Grounded)
- (1) 16-3 SJ Electric Cord (6 feet)

Setup

It only takes a few minutes to set up the pocket hole jig. Basically, it's just a matter of mounting a bit in the router and then installing the carriage.

SPIRAL BIT. The bit I use is called a *spiral upcut bit*, see Fig. 9. It produces a shearing type of cut that results in a smooth, clean pocket. (For more information about these router bits, refer to the article on page 30.)

DEPTH OF CUT. After mounting the bit in the router, you'll need to adjust it for the correct depth of cut. The goal is to create a $\frac{1}{2}$ "-deep pocket at the *end* of the cut. This creates a solid "seat" for the head of the screw.

To accomplish this, the bit needs to stick up $\frac{1}{2}$ " above the base *after* the carriage is installed, see Fig. 9a. In my case, this meant adjusting the height of the bit so it projects $1\frac{1}{8}$ " above the mounting plate, see Fig. 9.

INSTALL CARRIAGE. Once the bit is adjusted, you're ready to fit the carriage inside the base. This looks like a tight squeeze. But if you tip the top of the carriage under the stop (C), it slides right in, see Fig. 10. Then simply secure the carriage with the two

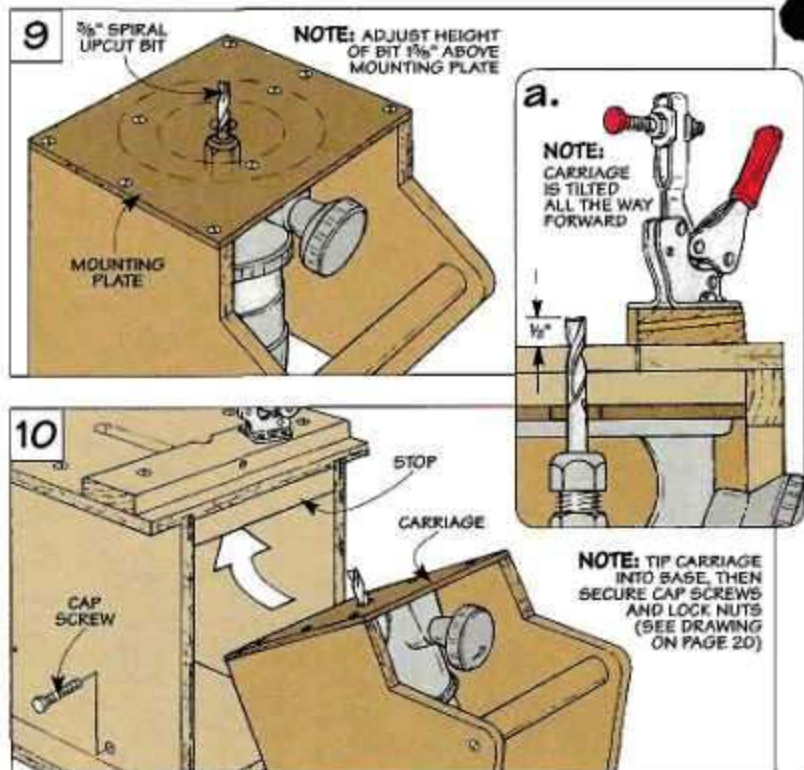

cap screws and lock nuts.

SUPPLIES. Before routing the pockets, it's a good idea to round up the supplies you'll need to assemble the joint. To get good results, it's worth getting screws that are specially designed for pocket hole joints, see box below.

And you'll need a long twist bit and driver bit to install the screws, see margin on page 23.

USING THE JIG

With supplies in hand, you're ready to start making some pocket hole joints.

Pocket Hole Screws

To create a strong pocket hole joint that's easy to assemble, we used special "pocket hole" screws.

SELF-TAPPING. This type of screw has a self-tapping "auger" point that drills into a workpiece. This point prevents the back piece of the joint (the one *without* the pilot hole) from splitting.

THREADS. To provide a secure grip in different types of materials, the screws are available with two kinds of threads. Deep threads keep the screw from pulling out of softwood. But you'll need a screw with fine threads to "bite" into hardwood. Note: These screws have a thicker shank to provide extra strength.

SQUARE RECESS. Finally, a square recess in the head will keep the driver bit from slipping out as you install the screw. (For sources of screws, see page 31.)

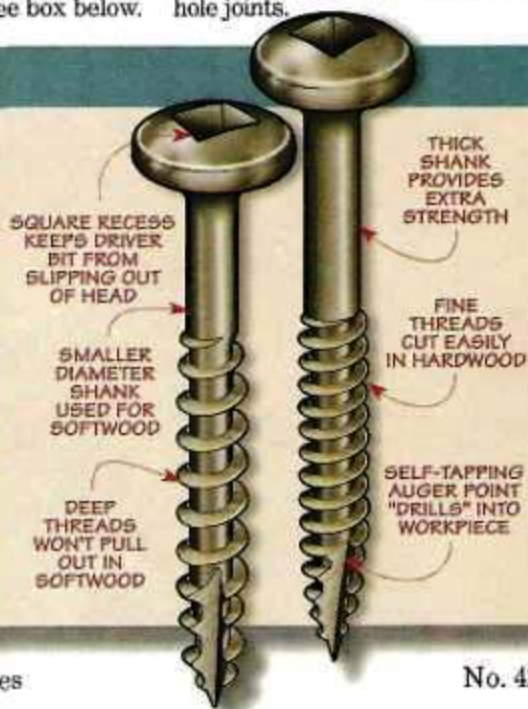

CUT PIECES TO LENGTH. One of the advantages of a pocket hole joint is the pieces are simply butted together. So start by cutting each piece to final length.

LAYOUT. Also, keep in mind that you rout the pocket and drill the pilot hole in one piece only. This means you only have to lay out the joint on that one piece.

With the workpiece lying flat on the jig, the pocket will be routed on the *bottom* side. So mark the location of the pocket on the *top* side where you can see it.

REFERENCE MARK. But the layout line won't show you where to position the workpiece on the jig. To do that, you'll need to draw a reference mark centered

on the length of the fence, see Step 1 below. This mark indicates the path of the router bit. So to cut the pocket exactly where you want it, just align the mark with the layout line on the workpiece.

ROUT POCKET. After clamping the workpiece in place, you're ready to rout the pocket, see Step 2. The pocket gets progressively deeper which means you'll be removing quite a bit of material. So give the router bit a chance to cut by *slowly* pulling the carriage forward.

PILOT HOLE. Once the pocket is complete, the next step is to drill the pilot hole, see Step 3. There's no need to unclamp the workpiece. The guide will auto-

matically center the drill bit on the pocket.

And don't worry about the depth of the hole. You'll feel the bit "give" just a bit as it breaks into the pocket.

ASSEMBLY. Now it's just a matter of assembling the joint, see Step 4. To ensure that the joint ends up flush in front, place the workpieces on a flat surface with their "good" sides face down.

Before installing the screws, don't forget to apply glue to the mating surfaces of the joint. Then just clamp the back piece to the worksurface. This will keep the joint nice and tight as you drive in the screws. ▲

▲ To drill a pilot hole for the pocket joint, I used an 1/8" twist bit (top) that's 6" long. Also, a 6"-long square-tipped driver bit (bottom) makes it easy to install the screws.

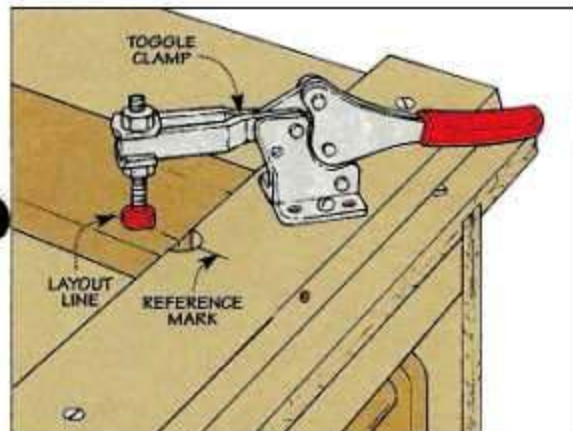

1 Start by aligning the layout line on the workpiece with the reference mark on the fence. Then butt the piece against the fence and clamp it in place.

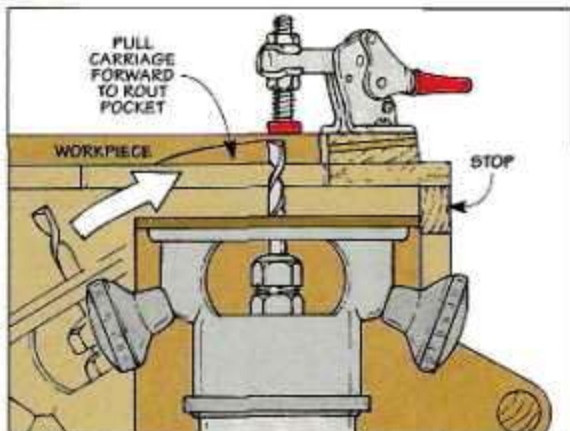

2 After turning the router on, slowly pull the carriage forward until it stops. As the carriage pivots, the router bit scoops out the pocket in the workpiece.

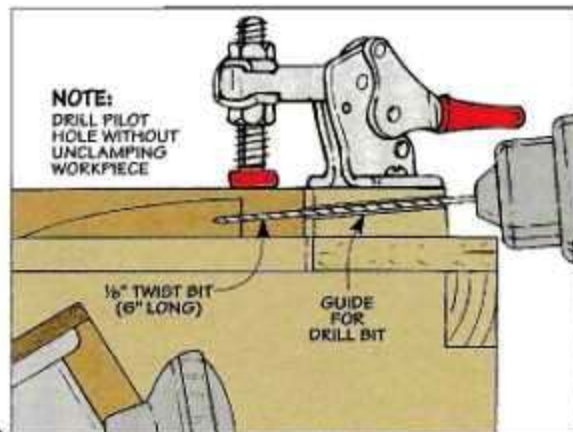

3 There's no need to unclamp the workpiece to drill the pilot hole. The guide in the fence will automatically center the twist bit on the pocket.

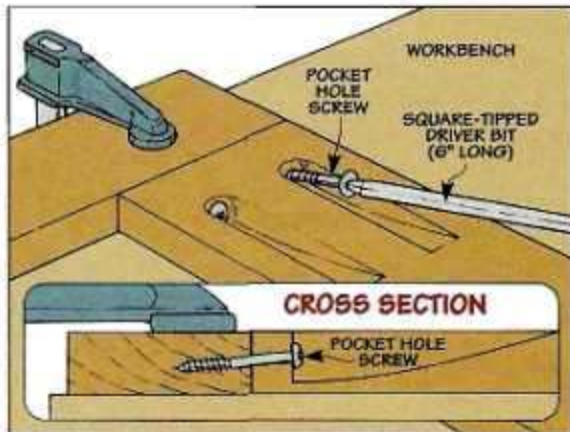

4 To assemble the joint, place both workpieces on a flat surface. Then clamp the back piece in place and use a long driver bit to install the screws.

Stacking Sawhorses

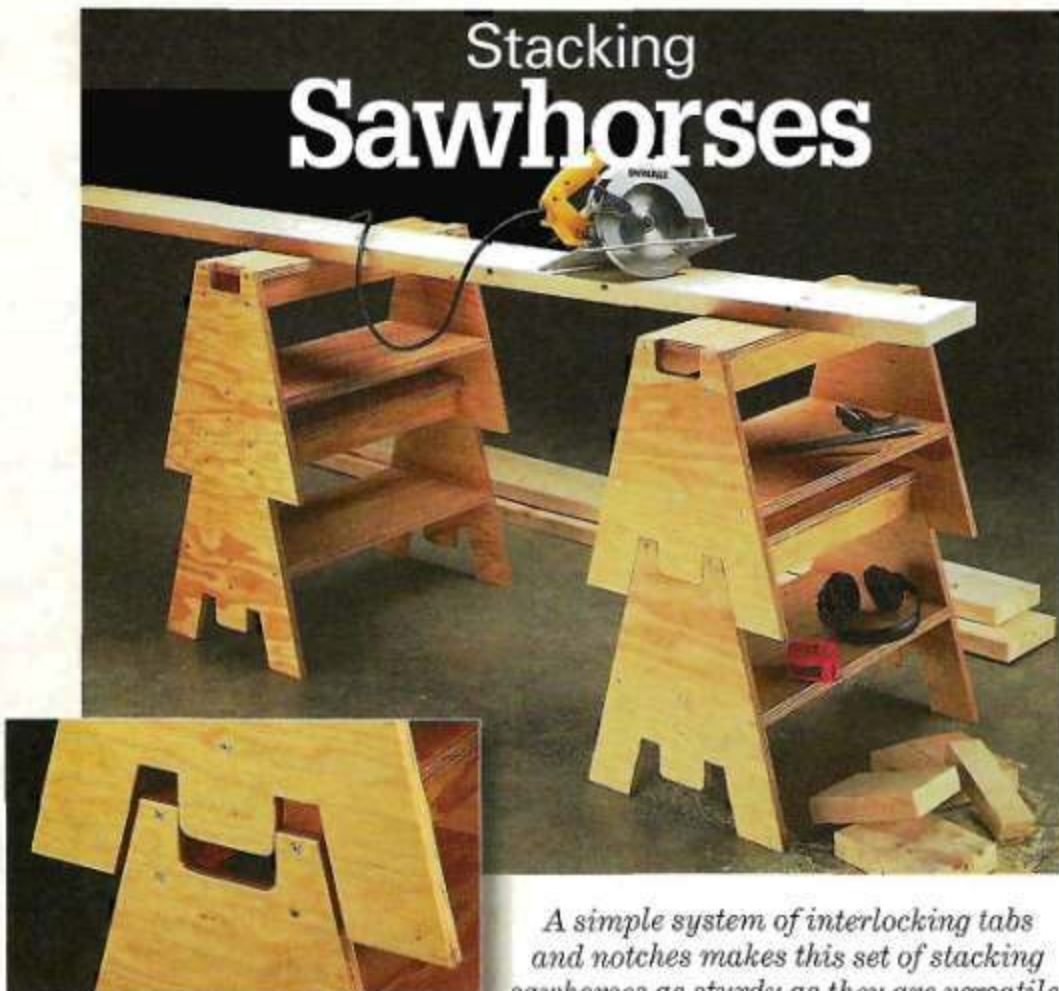

A simple system of interlocking tabs and notches makes this set of stacking sawhorses as sturdy as they are versatile.

Aren't they a little short? That was the question I heard most often as we were building this set of sawhorses. Actually, there are *two* answers to that question — yes and no. Let me explain.

First of all, the sawhorses *are* short. Each one stands in at only 17" tall. (Which is why one of the guys suggested we call them saw *ponies* instead.)

But it only takes a second to make the sawhorses "taller." You simply stack *one* sawhorse on top of another. This raises the top sawhorse to a height of 30."

That provides a comfortable working height for most jobs, see photo above. But if you need a work-surface that's not as tall (when assembling a large project for instance), it's just a matter of

unstacking the sawhorses, refer to back cover.

STORAGE. Once the job is completed, storage isn't a problem either. You can tuck a whole stack of sawhorses in a corner, see bottom photo on page 25.

TAB & NOTCH. But as much as I appreciate the convenience of these sawhorses, the thing that impresses me even more is how sturdy they are — even when they're stacked together. The secret is a system of interlocking tabs and notches that pre-

vents them from moving from side to side or from end to end, see inset photo.

PLYWOOD. One more note. You won't need a lot of material to build these sawhorses. In fact, you can make four complete sawhorses

PLYWOOD CUTTING DIAGRAM

48" x 96" - 1/4" PLYWOOD

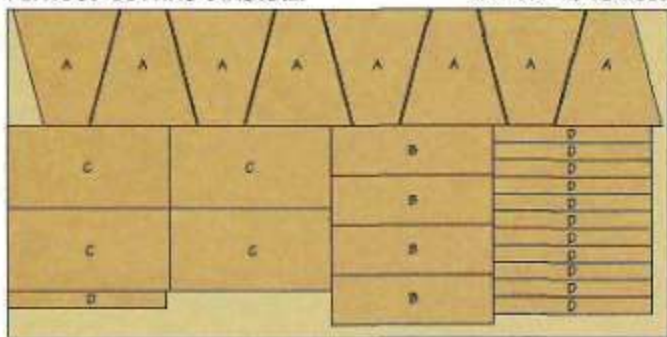

from a single sheet of plywood, see Cutting Diagram. (We used fir plywood with an 'AC' grade.)

TEMPLATE

The key to these stacking sawhorses is the 'M-shaped' pieces on the ends. Altogether, there are eight of these pieces. And the tab on one piece needs to fit the notch in another like the pieces of a jigsaw puzzle.

To produce a good fit, I began by making a template, see photo at right. This template ensures that all eight pieces are identical.

And it speeds up the process of making the end pieces.

LAY OUT TEMPLATE. The template starts out as a piece of $\frac{1}{4}$ " hardboard that's cut to the same width ($15\frac{1}{2}$ ") and height (17") as the end pieces, see Fig. 1.

To provide a firm footing, the end pieces taper gradually from a wide base to a narrow top. So in order to duplicate this taper, you'll need to lay out an angled line on each side of the template.

The next step is to mark the location of the tab and notch. The important thing is that each

one is the exact same size and shape.

PATTERN. An easy way to accomplish this is to make a pattern from a piece of posterboard and use it to lay out both the tab and the notch, see Fig. 1. To accurately position the pattern on the template, draw a centerline on each one and align the marks.

FEET. Now all that's left is to lay out the two "feet" at the bottom of the template. The lines that form the inside edge of these feet are parallel to the angled sides. But before drawing these lines, you'll need to establish the outside corner of the "ear" on each side of the tab.

CUT TO SHAPE. At this point, it's just a matter of cutting the template to shape. The goal is to make the edges of the template as smooth as possible. That's because they'll be used to guide a flush trim bit when the end pieces are routed to shape.

To cut the straight, angled sides of the template, I used a simple jig on the table saw, refer to page 28. It allowed me to cut right up to the layout line. But you'll need to cut the tab and notch with a band saw (or sabre saw). Just be sure to stay about $\frac{1}{8}$ " to the waste side of the line and then sand up to the mark.

LAY OUT END PIECES. Once the template is complete, you can use it to lay out the end pieces. It's possible to get all eight pieces from a 17"-wide strip cut from a full sheet of plywood. But there's not a lot of "extra" material.

So I started by positioning the template $\frac{1}{4}$ " in from the end to lay out the first piece, see Fig. 2. To lay out each remaining piece, simply turn the template end for end. Note: It's a good idea to leave a $\frac{3}{8}$ " space between layout lines. This way, you can use a sabre saw to separate them without cutting into either piece.



▲ A hardboard template provides a quick way to make identical end pieces.

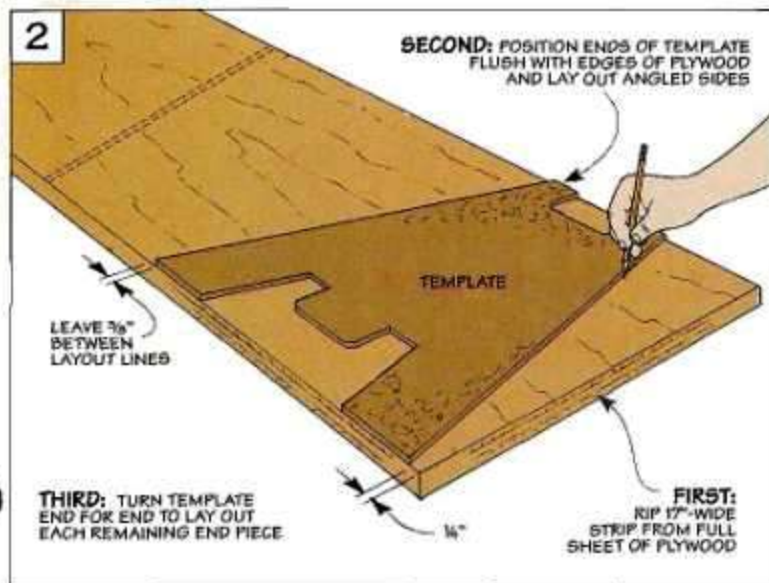
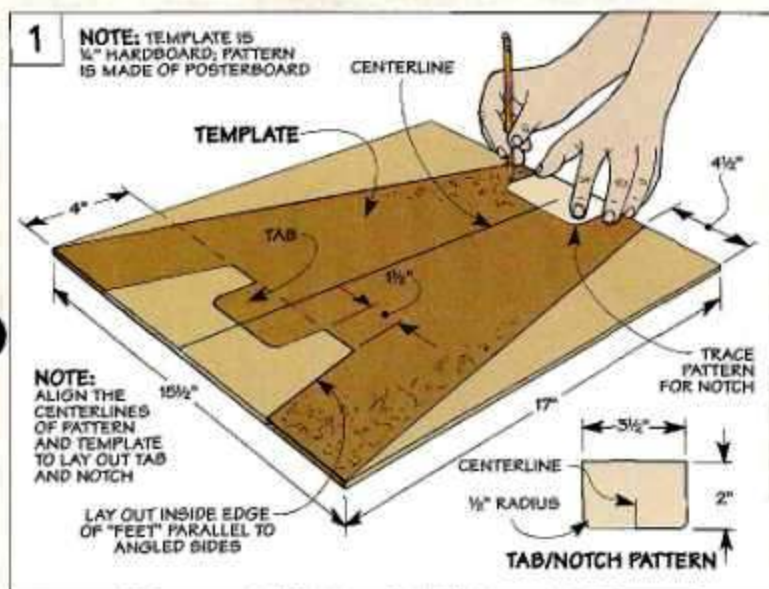

▲ When it's time to "stabilize" your sawhorses, they don't take up much floor space. Just stack all four together for storage.

Construction

At this point, the basic groundwork for the set of sawhorses is complete. Now it's just a matter of cutting the end pieces to final shape and connecting them with the top, shelf and supports, see Exploded View.

REMOVE WASTE. The first step is to remove the bulk of the waste from the area inside the notch and around the tab. There's no need to lay out these areas. Just carpet-tape the template to each *end piece* (A) and use a band saw (or sabre saw) to rough out the basic shape, see Fig. 3.

The thing to watch here is that you don't accidentally cut into the edge of the template. I make it a point to stay at least $\frac{1}{8}$ " away from the edge. This leaves a small amount of material that can be removed quickly and easily.

ROUT TO SHAPE. To do this, the end piece is routed to final shape with a flush trim bit mounted in the router table, see Fig. 4. The idea here is to adjust the height of the bit so the bearing rides against the edge of the template. This way, the cutting edge of the bit trims the end piece perfectly flush with the template.

But the router bit will leave the *inside* corners of the end piece slightly rounded. That's okay for the corners of the notch. But the corners of the "ears" around the tab will need some additional work.

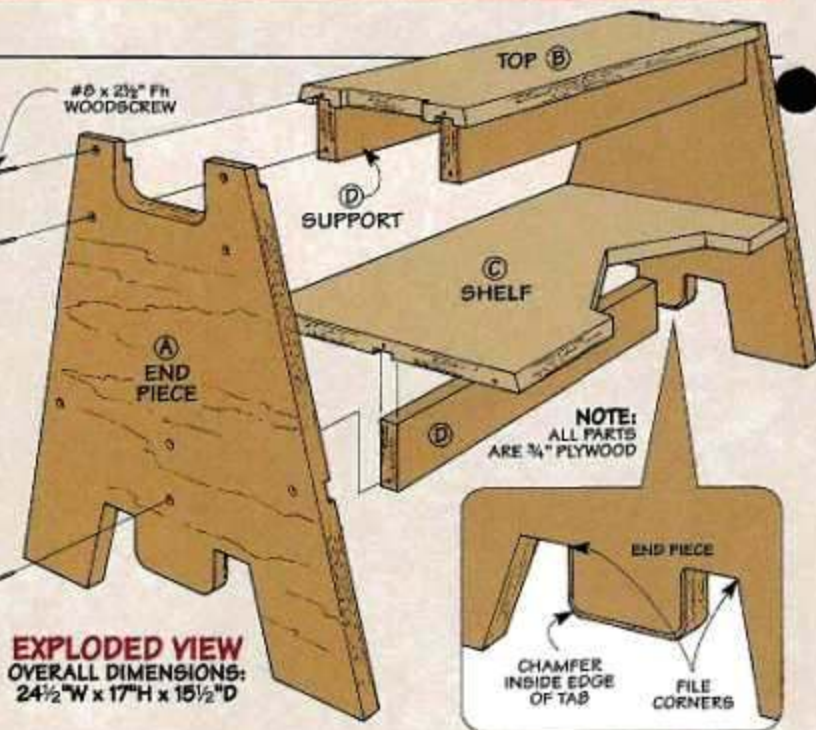

FILE CORNERS. To allow the tab on the top sawhorse to fit all the way down into the notch of the one below, you'll need to clean up these corners. A few strokes with a file is all it takes to get them nice and straight, see detail above.

CHAMFER TAB. While you're at it, it's a good idea to file a slight chamfer on the *inside* of the tab. This will make it easier for the tab to slip into the notch when stacking the sawhorses.

JOINERY. After repeating this process for all of the remaining end pieces, you can concentrate on the joinery that's used to assemble the sawhorses.

To provide sturdy support for the top of the sawhorse, it sits in a rabbet in the top edge of each end piece. And to strengthen the shelf, it fits into a dado.

AUXILIARY FENCE. But before cutting either the rabbet or dado, I attached a *long* auxiliary fence to the rip fence on the table saw, see Fig. 5. It's a scrap piece of wood that extends about 6" past the end of the rip fence.

The auxiliary fence lets you "bury" the blade when cutting the rabbet, see Fig. 5a. And it provides continuous support for the bottom edge of the end piece as you cut the dado, see Fig. 5b.

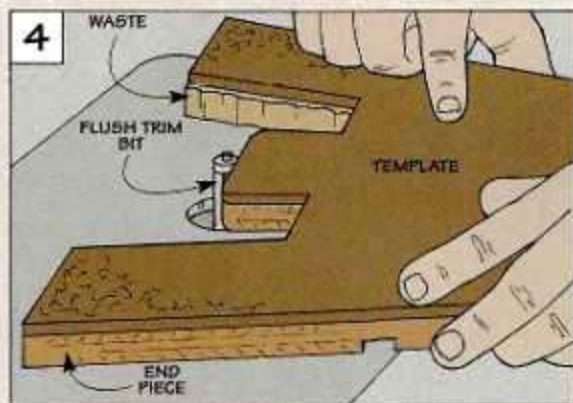
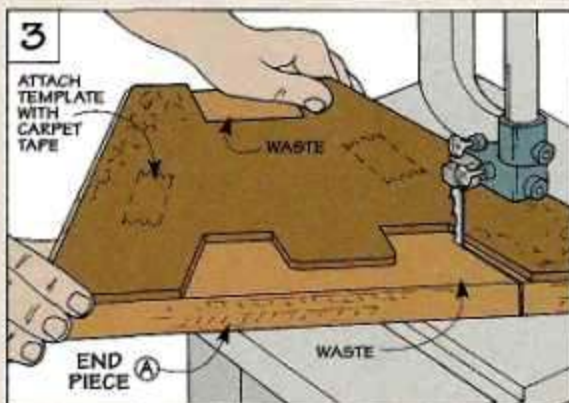

TOP & SHELF. With the ends complete, the next step is to add a plywood top (B) and shelf (C), see Fig. 6. The long edges of these pieces are beveled to match the angle of the end pieces.

Ripping the bevels is easy. The trick is to get the beveled edges to fit flush with the end pieces once the sawhorse is assembled.

The best way I found to do this is to first rip the pieces to rough width. Then sneak up on the final width by making a series of bevel cuts and removing a small amount of material with each pass.

CUT GROOVES. In addition to the bevels, you'll also need to cut two grooves in the top and a single groove in the shelf. These grooves will accept the supports that are added later.

RECESS. Before assembling the sawhorse, there's one more thing to do. That's to cut a shallow recess in each end of the top. Once the sawhorse is assembled, the recess will provide clearance so the tab can fit down in the notch.

To lay out this recess accurately, it's easiest to set the top in place, see Fig. 6a. Then, after attaching a tall fence to the miter gauge, make several passes over a dado blade to cut the recess, see Fig. 6b.

SUPPORTS. To help strengthen the sawhorse, I added three plywood supports (D), see Fig. 7. Two of these supports fit in the grooves in the top. And there's a single support below the shelf.

These supports are ripped to final width. But it's best to dry assemble the sawhorse before cutting them to final length.

ASSEMBLY. Now you're ready to assemble the sawhorses. The top and shelf of each one are glued and screwed to the end pieces, see Fig. 7. And the supports are glued into the grooves and secured with screws driven into the ends, see Fig. 7a. 

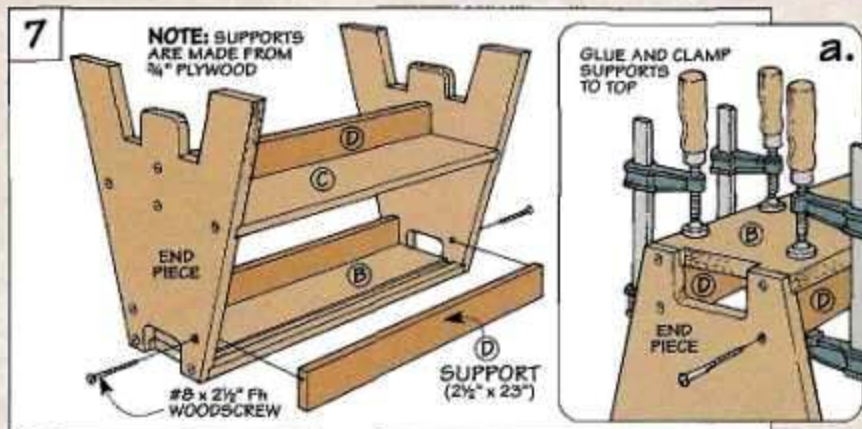
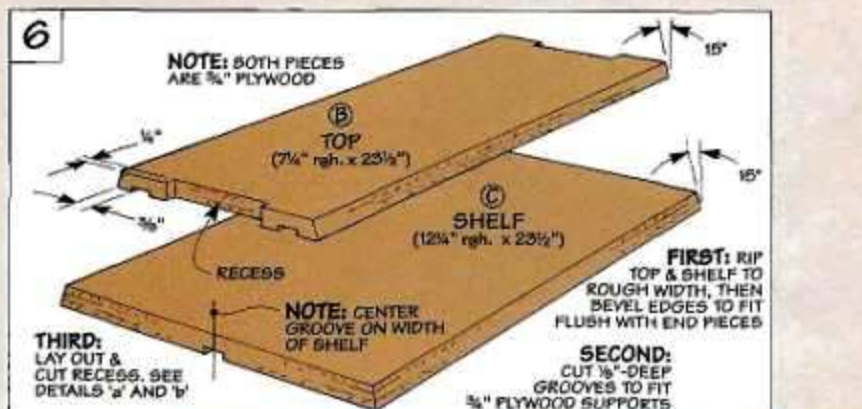
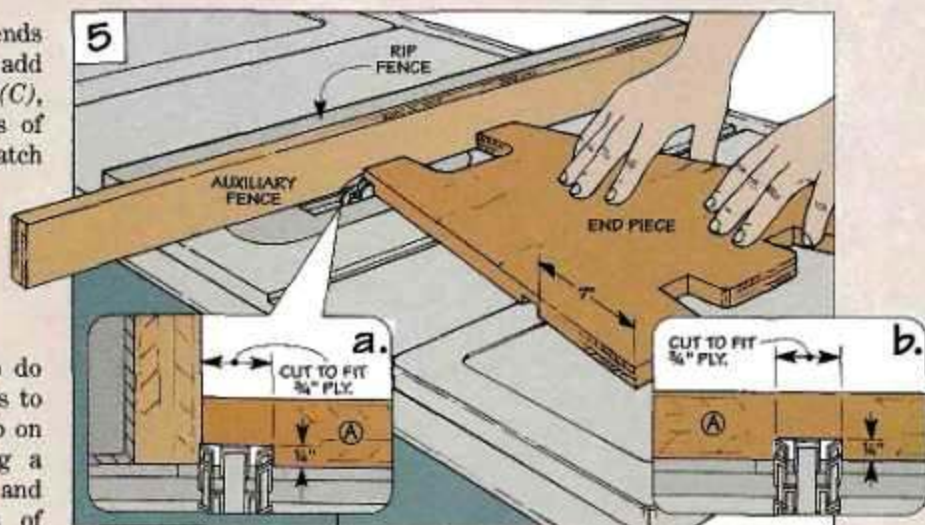

TAPER SLED

■ Using a template to make the end pieces for the Stacking Sawhorses (page 24) ensures each one is identical. But there's a "catch." To get the sawhorses to fit together nice and tight, each side of the template needs to be cut at the exact same angle.

To accomplish this, I made a sled for the table saw. It consists of two parts: a plywood *base* and a wood *stop*, see drawing.

REFERENCE EDGE. The idea here is to create a *reference edge* on the base that indicates the path of the saw blade. This edge is then used to position the template.

To establish the reference edge, rip the base to a width of 16". Then, without moving the rip fence, align one of the layout lines

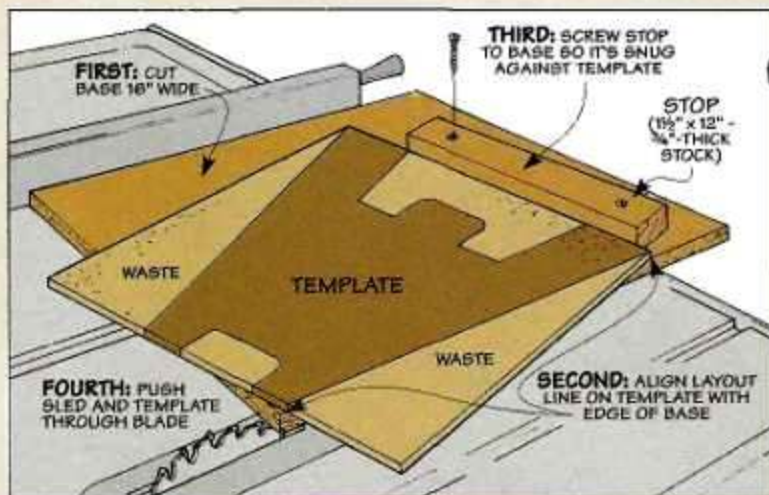

on the template with this edge.

ATTACH STOP. Before making a cut, you'll need a way to keep the template from sliding. So butt the stop against the bottom edge of the template and screw it to the base. Then turn on the saw and push the sled through the blade.

FLIP TEMPLATE. This takes care of the first side. But flipping

the template over to cut the opposite side hides the layout lines. That's the nice thing about the stop. It makes it easy to duplicate the angle that's already cut.

To do this, just place the bottom edge of the template against the stop. Then, after aligning the corner with the reference edge, cut the angle on the second side.

MITERING JIG

■ To provide clearance for the fingers of the Edge Clamp (page 6), the jaws of the middle layer need to be trimmed at an angle. The problem is the workpiece "rocks" when the curved edge is set against the miter gauge.

MITERING JIG. To hold the workpiece securely, I made a mitering jig for the table saw, see drawing. The jig consists of three parts: a *fence* that attaches to the miter gauge, a curved *cradle* to match the shape of the middle piece, and a *stop* to position the workpiece, see drawing.

The cradle is simply one of the curved scraps that remains after cutting the pieces that make up the edge clamp to shape. And the fence and stop are made from scraps of hardwood.

Both the stop and cradle are glued to the fence. Once that's complete, you're ready to attach the fence to the miter gauge.

SETUP. Before positioning the jig on the miter gauge, you'll need to first set the miter gauge to 47° to match the desired angle on the jaw. Then place the middle piece in the cradle with its back against the stop.

Once the piece is secure, slide the jig along the fence until the

edge of the blade aligns with the *waste* side of the layout line, see drawing. Then screw the fence to the miter gauge.

To trim the waste off of the jaw, simply slide the jig forward. Just be sure to stop before cutting into the opposite jaw.

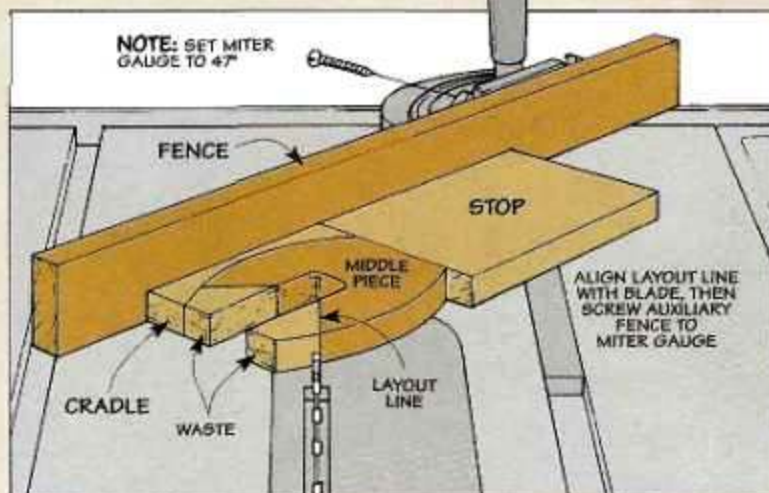

ASSEMBLY JIG

When it comes to gluing up workpieces face to face, I usually start with oversize workpieces and then trim them to final size once the glue dries. But with the three pieces that make up the Edge Clamp (page 6), I started with workpieces already cut to final shape. So the problem is keeping all the edges aligned as you clamp the assembly together.

ASSEMBLY JIG. To help keep everything aligned, I made a small assembly jig. The jig consists of a few simple parts: a hardboard base, a set of four alignment blocks, a wood spacer and an MDF clamping plate, see drawing.

The purpose of the alignment blocks is to "corral" the workpieces. To make it easy to set the workpieces in place, only three of the alignment blocks are glued to the base of the assembly jig.

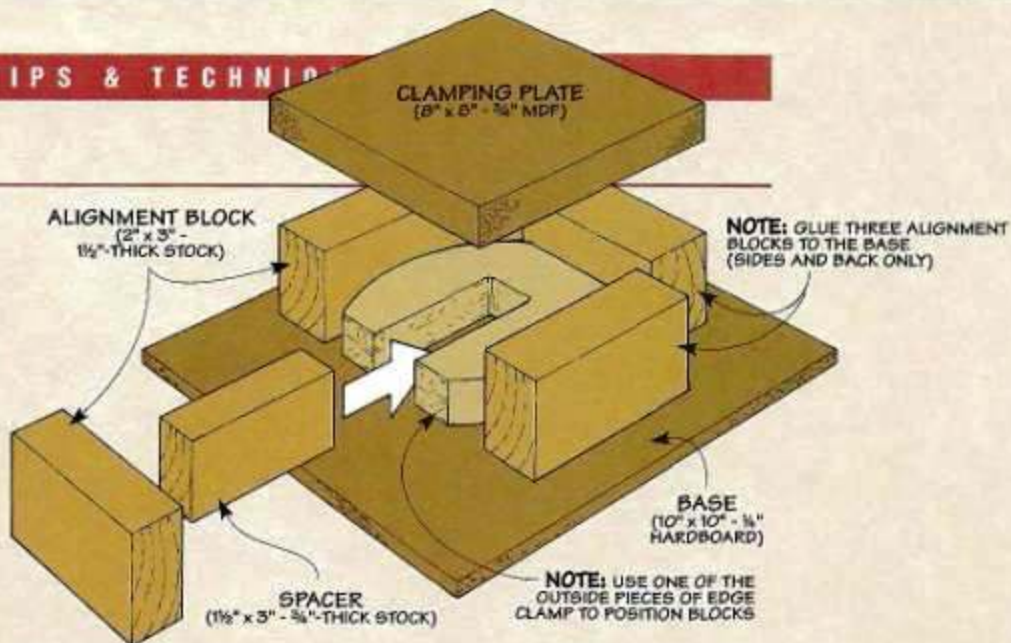

Note: I used one of the workpieces to help position the alignment blocks.

The fourth block serves two purposes. First, it keeps the outside edges aligned. And second, it pushes the spacer against the middle piece to keep it aligned with the top and bottom pieces.

CLAMP ASSEMBLY. After the fixed alignment blocks are glued in place, give everything a few coats of finish and a coat of paste wax to keep glue from sticking to the assembly jig. Once that's complete, gluing up an edge clamp is a simple four-step process, see photos below.



1 To assemble an edge clamp, start by applying glue to each of the workpieces and then stack them in the assembly jig like a layer cake.

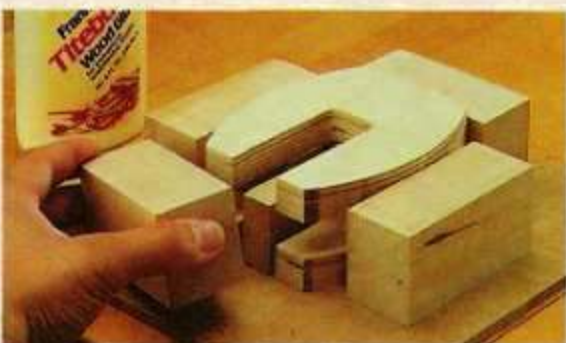

2 After slipping a spacer between the jaws to prevent the middle piece from shifting, set the last alignment block in place.

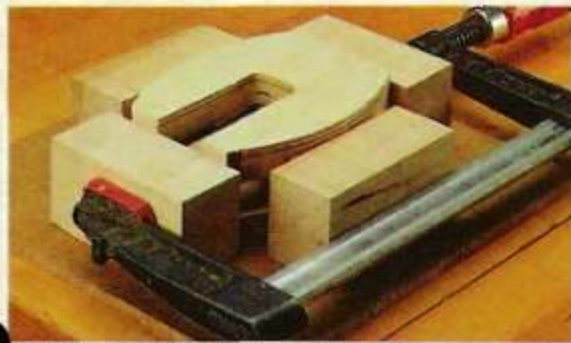

3 With the last block in place, clamp across the ends of the jig to prevent the workpieces from slipping out of alignment.

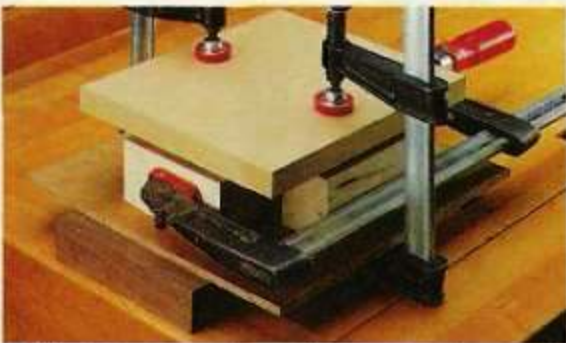

4 Next, use a couple small scraps to raise the jig. Then apply pressure to the entire assembly by clamping a scrap of MDF to the top of the jig.

Spiral Upcut Bits

What makes a spiral upcut bit so useful? It's designed to cut in two different directions.

The first time I used the pocket hole jig shown on page 16, I was a bit disappointed. Not so much at the start of the cut where the pocket was fairly shallow. But as the depth of the pocket increased, the router began to whine (even louder than usual). And it set up a vibration that I could feel through the handle of the jig.

Fortunately, the problem wasn't the jig or the router — it was the router bit. The straight bit I was using just wasn't doing the job.

That's when I decided to try a different type of bit — a spiral upcut bit. This time, the results were impressive. The bit produced a smooth, clean cut with considerably less effort.

DUAL CUTTING ACTION

The reason for this is simple — a spiral upcut bit is designed to cut in *two* directions. It has the plunge cutting ability of a drill bit. Yet it cuts sideways as well (like most router bits).

PLUNGE CUTS. Unlike a straight bit, a spiral upcut bit has cutting edges that extend all the way across the tip of the bit, see drawing above. As a result, the bit “drills” into the workpiece when you make a plunge cut. This makes it ideal for routing deep mortises or cutting stopped dados and grooves.

SPIRAL CUTTING EDGES. But the most unique thing about these bits is its spiral cutting edges. Instead of a straight cutting edge that's in-line with the shank (like a straight bit), it has two spiral cutting edges that twist steeply around the bit.

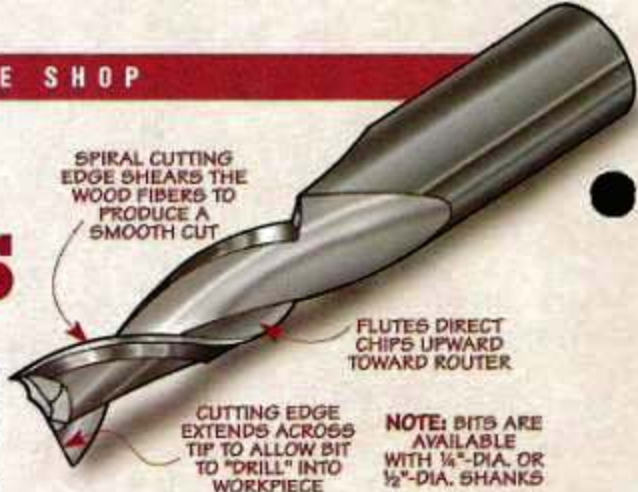

Note: There are some spiral upcut bits that have only a single cutting edge.

Because of their shape, the spiral cutting edges contact the workpiece at an angle when making a cut. This produces a shearing cut that removes material quickly and leaves a clean, smooth surface behind. (That explains why it worked so well when routing the pocket.)

CHIP REMOVAL

Okay, so the spiral cutting edge improves the quality of cut. Buy why is it called an *upcut* bit? It simply has to do with how the flutes of the bit remove the chips from the cut.

Say you're making a plunge cut to rout a mortise for instance. With an upcut bit, the chips are pulled up out of the cut (toward the router) so they don't clog up the mortise. This reduces the amount of heat that builds up which means you're not as likely to damage the bit.

But there is one drawback to directing the chips upward like this. If you're working with plywood, the thin layer of veneer on the surface may fray as the chips get pulled past. The solution is a spiral bit that pushes the chips *downward*, see box below.

SELECTING A BIT

Regardless of the style, there are several things to consider when selecting a spiral router bit.

STEEL OR CARBIDE? The first decision to make is the material that the bit is made from. They're available in either high-speed steel or solid carbide.

COST. Like you'd expect, the solid carbide bits are more expensive. As an example, the $\frac{3}{8}$ " carbide bit we used in the pocket hole jig cost \$48.99. (The same size high-speed steel bit was \$15.99.) That means it cost over three times as much.

DURABILITY. So is a carbide bit worth the extra expense? That depends. It will stay sharp much longer than high-speed steel. That's a plus if you do a lot of work or use abrasive materials like MDF. But if you work mostly with solid wood, a high-speed steel bit should last a long time. 

Downcut Bits

At a glance, a spiral downcut bit looks a lot like an upcut bit. But there's one key difference — the spiral twists in the *opposite* direction. So the flutes of the bit direct chips *away* from the router.

Because the chips get pushed downward, there's less chipout on the surface of the workpiece.

SHALLOW CUTS. This makes a downcut bit ideal for routing a shallow ($\frac{1}{4}$ "-deep or less) dado or groove — especially in materials



that are likely to chip out. If you're routing a dado in hardwood plywood, the fibers of the surface veneer won't fray. And it's a great way to rout a clean, crisp channel for inlay.

TEMPLATE ROUTING. Downcut bits also come in handy if you're using a template and a router with a guide bushing to cut pieces to shape. Again, since the chips are pushed downward, there's no chipout on the top.

Sources

PRODUCT INFORMATION



Downcut

Upcut

ShopNotes Project Supplies is offering some of the hardware and supplies needed to build the projects in this issue.

We've also put together a list of other mail-order sources that have similar hardware and supplies.



▲ Pocket Hole Screws

To produce a strong, easy-to-assemble pocket hole joint, we used self-tapping screws with a square recess in the head. See margin for mail-order sources.



▲ Toggle Clamp

To hold the workpiece in place on the Pocket Hole Jig, we used a hold-down style De-Sta-Co clamp (No. 227) with 500 lbs. of clamping pressure. For mail-order sources, see margin.

Spiral Router Bits ▶

The article on page 30 provides information about two types of Spiral Router Bits — an upcut bit and a downcut bit. They combine the plunge cutting ability of a drill bit with the sideways cutting action of a standard router bit. For mail-order sources, see margin.

Pocket Hole Jig ▶

We're offering a kit to build the Pocket Hole Jig featured on page 16. It has all the hardware you need including a toggle clamp and the copper tubing used as a guide for the bit. All you need to supply is a spiral upcut bit, a twist bit and driver bit, and the plywood and hardwood.

POCKET HOLE JIG KIT
6842-200.....\$23.95



▲ Edge Clamp Hardware Kit

When you're working with 3/4" plywood, the Edge Clamps shown on page 6 are a great way to apply hardwood edging. You just slip the clamp over the plywood and tighten the knob.

ShopNotes Project Supplies is offering a hardware kit that will allow you to build six Edge Clamps. You'll need to supply the plywood and hardwood.

EDGE CLAMP HARDWARE KIT
6842-100.....\$17.95

MAIL ORDER SOURCES

Woodhaven
800-344-6657

Spiral Downcut Bits,
Spiral Upcut Bits,
Toggle Clamps

Woodcraft
800-225-1153

Spiral Upcut Bits,
Toggle Clamps

Rockler
800-279-4441

Spiral Upcut Bits,
Toggle Clamps

McFeely's
800-443-7937

Pocket Hole Screws
Driver Bits

Woodworker's Hardware
800-383-0130

Pocket Hole Screws

STATEMENT OF OWNERSHIP MANAGEMENT AND CIRCULATION (Required by 39 U.S.C. 3685)

1. Publication Title: ShopNotes. 2. Publication No.: 10521076. 3. Filing Date: September 6, 1998. 4. Issue Frequency: Quarterly. 5. No. of Issues Published Annually: 4 (100). 6. Annual Subscription Price: \$23.95. 7. Complete Mailing Address of Known Office of Publication: 2200 Grand Avenue, Des Moines, (Iowa) 50312-5506. 8. Complete Mailing Address of the Headquarters or General Business Office of the Publisher: 2200 Grand Avenue, Des Moines, (Iowa) 50312-5506. 9. Full names and complete mailing addresses of publisher, editor and managing editor: Publisher: Harold S. Panchik, 2200 Grand Avenue, Des Moines, Iowa 50312; Editor: Tim Robertson, 2200 Grand Avenue, Des Moines, Iowa 50312; Editor: Shemar August Home Publishing Company, 2200 Grand Avenue, Des Moines, Iowa 50312; Harold S. Panchik, 2200 Grand Avenue, Des Moines, Iowa 50312. 11. Names, titles, and complete mailing addresses of all persons owning or holding one percent or more of total amount of stock, mortgages or other securities: None. 12. (Does not apply) 13. Publication Title: ShopNotes. 14. Issue Date for Circulation Data Below: July/Aug 1998 (9400) U.S. Postal authorization of circulation.

	Average no. copies each issue during preceding 12 months	Average no. copies of single issue published nearest to filing date
A. Total no. copies (net press run)	193,338	193,280
B. Paid and/or requested circulation:		
1. Sales through dealers, street vendors and counter sales	22,250	22,250
2. Mail subscriptions (paid and/or requested)	144,880	144,811
C. Total paid and/or requested circulation	167,130	167,061
D. Free distribution by mail, samples, complimentary and other free copies	228	250
E. Free distribution outside the mail (carriers or other means)	0	0
F. Total free distribution	228	250
G. Total distribution	167,358	167,311
H. Copies not distributed:		
1. Office use, left-overs, unaccounted, spoiled after printing	5,187	4,846
2. Returns from news agents	21,793	4,523
I. Total	193,338	193,280
Percentage paid and/or requested circulation	86.52%	86.52%
16. This statement of ownership will be printed in the May/June 1999 (9425) issue of this publication.		
17. I certify that the statements made by me above are correct and complete.		

(Signed) Tim Robertson, Editor

TO PLACE AN ORDER CALL
800-347-5105
(KEY CODE: SN 42)

Scenes from the Shop



▲ **Edge Clamps.** To release these Edge Clamps from the workpiece, simply loosen the lock knob and push the spring-loaded "fingers" forward. (Plans begin on page 6.)

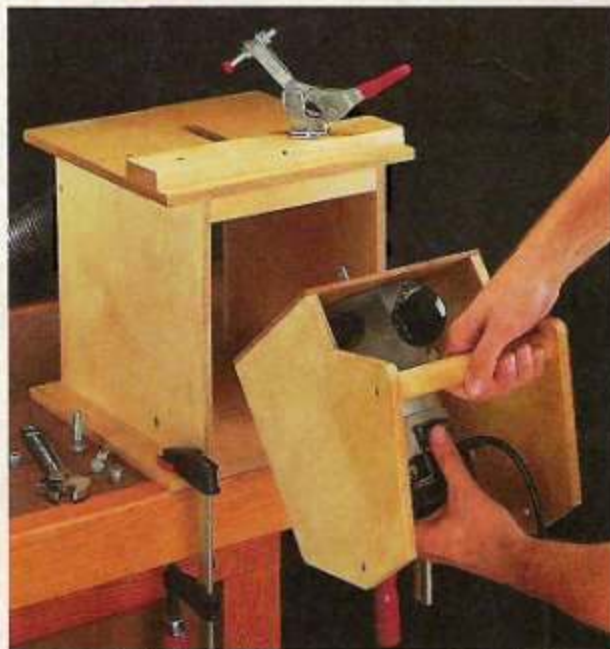

▲ **Pocket Hole Jig.** Setting up our Pocket Hole Jig (shown on page 16) is easy. That's because the router that cuts the pocket is mounted in a removable carriage.



▲ **Stacking Sawhorses.** Building a large project? This set of four Stacking Sawhorses provides a handy assembly area. Unlike a workbench that's often too tall, in easy reach. And they raise it off the floor so it's not a pain in the back to assemble. (See page 24.)