

TIPS • TOOLS • TECHNIQUES

ShopNotes

Vol. 7

Issue 37

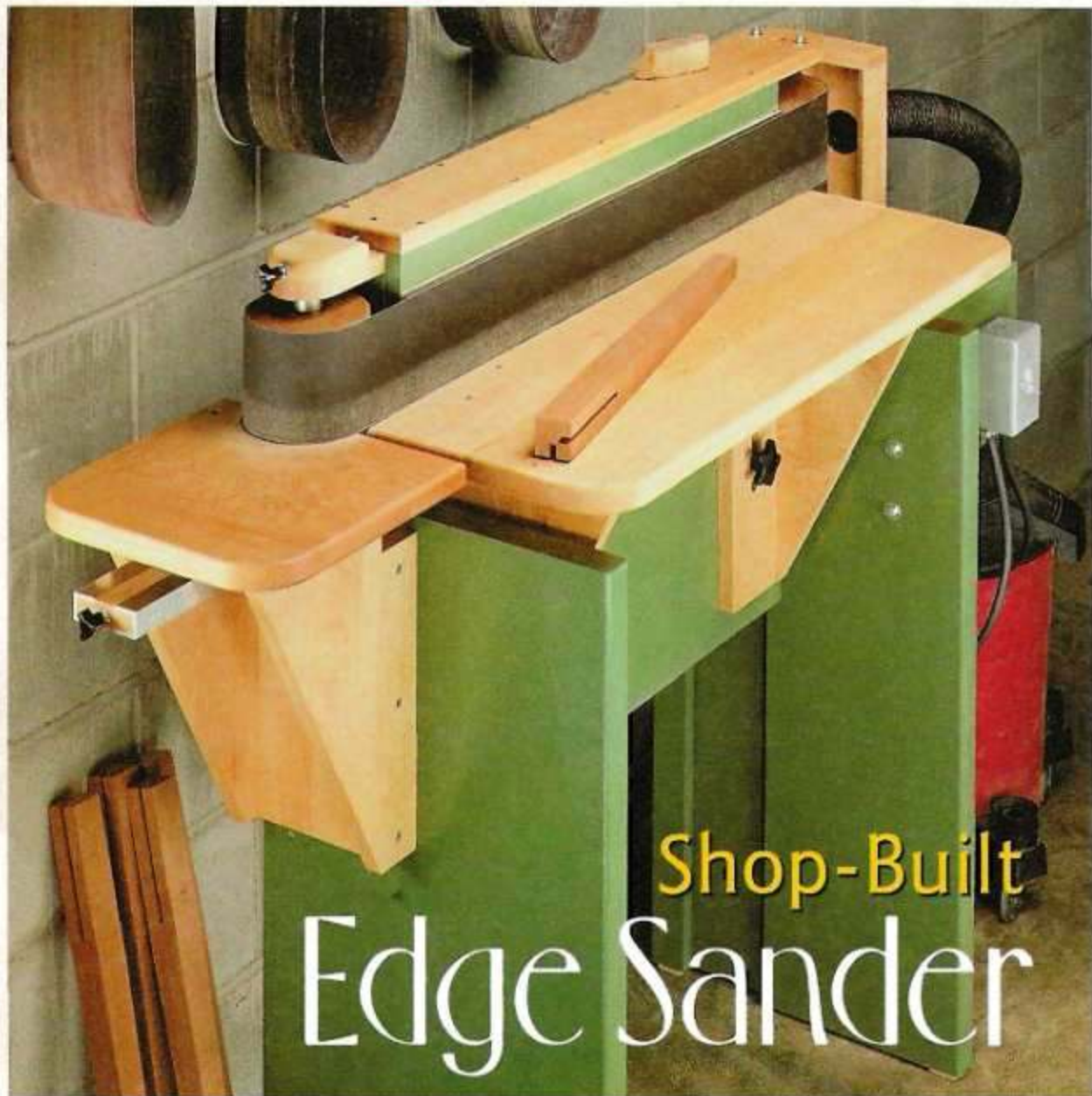

Shop-Built Edge Sander

- Small Parts Cabinet
- Making Dovetail Keys
- Chisel Case
- Wood Plugs
- Shop-Tested Tips



ShopNotes

Issue 37

January 1998

PUBLISHER Donald B. Peschke
EDITOR Tim Robertson
ASSISTANT EDITOR Bryan Nelson
ART DIRECTOR Cary Christensen
SR. GRAPHIC DESIGNER Kurt Schultz
SENIOR ILLUSTRATORS Roger Reiland
 Mark Higdon

CREATIVE RESOURCES

Creative Director: Ted Krulook • *Project Developer:* Ken Mackel • *Project Designer:* Ted Wang, Kevin Boyle • *Project Coordinator:* Kent Weink • *Shop Mgr.:* Steve Curtis • *Shop Craftsperson:* Steve Johnson • *Photography Director:* Lark Benfiterman • *Sr. Photographer:* Cayola England

BOOKS

Executive Editor: Douglas L. Hicks • *Art Director:* Linda F. Verme • *Sr. Graphic Designer:* Chris Glowacki

CIRCULATION

Sub. Serv. Dir.: Sandy Baum • *New Dir. Div.:* Ganda Battist • *New Bus. Mgr.:* Todd L. Steier • *Resonal. Mgr.:* Paige Rogers • *Billing Mgr.:* Rebecca Cunningham • *Asst. Sub. Mgr.:* Jay Krauss • *Press. Asst.:* Rick Jenkins • *Assoc. Graphic Design Dir.:* Blake Rider • *Sr. Graphic Designer:* Cheryl L. Simpson

CORPORATE SERVICES

Vice President of Planning & Finance: Jon MacCarthy • *Controller:* Robin Hutchinson • *Sr. Acct.:* Laura Thomas • *Accounts Payable Clerk:* Mary Schultz • *Production Director:* George Chmielarz • *Electronic Publishing:* Douglas M. Libster • *Production Asst.:* Susan Diokman • *Production Artist:* Jon Snyder • *Pre-Press Image Spec.:* Troy Clark • *New Media Manager:* Gordon C. Galupe • *Multimedia Art Dir.:* Eugene Pedersen • *Net. Admin.:* Al Barrie • *J.S. Support Asst.:* Chris Harrison • *H.R. Dir.:* Joyce Moore • *H.R. Asst.:* Kirsten Koels • *Admin. Asst.:* Julia Puh • *Recopy/Assmt. Inhouse:* Sheryl Hittney • *Bldg. Maint.:* Ken Griffith • *Special Proj. Dir.:* Daville H. Laman

MAIL ORDER

Operations Dir.: Bob Baker • *Mat'l Mgr.:* Mark Mattioli • *Cust. Service Mgr.:* Jeanie Ence • *Warehouse Supt.:* Nancy Johnson • *Buyer:* Linda Jones • *Op. Asst.:* Tammy Aklin • *Team Leader:* Karl Edinger • *Tech. Rep.:* Matthew ToRonde • *Cust. Service Reps.:* Aneta Cox, Margo Petrus, Tammy Truelsen, Adam Best, Nancy Downey, Deborah Blich • *Warehouse:* Sylvia Carey, Larry Price • *Qual. Control Tech.:* Frank Johnson

ShopNotes® (ISSN 1062-0096) is published bimonthly (Jan., March, May, July, Sept., Nov.) by August Home Publishing, 2200 Grand, Des Moines, IA 50312. ShopNotes® is a registered trademark of August Home Publishing. ©Copyright 1997 by August Home Publishing. All rights reserved.
 Subscriptions: Single copy: \$4.99. One year subscription (6 issues): \$24.95. Canada/Foreign add \$5 per year.
 Periodicals Postage Paid at Des Moines, IA and at additional mailing offices.
 Postmaster: Send change of address to ShopNotes, P.O. Box 97700, Boone, IA 50037-2700.
 Subscription Questions? Write to: ShopNotes Customer Service, P.O. Box 842, Des Moines, IA 50304-0842. Or call 1-800-383-6854, 9:00 am to 5:00 pm, Central Time, weekdays. FAX 515-283-0447
 E-Mail: ShopNotes@shopnotes.com
 Internet: http://www.shopnotes.com

PRINTED IN U.S.A.
 Reprinted 2002

WoodNet

NOW ON THE WEB!

- 50 Woodworking Tips Online
- Woodworking Techniques — Step-by-Step
- Project Plans you can download
- WoodNet Forum — Woodworkers' Q & A
- Power Tool Reviews

Point your browser to: <http://www.augusthome.com>
 Select "Woodworking" from the Welcome Page menu.

EDITOR'S NOTE

Cutoffs

If there's a woodworking show nearby, you can bet I'll be at it. What better place to check out a new jig, try out a dozen different cordless drills, or just "kick the tires" on a stationary power tool?

EDGE SANDER. It was at one of these shows that I saw an edge sander for the first time. Basically, it reminded me of a huge portable belt sander lying on its side. The belt was as big around as a tractor tire. And a large, cast iron table supported the workpiece next to the belt.

Together, they made this edge sander seem like the perfect tool for all kinds of sanding jobs — removing saw marks from a tapered leg, sanding the "pins" on a dovetailed box flush with the sides, or sanding a workpiece to shape.

But besides making quick work of tough sanding jobs, there was something else that impressed me even more about this edge sander — the belt sanded *in line* with the length of the workpiece. So there were no cross-grain scratches like you get with a disk sander.

The only drawback to this edge sander was the cost. With a price tag of over \$1000, I'd have to admit it was an impractical tool for most small shops.

But shortly after that, several manufacturers began making edge sanders for the *home* shop. That's when we decided to buy an inexpensive model for our shop. Unfortunately, we "bought" some problems along with it.

The sander vibrated and shook like a wet dog. And we were constantly fiddling with the tracking to keep the sanding belt adjusted properly. But the real clincher was when the bearings started that high-pitched scream that's a sure sign they're wearing out.

SHOP-BUILT SANDER. That's when Ken (our project developer) suggested that we *build* our own edge sander — a heavy-duty version with all the features of an industrial quality tool.

At first I thought he was joking. But he soon came up with a jig to solve one of the biggest problems — making the rollers. Or, to be more exact, creating a barrel-shaped "crown" that would center the sanding belt on the roller.

The jig was unusual looking — a small box with a crank on the side that turned the roller on the inside. As he turned the crank, I couldn't help thinking of an old-fashioned organ grinder. But there was no music. And no monkey.

Instead, he passed a hand-held router across the gently curved sides of the box to form a perfect crown on the roller. (For more information on the edge sander, see page 16.)

HELP WANTED. We're looking for an associate editor to join our staff here at ShopNotes. Ideally, this person will be enthusiastic about woodworking and have writing experience. If you're interested, send a resume and letter to: J. S. Moore, 2200 Grand Ave., Des Moines, IA 50312.



Tim

Contents

Techniques

Dovetail Keys _____ 12

Small wood "keys" create the traditional look of a dovetail joint — without all the work. Plus, they add strength to the mitered corners of a box.

Cutting Wood Plugs _____ 30

What's the secret to making a wood plug blend invisibly with the area around it? And which plug cutters are best? We take a look at the answers to both questions.

Projects

Chisel Case _____ 6

Made of quartersawn white oak and mahogany, this chisel case is as attractive as it is practical. Whether the case is hanging on a wall or sitting on a bench, a unique tilting rack provides easy access to your chisels.

Edge Sander _____ 16

This shop-built edge sander makes quick work of tough sanding jobs. It's made of common materials and hardware. Yet it offers a precision tracking system for the sanding belt, two adjustable sanding tables, and a convenient dust hook-up for your shop vacuum.

Departments

Readers' Tips _____ 4

A small parts cabinet with a special drop-down sorting tray is just one of the shop-tested tips provided by our readers.

Shop Solutions _____ 14

Use these tips from the guys in our shop to get professional looking results on the projects in this issue.

Sources _____ 31

Here's a list of hardware, supplies, and mail order sources for the projects in this issue.



Chisel Case

page 6



Dovetail Keys

page 12

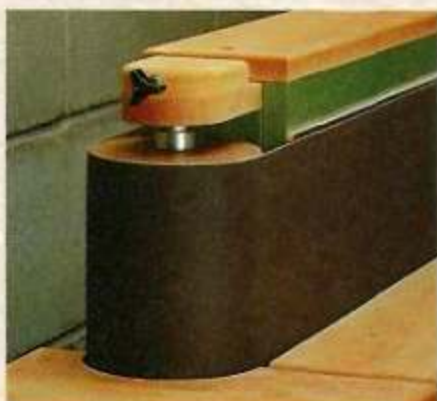

Edge Sander

page 16



Cutting Wood Plugs

page 30

Readers' Tips

Small Parts Cabinet

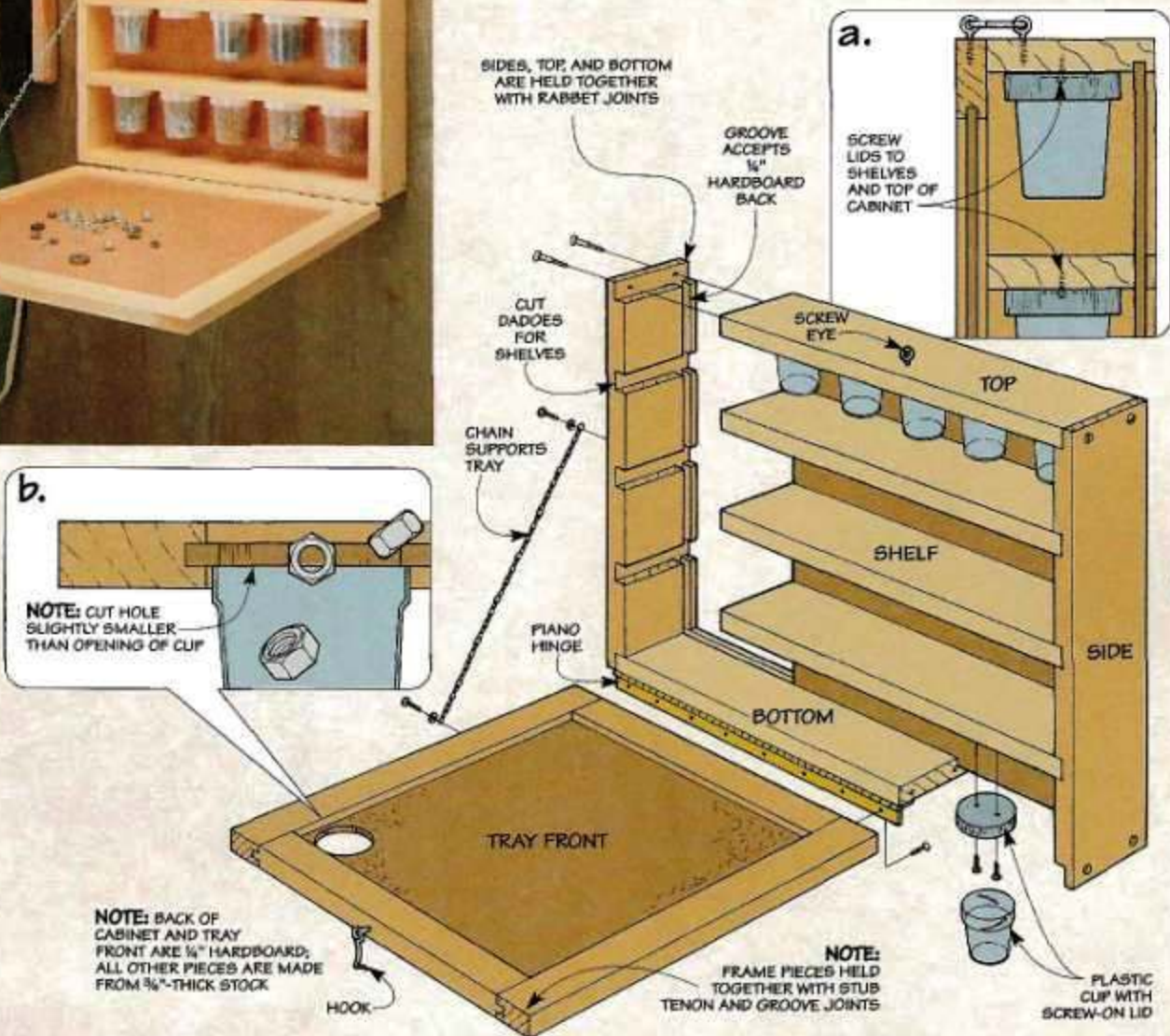

■ The plastic cups in this cabinet provide a handy way to organize small pieces of hardware. But there's something else about it I like even more — a drop-down sorting tray that doubles as the door of the cabinet.

After lowering the tray, you just dump out the contents of one of the cups to find the piece you want. Then sweep the remaining pieces through a hole

in the tray and back into the cup that's held below, see photo and detail 'b.'

Before building the cabinet, it's a good idea to have the plastic cups in hand. (I bought cups with screw-on lids from a medical supply company.)

What's nice about these cups is you can screw the lids under the shelves (or the top) of the cabinet, see drawing and detail

'a.' This way, all it takes is a quick turn of the wrist to remove a cup (or put one back).

The cabinet is quite simple — just an open box that's hinged to the tray. Attaching a short chain provides support for the tray when it's open. And when it's closed, a hook and screw eye lock the tray securely in place.

*Stephen Shaw
Long Beach, California*

Quick Tips



▲ By locating a block with a self-adhesive magnet near each tool, **D. Hicks** of Urbandale, Iowa never misplaces his metal rules.



▲ To provide better coverage when applying stain to a dowel, **R. B. Himes** of Vienna, Ohio cuts a V-shaped notch in a foam brush.



▲ With a scrap of Plexiglas carpet-taped to his work, **M. TeRonde** of Madrid, Iowa keeps the point of a compass from marring the surface.

Overhead Storage

■ Finding space in my basement shop to store short cutoffs was always a problem. At least until I realized that the steel I-beam running overhead offered a great storage solution.

To store these short pieces up out of the way, I hang support arms made from "two-by" material from the bottom flanges of the I-beam, see drawing.

Each support arm is held in place by two L-shaped hooks. The hooks are simply threaded into the support arms until they pinch tight against the I-beam.

*Ted Moravec
Palatine, Illinois*

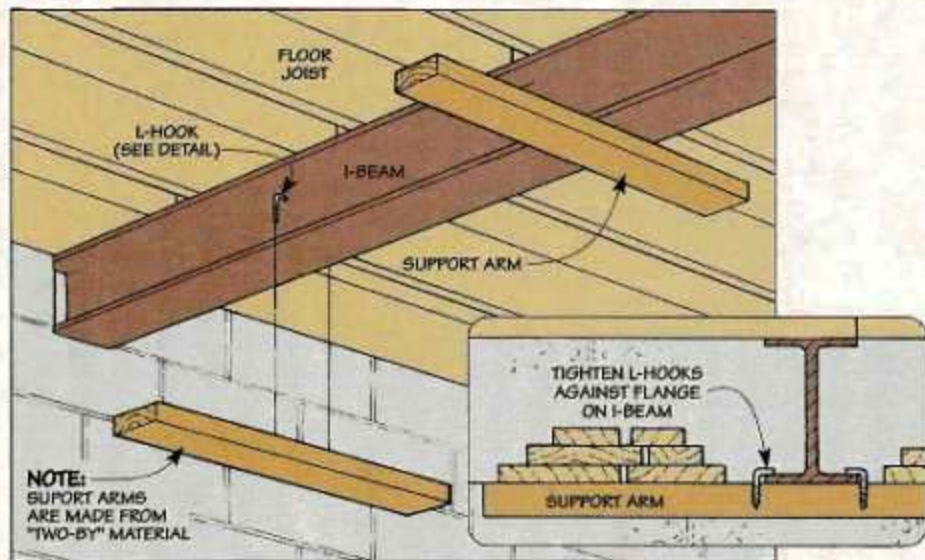

Woodscrew Tip

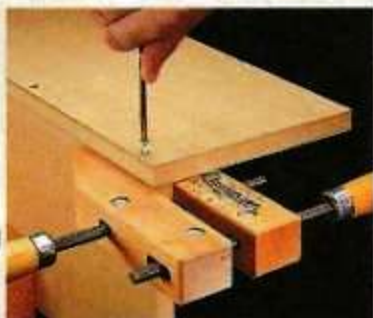

■ When installing woodscrews in the *edge* of manufactured materials like MDF, it's all too easy to split the sides of a workpiece — even if you drill a pilot hole first.

To prevent this, I support the sides by clamping an ordinary handscrew across the workpiece.

*Walter Peachey
Port Moody, B.C.*

Send in Your Tips

To share your original tips and solutions to problems you've faced, send them to: *ShopNotes*, Attn.: Readers' Tips, 2200 Grand Ave., Des Moines, IA 50312. (Or if it's easier, FAX them to us at: 515-282-6741.)

We'll pay up to \$200 depending on the published length. Please include a daytime phone number so we can call you if we have any questions.

Chisel Case

Whether you hang this case on a wall or set it on a bench, a tilting rack keeps your chisels right at hand.

There's no question that this chisel case is a great looking project. It's made of quartersawn white oak. And we used mahogany for the dovetail "keys" in the corners and the small accent pieces.

But what really intrigues me about this case isn't how it looks. It's how it *works*.

TILTING RACK. The chisels are held securely in place by a tilting rack. The unique thing is the rack locks in *two* different positions. This way, it provides easy access to your chisels whether the case is mounted on the wall (see photo above) or sitting on a bench, see center photo below.

WALL-MOUNTED. To "unlock" the case when it's hanging on a wall, you simply rotate a small wood turnbutton, see photo below right. Then flip up the cover, reach inside the case, and pull the rack forward. The cover drops neatly *behind* the rack, see Wall Mounted detail on page 7. And when you tip the rack back up, the turnbuttons lock it in place.

When working at your bench, the cover of the case props the rack at a convenient angle which makes it easy to remove a chisel.



▲ Made of quartersawn white oak and mahogany, this chisel case is as attractive as it is functional.



▲ To "unlock" the chisel case, simply rotate a turnbutton on each side. The turnbuttons also keep the rack from tipping too far forward when the case is mounted on the wall, see photo above.



HANGING SYSTEM. But just because the chisel case is mounted on the wall doesn't mean it's a permanent fixture. We've incorporated a hidden hanging system that lets you quickly remove the case and take it to your workbench.

BENCHTOP. With the chisel case lying flat on the benchtop, the rack needs to be propped up so you can slide the chisels in and out.

Here again, just tilt the rack up out of the case and lowering the cover behind it, see Benchtop detail. But here, the cover fits in a special wood catch that's attached to the back of the rack. This holds the rack at a convenient angle and locks it in place.

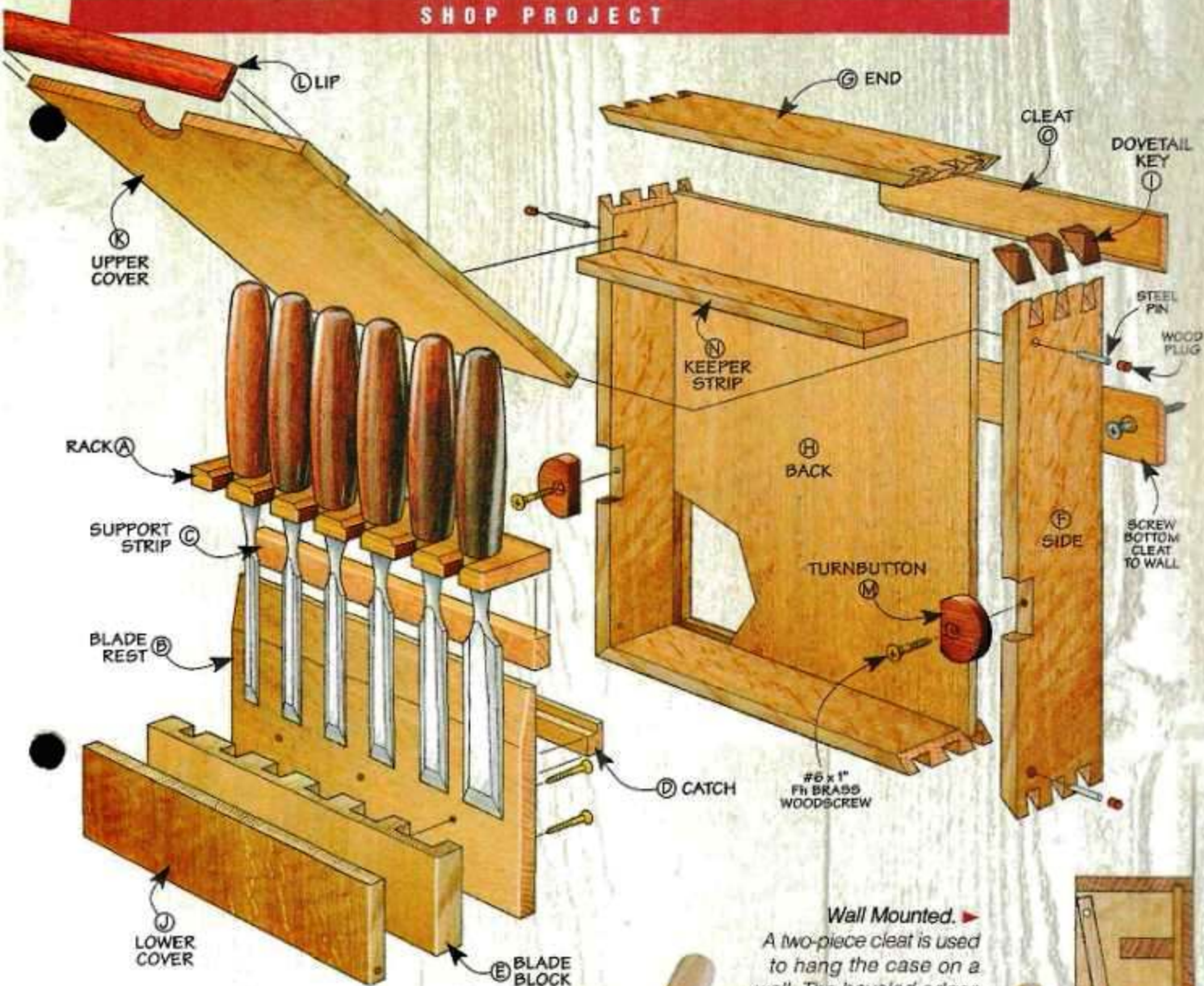

Materials

A Rack (1)	$\frac{1}{2} \times 1\frac{1}{8} - 10\frac{1}{8}$
B Blade Rest (1)	$\frac{1}{2} \times 5\frac{1}{8} - 10\frac{1}{8}$
C Support Strip (1)	$\frac{1}{2} \times 2\frac{1}{4} - 10\frac{1}{8}$
D Catch (1)	$\frac{1}{2} \times 3\frac{1}{4} - 10\frac{1}{8}$
E Blade Block (1)	$7\frac{1}{8} \times 10\frac{1}{8} - 2\frac{3}{4}$
F Sides (2)	$\frac{3}{8} \times 2\frac{1}{8} - 14$
G Ends (2)	$\frac{3}{8} \times 2\frac{1}{8} - 11$
H Back (1)	$10\frac{1}{8} \times 13\frac{5}{8} - \frac{1}{4}$ Ply.
I Dovetail Keys (12)	$\frac{1}{2} \times \frac{1}{2} - 1\frac{1}{2}$
J Lower Cover (1)	$\frac{3}{8} \times 10\frac{1}{8} - 2\frac{3}{4}$
K Upper Cover (1)	$\frac{3}{8} \times 10\frac{1}{8} - 9\frac{15}{16}$
L Lip (1)	$\frac{3}{16} \times \frac{3}{16} - 10\frac{1}{8}$
M Turnbuttons (2)	$\frac{3}{8} \times \frac{3}{8} - 1\frac{1}{8}$
N Keeper Strip (1)	$\frac{1}{2} \times 1\frac{1}{4} - 10\frac{1}{4}$
O Cleats (2)	$\frac{1}{4} \times 2 - 10\frac{1}{4}$

Wall Mounted. ▶

A two-piece cleat is used to hang the case on a wall. The beveled edges of the cleats hook together and allow you to lift the case off the wall.

◀ **Benchtop.** With the chisel case lying flat on a bench, the cover hooks into a wood catch in back of the rack to prop it at an angle.



Tilting Rack

The best way I found to make this chisel case is to work from the inside out. This way, I could customize the tilting rack to fit my chisels, then build the case around it.

RACK. I began by making a hardwood *rack* (A), with key-hole-shaped openings that hold the chisels securely in place, see drawing and Fig. 1.

The rack starts out as an extra-wide blank. Before determining the length of this blank, you'll need to lay out the locations of the openings for the chisels. This depends on the size of the handles at their *thickest* point.

To provide plenty of finger room when removing a chisel, I allowed $\frac{3}{8}$ " between the handles, see Fig. 1. And I laid out the centerpoints of the openings starting 1" in from one end, see Fig. 1a. After allowing an additional 1" at the opposite end, I cut the blank to length ($10\frac{1}{8}$ " long in my case).

Another thing to consider is the *size* of the openings. They need to be large enough to allow the metal ferrules on the handles to fit down inside, yet small enough that the chisels don't fall through.

Also, to keep the cover on the case from hitting the chisels when it's closed, the openings are located so the handles set back $\frac{1}{8}$ " from the front edge, see Fig. 1b.

Once you've laid out the openings, it's just a matter of drilling a series of holes (Fig. 2), then cutting intersecting notches, see Fig. 2a.

BLADE REST. The next step is to add the *blade rest* (B), see Fig. 3. Besides supporting the rack, it provides a flat surface for the backs of the blades to rest against.

The blade rest is the same

length as the rack, and its height (width) is designed to work for chisels up to $11\frac{1}{4}$ "-long.

Cutting a bevel along the top edge provides clearance for the tapered necks on the chisels, see Fig. 3a. (In my case, this bevel was 12° .)

At this point, you're almost ready to attach the rack. But first, you'll need to trim it to final width. The idea is to end up with a $\frac{1}{2}$ " overhang in back of the rest, see Fig. 3a. This way, the back edge of the rack will serve as a "stop" when it's lowered into the case.

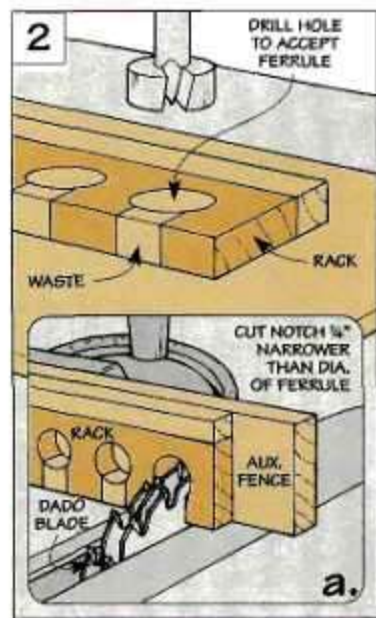
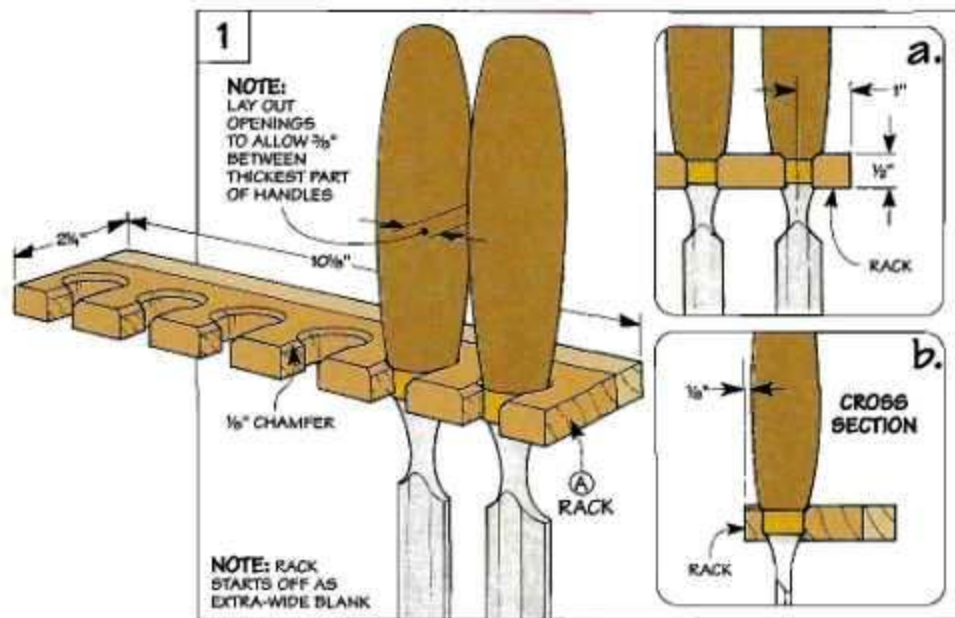

An easy way to determine the final width of the rack is to set a chisel in the opening at each end and press the blades against the rest, see Fig. 3. This moves the rack into its correct position so you can mark and trim it to width.

ATTACH RACK. Now you're ready to attach the rack. It sits on the top edge of the blade rest. Since this edge is quite thin, I added another hardwood strip to provide extra support, see Fig. 4. This *support strip (C)* is simply glued to the rest and the rack.

CATCH. The next step is to add a *catch (D)* to the back of the blade rest. It's a thin strip of hardwood that keeps the cover from dropping into the case when the rack is propped up. To form a lip that holds the cover in place, the catch is rabbeted and then glued in place, see Fig. 4a.

BLADE BLOCK. To complete the rack, I added a *blade block (E)*, see Fig. 5. It's a thick block with grooves that form pockets for the blades on the chisels.

I cut these grooves $\frac{1}{2}$ " deep. You'll want to check that they're deep enough that they don't restrict the blades when you lift out the chisels.

In addition to protecting the chisels, the blade block works together with the rack to support the two-part cover. So to ensure that both covers are flush when the case is closed, the blade block is thickened so it's in line with the front edge of the rack, see Fig. 5.

GRAIN. One last thing to note is the grain direction of the blade block. It runs up and down (the same direction as the lower cover that's glued on later). This means that it's *opposite* the grain direction of the blade rest.

So to allow for expansion and contraction with changes in humidity, the block is attached to the rest by drilling oversize shank holes and screwing it in place.

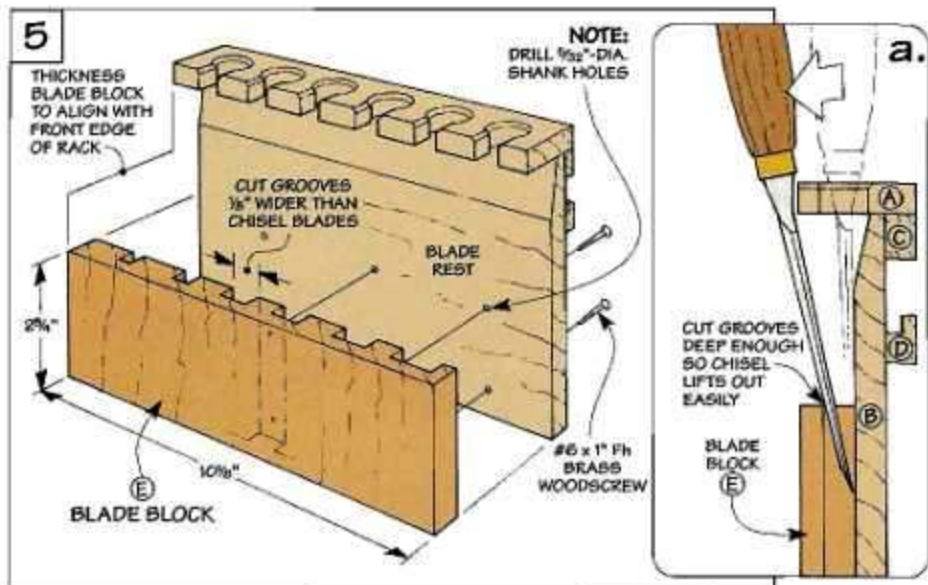
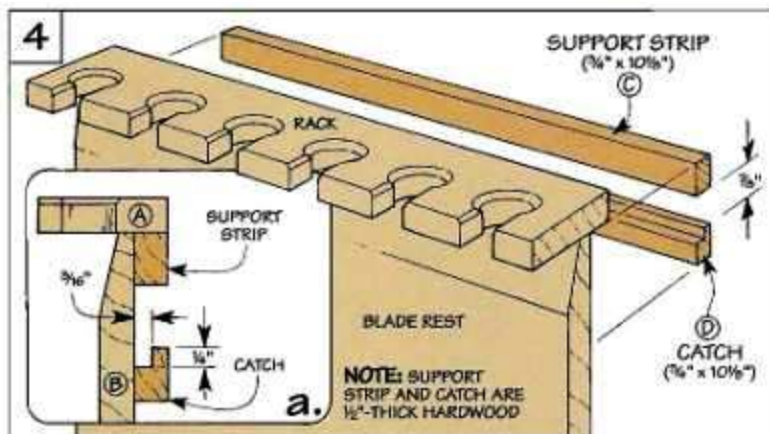
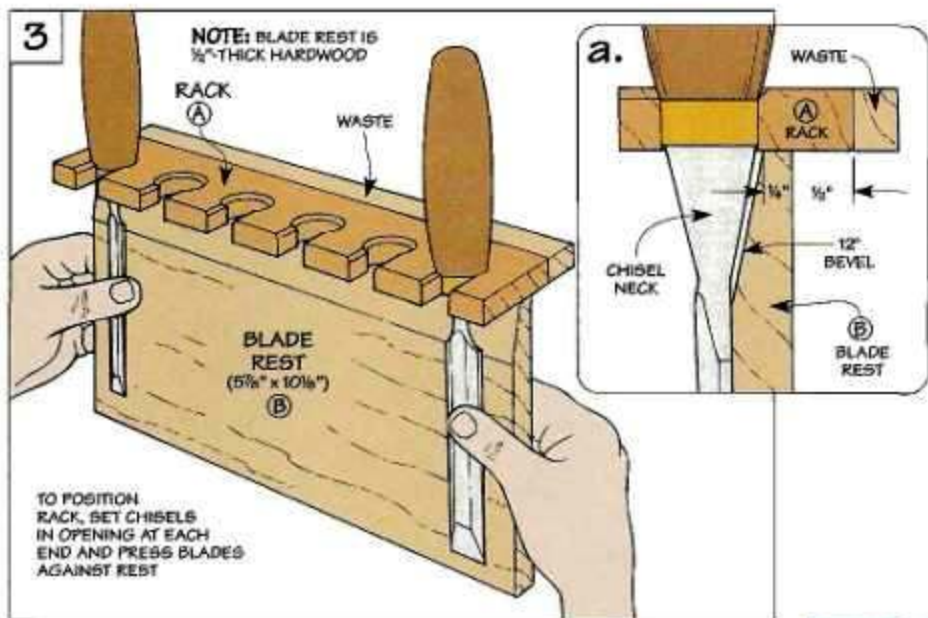

Shop Tip
Using a piece of scrap as a spacer makes it easy to properly position the catch.

Case

With the rack complete, all that's left is to build the case around it and add a two-part cover, see drawing at right.

The case starts out as a shallow box consisting of $\frac{3}{8}$ "-thick sides (F) and ends (G), see Fig. 6. They're joined at the corners with miters and strengthened with dovetail shaped keys.

WIDTH. Establishing the width of these pieces is easy. They're 1" wider than the thickness of the rack. This provides the depth that's needed inside the box for the rack. And to provide visual interest, it will allow the covers to be recessed $\frac{1}{8}$ " below the top edge of the case.

LENGTH. You'll also need to determine the length of the pieces. The ends are $\frac{7}{8}$ " longer than the width of the rack. And the sides are 14" long to accommodate chisels up to 11 $\frac{1}{8}$ " in length.

BACK. To enclose the rear of the case, I added a plywood back (H), see Fig. 6. It fits into a groove near the bottom of the ends and sides.

KEYS. After gluing the box together, I routed slots across the corners and glued in dovetail keys (I), see Fig. 6. (For more on this, refer to page 12.)

COVER. Once the case is complete, you can concentrate on the cover. It's made up of two parts: an upper cover that swings behind the rack to prop it up, and a lower cover that's attached to the front of the tilting rack.

To produce a consistent grain pattern, I made both covers from a single glued-up blank, see Fig. 7. It's $\frac{1}{8}$ " narrower than the case opening and about 2" longer.

The next step is to cut the lower cover (J) to match the length of the blade block and glue it in place. But before you cut the upper cover to length, there are two things to take into consideration.

First, there's an $\frac{1}{8}$ " gap between each cover and the ends of the box. And second, after a lip is attached later to the upper cover, there's an $\frac{1}{8}$ " gap between the covers.

Once the upper cover (K) is cut to length, I drilled a finger hole to make it easy to lift the cover, see Fig. 7. Also, a thin lip (L)

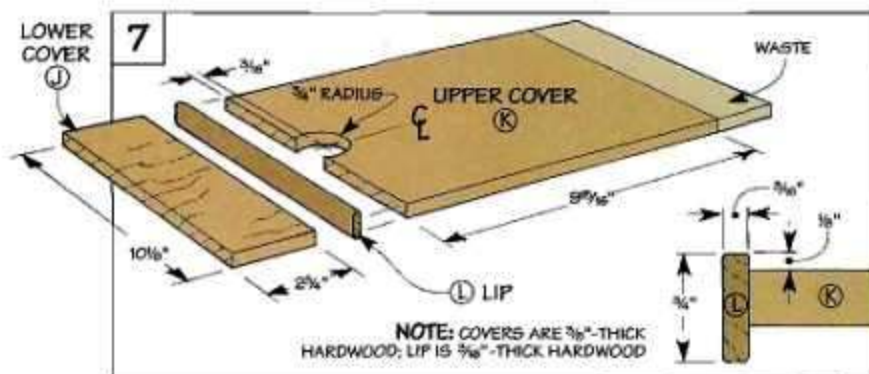
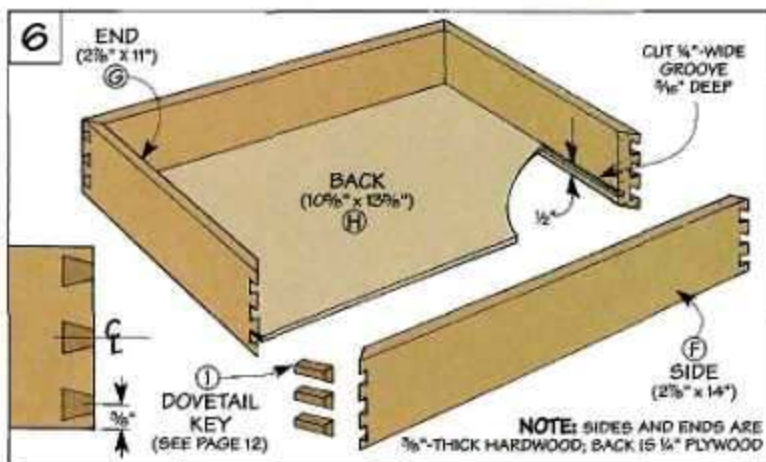
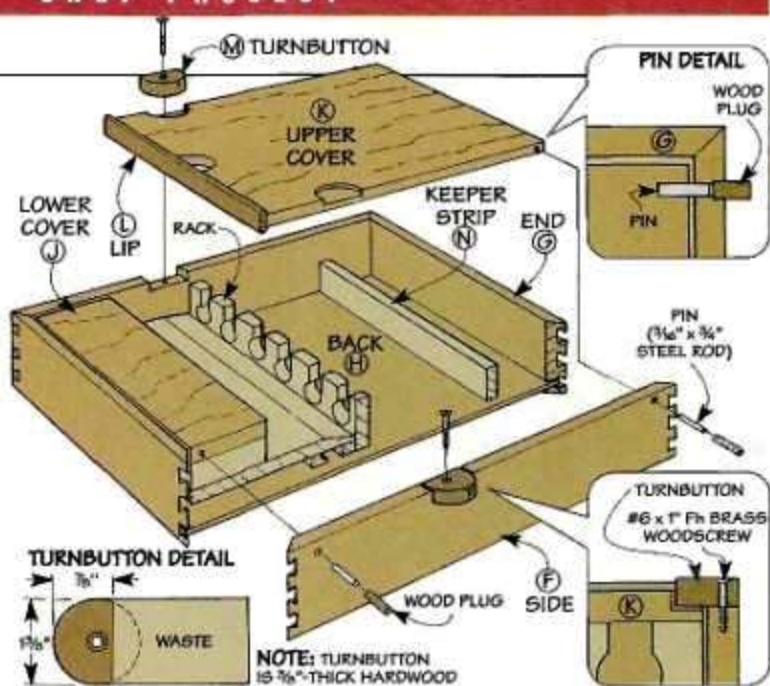

that's glued to the upper cover will hook into the catch on the back of the rack. (I used mahogany.)

ASSEMBLY. At this point you're ready to attach the covers (with rack attached). To allow the covers to swing in and out of the case, they're held in place with metal pins.

These pins pass through counterbores in the sides and into holes in the upper and lower covers. Locating these holes is easy. The trick is keeping the parts from shifting as you drill the holes.

The best way I found to do this is to place a spacer under the blade rest and upper cover, see Fig. 8. The idea is to size the spacers so the covers are flush with each other. After fitting shims into all the gaps, tighten a clamp across the ends and drill the holes, see Figs. 9 and 9a.

Now just push each pin into place and glue in a plug to hide the pin. (For more on cutting wood plugs, see page 30.)

TURNBUTTONS. Next, I added two mahogany *turnbuttons* (M), refer to drawing on page 10.

They rest in curved recesses drilled in the sides and cover, see Fig. 10. To minimize chipout, I clamped a scrap to each side of the case and carpet-taped two more scraps to the cover.

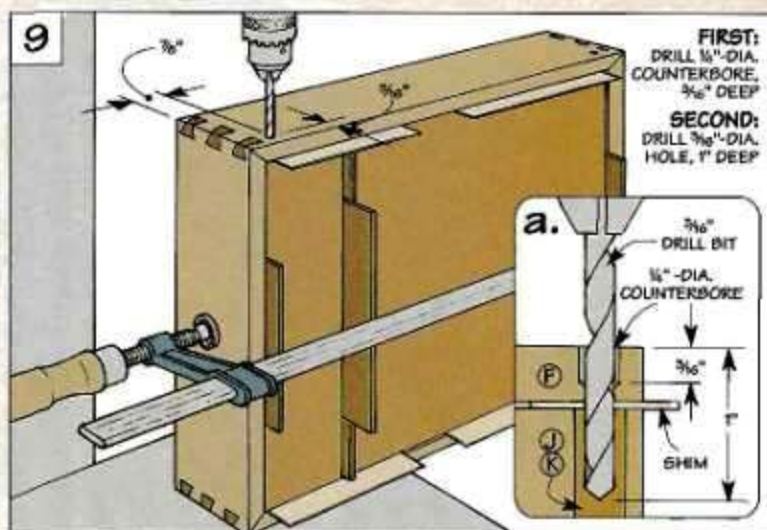
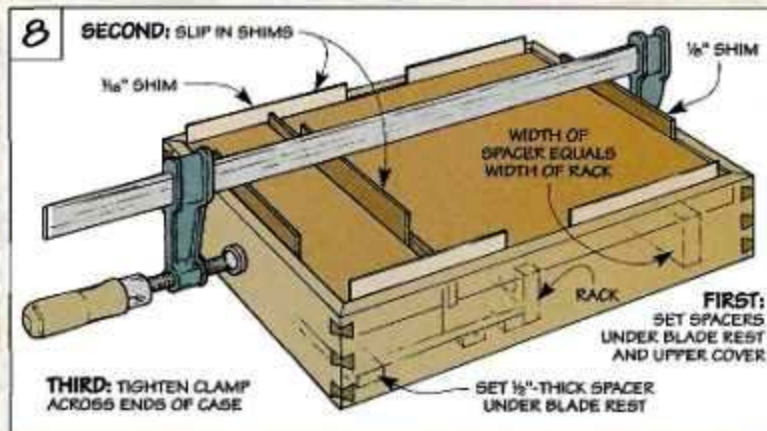

KEEPER STRIP All that's left to do is glue in a hardwood *keeper strip* (N), see Fig. 11. It keeps the chisels from slipping out of the rack when you carry the case.

CLEATS. Finally, to hang the case on a wall, I used two beveled *cleats* (O), see Fig. 12. Mounting the case is just a matter of "hooking" the cleats together.

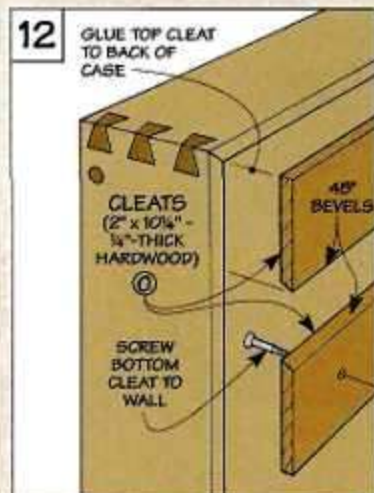
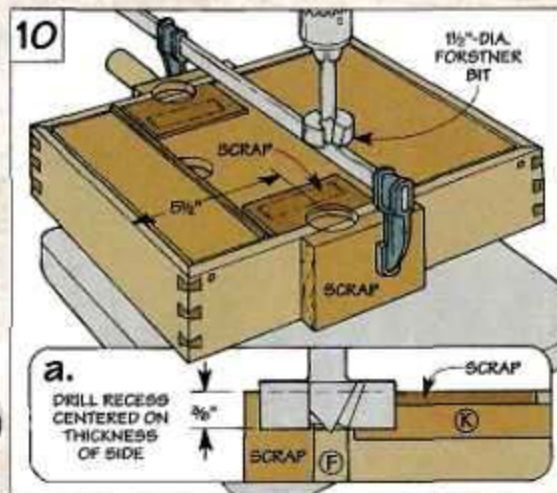

Dovetail Keys

If you take a quick glance at the corner of this box, it may appear to be held together with traditional dovetail joints. But it's not.

A closer look shows that the corner pieces are *mitered*. And there are dovetail-shaped "keys" (splines) running across the miter.

STRENGTH. One big advantage of these keys is they help strengthen the miter joint. That's because they're *glued* into slots that are routed across the miters, see photo at right. This creates a stronger glue joint

than the end grain surfaces of the mitered pieces.

CONTRAST. In addition to providing extra strength, the wood keys also produce a striking contrast. Take the chisel case shown on page 6 for instance. We used mahogany for the keys to contrast with the oak sides of the case.

SLOTS & KEYS. Although adding dovetail keys to a box looks like it might be complicated, that's really not the case. Basically, it's just a simple two-part process.

First, the slots are routed across the miter joints. (You'll need a dovetail bit and a "cradle"

to hold the box steady for this, see page 13.) And second, the keys are cut to fit the slots.

SLOTS

Routing the slots for the dovetail keys is easy. The trick is getting the slots in one corner to align with those in the others.

CLEATS. The best way I've found to do this is by "fencing" the box in the jig with two cleats. By preventing the box from shifting as you rout the slots, the cleats ensure a uniform look.

To position the cleats, all you need to do is lay out the location of the slots on *one* of the corners of the box.

Since the chisel case has an odd number of slots, I centered one mark on the corner, see Step 1. The two outside slots will be routed using the same setup, so a single mark takes care of both.

ROUT SLOTS. Once the cleats are attached, it's just a matter of routing the center slot in each corner, see Step 2.

Before routing the remaining slots, you'll need to reposition the cleats. This is where the *second* layout mark comes in handy, see Step 3.

After reattaching the cleats, you won't have to move them again. Just rout all of the slots near one edge, see Step 4. Then flip the box around to rout the remaining slots.

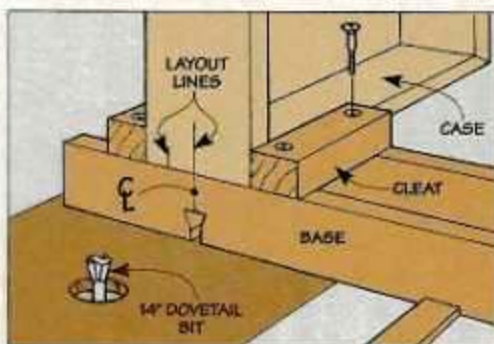

1 To locate the cleats, align the center mark on the box with the middle of the slot in the base. Then screw the cleats in place.



2 Now rout each center slot by fitting the corner of the box down into the V-groove and sliding the jig across the bit.

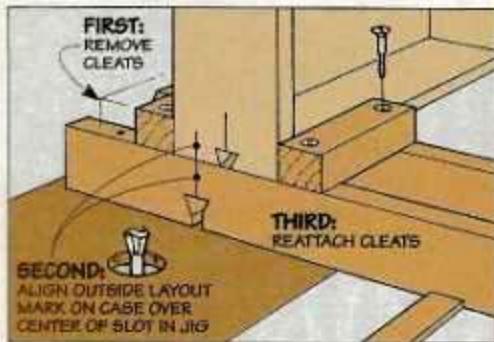

3 To reposition the cleats, align the outside layout mark with the center of the slot in the base. Then simply reattach the cleats.

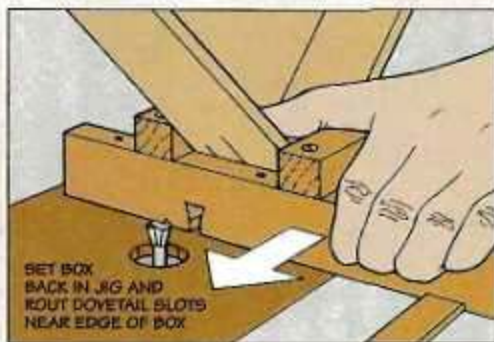

4 After routing the bottom slot in each corner, there's no need to move the cleats. Just turn the box around to rout the rest of the slots.

KEYS

Once the slots are completed, it's just a matter of adding the dovetail keys, see photo.

The keys are made using the same dovetail bit used to rout the slots. Since the keys are quite small, it's best to start with a long, extra-wide blank.

The goal is to rout dovetail-shaped strips on the blank that fit tightly in the slot, see Step 1. To do this, I "sneak up" on a perfect fit by making a series of passes and checking the fit frequently.

Ideally, the strip should feel like it's almost *too* tight. At that point, you can rip the strips from the blank (Step 2) and cut them into individual keys.

Before gluing the keys into the slots (Step 3), check the fit again. You may have to sand one side *lightly* to get a perfect fit.

After the glue dries, it's a simple matter to remove the excess waste, see Step 4. 

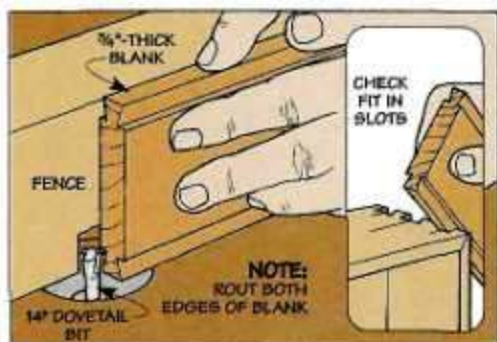

1 After raising the bit $\frac{1}{16}$ " higher than the depth of the slot, rout dovetail shaped strips on the blank that fit tightly in the slots.

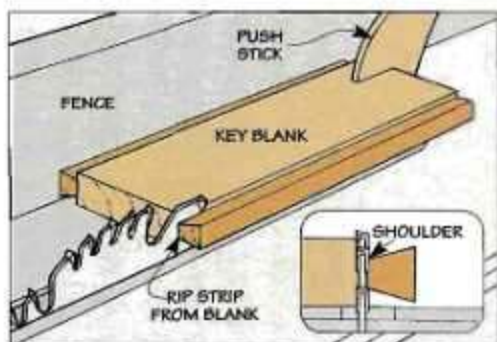

2 To rip the strips from the blank, position the fence on the table saw so the blade cuts to the waste side of the shoulder.

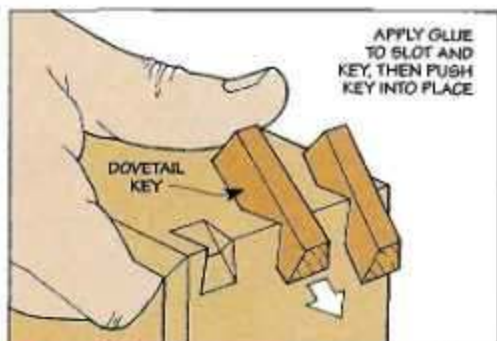

3 After cutting the strips into short pieces, apply glue to the key and the slot. Then push the key all the way through the slot.

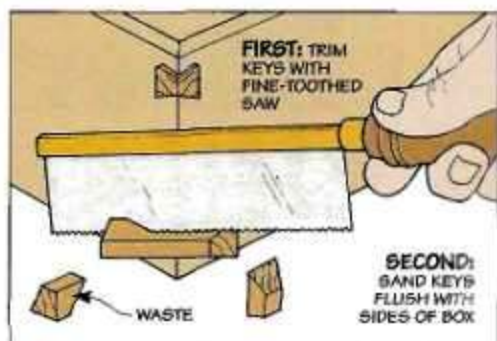

4 Once the glue dries, trim off the waste with a hand saw and sand the keys flush with the sides of the box.

Sliding "Cradle"

It's easy to rout a slot for a dovetail key in the mitered corner of a box. The hard part is holding the box at the proper angle.

That's where this sliding "cradle" comes in. The corner of the box rests in a V-shaped groove in the *base*, see drawing. And a *runner* guides the base in the miter slot of the router table. To keep the box from shifting, you'll also need to add two *cleats*. Note: These cleats are attached later, refer to text.

One thing to be aware of is the base raises the corner of the box *above* the router table, see detail 'a.' So to rout the slot, you'll need to raise the dovetail bit high enough that part of the

shank is exposed.

To clear a "path" for this part of the shank, rout a slot in the base with a straight bit first, see Step 1. Then complete the slot with a dovetail bit, see Step 2.

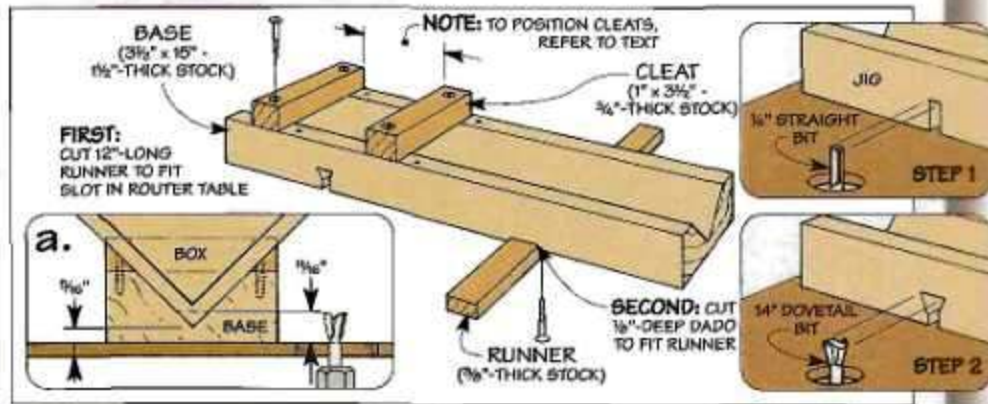

CIRCLE-CUTTING JIG



■ Cutting the disks that make up the rollers of the edge sander (page 16) is easy. All it takes is a band saw and a simple circle-cutting jig.

JIG. The jig consists of three parts: a *base* and *runner* made from MDF, and a short steel *pivot pin*, see drawing at right.

A runner sized for the miter slot in the table of the band saw fits a groove in the base. To keep from cutting into the jig, the groove is located so the base is $\frac{1}{16}$ " from the saw blade, see detail. Before adding the runner, you'll need to drill a counterbore for the pivot pin. The distance from the centerpoint of the counterbore to the saw blade equals the desired radius of the disk, see detail.

SETUP. Using the jig to cut a disk is a simple three-step process. The first step is to position the jig so the center of the

WORKING WITH STEEL ROD

■ When making the rollers for the edge sander, I used $\frac{5}{8}$ "-dia. steel rod for the shafts. But when I tried to slip the bearings (which had an *inside* diameter of $\frac{5}{8}$ ") onto the ends of the rod, they wouldn't fit.

That's because the rods had been *shear cut* to length, and this had flared the ends just a bit. So to get the bearings to fit, I filed the ends of the rod.

But even then, there was an



extremely thin coating on the rods that kept the bearings from sliding up and down. Here, a little sanding with silicon carbide sandpaper was an easy fix.

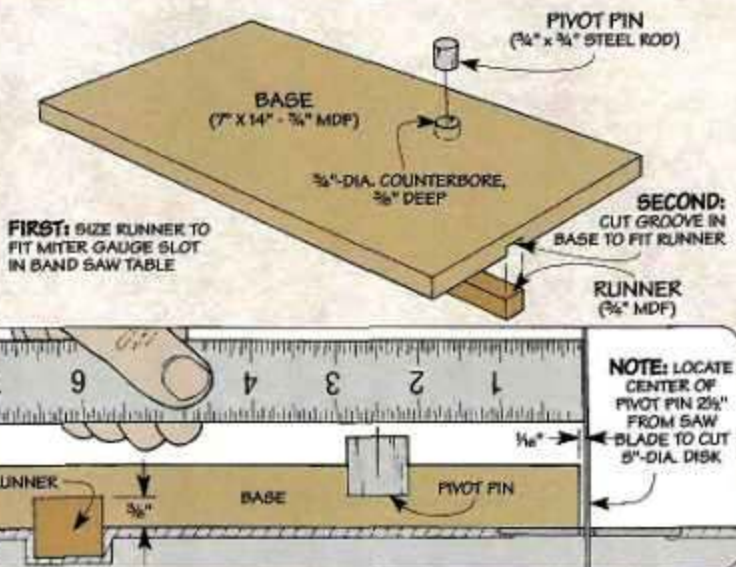

pivot pin is directly across from the leading edge of the blade, see Step 1 below. Then set a stop against the front edge of the jig and clamp it to the table.

CUT DISK. With the stop in place, fit the hole in the blank

over the pin. Then hold the blank securely as you slide the jig forward. When the front edge contacts the stop, rotate the blank clockwise to cut the disk. Once you've come full circle, slide the jig back and remove the disk.

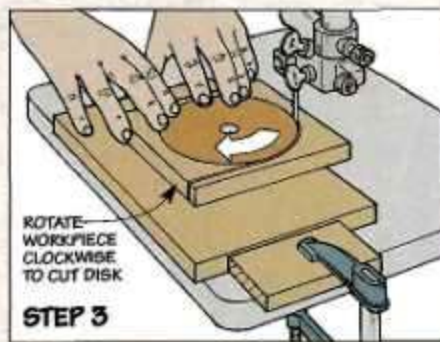
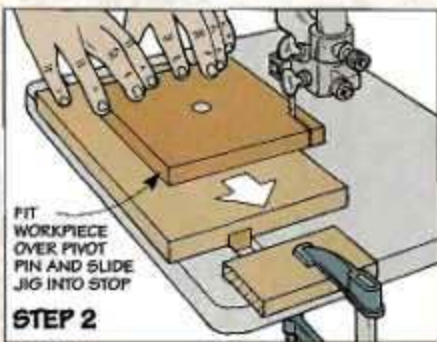
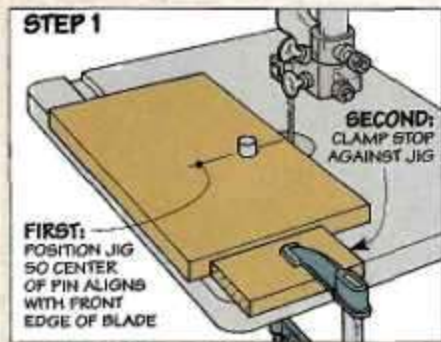

"TURNING" WITH A ROUTER

■ The rollers on the edge sander (page 16) are barrel-shaped with a slight "crown" in the middle. This keeps the sanding belt centered on the rollers and prevents it from slipping off.

To form this crown, I used a hand-held router with a straight bit and a simple "turning" jig, see photo at right.

TURNING JIG. The jig is just an open box with two *sides* and two *ends*, see Fig. 1. What makes it work is a curved "track" along the top edge of the sides that guides the base of the router. As the router follows the track, an identical crown is routed on the roller.

To lay out the curve for the track, I used an old trick. With a helper bending a scrap of hardboard to the desired shape, mark the curve along the top edge of the side, see Fig. 1a.

After sanding the sides to shape, you can complete the track by routing a rabbet along the top edge, see Fig. 1b.

In addition to the rabbets, you'll need to cut a pair of dados

in each side to accept the ends. The spacing between these dados allows the roller to fit between the ends with a $\frac{1}{16}$ " of clearance.

ENDS. With the sides complete, you can turn your attention to the ends. They're cut to length so the base of the router fits *between* the rabbets in the sides. Also, you'll need to drill a centered hole in each end to accept the metal rod that runs through the roller. (It's the $\frac{3}{4}$ "-dia. rod used when gluing up the roller.)

CRANK. Once the holes are drilled, you can add the crank that's used to turn the metal rod. The crank consists of a hardwood *arm* and a *handle* made from a short dowel, see Fig. 1.

The handle is simply screwed into a counterbore drilled in one end of the arm. At the other end, there's a hole with an intersecting kerf. A screw squeezes the kerf together and pinches the arm on the shaft.

SETUP. Now it's just a matter of setting up the jig. Start by placing a roller inside the box



and sliding the rod all the way through. Then set the base of the router in the track so the bit is centered on the length of the roller, see Fig. 2a. When determining the depth of cut, you want to adjust the bit so it just grazes the top of the roller.

ROUT CROWN. Now you'll need a helper to turn the roller while you rout the crown. The idea is to turn the roller *counterclockwise* while you slowly rout from one end of the roller to the other (starting near the crank), see Fig. 2. Note: You'll need to make several passes to clean up the roller.

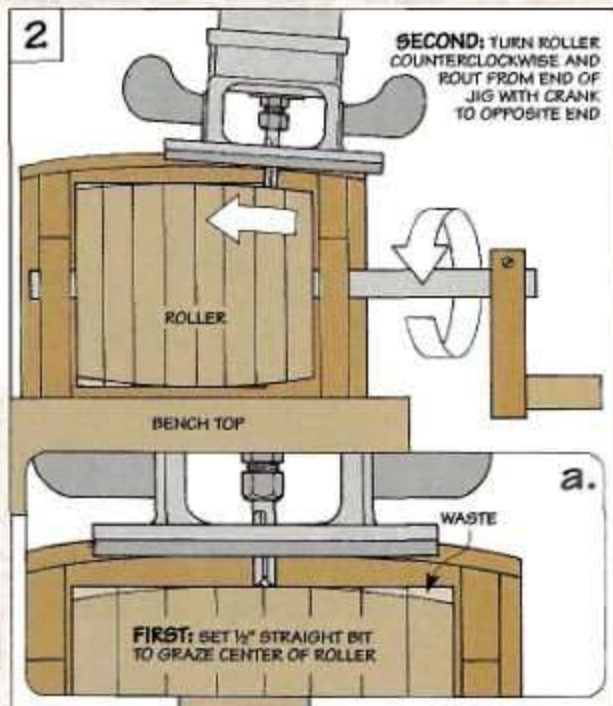
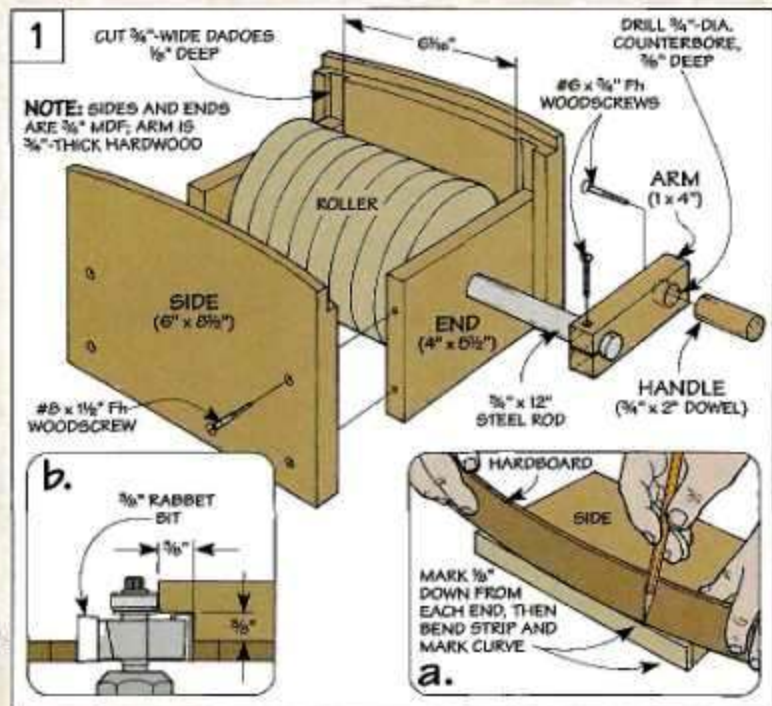

Shop-Built Edge Sander

A few years back, we bought an inexpensive edge sander for the shop. It sounded like a great way to take the drudgery out of sanding.

The basic principle of this sander was simple — it was like a huge portable belt sander lying on its side. With a long, wide sanding belt running around a pair of rollers, it removed stock in a hurry. And since the rotation of the belt was *in line* with the workpiece, it didn't leave cross-grain scratches.

In spite of that, I was still disappointed with the edge sander. It vibrated and shook like an old washing machine. And it was a pain trying to keep the tracking on the sanding belt adjusted properly. So when the bearings on the rollers finally seized up and died, all I could say was good riddance.

SHOP-BUILT SANDER. That's when Ken (our project developer) came up with the idea of building our own edge sander. At first, I thought it was a crazy idea. But now, I have to admit it. When you turn on the switch, this big, green sanding machine is an impressive tool, see photo.

It runs smooth and strong — just like you'd expect from an industrial quality tool. And when you adjust the tracking (see inset photo), the belt not only shifts up or down on the rollers instantly — it stays put.

If you combine that with the other features incorporated in this edge sander (see photos below), I'm convinced — this shop-built edge sander really is better.



▲ **Curved Pieces.** An end table "wraps" around a roller so you can sand curved workpieces.



▲ **Changing Belts.** A quick-release tension device makes it easy to change sanding belts.



▲ **Stop.** Clamping a stop to the front table allows you to sand the ends of a workpiece square.

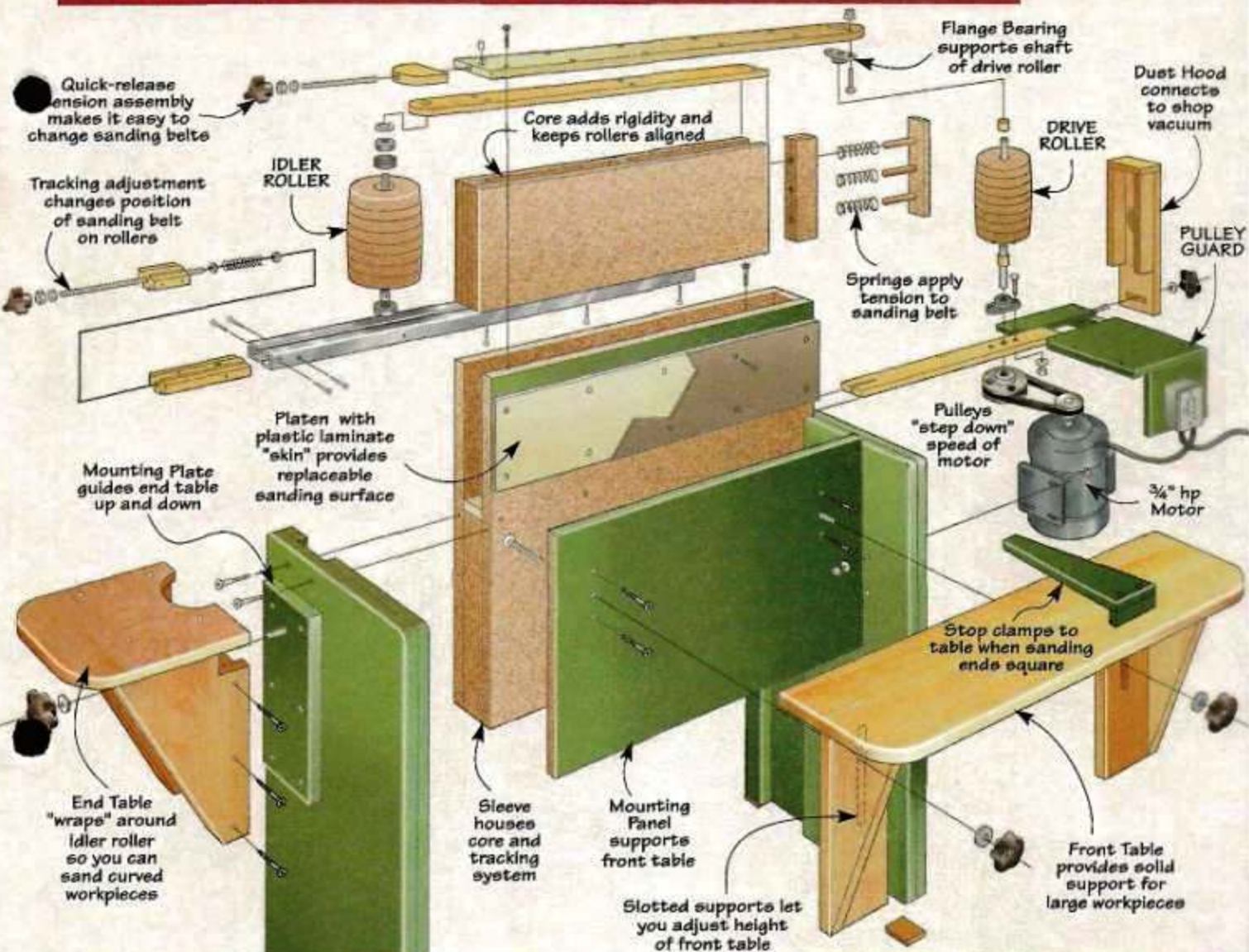

Materials

Base

H Sleeve Sides (2)	24 ⁵ / ₁₆ x 30 - 3/4 MDF
I Core Support (1)	3/4 x 3 - 30
J Lower Sleeve Ends (2)	3 x 14 ¹ / ₈ - 3/4 MDF
K Upper Sleeve End (1)	3 x 9 - 3/4 MDF
L Drive Roller Support (1)	3/4 x 3 - 18 ¹ / ₂
M Leg Panels (2)	17 x 34 ¹ / ₂ - 3/4 MDF
N Rear Leg Pieces (2)	2 x 34 ¹ / ₂ - 3/4 MDF
O Front Leg Pieces (2)	10 ¹ / ₂ x 34 ¹ / ₂ - 3/4 MDF
P Support Block (1)	3 x 9 - 3/4 MDF
Q Top (1)	3/4 x 4 ¹ / ₂ - 35 ⁷ / ₁₆

Pulley Guard & Platen

R Upper Front Cover (1)	9 ³ / ₄ x 8 ¹ / ₂ - 3/4 MDF
S Lower Front Cover (1)	7 x 7 - 3/4 MDF
T Back Cover (1)	2 ¹ / ₂ x 8 ¹ / ₂ - 3/4 MDF
U End Piece (1)	3/4 x 3 - 14 ¹ / ₂
V Platen (1)	6 ¹ / ₂ x 30 - 1/4 Ply.

Dust Hood

W Dust Hood Sides (2)	3/4 x 1 ¹ / ₈ - 8
X Back (1)	3/4 x 4 ¹ / ₂ - 11 ³ / ₄
Y Cap (1)	3/4 x 2 ¹ / ₈ - 4 ¹ / ₂

Sanding Tables

Z Mounting Panel (1)	16 x 28 ¹ / ₂ - 3/4 MDF
AA Adjust. Plates (2)	3/4 x 4 ³ / ₄ - 16
BB Suppt. Brackete (4)	3/4 x 8 - 16
CC Front Tabletop (1)	1 ¹ / ₈ x 12 - 35
DD Guide Block (1)	3/4 x 1 - 4
EE Stop (1)	3/4 x 4 - 12 ¹ / ₂
FF Mounting Plate (1)	6 x 12 - 3/4 MDF
GG Extension Strips (2)	3/4 x 2 ¹ / ₂ - 12 ¹ / ₂
HH Adjustment Plate (1)	3/4 x 6 - 12
JJ End Tabletop (1)	1 ¹ / ₈ x 12 - 12

You'll also need: (1) 7¹/₂" x 31" (ngh.) piece of plastic laminate, and (3) 3/4" x 6" hardwood dowels

Rollers & Core

A Disks (16)	6 x 6 (ngh.) - 3/4 MDF
B Spacers (6)	2 x 8 - 3/4 MDF
C Sides (2)	8 x 25 - 3/4 MDF
D Cover (1)	3/4 x 3 - 29 ¹ / ₂
E End Cap (1)	3/4 x 3 - 3 ¹ / ₂

Tracking System

F Fixed Block (1)	3/4 x 2 ⁵ / ₄ - 3
G Adj. Block (1)	3/4 x 2 ⁵ / ₄ - 10

PAD

Heavy "slab" legs dampen vibration

Rollers

Just like a belt sander, this edge sander has two rollers that guide the sanding belt: a *drive roller* and an *idler roller*, see margin.

DISKS. Each roller consists of a stack of eight disks made from $\frac{3}{4}$ " MDF, see Fig. 1. The disks start out as 6"-square blanks. (You'll need 16 altogether.)

To form pockets for a pair of bearings (added later), I drilled a counterbore in *two* of the blanks. And there's a $\frac{3}{4}$ "-dia. hole in *each* blank to accept the shaft of the roller.

After drilling all the holes, the *disks (A)* can be cut to shape. To ensure that each one is uniform in size, I used a simple circle-cutting jig, see page 14.

GLUE-UP. Now you're ready to glue the disks together to form the rollers. An easy way to keep the edges aligned is to slip the disks onto a $\frac{3}{4}$ "-dia. steel rod. Note: The two counterbores on the idler roller face the *outside*.

CROWN. When the glue dries, you'll need to rout a slight ($\frac{1}{16}$ ") crown across each roller. This crown centers the belt on the roller and keeps it from slipping off. A hand-held router and "turning jig" make quick work of this, see page 15.

SHAFTS. The next step is to add a metal shaft to each roller, see Figs. 2 and 3. (You'll have to remove the $\frac{3}{4}$ " rod first.) Each shaft is cut from a length of $\frac{3}{8}$ "-dia. steel rod. But the shafts are *not* identical.

IDLER SHAFT. One thing to note about the shaft for the idler roller is there's a hole near the bottom end, see Fig. 2. Later, this hole will accept a pin that's used to fasten the shaft to the tracking system.

To center the shaft inside the roller, a bearing is slipped over each end and pressed into the counterbore drilled earlier. The purpose of these bearings is to allow the idler roller (not the shaft) to spin freely.

With the bearings installed, it's just a matter of positioning the roller on the shaft. It's held in place by slipping a lock collar onto each end of the shaft and tightening a set screw.

DRIVE SHAFT. All that's left is to add the shaft for the drive roller, see Fig. 3. This shaft is *longer* than the one for the idler roller. (The extra length allows a pulley to be attached later.) And it isn't fixed. Instead, the shaft is "welded" to the roller with epoxy so they spin together as a unit, see margin on page 19.

BUSHINGS. Before the epoxy cures, you'll need to press a bushing into the opening at each



▲ Drive Roller.

A motor and a V-belt provide power for the drive roller at one end of the edge sander.



▲ Idler Roller.

The opposite end houses an idler roller that spins with the rotation of the sanding belt.

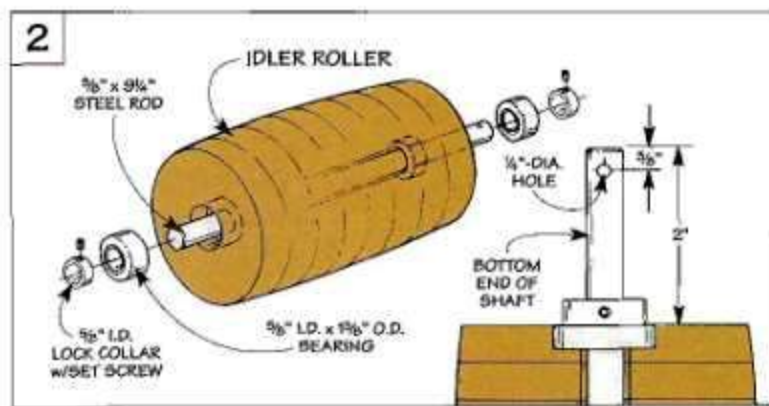
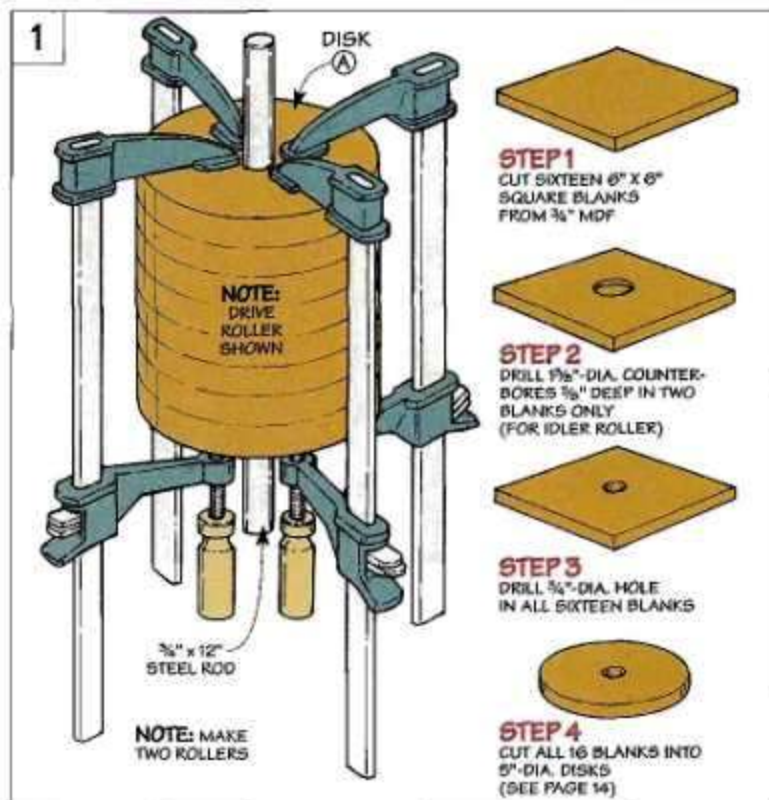

end of the roller. These bushings center the shaft inside the roller.

FLANGE BEARINGS. To allow the shaft to spin without building up heat, it's supported by a flange bearing that slips over each end. This is just a bearing that's housed in a metal flange.

Later, the flange is secured with carriage bolts. So it's easiest to install the bolts now, then tighten a set screw that holds each flange bearing on the shaft.

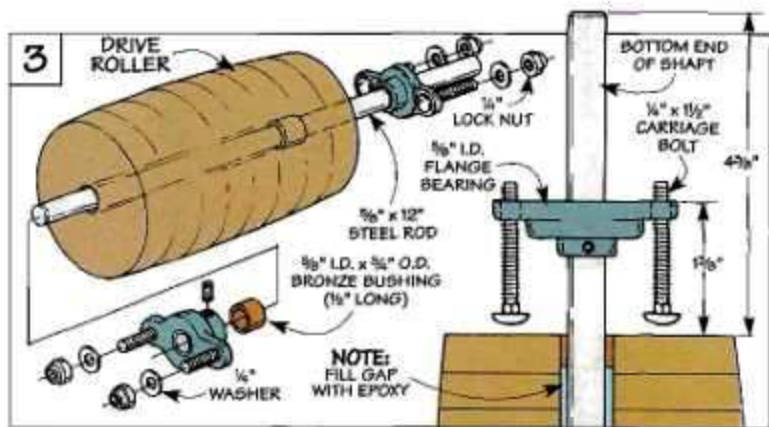

▲ A slow-setting epoxy fills the gap between the shaft and the drive roller. Before it "welds" them together press a bushing into the opening.

Core

Now you can turn your attention to the core. It's part of a system that applies tension to the sanding belt.

The core is a simple, rectangular assembly that consists of three narrow blocks sandwiched between two sides, see drawing.

Each block is made by gluing up two *spacers* (B), see Fig. 4. Before gluing on the *sides* (C) of the core, it's easiest to drill three holes in one of the blocks for a tension assembly that's added later.

COVER. The core is enclosed by a long, narrow *cover* (D), see Fig. 5. An oversized hole near one end accepts the shaft on the idler roller. To keep the shaft from denting the cover, I drilled holes

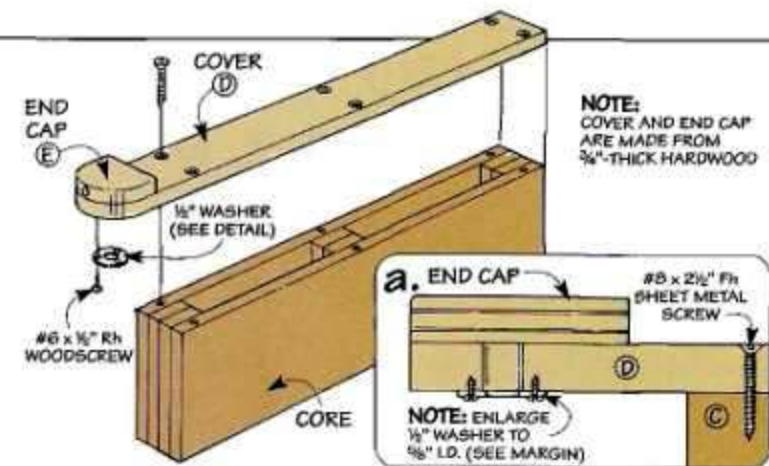

in a washer and screwed it over the hole, see detail above. Note: You'll need to first enlarge the hole in the washer, see margin.

END CAP. To complete the core, I added a short, hardwood *end cap* (E), see Fig. 5. It has a hole for a mechanism that releases tension on the sanding belt. After gluing the end cap to the cover and cutting a curve on the end, just screw the cover in place.

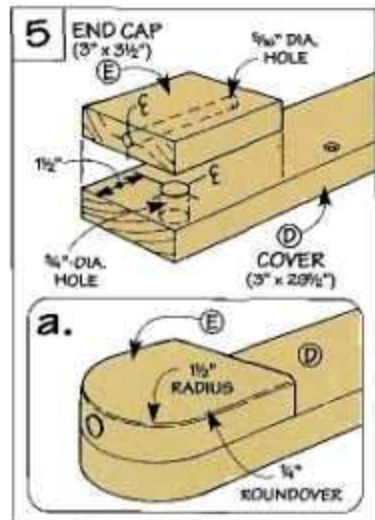
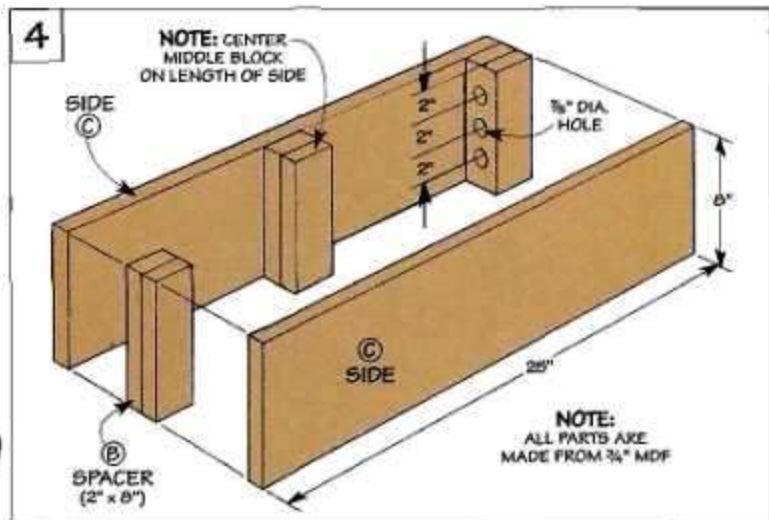

▲ To accept the end of the shaft on the idler roller, I screwed a 1/2\"/>

Tracking System

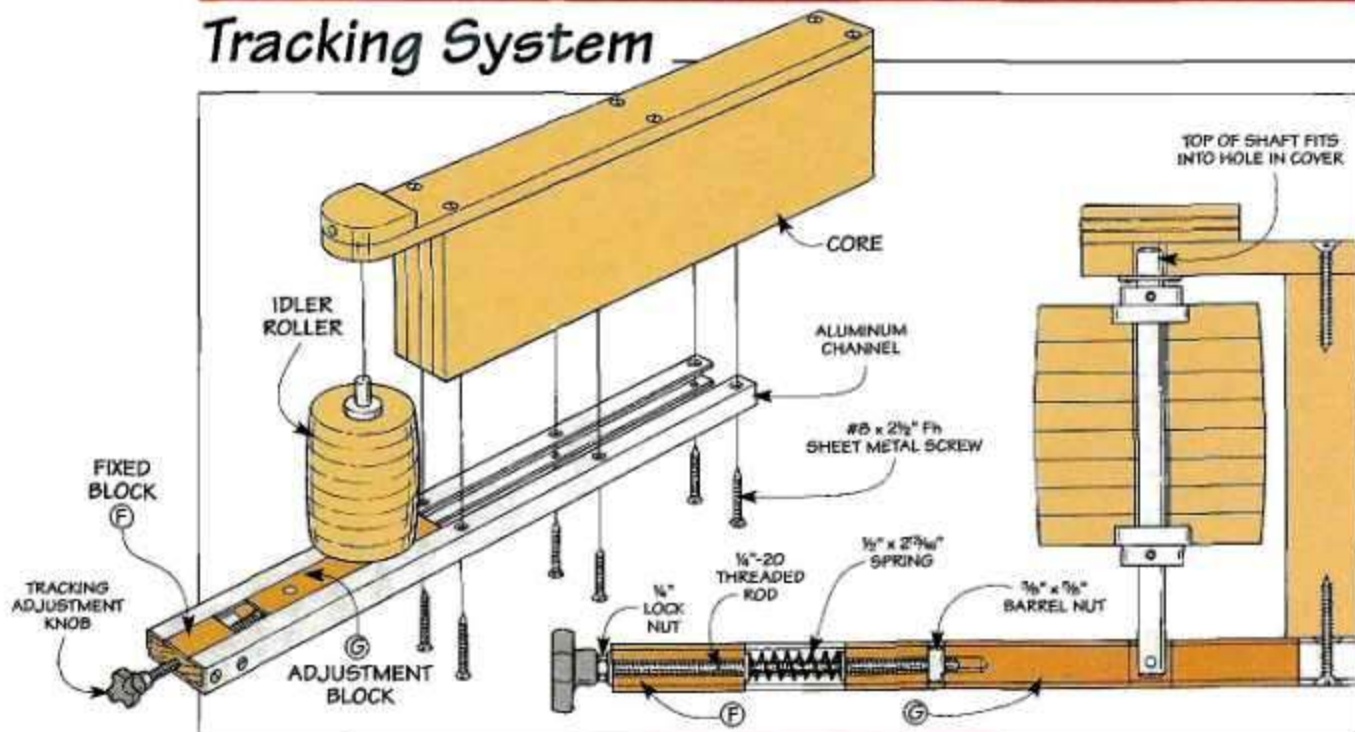

The heart of the edge sander is a unique tracking system that lets you quickly adjust the position of the sanding belt on the rollers.

This system consists of a pair of U-shaped pieces of aluminum channel that fit around two wood blocks, see drawing. A short, fixed block is permanently attached to the channel. And a long block slides back and forth *inside*.

The significant thing about the sliding block is it captures the *bottom* end of the shaft on

the idler roller, see detail above. This means that the shaft tilts to one side or the other as you adjust the block in or out. It's this tilting action that causes the sanding belt to travel up or down on the rollers.

ALUMINUM CHANNEL. I began by cutting the two pieces of aluminum channel to length, see Fig. 6. Drilling a pair of countersunk holes in the side of each piece will make it easy to attach the fixed block later. Also, it's

best to drill holes in the top and bottom which will allow the core to be attached, see margin.

BLOCKS. After drilling the holes, you can concentrate on the two blocks. They start out as a single oversize blank of hardwood, see Fig. 6. It's thickened to fit snug inside the channel, yet still slide back and forth.

Once you're satisfied with the fit, the blank can be ripped to width. The idea here is to make the *combined* width of the blank



▲ A countersink on the bottom of the aluminum channel recesses the screw head. The one on top forms a pocket for any wood fibers that pull out as you drive in the screw.

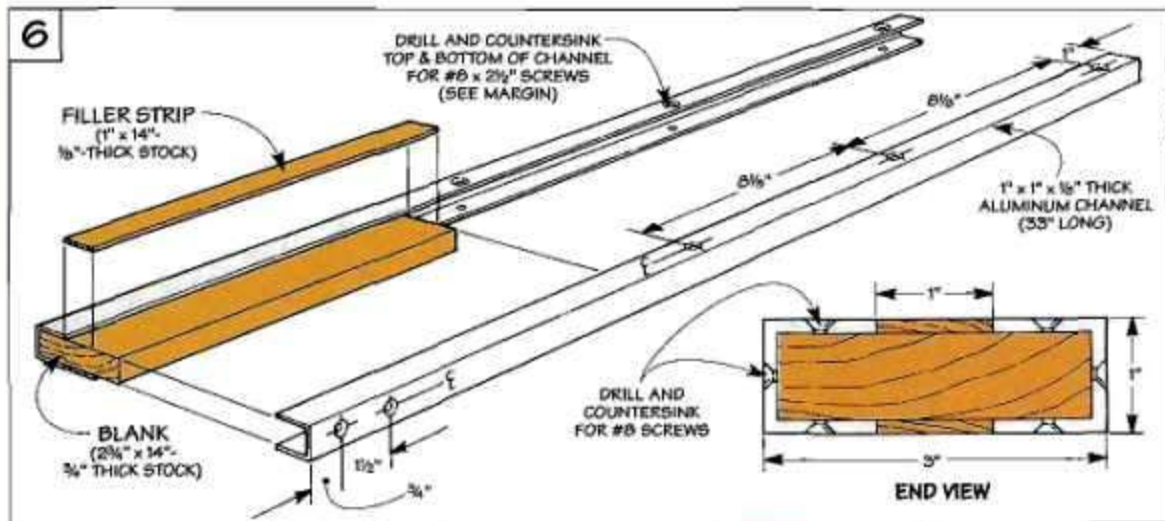

(with the aluminum channel attached) equal to the thickness of the core. This way, you'll be able to slide the entire assembly smoothly into a sleeve which is added later. (To accomplish this, I ripped my blank $2\frac{3}{4}$ " wide.)

FILLER STRIPS. After slipping both pieces of channel onto the blank, I added two filler strips, see Fig. 6. These are thin ($\frac{1}{8}$ " strips of hardwood that are ripped to width to fit between the channel then glued in place.

CUT BLOCKS TO LENGTH. When the glue dries, it's just a matter of removing the channel and cutting the fixed (F) and adjustment block (G) to length, see Fig. 7.

With blocks in hand, I drilled a hole in the end of each one for a threaded rod that's part of the adjustment mechanism. Note: I used a jig to hold the long adjustment block steady, see margin.

Before assembling the tracking system, you'll need to drill a few more holes in the adjustment block. A hole that intersects the hole for the threaded rod will hold a barrel nut (added later.)

Also, drilling two additional holes will allow you to secure the shaft of the idler roller. A slot provides clearance for the shaft as it tilts from side to side. And an intersecting hole in the edge will accept a metal pin that holds the shaft in place.

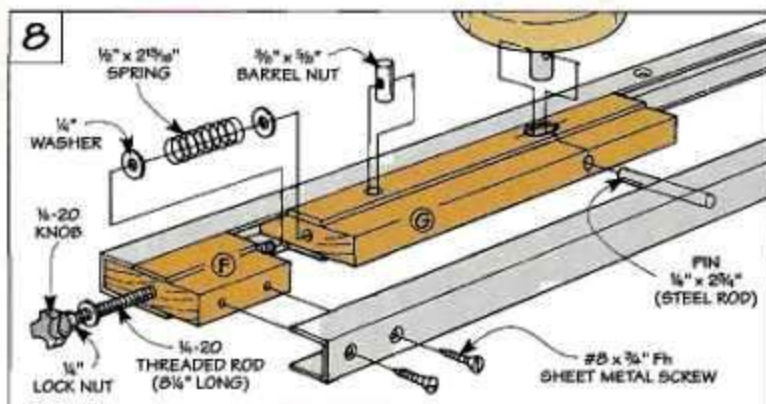
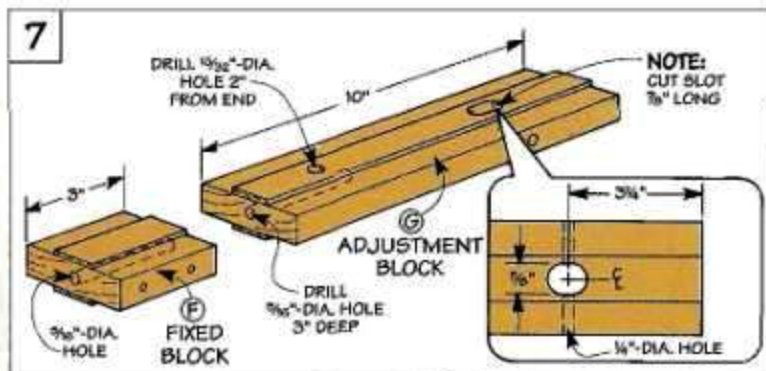

ASSEMBLY. Now you're ready to assemble the tracking system. Start by screwing the fixed block (F) to one piece only of the aluminum channel, see Fig. 8. Then, after fitting the adjustment block into the same channel, you can add the adjustment mechanism.

The key to this mechanism is a threaded rod that passes through the hole in the fixed block, see detail in drawing on page 20.

There's a knob tightened against a lock nut on one end of the rod. And a spring and two washers slip over the other end to prevent any vibration from affecting the adjustment. Now simply thread the rod into the barrel nut that fits in the hole in the adjustment block.

IDLER ROLLER. At this point, it's just a matter of securing the bottom end of the shaft on the idler roller. It fits in the slot in the adjustment block.

To hold the shaft in place, just tap a metal pin into the hole in the edge and through the hole in the shaft drilled earlier. Fitting the second piece of channel over the blocks and screwing it in place traps the pin.

ATTACH CORE. All that's left is to attach the core to the channel. After setting the cover (D) over the shaft of the idler roller, the channel is simply screwed to the sides (C), see Figs. 9 and 9a. Note: To avoid kinking the channel, don't overtighten the screws.

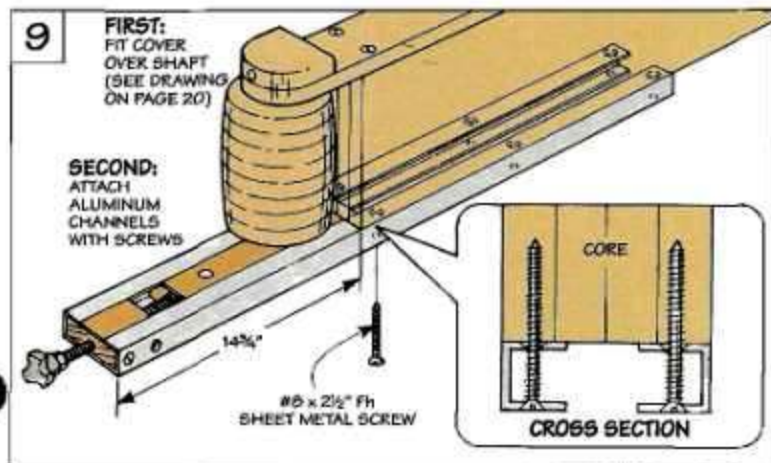

▲ An L-shaped support with a vertical cleat makes it easy to drill a hole in the end of a long workpiece like the adjustment block.

Base

The edge sander is supported by a heavy-duty base. It consists of four parts: a *sleeve* that houses the core, two *legs*, a *tension assembly* to keep the belt from slipping, and a *top*, see drawing at right.

SLEEVE

Besides connecting the legs, the sleeve forms an opening that allows the core assembly to fit inside.

SIDES. The sleeve is made up of two large *sides* (H) with narrow strips sandwiched in between, see Fig. 10. This creates an opening at the top for the core assembly. The important thing is the *size* of this opening.

To ensure the correct amount of tension on the sanding belt, it needs to be wide enough (and tall enough) so the core slides smoothly without binding. At the same time, you want a snug fit so the tension won't pull the rollers out of alignment.

To create this "friction fit," I ripped a hardwood *core support* (I) to width so it's just a hair wider than the thickness of the core assembly. It's positioned so the core assembly (which sits on

top of it) will end up just below the top of the sides.

The ends of the sleeve are enclosed by two *lower sleeve ends* (J) and an *upper sleeve end* (K). The thing to be aware of is the upper sleeve end doesn't extend all the way

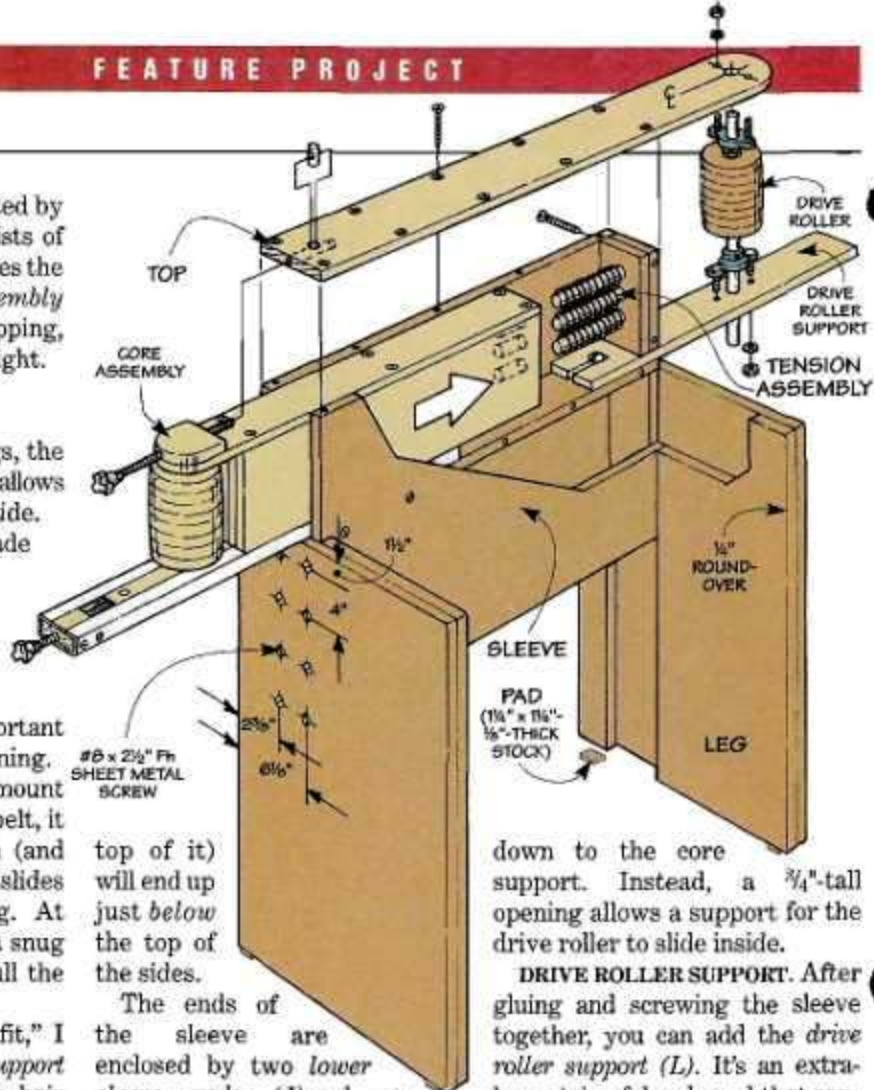

down to the core support. Instead, a 3/4"-tall opening allows a support for the drive roller to slide inside.

DRIVE ROLLER SUPPORT. After gluing and screwing the sleeve together, you can add the *drive roller support* (L). It's an extra-long strip of hardwood that cantilevers past the end of the sleeve.

The end that sticks out acts as a mounting platform for the lower

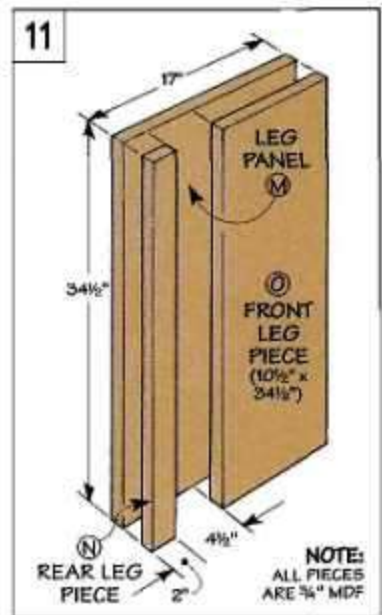
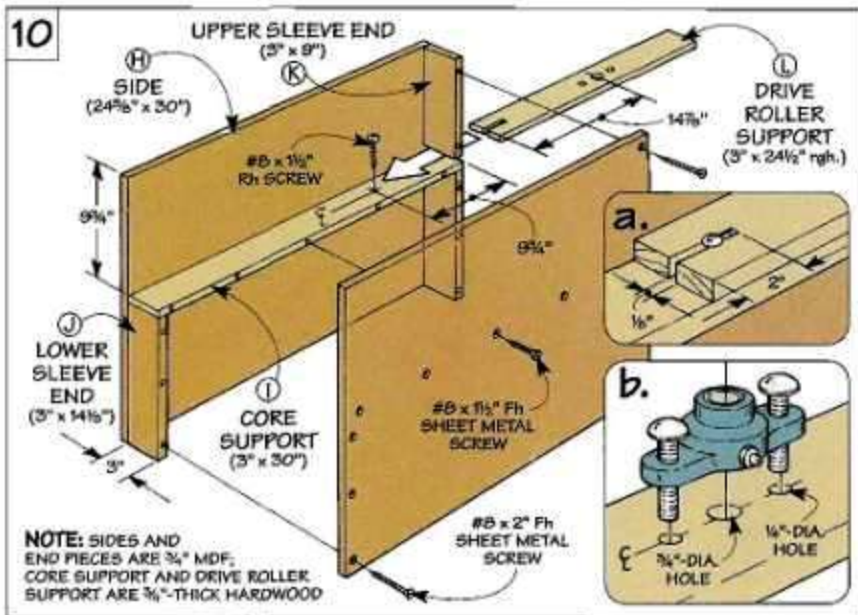

flange bearing on the drive roller, refer to Fig. 13b. So it's best to drill holes now for the shaft of the roller and the bolts that secure the flange, see Fig. 10b.

The end inside the sleeve has a short slot cut in it, see Fig 10a. Later, this allows you to make the initial adjustment on the drive roller. But for now, just "snug" the support down with a screw.

LEGS

Once the sleeve is complete, you're ready to add the legs.

SLAB. Each leg is a slab made by gluing up three pieces of MDF. There's a large *leg panel* (M) on the outside, see Fig. 11. And on the inside, a narrow *rear* (N) and wide *front leg piece* (O) form a groove that accepts the sleeve.

ATTACH SLEEVE. The sleeve is simply glued and screwed to the legs. Note: To position the sleeve, place the drive roller support and core assembly on top of the legs.

TENSION ASSEMBLY

At this point, you can add the tension assembly. Basically, it prevents the sanding belt from slipping on the rollers.

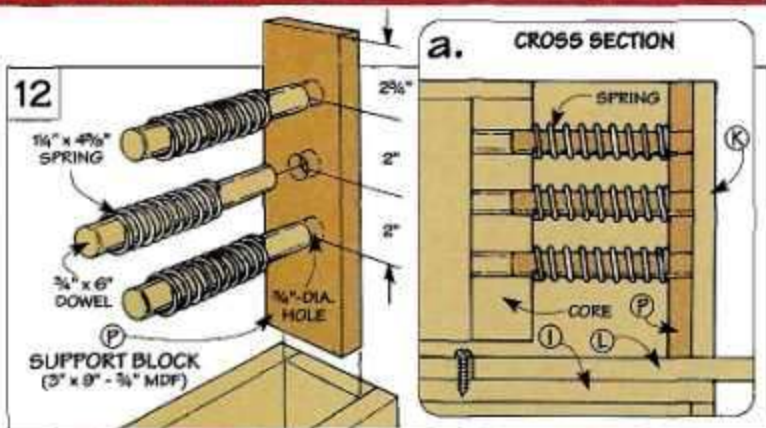

SPRINGS. The secret is a set of three heavy-duty springs that fit loosely over hardwood dowels, see Fig. 12. By pushing against the core, the springs exert outward pressure on the idler roller. It's this pressure that applies tension to the sanding belt.

To make this work, the dowels are glued into holes in a *support block* (P). Once the support block is glued to the upper sleeve end (K), the opposite end of the dowels fit into the holes in the core as you slide it into the sleeve, see Fig. 12a.

TOP

Now all that's left is to add a hardwood top. In addition to enclosing the upper part of the sleeve, the top has two other jobs.

ANCHOR. First, one end of the top (Q) anchors the upper flange bearing on the drive roller, see Figs. 13 and 13a. So here again, you'll need to drill holes for the shaft of the roller and the bolts that secure the flange bearing.

TENSION RELEASE. To make it easy to change sanding belts, the opposite end of the top has a mechanism that *releases* tension on the belt. This requires drilling two holes — one in the end, and an intersecting hole in the top.

When the top is screwed in place, the rod passes through the end cap (E) and threads into the barrel nut. Tightening a knob on the end of the rod moves the core assembly farther *into* the sleeve so you can slip a belt on or off.



▲ The heavy-gauge coils on these springs (actual size shown) exert pressure that applies tension to the sanding belt.



▲ Be sure to keep the flange bearings greased to prevent them from overheating.

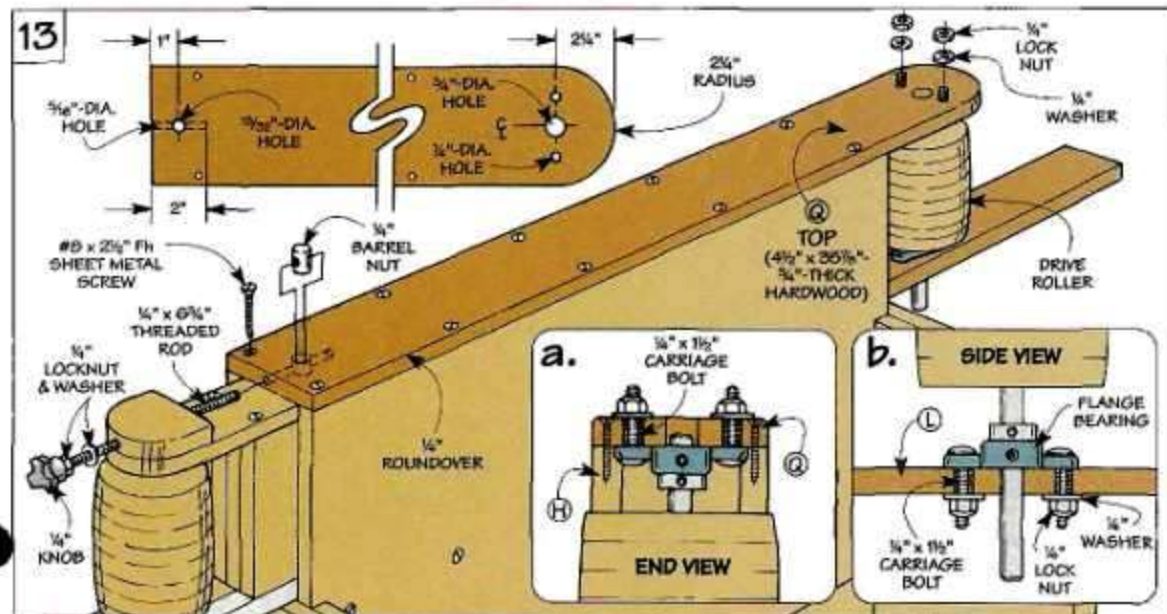

Motor & Pulley Guard

Once the base is complete, the next step is to mount the motor and add a pulley guard.

MOTOR. Because of the dust produced when sanding, I used a Totally Enclosed, Fan-Cooled (TEFC) motor. It's a $\frac{3}{4}$ hp motor with a $\frac{5}{8}$ " arbor, see Fig. 14.

The motor spins at 3450 rpm's. But I didn't want the sanding belt to turn that fast. At that speed, it's likely to burn the surface of the workpiece.

PULLEYS. So I reduced the speed of the belt by using two different size pulleys. A 3"-dia. pulley on the motor is secured with a key that fits a groove in the arbor. And a 4½"-dia. pulley on the drive roller is held in place by a set screw that tightens into an indentation drilled in the shaft.

MOUNT MOTOR. To mount the motor, start by slipping a V-belt onto the pulleys. Then, with the motor positioned so the belt is taut and the pulleys are aligned, mark and drill holes for the bolts that hold the motor in place.

14

NOTE: SECURE CARRIAGE BOLTS WITH $\frac{3}{16}$ " WASHERS AND LOCK NUTS

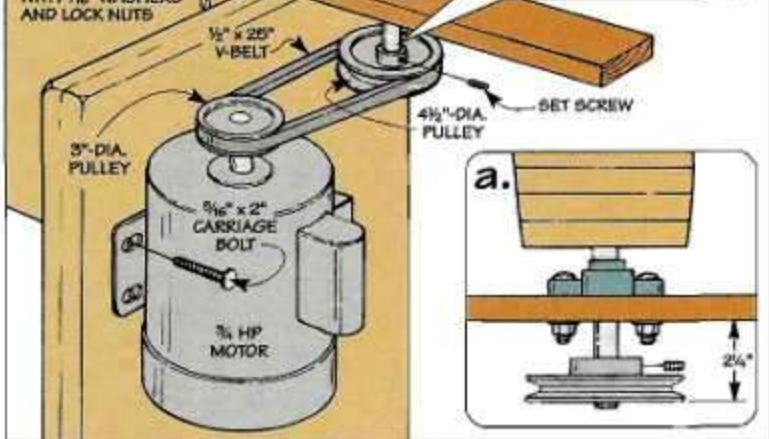

PULLEY GUARD. The next step is to add a guard to cover the pulleys and V-belt, see Fig. 15. The pulley guard is "pieced" together around the drive roller support.

The area above the pulleys and in front of the motor is enclosed by three cover pieces (R, S, and T) made from MDF. And a hardwood end piece (U) completes the

guard. To support a dust hood that's added later, I slipped a bolt through a hole in the end piece before attaching the pieces of the pulley guard with screws.

SWITCH. All that's left is to add an on/off switch. After mounting it to the lower front cover, just run a power cord between the motor and the switch, see box below.

Electrical

- (1) $\frac{3}{4}$ hp Motor w/ $\frac{5}{8}$ " arbor
- (1) Switch Box
- (1) Switch Cover
- (1) 15 Amp., 120 Volt Switch
- (1) 125 Volt Plug
- (2) #8 x $\frac{5}{8}$ " Panhead Screws
- (2) $\frac{5}{8}$ " Cable Connectors
- (2) Wire Nuts (Yellow)
- (2) No. 8 Spade Terminals
- (1) Grounding Pigtail (12 ga.)
- (1) 16-3 S.J Power Cord (10 feet)

Electrical Hookup

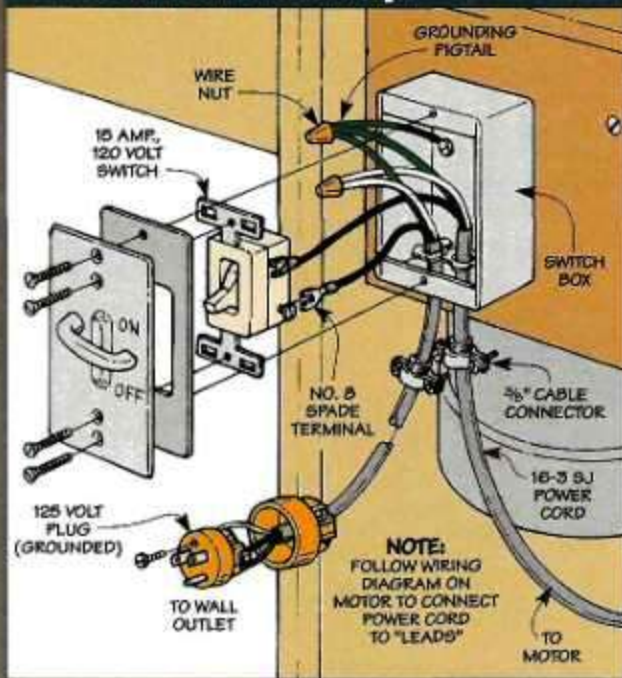

15

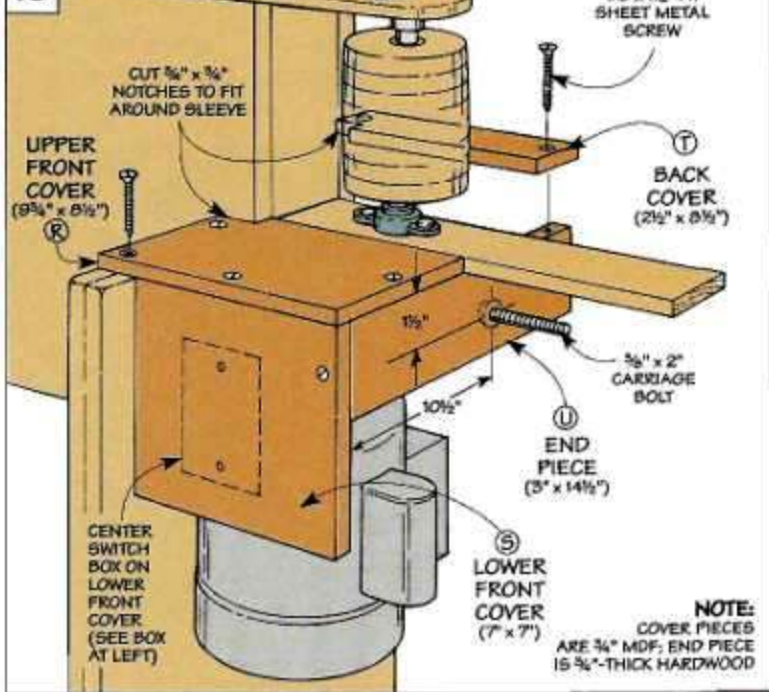

Platen

To produce a smooth, even surface when sanding, the belt on the edge sander runs across a platen attached to the sleeve.

The *platen* (V) is a piece of 1/4"-thick plywood with plastic laminate glued to the front, see Fig. 16. (I used contact cement.)

To ensure that the platen supports the entire width of the belt, the top and bottom edges extend 1/4" above and below the rollers.

By attaching the platen with screws only (no glue), it's easy to replace if the laminate gets worn.

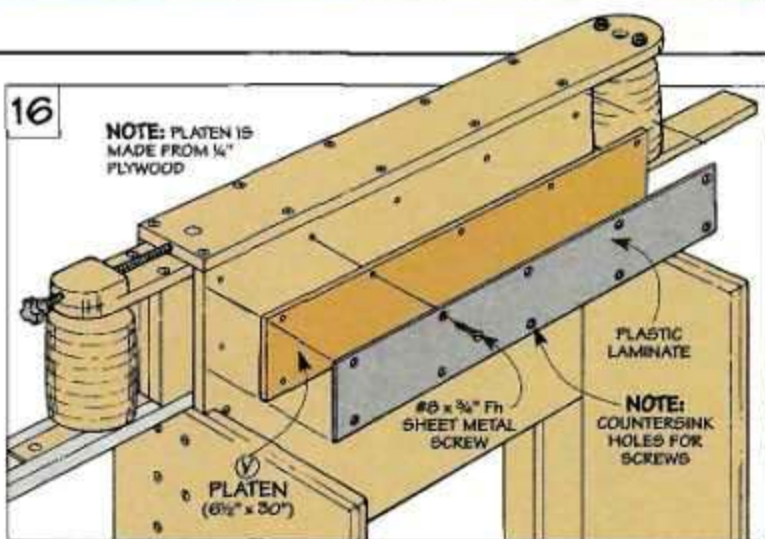

▲ To make the platen easy to replace if it gets worn, it's simply screwed to the sleeve.

Installing the Belt

With the platen in place, you're ready to install the sanding belt.

SANDING BELT. This edge sander is designed to use a 6"-wide sanding belt that's 89" long, see margin at right.

Of course, a belt that size isn't something you just pick up at your local hardware store. And you probably won't find one at a woodworking store either. That's because a long, wide belt like this needs to be specially made.

Now that may sound expensive. But that's really not the case. The belt we're using only cost \$13.47. (We ordered it from a company that specializes in sanding supplies, refer to page 31.)

GRITS. Okay, you've found a place to get a sanding belt. So which grit should you get? For most work, I've found that a 100-grit belt works just fine. But occasionally, if I need to "hog" off a lot of material, I'll switch to an 80-grit belt. And you may want to consider getting a 120-grit belt for more delicate work.

RELEASE TENSION. With a sanding belt in hand, the next step is to release the spring-loaded tension that's pushing the two rollers apart. To do this, just tighten the tension adjustment

knob, see Step 1 below. This pushes the entire assembly (the idler roller, tracking system, and core) into the sleeve.

INSTALL BELT Now it's just a matter of slipping the belt over the rollers. To put tension back

on the belt, loosen the adjustment knob, see Step 2. There's no need to "back" the adjustment mechanism all the way out. A half turn is all it takes to "pop" the core back out of the sleeve and apply tension to the belt.

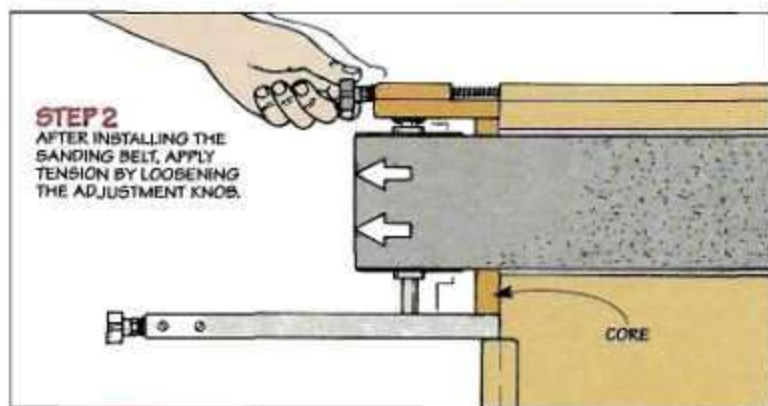
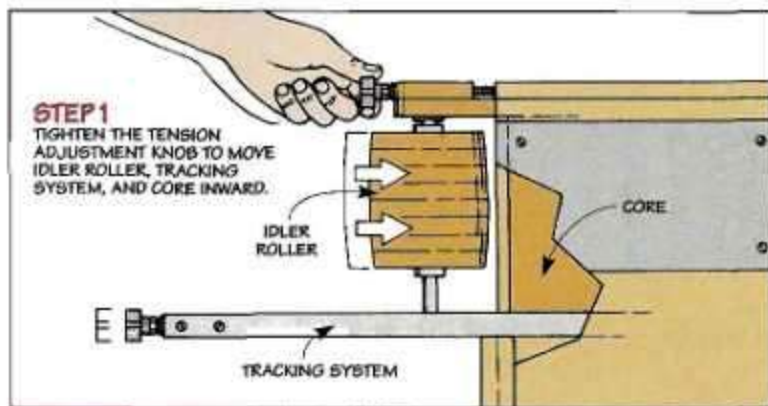

▲ This 6" x 89" sanding belt makes quick work of tough sanding jobs. (For sources, see page 31.)

Adjusting the Tracking

Making the initial tracking adjustment on the edge sander not only keeps the sanding belt centered on the rollers. It also establishes the final position of the drive roller.

Start by rotating the sanding belt *by hand* as you turn the tracking adjustment knob (Step 1) or tap the drive roller support in or out, see Step 2. Then flip the power switch quickly on and off to check the tracking.

Once you get the belt to track accurately, screw the drive roller support in place and cut off the waste at the end with a hand saw, see Step 3.

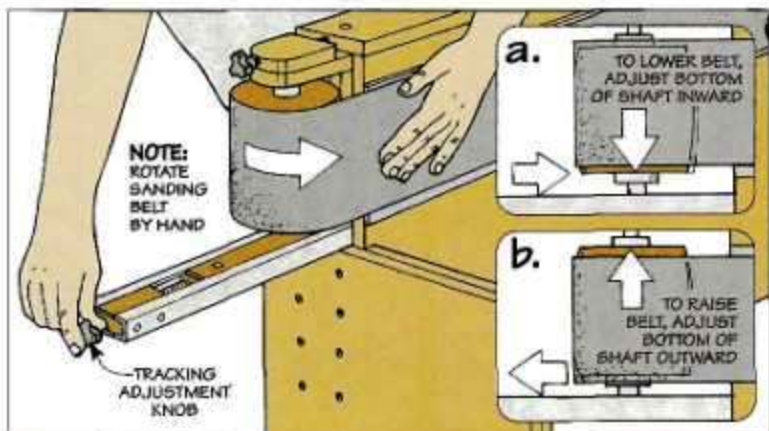

1 To adjust the tracking, slide the sanding belt across the platen by hand. If the belt rides too high (detail 'a') or too low (detail 'b'), turn the adjustment knob to move the roller in the direction shown.

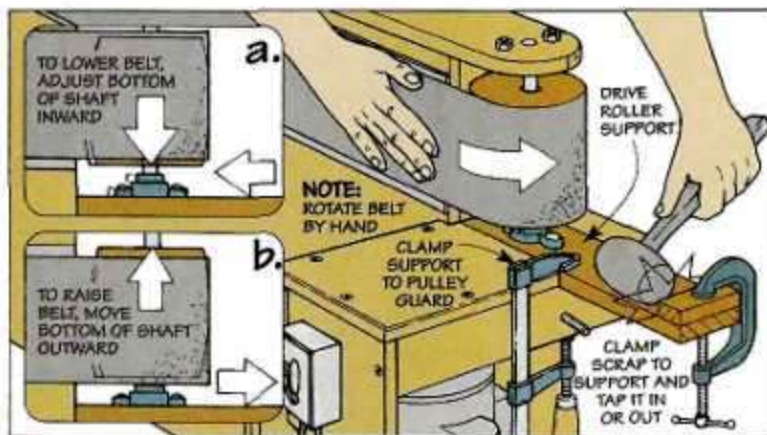

2 Now tap the support in or out to position the belt on the drive roller. Clamping the support snug (not tight) keeps the tension on the belt from shifting it out of position as you make the adjustment.

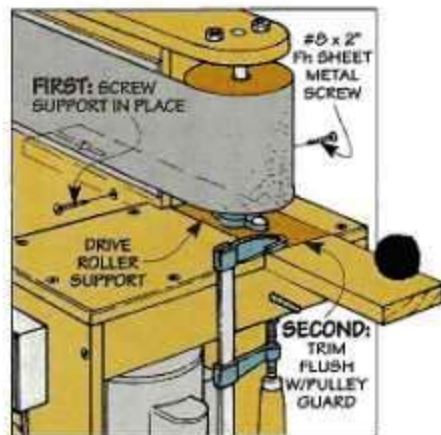

3 Finally, secure the drive roller support with screws and cut the end flush with the pulley guard.

Dust Hood

To collect the fine dust produced when sanding, I added a dust hood that hooks up to my shop vacuum.

The dust hood is quite simple. Two sides (W) and a back (X) form a U-shaped assembly that corrals the dust, see Fig. 19. And a cap (Y) encloses the top.

Before gluing up the dust hood, you'll need to cut a hole in the back to fit the hose on your shop vacuum. Also, there's a slot that fits over the bolt in the pulley guard. This lets you slide the dust hood back and forth, see margin.

▲ Slide the dust hood all the way forward for the most efficient dust collection (top). Move it back to allow long pieces to extend past the dust hood (bottom).

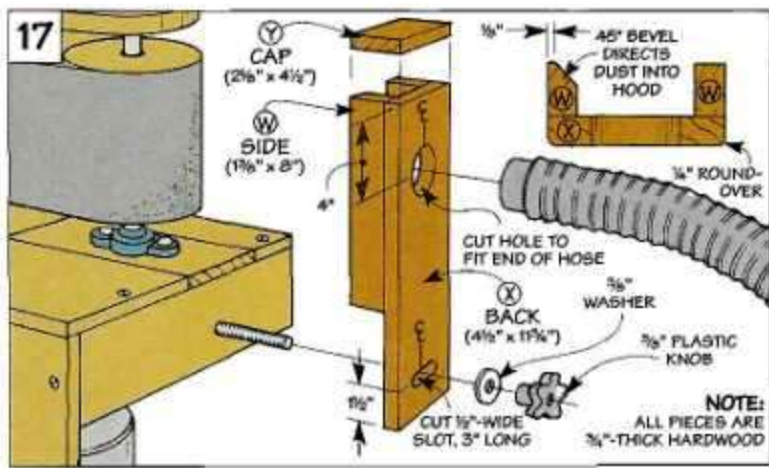

Front Table

This edge sander has a large *front table* that provides solid support for a workpiece. To take advantage of the full width of the sanding belt, you can raise the table up and down.

MOUNTING PANEL. The table is held in place by a large *mounting panel* (Z), see Fig. 18. It's attached to the sleeve so the top edge is 1 1/8" above the legs, see Fig. 18b. This way, the mounting panel acts as a stop that keeps the tabletop from dropping below the belt, see Fig. 18a.

Before screwing the mounting panel in place, I slipped two bolts into counterbored shank holes in the back. They're used as "hangers" to hold the table in place.

TABLE SUPPORTS. The next step is to add two hardwood table supports. Each one consists of a slotted *adjustment plate* (AA) and a triangular *support bracket* (BB) that are glued and screwed together, see Fig. 19.

TABLETOP. Now you're ready to add the *tabletop* (CC). It's a thick, glued-up slab of hardwood. To "soften" the look and feel of the tabletop, I shaped the outside corners in a curve and rounded over all the edges except the one closest to the sanding belt.

To provide support right up

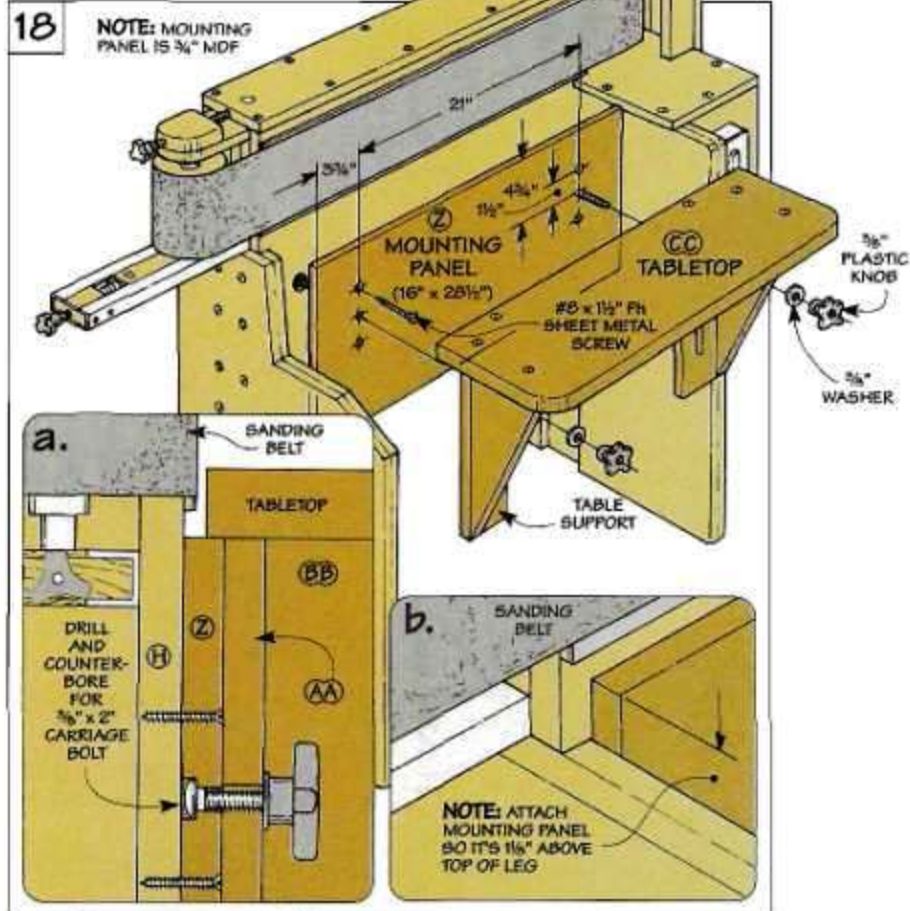

next to the belt, the tabletop is attached to the supports so there's a slight overhang. Note: To make it easy to position the tabletop, you may want to fit the

table supports on the bolts first. STOP Finally, to make it easy to sand the ends of a workpiece square, I added a two-part stop that clamps to the table, see Fig. 20.

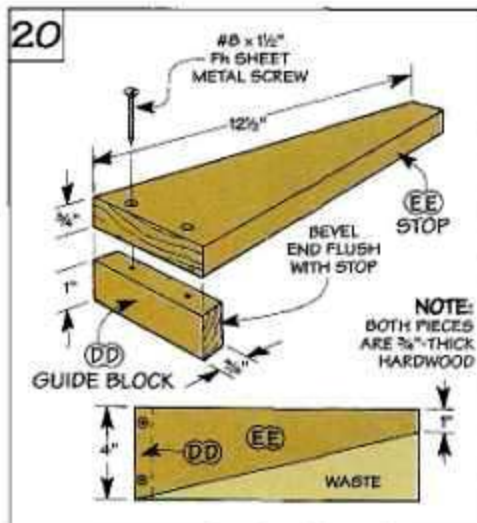
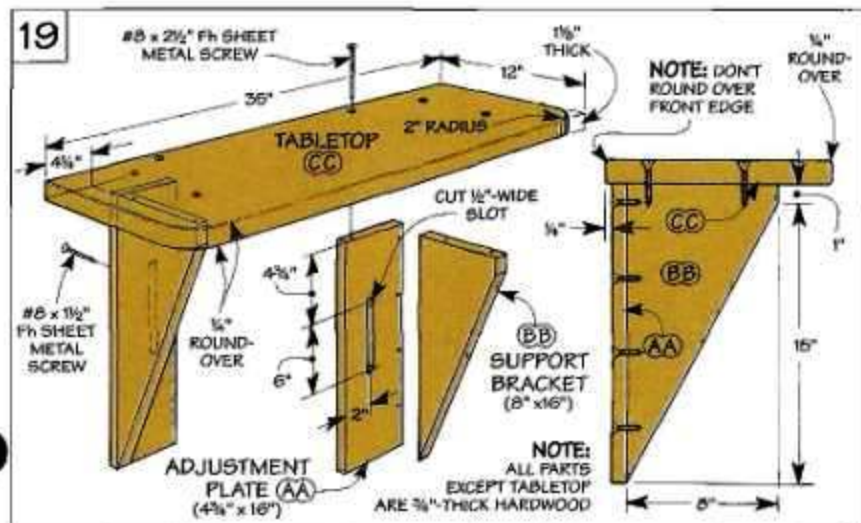

End Table

This edge sander does more than simply sand a surface flat. It can also be used to sand a *curved* workpiece. All you need to do is push the workpiece against the curved sanding surface created by the idler roller, refer to page 29.

To provide support for the workpiece, I added a sturdy end table that “wraps” around the idler roller. Like the front table, it adjusts up and down. So you can set both tables at the same height to increase the overall size of the worksurface.

MOUNTING PLATE. The end table is held in place by a *mounting plate (FF)*, see Fig. 21. Here again, a bolt slipped through from the back serves as a hanger, see Fig. 21a. Screwing the mounting plate to the leg traps the head of the bolt.

TABLE SUPPORTS. The next step is to add two table supports. As before, each one starts out as a triangular *support bracket (BB)*, see Fig. 22. But here, I glued an *extension strip (GG)* to each one. These strips do two things.

First, the strips are attached to a slotted *adjustment plate (HH)* to form a wide, U-shaped opening. This opening fits snug over the mounting plate (FF) which

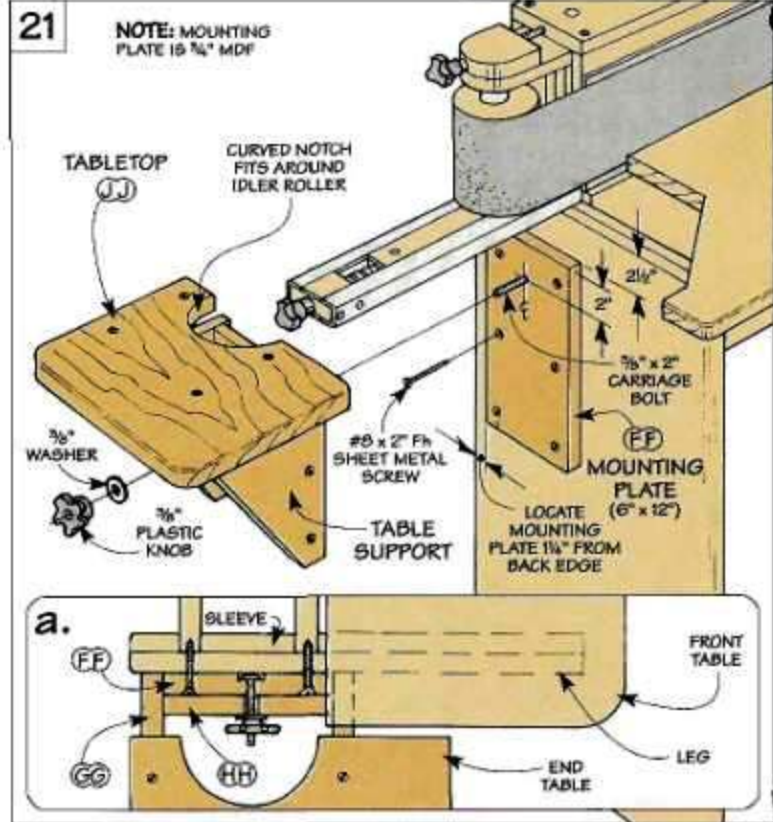

keeps the end table aligned as you slide it up and down.

The second purpose of the extension strips has to do with the front table. Since it overhangs the leg, the strips act as spacers

to provide clearance between the two tables, see Fig. 21a.

TABLETOP. Once the table supports are complete, you can add the *tabletop (JJ)*. Like the front tabletop, it's made of 1 1/8"-thick

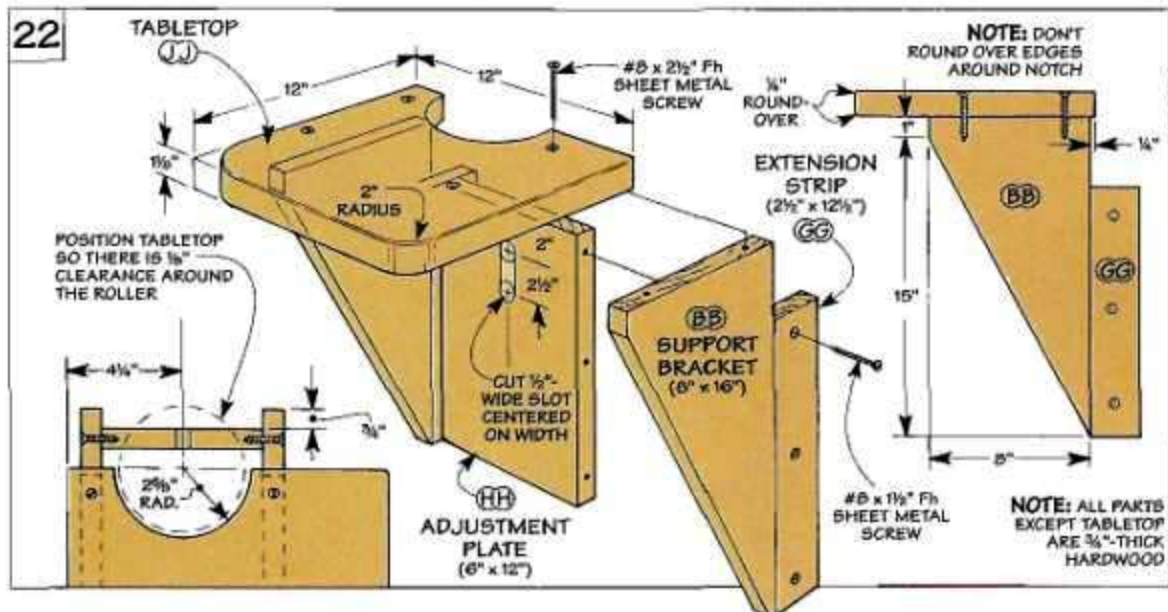

hardwood. But to provide support for the workpiece all the way around the idler roller, there's a curved notch on the inside edge.

In addition, I cut and sanded a curve on the outside corners. Then I eased the sharp edges by routing a roundover on all the edges except around the notch.

ATTACH TABLETOP. Now it's just a matter of attaching the tabletop. It overhangs the support by $\frac{1}{4}$ ". Also, you'll want to check that there's a consistent amount of clearance between the notch and the idler roller. 

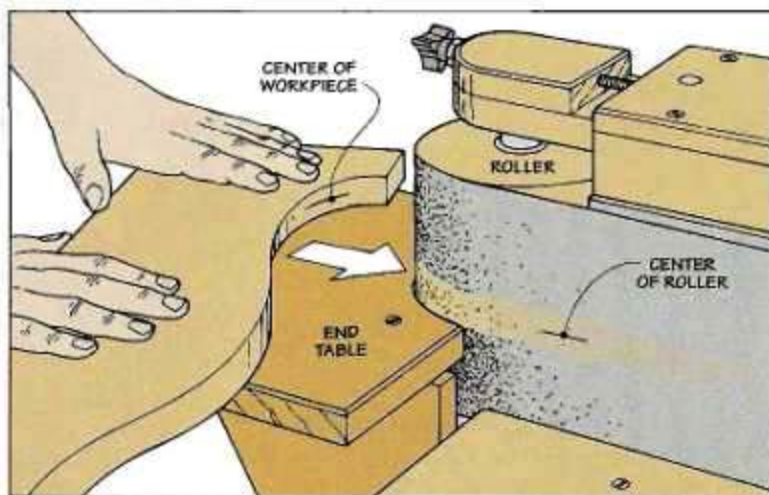

◀ When sanding a curved workpiece, raise the end table so the thickness of the piece is centered on the length of the roller.

Cutting Diagram

48" x 48" - $\frac{3}{4}$ " MDF

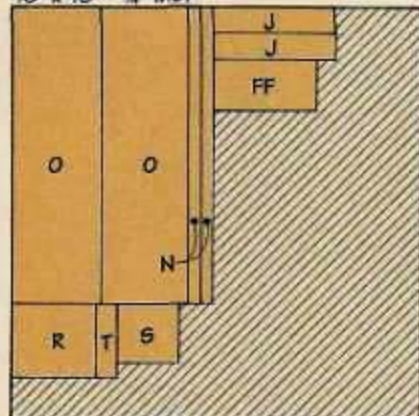

48" x 96" - $\frac{3}{4}$ " MDF

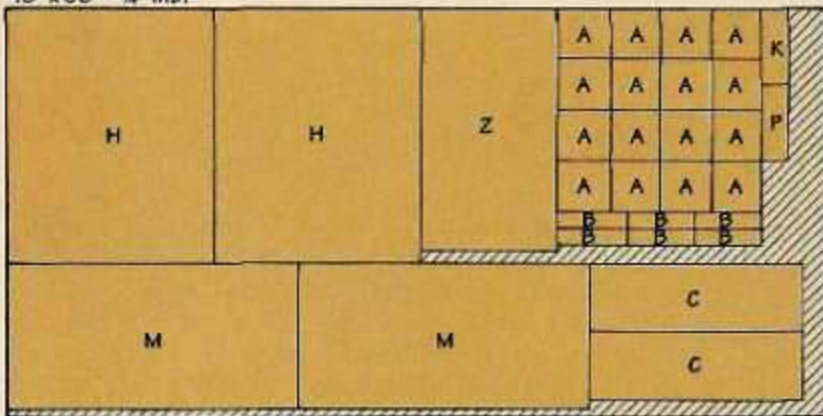

Hardware

- (2) 1" x 1" - 33" Aluminum Channel ($\frac{1}{8}$ " thick)
- (1) $\frac{5}{16}$ " x 9 $\frac{1}{4}$ " Steel Rod
- (1) $\frac{5}{16}$ " x 12" Steel Rod
- (1) $\frac{1}{4}$ " x 2 $\frac{3}{4}$ " Steel Rod
- (1) $\frac{1}{4}$ -20 x 8 $\frac{1}{4}$ " Threaded Rod
- (1) $\frac{1}{4}$ -20 x 6 $\frac{1}{4}$ " Threaded Rod
- (2) $\frac{5}{16}$ " I.D. x $\frac{7}{16}$ " O.D. Bearings
- (2) $\frac{5}{16}$ " I.D. Lock Collars
- (2) $\frac{5}{16}$ " I.D. Flange Bearings
- (1) 3" Motor Pulley ($\frac{5}{16}$ " Bore)
- (1) 4 $\frac{1}{2}$ " Motor Pulley ($\frac{5}{16}$ " Bore)
- (2) $\frac{5}{16}$ " I.D. x $\frac{3}{4}$ " O.D. Bushings ($\frac{1}{2}$ " long)
- (3) $\frac{1}{4}$ " x 4 $\frac{5}{16}$ " Springs (.120 ga.)
- (1) $\frac{1}{2}$ " x 2 $\frac{5}{16}$ " Spring (.062 ga.)
- (2) $\frac{1}{4}$ -20 Barrel Nuts ($\frac{5}{16}$ "-dia.)
- (1) $\frac{1}{2}$ " Flat Washer
- (4) $\frac{3}{16}$ " Flat Washers
- (8) $\frac{1}{4}$ " Flat Washers

5" x 96" - $\frac{3}{4}$ " HARDWOOD



5 $\frac{1}{2}$ " x 96" - $\frac{3}{4}$ " HARDWOOD



8 $\frac{1}{2}$ " x 96" - $\frac{3}{4}$ " HARDWOOD



7" x 96" - $\frac{1}{2}$ " HARDWOOD

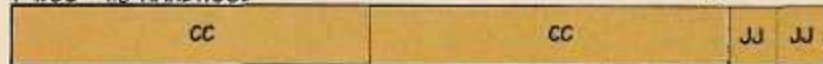

- (4) $\frac{5}{16}$ " Flat Washers
- (4) $\frac{5}{16}$ " Hex Nuts
- (6) $\frac{1}{4}$ -20 Lock Nuts
- (4) $\frac{1}{4}$ " x $\frac{1}{2}$ " Carriage Bolts
- (4) $\frac{5}{16}$ " x 2" Carriage Bolts
- (4) $\frac{3}{16}$ " x 2" Carriage Bolts
- (2) $\frac{1}{4}$ -20 Plastic Knobs
- (4) $\frac{3}{16}$ -16 Plastic Knobs

- (3) #6 x $\frac{1}{2}$ " Rh Wood screws
- (1) #8 x $\frac{1}{2}$ " Rh Wood screw
- (24) #8 x $\frac{1}{2}$ " Fh Sheet Metal Screws
- (54) #8 x 2 $\frac{1}{2}$ " Fh Sheet Metal Screws
- (36) #8 x 2" Fh Sheet Metal Screws
- (14) #8 x $\frac{3}{4}$ " Fh Sheet Metal Screws
- (1) $\frac{1}{2}$ " x 25" V-Belt

Cutting Wood Plugs



Q: When assembling a project with screws, I often use store-bought wood plugs to hide the heads of the screws. But sometimes the plugs draw more attention than if I had just left the screw heads exposed. What's the problem?

Jordan Anderson
Fargo, North Dakota

■ Most store-bought plugs are cut from the end of a dowel. When the finish is applied, the end grain of the dowel soaks it up like a sponge. This makes the plug darker than the wood that surround it.

CUSTOM PLUGS. An easy way to get around this is to cut your own plugs. This way, you can cut a *face grain* plug that will accept finish more evenly.

Another advantage is you can use the scrap pieces remaining from a project to create an almost invisible plug, see top center photo. Or maybe you'd like to highlight the plug by using a type of wood that contrasts in color, see bottom photo.

PLUG CUTTERS. Regardless of the appearance, you'll need a plug cutter to cut the plugs, see box below. Although most plug cutters work the same way, there are a couple of tricks to



ending up with a plug that fits in the hole like a cork in a bottle.

SLOW SPEED. One thing that's easy to overlook is to cut the plugs using a drill press that's running at a *slow* speed. (I set the speed on mine to 640 rpm's.) You also want to lower the plug cutter *slowly* into the workpiece. This reduces chipout on the sides of the plug which results in an almost seamless fit.

As long as you're cutting plugs, make quite a few extra, see Step 1 on page 31. This way, you'll be able to select a plug that best matches the color and grain of your project.

REMOVE PLUGS. Once all the plugs are cut, you'll need to free them from the workpiece. I used to "pop" the plugs loose with a screwdriver. But this often leaves a tiny dent in the side that shows up as a gap when the plug is installed. To prevent this, I cut the plugs free with a band saw, see Step 2.

MATCH GRAIN AND COLOR. With a pile of plugs, it's tempting to start gluing them in the holes. But it's worth taking a minute to select just the right plug — the one that comes closest to matching

the grain and color of the wood around it, see Step 3.

GLUE PLUGS. Now you're ready to glue the plugs into the holes. To avoid a big mess, I don't apply

Straight or Tapered?

Basically, there are two types of plug cutters. One cuts a plug with straight sides. And the other creates a gradual taper on the sides of the plug, see photos and drawings at right.

STRAIGHT PLUG CUTTERS. Most of the time, a straight plug cutter produces a plug with a consistent diameter, so you get a pretty good fit. But if there's any runout in the drill press, the plug will vary in size. This can create a gap when you tap the plug in the hole.

TAPERED PLUG CUTTERS. A tapered plug cutter solves this problem. As its name implies, it cuts a plug with *tapered* sides. So even if there's a bit of runout in the drill press, the tapered sides allow the plug to wedge tightly in the hole.

In addition, a tapered plug cutter creates more of a shearing cut than a straight plug cutter. Because of this, there's very little chipout on the sides of the plug, so you don't end up with a gap around the plug. (For sources of both types of plug cutters, refer to page 31.)

Straight



Tapered



glue to the plug. Instead, brush glue around the hole and then tap the plugs in place, see Step 4. Don't overdo it — the plug doesn't have to "bottom out" in the hole. All you're looking for is a snug fit.

REMOVE WASTE. Now it's just a matter of removing the part of the plug sticking up above the workpiece. A fine-toothed saw works fine here. But there's still enough "set" in the teeth that they can scratch the surface of the workpiece. So to protect the workpiece, I slip a scrap of posterboard with a hole in it over the plug, see Step 5.

SAND FLUSH. With the excess waste removed, it's just a matter of sanding the plugs flush with the surface. A block and some sandpaper make quick work of this, see Step 6. 



1 With a plug cutter chucked in a drill press, cut the plugs in a scrap from the project.



2 Now clamp a tall auxiliary fence to the bandsaw table and cut the plugs free.



3 Select a plug for each hole that matches the grain and color of the surrounding wood.



4 After brushing glue around the sides of the hole, tap the plug in place so it's snug.



5 Set posterboard over the plug to protect the workpiece as you saw off the waste.



6 Finally, sand each of the plugs flush with the surface of the workpiece.

Sources

PRODUCT INFORMATION

ShopNotes Project Supplies

is offering some of the hardware and supplies needed to build the projects in this issue.

We've also put together a list of other mail order sources that have similar hardware and supplies.

**▲ Edge Sander**

The Edge Sander featured on page 16 is an industrial quality tool that you can easily build in your own shop.

ShopNotes Project Supplies is offering a hardware kit to build the Edge Sander. It includes all the hardware you need except the motor and electrical components. You'll also need to supply the sanding belt and the plastic laminate that's used for the platen.

Note: We used a ¼ hp, Totally Enclosed, Fan-Cooled motor (3450 rpm) and a 6" x 80" sanding belt. For mail order sources of these items, see margin.

EDGE SANDER KIT

6837-100.....\$249.95

**◀ Plug Cutters**

When cutting wood plugs, you can use two different types of plug cutters: a straight plug cutter (top photo), or a tapered plug cutter, see bottom photo.

These plug cutters are available in many woodworking stores and catalogs. For mail order sources, see margin at right.

MAIL ORDER SOURCES**Woodworker's Supply**

800-645-9292

Tapered Plug Cutters,
Electric Motors

Lee Valley Tools

800-871-8158

Tapered Plug Cutters

Woodworkers' Store

800-279-4441

Tapered & Straight
Plug Cutters

Klingspor's Sanding Catalogue

800-228-0000

Sanding Belts

Tool Crib

800-358-3096

Electric Motors

TO PLACE AN ORDER, PLEASE CALL

800-347-5105

(KEY CODE: SN37)

Scenes from the Shop



▲ The large front table on our shop-built edge sander (page 16) provides rock solid support when sanding a workpiece. To take advantage of the full width of the

sanding belt, you can quickly adjust the height of the table. Just raise one end and lock it in place. Then repeat the process at the opposite end of the table.



▲ There's more to this chisel case than good looks. A tilting rack provides easy access to your chisels on the wall (above) or at your bench, see page 6.

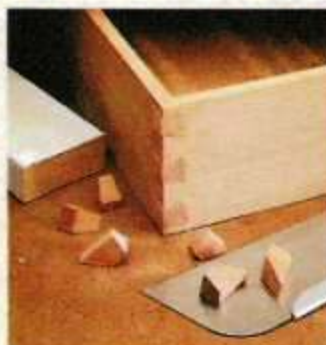

▲ Small wood "keys" create the traditional look of dovetail joints. And they strengthen the mitered corners of a box. Our simple step-by-step technique begins on page 12.