

TIPS • TOOLS • TECHNIQUES

ShopNotes®

Vol. 6

Issue 36

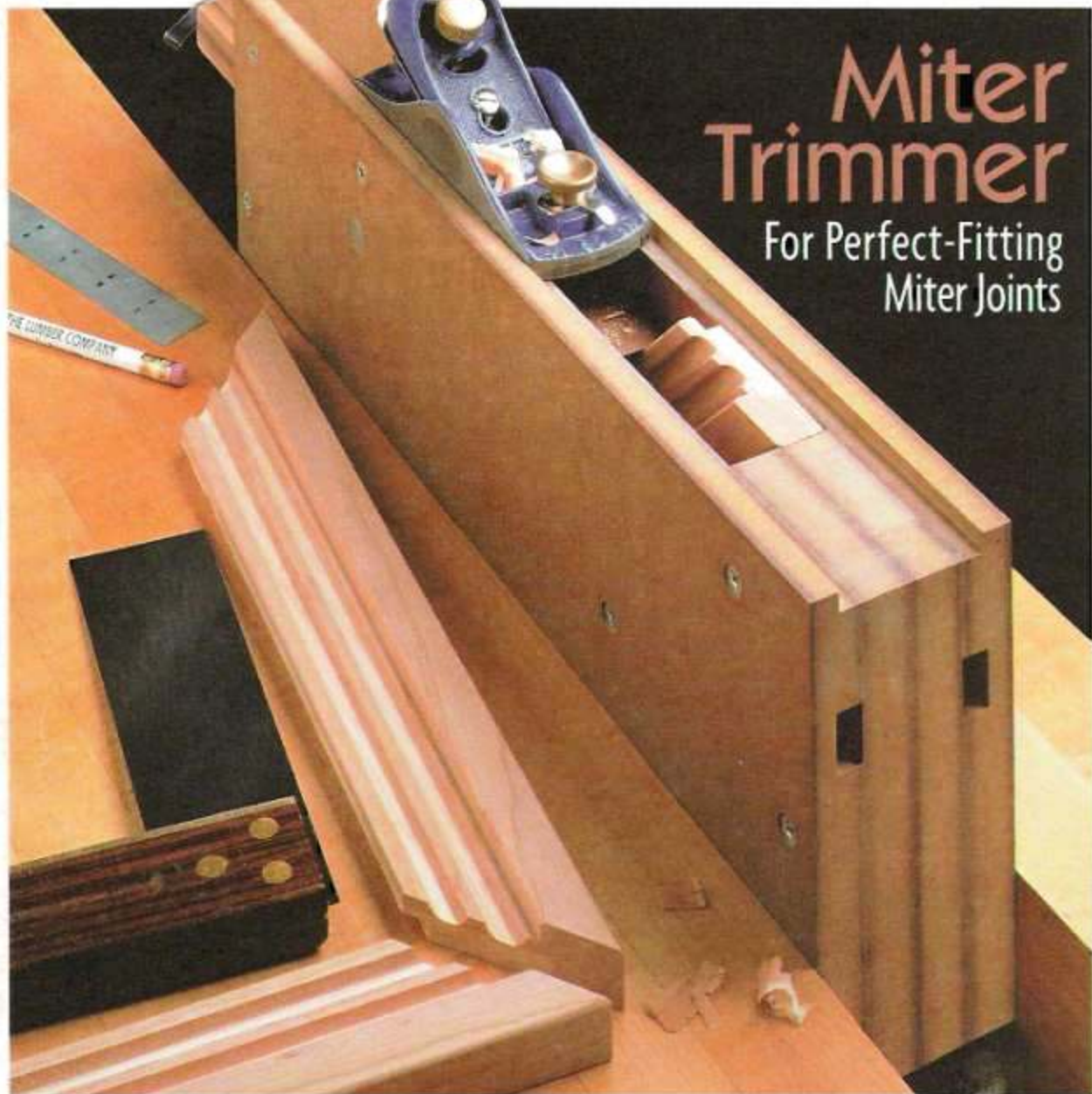

Miter Trimmer

For Perfect-Fitting
Miter Joints

- Block Plane Tune-Up
- Sabre Saw Tool Review
- Desktop Picture Frames
- Frame Clamping Jig



ShopNotes

Issue 36 November 1997

PUBLISHER Donald B. Peschke
EDITOR Tim Robertson
ASSOCIATE EDITOR Phil Totten
ASSISTANT EDITOR Bryan Nelson
ART DIRECTOR Cary Christensen
SR. GRAPHIC DESIGNER Kurt Schultz
SENIOR ILLUSTRATORS Roger Reiland
 Mark Higdon

CREATIVE RESOURCES

Creative Director: Ted Krulovich • *Project Developer:* Ken Martini • *Project Designer:* Ted Wang, Kevin Boyle • *Project Coordinator:* Kent Welsh • *Shop Mgr.:* Steve Curtis • *Shop Craftsmen:* Steve Johnson • *Photography Director:* Lark Southerman • *Sr. Photographer:* Crayola England

BOOKS

Executive Editor: Douglas L. Hicks • *Art Director:* Linda F. Verme • *Sr. Graphic Designer:* Chris Glowacki

CIRCULATION

Sales Serv. Dir.: Sandy Buzan • *New Bus. Dir.:* Glenda Buttles • *New Bus. Mgr.:* Todd L. Blier • *Resour. Mgr.:* Paige Rogers • *Billing Mgr.:* Rebecca Cunningham • *Asst. Sub. Mgr.:* Jay Krause • *Print. Asst.:* Rick Junling • *Asst. Graphic Design Dir.:* Susie Ricker • *Sr. Graphic Designer:* Cheryl L. Simpson

CORPORATE SERVICES

Vice Pres. of Planning & Finance: Jon Macneethy • *Controller:* Robin Hutchinson • *Sr. Acct.:* Laura Thomas • *Acct. Payable Clerk:* Mary Schultz • *Prod. Dir.:* George Chmielarz • *Exec. Pub.:* Douglas M. Lidster • *Prod. Asst.:* Susan Dickman • *Prod. Asst.:* Jen Snyder • *Pre-Press Image Spec.:* Troy Clark • *New Media Mgr.:* Gordon C. Gidpo • *Multimedia Art Dir.:* Eugene Pedersen • *Net. Admin.:* Al Barnes • *I.S. Support Asst.:* Chris Harrison • *H.R. Dir.:* Joyce Moore • *H.R. Asst.:* Klement Koble • *Admin. Asst.:* Julia Fish • *Recept.:* Joanne Johnson, Sheryl Ribbey • *Bldg. Maint.:* Ken Griffith • *Special Proj. Dir.:* Seville H. Inman

MAIL ORDER

Operations Dir.: Bob Baker • *Mat'l Mgr.:* Mark Mattioli • *Cust. Service Mgr.:* Jennie Etloe • *Warehouse Supv.:* Nancy Johnson • *Buyer:* Linda Jones • *Op. Asst.:* Tammy Aldini • *Team Leader:* Karla Eslinger • *Trck. Rep.:* Matthew ToRonde • *Cust. Service Rep.:* Anna Cox, Margy Putras, Tammy Truckenbrod, Adam Best, Nancy Dornsey, Deborah Rich • *Warehouse:* Chuck Carlson, Sylvia Carey, Larry Price • *Qual. Control Tech.:* Frank Johnson

ShopNotes® (ISSN 1062-0606) is published bimonthly (Jan., March, May, July, Sept., Nov.) by August Home Publishing, 2800 Grand, Des Moines, IA 50312.

ShopNotes® is a registered trademark of August Home Publishing ©Copyright 1997 by August Home Publishing. All rights reserved.

Subscriptions: Single copy: \$4.99. One year subscription (6 issues): \$24.95. Canada/Foreign add \$5 per year.

Periodicals Postage Paid at Des Moines, IA and at additional mailing offices.

Postmaster: Send change of address to ShopNotes, P.O. Box 37100, Boone, IA 50007-2103.

Subscription Questions? Write to ShopNotes Customer Service, P.O. Box 842, Des Moines, IA 50004-0842. Or call 1-800-361-5854, 8:00 am to 5:00 pm, Central Time, weekdays. FAX 515-281-0447

E-Mail: ShopNotes@shopnotes.com
 Internet: http://www.shopnotes.com

PRINTED IN U.S.A.

WoodNet

MOV ON THE WEB!

- 50 Woodworking Tips Online
- Woodworking Techniques — Step-by-Step
- Project plans you can download
- WoodNet Forum — Woodworkers' Q & A
- Power Tool Reviews

Point your browser to: <http://www.augusthome.com>
 Select "Woodworking" from the Welcome Page menu.

EDITOR'S NOTE

Cutoffs

One of the first power tools I ever bought was a sabre saw. With its plastic housing, a "pigtail" coming out the back end for a power cord, and a price tag of \$29.95, it wasn't what you'd call a heavy-duty tool. But all I needed was a "no-frills" saw anyway.

Or so I thought. It wasn't too long after I brought it home that I began having second thoughts about buying such a basic saw.

SINGLE-SPEED. For example, it only had one cutting speed — fast. That was okay when I was cutting wood. But it was far too fast when I needed to work with metal or plastic.

VIBRATION. Another thing that bugged me about the saw was the vibration. It shook so badly that my hand would go numb in a matter of minutes.

Also, this constant rattling would loosen up the set screw that held the blade in place. So I'd spend way too much time changing broken blades (and using pliers to yank out the part of the blade left sticking in the workpiece).

NO POWER. But the biggest problem with this saw is it just didn't have enough power. That became obvious one day as I was trimming the rafter "tails" on my roof. (I know, I should have been using a circular saw.)

Now the thing you should know about these rafters is they were made of Douglas fir which was so hard it bogged the saw down like a ball and chain. So

to make any progress at all, I was pushing it pretty hard.

This caused the plastic motor housing on the saw to heat up. At first, it was just a bit warm. But as I worked my way from one rafter to the next, it began to get uncomfortably hot.

That's when I noticed that something was wrong. Thick, black goo was oozing out of the saw — a combination of grease and grunge that had been liquified by the heat. Before I could shut it off, the saw had flung greasy black blobs everywhere. And smoke was curling out of the motor housing.

When the air cleared, one thing was plain to see — I'd be needing a new sabre saw. But this time, I'd get one with all the features that my old saw lacked.

SELECTING TOOLS. The point of all this is there's a lot more to consider when selecting a tool than just the price. What type of work do you plan to use it for? And what features does the tool have that will allow you to do that?

The tool you end up with may cost more than you expect. (The sabre saws we review on page 12 of this issue range in price from \$150 to \$200.) But the initial "sticker shock" is short-lived. In the long run, buying a strong running tool that gives you the performance you need is worth the money.

Tim

STATEMENT OF OWNERSHIP, MANAGEMENT AND CIRCULATION (Required by 39 U.S.C. 3685)

1. Title of Publication: ShopNotes. 2. Publication No.: 1062-0606. 3. Filing Date: September 10, 1997. 4. Issue Frequency: Bimonthly. 5. No. of Issues Published Annually: 6 (Jan., March, May, July, Sept., Nov.). 6. Annual Subscription Price: \$24.95. 7. Complete Mailing Address of Known Office of Publication: 2800 Grand Avenue, Des Moines, IA 50312. 8. Complete Mailing Address of Headquarters or General Business Office of the Publisher: 2800 Grand Avenue, Des Moines, IA 50312. 9. Full names and complete mailing addresses of publisher, editor, and managing editor: Publisher: Donald B. Peschke, 2800 Grand Avenue, Des Moines, IA 50312; Editor: Tim Robertson, 2800 Grand Avenue, Des Moines, IA 50312; 10. Owner: August Home Publishing Company, 2800 Grand Avenue, Des Moines, IA 50312. 11. Known Bondholders, Mortgagees, and other Security Holders (Give full name and address of each): None. 12. (Do not check) 13. Publication Title: ShopNotes. 14. Issue Date for Circulation Data Below: July/Aug 1997. 15. Issue and name of owner.

| | Average no. copies each issue during preceding 12 months | Average no. copies of single issue published nearest to filing date |
|--|--|---|
| A. Total no. copies (net press run) | 304,284 | 192,189 |
| B. Total paid or requested circulation: | | |
| 1. Sales through dealers, other vendors, out-of-state sales | 17,244 | 15,542 |
| 2. Mail subscriptions (paid/unpaid) | 154,404 | 147,575 |
| C. Total paid and/or requested circulation | 171,648 | 163,117 |
| D. Free circulation by mail, carrier, complimentary, and other free copies: | 78 | 89 |
| E. Free circulation outside the mail (carriers or other means) | 0 | 0 |
| F. Total free circulation | 78 | 89 |
| G. Total distribution | 171,726 | 163,206 |
| H. Copies not distributed: | | |
| 1. Office use, left-overs, unreturned, pulled after printing | 6,675 | 3,750 |
| 2. Returns from news agents | 34,297 | 22,367 |
| I. Total | 304,284 | 192,189 |
| J. Extent and nature of circulation outside the United States: | 99,945 | 91,956 |
| 16. The statement of ownership will be printed in the issue 1998 (1999) issue of the publication. | | |
| 17. I certify that all information furnished on this form is true and complete. I understand that anyone who furnishes false or misleading information on this form or who omits material or information requested on the form may be subject to criminal sanctions (including fines and imprisonment) and/or civil sanctions (including civil penalties). | | |

Legalized by Reference, LLC

Contents

Tools & Techniques

Tuning Up a Block Plane _____ 8

All it takes to turn your block plane into a precision tool is a simple tune-up. Here's our step-by-step approach.

Sabre Saws _____ 12

Our team of woodworkers tests six popular sabre saws and offers practical suggestions on the best one to buy.

Strengthening Miter Joints _____ 26

Three shop-tested techniques to strengthen the end grain to end grain glue surface of a miter joint. Also, three fasteners for making a strong mechanical connection.

Projects

Picture Frame Clamping Jig _____ 6

This simple clamping jig uses an ordinary band clamp to keep the mitered corners of a picture frame from slipping out of alignment during glue-up.

Miter Trimmer _____ 16

It's easy to get a perfect-fitting miter joint with this shop-made miter trimmer. With a built-in clamp holding the workpiece at a 45° angle, just take a thin shaving with a block plane to "true up" the mitered end.

Desktop Picture Frames _____ 22

You can build both of these desktop picture frames in a weekend. But with their intricate looking profiles and contrasting strips of wood, no one would ever guess.

Departments

Readers' Tips _____ 4

Our readers offer their own shop-tested tips for solving some of the most common woodworking problems.

Shop Solutions _____ 28

Use these tips from the guys in our shop to get professional-looking results on the projects in this issue.

New Products _____ 30

Here's a quick look at three new woodworking products that have earned a well-deserved place in our shop.



Picture Frame Clamp page 6



Sabre Saws page 12



Miter Trimmer page 16



Picture Frames page 22

Readers' Tips

Rip Fence Extension



■ When ripping a full sheet of plywood on the table saw, it's a bit tricky keeping it tight against the rip fence at the beginning of a cut. That's because there's only a short part of the fence that actually supports the workpiece.

So to provide additional support in front of the saw table, I slip a long extension over the rip fence, see photo. Basically, it consists of two U-shaped core assemblies that are held together with a pair of long side pieces,

see drawing below.

The long core assembly fits snug on the rip fence. By attaching two end caps with screws, you can keep the extension from sliding on the rip fence as you make a cut.

The short core assembly encloses the opposite end of the extension. And it creates an opening that provides access to the locking lever on the rip fence, see detail.

*Dick Dorn
Oelwein, Iowa*

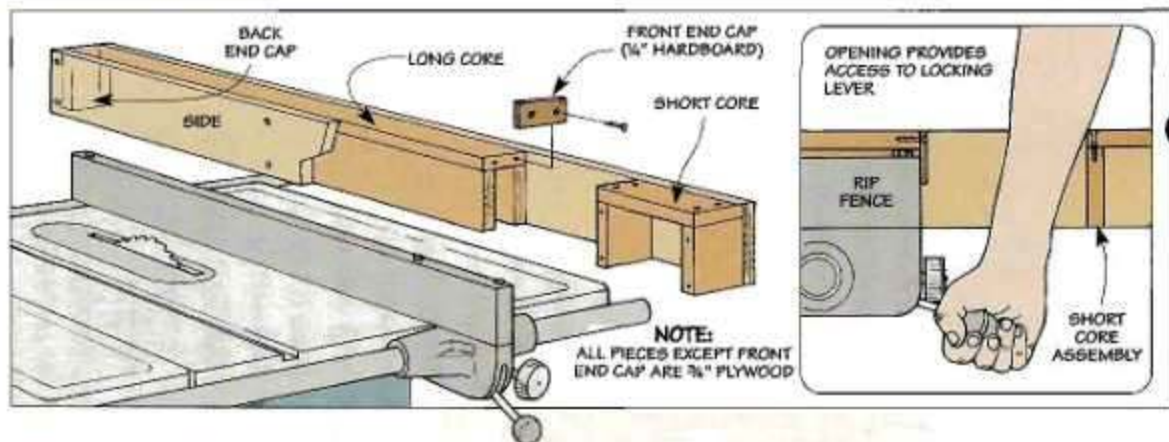

Quick Tips



▲ By "loading" his file with chalk, Pete Grimm of Eldridge, Iowa keeps it from getting clogged with metal shavings.



▲ When he drops the arbor nut on his table saw in the dust, Michael Burton of Ogden, UT retrieves it with a magnet epoxied to a scrap.



▲ Attaching a flexible, self-adhesive magnet to a scrap of hardboard makes a handy clamp pad for Tom Lee of Seattle, WA.

Tool Shelf

Besides providing storage for my portable power tools, this simple shelf solves another nagging problem as well — keeping the power cords from getting tangled up like spaghetti.

Each power cord fits in a separate compartment directly below the tool, see photo. These compartments are formed by a number of *dividers* that are sandwiched between a *top* and *bottom*, see drawing.

The location of the dividers is determined by the amount of space each tool requires. Note: To allow the base of the tool to sit flat on the shelf, you may need to modify the top by cutting slots or drilling holes.

*Fred Nordby
Red Deer, Alberta*

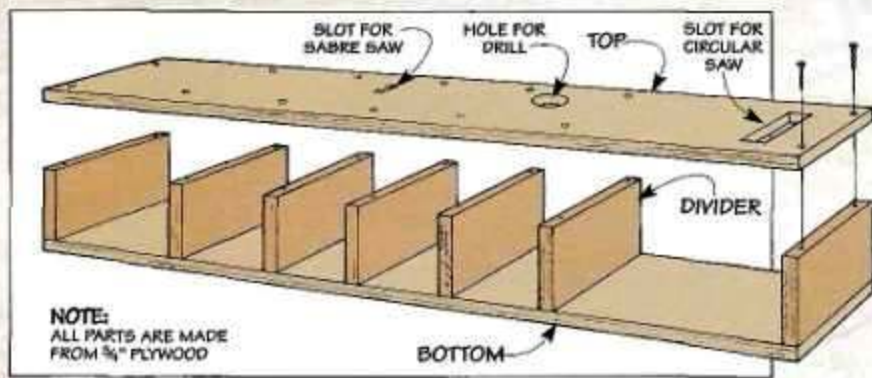

Label Holders

I've built several storage cabinets with a number of drawers to help organize small pieces of hardware. To see at a glance what's inside each one, I made these simple label holders that double as the drawer pulls.

Each holder begins as a scrap "two-by" that's cut to the desired length, see Fig. 1. But to form the recess for the label safely, it's best to use extra-wide pieces.

This recess is made by routing a shallow groove in the edge of the workpiece, see Fig. 1. Then, to create slots that hold the label in place, I use a bandsaw to cut two thin kerfs in the corners of the groove, see Fig. 2.

To complete each label holder, just rip off a narrow strip. Then glue and screw it in place.

*Steve Harris
Fairfield, California*

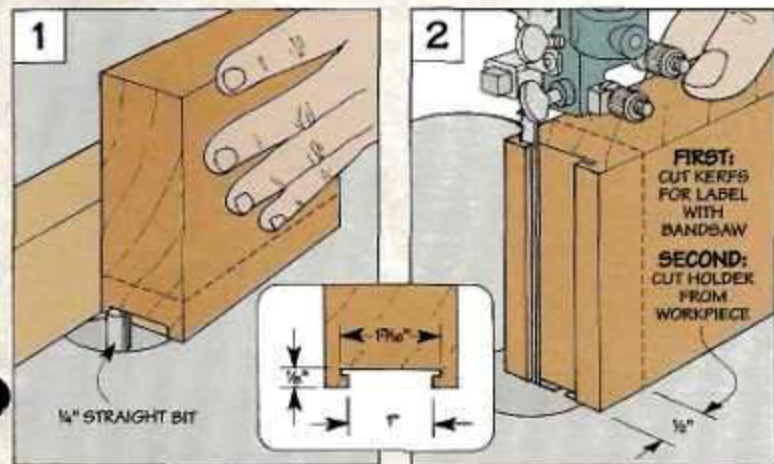

Send in Your Tips

To share your original tips and solutions to problems you've faced, send them to: *ShopNotes*, Attn.: Readers' Tips, 2200 Grand Ave., Des Moines, IA 50312. (Or if it's easier, FAX them to us at: 515-282-6741.)

We'll pay up to \$200 depending on the published length. Please include a daytime phone number so we can call you if we have any questions.

Picture Frame Clamping Jig



Gluing up a picture frame can be a frustrating experience. You have to get all four of the mitered corners perfectly aligned. But as you apply clamping pressure, the frame pieces tend to slip and slide out of alignment.

To keep these pieces from shifting out of alignment, I built the clamping jig shown above. By using a set of four corner blocks and an ordinary band clamp, it makes it easy to glue up a "picture-perfect" frame.

BASE. The clamping jig starts out as a *base* (A) made from $\frac{3}{4}$ " MDF, see Fig. 1. In addition to serving as a platform for the corner blocks, it provides a way to keep them aligned so the frame stays square.

The key to making this work is a pair of intersecting grooves. These grooves accept runners in

the bottom of the corner blocks that let you adjust the jig for different size frames.

CORNER BLOCKS. With the base complete, you can turn your attention to the four corner blocks. They start out as a single

blank that's made by gluing up two pieces of $\frac{3}{4}$ " MDF, see Fig. 1. As with the base, there are two intersecting grooves in the bottom for the runners that are added later, see Fig. 1.

After cutting the grooves, it's

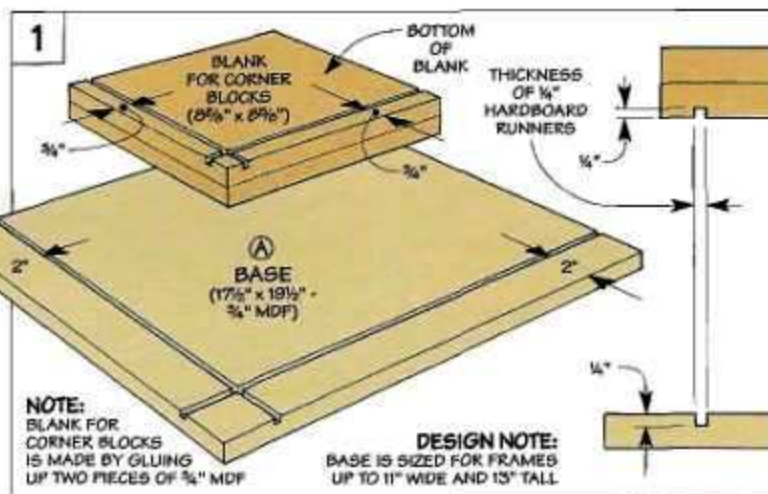

Making the Corner Blocks

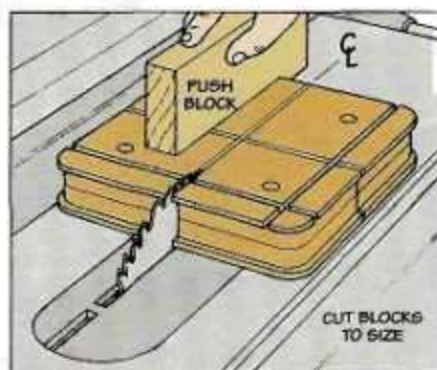
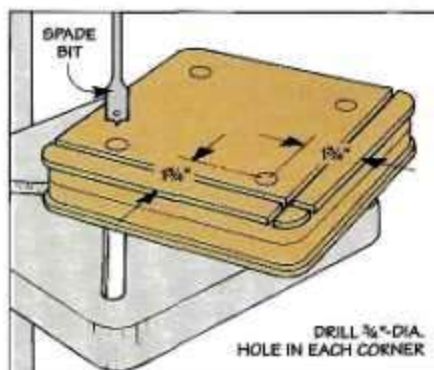
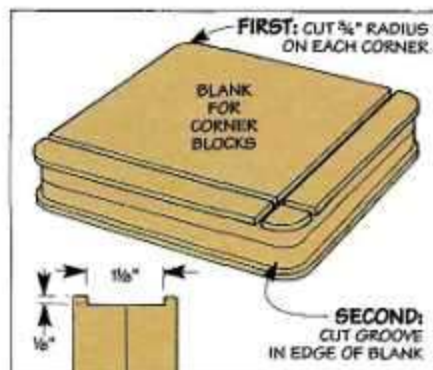

1 After cutting a gentle curve on each corner of the blank, cut a centered groove in the edge for the band clamp.

2 To provide a relief area for glue (and to protect the tips of the frame), drill a hole near each corner of the blank.

3 Cutting the individual corner blocks from the blank is a simple matter of ripping it into four pieces of equal size.

just a matter of following a simple sequence of steps to complete the blocks. To allow the band clamp to slide freely around the corner blocks, I cut a gentle curve on each corner of the blank, see Step 1 on page 6.

Also, cutting a wide, shallow groove around the edge of the blank forms a recess that keeps the band clamp from slipping off, refer to page 28. (I cut a 1 1/8"-wide groove for my 1"-wide band clamp.)

DRILL HOLES. Next, a hole is drilled near each corner of the blank, see Step 2. These holes will create an opening in the inside corner of each block that prevents the tips of the frame pieces from getting crushed. And they provide a relief area for glue squeezeout.

CUT BLOCKS TO SIZE. At this point, you can cut the *corner blocks (B)* to final size, see Step 3. A few passes on the table saw is all it takes to divide the blank into four separate blocks.

NOTCHES. To allow the blocks to fit around the corners of the frame, there's a notch in each one. It's easiest to cut these notches all at once by "ganging" the blocks together and making two passes on the table saw, see Step 4.

ATTACH RUNNERS. Now all that's left is to add the *runners (C)*, see

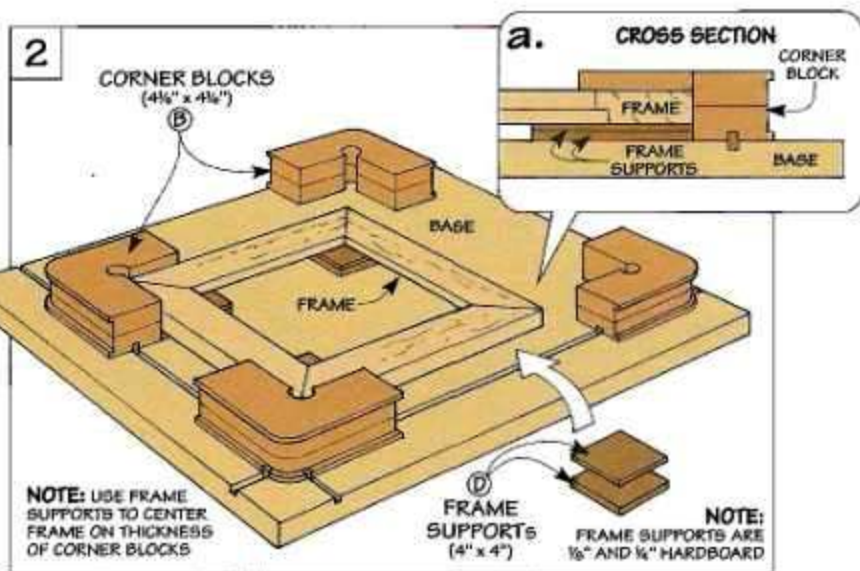

Step 5. These are strips of 1/4" hardboard that are glued into the grooves in the bottom of the corner blocks. One thing to notice here is the *number of runners* in each block.

There are two runners in the block with the intersecting grooves. This "fixes" it on the base. To adjust the jig for the width and height of the picture frame, you just slide the two blocks with a single runner along the grooves in the base. The fourth corner block (which doesn't have a runner at all) is simply placed against the remaining corner of

the frame, see Fig. 2.

While tightening a band clamp around the corner blocks keeps all the frame pieces aligned, it doesn't ensure that the frame will stay flat. To do this, you'll need to center the frame on the thickness of the corner blocks as you tighten the band clamp.

FRAME SUPPORTS. An easy way to do this is with a set of *frame supports (D)*. These are squares of 1/8" and 1/4" hardboard. Depending on the thickness of the frame, they're used in different combinations to raise the frame to the proper height, see Fig. 2a.

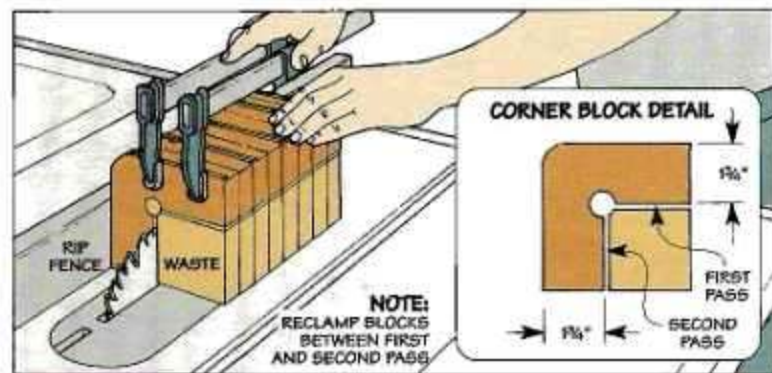

4 Next, set the rip fence so the blade will cut through the center of the relief hole. Then clamp the blocks together and make a single pass. To cut the waste free, reclamp the blocks and make a second pass.

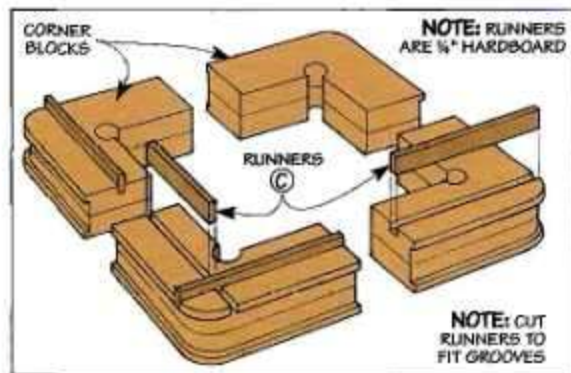

5 Finally, to make it easy to align the corner blocks on the base, cut runners to fit the three corner blocks with grooves, then glue them in place.

Tuning up a Block Plane

It's not often that I build a project without using my block plane. Whether I'm fitting a drawer, trimming a small piece, or just shaping the edge of a workpiece, I rely on it for all sorts of jobs.

But even though my block plane is a precision tool now, it didn't start out that way.

When I first took it out of the box, the cast iron body felt rough and gritty in my hand. And the adjustments on the plane were either too stiff or too loose. Even after fiddling with them, I still wasn't satisfied with the quality of cut.

Fortunately, there wasn't anything wrong with the plane. All it really needed was a tune-up.

FLATTEN THE SOLE

The first thing that needed attention was the sole (bottom) of the plane. Although it had been machined at the factory, it wasn't perfectly flat.

Why do you want the sole to be flat? Because if there's a slight hump, it will prevent the cutting edge of the blade from making full contact with the workpiece. And if there's a "dished out" area, it's just about impossible to plane a flat surface.

REFERENCE SURFACE. Before you can check whether the sole is flat, you need to establish a flat surface as a reference. This doesn't have to be anything fancy. A piece of $\frac{1}{4}$ "-thick glass works fine. Setting the glass on a scrap with a cleat at each end will prevent the glass from sliding.

Flattening the Sole



1 Using a permanent marker, draw a squiggly line across the sole of the block plane.



2 Then sand the sole on a sheet of 220-grit silicon carbide paper that's taped to a piece of glass.



3 Any dark lines that remain indicate low areas. So continue sanding until the marks disappear.



Setting a file in a scrap with a 45° saw kerf makes it easy to create a uniform chamfer on the bottom edges of the plane.

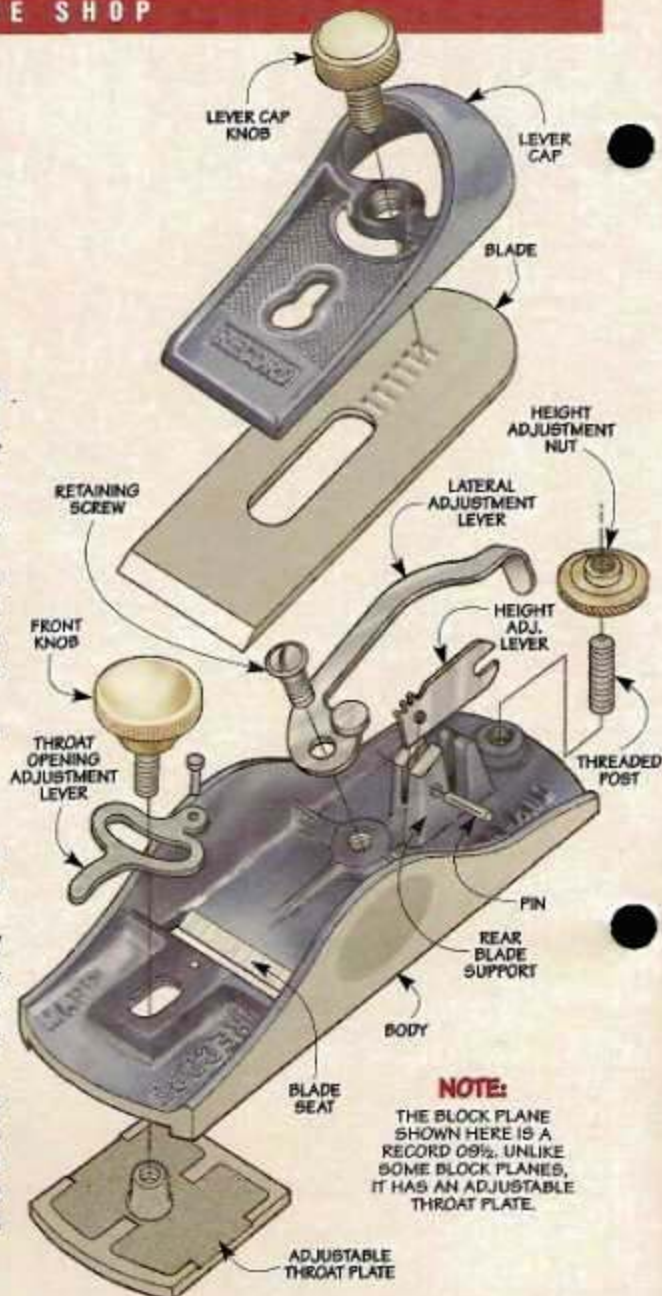

Checking the Height Adjustment



1 A loose fit between the "ears" of the height adjustment lever and nut results in a sloppy adjustment.



2 To improve the fit, start by using a nail and a vise to press out the pin that holds the lever in place.



3 Then lightly squeeze the ears of the lever together until it fits closely around the adjustment nut.

To check the sole, start by drawing a line across it, see Step 1 on page 8. Then sand the plane across a piece of silicon carbide sandpaper, see Step 2. After a few strokes, check your progress. Any low spots will show up as dark lines, see Step 3.

The idea is to continue sanding until the lines disappear. Then polish the sole on progressively finer grits of silicon carbide sandpaper (up to 400-grit). Lubricating the sandpaper with oil will carry away the metal "dust."

Note: Sand the plane with the blade installed (make sure it's retracted). This will "stress" the body of the plane like it is in use.

CHAMFER EDGES. Once the sole is flat, the bottom edges of

the plane may be sharp. So to avoid accidentally scratching the surface of a workpiece, I file a small chamfer on these edges, see margin on page 8. While I'm at it, I run a hand-held file across the top edges of each side to provide a comfortable grip.

THROAT PLATE. If your plane has an adjustable throat plate, it's also a good idea to see if it operates smoothly. Occasionally, there's a small burr on the edge which will make it stick. But a few strokes on a piece of sandpaper is a quick fix, see margin at right.

HEIGHT ADJUSTMENT

Another thing to check is the adjustment that allows you to raise and lower the blade.

Basically, it consists of two parts: a short lever with a C-shaped opening, and an adjustment nut that travels up and down on a threaded post. As you turn the nut, it pivots the lever up and down which raises or lowers the blade.

But sometimes the blade won't move right away when you turn the nut. Instead, there's a dead zone where you turn the nut and nothing happens. That can be caused by a gap between the "ears" of the lever and the nut, see Step 1 above.

To remove the slack from the system, you'll need to take out the pin that holds the lever in place, see Step 2. Then press the ears together until the lever fits closely around the nut, see Step 3.



To allow the throat plate to slide smoothly, sand each edge lightly on a piece of sandpaper.

Squaring Up the Throat Opening



1 Use a fine-tipped marker to square a line just behind the back edge of the throat opening.

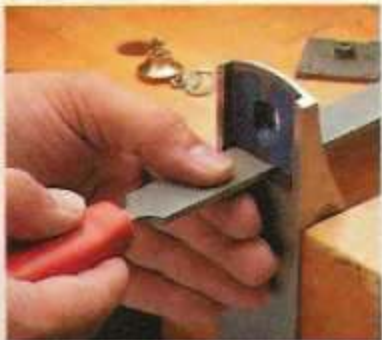

2 Now tighten the plane in a vise and take a few strokes with a file to remove material up to the line.

THROAT OPENING

At this point, you can turn your attention to the throat opening where the blade extends through the sole of the plane.

To produce a consistent cut all the way across the width of the blade, the back edge of this opening needs to be square to the sides of the plane.

MARK & FILE. To square up the opening, mark a line just in back of it, see Step 1 at left. Then make a few light passes with a file to square it up, see Step 2.

BLADE SEAT

One part of a block plane that's easy to overlook is the blade seat. This is the angled platform inside the body that supports the blade. To eliminate any "chatter" as you make a cut, you want the blade to sit flat against the blade seat.

But in a brand new plane, you may find that it's rough and covered with paint. As a result, the blade *can't* sit flat. The solution is to file the blade seat so it's smooth and flat, see Step 1 at right.

REST. To hold the file at a consistent angle as you're working, use the rear blade support as a "rest." Then make several long strokes across the blade seat and the rear blade support. One thing to watch for is that you remove the same amount of material all across the blade seat.

To check, hold the plane in your hand and look down into the throat opening. Then tilt the plane back and forth until the light catches the edge of the throat opening, see Step 2. The reflection of the light should reveal a consistent thickness all the way across.

LEVER CAP

Once the blade seat is nice and flat, you still need a way to hold the blade tightly against it.

Sanding the Lever Cap



1 Raise the back end of the lever cap slightly, then sand the nose by making a few smooth strokes.

Smoothing the Blade Seat



1 Use a file to make long, smooth strokes across the blade seat and rear blade support.



2 Then check that the front edge of the blade seat is a consistent thickness all the way across.

That's the job of the lever cap.

To apply pressure evenly across the entire width of the blade, the nose has to be smooth and flat on the bottom. But here again, a rough casting or uneven paint job will prevent the lever cap from fitting tight against the blade.

A little sanding is all it takes to get the nose of the lever cap flat and smooth, see Step 1 below. You'll know when you're done by the consistent pattern of scratches, see Step 2.

THE KEYHOLE

There's one last thing I do to the lever cap. That's to countersink the keyhole-shaped opening for the screw that secures the lever cap to the body of the plane.

The reason for this is simple. When I put my plane away, I always retract the blade. This means I have to loosen the knob that holds the lever cap in place. The problem is that when I tilt the plane to the side to check the blade, the keyhole slides over the screw and the lever cap falls off.

COUNTERSINK. An easy way to prevent this is to drill a countersink in the small opening in the keyhole, see Step 1 at top of page 11. This will "seat" the head of the screw and hold the lever cap in place, see Step 2.

SHARPENING THE BLADE

No matter how well you tune up the parts of the plane, you won't be able to get a quality cut without one thing — a sharp blade.

There are a number of different ways you can go about this. But the silicon carbide sandpaper used for the body of the plane can put a razor sharp edge on the blade as well.

THE EDGE. The thing to keep in mind as you're sharpening is that the edge is formed by the intersection of *two* surfaces — the back and the bevel. To get a sharp edge, the idea is to get each of these surfaces as smooth and flat as possible.

FLATTEN BACK. The first step is to flatten the back of the blade.



2 The nose of the lever cap should be flat and smooth after sanding off any paint.

Although this requires a little elbow grease, the nice thing is you only need to do it *one* time. Once it's flat, you just need to concentrate on the bevel the next time you sharpen the blade.

Here again, it's important to work on a *flat* surface (I use a piece of glass). And as before, marking the back of the blade will help keep track of your progress.

To flatten the back, I start with a piece of 220-grit silicon carbide sandpaper and sand until the marks disappear, see Step 1 below. At this point, the back is flat. But just being flat isn't enough.

That's because the coarse grit leaves a swirl of large scratches behind. And each scratch forms a tiny nick where it meets the cutting edge of the blade.

POLISH BACK. So in order to get the back as smooth as possible, I polish it with a progression of finer grits. I move on to 400 grit next, and then follow it up with 800 and 1000-grit sandpaper.

While this produces a serviceable edge, I continue polishing with 1500 and 2000-grit paper to get a mirror smooth finish. (I found these extra-fine grits of paper at an auto body parts store.)

FLATTEN BEVEL. Once the back is flat, you're halfway to a sharp edge. Now all that's left is to make the bevel as flat and smooth as the back.

Countersink the Keyhole



1 With the lever cap set against a fence clamped to the drill press table, countersink the keyhole.



2 The countersink should be deep enough to seat the head of the retaining screw.

CONSISTENT ANGLE. The secret to getting a smooth, flat bevel is to hold the blade at a *consistent* angle. To do this, I use a honing guide. Basically, this is a rolling clamp that holds the blade at the desired angle, see Step 2.

When securing the blade in the honing guide, try to match the existing angle of the bevel. To do this, position the blade in the guide so the entire surface of the bevel lies flat on the glass.

Now it's just a matter of sanding the bevel. Once again, the idea is to proceed from a coarse to a fine grit. The trick is knowing where to start.

GRITS. This requires matching the grit to the condition of the bevel. If there's a nick in the edge, I'll start with 180-grit sandpaper. But for most work,

this is too coarse. For example, a piece of 220-grit paper is fine for a new blade. But if you're just touching up an edge, you may want to start with 800-grit.

EVEN PRESSURE. Regardless of the grit, the key is to apply pressure *evenly* across the blade. The only exception is if the blade is out of square. In that case, you'll want to apply a little extra pressure on the high corner to square the blade as you sharpen.

BURR. As you work with each grit, a burr will start to form on the back of the blade. Although you can't see it, you can feel the burr by running your finger up the back of the blade.

When you get a nice, even burr across the entire width of the blade, remove it by sanding the back and the bevel, see Step 3. 

Sharpening the Blade



1 Using oil as a lubricant, sand the back of the blade back and forth across a piece of silicon carbide paper.



2 By holding the blade at a consistent angle, a honing guide ensures that the bevel remains flat as you're sharpening.



3 To remove the burr, alternately sand the bevel and the back with the final grit of sandpaper used to flatten the back.

Sabre Saws

The Testing Team

(From Left to Right)

Bryan: From cutting siding to sink openings, Bryan uses a sabre saw for all his remodeling jobs.

Kurt: Whether he's cutting lumber or sheet goods for his new house, Kurt uses a sabre saw extensively.

Chris: When Chris is working in his shop, he relies on a sabre saw for all his curved cuts.



How We Selected the Sabre Saws

Each saw we tested has:

- Variable Speed
- Orbital Action
- A Roller Guide

There are two things I remember about my first sabre saw — its orange, plastic body and the disappointment I felt whenever I used it.

Besides the fact the saw was noisy and vibrated like a jackhammer, it would bog down in a heavy cut. And when making a curved cut, it was even more exasperating. The saw blade inevitably deflected at an angle, so I'd end up with a bevel on the edge of the workpiece instead of a square cut.

Well, that old saw is gone now. And so are some of its problems. Today, manufacturers have come up with a whole new batch of

sabre saws that are designed to produce fast, accurate cuts.

The question is how well do they work? To find out, we bought six of the most popular sabre saws, see photos below.

TEAM. Then we rounded up a team of three woodworkers with different types of experience to test them, see photo above. Of course, one of the problems with this is you're likely to end up with more than one "best" saw.

But that's okay. Each person picked the saw that was best for the type of work he does most frequently. Which is just the kind of information I'd want when buying a saw.

PA The thing I'm curious about is the two different styles of handles. What can you tell me about them?

Kurt: The main thing is the handles on these saws don't just look different. (See inset photo above.) They feel different too. When I'm using a saw with an enclosed handle on top, it feels like I can cut to a line more accurately than

Top Handles



**DeWalt
DW321**

800-433-9258
\$165.95



**Hitachi
CJ65V2K**

800-546-1666
\$199.00



**Makita
4304**

800-462-5482
\$169.95

when I grip the barrel of the saw.

Chris: One thing that bothered me about the saws with a barrel grip is they're too thick for me to get a good grip. Especially since my hands are fairly small.

Q: So are you saying that the saws with the top handles are better?

Bryan: Not at all. I've had a saw with a top handle for years. So that type of handle feels more natural. But I could just as easily get used to the barrel grips.

I guess it all boils down to what you like. That probably explains why most companies that manufacture sabre saws have at least one model with a top handle and one with a barrel grip. (See chart.)

I'd recommend trying out both handle styles in the store. Then, once you decide which one you like, concentrate on the other features the saw has to offer.

Q: Like changing blades?

Bryan: Exactly. Since I work with all kinds of materials, I'm always switching from one type of blade to another. So the last thing I want is a saw where it's a hassle to change blades.

Fortunately, it's pretty easy to change blades on all these saws. The Hitachi, Makita, and Porter Cable all have a set screw that holds the blade in place.



▲ **Blade Changing.** While the Hitachi (left) requires a wrench to change blades, the DeWalt (center) only takes a couple turns of a knob. Even so, it's not as quick as the spring-loaded lever on the Milwaukee (right).

(See photos above.) So as long as I don't misplace the Allen wrench (or screwdriver) that's required, it's no big deal.

But I don't even have to worry about that with the other saws — they don't require any tools at all. With the Bosch and DeWalt, I just turn a knob on top of the handle.

That's pretty handy on the

Bosch. But I had to fiddle with the knob on the DeWalt. It keeps dropping into the recess in the plastic housing as I turn it.

Chris: It's hard for me to imagine a quicker way to change blades than with the Milwaukee. I just slide a lever over, pop in a blade, and release the lever. The whole operation only takes a few seconds.

Bryan: One nice thing about all these saws is they accept either a bayonet or universal blade — the two most common types of blades.

With the Milwaukee and Bosch saws, a bayonet blade is the *only* one you can use. But either a bayonet or a universal blade will work in the DeWalt, Hitachi, and Makita. And the Porter Cable accepts either a universal blade or a special hook blade.



Most sabre saws accept bayonet (top) or universal blades (middle). The hook blade (bottom) only fits the Porter Cable.

| Handle Styles | | |
|---------------------|------------|-------------|
| Model | Top Handle | Barrel Grip |
| Bosch | 1587DVS* | 1584DVS |
| DeWalt | DW321* | DW323 |
| Hitachi | CJ65V2K | CJ65VA2K |
| Makita | 4304 | 4305 |
| Milwaukee | 6266-6 | 6276-6 |
| Porter Cable | 7549 | 7649 |

* Trigger has built-in speed control



Bosch
1584DVS
773-286-7330
\$174.95



Milwaukee
6276-6
414-781-3600
\$179.95



Porter Cable
7649
800-487-8665
\$149.00

Barrel Grips

Performance



Test Procedures. A sabre saw has an incredibly tough job — making a controlled, accurate cut in all different kinds of materials. To test the performance of these saws, we plowed through 2"-thick oak (left), made intricate scroll cuts in plywood (center), and sawed heavy-gauge metal (right).

Q: When it comes to the overall performance of a sabre saw, what exactly are you looking for?

Bryan: It's really a combination of things. A sabre saw has to run smooth. Yet it needs to have enough power that I don't have to coax it along.

At the same time, I want a sabre saw that makes it easy for me to make a controlled, accurate cut — regardless of the type of material I'm working with.

That's why having variable speed control is so important to me. For making rough cuts in lumber or plywood, I adjust the saw for a fast cutting speed and don't worry too much about the quality of cut.

But if I'm working with metal or plastic laminate (or if the accuracy and quality of cut are more critical), I'll adjust the saw for a slower speed setting.

Kurt: The nice thing about each of these saws is I can dial in the exact speed I want. But the DeWalt has one additional feature that gives me just a bit more control over how fast I'm cutting.

With this saw, the trigger acts like the accelerator on a car. I can change how fast the blade is cutting by the amount of pressure I use to squeeze the trigger.

That comes in handy if I'm cutting around a tight curve. By easing off the trigger, I can slow down the cutting speed and make an accurate cut around the turn.

Editor's Note: The trigger on the top handle model of the Bosch has this same built-in speed control, see chart on page 13.

Q: But isn't there more to getting accurate results than being able to control the cutting speed?

Kurt: You bet. All the saws have some sort of guide system that keeps the blade from deflecting as you make a cut. But they go about it in different ways.

To limit the side-to-side movement of the blade on the Porter Cable, there's a pair of steel guide blocks attached to the base. (See photos at left.) And a roller provides support for the back of the blade.

The rest of the sabre saws

Guide Blocks.

Two guide blocks on the Porter Cable keep the blade from deflecting to the side as you make a cut. And a roller supports the back of the blade.



Guide Roller.

A roller with a centered groove supports the blade on all the other saws. The sides of the groove fit closely around the blade which limits the side-to-side movement.

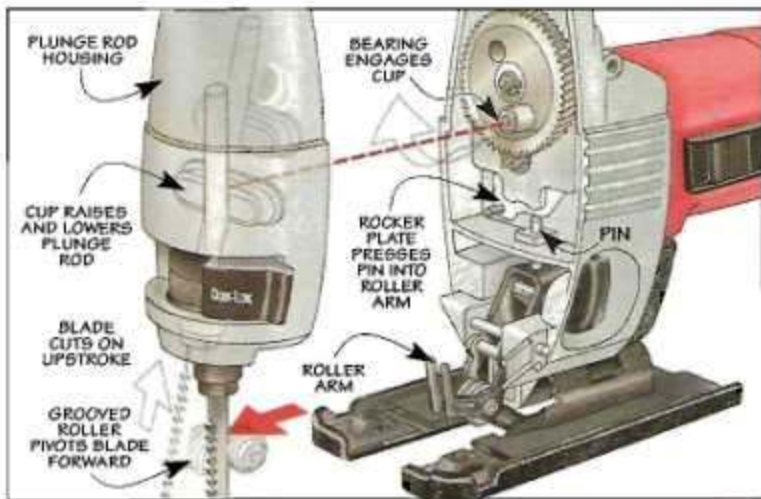

▲ Orbital Action. To produce a more aggressive cut, the roller pushes the blade forward into the workpiece during the upstroke. On the downstroke the blade returns to its normal position.

accomplish the same thing with a single roller. These rollers support the back of the blade just like the one on the Porter Cable.

But what's different is there's a groove running around the edge of each roller. The sides of this groove fit closely around the blade, so there's no side-to-side "play."

Bryan: There's one other thing that's worth mentioning about both types of rollers. They're part of a mechanism that can be adjusted to "kick" the blade forward at the same time as it's cutting up and down. This way, the blade cuts in more of an orbital motion. (See drawing on page 14.)

Q Why would I want to do that?

Kurt: It's great when you're making a rough cut and you want to get the job done in a hurry. By adjusting the saw for the maximum orbit, the blade really chews through the workpiece.

Bryan: But sometimes the orbital action is too aggressive. So if I'm working with materials that chip easily (like plastic laminate),

I adjust the saw so there's no orbital motion at all. This way, the blade cuts straight up and down and reduces chipout.

Chris: Another way to prevent chipout is to attach a plastic insert to the base of the saw. (See margin.) The insert fits closely around the blade. So the blade doesn't lift the wood fibers on the upstroke.

Bryan: It's not only the chipout I'm concerned with. If the metal base on the saw gets nicked, it can scratch the surface of a workpiece.

So I was pleased to see that each saw except the Porter Cable comes with an extra plastic base that protects the workpiece. (See photos at right.) That's good insurance when I'm working with delicate materials like plastic laminate or hardwood plywood.

Q How about tilting the base of the saw to make a beveled cut?

Chris: It's not something I do very often. And if I owned the Porter Cable I wouldn't do it at all. That's because it's the only saw



◀ Snap-on Base Plate. To protect surfaces that get scratched easily, the Milwaukee and DeWalt have a plastic base plate that snaps quickly onto the metal base of the saw.



◀ Replaceable Base Plate. The plastic base plates on the Hitachi, Makita, and Bosch also protect the surface from getting scratched. But before you can attach them, you need to remove the metal base on each saw.

with a base that doesn't tilt.

Kurt: What I like about the tilting base on the DeWalt is it has a built-in lever that only takes a few seconds to adjust. All the other saws require a separate wrench.

Q Is dust a problem with these sabre saws?

Chris: Not at all. Each one has a blower that directs air at the layout line. (See photos at left.) So I'm not constantly puffing the dust away when making a cut. Also, two of the saws have a port to hook up a shop vacuum. The only drawback is having to drag the hose across the workpiece. 



To prevent chipout, all the sabre saws except the Porter Cable have a plastic insert that fits in the base.



▲ Dust Control. A blower in each saw directs dust away from the blade so you can see the layout line as you make a cut (left). In addition, the Bosch (right) and Milwaukee each have a port for hooking up a shop vacuum.

Recommendations

Chris: Picking one sabre saw out of the bunch is easy for me. I'd choose the DeWalt.

It's one of the least expensive saws. But I get more for my money — plenty of power, speed control built into the trigger switch, and a quick blade change system. All in all, it's a pretty tough saw to beat.

Bryan: It's hard to choose between the DeWalt and the Bosch. I like the speed control in the DeWalt. But I can get the same thing in the top handle model of the Bosch.

In addition, I like the blade change system better on the Bosch. And it's the smoothest running saw of the bunch. So I'd buy the Bosch top handle saw.

Kurt: I picked the Milwaukee for one basic reason. All through the test, it stood out as a solid, strong running saw.

It has all the power I need. And its quick blade change system puts it a step above the rest.

Since I like a top handle saw, I'd get that model instead of the barrel grip saw that we tested.

Miter Trimmer

This shop-made miter trimmer and a block plane make it easy to refine a miter joint for a perfect fit.

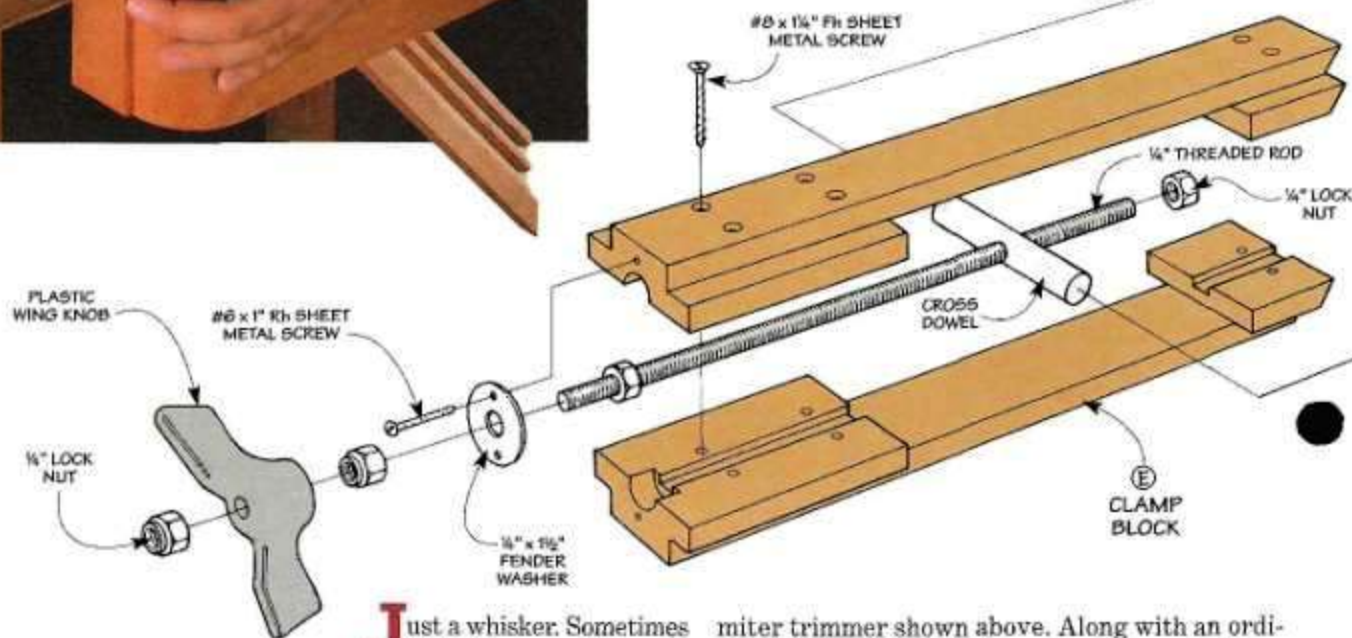

Just a whisker. Sometimes that's the only difference between a nice, tight-fitting miter joint and one that has a slight gap where the mitered ends meet.

Sure, you can readjust the angle of the miter gauge on the table saw and trim the ends again. But the angle may be "off" by such a small amount that even a tiny adjustment is often too much. As a result, you end up with a miter joint that still doesn't fit tight.

To avoid all this fussing around, I built the

miter trimmer shown above. Along with an ordinary block plane, this jig makes it easy to "true up" the mitered end of a workpiece and produce a perfect fitting joint.

HOW IT WORKS. The way this works is simple. The miter trimmer is tightened in a vise. (Or, you can clamp it to a bench, refer to back cover.)

Either way, you slip the workpiece into an adjustable throat opening inside the miter trimmer. By adjusting a simple built-in clamp, this throat opening will accept pieces up to 3½" wide, see photo at left.

As you tighten the clamp, the workpiece is pressed against an angled bed, see photo A on next page. This bed orients the workpiece at a 45° angle to a "track" that runs along the top edge of the miter trimmer.

By sliding the block plane in this track and across the end of the workpiece, you can slice off a paper thin shaving, see photo B. To create a perfect fitting miter joint, all you need to do is repeat this process for the mating piece.

Turning a large knob on the end of a built-in clamp lets you adjust the throat opening for workpieces of different widths.



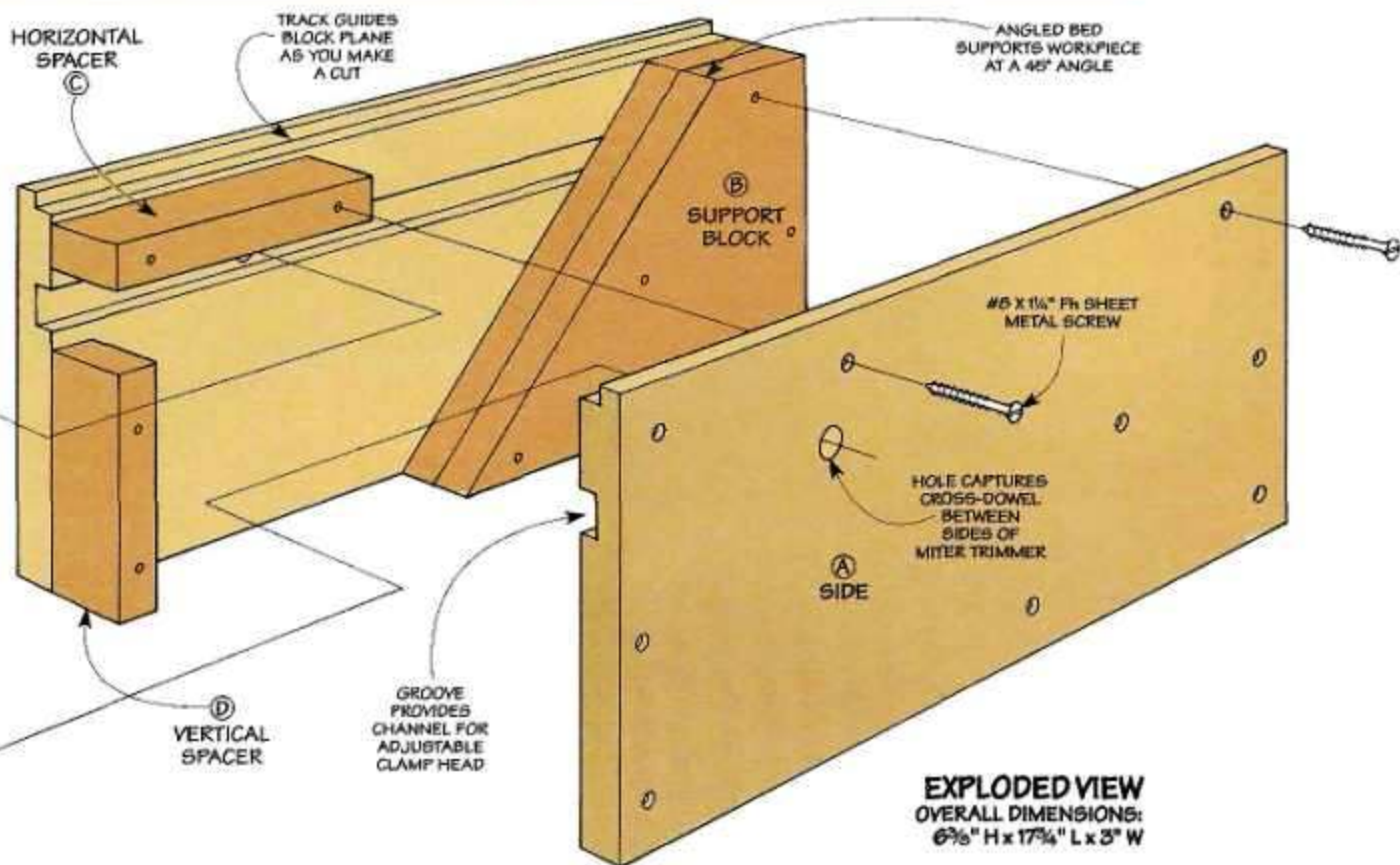

A. Position Workpiece. With the mitered end of the workpiece flush with a track in the top edge, a clamp head presses it against an angled bed.



B. True Up End. After adjusting the blade in a block plane for a very light cut, slide it along the track and across the workpiece to true up the end.

Materials

Body

| | |
|-------------------------|--|
| A Sides (2) | 6 ³ / ₈ x 16 ¹ / ₂ |
| B Support Blocks (2) | 6 ¹ / ₈ x 10 (rgh.) |
| C Horizontal Spacer (1) | 1 ¹ / ₂ x 5 ¹ / ₂ |
| D Vertical Spacer (1) | 1 ¹ / ₂ x 3 ³ / ₄ |

Clamp Head

| | |
|--------------------|--|
| E Clamp Blocks (2) | 2 ¹ / ₄ x 12 ¹ / ₂ |
|--------------------|--|

Note: All parts of the Miter Trimmer are made from 3/4"-thick Medium-Density Fiberboard (MDF).

Hardware

- (24) #8 x 1¹/₄" Fh Sheet Metal Screws
- (1) 1/2" x 3" Cross-Dowel*
- (1) 1/4"-20 x 11¹/₄" Threaded Rod
- (4) 1/4" Nylon Lock Nuts
- (2) #6 x 1" Rh Sheet Metal Screws
- (1) 1/4" x 1¹/₂" Fender Washer
- (1) 1/4" Plastic Wing Knob

*Cross-dowel is cut from round metal bar stock, then drilled and tapped for threaded rod, refer to page 20.

Body

I began work by building the body of the miter trimmer. Basically, the body is a narrow box with an angled platform inside that supports the workpiece at a 45° angle, see drawing.

In addition, the body houses a clamping system that holds the workpiece in place. And it provides a track for the block plane as you make a cut.

SIDES

The body starts out as two identical side pieces. They provide a flat, rigid clamping surface when you secure the miter trimmer in a bench vise.

The *sides* (A) are quite simple — just two pieces of $\frac{3}{4}$ " Medium-Density Fiberboard (MDF), see Fig. 1.

CUT GROOVES. With the sides in hand, the next step is to cut a groove in each one, see detail in Fig. 1. These grooves form a channel for an adjustable clamp head that's added later, refer to Exploded View on page 17.

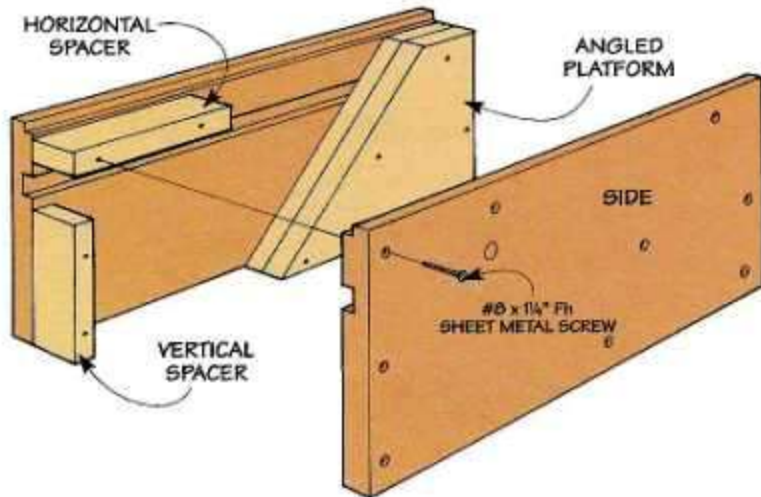

CUT RABBETS. In addition to the grooves, there's also a rabbet cut in the top edge of each side. When the body is assembled, these rabbets create a track that helps guide the block plane across the top edge of the miter trimmer.

DRILL HOLES. There's just one thing left to do to complete the sides. That's to drill a hole in each one to accept a steel cross-dowel that's part of the clamping

system, refer to the margin photo on page 20.

To ensure that this system operates smoothly, it's important that these two holes line up. So I used a simple "key" to keep the sides aligned and drilled both holes at the same time, see Fig. 2. The key is nothing more than a scrap of MDF that's cut to fit the grooves in the sides.

As an added benefit, the key

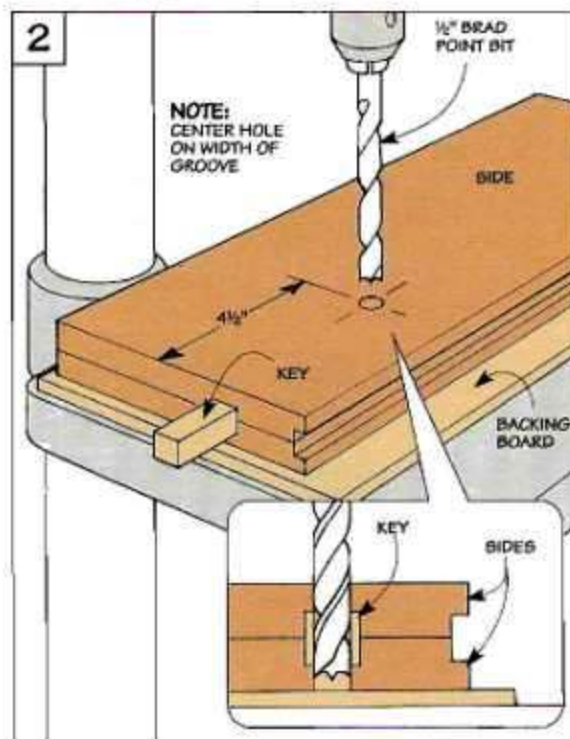
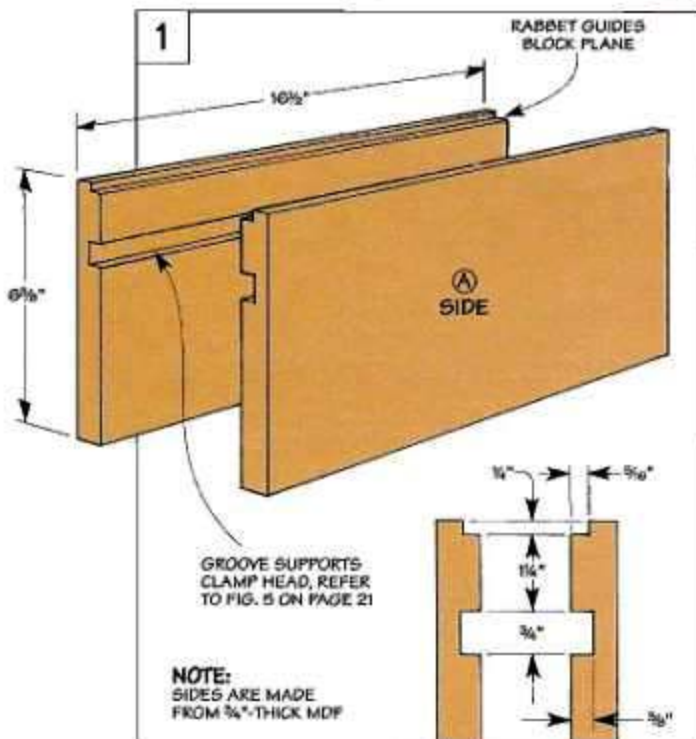

backs up the *inside* of the top piece so it won't chip out as the tip of the bit breaks through. A backing board on the drill press table prevents tearout on the *outside* of the bottom piece.

ANGLED PLATFORM

Once the sides are complete, you can concentrate on the angled platform. It establishes a "bed" that orients the workpiece at a 45° angle. And it supports the back edge of the workpiece so it doesn't chip out as you make a cut.

SUPPORT BLOCKS. The angled platform consists of two support blocks (B), see Fig. 3. These are pieces of 3/4" MDF that are glued together to form a thick blank and then mitered to length. Note: To avoid having to miter a short piece on the table saw, I glued up an extra-long blank.



▲ The accuracy of the miter trimmer is "built in" by carefully positioning the angled platform. Using a combination square, set it at a 45° angle to the track for the block plane. Then glue and screw it to one side only.

Before you cut the miter though, there's one thing to keep in mind. The accuracy of the miter trimmer depends on the fact that the angled edge of the platform is at a perfect 45° angle

to the track for the block plane. An easy way to "build in" this accuracy is to use a simple two-step process.

First, make sure you check that the 45° setting for the miter gauge on your table saw is accurate, refer to page 29. Then, once you've mitered the platform to length, carefully position it on the side before gluing and screwing it in place, see photo above. Note: The second side will be attached later.

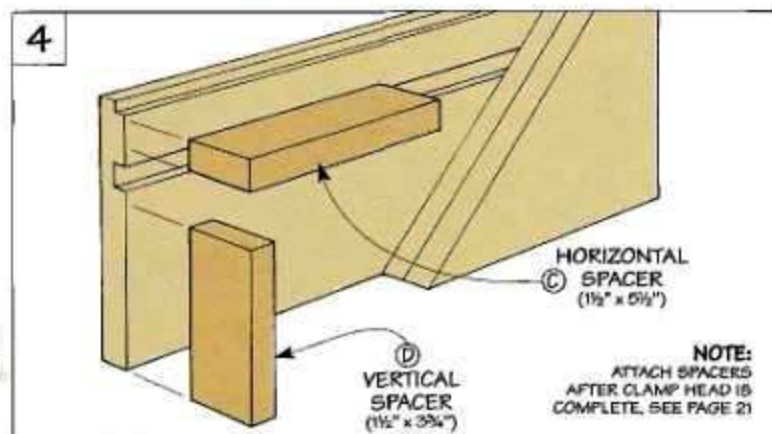
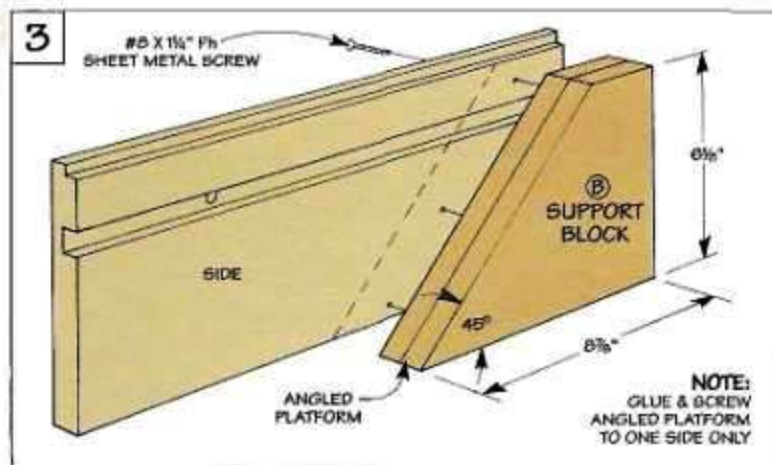

SPACER BLOCKS

All that's left to complete the body is to add two spacer blocks, see Fig. 4. They add rigidity to the end of the miter trimmer that's opposite the angled platform. But they serve another purpose too.

When you assemble the miter trimmer, the spacer blocks and angled platform will hold the sides apart. This is what creates the throat opening inside the body of the miter trimmer.

The *horizontal (C)* and *vertical spacers (D)* are pieces of 3/4" MDF that are ripped to the same width as the thickness of the angled platform (1 1/2"). Note: To make it easy to assemble the clamping system, the spacer blocks aren't attached until later.

Clamping System

The heart of the miter trimmer is a clamping system that holds a workpiece tightly in place as you trim the end. This system has two parts: a sliding clamp head, and an adjustment mechanism that applies the clamping pressure.

CLAMP HEAD

The clamp head is a long, narrow block that pinches the workpiece against the angled platform, refer to Fig. 5 on next page.

CLAMP BLOCKS. It's made up of two clamp blocks (E) that fit around the parts of the adjustment mechanism like a shell. Each clamp block starts out as an extra-long blank of $\frac{3}{4}$ " MDF that's ripped to final width, see Step 1.

WIDE NOTCH. With the blanks in hand, the first thing to do is cut a wide notch in each one. When the clamp head is assembled, these notches will form an opening that allows the clamp head to slide back and forth without hitting the cross-dowel that's part of the adjustment mechanism, see detail above.

GROOVE. After trimming the blanks to final length, a centered groove is cut in each workpiece,

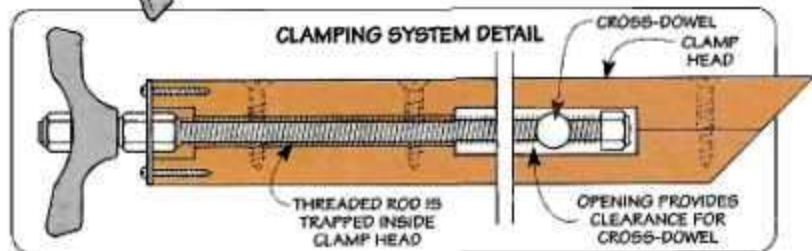
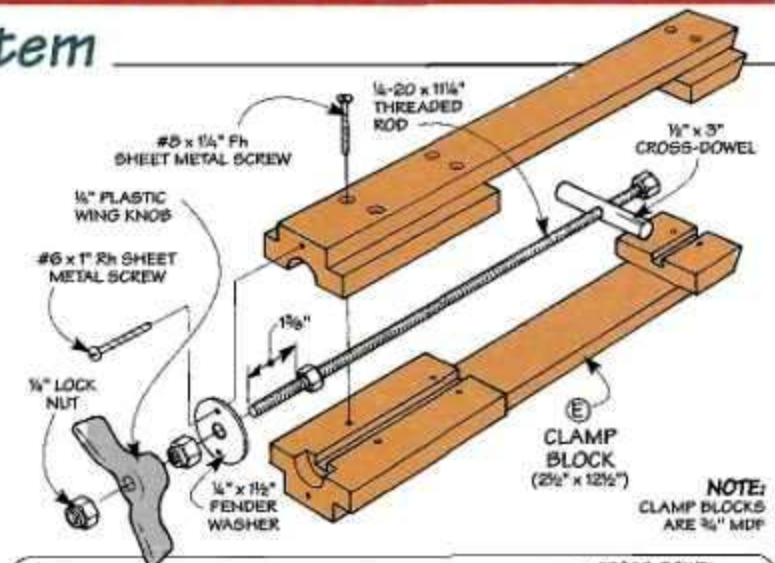

see Step 2. These grooves will create a recess for a threaded rod (added later).

At this point, you can temporarily screw the clamp blocks together. Don't apply glue just yet. You'll have to take the clamp head apart again to install the adjustment mechanism.

TONGUES. So why go to the trouble of assembling the clamp head now? The reason has to do with a tongue on each side of the clamp head that guides it in and out of the miter trimmer. To get the clamp head to slide smoothly without any "play," the tongues need to fit the grooves in the

Making the Clamp Blocks

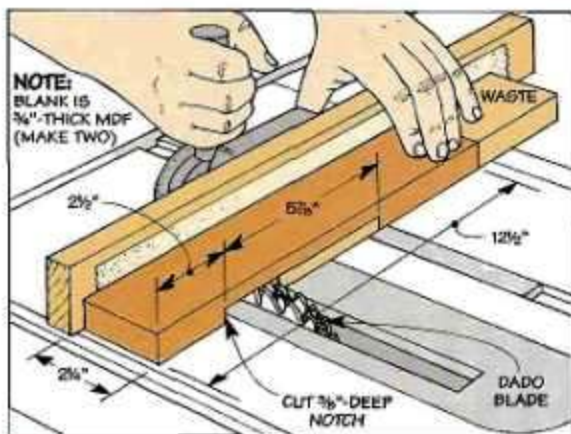

1 To create an opening that will allow the clamp head to travel back and forth without hitting the steel cross-dowel, cut a wide notch in each blank.

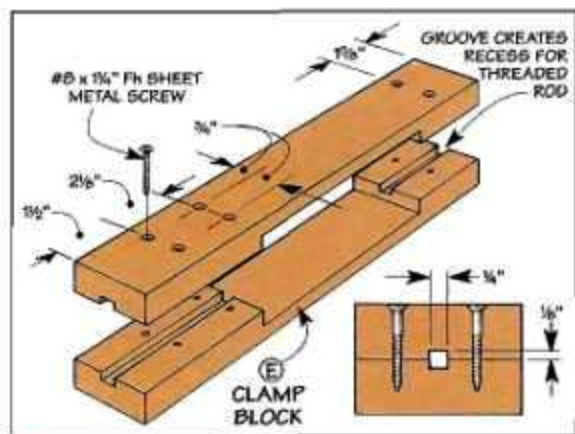

2 A centered groove in each block provides a recess for a threaded rod. After cutting the grooves, screw the two clamp blocks together.



It's easy to make the cross-dowel. After cutting a short length of steel rod, drill a $\frac{13}{64}$ "-dia. hole and cut the threads with a $\frac{1}{2}$ -20 tap.

sides (A) just right — not too tight and not too loose.

An easy way to do this is to assemble the clamp head, then rabbet all four edges to form the tongues, see Step 3. The idea here is to first cut the rabbets so the tongues are slightly oversize. Then “sneak up” on a perfect fit.

POCKET Next, to form a pocket for a lock nut, a counter-bored hole is drilled in the “adjustment” end of the clamp head, see Step 4.

MITER END. The opposite end of the clamp head is the one that makes contact with the workpiece. Since the workpiece is held at a 45° angle, you need to miter this end at the same angle so the clamp head exerts even pressure.

ADJUSTMENT MECHANISM

The clamping pressure is produced by the adjustment mechanism that’s housed inside the clamp head.

CROSS-DOWEL. The key to this mechanism is a steel cross-dowel that’s captured between the sides of the miter trimmer, see margin on opposite page. It’s just a short length of 1/2"-dia. steel rod that’s drilled and tapped to

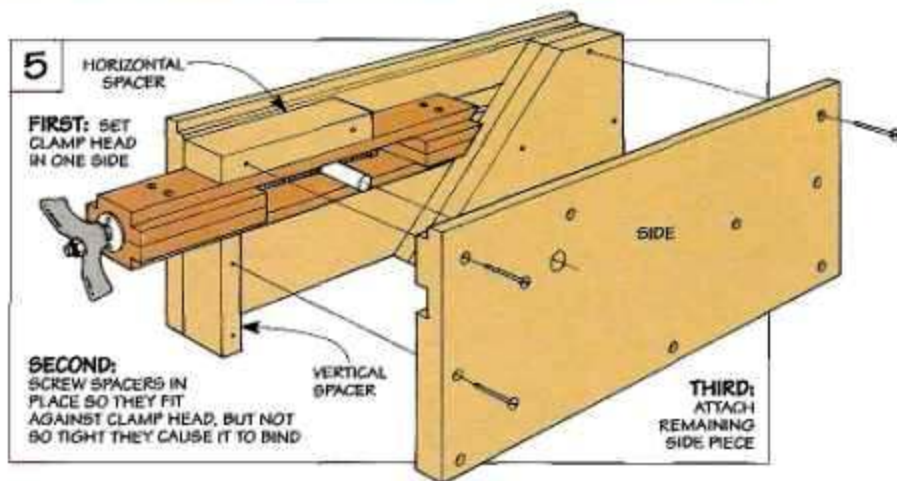

accept a threaded rod.

The important thing about the threaded rod is it’s *trapped* inside the clamp head. This means that as you thread the rod in and out of the cross-dowel, the clamp head also travels back and forth.

ASSEMBLY. To assemble the adjustment mechanism, start by threading the rod through the cross-dowel, see drawing on page 20. Adding a lock nut to one end keeps the rod from threading out of the cross-dowel. And a lock nut near the opposite end pushes against a fender washer so you can “back out” the clamp head.

This washer has two holes drilled in it which will let you

attach it to the clamp head. But first, you’ll need to take the clamp head apart. After separating the two halves, slip in the adjustment mechanism, then glue and screw the clamp head together.

Now it’s just a matter of screwing the washer in place and adding a plastic knob to operate the clamp head. Tightening two lock nuts against the knob keeps it from loosening up.

INSTALL CLAMP HEAD. All that’s left is to install the clamp head. After setting it in one side, the two spacers (D) cut earlier are screwed to one side, see Fig. 5. Then the remaining side is simply glued and screwed in place.

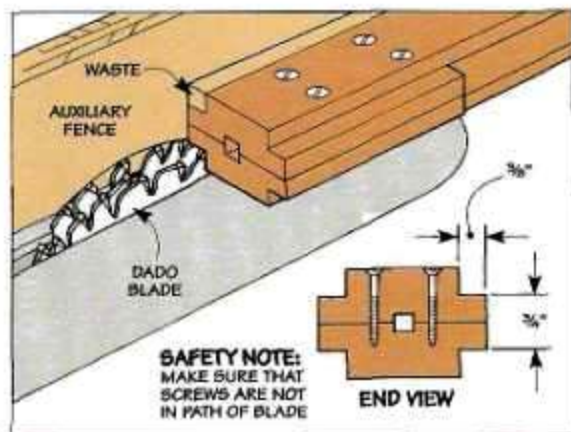

3 Cutting a rabbet on all four edges of the clamp head forms a tongue on each side that will guide it in and out of the miter trimmer.

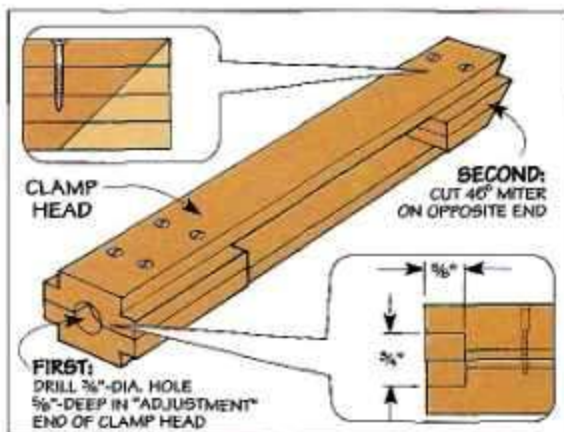

4 To make a pocket for a lock nut, drill a counter-bored hole in the “adjustment” end of the clamp head. Then cut the opposite end at a 45° angle.



Desktop Picture Frames

A simple design makes these desktop picture frames easy to build. And the molded profiles and contrasting wood make them good-looking, too.

**Accent Strip
Molding**



**Fluted Frame
Molding**



Whenver I think about making a picture frame, two things come to mind. First, it should be quick and easy to build. Second, the picture frame should look good too.

These desktop picture frames satisfy both requirements. In fact, you can probably take a photograph, get it developed, and knock out a frame for it — all in the same weekend.

And what you end up with isn't just an ordinary picture frame. A simple, yet attractive design makes these frames as special as the photos inside.

BUILT-UP MOLDINGS. One of the things that sets them apart is the “built-up” moldings that are used to make the frame pieces. We made two different moldings — one for an Accent Strip Frame (see page 23), and the other for a Fluted Frame (see page 24). These frame moldings are made by gluing up individual strips of wood, see photos at left.

CONTRAST. One advantage to making your own frame moldings is it allows you to

use different types of wood to produce a nice contrast. Here we used maple and cherry. But if your scrap bin is getting full, it's a good opportunity to experiment with other types of wood as well.

PROFILES. Using built-up moldings also allows you to create a profile that appears quite complicated with a set of ordinary router bits. (We used a straight bit, a roundover, and a core box bit.) You simply rout a profile on one strip of wood, then combine it with another to form the final profile.

FRAME SUPPORT. There's one last thing that any frame that's meant to sit on a desk or table should have — a support to prop it up. Instead of using a cardboard back with a hinged flap, I fit a simple wood spline in a groove in the back of the frame, see photo below.



Accent Strip Frame

At first glance, it's the two accent strips on this picture frame that catch your eye, see photo. But it's a subtle thing that gives this frame its contemporary look — to make the frame *appear* thinner than it is, the back edge is beveled at a slight angle.

ACCENT STRIPS. The outer part of the frame is highlighted by a thin strip of cherry sandwiched between two strips of maple. And a wide strip of cherry runs around the inside edge of the frame.

FRAME MOLDINGS. To make a frame for a 5" x 7" photograph, you'll need about four linear feet of frame molding. An 8" x 10" photo will require six feet. Once you make the frame molding (See Steps 1 through 3 below), simply miter the frame pieces to length and glue up the frame, refer to page 25.

GROOVE & BEVEL. There are just two things left to do to complete the frame. First, rout a groove for the frame support, see Step 4. And second, cut the bevel on the back edge of the frame, see Step 5.

CROSS SECTION

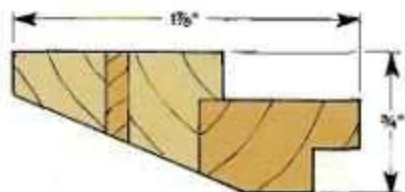

TWO ACCENT STRIPS AND A BEVELED BACK GIVE THE FRAME A CONTEMPORARY LOOK.

Step by Step

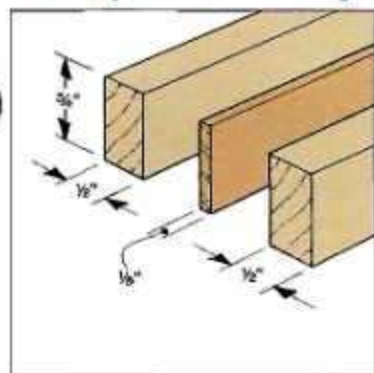

1 Start by gluing a thin accent strip (cherry) between two pieces of contrasting wood (maple.)

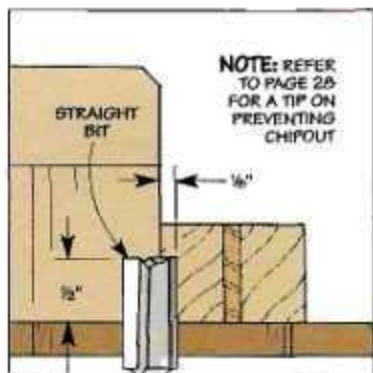

2 Routing a rabbet in one edge creates a lip for the wide accent strip that's added next.

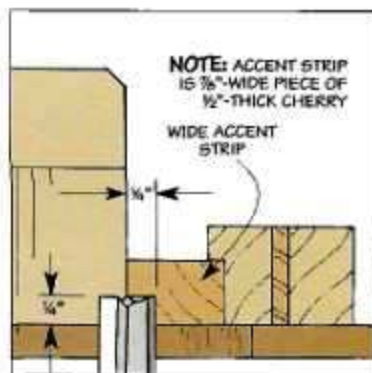

3 With both workpieces glued together, rout a recess for the glass and the backing board.

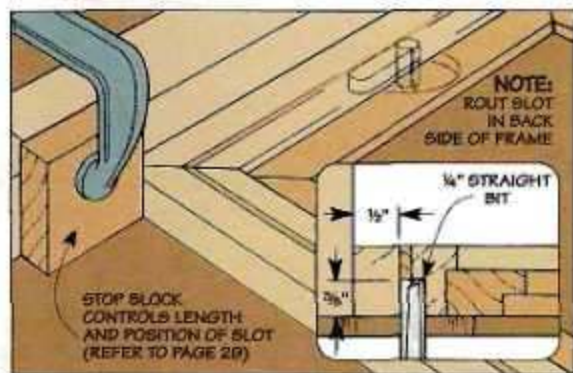

4 After mitering the frame pieces to length and gluing up the frame, a stopped groove for a wood support is routed in the back, see page 29.

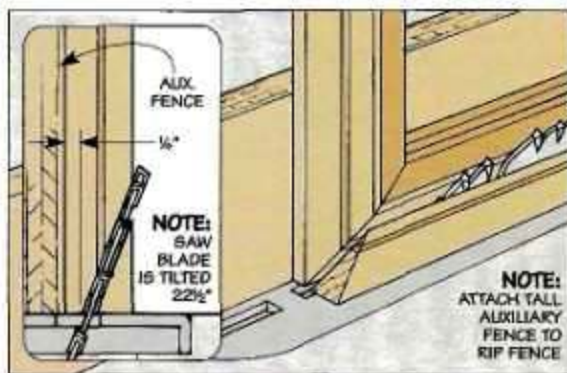

5 Finally, with a tall auxiliary fence clamped to the rip fence on your table saw, tilt the blade and bevel the back edges of the picture frame.

CROSS SECTION

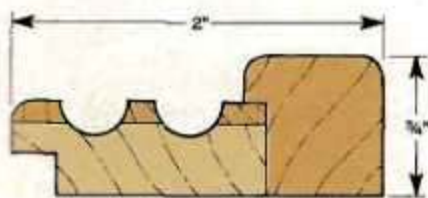

FLUTED PROFILE CREATES CONTRAST BY REVEALING LIGHT-COLORED WOOD UNDERNEATH

Fluted Picture Frame

It's not so much the fluted profiles that make this such an attractive looking picture frame. It's the dramatic contrast that occurs when the two curved flutes are "scooped out."

LAYER CAKE. To produce this contrast, the inner part of the frame molding is glued up like a layer cake. There's a thick piece of light-colored wood (I used maple) on the bottom, and a thin strip of a darker-colored wood (cherry) on top, see the Cross Section in drawing at left.

When you rout the flutes, the maple is revealed at the bottom of the "furrows." The cherry highlights the raised areas that remain, and it creates a soft shadow line along the curved sides of the flutes.

FRAME MOLDING. Although this creates a profile that looks quite complicated, the molding for this picture frame is simple to make, see Step by Step drawings below. Note: You'll need the same amount of frame molding as with the Accent Picture Frame.

Step by Step

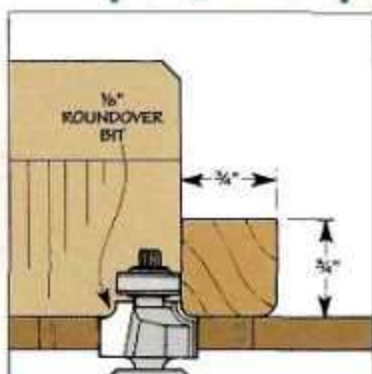

1 Start by rounding over two of the edges on the outer strip (cherry) of the frame molding.

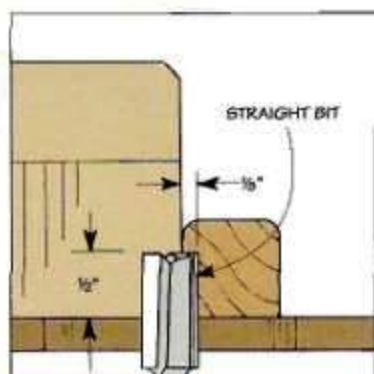

2 Routing a shallow rabbet in one edge creates a recess for the inner part of the frame molding.

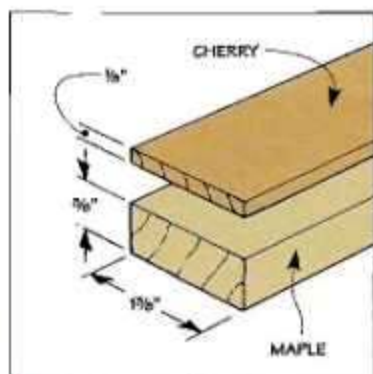

3 The inner part of the molding is formed by gluing a thin strip (cherry) to a thicker piece (maple).

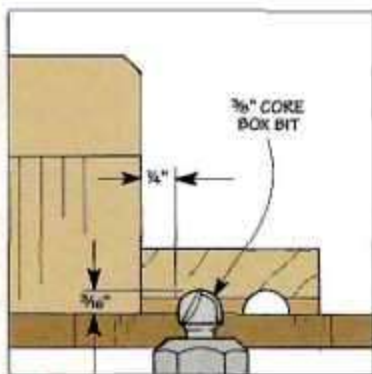

4 Now rout the two flutes using a core box bit and flipping the workpiece between each pass.



5 Rounding over one of the top corners will soften the edge around the inside of the frame.

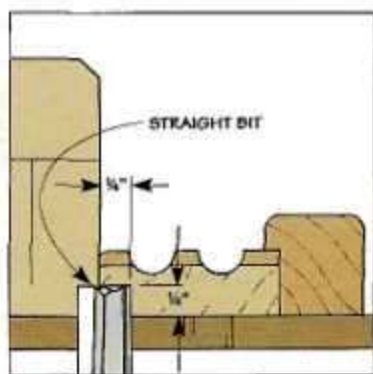

6 With both parts of the molding glued together, rout a rabbet for the glass and backing board.

Making the Frames

Once the frame molding is completed, you're halfway done. Now you're ready to make the picture frame.

LENGTH. The first step is to establish the length of the individual frame pieces. It's not the *outside* length of each piece that matters here. It's the length of the *inside* edge of the rabbet that holds the glass, picture, and backing board, see drawing.

This may sound like you're working backwards. But it makes sense. When the pieces of the frame are assembled, the picture has to fit between the rabbets.

So to make it easy to slip the picture in place, the goal is to miter each frame piece to length so the *inside* edge of the rabbet is $\frac{1}{16}$ " longer than the length (or width) of the picture.

To do this, first miter each

piece to rough length, see Fig. 1. Then, after measuring the picture (don't forget to add $\frac{1}{16}$ "), transfer this measurement to the frame piece and miter it to final length.

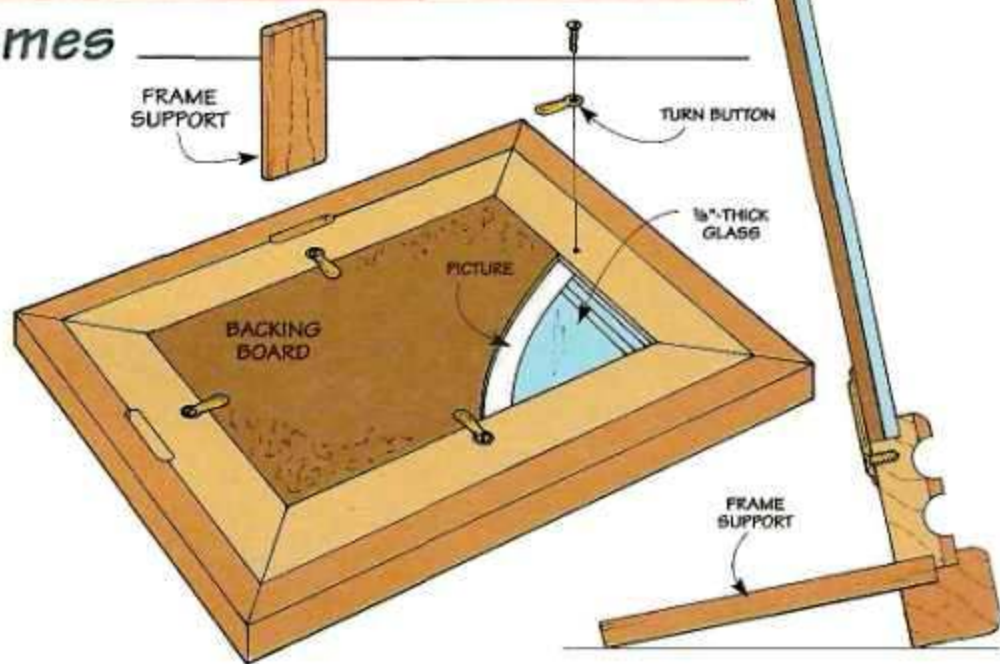
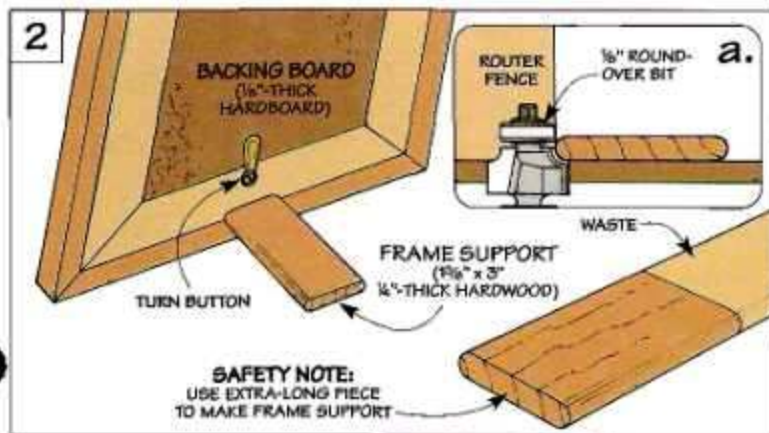
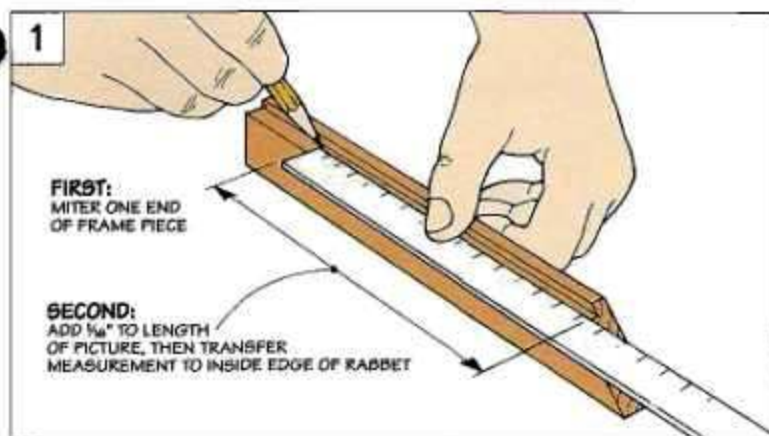

Shop Tip: To get a tight-fitting joint, the two frame pieces that are opposite each other need to be identical in length. So I clamp a stop block to an auxiliary fence on the miter gauge when cutting the frame pieces.

TEST FIT. At this point, you'll want to dry assemble the frame and check the fit of the miter joints. If there's even a slight gap, it's an excellent place to use the Miter Trimmer shown on page 16 to "true up" the mitered ends.

ASSEMBLY. Once you're satisfied with the fit, it's just a matter of gluing up the frame. A clamping jig like the one shown on page 6 makes quick work of this.

FRAME SUPPORT. When the glue dries, you can add the frame support, see Fig. 2. It's a short piece of hardwood that fits in a groove in the back of the frame. Rounding over the edges of the frame support allows it to fit the curved ends of the groove, see Fig. 2a. (For more on routing the groove, refer to page 29.)

FINAL DETAILS. All that's left is to cut a piece of glass to fit the frame, then add the picture. They're held in place with an $\frac{1}{8}$ "-thick hardboard backing board and four turn buttons.

Strengthening Miter Joints

A miter joint provides plenty of strength on a small project like a picture frame. But for large wood frames, it's a good idea to reinforce the miter joint. Here's how.

Wood Plug

■ One of the simplest ways to reinforce a miter joint is with a wood plug. It produces a strong joint because the face grain of the plug is glued to the face grain of the frame (not end grain to end grain like a typical miter joint).

The wood plug is added to the back of the frame after the miter joint is glued up. Start by drilling a hole that bridges the joint line, see drawing. (I usually drill halfway through the thickness of the frame.)

PLUGS. Once the holes are drilled, simply cut a plug from the

same material as the frame, see detail. Then glue the plug in place so the grain runs across the joint line, see photo. After the glue dries, it's just a matter of sanding the plug smooth.

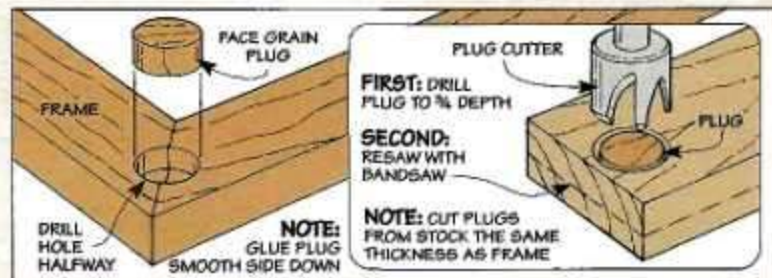

Open Spline

■ Another way to strengthen a miter joint is to use an open spline. This is just a thin piece of wood that's glued into a saw kerf in the mitered corner of the frame. What I like about an open spline is you can use different types of wood to create a nice contrast, see photo.

JIG. To cut the kerf for the spline, I use a simple jig that straddles the rip fence on the table saw, see drawing. Screwing two supports to the face of the jig at a 45° angle forms a "cradle" that holds the glued-up frame securely in place.

All you need to do to cut the kerf is set the frame in place and make a pass across the saw blade. (I use a rip blade to cut a flat-bottomed kerf.)

ASSEMBLY. Once the kerf is cut, you can glue in the spline. After gluing and clamping the joint (see detail), remove the excess material with a handsaw and sand the spline flush.

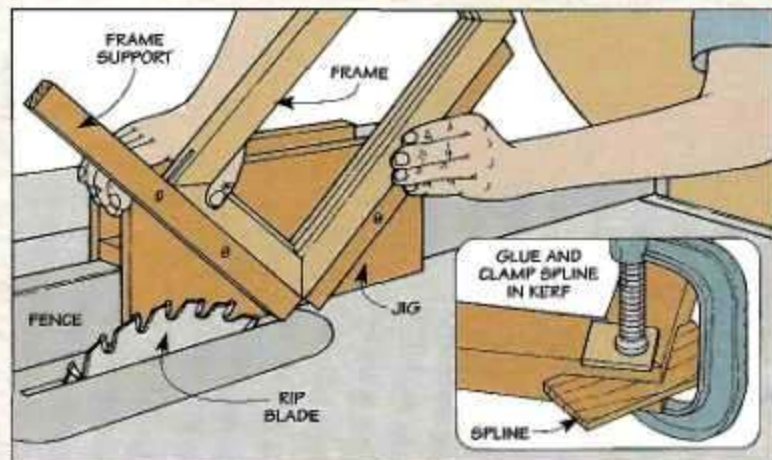

Biscuit

■ A football-shaped "biscuit" can also be used to strengthen a miter joint. Here again, the biscuit provides a large glue surface that gives the joint its strength. But this time, the biscuit is *hidden* inside a slot that's cut in the mitered ends of each workpiece.

Although you can cut this slot with a plate joiner and then glue in a special biscuit, there's another way to accomplish the same thing. Just use a slot cutter in a table-mounted router and make your own biscuit.

GUIDE. An easy way to do this is to use a *square* scrap of plywood as a guide. The idea is to use two adjoining edges of the guide to direct the mitered workpieces into the bit, see drawing and detail 'a.' Note: Clamping two scraps to the router table keeps the pieces from kicking to the side.

To center each slot on the end of the workpiece, position the guide so a line drawn between two opposite corners passes through the center of the bit, see drawing. The distance from the corner to



the bit equals *half* the length of the angled end of the miter.

BISCUITS. All that's left is to make the biscuits. To do this, draw a series of overlapping circles that match the diameter of the slot cutter, see detail 'b.' Then cut the biscuits to size. 

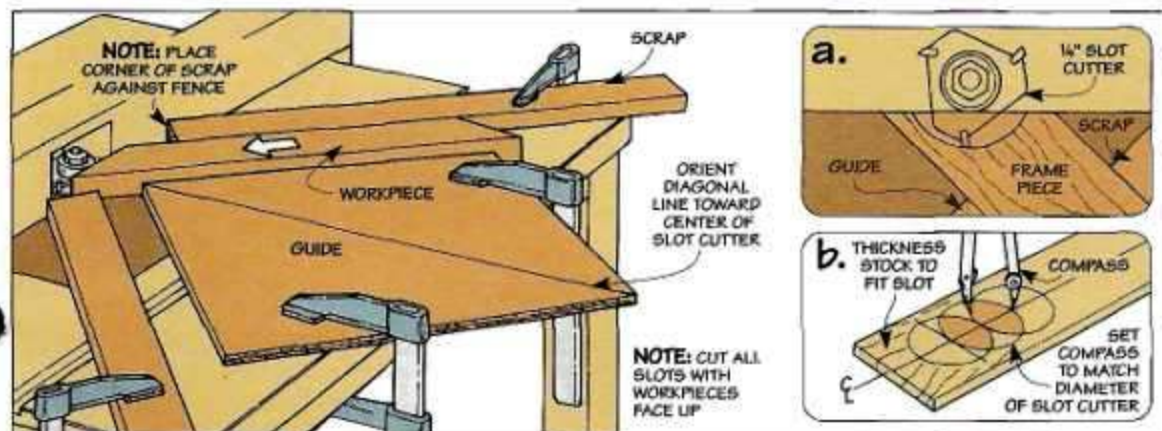

Mechanical Fasteners

Wood splines and plugs aren't the only way to strengthen a miter joint. There are also a number of different mechanical fasteners available that you can use to reinforce a miter joint, see photos below.

Installing these fasteners is easy. With the mitered pieces glued together, just use a hammer to tap the fas-

teners into the back of the miter joint. (As a rule, use at least two fasteners on each corner.)

The only drawback to these fasteners is they tend to crumple if you drive them into hardwood which can cause the wood (or the joint) to split. So it's best to use them only for softwood. For sources of fasteners, see page 31.



Corrugated Nails. The ridges on these corrugated nails hold the mitered corner of the frame tightly together.



Chevrons. Once these chevrons are tapped in place, the spring steel wings help strengthen the mitered corner.



Tack Plates. The sharp, angled claws on the bottom of these metal tack plates help reinforce the miter joint.

CUTTING A GROOVE IN A ROUND CORNER

■ Cutting a simple groove is one of the most basic tasks in woodworking — unless the groove is in a *round* corner that wraps around the edge of a workpiece.

But that's exactly what you need to do when working on the Picture Frame Clamping Jig on page 6. There's a shallow groove running around the perimeter of the blank that's used to make the corner blocks. And the corners of the blank are cut in a gentle curve.

A dado blade makes quick work of cutting this groove. But to make the cut safely, I attached two auxiliary supports to the table saw, see drawing above.

SUPPORTS. First, a tall fence is clamped to the rip fence to sup-

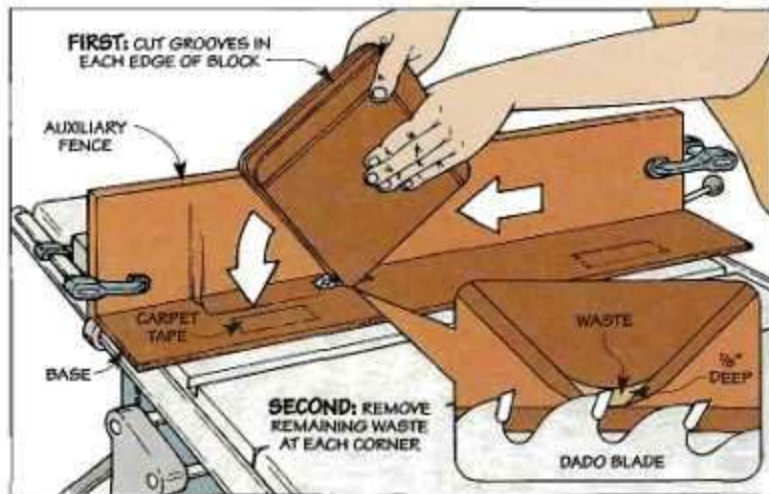

port the side of the blank. After positioning the fence, a piece of $\frac{1}{4}$ " hardboard is carpet-taped to the saw table. Raising the blade through the hardboard creates a "zero-clearance" base that keeps the blank from falling into the opening between the blade and the insert.

CUT GROOVE. Now you're ready to cut the groove. After

cutting the grooves in the straight edges, there will still be a small amount of waste at each corner, see detail.

To remove this waste, set the blank on a corner and slide it forward until it's roughly centered on the saw blade. Then rotate the blank all the way forward and back to clean up the corner.

"BACKROUTING" TO PREVENT CHIPOUT

■ It's one of the fundamental rules of routing — rout from *right to left* when working on the router table. This way, the workpiece is fed *into* the cutting edge of the bit. As a result, the bit won't grab the workpiece and

pull it away from you.

BACKROUT. But there are times when I make an exception to the rule and "backrout" from *left to right*. One of those times is when routing the rabbets for the moldings on the picture frames

shown on page 22.

CHIPOUT. The problem is if you rout in the normal (right to left) direction, the wood fibers can chip out on the edge of the rabbet. And this will be quite noticeable when you assemble the frames.

That's when backrouting comes in handy. To produce a clean, crisp edge, start by adjusting the bit to make a full-depth cut. Then, after setting the fence to produce a narrow ($\frac{1}{16}$ "-wide) rabbet, make a light scoring pass from left to right, see detail 'a.'

Note: To provide a secure grip and maintain control of the workpiece, I use a grout trowel to push the workpiece past the bit.

FINAL PASS. After completing the first pass, adjust the router fence so the bit will cut the entire width of the rabbet, see detail 'b.' Then make a final pass from right to left, see drawing.

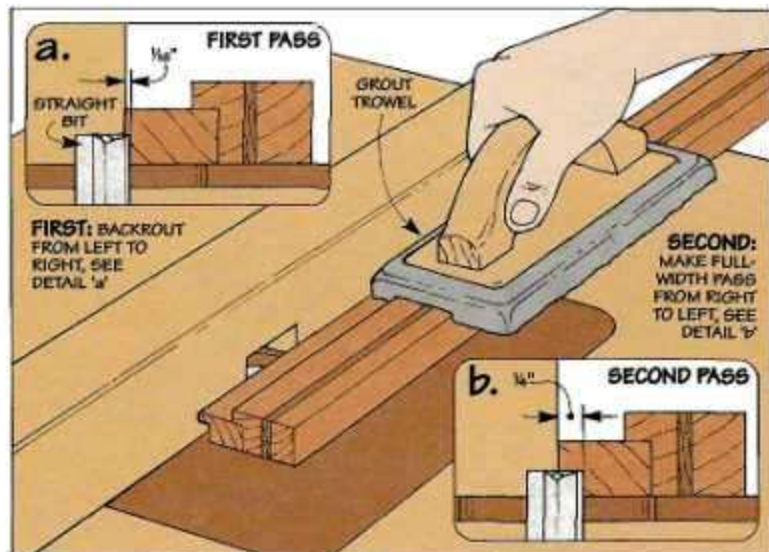

ADJUSTING A MITER GAUGE FOR 45° CUTS

There are a number of ways to adjust a miter gauge to make a perfect 45° cut. And most of them involve making a test cut.

The problem is you can use up a lot of valuable scrap pieces before you get the miter gauge adjusted just right. So I use a simple technique that doesn't require as much material.

After using a combination square to set the miter gauge (detail 'a'), the idea is to stack two pieces together and trim the ends, see drawing. Note: Both test pieces must be squared up.

When you fit the pieces together, they should form a perfect 90° angle, see detail 'b.' If not, simply readjust the miter gauge and trim the ends again. Even if you have to repeat the process several times, you still only use a small amount of material.

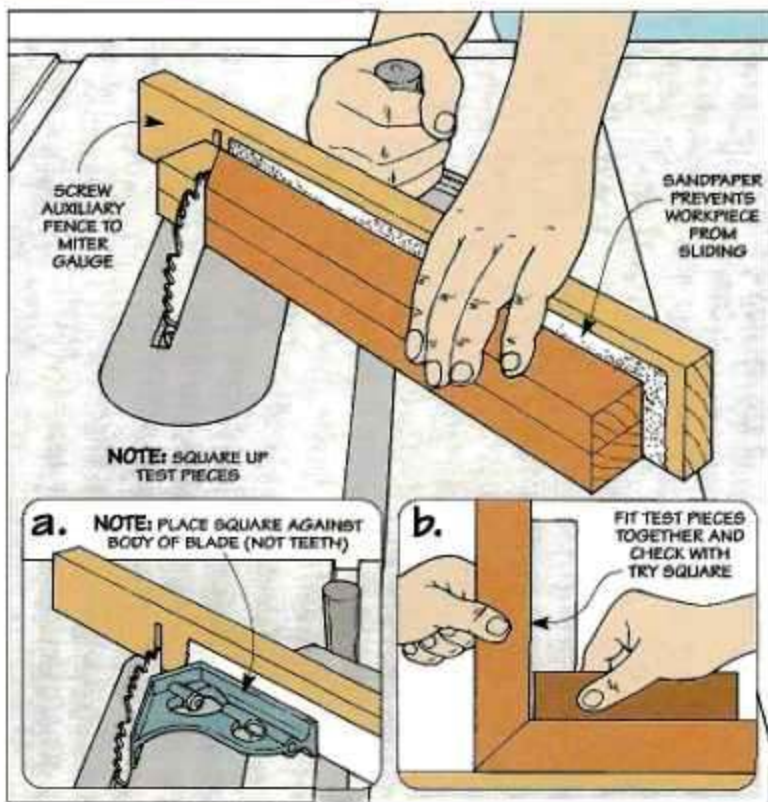

ROUTING A STOPPED GROOVE

The support that props up each Desktop Picture Frame on page 22 is quite simple — a wood spline that fits in a stopped groove in the back of the frame.

Routing this groove is easy. I used a 1/4" straight bit in a table-mounted router and made a plunge cut. The tricky part is establishing the starting and stopping points of the groove so it's not only the correct length, but centered on the frame as well.

STOP BLOCKS. This requires clamping two stop blocks to the router fence, see drawing. To determine how far apart to position these blocks, measure the width (or height) of the frame and add the desired length of the slot (1 1/4"). Then subtract 1/4" to account for the size of the bit.

Once you know this measurement, you can clamp the blocks in place. To end up with a centered groove, check that each block is exactly the same dis-

tance from the center of the bit.

ROUT GROOVE. Now all that's left is to rout the groove. With the frame against the fence and raised above the bit, set it

against the back stop block.

Then carefully lower the frame onto the spinning bit and slide it forward until it hits the opposite stop, see detail.

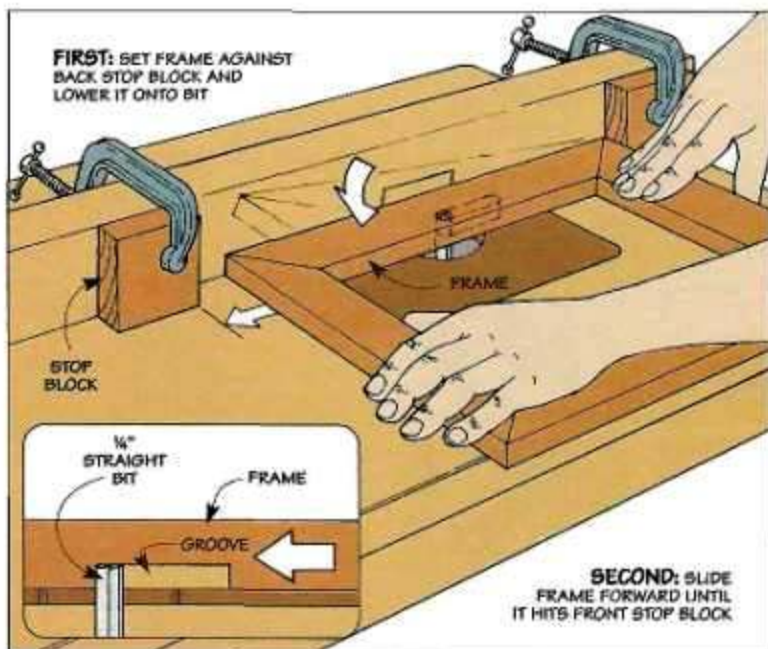

New Products

Mobile Base Kit

■ Mobile bases for stationary power tools have been around for years. But the idea behind this one is new.

Instead of a base that's designed to fit one particular tool, it's a *kit* that can be sized to fit any tool in your shop.

The size is determined by four hardwood rails that are used to connect a set of heavy-duty metal corner brackets, see photo. (You need to supply the wood.)

To roll a tool around, all you do is step on a foot-operated lever.



This raises the base onto two fixed casters and a single swivel caster. Releasing the lever lowers the base back on the floor.

(The Mobile Base Kit is made by Delta and costs about \$60.)

Pocket Hole Jig

■ After using this new Pocket Hole Jig, I know why it's called the *Rocket*. It makes drilling the angled holes for the screws that hold a pocket joint together incredibly fast and accurate.

The jig consists of two parts: a drilling guide and a quick-action clamp. With the drilling guide clamped to one workpiece, you use a special bit (included with the jig) to drill the angled holes, see photo A below. A collar on the bit controls the depth of the hole.

Another nice thing about this jig is there's no need to drill a

pilot hole in the adjoining workpiece. Simply use the clamp to hold the pieces together, then drive in the self-tapping screws, see photo B.

The screws create a strong, mechanical connection that's ideal for joining face frames, table legs and aprons, or the parts of a jig. (See page 31 for Sources.)

Scraping Plane Insert



■ You can't beat a hand-held scraper for smoothing the surface of a workpiece. But when working on a large area, it's hard to get a consistently *level* surface.

That's why I like this Scraping Plane Insert. By converting a standard bench plane into a scraping plane, it makes it easy to produce a flat, smooth surface.

The way it works is simple. You replace the blade and chipper

on the plane with an angled metal insert that holds a scraper.

With the insert held in place by the lever cap, you can still use the depth and lateral adjustment mechanisms on the plane to change the position of the scraper.

Turning a knurled knob on the insert lets you "fine tune" the cutting angle of the scraper to produce paper thin shavings. (For Sources, see page 31.)

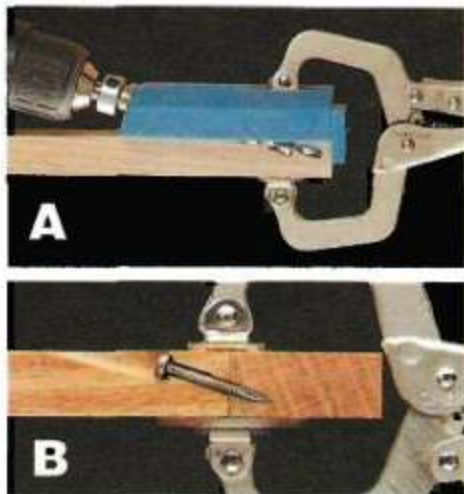

Sources

PRODUCT INFORMATION

ShopNotes Project Supplies provides you with information on the hardware and supplies you need to build the projects in this issue. We've also put together a list of mail order sources for the hardware and products shown at right.



▲ Miter Trimmer

Most of the hardware required to build the Miter Trimmer shown on page 16 is available at your local hardware store. To locate the large, plastic wing knob on the built-in clamp, refer to the mail order source listed in the margin.

Mechanical Fasteners for Miters ▶

If you're making a mitered frame out of softwood, these simple mechanical fasteners provide a quick way to reinforce the miter joints. The tack plates and corrugated nails are available at many hardware stores. And you can find the chevrons by calling the mail order source listed in the margin.

Tack Plate

Chevron

Corrugated Nail



◀ Veritas Scraping Plane Insert

The Veritas Scraping Plane Insert shown on page 30 allows you to convert a standard bench plane into a precision scraping and smoothing tool. All you need to do is replace the plane's blade and chipper with the insert. The Scraping Plane Insert costs about \$26. It's available directly through Lee Valley Tools by calling 800-871-8158.

Kreg Pocket Hole Jig ▶

The *Rocket Pocket Hole Jig* (page 30) is made by the Kreg Tool Company and sells for around \$55. It's available by calling the manufacturer at 800-447-8638 or through the mail order source listed in the margin.



MAIL ORDER SOURCES

Woodworker's Supply
800-645-9292
Chevrons

Reid Tool Supply Co.
800-253-0421
Plastic Knobs

Woodworkers' Store
800-279-4441
Pocket Hole Jig

Selected Guide to Our Best Projects & Issues

These jigs, tools, and accessories from past issues of *ShopNotes* are sure to come in handy as you build some of the projects shown in this issue.



▲ Band Clamp

This shop-made Band Clamp is ideal for applying pressure either on large or irregular-shaped projects.

ShopNotes Project Supplies is offering a hardware kit for the Band Clamp. Along with a 12-foot length of nylon band, it includes all the hardware you need to build one clamp. *ShopNotes* No. 17 is also included in this kit to provide complete step-by-step plans.

BAND CLAMP KIT
6817-300.....\$9.95



▲ Sabre Saw Table

Once you've decided on the best sabre saw to get for your shop (see the tool review that begins on page 12 of this issue), you can convert it into a benchtop power tool with this shop-made table.

We're offering a kit with all the hardware needed to build the Sabre Saw Table. Also, *ShopNotes* No. 23 is included to provide complete instructions on building the table.

SABRE SAW TABLE KIT
6823-200.....\$19.95



▲ Block Planes

The article on tuning up a block plane (page 8) features a Record No. 09½ block plane. But there are also a number of other types of block planes available.

In *ShopNotes* No. 32, we visit with four woodworkers about the block planes they use. If you'd like to find out what makes each block plane a favorite, this issue of *ShopNotes* is definitely worth a closer look.

SHOPNOTES NO. 32
SN32.....\$4.99

TO PLACE AN ORDER, PLEASE CALL
800-347-5105

Scenes from the Shop



▲ It's the details that count when you're making a picture frame for a special photograph — like getting the mitered corners to fit just right. By clamping this

Miter Trimmer to a worksurface (or tightening it in a vise, see page 16), you can use a simple block plane to "true up" the mitered ends of the frame pieces.



▲ To keep the miters perfectly aligned during glue-up, this Picture Frame Clamping Jig (page 6) uses a band clamp to apply pressure evenly across the frame.



▲ The reward for your effort is in the completed picture frames hanging on the wall. Or, make a support and stand them up on a desk, see page 22.