

TIPS • TOOLS • TECHNIQUES

ShopNotes®

Vol. 6

Issue 33

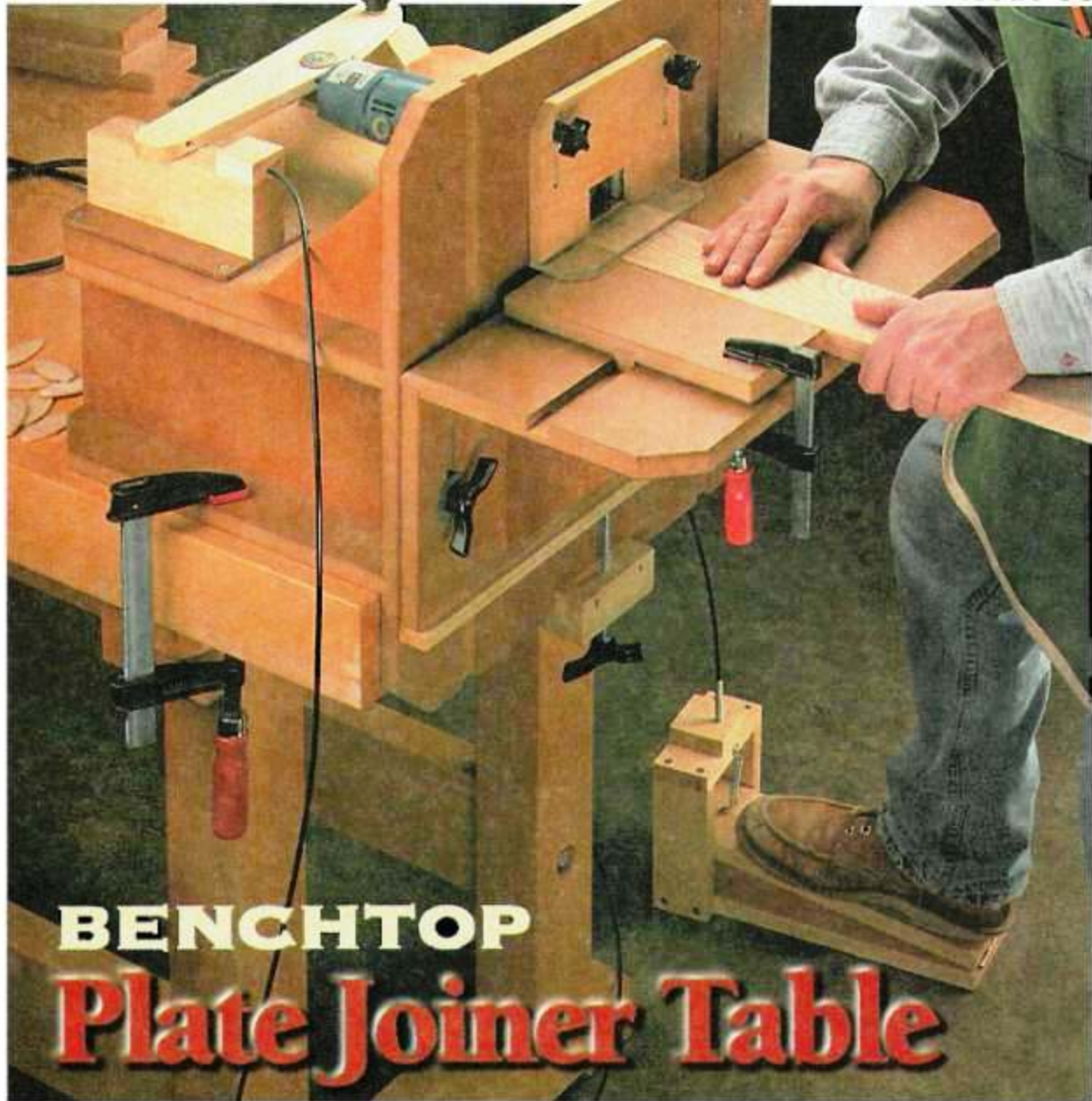

BENCHTOP

Plate Joiner Table

- Adjustable Taper Jig
- Folding Game Table
- Plate Joiners
- Tool Talk
- Shop-Tested Tips



ShopNotes

Issue 33

May 1997

PUBLISHER Donald B. Peschke
EDITOR Tim Robertson
ASSOCIATE EDITOR Phil Totten
ASSISTANT EDITOR Bryan Nelson
ART DIRECTOR Cary Christensen
SR. GRAPHIC DESIGNER Kurt Schultz
SENIOR ILLUSTRATORS Roger Reiland
 Mark Higdon

CREATIVE RESOURCES

Creative Director: Ted Kralicek • *Project Developer:* Ken Munkel • *Project Designer:* Ted Wong, Kevin Boyle • *Project Coordinator:* Kent Welch • *Shop Mgr.:* Steve Curtis • *Shop Craftsmen:* Steve Johnson • *Photography Director:* Lark Brothman • *Sr. Photographer:* Crystal England

BOOKS

Executive Editor: Douglas L. Hicks • *Art Director:* Linda F. Verneis • *Sr. Graphic Designer:* Chris Glowacki

CIRCULATION

Circ. Dir.: Susan DuBois • *Direct Mail Mgr.:* Glenda Battles • *Sub. Mgr.:* Sandy Hagan • *General Mgr.:* Paige Rogers • *Asst. Direct Mail Mgr.:* Julia Genesee • *Asst. Sub. Mgr.:* Joy Krause • *Assoc. Graphic Design Dir.:* Bardo Eldor • *Sr. Graphic Designer:* Cheryl L. Simpson

CORPORATE SERVICES

Vice Pres. of Planning & Finance: Jim McCarthy • *Controller:* Robin Hatchinson • *Sr. Accountant:* Laura Thomas • *Arts. Payable Clerk:* Mary Schultz • *Prod. Dir.:* George Christian • *Elect. Pch.:* Douglas M. Leluter • *Prod. Asst.:* Susan Dielman • *Prod. Artist:* Jon Snyder • *Pre-Press Inaug. Spec.:* Troy Clark • *Elect. Comm. Coord.:* Gordon C. Guippe • *Net. Admin.:* Al Barnes • *I.S. Support Asst.:* Chris Harrison • *Prof. Develop. Dir.:* Joyce Moore • *Human Res. Asst.:* Kirsten Koels • *Admin. Asst.:* Julia Fish • *Recpt.:* Jeanne Johnson, Sheryl Ribbey • *Idg. Mktg.:* Ken Griffith

MAIL ORDER

Operations Dir.: Bob Baker • *Mkt'g. Mgr.:* Mark Mattison • *Cust. Service Mgr.:* Jennie Enos • *National Sales Mgr.:* Kent A. Buckton • *Warehouse Supervisor:* Nancy Johnson • *Buyer:* Linda James • *Op. Asst.:* Tammy Aldrin • *Teles. Leader:* Karla Ellinger • *Trck. Rep.:* Matthew TeRonde • *Cust. Service Reps.:* Anna Cas, Mario Petrus, Tommy Trotterbrook, Adam Best, Nancy Downey • *Warehouse Clerk:* Carlson, Sylvia Carey, Larry Price, Nancy Conroy

ShopNotes® (ISSN 1092-9090) is published bi-monthly (Jan., March, May, July, Sept., Nov.) by August Home Publishing, 2209 Grand, Des Moines, IA 50312. ShopNotes® is a registered trademark of August Home Publishing ©Copyright 1997 by August Home Publishing. All rights reserved. Subscriptions: Single copy: \$4.99. One year subscription (6 issues), \$24.95. Canada/Foreign add \$6 per year. Periodicals Postage Paid at Des Moines, IA and at additional mailing offices. Postmaster: Send change of address to ShopNotes, P.O. Box 87105, Boone, IA 50037-2108. Subscription Questions? Write to: ShopNotes Customer Service, P.O. Box 842, Des Moines, IA 50304-0961. Or call 1-800-333-8884, 8:00 am to 5:00 pm, Central Time, weekdays. FAX 515-285-0447. E-Mail: ShopNotes@shopnotes.com. Internet: http://www.shopnotes.com

PRINTED IN U.S.A.

WoodNet

NOW ON THE WEB!

- 30 Woodworking Tips Online
- Woodworking Techniques — Step-by-Step
- Project plans you can download
- WoodNet Forum — Woodworkers' Q & A
- Power Tool Reviews

Point your browser to: <http://www.augusthome.com>
 Select "Woodworking" from the Welcome Page menu.

Reprinted 2002

Cutoffs

Whenever people stop by for a visit, we always spend awhile poking around the shop.

Usually, that's long enough to get a pretty good feel for the overall layout of the shop, which tools we use, and how we store lumber. But it's never enough time for one thing — checking out all the jigs that hang on the wall.

JIGS. More than anything else in the shop, it's these jigs that draw out the natural curiosity of woodworkers. What do you use this one for? How does it hold the workpiece?

Is there any way to make it adjustable? Now there's nothing all that surprising about this fascination with jigs. After all, woodworkers are a practical lot. And we're always looking for practical ways to solve problems.

But I've got a hunch that there's a lot more going on here than just these practical considerations. In fact, maybe the most interesting thing about a jig really isn't the jig at all.

PROCESS. It's the process involved in coming up with the best possible solution to a problem. Figuring out a way to make a cut easier, safer, or more accurate. Then gathering up simple materials and hardware to build a jig that does just that.

Sometimes this process goes quite smoothly. But more often than not, there will be some frustrating detours along the way. In the end though, it's a satisfying and rewarding experience.

Another intriguing thing about this process is it doesn't necessarily end when you complete the jig. How many times have you built a jig only to see that you could have done it differently — and better?

In fact, sometimes I wonder if a jig is ever really complete at all. Or if it's just in another stage of development.

TAPER JIG. A good example of that is the adjustable taper jig in this issue. It's the "end" result of a taper jig that has been modified three different times over the last few years. And each change has improved it just a bit.

ORIGINAL. The idea behind the original jig came about when Ken Munkel (our project designer at the time) needed a way to cut tapers on the legs of a table he was working on.

Part of his solution was to clamp the leg to a large platform that would slide across the table saw. But what was really unusual about this jig was that unlike the store-bought taper jigs (the kind with the metal arm that hinge together), it didn't need to be readjusted after cutting tapers on the first two sides.

SECOND GENERATION. Well, the jig worked fine. But then Doug Hicks (our Executive Editor) got an idea. By making some of the parts removable (and adding adjustable hold-downs), he could also use it to rip a straight edge on a rough board.

And while he was changing things, Doug added one more improvement — a way to adjust the jig to cut different size tapers.

EVOLUTION. But the jig still had one more evolution to go through. Ted Kralicek (our creative director) thought it would be handy to make the jig adjustable for legs of different thicknesses as well. So he added a unique adjustment bar that...

Well, you get the idea. The "completed" jig is shown on page 6. But I bet it won't stay that way for long.

Maybe a jig is never really complete at all. It's just in another stage of development.

Tim

Contents

Tips & Techniques

Readers' Tips _____ 4

Our readers offer their own shop-tested tips to common woodworking problems. Plus three quick tips.

Shop Solutions _____ 30

A collection of four great tips from the guys in our shop that will come in handy for the projects in this issue.

Projects

Adjustable Taper Jig _____ 6

Three jigs in one. That's what you get when you build this adjustable taper jig for your table saw. Use it to make long, angled cuts on a workpiece, cut perfectly consistent tapers, or rip a straight edge on rough-sawn lumber.

Folding Table _____ 10

The legs of this table fold up for storage. And the plastic laminate top is durable and easy to clean. Combine all that with the warm look of cherry, and this folding table is as good-looking as it is practical.

Plate Joiner Table _____ 16

This shop-built table converts your hand-held plate joiner into a benchtop tool. Adjusting a sliding table up or down makes it easy to locate the slot for the biscuit. And a unique, foot-operated plunge mechanism lets you cut the slot without having to clamp the workpiece.

Departments

In the Shop

Tool Talk _____ 14

Our mailbox is overflowing with questions about buying and maintaining tools. We answer six of them here.

Selecting Tools

Plate Joiners _____ 26

ShopNotes tests five popular plate joiners and offers practical suggestions on the best one to buy.

At the Store

New Products _____ 31

Here's a quick look at three new products that we've been using in our own shop.



Adjustable Taper Jig page 6



Folding Table page 10



Plate Joiner Table page 16



Plate Joiners page 26

Readers' Tips

Retractable Outfeed Support

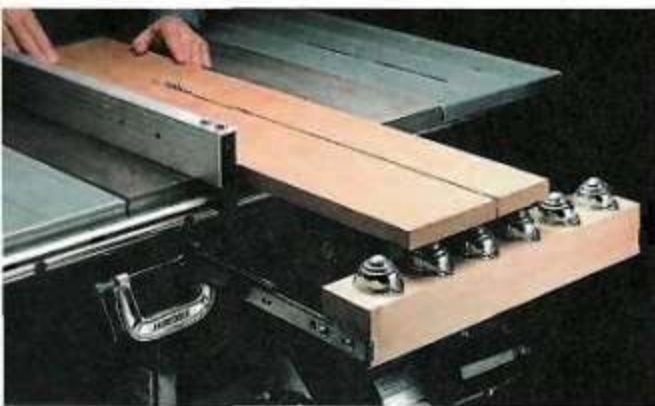

■ Like many woodworkers, I use an outfeed support to “catch” long boards when working on the table saw, see photo. But this one has an advantage over many outfeed tables I’ve seen — it retracts when I’m done using it, so it’s never in the way.

This outfeed support consists of two parts: a pair of full-extension drawer slides and a wood rail with ball bearing rollers attached to the top, see drawing. (Slides and rollers are available through woodworking catalogs.)

The drawer slides are simply bolted to the sides of the saw cabinet, see detail. Then with the

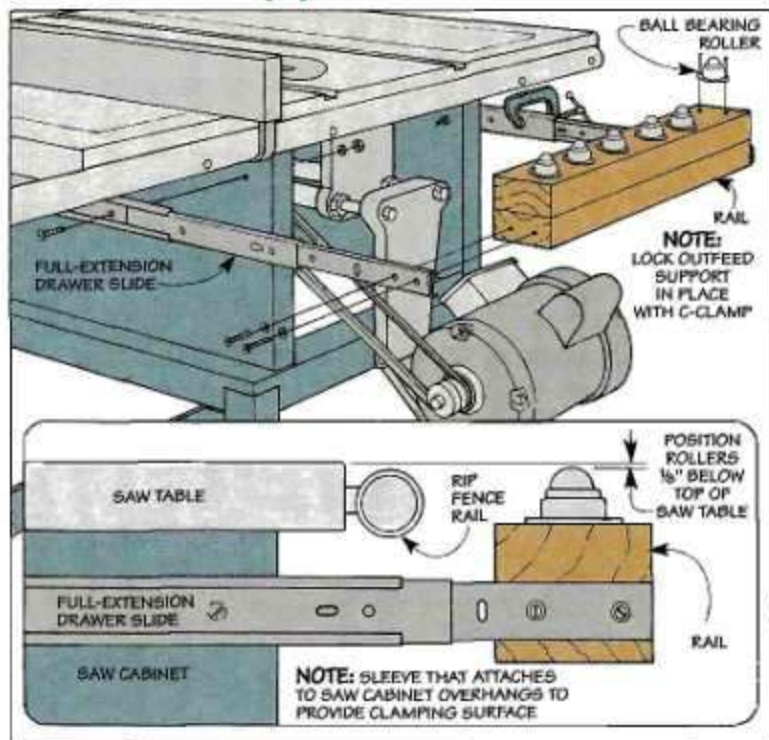

slides fully extended, the rail can be cut to fit between. (I glued-up two 2x4’s to make the rail.)

After screwing the rollers in place, it’s just a matter of mounting the rail to the slides. To support the workpiece as it comes

off the saw table, position the rail so the rollers are $\frac{1}{8}$ ” below the cast iron top. Note: Tightening C-clamps on the drawer slides locks the outfeed support in place.

*Ed Nelson
Dickinson, Texas*

Recutting Threads

■ When I need a short length of threaded rod, I sometimes cut the head off a bolt, see drawing. But this can damage the threads.

So to “recut” the threads, I simply back an ordinary hex nut off the cut end of the bolt. Just be sure to remove the burr first by filing a slight chamfer on the end of the bolt.

*Randy Fix
Mandan, North Dakota*

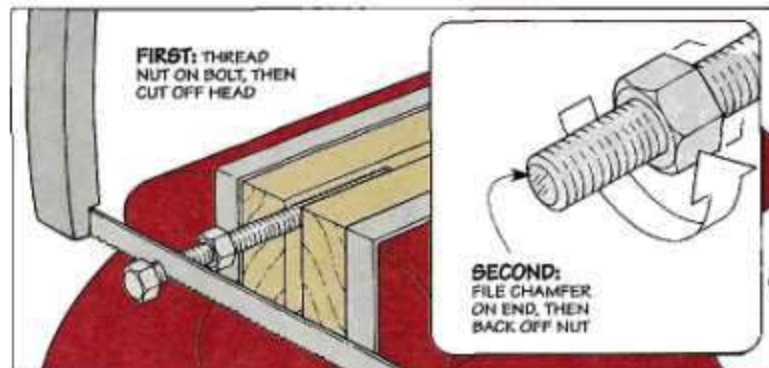

Quick Tips



▲ To cut a piece of plastic laminate to rough size, Pat Wagner of West Sacramento, CA uses ordinary tin snips.



▲ Grinding a nail to a sharp point and epoxying it in a hardwood scrap makes a handy scratch awl for R.B. Himes of Vienna, OH.



▲ To "erase" pencil marks from the surface of a workpiece, Bob Gosnell of Everett, Washington wipes them off with alcohol.

Plane "Boot"

■ To protect the blades in my hand planes from getting nicked when they're stored in my tool box, I made a custom-fit "boot" for each one, see drawing.

The boot has a wood plate that covers the sole of the plane. It's held in place by two wood clips.

To provide a pocket for the plane to slide into, the rear clip fits between the sides of the body. A rabbet lets you slide the back end of the plane underneath the clip. And a curved notch wraps around the handle.

The front clip is similar. But to lock it in place, there's a slot for a bolt that threads into an insert.

*Adolph Peschke
Des Moines, Iowa*

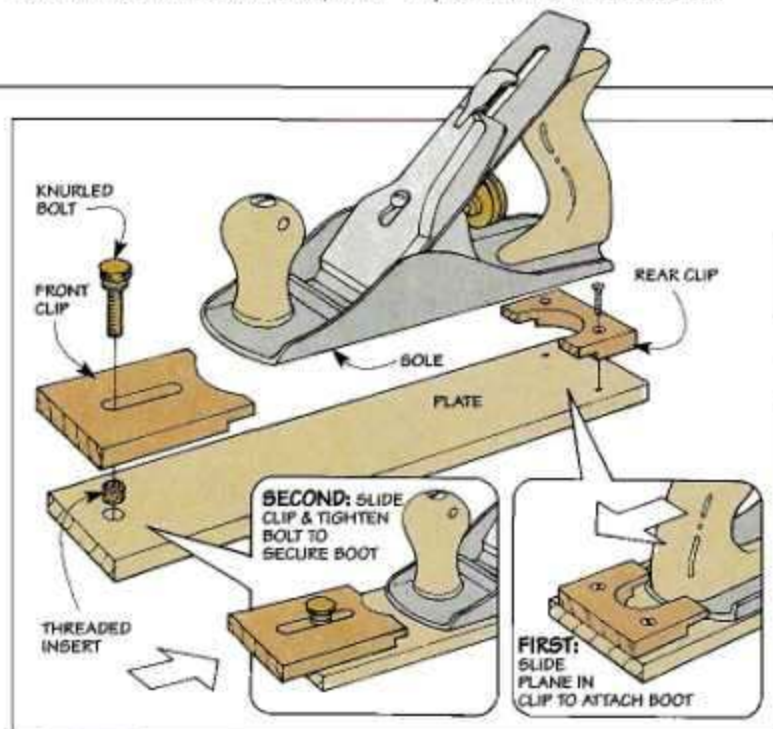

Easy-Read Rule



■ Because my eyesight isn't what it used to be, I sometimes have a difficult time reading the fine graduations on my steel bench rule.

So I made my own easy-read rule by applying a self-adhesive tape measure to a flat piece of aluminum bar stock, see photo.

*Andrew Albert
Mukwonago, Wisconsin*

Send in Your Solutions

To share your original solutions to problems you've faced, send them to: *ShopNotes*, Attn.: Readers' Tips, 2200 Grand Avenue, Des Moines, IA 50312. (Or if it's easier, FAX them to us at: 515-282-6741.)

We'll pay up to \$200 depending on the published length. Please include a daytime phone number so we can call you if we have any questions.

Adjustable Taper Jig

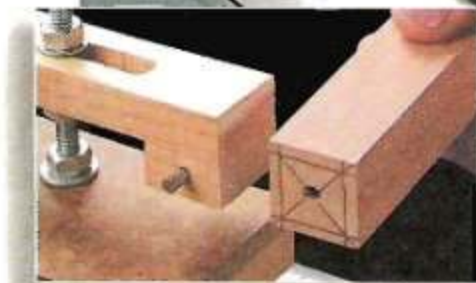
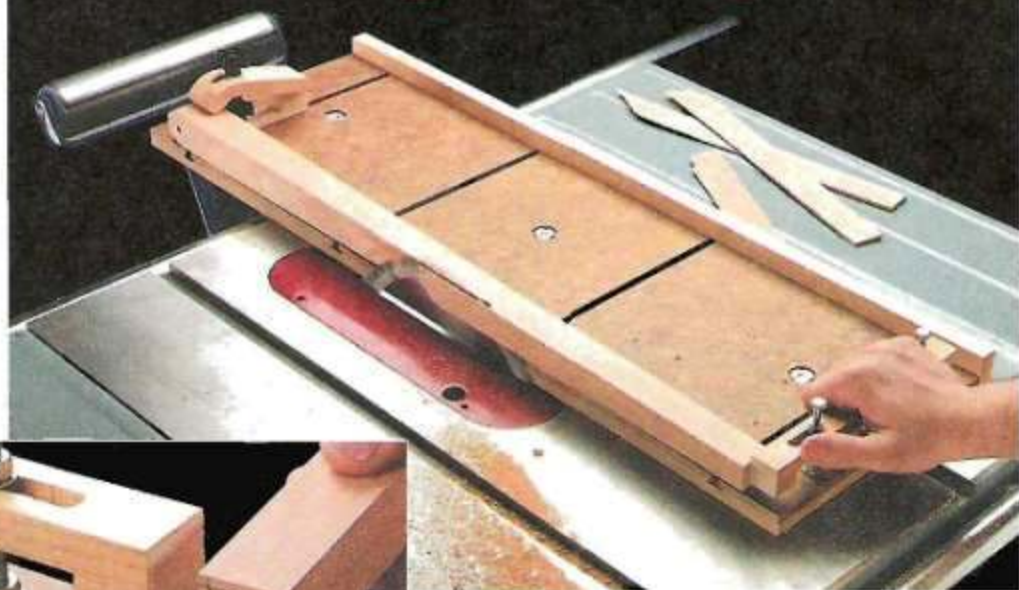

Sometimes a jig turns out even better than expected. Which is exactly what happened with this adjustable taper jig.

It started out quite simply — a platform that slides across the table saw and carries the workpiece past the blade. But it ended up as a jig that can do much more.

ADJUSTABLE. The first improvement was a built-in system that allows you to adjust the size of the taper. It's really nothing more than a piece of hard-

wood and a steel pin, see inset photo. But it makes it easy to remove the exact amount of material you need to form the desired “footprint” on the bottom end of the leg.

Once the jig is adjusted, you can cut four *identical* tapers in a matter of minutes — without changing the basic setup of the jig.

ANGLED CUTS. But as easy as it is to cut tapers, you'll probably use this jig just as often for another job. With two simple hold-downs clamping a workpiece securely in place, you can make long, angled cuts safely and accurately, see photos below left.

STRAIGHT-LINE RIPPING. These same hold-downs can be used when ripping a straight edge on a piece of rough-sawn lumber, see photos directly below.



Angled Cuts. Two adjustable hold-downs clamp work securely in place when making angled cuts.



Ripping. To rip a straight edge on a rough board, just remove the runner.



And if the workpiece is particularly long (or wide), you can remove the adjustment system and the runner that rides in the miter gauge slot and use the rip fence.

PLATFORM

The main part of this jig is a platform with four T-shaped slots. These T-slots serve as tracks for the adjustable hold-downs.

T-SLOTS. An easy way to form these T-slots is to make the platform out of two pieces and cut part of the slot in each one.

The *bottom* (A) has four wide dadoes cut in it to accept the head of a toilet bolt, see Figs. 1 and 1a. Then, after gluing on a hardboard *top* (B), complete the T-slots by cutting narrow dadoes for the shank of the bolt, refer to Fig. 4 on page 9.

RAIL. To ensure that the platform remains flat after it's built, I added a hardwood *rail* (C), see Fig. 2. It's simply glued to the edge of the platform.

RUNNER. The platform is guided by a hardwood *runner* (D) that slides in the miter gauge slot of the saw table, see Fig. 2. To avoid any "play" in the platform, you want the runner to fit snug in the slot, yet not so tight that it binds.

GROOVE. Once you're satisfied with the fit, the next step is to cut a groove in the bottom of the platform to accept the runner. Since the runner determines the position of the jig on the saw table, the location of this groove is important.

What you want is to locate the groove so when you install the

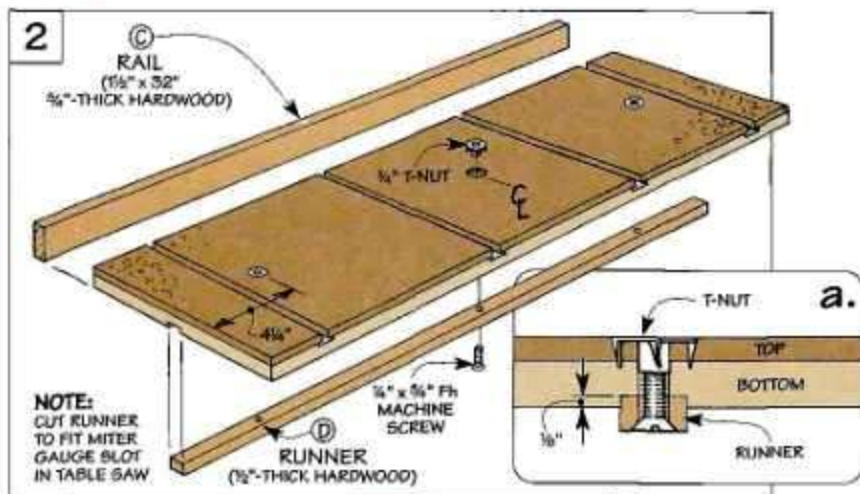
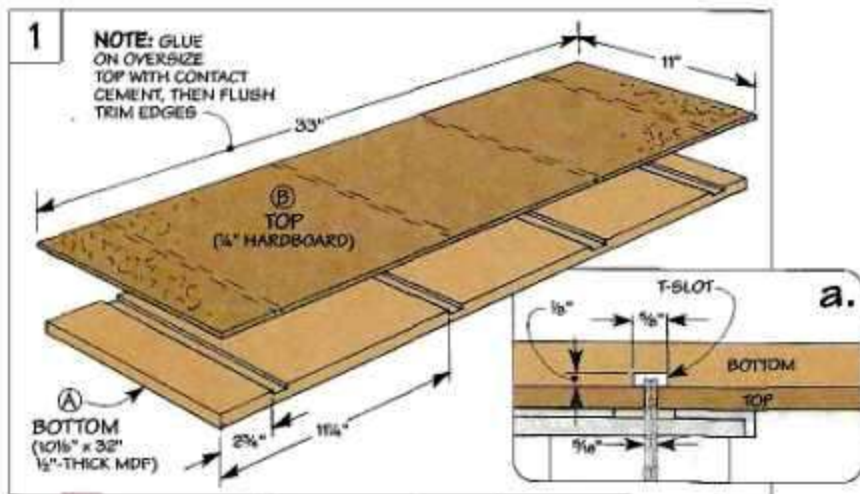

runner later, there's some waste on the edge of the platform. (This waste will be trimmed off when you make your first pass.)

REFERENCE EDGE. At that point, the edge of the platform becomes a *reference edge* that indicates the path of the saw blade. So to make an accurate cut on a workpiece, all you'll

need to do is align the layout marks with the reference edge.

THREE STEPS. An easy way to create this reference edge is to use a simple three-step process, see drawings below. But before trimming the edge of the platform (Step 3), you'll need to attach the runner with machine screws and T-nuts, see Figs. 2 and 2a.

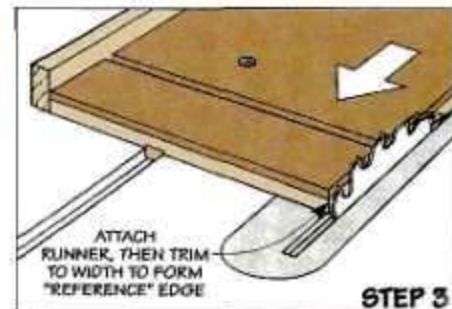
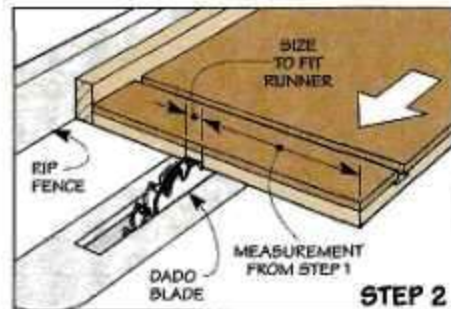
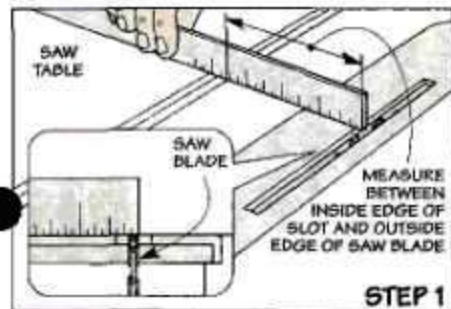

Adjustment Bar

The most unique thing about this taper jig is the adjustment bar. It's just a slotted wood strip and a block with a metal pin, see Fig. 3. But it does two important things.

First, it makes it easy to adjust the size of the taper. Second, it provides a way to cut perfectly identical tapers.

SIZE. The secret is a pin that fits in a centered hole in the end of the leg. This pin determines the position of the leg on the platform. By adjusting the bar, you can move the pin (and the leg) in two directions: *side to side* and *up and down*.

Say you want to cut a $\frac{1}{4}$ " taper for instance. Just slide the bar to the side so the leg overhangs the reference edge by $\frac{1}{4}$ ". To allow for pieces of different thicknesses, simply adjust the height of the bar.

IDENTICAL TAPERS. The pin also makes it easy to cut identical tapers without changing the setup of the jig. That's because it's centered on the end of the leg. Since the cut is referenced off a center-point, all you need to do is rotate the leg between each pass.

CONSTRUCTION. The adjustment bar is simple to make. After cut-

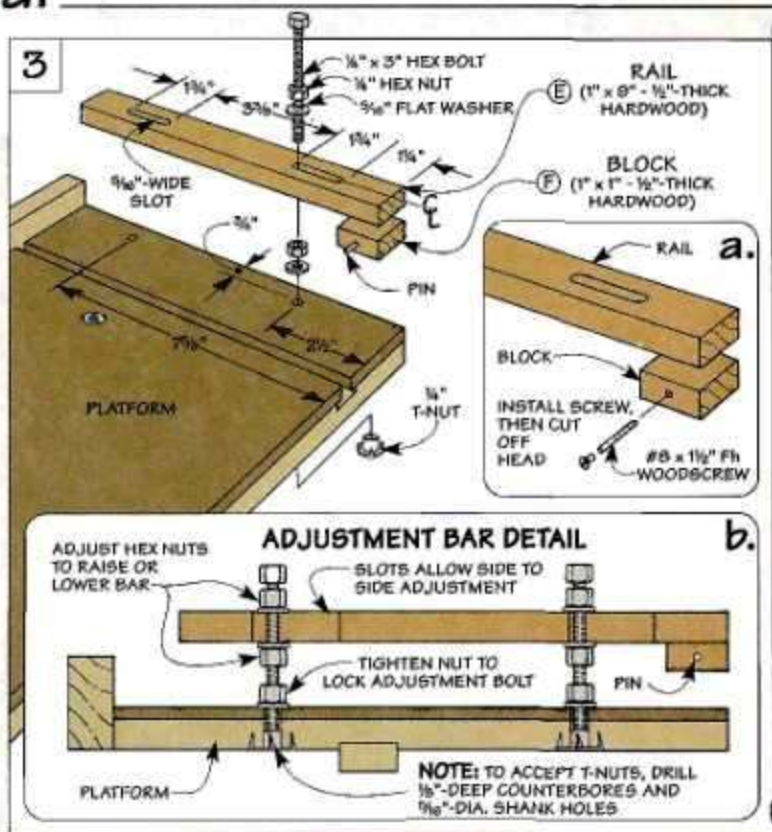

Hardware

- (5) $\frac{1}{4}$ " T-Nuts
- (3) $\frac{1}{4}$ " x 1" Fh Machine Screws
- (2) $\frac{1}{4}$ " x 3" Hex Bolts
- (6) $\frac{1}{4}$ " Hex Nuts
- (9) $\frac{3}{16}$ " Washers
- (1) #8 x $1\frac{1}{2}$ " Fh Woodscrew
- (3) $\frac{1}{4}$ " Knobs
- (2) $\frac{1}{4}$ " x 3 $\frac{1}{2}$ " Toilet Bolts
- (2) Aluminum Hold-Downs

For a complete hardware kit, call ShopNotes Project Supplies at 800-347-5105.

6633-100.....\$12.95



ting slots in the rail (E), the block (F) is glued on. And a cutoff screw serves as the pin.

The adjustment bar is attached to the platform by means of two

bolts that thread into T-nuts, see Fig. 3b. A pair of nuts "capture" the bar on the bolts. And tightening a single nut against the platform holds the bolts in place.

Hold-Downs & Stop

All that's left to complete the taper jig is to add a pair of wood hold-downs and a simple stop.

Note: ShopNotes Project Supplies is also offering aluminum hold-

downs, see margin at left.

HOLD-DOWNS. Like their name implies, the hold-downs clamp work securely in place as you make a cut. By sliding them along the T-

shaped slots in the platform, you can clamp different size pieces.

The unusual thing about the hold-downs is their angled shape, see pattern and drawing below.

FULL-SIZE PATTERN (GRID LINES ARE $\frac{1}{4}$ " APART)

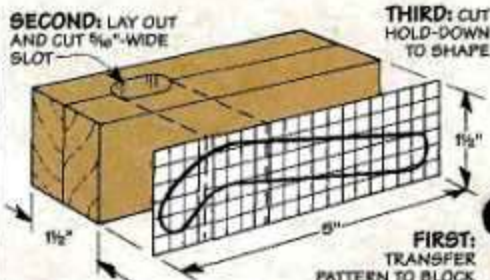
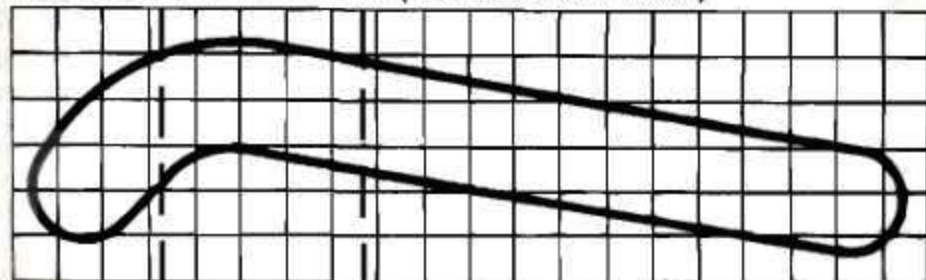

This shape allows the long, straight end to rest on the platform and the short, angled end to apply pressure on top of a workpiece.

The clamping pressure is produced by tightening a knob on the end of a toilet bolt that slides in the T-slot, see Fig. 4.

BLANK. Each *hold-down* (G) starts off as a 1½"-square blank, see drawing on opposite page. (I glued up two pieces of ¾"-thick maple.) Then a pattern of the basic shape is transferred to the side. (For more on this, see page 30.)

Note: Before cutting the hold-down to shape, it's easiest to lay out and cut a slot for the toilet bolt.

STOP Next, I added a hardwood stop (H), see Fig. 5. In use, the curved end of this stop butts against the top (untapered) end of the leg, see Step 5 below. This lets you reposition the leg at the

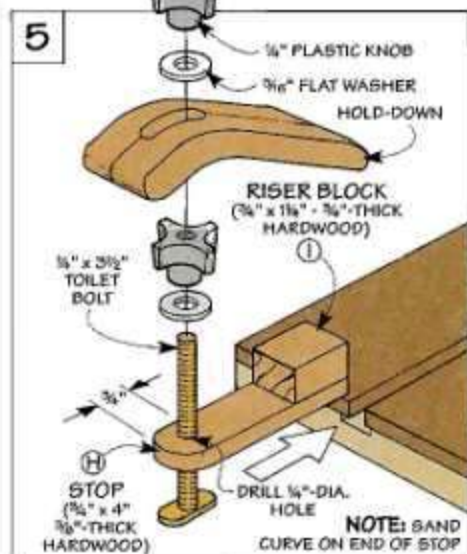

same place between each pass.

The stop is locked in place by tightening a knob on the end of a toilet bolt. To provide clearance for this knob when you use the

hold-down and the stop together, you'll need to glue on a small riser block (I). It acts as a platform for the "foot" of the hold-down to rest on, see Step 6. 

Using the Jig



Step 1. After laying out the tapers on the end of the leg, drill a centered hole to fit on the pin.



Step 2. With the leg in place, adjust the hex nuts up or down so it sits flat on the platform.



Step 3. Next, align the mark for the taper with the edge of the jig and tighten the adjustment nuts.



Step 4. Now lay out the starting point of the taper and align the mark with the edge of the jig.



Step 5. Slide the stop against the leg and lock it in place. Then tighten the hold-down on the leg.



Step 6. After cutting a taper on one side, rotate the leg and repeat the process for each side.

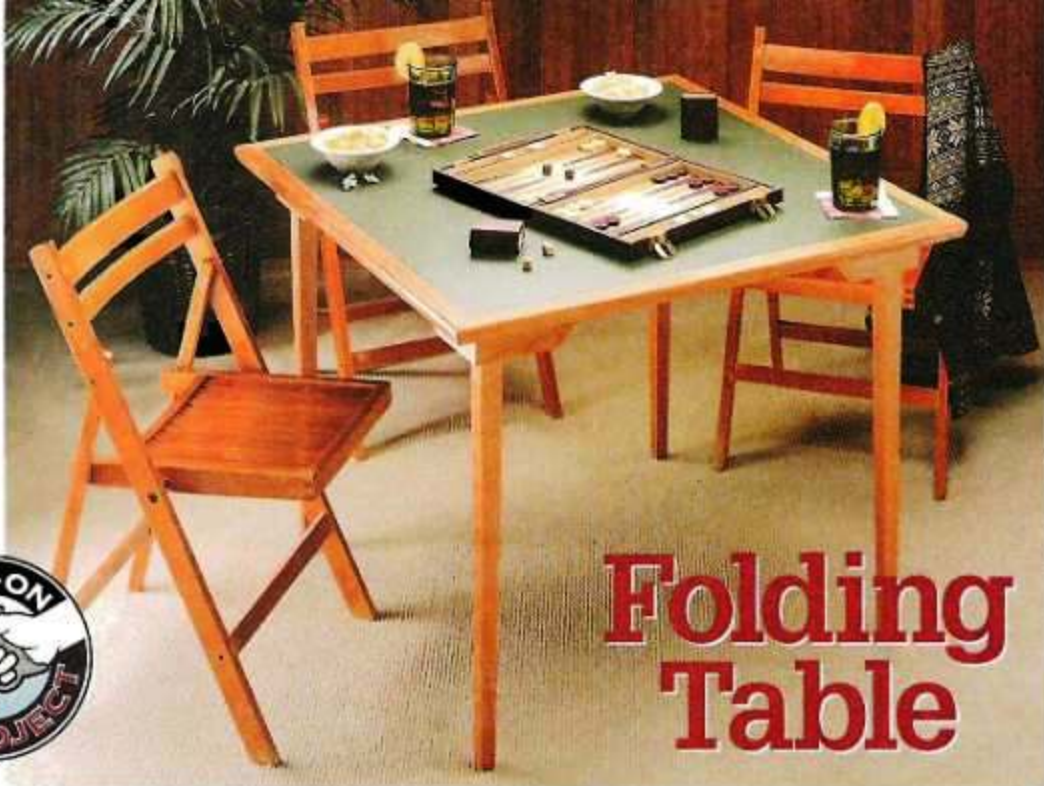

Folding Table

I guess you could say that the design for this table was a bit slow to "unfold." Not because it's all that complicated. But because we wanted the legs of the table to fold up for storage, yet still provide sturdy support when

they're fully extended.

As it turned out, that's easier said than done. We tried several different types of hardware that's specially designed for folding legs. But none of it kept the legs from wobbling. So we

experimented with different ways to lock the legs in place.

SPRING. The solution was as close as the scrap bin — a thin wood strip that works like a spring to apply pressure against each leg, see photos below left. The spring holds the leg securely in place in both the extended and folded position. To fold the leg up or down, just press down on the spring and swing the leg past.

Leg Extended. ▶
When each leg is extended, a thin wood "spring" holds it in place. And a small block adds rigidity.



Folding the Leg. ▶
To fold up a leg for storage, press the spring down and swing the leg past.



Locking Spring. ▶
Once you fold the leg all the way down, the spring pops back out to lock it in place.



▲ **Storage.** With all four legs folded, this table can be tucked into a closet for compact storage. Made of lightweight materials, it's easy to carry around.

TABLE TOP

I began work by building the top of the table. Basically, it's a plywood core that's covered with plastic laminate and then wrapped with hardwood edging.

CORE. To reduce the weight of the top, I cut a *core* (A) piece from $\frac{1}{2}$ " plywood, see Fig. 1. Then to ensure that the top stays flat, both sides of the core are covered with oversize pieces of plastic laminate, refer to page 30.

It's best to apply the plastic laminate to one side at a time. A flush trim bit and a hand-held router make it easy to trim the plastic laminate flush, see Fig. 1a.

TONGUE. The next step is to form a tongue on all four edges of

the top that will help align the edging, see Fig. 2a. Rabbeting both sides of the top all the way around makes quick work of this.

EDGING. All that's left to complete the top is to add the hardwood edging (B), see Fig. 2. To make the top appear thicker than it is, the edging is made from 1½"-thick stock (I used cherry), see Fig. 2a.

GROOVES. After cutting four extra-long pieces of edging, you'll need to cut a groove in each one to fit the tongue on the top, see Fig. 2a. The important thing here is to locate this groove so the top of the edging is flush with the plastic laminate.

Next, to create an angled profile, I ripped a bevel on the bottom, outside edge of each piece, see Fig. 2a. Then the pieces are simply mitered to length. Note: To get the miters to fit tight, it's best to sneak up on the final length.

Once the miters fit tight, the trick is to get them to *stay* that way as you glue on the edging. To do this, I used a simple assembly sequence, see box below.

Then I eased the top edges by routing a ¼" roundover all the way around, see Fig. 2b.

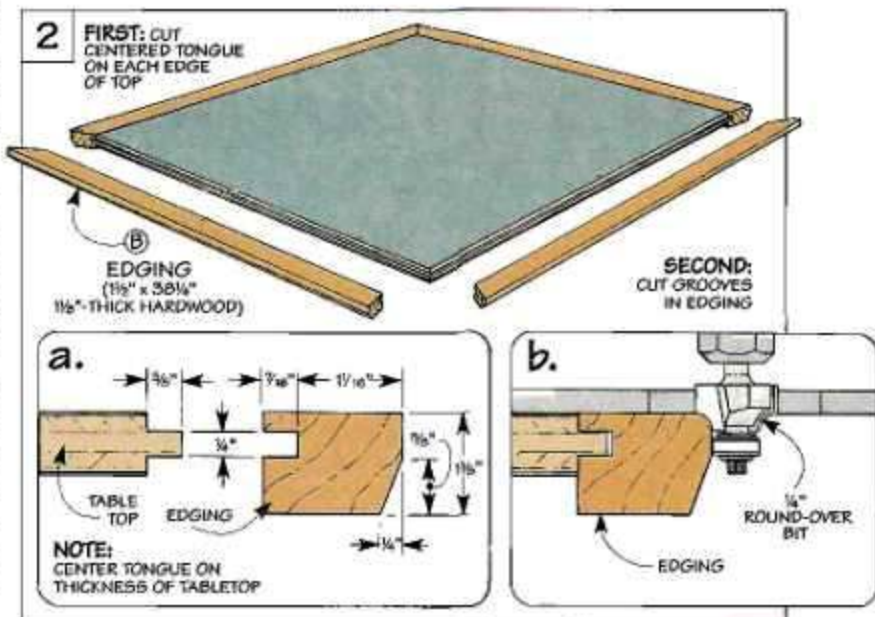
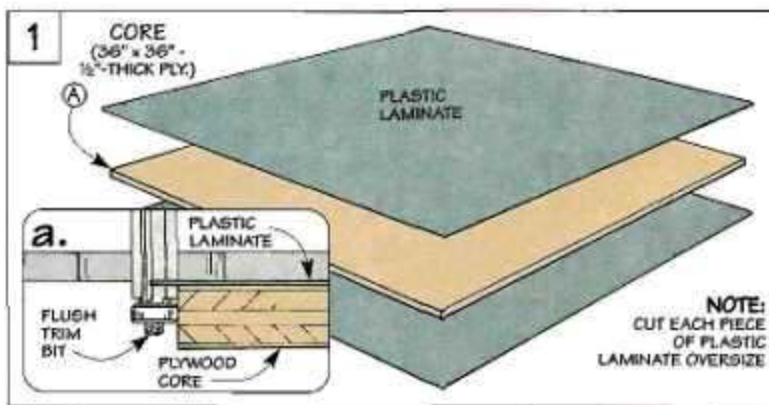

Gluing-Up a Mitered Frame

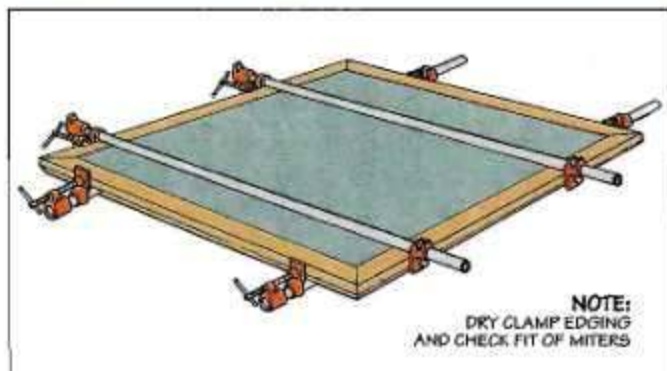

Dry Clamp. After mitering the four hardwood edging pieces to final length, dry clamp them to the table top to make sure that each corner fits tightly together.

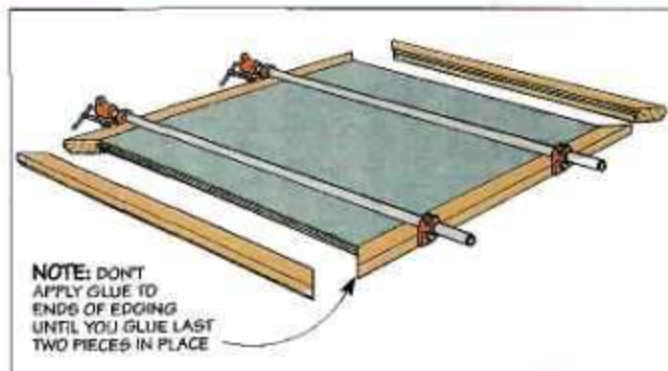

Glue-up. Now glue two opposite pieces of edging to the table at a time. The remaining pair that's either clamped (or glued) helps position the pieces to ensure that the miters stay tight.

Apron & Legs

The top of the folding table is supported by a hardwood apron with a tapered leg in each corner, see drawing.

APRON

Besides providing the framework for the tabletop, the apron houses a unique spring-loaded system that locks the legs in place after you fold them up or down.

SPLINED MITERS. The apron consists of four identical rails (C) that are held together with splined miter joints, see Fig. 3. (I used cherry for the rails.)

After mitering the rails to finished length, cut a kerf in the end of each piece for a spline that will help strengthen the corners of the apron, see Fig. 3a.

Before gluing the rails together, a few more things need attention. To create a recess for a figure-8 fastener that will be used to attach the top, two shallow counterbores are drilled along the top outside edge, see Fig. 3a. And there's a curved notch in the bottom edge to provide leg clearance, see Fig. 3b.

Also, it's best to drill a single

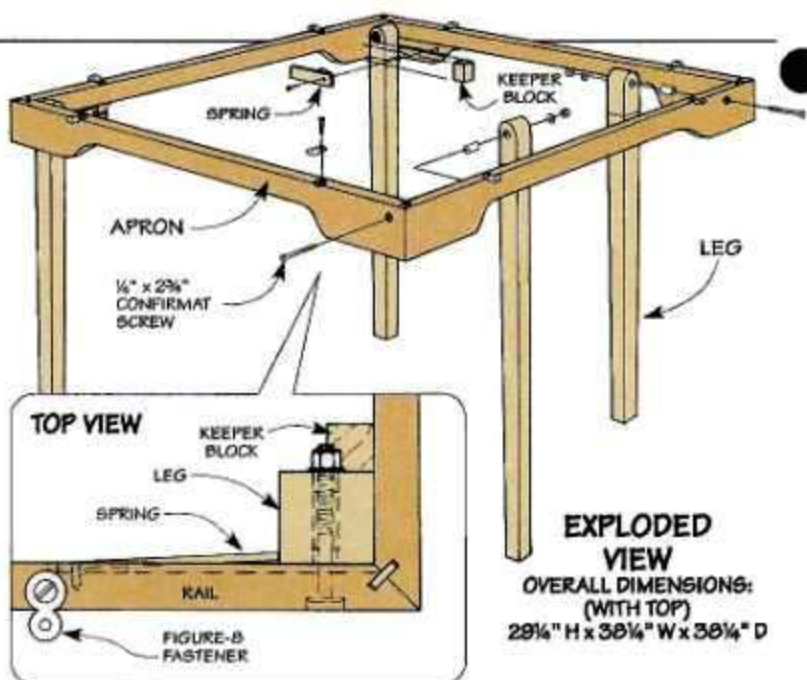

EXPLODED VIEW
OVERALL DIMENSIONS:
(WITH TOP)
29 1/4" H x 30 1/4" W x 30 1/4" D

Sources

Confirmat Screws (also called connector bolts) and Figure-8 Fasteners (table top fasteners) are available from:
The Woodworkers' Store
800-279-4441
Woodworker's Supply
800-649-9292



counterbored shank hole now for a special fastener that will be used to attach the legs later, see Fig. 3c. (I used a Confirmat screw, see margin.) Finally, to create a recess for the spring, cut a short groove in each rail.

ASSEMBLY. Now you're ready to glue up the apron. To do this, you'll need to cut four hardwood splines (D) that fit the kerfs in

the mitered ends, see Fig. 3. Note: To ensure that the corners of the apron are square, refer to Shop Solutions on page 30.

LEGS

With the apron set aside to dry, you can turn your attention to the tapered legs.

Each leg (E) starts out as a 1 1/2"-square blank (cherry), see

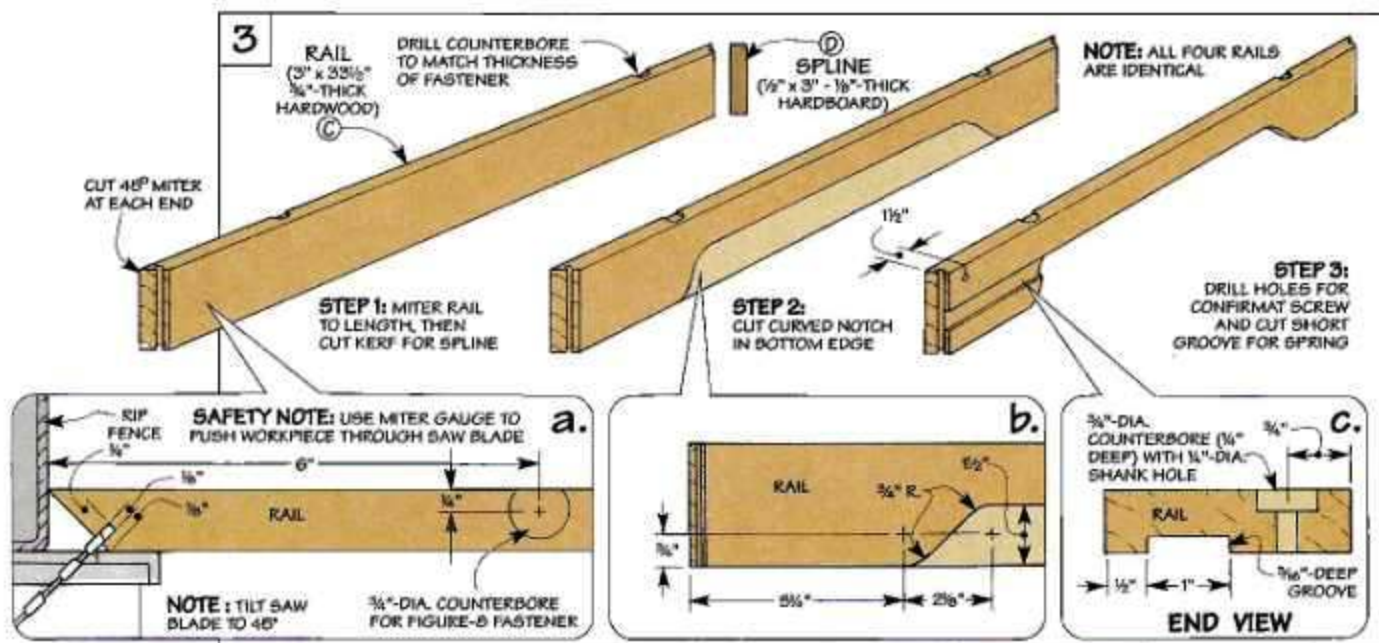
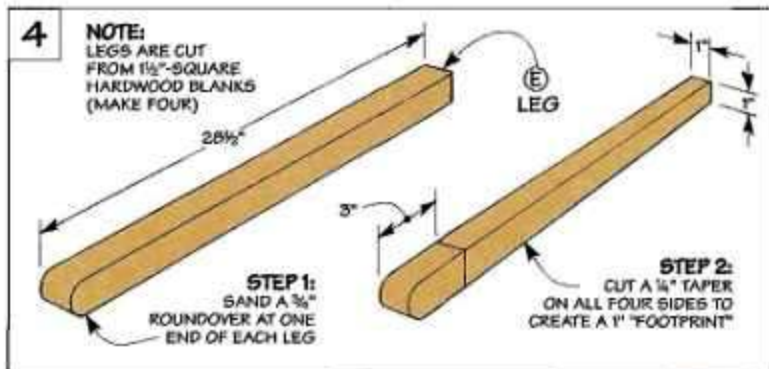

Fig. 4. To provide clearance as the leg is folded up and down, you'll need to sand a roundover on the top end of each blank.

TAPER. Then all four sides of the blank are tapered to give the legs a lightweight look and feel. There are two things to keep in mind here. First, the taper begins 3" down from the top of the leg. And second, you want to end up with a 1"-square footprint at the bottom. Note: The adjustable jig shown on page 6 makes quick work of tapering the legs.

ATTACH LEGS. Now you're ready to attach the legs. Each one pivots on a spacer that keeps the threads on the Confirmat



screw from digging into the leg, see Fig. 5.

An easy way to locate the hole for the spacer is to clamp each leg in place and use a brad point bit to mark the centerpoint, see

Fig. 5a. After drilling the hole and slipping in the spacer, just install the Confirmat screw and secure it with a lock nut.

SPRING. At this point, it's easy to fold up the leg — in fact it's too easy. To lock each leg in place either in the extended or the folded position, I added a thin wood "spring."

Each *spring* (F) is just a 1/8"-thick strip of hardwood that fits in the groove on the inside of the apron, see Fig. 6. With the leg fully extended (or folded) the spring sticks out from the apron and holds it in place, see detail in drawing on page 12. Pressing the spring into the groove lets you swing the leg up or down.

What makes this work is a small wood *wedge* (G) that's glued to one end of the spring, see Fig. 6a and margin. The wedge pushes the opposite end of the spring away from the apron until you're ready to fold the leg.

To locate the spring, the idea is to fit it tight against the leg when it's fully extended. After screwing the spring in place, I also glued a *keeper block* (H) to the apron so it fits tight against the adjacent side. This provides firm support on both sides of the leg to keep it from wobbling.

ATTACH TOP All that's left to complete the table is to attach the top. It's held in place by screwing the figure-8 fasteners to the apron and the top, see Fig. 7.

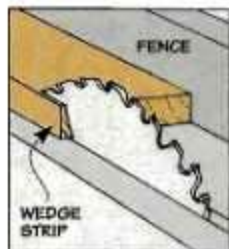

To make the wedges, tilt the saw blade and rip a thin strip on a long workpiece.

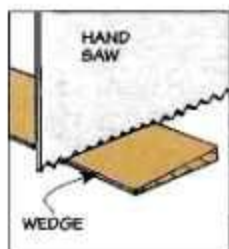

Then just cut each wedge from the strip with a hand saw.

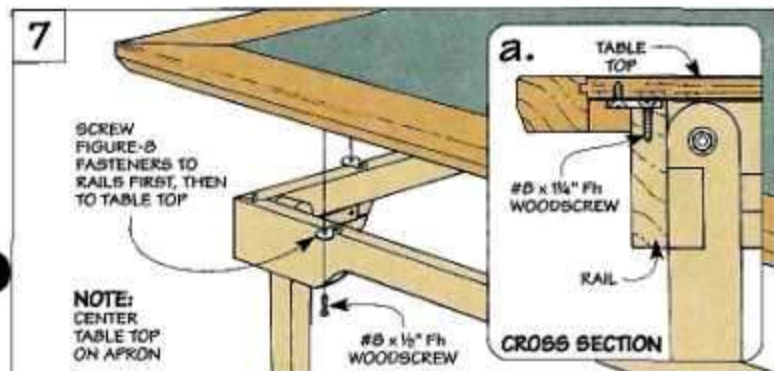
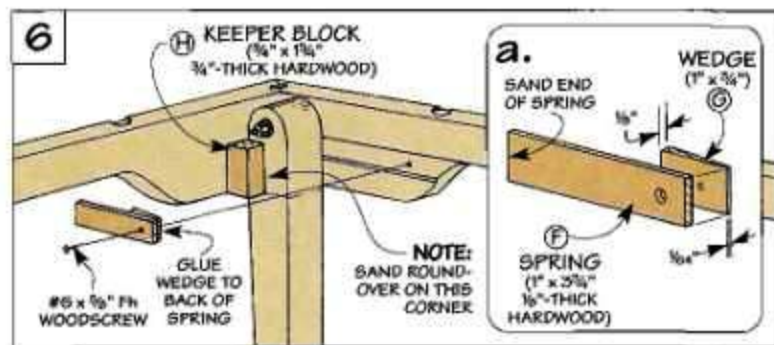
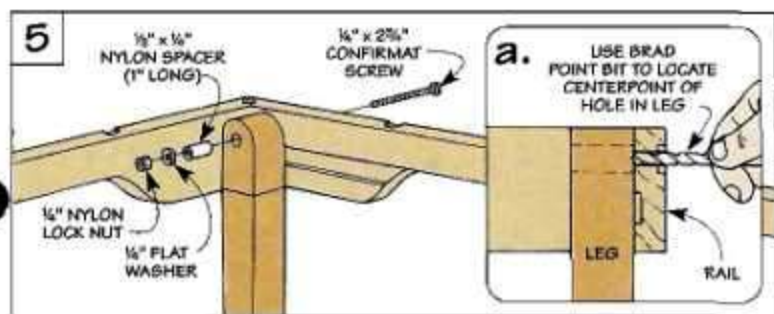

Tool Talk

When it comes to questions from our readers, buying and maintaining tools is at the top of the list. Here's a quick look at six common questions.

Variable Speed Control



Q: What's the advantage of a router with variable speed control?

A: The biggest advantage is when you need to use a router bit that's over 2" in diameter.

Take a 3½" panel raising bit for instance. The recommended safe speed is around 12,500 RPMs.

Since most variable speed routers can be adjusted to run

between 8,000 and 22,000 RPMs, you can dial in the correct (safe) operating speed. But you can't use that bit (or other large bits) safely with a single-speed router that runs at about 22,000 RPMs.

Another advantage is some types of wood (like cherry) burn easily when routed. By reducing the speed of the router, you'll get a clean cut with no burning.

Guide Blocks



Q: Is there any benefit in replacing the metal guide blocks in my band saw with non-metallic ones?

A: The guide blocks on a band saw have one main purpose — to prevent the blade from twisting and wandering off course as you make a cut. What I've found is metal guide blocks do that job better than non-metallic blocks.

The reason is the metal guide blocks don't wear down like the non-metallic blocks, see photos at left. So you don't have to readjust or resurface the blocks to keep the blade cutting straight.

The only time I'd recommend using non-metallic blocks is if you're working with a narrow (1/8" or less) blade. Then the blocks can be set closer to the blade without damaging the teeth, see photo.



NOTE:
LUBRICATE
BETWEEN
SEAL & INNER
RACE

**BALL
BEARING**

Router Bearings

Q: What's the best fix for a bearing on a router bit that doesn't spin freely?

A: Unfortunately, there's not much you can do.

If you're in the middle of a project, add a drop of sewing machine oil between the seal and the inner race, see drawing. (Be sure to wipe off the excess.)

But the best solution is to

replace the bearing. It's inexpensive. And it's good insurance against accidentally ruining a workpiece because the bearing seizes up and stops spinning.

So what makes a bearing go bad? Over time, dust and dirt can migrate into the bearing — even if it's sealed. And with the grease gummed up, it can't do its job of lubricating the bearing.

Motor Ratings

Q: One of the table saws I'm thinking about buying has a 1½ hp motor. Another one in the same price range says it "develops" 2½ hp. How do I compare how much power these two motors actually have?

A: Start by checking the plate that's attached to the motor, see photos at right. Sometimes it will list the *actual* horsepower or continuous-duty horsepower of the motor. The higher the number, the more power a tool has in normal use.

But some manufacturers don't list the horsepower rating of a motor. If that's the case, you can still compare the motors by checking the number of amps. As a rule, the higher the number of amps, the more powerful the motor.

So what's all this about a motor "developing" a certain horsepower? That's the maximum power of the motor when it's pushed to the limit (like when you're cutting through a thick piece of dense hardwood). And it can only main-

tain that power for a brief time before the motor either stalls or burns out (or you trip a circuit breaker).

Since the power isn't available continuously, it's misleading to rate a motor by how much horsepower it "develops."



On/Off Switches

Q: Is there any advantage in upgrading the standard on/off switch on my table saw with a magnetic switch?

A: A magnetic switch costs about \$125 compared to around \$45 for a standard on/off switch. But it provides a safety feature you won't get on a standard switch. To understand why, you need to know how each switch works.

MECHANICAL. When you turn on a standard switch, it completes a *mechanical* connection.

If the power goes out (or you trip a circuit breaker), the switch remains "on." The problem is that unless you remember to turn the switch off, the table saw will start up when power is restored. And that can create a safety hazard.

MAGNETIC. But a magnetic switch works differently. When you turn this type of switch on, a relay holds the switch in the

"on" position *magnetically*.

If the power goes off, the relay releases the switch. As a result, the tool won't start up accidentally when the power comes back on.



Mechanical



Magnetic

Battery Voltage

Q: The batteries on cordless drills come in such a wide range of voltages, I'm confused about which one to buy. How do I decide which size is best?

A: The main thing to remember is a drill with a higher voltage battery isn't necessarily better than one with a smaller battery. The "best" drill depends on the type of work you do.

If you're working on a project for hours at a time (or you're away from the shop), you'll want

a drill with a battery in the 12.0 to 14.4 volt range — one with a big "gas tank." It will drill considerably more holes or drive more screws between charges.

But if you just use a drill occasionally to assemble a project or for household chores, a 9.6 volt battery is more than adequate.

Besides the amount of work you can get done, there are a couple other things to consider. The bigger drills usually cost more. And their batteries are quite a bit bulkier (and heavier).



While this extra weight may not seem like much when you pick up a drill at the store, it can make a big difference in how comfortable it is to use. 🛠️

Plate Joiner Table

This simple shop-built table converts your plate joiner into a handy benchtop tool.

It's hard to imagine a quicker way to join two pieces together than to use a plate joiner. In fact, cutting the slots for the wood plate (biscuit) actually takes less time than clamping and unclamping the workpieces.

This constant fiddling with clamps can get to be a nuisance. Especially if I need to cut slots in a number of workpieces. So to make it easy to cut a slot without having to first secure the workpiece, I mounted my plate joiner to a table that clamps to my bench, see photo above.

The biggest advantage to doing this is it frees up *both* hands to hold the workpiece. But that presents another problem — how do you plunge the blade of the plate joiner into the workpiece to cut a slot?

PLUNGE SYSTEM. The solution is a simple plunge system that consists of a foot pedal and a wood arm.

When you step on the foot pedal, a wire cable pulls on the arm that's located on the plate joiner table, see inset photos above. As a result, the arm pivots against the body of the plate joiner and pushes it forward. This plunges the blade of the plate joiner into the workpiece which cuts a slot for the biscuit.



SLIDING TABLE. The up and down location of this slot is determined by the position of a large sliding table, see photo below. Depending on the thickness of the workpiece, you just raise or lower the table so the blade will cut at the desired height. With the table locked in place, it provides a large, stable worksurface.

QUICK RELEASE. One last thing. If you're working with an extremely large piece that's awkward to handle on the sliding table, it's easy to remove the plate joiner and use it in a hand-held position, see photo below left.



Sliding Table. A built-in height adjustment mechanism raises or lowers a sliding table. This establishes the location of the slot that's cut for the biscuit.

Quick Release. If you want to use the plate joiner in a hand-held position, simply loosen a pair of hold-downs and remove the pivot arm.



Materials

Base & Fence

A Top/Bottom (2)	15 1/4 x 20 - 3/4 MDF
B Sides (2)	6 1/2 x 15 - 3/4 MDF
C Fence (1)	20 x 20 - 3/4 MDF
D Fence Supports (2)	6 x 6 - 3/4 MDF

Sliding Table

E Adjustment Plate (1)	7 1/8 x 20 - 3/4 MDF
F Alignment Keys (2)	7/16 x 7/16 - 3/4 MDF
G Tabletop (1)	10 x 20 - 3/4 MDF
H Table Supports (2)	7 x 7 - 3/4 MDF
I Support Strip (1)	1/2 x 1 - 20
J Ht. Adj. Block (1)	1 1/2 x 2 5/8 - 4
K Stop (1)	4 x 9 - 3/4 MDF
L Runner (1)	3/4 x 4 - 3/4 MDF
M Guard Support (1)	3/4 x 5 - 7/2

Plunge System

N Cleats (2)	2 1/2 x 4 1/8 - 1/4 Hdbd.
O Hold-Downs (2)	3/4 x 3/4 - 2 3/4
P Arm (1)	1/2 x 2 1/2 - 13 1/2
Q Wheel (1)	2 x 2 - 1/4 Hdbd.
R Pivot Block (1)	1 1/2 x 2 1/2 - 3 3/4
S Mounting Plate (1)	3 3/4 x 4 - 1/4 Hdbd.
T Arm Support (1)	1 1/2 x 2 1/2 - 7 3/4
U Mounting Plate (1)	4 x 7 1/4 - 1/4 Hdbd.
V Upper Stop Block (1)	3/4 x 1 1/2 - 1 1/2

Foot Pedal

W Pedal (1)	3/4 x 3 7/8 - 14
X Base (1)	3/4 x 4 - 14
Y Sides (2)	3/4 x 2 1/2 - 6
Z Top (1)	3/4 x 2 1/2 - 5 1/2
AA Lower Stop Block (1)	3/4 x 2 1/2 - 2 1/2

EXPLODED VIEW OVERALL DIMENSIONS: 20 3/4" H x 20" W x 25 3/4" D

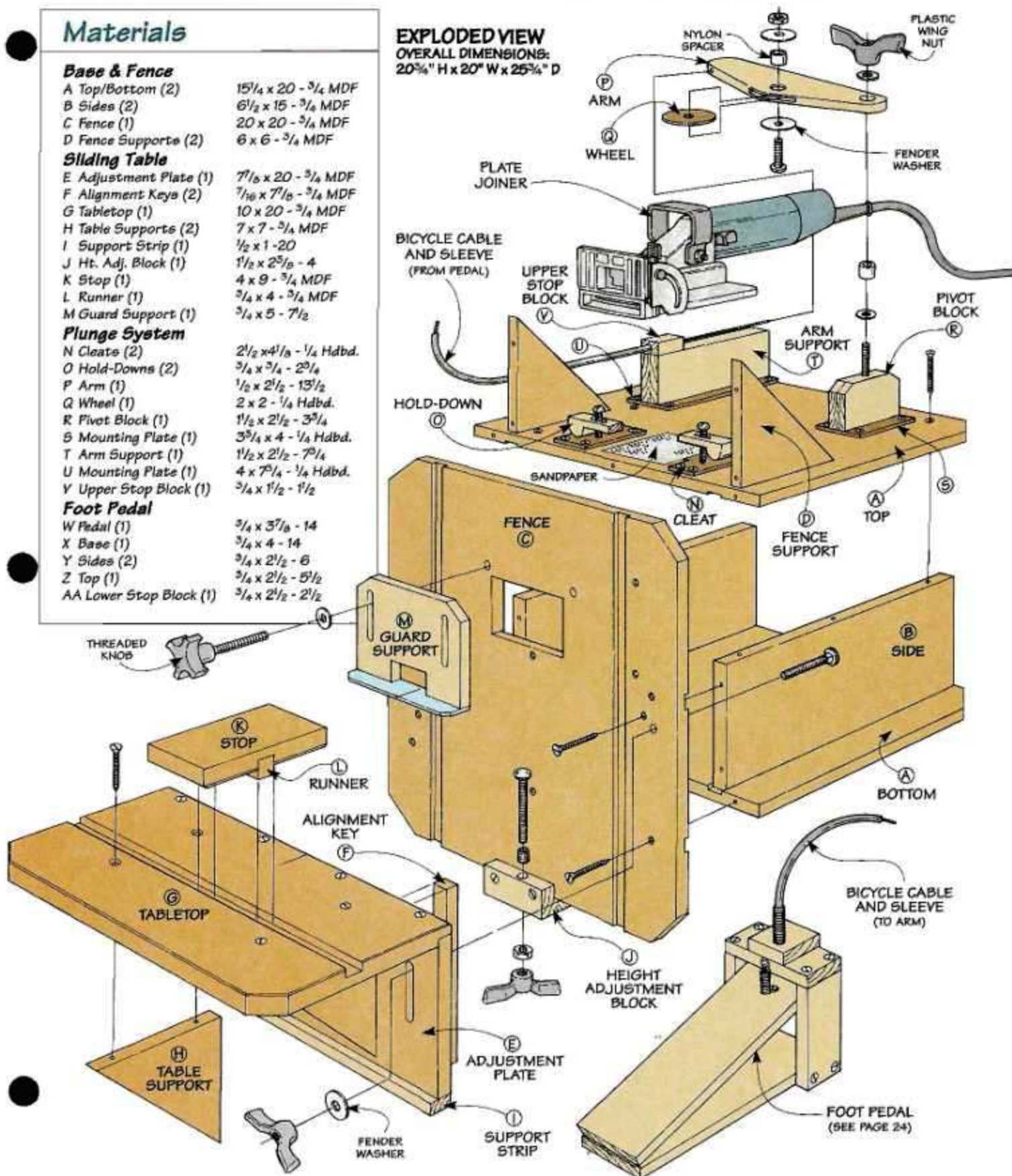

Base & Fence

I began work on the plate joiner table by building a base and a fence. The base provides a sturdy platform for the plate joiner, see drawing at right. And a tall fence supports the workpiece when making a cut.

BASE

The base is a simple box made from $\frac{3}{4}$ "-thick Medium Density Fiberboard (MDF). An opening in the back of the base provides a place to store the foot pedal, see margin.

TOP & BOTTOM. The base consists of a top and bottom that are held together by two sides. To create a clamping surface for securing the base to the bench, the sides fit into grooves that are set in from the edges of the top and bottom.

To ensure these grooves align, I started with a large blank that's cut to final width, but oversize in length, see Fig. 1.

Once the grooves are cut in the blank, you can cut the top and bottom (A) to final length. While I was at it, I cut an angled notch in the back corner of each piece, see Fig. 1.

SIDES. All that's left to complete the base is to add the two

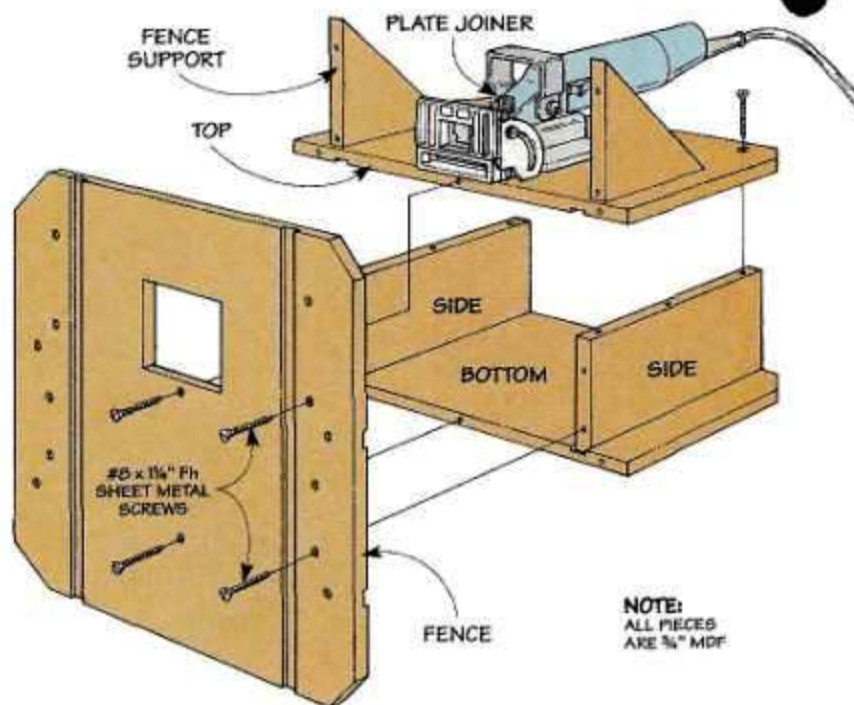

NOTE:
ALL PIECES
ARE $\frac{3}{4}$ " MDF



When you're not using the plate joiner table, just slide the foot pedal into the opening at the back of the base.

sides (B), see Fig. 2. One thing to be aware of here is the sides are set in $\frac{1}{4}$ " from the front edge of the top and bottom. That's because later on, the top and bottom will fit into dadoes in the back of the fence, refer to Fig. 5. And this $\frac{1}{4}$ " offset will allow the sides to fit tight against the back of the fence.

After cutting the sides to size, the base is simply glued and

screwed together, see Fig. 2. Note: To prevent the MDF from splitting, I used sheet metal screws with straight shanks.

FENCE

With the base complete, you can turn your attention to the fence. In addition to providing support for the workpiece as you make a cut, the fence guides the sliding table up and down.

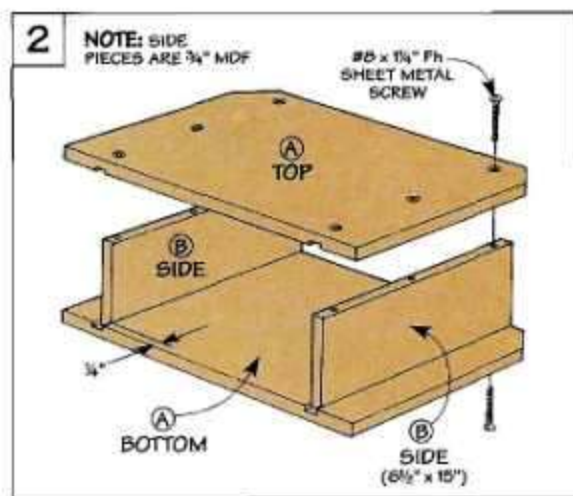
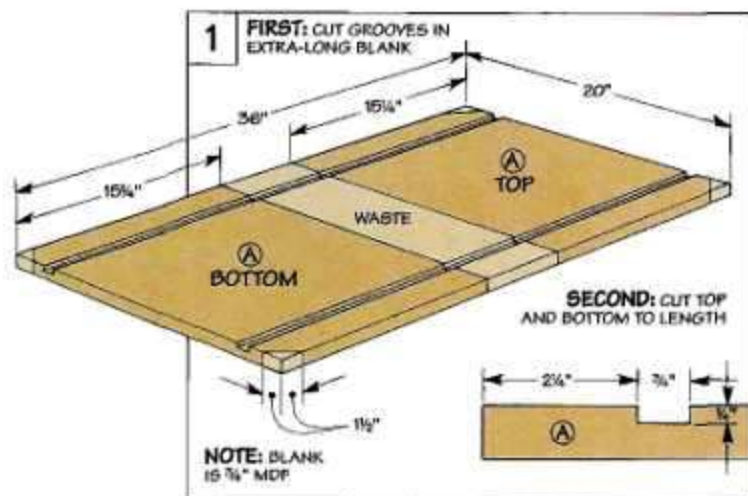

GROOVES. The way this works is simple. There are two grooves in the *front* of the fence that align with grooves in the *back* of the sliding table. A pair of keys (added later) that fit into these grooves will "track" the sliding table up and down the fence.

To get the table to slide smoothly (and evenly), it's important that these grooves align. So it's best to start with a single blank and cut the grooves in the fence (C) and the adjustment plate (E) for the sliding table at the same time, see Fig. 3.

Now it's just a matter of cutting both pieces to final length. After setting aside the adjustment plate, I cut an angled notch on each corner of the fence as before, see Fig. 4.

DADOES. The next step is to cut a pair of shallow dados in the back of the fence, see Fig. 4. These dados accept the top and bottom of the base.

OPENING. But before you attach the base, there's one last thing to do. That's to cut an opening in the fence for your plate joiner that allows the blade to plunge into the workpiece, see Fig. 4.

When determining the size of

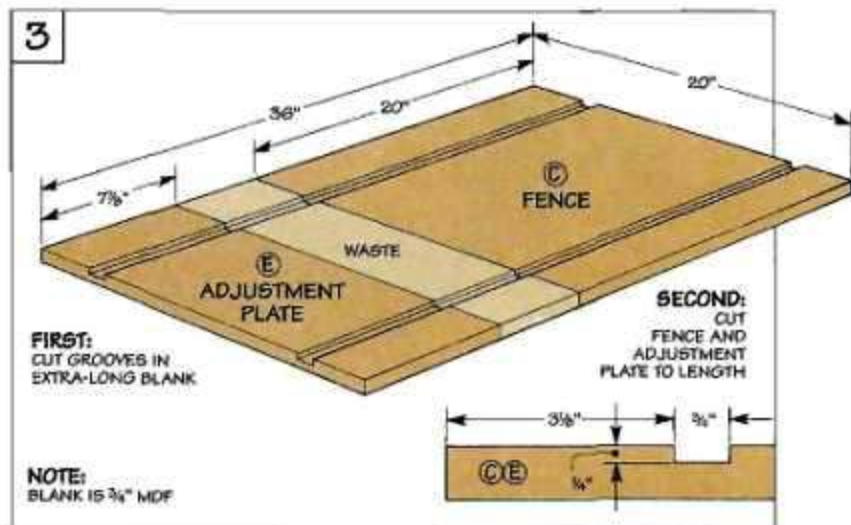

the opening, the goal is to make it large enough so the face of the plate joiner will sit flush with the front of the fence. So you want to check that there's enough clearance for any knobs or levers on the plate joiner. (I sized it to provide a 1/8" clearance all around.)

Once you've established the size, you're ready to lay out the opening. I centered it on the width of the fence and located it so the bottom of the opening is flush with the top dado, see Fig. 4.

An easy way to cut the opening is to drill a hole in each corner and

remove the waste with a sabre saw.

ATTACH FENCE. With the fence complete, you're ready to attach it to the base. To help strengthen the fence and keep it square to the base, I added two triangular supports (D), see Fig. 5.

These supports are screwed to the fence from the front. But to attach them to the base, you'll need to drill a counterbored shank hole in the angled edge of each support.

Once you've drilled all the holes, the only thing left is to glue and screw the pieces together.

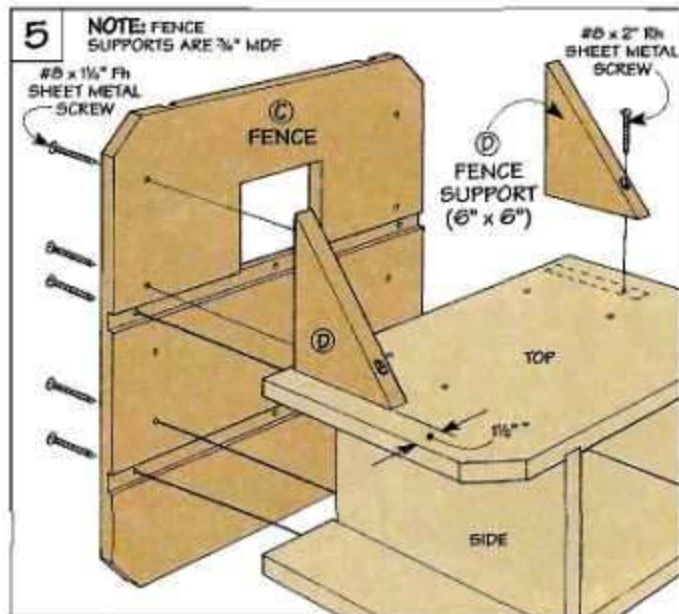
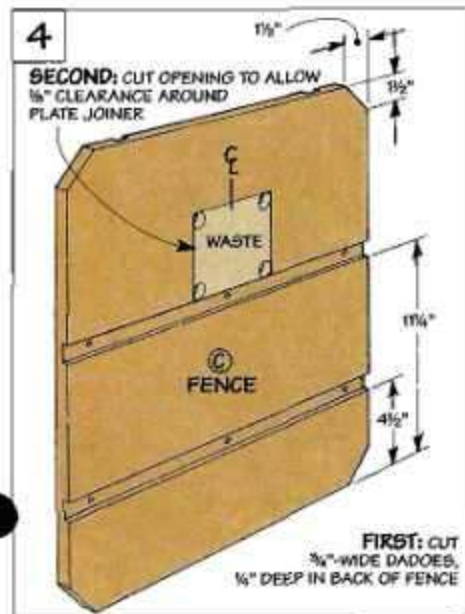

Sliding Table

With the base and fence complete, I added the sliding table. This is an L-shaped assembly that supports the workpiece as you cut the slot for a biscuit.

The height of the table determines the location of this slot on the *thickness* of the workpiece. To ensure the matching slots in two workpieces align, the table has to remain parallel to the blade of the plate joiner.

ADJUSTMENT PLATE. That's where the *adjustment plate* (E) comes in, see Fig. 6. (It's the remaining piece of the blank cut earlier when making the fence.)

To guide the table up and down, a pair of *alignment keys* (F) fit in grooves in the back of the adjustment plate. Since these grooves were already cut earlier, completing the adjustment plate is just a matter of cutting a pair of slots and gluing in the keys (F).

TABLETOP At this point, you can set aside the adjustment plate and start on the *tabletop* (G), see Fig. 7. It's just a piece of $\frac{3}{4}$ " MDF that's rabbeted along the back edge to fit the adjustment plate.

To accept a stop that's added

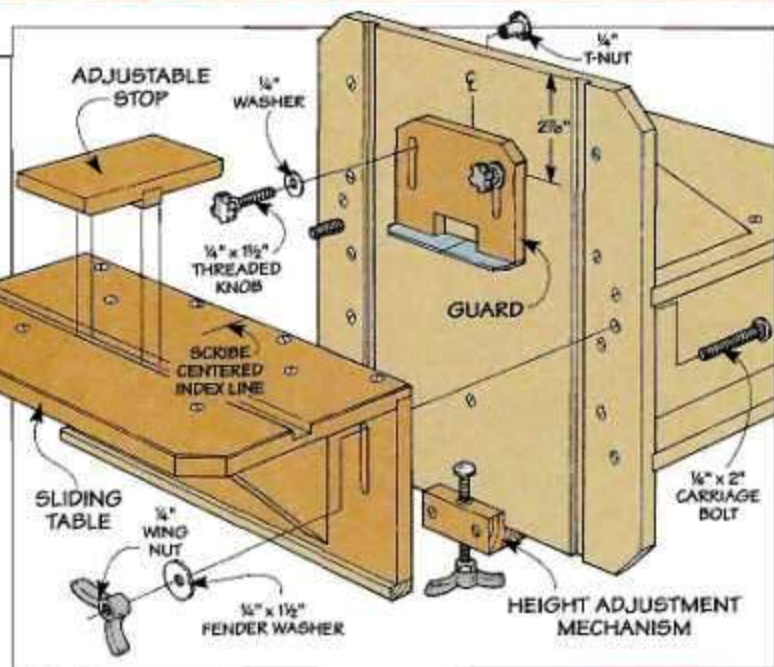

later, you'll need to cut a centered groove in the tabletop. And to avoid chipping the top edges with a workpiece, I routed a slight ($\frac{1}{8}$ ") chamfer around the top edges. (The chamfer along the back edge acts as a dust relief.)

ATTACH TABLETOP After trimming the front corners of the tabletop at an angle, you can attach it to the adjustment plate. Here again, a pair of large triangular *supports* (H) add rigidity to the table, see Fig. 8.

SUPPORT STRIP There's just one more thing to do before mounting the sliding table to the fence. To provide a solid bearing surface for a height adjustment bolt (added later), a thin, hardwood *support strip* (I) is glued and screwed to the bottom edge of the adjustment plate, see Fig. 8.

MOUNT TABLE. Now you can mount the table to the fence. It's held in place by two carriage bolts that pass through holes in the fence and the slots in the

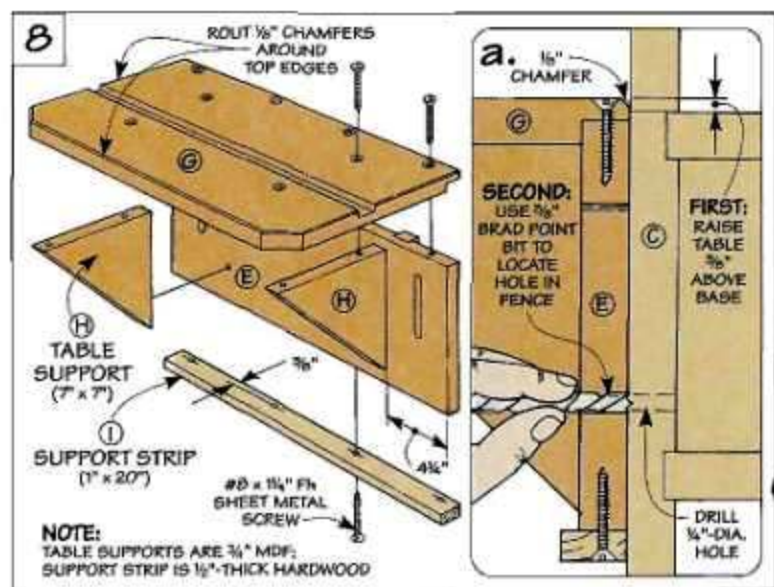
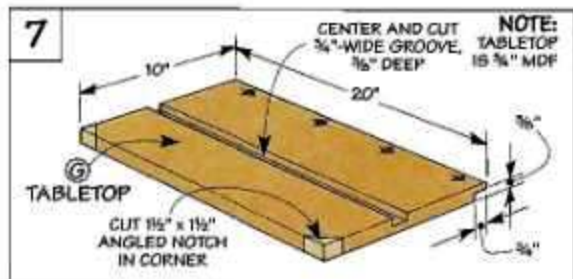
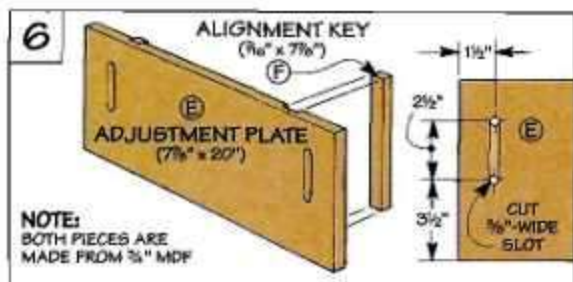

adjustment plate, see drawing on page 20. Tightening a wing nut on the end of each bolt locks the table in place.

When determining the location of the holes for these bolts, there's one thing to keep in mind. To avoid accidentally cutting into the table, you want to establish the *maximum* height that it can be raised.

An easy way to do this is to temporarily clamp the table in place so it's $\frac{3}{8}$ " above the top of the base, see Fig. 8a. Then just mark the *bottom* of the adjustment slots.

HEIGHT ADJUSTMENT. With the sliding table in place, you still need a way to move it up and down. That's the job of the height adjustment mechanism.

What makes it work is an ordinary carriage bolt. It threads into

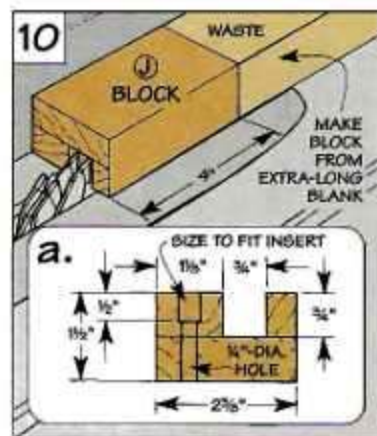
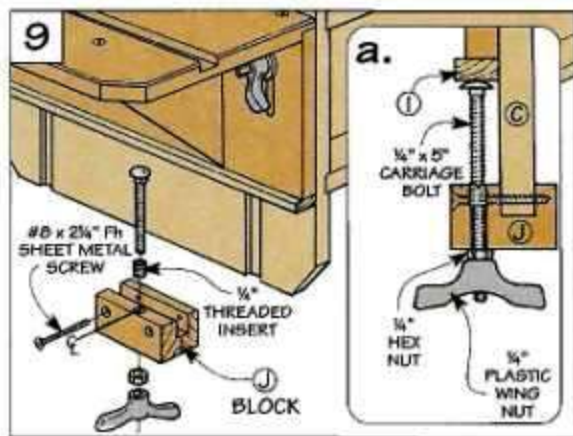

an insert that's installed in a wood block attached to the fence, see Fig. 9. The head of the bolt rests against the support strip (I) on the adjustment plate, see Fig. 9a. When you turn a wing nut that's tightened against a nut on the end of the bolt, the head raises (or lowers) the table.

Since the *block (J)* that holds the height adjustment mechanism is small, it's best to start with a long blank, see Figs. 10 and 10a. (I glued up two hardwood pieces.) After cutting a groove to fit the fence and drilling holes for the threaded insert and bolt, just screw the block in place, see Fig. 9a.

Adjustable Stop & Guard

To make it easier and safer to use the plate joiner table, I added two accessories: an adjustable stop and a blade guard, see drawing on opposite page.

STOP. If you're cutting a slot in end grain, the rotation of the blade will have a tendency to kick the workpiece to the side. To prevent this, a simple stop is clamped to the table, see margin.

The *stop (K)* is a piece of MDF with a *runner (L)* that fits the

groove in the tabletop, see Fig. 11. The runner is simply glued into a dado that's cut in the stop.

GUARD. The second accessory is a guard that protects your fingers when cutting a slot in the end or edge of a workpiece. The guard is an L-shaped assembly that consists of a hardwood *guard support (M)* and a piece of Plexiglas, see Fig. 12.

Before screwing the pieces together, you'll need to cut two

slots to make the guard adjustable. And a square notch helps visibility. Also, scribing a centered index line on the Plexiglas and filling it with ink will make it easy to position a workpiece when cutting a slot.

After attaching the guard to the fence with T-nuts and threaded knobs, I scribed another index line in the tabletop, see drawing on page 20.



An adjustable stop and blade guard provide safer cuts — especially when cutting a slot in end grain.

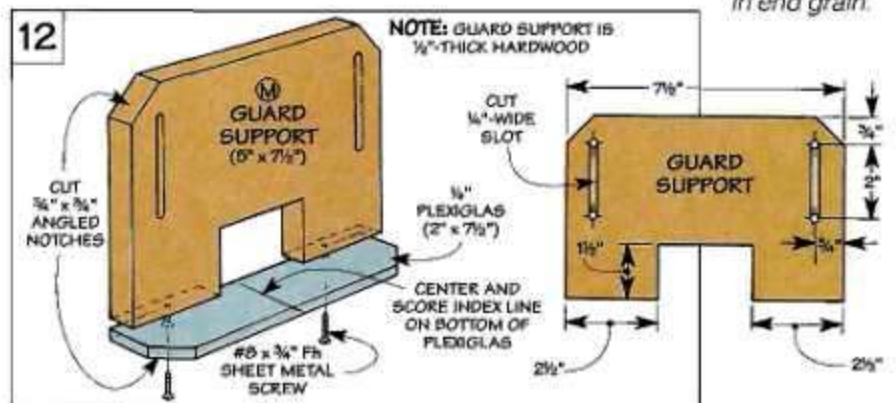
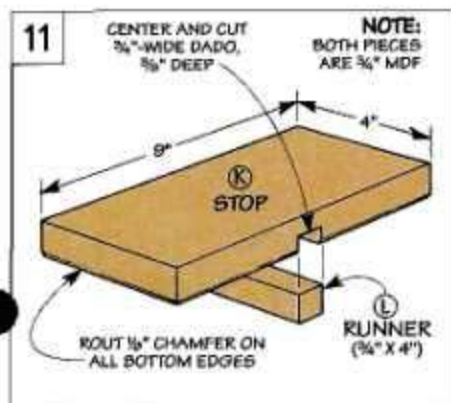

Plunge System



Holes in the base of this DeWalt joiner can be used to screw it directly in place.



With some plate joiners (like this DeWalt), you'll need to position the arm below the power cord.

The heart of the plate joiner table is a system that plunges the blade of the plate joiner through the opening in the fence.

This requires two things: a way to secure the plate joiner to the base, and an arm that applies pressure against the back of the joiner, see Fig. 13.

CLEATS. To keep the plate joiner from moving from side to side, a pair of hardboard cleats (N) fit against the base of the plate joiner, see Fig. 14. Note: Depending on your plate joiner, you may be able to mount it directly to the base, see top margin photo.

HOLD-DOWNS. In addition to the cleats, I added two whistle-shaped hold-downs (O) to apply downward pressure on the plate joiner, see Fig. 14b.

The curved end of each hold-down rests on the cleat, see Fig. 14a. And the opposite end sits flat on top of the base of the plate

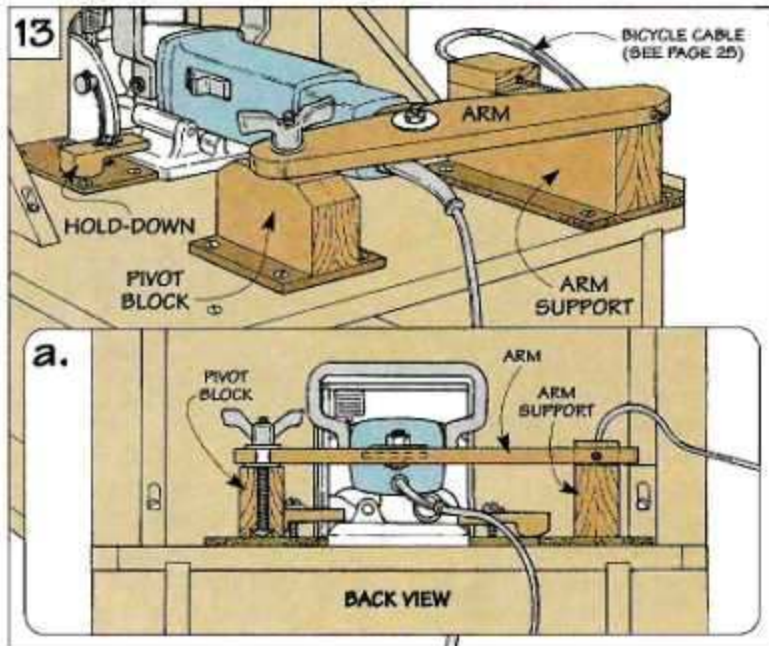

joiner. When you apply pressure on the hold-down, it rocks on its curved end and pinches the flat end tight against the plate joiner.

This clamping pressure is produced by a machine screw that passes through a slot in the hold-

down and into a T-nut installed in the base, refer to page 30.

ARM. Once the plate joiner is mounted to the base, you can start on the arm (P), see Fig. 15. It's a thin piece of hardwood that's shaped like a boomerang. This shape provides a single point of contact so the arm can push the body of the plate joiner forward and plunge the blade out of the opening in the fence.

A hole drilled in one end of the arm serves as a pivot point. And a counterbored shank hole in the opposite end accepts a cable that connects the arm to the foot pedal.

WHEEL. To reduce wear on the plastic housing of the plate joiner, I added a wheel (Q) that spins as the arm pivots, see Fig. 15. It's just a scrap of hardboard that fits into a deep mortise in the arm. The wheel is held in place with a nylon spacer and a lock nut that tightens on a machine screw.

SUPPORT BLOCKS. Before you attach the arm, you'll need to add two support blocks. These blocks raise the arm above the base so it contacts a flat spot on

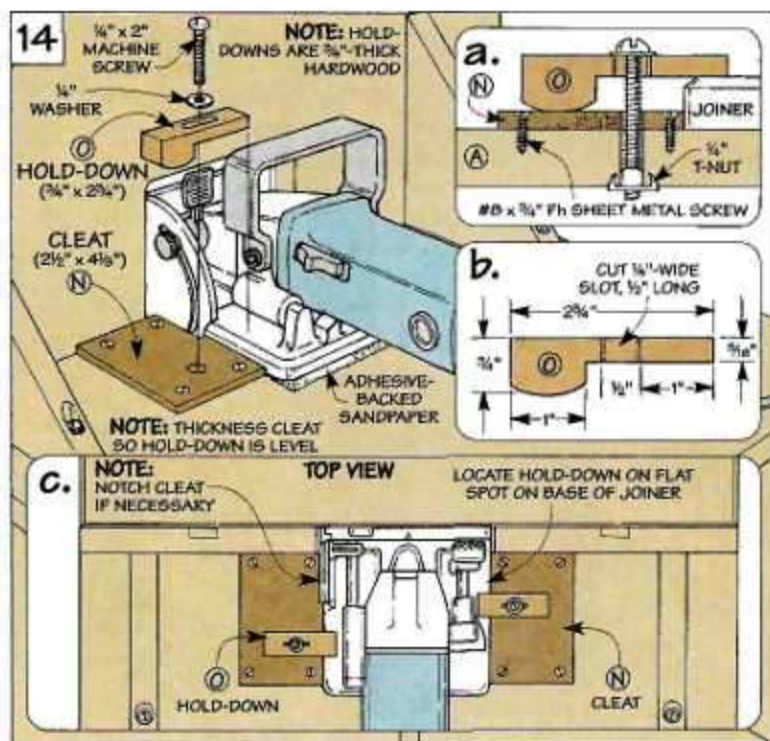

the end of the plate joiner.

PIVOT BLOCK. The arm is secured to the base by means of a thick, hardwood *pivot block (R)* and a *mounting plate (S)* made of $\frac{1}{4}$ " hardboard, see Fig. 16.

What's important here is the *combined* height of these two pieces. The idea is to make the pivot block tall (wide) enough so the arm contacts a *flat* place on the end of the joiner. Note: This may be either above or below the power cord, see bottom photo on page 22.

Once the height is established, just glue up two pieces of $\frac{3}{4}$ "-thick stock to make the pivot block. After installing a carriage bolt that will be used to hold the arm in place, the mounting plate is simply screwed to the bottom.

ARM SUPPORT. At this point, you can turn your attention to the arm support. It holds up the "free" end of the arm. And it serves as a platform for the block that the cable passes through.

Here again, the *arm support (T)* consists of two glued-up pieces of $\frac{3}{4}$ "-thick hardwood, see Fig. 17. And a $\frac{1}{4}$ " hardboard *mounting plate (U)* is screwed to the bottom. But this time, an *upper stop block (V)* with "stepped holes" drilled in it is glued to the top.

ASSEMBLY. Now you can begin assembling the parts. Attaching the arm is easy. Just slip it onto the end of the carriage bolt in the pivot block and thread on a knob. With the arm in place, you're ready to position the pivot block and arm support.

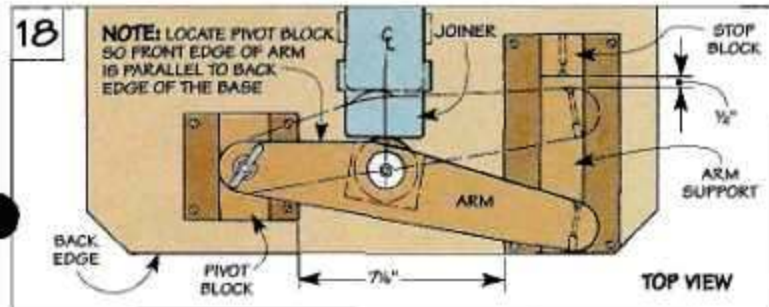
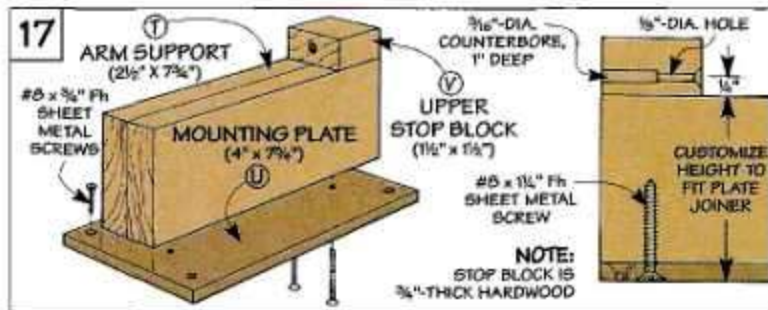
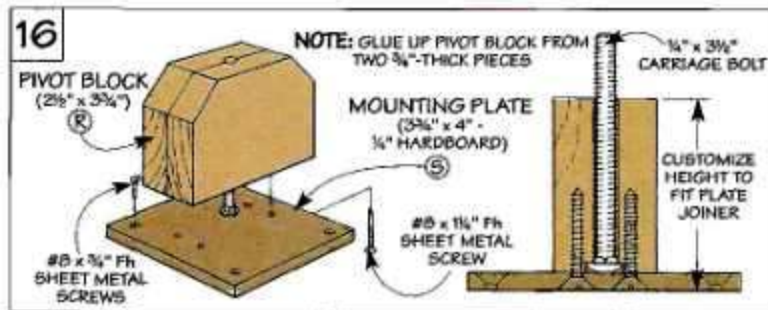
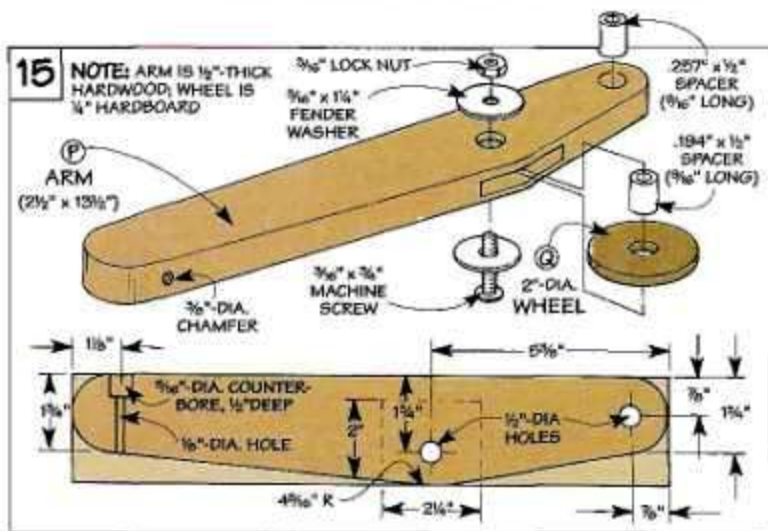

The goal here is to be able to push the arm all the way forward so it won't "bottom out" on the stop block, see Fig. 18. Note: Set the plate joiner for the max-

imum depth of cut.

The best way I found to do this is to temporarily clamp the pivot block in place and check the operation of the arm.

Start by positioning the *front* edge of the arm (nearest the pivot point) so it's parallel with the back of the base, see Fig. 18. Also, check that the wheel is centered on the end of the joiner.

Now push the arm all the way forward. (There should be about $\frac{1}{2}$ " clearance between the stop block and the arm.) Finally, screw both mounting plates to the base.

Foot Pedal



When you "step on the gas" with this foot pedal, it plunges the blade of the plate joiner into the workpiece.

With the plunge mechanism in place, the last thing to do is add the foot pedal, see photo.

It works like the accelerator pedal on a car. Only this pedal plunges the blade of the plate joiner through the opening in the fence and into the workpiece.

What makes this work is a wire cable that slides inside a flexible sleeve. The cable transfers the movement of the pedal to the arm behind the plate joiner.

PEDAL. I started work by making a hardwood *pedal* (W) and *base* (X), see Fig. 19. These pieces are identical in length. But to keep the pedal from binding when a frame is added later, the pedal is $\frac{1}{8}$ " narrower than the base. After drilling a hole in the pedal for the cable (Fig. 19a), just hinge the two pieces together, see Fig. 19b.

FRAME. To provide support for the pedal and base, the next step is to add a wood frame. It consists of two *sides* (Y) that are screwed to the base and a *top* (Z) that holds them together, see Fig. 20.

Before screwing the top in place, you'll need to glue on another *stop block* (AA) and drill a series of "stepped" holes for the cable and sleeve that are added next, see Fig. 20a.

CABLE & SLEEVE. There isn't anything unusual about either

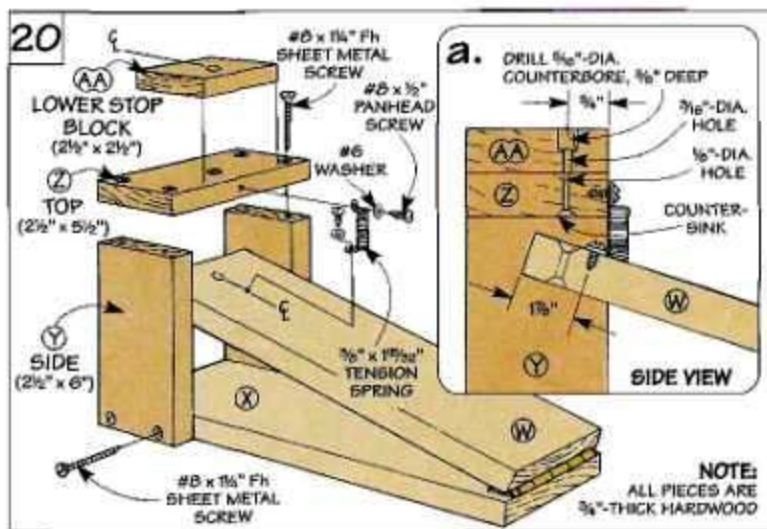
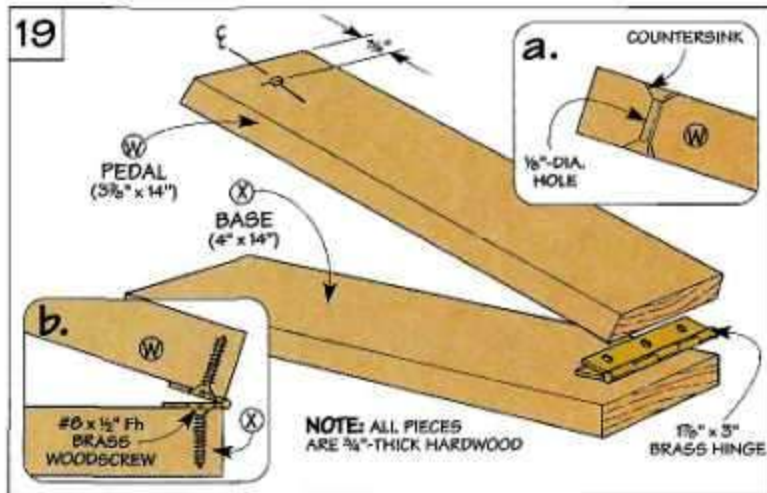

the cable or the flexible sleeve. (I picked both of them up from the local bike shop.) Just be sure they're long enough so you can put the pedal in a convenient place.

INSTALL CABLE. To install the cable, start by sticking one end through the holes in the foot pedal and fasten it to the end of the pedal (W) with a screw and a

Hardware

- (54) #8 x 1 1/4" Fh Sheet Metal Screws
- (2) #8 x 2" Rh Sheet Metal Screws
- (18) #8 x 3/4" Fh Sheet Metal Screws
- (2) #8 x 2 1/4" Fh Woodscrews
- (4) 1/4" Plastic Wing Nuts
- (2) 1 1/2"-Long Threaded Knobs
- (6) 1/4" Flat Washers
- (2) 1/4" x 1 1/2" Fender Washers
- (1) 1/4" x 3 1/2" Carriage Bolt
- (2) 1/4" x 2" Carriage Bolts
- (1) 1/4" x 5" Carriage Bolt

- (1) 1/4" Hex Nut
- (1) 1/4" Threaded Insert
- (4) 1/4" T-Nuts
- (2) 1/4" x 2" Rh Machine Screws
- (1) .257" x 1/2" x Nylon Spacer (9/16"-Long)
- (1) .194" x 1/2" x Nylon Spacer (9/16"-Long)
- (2) 3/16" x 1 1/4" Fender Washers
- (1) 3/16" x 3/4" Rh Machine Screw
- (1) 3/16" Nylon Lock Nut
- (1) 1/16"-Dia. Wire Cable (7 feet)
- (1) Flexible Sleeve (7 feet)

- (1) 1/16" Crimp-On Stop
- (1) 3/16" x 1 10/32" Tension Spring
- (1) 5/16" x 2 23/16" Tension Spring
- (3) #6 x 1 1/2" Panhead Sheet Metal Screws
- (3) #6 Flat Washers
- (1) #6 External Lock Washer
- (1) 1 1/8" Brass Hinge w/Screws
- (1) 2" x 7 1/2" - 1/4" Plexiglas

For a kit to build the Plate Joiner Table that includes all of the above parts, call 800-347-5105.

Kit No. 6833-200.....\$32.95

lock washer, see Fig. 21. Then slip the sleeve over the cable until it "bottoms out" in the stop block. To avoid getting a kink in the cable, slide a spring over the sleeve and push it into the stop block, see Fig. 21a.

SPRING. Before connecting the opposite end of the cable, I attached a spring to the pedal (W) and top (Z). The spring retracts the foot pedal after you step down on it.

CRIMP-ON STOP. There's one last thing to do. That's to run the cable through the upper stop block and arm, then secure it with a crimp-on stop, see Fig. 22.

The goal here is to seat the stop in the counterbore when the arm is "at rest." To do this, you'll need to push the arm forward just a bit. This way, when the spring-loaded base of the joiner pushes the arm back, the stop will be at the correct place.

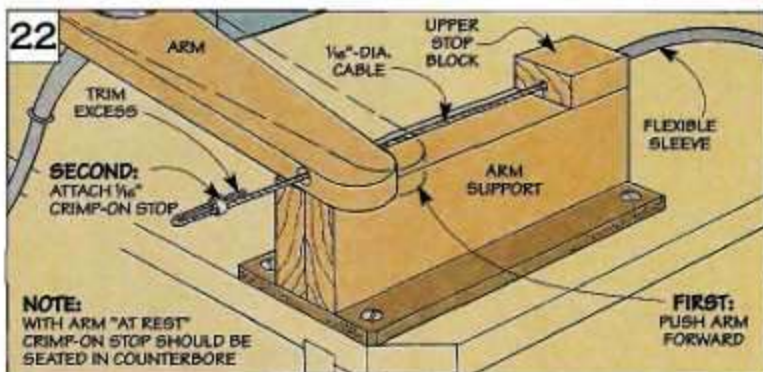
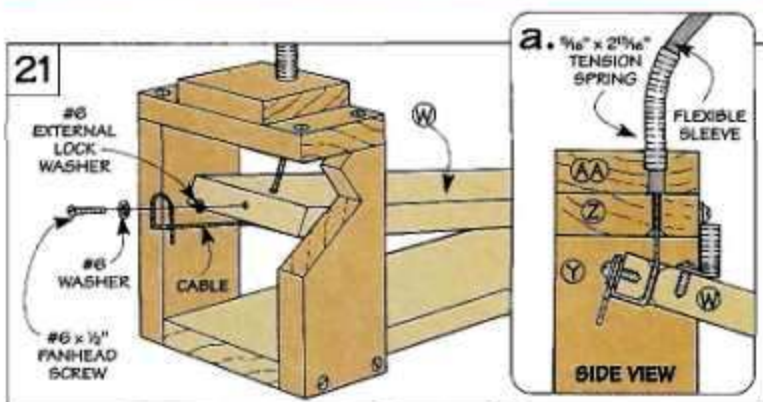

Making Plate Joints

The plate joiner table makes it easy to cut the slots for a biscuit. And it only takes a few minutes to set it up.

SETUP. Start by clamping the base of the table to your bench. Then raise (or lower) the sliding table so the blade will cut the slot at the desired height.

The up and down location of this slot is determined by the side of the workpiece that's face down on the table. So to ensure that the two mating pieces will be flush *after* they're assembled, you'll want to cut the slots with the "show" side down.

LAYOUT. This means you'll need to mark the layout lines for the joints on the *opposite* side. To do this, simply butt the pieces together and make a mark across the joint line.

When cutting a slot, align each mark with the index line on the guard or the table, see photos. 



◀ **Edge Joints.** It's easy to cut a slot in the edge of a board. Just align the layout mark for the slot with the index line on the guard. Then hold the workpiece firmly against the fence as you step on the foot pedal.



◀ **End Grain.** You can also cut a slot in the end of a workpiece. Only here, the adjustable stop is clamped to the sliding table so the rotation of the blade doesn't cause the workpiece to "walk" to the side.



◀ **Face Cuts.** To cut a slot in the face of a workpiece, first remove the guard. Then, with the layout mark on the workpiece aligned with the index line on the table, hold the workpiece securely against the tall fence as you make a cut.

Plate Joiners

I have to admit it. I felt a bit guilty when I first started using a plate joiner. After all, making a plate joint almost seemed *too easy* — like there should be more to it than just cutting a pair of curved slots and then gluing in a simple wood plate or “biscuit.”

But the more I use a plate joiner, the more I've come to appreciate it. I can lay out and cut the matching slots in a matter of seconds. And gluing in the biscuit creates an incredibly strong joint.

So I guess you could say I've changed the way I look at plate joiners. And that's not all that's changed.

NEW MODELS. Recently, a number of manufacturers have come out with new plate joiners (or added improvements to existing models).

To find out which one of these plate joiners is best, we bought and tested five of the most popular models, see photos at left and in margin on next page.

In addition, we took a look at the new Ryobi Detail Joiner, see box on next page.

TEAM. As usual, we rounded up our team of three woodworkers to test the plate joiners. Both *Ken* (a professional cabinetmaker) and *Steve*

(an advanced woodworker) have used plate joiners extensively in their shops. And *Cary* (who has been working wood for a couple of years now) has assembled a number of projects with plate joints.

Q: One of these plate joiners looks quite a bit different than the others. What's the reason for that?

Ken: I'd say the biggest reason has to do with the position of the motor inside the plastic housing of the plate joiners.

With the Porter Cable, the motor is directly *above* the blade. To cover the motor, the housing and handle are shaped like a 'D,' see bottom margin photo on page 27.

But the motor in the other joiners is *behind* the blade. So the housing is shaped more like a barrel.

With these “barrel grips,” my hand is down low — right behind the blade. So it feels like I have more control than with a D-shaped handle.



▲ These new plate joiners make it easy to cut the matching curved slots for a biscuit, see photo at left.



DeWalt DW682K
800-433-9258
\$219.00



Freud JS-102
910-434-3171
\$179.95



Makita 3901
800-462-5482
\$210.00



Plunge Systems

BODY OF PLATE JOINER SLIDES ON MACHINED STEEL ROD

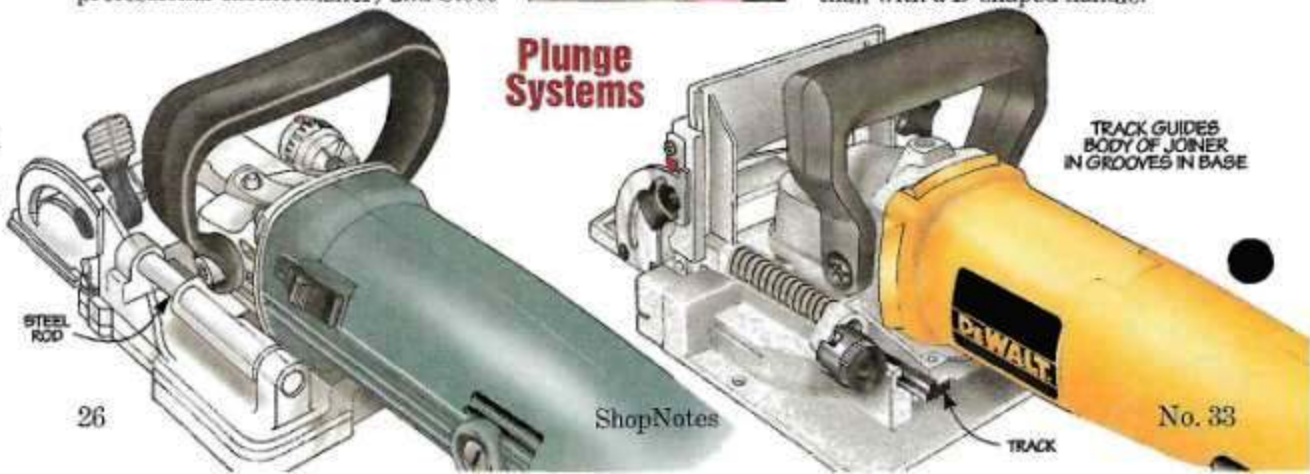

TRACK GUIDES BODY OF JOINER IN GROOVES IN BASE

STEEL ROD

26

ShopNotes

TRACK

No. 33

Steve: I like the barrel grips too. But with the Virutex, Freud, and Makita, the barrel is too thick for me to wrap my hand around comfortably. The slim barrel on the DeWalt is just about right for me.

Ken: Another thing I like about the DeWalt is that the on/off switch is right under my fingers when I pick up the joiner. (See photo A on opposite page.) So all it takes is a little squeeze and I'm off and running.

The slide switches on the Virutex, Freud, and Makita aren't quite as handy. I have to shift my grip a little. But of all these slide switches, the one on the Virutex makes the most sense. It's right on top of the barrel, so either a right-hander or left-hander can get to it. (See photo B.)

The switches on the Makita and Freud are on the left side of the barrel. So if you're a left-hander, it's going to be a two-handed job to turn on the plate joiner.

At least with the trigger switch on the Porter Cable you can use either hand. (See photo C.)

Q: What about the plunge operation of these joiners? Are any of them smoother than the others?

Ken: No doubt about it. The plunge operation on the Makita is the smoothest of the bunch. That's because the body of the joiner slides on two machined steel rods in the base — like a plunge router. (See drawings at bottom of page 26.)

All the other joiners are designed with tracks that slide in grooves in the base. These tracks aren't quite as smooth. But they work fine.

Cary: The only one I had a problem with is the Porter Cable. There's quite a bit of slop in the fit between the body and the base. So every once in awhile, it binds as I make a cut.

Ken: What bothers me more than that is the Porter Cable has a tendency to bog down when I'm making a cut — especially in hardwood.

Since it has about the same size motor as the other joiners, I thought the problem might be the blade. When I checked, I found it had twelve teeth instead of six like the other joiners. (See center photos above.)

To find out if the number of teeth might be the difference, I called the guys at Porter Cable. They told me the wrong blade had been installed at the factory. But when they sent a new one (also with twelve teeth), it didn't cut any better.



Changing Blades. To provide access to the blade on the Makita, just loosen a knob and flip up the base. But you'll practically have to disassemble the Porter Cable (right) to change blades.

Q: Do any of these plate joiners make it any easier to change blades?

Steve: It's a snap with the Makita. All I have to do is loosen one knob and the base flips up out of the way. (See photos above.)

Changing the blade on the DeWalt, Freud, and Virutex is pretty easy too — just remove a few screws to get to the blade. But changing the blade on the Porter Cable was more involved. I had a pile of parts on the bench by the time I got to the blade. And even then, getting the blade off is a pain. There's only one wrench. So I have to slip a screwdriver between the teeth of the blade to hold it in place while I loosen the arbor nut.

The Freud and Virutex both come with two wrenches which makes it easier to change blades.

Ken: Even so, when it comes to changing blades, it's hard to beat the DeWalt and Makita. They're the only joiners with a spindle lock. So all I have to do is push a button and loosen the arbor nut.



Virutex AB-11C
513-561-6560
\$235.00



Porter Cable 556
800-487-8665
\$139.95

Detail Joiner

This Ryobi Detail Joiner has one big advantage over a full-size plate joiner — it cuts a small slot.

The depth of this slot can be adjusted for three miniature biscuits, see photo. Note: The middle size '10' biscuit is shown in the background as a comparison.

Although these biscuits don't have the strength of the larger



biscuits, they're ideal for projects like small boxes and picture frames.

Note: The Ryobi is available at many home centers for about \$79.

Performance

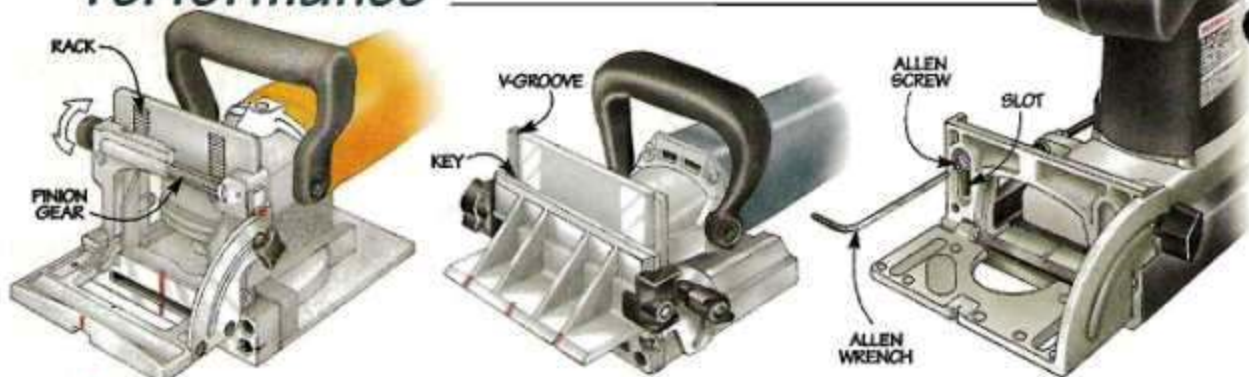

▲ **Fences.** The rack and pinion gear on the DeWalt (left) moves the fence smoothly and evenly up and down the face of the joiner. Although the "keyed"

system on the Freud (center) and the slotted fence on the Porter Cable (right) aren't as elaborate, they both do a good job of keeping the fence aligned.

Q: What's the most important thing to look for when it comes to the performance of a plate joiner?

Steve: The biggest thing for me is the accuracy of the fence. It has to lock perfectly parallel to the blade. Otherwise, the slot that's cut in one piece won't align with the slot in the other one when I glue in a biscuit.

Ken: With the fences on these joiners, each one did lock parallel. But they go about it differently.

The DeWalt and Makita both use a rack and pinion gear that guides the fence smoothly up and down the face of the joiner. (See drawings above.) It keeps the fence perfectly aligned. And it makes it easy to "tweak" the height of the fence.

Cary: I also liked the guide systems on the Freud and Virutex. Each of these joiners has a "key" that fits in a groove to keep the fence aligned.

Steve: The Porter Cable takes a different approach to keep the fence aligned. A pair of slots in the fence fit over Allen screws in the face of the joiner. This works fine. But fiddling with the screws each time I adjust the height of the fence is a hassle.

Ken: At least with the Porter Cable, the fence stays put when I tighten it down. I can't say that about the fence on the Virutex.

The problem with it is I need to adjust *two* separate levers to change the height of the fence. And one of these levers also locks in the *angle* of the fence. When I retighten this lever, the fence "creeps" just a bit which changes the angle. So every time I adjust the height of the fence, I need to double-check the angle.

Q: How do you adjust the angle on these joiners?

Ken: Each joiner has a fence that adjusts for the desired angle. And except for the Virutex, the knobs (or levers) that lock it in place are independent of each other. But what's different is how the fence is positioned on the workpiece.

Say I'm cutting a slot in the mitered end of a

Outside Reference. With a fence that "traps" the mitered end of a workpiece, the cut is referenced off the outside face. Besides providing more control, this ensures the two pieces will align — even if they vary in thickness.



Inside Reference. If the fence rests on the inside face of a workpiece when making an angled cut, the pieces need to be the same thickness to get them to align. Also, the joiner feels like it wants to slip up on top of the piece.



▲ **Face Cut.** When cutting a slot in the face of a workpiece, a flip-up fence (right) is handier than one you have to remove from the plate joiner (left).

SELECTING TOOLS

workpiece. The Freud, Makita, and DeWalt “trap” the long point of the miter. (See photos at lower left on page 28.) So the location of the slot is referenced off the *outside* face of the workpiece. This way, I know that the outside face of each piece will be flush — even if the pieces vary in thickness.

Cary: I can't count on that with the Virutex. That's because the fence rests on the *inside* face of the workpiece. Besides the possible alignment problems, I always get this feeling that the joiner is going to slip up onto the workpiece.

Steve: The same thing is true for the adjustable fence on the Porter Cable. But it also comes with a second “fixed” fence that traps the workpiece.

Q: What about cutting slots in the face of a piece?

Steve: With the DeWalt and Virutex, I just flip the fence up out of the way. (See bottom right photo on opposite page.) That's handier than having to remove the fence like on the other joiners.

Q: All these joiners have some type of system that grips the workpiece and keeps it from “walking” as you make the cut. How well do they work?

Ken: When the workpiece covers the front of the base completely, all the “grips” work great. But I noticed a big difference when cutting a slot in the end of a narrow piece.

The Makita is the only joiner that provides a positive grip on narrow stock. (See photos above.) The rubber “bumpers” on the Virutex and Freud and the metal pins on the DeWalt and Porter Cable are too far apart to be of any help on a narrow piece.



▲ Dust Control. Either a hook-up for a shop vacuum (left) or a dust bag is a “must” for a plate joiner. Otherwise, dust blows all over the shop (right).



RUBBER INSERT

◀ Grips. The wide rubber insert on the Makita (top) grips securely — even on narrow workpieces. But the metal pins (lower left) and rubber bumpers (lower right) are too far apart for narrow work.



Q: Cutting the slots for the biscuits creates lots of dust. How well do these joiners control dust?

Cary: The DeWalt, Makita, and Freud all have dust bags. But the bags fill up fast. So I'm glad these joiners also have a hook-up for a shop vacuum.

Ken: That's your only option with the Virutex. But that's okay — the vacuum hook-up works great. (See photos at lower left.)

Steve: What surprised me is the Porter Cable doesn't have anything at all to help control dust.

Q: One last question. Is it easy to set the depth of cut?

Steve: Once I set the initial depth of cut, it's a piece of cake. I just “dial in” the depth adjustment with a turret or stop rod. (See photos below.)



◀ Turret. You can set the depth of cut on the DeWalt, Makita, and Freud (shown) by simply rotating a turret. A screw on the body stops the blade at the correct depth.



◀ Stop Rod. To set the depth of cut on the Virutex and Porter Cable (shown), simply turn a knurled knob on the end of a stop rod. When this knob contacts a stop on the base, the cut is complete.

Recommendations

Ken: I picked the DeWalt as the best plate joiner. And the reason is simple — it's a quality tool.

That quality shows up in every detail — a precision fence, a switch that feels like it's part of the barrel, and even a spindle lock.

Steve: Deciding between the DeWalt and Makita was tough. But I finally chose the Makita.

The fence adjusts easily and accurately. And the plunge system is incredibly smooth when I'm cutting a slot.

Cary: I'd buy the Freud. It's a good, solid plate joiner that gives me a lot for my money.

The most important thing is the fence. It's simple. But the height and angle adjustments are well-thought out and easy to use. **▲**

GLUING-UP A MITERED CORNER

■ Gluing up all four mitered corners of a frame can be a challenge. That's because the slightest amount of extra pressure from one of the clamps can cause the frame to rack — which can create gaps in the corners.

So when gluing up the apron for the folding table shown on page 10, Steve (our shop manager) worked on *one* mitered corner at a time.

What keeps each corner square is a simple block of wood. (Just be sure you square up the block.) After gluing the ends of



the miters and inserting a spline, the block is clamped to the inside of the corner. Note: Chamfering the corner of the block provides a relief area for glue squeeze-out.

CONTACT CEMENT

■ Contact cement creates a strong instant bond as soon as the two glued-up surfaces touch. So trying to get the workpieces aligned *before* you stick them together is always a bit unsettling.

The solution is to use wood strips to raise the plastic laminate directly above the core piece, see Step 1 below. This allows you to position the plastic laminate so it overhangs the edges of the core piece all the way around.

Now remove the center strip and press the laminate in place, see Step 2. As you work toward each end, take out one strip at a time and continue to press the laminate against the core.

After all the strips have been removed, you'll need to use a roller (or a wood block with a hammer) to push out any trapped air bubbles and ensure a strong bond. Just be sure you don't accidentally crack the part of the laminate that overhangs the core piece.

Step 1. With contact cement applied to both surfaces, place wood strips between them. This keeps the pieces from sticking together while you position the laminate.



Step 2. Now remove the center strip and press the plastic laminate in place. Repeat this process as you work toward the edges. Then use a roller to remove any air bubbles.



TRANSFERRING A PATTERN



■ To make the hold-downs for the taper jig shown on page 6, we used a simple trick to transfer the pattern to the workpiece. All it requires is a photocopy of the pattern and an ordinary household iron.

With the photocopy placed



face down against the workpiece, slowly move the iron (set on high) back and forth, see photo above left.

The heat from the iron activates the toner which transfers the image to the workpiece, see photo above right.

INSTALLING A T-NUT

■ Normally, I use a hammer to tap a T-nut (with prongs) into a workpiece. But when installing the T-nuts for the hold-downs on the plate joiner table shown on page 16, there wasn't enough room to swing a hammer. So I used one of the large plastic wing nuts for the project and a bolt instead.

Start by threading the bolt all the way into the T-nut. Then slip the bolt and the barrel of the T-nut into the pre-drilled hole in the workpiece.

To seat the T-nut, just thread the wing nut on the end of the bolt. Tightening the wing nut draws the prongs into the workpiece, see photo below.



New Products

Spring-Loaded Punch

■ At first, I was pretty skeptical whether this spring-loaded center punch would work. But not after I used it to make a punch mark in a piece of round metal bar stock. It produced a clean, crisp indentation.

Unlike the center punches that you hit with a hammer, this one is designed to be used one-handed. Just position the tip and push down on the barrel until you hear the spring mechanism "pop." Depending on the type of metal (or how deep you want the punch mark), the tension on the spring can be easily adjusted. Note: This punch (Model 79) is made by General Tools and sells for around \$16.



Sources

To find these new products, you can call the companies listed below for your nearest dealer:

- **Spring-Loaded Punch**
General Tools
212-431-6100
- **Dado Shims**
SystiMatic
800-426-0035
- **Precision T-Rule**
Taylor Design Group
972-484-5570

Magnetic Dado Shims



■ Adjusting the width of a stacked dado blade with paper (or cardboard) shims can be a frustrating experience. The narrow opening for the table insert makes it difficult to reach inside the saw cabinet and slip the shims onto the arbor. And if the paper isn't the correct thickness, you have to start all over.

But these magnetic dado shims made by SystiMatic solve both problems. Since they're magnetic, they stick to the saw blade. So you can slap on the shim *before* you put the blade on the arbor, see photo at left.

Also, each pack of six shims has three different thicknesses. So it's easy to adjust a dado blade to the exact width you need. Note: A pack of magnetic shims costs about \$20.



Precision T-Rule

■ There's only one thing wrong with Incra's new 12" precision T-rule. If my projects don't turn out just right, I won't be able to blame it on the accuracy of this rule. After all, it's designed to do layout work with an accuracy of up to $1/64$ ".

What makes this possible is a series of tiny pin holes and slots that are graduated in three different increments ($1/16$ ", $1/32$ ", and $1/64$ "). To lay out a mark, you just poke the tip of a mechanical pencil down through one of the openings. Note: You'll need a pencil with 0.5 mm lead.

But this accuracy won't mean a thing if the "zero" increment on the rule isn't lined up with the edge of the workpiece. So the rule is designed with a fence that butts up against the edge of the workpiece and automatically "zeroes out" the rule.

Note: We bought our T-rule for about \$35, see Sources.



Scenes from the Shop

Back in the early 1900's, ▶ tapering a leg was quiet work. After laying out the taper with a straight edge and knife, a craftsman would reach for a jack plane like this Bailey No. 26. It offered the best of both worlds — an easily adjustable blade, and the feel of a wood-bodied plane as it peeled off shavings.

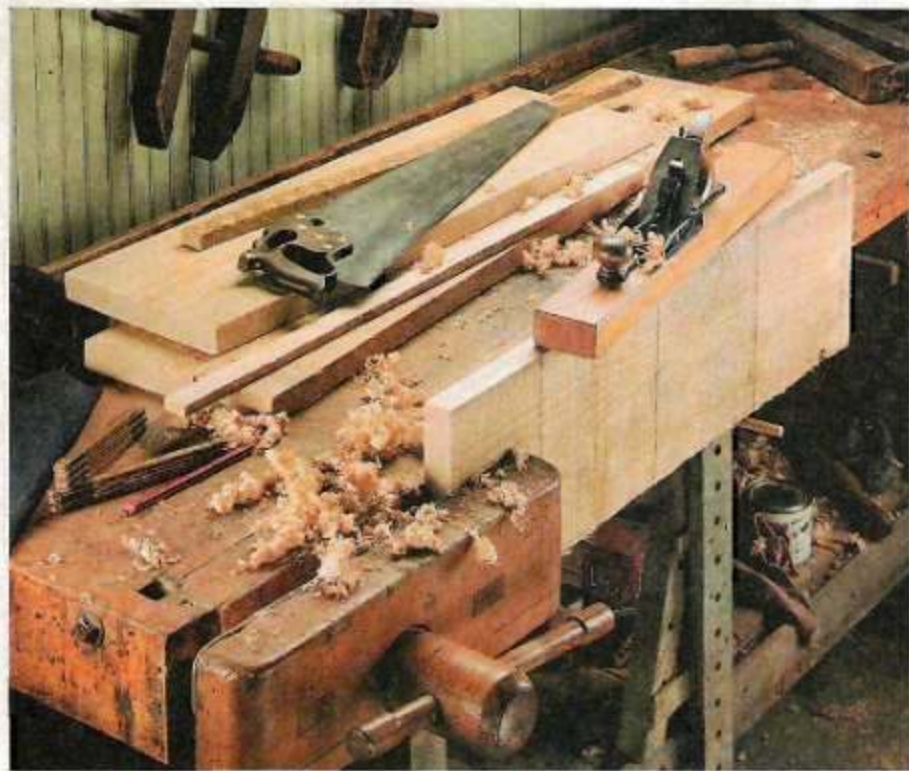

◀ This Stanley No. 31 jointer plane provided the same advantages of wood and metal. But it was 24" long — a full 9" longer than the jack plane. This extra length made it the ideal tool to true up the edge of a long workpiece.