

TIPS • TOOLS • TECHNIQUES

ShopNotes

Vol. 6

Issue 32

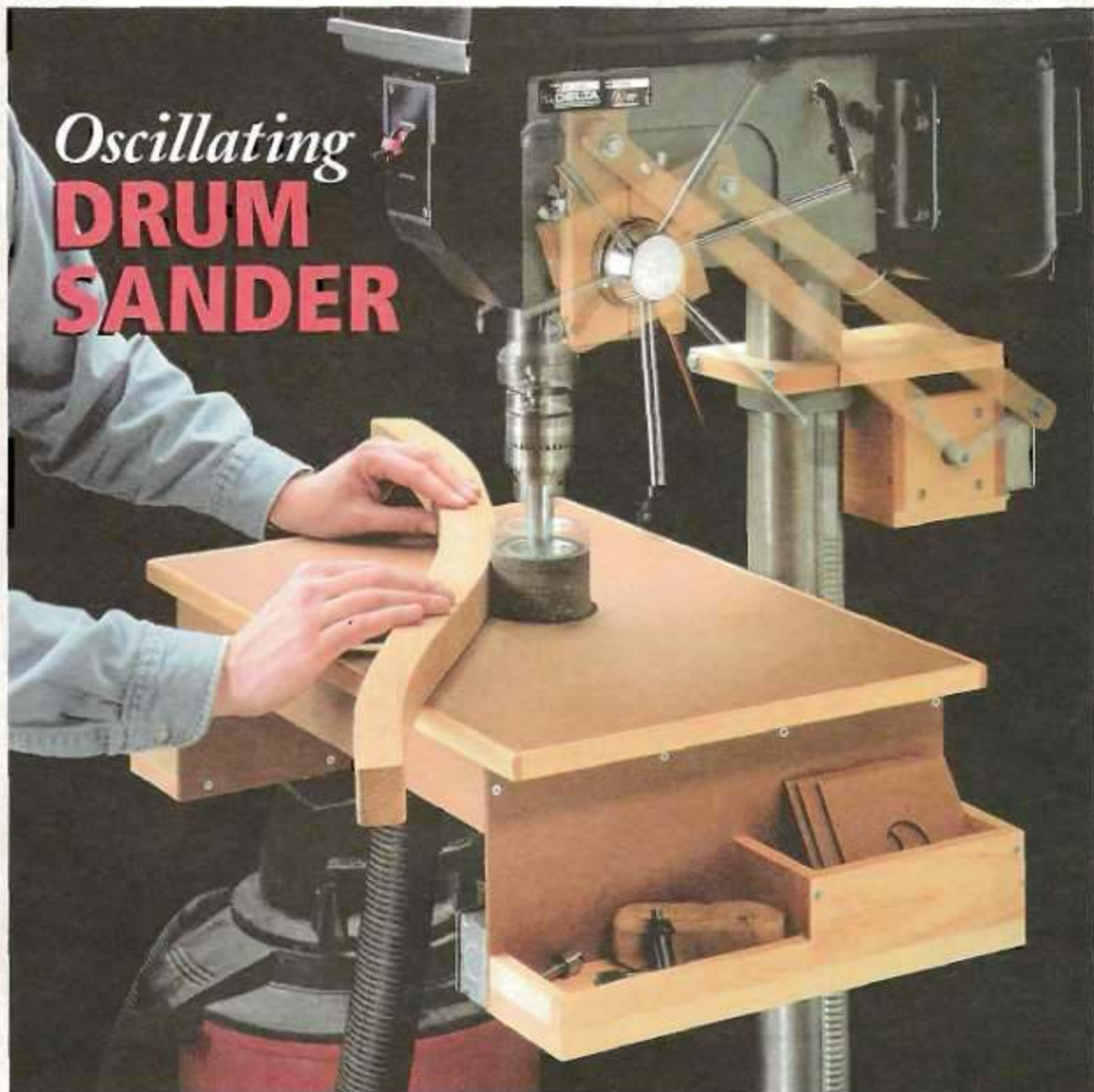

Oscillating
**DRUM
SANDER**

- Block Plane Review ■ Routing Finger Joints
- Clipboard Box ■ Sandpaper Storage ■ Parquetry



ShopNotes

Issue 32

March 1997

PUBLISHER Donald B. Peschke
EDITOR Tim Robertson
ASSOCIATE EDITOR Phil Totten
ASSISTANT EDITOR Bryan Nelson
ART DIRECTOR Cary Christensen
SR. GRAPHIC DESIGNER Kurt Schultz
SENIOR ILLUSTRATORS Roger Reiland
 Mark Higdon

CREATIVE RESOURCES

Creative Director: Ted Krausek • *Project Developer:* Ken Munkel • *Project Designer:* Ted Wong • *Shop Aids:* Steve Curtis • *Shop Craftsmen:* Steve Johnson • *Photography Dir.:* Lark Schroeder • *Sr. Photographer:* Gregory England

BOOKS

Executive Editor: Douglas L. Hicks • *Art Director:* Linda F. Vermie • *Sr. Graphic Designer:* Chris Glowacki

CIRCULATION

Circ. Dir.: Susan DeBols • *Direct Mail Mgr.:* Glenda Bittles • *Sch. Mgr.:* Sandy Baum • *Revenue Mgr.:* Paige Rogers • *Asst. Direct Mail Mgr.:* Julie Greenlee • *Asst. Sch. Mgr.:* Joy Krause • *Assoc. Graphic Design Dir.:* Susie Rider • *Sr. Graphic Designer:* Cheryl L. Simpson

CORPORATE SERVICES

Vice Pres. of Planning & Finance: Jim McCarthy • *Controller:* Robin Hutchinson • *Sr. Accountant:* Laura Thomas • *Accts. Payable Clerk:* Mary Schultz • *Prod. Dir.:* George Chauskars • *Elect. Pub.:* Douglas M. Lindler • *Prod. Asst.:* Susan DeLuzan • *Prod. Artist:* Jim Snyder • *Pre-Press Image Spec.:* Troy Clark • *Elect. Comm. Coord.:* Gordon C. Galpe • *Net. Admin.:* Al Barnes • *Prnt. Develop. Dir.:* Joyce Moore • *Human Res. Asst.:* Kirsten Koels • *Admin. Asst.:* Jahn Pisk • *Receipt.:* Jeanne Johnson, Sheryl Ribbey • *Bldg. Maint.:* Ken Griffith

MAIL ORDER

Operations Director: Bob Baker • *Materials Manager:* Mark Maitland • *Customer Service Manager:* Jennie Eng • *National Sales Manager:* Kent A. Buckton • *Warehouse Supervisor:* Nancy Johnson • *Buyer:* Linda Jones • *Operations Assistant:* Tammy Aldin • *Production Copywriter:* Dave Stone • *Typesetter:* Kirk Dillinger • *Tech. Rep.:* Matthew Tullomle • *Cust. Service Reps.:* Anna Cox, Margo Petrus, Tammy Trueland, William Nelson, Nancy Downey • *Warehouse:* Chuck Carlson, Sylvia Carey, Larry Price, Scott Gilliam

ShopNotes® (ISSN 1082-9086) is published bimonthly (Jan., March, May, July, Sept., Nov.) by August Home Publishing, 2290 Grand, Des Moines, IA 50312

ShopNotes® is a registered trademark of August Home Publishing ©Copyright 1997 by August Home Publishing. All rights reserved.

Subscriptions: Single copy: \$4.99. One year subscription (6 issues): \$24.95. Canada/Foreign add \$5 per year.

Periodicals Postage Paid at Des Moines, IA and at additional mailing offices.

Postmaster: Send change of address to ShopNotes, P.O. Box 37183, Boone, IA 50037-2191.

Subscription Questions? Write to: ShopNotes Customer Service, P.O. Box 342, Des Moines, IA 50304-0342. Or call 1-800-333-6654, 8:00 am to 2:00 pm, Central Time, weekdays. FAX 515-283-0447

E-Mail: ShopNotes@aol.com

Internet: <http://www.augusthome.com>

PRINTED IN U.S.A.

WoodNet

NOW ON THE WEB

- 50 Woodworking Tips Online
- Woodworking Techniques — Step-by-Step
- Project plans you can download
- WoodNet Forum — Woodworkers' Q & A
- Power Tool Reviews

Print your browser for <http://www.augusthome.com>. Select "Woodworking" from the Welcome Page menu.

EDITOR'S NOTE

Cutoffs



Recently, I got a letter

from a reader about a project he was building. To end the letter, he asked a question that gave me a good chuckle. And I have to admit, it had me stumped.

FLANNEL SHIRTS. What he wanted to know was where Norm (the popular host of *The New Yankee Workshop*) gets his flannel shirts. Now as a matter of fact, Norm *did* stop by here for a visit once. But I never asked about his shirts.

Nevertheless, I do know one thing. There seems to be some kind of strange connection between woodworkers and flannel shirts. In fact, the guys here at *ShopNotes* show up so often dressed in flannel shirts, we've even earned a new nickname — the flannels.

So what is it about flannel shirts anyway? Perhaps it's a combination of cold winters and drafty shops. Or maybe it's that they just plain *feel* good — a lot like the comfortable feel you get when using a special hand tool.

BLOCK PLANE. My block plane is a perfect example. I've spent some time tuning it up, so I'm familiar with how all the parts of the plane fit and work together. How the plane body fits easily and naturally into the cup of my hand. I've even softened the harsh metal edges, so it's like picking up a smooth river rock.

But that's enough about *my* block plane. After all, another woodworker might not like how it adjusts or the way it feels. And more than likely, he'd get results that are just as good (or

better) with his own block plane.

SELECTING TOOLS. Which brings up a point. In this issue, we've taken a different approach with our article on selecting tools.

We've visited with four different woodworkers about the block plane they use day in and day out. And even more important, the reasons *why* they use them. As you'd expect, what they had to say is as different as the wide range of block planes available.

One person doesn't like to sharpen blades. So he uses a plane with disposable razor blades. While another likes the traditional look and feel of a wood-bodied block plane. (For more on their favorite planes, refer to page 12.)

OSCILLATING DRUM SANDER. In this issue, we're also featuring a project that has attracted a lot of attention in the shop — an oscillating drum sander for your drill press.

The basic idea of this sander is simple. It lets you sand the edge of an irregular-shaped workpiece with a drum sander that spins around and goes up and down at the same time.

Now we can't take credit for getting the sanding drum to spin around (just flip the switch on the drill press).

But I'm pretty impressed with how Ken (our project developer) managed to get the sanding drum to move up and down — especially since his *first* idea was to mount a bowling ball to the end of a long bar and use it as a pendulum to move the feed lever back and forth.

The "real" solution is even better. It's a unique drive system that connects a small, electric motor to the feed lever. As the drive system moves the feed lever back and forth, the sanding drum moves up and down. (For the rest of the story, see page 16.)

Tim

Contents

Projects & Techniques

Clipboard Box _____ 4

It's a clipboard...and it's a box. Together, they provide a handy way to plan your projects. In addition to serving as a writing surface, the clipboard doubles as the top of the box to organize your writing materials and supplies.



Clipboard Box page 4

Parquetry _____ 8

Thin pieces of veneer cut in basic geometric shapes. That's the idea behind parquetry. And that's all it takes to create a striking wood pattern. Our step-by-step article shows you how to get professional-looking results.



Parquetry page 8

Oscillating Drum Sander _____ 16

This simple, shop-built accessory converts your drill press into an oscillating drum sander. With a small, gearmotor and a unique drive system, the sanding drum spins around and goes up and down at the same time.



Oscillating Sander page 16

Sandpaper Storage _____ 24

Keep your sanding supplies organized with these two storage projects. One presses sheets of sandpaper flat to prevent the edges from curling. The other holds a roll of sandpaper and makes it easy to cut strips to exact length.

Departments

Selecting Tools Block Planes _____ 12

A block plane that's used every day is like an old friend. We visit with four woodworkers about their block planes and find out what makes each one a "favorite."

Tips & Techniques Readers' Tips _____ 28

Our readers offer their own shop-tested tips: Retractable Chuck Key, Wedged Sanding Block, Plastic Knobs, Pocket Holes, and a Pencil Cushion.

Tips From Our Shop Shop Solutions _____ 30

We've also included a variety of tips from the guys in our own shop to help build the projects in this issue.

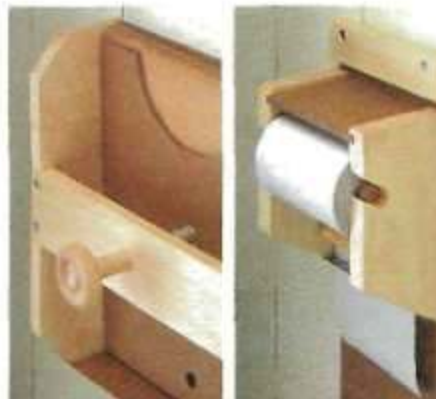

Sandpaper Storage page 24

Clipboard Box

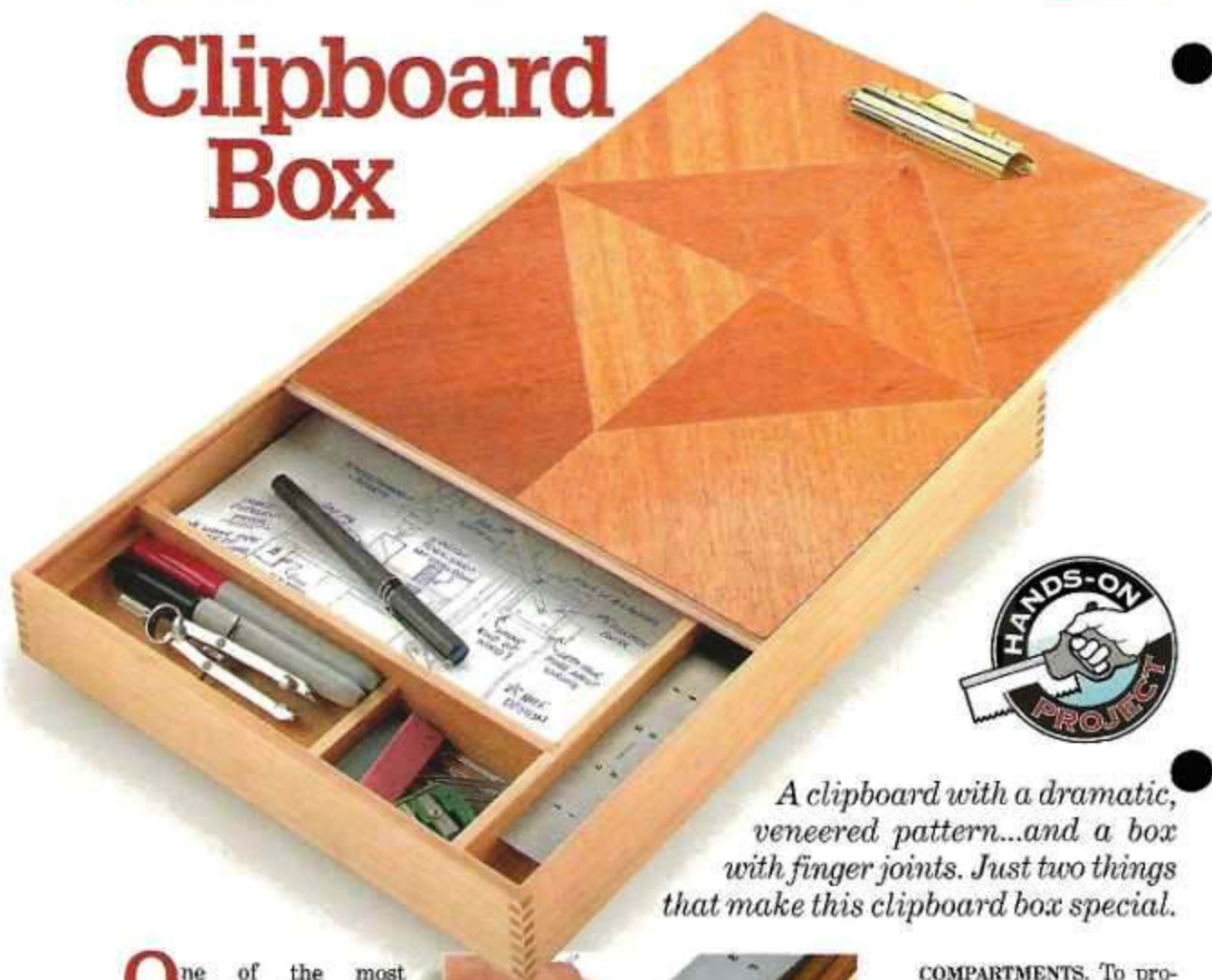

A clipboard with a dramatic, veneered pattern...and a box with finger joints. Just two things that make this clipboard box special.

One of the most striking things about this clipboard box is the dramatic pattern of thin, wood veneer that covers the top, see photo above.

Not exactly what you'd expect to find on a clipboard. But then again, it's not an ordinary clipboard — it's a *clipboard box*.

What makes this clipboard box unique is that it provides both a writing surface *and* a place to keep extra pencils, papers, and even a tape measure. So when it's time to make a list of materials, sketch out a drawing, or head down to the lumberyard, everything is in one place right where you need it.

DOUBLE DUTY. The secret to making this work is that the top of the box does double duty. It serves as the clipboard. (There's a brass, spring-loaded clip attached to the top to keep papers from sliding around.) And it acts as the top of a box that's divided into individual compartments.



COMPARTMENTS. To provide easy access to these compartments, you simply slide the top out of the box.

The large compartment is sized to fit standard 8½" x 11" sheets of paper. And the narrow one on the side holds a 12"-long metal rule. To

keep the rule from rattling around, it's held in place by a pair of magnets that sit *above* the bottom of the box. This way, when you lift out the rule, there's a place underneath for pencils as well, see inset photo.

VENEERED PATTERN. Now this "hidden" compartment isn't something most people will notice. But the veneered pattern on top is bound to attract a lot of attention.

To create the pattern, I used pieces of straight-grained mahogany and oriented them so the grain in one piece runs at an angle to the grain in the piece next to it. (There's a complete, step-by-step article on this process beginning on page 8.)

holes, see margin on page 6.

DIVIDERS

With the tray and rule supports glued in the box, all that's left is to add two dividers.

These are just strips of $\frac{1}{4}$ "-thick hardwood that form a compartment for a pad of paper. The *long divider* (G) has a shallow dado cut in it to accept the *short divider* (H), see Fig. 4a.

The dividers are simply glued in place. After gluing the long divider against the rule supports, just slip the short divider in place and glue it against the tray.

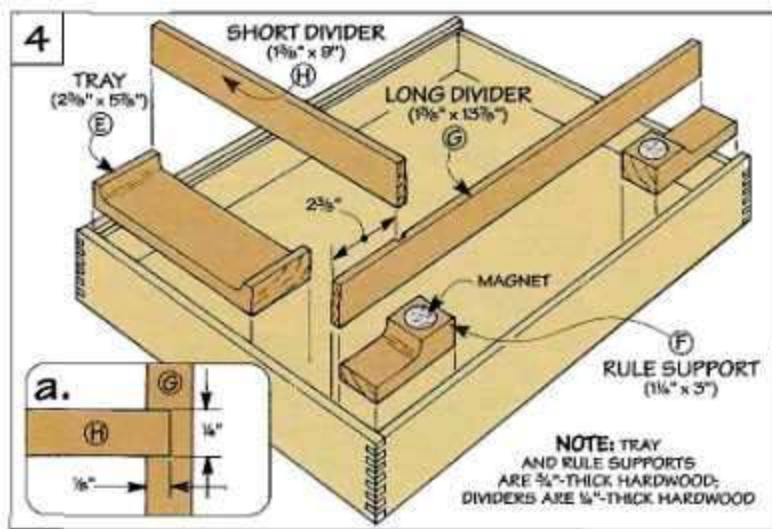

The Clipboard

This clipboard serves a purely functional purpose as a writing surface. But it's the contrast provided by the symmetrical pattern of veneer that makes it special.

CORE. The veneer is applied to a *core piece* (I) made from $\frac{1}{4}$ " plywood and "wrapped" with thin strips of hardwood *edging* (J), see photo at right. Note: These pieces are extra wide ($\frac{3}{4}$ "), then trimmed to width after you apply the veneer.

VENEER. To prevent the core piece from warping, I applied veneer to *both* sides. The top is "pieced" together like a jigsaw puzzle. And the bottom is simply two pieces of veneer that are taped together so it's wide enough to cover the core. (For more information on veneering, see page 8.)

TRIM. Now you can trim the clipboard to final size. The idea is to keep the pattern *centered* on the clipboard. So as you trim it to width (and length), you'll need to take equal amounts off each side (and the top and bottom edges).

To determine the overall width, measure the distance between the bottom of the grooves in the sides (A) of the

box. And it's cut to length so the top edge will be flush with the back (C) of the box when the clipboard is slid all the way into the groove in the front (B).

LIP. To guide the clipboard, there's a lip on each edge *except* the top. It's formed by cutting two different width rabbets, see detail below. To create a "shadow line" between the clipboard and the box, the rabbet cut on the front edging piece is *wider* than the one on the side.

FINAL DETAILS. There are just a few things left to do. First, I sanded the edges of the clipboard until it slid into the box without binding. Then, after applying four coats of varnish to create a hard writing surface, I installed a spring-loaded clip, see margin.



A spring-loaded clip with brass plating is available from:

• The Woodworkers' Store
800-279-4441

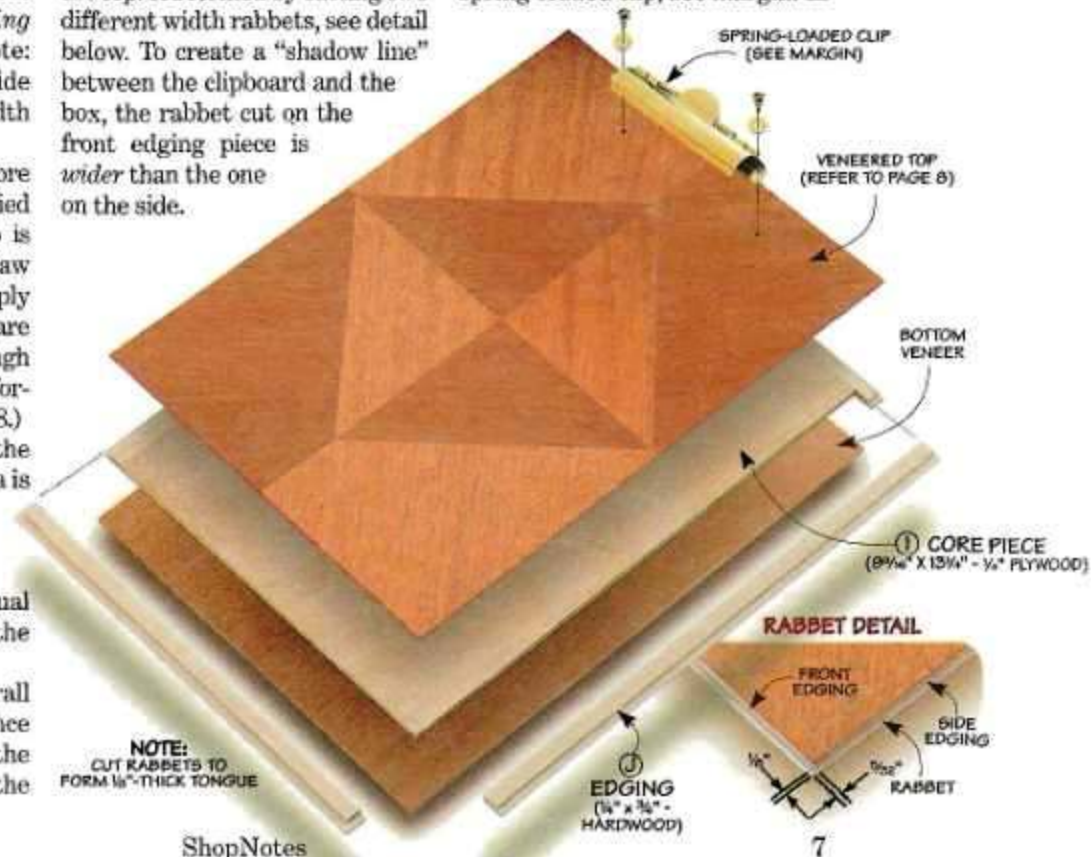

Parquetry

Even if you can't recall high school geometry, you can still make fancy patterns with veneer.

Ill be the first to admit it — I didn't pay much attention in high school geometry class. But lately, I've been buffing up on my lessons.

PARQUETRY. That's because I've been experimenting with a technique called *parquetry*. The basic idea of parquetry is to cut pieces of thin veneer into geometric shapes and arrange them in a pattern. Sometimes the symmetrical pattern that's formed is quite striking.

The top of the clipboard box shown on page 4 is a good example. It combines two different patterns. Four rectangular-shaped pieces of veneer are arranged in a herringbone pattern. And four triangular pieces form a diamond in the center.

CONTRAST. What I like about this pattern is the dramatic contrast of color *and* grain. This contrast is produced by arranging the pieces of veneer so the grain in one runs at an angle to the grain in the adjoining pieces. The key to making this work is to use veneer with extremely straight grain. (I used



straight-grained mahogany for the clipboard box.)

THICKNESS. When buying veneer, you'll find it's available in quite a range of different thicknesses. Since the surface is sanded lightly after applying the pieces, it's best to use a veneer that's thick enough so you won't cut through. I use veneer that's at least $\frac{1}{32}$ "-thick, see Sources on page 9.

FITTING THE PIECES. With veneer in hand, you're ready to start cutting and fitting the individual pieces. Now this appears as if it would be a tedious process that would require a lot of specialized tools. But that's not the case.

Along with some basic tools and materials, it's just a matter of following a few simple guidelines to ensure good results.

Cutting Veneer

One of the simplest things you can do is to use a template when cutting pieces of veneer to shape.

TWO TEMPLATES. To make the pattern for the clipboard box, I used two templates made of $\frac{1}{4}$ " hardboard, see margin.

A rectangular template is used to cut the pieces for the herringbone pattern. (To allow for trimming later, it's slightly oversize.) And a square template forms the diamond-shaped opening.

SPRAY ADHESIVE. But a template won't do any good if it slips around on the veneer as you make a cut. To prevent this, I apply a *light* coat of spray adhesive to one side of the template.

This makes the template just a bit tacky so it won't slip as you cut around it.

UTILITY KNIFE. The veneer is thin enough that a utility knife makes a crisp, clean cut. To ensure that you cut right up next to the

template, tilt the knife and position the tip of the blade first, see Step 1. After rotating the knife so the flat part of the blade is against the edge of the template, make several light passes to cut the veneer, see Step 2.

RECTANGULAR
TEMPLATE
(5 $\frac{1}{2}$ " x 7 $\frac{1}{16}$ ")

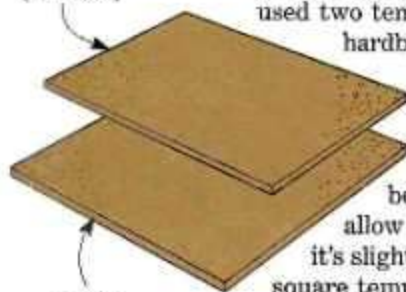

SQUARE
TEMPLATE
(6 $\frac{3}{8}$ " x 6 $\frac{3}{8}$ ")

NOTE:
TEMPLATES
ARE $\frac{1}{4}$ "-THICK
MASONITE

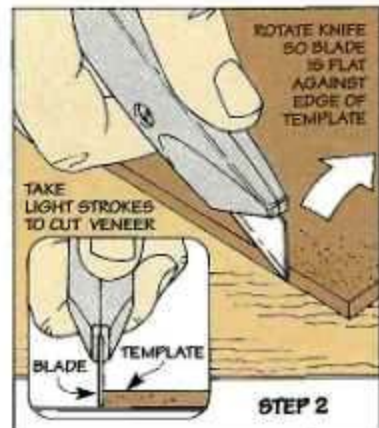
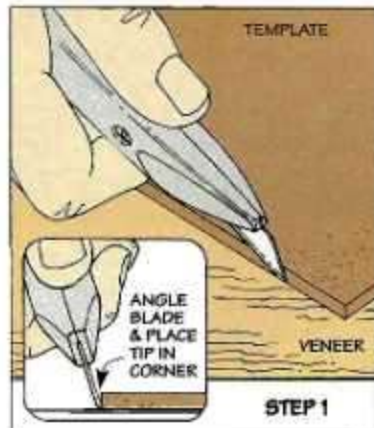

Jointing an Edge

To create a nearly invisible joint line when you fit pieces of veneer together, the edges need to be perfectly straight.

One way to produce a straight edge is to joint the pieces on an edge jointer. (If you don't have a jointer, a hand plane with a sharp blade will work fine.)

To do this, clamp the veneer between two pieces of hardwood so the bottom edges are flush, see Fig. 1. Then take a *light* pass over the jointer.

Safety Note: The clamps will prevent you from running the boards against the fence on the jointer. So it's a good idea to first

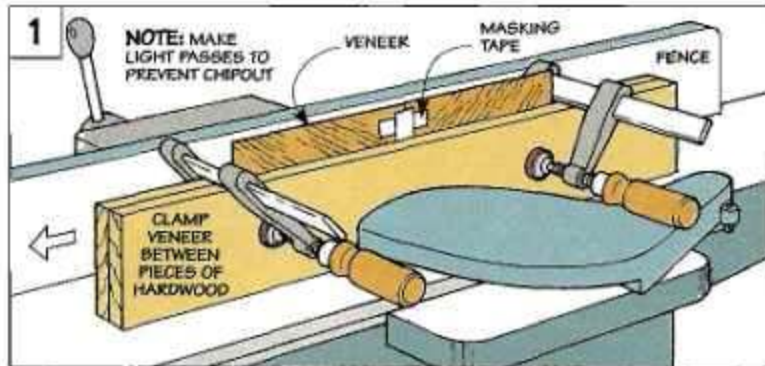

take a few test passes *with power off* to get the feel of it.

To keep chipout to a minimum, it works best if you joint *with* the grain. But sometimes (as in the

case of the two taped-up halves of the base) you'll need to joint against the grain, see Fig. 1. To do this, make a slow, deliberate pass over the jointer.

Sanding to Fit

Even with a jointed edge, there might still be an occasional irregularity that will create a gap when you fit the pieces together.

This is easy to remove by simply sanding the edge, see Fig. 1. Since the veneer is fragile, a light touch is all that's needed.

BEVEL. Another way to produce a good fit is to "undercut" the edge by sanding a slight bevel, see Fig. 2.

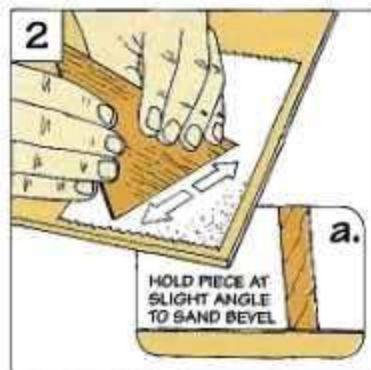
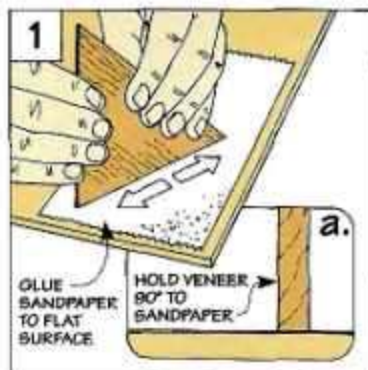

Cutting Diagram

BASE VENEER

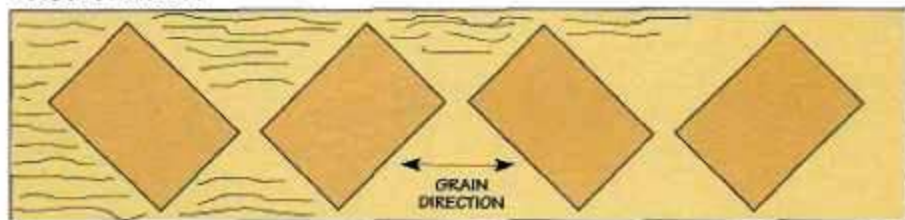

Cut four rectangular pieces for base from 10" x 48" sheet of veneer.

DIAMOND VENEER



Cut four triangular pieces from 5" x 36" strip of veneer.

Note: Pieces are arranged so good side of veneer is up when they're fitted together.

Sources

The following mail-order sources carry a wide variety of real wood veneer.

- Certainly Wood (716-655-0206)
- Constantine's (800-223-8087)
- The Hardwood Store (800-849-8174)
- Bob Morgan (502-456-2545)
- The Woodworkers' Store (800-278-4441)
- Woodworker's Supply (800-645-8292)

The Base

The base of the pattern on the clipboard consists of four rectangular pieces of veneer arranged in a herringbone pattern.

To create this effect, the rectangular template needs to be positioned at a 45° angle to the grain direction of the veneer as you cut the individual pieces, see Step 1.

After taping the pieces together (Steps 2 and 3), the veneer is applied

to a plywood core by using contact cement.

But to make it easy to remove the waste for the diamond-shaped part of the pattern which is added next, you'll want to first "mask" the back of the veneer and the core piece, see Steps 4 and 5.

Because contact cement bonds instantly, it's a little tricky positioning the veneer. So I use brown "kraft" paper to keep it from sticking prematurely, see Step 6.

After applying the veneer, just press it in place with a roller (see photo) or scrap of wood, see margin.



A hardwood block with the ends rounded over makes a handy veneer "roller."

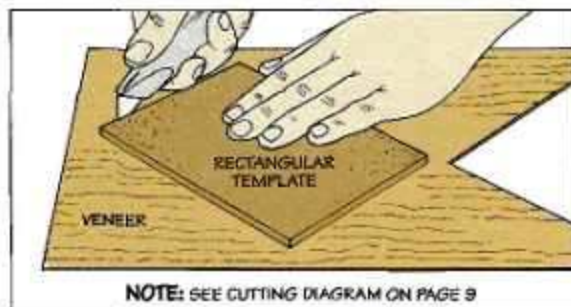

1 With the rectangular template held at 45° to the grain direction of the veneer, use a utility knife to cut the four pieces of the base to size.

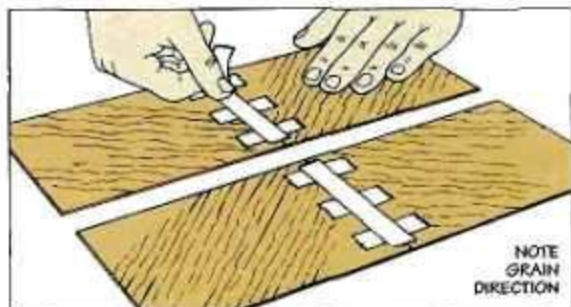

2 Now position the two rectangular pieces that form each half of the pattern as shown and apply masking tape to the "good" side of the veneer.



3 Before taping the two halves of the pattern together, joint the long edge of each one to produce a tight fit. (For jointing tips, refer to page 9.)

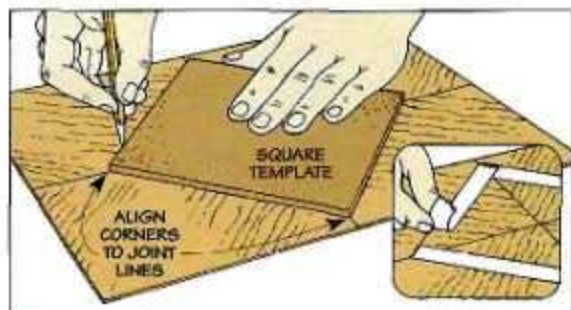

4 To avoid gluing down the waste in the center of the pattern, draw a diamond on the back of the veneer, then mask off the area with tape.

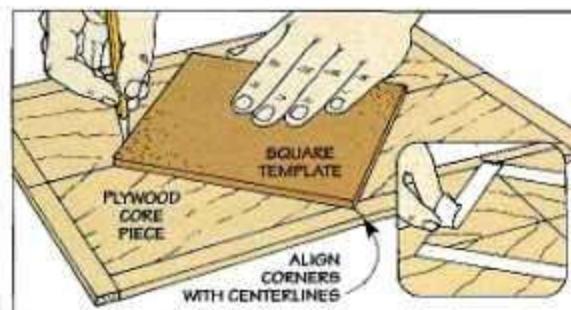

5 You also need to lay out and mask the diamond shape on the core piece. Drawing centerlines on the core piece helps position the template.

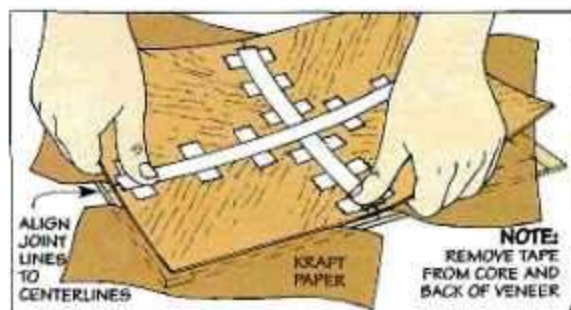

6 After applying contact cement, stick the veneer down in two places first. Then press the veneer in place as you slip out the "kraft" paper.

The Diamond

The second half of the pattern is shaped like a diamond. It's made up of four triangular-shaped pieces of veneer.

These pieces are fit one by one in a diamond-shaped opening that's formed by removing the part of the veneer *not* glued to the base, see Step 1.

Centering the square template on the base makes it easy

to cut the veneer.

And you can use a corner of the same template to cut the triangular pieces, see Step 2.

What's unusual here is you only cut *three* pieces to start and tape them in place, see Steps 3 and 4. That's because if you cut all four pieces to the same size,

the last one may not fit perfectly. So it's best to cut it *slightly* oversize ($1/16$ "), then sand it to fit.

After taping all the pieces together and removing them from the core, apply contact cement (Step 5) and press the diamond in place, see Step 6 and photo. 



1 With the square template centered on the base, cut the diamond-shaped piece of veneer that wasn't glued down and remove the waste.

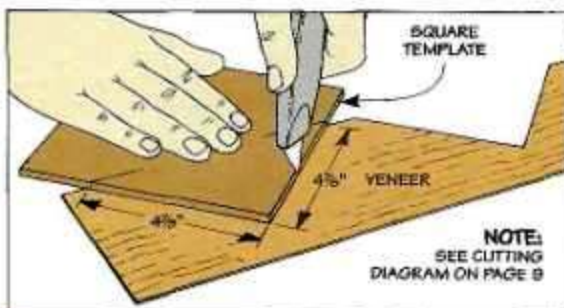

2 You can use a corner of the same template to cut the triangular pieces of veneer that make up the diamond-shaped part of the pattern.

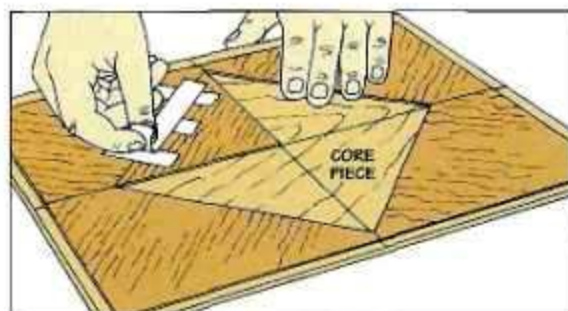

3 The first triangular piece of veneer is simply taped in place so the grain direction runs perpendicular to the grain in the piece next to it.

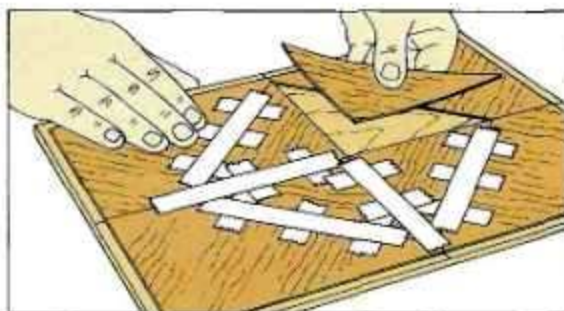

4 After repeating the process with the next two pieces, the fourth one is cut slightly oversize, then sanded to fit. (Refer to page 9 for sanding tips.)

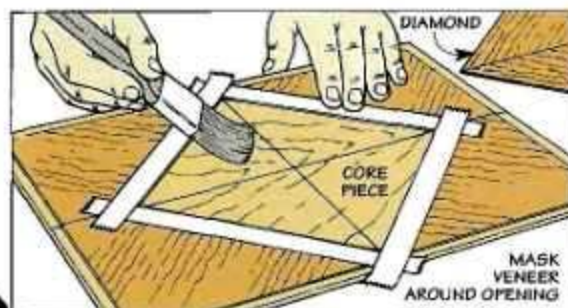

5 Once the diamond is taped together, remove it from the core. Then mask the veneer around the opening and apply contact cement to both surfaces.

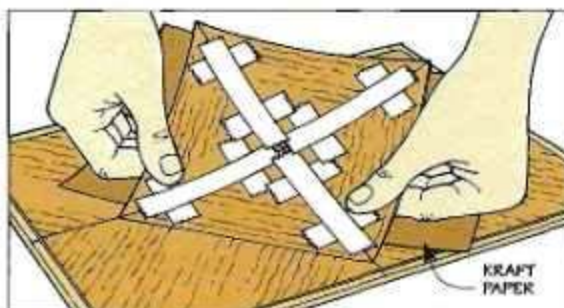

6 To position the diamond, carefully fit one edge into the opening. Then slip out the kraft paper as you press the rest of the diamond into place.



No kraft paper on hand? A brown paper bag works just as well.

Block Planes

Here's a look at four different block planes — and the woodworkers who use them. Find out what makes each of these block planes a favorite.

Lie-Nielsen

12½° Low-Angle
\$79.00

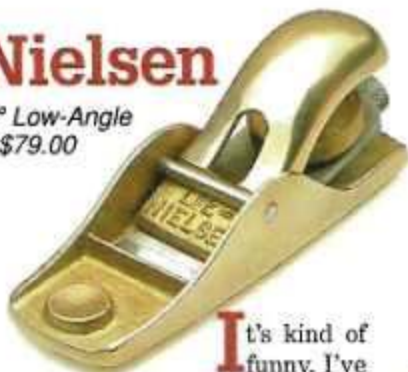

It's kind of funny. I've got a shop filled with big power tools. But when I bought this Lie-Nielsen low-angle block plane a few years back, what appealed to me was its *small* size.

The body of the plane is only about as big as a stick of butter. And it's shaped slightly like a boat — wide in the middle and tapered toward the ends.

Along with its small size and shape, the curved lever cap fits my hand just right. So it's easy to get a firm, comfortable grip. That's exactly what I need if I'm going to get good results with a plane that's intended to be used with one hand.

HEFT & BALANCE. For no bigger than it is, this plane has an amazing heft and balance. The castings for the body and lever cap are made of manganese bronze which is heavier than cast iron. (Not to mention I just plain like how it looks.)

This creates a dampening effect that keeps the blade from chattering. When you combine this extra mass with a thick, beefy blade, I'm able to plane a glass-smooth surface — even on a workpiece with tricky grain.

LOW ANGLE. That's especially true when I'm planing end grain.



▲ Steve Johnson (our shop craftsman) chamfers the end of a glued-up panel with his Lie-Nielsen low-angle block plane.



Since the blade is held at a low (12½°) angle, the cutting edge severs the wood fibers instead of tearing them out.

But this low-slung design backfires on me occasionally. When I'm working with long (edge) grain, the cutting edge can slip under the wood fibers and *pull* them up. So I make it a point to watch the grain direction carefully and take light cuts.

DEPTH ADJUSTMENT. Since the plane only has a few basic parts, adjusting the depth of cut is easy. A key on a depth adjustment knob fits in a notch in the bottom of the blade. After loosening a large lock knob, just thread the depth adjustment rod in or out to move the blade up and down.

Like everything else about this plane, it's simple. It's precise. And the quality is built-in.

EXPLODED VIEW

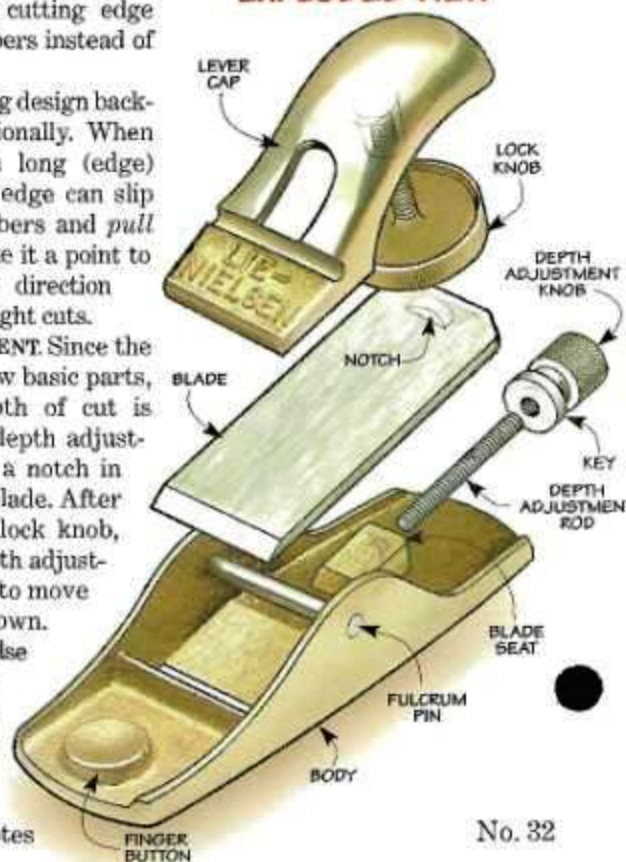

Sources

- Garrett Wade
800-221-2942
(ECE, Lie-Nielsen)
- Highland Hardware
800-241-6748
(ECE, Lie-Nielsen)
- Woodcraft
800-225-1153
(Rali, Record)
- The Woodsmith Store
800-835-5084
(Rali, Record)



Record

Model 060-1/2
\$46.95

■ I've used my *Record* low-angle block plane for a number of years now — long enough to know I'd have a hard time getting along without the adjustable throat opening that's built into the sole of the plane.

ADJUSTMENT PLATE. The thing that determines the size of this opening is a sliding metal plate that's fitted into the sole at the front end of the plane. (See drawing.) By sliding this plate forward or back, I can change the size of the opening between the sole of the plane and the blade.

QUALITY OF CUT. What I like about being able to adjust the throat opening is it gives me more control over the *quality* of cut. Let me give you an example.

Recently I needed to plane the pins of a dovetailed drawer so they were flush with the sides. (See photo above right.) Even with the blade set for a shallow cut, I was still a little concerned that the end grain of the pins would chip out.

That's where the adjustable throat opening came in handy. By loosening the front knob and sliding the adjustment lever over, I "closed" the opening so there was only a hairline crack between the metal plate and the blade.

This put pressure directly in front of the cutting edge. So I was able to shave the pins down without tearing the end grain.

But I'm not always as concerned about taking such a fine cut. The seat for a bench I was



▲ Using his low-angle *Record* block plane, Steve Curtis (our shop manager) trims the pins of a dovetailed drawer.



building recently is a good example. It had a large, gentle curve across the front edge.

Since I wanted to hog off material quickly to establish the basic shape, I set the blade for a deep cut. Then, to keep the shavings from clogging up the throat, I slid the plate forward to increase the size of the opening.

TUNE-UP. There's one other thing I want to mention about the *Record*. When I first bought it, it was a lot like a "kit." The parts were all there. But I had to spend some time tuning up the plane so they all worked together.

Which was okay with me. In fact, since the *Record* was fairly inexpensive compared to other block planes I'd seen, I *expected* to have to work on it a bit.

And there was a side benefit to all this that I hadn't counted on. By the time I had flattened the sole, smoothed the rough edges, and sharpened the blade, I knew the plane inside and out. It felt comfortable in my hand. And I had managed to turn my kit into a precision tool.

EXPLODED VIEW

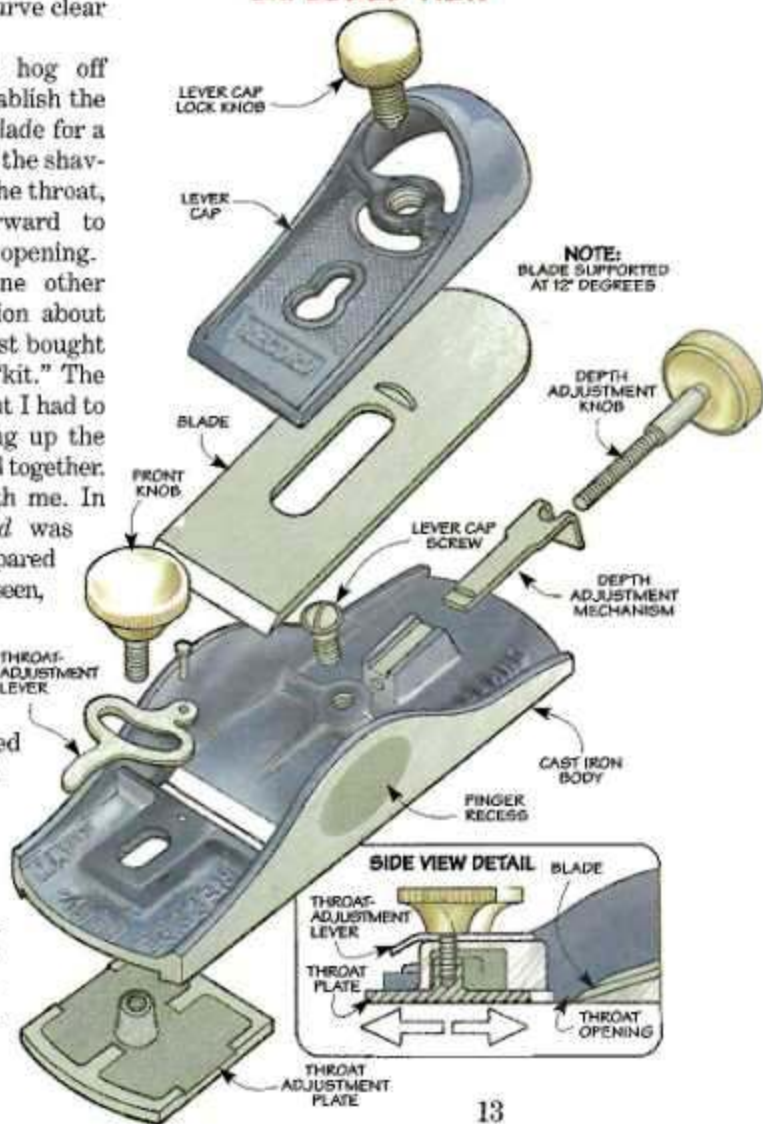



ECE
Block Plane
\$79.95

■ Call me old-fashioned. But one of the things I like best about woodworking is the look and feel of a traditional wood-bodied plane. Which is why I like this *ECE* block plane.

The body of the plane is made of lightweight hornbeam. And the sole is made from a dense, heavy wood called *lignum vitae*. They're held together with a series of precision tongue and groove joints that run diagonally across each part. (See drawing.)

LIGNUM VITAE. The most intriguing thing to me about all this is the *lignum vitae*. It's as tough and durable as an old tree root. So even though I've used the heck out my plane over the years, the sole still hasn't shown any signs of wear.

Another thing about *lignum vitae* is it contains oils that work like a natural lubricant. (Ship builders even used it as a self-lubricating bearing to support the propeller shaft on a ship.) So the plane glides smoothly across the surface of a workpiece.

As much as I like wood planes, adjusting the depth of the blade can be frustrating. But the *ECE* has solved the problem.

BLADE ADJUSTMENT. To adjust the blade depth, all I have to do is loosen the retaining screw and turn the depth adjustment knob. Now this is no dinky knob that I have to fiddle with. It's a large, solid knob with a knurled rim that lets me "fine tune" the exact depth of cut.

Even though the depth adjustment is extremely precise, it's a pretty simple mechanism. When

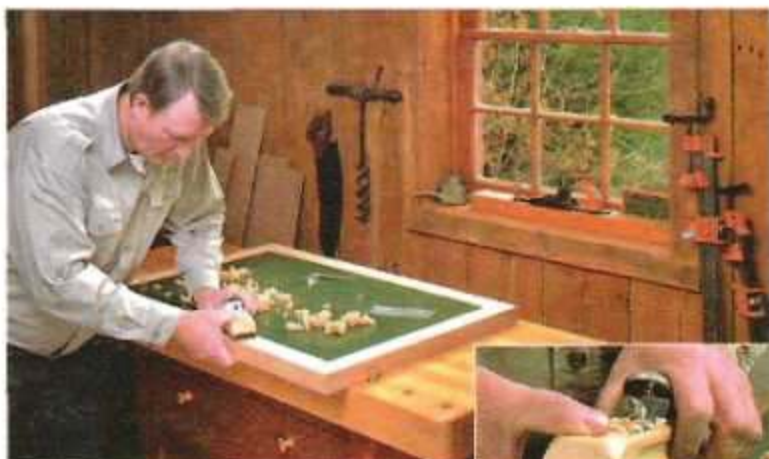

▲ Pat Lowry is a long-time woodworker who enjoys the traditional look and feel of his wood-bodied *ECE* block plane.

I turn the knob, a threaded rod moves a cross-dowel up or down. Since this cross-dowel has a pin that fits into a hole in the blade, the blade responds *immediately*. Not like some planes that have a "dead zone" before the adjustment kicks in.

BEVEL DOWN. Another thing that's different about the *ECE* is the blade is set in the body so the bevel faces *down* (not up as in a typical block plane). So if you want to get technical about it, it's really a small bench plane.

Even so, I use it just like a block plane — shaping edges, smoothing figured grain, and even trimming end grain. Every time I pick it up, I can't help but think this plane was designed by a woodworker who *uses* planes all the time.

Adjusting the blade is a snap. (I can be making paper thin shavings in a matter of seconds.) The depth adjustment knob doubles as a "rest" for my hand. And every edge on the plane is softened for a comfortable grip.

EXPLODED VIEW

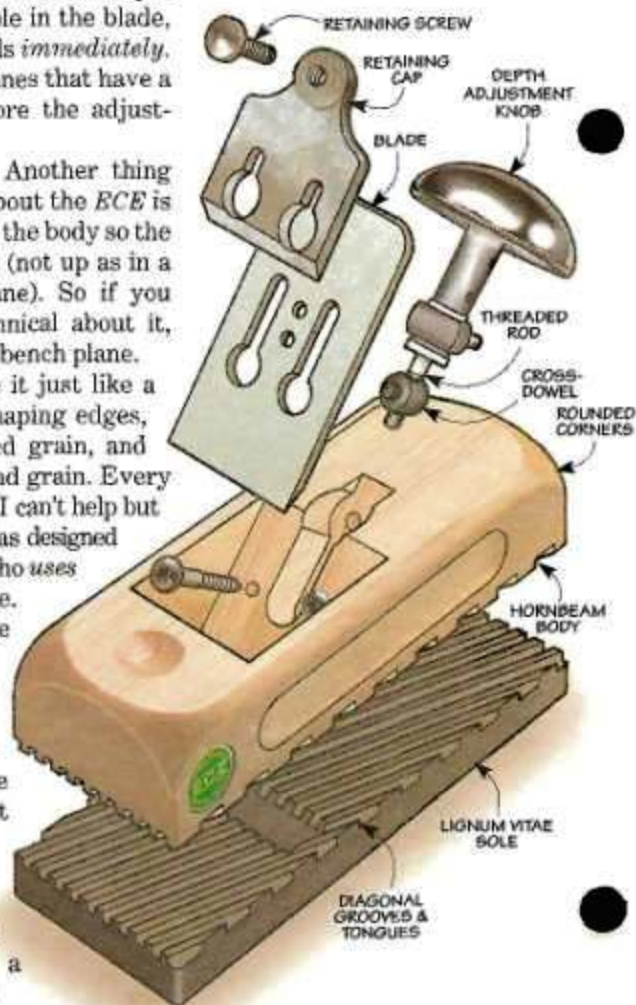



Rali

Model 105
\$59.59

■ Okay, so it looks a bit unusual. But this *Rali* is still the most *practical* block plane I've ever used. Which is just what I want for the type of carpentry work I do.

SOLE. Take the sole for instance. It's made up of a series of metal strips that are laminated together. And it's flat right out of the box. So I didn't have to go through that tedious process of flattening the sole.

RAZOR BLADES. But what really sold me on this plane is I never have to sharpen the blade. That's because the *Rali* doesn't have a traditional plane iron. Instead, it uses a heavy-duty razor blade.

And each razor blade is double-edged. So if I hit a knot or a nail and chip one edge, I can flip the blade around and use the other one. When both edges get dull, all I have to do is pitch the old blade and drop in a new one. (See photos at right.)

Altogether, I probably use a half dozen blades a year. At about seven dollars a pair, it costs me around \$21 a year. That's

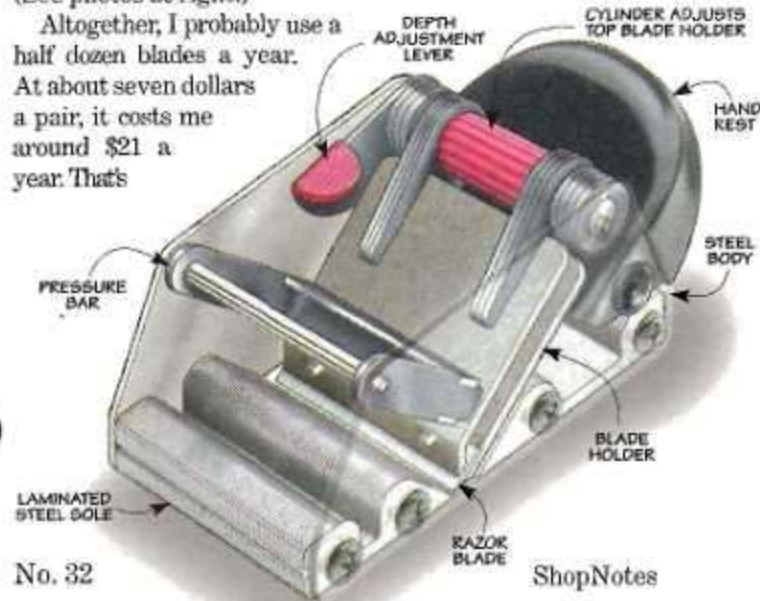

▲ As a carpenter, Kent Welsh likes the practical things about this *Rali* block plane — like not having to sharpen the blade.



not much when you look at the "downtime" I'd spend sharpening blades. And to be honest, I just don't *like* to sharpen blades.

ALIGNMENT. Once I install a new blade, it's *automatically* aligned. The reason is the blade has holes that fit over a pair of alignment tabs in a metal blade holder. Since there's no way for one corner of the blade to be lower than the other, I don't gouge the work as I'm planing.

DEPTH OF CUT. Setting the depth of cut is just as easy. The blade is sandwiched between two metal blade holders that are lowered into the body of the plane.

After flipping over a pressure bar so it rests on the top holder, a little pressure on a simple lever adjusts the depth of the blade.

One last thing. To provide support for the thin razor blade, the top blade holder slides down close to the cutting edge. All I need to do to adjust this blade holder is roll my finger across a ribbed cylinder on top of the plane. 🛠️



1 It's easy to install a new blade in the *Rali* block plane. Start by raising the depth adjustment lever and flipping the pressure bar up.



2 Now use the depth adjustment lever to lift the two metal blade holders out of the body of the plane.



3 With the blade holders opened like a clamshell, set the new razor blade in place so the holes fit over the metal alignment tabs.

Oscillating Drum Sander

Convert your drill press into an oscillating drum sander with this shop-built accessory.

I've always been impressed with the oscillating spindle sanders I've seen. They make it easy to quickly remove material when sanding the edge of a board.

The basic principle of these sanders is simple. They have a sanding drum that spins around and moves up and down at the same time.

It was this dual motion that was on my mind as I was using the sanding drum on my drill press recently. After all, it already spins around. So all I needed was a way to move the sanding drum up and down automatically.

GEARMOTOR. The solution was a small, electric gearmotor that attaches to the column of the drill press. This motor is connected to the feed lever on the drill press by means of a long arm. When you turn the motor on, the arm drives the feed lever back and forth like the pumping action of an old locomotive, see inset photo.

SANDING PLATFORM. But there's more to this oscillating drum sander than a unique drive system. A sanding platform that attaches to the metal table on the drill press also provides a large work-

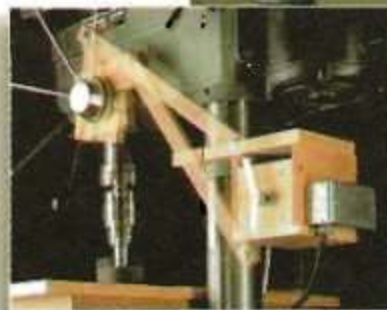

surface with an opening for the sanding drum as it moves up and down, see photo above.

INSERTS & STORAGE. And it's easy to change the size of this opening for different size sanding drums. Just slip in a different insert, see photo A below. The insert and drum that you remove store conveniently out of the way in two storage racks that hang on the platform like a pair of saddlebags, see photo B.

FENCE. Finally, the sanding platform doubles as a table for drilling. Simply disconnect the drive system and slide a fence onto the platform, see photo C.



A. Inserts. When you need to change the size of a sanding drum, just slip in an insert with a different size opening.



B. Storage. Keep your sanding (or drilling) supplies in easy reach with a storage rack on each side of the platform.



C. Fence. A simple fence with a built-in clamping system also lets you use the sanding platform as a drill press table.

EXPLODED VIEW

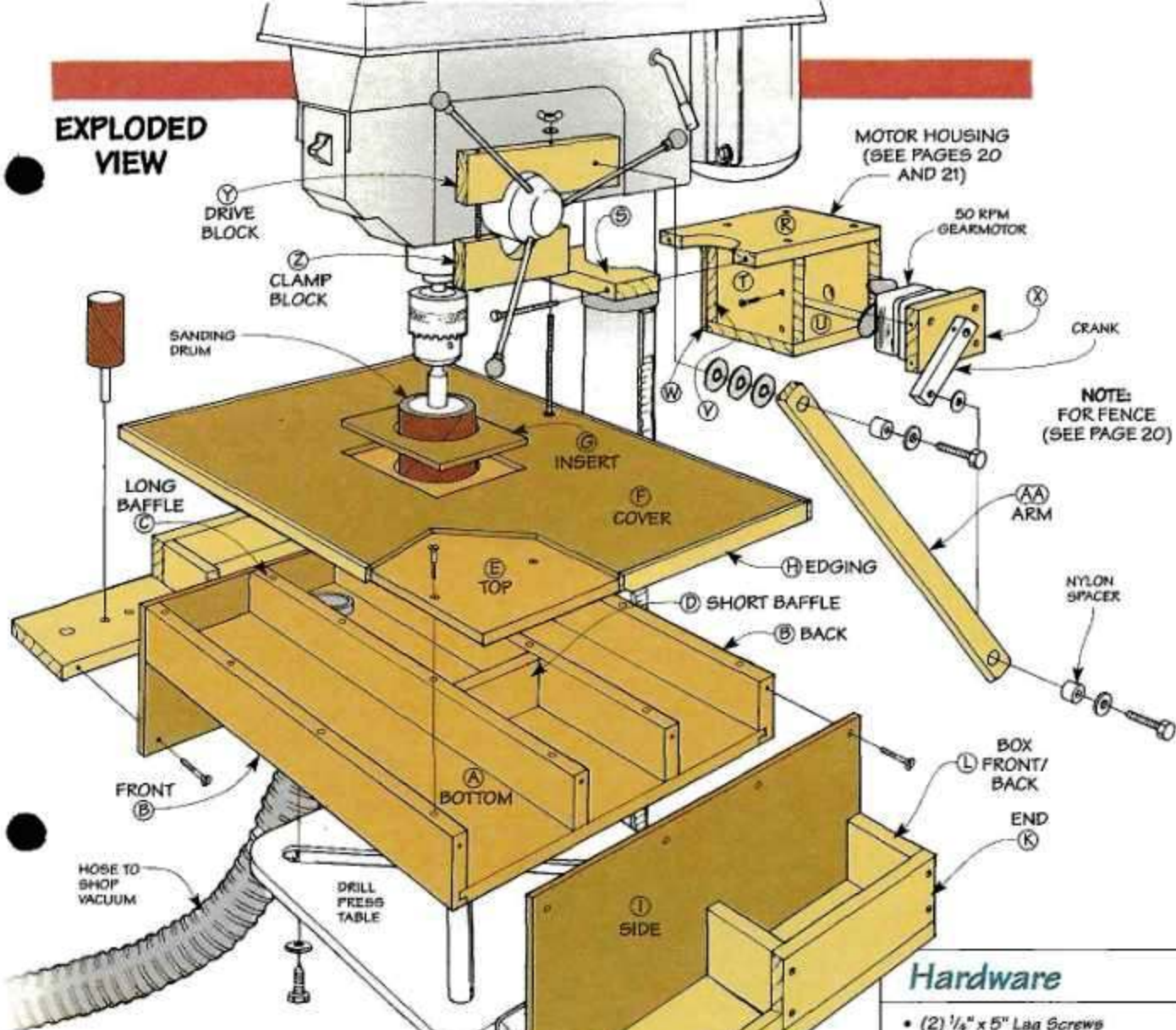

Materials

Sanding Platform

A Bottom (1)	15 x 20 - 1/2 MDF
B Front/Back (2)	2 x 20 - 1/2 MDF
C Long Baffles (2)	1 1/2 x 20 - 1/2 MDF
D Short Baffle (1)	1 1/2 x 3 1/2 - 1/2 MDF
E Top (1)	15 1/2 x 23 1/2 - 1/2 MDF
F Cover (1)	15 1/2 x 23 1/2 - 1/4 Hdbd.
G Inserts (5)	4 1/2 x 4 1/2 - 1/4 Hdbd.
H Edging	1/4 x 3/4 (7 Linear Ft.)
I Sides (2)	6 3/4 x 15 1/2 - 1/4 Hdbd.
J Shelves (2)	3/4 x 3 3/4 - 15 1/2
K Ends (2)	1/2 x 2 1/2 - 7 1/2
L Box Front/Back (4)	1/2 x 2 1/2 - 3 1/4
M Tray Piece	1/2 x 3/4 (12 Linear In.)

Fence

N Fence Piece (2)	2 1/2 x 27 1/8 - 3/4 MDF
O Spacer (2)	1 1/2 x 3 1/4 - 3/4 MDF (Rgh.)
P Clamp Heads (2)	2 x 2 1/2 - 3/4 MDF
Q Key (2)	1/2 x 2 1/2 - 1/8 Hdbd.

Motor Housing

R Top (1)	3/4 x 5 - 6 3/4
S Anchor Block (1)	3/4 x 2 3/8 - 5
T Sides (2)	1/2 x 4 3/8 - 4 1/2
U Bottom (1)	1/2 x 5 - 4 3/4
V Filter Panel (1)	1/2 x 4 3/8 - 4 1/4
W Filter Cover (1)	4 3/4 x 4 3/8 - 1/4 Hdbd.
X Motor Mount (1)	1/2 x 3 1/2 - 3 3/4

Drive Assembly

Y Drive Block (1)	3/4 x 2 - 7
Z Clamp Block (1)	3/4 x 2 - 4 3/4
AA Arm (1)	7/16 x 1 - 16 1/8

Hardware

- (2) 1/4" x 5" Lag Screws
- (7) 1/4" Flat Washers
- (12) #6 x 1 1/4" Fh Woodscrews
- (53) #6 x 1" Fh Sheet Metal Screws
- (4) #6 x 1/2" Fh Woodscrews
- (4) 10-32 x 1" Fh Machine Screws
- (1) 10-32 x 1/4" Set Screw
- (1) 1/2" x 1/2" x 3 3/4" Bar Stock
- (1) 1/4" x 1" Hex Bolt
- (2) .257"-I.D. x 1/2"-O.D. x 1/2" Spacer
- (1) 1/4" x 1 1/2" Lag Screw
- (4) 1/4" I.D. x 1" O.D. Fender Washers
- (2) 1/4" x 4 1/2" Carriage Bolts
- (2) 1/4" Wing Nuts
- (1) 3 3/4"-Dia. Dust Mask Filter
- (2) 5/16" Plastic Knobs
- (2) 5/16" x 2 1/2" Carriage Bolts
- (2) 5/16" Flat Washers
- (1) 50rpm, 115 VAC Gearmotor

For a kit to build the drum sander that includes all of the above parts, call 800-347-5106.

Kit No. 6832-100.....\$79.95

Note: The motor is also available separately from McMaster-Carr. To order, call 630-833-0300. (Part number 6142-K57.)

Sanding Platform

I began by making a sanding platform that attaches to the metal tabletop of the drill press. Basically, it's a shallow, enclosed box that consists of three parts: a base, a tabletop, and two storage racks, see Fig. 1.

Design Note: The overall width of the platform is 16". This means it will fit on a drill press with at least 8" of clearance between the column and the center of the chuck. For smaller drill presses, you'll need to reduce the width.

BASE

In addition to supporting the tabletop, the base houses a system of baffles that directs dust into a shop vacuum.

The base starts out as a *bottom* (A), and a *front/back* (B) made from 1/2"-thick MDF, see Fig. 2. These pieces are held together with simple tongue and groove joints. But before gluing them together,

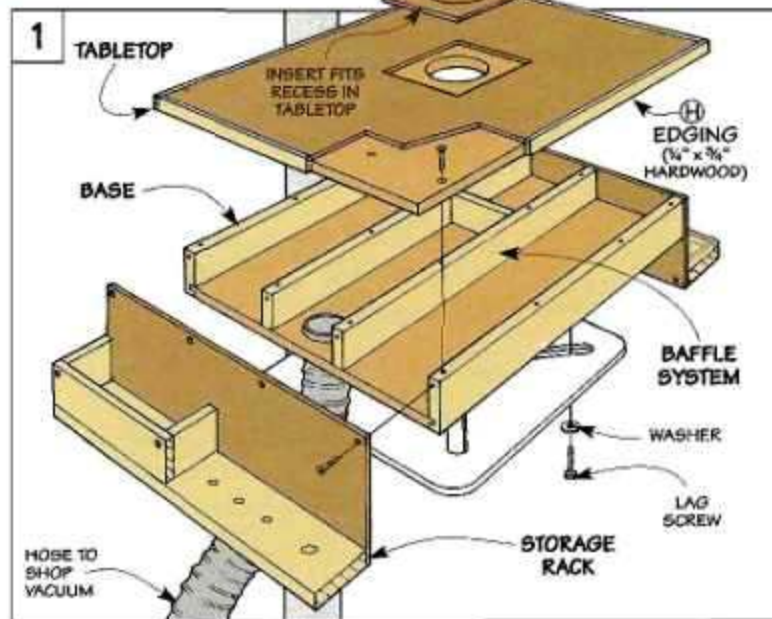

To collect dust that's produced when sanding, fit the end of the hose on your shop vacuum into a hole in the base.

you'll need to cut a hole near one end of the bottom to fit the hose on your shop vacuum, see margin.

BAFFLE SYSTEM. The next step is to add the baffle system. By

restricting the area inside the base, it improves the flow of air and dust that's drawn down through an insert in the tabletop and out into the shop vacuum.

The baffle system is made up of three strips of 1/2" MDF. Two *long baffles* (C) that run the full length of the base are glued and screwed in place, see Fig. 2. And a *short baffle* (D) fits between.

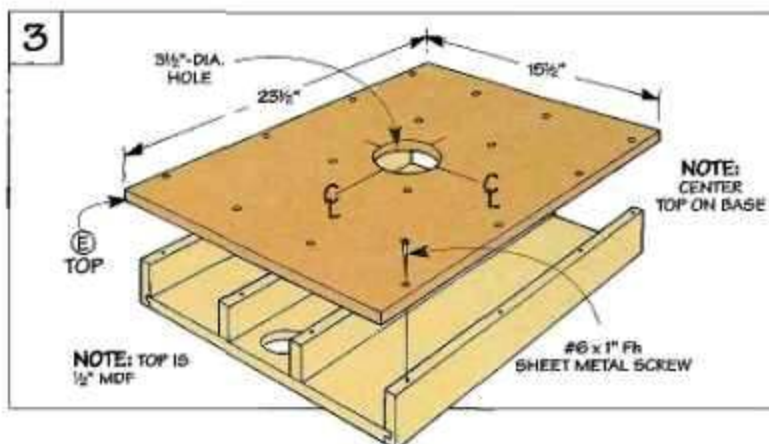
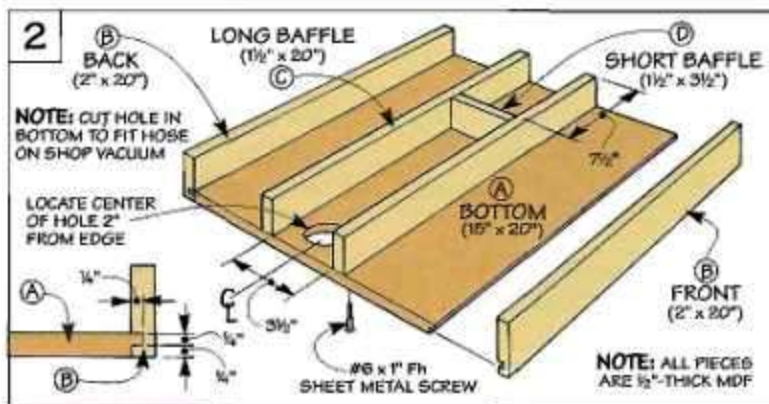

TABLETOP

With the baffle system in place, you can turn your attention to the tabletop. It serves as a large worksurface for the sanding drum as it moves up and down, see Fig. 1.

OPENING. This opening needs to be large enough to accept the biggest sanding drum you have. Yet you still want to reduce the size of the opening for smaller drums.

The solution is to use an insert with a different size hole for each sanding drum. These inserts fit in a recess in the tabletop.

To form this recess and provide support for the inserts, the tabletop is made up of two parts. A *top* (E) with a large hole is glued and screwed to the base,

see Fig. 3. Then later, a cover with a square opening will be attached to the top, see Fig. 4. This way, when you slip an insert into the square opening, it will be supported by the top underneath.

To produce a snug fit, it's best to start with an oversize cover (F) and use the inserts as a gauge when routing the opening. (For more on this, refer to page 30.)

INSERTS. Altogether, I made five inserts (G). Four have holes that are $\frac{1}{4}$ " larger than my sanding drums. And one has a small ($\frac{3}{4}$ ") finger hole to make it easy to lift out of the tabletop.

When cutting these holes, I tightened each insert in a hand-screw clamped to the drill press table — but there's a slight twist.

To provide clearance for the "wing" on the circle cutter, I set the insert on the threaded rods of the handscrew, see Fig. 5. Note: Placing a scrap piece under the insert protects the cutting edge of the circle cutter.

ATTACH COVER. With inserts in hand, I used the one with the largest hole to position the cover on the top (E). To do this, draw centerlines on the insert and top, see Fig. 4. Then clamp the insert to the top so the marks align. After

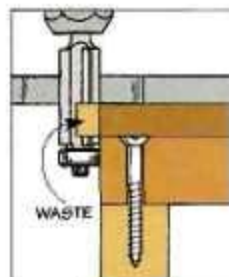
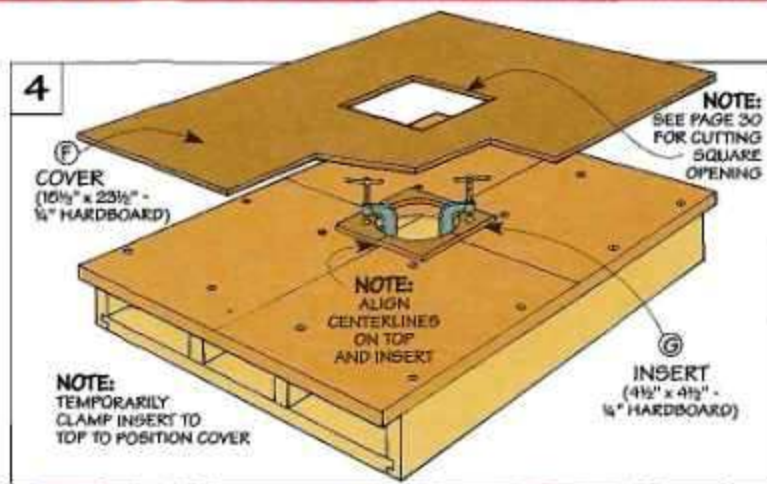

A flush trim bit in a hand-held router makes quick work of trimming the cover flush with the top.

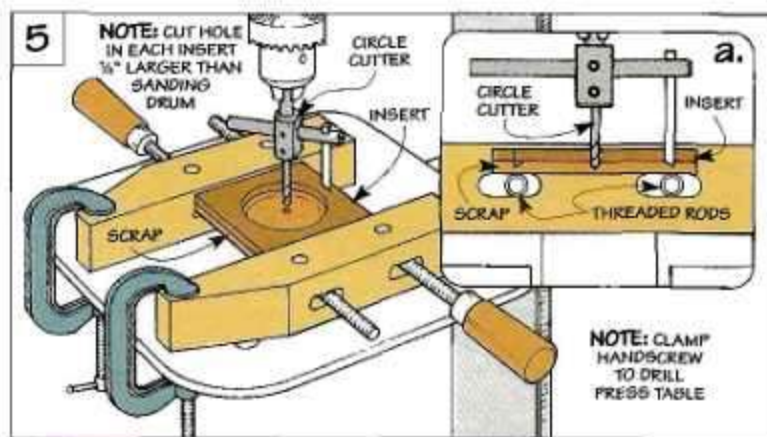

applying contact cement, lower the cover over the insert.

Now it's just a matter of trimming the edges of the cover flush (see margin) and applying strips

of hardwood edging (H), see Fig. 1.

STORAGE RACKS

To complete the sanding platform, I added two storage racks.

Each rack begins as an L-shaped assembly that consists of a side (I) and shelf (J), see Fig. 6. Before gluing and screwing these pieces together, I drilled holes in the left-hand shelf to accept my sanding drums.

To store sanding sleeves and inserts, I also added a three-sided box to each rack.

It's made up of a hardwood end (K) and a front/back (L) that are glued and screwed together.

Next, to create a lip around the right-hand storage rack that keeps my drill bits and chuck key from falling off, I glued two short tray pieces (M) to the shelf.

Finally, the storage racks are screwed to the sanding platform.

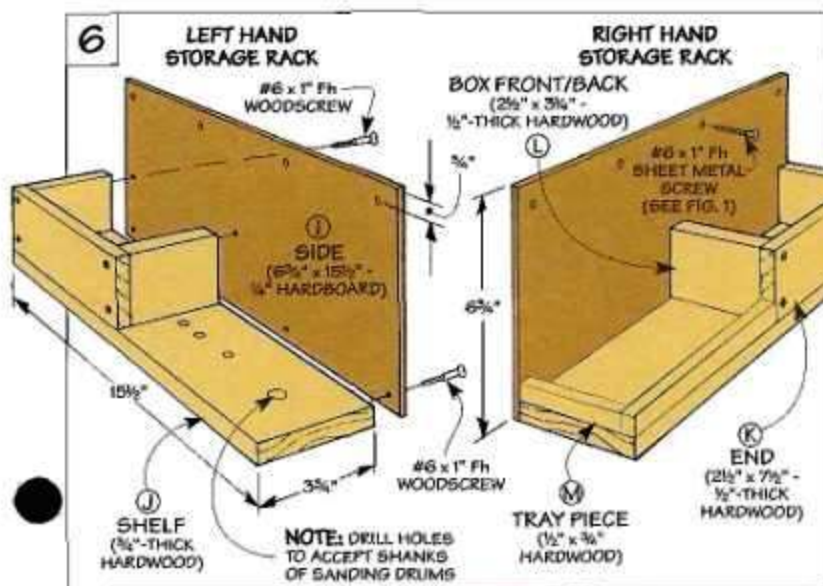

Fence

To use the sanding platform as a large table when drilling holes, I also added a simple fence.

It's nothing more than two *fence pieces* (*N*) glued together, to form an L-shape, see Fig. 7.

To lock the fence in place, there's a clamp at each end. Each clamp consists of a *spacer* (*O*) and a *clamp head* (*P*) that are kept aligned with a hardboard *key* (*Q*).

What makes the clamp work is the spacer is sanded slightly *thinner* than the tabletop. This way, when you tighten the clamp, the clamp head pinches against the bottom of the table.

Clamping pressure is applied by tightening a knob on the end of a carriage bolt that passes through the clamp and the fence.

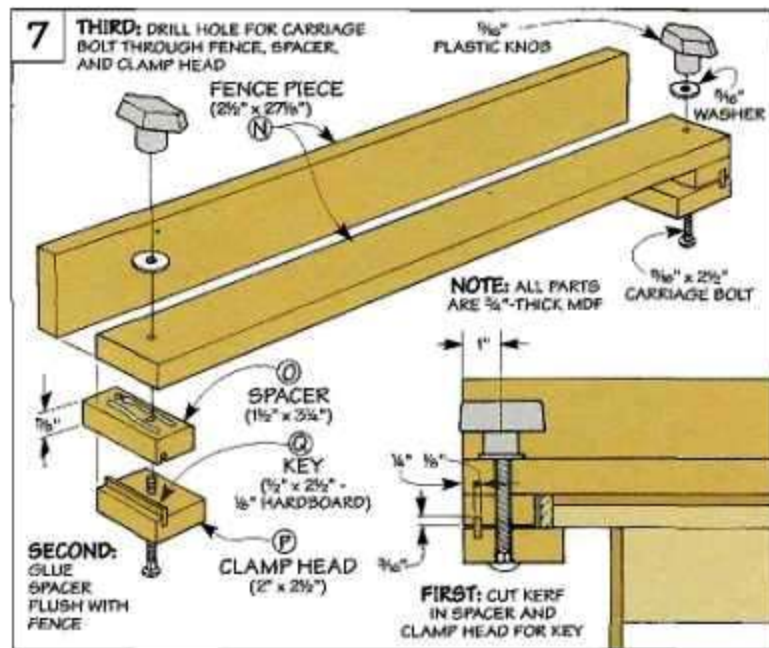

Motor Housing

The motor that drives the oscillating drum sander is enclosed in a wood housing that hangs on the column of the drill press.

COLLAR. The motor housing is supported by a two-piece wood collar with curved openings that fit around the column of the drill press, see Fig. 8. A *top* (*R*) doubles as the the upper part of the motor housing. And an *anchor block* (*S*) accepts two lag screws that hold the collar together.

To get the collar to fit tight, I used a simple trick. Start by slipping an 1/8" spacer between the two workpieces and "clamp" them together with the lag screws, see Fig. 9. After cutting a hole that matches the diameter of the column, the gap created by the spacer allows the collar to pinch tight, see Fig. 9a.

MOTOR HOUSING. With the collar complete, I began on the motor housing. It starts out as a U-shaped assembly that consists of two *sides* (*T*) and a *bottom* (*U*), see Fig. 8.

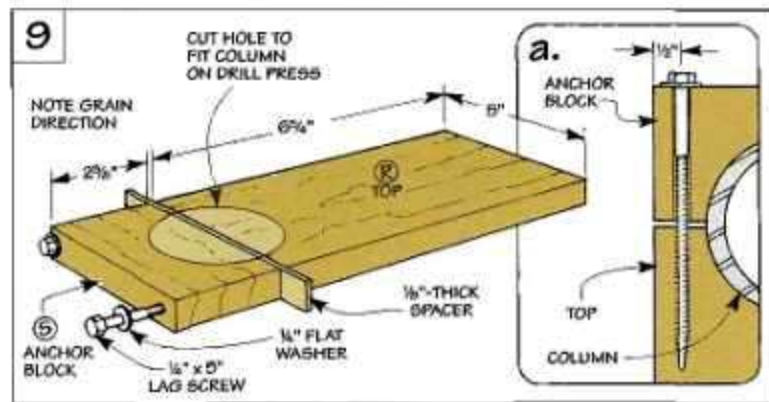
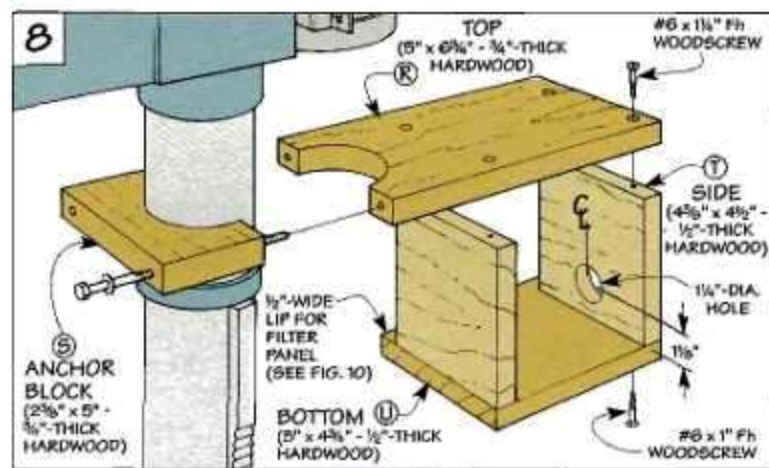

The heart of the oscillating drum sander is a small, electric gearmotor.

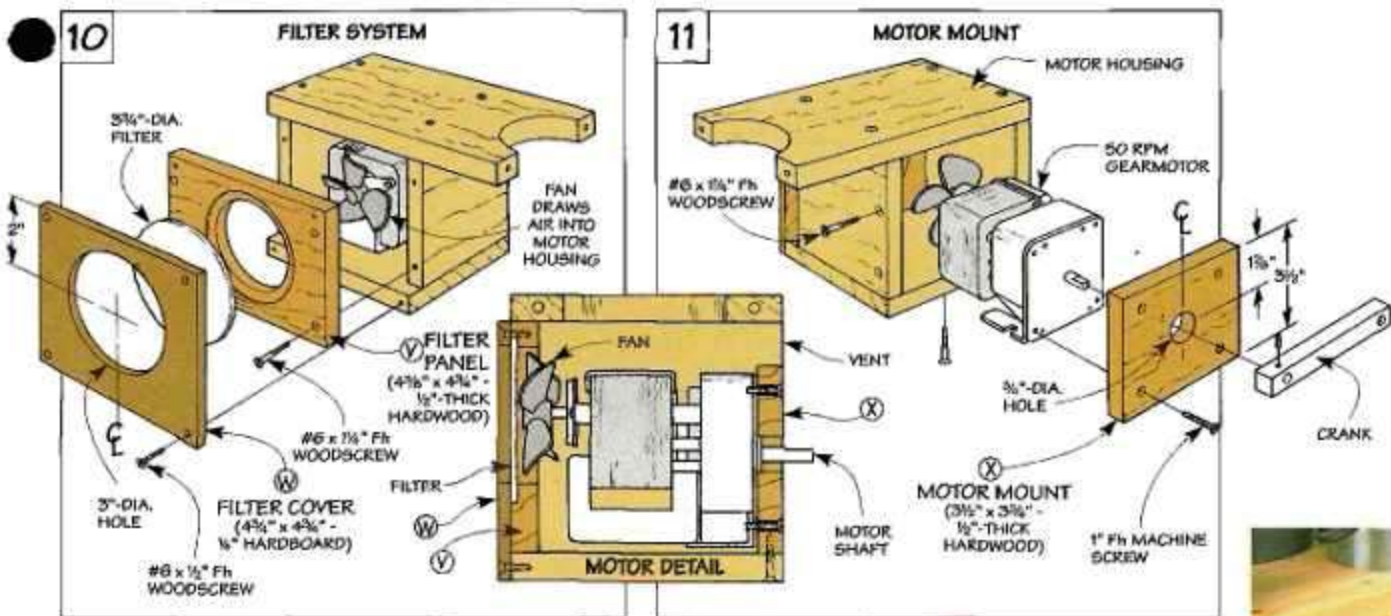

Before gluing and screwing this assembly together, drill a hole in the back side piece so you'll be able to feed the wires on the motor out of the housing. Then attach the top (R) with glue and screws.

FILTER & MOTOR MOUNT

At this point, the motor housing is open at each end. But one end will be enclosed by a filter system, see Fig. 10. And the other will hold a motor mount, see Fig. 11.

FILTER. To remove dust from the air that's drawn into the motor housing, I used an ordinary filter from a dust mask. It fits in a filter panel (V) with a hole cut in it so air can get through, see Fig. 12. Routing a rabbet around the hole forms a recess for the filter, see Fig. 12a. It's held in place by a hardboard filter cover (W) with another hole cut in it, see Fig. 10.

MOTOR MOUNT Now you can add the motor mount (X). It's a 1/2"-thick piece of hardwood that holds the motor securely in place just above the bottom (U) of the motor housing, see Motor Detail above. This makes it easy to slide the motor into the housing.

To vent the air from the housing,

the motor mount is shorter (narrower) than the sides. Drilling a hole in the motor mount allows the shaft of the motor to stick through. Also, you'll need to locate and drill holes for machine screws that secure the motor.

Once the motor is attached, simply slide it into the housing. To provide access if you ever need to remove the motor, the motor mount is attached to the sides with screws only (no glue).

CRANK. All that's left is to add a metal crank to the shaft of the

motor. Along with a drive assembly that's added later, this crank transfers the rotation of the motor to the feed lever.

The crank is a short piece of 1/2" metal bar stock, see Fig. 13. A threaded hole on one end accepts a drive arm. And two intersecting holes on the other let you attach the crank to the shaft.

A large, unthreaded hole fits onto the shaft of the motor. And a small (threaded) hole accepts a set screw that tightens the crank on the "flat" of the shaft.



The back of the motor housing encloses an ordinary filter from a dust mask.

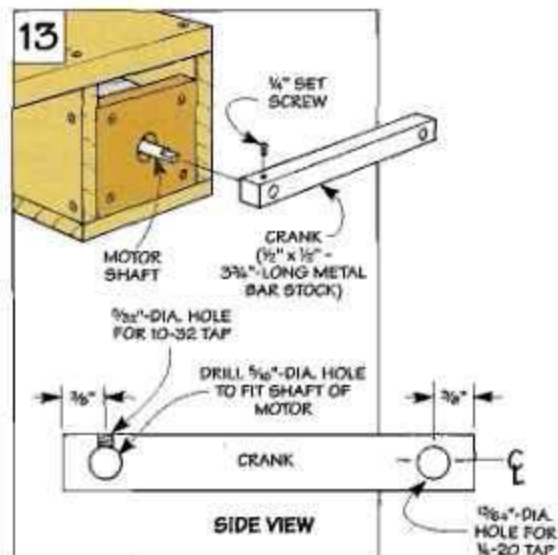
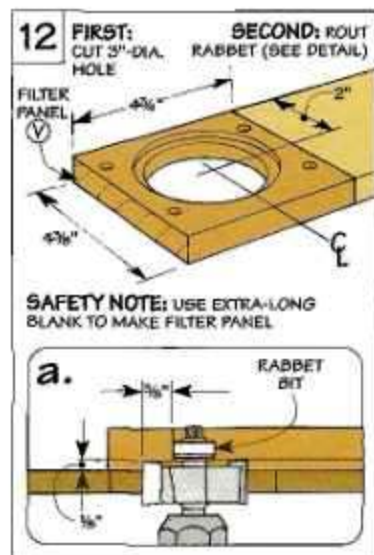

Drive System

With the motor housing mounted to the drill press column, you're ready to add the drive system.

The idea here is simple. A two-piece pinch block fits around the hub on the feed lever, see Fig. 14. This pinch block is attached to an arm that's connected to the crank on the motor. As the crank turns around, the arm drives the pinch block back and forth which moves the sanding drum up and down.

PINCH BLOCK. The pinch block is similar to the collar for the motor housing. Only this time, curved openings in a *drive block* (Y) and a *clamp block* (Z) fit the hub on the feed lever, see Fig. 15.

ARM. Now you can add the *arm* (AA), see Fig. 14. It starts out as an extra-long strip of hardwood (18" in my case).

Later, the bottom end of the arm is attached to the crank with a bolt. To allow the arm to spin freely, the bolt passes through a nylon spacer that fits in a hole drilled in the arm. Note: To keep the bolt from loosening, the arm is slightly ($\frac{1}{16}$ ") thinner than the length of the spacer, see Fig. 14b.

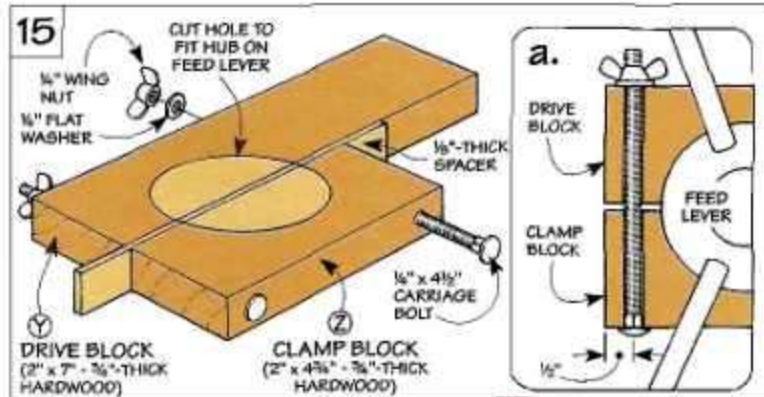
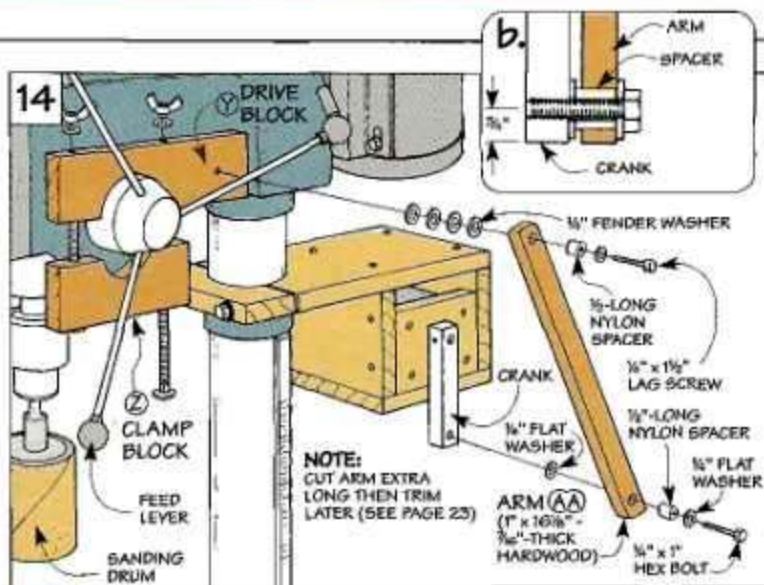

Electrical

- (1) 15 Amp., 120 Volt Switch/Receptacle
- (5) No. 8 Spade Terminals (16/14 ga.)
- (2) Utility Boxes
- (2) Grounding Pigtaile w/Screws (12 ga.)
- (2) $\frac{3}{16}$ " Cable Connectors
- (4) Wire Nut Connectors (Yellow)
- (4) #8 x $\frac{3}{16}$ " Panhead Sheet Metal Screws
- (1) Box Cover (Blank)
- (1) Box Cover (Duplex)
- (2) 15 Amp., 125 Volt Plug (Grounded)
- (1) $\frac{1}{16}$ "-Dia. Rubber Grommet
- 16-3 5J Electric Cord (14 feet)

Electrical Hook-Up

There are two ways to hook up the oscillating drum sander.

PLUG. The simplest one is to connect the two "leads" that come from the motor to a power cord and wire a plug on the end. With this type of hook-up, you'll need to plug the cord into a wall outlet each time you want to sand.

SWITCH. A handier solution is to just flip on a switch. To do this, you'll need to connect the leads to a short electric cord that runs from a box on the motor housing (Fig. 1) to a switch/receptacle mounted below the sanding platform, see Fig. 2.

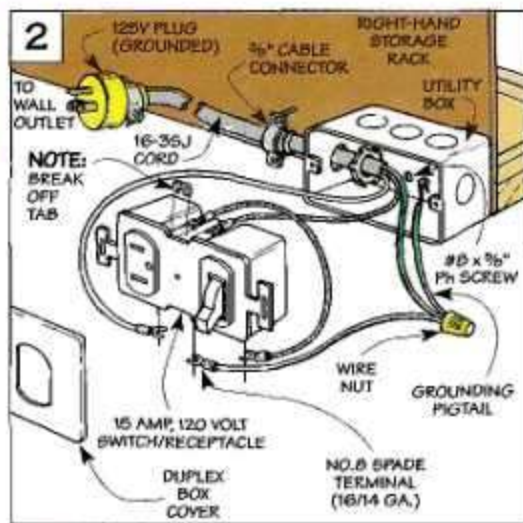
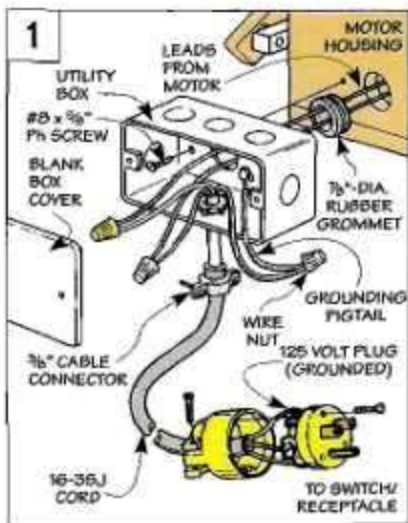

Setup

Setting up the oscillating drum sander is just a matter of attaching the arm so it connects the crank on the motor with the pinch block, see Side View.

DEPTH ADJUSTMENT. The first step is to set the depth adjustment on the drill press so the quill has the maximum amount of travel, see Step 1.

STROKE. Another thing to consider is the overall stroke of the sander (about 1" in my case). To keep the quill from hitting the housing of the drill press on its *upward* stroke, I used a 1½" tall (wide) scrap to temporarily position it farther *down* than the total amount of travel, see Step 2.

PINCH BLOCK. Next, tighten the pinch block on the feed lever, see Step 3. It's oriented straight up and down like it will be when the quill is at the bottom of its stroke.

ATTACH ARM. Now you can attach the arm. The bottom end is bolted

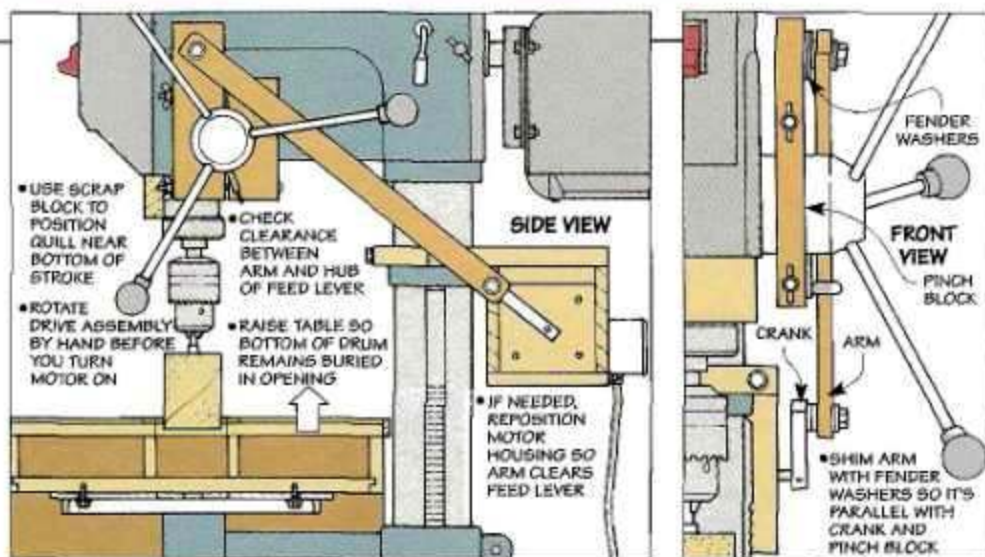

to the crank, see Step 4. But before you can attach the top end, you'll need to drill holes for a spacer and lag screw that hold it in place, see Step 5. To locate these holes, align the arm with the crank, see Side View. Then check for clearance between the arm and the feed lever and drill the holes.

After removing the scrap and adjusting the height of the drill press table (Step 6), all that's left is to check that the arm moves freely.

To do this, rotate the drive assembly *by hand*. If it binds, you may need to add or remove one of the washers that are used to shim the arm, see Front View. ⚠



Step 1. Start by setting the depth adjustment for the maximum amount of travel and lock it in place.



Step 2. Before attaching the arm, use a 1½" tall (wide) block to temporarily hold the quill down.



Step 3. Position the pinch block straight up and down and tighten it around the hub of the feed lever.



Step 4. Now bolt the arm to the crank and align the two parts as shown here and in Side View.



Step 5. After drilling a hole in the top end of the arm, cut it to length and attach it to the pinch block.



Step 6. Finally, remove the scrap block (see Step 2) and adjust the height of the sanding platform.

Sandpaper Storage



The drawer where I kept my sanding supplies just wasn't working out. Besides the fact it was stuffed so full I couldn't find what I needed, my supplies were getting damaged.

Because of the humidity in my shop, sheets of sandpaper had curled up at the edges. And the adhesive backing on my rolls of sandpaper had collected so much dust and dirt that it wouldn't stick any more.

To solve both problems, I built two simple storage units: a press for storing sheets of sandpaper (see photo at left), and a dispenser that holds rolls of adhesive-backed sandpaper, see photo at right.



Sandpaper Press

To keep sheets of sandpaper flat, I made a simple press that mounts on the wall. It's just an open box with a spring-loaded plate that applies pressure against the sandpaper.

SIDES. I began by making two sides (A), see Fig. 1. These are just $\frac{1}{2}$ "-thick pieces of hardwood with the outside corners cut at

an angle. To accept a rail that's added later, you'll also need to cut a notch that's centered on the outside edge of each side.

BACK. The sides are held together with a hardboard back (B), see Fig. 1. Besides adding rigidity to the sides, attaching the back creates an opening for full-sized sheets of sandpaper.

After drilling a pair of mounting holes in the back, it's simply screwed in place so it's flush with the sides.

BOTTOM. To keep sandpaper from falling out of the press when you pull back on the plate, there's also a $\frac{1}{4}$ " hardboard bottom (C) attached to the sides, see Fig. 2. It's beveled along the front edge to match the angle of the sides and then screwed in place, see Fig. 2a.

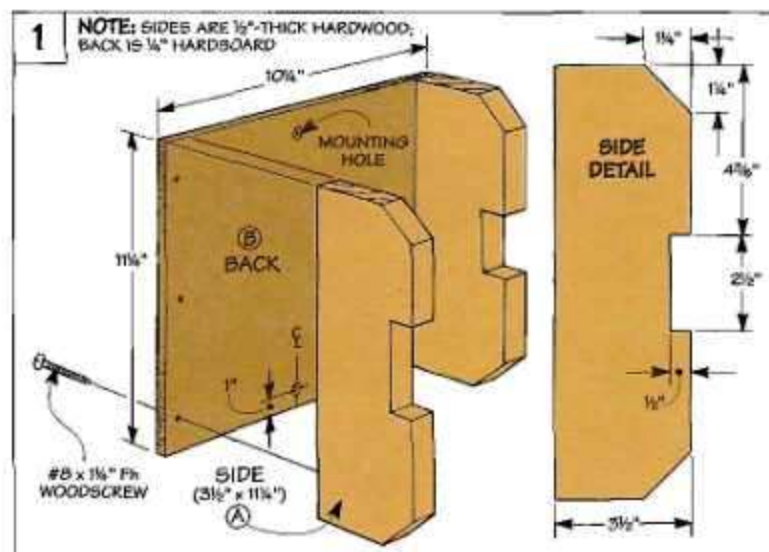

SPRING-LOADED PRESS

Once the basic box is complete, you can turn your attention to the spring-loaded press.

The press works like the lever on a pinball machine. When you pull the handle back, the plate compresses a spring, refer to Fig. 4. Releasing the handle pushes the spring against the plate which presses the sandpaper flat.

RAIL. To make this work, a hardwood rail (D) is added to the front of the press. It's ripped to width to fit into the notches

cut earlier in the sides, see Fig. 2.

A centered hole drilled in the rail guides a dowel that will be attached to the plate later. This keeps the plate centered in the press as it moves in and out.

To complete the rail, just drill a pair of holes in each end for screws that will be used to fasten it to the sides. But don't attach it yet. The rail is added later when you assemble the press.

PRESSURE PLATE. The next step is to add a hardboard *pressure plate (E)*, see Fig. 3. Like its name implies, it applies pressure against the sandpaper when the press is at "rest."

To keep the pressure plate from binding, it's cut to fit inside the box so there's a $\frac{1}{16}$ "-wide gap around the side and bottom edges. Cutting a curved opening in the top edge makes it easy to pull out a sheet of sandpaper; see Fig. 3a.

Also, there's a hole drilled near the bottom of the pressure plate, see Fig. 3. When the press is assembled, it provides access to the bottom hole in the back that's used to mount the press to the wall.

DOWEL. There's just one more thing to do before you assemble the press. That's to attach a dowel to the pressure plate. In addition to providing a way to pull the

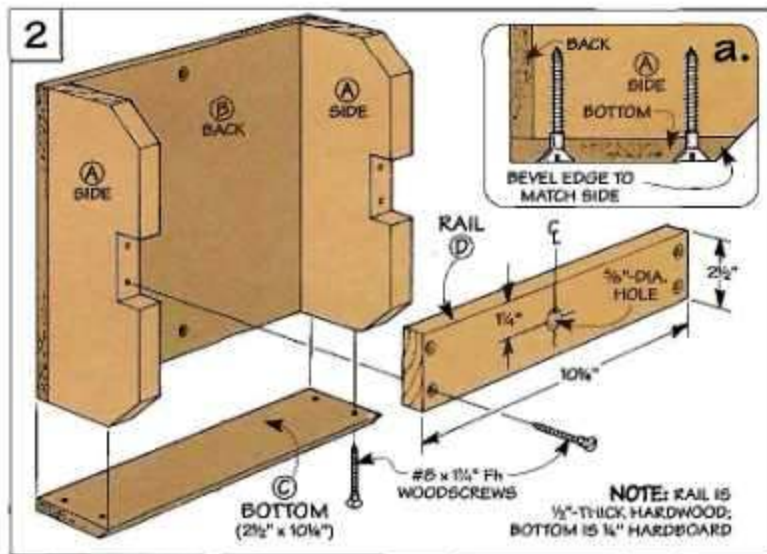

pressure plate away from the sandpaper, the dowel supports the compression spring, see Fig. 3.

The dowel is held in place with a deck screw. Since a deck screw has a straight shank and coarse threads, it's less likely to pull out when it's screwed into the end grain of the dowel.

ASSEMBLY. With all the parts complete, you're ready to assemble the press. The best way I found to do this is to lay the box on its back so the opening faces up.

Start by setting the pressure plate in the opening and slipping the spring over the dowel. Then

use the rail to compress the spring as you fit it into the notches in the side. (You'll need to hold the rail down as you screw it in place.) To make it easy to pull the plate back, I screwed a toy wheel to the end of the dowel, see Fig. 3.

MOUNT PRESS. Finally, it's just a matter of mounting the sandpaper press to the wall and loading it with sandpaper; see Fig. 4 and margin at right.

Note: If you have a lot of sheet sandpaper, you may want to "gang" several sandpaper presses together, refer to the photo on the back cover.



Using index tabs to separate different grits of sandpaper lets you find the sheet you need at a glance.

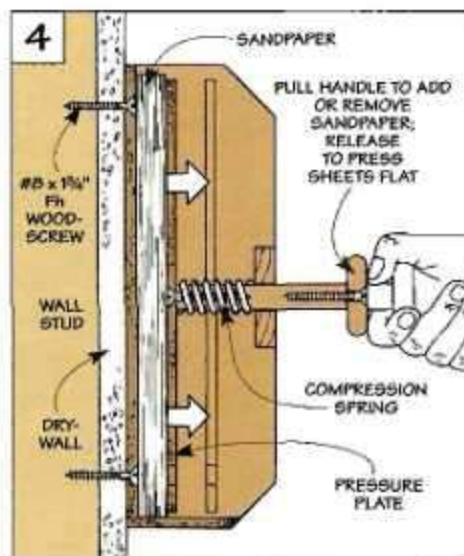
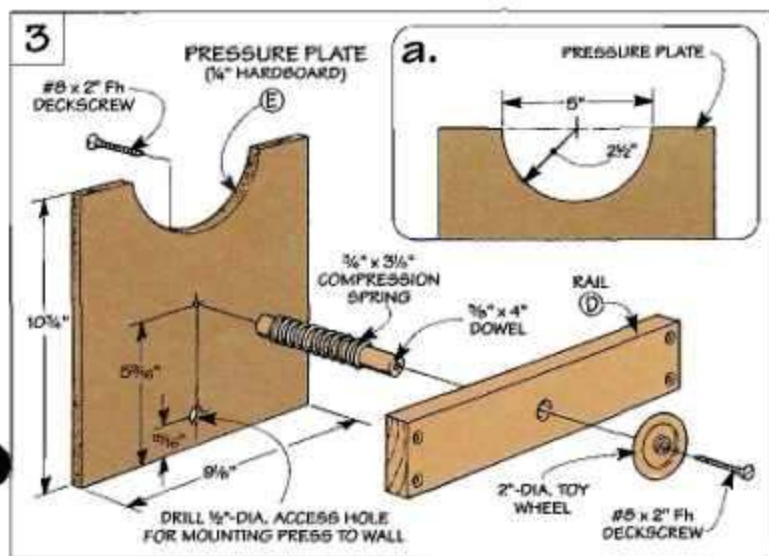

Roll Dispenser

In addition to holding a roll of adhesive-backed sandpaper, this dispenser provides a quick way to measure and cut strips of sandpaper to the exact length you need. Here again, you can make a single unit. Or "gang" several together for storing additional rolls, refer to back cover.

SIDES. I began by making two sides from $\frac{3}{4}$ "-thick hardwood, see Fig. 1. The sides support a pair of rollers. The upper one holds a roll of sandpaper. And the lower roller guides the sandpaper out the bottom, see Fig. 7.

Since the sides are fairly small pieces, I started with a single, oversized blank, see Fig. 2. A rabbet in the back edge accepts a hardboard back that's added later, see Fig. 2a. And there's a dado near each end for a lid, see Fig. 2b.

After drilling two shallow holes that will hold the lower roller, the sides (A) are simply mitered to final length.

ANGLED SLOTS. There's one last thing to do to complete the sides. To make the upper roller removable (and keep it from slipping out as you pull out a strip of sandpaper), there's an angled slot in each side, see Fig. 1. An easy way to align these slots is to carpet tape the sides together, see Fig. 3. Then drill a hole to form the



With a roll of adhesive-backed sandpaper stored in the dispenser, it's easy to tear off a strip the exact length you need.

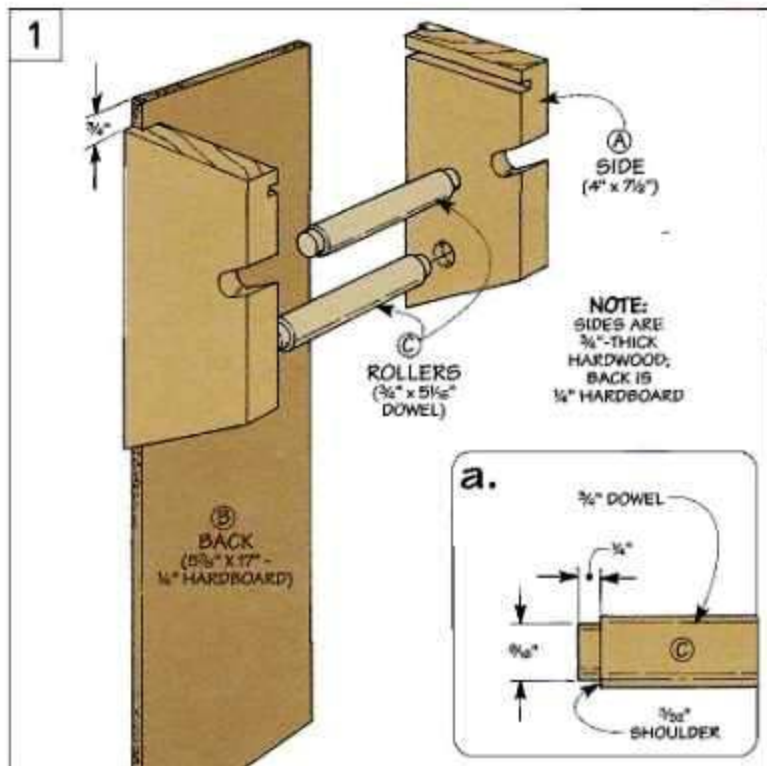

end of the slot and remove the waste with a band saw, see Fig. 3a.

BACK. With the sides complete, you can add the back (B), see Fig. 1. It's sized so the distance from the bottom edge to a cutter that's added later will fit a sander that uses a half-sheet of sandpaper.

ROLLERS. The next step is to make the two rollers (C), see Fig. 1. These are hardwood

dowels with a tenon at each end that fits *loosely* either in the angled slots or the holes in the sides drilled earlier, see Fig. 1a. The loose fit allows the rollers to spin freely as you pull out a strip of sandpaper. (For more on cutting tenons on dowels, see page 30.)

GLUE-UP At this point, you're ready to glue the sides to the back. Just remember to slip the

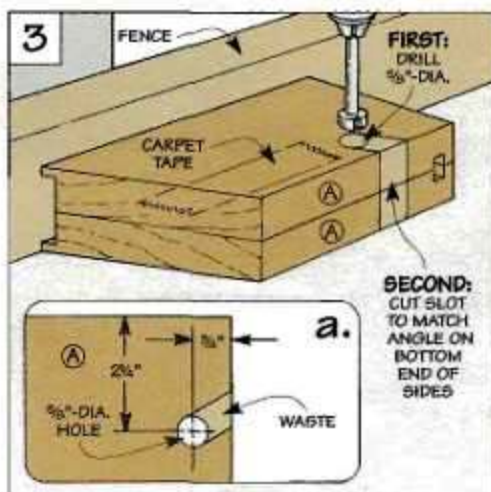
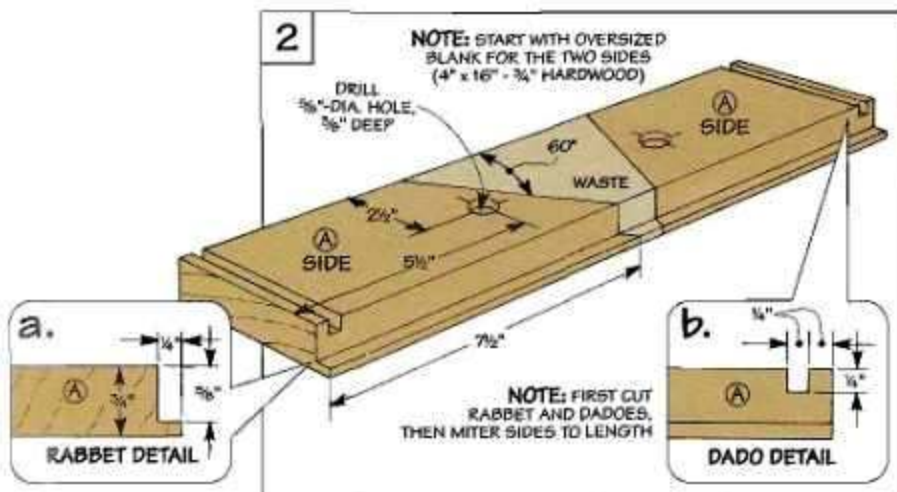

lower roller in place first (no glue) so it's trapped between the sides.

LID. When the glue dried, I added a hardboard lid (D), see Fig. 4. It keeps dust in the shop from settling on the exposed adhesive on the sandpaper. To make it easy to install a new roll of sandpaper, the lid slides in and out of the dadoes in the sides.

GUIDE BLOCKS. Besides the lid, you'll also need to add two small guide blocks, see Fig. 4. Along with the lower roller, they keep sandpaper from curling back around the roll. And they provide an opening for your fingers so you can pull out the sandpaper.

To make it easy to weave a strip of sandpaper around the lower roller, there's a bevel on the top of each guide block. And a bevel on the bottom matches the angle on the sides, see Fig. 4a.

Here again, it's safest to start with a long blank, see Fig. 4a. Then bevel both edges and cut the *guide blocks (E)* to length.

CUTTER. After gluing the guide blocks in place, there are a

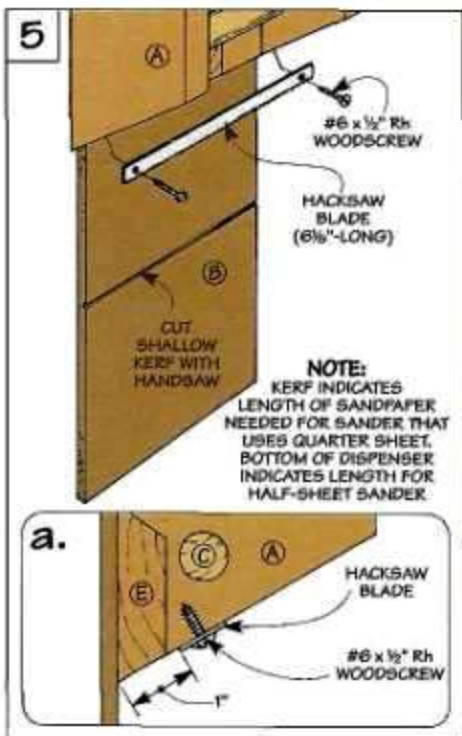
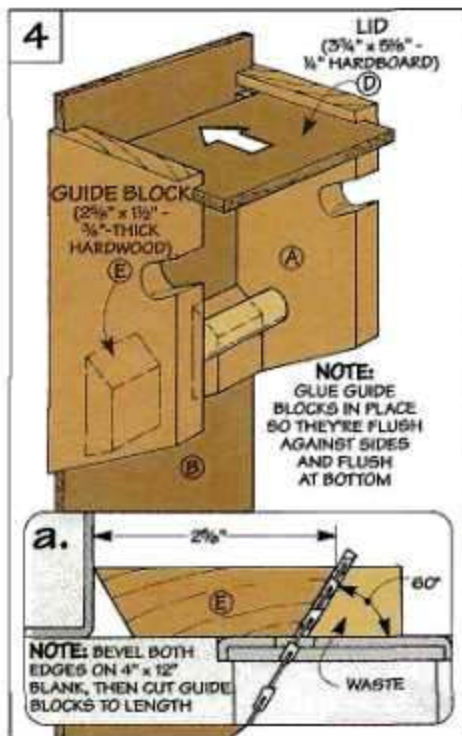

couple more things to do. To cut strips of sandpaper to length, I screwed a short piece of a hacksaw blade to the angled end of each side, see Figs. 5 and 5a.

Once the hacksaw blade is attached, you can cut a shallow kerf in the back that shows how far to pull out the sandpaper for a sander that uses a quarter sheet.

MOUNT DISPENSER. Now all that's left is to mount the dispenser to a wall. It's held in place by two hardwood cleats that are designed so you can easily remove the dispenser and carry it to where you're working.

What makes this work is each cleat is rabbeted to form a lip that holds the dispenser in place. To provide clearance when you remove the dispenser (or hang it up) the lip on the lower cleat is shorter than the one on top, see Fig. 7.

A quick way to make both cleats at once is to use an extra-long blank and cut a rabbet that's the same width as the one required for the upper cleat, see Figs. 6 and 6a. After cutting the *upper cleat (F)* to length, trim the lip on the remaining piece and cut the *lower cleat (G)* to length.

Finally, drill holes in the cleats and screw them to the wall.

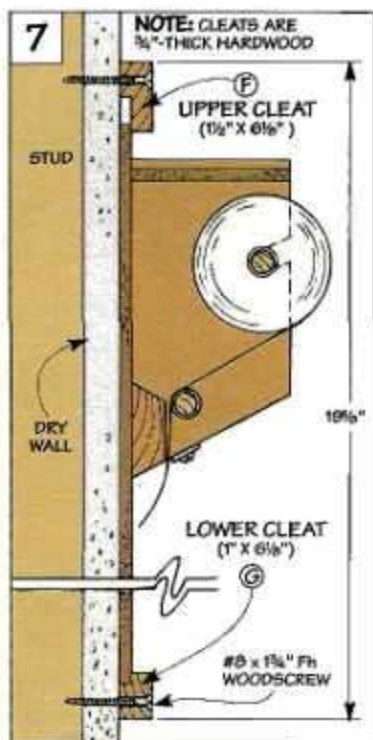
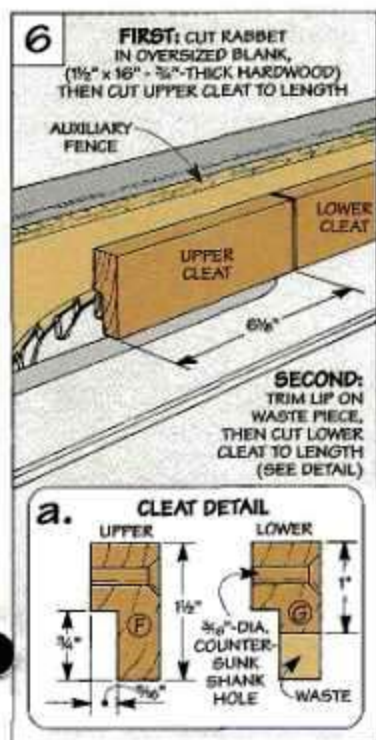

Readers' Tips

Retractable Chuck Key



And it's connected to the chuck key by means of a short dowel.

A hole drilled in one end of the dowel accepts the handle of the chuck key. (I used epoxy to hold it in place.) After screwing an eye hook in the opposite end, it's simply slipped onto the ring at the end of the key chain.

*Gary Vorgert
Epping, North Dakota*

■ I'm always misplacing the chuck key to my drill press. So I fastened it to a retractable key chain that's attached to the column of the drill press, see photo above.

The key chain is held in place with an ordinary hose clamp.

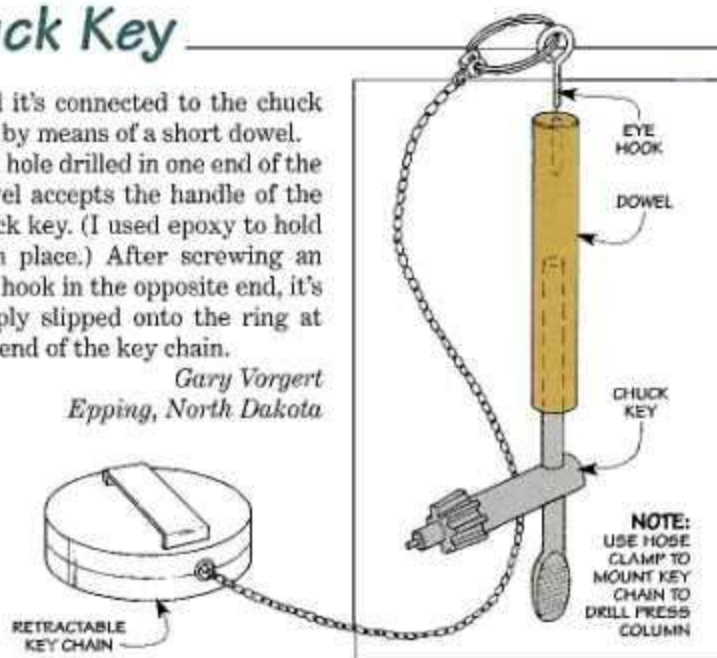

Wedged Sanding Block



■ Here's a handy sanding block that uses a belt from my portable belt sander. The belt is tightened on the sanding block by tapping in a simple wood wedge, see photo.

The sanding block is easy to make — especially since the wedge is cut from the block. The only tricky part is knowing how long a block to start with.

To find out, slip scraps of wood

inside the belt and slide them toward the ends, see Fig. 1. Then measure the inside length of the belt and add $\frac{3}{16}$ " for the saw kerfs.

After cutting the block to length, just round over the ends to match the curve of the belt. Then cut the wedge on a band saw, see Fig. 2.

*Dario Brisighella Sr.
Oak Creek, Wisconsin*

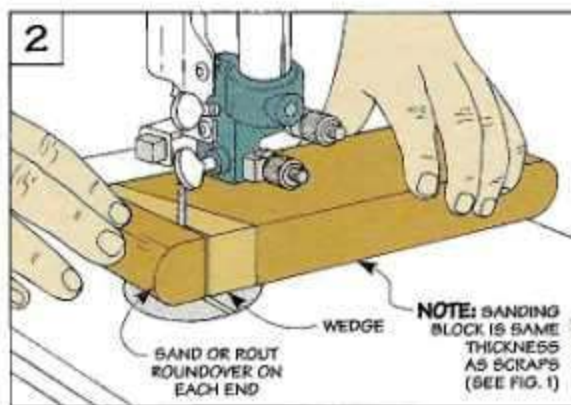
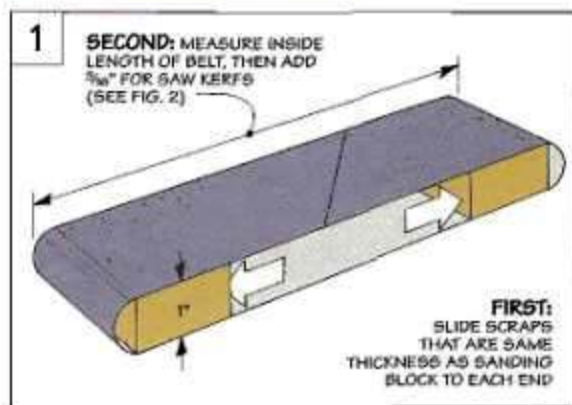

Plastic Knobs

Like many woodworkers, I use plastic knobs on many of the jigs in my shop. But I don't have to buy them. Instead, I make the knobs using plastic lids from ordinary household products.

Besides the fact I can "rescue" lids from the trash, they have one other advantage. The plastic ribbing around the lid provides a good grip when tightening or loosening the knob, see photo.

TWO TYPES. Depending on the application, you can make two types of knobs. One has internal threads that fit onto a threaded stud or bolt, see drawing. The other has an external threaded stud.

Regardless of the type of knob, they both start the same way. A wood block with a hole

drilled in it for a T-nut is cut to fit inside the lid. (Use epoxy to glue in the block and T-nut.)

You can use the threaded knob as it is. Or epoxy a cutoff bolt in the T-nut for the studded knob.

*Robert Llewellyn
Memphis, Tennessee*

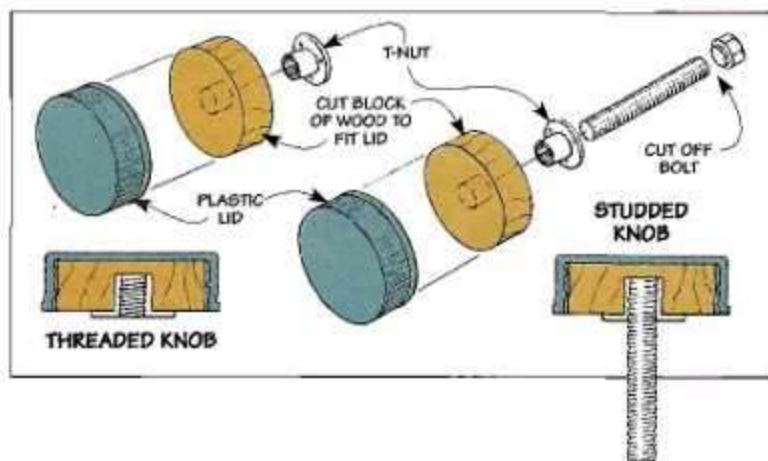

Pocket Holes

Occasionally, I join two pieces of wood with a screw that's driven in at an angle. But when drilling the angled holes for the screw, the bit tends to wander.

To prevent this, I drill a shallow pocket hole with a Forstner bit, see drawing. This creates a "ledge" that keeps the tip of the bit from slipping when drilling the holes for the screw, see details 'a' and 'b.'

*Adolph Peschke
Des Moines, Iowa*

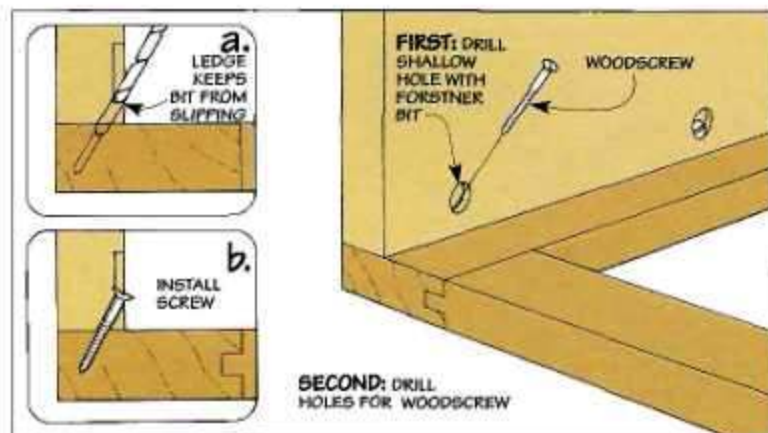

Pencil Cushion



Pencils used to have a mysterious way of disappearing in my shop — until I started using this "pencil cushion."

It's just a piece of pipe insulation that fits onto a wall stud, see photo. Sticking pencils in the cushion keeps them handy and keeps the tips from breaking.

*Peter Priestner
Chelmsford, Massachusetts*

Send in Your Solutions

If you'd like to share your original solutions to problems you've faced, send them to: *ShopNotes*, Attn.: Shop Solutions, 2200 Grand Avenue, Des Moines, IA 50312. (Or if it's easier, FAX them to us at: 515-282-6741.)

We'll pay up to \$200 depending on the published length. Please include a daytime phone number so we can call you if we have any questions.

ROUTING A SQUARE OPENING



■ Making the square inserts for the table on the oscillating drum sander shown on page 16 is easy. The challenge is cutting a perfectly square opening in the cover so the inserts fit tight — no matter which way you put them in. To do this, Steve (our shop craftsman) came up with a simple way to rout the opening on the router table.

LAYOUT. Start by laying out the location of the opening so it's centered on an oversized cover, see Fig. 1. Then cut the opening to rough size with a sabre saw.

The rest of the material is removed using a straight bit and running the cover against a fence. The idea is to position the fence so the bit cuts *short* of the layout lines. This way, you'll be able to sneak up on the fit. Note: Because of the large size of the cover, I clamped the fence to the *end* of the router table.

With the fence in place, lower

ROUND TENONS

■ A table saw makes quick work of cutting the round tenons on the dowels (rollers) for the sandpaper roll dispenser shown on page 26. All it takes is a dado blade and an auxiliary fence on both the miter gauge and rip fence.

SIZE. The diameter of the tenon is set by the height of the dado blade. To cut a $\frac{9}{16}$ "-dia. tenon on a $\frac{3}{4}$ " dowel, set the height of the blade to $\frac{3}{32}$ ".

The length of the tenon is established by the distance from the auxiliary rip fence to the outside edge of the dado blade, see detail 'a' below.

With the setup complete,



draw a line on the auxiliary fence to mark the center (high point) of the blade. Then, slide the miter gauge forward until the center of the dowel is in line with the mark, see photo above and drawing below.

To form the tenon, hold the miter gauge in place and hold the dowel *down* against the saw table as you rotate it *forward*.

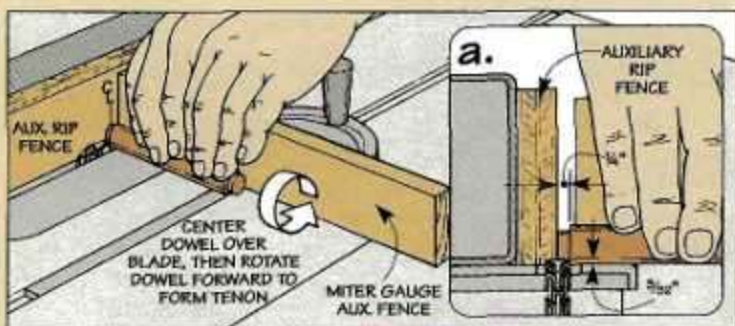

the cover over the bit. Then push the cover into the fence and rout one edge, see Fig. 2. After repeating this for the opposite edge, check the fit using one of the inserts, see photo above.

If it doesn't fit, just nudge the fence away from the bit, and rout

one edge only. Continue to make small adjustments until the insert just fits into the opening.

To rout the other two edges, reposition the fence and repeat the process. Once the insert fits, just square up the corners of the opening with a chisel.

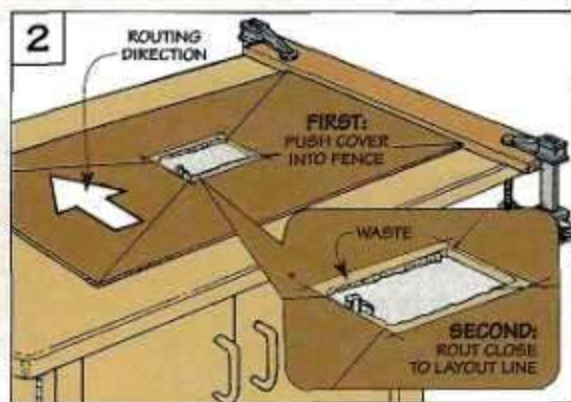
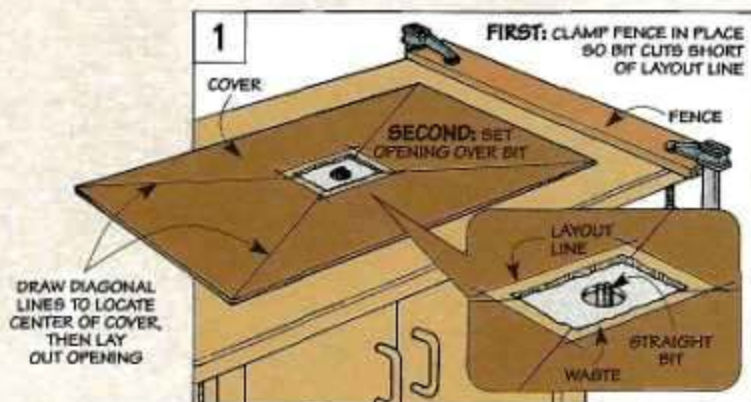

ROUTING FINGER JOINTS

■ Nice, tight finger joints like the ones in the clipboard box on page 4 require perfectly-straight fingers and flat-bottomed slots, see photo at right. To make them, I used an $\frac{1}{8}$ "-dia. straight bit in the router table and a simple jig, see drawing below.

JIG. The jig consists of three pieces. A hardwood *fence* supports the workpiece. And a *key* glued into a slot that's routed in the fence determines the spacing and tightness of the finger joint. Finally, a hardboard *base* carries the workpiece across the opening in the router table insert.

SETUP. The fit of the finger joints is determined by the location of the key. The idea is to clamp the jig in place so the key is $\frac{1}{8}$ " from the cutting edge of the bit, see margin.

TEST CUTS. Now you'll need to cut some test pieces to check the fit of the finger joints, see Steps 1 through 3 below. If the fit is too loose, loosen the clamps *slightly* and nudge the fence to the right. If it's too tight, move the

fence to the left.

Once you're satisfied with the fit, you can rout the finger joints in the real workpieces. Although the workpieces are cut to final *length*, it's best to start with them oversized in *width*. This way you'll be able to rip them to final width with a full finger (or slot) at each edge.

FRONT & BACK. Now you're ready to rout the fingers. Since there's a full finger on the top and bottom edges of the front and back pieces, I start with one of them.

To position the piece, place the edge against the key, see Step 1. Then slide the miter gauge forward to rout the first slot. Once

the first slot is routed, fit it over the key to position the workpiece for the next slot, see Step 2. Then just rout the rest of the slots in that end in the same way. To rout the slots in the opposite end, flip the workpiece end for end and repeat the process.

SIDES. With the front and back complete, you can start on the sides. Since the sides begin with a slot, you'll need to use a finger on the front (or back) to position the workpiece, see Step 3.

To do this, use the edge that's *opposite* the waste edge to position the side. Once you rout the first slot, the process is basically the same as with the front or back.

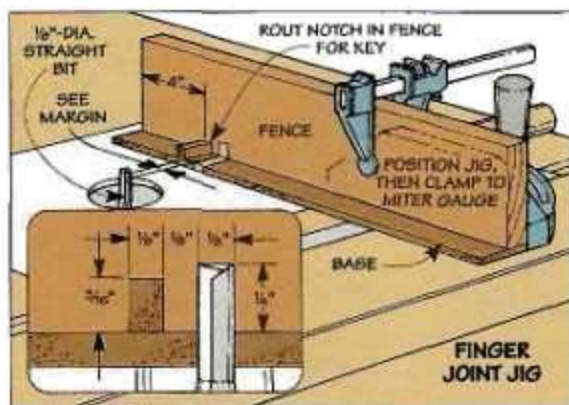

An $\frac{1}{8}$ " drill bit makes a handy gauge to help position the key.

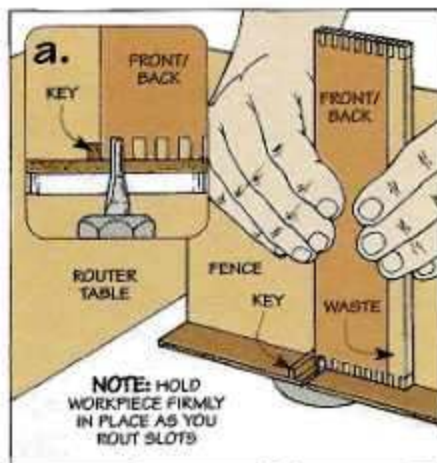

Step 1. To rout the first slot, place the edge of the front (or back) against the key and hold the workpiece firmly against the fence.

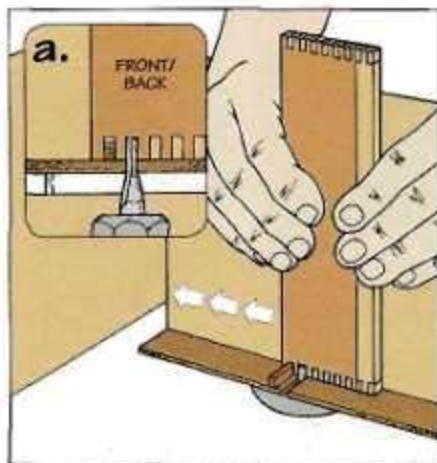

Step 2. Now fit the first slot over the key and make another pass. After routing all the slots in one end, flip the piece end for end and rout the opposite end.

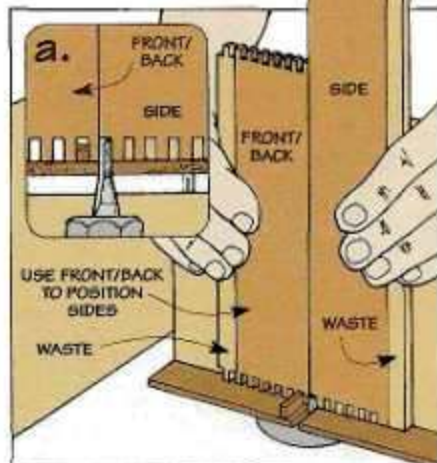

Step 3. The edge opposite the waste edge on the front/back is used to position the side. Just fit the slot nearest the edge over the key and butt the side against it.

Scenes from the Shop



▲ These block planes are as different as the craftsmen who use them. We visit with four different woodworkers to find out what makes each plane a favorite.



▲ Don't forget this clipboard box when you head down to the lumberyard. A fancy clipboard outside and a storage box inside makes planning your projects easy.



▲ A dispenser for rolls of adhesive-backed sandpaper. And a press for sheets of sandpaper. Build each one as a separate unit or "gang" them together for more storage.