

TIPS • TOOLS • TECHNIQUES

ShopNotes®

Vol. 5

Issue 28

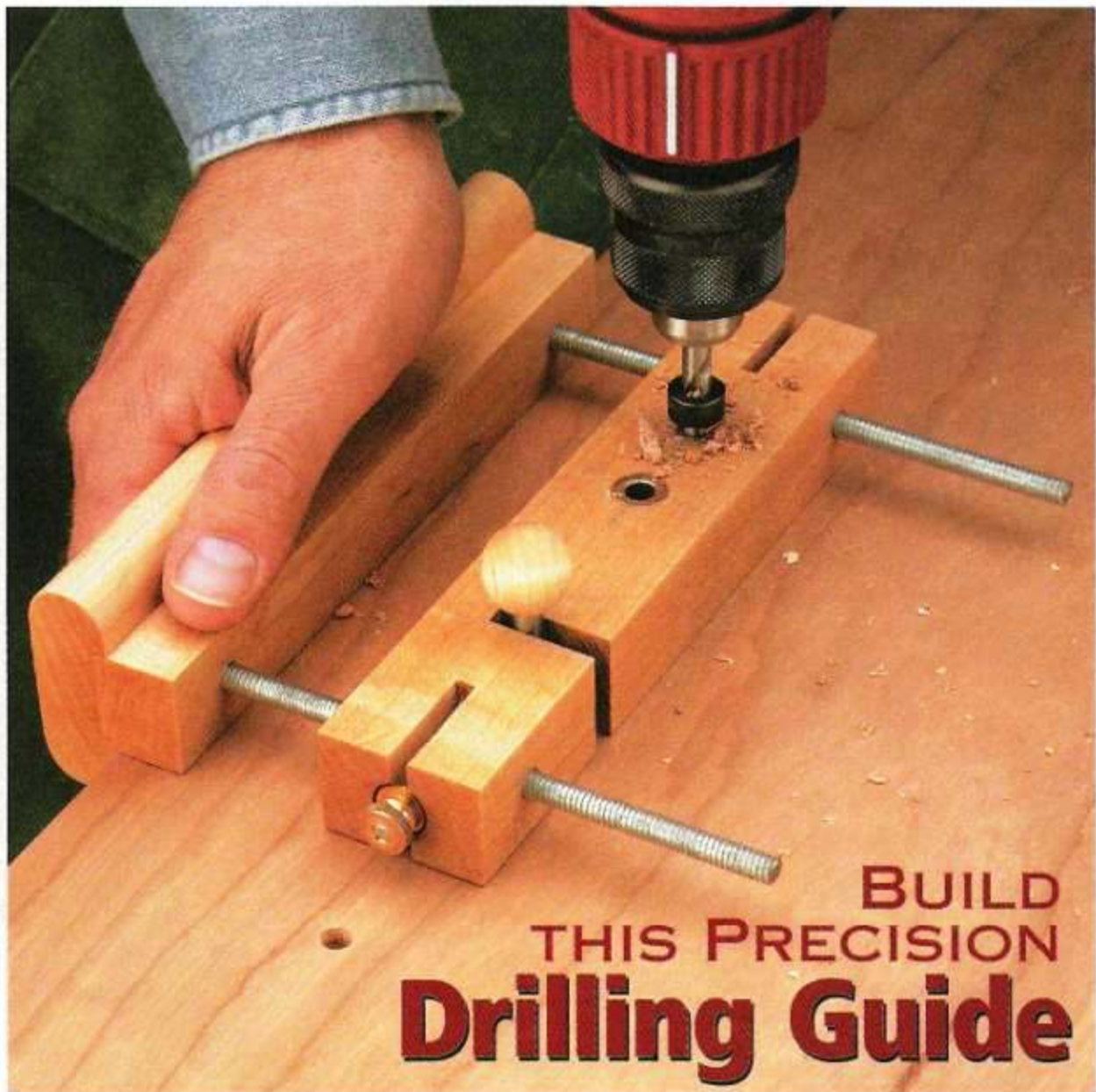

BUILD
THIS PRECISION
Drilling Guide

- Vertical Glue-Up Station
- Tips on Shop Layout
- Thickness Planers
- Crotchwood
- Shop Stool

PUBLISHER Donald B. Peschke
EDITOR Tim Robertson
ASSOCIATE EDITOR Phil Totten
ASSISTANT EDITOR Bryan Nelson
ART DIRECTOR Cary Christensen
SENIOR ILLUSTRATORS Kurt Schultz
Roger Reiland
Mark Higdon

CREATIVE RESOURCES

Creative Director: Ted Kralliek • *Project Design Director:* Ken Munkel • *Shop Manager:* Steve Curtis • *Shop Craftsmen:* Steve Johnson • *Photography Director:* Lark Glimmer • *Senior Photographer:* Crayola England

BOOKS

Executive Editor: Douglas L. Hicks • *Senior Graphic Designer:* Chris Glowacki

CIRCULATION

Circulation Dir.: Susan DuBois • *Asst. Circ. Dir.:* Troy J. Dowell • *Sub. Mgr.:* Sandy Baum • *Removal Mgr.:* Paige Rogers • *Asst. Direct Mail Mgr.:* Julie Greenlee • *Asst. Sub. Mgr.:* Jay Krause • *Associate Graphic Design Dir.:* Sude Rider • *Graphic Designer:* Cheryl L. Cynor

CORPORATE SERVICES

Vice President of Planning and Finance: Jon Macarthy • *Controller:* Robin Hutchinson • *Senior Accountant:* Laura Thomas • *Production Dir.:* George Chmieluz • *Electronic Pub.:* Douglas M. Lidster • *Prod. Artist:* Jon Snyder • *Prod. Mgr.:* Carol Quijano • *Elect. Comm. Coord.:* Gordon C. Gelppe • *Net. Admin.:* Al Barnes • *Prof. Develop. Dir.:* Joyce Moore • *Admin. Asst.:* Cheryl A. Lee, Julia Fluh • *Receipt.:* Jeanne Johnson, Sheryl Ribbey • *Building Maintenance:* Ken Griffith

MAIL ORDER

Operations Dir.: Bob Baker • *Art Dir.:* Cindy Scarpino • *Materials Mgr.:* Mark Mattiacci • *Cust. Service Mgr.:* Jennie Eason • *Nat. Sales Mgr.:* Kent A. Barkton • *Warehouse Supv.:* Nancy Johnson • *Buyer:* Linda James • *Sys. Op.:* Tammy Aidi • *Team Leader:* Karla Estinger • *Tech. Support:* Dave Stone • *Cust. Service Reps.:* Jennifer Murphy, Anna Cox, Kristi Andrews, Margo Petrus • *Warehouse:* Gloria Sheehan, Chuck Carlson, Sylvia Carey, Larry Prine, Scott Gilliam, Cathy Steiner

ShopNotes® (ISSN 1062-0690) is published bimonthly (Jan., March, May, July, Sept., Nov.) by August Home Publishing, 2200 Grand, Des Moines, IA 50312.

ShopNotes® is a registered trademark of August Home Publishing ©Copyright 1996 by August Home Publishing. All rights reserved.

Subscriptions: Single copy: \$4.99. One year subscription (6 issues), \$19.95. Two years (12 issues), \$35.95. Canada/Foreign add \$5 per year.

Second Class Postage Paid at Des Moines, IA and at additional offices.

Postmaster: Send change of address to ShopNotes, Box 11294, Des Moines, IA 50340-1294.

Subscription Questions? Call 1-800-383-6075, 8:00 am to 5:00 pm, Central Time, weekdays. FAX 515-283-6884

E-Mail: ShopNotes@aust.com

Internet: <http://www.augusthome.com>

PRINTED IN U.S.A.

WoodNet

COMPUTER BULLETIN BOARD FOR WOODWORKERS

- Project plans and photos to download
- Woodworking Techniques Forum
- Indexes for Woodsmith & ShopNotes
- FREE download on free call

To log on to WoodNet, call 1-515-245-9663. If you have any questions, please give us a call (voice) 1-515-282-7000 M-F 9-5 CST.

Cutoffs

Firing up the diesel engine that powered the huge (55") circular saw blade, Randy Johnson yelled over his shoulder, "You just never know what you'll find when you cut into a log." And the two walnut logs that his father, I.D. Johnson, ran through the sawmill proved his point, see photo.

CROTCHWOOD. As the blade sliced a thick slab of wood off the first log, it revealed exactly what they were looking for — the striking feathery grain that sometimes forms in the crotch of a tree.

BARK. But the second log was an altogether different story. Instead of the highly figured grain, there was a disappointing pocket of bark that threaded its way through the wood. Perhaps the result of the bark growing around a nut that a squirrel had stashed in the crotch of the tree.

Why all this talk about crotchwood? One reason is a number of readers have asked about the walnut crotchwood we used for the scraper plane in the last issue. So we decided to take a closer look at what it is, and where to get it, refer to the article beginning on page 30.

It's followed by a series of photos taken at the sawmill we visited. (If you like poking around sawmills as much as I do, these photos are the next best thing to being there.)

One thing we came across at the sawmill was an old, industrial planer. A cast iron monster that looks like you'd need a boom crane to move it.

THICKNESS PLANERS. The sheer mass of that planer made me appre-

ciate the small-scale portable thickness planers we tested for this issue. Weighing only 50 to 70 lbs., these planers are reasonably easy to move around. So you get the benefit of a big planer without creating a permanent fixture in your shop.

Okay, so they're portable. But can they handle the job? That's what our team of testers wanted to find out. And they weren't alone.

As soon as we unpacked the planers, the guys started circling around them like minnows in a bait bucket.

That's when the questions started. Is there any advantage to a four-post model? Or the fact that the cutterhead is fixed on one and it moves up and down on the others? And what's all this talk about

"throwaway" blades?

COST. One other question that came up was the cost. After all, these planers aren't exactly inexpensive (prices range from \$375 to \$500).

But the money you save by planing your own rough lumber (or just the convenience of planing stock quickly and accurately to the exact thickness you need) may make it worth the investment.

NEW FACE. Recently, Bryan Nelson has joined our staff here at *ShopNotes* as Assistant Editor. He's been a subscriber since Issue No. 1 (no kidding) and is an experienced woodworker.

Bryan will be writing articles and coordinating our upcoming tool tests. Since he's spent the last 13 years as a flight test engineer, he's bound to be a "natural."



Tim

Contents

Projects and Techniques

Vertical Glue-Up Station _____ 4

Gluing up solid wood panels is easy with this shop-built jig. And it doubles as a storage rack for your pipe clamps.

Shop Stool _____ 8

Comfort and strength. Two reasons why this may be the only stool you'll ever build for your shop.

Routing Tenons on Dowels _____ 11

A core box bit and a simple jig. That's all you need to rout tenons on the dowels used for the legs of the stool.

Gluing Up Panels _____ 12

Tips and techniques for gluing up an attractive solid wood panel that's perfectly flat — and stays flat.

Drilling Guide _____ 16

Building a cabinet with adjustable shelves? A unique indexing system on this drilling guide lets you drill identically-spaced holes for both rows of shelf pins.

Departments

Great Tips

Sharpening Tips _____ 14

A roundup of our best sharpening tips that will keep your chisels and plane irons in top shape.

Small Shop

Small Shop Layout _____ 20

Make a small shop work "big" by planning for work flow, tool groups, and infeed/outfeed requirements.

Selecting Tools

Portable Thickness Planers _____ 22

Our team tests six popular, portable thickness planers and offers practical suggestions on the best one to buy.

Readers' Tips

Shop Solutions _____ 28

ShopNotes' readers offer their own solutions to some of the most common woodworking problems.

Lumberyard

Crotchwood _____ 30

The dramatic grain patterns in crotchwood can turn an ordinary project into something special.



Glue-Up Station page 4



Shop Stool page 8



Drilling Guide page 16



Thickness Planers page 22

Vertical Glue-Up Station

This folding station makes it easy to glue up solid wood panels.



Okay, I'll admit it. Gluing up a solid wood panel with pipe clamps standing on end looks a bit unorthodox. But it works great. And with this vertical glue-up station to support the clamps, the whole glue-up process is simplified considerably.

CLAMP STORAGE. For example, there's no need to drag heavy pipe clamps around the shop. That's because the glue-up sta-

tion doubles as a storage rack, see photo A below.

WORK SURFACES. With a row of clamps on each side of the station, there are two flat work surfaces for gluing up panels, see photo B. So besides the fact you don't have to clear off a work surface somewhere else in the shop, you can glue up several panels at a time.

SAVES SPACE. Finally, to save space, the glue-up station hinges in the middle. So when the glue dries, just remove the panels and fold the station for storage, see photo C. Note: If floor space is limited, there's even a wall-mounted version, see page 7.

CONSTRUCTION

Basically, the station consists of two wood frames that are hinged



A. Storage Rack. A simple metal broom clip helps secure each pipe clamp for storage.

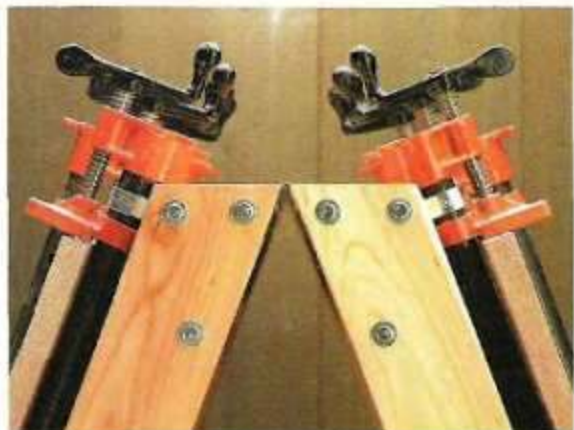

B. Two Work Surfaces. Each side of the glue-up station is designed to hold pipe clamps. So you can glue up several panels at once.



C. Compact Storage. When folded for storage, the glue-up station requires very little floor space.

together in the middle. (I used "two-by" Douglas fir.) Note: These frames are designed to hold 36"-long pipe clamps.

LEGS. Each frame starts off with a pair of legs (A), see Fig. 1. To tilt the frame at an angle so a workpiece sits flat against the pipe clamps, a 20° miter is cut on both ends of each leg, see Fig. 1c.

TOP RAIL. The legs are held together with a top rail (B) that's ripped at an angle on both edges, see End View.

The front edges are angled so when you attach broom clips (later) they'll be able to grab the pipe clamps. And the angle on the back edge keeps the top rails on each frame from binding when you fold up the station.

STRETCHER. After attaching the top rail to the legs with lag screws, I added a stretcher (C) to prevent the frame from racking. It's cut to fit between the legs and is screwed to the top rail, see Fig. 1a. Here again, I used lag screws to fasten the stretcher to the legs, see Fig. 1b.

BOTTOM RAIL. All that's left to complete the basic frame is to add a bottom rail (D) to the legs, see Fig. 2. Holes drilled in the top edge of this rail act as a "pocket" for the bottom end of each pipe clamp.

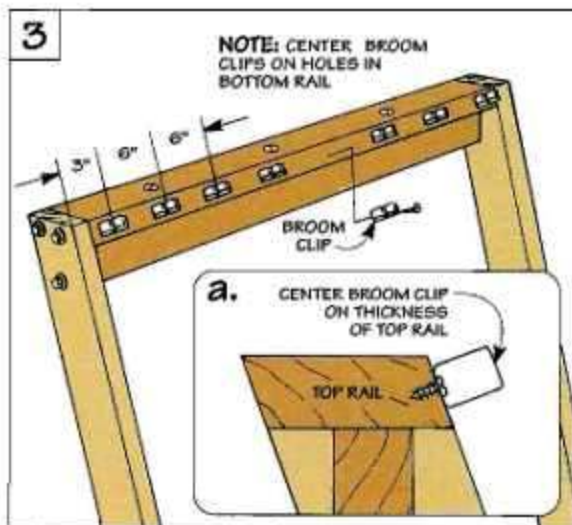
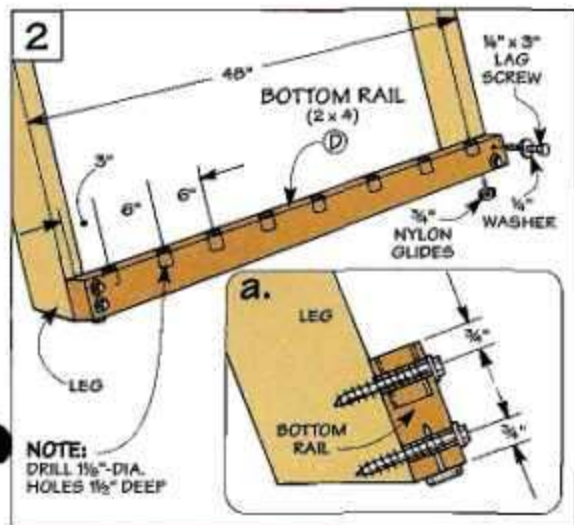
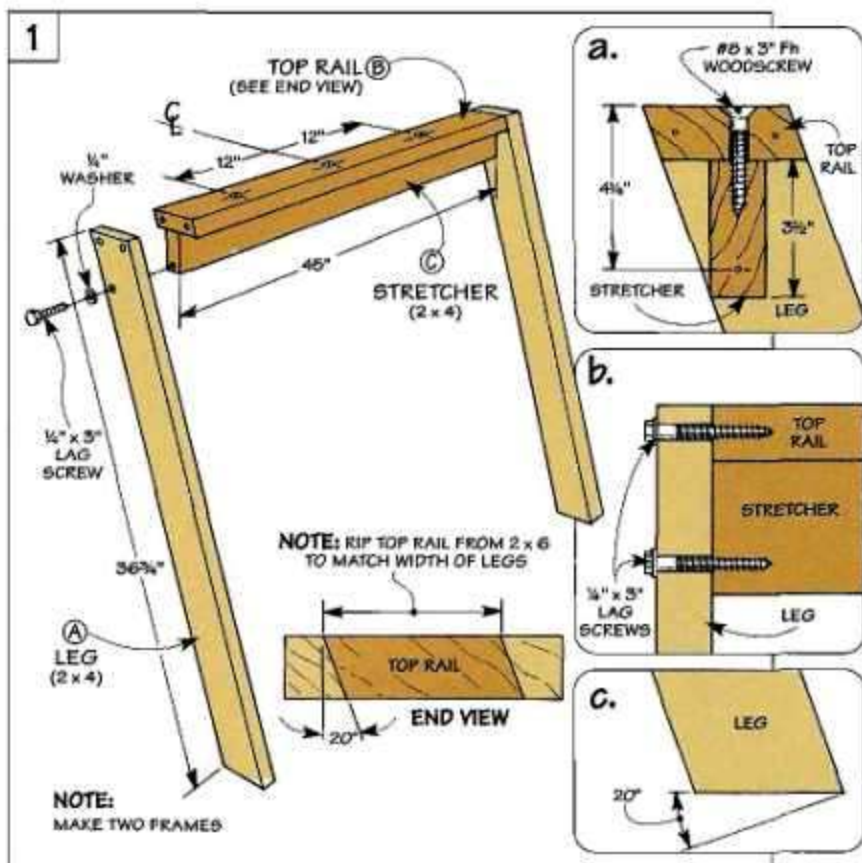

Assembly

With two frames completed, they're ready to be assembled.

HINGE. To make it easy to fold the clamping station for storage, the frames are held together with a piano hinge that's screwed to the inside edge of each top rail (B), see drawing and end view.

Mounting the hinge flush with the top rails creates a flat surface for holding glue supplies.

CHAIN. To prevent the frames from spreading too far apart and damaging the hinge, I installed a chain on the inside face of each leg, see inside view.

Finally, attaching a hook and eye to each leg locks the station together when it's folded for storage, see outside view.

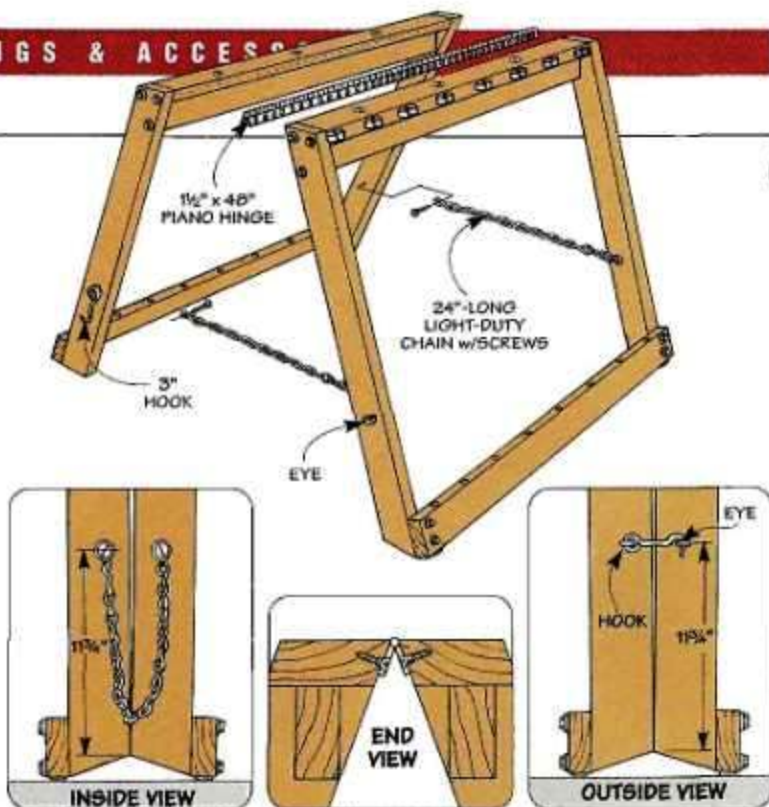

Hardware

(Free-Standing)

- (20) 1/4" x 3" Lag Screws
- (20) 1/4" Washers
- (1) 1 1/2" x 48" Piano Hinge w/Screws
- (2) 3" Hooks w/Eyes
- (16) Broom Clips
- (20) #8 x 3/4" Rh Woodscrews
- (2) 24" Light-Duty Chains
- (6) #8 x 3" Fh Woodscrews
- (4) 3/4" Nylon Furniture Glides

Using the Glue-Up Station

When using this glue-up station to make a wood panel, it's easiest to first adjust each clamp for the width of the panel, see Steps 1 and 2. (I position the clamp heads 1/2" farther apart than the width of the panel.)

Then it's just a matter of stacking the individual pieces and applying glue, see Step 3.

Finally, after tightening the back clamps, position clamps on top of the panel to apply even clamping pressure, see Step 4.

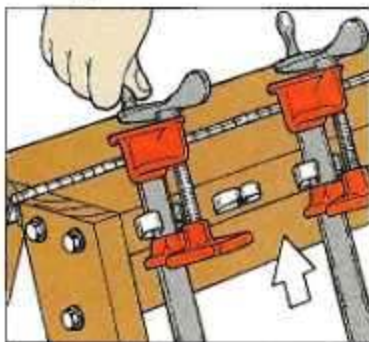

Step 1. Start by backing off the top clamp heads until they hit the bottom of the broom clips.

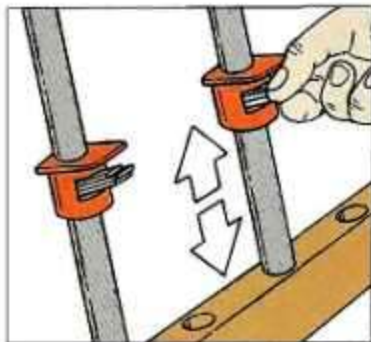

Step 2. Then adjust the bottom clamp heads to allow for the width of the panel.

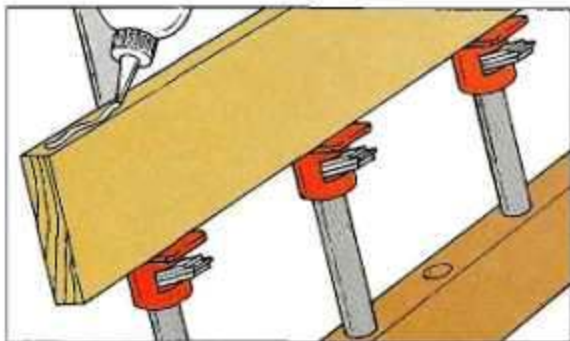

Step 3. Now lay the individual workpieces on the pipe clamps and apply glue to each one as you work your way toward the top of the panel.

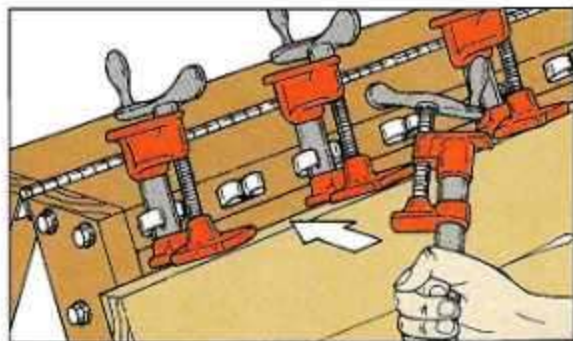

Step 4. After the last workpiece is positioned, tighten the back clamps. Then add another row of clamps across the top of the panel.

Wall-Mounted Station

If floor space is limited in your shop, you can build this wall-mounted glue-up station.

It's almost identical to the free-standing version. But the pipe clamps are held in place by a single frame that holds the clamps away from the wall at an angle when gluing up a panel, see photo. Then it folds up flat against the wall for storage.

SUPPORT. What makes this glue-up station work is a simple U-shaped support that pivots on the legs of the station, see Fig. 4. It consists of two short arms (I used scrap 2x4s) that are held together by a long bar.

A curve cut on one end of each arm (E) keeps the support from binding as it pivots up and down, see Arm Detail. The other end is mitered so the support fits tight against the wall when the station

is propped open.

BAR. Once the arms are mitered to length, you can add the bar (F), see Fig. 4. It's nothing more than a 1½"-dia. dowel that fits in holes drilled in the arms.

ATTACH SUPPORT. With the bar glued and screwed in place, you can attach the support to the frame. It's held in place with hex bolts that pass through holes drilled in the legs of the frame and the arms, see Figs. 4a and 5.

MOUNT STATION. After tacking nylon glides to the bottom of the frame, all that's left is to mount the clamping station to the wall.

Here again, a piano hinge secures the clamping station to

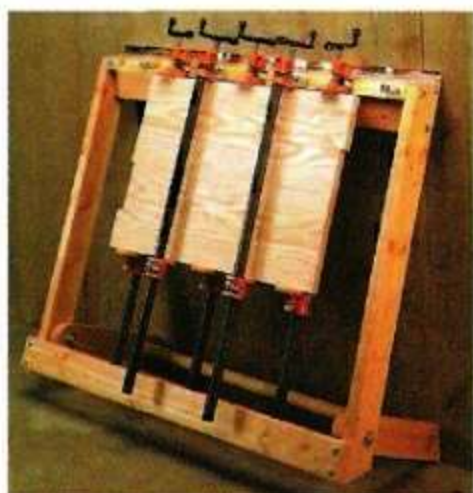

Hardware (Wall-Mounted)

- (10) ¼" x 3" Lag Screws
- (10) ¼" Washers
- (1) 1½" x 48" Piano Hinge w/Screws
- (8) Broom Clips
- (8) #8 x 2¼" Rh Woodscrews
- (5) #8 x 3" Fh Woodscrews
- (2) ½" x 4" Hex Bolts
- (6) ½" Flat Washers
- (2) ½" Lock Nuts
- (2) 5/8" Nylon Furniture Glides

the wall. But this time, one leaf of the hinge is screwed to the top of the frame, see Fig. 5a. Then, with the station folded up against the wall and resting on the floor, screw the other leaf to the wall. 

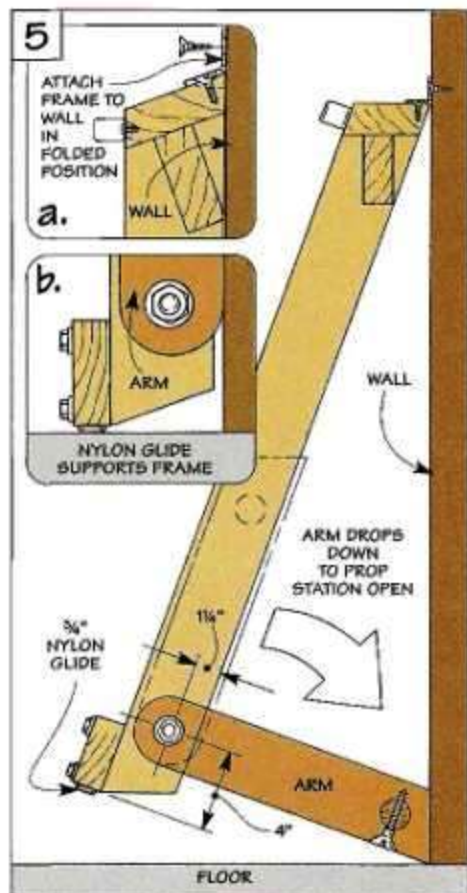
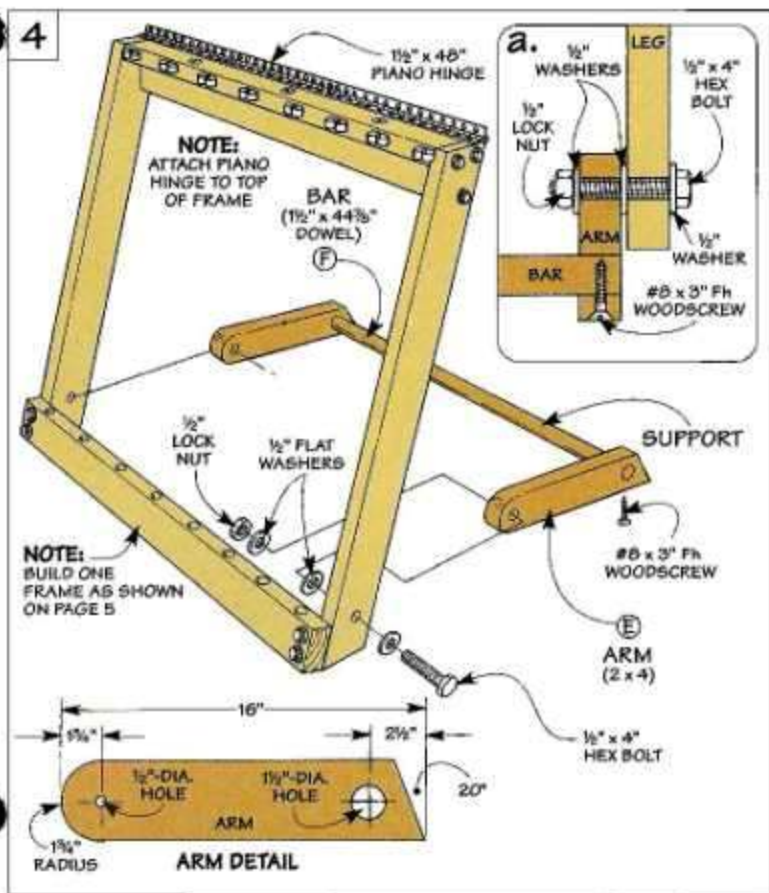

Shop Stool

With its thick slabs and beefy dowels, this shop stool is as sturdy as it is comfortable.



When the guys first saw this shop stool, they had to know one thing. Why was the seat square in front? But as soon as they sat down, it was obvious — it's more comfortable that way.

With the front edge removed, the seat doesn't dig into the back of my legs like a round stool. Especially when I prop my feet up on the large curved footrest.

Besides being comfortable, I also wanted the stool to be sturdy. So I used 1¾"-thick slabs of hardwood (maple) for the seat and footrest. And big, beefy 1½"-

diameter dowels serve as legs that angle outward for stability.

BLANKS. I started by making two blanks — one for the seat, and one for the footrest, see Fig. 1. After drawing a curve on each blank, the next step is to cut the *seat* (A) (not the footrest) to shape. (The curved waste section on the footrest will be used later to support the bit when drilling holes for the legs and center rung.)

LAY OUT. Now you can lay out the holes for the legs in both the



seat and the blank for the footrest, see Fig. 2. Four 1"-diameter holes on the *bottom* of the seat will accept tenons on the legs. And the two 1½"-diameter holes in the *top* of the footrest will fit around the front legs.

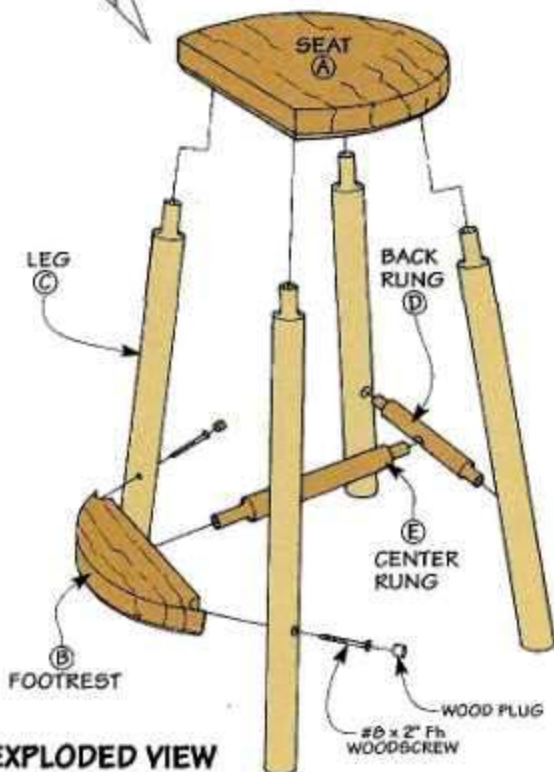

EXPLODED VIEW

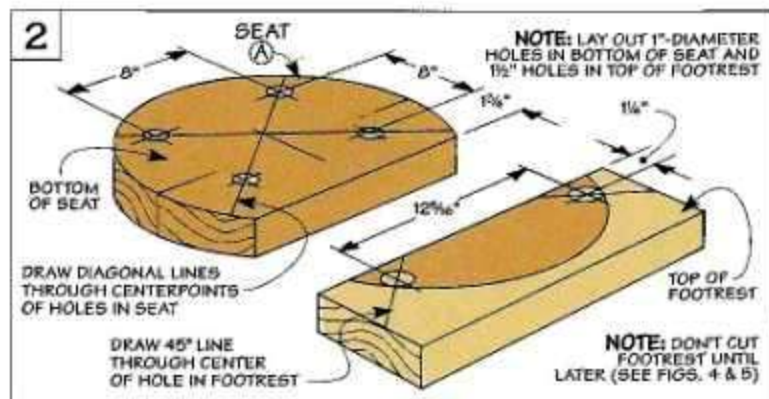
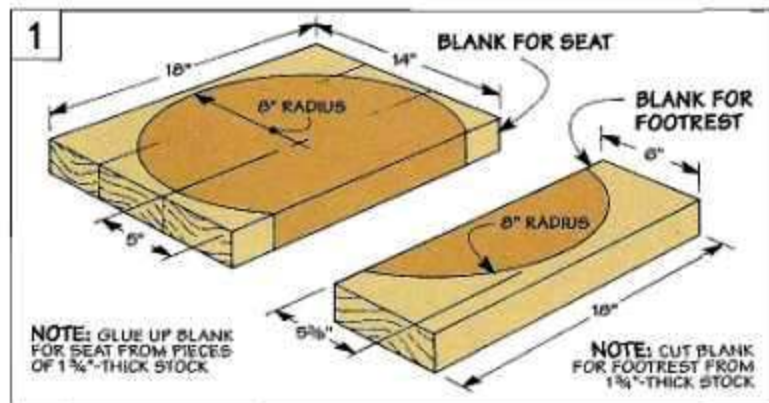

Since these holes are drilled at an angle, there are two things you can do to make it easy to align each workpiece. First, draw a circle (instead of just a centerpoint) for each hole. Second, draw a 45° diagonal line through the center of each hole.

DRILL HOLES. To drill the holes at a consistent angle, I used a Forstner bit and a simple jig, see box below. With the seat (or footrest) resting on the jig, the idea is to align the diagonal lines with the center of the drill press table, see Figs. 3 and 4. Then, position each circle under the bit so the rim scores the mark and clamp the workpiece in place.

There's one other thing to be aware of when drilling the holes. To hide the ends of the legs, the holes in the seat are "stopped," see Fig. 3a. But the holes in the footrest are drilled all the way through, see Fig. 4a.

OPENING. The reason for this is simple. These holes create part of a curved opening that fits around the front legs. The rest of this opening is formed as you complete the footrest. To do this,

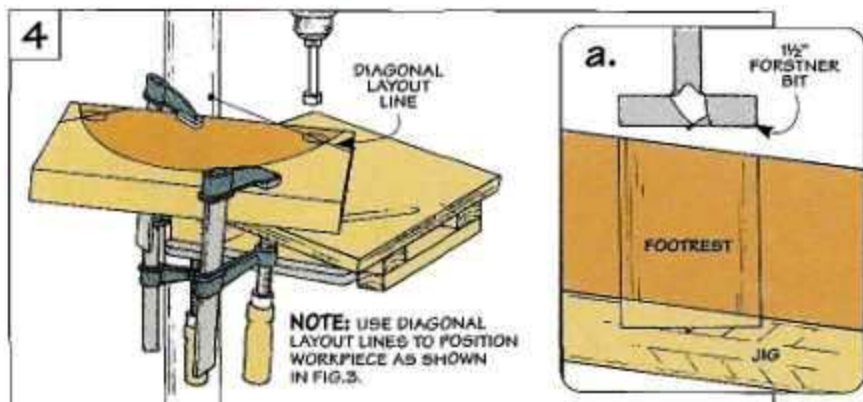
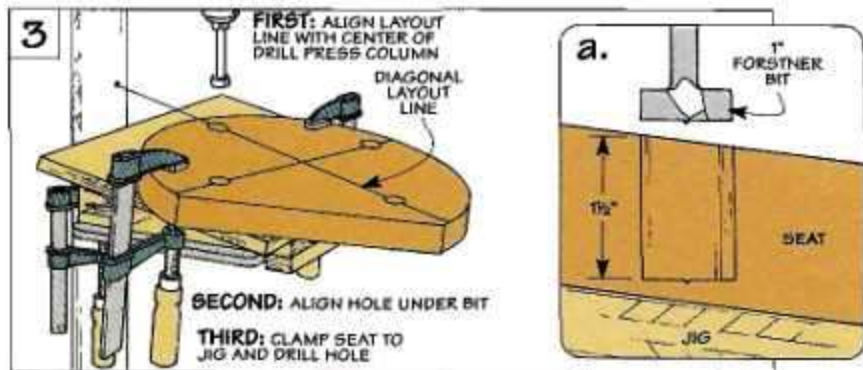

rip a strip off the back edge, see Fig. 5a. Then, after drilling a hole in the back edge for the center rung, cut and sand the footrest (B) to shape, see Figs. 5 and 5b.

SHAPE EDGES. To complete the seat and footrest, I routed a 1/4" roundover on the top edges and a 1/2" chamfer on the bottom edges, see detail in Exploded View.

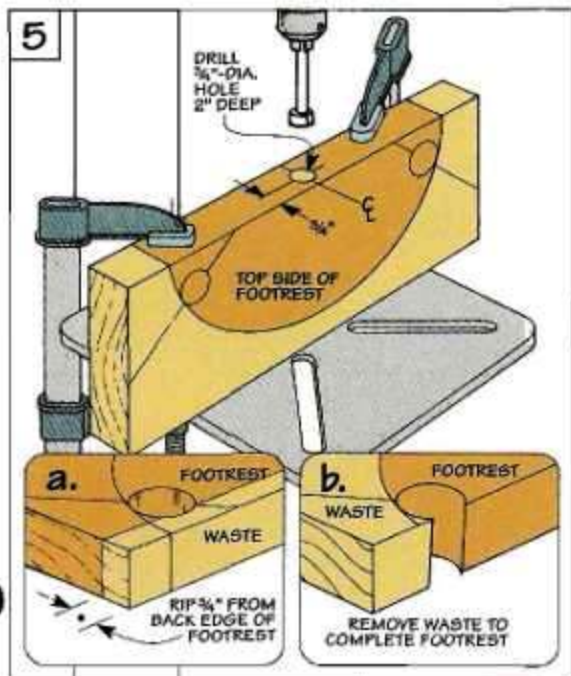

Angled Drilling Jig

The drilling jig is just an angled platform that clamps to the drill press table.

The top is made from 3/4"-thick plywood and screwed to two "two-by" side pieces that are cut at an angle. To position the jig against the table, a 3/4"-thick front cleat is attached to the side pieces. And a back cleat provides a clamping platform, see upper drawing.

To align the jig, first center the drill press table under the bit. Then, with the front cleat of the jig against the drill press table, clamp the jig in place, see lower drawing.

Legs & Rungs

After completing the seat and footrest, the next step is to add legs and rungs.

The legs are made from 1½"-dia. hardwood dowels that angle outward to provide a sturdy platform. (I used maple.) With the dowels in hand, the legs (C) can be cut to length, see Fig. 6.

RUNGS. The legs are held together with two rungs. A short back rung (D) spans the two rear legs, and a long center rung (E) connects it to the footrest, see Fig. 7. Like the legs, the rungs are made from hardwood dowels. Only this time, I used 1¼"-dia. dowels.

Tenons on both ends of each rung fit holes in the adjoining pieces. But before routing these tenons, it's best to drill the holes they fit into first.

DRILL HOLES. To accept the back rung, there's an angled hole in each back leg, see Fig. 7c. An easy way to hold the legs when drilling these holes is to use a block with a V-shaped groove, see Fig. 8. After tilting the drill press table to 7°, the block is simply clamped in place.

There's just one more hole to drill. That's a straight hole in the back rung to accept the center rung, see Fig. 7b. Again, I used the block to hold the rung steady.

ROUT TENONS. After drilling all the holes, you can turn your

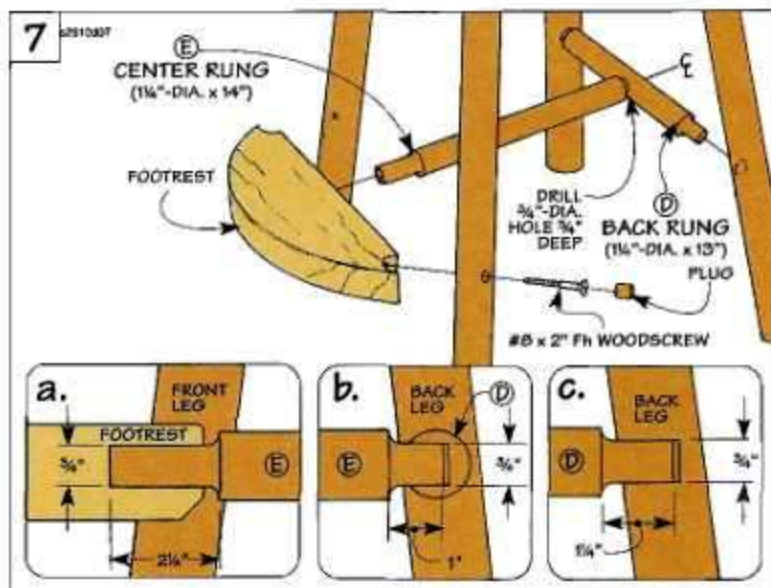
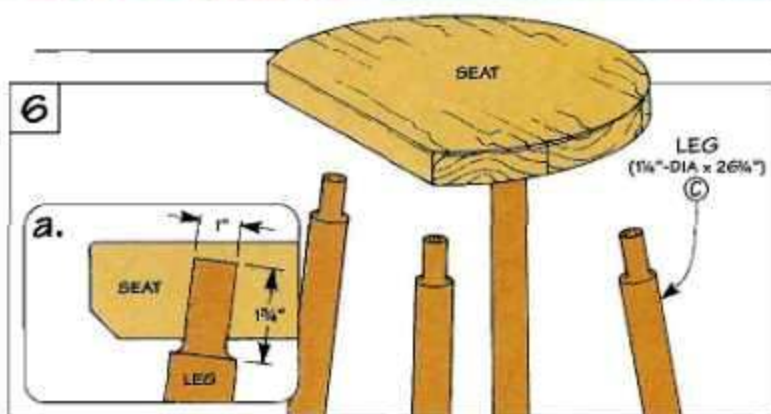

Using a pencil and a scrap of hard-board, mark a line around the bottom of each leg.



A small drill bit makes it easy to center the V-shaped groove.

attention to the tenons. I found it easiest to rout these tenons a bit large and "loosen" the fit by sanding. (For more on routing dowels, see page 11.)

Once you're set up, routing the tenons is a fairly quick

process. The large tenons on the ends of each leg are identical, see Fig. 6a. And so are the smaller tenons on the back rung, see Fig. 7c. But the center rung has a long tenon that fits in the footrest (Fig. 7a), as well as a short tenon that goes into the back rung, see Fig. 7b.

ASSEMBLY. After routing the tenons, you're ready to assemble the stool. To ensure a smooth assembly, it's best to make a "dry run" before gluing it up, see drawings on top of next page.

Finally, to keep the stool from rocking, I marked the bottom of each leg and trimmed it to sit flat on the floor, see upper left margin. Then, to prevent splintering, just ease the bottom edges with sandpaper.

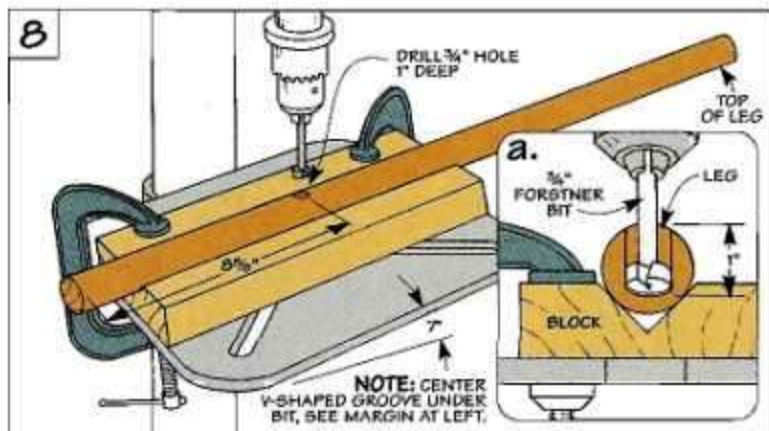

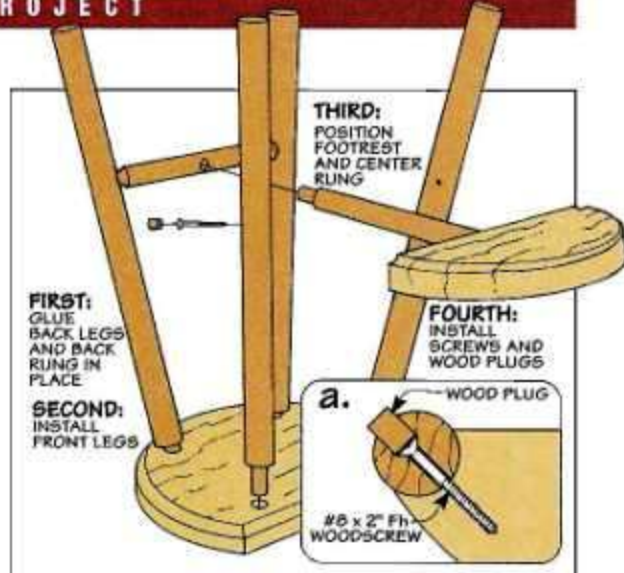
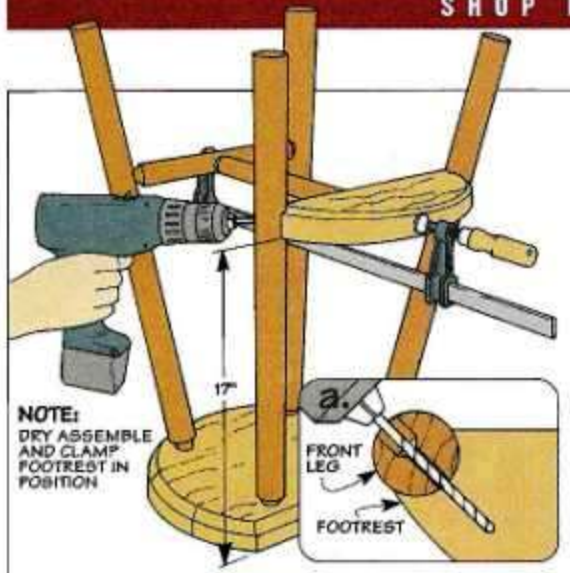

Dry Assembly. To dry assemble the stool, it's easiest to clamp the footrest in place. Then drill holes for the screws that hold it in place. Note: A counterbore provides a recess for a wood plug.

Glue-Up. When gluing up the stool, I used a slow-setting white glue and followed the sequence shown above. With the screws installed, just glue in wood plugs and trim them flush with the legs.

Routing Tenons on Dowels

All it takes to rout a tenon on the end of a dowel is a core box bit (to create a "soft" shoulder) and a simple jig.

JIG. The jig consists of two parts. An $\frac{1}{8}$ " Masonite base acts as a clamping platform, see Fig. 1. And a block with a V-shaped groove supports the dowel as you rout the tenon, see Fig. 1a.

SIZE. The diameter of the tenon is set by the height of the bit, see Fig.

2a. For example, to rout a $\frac{3}{4}$ "-dia. tenon on a $1\frac{1}{4}$ "-dia. dowel, remove $\frac{1}{4}$ " of material.

The length of the tenon is set by the distance from the fence to the far edge of the bit, see Fig. 1b.

ROUT With the setup complete, slowly push the end of the dowel into the router bit, see Fig. 2. After it bottoms out on the fence, rotate the dowel clockwise to form the shoulder, see Figs. 2 and 2b.



see Figs. 2 and 2b.

Then nibble away at the waste by taking small bites and rotating the dowel between passes, see photo. (Note: Fence is removed for clarity.)

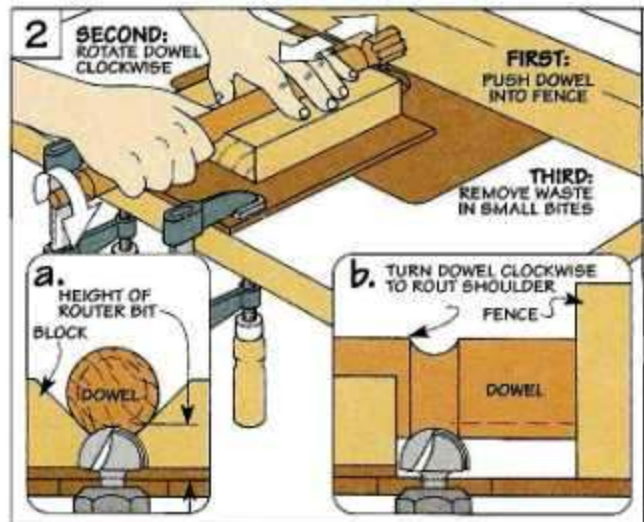
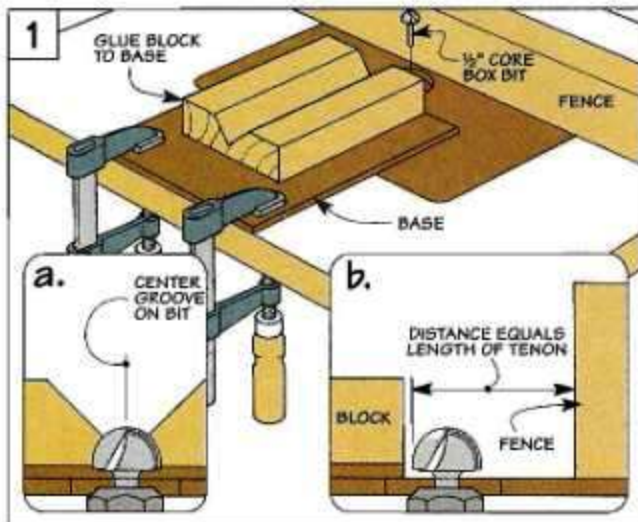

Gluing Up Panels

The secret to gluing up a solid wood panel is the arrangement of the boards.

It seems like such a simple thing — gluing up a bunch of narrow boards to make a wide panel of solid wood. But there's more to it than meets the eye.

The panel needs to look like a single, wide piece of wood. Which means the color of each board should match. And the grain should blend from one board to the next so the joint lines are as inconspicuous as possible.

Besides its appearance, the panel also needs to be glued up perfectly flat. And just as important, it has to stay flat with changes in humidity.

But getting a flat panel where the joint lines virtually "disappear" doesn't just happen when it's time to glue up the boards. It starts when you select the lumber for the boards.

SELECTION. As you sort through a pile of lumber, take some time to find boards that are close in color. And try to visualize what the overall grain pattern will look like when you cut the boards and lay them edge to edge.

APPEARANCE. To create a uniform-looking panel, the goal is to match the color and grain of one board as close as possible to the one next to it. So as you turn the boards over and flip them end for end, arrange them so one curve flows into another, see photos below. Or the straight-grained lines on one piece match those on the piece next to it.

MOVEMENT. Another thing to think about is how the panel will move with changes in humidity.

This depends on the growth rings on the end of each board.

For example, if the rings are all oriented the same way, the entire panel tends to cup in one direction, see Fig. 1a. But when you alternate the growth rings, each board moves in opposite directions. The end result of all this is a panel that stays flat.

GRAIN DIRECTION. If you're going to plane the panel once it's glued up, you also need to consider the grain direction of the boards. To prevent chipout, check the grain direction on the



Curved Grain. To avoid drawing attention to a joint line, arrange boards so curved patterns merge.



Straight Grain. Positioning one straight-grained board next to another creates an "invisible" joint.

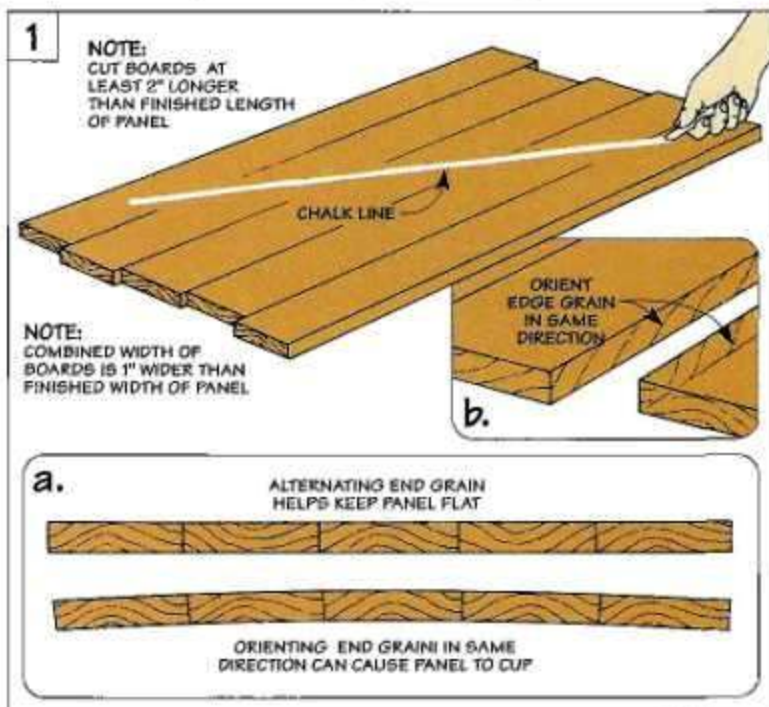

edge of each board, see Fig. 1b. Then position the boards so the grain runs in the same direction.

A PROBLEM. Although it makes sense to arrange boards for appearance, wood movement, and grain direction, this can also create a problem. Sometimes, no matter how much you shuffle the boards, there's a "stubborn" one that just won't fit.

Then it boils down to what's most important. For me, it's appearance. So I arrange the boards with that in mind.

EDGE PREPARATION. Now you can turn your attention to the glue joints that hold the panel together. To lay the groundwork for a strong joint, the edges of the boards will need some work.

The goal here is to get the edges of each board smooth, straight, and square. So after marking the panel with chalk to keep track of the position of each board, I joint a clean, crisp edge.

DRY CLAMP At this point, it's tempting to break out the glue bottle. But I always dry clamp the panel first. If the panel cups

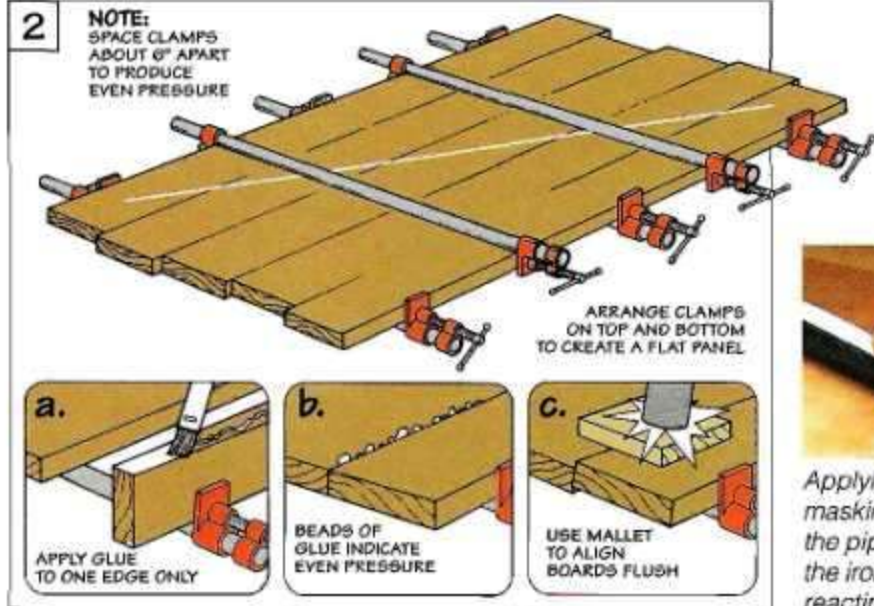

(or if there's a gap in one of the joints), the edges may need additional work, see box below.

GLUE-UP

Once you're satisfied with how the boards fit, you're ready to glue up the panel.

To keep the panel flat and produce even clamping pressure,

the idea is to arrange the clamps above and below the panel so they're about 6" apart, see Fig. 2.

GLUE. With clamps right at hand, you're ready to apply the glue. To speed things along, I squeeze out a generous line of glue on one edge only of each board and brush it to an even film, see Fig. 2a.

TIGHTEN CLAMPS. Now it's just a matter of tightening the pipe clamps. Start in the center of the panel and work toward the ends, alternating between the top and bottom clamps. Don't overdo it here. You want to apply just enough pressure so there's an even bead of glue along the top edge, see Fig. 2b.

Finally, if the surface of one board sticks up above the piece next to it, a mallet and a scrap of wood make quick work of getting them flush, see Fig. 2c. A simple bar clamp is all it takes to align a joint at the end of the panel, see margin tip at right.



Applying a strip of masking tape to the pipe prevents the iron from reacting with the water in the glue and staining the wood.



Tightening a clamp across the end of a joint line draws the surface of the boards flush.

Troubleshooting

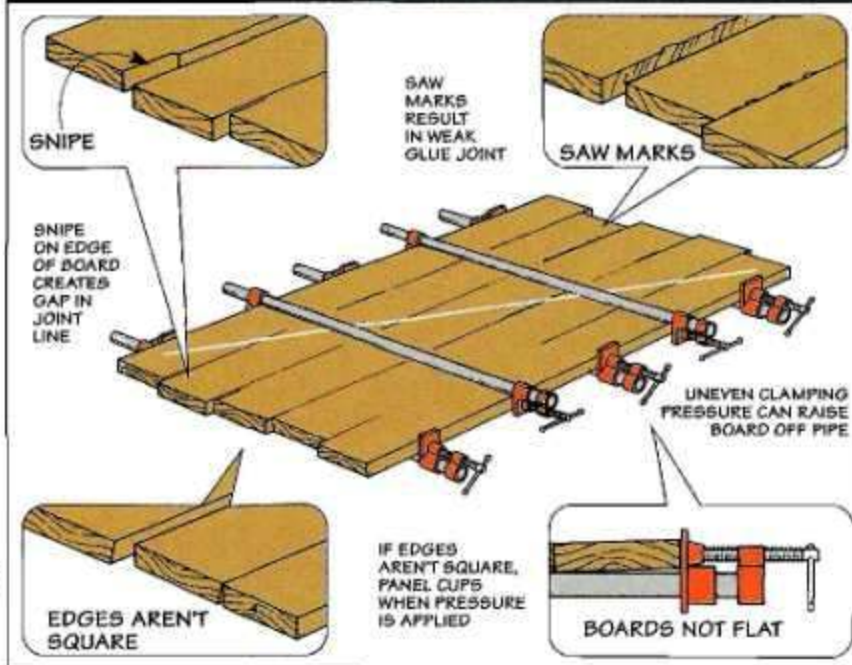

Sharpening Tips

Here are a few of our favorite tips to help you sharpen your chisels and plane irons — and keep them sharp.

Squaring the Edge

■ Before grinding the bevel on a chisel or plane iron, the first thing I do is check that the cutting edge is square to the sides of the blade, see Fig. 1.

If it's not square, I'll draw a thin line across the back of the blade with a permanent marker. Note: Draw the line right below any nicks in the blade.

While it's possible to square up the blade (and remove any nicks) as you grind the bevel at an angle, I use a slightly different approach. That's because the steel along the edge of the bevel is so thin it heats up

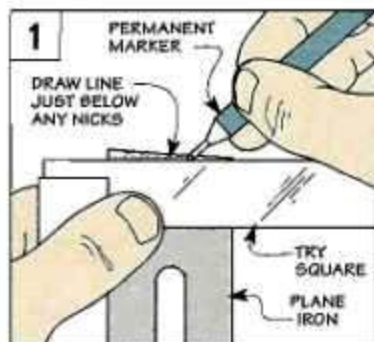

extremely fast.

To avoid burning the blade, I "build up" the thickness of the edge by grinding it square, see Fig. 2. This is just a matter of

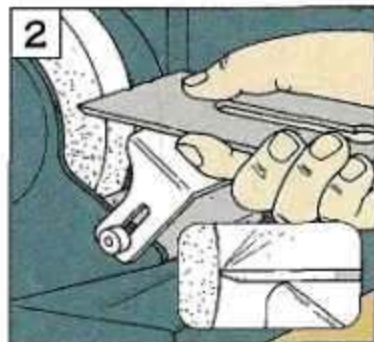

holding the blade perpendicular to the grinding wheel and removing the material up to the line. Then grind the bevel as you normally would.

Honing & Polishing

■ When honing a chisel or plane iron freehand, it's easy to end up with a series of small angled bevels — and a dull cutting edge.

One reason is it's tempting to inspect a blade more frequently than necessary. And each time you check the blade, there's a good chance you'll place it back on the stone with the bevel at a slightly different angle.

To create a single flat bevel, take two or three light passes to "lock in" the angle. Once you have a feel for the angle, slide the chisel back and forth across the stone in a smooth, rhythmic

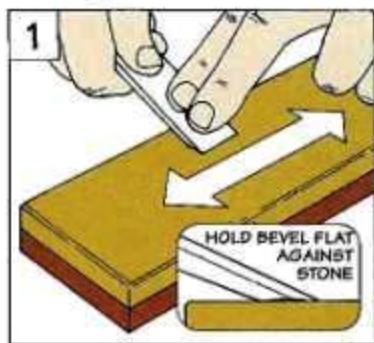

fashion (about 20 strokes), see Fig. 1. Then check the progress of the edge.

To create a razor-sharp edge, I polish the bevel with a leather

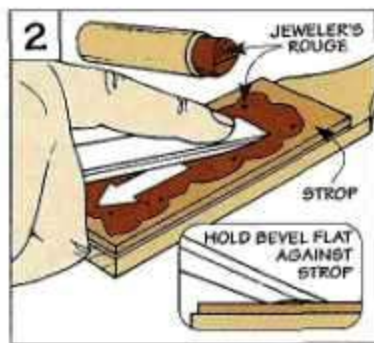

strop glued to a scrap of wood, see Fig. 2. Loading the strop with jeweler's rouge and pulling the edge across it two or three times creates a mirror finish.

Checking for Sharpness

■ As you sharpen a chisel (or plane iron), how do you know if it's sharp? An easy way to tell is to take a close look at where the two surfaces that form the cutting edge (the back and the bevel) come together.

To inspect the edge, tilt the blade under a bright light. If the edge reflects light, it needs more sharpening, see left photo. But if the edge virtually "disappears," you're ready to make a test cut, see right photo.

To check the cutting edge for



sharpness, simply pare off the corner (end grain) from a scrap piece of softwood.

A sharp edge easily slices through the wood and leaves a

smooth, clean surface, see right photo. But if the wood fibers tear and crumble, the chisel is dull and should be resharpened, see left photo.

Using & Storing Waterstones



Shelf Liner. A piece of shelf liner placed under a waterstone will keep it from slipping around as you hone a chisel or plane iron.



Stone Holder. To keep the sharpening mess to a minimum, set the stone on a simple holder that fits inside a plastic container.



Plastic Bag. A resealable bag is a handy way to store a waterstone so it stays wet and is ready to use when you need it.

Quick Tips



Remove Corners. To avoid gouging a workpiece, knock off the corners of a plane iron by dragging them across the stone.

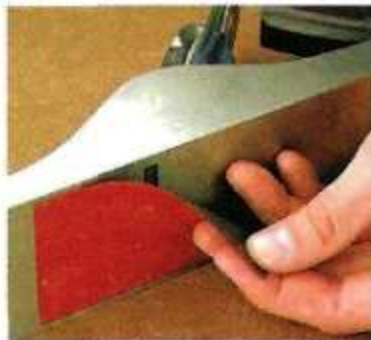

Magnet. When storing a hand plane, a flexible refrigerator magnet helps protect the blade from damage.



Tubing. An easy way to protect the edge of a chisel when it's not in use is to slip it into a short piece of plastic tubing.

Drilling Guide

for Indexing Shelf Pin Holes



Does this sound familiar? You've just built a cabinet with adjustable shelves. But when you set one of the shelves in place, it rocks back and forth on the pins that support it.

The reason is simple. One of the shelf pins isn't level with the other three. So the shelf won't sit flat on the pins.

When you think about it, it's easy to see how that can happen. Laying out and drilling each individual hole for the shelf pins is tedious and time consuming. And no matter how careful you are, it's all too easy to end up with one hole out of position.

INDEX. To solve that problem, this drilling guide indexes the holes for the shelf pins in *two* directions. It sets the distance *in* from the edge of the workpiece.

It's easy to drill identically-spaced holes for shelf support pins with this shop-made drilling guide.

And it accurately indexes the spacing *between* each hole.

LOCKING SYSTEM. This built-in accuracy starts with a unique locking system, see photo A below. Once you set the drilling guide for the desired distance in from the edge of the workpiece,

simply tightening a nut locks in the adjustment.

INDEX PIN. To ensure that the spacing between each hole is identical, an index pin fits into the last hole drilled, see photo B. Sliding a slot in the drilling guide over this pin automatically determines the spacing for the next hole.

GUIDE HOLES. Depending on the spacing you want, this hole can be drilled 2" or 3" from the pin using either one of a pair of guide holes, see photo C. To prevent the bit from enlarging the guide holes with repeated drilling, they're "lined" with bronze bushings.



A. Locking System. Tightening a knurled nut pulls an eye bolt tight against a threaded rod to lock in the adjustment.

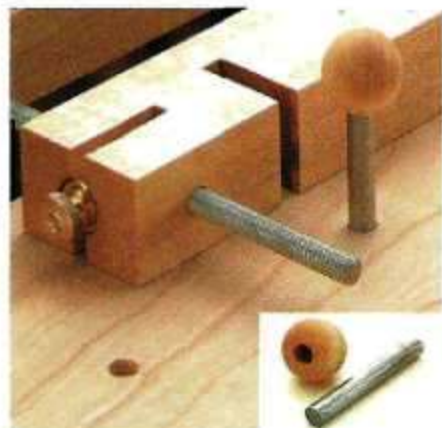

B. Index Pin. An index pin made from a cutoff bolt and a wood ball positions the drilling guide automatically.



C. Guide Holes. To reduce wear from repeated drilling, each guide hole is lined with a pair of bronze bushings.

EXPLODED VIEW

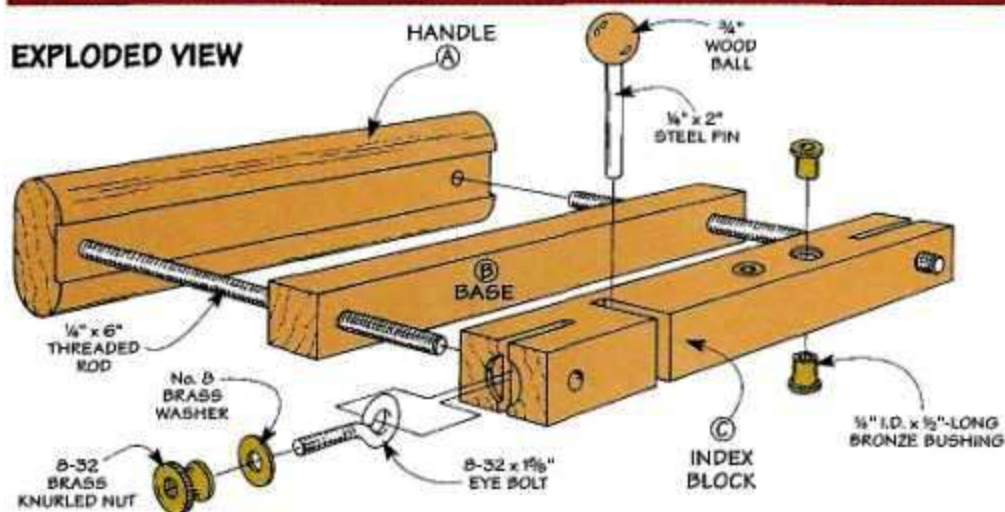

Hardware

- (2) 1/4" x 6" Threaded Rods
- (2) 8-32 x 1 1/2" Eye Bolts
- (2) 8-32 Knurled Nuts (Brass)
- (2) No. 8 Washers (Brass)
- (4) 1/2" I.D. x 1/2"-Long Bronze Bushings
- (1) 1/4" x 3" Hex Bolt (For Index Pin)
- (1) 3/4"-Dia. Wood Ball

ShopNotes Project Supplies is offering a complete hardware kit to build the drilling guide.

To order, call: 800-347-5105
682B-100.....\$11.95

Fence

The drilling guide consists of two parts. A fence positions the guide on the workpiece, see drawing. And an index block that slides on a pair of threaded rods establishes the location and spacing of the holes, see Exploded View.

FENCE. In use, the fence is held tight against the edge of the workpiece. This way, the shelf pin holes are the same distance from the edge of the workpiece.

The fence is made up of two hardwood blocks: a 3/4"-thick handle (A) and a 1"-thick base (B), see Fig. 1. To accept the base, there's a wide, shallow

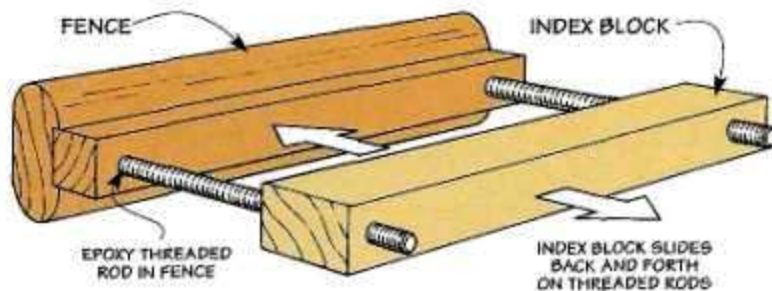

groove routed in the handle, see Fig. 1a. Before gluing these pieces together, I rounded the edges of the handle to provide a comfortable grip, see Fig. 1b.

THREADED RODS. Now you can add the threaded rods. They pass through holes drilled in the

index block and into the handle, see Fig. 2. So it's important to keep the holes aligned.

To do this, cut a blank for the index block (C) and temporarily carpet tape it to the handle. Then drill the holes and epoxy the rods in the fence.

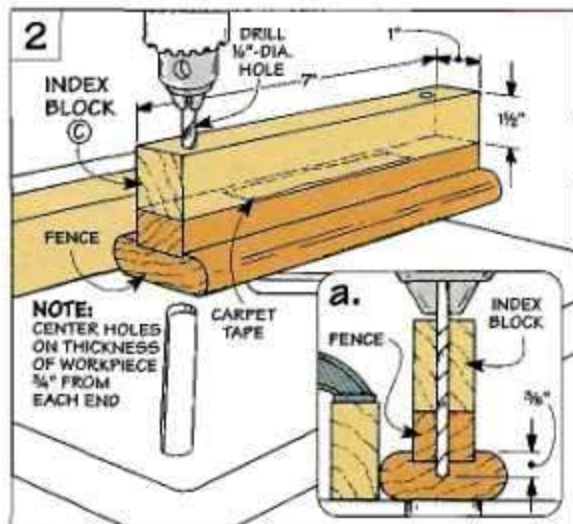
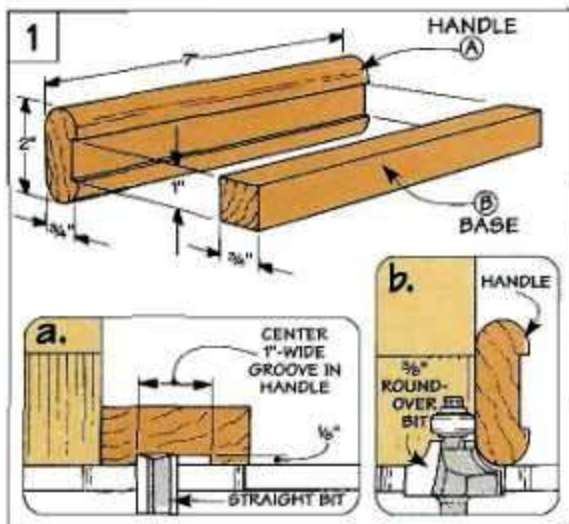

Index System

What's unique about this drilling guide is an index system that's used to establish the spacing of the holes for the shelf pins.

This system locates the holes in *two* directions. It sets the distance *in* from the edge of the workpiece. And it ensures identical spacing between each hole.

To make this work, there's a simple mechanism that locks the index block on the threaded rods.

LOCKING MECHANISM. The key to this mechanism is a pair of eye bolts. Each eye bolt fits in a slot in the end of the block, see drawing. The "eyes" of these bolts provide openings for the threaded rods to pass through, see detail 'a'. This way, when you tighten a nut (and washer) on the end of the bolt, it pulls tight against the rod and locks the index block in place.

Before cutting the slots for the eye bolts, it's easiest to drill a shallow counterbore for a washer centered on each end, see Fig. 3a. Then just cut the centered slots

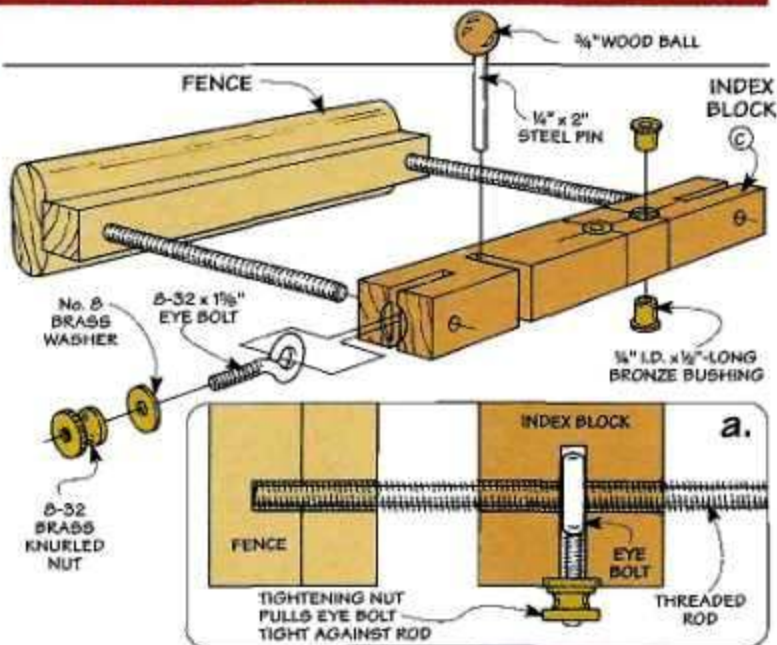

so the eye bolts fit snug.

There's one more slot to cut. But this time it's on the *edge* of the index block, see Fig. 4.

The purpose of this slot is simple. It slips over an index pin (added later) that's placed in the very last hole you've drilled in the workpiece. This automati-

cally indexes the drilling guide for the next hole.

To prevent any "play," it's important to cut the slot so the index pin fits snug, see Fig. 4a. (I used a 1/4"-dia. bolt for the pin and snuck up on the width of the slot.)

GUIDE HOLES. Once the slot for the index pin is cut, the next

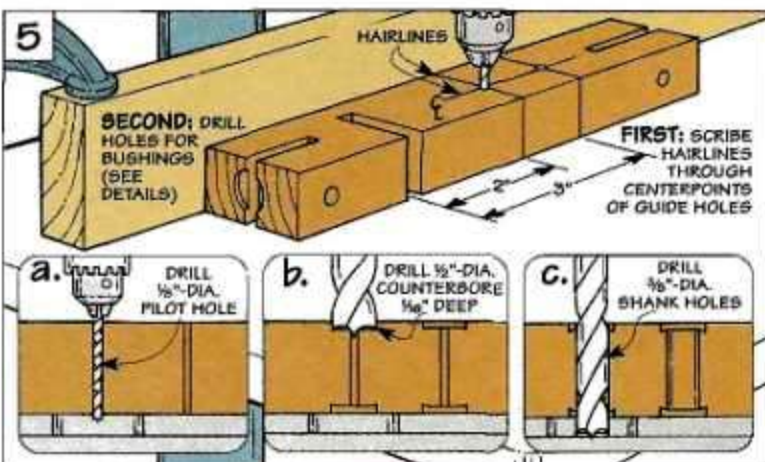
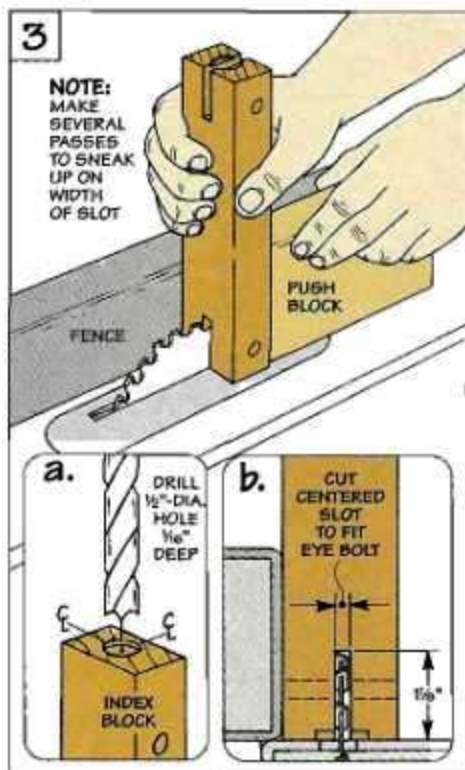

step is to lay out two holes that will be used to guide the bit when drilling the holes for the shelf pins.

To provide two options for the spacing between the pins, one hole is located 2", and the other is 3" from the center of the slot, see Fig. 5.

HAIRLINES. To make it easy to align the drilling guide later, I used a knife to scribe "hairlines" through the centerpoint of each hole and extended them around the block, see Fig. 5.

BUSHINGS. To keep from enlarging the guide holes, they're "lined" with two bronze bushings, see Fig. 6. A simple drilling sequence as shown in the details in Fig. 5 ensures that the bushings will line up.

Now it's just a matter of pressing the bushings into the guide holes. What I found works well here it to apply pressure

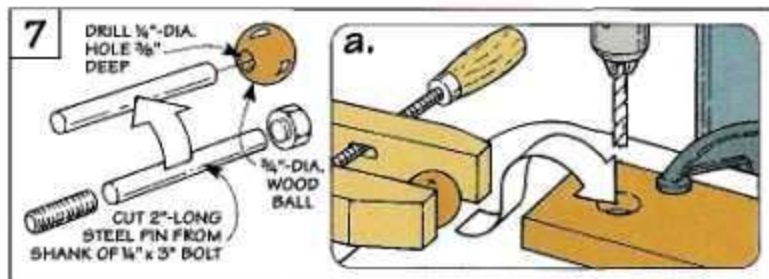
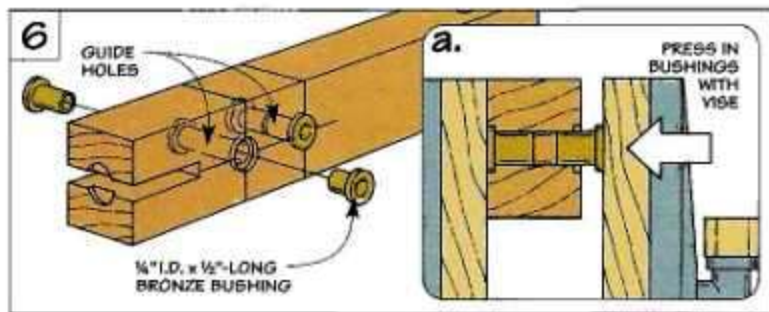

To make sure you drill in the same guide hole each time, tape over the one you're not using.

with a vise, see Fig. 6.

INDEX PIN. After assembling the drilling guide, all that's left is to add the index pin, see Fig. 7. It's just a cutoff bolt epoxied in a

hole drilled in a wood ball. Shop Tip: Cradling the ball in a hole drilled in a piece of scrap makes it easy to center the hole for the pin, see Fig. 7a.

Using the Drilling Guide

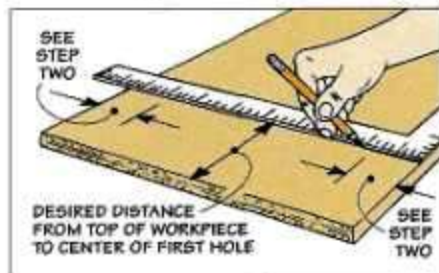

Step 1. Once you decide how far from the top (or bottom) to start the holes, square a line across the workpiece.

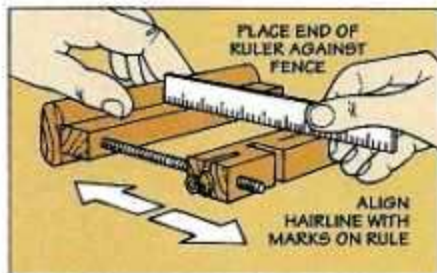

Step 2. To locate the holes in from the edge, slide the index block to the desired setting and lock it in place.

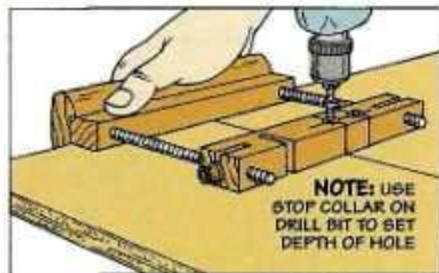

Step 3. After positioning the hairline on the layout line, hold the fence tight against the edge and drill the first hole.

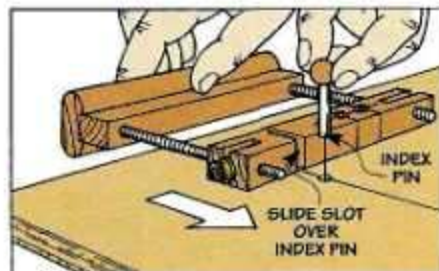

Step 4. Now fit the pin in the hole and slide the slot over it to automatically index the drilling guide for the next hole.

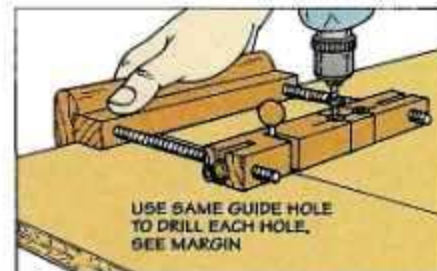

Step 5. Using either guide hole (for 2" or 3" spacing), drill the next hole. Then continue indexing and drilling the holes.

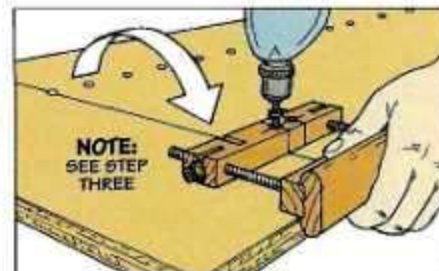

Step 6. To drill the opposite row of holes, flip the guide over and line it up again on the original layout line.

Small Shop Layout

In an ideal shop, there's always room for one more tool. And nothing gets in the way. But in all the shops I've set up, space (or the lack of it) is often a factor.

With all the tools and materials required for a project, a small shop can soon get crowded and cramped. Even so, there's no reason a small workshop can't work smoothly and efficiently. All it takes is a little planning.

WORK FLOW. The key to this planning is to think about how a typical project "flows" through the shop. Then establish an area for each part of the process.

For instance, when I bring lumber into the shop, it's handy to have a separate area to break

it down into manageable pieces, see drawing below. (This can be as simple as a pair of sawhorses and a circular saw.) And if possible, I position tools used for stock preparation (like the jointer,

makes it easy to assemble the project and apply the finish.

Besides the way a project moves from one area to the next, there are a couple other things to keep in mind as you lay out a shop. Is there any benefit to grouping tools together? Or what type of space requirements does each tool have?

All it takes is a little planning to make a small shop work "big."

table saw, and thickness planer) right nearby.

Once the stock is flat, straight, and square, the next step is to cut the joinery and shape the pieces. To make this go smoothly, I position the drill press, router table, and band saw near the workbench. By locating the workbench out in the open, there's access on all sides which

PAPER PLANNING. Rather than find the answers to these questions *after* dragging heavy tools across the floor, I plan the shop on paper first.

This is just a matter of drawing a floor plan of your shop to scale. Then cutting paper templates of your tools (also to scale) and positioning them around the "shop."

A small shop about the size of a single car garage is more efficient when work flows from one area to another.▼

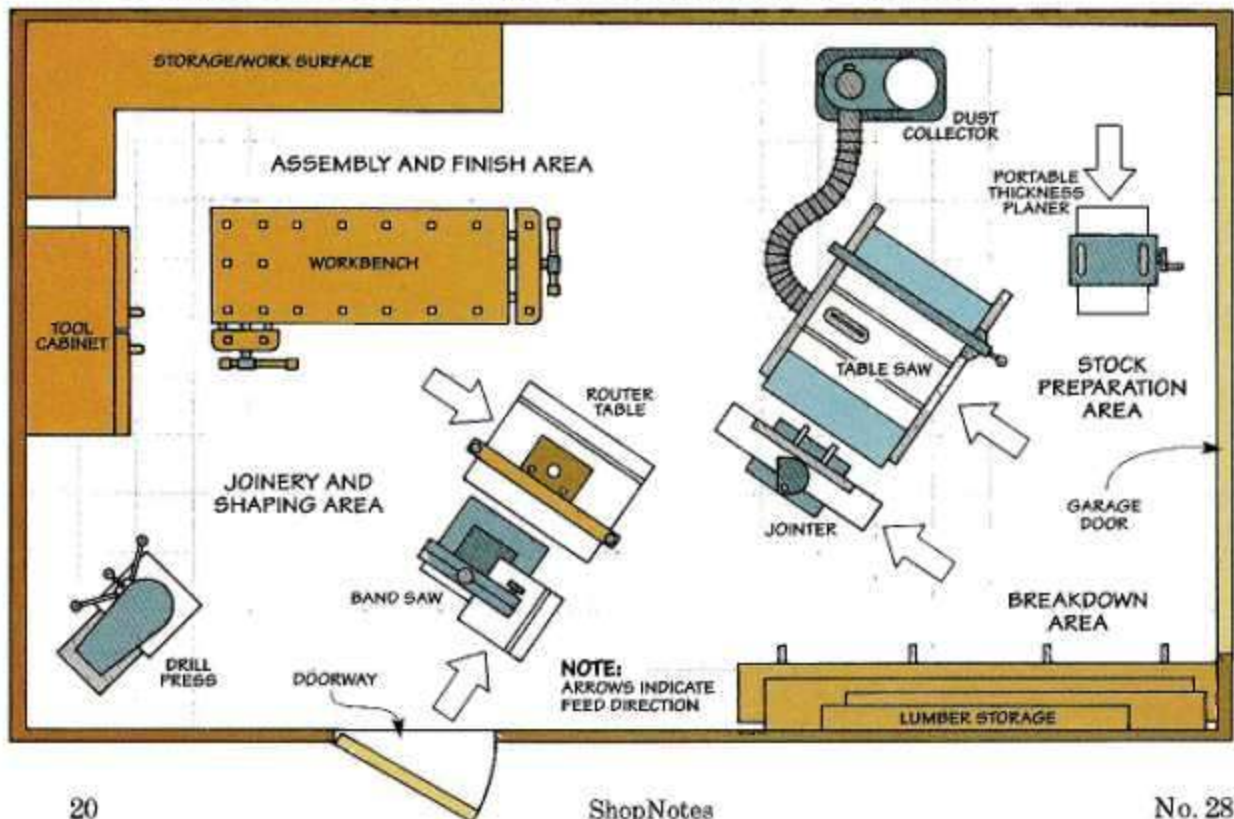

Tool Groups

When sliding the templates around, one thing that can make a small shop work “big” is to organize tools by groups.

JOB. One way of grouping that makes a lot of sense is to arrange tools by the job they do. For example, the table saw, jointer, and planer are all used during stock preparation. So it's convenient to cluster them together.

SUPPORT. You can also use tool groups to provide support for large workpieces. To provide side support when crosscutting a long workpiece on the table saw for instance, you can set your jointer next to it, see photo A.

Or if your router table is the same height (or a bit shorter)

than your table saw, the top can double as an outfeed support.

STORAGE. Finally, don't overlook the need for storage when arranging groups of tools. One of the most important “tools” in the shop is my workbench. But it

doesn't do me much good if I have to walk across the shop to get tools. So setting my tool cabinet near the bench to give me easy access to both hand and power tools is a must, see photo B.



A. Support. A board clamped to the fence of the jointer provides support for a long workpiece.



B. Storage. For efficiency, it just makes sense to position a tool cabinet next to your workbench.

Space Requirements

While a group of tools may look alright on paper, don't start muscling them into place just yet. Remember, each tool has its own space requirements.

This isn't just the visible “footprint” of the tool. But more importantly, it's the extra space that's needed so the workpiece that feeds in (or out) of one tool doesn't bump into another one.

CENTER STAGE. Take the table saw for instance. Because of the clearance required in front, back, and at the sides when cutting large workpieces, it usually claims more than its fair share of space in the center of the shop.

Even so, you can still work around these space requirements. Sometimes it's just a matter of positioning the table saw at an angle so workpieces feed into an open area of the shop, see drawing on page 20.

The table saw isn't the only tool that can gobble up space. When working with long pieces on a jointer, band saw, router table, or planer, you might also

need a sizable “run” at each end of the tool.

OVERLAP. One way to provide this space is to overlap the infeed and outfeed areas of two tools. For example, position a planer so the outfeed passes in front of the table saw.

Overlapping areas also works well with tools where the tables are at different heights. For instance, I park my band saw right next to the router table. This way, a workpiece that feeds off the table on the band saw passes above the shorter router table, see photo C.

DOORS AND WINDOWS. When planning infeed/outfeed requirements, don't overlook an opening provided by a door or window. Positioning a band saw or table saw near a door may be just the ticket for those extra-long pieces, see drawing on page 20.

CORNERS. One last note. The corners of a shop often get filled with clutter. But tucking a tool like a drill press into a corner can take advantage of wasted space. Yet you can still drill holes in a long workpiece because of the distance between the adjoining walls, see photo D. 



C. Overlapping. Take advantage of different table heights by overlapping infeed/outfeed areas.



D. Corners. Even with this drill press tucked in a corner, you can still work with long workpieces.

Portable Thickness Planers

If you're buying a thickness planer, our hands-on test of six portable models will point you in the right direction.

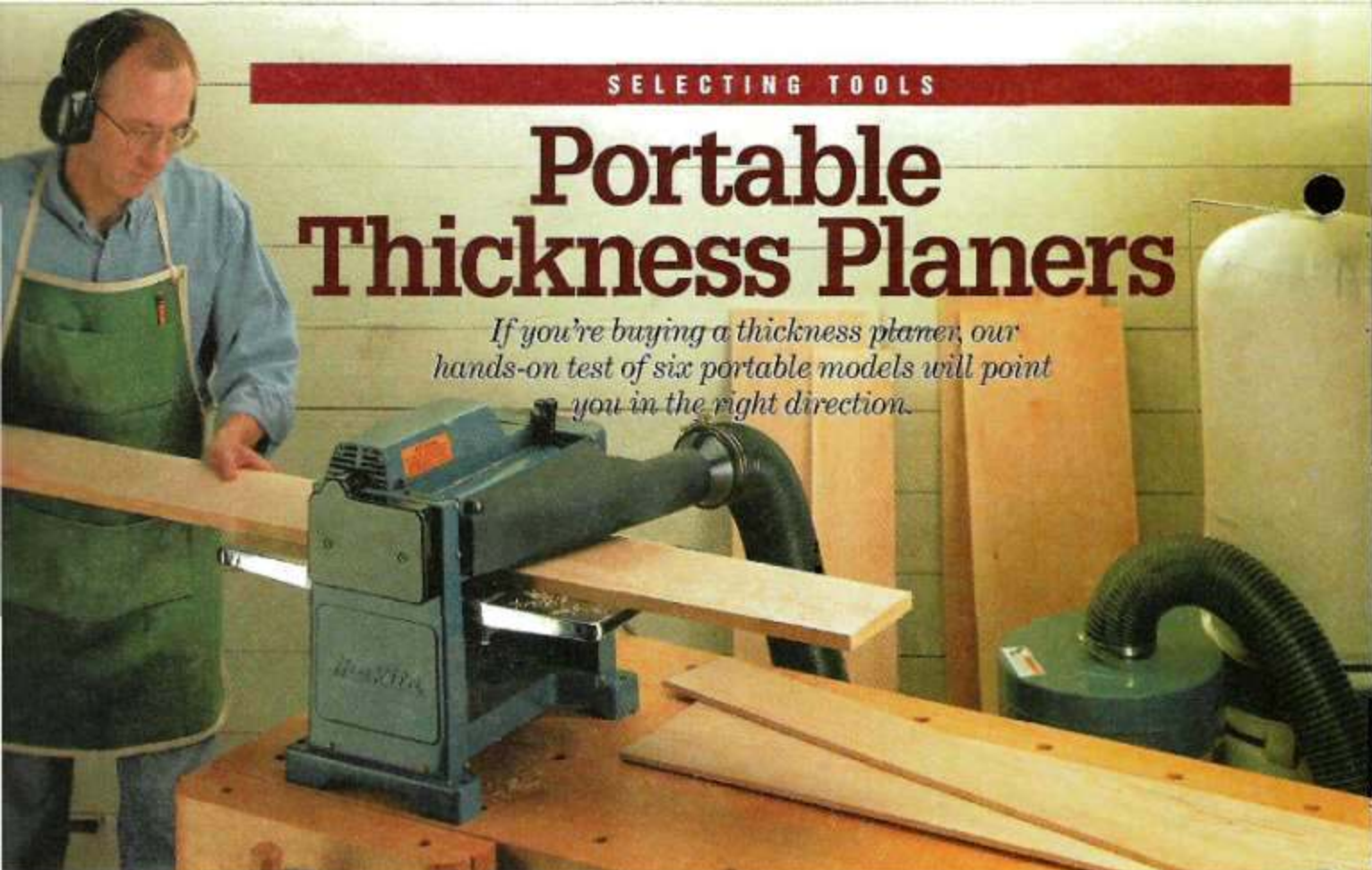

We bought a portable thickness planer for the shop a few years back. Although it cost considerably less than a big industrial planer, this scaled-down model is a real workhorse when it comes to reducing stock to uniform thickness.

Since that time, a number of companies have started manufacturing portable thickness planers of their own.

To find out which one is best,

we tested six commonly available models, see photos below. Each of these planers accepts stock up to 6" thick and 12" wide.

TEAM. Like our other tool reviews, we asked three woodworkers with different amounts of experience to test the planers. Both *Ken* (a professional carpenter) and *Steve* (an advanced woodworker) use a planer extensively in their shops. While *Cary* (who is just getting

started in woodworking) is thinking of buying one for his shop.

Q *What were your first impressions of these planers?*

Ken: The thing I noticed right off the bat is that even though the planers may look different, many of them appear to use the same parts. Take the Grizzly, Jet, Ryobi, and Sears for instance. Except for the color of the paint, the motors and the



Delta 22-540
(800-438-2486)
\$386



Grizzly G1017
(800-541-5537)
\$399



Jet JWP-12
(800-274-6848)
\$380

4-Post. Four steel posts provide solid support for the cutterhead.

cutterheads are practically identical. But that didn't seem to be the case with either the Delta or Makita planers.

Steve: One thing I noticed is the basic design of the planers is different. Four steel posts on the Delta and Grizzly guide the cutterhead up and down. (See drawing at right.) So the cutterheads are rock solid.

But because the Jet, Ryobi, and Sears use the frame of the planer to guide the cutterhead, there's a bit of "play." I guess we'll see how that affects the performance of the planers.

Cary: The Makita also relies on the frame. But since the cutterhead is fixed, it guides the bed of the planer up and down.

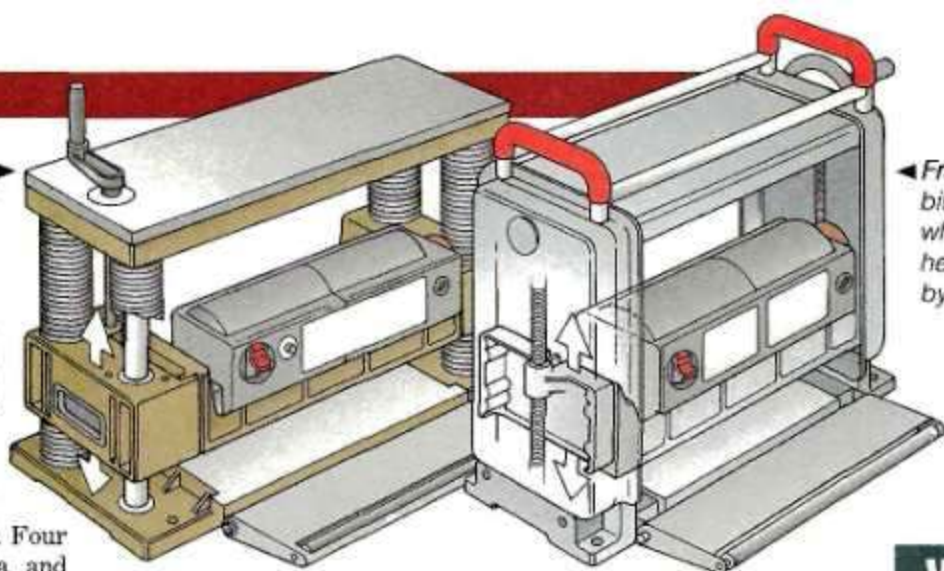

Frame. There's a bit more "play" when the cutterhead is guided by the frame.

Q: Are these planers really all that portable?

Cary: That depends. Ranging from 51 to 77 pounds, lifting them can be a real gut-buster. (See chart at right.)

Ken: Besides the weight of the planers, the location of the handles is important. Especially when I have to lift the planer onto a workbench or into my truck.

With handles on top, the Delta, Jet, Ryobi, and Sears are

a bear to lift high enough to get on a workbench. (See photos below.) And having only a single handle makes it even worse.

The low, recessed openings on the Grizzly and Makita make these planers more comfortable to carry.

Steve: One last thing about the handles on the Sears is they have built-in rollers. That's handy if I'm planing a lot of stock — a helper can roll boards back to me as fast as they feed out.

Weight

Delta	80
Grizzly	77
Jet	63
Makita	51
Ryobi	63
Sears	73



Portability. The single handle on top of the Ryobi (left) and the two handles on top of the Sears (center) make it difficult to lift the planers onto a workbench. But

the recessed openings in the Makita (right) and Grizzly let you hold these planers at a comfortable height which makes them easier to carry around.



Makita 2012
(800-462-5482)
\$500



Ryobi AP-12
(800-525-2579)
\$378

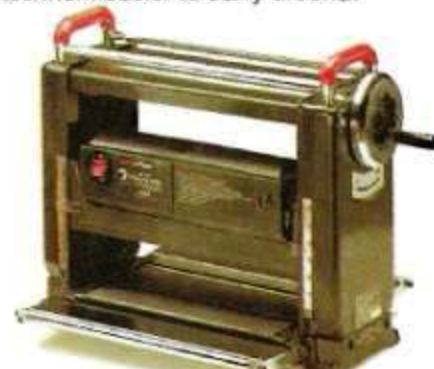

Sears 23373
(800-377-7414)
\$500

Performance

Q: When testing the performance of these planers, what exactly were you looking for?

Ken: What I want is to get a uniform thickness across the entire width of the board. (See photos at right.)

As it turned out, the biggest variations in thickness were in the boards I planed with the Grizzly (.011") and Sears (.009"). The Jet (.006") and Ryobi (.005") produced more consistent results. But they still weren't as close as the Delta (.004") and Makita (.003").

Cary: Will that small a difference really affect how a project fits together?



Testing Procedures. After running both hardwood and softwood pieces through each planer (left), we used a dial caliper (right) to check for any variation in thickness across the width of the board.

Steve: Probably not. But I think it gives you a pretty good indication of the overall quality of the planer.

Q: What about quality of cut?

Steve: The Makita and Jet both impressed me with the smooth surface they produced. (See chart on page 25.) Not that it's ready for a finish. But with a little scraping and sanding, it's darn close.

Ken: That brings up a point. Don't expect an absolutely "perfect" surface with any of these planers. There's bound to be some occasional chipout. (See margin.) Or if the planer isn't hooked up to a shop vacuum or dust collector, you'll get some "dents" in the surface of the board.

Cary: Another thing I noticed is it was fairly routine to see a shallow gouge at the ends.

Ken: To get rid of the gouges (snipe) you're talking about, I

just plane boards longer than I need and then cut off the ends.

Q: But shouldn't the infeed/outfeed supports of the planers take care of most of the snipe?

Ken: Only if they're adjusted correctly. What you're after is to make the support level with the bed of the planer. This way, when only one feed roller is applying pressure to the workpiece (at the beginning and end of a cut), the end of the board won't tip into the blades.

Steve: I guess that's why there was such a noticeable amount of snipe on the boards I planed with the Delta. In theory, the two removable trays are supposed to support the workpiece. (See photos below.)

But in practice, the boards ride above these trays. Since there's no way to adjust the trays up or down (besides shimming them), they're a real pain.

Chipout. Taking a deep cut (especially on a board with irregular grain) may cause chipout on the surface.



Dents. Tiny "dents" are caused when the feed rollers crush chips and dust into the surface of the board.



Snipe. If there's a snipe on the end of a board, it can probably be traced back to the infeed/outfeed supports.



Infeed/Outfeed Support. Unlike the removable trays on the Delta (left), the flip-down tables on the Makita (center) and Grizzly (right) are easily adjusted so they're flush with the bed of the planer. Whether or not these tables have rollers didn't affect how easy it was to feed stock through the planers.



Dust Hoods. A single port on Delta's dust hood (left) doesn't clog up during a heavy cut like the dual ports on the Jet (center). With no dust hood, the Sears (right) throws chips everywhere.

Cary: The infeed and outfeed support on each of the other planers makes a lot more sense to me. It's a metal table that flips down and easily adjusts level with the beds of the planers.

Steve: With the tables flipped down, the Makita has the longest bed of the bunch — almost a full two feet. Probably why the boards I planed with it had less snipe than the others. Also, the edges are rolled, so I can't accidentally "catch" my fingers.

Cary: The other planers all had a roller at the end of each table. While that's a nice feature, it didn't seem to make a difference in how smoothly a board feeds through the planer.

Ken: Besides the rollers on the tables, the Jet and Sears also had rollers built into the bed. These rollers are located directly under the feed rollers that hold the workpiece down flat against the bed. (See drawing below.)

That means there should be less friction between the bed and the workpiece. But the only time

I can see the bed rollers making a difference is if you're "hogging off" a lot of material.

Steve: That's not something I do much. Especially since it doesn't give me as smooth a cut. As a rule, I make more passes with a lighter depth of cut. (See photo above right.)

Q: Regardless of the depth of cut, you'll probably want to hook the planer up to a shop vacuum or dust collector. Which planers have a dust hood? And how did they handle the chips?

Cary: Except for the Sears, all the planers have an optional dust hood you can buy. These ranged in price from \$19.95 for the Delta, Grizzly, and Makita to \$39.95 for the Ryobi. The Jet fell in the middle at \$29.95.

Even though the Ryobi is the most expensive, it's the only one that comes with two hoses, a connector, and all the hardware required to hook it up to a shop vac.

Steve: Can they do the job? I found the large, single port dust

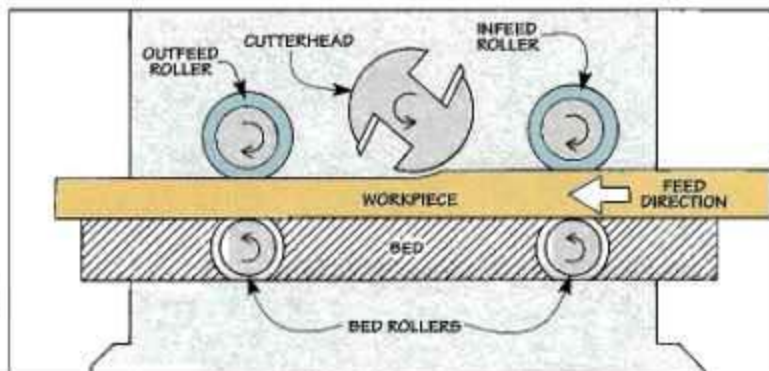

Chips. A heavy cut produces thick chips (left) and a rough surface. But you get fine shavings (right) and a smooth surface with a thin cut.

hood on the Delta and Makita worked better than the dual ports on the Grizzly, Jet, and Ryobi. (See photos above left.)

Just be prepared for one thing on the Delta. To keep boards that feed out from hitting the dust hood, you'll need to manually bend it around.

Ken: That beats sweeping up the piles of chips that pour out the back of the Sears. What's even worse is that when the feed rollers mash these chips into the board, it leaves little "dents" in the surface. (Refer to margin on page 24.)

Steve: In addition to all the chips and dust, these planers produced a lot of noise. Since they all have a high-speed universal motor, they're real screamers. (See chart at right.) Even though the Delta is "quieter" than the others, you still wouldn't catch me using it without my hearing protectors.



Controls & Adjustments

Q: By now, you probably have a pretty good "feel" for the controls and adjustments of these planers. How about something as simple as the on/off switch?

Ken: Maybe I'm picky. But the small push buttons on the Makita aren't as handy as the toggle switches on the other planers. (See margin at left.)

Steve: What bothered me wasn't the buttons as much as the "safety key" that's supposed to prevent someone from accidentally turning on the planer. I could turn it on even *without* the key.

Cary: Not only that, the key is so loose, I was afraid it would rattle out while I was planing.

Q: What did you think about the depth of cut adjustment?

Steve: Of all the planers, the Makita had the smoothest depth of cut adjustment. Maybe that's because it has a fixed cutterhead, so the only thing that moves is a lightweight aluminum table. (See drawing below.) On all the other planers, the bed is fixed, and the heavy cutterhead adjusts up and down.



Unlike the loose safety key on the Makita (top), the other planers use a plastic tab that snaps onto the switch (bottom).



Depth of Cut Adjusters. The handwheel on the Sears (left) and a folding crank on the Delta (center) are handy to use. But the crank on the Makita (right) has a lock knob that makes it a knuckle-buster.

Q: So which one is better?

Ken: Besides the ease of adjustment, I'd say it's a tossup.

Q: What about the handles used to adjust the depth of cut?

Ken: I like the big, beefy handwheel on the Sears. (See photos above.) And since you can attach it to either side, it's great for both right and left-handers.

Steve: The cranks on top of the Delta and Grizzly aren't removable. But I like the way they fold up for storage.

The Makita has a crank with a knob that "locks in" the depth of cut. That's nice if I'm planing a lot of stock at one setting. But it sure reduced the knuckle room I

needed to turn the crank.

Q: Can you depend on the scales and the indicators that tell you the thickness of the piece as it feeds out of the planer?

Ken: I usually use them as a rough indicator. But the scale on the Sears is so easy to read, I can see using it for more accurate work. (See photos lower left.)

Steve: That wasn't the case with the tape measure on the Grizzly. It's in a "window" on top of the planer. So it's about as accurate as reading a gas gauge from the passenger seat of a car.

Cary: Even so, it's better than the pointer on the Delta. The only way to adjust it is to bend the pointer.

Hairline Indicator. ▶

An adjustable hairline indicator makes the scale on the Sears planer easy to read.



Tape Measure. ▶

Unless you look right down into the tape measure on top of the Grizzly, it's hard to get an accurate reading.



Pointer. ▶

Since there's no up and down adjustment, you can't "fine tune" the pointer on the Delta scale.



Fixed or Movable Cutterhead?

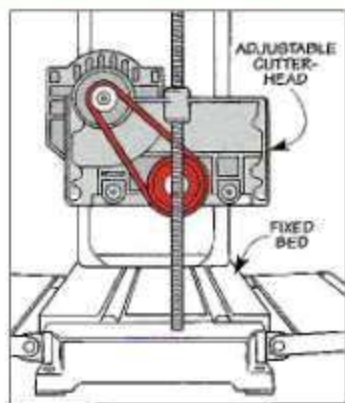
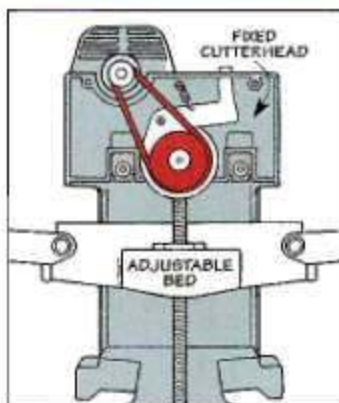

With a fixed cutterhead (left), the bed moves up and down as you adjust the depth of cut. But the cutterhead is adjustable on the planers with a fixed bed (right). Both types gave good results.

Changing Blades

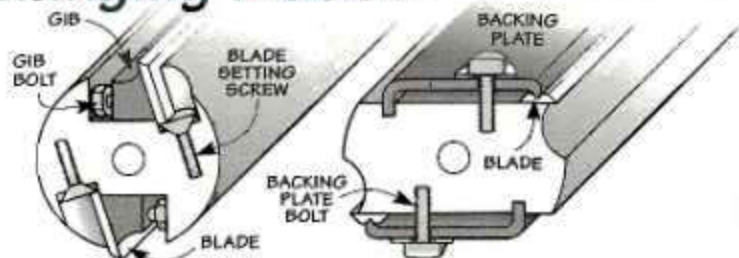

Cutterheads. A wedge-shaped gib provides a secure way to hold the blades in the cutterhead (left). But with this system, changing blades isn't as easy as with a backing plate that bolts to the cutterhead (right).

Q: A lot of guys dread changing blades on a planer. Is that true for these planers?

Cary: Just getting the blades out of the cutterhead was a bit of a challenge on the Jet, Delta, Grizzly, and Sears.

That's because they're held in place by a wedge-shaped gib that fits in an opening in the cutterhead. (See drawing above.) This puts my hand right in line with the blade when I'm loos-

ening the bolts that hold the gib. (See photos below.) And once it's loose, the only way to remove the blade is to grab the cutting edge with my fingers. That makes me nervous.

Steve: Removing the blades on the Makita and Ryobi is easier. With these, the blades are held in place with a backing plate that bolts to the cutterhead. (See drawing above.) And my hands aren't anywhere near the blade when I remove the plate.

Q: I've heard these blades called "throwaways." Is that true?

Ken: That's pretty accurate for the two-edged blades on the Delta, Ryobi, and Makita. (See top photo.) Mainly because it costs more to resharpen them than to buy new ones. Even though the single-edged blades cost more up front, they can be resharpened a number of times.

Steve: One nice thing about the double-edged blades is if they get nicked, I just reverse them and I'm back in business.

Q: What about the mechanisms for setting the blade height?

Steve: The Grizzly, Jet, and Sears all use a feeler gauge. (See margin.) But I don't like the fact that when the blade is set correctly, it "ticks" the metal gauge.

Even though there's still metal on metal, I liked the Delta system better. The blades are spring-loaded so they pop up to a bar that rests on the cutterhead.

Ken: But I liked the magnet on the Makita and reference tabs on the Ryobi best. They make setting the blade height automatic.

Blades. While the double-edged blades (top) are considered "throwaways," the blades with a single edge (bottom) can be resharpened.

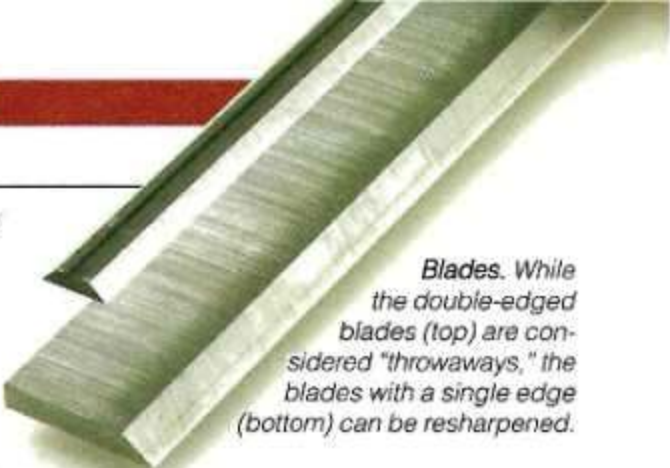

A feeler gauge is a clumsy way to set the blades (top). But spring-loaded blades that snap to a bar (center) and a magnet (bottom) that sets the blade on a backing plate are easier to use.



Hand Position. Changing blades on the planers that use a gib system (above) puts your hand right in line with the cutting edge. But you don't run the risk of a nasty gash with the Makita's T-handle and backing plate (side).



Recommendations

Ken: Picking one planer is tough. They can all handle the basic job — reducing stock to a uniform thickness.

But I picked the Delta. Besides giving me a smooth cut, I think the four-post design will stand up better over the long haul. And I can hook the 4" dust hood right up to my collector.

Steve: There's no question about it. I'd choose the Makita. What impresses me most about this planer is the consistent thickness of cut and the smooth surface it produces.

When you throw in the long support bed and an excellent fit and finish, it's an awfully hard planer to beat.

Cary: I'd buy the Makita too. Not just because it gave me the best cut of the bunch.

But also because of how easy it is to change blades. It's hard to go wrong with an automatic blade setting system like that.

If I could make one improvement, it would be to design a safety key that stays put. 🛠️

Shop Solutions

Router Table Insert



■ Recently, I noticed the phenolic insert in my router table had sagged a bit. As a result, I was having trouble getting an accurate depth of cut. To solve this problem, I replaced the old insert with a more rigid one made from $\frac{1}{4}$ "-thick aluminum, see photo. (I bought the aluminum plate at a local machine shop and had them cut it to the same size as the original insert.)

But because aluminum "transfers" to wood and leaves black streaks, I cemented plastic lami-

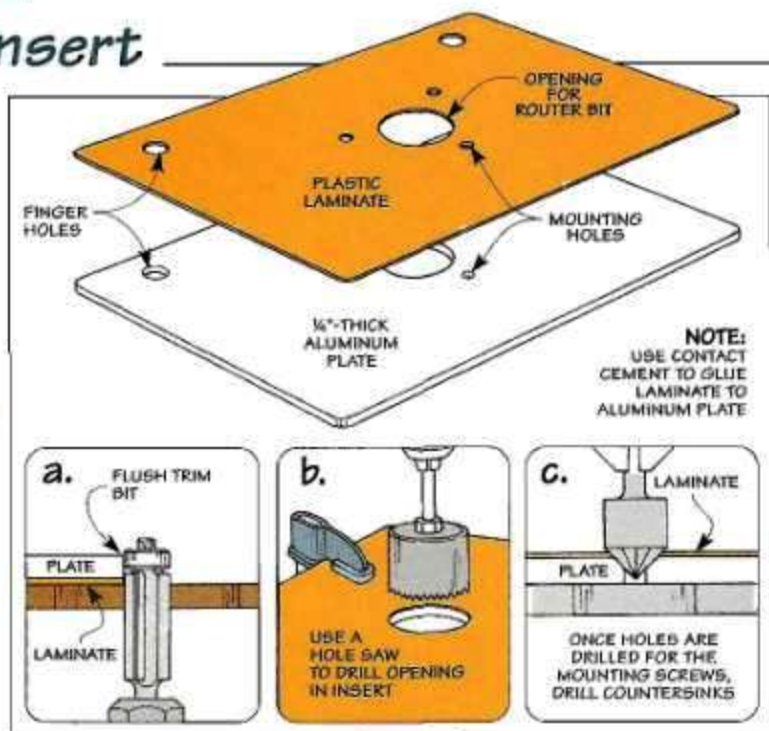

nate to one side, see drawing.

After routing the edges flush (detail 'a') it's just a matter of drilling finger holes and an opening for the bit, see detail 'b'.

Finally, soften the corners by sanding, and drill holes to mount the router, see detail 'c'.

*Kevin Grimm
Eldridge, Iowa*

Dust Enclosure

■ Besides making it easy to move my saw around, the mobile tool base featured in *ShopNotes* No. 22 has helped me solve another problem — containing the dust the table saw produces.

Along with four $\frac{1}{4}$ " Masonite panels cut to fit the sides of the stand, the tool base forms a dust enclosure. To hold the panels in place (yet still make it easy to remove them when cleaning out sawdust), the corners are "strapped" together with self-adhesive hook and loop fasteners.

*Chris Bucheit
La Crosse, Wisconsin*

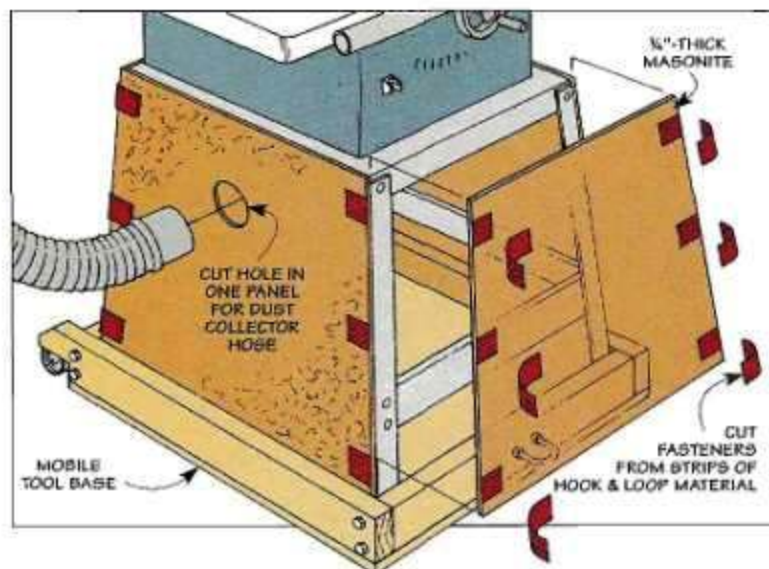

Quick Tips

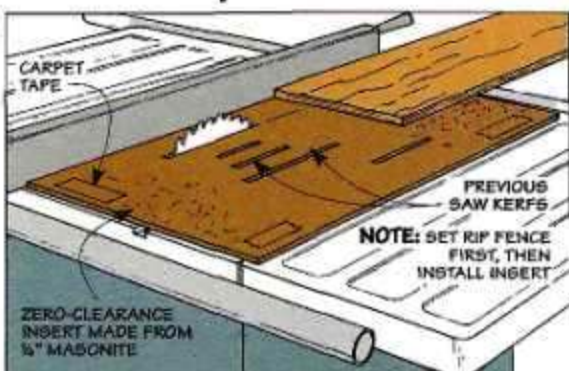

Insert. To make a zero-clearance insert, Charles Brownold of Davis, California, simply carpet tapes the Masonite to the saw table and raises the blade.

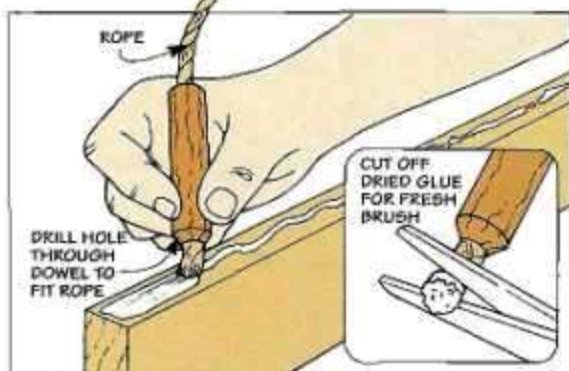

Glue Brush. The end of a Manila rope and a dowel serve as a glue brush for Bob Johnson of Peoria, Illinois. When the glue dries, just snip off the end.

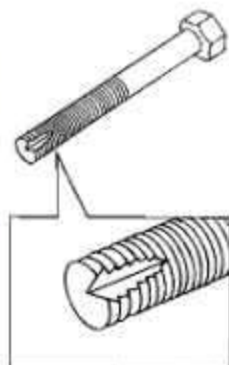

To make a simple tap for threading holes, grind a notch in the end of a bolt (or machine screw).

Marking Gauge



■ When scoring a layout line with a marking gauge, the pin often wanders in the direction of the grain. But the "sharpened" washer on this marking gauge scores a straight, crisp line, see photo.

The washer attaches to the end of an arm that's made from a short dowel, see drawing. To make the marking gauge adjustable, the arm slides in a hole drilled in a hardwood fence that rides against the workpiece.

The key to locking in this adjustment is a bandsawn kerf that extends through the hole in the fence. Tightening a wing nut on a machine screw that passes through holes in the fence pinches the kerf closed and locks in the adjustment.

To keep the machine screw from spinning, the top part is held tight in an undersize hole. (An

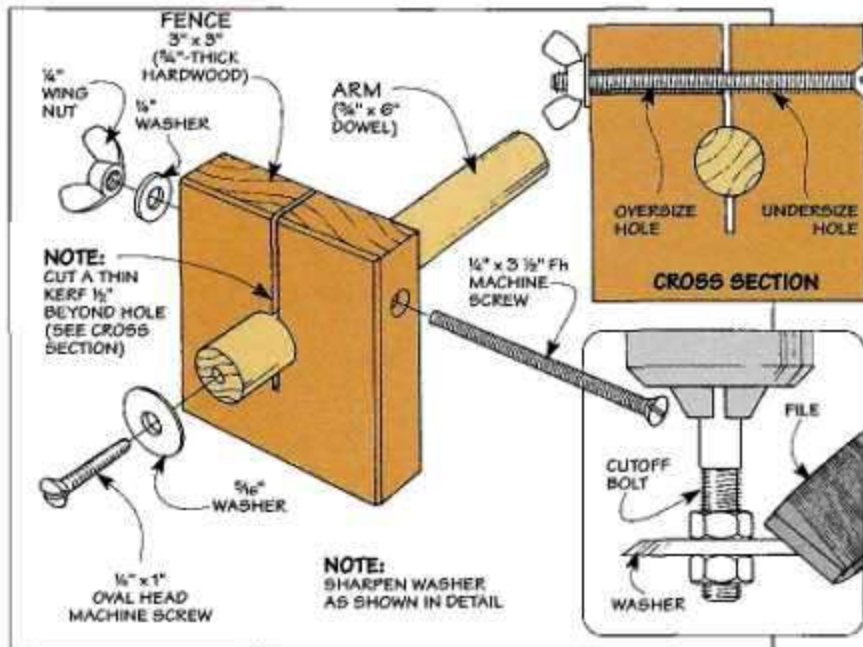

oversize hole for the bottom of the screw allows the kerf to close.) Note: To make it easy to thread in the machine screw, you can tap the small hole, see margin.

Finally, to sharpen the washer, I attached it to a cutoff bolt with two washers, see detail 'a'. Then, with the bolt chucked in the drill press, simply file a bevel and remove the burr.

Doug Perlick
Arden Hills, Minnesota

Send in Your Solutions

If you'd like to share your original solutions to problems you've faced, send them to: *ShopNotes*, Attn.: Shop Solutions, 2200 Grand Avenue, Des Moines, IA 50312. (Or if it's easier, FAX them to us at: 515-282-6741.)

We'll pay up to \$200 depending on the published length. Please include a daytime phone number so we can call you if we have any questions.

Crotchwood

There's often a treasure of highly figured wood where the limb of a tree joins the trunk.



Any kid can tell you that the crotch of a tree is the perfect place for a treehouse. But ask a woodworker, and you're likely to get a different answer.

That's because of the highly figured grain that often forms in the part of the tree where a limb joins the trunk. It swirls dramatically where the wood fibers have crowded and twisted together, then fans out gracefully like the feathers of a bird, see photo above.

Because of these striking patterns, a piece of crotchwood can turn an ordinary project into something special. Just right for a handcrafted tool or a small, decorative project, see photo at far right.

WHERE TO LOOK. If you decide to use crotchwood in a project, you probably won't find it in most lum-

The feathery grain that makes it easy to identify crotchwood fans out across the large chunk of maple (in back) as well as the walnut (right), white oak (front), and cherry (left).

beryards. In fact, you may have to hunt around a bit.

For example, a friend of mine cut the walnut crotchwood in the vase shown below from a tree that had fallen in the woods. But you could also rescue a likely chunk from the firewood pile. Or buy a piece from a sawmill that specializes in highly figured woods. (For a look at one of these mills, see page 31.)

ANGLE. One thing that's a good indicator of whether the crotchwood in a tree will have much figure is the *angle* formed by the limb and the trunk.

If the limb grows out at a wide angle and creates a "saddle" (like on some walnut trees for instance), there's a good chance of getting highly figured crotchwood. But it's not as likely where the limb forms a much steeper angle (a red elm for example).

TYPES. That's not to say that walnut is the only type of crotchwood. Even the most common hardwoods can produce striking grain patterns, see the photo below left.

SIZE. Regardless of the type of crotchwood, most of the pieces I work with are fairly small. (It takes a huge tree with massive limbs to produce a large piece.) So don't plan on using it for any large scale projects.

WORKABILITY. There's one other thing to keep in mind when working with crotchwood. Because the grain swirls in all directions, chipout can be a problem.

So it's a good idea to check the grain direction before making a cut (it runs "downhill" when you look at the edge of a piece). Finally, avoid using coarse sandpaper — the resulting scratches can be hard to sand out.



Crotchwood is ideal to use for a decorative wood vase, a fine hand tool, or a simple handle.

At the Mill



At first glance, it looked like your typical sawmill. Logs piled up waiting to be run through the mill. And sawdust streaming out of a chute onto a huge mound. But one thing was missing — there wasn't a stack of boards to be seen anywhere.

BLANKS. The reason is simple. The Johnson family (Randy, Byron, and their father I.D.) is in the business of sawing logs into thick wood blanks.

Not just ordinary chunks of wood. But special blocks of basswood for wood carvers. Bowl blanks of walnut, cherry, and butternut for wood turners. And highly figured pieces of redwood burl and birdseye maple.

CROTCHWOOD. As much as I liked these blanks, there's one thing that impressed me even more — the big slabs of figured

crotchwood that are the stock in trade of this sawmill.

Most of these large pieces are sold to make rifle stocks. But many smaller pieces with grain patterns every bit as striking are also available, see margin.

MILL. Regardless of the size, the basic process for sawing the logs that produced these pieces is the same, see photos.

When sawing a log, there's no guarantee that the crotch of a tree will yield highly figured wood. In fact, about half the logs have some sort of defect (a bark pocket for example).

DIAMOND. Fortunately, this gnarled old walnut log proved to be the diamond in the rough. ♣

Sources

For information and prices on wood blanks, call Johnson Wood Products: 319-933-6504



1 Standing this walnut log on end makes it easy to see the V-shaped crotch on the right.



2 A chain saw makes quick work of cutting the heavy log into manageable pieces.



3 To provide extra leverage, a cant hook is used to roll the log onto the saw carriage.



4 Pulling a metal rod moves the log across the saw carriage to establish the thickness of cut.



5 As the carriage advances the log, a 52"-diameter circular saw blade slices off a thick slab.



6 These thick slabs reveal the striking feathery grain that formed in the crotch of this tree.



7 After laying out the rough shape of a rifle stock on the slab, it's trimmed up on a band saw.



8 Finally, to prevent the wood from checking, hot wax is brushed across the surface.

Scenes from the Shop



Better known as a "scrub" plane, this Stanley No. 40 is a forerunner of the thickness planers on page 22. With a curved blade held in place by a metal wedge, the plane was worked across the grain to reduce stock to thickness. This created a scalloped surface that was often cleaned up only on the "show" side.