

ShopNotes®

Vol. 4

Issue 22

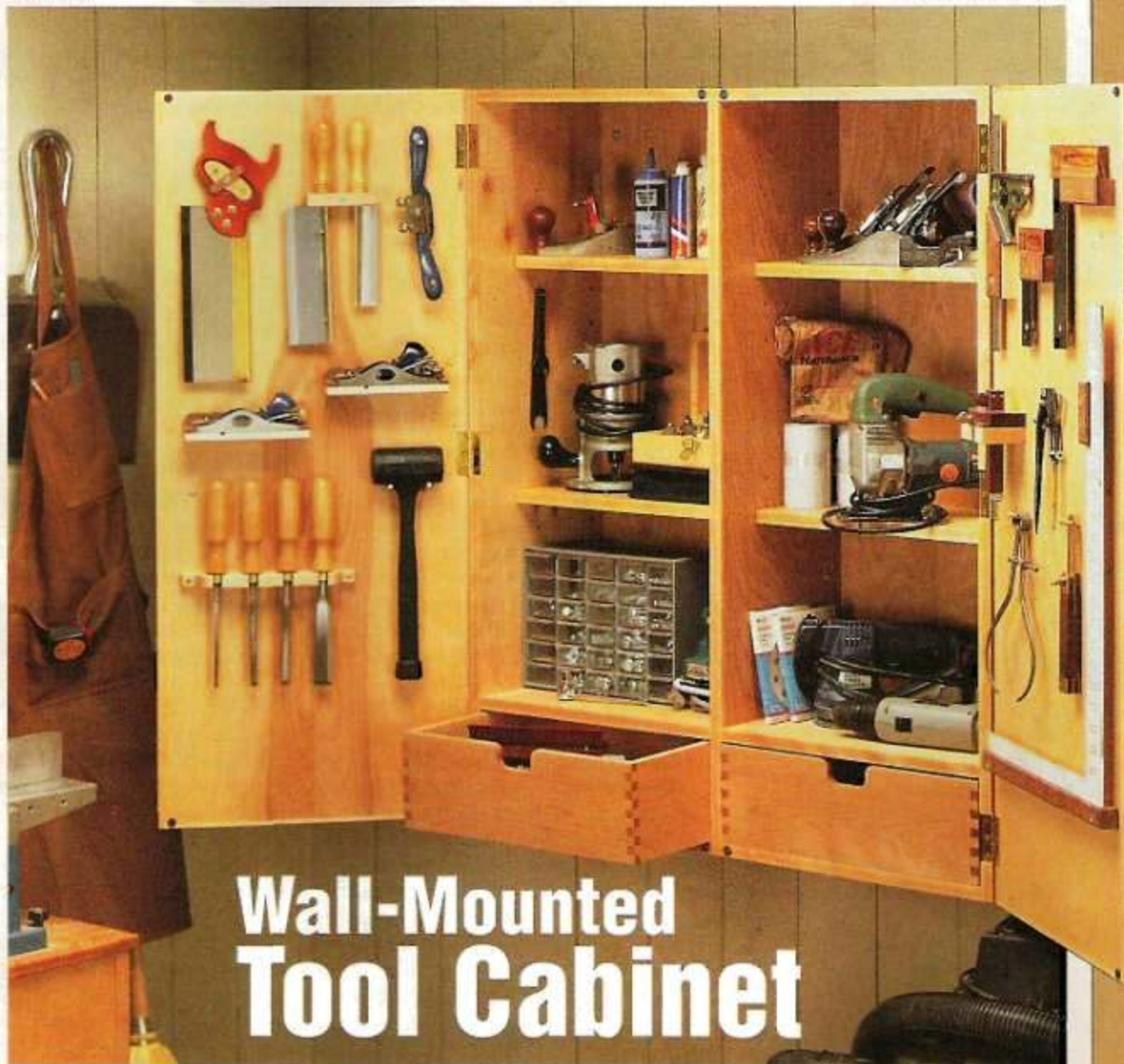

Wall-Mounted Tool Cabinet

- Drill Press Hold-Down
- Benchtop Sanding Table
- Router Table Box Joints
- Applying Wood Edging



ShopNotes

Issue 22

July 1995

EDITOR Donald B. Peschke
EXECUTIVE EDITOR Douglas L. Hicks
MANAGING EDITOR Richard S. Peters
ASSOCIATE EDITORS Tim Robertson
 Phil Totten

CREATIVE DIRECTOR Ted Kralicek
ART DIRECTOR Cary Christensen
SENIOR ILLUSTRATOR Kurt Schultz
ILLUSTRATORS Roger Reiland
 Mark Higdon
 Erich Lage
PHOTOGRAPHER Crayola England
ELECTRONIC GRAPHICS Chris Glowacki

DESIGN DIRECTOR Ken Munkel
SENIOR DESIGNER Kent Welsh
SHOP MANAGER Steve Curtis
SHOP ASST./FACILITIES Steve Johnson

CIRCULATION

New Bus. Mgr.: Sandy Baum • *Revised Mgr.*: Paige Rogers • *Direct Mail Mgr.*: Troy Dowell
Direct Mail Asst.: Julie Greenlee • *Newsstand Sales*: Kent A. Buckton • *Analyst*: Shane S. Francis

CORPORATE SERVICES

Plan. Dir.: Jon Macarthy • *Controller*: Robin Hutchinson • *Account.*: Laura Thomas • *Bkpr.*: Holly Lucas • *Prod. Mgr.*: Carol Quijano • *Pub. Serv. Mgr.*: Gordon C. Gaipe • *Artist*: Cheryl L. Cynar • *Info. Serv. Mgr.*: Joyce Moore • *Elect. Pub. Coord.*: Douglas M. Lichter • *Nat. Adm.*: Nick Thielen • *Admin. Assists.*: Cheryl Scott, Julia Fish • *Recept.*: Joanne Johnson • *Edip. Maint.*: Ken Griffith

PROJECT SUPPLIES

Art Dir.: Cindy Jackson • *Catalog Products Mgr.*: Bob Baker • *Inv. Control/Prod. Mgr.*: Mark Mattassi • *Proj. Supplies*: Linda Jones • *Tech. Support*: David Stone • *Sys. Oper.*: Tammy Aldini • *Ship. Supr.*: Nancy Johnson • *Fulfillment*: Gloria Steehan, Chuck Carlson, Sylvia Carey, Larry Price

CUSTOMER SERVICE

Mgr.: Jennie Etnos • *Team Leader*: Karla Cronin • *Customer Service Reps.*: Jennifer Murphy, Joy Krause, Sara Kono, Anna Cox, Lonnie Algreen, Adam Best, Kristi Andrews

ShopNotes® (ISSN 1093-9000) is published bimonthly (Jan., March, May, July, Sept., Nov.) by Woodsmith Corporation, 2200 Grand Ave., Des Moines, IA 50312.
 ShopNotes® is a registered trademark of Woodsmith Corp. ©Copyright 1995 by Woodsmith Corporation. All rights reserved.
 Subscriptions: Single Copy, \$4.95. One year subscription (6 issues), \$19.95. Two years (12 issues), \$35.95. Canada/Foreign, add \$5.00 per year.
 Second Class Postage Paid at Des Moines, IA and at additional offices.
 Postmaster: Send change of address to ShopNotes, Box 13204, Des Moines, IA 50340-1204.
 Subscription Questions? Call 1-800-333-8884, 9am to 5pm, Central Time, weekdays.
 E-Mail: Prodigy: EIDJ97A, CompuServe: 75030,2501, Internet: 75030.2501@compuserve.com, America Online: Shopnotes.

WoodNet

COMPUTER BULLETIN BOARD FOR WOODWORKERS

- Project plans and photos to download
- Woodworking Techniques Forum
- Indexes for Woodsmith & ShopNotes
- First month FREE for PC or MAC

To log on to WoodNet, call 1-515-245-9663. If you have any questions, please give us a call (voice) 1-515-252-7000 M-F 9-5 CST.

EDITOR'S NOTE

Cutoffs

When I first heard the squeaking, I thought there was something wrong with our heating system. But then I heard it again — this time followed by laughter.

Curious, I headed toward the shop to find the source of the noise. As I rounded a corner, I was surprised to find one of the editors hauling another one around in what looked like a poor excuse for a kid's wagon.

Tim stood with his hands on his hips and his feet planted firmly inside of a shallow wood tray. While at the same time, Phil wrestled with



what appeared to be a wooden garden hoe — except it had wheels and a hook on the front, see photo above.

Now you must realize the winters can drag into the spring here in Iowa. But I thought this was taking the cabin fever concept just a bit too far.

Then I remembered that Phil was working on an article he'd suggested for our Small Shop department — a mobile base that would allow you to quickly and easily roll around your stationary power tools.

COMMENTS & SUGGESTIONS. As the loud squeaks brought out more and more curious people to find out what was going on, the comments and suggestions started. Of course, everyone agreed we needed quieter wheels. So we switched from all metal casters to ones that used hard rubber wheels.

Likewise, agreement was quickly reached about the handle. Its short length required bending over in an uncomfortable position where it could be

all too easy to strain your back as you pulled the tool. The solution was to replace our original dowel (usually only available in 36" lengths) with a four-foot piece of closet rod. (The extra diameter also created a sturdier handle.)

And after hooking the handle on and off the base several times, we decided that stiffer hardware would be needed

for the tool base to stand up well under heavy loads.

The result of all of these improvements is the Roll-Around Tool Base shown on page 24. It's a perfect example of a good idea that got even better because a

group of people worked on it together.

LEND A HAND. And when you think about it, working together to lend a helping hand is one of the things that woodworkers do best. Take Habitat for Humanity for instance. All across the country, woodworkers (and non-woodworkers alike) are unselfishly donating their time and energy to create housing for those in need.

At the same time, generous individuals, organizations, and corporations are making sure that these people have all of the necessary tools and materials to get the job done.

As a matter of fact, that's where many of the tools we purchase for our Selecting Tools department end up after we've completed the article. (We also donate some of these tools to the Boy Scouts and to the local inner city tool lending "library.")

I'm sure you'll agree that there's nothing quite as satisfying as working together to improve something.

Contents

Projects & Techniques

Drill Press Hold-Down _____ 4

It's easy to drill precision holes on the drill press when you use this hold-down to "lock" your workpiece in position.

Sanding Table _____ 10

Eliminate the cloud of dust produced every time you sand with this benchtop sanding table.

Box Joints: Router Table _____ 12

Perfect box joints. That's what you'll get when you cut them on the router table using our simple step-by-step approach.

Wall-Mounted Tool Cabinet _____ 16

This wall-mounted cabinet provides a home for all your tools. It not only protects them — but organizes them as well.

Tool Holders _____ 20

One of the simplest ways to protect a tool is to make a holder for it. We'll look at customizing holders for nine different tools.

Solid Wood Edging _____ 26

You can give a plywood project the appearance of solid wood by trimming the edges with hardwood. Here's how.

Departments

Great Tips

Jointer Tips _____ 8

Our favorite tips to help you get the most out of your jointer.

Selecting Tools

Tape Measures _____ 22

Which of the eight popular tape measures that we tested is best for you? Our two-man team offers suggestions.

The Small Shop

Roll-Around Tool Base _____ 24

Moving heavy tools in the shop is no longer a wrestling match when you use this simple roll-around base.

Readers' Tips

Shop Solutions _____ 28

Six shop-tested solutions from our readers.

Lumberyard

Particleboard _____ 30

A look at different grades of particleboard and their uses.

Finish Room

Oil Stains _____ 31

True colors that don't fade. Oil stains offer this and more.



Drill Press Hold-Down page 4

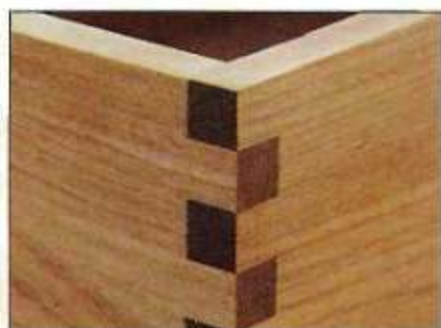

Box Joints page 12



Tool Cabinet page 16



Tape Measures page 22

Drill Press Hold Down



Accurate Drilling. The fence on this drill press table uses a stop block and a hold-down for clamping and accurately positioning a workpiece.



Improved Fence. If you already have a shop-made table with a fence, simply add the fence shown here to take advantage of the stop block and hold-down.

Drilling accurate holes on the drill press can be a challenge. A fence clamped across the table top helps, but it doesn't prevent the workpiece from shifting as the hole is drilled. And clamping the workpiece to the table top is a hassle — the ribs under the table always get in the way.

One solution is this shop-made hold-down, see photos above. It works with a built-in stop to first position the workpiece. Then "locks" it in place for drilling.

FENCE. Both the hold-down and the stop attach to a fence that either mounts onto a simple table or screws directly to your existing fence. A T-slot in the fence allows you to slide the stop or hold-down where needed.

TABLE. If you don't have a shop-made table for your drill press, you can build a table for the fence and hold-down, see next page.

EXISTING TABLE. But if you're already using a shop-made table, consider building just the fence (page 6) with the hold-down, see photo above right.

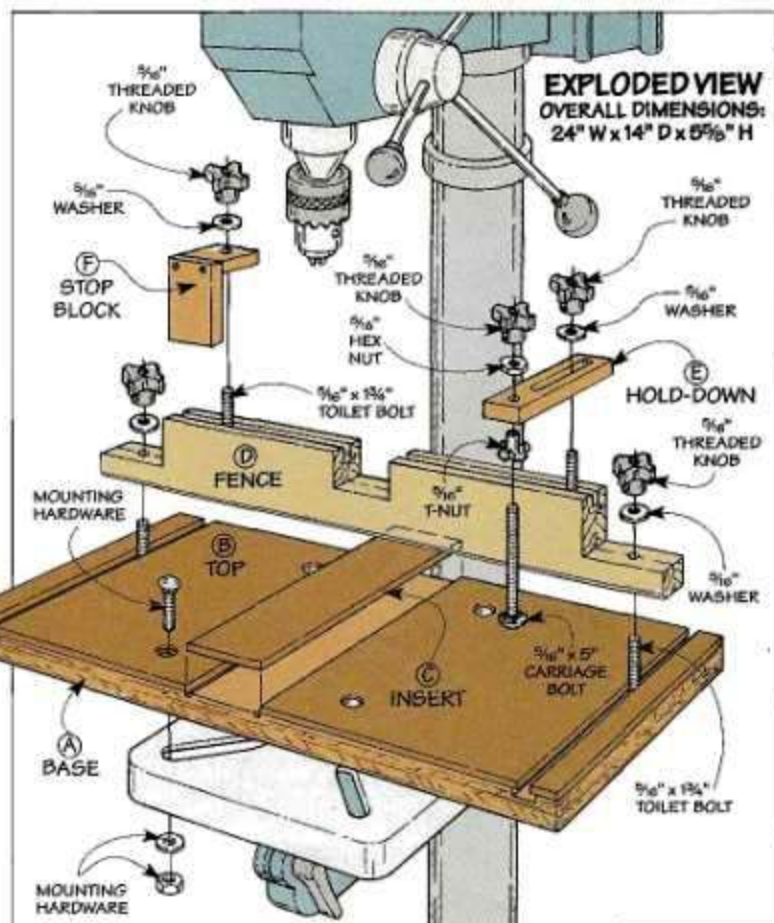

Hardware

- (5) $\frac{5}{16}$ " Plastic Knobs
- (4) $\frac{5}{16}$ " x $1\frac{3}{4}$ "-long Toilet Bolts
- (4) $\frac{5}{16}$ " Washers
- (1) $\frac{5}{16}$ " Hex Nut
- (1) $\frac{5}{16}$ " T-nut
- (1) $\frac{5}{16}$ " x 5"-long Carriage Bolt
- (6) #8 x 2" Fh Screws
- (2) #8 x $1\frac{1}{2}$ " Fh Screws

To order a complete hardware kit, call ShopNotes Project Supplies at 1-800-444-7527 622-6822-100... \$7.95

Table

The table for the hold-down attaches to your metal table top and provides a larger work surface. It consists of three parts: a base, a protective top, and a replaceable insert, see Fig. 1.

BASE. The *base* (A) for the table is just a piece of $\frac{3}{4}$ "-thick plywood, see Fig. 1. Two grooves are cut in it to form the bottom half of a T-slot for the fence, see Figs. 2 and 2a. (The second half of the T-slot is cut later.)

To ensure these grooves end up parallel, I cut them with a dado blade on the table saw. And used the same setup to cut each groove — flipping the base end-for-end between cuts.

TOP. The next step is to add a protective *top* (B), see Fig. 2. It's a piece of $\frac{1}{4}$ " Masonite that's cut slightly larger than the base and is attached with contact cement.

Note: To make it easy to remove a section of the top for a replaceable insert added later, don't apply contact cement in the center area as shown in Fig. 2. Instead, apply a strip of double-sided carpet tape in this area.

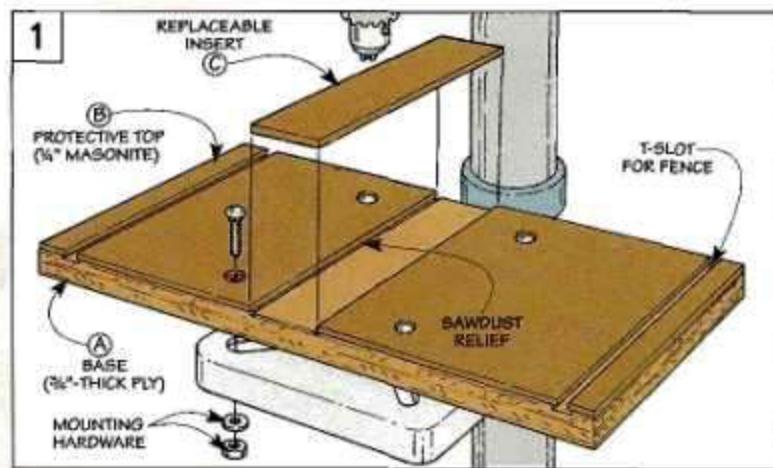

With the top glued in place, trim the edges flush with the base (I used a hand-held router with a flush-trim bit).

T-SLOTS. Now the T-slots can be completed by cutting a second set of grooves in the top (B), see Fig. 2b. To ensure the fence slides smoothly, center them over the grooves cut earlier in the base (A).

INSERT. All that's left to add is the *replaceable insert* (C). To do this, first remove the center section of the protective top (B). The easiest way I've found to do this

is with the table saw, see Fig. 2c.

Set the rip fence so it's 10" from the blade. And raise the blade to cut $\frac{3}{8}$ " deep. (This extra $\frac{1}{8}$ " prevents sawdust from getting in the way when replacing a chewed up insert.) Make the first pass, then flip the table end-for-end and make a second pass.

After removing the waste (and the double-sided tape), cut an insert (C) from $\frac{1}{4}$ " Masonite to fill the opening, see Fig. 1. Now the table is ready to be bolted to the drill press, see Figs. 1 and 3.

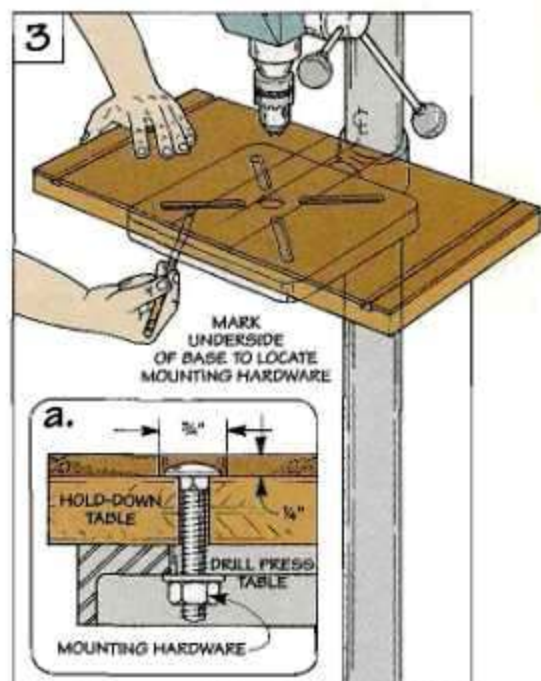
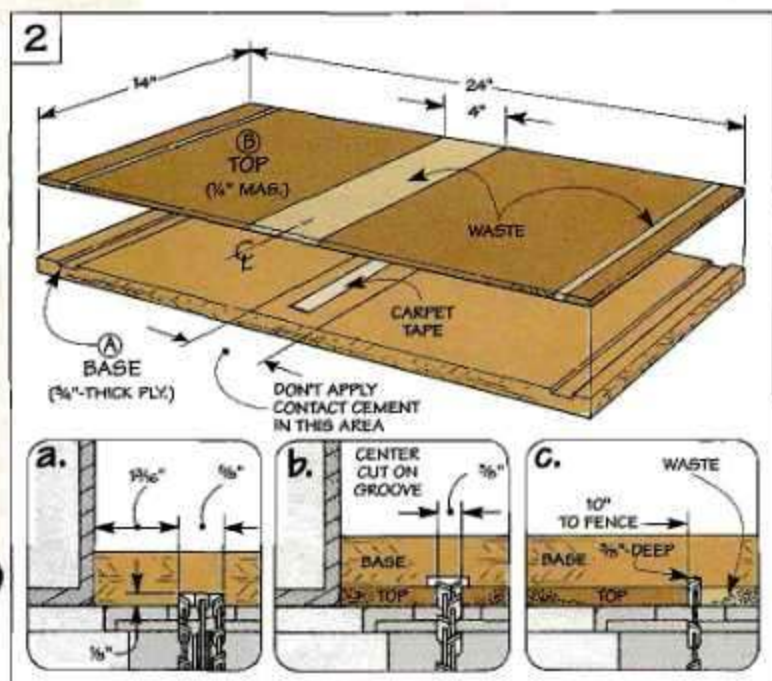

Fence

Whether you're building the fence for our table top (see Fig. 4) or for an existing table top (see box below), the construction is basically the same.

Start by cutting two fence pieces (D) from 3/4"-thick stock (I used maple), see Fig. 5. Then, to accept the hold-down and stop block shown on the next page, a T-slot is cut along the top edge of the fence, see Figs. 5a and 5b.

This slot is formed by first cutting a kerf in each piece before gluing them together, see Fig. 5a. Note: To keep the fence pieces aligned as you glue them up, see the margin tip at left.

When the glue is dry, the T-slot can be completed by cutting a groove centered along the top edge of the fence, see Fig. 5b.

NOTCHES. Now all that's left is to cut a notch in the center for chuck clearance, see Fig. 4a. And rout a chamfer along the front edge for sawdust relief, see Fig. 5.

Note: If you've built the top shown on page 5, you need to cut notches on the ends for the knobs that "lock" the fence in position, see Fig. 4b.

You'll also need to drill holes through the end notches for the bolts that attach the fence to the table. (A hardware kit is available, see page 4.)

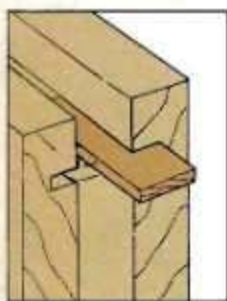

A waxed, wood "key" helps keep the T-slot aligned during glue-up.

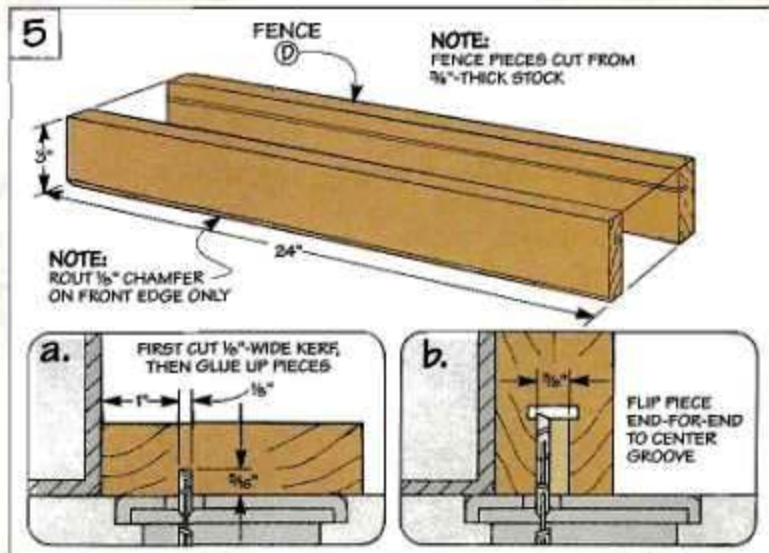
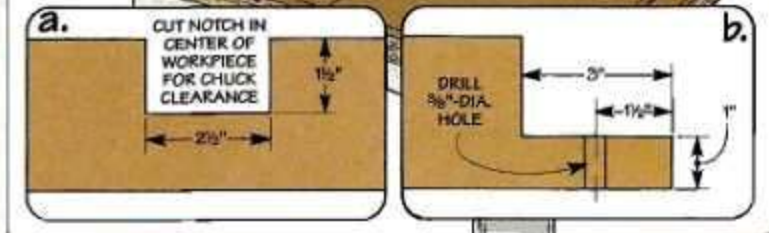
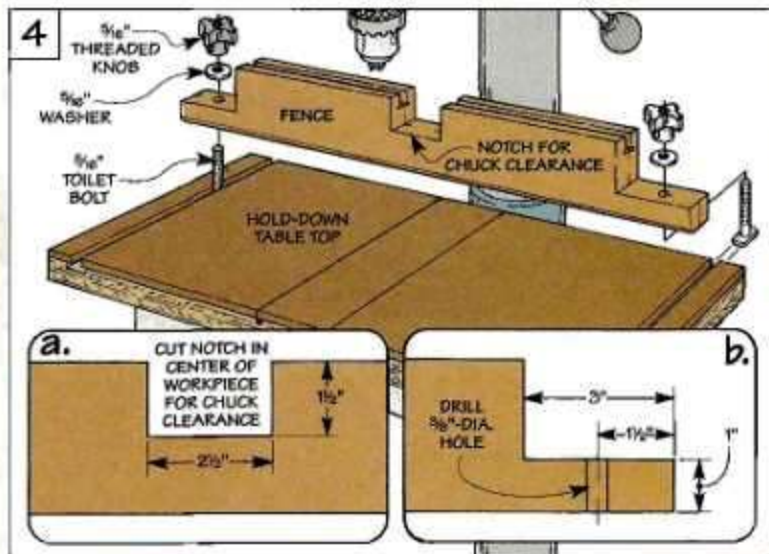

Adding to an Existing Table

To add the hold-down system to an existing table, build the fence shown above — just don't cut the notches in the ends used for the mounting knobs.

Then screw (or bolt) the new hold-down fence to your existing drill press fence, see drawing.

Once the fence is in place, build the hold-down bracket and stop block shown on the next page for your new fence.

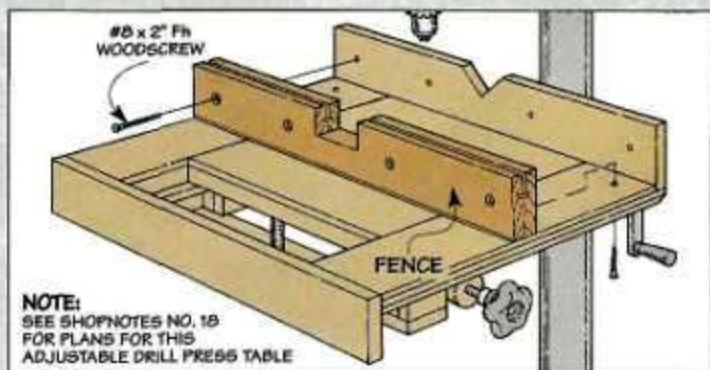

NOTE: SEE SHOPNOTES NO. 19 FOR PLANS FOR THIS ADJUSTABLE DRILL PRESS TABLE

Hold-Down



With the fence complete, you can turn your attention to the hold-down bracket that "locks" the workpiece in place for drilling, see photo above.

The hold-down slides in the T-slot in the fence so it can be positioned along its length.

SLOT. The *hold-down (E)* is just a $\frac{3}{4}$ "-thick piece of stock (I used hard maple), see Fig. 6.

In order to slide the hold-down in and out for different-size workpieces, a slot is cut near one end for a toilet bolt that rides in the T-slot in the fence.

To make the slot, I first drilled a series of overlapping holes. Then I used a chisel to clean out the waste.

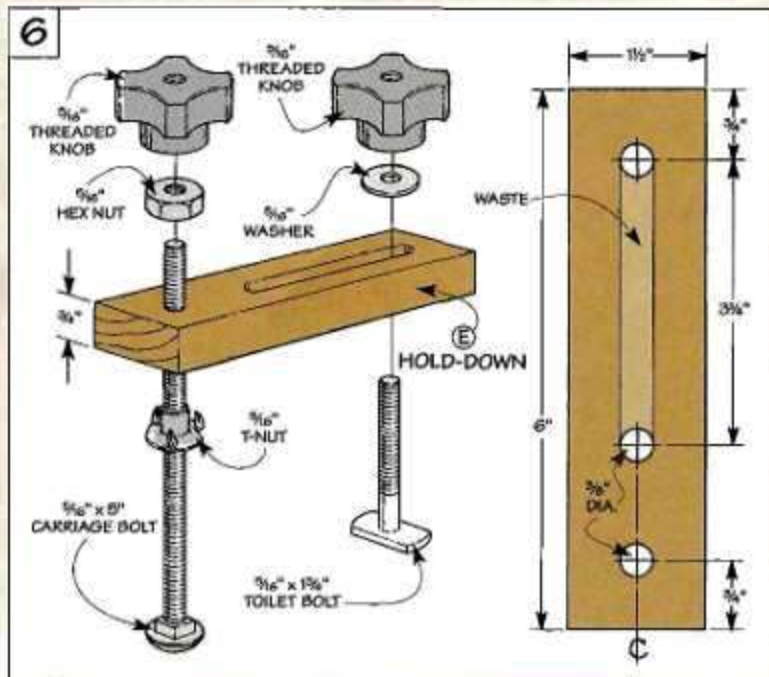

T-NUT. Once you've completed the slot, a hole is drilled in the other end for a $\frac{5}{16}$ " T-nut that holds a 5"-long carriage bolt. This bolt applies clamping pressure to the workpiece to hold it firmly

against the table top.

HARDWARE. Finally, a jam nut (hex nut) and plastic knob are attached, see Fig. 6. And the hold-down can be mounted to the fence with a toilet bolt and knob.

Stop Block



The last item to build for the drill press hold-down is an adjustable stop block, see photo above. It's used to accurately position the workpiece being drilled.

And when it's used along with the hold-down bracket, it helps prevent the workpiece from shifting as the hole is drilled.

TWO PARTS. The stop block is just an L-shaped bracket consisting of two parts: a stop (F) and a

rail (G), see Fig. 7. And like the hold-down, the stop block attaches to the fence by way of a toilet bolt that slides in the T-slot cut in the fence.

LONG BLANK. Since both the stop and the rail are such small parts, it's a good idea to start with an extra-long blank.

Then after drilling holes for woodscrews and a toilet bolt cut the *stop (F)* and *rail (G)* to final length from the blank. Note: The stop is cut $\frac{1}{8}$ " short to provide sawdust relief.

HARDWARE. Now the parts can be glued and screwed together to form the L-shaped stop block. Finally, add the mounting hardware and attach the stop block to the fence.

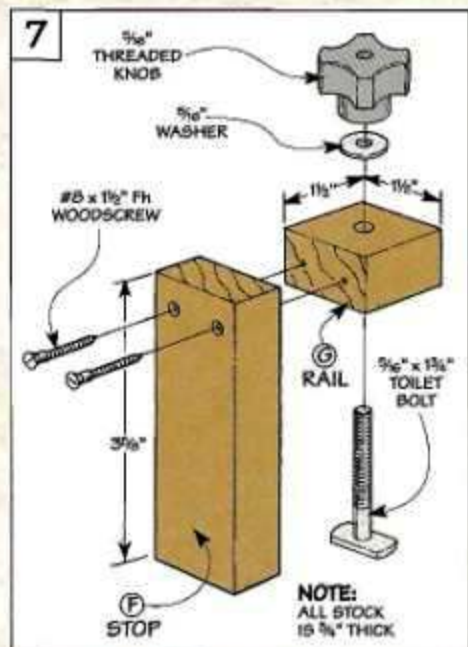

Jointer Tips

A few of our favorite tips to help you get more out of your edge jointer.



Feed Direction

To reduce the chance of chipout or tear out when edge jointing, always make sure you run the workpiece through the jointer so the knives cut with the grain, see Figs. 1 and 2.

To determine the proper feed direction, point the grain away from the knives, towards the in-feed table of the jointer.

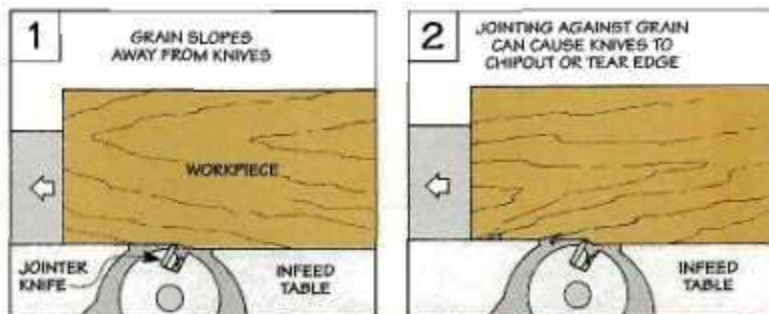

Rough-Sawn Lumber

The first step to working with rough-sawn or crooked lumber is to establish a straight edge. To do this quickly, I make a series of short passes over each end to "nibble" away the jagged ends, see drawing.

Once the ends are leveled, it's just a matter of making one or two full passes to edge joint the full length of the board.

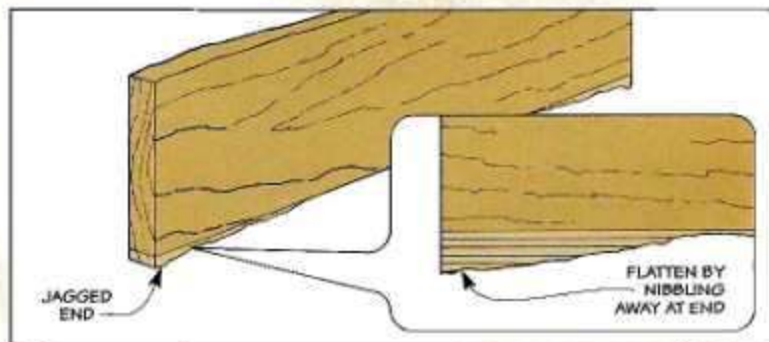

Pencil Track

It's often difficult to see when the entire edge of a board is jointed. So I use a simple visual reference that tells me when I've made a complete pass. First scribble a pencil line along the full length of the edge, see drawing.

Then after each pass check to see how much of the pencil line is left. You can stop once the line is completely gone.

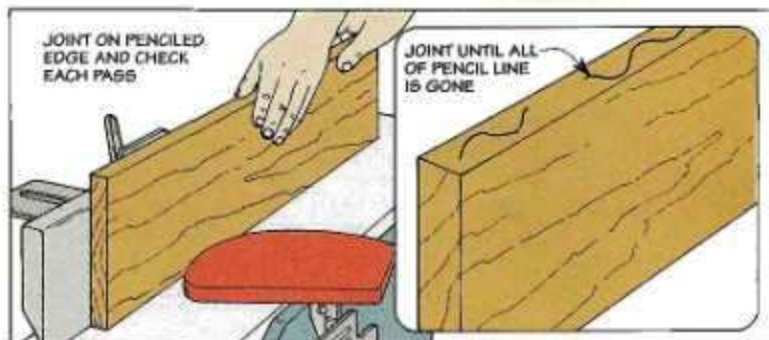

Uniform Tapers

When working with a tapered workpiece, you'll get a straighter, smoother edge if you first rough out the shape to within $\frac{1}{16}$ " of the layout line using a band saw (or sabre saw). Then finish up the cut with the jointer — stopping at the layout line, see drawing.

To end up with identical tapers on the workpieces, "clamp" the blanks together with double-sided carpet tape before finishing up the edges on the jointer.

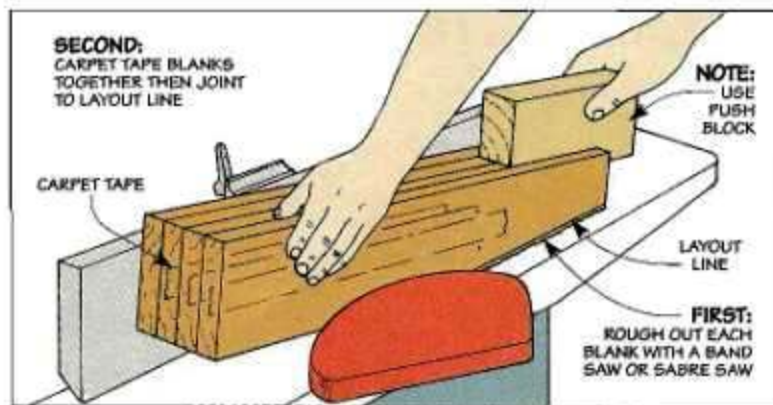

Jointing Plywood

Many woodworkers don't realize plywood can be edge jointed. I do it all the time to prepare plywood before gluing on hardwood edging.

But there's one thing to keep in mind when edge jointing plywood — the back edge needs to be supported to eliminate jointer chipout. To do this, just clamp a piece of scrap to the back edge, see drawing. Then joint the plywood edge like you would any other workpiece.

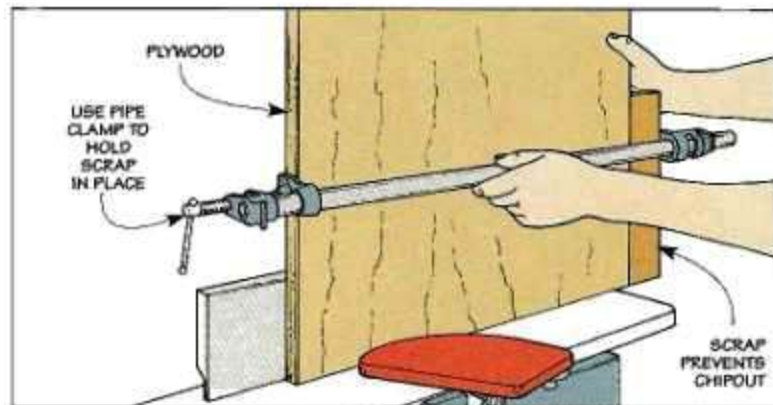

Bed Extensions

The bed on most bench-top jointers is too small to safely handle a long workpiece. To get around this, you can make a pair of simple extension tables. Each extension is made up of two lengths of $\frac{3}{4}$ " aluminum angle and a piece of $\frac{3}{4}$ " plywood, see drawing.

Note: The only modification you may need to make to the jointer is to drill (and possibly tap) holes in the infeed and outfeed tables for the screws used to mount the aluminum angle.

To allow the extension tables to be adjusted flush with the jointer tables, drill overlapping holes in the aluminum angle to form a slot. Then screw the plywood extensions in place.

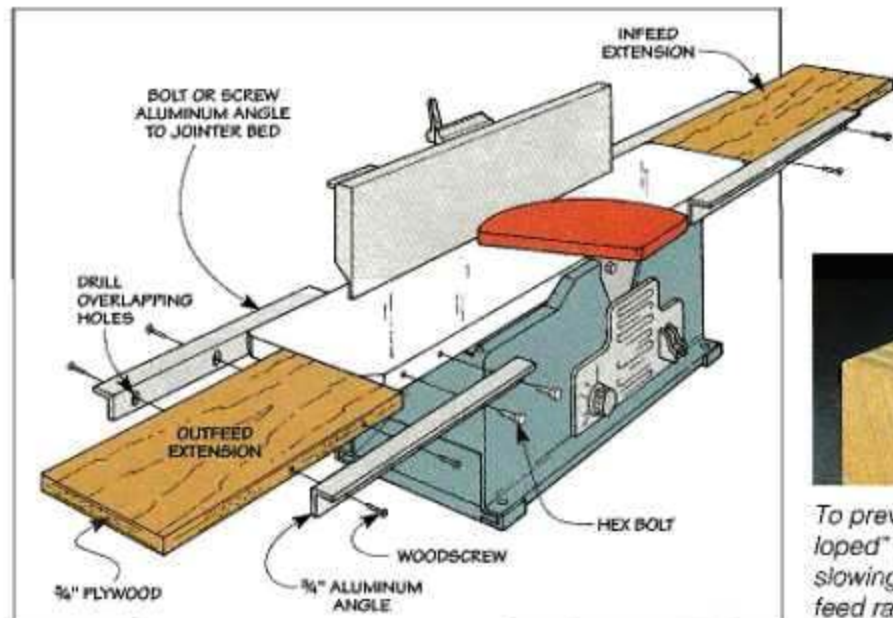

To prevent a "scallop" edge, try slowing down your feed rate.

Benchtop Sanding Table

This shop-built sanding table hooks up to your dust collector for dust-free sanding.



Most dust collectors do a great job of keeping the dust down. Especially when it comes to the big chips produced by large, stationary tools. But dealing with the fine dust that's generated when using a power sander is a different story.

These sanders kick up a cloud of dust that hangs in the air and fills my nose and lungs. And when it finally settles, there's a thin layer of dust that coats everything in the shop.

To remove this dust *before* it drifts into the air, I built a benchtop sanding table that hooks up to my dust collector, see photo

above. It provides a convenient sanding surface that pulls dust down through a perforated top and into the dust collector.

BOX

The heart of the sanding table is a simple box. In addition to supporting the top, the box houses a baffle that controls the flow of air inside the table.

The *sides (A)*, *front (B)*, and *back (C)* of the box are all made from $\frac{3}{4}$ "-thick plywood, see Fig. 1. A rabbet cut in the top edge of each piece accepts a $\frac{1}{4}$ " pegboard top (added later), see Fig. 1a. And the front and back pieces fit in

rabbets cut in the ends of the side pieces, see Fig. 1b.

REDUCER. To hook the flexible hose from your dust collector up to the sanding table, you'll also need to cut a hole in the front (B) for a plastic reducer, see Fig. 1. (Reducers are available from many woodworking stores and tool catalogs.)

BAFFLE. Before assembling the box, the next step is to add the *baffle (D)*. This is a piece of $\frac{3}{4}$ "-thick plywood that fits inside the box at an angle, see Fig. 1. By restricting the air flow at the back of the box, the baffle evens out the suction across the table.

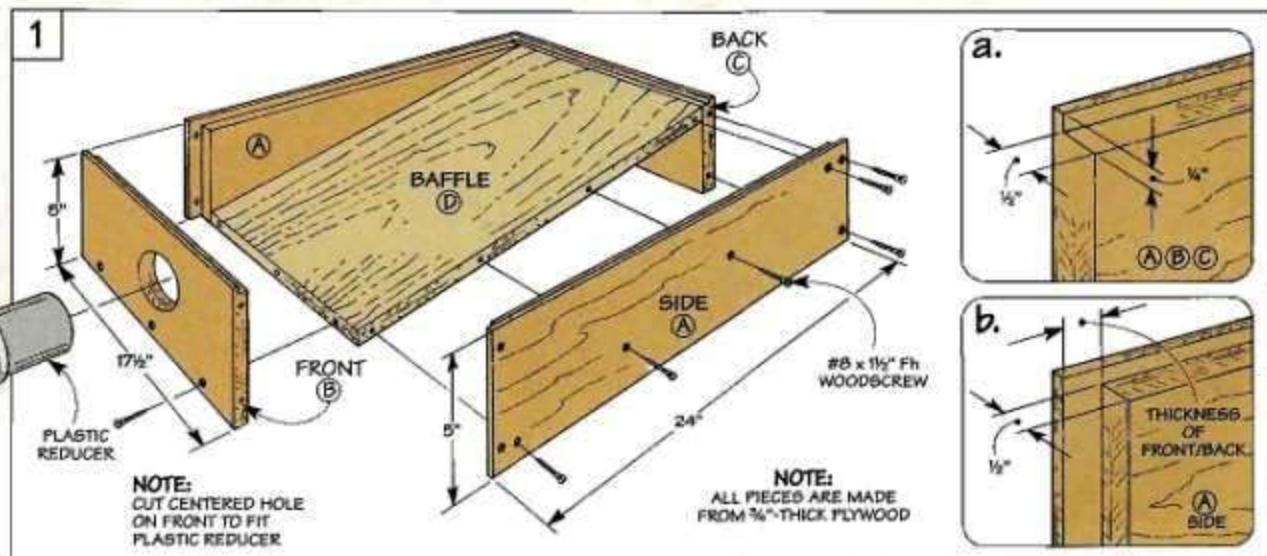

To produce a tight seal, it's important to cut the baffle for an exact fit. Since the baffle joins the front (B) and back (C) of the box at an angle, you'll need to bevel the ends. The trick is determining the angle of these bevels.

What I found worked best is to start with a workpiece that's longer and wider than the finished size, see Fig. 2. Then position it on a side piece as shown in Figs. 2a and 2b. After marking the two points on each face where the baffle meets the rabbet, simply draw lines across the edge between the marks.

Now it's just a matter of beveling the ends of the baffle as you cut it to length. Then assemble the box with glue and screws and rip the baffle to width to fit inside. After screwing the baffle in place, I applied a bead of silicone caulk around the top and bottom edges.

TOP

With the box complete, you're ready to add the top. It acts as a sanding platform and helps funnel dust down into the box.

What makes this work is a number of holes in the top. But rather than drill all those holes, I made the top (E) from a piece of 1/4"-thick pegboard that's cut to

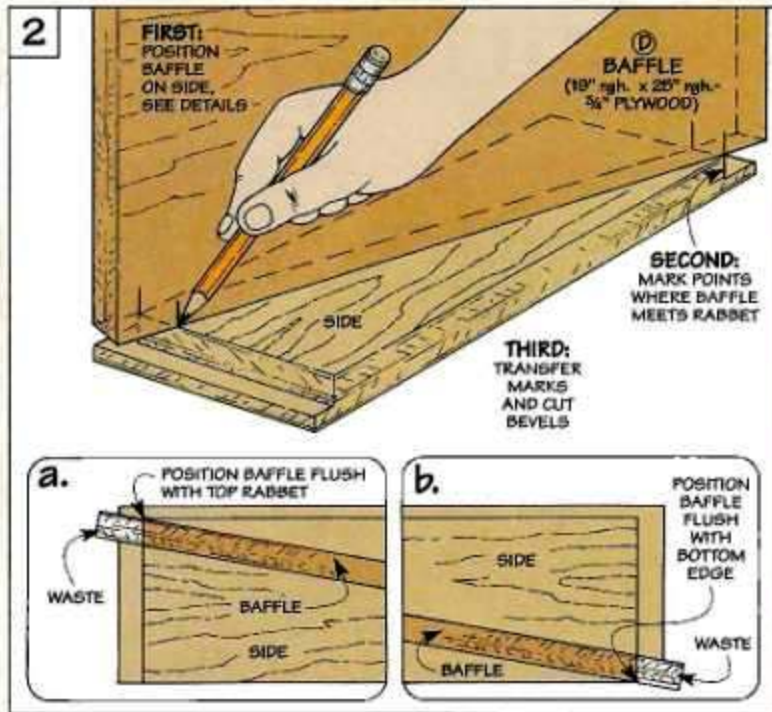

fit inside the rabbets, see Fig. 3. Note: To make it easy to screw the top in place, cut the pegboard so the centerpoint of the holes around the perimeter is 1/4" in from the edges, see Fig. 3a.

COUNTERSINKS. At this point, you can use the sanding table as it is. But to improve the airflow into the box, I enlarged all of the existing holes by drilling a shallow countersink, see Fig. 3a.

BUMPERS. All that's left to complete the sanding table is to screw four rubber bumpers to the bottom of the box, see Fig. 3b. These bumpers grip the surface of your bench and keep the sanding table from sliding around in use.

CLEAT. Finally, to keep the workpiece from moving across the table while you're sanding, you may want to add a cleat, see margin at right.



A scrap piece of Masonite with dowels fits into the pegboard to act as a simple cleat.

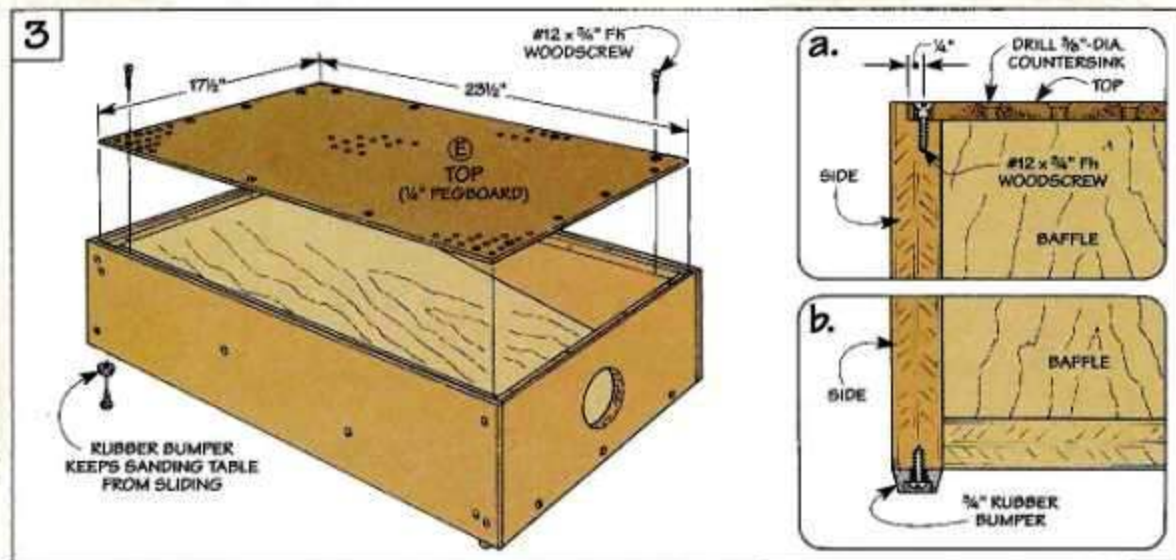

Cutting Box Joints

on a Router Table



I've always had a weakness for box joints. I suppose it's the symmetry of the joint — the evenly spaced pins and tails are hard to resist whenever I need to join together the parts of a drawer or small box, see drawing below. And next to its cousin (the dovetail), the box joint is one of the strongest ways to join wood together.

WHICH TOOL? The only dilemma I have when cutting box joints is choosing which tool to use — the table saw or router table. As a general rule of

thumb, if the stock is thicker than $\frac{1}{2}$ ", I use a dado blade on the table saw. (It's not safe to take this large of a cut in a single pass with a router bit.) But if the stock is less than $\frac{1}{2}$ ", I use the router table.

PERFECT JOINT. The advantage of using a router table is that a straight bit produces a perfect slot — smooth sides and a flat bottom (unlike the less than perfect cut from a saw blade). All you need to cut box joints on the router table is a jig (see opposite page) and our step-by-step directions, see page 14.

Box Joints Step-by-Step

- 1 Start with Front and Back.** Since a completed front (or back) piece is required to offset the slots in a side piece, start with the front and back of the box.
- 2 Rout the Slots.** Rout the first slot with the workpiece tight against index pin. Then slip this slot over the index pin and continue routing.
- 3 Flip End-for-End.** Now you can rout the slots in the opposite end of the front (or back) by flipping the workpiece end-for-end and repeating the indexing procedure.
- 4 Switch to the Sides.** Once the slots in the front and back are routed, you're ready to move onto the sides. Be sure to offset the first slot with a front (or back).
- 5 Complete the Sides.** After routing the first slot, set aside the front (or back) and rout the remaining slots by indexing the side piece as you did for the front and back.

BOX JOINT ANATOMY

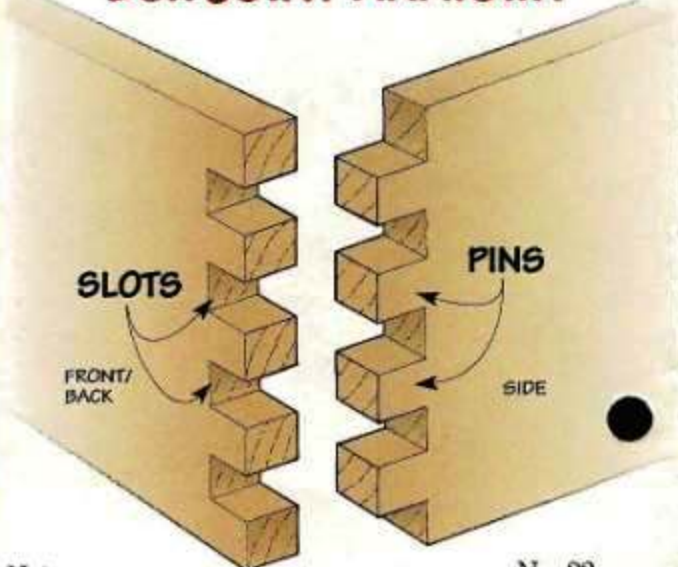

Box Joint Jig

To cut box joints on the router table, I built this simple jig. It's basically a three-piece sled that rides along the fence, see photo below and drawing at right.

(Note: Although the jig is designed to handle stock up to 5½" in width, it can be easily modified to handle wider stock.)

SLED. The sled is made up of a ¼" Masonite sled base and a hardwood backing board, see drawing. Attached to the backing board is an adjustable fence with a hardwood index pin that allows you to index your workpiece to make evenly-spaced cuts.

PIN. The size of this pin is what determines the width of the box joint. For example, if you're going to cut ¼" box joints, use a ¼" pin. Or for ½" box joints, use a

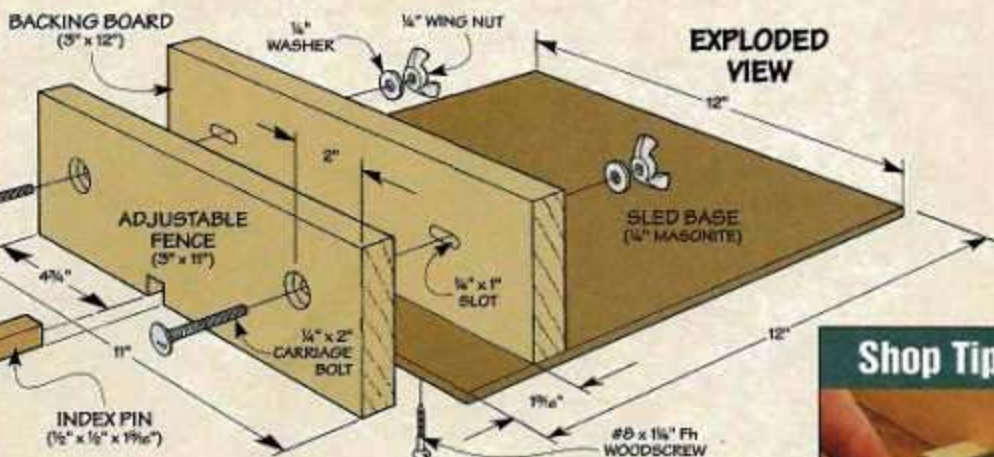

½" pin. (Note: You'll need to make a different backing board for each of the different-sized box joints you're going to cut.)

SLOTS. Then to allow for small adjustments when setting up the jig, slots are drilled in the backing board for the bolts that hold the adjustable fence in place.

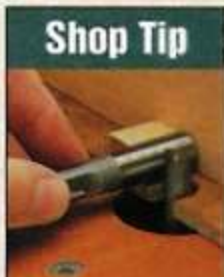
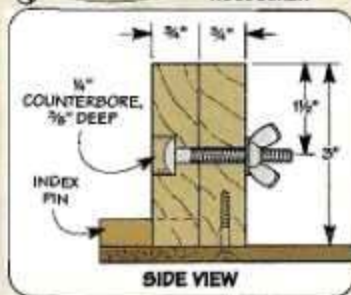

Shop Tip
The shank of a router bit makes a handy gauge to set up pin spacing.

Setup

Setting up the jig is easy. First, raise the bit above the sled to the desired height. (In our case, we're showing ½" x ½" box joints.)

Then to position the index pin, adjust the router fence so the gap between the bit and pin matches the width of the pin, see Step 1.

Next, to keep the jig from shifting during a cut, clamp a straightedge to the table, see Step 2. A stop clamped to the router table fence

prevents routing through the jig's backing board, see Step 3.

Now rout into the sled stopping just short of the adjustable fence. Turn off the router and fine-tune the distance between the pin and the bit, see margin tip at right. When it's right on, make a series of test cuts to check the fit.

Note: If you encounter any problems, refer to the troubleshooting section on page 15.



Precision Cuts: A stop block and a straightedge clamped to the router table guide the jig to ensure precision cuts.

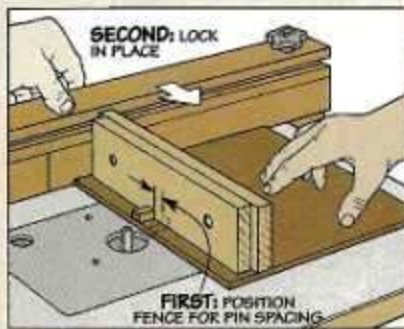

Step 1: Fence. Position router table fence so the gap between the bit and pin matches width of the pin.

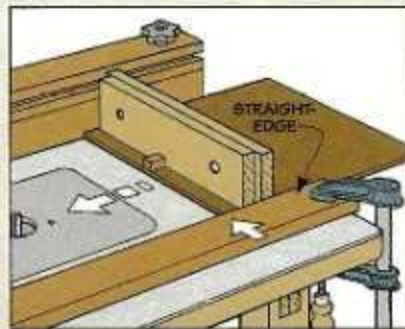

Step 2: Guide. To ensure an accurate cut, clamp a straightedge to the table top parallel to the fence.

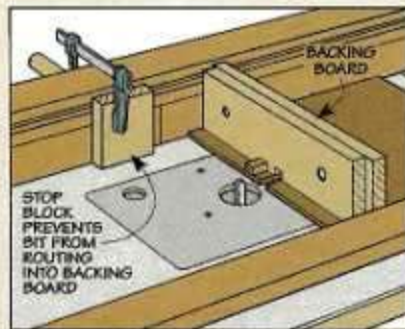

Step 3: Stop Block. Position a stop block on the fence to prevent the bit from cutting through backing board.

Step-by-Step Box Joints

1 Front & Back.

To begin, start with the front and back. When routing the first slot in the front (or back), hold the workpiece tight against the jig's index pin and backing board.

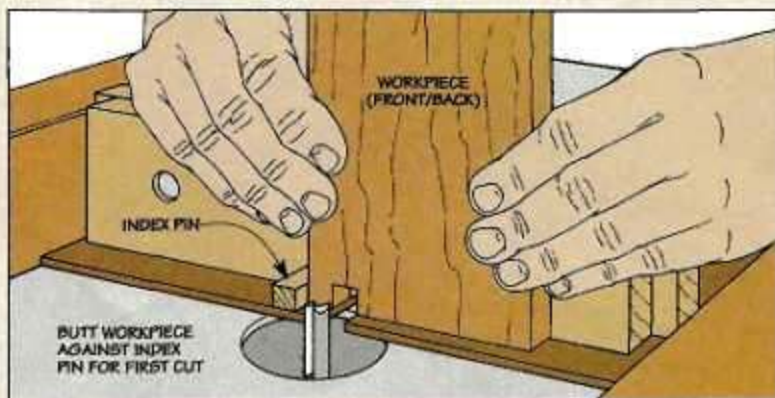

2 Index Workpiece.

To rout the next slot, simply lift the workpiece and slip it onto the index pin and take another pass. Repeat this until all the slots are complete.

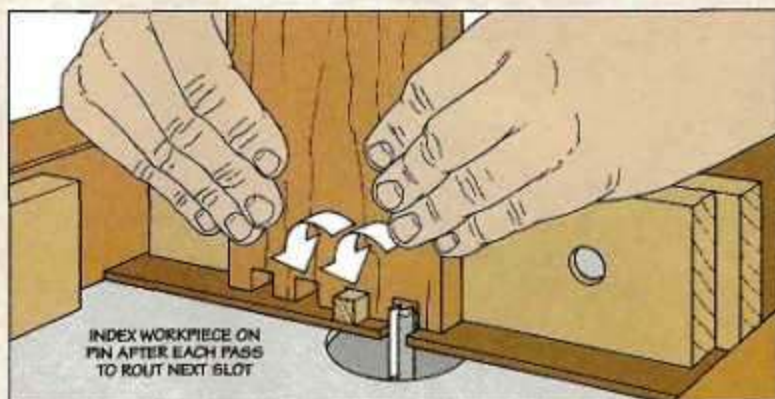

3 Flip End-For-End.

To cut matching slots on the opposite end of the workpiece, flip the workpiece end-for-end and repeat the procedure. Once the front and back are complete, work can begin on the sides.

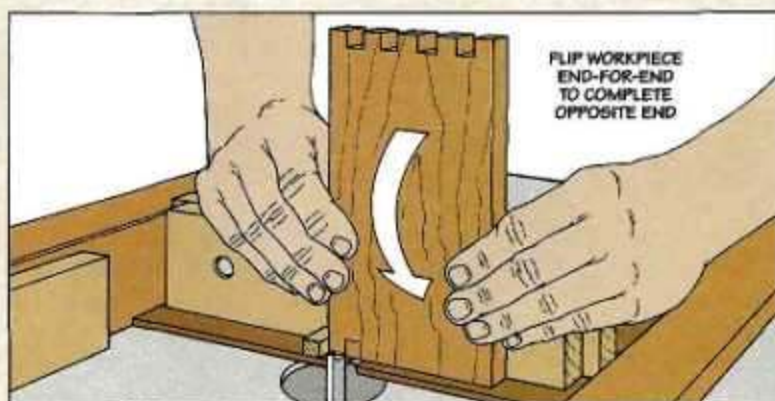

4 Side Pieces.

The next step is to rout the slots in the adjoining side pieces. The only difference here is you use a front (or back) as a reference to offset the slots in the sides. To do this, seat the last slot cut in the front (or back) on the index pin. Then butt one of the side pieces against it and take the first pass.

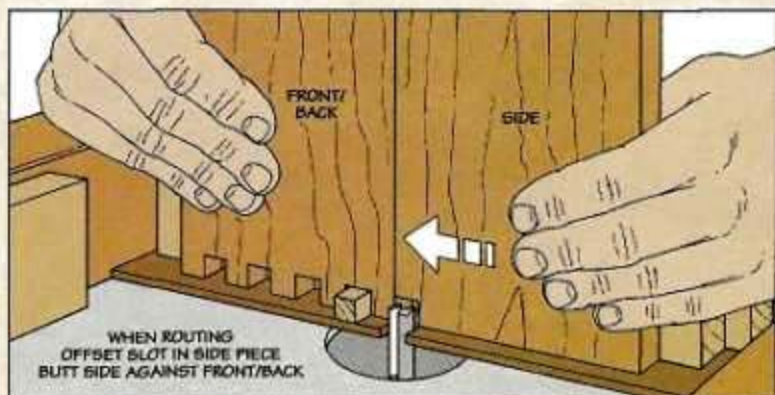

5 Complete Sides.

After routing the first slot, set aside the front (or back). Now rout the remaining slots just as you did earlier. Once you've completed one end, flip the workpiece end-for-end and rout the opposite end (remember to offset the first slot).

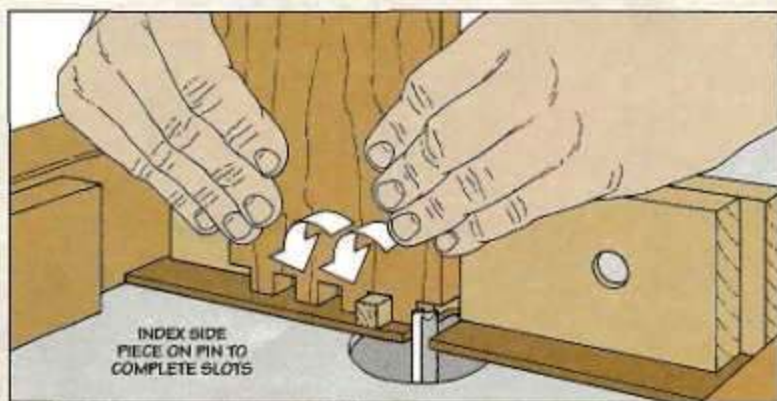

6 Bottom.

If you're adding a bottom to the box, you'll need to cut a groove in each workpiece. After the box is assembled, a square plug is cut to fill the notched pin on the ends of the front and back pieces. When the glue dries, trim the plugs flush and then sand them smooth.

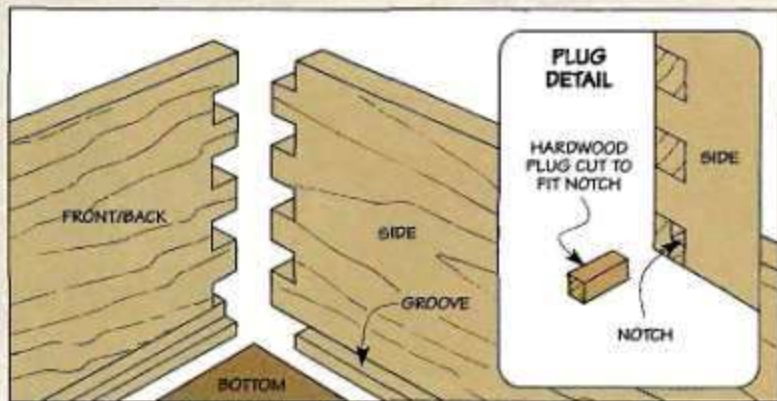

Troubleshooting Tips



Perfect Fit. On a perfect-fitting joint, the pins are flush with the sides, and there are no gaps.



Short Pins. If the router bit is set too shallow, you'll end up with pins that are too short.



Long Pins. Pins extending well beyond the sides are caused by a router bit that's set too deep.



Gap. A gap between each pin and slot is caused by an index pin that's too close to the bit.

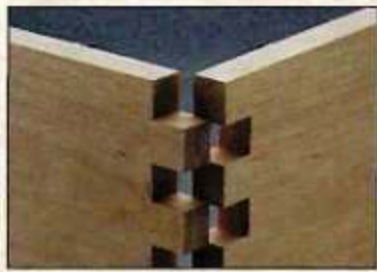

Too Tight. If the pins won't fit in the slots, the index pin is set too far away from the router bit.



Offset. An offset can be caused by not having a workpiece fully seated on the index pin or the jig.

Wall-Mounted Tool Cabinet



There's something reassuring about building your own tool cabinet. Knowing that each one of your special tools has a "home" where it won't get knocked around or damaged. And it provides you with the opportunity to organize your tools so they're right at hand where you need them.

All those things were in the back of my mind when I decided to build this wall-mounted tool cabinet, see photo. In addition, I wanted a simple, straightforward design to provide different types of storage for hand tools as well as power tools and accessories.

TOOL HOLDERS. Small hand tools hang on holders mounted on the inside of the cabinet doors, see

photo A below. To keep the tools from banging around when you open and close the doors, each holder is customized to fit the tool and "lock" it in place. (For more on tool holders, see page 20.)

SHELVES. A set of adjustable shelves also provides storage for larger hand tools and power tools, see photo B. But unlike some adjustable shelves that have a tendency to tip, a unique system holds them in place when you remove a tool or put it away.

DRAWERS. Finally, two large drawers can be used to keep accessories or shop supplies handy, see photo C. Tight-fitting box joints make these drawers as strong as they are good looking.



A. Tool Holders. Hand tools hang on special, shop-built holders to help protect them from damage.



B. Shelves. Adjustable shelves provide additional storage. And they stay put when removing a tool.



C. Drawers. Sturdy drawers held together with box joints are used to store accessories and supplies.

EXPLODED VIEW
OVERALL DIMENSIONS:
42"H x 36"W x 12³/₄"D

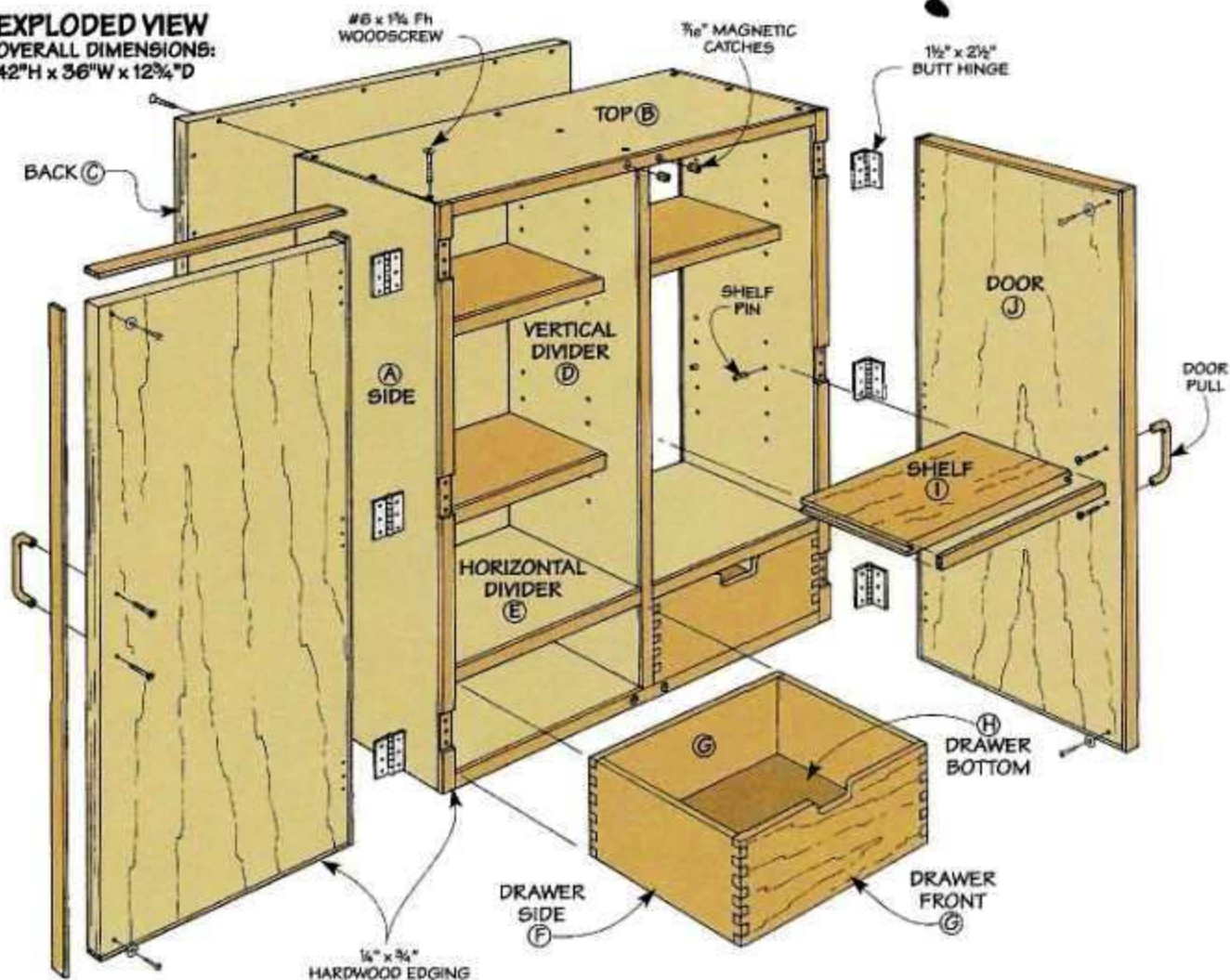

Materials & Hardware

Case

A Sides (2)	11 ³ / ₄ x 42 - 3/4 ply.
B Top/Bottom (1 each)	11 ³ / ₄ x 35 ³ / ₄ - 3/4 ply.
C Back (1)	35 ³ / ₄ x 41 ³ / ₄ - 3/4 ply.
D Vertical Divider (1)	11 x 41 - 3/4 ply.
E Horizontal Dividers (2)	11 x 17 ³ / ₈ - 3/4 ply.

Drawers, Shelves & Doors

F Sides (4)	1/2 x 5 1/2 - 11/4
G Fronts/Backs (2 each)	1/2 x 5 1/2 - 16 ¹³ / ₁₆
H Bottoms (2)	10 ³ / ₄ x 16 ⁵ / ₁₆ - 1/4 Mas.
I Shelves (4)	7 ³ / ₄ x 16 ¹³ / ₁₆ - 3/4 ply.
J Doors (2)	17 1/2 x 41 1/2 - 3/4 ply.

Also Needed:

3/4" x 6" - 48" piece of hardwood to cut 56 linear feet of 1/4"-thick by 3/4"-wide hardwood edging.

- (2) 3³/₄" Door Pulls (Maple)
- (3 pr.) 1¹/₂" x 2¹/₂" Butt Hinges
- (4) 7/16"-dia. Magnetic Catches
- (48) #6 x 1³/₄" Fh Woodscrews
- (1) 1/4" x 18" dowel (Maple)

To order a complete hardware kit, call ShopNotes Project Supplies at 1-800-444-7527, 522-6822-200...\$22.95

Cutting Diagram

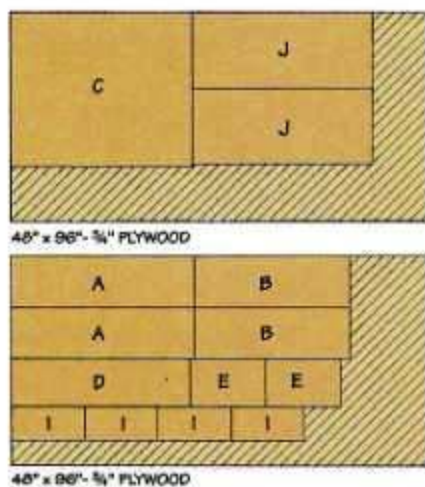

Case

I started on the tool cabinet by making the case. Basically, it's just an open box with dividers to separate it into compartments.

The sides (A), top and bottom (B) of the case are made from $\frac{3}{4}$ " plywood, see Fig. 1. (I used birch.) To accept the dividers added later, one dado is cut in each piece. There are dados centered on the length of the top and bottom. And the sides are dadoed near the bottom.

RABBETS. The top and bottom fit in a deep rabbet on each end of the sides (A), see Fig. 1a. And the back inside edge of each piece is rabbeted for a $\frac{3}{4}$ " plywood back (C), see Figs. 1 and 1b.

DIVIDERS. After assembling the case with glue and screws, you can add the dividers. A vertical divider (D) separates the case into two halves, see Fig. 2. But before installing it, a dado is cut on each face to match the dados in the sides, see Fig. 2a and margin at left.

Now just glue and screw the vertical divider in place. Then cut two horizontal dividers (E) to fit and attach them the same way.

EDGING. To complete the case, I covered the exposed edges on the front with thin strips of hardwood edging, see Exploded View on page 17. (For tips on applying solid wood edging, see page 26.)

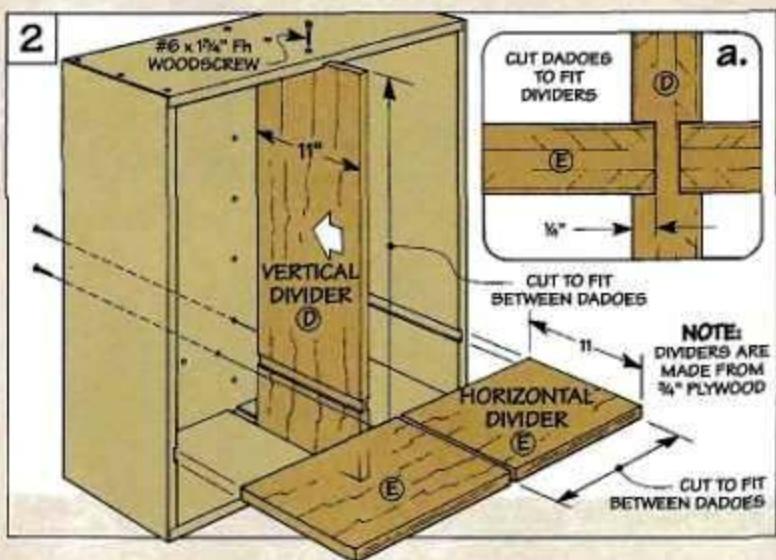
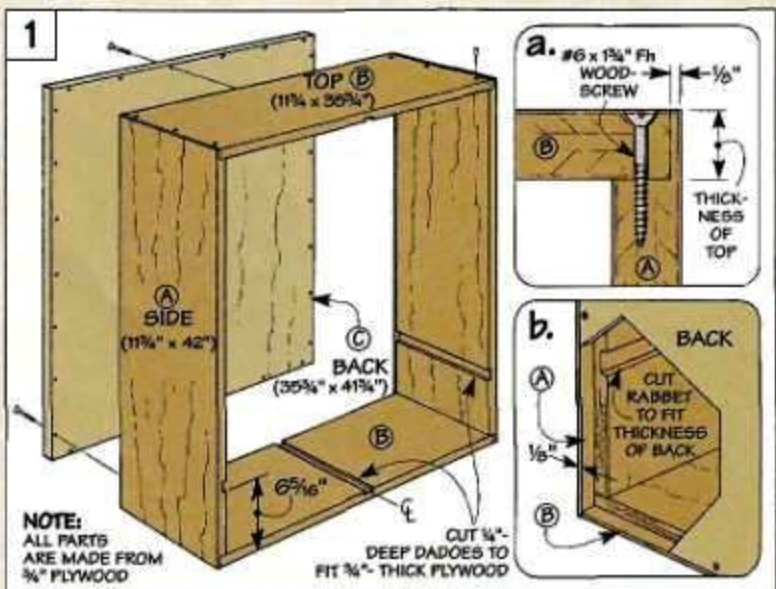

Drawers

The next step is to build the two drawers to fit their openings.

The sides (F), front and back (G) of each drawer are held together with box joints, see Figs. 3 and 3a. (For a step-by-step article on cutting box joints, see page 12.)

After cutting a finger recess in the drawer fronts (Fig. 3b), just cut a groove in each piece for a bottom (H) and glue up the drawers. Note: Wood plugs cover the ends of the grooves, see Fig. 3.

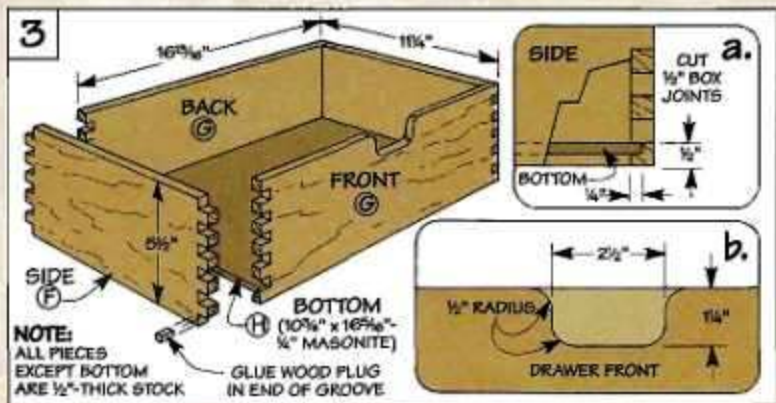

Use a scrap as a "story stick" to mark the location of the dado in the side.

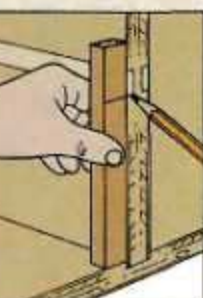

Then slide the divider into the case and transfer the location of the dado.

Shelves

To divide the storage space inside the tool cabinet into compartments, I added four shelves.

The shelves (*I*) are cut from $\frac{3}{4}$ "-thick plywood, see Fig. 4. They're wide enough to support a router or belt sander. But narrow enough so you can close the doors of the cabinet without having the tools hanging on them hit the shelves.

ADJUSTABLE. Since storage requirements change, I wanted the shelves to be adjustable. But I also wanted them to provide a solid support for my power tools.

GROOVE. To hold the shelves securely in place, a groove is cut in each end to fit over shelf pins, see Fig. 4a. (I cut pieces of $\frac{1}{4}$ " dowel for the pins.) The ends of the grooves are covered by applying hardwood edging to the front edge of each shelf.

HOLES. Now you can drill holes for the shelf pins. To ensure these holes align, I used a template to automatically locate them an equal distance from the top and bottom, see Fig. 5.

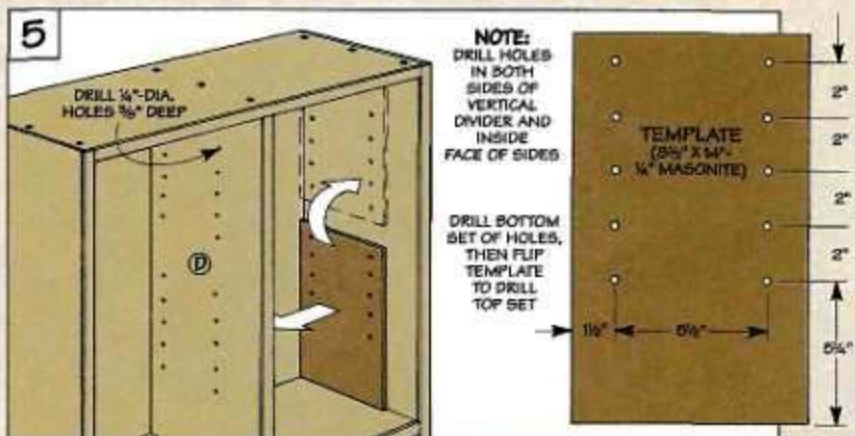
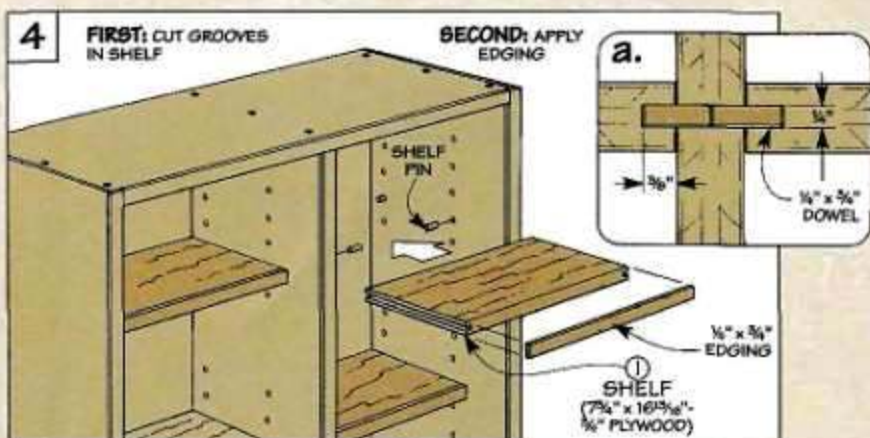

Doors

All that's left to complete the tool cabinet is to add a pair of doors. The doors (*J*) are just $\frac{3}{4}$ "-thick plywood panels trimmed with hardwood edging, see Fig. 6.

HINGES. Each door is attached with three butt hinges. The hinges are screwed into mortises cut in the edging on the case, see Fig. 6a. After mounting the doors, you may need to trim a bit off the inside edges. What you're looking for here is a consistent $\frac{1}{16}$ " gap.

PULLS & CATCHES. To make it easy to open and close the doors, I installed a pair of door pulls and four magnetic catches (two for each door), see Figs. 6 and 6b.

Finally, I attached the cabinet to the wall with lag screws. Note: Make sure to hit the wall studs.

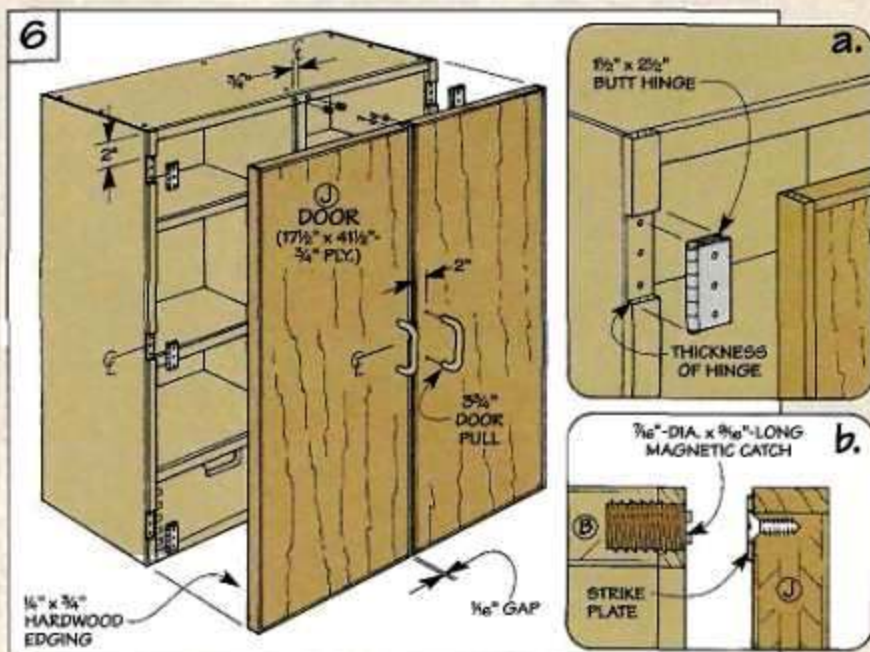

Tool Holders

You can protect and organize all of your special hand tools by hanging them up on custom tool holders made from pieces of scrap.

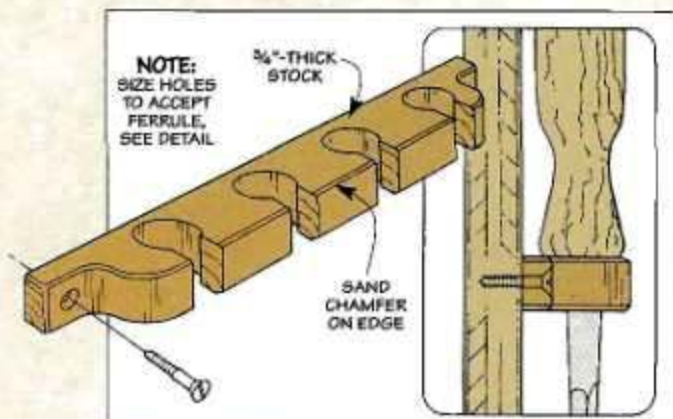

Chisels. To hold chisels firmly in place, the open-ended holes in this rack are smaller than the wood handle, but large enough to accept the metal ferrule.

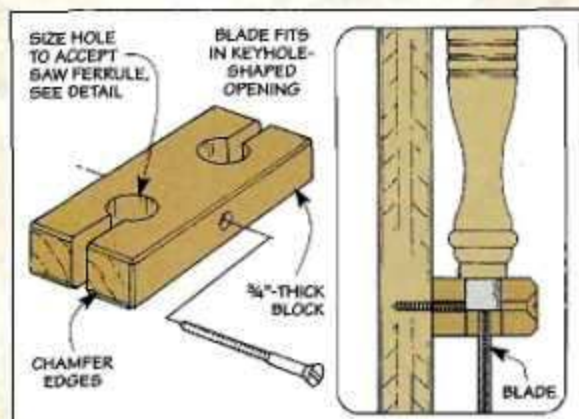

Gent Saws. The blade of a gent saw slips into a keyhole-shaped opening in the end of a block. And the ferrule fits down in the hole to secure the saw.

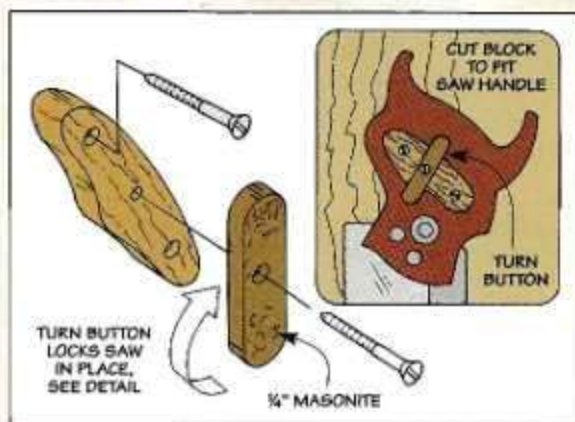

Back Saw. This back saw fits over a block that's cut to match the inside shape of the handle. Twisting a Masonite turn button locks the saw in place.

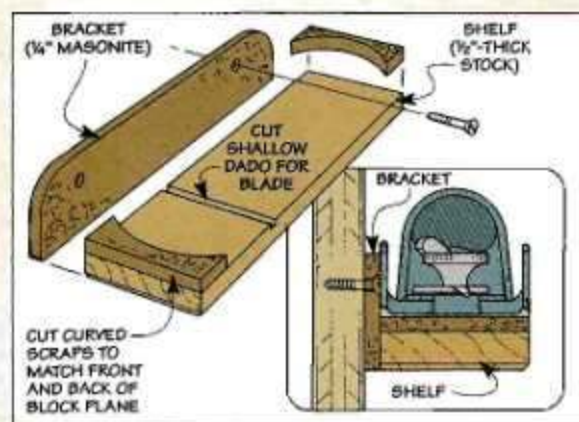

Block Plane. Curved scraps of Masonite keep a block plane from falling off a thin wood shelf. Gluing a bracket to the shelf makes the holder easy to mount.

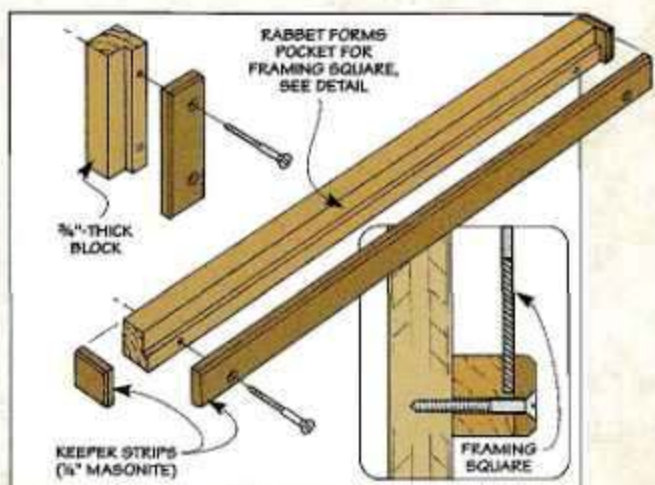

Framing Square. Along with a rabbet in each of these two blocks, Masonite "keeper strips" create a pocket to house the legs of a framing square.

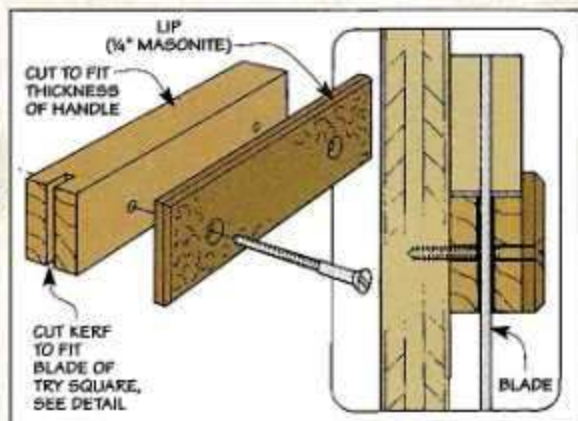

Try Square. The handle of a try square rests on top of a block while the blade slips into a kerf cut in one end. A Masonite lip keeps the square from sliding off.

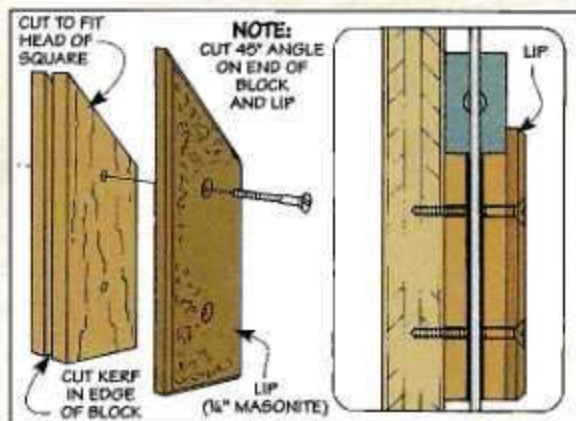

Combination Square. A block cut at a 45° angle cradles a combination square. Here again, the blade fits in a kerf and a Masonite lip holds the square snug.

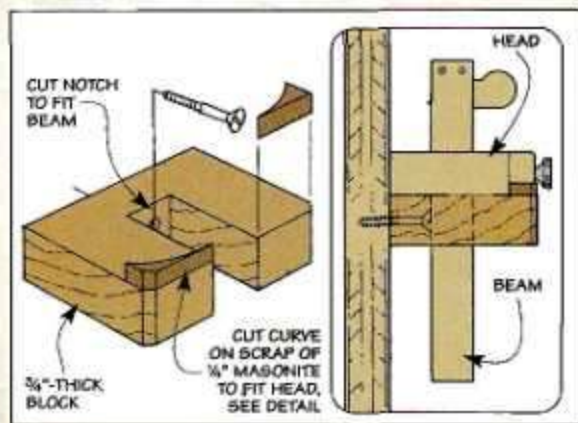

Marking Gauge. The beam of a marking gauge slips into the notch of this U-shaped block. And the head is secured by curved scraps of Masonite.

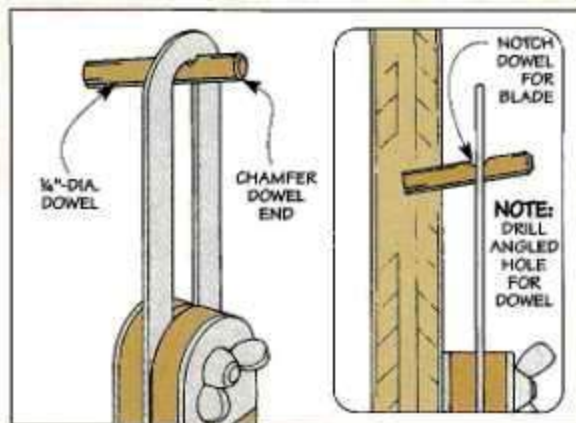

Bevel Gauge. A number of tools (like this bevel gauge) can hang on a dowel glued into an angled hole. A notch keeps the tool tight against the door.

Tape Measures

A tape measure can make or break a project. Here's a look at eight popular ones.

A tape measure is the one tool in a shop that can have the greatest impact on how a project turns out. In spite of this, we abuse them. They get dropped and banged around repeatedly. But we still expect them to provide accurate measurements.

To help you select a tape measure, we asked two woodworkers to test them out. While Cary spends many of his weekends down in the shop, you can find Steve building projects for his house or home almost everyday.

TAPES TESTED. Because most woodworkers prefer a small tape measure in the shop, we focused on tapes with a 1/2"-wide, 12'-long blade, see photos below.

Their compact size allows them to fit nicely in the pocket of a shop apron. And twelve feet is long enough for almost any woodworking project.

Q: *What's the first thing you notice about a tape measure?*

Steve: The fit. Without a doubt, I want a tape measure that's



Hook. Unlike the Lufkin (left), the Stanley (center) and Starrett (right) tapes are designed with

small, compact, and fits nicely in my hand. Here, I felt the Stanley tapes felt the most natural.

Cary: I agree with Steve. I want a tape that feels comfortable in my hand. But the first thing I look for is how well the hook on the end of the blade catches a workpiece.

Since I have a tendency to measure something three or four times (just to make sure), I end up pulling out the blade dozens of times during the course of a project. I don't want to think about hooking onto the workpiece — it needs to be automatic. Both the Stanley and Starrett tapes have

more hook exposed when the blade is retracted — which makes it easier to catch a workpiece.

a hook that catches well. (See photos above.)

Q: *What about the mechanisms that lock the blade in place? Some have thumb-action locks. Others have the lock on the bottom of the case. Any thoughts here?*

Cary: On the tapes with a thumb-action lock, it's awkward for me to raise my thumb to engage the lock, particularly with the Lufkin tapes. On those, I find myself looking for the lock — which means I'm not concentrating on the measurement.

With the Craftsman and the



\$8.99



\$10.86



\$10.99



\$10.99



\$6.99



\$9.34



\$9.29



\$7.99

Stanley Leverlock, I don't have to think about it since the lock is right there. Just squeeze the lever on the bottom of the case to extend or retract the blade.

The only problem with the Craftsman locking lever is the case extends past the back of the lock. So I tend to press on it rather than the lock.

Steve: Personally, I prefer a thumb-action lock — it's more positive. With the locking levers, I've found the blade can shift when it's bumped. And I do agree with Cary on the Lufkin tapes. It is awkward having to reach up with your thumb to engage the lock.

On the Starrett tapes, the lock is higher under my thumb than the lock on the Stanley Powerlock. It's contoured nicely to fit behind my thumb.

Q: Any comments about the graduations and print quality on the blades?

Cary: The Starrett blades are easiest for me to read. The print on these is the sharpest and brightest. The print quality on the Lufkin tapes isn't as clear. In some places the printing looks smeared and is hard to read.

Steve: I'm more concerned about the graduations. Although I'd prefer to have a brighter finish on the Stanley blades, I do



Locking Mechanism. Depending on your preference, there are three basic styles of locking mechanisms to choose from: a thumb toggle (left), a bottom locking lever (center), and a thumb slide (right).



Off-Brand Tapes. There are three major producers of nationally recognized tape measures. Each manufactures their own name-brand tapes (foreground) as well as off-brand tapes (background).

prefer their fine, crisp graduations over the others.

It looks to me like Stanley has intentionally sacrificed a brighter finish on their blades for the rugged Mylar coating used to protect their blades — which is fine by me.

Q: Okay boys, which tape measure goes into your shop apron?

Cary: The day-glow green Stanley Leverlock. I'm partial to

the lock on the bottom of the case. And the day-glow green will help me locate the tape when it's misplaced. My second choice is the Stanley Powerlock.

Steve: No question, the Stanley Powerlock. It fits naturally in my hand. And I like the crisp, precise graduations on the blade. The only way they could improve this tape measure is to make it in a day-glow color.

Changing a Blade

When a tape measure wears out (which usually means a broken or worn blade), the tape is tossed in the trash — but they can be repaired for another round of battle.

Replacement blades for most brands are available at your local hardware store. And they're easy to change, see drawing.

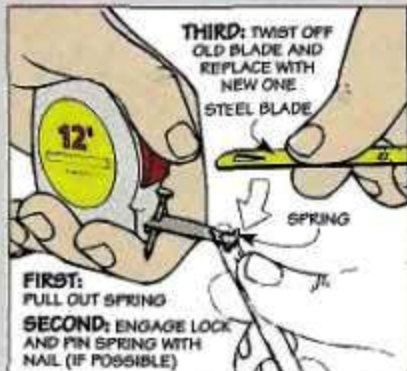

FINAL PICKS



Ratings	CARY	STEVE
FIRST CHOICE	Stanley Leverlock (33-982)	Stanley Powerlock (33-212)
SECOND CHOICE	Stanley Powerlock (33-212)	Starrett Day-Glow Red (SLO12)
	Lufkin Series 2000 (2212)	Lufkin Series 2000 (2212)



Roll-Around Tool Base

With this roll-around tool base, moving a heavy power tool isn't a back-breaking experience.

Even though most stationary power tools come with legs, they still can't walk. So when it comes time to move one around, you're faced with a dilemma.

You could take the brute force approach. But you'll probably end up with a sore back and a tool that has been jostled out of alignment.

A better solution is to use a roll-around tool base, see photo above. This way, just about any stationary tool can be moved without much effort.

SMALL SHOP. A roll-around tool base is especially useful in a small shop where tools are rolled out of the way when not in use. Or when a tool needs to be moved for a specific cut (like ripping a long board or crosscutting plywood).

TWO PARTS. The tool base consists of two main parts: a base for the tool to sit in and a handle to raise the base onto wheels so it can be towed around, see photo on next page. A simple hardware "hitch" connects the two parts

and lets you turn a tool on a dime. (A complete hardware kit is available, see left margin.)

BASE

I started by building the base that the tool sits in. It's just a 2x4 frame with a plywood bottom.

FRAME. The frame is sized to fit around the base of the tool, see photo above. The length of the front (A) and back (B) equals the outside-to-outside distance of the legs at the widest point — plus

Hardware

- (4) 2" Rigid Casters, with screws
- (1) $\frac{3}{16}$ " x 5" Screw Hook
- (8) $\frac{1}{4}$ " x $3\frac{1}{2}$ " Lag Screws
- (8) $\frac{1}{2}$ " Washers
- (1) $\frac{3}{16}$ " x $1\frac{3}{4}$ " U-bolt, with Plate and Nuts
- (2) $\frac{3}{16}$ " Washers
- (2) $\frac{3}{16}$ " Nuts
- (20) #8 x 1" Fh Screws

Two hardware kits are available from ShopNotes Project Supplies at 800-444-7527.

Kit #S22-6822-300 provides all the necessary hardware to build one tool base and one handle (\$19.95).

Kit #S22-6822-350 provides all the necessary hardware to build an extra tool base (\$10.95).

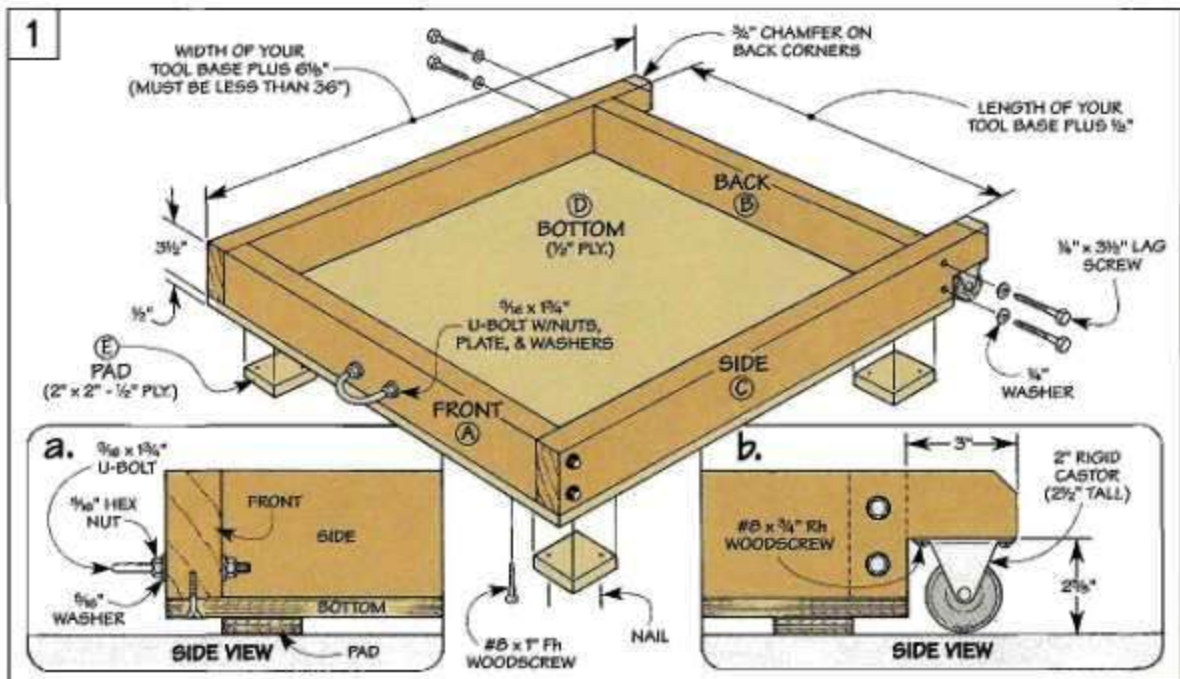

$\frac{1}{8}$ " for clearance, see Fig. 1.

Determining the length of the frame sides (C) is a bit trickier. After measuring the front-to-back distance of your tool's legs or base, add $6\frac{1}{8}$ ". (This provides an $\frac{1}{8}$ " clearance for the tool legs, 3" for the front and back frame pieces, and 3" for the wheels.)

Design Note: In order for the back wheels to ride on the floor when the base is raised, the sides must be less than 36" long.

BOTTOM. After screwing the frame together, a bottom (D) can be cut to fit from $\frac{1}{2}$ " plywood and screwed to the frame, see Fig. 1.

Next, to help stabilize the base whenever it's positioned on an uneven floor, glue and nail four $\frac{1}{2}$ "-thick plywood pads (E) to the bottom (D), see Fig. 1.

WHEELS. Now the wheels can be added to the base. To do this, you'll first need to cut a notch at the end of each side (C), see Fig. 1b.

NOTCH. It's the size of this notch that allows the roll-around base to work. By making it $\frac{1}{8}$ " taller than the wheels, the wheels are kept off the floor until the front is raised with the handle.

When the front is raised, this $\frac{1}{8}$ " gap is quickly closed. The wheels come in contact with the floor, and

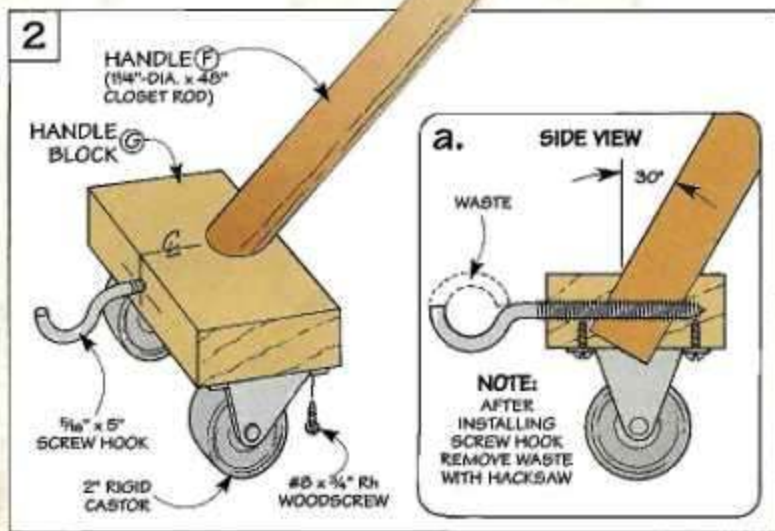

you're rolling, see photo below.

You can use either a sabre saw or hand saw to cut the notch. Just make sure to keep the cut as square as possible so the wheels ride flat on the floor.

To complete the base, a U-bolt that hitches the handle to the base is bolted to the front frame piece (A), see Fig. 1a.

HANDLE

All that's left to make is the handle that's used to tow the base.

DOWEL. The handle (F) is a four foot length of closet rod (available at most lumberyards),

see Fig. 2. It fits into a handle block (G) made from a scrap of 2x4.

To drill the hole for the rod, I used a $1\frac{1}{4}$ " Forstner bit and tilted the table top on my drill press to 30° , see Fig. 3.

The next step is to drill a $\frac{5}{16}$ "-dia. hole through the handle block and the rod for a screw hook, refer to Fig. 2. This hook locks the handle into the handle block and allows you to "latch" onto the U-bolt in the base to tow it around.

WHEELS. Finally, screw a set of wheels to the bottom of the handle block, see Fig. 2a. Then take your tool for a spin around the shop.

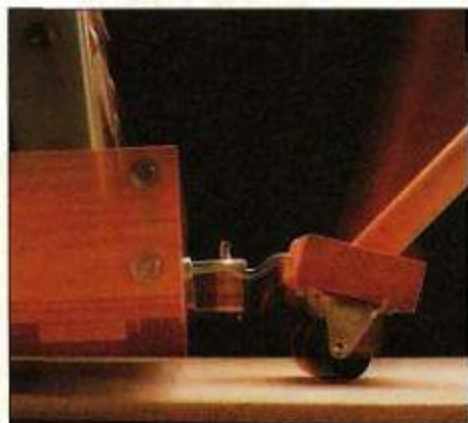
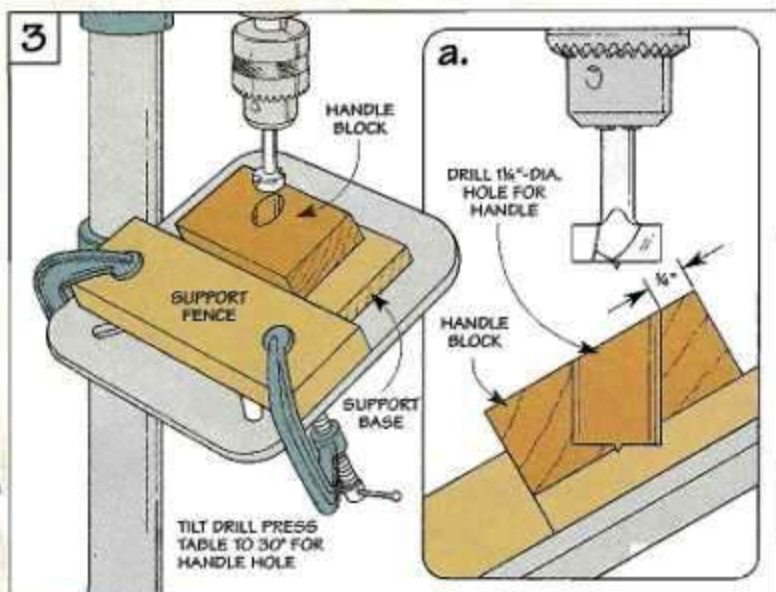

Easy Lifting. Leverage and this simple hardware hitch (consisting of a U-bolt and a screw hook) are all that's required to lift a heavy power tool and maneuver it around whenever you're in a tight space.

Solid Wood Edging

Strips of solid wood cover the exposed edges on plywood and create a durable edge as well.

There's always a certain "give and take" when working with plywood. It's a great source of large, ready-made panels that are dimensionally stable. But you still have to decide on the best way to deal with the exposed edges.

Although you can cover them with strips of veneer, sometimes that doesn't offer enough protection. So on projects that are going to take some knocks (like the tool cabinet on page 16), I apply strips of solid wood edging.

RIP STRIPS

When applying solid wood edging, the first step is to rip the strips on the table saw. Basically, you need to consider two things here: their thickness and width.

THICKNESS. As a rule, the thinner the strip, the more the panel looks like solid wood. But to create a durable edge, I often use strips that are at least $\frac{1}{4}$ "-thick. Note: If you plan to rout a profile on the edge, you'll want to make the strips even thicker.

WIDTH. While the thickness of the strips isn't critical, the *width* is important. To make the edging a bit less tricky to glue on (and ensure the edge is completely covered), I cut strips from a workpiece that's slightly thicker ($\frac{1}{16}$ ") than the plywood. When you apply the edging, this forms a small lip that's "proud" of the surface. (This is trimmed flush later.)

PUSH BLOCK. To safely rip strips that are a consistent thickness, I use a simple push block.



you're after here is to attach the edging so the ends aren't conspicuous.

On the tool cabinet, the vertical strips are glued on first so the ends are at the top and bottom of the cabinet.

Filling the spaces in between with horizontal pieces covers the ends of the strips.

It's just a piece of $\frac{3}{4}$ " plywood with a scrap of wood glued on so it overhangs the edge, see Fig. 1.

The idea is to fit the workpiece into the notch formed by the scrap. Then, after positioning the rip fence to cut a strip of the desired width, slide the push block and the workpiece through the blade, see Fig. 1a.

APPLY EDGING

Once the strips are cut, you're ready to apply the edging. What

between with horizontal pieces covers the ends of the strips.

LENGTH. If possible, another thing you'll want to do is cut the strips extra-long to start with. This way, you don't have to worry about getting them perfectly flush at the ends. Once the edging is glued in place, use a hand saw and chisel to trim the ends flush.

GLUE-UP. Now it's just a matter of gluing the edging in place. To apply enough clamping pressure, you may need to improvise a bit.

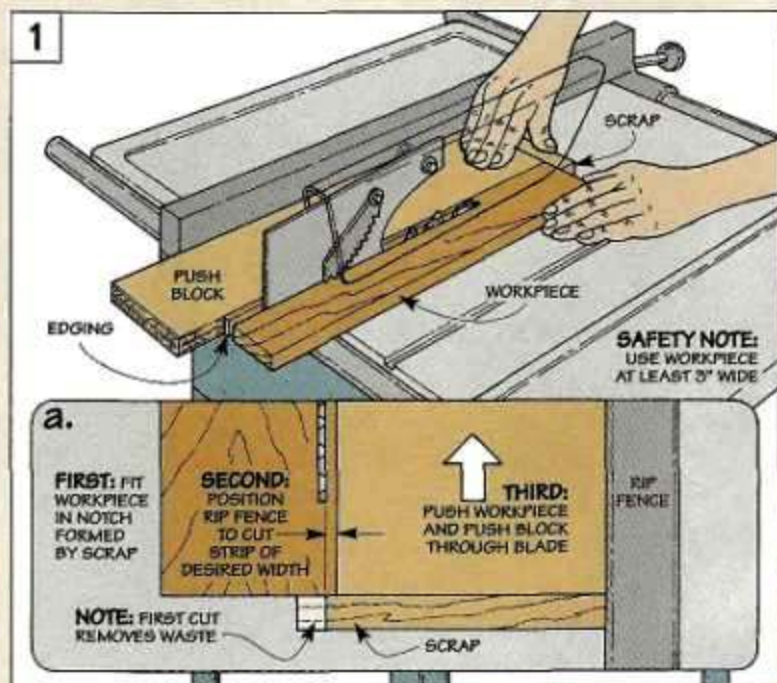

One reason is your clamps may not be long enough to reach across the workpiece. In this case, a pair of wood wedges tucked between a C-clamp and the edging can be used to apply pressure, see Fig. 2.

Even without C-clamps, you can still use wedges to apply pressure along the entire length of the edging. That's how I glued the center (vertical) strip on the tool cabinet.

STRETCHER. The trick is to cut a stretcher from a scrap 2x4 and raise it off the cabinet with a shim, see Fig. 3. To apply pressure at any point, slip a pair of wedges between the stretcher and the edging.

TRIM FLUSH

All that's left is to trim the edging flush with the plywood.

If the workpiece is easy to handle on the router table (like a panel or door), a special fence makes quick work of this, see box below. But if the edging is on a large cabinet, I use a block plane and sanding block.

BLOCK PLANE. To produce a clean cut, adjust the blade to re-

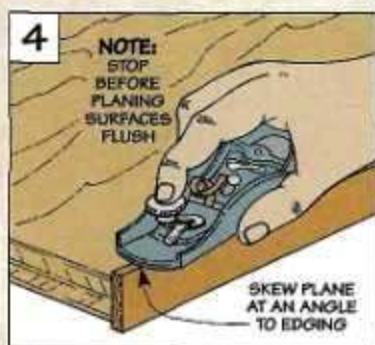
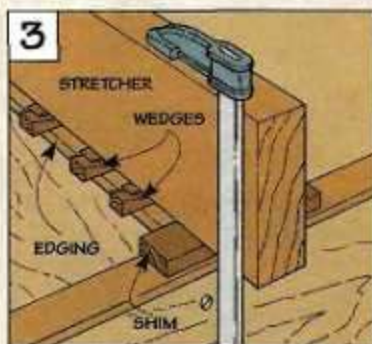
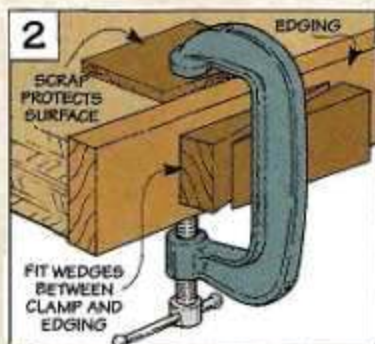

move a very thin shaving and skew the plane at an angle to the edging, see Fig. 4. Go easy here. You only want to remove material from the edging (not the plywood). What works best for me is to stop planing when the edging is just a hair above the surface of

the plywood.

SANDING BLOCK. The last bit of material is easily removed with a sanding block. To avoid scratching the surface, draw lines across both pieces and sand until the marks on the plywood start to disappear, see Fig. 5.

Flush Trim Fence

The lip that's formed when you apply edging so it's "proud" of the surface is easy to trim flush. I just use a straight bit and a simple fence that clamps to the router table, see photo at right.

The fence is made from a tall



▲ To trim the edging flush, a rabbet provides a recess for the lip that sticks up above the surface.

(wide) piece of $\frac{3}{4}$ " plywood that's cut to the same length as the router table, see drawing.

A rabbet in the bottom edge provides a recess for the lip so you can hold the workpiece flat against the fence, see photo below left. And a notch provides clearance for the router bit.

To support the fence, it's screwed to a plywood base with a curved opening cut in one edge for the bit. And triangular braces screwed to the fence and base keep it 90° to the router table.

Setting up the fence is easy. Just align the face with the edge of the bit and clamp the fence in place.

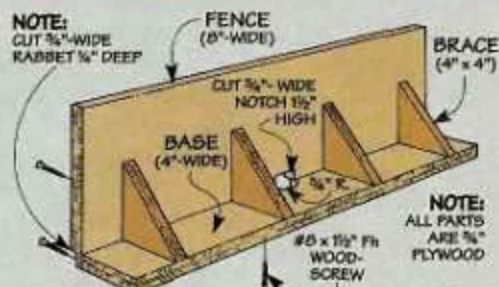
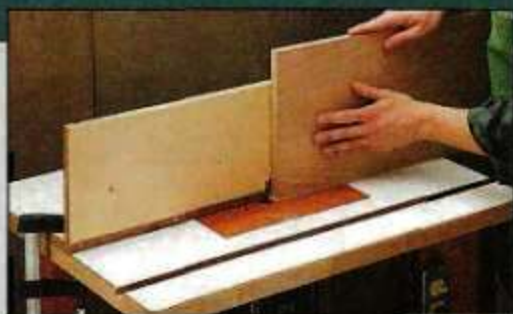

Shop Solutions

Thickness Planer Dust Hood



■ My thickness planer does a great job of surfacing stock — but it really makes a mess in the shop. That's until I made a dust hood that attaches to the back of the planer and accepts the hose from my shop vacuum, see photo above.

The dust hood is basically a four-sided funnel that replaces the chip deflector on the back of the planer, see drawing. It consists of five parts: a top, bottom, two sides, and an end cap.

For a tight seal, the top and bottom are cut to fit the opening in the back of the planer. I made the top extra-long so it can be contoured to snugly fit behind the

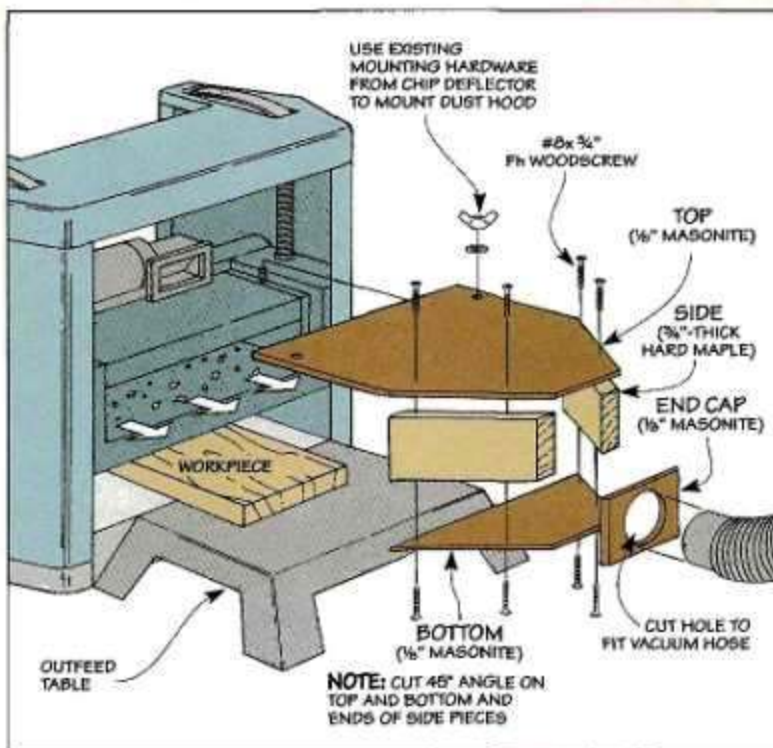

motor housing. The sides are angled to funnel the chips towards a hole drilled in the end cap that fits the vacuum hose.

To mount it, I replaced the chip

deflector on the back of the planer with the dust hood and used the same hardware.

*Raymond Sarkari
Cherry Hill, New Jersey*

Accurate Marking

■ Here's a layout tip I learned from a draftsman. Instead of positioning a square to a layout mark and then drawing the line, place the pencil on the mark first and then slide the square up against the pencil.

This way, the line will end up exactly where you want it — you don't have to offset the tool by the thickness of the pencil lead. (Which will vary depending on the sharpness of the pencil.)

*Ralph Bixby
Orlando, Florida*

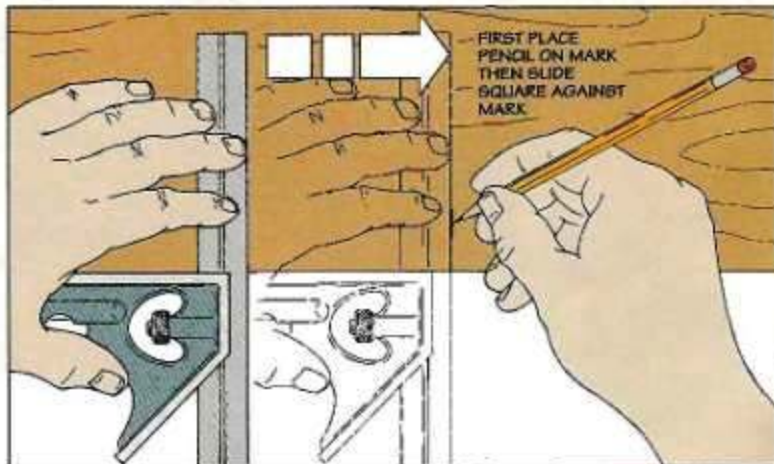

Roller Outfeed

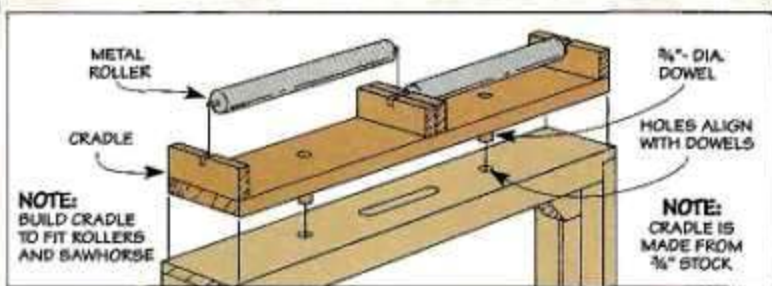

■ Shortly after building a pair of adjustable sawhorses from *ShopNotes* No. 17, I added a roller outfeed to one. This way it can be used to catch stock coming off my table saw, see photo.

The roller outfeed is just a pair of metal rollers (available through woodworking catalogs) that rest in a wooden cradle, see drawing.

To make it so the roller outfeed can be quickly and easily at-

tached or removed from the sawhorse, two dowels in the cradle fit into a pair of holes drilled into the top of the sawhorse.

*Merrill Almquist
Leland, Michigan*

Castor Bracket

■ To make it easy to roll my workbench around in my small shop, I made a set of castor brackets that lift the bench onto a set of wheels, see drawing.

The brackets work like landing gear on an airplane. When extended and locked in place, castors on the bottom of each bracket raise the legs up off the floor. When retracted, the legs drop back down.

To make it possible to attach brackets to your bench, you may need to screw "2by" stretchers between the legs, see drawing.

These stretchers allow the castor bracket to be mounted with butt hinges. They also provide a

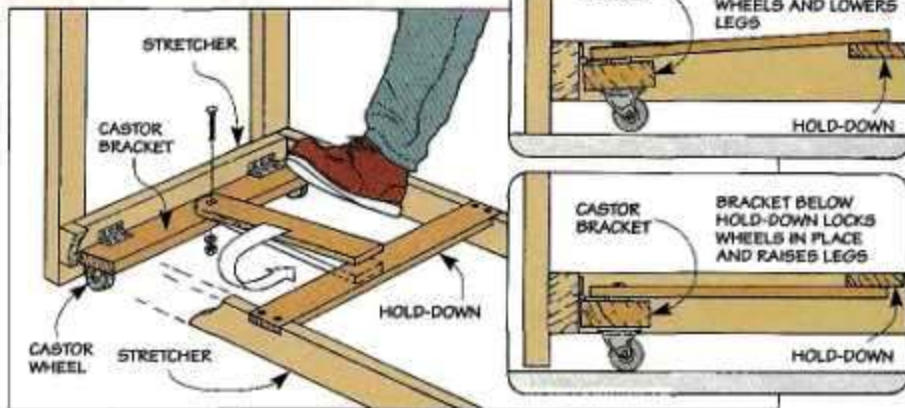

place to mount two hold-downs that lock the castors in the extended position, see details.

To move the bench, just push down the bracket with your foot

to lift up each end. Once each castor bracket is locked in place, the bench is ready to roll.

*Edmund Chavez
Moscow, Idaho*

Sanding Quick Tips

■ Here's a tip to prevent sandpaper from tearing. Just apply carpet tape to the back of the sheet, then fold it in half. By doubling over the sandpaper, I get a stiffer sheet that doesn't tear as easily as a single-layered sheet. Plus, the extra stiffness also helps when sanding in tight corners.

*John Schneeweis
Wilmington, Delaware*

■ Whenever I need to sand, clean, or polish a small surface or in a tight corner, I make a temporary sanding "stick." To do this, cut off a small piece of adhesive-backed sandpaper and stick it to (or fold it over) the blade of a putty knife, screwdriver, or pocket knife.

*Franklyn N. Arnhoff
Spotsylvania, Virginia*

Send in Your Solutions

If you'd like to share your original solutions to problems you've faced, send them to: *ShopNotes*, Attn.: Shop Solutions, 2200 Grand Avenue, Des Moines, IA 50312. (Or if it's easier, FAX them to us at: 515-282-6741.)

We'll pay up to \$200 depending on the published length. Please include a daytime phone number so we can call you if we have any questions.

Particleboard

When I buy particleboard at the local lumberyard, I'm never sure what I'm going to get. Sometimes the surface is smooth and uniform. Other times it looks like flakes of dry oatmeal. What gives?

*Dave Strong
Baltimore, Maryland*

Selecting the right grade of particleboard can affect the quality of your project.

■ Chances are you're not always getting the same grade of particleboard. Most lumberyards and home centers carry at least two different grades: floor underlayment and industrial.

UNDERLAYMENT. As its name implies, *floor underlayment* is used under carpeting or tile. It consists of a single layer of coarse wood particles that are coated with glue and pressed into sheets.

But the large size of these particles creates a rough texture on the surface. So this type of particleboard doesn't sand or machine well.

Nevertheless, it's inexpensive. And it's heavy. (A full sheet weighs 94 lbs.) Because of this, I occasionally incorporate it into a tool stand to help dampen vibration.

INDUSTRIAL. If you're building a cabinet or piece of furniture, you'll get better results using the *industrial* grade of particleboard.



It has a core layer of coarse wood particles that's reinforced by two outer layers of finer particles.

The high density of fine particles in the outside layers increases the overall strength of the particleboard. And it creates a smooth, uniform surface that's ideal for applying wood veneer or plastic laminate.

SURFACE TREATMENTS. While you can apply these materials yourself, many home centers offer particleboard with a number of different surface treatments already applied. For example, it's available with both melamine (a thin layer of plastic on each side) and wood veneer, see photo above.

STABILITY. Besides a smooth surface, particleboard is also extremely stable — there's almost no movement with changes in humidity. That's why manufacturers have started combining particleboard with more traditional core materials, see box below.

CARBIDE. Regardless of the product (or the grade), it's best to use a carbide-tipped saw blade or router bit when working with particleboard. Because of its high glue content, even a good quality steel blade or bit will dull quickly.

JOINERY. Another thing to consider when working with particleboard is how to join the pieces together. To maintain its strength, I avoid using joints that require cutting into the outside layers of the particleboard.

For example, a butt joint held together with biscuits produces a strong joint. Or simply glue and screw the pieces together.

What I've found is a screw with a straight shank and deep threads (like a drywall screw) isn't as likely to pull out as a standard woodscrew.

FINAL NOTE. To improve the screw-holding strength even more, use a longer screw instead of one with a larger diameter.

Mixed Core

Recently, I came across a new type of "plywood" at the local lumberyard. Instead of the typical fir plies, it uses *two* different core materials, see photo at right.

Layers of particleboard keep irregularities in the fir from transferring to the veneer. And since particleboard is more stable than fir, the veneer doesn't check.

Depending on the manufacturer, it's available under brand names like *Gold Ply*, *Day Core*, and *Classic Core*.



▲ The interior fir plies of this product are sandwiched with layers of particleboard.

Oil Stains

If there's one type of stain that's the bread and butter in my shop, it's an oil-based stain. Nothing fancy. Just your basic, off-the-shelf stain that's available at almost any hardware store.

One reason is oil-based stains are extremely easy to use. And they come in a wide range of colors that are resistant to fading.

PIGMENTS. Most oil-based stains color wood the same way paint does — with finely ground particles called pigments. When you open a can of stain that's been sitting around awhile, you'll notice the pigments have settled into a thick sludge at the bottom of the can, see photo above.

Stirring up this sludge suspends the pigments in the liquid in the can — a mixture of linseed oil and mineral spirits. When you apply the stain, the pigments lodge in the pores of the wood.

Since the larger pores of the end grain accept more pigment than the smaller pores of the surface grain, these areas stain darker. To help even out the color, I sand the exposed areas of end

grain one grit finer.

But end grain isn't always at the end of a board. Sometimes it swirls to the surface and produces a series of light and dark blotches. This is especially true of woods like pine and cherry.

CONDITIONER. To reduce blotching, I use a conditioner before applying the stain. The conditioner partially stops up the large pores so they don't hold as much pigment. The result is a more even stain, see photo A below.

SANDING. Even something as simple as sanding affects the color. Areas with large scratches left behind by coarse-grit sandpaper trap more pigment and stain darker. If you want to end up with a lighter color, use a finer grit.

TEST PIECES. To check the color, it's a good idea to apply the stain on a test piece. And since different types of wood accept stain differently, use a cutoff from the project you're working on that's sanded to the same grit.



▲ The thick sludge that settles to the bottom of a can of oil-based stain is formed by small colored particles or pigments.

APPLICATION. When applying the stain, the idea is to cover the entire surface before it starts to dry. One way to do this (on a large table top for instance) is to keep a "wet" edge by overlapping one stroke with the next.

Another is to break down a project into manageable sections. For example, stain the drawers and doors of a cabinet separately. Then stain the front and sides.

When the entire surface is covered, use a rag to wipe it down in the direction of the grain. The amount of stain you leave on will determine the final look of the project, see photo B.



A. Wood Conditioner. Applying an oil-based stain directly to this piece of pine creates a series of light and dark blotches (left). But using a wood conditioner first helps even out the color (right).



B. Dark or Light. Although it can obscure the grain of the wood a bit, leaving some of the excess stain on the board creates a dark color (left). To produce a lighter color, just wipe the board "dry" (right).

Tips on Staining

- 1 Stir the stain frequently to keep the pigments in suspension and ensure a consistent color throughout.
- 2 When working with woods that accept stain unevenly, use a conditioner to control the amount of blotching.
- 3 Test the color of the stain on a cutoff from the project you're working on that's sanded to the same grit.
- 4 To create a custom color, you can mix stains. Just be sure to stick with the same brand and type of stain.
- 5 Break a project down into manageable sections and keep a "wet" edge when applying the stain.

Scenes from the Shop



▲ Before steel tape measures, craftsmen often used folding rules to help lay out a project. To make long measurements, the wood strips on the Interlox rules (background) telescoped out like the ladder on a fire truck. And the aluminum Lufkin (foreground) and Stanley rule (right) fanned out in a zig-zag pattern.



▲ For rough measurements, these wind-up tape measures housed a long ribbon of cloth graduated in $\frac{1}{4}$ " increments. A hinged handle on the brass and yellow (or green) japanned steel case made it easy to retract the tape.