

TIPS • TOOLS • TECHNIQUES

ShopNotes®

Vol. 4

Issue 20

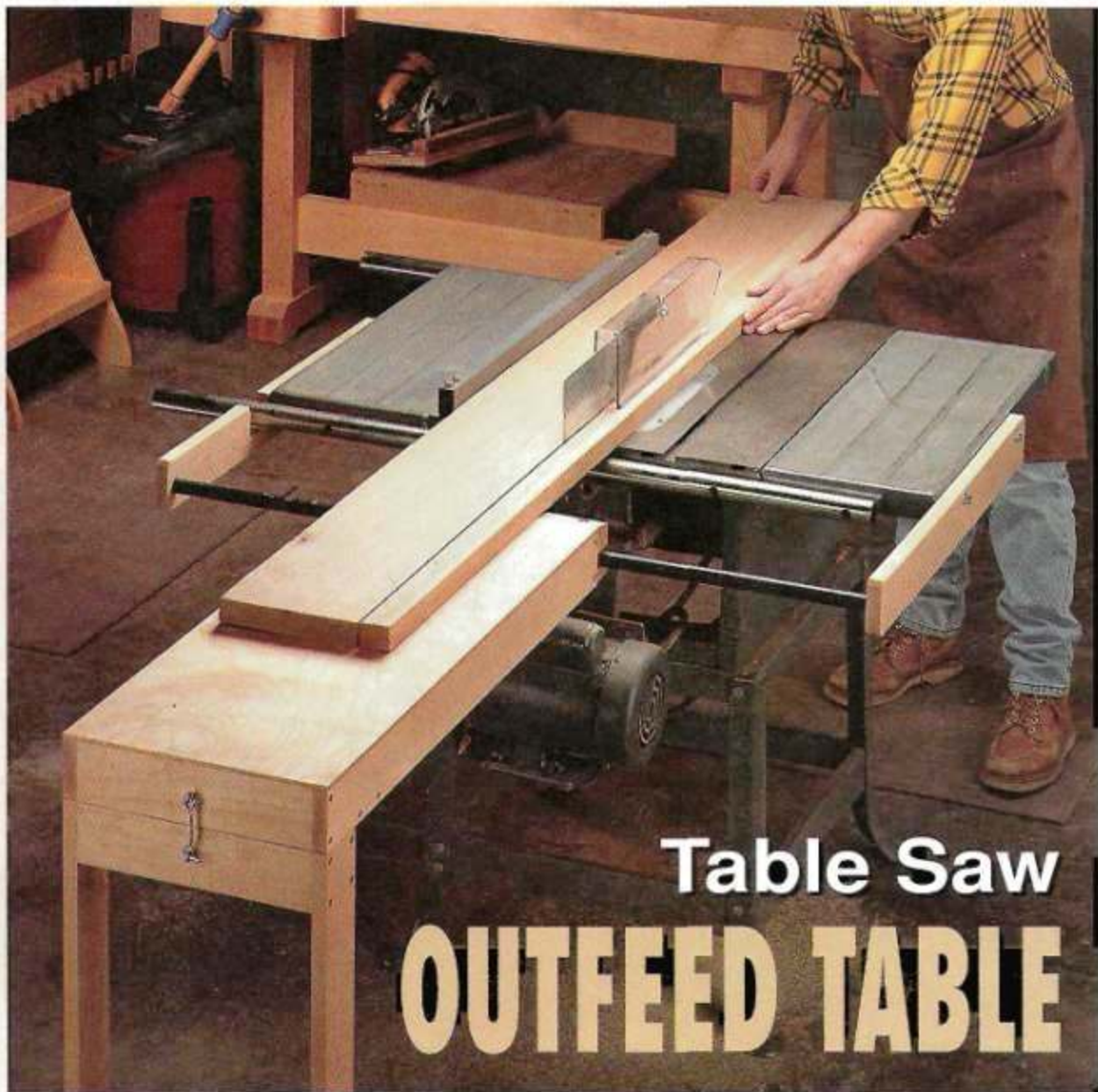

Table Saw **OUTFEED TABLE**

- Adjustable Dado Jig
- Tenons on a Band Saw
- Overhead Lumber Storage
- Quick-change Bits



ShopNotes

Issue 20

March 1995

EDITOR Donald B. Peschke
EXECUTIVE EDITOR Douglas L. Hicks
MANAGING EDITOR Richard S. Peters
ASSOCIATE EDITOR Tim Robertson
ASSISTANT EDITOR Phil Totten
CONTRIBUTING EDITOR Mark A. Williams

CREATIVE DIRECTOR Ted Kralicek
ART DIRECTOR Cary Christensen
SENIOR ILLUSTRATOR Kurt Schultz
ILLUSTRATORS Roger Reiland
 Mark Higdon
PHOTOGRAPHER Crayola England
ELECTRONIC GRAPHICS Chris Glowacki

DESIGN DIRECTOR Ken Munkel
SENIOR DESIGNER Kent Welsh
SHOP MANAGER Steve Curtis
SHOP ASST./FACILITIES Steve Johnson

CIRCULATION

Circulation Director: Liz Bredeson • *Subscription Manager:* Phyllis Jensen • *Direct Mail Mgr.:* Troy Dowell • *Newsstand Sales:* Kent A. Buckton • *Circulation Analyst:* Shane S. Francis

PUBLISHING SERVICES

Manager: Gordon C. Gaippe • *Graphic Artist:* Cheryl L. Cynor

CORPORATE SERVICES

Planning Director: Jon MacCarthy • *Controller:* Robin Hutchinson • *Accounting:* Laura Thomas • *Bookkeeping:* Julie Greenlee • *Prod. Manager:* Carol Quijano • *Info. Services Mgr.:* Joyce Moore • *Elect. Pub. Coordinator:* Douglas M. Lidster • *Network Administrator:* Nick Thielen • *Administrative Assistants:* Cheryl Scott, Julia Fish • *Receptionist:* Joanne Johnson • *Building Maintenance:* Ken Griffith

PROJECT SUPPLIES

Art Director: Cindy Jackson • *Catalog Products Manager:* Bob Baker • *Inventory Control/Prod. Mgr.:* Mark Mattussi • *Proj. Supplies:* Linda Jones

CUSTOMER SERVICE

Supervisor: Jennie Enos • *Customer Service Reps.:* Jennifer Murphy, Joy Krause, Sara Kono, Anna Cox, Lonnie Algreen, Karla Cronin

SHIPPING DEPARTMENT

Supervisor: Nancy Johnson • *Fulfillment:* Gloria Sheehan, Chuck Carlson, Sylvia Carey, Larry Price

ShopNotes® (ISSN 1069-9096) is published bimonthly (Jan., March, May, July, Sept., Nov.) by Woodsmith Corporation, 2200 Grand Ave., Des Moines, IA 50313.

ShopNotes® is a registered trademark of Woodsmith Corp. ©Copyright 1995 by Woodsmith Corporation. All rights reserved.

Subscriptions: Single Copy, \$4.95. One year subscription (6 issues), \$19.95. Two years (12 issues), \$36.95. Canada/Foreign, add \$5.00 per year.

Second Class Postage Paid at Des Moines, IA and at additional offices.

Postmaster: Send change of address to ShopNotes, Box 11204, Des Moines, IA 50310-1204

Subscription Questions? Call 1-800-333-5854, 9am to 5pm, Central Time, weekdays.

E-Mail: Prodigy: EDJE97A, Compuserve: 75330.2301, Internet: 75330.2301@compuserve.com, America Online: DonPeschke.

PRINTED IN U.S.A.

EDITOR'S NOTE

Cutoffs

I know it sounds crazy, but some of my most enjoyable woodworking is done without wood. I "build" the project in my mind. I'm sure you've done the same thing. You're working on a project and you find yourself thinking about it even when you're not in the shop — lying in bed late at night, or sitting on the bus heading to work.

You're planning ahead, thinking about the project. And questions start to pop up. Like what joinery is best. And what setups you'll use. Even something as far away as the type of stain or finish you'll apply.

IN YOUR MIND.

Going over and over the project in your mind like this has a couple advantages.

First, you get to "build" the project more than once. I have a friend who for health reasons has to stop at this stage. Although he can't work wood anymore, he says it's just as much fun as (and a lot cheaper than) going down into the shop.

And second, it's the best way I've found to avoid mistakes. I can't tell you how many times I've seen someone in a shop grab a piece of wood and make a cut without thinking. The result is a bad cut and an expensive piece of firewood.

Planning ahead also means choosing a finish early. And preparing the surface accordingly — as you build the project. This takes some advance thought. But it's worth it. It's one of the simplest tricks I know to ensure a perfect finish. (For more on surface preparation, see the special two-page *Finish Room* article starting on page 30.)

A PROBLEM. The only problem with advance planning is that some questions pop up that you don't have an answer for. And it's often at an odd hour.

What do you do? If you own a computer and a modem, I've got just the answer.

BULLETIN BOARD. We recently started a new service for woodworkers. It's a computer "bulletin board" called *WoodNet*. Here you can post your questions and get responses from fellow woodworkers (there may even be some night owls out there).

You'll also find other information such as tools for sale, lists of sources, and an index to 27 woodworking magazines (including *ShopNotes*, of course).

When we decided to set it up, I had two requirements. First, you shouldn't have to be a computer whiz to use it. And second, it shouldn't cost an arm and a

leg. I think we succeeded on both.

To keep the costs down, you don't have to be hooked up to Internet or any other commercial on-line service (with a high monthly service charge). All you have to do to access *WoodNet* is set up your computer to call 515-245-9663 and you're immediately hooked directly to *WoodNet*. It's that simple.

And, until April 1st, there's no charge for using *WoodNet*. After that you can still get into *WoodNet* and look around for free, but there will be one reasonable flat fee to use all the services.

I think we've made *WoodNet* simple, but if you need a little more help, give Gordon Gaippe a call at 515-282-7000 (on the "old-fashioned" telephone).

NEW DEPARTMENT. One final note. We've added a new department called *At the Store*. Here we test new products and let you know how they stood up in our shop. After you've read it, let me know what you think. (Why not give the new bulletin board a try?)

Some of my most enjoyable woodworking is done without wood. I "build" the project in my mind.

Contents

Projects & Techniques

Adjustable Dado Jig _____ 4

This shop-built jig offers a quick setup and guarantees a perfect fit when routing dados (or rabbets).

Step Stool _____ 8

Build this strong, sturdy stool in just a few hours with the help of our adjustable dado jig.

Cutting Tenons on a Band Saw _____ 10

Accurate cuts. And a quick, easy setup. Two reasons why a band saw is an ideal tool for cutting tenons.

Outfeed Table _____ 16

This outfeed table makes it easy to cut large workpieces on the table saw. And it folds away for compact storage.

Cutting Rabbets _____ 22

Two basic techniques for cutting rabbets on a table saw without using an expensive dado blade.

Departments

Great Tips

Router Table Tips _____ 14

Five tips to help you get the most out of your router table.

Selecting Tools

Quick-Change Bits _____ 20

Our team tests four quick-change bit systems for your drill. And offers practical suggestions on what to look for.

The Small Shop

Overhead Storage _____ 22

Three simple solutions to one of the most challenging problems in a small shop — storing lumber.

Lumberyard

Hardboard _____ 26

What it is. Where to find it. And how we use it.

At the Store

New Products _____ 27

We test three hot new tools for your workshop.

Readers' Tips

Shop Solutions _____ 28

Our readers offer solutions to woodworking problems.

Finish Room

Surface Preparation _____ 30

Careful preparation is the secret to a perfect finish.



Adjustable Dado Jig page 4

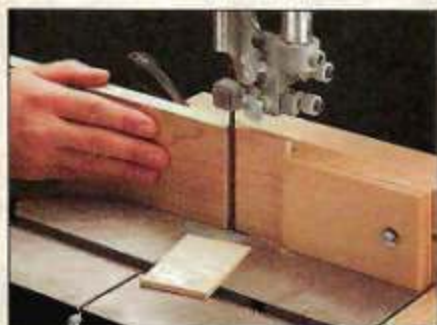

Band Sawn Tenons page 10



Outfeed Table page 16



Overhead Storage page 22

Adjustable Dado Jig

You can rout a tight-fitting dado joint in no time with this simple jig. But there's something else you'll like even better.



It's hard to decide what I like best about this jig. The fact that it allows me to rout perfect dados with pinpoint accuracy. Or how incredibly quick and easy it is to set up.

No more fiddling with a straightedge to get it positioned just right so the bit cuts exactly where you want. And even if you need to make two passes (for a wide dado or a piece of plywood that's an odd thickness), there's no need to readjust the jig to sneak up on the final width.

TEMPLATE. The reason is simple. The jig can be adjusted to form an opening that's an exact template of the width of the dado.

Once you set this opening to the correct width, what you see is what you get when you rout the dado, see photo above. (Note: You can use this jig to rout dados from 1/2" to 1 1/2" wide.)

ADJUSTMENTS. And setting the opening is automatic. Just insert the piece that's going to fit in the dado and close the jig around it, see photo A. Since the thickness of the workpiece is what determines the opening, you're guaranteed a tight fit.

Even easier than setting the opening is transferring it to the workpiece. Instead of the guesswork that's usually involved with a straightedge, simply clamp the jig to the workpiece so the opening aligns with the desired location of the dado, see photo B. (Note: This jig handles workpieces up to 25" wide.)

REFERENCE EDGES. What makes all this work is the edges on the parts of the jig that form the opening serve as a *reference* to indicate the path of the router bit. So as the base of the router rides against a guide strip, the bit cuts exactly at the reference edge, see photo C.

Step-by-Step

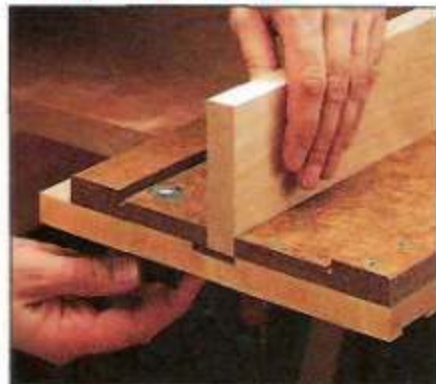

A. Adjust Opening. It's easy to adjust the opening to cut a perfect dado. Just insert the piece that fits in the dado, close the jig, and lock in the adjustment.



B. Clamp Jig. Now clamp the jig to the workpiece so the opening aligns with the location of the dado. A cleat in front helps square the jig to the edge.



C. Rout Dado. To rout a dado that aligns perfectly with the edges of the opening, run the base of the router against the two guide strips.

Base

The base of the adjustable dado jig consists of two parts that work together to form a template of the dado. One part is fixed, and the other is adjustable.

Except for the fact that one part moves and the other doesn't, they're basically the same. So it's easiest to build one large blank, then rip it into two equal parts.

BLANK. The blank starts out as two oversize *base pieces (A)* that act as a platform for the router, see Fig. 1. These are just pieces of $\frac{1}{4}$ " Masonite held together with contact cement.

GUIDE STRIPS. The router is tracked by a pair of Masonite *guide strips (B)* that are glued to the base pieces, see Fig. 1. Don't worry about getting the guide strips and base pieces perfectly flush. The accuracy will be built in as you true up the base.

Start by jointing one edge and then ripping the opposite edge. Once you have two "good" outside edges, you can cut the base to final length (29") and trim the *inside edges* — the ones that guide the base of the router.

Trimming these edges also serves another purpose. By adjusting the height of the saw blade so it cuts $\frac{1}{8}$ " deep into the base piece, it creates a relief for sawdust, see Figs. 2 and 2a.

Next, to make two equal halves, just rip the base down the middle, see Fig. 2b.

REFERENCE EDGE. Now you can establish the reference edges by routing the waste off each half. Keep in mind that these edges are only a reference for *your* router. So use the same router *and* bit as the one you plan to use with the jig. (I used a $\frac{1}{2}$ " straight bit.)

One thing to be aware of is the bit may not be centered in the router base. To get an accurate reference edge, draw an arrow on the base and always keep it against the guide strips, see Figs. 3 and 3a.

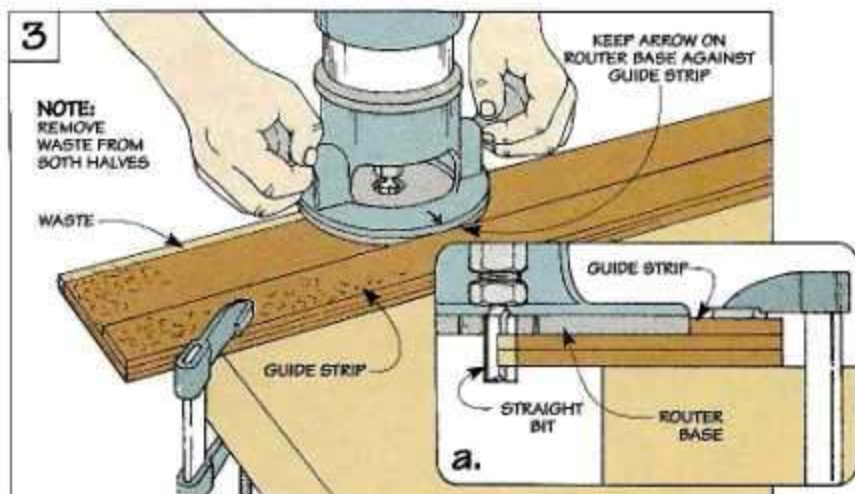
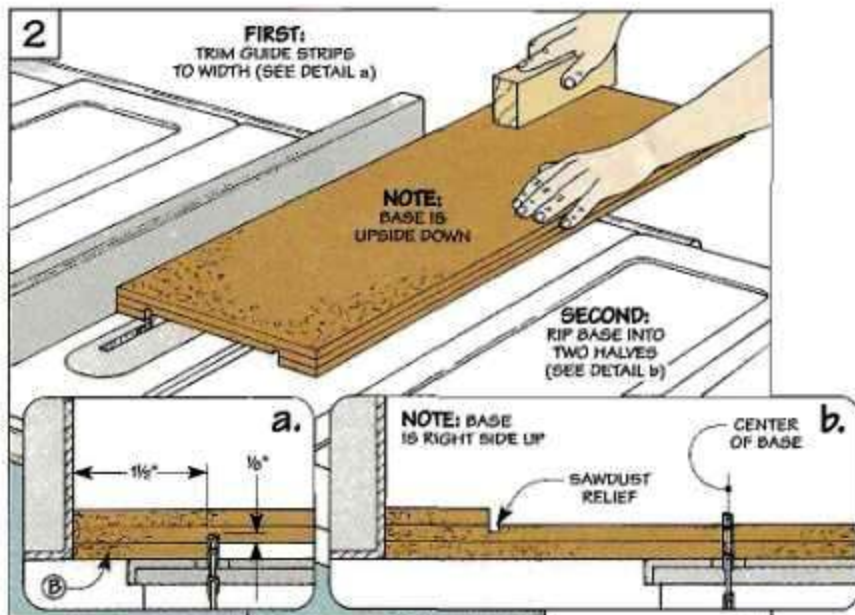
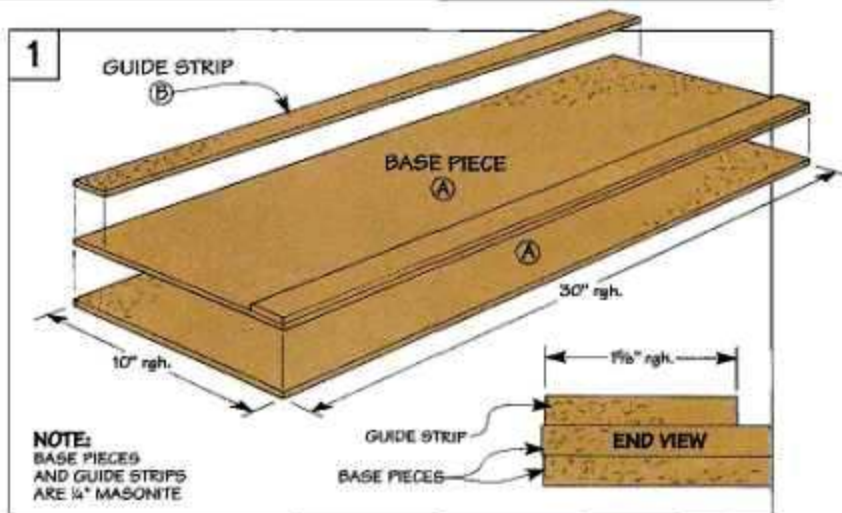

Cleats

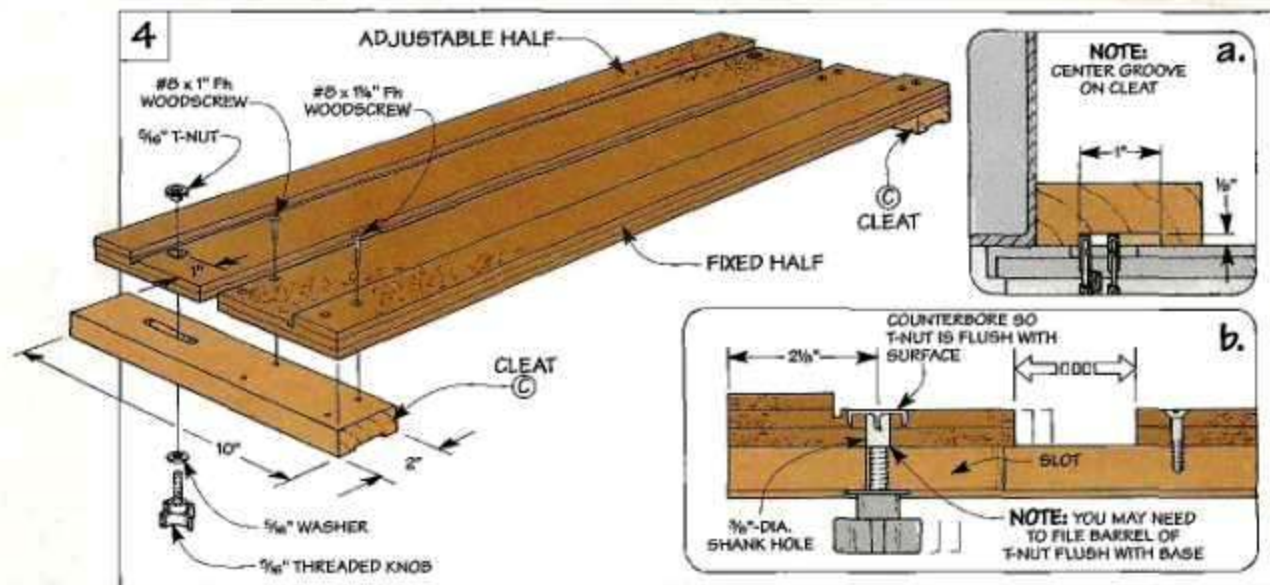

With the base complete, the next step is to add two cleats. These cleats help square up the jig to the workpiece. And they let you adjust the opening to the desired width of the dado.

Each *cleat* (C) is made from a piece of 3/4"-thick hardwood, see Fig. 4. (I used maple.) To provide a recess for a threaded knob and washer (installed later), there's a shallow groove running down the length of each cleat, see Fig. 4a.

SLOTS. The next step is to cut a slot in each cleat. These slots allow you to slide the adjustable half of the base back and forth to change the width of the opening.

Before locating the slots, you'll need to first decide which half of the base is the adjustable part. Then, after drilling a pair of counterbored shank holes for two T-nuts (added later), you can use the holes to locate the slots, see Figs. 4 and 4b.

This is just a matter of clamping the fixed half of the base to the cleats and butting the adjustable half against it, see Fig. 5. Now mark one end of each slot through the holes, slide the adjustable half back so it's flush with the ends of the cleats, and

mark the other end, see Fig. 5a. **ASSEMBLY.** After cutting the slots, all that's left is to attach the two halves of the base to the cleats.

When attaching the fixed half, check that the cleats are 90° to the base. Then glue and screw them in place so the ends are

flush with the edge of the base.

The adjustable part of the base is attached next. Each end is held in place with a threaded knob (or machine screw) that passes through the slot in the cleat and into a T-nut, refer to Fig. 4b. (For sources of knobs, see margin.)

Hardware

- (4) #8 x 1" Fh Woodscrews
- (4) #8 x 1 1/4" Fh Woodscrews
- (2) 5/16" T-Nuts
- (2) 5/16" Washers
- (2) 5/16" x 1" Threaded Knobs*

*ShopNotes Project Supplies is offering a set of four knobs (no. 7016-220) for \$7.95. To order, call 800-444-7002

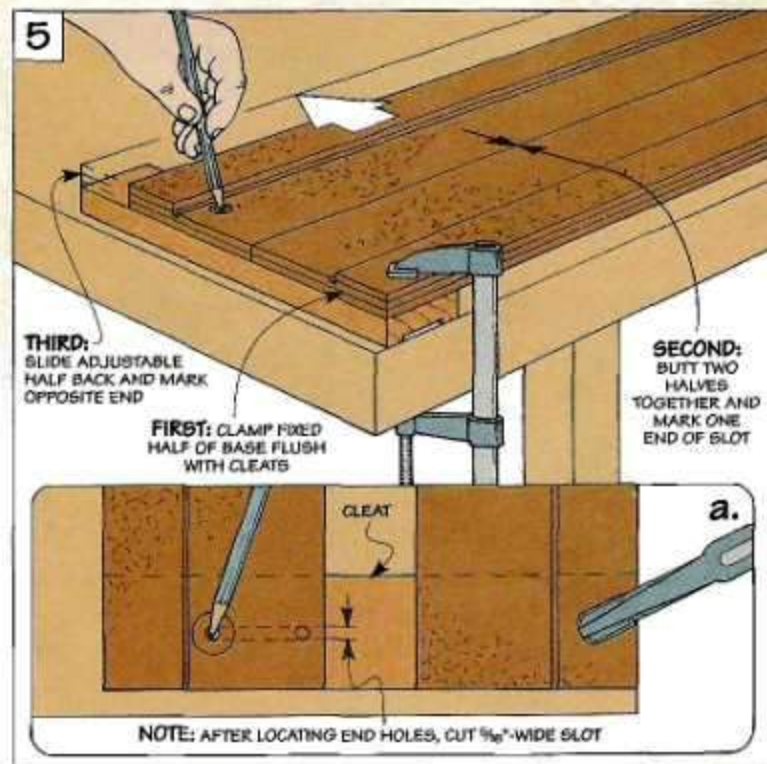

Using the Jig

It's hard not to get spoiled when using this adjustable dado jig.

A simple layout and a quick adjustment and you're ready to clamp the jig and rout the dado,

see Steps 1 through 4 below.

When clamping the jig, there are several options. A long workpiece can be extended over the edge of the bench or supported on

a pair of sawhorses. But to provide clearance for the clamp heads when routing a small panel, you'll need to raise the work off the bench with a scrap piece.



Step 1. Using a try square, lay out one side of the dado. To ensure that you rout on the correct side of the line, mark an 'x' to show the waste area.

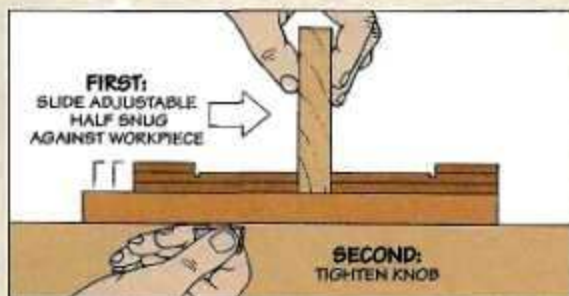

Step 2. To set the width of the opening, insert the piece that fits in the dado and slide the adjustable half of the jig against it. Then tighten the knob.

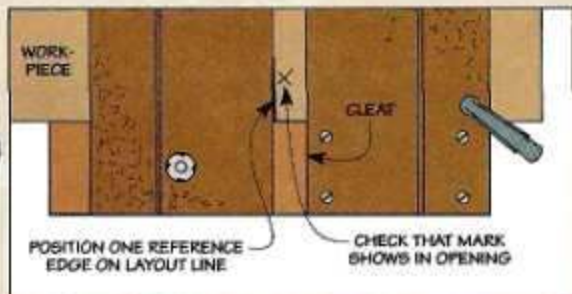

Step 3. With the cleat against the edge of the workpiece, clamp the jig in place so one reference edge is on the layout line and the 'x' shows in the opening.

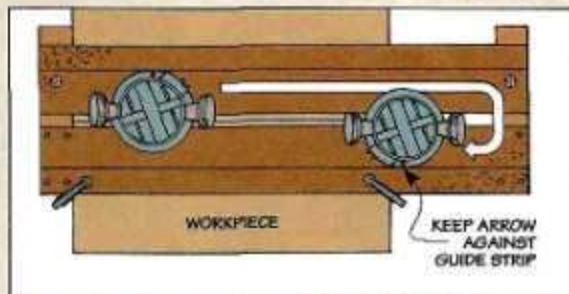

Step 4. After adjusting the depth of cut, rout in a clockwise direction. For a consistent cut, always keep the arrow on the router base against the guide strips.

Stopped Dadoes and Rabbets

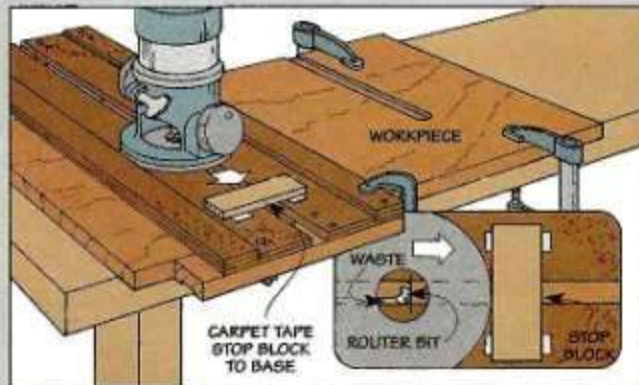

Stopped Dado. An easy way to rout a stopped dado is to carpet tape a stop block to the jig. To position the block, align the edge of the router bit with the end of the dado.

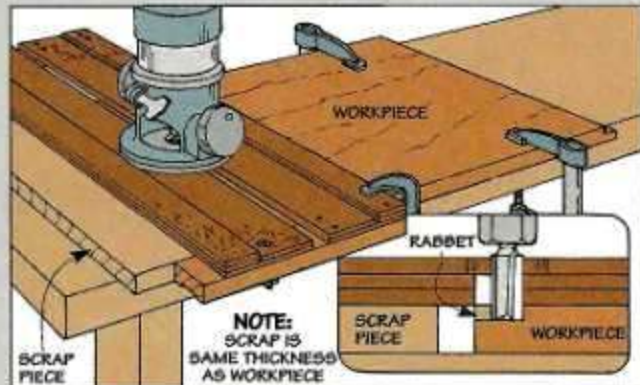

Rabbet. You can also use this jig to cut a rabbet. To support the jig (and ensure a consistent depth of cut), slide a scrap under the part that hangs over the workpiece.



Step Stool

Here's a strong, sturdy step stool you can knock out in a few hours.

It's always easier to tuck shop supplies up out of the way than it is to get them back down. And if something turns up missing, there's a good chance that it has migrated clear to the back of the highest shelf.

To make these supplies easily accessible, I decided to build a step stool for the shop, see photo. What I wanted was a stool with a simple design that I could knock out in a few hours. Yet it still had to provide a strong, sturdy platform to stand on.

SIDES. The key to this stability is to make the sides of the stool wide at the bottom, see Exploded View. That way, it distributes your weight across a larger area when you stand on the stool. Also, to keep from kicking the steps as you climb up, the sides are tapered.

Each *side (A)* starts out as a rectangular panel glued up from pieces of $\frac{3}{4}$ "-thick stock, see Fig. 1. (I used pine.) Cutting the panels to width is easy. Just rip them on the table saw. But cutting them to length is a bit trickier.



Since the ends are uneven, you can't run the panel against the rip fence. And using a miter gauge to crosscut a wide panel requires balancing it out in front of the saw table. So I used a circular saw instead, see left-hand box on page 9.

RECESSES. Once the panels are cut to size, you can cut recesses for the steps. There's a rabbet along the top edge of each panel for the top step, see Exploded

View. And a stopped dado near the middle for the bottom step.

An easy way to make both cuts is to use the adjustable dado jig shown on page 4. But in order to adjust the jig, you'll need to have the steps in hand. (For more on setting up the jig, refer to page 7.)

STEPS. To provide a strong platform to stand on, each *step (B)* is cut from a piece of "two by" lumber, see Exploded View. To

EXPLODED VIEW

OVERALL DIMENSIONS:
18" W x 18" D x 15" H

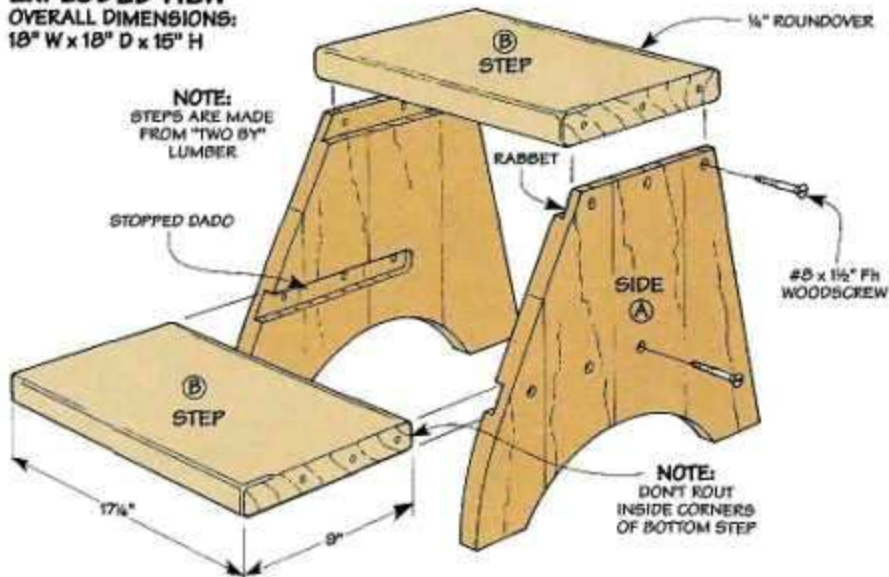

RABBET/DADO DETAIL

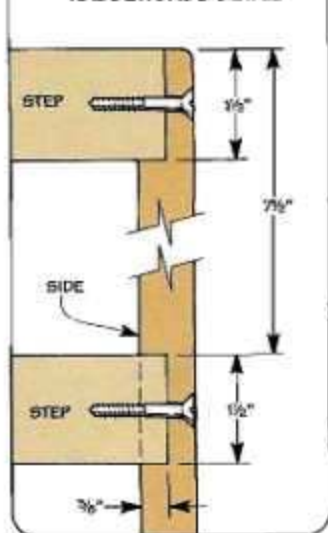

get the bottom step to fit snug in the curved corners of the stopped dado, I routed the top and bottom edges with a $\frac{1}{4}$ " round-over bit. And while I was at it, I rounded over all the corners except the two that fit in the stopped dado.

LAY OUT. Now you're ready to lay out the shape of the sides on the panels. In addition to the angled edges, there are two curves.

A long curve on the bottom forms two "feet" that prevent the stool from rocking, see Fig. 1. And there's a short curve on the front edge of each side to keep from accidentally kicking the stool when you're working around it. (For an easy way to lay out a curve, see the right-hand box below.)

To make both sides symmetrical, I carpet-taped them together before cutting the basic shape. Then, after rough cutting the shape with a band saw (or sabre saw), sand up to the lines and soften all the edges by sanding.

ASSEMBLY. All that's left to complete the stool is to assemble the pieces. After positioning the steps as shown in Figs. 2a and 2b, they're attached to the sides with glue and screws. Finally, to produce a durable finish, I brushed on three coats of polyurethane.

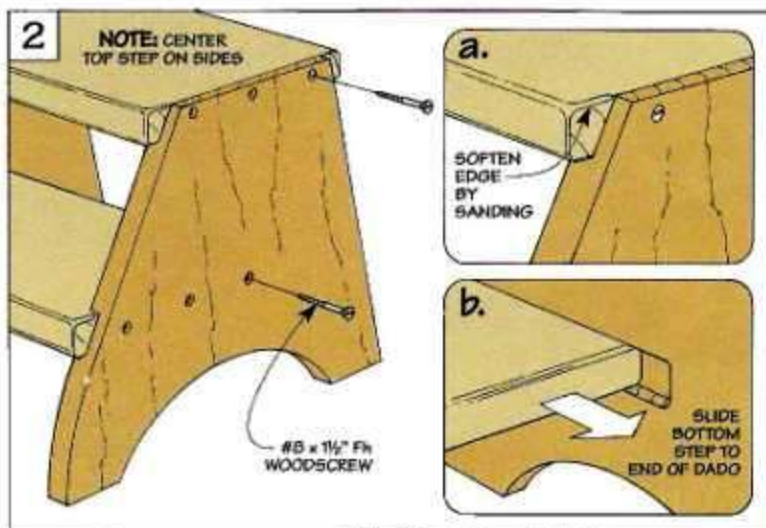
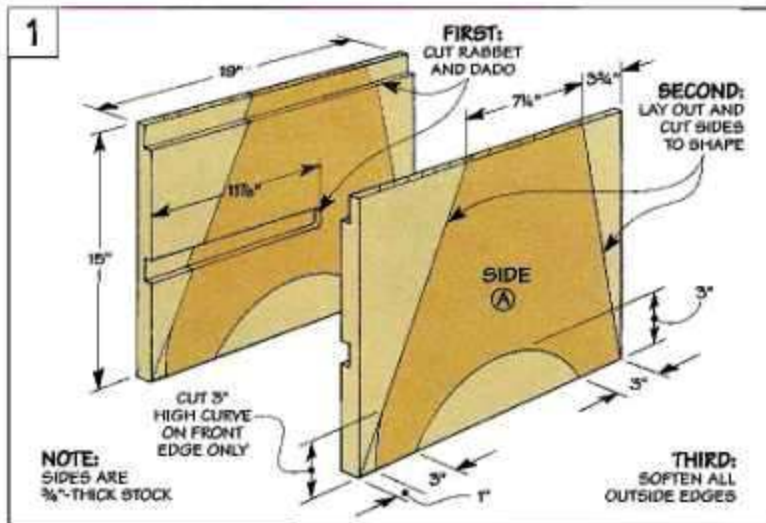

Crosscutting a Wide Panel

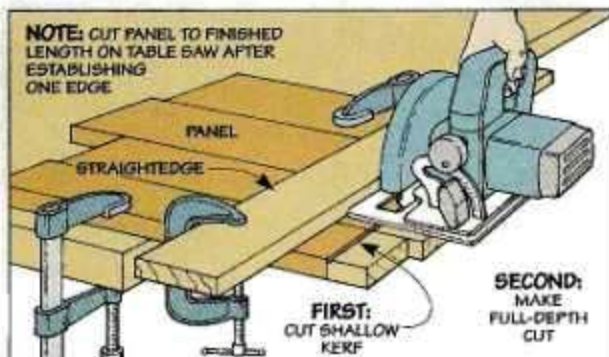

▲ With a straightedge clamped to the panel, use a circular saw to crosscut the end. To prevent chipout, make a light scoring pass followed by a full depth cut.

Laying Out a Curve

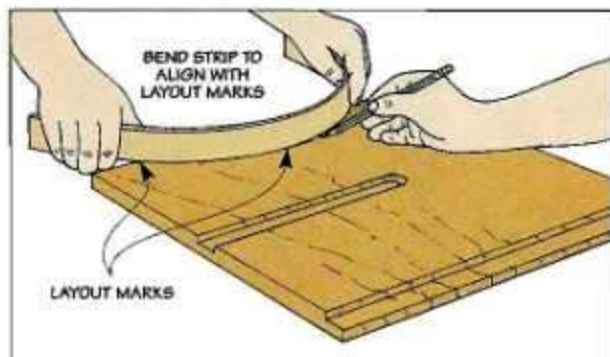

▲ An easy way to lay out a smooth curve is to bend a thin strip of wood so it contacts three layout points. Then just have a helper draw the curve on the workpiece.

Cutting Tenons

on a Band Saw

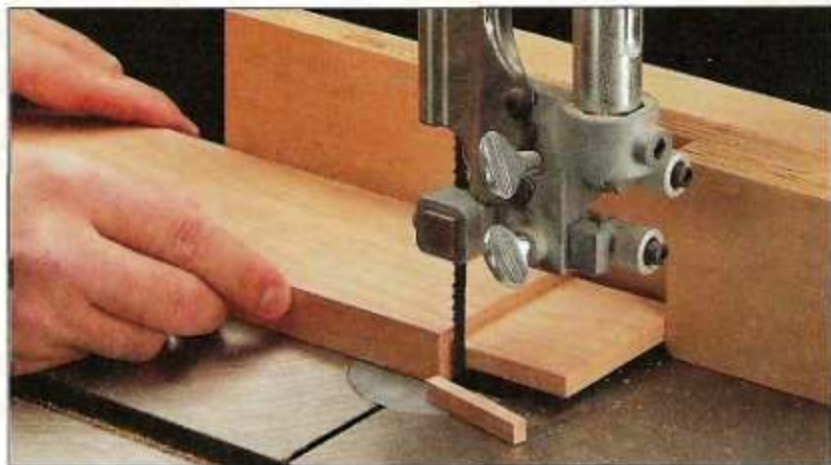

When it comes to cutting a tenon, there's one tool that often gets overlooked — a band saw. But when you stop and think about it, a band saw is the perfect tool for cutting tenons quickly and easily.

It's much faster than making a series of passes on the table saw (especially if you have a lot of tenons to cut). Or, if you normally stand the workpiece on end and clamp it in a special jig, you'll find that a band saw simplifies what can be a tricky cut.

TWO CUTS. That's because cutting a tenon on a band saw only requires two basic cuts. A *crosscut* to establish the shoulders, see left-hand photo below and drawing on opposite page. And a *rip cut* to

Our simple technique and a fence are all you need to cut perfect tenons on a band saw.

form the cheeks of the tenon, see right-hand photo.

TUNE-UP. To make these cuts as accurate as possible, it's a good idea to check that

your band saw is in top running condition, see checklist on page 11. In addition, a fence like the one shown on the next page will ensure straight, consistent cuts. (*Editor's Note:* There's also a complete band saw fence system in *ShopNotes* No. 8.)

CUT PIECES TO SIZE. One more thing. Before you get started, you'll need to cut all the pieces to finished size. When determining the length of each piece, don't forget to add the combined length of the tenons to the shoulder to shoulder distance required by the project.



Shoulders. To establish the shoulders of the tenon, crosscut all four sides. A fence acts as a stop. And a miter gauge squares the workpiece to the blade.

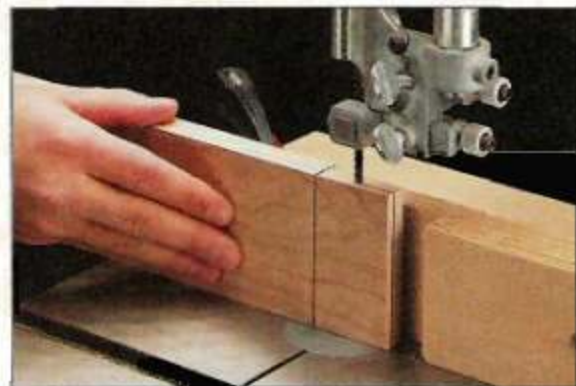

Cheeks. A rip cut forms the cheeks of the tenon. Just hold the workpiece against the fence and use a stop block to ensure a consistent depth of cut.

Band Saw Checklist

- Install a sharp band saw blade with 7-8 teeth per inch.
- Tension the blade as if you're using the next largest size.
- Use a try square to position the table so it's square to the blade.
- Square the head of the miter gauge to the miter gauge slot.
- Move the guide blocks as close to the blade as possible.
- Position the thrust bearings just slightly behind the blade.

TENON ANATOMY

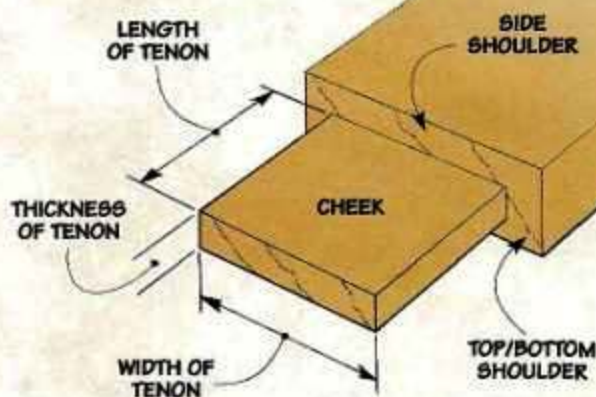

BAND SAW FENCE

The key to cutting a tenon on a band saw is to make straight cuts at a consistent depth. Which is what this shop-made fence and stop block are designed to do.

FENCE. The fence (A) is a 3"-tall (wide) strip of 3/4"-thick plywood with an open slot on one end for a stop block, see drawing. To provide a clamping platform, the fence is screwed to a plywood base (B) to form an L-shape.

RAIL. To keep the fence parallel to the blade, a rail (C) attaches to the base and slides along the edge of the table. Note: If the table casting is rough, see margin.

NOTCH. The rail has a notch cut in it to provide clearance for the bar on the miter gauge. To locate this notch, butt the fence against the blade and position one end of the rail flush with the base. Then mark the notch so it extends from the miter gauge slot to the other end of the rail.

STOP BLOCK. To control the depth of cut, I added a stop block (D). This is a 3/4"-thick plywood block that's attached to the fence with a carriage bolt and wing nut. Note: To provide sawdust relief, chamfer the bottom front corner.

NOTE:
ALL PARTS
ARE 3/4"-
THICK PLYWOOD

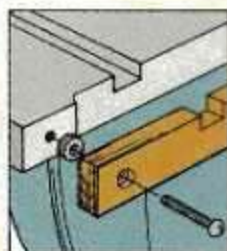
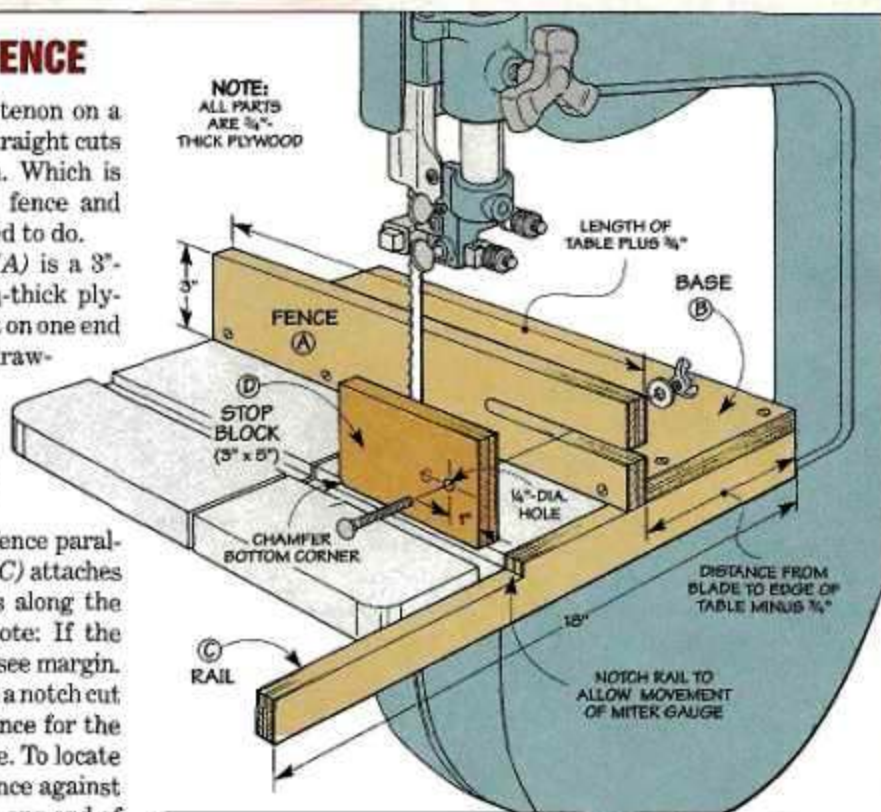

To compensate for an uneven casting, attach a rail to the table and shim it if necessary.

a. END VIEW

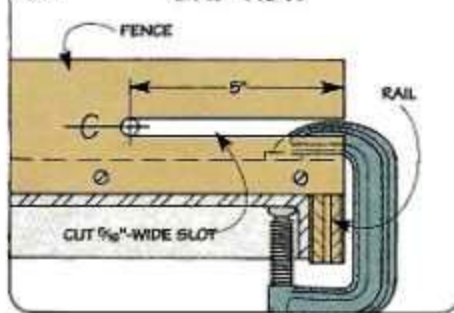

b. SIDE VIEW

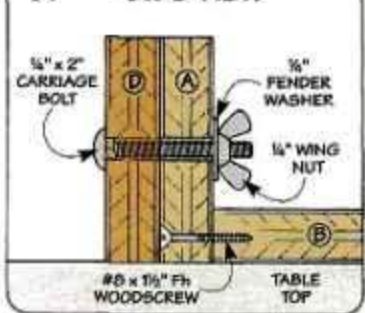

Layout

Trying to lay out a tenon without a mortise is like clapping with one hand. So the first thing I do is cut a sample mortise.

There's nothing critical about the length and depth of this mortise. The key is to cut it with the same size drill bit (or router bit) that you intend to use for the mortises on the project pieces.

This way, you can use the sample mortise as a gauge to lay out the *thickness* of the tenon, see left-hand photo. In addition to thickness, you'll also need to lay out the *length* of the tenon, see right-hand photo.



Thickness. To establish the thickness of the tenon, draw lines just inside the walls of the mortise.

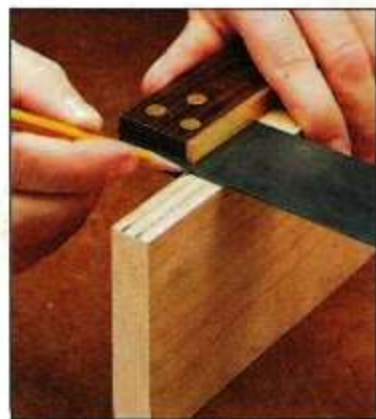

Length. Use a try square to lay out the shoulders and determine the length of the tenon.

Step-by-Step

Once you've laid out the tenon, it's just a matter of following a simple cutting sequence. First, the shoulders. Then the cheeks.

SHOULDERS

The shoulder cuts determine the *length* of the tenon. Typically, they're made on all four sides of the workpiece. To produce a tight fit with the adjoining piece, each cut needs to be an equal distance from the end.

STOP. An easy way to make these cuts accurately is to use

the fence as a "stop." To do this, clamp the fence in place so when the end of the workpiece is against it, the blade will cut just to the *waste* side of the shoulder line, see Step 1.

STOP BLOCK. In addition to length, you also need to establish a consistent *depth* of cut. That's where the stop block comes in. But before you can position the stop block, you'll need to cut one shoulder first.

The idea here is to use the miter gauge to cut slightly past the

point where the lines for the shoulder and cheek meet, see Fig. 2. This way, the waste piece will fall off when you cut the cheek later.

Once you make the first shoulder cut, turn off the saw and slide the stop block up against the workpiece. Tightening the stop block in place allows you to cut each of the remaining shoulders to a consistent depth, see Step 3.

Note: If the top and bottom shoulders of the tenon aren't the same depth as the side shoulders,

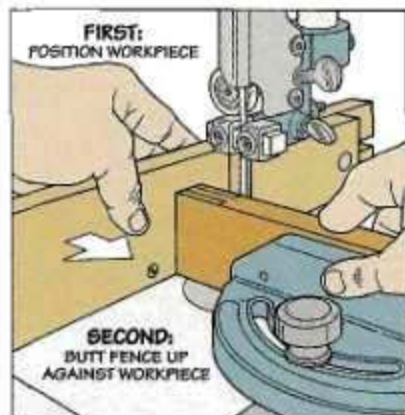

Step 1. Position workpiece so blade will cut just inside shoulder line and slide fence over as a "stop."

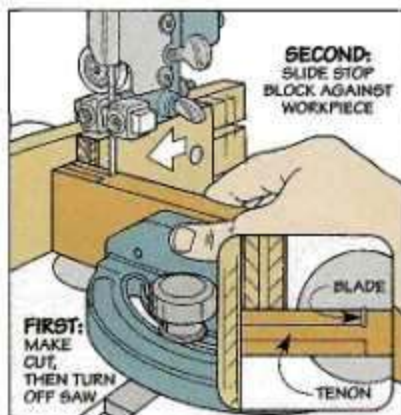

Step 2. After cutting just slightly into the tenon, turn off the saw and slide the stop block against the workpiece.

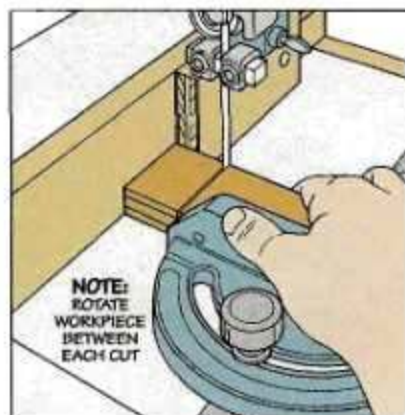

Step 3. Now make each of the remaining shoulder cuts, rotating the workpiece between each cut.

you'll need to reposition the stop block between cuts.

CHEEKS

After cutting all of the shoulders on the project pieces, you can concentrate on the cheeks. They establish the *thickness* of the tenon.

FENCE. What you want is to cut the cheeks so the tenon fits snug in the sample mortise. To do this, use the fence to position the test piece so the blade will cut the tenon just a bit "fat," see Step 4.

DEPTH OF CUT. Here again, the stop block is used to control the depth of cut. And as before, you'll need to cut the first cheek, turn off the saw, and lock the stop block in place, see Step 5. Then just flip the test piece and cut the other cheek.

CHECK FIT. Now you can fit the tenon in the sample mortise, see Step 6. If it's too tight, reposition the fence and take a bit off both cheeks. Once you're satisfied with the fit, you can cut the cheeks on the project pieces.

TRIM TO WIDTH. All that's left is to trim the tenons to width. This requires repositioning the fence (not the stop block) one more time, see Step 7.

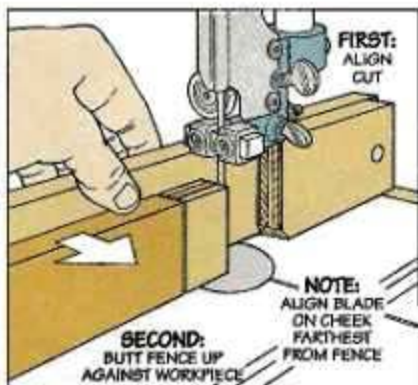

Step 4. To cut the cheeks, adjust the fence so the blade is aligned on the waste side of the layout line.

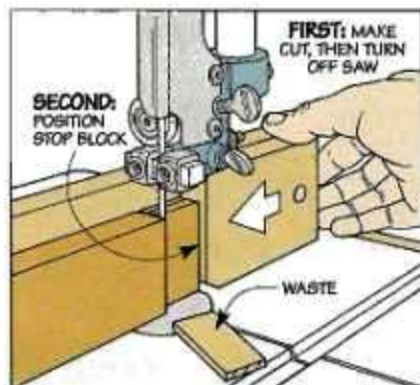

Step 5. After cutting the first cheek, turn off the saw. Then position the stop block and cut the opposite cheek.

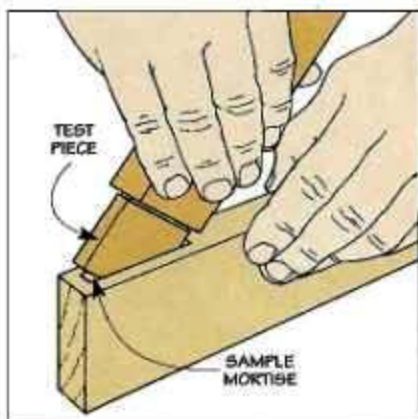

Step 6. Use the sample mortise to check the fit of the tenon. If necessary, shave a bit off both cheeks.

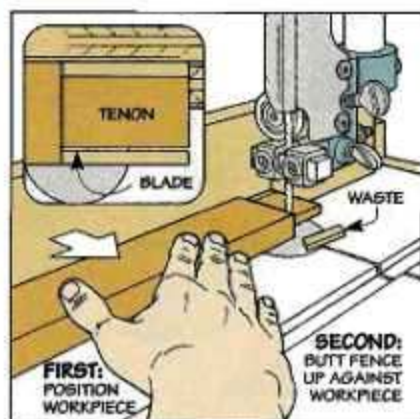

Step 7. To trim the tenon to width, adjust the fence so the waste falls to the outside of the workpiece.

Mortises

Once all the tenons are cut, you can use them to lay out the mortises on the adjoining pieces.

LENGTH. The length of the mortise is laid out on the edge of the workpiece. This is just a matter of using the width of the tenon to mark the ends of the mortise, see Step 1.

DEPTH. Now you can lay out the depth of the mortise on the face of the workpiece. To ensure that the pieces fit tight together (and to allow for any excess glue), make the mortise about $\frac{1}{8}$ " deeper than the length of the tenon, see Step 2.

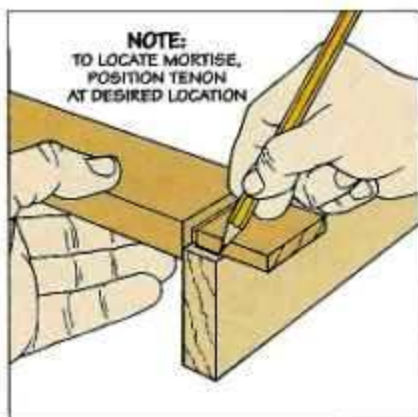

Step 1. To lay out the length of the mortise, place the tenon across the edge of the workpiece.

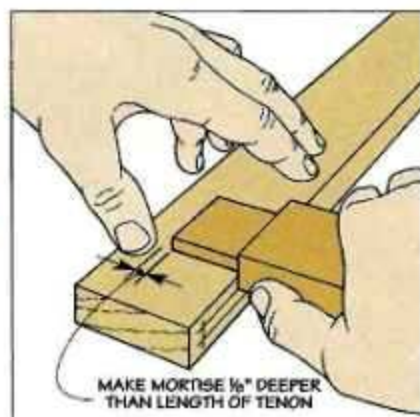

Step 2. To allow room for excess glue, the mortise should be about an $\frac{1}{8}$ " deeper than the length of the tenon.

Router Table Tips

Here are five great tips that will help make your router table more useful and safer as well.

Pushblock



Routing the end of a workpiece can be both difficult and dangerous. To do this easily and safely, I use a shop-made combination push block and backing board, see photo.

The push block is just a $\frac{3}{4}$ "-thick plywood base with a hardwood cleat attached to the front of the base, see drawing. Before

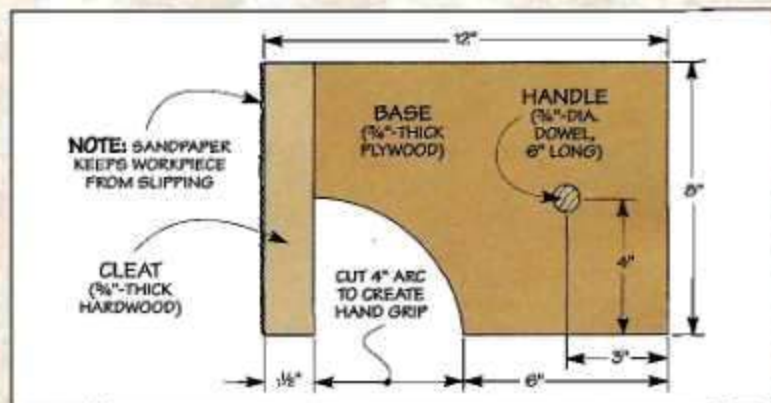

gluing the cleat in place, I cut an arc on the front, outside corner of the base so I'd be able to "clamp" the workpiece against the cleat with my left hand.

Also, to grip the workpiece

even more, I glued a piece of sandpaper to the cleat. And to help keep a constant feed rate on the workpiece and make it easier to control the push block, a dowel serves as a simple handle.

Fence Micro-Adjuster



It can be a challenge to move a router table fence just a touch. To do this, I use a micro-adjuster, see photo. It clamps to the edge of the table top and connects to the fence by way of a threaded rod and insert, see drawing.

The micro-adjuster is a block of wood with a hole in the center for the rod. In my case, I used a $\frac{1}{4}$ "

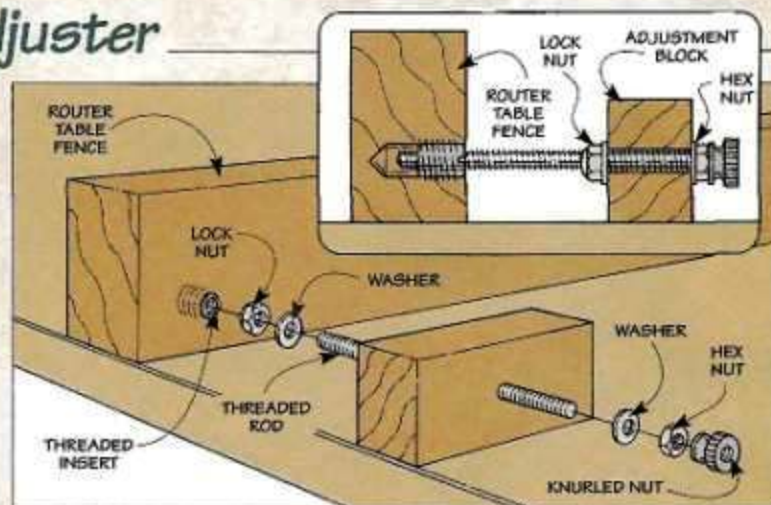

threaded rod with a hex nut and a lock nut to hold the rod in place. And a knurled nut tightened against the hex nut makes a handy knob.

After the fence is roughly positioned, clamp the adjuster to the table. Then fine tune its position by turning the knurled nut, and clamp the fence in place.

Routing Multiples

■ One of the simplest ways to duplicate curved parts is to use a template and a flush trim bit, see photo. It's quicker and more accurate than roughing out the shape on a band saw and sanding up to a layout line — especially when you're making multiples.

To start, make an exact template of the part (I use $\frac{1}{4}$ "-thick Masonite). Then trace the template on the workpiece and rough cut the shape to within $\frac{1}{16}$ " of the layout line. Once the part is roughed out, attach the template to the workpiece with double-

sided carpet tape.

To rout the final shape, adjust the flush trim bit so the bearing rides against the template. Feed the workpiece into the bit in a right-to-left direction — on the left side of the bearing.



Spring-Loaded Hold-Down

■ I often use the router table for cutting joints (such as rabbets and dados). One of the secrets I've found to routing an accurate joint is to make sure the workpiece is pressed firmly against the table top.

To apply constant, downward pressure, I made a simple "spring-loaded" hold-down. It's nothing more than a piece of wood with a thin strip glued to one edge, see drawing.

To build in some spring, remove two corners from the scrap

piece before attaching the strip.

In use, the hold-down is clamped to the fence so enough downward pressure can be applied to the workpiece to keep it flat against the table top — without causing the workpiece to bind.



Shop-Made Dowels

■ Quite often I don't have the dowel I need on hand — so I make my own using the router table, see photo. (Note: This technique works best for dowels that are $\frac{1}{2}$ " or larger.)

Here's how to do it. First, square up a piece of stock so it has the same finished dimensions as the diameter of the dowel you need. Then round over the four edges of the blank with a round-over bit that's half the diameter of the finished dowel you're after, see drawing.

As you're routing, leave a few inches at both ends square to prevent the workpiece from spinning. Once all four edges have been routed, just cut off the square ends and lightly sand the dowel smooth.

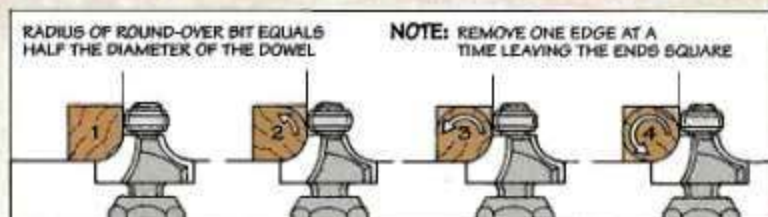

Outfeed Table



With this outfeed table attached to your table saw, you'll be able to cut full-size sheets of plywood and extra-long pieces of lumber — by yourself.

An outfeed table on the back of a table saw is like having a second pair of hands in the shop. This outfeed table is designed to “catch” a full sheet of plywood or a long board as you’re completing the cut, see photo above.

PIPE. Rather than connect the table directly to the saw, it rests on a pipe supported by arms bolted to your saw’s extension wings. (If your wings don’t have pre-drilled holes, you’ll need to drill them.)

Supporting the table like this does a couple of things. First, it allows the table to be mounted on any saw (even one with a rear mounted motor, see

photo above). And second, the arms hold the pipe out far enough past the back of the saw so a rear mounted motor can pivot when the blade is tilted.

ADJUSTABLE. But there’s another benefit to mounting the outfeed table this way. The table can be positioned anywhere across the back of the saw for any size piece of lumber your saw can handle, see photo A below. And to reposition the table, just lift up on the legs and slide it across the pipe.

STORAGE. When not in use, the outfeed table can be quickly and easily removed from the saw by pulling a pair of pins, see photo B. Also, the legs attach to the top by a pair of hinges so the support can be folded up for compact storage, see photo C.



A. Position. You can position the outfeed table anywhere across the back of the table saw — for any size workpiece.



B. Removal. The outfeed table can be quickly and easily removed from the saw by pulling two quick-release pins.



C. Storage. When you’re through using the outfeed table you can fold it up for compact, space-saving storage.

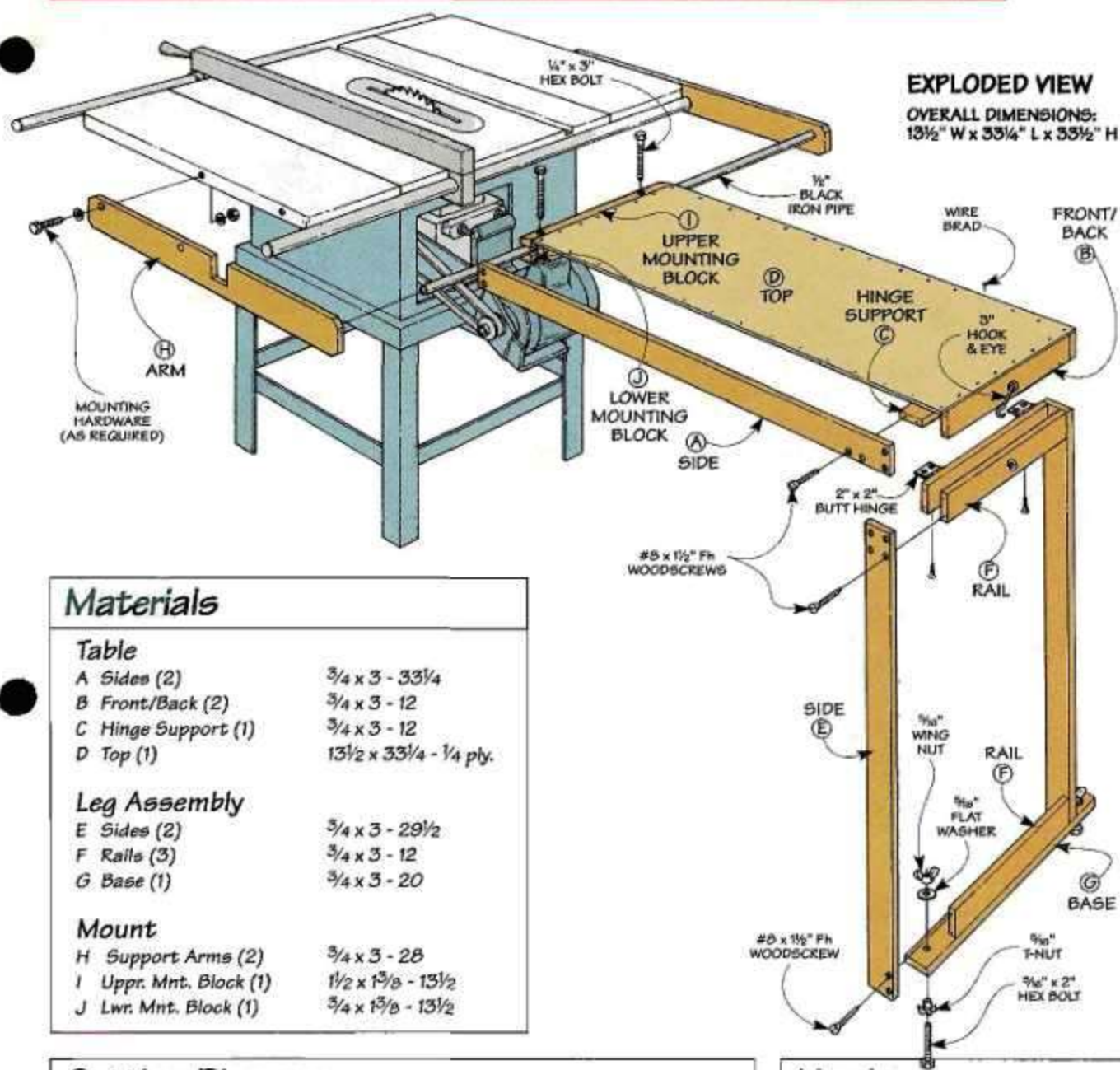

EXPLODED VIEW

OVERALL DIMENSIONS:
13 1/2" W x 33 1/4" L x 33 1/2" H

Materials

Table

A Sides (2)	3/4 x 3 - 33 1/4
B Front/Back (2)	3/4 x 3 - 12
C Hinge Support (1)	3/4 x 3 - 12
D Top (1)	13 1/2 x 33 1/4 - 1/4 ply.

Leg Assembly

E Sides (2)	3/4 x 3 - 29 1/2
F Rails (3)	3/4 x 3 - 12
G Base (1)	3/4 x 3 - 20

Mount

H Support Arms (2)	3/4 x 3 - 28
I Uppr. Mnt. Block (1)	1 1/2 x 13 1/8 - 13 1/2
J Lwr. Mnt. Block (1)	3/4 x 13 1/8 - 13 1/2

Cutting Diagram

3/4" x 4" - 96"



3/4" x 4" - 96"

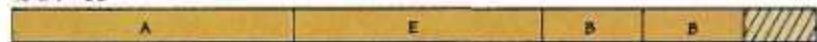

3/4" x 4" - 96"

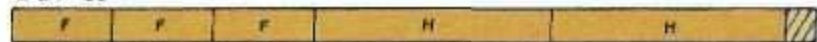

ALSO NEEDED: 24" x 48" - 1/4" BIRCH PLYWOOD

Hardware

- (32) #8 x 1 1/2" Fh Woodscrews
 - (1 oz.) 3/4" x #18 Wire Brads
 - (2) 5/16" T-nuts
 - (2) 5/16" x 2" Hex Bolts
 - (2) 5/16" Flat Washers
 - (2) 5/16" Wing Nuts
 - (1 pr.) 2" x 2" Butt Hinges w/Screws
 - (1) 3" Hook & Eye
 - (2) 1/4" x 3" Hex Bolts
 - (1) 1/2"-dia. x 48" (rgh.) Black Iron Pipe
- Also Needed: Mounting hardware to attach arms to table saw.

Table

The outfeed table consists of two main parts: a rectangular-shaped top, and an open-framed leg assembly, see drawing. They're connected with hinges to form an "L."

TOP

The top is nothing more than a four-sided frame made up of two sides (A), a front (B), and a back (C), see Fig. 1. (I used 3/4"-thick hard maple.) The sides are simply butted up against the front and back and then screwed together.

To provide a surface to screw the hinge into later, I added a hinge support (C) between the sides of the frame, see Fig. 1. With the frame complete, all that's left is to cut a top (D) to fit.

LEG ASSEMBLY

Now you're ready for the leg assembly. It's built much like the top, except it's open and has an oversized base, see Fig. 2.

To determine the length of your sides (E), measure from the top of the table saw to the floor. Then subtract 5". (This allows for

the table and levelers added later.) And to prevent racking, there are three rails (F) that fit between the sides: two at the top, and one at the bottom.

BASE. Once you've screwed the frame together, the next step is to add a base (G). It extends past the sides to provide a stable four-

pointed base. And allows clearance for two simple levelers, see Fig. 2a.

With the leg assembly complete, you can attach it to the top with a pair of 2" butt hinges, see detail 'a' above. Then to "lock" the table to the leg assembly when it's in use, install a screw hook and an eye, see detail 'b' above.

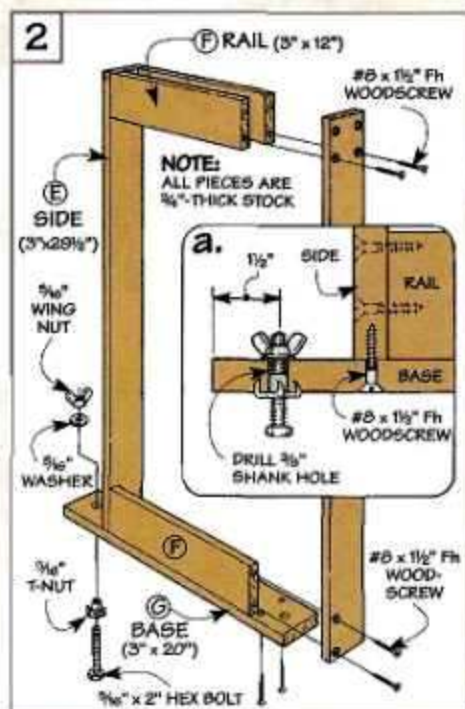
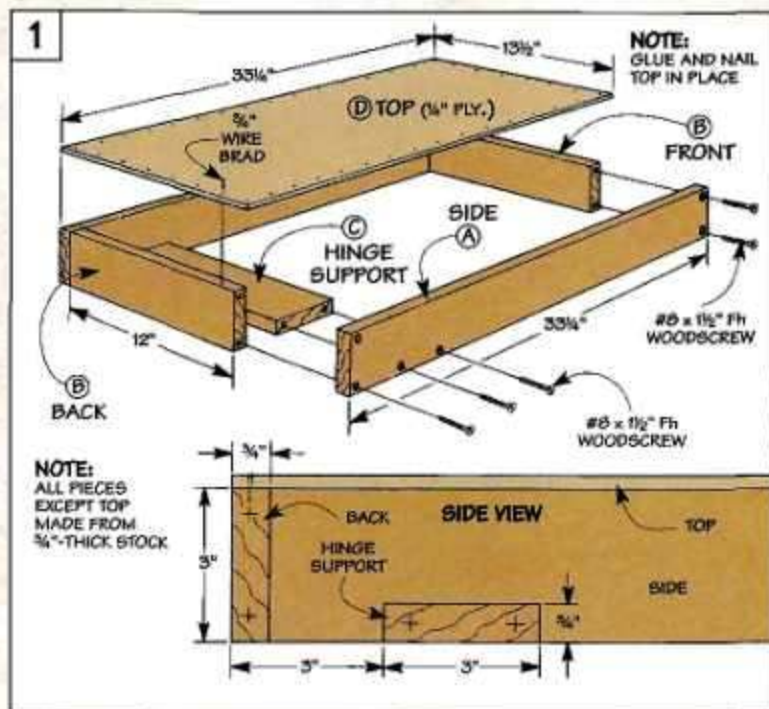

Mounting the Table

The outfeed table mounts to the saw by way of an iron pipe, a pair of support arms, and two mounting blocks, see Fig. 3.

ARMS

The support arms (H) are designed to bolt to the wings, see Fig. 3. They're identical except for two things. One arm has a notch cut near the middle so it can fit around the fence rail, see Fig. 3b. And there's a counterbored hole for the pipe on the inside face of each arm, see Fig. 3a.

Once the arms are complete, you can mount them to your saw (with the pipe cut to fit between them). Note: If you have to drill holes in the wings, clamp the arms in place and drill holes through both, see Fig. 3a.

As you mount the arms, make sure they're flush with the top of the wings and flush at the ends.

MOUNTING BLOCKS

Next, to provide a simple way for the outfeed table to "grip" the pipe (and still allow it to slide), I

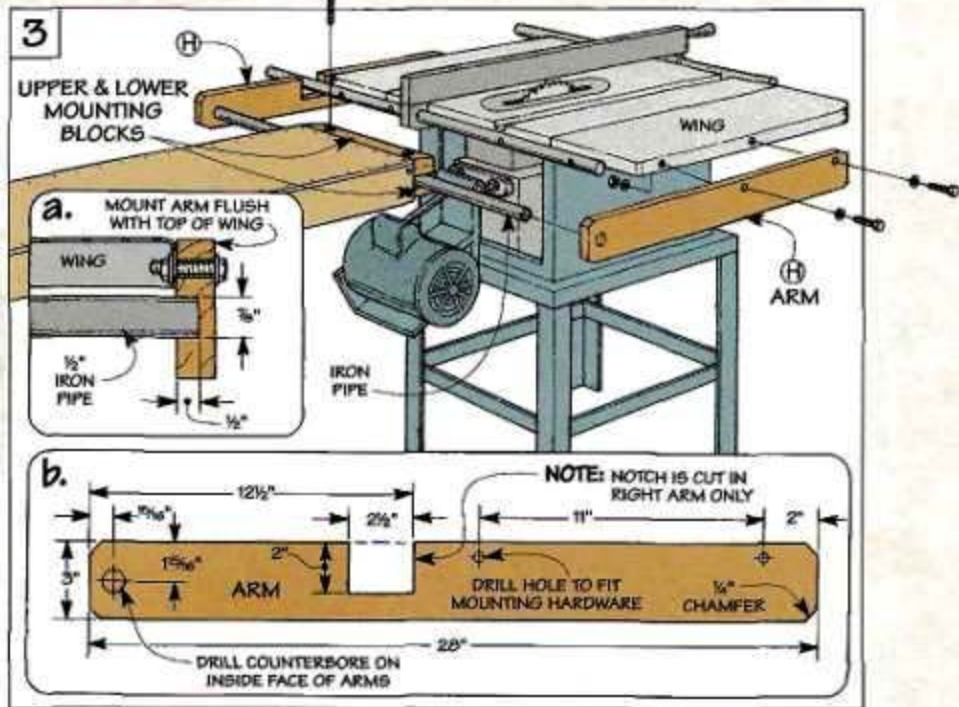

added an upper (I) and a lower mounting block (J) to the front of the top, see Fig. 4. These blocks are attached to the top to form a "channel" for the pipe.

The two mounting blocks are

made from 3/4"-thick stock, with the upper block consisting of two glued-up pieces.

After the blanks are cut to size, drill two counterbored holes for the two 1/4" pins (hex bolts) that "lock" the table to the pipe, see Fig. 4a. To ensure the shank holes in each block align, carpet tape the blocks together before drilling the holes.

Once the holes are drilled, separate the two pieces and cut a taper in the upper mounting block, see Fig. 4a. This taper prevents a workpiece from catching the top as it comes off the saw.

With the mounting blocks complete, all that's left is to screw them in place, see Fig. 4b. The top edge of the upper mounting block is flush with the top of the outfeed table. The lower block is positioned so the pipe is sandwiched between the two blocks.

Once the outfeed table is pinned to the pipe, adjust the levelers so the table top is even and level with the saw table, see margin tip at right.

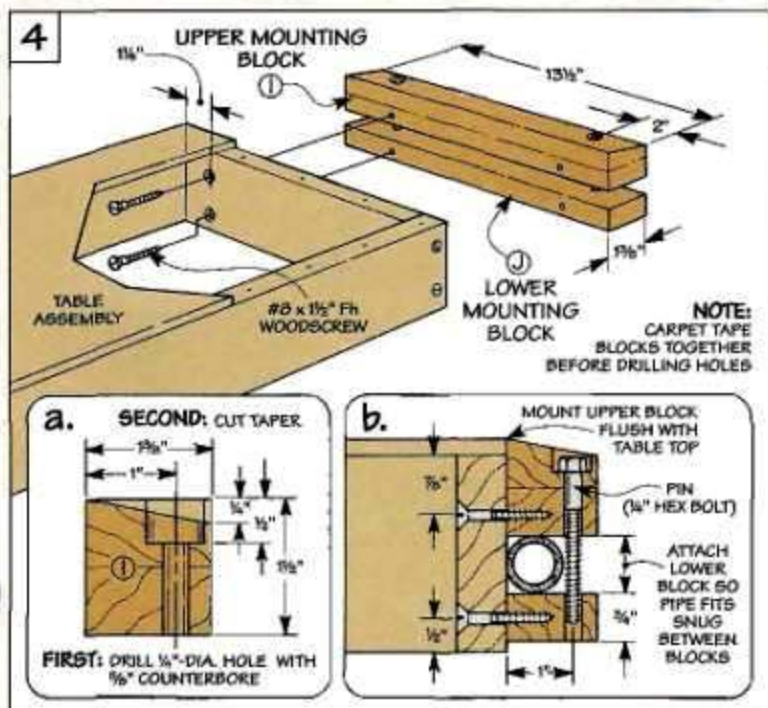

Two simple shop-made levelers allow you to compensate for an uneven floor.

Quick-Change Bits



Adapter. One quick-change bit system uses an adapter to hold a hex shanked drill or driver bit. To insert a bit, just pull back on the collar.



Combination Tool. For fast assembly, this system has a special holder that houses one bit while you're using the other one.

It's not that I'm in that big of a hurry. It's just that when I assemble a project with screws, there are always a few annoying things I could do without.

Like fumbling around with the chuck to change back and forth between a drill bit and a screwdriver bit. Or having the bit that I'm *not* using disappear in my apron pocket or roll under a pile of clutter.

And I've got a hunch I'm not the only one this happens to. Especially when you look at all the quick-change bit systems on the market. These systems mount in a hand-held drill and allow you to

drill a hole *and* drive a screw in a matter of seconds. To find out how well they worked, we tested four commonly available systems, see margin at left and Sources on opposite page.

TWO TYPES. Basically, these systems can be broken down into two types. The *adapter* system allows you to quickly insert a hex-shanked drill bit (or screwdriver bit) into a special holder that's tightened in the chuck, see photo above left. And the *combination tool* houses both bits in a single unit, see photo above right.

TESTERS. To provide a reliable comparison between the differ-

ent systems, we asked two woodworkers with different interests and experience to test them out. *Steve* has been building projects for his house and shop for years. While *Cary* is just getting starting in woodworking.

Q: Let's start with the adapter systems. How well do they live up to their "quick-change" name?

Steve: They're fast and simple to use as well. To insert a bit, I just pull back (or push forward) a spring-loaded collar that's like the fitting on an air hose. (See bottom left drawing.) This lets a ball bearing slip into a notch in the bit and lock it in place.

Systems

Adapter

Insty-Bit \$11.95
Sears \$9.99

Combination

Makita \$12.95
Drill-N-Drive \$12.39

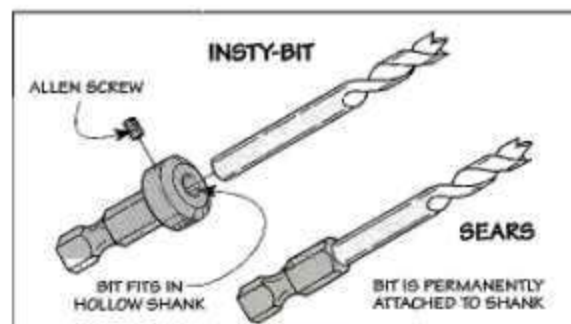
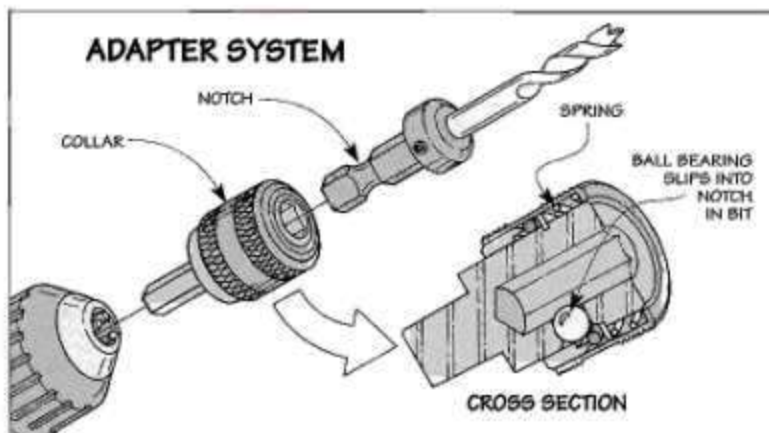

Hex Shank Bits. A hollow shank and an Allen screw make the Insty-Bit replaceable (left). But the Sears bit (right) is permanently attached to the shank.

Cary: The thing that bugs me is I have to slide the Sears collar forward while pushing the bit back into the adapter — like patting my stomach and rubbing my head at the same time. Pulling the collar back on the Insty-Bit adapter was a much more natural motion.

Steve: Another thing I liked about the Insty-Bit collar is it's made of metal — not plastic like the Sears. So I'd be willing to bet it will last a lot longer.

Q: What about the bits that come with the adapters?

Cary: The bits are sold separately. But what's nice is any hex shank drill or driver bit (with a notch) will work. In fact, I've seen twist bits, tapered bits, and even brad point bits with hex shanks.

Steve: One thing I'd look for is a bit that can be replaced when it gets dull or broken. (See bottom right drawing on opposite page.) There's no sense buying "throw-away" bits.

Q: How do the combination tool systems stack up against the adapter systems?

Steve: These systems look a bit clunky. But they work better than they look. Especially the Makita.

That's because it has a double-ended bit that's secured in a special holder. (See drawing above.) While I'm using the drill bit, the end with the driver bit fits in the holder. So I don't have to worry about losing a bit.

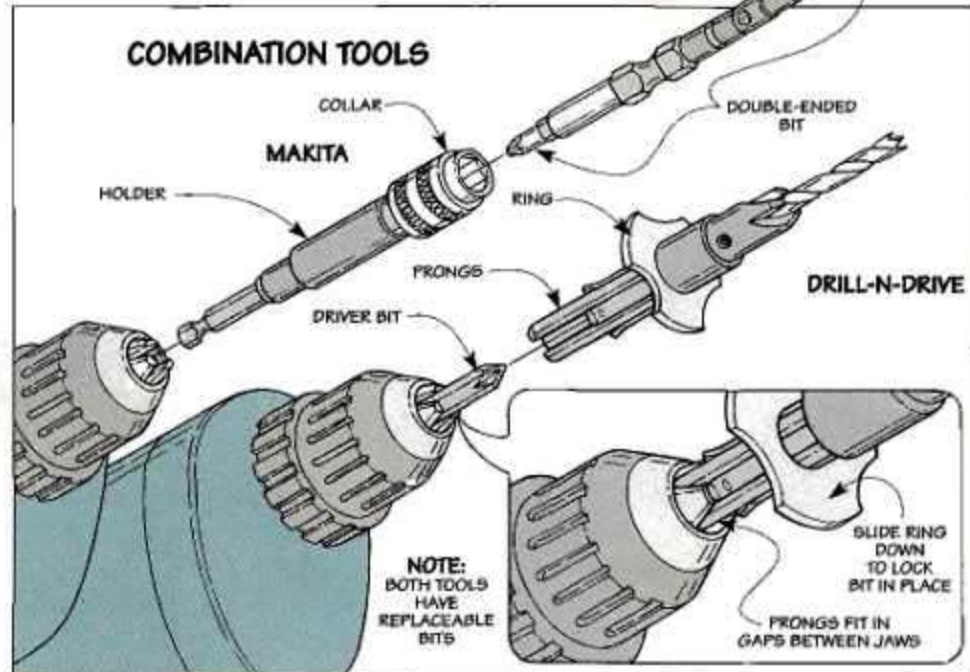

And locking the bits in place is simple. Just click down on a metal collar on the holder. When I'm really rolling, changing back and forth between bits is like pumping a shotgun between rounds.

Cary: The Drill-N-Drive (also called Chuck-Mate) uses a different system. Here, the driver bit is always chucked in the drill. (See drawing above.) And the drill bit is secured to a holder with prongs that fit down between the gaps in the jaws. At first, I thought the holder would slip. But a metal ring pinches the prongs together and locks it in place.

All in all, the Drill-N-Drive is as quick as the Makita. But not as convenient — it's still too easy to set down the drill bit and lose it.

Q: What did you think about the quality of the holes drilled — especially the countersinks?

Steve: I liked the clean holes cut by the countersink on the Makita. (See drawing below.) Although it tends to clog up a bit, it's easy to flick out the sawdust.

Cary: That was kind of a nuisance for me. I found that the countersinks on the Insty-Bit and the Drill-N-Drive didn't clog as much. And they cut perfect holes.

Q: Okay, it's time to show your cards. Which quick-change bit system would you buy?

Steve: The Makita is just what I need for fast assembly work. It drills a clean hole. And since it's self-contained, I don't spend time searching for lost bits.

Cary: No question about it. I'd get the Insty-Bit adapter. Even if I only bought a driver bit and countersink, I'd have the same capability as the combination tools. Yet I can make it more versatile by buying additional bits.

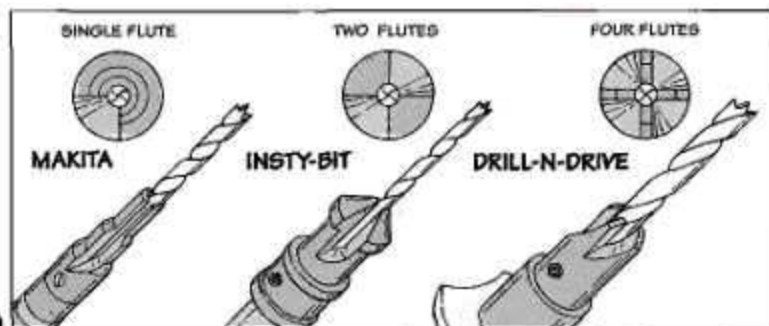

Countersinks. Each countersink above cuts a clean hole. But the single flute on the Makita (left)

tends to clog up unlike the double fluted Insty-Bit (center) or four-fluted Drill-N-Drive (right).

Sources

- Insty-Bit**
McFeeley's
800-443-7937
Woodworker's Store
800-279-4441
- Sears**
Sears Dept. Stores
- Makita**
Trendlines
800-767-9999
- Kel-Welco**
800-798-6969
- Drill-N-Drive**
Highland Hardware
800-241-6748
Woodworker's Supply
800-645-9292

Overhead Storage

Here are three simple ways to take advantage of the unused overhead space in your shop.

One of the toughest problems to overcome in a small shop is storage space — particularly when trying to store lumber. Walls and floor space fill up quickly. So just like a crowded city, sometimes the only way to go is up.

When you put your mind to it, it's amazing how much storage space is available overhead. Here's a collection of three of our favorite lumber storage ideas for the small shop. Rings cut from PVC pipe to hold dowels. A lattice system for storing and organizing strips and cutoffs. And a simple lumber rack for storing boards, see photo.

DOWEL RACK

If you're like me, you have quite a few different lengths of dowel on hand. In my shop, I have to dig around inside a box every time I need a dowel. One way to keep them organized and out of the way is with this joist-mounted dowel rack, see Fig. 1.

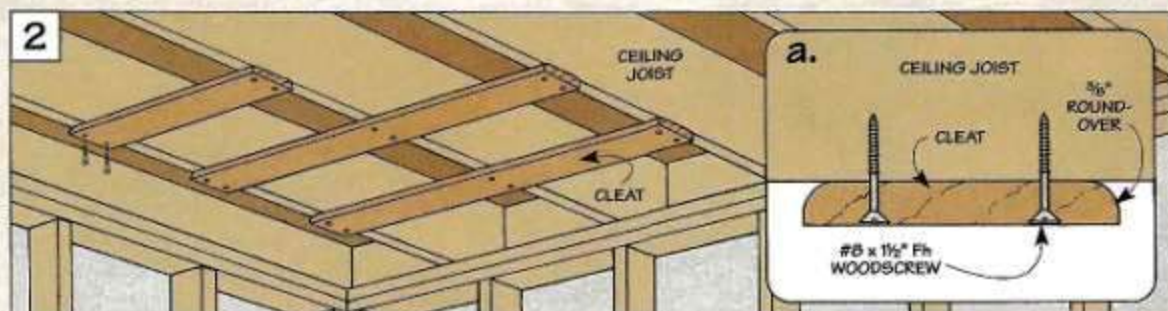
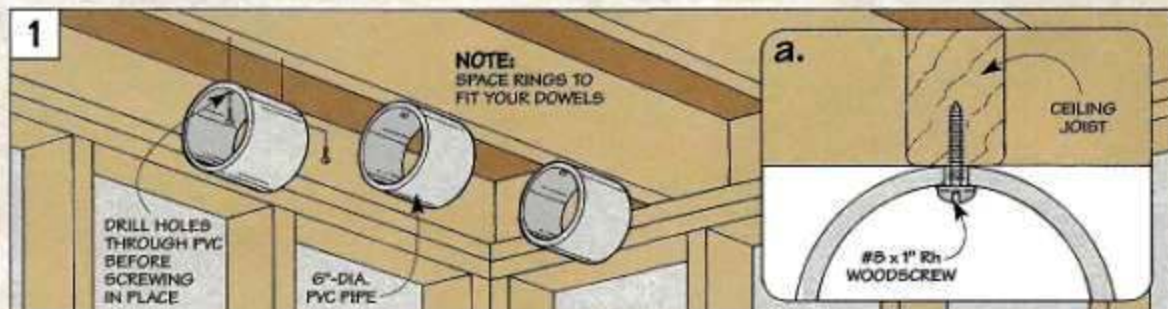

The dowel rack is nothing more than three 4"-long rings of 6"-diameter PVC pipe. (Your local hardware store should be able to cut the PVC to length for you. Or you can use a hack saw.) Then just drill a couple of holes in each ring and screw them to a ceiling joist.

CUTOFF ORGANIZER

Many woodworkers (myself included) seem to be collectors of cutoffs — strips of lumber that aren't

the right size for your project, but too good to use as firewood.

If you have an exposed ceiling, the space between the joists is a great place for storing and organizing those strips and cutoffs. The organizer is just rows of cleats that you screw to the joists to form a lattice, see Fig. 2.

Shorter cutoffs only require a few cleats. Longer cutoffs require additional cleats. To make it easy to slide pieces on top of the cleats, the edges are rounded over, see Fig. 2a.

LUMBER RACK

One of the toughest problems in a small shop is storing long pieces of lumber. This overhead lumber rack takes advantage of any unused space above a stationary tool or worksurface, see photo on opposite page.

The lumber rack consists of three parts: a support bracket and two identical arms — all cut from “two-by” material, see drawing at right.

To support a heavy load, the arms attach to the brackets with simple half-lap joints and are glued and screwed in place.

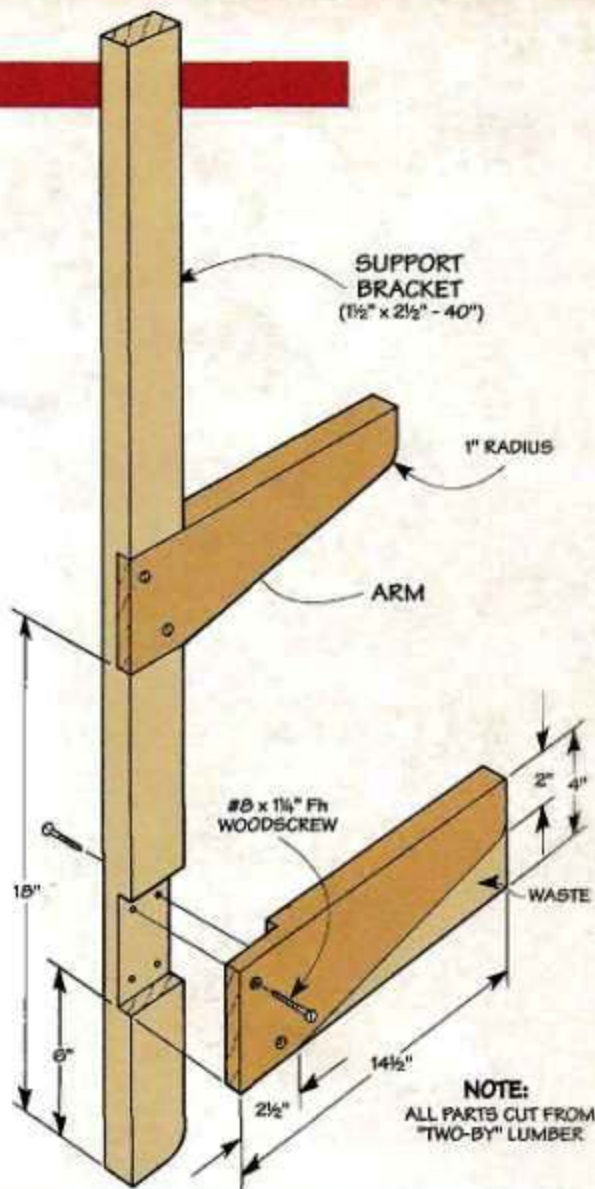
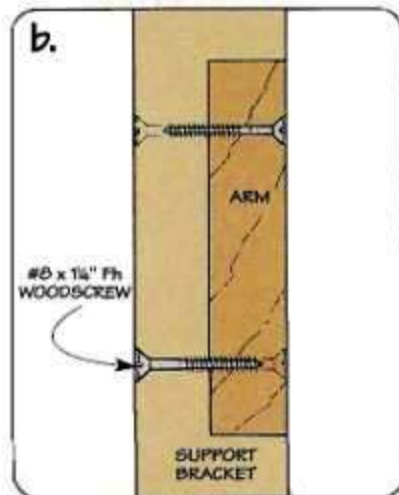
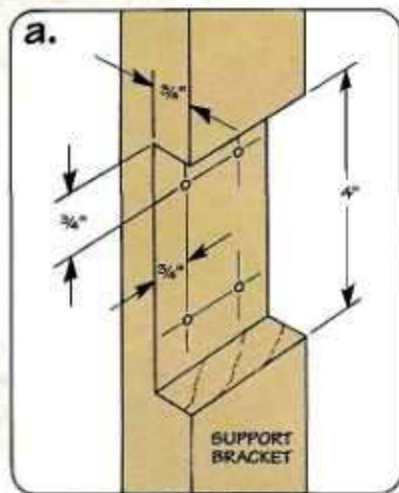

Rack Mounting Options

The lumber rack can be mounted to either a wall or a ceiling.

WALL. If you're mounting it to a wall, the first thing you need to do is locate the studs, see Fig. 1. Then, to support a heavy load, screw each rack to a stud with lag screws and washers.

If you're mounting the rack to a concrete or block wall, be sure to use the appropriate anchors and bolts to support the load.

CEILING. The rack can also be hung from the ceiling, see Fig. 2. For this, all you have to do is drill a couple holes through the joists and the rack for bolts.

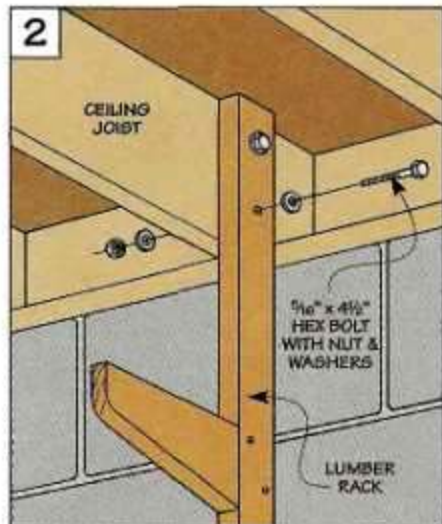
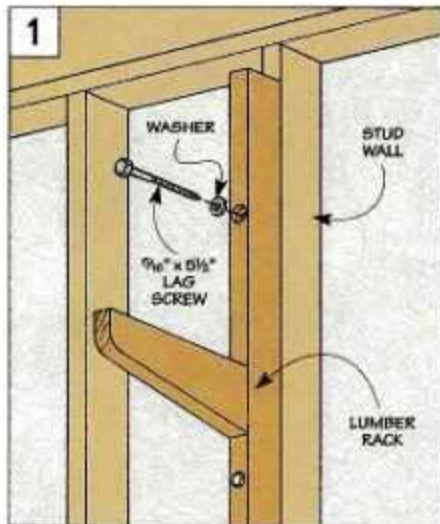

Cutting Rabbets on the Table Saw

Although many woodworkers think you have to own an expensive dado blade to cut rabbets on the table saw, you don't. In fact, for years all I ever used was my everyday saw blade. It's still the quickest way when I just need to cut a few rabbets and don't want to bother changing blades.

TWO METHODS. I use two methods to cut rabbets without a dado blade. One way is to make two cuts that intersect to form a rabbet. The other method "nibbles" away at the waste to create the rabbet. Depending on whether the rabbet is on the edge or end of the board, each has its advantages.



▲ You don't need an expensive dado blade to cut accurate rabbets on the table saw. Your everyday saw blade will work just fine.

Two-Pass Method

EDGE CUT

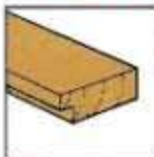

The smoothest rabbet is produced using the two-pass method. The first pass forms the shoulder of the rabbet, see Fig. 1. The second pass establishes the depth of the rabbet, see Fig. 2.

Note: When standing a wide workpiece on edge, it's best to support it with a tall auxiliary fence clamped to the rip fence.

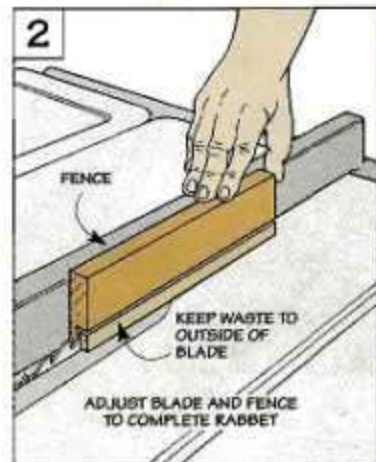
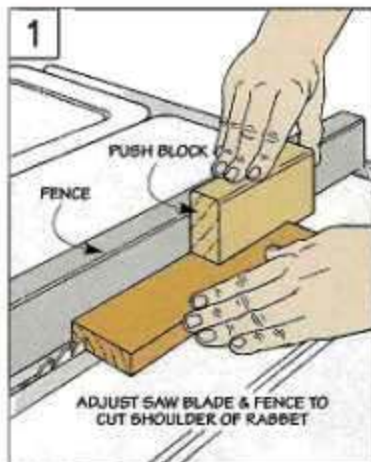

END CUT

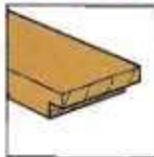

With the two-pass method, cutting a rabbet on the end of a board requires two setups. The first setup uses the miter gauge, with the fence as a stop, see Fig. 1.

For the next setup, you'll need a T-shaped support to hold the workpiece on end, see Fig. 2. This support rides along the top of the rip fence to ensure a 90° cut.

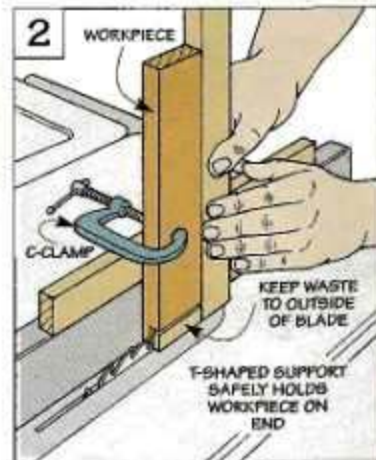
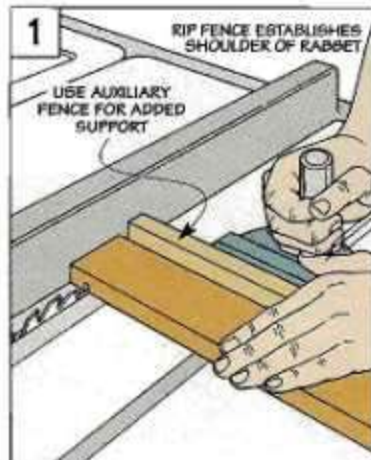

Multiple-Pass Method

END CUT



When I need to quickly cut a rabbet on the end of a board, I "nibble" away at the waste. Although it takes multiple passes, you don't have to deal with any special setups or hold-downs. All you need is a miter gauge with an auxiliary fence, see Fig. 1.

The height of the blade equals the depth of the rabbet, see Fig. 2. The distance between the fence and the *outside* edge of the blade equals the width of the rabbet.

When cutting the shoulder, keep the end of the workpiece against the fence. Then nibble away the waste by sliding the workpiece away from the blade an $\frac{1}{8}$ " after each pass. Continue sliding and nibbling until the rabbet is complete, see Fig. 3.

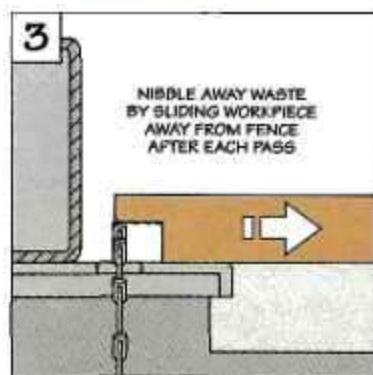
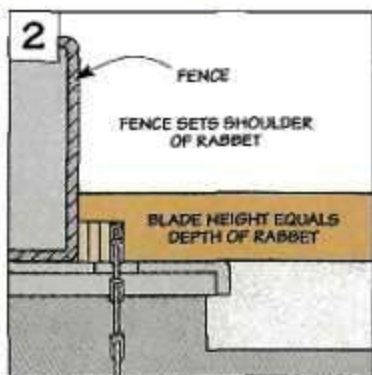
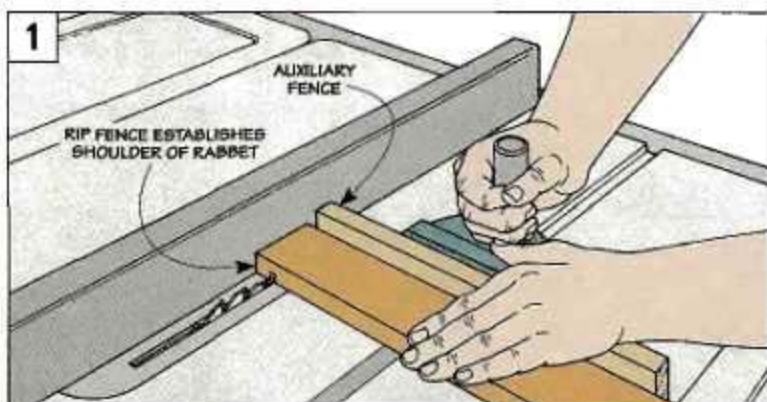

Shop Tip
You can avoid chipout on the end of a board by screwing an auxiliary fence to your miter gauge.

EDGE CUT

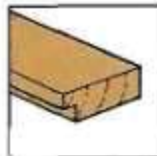

Rabbeting the edge of an *extra-wide* workpiece can be difficult using the two-pass method as described on the previous page.

To avoid standing an extra-wide workpiece on edge, I "nibble" away at the edge using a slightly different technique than the one described above.

You'll need an auxiliary fence so the blade can be buried during the last pass, see Fig. 1.

Start by setting the blade to the depth of the rabbet, see Fig. 2. Then position the fence for the shoulder. After you've cut the shoulder, it's simply a matter of moving the *fence* toward the blade an $\frac{1}{8}$ " at a time.

To complete the rabbet, bury the blade in the auxiliary fence and make one last pass, see Fig. 3.

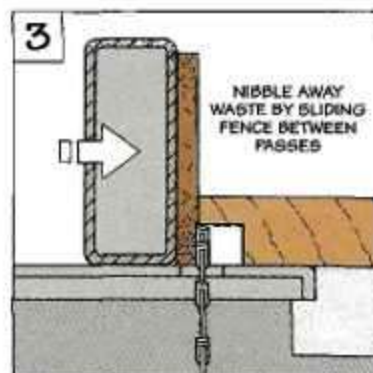
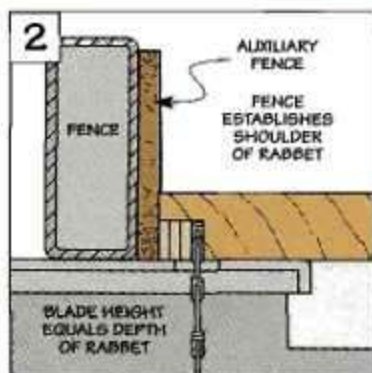
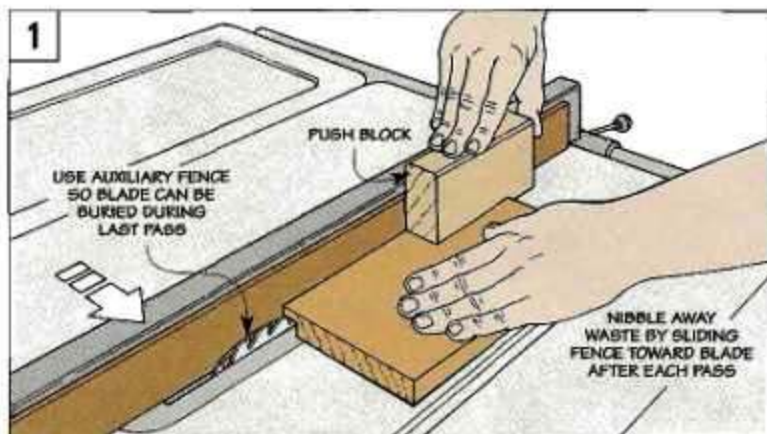

Hardboard

The project I'm planning to build from ShopNotes says to use Masonite. What is it, and where can I get some?

*Mark Jobst
Taos, New Mexico*

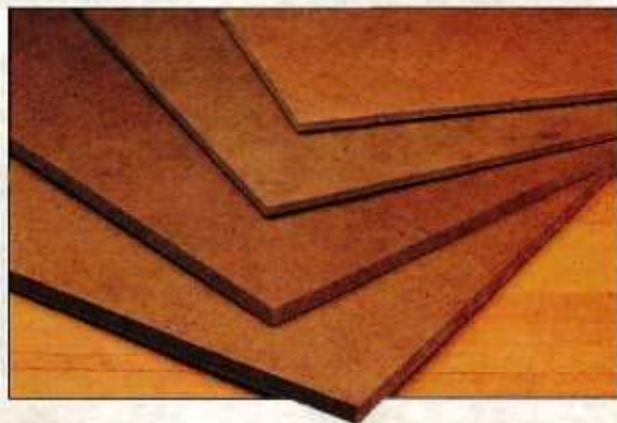

COLOR. Although many woodworkers believe you can tell the difference between standard and service-tempered Masonite by the color of the sheet, you can't. The color has more to do with the type of wood that was used to make the hardboard.

The only real way to tell the two apart is

Hardboard is an engineered wood product that's ideal for shop projects.

■ In *ShopNotes*, hardboard is referred to as Masonite for the same reason most of us refer to facial tissue as Kleenex, or cotton swabs as Q-Tips. Masonite Corporation is the leading manufacturer of hardboard products.

ENGINEERED WOOD. Basically, hardboard is a mixture of finely-ground processed wood and resins bonded together under heat and pressure — it's an engineered wood product.

It can be shaped into house siding, floor underlayment, paneling, and moldings. Or pressed into sheets. Sheets of Masonite are available at most lumber yards and home improvement centers in $\frac{1}{8}$ " and $\frac{1}{4}$ " thicknesses, see photo above.

DENSE & STABLE. In our shop, hardboard is mainly used for drawer bottoms and shop jigs and

fixtures. It's hard and dense, holds up well, and is extremely stable during changes in humidity.

This also makes it an ideal material for use as a base for supporting the finished surface of table tops and workbenches.

TWO TYPES. There are two basic types of Masonite available in 4x8 sheets: standard and service-tempered. I use service-tempered hardboard because it's harder and more resistant to moisture than standard hardboard.

Another reason I prefer service-tempered over standard is it glues up better. In the past, I've had standard hardboard delaminate on me. This is a problem I've never experienced with service-tempered hardboard.

to walk out into the lumberyard and look at the stack. Standard hardboard will have one green stripe painted along one side of the stack. Service-tempered will have two red stripes, see photo A.

Although you may be able to see the markings on the edge of an individual sheet, they're easier to see when you're looking at the whole stack.

SMOOTH BOTH SIDES. There's one more thing I look for when buying a sheet of Masonite — I make sure it's smooth on both sides. Some hardboard comes with one side smooth and the other side textured as a result of the equipment used to process it, see photo B.

During manufacturing, some hardboard factories deliver the formed sheet to the hydraulic press by way of a wire screen. This results in a "waffle" imprint on the back of the sheet after it has been pressed. Smooth on both sides is a result of the formed sheet being delivered to the press on a smooth plate.

One more thing. Like standard hardboard, I've also had a few problems gluing up service-tempered hardboard with one side textured. That's why I only use service-tempered hardboard that's smooth on both sides.



A. Class Markings. Two red stripes indicate service-tempered hardboard. One green stripe indicates standard hardboard.

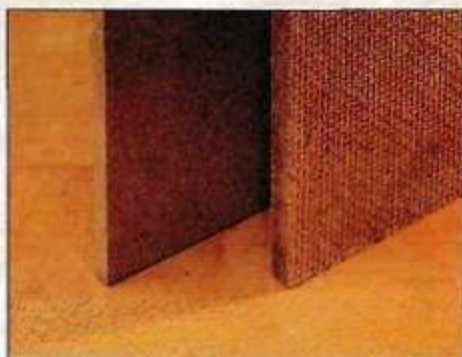

B. Textured Back. This "waffle" imprint is typical of what you'll find on hardboard that's smooth on one side only.

New Products

Here's a look at three new tools that have found a place in our shop.

Try Square

■ For years I've kept a small steel ruler and an engineer's square in the pocket of my shop apron. They're both handy for layout work and checking workpieces for thickness and square.

But when I came across this small adjustable try square in a recent Bridge City Tool Works catalog, I knew it was time to replace the square and ruler I'd been using. The Bridge City AS-3

(\$52) combines the two tools I use most often into one tool that fits nicely in the pocket of my apron.

It's the most accurate square I know of on the market today. It comes calibrated from the factory with an accuracy of at least .001" over the length of the blade.

And if it ever does go out of square I can recalibrate it by adjusting two small set screws located in the body, see photo.



Source:
• Bridge City Tool Works
800-253-3332

Miter Gauge

■ Most miter gauges on the market are either too expensive, too big, or have too many bells and whistles for me. But at \$79.95, this AngleWright miter gauge is exactly what I've been looking for. The price is reasonable. It's not too big. And it's simple to use.

But what impresses me the most is its accuracy. The manufacturer says it's accurate to within a 1/15th of a degree. And I

believe it. All my 90° crosscuts and 45° miters are dead on.

To change angles, it's simply a matter of loosening a brass knurled nut and repositioning the head on the bar. There are also three Teflon pins in the bar so you can adjust it to ride smoothly in the miter gauge slot with no slop.

And, the head even comes pre-drilled so you can add your own auxiliary fence.

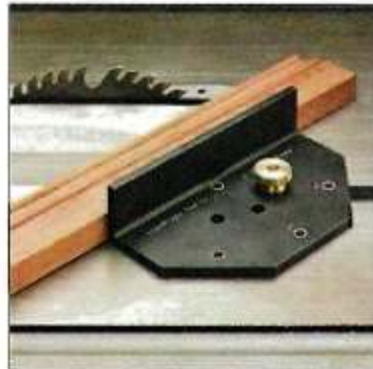

Sources:
• AngleWright Tool Co.
310-471-7432
• WoodsmithShop
800-444-7002

Bench Dogs

■ Adding a vise with a bench dog system to a workbench can be a challenge. It can also be expensive. But with these Veritas dogs (the Wonder Pup \$19.95 and the Wonder Dog \$24.95), it's just a matter of drilling a few 3/4"-dia. holes and dropping them in place.

The Wonder Pup is used like a traditional bench dog. Just drop it in the hole to hold a workpiece flat against the bench. The taller,

spring-loaded Wonder Dog is ideal for securing larger workpieces to the bench.

Both dogs come with the same 3/4"-wide (tall) brass head to protect your chisels and plane irons.

Also, in a pinch, a pair of them can even be used to make an extra-long bar clamp. To do this, first drill a hole in each end of a scrap piece of 2x4. Then insert a bench dog (or pup) in each hole.



Sources:
• Veritas Tools Inc.
800-267-8767
• Constantine's
800-223-8087
• The Woodworkers' Store
800-279-4441

Shop Solutions

Sanding Box



■ I sand a lot of curved parts with a drum sander in the drill press. In the past, I've used a separate table for each different sized drum. To simplify things, I made a sanding box that can be used with my entire set, see photo.

It's a deep plywood box with an oversized top and bottom, see drawing. There's a hole in the top for large drums and another one in the bottom for small drums. (The depth let's me "bury" the drum and use the full sanding

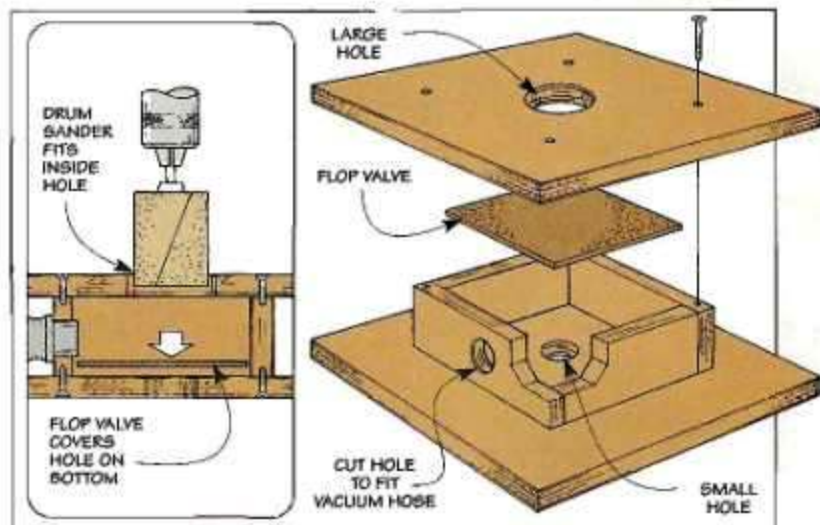

surface.) A third hole cut in the side is for a vacuum hose.

To improve suction, I added a "flop-valve." It's just a piece of Masonite that flops over to cover

the top or bottom hole when you turn the box over.

*Paul Herrick
Reedville, Virginia*

Band Saw Table Extension

■ Using a band saw is a quick way to cut large pieces of stock down to size. But the table that comes with most saws isn't built large enough to handle these pieces safely or comfortably.

To solve this problem, I made a

simple table extension. It's just a U-shaped piece of $\frac{3}{8}$ "-thick plywood that fits around my existing table, see Fig. 2.

To support the extension, I attached brackets directly to the saw table, see Fig. 1. They're po-

sitioned so that the extension ends up flush with the table top.

Then, to hold the table firmly in place, just screw down through the extension into the brackets.

*Bob Gessner
Kennesaw, Georgia*

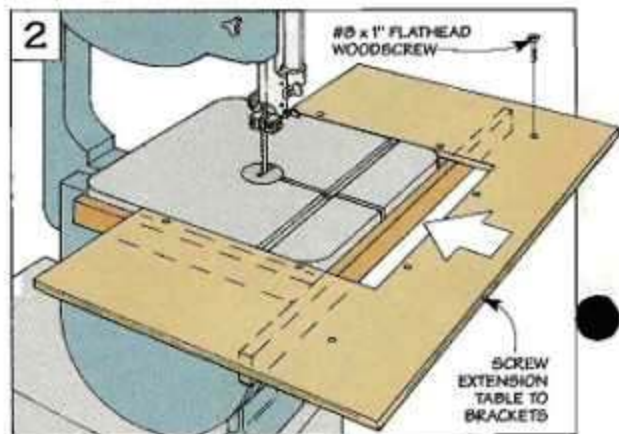
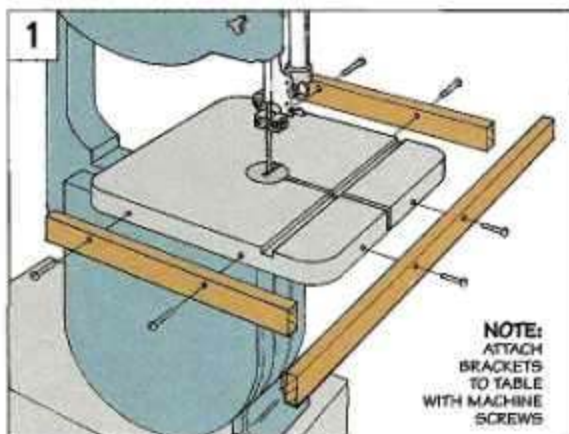

Quick Air Filter

■ Even though all the machines in my shop are hooked up to my dust collector, I've noticed there still seems to be a lot of fine dust left floating in the air after making a cut. To solve this, I made an "air" filter. It hooks up to my dust collector just like one of my machines, see drawing.

This air filter is basically a large plywood box with a lip on the front. This lip holds an inexpensive pleated furnace filter. Note: It's a good idea to purchase the filter before you begin construction on the box.

A groove cut in the top and bottom pieces creates a slot for the filter to slide in and out, see detail. And a hole cut in the back lets you hook up the hose or

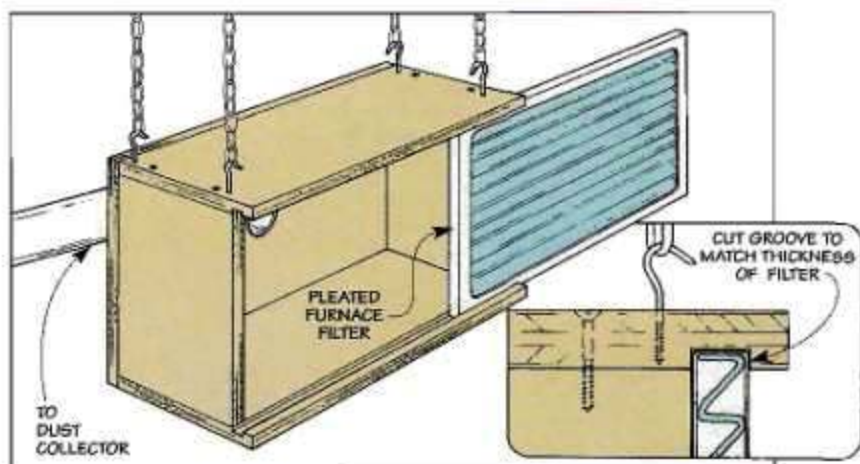

ducting from your dust collector.

For the best results, hang the air filter from the ceiling in a central location. And periodically check to make sure that the filter

isn't clogged — especially after you've completed a round of heavy sawing or sanding.

*Dave Zavada
Long Point, Illinois*

Band Clamp Corner Blocks

■ I've built the band clamps featured in *ShopNotes* No. 17. To make them even better I added corner blocks, see drawing. The 90° angle on each block automatically squares up your project when the clamp is tightened.

They're just shorter versions of the band clamp but without the eye bolt, wing nut, and end piece. With the end piece gone they're easier to add or remove.

*Bobby Cosey
Brewton, Alabama*

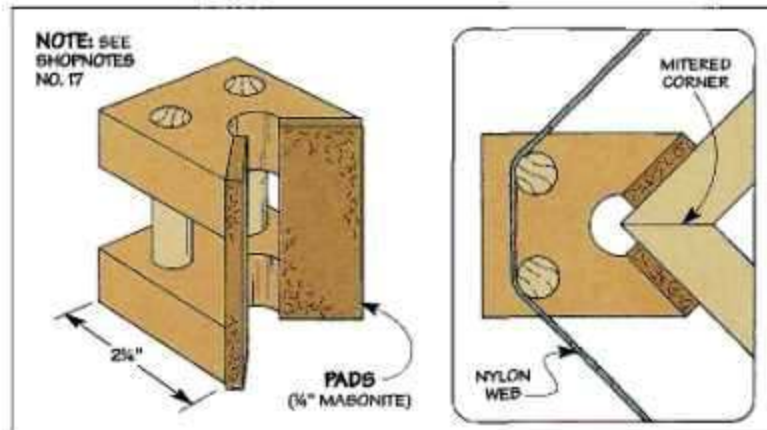

Magnetic Vise Pads



■ I often need to install or remove the pads from my metal bench vise. To make it easy, I made them magnetic, see photo.

Just drill several holes in the back of each pad and epoxy an inexpensive magnet in each hole. (Magnets are available at most craft and hobby stores.)

*Jeff Irland
Eatontown, New Jersey*

Send in Your Solutions

If you'd like to share your original solutions to problems you've faced, send them to: *ShopNotes*, Attn: Shop Solutions, 2200 Grand Avenue, Des Moines, IA 50312. (Or if it's easier, FAX them to us at: 515-282-6741.)

We'll pay up to \$200 depending on the published length. Please include a daytime phone number so we can call you if we have questions.

Surface Preparation

To end up with a professional looking finish, start with careful surface preparation.

Applying a finish is like a “Catch-22.” Although it emphasizes the color and grain of the wood, it also puts a magnifying glass on even the tiniest flaws.

Once you apply the finish, any tool marks, nicks, or glue spots will stand out like a chrome bumper on a hay wagon. Fortunately, you can prevent this by carefully preparing the surface of the wood.

As a rule, I get as many pieces as possible ready for the finish *before* assembly. Take a table for instance. It’s easier to sand the legs and apron separately than when they’re joined together at right angles. Note: To ensure a tight fit, just be sure not to sand around the areas where the pieces join together until after you assemble the project.

TOOL MARKS. Working on the pieces individually also makes it

easy to see the “ridges” that often get left behind by the cutters on a jointer, planer, or router. Especially if you shine a light across the work at

a low angle, see photo above. To remove these ridges, I use an ordinary hand scraper, see photo A.

But a scraper leaves a surface that looks different than the surrounding area when you apply a finish. So you’ll need to create a smooth, uniform surface by sanding.

SANDING. Although it’s not the most exciting job in the world, sanding doesn’t have to be a time-consuming chore. The key is to work more efficiently—not harder.

It goes without saying that a power sander speeds up the process, see photo B. But while this



works fine on large, flat surfaces, the “give” in the foam pad tends to round over the edges. To maintain a crisp edge (especially on narrow pieces), I switch to a sanding block, see photo C.

GRIT. Another thing to consider is the sandpaper grit. If it’s too coarse, the sandpaper leaves deep scratches that take a long time to sand out. So unless the surface is extremely rough, I start with 120-grit sandpaper on most projects.

Even so, don’t waste time with 120-grit if you run across a deep

Step-by-Step



A. Scraper. Use a scraper to remove any tool marks or ridges. Skew the scraper at an angle for the best cut.



B. Power Sanding. A power sander makes quick work of removing material on large, flat surfaces.



C. Hand Sanding. But on a narrow workpiece, a sanding block ensures a crisp corner and a flat surface.

scratch. Switch to a coarser grit to remove the scratch. Then, to ensure that the area takes the finish (or stain) evenly, go back over it with 120-grit sandpaper.

CHANGE PAPER. As you sand, change the sandpaper frequently. The abrasive particles only cut fast for the first few minutes. So it just doesn't pay to massage the surface with worn out sandpaper.

DIRECTION. The direction you sand is also important. The old rule of thumb holds true here — sand *with* the grain in a back and forth motion. The noticeable scratches left behind if you sand across the grain require a lot of resanding to remove.

CHECK PROGRESS. The dust that builds up as you sand will make the surface *feel* smooth. But the real test is how it *looks*. The goal here is to get a consistent pattern of scratches.

But in order to check, you'll need to clean off the dust, see photo D. This also picks up any loose pieces of abrasive which can leave telltale scratches of their own when you sand with a finer grit.

FINE GRIT. Basically, the fine grit sandpaper creates a series of small scratches that replace the ones made by the previous grit. While it's tempting to “jump” a few grits to save some time, you actually end up sanding *longer* with very fine grits. So I follow up with the next finest grit (150).

The final grit you work up to depends on the finish. For a thin, oil finish where the feel of the wood is important, I sand with 180 and 220 grits to create an extra-smooth surface. But with a built-up finish like varnish or lacquer, 150-grit is plenty smooth.

END GRAIN. One exception to all this is end grain. Because it's

Sanding doesn't have to be a time consuming chore. The key is to work efficiently — not harder.

porous and soaks up more finish (or stain), the color will be darker than surface grain. To get around this, an old trick that works well is to sand end grain one grit finer.

GLUE. Although it's convenient to sand pieces in advance,

Sanding Tips

- Start with 120-grit sandpaper, but use coarser grits for problem areas.
- Change sandpaper frequently to produce the best cutting action.
- Check that sandpaper is tight on power sander or sanding block.
- Use progressively finer grits of sandpaper without skipping grits.
- When hand sanding, use a back and forth motion and go with the grain.

there's a “catch” when you assemble the project. Any glue squeezeout that's left on the wood will show up as a light spot when you apply a stain or finish.

The best way to remove glue is to wait until it “skins” over and scrape off the excess, see photo E. Or simply keep the glue from getting on the wood in the first place, see margin at right.

MINERAL SPIRITS. One final note. No matter how careful you are, there's always a chance of a stray “glueprint” going unnoticed. To make these smudges reappear, I wipe down the project with mineral spirits, see photo F.

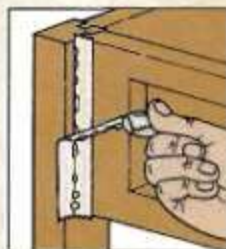

Use masking tape to keep any glue that squeezes out from getting on the wood.



D. Vacuum. Remove sanding dust and bits of abrasive that have fallen off with a shop vacuum and brush.



E. Remove Glue. After you've assembled the project, scrape off the “skinned over” glue with a chisel.



F. Mineral Spirits. Wiping down the surface with a rag soaked in mineral spirits reveals stray glue smudges.

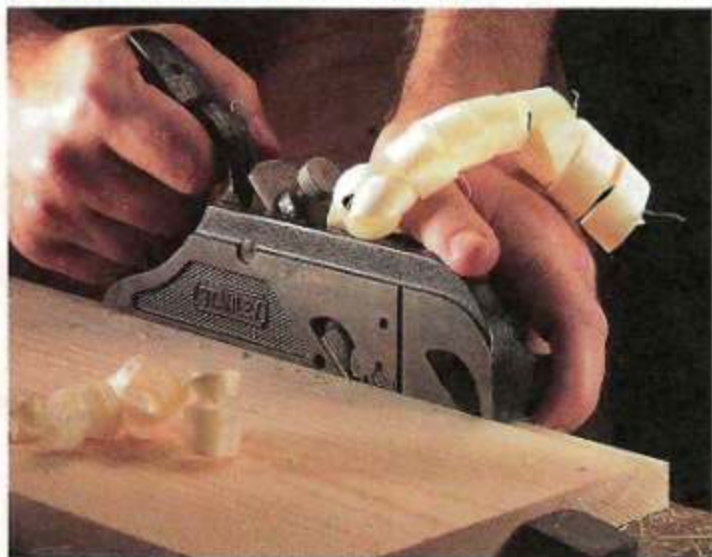
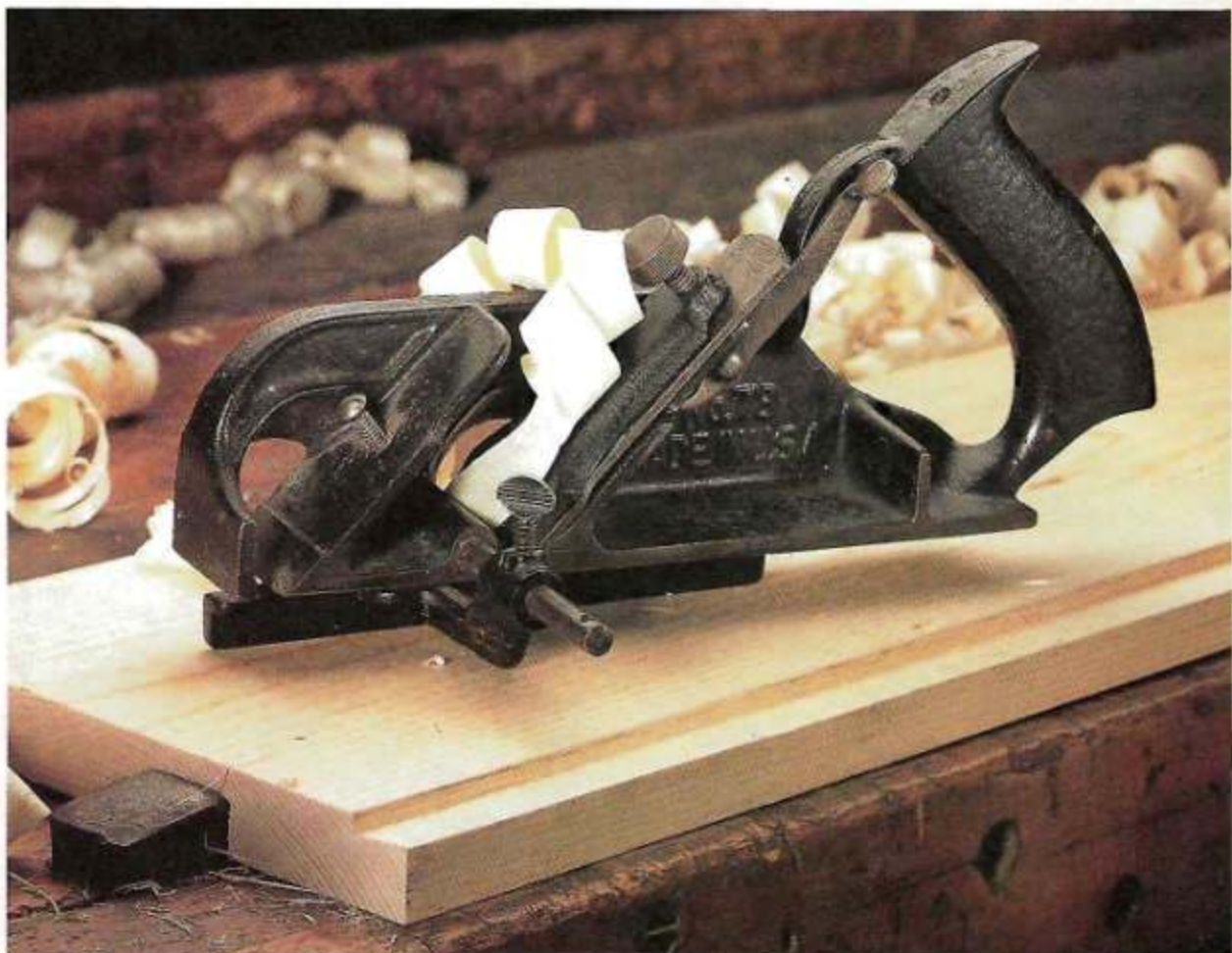

Scenes From the Shop

This classic Stanley No. 78 rabbet plane peels off ribbons of wood to produce a clean, crisp rabbet. The adjustable fence slides on a post to set the width of cut.

The single blade can be used in one of two positions. In the center, for a standard cut. Or up front in the "bull-nose" position when you need to cut in tight to a corner.