

TIPS • TOOLS • TECHNIQUES

ShopNotes®

Vol. 3

Issue 16

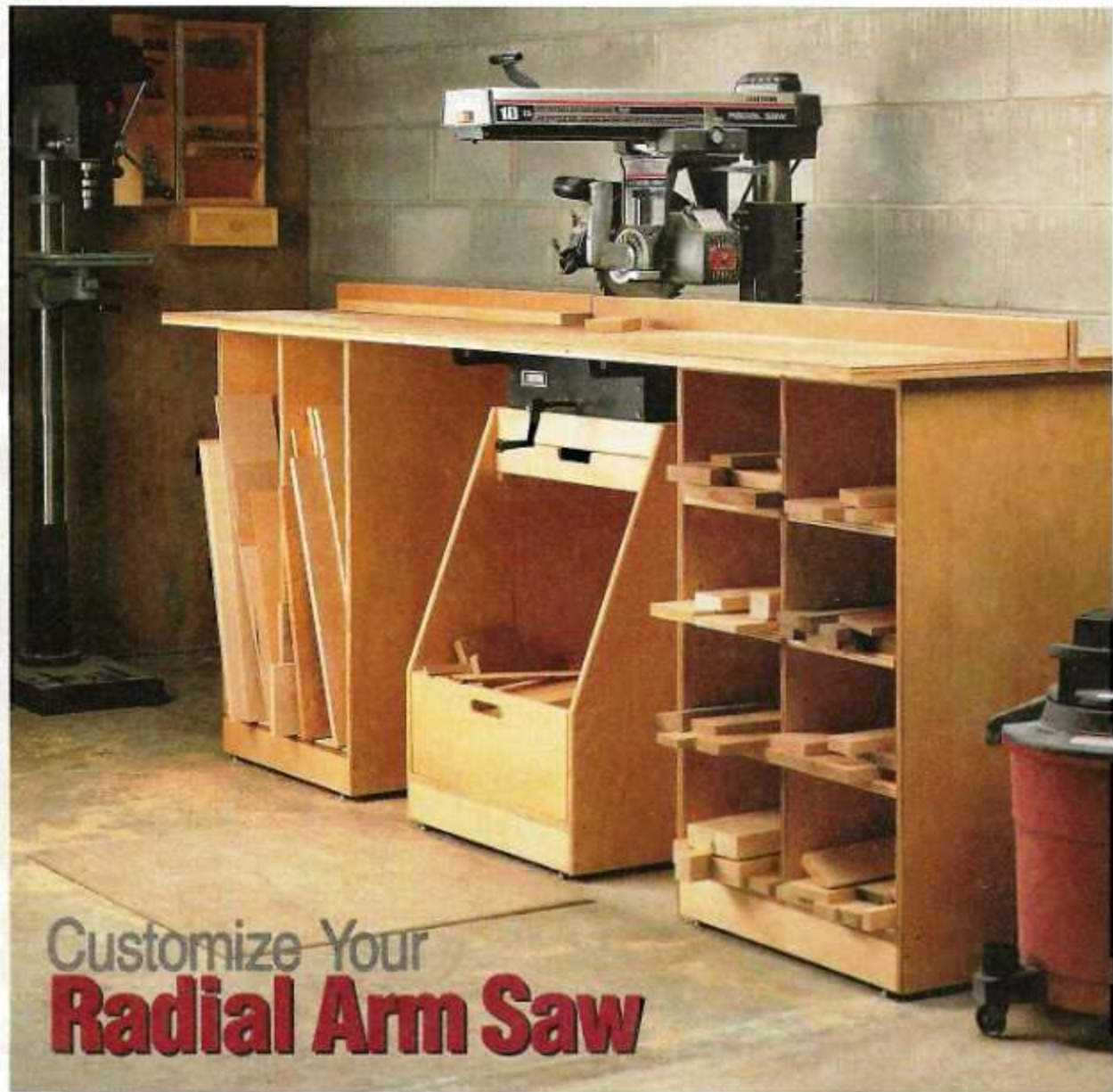

Customize Your
Radial Arm Saw

- Compact Drill Bit Cabinet
- Reducing Tool Noise
- Handy Circular Saw Cut-Off Jig
- Flexible Veneer



ShopNotes

Issue 16

July 1994

EDITOR Donald B. Peschke
EXECUTIVE EDITOR Douglas L. Hicks
MANAGING EDITOR Richard S. Peters
ASSOCIATE EDITOR Tim Robertson
ASSISTANT EDITOR Phil Totten
CONTRIBUTING EDITOR Mark A. Williams

CREATIVE DIRECTOR Ted Kralicek
ART DIRECTOR Cary Christensen
SENIOR ILLUSTRATOR Kurt Schultz
ILLUSTRATORS Will Niskanen
 Roger Relland
 Mark Higdon
PHOTOGRAPHER Crayola England

DESIGN DIRECTOR Ken Munkel
SENIOR DESIGNERS Jan Hale Svec
 Kent Welsh
SHOP MANAGER Steve Curtis
SHOP ASST./FACILITIES Steve Johnson

CIRCULATION

Circulation Director: Lia Bredeson • *Subscription Manager:* Phyllis Jensen • *Circulation Analyst:* Rod Cain • *Newstand Sales:* Kent A. Buckton

PUBLISHING SERVICES

Manager: Gordon C. Gaippe • *Senior Graphic Designer:* Robert H. Whitmer • *Graphic Artist:* Cheryl L. Cynor

CORPORATE SERVICES

Controller: Robin Hutchinson • *Accounting:* Laura Thomas • *Bookkeeping:* Julie Greenlee • *Production Manager:* Carol Quijano • *Info. Services Manager:* Joyce Moore • *Elect. Pub. Coordinator:* Douglas M. Lidster • *App. Specialist:* Linda Morrow • *Support Assistant:* Nick Thielen • *Admin. Assistant:* Cheryl Scott, Julia Fiah • *Receipt:* Jeanne Johnson • *Building Maint.:* Ken Griffith

PROJECT SUPPLIES

Marketing Director: Robert Murry • *Catalog Art Director:* Cindy Jackson • *Fulfillment Manager:* Valerio Wiese • *Catalog Products Manager:* Bob Baker • *Project Supplies:* Linda Jones • *Technical Support:* Jeff Jones • *Receipt:* Cynthia Kerman

CUSTOMER SERVICE

Supv.: Jennie Enos • *Cust. Serv. Reps.:* Jennifer Murphy, Joy Krause, Sara Kono, Anna Cox, Kristi Andrews, Lonnie Algreen, Karla Cronin

SHIPPING DEPARTMENT

Supervisor: Jerry Carson • *Fulfillment:* Gloria Sheehan, Don McVey, Chuck Carlson, Sylvia Carey

ShopNotes® (ISSN 1092-8636) is published bimonthly (Jan., March, May, July, Sept., Nov.) by Woodsmith Corporation, 2200 Grand Ave., Des Moines, IA 50312.

ShopNotes® is a registered trademark of Woodsmith Corp. ©Copyright 1994 by Woodsmith Corporation. All rights reserved.

Subscriptions: Single Copy, \$4.95. One year subscription (6 issues), \$19.95. Two years (12 issues), \$36.95. Canada/Foreign, add \$5.00 per year.

Second Class Postage Paid at Des Moines, IA and at additional offices.

Postmaster: Send change of address to ShopNotes, Box 11204, Des Moines, IA 50340-1204

Subscription Questions? Call 1-800-833-6554, Sun to 5pm, Central Time, weekdays.

PRINTED IN U.S.A.

EDITOR'S NOTE

Storage. It's one of the first things I notice whenever I visit a shop. Of course the tools also catch my eye. But it's the shop-made tool cabinet or unusual built-in that I wander over to first. I'll open a door and peek at the contents. Or slide a drawer out of a tool stand to see how things are organized.

Why such a fascination with storage? First of all, I think that you can learn a lot about a woodworker by how his shop is organized.

Second, over the years I've visited a lot of well-organized shops — some huge, some tiny. And there's a common string that ties them all together. It's that they use every square inch of space.

Granted, each of these shop owners said they could use more space. But I've discovered that their secret was they took advantage of the limited space they had. Sometimes filling in every nook and cranny.

The point is you can do this too. You don't have to go and buy all new tools to make your shop more organized — and more enjoyable to work in. Sometimes all it takes is a new tool stand, or a simple cabinet for your accessories.

RADIAL ARM STAND. Take the Radial Arm Saw Stand in this issue for example (page 16). It effectively organizes all your cutoffs. No more stacks or piles of scraps cluttering up the floor.

And best of all, it doesn't require any additional room. It replaces your old metal stand. And takes advantage of an area that's notorious for wasting space — under your saw.

DRILL BIT CABINET. But you don't have to build a tool stand to help organize your shop. You can make something simple. Like the Drill Bit Cabinet shown on page 12. It mounts on the wall

next to your drill press to keep all of your bits in one central location — and right at your fingertips.

NOISE IN THE SHOP. In addition to getting organized, there's something else you can do to make your time in the shop more enjoyable — reduce the noise level. Not only does this make it more comfortable (and safer) for you. It's also easier on family, friends, and nearby neighbors.

Reducing the noise level in your shop takes a concerted effort. I've found that it's the little things that add up. Using a variable speed tool at a slower speed.

Or using a rubber mat to help reduce vibration and noise.

In this issue, you'll find the first in a two-part series

on noise in the shop — reducing tool noise. Simple things that you can do to stop noise at the source. Next issue we'll look at what you can do to your shop itself (walls, ceiling, doors, etc.).

SOME CHANGES. There have been some changes here at ShopNotes. Terry Strohman, a driving force behind ShopNotes from the very start, has moved to become the Managing Editor of our other magazine, Woodsmith. I'm happy to announce that Rick Peters will take over the reins as Managing Editor of ShopNotes.

In addition, Tim Robertson has been promoted to Associate Editor. And Phil Totten has come over from Woodsmith as an Assistant Editor.

A couple new faces: Mark Williams is our new Contributing Editor. Nick Thielen, Support Assistant, keeps the computer system from acting up (most of the time). And Lonnie Algreen and Karla Cronin are full-time Customer Service Representatives. Now, if I can just remember all these new names.

You don't have to buy new tools to make your shop more enjoyable to work in.

Contents

Circular Saw Cut-Off Jig _____ 4

This shop-built accessory allows you to use your portable circular saw to make perfectly straight or angled cuts with dead-on accuracy.

Flexible Veneer _____ 8

A close-up look at the different types of flexible veneer. Also, step-by-step instructions for applying and finishing flexible veneer to produce professional-looking results.

Drill Bit Cabinet _____ 12

Organize your drill bits and accessories with this compact cabinet. It features storage trays that tilt out for easy access to your bits, and an optional drawer for accessories.

Radial Arm Saw Stand _____ 16

This modular system is more than just a stand for your radial arm saw. By taking advantage of the unused space under your saw, it makes it easy to organize cutoffs, sheet goods, and scrap pieces of wood.

Reducing Tool Noise _____ 24

The noise your tools generate doesn't have to drive your family (or neighbors) out of the house. Here are some simple tips for putting a damper on the worst offenders.

Shop Solutions _____ 28

Six Shop-Tested Tips: Band Saw Fence, Adjustable Runner for Miter Gauge Slot, Putty Shield, "Window" for your Dust Collector, plus two Quick Tips.

Medium-Density Fiberboard _____ 30

Because it's flat, smooth, and dimensionally stable, medium-density fiberboard (MDF) is an ideal material for many projects.

Sources _____ 31

Hardware, project supplies, and mail order sources for the projects in this issue.



Cut-Off Jig

page 4



Flexible Veneer

page 8



Drill Bit Cabinet

page 12

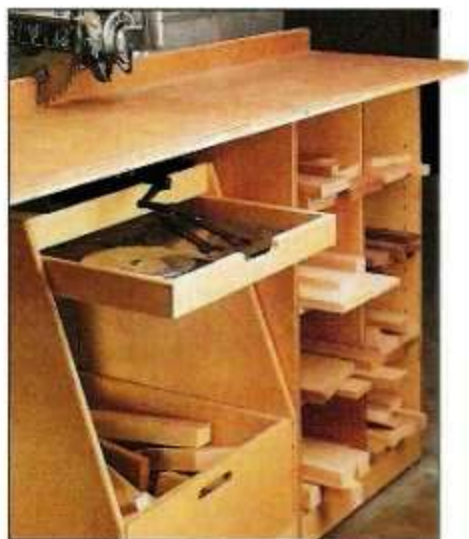

Radial Arm Saw Stand

page 16

Circular Saw Cut-Off Jig

You can turn your portable circular saw into a precision tool with this shop-built accessory.



It's hard to beat a radial arm saw (or power miter saw) for making a crosscut on a long board. But if you don't have one of these tools, this can be a real challenge.

Even though a table saw has the advantage of built-in accuracy, using it to cut a long workpiece is awkward at best. And if you make the cut with a portable circular saw, the results are often less than perfect.

To combine the accuracy of a table saw with the portability of a circular saw, I made a simple cut-off jig, see the photos above. This jig solves one of the biggest problems of using a circu-

lar saw — getting a perfectly straight cut that follows the layout line exactly.

REFERENCE. What makes it work is the edge of the jig serves as a *reference* to indicate the path of the saw blade. As a result, there's no guesswork when setting up.

Just mark the board, position the edge of the jig on the line, and make the cut. (For more on using the jig, refer to the boxes on page 7.)

ANGLED CUTS. Although I use the jig most often to make 90° cuts, it's designed to make angled cuts as well, see inset photo. In fact, this makes the jig so handy that it recently disappeared for

several days when one of the guys needed to miter the ends of the construction lumber he was using to build a deck.

CONSTRUCTION

Basically, the cut-off jig consists of four parts: a base for the saw to ride on, a fence that guides the saw, and a curved arm and edge guide that work together to make the jig adjustable, see the Exploded View below.

BASE. I began work by making the *base (A)* from a piece of $\frac{1}{8}$ " Masonite, see Fig. 1. Since I wanted the jig to span a 2x12 when cutting a 45° miter, I made the base $22\frac{1}{2}$ " long. And since the first cut is

Hardware

- (6) #8 x $\frac{1}{2}$ " Fh Woodscrews
- (1) $\frac{1}{4}$ " x $1\frac{3}{4}$ " Fh Machine Screw
- (2) $\frac{1}{4}$ " Washers
- (1) $\frac{1}{4}$ " Lock Nut
- (1) $\frac{1}{4}$ " x $1\frac{1}{2}$ " Carriage Bolt
- (1) $\frac{1}{4}$ " Hex Nut
- (2) $\frac{1}{4}$ " x $1\frac{1}{4}$ " Fender Washers
- (1) $\frac{1}{4}$ " Plastic Wing Nut

EXPLODED VIEW

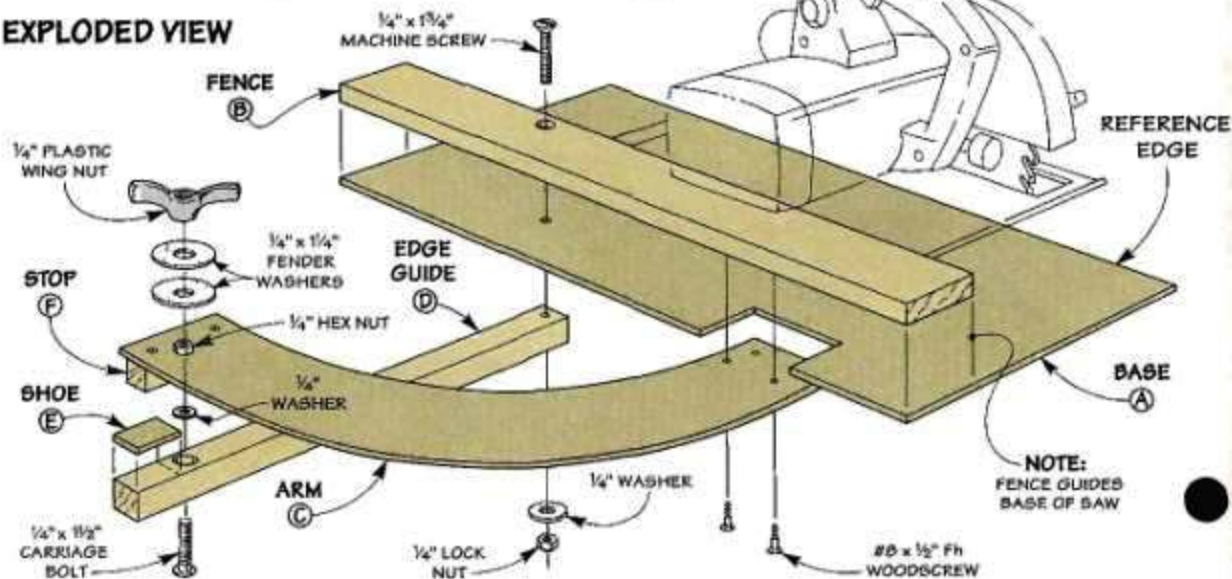

the one that creates the reference edge, it's *wider* than the distance from the edge of the saw base to the blade. (I started with a 10"-wide piece.)

NOTCH. After cutting the base to rough size, the next step is to cut a notch in one edge, see Fig. 1. This notch provides a recess for the arm that's added later.

FENCE. Once the notch is cut, you can add the *fence* (B), see Fig. 1. This is a piece of 1/2"-thick hardwood that guides the base of the saw during a cut.

To cover the notch in the base, the fence is 3" wide. And it's cut to match the length of the base (22 1/2"). After gluing the fence to the base so the edges and ends are flush, I drilled a countersunk shank hole for a machine screw that's added later, see End View in Fig. 1.

ADJUSTMENT SYSTEM

The most unique thing about this cut-off jig is a system that allows you to adjust it to make either 90° or angled cuts. This system is made up of two parts: the curved arm, and the edge guide that's added later, refer to Exploded View.

ARM. Basically, the arm acts as a "pressure plate" for a clamp that will be used to lock the edge guide in place. The arm is nothing more than a piece of 1/8"-thick Masonite that's cut in the shape of a curve, see Fig. 2. Note: There's a short (1 1/2"-long) "flat" along the edges of one end of the arm.

ATTACH ARM. Now it's simply a matter of fastening the arm into the notch that was cut earlier. To allow the clamp to apply pressure at any point along the arm, you'll need to orient the "flat" section so it extends away from the jig, see Fig. 3.

The opposite end is butted into the corner of the notch, see Fig. 3a. Then it's just glued and screwed to the fence. (For a complete hardware kit, see page 31.)

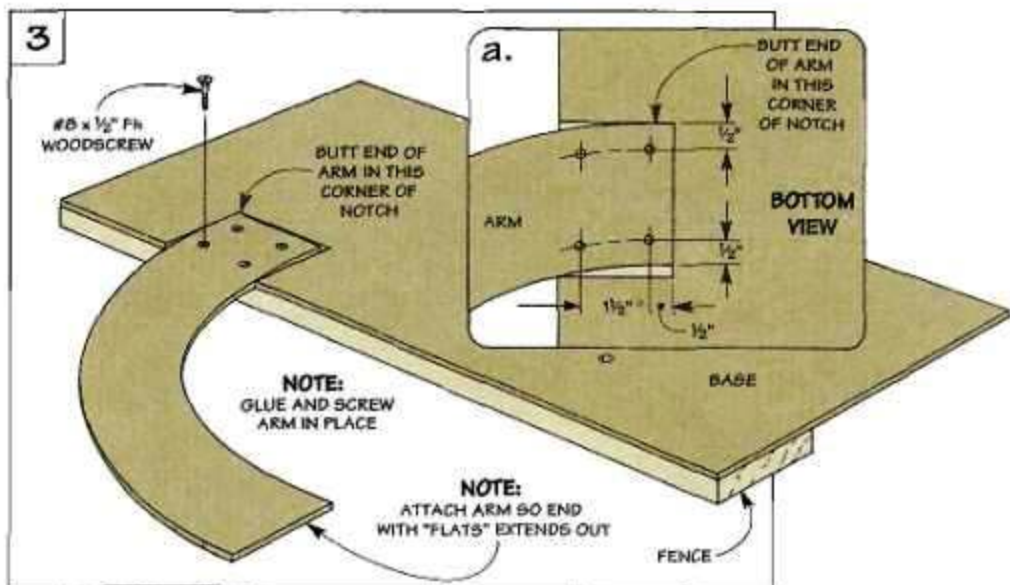
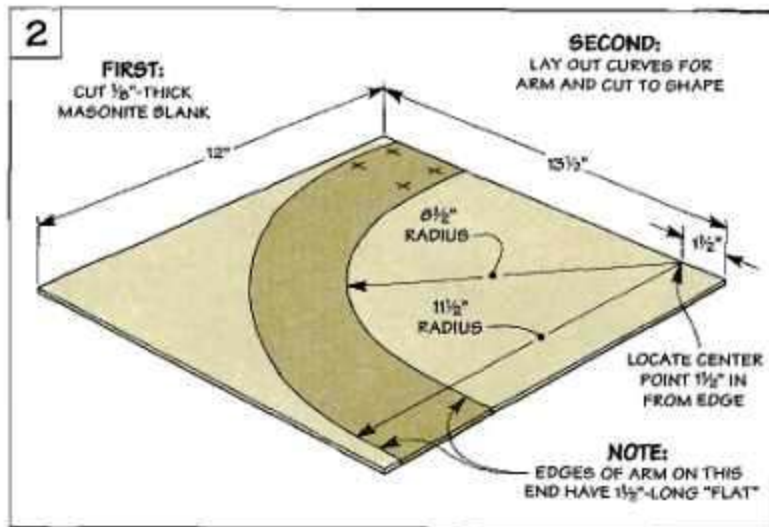
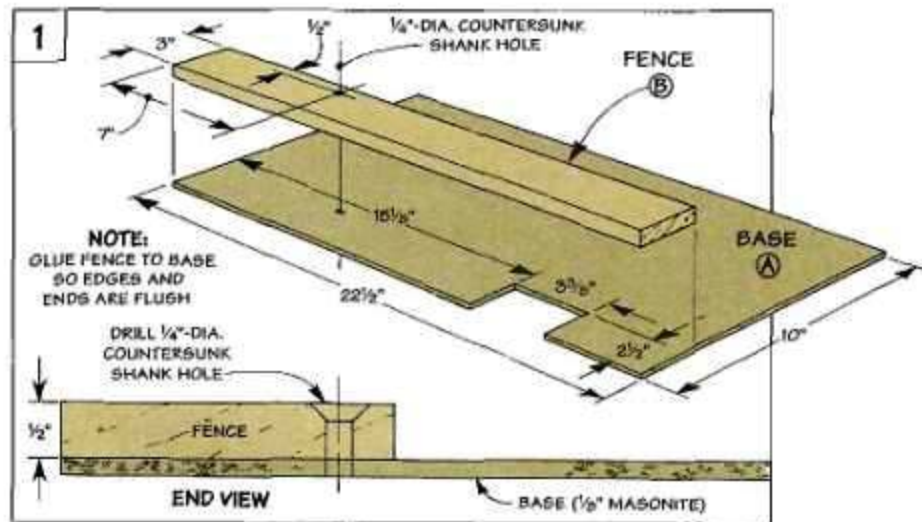

Edge Guide

With the arm in place, work can begin on the second part of the adjustment system — the edge guide. It pivots on the fence so you can make either 90° or angled cuts, see Fig. 4.

EDGE GUIDE. Basically, the edge guide (D) is nothing more than a 1"-wide strip of hardwood (maple) with two holes drilled in it, see Figs. 5 and 5a. One hole serves as a pivot point. And the other is a counterbored shank hole for a clamp assembly that's added later.

The edge guide is attached to the jig with a machine screw that passes through the hole in the fence and base that was drilled earlier, see Fig. 4b. To allow it to pivot back and forth easily, slip a washer over the end of the screw and tighten on a lock nut so it's just snug.

CLAMP ASSEMBLY. To lock the edge guide in place, I added a simple clamp assembly. It pinches the edge guide tight against the curved arm.

What makes this work is a carriage bolt that passes through the counterbored shank hole in the edge guide, see Fig. 4a. After securing the bolt with a washer and

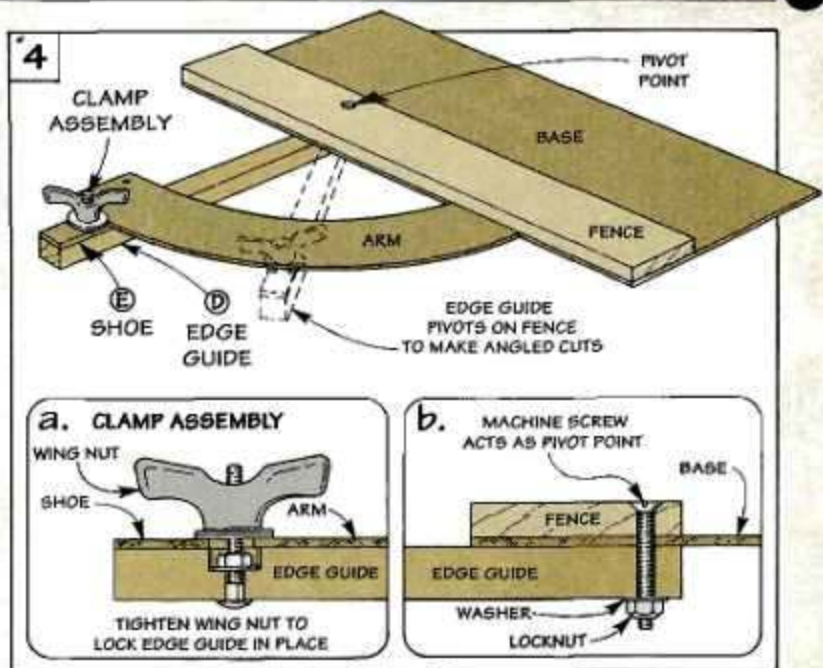

nut, clamping pressure is applied by tightening a plastic wing nut against two fender washers.

SHOE. To distribute the clamping pressure evenly on the washers, I shimmed the end of the edge guide with a "shoe." This shoe (E) is a piece of 1/8"-thick Masonite that's glued flush with the end of the edge guide, see Fig. 5.

STOP. The next step is to add a fixed stop (F), see Fig. 6. It provides a positive stop for the edge guide at 90° to the fence.

The important thing is to locate this block so the edge guide is perfectly square to the fence

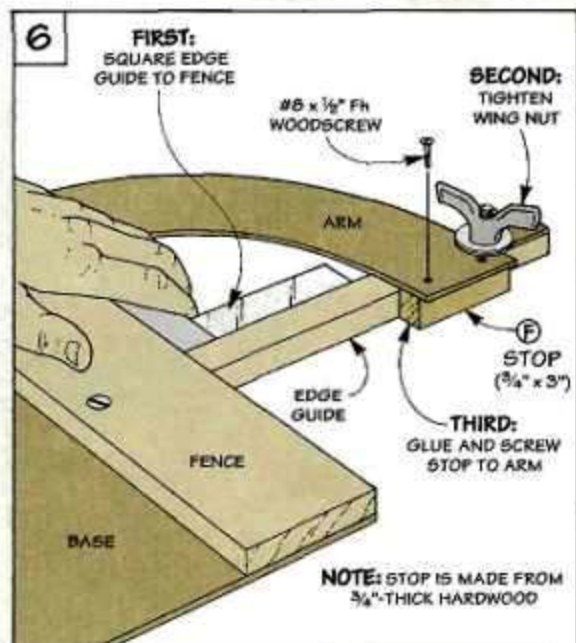
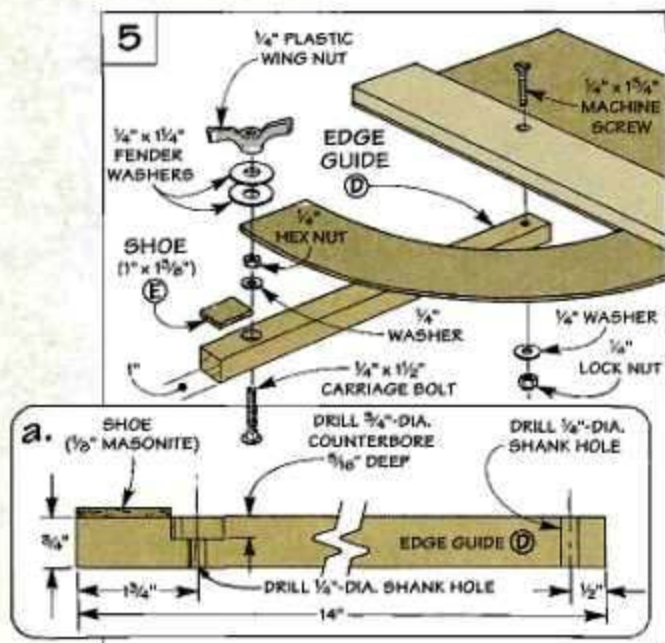

when it butts against the stop. To do this, I used a try square to position the edge guide so it's 90° to the fence. Then, after tightening the clamp, glue and screw the stop in place.

TRIM BASE. All that's left to do is trim the base to final width. This creates the reference edge that's used to position the jig. When trimming off the waste, I found it easiest to position the jig on a corner of the bench so it overhangs the edge, see Fig. 7. Note: For a tip on keeping the jig from shifting during a cut, see margin at right.

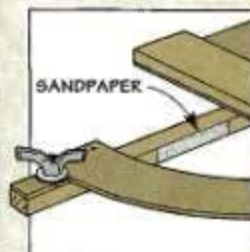
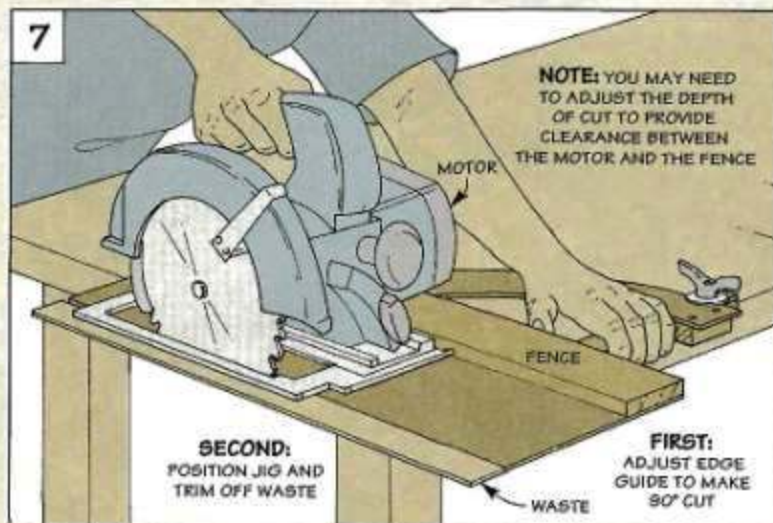

To keep the jig from creeping during a cut, apply a strip of sandpaper to the edge guide.

Square Cuts



Step 1: Position Jig. With the edge guide locked in place against the 90° stop, position the reference edge on the layout mark on the board.



Step 2: Make the Cut. Now hold the edge guide tight against the workpiece and run the base of the saw against the fence as you make a cut.

Angled Cuts



Step 1: Set Up Jig. To align the reference edge with the layout line, you'll need to pivot the edge guide and the base of the jig at the same time.



Step 2: Clamp and Cut. To prevent the jig from sliding when making an angled cut, use a C-clamp to hold the arm tight against the workpiece.

Flexible Veneer

The first time I unrolled a sheet of flexible veneer I couldn't believe how thin it was. Unlike veneer I've used in the past, it could be bent and rolled without cracking.

But the best thing I like about flexible veneer is you don't need to invest a lot of time and money to get professional-looking results. All you really need is a sharp knife and some contact cement.

WHY USE IT? For many projects, flexible veneer can be a low cost alternative to solid hardwood or hardwood plywood. You can cover a project with a fancy wood (such as birds-eye maple) at a fraction of the cost it would take to build it out of solid wood.

WHAT IS IT? Unlike standard veneer that's usually $\frac{1}{32}$ " to $\frac{1}{40}$ " thick, flexible veneer is cut much thinner — about *half* as thin.

Because it's so thin, flexible ve-

neer requires a special backing to keep the thin layer of wood from splitting and breaking up.

THREE TYPES

There are three types of flexible veneer available: paper-backed, pressure sensitive adhesive, and foil-backed, see Drawings below.

PAPER-BACKED. The most common (and least expensive) type of

Unlike veneer I've used in the past, flexible veneer can be bent and rolled without cracking.

flexible veneer is paper-backed veneer. As the name implies, paper-backed veneer has a layer of brown paper glued to the back. Because it's so easy to work with, it's my first choice for most veneering projects.

PSA. Pressure sensitive adhesive (PSA) veneer is commonly referred to as peel and stick veneer. The only difference between

it and paper-backed veneer is that it has a thin layer of adhesive on the back. The adhesive is protected by wax paper until it's time to be used. Then you just peel off the paper and press the veneer in place.

Although there's no glue mess to clean up with PSA veneer, there is one drawback. I've found that the veneer has a tendency to come unglued over time.

FOIL-BACKED. Although foil-backed veneer looks just like paper-backed veneer, there is a big difference.

Instead of a single backing, there are two layers of paper with a layer of foil sandwiched between them. The foil prevents a lacquer-based finish from dissolving the adhesive.

Unfortunately, foil-backed veneer is expensive. And, if the edges are exposed, the foil is noticeable. So I only use it when the edges will be hidden. Or when I know I'm going to finish the project with a lacquer-based finish.

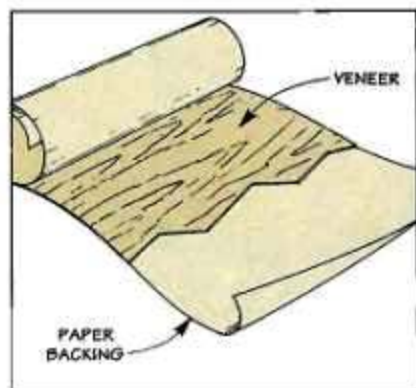

Paper-backed. The most common type of flexible veneer has a layer of brown paper glued to the back.

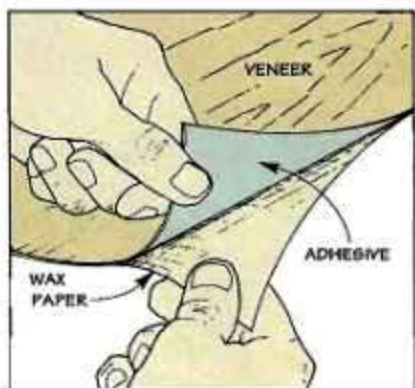

PSA. Commonly referred to as peel and stick, this veneer has a thin layer of adhesive applied to its back.

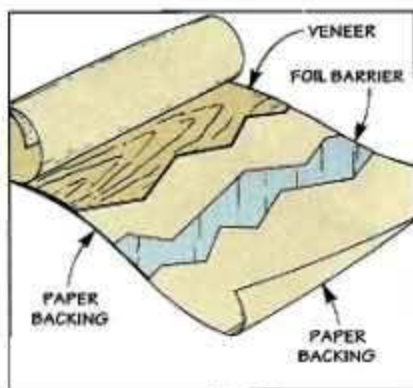

Foil-backed. A foil barrier prevents the adhesive from dissolving when using a lacquer-based finish.

Core Preparation

The goal with any veneer project is to keep the veneer glued *permanently* in place. I've found that it doesn't really matter how good the adhesive is unless you're using a suitable core material that has been properly prepared.

CORE MATERIAL. If I have a choice, I'll generally use medium-density fiberboard (MDF) for the core. (For more on MDF, see page 30.) But plywood can also be used.

If you do use plywood, the smoother the piece is, the better. I try to avoid any piece that has a lot of voids and cracks. But sometimes it just can't be avoided.

An example of this is when I need to laminate the *back* side of a piece of cabinet grade plywood. The back of this type of plywood is usually pretty rough. To improve this surface, I "prep" it.

CORE PREP. When preparing plywood, the first thing I do is give the surface a light sanding

with 180-grit sandpaper. This helps remove the fuzzy wood fibers that tend to stick straight up. Next, fill any holes or cracks with wood filler, see Step 1. Then when it's dry, sand the surface smooth again.

SEAL SURFACE. The next step is probably the most important. To help prevent the veneer from coming unglued, I seal the core

(regardless of the material) with sanding sealer, see Step 2.

This does two things. First, it fills the pores and cracks that the filler didn't cover. Second, it provides a more continuous surface for the adhesive to stick to.

Once the surface is completely dry, it's ready for the adhesive. (Unless of course you're using PSA veneer.)



Step 1. First, sand the surface and then fill any cracks and voids. After the filler dries, sand again.



Step 2. To help the contact cement stick, seal the surface with a thin coat of sanding sealer.

Applying Contact Cement

Once the surface is prepared, the next step is to apply contact cement to the core and veneer (unless you're using PSA veneer).

The problem is contact cement sticks instantly when two mating surfaces touch. So in order to ensure that the veneer covers all the edges completely, I cut it slightly *larger* than the core. This gives me a bit "extra" hanging over the edges to trim off later.

CEMENT. When shopping for contact cement, you should "stick" with a solvent-based adhesive. I've tried water-based contact cements — they just don't seem to hold as well.

BOTH SURFACES. For contact cement to work, both surfaces to be joined must be covered with adhesive. I use a stiff bristle brush to apply contact cement to small projects. But for larger pro-

jects, I use a small, short-nap paint roller, see Steps 1 and 2.

Be careful when rolling the adhesive not to go back over an area that you've already covered — the adhesive can stick to itself.

After the core and veneer are

both dry (about 15 to 20 minutes), check to see if a second coat is required. (You'll need a second coat if the first coat looks dull.)

Apply the second coat just like the first. Then after it dries, the veneer is ready to be applied.



Step 1. After the sanding sealer is completely dry, roll out one or two coats of contact cement.



Step 2. Next, you can apply one or two coats of contact cement to the paper-backed side of the veneer.

Placing Flexible Veneer

Since contact cement bonds instantly on contact, it's important to carefully align the workpieces before joining them together.

SMALL PIECES. When working with small pieces, I suspend the core over the veneer by hand, see Drawing A. Once it's "eyeballed" in place, lower the core.

Then I "roll" it out with a simple veneer burnisher, see Drawing B and margin tip at left. The rounded edge presses the veneer against the core, and forces out any trapped air.

LARGE PIECES. The trick to getting veneer exactly where you want it on a large core is to suspend the veneer over the core. To prevent the veneer from sticking before it's in position, I insert strips of wood between the core and the veneer, see Drawing C.

Then once the veneer is in place, slide out one strip at a time and press down the veneer. Shop Tip: To get the best possible bond after the veneer is in place, I use a shop-made veneer hammer, see the box below.



You can make a veneer burnisher by rounding over the bottom edges of a piece of 1/4"-thick Masonite.

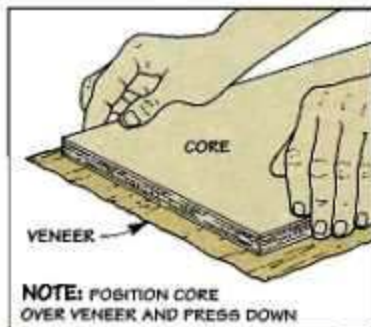

A. Small Pieces. First, position the core over the veneer. Then lower it down and press it in place.

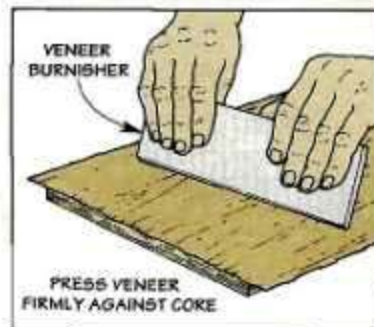

B. Veneer Burnisher. For a tight bond, use a veneer burnisher to press veneer against core.

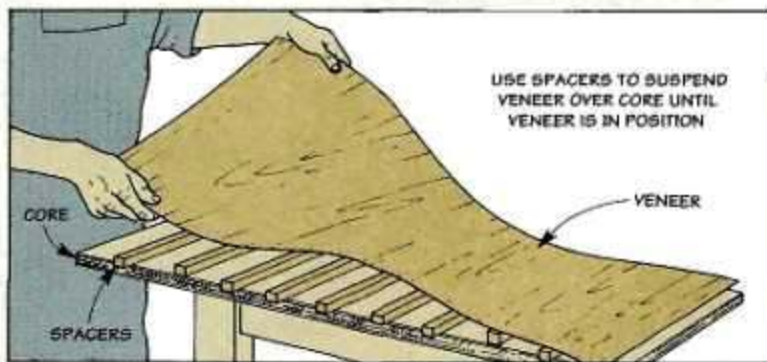

C. Large Pieces. When working with large pieces of veneer, it helps to have strips of wood between the core and the veneer. Once the veneer is aligned, remove the strips, one at a time.

Shop-Made Veneer Hammer

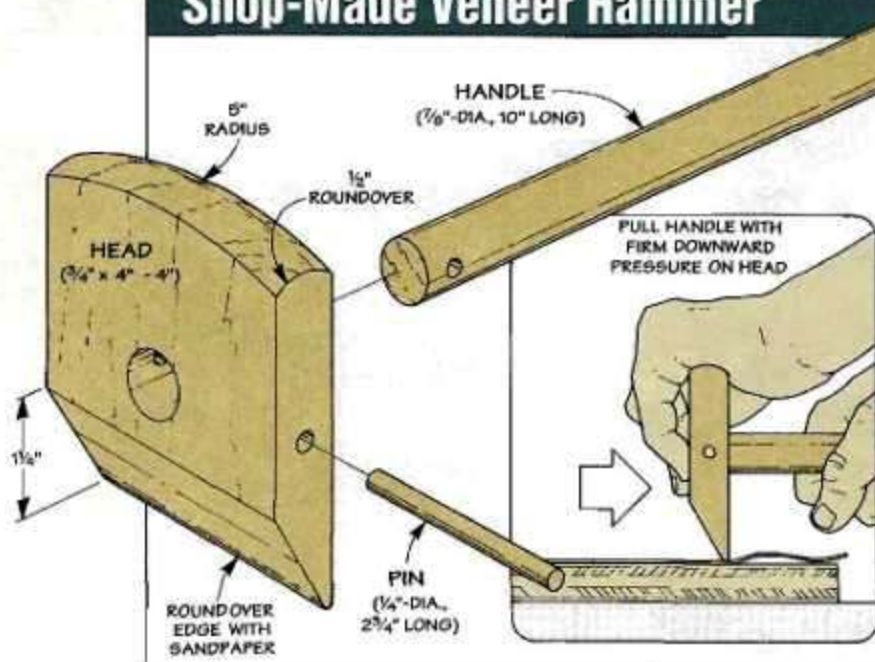

Even though this tool is called a veneer hammer, it's really not used to "pound" veneer. What it actually does is allow you to press veneer tightly against a core.

The idea is the narrower the head, the more pressure on a given area. And the more pressure, the better chance that the veneer will stick to the core.

HEAD. To get maximum pressure, I angled the bottom edge of the head and then rounded it over with sandpaper, see Drawing. And to comfortably press down on the head, I curved the top and rounded over the edges.

Finally, to provide leverage, I pinned a handle to the head.

Trimming & Finishing

Once the veneer has been pressed in place, the last step is to trim it to size.

KNIFE. My tool of choice for trimming most veneer is an ordinary utility knife, see Drawing A. The important thing is to use a sharp blade — it'll slice right through the thin veneer.

VENEER SAW. But whenever I have to cut highly figured veneer (like burl), I use a veneer saw, see Drawing B. To use the saw, place the side of the blade flat against the edge of the core. Then slide it back and forth as you would any other hand saw.

ROUTER. If you need to trim a lot of veneer, you can use a router with a flush trim bit, see Drawing C. Just run the router along the edge of the core. The bit trims the veneer perfectly flush.

TABLE SAW. Another quick way to trim a lot of veneer is to use a table saw — especially if the core and the veneer are oversize. But if the veneer is overhanging the core, the workpiece can't be placed against the rip fence.

To get around this, I "fool" the fence, see Drawing D. All it takes is a thin spacer between the core and the fence. After one side is trimmed, remove the spacer.

FINISHING

When you're ready to apply a finish, there are a couple of things to keep in mind.

SCRATCHES. First, since flexible veneer is extremely thin, you shouldn't use a cabinet scraper. If you do, you may cut through the veneer. If you have scratches to remove, sand them out with 240-grit (or finer) sandpaper.

THIN COATS. Second, some finishes can dissolve contact cement. So when you're applying a finish, apply several thin coats. This way, the solvents will evaporate before soaking through to the adhesive.

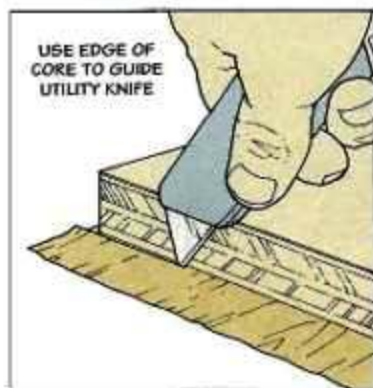

A. Utility Knife. When using a utility knife, flip the workpiece over and follow the edge.

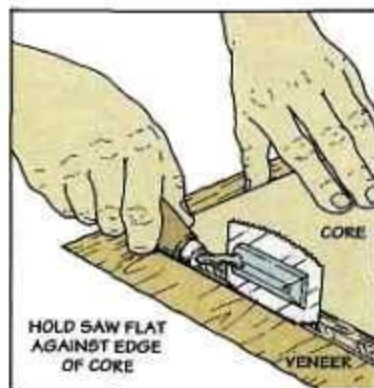

B. Veneer Saw. To trim the veneer, place the side of the saw flat against the edge of the core.

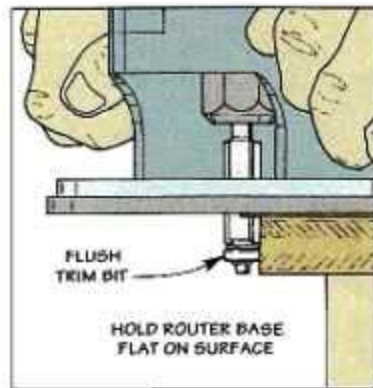

C. Router. A quick way to trim a lot of veneer is to use a flush trim bit and a hand-held router.

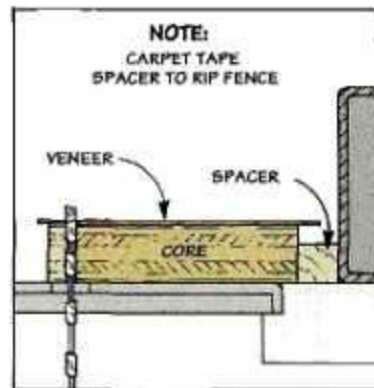

D. Table Saw. Another quick way to trim veneer is with a table saw. But you'll have to use a spacer.

Step-by-Step Veneering

- 1 Select Veneer.** Decide on a finish right away. Foil-backed veneer should be used for lacquer-based finishes. For other finishes, use paper-backed veneer.
- 2 Prep Core.** After filling dents or voids in the core with wood filler, sand the surface smooth and seal it with a coat of sanding sealer.
- 3 Apply Adhesive.** Apply contact cement to both surfaces. For small pieces, use a bristle brush. On larger projects, a short nap roller works best.
- 4 Place Veneer.** For greater control when working with small pieces, position core over veneer. For large pieces, use spacers to suspend veneer over core.
- 5 Press Veneer.** After the veneer is laid down, press it firmly in place with a shop-made veneer burnisher or a veneer hammer.
- 6 Trim Veneer.** For most projects, an ordinary utility knife will work just fine for trimming veneer. But you can also use a veneer saw, a router, or a table saw.
- 7 Apply Finish.** Carefully sand the veneered surface with fine grit sandpaper. Then apply several thin coats of finish to keep it from soaking through to the adhesive.

Drill Bit Cabinet

Tilt-out trays, shelves, and an optional drawer help store and organize your drill bits and accessories in one convenient place.



Sometimes it seems like there's a black hole in my shop where the one drill bit I need disappears. Although it eventually turns up, it's usually only after a frustrating search of all the different places I use to store drill bits.

To organize all of my drill bits

and accessories in one convenient place (and keep them from getting nicked or damaged), I built this simple cabinet, see the photo above. It's designed with one thing in mind — lots of storage in a compact space.

STORAGE. In spite of its small size, this cabinet provides all the storage I need. The back part of the cabinet houses two tilt-out trays that provide easy access

to my bits. And to store small accessories, there are two shelves inside the door. There's even an optional drawer that can be added if you need additional storage. (For more on this, refer to page 15.)

THE CASE

There's nothing complicated about building the case. It starts off as a simple wood box. Then it's cut apart to form two identical halves. This provides storage inside the door as well as the cabinet itself.

Basically, the case consists of a top and bottom (A) that are held together by two side pieces (B), see Exploded View. (I used $\frac{3}{4}$ "-thick maple.)

To accept the top and bottom, rabbets are cut on each end of the side pieces, see Rabbet Detail in Exploded View. Then two grooves are cut in each of the case pieces for a pair of plywood panels that are added next, see Groove Detail.

PANELS. The front and back panels (C) are made from $\frac{1}{2}$ "-thick plywood. This provides enough "thickness" to screw into when attaching the storage shelves and mounting the cabinet to the wall.

Shop Note: If you can't find $\frac{1}{2}$ "-thick maple plywood locally, you can glue up two pieces of $\frac{1}{4}$ "-thick birch plywood to make each panel.

EXPLODED VIEW

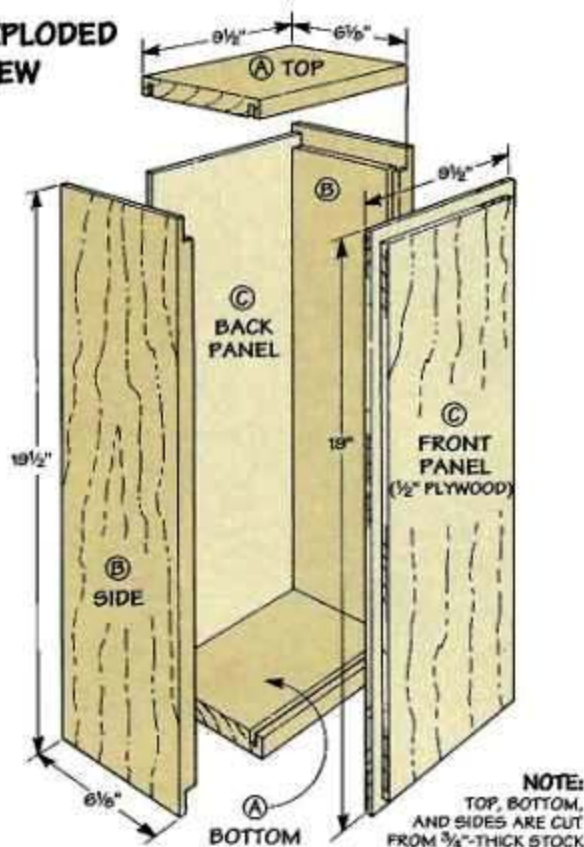

RABBET DETAIL

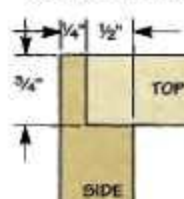

GROOVE DETAIL

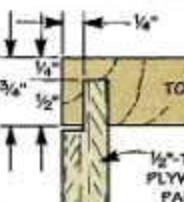

TONGUE DETAIL



RABBETS. With each of the panels cut to size, the next step is to cut rabbets around all the edges. This forms a tongue that fits in the grooves, see Tongue Detail in Exploded View.

The idea is to cut the rabbets deep enough so the tongue fits the groove. And wide enough to produce a slight "shadow line" between the sides and the panels. (I cut a $\frac{1}{16}$ "-wide rabbet which produces a $\frac{1}{16}$ " gap all the way around.)

GLUE-UP. After dry-fitting all the pieces, you're ready to glue and clamp the case together. Then, when the glue dries, it's just a matter of separating the case into two equal parts. (For more on cutting a box apart, see the box below.)

HINGE. The next step is to hinge the two halves of the cabinet together. To make it easy to install, I screwed a piano hinge into a shallow rabbet that's cut in one edge of each of the side pieces, see Figs. 1 and 1a. (For a complete hardware kit, see page 31.)

CATCH. After installing the hinge, a magnetic catch and strike plate are added to keep the

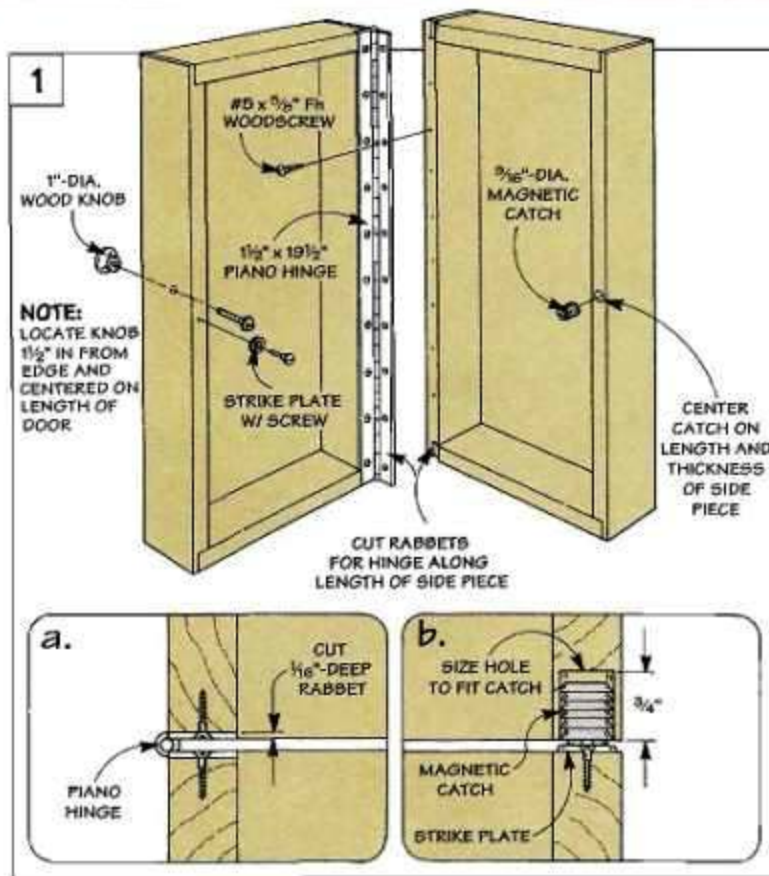

door of the cabinet closed tight, see Fig. 1. The catch fits in a hole that's drilled in the side piece on the back part of the cabinet, see Fig. 1b. And the strike plate is

screwed to the edge of the door.

KNOB. All that's left to complete the case is to add a wood knob. It's simply screwed in place on the door of the cabinet, see Fig. 1.

Hardware

- (6) #8 x $\frac{1}{2}$ " Fh Woodscrews
- (4) #8 x $\frac{1}{2}$ " Fh Woodscrews
- (1) $\frac{1}{2}$ " x $1\frac{1}{2}$ " Piano Hinge
- (20) #5 x $\frac{5}{8}$ " Fh Woodscrews
- (1) $\frac{3}{16}$ "-Dia. Magnetic Catch
- (2) 1"-Dia. Wood Knobs w/ Screws

Cutting a Box into Two Parts

Like a lot of woodworking operations, cutting a box into two parts looks more complicated than it is. All it takes is the right cutting sequence and a simple trick.

SEQUENCE. Start by cutting two opposite sides of the box, see Step 1. The problem is when you cut the next two sides, the saw kerfs can pinch the blade and cause kickback.

SPACERS. That's where the trick comes in. To prevent the kerfs from closing, slip a pair of spacers through the box, see Step 2.

After making the final two cuts, remove the tape and separate the two halves.

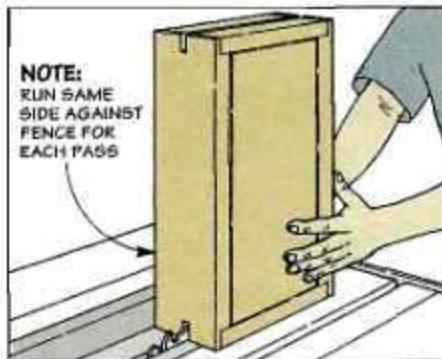

Step 1. After adjusting the height of the saw blade to cut through the thickness of the box, make a pass on opposite sides. Just be sure to run the same side against the fence for each pass.

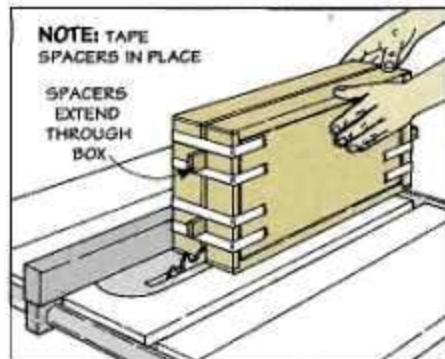

Step 2. To prevent the saw kerfs from closing up and pinching the blade, slip a pair of spacers made of $\frac{1}{8}$ " Masonite through the box. I use strips of masking tape to hold the spacers in place.

Storage Trays and Shelves

With the case complete, work can begin on the storage trays and shelves, see Fig. 2.

TRAYS

The back of the cabinet holds two trays for storing drill bits. To make it easy to remove a bit, these trays tilt forward out of the cabinet.

STAIRSTEP. Each tray organizes the bits in two "stairstep" sections. After building each section (I made four altogether) as a separate unit, they're simply glued together in pairs to form the trays.

CORE. Each section starts off as a *core piece (D)* made from $\frac{3}{4}$ "-thick hardwood, see Fig. 3. To allow the tray to tip out of the cabinet without binding, I cut each core piece $\frac{1}{16}$ " narrower (shorter) than the cabinet opening.

DADOES. To provide a separate compartment for each bit, there's a series of dados cut in each core piece. Depending on the bits you plan on storing, the size and spacing of these dados will vary, see the box on the opposite page.

BOTTOM AND COVER. Next, to keep the drill bits from falling out of the tray, glue on a $\frac{1}{4}$ "-thick hardwood *bottom (E)*, and a *cover (F)* cut from a piece of $\frac{1}{8}$ "-thick Masonite, see Fig. 3.

ASSEMBLY. With each of the sections complete, you're ready

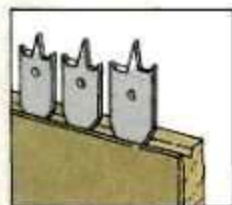

A V-shaped groove routed in the top edge of the tray keeps the paddles of your spade bits facing forward.

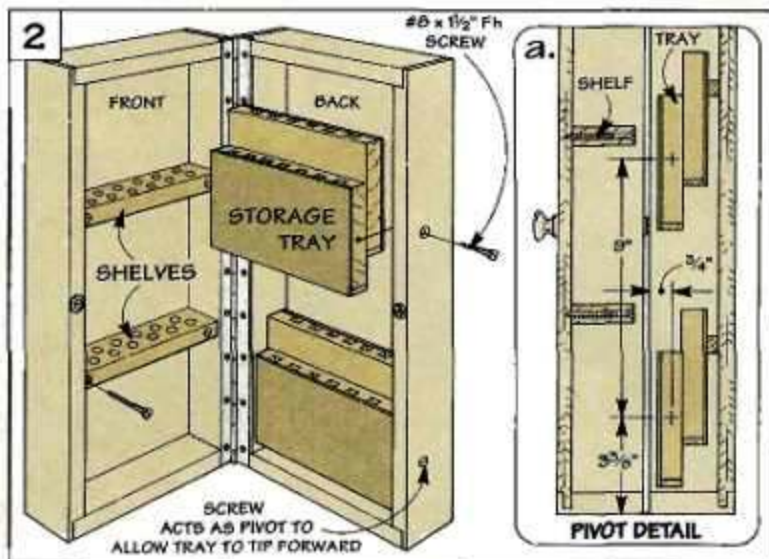

to assemble them in pairs, see Fig. 3a. Note: To provide plenty of finger room when removing a bit, the sections are glued together back to back.

INSTALL TRAYS. Now it's just a matter of installing the trays. A single screw on each side holds them in place and acts as a pivot point to allow each tray to tip out, see Figs. 2a and 3a. To keep the bits upright when the trays are pushed back in, a wood block is glued onto the back of each tray.

SHELVES

To take advantage of the space inside the door, I added a pair of

hardwood shelves for my accessories. Along with the shelves, I installed the index for my twist bits in the bottom of the door, refer to the photo on page 12.

CUSTOMIZE SHELVES. As with the storage trays, you'll need to customize the *shelves (G)* for your accessories, see Fig. 4. All I did was drill holes for my countersinks, plug cutters, and special drill bits.

ATTACH SHELVES. Finally, after locating the shelves so there's plenty of clearance to lift everything out, drill countersunk shank holes through the edges and screw the shelves to the front panel.

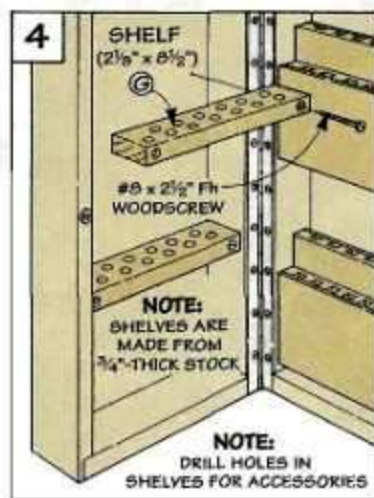
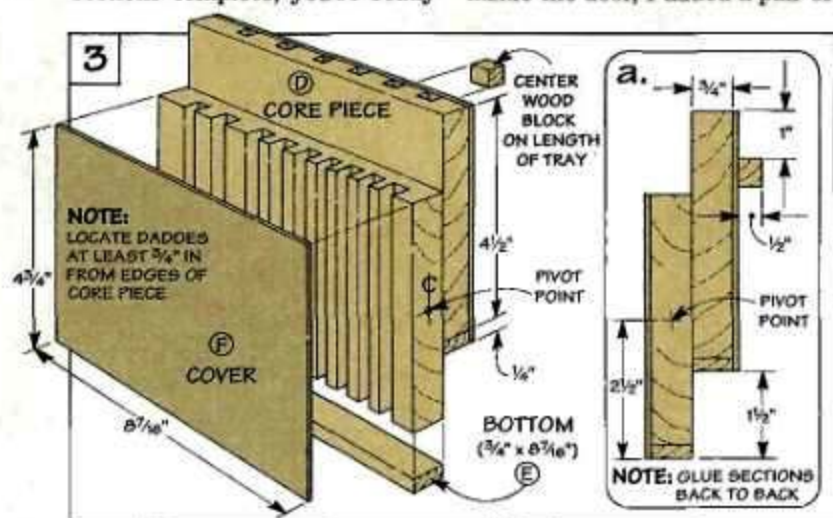

Radial Arm Saw Stand

A "system" for your radial arm saw that organizes your cutoffs by taking advantage of the unused space below the saw.

For years, the only "system" I had for dealing with the cutoffs from my radial arm saw was a pair of cardboard boxes shoved under the stand. One box was for pieces to be saved. The other for scraps earmarked for the fire-place (or trash can).

The only problem with this setup is it was all too easy to pitch a cutoff in the wrong box. And when it came time to locate a small piece for a project, I'd usually end up dumping out both boxes on the shop floor.

So recently, I decided it was time to end the clutter and build my own system, see Exploded View. The unique thing about this system is it can be tailored to fit

your shop, see photo on page 17.

BASE. I started by replacing the original metal stand with a sturdy base. The base features a lift-out bin for scraps that are too small to use. And there's a handy drawer for storing wrenches, extra blades, and accessories.

STORAGE UNITS. On each side of the base, there's a storage unit to organize the cutoffs you want to keep. To provide a "pigeon-hole" for different sizes (or types) of cutoffs, one unit has adjustable shelves. And the other is open to make it easy to store sheet goods.

TOP. To complete the system, I added a table top that features a replaceable insert. (For more on this, see page 23.)

EXPLODED VIEW
OVERALL DIMENSIONS:
30"D x 96"L x 41"H

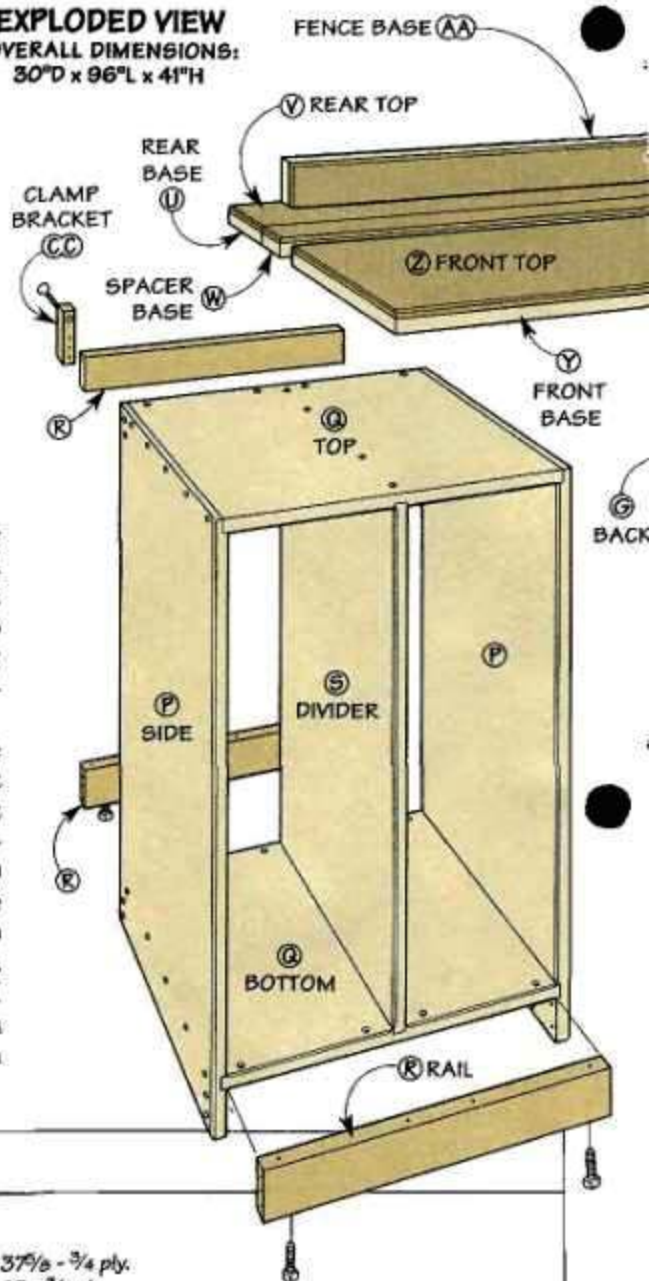

Materials

Stand

| | |
|----------------------|------------------------------|
| A Sides (2) | 30 x 32 - 3/4 ply. |
| B Supp. Cleats (2) | 3/4 x 1 1/4 - 21 |
| C Bottom (1) | 29 3/4 x 23 - 3/4 ply. |
| D Stretchers (2) | 6 x 22 1/2 - 3/4 ply. |
| E Top Rail (1) | 3/4 x 2 1/2 - 22 1/2 |
| F Btm. Rails (2) | 3/4 x 3 - 22 1/2 |
| G Back (1) | 23 1/2 x 32 - 1/4 Mas. |
| H Drawer Ft./Bk. (2) | 2 1/2 x 22 7/16 - 3/4 ply. |
| I Drawer Sides (2) | 2 1/2 x 21 1/4 - 3/4 ply. |
| J Drawer Btm. (1) | 21 9/8 x 20 11/16 - 1/4 Mas. |
| K Drawer Guides (2) | 3/4 x 1/2 - 21 3/4 |
| L Drawer Catch (1) | 3/4 x 1 1/2 - 1/4 Mas. |
| M Bin Sides (2) | 8 x 29 1/4 - 3/4 ply. |
| N Bin Ft./Bk. (2) | 8 x 22 7/16 - 3/4 ply. |
| O Bin Bottom (1) | 21 9/8 x 28 11/16 - 1/4 Mas. |

* Custom cut to match original table top.

Storage Units

| | |
|------------------|------------------------------|
| P Sides (4) | 23 7/8 x 37 7/8 - 3/4 ply. |
| Q Tops/Btms. (4) | 23 7/8 x 23 - 3/4 ply. |
| R Rails (6) | 3/4 x 3 - 22 1/2 |
| S Dividers (2) | 23 7/8 x 33 3/8 - 3/4 ply. |
| T Shelves (6) | 23 7/8 x 10 11/16 - 3/4 ply. |

Table Top

| | |
|---------------------|-------------------------|
| U Rear Base (1) | Custom* x 96 - 3/4 ply. |
| V Rear Top (1) | Custom* x 96 - 1/4 Mas. |
| W Spacer Base (1) | Custom* x 96 - 3/4 ply. |
| X Spacer Top (1) | Custom* x 96 - 1/4 Mas. |
| Y Front Base (1) | Custom* x 96 - 3/4 ply. |
| Z Front Top (1) | Custom* x 96 - 1/4 Mas. |
| AA Fence Base (1) | 3 1/4 x 96 - 3/4 ply. |
| BB Fence Front (1) | 3 1/4 x 96 - 1/4 Mas. |
| CC Clamp Brkts. (2) | 3/4 x 3/4 - 4 3/4 |
| DD Insert (1) | 6 x 17 1/4 - 1/4 Mas. |

Hardware

- (2) #8 x 1 1/2" Fh Woodscrews
- (1) #8 x 3/4" Fh Woodscrew
- (6) #8 x 1" Fh Woodscrews
- (18) #8 x 1 1/4" Fh Woodscrews
- (200) #8 x 1 1/2" Fh Woodscrews
- (25) #4 x 3/4" Fh Woodscrews
- (12) #6 x 1/2" Rh Woodscrews
- (12) 3/8" x 1 1/2" Lag Screws
- (2) 1/4" Threaded Inserts
- (2) 1/4" x 1 1/2" Thumbscrews
- (2) 1/4" Lock Nuts
- (24) 1/4" Shelf Supports

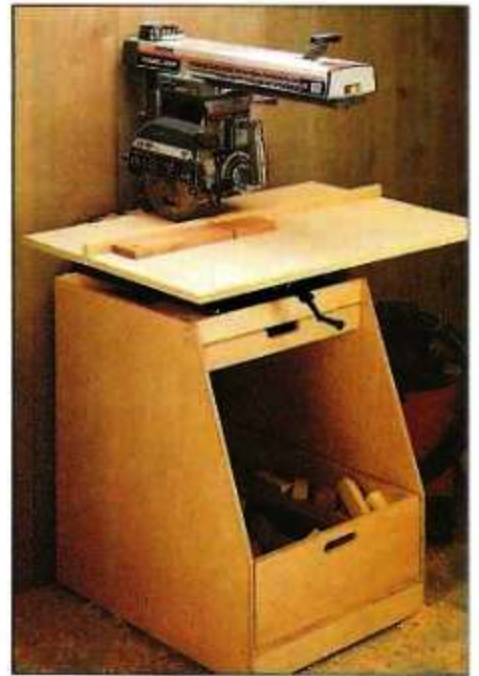
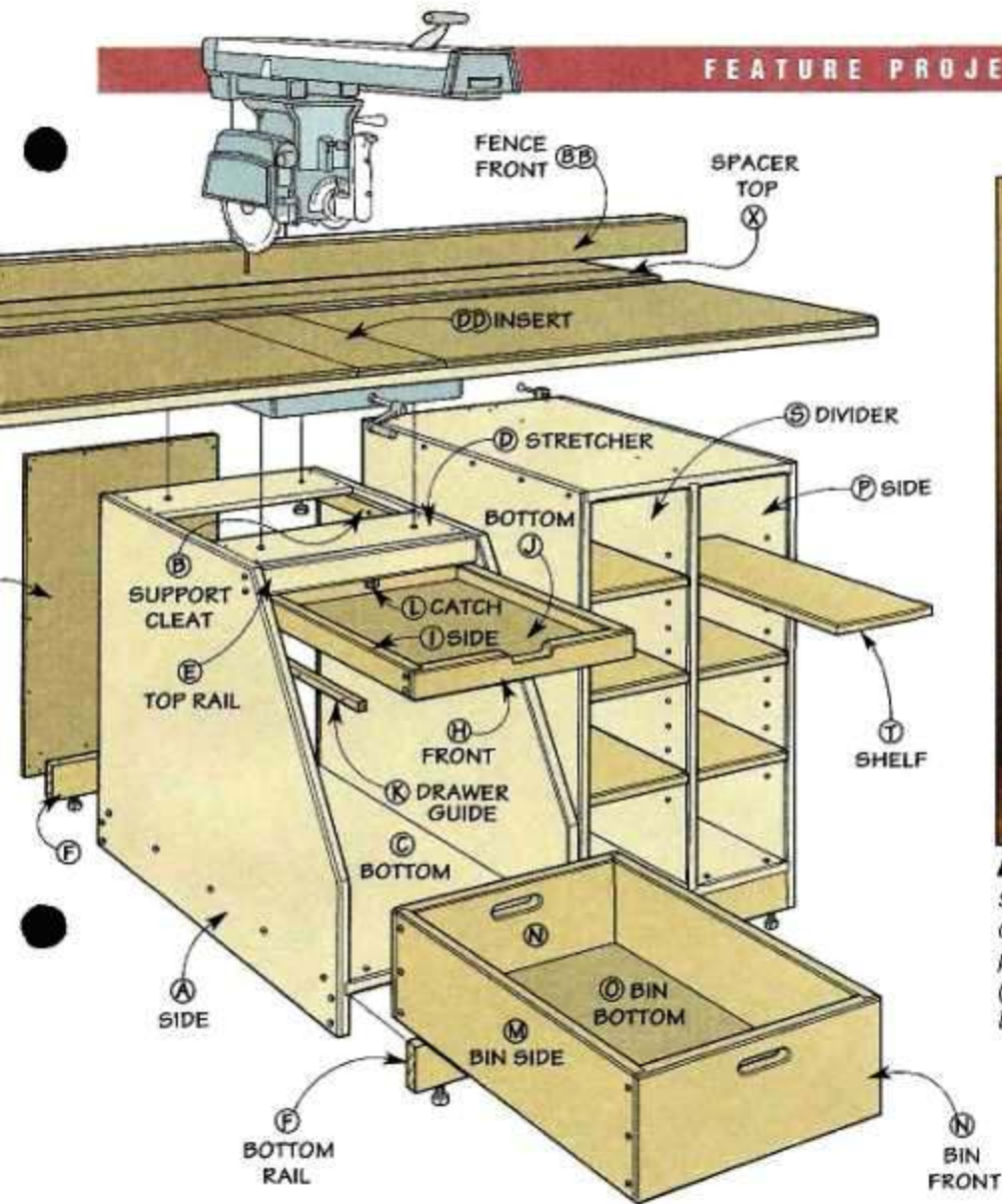

▲ The adaptable design of this radial arm saw stand allows you to build all or part of the storage system. You can just replace your old stand with a new base (photo above). Or build one or both lumber storage units (see front cover).

Cutting Diagram

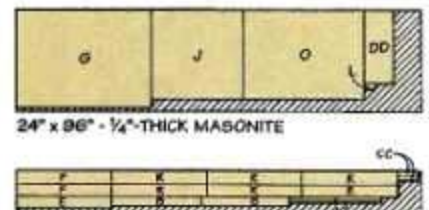
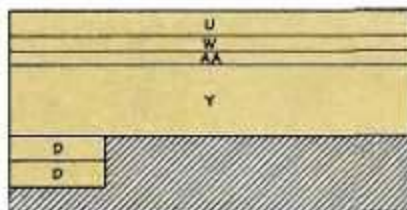
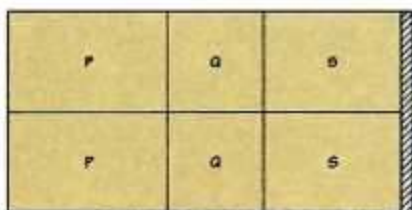
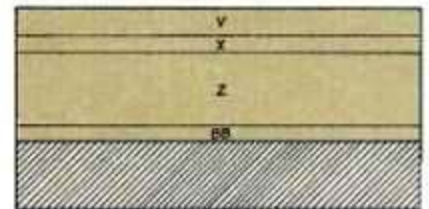
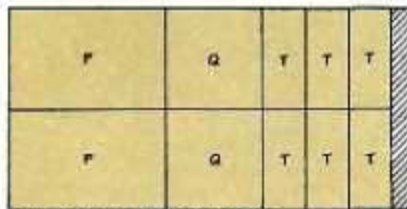
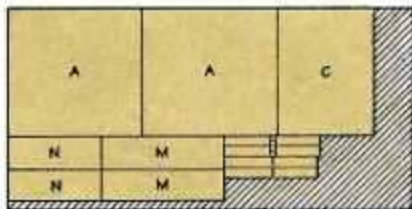

Base

I started work on the radial arm saw stand by building a base to support the saw. It's basically a plywood case that's open in the front, see Fig. 1. On top there's a set of stretchers that strengthen the cabinet and provide a convenient way to mount the saw.

CASE

The first step is to make a U-shaped case that consists of two sides and a bottom. Depending on the frame of your saw, you may need to cut the sides (A) at an angle to provide clearance for the handle that adjusts the height of the blade, see photos below.

SIDES. To determine how much you'll need to angle your sides, first measure the depth of your saw frame (front to back). Then add $\frac{1}{8}$ ". (This allows room for a chamfer that's routed later.)

To lay out the angle, first transfer this measurement to the top edge of both side pieces, see Fig. 2. Then measure up $11\frac{3}{4}$ " from the bottom of the sides and connect the two marks. Now you can cut out the shape with a sabre saw and sand the edges smooth.

Next, cut a dado and a rabbet

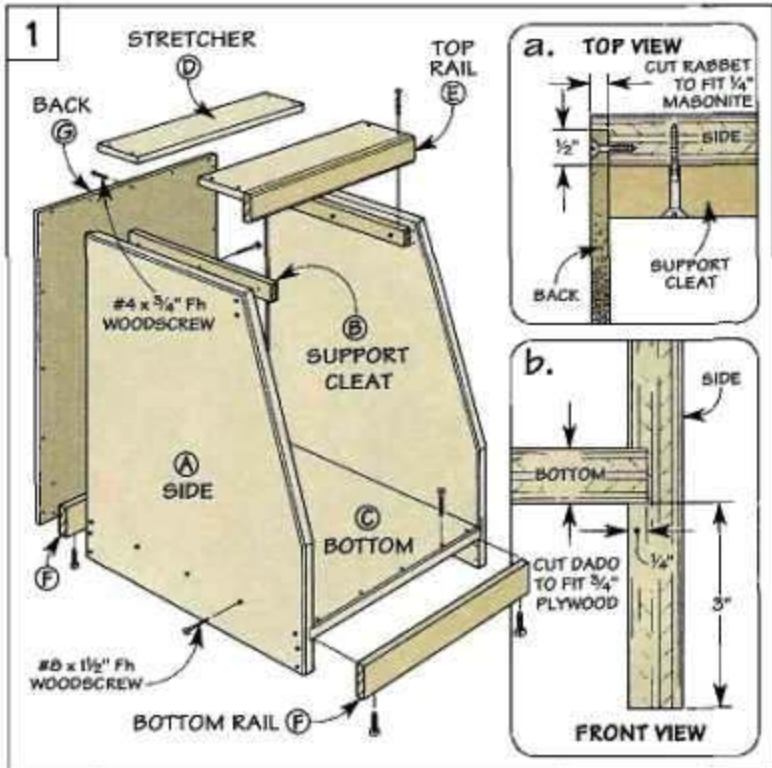

in each side piece for the bottom (C) and back (G) that are added later, see Figs. 1a and 1b.

The sides are held together by the bottom and a pair of stretchers (D) on top, see Fig. 1. The stretchers rest on two support

cleats that are attached to the sides, see Fig. 2.

CLEATS. To determine the length of these support cleats (B), first measure the width of your side panels (at the top). Then subtract 1" from this meas-

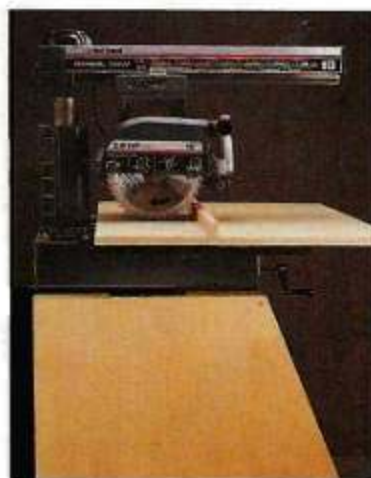

▲ If you have a saw with a short frame, you'll need to cut the sides at an angle to provide clearance for the height adjustment handle.



▲ If you have a saw with a long frame, it may not be necessary for you to angle the front for the height adjustment handle.

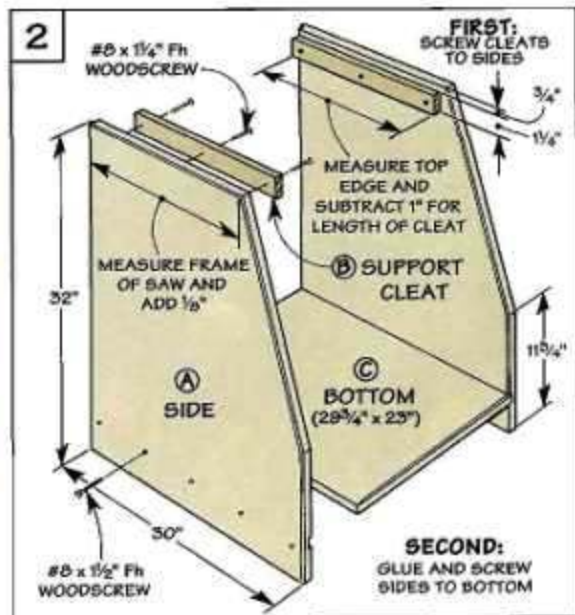

urement ($\frac{1}{4}$ " for the rabbet running along the back edge, and $\frac{3}{4}$ " to allow for the thickness of a rail that's added later).

Once they're cut to size, the cleats can be positioned and screwed to the sides. Note: Position them $\frac{3}{4}$ " down from the top edge, and flush with the rabbet in the back edge, see Figs. 2 and 4a.

After you've screwed the cleats in place, form the "U" by gluing and screwing the sides (A) to a $\frac{3}{4}$ "-thick plywood bottom (C), see Fig. 2.

TOP

Instead of a solid top for the base, I used a pair of plywood stretchers (D) that allowed me to reach up into the bottom of the saw frame when installing the mounting bolts, see Fig. 3.

But before attaching the stretchers (D), I did two things. First, I glued a hardwood top rail (E) to the front stretcher to prevent the case from racking, see Fig. 3.

Then to soften the sharp edges, I routed an $\frac{1}{8}$ " chamfer along the front edges of the rail, see Fig. 3a.

To install the stretchers, position the front stretcher (the one

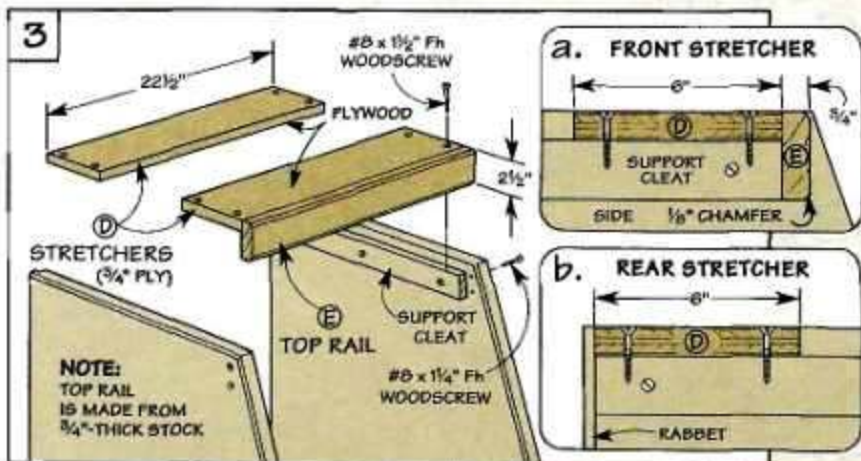

with the rail attached) flush with the front of the cleats.

Then to allow the back (G) to be installed flush with the top of the stretchers, position the rear stretcher flush with the rabbet, refer to Fig. 3b.

After the stretchers (D) are screwed in place, the next step is to add a pair of bottom rails (F) to accept levelers that are added later, see Fig. 4.

BACK. To strengthen the base (and to help keep sawdust out of my scrap bin) I added a back (G). It's just a piece of $\frac{1}{4}$ " Masonite cut to fit in the rabbet in each side piece, see Fig. 4.

Once the back is screwed in place, soften all the exposed edges of the case with an $\frac{1}{8}$ " chamfer. To do this, I used a chamfer bit mounted in a handheld router. (But a sanding block will also work.)

LEVELERS. Finally, to compensate for an uneven floor, I added a set of levelers. These are just lag screws that are screwed into the bottom rails, see Figs. 4 and 4b. Note: To prevent the rails from splitting, you'll need to pre-drill holes for the lag screws.

With the base complete, you can bolt your radial arm saw to the stretchers, see Fig. 4a.

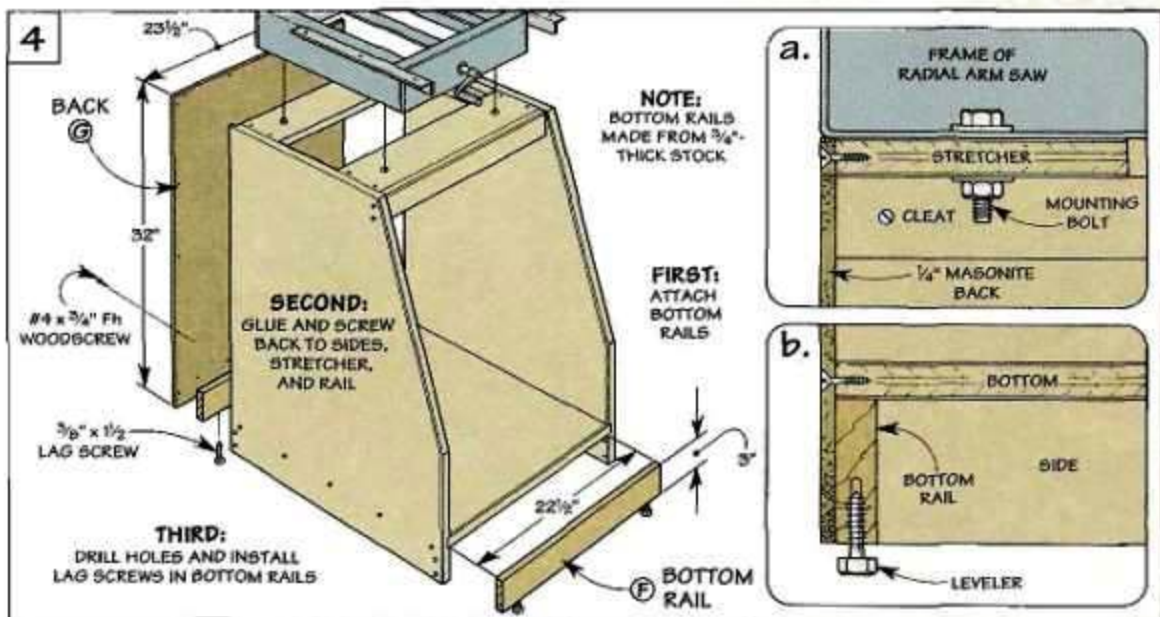

Drawer & Cutoff Bin

All that's left to complete the base is to add a drawer for accessories and a lift-out bin for scraps.

DRAWER. I started by building the drawer. Determining the length of the *drawer front* and *back (H)* is easy. Just measure across the opening of the base and then subtract a $\frac{1}{16}$ " for clearance, see Fig. 5. (In my case, the front and back are $22\frac{1}{16}$ " long.)

Next, to determine the length of the sides (I), first measure from the front of the top rail (E) to the back of the stand. Then subtract $\frac{1}{2}$ " for rabbets that join the pieces together, see Figs. 5a and 6.

To complete the drawer, there are two more things left to do. First, cut grooves in each piece for a *bottom (J)* made of $\frac{1}{4}$ " Masonite, see Fig. 6b. Then to make it easy to pull open the drawer, a notch is cut in the drawer front, see Fig. 6a.

GUIDES. The drawer slides on a pair of hardwood *drawer guides (K)* that are screwed to the sides of the base, see Fig. 5b. These guides are cut to match the depth (length) of the drawer.

Then to prevent a drawer full of saw blades from falling on your toes, screw a *catch (L)* to the back of the drawer, see Fig. 5.

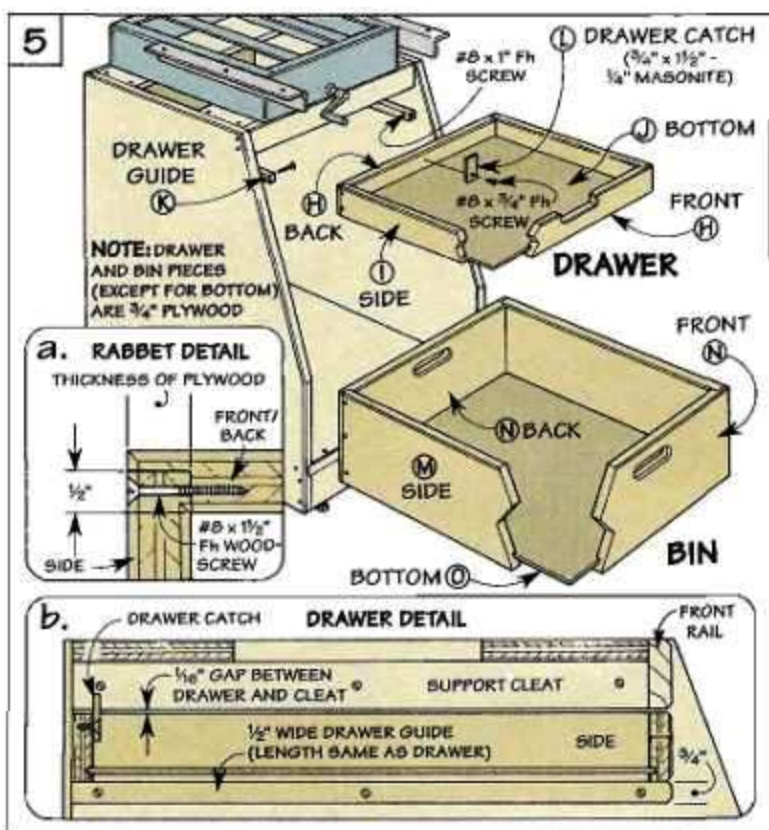

BIN. The construction of the lift-out bin is identical to the drawer. Rabbets are used to hold the *sides (M)* to the *front and back (N)*, see Fig. 5a and 7. And grooves hold the *bottom (O)* in place, see Fig. 7b.

The only difference is the bin is deeper than the drawer and it's cut to fit the full depth of the base, see Figs. 5 and 7.

To lift the bin out, I cut handle holes in both the front and the back (N) pieces, see Fig. 7a.

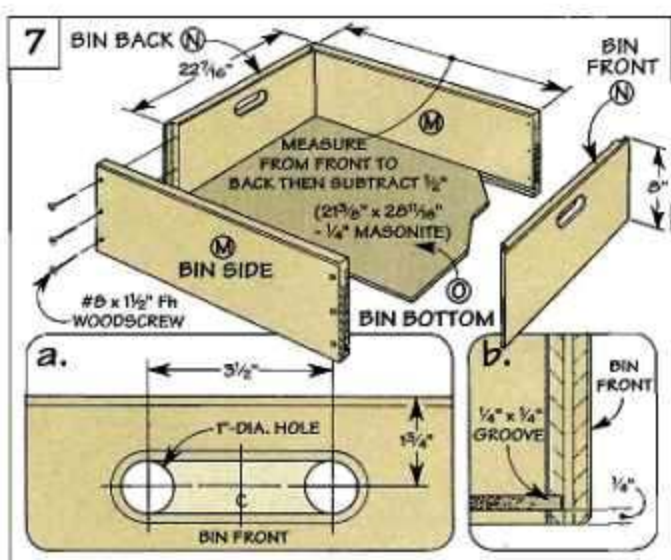
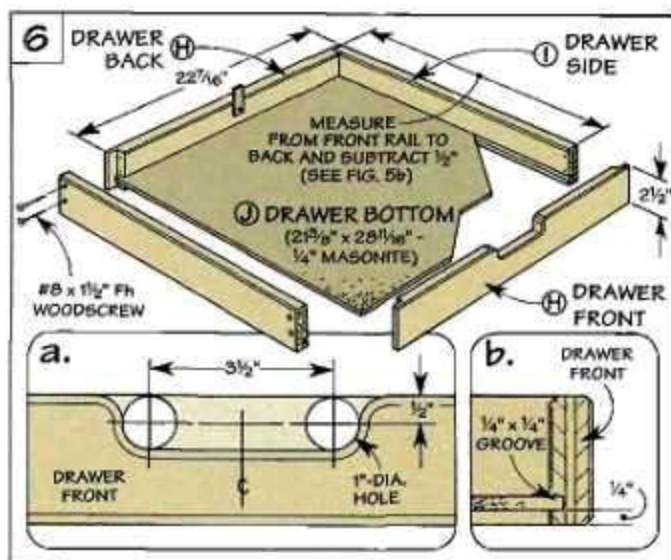

Storage Units

With the base complete, you can turn your attention to the storage units. They both start as identical plywood boxes that are open in the front and back.

The only difference between them is one has adjustable shelves for lumber, and the other is open to hold sheet stock.

SIDES. In addition to holding lumber, both units support the ends of the table top.

So when cutting the *sides (P)* of the storage units to length, cut them so their length equals the height of the saw frame *plus* the height of the base of your stand, see Figs. 8 and 9.

Next, rabbets are cut to accept a plywood top. And dados are cut to fit a bottom, see Fig. 9.

After the *tops* and *bottoms (Q)* are cut to size, a 1/4"-deep dado is cut for a divider that's added later, refer to Figs. 9 and 11. Now each unit can be glued and screwed together.

SUPPORT. To extend longer pieces of lumber out the back, I left both units open in the back. But without a back, each unit

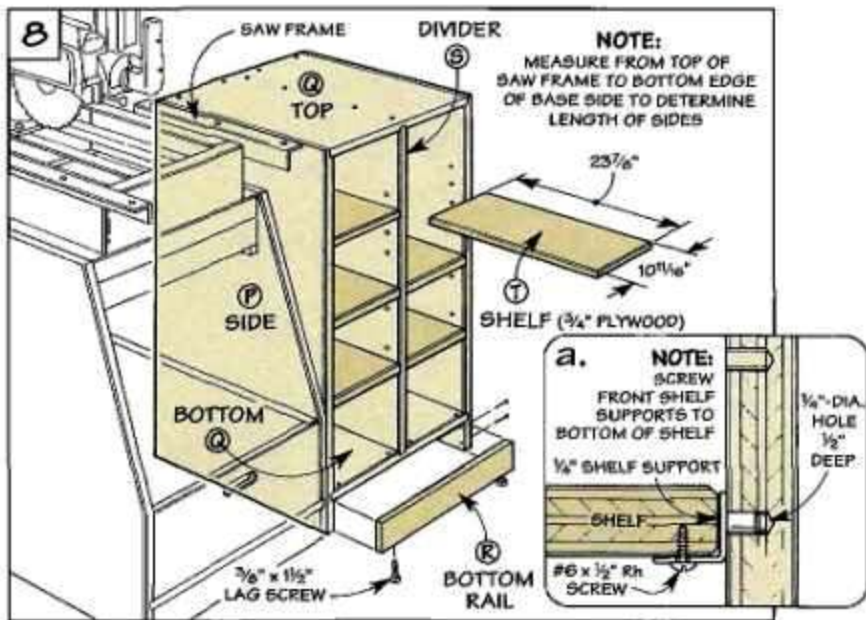

could rack. To prevent this from happening, I screwed a *top rail (R)* and two *bottom rails (R)* to between the sides, see Fig. 10.

DIVIDERS. Next, a *divider (S)* can be cut to fit each unit, see Fig. 11. But in order for it to fit flush with the front of each case, you'll need to cut a notch in the back of each divider, see Fig. 11.

Before screwing the dividers in place, I found it easiest to drill holes in the sides and divider for the shelf supports that hold the shelves added next.

SHELVES. After chamfering the exposed edges on both units, install the levelers. Finally, I added a set of six shelves to one of the storage units, see Fig. 8.

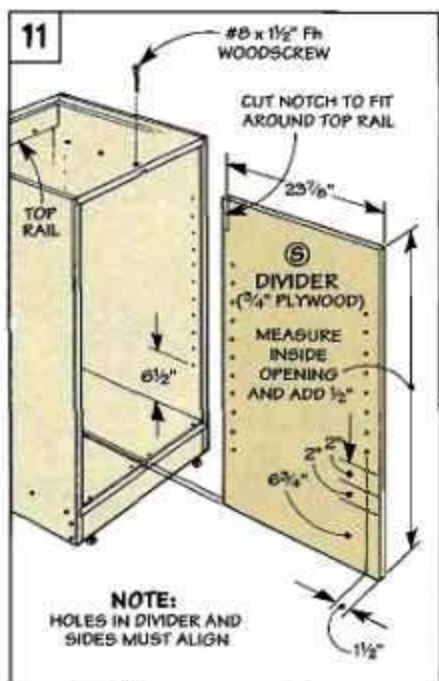
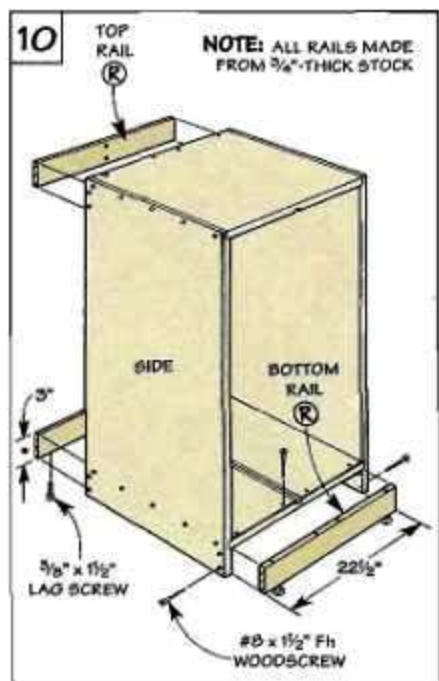
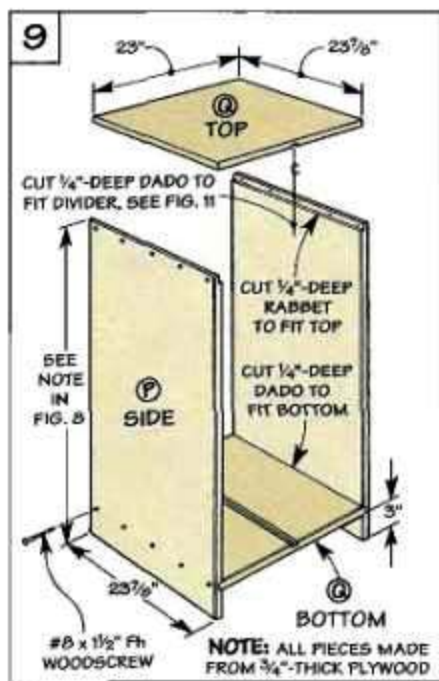
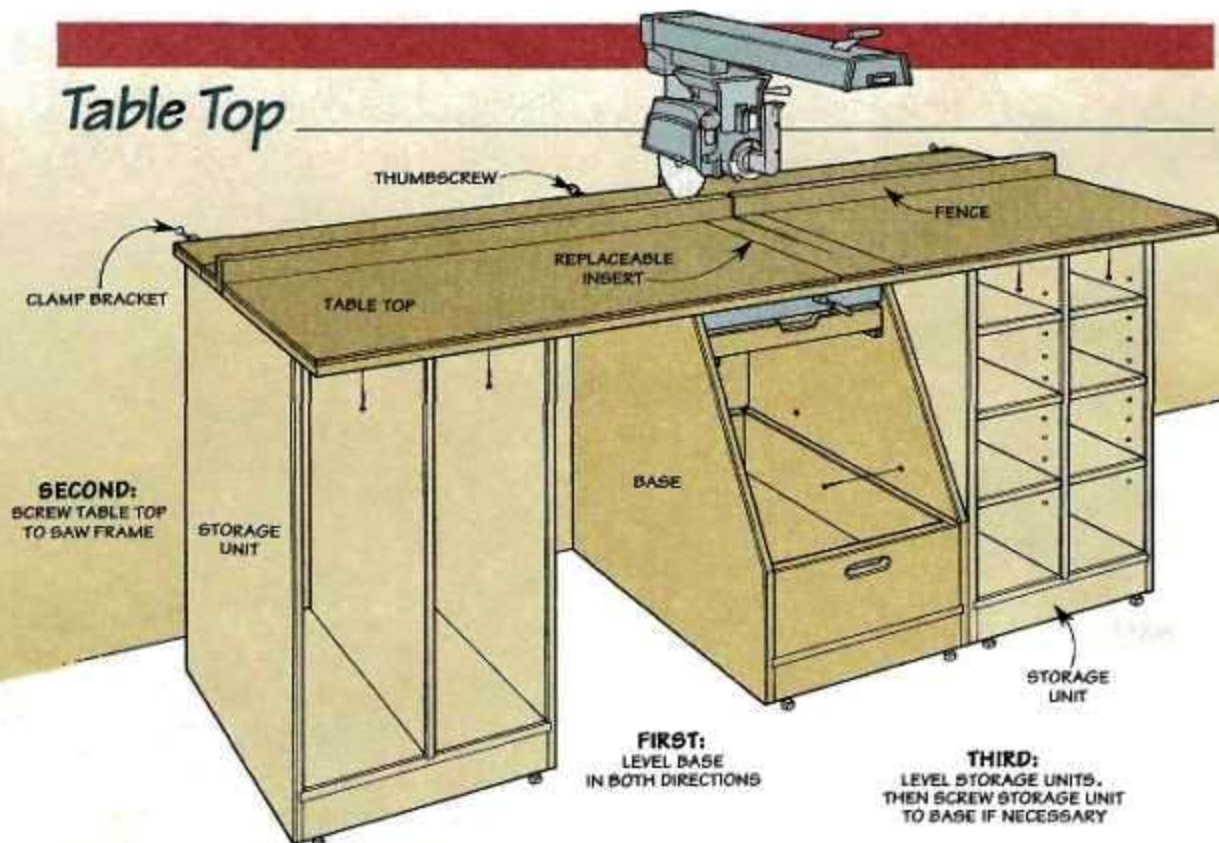

Table Top



After you've completed the storage units, the next step is to build the table top, see Drawing above.

Just like my old table top, this top is made up of four pieces: a front piece, a fence, and a "split" rear section, see Fig. 12.

DIMENSIONS. Determining the width of each piece was easy. I just made them the same width as the pieces of my original table top. But the length takes a little more planning.

The first thing to do is arrange

the base and storage units where you want them in your shop. Then, measure across the total width and add 2" for a 1" overhang at each end, refer to Fig. 13. (In my case, the top is 8 feet long.)

LAMINATE PIECES. After cutting the *base pieces* (U,W,Y) and the *fence base* (AA) to size, I laminated each piece with a 1/4" Masonite top (V,X,Z) and *fence front* (BB), see Fig. 12. This helps protect the top and provides a smooth surface for ripping.

To do this, I used contact cement to attach a slightly oversize piece of Masonite to each piece. Note: If you're planning on adding a replaceable insert, refer to the box on the opposite page now.

Then trim the Masonite to match the plywood with a flush trim bit in a hand-held router.

CHAMFER EDGES. Finally, I softened the sharp edges by routing an 1/8" chamfer along the edges of the Masonite. Note: Don't chamfer the *inside* edges of the table top pieces or the *bottom* edges of the fence, see Drawing above.

ASSEMBLY Once the table top is complete, the stand is ready to be assembled. With the base and storage units positioned where you want them, adjust the levelers on the bottom of the base until it's level in both directions.

MOUNT TOP. Now the front table top can be mounted to the saw frame. Start by backing out the thumbscrews that pinch the split rear section against the fence.

Then position the new table top pieces (and the fence) as they were positioned on your old top.

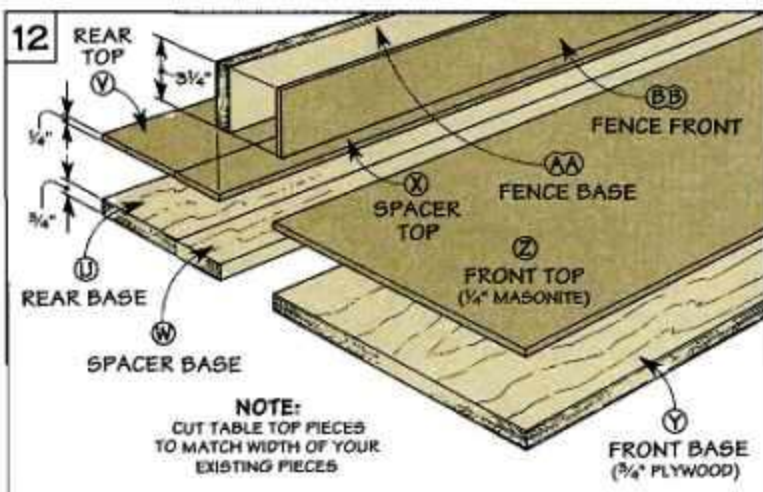

Next, with the table top pushed against the thumbscrews, use a square to check that the fence and the blade are square to each other. If they're not, adjust one of the thumbscrews.

Once the fence is square, attach the front table top to the saw by screwing up through the saw frame and into the top. To lock the remaining table top pieces in place, just tighten the thumbscrews (finger tight only).

STORAGE UNITS. Now you can level the storage units. To do this, first position them so the table top overhangs the ends about an 1". Then adjust the levelers so the top is level along its entire length.

Once the top is level, screw the storage units to the base if they're positioned against it, see Drawing on opposite page. Then

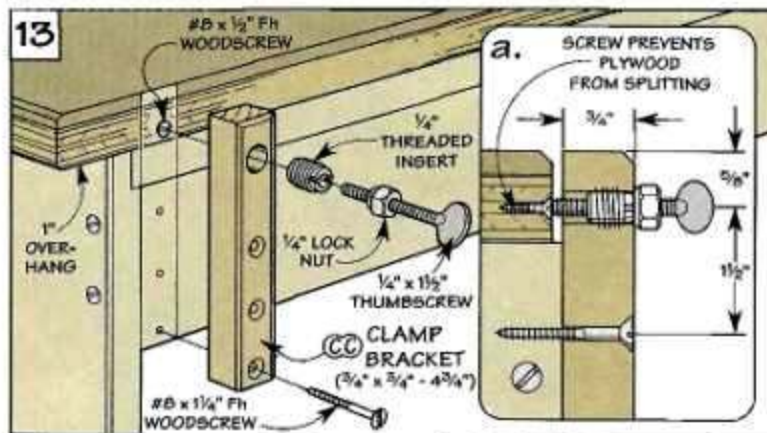

screw the storage units to the bottom of the front table top.

CLAMP BRACKET. Because the ends of my table top are quite a ways away from the thumbscrews, I added a simple *clamp bracket* (CC) to each storage unit to pinch the ends of the top pieces

and the fence tight, see Fig. 13.

This bracket is nothing more than a block of wood, a threaded insert, and a thumbscrew.

A screw in the top prevents the thumbscrew from splitting the plywood, see Fig. 13a. And a lock nut keeps the thumbscrew in place.



To make it easy to find the right cut-off, mark the dimensions on the end of each piece.

Replaceable Insert

With use, the table top on a radial arm saw can quickly get chewed up. So instead of making a new top when this happens, I use an "insert" that's easy to replace, see photo. It's just a piece of 1/4" Masonite that fits into a dovetail-shaped opening cut into the front section of the table top, see Fig. 1.

The advantage to shaping the opening like a dovetail is you don't need any hardware to hold the insert in place. Just bevel the edges of the insert and then slide it in the opening.

NO GLUE. To cut the opening in the top, I used a 1/2" dovetail bit in a handheld router, see Figs. 2 and 2a.

You could waste out the entire insert area once the top is glued up. But I found it's easiest to first mark the location of the insert on the plywood base (Y) before gluing on the Masonite top (Z), see Fig. 1. (I used masking tape to mark off the area.)

Then if you don't apply any contact cement to this area, you can cut the opening in two passes, see Fig. 2.

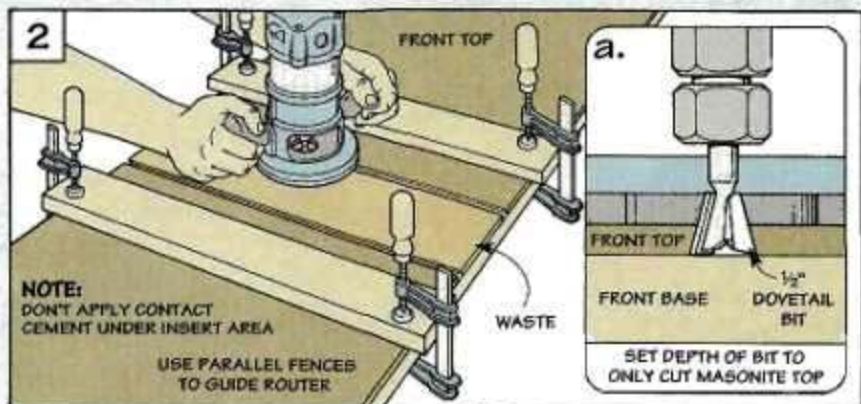
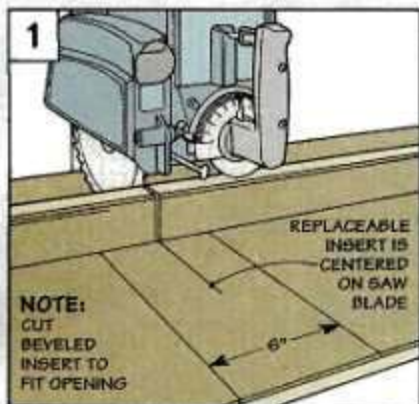



Reducing Tool Noise

Power tools and noise go together. Fortunately, there are some simple remedies that can put a damper on the worst offenders.

Let's face it. Noise is a fact of life in most shops. And even though you can insulate yourself with a pair of hearing protectors, the high-pitched whine of a router or table saw still carries throughout the house (and sometimes even to the neighbor's).

To avoid disturbing them (and having to close down shop early in the evening), I've been experimenting with different ways to put a damper on the tools that generate the most noise.

METER. As a starting point, I wanted to get an idea of just how noisy my tools were to begin with. So I bought a "noise meter" from a local electronics store, see photo above.

This meter measures the *intensity* of the sound in decibels

(dB). And since this intensity usually increases as you make a cut, all of the readings were taken with the tool in operation, see the chart below right.

BENCHMARK. Although this gave me an initial noise level that served as a "benchmark," I was surprised by one thing. There wasn't as much of a range as I'd expected between the decibel readings of a relatively quiet tool (a drill press for example) and those of an "earbuster" (like a table saw).

SCALE. To find out why, I called a local hearing specialist. He said that the scale used to measure decibels was *logarithmic*. What this means is that a slight increase (or decrease) in the decibel reading has a much more signifi-

cant effect than you'd think.

For example, for every 3 dB increase in the decibel reading, the intensity of the sound doubles. So if one shop vacuum spikes 90 dB, two shop vacuums would top out at 93 dB on the meter.

Understanding how the scale works is one thing. But when it comes to dampening tool noise, the real test is to use the scale as a measuring stick to see (or hear) what works and what doesn't.

MULTIPLE SOLUTIONS. What I found is there's no single solution that's going to dramatically reduce the noise level of the tools in your shop. But there are a combination of little things you can do that soon add up to produce a quieter shop, see the box below left and the article that follows.

Noise Reduction Strategies

Tool Selection. Consider the design features that will contribute to quieter operation when buying a tool.

Tool Stands. Tighten up metal stands that rattle, or build shop-made tool stands from heavy, dense materials.

Belts and Pulleys. Replace worn belts and align pulleys to quiet noisy tools. Or, upgrade existing belts and pulleys.

Motor Vibration. Dampen noise-producing vibration set up by the motor with rubber pads or special mounts.

Saw Blades. Reduce the noise level of a saw blade by keeping it clean and sharp, or using a new "quiet" blade.

How Loud Is Loud?

DRILL PRESS 77dB

SCROLL SAW 88dB

SHOP VACUUM 90dB

TABLE SAW 92dB

ROUTER 96dB

Tool Selection

If you're planning to buy a new tool, one of the simplest things you can do is select a quiet one. While some manufacturers include decibel readings along with other information about the tool, that seems to be the

exception—not the rule.

NOISE TEST. So what I do is fire up the tool in the store. After all, if it's too loud in a wide open space, it's not going to get any quieter when you bring it into a small shop.

FEATURES. Another thing that's worth considering before buying a tool is the features it has that can contribute to quieter operation. This is especially true of the motor, drive system, and the speed of operation.

MOTOR

One thing that affects the noise produced by a tool is the type of motor. Because it runs at a higher speed, a universal (brush-type) motor is louder than an induction (brushless) motor. Note: To tell them apart, check for the "caps" that hold the brushes in place.

Although most hand-held power tools use a universal motor, you'll often have a choice when buying a stationary power tool, see photos.



▲ **Universal Motor.** Because it operates at high speed, a tool with a universal motor runs louder.



▲ **Induction Motor.** A heavy motor housing and slower speed contribute to a quieter running tool.

DRIVE SYSTEM

The drive system of a tool also makes a difference in the noise it generates. As a rule of thumb, a gear-driven tool runs louder than one that's belt-driven, see photos.

The reason is simple. There's a certain amount of "transmission" noise caused by the gears meshing together.

But if you transfer power from the motor to the blade through a belt, it eliminates this noise.



▲ **Gear-Driven.** A tool that transfers power through a system of gears tends to run louder.



▲ **Belt-Driven.** A belt-driven tool offers a quieter method of getting power from the motor to the blade.

VARIABLE SPEED

Although it's not specifically designed to reduce noise, a tool with a variable speed control can be set to run considerably slower and quieter than a single speed tool.

For example, the decibel reading of the variable speed router in the left photo drops from 100 dB to 78 dB at the slowest speed.

If you already have a fixed speed router, you can use a control like the one in the photo at right.



▲ **Variable Speed.** A router with a built-in variable speed control can be set to run slower and quieter.



▲ **Speed Control.** To reduce the RPM's (and noise) of a fixed speed router, use a speed control unit.

Tool Stands

Sometimes even the stand that a tool is mounted on can add to the noise level in your shop.

TIGHTEN BOLTS. Because a stand can loosen up with use and start to rattle, it's a good idea to tighten down the bolts that hold it together. And to keep them from vibrating loose again, replace any flat washers with lock washers.

But noise can still be a problem if the stand flexes when the tool is running. To keep the metal parts from rubbing against each other, you need to "insulate" the stand.

INSULATE. One way to do this is to disassemble the stand and apply a bead of construction adhesive between any parts that touch. Or, just add weight or ballast to the stand. (Concrete blocks or sand both work well.) To insulate the stand from the floor of the shop, see the margin tip at left.

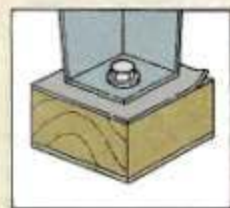

A block sand-washed between rubber strips keeps vibration (and noise) from transferring to the floor.

SHOP-BUILT STANDS. But perhaps the best way I've found to dampen the noise of a metal stand is to replace it with a shop-built one. To absorb as much vibration (and noise) as possible, try to incorporate heavy, dense materials like

particleboard or medium density fiberboard (MDF) into the stand.

To further reduce noise, enclose the tool *inside* the stand, see photos. Just be sure to provide plenty of ventilation to prevent heat build-up.



▲ **Router Cabinet.** An enclosed cabinet decreases the noise level of this router from 100 to 90 dB.



▲ **Shop-Vacuum.** Here, an enclosed cabinet is used to muffle the shrill pitch of a shop-vacuum.

Belts and Pulleys

Although it's easy to overlook them, the drive belt and pulleys on a motor also contribute to how much noise a tool makes.

BELT. With use, a "lump" can form on the belt where it's fused together. As this lump passes across the pulleys, it can sound like a washing machine that's out of balance.

When replacing the old belt, you can use a standard V-belt. But a belt like the one shown in the left-hand photo is specially designed to reduce noise and vibration. (For sources, see page 31.)

TENSION. No matter which one you use, a belt that's too tight runs louder. So on tools with a fixed (not hinged) motor, I back off the tension just enough so the belt doesn't slip, see margin tip.

PULLEYS. Noise can also be traced back to the pulleys on a tool. Typically, many tools have

pulleys that are *cast* from a soft metal. Since these pulleys aren't always perfectly balanced, they tend to wobble and make noise.

My solution is to replace the old pulleys with ones that are *turned* from solid pieces of steel, see

right-hand photo.

ALIGNMENT. Regardless of the pulleys, they won't run quiet unless they line up. To check this, I use a straightedge. When held against the pulleys, it should touch the outside edge of both pulleys.

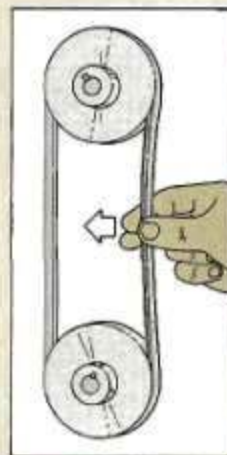

As a rule of thumb, I loosen the belt tension enough to push the belt in about an inch.



▲ **Link Belt.** The interlocking links create a flexible belt which makes a tool run smooth and quiet.



▲ **Turned Pulley.** Balanced to run true, this turned steel pulley reduces noise caused by vibration.

Motor Vibration

One of the main sources of tool noise is the vibration that's set up by the motor. The best way to dampen this noise is to absorb the vibration *before* it's transferred to other parts of the tool or stand.

PAD. One way to do this is to insulate the base of the tool from the stand. To do this, you can use a rubber-like pad that's specially designed to absorb vibration, see left-hand photo.

This pad can either be cut to match the "footprint" of the tool. Or you can cut strips to fit between the frame of a motor and the mounting plate. (See page 31 for sources of anti-vibration pads.)

ISOLATION MOUNTS. But the best thing I've used for soaking up motor vibration is a special product called an "isolation mount." Basically, it's a hard rubber cylinder with a threaded hole

at each end for a mounting bolt, see right-hand photo.

What makes these mounts work is that the holes (and the mounting bolts that thread into them) don't go all the way through. Instead, they're separated by a rub-

ber "cushion" that helps dissipate the vibration.

Note: Be sure to select a bolt that's short enough so it won't "bottom out" before it tightens up. (For sources of isolation mounts, see page 31.)



▲ **Anti-Vibration Pad.** This rubber-like pad absorbs vibration instead of transferring it to the stand.



▲ **Isolation Mounts.** Hard rubber cylinders "isolate" the vibration set up by the motor on a tool.

Saw Blades

When it comes to noise, one of the worst culprits in my shop is the blade on my table saw. Luckily, there are some easy remedies to reduce its shrill sound.

SHARP AND CLEAN. First, it just makes sense that cutting with a sharp, clean blade produces less noise than a worn blade (about 3 dB difference).

I also make it a habit to raise the blade so it's only slightly higher than the thickness of the workpiece. This can make a difference of 2 dB compared to when the blade is set to maximum height.

STABILIZER. Another thing you can use to reduce the noise of a blade is a *stabilizer*, see left-hand photo. It's designed primarily to help stiffen a blade when cutting thick stock. But I've found that it dampens noise by as much as 2 dB.

QUIET BLADES. Finally, several manufacturers have started to

produce "quiet" blades. These blades are designed to reduce the high-pitched ringing you typically get when you make a cut.

The secret is a series of slots that are cut in the body of the blade, see right-hand photo. While

these slots don't eliminate the vibration that causes the ringing, they do direct it to a "plug" at each end of the slot. These plugs act as shock absorbers to dampen the sound. (For sources, see page 31.)



▲ **Stabilizer.** By adding side support, a stabilizer dampens noise produced by a wobbly blade.



▲ **Quiet Blade.** Slots and sound-absorbing plugs reduce the noise level of this blade from 92 to 88 dB.

Shop Solutions

Band Saw Fence

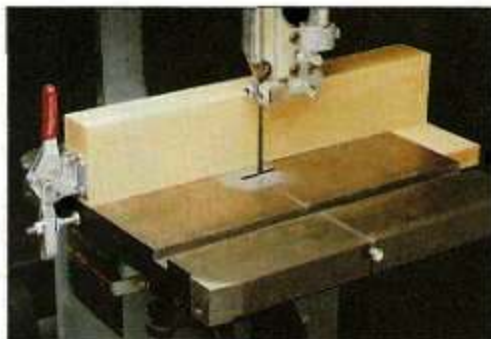

■ My band saw didn't come with a fence. Instead of buying one (they cost around \$75), I decided to build my own.

TWO PIECES. It's basically just two pieces of hardwood shaped into a "T," see photo. A 1 $\frac{3}{4}$ "-thick piece rests on the table and makes a sturdy fence, see Drawing. (I used maple.) And a short $\frac{3}{4}$ "-thick piece rides against the back of the table and keeps the fence aligned with the blade.

TOGGLE CLAMP. To lock the fence in position, I attached a quick-action toggle clamp to one end, see detail 'a.' (Many woodworking catalogs sell these.) The nice thing about a toggle clamp is

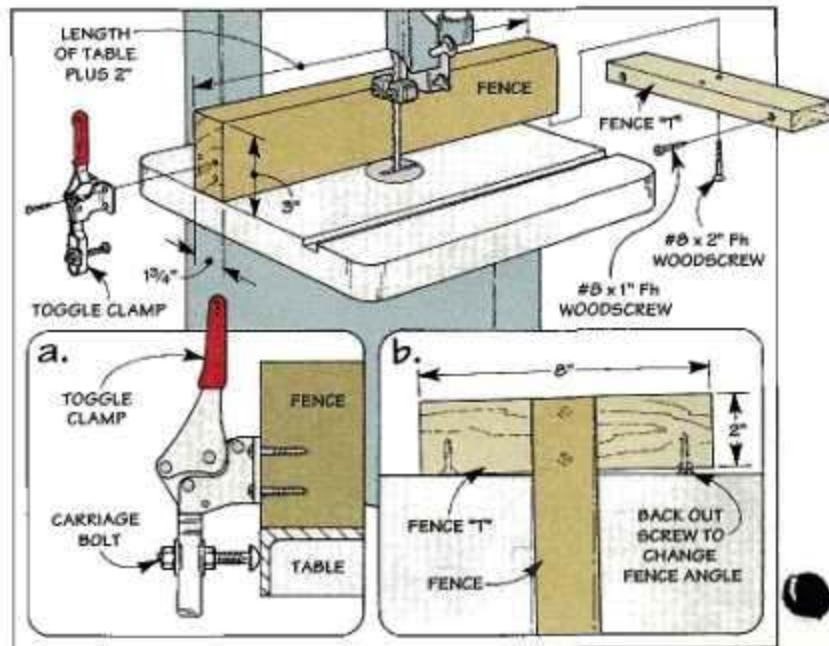

you can quickly loosen the fence, slide it to a new location, and then lock it in place.

DRIFT. Finally, to compensate for drift (usually caused by the uneven set on a band saw blade), I added a pair of screws to the face of the "T," see detail 'b.' The idea here is simple. By backing

out either of the screws, I can change the angle of the fence to match the drift of my saw blade.

Now when I lock the toggle clamp against the table, it automatically brings the fence into alignment with the blade.

Chuck Guffey
Cedar Mountain, North Carolina

Adjustable Runner

■ Many of the jigs I make for my shop are designed to slide in a miter gauge slot. But getting the wooden runners to fit snug in the slot without binding has always been a problem.

To solve this, I make the runner slightly undersize and then cut adjustable wooden "flaps," see Drawing. Allen screws allow me to adjust the flap until the runner slides perfectly in the slot.

Donald Rintelman
Southbury, Connecticut

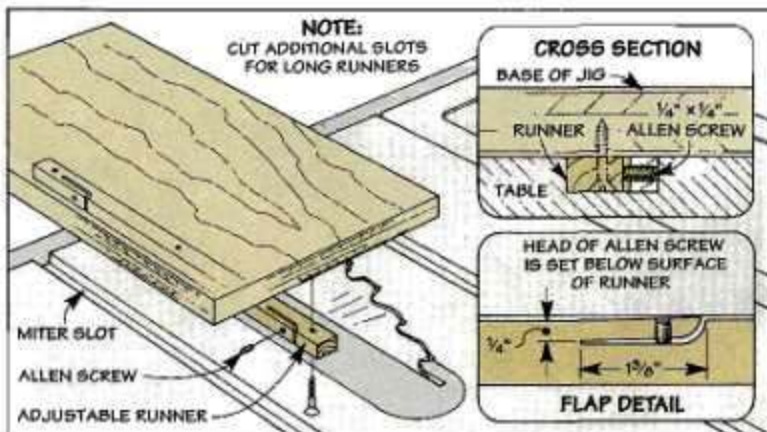

Putty Shield

■ Filling in nail holes with wood filler or wood putty has always given me problems. No matter how careful I am, I always end up filling the wood pores surrounding the hole. Then later when a finish is applied, it's painfully obvious where the nail holes are.

To get around this, I use masking tape as a putty "shield." It allows me to put the putty exactly where it belongs — and protects the wood around it.

The trick is to apply a strip of masking tape *before* you pick up the hammer and nails, see left-hand photo. Then, drive and set



the nails through the tape. (When working with hardwood, it's best to pre-drill the holes.)

Now you can force putty into the holes and remove the tape,



see right-hand photo. All that remains is a small bump of putty that can be sanded smooth.

*Ray Drummond
Yuba City, California*

Dust Collector Window

■ I built the dust collector system featured in *ShopNotes* No. 13. To make it easy to check when the chip bin is full, I added a "window" that lets me peek into the bin without having to unlatch it.

I cut a small hole in the bin and then covered it with a piece of Plexiglas, see Drawing. Note: Before screwing the Plexiglas in place, apply a bead of caulk to stop any air leaks.

Now when I want to check the chip level inside the collector, all I have to do is look through the Plexiglas window.

*Mark Welch
Elgin, Illinois*

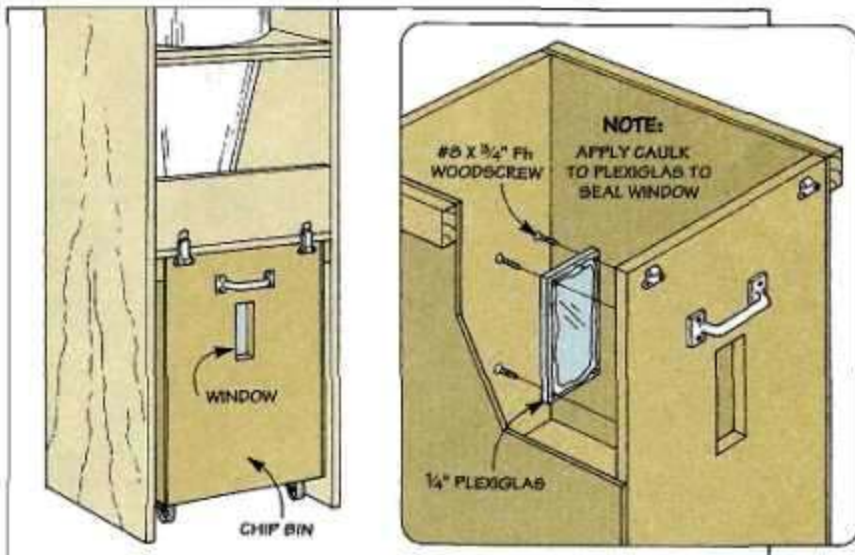

Quick Tips

■ Moving large sheets of plywood or drywall is difficult if you can't get a good grip on them.

That's the problem my husband was having because his hands were too dry. He tried using hand lotion, but it stained the wood. So I lent him a pair of my kitchen rubber gloves for a no-slip grip.

*Marilyn Davidson
Rye, New Hampshire*

■ To raise a project off my workbench for finishing, I use the three-legged plastic "stools" that come in carry-out pizza boxes.

I turn them *upside* down so just the tips of the three small legs make contact with my project. And if they get broken or lost, I just order more pizza.

*Daniel Porter
Woodbridge, Virginia*

Send in Your Solutions

If you'd like to share your original solutions to problems you've faced, send them to: *ShopNotes*, Attn: Shop Solutions, 2200 Grand Avenue, Des Moines, IA 50312. (Or if it's easier, FAX them to us at: 515-282-6741.)

We'll pay up to \$200 depending on the published length. Please include a daytime phone number so we can call you if we have questions.

Medium-Density Fiberboard

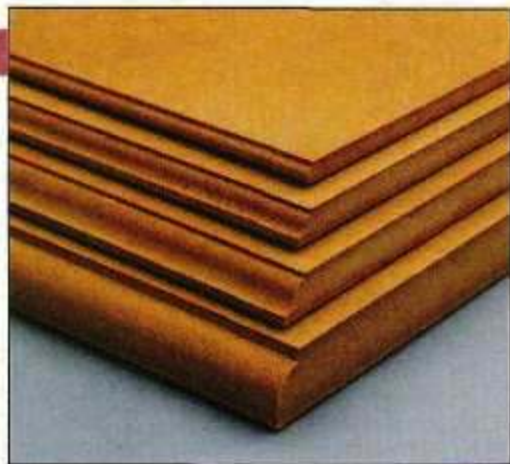

■ I'd like to know more about a material often mentioned in various projects — MDF (medium-density fiberboard). Just what is it? And where can I find it?

Robert Landis
St. Marys, Pennsylvania

Medium-density fiberboard (MDF) is an engineered (man-made) wood product that's been around since the 1960's.

According to Mike Hoag at the National Particleboard Association (NPA), it's in the same family as particleboard. Unlike particleboard (which is basically a mixture of wood chunks and shavings held together with resin), MDF is much more refined, see photo at left.

And the finer the material, the tighter it can be compressed to form a denser, stronger panel. To give you an idea how fine the fiber is, it takes approximately 23" of fiber/resin mix to make a 3/4"-thick sheet of MDF. It only takes about 4" to 6" of wood chips and sawdust to form a 3/4"-thick sheet of particleboard.

ADVANTAGES. Breaking down wood into a fibrous material has a number of advantages. First, there's no grain to it. This means changes in humidity have little effect on MDF — it's extremely stable. Red oak, for example, will

expand or contract approximately 1% in width. MDF on the other hand, will move as little as 0.1%.

And second, the finer material results in a very smooth, flat, and uniform surface. This makes it the perfect base for wood veneer and plastic laminate.

You'll also find that it has a tighter density than particleboard. So it holds an edge better. And you won't have problems with voids, like plywood.

MACHINING. Over the years, I've heard rumors about MDF being hard on tools. To find out if this was true, I called Harold Stewart at the Mississippi State Forest Products Lab. According to Harold, MDF isn't a problem for the average woodworker.

MDF can be worked like any other wood product — as long as carbide cutters are used. About the only thing you shouldn't do to MDF is run it through a thickness planer or over an edge jointer.

Safety Note: Whenever you work MDF, treat it like any wood product. Use a dust collector if you have one, and always wear a dust mask — especially when you're sanding. Since the fibers are so fine to begin with, sanding MDF tends to kick up a lot of fine dust that can hang in the air for quite a while.

FINISH. One more thing to keep in mind about MDF is it's not usually stained or fin-

ished naturally. It's typically covered with wood veneer or plastic laminate — or it's painted.

And I've found that MDF takes paint well. Unlike particleboard or plywood where the surface texture (or grain) shows through, MDF looks good with a coat of primer and a couple coats of paint.

Note: Whenever I use MDF for shop jigs, I don't bother with paint. Instead I protect it with a couple coats of varnish.

AVAILABILITY. Like particleboard, a standard sheet of MDF is 49" by 97" (the extra is for trimming). And it's available as thin as 5/32", and as thick as 1 5/8", see photo above. Although it costs about twice as much as particleboard, a sheet of MDF is about half as much as a sheet of cabinet grade plywood.

About the only problem I've found with MDF is it can be difficult to locate. And although it's gaining in popularity, not all lumberyards carry it.

To find your nearest dealer, call any of the manufacturers listed below. Or the NPA, they will be happy to help you out.

MDF Sources

- Georgia-Pacific 800-284-5347
- Medite Corporation 503-773-2522
- Plum Creek Timber 406-892-6237
- Blue Ridge Lumber 403-648-6323
- Willamette Industries 501-337-4900
- NPA 301-670-0604

The wood material that goes into MDF is a very fine fiber that's similar to sawdust.

Sources

ShopNotes Project Supplies is offering some of the hardware and supplies needed for the projects in this issue. We've also put together a list of other mail order sources that have the same or similar hardware and supplies.

CIRCULAR SAW CUT-OFF JIG

Using a portable circular saw to make straight, accurate cuts is easy with the Cut-Off Jig shown on page 4. This jig has a unique pivoting guide that allows you to make either 90° or angled cuts.

ShopNotes Project Supplies is offering a hardware kit for the Cut-Off Jig. The kit has all the hardware you'll need. All you need to supply is 1/8"-thick Masonite and 1/2" and 3/4"-thick hardwood.

S16-6816-100 Circular Saw Cut-Off Jig Kit\$4.95

FLEXIBLE VENEER

The article on flexible veneer (shown on page 8) provides a close-up look at three of the most commonly used types of veneer.

You can find supplies and veneer at some woodworking stores. If they're not available locally, see the mail order sources below.

DRILL BIT CABINET

To organize all your drill bits and accessories in one convenient place, you can build the Drill Bit Cabinet shown on page 12.

Drill bits are stored in trays that tilt forward out of the cabinet. And there's a drawer and a pair of shelves to keep accessories for your drill press (or hand drill).

ShopNotes Project Supplies is offering a complete hardware kit for the Drill Bit Cabinet. All that you have to supply is the hardware, plywood, and Masonite.

S16-6816-200 Drill Bit Cabinet Hardware Kit.....\$10.95

RADIAL ARM SAW STAND

The Radial Arm Saw Stand shown on page 16 is a modular system that's designed to organize the clutter that always seems to accumulate around your saw.

The base that supports the saw houses a drawer for storage and a lift-out bin to hold scraps earmarked for the fireplace. And to organize the cutoffs you want to save, there's a storage unit on each side of the base.

ShopNotes Project Supplies is offering a kit that includes all the

hardware you'll need to build the Radial Arm Saw Stand.

S16-6816-300 Radial Arm Saw Stand Hardware Kit..... \$12.95



▲ An anti-vibration pad, link belt, and isolation mounts all help dampen noise and vibration.

REDUCING TOOL NOISE

ShopNotes Project Supplies is offering three of the products mentioned in the article on page 24, see photo above. Each of these products is designed to reduce noise that's caused by vibration.

S16-5503-370 Anti-Vibration Pad (1/8" x 12" x 12").....\$18.95

S16-6804-500 Interlocking Link Belt (4-feet long).....\$29.95

S16-5503-116 Isolation Mounts (Pkg. of 4).....\$17.95

Note: Mounts are 1" dia. by 1" tall and accept 5/16"-dia. bolts.

MAIL ORDER SOURCES

Similar hardware and supplies may be found in the following catalogs. Please call each company for a catalog or for ordering information.

Constantine's

800-223-8087
Flex. Veneer & Supplies

Highland Hardware

800-241-6748
Router Speed Control,
Blade Stabilizers

Leichtung Workshops

800-321-6840
Anti-Vibration Pads

McMaster-Carr

708-834-9600
Isolation Mounts

MLCS

800-533-9298
Router Speed Control

Bob Morgan

Woodworking Supplies
802-456-2545
Flex. Veneer & Supplies

Trendlines

800-767-9999
Router Speed Control,
Anti-Vibration Pads

Woodcraft

800-225-1153
Steel Pulleys, Link Belt,
Blade Stabilizers,
Anti-Vibration Pads

The Woodworkers' Store

800-279-4441
Flex. Veneer & Supplies

Woodworker's Supply

800-645-9292
Link Belt, Quiet Blades,
Router Speed Control

ORDER INFORMATION

BY MAIL

To order by mail, use the order form that comes with the current issue. The order form includes information on handling and shipping charges, and sales tax.

If the mail order form is not available, please call the toll free number at the right for more information on specific charges and any applicable sales tax.

BY PHONE

For fastest service use our Toll Free order line. Open Monday through Friday, 7:00 AM to 7:00 PM Central Time.

Before calling, please have your VISA, MasterCard, or Discover Card ready.

1-800-444-7527

Note: Prices subject to change after September 1, 1994.

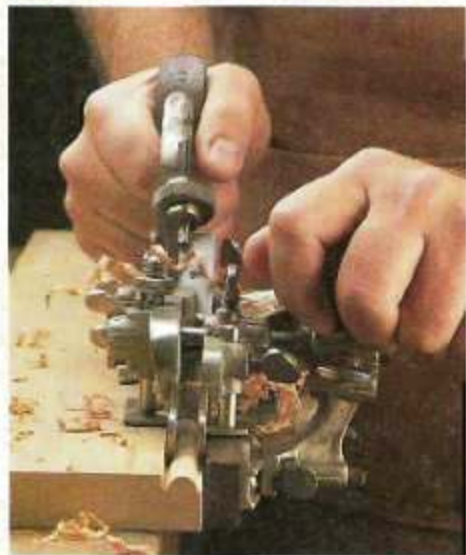

Scenes From the Shop

Before electric routers, a combination plane like this Stanley No. 45 was used to cut beads or decorative grooves in a workpiece. While a number of different

cutters provided a variety of profiles, the basic idea was the same. To produce a crisp cut, a series of light passes was made until the cutter reached a preset depth.