

TIPS • TOOLS • TECHNIQUES

ShopNotes®

Vol. 3

Issue 15



TABLE SAW UP-GRADE
Sliding Table

- Band Saw Circle Jig
- Belt Sander Maintenance
- Shop Tote
- Chisel Techniques
- Epoxy Systems



ShopNotes

Issue 15

May 1994

EDITOR Donald B. Peschke
EXECUTIVE EDITOR Douglas L. Hicks
MANAGING EDITOR Terry J. Strohmman
ASSOCIATE EDITOR Richard S. Peters
ASSISTANT EDITOR Tim Robertson
CONTRIBUTING EDITOR Phillip A. Totten

CREATIVE DIRECTOR Ted Kralceek
ART DIRECTOR Cary Christensen
SENIOR ILLUSTRATOR Kurt Schultz
ILLUSTRATORS Will Niskanen
 Roger Reiland
 Mark Higdon
PHOTOGRAPHER Crayola England

DESIGN DIRECTOR Ken Munkel
SENIOR DESIGNERS Jan Hale Svec
 Kent Welsh
SHOP MANAGER Steve Curtis
SHOP ASST./FACILITIES Steve Johnson

CIRCULATION

Circulation Director: Lita Broleson • *Subscription Manager:* Phyllis Jensen • *Circulation Analyst:* Rod Cain • *Newsstand Sales:* Kent A. Buckton

PUBLISHING SERVICES

Manager: Gordon C. Guipke • *Senior Graphic Designer:* Robert H. Whitmer • *Graphic Artist:* Cheryl L. Cynor

CORPORATE SERVICES

Controller: Robin Hutchinson • *Accounting:* Laura Thomas • *Bookkeeping:* Julie Greenlee • *Production Manager:* Carol Quijano • *Info. Services Manager:* Joyce Moore • *Elect. Pub. Coordinator:* Douglas M. Lidster • *App. Specialist:* Linda Morrow • *Admin. Assistants:* Cheryl Scott, Julia Fish • *Receipt:* Jeanne Johnson • *Building Maint.:* Ken Griffith

PROJECT SUPPLIES

Marketing Director: Robert Murry • *Catalog Art Director:* Cindy Jackson • *Fulfillment Manager:* Valerie Wiese • *Catalog Products Manager:* Bob Baker • *Project Supplies:* Linda Jones • *Technical Support:* Jeff James • *Receipt:* Cynthia Kerman

CUSTOMER SERVICE

Supervisor: Jennie Enos • *Customer Service Representatives:* Jennifer Murphy, Joy Johnson, Sara Koso, Anna Cox, Kristi Andrews

SHIPPING DEPARTMENT

Supervisor: Jerry Carson • *Fulfillment:* Gloria Shoehan, Don McVey, Chuck Carlson, Sylvia Carey

ShopNotes® (ISSN 1092-9898) is published bimonthly (Jan., March, May, July, Sept., Nov.) by Woodsmith Corporation, 2500 Grand Ave., Des Moines, IA 50312.

ShopNotes® is a registered trademark of Woodsmith Corp. ©Copyright 1994 by Woodsmith Corporation. All rights reserved.

Subscriptions: Single Copy, \$4.95. One year subscription (6 issues), \$19.95. Two years (12 issues), \$35.95. Canada/Foreign, add \$5.00 per year.

Second Class Postage Paid at Des Moines, IA and at additional offices.

Postmaster: Send change of address to ShopNotes, Box 11204, Des Moines, IA 50319-1204.

Subscription Questions? Call 1-800-333-6854, Sun to 5pm, Central Time, weekdays.

PRINTED IN U.S.A.

EDITOR'S NOTE

One of the most impressive things about watching Steve (our Shop Manager) work is what he *doesn't* do when he first receives plans for a project. He doesn't start cutting wood and fitting joints. Instead he calmly sits at the workbench (sometimes for hours) — and *plans*.

Like Steve, I've always felt that advanced planning is one of the most important (and often overlooked) steps in woodworking.

And the same is true for a woodworking magazine. We start planning many of

the projects that appear in an issue as much as a year in advance. This gives us the time to design the projects, work out the bugs, and redesign them if necessary. An example of this process is the Sliding Table shown on page 16.

SLIDING TABLE. We knew from the start that we wanted a shop-built version of a commercial sliding table. It would mount to the left side of a table saw and allow for easy crosscutting of panels up to 24" wide.

After determining *what* we wanted to do, the next step was to figure out *how* to do it. And that took some time. About six months.

The problem wasn't coming up with a solution that worked. It was coming up with a *simple* solution.

We started by designing a table that used components similar to those found on commercial tables — roller bearings and metal rails. Although it worked well, it was difficult to build and expensive. (The bearings alone cost over one hundred dollars.)

So we tried to find an inexpensive substitute for the bearings. After looking in dozens of catalogs and rummag-

ing through all the local hardware stores we tried using replacement wheels for a sliding door. This worked fine and was inexpensive. But once again, it was very difficult to build.

A DIFFERENT APPROACH. The solution that Jan (our Senior Designer) came up with was to use a different approach altogether. He got rid of the rollers. And substituted plastic laminate. The results were surprising — a table that slid smoothly, was inexpensive, and simple to make. (For more on this, see page 16.)

SHOP TOTE. But not all projects require as much planning as the Sliding Table. Every now and then someone shows me a project that I just can't wait to build and feature in the magazine.

That's what happened when I first saw a prototype for the Shop Tote shown on page 10. It looked like a deep tray with a handle, but when I lifted up the handle I discovered that only half of it came away with the tray. That was when I realized the handle was "split" and there were actually two trays.

I knew then that it was the kind of interesting project I wanted to build — and feature in *ShopNotes*.

A SQUEAL. Around here the squeal of a high pitched router usually goes unnoticed. But when the squeal comes out of a baby, it's another story. Recently, production came to a standstill when Terry and Christy Strohmman brought in their new baby boy. All the crew gathered around to welcome Richard into our extended family.

Note: Terry mentioned that Richard already has a roll-around tool chest. And he uses it every day — it's his changing table.

We start planning many of the projects that appear in an issue as much as a year in advance.

Contents

Band Saw Circle Jig _____ 4

Cutting perfect circles is easy with this shop-made jig for your band saw. A built-in tape and indicator let you quickly set up to cut almost any size circle.



Band Saw Circle Jig page 4

Belt Sander Maintenance _____ 8

All it takes to keep your belt sander running smooth and trouble-free is a routine cleaning and inspection.

Shop Tote _____ 10

A unique design provides a handle for each tray of this handy tote. Then the two halves combine to form one grip to carry parts, tools, or hardware wherever you need them.



Shop Tote page 10

Epoxy Systems _____ 14

An in-depth look at using epoxy systems in the shop: from measuring and mixing, to tips on application. Plus step by step instructions on how to make your own filler.

Sliding Table _____ 16

If you've ever tried to crosscut a large panel on a table saw, you'll appreciate this shop-built sliding table. It features a built-in fence that slips on and off for quick and accurate set-ups.



Sliding Table page 16

Chisel Techniques _____ 24

Making a controlled cut with a chisel depends on using the right grip and a few simple techniques.

Shop Solutions _____ 28

Five Shop-Tested Tips: C-Clamp Rack, Hole Saw Relief, Cut-Off Gauge, Pinch Blocks, and a Tip for Keeping Power Cords Out of the Way.

Springs _____ 30

Two types of springs to improve the performance of your shop-built jigs and fixtures.

Sources _____ 31

Hardware, project supplies, and mail order sources for the projects in this issue.



Chisel Techniques page 24

Band Saw Circle Jig

There's only one adjustment to make with this jig. Just select the exact size circle you want and cut.



One of the easiest ways to make a perfect circle is to cut it on a band saw. All it takes is a pin to spin the workpiece on.

The problem is accurately positioning the pin to get the correct size circle. To solve this, we designed a circle cutting jig that allows you to quickly set up for an exact cut, see photo.

There are two main parts to the jig: a "split" base, and an adjustable rail, see Exploded View.

The base serves as a carriage for the workpiece and allows you to slide both it and the jig into the saw blade as you start the cut.

Then a cleat on the front of the jig catches the saw table and locks the jig in place with the pin automatically aligned to the saw

blade. All you have to do is set the adjustable rail for the exact size circle you want.

BASE

I began work on the jig by building the base. It consists of a *front* (A) and a *rear* base (B). To make these, I started with two identical pieces, see Fig. 1. The size of the pieces depends on your saw.

To determine their width, measure from the teeth of the saw blade to the front edge of the table and add a $\frac{1}{2}$ " ($7\frac{1}{4}$ "), see Fig. 1. (Note: If your saw has a rip fence, you'll need to measure to its front edge.) To find their length, measure from the inside (throat) edge of the table to the saw blade and add 14", see Fig. 1.

(In my case, they're 21" long.)

TONGUE. The next step is to cut a tongue on the base pieces for the adjustable rail that's added later, see Fig. 1. The tongue is $\frac{7}{16}$ " thick and is centered on the thickness of each base piece, see Detail in Fig. 1.

CLEAT. Before the base pieces can be joined together, there's one more thing to do — add an L-shaped cleat to the front base (A), see Fig. 2.

The cleat consists of a *front rail* (C) which acts as a stop to automatically align the pin with the blade. And a *keeper* (D) that forms a lip to catch the table top.

Both pieces are the same length as the front base (21"). But their widths are different.

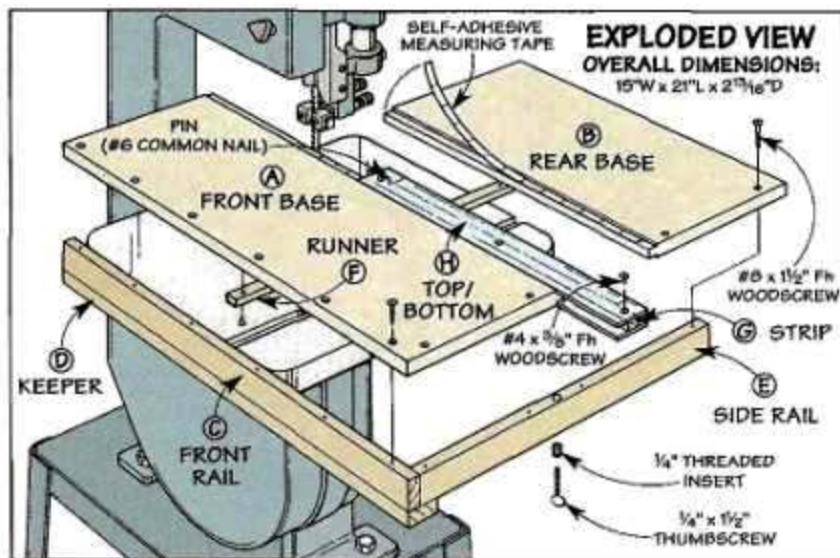

Materials & Hardware

- | | | |
|---|----------------|---|
| A | Front Base (1) | $7\frac{1}{4} \times 21 - \frac{3}{4}$ " ply. |
| B | Rear Base (1) | $7\frac{1}{4} \times 14 - \frac{3}{4}$ " ply. |
| C | Front Rail (1) | $\frac{3}{4} \times 15\frac{1}{16} - 21$ " |
| D | Keeper (1) | $\frac{3}{4} \times 1\frac{1}{2} - 21$ " |
| E | Side Rail (1) | $\frac{3}{4} \times 15\frac{1}{16} - 14\frac{1}{4}$ " |
| F | Runner (1) | $\frac{3}{8} \times \frac{3}{4} - 14\frac{1}{4}$ " |
| G | Strip (1) | $\frac{1}{2} \times \frac{1}{2} - 14$ " |
| H | Top/Btm. (2) | $1\frac{1}{2} \times 14 - \frac{1}{8}$ " Plex. |
- (16) #8 x $1\frac{1}{2}$ " Flathead Woodscrews
 - (4) #8 x $\frac{3}{4}$ " Flathead Woodscrews
 - (7) #4 x $\frac{3}{8}$ " Flathead Woodscrews
 - (1) #6 Common Nail
 - (1) $\frac{1}{4}$ " x $1\frac{1}{2}$ " Thumbscrew
 - (1) $\frac{1}{4}$ " Threaded Insert
 - (1) 48" L-R Reading Self-adhesive Rule

To determine the width (height) of the front rail (C), measure the thickness of your table top (or table top plus fence) and add $\frac{1}{16}$ " for clearance ($1\frac{15}{16}$ "), see Figs. 2a and 2b. The keeper (D) is easier — it's just $1\frac{1}{2}$ " wide.

After you've cut these pieces to size, they can be attached to the front base, see Fig. 2.

SPACER. With the cleat in place, the two halves of the base can be joined together. To create a uniform gap, I clamped a temporary spacer (a $\frac{1}{2}$ " square piece of hardwood) between them, see Fig. 3. (Note: Save this spacer, you'll use it later for the adjustable rail.)

SIDE RAIL & RUNNER. The two halves of the base are connected with a side rail and a runner, see Fig. 3. The side rail (E) adds strength to the jig. It's cut the same width as the front rail ($1\frac{15}{16}$ ") and screwed to the base flush with the edge.

The runner (F) allows you to quickly slip the jig in place and is

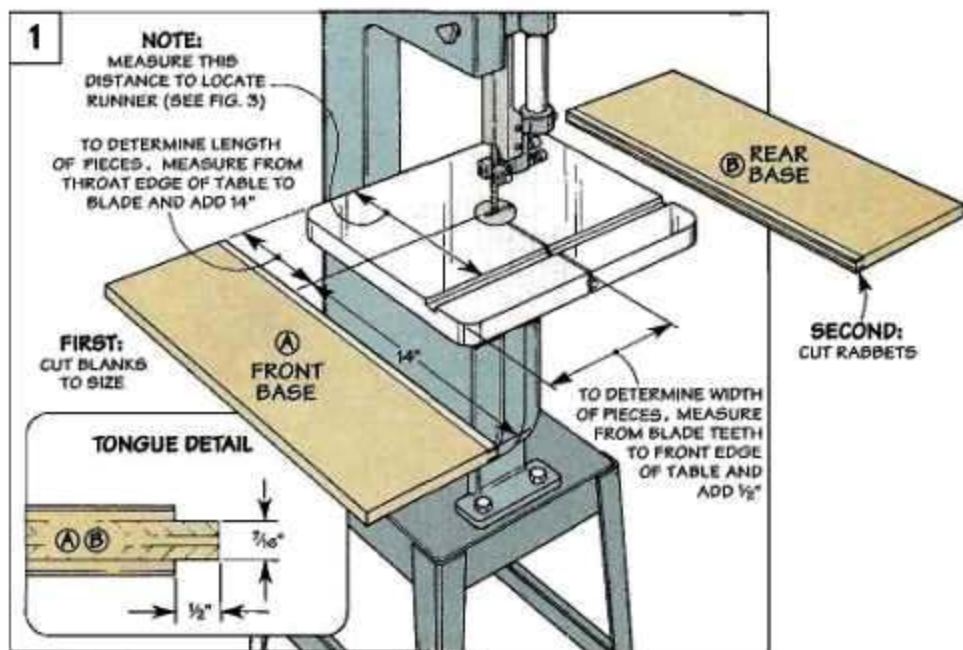

cut to fit in the miter gauge slot on your saw. To locate it on the base, first measure in from the throat side of your saw table to the edge of the miter slot, see Figs. 1 and 3. Then transfer this

to the bottom of the jig and screw the runner in place.

To complete the base, all that's left is to remove the spacer and trim the rear base (B) to length, see Fig. 4.

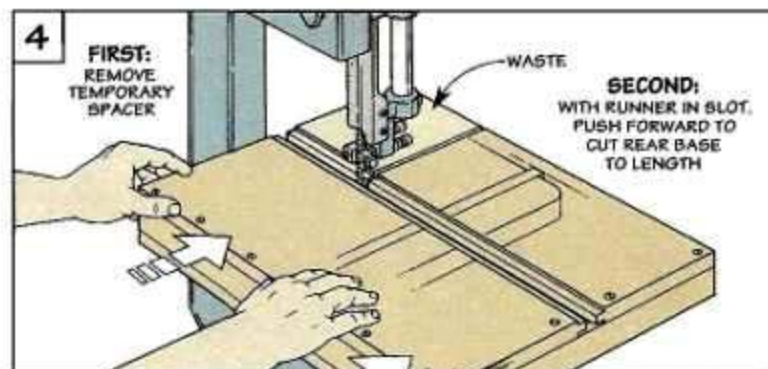
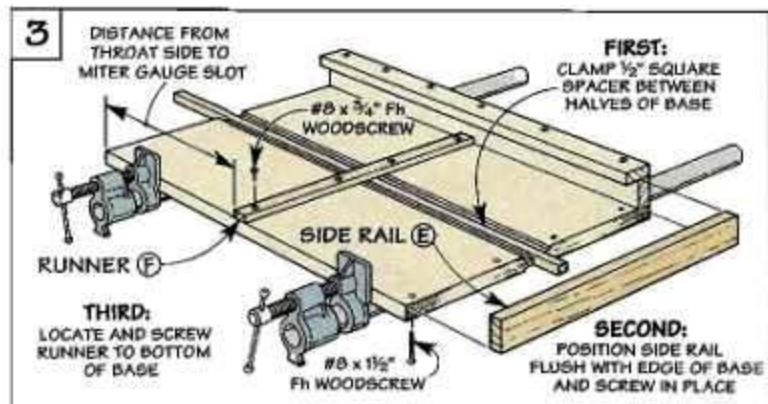
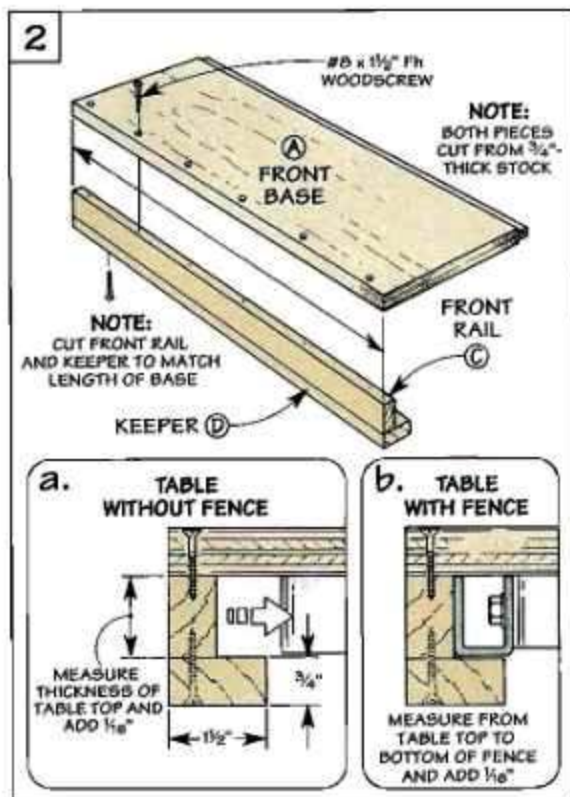

Adjustable Rail

After trimming the rear base to size, work can begin on the adjustable rail. This rail slides between the halves of the base so you can adjust the position of the pin, see Fig. 5. It's shaped like an I-beam—a hardwood strip fits between a Plexiglas top and bottom.

STRIP. You've made the *strip* (G) already. It's the spacer you used earlier, see Fig. 5. All that's left is to cut it to match the length of the rear base (14"). Then sand about $\frac{1}{32}$ " off the width and thickness. This ensures the rail will slide easily, and the top (added next) will be flush with the base.

TOP & BOTTOM. The $\frac{1}{8}$ "-thick Plexiglas *top* and *bottom* (H) are the same length as the strip (14"), see Fig. 6. As for their width, they're cut to slide in the rabbets in the base (1 $\frac{1}{2}$ ").

Before you assemble the rail, first scratch two indicator marks on the *bottom* face of the top piece, see Fig. 6a. These marks are used with the measuring tape added later to position the rail.

ASSEMBLY. Now you can assemble the rail. To ensure alignment, it's a good idea to screw the top and bottom to the strip with it in place in the base, see Fig. 5.

PIN. To complete the rail, just add a pin for the workpiece to spin on. This is a #6 common nail with the head cut off and filed to a slight crown, see Fig. 6b.

LOCKING SYSTEM. With the rail complete, I added a simple locking system to hold the rail in place—a threaded insert and a thumbscrew, see Fig. 7.

The threaded insert fits in a centered hole in the side rail, see Fig. 7. The thumbscrew threads in the insert to pinch the rail against the base, see Fig. 7a.

FINISH. All that's left is to apply two coats of tung oil to the jig. This protects it and also creates a surface that the self-adhesive rule (added next) will stick to.

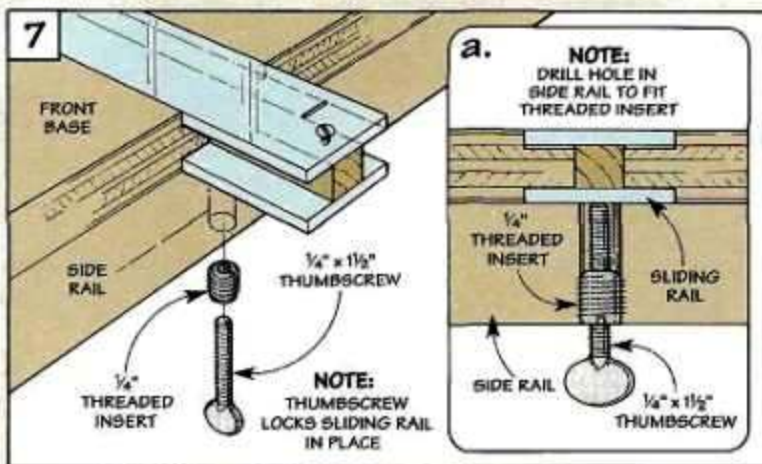
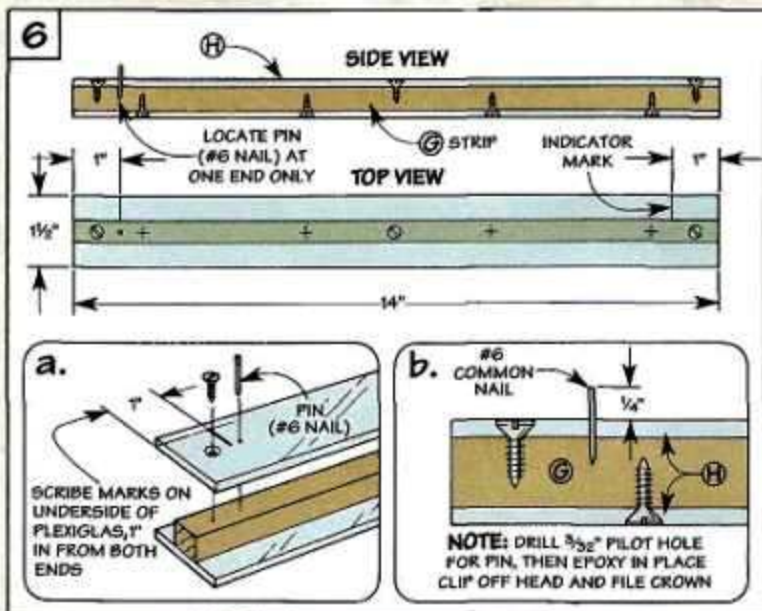
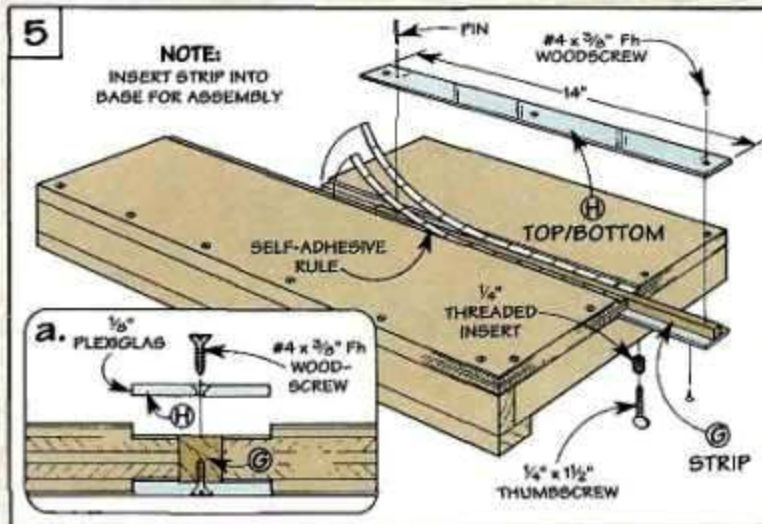

Adding the Tape

Once the finish has dried, you can add the measuring tape. I used a self-adhesive left to right reading tape and cut it in two pieces, see Fig. 8. (For a complete hardware kit, see page 31.)

TWO PIECES. The first piece goes in the rabbet in the rear base (B), and is used when cutting small circles (2 to 26" diameter). The other piece fits in the rabbet in the front base (A), and is used when cutting larger circles (26" to 48" diameter), see Figs. 8a and 8b.

USING THE JIG. In use, the adjustable rail is inserted into the base so the pin end is closest to the saw blade, see box below left. And to cut larger circles, the adjustable rail is turned around so the pin end is away from the saw blade, see box below right.

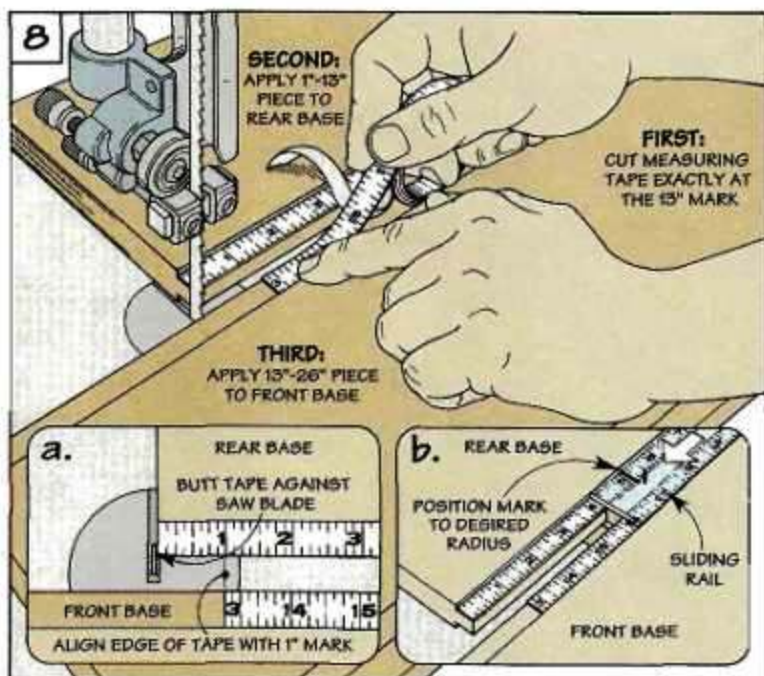

Drill a $\frac{3}{32}$ " hole in the underside of your workpiece for the pin.

Cutting Small Circles

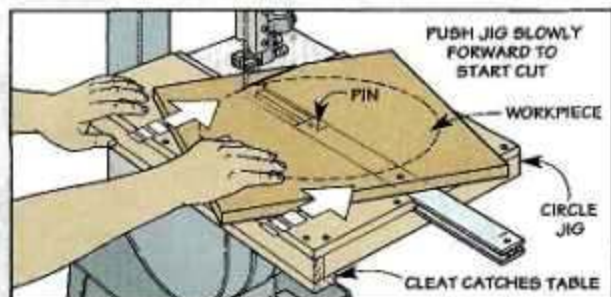

Step 1: Slide the Jig Forward. With workpiece resting on the pin, turn on the saw and slide jig slowly forward. Continue until the cleat catches the table.

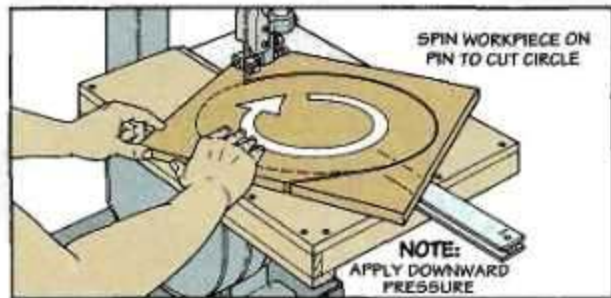

Step 2: Spin the Workpiece. Now to cut the circle, slowly spin the workpiece in a clockwise direction while applying downward pressure.

Cutting Large Circles

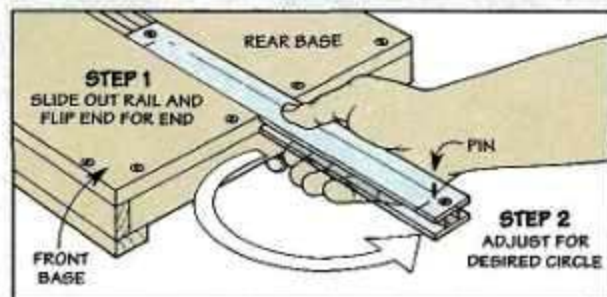

Step 1: Flip Adjustable Rail. For larger circles (more than 26"), remove adjustable rail and flip it end for end. Then slip it in the base and set it for the desired cut.

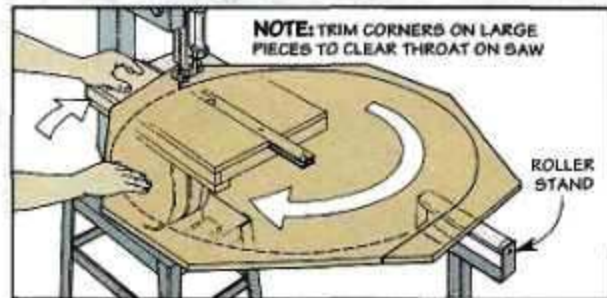

Step 2: Extra Support. To cut larger circles (over 26") I use the same technique that's used for smaller circles except I add extra support under the workpiece.

Belt Sander Maintenance

Routine cleaning and an occasional check for worn parts will keep your belt sander running smooth and trouble-free.



When it comes to removing a lot of material quickly, my belt sander is a real workhorse. But the heat and dust that this generates can eventually take their toll on a belt sander.

That's why I like to invest a few minutes on some preventive maintenance before putting it back on the shelf. In most cases, all it takes is some routine cleaning and a check for worn parts to keep your belt sander running smooth and trouble free.

CLEANING

One of the easiest (yet most effective) things you can do to

Remove packed-in dust with a small brush and vacuum to keep it from clogging up the belt sander.



An abrasive pad (like a Scotch-Brite pad) and some lacquer thinner make quick work of cleaning the rollers.



avoid problems is to give the belt sander a good "once-over."

REMOVE DUST. To prevent dust from working into the motor or bearings, the first thing is to remove the packed-in dust. I use a small brush and vacuum to avoid driving the dust farther into the sander, see top photo below.

ROLLERS. Dirt and grease can also accumulate on the front and back rollers and cause the belt to slip. To clean the rollers, I use an abrasive pad and some lacquer thinner, see bottom photo below.

WORN PARTS

Besides the routine cleaning, I make it a habit to check and replace worn parts. Note: You can get replacement parts at most repair shops.

BRUSHES. With use, the "brushes" on your sander may need to be replaced. These are rectangular pieces of carbon that transfer the electric current to the motor, see Fig. 1.

As the brushes wear down, you'll notice more sparking than usual around the motor. And when you apply pressure, the sander will tend to bog down. If the brushes are extremely worn, the sander may not even start or will only start intermittently.

To check for wear, just remove the retaining caps and slip the brushes out, see Fig. 1. What you're looking for here is the *length* of the brushes. Some brushes will have a "wear line" that indicates when they need to be replaced. But for others, you'll need to check your owner's manual to see how long they should be.

DRIVE BELT. Another common problem is the sanding belt "stalls" when you apply pressure on a workpiece. This can often be traced back to the rubber drive belt that transfers power from the motor to the back roller, see Fig. 1.

With use, this belt gets brittle, and the "teeth" start to chip and break. To check, just remove the cover on the side of the sander and replace the belt if necessary.

PAD AND PLATEN. Two other parts that may need attention are the cork pad and the thin metal platen (plate) that the sanding belt rides across, see Fig. 2. To produce a smooth, even surface when sanding, the platen and pad need to be flat.

But what happens is the friction and heat that are generated when sanding eventually start to burn the back edge of the platen. And the cork pad dries out to the point that pieces of it get torn out.

To replace the pad and platen, all that's needed is to remove the metal bar that holds them in place, see Fig. 2. As before, new replacement parts are available at

most repair shops. (For information on a different type of platen, see the box below.)

TRACKING

Perhaps the most frustrating problem to deal with is when the belt just won't stay on the sander. It either shoots off the open end. Or it slides into the housing and slices the belt to ribbons.

BELT STRETCH. When this happens, the first instinct is to adjust the tracking knob. But often the problem is the sanding belt itself. Sometimes it has stretched out to the point that no amount of adjustment will make it track accurately. So the first thing I do is install a new sanding belt.

If that doesn't work, it's most likely the tracking system itself. Basically, this system has two parts: the back drive roller and a front roller assembly, see Fig. 3.

BACK ROLLER. The back roller has a slight "crown" that centers the sanding belt and keeps it from sliding off. With use, this crown wears down and causes the belt to wander.

To check the crown, hold a metal rule against the roller, see Fig. 3. If the roller has worn flat, replacing it is best handled at a repair shop.

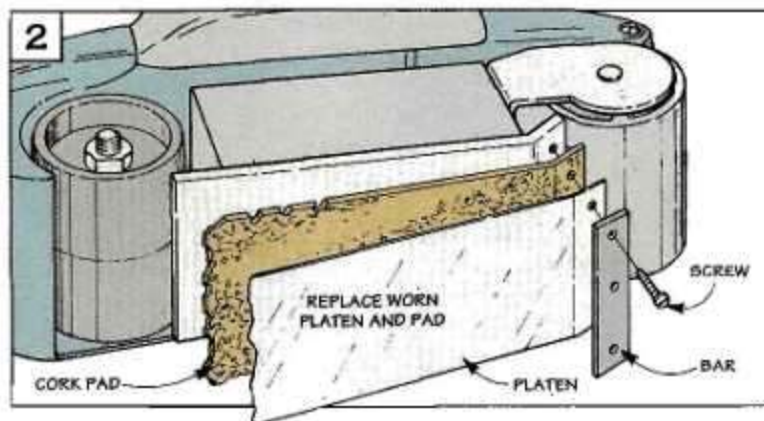
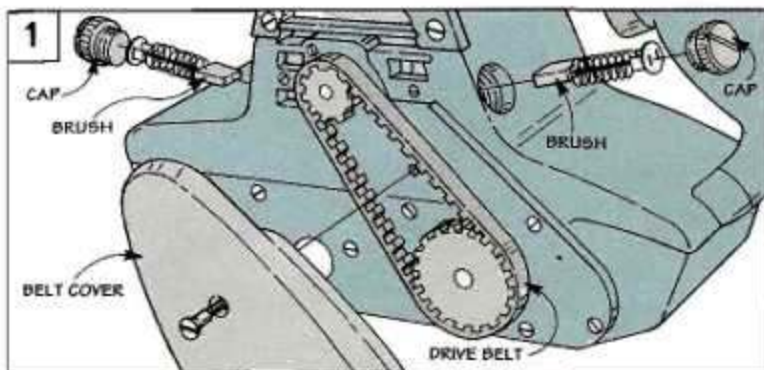

FRONT ROLLER. The second part of the adjustment system is the front roller assembly. It consists of a fork that holds the front roller and an adjustment knob, see Fig. 3. Turning the knob tilts the fork and tracks the sanding belt one way or the other.

If the sander has been dropped or damaged, the fork may be bent.

Here again, replacing it is a job for the repair shop.

FINAL THOUGHTS. But taking your belt sander to the repair shop is the exception — not the rule. Even when you push your belt sander to its limits, a regular cleaning and inspection for wear are usually all that's needed to keep it in top running condition.

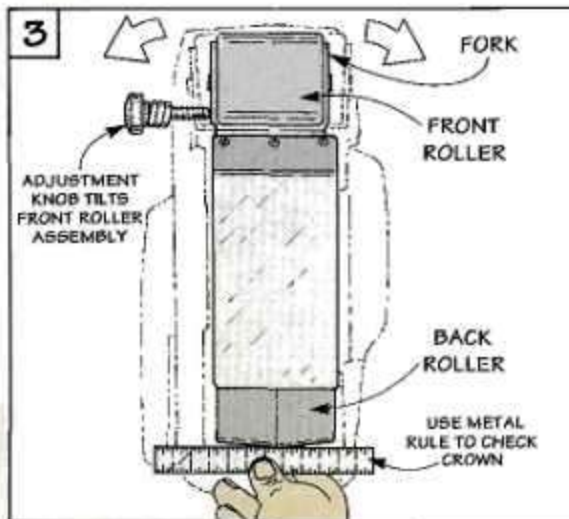

Graphite Platens

The basic idea of this graphite platen is simple. As the sanding belt runs across the platen, the graphite lubricates the back of the belt and makes it run cooler.

The platen is made from a flexible, canvas-like material. To install it, you'll need to trim the platen to fit your belt sander and punch holes in the end for the screws that hold down the retaining bar, see photo. (For sources of graphite platens, see page 31.)



A graphite platen helps reduce heat build-up and extends the life of your belts.

Shop Tote

A unique "split" handle design provides a handy grip for each tray and allows you to stack them on top of each other.



When Steve (our Shop Manager) walked into the workshop the other day, the first thing I noticed was the sly grin on his face. Then I realized he'd brought a prototype of a project for me to look at — a small tote for organizing and carrying around hardware, hand tools, or whatever, see photo above.

TWO TRAYS. At first glance, I thought that it was just a deep box with a handle. But on closer inspection, I realized that there were actually *two* trays, one on top of the other.

Intrigued, I lifted up the top tray only to find that "half" of the handle came along with it (Steve's grin got wider). The other "half" of the handle was built into the bottom tray. Ingenious. This way each tray has its own handle. And when the trays are stacked up, the handles combine to form a heavy-duty grip for the entire tote.

DIVIDERS. In addition to the unique handle design, this Shop Tote also features a set of built-in dividers. These dividers allow you to customize each tray to help organize its contents. (For more on this, see page 12.)

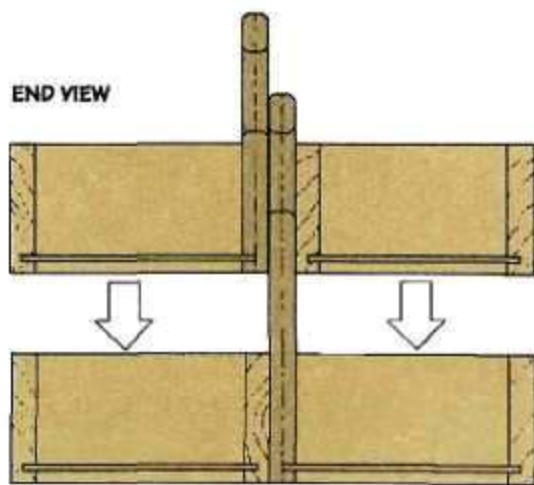

Materials

- | | | |
|---|--------------------|------------------------------|
| A | Fronts/Backs (4) | 1/2" x 2 1/2" - 14" |
| B | Ends (4) | 1/2" x 2 1/2" - 9 9/16" |
| C | Center Rails (2) | 1/2" x 2 1/2" - 13" |
| D | Lower Handle (1) | 1/2" x 7 1/2" - 13" |
| E | Upper Handle (1) | 1/2" x 5" - 13" |
| F | Bottoms (3) | 4 1/2" x 13 1/2" - 1/8" Mas. |
| G | Narrow Bottom (1) | 4" x 13 1/2" - 1/8" Mas. |
| H | Dividers (6) | 1/2" x 2 1/8" - 4" |
| I | Short Dividers (2) | 1/2" x 2 1/8" - 3 1/2" |
- * Two layers of 1/4" Masonite

EXPLODED VIEW

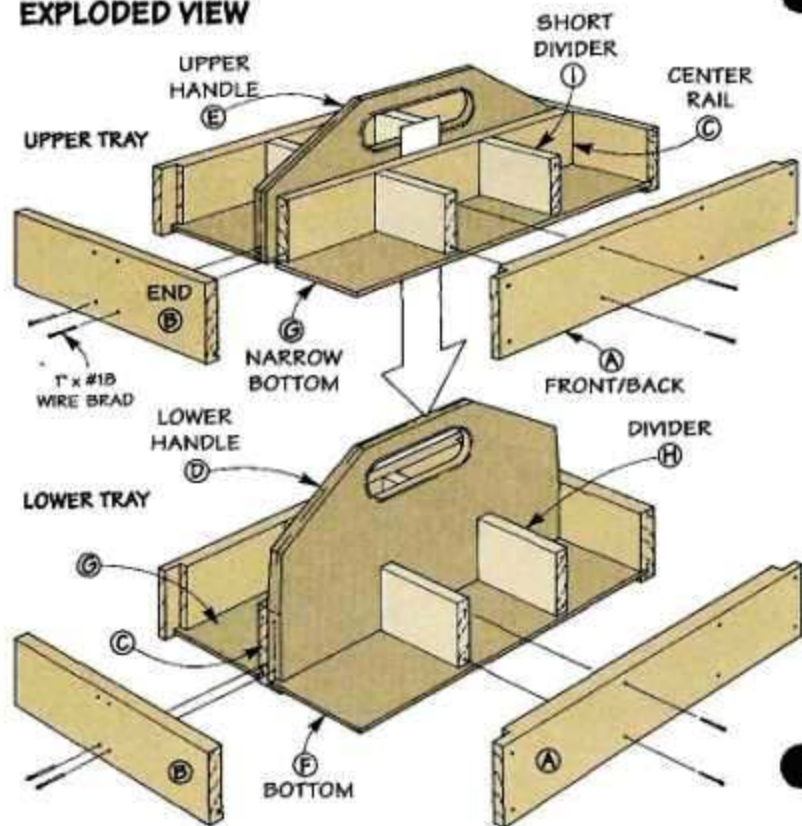

Tray Parts

Since the basic parts of the upper and lower trays are identical, I started with blanks wide enough to make both trays, see Drawing at right. Then trimmed the individual pieces to finished width later.

FRONT, BACK, & ENDS. All of the tray blanks are the same width (height) — $5\frac{1}{8}$ ". But their lengths are different. The blanks for the front and back pieces (A) are 14" long. Then they're rabbeted on each end to receive the end pieces, see Drawing and Detail at right. The blanks for the ends (B) are $9\frac{9}{16}$ " long.

CENTER RAILS. After the front, back, and end blanks are cut to size, the next step is to make a blank for the two center rails (C), see Drawing. To determine the length of this blank, measure the distance between the shoulders of the rabbets on a front or back blank. (In my case, it's 13" long.)

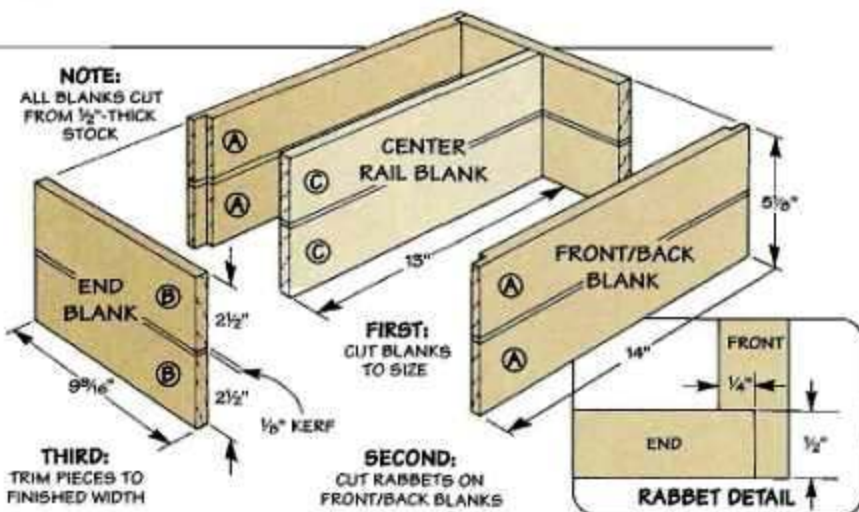

see Drawing. To determine the length of this blank, measure the distance between the shoulders of the rabbets on a front or back blank. (In my case, it's 13" long.)

CUT TO WIDTH. Now you can rip all of the tray pieces (A, B, and C) to their finished widths ($2\frac{1}{2}$ "). Then set these pieces aside, they're used later.

Handles

After the tray pieces are cut to size, you can turn your attention to the handles. On his original tote, Steve used hardwood handles. But I was concerned they might warp and prevent the trays from sliding together.

MASONITE. To get around this, I used a material that was more stable than solid wood — Masonite.

To make each handle, I glued up a blank made from two layers of $\frac{1}{4}$ "-thick Masonite, see Fig. 1.

Each handle blank is the same length (13"). The only thing different is their height (width). The lower handle (D) is $7\frac{1}{2}$ " tall. But since the upper handle (E) rests on top of the lower tray, it's $2\frac{1}{2}$ " shorter (5" tall).

HANDLE SHAPE. To make sure the handle shapes match, I carpet taped the blanks together and laid out the shape on top, see Figs. 1 and 1a. Then with the blanks still taped together, cut out the shape.

ROUND-OVER. Finally, separate the pieces and round over the holes and top edges only on the router table, see Figs. 2 and 2a.

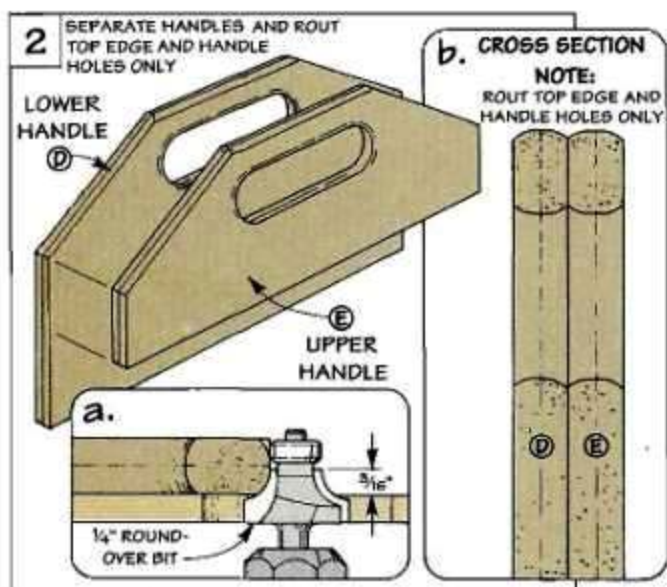
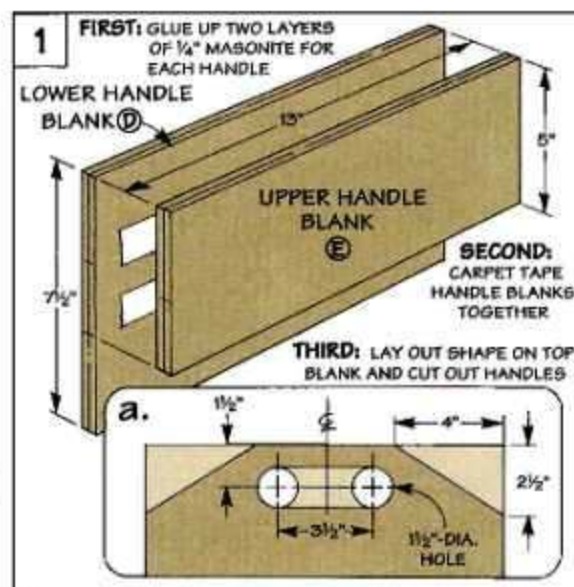

Lower Tray

Now that the handles are complete, you can start work on the lower tray. The lower tray uses the taller ($7\frac{1}{2}$ " of the two handles, see Drawing at right.

CUT GROOVES. The first step is to cut grooves for the tray bottoms that are added later. These $\frac{1}{8}$ "-wide grooves are cut on the *inside* bottom edge of each lower tray piece (including the handle), see Figs. 3 and 3a.

TAPER HANDLE. Next, to make it easier to slide the upper tray over the handle of the lower tray when it's assembled, I sanded a slight taper on the ends of the handle, see Fig. 4.

TRAY BOTTOMS. With the handle tapered, the next step is to determine the size of the tray bottoms, see Fig. 3. To do this, first dry clamp the tray together. Then position the center rail (C) and handle (D) so they're centered on the width of the tray, see Drawing above.

Next, measure each of the openings and add $\frac{1}{2}$ " to both the length and the width. Now you can cut two $\frac{1}{8}$ "-thick Masonite bottoms (F) to size, see Fig. 3. (In my case, they're $4\frac{1}{2}$ " wide and $13\frac{1}{2}$ " long.)

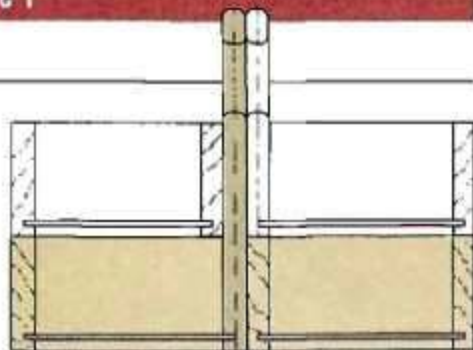

ASSEMBLY. After the bottoms have been cut to size, all that's left is to assemble the lower tray. Start by gluing the center rail to the handle so the grooves on each are facing out, see Fig. 4. Then apply glue to the remaining tray parts and nail the tray together, refer to Fig. 3.

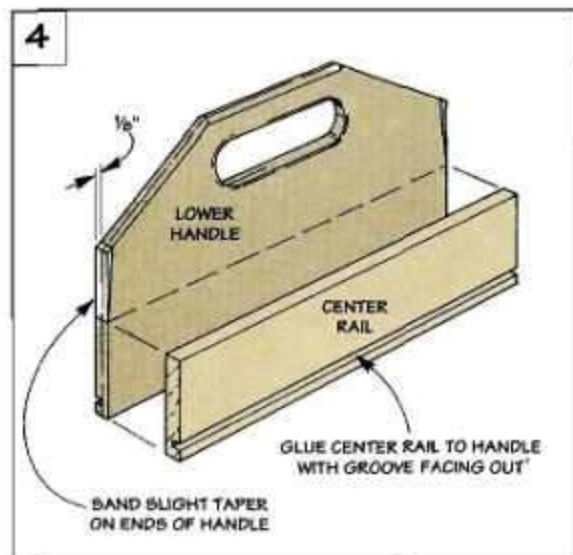
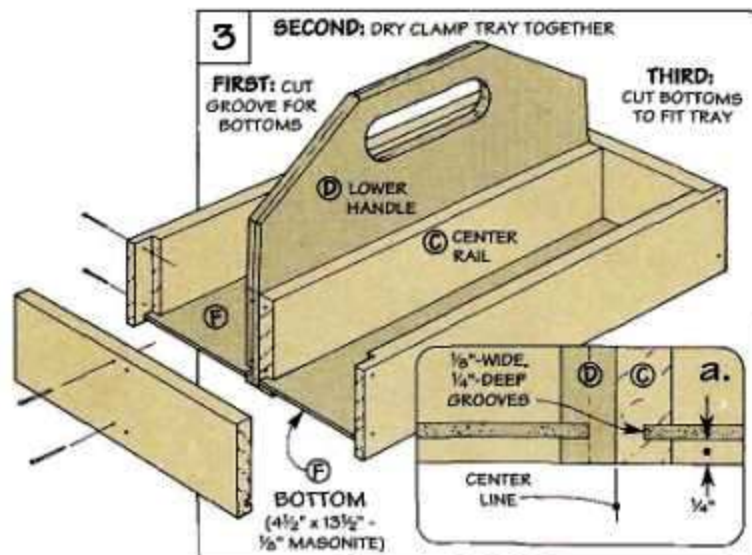

▲ The upper tray is a convenient way to keep some of your most often used tools right at hand.



▲ The lower tray is a handy place for storing and organizing screws, nails, and assorted hardware.

Upper Tray

After you've assembled the lower tray, you can begin work on the upper tray.

CUT GROOVES. Just as you did with the lower tray, the first step is to cut $\frac{1}{8}$ "-wide grooves in all of the tray pieces for the Masonite bottoms, refer to Fig. 3a and the Drawing at right.

TRAY BOTTOMS. To determine the size of the tray bottoms, I again dry clamped the tray. Only this time, I clamped it up around the handle and the center rail before nailing it in place, refer to Fig. 6.

First, it ensures that the sides and ends of the upper tray will align with those on the lower

tray. And second, it positions the upper handle and center rail in the correct positions for the handle of the lower tray to slip through, see Drawing at right.

Note: To make sure there's enough clearance for the upper tray to slide over the handle, I inserted a paper shim (posterboard) between the handle and the center rail before nailing it in place, refer to Fig. 6.

Although the length of both bottom pieces is the same ($13\frac{1}{2}$ "), their widths are different. The narrow bottom (G) that fits on

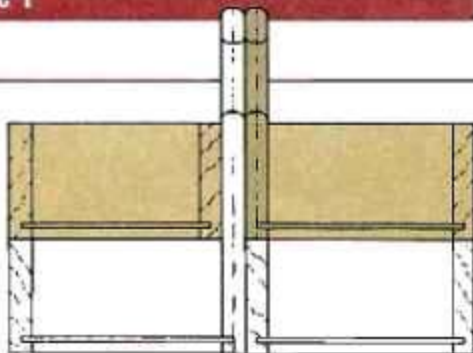

the center rail side is $\frac{1}{2}$ " narrower than the other side. (In my case, it's 4" wide.) The other bottom (F) is $4\frac{1}{2}$ " wide, see Fig. 5.

ASSEMBLY. After you've cut the bottoms to size, the upper tray can be assembled. Here again, I glued, clamped, and nailed it together on top of the lower tray, see Fig. 6.

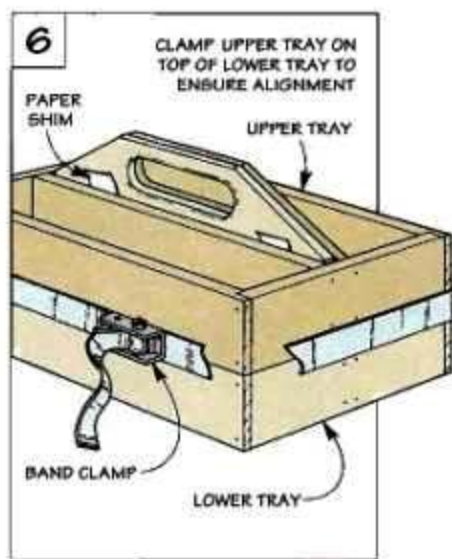
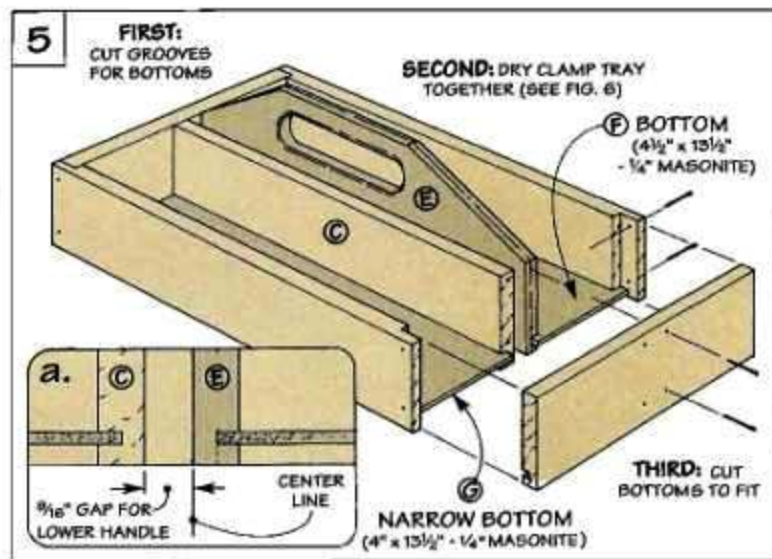

Dividers

To complete the trays, I added a set of dividers, see Fig. 7. They're just pieces of $\frac{1}{2}$ "-thick stock cut to fit inside the tray.

The dividers (H) for the lower tray and one side of the upper tray are the same — $2\frac{1}{8}$ " high (wide) and 4" long. But the short dividers (I) for the other side of the upper tray are only $3\frac{1}{2}$ " long.

When they're cut to size, position the dividers in the tray and nail them in place, see Fig. 7.

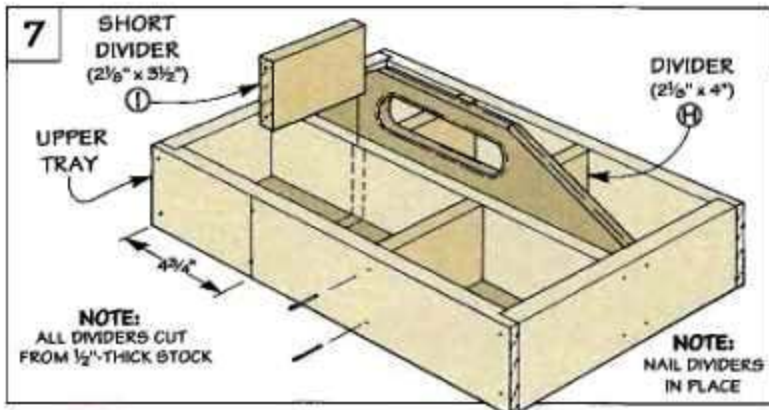

Epoxy Systems



For years the only type of epoxy I used was the “five minute” variety sold at most hardware stores. It was great for quick repairs — to mend a cracked plate or fix a broken toy.

It wasn't until I discovered epoxy “systems” that I realized how useful epoxy can be for woodworking. It's extremely strong, virtually waterproof, and doesn't shrink at all.

TWO PARTS. Like the five minute varieties, an epoxy system comes in two separate parts: a *resin* and a *hardener*. When the two parts are mixed together, a *chemical reaction* occurs that hardens or “cures” the epoxy.

What makes an epoxy system special is you can vary the curing time by choosing the type of hardener. Fast hardeners cure in

about ten minutes. Slow hardeners offer a much longer assembly time — up to an hour. This makes it the perfect choice whenever you need to glue up a project that has a lot of parts.

In addition to this, epoxy does some things other glues can't. It can bond dissimilar materials together — like metal to wood. I often use it to glue a bolt in a jig. Or to repair a stripped-out screw.

And since epoxy only requires

It wasn't until I discovered epoxy “systems” that I realized how useful epoxy can be.

that the parts touch each other for a good bond, it's the perfect solution for those awkward situations where you just can't get a clamp onto something.

CUSTOMIZE. But the thing that I like best about epoxy systems is they allow you to customize the epoxy to fit your application. By varying the mix ratio on some systems, you can change the curing time. Other systems provide a variety of *fillers* that can be used to change the consistency of the epoxy. (For more on this see the box on page 15.)

DRAWBACKS. The only drawback to using epoxy systems is they can be expensive. And since they come in two parts, they're not as convenient as pre-mixed glues. (Epoxy systems can be found at some wood-

working stores. Or they can be mail ordered, see Sources on page 31.)

THREE STEPS. There are three basic steps to working with any epoxy system: measuring out the two parts, mixing them together, and applying the mixture.

MEASURING

By far the most important step to working with an epoxy system is measuring. When measuring out the parts, make sure you follow the directions.

Some manufacturers allow you to vary the mix ratios. Others don't, and they warn that an improper ratio can result in a mix that won't cure (what a mess), or one that is weakened if it does cure.

The most typical mix ratio is two parts resin to one part hardener. But depending on the product, it can vary up to five parts resin to one part hardener.

One trick that I discovered when measuring out epoxy is to only measure out what you'll need — you can't save the leftovers. (If you're working on a large job, it's best to use several smaller batches.)

As you measure out the parts, it saves clean-up time if you pour them into a disposable container (such as a plastic yogurt cup or a small can). Just keep in mind that as soon as the two parts are combined, a chemical reaction begins and the epoxy mixture will get hot. So don't use Styrofoam cups — they can melt.

SAFETY TIPS. There are a couple other things to keep in mind

Epoxy Systems Tips

- Use an epoxy system when you need a bond that's strong, waterproof, or won't shrink.
- Select a hardener to provide the working time you'll need (slow, medium, or fast).
- Measure out only what you'll need.
- Mix thoroughly, scraping the container often.
- Add sanding dust (if desired) to make a filler.
- No clamps required, just immobilize the parts.
- Remove any squeeze-out before epoxy cures.
- Heating up epoxy causes it to cure faster.
- Cooling down epoxy causes it to cure slower.

when working with epoxy. First, avoid skin contact — wear gloves. Second, epoxy fumes can be hazardous. So make sure there's adequate ventilation. And wear a respirator and eye protection.

Safety Note: If you do get epoxy on your skin, *don't* use a solvent (such as lacquer thinner or denatured alcohol) to remove it. Solvents only drive the epoxy in deeper. Instead, use a waterless hand cleaner (like *Goop*) used by auto mechanics.

MIXING

Once you've measured out the two parts, you're ready to combine them. Stir the mixture well, scraping the container sides often. Mixing takes anywhere from 30 seconds to five minutes depending on the size and shape of the container, and the amount and type of epoxy you're mixing.

ShopTip: It's a good idea to write the time you mixed the epoxy on the cup or can. This way

you'll know how much time you have before it begins to set.

APPLYING

Before you apply the epoxy, first make sure the parts to be joined are clean and free from dirt and dust. If you're gluing wood to wood, I've found a freshly cut or planed surface works best. And if you're gluing metal to wood, it's a good idea to slightly roughen the metal before applying the epoxy.

To apply the epoxy, I use a disposable glue brush. The secret to a good bond is to apply the epoxy to *both* surfaces. This ensures that the glue joint won't be "starved" — that there will be plenty adhesive for a strong joint.

Note: If you're going to add a filler (such as sawdust) now is the time to do it, see box below.

Once the parts have been coated, all you have to do is press them together and hold them in place long enough for the epoxy to set. (You don't have to apply a

lot of pressure. So this can be done with string, tape, or even rubber bands.)

After the parts are immobilized, it's important to scrape off any squeeze-out with a putty knife while it's still slightly soft and doughy. Once epoxy has cured it's difficult to remove — and it's tough on your tools.

HEAT TRICKS

Since epoxy generates heat as it cures, you can (to some extent) control how long it takes to cure by varying the temperature.

If you want a quicker cure, use a heat lamp or hair dryer to heat up the joint. If you need more working time, work in a cooler place (like your basement). Or use a portable fan to help dissipate the heat that's generated.

One Final Note: Never throw unused epoxy in the trash before it's completely cured. The heat it generates as it finishes curing could start a fire.

Using Fillers with Epoxy

One of the unique features of an epoxy system is that you can mix in an additive or "filler." This allows you to vary the consistency (anywhere from thickened honey to peanut butter) to suit your application.

Thin for most gluing jobs. And thicker when you need a filler that also creates a strong bond (such as

repairing a crack or split on a turned bowl, see Steps 1 through 3 below).

Although epoxy system manufacturers sell a variety of fillers with strange names (plastic fibers, silica thickener, and phenolic microballoons), I've found that good old sawdust works best for woodworking. But not ordinary sawdust — *sanding*

dust (it's finer than sawdust). To make your own, just pick a scrap piece of wood that matches your project and sand it with fine (320) grit sandpaper. (For this, I like to use a power sander with an attached dust bag.)

Note: Mixing in sanding dust helps the epoxy take a finish better. But like any adhesive, it won't accept a stain.



Step 1: Mix the resin and hardener together thoroughly and apply a coat to both surfaces to be joined.



Step 2: Now you can add filler to the remaining mixture. Keep adding filler until desired consistency is reached.



Step 3: Apply the thickened mixture to one surface only. Then bring the parts together and allow to cure.

Sliding Table

Straight, accurate crosscuts on wide panels . . . that's the idea behind this shop-built sliding table.



Crosscutting a wide panel on the table saw can be a real juggling act. One hand to balance the workpiece (the saw table in front of the blade is too small to provide much support). And the other to steady the miter gauge (that is, if the runner hasn't already come out of the slot).

MORE SUPPORT. One solution I've seen in a lot of production cabinet shops is a sliding table. To provide more support for the workpiece, a sliding table extends in *front* of the saw table.

There's only one drawback with most commercial tables. They're expensive. So I decided to build my own shop-made version, see photo above.

CONSIDERATIONS. Basically, I had two things in mind when working on this sliding table. First, it had to crosscut workpieces up to 24" wide. And second, I wanted an easy-to-build table that didn't have a lot of complicated hardware.

SIMPLE DESIGN. The end result is a table with a simple, straight-forward design. It slides on two rails that are supported by a shallow tray, see photo A. And I used

plastic laminate to create a slick, durable surface for the table to slide across.

FENCE. To ensure accuracy when crosscutting, this table also features a fence that can be adjusted so it's precisely 90° to the saw blade. And when you're not using the table, just loosen a pair of knobs to remove the fence, see photo B.

REPLACES EXTENSION. Like most commercial tables, this sliding table replaces the left extension wing on your saw table. To provide clearance when you pull the table back, you'll need to move (or cut off) the rails that guide the rip fence, see the photo on the opposite page.

A. Guide System. To ensure accurate cuts, a built-in guide system tracks the table straight and true. Applying plastic laminate to the parts creates a slippery surface for the table to slide across.



B. Fence. Loosening a pair of knobs makes it easy to remove the fence. When you put it back on, a unique stop system lets you quickly reposition the fence so it's 90° to the saw blade.



Hardware

- (42) #8 x 2" Fh Woodscrews
- (18) #8 x 1/4" Fh Woodscrews
- (8) #8 x 1" Fh Woodscrews
- (8) #10 x 1" Sheet Metal Screws
- (8) 3/16" Flat Washers
- (1) 3/8" x 3" Carriage Bolt
- (2) 3/8" Lock Nuts
- (1) 3/8" x 1/2" Fender Washer
- (1) 3/8" Flat Washer
- (1) 1/4" x 1 3/4" Hitch Pin
- (3) 3/8" x 1 1/2" Lag Screws
- (2) 1/4" x 1 1/2" Cap Screws
- (3) 1/4" Flat Washers
- (3) 1/4" Threaded Inserts
- (2) 1/4" x 1" Fender Washers
- (2) 1/4" Press-On Knobs
- (1) 1/4" x 1/2" Hex Bolt
- (1) 1/4" Hex Nut

EXPLODED VIEW
OVERALL DIMENSIONS:
 14" W x 48" L x 34½" H

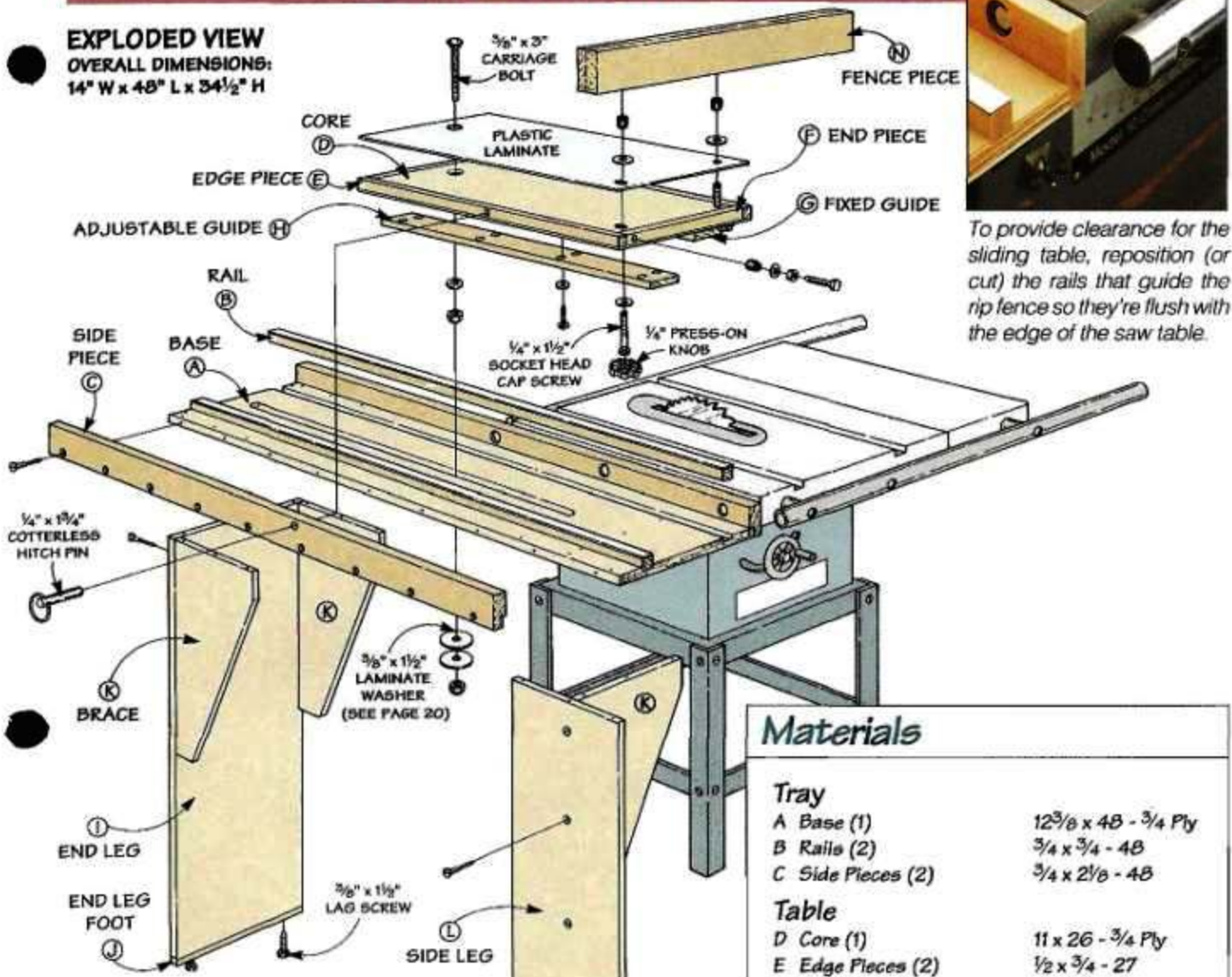

To provide clearance for the sliding table, reposition (or cut) the rails that guide the rip fence so they're flush with the edge of the saw table.

Materials

Tray	
A Base (1)	12 ³ / ₈ x 48 - 3/4 Ply
B Rails (2)	3/4 x 3/4 - 48
C Side Pieces (2)	3/4 x 21/8 - 48
Table	
D Core (1)	11 x 26 - 3/4 Ply
E Edge Pieces (2)	1/2 x 3/4 - 27
F End Pieces (2)	1/2 x 3/4 - 11
G Fixed Guide (1)	1/2 x 2 1/2 - 27
H Adjustable Guide (1)	1/2 x 2 1/2 - 27
Leg Assembly	
I End Leg (1)	12 x 30 1/2 - 3/4 Ply
J End Leg Foot (1)	3/4 x 3/4 - 12
K Braces (3)	10 x 16 - 3/4 Ply
L Side Leg (1)	10 x 30 1/2 - 3/4 Ply
M Side Leg Foot (1)	3/4 x 3/4 - 2
Fence	
N Fence Pieces (2)	5/8 x 23/4 - 26

Cutting Diagram

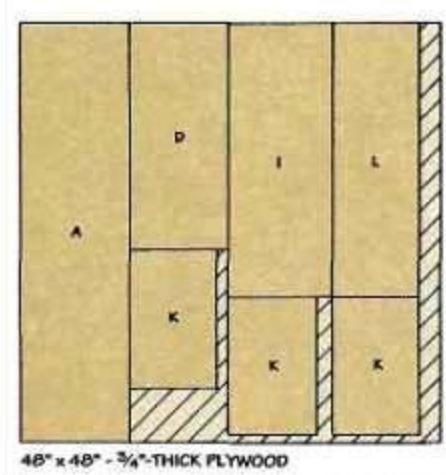

NOTE:
 YOU'LL ALSO NEED
 A PIECE OF PLASTIC
 LAMINATE THAT'S
 AT LEAST 36" x 48 1/2"

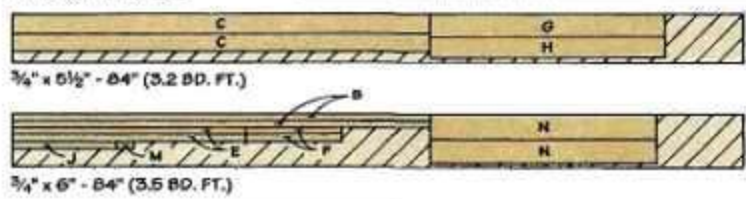

The Tray

The heart of the sliding table is a long tray that mounts to the side of the saw table. This tray simply replaces the left extension wing. Because of this, you may need to move (or cut off) the rails that guide the rip fence, refer to page 17.

BASE. I started work on the tray by making a plywood base (A), see Figs. 1 and 2. The length of the base determines how far you can slide the table back and forth. To provide enough travel to cut a 24"-wide panel, I made the base 48" long, see Fig. 2.

RAILS. After cutting the base to size, the next step is to add a pair of rails. The rails act as glides for the table to slide across, see Figs. 1 and 1a. And they're part of the system that tracks the table in a straight line.

The rails (B) are narrow strips of hardwood (maple) that fit in shallow grooves cut in the base, see Figs. 2 and 2a. To prevent the table from binding, the important thing is that these grooves are parallel to each other.

An easy way to ensure that they're parallel is to cut one groove, reposition the fence, and

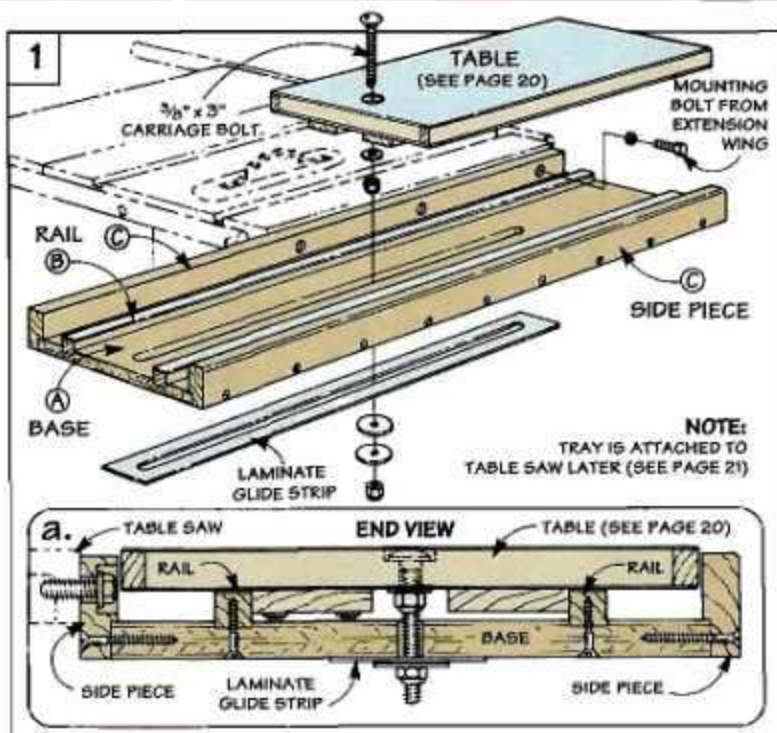

then run the same edge against the rip fence to cut the second groove, see Figs. 3 and 4.

LAMINATE. After screwing the rails in place, the next step is to apply a strip of plastic laminate to the top of each rail. This creates a hard, slick surface for the table to

slide back and forth on.

Attaching the laminate strips is easy. Just cut oversize pieces and glue them in place with contact cement. The only problem is the rails are narrow, so it's hard to hold the router steady when trimming the edges flush. To

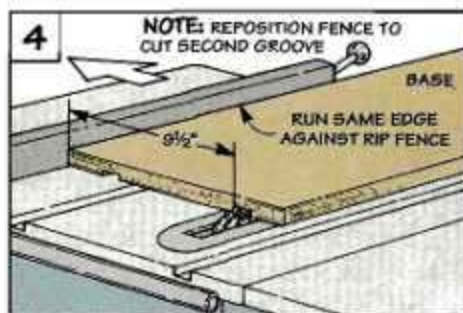
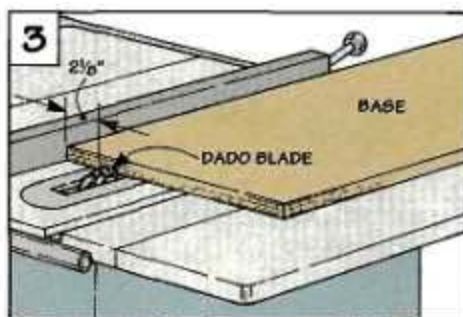
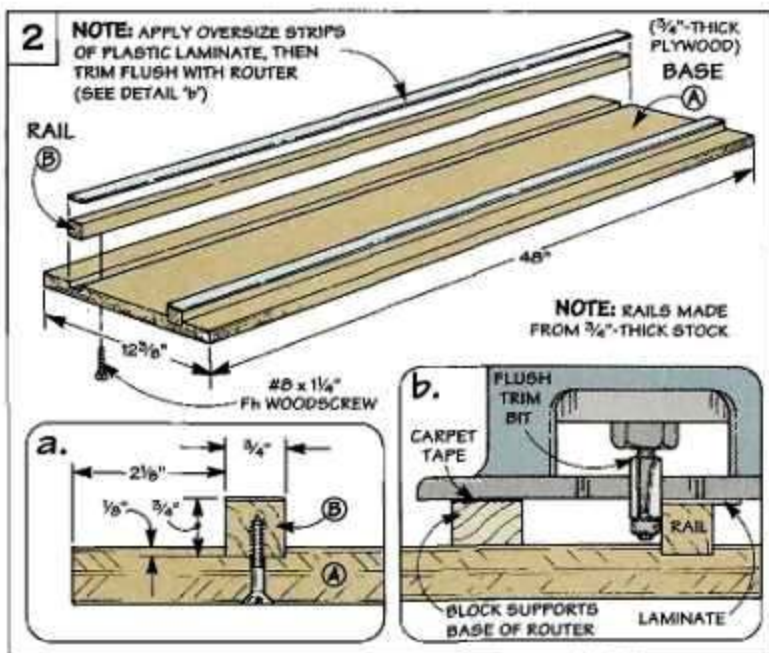

keep the router from tipping, I carpet-taped a support block to the base, see Fig. 2b.

I also wanted a slick surface on the bottom of the base. That's because the hardware that secures the table to the tray rides against the bottom as you make a cut, refer to Fig. 1a.

GLIDE STRIP. Here again, I used a strip of laminate to create a slippery surface. After laying out the location of this "glide strip" as shown in Figs. 5 and 5a, I ran pieces of masking tape around the lines to avoid slopping contact cement onto the base.

SLOT. With the glide strip in place, the next step is to cut a slot in the base for a bolt that holds the table in place, refer to Fig. 1a. To prevent the bolt from binding as the table slides back and forth, I cut a 1/2"-wide slot, see Fig. 5a.

SIDES. All that's left to complete the tray is to add two side pieces (C), see Fig. 6. Both pieces are made from 3/4"-thick hardwood and are rabbeted to fit the edge of the base, see Fig. 6a.

But before attaching the side pieces, you'll need to drill holes in one of them so the tray can be

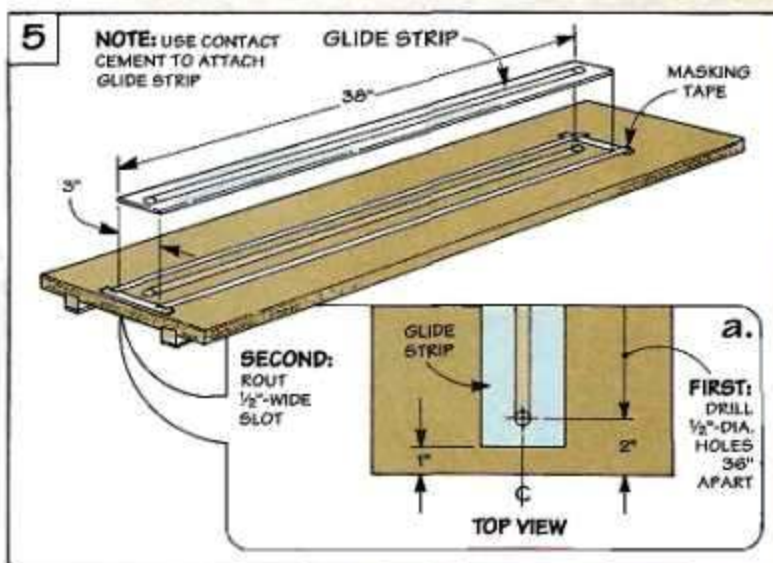

installed on the saw table. To locate the mounting holes, I used the existing holes in the edge of the saw table as a template, see Fig. 7. Note: Position the side piece 1/8" below the saw table and flush at the end, see Fig. 7a.

DRILL HOLES. Now it's just a matter of drilling holes for the mounting bolts. The size of these holes depends on the bolts that held your extension wing in place.

The thing to keep in mind is to drill the counterbores large

enough so you can get a socket wrench inside when tightening the bolts, see Fig. 7a. Then drill oversize shank holes to allow the tray to adjust up and down. (I drilled 1/2"-dia. shank holes for 3/16" dia. bolts.)

ATTACH SIDES. After gluing and screwing the side pieces to the base, the tray is basically complete. But I didn't attach it to the saw table yet. This makes it easier to work on the table and legs that are added later.

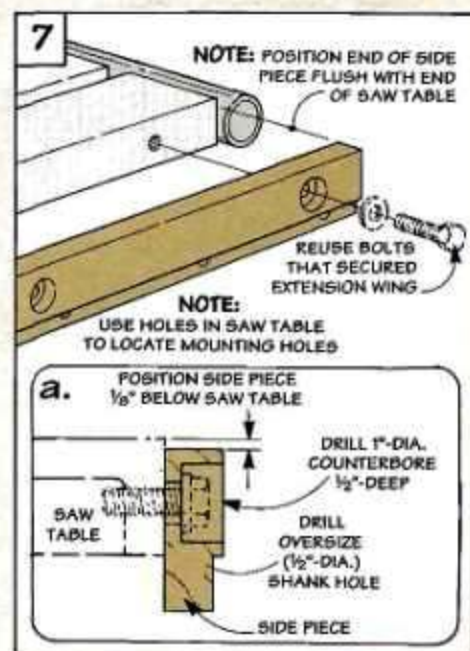
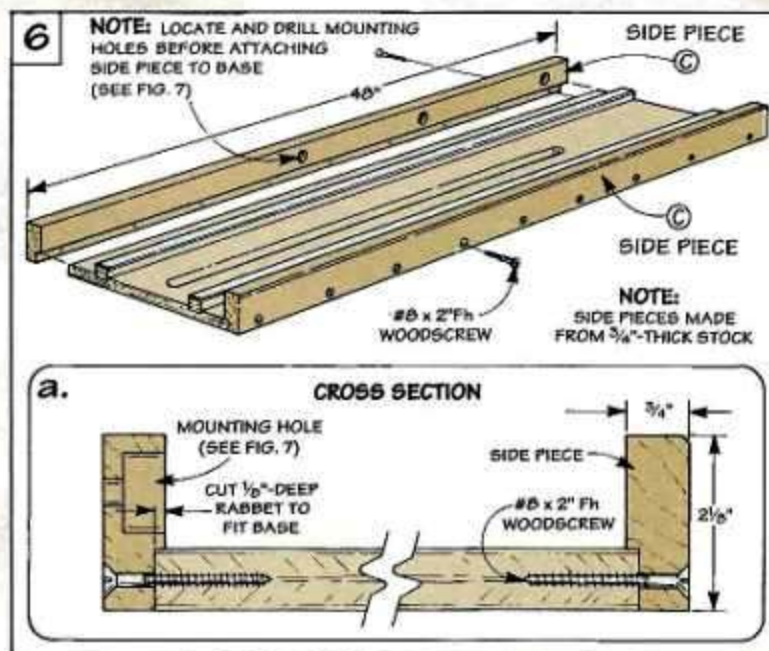

The Table

With the tray complete, work can begin on the table. To produce accurate cuts, the table needs to be flat and sturdy.

So I built it up from a plywood core (D) and wrapped hardwood edge (E) and end pieces (F) around it, see Fig. 9. Then I covered both sides with plastic laminate. Note: To avoid accidentally "catching" the laminate, I routed a small ($\frac{1}{8}$ ") chamfer around the top edges.

SIZE. To fit inside the tray (and still have clearance on each side), the finished width of the table is 12". And it's 27" long to match the length of the saw table.

MOUNTING SYSTEM. The table is held in place with a carriage bolt that passes through a counterbored shank hole drilled in the table and the slot in the tray, see Figs. 8a and 9.

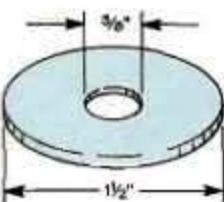
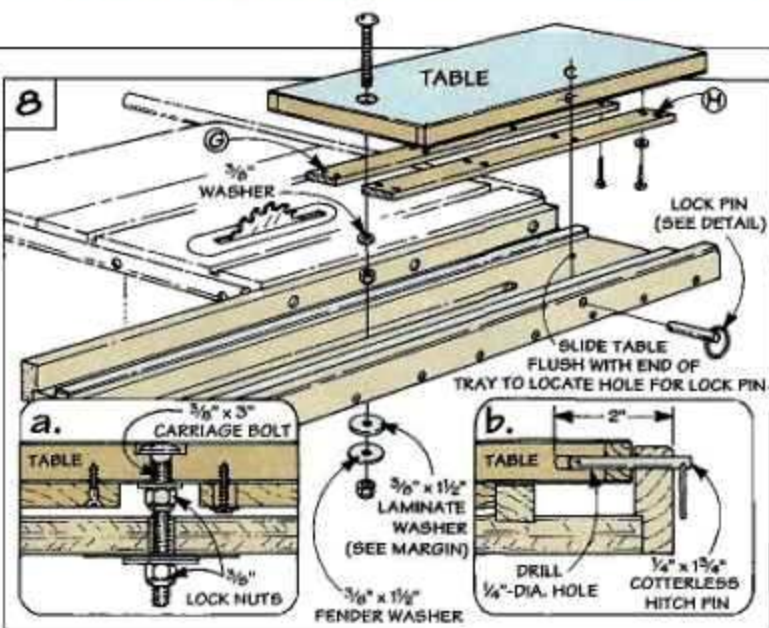

To create a slick surface that rides against the glide strip, I made a washer from a scrap of laminate.

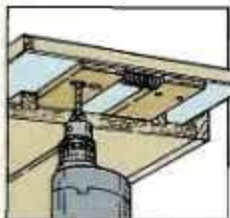
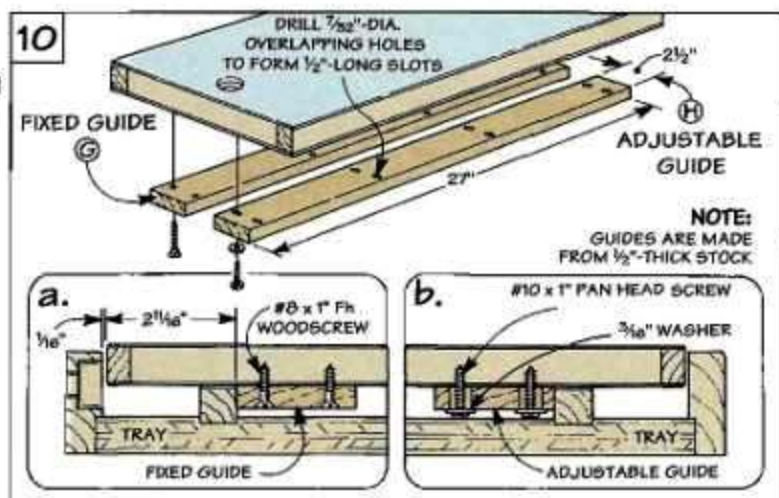
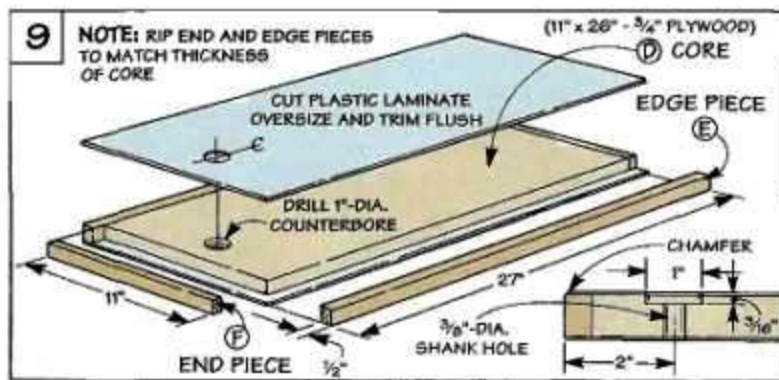

A spring keeps tension on the adjustable guide while you drill pilot holes in the center of the slots.

In use, this bolt is held in place with two lock nuts, see Fig. 8a. After slipping on a special washer (see top left margin), the bottom lock nut is tightened just enough

to hold the table in place, yet still allow it to slide easily.

GUIDES. But the bolt doesn't keep the table from moving from side to side. So I added a pair of guides, see Fig. 10. These guides run against the inside edge of the rails which tracks the table in a straight line, see Figs. 10a and 10b.

To make this work, one of the guides is fixed (G), and the other is adjustable (H). (I drilled a series of overlapping holes to form adjustment slots.) Attaching the fixed guide is easy. It's screwed in place $2\frac{1}{16}$ " in from the edge of the table. The challenge is positioning the adjustable guide.

What you're looking for here is to get the guide so it's snug against the rail, but not so tight it's hard to push the table. The thing that worked well for me is to temporarily fit a spring between the guides at each end of the table, see bottom left margin.

LOCK PIN. Finally, to keep the table from sliding when it's not in use, I added a lock pin. After drilling a hole through the side piece (C) and into the table, I used a cotterless hitch pin that I picked up at the local hardware store, see Fig. 8b. (For a complete hardware kit, see page 31.)

The Legs

After completing the table, I added two legs for support: an end leg and a side leg, see Fig. 11.

END LEG

The *end leg* (I) is just a 12"-wide piece of $\frac{3}{4}$ "-thick plywood, see Fig. 12. To determine the length of this leg, measure the distance from the top of the saw table to the floor and subtract 4". (In my case, the end leg is 30½" long.)

LEVELERS. After cutting the leg to size, the next step is to add a pair of levelers. These are nothing more than lag screws that tighten into a hardwood *foot* (J) glued to the bottom of the leg, see Figs. 12 and 12a.

ATTACH LEG. To make it easy to attach the end leg, I bolted the tray to the saw table and temporarily propped up the opposite end. Then, after positioning the leg so it's centered on the width of the tray and flush with the end, it's simply screwed in place, see Figs. 11 and 11a.

BRACES. Next, to help stiffen the leg, I added a pair of *braces* (K), see Fig. 12. These braces

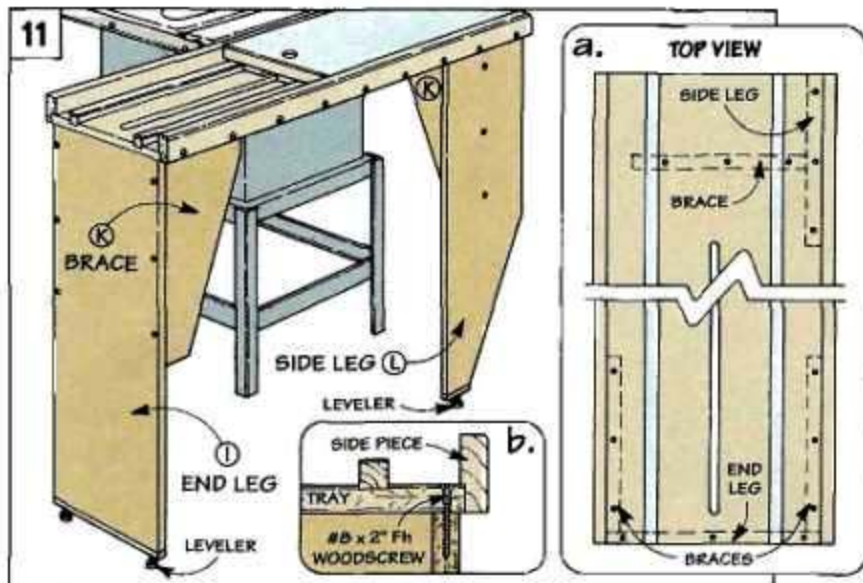

are just triangular-shaped pieces of $\frac{3}{4}$ "-thick plywood that are glued and screwed to the leg and the base of the tray, see Figs. 11a and 12.

SIDE LEG

To support the other end of the tray, the next step is to add a side leg. The *side leg* (L) is also made from $\frac{3}{4}$ "-thick plywood, see Fig.

13. To avoid accidentally kicking it, I cut a taper on the lower part of the leg.

Here again, I glued on a *hardwood foot* (M) and drilled a hole for a leveler, see Fig. 13a. As before, the side leg is screwed to the base of the tray, see Fig. 11a. But this time, I screwed on a single plywood brace (K) that's centered on the width of the leg.

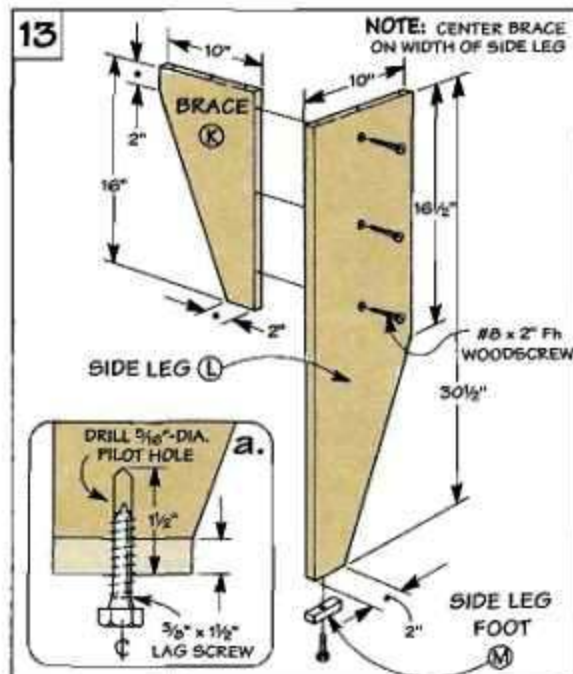
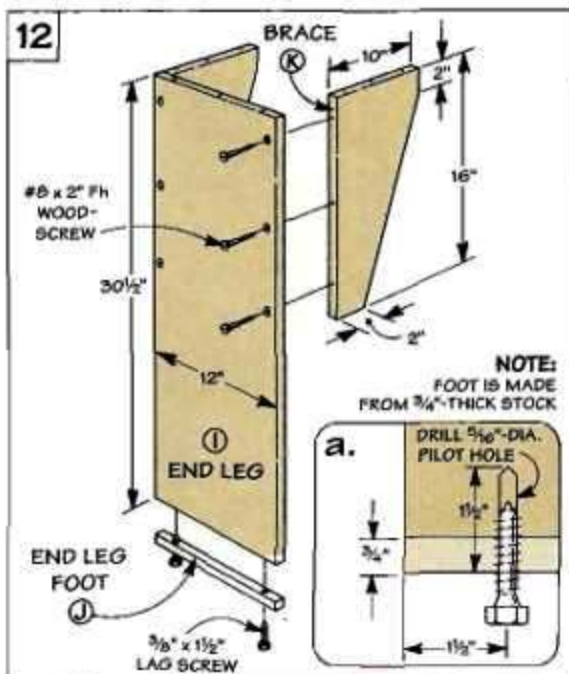

The Fence

This sliding table has a fence that can be quickly set so it's 90° to the saw blade. When it's not needed, the fence lifts off the table.

Editor's Note: There's also a fence featured in ShopNotes No. 14 that can be used with this sliding table. It features a built-in stop block and measuring tape, see Sources on page 31.

FENCE. The fence consists of two hardwood fence pieces (N), see Fig. 15. After gluing up the fence, I routed a chamfer on all the edges, see Fig. 15a.

The fence is held in place with two cap screws that pass through holes in the table and tighten into threaded inserts in the bottom of the fence, see Figs. 14 and 14b. (I added press-on knobs to the screws to make the fence easy to remove.)

Building in an adjustment so you can square up the fence is easy. Just drill a slotted hole in the table, see Fig. 16. But what I wanted was to slip the fence off and put it back on without having to reset it each time. To do this, I added a simple "stop."

STOP. The stop is a bolt that threads into an insert in the end of the table until it hits the shank

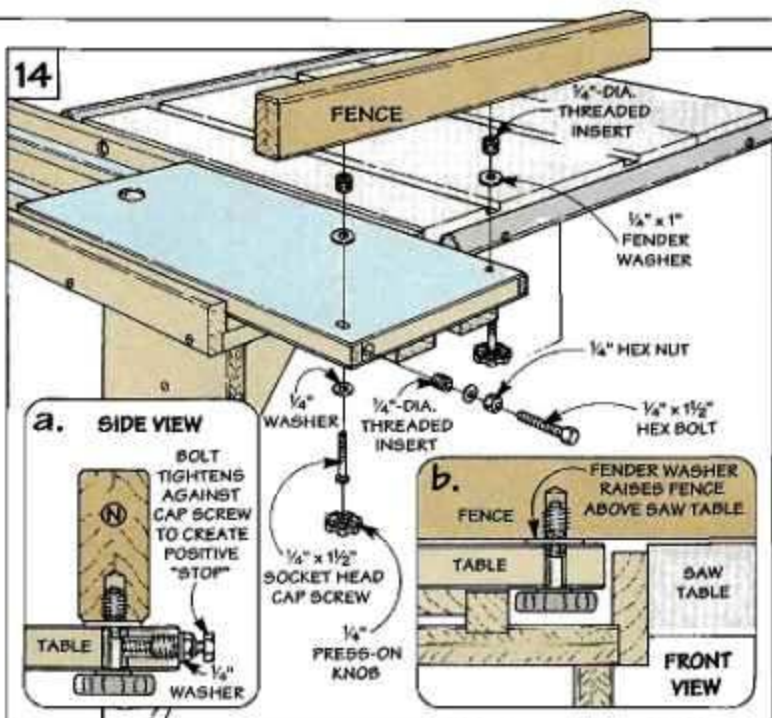

of the cap screw, see Fig. 14a. To make this work, you'll need to drill a hole that intersects the adjustment slot, see Figs. 16 and 16a.

The next step is to locate the holes for the threaded inserts in the bottom of the fence. This is just a matter of squaring up the fence so the end butts against the saw blade and then transferring

the hole locations, see Fig. 17.

ATTACH FENCE. After drilling the holes and installing the inserts, you can attach the fence. To prevent it from dragging on the saw table, I slipped fender washers between the fence and the table, see Fig. 14b. Then I threaded a hex nut onto the stop to keep it from loosening up.

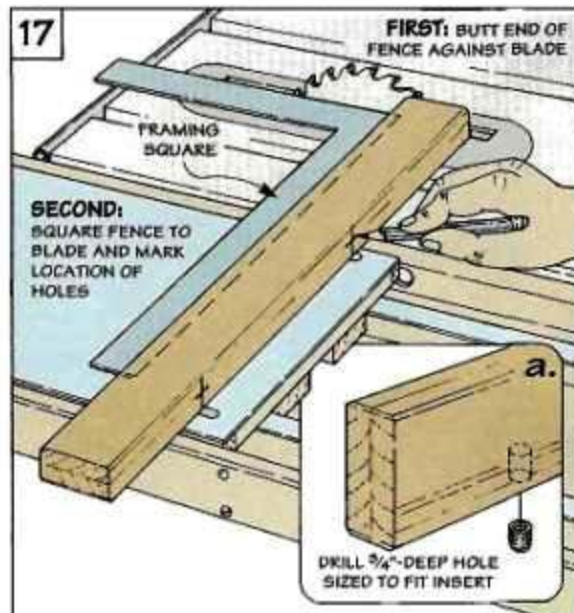
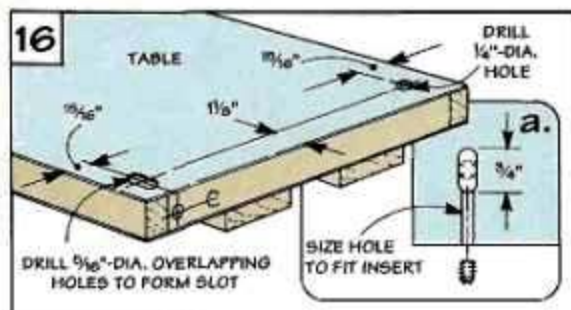
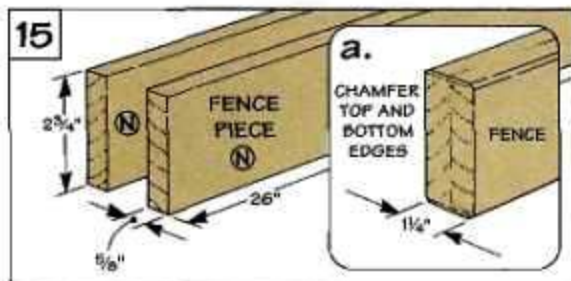

Adjustment

As with any precision tool, you'll need to adjust the sliding table to produce accurate cuts. Basically, you're looking for three things here.

VERTICAL ADJUSTMENT. First, the sliding table needs to be *flush* with the surface of the saw table. This is simply a matter of backing off (or tightening) the levelers to raise (or lower) the tray, see Steps 1 and 2 below.

SQUARE FENCE. Once you've got a continuous flat surface across both tables, the next step is to square the fence up to the saw blade, see Step 3. At this point, you can make a test cut to check the accuracy of the setup, see Step 4.

PARALLEL TRAVEL. If the test cut isn't square, chances are the problem is the table isn't sliding parallel to the miter gauge slot. To correct this, you'll need to shim the tray out just a bit, see Step 5.

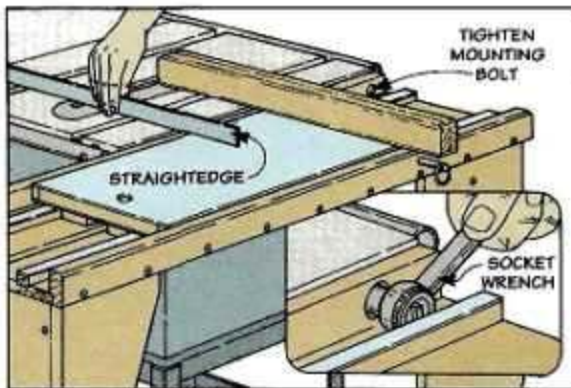

Step 1: Tighten Bolts. With a straightedge across the saw table and the inside edge of the sliding table, raise (or lower) the tray until both surfaces are flush. Then tighten the mounting bolts.

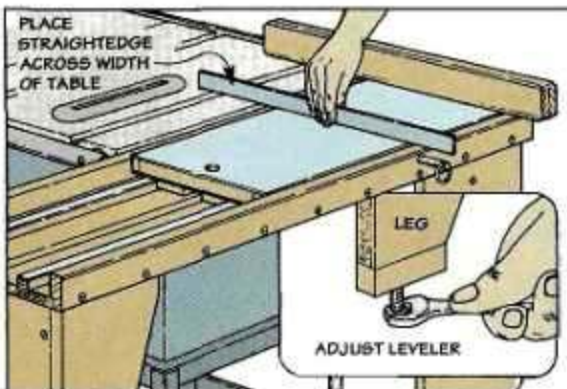

Step 2: Adjust Levelers. Now place the straightedge across the width of the table to check that the outside edge is level with the saw table. To raise (or lower) the table, back out (or tighten) the levelers.

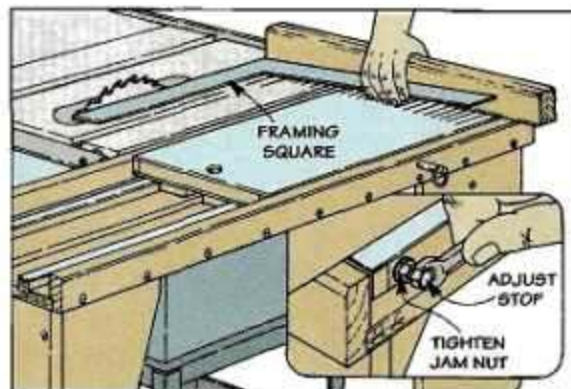

Step 3: Square Fence. After squaring the fence up to the blade, tighten the knobs that lock down the fence. Now thread in the stop until it hits the cap screw and tighten the "jam" nut.

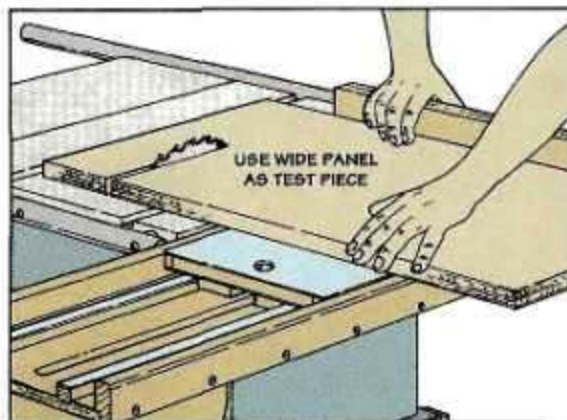

Step 4: Test Cut. The accuracy of the setup can be checked by making a test cut. To provide the best indication of whether or not you'll need to shim the tray, use as wide a panel as possible.

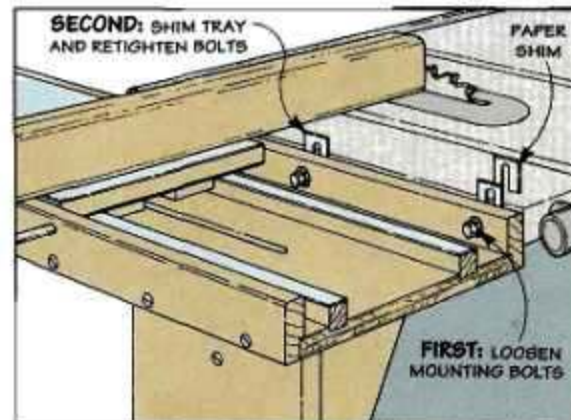

Step 5: Shim Tray. If you need to shim the tray, loosen two of the mounting bolts and slip paper shims over them. Then retighten the bolts and repeat Steps 3 and 4.

Chisel Techniques

It's easy to make precise, controlled cuts with a chisel when you use the right grip and a few simple techniques.

I can't remember when I've built a project without using a chisel. Granted, much of the work is done with power tools. But it seems I'm always reaching for a chisel to make the final paring cuts that get a project to fit together just right.

Whether I'm cleaning up a mortise, paring a tenon, or flattening the bottom of a groove, this means using the chisel like a scalpel to remove extremely *thin* slices of material.

While a sharp chisel is important, there's more to it than that. The secret is to use a grip that

lets you make a *controlled* cut.

UNDERHAND GRIP. When I hold the chisel in a horizontal position to make a cut (paring a tenon for example), I use an underhand grip. To do this, hold the chisel comfortably in the palm of your hand and grasp the blade between your fingers, see photo A.

This allows you to lead the cutting edge of the blade into the work exactly where you want it. As you "lean" into the cut, you can stop the blade at any point by pinching it between your fingers.

OVERHAND. Another grip I use to slice *down* into a workpiece

(for instance, when cleaning out a mortise) is an overhand grip. Here again, hold the blade between your fingers. But this time, grasp the chisel with your thumb on the end of the handle, see photo B.

The idea here is to bend your elbow and bring the chisel in close to your body. Then, to make a cut, push down with your thumb as you lean forward.

BLADE GRIP. But there are times when I don't hold the handle at all. When using a mallet, I hold the *blade* of the chisel like a pencil, see photo C. This gives me pinpoint control over where the cutting edge enters the workpiece.

This grip also comes in handy when using the chisel like a scoring knife. For example, when making a slicing cut with the corner of the blade, refer to page 27.

MIXED BAG. But there's no single grip that works all the time. As you can see in the following examples, I use a "mixed bag" of grips, switching from one to the other to get the job done.

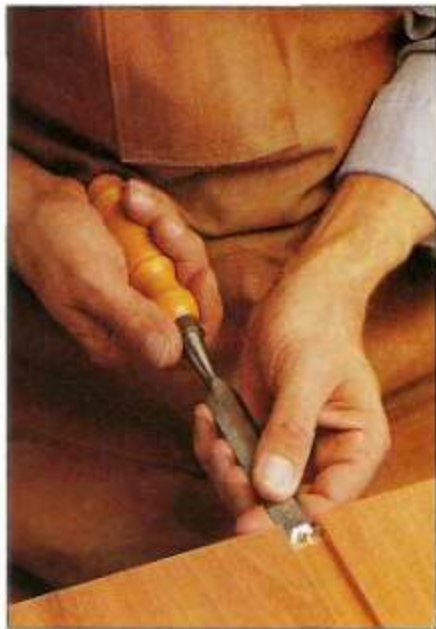

A. Underhand Grip. To make a horizontal cut, grasp the handle of the chisel in an underhand grip. Pinching the blade between your fingers stops the cut.



B. Overhand Grip. When making a vertical cut, an overhand grip lets you pare straight down. To help guide the blade, hold it loosely between your fingers.



C. Blade Grip. Holding the blade of the chisel lets you pinpoint where the cutting edge enters the work. This is especially handy when using a mallet.

Mortise

One common way to make a mortise is to drill a series of overlapping holes, then remove the rest of the waste with a chisel.

To produce a tight fit, the important thing is to end up with sides and ends that are vertical. The solution is to use an overhand grip and pare straight down.

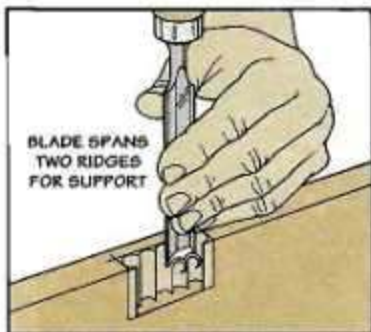

1 To support the blade, use a chisel that's wide enough to span across two of the ridges and pare straight down.

SIDES. I start with the sides. In addition to the grip, the width of chisel you use can help produce a straight, vertical cut, see Step 1.

ENDS. A similar approach works well on the ends. But this time, select a chisel that matches the width of the mortise, see Step 2.

CLEANUP. To clean up any re-

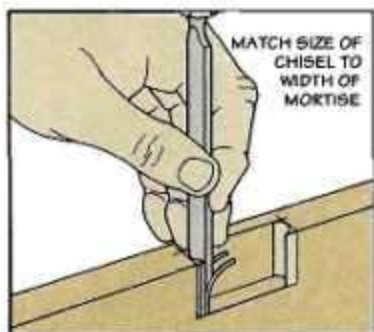

2 Next, with a chisel that's the same width as the mortise, pare straight down on the ends using an overhand grip.



Using an overhand grip allows you to pare straight down when cleaning out a mortise.

maining material, I've found that pivoting the blade across the side of the mortise creates a crisp, clean cut, see Step 3.

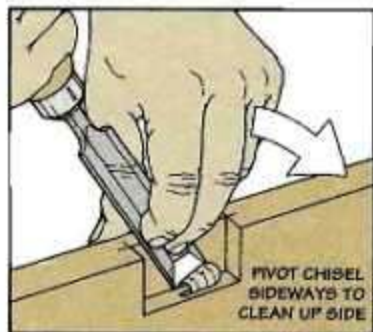

3 As a final cleanup, press the flat part of the blade against the side of the mortise and pivot the handle to slice off a thin shaving.

Tenon

It doesn't take much of a "step" on the shoulder of a tenon to keep two pieces from fitting tightly together. Even though there's not much material to remove, paring off this "step" can be a challenge.

WIDTH OF BLADE. To avoid damaging the adjacent shoulder, I use a chisel that's narrower than

the the thickness of the workpiece, but wider than the thickness of the tenon, see Step 1.

TWO GRIPS. What gives me the best control here is to use a combination of grips. An underhand grip as you pare toward the base of the tenon. And an overhand grip to remove the shavings.



An underhand grip helps control the cut when paring the "step" off a tenon.

To keep from cutting too deep into the stepped shoulder, I slice the remaining waste off with a shearing cut, see Step 2.

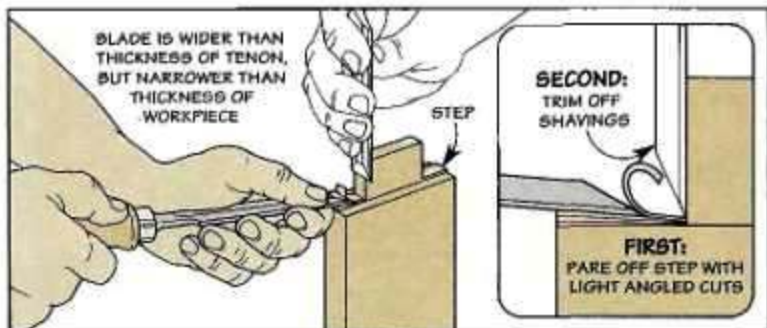

1 To pare the step off a tenon, start with an underhand grip and lead the cutting edge into the step at a high point on the shoulder.

After making several paring cuts down toward the base of the tenon, trim off the shavings by cutting straight down.

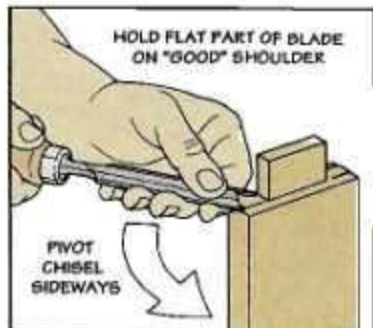

2 With the flat part of the blade held firmly on the "good" shoulder, pivot the handle to make a shearing cut across the shoulder.

Hinge Mortise

Make a series of light paring cuts to remove the waste left behind after routing a hinge mortise.

Unlike a lot of chisel work that's hidden when the project is assembled, a mortise for a hinge is quite conspicuous. Too large and it looks sloppy. Too small and the hinge won't fit.

The solution is to "sneak up" on a perfect fit. Whether you rout out most of the waste first or cut

the mortise by hand (see box below), this requires a light touch.

THIN SHAVINGS. It's tempting to remove the waste with a single cut. But I prefer to use an over-hand grip and take a number of thin shavings, see Step 1.

TEST FIT. As you approach the layout line, check the fit of the



hinge. If you still need to trim a bit off the edges, a blade grip lets you shear off just the right amount of material, see Step 2.



1 To remove the waste that's left after routing a hinge mortise, start by holding the chisel at an angle and make thin paring

cuts inside the layout line. Then work your way back to the line, gradually raising the handle of the chisel until it's vertical.

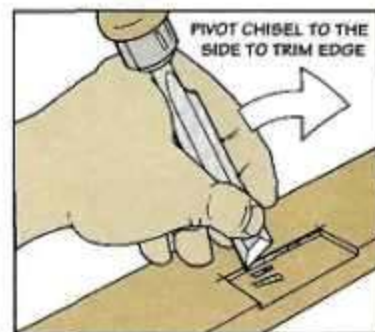

2 Using the corner of the blade as a pivot point, shear down across the edge of the mortise to make the final clean-up cuts.

Cutting a Hinge Mortise

If you only have a few hinges to install, sometimes it's easier (and just as fast) to cut the mortises by hand.

Start by laying out lines for the mortise. The key is to position the hinge so it's square on the workpiece and then trace around it with a sharp pencil.

SCORE LINE. To keep the wood fibers on the surface from tearing out,

the next step is to score a line with a utility knife. But not right on the layout line. To compensate for the thickness of the pencil lead, I score the line *inside* the mark, see Step 1.

FLAKES. Now it's just a matter of wasting out the material up to the score line. What I've found works best is to cut a number of thin "flakes" by

tapping the handle of the chisel with a mallet, see Step 2.

TRIM TO FIT. Once the bulk of the waste is removed (Step 3), you can trim the edges of the mortise to fit the hinge. Here, I start with the chisel held at an angle and pare off thin slices, see Step 4. As you approach the pencil line, gradually raise the handle of the

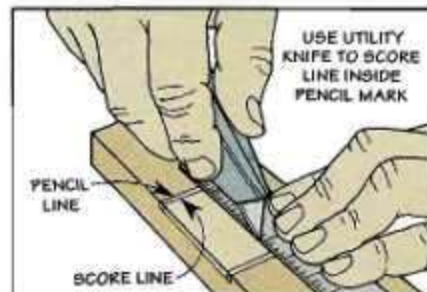

1 After laying out the hinge location with a pencil, use a utility knife to score a line on the inside of the marks.

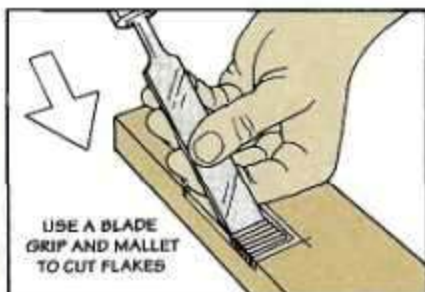

2 With the bevel down, cut a series of "flakes" along the length of the mortise by tapping the handle with a mallet.

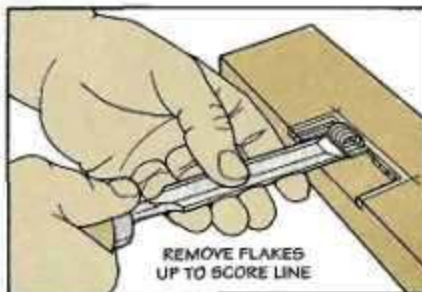

3 To remove the waste, use your finger as a depth stop. Then lift the flakes by paring up to the score line.

Groove

Sometimes the bottom of a groove (or dado) isn't perfectly flat. Or the saw blade leaves "tracks" that make it hard to fit the pieces together. To smooth the bottom of a groove, I use several different techniques.

DEPTH STOP. Since there's no support for the blade at the end

of the groove, an underhand grip lets you use your finger as a simple depth stop, see Step 1.

BEVEL DOWN. Another way to avoid cutting too deep is to place the bevel of the blade face down, see Step 2. And since this raises the handle, there's more "knuckle room" in the middle of the groove.



Use the chisel with the bevel face down to keep from cutting too deeply into the bottom of a groove.

KNIFE. To remove material from the corner of a groove, I hold the blade of the chisel and use it like a scoring knife, see Step 3.



1 When cleaning out the end of a groove (or dado), use your finger as a depth stop to keep the blade from cutting too deep.

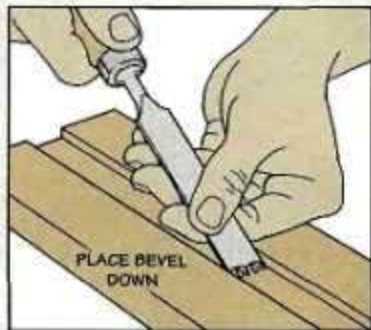

2 To make a smooth-bottomed cut, place the beveled side of the blade down and "plane" along the groove.



3 An easy way to clean out the corner of a groove is to use the chisel as a knife and slice the wood fibers with the corner of the blade.

chisel until it's vertical.

SAVE LINE. The thing to keep in mind is that the pencil line represents the *outside* of the hinge. So I pare up to the mark, but make it a point to "save" the pencil line.

TEST FIT. While you're working up to the line, it's a good idea to test fit the hinge. To get it to fit perfectly, you may

need to do a little more trimming around the edges. As before, a shearing cut leaves a crisp, clean edge, see Step 5.

SMOOTH BOTTOM. To get the hinge to sit flat, the bottom of the mortise may also need attention. When smoothing out the rough spots, it's best to hold the chisel with the bevel face down to avoid cutting too deep, see Step 6.

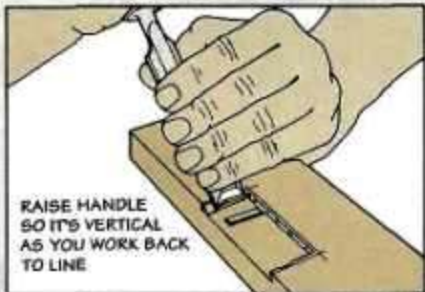

4 Now make a series of light paring cuts back to the pencil line. Just remember to "save" the line.

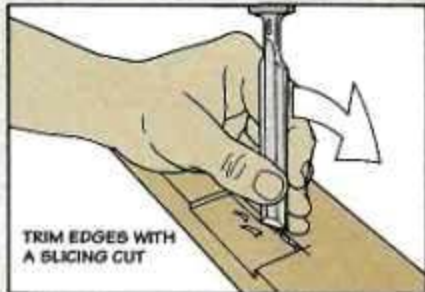

5 If you need to trim the edge after test fitting the hinge, rock the chisel on its corner to remove a thin shaving.

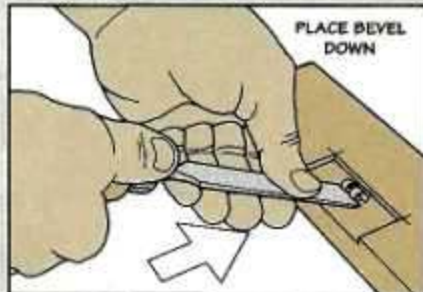

6 To avoid cutting too deep when cleaning up the bottom, make thin paring cuts with the bevel face down.

Shop Solutions

C-Clamp Rack



I've tried a number of different ways to store my C-clamps. But the handiest solution I've found is this pull-out storage rack, see photo above. It mounts under my bench top and pulls out like a drawer when I need a clamp.

The pull-out storage rack consists of a U-shaped frame with an angled bar for clamps to rest on, see Drawing.

Two end caps screwed to the frame serve as stops for the rack and help strengthen the frame. And to make it easy to pull out the rack, I screwed a drawer pull to the front end cap.

To mount the rack to the bench, I used a pair of L-shaped brackets, see Drawing. They're posi-

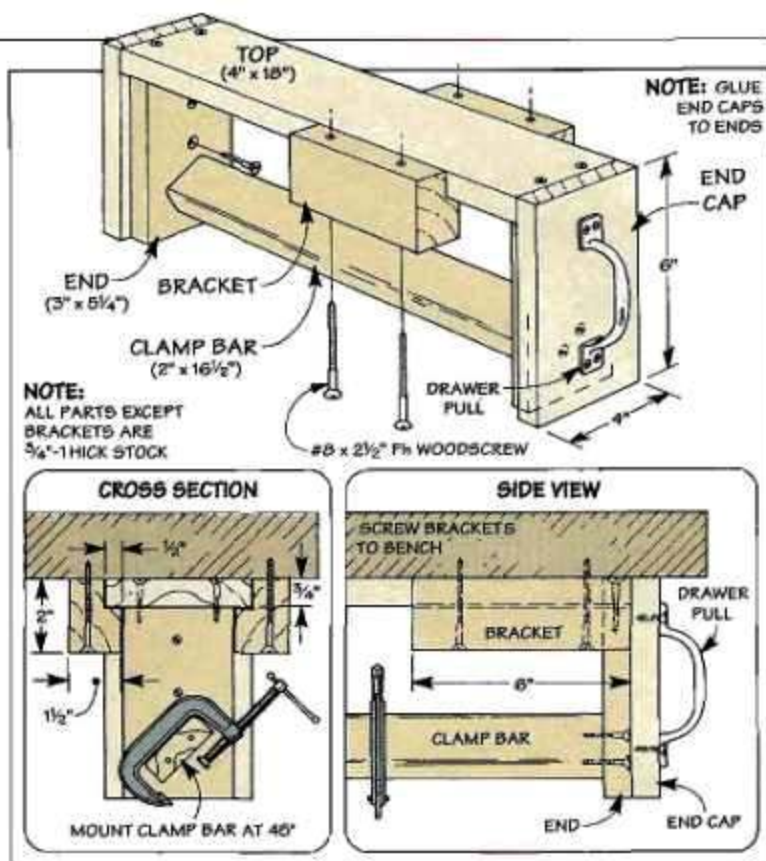

tioned so the drawer pull is flush with the front of the bench top, see Side View.

Larry Conner
Longview, Washington

Editor's Note: Larry's clamp rack is designed to hold 2½" to 4" C-clamps. If your clamps are different you may have to modify the size of the clamp bar.

Hole Saw Relief

When using a hole saw, trapped sawdust can build up a lot of heat. To reduce the build-up, I first drill a relief hole for the sawdust.

The relief hole should always be in the *waste* portion of your workpiece. For example, if you're making a wheel, drill the relief on the *outside*, see Fig. 1. And if you're making a hole, drill a relief hole on the *inside*, see Fig. 2.

Frank Coats
San Jose, California

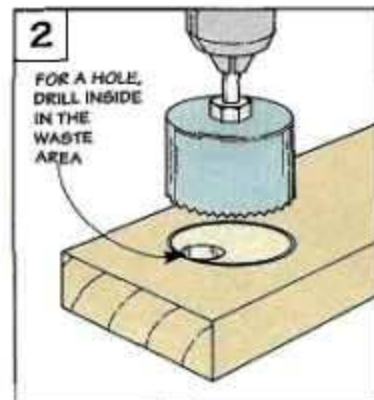
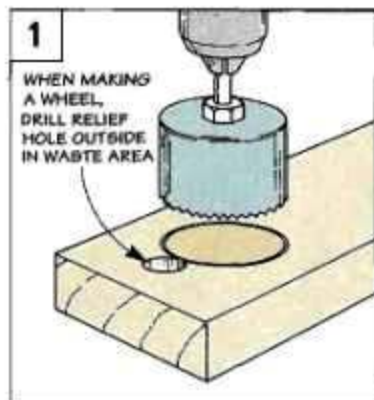

Cut-Off Gauge

On my power miter saw, the blade guard makes it hard to see the cut line. To solve this, I made a simple gauge that allows me to use an "offset" reference mark that's easy to see.

To make the gauge, first clamp a scrap of wood to the fence so one end extends past the blade, see Fig. 1. Then to create the refer-

ence mark on the fence of the chop saw, scribe a line on the fence that corresponds to the other end of the scrap piece. Now all you have to do is cut the scrap to length and save it as a gauge.

To use the cut-off gauge, start by measuring and marking the workpiece you're going to cut as you normally would. Then align

one end of the gauge to the layout line and mark the workpiece at the other end of the gauge (this is the offset), see Fig. 2.

Now simply line up this offset mark with the scribed line on the fence and cut the workpiece to length, see Fig. 3.

*Tom Bogan
The Colony, Texas*

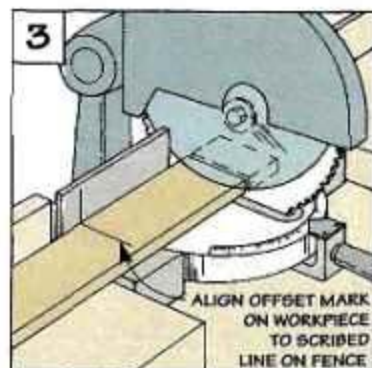
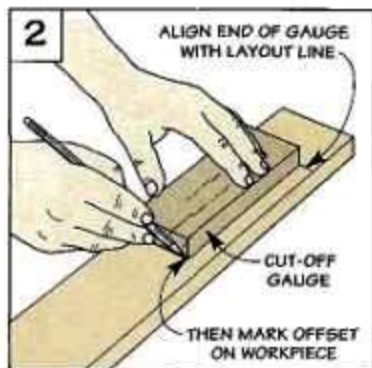
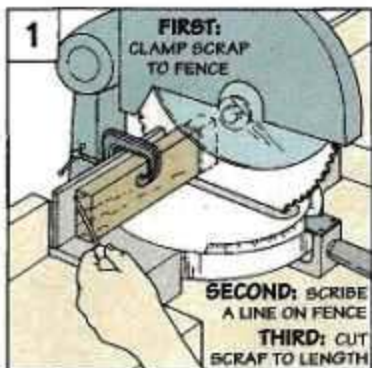

Pinch Blocks

It seems that every time I glue up a panel, the boards shift when I apply the clamps. To prevent this, I slip a pinch block over each glue joint until I get the clamps set.

Each block is a scrap of wood with a notch cut in it to match the thickness of the panel. Once the clamps are tightened, remove the blocks before the glue dries.

*Roopinder Tara
Willow Grove, Pennsylvania*

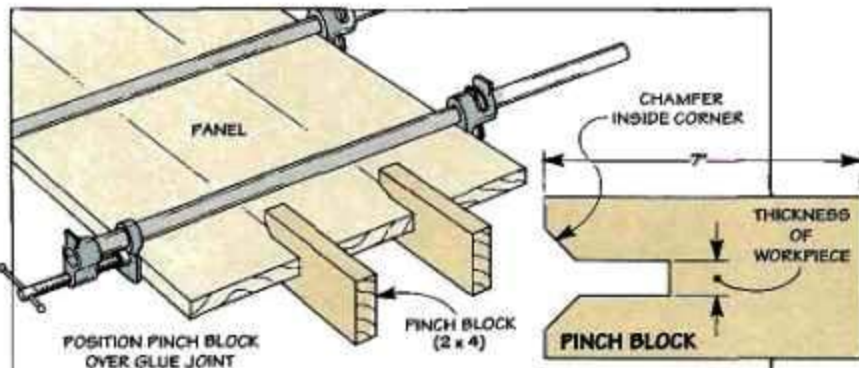

Power Sanding Tip

To keep the cord on my portable sander out of the way when sanding, I suspend it from the ceiling by a chain of rubber bands. (The chain I use is made up from six large rubber bands that I collected over a period of time from our Sunday newspaper.)

One end of the chain is looped around the cord (about one foot from the plug). The other end is

looped over a screw hook mounted in the ceiling.

Now when I'm power sanding, the cord doesn't drag on my project. And when I'm through sanding, I just reach up and slip the chain off the hook. This way, it stays on the power cord and is ready whenever I'm going to sand.

*Clyde Bachman
Olympia, Washington*

Send in Your Solutions

If you'd like to share your original solutions to problems you've faced, send them to: *ShopNotes*, Attn: Shop Solutions, 2200 Grand Avenue, Des Moines, IA 50312. (Or if it's easier, FAX them to us at: 515-282-6741.)

We'll pay up to \$200 depending on the published length. Please include a daytime phone number so we can call you if we have questions.

Springs

An ordinary spring can dramatically improve the performance of a tool or a shop-built jig.



Small details can make a big difference. Take an ordinary spring, for instance. Sometimes that's all it takes to improve the performance of a tool or a shop-built jig.

Depending on what the jig is designed to do, I use two different types of springs. A *compression* spring like you'd find in a ball point pen. Or an *extension* spring like you'd see on a screen door. Note: Both types of springs are

readily available at most hardware stores.

COMPRESSION

Basically, a compression spring is designed to *push*. To make this work, it consists of a series of open wire coils. When the coils are compressed, the ends of the spring exert pressure outward.

QUICK RELEASE. Because of this, I often use compression springs as a "quick release" on a

jig that has a built-in clamp, see Drawing A. When you loosen the clamp, the springs pop up the bar that holds the workpiece down. This allows you to quickly reposition another workpiece.

CONSTANT PRESSURE. Another place I've found where compression springs work well is when you need to exert constant pressure. For instance, to keep a machine screw that's used as a micro-adjustable "stop" from vibrating out of adjustment, just slip a spring over the shank of the screw, see Drawing B.

Compression Springs

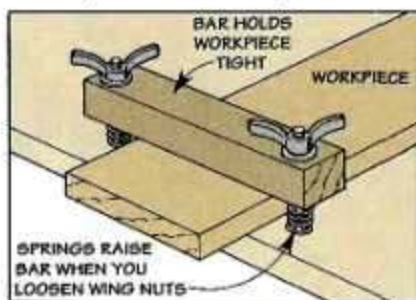

A. Quick Release. To quickly position a workpiece, springs pop up the bar on this shop-built clamp.

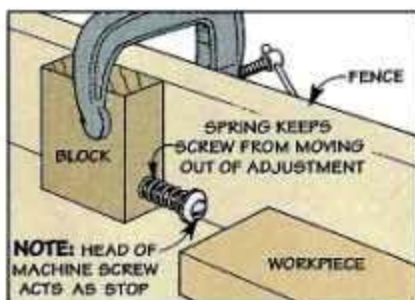

B. Constant Pressure. A spring holds the machine screw on this micro-adjustable stop exactly where you set it.

EXTENSION

Unlike a compression spring, the wire coils on an extension spring are wound tightly together. When the coils are stretched apart, the tension that's produced *pulls* the spring back together.

RETURN. This makes it an ideal choice when you want to return something to its starting point. For example, running an extension spring between the carriage of a radial arm saw and an anchor point pulls the blade safely back behind the fence after you make a cut, see Drawing C.

HOLD-DOWN. But an extension spring can also be used to apply pressure *downward*. When ripping thin stock that has a tendency to "chatter," I use a simple spring-loaded hold-down, see Drawing D. This is just a piece of wood that pivots on an auxiliary fence as you slide a workpiece underneath. As the spring pulls back to its relaxed position, the hold-down applies pressure downward.

Extension Springs

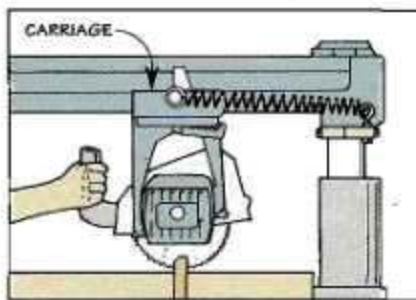

C. Return. After you make the cut, the spring returns the radial arm saw carriage to its starting point.

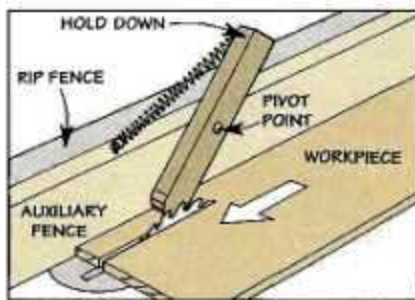

D. Hold-Down. This spring-loaded hold-down prevents thin stock from chattering as you make a cut.

Sources

ShopNotes Project Supplies is offering some of the hardware and supplies needed for the projects in this issue. We've also put together a list of other mail order sources that have the same or similar hardware and supplies.

BAND SAW CIRCLE JIG

Cutting precision circles is easy with the Band Saw Jig shown on page 4. A built-in measuring tape and indicator allow you to quickly and accurately set up the jig to cut almost any size circle.

ShopNotes Project Supplies is offering a hardware kit for the Band Saw Circle Jig. The kit has all the hardware you'll need, including the measuring tape and Plexiglas strips (you'll need to cut them to length). All you need to supply is $\frac{3}{4}$ " plywood and $\frac{1}{2}$ " and $\frac{3}{4}$ "-thick hardwood.

S15-6815-100 Band Saw Circle Jig Kit\$8.95

SLIDING TABLE

The Sliding Table shown on page 16 allows you to accurately cut wide panels on the table saw. Just set the panel on the table and position it up against the fence (you can also build the Optional

Fence described below). Then simply slide it forward to make the cut. Note: The Sliding Table replaces the left extension wing on your table saw.

ShopNotes Project Supplies is offering a complete hardware kit for the Sliding Table. All that you have to supply is $\frac{3}{4}$ "-thick hardwood and plywood, and the plastic laminate.

S15-6815-200 Sliding Table Hardware Kit.....\$11.95



▲ You can add an adjustable stop to the Sliding Table by building the optional fence shown above.

OPTIONAL FENCE

By adding a stop to the fence on the sliding table, you can increase your accuracy whenever you

make a cut. You can replace the simple fence shown in the Sliding Table article with the Miter Gauge Fence shown in *ShopNotes* No. 14, see photo.

ShopNotes Project Supplies is offering a hardware kit for this fence. This kit includes all of the hardware you'll need, including the measuring tape and indicator.

S15-6814-100 Miter Gauge Fence Kit.....\$17.95

BELT SANDER

To help reduce heat build-up on your sanding belts, you can replace the platen with one made from graphite. They're available at some woodworking stores. But if you can't find them locally, see the sources listed below.

EPOXY

The article on epoxy (shown on page 14) provides an in-depth look at using epoxy systems in the shop. An epoxy system consists of a resin and hardener. Plus a variety of fillers or additives.

You may be able to find these at some woodworking stores and home outlets. If you can't, they can be ordered from some of the mail order sources listed below.

MAIL ORDER SOURCES

Similar hardware and supplies may be found in the following catalogs. Please call each company for a catalog or for ordering information.

Constantine's
800-223-8087
G-2 Epoxy

Systems Three
800-333-5514
Epoxy Systems

Woodcraft
800-225-1153
G-2 Epoxy

Jamstown Distributors
800-423-0030
Epoxy Systems

Trendlines
800-767-9999
Graphite Platen

Woodworker's Store
800-279-4441
G-1 Epoxy

Garrett Wade
800-221-2942
G-2 Epoxy

West Systems
517-684-6881
Epoxy Systems

Woodworker's Supply
800-645-9292
Graphite Platen

ORDER INFORMATION

BY MAIL

To order by mail, use the order form that comes with the current issue. The order form includes information on handling and shipping charges, and sales tax.

If the mail order form is not available, please call the toll free number at the right for more information on specific charges and any applicable sales tax.

BY PHONE

For fastest service use our Toll Free order line. Open Monday through Friday, 7:00 AM to 7:00 PM Central Time.

Before calling, have your VISA, MasterCard, or Discover Card ready.

1-800-444-7527

Note: Prices subject to change after July 1, 1995.

Scenes From the Shop



Circle Jig

The Band Saw Circle Jig (shown on page 4) "carries" a workpiece into the blade at the start of a cut. This allows you to start with an oversize blank — there's no need to pre-cut it to the desired diameter. Instead, just use the built-in tape to select the exact size circle you need.



Sliding Table

To provide support when crosscutting wide panels, the Sliding Table (shown on page 16) pulls back in front of the saw table. This table features a simple, adjustable guide system that ensures accurate cuts. And plastic laminate creates a slick surface for the table to slide across.

