

TIPS • TOOLS • TECHNIQUES

# ShopNotes®

Vol. 2

Issue 12



- Shop-Built Disk Sander ■ Straight-Edge Cutting Guide
- Tips on Using Dado Blades ■ Changing Jointer Knives



# ShopNotes

Issue 12 November 1993

<b>EDITOR</b>	Donald B. Peschke
<b>EXECUTIVE EDITOR</b>	Douglas L. Hicks
<b>MANAGING EDITOR</b>	Terry J. Strohmam
<b>ASSOCIATE EDITOR</b>	Richard S. Peters
<b>ASSISTANT EDITOR</b>	Tim Robertson
<b>CONTRIBUTING EDITOR</b>	Philip A. Totten
<b>CREATIVE DIRECTOR</b>	Ted Kralicek
<b>ART DIRECTOR</b>	Cary Christensen
<b>SENIOR ILLUSTRATOR</b>	Kurt Schultz
<b>ILLUSTRATORS</b>	Will Niskanen Roger Reiland Mark Higdon
<b>PHOTOGRAPHER</b>	Crayola England
<b>DESIGN DIRECTOR</b>	Ken Munkel
<b>SENIOR DESIGNER</b>	Jan Hale Svec
<b>DESIGNER</b>	Kent Welsh
<b>SHOP MANAGER</b>	Steve Curtis
<b>SHOP ASST./FACILITIES</b>	Steve Johnson

**CIRCULATION**

Circulation Director: Lita Bredeson • Subscription Manager: Phyllis Jensen • Circulation Analyst: Rod Cain • Newsstand Sales: Kent A. Buckton

**PUBLISHING SERVICES**

Associate Editor: Gordon C. Galpe • Sr. Graphic Designer: Robert H. Whitmer • Graphic Artist: Cheryl L. Cynor

**CORPORATE SERVICES**

Accounting: Laura Thomas • Bookkeeping: Julie Greenlee • Info. Services Manager: Joyce Moore • Electronic Pub. Coordinator: Douglas M. Lichter • Administrative Assistants: Cheryl Scott, Julia Fish • Receptionist: Jeanne Johnson • Building Maintenance: Ken Griffith

**PROJECT SUPPLIES**

Marketing Director: Robert Murry • Catalog Art Director: Cindy Jackson • Catalog Products Manager: Bob Baker • Project Supplies: Lita Jones • Technical Support: Jeff Jones • Systems Operator: Linda Morrow

**CUSTOMER SERVICE**

Manager: Valerie Wiese • Supervisor: Jennie Einos • Customer Service Representatives: Jennifer Murphy, Joy Johnson, Sara Kono, Ami Blanchan, Anna Cox, Chris Lo

**SHIPPING DEPARTMENT**

Supervisor: Jerry Carson • Fulfillment: Gloria Sheehan, Don McVey, Chuck Carlson, Sylvia Carvy

ShopNotes® (ISSN 1042-5666) is published bimonthly (Jan., March, May, July, Sept., Nov.) by Woodsmith Corporation, 2200 Grand Ave., Des Moines, IA 50312.

ShopNotes® is a registered trademark of Woodsmith Corp. ©Copyright 1993 by Woodsmith Corporation. All rights reserved.

Subscriptions: Single Copy, \$4.95. One year subscription (6 issues), \$19.95. Two years (12 issues), \$36.95. Canada/Foreign, add \$4.00 per year.

Second Class Postage Paid at Des Moines, IA and at additional offices.

Postmaster: Send change of address to ShopNotes, Box 11204, Des Moines, IA 50310-1204.

Subscription Questions? Call 1-800-833-5854, Sun to 4pm, Central Time, weekdays.

PRINTED IN U.S.A.

Selecting hardware is an important part of every project that we design and build. Whenever possible we try to use hardware that is readily available. But every now and then we design a project around a *special* piece of hardware. One example is the Disk Sander in this issue.

**DISK SANDER.** From the beginning, I wanted to build a professional-quality disk sander. So I started with an extra-large metal sanding disk and built the project around it. The sanding disk works great, but we've only been able to find one mail-order source. (For more on this, see Sources on page 31.)

**FOOT PEDAL.** Another project in this issue that started with a unique piece of "hardware" is the Drill Press Foot Pedal on page 8. This time we found what we needed at a local bicycle shop — a length of brake cable sleeve.

But enough about the projects, I want to bring you up to date on some of the other things that have been happening around here.

**THE FLOOD.** In the last issue (*ShopNotes* No. 11), I mentioned some of the problems we had encountered due to flooding. Well I'm happy to report that the flood waters have receded. Clean-up and repairs are complete. And things are finally back to normal.

It was impressive to watch such a big job get done so quickly. But what really impressed me were the letters and phone calls we received from our readers. Your concern and understanding was appreciated by everyone here.

While the flood is something I'll never forget, I'd rather tell you about some of the other things that have been going on.

**NEW INDEX.** Over the last few weeks we've been putting the finishing touches on a project that I'm very excited about. It's a new reference guide called *Projects, Plans, & Techniques*.

This guide features a complete index to all of the projects and articles that have appeared in the past issues of *ShopNotes*. And it includes descriptions of all the hardware kits that are available to build the projects.

*Projects, Plans, & Techniques* also contains an index of all the projects and articles that have appeared in *Woodsmith* magazine (issues 1-89).

To receive your free copy of *Projects, Plans, & Techniques*, all you have to do is mail in the order card that's bound in this issue. If the order card is missing, you can also get a copy by writing to: *ShopNotes*, P.O. Box 842, Des Moines, IA, 50304-9961.

**LUNCH WITH NORM.** About a month ago Kent Buckton (Newsstand Sales) told me that Norm Abram was coming to town for a woodworking show. Several people here (myself included) have been watching Norm on public television for years. (Norm Abram is featured on *The New Yankee Workshop* and *This Old House*.)

Well, Kent wanted to invite Norm over to meet everyone. I thought it sounded like a great idea. But I told Kent not to get his hopes up. After all, Norm was only going to be in town for one day, and he had a lot of things to do.

Several days went by and I forgot about the whole thing. But Kent didn't. After making dozens of phone calls, he finally arranged for Norm to come over for lunch and a short tour.

Now I was in a bit of a panic. I didn't have a clue about what to do for lunch. Luckily, Julia Fish (Administrative Assistant) came to my rescue. She took care of all the details and we all had a great time.

**ADDITIONS.** Since the last issue of *ShopNotes* we've added a couple of new faces. Steve Johnson will be helping out in the shop. And Cheryl Cynor has joined the Publishing Services team.



# Contents

## Straight-Edge Cutting Guide \_\_\_\_\_ 4

A unique clamping system makes it easy to guide your circular saw for straight and accurate cuts.



Cutting Guide page 4

## Drill Press Foot Pedal \_\_\_\_\_ 8

This foot pedal frees up your hands so that you can accurately position a workpiece for drilling.



Foot Pedal page 8

## Dado Blades \_\_\_\_\_ 10

A look at the different types of dado blades. Plus some new variations on traditional blades.

## Tips on Using Dado Blades \_\_\_\_\_ 12

Tips and techniques to make clean and accurate cuts with a dado blade.

## Changing Jointer Knives \_\_\_\_\_ 14

All it takes to change and adjust the knives on your jointer is a straightedge and a little patience.



Dado Blades page 10

## Disk Sander \_\_\_\_\_ 16

Get professional quality results with this shop-built bench-top disk sander. It features a large, flat table that tilts for angled sanding, and a built-in vacuum port.

## Disk Sander Stand \_\_\_\_\_ 25

This stand provides a stable foundation for the disk sander. A hollow column can be filled with sand or bricks to "anchor" the stand in place and reduce vibration.



Disk Sander page 16

## Shop Solutions \_\_\_\_\_ 28

Six Shop-Tested Tips: Knock-Down Sawhorse, Alternate Bench Vise, Clamp Pad, Allen Wrench Organizer, Tip for Cutting Metal Threads, and a Leather Strop Tip.

## T-nuts \_\_\_\_\_ 30

These inexpensive knock-down fasteners hold a project together securely without stripping out. And best of all, they're readily available at most hardware stores.

## Sources \_\_\_\_\_ 31

Hardware, project supplies, and mail order sources for the projects in this issue.

# Straight-Edge Cutting Guide

*Straight, accurate cuts with a circular saw... and no clamps in the way.*



**S**ometimes the solution to one problem just leads to another. For instance, clamping a fence to a piece of plywood to get a straight cut with a circular saw.

The fence guides the saw for a straight cut, but the clamps always seem to get in the way. So you end up having to stop and reposition them to complete the cut. To prevent this, I made a cutting guide with a built-in clamping system, see photo.

**CLAMPING SYSTEM.** The unique thing about this system is that it runs in a T-slot that's underneath the guide, see Exploded View.

This lets you secure the guide to a workpiece without having the clamps interfere with the saw.

**CUTOFF LINE.** Another thing that's handy about this guide is it's designed so the *edge* serves as the cutoff line for your circular saw blade. This way, all you need to do is align the edge with your layout line, tighten the clamp, and make the cut, see inset photo.

## BASE

I started work by making the *base* (A), see Exploded View. It's built up of three long strips of 1/4"-thick Masonite. This allows you to cut each part of the T-slot

as the strips are added.

To provide room for the clamping system and still be able to crosscut a full sheet of plywood, each strip is 56" long, see Detail in Exploded View. After cutting the strips to length, they're glued together with contact cement so you don't have to use a lot of clamps.

The only problem is it's hard to keep the edges flush and square. As a result, when it's time to cut the grooves that form the T-slot, there's no reliable edge to run against the rip fence.

**REFERENCE EDGE.** The solution is to establish the edge of *one*

## Hardware

- (2) #8 x 1/4" Fh Woodscrews
- (10) #8 x 1" Fh Woodscrews
- (1) 5/16" x 4" Hex Bolt
- (2) 5/16" Lock Nuts
- (1) 5/16" x 18 Threaded Insert
- (1) 5/16" Plastic T-Knob
- (1) 5/16" x 1 3/4" Toilet Bolt
- (1) 5/16" Plastic Wing Nut

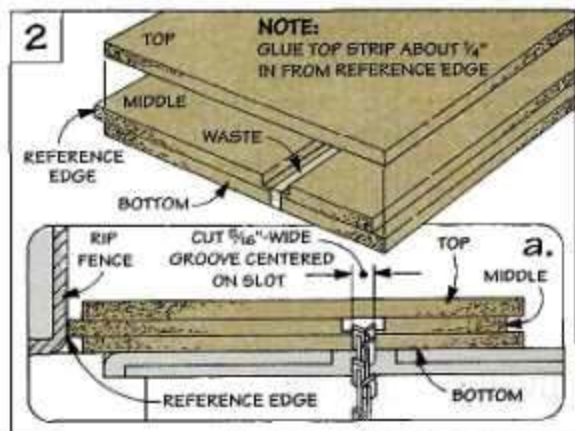
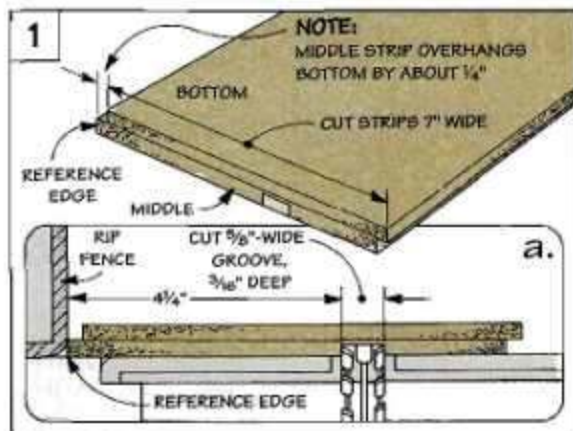

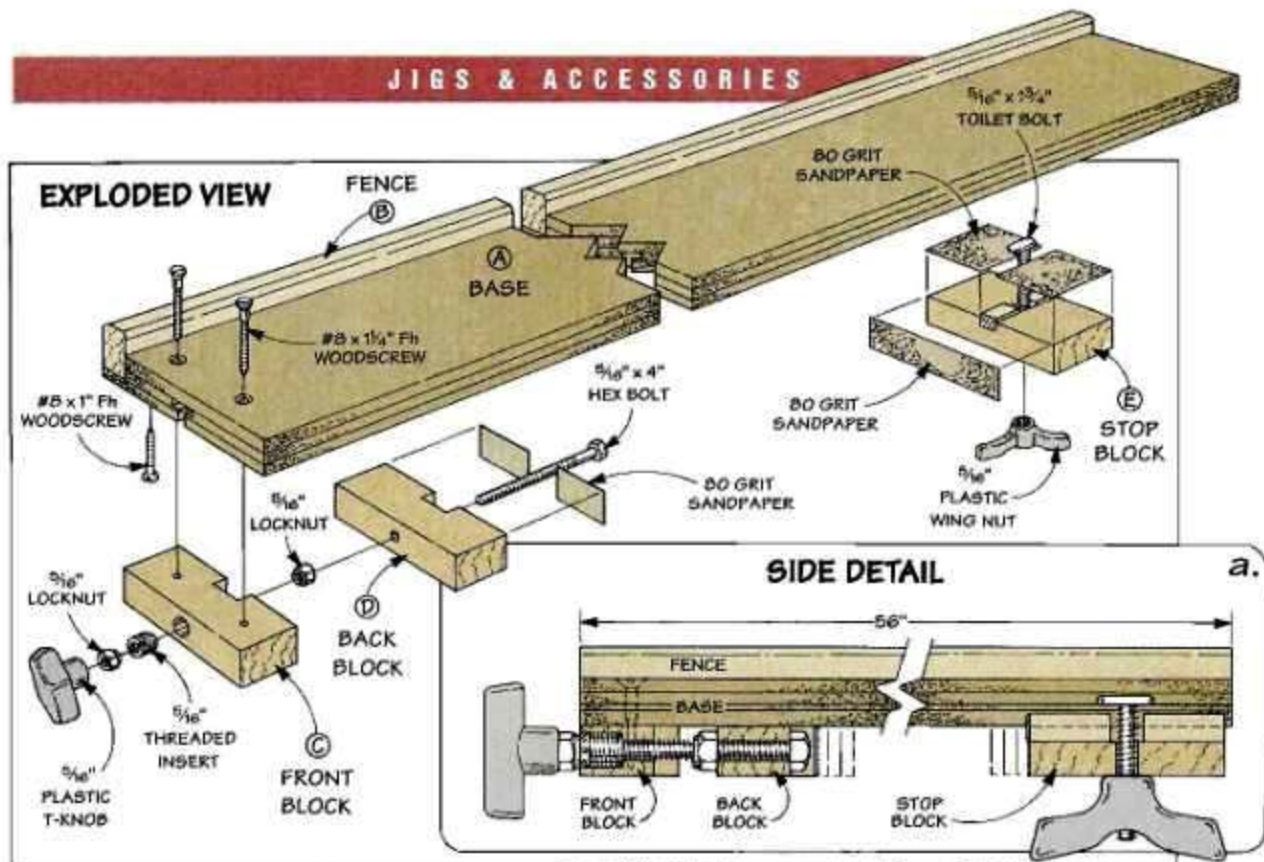

strip as a reference. This way, you can use it against the rip fence when cutting each part of the T-slot and when trimming the base to width later.

To create this reference edge, I glued the bottom and middle strips together so there's about 1/4" overhang, see Fig. 1. Then I used the edge of the middle piece as a reference to cut the groove that forms the top part of the T-slot, see Fig. 1a.

**TOP STRIP.** The next step is to glue on the top strip. Here again, the idea is to offset this strip

about 1/4" so you maintain the same reference edge, see Fig. 2. Now it's just a matter of cutting another groove for the lower part of the T-slot in the bottom layer, see Fig. 2a.

**TRIM WASTE.** After completing the T-slot, you'll need to use the reference edge one more time — to trim the base to rough width, see Fig. 3a. To provide plenty of room for the base of my circular saw, I trimmed it to a width of 7". This produces a square edge to work off when adding the fence later, see Fig. 3.

**FENCE**

With the waste trimmed off, the next step is to add the fence (B). This is a straight piece of hardwood (maple) that's cut to the same length as the base, see detail in Exploded View and Fig. 4a.

The fence ensures a straight cut by guiding the base of the circular saw. To attach the fence, I cut a rabbet in the edge of the base, see Fig. 4. Then, after chamfering the top edges of the fence, it's glued and screwed in place, see Figs. 4 and 4a.

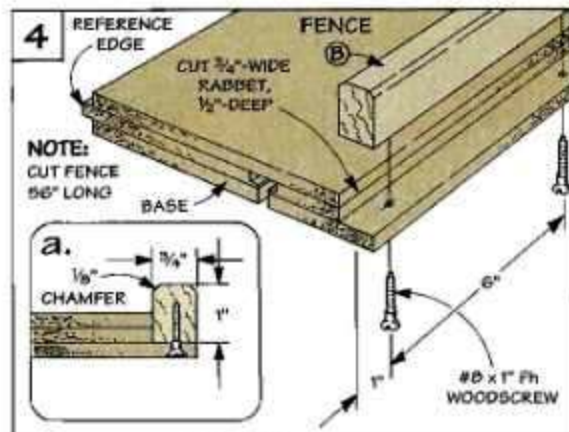
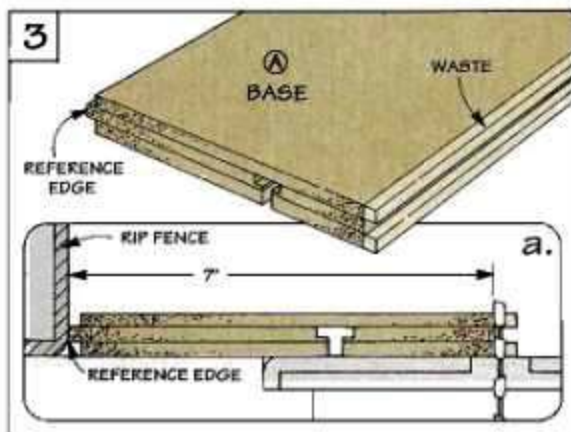

# Clamping System

The heart of this cutting guide is the clamping system. It consists of two parts: a clamp head and a stop block, refer to the Exploded View on page 5.

## CLAMP HEAD

The clamp head is made up of two hardwood blocks: a *front block* (C) that's attached permanently to the base, and a *back block* (D) that applies pressure against the edge of a workpiece, see Fig. 5.

This clamping pressure is produced by a hex bolt that passes through a hole in each block, see Fig. 5. The shank of the bolt threads into an insert in the front block. When you turn a knob on the end of the bolt, the back block presses against the workpiece.

The key to making this work is to get the holes in the blocks aligned. To do this, I set up a fence and stop block on the drill press, and used a two-step drilling sequence, see Fig. 6.

First, the hole for the threaded insert is drilled in the front block, see Fig. 6a. Then the shank holes are drilled in each block.

**NOTCHES.** After drilling the holes, the next step is to cut a notch in each block, see Fig. 7a. The notch in the back block creates a recess for the head of the bolt. And the notch in the front block serves as a "pocket" for a lock nut that holds the back block on the bolt, refer to Fig. 5.

**Safety Note:** To safely hold the blocks when cutting the notches, I clamped each one to an auxiliary fence that's screwed to the miter gauge, see Fig. 7.

**ASSEMBLY.** To assemble the clamp head, slip the bolt through the hole in the back block, and tighten on a lock nut, refer to Fig. 5. Note: The nut should be snug, yet still allow the bolt to turn. Then install the threaded insert in the front block, and thread the bolt through. Finally, to keep the

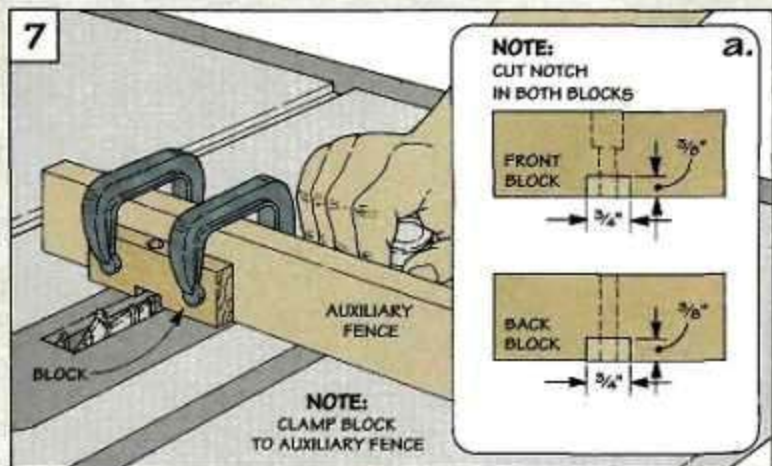
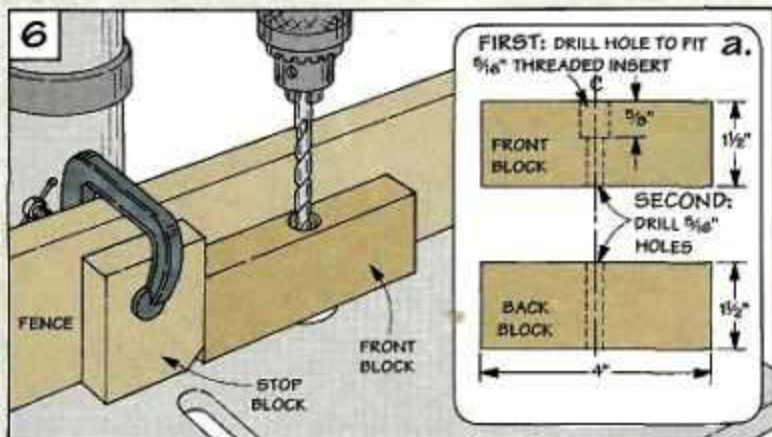
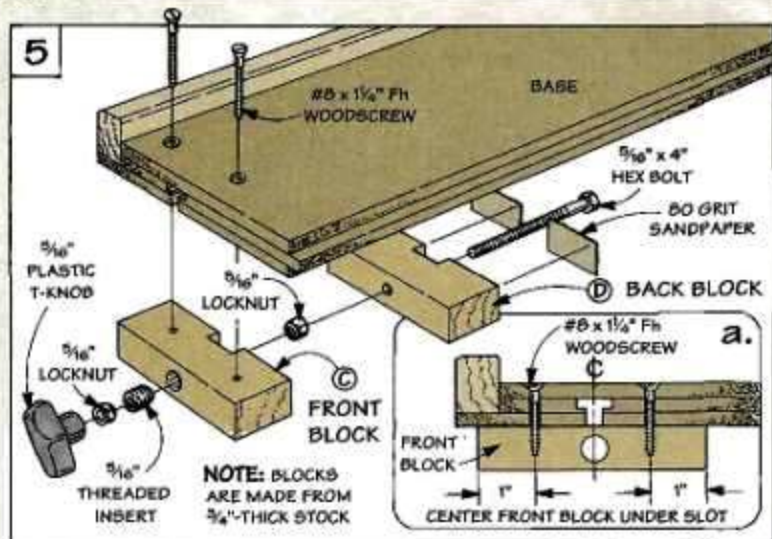

knob from working loose, tighten it against a lock nut on the end of the bolt.

**INSTALL CLAMP HEAD.** Now it's just a matter of installing the

clamp head. To do this, position the front block so it's flush with the end of the base and centered under the T-slot, refer to Fig. 5a. Then glue and screw it in place.

### STOP BLOCK

To make the cutting guide adjustable for different size workpieces, the next step is to add a *stop block (E)*. This is a hardwood block that slides back and forth in the T-slot. To hold it in place once it's positioned, the stop block locks against the bottom of the base.

The key is a toilet bolt that I picked up in the plumbing section at the hardware store, see Fig. 8. The head of the bolt is captured in the T-slot, while the shank passes through a hole that's centered on the stop block. Tightening a wing nut on the end of the bolt draws the head against the slot and holds the block in place.

**ALIGNMENT KEYS.** To keep the stop block from spinning, I added two *keys (F)*, see Fig. 8. These are strips of hardwood that are glued in a shallow dado cut in the top of the stop block, see Fig. 8a.

**SANDPAPER.** Next, to prevent the stop block from creeping as pressure is applied by the clamp head, I glued a piece of 80 grit sandpaper to the top of the block, see Fig. 8. Note: I also glued strips to the inside edges of the stop block and clamp head, see Figs. 5 and 8.

**TRIM EDGE.** All that's left to do is to trim the edge off the guide, see Fig. 9. The idea here is simple. The

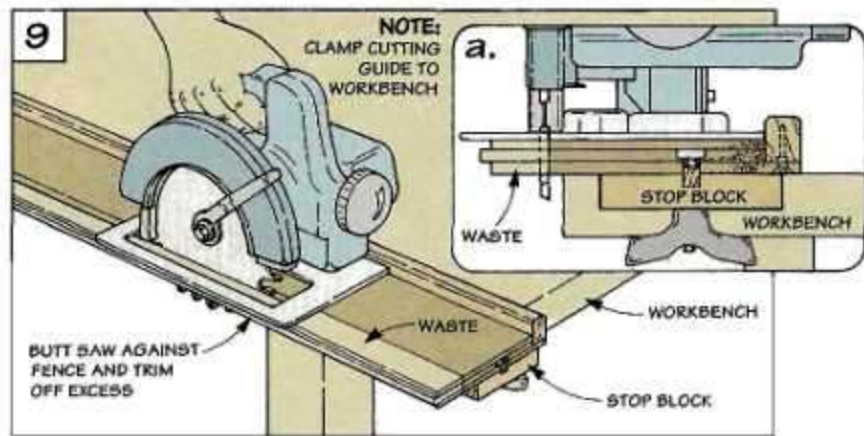
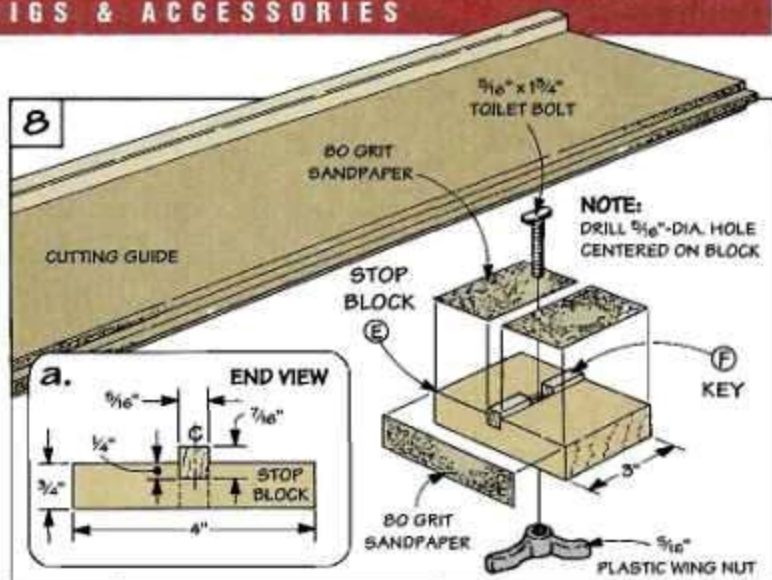

edge that's trimmed matches the cutoff line for the blade on your circular saw. This makes it easy to set up a cut by positioning the edge of the guide on the layout

lines on your workpiece.

To secure the guide when trimming the edge, I clamped it to a bench, see Fig. 9a. Just be sure the blade clears the bench.

## Using the Cutting Guide

Setting up the cutting guide to make a cut is easy. Start by marking layout lines on the workpiece. Then, since the edge of the guide serves as the cutoff line for your saw blade, position this edge on the layout lines, see Drawing.

To secure the guide, lock the stop block against one edge of the workpiece, and tighten the clamp head against the opposite edge. Then use the fence to guide your saw across the base.

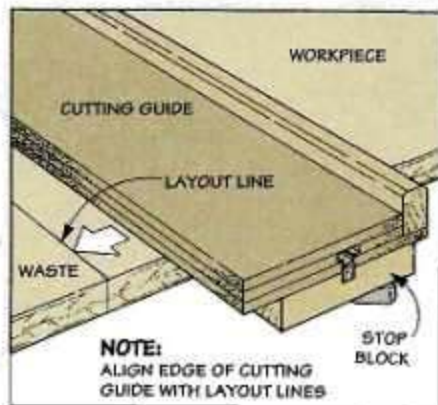

The fence doubles as a straightedge to guide the base of your router. Since the clamping system is beneath the guide, it won't get in the way of the motor housing.

# Drill Press Foot Pedal



**L**ike most woodworkers, I often need a "third hand" around the shop when drilling holes in a large workpiece. Two hands to hold the piece in the correct position. And a third hand to operate the quill feed.

To free up both hands, I added a foot pedal to my drill press. Basically, it works like the accelerator pedal on a car. To lower the bit, just step on the pedal. Easing off the pedal returns the bit to its starting point.

What makes this work is a wire cable that slides inside a flexible "sleeve." The cable transfers the movement of the pedal directly to the quill feed on the drill press.

**PEDAL.** I started work by making the two-piece pedal (A), see Fig. 1. To maintain tension on the cable, I used a pair of spring hinges to connect the pieces. There's a cleat (B) screwed to one

end of the top piece to keep your foot from slipping off, and a hole drilled through the other end for the cable to pass through.

**FRAME.** To support the pedal, I built a simple frame. It consists of two sides (C) screwed to the bottom piece of the pedal and a top (D) that holds the sides together.

Before attaching the top, I glued on a lower stop block (E). A series of holes is drilled in the block and through the top — a large diameter hole for a spring added later, and smaller holes for the cable

and the sleeve, see Fig. 1a. Note: I bought a sleeve for a brake cable from a local bike shop. (For a complete hardware kit, see page 31.)

**COLLAR.** To secure the other end of the sleeve, I fit a collar around the drill press column that supports another stop block. The collar (F) starts out as a single hardwood blank, see Fig. 2.

After laying out a circle the same diameter as your column, the blank is ripped down the center. Then the curved openings are cut, and holes are drilled in each

Hardware	
• (2) 1/16" x 1 5/8" Spring Hinges	
• (2) #8 x 1/4" Fh Woodscrews	
• (1) 7/16" x 5" Spring	
• (8) #8 x 1/2" Fh Woodscrews	
• (2) 1/4" x 5 1/2" Hex Bolts	
• (4) 1/4" Flat Washers	
• (2) 1/4" Hex Nuts	
• (1) 3/2"-Dia. Pulley w/ 1/2" Bore	
• (1) 1/16" Crimp-On Stop	
• (1) 1/16" Cable Clamp	
• 1/16"-Dia. Wire Cable (14 feet)	
• Flexible Cable Sleeve (10 feet)	

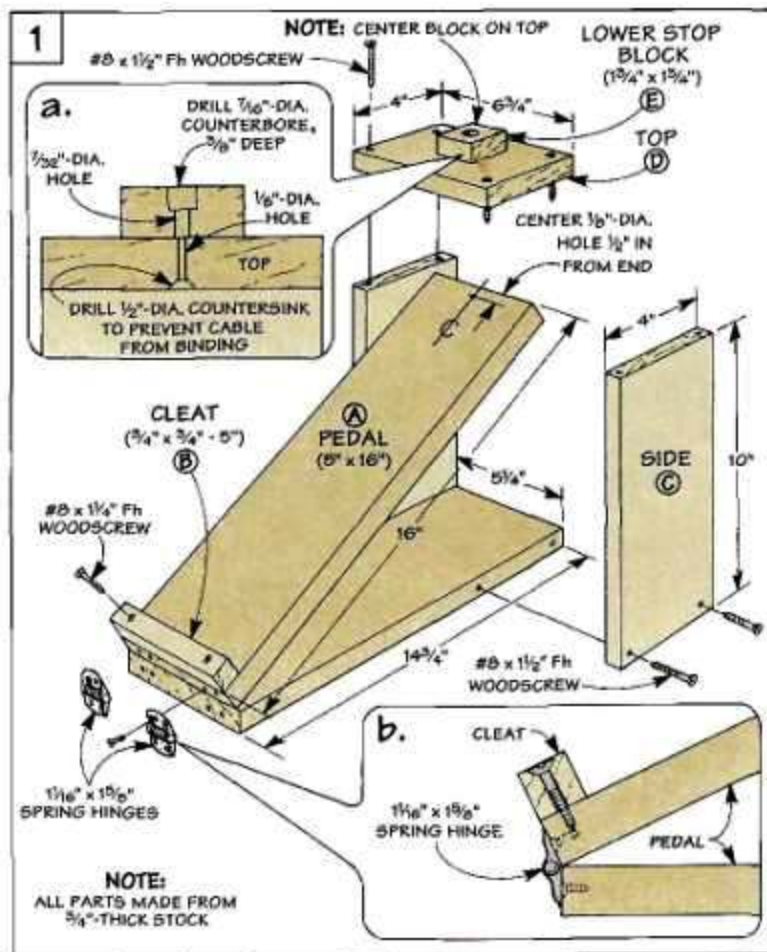



piece for a pair of bolts that hold the collar in place.

The next step is to add the upper stop block (G), see Fig. 2. Here again, I drilled a counter-bored hole for the cable and sleeve, then glued the block to the collar, see Figs. 2 and 2a.

**PULLEY.** After attaching the collar, I added a pulley to the shaft that runs through the quill feed, see Fig. 3. This way, when the cable is attached, the pulley turns the shaft that raises and lowers the bit. Note: Since my drill press has a 1/2"-diameter shaft, I used a pulley with a corresponding size bore, see Hardware List on opposite page.

Regardless of the size, you'll need to provide a way to attach the cable to the pulley. To do this, I drilled a small hole near the bottom of the V-groove, see Fig. 3.

To make room for the pulley, I removed the two nuts that hold the return spring in place. Then I filed a "flat" on the shaft, slipped on the pulley, and tightened down the Allen screw, see Fig. 3a.

**INSTALL CABLE.** Now you're ready to run the cable from the pulley to the pedal. The thing to be aware of is to make both the cable and the sleeve long enough so the pedal can be positioned in a convenient location. (I used a fourteen foot length for the cable and a ten foot sleeve.)

Once the cable is cut to length, start by inserting one end through the hole in the pulley, and attach a crimp-on stop, see Fig. 3a. Then, after taking a couple of wraps around the pulley, pass the other end through the upper stop block, and slip the flexible sleeve over the cable.

Next, to keep the cable from kinking, I slid a spring over the sleeve and pushed it into the lower stop block, see Fig. 4a. Then it's just a matter of threading the cable through the pedal and securing it with a cable clamp.

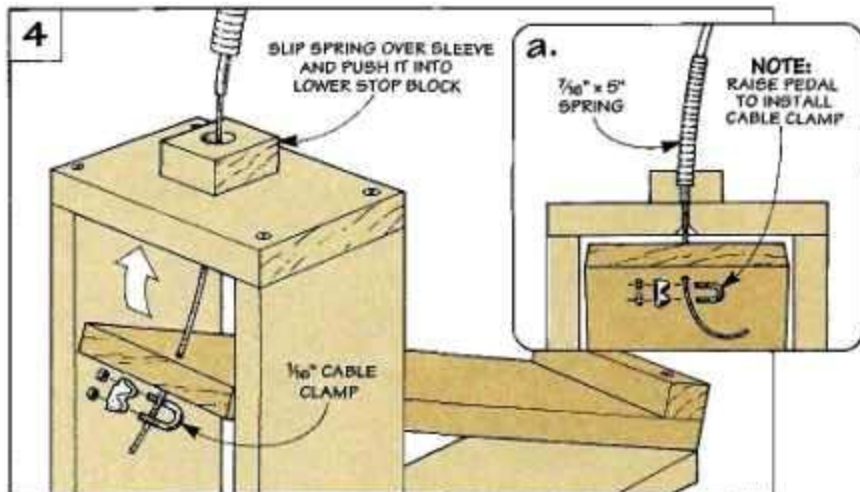
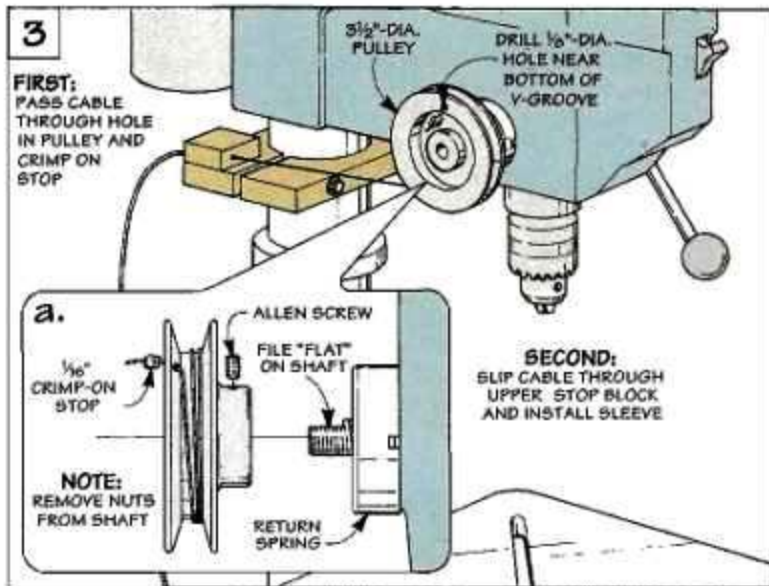
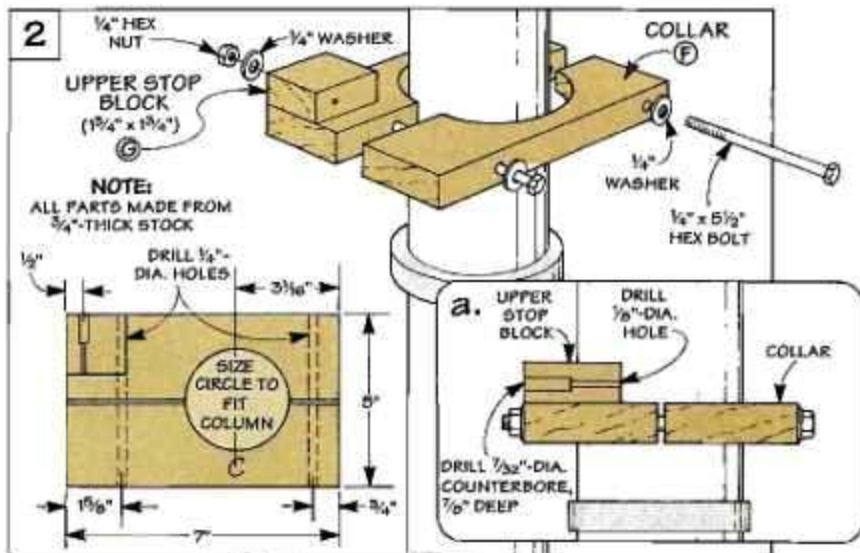

# Dado Blades



*What to look for when buying a dado blade.*

Every time I open a woodworking catalog, it seems like there's a new kind of dado blade available. This makes it a little confusing if you're buying a new blade. But when you boil down the choices, there are just a few things you need to look for when selecting a dado blade.

Basically, there are two types of blades: stack dados and adjustable dado blades. While both of these blades are designed to make a cut that's wider than a standard saw kerf, they go about it in different ways.

## STACK DADOES

A stack dado blade gets its name from a set of individual parts that are stacked on the saw arbor. These parts fall into two basic groups — cutters and chippers.

**CUTTERS.** To create the sides of the dado (or groove), there's a cutter on each side of the stack, see Fig. 1. Most cutters have

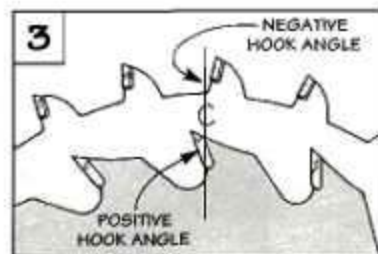
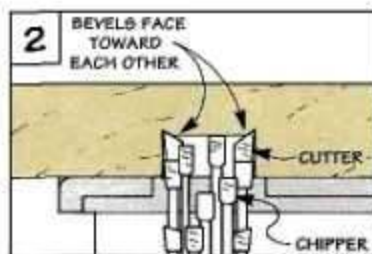
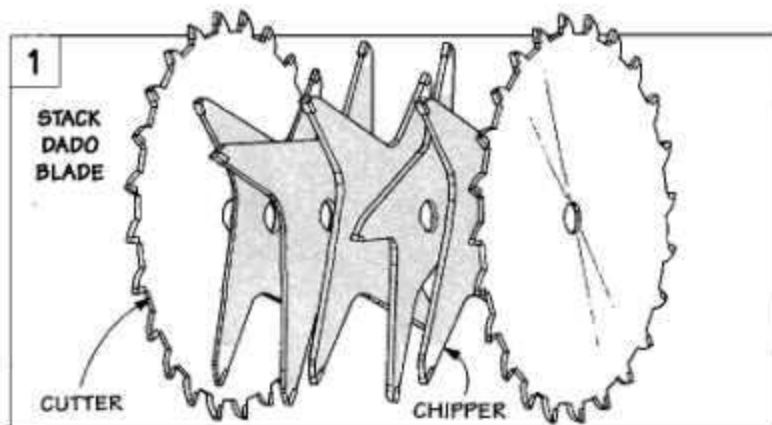

some combination of flat-topped and beveled teeth. One thing I've found is that the *direction* of the beveled teeth determines how well the blade will cut.

To produce a clean cut, I look for cutters where the beveled teeth face *toward* each other, see

Fig. 2. This means the tips of the teeth shear off the wood fibers at the edge of the dado and produce a smooth-sided cut.

**CHIPPERS.** The second part of a stack dado blade are the chipper, refer to Fig. 1. All the chippers do is remove the material between the cutters.

Most stack dado blades have a set of four or five chippers that vary in thickness. This lets you arrange them in different combinations to change the width of cut. Note: With all the chippers in place, you can produce a cut that's  $1\frac{3}{16}$ " wide.

**TEETH.** Regardless of the number of chippers, they all have one thing in common. To produce a flat-bottomed cut, the teeth are ground *flat* across the top.

The unusual thing is there are only two to four teeth on each chipper. This allows the chippers to remove a lot of material quickly. The only difference I've

## Safety Dado Blade



This Freud dado blade is one of the oddest looking blades I've seen.

That's because there's a tall "shoulder" that sits directly in front of each tooth, see photo. The shoulder limits the size of the chip that each tooth cuts. This prevents the blade from grabbing the workpiece and reduces the chance of kickback.

This also makes it ideal for a radial arm saw where a dado blade has a tendency to "climb" the workpiece. (For sources, see page 31.)

found is chippers with four teeth make a slightly smoother cut.

**HOOK ANGLE.** Another thing to keep in mind when selecting a stack dado is the hook angle of the teeth on the cutters and chippers.

If the teeth lean *forward* (positive hook), the blade pulls the workpiece into it as you make a cut, see Fig. 3. This makes it easy to feed the workpiece quickly through the blade. The only problem is sometimes the blade can grab the workpiece and make it hard to control.

The other option is to choose a blade where the teeth angle *backwards* (negative hook), see Fig. 3. With this type of blade, you have to feed the workpiece through much slower. But since the teeth don't have a tendency to grab, it's easier to control the workpiece.

**Note:** For information on a new type of dado blade, see the box on the opposite page.

### ADJUSTABLE DADOES

The alternative to a stack dado is an adjustable dado blade. It uses a single blade instead of a set of individual parts.

The basic principle is simple. An angled disk is built onto each side of the blade, see Fig. 4. When you turn a metal collar that rotates

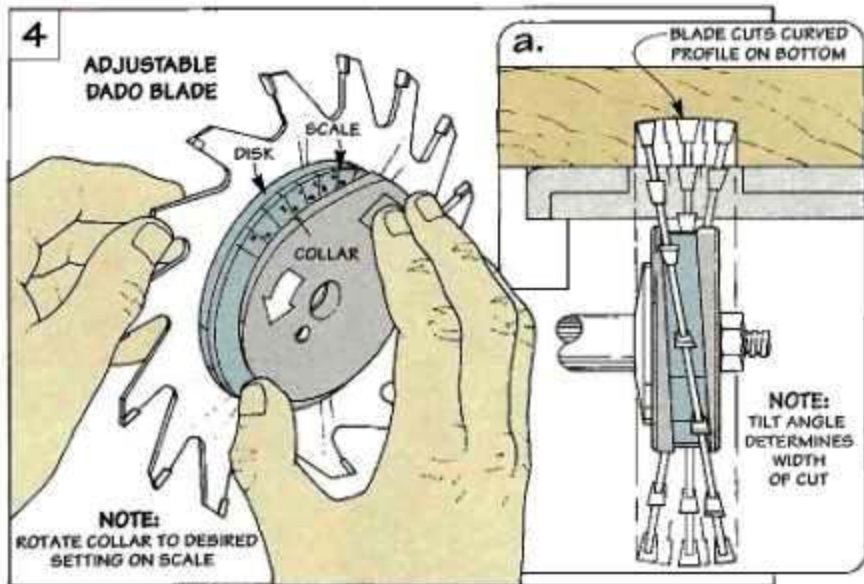

on top of these disks, the blade tilts. The more the blade is tilted, the wider the cut, see Fig. 4a.

Since the blade is tilted, it appears to wobble in an hourglass pattern as it spins. Because of this, these blades are often called "wobble blades." (For a different type of wobble blade, see the box below.)

**FINE ADJUSTMENT.** Like a stack dado, a wobble blade can be adjusted to make a cut between  $\frac{1}{4}$ " and  $1\frac{3}{16}$ " wide. You just "dial" the collar to the desired setting on a scale that's etched in the disk, see Fig. 4.

In theory, this sounds good. But when you "fine tune" the width of cut, I've found it's easy to lose track of how much you've moved the collar.

**VIBRATION.** Another thing you'll notice with wobble blades is they have a tendency to vibrate. There are a couple of reasons for this.

First, the blade is spinning off-center on the arbor. Second, most wobble blades don't have a lot of teeth. As a result, each tooth has to remove a lot of material which can cause a rough cut.

**BOTTOM PROFILE.** There's one other thing you'll have to learn to live with if you decide on an adjustable dado blade. Because the blade is tilted, it produces a cut with a rounded bottom, see Fig. 4a. This really isn't a problem when making a narrow cut. But the wider the cut, the more exaggerated the curve.

**CONCLUSIONS.** So what's the bottom line? That depends. A wobble blade is considerably less expensive than a stack dado blade. And for occasional use, it works just fine. But if you're looking for the best quality cut (and price isn't a factor), I'd go with a stack dado blade.

## Twin Blade

One variation of an adjustable dado blade is a twin wobble blade. The biggest advantage of this blade over a single wobble blade is it has a lot more teeth. This reduces the amount of vibration, so you end up with a crisper cut. (For sources, see page 31.)

To make it adjustable, the blades ride in converging grooves that are set in a movable hub. Turning the hub tilts the blades in a V-shaped pattern which can be adjusted for cuts from  $\frac{1}{4}$ " to  $1\frac{3}{16}$ " wide.



# Tips on Using Dado Blades

Using a dado blade is the fastest way I know to cut a dado, rabbet, or groove. But like any specialized accessory, there are some special requirements. In fact, there are a few things to consider before you even make your first cut.

**INSERT.** Since the opening in the metal insert that comes with the table saw isn't wide enough for a dado blade, you'll need a different insert. Although you can buy a metal dado insert, I've found that the blade opening is *too* wide. So I prefer to make my own.

It's nothing more than a piece of hardwood that's cut to fit the opening for the original insert, see Fig. 1. To cut the slot for the blade, clamp a board across the top of the insert. Then turn the saw on, and slowly raise the blade

through the insert. Note: I set the dado blade to the maximum width setting ( $1\frac{3}{16}$ ").

**WIDTH OF CUT.** Another consideration when using a dado blade is adjusting the width of cut to get a perfect fit. The basic idea is simple — adjust the width of the blade to match the thickness of the mating workpiece.

This would be easy, except for one thing. It never seems to fail that the thickness of your workpiece isn't a nice, neat increment ( $\frac{1}{2}$ ",  $\frac{5}{8}$ ",  $\frac{3}{4}$ ", and so on). Usually, it's just a fraction over or under.

**TRIAL AND ERROR.** Because of this, the only way I've found to get a truly accurate setting is by trial and error. Make a test cut, check the fit, then readjust the blade if necessary.

With a wobble blade, you can



adjust the width of cut without removing it from the arbor. Just loosen the arbor nut, and turn the collar. But fine tuning a stack dado blade isn't quite as simple.

**SHIMS.** The problem is adding (or removing) one chipper changes the width of cut dramatically. The solution is to adjust the width of the blade just a hair by slipping one (or more) *shims* onto the arbor, see Fig. 2.

For years, I've used paper disks cut from a piece of lightweight cardboard for shims. This works fine, but they tend to wear out with use. So recently when I saw some other types of shims, I decided to give them a

## Shims



### Brass:

Five different thicknesses let you make precise adjustments to the width of cut with these brass shims.



### Plastic:

Color-coded by thickness, these plastic shims fit on the arbor without disassembling the dado blade.

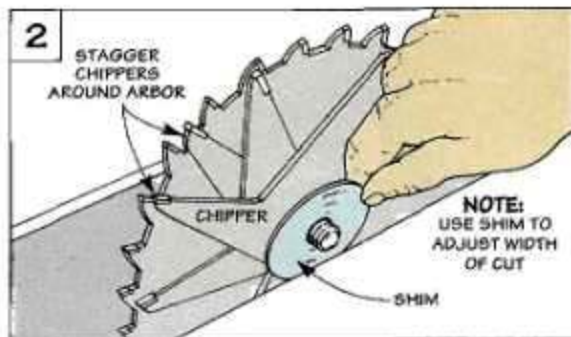
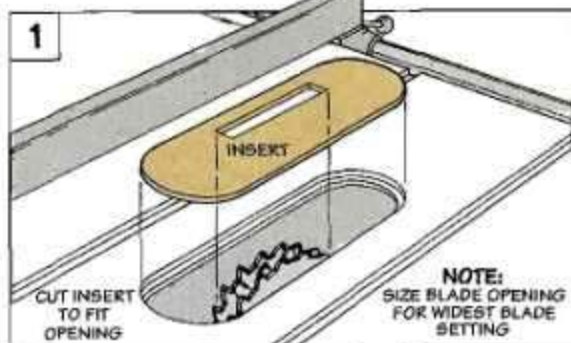

try, see the box on page 12 and Sources on page 31.

**STAGGER CHIPPERS.** Whether you use shims or not, just be sure that the chippers are staggered around the saw arbor, see Fig. 2.

## DADOES

When using the miter gauge to cut a dado, it's hard to position the workpiece so the blade cuts *exactly* where you want it.

To solve this, I start by screwing a tall auxiliary fence to the head of the gauge. Then, with the blade raised about  $\frac{1}{4}$ " higher than the thickness of your workpiece, cut a notch in the fence, see Step 1.

Now just use the notch to locate the path of the blade, see Step 2.

This prevents the sides of the teeth from touching (and damaging the blade). And it ensures that all the parts are flat against each other so the arbor nut can be tightened securely.

**SETUP.** Besides mounting the blade correctly, there are a few other things to be aware of when setting up a cut. Basically, they depend on whether you're cutting a dado, groove, or rabbet.

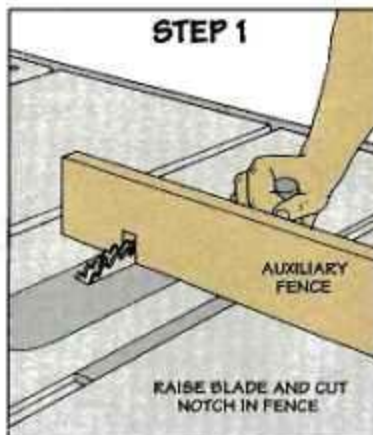

## GROOVES

Using the rip fence to cut a groove with a dado blade presents a different alignment problem.

To indicate the path of the blade, I make a test cut in a scrap piece of wood. Then, after backing off the scrap, the edges of the cut are marked on the insert, see Step 1.

Now you can line up the layout lines on your workpiece with the marks on the insert, lock the rip fence, and make the cut, see Step 2.

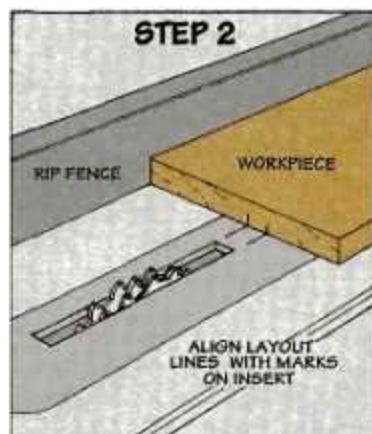
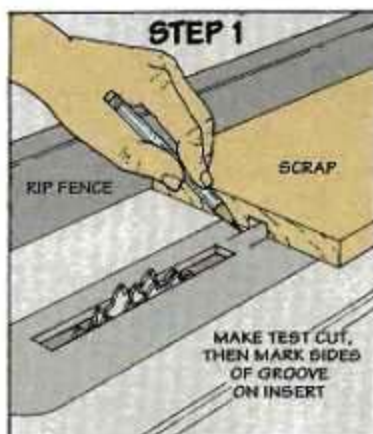

## RABBETS

Cutting a rabbet on the edge of a board also requires using the rip fence. But in this case, part of the blade is "buried" in an auxiliary fence that's clamped to the rip fence, see Drawing. The amount of blade that sticks out determines the width of the rabbet, see Detail.

Why not just move the rip fence away from the blade and cut the rabbet on the opposite edge? Because the workpiece can get pinched between the blade and the fence. This can cause the blade to grab the work and kick it back at you.

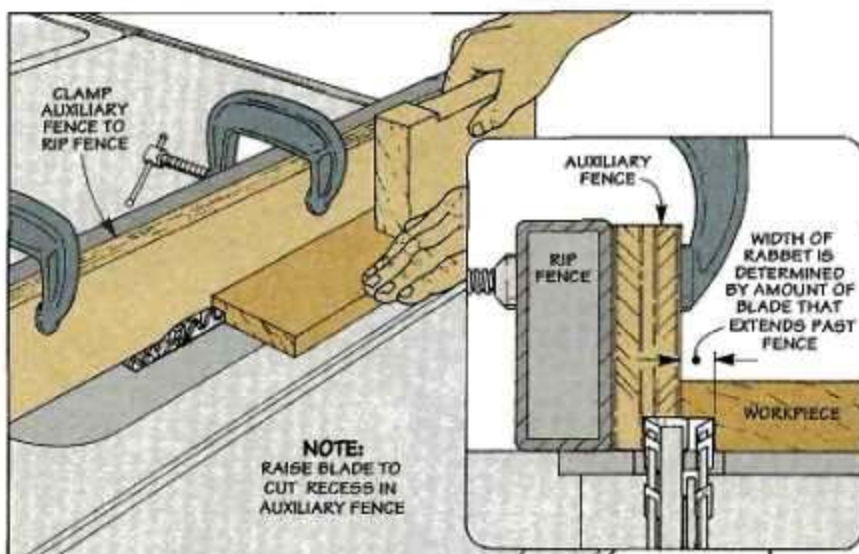

# Changing Jointer Knives



All it takes to change and adjust the knives on your jointer is a straight-edge and a little patience.

A friend of mine has the same attitude about changing jointer knives as he has about doing taxes. He keeps putting it off, and putting it off — even when his jointer knives are dull or chipped.

The good news is changing knives isn't nearly as complicated as taxes. There's really only one adjustment to be concerned with — the height of the knives. The reason this is so important has to do with the way a jointer works.

**JOINTING.** In use, a workpiece is pushed along an adjustable infeed table that's set lower than the knives. As the workpiece is

pushed across the cutterhead, a set of knives (two or three) cut into the wood. The outfeed table supports the workpiece and prevents the knives from taking too deep a cut.

The secret to getting a smooth, square cut on a jointer is to keep the knives adjusted perfectly flush with the outfeed table. The problem is every time you sharpen the knives, it reduces their height. Which means you have to raise them up to compensate for the metal that was removed.

**LEVELING SCREWS.** Raising the knives is easy. All you have to do is turn a pair of leveling screws to push a knife up. (For more on this, refer to Step 3 on page 15.) But holding the knives at the correct height is another story.

**HOLDING KNIVES.** The method for holding knives in place varies from jointer to jointer. But there are basically three common ways to do this, see Drawings at left.

The knives are either pinched against the sides of the slot in the cutterhead by a metal wedge and screws, or by a gib plate and bolts. Or they're attached directly to the cutterhead.

**MOVEMENT.** The problem occurs when these screws (or bolts) are tightened. As soon as you tighten them, the knives move. The trick is to anticipate this movement.

What I've found works best is to set each knife slightly below the outfeed table. To make sure the knives stay parallel to the outfeed table, adjust the leveling screws the same amount. (I use the slots in the screw heads or the position of an Allen wrench as a visual reference.)

All it takes is the slightest turn of a leveling screw — maybe just an eighth of a turn. Then, tightening the mounting screws will push the knife into adjustment. This isn't difficult, it just takes patience.

To check to see if the knife is adjusted properly, I use an accurate straightedge and listen for a "tick." (For more on this, refer to Step 3 on page 15.)

**SAFETY TIPS.** Once you've adjusted all the knives, double check that all the wedge screws are tight. Then stand to one side and turn on the jointer. Finally, check to see how it cuts by jointing the edge of a board.

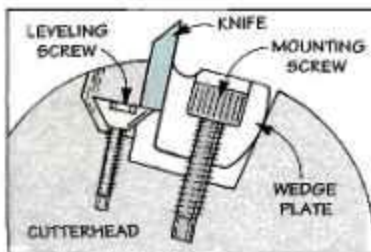

◀ **Wedge.** Tightening a pair of mounting screws forces the wedge-shaped plate down into the tapered slot to hold the knife in place.

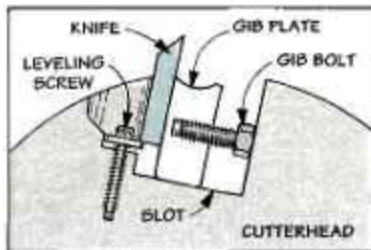

◀ **Gib Plate.** A set of bolts threaded into a gib plate are tightened to pinch the knife between the plate and the slot in the cutterhead.

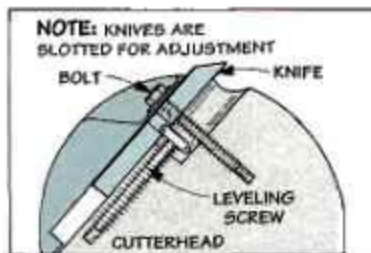

◀ **Bolts.** On some smaller (benchtop) jointers, the knives are slotted for adjustment, and bolt directly to the cutterhead.

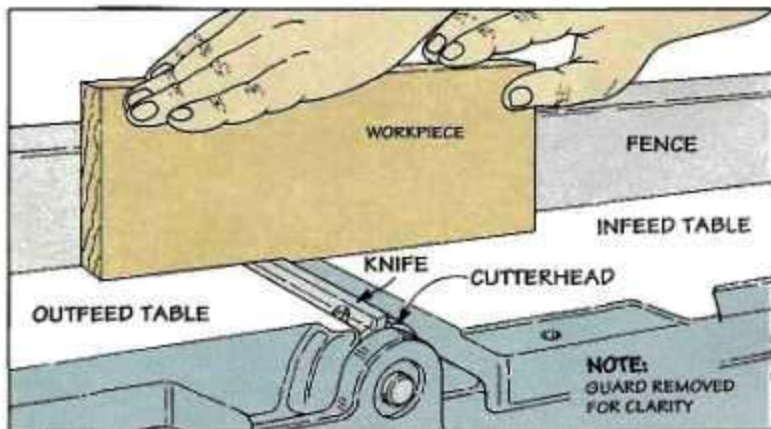

# Changing Knives Step-By-Step

## Step 1: Remove One Knife.

To start, unplug your jointer and remove the fence. Then remove the cutterhead guard (or wedge it out of the way). Next, loosen the mounting screws on one knife. Lift out the knife and wedge plate and clean the parts and slot with an oil-free solvent.

**ShopTip:** To keep my sharpened knives from getting mixed up with the dull ones, I mark each dull knife with a felt-tip pen.

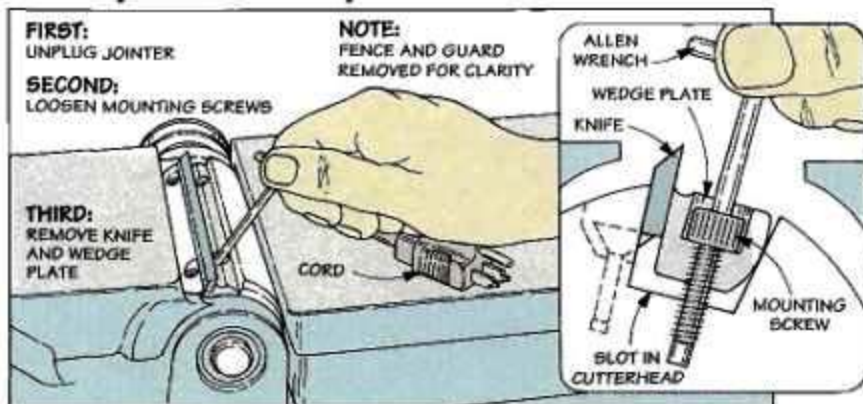

## Step 2: Insert Sharp Knife.

Once all the parts are clean, insert the wedge plate in the slot. Then, with the beveled edge of the knife facing the outfeed table, place it between the wedge plate and the front of the slot. Now tighten the mounting screws just enough to hold the knife in place.

**ShopTip:** If there are more than two mounting screws, start in the center and work toward the ends to prevent the knife from twisting.

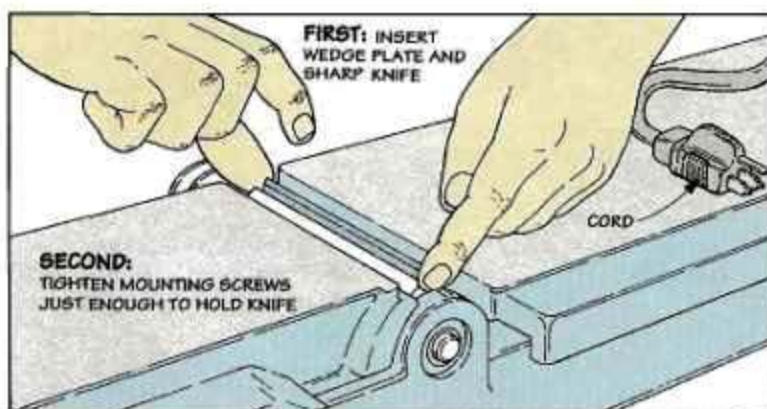

## Step 3: Adjust the Knife.

Next, place a straightedge on the outfeed table so it extends over the knife. Then adjust the leveling screws so the knife is just below the straightedge. Now you can tighten the mounting screws.

To check the adjustment, rotate the pulley (or belt), and listen for a "tick" that indicates that the knife is just barely touching the straightedge. (Check this at both ends of the knife.)

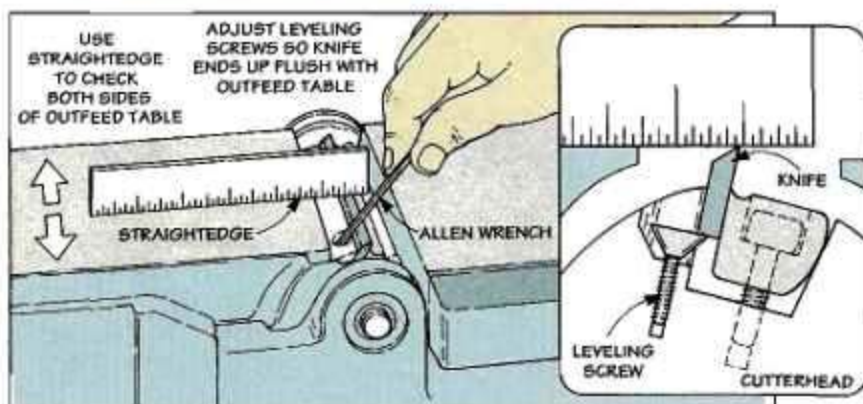

## Step 4: Test the Jointer.

After you've set all the knives and checked to make sure they're "locked" in place, replace the cutterhead guard and fence. Then make a series of test cuts across the width of the table.

If the knives are too low, the end of the workpiece will run into the outfeed table. If they're too high, you'll get a deeper cut (snipe) at the end of the cut.

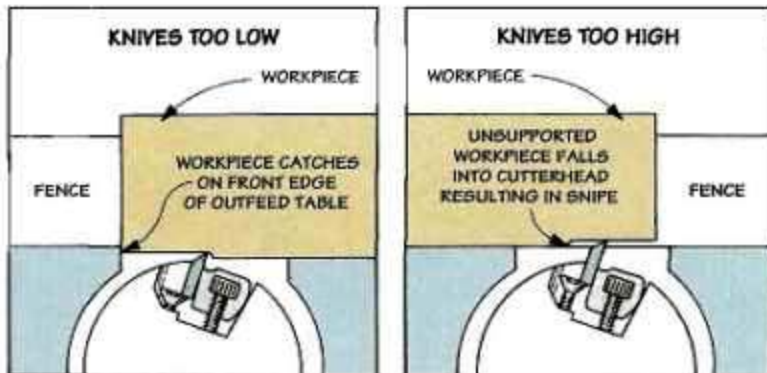

# Disk Sander

*A professional-quality power tool for your shop that combines heavy-duty construction with easy-to-use features.*



**A** disk sander is something you usually find only in a production cabinet shop. The large sanding surface and heavy-duty construction make it ideal for quickly sanding to a line, chamfering, mitering, or removing a lot of stock.

An industrial-quality tool like this would be a great addition to any shop. But the high cost makes it hard to justify buying one. So I decided to build my own and add a number of features to make it easy to use and improve accuracy.

**THE TOP.** The most noticeable design feature of this disk sander is the top. It's curved to follow the shape of the sanding disk. The top serves as a cover for the motor and helps keep it free from dust. It also protects you by covering the edge of the spinning disk. And at the same time, it directs sawdust into a built-in vacuum port.

**THE TABLE.** The table of the disk sander is also

unique. First of all, it's larger than the tables found on most sanders. This makes it easier to support and accurately sand a large workpiece. And the larger table allows you to use a full-size miter gauge — not the scaled-down ones found on most other power disk sanders.

Another problem with the tables on most disk sanders is you have to find a wrench whenever you want to tilt the table. To get around this, I added a pair of knobs to make it easy to tilt and lock the table firmly in place. And to make changing sanding disks a snap, the table lifts off to give you total access to the disk.

**THE BASE.** If space is limited in your shop, you can add a pair of "feet" to the sander and clamp it to your workbench, see photo above. Or you can build an optional stand, see photo on the bottom of page 17. The stand is wide at the base to provide a stable foundation. And the column is hollow so you can fill it up with sand or bricks. This extra ballast helps to anchor the sander and virtually eliminates vibration. (For detailed instructions on how to build this stand, see the article on page 25.)

## Cutting Diagram

24" x 48" - 1/4" TEMPERED MASONITE

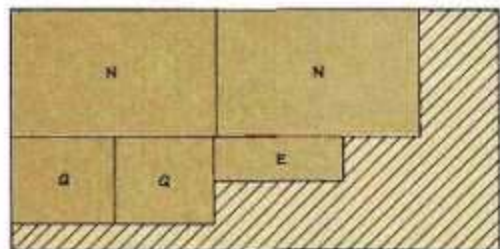

3/4" x 8" - 84" (4.750 FT.)

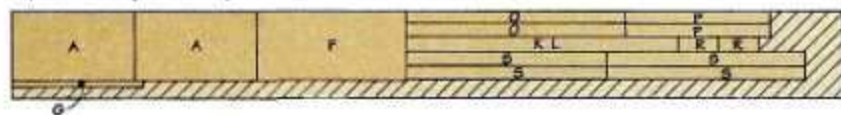

*Note: You can get all the plywood parts for both the disk sander and the stand from a single 48" x 96" sheet of 3/4"-thick plywood.*

48" x 36" - 3/4" PLYWOOD

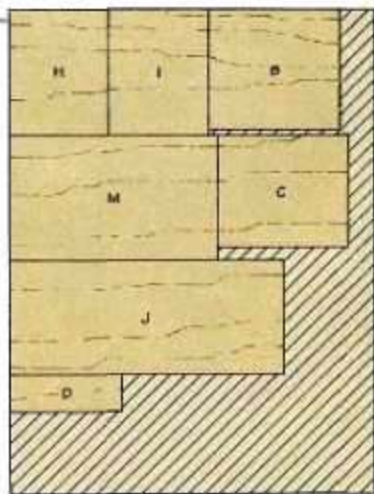



## EXPLODED VIEW

w/o STAND  
16"H x 22"W x 29"D  
w/ STAND  
42½" H x 22"W x 29"D

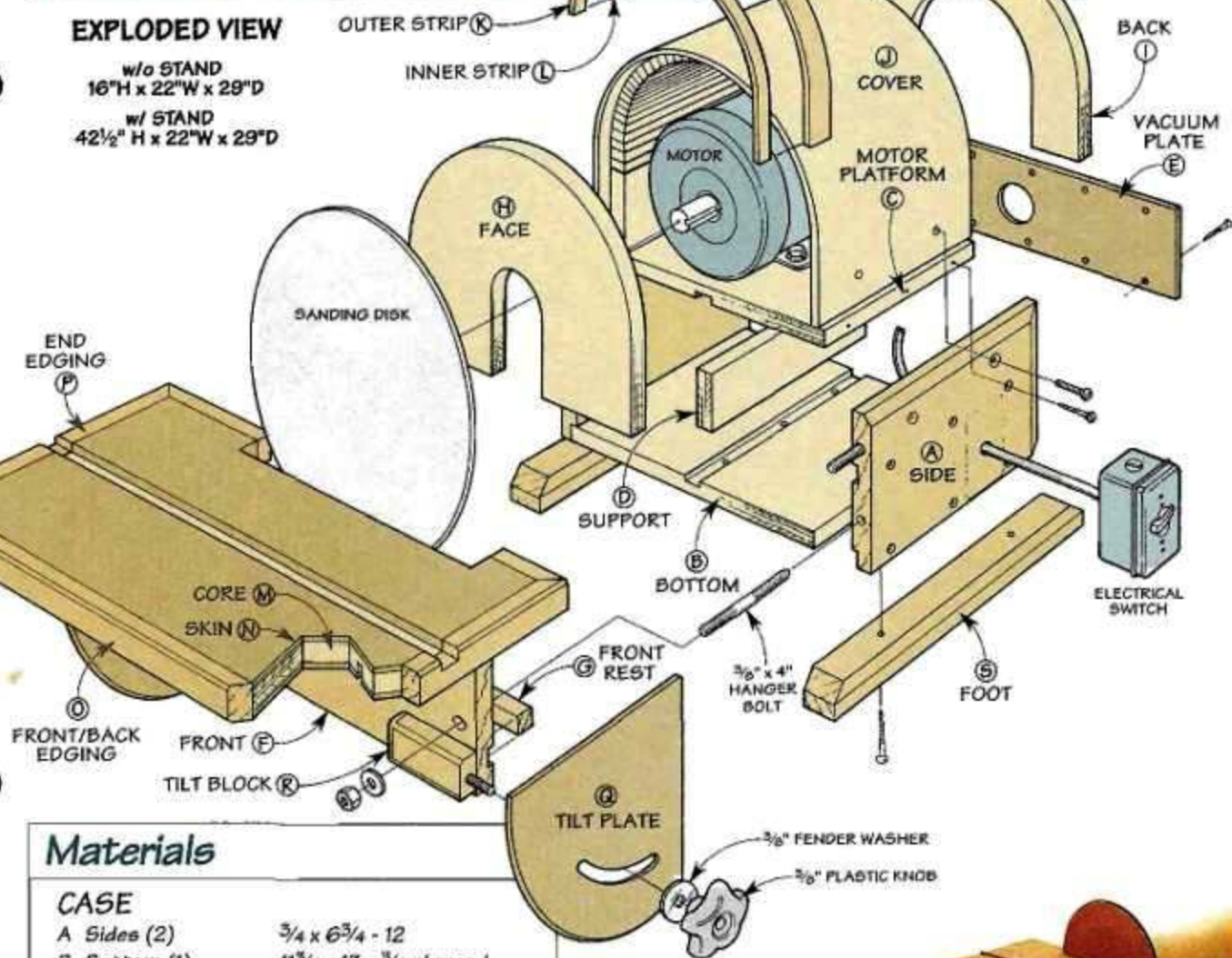

## Materials

### CASE

A Sides (2)	¾ x 6¾ - 12
B Bottom (1)	11¾ x 13 - ¾ plywood
C Motor Platform (1)	11 x 13 - ¾ plywood
D Support (1)	3½ x 11 - ¾ plywood
E Vacuum Plate (1)	4½ x 13 - ¼ Masonite
F Front (1)	¾ x 6¾ - 14¾
G Front Rest (1)	¾ x ¾ - 12½

### TOP

H Face (1)	12¼ x 9½ - ¾ plywood
I Back (1)	12¼ x 9½ - ¾ plywood
J Cover (1)	11¼ x 27 (rgh.) - ¾ plywood
K Outer Strip (1)	½ x 1½ - 27 (rgh.)
L Inner Strip (1)	½ x 5/8 - 27 (rgh.)

### TABLE

M Core (1)	12½ x 20¼ - ¾ plywood
N Skins (2)	12½ x 20¼ - ¼ Masonite
O Fr./Bk. Edging (2)	¾ x 1¼ - 21¾
P End Edging (2)	¾ x 1¼ - 14
Q Tilt Plates (2)	8½ x 10 - ¼ Masonite
R Tilt Blocks (2)	¾ x 1½ - 4
S Feet (2)	1½ x 1½ - 18

\* not required if you build the stand on page 25

## Hardware

- (1) 1½" x 14" Piano Hinge
- (14) No. 5 x 5/8" Fh Woodscrews
- (6) 3/8" x 4" Hanger Bolts
- (4) 3/8" Hex Nuts
- (4) 3/8" Flat Washers
- (2) 3/8" Plastic Knobs
- (2) 3/8" Fender Washers
- (4) ¼" x 1½" Fh Machine Screws
- (4) ¼" T-nuts
- (26) No. 8 x 1½" Fh Woodscrews
- (4) No. 8 x 2½" Fh Woodscrews
- (1) Switch Box
- (1) Electrical Switch
- (1) Switch Plate
- (1) Electrical Cord w/Plug
- (4) Bolts, Washers, Lock Washers and T-nuts to Mount Motor

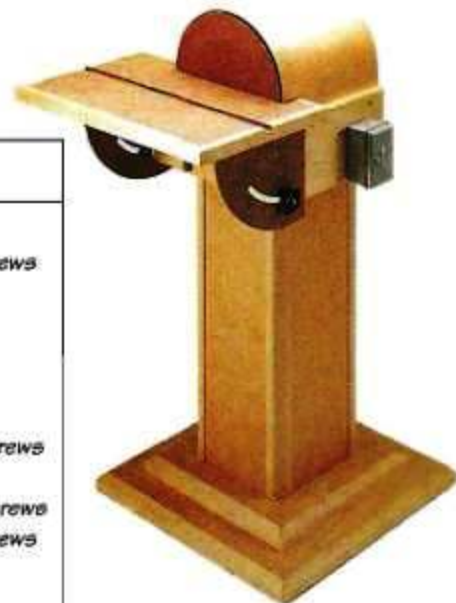

**Optional Stand:** If you prefer a stationary tool, the disk sander can be mounted to this shop-built stand. (For more on this, see page 25.)

## The Case

The Disk Sander is made up of three main parts: a case, a top cover, and an adjustable table. I started by building the case. (Note: This case is sized for a 12" sanding disk, see Sources on page 31.)

The case is just a rectangular box with tall sides, see Fig. 1. The sides extend up to hold the cover in place when it's added later.

**SIDES.** To make the case, start by cutting a pair of sides (A) to size from  $\frac{3}{4}$ "-thick hardwood, see Fig. 2. Next, the sides of the case are grooved to accept a motor platform for the motor. And rabbeted for a plywood bottom, see Fig. 2.

In addition to the rabbet for the bottom, you'll also need to rout a rabbet for a vacuum plate that's added later, refer to Fig. 4. This rabbet is on the back edge of each side (A) between the rabbet and groove, see Fig. 2.

While I was at it, I drilled two holes in the front end of each side piece, see Fig. 2. These will be used later to attach the table to the case. To drill these holes straight, I used a jig on the drill press, see photo below.

To complete the sides, I routed a chamfer on the top and back out-

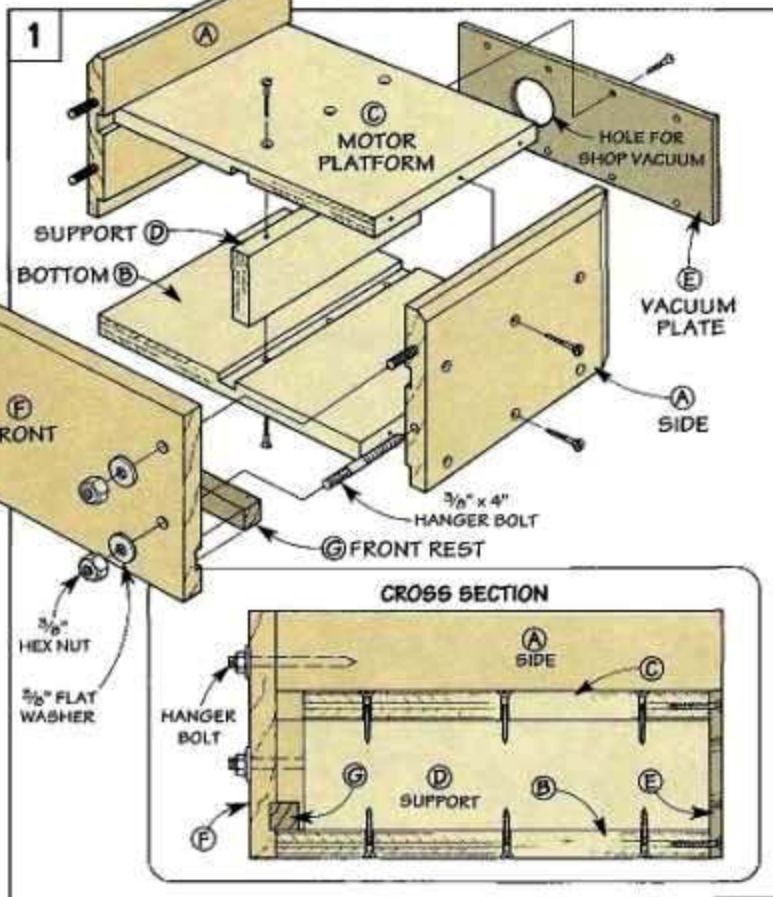

side edges of each side, see Fig. 2.

**BOTTOM & PLATFORM.** Once the sides are complete, the next step is to make the bottom (B) and the motor platform (C). Both of these pieces are cut from  $\frac{3}{4}$ "-

thick plywood to the same length (13"), see Fig. 3. But their widths (depths) are different.

The motor platform (C) is cut  $\frac{3}{4}$ " shorter than the bottom (B), see Fig. 3. This creates a pocket

**Drilling Jig**  
To ensure straight holes when drilling into the end of a workpiece, I use this simple jig. Wedge-shaped supports keep two scrap pieces of plywood at a right angle. And a cleat serves to hold the workpiece vertical.

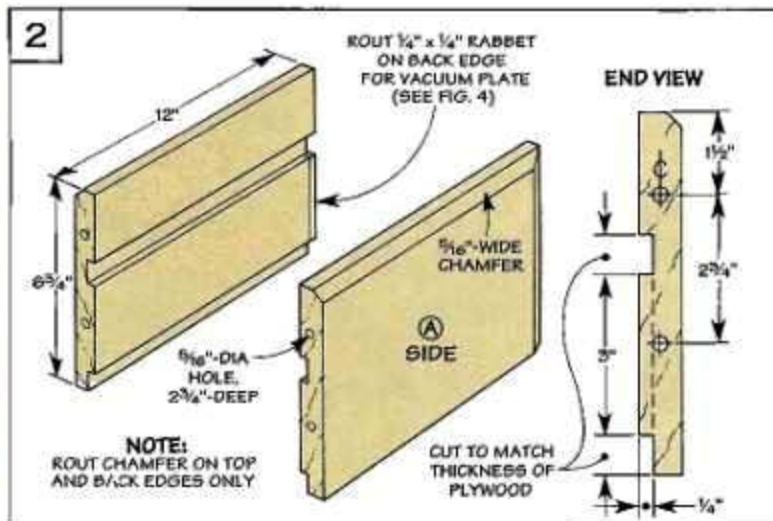
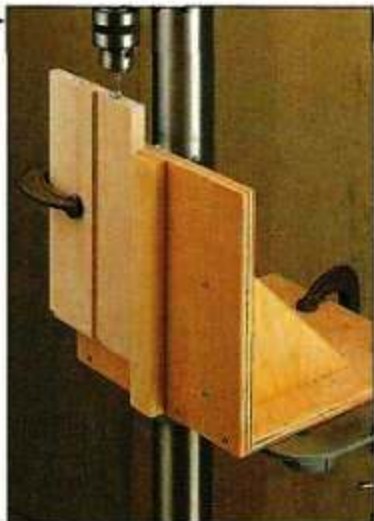

for the bottom half of the sanding disk that's added later.

Before assembling the case, you'll need to cut a dado down the center of the platform and bottom for a support piece, see Fig. 3.

After the dados are cut, glue and screw the case together, see Fig. 4. Note: The bottom (B) and motor platform (C) are attached flush with the *inside* edge of the rabbets cut in the sides for the vacuum plate, refer to Fig. 1a.

**SUPPORT.** Next, to prevent the motor platform from bowing under the weight of the motor, I added a support. The support is just a piece of plywood cut to fit in the dados in the platform and bottom, see Fig. 4.

Position the support in the case so it's flush with the *front* edge of the motor platform and screw it in place, refer to Fig. 1a.

**VACUUM PLATE.** To allow a shop vacuum to be hooked up to the sander, a  $\frac{1}{4}$ "-thick Masonite vacuum plate (E) is cut to fit between the rabbets in the sides and flush with the motor platform and bottom, see Fig. 4.

Once the plate is cut to size, drill a hole in it to fit your shop vacuum and screw it to the back of the case, see Figs. 4 and 1a.

**CASE FRONT.** All that's left to complete the case is to add a hardwood front, see Fig. 5. The front (F) covers the end of the case. And it will be used later to attach and support the adjustable table.

The width (height) of the front is the same as the sides ( $6\frac{3}{4}$ "). To provide the necessary clearance for the table ( $\frac{3}{8}$ " on each side), I cut the front  $\frac{3}{4}$ " longer ( $14\frac{3}{4}$ ") than the overall width of the case, see Fig. 5.

**FRONT REST.** To hold the front in place and support the weight of the table, I added a hardwood rest (G), see Fig. 5. This rest fits into a shallow groove that's cut on the inside face of the front (F).

**ASSEMBLY.** Once the rest is

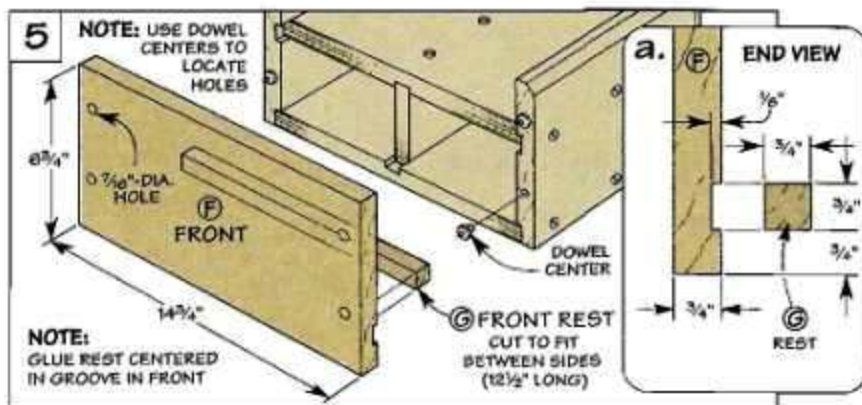
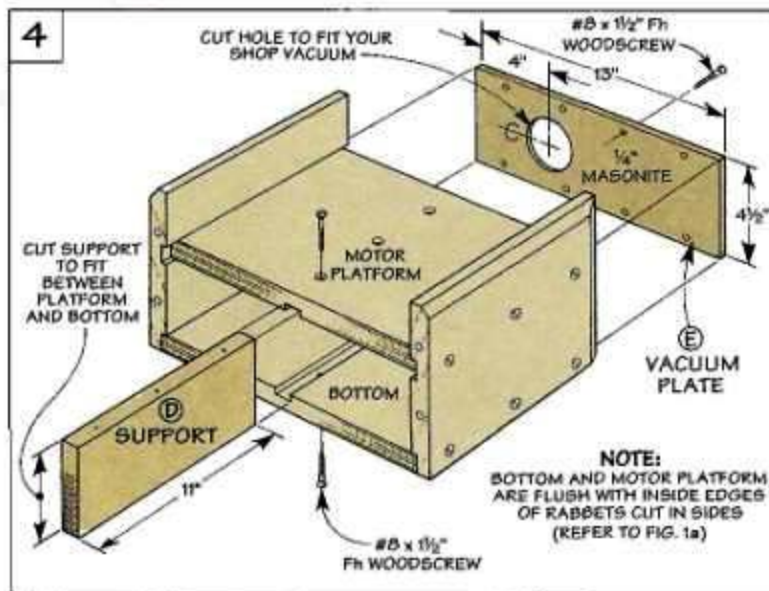
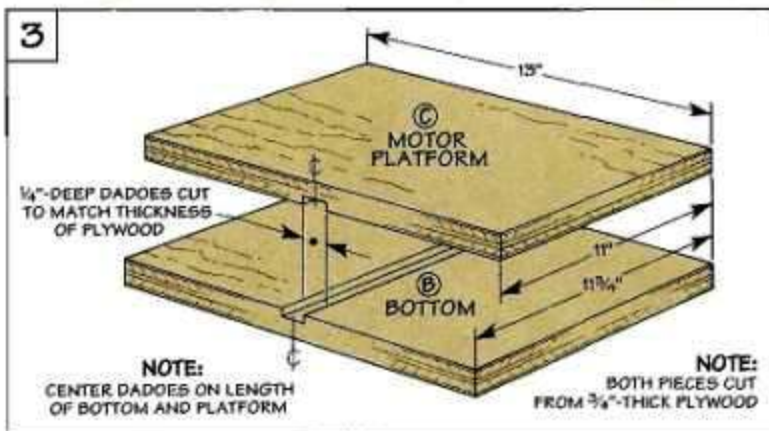

To protect the full length of the threads on a hanger bolt, I use a coupling nut. A "jam" nut prevents the coupling nut from turning.

glued in place, the front can be attached to the case, refer to Figs. 1 and 1a. The first step is to transfer the locations of the holes in the sides to the front. To do this, I used dowel centers, see Fig. 5.

With the holes marked, drill over-size ( $\frac{7}{16}$ ") shank holes in the front. Then thread hanger bolts in the sides, see margin tip above. Finally, slip on the front and secure it with washers and hex nuts.

# Top Cover

## FACE DIMENSIONS

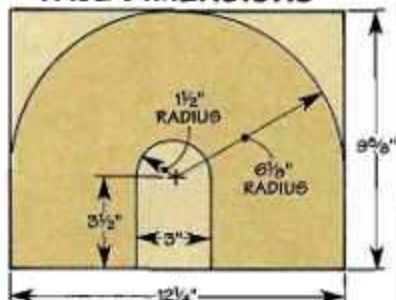

## BACK DIMENSIONS

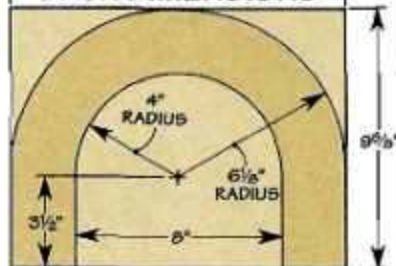

To get identical curves on the face and back, I used one piece as a template. And trimmed the other piece to match with a flush trim bit.

Once the case is complete, the next step is to make a top cover to fit between the sides, see Fig. 6. The top is barrel-shaped to fit over the motor and sanding disk. To create this shape, I bent a piece of plywood over two U-shaped pieces, see Fig. 6.

**FACE AND BACK.** These pieces, a face (H) and back (I), are cut from two identical blanks of 3/4"-thick plywood. The width of the blanks is determined by measuring the distance between the

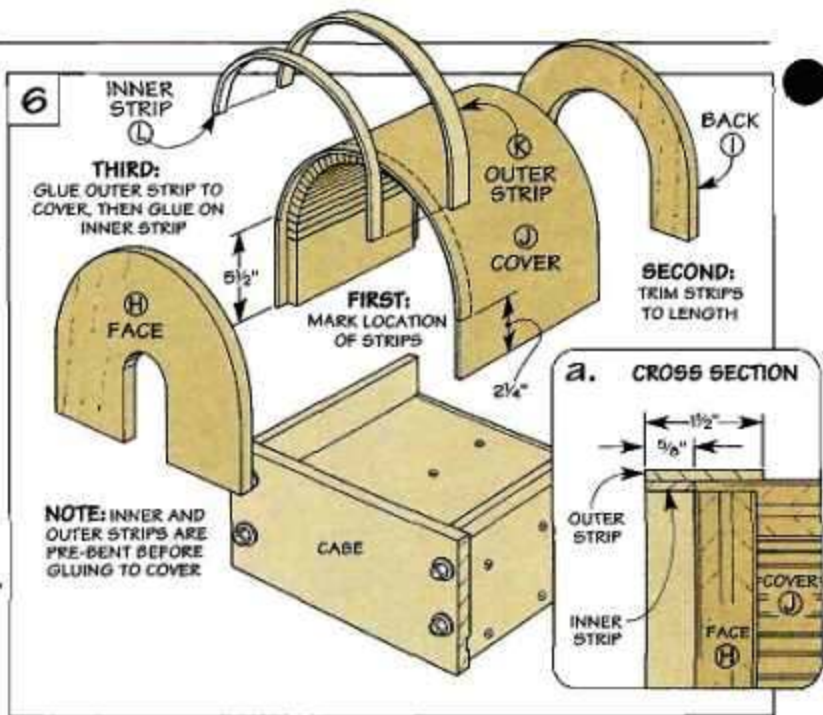

sides of the case and subtracting 1/4" for clearance (12 1/4").

The next step is to lay out the top cover to fit between the sides, see Fig. 6. The top is barrel-shaped to fit over the motor and sanding disk. To get a good fit when the top cover is glued on later, it's important that these top curves are cut identical.

To do this, I started by laying out and cutting the curve on one piece, see Drawings above. Then I used this as a template to shape the other piece.

This is just a matter of trim-

ming the other blank to rough size, then using a flush trim bit in a router, see margin tip at left.

Once you've shaped both pieces, all that's left is to lay out and cut the curved opening in each piece. The face (H) has a small opening for the motor shaft. And the back (I) has a large opening to allow air to flow over the motor, see Drawings above.

**COVER.** With the back and face complete, the next step is to cut the top cover (J) from 3/4"-thick plywood, see Fig. 7. It's 11 1/4"-wide and cut extra-long (27").

Now, cut 3/4"-wide rabbets along the length of the cover. These rabbets allow the face and back to fit flush with the edges of the top cover.

**KERFS.** Next, to get the plywood to bend easily, I cut a series of uniformly-spaced saw kerfs, see Fig. 7. To cut the kerfs, I use a simple jig that attaches to the miter gauge on my table saw, see box on opposite page.

Note: Since the sides of the cover are straight near the bottom, you'll only need to kerf to within 3 1/2" of each end, see Fig. 7.

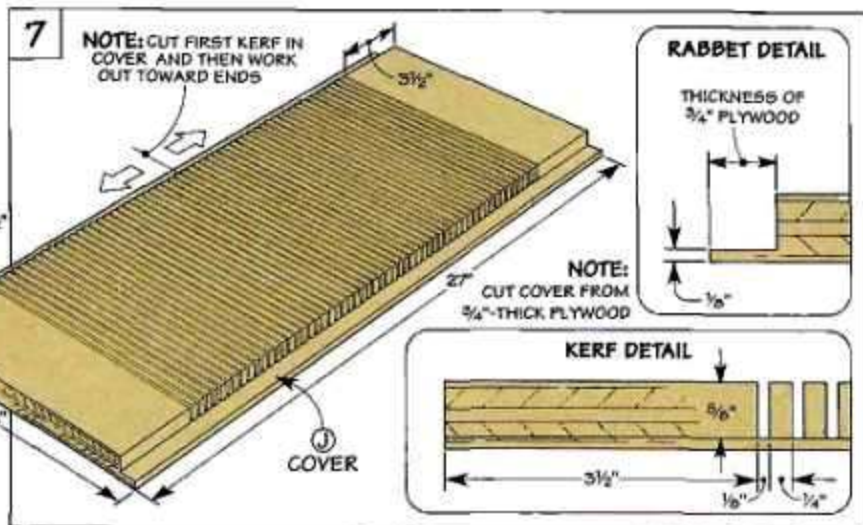

**ASSEMBLY.** At this point the cover can be glued to the face and back. But instead of trying to glue, bend, and clamp these pieces together all at once, I used a two-step process.

First, to keep the curved face and back aligned with the edges of the top, I glued the *flat* section of each piece flush with one end of the cover, see Fig. 8.

Then after the glue had dried, I used band clamps to pull the cover tight over the face and back. But there's a problem here. Since the cover was cut extra-long, it extends past the ends of the face and back.

To prevent the band clamps from crushing the edge of the plywood, I temporarily tacked cleats to the bottom of the face and back, see Fig. 9.

With the cleats in place, wrap the band clamps around the cover and cinch them down. Then when the glue is dry, trim the end of the cover flush with a hand saw.

**TOP STRIPS.** To complete the top, I added a pair of thin hardwood strips to the front edge of the cover, refer to Figs. 6 and 6a. The *outer* (K) and *inner strips* (L) cover the exposed plywood edge and help direct sawdust to the vacuum port.

These strips are cut extra-long

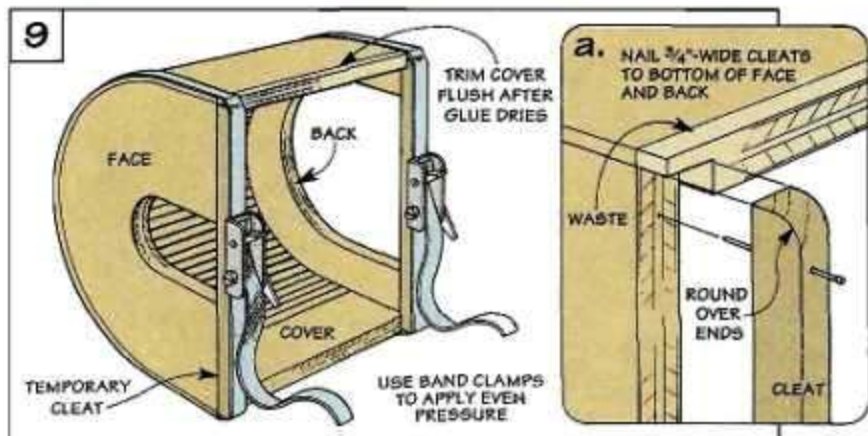
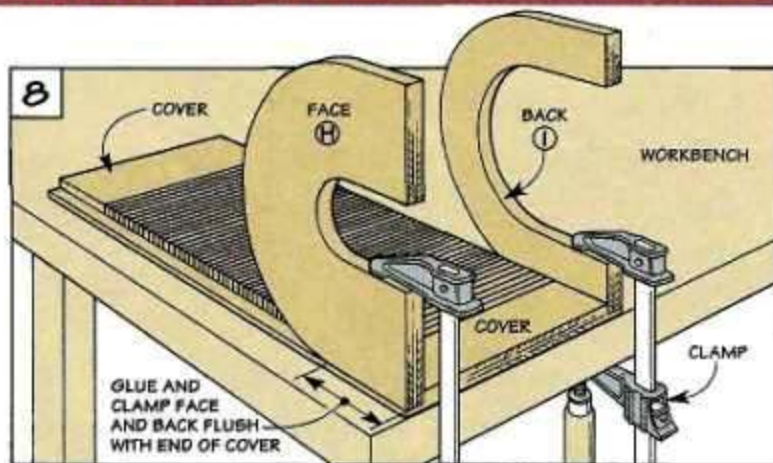

(27") and then trimmed to exact length later. To get the strips to match the curve of the top, I prebent them. This can be done by first soaking them in water for an hour. Then clamp them around the top and let them dry.

While they were drying, I

marked the location of each end on the cover, refer to Fig. 6. After the strips are dry, set them on the cover and transfer the marks.

Finally, cut the strips to length and glue them in place. At this point you can set the cover aside. It's attached to the case later.

## Kerfing Jig

To cut kerfs in the top cover, I made this L-shaped jig, see photo. It attaches to the miter gauge on my table saw.

The bottom of the "L" fits under the rabbet in the cover and holds an indexing pin. This pin (just a screw with the head cut off) automatically positions the cover to cut evenly spaced kerfs.

The trick to using this jig is to start kerfing in the center and work your way out towards the ends. To do this, first cut a kerf in the center of the cover. Then place the cover on the jig

so the kerf you just cut fits over the indexing pin. Now make a pass.

Continue kerfing like this to within 3 1/2" of the end. Then flip the cover and kerf the other end.

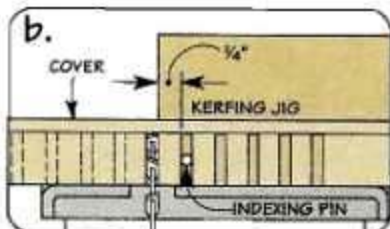
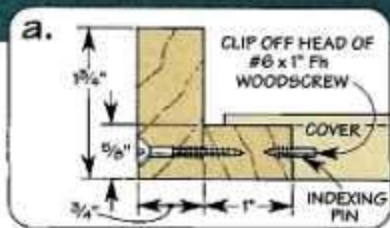
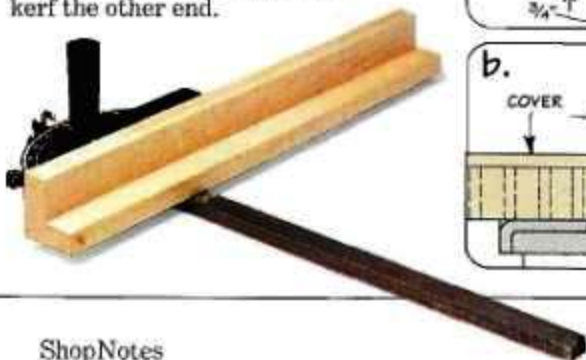

# Adjustable Table

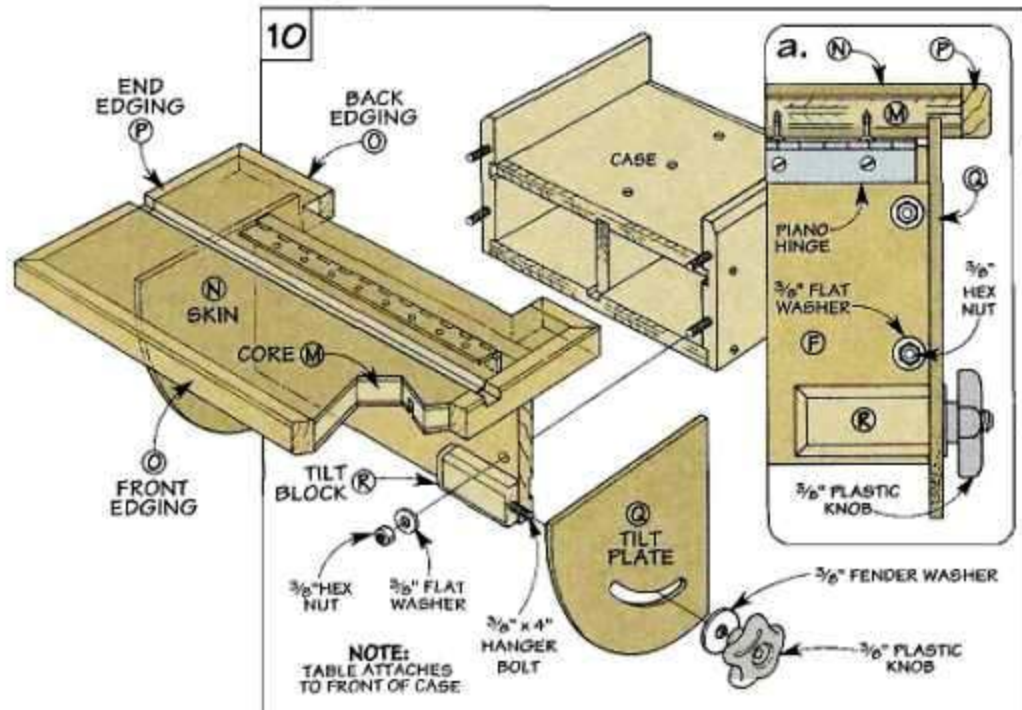

With the top cover finished, work can begin on the adjustable table, see Fig. 10. The table provides a large, flat work surface for sanding. And it can be tilted for sanding at an angle.

**TABLE.** The table is made up of a plywood and Masonite "sandwich" that's edged with hard-

wood, see Fig. 11. I started by cutting a  $\frac{3}{4}$ "-thick plywood core (M) to size, see Fig. 11. Then, cut two  $\frac{1}{4}$ "-thick Masonite skins (N) slightly oversize and glued them to the core, see Fig. 11.

To get the edges flush, I used a flush trim bit in a router, refer to the margin tip on page 20.

Before adding the edging, I cut two grooves in the bottom of the table, see Fig. 11. These grooves are  $\frac{1}{2}$ "-deep, and they're cut to match the thickness of the tilt plates added later ( $\frac{1}{4}$ "). The distance between these grooves is the same as the length of the case front ( $14\frac{3}{4}$ ").

**EDGING.** To cover and protect the edges of the table, I cut *front, back, and end edging* (O,P) to fit and glued them in place, see Fig. 11. Then I routed an  $\frac{1}{8}$ "-wide chamfer on the top and bottom edges.

**MITER GAUGE.** Next, to provide better control when sanding miters and small pieces, I cut a groove in the table top for a miter gauge. Cut the groove centered on the width of the table top to fit your miter gauge, see Fig. 11. (I used the miter gauge from my table saw.)

**CUT NOTCH.** Also, I wanted as much support as possible when sanding near the edge of the disk. So I cut a notch on the *back edge*. This way the table "wraps" around the case, see Figs. 10 and 11.

To do this, cut a 2"-wide x 13"-long notch centered between the grooves for the tilt plates.

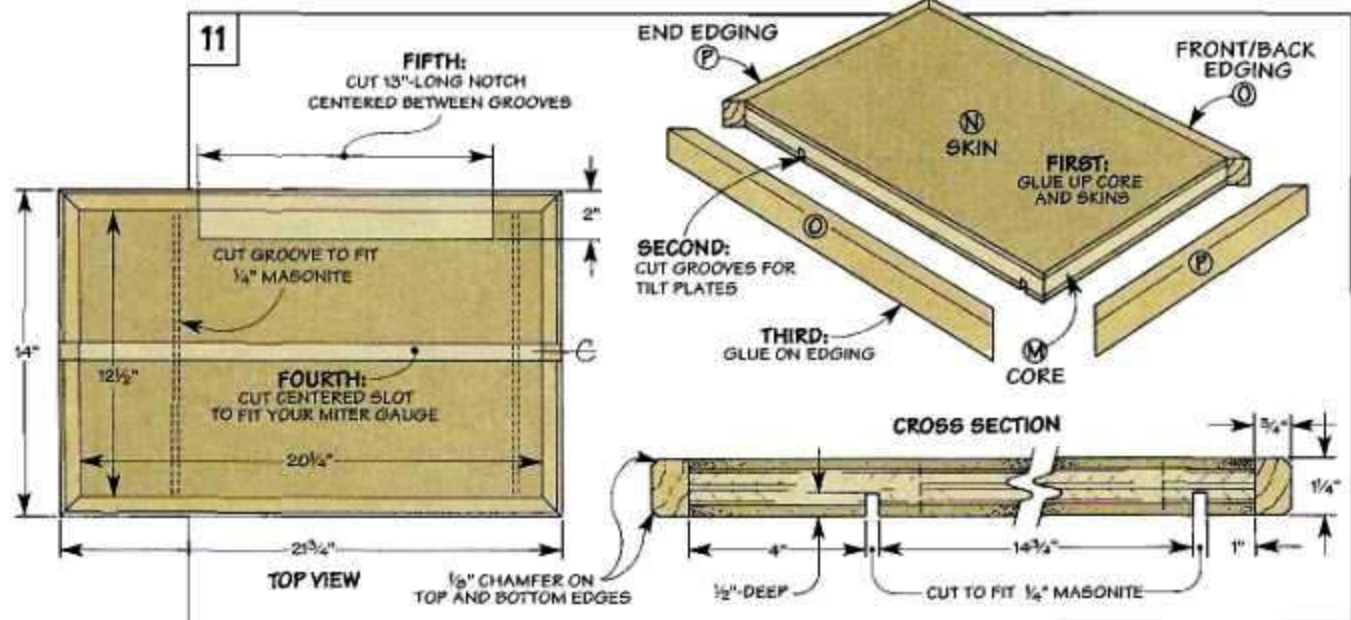

**TILT PLATE DIMENSIONS**

(TWO PIECES, 1/4"-THICK MASONITE)

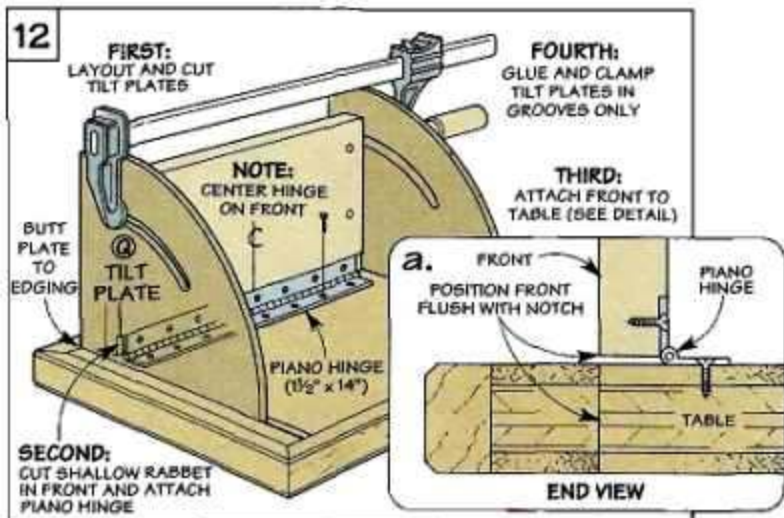
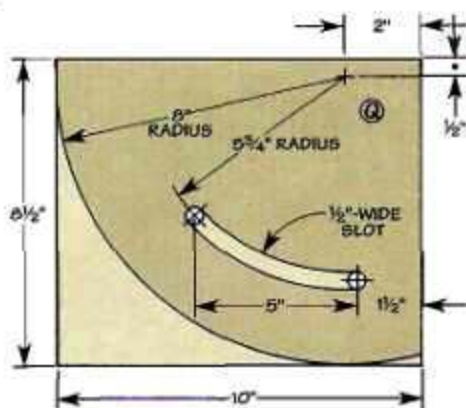

**TILT PLATES.** To allow the table to be angled for sanding, two *tilt plates* (Q) made from 1/4" Masonite fit into the grooves you cut earlier in the table, see Fig. 12.

To make identical plates, I carpet-taped two pieces of 1/4" Masonite together and laid out the curves. Then I cut out the shape with a band saw (or you could use a sabre saw) and sanded the edges smooth.

Next, curved slots are cut in the plates, see Fig. 12. These are used later to lock the table at different angles. To cut the slots, I drilled a hole at each end of the slot and then removed the waste with a sabre saw.

Once the slots are cut, the tilt plates can be attached to the table. But first, place the table face down on a bench. Then to keep the plates square to the table, attach the front (F) of the case to the table with a piano hinge, see Fig. 12. (You'll need to remove the front from the case to do this.)

To align the hinge, I use a simple trick, see margin tip at right. Then after screwing the hinge to the table, I glued and clamped the tilt plates in the grooves using the front (F) to square them up, see Fig. 12.

**TILT BLOCKS.** Finally, to lock the table in place, I added a *tilt block* (R) to each end of the front

(F), see Figs. 10 and 13. Holes drilled in the blocks accept 3/8" hanger bolts that pass through the tilt plates, see Fig. 14.

The unusual thing here is the hanger bolts are installed *before* the tilt blocks are attached. This allows you to position (and glue) the tilt blocks to the front (F) with the bolts centered in the slots, see Fig. 14a. This way the plates won't bind on the bolts when the table is tilted.

Plastic knobs thread onto the ends of the hanger bolts and pinch the tilt plates against the blocks to lock them in place. Once the knobs are in place, re-attach the front (and table) to the case.



It's easy to install a piano hinge when you cut a shallow "alignment" rabbet for it to sit in.

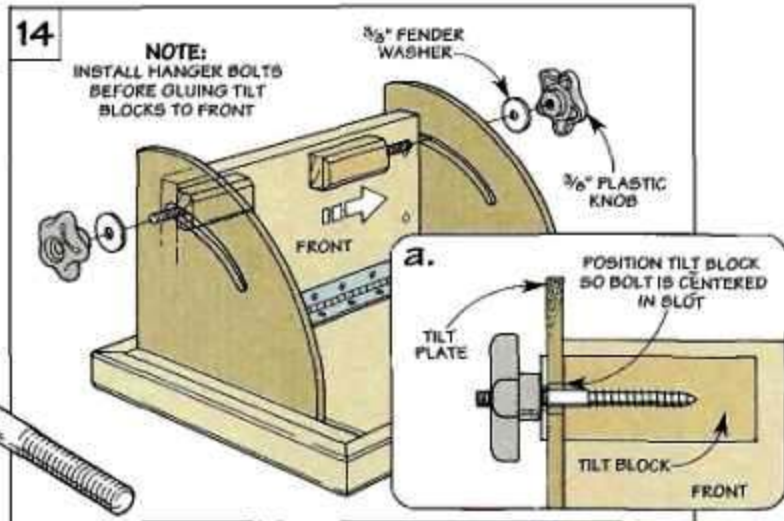
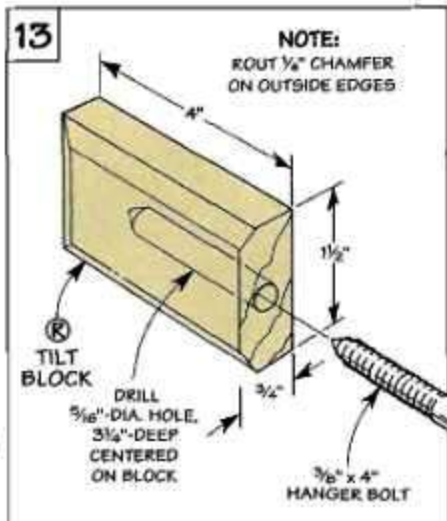

# Assembly

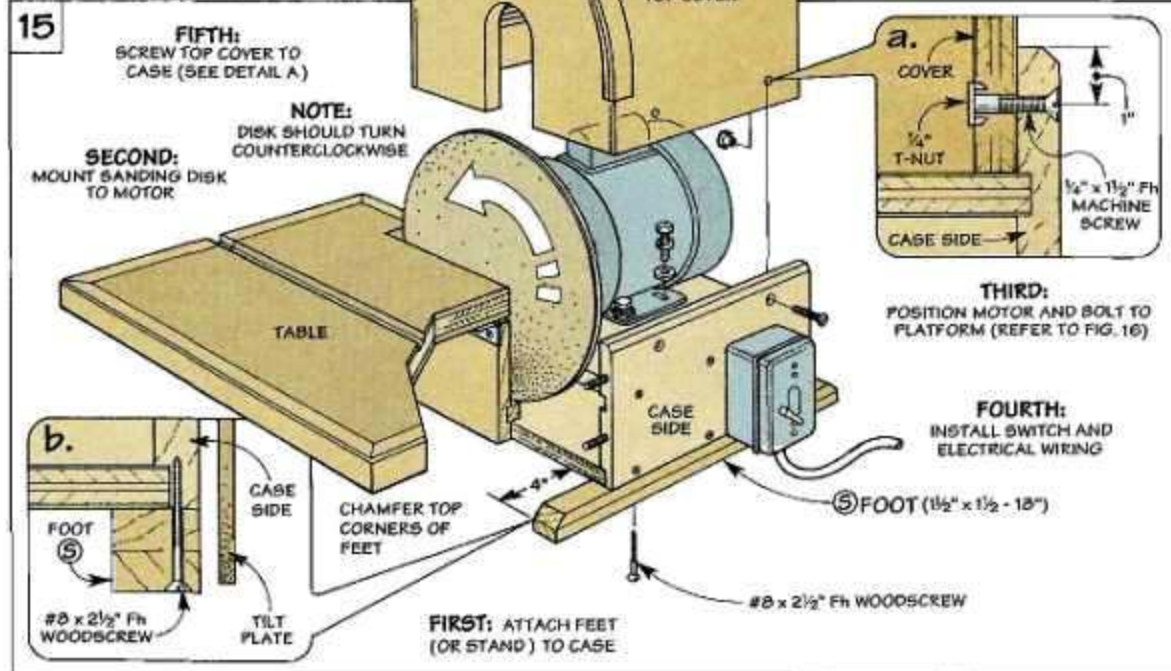

The disk sander can be used on top of a workbench, or it can be mounted to a stand. (For more on the stand, see page 25.) If you're going to use it on your bench, you'll need to screw a pair of feet (S) to the case so you can clamp the sander in place, see Fig. 15.

**MOUNT MOTOR.** After attaching the feet (or stand), the next step is to locate the holes for mounting the motor. The size (horsepower) of the motor can vary. The important thing is to

make sure that the direction and speed are correct.

The motor should turn counterclockwise and run at 1725 RPM. This keeps the disk from spinning too fast and reduces the chance of burning a workpiece.

To position the motor on the platform, you'll first need to attach the sanding disk. It mounts directly to the 5/8" shaft of the motor and is locked in place with a set screw, see Fig. 16.

With the disk in place, center

the motor on the platform (C) from side to side. Then slide it forward so there's about 1/8" of clearance between the sanding disk and the notch in the adjustable table, see Fig. 16.

Now you can drill shank holes centered in the slots in the motor's base. Then secure the motor with hex bolts, washers, lock washers, and T-nuts.

**WIRING.** Once the motor is in place, the next step is to wire it up to a switch and an electrical cord. (Note: I used a sealed switch box to keep out sawdust.)

**Safety Note:** Wiring a motor can be a bit confusing. So if you don't feel comfortable doing this, it's a good idea to consult a licensed electrician.

**COVER.** All that's left to complete the disk sander is to add the cover, see Fig. 15. It's held in place with machine screws and T-nuts, see Fig. 15a. Position the cover so the back edge is flush with the rear of the case. Then locate and drill four countersunk holes, insert the T-nuts, and screw on the cover.

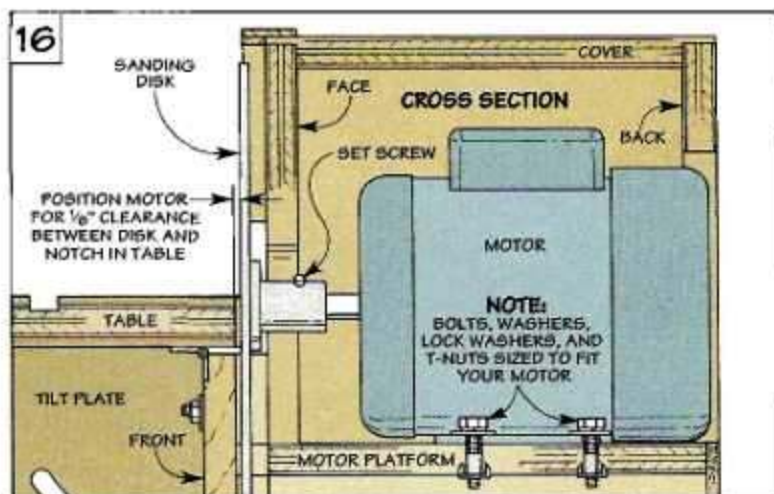



# Disk Sander Stand

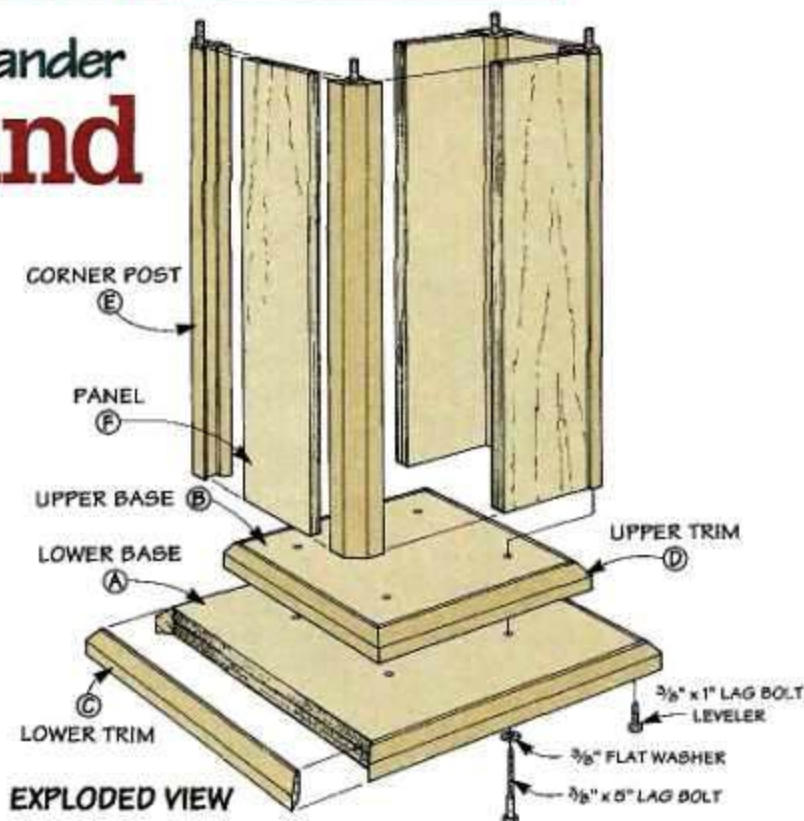

The Disk Sander shown on page 16 can be clamped directly to a bench in the shop. Or you can build the stand shown here and turn the sander into a stationary power tool.

The stand consists of two main parts: a wide base that provides a stable foundation, and a column that raises the sander up to a comfortable working height.

**THE BASE.** I started by making

the base, see Fig. 1. It's made up of a lower and an upper section. The construction of each section is the same. They're just two plywood squares that are glued and screwed together. The only difference is their size. The *lower base (A)* is 20½" square. And the *upper base (B)* is 14½" square.

**TRIM.** To hide the edges of the plywood, I wrapped each section with a band of ¾"-thick hard-

wood edging. The *lower (C)* and *upper (D)* trim pieces are cut to match the height of each base (1½"). To relieve the sharp edges, a ⅝" chamfer is cut on the top of each piece. Then the trim pieces are cut and glued in place, see Fig. 1.

**ASSEMBLY.** To complete the base, center the upper base on the lower base and apply clamps. Then screw them together up from the bottom, see Fig. 1a.

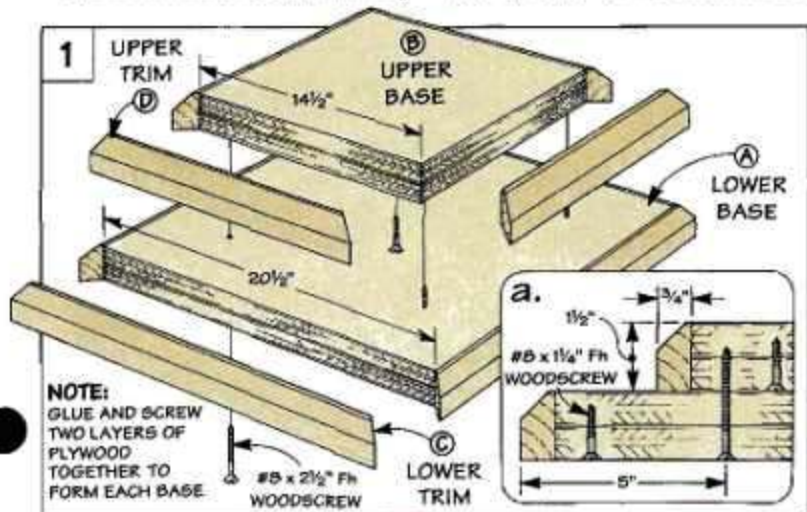

## Materials & Hardware

- A Lower Base Pcs. (2) 20½ x 20½ - ¾ ply
- B Upper Base Pcs. (2) 14½ x 14½ - ¾ ply
- C Lower Trim Pcs. (4) ¾ x 1½ - 22
- D Upper Trim Pcs. (4) ¾ x 1½ - 16
- E Corner Posts (4) 1½ x 1½ - 25
- F Panels (4) 7¾ x 25 - ¾ ply
- (4) ⅜" x 4" Hanger Bolts
- (4) ⅜" Hex Nuts
- (B) ⅜" Flat Washers
- (4) ⅜" x 5" Lag Bolts
- (4) ⅜" x 1" Lag Bolts
- (2B) #8 x 1¼" Fh Woodscrews
- (4) #8 x 2½" Fh Woodscrews

## Column

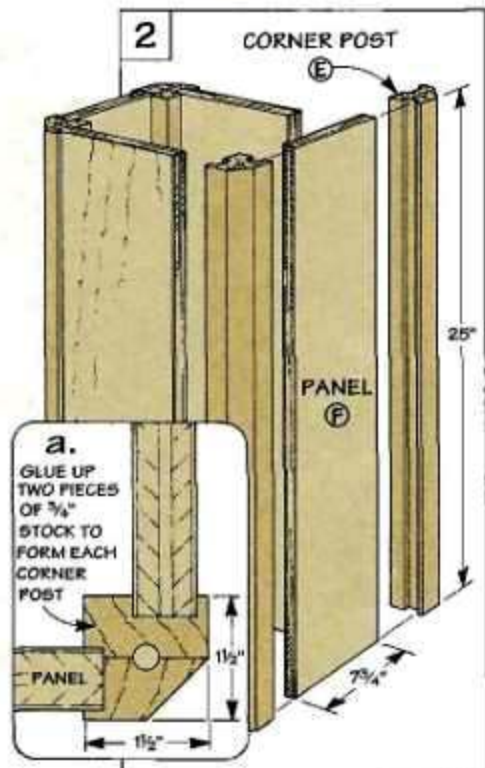

After the base is complete, work can begin on the column. It's basically a hollow tube made up of hardwood corner posts and plywood panels, see Fig. 2. The advantage to building a hollow column is that after it's assembled you can fill it with sand or bricks to help anchor the stand and deaden vibration.

**CORNER POSTS.** I started by making the four *corner posts* (E), see Fig. 2. Each post is glued up from two pieces of  $\frac{3}{4}$ "-thick hardwood. (I used maple.)

Then to accept the plywood panels that are added later,  $\frac{1}{4}$ "-deep grooves are cut in each post, see Figs. 3 and 3a. Next, I cut a  $\frac{3}{4}$ "-wide chamfer on the outside corners, refer to Figs. 2a and 4.

To complete the posts, I drilled  $\frac{5}{16}$ "-dia. pilot holes in each end, see Fig. 4. These holes are for a set of bolts that are added later to attach the base and disk sander to the column. (See page 18 for a shop-made jig that makes drilling

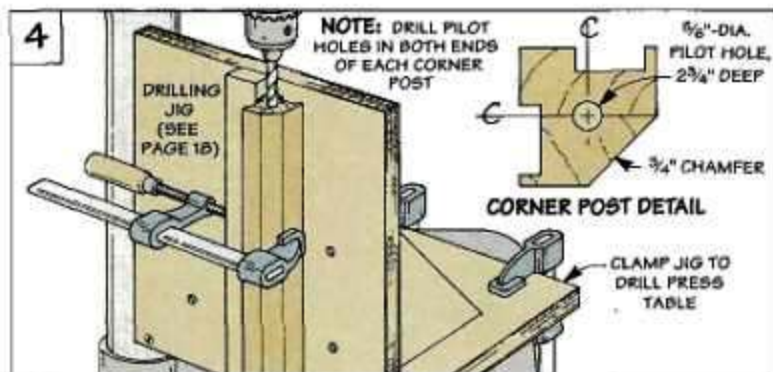
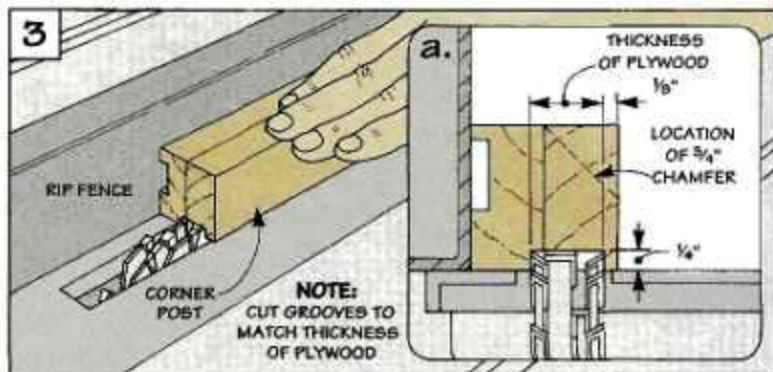

these holes easy.)

**PANELS.** After completing the corner posts, the next step is to cut four *panels* (F) from  $\frac{3}{4}$ "-thick plywood, refer to Fig. 2. These panels form the walls of the column and fit into the grooves you cut in the corner posts.

Once the panels are cut to size, you can begin assembling the column. Instead of trying to glue and clamp up everything at once, I did this in two steps.

First, I glued up corner posts and panels to form two sections, see Fig. 5. The important thing here is that the panels end up flush with the ends of the posts.

Then when these sections were dry, I applied glue, assembled the column, and held it together with band clamps, see Fig. 6.

**FINAL ASSEMBLY**

Once the column is complete, it can be attached to the base with

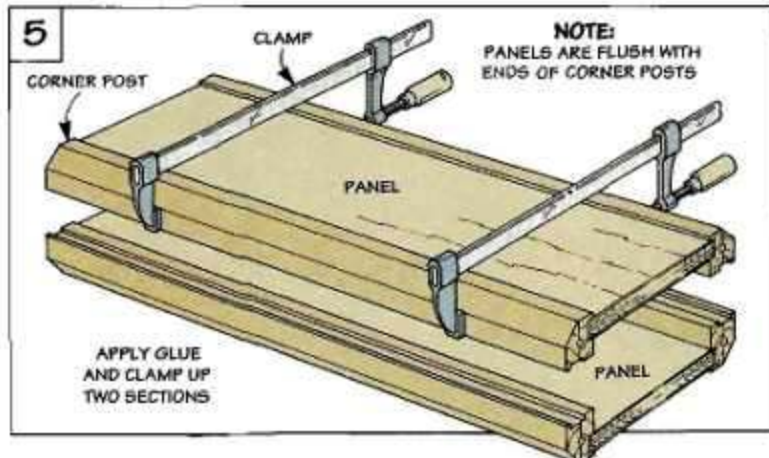

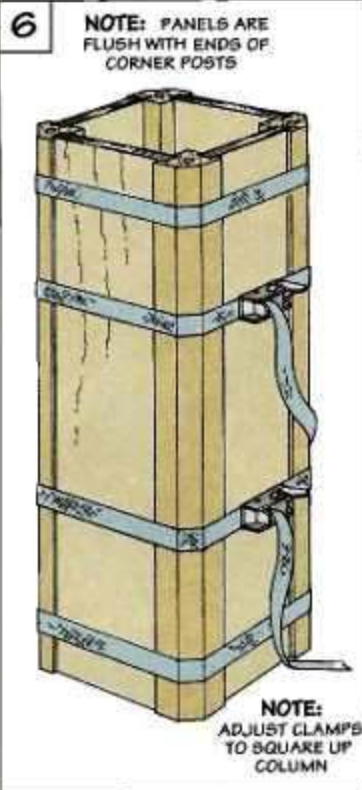

lag bolts. You've already drilled the holes in the column corner posts for the bolts. The tricky part is transferring the locations of the holes to the base.

To solve this, I used dowel centers, see Fig. 7. First, insert the dowel centers into the bottom of the column. Then center the column on the base and press down.

Once you've marked the hole locations on the base, the next step is to drill the holes for the lag bolts. The only problem is these holes need to be counterbored — from the *bottom*, see Fig. 8a.

To transfer the hole locations to the bottom, I drilled a 1/4"-dia. reference hole through all four layers of the base. Then it's just a matter of counterboring and enlarging the hole to 3/8".

After the counterbored shank holes are drilled in the base, bolt the base to the column with 3/8" lag bolts and washers, see Fig. 8.

To complete the stand, I added four lag bolts to the bottom cor-

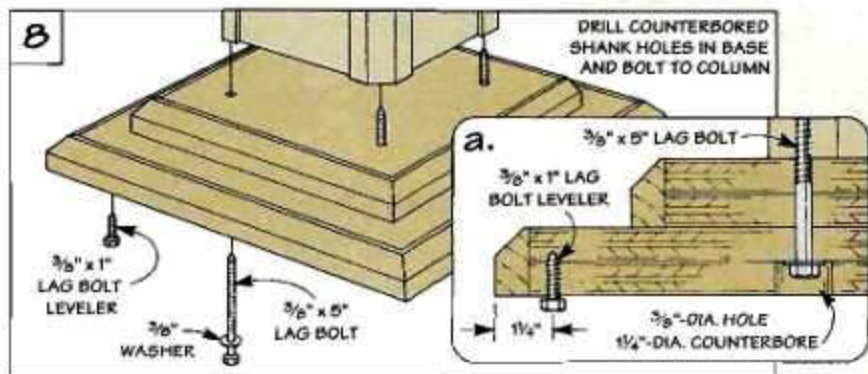
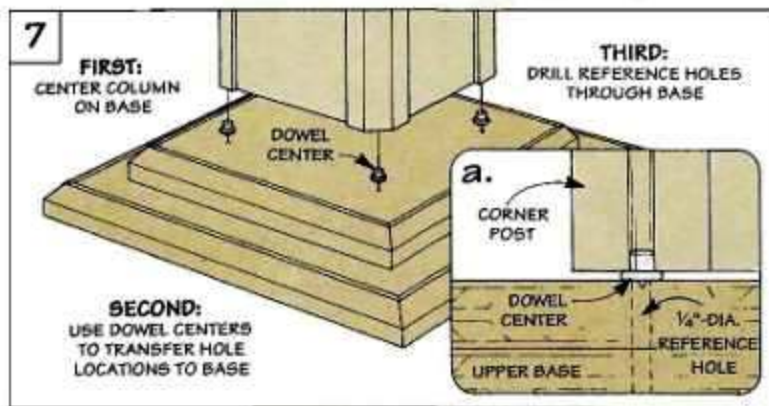

ners of the base, see Fig. 8a. These bolts serve as simple levelers. This way you can adjust the bolts to compensate for any variations in your workshop floor.

**ATTACH THE SANDER.** With the stand complete, all that's left is to attach the disk sander to the column. Start by removing the front (F) from the case.

Then I used dowel centers to

transfer the hole locations in the corner posts to the bottom of the case, see Fig. 9. **NOTE:** The case is centered on the column from side to side and front to back.

Finally, drill four 3/8"-dia. holes in the bottom of the case, and attach the case to the column with 3/8" hanger bolts, washers, and hex nuts. (Refer to page 24 to complete the sander.)

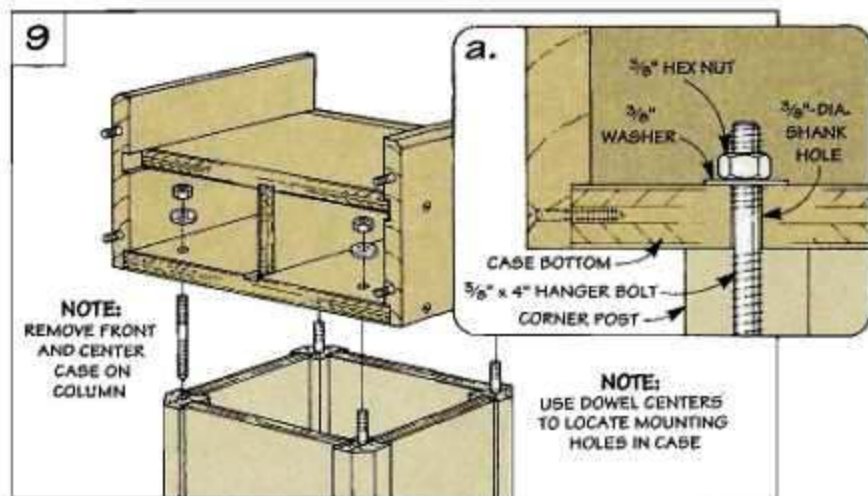

# Shop Solutions

## Knock-Down Sawhorse



■ Like many woodworkers, I have an occasional need for a sawhorse. But the problem is, my shop doesn't have a lot of extra storage space for one — let alone two sawhorses. To get around this, I made a pair of sawhorses that knock down for storage and take up very little space.

Each sawhorse consists of four identical legs and a stretcher, see Drawing. I started by cutting the angled legs.

The legs overlap at the top to form an inverted "V." A tenon is cut at each end of the stretcher, see Detail a. And the tenons pass through mortises cut in each leg, see Detail b.

I used a keyed mortise and tenon joint (no glue or metal fasteners required) to hold the stretcher and the legs together, see photo above. This joint also

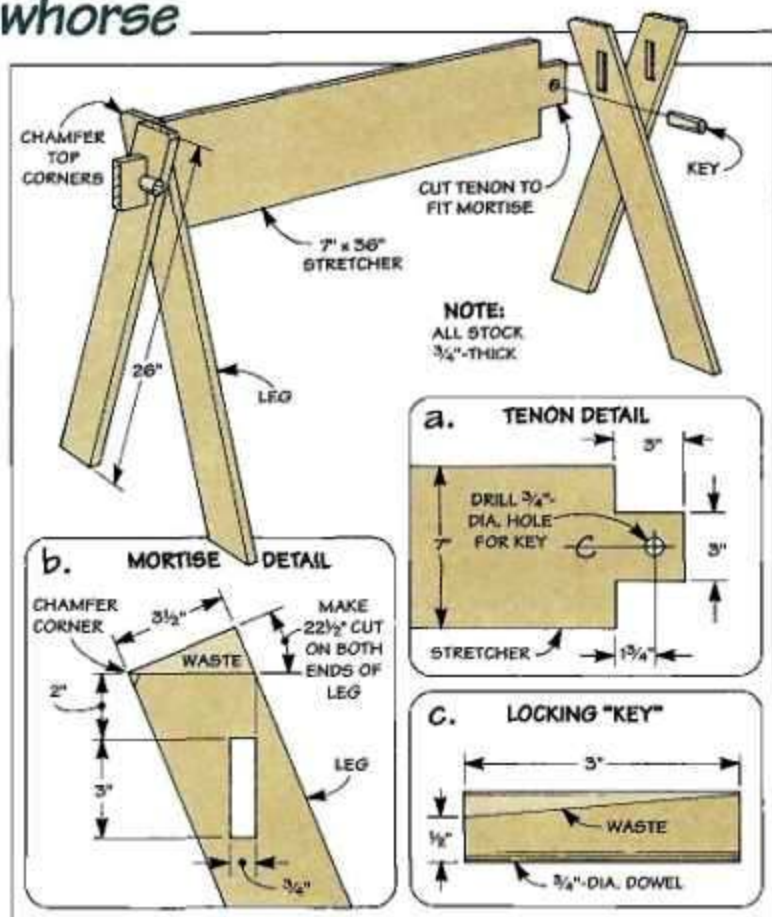

allows me to knock down and re-assemble the sawhorse quickly.

The "key" that's used to pin the joint is made from a 3/4"-dia. hardwood dowel, see Detail c. I ta-

pered the key slightly so the joint would draw in tight when it's wedged in place with a hammer.

*Milo C. Dvorak  
Garland, Texas*

## Alternative Edge Vise

■ I read with interest the pipe clamp edge vise tip published in *ShopNotes* No. 10. I also don't have a vise on my bench. To clamp a board on edge, I use two hand screws and two bar clamps, see Drawing. The hand screws hold the board on edge. And the bar clamps prevent it from sliding.

*William Rubin  
Bethesda, Maryland*

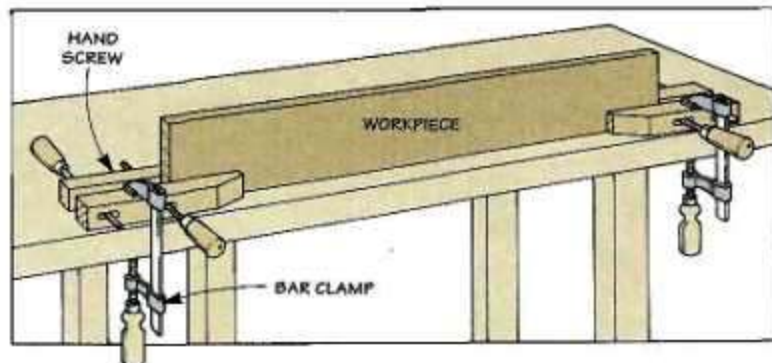

## Clamp Pads

■ When gluing up panels, iron pipe clamps have a tendency to stain the wood. And if the clamping pressure isn't centered on the edge of the piece, the panel can cup. To protect the panel and center the clamping pressure, I place dowels and small pads between the clamp and the panel.

But rather than fumble around for small dowels and pads during glue up, I nail the pads to the dowels, see Drawing. This way, when the pad is in place, the dowel stays put.

*James L. Schenfield  
Dayton, Ohio*

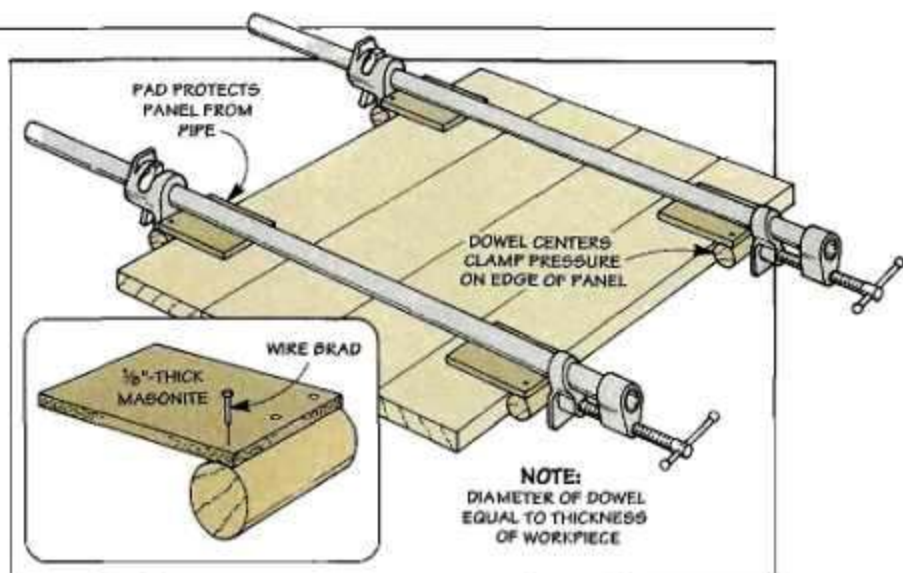

## Allen Wrench Organizer

■ Many adjustments on my power tools require an Allen wrench. But when I need a particular wrench, it seems like I have to dig for one. To avoid this, I made a wall mounted organizer that lets me quickly select the correct wrench, see Drawing.

The organizer is cut from a scrap piece of hardwood. A series of holes, spaced 1" apart, are drilled to fit each wrench. To keep the wrenches facing forward, I cut a slot centered over each hole.

Then I mounted the organizer to the wall with two screws.

*Stephen J. Sabo  
Cleveland, Ohio*

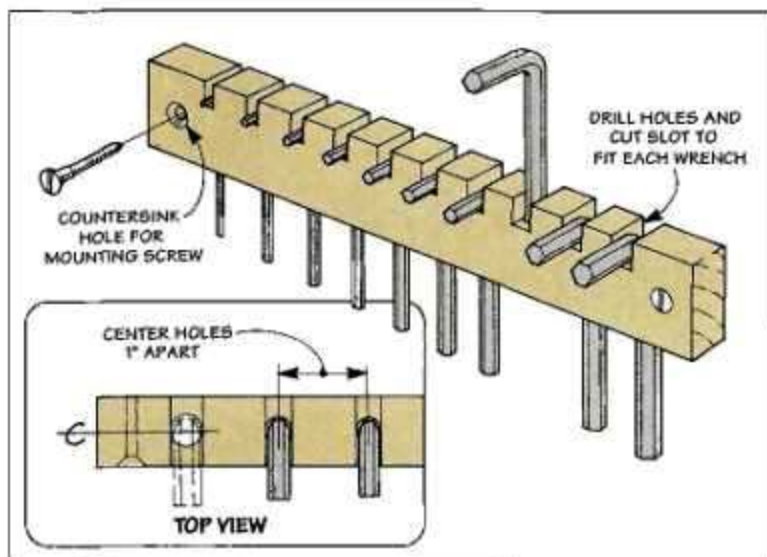

## Quick Tips

■ Occasionally, I cut threads in metal with a tap. But guiding the tap in straight by hand can be difficult. To solve this, I guide the tap with the drill press.

With the tap in the chuck, pull down on the arm of the drill press (power off). Then turn the chuck by hand to cut the threads.

*Felix Johnson  
Waterbury, Connecticut*

■ I like to use a leather strop after sharpening my chisels. To avoid hunting around the shop for the strop, I glued it to the top of the box that I made for storing my combination waterstone.

This way, everything required to sharpen a chisel is together when I need it.

*William W. Price  
Garfield Heights, Ohio*

### Send in Your Solutions

If you'd like to share your original solutions to problems you've faced, send them to: *ShopNotes*, Attn: Shop Solutions, 2200 Grand Avenue, Des Moines, IA 50312. (Or if it's easier, FAX them to us at: 515-282-6741.)

We'll pay up to \$200 depending on the published length. Please include a daytime phone number so we can call you if we have questions.

# T-Nuts

*A simple T-nut and ordinary fasteners create a strong knock-down fitting.*

**T**here's something to be said for simplicity. Especially when it comes to a piece of "knock-down" hardware.

Take T-nuts for example. They allow you to use an ordinary machine screw or bolt to assemble a project. And unlike some of the more specialized knock-down fittings, they're available at most hardware stores. (For other sources, see next page.)

**BARREL.** What makes a T-nut work is the threads are housed in a barrel that fits in a hole drilled in the workpiece, see Drawing below. As a rule of thumb, the length of the barrel should be slightly shorter than the thickness of the workpiece.

To make it easy to install, the barrels on some T-nuts are tapered. The small end drops into a hole that's sized to fit the large end of the barrel. When you "press fit" the nut into place, the barrel automatically centers itself in the hole.

**PERMANENT THREADS.** With the nut installed, the threads are more or less a "permanent"

part of the workpiece. They won't strip out like those cut by an ordinary woodscrew.

And unlike a hex nut, a T-nut won't fall off and get lost when you take a project apart.

## THREE TYPES

There's a variety of T-nuts available. The three most common types are pronged, round base, and slab base, see Drawing below.

**PRONGED.** When working with softwood or plywood, I often use a pronged T-nut. The prongs act like small knives that bite into the wood when you drive the nut in with a hammer. This keeps the nut from turning when tightening a screw or bolt into the barrel.

But a pronged nut isn't always the best solution. The prongs can split a narrow or thin piece of hardwood. And it's hard to drive them into materials like Masonite. In this case, I use a different style.

**ROUND BASE.** Instead of using prongs, a round base T-nut has holes in the flange. These holes

provide a couple of different options for securing the nut.

The most common way is to drill pilot holes in the workpiece, and attach the nut with brads or small screws. Or you can epoxy the nut in a shallow counterbore. This creates a "pocket" so when the epoxy oozes through the holes, the nut is locked in place.

**SLAB BASE.** A third kind of T-nut has a slab or rectangular base. Like a round base nut, this type has mounting holes. But I've found it's handy when I don't want the nut to be permanently attached to the workpiece.

The trick is to keep the nut from spinning when you tighten the screw — especially if it's not easily accessible with a wrench. To do this, you can install a slab base T-nut in a shallow groove (or dado). This way, when you thread in the screw, the "corners" of the base hit the sides of the groove and prevent the nut from turning.

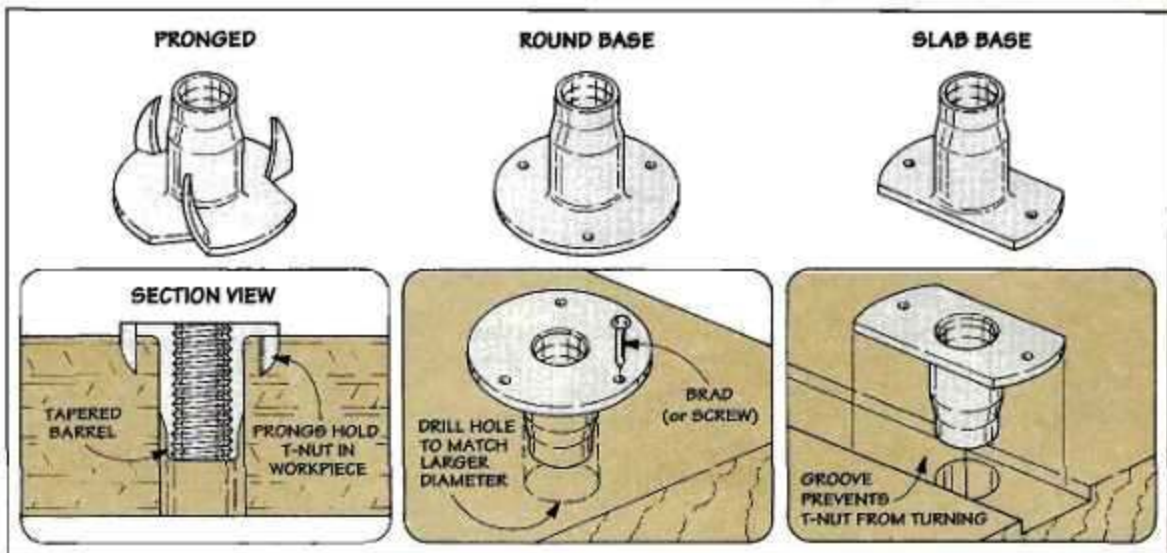

# Sources

*ShopNotes Project Supplies* is offering some of the hardware and supplies needed for the projects in this issue.

We've also put together a list of other mail order sources that have the same or similar hardware and supplies.

## FOOT PEDAL

The Drill Press Foot Pedal (shown on page 8) lets you use both of your hands to accurately position a workpiece on the table for drilling. Then it's just a matter of stepping on the pedal to drill the hole.

The secret to this jig is a length of cable (similar to the brake cable on a bicycle) that runs between the foot pedal and the quill feed on your drill press. It transfers the movement of the foot pedal to the drill bit.

*ShopNotes Project Supplies* is offering a hardware kit for the Foot Pedal. The kit includes all the hardware necessary to build the foot pedal for your drill press (including approximately 14 feet of cable). All that you need to supply is the hardwood.

**S12-6812-100** Foot Pedal  
Hardware Kit .....\$19.95

## DADO BLADES

The article on dado blades (shown on page 10) provides a look at the various blades currently available. Traditional stack dado sets and wobble-type blades can be found at many local hardware stores and home centers.

The new blades (such as safety blades and twin wobble blades) can be ordered from some of the mail-order sources listed below.

To "sneak up" on a perfect cut, I often use plastic or metal shims with my stack dado set. They're available from some of the mail-order sources listed below.

## DISK SANDER

You can achieve professional quality results with the shop-made Disk Sander shown on page 16. It features a large, flat table that adjusts for angled sanding.

There's even a built-in vacuum port for dust collection. The unique curved top also helps to direct sawdust to the vacuum port for dust-free sanding.

*ShopNotes Project Supplies* is offering a hardware kit for the Disk Sander. (It also includes all the hardware necessary to build

the Stand shown on page 25.)

Note: The kit does *not* include the motor, switch or electrical cord. Or the hex bolts, washers, lock washers, and T-nuts to mount the motor to the case (these are sized to fit your motor).

To build the disk sander, all you need is 3/4"-thick hardwood and plywood, and 1/4"-thick Masonite. And a 12" metal sanding disk. The sanding disk can be ordered from Woodworking Unlimited (for about \$30), see below. (Twelve inch diameter sandpaper is available from the sources listed below.)

**S12-6812-200** Disk Sander  
Hardware Kit ..... \$12.95

## KNOBS

In addition to the hardware kits described above, some of the plastic knobs we use often in our kits are available separately. *ShopNotes Project Supplies* is offering them in packages of four.

Note: The Straight-Edge Cutting Guide (shown on page 4) requires one each of the 5/16" wing nut and 5/16" T-knob.

**7016-120** Plastic Wing Nuts (4)  
5/16" -18 ..... \$7.95  
**7016-210** Plastic T-Knobs (4)  
5/16" -18 ..... \$7.95

## MAIL ORDER SOURCES

Similar hardware and supplies may be found in the following catalogs. Please call each company for a catalog or for ordering information.

**Constantine's**  
800-223-8087  
Dado Blades, T-Nuts

**Garrett Wade**  
800-221-2042  
Plastic Shims

**Highland Hardware**  
800-537-7820  
Safety Dado Blades

**Sanding Catalogue**  
800-228-0000  
12"-dia. Sandpaper

**Sears**  
800-277-7414  
Twin Wobble  
Dado Blades

**Trendlines**  
800-767-9999  
T-Nuts, Twin  
Dado Blades

**Woodcraft**  
800-225-1153  
Dado Blades

**The Woodsmith Store**  
515-255-8979  
T-Nuts, Dado Blades,  
Plastic Shims

**Woodworker's Supply**  
800-646-0292  
Safety Dado Blades,  
Brass Shims, T-Nuts

**Woodworking Unlimited**  
800-543-7586  
12"-dia. Sanding Disk  
and Sandpaper

## ORDER INFORMATION

### BY MAIL

To order by mail, use the order form that comes with the current issue. The order form includes information on handling and shipping charges, and sales tax.

If the mail order form is not available, please call the toll free number at the right for more information on specific charges and any applicable sales tax.

### BY PHONE

For fastest service use our Toll Free order line. Open Monday through Friday, 7:00 AM to 7:00 PM Central Time.

Before calling, have your VISA, MasterCard, or Discover Card ready.

**1-800-444-7527**

Note: Prices subject to change after January 1, 1994.



## Scenes From the Shop

*Although these vintage hand-held power tools may not be considered antiques, they're still classics. With their tough metal exteriors and heavy-duty construction,*

*some of the tools shown here have over forty years of "experience." Yet when pressed into service, these hard-working old friends can still get the job done.*