

TIPS • TOOLS • TECHNIQUES

# ShopNotes™

\$4.95

Issue 6

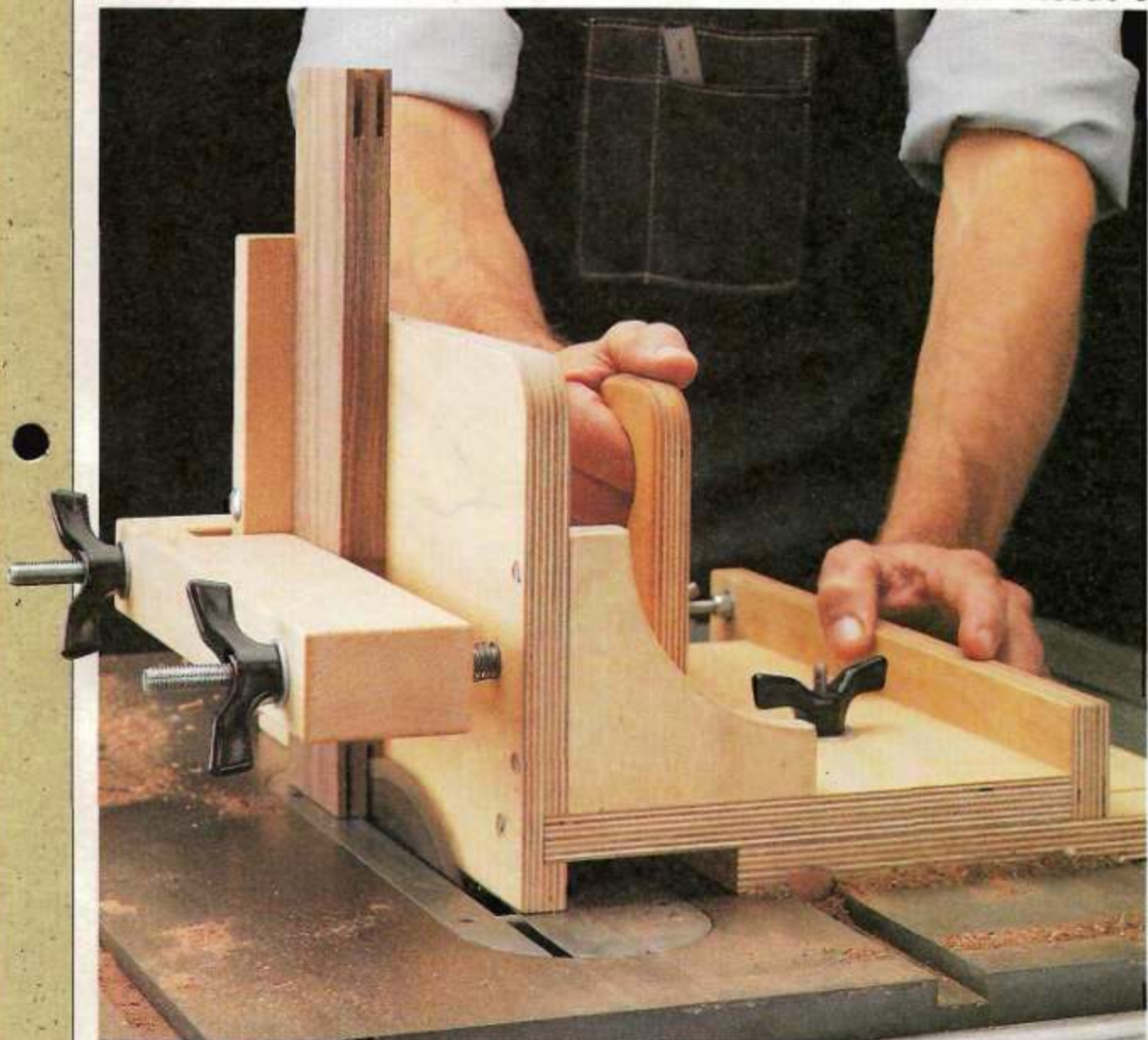

- Table Saw Tenoning Jig
- Tilting Drill Press Table
- Tips for Cutting Tenons
- Handy Shop-Built Clamps



# ShopNotes

Issue 6

November 1992

<b>EDITOR</b>	Donald B. Peschke
<b>EDITORIAL DIRECTOR</b>	Douglas L. Hicks
<b>MANAGING EDITOR</b>	Terry J. Strohman
<b>ASSOCIATE EDITOR</b>	Richard S. Peters
<b>ASSISTANT EDITOR</b>	Tim Robertson
<b>CREATIVE DIRECTOR</b>	Ted Kralicek
<b>ART DIRECTOR</b>	Cary Christensen
<b>ILLUSTRATORS</b>	Kurt Schultz Will Niskanen Roger Reiland Mark Higdon
<b>DESIGN DIRECTOR</b>	Ken Munkel
<b>DESIGNERS</b>	Jan Hale Svec Kent Welsh
<b>PHOTOGRAPHER</b>	Crayola England
<b>SHOP MANAGER</b>	Steve Curtis
<hr/>	
<b>CIRCULATION DIRECTOR</b>	Liz Bredeson
<b>SUBSCRIPTION MANAGER</b>	Phyllis Jessen
<b>CIRCULATION ANALYST</b>	Jim Woodson
<b>NEWSSTAND SALES</b>	Kent A. Buckton
<hr/>	
<b>CONTROLLER</b>	Paul E. Gray
<b>ACCOUNTING</b>	Linda O'Rourke
<b>BOOKKEEPING</b>	Julianne Spears
<b>NETWORK ADMIN.</b>	Douglas M. Lidster
<b>ADMINISTRATIVE ASSTS.</b>	Cheryl Scott Julia Fish
<b>RECEPTIONIST</b>	Jeanne Johnson
<b>BUILDING MAINTENANCE</b>	Ken Griffith
<hr/>	
<b>MARKETING DIRECTOR</b>	Robert Murry
<b>PROJ. SUPPLIES ART DIR.</b>	Cindy Jackson
<b>CUSTOMER SERVICE MGR.</b>	Laura McNelly
<b>PROJECT SUPPLIES</b>	Leslie Ann Gearhart Linda Jones
<b>TECHNICAL SUPPORT</b>	Jeff Janes
<b>SYSTEMS OPERATOR</b>	Linda Morrow
<b>RECEPTIONIST</b>	Keri Lee
<hr/>	
<b>CUSTOMER SERVICE</b>	
Jennie Enos (Supervisor), Joy Johnson, Sara Johnson, Ami Blanshan, Anna Cox, Jennifer Murphy, Chris Lo	
<hr/>	
<b>SHIPPING DEPARTMENT</b>	
Jerry Carson (Supr.), Gloria Sheehan, Ronald Long, Don McVey, Chuck Carlson	
<hr/>	
<small>ShopNotes (ISSN 1052-2008) is published bimonthly (January, March, May, July, September, November) by Woodsmith Corporation, 2200 Grand Ave., Des Moines, IA 50312. Printed in U.S.A. ShopNotes is a trademark of Woodsmith Corporation. ©Copyright 1992 by Woodsmith Corporation. All rights reserved. Subscriptions: Single Copy, \$4.95. One year subscription (6 issues), \$19.95. Two years (12 issues), \$35.95. Canada/Foreign, add \$4.00 per year. Second Class Postage Paid at Des Moines, IA and at additional offices. Postmaster: Send change of address to ShopNotes, Box 11204, Des Moines, IA 50310-1204 Subscription Questions? Call 1-800-333-5854, Sun to 5pm, Central Time, weekdays.</small>	

**I**nventive individuals. Put a group of woodworker's together and you're sure to come up with several ways to solve a problem. The same holds true for the way we design and build the projects for *ShopNotes*.

**DESIGN.** When we decide to build a particular project, a rough prototype is built in the shop. Then the artists, editors, designers, and the shop manager get together and review the completed prototype.

Everyone has a chance to ask questions and offer suggestions on how to make the project better. Then it's back to the shop to build another prototype, and the process starts all over again.

It takes a lot of time and can be frustrating, but in the end it makes a better project.

**TENONING JIG.** A good example of this is the Tenoning Jig featured in this issue. We went through at least four prototypes and countless modifications.

The end result is a tenoning jig with several unique features: a spring-loaded hold-down bar for securing the workpiece to the jig. An adjustable runner that fits in the miter gauge slot. And a unique stop system that lets you cut *both* cheeks of the tenon — without removing the workpiece from the jig.

**HARDWARE.** The selection and use of hardware is an important part of every project. Whenever possible we try to use *basic* hardware.

Wing nuts, carriage bolts, threaded rod, lock nuts, all of these items are readily available at local hardware stores or building centers.

The challenge is, coming up with ways to use everyday hardware to solve unique problems.

For instance, on the Drill Press Table (shown on page 4) we needed a way to hold the table in position. The solution was to use an ordinary coupling nut. The only modification was to drill a hole in it for a steel rod to pass through. Simple hardware — simple solution.

Sometimes the answer to a problem is right under your nose. We wanted a pad on the jaws of the Fast Action Clamp shown on page 14. I found the solution in my kitchen junk drawer — nylon furniture glides.

So what's the point to all of this? The point is: being a woodworker means being inventive. We try to provide you with *our* solution to a problem. But all of the projects can (and should) be modified to fit your needs.

**KNOBS.** I'd like to mention one more thing about hardware. We often use plastic knobs and wing nuts on the projects in *ShopNotes*.

For years I put up with little metal wing nuts and thumb screws that I couldn't tighten. The only solution was to make my own, see page 13 for an example of a shop-made wing nut.

Then, awhile back I came across a selection of plastic replacement knobs and wing nuts.

I was hooked. They're easy to grab onto, provide more leverage, and look better than any knob or wing nut I'd used before.

The problem has been finding them. So in this issue we're listing mail order sources for plastic knobs and wing nuts, see page 31.

# Contents

## Tilting Drill Press Table \_\_\_\_\_ 4

A tilting table, an adjustable fence, and a replaceable insert make it easy to drill straight or angled holes.



Drill Press Table page 4

## Adjustable Stop Block \_\_\_\_\_ 8

This stop block is ideal for making stopped cuts on a router table, band saw, or drill press. It's "micro-adjustable" so you can fine tune the position for an exact cut.

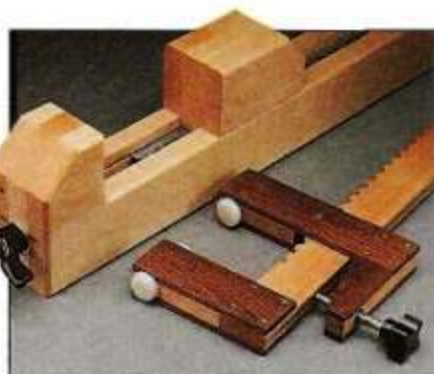

Shop-Built Clamps page 12

## Forstner Bits \_\_\_\_\_ 10

Guided by its rim instead of a centerpoint, a Forstner bit cuts near perfect flat-bottomed holes at any angle.

## Shop-Built Clamps \_\_\_\_\_ 12

Two clamps you can build at a fraction of the cost of store-bought clamps. One for gluing up panels and the other for quick clamping jobs.

## Table Saw Tenoning Jig \_\_\_\_\_ 16

Precision tenons are easy with this shop-made jig for your table saw. It features a unique double-stop so you can cut both sides of a tenon without flipping the workpiece.

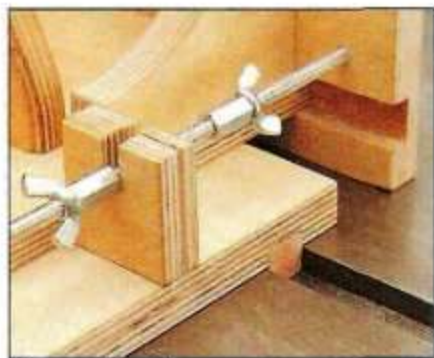

Tenoning Jig page 16

## Tips for Cutting Tenons \_\_\_\_\_ 24

From stock preparation and layout, to cutting the cheeks and shoulders, these helpful tips will show you how to cut a tenon that fits perfectly.

## Shop Solutions \_\_\_\_\_ 28

Five shop-tested tips: Zero Clearance Insert, Depth Gauge, Cut-off Jig for a Circular Saw, Squaring a Mitered Corner, and a Tip for Mortising Hinges.

## Knock-Down Fittings \_\_\_\_\_ 30

All it takes to build furniture that's easy to knock down and put back together again is the right hardware.

## Sources \_\_\_\_\_ 31

Hardware, project supplies, and mail order sources for the projects in this issue.

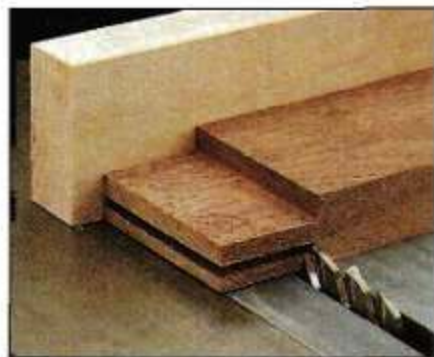

Tenon Cutting Tips page 24

# Tilting Drill Press Table

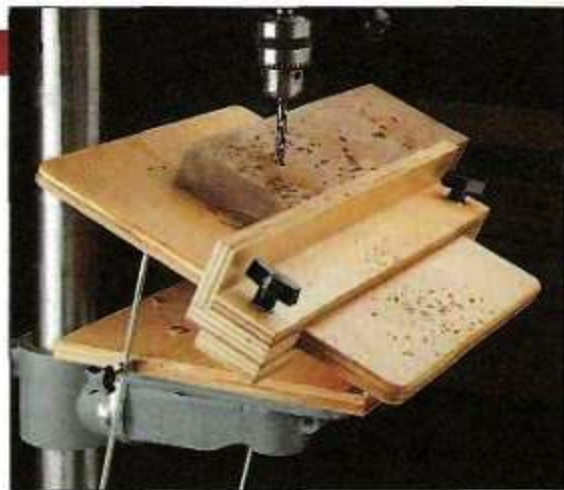

*Building this tilting table eliminates the guesswork when you want to drill precisely angled holes on the drill press.*

**D**rilling angled holes on a drill press can be a real pain. Usually, you have to reach under the table and use a wrench to loosen a bolt. Then you have to set the angle with one hand and retighten the bolt with the other.

Instead of doing all this, I built a separate table that adjusts easily for drilling angled holes. And the table lies flat for drilling vertical holes.

Then, to accurately position the workpiece, I added a fence with a built-in clamping system.

**BASE.** The table consists of two parts: an adjustable base and a

top that's added later. The base (A) is made up of two square pieces of  $\frac{3}{4}$ " plywood held together with a piano hinge, see Fig. 1.

**DETERMINE SIZE.** The size of the base pieces will vary depending on the capacity of your drill press. For example, on my 16" drill press, I can drill to the center of a 16" workpiece. This means the distance from the column to the center of the bit is at least 8".

Once this is determined, the base pieces are cut 3" smaller than the capacity. (In my case, the base pieces are 13" square.)

After cutting the pieces to size,

install the hinge along one edge. Then, to compensate for the thickness of the hinge, add a "leveling" screw to the base, see Fig. 1a.

**SUPPORT SYSTEM.** When the base is assembled, the next step is to add a support system to hold the table at the desired angle.

This system consists of two 18"-long steel rods. (See page 31 for sources.) One end of each rod is bent at a 90° angle, see Fig. 2. Then this end is inserted in a hole drilled in the side of the top base piece, see Figs. 1a and 1b.

The key to the support system is finding a way to hold the rod in

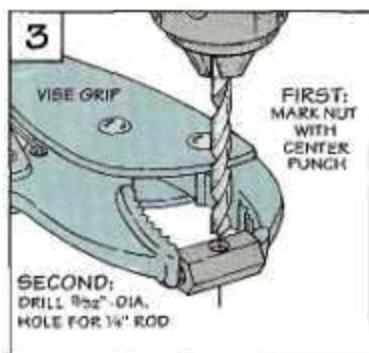
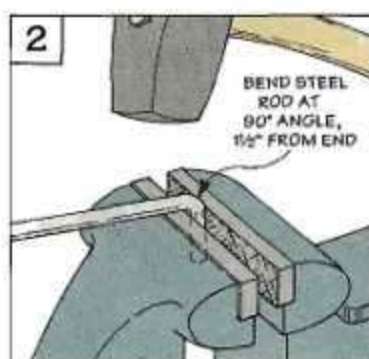
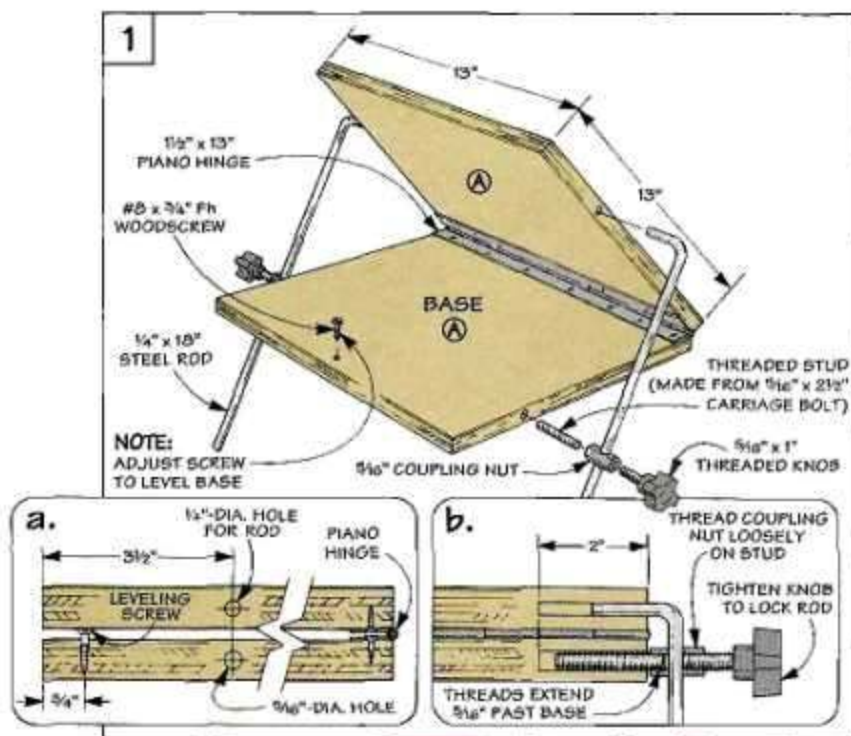

place when the table is tilted — I used a coupling nut.

**COUPLING NUT.** The coupling nut serves two purposes. First, by drilling a hole through the nut, the rod can slide up and down as the table is tilted, see Fig. 3.

The nut also acts as a pivot. It's threaded *loosely* on a "stud" that's epoxied into the bottom of the base, see Fig. 1b. (I cut a 2" section off a carriage bolt and pushed it in place leaving a 5/16" stud.)

As the table is tilted, the nut turns on the stud. Then by tightening a threaded knob (or thumbscrew) into the coupling nut, it pinches the rod and locks the table in place, see Fig. 1b.

**TOP.** After installing the support system, the next step is to add the top. The top is designed with a *center insert* (B) that can be replaced when it gets "chewed up," see Fig. 4.

The size of the top pieces is determined by the size of the base. Overall, the top is 3" larger than the base (16" square in my case). This creates a 1 1/2" lip for the fence that's attached later, see Fig. 4a.

To end up with a top this size, I cut the center insert 4" wide by 16" long and two *side pieces* (C) 6" wide by 16" long. Then the in-

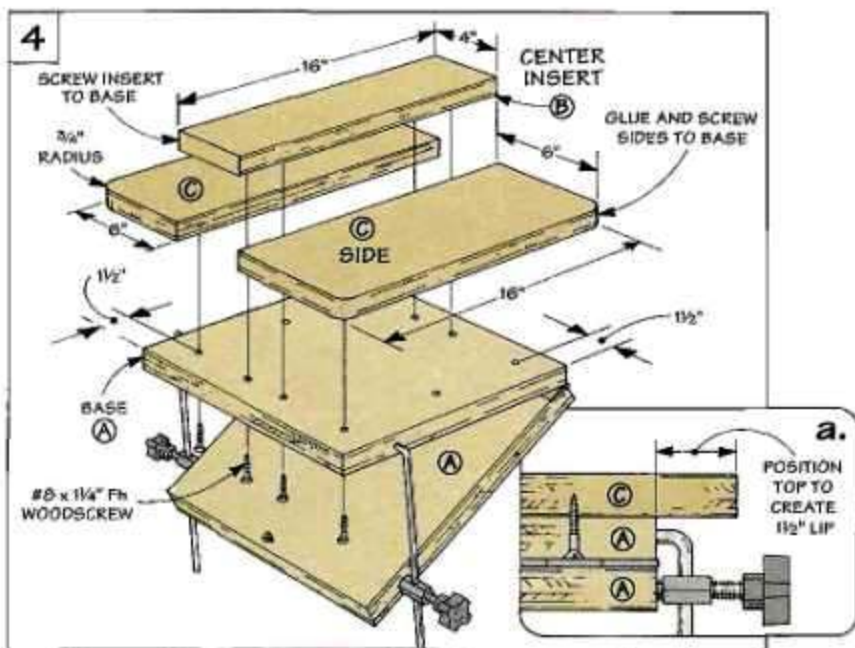

sert is screwed to the base (don't glue it). Next, round over the outside corners of the sides, and glue and screw them in place.

**CENTERING PEG.** With the top complete, the next step is to align the tilting table on the metal drill press table. To do this, I added a centering peg, see Fig. 5.

The peg is just a dowel the same diameter as the hole in the metal table. It's glued into a shallow hole centered on the bottom of the base.

By fitting the peg into the hole on the metal table, the tilting table is automatically centered.

**LOCATE HOLES.** The next step is to locate the holes to attach the tilting table. But before you can do this, you'll need to align the table to the drill press column, refer to Steps 1 and 3 on page 7.

Once the table is aligned, just mark and drill the holes. Then attach the table with carriage bolts and T-knobs (or wing nuts).

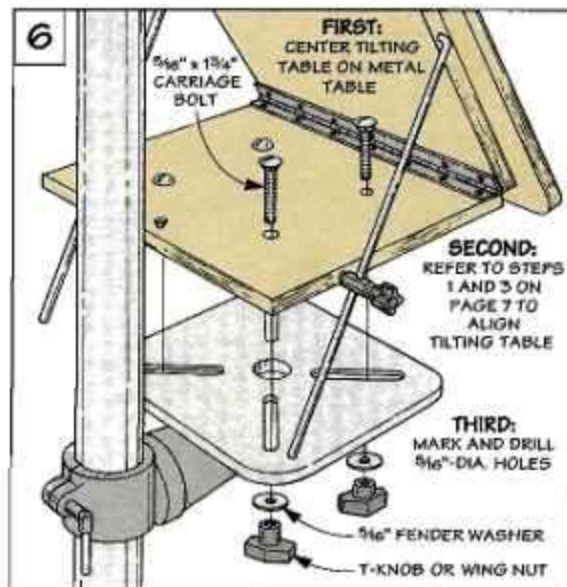
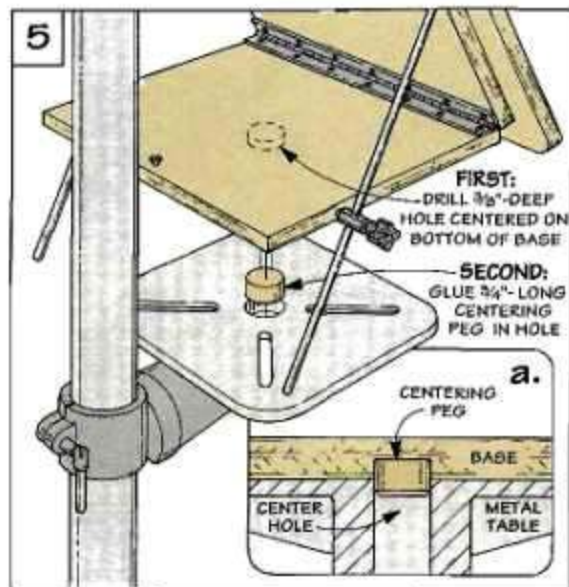

Hardware

- (1) #8 x 3/4" Fh Woodscrew
- (10) #8 x 1 1/4" Fh Woodscrews
- (4) #8 x 2" Fh Woodscrews
- (4) 5/16" x 1 3/4" Carriage Bolts
- (4) 5/16" x 2 1/2" Carriage Bolts
- (4) 5/16" x 1 5/8" Fender Washers
- (2) 5/16" Flat Washers
- (6) T-Knobs with 5/16" Insert
- (2) 5/16" x 1" Threaded Knobs
- (2) 5/16" Coupling Nuts
- (1) 1 1/2" x 13" Piano Hinge
- (2) 1/4" x 18" Steel Rods

# The Fence

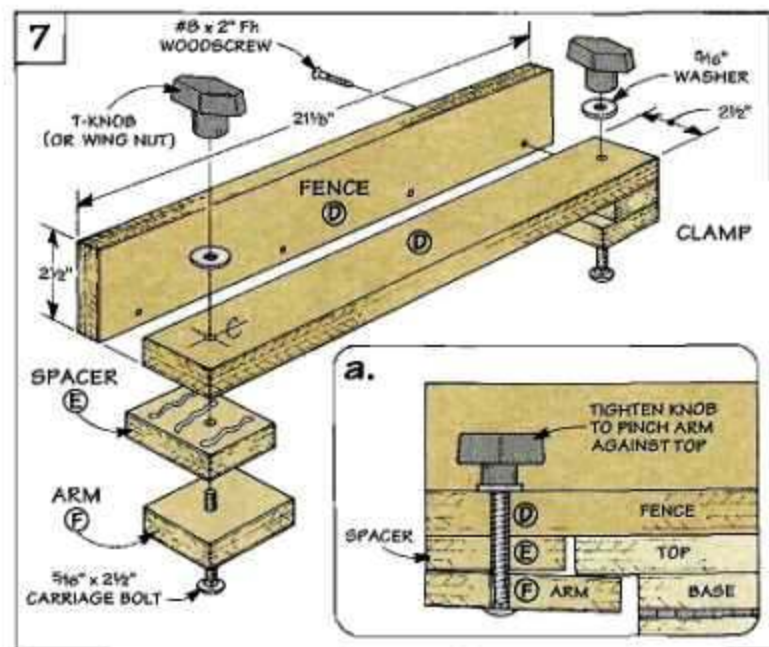

To complete the drill press table I added a fence with a built-in clamping system.

**L-SHAPE.** The fence (D) is just two strips of 3/4"-thick plywood that are glued and screwed together to form an L-shape, see Fig. 7. The width of each strip is 2 1/2", but the length is determined by the size of the top.

To figure out this length, add 5 1/8" to the width (or length) of your top. This allows space for the clamping system that's added

later. (In my case, these pieces are 21 1/8"-long.)

## CLAMPING SYSTEM

After gluing and screwing the fence together, the next step is to add the clamping system.

The system consists of a clamp at each end of the fence, see Fig. 7. Each clamp is made up of two blocks: a spacer (E) and an arm (F), see Fig. 7a.

What makes the clamp work is the spacer is slightly thinner than

the top of the table. So when you tighten the clamp, the arm pinches against the bottom of the table top, see Fig. 7a.

To provide the clamping pressure, a carriage bolt passes through the arm and spacer, and up through the fence. By tightening a T-knob (or wing nut) on the bolt, the arm tightens against the top and locks the fence in place.

**CUT BLOCKS.** The blocks for the spacers and arms are cut from a single 16" long blank, see Fig. 8. Note: I trimmed 1/16" off the thickness of the whole blank before cutting the individual spacers and arms, see Figs. 8 and 8a.

**GLUE SPACERS.** Then cut the pieces to size. Next glue the spacers flush with the ends of the fence, see Fig. 9.

**DRILL HOLES.** When the glue dries, holes can be drilled for the carriage bolts. The important thing is to keep the pieces aligned while drilling the holes.

To do this, temporarily attach the arms to the spacers with double-sided carpet tape. Then drill the holes. Now remove the tape, install the bolts and washers, and thread on the knobs.

**FINISH.** Finally, to protect the surface of the fence and table, wipe on a couple coats of tung oil.

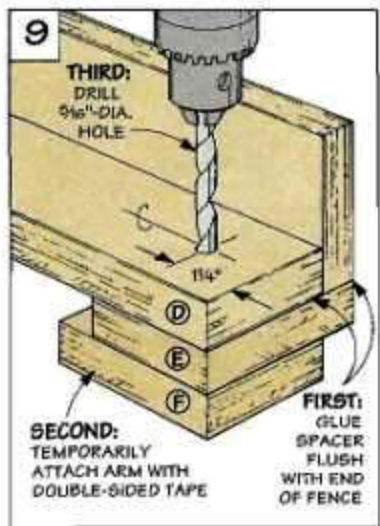
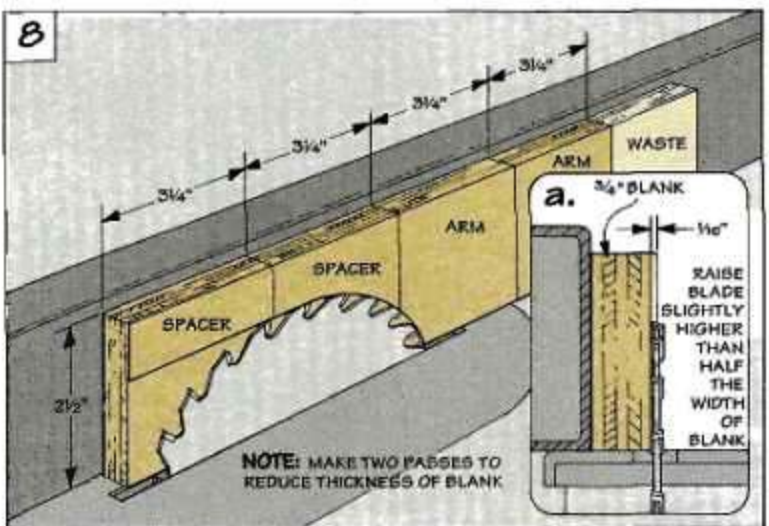

## Using the Drill Press Table

■ It only takes a few minutes to attach the tilting table to the drill press. But before you do, you need to align the table.

The idea here is to orient the table to an "imaginary" centerline on your drill press, see Steps 1 and 3.

After the table is aligned, a corresponding centerline is drawn down the middle of the insert, see Step 4. This makes it easy to reposition after raising or lowering the height of the table.

Now all that's required is to set the table to the desired angle and square the fence to the edge of the top, see Step 5.

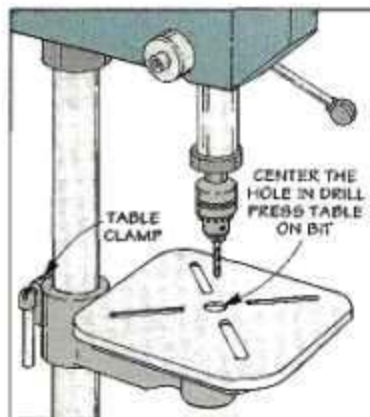

**Step 1:** After loosening the table clamp, center the hole in the table on a bit chucked in the drill press. Then retighten the clamp.

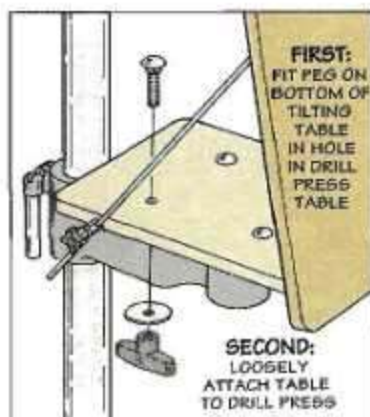

**Step 2:** Next, set the tilting table on the drill press table and attach it loosely with carriage bolts, washers, and T-knobs.

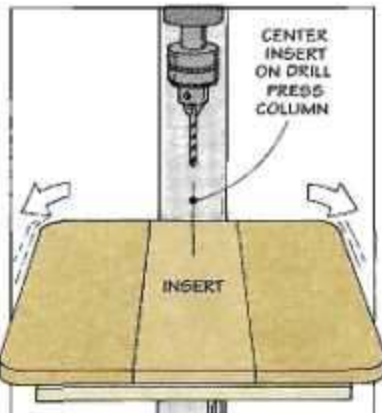

**Step 3:** Now gently twist the tilting table until the insert is centered on the column of the drill press. Then tighten the knobs.

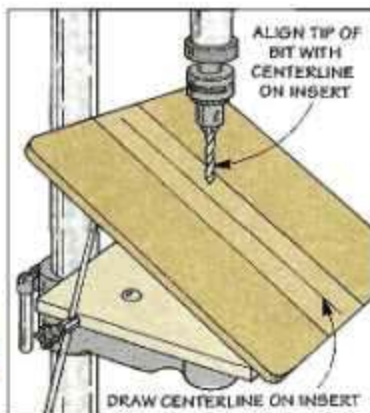

**Step 4:** After adjusting the height of the metal drill press table, simply line the bit up with a centerline drawn on the insert.

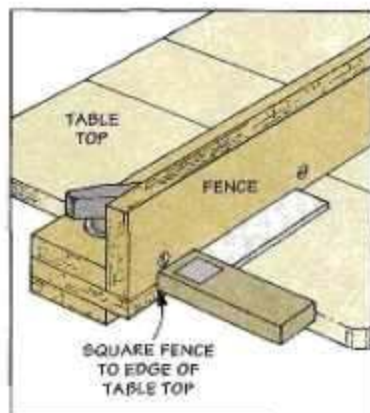

**Step 5:** To avoid drilling compound angle holes, square the fence to the edge of the table before tightening the clamps.



▲ Locking the fence on the top of the table helps hold the workpiece in place when drilling angled holes.



▲ When drilling long pieces, the table can be turned 90°. To prevent the workpiece from sliding, clamp it to the fence.

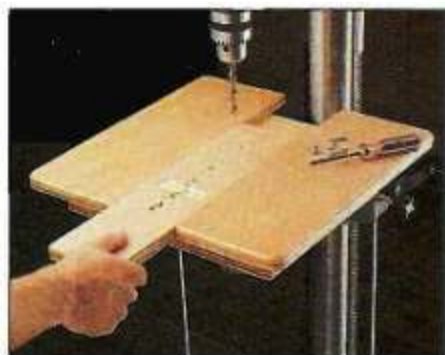

▲ When the insert gets chewed up after drilling many holes, just remove the old insert and screw on a new one.



# Adjustable Stop Block

*This stop block is "micro-adjustable" so you can easily position it for an exact cut.*

**R**outing a stopped chamfer, groove, or dado in a workpiece is simple. You just clamp a scrap block to the fence on your router table where you want the workpiece to stop.

But making slight adjustments to get the block in the exact position can involve a lot of trial and error. To eliminate the guesswork and to increase the precision on stopped cuts, I made a micro-adjustable stop block, see photo.

**TWO PIECES.** The stop block is made up of two pieces: a fixed block (A), and an adjustable stop (B), see Fig. 1. A threaded rod connects both pieces so you can fine tune or "micro-adjust" their position.

Both blocks attach to the router table fence with T-slot nuts and threaded knobs, see photo. Note: Although this stop block is designed for use with the Router Table

Fence shown in *ShopNotes* No. 1, you can use it on any fence by substituting C-clamps for the T-slot nuts and knobs, see inset photo.

## CONSTRUCTION

The first step is to make the *fixed block (A)*, and the *adjustable stop (B)*. Since these are small pieces, I started with an oversized blank, see Fig. 2.

**L-SHAPE.** Then, lay out the two L-shaped blocks on this blank, see Fig. 2. The L-shape allows the adjustment nut to "set-in" from the edge of the

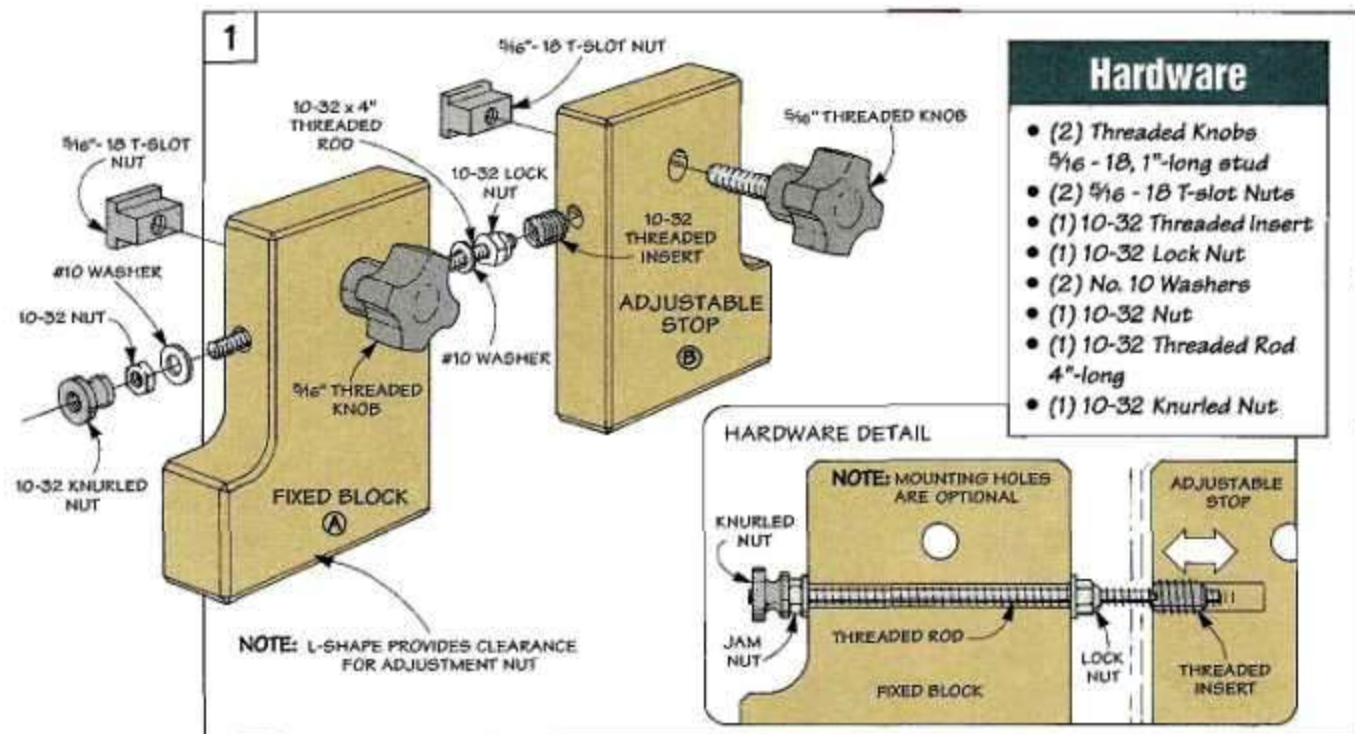



block. This way you can butt a workpiece up against either end of the stop block, see photos on the opposite page.

To make the blocks, first drill two  $\frac{3}{4}$ "-dia. holes at the marked locations shown in Fig. 2. Then, cut the pieces to shape and sand the edges smooth.

**MOUNTING HOLES.** To attach the stop block to the router fence, drill  $\frac{5}{16}$ "-dia. mounting holes for threaded knobs, see Fig. 3. (I used threaded knobs, but thumbscrews would work just as well.)

Note: If you're going to clamp the stop block to your fence, don't drill the mounting holes.

**CHAMFER EDGES.** Before you drill holes to mount the threaded rod, rout a chamfer on *all* the edges of both blocks, see Fig. 3.

**MICRO-ADJUSTER.** The key to making the stop block micro-adjustable is the threaded rod.

The threaded rod has a knurled nut and a jam nut on one side and serve as a simple adjustment knob, see Fig. 1a. Then the rod runs through the fixed block (A) and is "captured" by a lock nut on the other side.

From there, it screws into a threaded insert that's installed in the adjustable stop (B). (For a hardware kit, see page 31.)

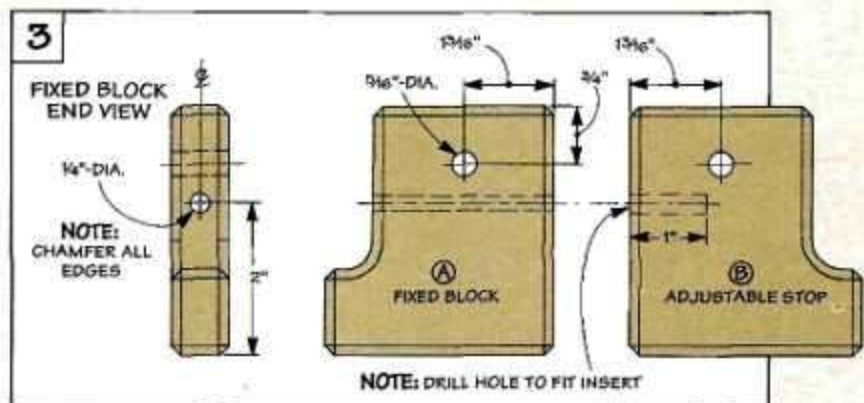
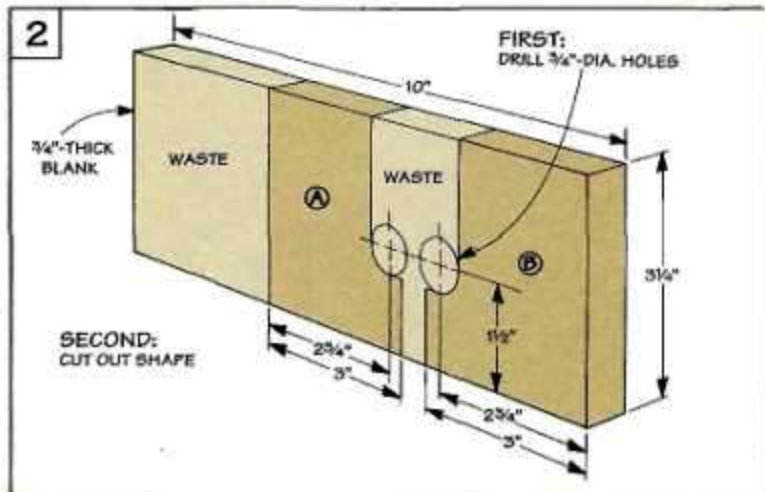

**DRILL HOLES.** So to make the stop block adjustable, first locate and drill a  $\frac{1}{4}$ "-dia. hole in the fixed block for the threaded rod, see Fig. 3. Then drill a hole in the

adjustable stop (B) to fit your threaded insert.

Finally, to complete the stop block, apply a couple coats of tung oil and add the hardware.

## Using the Stop Block

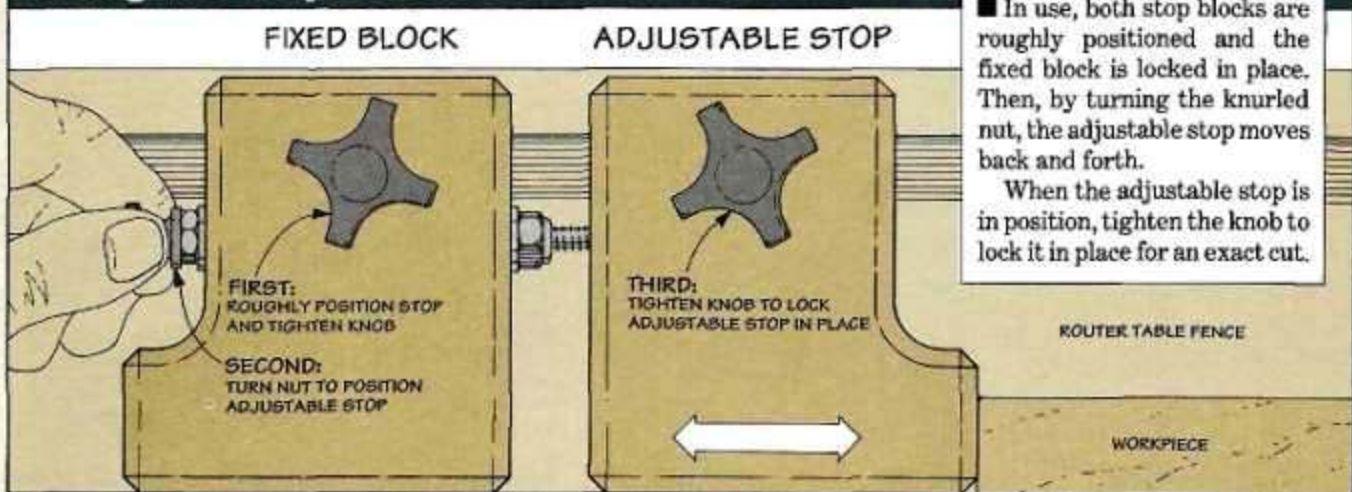

# Forstner Bits

**H**ave you ever drilled a hole part way through a workpiece only to have the point of the bit poke through the other side?

In 1886, Benjamin Forstner (a gunsmith from Orem, Utah) had the same problem. He solved the problem by developing a bit that cuts clean, flat-bottomed holes, see photo and Fig. 1a.

**THE RIM.** The reason that a Forstner bit can do this is the bit is guided by its rim instead of a centerpoint. (In fact, the centerpoint is so small, it's only used to help align the bit, see Fig. A.)

So how does this bit work? First, the rim guides the bit scoring the outer edge like a knife, see Fig. B. Then, two chisel-like lifters pare away the wood in a planing action, see Fig. C.

This (along with the small centerpoint) creates a near-perfect, flat bottomed hole, see Fig. 1a.

**NO WANDER.** Since a Forstner bit is guided by its rim, it excels at drilling holes into end grain or "wild" grain. It also makes it easy to drill holes at an angle without wandering, see Fig. 1b.

Guiding the bit by the rim also lets you bore partial holes on the edge of a workpiece — it's the *only* drill bit that can easily and cleanly cut a partial hole on an edge, see Fig. 1c.

You can also drill overlapping holes without the bit wandering. This makes a Forstner bit an excellent choice for drilling out a mortise, see Fig. 1d.

**DRILLING TIPS.** Regardless of the type of wood that you're going to be drilling with a Forstner bit, there are three simple rules to remember.

First, always use the *slowest* possible speed. Most Forstner bits aren't made of high-speed



steel. When they're run at high speeds, they heat up quickly and burn the bit and the workpiece.

Second, Forstner bits are designed for use *only* in a drill press. It's difficult to maintain a constant, slow speed with a hand-held variable speed drill. That's because as you press down, there's a tendency to increase the speed.

Third, make sure the bits are sharp. A sharp Forstner bit slices through the wood and produces long ribbons of shavings, see photo above.

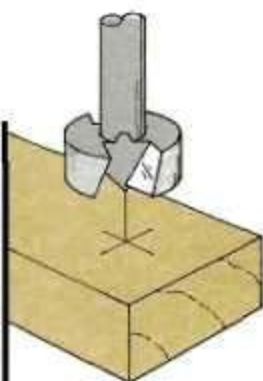

▲ Fig. A: Point helps align bit.

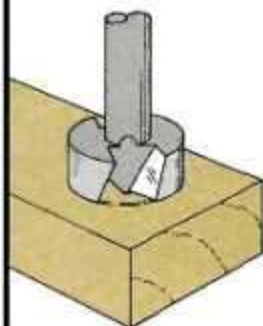

▲ Fig. B: Rim of bit scores edge.

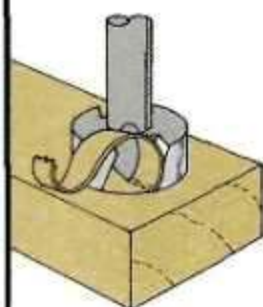

▲ Fig. C: Lifters plane away wood.

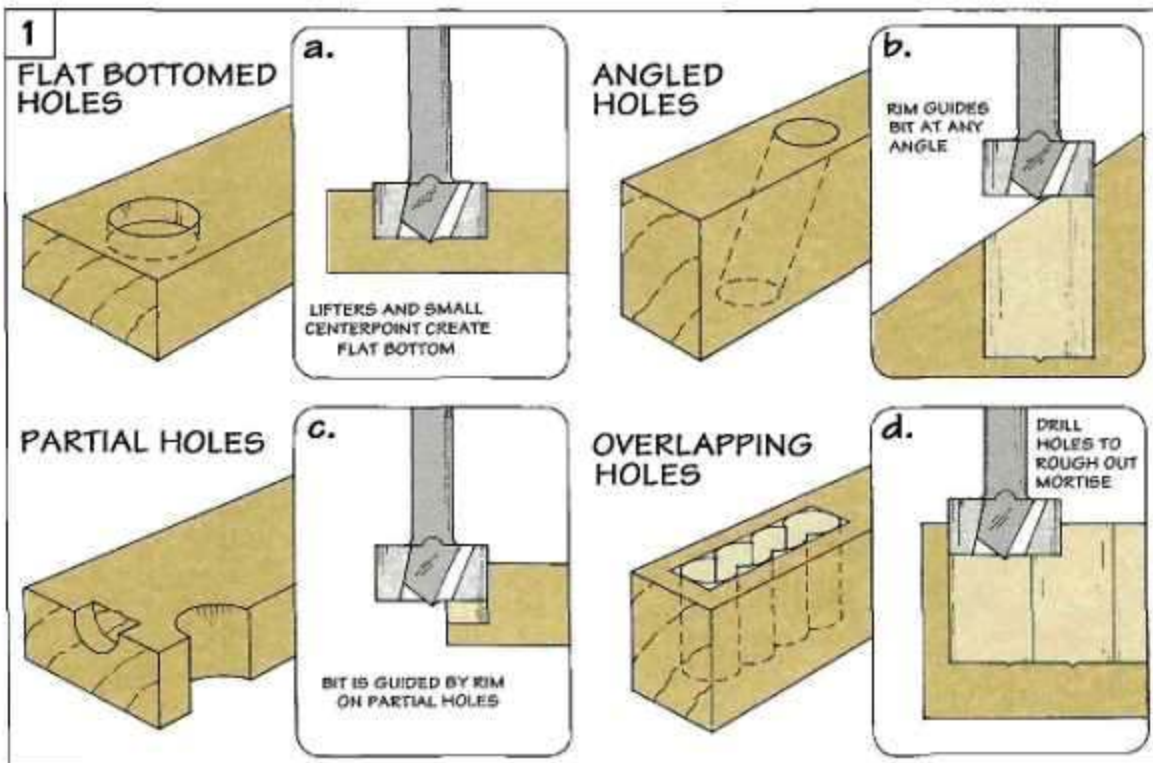

## Forstner Bit Types

Manufacturers currently call any rim-guided bit with a single or double lifter a "Forstner" bit. (For sources, see page 31.)

### DOUBLE-LIFTER BITS

Double-lifter bits are the most common of the Forstner bits.

**CONVALCO.** Connecticut Valley Manufacturing Company (CONVALCO) is the only company we know of that still makes a *true* copy of the original Forstner bit, see Fig. 2. They're available in sizes from 1/4" to 3" in 1/16" increments.

Although the most costly of the steel bits, they're machined from solid stock and are *hand* sharpened. The tiny centerpoint leaves a clean flat-bottomed hole, see Fig. 2. (But this can make it difficult to position the bit.)

**IMPORTED BITS.** Several foreign companies manufacture their own version of a Forstner bit. They're easy to identify with their long centerpoint and notched rim, see Fig. 2. (The notch allows the manufacturer to grind the lifters by machine.)

Available in 1/8" increments, they produce fairly clean holes at a relatively low cost — but with a noticeable centerpoint.

### SINGLE-LIFTER BITS

Another variation on Forstner bits are single lifter bits, some-

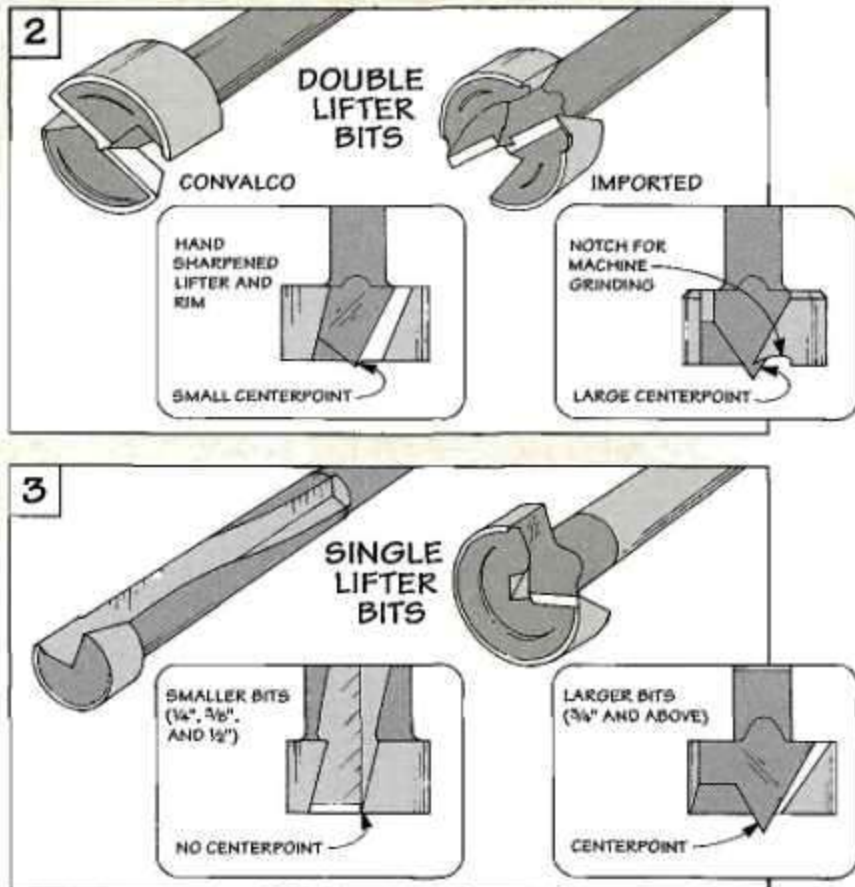

times called mortising bits (like those manufactured by Vermont American), see Fig. 3.

These inexpensive bits have a notch cut out of the rim to form a single lifter. They are designed for use in a drill press and drill

precise, flat-bottomed holes that require little clean-up.

The only problem with these bits is the feed rate. Since the bit only has a single lifter to pull out the chips, you need to ease the bit slowly into the workpiece.

## Carbide-Tipped Forstner Bits

It was just a matter of time before someone combined the cutting action of a Forstner bit with the durability of carbide.

One line of carbide-tipped Forstner bits is offered by Freud.

Freud says these bits last 40 times longer than steel bits. In addition, they can bore through Formica and other solid surface

materials (such as Corian) without dulling quickly.

Another company that offers carbide-tipped bits is MLCS, see photo. Available in diameters from 3/4" to 3 1/8", they look like a modified router bit, but perform just like a standard Forstner bit.

The only problem is their short length limits the depth of the hole you can drill. (For sources of carbide-tipped bits, see page 31.)

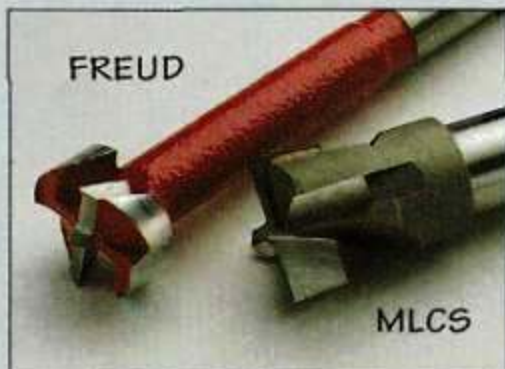

# Shop-Built Clamps

Build a fast-action clamp and a bar clamp from scrap pieces of wood and a few pieces of hardware.

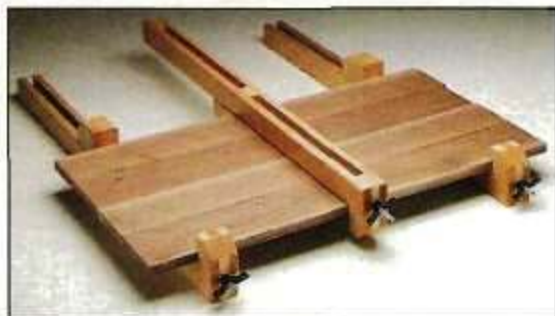

photo. (For sources of hardware to make both clamps, see page 31.)

**GROOVES.** After the rails are cut to length, a groove is cut along the inside face of each rail, see Fig. 1b. The grooves create a channel for a metal strap that's used to adjust the clamp.

**ASSEMBLE BAR.** Now the bar can be assembled by gluing two small *spacer blocks* (B) between the rails, see Fig. 1.

Also, a large *fixed head block* (C) is glued between the rails at one end. However, before gluing this block between the rails, drill a hole to allow a threaded rod

## Hardware

- (1) 1 3/8" x 36" Perf. Metal Strap
- (1) 3/8" x 8" Threaded Rod
- (2) 6d Nails
- (1) 3/8" Washer
- (1) 3/8" Plastic Wing Nut
- (2) #8 x 1" Rh Woodscrews

**N**o matter how many clamps you have, there's always a project that requires a few more. But rather than *buy* more clamps, I decided to *build* my own.

One is a fast-action clamp for light jobs, see top photo. (To build this clamp, see page 14.) The other is a bar clamp designed for gluing up wide panels, see bottom

The bar clamp has three main parts: a bar, a fixed clamp head, and an adjustable clamp head.

**BAR.** The bar consists of two rails (A), see Fig. 1. The length of these rails (minus the length of the two clamp heads) determines the *useful* length of the clamp. I cut the rails 42" long to get a useful length of 36".

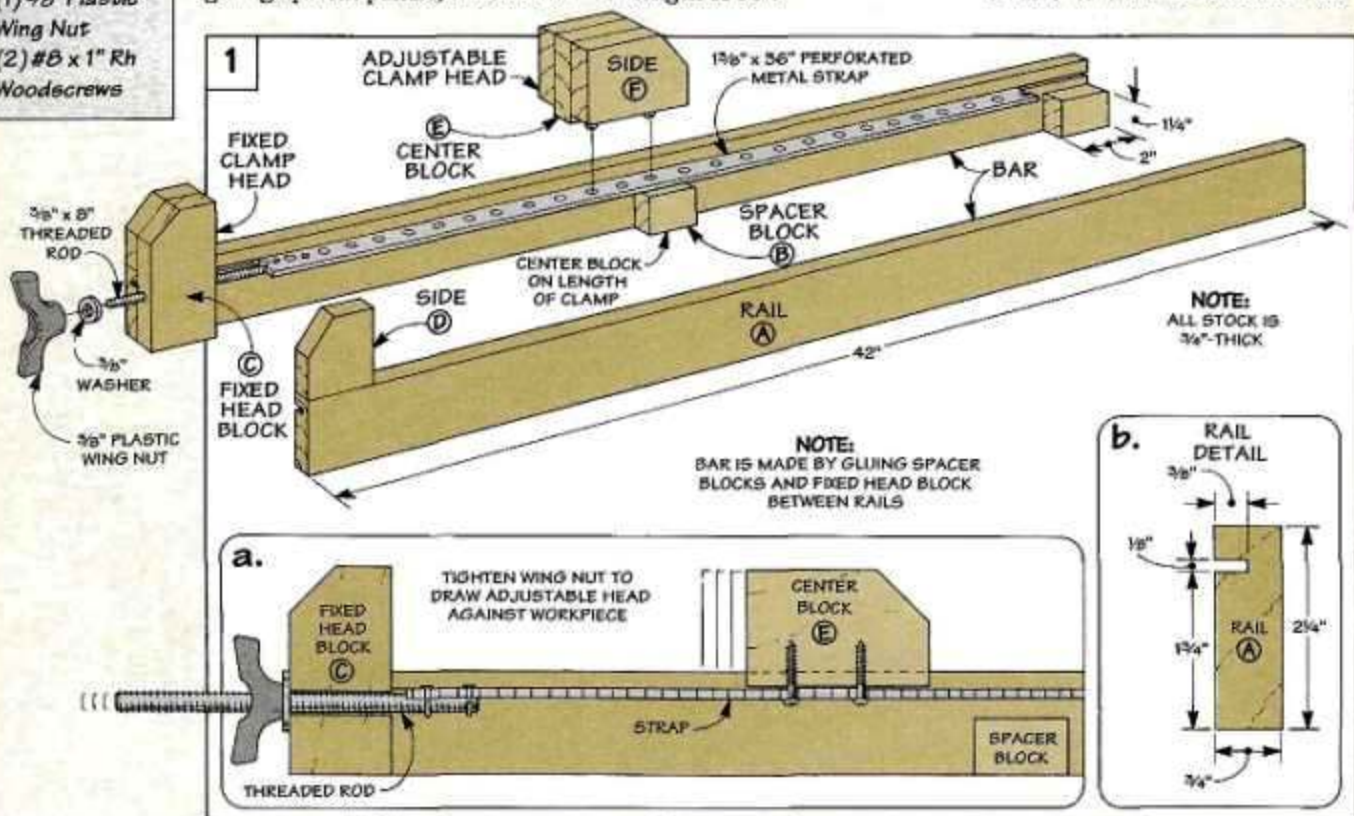

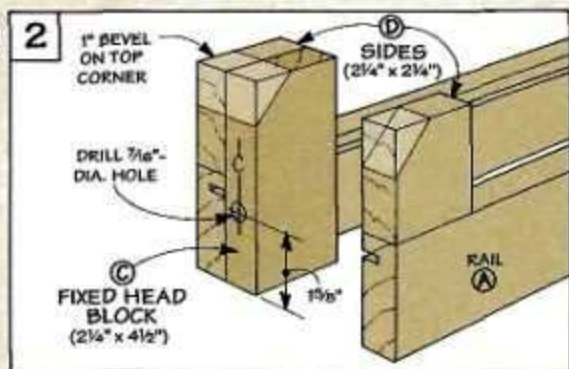

(which is added later) to pass through, see Fig. 2.

**ADD SIDES.** To strengthen the fixed head block, I added two  $\frac{3}{4}$ "-thick side pieces (D). Then bevel the top outside corner to relieve the sharp edges.

### CLAMP MECHANISM

After completing the fixed clamp head, the next step is to add the clamp hardware.

**STEEL STRAP.** What makes this clamp work is a 36" length of perforated (rigid) metal strap, see Fig. 1. It's sold in home centers and used to brace walls in house construction.

**THREADED ROD.** The strap is attached to a threaded rod. To do this, grind a "flat" on the rod and then drill holes in both pieces, see Fig. 3. I used 6d nails to fasten the strap to the rod, see Fig. 3a.

**INSTALL ASSEMBLY.** Now the clamp mechanism can be installed. Just slide the rod into the open end of the bar so the strap follows the grooves in the rails. Then pass the rod through the hole in the fixed head, refer to Fig. 1a.

Next, slip on a washer and thread a plastic wing nut on the rod. (Or you can make your own wing nut, see box.) By tightening the nut, the strap slides through the grooves. That's where the adjustable clamp head comes in.

**ADJUSTABLE HEAD.** Like the fixed head, it's built up by gluing a center block (E) between two side pieces (F), see Fig. 4. The

center block is cut wider (taller) than the side pieces so it fits down between the rails.

**SCREWS.** After the glue dries, two roundhead screws are installed in the bottom of the center block. The heads of the screws drop into the holes in the metal strap. Then as the strap slides in the grooves, the adjustable head draws tight against a workpiece.

To adjust the clamp for a differ-

ent size panel, just fit the screws into another set of holes. Note: Be sure to locate the screws to match the centerpoints of the holes in the strap, see Fig. 4a.

Here again I beveled the top corner of the adjustable head. Then rout or sand a chamfer on the outside edges of the bar and both clamp heads.

**FINISH.** Finally, brush on a couple coats of polyurethane.

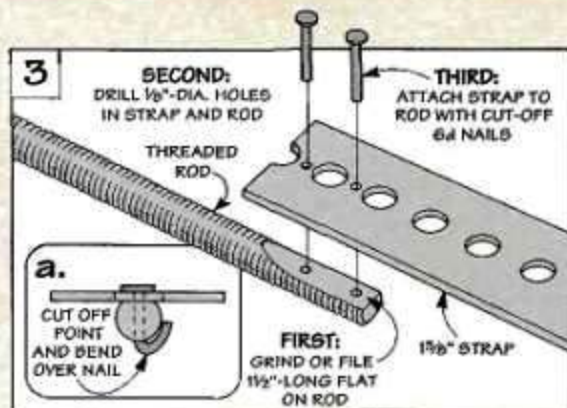

### Shop Tip

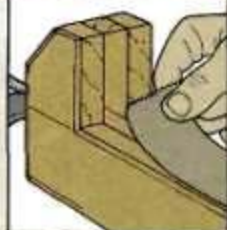

A wide strip of masking tape keeps the bar and the strap free of glue.

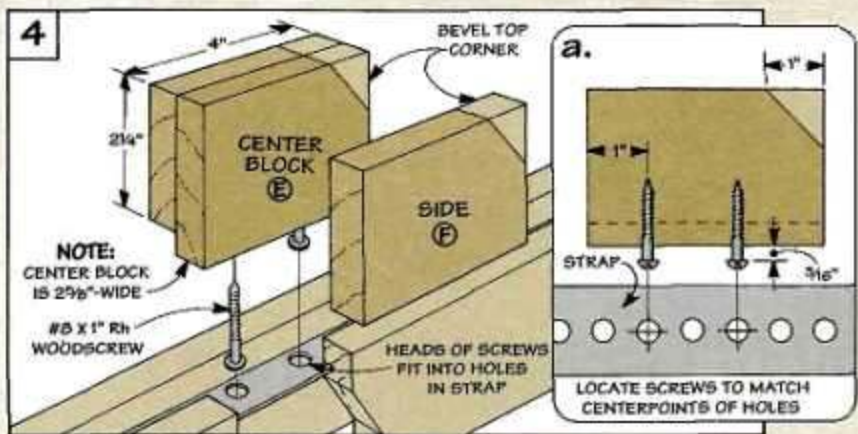

## Shop-Made Wing Nut

Here's an easy way to make a wing nut from a scrap piece of  $\frac{3}{4}$ "-thick stock and a hex nut.

Just drill a counterbored hole and drive in the nut so the "corners" cut into the side of the hole.

To provide knuckle room, I cut away part of the bottom edge of the block and then chamfered the sharp edges.

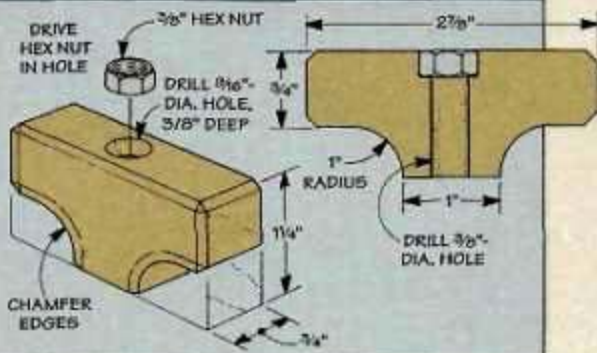

## Fast-Action Clamp

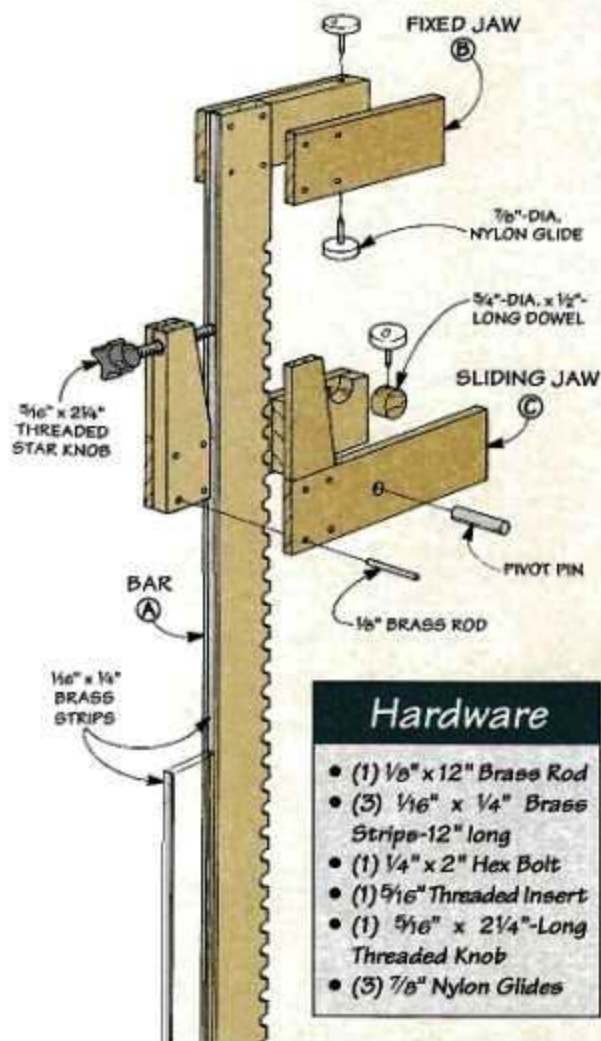

## Hardware

- (1)  $\frac{1}{8}$ " x 12" Brass Rod
- (3)  $\frac{1}{16}$ " x  $\frac{1}{4}$ " Brass Strips—12" long
- (1)  $\frac{1}{4}$ " x 2" Hex Bolt
- (1)  $\frac{5}{16}$ " Threaded Insert
- (1)  $\frac{5}{16}$ " x  $2\frac{1}{4}$ "-Long Threaded Knob
- (3)  $\frac{7}{8}$ " Nylon Glides

## Spreader Clamp

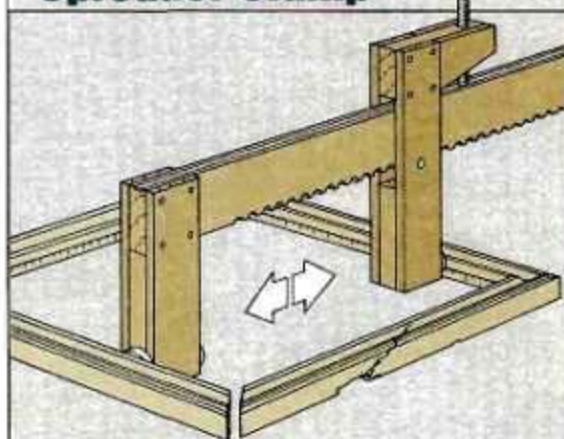

To apply outward pressure with the fast-action clamp, reverse the jaw. As the clamp is tightened, the jaws work like a spreader.

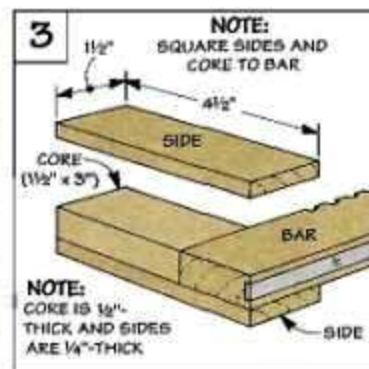
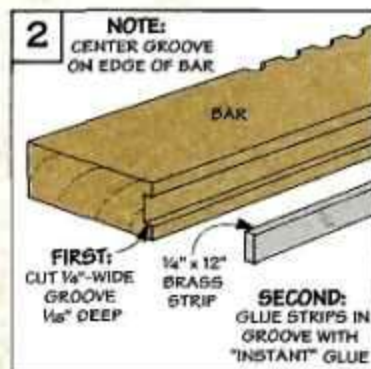
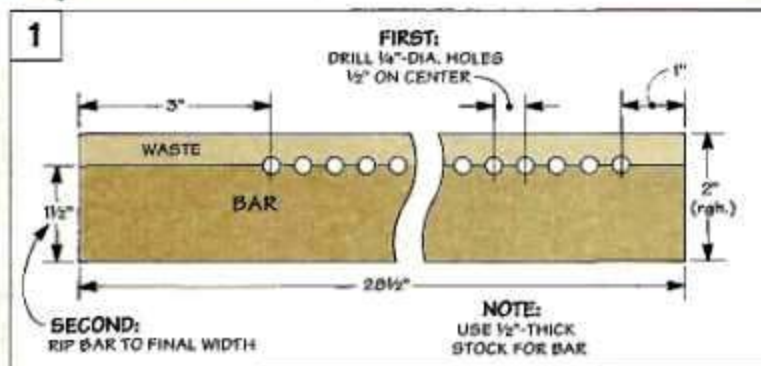

Another shop-made clamp that I find especially handy is the fast-action clamp shown at left.

The clamp is designed with three parts: a bar, a fixed jaw, and a sliding jaw. The principle behind this clamp is a simple pivot.

The pivot point is a steel pin in the sliding jaw, refer to Fig. 7. When you slide the jaw snug against a workpiece, the pin "catches" in one of the serrations on the edge of the bar. Then, tightening a threaded knob pivots the jaw against a workpiece.

**BAR.** I began building the clamp by making the *bar* (A). It starts as a blank of  $\frac{1}{2}$ "-thick stock (I used maple) that's cut to a rough width of 2", see Fig. 1. Note: The length of the bar is  $4\frac{1}{2}$ " longer than the *usable* clamping distance. To clamp projects up to two feet, I cut the blank  $28\frac{1}{2}$ " long.

**SERRATIONS.** The next step is to cut the serrations in the bar. This is a two-step process. First, drill a series of holes centered  $1\frac{1}{2}$ "

from one edge, see Fig. 1. Then rip the bar to final width, cutting the holes in half to create the serrations.

**BRASS STRIP.** To protect the bar from dents when the threaded knob is tightened, I cut a groove and glued brass strips on the edge opposite the serrations, see Fig. 2. (For sources of brass, see page 31.)

**FIXED JAW.** After completing the bar, I added the *fixed jaw* (B). It's made by gluing up three  $1\frac{1}{2}$ "-wide pieces to the end of the bar—a core and two side pieces, see Fig. 3. (I chose maple for the core and walnut for the sides.) Later, pins are also driven in the jaw.

**SLIDING JAW.** All that's left to complete the clamp is to make the sliding jaw. Like the fixed jaw, it's built up in layers, see Fig. 4. But it has a "foot" and a "leg," so you'll need two core pieces and four sides.

The foot and the leg work together to exert pressure on a workpiece. Threading a knob into an insert in the foot pivots the jaw on the pin. This presses a ny-

ion "shoe" on the leg against the workpiece. (I used a nylon furniture glide for the shoe.)

**SHOE.** The trick is to make the shoe pivot so it remains flat against a workpiece even when the clamp is tightened at an angle. To do this, I added a simple pivot device.

A short section of dowel rests in a partial hole on the edge of the core piece, see Fig. 4. When the sides are glued on later, the dowel is "captured" in the opening. Attaching the shoe to this dowel allows the shoe to pivot as the dowel rotates in the opening.

**DRILL OPENING.** To make the opening, first cut the core piece for the leg to rough width, see Fig. 5. Then drill a 3/4"-dia. hole and rip the core piece to its finished width, see Fig. 5a.

**ASSEMBLE JAW.** Now the layers of the jaw can be glued up, see Fig. 4. To prevent glue from locking the dowel in place, I waxed the dowel and opening.

**THREADED INSERT.** After the glue dries, drill a hole in the foot for a threaded insert, see Fig. 6a. But before installing the insert, trim the foot at an angle to increase the swing of the jaw, see Fig. 6.

**PIVOT PIN.** The next step is to drill a hole in the leg for the pivot pin, see Fig. 7. To make the pin,

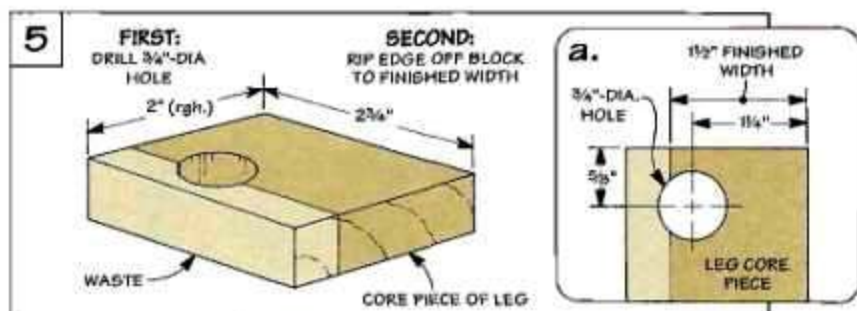
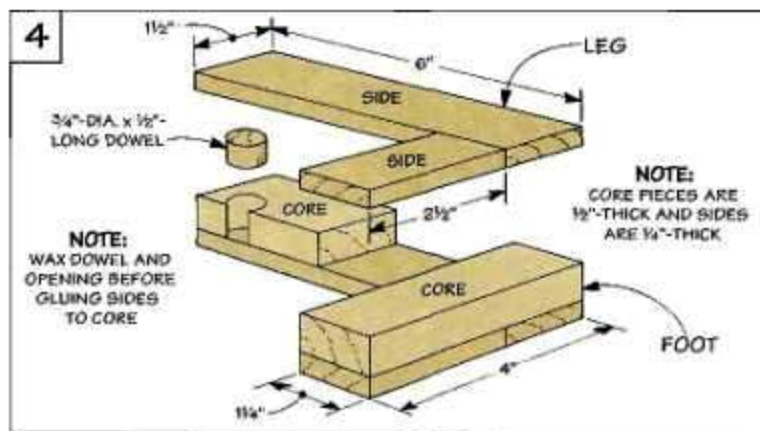

cut the head and threads off a hex bolt. Then epoxy the smooth part of the shank in the hole and file the ends smooth.

**FINAL DETAILS**

All that's left to complete the clamp is to add a few final details.

**BRASS ROD.** First, the corners of each jaw are reinforced with

pieces of 1/8" brass rod, see Fig. 7. After drilling the holes, drive in short pieces of brass rod and file the ends flush with the surface.

**SHOES.** The last step is to drill holes and attach the shoes (nylon glides). To use the clamp as a spreader, I added a shoe to both sides of the fixed jaw, refer to box on page 14.

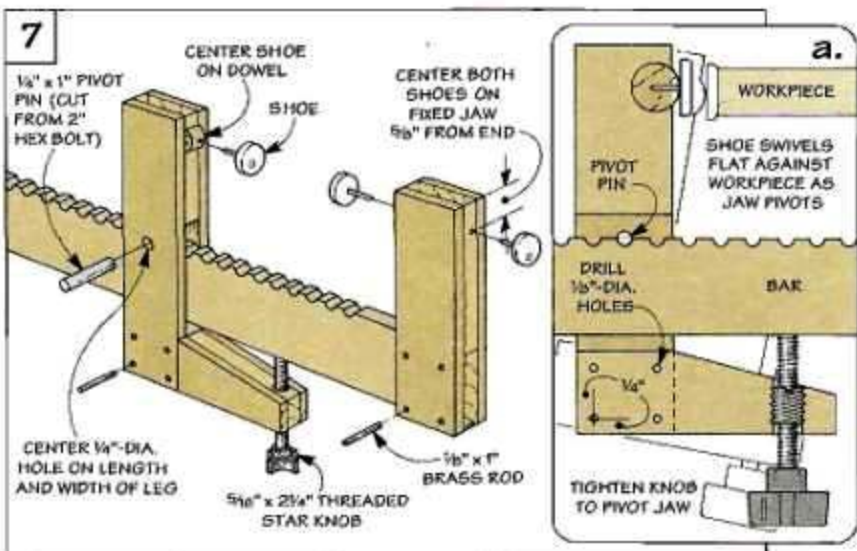
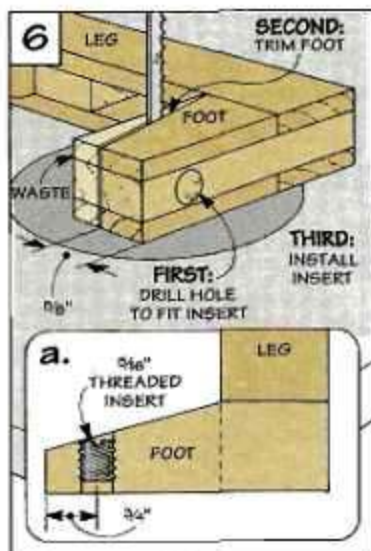

# Table-Saw Tenoning Jig

*A unique double-stop system allows you to cut both tenon cheeks without flipping the workpiece. And a built-in clamp ensures accurate tenons.*



One of the fastest ways to cut tenons on the table saw is to use a tenoning jig. The typical versions of these jigs allow you to hold the workpiece vertically so you can cut one cheek of the tenon in a single pass over the saw blade. (For more on this, see page 23.)

But these types of tenoning jigs have a couple of drawbacks. First, to make the second cheek cut you need to unclamp the workpiece, flip it around, then clamp it in place again. Second, it's very difficult to cut an accurate *offset* tenon. (A tenon that's *not* centered on the thickness of the workpiece.)

**DOUBLE-STOP SYSTEM.** The double-stop system on this jig solves both of these problems, see photo (A). Once the stops are adjusted you can make both

cheek cuts *without removing the workpiece*. In addition, this jig makes it easy to adjust the width and position of the tenon on the end of the workpiece.

**BACK STOP.** Another interesting feature of this tenoning jig is the back stop, see photo (B). The back stop supports the workpiece as it's pushed through the saw blade. It can be adjusted up and down so you won't cut through the stop when cutting tenons.

**HOLD-DOWN BAR.** To cut accurate tenons, the workpiece needs to be securely clamped to the tenoning jig. The problem with most clamps is you need three hands to use them—two to hold the clamp, and one to position the workpiece. Instead, I added a spring-loaded hold-down bar to hold the workpiece in place, see photo (C). (For hardware, see page 31.)

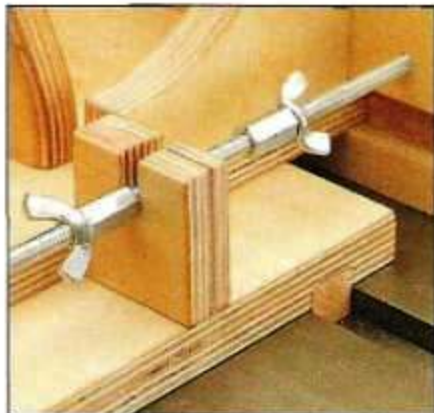

**(A) Double-Stop System:** This unique stop system lets you cut both cheeks of a tenon without flipping the workpiece.



**(B) Back Stop:** The height of the back stop is adjustable to prevent the saw blade from cutting through it.

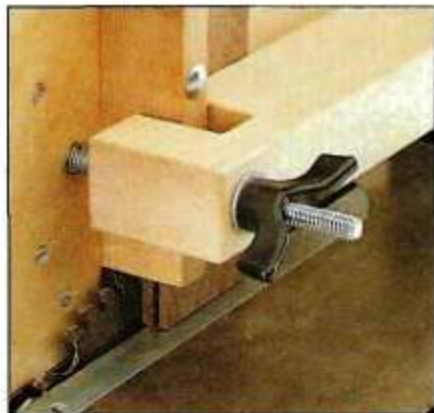

**(C) Hold-Down Bar:** This spring-loaded clamp holds the workpiece secure as it's pushed past the saw blade.



EXPLODED VIEW

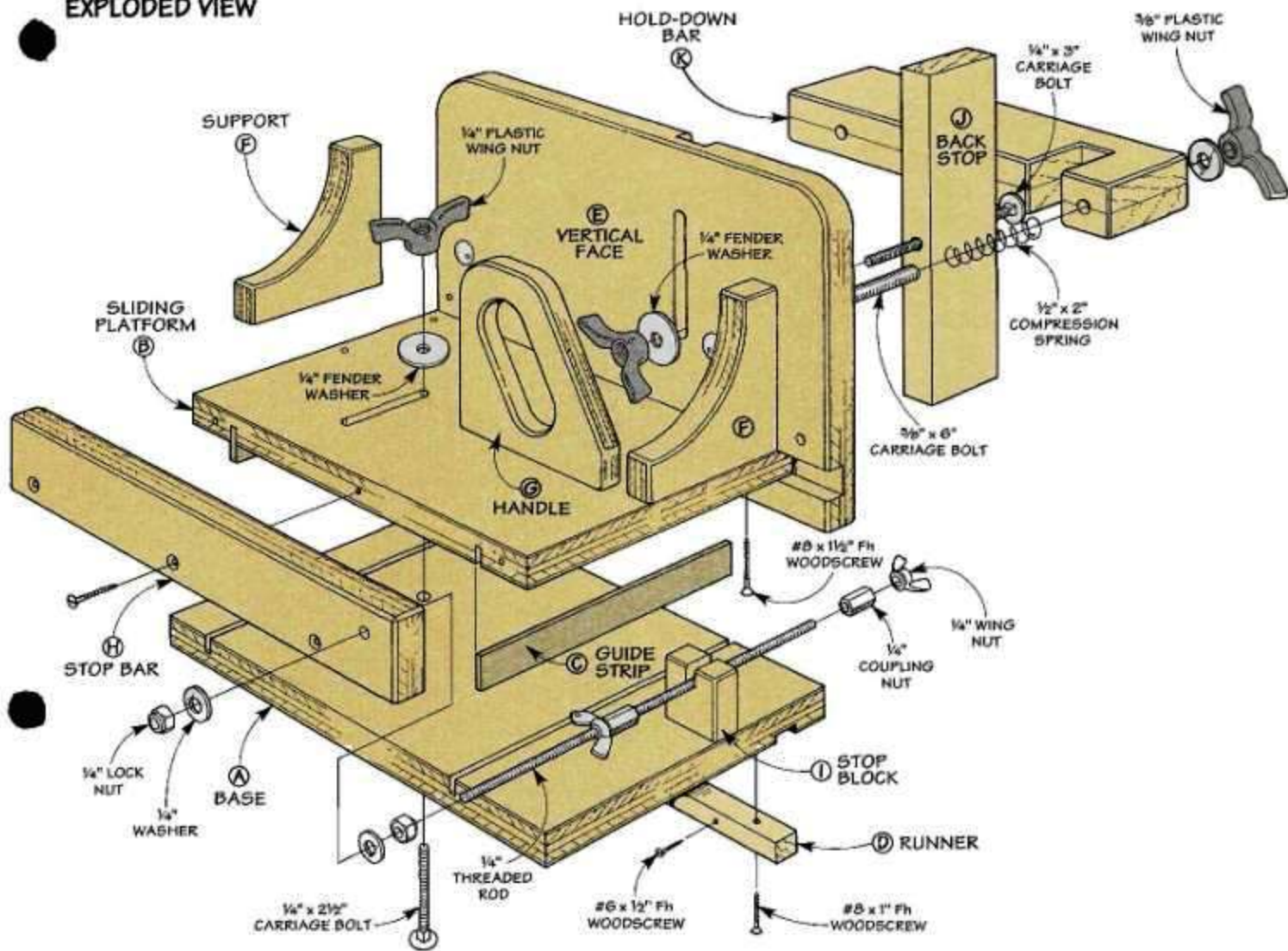

Materials List

Wood Parts

A Base (1)	9 x 14 - 3/4 Plywood
B Sliding Pltfrm. (1)	8 5/8 x 12 1/4 - 3/4 Plywood
C Guide Strips (2)	1 1/16 x 8 1/4 - 1/8 Masonite
D Runner (1)	5/8 x 3/4 - 14"
E Vertical Face (1)	8 x 14 - 3/4 Plywood
F Supports (2)	4 x 4 - 3/4 Plywood
G Handle (1)	5 1/2 x 5 1/2 - 3/4 Plywood
H Stop Bar (1)	1 3/4 x 14 - 3/4 Plywood
I Stop Block (1)	1 3/4 x 1 3/4 - 3/4 Plywood
J Back Stop (1)	3/4 x 1 3/4 - B
K Hold-Down Bar (1)	1 1/2 x 2 1/2 - 11 3/4

Hardware

- (4) No. 6 x 1/2" Fh Woodscrews
- (3) No. 8 x 1" Fh Woodscrews
- (18) No. 8 x 1 1/2" Fh Woodscrews
- (1) 1/4" x 2 1/2" Carriage Bolt w/Fender Washer
- (1) 1/4" x 3" Carriage Bolt w/Fender Washer
- (2) 1/4" Plastic Wing Nuts
- (2) 3/8" x 6" Carriage Bolts w/Washers
- (2) 3/8" Plastic Wing Nuts
- (2) 1/2" x 2" Compression Springs
- (1) 1/4" - 20 Threaded Rod, 10"-long (rgh)
- (2) 1/4" Wing Nuts
- (2) 1/4" Coupling Nuts
- (2) 1/4" Lock Nuts w/Washers

\* runner is sized to fit your table saw

## Base and Sliding Platform

A basic feature of this jig is the sliding platform. The platform slides back and forth on a fixed base, refer to Fig. 2. This allows you to adjust the jig to cut tenons of varying thickness.

**GROOVES.** To allow the platform to slide on the base without twisting, grooves are cut in both pieces for a pair of Masonite guide strips, see Figs. 1 and 2.

The tricky part is getting these grooves to align. To do this, start with an oversize blank and cut the grooves first. Then cut the *base (A)* and *sliding platform (B)* to size, see Fig. 1. (The sliding platform is smaller than the base to allow room for a stop system that's added later.)

**A SLOT.** The sliding platform is held on the base with a bolt and a wing nut, refer to Fig. 3. To make the platform adjustable, a slot is cut for the bolt to pass through, see Fig. 2. To do this, simply drill a series of holes and clean up the slot with a file.

**GUIDE STRIPS.** The next step is to glue a pair of  $\frac{1}{8}$ "-thick Masonite *guide strips (C)* into the grooves cut in the sliding platform, refer to Fig. 2. For clearance, the width of these strips is  $\frac{1}{16}$ " less than the combined height of the two grooves ( $1\frac{1}{16}$ ").

**STOP BAR.** Next, I added a *stop bar (H)*, see Fig. 3. (The stop bar is part of the stop system, see page 21.) It's cut to match the length of the base and is screwed to the edge of the sliding platform.

**LOCATE HOLE.** With the stop bar in place, the next step is to locate the bolt hole in the base. The important thing is to position the platform so there's a  $\frac{3}{8}$ " lip on the *right* side of the base, see Fig. 3. (Note: This lip fits in a dado that's cut in the vertical face later.)

With the platform in position, drill a counterbored hole in the base. Then slip in the bolt and washer, and thread on a wing nut.

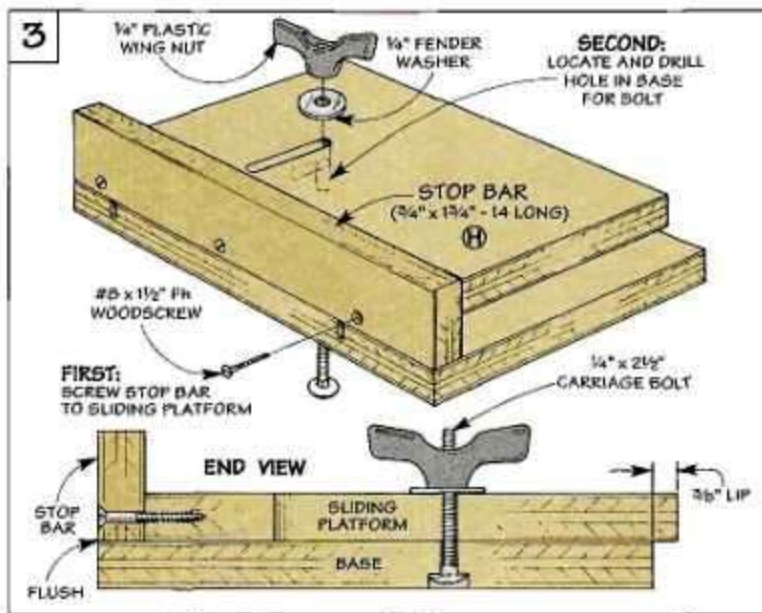
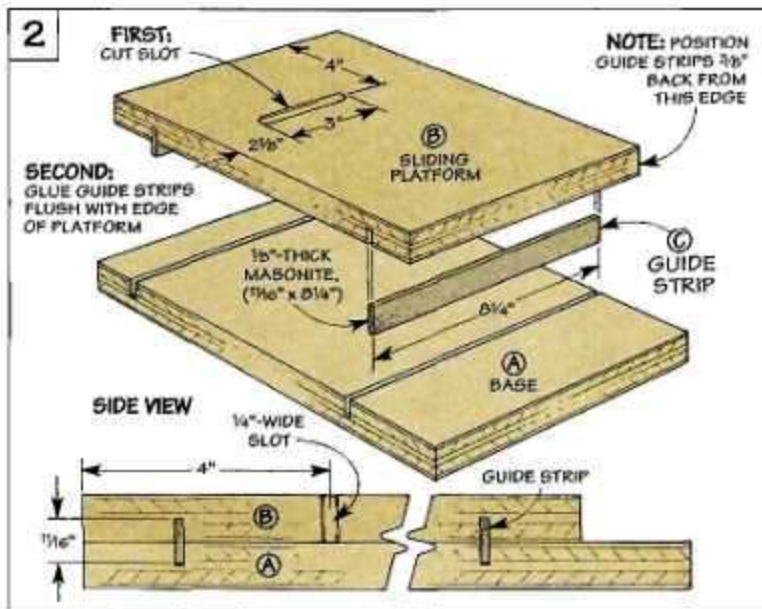
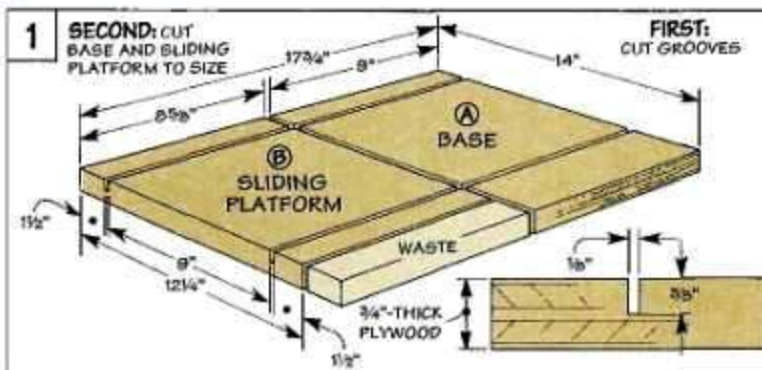

# Vertical Face

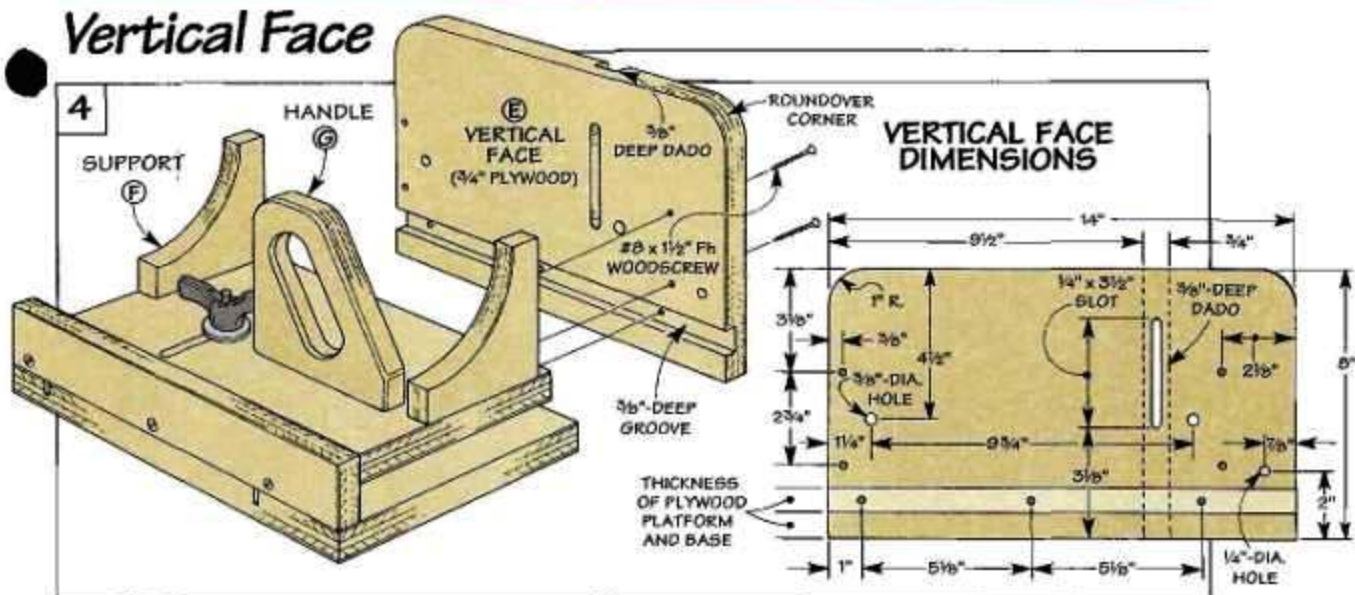

With the base and sliding platform complete, the next step is to add the vertical face, see Fig. 4.

**VERTICAL FACE.** The vertical face (E) is screwed to the sliding platform and supports the workpiece during a cut, see Fig. 4. It's just a piece of 3/4"-thick plywood with the top corners rounded.

The only unusual thing is you need to cut a groove, a dado, and drill screw and assembly holes in the vertical face *before* attaching it to the sliding platform.

**GROOVE AND DADO.** The groove is cut near the *inside* bottom edge, and sized to accept the sliding platform, see Fig. 4.

The dado is cut on the *outside* of the face and forms a channel for a back stop that's added later. A slot cut through the dado allows the stop to move up and down, see Fig. 4.

**DRILL HOLES.** Next, drill four countersunk shank holes for No. 8 screws in the face, see Fig. 4. Note: There's also three holes (used later to assemble the jig) to drill: two 3/8"-dia. holes and a 1/4"-dia. hole, see Fig. 4. Now you can screw the face (E) to the platform (B).

**SUPPORTS.** To hold the vertical face in place, I added a pair of supports (F), see Figs. 5 and 5a. Each support is cut from a square blank, then they're screwed to

the base and the vertical face.

To make sure the vertical face stays 90° to the saw table, clamp each support to the platform and vertical face, see Fig. 5.

holes and screw them in place.

**HANDLE.** Finally, to make it safe and easy to push the tenoning jig, I added a *handle* (G) cut from 3/4" plywood, see Fig. 6.

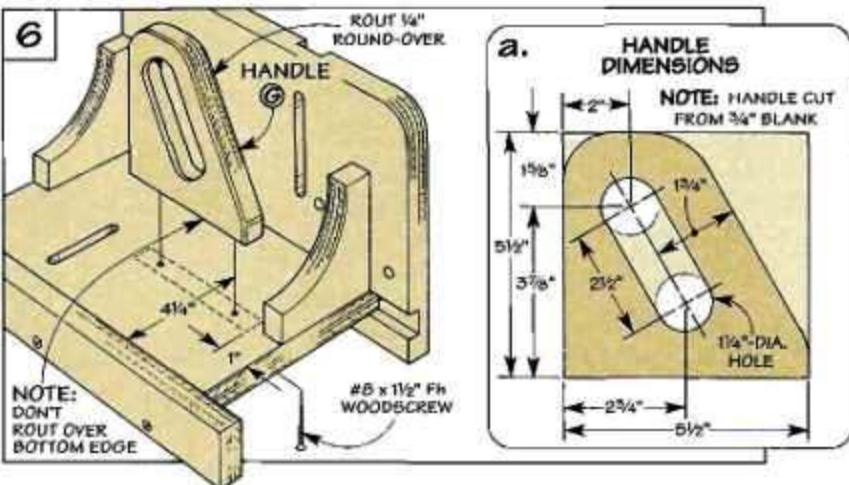
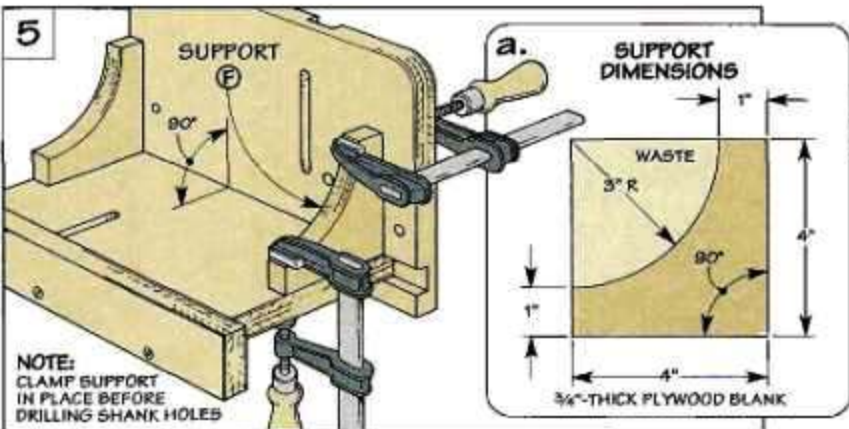

# The Runner



**Adjustable Runner:** Screws in the side of the runner allow you to adjust the fit to compensate for seasonal changes in humidity.

After the handle is attached, the next step is to add a hardwood runner. The runner fits in a groove cut in the bottom of the base and keeps the jig (and workpiece) parallel to the blade. The only problem with using wood for the runner is it can bind with seasonal changes in humidity.

To solve this, I made the runner narrower (about  $\frac{1}{32}$ " ) than the miter gauge slot. Then I added adjustment screws, see photo above. This way the runner can be adjusted for a fit that's snug, but still slides smoothly.

**TWO STEPS.** Installing the runner is a two-step process. First, you need to locate and cut a groove in the base. Then cut the runner to fit the groove.

**GROOVE.** To locate the groove, start by extending the platform (B) as far as it will go, see Fig. 7. Then raise the blade and butt the vertical face against it, see Fig. 7.

Next, mark the side of the miter slot closest to the blade, see Fig. 7. Now cut a  $\frac{1}{4}$ "-deep groove on the waste side of this mark about  $\frac{1}{32}$ " less than the width of your miter gauge slot, see Fig. 8a.

**RUNNER.** After the groove is cut, the next step is to make the

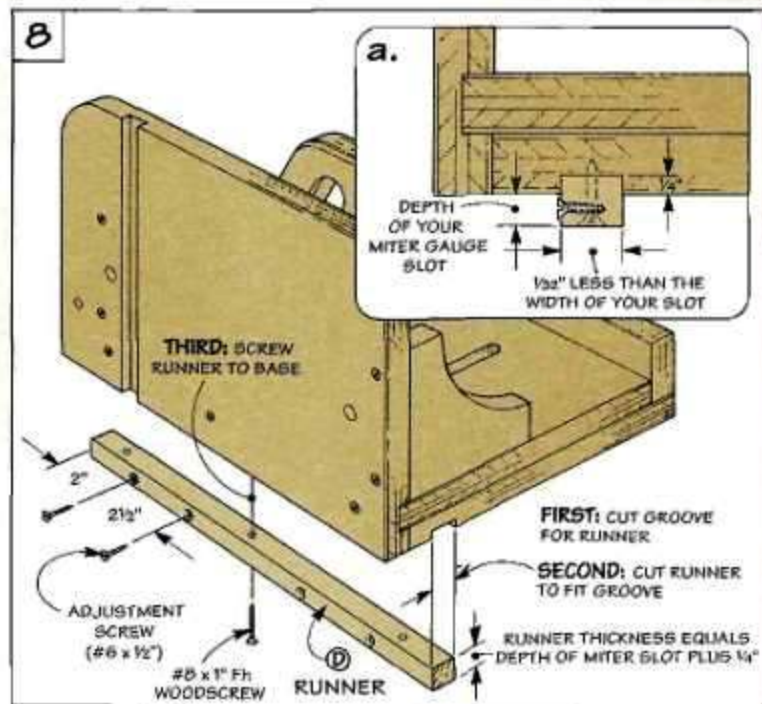
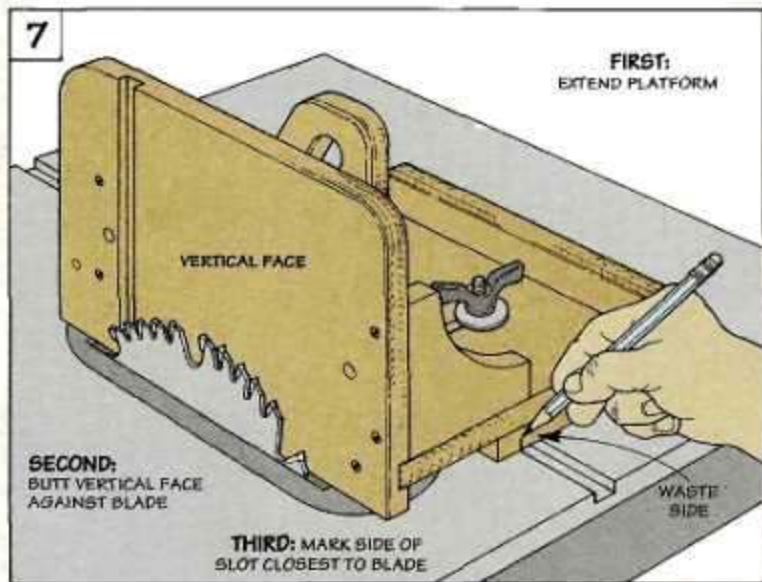

runner (D), see Fig. 8. (I used maple.) The length and width are easy. Cut the runner to match the length of the base (14") and to fit the groove in the base.

But the thickness may vary depending on the depth of your miter gauge slot. To determine the thickness, measure your slot and add  $\frac{1}{4}$ " for the groove in the base.

Then cut the runner to size.

Before attaching the runner to the base, drill countersunk holes in the side of the runner, see Fig. 8. Then add the adjustment screws, and screw the runner to the base.

**ADJUSTMENT.** Finally, adjust the runner by backing out each adjustment screw the same amount until the runner slides smoothly.

# Double-Stop System

The double-stop system is designed so you can accurately preset the movement of the vertical face. This allows you to cut both cheeks of a tenon *without* flipping the workpiece. (For more on this, refer to page 23.)

**STOP BLOCK.** I started work on the stop system by making the stop block (I), see Fig. 9. It's just a 1 $\frac{3}{4}$ " square piece of plywood with a notch cut in it for a length of  $\frac{1}{4}$ " threaded rod.

**NOTCH.** The trick is to cut the notch so it aligns with the hole you drilled earlier in the vertical face (for the threaded rod), see Fig. 9a. I made the notch by first drilling a  $\frac{1}{4}$ "-dia. hole using the vertical face as a template, see Fig. 10.

To do this, just clamp the stop block on the *inside* of the vertical face, see Fig. 10. Then, use the  $\frac{1}{4}$ "-dia. hole in the vertical face (for the threaded rod) to guide the drill bit through the block.

After the hole is drilled in the stop block, complete the notch with a sabre saw or band saw.

**STOP BAR.** A hole drilled in the stop bar supports the other end of the threaded rod. To drill this  $\frac{1}{4}$ "-dia. hole, I used the notch in the stop block as a guide. Simply clamp the stop block (I) to the stop bar (H), rest the drill bit in

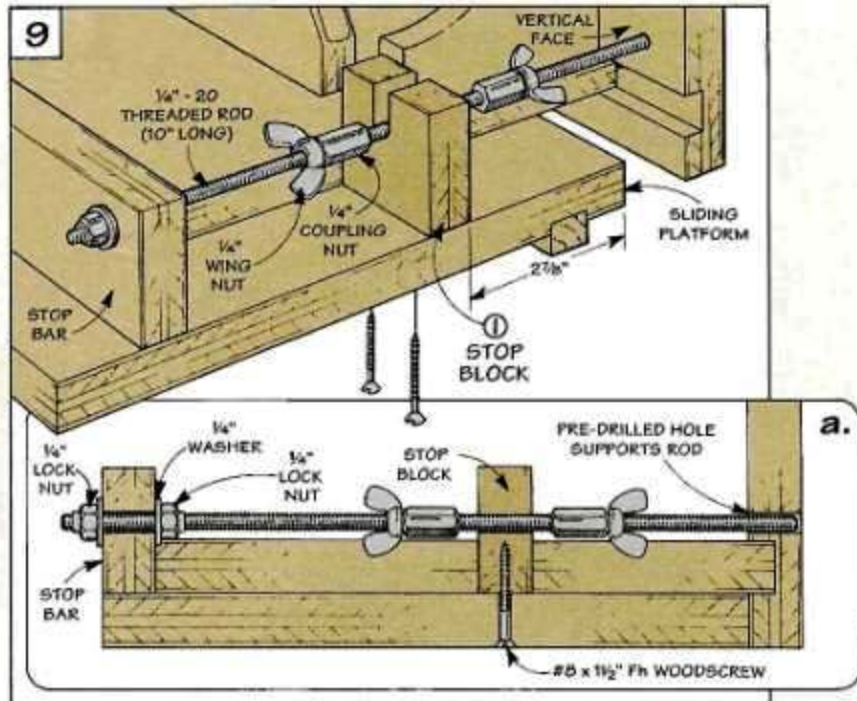

the bottom of the notch, and drill the hole, see Fig. 11.

Once this hole is drilled, screw the stop block to the sliding platform, refer to Fig. 9.

**ADD HARDWARE.** With the stop block in place, the last step is to add the threaded rod and hardware. A 10"-long piece of threaded rod runs through the stop bar, stop block, and into the vertical face, refer to Figs. 9 and 9a.

Threaded onto this rod (on

each side of the stop block) are a coupling nut and a wing nut.

The coupling nuts butt up against each side of the stop block and allow you to preset one of the cheek cuts. The wing nuts lock the coupling nuts in place after they've both been positioned.

To keep the threaded rod from spinning when the wing nuts are tightened down, I used two lock nuts and washers to secure the rod to the stop bar, refer to Fig. 9a.

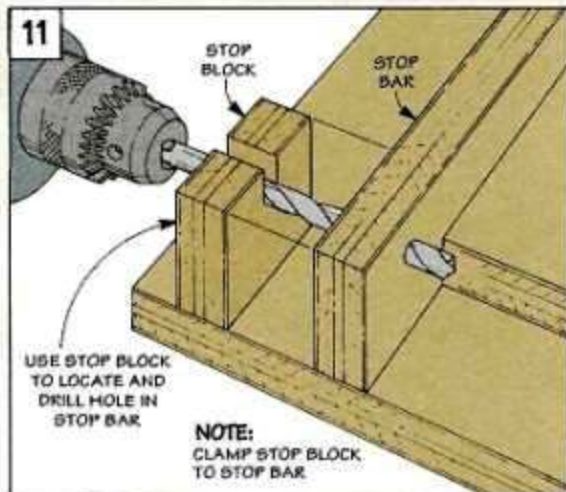
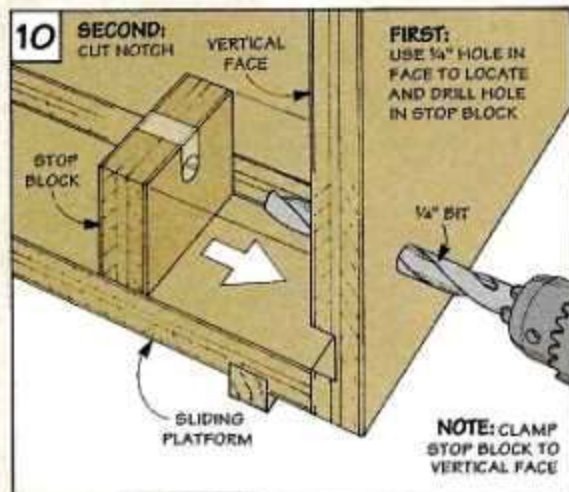

## Back Stop

The *back stop* (J) of the tenoning jig helps keep the workpiece vertical. And it acts like a push block to push the workpiece through the saw blade, see Fig. 12.

**SLOTTED DADO.** The back stop is a  $\frac{3}{4}$ "-thick piece of hardwood that fits in the dado (cut earlier) in the vertical face. The slot in the dado makes the stop adjustable (For more on this, see page 23.)

The back stop is held in place with a carriage bolt and a wing nut. To locate the hole for the bolt, insert the stop in the dado flush with the bottom of the base (A). Then make a mark near the bottom of the slot. Finally, drill the hole and bolt the back stop in place, see Fig. 12a.

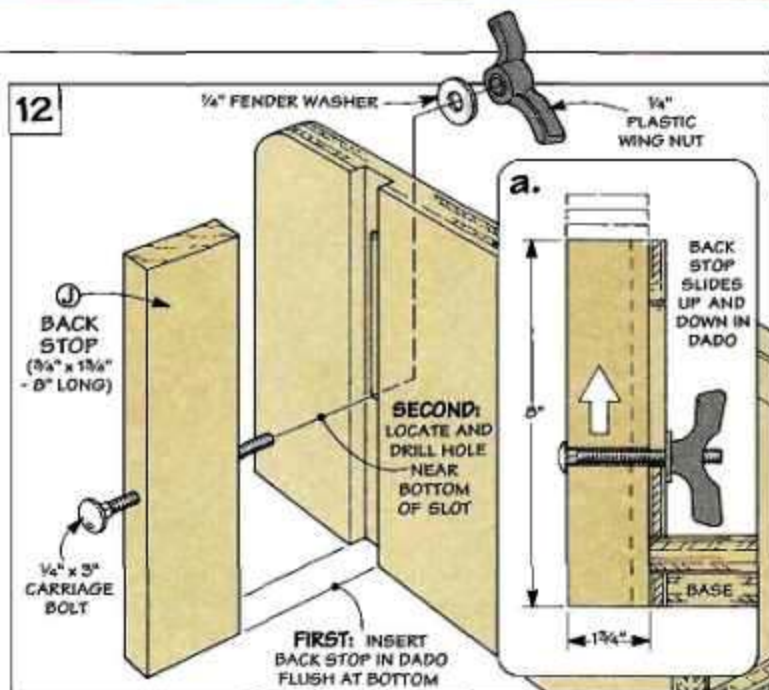

## Hold-Down Bar

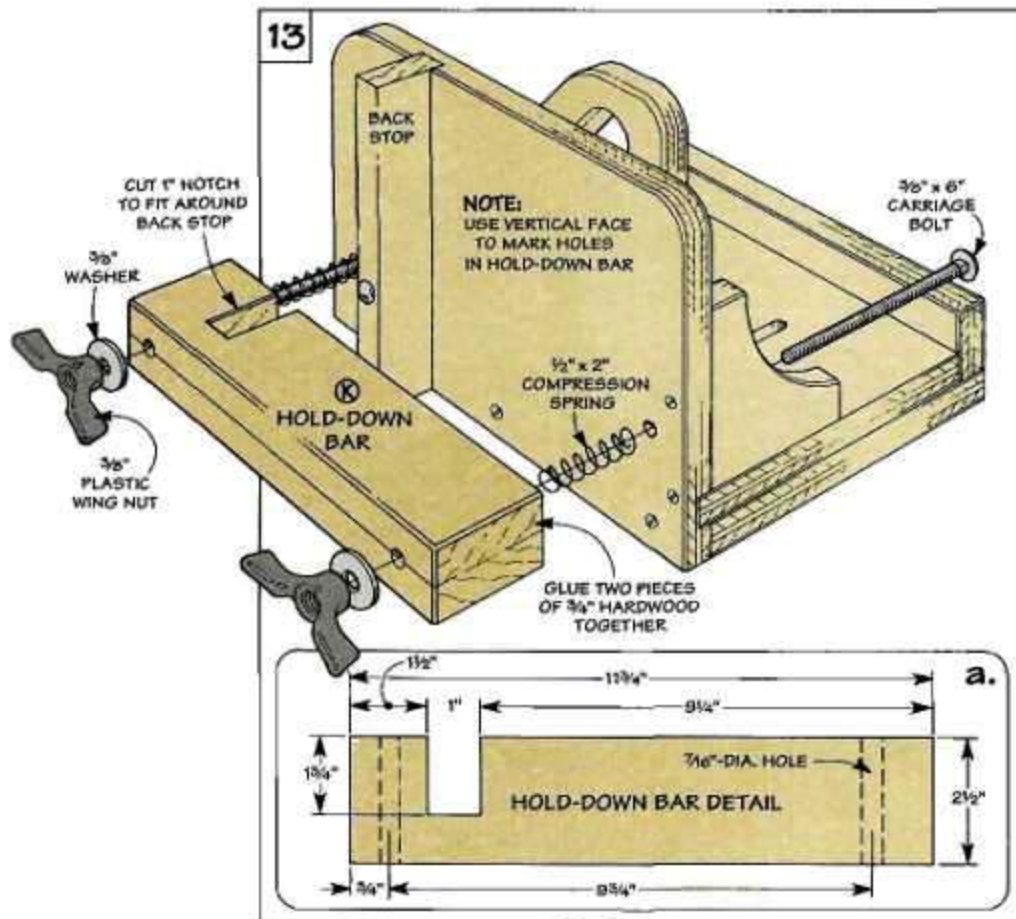

To keep the workpiece in place during a cut, I added a spring-loaded *hold-down bar* (K), see Fig. 13. I glued up the bar from two pieces of  $\frac{3}{4}$ "-thick stock.

**NOTCH.** The next step is to cut a notch near the end of the hold-down bar to fit around the back stop (J), see Fig. 13a.

**CARRIAGE BOLTS.** The clamping power comes from a pair of  $\frac{3}{8}$ " carriage bolts and wing nuts. The bolts run through the hold-down bar and pass into the  $\frac{3}{8}$ "-dia. holes in the vertical face you drilled earlier, see Fig. 13.

To mark the holes in the hold-down bar, use the holes in the vertical face as a template. After the holes are drilled, install the carriage bolts.

**SPRINGS.** Next, I slipped a pair of springs over the bolts to push open the hold-down bar as the wing nuts are loosened.

**FINISH.** With the hold-down bar complete, the only thing left is to soften the sharp edges on all the jig parts and apply a finish. (I wiped on two coats of tung oil.)



# Using the Tenoning Jig

*Setting up the tenoning jig to cut precise tenons is a simple four-step process.*

## Step 1: Adjust Blade Height.

First, lay out the tenon on the workpiece (see page 25). Then butt the workpiece up against the back stop and clamp it in place with the hold-down bar. Next, adjust the height of the blade for desired depth of cut (length of tenon).

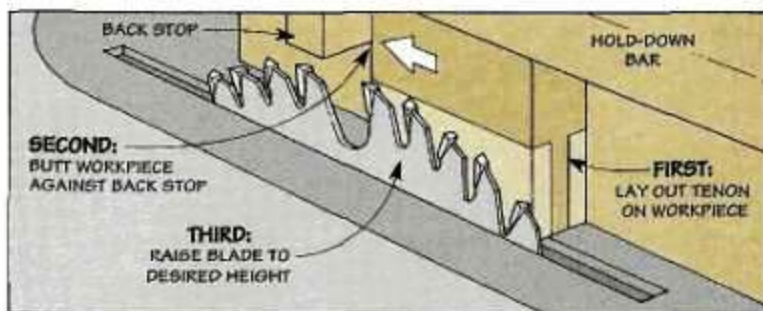

## Step 2: Adjust Back Stop.

Now you can adjust the back stop. To do this, slide the tenoning jig so the back stop is over the blade. Then lower the back stop until it just touches the saw blade at its highest point.

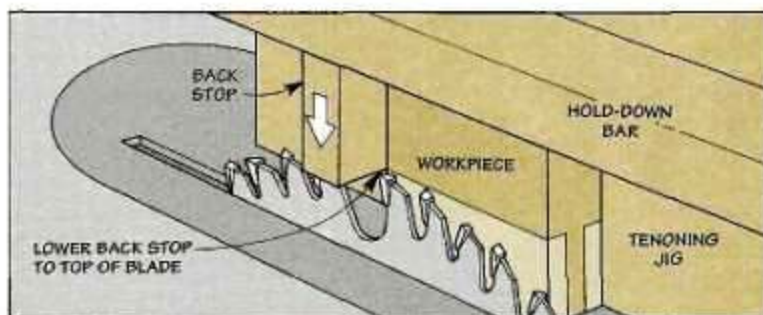

## Step 3: Set Stop for Inside Cut.

To set the cut for the inside cheek, slide the platform so the blade aligns with the inside layout line. Then thread the left coupling nut against stop block and tighten the wing nut.

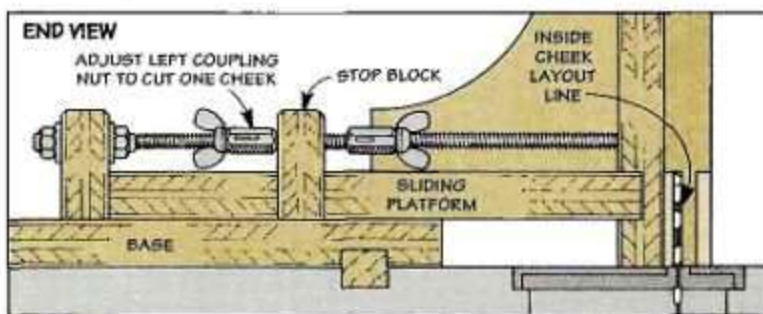

## Step 4: Set Stop for Outside Cut.

Now, move the platform so the blade aligns with the layout line for the other cheek. Then adjust the right coupling nut, tighten the wing nut, and make a test cut. To complete the tenon, remove the workpiece and make the shoulder cuts (see page 26).

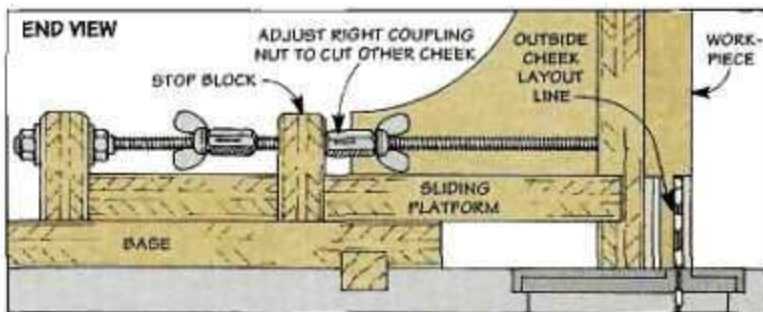

# Tips for Cutting Tenons



**A** tenon has two essential parts — the cheeks and the shoulders, see Fig. 1.

**CHEEKS.** The purpose of the cheeks is to provide a gluing surface against the sides of a mortise (a square hole or slot cut in the adjoining piece to accept the tenon).

When you cut the cheeks, you also define the thickness of the tenon. This is the critical dimension for a strong glue joint — the tenon must be thick enough to fit snugly into the mortise. But not so tight that it squeezes the glue out of the joint.

**SHOULDERS.** The other important parts of a tenon are the shoulders. The shoulders are designed to do a couple of things.

First, they cover up any small gaps around the mortise. And they contribute to the mechanical strength of the joint.

In its simplest form a tenon has two long shoulders which are cut on the *faces* of the workpiece, see Fig. 1.

These shoulders define the length of the tenon and deter-

mine how deep the tenon slides into the mortise.

In addition, many woodworkers also cut short shoulders on the *edge* of the workpiece, see Fig. 1. These short shoulders create resistance to any up and down movement of the tenoned piece.

## CUTTING A TENON

There are two basic methods for cutting a tenon on the table saw — the single-pass method and the multiple-pass method, see Figs. 2 and 3.

**SINGLE-PASS.** With the single-pass method, the workpiece is held *vertically* in a jig and passes through the saw blade to cut one cheek at a time, refer to Fig. 2. (For more on this, see page 23.)

Then the workpiece is taken out of the jig to make the shoulder and the thickness of the tenon cuts.

By cutting tenons like this, it's easy to produce a very smooth cheek — which makes an excellent gluing surface.

**MULTIPLE-PASS.** When you use the multiple-pass method on

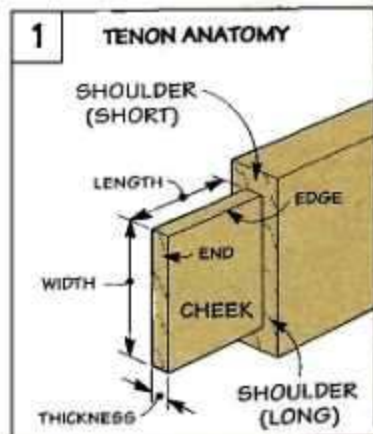

the other hand, the workpiece is laid *flat* on the table saw, see Fig. 3. The tenon is then cut by making a series of passes over a saw blade (or dado blade).

Since the first cut is made at the shoulder line, both the shoulder and the thickness of the tenon are established with one cut.

This method requires very little set-up time and is a quick way to cut tenons, especially if you're cutting just a few. The only problem is it can leave a rough glue surface on the cheeks.

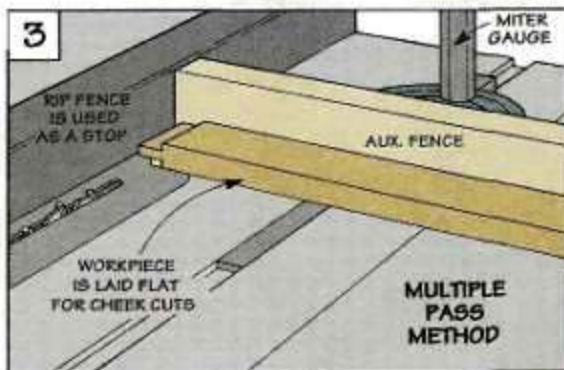



## Preparation and Lay Out

Even before you lay out the size of the tenon there are a couple of things you can do to ensure a good fit.

**STOCK PREPARATION.** First, square up the ends and edges of all the pieces. This will prevent gaps around the shoulders of adjoining pieces.

Second, if you are cutting tenons of the same size on several pieces, make sure all the pieces are identical in thickness. Otherwise the thickness of the tenon will vary according to the thickness of each piece.

**LAY OUT.** After the stock is prepared, the next step is to lay out the tenon. Note: I always cut the mortise first, then size the tenon to fit. This way I can use the mortise as a template, see Step-by-Step drawings at right.

**ShopTip:** I like to use a knife to transfer dimensions because the sharp lines are more precise than a pencil line.

**TRANSFER DIMENSIONS.** To transfer the dimensions of the mortise to the workpiece, start by marking the thickness of the tenon, see Step 1. Then, mark the width of the tenon, see Step 2.

Finally, mark the length of the tenon on the workpiece and check the depth of the mortise to make sure it will fit, see Steps 3 and 4.

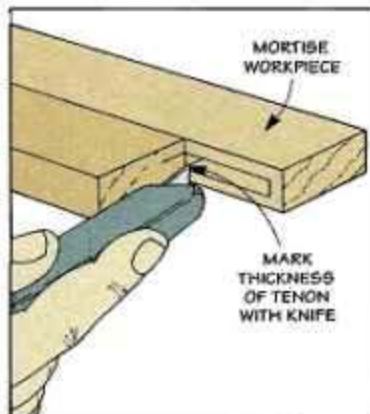

**Step 1: Mark Thickness.** Butt the workpiece against mortise and lay the knife blade flat on the mortise to mark the tenon thickness.

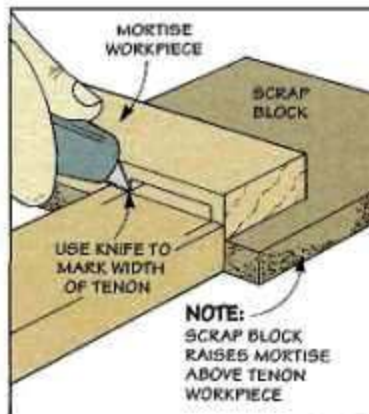

**Step 2: Mark Width.** Place the tenon perpendicular to the mortise and flush at the end to mark the width of the tenon.

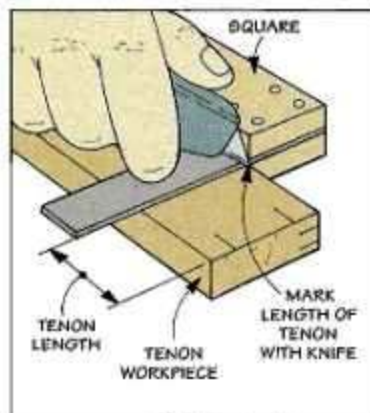

**Step 3: Mark Length.** Next, mark the length of the tenon on the workpiece. Once again, use a knife to score the lines.

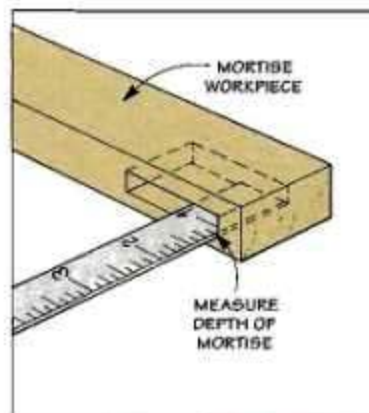

**Step 4: Check Depth.** Finally, to make sure the tenon will fit in the mortise, insert a ruler in the mortise and measure the depth.

## Square or Round Tenons?

If you use a drill press or a router to cut a mortise, you'll end up with a mortise that's rounded on the ends — a slot. This leaves you with the old square peg in a round hole problem.

There are two basic solutions to this. You can either square up the mortise, or round over the tenon.

**SQUARE MORTISE.** Whenever I use a drill press to rough out a mortise, I square up the mortise.

That's because I have to use a chisel to clean up the sides anyway — it only takes a few more minutes to square up the corners of the mortise.

**ROUND TENON.** On the other hand, if I use a router to cut a nice clean slot mortise, I think it's better to round over the edges of the tenon. Use a file to round over the square edges of the tenon to match the mortise.



## Test Fit

The secret to getting a tenon to fit snugly in a mortise is to make trial cuts on a test piece. (Note: The test piece must be *exactly* the same thickness as the workpiece.)

**SINGLE-PASS.** To do this with the single-pass method, make the cheek cuts. Then, since the waste isn't removed until the shoulders are cut, saw off a corner of each waste piece to check the fit, see Fig. 1.

**MULTIPLE PASS.** If you're using the multiple-pass method, take a few passes to create a "mini" tenon at the end, see Fig. 2.

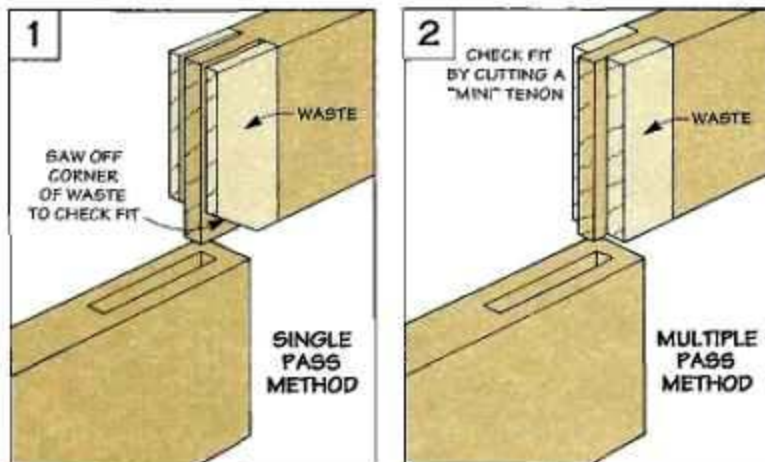

## Shoulder Cuts

If the workpieces have tenons on both ends (such as the rails for a frame), the distance between the shoulders is critical. If they're not the same on every workpiece, the frame won't be square.

**STOP BLOCK.** One way to cut accurate shoulders is to add a long fence to the miter gauge and use a stop block, see Fig. 1. The stop positions the workpiece precisely for every cut. The fence prevents chip-out, and reduces kickback.

**LONG WORKPIECE.** If the workpiece is long, clamp a stop block to the rip fence, see Fig. 2. Then, butt the workpiece against the stop block and clamp it in place before making the cut.

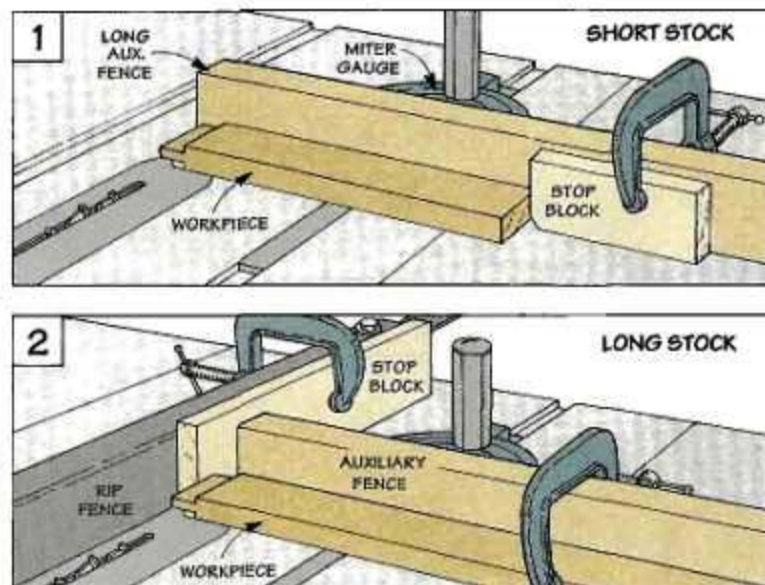

## Duplicate Tenons

Here's a quick tip when you need to cut several identical pieces with tenons on the ends (such as rails for a set of frames).

**WIDE BLANK.** Instead of cutting the pieces individually, start with a wide blank and cut tenons on the whole width of the blank, see drawing.

**RIP STRIPS.** Now just rip the blank into strips to produce pieces with identical tenons.

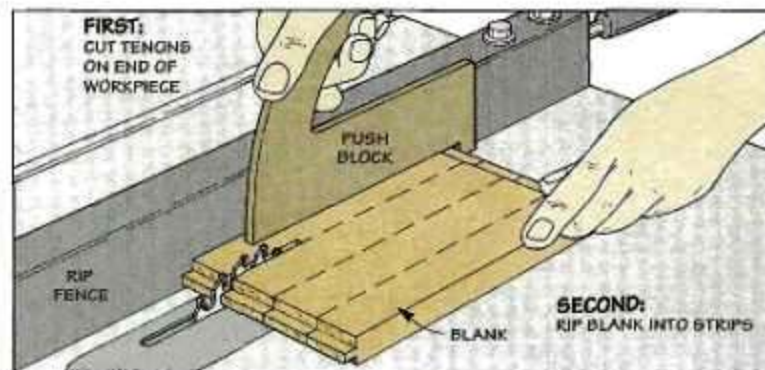

## Stepped Shoulders



A common problem when cutting tenons is that the shoulders come out uneven, see photo. This is usually caused by a rip fence that isn't 90° to the table, see Fig. 1.

As you cut the long shoulders, the piece contacts the fence at the bottom, see Fig. 1. But when you flip the piece on edge to cut the short shoulders, it contacts the fence

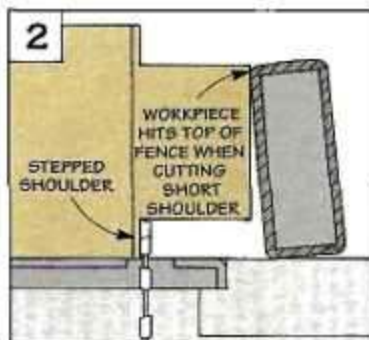
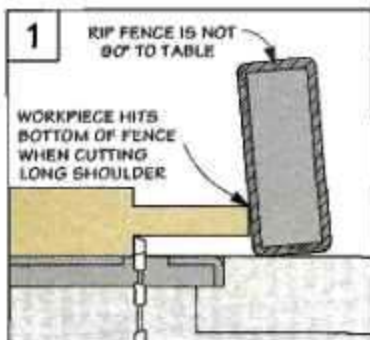

higher up, see Fig. 2. This pushes the piece away from the blade creating a "stepped" shoulder.

**SOLUTIONS.** The best way to solve this is to adjust the rip fence on your saw.

Another way is to clamp a block to the fence, see Fig. 3. This doesn't eliminate the problem, but it does minimize it.

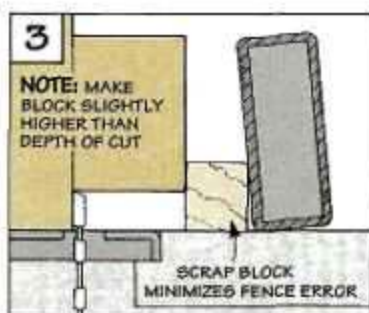

## Undercutting



The saw blade often leaves a "ridge" between the cheek and shoulder, see photo. This prevents the shoulder from fitting tight against the mating workpiece.

**UNDERCUT TENON.** One way to get around this is to undercut the tenon. I do this by making the shoulder cuts slightly deeper ( $\frac{1}{32}$ ") than the cheek cuts, see Fig. 1.

**SHOULDERS.** Another way is to undercut the inside corner of the shoulders with a chisel, see Fig. 2. Just pare away a small amount of end grain leaving a  $\frac{1}{16}$ " wide border.

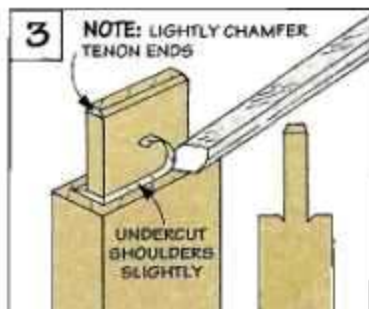
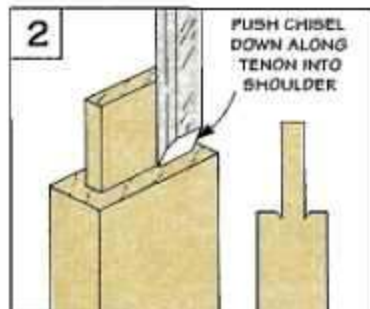
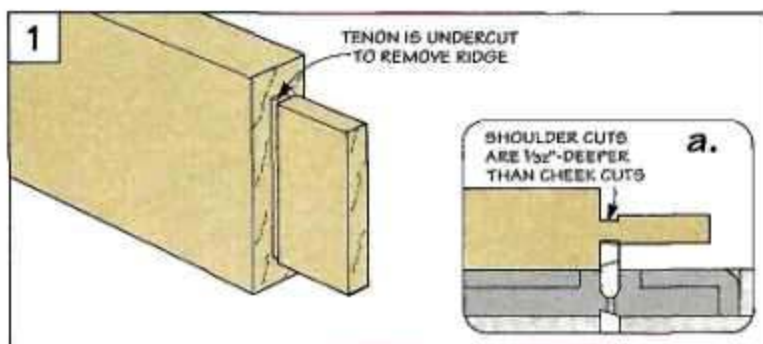

To do this, start by pushing the chisel straight down alongside the tenon, see Fig. 2. Do this all the way around. Then, tip the chisel at an angle to remove the

waste around the shoulder of the tenon, see Fig. 3.

**CHAMFER ENDS.** Finally, pare a slight chamfer on the ends of your tenons, see Fig. 3.

# Shop Solutions

## Zero Clearance Insert

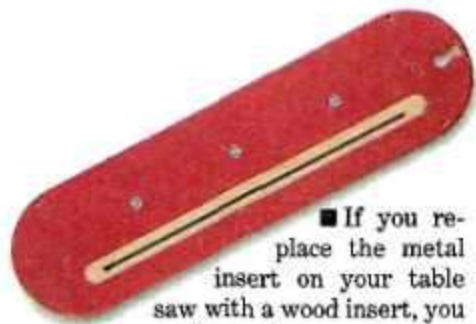

■ If you replace the metal insert on your table saw with a wood insert, you can cut a “zero clearance” slot just wide enough to keep small pieces from falling into the blade opening.

The only problem is if the metal insert is *thin*. When you pass a

workpiece across a thin wood replacement insert, there's enough flex in the insert to affect the cut.

So instead of replacing it, I made a “filler” just large enough to reduce the size of the blade opening in the metal insert. To do this, cut away the top surface of a 1/2”-thick piece of stock, leaving a strip wide enough to fill the opening, see Fig. 1. Then round the ends of the strip to match the opening.

Note: Before attaching the filler to the metal insert, you may need to cut a groove in the bot-

tom. This allows the blade to clear the filler when you set the insert in the table.

Next, the filler is attached to the insert with machine screws and nuts. This requires drilling countersunk holes in the insert.

When cutting the zero clearance opening, clamp a board to the rip fence to hold down the insert, see Fig. 2. Then lock the fence, turn on the saw, and raise the blade through the filler.

Thomas Wilson  
Carterville, Illinois

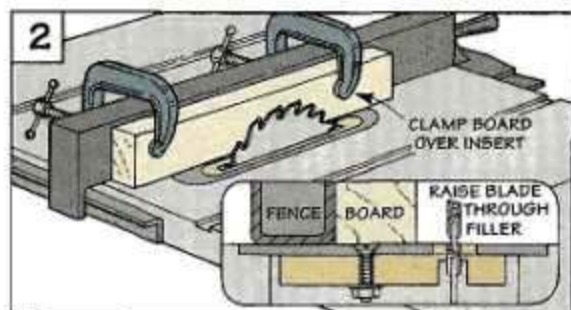
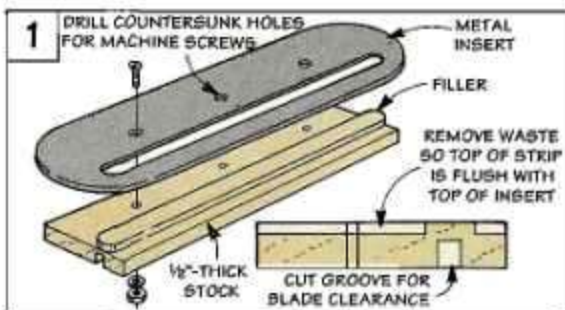

## Depth Gauge

■ To save time when adjusting the depth of a router bit, I use a simple gauge. The gauge is a block of wood with a series of flat-bottomed holes drilled at increasing 1/8” depths, see Fig. 1. (I used a Forstner bit to drill the holes.)

After drilling the holes, rip the front edge off the block, see Fig. 2. This creates a cutaway view of the holes and makes it easy to see when the bit is “zeroed in” at the desired depth.

To set the depth of a cut, all I have to do is lower the bit in the correct hole until it just touches the bottom of the hole.

F. J. Palumbo  
Bowie, Maryland

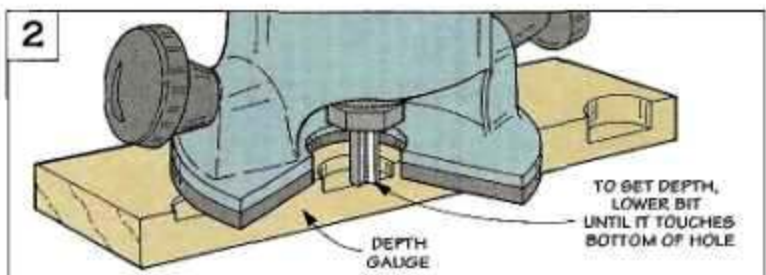
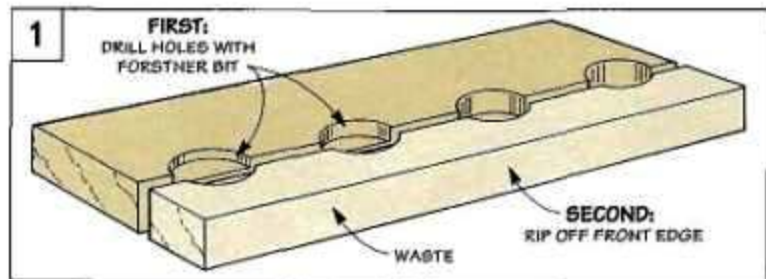

## Cut-Off Jig for Circular Saw

■ Making a square cut on the end of a board with a circular saw can be a problem. To ensure accurate cuts, I use this cut-off jig to guide the saw, see drawing.

The jig has three parts: a *base*, a *saw guide*, and a *cleat*.

The idea here is simple. The saw rides against the guide, so the edge of the base marks the cut-off line for the blade. To keep this edge square to the work, the cleat butts up against the edge of a workpiece when making a cut.

The only trick to making the jig is to leave a little "waste" on the right side of the base when you screw on the guide, see detail. Your first cut trims the waste and creates a reference for future cuts.

*Donald Myers  
Alliance, Ohio*

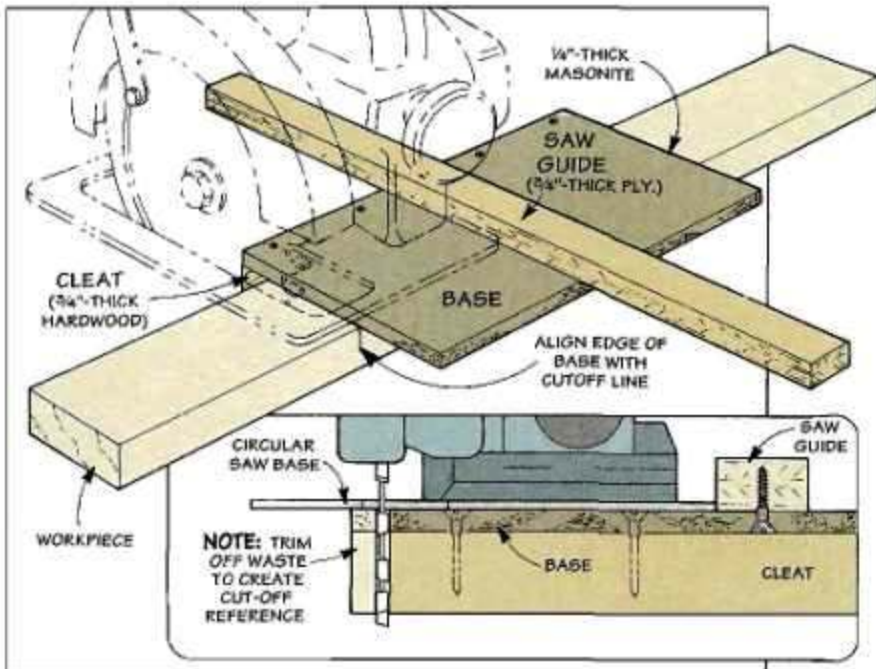

## Squaring a Mitered Corner

■ Using a band clamp on a project with mitered corners can cause the miters to slip out of alignment as the clamp is tightened.

So in addition to the band clamp, I clamp short pieces of aluminum angle "iron" to the *inside* of each corner to draw the miter together.

To allow room for glue squeeze-out, round the corner of the aluminum angle, see detail.

*Claud Fisher  
Kalispell, Montana*

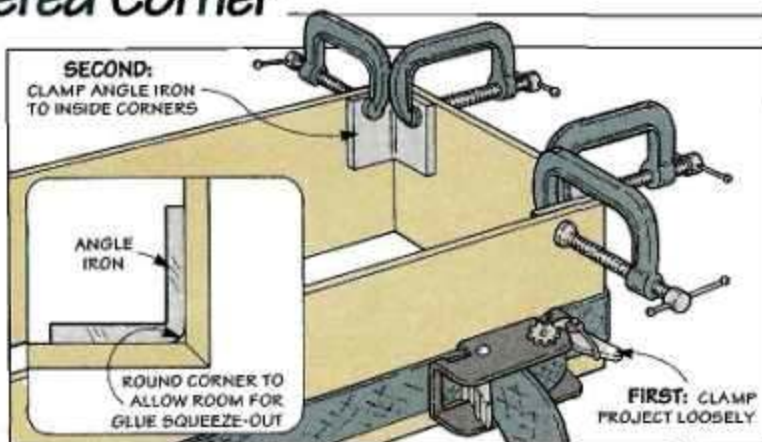

## Tip for Mortising a Hinge

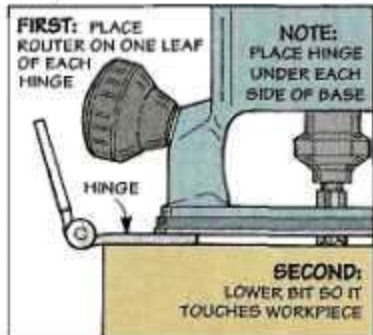

■ Here's an easy way to find the *exact* depth of cut when routing a mortise for a hinge. Just use a pair of hinges to support the base of the router.

Then lower the bit so it touches the workpiece. Now remove the hinges and make the cut. The mortise will be just the right depth.

*Michael Edelman  
Staten Island, New York*

### Send in Your Solutions

If you'd like to share original solutions to problems you've faced, send them to: *ShopNotes*, Attn: Shop Solutions, 2200 Grand Ave., Des Moines, IA 50312.

We'll pay up to \$200 depending on the published length. Send an explanation along with a photo or sketch. Include a daytime phone number so we can call you if we have questions.

# Knock-Down Fittings



Some of the projects I build are designed with one idea in mind — to be “knocked down” and reassembled quickly and easily.

This requires a specialized piece of hardware — a knock-down fit-

ting. Basically, these fittings hold the parts of a project together *mechanically* instead of with glue.

Because of this, the joinery involved in building a project is simplified considerably. Just cut

the pieces to final size to form either a butt joint or lap joint. Then fasten the pieces together with a knock-down fitting. The result? A strong joint that can be taken apart and reassembled.

## PIN AND COLLAR

One of the most ingenious knock-down fittings is this steel pin and collar connector.

The pin threads into an expanding nut which spreads the “fingers” of the nut and locks it in place. A cam-operated “collar” in the mating workpiece accepts the head of the pin. Turning the collar captures the pin and draws the pieces tight.

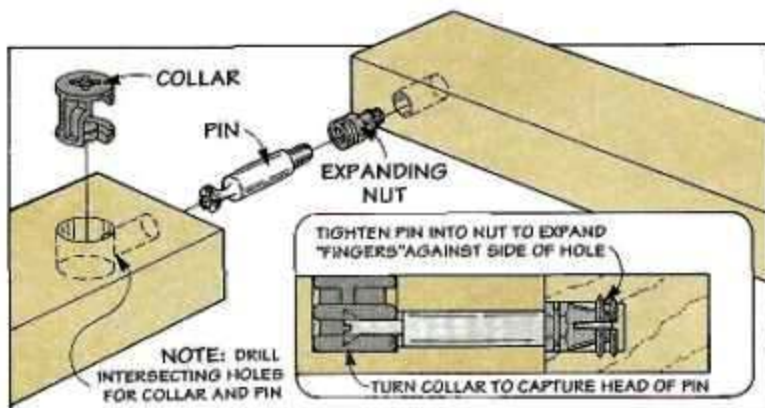

## CONNECTOR BOLT

It's hard to imagine a simpler knock-down fitting than this connector bolt.

After passing through a hole in one piece, the bolt is threaded into a cap nut installed in the mating workpiece, see drawing. An Allen wrench fits into a recess in the head of the bolt to tighten (or disassemble) the joint.

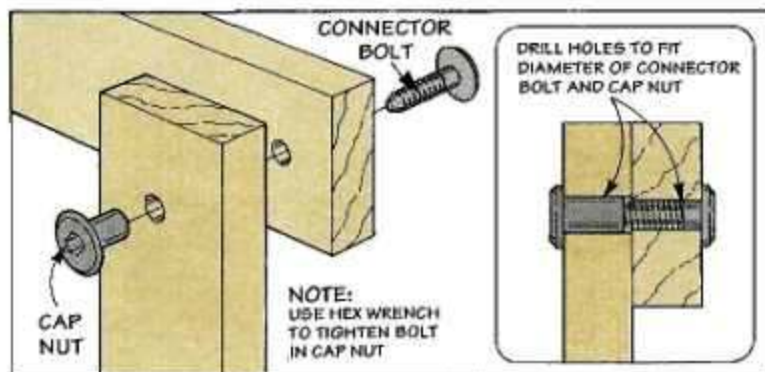

## CROSS-DOWEL

A connector bolt can also be used to join pieces together at right angles. But here the bolt is threaded into a hole in a steel cross-dowel. To align the hole with the bolt, just turn the slot on the end of the cross-dowel.

Since the cross-dowel is perpendicular to the grain, it provides a strong anchor for the bolt.

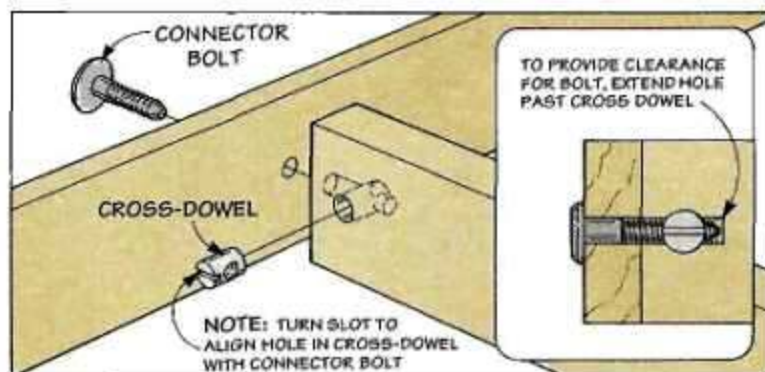

# Sources

*ShopNotes Project Supplies* is offering some of the hardware and supplies needed for the projects in this issue.

We've also put together a list of other mail order sources that have the same or similar hardware and supplies.

## DRILL PRESS TABLE

We're offering a hardware kit for the Tilting Drill Press Table shown on page 4. The kit includes all of the hardware necessary to build this project. You will need to supply all of the wood.

Note: The plastic knobs can also be ordered separately, see column at far right.

**S6806-200** Drill Press Table Hardware .....\$21.95

## ADJUSTABLE STOP BLOCK

*ShopNotes Project Supplies* is offering a kit that contains all of the hardware (not the wood) needed to build the Adjustable Stop Block shown on page 8.

Note: The star knobs and the steel T-slot nuts can also be purchased separately, see column at far right.

**S6806-100** Adjustable Stop Block Hardware .....\$13.95

## BAR CLAMP

For your convenience we are offering a hardware kit to make the Bar Clamp shown on page 12. This kit includes all of the hardware (but not the wood).

Note: The plastic wing nut is also available separately, see column at right.

**S6806-300** Shop-Made Bar Clamp Hardware ....\$10.95

## FAST ACTION CLAMP

*ShopNotes Project Supplies* is also offering a hardware kit to make the Fast Action Clamp featured on page 14. The kit includes all of the hardware (not the wood) you need to build one clamp. (Brass strips can also be found at most local hobby shops.)

Note: The plastic star knob can also be purchased individually, see column at right.

**S6806-400** Fast Action Clamp Hardware .....\$6.95

## TENONING JIG

A hardware kit (not the wood) is available for the Tenoning Jig shown on page 16. Similar hardware can usually be found at local hardware stores.

Note: You can also purchase the plastic wing nuts individually, see below.

**S6806-500** Tenoning Jig Hardware .....\$8.95

## KNOBS & NUTS

*ShopNotes Project Supplies* is offering the knobs and nuts we used in this issue individually.

■ Star knobs have a plastic head and a threaded shaft. Refer to the article for the length you need.

**S1065-204** Plastic Star Knob, 5/16"-18 x 1"-long .....\$1.95

**S1065-208** Plastic Star Knob, 5/16"-18 x 2 1/4"-long .....\$2.50

■ The T-slot nut fits in a T-shaped channel, making it easy to attach accessories to a fence or table.

**S1045-516** T-slot Nut, fits 5/16"-18 threads .....\$3.50

■ A T-knob fits on the end of a threaded rod or bolt. The plastic knob protects your hand and provides extra leverage.

**S1065-215** Plastic T-Knob, fits 5/16"-18 threads .....\$1.65

■ Plastic wing nuts can be used on any length bolt or rod.

**S1065-403** Plastic Wing Nut, fits 1/4"-20 threads .....\$1.65

**S1065-110** Plastic Wing Nut, fits 3/8"-16 threads .....\$1.65

## MAIL ORDER SOURCES

Similar hardware and supplies may be found in the following catalogs. Please call each company for a catalog or for ordering information.

### Constantine's

800-223-8087  
Hardware, Knock-Down Fittings

### McFeely's

800-443-7937  
Knock-Down Fittings

### Trend-Lines

800-767-9999  
Knock-Down Fittings, Hardware

### Woodcraft

800-225-1153  
Plastic Knobs, Knock-Down Fittings, Hardware

### Woodhaven

800-344-6657  
Plastic Knobs

### The Woodworkers' Store

612-428-2199  
Plastic Knobs, Knock-Down Fittings, Hardware

### Woodworker's Supply

800-645-9292  
Knock-Down Fittings, Hardware

## ORDER INFORMATION

### BY MAIL

To order by mail, use the form enclosed with a current issue. The order form includes information on handling and shipping charges, and sales tax. Send your mail order to:

**ShopNotes  
Project Supplies  
P.O. Box 842  
Des Moines, IA 50304**

### BY PHONE

For fastest service use our Toll Free order line. Open Monday through Friday, 7:00 AM to 7:00 PM Central Time.

Before calling, have your VISA, MasterCard, or Discover Card ready.

**1-800-444-7527**

Note: Prices subject to change after Jan. 1, 1993.



## Scenes From the Shop

*Clamps of all shapes and sizes — even the workbench itself, have always been the cornerstones of a woodworking shop. While not as glamorous as some woodworking*

*tools, the versatility of clamps is almost endless. Whether used as an extra set of hands or to glue up a panel, clamps are one of the most used tools in the shop.*